



RADIO'S LIVEST MAGAZINE

Special RADIO VOCATION Number

Radio-Craft

November

25 Cents

Canada 35c

HUGO GERNSBACK Editor

WHERE DO I FIT IN IN RADIO?

See Page 275



New Opportunities in Radio - How to Make a Midget Preamplifier
New "Mystery" Ray - All-Wave Metal Tube "2" - Theatre Television

"Roaming Filaments"

The first all-metal tubes announced had the filament or heater circuits terminate at pins numbered 2 and 7. Subsequently, the metal tube 5Z4 was announced with a filament circuit terminated by pins number 2 and 8, so that two 8-prong sockets or an extra switch had to be incorporated in tube tester designs, unless socket contacts No. 7 and No. 8 were connected together within the tester, thereby providing incomplete test of ALL octal tubes.

Supreme engineers, however, foresaw at the time that other tubes would be announced in which a filament circuit would not necessarily terminate at pins No. 2 and No. 7 or No. 2 and No. 8, but that the filament COULD terminate at any one of eight possible positions. Supreme anticipated "Roaming Filaments" and incorporated in 1936 Models an exclusive feature "Filament Return Selection" whereby the filament current,

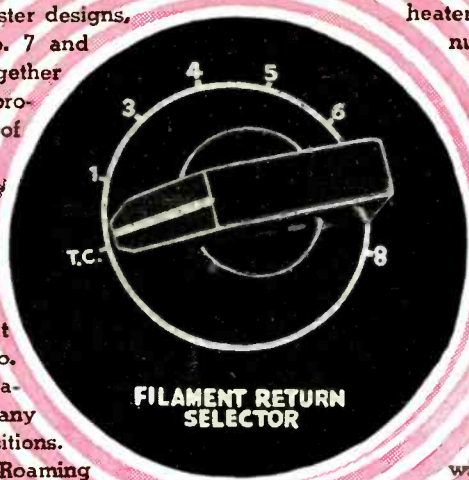

which may be considered as entering the No. 2 pin of octal tubes, could return through the "top cap" or through ANY of the tube base prongs.

This development enables Supreme owners to immediately take care of such new tubes as the type 6P7, just announced, in which the heater circuit is terminated by pins numbered 2 and 3 or any other new tube which may be announced in the future in which the filament (or heater) current returns through any pins other than those specified in the original series of octal tubes.

Remember, "Filament Return Selection" is found only in 1936 Supreme Instruments. An exclusive development of Supreme engineers, it is just one more reason most wide-awake servicemen are choosing new Supreme models in preference to any other make.

● **NEW SUPREME CATALOG NOW READY—FREE** ●
 Practically all good jobbers now have these instruments in stock for demonstration and for your inspection—Supreme's new complete catalog, just off the press and sent to you without obligation, tells you more about "Roaming Filaments."

SUPREME INSTRUMENTS CORPORATION

534 Supreme Bldg.
 Export Dept., Associated Exporters Co., 1457 Broadway, New York City.

Greenwood, Mississippi
 Cable Address, LOPREH, New York

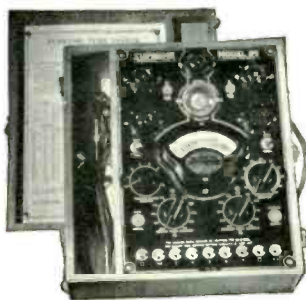

SUPREME 89—STANDARD TUBE TESTER

A new low priced Tube Tester, featuring Supreme's famous Neonized leakage test. \$34.95

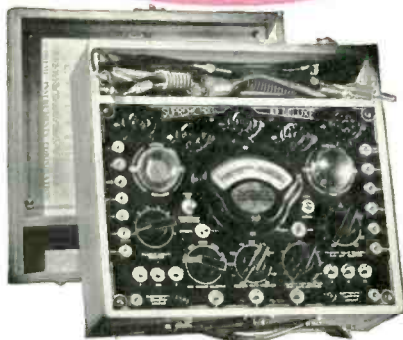

SUPREME 89 DELUXE TUBE TESTER

The 7-in-1 instrument. Resistance ranges to 20 megohms are with self-contained power supply . . . \$45.95

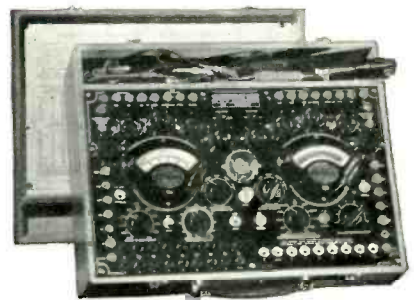

SUPREME 385—AUTOMATIC

A multi-unit instrument, combining features of 339—DeLuxe Analyzer and 89—DeLuxe Tube Tester, plus other flexibility features possible only through Supreme's exclusive uni-construction \$77.95



STUDENTS BUSY AT WORK IN GREAT COYNE SHOPS

Learn RADIO

SEND TODAY FOR DETAILS OF MY Pay-Tuition-after-Graduation Plan!

Train for Radio in 12 weeks, right here in the great Coyne Shops — not by correspondence — but on real Radio, Sound and Television equipment. Mail the coupon below. If you are short of money I'll send you all details of my finance plan and consider your application. If accepted, you won't have to start paying tuition back until five months from the date you start school, and then you'll have over a year to complete your payments.

Tremendous Developments Ahead in Radio and Television!

HERE is YOUR opportunity to cash in. Every day brings news of new developments in every branch of Radio and Television, with more opportunities, more jobs, and a greater future for the trained man than ever before. I consider the fellow who is ambitious enough to want to get ahead by taking my Training, worthy of my help. MAIL THE COUPON BELOW and you can prove to me that you are willing to spend just 12 weeks in the Coyne Training Shops learning Radio. Then, I'll tell you about my finance plan which has enabled many to get complete Training and pay tuition back later.

Learn By Doing In 12 Weeks

I don't care whether you are 16 or 45. It makes no difference to me if you don't know an oscillator from a spark coil. You don't need any previous experience or advanced education to master my Shop Training. Don't let lack of money hold you back from getting all details of my amazing plan.

MANY EARN While LEARNING

If you need part-time work to help pay your living expenses and will tell us your problems we may be able to help you as we have thousands of others. Then, in 12 brief weeks, in the great Training shops of Coyne, you will learn on a wide variety of modern, up-to-date A. C. Super-heterodyne sets, oscillators, analyzers and test instruments. Prepare for Amateur Broadcast, or Telegraph Radio Operator's License and to know all code and Dept. of Commerce rules for a government License Examination.

TRAINING

By Actual Work

No dull books . . . you get individual training . . . real actual work with only the theory you will need. Building real radio sets,



Auto Radio Instruction Prepare For Jobs Like These

Here are a few of hundreds of positions in the Radio field. My free employment bureau gives you life-time employment service.

- AIRCRAFT RADIO OPERATOR
- SHIP RADIO OPERATOR
- RADIO SERVICING
- PUBLIC ADDRESS SYSTEMS
- BROADCAST STATION OPERATOR
- TALKING PICTURE STUDIOS
- TELEVISION LABORATORY MAN

doing radio wiring and testing, trouble-shooting, repairing and servicing. That's a glimpse of how we help to make you a Radio expert, and fit you to qualify for jobs leading to the biggest pay.

Jobs - Pay - Future

"I got my present job two days after graduation, at shorter hours, and wages increased 60% over my old job," reports Arne Wiklem of Minnesota. "I have my own shop, own a real car and make fine money in the radio business," writes E. Allen of Montana, "All this is possible because I came to Coyne." And I could go on quoting from hundreds of letters of successful Coyne Trained men. What they have done, you should be able to do.

Electric Refrigeration Air Conditioning

Right now I'm including my big new Electric Refrigeration and Air Conditioning course at no extra cost.

GET THE FACTS

Coyne is your one great chance to get into Radio. This school is 36 years old—Coyne training is tested—proven beyond all doubt—endorsed by many large concerns. You can find out everything absolutely free. Simply mail the coupon and let me send you the big, free Coyne Book with photographs . . . facts . . . jobs . . . salaries . . . opportunities. Tells you how many earn expenses while training and how we assist our graduates in the field. This does not obligate you. So act at once. Just mail coupon.

Get this Free Book



Home of Coyne Shops

This is our fireproof modern Building wherein is installed thousands of dollars' worth of Radio equipment of all kinds. Every comfort and convenience has been arranged to make you happy and contented during your Training.



COYNE H. C. LEWIS, President **Founded 1899**
RADIO & ELECTRICAL SCHOOL
 500 South Paulina Street Dept. 85-8H, Chicago, Ill.

H. C. LEWIS, President
Coyne Radio & Electrical School
 500 S. Paulina St. Dept. 85-8H, Chicago

Dear Mr. Lewis: Without obligation send me your big free catalog and all details; also tell me all about your "Pay-Tuition-After-Graduation" Plan.

Name.....Age.....
 Address.....
 City.....State.....

Please Say That You Saw It in RADIO-CRAFT



CONTENTS—NOV., 1935, ISSUE

Volume VII

Number 5

ORSMAs Members' Forum	260
Editorial: Radio as a Vocation	Hugo Gernsback 263
The Radio Month in Review	264
An Improved Radio-Controlled Sailboat	Robert H. Packard 266
The New Mystery Ray	267
Some Facts About Radio as a Career	Wilhelm E. Schrage 268
A Beginner's All-Wave Metal Tube "2"	H. G. Cisin 270
"Finding Yourself" in the Technical World	271
Television and High Fidelity as a Study	271
Trained Radio Men	E. L. Richards 272
Making Money in Sound Recording	Arthur Heine 272
How to Make a Midget Preamplifier	Howard G. McEntee 273
The Radio Field as a Future	W. Werwath 274
A Multi-Range Meter Kit	D. L. Van Leuven 274
New Opportunities in Radio	R. D. Washburne 275
"Quality Control" an Aid to Old Sets	C. K. Krause 276
How to Equip a Sound Truck for Electioneering, etc., Part I	Charles R. Shaw 277
The Radio Engineering Vocation	E. B. Redington 277
Should I Take Up Radio?	J. B. Hershman 278
Important Data on Vibrator "B" Units	B. Thomas 278
Operating Notes	279
A "Radio" Bull-Fiddle	Edward Kassel 280
Selecting a Career in Radio	Louis L. Credner 280
The Listening Post for All-Wave DX-ers	C. A. Morrison 281
International Radio Review	282
Vocational Possibilities in Radio	283
Television in the Theatre, Part I	Alfred N. Goldsmith 283
How Metal Tubes are Made	284
Short-Cuts in Radio	285
Sweep and Wobble Circuits for Cathode-Ray Tubes	Alfred A. Ghirardi 286
The Correct Use of Loudspeaker Horns	R. C. Reinhardt 286
RADIO-CRAFT'S Information Bureau	287
An Easily-Built Universal Bridge	Hubert Shortt 288
Radio Student Requirements	J. F. Witkowski 288
The Latest Radio Equipment	289
What is the Future of Radio Servicing?	F. L. Sprayberry 291
RADIO CRAFT'S "Ideal Radio Service Shop" Contest	291
RADIO SERVICE DATA SHEETS:	
No. 149—Howard Model G-26, and Airplane Four, Model AA25 T.R.F. Set; Atwater Kent Model 649 All-Wave 9 Metal Tube Set	290
No. 150—Stewart-Warner "Ferrodyne" Chassis Model R-136 7 Metal Tube All-Wave Superhet.	292
Technicians' Data Service	294

HUGO GERNSBACK, Editor-in-Chief

C. W. PALMER
Associate Editor

H. G. McENTEE
Associate Editor

R. D. WASHBURNE, Technical Editor

EXPERIMENTAL RADIO IN OUR NEXT ISSUE

The forthcoming RADIO EXPERIMENTERS' issue of RADIO-CRAFT will be chock full of ideas and circuits which will whet the interest of every radio man whether he is a beginner or an "old hand at the game." Articles will be found on new apparatus and circuits with which every radio man will want to experiment.

Latest developments will be discussed from a practical angle so that as far as possible the experiments can be duplicated.

For those interested in electronics, there will be some interesting information concerning the photoelectric cell and its application.

The issue will be *experimental* even to the inclusion of an article on how to make a coil winder from parts found in the average junk box.

Ask your newsdealer today to reserve your copy!

RADIO-CRAFT is published monthly, on the first of the month preceding that of date; its subscription price is \$2.50 per year. (In Canada and foreign countries, \$3.00 a year to cover additional postage.) Entered at the post office at Mount Morris, Ill., as second-class matter under the act of March 3, 1879.

Text and illustrations of this magazine are copyright and must not be reproduced without permission of the copyright owners. We are also agents for WONDER STORIES and EVERYDAY SCIENCE AND MECHANICS. Subscription to these magazines may be taken in combination with RADIO-CRAFT at reduced Club rates. Write for information.

Copyright 1935. Continental Publications, Inc.

HUGO GERNSBACK, President I. S. MANHEIMER, Secretary

Published by Continental Publications, Inc. Publication office: 404 N. Wesley Ave., Mount Morris, Illinois. Editorial and Advertising Office: 99 Hudson Street, New York City. Chicago Advertising Office: L. F. McClure, 919 North Michigan Avenue, Chicago, Ill. Western Advertising Office: Loyd B. Chappell, 511 So. Alexandria St., Los Angeles, Calif.

European Agents:

London—Gorrings' American News Agency, 9A Green St., Leicester Square, London, W. C. 2.
Paris—Messageries Dawson, 4 Rue Faubourg, Poissonniere, Paris, France.
Australian Agent: McGill's Agency, 179 Elizabeth St., Melbourne.

Read what happened



YES!

I'll take your training. That's what S. J. Ebert said. He has made good money and found success in Radio.

to these two men when I said:



NO!

I'm not interested. That's what this fellow said. Today he would be ashamed if I gave you his real name.

I will Train You at Home in Spare Time for a GOOD JOB IN RADIO

These two fellows had the same chance. They each clipped and sent me a coupon, like the one in this ad. They got my book on Radio's opportunities.

S. J. Ebert, 104-B Quadrangle, University of Iowa, Iowa City, Iowa, saw that Radio offered him a real chance. He enrolled. The other fellow, whom we will call John Doe, wrote that he wasn't interested. He was just one of those fellows who wants a better job, better pay, but never does anything about it. One of the many who spend their lives in a low-pay, no-future job, because they haven't the ambition, the determination, the action it takes to succeed.

But read what S. J. Ebert wrote me and remember that John Doe had the same chance: "Upon graduation I accepted a job as serviceman, and within three weeks was made Service Manager. This job paid me \$40 to \$50 a week compared with \$18 I earned in a shoe factory before. Eight months later I went with station KWCR as operator. From there I went to KTNT. Now I am Radio Engineer with WSUL. I certainly recommend the N.R.I. to all interested in the greatest field of all, Radio."

Get ready for Jobs like these. Many Radio Experts make \$30, \$50, \$75 a week

Spare time and full time set servicing; installing, operating, maintaining broadcast, avi-

Get My FREE LESSON on Radio Servicing Tips

I'll prove that my Training gives practical, money-making information, that it is easy to understand—that it is just what you need to master Radio. My sample lesson text, "Radio Receiving Troubles—the Cause and Remedy" covers a long list of Radio receiver troubles in A.C., D.C., battery, universal, auto, T. R. E., super-heterodyne, all-wave, and other types of sets, and a cross reference system gives you the probable cause and a quick way to locate and remedy these set troubles. A special section is devoted to receiver check-up, alignment, balancing, neutralizing and testing. Get this lesson **Free**. No obligation. Just mail coupon.



"I want to help you. If you are earning less than \$35 a week I believe I can raise your pay. However, I will let you decide that. Let me show you what I have done for others, what I am prepared to do for you. Get my book, read it over, and decide one way or another." J. E. Smith.

ation, commercial, police, ship, and television stations. Opportunities with Radio dealers and jobbers. A service shop or retail Radio business of your own. I'll train you for these and other good jobs in connection with the manufacture, sale and service of Radio sending and receiving sets, auto Radios, loud speaker systems, short wave sets, etc.

Save Money—Learn at Home. Money Back Agreement Protects You

Hold your job. I'll train you quickly and inexpensively right at home in your spare time to be a Radio Expert. You don't need a high school or college education. My 50-50 method of training—half with lessons, half with Radio equipment—gives you broad practical ex-

perience—makes learning at home easy, fascinating, practical. I will agree in writing to refund your money if you are not satisfied with my Lesson and Instruction Service when you graduate.

Many Earn \$5, \$10, \$15 a Week in Spare Time While Learning

That's what many of my students earn in spare time while taking my Course. I send you Extra Money Job Sheets containing tested plans and ideas to help you do it. Many students have made \$200 to \$1,000 in spare time while learning. Nearly every neighborhood offers a spare time serviceman an opportunity to make good money. I'll show you how to "cash in"—show you why my Course is famous as "the Course that pays for itself."

Find Out What Radio Offers You

Mail the coupon. My book is free to any ambitious fellow over fifteen years of age. It tells you about Radio's spare time and full time opportunities—about my Course, what I give you, what my students and graduates do and earn. There is no obligation. Act today. Mail coupon in an envelope or paste on a 1c postal card. Do it right now.

J. E. SMITH, President
National Radio Institute, Dept. 5MX
Washington, D. C.



FOR FREE BOOK OF FACTS ABOUT RADIO

J. E. SMITH, President
National Radio Institute, Dept. 5MX, Washington, D.C.

Dear Mr. Smith: Without obligation, send me the sample lesson and your free book about spare time and full time Radio opportunities and how I can train for them at home in spare time. (Please print plainly.)

Name Age

Address

City State 14X-1

Please Say That You Saw It in RADIO-CRAFT



A department devoted to members and those interested in the Official Radio Service Men's Association. It is the medium for exchanging ideas, kinks, gossip and notes of interest to Service Men, or others interested in servicing.

THE "EXPERIMENTERS' NUMBER" OF RADIO-CRAFT WILL CONTAIN—

—All sorts of things for the man (young or old) who "makes things" just for the unadulterated pleasure it gives him. Experimental set-ups incorporating the new metal tubes of course will be included in the "technical feast"; so, too, will be novel circuit arrangements, construction data on an easily-built coil winder, a whole fistful of useful "kinks," a lot of information for electronics dabblers concerning photoelectric cell equipment, and scads of other good things we've not had an opportunity to print in past issues of RADIO-CRAFT. ORDER YOUR DECEMBER RADIO-CRAFT NOW!

ADDING EARPHONES

RADIO-CRAFT, ORSMA Department:

I have a side-line business of renting out radio sets for use in hospitals and in homes. I use mostly the small RCA Victor R27.

When these sets are used in the hospitals the use of speakers is not allowed. Therefore, I am forced to disconnect the speaker and hook up earphones. As it is a bother every time to do this and connect the speaker up again for home use, I inserted a double closed circuit jack in the set. This is put on the side by the volume control.

It now takes only a few seconds to plug in phone plug, and the speaker is cut out. Figure 1 shows connections.

I hope this idea may be of help to others.

R. S. BAKER,
Hudson, N.Y.

This idea will probably be of help to other members who rent sets, since it can be used not only for the purpose mentioned but can be sold to DX listeners (who often wish to use headphones), and for other purposes the alert Service Man will think of.

"CONDENSER TESTER"

RADIO-CRAFT, ORSMA Department:

I see that you published my condenser tester in the ORSMA department in the July issue of *Radio-Craft*.

I have received many letters pertaining to same, and asking whether it can be used to test electrolytic condensers.

The diagram, Fig. 2, shows how this is done. A S.P.D.T. switch, Sw. 1, is placed in position 1 when testing paper condensers, and in position 2 when testing electrolytics. The latter must be tested according to polarity. Switch Sw. 2 is closed when first testing electrolytics, for protection of the meter, then opened and a reading taken. If the condenser passes more than ½-ma. per microfarad, it should be discarded.

In testing paper condensers, with Sw. 1 in position 1, the voltage can be regulated to the working voltage of the unit being tested. The 500 V. D.C. meter is for this purpose, and while not absolutely necessary, it is very handy.

For further information, see *Radio-Craft* for July, 1935, page 35.

If you will publish the above information, you will save me a great deal of time and trouble in answering all the letters.

ALFRED KAFOURY,
Greenville, Miss.

We know this tester made a hit as we have received many letters of inquiry on it ourselves, so the comments of Mr. Kafoury will doubtless be of interest to those who have built the unit.

FOREIGN MEMBERS

RADIO-CRAFT, ORSMA Department:

We are specialists in radio servicing, and as one of our Service Men, who is a member of some of the Radio Institutes in your country is interested in your association, kindly let us know if the association is open to foreign members. If so, please state the terms and conditions of membership.

We thank you beforehand and await the pleasure of hearing from you.

JOSE FARIA, L. DA,
Porto, Portugal

We were indeed glad to welcome members from foreign lands. We are at present making negotiations with associations in both England and Australia to combine with us. Thus either individuals or existing organizations are eligible.

TIRE STATIC

RADIO-CRAFT, ORSMA Department:

I have come across a case of trouble that I think may be of interest to other members.

A very bad case of tire static was found to be coming from the tire casing patches, which had a coating of aluminum paint on the tube side.

Interference coming from this source seems to be worse on concrete or stone roads and is totally eliminated when the road surface is wet.

This type of interference is evidenced by a loud rasping sound in the speaker, the rapidity of which depends on the speed of the car, and the number of patches in the tire.

R. N. VAN GELDEN,
Sussex, N.J.

This is a very interesting hint and no doubt will be of help to many auto Service Men trying to track that elusive last trace of "static."

HOUSTON ORDINANCE

RADIO-CRAFT, ORSMA Department:

I note your item in *Radio-Craft* for August, relative to an ordinance to regulate and license Radiotricians, proposed by IRSMA of Houston, and Associated Radio Craftsmen of the same city.

"A reporter" is either ignorant of the facts or has made a gross misstatement,

(Continued on page 318)

Fig. 1, below. Adding a pair of headphones.

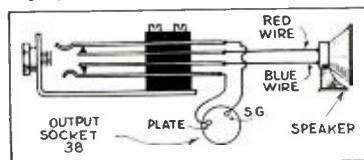
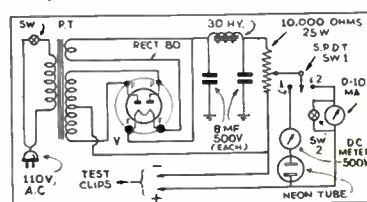
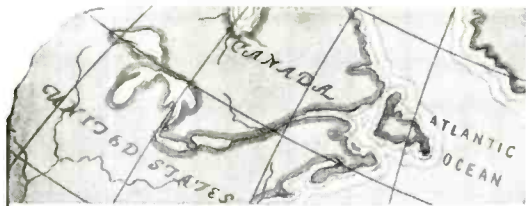
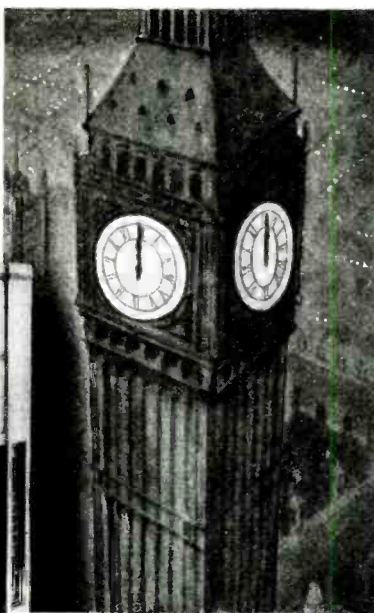
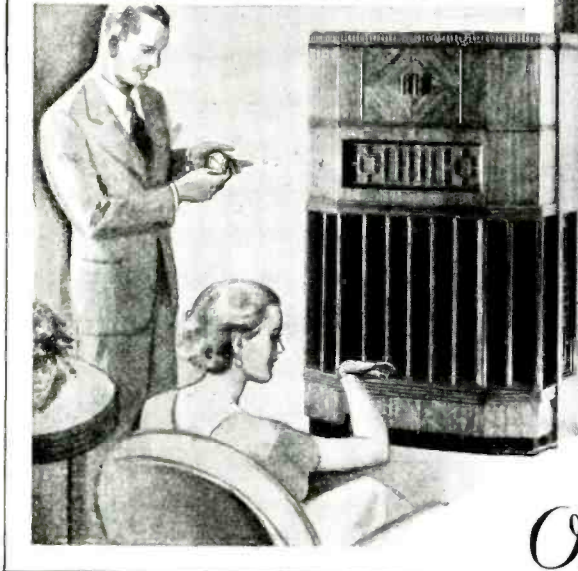

Fig. 2, below. Improved condenser tester.





— INTO YOUR OWN HOME —



— FROM ALL THE WORLD

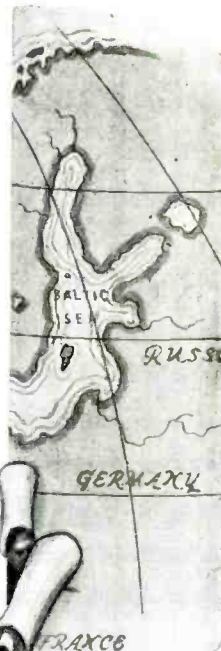

Brings **YOU PARLIAMENT'S MIDNIGHT CHIMES WITH SUCH THRILLING TRUE TONE**

Only the **SCOTT**
Full Range Hi-Fidelity
ALL-WAVE

London midnight — full of stars and historic towers! And the great chimes of Big Ben booming the hour across the darkness!

And in another quarter of the world: at the same instant—at a touch of the dial of your new SCOTT—you set your own watch to the same thundering measure of these great chimes ringing out over the British Parliament!

THE YARDSTICK FOR ALL DX RECEPTION

A nightly modern miracle — yours with the magnificent new SCOTT! World events—world views—inspiring music from foreign stations you have never heard before, brought in with a power and tonal splendor that stop your breath, so thrilling is the realism of SCOTT recreation.

SCOTT distance records are unchallenged throughout the radio world. London — Paris — Madrid — Geneva — Brussels — Berlin — Rome — all with the clear, enjoyable sparkle possible only with the SCOTT Higher Useable Sensitivity.

Reserve power not even claimed for any other receiver. "Peak" fortissimos of a Beethoven symphony or popular dance arrangement with a brilliance and freedom from distortion that elevates the SCOTT to a class by itself.

DOUBLE THE TONAL RANGE OF ANY RECEIVER

The SCOTT Full Range Hi-Fidelity AllWave is the only receiver today which captures all the dazzling overtones of voice, violin, oboe, and trombone, from the 16,000 cycle high fidelity stations. Regular high fidelity radios with 7,500 cycle limit miss more than half the overtone range.

BULLET DIRECT SELECTIVITY—Piercing the most powerful adjacent wave length stations to bring you more foreign stations than you have ever heard before. 2 to 16 K. C.

HIGHEST USEABLE SENSITIVITY—guaranteeing less noise on distance reception than any receiver today.

PERFECTED AUTOMATIC VOLUME CONTROL—keeps distant world programs at even level.

E. H. SCOTT RADIO LABORATORIES, INC.
4404 RAVENSWOOD AVE. DEPT. 24T5, CHICAGO, ILL.

DISTORTIONLESS PEAK RECEPTION — 35 Watts pure Class "A" output. Six times average power for unwarped tone.

SHORT WAVE STATION LOCATOR—gives clear momentary whistle when you tune in distant stations.

SOUND DIFFUSION—the only radio today with scientifically designed sound diffusers for perfect distribution of all tones.

FULL RANGE HI-FIDELITY — twice the tonal range of any other high fidelity receiver. 25 to 16,000 cycles.

THE RECEIVER THE CELEBRITIES OWN

The unparalleled performance of the SCOTT is backed by a five year guarantee of perfect service on all parts except tubes. Custom-built and sold direct from the laboratories on a thirty day home trial (U. S. A. only). Send TODAY for complete information on the new SCOTT Full Range Hi-Fidelity AllWave — the receiver owned by Toscanini, Jeritza, Rudy Vallee, Guy Lombardo, Walter Winchell, and many other celebrities.



SEND THIS COUPON TODAY—DETAILS FREE

E. H. SCOTT RADIO LABORATORIES, INC.
4404 Ravenswood Ave., Dept. 24T5 Chicago, Ill.

Send me complete details of the new SCOTT Full Range Hi-Fidelity AllWave, "94 PROOFS" of its superior tone and DX performance, and particulars of your 30 day trial offer.

Name _____

Street _____

City _____ State _____

Please Say That You Saw It in RADIO-CRAFT

RAYTHEON

TRADE MARK

presents

"33 DEALS FOR YOU!"

Raytheon's 33 New Tube Deals

offer a wide range of service equipment, designed to meet 1935-36 conditions including the special requirements of metal tubes and octal sockets.

"TUBE TALKS" Modern Radio Service and Merchandising (including tube complements). This 48-page book is hot-off-the-press, full of sales ideas, service tips and constructive suggestions, which have been tried out and proved in actual practice. Subjects cover not only radio tubes but also include sound methods applicable to all radio products.

Finally, 30 of the 48 pages are devoted to a tube complement section which lists the types and numbers of tubes required by various model receivers of 25 well-known radio manufacturers. This data covers over 2,000 models. This information should be available for reference, in all dealers' sales and service departments and by all independent service men.

This is the start of a service reference library. The binding, designed especially for this book, permits the addition of supplementary pages which we will supply periodically . . . We believe this book is unique and is worth many times the price placed upon it. First edition is limited **Mailed prepaid for 50c**

and

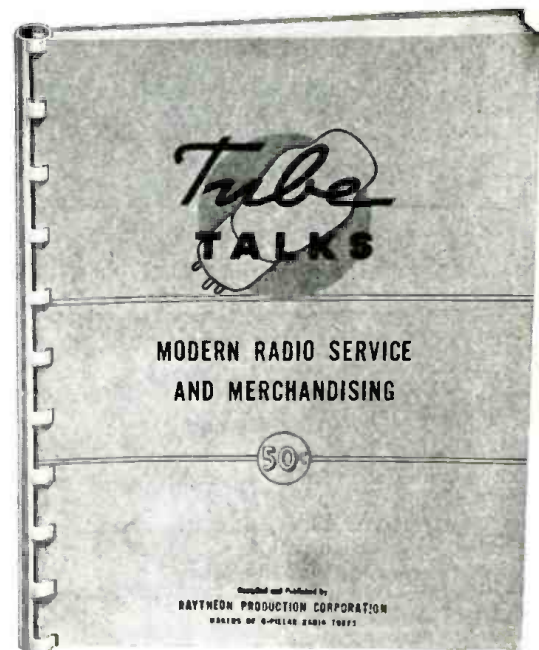

Ask your Jobber for complete details of Raytheon's New Tube Deals or write to

RAYTHEON PRODUCTION CORPORATION

General Sales Office: Dept. E-11, 30 East 42nd Street, New York

Please Say That You Saw It in RADIO-CRAFT



RADIO AS A VOCATION

An Editorial by HUGO GERNSBACK

IT IS estimated from best available sources that the radio industry as a whole today employs no less than 150,000 men in all its branches. This includes everybody, from the lowest-paid radio assembler girl up to the highest-priced radio executive. In between, we run the entire gamut of all classes of radio men and the classification of all of them would take more space than this printed page!

The young man eager to enter the radio field today has a tremendous field before him with numerous branches of the industry from which to choose. Each succeeding year, new sub-divisions of the various branches are being added and the field constantly expands and keeps enlarging. The major branches of radio today may be roughly summarized as follows:

Radio set manufacturing, radio tube manufacturing, radio parts manufacturing, television, general electronics, radio broadcasting, radio servicing; and a great many minor branches.

I constantly receive letters from young men who write to me that they "wish to get into the radio game." As a rule, the writers do not state their qualifications or their educational background, and it is almost impossible, without closely questioning the subject, to determine just where he will fit in best. It is useless to speak in generalities to these people without having made a careful survey of their mental equipment. One man might fit in well as a Service Man and might make a success of it, while the same man as a research engineer or broadcasting engineer would be totally unfit. For this reason, it is impossible to give hard and fast rules, it being impracticable for the outsider to arrive at any definite conclusion.

We cannot all be radio executives or research engineers of high order. We may not have the right mental equipment for this. In many ways, the college graduate who has taken up electrical engineering is fitted for an entirely different capacity than the man who has only a high school education; but, of course, there are exceptions. Some of our best radio executives have had no college education. Here then, again, the mental equipment and other educational background play a big rôle. No two cases are ever alike for two men. No two men will react exactly alike; or will their likes be exactly the same; or will they fit into the same position equally well.

There is, however, a general rule—that may be summarized in *one word*—which the young man who wishes to enter the radio industry should be told about. In the first place, what are his personal likes in the matter? What are the goals he is striving for? Some men who wish to reach the top do not care how low they start; anything that comes along will be taken as the first rung of the ladder to be climbed. Others have fixed ideas as to what they wish to tackle. My own recommendation to would-be aspirants to a position of importance in the radio industry has always been expressed in one word—"Specialization."

What the radio industry of today needs more than any-

thing else is specialists in the various branches. There are too many half-baked, irresponsible young men who just hold down jobs and never get anywhere. These form by far the largest percentage of the total manpower of the radio industry. *It is the minority who specialize, and who, as a rule, get somewhere.*

And it makes little difference in this respect whether they are college graduates or not. Of course, if you can afford to go through college and take the various courses (always providing that you know how to take advantage of the teaching offered at college), you will emerge from college with a first-class background which will enable you to "go places" in the radio industry. By far, the greater majority of young men, however, are not so fortunate. They find it necessary to earn a living after they leave high school. A large proportion of these either take a good radio correspondence course or visit a resident school for a number of months. Others, who cannot afford this, get their entire knowledge from practical work in the field and from radio books and publications. In the end, it all amounts to the same thing. If they have the correct mental make-up, it will get them just as far with one type of education as with another,—and often the self-taught man has been able to go as far as the college graduate. Edison, for instance, never had better than a high school education, yet he had a mentality of the highest calibre; and most of his knowledge was gained from books and publications.

In the final analysis, everything depends upon yourself. The more you know about a given subject, the more you specialize in it; and the more you know about it the greater are the chances that you will succeed.

Coupled with this, you require other qualities. It is, for instance, not enough that you are another Edison or a Marconi unless others know about your qualifications. The world, as a rule, does not run after you, *you must put yourself ahead*; in other words, you must know how to sell yourself to the radio industry. This can only be accomplished by bringing yourself to its attention, either by personal contact, by letter writing, or by writing for various radio publications and thus getting a reputation in the radio industry.

The radio industry is no different than any other, when it comes to manpower. Competition is just as keen in the radio industry, as it is in any other industry, and perhaps in many respects more so. It has, however, plenty of room for the young man of the right mental calibre. Every radio organization needs good men and is willing to pay their price; every organization needs specialists in their own line, men who can think for themselves, men who can do things, men with initiative, and men who believe in the future of radio. And after everything is said and done, always remember that radio is still in the earliest stage of its infancy; and that the young men who enter radio (and its legion of subdivisions) today, will "make" the great radio industry we will have tomorrow.

THE RADIO MONTH



The U.S. Signal Corps station at Point Barrow.

ROGERS-POST NEWS HALLOWS "POINT BARROW"

RADIO, which played such an important part in the success of Will Rogers also played an outstanding role in his "last round-up" when that sad accident took him and his companion, Wiley Post, from us, last month.

It was the radio that sent the first word to the world, from the U.S. Army Signal Corps station at Point Barrow, Alaska, of the fatal accident—and radio also permitted people all over the world to be present (in spirit at least) when the "Jester to the American People," as he was so aptly called in newspaper accounts, was placed at his final rest.

The world will long miss the frank opinions woven into his home-spun humor and his place in radio broadcasting will never be filled.

BOOM IN SET SALES NEXT SEASON

ACCORDING to the financial page of the *New York Times*, one day last month, the radio industry is looking forward to an increase of 60 to 100 per cent in set sales this season.

The statement is, in part, as follows: "In radio, Wall Street sees the next factor contributing to a greater recovery.

"A survey of the outstanding radio manufacturers in the U.S. indicates that plans for the coming season provide increases in production ranging from 60 to 100 per cent.

"The obsolescence of more than 25 per cent of the receiving sets in use today—a parallel to the situation in the motor industry at the opening of the "model year" now drawing to a close—is given by manufacturers as the outstanding basis for the belief that a record year for sales of units is about to be established.

"Officials of the RCA have announced that their program for the new year contemplates an increase in production

of approximately 100 per cent over the total for the year now closing.

"In addition to the expanding foreign markets, manufacturers of sets have found an ever-increasing field in the automobile market. Aside from these outlets, the home set field still remains the great avenue for new distribution without considering replacements.

"Units sold in the U.S. in 1934 amounted to 4,084,000, the highest mark since 1929, when 4,438,000 units were marketed against 3,806,000 in 1933. Estimates now in preparation indicate that sales for this year will reach if not surpass the 5,000,000 mark.

"Leaders in the industry, mindful of the drop in sales two years ago when prices were increased, are tending toward a lower price list for the new season. While the so-called "midget sets" will continue in vogue, retailing anywhere from \$8.00 up, the regular or standard sets will have a starting figure of \$18.00 to \$20.00."

ONCE AGAIN—THE THIRD CHAIN

WMCA which has figured so often in attempts to form a third national network once again took the spotlight, last month with an announcement that the American Broadcasting System had just started operating on a "national" network, with WMCA as its key station.

The complete network of the American Broadcasting System, though heralded as the third national chain, actually does not reach further west than St. Louis, covering only the eastern states. The full roster of stations includes: WJJD, Chicago; WIND, Gary, Ind.; WHBF, Rock Island, Ill.; WIL, St. Louis; WFBE, Cincinnati; WJBK, Detroit; WEBR and WKBW, Buffalo; KQV, Pittsburgh; WWVA, Wheeling, W.Va.; WDEL, Wilmington, Del.; WTNJ, Trenton, N. J.; WHDH and WAAB, Boston; WPRO, Providence, R. I.; WMCA, New York; WIP, Philadelphia; WCBM, Baltimore, and WOL, Washington, D. C.

The locations of the "outlets" of the A.B.S.

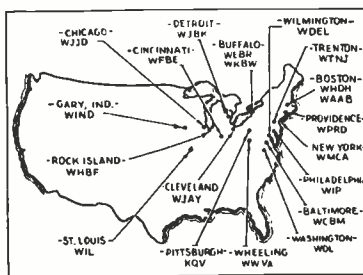

The Ethiopian radio station installed at Harrar.

RADIO IN ETHIOPIA

WITH extensive preparations being made as this magazine goes to press, by both the Ethiopian and Italian forces, radio is playing an important part as a reliable means of communication.

Contrary to what might be expected, the Ethiopian forces are well fitted with radio equipment as the photo here (which was made last month) shows.

It is interesting to compare the modern radio method of communication, with the tom-toms and signal fires which were used to keep outposts in touch with army headquarters, in previous African conflicts.

WORLD'S LARGEST S.-W. RADIO STATION!

ACONSTRUCTION permit was granted by the Federal Communications Commission, last month, for the highest-powered short-wave radio transmitter in the Western Hemisphere and possibly in the world. The permit was granted to RCA Communications, which will erect the transmitter at Rocky Point, L.I. The station antenna power will be about 200 kw. and is expected to be ready for operation about the middle of November.

Engineers of the company said that the station, which will have the call letters of WEF, will be used from time to time for relaying radio programs to Europe for re-broadcasting purposes.

The installation will be considered experimental until the results of tests tell whether such high power is economical. At present, station WEF operates with a power of about 40 kw. in the antenna.

It is expected that this new transmitter will provide better telegraph service to foreign countries at higher speeds of transmission which will eventually result in lower rates for such messages.

IN REVIEW

Radio is now such a vast and diversified art it becomes necessary to make a general survey of important monthly developments. RADIO-CRAFT analyzes these developments and presents a review of those items which interest all.

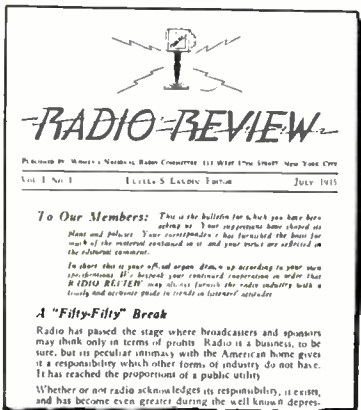

Part of the front page of the new magazine.

CAN CLUBWOMEN AID RADIO?

VOLUME 1, number 1, of a new publication of the Women's National Radio Committee made its appearance last month and immediately received both loud applause and catcalls from the press.

It will be remembered that the Women's National Radio Committee, representing over 17,000,000 club women in the U. S., has made a bid in recent months for the role of David in stoning the Goliath of inferior radio entertainment.

In an editorial in *Radio Review*, the new magazine, a plea is made, as follows:

"The present preponderance of light programs is conditioning an entire nation, and particularly the proportion thereof which has never been exposed to culture, to an appreciation of inferior entertainment. It would be just as easy to develop a liking for better things by giving the people a greater number of worth-while programs. This does not mean that there would be no lighter features, but merely that the world's finest music, literature and drama would be available in the same proportion."

2 1/2 MILLION DOLLAR BERLIN RADIO FAIR DESTROYED!

IN A fire even more spectacular than the burning of the Reichstag, flames destroyed Germany's great annual radio exposition, one day last month.

The cost of the fire, which was started by a short-circuit, was estimated at about \$2,500,000. Fortunately there were few fatalities, though the Fair was crowded when the fire broke out.

"WHAT PRICE TELEVISION?"

IN AN address given by A. W. Cruse of the U.S. Department of Commerce, last month, some very interesting summaries concerning the present status of television were presented.

Mr. Cruse said—"Television transmissions over distances of, say 25 miles, are indeed practical. I have seen such transmissions reproduced on 9 x 12 in. screens with fidelity greater than that of the best quality of home motion pictures.

"Television in Europe—particularly in England and Germany—is moving ahead under the protecting wing of strong government subsidies—and I believe that within the next year they will be giving Television to the public living in a few of their principal population centers for short periods each day.

"It will be some time before you need worry about getting a set combined with a Television receiver and you may rest assured that even if you do miss the first Television receiving set off the assembly line—and, by the way, it will probably cost you at least \$250—you won't be badly off by failing to keep up with the Joneses in this respect."

THE RADIO PLOW

THE truth of the old saying that "necessity is the mother of invention" was amply proven last month, by a farmer in Sigourney, Iowa. Mr. A. D. Hart, the farmer, is also a baseball fan, and according to the story received by *Radio-Craft* he couldn't see the justice of being deprived of hearing a baseball game in order to plow over a corn field. So Mr. Hart took the radio set out of his car and mounted it in a box on the plow frame.

The results were more than expected, for the signals were so loud that farm hands working in a neighboring field were also able to enjoy the announcements of the game!

The auto-radio set and battery on the plow.



The Russian blind-reading device in use.

A BOOK READER FOR THE BLIND

A DEVICE enabling blind persons to read ordinary books has been designed by a Russian scientist, according to reports received by *Radio-Craft*, last month.

The machine consists of a carriage which slowly moves the book, line by line, under a powerful magnifying glass. The enlarged images of the letters are projected upon a special photoelectric device which converts the light into corresponding electrical impulses.

These electrical impulses actuate a special desk upon which the blind person lays his fingers. Small rods are pushed up by the electrical impulses, according to the letter, and the blind persons are taught to interpret these, similar to the raised letters of the Braille system.

According to the reports, several desks can be attached to the machine, so that more than one person can read.

NOW—REMOTE PUBLIC ADDRESS!

WHAT promises to be a new and fruitful business for P.A. service companies was inadvertently started last month, when George N. Ayres, of Des Moines, Iowa, president of a life insurance company, was prevented from attending and addressing a group of his associates at a Yellowstone Park meeting.

When it was discovered that Mr. Ayres could not attend the meeting, an aggressive P.A. service company arranged to have him give his speech over the telephone, from which it was picked up, amplified and projected by means of loudspeakers.

The possibilities of remote P.A. service can not at first be realized. However, when one considers how often an important speaker is absent from political, social and business gatherings, the applications begin to take form. It does not take too great a stretch of the imagination to foresee a national network of such P.A. service companies.



AN IMPROVED RADIO-CONTROLLED SAILBOAT

A detailed description of a radio-controlled yacht. The experimenter may wish to similarly control other devices.

ROBERT H. PACKARD

THE REMOTE CONTROL of apparatus by means of radio is becoming an increasingly popular hobby with many experimenters, and one of its most fascinating applications is the control of model sailboats. It is a mystifying and thrilling experience to watch a small sailboat some distance off shore going through all the maneuvers of a full-sized yacht—running before the wind, coming about, tacking and gybing—just as if there were a Lilliputian crew aboard. And to the skipper on shore who is responsible for these uncanny actions, the thrill is an even greater one!

Such a model can be constructed quite inexpensively and without a technical knowledge of radio. The following description is intended to be a supplement to a less detailed account published in the July, 1934, issue of *Radio-Craft* and gives the method of constructing the various components of the controlling mechanism.

Briefly, the theory of control is as follows: radio impulses sent out from the transmitter on shore are picked up by the receiver aboard the boat and cause a relay to close at every impulse. This relay actuates a selector switch which in turn governs the operation of electrical devices which move the rudder and adjust the sails. The number of impulses or "dots" which are sent determines which device will respond.

THE TRANSMITTER

The transmitter, shown in Fig. 1A, is a one-tube, unmodulated, "modified, tuned-grid, tuned-plate" oscillator, operating at 78 meters. It is fundamentally conventional with only minor additions for convenience and compactness. The trimmer condensers are used to enable the transmitter frequency to be initially adjusted to

within the tuning range of the receiver. The fine control for occasional tuning during operation is done with the 2-plate midge condenser, C6. Coils L1 and L2 are wound on tube-base forms and L1 may be moved with respect to L2 to vary antenna coupling. A 2.5-V. lamp in the antenna circuit is used to check oscillation by throwing the switch Sw.1, putting the lamp in series with L1 and C1. The antenna, a quarter-wave Marconi type, consisting of 58 ft. of No. 24 enameled wire, is shown in Fig. A, together with some string and a 3-foot ground wire on a reel at the right-hand end of the transmitter.

The "B" supply is composed of 2 portable type, 45-V. batteries and one small 22½-V. battery. In normal operation the switch Sw.2 connects to the 90-V. point but when the boat is very near the transmitter, the voltage has to be reduced to 67.5 V. to prevent "locking-in" of the receiver with the transmitter. The 22½-V. battery is used to temporarily increase the power in case the boat should get out of range at the 90-V. power. The filament supply is a home-made, 3-lb., 6-V. storage battery made with standard-size plates cut into quarters and placed in a cut-down motorcycle battery case with 1 positive and 2 negative plates per cell (see Fig. 3). Control signals are sent by pressing the pushbutton Sw.3 which is at the end of a 6-ft. flexible cord plugging into the Jack, J1. The complete transmitter is built into a 5x8½x10½ in. wooden box and weighs only 15 lbs.

THE RECEIVER

The receiver is a standard three-tube regenerative set with a sensitive relay in place of phones at the output, as shown in Fig. 1B. An R.F. signal
(Continued on page 295)

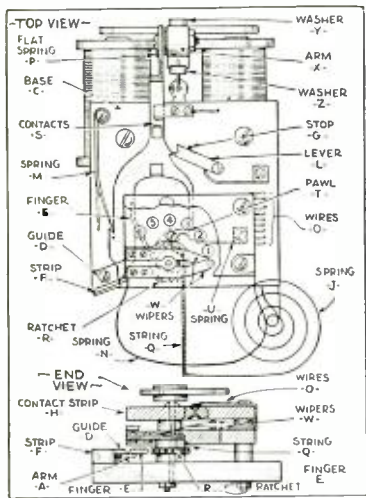

Fig. 2A and B, above; Fig. 2C, below. Details of the selector unit.

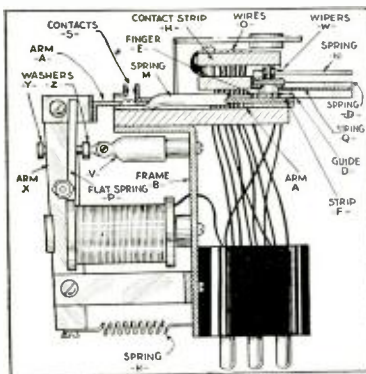
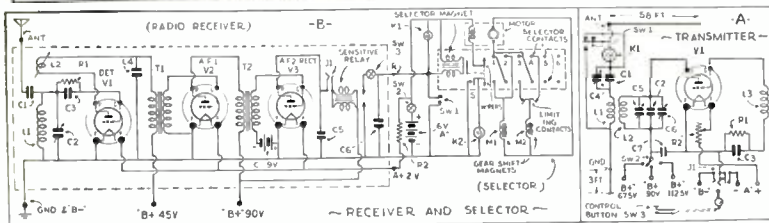
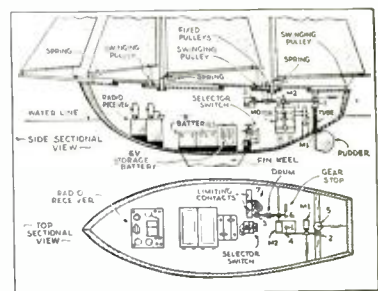

Fig. 1, below. The circuit of the transmitter at A, and the receiver, B.
Fig. 3, right. The parts in the hull.



THE NEW "MYSTERY RAY"

This new ray—developed simultaneously by three World Powers—depends upon the beam-effect and reflection of "centimeter"-length or ultra-ultra-short waves to "spot" enemy planes, ships, etc. Fortunately, there are valuable commercial applications for this new tool of warfare and destruction.



The ray transmitter with the dipole antenna at left.



Tugboat being guided into a harbor.

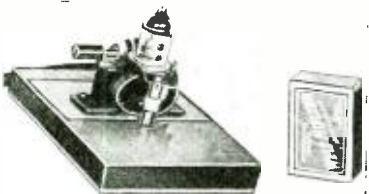

Above, receiver for the rays. Below, transmitter with "wing" reflector.



IN THE PAST half-year many exciting reports have been published concerning a new invention, which may be used to produce the most perilous of all war weapons, the often predicted—but never presented "death rays." Comments from experts concerning these exciting reports have firmly indicated that death rays are mere daydreams, at least on the basis of present technical progress, and that the existence of these "extremely dangerous" rays may fit well into the realms created by Hollywood studio facilities but not in the world of realities.

The public mind, however, fascinated by the horrible prospects of these death rays in a future war, took these unconfirmed reports as scientifically verified facts and mystery story authors even started at once to lubricate their typewriters and do their part in confusing the public mind!

This, quite muddled, situation has recently been even more confused by an interview given to the press by Senatore Guglielmo Marconi concerning a new kind of ray, of which he predicted some extraordinary possibilities through their application in case of war. This interview by the head of Marconi Wireless Ltd. induced its competitor in the world market, the German Radio Corporation (Telefunken Company), to unveil some results of their recently finished secret experiments with a kind of ray similar in its qualities to the mystery rays of Marconi.

According to recently printed newspaper reports the U.S.A. Signal Corps also has a mystery ray device in development, which seems to be equal

(Continued on page 299)

The transmitter compared to match box.

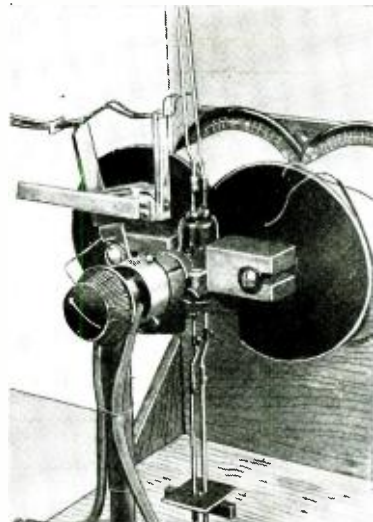
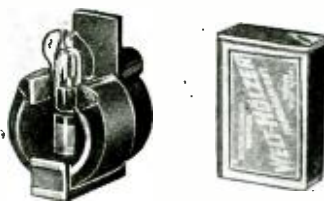

Experimental magnetron tube transmitter.

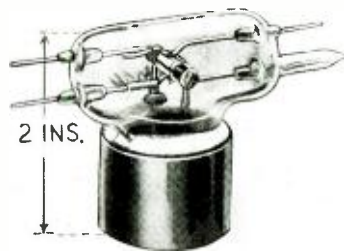

Above, split-magnetron sending-receiving tube. Below, dipole antenna for transmitter.



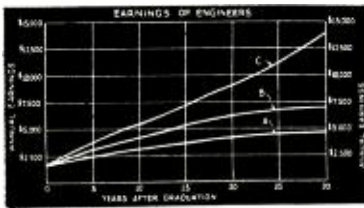

Fig. 1. Annual earnings of engineers.

SOME FACTS ABOUT

Are you thinking of making radio your livelihood? If so, you will find this article an invaluable reference.

WILHELM E. SCHRAGE

EACH YEAR thousands of young boys, already provided with all the educational tools our excellent school system can offer, are confronted by one of the most important problems in life; they are puzzled about their future careers. A hasty step taken in this period under the influence of either youthful enthusiasm, or the romantic ideas of us older ones, may later bring on the dissatisfaction resulting from a wrong choice or, what is still worse, if adverse circumstances occur, even cause complete failure. This is more likely to happen when there is a lack of intelligent inspiration to carry on through the conflict and disappointments which arise in life.

PRELIMINARY THOUGHTS

Not only strong inclination toward a certain profession, but proven abilities, which promise a real success should influence the decision. The attraction of an interesting hobby does not prove that particular profession will insure a successful life; but, on the other hand, the failure of a relative or acquaintance in some business or profession—should not be taken as an indication that our boy will be unsuccessful in his chosen field.

ABILITY, NOT LUCK, DETERMINES SUCCESS

Life is too complicated for us to forecast what may happen tomorrow. How, then, can we dare to predict with any assurance the possible future of an adolescent human being, when the bases of this decision are provided only by our emotions. Actual, measurable qualities, such as knowledge and ability, are the factors which govern success in life, and those facts alone should be decisive. These qualities are the essential ones; there is no occasion to take into calculation that indefinable something called "luck"!

How foolish it is to believe that lack of ability can be compensated by "luck" will be explained by a few examples from daily life. Even the common remark, that "luck" caused the elevation of a certain person far above his normal professional and economical level, is not proof but rather a shabby excuse for competitors who have not reached even a mediocre level.

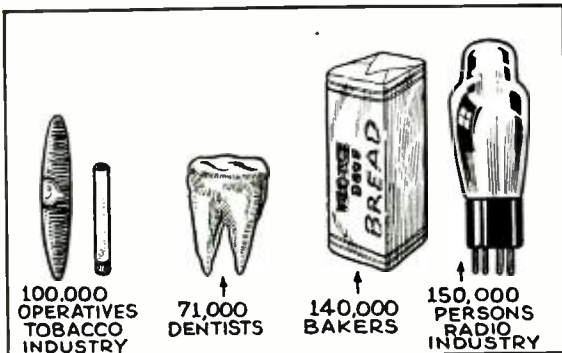

Fig. 2. Comparison of employment in radio and other industries.

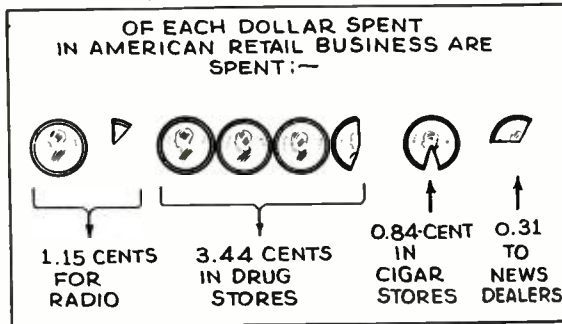
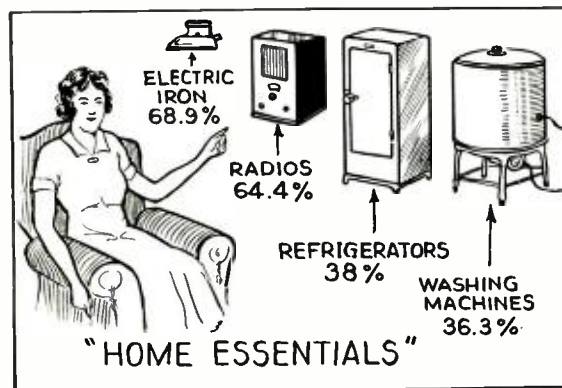

Fig. 3. How part of the American Consumer's dollar is spent.



EVERYBODY HAS HIS OPPORTUNITY

Thoughts of this kind mislead us. We are the greatest enemies of ourselves and of our children, if we believe lack of ability may be overcome by a run of "luck"; because there is no "luck," in the colloquial sense, in this world. What is usually called "luck" is, in 99 of 100 cases, only opportunity properly utilized.

Each of us is given his opportunity, but only a few of us are able to recognize it at the right moment. The alert will grab it at once—long, long before the mentally clumsy person detects that he has missed something.

THE BEST METHOD TO HELP YOUNG MEN

If we wish to help our boys, really careful judgment of their qualifications is necessary. Another assistance which we can give them is by a thorough survey of the economic prospects and conditions prevailing in the profession under consideration. If this task is to be executed in an efficient and proper way, we face a job which will give us plenty

Fig. 4, left. A comparison of electrical home necessities. Radio is second in importance on the list.

Fig. A, right. The volume control board used for long-distance telephony. This control is used to insure the greatest speech intelligibility.

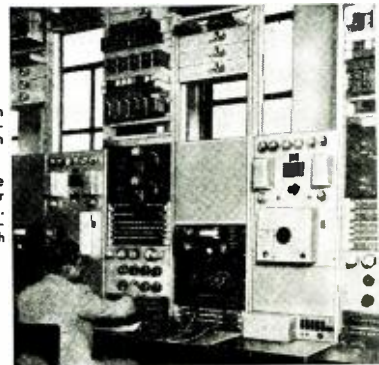

RADIO AS A CAREER

An old timer, who has seen the progress of radio on both sides of the Atlantic, gives a message to young men and their parents and a guide along the possible paths to follow.



Fig. 8. Set distribution in the World.

to worry about. We older ones should not interfere too much with the deliberate and reasonable decisions of our children, since youth itself is alone entitled to decide ultimately upon its future career. It is our duty only to be a source of friendly guidance and information. We should, furthermore, try not to inject personal bias against a certain profession into the cautious solicitude which we are obliged to show towards the welfare of our offspring.

AGAINST TOO OPTIMISTIC PARENTS

Those cautions are important, if parents happen to be pessimistic towards the vocational choice of their children; but there is also another group of parents who will accept anything and everything their children say, and it is difficult to say which of these groups is more dangerous.

WHAT A HOBBY INDICATES

Let us, for example, consider that our boy concentrates his thoughts upon a study of radio as the area of his future professional activity. And let us further assume that he believes that this particular profession is the only one from which he can "get something out of life." And finally let us consider the common argument which parents make in respect to their son's radio technique, that this choice must be the right one since the boy has often shown that he knows quite a bit about radio, that he reads all the radio magazines, and understands them so well as to have constructed his own custom-built radio set, and a very good one at that.

Does this really prove that this boy is a born radio engineer?

RADIO ENGINEER OR BIOLOGIST

Many parents believe such indulgence in a hobby is perfect proof of adaptability. But we should consider that the construction of radio sets is today a popular hobby and, if one boy in a crowd starts to build a set, all the others will very likely wish to do the same. The second factor to be taken into account is the fact that his favorite radio magazine furnishes him with carefully tested radio circuits, which have been designed by experienced radio engineers. Such a radio circuit often involves hundreds of experiments to make the construction of such a set easy. Consider, how it would be if this same boy lived in a group among whom microscopy was a great hobby, and he played with magnifying glasses, microscopes, slides, and test tubes. Would he be a born biologist?

CREATION OR RECONSTRUCTION?

We realize that a hobby does not mean much if it consists only of carrying out thoughts and ideas picked up from a magazine which publishes them in such a way that even a layman is able to follow them. There are, of course, specific conditions necessary to induce interest in a particular field, and also a skilful hand is needed to do the work in a neat way; but manual dexterity alone does not determine the successful radio technician. That might be enough for a radio set assembler who does piecework. We find today in radio plants hundreds of unskilled laborers working

(Continued on page 300)

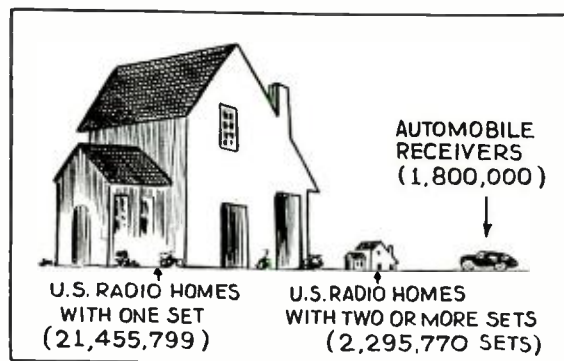

Fig. 5. The number of home and auto sets in the U.S.

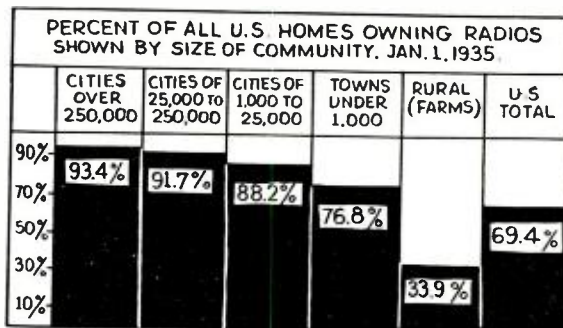

Fig. 6. Possible radio sales are segregated in this way.

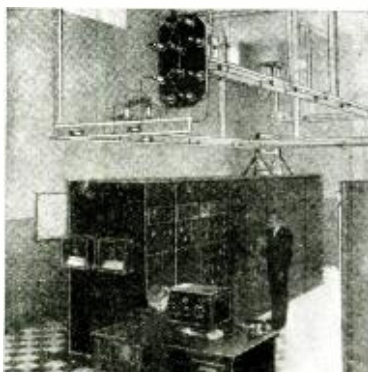
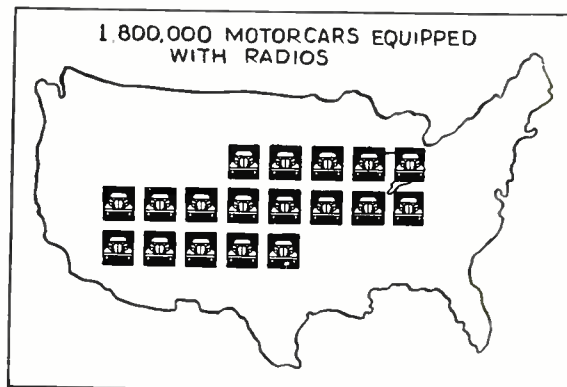
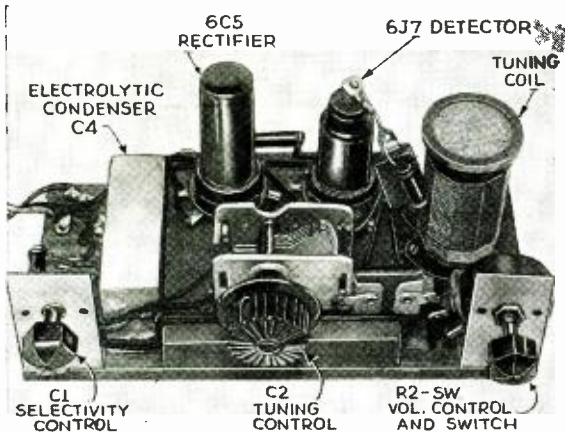

Fig. 8, left. One of the transmitters installed at Lawrenceville, N.J., for use in transoceanic telephone work.

Fig. 7, right. The number of auto-radio receivers in use in the United States, today. This represents an enormous field for sales and service work.





A BEGINNER'S ALL-WAVE METAL-TUBE "2"

This set was designed specifically to acquaint the experimenter with the new metal tubes. It uses a breadboard type chassis.

H. G. CISIN

THE ADVENT of the metal tubes has created a vast amount of interest and many fans, set builders and Service Men find themselves in an embarrassing position, because of lack of specific knowledge regarding this new development.

Of course, it is possible to get data sheets, curves and other technical information about the new tubes, but the information derived therefrom is too general and is not to be compared with knowledge derived from actual experience.

With this thought in mind, the construction of a 2-tube all-wave set is described in this article. This set is designed around the metal tubes and shows how to use them to the greatest advantage in a simple but powerful regenerative circuit. Not only the circuit, but the entire design of this receiver, renders it particularly applicable to the beginner. In spite of this, the set when completed is very efficient and will bring in foreign stations in most localities with a fair degree of regularity.

It will be noted from the illustration, that this 2-tube set differs considerably in appearance from the ordinary radio receiver. This is because all non-essentials have been discarded in an effort to provide maximum efficiency at lowest possible cost.

The Beginner's Metal Tube Set is designed for phone operation only, although it is possible to operate a small loudspeaker with it on exceptionally strong stations. It uses overlapping plug-in coils to cover the band from 10 to 550 meters. Plug-in coils, although not quite as convenient as a switching arrangement, are more efficient (lower losses) and also cheaper. It is possible to receive long waves also with this set, by using a special coil having more turns and by shunting the variable condenser with either one or more small mica condensers, each having a capacity of about 100 mmf.

The plug-in coils are of the 4-prong type, being inserted in a standard 4-prong tube socket. Two of the prongs are connected to the long winding which determines the frequency band to be covered. The other two prongs connect to the tickler winding.

Before discussing the metal tubes and their use in this circuit, it is advisable to analyze the circuit itself. The schematic diagram, Fig. 1, and picture diagram, Fig. 2, disclose a standard regenerative circuit, using a separate rectifier tube so that the power supply is an inherent part of the set itself. The A.C.-D.C. circuit is employed, making the little receiver extremely versatile in that it can be energized from any A.C. source regardless of the frequency and also from any D.C. source. While normally designed for use on any 105 to 120 V. circuit, it can also be used on 220 V. or even higher by inserting a special ballast resistor between the outlet and the set.

Through the use of the A.C.-D.C. circuit it is possible to discard or eliminate bulky and expensive items such as power supply and filament supply transformers. Further simplification of the circuit has even eliminated the usual filter choke, which is replaced in this receiver with a simple 10,000 ohm carbon resistor. This is bypassed at either end by electrolytic condensers of sufficient capacity to remove the last vestige of hum, smoothing out the current so effectively that no A.C. hum can be heard, even when using a very sensitive pair of earphones. To save space, the two electrolytic condensers are combined in a single compact cardboard container. The voltage limiting resistor used in the filament circuit is contained in the line cord. This also saves space and serves to distribute the heat away from the electrolytic condensers and other components of the set.

The antenna trimmer, C1, shown in series with the antenna and the long winding of the coil, is an important adjunct to this circuit. It is adjustable from about 2 to 50 mmf., permitting the set to be used with any length aerial. It is also of great value in tuning in weak, distant, short-wave stations. When used with the broadcast coils, it offers a means of separating stations which otherwise would overlap. In other words, loosening the antenna trimmer will bring the set to almost any required degree of selectivity. When used with the short-wave coils, the antenna trimmer performs an entirely different function, for with these coils, its regulation cuts out "dead spots" so that the circuit will oscillate and bring in stations at any desired wavelength within the range of the coil.

The station selector condenser is a 140 mmf. variable
(Continued on page 302)

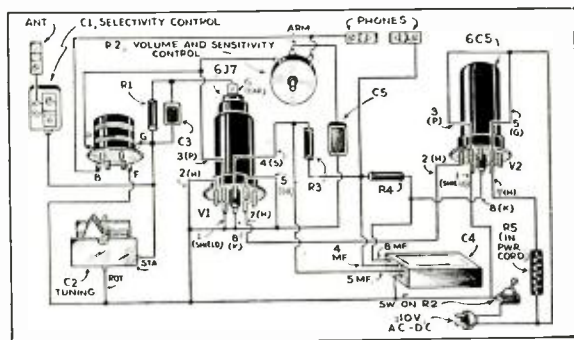

Left, the picture diagram of the Metal-Tube "2." Below, the Schematic circuit of the regenerative set.

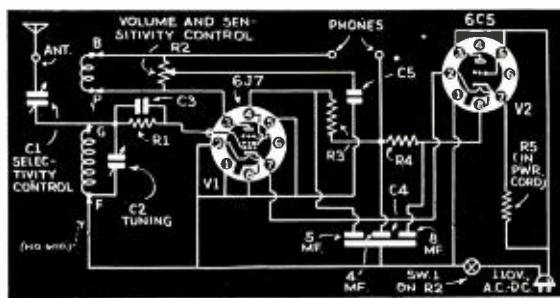

"FINDING YOURSELF" IN THE TECHNICAL WORLD

The "danger line" for a college man is the 2-year period immediately following his graduation, when he is most apt to find himself installed in jobs to which he is ill-suited.

"SHOULD the job suit the man, or should the man suit the job?" All too often the graduate radio-man becomes calloused to the phrase,

Another view at Bell Tel. Labs. Here, a laboratorian is shown putting a new form of gas-filled rectifier through its paces.



"We'll get in touch with you if we have an opening," without ever realizing that *perhaps an opening already exists for a QUALIFIED technician!*

Securing a suitable position is often a difficult one for the college graduate. Many of these trained men have a deep-seated conviction that the business world is waiting with open arms to receive them; and many prospective college students are of the opinion that they have only to buckle down to 4 or 5 years of college work in order to bring Success within arm's reach upon completion of their studies.

Unfortunately, the factors that enter into the selection of personnel for a high-grade organization constitute a much more complicated one than this; and, as is indicated by the following review of data presented (in connection with a highly informative talk delivered by John Mills representing Bell Telephone Laboratories) at the recent annual convention of the American Management Association, the uphill task of becoming a success in business often begins right at the doorknob of the portal lettered "Employment Man-



A scene at Bell Tel. Labs. An expert technician is interpreting an oscillogram during the development of a radio set.

ager" (though few men realize this)!

Colleges are a logical source of good labor material as it is from the colleges the personnel director hopes to obtain men of good mental ability and personality, who have acquired habits of thought and study which will enable them—(a) to see *broadly* the business and technical problems of the future; (b) to analyze the factors involved; (c) to arrive objectively and without prejudice at solutions; and, (d) to give those solutions weight and effectiveness

(Continued on page 302)

TELEVISION AND HIGH FIDELITY AS A STUDY

An outline of the training in these two "live" subjects received at one school is presented.

THE STUDY of high-fidelity radio and the science of television offer, perhaps, a more potential future for both the beginner and the advanced radio man than any other branch of the radio industry, today.

High-fidelity radio is, today, one of the big improvements that the radio set manufacturers are incorporating in their new models. The Federal Communications Commission is likewise interested in the improvement of transmission quality which naturally means high-fidelity broadcasting.

Television in its commercial form will no doubt be the next big movement in the radio industry. It looks as if England and Germany are leading the way in bringing television out of the laboratories into the home. However, this is being contested by the subtle activities of the larger radio companies in America who claim that "you ain't seen nothing yet" until you have had the opportunity to witness the new, high-definition pictures that they are able to produce with excellent results.

First National Television, Inc., through the facilities of their two broadcast stations, W9XAL for Television, and W9XBV for High-Fidelity Radio, have set up research and development laboratories for the purpose of experimenting



At work in one of the laboratories.

in both of these fields. This school maintains a staff of seven expert engineers for the purpose of conducting tests, from the "practical" sense.

The training division operates a school for student-engineers who study a course of instruction and training which specializes on high-fidelity and television broadcasting and reception. The student-engineers go through a regular course of training until they have qualified for a radio telephone operator's license. After getting their government license, they are put through an advanced training in practical broadcasting and are qualified to participate in

(Continued on page 303)

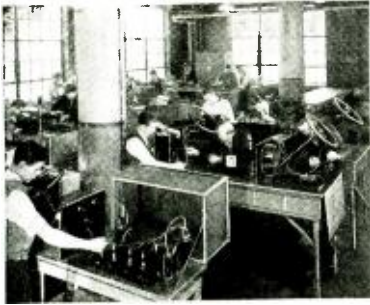

TRAINED RADIO MEN

The author points the "straight and narrow" path that the potential radio technician must follow to success.

E. L. RICHARDS*

VERY FREQUENTLY, we are asked, "Is Radio a profitable profession to follow, or has it passed its boom days and developed into a field in which excessive competition restricts opportunity for profit?" This question always reminds me of the employee of the United States Patent Office who, before the advent of the automobile, airplane, radio, air conditioning and many other marvelous modern devices, is said to have decided that everything worth while inventing had been patented and, therefore, there being no further need for his services, committed suicide!

Radio may have passed its boom period in the same sense that many other industries experienced a very unhealthy inflation and over-expansion in the late twenties. However, radio has already accomplished a much bet-

*Shop Super., Coyne Electrical and Radio School.

ter job of recovery than many of the other major industries. *Radio should continue to contribute substantially to the progress of industry and increased employment in this country for many years, and ambitious young men of the nation may safely plan to spend a profitable lifetime in this field.* Radio is still a very young industry with many years of profitable development and expansion still ahead of it. The radio industry is definitely and rapidly expanding in many of its branches today, while certain other industries and trades are actually declining and employing less trained workers every year. This is not alone due to the depression, but to natural economic laws and the relentless trend toward modernization, mechanization and improvement. *Many of these same forces which tend to reduce the need for certain trades, help to expand radio and electronic devices and their diversified applications!* Therefore, the writer sincerely feels that anyone who is ambitious and willing to apply himself conscientiously to the task of becoming thorough trained should make no mistake by investing

his time, money and effort in preparation for the future which unquestionably lies ahead in this important phase of industry.

In the field of household radio, for instance, there are estimated to be over 25,000,000 radio sets in this country alone. With constant improvements in receiver circuits, multiple-purpose and new metal tubes, tone control, wide-range amplification, high-fidelity reproduction, automatic tuning, all-wave receivers and other refinements, many millions of these present sets will be replaced during the next several years
(Continued on page 303)

The school gives practical experience in shops.

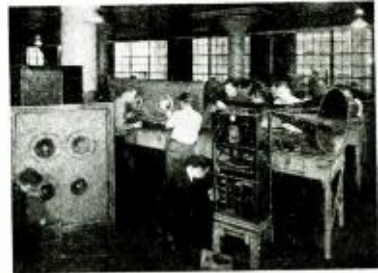

A high-grade recording studio catering to "mike" artists.

MAKING MONEY IN SOUND RECORDING

A profitable business medium has been found in "recording studios," which the radio man may establish at little expense.

ARTHUR HEINE*

amusement mad. This mass appetite has been further superinduced by the fascination of two modern media: Radio and Motion Pictures.

The tremendous demand for change and improvement in these forms of entertainment, threatens to exhaust the supply of talent and unless new sources are quickly tapped and developed, a famine of performers may inflict us.

In former days, before the advent of these two fields, a vaudeville artist could carry the same program around the country for a year or two. Now, the public asks this same performer, when he becomes a radio entertainer, for a new program every week or every day! *Unless there is a complete change of script, only a new performer will satisfy!*

(Continued on page 304)



PEERING down the corridor of time, historians have noted that the greater the distress a nation endures, either through war or economic depressions, the more hungry the people become for recreation. Carlyle emphasized in his "French Revolution," that during the turmoil in Paris when the guillotine was working overtime and the streets were barricaded by opposing armed factions, a large number of theatres remained open and were crowded to the doors!

Here, in America, during our late lamented depression, which happily is fast disappearing, our people have gone

*Speak-G-Phone Co., Inc.

HOW TO MAKE A MIDGET PREAMPLIFIER

The use of a midget screen-grid tube and a new type of portable "B" battery make this amplifier unusually handy for P.A. and transmitter use.

HOWARD G. McENTEE

THE P.A. technician often has need for a completely self-contained preamplifier, as for example, when the mike is located at a distance from the main unit. No external power should be required for such use, either batteries or line current. Also it should be small and unobtrusive, so that it can be carried or put away out of sight.

The tiny unit here described is just right for such use. It uses one of the new English-made baby screen-grid tubes (which are now available in this country). The batteries are also a new development of very small size, the two together making possible a midget unit of high efficiency.

The circuit is quite flexible since any type of mike can be used. Without additional equipment, either crystal or condenser mikes may be used, either one being connected between the ground terminal and its own input terminal. Velocity mikes are usually made with a built-in transformer so they may be used by connecting the leads between ground and the crystal mike terminal. The same connection is used for a carbon microphone, but, of course, a transformer and mike batteries are needed.

The output is also variable, since either high- or low-impedance connections are possible. The high-impedance connection is designed to connect directly to the grid of the amplifier. For this reason, it can only be used when the preamplifier is a short distance from the main unit. The low-impedance connection allows the preamplifier to feed directly into the mike winding of the input transformer. Even more flexibility may be secured if the output transformer is of the double-button type. This was not needed on the original

unit, and was not provided for.

The preamplifier chassis with all batteries is housed in a small sheet steel case. The steel case is advisable, in order to provide some shielding against magnetic fields. The case is usually grounded, the shield on the output lead being sufficient in most cases. The two midget 45 V. "B" batteries, and one 3 V. "A" battery are held in place by a single bracket bent from 1/16 x 1/2-in. aluminum.

The actual chassis is bent up from 1/16-in. aluminum. The drawings give full details of this part. The output transformer is the largest part to be accommodated, so if the type specified cannot be obtained, the chassis may have to be changed somewhat.

The slot in the top of the chassis makes it easier to install or remove the pilot bulb, which is of 2 V., 60 ma. type, and generally available as equipment for use in air-cell sets. The bulb acts as a dropping resistor as well, the drop also providing "C" bias for the tube. It may be necessary to shunt a small resistor across the tube filament, to keep the voltage down to exactly 2. This resistor may be around 60 ohms and is shown in the diagram, Fig. 1, as Rx. It should be adjusted to the proper value, and may be of the flexible, wire-wound type. The pilot bulb will not light to full brilliancy, since it only gets about 1 V. This filament arrangement is very satisfactory and provides the much-needed tell-tale to show when the unit is in operation. The total filament drain is about 70 ma. at 3 V.

The output transformer is a midget microphone type and may be either single or push-pull, as previously explained.

The secondary of the transformer is (Continued on page 304)

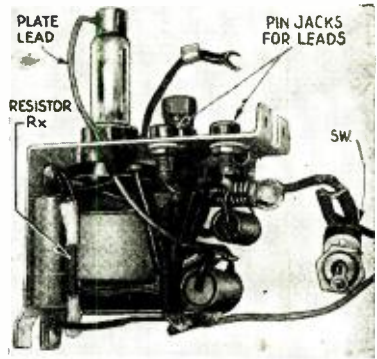

Fig. A. The tiny amplifier chassis.

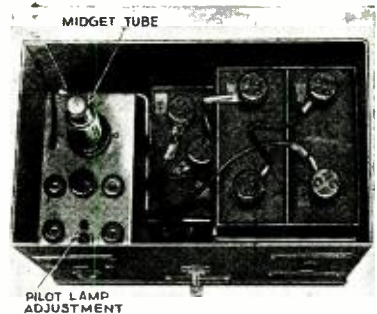

Fig. B. The top of the amplifier and batteries in their steel box. The tube is only slightly larger than a cigarette!

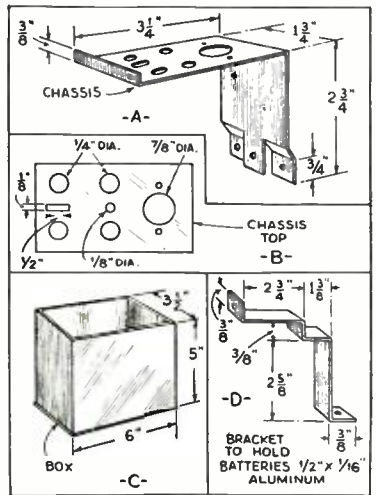

Fig. 2, above. The chassis and box details. The small size of the unit is evident.

Fig. C, below. The complete amplifier as used in amateur station W2FHP.

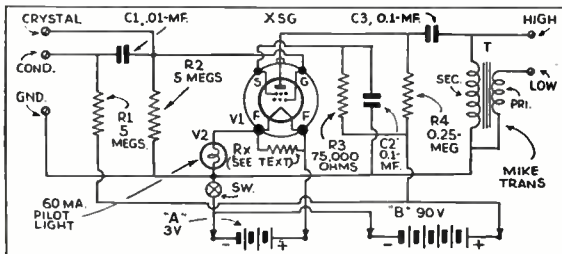
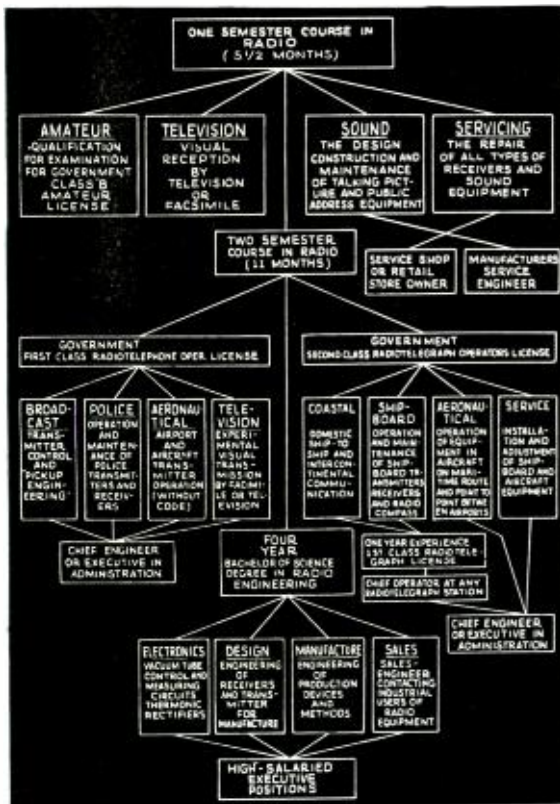

Fig. 1, left. The circuit of the unit. Resistor Rx shunts the filament of the screen-grid tube, thus limiting its current. Connections for crystal and condenser mikes are indicated.



(Courtesy, Milwaukee School of Engineering)

THE RADIO FIELD AS A FUTURE

A complete break-down of the radio possibilities is presented in chart form for the student and prospective radio technician.

W. WERWATH

THE "PRACTICAL" radio man often asks himself, "What good will it do me to take up a course of study in radio, when I am making a reasonable income and have no difficulty in servicing and building sets?" This is, to be sure, a narrow viewpoint. Granted that the man can fix radio sets fairly well, he will probably not progress much farther than that stage. There is no doubt that he will gather a great fund of valuable practical experience, but it is only when this experience is combined with properly assimilated technical theory that the man becomes one for whom the executive positions are held open.

The radio field is expanding so rapidly nowadays, that the Service Man is often called upon to handle work in other fields, such as television, electronics, high-frequency equipment, and so on. If he cannot handle such work intelligently, his prestige drops rapidly, and no matter how good a Service Man he may be, his business also will drop off.

The whole thought here is that the "practical" radio man these days must have something to back up his *field experience* in order to "get along." With this thought in mind let us look at the accompanying chart which shows how the various branches of Radio Engineering and Electronics are related, and what degree of success may be expected from

(Continued on page 305)

A MULTI-RANGE METER KIT

A useful service and test instrument which combines the advantages of many other units. The ohmmeter is particularly useful.

D. L. VAN LEUVEN*

THE UTILITY of the ranges covered by this instrument has many added measurements and accomplishments, besides the usual volt, ohm and milliampere combination tests. These added features are mostly due to the novelty of the scale arrangement on the meter dial, calibrated for 1 ma. meters having 50 ohms internal resistance. See Fig. A.

Five sets of scales are etched on this meter face, two for resistance measurements and three for milliamperes, volts, millivolts, microamps., etc. By the use of imaginary decimal points and added zeros many more scale ranges may be obtained. (One should be fully acquainted with the reading of component scales. Another important rule to keep in mind is the meter current relation to the resultant resistance range.)

The foregoing pertains to both III and LO scales, even if there are different principles involved. As for example: Take the usual 100,000 ohms scale, using a 4½ V. battery and a 1 ma. meter in the usual "series ohms" circuit. Now if a shunt be connected in the proper manner so that the current followed is 10 ma., the original scale reading will be reduced by 1-10th and the meter reading becomes 0-10,000 ohms, full-scale; the same calculation being true when using the 100 ma. shunts, etc. This explains the use of shunts to obtain lower resistance readings in "series

*D. L. Van Leuven Labs.



Fig. A, panel.

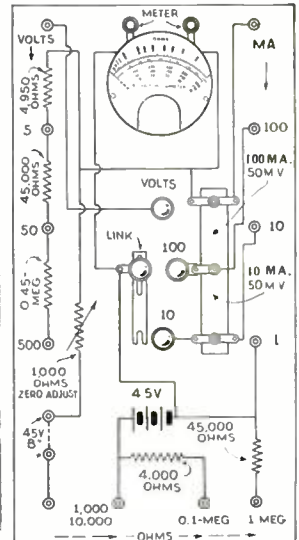

Fig. 1, circuit.

ohms" circuits.

These same three circuits are now going to be used in the "clockwise" or low-reading scales to establish the correct current through the meter-and-shunt circuit. Three values of current are to be used, 1, 10, and 100 ma., with respective values of 100,000, 10,000, and 1,000 ohms readings in the series circuits, and 500, 50, and 5 ohms full-scale using the LO range meter terminal extension.

As shown in the illustrations and drawing there are two heavy copper extensions connected to the meter binding

(Continued on page 305)

NEW OPPORTUNITIES IN RADIO

School graduates often are confused by the variety of radio activities confronting them; practicing technicians often overlook utilizing advances in radio spheres outside their own. This article is aimed to interest both groups.



R. D. WASHBURNE

THE AVERAGE radioman has his nose so close to the grindstone he doesn't realize the tremendous changes that have occurred in radiotechnical work—changes that betoken better times for all concerned. If, however, the individual is better represented by the pensive young man in the heading illustration, who gazes with impartial eye upon a field of myriad radio potentialities for lucrative employment, he may wish to be set aright regarding the comparative values of radio opportunities today. (Refer to Table I on page 306, "The Trend of Radio Development," reproduced from an article by J. Kaufman, of National Radio Institute, in the Jan., 1934 issue of *Radio-Craft*. Also, see "Radio Opportunities," March, 1934, pg. 517; and, "Modern Radio Beginners," March, 1935, pg. 517.)

To be more specific, let's refer, by hour, to the "clock" of 12 new developments in radio. (References to some of the articles on the subjects mentioned, that have appeared in *Radio-Craft*, are given for the benefit of those who may wish to secure additional data concerning one or more of the items mentioned.)

1 O'Clock—Police and Boat Radio. Few radiomen realize that rapid strides are being made in the development of radio equipment not only for use in squad cars designed for 1- and 2-way operation on ultra-short waves, but also in *radio apparatus designed for use by a patrolman*. Thus, the thousands of individual foot-policemen in every city and hamlet in the United States become logical prospects for radio equipment (and subsequent service). This "personal set" idea is a "honey."!

(See, "Radio-Equipped Policemen," *Radio-Craft*, June 1934, pg. 720; and, "How to Make the World's Smallest Tube Set," Sept. 1935, pg. 138.)

By "boat radio" we refer to the tens of thousands of small yachts, launches, motorboats, and even rowboats that dot every navigable plot of water in the United States, every one of which should be equipped with a receiving set—at least! In fact, the writer is in favor of F.C.C. regulations that would compel the use of small transmitters, as well, aboard small boats carrying more than a very limited number of persons; such ruling would greatly reduce our annual mortality figures due to drownings caused by misfortunes to small boats unable to signal for help in bad weather.

(See, "Car-Radio Sets Afloat," *Radio-Craft*, June 1935, pg. 717; and, "Build the '6-in-4' Rowboat Portable," Sept. 1935, pg. 139.)

2 O'Clock—5-Meter, and "Centimeter" Waves. Although considerable advance has been made in radio operation at the ultra-short wavelengths in the region of 5 meters, and the ultra-ultra-short or "super"-short wavelengths no longer than a few centimeters, tremendous advances are yet to be made in these directions.

In 5-meter operation, we have ahead

of us really widespread adoption of point-to-point communication between home and office, between factories, and between mobile units of every

description, where communication is desired over a wide angle, as in broadcasting to points that are not in sight but which are within range. (The dimensions of the 5-meter antenna often determine the service.) In fact, it is even possible that the use of high power may point the way to practical means for (comparatively) DX operation on 5 meters. The possibility of such transmissions has been mentioned (See, "600 Miles on 5 Meters," *Radio-Craft*, Sept. 1935, pg. 135. The practical test will occur this Fall, when RCA completes a 200 kw. station at Rocky Point, Long Island, N.Y.!). Much more efficient 5-meter transmitters, and more compact and efficient receivers must be built.

It will be recalled that at 5 meters, static, both man-made and natural, is a practically non-existent phenomenon; consequently, ultra-short wavelengths permit much more satisfactory performance in sound and television operation. Also only a small amount (Continued on page 306)

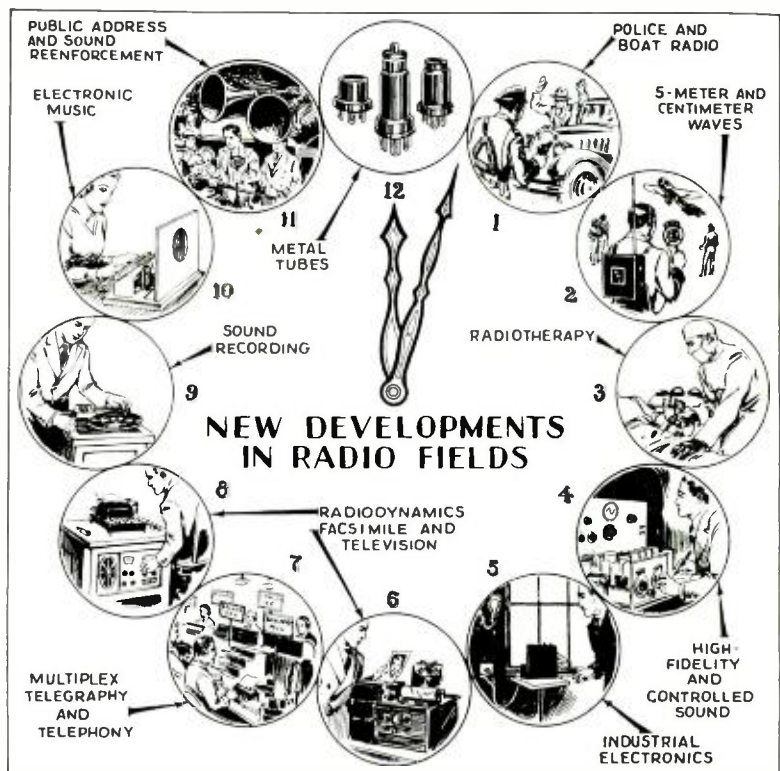

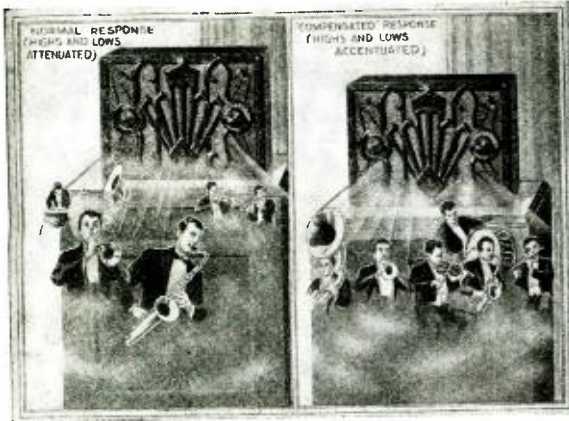

"QUALITY-CONTROL" AN AID TO OLD SETS

A method of A.F. equalization that obtains realism and naturalness in speech and music reproduction. Service Men can make money adding this unit to new and old amplifiers and sets, simulating hi-fidelity results.

C. K. KRAUSE

NOW that the layman is being educated to be conscious of the quality or fidelity of music and speech that he listens to reproduced electrically, and the radio and sound engineers are being called upon to bring out realism and naturalness, one form or another (or combination of forms) of quality controls will be necessary.

Perhaps some brief explanation of why there is a need for a method to correct or equalize a reproducing system is in order. It is oftentimes considered that if an amplifier and its associated equipment is designed and carefully constructed to give an overall fidelity response that will be reasonably flat over a desired range of audio frequencies, the ultimate of faithfulness and naturalness (assuming no distortion) has been achieved. In the case of amplifiers used for broadcast purposes, this may be the ultimate to be desired, but for a reproducing system, whether it be radio, phonograph, or public address, a flat frequency response (if such a thing is possible) is far from the desired ultimate of fidelity.

To answer the question why, let us consider in a general way just what a reproducing system has to accomplish and the obstacles that have to be overcome.

First, we have a loudspeaker which, aside from having a lot of peaks, is going to attenuate the audio frequency band at the low and high ends. Second, and just as important as the first reason, but usually the least considered, are the conditions under which the loudspeaker has to operate. Take the speaker to be used in the home for

reproducing radio programs, assume that it is the best that money can buy today, and what is the result? We say it sounds good simply because we know no better. Since the area of the baffle is naturally limited to keep peace in the family, the bass end decreases a few more db. (almost out of hearing) and then in the average home the room characteristics still including the baffle are of such dimension and filled with objects and reflecting surfaces that the other end of the frequency range, the highs, soon fall by the wayside (assuming another virtual impossibility, a perfect R.F. amplifier without cutting side bands) and we tend to accentuate our first reason until all we have left, in any appreciable quantities, is *middle* note response. The third and perhaps the most difficult to overcome is the fact that we can never achieve 100 per cent fidelity, that is, with all the quality control possible we will never be able to reproduce a symphony orchestra in the home just as it sounds when we go to the music hall to hear the same orchestra. We can and will, however, approach that point where it will be so faithfully reproduced in the home that we can honestly say that it does sound very good and not just like a radio.

The fundamental principle involved in this quality controller is the phenomenon of parallel resonance. That is, the building up of an apparently high impedance at a particular frequency. With this in mind then it can readily be seen how this method can be most beneficially adapted to the audio end. Furthermore, it permits of a highly desirable flexibility of control that is not available in other sys-

tems of control. This system does not restrict the constructor to any particular frequencies or any limited group, but rather the two limiting ends of the band are selected as determined by the speaker and the range desired and then the equalizer is made to fit.

As for the mechanics of setting the controls of the equalizer, it should be kept in mind that the primary purpose is to secure a proper balance between highs and lows which are going to be strengthened and middle frequencies which are going to be reduced. A full appreciation of what can be accomplished in an amplifier with this form of equalization is shown in Fig. 1. The original amplifier without any form of quality control is for all practical purposes flat from 30 to 6,000 cycles. With equalization applied designed to have a 42 to 5,200 cycle band width, it can be seen that the amplifier now has two predominant peaks, one at the lower end at approximately 45 cycles and at the higher end at somewhere near 5,200 cycles with the middle frequencies being down about 20 db. This curve represents full equalization, (Continued on page 309)

Fig. 1. Response curves, before and after equalization.

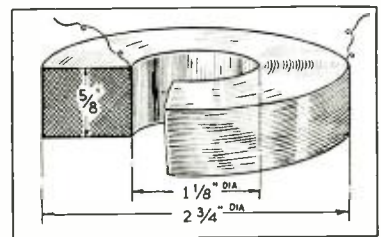
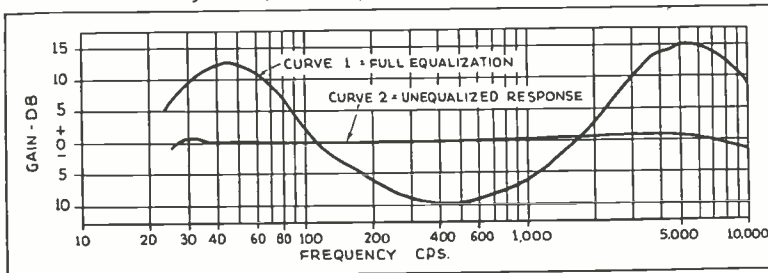
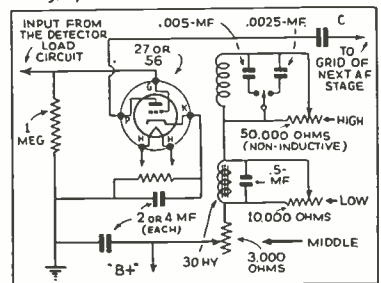

Fig. 3, above. The high-frequency inductance.

Fig. 2, below. The circuit of the equalizer.



HOW TO EQUIP A SOUND TRUCK FOR ELECTIONEERING, ETC.

With election day fast approaching, there is a real demand for high-power sound trucks.

CHARLES R. SHAW* _____ PART I

THE PAST year has seen many noteworthy advances in the design of mobile P.A. systems, not only in complete units, but in many cases, fundamental components such as tubes, microphones, speakers and amplifiers.

Extremely compact, portable and highly efficient amplifiers have been placed on the market which can easily be temporarily or permanently installed in touring cars or commercial trucks.

New auxiliary components when used with the latest design, storage battery operated amplifiers are capable of developing sufficient power to adequately cover outdoor areas of 80,000 square feet. New circuits have been developed which faithfully amplify over an extended frequency range, new high- and low-frequency speakers have made their appearance in sound cars. In short, the mobile P.A. field now offers the Service Man, sound technician, and dealer fertile fields for aggressive merchandising of correctly designed equipment.

While there has been considerable technical and descriptive material printed in the past issues of *Radio-Craft* dealing with circuit constants and functions of the various

*Design Engineer, Columbia Sound Co., Inc.



(Photo courtesy Wright-Det'oster, Inc.)

components, these articles in the main have been of a general nature. It will be the purpose of this article to take up the installation of specific equipment in a modern high-power sound car.

REQUIRED POWER OUTPUT

As a first consideration in the planning of a mobile sound system, the kind of amplifier to be used should first be determined.

Although arbitrary recommendations as to power requirements will not as a rule, cover all conditions of normal noise levels, the tabulation given in Table I may be used to obtain a general estimate of the power required to cover any desired outdoor area. (The figures for this compilation have been carefully checked in (Continued on page 307)

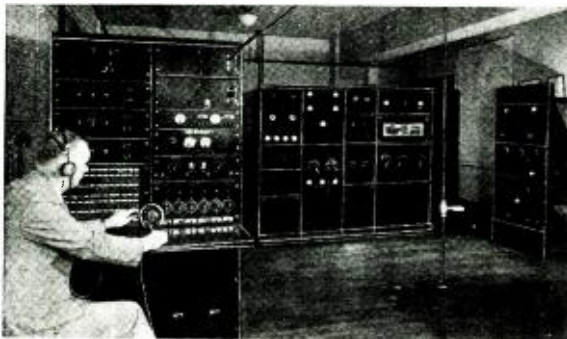

THE RADIO ENGINEERING VOCATION

One well-known course for teaching radio engineering is outlined for the radioman.

E. B. REDINGTON*

THE RADIO industry is definitely past the "barnstorming" stage. Success in this field can be attained today only by definite, specialized study. The possibilities for the trained man are better than ever before. The technical end of broadcasting is daily enlarging its scope, filling the new positions with men particularly trained for its special needs. The following comments may serve to crystalize these statements.

Aviation companies are expanding their radio facilities to meet recent and anticipated government regulations. A large eastern air transport company is at this writing completely rebuilding its entire communication chain. An official of another major air-transport company stated that his company would

*Capitol Radio Engineering Institute.

within the next 6 months hire a considerable number of radio men who would have to be specialists in their lines. Production of equipment is being stimulated by advancements in broadcasting technique. High-fidelity broadcasting is making almost every present-day radio receiver obsolete. Millions of new automobiles will be equipped with receivers. The all-wave receiver production has just begun.

Of the residence class just graduated (June) from the Capitol Radio Engineering Institute, 25 per cent found almost immediate employment in responsible positions with receiver manufacturers. The man with the *right kind* of technical education has a job. Without considering the tremendous possibilities of the industrial applications of electron tubes, television and ultra-

short wave applications, but only the well-established branches of the industry, the files of the Institute indicate that the men with the specialized training are in the positions of responsibility. Industry is absorbing them almost as rapidly as they can be trained.

The curriculum of the school is founded on the basis that the properly trained engineer is definitely trained in theory and practice, and that this training is needed to rise above the crowded lower stratum. Both the home study and residence courses are directed toward providing the serious student with the advanced technical education which he must have to succeed in this highly technical field.

The home study courses consider the needs of the average professional radioman in (Continued on page 307)



Students operating station equipment.

SHOULD I TAKE UP RADIO?

The rapid expansion of the radio industry is pointed out by a man who is qualified to write on the subject.

J. B. HERSHMAN*

THE QUESTION as to whether or not an investment in radio is justifiable at this time, is one uppermost in the minds of a large number of young men. I shall endeavor to set forth a few facts relative to the subject, leaving the reader free to draw his own conclusions as to the correct answer.

There never has been a time in the history of the world when technical developments have reached the present state of perfection. This is especially true in the field of radio. Many millions of dollars are invested in equipment which cannot be entrusted to the care of untrained individuals. (See the article, "Facts About Radio as a Career," in this issue.—*Editor*) The operator or broadcast engineer who does not have a thorough background

in the fundamentals of radio, is finding it more and more difficult to understand satisfactorily the new equipment which is being placed in his care. There always has been and always will be a place in the industry for one who knows the fundamentals of radio and is interested enough to put forth the effort for a constant improvement and broadening of that knowledge. The field is *not* crowded in the least with technicians who have thoroughly prepared themselves.

Any person who has interests along certain lines of endeavor should always put forth a vast amount of effort to prepare himself for an occupation in that particular field. Since it seems that the average person must do a certain amount of work for a livelihood, a young man should always select an occupation that will be interesting and hence enjoyable and not just a job. Some of those rare species of the human race, who become perpetual growlers and grumblers, are per-

sons whose daily work is of little interest to them, hence monotonous, and a thing to be avoided as much as possible.

In marine radio, broadcasting, manufacturing, selling and servicing, there are always new developments which make for more interesting work be-

(Continued on page 308)

Students learning studio technique.



*Director of Radio, Dodge Telegraphs & Radio Inst.

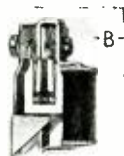

Old- (A) and new- (B) type "B" vibrators.

IMPORTANT DATA ON VIBRATOR-"B" UNITS

Information of great interest to the auto-radio Service Man since it describes the operation of all types of vibrators.

B. THOMAS*

radio family—metaphorically speaking.

There isn't much that can be said for the first vibrators, to be sure. They were frowned on as illegitimate offsprings by all but a few far-sighted engineers who saw in these crude, inefficient devices, the possibilities of development of a trouble-free method for converting the 6V. current of the automobile battery into alternating current that could then be stepped up to the high plate potentials required for efficient auto-radio receiver operation.

That these possibilities have been fully realized may be judged from the

fact that vibrators today are employed for this purpose in virtually every automotive broadcast receiver now manufactured.

While the first vibrators were materially handicapped by their mechanical design and construction, the fact that they were of the "series" type precluded any real progress until the "shunt" principle was introduced.

In the series vibrator, current flows through the magnet coil only when the vibrator reed is in contact with one of the vibrator points, so that in starting position the reed must be in contact.

(Continued on page 311)

THE VIBRATOR, that much maligned child of the auto-radio industry, after 3 years of struggle and adversity, of being kept in the back kitchen whenever polite company was in the drawing room, at last has grown out of its moronic state and now has taken its place at the dining room table on an equal footing with other fullfledged members of the

*Manufacturer's name on request.

Fig. 1. The action of the various types of vibrators is shown in the drawings below. Figs. A and B show the simple series vibrator. Figs. C, D, and E show the action of the more complicated parallel or shunt vibrators. The small arrows designate direction of current flow.

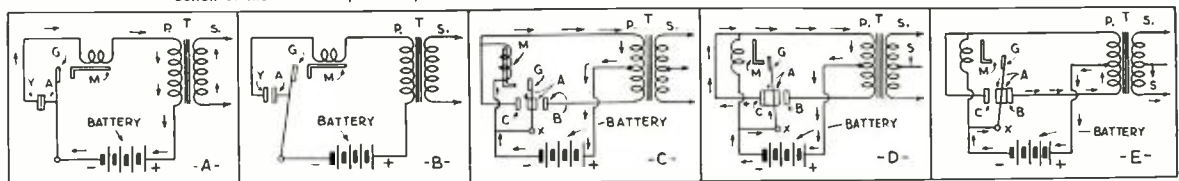

ANALYSES of RADIO RECEIVER SYMPTOMS OPERATING NOTES

PILOT SETS

THREE Pilot long-wave sets all had low volume. Continuity test showed all parts to be good. A stage-by-stage test with an oscillator showed no gain in the second I.F. transformer. Since no parts could be obtained, a 250 mmf. condenser run as shown in Fig. 1, cleared up the trouble. The sets worked "better than new," the only difference being that the detector stage tuned broader.

1933 CROSLEYS

ALL 1933 Crosleys. Set stopped after being worked for half an hour. All resistance values and voltages checked correctly, these checks being made both when the set was playing and after it stopped. The set performed perfectly after a new 2nd I.F. transformer was installed. This transformer becomes excessively hot due to close proximity to the tubes.

ERNESTO SANTANA,
Ponce, Porto Rico.

EDISON SETS

IN THE model using five 27s and two 45s, the push-pull input transformer has a fixed condenser built inside the case. This condenser is used to keep the "B" current out of the primary, and the resistor which feeds the plate of the first A.F. tube is located at the rear of the multi-plug. I have had several of these sets in which the fixed condenser has either shorted or opened, in either case the plate reading on the first A.F. plate was normal. My remedy is to cut out the primary of the transformer and connect a condenser of about 1-mf. from the plate side of the resistor mentioned, to either of the grids of the type 45 output tubes (Fig. 2B). This gives as good tone and volume as the original hook-up (Fig. 2A).

R. L. DEARING.

CLARION 220

THE COMPLAINT was no reception. This trouble was finally traced to the control-grid lead of the detector-oscillator tube (a 24A). The wire connecting the clip to the tuning condenser is really a 1,000 ohm hair-size-wire resistor, inside of the sheath, and cannot be noticed or found except by complete analysis of the receiver. The trouble can be remedied by using a 1,000 ohm metallized resistor in series with the grid lead to the tuning condenser. See Fig. 3.

The break is caused, no doubt, by the removal and replacement of the tube during testing or servicing.

D. R. BITTERMAN

THE PURPOSE OF THIS DEPARTMENT

It is conducted especially for the professional Service Man. In it will be found the most unusual troubles encountered in radio service work, written in a practical manner, by Service Men for you.

Have you, as a professional man, encountered any unusual or interesting Service Kinks that may help your fellow workers? If so, let us have them. They will be paid for, upon publication, at regular space rates.

CROSLEY SHOWBOX 706

THERE ARE a great many of these machines in service over the country and under ordinary conditions they give very reliable service. Our experience with this machine has been that a good bit of the trouble is confined to an open circuit of the primary of the input transformer. The trouble here is that the two A.F. transformers are in one can and there is hardly room in the set to put in a replacement. The transformer assembly for this job nets for \$3.85 and by the time the profit for the part and the labor charge is added, the cost is about as much as the value of the set. I have used the connection shown in the diagram to advantage and it only takes a short while to change

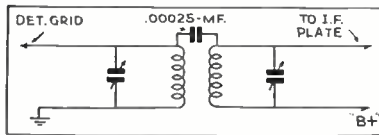

Fig. 1, above. Trouble in a Pilot long-wave set due to defective 2nd I.F. transformer. Fig. 4, right. Crosley Showbox trouble easy to cure. Fig. 2, below. Repairing a defective Edison set.

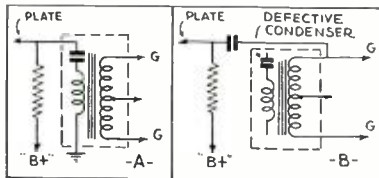
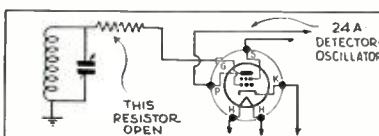

Fig. 3, below. Complaint of "no reception" on Clarion 220 is easily repaired. Fig. 5, right. Pepping up an A.K. 155 by replacing the 85 tube with a 75. Few circuit changes are needed.



the set from push-pull to parallel operation. The loss in volume is so small so as not to be objectionable.

The procedure is as follows: disconnect the secondary center-tap from ground and tape it over. Parallel the grids and connect them to one end of the secondary and ground the other end. Parallel the plates and connect them to one end of the transformer primary; the other end goes to the post formerly used by the output choke center-tap. The voice coil connects across the choke instead of to the plates as it formerly did. A .1-meg. resistor is used in place of the open primary and a .01-mf. condenser used for coupling from grid to plate. This explanation may not be complete but will be easily followed with the diagram shown (Fig. 4). This method may also be applied to other receivers using "hard to get" transformers.

RCA MODELS 44-46

THESE machines have only 5 tubes, and are sensitive—considering this fact, but usually after a year or so they gradually shift off scale and suffer a loss of volume, until they will finally bring in only the most powerful local stations. This condition is due, as a rule, to the chassis expanding and causing the tuning condensers to be forced out of line. The chassis is made of cast metal. The best method to repair the set is to ream the holes in the bakelite plates that hold the stators.

(Continued on page 311)

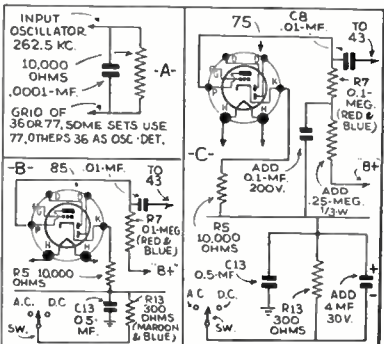
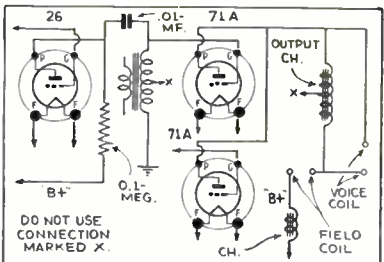



GETTING thunderous volume from a battery of double-basses in Stokowski's Philadelphia Orchestra is one of the wrinkles which the maestro has succeeded in accomplishing lately. Adding more double-basses helps slightly to increase their volume but fails to solve the problem.

Ivan Ivanovitch Eremeeff, who is an associate of Dr. Leopold Stokowski in the development of problems of a musi-

A "RADIO" BULL-FIDDLE

A piezoelectric crystal pickup and 30 W. amplifier allows one double-bass to override a symphony orchestra!

EDWARD KASSEL

cal and acoustical nature, has developed an amplification system so that one double-bass plays 10 times as loud as a battery of basses, to the delight of the conductor and to the chagrin of double-bass players.

Tests have been made in the Academy of Music, Philadelphia, with two very large theater horns, each located in an opera box near the stage and ceiling, directing sound into the audience. A 30 W. amplifier was used for this purpose.

The amplification of the double-bass is dependent upon the use of two small plates of a piezoelectric crystal, enclosed in a very small bakelite case, approximately 3/16-in. thick and 1/4-in-square! A thin shielded wire connects the piezoelectric pickup with the volume knob on the amplifier. The plate containing the piezoelectric crystal is attached to any part of the instrument by adhesive tape, as a musician generally does not care to submit his instrument to engineers for putting in screws

or drilling holes. A volume knob usually is located on a stand near the musician, or the musician is provided with a pedal with which he regulates the volume by foot, at the times when large volumes are required by the conductor.

(Continued on page 311)

Fig. 1. Electrical connections and volume control.

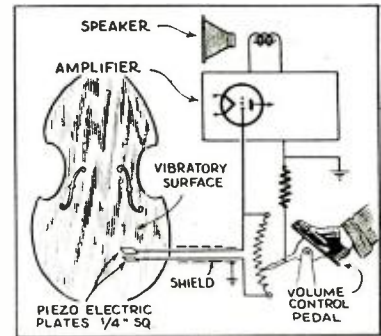

DURING THE comparatively short period of a decade, the rapid strides made in the development of radio have been nothing short of amazing. Noteworthy progress has been achieved in improving the efficiency of Operating, Servicing, Broadcasting, Sound Pictures, Maintenance, Electronics, Research and allied activities. New ideas and new methods have been utilized to make radio virtually indispensable in commerce, industry and the home.

The result is that radio is here to stay. It is little wonder, then, that the thoughts of forward-looking young men should be turning more and more to radio work as a permanent vocation.

No other medium has been so largely responsible for the present popularity and widespread use of radio as has

SELECTING A CAREER IN RADIO

The many diversified applications of vacuum tubes in the past decade have created a tremendous field for radio men.

LOUIS L. CREDNER*

the vacuum tube. Because of it, radio broadcasting and sound pictures have to a great extent attained their present state of development. Recently, its use has been extended to industrial applications through application of the photoelectric cell as well as commercial thyatron and phanotron rectifiers. In addition, the vacuum tube is now employed in such widely different fields as Metallurgy, Medicine, Biology, Botany and Music, to all of which it has contributed many definite advantages.

There is no denying the fact that before radio reaches its peak, other important and astounding inventions and applications relating to its use will be made. Indicative of what may be expected in this process of radio's evolution is the therapeutic branch of short waves now in its early stages of evolution. Already, experiments in short-wave fever therapy are being conducted by hospitals and in the laboratories of physicians and dentists. Short waves are also being used for purposes gen-

erally unknown to the public such as in the elimination of insects and in the exploration of the soil for mineral deposits.

In the broader fields, there seems to be a general agreement among leaders in the field of radio that great opportunities exist in facsimile, television, and the many applications that could

(Continued on page 309)

Good training is essential to success.



*Principal, Trade and Tech. School, N.Y. Y.M.C.A.

THE LISTENING POST FOR ALL-WAVE DX-ERS

C. A. MORRISON

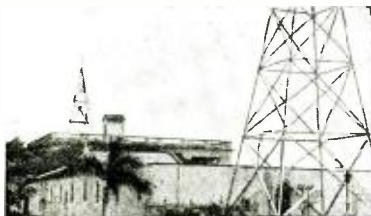

Station HP5B, situated at the Miramar Club, Panama City, Republic of Panama.

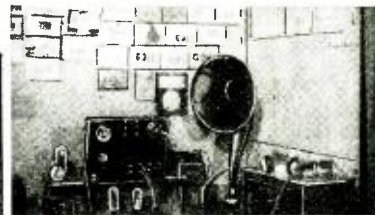
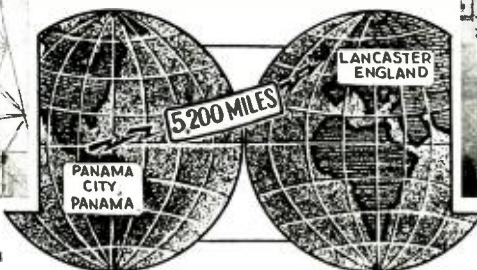

The listening post of Henry B. Shields in Failsforth, England.

WRITING to foreign stations for confirmation of reception it is essential that you enclose return postage for a reply. This courtesy will practically always insure an answer to your communication. It would be of no value to enclose U.S. postage stamps in your letter, as they would be useless in a foreign country. Return postage can be insured in three different ways, namely, International Postal Reply Cards, International Reply Coupons, or unused postage stamps of the foreign country from which you wish a reply.

The International Postal Reply Card may be used for brief messages, and consists of a double Postal card, one side of which is a duplicate attached by a perforated edge and to be used for the reply. These double Postal cards can be purchased at any first class Post Office. For a reply from Canada, Newfoundland, Haiti, Mexico, Spain, Central or South America, the double card costs 4c. For a reply from any other foreign country the cost is 6c.

Where it is necessary or advisable to insure a reply in the form of a letter, the "International Reply Coupon" may be used. The International Reply Coupon may be purchased from any first class Post Office for 9c each. An International Reply Coupon may be exchanged in any country in the International Postal Union for one postage stamp of their (own) country. International Reply Coupons must be stamped with the date of their purchase by the Postmaster from whom you buy them, or they are not valid, and of no value.

Probably the least common method of insuring a reply is by enclosing the postage stamp of the foreign country to which you are writing. It is obviously impossible to keep a supply of the stamps of even the main foreign countries on hand for this purpose. For those who wish to use this method for reply a service has been established called the "Stamp Window Ltd.", Missoula, Montana. This Stamp Window carries in stock, stamps of common denomination of some 92 foreign countries. These stamps, we understand, can be purchased at their regular face value plus a small charge for operating the service. The "Stamp

Window Ltd." is not a commercial enterprise, but run mainly for service to DX-ers.

TUNING THE BROADCAST BAND DURING OCTOBER-NOVEMBER

During the cool nights of October and November the DX listener can get an early start in logging those elusive foreign stations. Reception of the stations from Australia and New Zealand will be at its fall peak, and we would advise you to watch closely for the appearance of these stations in North America during the hour before dawn.

Japanese and Chinese stations will be showing up in profusion on the Pacific Coast, although it will still be a little early for their reception in the Central or Eastern areas. These stations are best from about 2:00 to 4:00 a.m. P.S.T.

European stations will begin to appear about now in Newfoundland, Nova Scotia, and perhaps the extreme North-East New England coast region. Next month, as these stations gain in signal strength, and are being heard over a wider area we will bring you a lot of information on tuning them in.

PIETERMARITZBURG, NEW SO. AFRICAN DX GOAL

The new Pietermaritzburg station of the South African Broadcasting Co. was officially opened on July 15th.

Previous to that time it was heard testing on about 698 kc., and it will probably use this frequency permanently. The call letters are ZTP, and the power of the station 10 kw. The transmitter being almost identical to those of Grahamstown, and Cape Town. The installation was made by Marconi Wireless Telegraph Co., Ltd. The Aerial towers are 328 ft. high, and stand on wonderful "World View Hill," which is over 4,000 feet high itself. ZTP will take the Durban programs by land line. Reports can be addressed to "Radio Station ZTP," African Broadcasting Co., Pietermaritzburg, Union of South Africa.

OTHER NEW BROADCASTING STATIONS

A. Saito, of radio station JOGK, Kumamoto, Japan, informs us that JFCK, Taichu, Taiwan Island, is now officially on the air on 580 kc. with 1,000 W. (Owner—the Broadcasting Corp. of Taiwan). JBAK, Fuzan, Chosen, will be opened before September with an antenna power of 500 W., on about 1,020 kc. (Owner—the Broadcasting Corp. of Chosen). Stations at Kagashima, and Toyama will be opened this fall with a power of 500 W. each. The stations will operate on 1,060, and 760 kc., respectively (Owners—the Broadcasting Corp. of Japan).

The new long-wave station *Radio Brasov*, Romania using 150 kw. is official. (Continued on page 313)

Here is an interesting verification-request card used by one DX-er in requesting stations to send "veris." The back of the card lists the time, call and program heard, as well as details of the receiver used, etc. A station receiving such a concise card will certainly reply.



INTERNATIONAL RADIO REVIEW

RADIO-CRAFT receives hundreds of magazines from all parts of the world. Since the cost of subscribing to each of these would be prohibitive for most radio men, we have arranged with technical translators to prepare reviews for our readers.

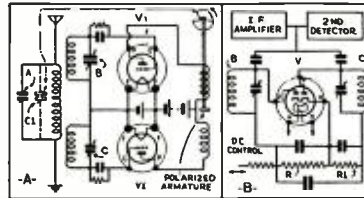
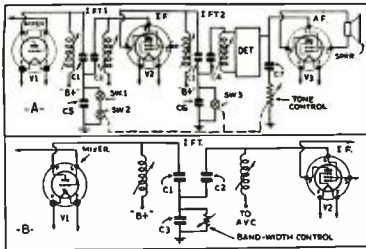

Fig. 1, left. Variable-band I.F. transformers.
Fig. 2, above. The method shown above assures perfect tuning of any station.

Fig. 8. This oddly-shaped cabinet houses one of the new English sets.

VARIABLE I.F. AMPLIFIER COUPLING

WHILE the "high-fidelity" bug has not taken hold in Europe to the degree that is apparent in the U.S., several really worth-while articles on this subject have made their appearance in foreign magazines in the last few months.

One of these was printed in the Viennese magazine *Radio Amateur*, recently. The article, entitled "Band Widening—Some Practical Circuits" covers the subject of I.F. transformer and circuit design, to permit the "pass band" to be widened sufficiently for high-fidelity work.

The article covers, in general, the use of special iron cores in the I.F. coils which serve the dual purpose of increasing the gain and permitting the circuits to be trimmed to the desired frequency.

Two interesting circuits are included. The first shows the use of a capacitive type band filter for coupling the various I.F. stages, shown in Fig. 1A. By short-circuiting the condensers C5 and C6, the band width is changed from the normal (about 10 kc.) to the wide-frequency position. A toggle switch on the tone control knob permits this change.

The second circuit is a variation of the first idea, in which a variable resistor is shunted across the condenser C3 to vary the band width. These theoretical circuits show the progress that is being made in Europe in the development of high-fidelity sets.

AN ITALIAN CONSOLE

THE MAGAZINE *Radio Industria*, published in Milan, Italy, recently contained the description of a new console type receiver of unusual appearance.

An exceptionally large, easy-to-read dial is the first fact

Fig. A. An expensive console of Italian origin.



Fig. 3, below. The "thermometer" dial.

Fig. 4, right. Robot plane control circuit.

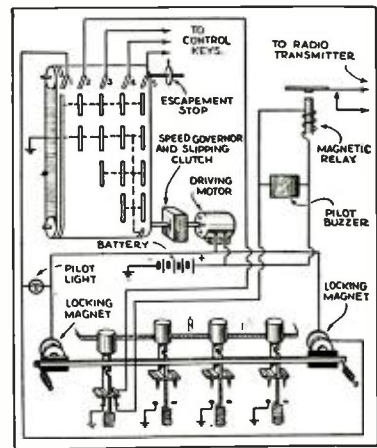
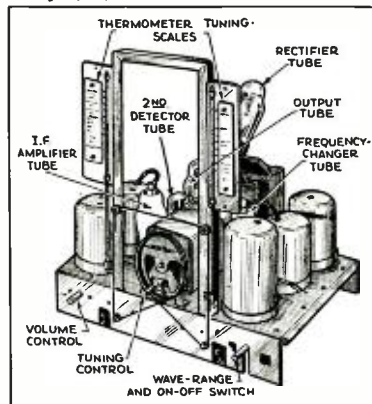

that stands out upon examining the photo, Fig. A. This greatly facilitates tuning, especially on the high-frequency bands.

The attractive and unusual cabinet style is the second outstanding point. When closed, the cabinet resembles an organ with the overhanging front panels and protruding base.

The third outstanding fact is the receiver itself which covers all wavelengths from 10 to 2,000 meters, giving a full 12 W. of undistorted output. A phonograph turntable is also included, with an automatic record changer.

"SELF-TUNED" RECEIVERS

A DISTINCTLY novel idea for superhet. receivers appeared recently in an English magazine—*Popular Wireless*.

In this type of set, when A.V.C. is employed, it is necessary to tune a station in accurately, due to the tendency of the A.V.C. to bring up the signal strength to normal even if the set is mis-tuned. This results in distortion and the use of visual tuning indicators has thus become standard practice.

To simplify the tuning in such sets, the idea shown at A and B, Fig. 2, was developed. Referring to Fig. 2A, which presents the basic principle, it will be seen that two detectors are fed from the aerial coil, and the outputs of these two tubes are fed to a balanced magnetic circuit, mechanically coupled to a trimmer condenser, C1. If condensers B and C are adjusted, one a little above the station frequency and the other a little below, it can be readily seen that if condenser A is tuned to a frequency slightly higher than that of the station, a greater current will flow in tube V which will turn trimmer C1 out, thus

(Continued on page 310)

VOCATIONAL POSSIBILITIES IN RADIO

The similarity of requirements for all types of communication engineering is shown, in a comparison of theory and practice.

J. K. WHITTEKER*

THE SCIENCE of electrical communication may be generally divided into three classifications: (1) Telegraph Engineering; (2) Telephone Engineering; and, (3) Radio Engineering.

While each of these divisions may appear to the layman to be separate and distinct branches of engineering, a little careful thought will prove the reverse to be true. Our first system of electrical communication was the telegraph. Out of this grew the telephone and from the two came the radio.

As our first example, let us take an engineer in a radio telegraph system. Roughly, his technical knowledge must be about as follows: (1) knowledge of radio transmitters; (2) knowledge of radio receivers.

The radio transmitters and receivers are connected to the control station by wire lines (telegraph circuit). This control station may be from 50 to 100 miles from the transmitters and receivers.

The transmitter is keyed by, and received signals are recorded by devices like those which perform corresponding duties in the telegraph cable office.

There is also a growing tendency to apply the multiplex

*Chief Instructor R. C. A. Institute, Inc.

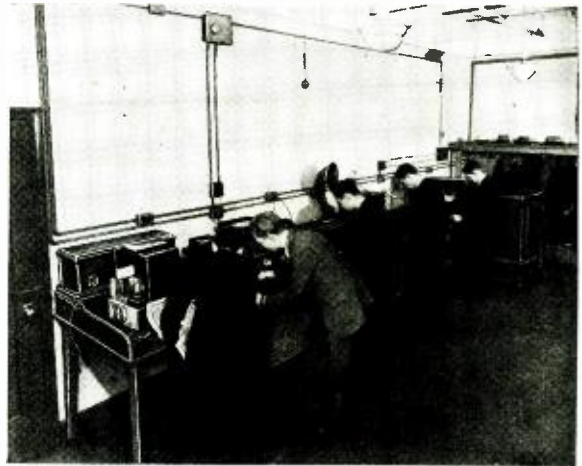

Service laboratory of RCA Institutes.

and printer telegraph system to radio. Here we apply to radio some of the most advanced wire telegraph practice, so we may now add a third requirement to the list of things the radio telegraph engineer must know: (3) knowledge of telegraph engineering.

The engineer in radio broadcast (telephone) work will be taken as our second example. Requirements (1) and (2) remain the same as in the first example. Here again the transmitter may be located many miles from the control station (studio). Signals consisting of speech and sound, musical or otherwise, must be carried by wire lines from one point to the other. Immediately we are involved in a problem of telephone engineering of the highest order since higher quality lines and apparatus are involved than would ordinarily (Continued on page 312)



Untouched Television view—reproduced by a Von Ardenne cathode-ray scanner. Remarkable grain and line structure are indicated.

THE RELATIONSHIP of motion pictures and television is an important one that merits thoughtful and impartial analysis. It is hoped that the following article, which is based on the writer's article, "Television and Motion Pictures," delivered at the Spring, 1935 Meeting of the Society of Motion Picture Engineers, will be of interest to those who are closely following "television-telephone" (television and synchronized sound) development.

COMPARISON OF THEATRE AND HOME TELEVISION

(1) Mode of Picture Production.

that may seem. The theatre picture is projected as a complete unit, one entire frame at a time. The delineation is produced and limited by aggregates of silver grains in the developed positive image.

The television picture is produced by a luminous dot (or "dot-element"), the brightness of which is accurately controlled as it passes in succession over a series of parallel and closely adjacent lines until it has covered the entire area of one frame.

In the theatre case, the entire picture is on the screen at a given instant of time, to be succeeded by full-screen

(Continued on page 316)

TELEVISION IN THE THEATRE

PART I

One of the greatest opportunities for the radio man will be in the development of television. This is the first complete review.

ALFRED N. GOLDSMITH

The methods of producing the pictures are entirely different in the two cases of theatre motion picture, and home television reception, odd as

A modern talkie projector, used for film scanning in the new Berlin television station.

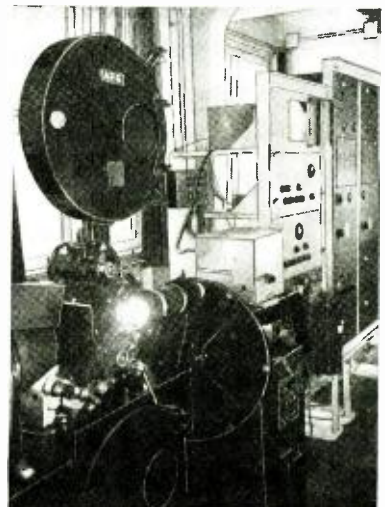

HOW METAL TUBES ARE MADE

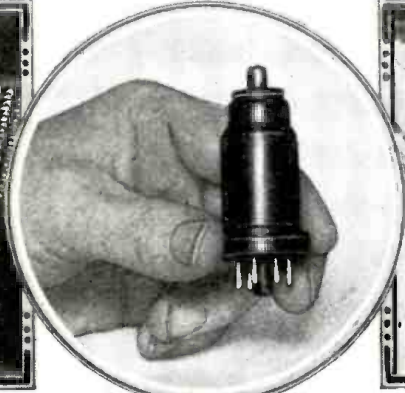
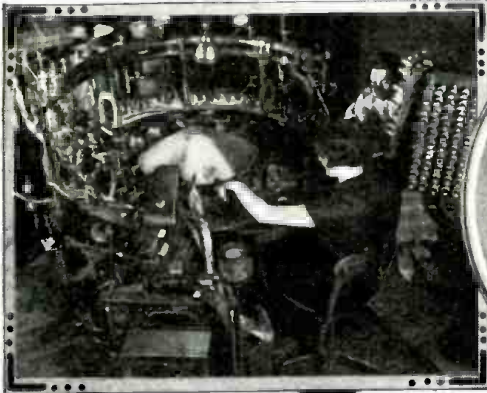

ABOVE, CENTER—the finished product. The metal tube, designed by G.E., is being constructed by RCA Radiotron and many of its licensees. A feature of the new tubes is their small dimensions. ABOVE, LEFT—exhausting the air from the metal tubes. Pumps draw off the air from the tube as it rotates through the gas flames which heat it to drive out gases occluded in the metal. ABOVE, RIGHT—assembling plate and header. Eyelets fasten the plate to its mica supports. LEFT—welding eyelets

to the header. The metal headers are supplied to this machine with eyelets inserted. The water-cooled welding plunger carries a heavy current to the assembly and welds it in one stroke. These eyelets are the ones through which the leads of the finished tube run, the necessary insulation being supplied by beads of a special high-resistance glass. The beads in the base, and those used in tubes having a top-cap lead, constitute the only glass used in the complete structure. RIGHT—placing the metal shell over the completed "mount." The mount is the finished internal structure of the tube, with all elements in place. After the shell is put in place the assembly is ready to be welded. Neither base nor cap are added yet, since heat used in exhausting would destroy them.



← LEFT—the sealing machine. This close-up shows 8 assemblies in place ready for the sealing operation. The machine is automatically controlled, and applies a current of 75,000 amperes to the weld for 1/30 of a second! Thyatron tube controlled timing assures very accurate results.



RIGHT—the final factory test. Here many separate, operation tests are given to each individual tube to insure that it is as near perfect as possible. It is said that the metal tube design effects a big decrease in the number of rejects due to inferior tubes.



← LEFT—welding exhaust tube to the header. The tube is held in position by a jig as the operator spot-welds them to the header. Welding is again employed in the exhausting process, since when this is completed, the exhaust tube is pinched together in a spot welder so that the pinch is made vacuum tight.



RIGHT—seasoning the finished tubes. Before final inspection, they are operated for a time sufficient to stabilize their characteristics. (RCA Radiotron Photos)

FIRST PRIZE \$10.00
 SECOND PRIZE 5.00
 THIRD PRIZE 5.00
 Honorable Mention

EXPERIMENTERS: Three cash prizes will be awarded for time- and money-saving ideas. Honorable mention will be given for all other published items. Send in your best "kinks"!

SHORT-CUTS IN RADIO



Fig. 1, above, shows the appearance of the multiple switch; Fig. 1, below, connections.

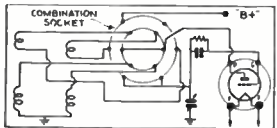

FIRST PRIZE—\$10.00

A MULTIPLE SWITCH. The arrangement in Figs. A and 1 may be made with any number of prongs from 4 to 7, depending upon the number of circuits it is desired to break. The two sockets are the same and are fastened firmly to each other. The particular unit shown was made for use in a short-wave set, two sets of coils being made available. The 6-prong tube base has every other prong cut off for this use, so that to shift from one circuit to the other it is only necessary to pull the plug out and turn it 1/6th revolution before replacing it. When used simply to break a number of circuits at once, no prongs need be cut off.

W. A. GUIDER

SECOND PRIZE—\$5.00

SPEAKER CORD EXTENSION. It is often a time-wasting job to remove a speaker from a console cabinet, in order to work on a set on the bench. To avoid this, I made up an extension, of a length of flexible cable and a tube base and socket. It is best to use cable of the 8-conductor type and use adapters at each end of the cord, since some modern sets have as many as 8 active conductors in the speaker cord. See Fig. 2.

Adapter kits may be made to suit individual localities, as required.

GASTON BERTRAN

THIRD PRIZE—\$5.00

INDUCTIVE LEAD-IN. The lead-in is often a problem, particularly

Fig. 2. A speaker cord extension for the busy Service Man is a time saver.

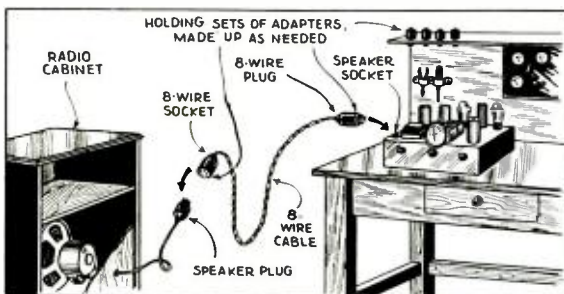

when there is an objection to piercing the walls or window casements. A way to overcome this objection and yet retain full efficiency of set and antenna is pictured in Fig. 3. The coils are preferably of the spiderweb type ("regular" coils of solenoid type may be tried, however) and are wound with about 45 T. of No. 26 enameled wire. Hang or fasten one coil on each side of the window, directly opposite each other. The antenna and ground go to the outside coil, with a lightning arrester across the coil to satisfy regulations. The inside coil is connected to the set as pictured. Some sets require the stabilizing effect of a ground so this is connected to the ground post through a 2,000 to 5,000 ohm resistor. If this ground lead is more than 4 ft. long it should be shielded and the shield grounded at the lower end. Where no window is available, try the stunt directly through the wall. In this case larger coils would probably help.

Be sure to properly weatherproof the "inductive lead-in."

WALTER E. KEEVER

HONORABLE MENTION

PORTABLE METER MOUNTING.

The little tin can may be elevated to a position of prominence by using it as a base for mounting a meter. Figure 4 illustrates the idea. ("Gresolvent" cans and certain coffee cans are the best for this use.) A coat of paint will give that "professional" appearance.

JOSEPH LEEB

HONORABLE MENTION

STARTING NUTS. A great amount of time is often lost in starting nuts in "hard to get at" places, as it is usually impossible to use pliers or socket wrenches. Procure a long tapered scriber, and slip the lock washer on it until it will hold itself. Place the point of the scriber on the end of the screw and slide the washer down with a screwdriver. (See Fig. 5).

The nut may be put in place in the same manner. In this case, turn the nut with the screwdriver until a thread is caught before removing the scriber. The nut may then be tightened by the more usual methods.

AL ANDERSON

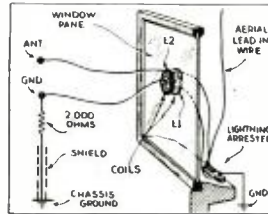

Fig. 3. An inductive lead-in.

HONORABLE MENTION

INCREASING SET SENSITIVITY. Many of the popular 4-tube midget sets with a single stage of R.F. are somewhat lacking in selectivity and sensitivity, and may be improved by the addition of a tuned antenna stage. The size of the coil will depend on the set and antenna used, but as a rule 70 T. of No. 30 D.C.C. wire on a 1 1/4 in. form will be about right when tuned by a 350 mmf. condenser. The coupling coil consists of 10 or 15 turns of the same size wire wound on top of the other coil. "A" and "G" of Fig. 6 go to the antenna and ground connections of the set. If the set has no ground connection, the "G" post may be connected to chassis. In Fig. 6 B, the same circuit is shown with a switch added to cut out the tuner if desired.

Service Men should find this gadget an excellent demonstrator to aid in showing the need for modernizing older sets.

G. H. BAIRD

HONORABLE MENTION

VIBRATOR-"B" ADJUSTMENTS. This simple adapter illustrated in Fig. 7, makes it possible to adjust an auto-set vibrator in actual operation. This saves a great deal of time and labor and also produces a much better job. It would be advisable to make several of these adapters, for vibrators with different bases, but this is no hardship as the device is so simple and cheap.

WILLIS DENMAN

HONORABLE MENTION

A SIMPLE FIELD SUPPLY. This device may be used to (Continued on page 310)

Fig. 4. A portable meter mounting.

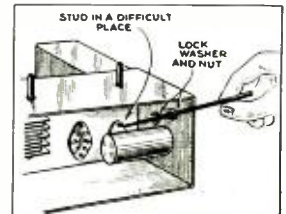
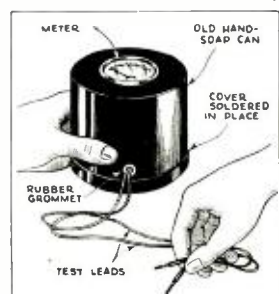

Fig. 5, above. Starting nuts or washers.

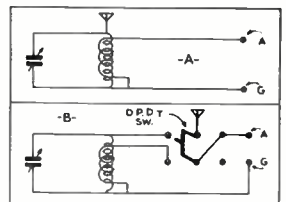

Fig. 6. Increasing sensitivity of midgets.

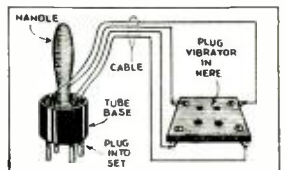

Fig. 7. Vibrator adjusting adapter.

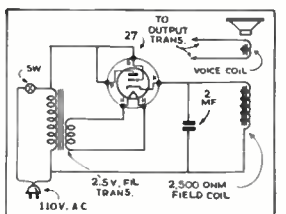

Fig. 8. A simple field supply.

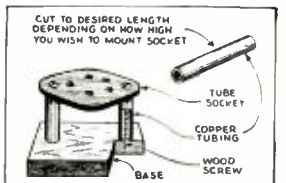
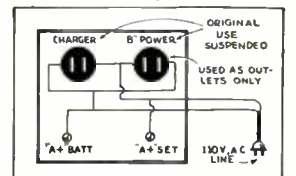

Fig. 9, above. Copper tubing supports.

Fig. 10, below. A handy extension plug.



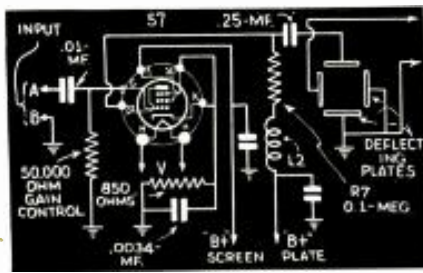

Fig. 1. The sweep circuit amplifier.

THE SENSITIVITY of the ordinary cathode-ray tube is such that an appreciable voltage is required to deflect the beam over a 3 or 4 inch screen. For instance, the sensitivity of a well-known make of cathode-ray tube is such that a potential of 75 V. is required to deflect the beam either horizontally or vertically a distance of 1 in. Because the output voltage of the ordinary electrical sweep circuit is very small, an amplifier is usually used to step it up. A high-gain linear amplifier suitable for this purpose is shown in Fig. 1. Terminals A and B connect to the corresponding output terminals of the sweep circuit. The output terminals of the amplifier connect to the proper pair of deflecting plates in the cathode-ray tube. This amplifier stage will produce a gain of approximately 40 and the amplification is linear from 20 cycles to 90,000 cycles \pm 10 per cent. The frequency response is excellent, mainly because of the use of the combination resistance and inductance

*Radio Technical Publishing Co.

SWEEP & WOBBLE CIRCUITS FOR CATHODE-RAY TUBES

Further details concerning the specific use of a cathode-ray tube for service work are given below.

ALFRED A. GHIRARDI*

load R7, L2, in the plate circuit of the tube. This same amplifier may be used to amplify the voltage which is to be observed in the cathode-ray tube, if this voltage is small.

WOBBLING THE TEST OSCILLATOR SIGNAL FOR VISUAL I.F. STAGE ALIGNMENT

Now that we are acquainted with the construction and operation of the cathode-ray tube, the sweep circuit and the amplifier, we are prepared to consider the use of the cathode-ray tube as a visual resonance curve tracer in the alignment of the tuned circuits of I.F. amplifiers. The advantages and reasons for the use of the cathode-ray tube in this work have already been stated. We are interested here merely in how it is accomplished.

Let us suppose that the response characteristic of a flat-topped I.F. amplifier in a superheterodyne receiver is to be observed either when checking over the receiver or when actually aligning the I.F. stages. Ordinarily, a service test oscillator would be connected to this I.F. amplifier and its fre-

quency would be varied over the flat-top frequency range of the I.F. amplifier; the reading of the output meter connected to the receiver then would be watched to determine whether the flat-top characteristic extended over the proper band of frequencies. If the characteristic of the circuit was seen to be below par, adjustments would be made to align the circuit as nearly as possible so that it would conform to the desired characteristic. (In this cathode-ray tube method of checking performance, the cathode-ray tube instead of the output meter is connected to the

Fig. 2. A typical form of wobbler.

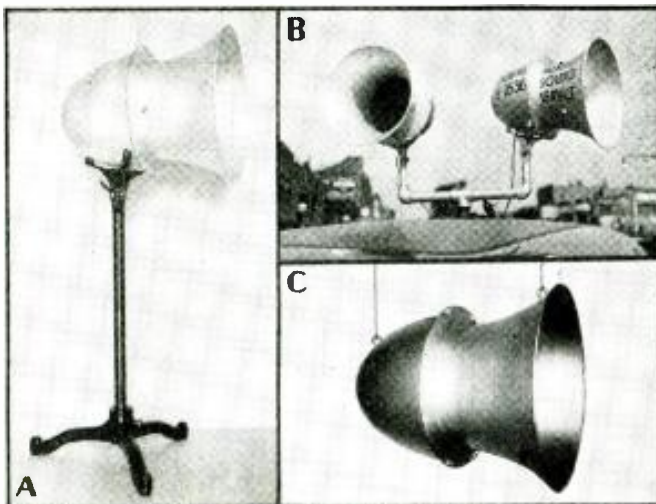
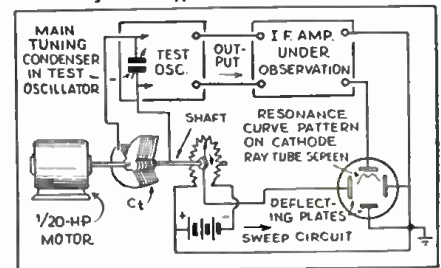
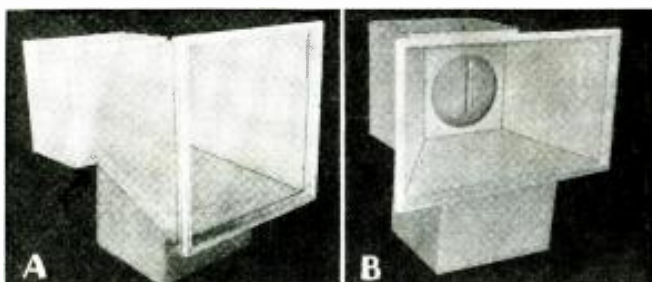

Fig. 2, above. Two views of an efficient speaker and a typical sound car installation.

Fig. 1, below. Two forms of focused speakers for P.A. work—these are useful outdoors.

*Manufacturer's name on request.



THE CORRECT USE OF LOUDSPEAKER HORNS

In P.A. work the speakers play the most important role in the entire set-up.

R. C. REINHARDT*

AP.A. SYSTEM is often simlized by a chain and described by the expression "No better than its weakest link." The last link, the reproducer, must be the strongest!

This final stage of the amplifying system performs the most difficult task of converting the A.F. electrical impulses to air vibrations or sound pressure variations.

Due to the complexity of electrical, mechanical and acoustical requirements, and their reaction upon each other, the design of an efficient and wide-fidelity speaker is not a simple matter. Therefore, let us assist the reproducer in every possible manner with the use of either, or both, a properly designed reflector or (and) baffle.

The importance of the use of a directional baffle or horn, as it is generally called, is unfortunately often neglected. A flat baffle is usually not satisfactory unless its size is extremely large and even then it does not permit the speaker diaphragm to push against or grip a quantity of air. This means that the sound builds up little pressure and may be compared to water leaving the end of a nozzleless hose.

A baffle of inexpensive and simple construction is illustrated in Fig. 1A. This baffle may be used as shown together with a square housing enclosing the loudspeaker

(Continued on page 314)

SPECIAL NOTICE

Those questions which are found to represent the greatest general interest will be published here, to the extent that space permits. (At least 5 weeks must elapse between the receipt of a question and the appearance of its answer here.) Mark such inquiries, "For Publication."

Replies, magazines, etc., cannot be sent C.O.D. Back issues of **RADIO-CRAFT** prior to December, 1932, are available at 50¢ per copy; except the following issues: 7/29, 1, 2, 3, 4, 6, 7, 9 and 11/30; 5, 8 and 9/31; and 7/33, which are out of print. Succeeding issues are still available at the regular price of 25¢ per copy.

Inquiries to be answered by mail **MUST** be accompanied by 25¢ (stamps) for each separate question; answers are subject to subsequent publication if considered of exceptional interest.

Furnish sufficient information (in reference to magazine articles; be sure to mention issue, page, title, author and figure numbers), and draw a careful diagram (on separate paper) when needed to explain your meaning; use only one side of the paper. List each question. Be **SURE** to sign your name AND address.

Enclose only a **STAMPED** and self-addressed envelope for names and addresses of manufacturers; or in connection with correspondence concerning corrections to articles, as this information is gratis.

Individual designs can be furnished at an additional service charge. The fee may be secured by addressing the inquiry to the **SPECIAL SERVICE** department, and furnishing **COMPLETE** specifications of desired information and available data.

RADIO-CRAFT'S INFORMATION BUREAU

MIDWEST "TUNING LIGHT" CIRCUIT

(347) Mr. Cy Lestring, Detroit, Mich.
(Q.) In connection with service work I have come across the diagram of a new Midwest set, which has a tuning indicator incorporating a separate tube. This tube seems to operate without "B" voltage, although I have been assured that the circuit enclosed is correct. Can you tell me briefly how it operates?

(A.) The circuit as shown in Fig. Q347A, is quite correct. The small transformer in the bulb circuit applies an A.C. potential between plate and cathode of the 6C5 triode, causing a flow of current in the tube. The transformer is wound so that with no signal coming into the set, its windings are balanced to allow the bulb to operate at full brilliancy. When a carrier is tuned in, the negative bias on the 6C5 is increased, through the lead to the diode detector, the higher bias causing the plate current to drop. The lower plate drain from the secondary results in lower current in the primary, therefore the bulb will glow more weakly. Fig. Q348B shows the same idea in simplified form, the triode being replaced by a simple resistance in the secondary circuit. Increasing the resistance decreases the load on the transformer, resulting in lower primary current and less light from the bulb.

In practice the transformer is run very close to the saturation point, so that the variation in bulb current and brilliancy will be as great as possible. This means that even a weak station will cause a noticeable variation in the light.

"VERSATILE CONDENSER TESTER" (A CORRECTION)

(348) Mr. W. H. Milsap, Houston, Texas.
(Q.) In the August, 1935 issue of *Radio-Craft*, page 94, a versatile condenser tester was described by Mr. J. R. Williams. I believe this diagram was incorrect, and would like to have the proper one if possible.

(A.) The diagram of the condenser tester as corrected by Mr. Williams, appears herewith. See Fig. Q348.

FORESTRY PORTABLE SET

(349) G. K. Landin, Kester, Colo.
(Q.) I have seen the foresters using a small telephone set which works by radio. Only a very small aerial is used. Can you give me any information on such equipment, and could it be home built? (A sending license will be obtained.)

(A.) The outfit you refer to is probably an ultra-high frequency set, the diagram of which is illustrated in Fig. Q349. This is very similar to the so-called transceivers used by many amateur operators on the 5-meter band. A kit is made for this particular set and similar ones can be bought in kit form or already built.

TREASURE LOCATOR

(350) Mr. Joe Wildowi, Tulsa, Okla.
(Q.) I have built the treasure locator described by Mr. H. L. Berry, in the August, 1935 issue of *Radio-Craft*, and would like to know if there are any points that you have heard from the author on the building or use of this apparatus. Are there any improvements that could be made?

(A.) Mr. Berry writes us as follows: "I mentioned 1 lb. of wire because I find the experimenter will need more than one coil of each kind to complete the instrument."

"A difference of 1 ohm in the meter, cable, tube resistance, etc., will change the entire hook-up and if the constructor has several coils he may hit on the correct one, by elimination, to match the balance of the circuit. The diagram as published is very simple at first glance, and the would-be builder may have plenty of grief. I know of no way to overcome this."

(Continued on page 319)

P.A. QUESTIONS & ANSWERS

Conducted by
CHARLES R. SHAW

Here is a new department for the Radio Dealer, Service Man and Sound Technician who require general information and help in P.A. work. This department will furnish valuable aid for the asking. Address all questions to *Radio-Craft's* Public Address Forum. Only those questions of general interest will be published and we reserve the right to publish any of these inquiries and answers.

SPEAKER CONNECTIONS

(21) Mr. Charles Feldman, Louisville, Ky.
(Q.) How can I use a 3-wire cable for connecting two widely separated speakers. The circuit requirements necessitate that the dynamic speaker fields be connected in series, while the voice coils are connected in parallel. Both speakers are now wired with a common voice coil and field connection for use in another amplifier. I would like to meet the requirements of the above circuit without changing the present speaker wiring.

(A.) The circuit is shown in Fig. Q21. It will be noted that the voice coils will be at the field potential above ground. It will therefore be impossible to ground either side of the voice coil, for, if this is done, one of the fields will be "shorted." However, the junction between voice coil and the field coil may be grounded, if necessary, by removing the ground shunt.

REMOTE CONTROL

(22) Mr. George Altu, San Francisco, Calif.
(Q.) I find it necessary to be able to operate the "ON-OFF" switch of my P.A. outfit from two remote points, that is the A.C. must be "opened" or "closed" from two separate switches, and so arranged that either switch will operate regardless of the setting of the other switch. Is this possible? If so, please supply a circuit for this setup.

(A.) The circuit is shown in Fig. Q22. Two single-pole double-throw switches are required. Either switch will put the amplifier into operation and shut it off regardless of the setting of the remaining switch.

(Continued on page 319)

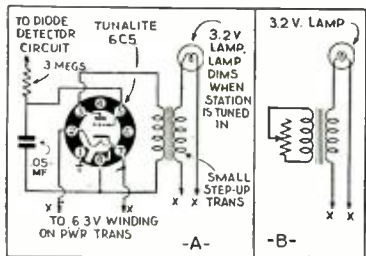

Fig. Q 347, above, Midwest tuning light. Fig. Q 348, below, Tester.

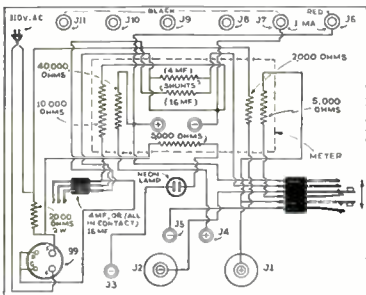

Fig. Q 349, below, Forest Service transceiver.

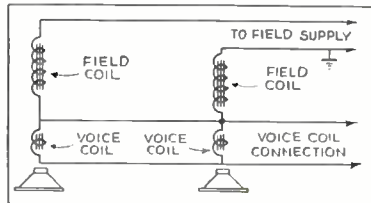
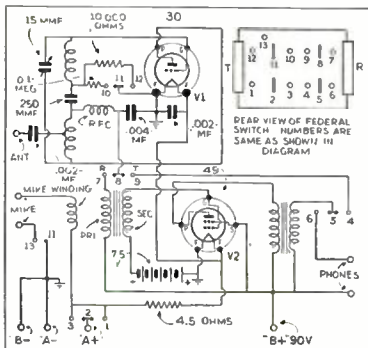
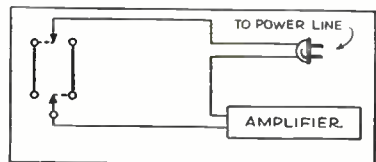
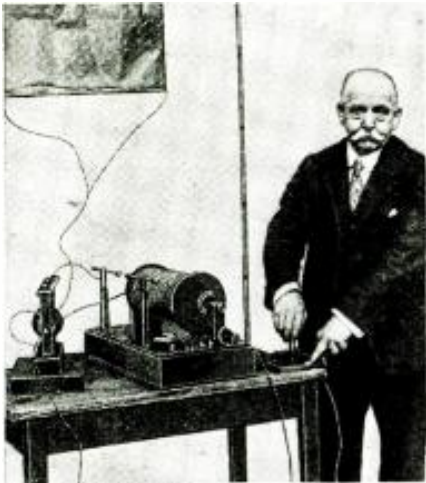

Fig. Q 21, above, Multiple speakers. Fig. Q 22, below, Circuit to control amplifier from two locations.





Radio's development is aptly demonstrated by the two photos here. Above is a view of G. S. Kemp, an early assistant of Senatore Marconi, shown with the latter's first radio transmitter, in 1895!

Below is a contrasting view, showing part of Marconi's 1935 "floating laboratory" equipment, worth thousands of dollars, aboard his yacht, "Elettra."



RADIO STUDENT REQUIREMENTS

Two ways to success are pointed out by the author: technical training in an engineering school; and, home study.

J. F. WITKOWSKI*

RADIO ENGINEERING embraces not only the broadcasting of programs and the transmission of messages, but many applications of radio science which are still largely unfamiliar to all but the expert.

Two courses are open to the young man who chooses radio engineering as a career. He can acquire his technical training by attending an engineering school at one of the universities, and then proceed to its application. If this is impractical, he can seek a beginner's position in some branch of the radio industry and acquire his technical knowledge along with his practical experience, by study in spare time. Whichever course is chosen, hard and persevering study will be required, for the technical problems involved are so complex that real success can come only to the thoroughly trained man.

The possibilities of television are

rapidly becoming better understood and the day when a television set can be installed in the home seems to be not far distant.

Radio beacons are guiding the aviator by night. Research is turning to the radio tube to provide constant indication of a plane's altitude above the earth and of its approach to a mountain side or another plane. The tube
(Continued on page 317)

The yacht "Elettra"—the scene of Marconi's recent experiments in ultra-high frequency transmission.

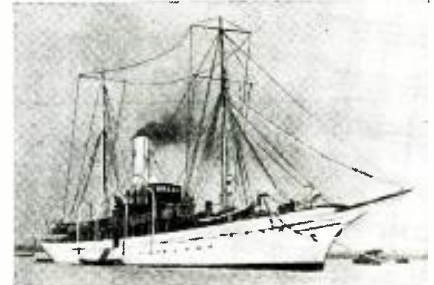

*Principal, School of Radio, International Correspondence Schools.

AN EASILY-BUILT UNIVERSAL BRIDGE

The Wheatstone bridge, one of the oldest electrical instruments, has many A.C. and D.C. applications in radio.

HUBERT L. SHORTT*

WITH THE introduction of more and more complicated all-wave receivers, phonograph-radio combinations and P.A. amplifiers, the accurate measurement of resistors and condensers is becoming increasingly important from the standpoint of the Service Man. For instance, in A.V.C. circuits, where the time action is a function of resistance and capacity, replacements of defective units cannot be made with confidence unless the true value of the new part is definitely known. In certain amplifiers using

phase inverting circuits to produce push-pull action without the use of transformers, a critical grid resistor must be just right or the amplifier sounds peculiar.

Manufacturing tolerances being what they are, the labels on resistors and condensers cannot always be trusted, and if they should be missing altogether, or if the color bands are charred or faded, the Service Man is just out of luck unless he owns a bridge of some sort.

The usual small "volt-ohm-meter," consisting of a milliammeter in series with a local battery and a zero-adjusting resistor, is all right for casual measurements of resistors of medium value, but is admittedly unsatisfactory for either very low or very high values. It is of no value at all for condenser measurement.

To meet these new service conditions, Mr. Gerard Kelly, working in the writer's laboratory, has developed a compact, reliable universal "Wheatstone

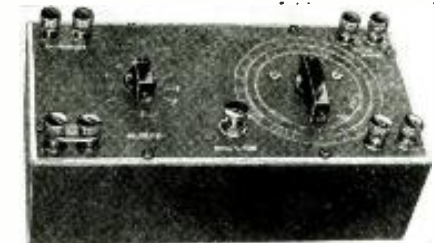

bridge" that accurately measures resistance from .01-ohm to 1 meg., and capacity from 100 mmf. to 100 mf. Now the *Wheatstone bridge* is one of the classical instruments of the electrical art and has been known for more than sixty years, but in its laboratory form (as most Service Men remember it from their high-school days) it is a rather unwieldy device and involves mathematical computations for which
(Continued on page 317)

The circuit of the A.C. bridge, with values.

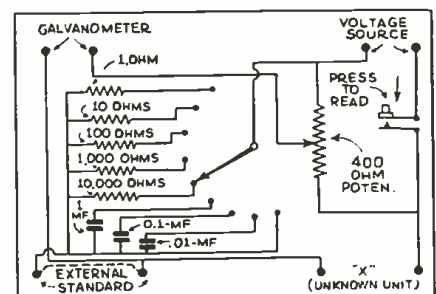

*Chief Engr. Wholesale Radio Service Co., Inc.

The rear of the panel of the bridge unit.

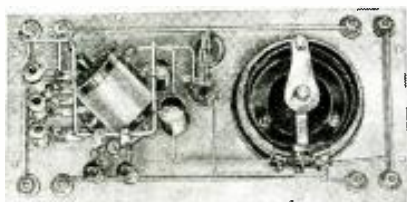

THE LATEST RADIO EQUIPMENT

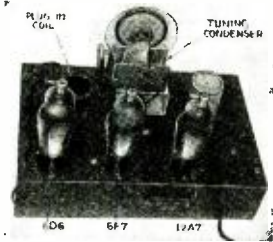

A 3-tube short-wave set which gives loudspeaker results. (832)

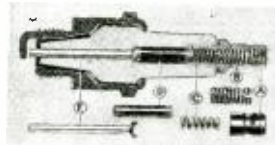

"Suppressor" spark plug. (837)



Space-saving insulated resistor. (838)

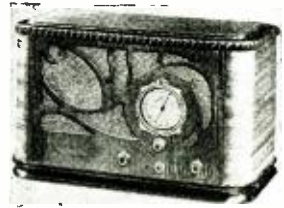

An all-wave set incorporating the metal tubes. (839)

SHORT-WAVE RECEIVER (832)

(Ellen Radio Labs.)
USING only 3 tubes, but giving results equivalent to 5, this new outfit is complete except for the speaker. Sold in kit form; matching speaker in separate case is available. Some features are: illuminated airplane dial, smooth regeneration control, band spread, large power output. Plug-in coils are used for simplicity and efficiency.

sensitivity type; output utilizes a 2A5 tube. Sold in either kit form or completely assembled.

SPARK PLUG (837)

A COMBINED spark plug, and car-radio noise suppressor. The feature is that resistor D is easily removable for replacement. Item A is a universal cap; stud B and spring C make resistor accessible; E is the center electrode. This spark plug is made in types to fit all cars; its use simplifies car-radio installation and service.

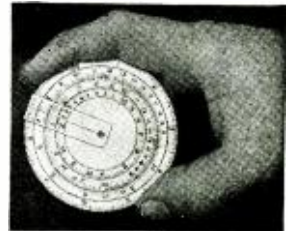

Midget circular slide rule. (840)



A handy set chassis holder. (833)

HANDY SET HOLDER (833)

SERVICE MEN will be interested in this new development. The 2 main frames may be separated to accommodate any chassis up to 30 ins. in length (C). Hooks, B, hold the chassis on the arms, A. Knobs, D, allow the set to be turned to any convenient angle. Prevents damage to tubes, tuning condensers, dials, wiring, etc.

INSULATED RESISTOR (838)

(International Resistance Co.)
SMALL size is the feature of these units (shown in comparison with a pen nib), yet they retain all the advantages of the metallized type. Made in two sizes, ½ (illustrated) and 1 watt. The markings are both color-coded and printed, in standard values. Leads are tinned.

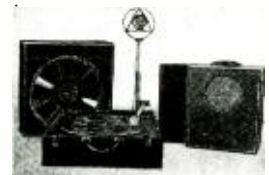

Portable sound outfit. (841)



Small aircraft transmitter. (834)

SMALL AIRCRAFT TRANSMITTER (834)

THIS COMPANION unit to item No. 747, Aug., '35 *Radio-Craft* weighs only 11 pounds, and can be used for voice, tone or C.W. transmission. Two frequencies are available; output, 5 W. on modulated signals, and 15 W. on C.W. Measures 8 ½ x 6 ½ x 9 ½ ins. high.

ALL-WAVE SET (839)

THIS new set uses the now common metal or metal-glass tubes in an A.C. circuit. The wave coverage is continuous from 22.5 mc. to 540 kc., in 3 bands. A special switch with visual indication is used. Incorporates full A.V.C.; coils impregnated for tropical use; and, tone control. A type 6F6 tube provides an output of 4 W. Note the unusual cabinet style.

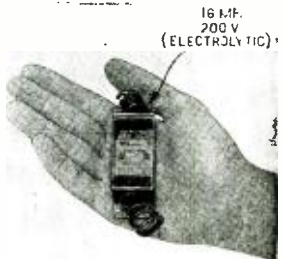

The newest in small electrolytic condensers is illustrated. (842)



No mounting is required for the desk microphone above. (835)

DESK MICROPHONE (835)

NO MOUNTING is required for this crystal microphone, since it rests directly on the table in front of the speaker. Four sound cells are connected in series-parallel for the element. Output level is -74 db.; frequency curve is flat to 6,000 cycles, rising slightly after that.

SLIDE RULE (840)

(Tavella Sales Co.)
ALTHOUGH only 2 ¼ ins. in dia., this washable, white celluloid slide rule gives results somewhat more accurate than the usual 10 in. straight rule; is supplied with a durable case. All usual scales are provided.

A test speaker for use with any set or output tubes. (843)



SHORT-WAVE SUPERHETERODYNE (836)

PLUG-IN coils are used for highest efficiency in this self-contained 7-tube A.C. set. A beat-frequency oscillator is built-in. Range, 14 to 185 meters. Incorporates high-gain I.F. transformers; second-detector is of high-

PORTABLE SOUND OUTFIT (841)

HOUSED in 2 neat cases this complete sound outfit affords efficient operation and fine quality. It can be used for the reproduction of any standard type or speed record, or it can be used as the
 (Continued on page 315)



Name and address of any manufacturer will be sent on receipt of a self-addressed, stamped envelope. Kindly give (number) in above description of device.

HOWARD MODEL G-26, AND "AIRPLANE 4" MODEL AA25 A.C.-D.C. AND BATTERY T.R.F. SET
(Illuminated airplane dial; large dynamic speaker; highly-finished cabinet; A.C.-D.C. operation.)



Four of the newest-type glass tubes are used in this compact set. The T.R.F. circuit is designed for the utmost gain from the tubes available, and is very efficient. The airplane-type dial (model AA25 set) includes two standard pilot lamps, across which is wired a limiting resistor. (Placing the tuning dial directly in the center of the reproducer tends to improve tone quality by reducing the amount of highs in the reproduction.)

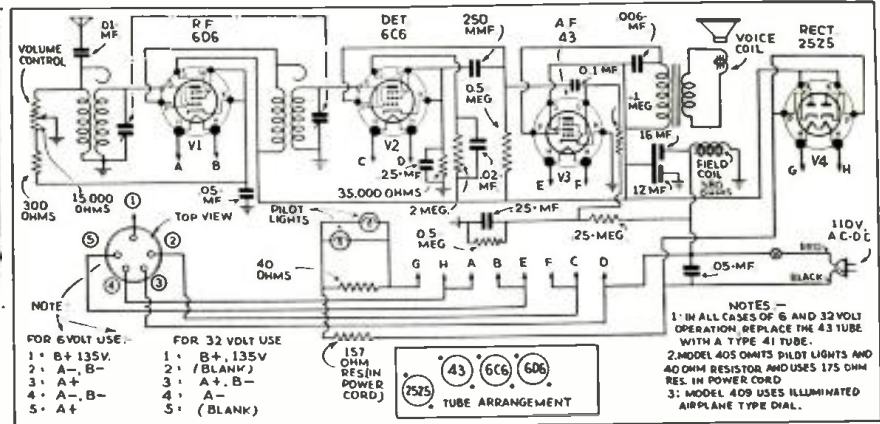

For battery "A" use, on either 6 or 32 volts, there is a socket at the rear of the chassis. The circuit drawing shows the plug connections needed for proper operation on

either of these voltages.

The placement of the tubes on the chassis is shown on the sketch at the bottom of the circuit drawing.

ATWATER KENT MODEL 649 ALL-WAVE 9 METAL TUBE SUPERHET. SET
(Range, 540 to 18,000 kc.; 6.6 W. power output; selectivity control combined with fidelity control; shadow tuning.)

The airplane dial of this set changes illumination as the bands are shifted. Both halves are lighted on the broadcast band, the upper half on the S.-W. band, and the lower half on the police band. The tuning ratio is 60-to-1 on the high position.

The selectivity control makes possible true high-fidelity when in the low selectivity position. In addition, a 4-position tone control is used. Correct tuning is shown by observing the shadow tuning meter, which is operated by the plate current of V2 and V3.

The set draws 120 W. from the line. The range switch has 3 sections, each of which changes 3 separate circuits.

The following table gives voltage readings:

Tube No.	Cath. Volts	C.-G. Volts	S.-G. Volts	Plate Volts
V1	3	3	90	250
V2*	3	3	75	250
V3	2	2	90	250
V4	5	5	80	260
V5	2	—	—	—
V6	4	—	—	100
V7	15	15	230	230
V8	15	15	230	230
V9	365	—	—	—

*Anode grid, 215 V.

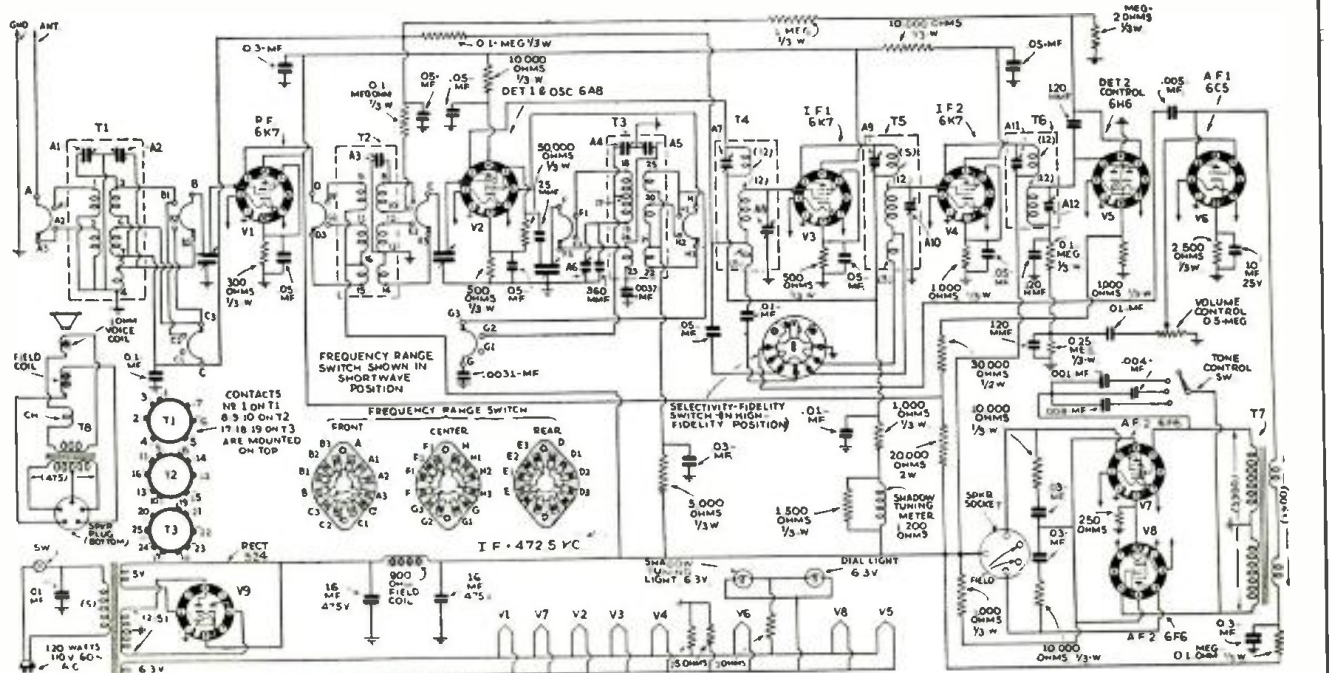
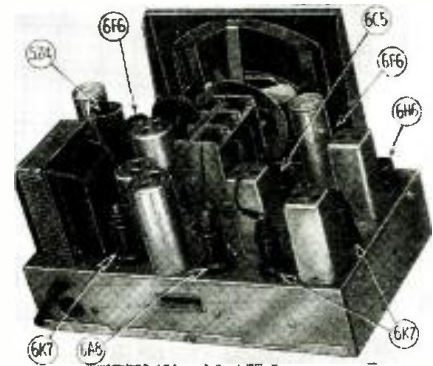

WHAT IS THE FUTURE OF RADIO SERVICING?

The man engaged in service work can look forward to greater prosperity, if he will but train himself to meet forthcoming demands.

F. L. SPRAYBERRY*

THE MAN who is engaged in the radio industry today should consider himself fortunate.

Probably no industry in the world holds such tremendous and immediate possibilities for sudden growth. For instance, not only is the alert Service Man enjoying good business today, but forthcoming developments are such that he will almost surely share in new and greater prosperity on the not far distant morrow. Short-wave developments are coming thick and fast. Facsimile broadcasting with all its vast potentialities for the advertising and publishing trades as well as for home reception is far nearer to being a popular reality than many now imagine. Magazines and newspapers are full of talk about television, coaxial cables and the like. Power amplification, theatrical sound work, aviation

and army radio, etc., are becoming increasingly important and bringing new opportunities for those qualified to handle it. Metal tubes, new circuits and unique new models in home radio receivers, which are being offered this Fall, will mean that there will soon be several million new sets in American homes which, sooner or later, will require efficient attention by skilled Service Men.

Broadcasting developments also favor a big increase in popular radio interest. Next year's presidential campaign alone will create listener interest to the extent of hundreds of thousands of dollars worth of additional work for Service Men.

So much (Continued on page 319)

*Sprayberry's Practical Mechanics of Radio Service.



Two views of Joe Kiss's "drive in" auto radio shop in New York City.



Mr. Abbott's novel shop-front follows an A.K. "Tune-O-Matic" design.

AS STATED in our October issue, the response to *Radio Craft's* "Ideal Radio Service Shop" contest was so tremendous as to render it utterly impossible for the judges to complete a careful check of all the entries, in time for the November issue; also, since sufficient time must elapse to permit entries to be received from remote points it was necessary to schedule announcement of the winners for publication in the forthcoming December number. As mentioned (July *Radio-Craft*), the prizes are:

First Prize—RCA No. 9545 portable cathode-ray oscilloscope. Value, \$84.50.

Second Prize—Weston model 663 volt-ohmmeter and carrying case. Value, \$48.75.

Third Prize—Hickok model OS 7 all-wave service oscil-

RADIO-CRAFT'S "IDEAL RADIO SERVICE SHOP" CONTEST

"As we go to press letters continue to pour into RADIO-CRAFT from all over the world in connection with this \$400 contest. Radio men from South Africa seem just as anxious to get an oscilloscope as are service technicians in the States. The December issue will tell the story of who won the prize!"
Signed. JACK GRAND, DIRECTOR

lator. Value \$48.00.

Fourth Prize—Supreme model 333 deluxe set analyzer; or, optionally, Supreme model 85 tube checker (in either counter or portable model). Value, \$39.95.

Fifth Prize—Clough-Brengle model UC portable vacuum tube voltmeter. Value, \$34.80.

Sixth Prize—Triplet No. 1200 multimeter and No. 1220 free-reference-point tester. Value, \$34.67.

Special Prize—Six Consolidated Official Radio Service Manuals. Value, \$17.50 (each). (Except for the manuals, above are net values; in several instances list prices are considerably higher.)

The most interesting contribution was received from Mr. Lawrence Abbott, and while the letter did not make the grade as a contest winner it (Continued on page 318)

STEWART-WARNER "FERRODYNE" CHASSIS MODEL R-136 7 METAL TUBE ALL-WAVE SUPERHET.

(Receiver models 1361 to 1369; temporary diagram. All-wave operation; all metal tubes; multi-color, 2-speed airplane dial; tone control; AVC; dual line filter; 8-in. dynamic loudspeaker; automatic station register; doublet antenna provision.)



Above, Model 1362 Ferrodyne, front view.

The model 1362 set (illustrated), which has the type R-136 chassis, has a new-style cabinet. Three wave bands are available. The set is designed to get the most out of the new metal tubes, and the so-called Ferrodyne chassis is used, this chassis having been designed only for use with the metal tubes. It is used in several receiver models (Nos. 1361 to 1369), which include all cabinet types.

The following table gives numbers of the various trimmers, as they are designated on the chassis photograph:

1. 1st I.F. transformer trimmers
2. 2nd I.F. transformer trimmers
3. Broadcast oscillator shunt trimmer
4. Broadcast detector shunt trimmer
5. Broadcast antenna shunt trimmer
6. Broadcast oscillator series padder
7. Band No. 2 oscillator shunt trimmer
8. Band No. 2 detector shunt trimmer
9. Band No. 2 antenna shunt trimmer
10. Band No. 3 oscillator shunt trimmer
11. Band No. 3 detector shunt trimmer
12. Band No. 3 antenna shunt trimmer

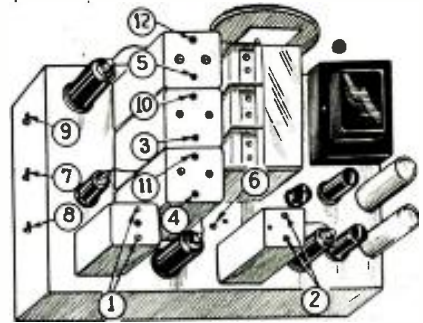

Numbers correspond to those in table at left.

The use of a doublet-type antenna with this set is highly recommended. This may consist of a 41 ft. length of wire split in the center by an insulator, and provided with two twisted wires as a lead-in. No special kit is required. An ordinary antenna will, however, give very satisfactory results, especially on the broadcast band.

The dual line filter is designed to remove any noise that may come in over the power

line and is very efficient for this purpose.

The 2-speed station selector is ball-bearing, gear driven, and provides accurate control of station selection. Automatic station register permits the operator to instantly tune in the station desired to perfect resonance. Metal tubes *must* be used in this set, as it was not designed for glass tubes.

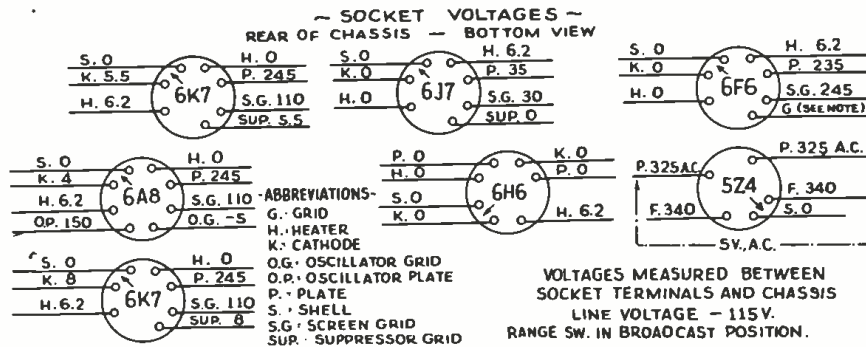

Above, left, are the actual voltages at the sockets of the set as viewed from the bottom. This table also will give location of the various tubes on the chassis. Right, photo of chassis. Below, actual circuit diagram.

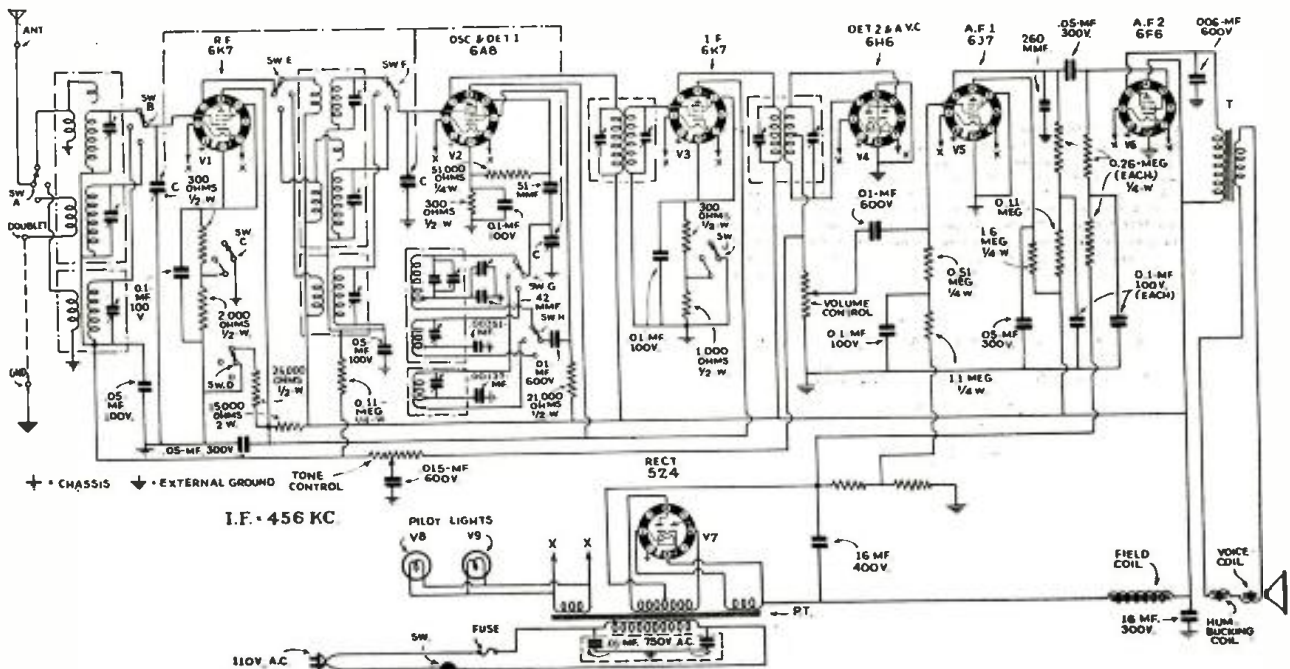
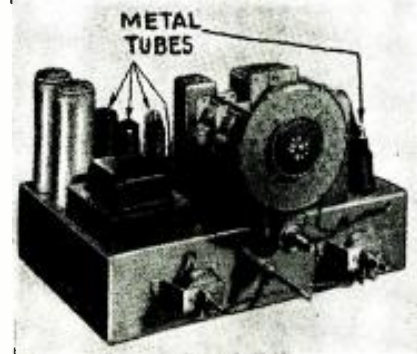

FREE!

The Largest RADIO CATALOG Ever Published!



**The New 1936
WHOLESALE RADIO
SERVICE CATALOG**

ALL METAL TUBES—rebroadcast any tuning ever—sets an original and effective line that they never consider our previous catalog. In radio performance—improved P.A. equipment—new type receiver—free air—Tara Receivers—these are only a few of the many new items in the 1936 Catalog. Radio's largest show and Wholesale Radio Service Co. is keeping pace with the new Mail Order Center has been opened in Chicago. The new 1936 Wholesale Catalog—largest radio catalog ever issued—features the greatest assortment of radio merchandise ever gathered together in the pages of any single book. Every person, Radio, and Serviceman will find this 1936 edition of Radio's Bargain Book a valuable asset. Send for it today!

*"Everything in Radio - at
LOWEST WHOLESALE
PRICES"*

- ★ 196 Pages
- ★ Over 50,000 Items
- ★ World's Largest Stock of Parts
- ★ Newest All-Wave Receivers
- ★ Latest P. A. and "Ham" Equipment
- ★ Glass and Metal-Tube Receivers
- ★ Great New 24-TUBE Year-Ahead Set

WHOLESALE RADIO SERVICE CO.
NEW YORK, N.Y.
100 SIXTH AVE.
CHICAGO, ILL.
901 W. JACKSON BLVD.
ATLANTA, GA.
430 W. PEACHTREE ST. N.W.

Wholesale Radio Service Co., Inc. Dept. C-115
100 Sixth Ave., New York, N.Y.

Please rush FREE copy of your new 1936 Catalog No. 59.

Name _____

Street and Number _____

City _____ State _____

Please Say That You Saw It in RADIO-CRAFT

EXPERIENCED MEN Get the Big Radio Jobs

S. Q. NOEL
PRES. FIRST NATIONAL TELEVISION, INC.

"Every qualified man I train puts in actual hours at my 1,000 Watt Commercial Radio Station! When you have completed my training course, you are a tested radio and television expert—ready to step into the BIG PAY class! You have had actual experience behind you in genuine radio broadcasting work which gives you preference in any radio job. The hours you spend in my ultra-modern, "Hi-Fidelity" commercial station W9XBY and my licensed television experiment station W9XAL mean dollars to you. Never before have you been offered so great an opportunity! Tune in on "Hi-Fidelity" Station W9XBY—1530 kilocycles.

Get your license while learning

A government operator's license is a passport to a real job with a future! My students qualify for their licenses and get certified service records while learning. FREE employment service for life on graduation. No previous experience needed. Write today and let me point the way to the highest-pay radio jobs!"

MAIL TODAY

S. Q. Noel, Pres. First National Television, Inc. (Training Division)

Dept. CC-11, Power and Light Bldg., Kansas City, Mo.

Without obligation, send me postpaid FREE Illustrated Folder telling about new opportunities in radio and television. I am 17 years or older.

Name _____ Age _____

Address _____

YOUR MONEY'S

Built in the world's largest condenser plant devoted exclusively to the manufacture of condensers, you are assured of the best that money can buy when you demand C-D electrolytic, paper, oil and mica condensers.

Unconditional guarantee assures you absolute satisfaction.

Write for descriptive catalog No. 128 today.

WORTH

CORNELL-DUBILIER
CORPORATION
4347 BRONX BOULEVARD
NEW YORK

BI-DIMENSIONAL HIGH GAIN 2-CHANNEL HIGH FIDELITY AMPLIFIERS

WITH 4 CHANNEL MIXERS for any type of microphone, phono, etc. with 50, 6A6, 6B5 or 6A3 output tubes of 12-15-20-25-40-50 watts output. Special prices with Rola G-12 concert dynamic speaker, crystal mikes and pickups.

COLUMBIA SOUND COMPANY, Inc.

135-R Liberty St., New York, N. Y.

NOISE-REDUCING TWINS

LYNCH HI-FI ASSEMBLED ALL-WAVE ANTENNA

All ready to hang. Gives 90% of installation time. Amazing results.

\$6.75

List

LYNCH FILTERADIO

Cuts out objectionable noise from the light line. Easy to install. Simple to adjust.

\$5.00

List

If your dealer cannot supply you, order direct, or write for folder.

Arthur H. Lynch, Inc., 227 Fulton St., N. Y. PIONEER OF NOISE-REDUCING AERIALS

TECHNICIANS' DATA SERVICE

JOSEPH CALCATERRA DIRECTOR

The literature listed in this department contains a wealth of very useful information.

A special arrangement between *RADIO-CRAFT* magazine and the publishers of this literature, which permits bulk mailings to interested *RADIO-CRAFT* readers, eliminates the trouble and expense of writing to each individual organization represented in this department.

2. **HAMMARLUND 1935 CATALOG.** Contains 12 pages of specifications, illustrations and prices on the new line of Hammarlund variable, mid-gate, band-spread and adjustable condensers; trimming and padding condensers; R.F. and I.F. transformers, coils and coil forms; sockets, shields, chokes and miscellaneous parts for ultra-short-wave, short-wave and broadcast operation.

3. **HOW TO GET A HAMMARLUND 1935 SHORT-WAVE MANUAL.** A circular containing a list of contents and description of the new 16-page Hammarlund Short-Wave Manual, which contains construction details, wiring diagrams, and list of parts of 12 of the most popular short-wave receivers of the year.

4. **THE "COMET PRO" SHORT-WAVE SUPERHETERODYNES.** Describes the outstanding features of the standard and crystal-type Hammarlund "Comet Pro" short-wave superheterodynes designed to meet the exacting demands of professional operators and advanced amateurs for a 15 to 250 meter code and phone receiver, but which can be adapted by anyone for laboratory, newspaper, police, airport and steamship use.

5. **ELECTRAD 1935 VOLUME CONTROL AND RESISTOR CATALOG.** Contains 12 pages of data on Electrad standard and replacement volume controls. Truvoit adjustable resistors, vitreous wire-wound fixed and adjustable resistors and voltage dividers, precision wire-wound non inductive resistors, center-tapped filament resistors, high-quality attenuators, power (50- and 150-watt) rheostats and other Electrad resistor specialties.

25. **LYNCH NOISE-REDUCING ANTENNA SYSTEMS.** Complete descriptions and instructions issued by Arthur H. Lynch, Inc., for making all kinds of antennas for broadcast and short-wave reception, with a special supplement covering Ham Antenna Design for transmitting as well as receiving all the amateur bands, including the ultra-high frequencies.

26. **LYNCH AUTO RADIO ANTENNAS, FILTERS AND NOISE SUPPRESSORS.** This folder describes a complete line of Lynch antennas, filters and ignition noise suppressors designed for auto radio installations. The antenna system is of the under-the-car type for easy installation. It includes data on Hi-Gain matched-impedance transmission lines which make the under-car antenna highly desirable for use with the new "Turret-top" cars.

28. **LYNCH SUPER-FILTASTATS FOR AUTO RADIO INSTALLATIONS.** Describes and illustrates, with instructions for using, the new Lynch Super-Filtastats which do away with the need for suppressors in auto-radio installations, giving better performance in operation for both the car and radio set.

57. **RIBBON MICROPHONES AND HOW TO USE THEM.** Describes the principles and operating characteristics of the Amperite velocity microphones. Also gives a diagram of an excellent humless A.C. and battery-operated preamplifier.

62. **SPRAYBERRY VOLTAGE TABLES.** A folder and sample pages giving details of a new 300-page book, containing 1,500 "Voltage Tables" covering receivers manufactured from 1927 to date, published by Frank L. Sprayberry to simplify radio servicing.

64. **SUPREME No. 385 AUTOMATIC TESTER.** A technical bulletin giving details, circuits and features covering this new Supreme development designed to simplify radio servicing. In addition to the popular features of Supreme analyzers and tube testers it contains many direct-reading features which eliminate guesswork or necessity of referring to charts or tables.

67. **PRACTICAL MECHANICS OF RADIO SERVICE.** Information, including cost, features and outline of lessons of the Frank L. Sprayberry course in Radio Servicing, and list of Sprayberry Data Sheets for modernizing old radio equipment.

Radio-Craft Technicians' Data Service
99 Hudson Street,
New York City, N.Y. RC-1135

Please send to me, without charge or obligation, the catalog, booklets, etc. the numbers of which I have circled below.

2	3	4	5	25	26	28
57	62	64	67	72	74	75
76	77					

My radio connection is checked below:

- Service Man operating own business.
- Service Man for manufacturer.
- Service Man for jobber.
- Service Man for dealer.
- Service Man for servicing company.
- Dealer.
- Jobber.
- Experimenter.
- Professional Set Builder.
- Amateur Set Builder.
- Licensed Amateur.
- Station Operator.
- Radio Engineer.
- Laboratory Technician.
- Public Address Worker.
- Manufacturer's Executive.
- Student.
-

I am a:

- Subscriber Newsstand reader

I buy approximately.....of radio material a month. (Please answer without exaggeration or not at all.)

Name

Address

City..... State.....

(Please print name and address)

Avoid delay. The catalogs and booklets listed are now in stock and will be sent promptly as long as the supply lasts.

72. **HALLCRAFTERS' SKYRIDER SHORT-WAVE RECEIVERS.** Description of the Skyriders tuned R.F. and Super Skyriders superheterodyne short-wave receivers designed and built by Hallcrafters, Inc. Features: range of 13 to 200 meters (with broadcast or 10-meter band optional), automatic wave-change switch, continuous band-spread, built-in monitor, speaker and power supply (or batteries), high-fidelity audio, and other refinements.

74. **SPRAGUE 1935 ELECTROLYTIC AND PAPER CONDENSER CATALOG.** Gives specifications, with list and net prices on a complete line of wet and dry electrolytic, and paper condensers made by the Sprague Products Co. for radio Service Men, set builders, experimenters and engineers. Information on the Sprague Capacity Indicator, for making capacity tests on condensers and in servicing receivers, is included.

75. **SPRAGUE TEL-U-HOW CONDENSER GUIDE.** A valuable chart, compiled by the Sprague Products Co. which tells the proper types, capacity values and voltages of condensers required in the various circuits of radio receivers and amplifiers, and how to locate radio troubles due to defective condensers. Includes data on condenser calculations.

76. **FACTS YOU SHOULD KNOW ABOUT CONDENSERS.** A folder, prepared by the Sprague Products Co., which explains the importance of various characteristics of condensers, such as power-factor, leakage, capacity and voltage in determining the efficiency or suitability of a given condenser to provide maximum filtering and safety in operation.

(Continued on page 305)

Please Say That You Saw It in RADIO-CRAFT

AN IMPROVED RADIO-CONTROLLED SAILBOAT

(Continued from page 266)

from the transmitter, picked up by the ship's antenna, produces an A.F. beat-note in the oscillating detector. This is amplified by two transformer-coupled tubes, the second of which acts also as a rectifier for the signal because it is biased to plate-current cut-off by about 9 V. of "C" battery. Thus, when a signal comes through, the plate current of the last tube rises from zero to a few milliamperes and operates the sensitive relay.

This relay which trips on about 1 ma. was made by winding 2 coils of 12,000 turns each with No. 36 enameled wire and slipping them over a U-shaped core made from transformer laminations. The armature is a piece of soft iron 2x1/2x1/16-in. with a vortical bearing at one end. It is counterweighted with a lump of lead and is mounted in the boat so that the tip of the arm moves fore and aft to minimize effects of rocking and rolling of the ship which might tend to close the contacts. The receiver is built on a 5x6-in. bakelite panel with the transformers and "C" batteries mounted below to keep the center of gravity as low as possible. It rests on the bottom of the boat near the bow and is held in position by 6 binding posts fastened to the sides of the boat which also make the 6 connections to the external circuit, marked ANT, GND, "B+45," "B+90," "A+2," and R in Fig. 1B. Thus the set may be quickly removed from the boat through a 5x6-in. hatch for servicing.

The trimmer condenser C2 is used to initially tune the receiver to the transmitter and is also useful in adjusting the receiver to maximum sensitivity. To do this a milliammeter is plugged into the home-made jack J1 to indicate plate or relay current, and with the transmitter on, C2 and L2 are varied until the maximum current is obtained. The coils L1 and L2 are wound on tube-base forms, the tickler L2 being mounted on screws so that its distance from L1 may be varied.

The 9-V. "C" bias for the last tube is obtained from six small flashlight batteries which are taped to the underside of the receiver. The "B" supply consists of two portable 45-V. batteries and the "A" supply is taken from a 6-V. storage battery (identical with the one used in the transmitter) through the resistor, R2, which drops the voltage to slightly over 2 V. A switch, Sw.2, is mounted on the deck of the boat to enable the entire controlling mechanism to be turned on or off. Also built into the deck is a pushbutton, Sw.1, which closes the same circuit as the sensitive relay does, and which was found very useful for checking operation of the selector and machinery when the hatches were closed. Switch Sw.3 is merely used to prevent operation of the selector while tuning the receiver.

THE SELECTOR

The selector may well be called the heart of the control system and is perhaps the most difficult piece of apparatus to construct. As seen in Fig. 2, there are two moving contactors or wipers which advance together one step at a time along two rows of contacts. These wipers are attached to a ratchet gear that is actuated by the selector magnet so the motion is along the arc of a circle (shown as a straight line in Fig. 1B for simplicity). By tracing the wiring in the right-hand part of Fig. 1B (remembering that the motor will not operate through the high-resistance path of a lamp), it will be found that the motor operates, through the contact S, in one direction when the wipers are at positions 1 and 3, and in the reverse direction at positions 2 and 4. In positions 1 and 2, the gear-shift magnet M1 is in series with the motor and so it closes causing the rudder gears to operate. In positions 3 and 4 the magnet M2 closes, operating the gears which wind up or unwind the strings attached to the sails. Positions 5 and 6 may be used for any other controls which may be desired such as an auxiliary propeller, or lights, or a horn, etc.

The contact S which completes the return circuit from the wipers to the negative side of the battery is open while the wipers are advancing, but closes if a pause of more than 1/2-second is made at any position. Thus the wipers are dead while they are sliding over the contacts, a fact which not only prevents actuating some machinery on the way to a higher position

(Continued on page 296)

It Pays to KNOW! This NEW 100-Page VOLUME CONTROL GUIDE Gives Essential Facts on Volume Control Replacement



ELECTRAD has gone to great trouble and expense in compiling this handy, 6 1/4" x 9 1/4", Volume Control Guide. It is an invaluable addition to the busy service man's kit. Contains a complete alphabetical list of receiver models for which Electrad standard or special replacement controls are made. Includes name of receiver manufacturer, model number, catalog number of proper Electrad replacement control, resistance value and list price—facts you must have to make a quick, intelligent, satisfactory volume control replacement.

How to obtain YOUR COPY FREE

The cost of this guide prohibits general free distribution. But you may have a copy if you send us the flap (part showing specification and resistance) torn from any new-type Electrad Carbon Volume Control carton, together with your business letter-head or business card. Address Dept. RC-11.



Resistor Specialists

Featuring:
QUIET CARBON VOLUME CONTROLS
VITREOUS RESISTORS
TRUVOLT RESISTORS
POWER RHEOSTATS

Speakers by OXFORD



WE'VE GOT SOMETHING HERE! You simply haven't heard modern radio or public address until you've heard it from the new **OXFORD CHROMAVOX SPEAKERS**. They give you **VOLUME** with remarkable purity of tone, and a **BALANCED FIDELITY**, reproducing highest overtones of the piccolo as well as the lowest pedal notes of the organ. Surpass the most exacting engineering requirements—and they're *sturdy* units that stand hard service. *Investigate.*

Ask your jobber or write us for full information.

OXFORD RADIO CORP.

Dept. C, 350 W. Huron St., Chicago

ACCEPTED BY SOUND JUDGEMENT

TURN SCRAP INTO MONEY



The new and revised edition of "Auto Power" with all the ten original specifications and ten new ones is now off the press. Convert old generators into A. C. and D. C. Generators and motors with voltages of 6 to 400 volts for power, light, welding, and radio operation. Create new generators adaptable for home, automobiles, or trucks. They can be driven by fan belt, wind or water. This book, with complete illustrations, tells you how easily and economically these changes can be made. Also instructions for rewinding auto armatures. 350 definitions of electrical terms, etc. Already used and endorsed by thousands. Price \$1.00 postpaid.



AUTO POWER Dept. C 414 S. Hoyne Ave. Chicago

Please Say That You Saw It in RADIO-CRAFT

"YOUR NEW BOOK SURE FILLS THE BILL"



**THERE'S NO CHARGE
.. SEND FOR YOUR
FREE COPY TODAY**

● Send for your free copy of Sylvania's New Volume of Service Hints . . . Service Men All Over the Country Tell Us They Wouldn't Be Without It . . . Short Cut Solutions and Inside Dope on Everyday Problems.

New ways to solve everyday problems . . . hundreds of short cuts that practical service men have discovered for themselves . . . get these up-to-date tips in Sylvania's new Volume of Service Hints!

You may have helped write this book . . . hundreds of successful service men did . . . sent in their solutions of tough problems . . . and Sylvania compiled them all in this Free booklet that's yours for the asking. It will pay you to send for it, because it may save you hours of trouble shooting on some hard to crack job.

Don't wait. Mail the coupon below for your copy of Volume 2 of Sylvania SERVICE HINTS today. The up-to-the-minute tips contained in it will put you in line for jobs you didn't know you could do! Clip the coupon now and your copy of Sylvania SERVICE HINTS will be mailed to you in a few days.

Hygrade Sylvania Corporation. Makers of Sylvania Radio Tubes and Hygrade Lamps. Factories at Emporium, Pa., Salem, Mass., and St. Mary's, Pa.

SYLVANIA

THE SET-TESTED RADIO TUBE

Hygrade Sylvania Corporation.
Emporium, Pa.
Please send me free, without obligation, Volume 2 of Sylvania's "Service Hints."
 Experimenter Amateur Call _____
 Serviceman Employed by dealer Independent

Member Service Organization.....
 NAME
 ADDRESS
 CITY..... STATE.....
 NAME OF JOBBER.....
 ADDRESS RC-11

AN IMPROVED RADIO-CONTROLLED SAILBOAT

(Continued from page 295)

tion, but also eliminates sparking and consequent pitting of the contact points. Once this contact has closed, the next throw of the selector arm sends the wipers back to the starting position and at the same time opens contact S.

When the selector magnets are energized they attract the armature, pushing the arm A forward from the position shown in Fig. 2, so that the "finger" E engages with the ratchet R and advances the wipers W to the first position. At the same time the air dash-pot V is pushed in slightly because of the arm X striking the washer Z attached to the dash-pot. Now if the magnets are de-energized the spring K causes the arm X to spring back, but due to the washer Y attached to the dash-pot this return motion is slowed down so that the arm A slowly retracts. Just before the contact S (which also acts as back-stop) closes, a small projection on the edge of arm A falls into a notch of the end of the lever L. Then contact S closes, allowing current to flow through the wipers and the external circuit connected to position 1.

The next time the magnets are energized the finger E is prevented from engaging with ratchet R because as arm A advances it also has to move to the right a little since it is hooked to the end of lever L which turns in an arc. Thus the short branch of the arm strikes the "tail" end of pawl T, releasing the ratchet and allowing the wipers to snap back to the zero position. At the same time the tip of the longer branch strikes the vertical slanting stop P and is forced sharply to the right beneath guide D, allowing lever L to become unhooked and to snap back to its original position, against the stop G.

Now when the armature is released, arm A slowly returns and would again become hooked to lever L if it were not for the fact that a thin, flat spring M became engaged in a notch I when the tip of the arm A was against the stop P, preventing the arm from returning too far. This spring must be stiff enough so as not to buckle when resisting the backward motion of the arm A, but flexible enough to allow the arm to move to the left so that the finger E may engage with the ratchet on the next impulse. The normal position of this spring, which is assumed while the wipers are advancing, is shown dotted.

If it is desired to reach position 2, it is only necessary to give the selector two impulses in quick succession so that there is not sufficient time between them to allow arm A to become hooked to the lever L. This time may be varied by adjusting the spring K and the distance between washers Y and Z. Similarly any other position may be reached by giving the correct number of impulses and after a pause of about one-half second at any position, the next impulse will send the wipers back to the neutral position.

SELECTOR CONSTRUCTION

The selector magnets and armature are taken from a 20-ohm telegraph sounder together with the sounder arm and its bearings. These are attached to the lower part of a right-angled piece of aluminum, B, 2 ins. wide as shown in Fig. 2, and a 2-in. square of bakelite, C, is screwed to its top, forming the basis for construction of the unit. A small strip of fibre is screwed to the top of a ratchet gear, R, (taken from an old alarm clock) and two strips of spring brass, with small pieces of silver, soldered to the ends, are screwed to this fibre, forming the wipers W, as shown in the detail drawing in Fig. 2. Current is taken from one wiper through a very flexible flat lead N in a wide arc to one of the mounting screws. The other wiper is "grounded" to the ratchet R and another flexible lead runs from a hub on the top of the ratchet shaft to an upright attached to the moving arm A. The bearing shaft is soldered to the center of the ratchet and turns in holes in the base C and top contact strip H. This strip and its companion strip about 1/8-in. below it are made of 1/4-in. bakelite and are fastened to the base C by three screws, and are separated from each other and from the base by six collars.

The twelve contacts which are cut from an old silver spoon and filed into 1/8-in. discs are set into 1/8-in. holes drilled far enough into the inner surfaces of the strips so that the discs

set in them, flush with the surface of the bakelite. They are held there by drops of solder placed in similar holes drilled part way through from the opposite side. The lead wires O are soldered to these points as shown in the sectional view in Fig. 2 and pass through holes in the base C down to two six-prong tube-bases which are screwed to the bracket B and act as mechanical supports for the selector. Not all these leads need to run to the sockets for, as seen in Fig. 1B, upper contacts 1 and 3 may be connected together and to lower contacts 2 and 4, before leaving the selector.

A spiral clock spring J keeps tension on the string Q which is wound around the hub of the ratchet R so that the wipers will return to the first or "zero" position when the ratchet is released. This hub is filed to an approximate spiral so that its radius decreases as the string winds up, a fact which keeps the torque constant even though the spring tension increases. Thus the magnet does not have to work any harder to advance to the higher contacts than to the lower ones, a great aid to the efficiency of the selector. The ratchet is prevented from slipping backwards at each step by the pawl T mounted on the base C beneath the lower row of contacts as shown dotted in the top view and is held against the ratchet by the flat spring U. The selector arm A is composed of two pieces cut from sheet brass and soldered together at right-angles and is bolted loosely to the driving arm X so that considerable side motion is possible. A short piece of 1/16-in. steel wire E is bent and filed to fit the ratchet teeth and soldered to the longer branch of the arm A to serve as a "finger" to advance the ratchet R. The shorter branch is twisted at right-angles near its end and bent so that it just clears the "tail" end of the pawl T while the finger E is advancing the ratchet. The tip of the longer branch rests on a small flat piece of brass screwed to the base C and is prevented from lifting by wire D.

The flat spring P is bolted to the arm X so that it bears against the vertical surface of the arm A, thus tending to hold the arm and finger E against the ratchet. The air dash-pot, V, which consists of a smoothly bored tube closed at one end sliding over a close-fitting solid piston is attached to the bracket B; a short wire with two washers Y and Z soldered to it is fastened to the moving cylinder and passes through a hole in the arm X.

THE BOAT AND CONTROLLING MACHINERY

It is not within the scope of this article to describe, except very briefly, the construction of the hull of the boat and the reader will do well to use his own ideas on the subject. The important points are to have enough displacement to carry the necessary weight, enough sail to move this weight, and enough keel to balance this sail. For a 4-ft. model the hull must be quite "tubby," the rigging much over-sized, and the keel deep and heavy, unless the weight of the apparatus is considerably reduced, which is quite possible. The writer's hull is 48x12x9 ins. deep and has 8 lbs. of lead at the end of an 8-in. deep brass fin keel. The masts are 63 and 49 ins. above deck and the total sail area is 1,300 sq. ins.

Figure 3 shows the location of apparatus within the hull. The "B"-batteries and the storage battery are located amidships, the selector and controlling mechanism near the stern, and the receiver in the bow. The antenna runs (Continued on page 298)

Fig. A. A view of the self-contained control transmitter, with a wire reel aerial on the side.

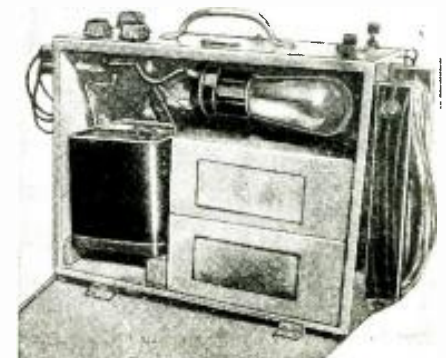

Please Say That You Saw It in RADIO-CRAFT

ALLIED SELLS FOR LESS!

This Great Catalog proves it 10,000

When you order from your new 1936 ALLIED Catalog you will be getting **bigger values than ever before**. That's saying a lot—when you consider that we've had a great reputation for selling the best radio equipment for less money ever since the early days of radio. We say that you can't buy identical brand and quality **anywhere** for less—if you can—we'll **refund the difference in a jiffy**. Send for the new 1936 ALLIED Catalog right now. Page by page, it will prove to you that we sell for less.

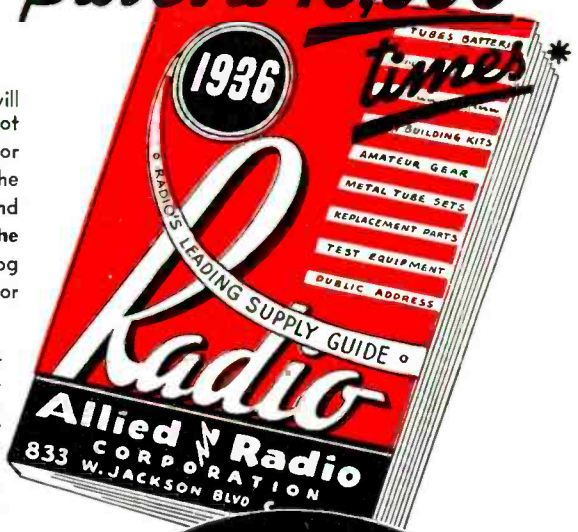

How ALLIED saves you money: We don't have to bear a terrific overhead in maintaining branches, and we pass our savings along to you. **We ship from one great center where we have assembled radio's biggest stock.** We are 100% Radio Specialists—our buyers have a genius for getting value-scoops. We buy in vast quantities—get lower prices—and pass them on to you—so that you can buy for less. **That's how we save you money!**



Why ALLIED serves you better: We are located in the very nerve center of America's transportation system. That's why we ship your order fast. Under one big roof—on 45,000 square feet of modern floor space—we have gathered the choicest and most complete radio stock in the country. Your whole order is shipped from one location **without delay**. An alert, really peppy radio organization sees each order through. **That's why we serve you better.**



ALLIED puts meaning into PERSONAL SERVICE: We are not an organization carrying on a cold impersonal chain business. **We're a big friendly close-working group** with a real interest in your needs and your problems. We invite and like the thousands of inquiries you send in each month. We'll answer you always in an intelligent, valuable and personal way that you'll like. As a customer, you are always an individual at ALLIED—not just an order number.

Send for your copy of the new 1936 ALLIED Catalog right now. Buy for less and be better served. We have bigger stocks than ever before—more people to serve you—thousands of feet more space—more live high grade lines, more Personal Service—**more Value than ever before.**



FREE

RADIO'S LEADING SUPPLY GUIDE

★ There are more than 10,000 quality items in the 1936 ALLIED Catalog—each an unbeatable value. Five great sections answer the needs of every one in radio. They feature thousands of exact duplicate and replacement radio parts, radio tools and latest test equipment; complete lines of Short Wave and Amateur receiving and transmitting gear; dozens of new kits to warm the set-builder's heart; an amazing array of new Public Address Systems, amplifiers, microphones, recording equipment, etc.; newest metal tube and glass tube receivers, battery, 32 volts, and auto radios. **Everything you need in radio is in this FREE Catalog. Write for it now.**

Allied Radio CORPORATION

833 W. JACKSON BLVD.
CHICAGO, ILLINOIS

ALLIED RADIO CORPORATION
833 W. JACKSON BLVD.
Chicago, Illinois, Dept. D.
Send me your FREE 1936 CATALOG—
RADIO'S LEADING SUPPLY GUIDE.



Name.....
Address.....
City..... State.....

Please Say That You Saw It in RADIO-CRAFT

New! MUTER Interference Filters

STOP
Man Made Interference!

This "Traffic Cop" of Radio absolutely eliminates the man made interference that comes in over the power line. With a MUTER Interference Filter on your set, you can enjoy clearer foreign and domestic programs without the accompaniment of your refrigerator, light switches, electric irons or other interfering noisy equipment.

NO MORE POWER LINE NOISES

when you are tuning in your favorite program—just clear, unspoiled reception.

A Muter Interference Filter on your receiver itself is usually sufficient, but, when a particularly offensive electrical device is spoiling reception for yourself and your neighbors, attach a Muter Interference Filter direct to the offending equipment to silence it forever.

The Muter Filter has a capacity to silence interference from motors as large as 1/2 H.P., oil burners, flasher signs and similar high frequency disturbers.

Send for it today and learn what unalloyed pleasure you can get from an interference-free program.

MAIL THIS COUPON!

THE MUTER COMPANY
1255F South Michigan Avenue
Chicago, Illinois

Please RUSH me (postage paid) a Muter Interference Filter.
 Send FREE General Catalog including list of Candohm original equipment resistors.
 I am enclosing \$3.00 I will pay postman \$3.12

SATISFACTION GUARANTEED

Name.....
Address.....
City.....State.....

RECOMMEND IT TO THAT OFFENDING NEIGHBOR

When some one's electrical equipment is "raising hob" with the radio reception of his neighbors, suggest installation of a Muter Interference Filter. He'll receive a vote of thanks from the whole neighborhood. If your jobber can't supply you, send the coupon.



THE MUTER COMPANY
1255F So. Michigan Ave.
CHICAGO, ILLINOIS
U.S.A.

AN IMPROVED RADIO CONTROLLED SAILBOAT

(Continued from page 296)

out through a hole in the deck to the tip of the bowsprit, thence to the tops of foremast and mainmast (serving also as a stay) and down the latter to a dead end a few inches above the deck.

The motor is mounted with its shaft and worm gear No. 1 vertical as shown in Fig. 3. The rudder drive shaft has a fixed bearing at its left end so that flat gear No. 4 is always engaged with worm gear No. 1, but its other bearing near magnet M1 is movable so that worm gear No. 2 can move toward or away from flat gear No. 5 under the action of M1. So when M1 closes and the motor runs, gear No. 5 together with the rudder turns in one direction or the other depending on which way the motor is turning. When the rudder is hard over against a stop, gear No. 5 keeps on turning but the rudder does not due to a friction connection between the gear and the shaft. Thus the rudder can be held hard over as long as desired. When the motor stops and M1 releases, worm gear No. 2 backs off allowing the rudder to spring back to its neutral position under the action of a spring.

The sail drum shaft has a fixed bearing at its left end and a moving one at its right end, and this means that flat gear No. 6 is not engaged with worm gear No. 1 except when the magnet M2 closes. The drum itself was machined from a brass rod and has three sections. Worm gear No. 3 drives flat gear No. 7 operating the limiting contacts which stop the motor whenever the sails are all the way out or in.

Wire stays are used on the boat and serve the dual purpose of strengthening the masts and carrying current to the two bulbs on the mast-heads. These bulbs are necessary to tell from shore what is happening aboard the ship. Referring to Fig. 1B, it is seen that lamp K1 will light whenever the selector magnets are energized so this lamp gives a check on the overall reception of the signals. The other lamp, K2, lights while the selector wipers are advancing and goes out as soon as contact S closes, indicating that the motor is running and facilitating timing of the various controlling operations.

There is practically no limit to the variations and improvements it is possible and advisable to make in the system of radio-control just described.

LIST OF PARTS

- Transmitter (Fig. 1A)
- One 150 mmf. fixed condenser, receiver type, C1;
 - Two 250 mmf. fixed condensers, receiver type, C2, C3;
 - Two approx. 50 mmf. trimmer cond., C4, C5;
 - One 2-plate midget variable condenser, receiver type, C6;
 - One .002-mf. bypass cond., receiver type, C7;
 - One 15 turn coil, No. 19 enameled wire, 1 in. form, L1;
 - One 10 turn coil, No. 13 enameled wire, 1 1/4 in. form, L2;
 - One 57 turn coil, No. 29 silk-covered wire, 1 in. form (grid coil), L3;
 - One 10,000 ohm gridleak, 1 W., R1;
 - One 5 ohm filament rheostat, R2;
 - One type 71A tube, V1;
 - One open-circuit jack with filament control, J1;
 - One 2.5-V. flashlight bulb, K1;
 - One single-pole double-throw switch, Sw.1;
 - One single-pole triple-throw switch, Sw.2;
 - One single circuit pushbutton, Sw. 3;
- Receiver (Fig. 1B)
- One condenser made from two 1/2-in. square metal plates, about 1/4-in. apart, C1;
 - One Approx. 50-100 mmf. trimmer cond., C2;
 - One 100 mmf. fixed condenser, C3;
 - One .002-mf. bypass condenser, C4;
 - Two 1 mf. bypass condensers, C5, C6;
 - One 23 turn coil, No. 24 D.S.C. wire, 1 1/4 in. form, L1;
 - One 6 turn coil, No. 24 D.S.C. wire, 1 1/4 in. form, L2;
 - One 4 meg. gridleak, R1;
 - One 22 ohm fixed filament resistor, R2;
 - One audio transformer, 5/1 ratio, T1;
 - One audio transformer, 6/1 ratio, T2;
 - Three type 30 tubes, V1, V2, V3;
 - One closed-circuit jack, J1;
 - Two 5-volt flashlight bulbs, K1, K2;
 - One single-circuit pushbutton, Sw. 1;
 - One on-off switch, Sw.2.

LEARN CODE



There is only one way to learn to read code and that is by listening to code. There is only one way to learn to send code and that is by hearing your own sending repeated back to you. With the Master Teleplex (Code Teaching Machine) you learn code the natural, easy, fascinating way. Only instrument ever produced which records your sending in visible dots and dashes (on copper tapes)—then SENDS BACK your own key work at any speed you desire. We furnish complete course, lend you the New Improved Master Teleplex, give you personal instruction with a MONEY BACK GUARANTEE—all at a surprisingly low cost per month. Write today for FREE catalog "A"-35. No obligation.

TELEPLEX COMPANY
76 Cortlandt Street New York, N. Y.
"MASTER TELEPLEX—the choice of those who know"

MORE \$\$\$\$ FOR YOU

We can show you how to devote spare time to making money for yourself. Simple, easy work—only an hour or two a day, brings you extra dollars. AND, there's no limit to what you can earn. With this extra money you can buy things you want—or save your earnings. There's hundreds of things you can do with a few extra dollars.

Everyone in your neighborhood is a prospect—your friends, relatives—all would be interested in what you have to offer.

Write to us for your plan "EXTRA MONEY IN YOUR SPARETIME." We'll send you the details promptly. Address

Circulation Manager
RADIO-CRAFT
99 Hudson Street New York, N. Y.

Please Say That You Saw It in RADIO-CRAFT

THE NEW "MYSTERY RAY"

(Continued from page 267)

in its qualities to the German and Italian ones. The kind of rays and devices used by the Signal Corps could not be learned, since all details concerning the devices made by the General Electric Co. have been enveloped in great secrecy. While the Signal Corps conducted its first practical tests at the Lighthouse Station on the Navesink Hills near Highland, N.J., a heavy military police line was thrown around the station.

These circumstances make the demonstration of the German mystery rays, recently conducted in a suburb of Berlin especially interesting. These demonstrations disclosed to the invited newspapermen, and foreign military attaches, contrary to all expectations—were not units of tremendous dimensions, but tiny devices about as large as a normal match box! The new mystery-ray machines do not operate as has often been predicted with millions of watts, but radiate only a few watts in the form of very short waves (from 5 to 15 centimeters) into the "air." The energy necessary to operate these mystery ray transmitters is provided by regular dry-cell batteries of normal size and weight. The produced beam radiated by these transmitters is as narrow and "confined" as a water pipe of ordinary dimensions, and despite the fact that they are not really death rays, in the sense fiction story writers put it, they are actually able to bring death and destruction to ships and aircraft.

The reason for this ostensibly seeming paradox is explained by the fact that, although these rays do not kill or destroy directly they do so indirectly by furnishing the means to detect and localize airplanes even if hidden by clouds, smoke, snow or rainfall.

It is said that these valuable uses are possible through the ability of the mystery rays to penetrate the sight obscuring elements without being absorbed or dispersed as would be the case if a normal light beam (and under certain circumstances, even a strong beam of ultra-red light) was used. These newly utilized rays have, however, the advantage of being as easily reflected as a normal light beam. How these qualities of the newly utilized "ultra-ultra" short-waves may be used for air defense will be shown by the following example.

Along the borderline of the country a great many of these small, mystery-ray transmitters will be fixed atop east-iron posts or, perhaps, hidden on church towers or tall buildings. The transmitters are so adjusted that their beams are radiated at a slight angle into the sky. Any airplane flying through these invisible "feelers" will reflect the beam back to earth. Since these beams obey the well known optical law, that "the angle of reflection is equal to the angle of incidence," it is easy to install a great many of these receivers in such close proximity that at least one of them may be depended upon to pick up the reflected beam, regardless of how high or how low the plane flies.

Since the use of so many receivers might create some difficulties in controlling them all at the same time (which is necessary for an efficient air defense) an automatic system, operating similarly to the relays used in automatic telephony, to connect two telephones without help of human hand, will be developed. The various transmitters will be modulated by certain current impulses, and if such a succession

How the ray shows the location of enemy aircraft.

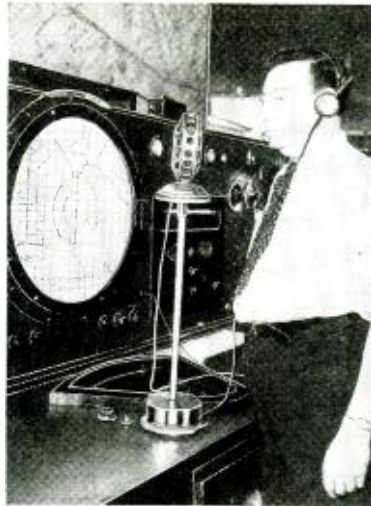
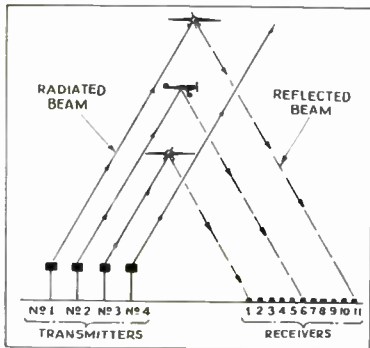

Dr. S. Spitz, of Burbank, Calif., developed this amazing machine, which indicates as a moving spot of light, the location of an airplane; the 'plane's sound automatically actuates the device. The same principle probably could be applied to silent 'planes, the actuation then being obtained by means of centimeter (the "mystery ray" mentioned in this article) waves reflected from the 'plane!

of impulses is received, the "telephone" relay will indicate the position of transmitter and the receiver in operation upon a kind of annunciator. (See the photograph on page 267.)

These rays are produced by tiny split-plate magnetron tubes (The split-plate magnetron is illustrated and described in considerable detail in the article, "Super-short Radio Waves," which appeared in the October, 1934, issue of *Radio-Craft*.—Editor), which are also used for the reception of these rays. The electro-magnet used for these transmitters is of surprisingly small dimensions but produces (through the application of a special high grade of iron) a remarkably strong magnetic field.

The new German ultra-ultra-short-wave receivers and transmitters have been developed by the Drs. H. Scharlau and W. Runge, of the Telefunken Laboratories. As Dr. Runge recently demonstrated, these newly utilized rays may be of great value in piloting incoming ships into foggy harbors. For this purpose two parallel "running" beams are radiated by two transmitters with any desired spread between them. Two receivers are installed aboard the ship to be piloted which are connected to a pilot indicator instrument by means of a bridge circuit. As long as the ship follows the proper direction, the indicator of the pilot instrument will stay at the "on course" line. If the ship shifts more to one side, thus leaving the proper direction, the field strength of one of the very sharply concentrated beams will rise, while the other beam will be received with decreasing strength.

The mystery-ray devices might also be useful for private telephone connections between two points as far distant as sight is possible. If receiver and transmitter are installed on high points, the maximum bridged distance will approach 50 miles. The communication can be kept secret because no reception outside of the very narrow "beam line" between transmitter and receiver is possible.

Construction and circuit of the "split magnetron".

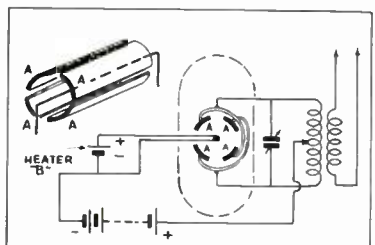

Please Say That You Saw It in RADIO-CRAFT

Readrite

NEW TUBE TESTER



DEALERS PRICE \$18.00

A new tube tester that tests all tubes, metal and glass-metal, has these features, Double grid cap for glass and metal tubes, Shadow Type AC meter for adjusting line voltage, leakage and short test, tubes tested on load, Housed in beautiful quarter oak case with all metal lithographed panel, Especially constructed against shock, No. 430 complete with Triplett Model 23 meter Good-Bad scale, protected against damage, Dealer Net Price **\$18.00**

Model No. 431—same as No. 430 except has READRITE Good-Bad Meter instead of Triplett, Dealers Net Price **\$14.40**



MODEL 554-A

ALL-WAVE SIGNAL-GENERATOR

With all improvements of present day engineering, All frequencies are fundamentals and stabilized, completely labeled and tube substituted, 1500-in coils for present 3 frequency bands, 150 to 21,000 Kc, (any new frequency range can be added by new coils), Calibration curves supplied, In leatherette case complete with batteries and two No. 20 tubes, Dealer Net Price **\$14.40**

FOR MORE DETAILS—SEE YOUR JOBBER OR WRITE

MAIL COUPON NOW

Readrite Meter Works, Dept. C, Bluffton, Ohio
Gentlemen:

Please send me more information—

Model No. 430 Model No. 431
Model No. 554-A Catalogue

Name
Address
City State

Servicemen!



Let Me Help You Build a **REAL SERVICE BUSINESS**

Naturally, I don't claim that every serviceman who has taken Sprayberry training is making "big money." But taken by and large, you'll find Sprayberry graduates forking ahead far more rapidly than competitors who drift along, relying solely on their own resources and ideas.

In almost every case, a modest investment in Sprayberry training has netted handsome dividends. Dozens of enthusiastic letters prove this.

...BUT GET ALL THE FACTS!

Let me tell you about this modern course designed exclusively for forward-looking servicemen. This information will cost you nothing and, as it has already done for so many others, may point the way to a better, brighter future in the work to which you are devoting your life.

Send the coupon NOW!

F. L. SPRAYBERRY 2548 University Place, N.W. Washington, D.C.
Without cost or obligation, please send your book "PUTTING PROFITS AND EFFICIENCY INTO SERVING."

Name
Street
Address RC11/35

SPRAYBERRY'S PRACTICAL MECHANICS OF RADIO SERVICE

CHEKATUBE \$15.95 f.o.b. Factory



TESTS METAL TUBES and all others without adapters. Also BH rectifiers, diodes—Screen plate. Automatic plate shorts with Neon white filament in hot. Scale shows POWER GOOD and line volts on sensitive D'Arsonval type meter. Portable type—cover not shown—size 10x11x6 inches. Weight 10 lbs. Highest grade equals \$10 testers—Money Back Guarantee—regular price \$21—Order today for only \$15.95 cash or \$2 with order for C.O.D. shipment.

Established 1922 **J-M-P Manufacturing Co., Inc.** 3032 N. 24th St. Milwaukee, Wis.

QUALITY recommends **Condensers by SOLAR**

WET... DRY PAPER MICA... THIMMER

SOLAR MFG. CORP. 593-501 Broadway New York City

SOME FACTS ABOUT RADIO AS A CAREER

(Continued from page 269)

as set assemblers, and it is not always the most able workers who choose this kind of job, since other industries often pay much more for intelligent workers. Such a job is always open for a competent boy at the beginning of a career but, if he wishes to make a real place for himself in the radio field, more than merely manual skill is necessary.

NO. SUCCESS WITHOUT TRAINING

However, as we indicated before, thorough knowledge of electricity, physics and especially mathematics, sometimes even knowledge of chemistry, are the surest keys to a great career in the radio field. These important weapons, to fight through all competition to the top of the radio engineering profession, are obtainable only by a thorough training in high-grade schools. But, even for the foreman with a well-paid position in the radio plant, or for a Service Man who desires to make more money than his average competitors, a good school training is essential. There are, as you will find described elsewhere in this issue, a great many radio schools in this country which provide means for obtaining the knowledge necessary for making a career in the radio field.

THE VALUE OF AN EDUCATION

The American Society of Mechanical Engineers, in the year 1930, made a study of the earnings of its 20,000 members. One of the important findings was that engineers (all men with a proper professional education) reach their maximum earning power in later years, at an age when the non-professional men are often considered out of the market, because younger ones, in possession of their full power, do the work as well and ask for less money.

The accompanying diagram (Fig. 1) shows (see curve A) the slow rate and small total earnings of an average man, even if he is an engineer. Curve B indicates the progress in earnings of the mediocre engineer, especially as he gets older. And, finally, curve C shows the more rapid rate and much greater increase of income which a really gifted engineer might obtain.

Since similar surveys, made by the American Institute of Chemical Engineers, and by the Society for the Promotion of Engineering Education, are in agreement with this, similar conclusions may be made for men working in the radio field.

EARNINGS IN THE RADIO FIELD

(a) *Engineer.* The first valuable figures ever published in respect to the earnings of radio engineers have been compiled by Mr. Keith Henney, editor of *Electronics* and read by him before the December meeting of the Institute of Radio Engineers last year. A part of Mr. Henney's survey was published in *Electronics*, January, 1935, and the remainder in the *IRE Proceedings*, May 1935. Mr. Henney divided the plants under survey into three groups: (1) those making 10,000 sets or less per year; (2) those making between 10,000 and 100,000 sets per year; and, finally (3), those larger manufacturers whose output is in excess of this.

TABLE A
Radio Set Engineers' Salaries

Title	Plants Making 10,000 Sets or Less Per Year—35		100,000 to 1,000,000 Sets Per Year—70		Total Plants 115	Total Payroll
	Avg. Annual Salary	No. Per Plant	Avg. Annual Salary	No. Per Plant		
Chief Eng.	\$ 3,800	0	\$ 5,650	1	1	\$ 612,000
Dept. Head	2,780	1	4,200	1	4	484,000
Senior	2,260	1	3,200	3	7	1,012,500
Junior	2,160	1	2,380	4	8	938,500
Lab. Asst.	1,300	2	1,350	5	12	741,000
Avg. Annual Eng. Payroll	\$11,400		\$35,900		\$7,170	

(b) *Average Factory Worker.* The great difference between the earnings of a well educated professional man working in the radio field, and the average radio factory worker, may be seen from facts available through the courtesy of the Radio Manufacturers Association. According to these facts the earnings per capita in radio factories are about \$18.75 per week.

(c) *Service Men.* Better chances to obtain an income exceeding that of the average laborer in a radio factory, and the possibility to do interesting work which is by no means comparable with the routine work in set manufacturing, are open to the radio Service Man if he is intelligent and has the proper educational background. It is easy for a good Service Man to get a job which brings him more than \$25 per week. There are of course some owners of radio service shops who do not make much more money per week (see *Radio-Craft*, July 1935, "The Radio Service Business"), but it is their own misfortune: because some of them did not have the desire to obtain the proper professional school training, and are no more radio Service Men in the real sense of the term, than a quarryman is a sculptor!

(d) *Broadcast Station Engineer.* There are many other well-paid and interesting positions in the radio field—for example, that of radio engineer in a broadcasting station. Exact facts as to how much the average broadcasting station engineer is earning are at present not available since the only survey at hand (made by Mr. Donald G. Fink of the editorial staff of *Electronics*) is not as yet complete. Approximately 600 questionnaires have been sent out and so far only 86 replies have been returned.

TABLE B
Broadcast Station Engineers' Salaries

Power of station in watts	100	250	500	1,000	2,500	5,000	10,000	50,000 and there
Number of stations in this power class	191	74	103	132	18	14	11	32
Number of engineers, etc., per station	3	3	4	4	5	5	6.7	9-10
Salary paid for the technical staff per station in dollars	2,750	4,230	6,360	8,570	11,300	16,000	24,000	31,000
Total number of technical staff for station power class	573	210	400	470	90	70	70	310
Percentage answering questionnaires	8.9%	11.8%	10.6%	13.6%	27.5%	38.9%	18.2%	12.8%

(e) *Radio Operator.* Another vocational field in radio is the position of radio operator on a ship. These men are ranked as officers, and are given good accommodations on board. The average income of a ship operator, according to the information furnished from the Radio Telegraphers Association, is about \$113.00 per month.

(f) *Radio Sales Engineer.* There are, in addition to the previously-mentioned positions, great possibilities for well-trained radio technicians with sales ability, to go into the field of radio salesmanship, jobs in which are generally considered as being among the most lucrative ones in the entire radio field. According to unconfirmed information an income of about \$10,000 per year is possible for key men.

HOW MANY JOBS IN THE RADIO FIELD?

Employment in the radio manufacturing industry, according to a letter from the Radio Manufacturers Association, is seasonal and varies greatly. "From 30,000 to 60,000 factory operatives are employed in radio manufacturing and probably 125,000 altogether, including executives, salesmen, radio jobbers and dealers. To this may be added 20,000 to 30,000 professional Service Men."

The occupational statistics of the U.S. Census of 1930 included 4,955 radio operators.

Chart of tube and set sales, by years.

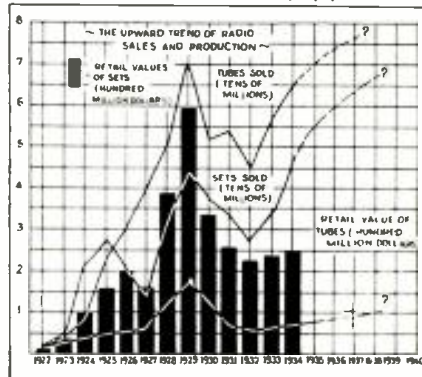

Please Say That You Saw It in RADIO-CRAFT

About 2,000 men are employed on the technical staff of the 600 broadcasting stations in the U.S. And about 1,000 men may be added, according to an estimate, as having positions in the airway industry as radio operators of airplanes and airports, or working as operators in the forestry field, and in police broadcasting. Considering that part of the radio industry is influenced by seasonal fluctuations, it might be said that on the average 150,000 persons (see Fig. 2) are working in the American radio field. (Also, see the article, "New Opportunities in Radio," in this issue.—Editor)

RADIO A GROWING ECONOMIC POWER

What radio means to American consumption and production is impressively shown by the following figures, which have been prepared from material given in the U.S. Census of 1930. Of each dollar spent by consumers in all retail stores, the radio store gets 1.15 cents. (See Fig. 3). What this figure actually involves in money may be seen by comparing the drug store's percentage share of each dollar spent by consumers, which amounts to 3.44 cents. The share of another great American industry, the cigar stores, is 0.83-cent, whereas the news dealers get 0.31-cent from each dollar spent.

RADIO A "HOME ESSENTIAL"

What the average housewife (who is "the buyer" in the American market) thinks about the question, "Is a home radio essential?" (an important problem for the future of the broadcast and radio industry) has been answered very impressively by a survey made by *McCall's Magazine* among 1,017 housewives in New Jersey. Asked to vote on the most essential household electrical equipment the New Jersey housewives voted as follows (see Fig. 4):

Irons 68.9 per cent, radio 64.4 per cent; refrigerators got their share, being 38 per cent essential; and a similar large vote of 36.3 per cent goes in favor of washing machines.

25 MILLION RECEIVERS

According to a newly-compiled statistical survey published recently by the Columbia Broadcasting System (see Fig. 5) there are at present 25,551,569 radio sets in use in American homes. This figure includes 1,800,000 auto receivers, and 2,295,770 receivers in homes with more than one set. Quite a few of these 25 million receivers are obsolete and will have to be replaced in the next few years. Even if America's radio audience should not grow any larger in the years to come (though it certainly will) the replacement business alone can keep the radio industry busy. If we take the average lifetime of a modern radio set as about 8 years, approximately 3 million sets will be sold in the next few years for replacement. That means that about 75 per cent of the sets sold on the domestic market will go to people who at present own obsolete receivers. Of the remaining 25 per cent one-half will consist of battery-powered receivers which will be sold to farmers.

FAVORABLE ECONOMIC FORECAST

According to another CBS statistical survey (see Fig. 6) only 33.9 per cent of all the farms of America are equipped with radio sets; but the average percentage of all American homes equipped with radio receivers (including the farms) is 69.4 per cent, and in reality much larger when the rural districts are subtracted. Since this percentage is not at the saturation point (as the percentage in radio set ownership of Denmark, one of the foremost agricultural countries of Europe, impressively indicates) domestic radio sales might experience a further increase. Especially great sales possibilities are provided in the automobile radio field. There are at present 21,430,000 passenger cars in use in this country (see Fig. 7), but only 1,800,000 of these cars are equipped with radio sets.

As the map (Fig. 8) indicates, which shows the various continents of the globe and their ownership of radio sets, tremendous export possibilities are open for the American radio industry in the future.

A more thorough analysis of the economic facts of the radio field of today will perhaps serve even better to illustrate the prediction that THE FUTURE POSSIBILITIES FOR A YOUNG MAN IN THE AMERICAN RADIO INDUSTRY ARE EQUAL TO, IF NOT BETTER THAN, THOSE IN ANY OTHER INDUSTRIAL VOCATION!



Glass or Metal Radio Tubes

Dependable

Suited to SERVICE MEN'S NEEDS
* HIGHEST QUALITY *
SOUND ENGINEERING

Ken-Rad Radio Tubes

THE KEN-RAD CORPORATION, Inc., OWENSBORO, KY.
Division of The Ken-Rad Tube and Lamp Corporation
Also Manufacturers of Ken-Rad Incandescent Electric Lamps

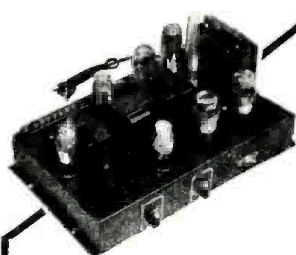

"STENTORIAN"
Sound Amplifier
Nucleus

● POWER supply units are the nucleus—the very heart of good Sound Amplifiers. Build your amplifiers the "STENTORIAN" way for the finest results in this great new field.

The *Nucleus* includes matched power transformer, chokes, audios and outputs, with a black wrinkle-finished chassis equipped with lettered terminal strips and marked tube sockets—for 5, 10, 15 and 30 watt Amplifiers. Some Class A and Class AB amplification. 2.5 and 6.3 volt tubes. Nuclei for two additional 6 and 15 watt Amplifiers—using the new All Metal tubes; for crystal or condenser mike Preamplifiers; and for small Class B battery Amplifier.

The "STENTORIAN" way Sound Amplifiers provide clear, powerful sound coverage for convention halls, auditoriums, refectories, for athletic fields, ballrooms, night clubs, taverns, lodge halls, political rallies, banquet programs, office and factory call systems, truck and auto advertising, and for depot train-call systems, race track announcements, concession barkers and the like.

Free for the Asking!

THE "STENTORIAN" WAY IS THE MOST ECONOMIC WAY FOR QUALITY SOUND AMPLIFIERS

Fully illustrated bulletin on the "STENTORIAN" Sound Amplifier Nucleus and the name of our nearest distributor.

General Transformer Corporation
504 S. Throop Street Chicago, Ill.

Manufacturers of Replacement Units

SEND FOR THIS FREE CATALOG

Check full of BARGAINS in RADIO SETS, Long and Short Wave Apparatus, Servicemen's Repair and Replacement Parts, Electrical Appliances and hundreds of Miscellaneous Specials at **TREME ENDS SAVINGS**. Get this big new Bargain Book. It's absolutely **FREE** without obligation—just send us your Name and address on a post card.

RADIO CIRCULAR CO., INC.
225 Varick St., Dept. R. C., New York, N. Y.

The Raco 339 All-Wave Direct Reading Signal Generator

(54-17000 K.C. on fundamentals) 1% accuracy on all bands 54-17000 K.C. all on fundamentals. Dial calibrated in both meters and kilocycles modulated or unmodulated as will by means of on-off switch. At-tor tube, so that D.C. is used on the plate, while modulation is provided by a neon tube relaxation oscillator at a frequency of about 1000 cycles. Wired, tested, calibrated, with 3 tubes (6C6, 37, neon), \$16.00 net to Servicemen.

RACO RADIO CONSTRUCTORS LABORATORIES
136 Liberty St., N.Y.C., N.Y. Dept. RC2

Please Say That You Saw It in RADIO-CRAFT

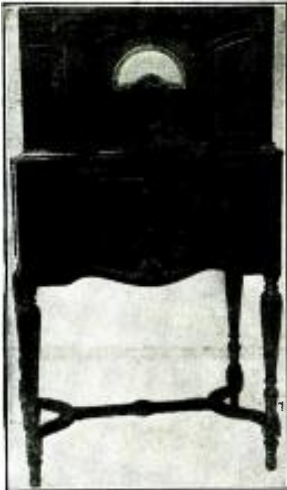

ONCE THIS WAS AN OLD-FASHIONED RADIO RECEIVER

TODAY IT Reaches Round the Earth!

In your customers' homes there are radios which cost hundreds of dollars not so long ago. They stand as lovely pieces of furniture in living rooms. Obsolete but beautiful and dear to the heart! A new idea developed by Zeh Bouck, famous consulting engineer and explained in a new book by him, tells how you may convert old radios into modern All-Wave Receivers which will span the world, bringing choice programs from far-away lands—and a new income to YOU! Send for Mr. Bouck's Book today! The cost is only 25c which but partially covers the cost of handling. With the book comes a complete merchandising kit and plan outlining how you may become a modernization engineer. Don't delay, send today!

TOBE DEUTSCHMANN CORPORATION
CANTON Dept. C-115 MASSACHUSETTS

A BEGINNER'S ALL-WAVE METAL-TUBE "2"

(Continued from page 270)

condenser shunted across the longer winding of the plug-in coil. This particular capacity has been selected because it is best adapted to cover the range from 10 to 550 meters or even higher.

As mentioned above, the shorter winding of the plug-in coil serves as the regenerative or tickler winding. It is connected in the plate circuit of the pentode regenerative detector tube, providing very efficient regeneration, which "peps" up the receiver giving the necessary sensitivity for foreign reception. Regeneration also aids selectivity, so that even in localities where the stations are badly congested, it is possible to separate them. A 75,000 ohm potentiometer is shunted across the tickler. The center-arm of the potentiometer is connected to a 500 mmf. mica condenser and the other terminal of this condenser is grounded. This connection gives exceedingly smooth regeneration control and experience has shown that it is superior to the screen-grid method of control. As a result, tuning in short-wave stations is made very much easier. Gridleak detection is employed, a 2 meg. gridleak being shunted by a 100 mmf. mica condenser. The voltage on the screen-grid is reduced to two-thirds that on the plate of the pentode by using a 25,000 ohm resistor in series with the screen. It will be noted that the screen-grid is bypassed by a .1-mf. cartridge type condenser.

CONSTRUCTIONAL DETAILS

In assembling the Beginner's Metal Tube "2", the smaller wood pedestal is first nailed to the thin wood base. Two holes are drilled for mounting the variable condenser, this being held from the underside by means of two 1 1/4-in. screws (8/32). Two brackets are then fastened at front right and left, using small wood screws. The antenna trimmer is mounted at the left bracket and the combined regeneration control potentiometer-switch is mounted on the right-hand bracket. The sockets are fastened to the pedestal and base, as indicated, by 5/8-in. wood screws. Three small wood screws with lugs provide anchorage for the line cord. A fahnestock clip at the right rear serves as the binding post for the antenna. Two other clips, fastened to the rear of the pedestal are used for making the phone connections. The dual electrolytic condenser is mounted close to the pedestal at the right of it. The fixed 500 mmf. condenser is soldered directly to the stator of the variable condenser, and placement of the other parts is clearly shown in the illustration.

In wiring the set, wire in the filament circuit first, then plate, grid and cathode, filter, bypass condensers and finally solder in the line cord. Wiring is simple and straightforward, but care should be used in wiring in the new-type tube sockets. However, if the diagrams are followed, no trouble whatsoever should be experienced.

LIST OF PARTS

- One Hammarlund antenna trimmer, type MICS-70, C1;
- One Hammarlund variable tuning condenser, type MC-140-M, C2;
- One Cornell-Dubilier mica cond., 500 mmf., C5;
- One Cornell-Dubilier mica condenser, 100 mmf., 200 V., C3;
- One Cornell-Dubilier 3-section electrolytic cond., 8 mf., 200 V., 4 mf., 200 V., and 5 mf., 35 V., C4;
- One set of 5 Hammarlund plug-in coils covering the band from 70 to 560 meters;
- One I.R.C. metallized resistor, 1 meg., R1;
- One Electrad potentiometer with switch, 75,000 ohms, R2, Sw.1;
- One I.R.C. metallized resistor, 25,000 ohms, 1/4-W., R3;
- One I.R.C. metallized resistor, 10,000 ohms, R4;
- One power cord with 350 ohm resistor, R5;
- One Na-Ald 4-prong socket for coil;
- Two 8-prong sockets for metal tubes;
- One special screen-grid clip for 6J7 tube;
- One 6J7 metal tube;
- One 6C5 metal tube;
- One wood base 9x4 1/4 x 3/16-in.;
- One wood pedestal 1 1/4 x 1 1/4 x 3/8-in.;
- Three fahnestock clips;
- Two metal brackets for antenna trimmer and potentiometer;
- Three knobs;
- One roll of push-back hookup wire;
- Hardware, screws, lugs, etc.

15 YEARS OF MIGHTY VALUES

Illustrated and fully described in the new 1935 general catalog No. 188. A completely equipped plant, with up-to-date modern production facilities assure you of the lowest in prices on quality radio parts. Get a copy today. The catalog is waiting for you.



ICA Acorn Tube Sockets, designed for Ultra Short Wave work, constructed of Insulex. Extremely small in size for Acorn tubes No. 954 & 955 1 1/4 diameter x 3/8 high. No. 959 List \$1.00

ICA Wafer Sockets, Adaptable for either sub-panel or for base board mounting. A truly low loss socket made of "INSULEX"—a non-hygroscopic ceramic composition unaffected by climatic conditions. Nos. 2600-2605 From .40 list

Mail 10c in stamps or coins to cover cost of handling and mailing catalog

INSULINE CORP. of AMERICA
25 Park Place - New York, N. Y.

Become a Radio Expert

GOOD JOBS Learn RADIO-TELEVISION

Electricity—Talking Pictures—in Los Angeles
Learn profitable trade by practical shop methods. Enroll with National, oldest, largest trade school in the West. 30,000 graduates. Quality as a radio repair man; television expert; sound expert; broadcaster; station technician; electrician and for many other jobs. Earn room and board while learning. Biggest opportunity for you. For limited time we will allow each railroad fare to Los Angeles. Send for free book which gives full details about different jobs you can qualify for, complete course of instruction and photographs of school operation. Sign and mail coupon.

NATIONAL SCHOOLS, Dept. 13-RC, 4000 So. Figueroa St., Los Angeles, Calif.
Please send me your Big Free Book on Television, Talking Pictures Radio and Electricity. Also details of R. R. fare offer.
Name.....
Address.....
City..... State.....

We SPECIALIZE in the Design and Manufacture of Public Address Amplifiers
SEND FOR FREE CATALOG!
Number K-30

Describes in detail 86 different models and complete P.A. Systems ranging up to 200 audio watts output. 6 volt; AC; DC.
Buy Direct from Manufacturer AND SAVE BIG MONEY
Coast to Coast Radio Corp.
159-R Sixth Ave. New York, N. Y.

"FINDING YOURSELF" IN THE TECHNICAL WORLD

(Continued from page 271)

through personality and executive ability.

What are looked for then in college graduates are trained brains, in vigorous bodies, with pleasant but dynamic personalities—men who may make creative contributions to respective businesses or arts and, in a sufficient number of cases, develop as capable executives.

Granting that we may reasonably expect such qualifications from a college man, we then may draw up in detailed form tentative requirements for such a man; 6 such specifications follow:

(1) Intellectual Curiosity. That is, the unquenchable curiosity which leads to a continued and orderly effort to determine the "why?" of the physical or social phenomena of the world about us. *This is the first requisite for growth in a rapidly progressing age.*

(2) Ability to Study. Learning looks to the past, while study looks to the future. An ability to apply the mind toward acquiring knowledge by effort is a prerequisite in industry.

(3) Habit of Study. The ability to study is a habit that apparently takes time to acquire and even the 4 years of a college course frequently prove insufficient.

(4) Ability to Learn from Men.

(5) Ability to Cooperate with Men.

(6) An Aspect of Leadership. That is, possession of a viewpoint that gives promise to lead and influence men.

Having established these "specs." the next step is to interrogate the applicant in order to determine whether he can meet these requirements; the following 3 generic questions, correctly couched, incorporate the requisite tests:

(1) Along what lines of endeavor lie (a) his fundamental interests and urges, and (b), his aptitudes?; (2) has he the mental foundation to produce in lines (a) or (b)?; and (3) has he personality, character, and physical qualifications for such productive work?

To determine the aptitudes of an applicant it is necessary to get below the surface of conventional preferences. The method described in the *Journal of Personnel Research* under the title of "Engineering Aptitudes," which may be consulted for detailed procedure, involves the use of four classes of questions, which in abstract form are as follows: first—what is his preferences as to the numerical order of the following four "fields" or media of employment—(1) ideas, (2) men, (3) things, and (4) economic symbols?; second—what is his preferences between technical and supervisory responsibility?; third—what is the applicant's estimate as to his proportion of the three motivating instincts—(1) economics, (2) ambition, and (3) perfection?

To a far-sighted concern the time investment of an engineering applicant may shape up about as follows: 8 years in elementary schools, 4 years in high school, 4 years in college, 3 years in which to adjust himself to employment, and 10 years to reach a responsible position.

If the embryo technician aspires to a position of real importance, he will do well to analyze himself on the basis of the above summary, in order to better appreciate the general viewpoint of many employment managers.

Please Say That You Saw It in RADIO-CRAFT

TELEVISION AND HIGH FIDELITY AS A STUDY

(Continued from page 271)

the program of experimental work which is required by the Federal Communications Commission in connection with the two experimental transmitters.

Two transmitters are used for Experimental Television Station W9XAL. The older and the larger of the two has a maximum power output of 400 W. and operates on a frequency of 2,800 kc., this being the center of the 100 kc. band (2,750 to 2,850 kc.). The second, recently completed is a 15 W. master oscillator, power amplifier, ultra-high-frequency transmitter, operating on a frequency of 44,000 kc.

Both of these transmitters were built in our own laboratories. In the larger transmitter, a total input power of 1,200 W. is used, making it possible to secure a power output of approximately 400 W. The transmitter itself is located on the 31st floor of the building in which the school is located. It is 387 feet above street level. Extending above the 31st floor is a 137 ft. tower. A vertical antenna stretched from the top of this tower to one of the off-sets of the building is fed by a special two-wire transmission line from the transmitter to the top of the antenna. Because excessive "ghosting" was encountered in the operation of this station, it was necessary to feed this antenna at the top end instead of feeding it at the bottom end as is usually the case. This condition was necessary because of the relation between the height of the building and the frequency of operation.

The second transmitter uses a push-pull oscillator employing special, type 10 tubes designed for ultra-high-frequency operation. This transmitter is also located on the 31st floor of the building. Considerable difficulty was encountered in securing a good radiating system for these ultra-high frequencies. However, the problem was finally solved in the following manner. A 16 in. iron pipe runs from the extreme top of the building to the 15th floor, used as a ventilating pipe in the building's air system. A special 2 wire transmission line was constructed and this pipe used as a shield for the line, so that the line could be run from the 31st floor to the extreme top of the building. Here, a special half-wave antenna is located, fed at the center with this special two wire line. The antenna itself is 487 feet above street level. Since this is the highest spot in the state of Missouri, excellent results have been secured even though only a small amount of power has been used. Using voice transmission, distances from 25 to 40 miles are regularly covered. On television transmission, good pictures are secured in any part of the city, or distances up to and including 15 miles from the building.

The school operates one of the four new high-fidelity broadcasting stations recently assigned to the band between 1,500-1,600 kc.

Two special studios are used in the operation of W9XBY with the control room between the two. A high-fidelity monitoring system is also provided so that the operators of the station may have a constant check on the quality of transmission. A special double voice coil dynamic speaker mounted on a baffle board is driven by a four-stage high-fidelity monitoring amplifier. The frequency response characteristic of the entire audio system from microphone to telephone lines is flat within 2 db. from 30 to 10,000 cycles.

Since the studios and transmitter are separated by a distance of 8 miles, it was necessary to install special telephone circuits in order to maintain the high audio quality necessary in the operation of such a station.

Because of slight variations in equipment as well as telephone lines, it is necessary to take a complete A.F. response curve on this equipment every two weeks. This is done to assure a performance of high standard. Using a special beat-frequency oscillator, the curves are taken from the microphone input circuit to the cathode-ray oscilloscope which checks the output of the transmitter. The complete over-all curve shows a response characteristic flat within 2 db. from 30 to 10,000 cycles.

All of the graduating students first secure a radio-telephone first-class operator's license as well as actual and practical experience in the operation of both W9XAL and W9XBY. When they leave this institution they are expertly trained men with experience to back training.

TRAINED RADIO MEN

(Continued from page 272)

and many millions of homes that still have no radio, should purchase one. The designing, manufacturing, testing, inspecting, selling, installation and servicing of this vast number of units provide a tremendous field of opportunity for those who train and qualify themselves to stand out above the mass of poorly qualified, untrained dabblers in this field.

The refinements and improvements in late type receivers and the new models expected to appear on the market soon will make it still more difficult for the poorly trained man to continue in the servicing field. Additional circuits, parts, tubes, and controls, many of which have entirely new characteristics, require a more complete knowledge of fundamental principles of electricity and radio and also a better understanding of modern up-to-the-minute service methods and instruments than ever before. This makes it almost impossible for the man who has only a limited "picked up" knowledge of radio to keep up with these new technical developments, and to compete with the Service Man who has the benefit of a specialized practical training on modern equipment.

Without waiting for the long-promised development of television, we have another big branch of radio already launched into heavy commercial development. I refer to automobile radio sets which are now being manufactured and sold by the hundreds of thousands and for which we have a potential market in this country even exceeding the huge number of household sets now in use!

The fields of public address and sound pictures are in a constant state of development. We find great activity in this field already. Thousands of trained men are required to operate and service the sound equipment in theatres, schools, churches, hotels, auditoriums, ball parks, amusement parks, stores, sound trucks, etc.

Photoelectric cells with their accompanying amplifiers have recently found hundreds of new applications in industry and the limit of their application is still beyond conception. Vacuum tubes in small and huge sizes not only for detection, amplification, rectification and oscillators in radio sets, but for converters, inverters, oscillators, rectifiers and amplifiers in industrial and power application, are just beginning to show the real possibilities of enormous future development and added opportunities in this branch of electronics.

Radio operating in hundreds of broadcast stations, aboard thousands of ships, at airports, on airplanes, and in forestry and weather bureau stations, also provides real opportunity for ambitious, wide-awake men with the proper training. Recognition of the vital importance of these men and their work was recently reflected in a substantial increase of their salaries by shipping companies. The more rigid requirements in connection with Government examinations for operators' licenses, and the improved standards adopted by the more reliable schools should also aid to further increase the opportunities for those who are wise enough to get the best available training in this branch of radio.

With the renewed interest and increased financial expenditures in the development of television during recent months, we may not have to wait as long as many people have predicted for some large-scale commercial development. Unquestionably, television holds far too great an appeal to the buying public coupled with the enormous commercial possibilities, to be long resisted or kept in the background.

A CORRECTION

Concerning the short item which appeared on page 166 of the September, 1935, issue of RADIO-CRAFT, entitled "A Tube Tester Patent" it is necessary to state that if "English-reading" testers are made which do not involve the use of an adjustable shunt for making all "good" tubes read at the same point on the meter or other items covered by this patent, they will be in no way affected by or infringe upon this patent. In other words all "English-reading" tube testers do not employ the methods outlined in the patent and some manufacturers produce such instruments which do not infringe.

Another Kendall Clough Achievement!



—the new Model 82 low price, all-wave, direct reading, R.F. Signal Generator

—has every modern oscillator feature, plus C-B guaranteed performance and dependability, at less than is usually asked for an ordinary instrument.

Continuous coverage, all on fundamentals from 85 kc. to 21 m.c. Calibrated directly on the 8½" scale of the open-face tuning dial. Ladder-type attenuator with interpolating vernier control. Uses two type '30 tubes.

Write for complete literature describing this and the many other new CLOUGH-BRENGLE instruments. Complete with tubes, less \$19.90 batteries, net price only

"The Most Complete Line of Radio Instruments"

Whatever your instrument needs are, see your local CLOUGH-BRENGLE distributor today, or use the coupon below.

Model CRA Oscilloscope with built-in amplifiers and linear sweep, complete with Cathode-ray and all other tubes, net \$84.50

Model CRB Oscilloscope, same as above, less linear sweep circuit, net \$69.50

Model OM R. F. Signal Generator with built-in frequency modulator, complete with tubes, net only \$57.85

Model OC, new improved series with direct reading frequency chart and carrying handle on top of case, net only \$32.90

Model 81 Fixed-Sweep Heterodyne Frequency Modulator converts any other R.F. signal generator for use with an oscilloscope. Complete with tubes, net only \$34.25

Model 79 Beat-Note Audio Oscillator, calibrated from 50 to 10,000 cycles. Has built-in power pack and vacuum-tube voltmeter. Uses six tubes. Complete with tubes, net only \$51.90

For complete description of these and the many other CLOUGH-BRENGLE instruments, clip and mail the coupon

THE CLOUGH-BRENGLE CO.

1130 W. AUSTIN AVE., CHICAGO, U. S. A.

Mail Coupon Today
for FREE Catalog

Send me your new catalog listing the complete CLOUGH-BRENGLE line of instruments.

Name

Address

Please Say That You Saw It in RADIO-CRAFT

LIBERAL ALLOWANCE MADE ON YOUR OBSOLETE INSTRUMENTS

Trade in your obsolete meter and purchase the modern service-man's Universal Tester



Volts A.C.—D.C.
5-25-100-250-1000
1000 ohms per volt

Milliamperes D.C.
1-10-100-1000

Capacity
.001-10 Mfd.
Paper or electrolytic
condensers.

Inductance
1-10,000 Henrys

D.C. Resistance
.5-5,000,000 ohms.

Send full description of obsolete instrument you wish to trade in, and 6c in stamps for Bulletin 611-PB describing the Shallcross Universal Tester.

Shallcross Mfg. Company, Collingdale, Pa.

QUALITY TUNER AC Self Powered

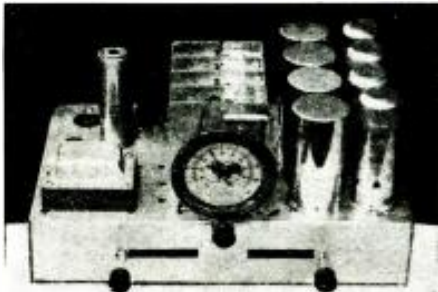

Featured in August Issue of Radio World
This up to the minute newly designed tuner employs 5 Tubes—three 588, one 2A and one 80. Complete kit of quality parts, with Litz Wound coils. **\$11.50**
Special: Matched kit of tubes \$2.40 extra.

Special: FREE DIAGRAMS sent upon request for any of the THOR Amplifier or Tuner Kits.

MAIL ORDERS PROMPTLY FILLED

THOR RADIO
CORP
167 GREENWICH ST. NEW YORK, N. Y.

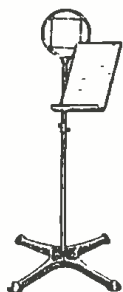

UNIVERSAL Combination Floor Stand

A rugged three-piece, telescoping, combination banquet and floor stand—Complete—light weight—smooth in operation—Finished in lully polished nickel plate—Equipped with cadmium plated, adjustable and detachable copy holder, mounted on a flexible steel arm—A clean, workmanlike job—designed and manufactured to Universal standards of quality—List Price complete with 8 springs, \$10.00.

Universal Microphone Co., Ltd.
424 Warren Lane
Inglewood, Calif., U. S. A.

MAKING MONEY IN SOUND RECORDING

(Continued from page 272)

The neighborhood picture house must give their customers four new features every week, but each of several hundred broadcasting stations must furnish a new program each 15 minutes for 18 hours per day!!

Where is the supply of talent coming from to satisfy the "radio" customer?

In every hamlet of the country, thousands of men and women, boys and girls are searching their innermost selves, to discover if they can fill a niche in this fertile field of occupation.

To establish and maintain a Recording Studio, first provide a place where prospective and embryo artists can test their voices, play their instruments, read their script, recite their monologues and dialogues, and otherwise endeavor to qualify for occupation in this lucrative field.

By means of this new and specialized business, one can speak before the microphone and instantly receive and hear a record of his or her work. Immediately after a recording is completed, it can be played back on the same instrument or any one of the 15,000,000 phonographs that exist in the U.S.

The recorder after many years of research and experimentation has emerged from a status as an intriguing toy, to an essential and perfected tool used in many fields of human activity.

In its latest form, it is 100 per cent fool proof in construction and operation. It requires no technical knowledge or skill and can be thoroughly understood and operated in one hour. And the records are permanent and imperishable. The cost has been brought down to a very reasonable figure and maintenance is practically nil, amounting to the consumption of a few watts of electricity per day.

In every city of the U.S. with a population from 25,000 upward, a recording studio can be established, and maintained with substantial profit. Any business that has for its incentive the promotion of recreation and the development of talent for the radio and motion picture is practically bound to succeed.

The efficacy of recording is well illustrated by a distinguished and popular idol, whose radio premiere was widely disparaged by the critics. This conscientious artist uses a phono, recorder religiously for pre- and post-audition tests. The critics are still mystified by the remarkable improvement between the first broadcast and the third and subsequent ones.

THOUSANDS OF USES FOR RECORDINGS

Service at profitable fees can be rendered to banquets, reunions, conventions and sales meetings, where organizations and participants are eager to preserve an audible record of the proceedings for sentimental, archive and reference purposes. Such a studio can be made available to schools, colleges, and individual teachers for bringing their students there to advance them in music, public speaking, phonetics, diction, foreign languages, etc.

By simply attaching the recorder to a radio set, programs can be instantly recorded off the air with high fidelity and sold to sponsors, advertising agencies, broadcast stations and individual performers. (Insofar as copyrights permit.—Editor)

The making of personal phonograph recordings is not confined to artists, educators, students, musicians, performers, dramatists, broadcasters, etc., but is for every man, woman and

child who has something to say, a song to sing, an instrument to play or a memory to preserve.

child who has something to say, a song to sing, an instrument to play or a memory to preserve.

Many and varied are the reasons for making personal recordings. One woman thus preserved the songs of her two favorite canaries. A man has ready his own funeral oration long before his demise, to be gently spoken with comforting words to the mourners when his funeral occurs. Complete wedding ceremonies have been recorded. Reno's traffic could perhaps be greatly reduced if the actors in the original ceremony could only hear repeated the impressive words. Preserving children's voices in the same sentimental way that mothers treasure periodical photographing of their offspring, the bronzing of baby's shoes and the sculpturing of hands, is yet another application.

Gloria Caruso's voice is already recorded.—Lindbergh's first speech is preserved—John McCormack's children likewise and thousands of distinguished citizens.

Business executives with big ideas lose their potency when they dictate and see their words in weary, flat, stale and unprofitable type. Now, Mr. Thos. A. Watson of the International Business Machines Corporation and James H. Rand of Remington-Rand Company and many others are able to step up to the microphone of their private recorders and "deliver the goods" in their own characteristic and effective ways on permanent discs and then send them out to their various outlying branches.

A studio established in summer resorts, amusement parks and along well traveled city avenues presents the novel and intriguing opportunity to "speak" to far off friends, sweethearts and dear ones at home in what may be called an "audible greeting card."

(An interesting article on sound recording to which the reader may wish to refer, appeared in the February, 1935 issue of Radio-Craft. The article is entitled, "Broadcast Artists Record their Programs."—Editor)

HOW TO MAKE A MIDGET PREAMPLIFIER

(Continued from page 273)

used as a high-impedance load in the plate circuit of the tube, but no D.C. passes through it, since the plate is fed by a ¼-meg. resistor. The low-impedance mike winding is used to feed the line to a regular amplifier unit.

All resistors except Rx are of the ¼-W. insulated type, as the current to be carried is very low, and space is at a premium.

The various condensers used should be of the best possible make, as should all other units, to minimize noise. Condensers of 200 V. rating, are satisfactory.

The results obtained with this amplifier were very satisfactory. No test equipment was handy to make actual gain tests, but the pre-amplifier in connection with an ordinary condenser mike, gave quite a bit more gain than a very high-sensitivity single-button carbon type, used without it. The A.F. response characteristic is apparently very good, and the lack of hum and hiss make the result very pleasing.

The batteries last a long time, since the "B" current drain is only around 1 or 2 ma. while, as stated, the "A" drain is only about 70 ma.

This unit may be used for any type of amplification requirements besides P.A. work, such as for use in amateur transmission. In fact it has been used for such work most of the time since it was built.

LIST OF PARTS

One Thordarson midget microphone transformer.

T:

*One Hi-Vac type XSG tube (and special socket for same), V1:

One Blau off-on toggle switch, Sw.:

One 60 ma. pilot bulb (and socket for same), V2:

Four Na-Ald insulated pin jacks:

One Na-Ald insulated binding post:

**Two molded resistors, 5 megs., ¼-W., R1, R2:

**One molded resistor, 75,000 ohms, ¼-W., R3:

**One molded resistor, ¼-meg., ¼-W., R4:

One Cornell-Dubilier tubular condenser, .01-mf., 200 V., C1:

Two Cornell-Dubilier tubular condensers, 0.1-mf., C2, C3:

One Try-Mo steel case, 5x6x3½ ins. wide:

Hardware, wire, grid clip, etc.

*Name of distributor upon request. **Name of manufacturer upon request.



Please Say That You Saw It in RADIO-CRAFT

A MULTI-RANGE METER KIT

(Continued from page 274)

posts to permit connection of the "unknown" resistor for measurements without introducing additional resistance. The "unknown" resistor to be measured is now connected in parallel with the internal resistance of the meter, thus affecting the current flow and actuating the meter, and indicating the proper value of the "unknown." Caution should be used to connect the shunts to the meter, in the series ohm circuit, with short and heavy wires as you are paralleling the "unknown" resistance with both the meter and shunt. Any appreciable amount of resistance in these shunt "leads" will cause error in the LO reading scales.

In Fig. 1, you will observe a link switch providing for a low-loss arrangement which proves very effective. It is also used in connection with current measurement on the right side through tip-jacks; also, for HI and LO ohm circuits at the bottom of the panel; and volts on the left.

OPERATING DIRECTIONS

Testing Current. Up to 100 ma. Swing the link to 100 and connect one test lead to the common jack marked MA. at the top, and plug in the other tip at the jack marked 100. For 10 ma. use the same operation, turn link to 10 and take off with tip-jack leads. For 1 ma. leave the link open, and use proper jacks as marked.

Testing Voltage. Set link to VOLTS and use jacks on the left side marked VOLTS. Any range available on the dial may be had by use of different multipliers.

Testing Resistance. With the shunt link open as shown at Fig. 1, short the common jack marked OHMS at the bottom of the panel to the 100,000 jack and regulate the OHM ADJ. until the meter reads full-scale, which is the 1 ma.-100,000 ohms fundamental. Keep this circuit closed and we now have the 0 to 500 low-range fundamental, using the heavy terminal leads. Slip the link to 10 ma. and, readjusting the meter after shorting the common and 1,000 ohms jacks with a test lead, the HI fundamental now reads 0-10,000, and the LO has a measurement of 0 to 50 ohms. Again change the link to 100 and re-adjust for full-scale, the HI reading will now be 0-1,000 ohms and when left connected at full-scale the LO scale will be 0 to 5 ohms. The lowest division reading .01-ohm. To conserve the battery, disconnect the test lead short in the series circuit.

10 Meg. Scale. Measurements higher than the fundamental, (1 ma. and 100,000 ohms), are changed by raising the voltage, thus 4½ V., 45 V. and 450 V. applied to a 1 ma. meter through 4,500 ohms, 45,000 and 450,000 ohms, will give the resultant full-scale readings of 100,000 ohms, 1 meg. and 10 meg., respectively. For the 10 meg. voltage supply, connect through a 0.4-meg. wire-wound resistor to the panel terminals marked EXT. and VOLTS, two leads from a standard type

of radio-set voltage divider, rectifier tube or power supply having a drop of 450 V. or more available. An adjustable resistor in the power supply line to the transformer may be used to adjust for the 450 V. properly required, which will be shown by the meters reading full-scale at tip-jacks OHMS, COM., and 1 MEG.

1 Megohm. The circuit in Fig. 1 shows a 45,000 ohm resistor in series with the 1 meg. jack, therefore only a midsize 45 V. battery will be necessary for this current supply. Be sure to close the EXTERNAL VOLTS circuit after using.

LIST OF PARTS

- One Van type 3X dial;
- One Weston 1 ma. meter having 50 ohms internal resistance, models 301-88. and 321;
- One Van type 50 S-2 series shunt (50 millivolts at 10 and 100 ma.);
- One panel, 3½x6 ins.;
- One Electrad or C.R.L. midsize 1,000 ohm rheostat or potentiometer;
- Eight Eby binding posts;
- Twelve Na-Aid tip-jacks;
- Voltage multipliers**
- One Shallcross resistor, 4,000 ohms, for ohms circuit;
- One Shallcross resistor, 45,000 ohms, for ohms circuit;
- One Shallcross resistor, 4,950 ohms;
- One Shallcross resistor, 45,000 ohms;
- One Shallcross resistor, 450,000 ohms;
- One 4½ V. battery, small size;
- Lugs, heavy copper bus wire, copper straps, etc.

THE RADIO FIELD AS A FUTURE

(Continued from page 274)

various periods of properly-directed study. It may be seen, for example, that one semester's work leads to a class B amateur license, while two are needed to attain a First-Class Radiotelephone or a Second-Class Radiotelegraph license. The latter can be increased to a First-Class Radiotelegraph ticket after a year of experience. The man may then be made chief operator of any radio station.

A 4 year course would probably lead more directly to a high-salaried position, without some of the intermediate steps needed with less training.

Not all men wish to enter the operative fields, quite naturally, so the chart includes many others, such as service, executive, and engineering. The "practical" Service Man might well take such a course as a responsible school can offer, in order to fit himself to attain, more quickly, the position of service manager or service engineer of a radio corporation—a position he of course might achieve otherwise, but certainly only after many extra years of work.

We must never lose sight of the fact that the years of experience that the radio Service Man has acquired are of great help to him, no matter what study course he undertakes. A man who has had much practical experience is a great deal more valuable, both to himself and to his employer, than one who, although he has had the same amount of school study, lacks the background of practical knowledge. The former will be able to apply his theory in a direction his practical knowledge tells him is correct, while the "theoretical engineer," although his solution of a problem may be quite correct on paper, will find it does not stand up under actual use. Thus the "practical" man should not bemoan the time he spent before taking up actual study of his chosen line, for his former knowledge will always be of the greatest help to him.

TECHNICIANS' DATA

(Continued from page 294)

77. SUPREME 391 P.A. ANALYZER. This booklet describes the features and use of the new Supreme 391 P.A. Analyzer, designed to equip the radio Service Men to cash in on the constantly growing opportunities for service in the sound equipment and public address systems used in movie theatres, schools, churches, auditoriums, etc.

Please Say That You Saw It in RADIO-CRAFT

They say



it's great!

Editors, experts, students, technicians—radio men from all over the country are unanimous in declaring Ghirardi's MODERN RADIO SERVICING to be the finest book ever written for service men. "The most valuable piece of equipment in my shop," writes one of them, and he is typical of many others whose enthusiastic reception has far exceeded our most optimistic expectations. *It's time for YOU to look into this!*

MODERN RADIO SERVICING

Every phase of radio servicing as it is practiced today by the most successful service organizations in the U. S. Every modern test instrument and method (including the Cathode-Ray Oscilloscope) clearly described and explained. Shows you how to do every kind of test and repair job the best and quickest way. All the latest 1935 dope presented in clear, easy-to-understand language. 1300 pages, 706 illustrations, 723 Review Questions. Price \$4.00.

RADIO FIELD SERVICE DATA

B. M. Freed, co-author

Supplement and Answer Book to MODERN RADIO SERVICING. Contains over 25 invaluable tables and charts for quick and handy use in practical service work—including table of trouble symptoms and remedies for over 750 receivers, complete table of i.f.'s for all superhets (2,790 in all!), etc., etc. 240 pages. 41 illustrations. Price \$1.50.

Introductory Combination Offer.

MODERN RADIO SERVICING and RADIO FIELD SERVICE DATA \$5.00 (if purchased together)

RADIO PHYSICS COURSE

The standard text on radio principles used by schools, experimenters and technicians the world over. Complete, up-to-date. Authoritative. 972 pages. Over 500 illustrations. 856 Review Questions. 2nd Revised Edition. Price \$4.00.

FREE CIRCULARS

Mail This Today

RADIO & TECHNICAL PUBLISHING CO. 45 Astor Place, New York, Dept. RC-11

Please send free literature on the books described in RADIO CRAFT.

Name _____
Address _____

Train Now for New RADIO Opportunities



Get Into a Line Where There's Action—Every Day—And a Payday Every Week—You Be the Boss!

Analyzer & Resistance Tester—Latest Design—YOURS Without Extra Cost

Right now while hundreds are looking for work where there isn't any, the radio service field can use trained men. With the proper training and the necessary equipment, you can enter this field and make a comfortable living. We include with our course this modern set analyzer and trouble shooter without any extra charge. This piece of equipment has proved to be a valuable help to our members. After a brief period of training you can take the set analyzer out on service calls and really compete with "old timers." We show you how to wire shortwave receivers—analyze and repair all types of radio sets and many other profitable jobs can be yours. Teaching you this interesting work is our business and we have provided ourselves with every facility to help you learn quickly yet thoroughly. If you possess average intelligence and the desire to make real progress on your own merits, you will be interested.

ACT NOW — MAIL COUPON

Start this very minute! Send for full details of our plan and free booklet that explains how easily you can now cash in on radio quickly. Don't put it off! Write today. SEND NOW!

RADIO TRAINING ASSN. OF AMERICA
Dept. RC-511, 4513 Ravenswood Ave., Chicago, Ill.

Gentlemen: Send me details of your Enrollment Plan and information on how to learn to make real money in radio quick.

Name.....

Address.....

City..... State.....

RADIO Made Easy

(1)—Write for FREE NEW CATALOG of Condensers, Transformers, Chokes, Sockets and general equipment for receiving and transmitting.

(2)—SEND 10c for New 32-page Manual of most popular Short-Wave Receivers, with illustrations, diagrams and parts lists.

Address Dept. RC-11
HAMMARLUND MANUFACTURING CO.,
424-438 W. 33rd St., New York



30-15,000 CYCLES ± 1 D. B.
MULTIPLE COIL
Hum Free Construction Each
Audio Transformers \$3.75
In Hum-Proof Cases

Single or Push-Pull High and Low Equalizers in Alloy Case, \$1.50
Hum Proof Alloy Case 0.75

ALLOY TRANSFORMER CO., 135R Liberty St., New York City

New Service Instrument!



New Peak Output Visualizer. An indispensable device for lining up super and T.R.F. receivers. Replaces expensive meters. Cannot burn out or get out of order. \$1.75 Postpaid

RADIO DESIGN COMPANY, 98 Park Place, New York, N.Y.

STOP GUESSING! WHAT IS WRONG WHAT TO CHARGE



Every member of The Phila. Radio Service Association owns a CHUCKER, trouble-graph and repair-prim! You can't afford to be without one. Price 50c postpaid. (No Stamps)
PAUL G. FREED (Publishing Division R)
5053 Baltimore Ave. Philadelphia, Pa.

NEW OPPORTUNITIES IN RADIO

(Continued from page 275)

of power is required for most types of transmission; and, a combination transmitter-receiver or "transceiver" may be built at slight cost. Many new uses have been found, too.

(See, "Armstrong Invention Ends Static!," *Radio-Craft*, July 1935, page 6; "Radio Waves Now Kill Plant Pests and Insects," November 1934, page 272; "Ultra-Short-Wave Radio for the Freight Train," May 1934, page 646; "How to Make an Experimental Radiophone," October 1933, page 200; "Professor Lectures Class from Home," April 1935, page 582; "S.-W. Radio for N. Y. Stock Exchange," September 1935, page 134; and, "Transceivers in Tomorrow's Car," June 1935, page 714.)

Centimeter-wave operation, in contrast with 5-meter performance, is ultra-new,—at least, insofar as securing any considerable amount of power-radiation is concerned. New developments in the "magnetron" type of tube have made it possible to secure very high efficiency at wavelengths only a few centimeters long.

(See, "The New 'Mystery Ray'," in this issue of *Radio-Craft*; "Super-Short Radio Waves," October 1934, page 213; and, "Marconi's New Invention," October 1934, page 199.)

(Also, refer to the January 1935, SHORT-WAVE NUMBER; note the item, "Short-Wave Applications," page 391.)

3 O'Clock—Radiotherapy. A few, well-equipped organizations are supplying limited types of radiotherapy equipment; further expansion will soon establish a demand for advanced technicians to construct, install, operate and service this high-priced, precision apparatus.

(See, "Machine for Amplifying Heart-beats," *Radio-Craft*, September 1935, page 137; "An Artificial Fever Apparatus," July 1934, page 9; "The 'Radio Knife'," August 1934, page 72; and "Curing 'Stiff Shoulder' by Radio," July 1935, page 8.)

4 O'Clock—High-Fidelity and Controlled Sound. First, continual improvements in (a) reproducers, (b) tubes, (c) circuits, and (d) microphones, and other associated components; second, improved broadcasting facilities; and, third, improvements in the technique of manipulating sound set-ups have made sound reproduction not only indistinguishable from the original, but also far more effective.

(See, "How to put 'High-Fidelity' into Old Sets," *Radio-Craft*, March 1935, page 537; "High-Fidelity on Short Waves," January 1935, page 396; "The Problems in High-Fidelity Design," December 1934, page 339; and, "How WHAM Goes High-Fidelity," December 1934, page 357.)

Controlled sound, a new term in the radio field, is to the sound field what perspective and color are to the motion picture field—in fact, we forecast a wonderful hoost in the motion picture business when this industry awakens to the possibilities for expression afforded by the use of controlled sound. For, in a word, controlled sound supplies not only the "depth," in sound, that perspective gives to motion pictures, but also contributes the emotional control that is achieved, in pictures, by the use of color. (See, "Controlled Sound" for Modern Theatres," *Radio-Craft*, September 1935, page 157; "Third Dimension in Music," May 1934, page 654; and, "Elements of 4th-Dimension P.A. or Sound Systems," Part I, January 1935, page 407, and Part II, February, page 481.)

5 O'Clock—Industrial Electronics. Said David Sarnoff, formerly president of RCA, "Without electrons we would have no radio sets, sound moving pictures, long-distance telephony, 'talking books' for the blind, facsimile transmission; nor thousands of other devices which make our lives more pleasant, such as light measurement and control, automatic counting and sorting devices, protection of machine operators, burglar alarms, etc."

Industry has taken electronics, in the garb of the photoelectric cell, to its corporate bosom. Inside of 5 years, we will look back and wonder why we hadn't previously thought of the thousands of additional applications which will have been developed in the interim.

Service Men specializing in electronics will then be with us in "profusion," so to speak.

(See, "The Electronic Art," *Radio-Craft*, April 1935, page 581; "The P.E. Cell," August 1934, page 86; "A Cold Radio Tube," December 1934, page 326; and, "Home Electronics," April 1935, page 595. Also, refer to the April, 1935 ELECTRONICS NUMBER.)

6 O'Clock—Facsimile and Television. We place these items in the order indicated, since the commercial status of transmission and reproduction of facsimile views and illustrations is higher in the U.S. than is that of television.

(See, "New National Wirephoto Service," *Radio-Craft*, April 1935, page 591; "Announcing—Electrolytic Pictures via an Improved System," June 1935, page 718; "Radio Set Prints Newspaper," April 1934, page 590; "The Radio Pen," July 1935, page 13; "Ultra-Short-Wave Photogram Service," April 1934, page 583; and, "How to Make a Facsimile Sender and Recorder," August 1935, page 85.)

Television is very much in a state of flux. Nevertheless, it is inexorably progressing to the position of a domestic and commercial actuality.

(See, "Latest in Television," *Radio-Craft*, December 1934, page 330; "A Modern Picture of Television," Part I, April 1935, page 589, and Part II, May, page 673; and, "World-Wide Television," August 1935, page 76. Also, refer to the August, 1935, TELEVISION NUMBER.)

7 O'Clock—Multiplex Telegraphy and Telephony. Right at the start, let us mention that this reference is *not* to the previous methods of multiple transmission, but to the advanced systems that utilize, for instance, "frequency" modulation, and "coaxial" conductors. The latter, for instance, permits 200 conversations to be carried on, between 400 persons, over a single pair of "coaxials"; the previous limit was 2 (or, at most, by using a "phantom" circuit, 3), conversations between 4 (6) persons!

(See, "Frequency" vs. "Amplitude" Modulation," *Radio-Craft*, August 1935, page 75; "Inter-City Commercial Radio Service," July 1934, page 6; "Frequency Modulation" in Tomorrow's Set," September 1935, page 152; and, "Television Hook-Up from N.Y. to Philadelphia" [an item concerning coaxial cable], August 1935, page 70.)

8 O'Clock—Radiodynamics. Remote operation of mechanical devices has always stirred the imagination, but "radiodynamics," or the remote control of equipment by means of radio signals is going to do more than that—for, it has already started to stir the pocketbooks of manufacturers and technicians. Airplanes, boats and other devices have been brought under control of the lengthy finger of radio waves; even the typewriter has succumbed to radio control.

TABLE I

THE TREND OF RADIO DEVELOPMENT

Government	Maneuvers Messages Navigation aids	Army Navy Gov't business Time signals Weather data Facsimile Newspaper Cable
Commercial	Trans-Oceanic & Continental Railway Mobile Ship, Aircraft & Land Voice programs Television Home talkies	Telephone Typewriter Multiplexing Message traffic Dispatching Warning Distress Communication Navigation Alarms, Short- & Broadcast bands Moving pictures Sound projection Photo-relay pickup Recording & Reproducing Home receiving
Broadcasting	Radio	Remote control Automatic radio Analyses & tests Measurement Repairing
Home use	Serviceing Measurement	Noise location A.C. & D.C. Power circuits Hotels & hospitals Apt. houses Halls, outposts Theatres & Studio Machine control Light, elev. & draught control Alarm systems Color matching Counting, grading & sorting Analyses Traffic control Analyses Measurements Piano, Violin, Organ & Thremin Curative & surgery Speeding growth Killing insects Prospecting & Geophysics Ultra-high frequencies Light-beam transmission Altimeter, Recorder Sonic & Super-sonic work Remote control
Maintenance	Public Address Talkies Power	
Sound Projection	Industrial	
Electronics	Metallogury	
Research	Musical Inst's Medicine Botany Biology	

Please Say That You Saw It in RADIO-CRAFT

(See, "Radio Telemechanics," *Radio-Craft*, September 1934, page 133; "The New Radio Garage Door Opener," September 1933, page 138; "An Introduction to Radio-Dynamics," February 1934, page 472; "The 'Human' Ford Car," March 1934, page 519; "Radio Controls Battleships," April 1934, page 592; and, "A Radio-Controlled Boat," July 1934, page 18.)

9 O'Clock—Sound Recording. There are several "angles" to the recording of sound. There is, for instance, the "transcription" record, which is a veritable radio program, from A to Z, with announcements, advertising matter, and entertainment material, all combined in one or more superlative recordings. Only experts can qualify for positions here. Other types of recordings are open to somewhat less-skilled labor, and include the outdoor job of making bird-sound records; and studio work such as (a) recording radio programs for checkback as to enunciation, speed of delivery, etc., and, (b) making impromptu recordings for mailing to relatives, etc.

(See, "How Broadcast Artists Record their Programs," *Radio-Craft*, February 1935, page 463; "How the Sounds of Birds are Recorded on Film and Disc," February 1934, page 463; "Records 'Play' 3 Hours," July 1934, page 9; and, "High-Fidelity Reproduction from Records," May 1935, page 669.)

10 O'Clock—Electronic Music. Music lovers the world over are slowly awakening to the possibilities of electronic music, and with increased interest will come increased business of this type for thousands of apparatus builders.

(See, "A 'Syntronic' Organ," *Radio-Craft*, August 1934, page 77; "And Now—The Electric Violin," August 1933, page 85; "How to Make the Beginner's Pianotron," January 1934, page 404; "The 'Polytone' Electronic Organ," May 1934, page 657; "An Easily-Built 'Theremin,'" April 1935, page 600; "The Marimhalite," October 1934, page 205; "The Latest Electronic Organ," April 1935, page 600; and, "Hammond Electric Organ," July 1935, page 9.)

11 O'Clock—Public Address and Sound Reinforcement. Under this heading are several new items to which attention should be called, but the very first thing to do is refer to the listing of 101 applications of P.A. equipment, under Table I, in the article, "The Growth of 'Public Address'," by D. H. Wright of Wright-DeCoster, Inc., in the May 1935 issue of *Radio-Craft*, page 654.

It is not every day that a stadium can be sold on sound equipment, but they are slowly coming into the fold; even existing installations afford work that is requiring the full-time attention of hundreds of radiomen.

Private homes are still an excellent source of income, for, the owners of swanky estates ordinarily are anxious to keep their sound installations (usually, a radio-phonograph combination with long-playing records, and "piped" to many reproducers within, and outside the house) right up-to-date.

(See, "A Super-Power and -Quality P.A. System," Part I, *Radio-Craft*, December 1933, page 338, and Part II, January 1934, page 400; "Amplified Chimes for Schools—Churches," June 1934, page 718; "Reinforcement Systems in Stadiums," May 1935, page 648; "Centralized Sound for Schools," May 1935, page 661; "A New Giant, Mile-Range Loudspeaker," December 1934, page 334; and, "New Money-Making Possibilities in a Portable P.A. Demonstrator," July 1935, page 24. Also, refer to the May, 1935 PUBLIC ADDRESS NUMBER.)

12 O'Clock—Metal Tubes. As the writer stated in an article in the preceding issue of *Radio-Craft*:

"Definitely, metal tubes are here to stay. Therefore, the radioman might just as well start right now to absorb every available bit of technical data relating to them, if he wishes to keep abreast of future developments in metal tubes."

Unquestionably, we have entered the "Metal Tube Era," in which the old, glass-type tubes will play but little part, and that mostly as replacement in out-moded equipment.

(See, "Now—Metal Tubes," *Radio-Craft*, June 1935, page 726; and, "Tube or Not Tube," July 1935, page 7. Also, refer to the October, 1935 METAL TUBE NUMBER.)

Although this resumé of new opportunities in radio is very incomplete, the writer will feel exceedingly happy, indeed, if the reader has found the article sufficiently entertaining to have realized in some measure the tremendous scope of present-day radio activities.

HOW TO EQUIP A SOUND TRUCK FOR ELECTIONEERING, ETC.

(Continued from page 277)

actual installations.) The following is the approximate relation between audio power output of a P.A. system and outdoor coverage in square feet.

Audio Power In Watts Developed by Loudspeakers	Approx. Coverage In Sq. Ft.	Audio Power In Watts Developed by Loudspeakers	Approx. Coverage In Sq. Ft.
1	100	20	8,000
2	200	25	11,000
3	300	30	15,000
4	550	35	21,000
5	1,000	40	30,000
7.5	2,000	45	55,000
10	3,000	50	80,000
15	4,700		

SELECTING THE AMPLIFIER

The actual selection of a specific amplifier for any given sound system is of course a matter into which many factors enter. For the amplification of voice only, a high-fidelity amplifier is not required inasmuch as speech itself is limited to a comparatively narrow frequency band. For the quality amplification of phonorecords or for the "re-enforcement" of orchestral and vocal selections, a high-fidelity type of amplifier is desirable for best results. Of course, a number of other vital factors enter into the selection of an amplifier which are directly determined by the type of associate equipment to be used with the system. For instance, if it is decided upon to use the new crystal type microphones, the amplifier must develop sufficient gain to provide full output with normal voice inputs. Likewise, the efficiency of the speakers employed must be taken into consideration, for speakers of 75 per cent efficiency will require an audio amplifier capable of developing 66.5 W. in order to cover an area of 80,000 square feet, 16.5 W. (or 25 per cent of the amplifier output) being wasted in the conversion of electrical impulses into sound waves.

WIDE-RANGE AMPLIFIER

Let us for a moment consider the wide-range variable output P.A. amplifier described in the December, 1934 issue of *Radio-Craft*, page 347, as the one which most closely fulfills our needs from the viewpoint of (1) sound coverage, (2) flexibility of operation, (3) simplicity of installation and removal, (4) compactness, (5) light weight, (6) universal power supply, (7) completeness, (8) economy of operation, and (9) low cost.

The variable output feature of the amplifier provides for 5, 25 or 50 W. output with attendant economies at the lower levels.

(This interesting discussion of amplifier choice will be concluded in the next issue.—Editor)

THE RADIO ENGINEERING VOCATION

(Continued from page 277)

the light of specialized training in his particular field. Graduates of this course are well qualified professional men in the strict sense of the word.

There are 3 residence courses. One, for home study graduates only, is comparatively short, aimed entirely at the radioman with considerable practical experience who wishes to enrich his knowledge of the higher theoretical considerations, together with the practical ends involved. It extends for 10 weeks of intensive training during the summer months. The second is the one-year residence course. No particular prerequisites are expected of the student of this course except that he have a high school education or its equivalent. A man experiencing this training will receive well-balanced theory and practice. His time will be divided as follows:

- 35 per cent theoretical instruction
- 35 per cent actual laboratory practice
- 20 per cent construction, and
- 10 per cent mechanical drawing, etc.

The aim of all the courses is the training of practical radio engineers. The results which have been attained prove the wisdom of the original concept.

Please Say That You Saw It in RADIO-CRAFT

Save Money! New "DEPENDABLE" TESTS SETS As Well as TUBES



Model 305
Kit, \$17.85

Ready to Operate, \$21.95

THIS newest Radio City development is an excellent capacity and resistance tester, in addition to testing accurately all present and new type tubes.

This double-service makes it especially useful and the low price should appeal to service men who wish to save on their test equipment cost.

Latest design 5" Bakelite fan-type meter in full view. Unusual Neon lamp indicates shorts, also leakages above 500,000 ohms. Handsome, black, etched, sloping metal panel; waterproof case. Counter, portable and deluxe models.

"DEPENDABLE" MULTITESTER

Only \$13.95
Ready to Operate



Accurate, up-to-date testing assured when used with "RC" Analyzer Unit, or your old analyzer. Contains 3-range voltmeter; 4-range ohmmeter; microammeter; milliammeter and batteries.

KIT, \$10.65

No. 403-A

Write Dept. RC-11 for New 1936 Bulletins

RADIO CITY PRODUCTS CO.
88 Park Place, New York

STEP AHEAD

IN THE SERVICE PROFESSION WITH CASE RECORDS OF BROADCAST RECEIVER REPAIRS

ADD 10,000 HOURS to your experience! ELIMINATE GUESS-WORK in your servicing. DON'T PUZZLE YOUR PROFITS AWAY!

Your work is already done and recorded for you in "CASE RECORDS." This 312-page leatherette binder CONTAINS 1,500 alphabetically and numerically arranged case records of SUCCESSFULLY COMPLETED SERVICE JOBS. Each Record tells — symptom — data responsible — electrical value — location — and best replacement or repair. Fastest Servicing technique known. 108 Receiver Makes — 3,000 Models. SUPPLEMENTED QUARTERLY FREE for 1 Year.

CAPITOL RADIO RESEARCH LABORATORIES INC.
933 National Press Bldg.
Washington, D. C.

Kindly forward full details on "CASE RECORDS."

NAME.....

ADDRESS.....

CITY.....State.....

COMPLETE DESIGNS of 10 Public Address AMPLIFIERS

A manual of circuits of Audio Amplifiers. One for every purpose. From 3 watts to 30 watts. All tried and tested designs. With complete lists of parts and their values.



FREE!

VALUABLE REFERENCE BOOK.

This advertisement and 10c INSTAMPS, to cover mailing expenses, will bring you FREE copy of this valuable Reference Book. There is no obligation.



STANDARD TRANSFORMER CORPORATION
851 Blackhawk St., Chicago

AEROVOX MIDGET ELECTROLYTICS

For assemblies where space is limited . . . or as replacements in midget sets. Remarkably compact . . . yet safety factors remain adequate. In 200-volt and 450-volt ratings. 2 to 16 mfd. Use them in those tight places . . . and forget your condenser headaches!

DATA Send for latest catalog covering complete condenser and resistor line. Also sample copy of monthly Research Worker.



A-C CURRENT-ANYWHERE!

WITH Kato LIGHT PLANTS

A little gas and a Kato AC plant enables you to operate AC radios, amplifiers, refrigerators and other standard household appliances. Sizes 300 watts and up. Write for interesting descriptive literature on AC and DC models. Burn Kerosene, 3 & 5 KW Diesel driven.

KATO ENGINEERING CO. Mankato, Minn., U. S. A.
AC generators, converters for operating AC radios on 22 and 110 volts DC, windmill light plants & battery chargers

RADIO ENGINEERING,

broadcasting, aviation and police radio, servicing, marine radio telegraphy and telephony, Morse telegraphy and railway accounting taught thoroughly. Engineering course of nine months' duration equivalent to three years of college radio work. All expenses low. Catalog free. School established 1874.
Dodge's Institute, Hudson St., Valparaiso, Ind.

SHOULD I TAKE UP RADIO?

(Continued from page 278)

cause of their element of newness and change. Success in every sense of the word comes to that person who finds himself engaged in profitable and interesting work.

Since radio work calls for trained workers (with more training at present than ever before) only those who have the ability and previous preparation can succeed—this limits automatically the number of persons with whom one must compete in securing suitable employment. For the past few years every field of endeavor has suffered from lack of employment, but the untrained man has borne the brunt of the economic depression since almost anyone could replace him.

Professional men, whether they be doctors, lawyers, dentists, teachers or radio technicians are recognized as such by the community in which they reside. A person thoroughly trained in some particular field always holds a more secure social position than a "jack of all trades."

The institution with which I am identified has, for the past 21 years, succeeded in preparing young men for the radio profession. There is probably no other school of this type more widely known to the radio fraternity as a whole, starting as it did, in the days of the arc and spark transmitters and continuing to the present time, as a school devoted exclusively to telegraph and radio instruction.

In order to keep abreast of the field of radio, and, in fact, to anticipate some of the future developments, we have found it necessary to make constant revision of the types of courses, methods of instruction and laboratory procedure. Such courses as Mathematics, Electronics and A.C. and D.C. Electrical Theory have been added to the curriculum of this school, due to the increasing need for a more fundamental knowledge of these subjects as radio apparatus becomes more and more complicated. We are able to prepare young men in a period of 9 months, to enter the radio profession in a worthwhile capacity, by including only those parts of Mathematics and Electrical Theory that are directly related to the field of applied radio. We require high-school graduation of students enrolling for the Broadcast Engineering course; those enrolling for Radio Servicing and Marine Radio Operating must have at least 2 years of high-school training. In view of the fact that high-school graduation is required for the Broadcast Engineering student, most of the instruction given is on a college level.

With the full realization that a course in radio cannot be complete without a well-equipped laboratory, in which the students themselves may gain first-hand information concerning the subject matter covered in their text books, this school takes pride in the type of laboratory instruction which it provides. The laboratory courses are not designed to give routine manipulation of specific types of apparatus, but to develop the student's ability to think for himself concerning radio problems and their solution. The laboratories are well equipped for this purpose. From the elementary experiments to the more advanced, the student is led, in logical sequence; experiments becoming more complicated as his knowledge of radio increases. These experiments are checked and graded by the laboratory instructors, as the student progresses in his work; each student receiving as much personal supervision as is necessary for the complete understanding of the principles involved. The school maintains a general laboratory, in which most of the experiments of a fundamental nature are performed. Besides the general laboratory, the school maintains a Service laboratory, equipped with the latest types of test equipment and radio receivers, from the earliest to the latest.

All students, except those enrolling for Radio Servicing, are required to learn the Continental (Morse) code, making it possible for graduates to procure either first-class telephone or second-class telegraph licenses, or both, thus giving the graduate from this institution a greater opportunity for obtaining employment.

In summarizing, radio training offers the following advantages to the person willing to devote time and study to its attainment: radio is an expanding industry, offering excellent opportunities to those with thorough training; it provides the means of a livelihood which yields both cash dividends and enjoyment; it provides a vocation which yields income over a long period of time, giving professional standing and greater social security.

tests both ALL-METAL and GLASS TUBES

Plugs into 110 Volt AC Line



Combined TUBE and SET TESTER

Tests every type of receiving tube made including all-metal and glass types. Uses 5" fan-type meter with English reading "Good-Bad" scale. Tests shorts and leakages with neon light. Makes continuity and ohmmeter tests. Tests paper and electrolytic condensers. Simple to operate—no adapters required. Separate line voltage meter. Counter model. Ship. wt., 10 lb.

No. 305KC Tube Checker Kit \$17.85
Y.O.R. PRICE
No. 305C Tube Checker, completely wired and tested. Y.O.R. PRICE \$21.95

Radio Trading Co.

97 Hudson St., New York, N. Y.

WESTINGHOUSE POWER GENERATOR

Manufactured for U. S. Signal Corps
200 Watt. 110 V. AC

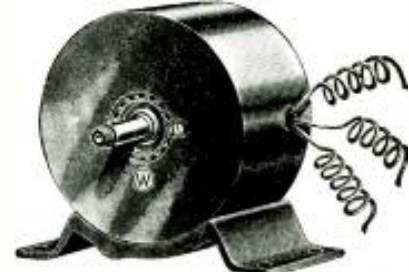

A. C. ELECTRICAL POWER

from a Windmill, from available Waterpower, from your Automobile, from your Motorcycle, from your Bicycle, Foot-pedals or Handcrank (for transportable Radio Transmitters, Strong Floodlights, Advertising Signs); do you want to operate AC Radio sets from 32 V. DC farm light systems; operate two generators in series to get 200 V. AC; obtain two phase and three phase AC, etc., etc.

There Are Over 25 Applications
Some of which are:

A.C. Dynamo lighting from eight to ten 20 Watt 110 Volt lamps. Short Wave Transmitter supplying 110 Volts AC for operating "Ham" transmitter. Operating 110 V. AC 60 Cycle Radio Receiver in DC districts. Motor Generator. Public Address Systems. Electric Sirens on motor boats, yachts, etc. Camp Lighting. Short Wave artificial "fever" apparatus. Television. Pelton Waterwheel for lighting or other purposes. Airplane: for lighting strong search lights or electric signs. Laboratory work, etc. ¼ to ½ H.P. needed to run Generator.

BLUE-PRINT 22 x 28 in. and Four-Page 8½ x 12 in. INSTRUCTION SHEETS FREE.
Generator, as described, including four replacement carbon brushes. Blue-print and instructions \$7.90

Send \$2.00 deposit balance C.O.D. Shipping weight 18 lbs.
(Replacement carbon brushes bought separate \$1.50 per set of four. Set of instructions bought separate \$1.00.)

MONEY-BACK GUARANTEE.

WELLWORTH TRADING COMPANY

560 West Washington Blvd., Dept. RC-1135, Chicago, Ill.

Please Say That You Saw It in RADIO-CRAFT

"QUALITY-CONTROL" AN AID TO OLD SETS

(Continued on page 276)

that is, with the high and low portions full on and the middle portion almost off. This is an overall curve from the output of the detector up to and including the output transformer.

Curve No. 1 was taken on the audio amplifier only and the increase at the two ends allows for the attenuation that will occur in the speaker, baffle, and surroundings.

When the equalized audio amplifier is used in conjunction with a radio frequency amplifier, the results of equalization will be at a minimum unless the R.F. amplifier will pass sufficient frequency width to allow the equalizer full control. Cutting of side bands in the radio frequency stages can only be partially compensated for in the equalizer. On the other hand, if the radio frequency band is made wide, at least 13 to 15 kc. total, the equalizer can, when necessary, by operation of the high controller narrow the band that will be reproduced.

CONSTRUCTION DETAILS

The method of assembling the component parts and connecting the unit in an amplifier is shown in Fig. 2.

Assuming that the audio range to be reproduced with successful results is to be approximately 45 to 5,200 cycles, the following combination of coils will be necessary. For the high end there will be required a coil having an inductance of 200 mhy. and this will be shunted with a .005-mf. mica condenser and a 50,000 ohm control. The inductance should have a relatively low resistance and to the best of the writer's knowledge none now on the market will do, consequently it will have to be made. The constructional details are shown in Fig. 3 and are self explanatory. The resistance control should by all means be non-inductive, which means that it should be of the carbon type rather than the wire-wound variety, otherwise any change in the resistor control will have a tendency to change the frequency to which the high control is tuned as much as several hundred cycles.

The equalizer for the bass end consists of a well designed 30 hy. iron-core inductance (power supply filter choke) in parallel with a .5-mf. paper condenser and a 10,000 ohm volume control. In this portion of the equalizer it makes little difference what type of variable resistor control is used.

The coupling condenser, C, should be the best obtainable preferably of the 1,000 volt variety. Its size will depend upon the grid resistance which will be used on the input to the tube following the equalizer. The basis for determining the size is that the impedance of the condenser at the lowest frequency of the equalizer should not be greater than 1/10 to 1/6 of the value of the grid resistor.

The equalizer control for the middle portion of the response consists simply of a 2,500 or 3,000 ohm volume control either carbon or wire wound. The entire equalizer consisting of the low, middle, and high control is finally bypassed by a 2 or 4 mf. condenser as shown in the diagram. This is important, otherwise the amount of equalization will be decreased approximately 5 db. Operation of the equalizer is simply a function of the amount of resistance in shunt with the individual resonant circuits. The variable resistances used to control the gain of the equalizer should have a taper either of the "C" bias or antenna type.

If it is desired to broaden the response offered by either the high or low equalizer, this can be accomplished by inserting a small size non-inductive resistance in series with the inductance coils. This resistance is usually not necessary and should never be over 200 ohms.

One thing that the builder should expect when the equalizer is installed is an appreciable increase in the hum level of the amplifier. This is natural and is occasioned by the fact that the amplifier is being made to respond to the lower frequencies (including 60 cycles). Undoubtedly, additional filtering will be necessary. It may even be found desirable to filter the equalizer stage independently. If so, filtering should be done with a fixed resistor and condenser rather than with a choke coil.

There are two possible methods of incorporating this equalizer in an audio amplifier; by substituting it as the plate load in place of the

resistor or transformer load of the amplifier; or by making a single-stage amplifier consisting of tube with equalizer units as the plate load and connecting the entire unit into the present amplifier. The latter method is preferable inasmuch as the overall maximum gain of the amplifier will remain the same (the losses of the equalizer being absorbed by the additional amplifier tube).

Regardless of which method is used, the equalization for obvious reasons should be accomplished at low level. If the equalizer is to be substituted for the plate load of a present tube, it should be the plate of the detector (the triode section of a 55 tube); or, if a separate amplifier unit is used, this unit should follow the detector.

Several points that are worthwhile considering in order to secure the maximum advantage from this equalizer are—never set the middle range control at zero. In 90 per cent of the cases this control can be set at approximately 500 ohms and forgotten. If quality with minimum distortion is expected from an amplifier, it is essential that for a band extending out to 5,000 and 7,500 cycles the final amplifier be operated at very low output. As an example, it is believed that for ordinary home use the type 250 tubes in push-pull class A with fixed bias is necessary. Furthermore, one should not expect 15 to 20 watts output if the frequency range goes out to 5,000 cycles or greater, but rather in order to keep harmonic distortion to a minimum, the amplifier should be derated to perhaps 5 W.

As will be noticed in the circuit diagram, the high frequency equalizer is shunted by means of a suitable switch with two condensers, the second condenser of .0025-mf. capacity being used to extend the frequency range to about 7,200 cycles.

Several points that should be remembered: Select the best speaker possible, not necessarily the one capable of handling the most power or with the greatest per cent efficiency, but rather the one having the flattest average response over the maximum audio range. This coming year will undoubtedly see better response speakers. If it is necessary, several equalizer units may be incorporated in one amplifier, either in the same stage or separate stages. For example, the speaker used starts to attenuate slowly at say 4,600 cycles and the response desired is to extend out to 6,500 cycles. The obvious answer is to build two high traps using two coils of 200 mh. of inductance with different condensers.

It is the writer's humble opinion that 1936 will witness the era of high fidelity both from a receiving standpoint and from the transmitting end not only on the new band from 1,500 to 1,600 kc. but over the entire broadcast range.

SELECTING A CAREER IN RADIO

(Continued from page 280)

be developed from the basic electronic principle, and that these offer the greatest future in the art of radio science. While it is claimed that television is here, up to the present time critics seem to feel that the pictures are not clearly enough defined to make it popular for home use.

Tremendous developments are constantly being made in the electronic fields. Trade journals are publishing articles on many electronic devices that have been developed for radio and industry, such as making it possible to control flying field lights by a photo-tube device.

Many uses are now being made to measure, count and weigh objects. Through the application of the electronic relay it is possible to measure with such a device a millionth of an inch or to determine deflections by measurements as small as five one-millionths of an inch!

From the foregoing, it will be obvious that numerous attractive opportunities exist today in the radio field. Broadcast stations must have capable men for installing, maintaining and repairing their equipment. The sound picture industry requires thoroughly trained, highly skilled technicians for the maintenance and repair of sound picture apparatus. In fact, the trend of radio development offers unlimited possibilities. And whatever phase of radio one decides to specialize in as a career, a good general training in electrical and radio technique is essential.

Now—a high-powered—



Radio Engineering Library

—especially selected by radio specialists of McGraw-Hill publications

—to give most complete, dependable coverage of facts needed by all whose fields are grounded on radio fundamentals

—available at a special price and terms.

These books cover circuit phenomena, tube theory, networks, measurements, and other subjects—give specialized treatment of all fields of practical design and application. They are books of recognized position in the literature—books you will refer to and be referred to often. If you are practical designer, researcher or engineer in any field based on radio, you want these books for the help they give in hundreds of problems throughout the whole field of radio engineering.

5 volumes, 2981 pages, 2000 illustrations

1. Everitt's COMMUNICATION ENGINEERING
2. Terman's RADIO ENGINEERING
3. Chaffee's THEORY OF THERMIONIC VACUUM TUBES
4. Hund's HIGH FREQUENCY MEASUREMENTS
5. Henney's RADIO ENGINEERING HANDBOOK

10 days' examination. Special price. Monthly payments. \$26.00 worth of books cost you only \$23.50 under this offer. Add these standard works to your library now; pay small monthly installments, while you use the books.

SEND THIS ON-APPROVAL COUPON

McGraw-Hill Book Co., Inc.
330 W. 42nd St., New York, N. Y.

Send me Radio Engineering Library, 5 vols., for 10 days' examination on approval. In 10 days I will send \$2.50, plus few cents postage and \$2.00 monthly (till \$25.50 is paid, or return books postpaid). No pay postage on orders accompanied by remittance of first installment.

Name
Address
City and State
Position
Company

"HEY FELLAS"
HERE'S SOMETHIN'
REAL HOT" says
"EMANUEL ESICO"



Something really hot in the way of electric soldering irons. An iron that is hot, stays hot and doesn't burn out. A quality iron that you can depend on every time.

● A low priced iron with high priced characteristics.

Your cost as low as 66¢* at all Esico distributors.

*Model Nick Nack 55 watts.

Electric Soldering Iron Co., Inc.

342 West 14th Street

New York, N. Y.



FREE OFFERING

R. C. A. ALL-METAL TUBE BULLETIN
HAMMARLUND SHORT-WAVE MANUAL
WORLD-WIDE SHORT-WAVE MAP

(Send DIME Each to cover Postage, etc.)
Factory Prices Kits—Sets—Parts

RADIO CITY LABS., Suite 1222-R
30 Rockefeller Plaza New York

Please Say That You Saw It in RADIO-CRAFT

**Tomorrow's
MAGNETIC SPEAKER
Today!**
**The Revolutionary NEW
WRIGHT-DECOSTER
"HYFLUX"**



- High Efficiency
- Wide Frequency Range
- Permanent Dust Proofing
- Rugged Construction

Write For Complete Details.
Specifications, Prices

WRIGHT-DECOSTER, Inc.
2251 University Ave. St. Paul, Minn.
Export Dept.: M. Simons & Son Co.
Cable Address: SIMONTRICE, New York

**This midget RESISTOR
does a BIG job well!**

Our type "R" MICROHM 1/2-watt Resistor shown here, actual size, is ideal for Analyzer, meter conversion and many other uses, where a compact, low-priced Resistor is required. Resistance up to 500,000 ohms. Companion to above unit is our type "L" 1 watt which may be obtained in resistance values up to 1 Megohm. Write for samples, further information and our new catalog.



PRECISION RESISTOR CO.
334 Badger Avenue, Newark, N. J.

MICROHM
WIRE WOUND RESISTORS

**SPEAK-O-PHONE
COMPANY, INC.**

33 West 60th Street
New York

SOUND ENGINEERING
Designers and Manufacturers of

SPEAK-O-PHONE (INSTANTANEOUS) RECORDERS AND REPRODUCERS

for Professional and Non-Professional use

Learn Radio the Gould Way

How to make money in RADIO Servicing

A Practical Course in Applied Radio, prepared by the Radio Institute of America, includes:

- 40 lessons, 100 hours of instruction
- 200 illustrations
- 100 tests
- 100 practical exercises
- 100 projects
- 100 experiments
- 100 assignments
- 100 questions
- 100 answers
- 100 problems
- 100 solutions
- 100 puzzles
- 100 riddles
- 100 jokes
- 100 stories
- 100 songs
- 100 plays
- 100 comedies
- 100 tragedies
- 100 histories
- 100 geographies
- 100 biographies
- 100 autobiographies
- 100 letters
- 100 telegrams
- 100 telegrams
- 100 telegrams
- 100 telegrams

For Part 25, 100 Lessons, 100 Hours, 100 Tests, 100 Projects, 100 Experiments, 100 Assignments, 100 Questions, 100 Answers, 100 Problems, 100 Solutions, 100 Puzzles, 100 Riddles, 100 Jokes, 100 Stories, 100 Songs, 100 Plays, 100 Comedies, 100 Tragedies, 100 Histories, 100 Geographies, 100 Biographies, 100 Autobiographies, 100 Letters, 100 Telegrams, 100 Telegrams, 100 Telegrams, 100 Telegrams.

Send for your copy today! Write to: Radio Institute of America, 100 East 17th Street, New York, N.Y.

INTERNATIONAL RADIO REVIEW

(Continued from page 282)

compensating for the mis-tuning of condenser A, since C1 is shunted across A. Thus, exact tuning is assured.

In actual practice, the arrangement shown at Fig. 2B is used. The tuning compensator is coupled in the I.F. amplifier circuit, which is also controlled by the A.V.C. Circuits B and C are tuned slightly above and below the I.F. respectively, so that when the set is mis-tuned, the currents in R1 and R2 do not match, and current will flow in either one direction or the other. Instead of making this control current operate a relay, as shown in Fig. 2A, it is used to alter the grid bias on one or more of the preceding tubes so as to increase or decrease the damping effect on the tuned circuits, or it is passed through iron core tuning coils, so as to alter their effective inductance by saturation.

NEW ENGLISH RADIO SETS

SEVERAL new innovations in radio set design appeared in recent issues of *Wireless World* magazine. The first, shown in Fig. 3, is a new form of dial, known as a "thermometer" dial, in which the tuning is indicated by the positions of black metal rods which run up and down in glass tubes, at the sides of which are calibrated scales.

The second novelty is in the form of cabinet used for a new set which has just made its appearance on the English market. The odd shape of this cabinet is shown in Fig. B and is certainly motivated by the stream-lined vehicles which are becoming so popular, the world over.

THE ROBOT AIRPLANE

LAST MONTH, we announced the results of some experiments by the British Army in flying a full-sized plane without any pilot aboard, by means of radio dynamic control.

In the latest issue of *Popular Wireless*, a simplified diagram of the apparatus which controls the plane from the ground was printed. An examination of the circuit reveals the method of operating the control. A motor driven endless tape is perforated to contain the signals required to actuate the mechanism on the plane. A group of buttons connects the contacts through the signal ribbon, closing a magnetic relay which connects this control to a radio transmitter tuned to a predetermined point in the ultra-high frequency spectrum. A locking control on the signalling buttons prevents a second button from being pushed down until the previous signal has been completed. Each of these signal buttons controls one movement of the plane, such as "bank left", "rise", "glide", etc.

SHORT CUTS IN RADIO

(Continued from page 285)

add a dynamic speaker to any set not having a field current supply. As shown in the hook-up, Fig. 8, the parts needed are simple and few. The 2 mf. condenser smooths the D.C. so that the hum is hardly perceptible. The current is around 40 ma., when using a 2,500 ohm field, which does not tax the 27-type rectifier.

CLYDE W. PREBLE

HONORABLE MENTION

COPPER TUBING SUPPORTS. Copper tubing pieces may be secured from any auto shop by asking for a "gas. line." This tubing is very handy for mounting wafer sockets in a breadboard type of set. A single long screw will hold both the socket and tube hushing at each end of the socket. (See Fig. 9).

FRANK RADER

HONORABLE MENTION

HANDY EXTENSION PLUG. Almost everyone has an old automatic control unit, of the type used to operate a trickle charger and "B" eliminator, laying idle in the junk box. This can easily be made into a handy extension plug with double outlet, as shown in Fig. 10. The relay is removed (for possible use elsewhere) and the two sockets wired together so that they are both "hot." The two binding posts may also be wired into the line.

IVER PAULSEN

Please Say That You Saw It in RADIO-CRAFT

HANDY Electric PAINT SPRAYER

ONLY \$14.50
Complete Outfit and Spray Gun

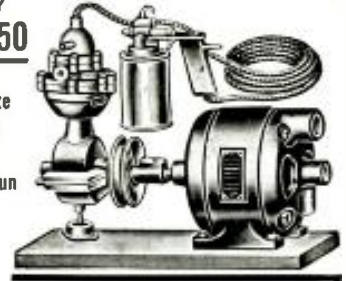

Startling offer! Famous spraying outfit includes pressure internal mix spray gun, adjustable, non-clogging, fan and round spray nozzles. Ideal for spraying paint, varnish, enamel, lacquer, shoe dyes, etc. The power is saved time and labor and does better work. Outfit complete with spray gun, National Compressor with sealed piston (cannot dump oil), heavy duty Westinghouse motor, 110 volt, 60 cycles, A.C., plug and cord, safety valve, 15 ft. air hose. Just plug into light socket and it is ready for operation. \$14.50 complete. Send \$3.00 deposit, balance C. O. D. Shipping weight, 30 lbs. Sold on money-back guarantee basis.

WELLWORTH TRADING COMPANY
560 W. Washington Blvd., Dept. RC-1135, Chicago, Ill.

-- a new magazine for short-wave fans!
SHORT WAVE LISTENER

4,600 Short Wave stations listed



25c THE COPY

ON ALL NEWSSTANDS

THE finest magazine of its kind ever published—totally different in get-up and contents from any other. Contains the largest listing of short wave stations in the world, up-to-the-minute, including "Police," "Television" and short-wave stations, as well as a special list of the star short-wave stations with their frequencies and call letters. Also contains photos and descriptions of short-wave broadcasting stations in various parts of the world with photos of short wave studio artists.

SHORT WAVE LISTENER
99 Hudson St. New York, N. Y.

FREE

OFFICIAL RADIO BARGAIN CATALOG

RADIO TRADING CO.

IMPORTANT ILLUSTRATED BUYING GUIDE FOR RADIO EXPERIMENTERS, SERVICE MEN, AND SHORT-WAVE FANS.—32 Pages—Two Colors—Profusely Illustrated

This Book Will Save You Money!

Packed between the covers of this 32-page book is a tremendous array of modern radio equipment and other electrical and scientific merchandise—the very material for which you have been looking—and at prices which cannot possibly be any lower.

Radio sets and parts, low priced microscopes, automobile radio sets, complete public address equipment, field glasses, the finest short-wave equipment available, crystal receivers, radio replacement parts, etc. Name the item and it's in the book! This amazing book will show you how to save money. You save by buying at the lowest possible prices. Why not start saving now? Don't delay! Write today! Send postcard or letter. Book by return mail. It's free!

RADIO TRADING COMPANY
97 Hudson Street, New York, N. Y.

If you are interested in servicing electric refrigerators, write today for complete details about the Second Volume to the OFFICIAL REFRIGERATION SERVICE MANUAL. Address, GERNSBACK PUBLICATIONS, Inc., Dept. RC, 99 HUDSON ST., NEW YORK, N. Y.

IMPORTANT DATA ON VIBRATOR-"B" UNITS

(Continued from page 278)

The 6 V. coil of the power transformer is the only resistance in the circuit at starting, accordingly there is very heavy load of about 10 to 12 A. placed across the battery. Since the resistance of the filaments is also low when they are cold, there is an additional load of something like 10 A. or a total of 20 A. at starting.

When this drain is placed on a partially discharged or undersized battery, it can very easily drag the battery voltage down to a point where there is insufficient voltage to start the vibrator.

When such a condition occurs it may result in the burning out of the vibrator or the power transformer or at least opening the line fuse.

Fundamental design of the shunt vibrator overcomes all of these difficulties. In this type of unit at starting or neutral position, the vibrator reed rests midway between the two contact points. A high-resistance magnet coil is inserted in between the battery and the vibrator and is shunted out when contact is made at the vibrator points. The result of this resistance is a reduction in starting drain from 10 to 2 A. Should the vibrator fail to start (and the low drain makes starting considerably easier), the vibrator cannot be harmed because it is out of the circuit, and the high-resistance magnetic coil guards the power transformer.

Vibrator engineers have continued to make progress in mechanical as well as in circuit design, as may be seen readily in comparing the modern Radiart Corporation full-wave shunt vibrator illustrated with the older model, full-wave series vibrator it was designed to replace.

The new shunt vibrator will give more than three times the life of the older model, and at the same time deliver considerably more current at higher voltage. Likewise it provides a steadier output, and it might also be mentioned that it requires less than 1/6th the space.

Two years of intensive research with materials has resulted in better spring steel for the reeds, better tungsten for the points, and better bronze for the contact arms.

Development has proceeded steadily in increasing the frequency of the vibrators, which likewise has contributed to steadier operation, longer life and lower "hash" or interference level.

Workmanship has, of course, kept step with other developments. Through the use of such modern scientific instruments as the "comparator" and the "oscilloscope," vibrators now coming from the production line are held to very close limits of adjustment and performance.

Figure 1A represents the half-wave non-synchronous vibrator at its starting position.

Arrows show current flowing from the negative terminal of the battery, up the vibrator reed, across point A-Y through magnet coil M, around through the transformer and returning to the positive side of the battery. This flow in the primary sets up a secondary current, flowing in the opposite direction.

When the current flow reaches the magnet coil, it causes the magnet to attract counterweight G, breaking the contact Y-A. Breaking the circuit halts the action of the magnet, and the spring action of the vibrator reed causes it to rebound, again making contact at Y-A.

Because of the heavy drain at starting, this type of vibrator is difficult to start and should it fail, it will be observed that the vibrator points must carry the load of the low-resistance magnet coil and the transformer primary in series across the battery.

Figures 1C, D and E represent the complete action of the full-wave, shunt-type, non-synchronous vibrator.

In the starting position it will be seen that the vibrator reed rests midway between the two points and should it fail to start, the vibrator will not be damaged. Also the fact that the magnet coil in this shunt vibrator may be of high resistance, as it is shunted out of the circuit, when contact is made at either point, protects the transformer.

Figure 1C shows current flowing through the magnet coil, attracting counterweight G, causing the action outlined in Fig. 1D. Contact has been made at A-C, shunting the magnet coil from the circuit, and current continues to flow through the upper half of the primary of the transformer. The secondary current is, of course set up in the opposite direction.

Shunting the magnet coil from the circuit has caused it to lose its attraction for counterweight G and spring action in the reed causes it to rebound until contact is made at A-B as shown in Fig. 1D.

Here it is seen that the flow of current in both primary and secondary has been reversed from that of Fig. 1D, and a more or less true form of A.C. has been generated.

After contact has been made at A-B, spring action causes reed to reverse itself, breaking contact, and putting magnet back in circuit. Figures 2A and B represent the old type full-wave series vibrator (as illustrated).

Here the core of the transformer is used as the magnet. At starting position the reed is in contact with the lower point, permitting current to flow from the negative pole of the battery, as shown by the arrows, through the upper half of the primary of the transformer. The pull of the magnet attracts the reed counterweight, breaking the contact and halting the flow of current. The reed continues its swing until contact is made with the upper point of the circuit causing current to flow.

Objections to this type of vibrator are the same as to any series vibrator.

The action of the full-wave series vibrator.

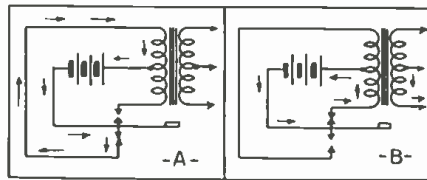

OPERATING NOTES

(Continued from page 279)

The latter can then be lined up exactly, and the original sensitivity restored.

L. H. STEINMANN

ATWATER KENT MODEL 155

THE MAIN complaint is lack of volume. It gets out of alignment and the screen-grid resistor in the oscillator-detector circuit goes off value.

I have often put twice as much pep in the model 155 by replacing the 85 tube with a 75 tube. The method is shown in Fig. 5B.

There is a special way to line-up the I.F. on these sets and a coupler is needed. Figure 5A shows the coupler and its method of attachment to the set. The condenser gang should be set at about 540 kc. Peak the trimmers, A6, A5, and A4 in order listed for maximum signal strength. Use the weakest oscillator signal possible, and turn the volume control on full. The I.F. is 262.5 kc.

GEORGE GREENBERG

TESTING THE 6P7 TUBE

THE latest arrival in the new series of metal tubes—the 6P7—(which combines in one metal envelope a pentode and a triode) has caused confusion because the heater is not connected to the same prongs as the heaters of the others in the metal-tube series.

The present line of Supreme Instruments Corp. tube testers however, is not affected by this discrepancy in the terminals. By incorporating in these testers a specially designed filament-return selector switch, by means of which any pin or even the top cap terminal may be disconnected from other parts of the tube tester outfit and connected to the filament or heater windings of the power transformer, the use of adapters or extra sockets is entirely eliminated.

A "RADIO" BULL-FIDDLE

(Continued from page 280)

Using amplification for double-basses provides unlimited volume for the foundation of a symphony orchestra, especially in compositions requiring the double-basses to override with ease the output of a large symphony orchestra playing at full volume!

The diagram (Fig. 1) shows Eremceff's arrangement for double-bass—and, in fact, for any vibratory bodies. The photo-insert shows a close-up view of the piezoelectric pickup tied by a string to the hook-shaped opening of the double-bass.



Centralab SAVES THE DAY

Not a rough and tumble player, either... but a smooth article, this hero of a million touch-downs.

If its tough going in the "service game" change to CENTRALAB and watch your score go up. For CENTRALAB Controls (a mere handful) do the trick with practically every set ever built.

Centralab smoothness results from the patented Centralab non-rubbing contact whereby a strip of polished metal rocks on the resistor so that the only rubbing action is between an oilless wood bearing and the polished metal.



Every Radio Service Man should be a member of the Institute of Radio Service Men.

Centralab
MILWAUKEE WIS.
RADIOHMS
FIXED RESISTORS

Learn RADIO from REAL RADIO ENGINEERS!



Rendell Cough
Phil Entner,
Elmer Strick Co.
E. E. Gromer
Earl Engerer,
Hinsdale Transformer Co.
Karl E. Hoosal
Hart Radio Institute,
Groun, Va. Made.
H. C. Yellie
Service Manager Philco
Radio & Television Corp.
Dr. C. M. Blackburn
Radio Engineer,
R. Mallory & Co.

MANY R-T-I TRAINED MEN Earn \$35 to \$75 a Week

These industry appointed engineers, who work for large radio manufacturers, will supervise your Training at home, and get you ready for road-pay jobs in Radio Broadcasting, Installation, Servicing, Public Address System and Photo Electric Cell work. Also for coming activity in Television. Opportunities for properly trained men better than ever before. Earn while you learn. Some make \$5 and \$10 a week extra in spare time one to two weeks after starting. Many earn \$35 to \$75 a week in full time, jobs or their own business. No other training like mine. Get the facts if you want a better job. Write now for my free book. Ray D. Smith, President.

RADIO AND TELEVISION INSTITUTE
Dept. 48, 2150 Lawrence Avenue, Chicago, Ill.

H. G. CISIN METAL TUBE ALL ELECTRIC AIR SCOUT

Efficient - 10 to 550 meters - Powerful

Complete, Assembled Kit, with instructions and picture diagram, and all four short wave coils, ready to wire... \$395

Set off Mathered (MG) Metal Tubes... \$2.50
Special Long Wave Unit... \$1.45
Coil... .95
Broadcast Coils (Two)... \$1.45
Earphone (Single)... .50
Special Combination Offer—Assembled KIT, metal \$840 tubes, 7 coils including Long Wave Unit, earphone Above, Custom-Built, Wired and Laboratory Tested, ready to use, \$1250
H. G. CISIN, Chief Engineer, Allied Engineering Institute Dept. CR2 98 Park Place, New York, N.Y.

Please Say That You Saw It in RADIO-CRAFT

ELECTRICAL BOOKS
shipped
FREE

10 BIG BOOKS

A-C-RADIO TELEVISION
EVERY ELECTRICAL SUBJECT COVERED

Here's great news for anybody interested in Electricity. BRAND NEW edition of Applied Electricity brought right down to date with every NEW Electrical subject fully covered. 10 big Volumes and all shipped FREE for examination. See special offer below.

For Beginners and Experts

Over 3000 pages—hundreds of illustrations—the most complete work of its kind ever published. Dynamos, motors, power stations, radio, television, everything electrical explained clearly so anyone can understand them.

BIG FIELD! Big Demand! Big Pay! Men who understand electricity are urgently needed right now in thousands of industries. Autos, airplanes, machine shops—practically every industry depends on electricity and men who know this subject make big money. Pleasant, fascinating work, easy to learn and do. Send coupon for a set of these books for FREE examination.

FREE S. Gernsback's famous Radio Encyclopedia (latest edition) given free with these electrical books if you send NOW. Available in any Radio work. Covers whole Radio field.

American Technical Society, Drexel at 58th St., Dept. E 826, Chicago

Send for 10 days' free use. BRAND NEW 10 volume set of Electrical Engineering. Include free membership in the American Technical Society and S. Gernsback's Encyclopedia. I will pay the few cents delivery charge on the books. If I wish I may return them in 10 days and owe you nothing, but if I keep them I will send \$2.00 after 10 days, then \$3.00 a month until the special price of only \$29.80 is paid.

Name.....

Address.....

City..... State.....

Attach letter stating age, occupation and name and address of employer and at least one business man as reference.

Regent 5 Band 15-550 Meter

Switch Receiver

This new improved "Regent" completely eliminates the use of plug-in coils. Independent tuning of the five separate bands is accomplished by means of a five-band switch. No more searching around for the proper coils. A great distance getter that will fulfill the requirements of every radio experimenter or amateur. Uses 2-58's, 1-80 and 2-2A5's. All controls on front of cabinet. Complete kit of parts including speaker, airplane dial, blueprints, and all accessories and cabinet.....\$12.50

Labor for wiring (Extra)..... 2.00

Set of Matched R.C.A. Licensed Tubes..... 2.00

Write for our latest catalog or circular.



TRY-MO RADIO CO., INC.
85 Cortlandt St. New York City
This is our only address.

Round the World RADIO LOG

For eleven years Haynes has served the industry with a superior radio log. Always the favorite with listeners because COMPLETE COMPACT CONVENIENT CORRECT. The NEW log, a real achievement in logging short wave stations. Invaluable to the owner of an all-wave receiver. Put one in his hands—earn his gratitude—and business! There are official issues for the dealer selling Philco, Stromberg-Carlson, Zenith, Sylvania, and Grunow. Sold in lots of 100, 250, 500, at \$2.25 per hundred. We will print your name, address, phone, slogan, etc., on any quantity for only \$1.50 additional. Special issues made to order in every detail. Send your requirements, ask for details and sample special Xmas issue. Save time—Take a chance. Send \$2.25 for a trial 100. They MUST be good, and you'll say they are the best you've ever seen.

HAYNES' RADIO LOG
161 West Harrison St., Chicago, Illinois

METAL TUBE AMPLIFIER
\$7.49 less tubes

Write for catalog

CONSOLIDATED RADIO PRODUCTS CO.
Northwestern Station, Box 23
Detroit, Michigan, Dept. 221

LES Correspondence Courses in RADIO and ELECTRICAL ENGINEERING

ELECTRICAL ENGINEERING covers complete electrical field. Most modern course. So simplified anyone can grasp quickly. **LOW COST!**

RADIO ENGINEERING Ultra-modern course in radio, public address, photo-electric work. Trains you to be super-service man, real vacuum tube technician. Run like college. Diploma given. Tuition only \$25, either course. Deferred payment plan.

WRITE TODAY for free copies of school catalogs, student magazines, etc. **SEND NOW!**

LINCOLN ENGINEERING SCHOOL
859-A So. 37th St., Lincoln, Neb.

VOCATIONAL POSSIBILITIES IN RADIO

(Continued from page 283)

be used for commercial telephony. The additional requirement for this engineer then is: (4) knowledge of telephone engineering.

Our analysis now shows that the well-trained engineer not only has a thorough training in radio communication equipment as such, but is required to have a broad knowledge of wire telephone and telegraph practice as well.

SUBDIVISION OF RADIO ENGINEERS;

Radio work is further subdivided by many as follows: (a) public addressing systems; (b) sound recording and reproducing.

Training for a Position in Radio Engineering. The foregoing analysis makes rather clear the technical educational requirements of the radio engineer.

The training of radio engineers has, for many years, been a more or less haphazard process. No special course in such work has been offered by any of our American colleges or universities. Persons seeking such knowledge have usually maturated for electrical engineering courses, taking in conjunction any special subject which the school might have pertaining to communications.

Probably the greatest difference between the training of the power engineer and the communication engineer is the point of view. This was most aptly expressed in an editorial which appeared in the August, 1933, issue of *The Electric Journal* which stated, in part, as follows:

"When one approaches a physical problem in our ordinary world, his previous experience and training have much to do with his attitude of mind. To the average engineer used to dealing with 60-cycle currents, a foot more or less in the length of a lead is of negligible consequence. He knows, to be sure, that a foot of wire has resistance, inductance, and capacitance to ground or surrounding conductors; but these quantities are too small to have any significance. It is little wonder then that the power engineer approaching a problem of suppressing radio interference from a sparking commutator, should find difficulty in adjusting his mental attitude to an appreciation of the great importance of the inductance of one foot of wire at a frequency of a million cycles per second. Failure to attain the correct mental perspective in this particular problem has been known to cost hundreds of dollars and unnecessary weeks of annoyance."

The foregoing makes it rather evident that the teaching of communication engineering is highly specialized. Throughout the entire course applications must be stressed, but at the same time the training in fundamentals must in no way be slighted.

In order to insure teaching on this basis, the staff has been selected from engineers of long experience in the communications field. Academic background has also been given due consideration, and of the entire staff of 14 instructors, the majority have academic degrees or the equivalent.

WHO IS MOST LIKELY TO SUCCEED

In stating who is most apt to succeed in the profession of radio engineering, it is probably best to cite what we will call an ideal case and assume that each person's success will be proportional to his approach to this ideal.

The young man most apt to succeed in radio engineering is generally one who has graduated in the upper tenth of his class, majored in mathematics and science. English is also of great importance since the ability to express himself is an extremely valuable asset. He should have taken an active interest in school activities such as science, mathematics, debating clubs, and dramatic societies.

His interest in these organizations should have been such as to indicate potential abilities for leadership.

For hobbies, the boy should have actively and efficiently operated an amateur radio station. Such experience will be of more value than haphazard "dabbling" in radio with no particular aim in view.

Another hobby that will later prove to be of great value is music. In fact, a course in music appreciation should not be overlooked as part of the high school curriculum.

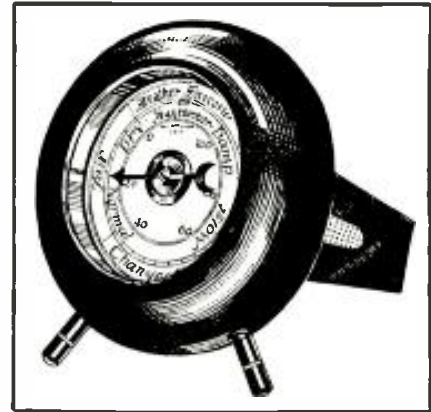

Something NEW!

Weather Forecaster and Humidity Tester

"HYGROSCOPE"

The Ace of Weather Forecasters

When placed in a well-ventilated room or in the fresh air, the HYGROSCOPE foretells coming weather conditions from eight to twenty-four hours in advance. It also accurately records outdoor humidity, and when placed inside it gives the humidity within the house or room.

The HYGROSCOPE is automatic, self-adjustable, simple American-precision made. It cannot get out of order at any time. The dial measures 2 3/4" is enclosed in a 6" round hardwood case, with either walnut or mahogany finish. It is attractive for desk or living room.

OUTSIDE DIAL FORECASTS WEATHER

Fair—rain—or changeable is indicated on the outer dial when the HYGROSCOPE is placed in a well ventilated room or out-of-doors. If indoors, place the instrument near an open window.

INNER DIAL SHOWS THE HUMIDITY CONTENTS

The HYGROSCOPE also acts as a hygrometer. Numbers on the inner dial indicate the degree of humidity present in the air and in artificially heated rooms.

SEND YOUR ORDER NOW! Get your HYGROSCOPE today. Your remittance in form of check or money order accepted. If you send cash or unused U.S. Postage Stamps, be sure to register your letter. Also specify if you prefer the HYGROSCOPE in Walnut or Mahogany. All orders are shipped immediately.

\$2.00
POSTPAID

GRENPARK COMPANY
99 Hudson St. New York, N. Y.

MAIL THE COUPON BELOW!

GRENPARK COMPANY RC-1135
99 Hudson Street, New York, N. Y.

Enclosed you will find my remittance of \$..... for which send me at once, POSTAGE PREPAID, HYGROSCOPES at Two Dollars each.

Walnut Model Mahogany Model

Name

Address

City State.....

(Send your remittance in check or money order. If your letter contains cash or unused U. S. Postage Stamps, be sure you register it.)

Please Say That You Saw It in RADIO-CRAFT

THE LISTENING POST FOR ALL-WAVE DX-ERS

(Continued from page 281)

cially on the air on 1,875 meters.

We take pleasure in presenting on the following pages an up to the minute list of the principal South American broadcasters by order of frequency, for your guidance in "trying for them." (We believe this is the first time such a complete, and accurate South American list has appeared in an American radio periodical.—Editor.)

SHORT WAVE NOTES

The Colonial Postmaster, in Belize, British Honduras informs us that the only short-wave stations in British Honduras are the following amateur stations each using 50 W. output: M. D. Russell, Belize, VP4MR; Ernest Baber, Belize, VP4WB; Elmer Smith, VP4BA; I. Dwight Hunter, Belize, VP4AA; Louis Moran, Belize, VP4BL.

The following Official Data on short-wave stations in western Nicaragua was supplied by American Vice-Consul George M. Graves, stationed at Managua: Station Bayer, YNOP, located at Managua, operates on 4,054 kc., with 1,000 W. of power, daily from 7:30-9:00 p.m. (owned by Edmundo Tefel, and Ernesto Andrea.) "Voz de Nicaragua," Station YNLF, located at Managua, operates on 6,750 kc. with 1,000 W., and operates daily from 6:00 to 8:00 p.m. (owned by Moises Le Franc). "Ruben Dario," Station YNVA, located at Managua operates on 8,000 kc., with 100 W., from 6:15 to 9:00 p.m. daily (owned by Victorino Arzuella). "Voz de los Lakos," Station YNIGG, located at Managua, operates on 6,450 kc. with 150 W. power daily from 6:00 to 9:00 p.m. (owned by Raul Gutierrez). "Alma Nica" Station YNGU, operates on 9,000 kc. with 30 W. of power from 5:00 to 6:00 p.m. (owned by Matilde Aydee Diaz). "Hermanos Cristianos," station YNIP, located in Managua, operates on 26 meters with an experimental power of 4 W., and broadcasts on Sundays, and holidays from 9:00 to 10:00 a.m. (owned by the Instituto Pedagogico). The following amateurs are operating on the 40-meter band in Granada, Humberto Salvo, YNIHS; Justo Garcia Zaldana, YN2JG; J. Francisco Tercero, YNLMT; and Leonidas Tenorio YNLAT.

R. Austin Acly, American Vice-Consul in Tegucigalpa, Honduras states that the only short-wave station in Honduras is station HRB,

owned by the Tropical Radio Tel. Co., and operates on 6,005 kc. with 350 W., and on 11,740 kc. with 360 W.

O. Gaylord Marsh, American Consul-General at Guatemala, Guatemala, says that the only short-wave stations in Guatemala are Radio-difusora Nacional, Station, TGW, 5,940 kc., 50 W., and Liberal Progresista, station TGX on 50.5 meters with 10 W. of power.

It is reported that W2XH, WOR's new short-wave relay station is now testing in the evenings.

According to reports from Gt. Britain, Iceland is at last broadcasting on the short-waves. The new station has been heard testing on 12.24 mc., and announced as "Hier ist der Reykjavik, Iceland." "Here is the new short-wave transmitter at Reykjavik testing on a wavelength of 24.52 meters." They were also heard on their 33.11 meter wavelength. They stated they were using 7 kw. of power.

The Empire Broadcast from Japan intended especially for reception in North America is now being radiated over JVH, Nazaki (14.6 mc.) from 12 midnight to 1:00 a.m. daily E.S.T. The signals are being well received.

W2XE, W2XAF, and W2XAD are now signing off with the "Star Spangled Banner," our National Anthem. This provides a distinctive touch to our American broadcasts which has been lacking heretofore, as the playing of "God Save the King," at the end of the British transmissions never fails to thrill millions of listeners.

Try for GSJ, J for justice, on the very short wavelength of 13.93 meters. This new Daventry station was first brought into use on July 19th, and at present is operating daily from 6:00 to 8:45 a.m.

Another new short-wave transmitter is that of COCD, at Havana, Cuba. COCD is on 6.13 mc., and usually is heard late at night.

RV15, Khabarovsk, U.S.S.R. on 4.27 mc. long one of the most eagerly sought DX goals will now take on an added interest, as we learn they will issue verifications in the near future. Due to no one at the station speaking or writing the English language heretofore no verifications have ever been issued from this station.

Programs of Eastern music are being broadcast every Tuesday morning from PLV, in Bandoeng, Java (9.42) and irregularly on other days. These transmissions take place at 10:00-10:30 a.m., and are beamed on the U. S.

Another new short-wave station is "The Voice of Colon," HP5H, of Colon, Panama on about 6.07 mc. The transmitter has a power of 300 W.

PRINCIPAL SOUTH AMERICAN BROADCASTING STATIONS

KC.	WATTS	CALL	LOCATION	NAME
590	5,400	LSJH	Buenos Aires, Argentina	Radio Callao
600	25,000	PR112	Porto Alegre, Brazil	Soc. Radio Parouplha
630	5,070	LSJ3	Buenos Aires, Argentina	Radio Mayo
650	10,000	CX26	Montevideo, Uruguay	Estacion Oficial
670	5,090	LS4	Buenos Aires, Argentina	Radio Portena
710	5,000	LS1	Buenos Aires, Argentina	Radio Municipal
750	18,000	LR7	Buenos Aires, Argentina	Radio Club de Pernambuco
760	3,000	PR4X	Recife, Brazil	Coop. Vituloria
765	10,000	CE76	Valparaiso, Chile	Radio del Editor
780	3,700	LT1	Rosario, Argentina	Sociedade Radio Nacional
788	5,000	PR18X	Sao Paulo, Brazil	Radio Cultura
790	11,050	LR10	Buenos Aires, Argentina	El Espectador Ltda
810	5,000	CX11	Montevideo, Uruguay	Radio Educadora Paulista
815	10,000	PR4G	Rio de Janeiro, Brazil	Radio Panama
820	5,000	PR18X	Buenos Aires, Argentina	Radio Exelior
830	20,000	LR7	Buenos Aires, Argentina	Radio Club do Brasil
860	2,500	PR43	Rio de Janeiro, Brazil	Radio La Nacion
870	39,000	LR6	Buenos Aires, Argentina	Radio Difusora Sao Paulo
1,885	1,500	Z199	Asuncion, Paraguay	Radio Argentina "Journal do Brasil"
900	5,000	PRF3	Sao Paulo, Brazil	Radio Montecarlo
910	9,820	LR2	Buenos Aires, Argentina	Radio Heterogeneo
923	16,000	PRF1	Rio de Janeiro, Brazil	Broadcasting Caracas
930	2,000	CX20	Montevideo, Uruguay	Radio Club de Santos
950	39,000	LR3	Buenos Aires, Argentina	Sociedade Radio Philips
960	5,000	YY1RC	Caracas, Venezuela	Radio Solentillo
960	3,000	PRB1	Rio de Janeiro, Brazil	Radio Sociedade Mayrink Veiga
980	5,000	PRC6	Santos, Brazil	SADIREP
990	15,960	LR4	Rio de Janeiro, Brazil	Radio Sociedade Record
1,000	25,000	PR49	Rio de Janeiro, Brazil	Radio Sociedade Guanabara
1,010	2,000	CX21	Montevideo, Uruguay	Radio Fenix
1,017	10,000	PRB9	Sao Paulo, Brazil	Radio Ilhami
1,030	5,000	PRC8	Rio de Janeiro, Brazil	Radio Uruguay
1,030	3,880	LR9	Buenos Aires, Argentina	Radio El Mundo
1,040	10,000	PT1	La Paz, Bolivia	Radio Tupy Sao Paulo
1,050	2,000	CX26	Montevideo, Uruguay	Radio Social Rural de Cerealistas
1,070	10,000	LR1	Buenos Aires, Argentina	Edison Broadcasting
1,075	10,000	PTG2	Sao Paulo, Brazil	Radio Sociedade Gaucha
1,080	4,262	LT3	Rosario, Argentina	Radio Rivadavia
1,090	3,000	CX28	Montevideo, Uruguay	Piratininga
1,091	3,000	PRC2	Porto Alegre, Brazil	Radio Paris
1,110	5,000	LS5	Buenos Aires, Argentina	Radio Trefio
1,120	10,000	PRH3	Sao Paulo, Brazil	Radio Transmisora Brasil
1,150	7,000	LR8	Buenos Aires, Argentina	Radio Nacional
1,190	30,000	LS2	Buenos Aires, Argentina	Sociedade Radio Nacional
1,200	3,000	YY3RC	Caracas, Venezuela	Radio La Voz del Aire
1,220	10,000	PRF3	Rio de Janeiro, Brazil	Radio Tupy S.A.
1,230	10,000	LS8	Buenos Aires, Argentina	Radio del Pueblo
1,250	5,000	CXN	La Paz, Bolivia	Radio Univ. Nac. de La Plata
1,250	3,000	TLIABRK	Medellin, Colombia	Radio Pais de Bs. Aires
1,270	7,000	PRB8	Rio de Janeiro, Brazil	
1,270	6,100	LS9	Buenos Aires, Argentina	
1,282	10,000	PRG3	Rio de Janeiro, Brazil	
1,350	4,000	LS6	Buenos Aires, Argentina	
1,390		LR11	Buenos Aires, Argentina	
1,430	700	LS11	Buenos Aires, Argentina	

Please Say That You Saw It in RADIO-CRAFT



"WATT" a Guide to Greater Profits!

FREE RADIO PARTS CATALOG Ever Published

The New Radolek 1935 Fall Edition of the Profit Guide is the most complete Radio Parts Catalog ever published—new, bigger and better. Everything in radio—at the right prices. Over 160 pages of valuable, money-saving "radio-buying" information. Over 10,000 separate Repair Parts—hundreds of new items—a complete, new selection of Radio Receivers and Amplifiers. Contains the most complete, exact duplicate, replacement parts listings, of volume controls, condensers, transformers, vibrators ever compiled. Nowhere, ever, has there been a Radio Parts Catalog comparable to this superb book. Every page brings you extra profits. This is your book—it's FREE. If you want the best Radio Parts Catalog—if you want to give better service at bigger profits—then send for this NEW Radolek Profit Guide.

RADOLEK restricts distribution of this catalog to active and legitimate Radio Men. Please enclose your business card or letterhead—

THE RADOLEK CO.

634 West Randolph Street, Chicago, Ill.

Send me FREE the Big New RADOLEK PROFIT GUIDE

Name

Address

Are you a Serviceman? Dealer? Expm?

WHEN CHOOSING A RADIO SCHOOL



RCA Institutes, with its reputation established by 26 years service, is an institution recognized as an important factor in the radio industry. Whether elementary radio principles or advanced subjects, sound applications or practical radio engineering, RCA Institutes is prepared to give you the instruction you need.

RESIDENT SCHOOLS NEW YORK AND CHICAGO

with modern standard equipment
EXTENSION COURSES FOR HOME STUDY
under convenient "no obligation" plan
Illustrated Catalog on Request.

R. C. A. INSTITUTES, Inc. Dept. RT-35
75 Warwick St., New York—1154 Merchandise Mart, Chicago

YOUR OBSOLETE ANALYZER "PRECISION" MODERNIZED

INTO A TWO METER MASTER ROTARY SELECTIVE SYSTEM

Write for our Plan
Mention Model Number of
Your Old Analyzer

PRECISION APPARATUS CORP.
Modernization Division
821 E. N. Y. Avenue : Brooklyn, N. Y.

TUBE PRICES REDUCED!

ARCO Tubes—Guaranteed 6 Months—Licensed by R. C. A.—All prices F. O. B. factory, Newark, N. J. Orders for less than \$3.00 not accepted. 20% deposit required on all orders.

Type	Price	Type	Price	Type	Price
6K7	\$.99	6H6	\$.89	6F5	\$.89
6A8	1.09	5Z4	1.29	25Z5-MG	1.05
6J7	.99	6F6	1.05	43-MG	1.09
6CS	.89	6L7	1.09	Ballast Unit	.65

Your Cost	Your Cost	Your Cost	Your Cost	Your Cost	Your Cost	Your Cost	Your Cost
.26c	.31c	.40c	.44c	.56c	.68c	.90c	\$1.13
Type 26	Type 27	Type 35-51	Type 20	Type 1V	Type 00A	Type 83V	Type 10
80	30	36	33	22	6F7	12A5	2B6
	31	38	42	32	P2H	12A7	586
	37	39	43	34	182B	401	403
	40	41	46	53	183		BH
	45	44	49	59	484		
	56	47	55	79	485		
	71A	57	75	84	686		
	76	58	77	99 Std			
		82	78	WD11			
		83	85	WD12			
		5Z3	89	1A6			
		6D6	99V	2A3			
			99X	2A7			
				2A5			
				2A6			
				6A6			
				6C6			
				12Z3			
				6A7			
				25Z5			
				6Z4(84)			

Type	Your Cost	Type	Your Cost	Type	Your Cost
2A7S	\$1.04	6D7	\$0.79	5S5	\$0.77
2B7S	1.04	6E7	.79	27S	.36
2S-4S	1.19	6F7S	.86	35S-51S	.63
2Z2-G84	.83	6Y5	.86	585	.59
6A7S	1.04	6Z4	.59	57S	.79
6B7S	.95	6Z5	.86	58S	.79
6C7	.86	2A5	.59	75S	.77
		2S-25S	1.22	85S	.77

Quotations on Transmitting Tubes, Television Tubes, Charger Bulbs, Photo Cells, Crater Tubes, Cathode Ray Tubes sent upon request.

ARCO TUBE CO. 227 CENTRAL AVENUE, NEWARK, NEW JERSEY

A NEW DEVELOPMENT IN THE MICROPHONE FIELD

The New LIFETIME ELECTRO-STATIC MICROPHONE is made possible because of the recently developed dielectric diaphragm by LIFETIME Engineers.

The inherent dielectric incorporated in this specially and scientifically developed diaphragm is 500 volts rendering it immune to short circuits.

In addition the LIFETIME Electro-Static Microphone has no inherent noise, is immune to temperature and atmospheric changes, has a high impedance—direct to grid—no matching transformer to pick up hum.

List \$20.00 Net Price to Dealers \$9.95

At your jobbers—or direct from factory on receipt of order and remittance.

Write for complete catalog of AMERICA'S OUTSTANDING VALUES in Carbon, Condenser, Crystal and Velocity Microphones and Sound Equipment.

The Lifetime Corp. Toledo, Ohio

POWERTONE SPECIAL!

Serviceman's Utility Kit



Consists of a number of parts, which if bought separately would cost four times the cost of the kit. As a special offer, with every kit purchased, you will receive a shelf a tray tool chest and the Buy now \$1.25

"Servicemen's Handy Guide," while the kits last.

SEND FOR OUR NEW CATALOG OF RADIO SETS, PARTS, TEST EQUIPMENT, etc.

POWERTONE ELEC. CORP.

221 Fulton St., 179 Greenwich St., New York, N.Y.

RADIO COURSES

RADIO OPERATING: Prepare for Gov't License Exam. ● RADIO SERVICING: Including Short Wave ● AMATEUR CODE ● New Course in ELECTRONICS: Day Only. Other courses, Day and Evening Classes.

Resident Courses—Write for Booklet

NEW YORK YMCA SCHOOLS 4 W. 64th St. N.Y. City

EVEREADY SERVICE CEMENT

"The Original Speaker Cement"



This is the best cement for replacing speaker cones, repairing old rattling or torn cones. It can be used for other Rad work, such as sealing adjustments, cementing loose tube bases, etc. It is Vibration Proof and Fast Drying. Ask for it by name, at your jobbers. If he can not supply you, write us. Send for large circular of other Service Aids. List Price \$0.60 per large bottle.

General Cement Mfg. Co., Rockford, Illinois

SWEEP & WOBBLE CIRCUITS FOR CATHODE-RAY TUBES

(Continued from page 286)

receiver output, the voltage output of the I.F. amplifier being viewed on the tube screen.)

When the cathode-ray tube is employed to view the resonance curve of the I.F. amplifier the object is: to produce a visual plot of the exact voltage output of the tuned stage (or stages) under consideration, when an input signal voltage of constant amplitude but varying over the frequency band at which the resonance curve is to be observed is applied to the stage (or stages). To obtain this resonance curve, it is first necessary to have a signal source of variable frequency covering a range which extends sufficiently above and below the resonant frequency of the I.F. amplifier so that the complete I.F. resonance curve may be traced. The input signal must be varied or "wobbled" over this frequency range repeatedly, at a speed sufficiently high so that the individual output curve-traces which appear on the screen of the cathode-ray tube occur fast enough to appear continuous (say about 20 times per second).

Electrical means of somewhat complicated design are available for wobbling the alignment signal. However, the principle involved is more readily illustrated by reference to a mechanical system, as shown in Fig. 2. To the shaft of the same motor that drives the sweep-frequency generating arrangement, is ranged the rotor shaft of a small tuning condenser, Ct. This condenser is then connected in parallel with the main tuning condenser of the ordinary test oscillator which is to be used as the source of I.F. signal voltage to be fed to the I.F. amplifier.

Mounted on the same shaft with this condenser is the sweep circuit potentiometer, P, (see Fig. 2) the voltage of which controls the horizontal sweep of the cathode-ray beam. For a single rotation of this condenser, the sweep circuit potentiometer makes one complete rotation, so that by properly synchronizing the two units, the saw-tooth sweep voltage is zero at the lowest frequency of the oscillator and is maximum at the highest frequency of the oscillator.

The output of the second-detector of the I.F. amplifier is connected to one pair of deflecting plates of the cathode-ray tube. The saw-tooth timing (sweep) voltage is connected to the other pair. Now, as the output of the I.F. amplifier changes from instant to instant because of the varying frequency of the steady signal applied to it during one rotation of Ct, the sweep circuit is spreading this response out on a horizontal axis of the cathode-ray tube, so that the response curve is traced on the screen; and since the image is repeated 20 times a second (the speed of the motor), it will appear stationary. Hence, the screen of the tube will show a resonance curve of the entire I.F. amplifier.

THE CORRECT USE OF LOUD-SPEAKER HORNS

(Continued from page 286)

unit. The housing lowers the natural frequency cut-off of the baffle, reduces the possibility of microphone coupling or feed-back and improves the front-side radiation and efficiency of the cone.

On installations erected out of doors it is very important to control the distribution of the sound and limit it only to the location requiring it. Indoors, the sound often reflects from the walls, ceiling, etc., and tends to fill all sections of the enclosure. It is impossible to fill all outdoors with sound; for this reason horns that emit a gradually widening beam should be used. Figure 1B illustrates a horn that is focused in the manner of a searchlight, and directed to the location requiring the sound coverage.

Figures 2A and 2C illustrate a general-purpose baffle designed for both indoor and outdoor use. It combines all necessary requisites for general use and also permits convenient installation. Its modern appearance offers fine eye value and usually harmonizes with all types of interior decoration.

Figure 2B illustrates a well-equipped sound truck showing the method of properly mounting dynamic cone speakers for maximum efficiency in operation.

—for the real
servicing "dope"
you can't find a
better book!



NO other radio book is comparable to the new 1935 OFFICIAL RADIO SERVICE MANUAL. In contents, in style of printing, in grade of paper, in illustrations, there has never been published such a comprehensive volume.

The 1935 Manual contains over a thousand pages—yet it is only 1 1/4 inches thick because it is printed on a special Bible stock which is an exceptionally good stock, yet one of the thinnest and most durable papers. This 1935 Manual is the most authentic and elaborate service guide ever used in the radio industry. Service Men and dealers who use this 1935 Manual are astonished by finding in it such a wealth of profitable service information which has never been published before.

Contents of the 1935 Manual

Over 1,000 pages full of diagrams and essential information of manufactured receivers—only data of real use in servicing is included. This new Manual is really portable since it will be extremely thin and light as well. ● Volume V continues where the preceding manual left off. ● Many circuits of old sets are included. ● Service Men know every set has certain weak points which are really the cause of trouble. Wherever the information could be obtained, these weaknesses with their cures are printed right with the circuits. This is an entirely new and valuable addition to the Manual. ● All the latest receivers are included—all-wave sets, short-wave sets, auto-radio sets, midget and cigar-box sets, etc., as well as P.A. amplifiers and equipment, and commercial servicing instrument. ● The cumulative index is even more complete than before; including cross-reference to sets sold under different names and type numbers. ● Volume V includes resistance data; socket layouts; I.F. data; and voltage data. ● Tube data on latest tubes. ● Free question and answer service—as included in our last three manuals.

OVER 1,000 PAGES

Over 3,000 Illustrations. Flexible, loose-leaf, leatherette covers. Size 9 x 12"—yet only 1 1/4" thick

GERNSBACH PUBLICATIONS, Inc.
99 Hudson Street New York, N. Y.

MAIL COUPON TODAY!

GERNSBACH PUBLICATIONS, Inc.,
99 Hudson St., New York, N.Y.

Enclosed find my remittance of \$7.00 for which send me POSTAGE PREPAID. One copy of the 1935 OFFICIAL RADIO SERVICE MANUAL. [Send remittance by check or money order; or register letter if it contains cash, currency or unused U.S. Postage stamps.]

NAME

ADDRESS

CITY..... STATE..... RC-11-35

Please Say That You Saw It in RADIO-CRAFT

THE LATEST RADIO EQUIPMENT

(Continued from page 289)

amplifier section of any radio set. Connecting cable between the cases is 50 ft. long and fully shielded.

SMALL CONDENSER (842)

(Aerovox Corporation)

ESPECIALLY suited for use in the popular midget sets, or any other applications where a 200 V. (peak, 250 V.) midget condenser is needed, this unit has a capacity of 16 mf. Exclusive of mounting tabs, the size is 2 7/8 x 1 in. wide. The case is of heavy waxed cardboard.

MULTI-TEST SPEAKER (843)

(Wright-DeCoster, Inc.)

BY THE use of this test speaker, a proper match can be made with any tubes and set, as a universal output transformer, and tapped field coil are included. The steel panel is removable for test bench mounting if so desired. All the taps are brought to switches on the panel.

5-METER TRANSCEIVER (844)

(Radio Constructors Labs.)

THIS small set can be used on either 5 or 10 meters, by changing the plug-in coils. A single, type 19 tube is used, and the circuit is transferred from "send" to "receive" by a D.P.S.T. switch. The receiver is very sensitive since the super-regenerative principle is used. Available in both kit and completed form.

DISTRIBUTOR "SUPPRESSOR BRUSH" (845)

(Continental Carbon Co.)

A DISTRIBUTOR suppressor of improved type, for use on the Ford V-8 car has recently been announced. It is made to fit in place of the brush on the distributor of these cars, without any alterations. The added resistance in the circuit reduces the interference without appreciably weakening the spark. It is heat, moisture, and humidity proof.

CONDENSER MICROPHONE (846)

THIS microphone is of the condenser type and has very high output. It is furnished in a crackle-finish metal case, and is very rugged. An off-on switch is provided in the handle.



Above, (844) a single-tube transceiver for the 5 and 10 meter bands. Below, (846) condenser mike.



Above, (845) high resistance distributor brush. Below, (847) midget imported tube with socket.



NEW MIDGET-TUBE SOCKET HOLDS TIGHTLY BY TORSION (THE TUBING IS SLOTTED DIAGONALLY)



HAIR-FINE BALLAST RESISTANCE WIRE



PIN-TYPE BASE

The head unit is not affected by dampness, or other weather conditions; may be operated up to several hundred feet from the amplifier.

MIDGET LOW-POWER TUBE (847)

HERE is the tube the portable set bug has waited for. The one illustrated is a power triode, with a 2 volt, 60 ma. filament. Two other triodes of different internal characteristics, and a screen-grid tube are offered in the line, with others to come. All have the same filament drain. The triode measures 2 3/4 ins. x 5/8 in. in dia. The tubes, although made in England, are available in this country.

REGULATING TUBES FOR BATTERY SETS (848)

(National Union Radio Corp.)

TWO TYPES of these tubes are made. They are designated 1B1, rated at .36-A, with 0.7-V. drop across the tube, and the 1E1, to be used with any combination of 2 V. series tubes having filament currents adding up to .48-A. These tubes hold the current steady over the useful life of dry cells.

TUBE TALKS

A HANDY loose leaf data book published by Raytheon Production Corp. which gives many helpful suggestions on the sale of radio tubes. Many suggestions of a general nature helpful to the Service Man are also included. There are 30 pages devoted to a tube complement section which lists the types and numbers of tubes required by various model receivers of 25 well known manufacturers.



Below, (848) a ballast tube for use with dry-cell sets. It is made in several ratings.

TRY THIS NEW SPEAKER ASSEMBLY

FIND out for yourself about tremendously increased measure of performance, adaptability and good appearance embodied in this amazing new outfit for every indoor requirement. All-aluminum baffle housing, adjustable wall mounting bracket, improved speaker efficiency with feed-back practically eliminated. Like all Toledo equipment it is dependable first, last and all the time. Write for catalog, prices and data on the laboratory-built TOLEDO line. Learn about our liberal free 5-day trial.



Learn about our liberal free 5-day trial.

OTHER TOLEDO PRODUCTS

- Portable Sound Systems • Electro-Dynamic Units • Carbon Microphones • Amplifiers • 4, 5 and 6 Ft. All Aluminum Natural-tone Trumpets • Field Exciters • Air Column Horns • Low and High Frequency Units For Wide Range Theatre Use

TOLEDO SOUND EQUIPMENT LABORATORIES
Formerly Bud Speaker Co.
1154 JACKSON STREET • TOLEDO, OHIO, U. S. A.

Listen to C-W Signals on your present all-wave receiver

The RCA Beat Oscillator is easily connected to any superheterodyne receiver, permitting beat reception of c-w signals. Has vernier adjustment for controlling the pitch. Powered from receiver. Uses either 2.5 or 6.3 volt tube. Net price, \$7.50



GET THIS CATALOG

Contains 92 pages, lists thousands of parts for replacement in any set; special replacement parts guide for RCA Victor, G. E., Westinghouse and Graybar sets. Tube Charts, Diagrams. Ask your RCA parts distributor for a free copy.



RCA PARTS DIVISION
RCA MANUFACTURING CO., INC.
CAMDEN NEW JERSEY

Please Say That You Saw It in RADIO-CRAFT

A MASTERPIECE!



Model 420
R.M.A. Tests
Duo-Purpose
Tube Tester



Another TRIUMPH Masterpiece—One Instrument—Two Purposes—A Combination Counter-Portable—Solid Walnut Cabinet—Etched Two-Tone Panel—Tests All Tubes Thoroughly—New Triple Load Test. Each Element Selectively Tested. High Sensitivity Leakage Test With Tube Hot. Test Circuits Isolated From Power Line. Unique Line Check By Meter. Simplicity—Beauty—Convenience. Dealers Price Only \$29.94.

ALSO MODEL 400

Dynamic conductance tester. Checks emission conductance and leakage of glass and metal tubes. \$34.95 net.

See your jobber or write direct.

TRIUMPH MFG. CO.,
4017 W. Lake St.,
Chicago, Illinois

Gentlemen:—Please send me your literature on

Signal Generators Meter.
 Tube Testers Analysers

Name

Address



NEW
INSULATED
Metallized **RESISTORS**
IRC

Radio's most important resistor development! Insulated against shorting—humidity—opens—breakage. Famous Metallized resistance principle. See them at your jobbers. Write for catalog.

INTERNATIONAL RESISTANCE CO.
Toronto, Canada Philadelphia, Pa.

TELEVISION IN THE THEATRE

(Continued from page 283)

darkness prior to the projection of the next frame, and so on.

In the television case, there is never anything more than a more or less bright dot upon the screen! The television picture depends even more upon persistence of vision than the theatre picture, being in fact nothing more than a flickering and flying dot. (It must be added that certain technical details of television picture production have not as yet been standardized. However, the above-cited features appear likely to be permanently present.)

(2) Number of Picture Elements. The number of picture elements determines the detail or (roughly) the story-telling capabilities of the picture. In round numbers, the theatre picture has something of the order of 5,000,000 picture elements, whereas even a good home television picture will probably have something like 150,000 elements. This is a ratio of 30-to-1 in favor of the theatre picture.

However, it must be noted that the entertainment value of a picture in motion (whether produced by projection or by television) is not in direct proportion to the number of picture elements which it contains, so that we are not entitled to draw the conclusion that theatre pictures, though more detailed in structure, are necessarily far more entertaining (particularly on the small home screen) than television pictures. Probably a television picture in the home will be described by most as a "fair home movie."

(3) Grain and Line Structure. Theatre pictures of reasonable size from a suitable positive show negligible grain if viewed at moderate and practicable distances, and of course show no line structure (for monochrome pictures).

Television pictures show no grain structure, but may show a slight line structure if viewed too closely. However, high-detail television pictures, viewed at normally comfortable distances, will show practically no line structure—and certainly none that is objectionable.

(The "grain," and the detail possible in a cathode-ray type home television receiver of late design are illustrated in the Von Ardenne view. The reader must take into consideration that a 100-line printing screen has been used.—Editor)

(4) Color of the Picture. Theatre pictures are normally black in the shadows and white (blue-white or yellow-white) in the highlights. When projected from toned or tinted positives, they show the corresponding hue.

Television pictures are also practically black in the shadows, but the highlights may be bright yellow, greenish yellow, or even a practically neutral white. (The latter color will probably become common practice in television as development of the art proceeds.)

(5) Possibility of Full-Color Pictures. It is readily possible today to produce theatre pictures which show substantially the colors of nature or at least an acceptable approximation thereto, although there are definite economic handicaps in production and reproduction of such pictures.

Television in full-colors seems to be an almost impracticable proposition in the present or likely early state of that art. (However, small-scale demonstrations of its abstract possibility have indeed been given.)

(The remainder of this tabulation, including (6) Size of the Picture; (7) Picture Brightness; (8) Flicker of the Picture; (9) Viewing Distance; (10) Audience Size; and (11) Synchronization of Picture with Sound, will be discussed in Part II in the forthcoming December issue.—Editor)

BOOK REVIEW

MODERN RADIO SERVICING, by A. A. Ghirardi. Published by Radio Technical Publishing Co., 1935. Size 6 x 8 1/4 ins. 1300 pages.

This book is written in textbook style, and in fact, is being used in some of the large schools. It is thoroughly practical, and contains much information on every possible angle of service work, including Auto Radio, Repairing Parts, Interference Finding, Selling Service, and many others. The use of cathode-ray equipment is well covered. Complete instructions for the construction of servicing apparatus is given.

This is a work that no student of radio can afford to be without.

NOW READY!

The 1935 OFFICIAL AUTO-RADIO SERVICE MANUAL

240 Pages \$250 PER COPY Over 500 Illustrations

HERE NOW—is the second volume of the OFFICIAL AUTO-RADIO SERVICE MANUAL—the 1935 Edition.

With so large a number of new auto-radio sets placed on the market by different manufacturers, the 1935 OFFICIAL AUTO-RADIO SERVICE MANUAL becomes an essential part of Service Men's equipment. Remember, there are nearly 1,800,000 auto-radio sets in use today.

THERE IS ABSOLUTELY NO DUPLICATION OF MATERIAL BETWEEN THE 1933 EDITION (VOLUME I) AND THE NEW 1935 EDITION (VOLUME II). THE MATERIAL IS 100% NEW.

Every radio man connected in any way with the booming auto-radio business, needs a copy of the new OFFICIAL AUTO-RADIO SERVICE MANUAL. It contains only auto-radio service "dope."

HERE ARE HIGHLIGHTS OF THE 1935 AUTO-RADIO SERVICE MANUAL

240 pages crowded with diagrams, service material and other essential data required for proper servicing of new auto-radio receivers. Included are diagrams of sets which appeared during 1934, and which were not included in the supplement to the first edition.

Complete schematic diagrams, chassis layouts, voltage tabulations and servicing instructions are included for practically all sets. "Under-wire" tube symbols are also included to facilitate the job of servicing the sets.

Instructions are included with many sets telling how to address stubborn cases of ignition interference. This includes the newest "suppressorless" sets—and what to do when interference is encountered with this type of set.

Details on how to make installation in "turret-top" cars are included. The different methods used by car makers and set manufacturers are listed with the individual circuits and service information.

The index contains the listing of all sets which were published in the first edition, as well as the sets which appear in the new volume. This information helps the Service Man to locate the circuit and details for any receiver that has been made.

The book is bound in a handy, flexible leatherette cover. To be sure the pages are sturdy, in withstand constant use, the book will be printed on a special "Bible" stock. This is a very durable, but thin paper. The book printed on this paper can be easily rolled to fit into your pocket or slipped in the service kit.

Here is a Partial List of Sets Covered

- | | |
|--------------------------------|---------------------------------|
| Atwater Kent Mfg. Co. | P. R. Mallory & Co. |
| Audiola Radio Co. | Montgomery Ward & Co. |
| Autocrat Radio Co. | National Company, Inc. |
| Belmont Radio Corp. | Noblitt-Sparks Industries, Inc. |
| Century Radio Products Corp. | Philo Radio & Television Corp. |
| Chevrolet Motor Corp. | Pierce Airo, Inc. |
| Chrysler Motor Corp. | RCA Manufacturing Co., Inc. |
| Colonial Radio Corp. | Sears Roebuck & Co. |
| Crosley Radio Corp. | Sentinel Radio Corp. |
| Delco Appliance Corp. | Sparks-Washington Co. |
| Detroit Radio Corp. | Stewart Radio Corp. |
| Emerson Radio & Phonograph Co. | Stewart-Warner Corp. |
| Fada Radio & Electric Corp. | Stromberg-Carlson Tel. Mfg. Co. |
| Ford Motor Corp. | Transformer Corp. of America |
| Ford-Malestic | United American Bosch Corp. |
| Franklin Radio Corp. | United Motors Service, Inc. |
| Galvin Mfg. Corp. | U.S. Radio & Television Corp. |
| General Electric Co. | Wells Gardner & Co. |
| General Motors Corp. | Wilcox-Gay Corp. |
| Graham-Paige Motor Corp. | Rudolph Wurlitzer Mfg. Co. |
| Grigsby-Grunow Co. | Zenith Radio Corp. |
| Chas. Hoodwin Co. | |
| Howard Radio Co. | |
| Hudson Motor Car Corp. | |
| International Radio Corp. | |
| Karalia Corp. | |

Printed on Special Thin "Bible Paper"
Flexible, Looseleaf Leatherette Cover
GERNSBACK PUBLICATIONS, Inc.
99 Hudson Street New York, N. Y.

MAIL COUPON TODAY!

GERNSBACK PUBLICATIONS, Inc., Dept. RC-1135
99 Hudson Street, New York, N. Y.

Enclosed you will find my remittance of \$2.50 for which send me One Copy of the 1935 OFFICIAL AUTO-RADIO SERVICE MANUAL (Volume II). (Send remittance in check or money order; register letter if it contains cash or currency.)

Name

Address

City State

(The 1935 OFFICIAL AUTO-RADIO SERVICE MANUAL is shipped postage prepaid.)

COMBINATION WOOD and METAL CUTTING LATHE



Only \$7⁹⁵
(Less Chuck)

\$3.50 extra for chuck (4 jawed, 3 in.)
Bushing to Fit Chuck to Lathe 50c

65c extra for 5" woodworking "T" rest
LENGTH: 20 in.
WIDTH OF BASE: 4 in.
HEIGHT OVERALL: 9 in.
WEIGHT: 21 lbs.
SPEED: Two-step pulley.
FINISH: Baked on GRAY ENAMEL.
COMPLETE with Compound Slide rest.

Slide rest having Swivel base and tool holder.
Large oversized bronze bearing. Accurately planed bed, machined face plate. Hollow spindle, 5 in. swing. Standard Morse tapers; 13 in. between centers. Shipping weight: 26 lbs.
Send \$2 deposit balance C.O.D. Sold on money-back guarantee basis.

Wellworth Trading Company
Dept. RC-1135
860 West Washington Boulevard, Chicago, Illinois

CLASSIFIED ADVERTISEMENTS

Advertisements in this section are inserted at the cost of twelve cents per word for each insertion—name, initials and address each count as one word. Cash should accompany all classified advertisements unless placed by a recognized advertising agency. No less than ten words are accepted. Advertising for the December, 1935, issue should be received not later than October 5th.

A.C. AUTO GENERATORS

TWENTY NEW PRACTICAL CHANGES FOR AUTO-mobile generators. See our advertisement at bottom of page 295, Auto Power Inc.

ELECTRICAL SUPPLIES

INSULATION, WIRE, VARNISHES, SUPPLIES, ETC. Send 3c stamp for bulletin. Auto Power, 414-C S. Hoyne Ave., Chicago.

RADIO

RADIO ENGINEERING, BROADCASTING, AVIATION and police radio, servicing, Marine and Morse Telegraphy taught thoroughly. All expenses low. Catalog free. Dodge's Institute, Pine Street, Valparaiso, Indiana.

BUILD IT YOURSELF

You can build this Trailer with ordinary tools easily from our step-by-step constructional sheets and large sized blueprints. Finest designed trailer in existence, sleeps 4. Toilet, Shower, Electric Light, etc. Save 75% of the cost by building it yourself. Send 25c for plans sheet, illustrations and details.

THE PLAN SHOP, 910 Palmothe Bldg., Chicago, Ill.

SEND FOR THE LATEST

and complete authorized information on testing the new Octal Metal tubes, the new Octal analyzer plug with Dual Grid cap and 9 wire cable, plug and socket and associate adapters, the new Octal socket, the new Octal grid clips, etc. **VOV** the new "Tuning Fork" clip is available in every type of socket including the new Octal types. Life tests are now approaching 2,000,000 perfect contacts without failure.

ALDEN PRODUCTS CO.
Dept. RC-11 715 Centre St.
BROCKTON, MASS.

Radio Dealers & Servicemen!

S. O. S. CINEMAPHONE
16 and 35 m. m. Talking Picture Equipment

Lowest Prices!
Free Literature! may also be ideally used for Public Address

S. O. S. CORP. 1600 B'way., N. Y. C.

SAVE MONEY!

on Replacement Parts

100 Carbon Resistors; 1, 1/2, 1/4 sizes, mostly 1 watt	\$2.69
8 mfd.-450 V. W. Electrolytic Cond. cardboard	.29
8 mfd.-450 V. W. Electrolytic Cond. Alum. Can.	.49
P.P. Input Transformers, for 45's and 47's, unass.	.49
P.P. Output transformers, unass.	.49
Genuine Victor R-32 power transformers	1.00
Tubular condensers—guaranteed—400 v.-.01 mfd.	.07
1 mfd. 10c; 1/2 mfd. 11c; 1/4 mfd. 12c	

We carry a complete line of replacement parts and test equipment for servicemen. Write for price—Remember! you save money by buying from us.

M. SCHWARTZ & SON, 710-712 Broadway, Schenectady, N. Y.

RADIO STUDENT REQUIREMENTS

(Continued from page 288)

controls the speed and security of express trains, is finding its way into the textile industry, the automobile industry, and into mining where it is used to indicate the location of mineral deposits. Today no one can foresee how far the development of radio will proceed or what new directions it may take. It seems certain, however, that the developments of the future will be no less important than those of the past.

AN EASILY-BUILT UNIVERSAL BRIDGE

(Continued from page 288)

practical Service Men have neither the time nor the knowledge.

In the universal bridge designed by Mr. Kelly, all mathematics other than simple multiplication has been eliminated, and the readings become practically self-indicative. The bridge itself is a small affair measuring only 9x4 1/2 x3 ins. deep, the container being a strong black enameled steel box with spot-welded joints. On the top of the panel are 8 binding posts, 2 knobs and a button. The small knob on the left represents a 9-position switch, the large knob on the right, a husky 400-ohm potentiometer that forms two of the sides of the bridge.

The switch knob is marked "Multiply By", and the five resistor positions are marked 0.1, 1, 10, 100 and 1,000; the condenser positions are marked 0.1, .01, and .001. The potentiometer knob travels over two concentric scales. The inner one, applied against the resistor markings of the switch, reads from 0.1 to 1,000; the outer one, for condensers, reads from 0.1 to 1,000 in the other direction. The fact that there are ten clear and open divisions from 0.1 to 1 on both scales permits exceedingly accurate measurements to be made. The Service Man will begin to appreciate the value of this accuracy when, for instance, he measures two apparently identical R.F. transformer secondaries and finds one reads 3 ohms, as it should, and the other 75 ohms because of a poorly soldered joint.

The internal connections of the bridge are simple and are shown in the diagram. The post marked "External Standard", which are located in the lower left corner of the panel, are normally short circuited by a piece of No. 12 wire. They are provided so that external resistors or condensers of known value may be used for experimental purposes.

The best "voltage source" is a small filament lighting transformer with a single heavy winding giving 2 1/2, 5, 6 or 7 1/2 V., the actual value being unimportant. This is much better than a dry battery, as the voltage source is practically short circuited when low value resistors or suspected circuits are being investigated.

Under some conditions in the field, in D.C. districts for example, a battery must be used. If the Service Man has much of a D.C. trade, he can still handle condensers with this bridge by merely using an ordinary buzzer to give an interrupted voltage source.

In the absence of an output meter, the 0-1 ma. range of the regular analyzer meter can be used as the galvanometer, if D.C. is the voltage source on the bridge. If the analyzer is not already equipped with a pole changer, it can easily be fitted with one in the form of a double-pole double-throw switch of the telephone type. This is necessary because during the balancing operation current flows through the meter first in one direction and then in the other, balance being indicated by a zero reading. (If the meter isn't reversed when the bridge is off-balance in the backward direction, the needle is likely to wrap itself around the adjacent stop!)

A SERVICE MAN'S RADIO LOG

Service Men will find Haynes' Radio Log a fine means of getting his name permanently before prospective customers. These Logs, which can be obtained in lots as small as 1,000, contain a complete list of broadcast stations and short-wave stations by frequency and time of operation. They can be mailed without an envelope.

NEW! FREE WITH NATIONAL UNION RADIO TUBES 3 TESTERS IN 1

This remarkable instrument is the latest development of the Apparatus Design Company, famous makers of Confidence Instruments. You can own it the easy National Union way, the way in which more than 21,000 dealers have obtained the finest instruments built. It costs you nothing. You make a small deposit which is rebated when tube purchases are completed. Get details.

- 1. TESTS ALL TUBES**
(Including new metal types)
- 2. TESTS VIBRATORS**
(Tests all types as easily as testing tubes. Saves buying separate tester.)
- 3. TESTS CONDENSERS**
(Tests leaks, opens, shorts in electrolytic, mica and ignition condensers.)

★ **If you act fast you can get this instrument at a \$16.00 deposit. This deposit advances OCT. 15th!**

National Union Radio Corporation of N. Y.
570 Lexington Ave., New York, N. Y.

How can I get the new 3 in 1 tester?

Name _____

Street _____

City _____ State _____

RC-11

THESE DEVELOPMENTS WILL MAKE CONDENSER HISTORY!



Exclusive new improvements make Sprague "600" Line Dry Electrolytics far and away the BEST CONDENSERS YOU'VE EVER USED AT ANY PRICE. Moreover, each unit is **DOUBLE TESTED**—then backed with our **ABSOLUTE GUARANTEE** which doubly assures your satisfaction. These 1935 Sprague electrolytics have extremely good humidity characteristics, low leakage, low power factor (averaging 5%) and will stand high surges. They are, in short, the BEST CONDENSERS WE KNOW HOW TO MAKE!

SPRAGUE PRODUCTS CO.
NORTH ADAMS, MASS.

SPRAGUE CONDENSERS

Every Radio Service Man should be a member of the Sprague 600 Line



UTAH 8" MAGNETIC SPEAKERS
 Limited Quantities
 Shipping Weight—3 lbs.
 This highly efficient speaker is an outstanding value. It has an extra heavy magnet and is ideal for use as an extra extension speaker or in battery sets. Mounted on a rigid steel frame with mounting holes.

\$1.55 each

Write for our special circular radio parts and tubes.

UTAH 6" AUTO DYNAMIC SPEAKERS

FULLY GUARANTEED

First quality of latest design. Excellent full rich tone. Rigid construction.

\$1.55 each

7-TUBE SUPER KIT

Kit Includes: ANTENNA COIL; R.F. COIL; OSCILLATOR COIL; 1st I.F. COIL; 2nd I.F. COIL; INPUT TRANSFORMER; OUTPUT TRANSFORMER; 3-GANG TUNING CONDENSER. Price **\$2.25**

Schematic circuit diagram for A.C. and Auto Receiver furnished.

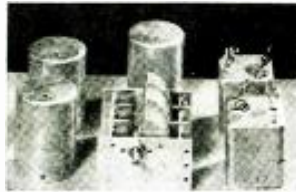

T.R.F. KIT

ANTENNA COIL; 2 R.F. COIL; 3-GANG DEJUR TUNING CONDENSER. Price **\$1.25**

Send enough money for parcel post or we ship by express collect.

ARROW SALES CORPORATION

549 West Randolph St. Chicago, Illinois

ORSMA MEMBERS FORUM

(Continued from page 260)

for the proposed ordinance was killed before ever becoming a law, by efforts of the Radio Service Men's Protective Association, of which I am a member. The ordinance could never have stood up in any court in the land, for after studying it you will note several clauses which are contrary to every principle pertaining to Americanism.

I will admit that regulations are necessary in the service industry, but we need regulation to detect and prosecute those who wilfully change circuits to destroy tone quality, throw sets out of balance, or cause other sections of the set to open or short out. I'll let the Service Men themselves decide which is the greater of the two evils, those we know as the "back yard gyp," or the big fellows who flash the neon signs and claim to know it all, but deliberately xyp the unsuspecting public just the same.

I am working on a plan now with the thought in mind of presenting it to the city council. The idea is to create a radio complaints department in the existing Public Service Commission, whereby the public may have some redress for shoddy and faulty repairs and excessive service charges. Of course, the service shops in the city will naturally be taxed to support the radio branch, as are the other public utilities.

The Radio Service Men's Protective Association stands for a fair deal for all, and we are utterly opposed to monopoly, legalized or otherwise.

I trust that you will publish this in an early issue of *Radio-Craft*, so that Service Men throughout the country may be assured that there are a majority in the service end of the radio industry who believe in sticking to, or for their rights.

E. C. ROSEBERRY,
 Houston, Texas.

Thanks for your correction, Mr. Roseberry, and we are glad to run it. This is of great interest to every Service Man and we are more than glad to print any solutions to such a difficult problem.

RADIO-CRAFT'S "IDEAL RADIO SERVICE SHOP" CONTEST

(Continued from page 291)

certainly deserves special mention. The radio shop which Mr. Abbott describes in his apparently is an actuality and the photograph submitted with his letter is reproduced in this issue. The letter that describes this illustration reads as follows:

Contest Director:

The shop I wanted and now own is described as follows: The front of the building represents an over-grown radio set, with the grille as the door. This design was taken from the Atwater Kent No. 511-W Tune-O-Matic receiver, and reproduced 4 times (as you can see by the picture). This gives one an entrance and offers a unique advertisement of what one has to offer. Now for the shop itself. I have a suitable lounge to show merchandise, and a place where a person may come in to sit down and relax while looking at the merchandise they are interested in, or while their radio set is being checked or repaired.

The service shop is in the rear of the building; the service bench has a 3 x 6 ft. test panel containing modern test equipment, such as a set analyzer, tube checker, service oscillator, a condenser and resistor tester, and speakers mounted for testing.

(This type of panel should be offered by some company and the instructions of such a panel be given in *Radio-Craft* for all Service Men.)

Then, as added equipment, there is a table on one side of the test bench; it contains an oscilloscope for more extensive test of sets. On the other side of the test panel is cabinet where all parts are kept.

All published service items are filed as to make, and the page and month they appear in *Radio-Craft* and other publications. All service manuals and magazines are filed for quick reference. This is my Ideal Radio Service Shop.

LAWRENCE ABBOTT,
 Niles, Mich.

Stop! Look!!
TWO NEW
10^C
BOOKS

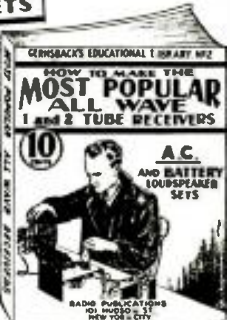
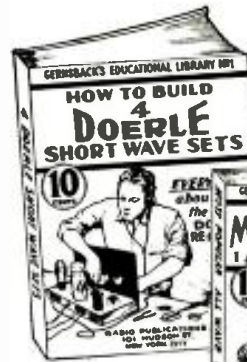

Each book contains 32 pages—and is well illustrated.

LITERALLY thousands of radio fans have built the famous DOERLE Short Wave Radio Receivers. So insistent has been the demand for these receivers, as well as construction details, that this book has been specially published.

HOW TO MAKE FOUR DOERLE SHORT WAVE SETS

Contains EVERYTHING that has ever been printed on these famous receivers. These are the famous sets that appeared in the following issues of *SHORT WAVE CRAFT*: "A 2-Tube Receiver that Reaches the 12,500 Mile Mark," by Walter C. Doerle (Dec., 1931-Jan., 1932); "A 3-Tube 'Signal Gripper,'" by Walter C. Doerle (November 1932); "Doerle '2-Tube' Adapted to A. C. Operation" (July 1933); "The Doerle 3-Tube 'Signal-Gripper' Electrified," (August 1933) and "The Doerle Goes 'Band-Spread'" (May, 1931).

Due to a special arrangement with *SHORT WAVE CRAFT*, we present a complete 32-page book with stiff covers, printed on an extra heavy grade of paper with numerous illustrations. Nothing has been left out. Not only are all the DOERLE sets in this book, but an excellent power pack if you wish to electrify any of the DOERLE sets, is also described.

HOW TO MAKE THE MOST POPULAR ALL-WAVE 1- and 2-TUBE RECEIVERS

THERE has been a continuous demand right along for a low-priced book for the radio experimenter, radio fan, radio Service Man, etc., who wishes to build 1- and 2-tube all-wave sets powerful enough to operate a loud-speaker. For the thousands of readers who wish to build such sets, this book has been especially published.

This book contains a number of excellent sets, some of which have appeared in past issues of *RADIO-CRAFT*. These sets are not toys but have been carefully engineered. They are not experiments. To mention only a few of the sets the following will give you an idea.

- The Megalyne 1-Tube Pentode Loudspeaker Set, by Hugo Gernsback.
- Electrifying The Megalyne.
- How To Make a 1-Tube Loud-speaker Set, by W. P. Chesney.
- How To Make a Simple 1-Tube All-Wave Electric Set, by W. Green.
- How To Build A Four-In-Two All-Wave Electric Set, by J. T. Iversley, and others.

Not only are all of these sets described in this book, but it contains all of the illustrations, hookups, etc.—the book, in fact, contains everything. Nothing at all has been left out.

And believe it or not, each book contains over 15,000 words of new legible type. Each book is thoroughly modern and up-to-date. They are not just a reprint of what was printed before. All the latest improvements have been incorporated into the sets.

Remember, these books sell at the extraordinary low price of ten cents; you can not possibly go wrong in buying them. Despite its low cost, our usual guarantee goes with this book as well!

IF YOU DO NOT THINK THAT THIS BOOK IS WORTH THE MONEY ASKED FOR IT, RETURN IT WITHIN TWENTY-FOUR HOURS AND YOUR MONEY WILL BE INSTANTLY REFUNDED.

There has never been such a wealth of data published in a low-priced radio book of this type in the history of the radio publishing business.

Take advantage of the special offer we are making and use the coupon below.

RADIO PUBLICATIONS
 103 Hudson Street
 New York, N. Y.

RADIO PUBLICATIONS RC-11-35
 103 Hudson Street
 New York, N. Y.

Please send immediately books checked:
 How to Build Four Doerle Short-Wave Sets.....10c
 How to Make the Most Popular All-Wave 1- and 2-Tube Receivers.....10c
 I am enclosing; the price of each book is 10c. (Coin or U.S. Stamps acceptable.) Books are sent post-paid.

Name
 Address
 City..... State.....

TYPEWRITER BARGAIN

10-DAY FREE TRIAL OFFER

FREE HOME TYPING COURSE



ONLY 10¢ A DAY

BRAND NEW MODEL No. 5 REMINGTON PORTABLE

● A brand new Remington for only 10c a day. An easy, practical Home Typing Course FREE. With it anyone quickly becomes expert on this machine...the most rugged, dependable portable made. Not used or rebuilt. Standard 4-row keyboard. Standard width carriage. Margin release on keyboard. Back spacer. Automatic ribbon reverse. Every essential feature of big office typewriters. Carrying Case FREE. Try it for 10 days without risking a cent. If you don't agree it is the finest portable at any price, return it at our expense. Don't delay. Without obligation, write now. Remington Rand Inc., Dept. 189-11, 205 East 42nd Street, New York, N.Y.

RADIOS..SAVE UP TO 50%

DEAL DIRECT: Factory Prices. Many models to select from. A.C.D.C. All-wave. Farm, Car and new metal Tube Models. Your name and address on postcard brings you NEW 24 page 1935 Bargain Catalog in colors FREE. Get details of 30-DAY TRIAL plan and Agent-User proposition. Goldentone Radio Co., Dept. 209, 8780 Grand River, Detroit, Mich.

Free Catalog

30 DAY TRIAL \$6.98

Please Say That You Saw It in *RADIO-CRAFT*

KABLE BROS. CO., PRINTERS

RADIO-CRAFT'S INFORMATION BUREAU

(Continued from page 287)

"This writer spent a large part of 2 years to develop a device to wind these coils, and without the proper coils it is impossible to complete the instrument and have any worth-while results. For that reason we have decided to furnish matched coils for those who want them, at a reasonable price.

"There are no improvements in this particular model."

P. A. QUESTIONS & ANSWERS

(Continued from page 287)

CRYSTAL MIKES AND PICKUPS

(23) Mr. H. G. Ostrow, Bethlehem, Pa.
 (Q.) What is the relative output level of a crystal phono. pickup and a diaphragm-type crystal microphone?

(A.) Diaphragm-type crystal microphones have outputs ranging from -65 db. to -55 db., or an average of 6 micro-milliwatts. Crystal pickups range in output level from -14 db. to -9 db., or an average of approximately a hundred thousand times greater than that of the crystal diaphragm-type microphone.

4TH DIMENSION SOUND-ON-FILM

(24) Mr. Otto Januck, Seattle, Washington.
 (Q.) I have read with considerable interest your articles on fourth dimensional sound systems. How can I apply this principle to the reproduction of sound-on-film in four dimensions?

(A.) Sound-on-film can be reproduced with a fourth dimensional effect only if it is recorded for this purpose. To attain the desired results, it is necessary to provide for four sound tracks

on the film, each one of which is individually recorded through a separate sound-on-film recorder activated by separate microphones correctly placed. Naturally, each one of the microphones feeds into an isolated audio channel, the outputs of which simultaneously activate the four sound-on-film recorders. For the reproduction, four photo-cells are required (to pick up each sound track), the output of each of these photo-cells are fed into four clear audio channels connected to four banks of speakers which are placed in the same relative position as were the original four microphones.

OUTPUT VOLTAGE

(25) Mr. Perry Pearce, Chatanooga, Tenn.
 (Q.) How can I determine the A.C. voltage which would appear across a 15 ohm output line at a given output?

(A.) A convenient formula for the determination of any voltage across any output line at any watts rating is given below:

$$E = \sqrt{WZ_L}$$

Where E = Volts; W = Watts; Z_L = Loaded line impedance.

Thus the voltage appearing across a loaded 15 ohm line at 10 watts would be

$$E = \sqrt{10 \times 15} = \sqrt{150} = 12.247 \text{ volts.}$$

WHAT IS THE FUTURE OF RADIO SERVICING

(Continued from page 291)

for the outlook. Now, let's have a look at the present:

The point everyone engaged in radio servicing should remember is simply this: Only today is the radio industry growing out of its "knee pants" stage. Future success is going to call for constant study, for greater skill—for men who give the business the care and attention its possibilities so well warrant.

Index to Advertisers

A	Aerovox Corporation..... 308	N	National Radio Institute..... 259
	Alden Products Company..... 317		National Schools..... 302
	Allied Radio Corporation..... 297		National Union Radio Corp..... 317
	Alloy Transformer Corp..... 306		New York YMCA Schools..... 314
	American Technical Society..... 312	O	Oxford Radio Company..... 295
	Arco Tube Company..... 314	P	
	Arrow Sales Corp..... 318		The Plan Shop..... 317
	Autopower, Inc..... 295		Powertone Electric Corp..... 314
C			Precision Instrument Corp..... 313
	Capitol Radio Engineering Inst..... 319		Precision Resistor Company..... 310
	Capitol Radio Research Labs., Inc..... 307	R	
	Central Radio Laboratories..... 311		R-S Merchandising Committee..... 319
	H. G. Cisin..... 311		Radio & Technical Pub. Co..... 305
	Classified Section..... 317		Radio & Television Institute..... 311
	Clough-Brengle Company..... 303		Radio-Amp. Publishing Company..... 319
	Coast-to-Coast Radio Corp..... 302		Radio Circular Company..... 301
	Columbia Sound System Co., Inc..... 294		Radio City Laboratories..... 309
	Consolidated Radio Products Co..... 312		Radio City Products Company..... 307
	Cornell-Dubilier Corp..... 294		Radio Construction Labs..... 301
	Coyne Electrical School..... 257		Radio Design Company..... 306
D			Radio Publications..... 318
	Tobe Deutschmann Corp..... 302		Radio Trading Company..... 308, 310
	Dodge's Institute..... 308		Radio Training Association..... 306
E			Radolek Company..... 313
	Electrad, Inc..... 295		Raytheon Production Corp..... 262
	Electric Soldering Company..... 309		RCA Institutes, Inc..... 313
F			RCA Mfg. Company..... 315
	First National Television, Inc..... 294		Readrite Meter Works..... 299
	Freed Radio Company..... 306		Remington Rand, Inc..... 318
G		S	
	General Cement Mfg. Co..... 314		S. O. S. Corporation..... 317
	General Electric Company..... Back Cover		M. Schwartz & Son..... 317
	General Transformer Corp..... 301		E. H. Scott Radio Labs..... 261
	Goldentone Radio Company..... 318		Servicemen's Pub. Company..... 310
	Grenpark Company..... 312		Shallcross Mfg. Company..... 304
H			Solar Mfg. Company..... 300
	Hammarlund Mfg. Company..... 306		Speak-O-Phone Company..... 310
	Haynes Radio Lbr..... 312		Sprague Products Company..... 317
	Hygrade-Sylvania Corp..... 296		F. L. Sprayberry School..... 300
I			Standard Transformer Corp..... 308
	Insuline Corp. of America..... 302		Supreme Instruments Corp..... Inside front cover
	International Resistance Company..... 316	T	
J			Teleplex Company..... 298
	J-M-P Mfg. Company..... 300		Thor Radio Company..... 304
K			Toledo Sound Equipment Labs..... 315
	Kato Engineering Company..... 308		Triplett Elec. Instrument Co..... 320
	The Ken-Rad Corporation..... 301		Triumph Mfg. Company..... 316
L			Try-Mo Radio Co., Inc..... 312
	Lifetime Corporation..... 314	U	
	Lincoln Engineering School..... 312		Universal Microphone Company..... 304
	Arthur H. Lynch, Inc..... 294	V	
M			D. L. VanLeuven Labs..... 319
	McGraw-Hill Book Company..... 309	W	
	M & H Sporting Goods Company..... 319		Wellworth Trading Company..... 308, 310, 317
	Midwest Radio Corp..... Inside back cover		Wholesale Radio Service Co..... 293
	The Muter Company..... 298		Wright-DeCoster, Inc..... 310



BUILD this 10-tube Professional Superhet and save over 50%

SILVER
 HIGH-FREQUENCY SUPERHETERODYNE

HERE'S the latest and hottest in high-frequency superhets—one that you can assemble, test and align in one evening at home. It's designed by McMurdo Silver, Frank Jones and fifteen leading manufacturers—and it brings you

- Two tuned r. f. stages on all four bands.
- Ten Raytheon tubes
- Four low-C tuning bands, 1600 to 33,000 kc. 19 to 200 meters.
- Ample Crowe band spread tuning anywhere in its range.
- Billey crystal single signal filter that doesn't cut volume.
- All Chitran A. C. operated—no unit—no hum.
- 8-inch Jensen speaker—and phone jack.
- Polished chromium welded chassis.
- Air tuned Polyiron i. f. transformers.
- Separator f. coils positively switched for each band—all Hammarlund air trimmed.
- Sensitivity 1 microvolt absolute.
- Selectivity—variable 150 cycles to 10 kc.
- Amplified automatic volume control.
- No inherent circuit or tube noise.
- Wired with made-up color coded cable—requires no circuit tracing, or even a diagram.

START FOR AS LITTLE AS \$7.30 BUY THE PARTS AS YOU BUILD!

Now is time to get ready for the new DX season. The 32-page "HOW TO BUILD IT" Book (sent for 10c, stamps or coin) tells the whole story of 1935's outstanding communication receiver. You can build and align it in a few hours... or you can buy its standard parts from your local jobber as you build if you haven't already got many of them.

SEND 10c for 32-page book "HOW TO BUILD IT"

SPONSORED BY:
 Billey Piezo Electric Co., Crowe Name Plate and Mfg. Co., Hammarlund Mfg. Co., Chicago Transformer Corp., Yaxley Div. of P. H. Mallory Co., Jensen Radio Mfg. Co., Sprague Products Co., Continental Carbon Co., Ohmite Mfg. Co., Readrite Meter Works, Raytheon Production Corp., Aladdin Radio Industries, Inc., Steel Box & Display Co., Filtermatic Mfg. Co., McMurdo Silver Corp.

Address: R-S MERCHANDISING COMMITTEE 1709 Roscoe St., Chicago, Ill., U. S. A.

"E. H. Pietzke SPEAKING!"

"My Most Important ANNOUNCEMENT...!"

America's Outstanding Engineering School Will Soon Offer a New **COURSE for SERVICEMEN**

Hundreds asked us for it, and now we soon will announce this new Service Course within the price and understanding of every serviceman. Get on our mailing list now, so you will receive literature as soon as it comes off the presses. Write to—

CAPITOL RADIO ENGINEERING INST.
 Dept. RC-11 Washington, D. C.
 14th and Park Rd.

Brighten Up Your Instruments with VAN Dials for Small Meters

They are ETCHED, SILVERED and DIE cut from 26 gauge brass.

Use VAN SHUNTS in remodeling Analyzers for Metal Tubes.

Available from dealers, or send for Name and Folder.

D. L. VAN LEUVEN, 410 E. 15th St., New York, N.Y.

P. A. AMPLIFIER

Prospective Purchasers—Users: **YOU NEED THIS AMPLIFIER TREATISE**

Page after page brimful of valuable Postpaid data, suggestions, and diagrams, etc. Tells you how to buy and use equipment correctly—saves you money!

25¢

RADIO-AMP. PUBLISHING CO.
 561 8th Ave., New York City, U. S. A.

METAL TUBES

FOR ALL THE LATEST CIRCUITS WE CAN MAKE IMMEDIATE SHIPMENTS AT REGULAR DISCOUNTS PHILA. SERVICEMEN'S HEADQUARTERS

M&H Sporting Goods Co.
 512 MARKET ST., PHILADELPHIA

NEW Power Output TUBE TESTER

OTHER NEW MODELS

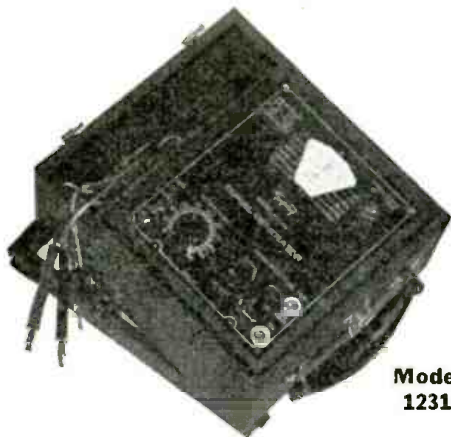

Model 1231

ALL WAVE DIRECT READING SIGNAL GENERATOR. All frequencies fundamentals, stabilized 100-30,000 KC. Jacks for 400 cycle audio note. Very accurate yet easy to operate. Model 1231 complete with batteries and two No. 30 tubes. Dealer net price **\$26.67** A.C. Dealer net price **\$26.67** Carrying Case Shown—Dealer net price..... 4.00

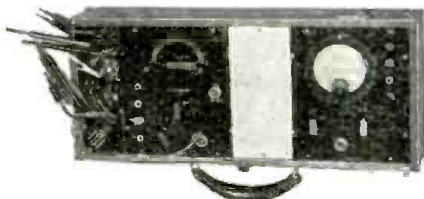

FREE POINT TEST SET Model 1181-A combines three essential units: No. 1125 Volt-Ohm-Milliammeter, 1151 All Wave Oscillator, 1166-A Free Point Auxiliary Set Tester—units can be purchased separately if desired. Dealer net price... **\$38.00**



MASTER UNIT COMPLETE Model 1206—A complete, up-to-date laboratory contains Nos. 1200 Volt-Ohm-Milliammeter, 1210 A Tube Tester, 1220-A Free Point Tester, 1231 or 1232 All-Wave Signal Generator and No. 1204 Case. All items can also be purchased separately and complete unit built up over period of time. Dealer net price... **\$82.67**

TRIPLETT MANUFACTURES

a complete line of electrical instruments for radio, electrical and general industrial purposes — both standard and custom built. Write for Catalogue.

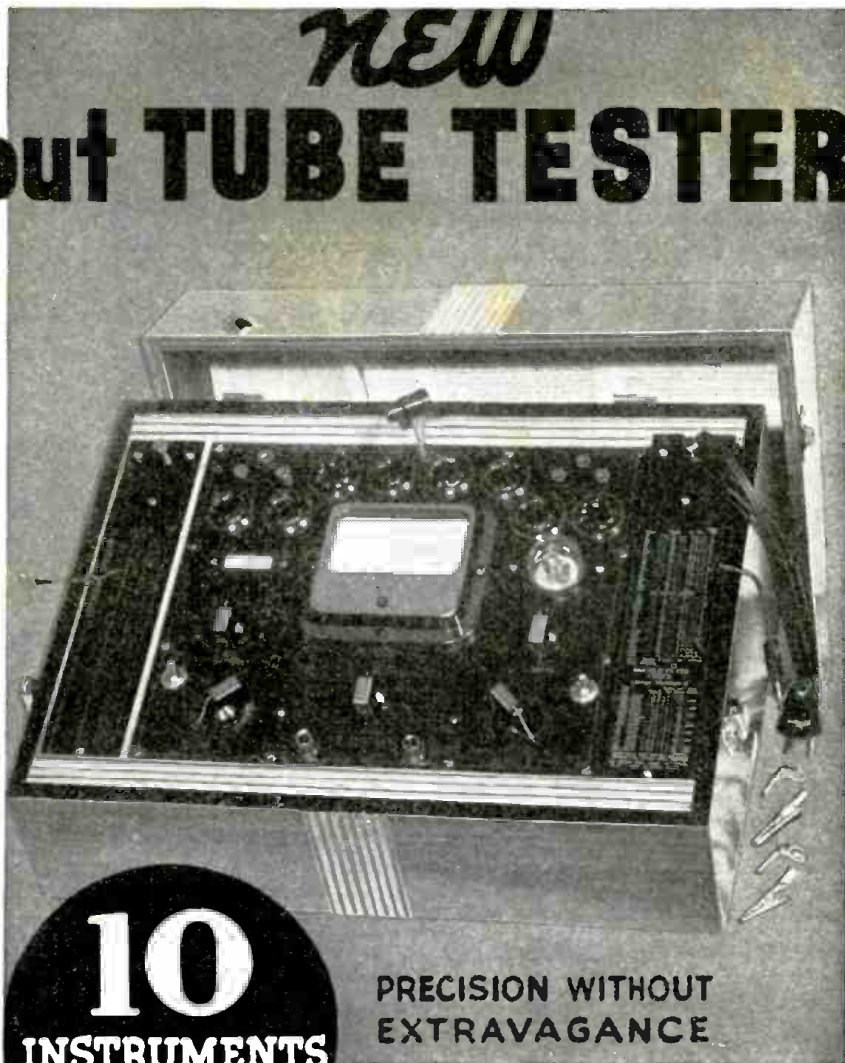

10 INSTRUMENTS IN ONE

PRECISION WITHOUT EXTRAVAGANCE

Model 1501 **\$46.67**
Dealers Net **46.67**

THE NEW MULTI PURPOSE TUBE TESTER MODEL 1501—Radio service dealers have always wanted a tube tester that would test tubes under conditions approximating their use in a radio set. Here it is! Model 1501 combines in one unit ten instruments that are needed by radio servicemen in their daily work. Here are the ten instruments:

1. Test all type tubes (New Power Output Test).
2. Neon short test.
3. Separate Diode Tests.
4. Neon Paper Condenser Tests.
5. Electrolytic Condenser Leakage.
6. D. C. Voltmeter and Milliammeter.
7. Ohmmeter.
8. A. C. Voltmeter.
9. Decibel Meter.
10. Impedance Meter.

TESTS ALL TYPES—old style, new style, both metal and glass-metal—specially constructed against obsolescence.

Bring on your trick tubes that get by other testers—try them in TRIPLETT'S new Power Output Tester—see for yourself how this instrument can save you time in hunting for troubles and help you to sell more tubes. Each tube is measured by output test, that is, the tube is fully loaded and does not have an opportunity to reheat for an instantaneous test. It will definitely help you sell more tubes by finding more bad and weak ones.

Model 1500 is a power output tube tester with neon short test and shadow-graph line voltage indicator. Same case as Model 1501. Dealer net price \$36.67

THE TRIPLETT ELECTRICAL INSTRUMENT CO.
BLUFFTON, OHIO



Please Say That You Saw It in RADIO-CRAFT

SAVE UP TO 50% by BUYING YOUR RADIO *Direct from* MIDWEST LABORATORIES

Glorious Tone Realism.. World-Wide Entertainment Guaranteed!
with New 1936 SUPER *Deluxe*

METAL TUBE MIDWEST



18 TUBE RADIO 6 TUNING RANGES

ONLY
RADIO COVERING
4½ TO 2,400 METERS.

30 Days FREE Trial!



WORLD'S GREATEST
RADIO VALUE

59 ⁵⁰
with New
GIANT
THEATRE-
SONIC
SPEAKER

TERMS AS LOW AS \$5⁰⁰ DOWN



PUSH-BUTTON TUNING
(Noises Suppressed)

Now, Push Button Silent Tuning is offered for first time! Simply pushing Silencer Button hushes set between stations... suppresses noises. Pressing Station Finder Button automatically indicates proper dial position for bringing in extremely weak stations.

Acousti-Tone V-Spread Design
(Patent Pending)

Establishes new radio style overnight! The V-Front Dispersing Vanes were developed by Midwest engineers as a result of a study of directional effect of the Midwest Full Scope High Fidelity Speaker. These Vanes spread the beautiful lacework of the "highs" throughout the entire room in a scientific manner... directing the High Fidelity waves uniformly to the ear. Send for new FREE 40-page catalog. It pictures the complete line of beautiful 1936 Acousti-Tone V-Spread consoles... and chassis... in four colors.

FULL SCOPE HIGH FIDELITY

Brilliant Concert Tone

Now, get complete range of audible frequencies from 30 to 16,000 cycles, being transmitted by four new High Fidelity Broadcasting stations—W1XBS, W9XBY, W2XR and W6XAL. Glorious new Acousti-Tone is achieved... assuring life-like, crystal-clear "concert" realism.



V-FRONT

EVERYWHERE, radio enthusiasts are praising this amazingly beautiful, bigger, better, more powerful, super selective, 18-tube 6-tuning range radio. They say it is a tremendous improvement over Midwest's 16-tube set, so popular last season. It is sold direct to you from Midwest Laboratories at a positive saving of 30% to 50%. (This statement has been verified by a Certified Public Accountant who conducted an impartial survey among representative Ohio, Kentucky and Indiana radio retailers.) Before you buy any radio, write for FREE 40-page 1936 catalog. Never before so much radio for so little money. Why pay more? You are triple-protected with: One Year Guarantee, Foreign Reception Guarantee and Money-Back Guarantee! This super Midwest will out-perform \$200 to \$300 sets on a point-for-point comparison. That is why nationally known orchestra leaders like Fred Waring, George Olsen, Jack Denny, Ted Fio Rito, and others use Midwest sets to study types of harmony and rhythmic beats followed by leading American and Foreign orchestras.

80 ADVANCED 1936 FEATURES

Scores of marvelous features, many exclusive, explain Midwest super performance and thrilling world-wide all-wave reception... enable Midwest to bring in weak distant foreign stations, with full loud speaker volume, on channels adjacent to locals. Only Midwest offers so many features... only Midwest tunes as low as 4½ meters... only Midwest gives the sensational new Push-Button Tuning feature, etc. See pages 12 to 21 in FREE catalog for description of the 80 features. Read about advantages of 6 Tuning ranges... offered for first time: E, A, L, M, H and U. They make this Super De Luxe 18-tube set the equivalent of six different radios... offer tuning ranges not obtainable in other radios at any price!

DEAL DIRECT WITH LABORATORIES

No middlemen's profits to pay — you buy at wholesale price direct from laboratories... saving 30% to 50%. Increasing costs are sure to result in higher radio prices soon. Buy before the big advance... NOW... while you can take advantage of Midwest's sensational values. You can order your Midwest 1936 Full Scope High Fidelity Acousti-Tone radio from the 40-page catalog with as much certainty of satisfaction as if you were to come yourself to our great radio laboratories. You save 30% to 50%... you get 30 days FREE trial... as little as \$5.00 puts a Midwest radio in your home... Satisfaction guaranteed or money back. Write today, for FREE catalog.

SAVE UP TO 50%



Thrill to new explorations in sections of radio spectrum that are strangers to you. Every type of broadcast from North and South America, Europe, Asia, Africa and Australia is now yours. Send today for money-saving facts.

GEORGE OLSEN PRAISES LIFE-LIKE TONE REALISM

Long Island, N. Y.—After comparing many different makes, I finally decided upon Midwest. It out-performs other radios costing almost twice as much. The crystal-clear tone is so life-like that it sounds as though I am in the studios, actually hearing artists performing.



TODAY'S FINEST RADIO SAYS TED FIO RITO

My new Midwest is finest radio I have had pleasure of hearing. Bass-Treble control is marvelous... enables one to hear every instrument in orchestra.



METAL TUBES

This Midwest is engineered from the ground up to see either the new METAL tubes or glass-metal counterpart tubes. Octal sockets and newest circuits permit use of either type... just as you desire.

MAIL COUPON TODAY! FOR FREE 30-DAY TRIAL OFFER and 40-PAGE FOUR-COLOR FREE CATALOG

MIDWEST RADIO CORP., Dept. 12E, Cincinnati, Ohio

User-Agents Make Easy Extra Money

Without obligation on my part, send me your new FREE catalog, complete details of your liberal 30-day FREE trial offer, and FREE Miniature Rotating 18-tube Dial. This is NOT an order.

Check Here for details

Name _____
Address _____
Town _____ State _____
 Check Here, if interested in a Midwest All-Wave Battery Radio

MIDWEST RADIO CORP.

DEPT. 12E CINCINNATI, OHIO U.S.A.

Established 1920 Cable Address MIRACO All Codes

EFFECTIVE SHIELDING

keeps out interference racketeers . . .

You can't keep destructive interference off the air by calling in the G-men, but you can rid your reception of this enemy to radio enjoyment by calling in the "G-E" men by listening in on a General Electric Radio.

Here are five General Electric advantages that protect you from interference pumped into the ether:

1. Sentry Box—Shields and isolates each R.F. circuit.
2. Metal Tubes—A continuous metal envelope eliminates outside noise and interaction between circuits.
3. Shielded Power Transformer—Eliminates stray hum.
4. Line Condenser—Keeps out interference via the power line.
5. V-Doublet Antenna—Rejects all man-made interference on short-wave.

The 1936 General Electric Radio gives you a realism and fidelity of tone unlike anything you have ever heard before.

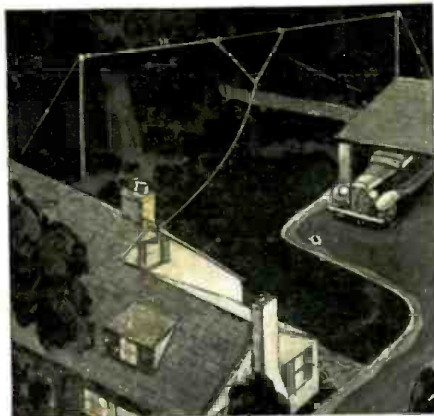
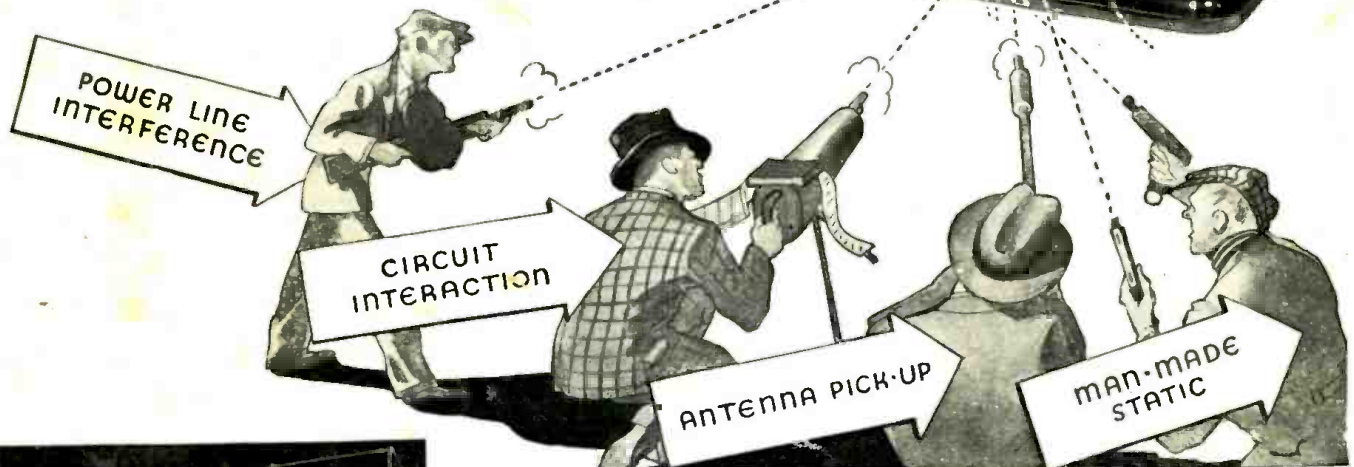

MODEL A-82 - IDEAL FOR DX-ERS

Short-wave listeners and amateur operators will find in Model A-82 many exclusive features that contribute to greatly improved performance — Permaliners • Sentry Box • Sliding-rule Tuning Scale • Stabilized Dynamic Speaker • Noise Control • Automatic Lo-note Compensation • Eight Metal Tubes • Four Bands of reception. CW Oscillator may be added.

\$94.50
(Eastern List Price)

G-E V-DOUBLET ANTENNA SYSTEM

This new antenna system, developed by General Electric, provides uniformly good reception on all short waves and all long waves alike . . . assures maximum receiver efficiency . . . minimum interference. This antenna is a V-Doublet below 55 meters and a conventional T-type broadcast antenna above 55 meters. Change-over from one type to another is automatic.

\$5.95

Write for complete details of 1936 General Electric Radio and the V-Doublet Antenna System.

GENERAL ELECTRIC

RADIO

MERCHANDISE DEPARTMENT, GENERAL ELECTRIC COMPANY, BRIDGEPORT, CONNECTICUT