



RADIO'S LIVEST MAGAZINE

Special
**AUTO-
RADIO**
Number

Radio-Craft

June

25 Cents

Canada 30c

HUGO GERNSBACK Editor



**"TRANSCEIVERS"
IN TOMORROW'S CAR**
See Page 714

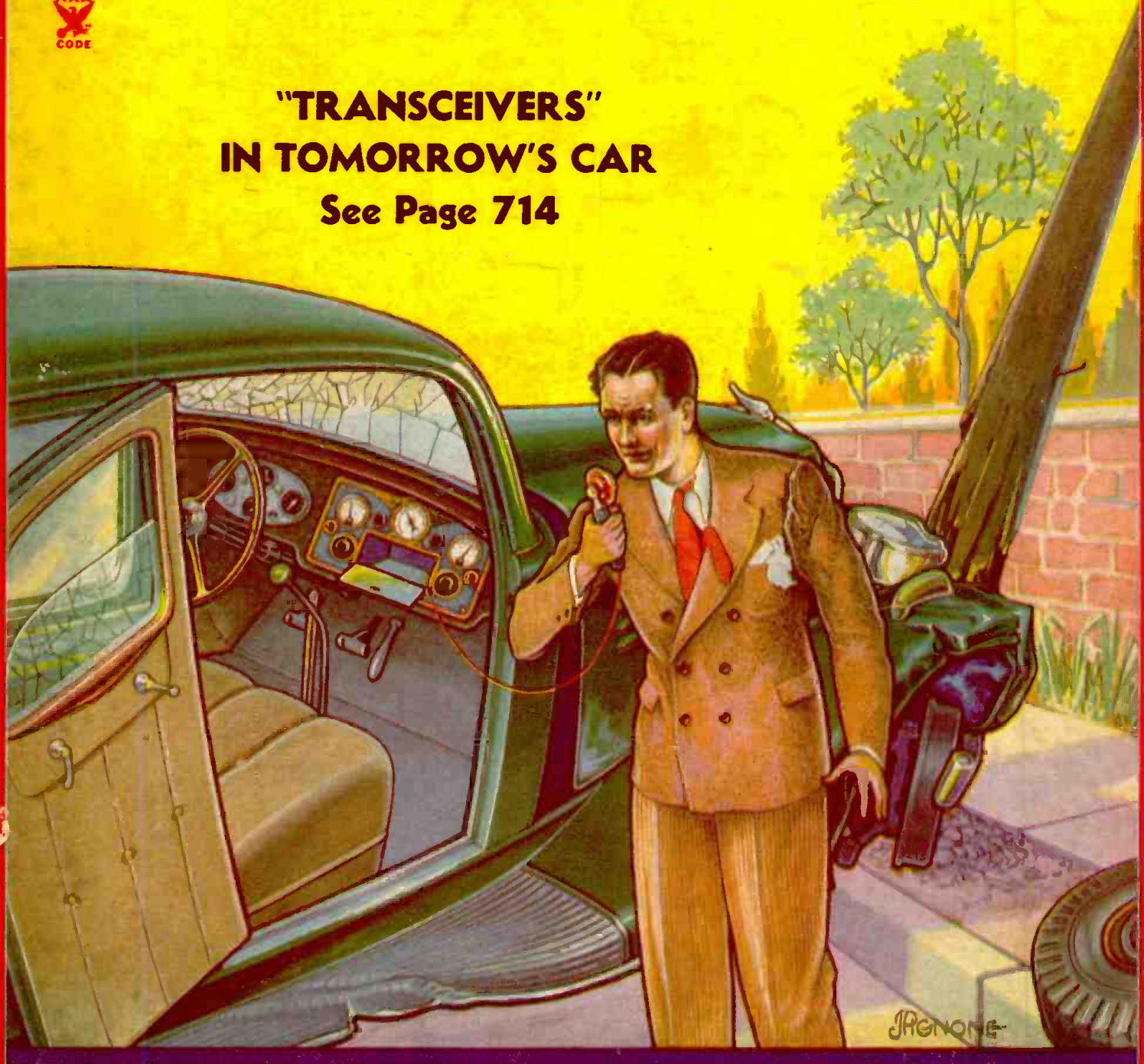

J. PENONE

**How to Make a Dual-Wave Car-Radio Set—Antennas for Turret-Top Cars
"Suppressor-less" Car Sets—Fultograph "Pictures"—Car-Radio Circuits**

Radio Men!

**GOOD BOOKS WHICH HELP
MAKE RADIO WORK MORE PROFITABLE**

Presented on this page are books of the RADIO-CRAFT LIBRARY SERIES—a most complete and authentic set of volumes treating individually, important divisions of radio. Each book has been designed to give radio men the opportunity to specialize in one or more of the popular branches of the industry. You will find them a real help in your work and they will contribute to your money earning capacity. Read these books during your spare time at home.

The authors of these books are well-known to everyone. Each is an expert radio man; an authority on the subject—each is thoroughly familiar with the field which he represents.

This is the first real opportunity that you have ever had to build a library of radio books that are authentic. **MOST OF THE BOOKS HAVE BEEN RECENTLY REVISED AND REWRITTEN TO KEEP THEM UP TO THE MINUTE.** Mail coupon below for your books.

Book No. 1
Radio Set Analyzers
And How To Use Them
By L. VAN DER MEL
With Full Instructions and Descriptions of Set Analyzers, Tube Checkers, Oscillators, etc. (Just revised.)

Book No. 2
Modern Vacuum Tubes
And How They Work
By ROBERT HERTZBERG
With complete Technical Data on All Standard and Many Special Tubes. (Just revised.)

Book No. 3
The Superheterodyne Book
All About Superheterodynes
By CLYDE FITCH
How They Work, How to Build and How to Service Them.

Book No. 4
Modern Radio Hook-Ups
The Best Radio Circuits
By R. D. WASHBURNE
A Complete Compendium of the Most Important Experimental and Custom-built Receivers.

Book No. 5
How to Become a Radio Service Man
By LOUIS MARTIN
How to get started in the business of servicing radios and how to make money in this field.

Book No. 6
Bringing Electric Sets Up to Date
By CLIFFORD E. DENTON
With Pentodes, Multi-Mus. Dynamic Speakers—Complete Information How to Modernize A. C., D. C. and Battery Operated Receivers.

Book No. 7
Radio Kinks and Wrinkles
By C. W. PALMER
For Service Men and Experimenters
A Complete Compendium on the Latest Radio Short-Cuts and Money Savers—These Kinks Are Great Time-Savers.

Book No. 8
Radio Questions and Answers
By R. D. WASHBURNE
A Selection of the Most Important of 5,000 Questions Submitted by Radio Men During the Course of One Year—They Are All Answered by a Technical Expert.

Book No. 9
Automobile Radio and Servicing
By LOUIS MARTIN
A Complete Treatise on the Subject Covering All Phases from Installing to Servicing and Maintenance. A Book That is Greatly Needed Today. (Just Revised.)

Book No. 10
Home Recording and All About It
By GEORGE J. SALIBA
A Complete Treatise on Instantaneous Recordings, Microphones, Recorders, Amplifiers, Commercial Machines, Servicing, etc.

Book No. 11
Point-to-Point Resistance Measurements
By CLIFFORD E. DENTON
The Modern Method of Servicing Radio Receivers—a Book Which Radio Service Men Have Referred to More Than Any Other.

Book No. 12
Public Address Installation and Service
By J. T. BERNSELY
Modern Methods of Servicing and Installing Public Address Equipment.

Big Discount To You
In order to make it possible for everyone to buy these books, the fifty (50) cent price has been made uniform for all volumes. You can buy these books separately, but you should take advantage of our special offer:
When Five (5) Books Or More Are Ordered Deduct 20% From Your Remittance
Simply fill in the coupon at left, and mail it to us together with your remittance. Checks, stamps or money orders accepted.

Here are the subjects covered--

- Set Analyzers
- Tubes
- Superheterodyne Circuits
- Radio Hook-ups
- Servicing Business
- Modernizing Electric Sets
- Kinks and Wrinkles
- Questions and Answers
- Auto-Radio Servicing
- Home Recording
- Resistance Measurements
- Public Address

All Books Uniform
Volumes are all uniform size, 4 x 9 inches, and contain on an average of 50 to 120 illustrations. Each book is printed on fine paper and no expense has been spared to make it an outstanding value.



CLIP—MAIL THIS COUPON TODAY!

GERNSBACK PUBLICATIONS, INC., 99 Hudson Street, New York, N. Y.

I have circled below the numbers of books in the RADIO-CRAFT LIBRARY SERIES which you are to send me, and have deducted 20% for ordering five (5) books or more. I have included my remittance in full, at the price of 50c each, when less than five books are ordered.

The amount of my remittance is.....(Stamps, checks or money orders accepted.)
Circle numbers wanted: 1 2 3 4 5 6 7 8 9 10 11 12

Name Address

City State 167-635

Read what happened



YES!

I'll take your training. That's what S. J. Ebert said. He has made good money and found success.

to these two men

when I said:



NO!

I'm not interested. That's what this fellow said. Today he would be ashamed if I gave you his real name.

I will Train You at Home in Spare Time for a GOOD JOB IN RADIO

These two fellows had the same chance. Not long ago they each clipped and sent me a coupon like the one in this ad. They got my book on Radio's opportunities.

S. J. Ebert, 49-B Quadrangle, University of Iowa, Iowa City, Iowa, saw that Radio offered him a real chance. He enrolled. The other fellow, whom we will call John Doe, wrote that he wasn't interested. One of those fellows who wants a better job, better pay, but never does anything about it. One of the many who spend their lives in a low-pay, no-future job, because they haven't the ambition, the determination, the action it takes to succeed.

Read what S. J. Ebert wrote me and remember that John Doe had the same chance: "Upon graduation I accepted a job as serviceman, and within three weeks was made Service Manager. This job paid me \$40 to \$50 a week compared with \$18 I earned in a shoe factory before. Eight months later I went with station KWCR as operator. From there I went to KTNT. Now I am Radio Engineer with WSUI. I certainly recommend the N.R.I. to all interested in the greatest field of all, Radio."

Get ready for Jobs like these. Many Radio Experts make \$40, \$60, \$75 a week

Spare time and full time set servicing; installing, operating, maintaining broadcast, aviation, commercial, police, ship and tele-

FREE

LESSON ON AUTO RADIOS

Mail the coupon now and in addition to my big FREE BOOK—"Rich Rewards in Radio"—I will send a Lesson Text on Auto Radio from my regular Course. This Lesson is crammed with practical, up-to-the-minute facts and information on installing and Servicing Auto Radios. It tells how to install efficient auto antennas, how to mount receivers, how to eliminate interference, how to service "B" eliminators and their vibrators, etc. This sample Lesson will prove how thoroughly my Training covers Radio's newer developments.



"I want to help you. If you are earning less than \$35 a week I believe I can raise your pay. However, I will let you decide that. Let me show you what I have done for others, what I am prepared to do for you. Get my book, read it over, and decide one way or another." J. E. Smith.

vision stations. Good jobs with Radio dealers and jobbers. A service shop or Radio retail business of your own. I'll train you for these and other good jobs in connection with the manufacture, sale and service of Radio sending and receiving sets, auto sets, loud speaker systems, short wave sets, etc.

Save Money—Learn at Home. Money Back Agreement Protects You

Hold your job. I'll train you quickly and inexpensively right at home in your spare time to be a Radio Expert. You don't need a high school or college education. My 50-50 method of training—half with lessons, half with Radio equipment—gives you broad practical experience—makes learning at

home easy, fascinating, practical. I will agree in writing to refund your money if you are not satisfied with my Lesson and Instruction Service when you finish.

Many Earn \$5, \$10, \$15 a Week in Spare Time While Learning

That's what many of my students do soon after enrolling. I'll give you special training, plans and ideas to help you do it. Many students have made \$200 to \$1,000 in spare time while learning. Nearly every neighborhood offers a spare time serviceman an opportunity to make good money. I'll show you how to "cash in"—show you why my Course is World-Famous as "the Course that pays for itself."

Find Out What Radio Offers You

Mail the coupon. My book is free to any ambitious fellow over fifteen years of age. It tells you about Radio's spare time and full time job opportunities—about my Course, what I give you, what my students and graduates do and make. There is no obligation. Act today. Mail coupon in an envelope or paste on a 1c postal card. Do it right now.

J. E. SMITH, President
National Radio Institute, Dept. 5FX,
Washington, D. C.



MAIL THIS NOW

FOR FREE BOOK OF FACTS ABOUT RADIO

J. E. SMITH, President
National Radio Institute, Dept. 5FX, Washington, D. C.
Dear Mr. Smith: Without obligation, send me the sample lesson and your free book about spare time and full time Radio opportunities, and how I can train for them at home in spare time. (Please print plainly)

Name, Age,
Address,
City, State



CONTENTS—JUNE, 1935, ISSUE

Volume VI Number 12

Editorial: Auto-Radio Developments.....	Hugo Gernsback	709
The Radio Month in Review.....		710
Radio Pictorial.....		712
The Two-Way Auto-Radio of the Future.....	Hugo Gernsback	714
How to Make an Advanced Dual-Wave Car-Radio Set.....	C. W. Palmer	715
The Present Status of Automotive Radio.....	Wilhelm E. Schrage	716
Car-Radio Sets Afloat.....		717
Novel Ideas in Car-Radio.....	R. D. Washburne	717
Announcing—Electrolytic Pictures via a New Method.....	Otho Fulton	718
Portable "P.A.-Radio" Systems.....	Louis B. Sklar	719
Making a Vibrator "B" Test Board.....	D. A. R. Messenger	719
New Car-Radio Equipment.....		720
The Newest in Car Antennas.....		721
Modern Automotive-Radio Sets.....		721
Circuits of the Newest Car Sets.....		722
The "Bumper Antenna" for 1935-'36 Cars.....	James Caulfield	724
Beginner in Car-Radio.....		724
The Latest Radio Devices.....		725
Now—Metal Tubes.....		726
The New R.K.-31 Hi-Power Tube.....	Clifford E. Denton	726
Improvements in Auto-Radio Antennas.....	Arthur H. Lynch	727
How to Make a Fidelity-Equalizer Adapter.....	J.B. Carter	727
How to Install Replacement "B" Genemotors.....		728
Deaf-Aid Equipment—A Service Market.....	R. M. Gray	728
A Car-Type Portable P.A. Amplifier.....	Charles R. Shaw	729
Obscure Sources of Car-Radio Noise.....	H. K. Bradford	729
Cathode-Ray Oscilloscope for Vibrator "B" Testing.....	B. W. Robins	730
A New High-Fidelity All-Wave Receiver.....	A. C. Matthews	730
A New 23 Tube High-Fidelity All-Wave Receiver.....	E. H. Scott	731
Short-Cuts in Radio.....		732
Curiosa in Radio.....		733
International Radio Review.....		734
The Listening Post for All-Wave DX-ers.....	C. A. Morrison	735
Operating Notes.....		736
Readers' Department.....		737
RADIO-CRAFT'S Information Bureau.....		738
ORSMA Members' Forum.....		739
RADIO SERVICE DATA SHEETS:		
No. 139—Zenith 5-Tube Triple-Wave Superhet. Chassis Nos. 5508 and 5509; Emerson Models 38, 42 and 49, 6-Tube Dual-Wave Super, Chassis No. V6; General Electric Model C-62 6-Tube Battery Superheterodyne.....		740
No. 140—Useful Automotive-Radio Reference Information.....		742
Service Men—Protect Your Trade Discount!.....	Charles Golenpaul	741
Technicians' Data Service.....		744

HUGO GERNSBACK, Editor-in-Chief
 C. W. PALMER Associate Editor
 J. S. CAULFIELD Associate Editor
 R. D. WASHBURNE, Technical Editor

FEATURING— THE SERVICE MAN IN OUR NEXT ISSUE

An exceedingly wide field of "radio" applications is now embraced when we mention the word "service." We now have to differentiate—radio (in the home), public address, theatre talkies, home talkies, car radio, centralized radio, airplane radio, marine radio, electronic equipment, therapy apparatus, broadcast and other types of transmitter repair and maintenance, etc. And there are innumerable subdivisions of these fields of operation. So, when we announce that the next issue of RADIO-CRAFT is dedicated to the Service Man, the very wide scope of the contents becomes evident. Test apparatus of all sorts will be illustrated and described. New methods of servicing will be discussed. Helpful information of every imaginable kind will be given, to aid Service Men to operate more rapidly and with greater profit than heretofore. DON'T MISS YOUR ISSUE—the Service Number of RADIO-CRAFT.

RADIO-CRAFT is published monthly, on the first of the month preceding that of date; its subscription price is \$2.50 per year. (In Canada and foreign countries, \$3.00 a year to cover additional postage.) Entered at the post office at Mount Morris, Ill., as second-class matter under the act of March 3, 1879.

Text and illustrations of this magazine are copyright and must not be reproduced without permission of the copyright owners. We are also agents for WONDER STORIES and EVERYDAY SCIENCE AND MECHANICS. Subscription to these magazines may be taken in combination with RADIO-CRAFT at reduced Club rates. Write for information.

Copyright 1935. Continental Publications, Inc.

HUGO GERNSBACK, President I. S. MANHEIMER, Secretary
 Published by Continental Publications, Inc. Publication office: 404 N. Wesley Ave., Mount Morris, Illinois. Editorial and Advertising Office: 99 Hudson Street, New York City. Chicago Advertising Office: L. F. McClure, 919 North Michigan Avenue, Chicago, Ill. Western Advertising Office: Loyd B. Chappell, 511 So. Alexandria St., Los Angeles, Calif.

European Agents:

London—Gorrings' American News Agency, 9A Green St., Leicester Square, London, W. C. 2.
 Paris—Messageries Dawson, 4 Rue Faubourg, Poissonniere, Paris, France.



- - - for the real servicing "dope" you can't find a better book!

NO other radio book is comparable to the new 1935 OFFICIAL RADIO SERVICE MANUAL. In contents, in style of printing, in grade of paper, in illustrations there has never been published such a comprehensive volume.

The 1935 Manual contains over a thousand pages—yet it is only 1¼ inches thick because it is printed on a special Bible stock which is an exceptionally good stock, yet one of the thinnest and most durable papers. This 1935 Manual is the most authentic and elaborate service guide ever used in the radio industry. Service Men and dealers who use this 1935 Manual are astonished by finding in it such a wealth of profitable service information which has never been published before.

Contents of the 1935 Manual

- Over 1,000 pages full of diagrams and essential information of manufactured receivers—only data of real use in servicing is included. This new Manual is really portable since it is extremely thin and light as well.
- Volume V continues where the preceding manual left off.
- Many circuits of old sets are included.
- Service Men know every set has certain weak points which are really the cause of trouble. Wherever the information could be obtained, these weaknesses with their cures are printed right with the circuits. This is an entirely new and valuable addition to the Manual.
- All the latest receivers are included—all-wave sets, short-wave sets, auto-radio sets, midget and cigar-box sets, etc., as well as P. A. amplifiers and equipment, and commercial servicing instruments.
- The cumulative index is even more complete than before; including cross-reference to sets sold under different names and type numbers.
- Volume V includes resistance data; socket layouts; I.F. data; and voltage data.
- Tube data on latest tubes.
- Free question and answer service—as included in our latest three manuals.

What Others Say about this Manual:

Norfolk, Va.
I received the OFFICIAL RADIO SERVICE MANUALS ordered as per my letter of March 29, 1935 in good order. I am very well pleased with same, as it is a very valuable Radio Service data reference and guide.
ARTHUR J. FREENEY.

Detroit, Mich.
Received your 1935 OFFICIAL RADIO SERVICE MANUAL and certainly is something to rave about. It's great.
A. HEDKE.

Stillwater, Maine.
I have received the 1935 Manual, and I am very much pleased with my investment.
FRANKLIN J. HOLMES.

Swift Current, Saskatchewan, Canada.
I beg to acknowledge receipt of my 1935 issue of the OFFICIAL RADIO SERVICE MANUAL. Your Manual is fine, and would not be without any of them. The Manuals may be improved for Canadian use.
A. M. FORD.

Kilbyville, Texas.
I was an original subscriber to the Gernsback Manuals and the magazine, RADIO-CRAFT. They have been a great pleasure and help to me.
H. K. WHITTINGTON.

Bronton, Mo.
I have lately purchased the 1935 OFFICIAL RADIO SERVICE MANUALS and sure am proud of same. Wish to say also that RADIO-CRAFT Magazine is a lifesaver for service men. I would not be without either.
THOMAS J. MAYES.

CLIP-MAIL COUPON TODAY!

GERNSBACK PUBLICATIONS Inc., 99 Hudson St., New York, N.Y.
Enclosed find my remittance of \$7.00 for which send me, POSTAGE PREPAID, One Copy of the 1935 OFFICIAL RADIO SERVICE MANUAL. [Send remittance by check or money order; or register letter if it contains cash, currency or unused U.S. Postage stamps.]

NAME.....
ADDRESS.....
CITY..... STATE..... RC-6-35

OVER 1,000 PAGES

Over 3,000 Illustrations. Flexible, loose-leaf leatherette covers. Size 9x12"—only 1¼" thick

GERNSBACK PUBLICATIONS, Inc.
99 Hudson Street New York, N. Y.

Please Say That You Saw It in RADIO-CRAFT

ANNOUNCING The 1935

Official AUTO-RADIO SERVICE MANUAL



HERE NOW— is the second volume of the OFFICIAL AUTO-RADIO SERVICE MANUAL—the 1935 Edition.

With so large a number of new auto-radio sets placed on the market by different manufacturers, the 1935 OFFICIAL AUTO-RADIO SERVICE MANUAL becomes an essential part of Service Men's equipment. Remember, there are nearly 1,800,000 auto-radio sets in use today.

The 1935 OFFICIAL AUTO-RADIO SERVICE MANUAL (Volume II), contains 100% new material. It gives schematic diagrams, chassis layouts, mounting instructions, and trouble-shooting hints on all modern auto-radio receivers, and older models as well.

THERE IS ABSOLUTELY NO DUPLICATION OF MATERIAL BETWEEN THE 1933 EDITION (VOLUME I) AND THE NEW 1935 EDITION (VOLUME II). THE MATERIAL IS 100% NEW.

Every radio man connected in any way with the booming auto-radio business needs a copy of the new OFFICIAL AUTO-RADIO SERVICE MANUAL. It contains only auto-radio service "dope."

HERE ARE ADDITIONAL HIGHLIGHTS OF THE NEW, 1935 EDITION OF THE OFFICIAL AUTO-RADIO SERVICE MANUAL

- 240 big pages crowded with diagrams, service material and other essential data required for proper servicing of new auto-radio receivers. Included are diagrams of sets which appeared during 1934, and which were not included in the supplement to the first edition.
- Complete schematic diagrams, chassis layouts, voltage tabulations and servicing instructions are included for practically all sets. "Under-side" tube symbols are also included to facilitate the job of servicing the sets.
- Instructions are included with many sets telling how to suppress stubborn cases of ignition interference. This includes the newest "suppressorless" sets—and what to do when interference is encountered with this type of set.
- Details on how to make installation in "turret-top" cars are included. The different methods used by car makers and set manufacturers are listed with the individual circuits and service information.
- The index contains the listing of sets which were published in the first edition, as well as the sets which appear in the new volume. This information helps the Service Man to locate the circuit and details for any receiver that has been made.
- The book is bound in a handy, flexible leatherette cover. To be sure the pages are sturdy, to withstand constant use, the book will be printed on a special "bible" stock. This is a very durable, but thin paper. The book printed on this paper can be easily rolled to fit into your pocket or slipped in the service kit.

Volume II

Over 240 Pages
Printed on Special
Thin "Bible Paper"

Over 500 Illustrations
Flexible, Looseleaf
Leatherette Cover

**GUARANTEED
PUBLISHING DATE
June 15, 1935**

MAIL COUPON TODAY!

GERNSBACK PUBLICATIONS, Inc. Dept. RC-635
99 Hudson Street, New York, N.Y.

Enclosed you will find my remittance of \$2.00 for which send me One Copy of the 1935 OFFICIAL AUTO-RADIO SERVICE MANUAL (Volume II) at the special pre-publication price. I understand that the book will be \$2.50 as soon as it is published. (Send remittance in check or money-order; register letter if it contains cash or currency). The book will be ready on or before June 15th.

Name

Address

City.....State.....

(The 1935 OFFICIAL AUTO-RADIO SERVICE MANUAL is shipped postage prepaid.)

Special Pre-Publication Offer!

You now have the opportunity to order the 1935 OFFICIAL AUTO-RADIO SERVICE MANUAL before it comes off press. . . You will save money.

The list price of this book is \$2.50. AT THE SPECIAL PRE-PUBLICATION PRICE YOU CAN BUY THE BOOK FOR \$2.00. THIS IS THE FIRST AND ONLY ANNOUNCEMENT WHICH WILL BE MADE BEFORE THE BOOK IS PUBLISHED. IT IS OUR GUARANTEE THAT THE BOOK WILL BE READY FOR DELIVERY ON OR BEFORE THE 15th OF JUNE. ONCE THE BOOK IS PUBLISHED, THE LIST PRICE WILL PREVAIL.

GERNSBACK PUBLICATIONS, INC.
99 HUDSON STREET NEW YORK, N. Y.

Please Say That You Saw It in RADIO-CRAFT



“Takes the Resistance out of Radio”

Editorial Offices: 99 Hudson St., New York, N.Y.

HUGO GERNSBACK, Editor

Vol. VI, No. 12, June, 1935

AUTO-RADIO DEVELOPMENTS

An Editorial by HUGO GERNSBACK

IT HAS been estimated that there are in use in the United States about 1,800,000 automobile radio sets. Set against this the figure of 21,000,000 automobiles, according to the latest available information, and it will be seen that only a small percentage, i.e., only 14 per cent are equipped with radio.

Sets are becoming much more standardized; they are continuously being made smaller, more compact; they are built better from a mechanical standpoint to withstand the shocks they receive. It may be said that, in general, automobile radio is on the increase.

What about the future? What improvements, what changes are apt to be made in car radio sets? In the first place, in the next few years all new cars will have metallic bodies that will not permit use of the aerial, close to the car (under the roof, for instance), to which we have been accustomed. Consequently other points of advantage must be found. These are mainly underneath the car, or outside, at some distance from the main body of the car, as in the case of insulated bumpers, etc.

The “multiple operation” idea, whereby the set can be switched on and tuned not only by the driver but by the passengers in the rear compartment as well, will gain more and more adherents. Frequently, people in the rear compartment wish to operate the set independently of the driver and this convenience can be made available by means of extra controls.

While many refinements have been made in car radio sets, it would be foolish to say that the end of development has been reached. As a matter of fact, we have only witnessed the beginning. In a few years television will be with us, and you may rest assured that as soon as it has been accomplished in your home it will also be an accomplished fact for your car. There is no reason why a person sitting in a private car, in a limousine or in a bus should not have the benefits of television when it finally comes about. Of course, it is a far cry from the present television sets to the small compact “televisor” less than a foot square installed in your car ten or fifteen years hence, but that image reception in your car will come no one doubts.

What next? We have had under discussion aural as well as visual radio. What else can there be? The art of electronics—closely allied with radio in general—furnishes the answer, and it seems to me that one of the greatest contributions radio engineers can make in the future lies in safeguarding the lives of automobilists and pedestrians.

The great number of deaths due to careless driving, negligence, and many other personal equations due to automobiles is becoming more appalling as time goes on. In the United States, during 1934, there were 36,000 persons killed, 954,000 persons injured, due to automobile accidents. Many of these accidents were preventable, and the radio engineer is the one who can cut down the percentage tre-

RADIO TO MAKE CARS COLLISION PROOF

Auto radio sets of the future will not only produce entertainment, but will make your car practically safe from collisions. This and a number of other new ideas are advanced in this editorial, which should be of more than passing interest to radio engineers and all car owners.

mendously, due chiefly to electronics incorporated in the car radio of the future.

By means of photoelectric cells and capacity-effect devices it should not be a very difficult problem for radio engineers, in conjunction with automobile technicians, to evolve ways and means to make automobiles safer—far safer than they are today.

To mention just a few ideas on the subject, all of which are possible even today:

Many accidents are caused today by cars colliding, that is, by one car running into another, by one car being bumped in the rear by another, etc. Authorities have long agreed that cars, even when stopping, should not come more closely than within two or three feet of each other. If a capacitative device were installed on all cars, on the front fender, then as soon as any body having a large capacity, as for instance an automobile, truck, pedestrian, etc., came within say, two feet of it, a relay would automatically cause the brakes to be put on. This would obviate a great many collisions, and while it would not stop all collisions, it would certainly minimize the effects thereof. It is reasoned that it is often better to stop a car suddenly, without hitting another car, even if slight injuries are resulted thereby, than to have serious collisions not only with the direct result of killing the driver or passengers outright when the cars actually crash, but also, indirectly as a consequence of fires which often break out. While it is true that such an automatic capacity-operated device would not be very effective when a car going at 40 miles an hour suddenly came within two feet of a pedestrian, still the chances are that the damage done might not be as great as if the progress of the car had not been halted. It is one thing to strike a human being with a car going 40 miles an hour and quite a different thing if the car strikes at a speed of 8 or 10 miles an hour. The difference may be in saving of the life of the person so struck.

The car radio of the future will also help to overcome other human handicaps, of which there are many. One of the worst at the present time is that people forget to turn on their headlights and rear lights in approaching darkness. The result is that other cars cannot see the unilluminated car and crashes are often due to this. The photoelectric cell is the answer. One or two such cells stationed somewhere near the top of the car would automatically turn on the lights as soon as the visibility falls below a certain level, and it will make little difference whether the requirement is during the daytime due to approaching storm, due to entering a tunnel, or when driving through a dense forest road where the visibility is poor. The lights will automatically go out as soon as a high visibility is again reached, all without the driver having to touch anything.

THE RADIO MONTH



A heated controversy between legislators and insurance companies—and radio manufacturers and car radio owners.

AUTO RADIO— PRO AND CON

EVER since auto-radio installations became popular, a controversy has been going on—between legislative authorities and insurance companies on one hand, and radio manufacturers and car radio owners on the other—as to whether auto radio presented an accident hazard or not.

Last month, the state of Connecticut went so far as to introduce a bill providing a \$50 penalty for the installation in an automobile of a radio set or any other device which “tends to distract the attention” of the operator!

However, the RADIO MANUFACTURERS ASSOCIATION which has been instrumental in bringing auto radio to its present popular position says in a letter to RADIO-CRAFT—“We have no information that the bill is being pressed or seriously considered.”

Mr. Bond Geddes, Executive vice-president and general manager of the RMA made the following summary of the situation. “Since that time (when auto radio first became popular) there has not been a single case according to any information in our possession where an automobile radio has been the cause of any major accident. Against this is the almost unanimous opinion of operators of automobiles equipped with radio that they tend to reduce speed and, therefore, are not a source of danger but actually become a safety-factor.”

In a survey of the insurance companies interested in car insurance which was made a short time ago by RADIO-CRAFT, many interesting replies were received to the questions asked. The majority of the companies evaded the issue of whether radio installations might influence their insurance rates or their desire to insure cars so equipped.

Ser. No. 360,520 L. BAMBERGER & Co., Newark, N. J.
Filed Jan. 22, 1935.

WOR

For Radio Receiving Sets and Radio Tubes.
Claims use since Dec. 19, 1934.

Soon we'll listen to WOR on WOR sets equipped with WOR vacuum tubes.

WOR IS DECLARED—

WOR is declared to be the name of a new line of radio sets and tubes to be introduced by L. Bamberger & Co., if we can believe the above copyright notice published last month in the Patent Gazette.

“America's Great Store” broadcast station—now 50,000 watts—seems to have gone not only high-fidelity, but also high-hat!

According to this notice, the set buying public in the vicinity of Newark, N.J., will soon be buying WOR sets equipped with WOR tubes to listen to programs from WOR. And just think of the dilemma that will result if other broadcast stations start using their call letters for the names of radio sets and accessories. We'll probably have such names as KOP transceivers—KICK tubes—KIT aerials—KID juvenile sets—WHAM lightning arresters—WAVE aerial wire—KOIL tuners and WOW noise suppressors (hi!!)

THE FIRST ELECTRONIC SHOW

THE electronic branch of “radio” has now achieved such proportions that an Electronic Show—the first of its kind—was held, with great success in Chicago, last month.

The Chicago Civic Opera Building was filled to capacity with photo-cells in all their numerous forms, and functioning all the way from door opening to sorting poker chips. Of course, there were other gadgets besides photo-cells, but the lion's share was taken by light sensitive devices.

The importance of electronic devices (or as David Sarnoff, president of RCA recently described them—“the new miracle workers of our day,”) cannot be over emphasized. Without electrons we would have no radio sets, sound moving pictures, long distance telephones, talking books for the blind, facsimile transmission, nor thousands of other devices which make our lives more pleasant, such as light measurement and control, automatic counting and sorting devices, protection of machine operators, burglar alarms, etc.

BELGIAN FREIGHTER IN DISTRESS

SEVERAL months ago, on this page, we told of the heroic efforts of the crews of several ships in rescuing the survivors of other ships, wrecked by the terrific storms which raged over the seas at that time.

One of these ships was the Usworth, an English freighter which foundered in the midst of one of these storms. A volunteer lifeboat crew from the Belgian ship Jean Jadot saved many of the Usworth's crew, it will be remembered.

And now comes news that the Jean Jadot also had to send for assistance, last month, when she broke her rudder, 450 miles east of Halifax. A Coast Guard cutter towed her to safety, however, in answer to her SOS.

MORE ABOUT FIRE-ENGINE RADIO

THE radio industry seems to have become fire engine conscious. Last month, we predicted the use of P.A. equipment for the direction and control of fire apparatus and now comes news of an honest-to-goodness short-wave installation in a fire engine.

In order to provide communication between the scene of the fire and headquarters, the new hook-and-ladder acquired last month by the Northwood (Middlesex, England), fire brigade is equipped with a short-wave transmitter and receiver as the rural area of 20 square miles, makes it difficult to get in touch with the fire station during a distant call. Hence the radio equipment.

Incidentally, while on the subject of radio and fire engines, it is interesting to note that practical jokers who delight in “putting in” false alarms, in New York, will find themselves in a heap of trouble now that all fire alarms are also sounded at police headquarters. A radio car is dispatched to the fire box, post haste, as soon as the alarm sounds!

Short-wave radio has found another use—in fire engines—to contact the fire house.



IN REVIEW

Radio is now such a vast and diversified art it becomes necessary to make a general survey of important monthly developments. RADIO-CRAFT analyzes these developments and presents a review of those items which interest all.

THE MOON AND RADIO

TWO interesting developments in the theory of radio wave propagation, took place last month.

The first of these was the discovery by Dr. Harlan T. Stetson, that mysterious electronic tides in the ionosphere, about 200 miles above the earth, and apparently caused by the moon, take place, with a marked effect on radio transmission.

Dr. Stetson said—"An analysis of measurements appears to indicate that radio waves are received much more strongly during nights when the moon is below the horizon."

The second news item comes from the Bureau of Standards which has discovered a new reflecting layer above the earth, similar to the Kennelly-Heaviside and the Appleton layers, but higher, than the "E" and "F" layers.

The new layer which has been called the "G" layer, reflects high frequency signals which penetrate the other two ionized reflecting layers.

A NEW ENGLISH FACSIMILE SYSTEM

THE transmission of pictures by radio has been advancing by leaps and bounds during the past months.

The latest development along this line comes from England, where the Marconi company has set up a system between London and Melbourne, Australia. This new service was announced last month by the Marconi Co., and is advertised for the transmission of photos, written or typed matter or drawings.

The system depends on a rotating optical system, within a stationary drum, for scanning the original. The receiver utilizes a special glow discharge tube which exposes a minute spot on commercial bromide photo paper.

The new Marconi facsimile system which operates between London and Melbourne.

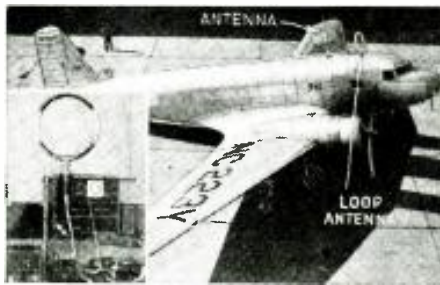

The "mystery" plane and Kreusi homing compass.

THE NAVY'S MYSTERY RADIO PLANE HOAX

LAST month the newspapers were set agog by rumors of a mystery plane which the U.S. Navy had fitted up with robot flying devices and expected to send to Australia, from California without a soul aboard.

For a week or more, the papers were splurging this supposed news about the mystery plane. One New York paper even went so far as to make an artists conception of the interior of the huge Douglas transport plane with its radio control devices.

A little detective work and a statement from Geoffrey G. Kruesi who developed the "homing compass" installed in the plane disclosed that there was no mystery at all in the tests conducted on the "coast."

All that the Navy wanted to determine was whether the homing compass was dependable for guiding a plane over the ocean, when the nearest station (disregarding ships) is sometimes thousands of miles away. In other words, it was simply a routine test of a device which was used by Wiley Post in his 'round the world flight and has been applied to the blind landing system worked out by the Bureau of Air Commerce.

Mr. Kruesi said—"The device eliminates a lot of calculations and permits a flyer to set any course he chooses, using the regular broadcast stations for his bearings. For instance if a man wanted to fly from Oakland to Hawaii he would tune in on the station at Honolulu and as long as he continued flying straight the needle on the dashboard would stand perpendicular. If he deviated to the right or left the needle would move to the right or left, showing the degrees he was off, so that he could get right back on the course."

An important aspect of this "mystery flight" however is the prospect of a trans-pacific air line which is said to be the reason for all the hullabaloo.

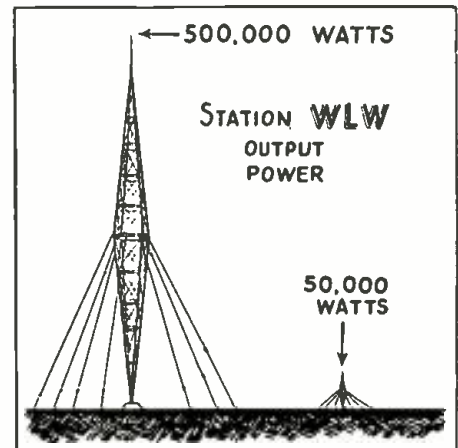

The comparative power of WLW before and after the F.C.C. changed their minds.

WLW REDUCED TO 50 KW.

A SERIOUS blow to Uncle Sam's prestige as operator of

the world's most powerful broadcast station came last month when the Federal Communications Commission ruled that "America's Station" would have to go back to 50,000 watts in the evening hours instead of the 500,000 watts they had been distributing over the country-side.

It all came about because of a complaint from Toronto's CFRB that the Crosley station blotted out its signals. The decision of the F.C.C. comes as rather a surprise as their previous viewpoint was to "tell the listeners to get better sets" and thus avoid the blanketing of a powerful station. Apparently they changed their minds!

This leaves Russia as the claimant for having the world's most powerful broadcast station.

KITCHEN RADIO SETS TO SELL REFRIGERATORS

RADIO—as the world's foremost salesman—has taken over a new line of selling, according to news which reached RADIO-CRAFT last month.

A large refrigerator manufacturer is introducing a combination kitchen "recipe radio" and coin meter to aid in their merchandising efforts. According to an official of this company the new radio and meter combination is tamper-proof and constructed so that the coin which keeps the refrigerator operating also provides the current for the radio set.

It seems that there is no end to the number of ways in which radio broadcasting can be applied to advertising or selling. (Continued on page 767)

RADIO PICTORIAL

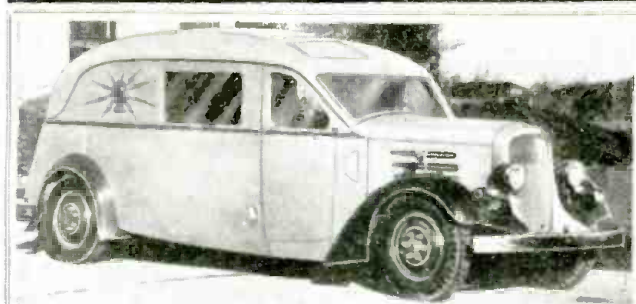

A broadcast studio—at 70 miles an hour! N.B.C.'s new mobile studio carries 4 separate transmitters, 5 receivers, and a power plant! The strongest transmitter is 150 watts; it covers 100 miles with high-quality programs while stationary and 50 miles when in motion.



ANTENNA

Broadcasting from a bobsled skimming over ice at 70 miles per hour! The transmitter is strapped to No. 3 man. A 5 ft. vertical rod is the antenna. A close-up of the 7-meter, 1-watt transmitter is shown (right) on the operator's back.

Photo G. E. Co.



First W.E. police radio ultra-high frequency is used in Newark, N.J. A 500-watt amplifier drives the 50-watt transmitter. The dispatcher keeps track of the patrols with miniature cars.

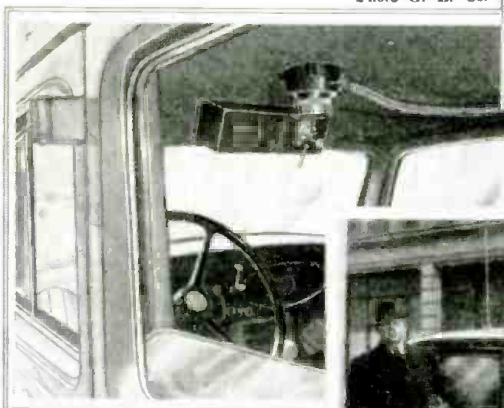

The aerial on a novel English mono-car, built like a ship, and equipped with a radio set.

Photo by Fox.

Freedom from atmospheric disturbances is the outstanding advantage of the police radio at Newark, N.J., working on 9 meters. The control for maintaining this frequency is a quartz crystal which is ground to paper thickness, and vibrates 5 million times a second.

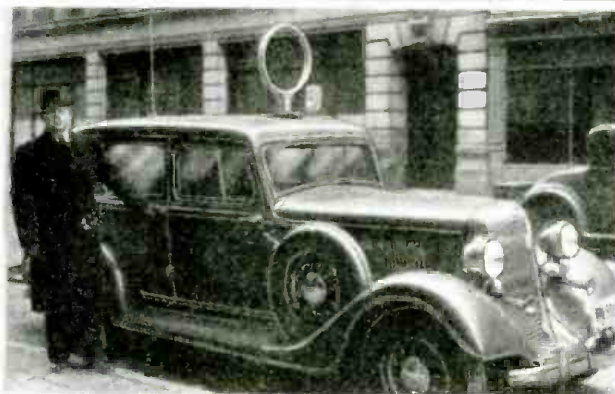

The Lear radio direction finder or "homing" device installed in a car for experimental purposes, and field strength checks. Recent tests have shown it to be an infallible radio compass for airplanes or ships. It may be employed as a regular radio receiver for broadcast programs or, it may be utilized as a visual type homing instrument by which a "course" may be directly and accurately steered toward a distant radio station. The receiver tunes from 195-415 kc. for beacons and 550-1500 kc. for broadcasters. A combination visual indicator and remote control is shown above the windshield. A calibrated compass projects through the roof of the car. The antennas are mounted on the roof of the car. A vertical antenna is used for the visual indicator and the loop for plotting the course.

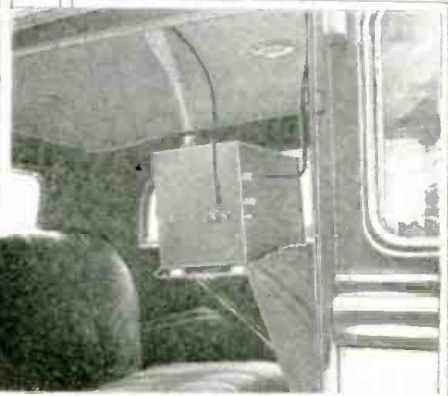
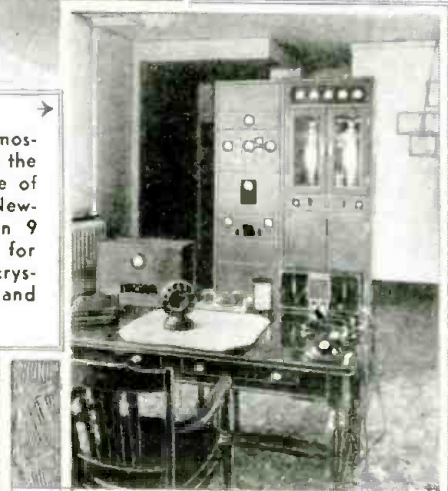

Radio for the nurse is a new wrinkle in baby carriages. However, no provision is made to lull "Jr." to sleep. Batteries are mounted in the rear of the set.



The highly directional antenna system of WOR's new 50,000 watt, high-fidelity transmitter (old power—5,000 watts) sprays high-powered radio waves over an area shaped like an "hour-glass." The program signals are focused over an area of greatest population. A "concentric" transmission line terminates in the antenna, and two half-wave "power reflectors" which "buck" the antenna output in two directions. A ground of 40 miles of buried copper wire is used. A master control desk (lower left) is the nerve center of new WOR. Seen through the observation window is an operator seated at the transmission control desk. At lower-right is illustrated front of the transmitter, showing the control desk; a floor layout is used that places the control man nearly equidistant from all panels and controls.

It is the first station to have an absolutely windowless building, and the first to utilize the hot water generated by the eight 35 kw. tubes to heat the building. The wire lath is welded together to form a solid ground.

Photos courtesy W. E. Co.

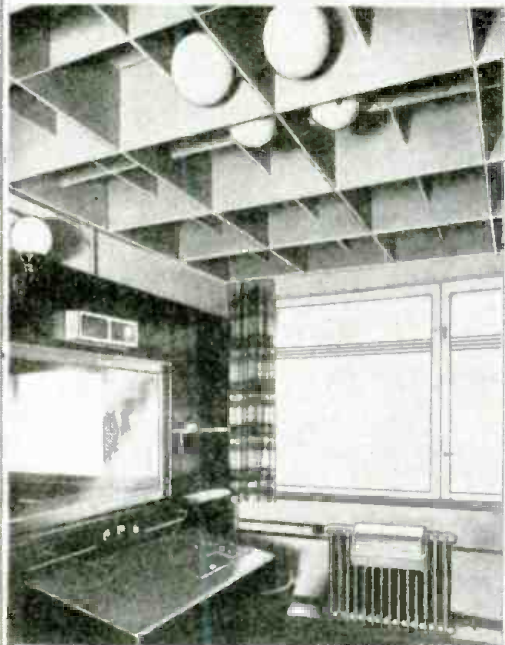
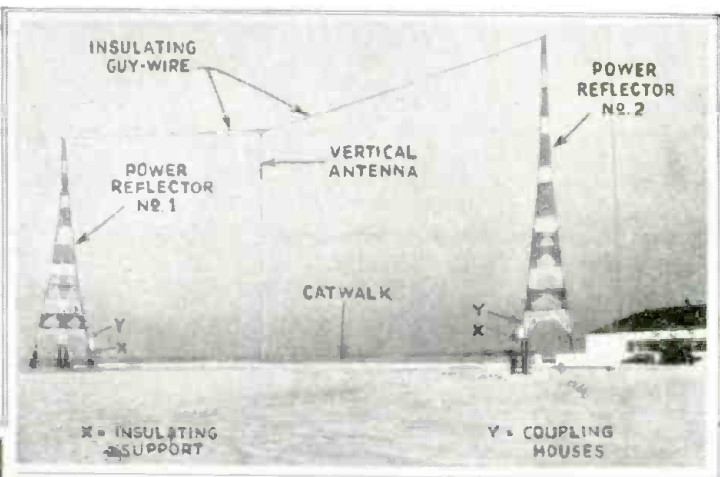

The Koenigsberg radio station in Germany is an acoustic marvel. In addition to the usual damping methods, which tend to acoustically enlarge the rooms, special attention has been given to means for rifting all large areas. For instance ceilings are boxed, as illustrated, and adorned with acoustic stalactites.

Photo by Globe.

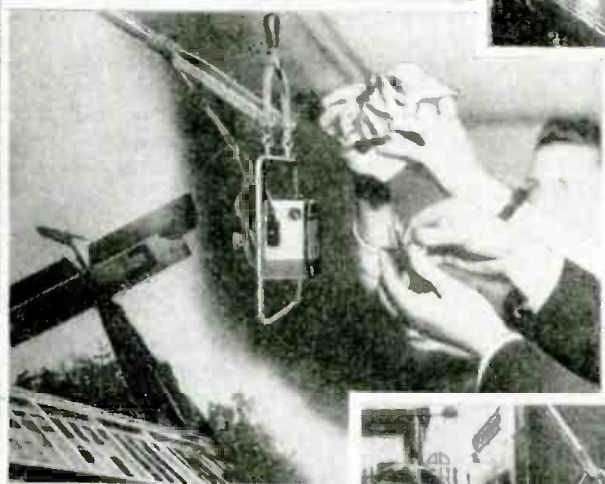
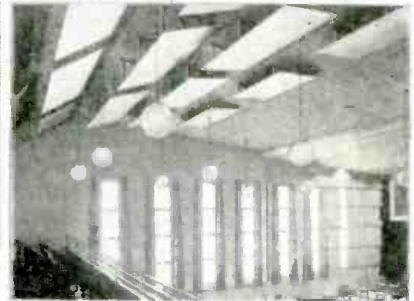

In the studios of Germany's new Koenigsberg station are employed extensive means to secure a low angle of incidence, in order to obtain an optimum echo time. Ceilings are equipped with tilted areas of planking that prevent direct reflection; similarly, the walls are built as sections, slanting in a horizontal plane.

Globe Photo

The sound effects man simulating unusual noises in the B.B.C. Above, the crash of airplanes imitated by crushing a match box, and tearing and rustling brown paper; an earthquake (left) obtained by sliding rocks down a sandpaper board to a bass drum. Rice dropping on brown paper (right) imitates rainstorm.



THE TWO-WAY AUTO-RADIO OF THE FUTURE

HUGO GERNSBACK

Auto radio is in the very beginning of its development stage, according to this forecast by Hugo Gernsback. The auto-radio receivers, which we are inclined to consider "the last thing," are really only crude experiments.



Two-way communication and television for the car are two predictions of the future of automobile radio. The transceiver, which is practical today, has many uses, such as calling for aid in case of breakdown, etc.



WE HAVE become accustomed to our automobile radio sets, and in this country, at least, they are no longer a novelty. They are, however, still in their development stage and the latest word on this subject has not been said, (as I have also pointed out in my editorial in this issue of RADIO-CRAFT).

There are many possible developments and the radio engineer is constantly under pressure for new ways to make the automobile set not only more perfect but to have it embrace new duties, as well.

One of these, especially, I wish to discuss in this article because I believe not only that it is a needed improvement, but also that it can be the means of saving not only untold annoyances—but *lives* as well! Our present radio sets (and this is true of all of them) work only one way—that is, they can emit transmitted programs, but as for originating music or speech, they are mute.

Picture a scene which can be reconstructed from any Monday morning's newspaper—indeed, almost any newspaper of any day throughout the length and breadth of this country. The driver on the highway, due to carelessness, or due to intoxication, or because he fell asleep while driving, runs into a telephone or telegraph pole, partially demolishing his car. Let us assume in this instance that he has not been killed outright, because not all accidents are fatal. One of the passengers, however,

has been seriously injured. The accident is on a little frequented road. It will take time to summon help, granting that there are passing automobilists who may have witnessed the accident. If it happens in the daytime, passing cars may be relied upon, of course, to tell about the accident at the next town. However, if the accident happens at night and the car ran off the road where it is not visible, the injured party or parties may lie for hours before they are discovered—and in the meanwhile death may occur!

Suppose, now, that we have the car radio set (a *transceiver*, or convertible type of set capable of operation as either a transmitter or a receiver, at will) available in working order, (the radio set of the future will not be in the front of the car but will probably be under the seats in the rear compartment so it will stay in operation, unless the entire car is smashed to pieces). Even if the driver or the other passengers of the car are injured to some extent, they still may have the strength to flip a switch and talk into a microphone placed conveniently in some compartment in the front or rear of the car. An SOS is sounded, the car giving directions where the wreck occurred, and in very little time help will arrive at the spot. In addition to occasionally saving lives, it will often save untold suffering, because ambulances may thus be summoned quickly, and in the case of a minor accident, a towing car can reach the wreck with the least possible delay.

As to technical details, most any radio engineer today can visualize them. Practically every set on the market today could be instantly converted into a transmitter simply by turning a switch. This would put the circuit of the set into an oscillating condition, so that when a person talked into a microphone connected to the input side, the impulses would be sent out (preferably, on short waves), the same as they do from any other transmitter.

I know there will immediately be a chorus of objectors to this scheme because there appear to be many loop-

holes in it—which, however, can easily be overcome, as you will see.

In the first place, a special wavelength for automobiles must be set aside by the Federal Communications Commission. This must be a frequency below 6 meters; preferably, such a frequency where the effects of the broadcast transmission are ineffective beyond the horizon, or, let us say, within a radius of 20 miles or less. The reason for this is obvious. If you choose a higher wavelength, then the SOS will go out indiscriminately over a very large area and the result would be that too many wrecking cars or ambulances might be summoned. By choosing the correct frequency, however, only a few miles will be effected. The power of the "transceiver" should be such that it need not reach more than about 10 miles. This should be sufficient for all ordinary purposes. (The transmitter must be crystal-controlled so that communication is only possible in this particular channel.)

Every service station in the country would then have in continuous operation a special short-wave receiver tuned only to this frequency. Any incoming call could, therefore, be heard and the attendant would immediately know where the accident occurred. (If he believes that another service station is nearer he will not go for help, unless the call is repeated within ten or fifteen minutes.) If ambulance service is required, he can telephone to the

(Continued on page 752)

HOW TO MAKE an ADVANCED DUAL-WAVE CAR-RADIO RECEIVER

Suppressor-less design and features not found in manufactured sets make this receiver worth while. C. W. PALMER

IS IT worth while for an individual to attempt the home construction of a car radio set?" is the question being asked on all sides today. "Yes," is the author's answer to the Service Man looking for an opportunity to make a little "side money," and to the person who wishes to have available in his car features not available in automotive radio sets now on the market.

"Suppressor-less" operation (in most cars), broadcast and International short-wave program reception, "leakage reactance" tone control, and low car-battery drain—these are the outstanding features of the "letter size" automobile radio receiver designed by the writer; features which warrant construction of the instrument in the face of existing low-price sets of even smaller dimensions. (The set is referred to as "letter size" because the aluminum chassis is exactly the same size as standard letter-size writing paper, or 8½x11 ins.)

Although dynamometer tests seem to indicate that car ignition-system suppressors are not harmful, present engineering practice calls for utmost effort to produce a radio receiver design which will permit satisfactory reception without recourse to suppressors. The construction details of this interesting receiver indicate that the newest ideas are now available in a tested custom-built automotive radio receiver.

ENGINEERING DETAILS

Separate aluminum shields for the

first R.F. and first I.F. stages prevent pick-up of ignition interference at these most susceptible points; in addition, they prevent eddy currents in the chassis from inducing noises at these points. The over-all, crystalline-finish iron cabinet does not have any heat-vents—the metalwork of the receiver affords adequate cooling by conduction, of the single low-voltage electrolytic condenser used in the set. A special, low-resistance "A" filter (made especially for this set by a well-known manufacturer) is incorporated right in the chassis to keep out ignition and generator noise. The carefully-planned layout maintains short grid and plate leads; all possible leads are shielded. A "genemotor" type of "B" supply unit was selected as having least tendency to produce noise; further, this unit was located remote from the set, only a single, well-shielded lead, bypassed right where it enters the set, being used.

A feature of exceptional interest to most radio listeners is the provision for dual-wave reception of broadcast programs. Since many states and cities ban the use of sets which cover the police wavelengths, it was decided that the only way to get from the broadcast band to the desired portion of the short-wave band was to skip right over the police band—in order to land in the "international" short-wave bands of 19, 25, 31 and 49 meters. During the summer months especially, short-wave signals are quite strong, and clear from static interference due to electric storms, and anyone accustomed to reception of these programs on their

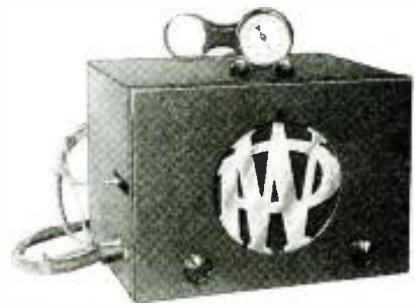

Fig. A
The complete set in its crackle-finish box and chromium speaker grille.

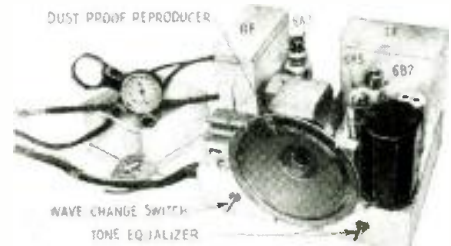

Fig. B
The chassis, generator "B" unit and remote control—showing positions of parts. Note how speaker is recessed into the chassis.

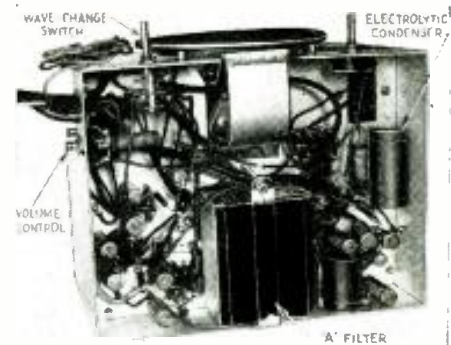
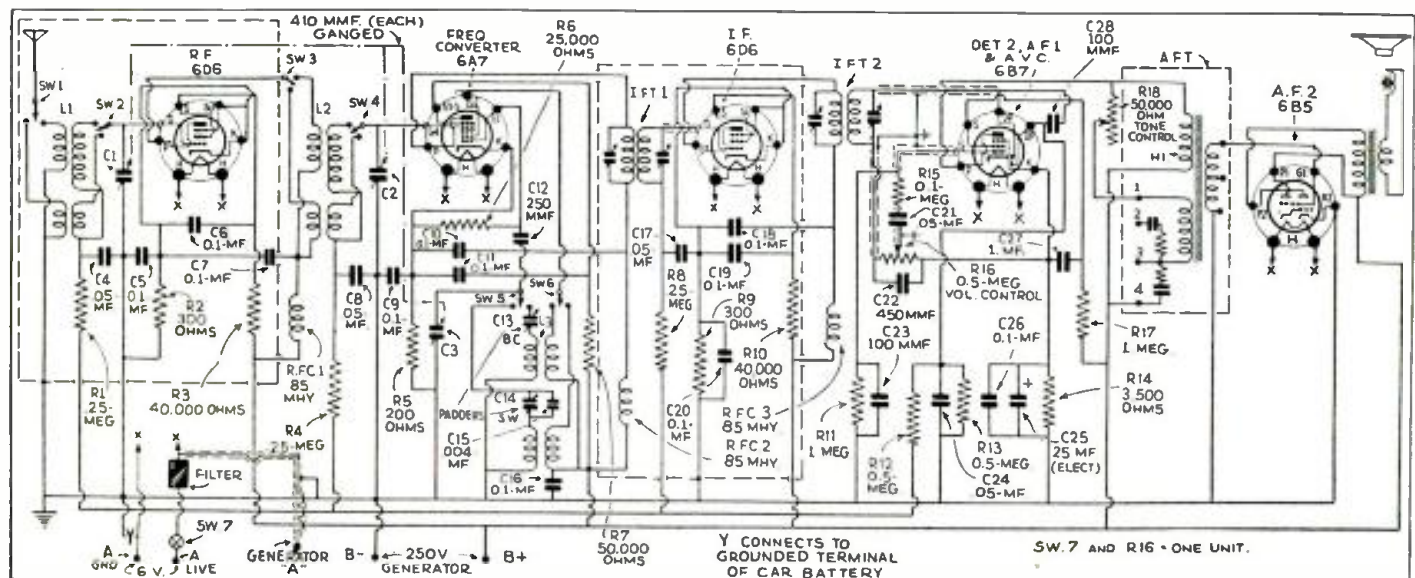

Fig. C
The under-chassis view showing the condensers, resistors, tube sockets and wave-change switch.

home "all-wave" receiver will relish the opportunity of receiving their favorite station while away on trips. Of course, (Continued on page 748)

Fig. 1—The circuit of the complete dual-band set, with values of all parts—the intermediate frequency is 456 kc.





THE PRESENT STATUS OF AUTOMOTIVE RADIO

WILHELM E. SCHRAGE

In this survey of the auto-radio field, the author covers every salient fact concerning the design, installation and operation of car-radio sets.

AUTOMOTIVE radio receivers, which only a few years ago played an unimportant role in the production division of the American radio industry, now play a prominent—almost a life-saving—part in the sales program of many radio manufacturers. As for instance, about 20 per cent of all sets sold during the last two years have been auto-radio receivers (see Fig. 1A), and for 1935 far greater sales figures are prognosticated.

While in 1932 dealers succeeded in distributing only 142,000 auto-radio receivers, the statistics for 1933 tell about sales five times as big—and involving the tremendous number of 724,000 receivers! This unexpected expansion, without any parallel in American radio history, has been surpassed during 1934 by sales of more than 780,000 auto sets (figure, courtesy ELECTRONICS), (see Fig. 2), and the estimates for 1935 forecast a distribution of about 1,000,000 auto-radio receivers!

According to the sales figures given above there are between 1.7 and 1.8 million automotive radio receivers in use today; a relatively small number if we consider that there are about 21 million passenger cars in operation. This means that only 14 per cent of all passenger cars are equipped with sets, while 86 per cent remain as virgin sales opportunities. (See Fig. 1B.) These figures would seem to justify the statement that these sales possibilities, rather than television (see the author's article, "A Modern Picture of Television," in the April and May, 1935, issues of RADIO-CRAFT), will bring the much-prayed-for radio "boom," because auto-radio sets are on the way to becoming standard equipment in every modern American car.

BLACK CLOUDS IN THE BLUE SKY

However, this pretty picture of the future changes quite a bit when attention is paid to modern construction trends in car design. The *dernier cri* of the auto industry now is the "turret top"—the all-metal roof employed in many of the 1935 cars; and in most designs projected for 1936! So far as safety is concerned there is no doubt that this improvement represents remarkable progress in car manufacturing, but for the radio industry the all-

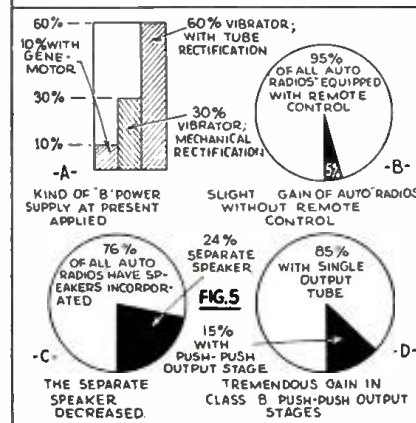
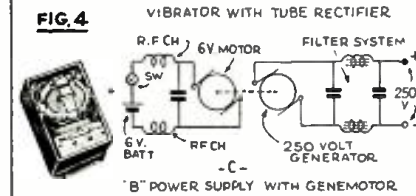
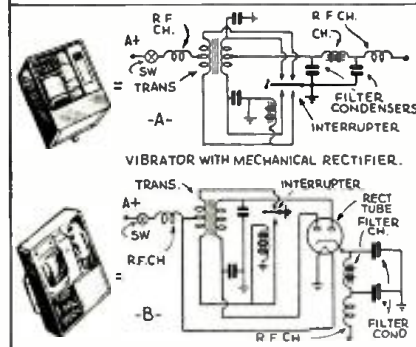
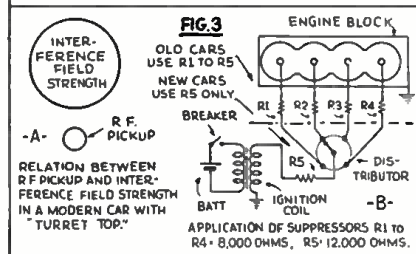
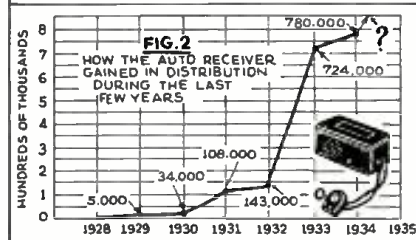
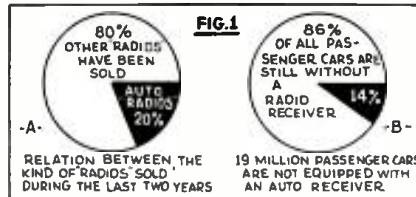

metal roof is paralyzing! For, the "turret top" is not only a very efficient shield against thefts and car accidents, but also serves as a very efficient shield against radio waves, making many of the approved auto aerials of previous years very inefficient, and ripe for the museum!

The performance of a car-radio set is dependent upon the strength of the R.F. pick-up brought to the first stage of the receiver. Heretofore, with its shielded lead-in, the sedan-roof antenna (with a capacity of 200 mmf. and a resistance of 1.5 ohms at 1000 kc.), remote from ignition interference and having maximum effective height, has been just about perfect. But this tranquil state has passed. The turret top has now obsolesced the roof antenna, thus putting the radio engineer "on the spot" to find a substitute giving an equal interference-free R.F. input of sufficient strength.

SOMETHING ABOUT ANTENNAS

In recognizing this difficult situation there is now much talk among auto-radio Service Men about the so-called "underslung" antenna (which works with impedance-matching transformers to maintain the signal level, and a special R.F. transmission line to keep the interference level down). In this connection it should be noted that its effective height is only 1/3 to 1/2 that of a roof antenna.

According to Cutting and Gates, the roof-type antenna has an average effective height of about 1/2-meter. This means that an R.F. pick-up of 20 microvolts may be obtained with a good roof antenna if a "field strength" of 100 microvolts-per-meter is available; now, in consideration of the very high noise level of a car, an output of 2 to 2.5 watts is necessary to obtain sufficient volume to over-ride the car noise level. Consequently, a gain of 111 db. (about twice the sensitivity of an ordinary "home" receiver) must be provided to raise the 20 microvolts R.F. input to an A.F. power output of 2.5 watts; the problem in turret-top cars is several times more difficult!

In turret-top cars, to secure with an underslung antenna the output obtained in non-turret-top cars and a roof antenna, would require a receiver gain of

(Continued on page 747)

CAR-RADIO SETS AFLOAT

The car-radio set is ideally adapted for use in small boats as this article explains.

THAT the "automobile" type of radio receiver is ideally suited for use in the some 200,000 craft that constitute the "small boat" floatilla in American waters, is a fact little realized by the average technician—in fact, even the industry as a whole has passed right by this lucrative field as though it were a plague! The car set, it must be remembered, is very compact and sensitive; too, it is conveniently controllable from any location near the helm.

The most important consideration when installing a car-radio set in a motor boat, is the location of the chassis. It is *imperative* that the receiver be mounted or placed out of the field of spray. The boat builders invariably place



Fig. A. The remote control, like in a car, can be mounted on the dash.

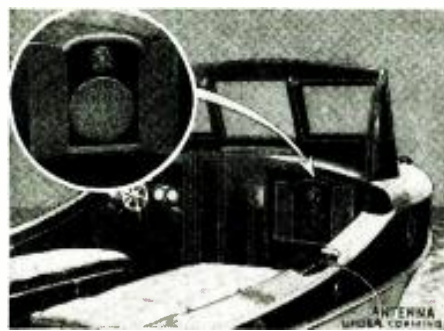

Fig. B.

The small cabin boat is a fine place for a car radio. It is necessary to protect it from the effects of salt water, though, or trouble will ensue.

the receiver in a closet or cabinet. Boat owners usually mount the set on a wall or partition in the cabin.

After a suitable location has been found, the speaker and set, or the entire unit if the speaker is integral, should be given two or three coats of shellac, clear Duco, or varnish. This *must* be done to prevent rusting and corrosion of the metal housing and of the components due to the salt air.

In the event the set must be installed in the cockpit of an open boat or otherwise in the field of spray, then, not only must the set receive three coats of the above finishes, but also the metal parts of the speaker—including the voice coil, if it is a dynamic reproducer. This practice must be followed on every job.

The illustrations show three common locations of the
(Continued on page 745)

Here are a few of the multitude of possible uses of radio in cars which may be turned to profitable side-lines by Service Men.

R. D. WASHBURNE

WHILE auto radio has advanced by leaps and bounds during the past year, and many novel and interesting uses have been devised for car-radio sets, there are many others which may be turned by the Service Man into profitable side lines.

For instance, in sedan and touring cars, the passengers in the back seat have no control over the radio set, either volume or station selection. How much handier it would be if there were

two controls, one for the driver and the other for the use of a person in the back of the car! And this can be worked out without great difficulty by the Service Man, by the use of a long flexible cable (such as the one shown on page 156 of the September 1934 issue of RADIO CRAFT) and a friction drive, attached to the present remote control. A rubber wheel attached to the front-seat control and a similar one attached to the new remote control, arranged so

that the two wheels press tightly together will permit the second dial, in the back seat to function.

Another interesting possibility for the car-radio enthusiast is the use of ultra-short-wave transmitters and receivers in cars for "hound and hare" games. This is fine sport in the country, for vacations and outings. One car is equipped with a small portable transmitter (under the direction of a
(Continued on page 754)

NOVEL IDEAS IN CAR RADIO

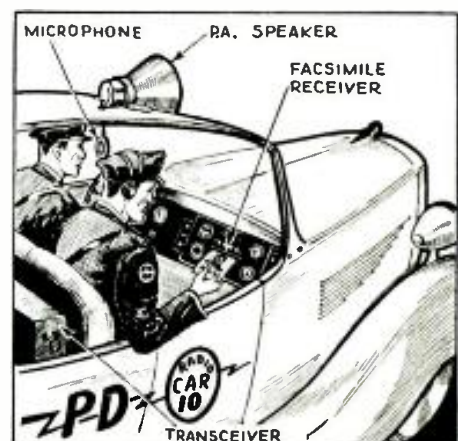
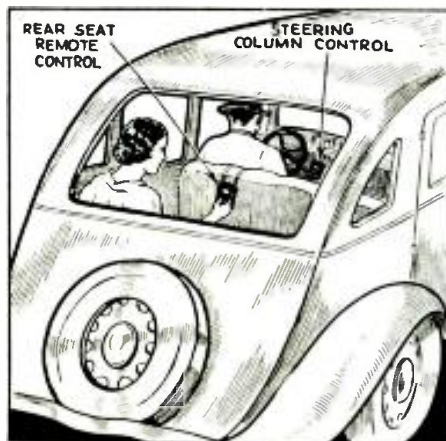

ANNOUNCING—

OTHO FULTON

ELECTROLYTIC PICTURES VIA AN IMPROVED SYSTEM

A description of a new method of sending and receiving pictures which is extremely simple yet produces a definition equal to the best photographic facsimile process in use.

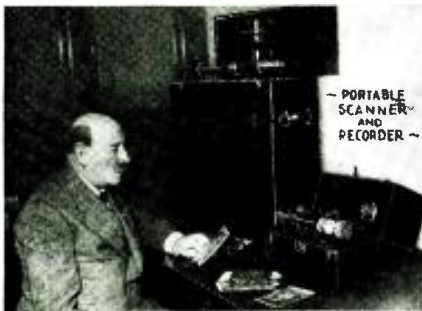

Fig. A. Complete scanner and recorder.

SEVERAL years ago the radio world was startled to hear that a picture was sent through the ether from London, England, to Sidney, Australia. It was essentially an experiment at that time, but it was the forerunner of the development of an extremely practical and foolproof method for sending photos, drawings, printed matter, etc., over great distances with faithful reproduction at the receiving end.

Today the system has been perfected, and in a short time it will be placed on the market under the trade name "Fultograph."

The Fultograph greatly differs from other telephoto machines, in that a light beam and photoelectric cell are not used in the receiver, commonly called the recorder. Instead, reproduction is accomplished by the "electrolytic" action (decomposition of a chemical compound by electricity) of a stylus contacting a paper moistened with a special (copyright pending) iodide solution. The recorder develops a 4x6 in. picture in about 4 minutes.

When the electrolytic action occurs (which is practically instantaneous), shading results as a "positive," completed picture in "sepia" (a beautiful shade of brown), which corresponds in density to the print or "negative" at the transmitter, or scanner as it is properly called. An advantage of the system is that the operator can control the density or contrast by varying a volume control which adjusts the current flowing to the stylus.

THE PORTABLE INSTRUMENT

A complete picture system for portable use is shown in Fig. A; the electrical circuit is shown in Fig. 1. Note the absence of intricate mechanism. This type of apparatus is now being tested by various police departments for the transmission of pictures from

headquarters to cruising police cars on patrol.

Figure B more clearly illustrates the simplicity of the scanner. In place of using a series of complex lenses to reflect the shading of the picture to the photoelectric or "PE." cell, a more direct system is used. The PE. cell is placed inside of a glass cylinder which is coupled to a "synchronizer." The print or negative is placed around this cylinder. A light beam for energizing the PE. cell is produced by a lamp and a condenser lens, set in a housing which rests on the cylinder.

The light beam is adjusted so that it passes through the negative and falls on the plate of the PE. cell. As the cylinder is rotated, the beam of light will vary in intensity as the negative density also varies.

Thus a fluctuating potential is set up by the PE. cell and a corresponding fluctuating potential is produced at the input of the radio transmitter, and finally out into the ether.

At the receiving station the picture "signal" is tuned in just like a regular music program, the impulses finally being fed into a power amplifier, which is mounted in the base of the instrument as shown in Fig. C. The ampli-

RADIO-CRAFT takes pleasure in presenting for the first time in this country, complete details on the Fultograph system of picture transmission. This extremely simple device develops pictures within the home in 5 minutes.

fier increases the strength of the impulses to a point where the electrolytic pencil or stylus will literally burn the picture into the print. The current is usually from 2 to 5 ma., depending upon the picture "contrast" the operator desires.

In the recorder the stylus forms one contact, and the metal cylinder on which the print is mounted, the other. The print is moistened in the special iodide solution, thereby forming a conductor in order that current can flow from the stylus to the cylinder.

As the current flows from the stylus through the damp print to the cylinder, an electro-chemical action occurs which produces on the print a shade, (Continued on page 743)

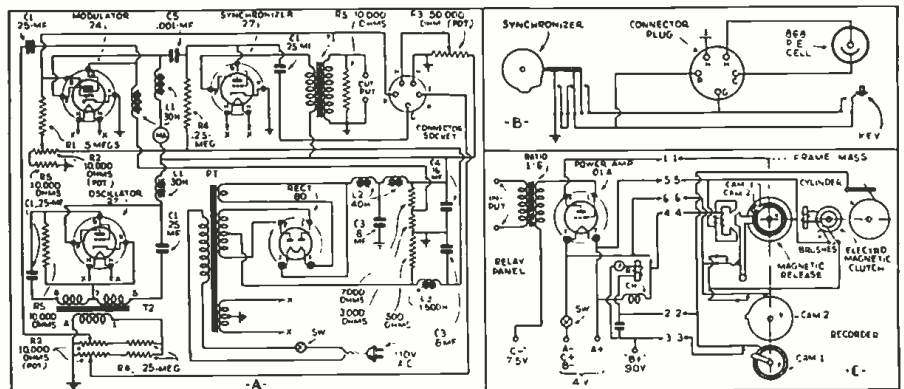

Fig. 1. Above. Circuit constants and diagram of Fultograph system.

Fig. C. Relay panel and recorder.

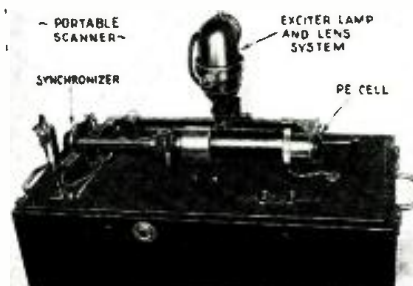

Fig. B. Details of scanner.



PORTABLE "P.A.-RADIO" SYSTEMS

The Service Man will find in this handy, portable outfit, a fine source of income either through sales or rentals.

LOUIS B. SKLAR

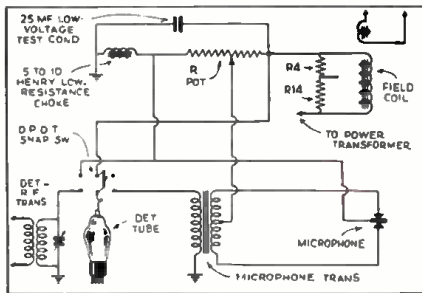
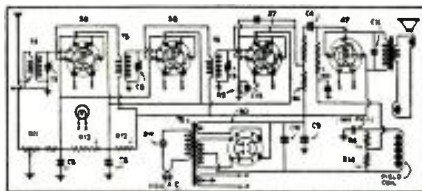

Fig. 1, above
The changes in the circuit of the receiver.

Fig. 2, below
The original circuit of the radio receiver.



OVER a year ago the writer was called upon by a well-known company owning many drug stores in Philadelphia, to supply them with a number of speech amplifiers and radio combinations. Their main reason for the use of radio entertainment in addition to the microphone was as follows: The microphone can only be used during those times of the day when pedestrian traffic is heaviest. Even under this limitation the microphone still is used about eight hours a day. Since no one man could stand the ordeal of talking into the microphone for eight hours straight without a stop, two men were used for this purpose, alternating every half-hour. Now, in order to obtain maximum value from their investment in a P.A. system and the services of two operators, the owners of the stores asked that the instrument be one which would give the passers-by some sort of entertainment to demand atten-

tion to the window display at all times.

Their specifications continued, as follows: a compact speech amplifier and radio combination that would be portable, with microphone, speaker, speaker-cable, plugs, etc., incorporated in the same carrying case. Its installation or removal should not be any harder than removing or installing an ordinary midget-type radio set, so that any clerk in the store could take the outfit from one store and install it in another store without any trouble.

With this view in mind the writer de-
(Continued on page 746)



MAKING A VIBRATOR "B" TEST UNIT

The circuit and instructions for making this tester.

D. A. R. MESSENGER

The meter panel is located on the panel of the service bench, where it is out of the way. The "socket unit" measures about 10x6x6 ins., and can be kept on a shelf when not in use.

Now for the actual construction. The meter panel comes first. The constructor can, of course, use his own judgment as to the materials and design used. The 300 V. D.C. meter should have a resistance of 1000 ohms per volt. The A.C. meter may be omitted if desired. (I incorporated it to measure the A.C. voltage developed across power transformer secondaries, thus being able to quickly detect defective transformers.) This meter is connected to meter jacks only, as it is not used in routine testing. The D.C. ammeter is also brought out to jacks, for convenience in measuring current drawn by an auto set being tested.

After the panel is completed, and it is mounted in place on the bench, the two terminals marked 6 V. are connected to a 6 V. source, either a storage battery, or an eliminator. A switch can be wired in series with the positive lead as well as a 10 A. fuse. A storage bat-
(Continued on page 750)

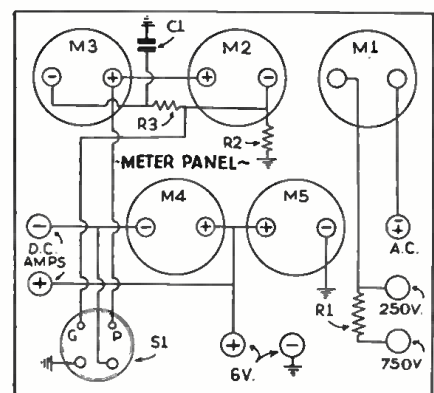

Meter panel, above; socket unit, below.

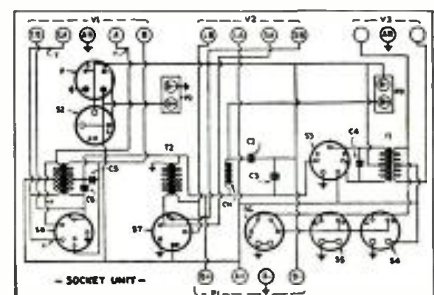

AUTO-RADIO "B" power vibrators have now been in use for over two years, and are giving trouble, due to prolonged use. To facilitate repairing these units, I designed and built a vibrator tester for the service bench. The primary considerations in the design of such a unit are efficiency, compactness, and economy. I believe that the tester to be described is all that can be desired.

Any type of vibrator in common use today can be tested under actual working load, the meters showing simultaneously the input voltage and current, and output voltage and current. In addition, all Motorola powerpacks can be tested under the same conditions.



A metallic-flap extension is shown.

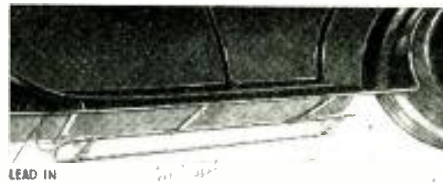
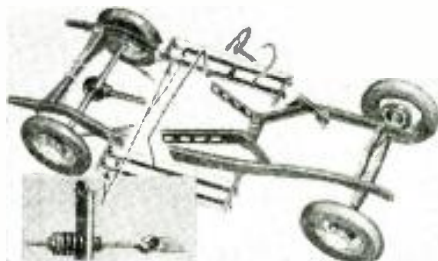

Above, dipole balances out noise.

Left, both runningboards are used.

THE NEWEST IN CAR ANTENNAS

Diversified ideas for the car antenna are described in these interesting items.

THE DROP-FLAP ANTENNA

(Ward Products Corp.)

EVERYTHING in antennas these days, in the matter of car aerials, seems to run to runningboard patterns of one type or another. We have become familiar with the design of under-runningboard antenna that consists of a plain panel of metal suspended on stand-off insulators. Now, a manufacturer has found that adding a conductive flap at one end of the metal plate greatly increases the signal strength.

The metal-work of the flap is protected from the elements by means of a rubber covering. The flap is quite rigid, and tends to maintain its normal position, with the edge about 2 ins. from the ground, at all times regardless of car speed.

DUAL RUNNINGBOARD ANTENNA

(Delco—United Motors Corp.)

COINCIDENT with the new cars have been the antenna offerings of various manufacturers. A few of these ideas have been backed by independent manufacturers, but the majority of the more successful ones have been sponsored by those engineering departments directly connected with the car manufacturers, and thus in best position to work on the problem.

Thus, one manufacturer of a number of different brands of cars is content to mount four metal laths horizontally underneath the runningboard. A spring suspension is employed at one end of each strip, to keep the strip taut. This antenna is the manufacturer's answer to the "turret top" problem.

THE "DIPOLE" CAR ANTENNA

(RCA Manufacturing Co., Inc.)

UPON checking up the characteristics of the new "dipole" car under-runningboard antenna we are reminded of the old song which bids us "pack up our troubles in our old kit bag and smile, smile, smile!" For, this new antenna not only affords excellent signal strength in turret-top cars, but it also is self-neutralizing with respect to car interference—noise voltages are picked up by both poles of the dipole antenna, and balance out at the receiver, leaving only the regular broadcast signal. A more detailed description of this exceptionally interesting development in car radio equipment is given for the benefit of those who want technical proof.

(Continued on page 763)

MODERN AUTOMOTIVE-RADIO SETS

The new car radio sets for 1935. Schematic circuits appear on the following two pages.



BOSCH 524 A

(1) "Integral construction" is the keynote of this set. The 5-tube chassis, power pack and reproducer are in one "can."

(2) New Chevrolet cars provide for this 4-tube set, with its overhead reproducer, and antenna-impedance matching adjustment.

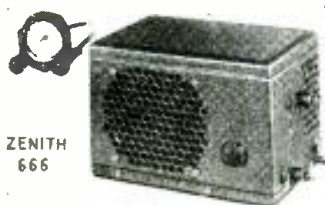

ZENITH 666

(3) This 6-tube set is carefully designed on the basis of "suppressor-less" operation, extended-range tuning, and high output (3W.).

(4) A 5-tube set, in a die-cast housing. Chassis is "fortified" (protected against shocks, dust, and temperature extremes).

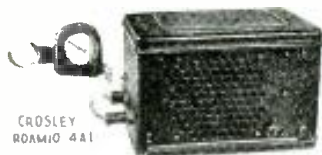

CROSLY ROADIO 481

(5) Seven-tube performance with 4 tubes, is claimed for this set. Battery drain is only 5A. The set is designed for easy service.

(6—lower right) An overhead-speaker, 6-tube job for the new "turret-top" Fords. Finished to match interior of car.

(7) An 8-tube, "suppressor-less" set, in two types: "header" type for Fords; and panel, for General Motors cars. Of exceptional interest is the "anti-noise" device built into back of set; it "balances out" car noise.



RCA VICTOR MEISSL 811M

(8—above) A 5-tube set with remote control "stream-lined" for eye-appeal. Requires the use of only a distributor suppressor. The highly-developed input circuit that characterizes all "magic brain" designs is employed in this receiver.

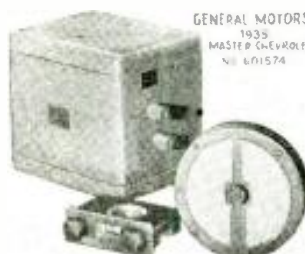

GENERAL MOTORS 1935 MASTER CHEVROLET NO. 601574

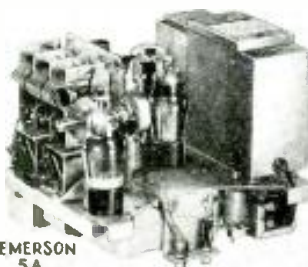

EMERSON 5A



GALVIN 5000



ARVIN FORD 12-A

SPEAKER IN HEADER

REMOTE CONTROL

RADIO SET

(5) **Crosley Roamio 4-A-1.** A self-rectifying vibrator—"B" unit is used in the power supply of this receiver. High gain in this receiver has been achieved through the use of high-efficiency R.F. and I.F. coils. This set mounts under the cowl section of the car, with the dial visible below the instrument panel. Thereby, the lid is easily removable for convenient service.

Voltages: Plate—V1, 230; (Osc., 60); V2, 230; V3, 60; V4, 220; Sup.-G.—V4, 3. S.-G.—V1, 100; V2, 100; V3, 25; V4, 230. Cath.—V1, 8; V2, 3; V4, 3; V5, 16. All voltages should be plus or minus 10 per cent, and measured to chassis with 500 volt 1000 ohms per-volt voltmeter.

(6) **Arvin-Ford 17-A.** A 2-way plug switch provides extreme sensitivity for country driving, and lowered sensitivity and reduced noise level for city driving. Tuning condensers and tuning mechanism float on rubber to prevent car vibration from detuning the set. Filter condensers are hermetically sealed. Noise-filter circuits are built into the set. The vibrator—"B" unit is of the non-synchronous type; a type 84 tube supplies the required rectification. Field current for the dynamic reproducer is obtained by connecting the field coil directly in shunt with the car battery. A stage of tuned R.F. amplification ahead of the first-detector eliminates image-frequency response. The oscillator circuit is tuned by a shaped-plate condenser.

Voltages: Plate—V1, 220; V2, 220 (Osc.—175); V3, 220; V4, 115; V5, 208; V6, 230 A.C. S.-G.—V1, 70; V2, 70; V3, 70; V5, 220. Cath.—V1, 3.3; V2, 3.3; V3, 2.5; V4, 1.5; V5, 14; V6, 225. Sup.-G.—V1, 3.3; V3, 2.5 Osc. Grid.—5-10. Make voltage tests with at least a 1000 ohm-per-volt-voltmeter. Plus or minus 20 per cent on all voltages is acceptable.

(7) **Motorola 100.** An 8-tube set of outstanding design. Of foremost importance is the use of a balancing-out circuit for counterbalancing car ignition-system interference. (When balancing out interference by the method used in this receiver, it is advisable to clamp the car hood down tight with the hood hasps, and to sit in the driver's seat; otherwise, in extreme cases, if the noise is balanced out without anyone in the driver's seat it may reappear when the driver is seated.) The reproducer (except for header types) is equipped with a universal mounting which permits swivel adjustment to take full advantage of car acoustic conditions. A novel push-pull output circuit is utilized in which one (treble) tube, V6, is capacity-inductance coupled from the plate of V5. The other (bass) tube, V7, is conductive-inductance coupled from the grid of V5, thus producing the desired 180 deg. phase shift. Tone control is then accomplished by varying the degree of amplification by tube V6.

Voltages: Plate—V1, 195; V2, 195; V4, 35; V5, 45; V6, 195. S.-G.—V1, 75; V2, 75; V3, 75. Cath. V1, 8; V2, 8; V3, 7; V6, 39. All voltages measured from tube contacts to ground.

(8) **RCA Victor M-104 (and M-108).** The M-104 is a single-unit receiver; the M-108 has the reproducer separate from the set assembly. From antenna to reproducer, this car-radio receiver has been designed for interference-free operation without recourse to suppressors. The ground-end of the antenna coil, for instance, is not grounded directly at the receiver chassis, but is carried to a point on the car frame at which circulating noise-currents do not become mutual to the receiver input; the R.F. transmission line favors broadcast signals and greatly attenuates interference frequencies. A self-rectifying, synchronous plug-in vibrator—"B" unit is used. A tone- or speech-clarity control, Sw. 2, is used which varies only the bass response by changing the value of the condenser in the coupling circuit of the output tube. Battery consumption is 5.8 A.; power output, 1.75 w., undistorted, and 3.5w., maximum.

Voltages: Plate—V1, 215; V2, 215 (Osc.—215); V3, 215; V4, 90; V5, 245. S.-G.—V1, 82; V2, 82; V3, 82; V4, 20; V5, 255. Cath.—V1, 5.4; V2, 5.4; V3, 3.5, 20. (*) Cannot be measured with an ordinary voltmeter.

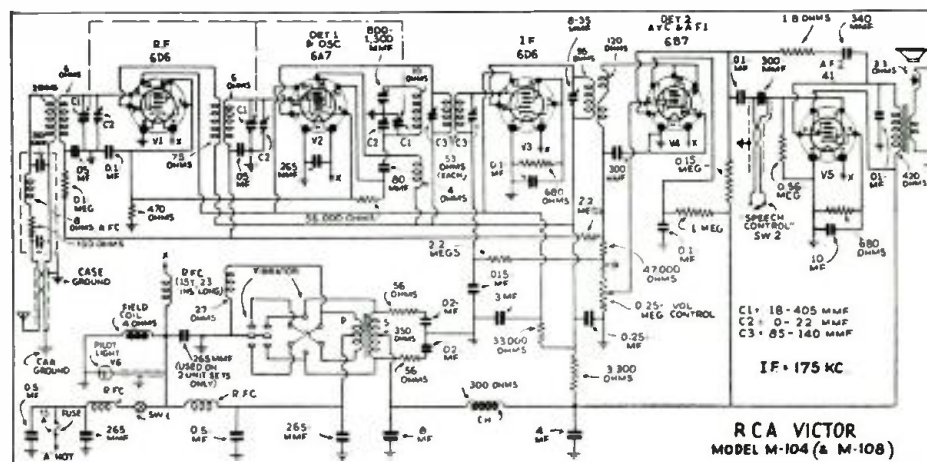
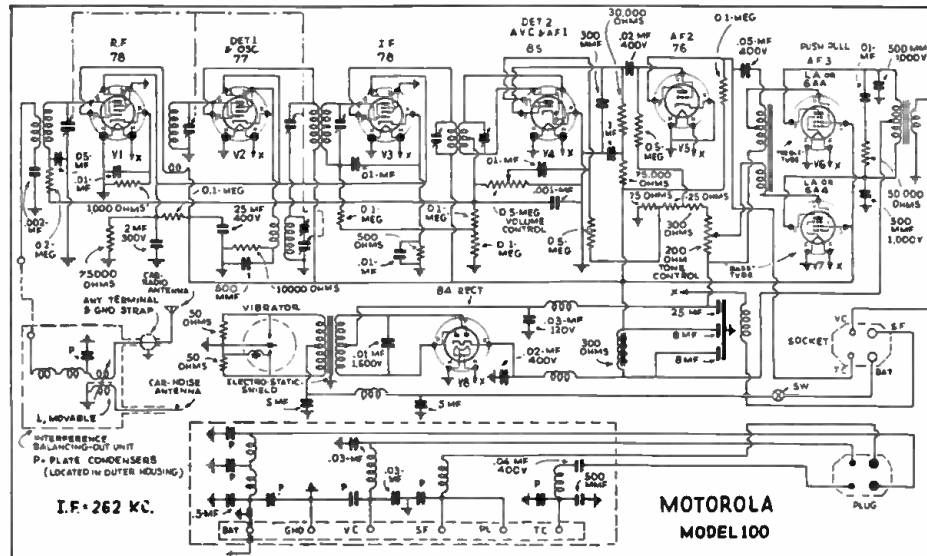
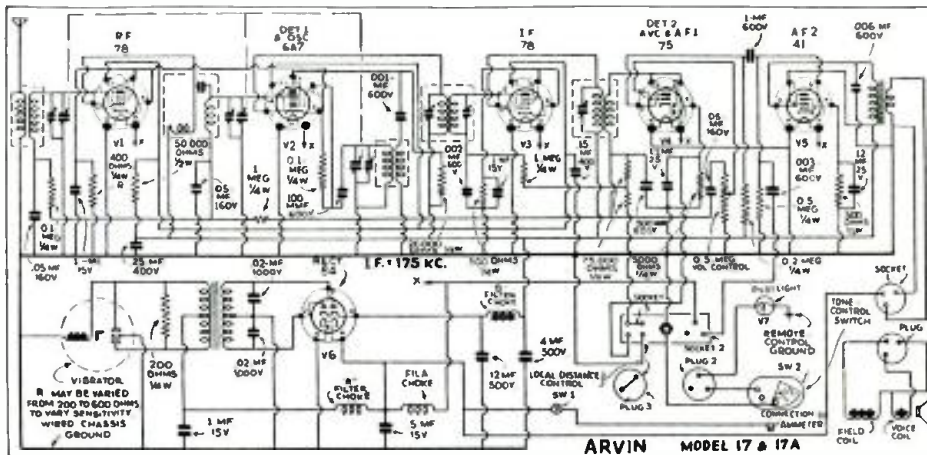
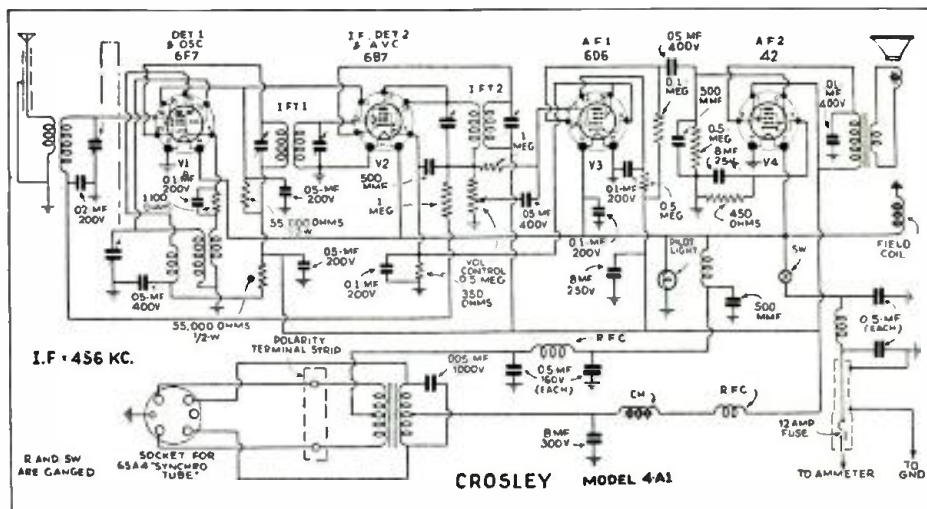

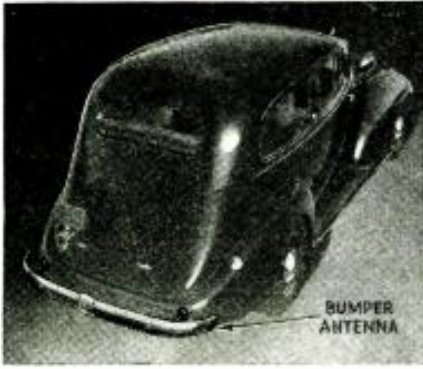

THE "BUMPER ANTENNA" FOR 1935-'36 CARS

A practical solution to the bugaboo of turret-top aerials.

JAMES CAULFIELD

advantages of the roof antenna and none of the disadvantages of the underslung antenna it was decided to try as the aerial *the rear bumper*.

This part of the car presented a pick-up that was far removed from ignition interference, but did not have the "effective height" of the roof antenna. It did, however, possess the unquestioned advantage of being spaced away from the body of the car. The latter point would offset the low effective height.

Taken as a whole, the bumper pick-up solved the antenna problem—it produced a good signal-to-noise ratio, did not harm the looks of the car and it was rigid to road shocks.

When considering the use of the rear bumper for an antenna two forms of bumper construction must be considered. First, there is the universal method of clamping the bumper to the chassis; second, there is the Ford method of bolting the job directly to the frame. See Figs. 1 and 2.

Let us start with the former since it is the most popular. Remove the
(Continued on page 746)

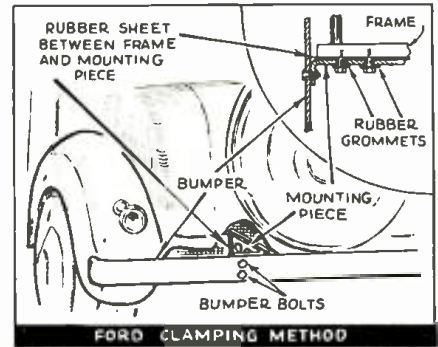
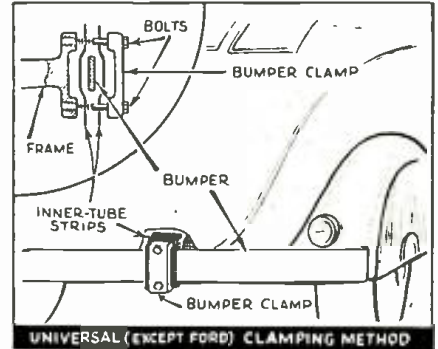

THE newer cars, namely, the turret-top type, are presenting a problem for R.F. pick-up. This type of car is made with an all-steel body, including the top, and is in one piece. It forms a perfect shield, permitting only a minute signal to seep in through the windows. Nevertheless, manufacturers are delivering these cars with inside roof antennas! The result is that the radio installation has practically no signal pick-up but a "whale" of a lot of noise! Therefore, a substitute, more suitable antenna *must* be found.

It is a universally accepted fact that the best form of pick-up is an antenna which is remote from the ignition system and an optimum distance from the car body.

In casting about for a new form of pick-up that would possess some of the

BEGINNER IN CAR RADIO

THE Service Man who tackles his first car-radio installation is usually due for a shock. There are so many tricks to successful installation of car sets that the beginner is up against it.

Before trying to install your first set, obtain every piece of literature and every service manual you can lay your hands on—read them carefully and make a mental or written summary of all the ideas, for you will need them all.

Then when you get your first installation job, try the set on a service bench; test it on the car aerial; run the motor and reduce the noise as much as possible by every kink learned from the manuals and articles you have read; then adjust the aerial compensator of the set for greatest signal strength and mount the set in place.

The photos show: the installation of a reproducer in the floor of a car, the installation of a running board aerial, and the replacement of "chicken wire" aerial with a fine copper screen.

Photos by Halbran



THE LATEST RADIO EQUIPMENT



High sensitivity in this unit is also available for airplane waves. (710)

OPTIONAL-RANGE CAR SET (710)

A RUGGED 5-tube auto-radio superheterodyne. Single unit with illuminated, airplane-type remote control. Easy to install; one point mounting; only two connections—ammeter and aerial. Available in either broadcast (550 to 1,500 kc.) or airplane range (150 to 375 kc.).

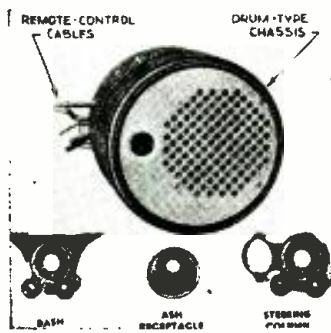

Features mechanical improvements. (711)

DRUM-TYPE AUTO-RADIO RECEIVER (711)

A COMPLETE set mounted in a cylindrical case, with 6 in. dynamic speaker, shown in photo and having a choice of three remote controls—steering column, dash mounting and "ash receptacle." It is claimed that the drum-type design eliminates rattles caused by ordinary mountings. A 6-tube superhet. circuit is employed. Removable cover and plug-in speaker connections provide easy tube replacement and adjustments.

4-RANGE TESTER (712)

(Radio City Products Co.)

THE twelve scales on the four essential ranges of this newest tester permit a wide number of tests. An automatic selector switch instantly connects the meter to desired circuit and range; and guards against burn-out by disconnecting the meter from all other circuits and ranges. Ohmmeter range: $\frac{1}{4}$ -ohm to 2 megohms. Sensitivity: 2,000 ohms-per-volt. Voltages: 5 to 750 V., A.C. or D.C. Milliammeter: three ranges, up to 250 ma. A bridge-type copper-oxide rectifier is used to obtain full-wave rectification.



Multi-scale, multi-use tester. (712)

DUPLEX-TRIODE POWER AMPLIFIER (713)

(National Union Radio Corp.)

A LOW-MU twin-triode of the cathode type for use in 6 V. operation has just been announced—it is designated as the 6E6. Designed for use in output stage of car-radio and A.C.-D.C. sets. May be used singly, or in push-pull.

Use self-bias; 180 V., 870 ohms, and 250 V., 770 ohms. Characteristics follow: *Plate, 180-250 V.; 11.5-18 ma. Grid, -20 to -27.5 V. *Mutual Conductance, 1,400-1,700 mmhos. Amplification factor, 6. Plate resistance, 4,300-3,500 ohms. Load resistance, plate-to-plate, 15,000-14,000 ohms. **Undistorted power output, 0.75 to -1.6 W. (*Per triode; **per pair of triodes.)

CAR-RADIO WITH MAGNETO-DYNAMIC REPRODUCER (714)

THIS auto-radio set is equipped with a permanent-magnet dynamic speaker (thus reducing battery drain). Set has 3.2 W. output. Made in 5- and 6-tube models.

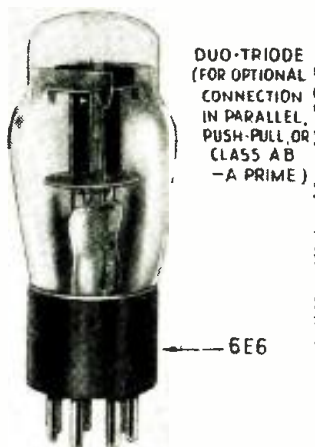

DUO-TRIODE (FOR OPTIONAL CONNECTION IN PARALLEL, PUSH-PULL, OR CLASS AB -A PRIME)

WESTON ALL-WAVE OSCILLATOR (715)

(Weston Electrical Instr. Corp.)

THIS battery-operated all-wave test oscillator, using two type 30 tubes, has a fundamental-frequency range from 100 kc. to 22 megacycles, obtained by means of 6 plug-in coils. A special attenuator makes possible a minimum output of 1.0 microvolt (important for receivers equipped with A.V.C.). A constant impedance of 200 ohms is maintained at the output jacks, throughout the attenuator range. Constant internal modulation of 50 per cent is provided at all frequencies by a separate, switch-controlled modulator tube. (External modulation may be used.)

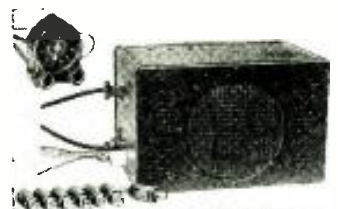

This car-radio set incorporates a permanent-magnet reproducer. (714)

26 OR 52 W. P.A. AMPLIFIER (716)

(Coast-to-Coast Radio Corp.)

HERE is a compact, versatile and powerful P.A. amplifier which operates from either 110 V. A.C. or from a 6 V. storage battery. Dual channels provide 26 or 52 W. output. The universal input circuit permits coupling to any line, preamplifier, radio tuner, phono, pickup or microphone. Self-contained microphone current supply, current-reading meter, current control, selection switch and tone control are additional features.



All-wave service oscillator. (715)

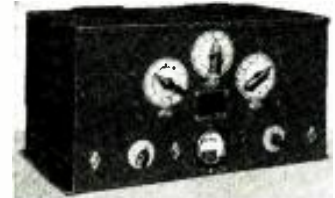

Dual-channel power amplifier. (716)

TUBE "ANALYZER" (717)

A TUBE tester has been developed which "analyzes" all types of tubes in each of the following three ways: Test No. 1—internal resistance between elements; No. 2—"hot" cathode leakage test; and, No. 3—standard tube merit test. Made in three types—counter, portable and panel. Tests over 208 types of tubes.



Triple-test tube "analyzer." (717)

30 AND 50 W. AMPLIFIERS (718)

(The Webster Company)

ONE new amplifier, connected for push-pull class A operation throughout, develops an output of 30 W. A second model has 50 W. output, and is class B in operation.

Both amplifiers are similar in construction, have individual volume controls on both the microphone and radio-set input circuits, with mixing arrangement and carbon microphone voltage self-contained. A milliammeter reads microphone current.



Two new high-watt amplifiers. (718)

THE 954 "ACORN PENTODE" (719)

THE 954* is an "acorn"-size heater-cathode type pentode designed primarily for radio amateurs and experimenters working with wavelengths as short as 0.7-meter. As an R.F. amplifier at a wavelength of 1 meter it will produce a voltage gain as great as three or

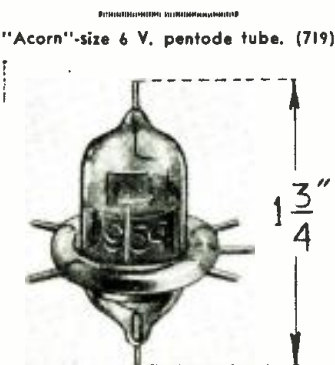

(Continued on page 757)

Name of manufacturer of any device will be sent on receipt of a self-addressed, stamped envelope. Kindly give (number) in description under picture.

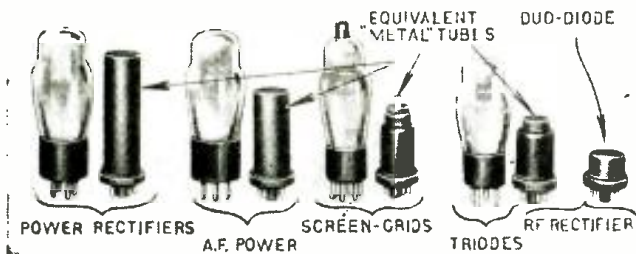

NOW—METAL TUBES

As first announced by RADIO-CRAFT, last month, the new all-metal tubes are making their appearance. Many advantages are claimed for the new tubes, as explained.

SINCE the brief mention made on page 646 of May 1935 RADIO-CRAFT of the new metal tubes, definite information has been released by the General Electric Co. who developed the new method of manufacture for the RCA Manufacturing Co., Inc.

There are many advantages claimed for the new tubes. They are smaller in size, being 1 in. in diameter at the largest point and varying between 5/8-in. to 3 ins. high (above the base or sub-panel). They provide their own shielding by virtue of the metal shell and this shell is a better heat conductor and radiator than glass. Because of the method of construction, the leads are shorter, within the tube, which permits greater amplification at the higher frequencies (the inter-electrode capacity is approximately 1/3 of the value for the equivalent glass tube capacity) and the more effective shielding assures greater stability.

Ten types of these metal tubes have been developed, to date, having 6.3 V. filaments. Some of these tubes have identical characteristics with present glass tubes (some of them are shown in the photo above, along with their glass twins) though several new types are planned including a double diode and a hexode which is an improved pentagrid converter.

The new tubes have one more base pin than comparable glass tubes, since the metal envelope has become a shield,

and provision must therefore be made to ground this envelope. Designers of the tubes have even taken into consideration ease of inserting them in their sockets. The contact pins are all the same diameter and in the center is a longer, larger, insulated keyed pin. By placing this insulated
(Continued on page 764)

The mechanical construction of the new tubes is evident from these detailed sketches of a screen-grid type.

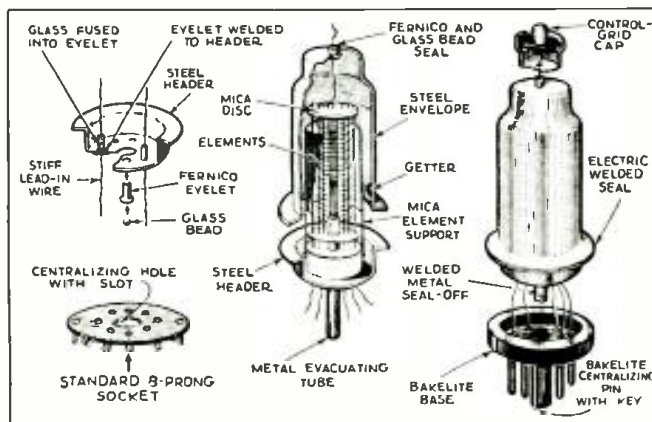

THE NEW RK-31 HI-POWER TUBE

Here is a new high-power class B tube which will interest the P.A. man. It uses no "C" bias.
CLIFFORD E. DENTON

A NEW tube of special interest to the P. A. man and transmitter builder has appeared which really offers a degree of performance with available equipment that is hard to beat.

The new RK-31 is a class B tube, suitable for high power P.A. installations where 100 W. or more of audio power is required; or it can be used as a class B or class C final stage in an amateur or commercial transmitter. Other possibilities will make themselves apparent as designers become more familiar with the tube.

The most striking characteristic of the tube is that it can be operated at 0 bias with an effective plate voltage of 1,250 V. The tube is rated tentatively at 125 W. In tests using two of these tubes in a class B circuit an A. F. power output of over 140 W. was obtained, with the plates of the tubes showing just a slight trace of color. Remember, no "C" bias batteries or "C" bias power supplies are necessary for use with operation of this tube. Every amplifier builder who has had experience with RK-18, 203A, etc., in class B circuits, knows that the bias supply

section of the amplifier was always a headache. With this tube, bias supply is no longer a problem, since no bias is required. While the author has only had time to play with this tube in audio frequency circuits, it is apparent that the tube will take a very definite place in the sound reproduction and in the transmitting fields.

The following characteristics have been assigned to this tube at the present writing: The filament is rated at 7 1/2 volts at 3 amperes. Nominal plate voltage—1,250 V.; grid bias voltage—0; peak plate current—275 ma.; plate to plate load, 13,000 ohms; plate current—85 ma.; rated power output two tubes—125 W. This is for class B operation. At the present time no other information is available for class C performance, although this information should be coming forward very shortly.

The tube has an overall height of 7 3/4 ins. and the diameter is approximately 2 ins. The plate terminal connection is made from the top of the tube, and the grid and filament circuits are made in the conventional manner to a regular 4 prong socket. The
(Continued on page 765)

The appearance of the new RK-31 tube can be seen on the right. In appearance it resembles the RK-18—but it has many advantages over the latter.



Fig. 1
The internal appearance of the RK-31 showing how the two grids are connected together.

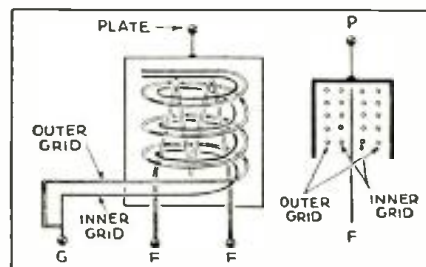

IMPROVEMENTS IN AUTO-RADIO AERIALS

Turret-top cars are causing havoc in the auto-radio business. Here is a practical solution to the aerial problem.

ARTHUR H. LYNCH*

QUITE contrary to general belief, the best possible type of automobile antenna is a suitably installed, large-surface screen, in the roof of a 7-passenger sedan, or touring car. (As the size of the aerial decreases, its pick-up decreases also.) The new "turret-top" cars, however, have an all-metal top that renders it a veritable shield can on wheels, and the resulting performance of the roof antenna is most discouraging.

LEAD-IN WIRES

Taking the best possible aerial and considering it as the basis from which others may be judged, it is desirable to understand just how the best of aerials may be connected to the receiver with the least loss of signal strength and with the least tendency to pick up interference created by the ignition system of the car. In Fig. 1 it will be observed that the same type of aerial is shown for the three types of lead-in systems now in common use.

The question is likely to arise, as a result of observing this figure, as to
*Pres., Arthur H. Lynch, Inc.

why system B does not show a greater signal strength than system A, in view of the fact that the lead-in wire itself actually becomes a portion of the antenna and should, therefore, give an increased signal response. There is a two-fold answer to this question.

First of all, while it is true that the additional antenna effect created by the lead-in results in an increase of signal strength, it should be borne in mind that this lead-in is generally brought through one of the corner upright columns in the front of the car and is carried in close proximity to the car ammeter, the ignition switch and other portions of the wiring system which make it very much more susceptible to ignition interference than would be the case if, for instance, the receiver were located in the back of the car and the mechanical remote control were provided on the dash. If the additional pickup is utilized, it is accompanied by more interference.

The second reason for the failure of
(Continued on page 752)

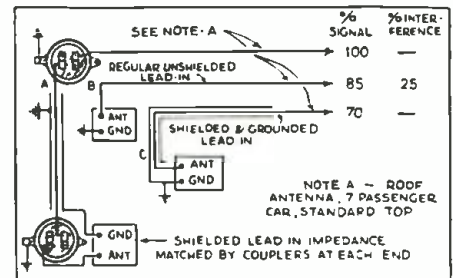
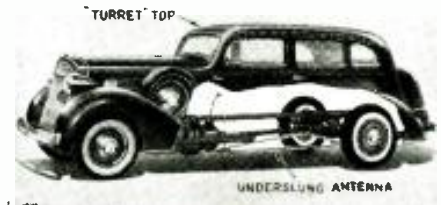
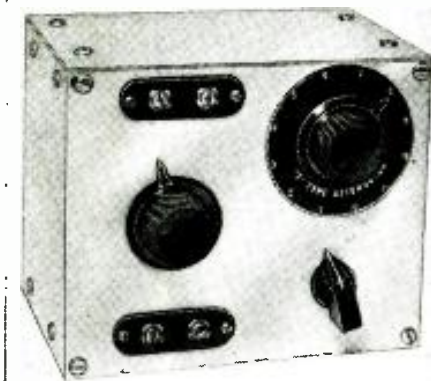
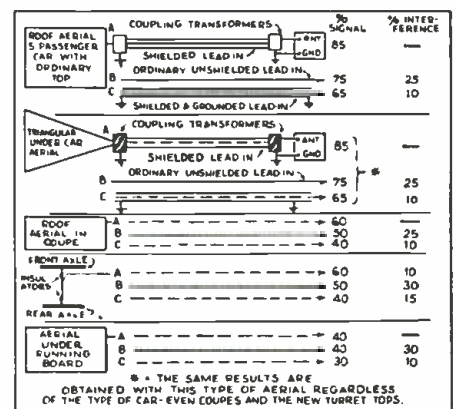

Fig. 1, above—and Fig. 2, below.



THE PRIME object of any audio amplifier used for P.A. or sound picture work is to reproduce the music or speech faithfully without any noticeable change or distortion of any kind. Speaking in more detail, to obtain true reproduction the entire equipment should not introduce or suppress any of the frequencies present in the signal, nor should they be partial to certain frequencies and amplify them more than they do others. While this is ideal in theory, in practice it is rarely accomplished due to speaker and transformer peaks. Furthermore, the acoustic conditions of the various locations often accentuate certain frequencies which result in a change of timbre or tone color.

To offset this effect in poorly engi-

HOW TO MAKE A "HIGH-FIDELITY ADAPTER"

The tone quality of an amplifier can be greatly improved by a correctly designed equalizer for low and high tones. J. B. CARTER

needed amplifiers the inclusion of a tone control has become quite common. Most of these so-called tone controls act to reduce the amplification of the high audio frequencies. This produces the effect of making the speech or music sound low-pitched. Thus a deep note effect is produced without increasing the amplification of the low notes. This method of apparent low note boosting does not produce natural reproduction, for since the high notes are cut off, the sound loses its brilliance and crispness.

A new form of tone control which actually increases or decreases the low or high, frequencies is shown in Fig. 1. This unit is a simple device which may be bridged directly across any 500-ohm line or, by means of an impedance-matching transformer, may be bridged across any line for the purpose of modifying the character of the input signal to an amplifier. It is designed to correct for deficiencies in response characteristics of an amplifier, or to reinforce the high and low frequencies
(Continued on page 751)

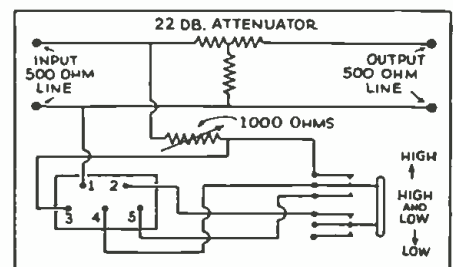

The circuit of the equalizer (Fig. 1, above) and some typical response curves, (Fig. 2, below) showing low and high frequency equalization effects.

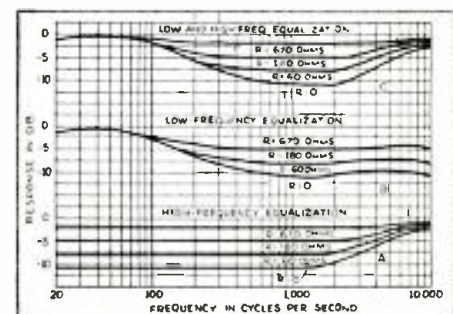

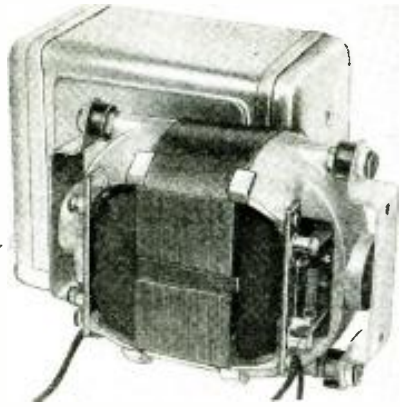

HOW TO INSTALL REPLACEMENT-"B" GENEMOTORS

When vibrator-"B" units give trouble, one way to cure the trouble is to install a replacement generator unit.

IN AN automobile radio receiver of any make or model, a careful analysis has shown that almost 90 per cent of the troubles which are referred to the Service Man have their primary origin in a defective power supply unit. Two types of power supply unit are commonly employed in auto-radio sets; the vibrator or buzzer type, and the motor-generator or dynamotor.

Many automobile radio sets obtain their high voltage power supply through some form of vibrating reed interrupter which rapidly makes and breaks the battery current to produce a pulsating direct current which is in turn stepped up and rectified, usually by a tube rectifier, the output of which

is then filtered and applied to the plates of the tubes.

Even the best vibrator contact points will show some evidence of wear over a sufficiently long period of service. The result of such wear will be found in the refusal of the reed to start vibrating. Some vibrators are equipped with adjustments to compensate for wear, but in many cases replacement of the contacts is necessary because of the fact that the wear does not take place equally over the entire surface of the contact points.

The new replacement *genemotor* for car sets possesses none of the inherent faults of the vibrator. It is an extremely compact dynamotor producing directly a high-voltage direct current of constant amplitude and practically no commutator ripple, free from all vibration and wear and creating no radio frequency interference.

Only two models are needed to handle

all replacements; one of the models JW-F has easy plug-in attachment for Fords, and a "standard" model is supplied for all other replacements.

Sufficient room may be found in the power supply unit of the set for mounting the unit. It may also be mounted
(Continued on page 754)

The complete circuit of the genemotor and filter. The filter of the set may be used advantageously.

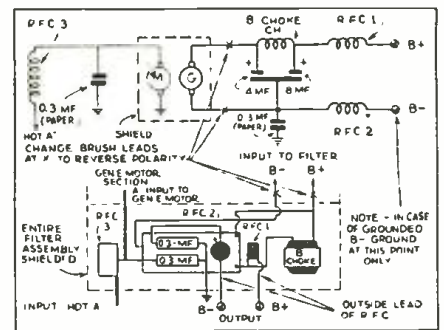

DEAF-AID EQUIPMENT -A SERVICE MARKET

The wide-awake Service Man can make a fine business of selling "hearing aids" to theatres and churches.

R. M. GRAY*

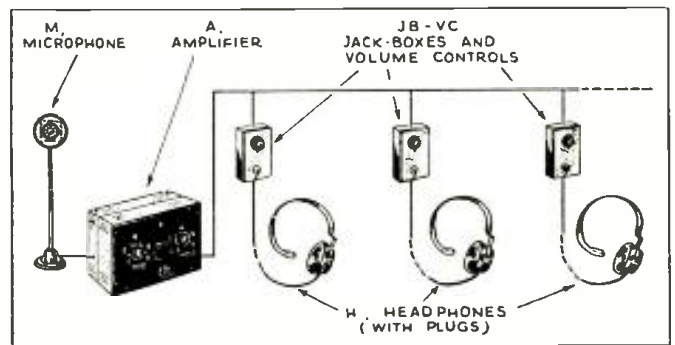

A complete set-up of mike, amplifier, jack boxes and phones.

THAT old adage about a man building a better mouse trap and having the world beat a path to his door doesn't work out in these times of high-pressure salesmanship and new scientific developments. In the field of Sound Distribution, or what is more frequently called Public Address, this condition is quite apparent. Selling sound equipment is still a pioneering job and requires the Service Man and dealer not only "digging up" the potential users of this equipment but also selling them to the idea that they cannot economically get along *without* the use of amplifying equipment.

The merchandising of "Aids to the Hearing" equipment has advantages that are three-fold: First, its installation is a boon to that large and many times influential section of humanity, the hard-of-hearing; second, it increases the attendance and hence the income of the theatre, church, etc., taking advantage of these improvements; third, it makes money for the Service Man and dealer who sells and installs the apparatus.

Consider the market for such equipment. Mr. Rupert Hughes, who is, himself, afflicted with impaired hearing, writing in the January 26th issue of LIBERTY magazine, says—"the number of people in this country with impaired hearing is approximately 16,000,000. There are nearly

twice as many deaf people in the United States as there are men and women and children in the whole city of Chicago!"

In other words, over 10 per cent of all people in the United States, an average of more than one out of every ten people, are barred from enjoying such pleasures as talking pictures, church sermons, lodge meetings, lectures and countless other activities.

SELLING HEARING AIDS

A good place to start is with the neighborhood theatre owner. First, find out his average daily attendance. Considering the above figures of one out of ten people having defective hearing, it is surely conservative enough to figure that one for every hundred of his daily attendance could be an added "deaf" customer, providing facilities were available for him to *hear* as well as see. If this daily attendance is, say 750—seven new customers—seven times his admission price is conservatively extra daily income to be applied to the cost of the system. Another fact not taken into consideration in the above figures is that such

(Continued on page 761)

*Sales Engineer, The Webster Co.

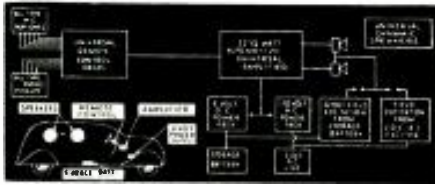

A CAR-TYPE PORTABLE P. A. AMPLIFIER

An outline of the design considerations for such amplifiers.

CHARLES R. SHAW*

PUBLIC ADDRESS engineers are working today with new microphones, new tubes, new circuits, new power supplies and new standards of performance which were unknown, impractical or unattainable a few years ago; new high-gain circuits now make it possible to use noiseless microphones—to eliminate batteries and expensive, gasoline-driven generators—to produce high power outputs (12½ to 50 W. from one or four output tubes operating with 300 volts on their plates)—to eliminate preamplifiers—to control audio feedback—and to eliminate microphone hiss, and intermittent granular-carbon disturbances due to motion of the car.

No man is wise enough to say what these developments and the trained imagination of the men who use them will bring to the automotive P.A. field within the next few years. This month however, will bring more and more P. A. systems on the country roads and city streets via the automobile.

Before entering into a detailed discussion of the amplifier illustrated here let us briefly review the prime requisites for an ideal mobile P.A. sound system.

1. *Adequate Power Output* should be the cardinal consideration in the selection of an amplifier. (The schematic diagram, Fig. 2, shows the amplifier, described below, which can be used to cover between 4,000 and 6,000 square feet outdoors or be used indoors for 3,000 to 4,000 people.)

2. *Small Size* so as to occupy the smallest amount of space while in operation.

3. *Ease of Control.* All operating controls must be well within the reach, if not at the finger tips, of the driver. (To attain this end, all of the vital controls of this P.A. system have been segregated and attached to the steering column of the car well within the reach of the operator. See Fig. 3).

4. *Economy of operation.* Minimum operating power consumption and low maintenance costs should be a predominating characteristic of every automotive P.A. System. Correctly designed class B circuits (Fig. 2) are the logical solution for the production of high power outputs with low operating power consumption. (All four tubes of the unit

(Continued on page 755)

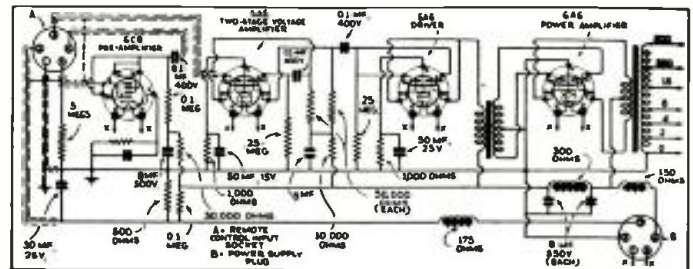

Fig. 2—the circuit of the auto P.A. amplifier.

OBSCURE SOURCES OF CAR-RADIO NOISE

When ordinary methods of noise elimination fail, try these unusual hints.
H. K. BRADFORD*

THERE are quite a number of sources of automotive interference which are obscure in that they have no connection with any of the electrical wiring of the car.

The first important point for consideration is that of bonding between the various metallic members of an automobile equipped with a radio set. Such members include the choke wire housing which may vibrate and touch various members of the engine, body, or chassis of the car, closing a metallic circuit and thus distorting the field of the radio wave about the antenna intermittently. Other housings such as ventilator control cables, winter-front apparatus, manifold temperature control devices, accelerator rods, spark levers and rods, brake cords, lighting conduit housings, etc. must be bonded by clamping or soldering to the body or chassis of the car. (See, for instance, the November 1933 and April 1934 issues of RADIO-CRAFT for addi-

tional data on this subject.—Editor)

In some automobiles, the bodies are electrically isolated from the chassis and the engine by rubber mountings, and charging or discharging currents resulting from differences of potential established between the two metallic bodies will cause considerable trouble. The two members mentioned should be connected at one or more points so that they will remain at this same potential. In some cases, the engine is "floated" on insulating material in which case it should be electrically connected to the chassis in the same way. Differences in potential are quite often established between these units due to air friction.

Even while the car is running and brakes are not applied, considerable interference may result from brake linings. In many cases they are made with small pieces of copper and other metals in them which make and break tiny electrical circuits with the brake drum, causing minute charging and discharging currents which are picked up by the receiver antenna. A test for

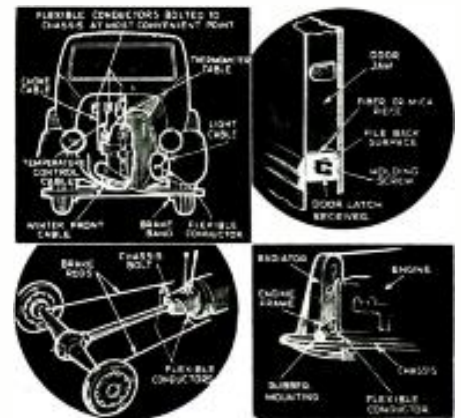

this, of course, would be to compare the reception while running, with that while the car is standing still with the engine running only. The only remedy found for this trouble is replacing the brake lining. This, of course, may occur again, but only after the brake linings have sustained considerable wear.

Very often clutch plates are made in this way and will give rise to the same type of trouble. Operation of the clutch will disclose the source of trouble in this case.

When the door of the car is closed an electrical circuit is usually completed through the door latch to the body of the car. If the pressure on the door

(Continued on page 754)

*Pres. Capitol Radio Res. Labs. Inc.

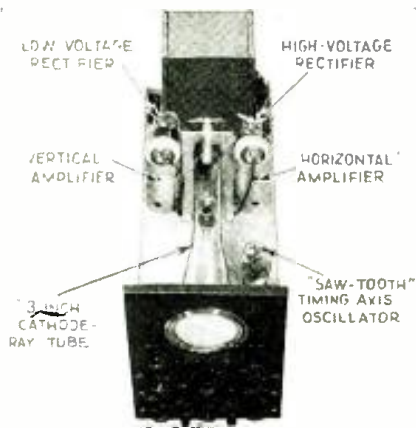

CATHODE-RAY OSCILLOSCOPE FOR VIBRATOR—"B" TESTING

The difficult task of properly adjusting vibrator-"B" units becomes relatively simple with the cathode-ray tube.

B. W. ROBINS

AS COMMONLY constructed, a "vibrator power unit" consists essentially of the vibrator itself, a step-up transformer, radio- and audio-frequency filters, and may or may not include a rectifier tube. Several different types of vibrators have been successfully employed by various manufacturers. However, one function is common to all these vibrators—the interrupting of the power from the battery impressed across the transformer primary.

In all cases the motive power for the vibrator is supplied by a solenoid provided for that purpose, but some vibrators employ a separate set of contacts for interrupting the current to this

driving coil, and others use one of the contacts already provided for breaking the transformer primary circuit. One type of vibrator—the "rectifier vibrator"—includes a pair of contacts for rectifying the transformer output; another type—the "tube vibrator"—omits this latter function and is used in conjunction with a full-wave rectifier tube.

Two obvious advantages of the rectifier vibrator are the elimination of the tube and the almost complete absence of voltage drop. However, the vibrator which only interrupts the primary current has the advantage of greater simplicity and less cost (cost of the vibrator alone). Both systems can be made to work satisfactorily, and the choice between the two must be based on economic factors, space requirements, and the like.

ACTION OF RECTIFIER VIBRATOR

The action of a properly designed rectifier vibrator can be briefly described as follows: The vibrator arm

is driven at a low audio frequency (usually between 50 and 200 cycles) by the driving solenoid and its interrupter.

(Continued on page 754)

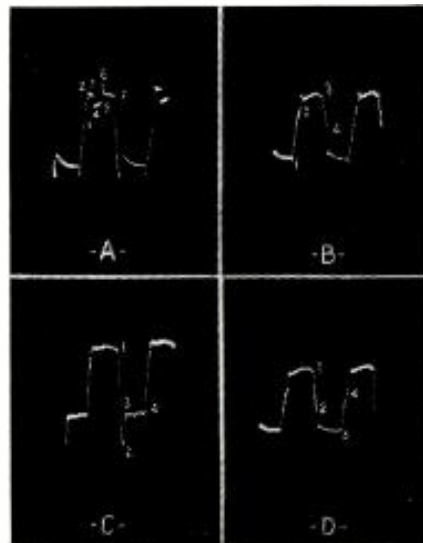

A NEW HIGH-FIDELITY ALL-WAVE RECEIVER

A combined T.R.F. and superhet. set for high-fidelity or high sensitivity operation on all bands.

A. C. MATTHEWS*

RECENTLY, the Federal Communications Commission set aside a frequency band above 1500 kilocycles to permit high-quality or "high-fidelity" broadcasting to be tested experimentally. The term "high fidelity" has been generally accepted to mean the uniform reproduction, within 5 decibels, of frequencies from 50 to 7,500 cycles or above. It now remains for the prospective buyer of a radio to insist upon an instrument design that will encompass this frequency range.

However, an extended frequency range alone is not sufficient to secure high-fidelity home reproduction of the

*Pres. Matthews Radio

Fig. 1—The response curves for high sensitivity or high fidelity.

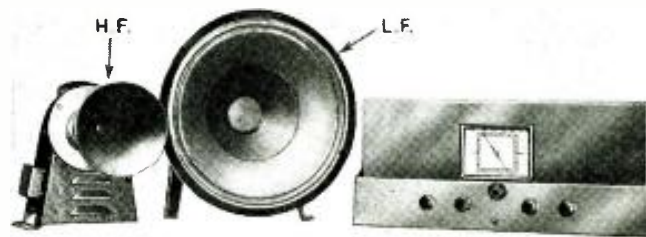
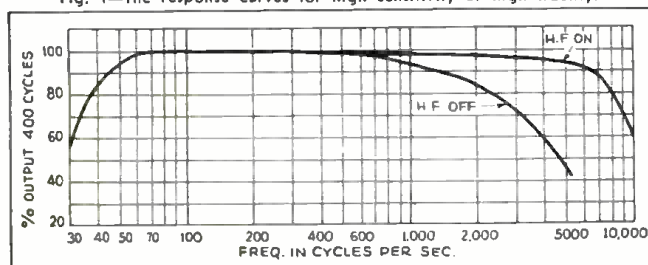

studio program. A minimum electrical power output of 10 W., with a distortion factor not exceeding 5 per cent at full output is fully as important as the extended frequency range. The design of a high quality audio amplifier with a frequency range of from 50 to 8,000 cycles is comparatively simple especially with the elaborate testing facilities of a modern radio laboratory. A power output of 10 watts with a total distortion of less than 5 per cent is also comparatively simple with the advent of class A prime operation of modern tubes. Thus it is readily seen that the solution of the problem lies in the radio frequency section of the receiver.

Several methods of expanding the selectivity or band width of a receiver are possible. The I.F. amplifier may be so designed as to pass a band of 20 kc. by introducing a third winding in the I.F. transformer which can be damped by means of a variable resistor to give the amount of broadening desired. The oscillator may be shifted slightly and several other "tricks" employed which do, more or less, give the desired result.

Considerable thought and experimental investigation has preceded the development of this new high-fidelity receiver. Many special I.F. transformers were tried using mechanical as well as electrical methods of band expansion, and finally it was decided to eliminate the I.F. amplifier

(Continued on page 760)

A NEW 23-TUBE HIGH-FIDELITY ALL-WAVE RECEIVER

Variable selectivity from 10 kc. to full range "high fidelity" covering 25 to 16,000 cycles and 50 W. output are outstanding features of this new de luxe type receiver chassis.

E. H. SCOTT*

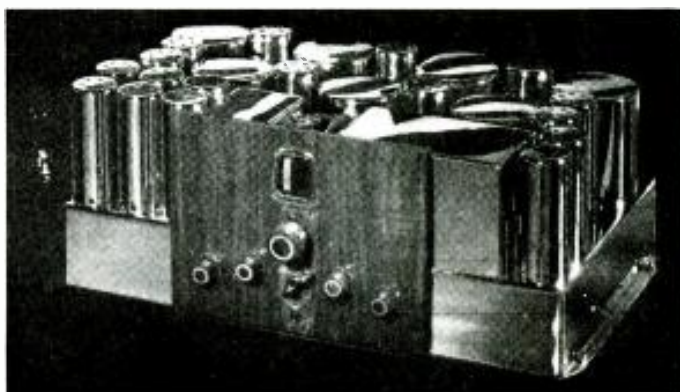

The chassis of the 23-tube receiver described here.

THE all-wave receiver to be described has been designed primarily for the radio fan who is looking for an instrument which will give the best possible reception of distant stations in every part of the world, combined with the finest tone quality.

Laboratory tests prove it has *twice* the frequency range of even the finest of the "high fidelity" receivers available today, with a practically flat response from 25 to 16,000 cycles. The selectivity is continuously variable from as sharp as 10 kc. at 5,000 times field strength, to a band wide enough to allow frequencies up to 16,000 cycles to pass without attenuation. Such results have never before been attained in any excepting a few extremely costly receivers built especially for laboratory use.

The new Scott Imperial All-Wave receiver is a very highly developed superheterodyne, with a wavelength range from 13 to 556 meters. The 23 tubes incorporated in its design are used as follows: R.F. stage using 1 type 6D6 tube; oscillator using 1 type 76 tube; oscillator voltage regulator using 2 high-conductance gaseous tubes; converter stage using 1 type 6A7 tube; first, second, and third I.F. stages using 3 39/44 tubes; fourth I.F. stage using 1 type 6D6 tube; det., I.F., and A.V.C. system using 1 type 76 tube; first audio stage using 1 type 6C6 tube; second audio stage using 2 type 6C6 tubes in push-pull; third audio stage using 4 type 2A3 tubes operating as parallel push-pull pure class A power output tubes; rectifiers using one type 83-V heavy duty tube and 1 type 5Z3 tube; noise suppressor using 1 type 76 tube; beat frequency oscillator using 1 type 76 tube; R.F. and converter A.V.C. amp., 6B7; and, a 76 as tuning meter amplifier.

It will be noticed that although 23 tubes are used, a careful study of the specifications will show that every single tube incorporated in the set has a very definite function to perform.

FULL-RANGE "HIGH FIDELITY"

If a radio receiver is to give perfectly natural reproduction on all notes or sounds, it *must* have a frequency range that covers the entire tonal range of the human ear, or from 25 to 16,000 cycles. (Some musical instruments are richer

*President, E. H. Scott Radio Labs., Inc.

The amplifier which operates at class A up to 35 watts, and class A prime to the limit of 50 watts.

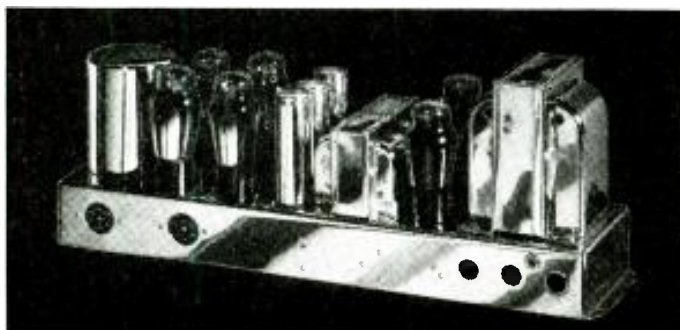

in harmonics or overtones—the higher frequencies that enable one instrument to be distinguished from another—than others; for example, the harmonics of the cello go up to 8,500 cycles; the bass clarinet to 10,000 cycles, and the violin to 14,000 cycles.) It can clearly be seen, therefore, that if you are to secure absolute naturalness and lifelike fidelity of musical instruments or voice, a *radio receiver must be capable of reproduction on all frequencies without attenuation from as low as 25 cycles up to 16,000.*

At the present time, the highest frequency reproduced by sets in each "class" is as follows: (1) popular-price sets, up to 3,500 cycles; the medium-price receivers, up to 5,000 cycles; higher-price models up to 6,000 cycles; and a few of the high-price "high fidelity" receivers, up to 7,500 cycles. The new "Imperial" has *twice* the frequency range of the latter receiver, thus establishing a new standard in home radio reception.

NEW POWER AMPLIFIER PREVENTS OVERLOADING

High fidelity is a function not only of *frequency* but also *volume*. To secure the most perfect reproduction at all times, it is necessary that the receiver be capable of handling every loud passage or "peak" that comes in *without overloading or distorting*. Most of the time the audio power level does not exceed 6 watts, but there are often dozens of passages in the course of a single program where "peaks" or loud passages may rise for short periods to power levels as high as 30 or 40 watts, and it is necessary that we have a reserve power of about five times above the normal level if we are to eliminate distortion during these loud passages or sudden "peaks" in the reproduction of speech and music.

One of the many unusual features of the power amplifier of this new set is the 35 watts of *undistorted output with strict class A operation and from 35 to its full 50 watts, class A prime*. These results have been attained in our new amplifier by the use of a constant fixed bias; practically ideal plate voltage regulation, having an exceptionally low resistance; the use of a total filtering capacity exceeding 100 mf.; a first A.F. stage using a 6C6 as a triode; a second A.F. stage using 2 type 6C6 triodes in triode push-pull; and a third audio stage using 4 2A3 triode tubes operating as parallel push-pull pure class A output tubes.

SELECTIVITY CONTINUOUSLY VARIABLE

The degree of selectivity possessed by a receiver determines its ability to tune through powerful local stations and bring in weak distant signals. To secure the maximum degree of selectivity, and at the same time a high degree of fidelity, a new selectivity-fidelity control is incorporated, which is continuously variable. In the most selective position, adjacent channel discrimination of approximately 5,000 to 1 is obtained, while at the maximum fidelity position, reproduction up to the limit of the human ear, or the limit of the highest frequency being broadcast by the station selected is obtained. This enables the listener not only to reach out and bring in weak dis- (Continued on page 751)

SHORT-CUTS IN RADIO

FIRST PRIZE \$10.00
 SECOND PRIZE 5.00
 THIRD PRIZE 5.00
 Honorable Mention

EXPERIMENTERS: Three cash prizes will be awarded for time- and money-saving ideas. Honorable mention will be given for all other published items. Send in your best "kinks"!

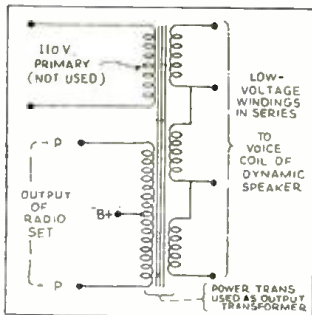

Fig. 1, an emergency output transformer.

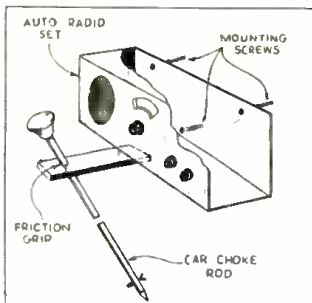

Fig. 2, auto radio "third hand."

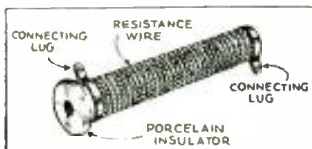

Fig. 3, home made resistors.

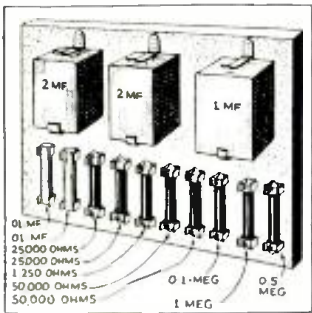

Fig. 4 Resistor and condenser tester.

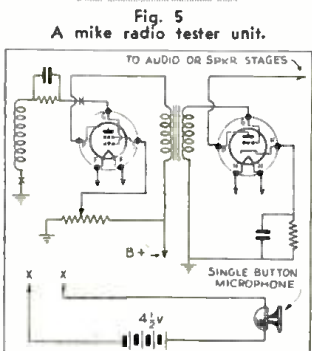

Fig. 5 A mike radio tester unit.

FIRST PRIZE—\$10.00

OUTPUT TRANSFORMER FROM POWER TRANSFORMER. An ordinary radio power transformer will be found useful as an emergency output transformer. Using the high-voltage secondary as the primary and the low-voltage secondaries as voice-coil windings, considerable flexibility is possible in matching dynamic speakers.

GERALD BATES

SECOND PRIZE—\$5.00

SUPPORT FOR INSTALLING AUTO-RADIO SETS. The small tool described and shown in the diagram (Fig. 2.) will be found very useful to the car-radio Service Man. With it he need not call a second party to hold the set in place while bolting it to the dash. The device is made from an old discarded choker rod taken from a model A Ford, and a short piece of strap iron $\frac{1}{4} \times \frac{3}{4} \times 4$ ins. The rod is $\frac{1}{4}$ -in. in dia. and 18 ins. long. A $\frac{5}{16}$ -in. hole is bored in the end of the strap iron. The strap of iron will catch anywhere on the rod and will never slip when the tip as shown.

R. V. CRADDOCK

THIRD PRIZE—\$5.00

HOME-MADE POWER RESISTORS. Obtain a porcelain tube such as used in house wiring; this tube cannot be cut or broken to reduce the length but must be ground off on an emery wheel. Fit lugs on each end; wind wire to suit your needs, leaving space between turns. Then dip assembled resistor in a paste made of water and plaster of paris.

This makes a resistor that will stand plenty heat; and can be mounted with a bolt through the center.

O. E. PAYNE

HONORABLE MENTION

MOUNTING PANEL FOR RESISTOR AND CONDENSER TESTING. Here is a wrinkle which makes it easy to test condensers and resistors, and to compare their values with standard parts. Bolt brass clips to a large board, and connect the clip through an ohmmeter to an old power pack. A neon tube can be used for the condenser test. Label the values of each unit over its respective clips. To determine the value of an unknown resistor, merely insert it into the clip which has a reading nearest to its rated value.

D. F. MORRISON

HONORABLE MENTION

MIKE AND "C" BATTERY STAGE-TESTER. A very handy and efficient tester for checking individual stages of a receiver can be made from a single-button mike and a $4\frac{1}{2}$ V. "C" battery. Simply connect between grid and ground in each stage and talk. A faulty stage usually is indicated by distortion or no signal.

E. L. DUFFIELD

HONORABLE MENTION

AN INEXPENSIVE OUTPUT METER. Here is the circuit of an output meter which is efficient and inexpensive. The meter used is a Weston model 506 0-8 voltmeter with a lead brought out between the movement and the multiplier to permit it to be used as a milliammeter. Any milliammeter with a low range may be used.

The rectifier is one out of an old Elkon 3 Amp. charger which had worn out. The rheostat is 20 ohms, and is used as a shunt when necessary. A "dynamic" output transformer is used, though none is needed when connecting to the voice-coil leads of the radio set.

(Such a transformer may be made by removing the secondary from an A.F. transformer and winding about 50 turns over the primary.)

CARROLL S. WHITE

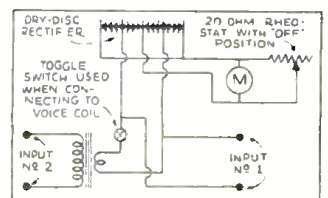

Fig. 6, output meter-rectifier unit.

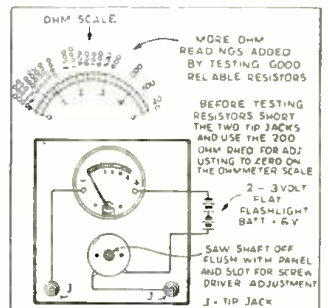

Fig. 7, an ohmmeter from filament meter.

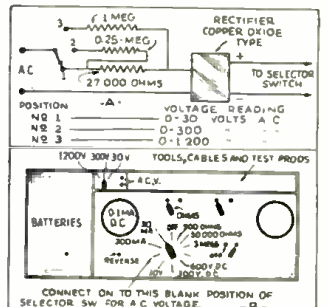

Fig. 8, improving Readrite 1000 analyzer.

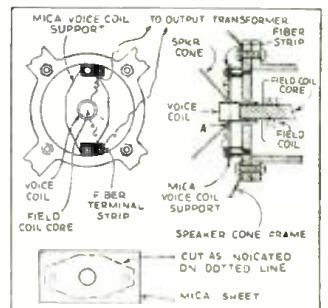
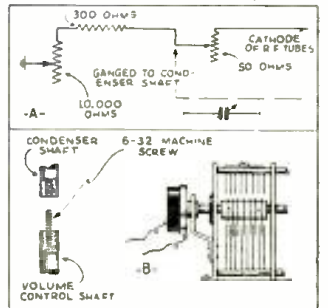

Fig. 9, above, repairing voice coil.

Fig. 10, below, sensitivity compensator.



CURIOSA IN RADIO

The well-known saying that "truth is stranger than fiction" is amply demonstrated by some of the strange facts which have been collected here from all parts of the world. These bits from here and there add zest to radio study.

**ONLY 1.1% OF SET MANUFACTURERS
IN BUSINESS IN 1924, ARE
BUILDING SETS
TODAY!**

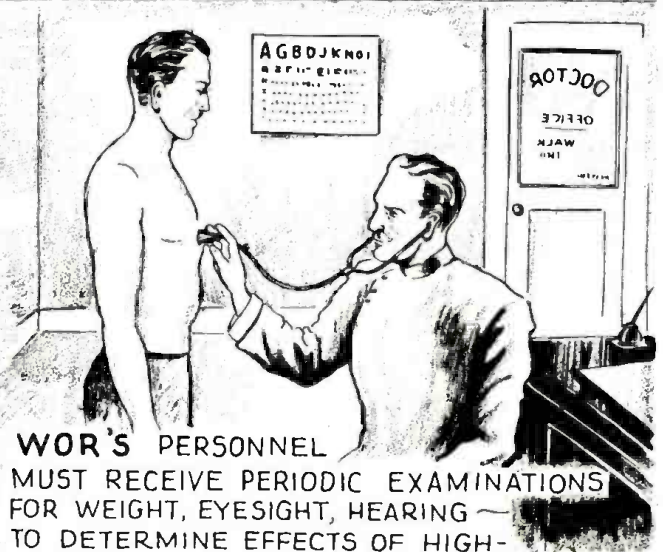
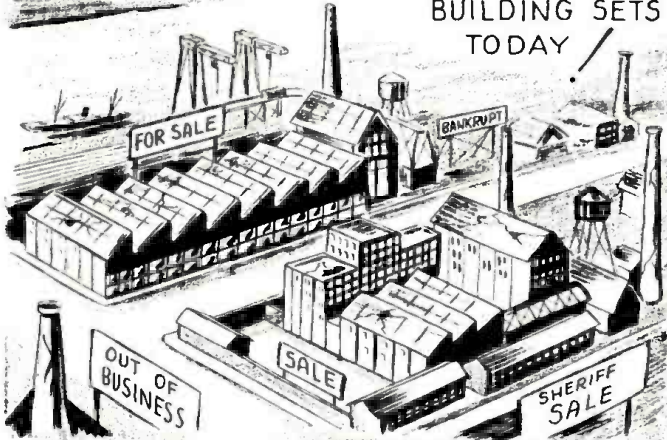

**WOR'S PERSONNEL
MUST RECEIVE PERIODIC EXAMINATIONS
FOR WEIGHT, EYESIGHT, HEARING
TO DETERMINE EFFECTS OF HIGH-
FREQUENCY RADIATION.**

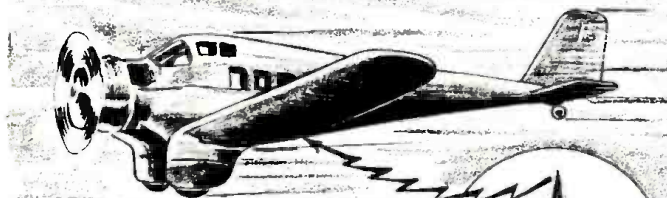

**RECENTLY 2-WAY
COMMUNICATION WAS HELD
BETWEEN LAND STATION
AND A PLANE 8,000
MILES AWAY.**

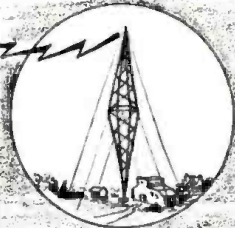

**ALL NOMADS
OVER 21 YEARS
OF AGE, ARE
REQUIRED TO
LISTEN TO
TURKISH
POLITICAL
BROADCASTS**

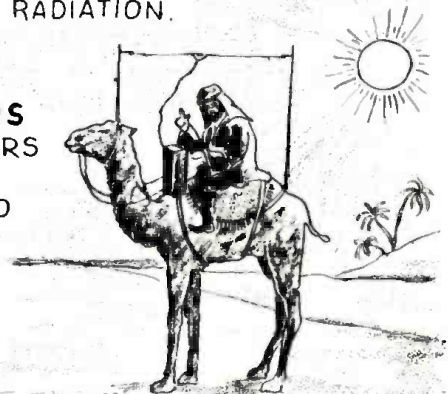

**DEAF-MUTE HAS 900
ACKNOWLEDGMENTS
FROM STATIONS ALL
OVER THE WORLD
(HE USES A TAPE-
RECORDER!)**

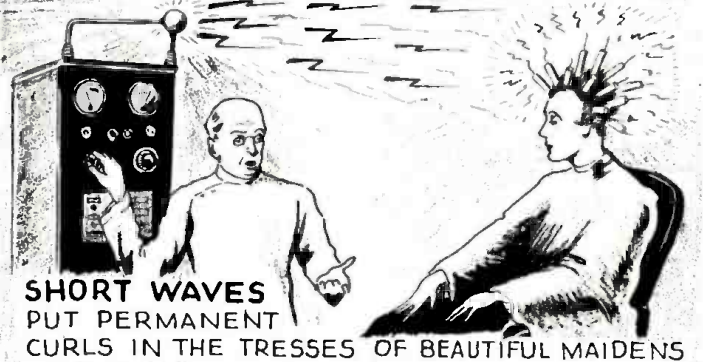

**SHORT WAVES
PUT PERMANENT
CURLS IN THE TRESSES OF BEAUTIFUL MAIDENS**



**35 MILES OF COPPER
CONDUCTORS WERE
BURIED, TO PROVIDE
THE GROUND FOR
WOR'S NEW
TRANSMITTER—
SOME GROUND
EH WHAT?**



**IN A RECENT RADIO POLL IN GERMANY, OVER 94%
OF THE ANSWERS STATED AND DECIDED PREFERENCE
FOR BOOKS AGAINST RADIO**

INTERNATIONAL RADIO REVIEW

RADIO-CRAFT receives hundreds of magazines from all parts of the world. Since the cost of subscribing to each of these would be prohibitive for most radio men, we have arranged with technical translators to prepare reviews for our readers.

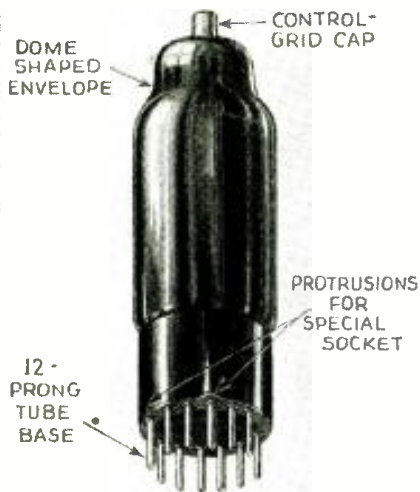

Fig. A

The new composite tubes have 12-prong bases of special construction. The same base is used for all types whether all prongs are used or not.

TWELVE PRONG TUBES

PERHAPS the most outstanding item in this month's crop of radio magazines is the announcement of a series of multi-element tubes having 12 contact pins on the base. These tubes are products of the D. S. Loewe company of Germany. The announcement appeared in *FUNK-TECHNISCHE MONATSHEFTE*, a technical magazine.

The appearance of the new tubes with their multi-pin bases is shown in Fig. A, here. Due to the many contacts, special sockets are required which fit three protrusions on the sides of the tube bases. This assures each tube being inserted into its socket in the correct manner.

Four combinations of elements are available and it is interesting to note that the same 12-prong bases are employed for all these tubes, regardless of whether all the contacts are used or not. (This is a new idea in tube manufacture which will be utilized in connection with the new line of metal radio tubes which will shortly make their appearance on the American market—see page 726 of this magazine—that is, the use of one standard tube base for all types of tubes.)

The first type of tube, shown in Fig. 1A, contains a pentode of the R.F. type, which can be used as a T.R.F. amplifier or I.F. amplifier; in addition, a screen-grid tube is enclosed in the same glass envelope. The latter section is equipped with a grid condenser and gridleak and is specifically designed as a detector. The two tubes have separate cathodes and are entirely separated except for the 20V. filament which is common for both.

The second tube (Fig. 1B) contains an R.F. pentode, a diode (which may

be a rectifier or a diode detector), and a screen-grid section. The third tube (Fig. 1C) is specifically designed for superheterodynes and contains a pentode mixer tube, a triode oscillator and a pentode I.F. tube. The fourth (Fig. 1D) contains an R.F. pentode, a screen-grid (detector), and an output or A.F. pentode.

The fact that the individual sections of these tubes are entirely independent except for the filament which does not enter into the actual operation of the tubes except as a cathode heater, makes them useful for many different purposes. A 3-in-1 tube radio receiver supplying loudspeaker volume is readily attainable—a one-tube superhet. is also possible—and the adaption of the elements to present multi-tube set designs is almost unlimited.

AUTO RADIO ABROAD

AUTO-radio receivers have reached such a stage of development in this country that it is interesting to take representative examples of the auto radio receivers from other countries and compare the degree of advancement as indicated by the sets chosen.

For example, in Fig. B1 is an Italian set described in *RADIO INDUSTRIALIA*. This set is completely power operated, by virtue of the vibrator-type power unit at the right of the illustration. It will be noticed that the set uses the rather antiquated "unit" design having three separate boxes to be mounted in the car.

A contrasting design is shown in Fig. B2 which illustrates a German Telefunken set. This receiver is completely self-contained, having a dial on the

(Continued on page 762)

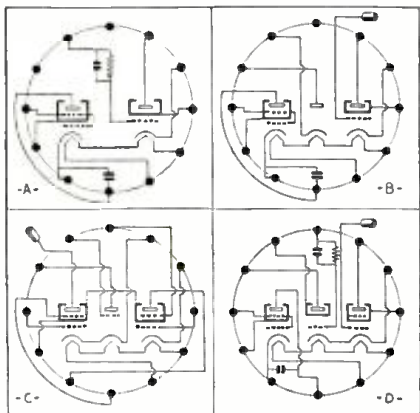
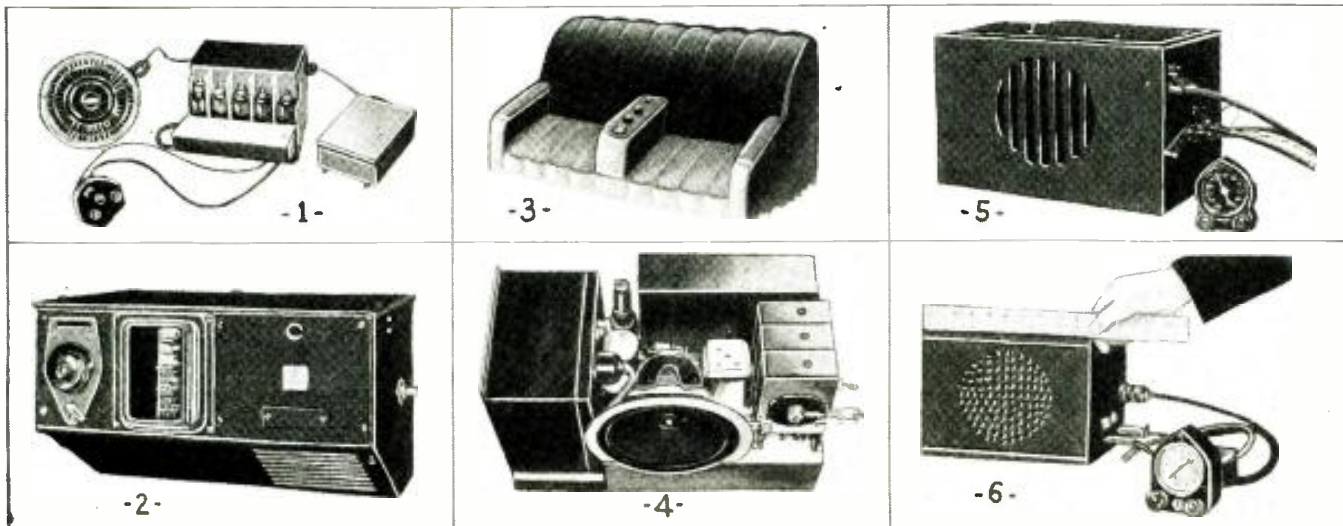

Fig. 1

The electrical make-up of the four new tube types—their versatility is evident.

Fig. B—Six new foreign auto-radio receivers—the contrast with American design is evident.

Each set is described in the text.



THE LISTENING POST FOR ALL-WAVE DX-ERS

C. A. MORRISON

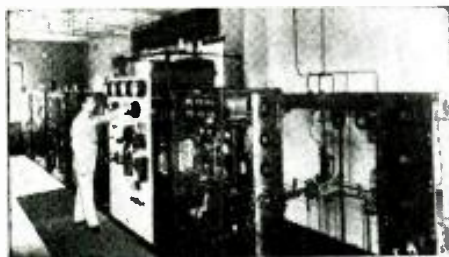

The 20 kw. S.W. transmitter VK2ME at Sydney, Australia, heard in Baltimore, Md.

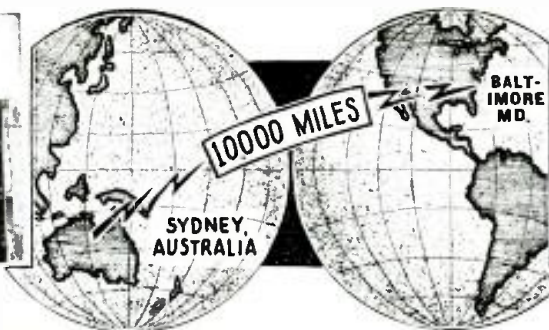

The listening post in Baltimore, Md., of Mr. Robert Base who has verifications from all over the world

ONE REASON for the immense popularity of short-wave Dx-ing is that it may be enjoyed the year around. By this time most Dx-er's broadcast band log books have been definitely closed for the season, but short-wave Dx-ers are just rolling up their sleeves for some real summer thrills on the higher frequencies.

We take please in presenting here an article dealing with radio in that faraway and little known island of Malta.

RADIO IN MALTA

A search on a map of Europe, will reveal a tiny speck in the middle of the Mediterranean Sea. This is the island of Malta with an area of 120 square miles and a population of about a quarter of a million.

The officially licensed listeners in Malta number more than 3,000; but as usually is the case with countries where a license fee is levied, the actual number of listeners is believed to be still greater.

A wireless license costs ten shillings (\$2.50, approx.) annually, and yet we have no local transmitting station. Notwithstanding the fact that an official wavelength (255.1 m.-1176 kc.) has been assigned to Malta by the Lucerne Conference and several attempts have been made by private parties to install a local radio station, the island is deprived of this luxury.

The authorities seem to be opposed to the idea of a local transmitter, and consequently there have been, up to the present, two attempts on the part of private parties to install a "radio distribution service." The local government is inclined to favor the latter system in preference to the former. However, this does not appear to have taken the fancy of local amateurs, with the result that the Maltese are still without either system.

For this reason local lis-

ALL-WAVE DX CONTEST

Don't forget the valuable prizes that are given each month for the best DX verification received by the DX Contest Editor. All you have to do is send in your best verification according to the simple rules listed on page 689 of the May 1935 issue of RADIO-CRAFT. A new group of worthwhile prizes is given each month! Get yours!

other countries are also imported, the American ones are by far the best sellers.

Many high-powered European stations provide the listener in Malta with good programs. Rome is regarded here as a "local," as dependable listening from this transmitter can be had at any time of the day. American stations can also be tuned in with good loudspeaker strength in the small hours of the morning. This applies to listening confined to the broadcast band.

Since the establishment of the Empire Broadcasting Service by the B.B.C., short-wave listening is gaining popularity and all-wave sets are the craze of the day. This service brings to the homes of S.W. fans very good programs from Daventry and other reliable S.W. stations such as Zeesen (Gr.), Radio Colonial (Fr.), Rome (Italy), Pittsburgh, and Bound Brook.

The local naval authorities are very courteous, and re-radiate important events on special occasions, such as the B.B.C. Empire Broadcasts, H.M. the King's Christmas speech, and the marriage of H.R.H. the Duke of Kent with Princess Marina. These re-broadcasts are made for the benefit of medium-wave listeners and are radiated from Malta on a wavelength of (230 m.-1300 kc.).

(Editor's Note: Mr. Joseph Mercieca who wrote this interesting description is one of the best-known radio pioneers and writers in Malta, and we present for the first time in any radio journal this, Mr. Mercieca's own account of Radio in Malta.)

LATEST SHORT-WAVE NOTES

A new Daventry station GSL ("L for Liberty") is now on the air on a wavelength of 49.10 m.-6.11 mc. Station GSL is used simultaneously with GSC, 9.58 mc. to transmit the new Daventry transmission No. 6, which takes the air from 8:30

(Continued on page 756)

The amateur transmitter, listening post, and television transmitter of O. M. Bailey in Manchester, England.



THE ANALYSIS of RADIO RECEIVER SYMPTOMS

OPERATING NOTES

MIDWEST 12

AN UNUSUAL situation was recently encountered on the Midwest model 12 receiver.

The complaint was excessive hum, and after replacing a 5 mf. condenser that was found to be open in the cathode of the 58 second A.F., the hum was considerably reduced, but still there existed an unusually loud hum.

After several hours of unsuccessful testing I decided to tighten the bolts that hold the core of the power transformer together. Attempting to tighten this bolt I first removed a lug which was grounded to the bolt; when this was done the hum disappeared completely.

Tracing this circuit out I found this lug was soldered to a shield which shielded the lead from the last I.F. transformer secondary to the volume control.

This lug was grounded to the chassis completing the job. Figure 1 shows circuit.

R. W. TINER

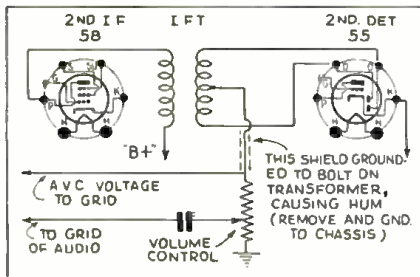

Fig. 1: Eliminating excessive hum in the Midwest 12 (due to control-grid shield pick-up).

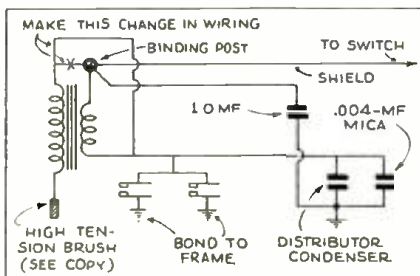

Fig. 2: Curing Ford V8 noises.

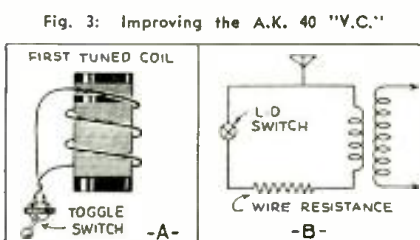

Fig. 3: Improving the A.K. 40 "V.C."

FORD V8 MOTOR NOISE

THE FOLLOWING kink when applied to the coil and distributor of the Ford V8 will invariably cure the worst case of motor interference encountered with this make of car.

The coil and distributor are mounted together just below the radiator fan. The coil is fastened on top of the distributor by three screws. Remove these three screws and disconnect the only wire, which is the "A" wire going to the switch. The coil with the distributor condenser attached can now be lifted off.

Remove the high-tension brush from its spring. Obtain a 50,000 ohm, 1 W. carbon resistor and file it down to the exact dimensions as the original brush. The final resistance of this suppressor will be around 20,000 ohms. Put it back in place of the brush. This is the only way a suppressor can be applied to this distributor.

With this coil, the low side of the secondary winding is connected to the high side of the primary, inside the housing, which is O.K. as far as ignition work is concerned, but no good for radio work. To remedy this, file off the tops of the rivets holding the coil housing together, being careful not to break the wires. Next, carefully disconnect the fine secondary wire from the binding post and solder it to the heavier wire leading to the strong spring which contacts the "hot" side of the two breaker points. Replace the housing, then replace the coil.

The wire from the coil to the generator to the ammeter are both run in the same metal casing with the high-tension wires. These wires should be shielded.

The above method will usually eliminate the need for spark plug suppressors.

Another help is to remove the two rubber plugs that are in the holes through which the two breaker points are adjusted. Clip a piece of shielding to each screw with small alligator clips. Ground the other end of the shields to the frame. If the shields help, they

Fig. 4: Lead-in for 1932 Frontenac.

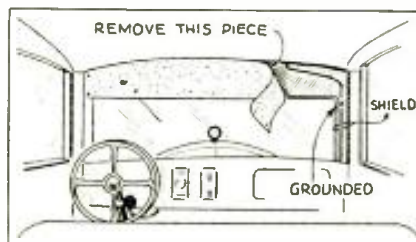

THE PURPOSE OF THIS DEPARTMENT

It is conducted especially for the professional Service Man. In it will be found the most unusual troubles encountered in radio service work, written in a practical manner, by Service Men for you.

Have you, as a professional man, encountered any unusual or interesting Service Kinks that may help your fellow workers? If so, let us have them. They will be paid for, upon publication, at regular space rates.

should be permanently soldered in place.

JOHN T. BAILEY

ATWATER KENT 40

WHEN the volume control strip in the A.K. 40 is replaced it is very often erratic in operation. This is due to the set having gain which cannot be practically controlled by a single unit, or the fact that at certain volume-control positions tube distortion, cross-talk, or oscillation occur. This can be corrected by the addition of a switch and several turns of wire around the coil of the first tuned stage (as shown in Fig. 3).

The switch is mounted on the rear of the cabinet and is used as a local-distance switch, closed for local and open for distance.

A preferable method for sets where the coils are shielded is to use a switch and a fixed wire resistance (as shown in Fig. 3). The resistance should have a nominal value of 50 ohms. For high gain a 25-ohm resistor should be used.

M. F. GODBOUT

ANTENNA TROUBLES

ON INSTALLING a radio set in a 1932 Frontenac I found that the antenna was grounded. Taking off the front piece above the windshield and a few tacks along the right side expose the antenna and lead-in connection. Checking both lead-in and antenna for grounds (separately) I found that the antenna was O.K. and the lead-in was grounded. Then taking off

(Continued on page 759)

Fig. 5: Philco volume controls.

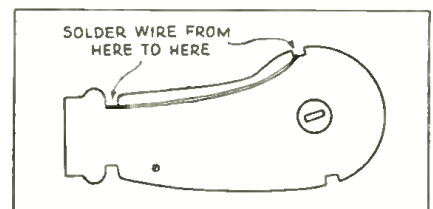

A department in which the reader may exchange thoughts and ideas with other readers.

READERS' DEPARTMENT

MANUFACTURERS—PLEASE NOTE

Editor, RADIO-CRAFT:

The editorials that precede the excellent contents in your publication are a source of great interest to me. It seems that you have as much "info." on radio as Winchell has on "Reno and other indoor sports."

In view of the above, I would like to make a suggestion which, if in your opinion is of value, could be incorporated in a future issue.

Here 'tis:—A lot of people buy radio sets and find they have insufficient "coverage" for their apartment, house, or what have you. So-o-o they call in a Service Man and ask about an extra speaker. Then, as you know, out come condensers, chokes, etc., and lo, a remote speaker is attached with (sometimes) indifferent results.

As a remedy for this condition, why wouldn't it be a good idea to incorporate in the output transformer of the set, a winding to match a high-impedance permanent magnet speaker—or, in the "classy price" jobs, a universal output winding, say 4, 6 and 8 ohms, and 3000 ohms, which would allow a customer to use a dynamic speaker if desired. This would facilitate the Service Man's job, greatly.

REESE NELSON,
4128 N. Kedvale Ave.,
Chicago, Ill.

LUXEMBOURG EFFECT IN THE U.S.

Editor, RADIO-CRAFT:

Having just read the article "The Luxembourg Effect in Radio" in the February issue of RADIO-CRAFT, I wish to report that WLW (700 kc.) can be heard faintly in the background while listening to KDKA (980 kc.) in this community. I have heard this effect several times lately and at first, having heard it on a superheterodyne receiver, thought it was due to some beat phenomenon within the receiver itself, but later, I found it was also present on a T.R.F. set. As mentioned above, I have noticed this several times recently, but can give the exact time and date of only one occasion—Jan. 15, 1935; 6 p.m., C.S.T. Cincinnati is approximately 650 miles from here, while Pittsburgh is approximately 950 miles away.

J. H. ASKEW,
Waldo, Ark.

Editor, RADIO-CRAFT:

Your article on page 467 of February 1935 RADIO-CRAFT

has answered a question for me. This "Luxembourg Effect" is noticed here on WLW. I believe we should call it the "Nation's station' Effect" though, since WLW causes the interference.

I have heard WLW's signals in the background of the following stations between sundown and midnight: WTAM, WGY, KDKA, WSM, WSB, and WJZ. You will notice that these stations are all in an east-south direction from Terre Haute. I have tried to get this on western and northern stations but have never heard it as yet.

I first noticed this condition about a month after WLW started using 500 kw. regularly. I hope this letter may be of some help to you and World-Radio Research League.

I have been a Service Man for about 8 years. I have heard this condition in different locations and with different receivers. The only time WLW signals can be heard is when the program of the station tuned in is stopped for announcements or studio change, etc. The interfering signals are not loud enough to be heard when the programs are in progress.

ROBERT CHISLER,
126 No. 7th. St.,
W. Terre Haute, Ind.

So we have "Luxembourg Effects" in the U.S. after all. Perhaps other readers have noticed this odd form of interference. If so, we will greatly appreciate hearing from you. Kindly give the facts mentioned in the article on page 467 of the February 1935 issue of RADIO-CRAFT—your aid in this matter may be of material help in solving the

Here is an interesting installation made in a large Victor cabinet. The reproducer uses a multitude of resonating tubes and the sound is reflected by a pool of water. This is said to give superior quality. (See "The New Resonator Loudspeaker," November, 1933; the Volf resonator illustration, page 520, March 1934; and, "Resonator Loudspeaker," page 566, March 1934.) The resonating tubes of this reproducing system are fed with sound vibrations from a high-quality dynamic speaker. The sound is projected by that tube which responds to the frequency of the individual sound and the pool of water, below, reflects the sound into the room. It is claimed that the water reflector maintains the high quality of the sounds because of its lack of natural resonance.

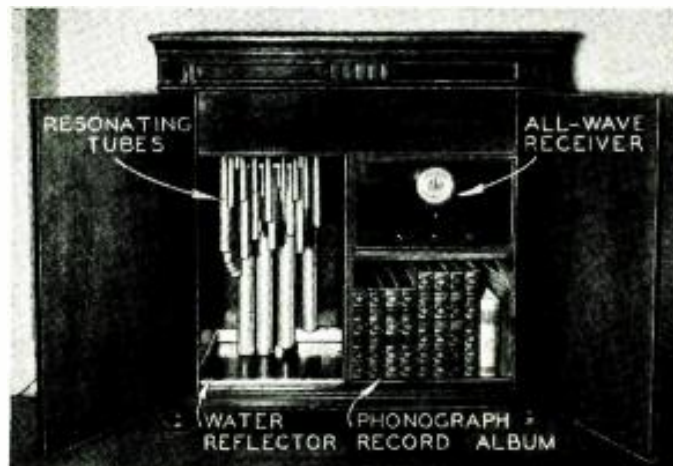

riddle and thus give a clue as to how the nuisance can be eliminated.—Ed.

TRY THIS ONE ON YOUR—

Editor, RADIO-CRAFT:

I've read a number of your editorials in RADIO-CRAFT and judge from your articles that you are profoundly interested in radio.

Now, I'll ask you if you want a genuine thrill; if so, procure a Philco 96 or any other good high-gain T.R.F. receiver with A.V.C. Now discard the A.F. end, retaining the detector. Next procure a modulator and oscillator, coupling the modulator in parallel with the detector (original detector) of the T.R.F. set.

Feed the modulator's output to a crystal intermediate-frequency amplifier which is in turn connected to a high-gain P.A. amplifier.

The original idea was to feed as constant a signal to the modulator as possible, but the all-round improvement over a conventional superhet. is so great that it must be tried to be appreciated.

I'm sure a thrill awaits you!

JOHN R. REGIS,
115 N. Pittsburg St.,
Spokane, Wash.

We wonder if Mr. Regis connects a pair of phones to the output of his set to hear the locals—Hi!

WE STAND CORRECTED

Editor, RADIO-CRAFT:

We note with interest the article entitled "An Inexpensive High-Gain Amplifier" in the October 1934 issue written by Messrs. H. V. Badinski and Jerome Newman. We wish, however, to call your attention to a misstatement which we quote as follows:

"The best high-impedance phonograph pickup made will not deliver more than one-half volt. Most good pickups will deliver about ¼-volt."

We should like to call your attention to the account in the current issue of the *Gramophone*, published in London and giving an independent test of the piezo-electric pickup being manufactured by our licensee, the Astatic Microphone Lab., of Youngstown, Ohio. We believe that if you care to look up this article, you will find it extremely interesting and particularly so in view of the article on the opposite page, giving a comparative test of

(Continued on page 763)

RADIO-CRAFT'S INFORMATION BUREAU

SPECIAL NOTICE

Those questions which are found to represent the greatest general interest will be published here, to the extent that space permits. (At least 5 weeks must elapse between the receipt of a question and the appearance of its answer here.) Mark such inquiries, "For Publication."

Replies, magazines, etc., cannot be sent C.O.D. Back issues of RADIO-CRAFT prior to December, 1932, are available at 50c per copy; except the following issues: 7/29, 1, 2, 3, 4, 6, 7, 9 and 11/30; 5, 8 and 9/31; and 7/33, which are out of print. Succeeding issues are still available at the regular price of 25c per copy.

Inquiries to be answered by mail MUST be accompanied by 25c (stamps) for each separate question; answers are subject to subsequent publication if considered of exceptional interest.

Furnish sufficient information (in reference to magazine articles, be sure to mention issue, page, title, author and figure numbers), and draw a careful diagram (on separate paper) when needed to explain your meaning; use only one side of the paper. List each question. Be SURE to sign your name AND address.

Enclose only a STAMPED and self-addressed envelope for names and addresses of manufacturers; or, in connection with correspondence concerning corrections to articles, as this information is gratis.

Individual designs can be furnished at an additional service charge. The fee may be secured by addressing the inquiry to the SPECIAL SERVICE department, and furnishing COMPLETE specifications of desired information and available data.

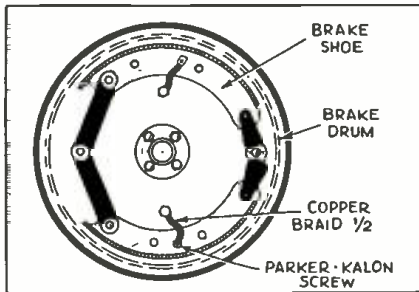

FIG. Q 326—Method of bonding brake shoes.

SUPPRESSORS EFFECT ON MOTOR OPERATION

(324) Mr. A. F. Richardson, White Plains, N.Y.

(Q) Have installed many radio sets in automobiles. Lately several customers are having trouble with the performance of their motors, and they are trying to blame me for putting the suppressors on the spark plugs. Apparently some auto mechanics have told them that spark plug suppressors cut down the efficiency of the engine. What is the true effect of suppressors on motor operation?

(A) The opinions on the effects of suppressor resistors on automobile performance have run the gamut from flat statements that resistances increase starting difficulty or decrease gasoline mileage to the opposite extreme that suppressors improve car performance.

In contacting electrical engineers of the motor car manufacturers, however, quite a different story was found. The general opinion of the experts is, that the use of suppressors does not effect in any detectable way the operation of a normal engine.

Dynamometer tests do not show any difference whether the resistors are used or not; tests in cold rooms running as low as 30 deg. below zero showed no noticeable difference in starting when the suppressors are used.

However, there is one point which may contribute to the feeling that resistors cause misfiring. The great majority of motor cars now on the road are operating with poor motor adjustment. Many cars have carburetors incorrectly adjusted, with leaky valves and with fouled spark plugs. When suppressors are added to such cars, trouble will undoubtedly be experienced.

Therefore if the addition of suppressors effects the operation of the engine, then it is a sure indication that the motor is out of adjustment.

TYPICAL BENCH SET UP FOR TESTING VIBRATORS

(325) Mr. George Zwiefel, Ellenville, N.Y.

(Q) Although my business is repairing automobiles, most of the car owners drive in when their radio is not functioning properly. It seems that most of the troubles on the radio occur in the vibrators. Since we are a long distance from suppliers, I am in need of some sort of test device that will check the vibrators.

(A) The best way to test vibrators is by means of the bench layout illustrated. It will permit proper test of vibrators for all important qualities except R.F. interference. The latter test must be made by installing the vibrator in the instrument in which it is to be used. Although only one transformer is shown in the illustration, three are actually used. The RCA transformer numbers are, 7604, 7689 and 7694, for vibrators B-40, C-41 and B-52. The load resistance and minimum output at 6 volts input is as follows: B-40 is 5000 ohms and 210 volts, C-41 is 5000 ohms and 180 volts, B-52 is 7000 ohms and 240 volts. The vibrator should start every time the circuit is properly connected across the 6 V. section of the battery. Check starting by feeling for a slight vibration or listening for vibrator noise.

FRONT WHEEL STATIC

(326) Mr. John Liddell, Greenwood, Miss.

(Q) Is it possible for the brakes on a car to cause static in the radio receiver due to the friction set-up while braking? I have noticed a terrific roar

in the set when the brakes are applied, and suspect that this is caused by the friction of the brakes. If this condition exists how can one get rid of it?

(A) Front-wheel static is often the cause of severe interference in motor car receivers. It produces a continuous roar, resembling heavy static. This phenomena seems to be due to an electrostatic charge built up by the wheels of the car due to the tires flexing when coming in contact with the road. Also, it is partially due to the friction with the wheels.

The voltage charge is accumulated until the leakage to the car body or
(Continued on page 766)

FIG. Q 325—Bench layout for testing vibrators.

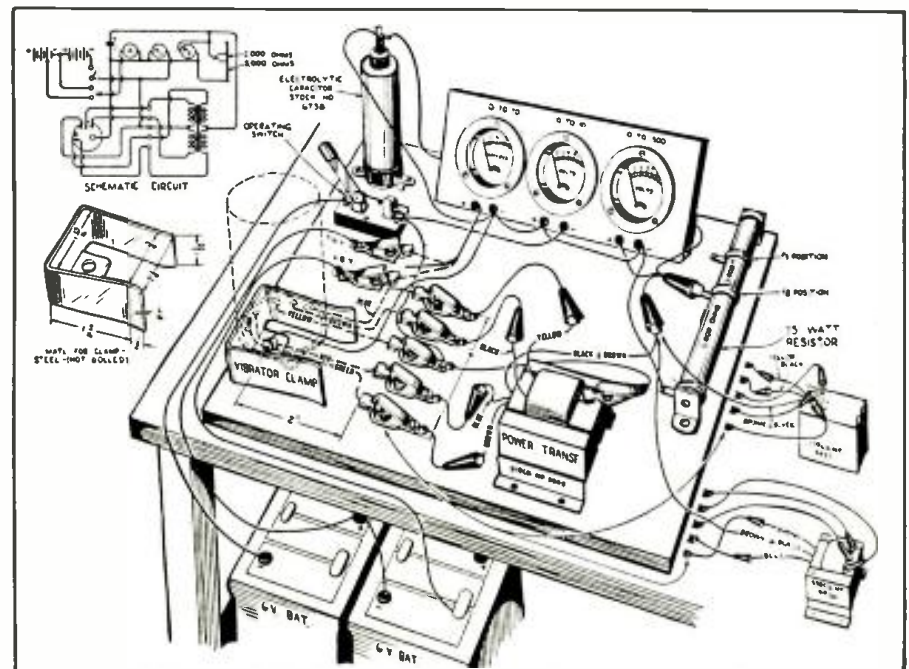



A department devoted to members and those interested in the Official Radio Service Men's Association. It is the medium for exchanging ideas, kinks, gossip and notes of interest to Service Men, or others interested in servicing.

COOPERATION REQUESTED

RADIO-CRAFT, ORSMA Dept.:

I think that members of the ORSMA should use their FORUM page to more advantage—the letters published so far do not show enough spirit of cooperation. I mean that members should really use this page as a FORUM and not simply a place to tell about this or that piece of apparatus they have made or some peculiar experience which may or may not interest other members.

These letters are all right, but I think that if members would air their problems—and we all have them—the entire membership would profit more than at present. Such letters as Mr. Smith's in the January 1935 issue, concerning auto-radio vibrators, is what I mean.

I have done quite a bit of auto-radio installation and servicing during the past two years and I have a problem which may interest other members—and perhaps someone can help me. In installing sets, especially in cars which are not up-to-the-minute in design, I have encountered a great deal of trouble in eliminating or reducing the ignition interference. Of course, I am familiar with the usual methods of installation—using spark plug and distributor suppressors; condensers and filters for dome and tail lights; generator and starter motor condensers, etc., but the type of trouble I refer to is heard whether the aerial is connected to the set or not and is obviously picked up through the power supply or through the shielding around the set itself.

Have any other Service Men encountered such ignition trouble and if so, how did they minimize the noise to an extent satisfactory to their customers?

L. M. MCGRAW,
Chicago, Ill.

ORGANIZE FOR PROTECTION

RADIO-CRAFT, ORSMA Dept.:

A group of Service Men in Pittsburg (Kansas) and the surrounding territory, are planning to organize for the

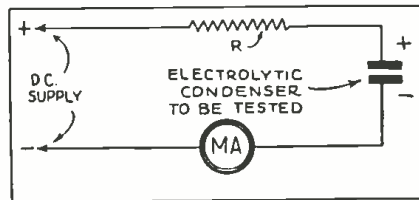

The circuit of a simple test unit for electrolytic condensers.

sake of price stabilization and high-quality service work. Most of our prospective members are also members of the ORSMA and we would like to have this national organization back us and give suggestions as to how to accomplish our purpose.

We feel that organization is the only way to receive justice as far as price-cutting is concerned.

MR. ZETKO,
ZETKO RADIO LAB.,
Croweburg, Kansas.

Thank you for your letter Mr. Zetko—we are glad to see that radio Service Men are really getting interested in local organization plans. It will be remembered that ORSMA advocated this action as far back as January 1933, when the first ORSMA BULLETIN was published.

We shall be glad to assist you and your associates in any possible manner, Mr. Zetko. Just let us know in what way we can assist you in forming your local organization and getting the necessary cooperation from your city government to enforce fair practices.

The service bench of the Scalza Radio Service in Brooklyn, N.Y. This is a very complete layout containing every instrument needed for set repairing.



VIBRATORS IN NEW ZEALAND

RADIO-CRAFT, ORSMA Dept.:

In the Members' Forum in January 1935, there is a letter by Jesse Smith, Jr., regarding various makes of vibrators, in auto sets, which are giving trouble. The letter aroused my interest and it might interest Mr. Smith and other members to know that I was employed for a considerable time by the N.Z. agents for Philco radio sets. I was one of the five Service Men at the Auckland branch.

During this time we had several instances of vibrator trouble in auto sets and we found that after cleaning and adjusting, 90 percent of these units would work quite satisfactorily.

Quite a number of sets were imported with the vibrators stuck and no amount of jolting or banging would set them going—but a good clean-out would. I am simply referring to the Philco vibrator, as I have never had any experience with the other makes mentioned.

I hope this information will be of use to Mr. Smith, and I can tell him that cleaning points and adjusting gaps is quite O.K.—as far as Philco vibrators are concerned, at any rate—but care must be used, otherwise a new unit will be needed!

B. W. H. POFFLEY,
Auckland, New Zealand.

ANOTHER VIBRATOR HINT

RADIO-CRAFT, ORSMA Dept.:

The writer is employed in the service department of United Motors Service, Pittsburg Branch and wishes to reply to the query of Mr. J. Smith.

In repairing hundreds of car radio sets the writer has found that stuck vibrators—both synchronous and non-synchronous—are in most cases not due to any fault in the construction of the shaker (vibrator) but can in a great many cases be traced directly to the "dumbbell" who set the car-generator wide open which means a voltage of well over 8 volts on a (Continued on page 767)

ZENITH 5-TUBE TRIPLE-WAVE SUPERHET. CHASSIS NOS. 5508 AND 5509

Operating voltages for this receiver are measured as follows. Line voltage, 112 V.; antenna and ground disconnected; measurements taken to ground; G1 is control-grid, G2—screen-grid, G3—suppressor-grid. (The output of V5 is not given.)

Tube V1: (first-detector section)—K, 4; G1, 0; G2, 80; P, 260. (Oscillator)—G1, 0.6; P, 260.
 Tube V2: K, 5.2; G1, 0; G2, 80; G3, 5.2; P, 260.
 Tube V3: K, 1.5; G1, 0; P, 135.

Tube V4: K, 0; G1, 0.7; G2, 260; P, 245.
 Alignment data: For I.F. adjustment, connect service oscillator to G1 of V1, and gnd. Align C band at 15 megacycles (service oscillator connected to ant. and gnd. posts); align A band at 600 and 1400 kc.

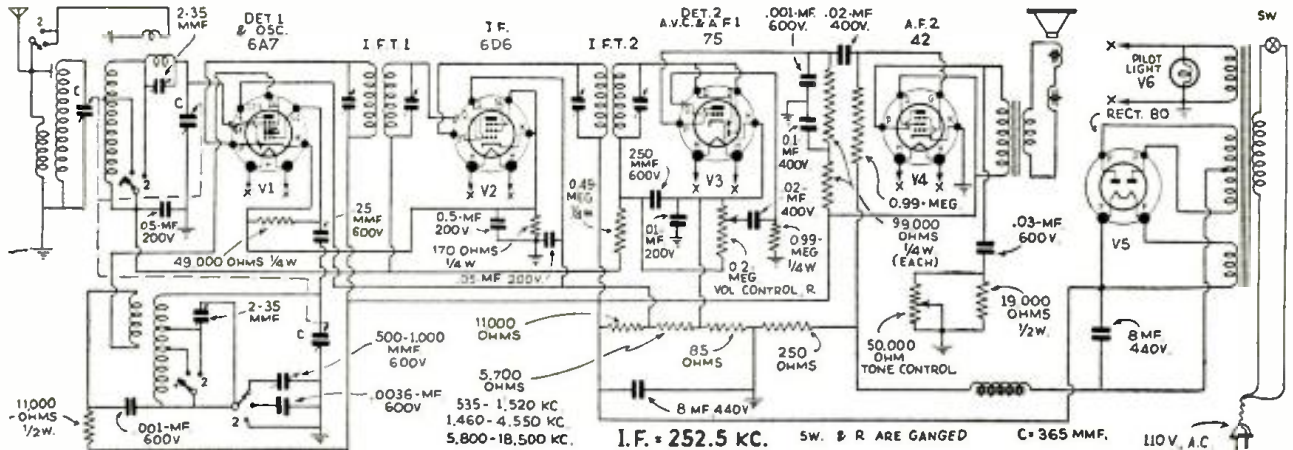

EMERSON MODELS 38, 42 AND 49, 6-TUBE DUAL-WAVE SUPER. (CHASSIS U6)

See earlier modifications—May RADIO-CRAFT Data Sheet No. 138 (chassis Nos. U6D-1

U6D-3). Only voltage changes in U6 follow (line, 117.5 V., D.C.). Plate: V1, 80; V2, K; V3, 4; V5, 13.5. Sup.: V3, 4.

100; V4, 35; V5, 95. S.-G.: V1, 45; V2, 45.

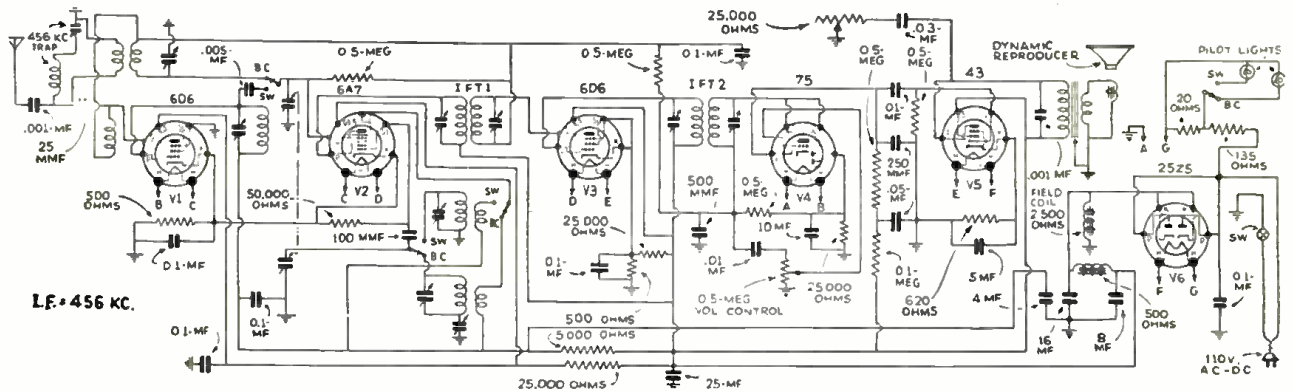

GENERAL ELECTRIC MODEL C-62 6-TUBE BATTERY SUPERHETERODYNE

The low-current pilot light is a feature of this set. A 4-pole switch controls all battery circuits. The total "A" drain is 0.45-A.; "B", 15 ma. Maximum undistorted output, 0.7-W. Align at 1,400 and 600 kc. Tube voltages and current are measured to ground, with no signal and R7 at maximum.

Tube	C.-G.	S.-G.	Pl. V.	Pl. Ma.
V1**	*3.0	67.5	135	1.7
V2	*3.0	67.5	135	1.8
V3	*6.5	67.5	*95	0.4
V4	*9.0	130	3.5
V5	12.0	135	1.0
V6	12.0	135	1.0

(* Cannot be measured with ordinary voltmeter; obtained by means of high-resistance bleeders across a 22.5 V. "C" battery. (**) Oscillator C.-G.—; S.-G.—; Pl. V., 135; Pl. Ma., 1.8. The 600 kc. padding condenser is available from the rear of the chassis. Fuses, 0.5-A.

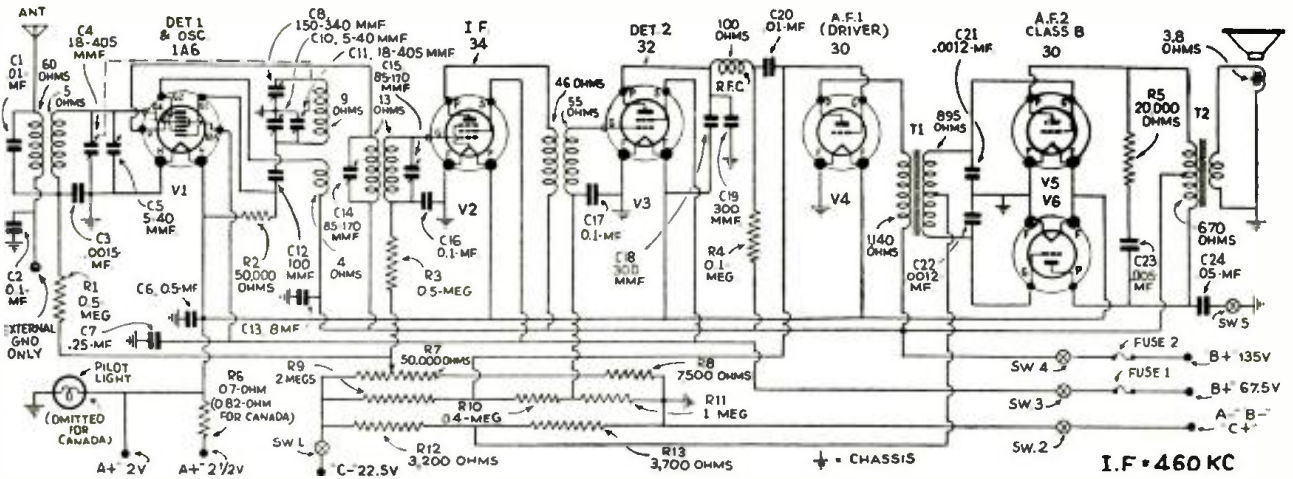

SERVICE MEN

PROTECT
YOUR BUSINESS

Charles Golenpaul*

A TREMENDOUS amount of business is being lost by Service Men, because they inform the customer of the details of the troubles in the set. As soon as the set owner knows the details of the faults in the circuit, he either removes the defective part and has the jobber replace them or else he clearly remembers the diagnosis and purchases new parts at a supply house.

It is a common occurrence for a Service Man to say that the set needs a new 8 mf. electrolytic condenser and a 25,000 ohm resistor. Then what happens? The customer says call back in a week; and then in the meantime, the customer goes to the jobber, obtains the parts and repairs the set. When the Service Man returns his services are no longer required. Whereupon the Service Man is perturbed at the jobber for selling directly to the layman at trade discounts.

Isn't it true that the Service Men in general are to blame for this breakdown and shunting of legitimate radio servicing? The situation is serious enough to warrant you doing your share henceforth to help eliminate this growing evil.

Put yourself in the place of the radio jobber. A chap walks into the store. He wears no label to indicate whether he is a Service Man or layman. So the jobber must use his own judgment. He asks for an 8 "mike" aluminum can electrolytic and a 25,000 ohm carbon resistor. This is sure a Service Man's language. Therefore the clerk serves him.

This evil must be cured at the root. How? Don't tell the set owner exactly what the trouble is—where the defective parts are—or even the exact values. Never show a parts catalog, nor prices and never mention that there is a discount off list for the Service Man. For in these penny pinching days many a set owner will hie off to the jobber, buy the parts, and do the job himself.

The Service Man must not give away his findings. It is sufficient to state that a filter condenser and a bias resistor must be replaced. The exact units need not be indicated nor the values given. The set owner should be interested solely in getting the set functioning once more through the Service Man's efforts.

This radio servicing is still a very young game. There is much it can learn from its older brother, the electrical contracting industry. Call an electrical contractor to your home and ask him for an estimate on wiring. Does he tell you the job will take so many feet of cable, such and such boxes, so many straps, etc.? Certainly not. You get an estimate of the job complete. It is not the material list you want. It is a finished job.

Take your work seriously. Evaluate your experience and skill on the same basis as that of an electrical contractor. Bear in mind, you must be paid for what you know quite as much as for what you do. The diagnosis is usually more valuable than the cure. Be sure you safeguard that diagnosis and convert it into remuneration, quite as well as the actual repair work. The average set owner pays you not for telling him what is wrong, but for the restoration of the set to operating condition. Don't fail to keep the exact details to yourself while rushing through the actual replacements or repairs so as to qualify for a satisfactory and prompt payment.

Therefore, don't cuss the jobbers if they occasionally sell to your customers at trade prices and by-pass your service work. When it happens, it simply means that some Service Man—perhaps yourself—talked too much, and gave away the diagnosis and hence the actual business.

*Aerovox Corporation.

EQUIPPED FOR *profitable* AUTO RADIO WORK!



Instruments being used servicing auto radio are:

- Weston Model 692 Oscillator
- Weston Model 665 Analyzer
- Weston Model 682 Tubechecker

The servicemen who are getting the profitable auto servicing business today . . . who will be getting it tomorrow . . . are the men who have the right equipment necessary to do an efficient servicing job. No auto dealer can be expected to recommend a serviceman unless he is properly equipped.

With the Weston instruments illustrated, any serviceman is fully equipped to service any type or make of auto radio receiver. In addition, the name these instruments bear is widely recognized, and stamps the owner as a careful, competent craftsman. Start building a profitable auto business today with the right equipment. Ask Weston to send full details . . . Weston Electrical Instrument Corporation, 599 Frelinghuysen Avenue, Newark, New Jersey.

WESTON
Radio Instruments



WESTON ELECTRICAL INSTRUMENT CORPORATION
599 Frelinghuysen Avenue, Newark, N. J.
Send bulletin on Weston Radio Instruments.

Name

Address

City and State

Please Say That You Saw It in RADIO-CRAFT

USEFUL AUTOMOTIVE-RADIO REFERENCE INFORMATION

A compilation of valuable data, for speeding auto-radio service work, which includes: intermediate frequencies; type of tuning control; number of units to the assembly, and number of tubes in the chassis; and type of "B" supply. This information relates only to the newer sets; see Data Sheet No. 118, in July, 1934, Auto-Radio Number of RADIO-CRAFT, for data on earlier models. Also, servicing data with respect to individual makes of cars are given.

REFERENCE DATA ON LATE-MODEL RECEIVERS

Name of Manufacturer	Model (& Notes)	I.F. (Kc.)	No. of Tubes	Re-mote of Control	No. of Units	Type "B"
American Bosch	634A	175	6	X	1	V
American Bosch	324A	456	5	X	1	V
Arvin—Noblitt—Sparks	7	170	5	X	1	V
Arvin—Noblitt—Sparks	17	170	6	X	1	V
Arvin—Noblitt—Sparks	27	175	7	X	1	V
Arvin—Noblitt—Sparks	37(D*)	175	8	X	2	V
Atwater Kent Mfg. Co.	776(B*)	264	6	A*	1	V
Autocrat Radio Co.	5	5	X	1	V	
Autocrat Radio Co.	60	6	X	1	V	
Belmont Radio Corp.	670	175	6	X	1	V
Auburn Automobile Co.	A5A3	181.5	5	X	1	V
Crosley Radio Corp.	4A1	456	4		1	V
Crosley Radio Corp.	5A3	181.5	5		1	V
Deleo—United Motors	629	262	4	X	1	V
Deleo—United Motors	626	262	5	X	1	V
Deleo—United Motors	627(C*)	262	5	X	2	V
Deleo—United Motors	628(D*)	262	6	X	2	V
Detrola Radio Corp.		6	A*	1	V	
DeWald—Pierce-Airo,	605	175	6	X	1	V
Emerson Phono. & Radio	5-A	172.5	5	X	1	V
Emerson Phono. & Radio	6-A	172.5	6	X	1	V
Fada Radio & Electric Corp.	166	175	6	X	1	V
Ford Motor Co.	V-8(D*)	175	6	X	2	V
General Electric Co.	D-51	175	5	X	1	V
General Electric Co.	D-52(D*)	175	5	X	1	V
General Electric Co.	B-40	175	4	X	1	V
Graham-Paige Motors	AT1-101(B*)	175	5	X	1	V
Graham-Paige Motors	ATP-102(B*)	175	5	X	1	V
Howard Radio Co.	HA-1	175	6	X	1	V
Howard Radio Co.	HA-2	175	5	X	1	V
Hudson Motor Co.	680	6	X	2	V	
Hupp Motor Car Corp.	HIT-2	260	6	X	1	V
Hupp Motor Car Corp.	HH1(D*)	260	7	X	2	V
International Radio Co.	K-6	262.5	6	X	1	V
Karadio Corp.	150	5	X	1	V	
Karadio Corp.	160	6	X	1	V	
Karadio Corp.	180	7	X	1	V	
Laurehk Radio Mfg. Co.	AE-5	456	4	X	1	V
Laurehk Radio Mfg. Co.	AE-6	175	5	X	1	V
Mission Bell Radio Co.	14(B*)	5	X	1	V	
Mission Bell Radio Co.	11(B*)	6	X	1	V	
Motorola—Galvin	100(B*)	262	8	X	2	V
Motorola—Galvin	75(B*)	262	6	X	1	V
Motorola—Galvin	57(B*)	456	5	X	1	V
Packard Motor Co.	12(D*)	260	7	A*	2	V
Pontiac Motor Co.	544	262	4	X	1	V
Remler Company	36	450	6	X	1	MG*
Sentinel Radio Corp.	10M	370	5	X	1	V
Sentinel Radio Corp.	7M	262	6	X	1	V
Stewart-Warner Corp.	R-131	177.5	6	X	1	V
Studebaker Sales Corp.	AC-266	6	X	2		GEN*
Transformer Corp. of America	TC-50	175	6	X	1	V
Transitone Automobile Radio Corp.	805	260	5	X	1	V
Transitone Automobile Radio Corp.	806	260	6	X	1	V
Transitone Automobile Radio Corp.	807	260	7	X	1	V
Transitone Automobile Radio Corp.	808(D*)	260	7	X	2	V
Wells-Gardner & Co.	25Y1	175	5		1	V
Wells-Gardner & Co.	25S1	175	6	X	1	V
Wholesale Radio Serv.	AM-20	6	X	1	V	
Wholesale Radio Serv.	B-42	5	X	1	V	
Westinghouse E&M Co.	WR-500	175	6	X	1	V
Westinghouse E&M Co.	WR-501	176	6	X	1	V
RCA Mfg. Company	M-104	175	5	X	1	V
RCA Mfg. Company	M-108	175	5	X	2	V
RCA Mfg. Company	M-109(B*)	175	7	X	2	V
Zenith Radio Corp.	664	456	5	X	1	V
Zenith Radio Corp.	666	252½	6	X	1	V
Zenith Radio Corp.	668(D*)	252½	6	X	2	V

A—Available in either direct- or remote-control type.

B—Suppressors not needed.

C—Overhead speaker.

D—Speaker separate.

MG—Motor-Generator.

GEN—High-output generator; not integral with set.

(See RADIO-CRAFT Library Series Book No. 9, "Automobile Radio and Servicing," for detailed information concerning car-radio service work.)

SHORT-CUTS IN CAR-RADIO SERVICE WORK*

BUICK 1932. Annoying static interference in Buick 1932 radio installations, when driving around 25 to 35 miles an hour, is usually caused by the brakes rubbing. Check this by driving for some time; due to the friction one of the brakes will feel warm. To remedy, remove the wheel, clean the drums and re-adjust the brakes.

BUICK 1933. A bad source of brake interference in this car is usually localized to the front wheels. In each wheel assembly a cotter pin will be found to be loose and causing the noise. Place a lock-washer underneath each pin in order to hold it rigid.

CHEVROLET 1933. To reduce interference from the ignition system, remove the ignition coil from the bulkhead and, using the valve inspection plate bolt, fasten it to the motor.

To completely eliminate generator interference connect a condenser to the second field wire of the generator.

A screen 8 ins. square placed on the front floor board, on the passenger side, and grounded will eliminate all noises transmitted, by the passenger, from the engine bulkhead to the roof aerial. It is advisable to check the gap of the distributor rotor. Additional filtering may be needed on the wire terminals at the ignition switch.

Sometimes quite stubborn interference is caused by the stop-light switch. It may be necessary to bridge the stop-light switch with a 1. mf. fixed condenser. This condenser must not be connected from terminal to ground (the usual practice), but from terminal to terminal. Be sure to install the receiver on the left, or driver's side.

CHRYSLER CARS. On all cars of this make with floating power, bond from the base of the distributor to the frame, from the steering columns to the bulkhead, and from the free-wheeling control cable to the bulkhead, with 3/4-in. flexible copper braid.

On cars having floating power a static discharge due to the emergency brake on the drive shaft occurs whenever the motor is not delivering power to the drive shaft. The use of a small carbon brush and holder will eliminate this source of noise. Mount the holder at any convenient place so that the brush makes contact with the emergency brake drums, and ground the brush holder.

DODGE. Shield the ignition cable from the switch and connect a fixed condenser from the switch side of the coil to ground.

FORD V8. Take off the top section of the distributor by removing the screws on the flange. Pry apart the two parts comprising this section by raising the edges of the eyelets which hold them together. Carefully pull up the wire fastened to the bottom of one section (being very careful not to break it) until there is sufficient room to permit a 25,000 ohm, 1 W. resistor to be soldered in series with it. Wrap the resistor in Empire cloth, imbed it in the compound, and replace the assembly.

FORD 1933. The antenna lead is usually under the rear seat or right-front post. If suppressors do not eliminate interference try one of these methods: (1) shield and separately ground the coil, generator, and distributor wires; (2) ground the steering post, motor, bulkhead and dash; (3) bypass the dome-light wire at the bulkhead by means of a 0.5-mf. fixed condenser.

FORD MODEL T. Installation of the radio set on the right-hand side of this well-known car model may be accomplished by replacing the rigid choke rod with a flexible one.

PACKARD. Be sure to bypass all dome-light leads and ground the protective cable on the spot-light. Also, on all sport models ground the tire standard.

PLYMOUTH 6. A generator noise sometimes results, although there is a condenser at the cutout, with the wire connected to the correct position. The trouble is eliminated by making sure that the condenser is fastened under the cutout screw next to the engine—not under the one next to the hood.

PLYMOUTH 1933. A common source of noise is the free-wheeling cable which is quite near the distributor head. This noise is eliminated by using a clamp, grounding the clamp to the frame of the car.

PONTIAC. On this and all other cars having a shielded down-lead located in the right-side post, thus requiring set installation on the driver's side, extend and carry the shielded lead-in underneath the floor boards rather than under the dash.

STUDEBAKER 1934. If noise in this car model is not completely eliminated after having followed the regular system of noise elimination, shield the dome-light wire. Extend this shielding from the right-hand windshield post to the fuse block on the rear of the instrument panel, grounding the shield at both ends.

CONTINENTAL BEACON. Regardless of suppressors an annoying spark noise is usually encountered, due to the rear spark plug, which is very close to the bulkhead. Place a copper can 3 ins. square over the plug, and shield its lead.

GENERAL MOTORS 1933. In the closed models of 1933 General Motors cars, noise pick-up from the dome-light is eliminated by connecting a 0.5-mf. condenser from the lamp side of the switch to ground.

*Reprint courtesy Hysgrade Sylvania Corp.

A FAIR DEAL TO ALL...

RAYTHEON's New Price Plan effective April 1st, 1935 is built upon this keystone: "A Fair Deal to All"—consumer, dealer, service man and jobber. Its need was never more acute—a sixty-five million dollar replacement tube market slashed during the last five years to twenty-four million dollars—reduced prices and profits—loss of public confidence. **THE AVERAGE** list price per tube on January 1st, 1930 was \$2.63; the average price per tube on April 1st, 1935 was \$.80 and no increase in consumer sales. An \$.89 price will sell no more tubes than a \$1.00 price.

RADIO TUBES are service items, not ordinary shelf or counter merchandise; tubes must be tested

and installed; purchasers require information and advice, service questions arise; and for all this work the trade must be fairly compensated.

RAYTHEON's new selling plan was built after weighing these factors; it incorporates the answer the trade is seeking and includes the only tube distinctly different in design—4-Pillar Construction—unexcelled quality, consumer acceptance and competitive trade prices—not price-slashing lures, but profit-building list prices. All 4-Pillar Tubes bear the Raytheon name; the story is easy to tell—the 4-Pillars are plainly visible to the consumer. Reputable dealers and service men everywhere recommend, endorse and sell them.

Ask your jobber for complete details of Raytheon's plan, or use the coupon.



RAYTHEON PRODUCTION CORPORATION

30 E. 42nd St. New York 55 Chapel St. Newton, Mass. 445 Lake Shore Drive Chicago 555 Howard St. San Francisco

RAYTHEON

4-PILLAR RADIO TUBES

RAYTHEON PRODUCTION CORPORATION
Dept. E-5, 30 E. 42nd St., New York.
Please send Details New Price Plan
 Display Material

NAME _____
ADDRESS _____
CITY _____

ANNOUNCING— ELECTROLYTIC PICTURES VIA AN IMPROVED SYSTEM

(Continued from page 718)

of varying density, identical to the print at the scanner. (The "screen" of the portable model is 60 lines; a "high-fidelity" model for use is capable of 120-line quality.)

Since the recorder is equipped with a spring motor (Note the crank in Fig. C), synchronization is comparatively simple. When the scanner is started a continuous 1,100-cycle carrier is sent to the recorder, which trips a relay and releases an electro-magnetic clutch, which permits the cylinder to start revolving. After one revolution of the recorder is completed it automatically stops, and does not again start rotating until another jump (impulse) in the carrier current, due to a little light-interrupting flag on the scanner, again trips the recorder's start relay; whereupon, scanner and recorder start turning over for one more revolution—and so on until the picture is completed,

THE SCANNER CONTROLS

The first of four controls for correct adjustment of the scanning equipment determines the amount of unmodulated signal that will pass from the screen-grid of the modulator tube when the grid is biased most negatively. This controls the shading or background of the picture. It should be set so that the response on the relay meter reads about 0.2-ma. when the lamp in the scanner is covering the aperture and is turned off.

The second control, R2, regulates the current for the synchronizing note or impulse. This should cause the meter to read 3.0 ma. The meter is in the plate circuit of the modulator tube.

The third control governs the bias on the modulator tube and should be adjusted to 10

microamps. The setting of this will effect control R1 and should be changed only when a different tube is used.

A fourth control, R4, varies the voltage applied to the PE. cell, and should be adjusted with each photograph so that maximum reading is between 100 and 150 microamps, when the light traverses the most transparent part of the negative.

Details of the starting connection and the contacts to the synchronizing switch are shown in B of Fig. 1.

The recording end of the system is illustrated in C of the same figure, and consists of the relay panel and the recorder. Batteries are used in the operation of the recorder as noted on the diagram.

THE RECORDER MECHANISM

The action of the mechanism will be explained starting with the cylinder at rest. (Refer to Fig. 1C.) Cam 1 connects wire 2 to the frame and through wire 1 to the plate of the power tube, and opens the switch which normally shorts the meter and high-frequency relay.

When the synchronizing note is received, the meter kicks to 3 ma. and the relay closes the contact from 6 to 4. This operates the release and allows the cylinder to start revolving. Cam 1 then passes its switch, and the relay is shorted; this reopens wires 6 and 4, opening the release and the lock falls back to ride on the cam wheel.

However, while the release is working it also closes a switch to engage the clutch, assuring positive coupling between cylinder and the spring motor. Before the release drops back cam 2 which has held the clutch circuit open passes, and the clutch remains engaged for the remainder of the revolution. The passing of cam 1 places the stylus and cylinder in series in the plate circuit. Thus the relay and the release are energized only at the start of each revolution, while the clutch is connected for the remainder of the time,

The recorder has a friction clutch as well as an electromagnetic clutch, and is adjusted by set screws in one of the helical gears. It is used so that the drag on the motor is the same whether or not the cylinder is rotating. It is of utmost importance to keep the slip rings on the clutch and the switch points clean, and the motor well oiled, or the synchronization of the picture will be poor.

If the picture shows lines and speckles that are not due to static, the stylus is at fault. The stylus has a platinum point and when new must be worn smooth. This accomplished by placing fine sandpaper on the cylinder and allowing the stylus to rub for an inch or two, and repeating with crocus cloth. In order to make the cylinder rotate when no picture is being transmitted, reduce the bias on the tube or merely reverse the leads to the storage battery. Enough plate current will flow to operate the relay and also shade the paper to determine if the stylus is all right.

The solution should be kept in an amber-tinted bottle. When using, pour into a clean fibre tray or china dish. Enamel is not good because it is hard to clean. After moistening the paper blot it with clean blotting paper.

When using the receiver for demonstration or test, it can be coupled directly by wires to the output of the scanner. For radio work it is best connected in parallel with the loudspeaker or headphones, with a .25-mf., condenser in each lead. It is important to note that reversing the radio receiver leads to the relay panel gives a different response on the meter, and the connection giving the highest reading should be used. This is also true in line telephone work. An additional volume control may be desirable, and can be a 5,000 ohm potentiometer in shunt with the relay panel.

"EARLIEST LOUDSPEAKERS" (A NOTICE)

We are advised by Mr. Pierre Hemardinquer, of France, that he is the author of the original article that we reproduced in the March, 1935 issue of RADIO-CRAFT under the title, "The Earliest Loudspeakers."

Please Say That You Saw It in RADIO-CRAFT

MAKE MORE CALLS and BIGGER PROFITS

with New
READRITE
Point to Point
TESTER
• NO 720 •



HERE is the tester that every serviceman needs for properly servicing radio receivers. The new Readrite No. 720 Tester enables you to make more calls per day at less cost per call—and make bigger profits because of its speed, its accuracy and its dependability.

The new No. 720 unit operates *faster* . . . more *efficiently* and with *less manipulation*. It tests all resistances, capacitivities, voltages, current and capacities from the set socket by the reliable point-to-point method. And it is built to withstand severe field service.

Two highly developed Vane-type AC and DC meters are incorporated into this new tester. They are simple in design and dependably accurate. The DC scales are 15, 150, 300 and 600 volts, 15-150 milliamperes. AC scales 10, 25, 150 and 750 volts.

Your Jobber Can Supply You . . .

With the Readrite No. 720 Tester at Dealer's net price of only \$15.00. Write direct for literature to

READRITE METER WORKS
155 College Ave. Bluffton, Ohio

MAIL COUPON FOR CATALOG

Readrite Meter Works
155 College Avenue. Bluffton, Ohio.

Send me catalog on Readrite No. 720 Tester and folder showing Readrite leadership.

Name.....
Address.....
City..... State.....

TECHNICIANS' DATA SERVICE

JOSEPH CALCATERRA DIRECTOR

The literature listed in this department contains a wealth of very useful information.

A special arrangement between RADIO-CRAFT magazine and the publishers of this literature, which permits bulk mailings to interested RADIO-CRAFT readers, eliminates the trouble and expense of writing to each individual organization represented in this department.

2. **HAMMARLUND 1935 CATALOG.** Contains 12 pages of specifications, illustrations and prices on the new line of Hammarlund variable, mid-ket, band-spread and adjustable condensers; trimming and padding condensers; R.F. and I.F. transformers, coils and coil forms; sockets, shields, chokes and miscellaneous parts for ultra-short-wave, short-wave and broadcast operation.

3. **HOW TO GET A HAMMARLUND 1935 SHORT-WAVE MANUAL.** A circular containing a list of contents and description of the new 16-page Hammarlund Short-Wave Manual, which contains construction details, wiring diagrams, and list of parts of 12 of the most popular short-wave receivers of the year.

4. **THE "COMET PRO" SHORT-WAVE SUPER-HETERODYNES.** Describes the outstanding features of the standard and crystal-type Hammarlund "Comet Pro" short-wave superheterodynes designed to meet the exacting demands of professional operators and advanced amateurs for a 15 to 250 meter code and phone receiver, but which can be adapted by anyone for laboratory, newspaper, police, airport and steamship use.

5. **ELECTRAD 1935 VOLUME CONTROL AND RESISTOR CATALOG.** Contains 12 pages of data on Electrad standard and replacement volume controls. Truvolt adjustable resistors, vitreous wire-wound fixed and adjustable resistors and voltage dividers, precision wire-wound non inductive resistors, center-tapped filament resistors, high-quality attenuators, power (50- and 150-watt) rheostats and other Electrad resistor specialties.

25. **LYNCH NOISE-REDUCING ANTENNA SYSTEMS.** Complete descriptions and instructions issued by Arthur H. Lynch, Inc., for making all kinds of antennas for broadcast and short-wave reception, with a special supplement covering Ham Antenna Design for transmitting as well as receiving on all the amateur bands, including the ultra-high frequencies.

26. **LYNCH AUTO RADIO ANTENNAS, FILTERS AND NOISE SUPPRESSORS.** This folder describes a complete line of Lynch antennas, filters and ignition noise suppressors designed for auto radio installations. The antenna system is of the under-the-car type for easy installation. It includes data on Hi-Gain matched-impedance transmission lines which make the under-car antenna highly desirable for use with the new "Turret-top" cars.

28. **LYNCH SUPER-FILTASTATS FOR AUTO RADIO INSTALLATIONS.** Describes and illustrates, with instructions for using, the new Lynch Super-Filtastats which do away with the need for suppressors in auto-radio installations, giving better performance in operation for both the car and radio set.

34. **SERVICE MAN'S 1935 ELECTRAD REPLACEMENT VOLUME CONTROL GUIDE.** A 52-page vest-pocket size booklet containing a revised, enlarged and complete list, in alphabetical order, of all old and new receivers showing model number, value of control in ohms and a recommended Electrad control for replacement purposes. Contains specifications and volume-control circuits for over 2,000 receiver models.

57. **RIBBON MICROPHONES AND HOW TO USE THEM.** Describes the principles and operating characteristics of the Amperite velocity microphones. Also gives a diagram of an excellent humless A.C. and battery-operated preamplifier.

62. **SPRAYBERRY VOLTAGE TABLES.** A folder and sample pages giving details of a new 300-page book, containing 1,500 "Voltage Tables" covering receivers manufactured from 1927 to date, published by Frank L. Sprayberry to simplify radio servicing.

64. **SUPREME NO. 385 AUTOMATIC TESTER.** A technical bulletin giving details, circuits and features covering this new Supreme development designed to simplify radio servicing. In addition to the popular features of Supreme analyzers and tube testers it contains many direct-reading features which eliminate guess-work or necessity of referring to charts or tables.

65. **SUPREME 1935 LINE OF TESTING INSTRUMENTS.** A 20-page catalog which gives complete information on the entire Supreme line of testing instruments, including the new 5-in. Supreme fan-shape meter, the new Model 333 De Luxe and low-priced analyzers, the improved Model 85 tube tester, the Model 61 oscillator and the Model 180 precision multi-wave signal generator.

66. **A SUPREME A.C.-D.C. TESTER WHICH CAN BE BUILT AT HOME AT LOW COST.** Gives complete information about the Supreme 5-in. fan-shape meter, rectifier and resistor kit for the home construction of an inexpensive A.C.-D.C. tester.

67. **PRACTICAL MECHANICS OF RADIO SERVICE.** Information, including cost, features and outline of lessons of the Frank L. Sprayberry course in Radio Servicing, and list of Sprayberry Data Sheets for modernizing old radio equipment.

69. **CASE RECORDS OF BROADCAST RECEIVER REPAIRS.** Gives plan, contents and price of the Capitol Radio Research Laboratories' loose-leaf case records of 1,500 service jobs showing how actual troubles were corrected. Serves as a guide in correcting troubles in all types of receivers and power-supply units.

70. **DATA SHEET ON BUILDING AN ANALYZER ADAPTER.** Compiled by the Capitol Radio Research Laboratories to show Service Men how any analyzer may be brought up to date; or how to build a complete, modern analyzer out of spare parts and the use of only a multimeter.

72. **HALICRAFTERS' SKYRIDER SHORT-WAVE RECEIVERS.** Descriptions of the Skyrider tuned R.F. and Super Skyrider superheterodyne short-wave

(Continued on page 766)

Radio-Craft Technicians' Data Service
99 Hudson Street,
New York City, N.Y. RC-635

Please send to me, without charge or obligation, the catalogs, booklets, etc., the numbers of which I have circled below.

2	3	4	5	25	26	28
34	57	62	64	65	66	67
69	70	72	73	74	75	76

My radio connection is checked below:

- Service Man operating own business.
- Service Man for manufacturer.
- Service Man for jobber.
- Service Man for dealer.
- Service Man for servicing company.
- Dealer.
- Jobber.
- Experimenter.
- Professional Set Builder.
- Amateur Set Builder.
- Licensed Amateur.
- Station Operator.
- Radio Engineer.
- Laboratory Technician.
- Public Address Worker.
- Manufacturer's Executive.
- Student.

I am a:
 Subscriber Newsstand reader.

I buy approximately \$.....of radio material a month. (Please answer without exaggeration or not at all.)

Name.....

Address.....

City..... State.....

(Please print name and address) Avoid delay. The catalogs and booklets listed are now in stock and will be sent promptly as long as the supply lasts.

Please Say That You Saw It in RADIO-CRAFT

CAR-RADIO SETS AFLOAT

(Continued from page 717)

"car-radio" aboard various boats. The boat shown in Fig. A is an Elco Cruisette. Here the set is mounted in a recess behind the helmsman's seat. The remote control is placed below the instrument panel.

An ideal marine installation of a car radio is shown in Fig. B. This boat is a runabout and therefore the set is subject to considerable spray. Note that the set has been recessed in the partition under the cowl, permitting two doors to be hung (which protect the set in heavy weather).

If the boat owner desires or purchases a car radio with an external speaker, then the location should be somewhat similar to the installations shown in Fig. C. In one installation the speaker is mounted behind the two doors of the closet. The door panels are taken out and a cane-covered frame substituted. The other installation has the speaker mounted behind a grille cut in the closet alongside the controls.

Most boat owners like to have the ship sleek and clean. This makes the installation of the antenna a special problem.

When you consider the small size of antenna with which a radio works in an automobile and the lack of ground connection, one can realize that it is easy to arrange a suitable aerial on a boat.

When the boat is equipped with a mast the antenna is attached from top to bottom of same, using No. 14 or 16 rubber-covered wire. Some boat owners claim exceptional results are obtained by running small copper tubing up the mast, insulating it with small stand-off insulators.

If the cockpit is roofed over an excellent antenna can be obtained by running rubber-covered wire around the inside edge of the canopy.

In case there is no mast or canopy on the boat, then a single wire is tacked unobtrusively under the coaming, as shown in Fig. B. Tape the dead end.

The ground connection is next. Rubber-covered wire is also used for this connection. Make the ground solidly to the engine; or to the rudder post, if the latter is metal.

Special note: All connections and joints after being tightened or soldered, should be painted, varnished or shellaced, to prevent corrosion and galvanic action.

The final step is the suppression of noise. (Due to the high signal/interference ratio afloat, the electrical problem is not a serious one; the exhaust sounds, too, cause little trouble due to the fact that the boat is always traveling away from each exhaust sound wave.) The suppression system used in cars and described elsewhere in this issue of RADIO-CRAFT is also used on boats, namely: a carbon suppressor for each spark plug; a suppressor for the high-tension side of the distributor; and a condenser on the generator.

A lucrative market awaits the progressive radio man who goes after the boat radio business this season.

Fig. C

At the right a car radio set is installed behind the two doors at the bottom. The remote control is recessed in the center. The installation at the left is a two unit car radio.

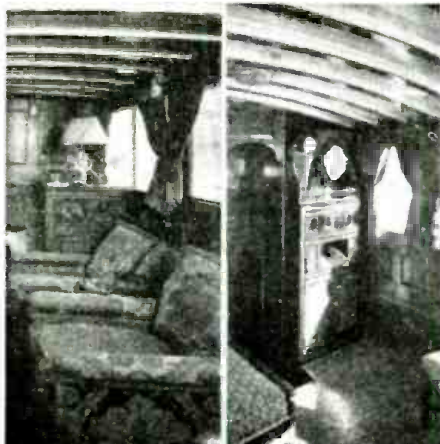

YOU'RE the TOP

*The Whole Radio World is Singing
the praise of this Sensational*
100% RADIO CATALOG

Certainly it's the TOP CATALOG of the Radio Industry—because there are more items listed (over 50,000), more specialized departments; more pages of special BARGAINS; more special summer items; more nationally known lines; the greatest line of S.W. and All-Wave Receivers (24 pages of them).

SHORT WAVE and ALL WAVE RECEIVERS

No matter what you seek in S.W. or All-Wave Receivers . . . we have it. A big 24 page section is devoted to receivers from 5-12 tubes; all latest circuits, beautiful cabinets; phono-radio combinations, etc. We carry following nationally known Sets and Kits in stock: All STAR and ALL STAR Jr. Kits, Browning "35" Kit, full line of Lafayette Kits; Hammarlund Comet Pro and R.C.A. ACR-136 Receivers!

Public address is featured . . . 30 pages of Everything in Amplifiers from 3½ to 100 watts, complete systems suggested and illustrated for each amplifier. Permanent, portable and mobile systems for 6V. battery or 110V. operation; plus thousands of parts and accessories. The most comprehensive P.A. selection in America to-day!

AUTO RADIOS and ACCESSORIES

Featuring Lafayette receivers to meet every requirement. Prices from \$19.95 up. New SUPPRESSORLESS Type receivers, DASHBOARD Types and the New SELF ALIGNING Types which are so easily serviced. Also a complete selection of Auto Aerials—including those designed for the all metal turret-topped cars, noise suppressors, etc. This big section is a complete Auto Radio Catalog in itself!

WHOLESALE RADIO SERVICE Co.
Main Office and Warehouse:
100 SIXTH AVENUE - NEW YORK, N.Y.

BRIDGE PLAZA - NEW YORK, N.Y. ATLANTA, GA. MEMPHIS, TENN. KANSAS CITY, MO.

Wholesale Radio Service Co., Inc.,
100 Sixth Ave., Dept. C-65,
New York, N.Y.

Send me your new FREE Catalog No. 57.

Name.....
Address.....
City..... State.....

HAVE YOU A RADIO-CRAFT INDEX? Covering the issues from July 1929 to June 1932—this index will save you considerable time and money. Send 25c in stamps or coin for your copy.

"Pioneers of Quality" in SOUND EQUIPMENT

We are designers and manufacturers of all types of PUBLIC ADDRESS EQUIPMENT. This is our only field. Send three cents (3c) in stamps for our new 1935 Amplifier Catalog. Address Department RC.

INTRODUCTORY OFFER!

2-button heavy-duty broadcast-type—lustre chrome finish microphone with beautiful lustre chrome desk stand and springs. Value \$11.75
SPECIAL PRICE \$5.75
F.O.B. New York



RADIO AMPLIFIER LABORATORIES, 291 East 137 St., New York, N. Y.

Please Say That You Saw It in RADIO-CRAFT

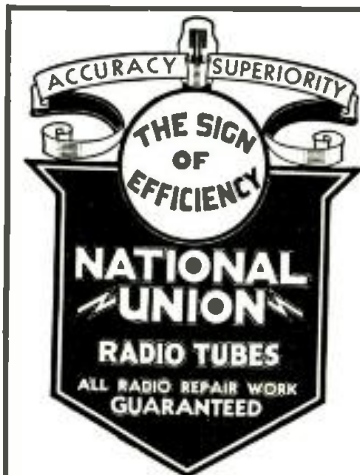

Service Dealers!

Do you know that this emblem stands for a bigger better business for you? Do you know of all the shop equipment National Union gives you, has given to thousands of your fellow service experts everywhere? Do you know about National Union business building helps and plans? Do you know why National Union means a more profitable radio service business? You can't afford not to find out all about National Union tubes and why they are sold by more service men than any other make. Find out! Send the coupon!



National Union Radio Corporation of N. Y.
570 Lexington Avenue, New York City RC-635



Send me your free book "Merchandising Radio Service" and tell me about free shop equipment.

Name.....
Street.....
City..... State.....

Mail
the
Coupon
Now!

MARLO presents A COMPLETE 15 WATT SOUND SYSTEM That Cannot be Duplicated! at Twice the Price



- Including:
The Standard Marlo
Class A Prime 4 Stage
15 Watt Amplifier
2—11-inch Heavy Duty Super Dynamic
Reproducers
1—Standard Large Size Chromium
Plated Double Button Microphone
1—Beautiful Full Length Adjustable
Floor Stand
1—Complete Microphone Input "Mixer"
Stage for Remote Control Operation
- Price Complete \$41.95
As Illustrated Less Tubes
MARLO RADIO PRODUCTS
16 HUDSON ST. N. Y. C.

THE "BUMPER ANTENNA" FOR 1935-'36 CARS

(Continued from page 724)

bumper completely. In doing so, you will find that a clamp at each side of the member holds it to a similar clamp fastened to the frame. These two mechanical connections must be insulated so that there is no physical (metal) connection of the bumper to the frame.

This can easily be done with pieces of an old inner tube. (The ceramic, "steatite," may be used, but is much more difficult to obtain and will require machine-shop facilities.) In Fig. 1, note that two pieces of inner tube are cut for each clamp. Be sure to cut the rubber so that it is about 1/4-in. oversize. (It is better to be oversize than undersize so as to be safe on the insulation.)

Next the longest part of the bumper is drilled for clearance for a 6-32 machine screw. The screw is used to fasten a soldering lug to what is now the aerial.

In the event the bumper is of small size and the pick-up is low, then the same procedure can be applied to the front bumper and the two joined together. Remember that the front antenna is nearer the ignition interference, however, in general, the combined pickup will produce a sufficient signal to noise ratio.

The latter method (Ford-type bumper) shown in Fig. 2 entails more work. Rubber (or, preferably, "steatite") is used to insulate the mounting from the frame, but in addition the bolt holes are drilled larger and rubber grommets inserted.

(A variation to the bumper antenna is two chromium-plated rods mounted on the rear of the car. The rods will have to be set on "steatite" stand-off insulators about 2 ins. high. This should only be used as a makeshift over the bumper antenna.)

The bumper-type antenna has proved its suitability for use in police cars (RADIO-CRAFT, December 1934, page 328); its use in private cars is now but a matter of time.

PORTABLE "P.A.—RADIO" SYSTEMS

(Continued from page 719)

signed the portable radio-P.A. combination illustrated in the photographs, and shown by diagram.

The change-over from radio receiver to speech amplifier is clearly indicated on Fig. 1. The D.C. for the microphone is obtained by opening up the lead from the dynamic speaker field to the ground, and inserting a 50-ohm potentiometer, shunting this unit, R, by the 200-ohm microphone and microphone transformer.

The 5-tube T.R.F. radio set may be any good, standard radio chassis, home- or ready-made, having an output of about 2 1/2 W., or more.

Potentiometer R in Fig. 1 is used to control the volume at low-volume levels; therefore the microphone carries only a portion of its maximum permissible current, thus greatly increasing its useful life.

The leatherette carrying case shown in Fig. A measures 17x14x9 ins. deep. The speaker section is 5 1/2 ins. deep and is held firmly by four catches, two on each side of the case. In the rear of the case a flap about 3 ins. wide on the top of the case is provided for accessibility to the tubes; this flap is kept open during operation to provide ventilation.

A slight change in location of the microphone transformer (which bolts to the side of the case) will eliminate any trace of hum. All other hum is eliminated by means of the 10 henry, low-resistance choke and condenser shown in Fig. 1.

These sets are still in use occasionally in indoor P.A. work, as their use outdoors is now prohibited in Philadelphia by an ordinance of the city council. Any Service Man living in a community where there is no law against the use of amplifiers for commercial purposes can take advantage of the information contained in this article and build an efficient radio and P.A. combination at very low cost.

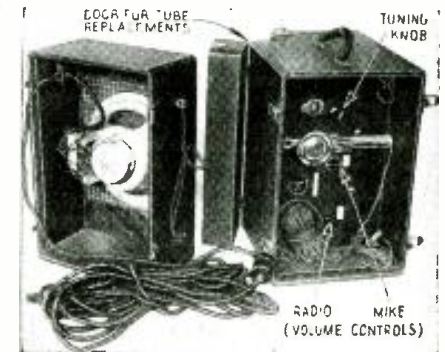

Fig. A, above
The leatherette covered case opened up.

Fig. B, below
The radio receiver portion of the system.



RE: "WIDE-FREQUENCY PHONO PICKUP" (A Correction)

We wish to take this opportunity to apologize to Mr. John Erwood (Vice-President and Sales Engineer of The Webster Co., Chicago, Ill.) for having accidentally printed his name as author of the above article in the May issue. The correct credit should have been Ray Dally, Chief Engineer (of Webster Electric Co., Racine, Wis.).

Please Say That You Saw It in RADIO-CRAFT

SEND FOR OUR NEW
FREE RADIO AND
AMPLIFIER CATALOGUE
WE ARE HEADQUARTERS FOR
PUBLIC ADDRESS SYSTEMS
Coast-To-Coast Radio Corp.
559 R Sixth Ave., New York, N. Y.

THE PRESENT STATUS OF AUTOMOTIVE RADIO

(Continued from page 716)

about 120 db. (approximately three times the sensitivity of an ordinary "home" set)! However, instead of entirely solving the problem, a new one is introduced, to wit: increased noise pick-up.

DETROIT'S DICTATORSHIP

This unpleasant situation did not appear through the inability of the radio designers but rather through the dictatorship of Detroit, which brought the radio designer in a position comparable with the man whose hands are tied behind his back, and then told to fight! That is, the radio engineer is confronted with ignition interference field strengths of about 500 to 1000 microvolts, against an R.F. input which is only between 5 and 20 microvolts (as delivered by the underslung antenna—see Fig. 3A), and is told to find a radio receiver installation that will result in acceptable performance.

Detroit eliminated the use of the excellent roof aerial. It is now their duty to furnish the radio engineer with at least an ignition system practically free of interference. (RADIO-CRAFT submits to "Detroit," as the author phrases it, as a practical solution of the antenna problem the "rear-bumper" antenna described elsewhere in this issue.)

DOES THE SUPPRESSOR EFFECT AUTO OPERATION?

In addition to suitable shielding of the receiver, and the use of a shielded lead-in, the best available method of avoiding trouble through ignition interference is the use of suppressor resistors.

When auto radio became popular suppressors were commonly 25,000 ohms. (This value is higher than necessary to satisfy the equation of: $R = \frac{1}{LC}$ and to 2L — being equal to, or greater than $\sqrt{\frac{1}{LC}}$ and to 2L obtain a condition in which oscillation, and therefore radiation is impossible.)

The engineers dropped this value to 15,000 ohms because a resistor with too high a value reduced the maximum current that could be reached when the spark gap broke down. However, it should not be overlooked that the actual ignition of the charge occurs at the first breakdown of the gap, before the current has had an opportunity to build up to its maximum value. Today, resistors of 8,000 to 12,000 ohms are more or less standard. (See Fig. 3B.)

If the engine is tuned up properly no trouble will occur by the use of suppressors of correct value; poor car performance, then, is more a sign of an unhealthy engine, especially of poor carburetor turbulence (mixture).

The automotive engineers have of course recognized the radio problem, and much work has been done especially during recent months on new ignition systems, on new dispositions of car wiring, and last but not least, on developing an electron tube type of distributor to replace the sparking type. However, this is only sweet music of the future. Meanwhile, installation and service technicians may expect to experience considerable trouble due to the extremely small R.F. pick-up in proportion to the high interference field strength.

POWER SUPPLIES

There are three types of power supplies available for converting the 6 V. power of the battery into about 250 volts for plate supply. First, motor-generator, or "genemotor" (Fig. 4A); second, vibrator with mechanical rectification (Fig. 4B); and, third, vibrator with rectifier tube (Fig. 4C.)

From the point of dependability and ease of filtering the genemotor is to be preferred. However, its starting current is about three times greater than its normal current; at which, if well built, it develops an efficiency of about 30 to 50 per cent. The vibrator with mechanical interrupter operates at about 69 percent efficiency. The vibrator with tube rectification has an efficiency of about 65 per cent.

There are today about 100 individual makes of auto-radio receivers on the market. The

proportionate use in these sets of the three types of "B" supply mentioned above is indicated in Fig. 5A.

However, present methods of supplying "B" power may soon all be scrapped in favor of using voltage supplied by an additional winding on the regular car generator. The present trend is to install such generators in the car at the factory as standard equipment.

THE SERVICE PROBLEM

The most encouraging fact for car owners is the remarkable improvement in the rigidity and strength of car sets; mechanical troubles due to vibration, etc., are rapidly becoming but a minor element in car-radio service. The major troubles that now result are due to the amazingly small dimensions of the modern car-radio set. Also, faults due to extremes of temperature and humidity have not yet been solved 100 per cent.

It is of special interest to Service Men that receiver design has been slightly improved to facilitate servicing; as for instance in the use of integral controls (see Fig. 5B).

Although about 76 per cent of the auto sets now on the market have an incorporated speaker (see Fig. 5C), in the interest of improved tone quality the trend is toward the use of a separate reproducer built into the car at the factory. Since 14 per cent of the street-dust consists of iron particles, an important feature of these new reproducers is their practically dust-proof construction.

The output stage of the new sets often incorporates class B operation (see Fig. 5D), thus considerably increasing the available power output; the A.V.C. control range has been increased, and now covers, in most sets, a 40 db. variation. Both improvements promise to make the listener forget that there is any such thing as changing field strength due to electrical shadows.

A FORECAST—THE "UNIVERSAL" SET

The so-called "cigar box" variety of auto receiver, which may be used in the car with the 6 V. battery, or at home with 110 V. either A.C. or D.C., appears on the American market only in one model (which, however, is distributed under several different brands). This type of auto receiver (illustrated in the heading) although not heavily sold in the past has great future possibilities—especially, for the car owner who likes to use his auto-radio receiver in the hotel room during a trip through the country; and who is interested, for example, in picking up the weather reports which are broadcast every hour from the 68 airways radio stations. These reports give the automobilist the opportunity of changing his route if the weather conditions (for example, ahead, during a cross-country trip) are unfavorable. While in some states auto receivers with police-call band reception are not allowed, no state would have objections to auto receivers with an additional wavelength range of about 200 to 400 kc. (1,500 to 750 meters).

(Another possibility for increased utility of the "universal" set is in the reception of overseas stations operating on the "international" bands of 19, 25, 31 and 49 meters. Such "dual-wave" operation is taken into account in Mr. Palmer's car-radio construction article appearing in this issue of RADIO-CRAFT. Of special importance is the fact that these wavelengths are entirely outside the short-wave and ultra-short-wave bands assigned for police calls. Any attempt to outlaw the reception in cars of the wavebands assigned by international agreement for overseas programs should be fought tooth and nail by every available agency; inasmuch as such legal restrictions would be due to nothing short of downright ignorance of fundamental regulations of our own Federal Communications Commission regarding frequency assignments for various services.—Editor)

CONTEST FOR SERVICE MEN

How would you like to win a valuable test instrument for your shop? Then join the contest for Radio Service Men which will start in the next issue of RADIO-CRAFT. The contest will be held to determine what testing equipment a Service Man needs for an ideal service station. Everyone is eligible—it will cost you nothing.

SAY BROTHER

I'LL FINANCE YOUR TRAINING IN RADIO

LEARN BY DOING IN 10 WEEKS



mail the coupon below and I'll send you my big FREE Book and tell you how you can get my training free, then pay for it in easy monthly payments extended over a year, starting 60 days AFTER your regular training period is over. Then after I have given you this training I'll give you lifetime employment service.

Here at Coyne you are trained on actual RADIO-TELEVISION and TALKING PICTURE equipment and machinery, and not by books or lessons. You DON'T NEED advanced education or previous experience.

Right now I'm including my big new ELECTRIC REFRIGERATION and AIR CONDITIONING course at no extra cost.

If you send the coupon today I will send you complete details of my sensational new plan and my big free book telling all about Coyne and how many earn while learning. H.C. Lewis

H.C. LEWIS-PRES. DEPT. A5-8H
COYNE RADIO SCHOOL
500-SOUTH PAULINA ST.
CHICAGO, ILLINOIS.

SEND ME ALL THE FACTS

NAME _____
ADDRESS _____
TOWN _____
STATE _____

PORTABLE SOUND SYSTEMS
ELECTRO DYNAMIC UNITS
CARBON MICROPHONES
AMPLIFIERS
4, 5 & 6 FT. ALL ALUMINUM TRUMPETS
FIELD EXCITERS
AIR COLUMN HORNS
LOW AND HIGH FREQUENCY UNITS FOR WIDE RANGE THEATRE USE

TRY IT 5 DAYS FREE

Learn about the amazing performance and dependability of Toledo P. A. Equipment without cost or risk—accept our free trial offer—no conditions or obligations.

Write for folder giving complete data on the Toledo P. A. line.



New exclusive feature of Toledo Portable Sound System—wall bracket speaker and baffle housing. Adjustable to any angle.

TOLEDO SOUND EQUIPMENT LABORATORIES
 Formerly Bud Speaker Co.
 1149 JACKSON STREET • TOLEDO, OHIO, U. S. A.

Radio Men—hundreds of NEW SERVICING IDEAS

for you in **"CASE RECORDS OF BROADCAST RECEIVER REPAIRS"**



Here are 1,500 actual service tests—each one a successfully completed service job. Alphabetically and numerically indexed, this authoritative service data in all covers 3,000 models of 108 set manufacturers. One week's use of "CASE RECORDS" adds years to your servicing experience.

Planned Service Work, as you find in "CASE RECORDS" eliminates guess-work—adds speed to servicing jobs and more profits. The only volume which actually does the job for you.

Bound in convenient, 9 x 12 inch loose-leaf binder. With FREE SUPPLEMENTS ISSUED QUARTERLY FOR A YEAR. Send remittance now and receive 1st Supplement with your copy of "CASE RECORDS". In addition you will receive FREE, the "CRRLE" Data Sheet on "Building an Analyzer Adapter." The purchase price of Manual is refunded if returned within 10 days.

CAPITOL RADIO RESEARCH LABORATORIES, INC.
 704 National Press Bldg. H. K. Bradford
 Washington, D.C. President

AUTO RADIO SERVICE MEN

YOU CANNOT AFFORD TO BE WITHOUT UP TO DATE TEST EQUIPMENT BUILD THE NEW VIBRATOR "B" TEST BOARD AND END YOUR AUTO RADIO HEADACHES COMPLETE KIT PARTS IN STOCK

M & H SPORTING GOODS CO.
 512 Market St. Philadelphia, Pa.

HOW TO MAKE AN ADVANCED DUAL-WAVE CAR-RADIO RECEIVER

(Continued from page 715)

short-wave reception is not at its best when the car motor is turning over, but the average ignition system has a natural wavelength of only about 7 meters, and if unusual care is exercised in arranging the antenna system it should be possible to so reduce interference as to make reception *en route* quite enjoyable; then, too, the car isn't always in motion—what about the hours at the roadside, when the picnic lunchbasket comes into its own?

To provide maximum sensitivity and volume much time was spent in design of the circuit. Unusual care was exercised in filtering every plate, screen- and control-grid lead so that the greatest possible amplification could be obtained from each stage. For this reason, too, the "B" supply selected for this receiver delivers the highest convenient voltage. (The resulting high gain of the set is especially useful in compensating for the characteristics of the "varitone" tone compensator built into the instrument.) A stage of R.F. amplification utilizing a 6D6 tube is included ahead of a combined first-detector and oscillator multipurpose type 6A7 tube, to give the desired selectivity and freedom from "birdies," and to improve the stability of the receiver. Because of its high power output sensitivity, and fine power-handling ability, the new type 6B5 tube (see RADIO-CRAFT, April 1935, "The New 6B5 Dynamic-Coupled A.F. Tube.") is included in the power audio stage. A multi-purpose, type 6B7 tube is used as diode detector, delayed A.V.C., and pentode A.F. stage; an unusual A.F. transformer is used to couple this tube to the 6B5. This transformer (known as the "varitone"—see RADIO-CRAFT, May 1935, "Variable-Fidelity A.F. Transformers") has a tertiary winding which permits tone compensation on the low and high frequencies without the usual "ills" of tone controls. (It also has a low-impedance primary which can be used by the ambitious constructor for a "mike" or phono. pickup, using the A.F. amplifier section and reproducer of the set as a small P.A. system.)

The special dust-proof magneto-dynamic (permanent-magnet) speaker specified for this chassis supplies "dynamic" quality without the usual 2 or 2.5 A. drain for field current. (The reproducer selected for the job is the smallest available, and was especially equipped at the factory with an output transformer to meet the writer's specifications, which called for the use of a type 6B5 output tube.) The resulting drain from the car battery is only 5 A. for the entire 5-tube receiver!

It was necessary to design a special set of R.F. coils for this car-radio set, in order to obtain proper impedance match between the car antenna and the input circuit of the set. (This problem has always presented one of the greatest difficulties in auto set design, due to the limited pick-up of the car antenna.) The manufacturers of the coil kit have done a fine job.

CONSTRUCTION DATA

An examination of the circuit diagram, Fig. 1, and the accompanying photos will show the circuit arrangement and the layout of the parts. The two shield boxes shown in Fig. B contain the tube, coil and R.F. choke for the R.F. amplifier and the I.F. amplifier stages. The one on the left is the R.F. stage; that on the right, the I.F. amplifier.

The dimensions of the chassis, the shield boxes and the crackle-finished container are given in Fig. 2. The positions of the holes, of course depend upon the individual parts used. Do not change the positions of the parts, as the layout is quite important in the final operation of the receiver.

We will not go into details regarding the actual mounting and wiring of the set. Obviously, it is not a set for the beginner—and the experienced radio constructor will find all the necessary information in the drawings and photos.

ALIGNMENT

When the parts have all been mounted and the wiring is completed according to the circuit diagram, the receiver is ready for alignment.

A good service oscillator delivering accurately-calibrated fundamental frequencies will be required; it must cover not only the broadcast band and the I.F. of 456 kc., but also the 49 meter short-wave band. The I.F. is the first adjustment to tackle. Take the grid cap from the 6A7 tube and connect the oscillator input to the tube cap. Adjust the oscillator to 456 kc., and connect the output meter to the plate circuit of the 6B5 tube, in the usual manner. Align the I.F. trimmers for greatest meter deflection.

When this operation is completed, replace the grid clip and connect the service oscillator to the aerial wire, having the wave-change switch in the broadcast position. Tune the service oscillator to 500 kc. and turn the knob on the remote control until the pointer also reads 500. Then align the oscillator broadcast band padder for greatest deflection on the output meter. Two points will be found where the service oscillator signal can be heard. Use the louder (higher frequency) position.

Next tune the oscillator to 1,400 kc. and adjust the broadcast trimmers in the R.F., intermediate (first-detector) and oscillator coil cans for greatest output meter deflection. Check the alignment at several other points across the band, and if necessary, bend the slotted end plates of the variable condenser sections to correct for misalignment. Do not touch either the padder or trimmer condensers once they are adjusted.

The short-wave alignment is carried out in the same manner as the broadcast adjustment, but with the wave-change switch in the short-wave position. In this case, tune the receiver condenser to nearly maximum capacity and adjust the service oscillator until the signals are heard in the speaker; then, adjust the oscillator short-wave padder for greatest meter deflection. Finally, move the condenser plates to a point near minimum capacity, find the resonant point

Fig. 2 The chassis layout and size of the iron box as well as the individual shields.

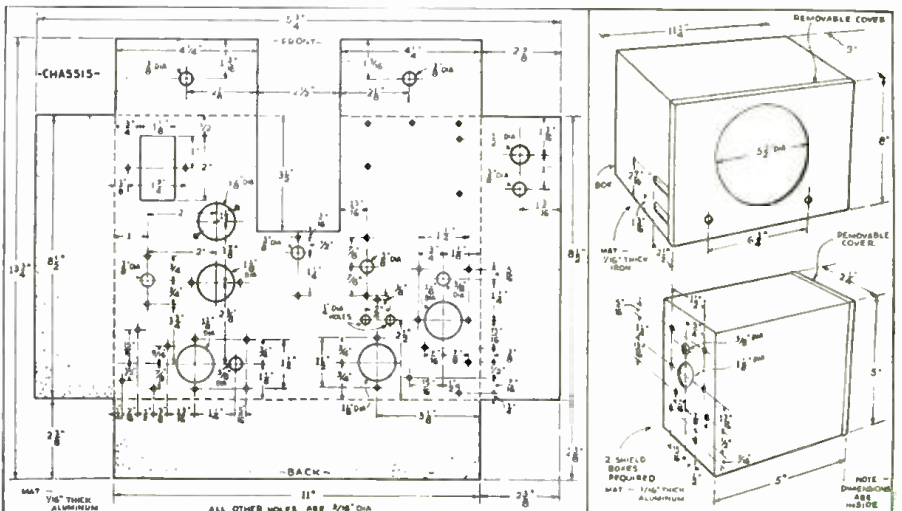

Please Say That You Saw It in RADIO-CRAFT

on the oscillator, and then adjust the trimmers (short-wave trimmers, which are the lower ones) on the three coils for greatest meter deflection.

A few suggestions regarding the construction and operation of the set may not be amiss.

First, shielded transmission lines of the type designed for car sets cannot be used for the short-wave band, so it is best to provide for a separate aerial and lead-in for this band. Perhaps a flexible wire which can be slung over a nearby tree is the most logical answer. The individual set maker can settle this point himself.

In the installation of the set in a car, the usual precautions of bonding wires and metal tubes at the fire-wall; bypassing the generator and starting motor and dome light, etc., must be taken care of. (See RADIO-CRAFT Library Book No. 9, "Automobile Radio and Servicing.") This set is designed to operate without ignition suppressors, consequently, every precaution must be taken to prevent ignition pick-up in the aerial. In very difficult cases, a single suppressor in the lead to the center of the distributor cap is usually sufficient.

LIST OF PARTS

*One set of special shielded, dual-range, high-gain R.F. and I.F. coils (see text), L1, L2, L3, IFT1 and IFT2;

*One 410 mmf. three-gang condenser and remote control with 2 flexible shafts, C1, C2, C3;

*One dual 6-plate padding condenser, C13, C14; Five Cornell-Dubilier .05-mf. 200 V. paper condensers, C4, C8, C17, C21, C24;

Four Cornell-Dubilier .1-mf. 200 V. paper condensers, C5, C9, C20, C26;

Eight Cornell-Dubilier .1-mf. 400 V. paper condensers, C6, C7, C10, C11, C16, C18, C19, C27;

Two Cornell-Dubilier 100 mmf. mica condensers, C23, C28;

One Cornell-Dubilier 450 mmf. mica condenser, C22;

One Cornell-Dubilier 250 mmf. mica condenser, C12;

One Cornell-Dubilier 25 mf. low-voltage electrolytic condenser, C25;

One Cornell-Dubilier .004-mf. mica condenser, C15;

Three I.R.C. .25-meg. carbon resistors, 0.3-W., R1, R4, R8;

Two I.R.C. 40,000 ohm carbon resistors, 1-W., R3, R10;

Two I.R.C. 300 ohm carbon resistors, 0.3-W., R2, R9;

One I.R.C. 200 ohm carbon resistor, 0.3-W., R5;

One I.R.C. 50,000 ohm carbon resistor, 1-W., R7;

One I.R.C. 25,000 ohm carbon resistor, 0.3-W., R6;

Two I.R.C. 1-meg. carbon resistors, 0.3-W., R11, R17;

Two I.R.C. .5-meg. carbon resistors, 0.3-W., R12, R13;

One I.R.C. .1-meg. carbon resistor, 0.3-W., R15;

One I.R.C. 3,500 ohm carbon resistor, 0.3-W., R14;

One Centralab .5-meg. volume control potentiometer with switch, R16;

One Centralab 50,000 ohm tone-control potentiometer, R18;

One United Trans. Corp. VT-1 Varitone transformer, A.F.T.;

*One 6 in. permanent-magnet dynamic reproducer with special transformer to match type 6B5 tube;

*One special, "A"-circuit filter;

*One genemotor "B" unit;

*Three 6 pin wafer sockets;

*Two 7 pin wafer sockets;

One 6-pole 2-throw wave-change switch, Sw.1 to Sw.6;

Two Hygrade-Sylvania type 6D6 tubes;

One Hygrade-Sylvania type 6A7 tube;

One Hygrade-Sylvania type 6B7 tube;

One type 6B5 tube;

One Blan aluminum chassis;

Two Blan aluminum shield boxes;

*One crackle-finish iron case;

One 3-wire battery and genemotor cable (two No. 10 and one No. 14 flexible wires, 10 ft. long);

Four National Union form-fitting tube shields;

Three Hammarlund 85 mhy. R.F. chokes, R.F. C.1; R.F.C.2. R.F.C.3;

Four screen-grid caps;

Shielded and plain hook-up wire, screws, soldering lugs, etc.;

(The names of manufacturers of parts marked * will be sent upon request.)

Electrical Efficiency

plus

BRUTE STRENGTH

BOTH frame and plates are "oversize," assuring greater rigidity and steadiness of signal. Features usually associated with only the highest-power transmitting condensers. Heavy aluminum ends, four sturdy duralumin posts and Isolantite insulating cross-bars. Wide-spaced plates have

rounded edges for greatly increased voltages. Smooth bearings; self-cleaning contacts. With a stator of the split-stator model (illustrated) connected to each side of the coil, the rotor is at ground potential. This permits mounting on a metal panel without insulation and reduces hand capacity. Single and split-stator models; 18 capacity ratings. List prices, \$5.00 to \$18.00. Write Dept. RC-6 for New Catalog.

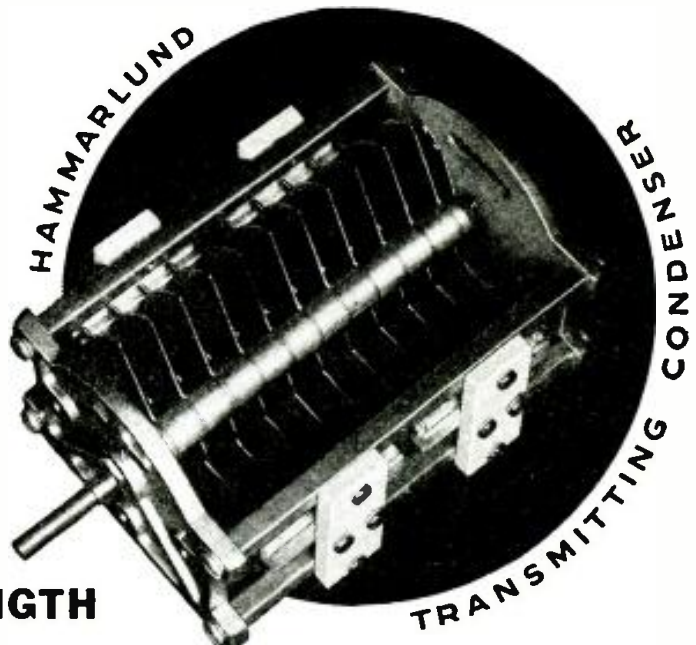

Hammarlund Manufacturing Co., 
424-438 W. 33rd St., New York

an aid to High Fidelity



BLEQ LINE EQUALIZER

KENYON offers controlled frequency compensation to the public address technician. A Kenyon BLEQ equalizer makes it possible to change the frequency response of any amplifying system in accordance with the equalization curves provided with each of these units.

High frequency alone can be emphasized

—or—

Low frequency alone can be emphasized

—or—

Both High and Low Frequencies can be emphasized

Ask your dealer for Bulletin M-1 showing performance data on this unit. If he cannot supply you, write us direct.

KENYON TRANSFORMER CO.
810 BARRY ST.
New York City

MAIL THIS TODAY

Kenyon Transformer Co., Inc.
840 Barry St., New York City.

Send me Bulletin M-1 which explains the BLEQ LINE EQUALIZER, giving curves, etc.

Name.....

Address.....

City.....State.....

TURN SCRAP INTO MONEY



The new and revised edition of "Auto Power" with all the ten original specifications and ten new ones is now off the press. Convert old generators into A.C. and D.C. generators and motors with voltages of 6 to 100 volts, for power, light, welding, and radio operation. Create new generators adaptable for home, automobiles, or trucks. They can be driven by fan belt, wind or water. This book, with complete illustrations, tells you how easily and economically these changes can be made. Also instructions for rewinding auto armatures, 250 definitions of electrical terms, etc. Already used and endorsed by thousands. Price \$1.00 postpaid.



AUTO POWER Dept. C 414 S. Hoyne Ave. Chicago

Please Say That You Saw It in RADIO-CRAFT

New 7-POINT MIKE ACHIEVES GREATER VOLUME and PERFECT REPRODUCTION WITHOUT FEEDBACK

The Ideal microphone brought within your reach . . . and guaranteed to be the finest value in mikes, regardless of price, or your money back! For the first time in America the new Super-flux Nickel Aluminum Magnets are used . . . magnets more powerful than even 36° Cobalt. You get 8 times more volume without feedback than you can get with diaphragm type mike. Completely free from distortion, peaks, or hum pickup. Rugged. Fitted with swivel bracket. Two Models: RB-S, especially designed for speech; output, —68 db. RB-M, recommended for speech and music; output, —64 db.



A. C. PREAMPLIFIER
Thoroughly shielded and guaranteed humless. 30-14,000 cycles (1 db.). Hum level, —100 db.

Write for Illustrated Bulletin RC-4
AMPERITE Corporation
301 BROADWAY NEW YORK

AMPERITE 7-POINT Velocity MICROPHONE



Model 390 VC

**Replace
Speakers
for Profit**

**GONE are
Cone Re-
placements!**

Now you can install a **WRIGHT-DECOSTER** Chassis for practically the same price as it costs to install a Cone . . . and the **WRIGHT-DECOSTER** assures a thoroughly satisfied customer, more profit and dollars ahead in sales. There is one to fit every radio. No dirt, grit or filings can get into the air-gap of a Wright-DeCoster Speaker due to the patented solid center-spacer.

Model 390 VC—5-inch Chassis—\$3.90

REAL PROFIT IN SEPARATE SPEAKERS

All high priced car sets have separate speakers. Now the smaller, less expensive sets can have all the finer tone qualities of the larger sets by installing a separate Wright-DeCoster Vehicle Speaker. The difference in quality of tone will be astounding.

Model 780 VS 8" Vehicle Speaker—\$7.80

Write for complete catalog, dealer's discount and name of nearest distributor. You will find the Wright-DeCoster distributor anxious to cooperate in every way possible.



Model 780 VS

**WRIGHT-
DeCOSTER
Incorporated**

2251 University
Ave.,
St. Paul, Minn.

Export Dept.: M.
Simons & Son Co.
Cable Address:
SIMONSTRICE,
New York

MAKING A VIBRATOR "B" TEST UNIT

(Continued from page 719)

tery is the best current supply for testing, and a 2 A. charger can be used to keep it charged. This charger must be disconnected while testing vibrators. If an eliminator is used, some means must be provided to keep the voltage at 6 V. Either a heavy-duty rheostat in one of the "A" leads, or a rheostat in one of the A.C. leads will do the trick.

A 6 V. dial lamp connected in series with the millimeter will act as a ballast, in the event of an overload.

Socket S1 is conveniently located near the base of the bench panel. A length of 3-wire shielded cable is used to wire it to the panel, using the shield for the "A—" wire. (By using two of these sockets, one near each end of the bench, the Service Man avoids disturbing any work at either end of the bench.)

The "socket unit" comes next. I used a shield can from a discarded "B" eliminator for the base. The size and shape of this can permits mounting the transformers, choke, 81 tube and condensers inside, out of sight, without undue overcrowding.

After the wiring is completed according to the circuit, the entire tester is ready for use. Connect the socket unit to the meter panel by plugging P into S1. Insert an 84 tube in S3. The 8 V. meter should read 5.8 to 6.3 volts, and the 10 A. meter about 1 A., dropping to about .3 A. as the 84 tube heats up. Now try a good Philco vibrator in S4. The 10 A. meter should now read about 2½ A., the 300 V. meter 175 to 225 V., and the 100 Ma. meter between 25 and 30 Ma. If this checks O.K., sockets S4, S5 and S6 can be assumed to be all right. Next try a Mallory 30 or similar vibrator in S7. The meter readings should be about the same as above. A Mallory 60 or similar vibrator in S8 should again give about the same readings. If the 300 V. meter tends to swing backward with the last type, reverse the wires marked X on the diagram.

VIBRATOR-TEST PROCEDURE

Full-wave synchronous vibrators of the type used in Emerson 678 receivers are connected to Fahnestock clips V1 in this manner; connect the armature to the center clip, the "A" reed with the magnet coil wired to it, to the clip marked CA, the "B" reed on this same side of the vibrator, to clip marked CB, and the other two reeds to clips marked A and B respectively. Again, if the meter tends to swing backward, reverse the wires marked Y.

Half-wave synchronous vibrators, such as the one used in Motorola 55, are connected to clips V2. This vibrator has two sets of reeds, two each "A" and "B." The long "B" reed connects to clip marked LB, the long "A" reed to clip marked LA, the short "B" reed to clip marked SB, and the wire from the magnet coil, to clip marked SA. The circuit from the "A" battery must be opened while connecting the last two vibrators, or a nasty shock may result.

Nonsynchronous vibrators are connected to clips V3; the armature to the center clip. If any serious discrepancy in the meter readings occurs while making any of the above tests, check the circuit involved for errors in wiring or short circuits.

Complete Motorola powerpacks may be plugged into their respective sockets with their lids off, and adjustments made while operating. Motorola

The interior of the socket unit showing the positions of the power transformers, sockets and the rectifier tube.



53

55 packs are connected to clips P1, located on the front face of the base of the socket unit. The markings of these clips are self-explanatory. Note that the self-contained filter system is used with these type 55 packs.

POWERPACK-TEST PROCEDURE

This test unit also serves as a very efficient powerpack, provided the 6000-ohm resistor is disconnected, and a non-synchronous vibrator is used. For those who don't know, I will explain that synchronous vibrators are those which rectify mechanically, and those which require a tube rectifier are nonsynchronous.

A chart made up showing meter readings of good vibrators will furnish a guide for future reference. Any not up to par, may be repaired or replaced with a new one.

Unless you have had experience in adjusting vibrators, do not try it on your customers until you have studied the adjustment, spring tension, etc., of new vibrators, and have spent quite some time with discarded ones, rebuilding them and making them work. A poor job is worse than none at all, and only wastes the customer's money and loses you his good will.

There is a very good profit to be made repairing vibrators. The average charge for this work in my locality is \$2.50 for nonsynchronous types, and \$3.50 for synchronous types. These charges include replacement of broken or badly pitted reeds, defective insulation and condensers, and cleaning and dressing of pitted or sticking reeds. The parts are usually obtained from discarded vibrators, although the cost of new ones is relatively small. Unless damaged very badly, vibrators repaired in this way by a skilled man are as satisfactory in operation as new ones, giving many months of additional service, and saving the customer considerable money.

LIST OF PARTS

- One Triplet 250 V. A.C. meter, M1;
- One Triplet 300 V. D.C. meter (1,000 ohms per volt), M2;
- One Triplet 100 mil. D.C. meter, M3;
- One Triplet 10 amp. D.C. meter, M4;
- One Triplet 8 V. D.C. meter, M5;
- One multiplying resistor for A.C. meter, 750 V., R1;
- One resistor, 500 ohms, 10 W., R2;
- One resistor, 6,000 ohms, 25 W., R3;
- Three electrolytic condensers, 8 mf., 300 V., C1, C2, C3;
- One tubular condenser, .01-mf., 1,600 V., C4;
- Two tubular condensers, .006-mf., 300 V., (.002 to .01 will do), C5, C6;
- Four 4-prong tube sockets, S1, S2, S4, S5;
- Three 5-prong tube sockets, S3, S7, S8;
- One 6-prong tube socket, S6;
- One 4-prong male plug, P;
- Four Fahnestock clips (or binding posts), P1;
- Two Motorola 2-prong female sockets;
- Twelve Fahnestock clips (or binding posts), V1, V2, V3;
- One low impedance "B" power choke;
- One Motorola D6 power transformer for non-synchronous vibrators, T1;
- One Motorola 55 power transformer for half-wave vibrators, T2;
- One Motorola S6 power transformer for full-wave vibrators, T3;
- Five insulating-type meter jacks, or binding posts; 1 complete can from Mallory No. 6 "B" eliminator; 17x12 ins. panel; 8 ft. 3-wire shielded cable; and necessary screws, hardware, hookup wire, etc.

The rear view of the meter panel, completely wired, with the connecting cables attached

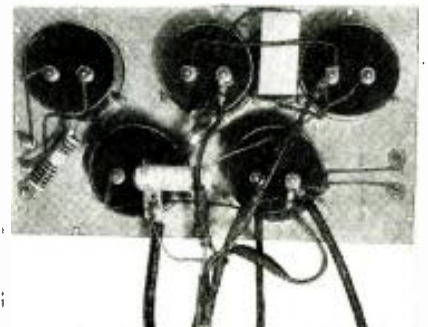

Please Say That You Saw It in RADIO-CRAFT

HOW TO MAKE A "HIGH-FIDELITY" ADAPTER

(Continued from page 727)

of the signal itself—if this be found desirable. Three major frequency response modifications or types of equalization are provided:—

(1) High frequencies can be emphasized (Fig. 2-A).
 (2) Low frequencies can be emphasized (Fig. 2-B).

(3) Both high and low frequencies can be emphasized (Fig. 2-C). Through the use of a selector switch any three of the equalization characteristics may be obtained at will.

The degree of the change produced by the unit may be controlled by a variable 1000-ohm resistor from no change at all, to a maximum difference between 60-cycle and (or) 8,000-cycle response; and 1000-cycle response of approximately 10 db. Figure 2 shows the equalization obtained with the 1000-ohm resistor set at 0, 60, 180, or 670 ohms for all three available conditions.

The use of this unit will generally be found to add considerably to the quality of electrical reproduction of phonograph recordings. An amplifier, which by itself, has only a fair frequency response, may be corrected to give the performance of a much better unit. It is also possible to attenuate any particular frequencies that are over-emphasized (because of resonance in the electrical or mechanical network); or because of the particular physical or acoustical conditions existing in the places where the reproduction is taking place, or where the recordings were made. This unit may also be used to advantage with home amplifiers by utilizing simultaneous high- and low-frequency equalization for tone compensation when listening to programs at low volume.

Those who contemplate installation of this unit must bear in mind that the high equalization obtainable with this unit lowers the gain at the frequencies where response is too prominent. In order to utilize this device to maximum advantage, the associated power amplifier should have at least 15 db. more gain than is required to obtain maximum desired output without the equalizer.

The T-type attenuator used is of constant impedance and is attenuated in steps of 2 db., the maximum attenuation being 22 db. The tap switch arrangement as used in this control utilizes self-cleaning contacts that are noiseless in operation over long periods of time. The resistor elements are wire-wound, and maintain their calibration; also, they are non-inductive, low capacitive and absolutely quiet. In operation they will safely carry 8 W. of signal energy.

LIST OF PARTS

- One Blau shield can;
- One Electrad T-type attenuator, type 8AT502;
- One Electrad 1000-ohm variable resistor, type 276W;
- One Kenyon equalizer, type BLEQ;
- One DP-DT. switch, with neutral position.

The rear view of the adapter unit showing the positions of parts

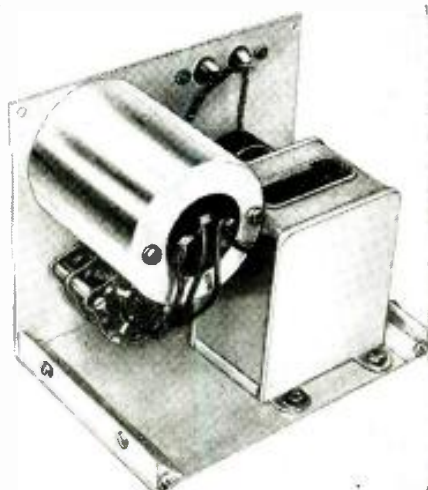

A NEW 23-TUBE HIGH-FIDELITY, ALL-WAVE RECEIVER

(Continued from page 731)

tant stations which would ordinarily be blanketed by interference from powerful nearby stations on adjacent channels, but also to listen to programs with the most perfect tone ever heard from a radio receiver.

Four stages are used in the I.F. amplifier system which represents the ultimate in high gain, combined with absolute quietness of operation and exceptional selectivity. By using four I.F. stages, less gain is required per stage. This permits use of the type 39/44, the high plate impedance of which more nearly matches into the tuned primary of the I.F. transformer.

DOUBLE A.V.C. SYSTEM

Everyone who has tuned for weak, distant foreign stations knows from experience how reception is frequently spoiled by the constant fading in and out of the signal. To obtain the best possible reception from stations in all parts of the world, this receiver incorporates not merely the regular single type of A.V.C., but two distinct A.V.C. systems, each designed to provide the most efficient A.V.C. action, and keep the signal practically constant at any desired volume level, irrespective of variations in signal strength.

For the finest noise-free reception of very weak to moderately strong signals, the R.F. stage should be operated at all times with maximum gain—that is, with no A.V.C. in it. However, due to the great field strength of local and superpowerful broadcast stations, the R.F. tube would be overloaded when tuned to these powerful stations if it were worked without A.V.C. This problem has been solved by providing a separate R.F. stage, A.V.C. system, which allows the R.F. circuits to operate at maximum efficiency, but prevents overloading of the R.F. and converter tube when tuned to a very powerful local station.

A second section of the A.V.C. system controls the converter and I.F. tubes. The major part of maintaining the volume level constant in reception of all signals from the weakest to the strongest stations, is done by this part of the system, which is adjusted so that its action extends completely down to the noise level of the quietest possible location.

BETWEEN-STATION NOISE ELIMINATED

If a receiver is to bring in station programs from distant parts of the world, it must have a very high degree of usable sensitivity. If it is to hold the signal from a distant station at a constant level, it must have a very efficient A.V.C. system. But a highly sensitive receiver, with a very efficient A.V.C. system, means that when you tune between stations your A.V.C. opens up the full sensitivity of the receiver, in which case, unless you are in a location that is extremely quiet and free from all forms of electrical interference, you can't help bringing in a large amount of noise when tuning from one station to another.

The idea of the noise suppressor between stations is not new. However, in all systems so far introduced, the principal fault has been to destroy the effectiveness of the A.V.C. system when the noise suppressor was in operation, and also to cause considerable distortion on medium weak signals. All of these defects have been eliminated in the new noise suppressor incorporated in the receiver described here.

In this short magazine article it has been possible to touch on only a few of the outstanding features of this new receiver. In addition to those mentioned, it also has incorporated a perfected bass control, which allows the bass response to be adjusted at five separate cutoff points between 25 and 150 cycles; an attenuation equalizer at 10,000 cycles, which eliminates the high-pitched whistle from adjacent channels when using the receiver for reception of programs above 10,000 cycles; a visual indicator making it easy to tune in every station perfectly; an improved beat-frequency oscillator which makes it just as simple to tune in stations on the short waves as on the regular broadcast band; a self-stabilized oscillator with voltage regulation which keeps the plate voltage on the oscillator constant at all times.

GET THIS FREE!
Radio Comparison CHECK LIST
Tells you how to learn the TRUTH about today's Radios

"World-wide reception!" "Beautiful tone!" Claims! Claims! Claims! The receiver at a "bar-gain basement" price boasts as loudly as the custom-built instrument. Yet there *must* be a difference—somewhere! We have devised a plan that shows you how to get the cold, hard facts about values. Whether or not you are in the market for a radio now, get this revealing Check List that shows you how to get the "low down!"

We honestly believe we build "The World's Finest Receiver" —but we cordially invite you to CHECK UP ON US...

The SCOTT Imperial Hi-Fidelity All Wave is the greatest distance-getting radio ever built . . . It has full range high fidelity—25 to 16,000 cycles . . . it has ample reserve power—35 watts strictly class "A" . . . It combines the greatest known sensitivity and selectivity with the finest tonal reproduction ever known in radio . . . It is custom-built to the most exacting standards known in radio. But those are mere statements—some of them so startling that you may doubt them. That's your privilege—but we ask you to CHECK THESE STATEMENTS—and the claims of other manufacturers. We will gladly rest our case on your impartial findings. Furthermore—when and if you decide to buy a SCOTT Imperial Hi-Fidelity All-Wave, you can have it for 30-day FREE TRIAL in your own home anywhere in the U. S. A., in side-by-side competition with any other radio. If it isn't better in every way, your test won't cost you a single penny. But first, learn to your own satisfaction which radio is REALLY best!

SEND NOW FOR YOUR FREE Radio Comparison CHECK LIST

E. H. SCOTT RADIO LABORATORIES, Inc.
 4404 Ravenswood Ave., Dept. 24K5 Chicago, Illinois

Send me at once a copy of your Radio Comparison CHECK LIST, and complete details about the NEW SCOTT Imperial Hi-Fidelity All-Wave.

Name _____

Address _____

City _____ State _____

Please Say That You Saw It in RADIO-CRAFT

EBY
PATENTED

Specializes in
Quality

**Binding Posts
Tip Jacks
Male Plugs
Female Plugs
Low-Loss Sockets
A-C Switches
Tap Switches
Terminal Strips
Short Wave Switches**

Write for Latest Bulletin

HUGH H. EBY Inc.
2066 Hunting Park Ave.
PHILADELPHIA, PENNA.

THE MATTHEWS
Challenger

again leads all Custom Built receivers with
HIGH FIDELITY



● All Wave ● Fourteen tubes ● Chromium plated chassis ● Four gang condenser ● Frequency Converter Stage ● Fifteen watts output ● Ten Kilocycle Selectivity ● No Noise ● Inter-station Noise Suppression ● Headphone Jack ● Audio Beat Station Locator ● Phonograph connection.

Custom Built to your Requirements in Our
New Modern Laboratories

MATTHEWS RADIO CAPE MAY
NEW JERSEY

Service Aids FOR YOU!

A POCKET TOOL CASE

You need this genuine leather case that will fit your hip pocket and hold all your pocket tools required on the job. Sizes your pocket and holds the tools. A neat case that you will be proud to use. List Price \$1.00

R-S SPEAKER SHIMS

You need speaker shims to center voice coils and cones on speakers. These are the best shims you can buy and are a permanent and because they are made of flexible steel. Four sizes in a leather case. List Price 65c

EVEREADY SPEAKER CEMENT

This is the original speaker cement and the best you can use for retaking or repairing speaker cones. It is fast drying, vibration proof, waterproof and transparent. It can also be used for other radio work. List Price 50c Large 2 oz. bottle

EVEREADY DIAL-LITE COLORING

Here's something new! A coloring for dial faces. Just dip the dial face in any of the four colors and—Presto—a different dial on the radio. It dries instantly, and enables you to make extra money on every job. Red-Green-Blue-Amber and Solvents in a kit. List Price 50c per kit

Service trade discount is 50%. Buy from your jobber, if he cannot supply you write us. Send for large circular of other Service Aids.

GENERAL CEMENT MFG. CO.
ROCKFORD, ILLINOIS

THE TWO-WAY AUTO-RADIO OF THE FUTURE

(Continued from page 714)

nearest hospital in case the accident is serious. Thus, help can be summoned within a very short time.

Not only in connection with accidents will this system prove its worth, but in the apprehension of criminals, by identification of license numbers of fleeing cars. The numbers of these cars, reported to the nearest service station, will be immediately passed on to the nearest police post, thus almost instantaneous information can be given about cars on the road.

The same is the case with fires. A passing automobilist may see the beginning of, for example, a forest fire. He relays the information to the nearest service station, which will promptly inform the proper authorities. And the same is true with obstructions in the road. Trees which may be blown down, boulders or rocks, etc., may endanger the lives of other drivers. Such information can be given to the proper authorities by observing car drivers.

Or, as has happened to many of us, we may run out of gas while five miles distant from the nearest service station, or may have a blowout or other minor repair that stalls or stops the car. A "2-way" automobile set will remedy all such situations.

You may rest assured that during the next ten years all automobiles will be equipped with their 2-way radio units, which the technician calls transceivers.

RADIO SOUND EFFECTS

It is a pleasure to present "Zounds! What Sounds!" a typical poem by Al. Sinton, Sound Effect Expert, who is now identified with World Broadcasting System, Inc. The poem will be dramatized over the air.

In the Movies as in Radio Shows, Mr. Sinton's talent has been frequently in demand. He was the expert who produced the sound effects in such prominent moving pictures as "Wild Cargo" and "Adventure Girl." While in Radio shows his efforts are now featured in "Bond Bread" Terry and Ted Adventures and Ida Bailey Allen's Cooking School.

ZOUNDS! WHAT SOUNDS!

Some life, that of a Sound Effect Man
You try to forget it but never you can
From early morn' till the Studios close
You're creating sounds for Radio shows.

One script will call for the squeal of a mouse,
The roar of a lion, the collapse of a house,
The slamming of doors, the barking of dogs,
Hammering nails and the sawing of logs.

Then in Studio "B," that's right next door
They call for the sound of an oyster's snore,
The falling of snow, and the flapping of wings,
The cry of a Goldfish and such goofy things.

Then in Studio "C," on the floor above
The script there calls for the coo of a dove
Teahouse bells and wireless buzzers,
Steamboat whistles and hundreds of others.

About this time you're thinking of lunch
But somehow or other you have a hunch
That some director will camp on your trail
And start to cry and hemoan and bewail.

You may not believe it but it's on the level
You just get your sandwich, when up pops the Devil
Says, "You're on my show, rehearsal is 'C',
I want some hoofbeats and the buzz of a Bee."

You try once more to concentrate on your food
And to get rid of the Pest, without being rude
But on he raves, causing pains in the head
So you cancel the food and take aspirin instead.

Then back to the Studios once more to make sounds
Of a rotamine motors and the buzz of sounds,
The sound of a Taxi, the sound of its horn,
The noises of traffic and the sounds of a storm.

And so you go on, making noises galore
Steam engines, derricks and a battle's roar,
Surf on a beach, church bells and say,
By that time you're ready to call it a day.

All at once a director looms up like a spectre
And says "When you're through come to Studio 'D'
Here!"

The script only calls for a soft low moan,
And when you've done that you can go home."

So on the way there, very much to your sorrow
You're reminded of Sound to be made on the morrow
But at least from now till it's time to turn in
You're free from the Studios and the unfounded din.

Ah! Home and some dinner and then off to bed,
And complete relaxation for this dizzy old head
And thus you round out another day's span
In the hectic life of a Sound Effect Man.

Copyright, 1935, Al. Sinton—All Rights Reserved
(From World News, March 1935)

IMPROVEMENTS IN AUTO-RADIO AERIALS

(Continued from page 727)

system B to give response equal to system A. results from the fact that the impedance-matching devices and a shielded line, acting together, produce what may be considered a semi-tuned antenna circuit, which is resonant over the entire broadcast band and for that reason a greater signal is found at the receiver terminals than is possible with a non-resonant circuit.

To return to system B, which is very common, it has been found to respond to a great deal of ignition interference. It is, therefore, a common practice in most auto installations whether the antenna be located in the roof or beneath the car, to overcome the interference normally picked up by the lead-in, by utilizing a shielded connection between the antenna and receiver; grounding this shielded lead-in at a point in the roof as well as a point as near the receiver as possible, as shown by system C. This procedure results in a loss of sensitivity which is equivalent to approximately 1/4 of the amplification of a stake of audio frequency or about 4 db.

A rather comprehensive understanding of how this works out may be had from observing Fig. 2. It will be seen at once that the running board type of antenna produces by far the least satisfactory results regardless of the type of lead-in, and a comparison of this type with the one illustrated immediately above it, which represents a single wire, run from the front to the rear axle, will lead to questions as to why the matched-impedance, resonant line shows no improvement over an ordinary line and why the interference is greater with the single wire than with the running-board antenna, regardless of the type of lead-in used.

The surface of the running board aerial is so small and its capacity is so low that the impedance-matching devices, designed for use with antennas of greater capacity, do not function satisfactorily with it and since they do not bring about a condition of resonance or a suitable impedance-match, their use not only provides no improvement, but in some instances, an actual drop in signal strength has been noted.

OVERALL PERFORMANCE

Further perusal of Fig. 2 indicates that a suitable undercar antenna, properly installed, is just as good as a roof antenna in a 5-passenger sedan or touring car. No matter what precautions are taken in this installation, it can never be made to give the same performance as the antenna in a car of the larger size. This holds true even though the size of the antenna under the car is quite materially increased. In its normal form, the undercar antenna assumes the position illustrated in Fig. 3. For all prac-

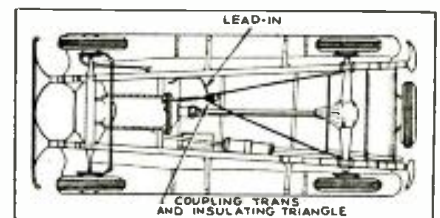
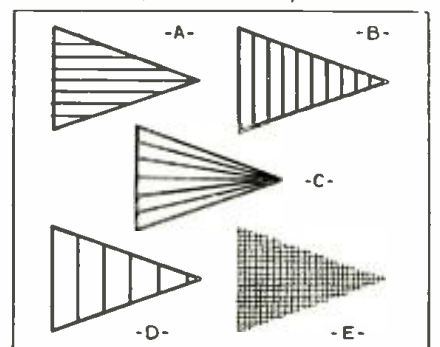

Fig. 3, above
The under-car antenna in its accepted form.

Fig. 3A, below
Some of the aerials tried by the author.



Please Say That You Saw It in RADIO-CRAFT

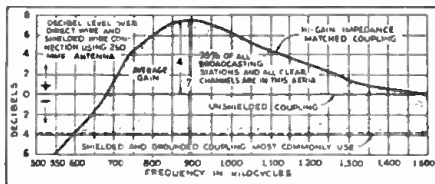

Fig. 4

Relative signals for matched and shielded lead-ins.

tical purposes this method of installation is the best.

Experiments with undercar antennas of larger size, made by carrying the antenna back to supports on the rear bumper instead of the rear axle, produced an increase in signal which was so small as to be of no practical value. Duplicating the rear triangle by another, running to the forward axle and using the two together showed little or no gain in signal strength but did show a considerable increase in ignition interference. Furthermore, this additional antenna introduced quite a number of mechanical problems and it required frequent repair and adjustment.

Additional wires were stretched longitudinally in one instance, horizontally in another, fan shaped in another, within the triangle itself and various combinations of all three in the form of a network were also tried. In one instance a copper screen, cut to the precise size of the undercar triangle, was soldered over the entire edge and the increase in signal strength was found to be so little as to make the trouble unwarranted.

The modern undercar antenna, shown in Fig. 3, taken from the standpoint of electric performance, is just about everything that is required, especially if suitable precautions are taken for connecting it to the receiver.

It should be borne in mind that the performance of the triangular undercar antenna is just as good when installed on a coupe as it is on a 7-passenger sedan and for that reason it has been increasing in popularity during the past year, especially with police departments.

MATCHED LINE GOOD ON "REGULAR" INSTALLATIONS

Many Service Men have been under the mistaken impression that a matched-impedance type of transmission-line for automobile use has been primarily designed for cutting down ignition interference and that its use was confined to undercar aerials of the triangular type. Neither of these premises are correct. A suitably designed transmission line with couplings transformers which provide an impedance-match between the antenna and the lead, as well as the lead and the input circuit of the receiver, will improve the performance of any antenna. While this is well illustrated in Fig. 1, reference to Fig. 4 will indicate just how the entire system will function, with the average auto receiver and any antenna of reasonable dimensions.

Figure 4 represents the performance of a coupling system which has been on the market for nearly two years and it will be observed that the bottom of the shaded portion indicates the performance of an average antenna connected to an average receiver with a shielded and grounded lead-in. Removing the shield raises the performance to the line on the chart indicated by the zero point, which may well be considered standard. Using the matched-impedance, resonant line produces the results shown by the curve. It will be seen from this curve that, while there is practically no portion within the broadcast band where the system is not as good as the shielded and grounded line without impedance matching devices, there is an area in the frequency range between 500 and 750 kilocycles where improvement is desirable.

The family of curves shown in Fig. 5A indicates some of the laboratory measurements made with various types of transformers designed for the purpose of producing better results on that important part of the broadcast band where the original transformers were deficient. From these curves, it will be observed that each of the various transformers shows a pronounced resonant peak on some particular frequency and a rather sharp drop-off at each side of this peak. It will be observed that two of the transformers showed a double peak. It is also significant to notice that despite the apparent drop-off in signal strength at the points of resonance, there is no point on any of these curves which indicates a performance characteristic as low as the performance of the

shielded and grounded line used without impedance-matching transformers.

Obviously, curves of this nature cannot be considered as a positive indication of the manner in which the system will perform in every case because nearly every auto radio installation brings a varying group of factors to light. For the purpose of comparison and guidance, they may well be considered as average and a suitable indication of the average results to be expected if the antenna employed has a capacity of approximately 250 mmf. (R.M.A. standard) and the receiver input circuit has an impedance of 6,000 ohms.

Lowering the capacity of the antenna would result in a shift of the curves to the right, and vice versa. (The movement of the curves would be an inverse function of the square root of the capacity.) It was thought that a combination of transformer ratios, having the most desirable characteristics for the greatest coverage, could be made by combining the transformers represented by the curve A with those of the curve E. Little or no improvement resulted.

THE IDEAL TRANSFORMER

While the ideal transformer for this type of work has not yet been developed, experimental work seems to indicate that it can be brought into existence reasonably soon and work along this line is being continued.

In the meantime, Fig. 5A indicates the performance characteristic, under average conditions, of the nearest approach to the ideal now available. While it will be observed that the curve leaves much to be desired, it should be borne in mind that the overall performance is much better than is possible with either an ordinary lead-in or with the shielded and grounded lead-in or transformers of the older type. Some of the possible gain on the low frequency end of the broadcast band as shown in Fig. 5A has been sacrificed in order to obtain improved performance on the high-frequency end.

From a practical point of view there is very much more to be said for the performance of the transformers represented by the heavy curve in Fig. 5B, than is apparent from the curve itself. First of all the average listener, regardless of the section of the country in which he is located, finds the majority of the programs which intrigue him are found somewhere below 1,100 kilocycles. This is a fact gleaned from the operators of the large chains.

Another practical point to be considered in estimating the overall performance in the system of this nature, is the fact that nearly all automobile radio receivers are regenerative above 1,200 kilocycles. This results in a greater inherent sensitivity and for that reason when used with the antenna system illustrated graphically in Fig. 5B, the overall performance would approximate the dotted curve in the same figure and is a close approach to the ideal. No measurements were made to prove this point but the performance of a number of receivers of different makes were observed and indicated that the curve illustrated by the dotted line, may well be considered a reasonable average.

Fig. 5

Facts about the auto-antenna lead-in problem.

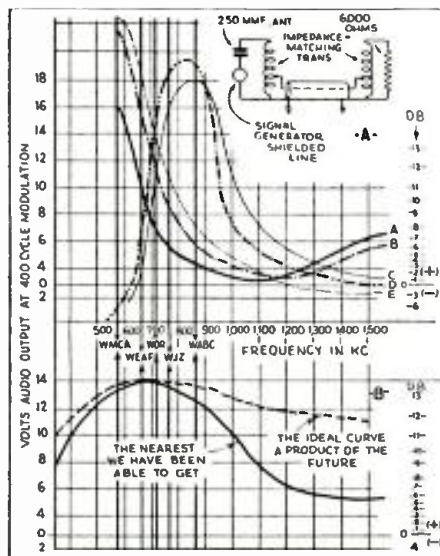

FOR THOSE WHO DEMAND THE FINEST



THE **Test Set No. 1205**



DEALERS and servicemen who are equipped with Triplet Master Units can handle every servicing operation quicker and more accurately than ever before—no matter how difficult or complicated. Nothing has been spared to make the 1205 Test Set an outstanding instrument for present-day and future needs.

TRIPLETT MASTER TEST SET, NO. 1205, INCLUDES:

No. 1200 Volt-Ohm-Milliammeter, DC scales readings: 1/2 to 1,000 volts (2,000 ohms per volt)—20 microamperes to 250 milliamperes—0 to 3,000,000 ohms, AC scale readings: 1 to 1,000 volts. Capacity charts furnished. Dealers' net price, unit only\$21.67

No. 1210 Tube Tester. Contains the most efficient short check known. This unit incorporates an improved load control which places the proper load on the tube under test. The new and exclusive circuit in this tester is approved by leading tube engineers, embodying every essential for a dependable emission test of tube values. Dealer's net price, unit only\$20.00

No. 1220 Free-Point Tester. Makes all series or parallel meter connections to the set sockets. Dealer's net price, unit only \$8.33

No. 1230 All-Wave Signal Generator. Frequencies: 100 KC to 18 Megacycles. Perfect attenuation. Modulated or unmodulated. Dealer's net price.....\$15.33

No. 1205. Complete with above four units in case. Dealer's net price....\$71.33

Triplet Interchangeable Master Units make possible different combinations of test equipment to suit every servicing requirement. These units can be used as furnished, or, placed in convenient portable cases that old one, two, three or all four units.

YOUR JOBBER CAN SUPPLY YOU Triplet Electrical Instrument Co.

146 Main Street Bluffton, Ohio

Mail today for details

Triplet Electrical Instrument Company, 146 Main Street, Bluffton, Ohio. Gentlemen:

Please send your latest literature. I am particularly interested in receiving information on Triplet Instrument No. 1205.

Name.....

Address.....

City..... State.....

Please Say That You Saw It in RADIO-CRAFT

AT LAST! The Ultimate in Design...

Twelve Amplifiers in One
Solves All of Your **SOUND** Problems

Out of the Columbia Sound Laboratories comes a totally new kind of Amplifier—the greatest single development in Public Address. Operates directly with all crystal, velocity (ribbon) condenser, dynamic and carbon microphones. **ELIMINATES PRE-AMPLIFIERS!** Models available for 110 volt A.C., 6 volt D.C. or Universal Operation. Free Consultation Service: **Write to Mr. C. R. Shaw for help.**

Send for complete details and NEW FREE Series of Public Address Bulletins with confidential amazingly low net prices.

COLUMBIA SOUND CO. Inc.
133 LIBERTY ST. NEW YORK, N.Y.



CATHODE-RAY OSCILLOSCOPE FOR VIBRATOR-"B" TESTING

(Continued from page 730)

This action is the same as that of an ordinary buzzer. The center-tap of the transformer primary is connected to one side of the storage battery, the vibrator arm to the other side, and the ends of the transformer primary are connected to two contacts on opposite sides of the vibrator arm. Thus, as the arm vibrates the two ends of the transformer primary alternately return to the battery, current flows alternately in the two halves of the primary, and an A.C. voltage is induced in the secondary. The rate of change of primary current is constant while either primary contact is closed. Since the voltage induced in the secondary is proportional to rate of change of primary current, it follows that the voltage output is also constant—a highly desirable condition.

Two additional contacts on opposite sides of the vibrator arm are connected to the ends of the transformer secondary and the rectified voltage is obtained between the center-tap of the secondary and the vibrator arm. A condenser is connected across the secondary, of such a value as to cause the instantaneous voltage of the arm and any contact immediately preceding a "nake" to be approximately equal; in this manner sparking is minimized and the wave-shape of the output voltage is as desired. This is accomplished by so choosing the size of the condenser as to cause the oscillatory transfer of energy (between the transformer and the condenser), which starts when the contacts open, to give the desired condition just before the contacts close.

From the foregoing discussion it is evident that the adjustment of the arm and contacts for proper operation of the vibrator unit might be critical. Such is the case. Mechanical fixtures will afford adjustment which might be called a rough preliminary setting, but it is difficult or impossible to obtain a satisfactory final adjustment in this manner. Electrically, there are three values which can be used as the determining factors for adjusting the vibrator. The unit can be adjusted for minimum sparking, but this method has proven unsatisfactory time and again. Another method is to adjust so that the time of contact is the same in both directions with the unit actually operating. This can be done with a D.C. meter used to read average current, but can be done more effectively with an oscilloscope. The third and best method is to check the length of time the contacts are open, and this can be effectively done only by observing wave-shape on an oscilloscope.

OSCILLOSCOPE WAVEFORM IN VIBRATOR-"B" ADJUSTMENT

In using a cathode-ray tube for vibrator analysis, the most informative voltage is that across the full secondary winding with normal load imposed on the unit. This voltage is consequently used for vertical deflection. If the voltage on the horizontal deflecting plates has a "saw-tooth" characteristic and has a frequency of one-half that of the vibrator, then two cycles of the A.C. voltage existing across the secondary will appear on the screen. Further, if the proper amount of synchronizing voltage is used the image will remain stationary even though the vibrator shifts frequency as much as ten per cent.

Since the oscilloscope shown as the heading illustration of this article has a "saw-tooth" timing axis supply which can be set at any frequency between 20 and 15,000 cycles, it can be readily set for one, two, or three cycles of the output voltage on the screen when testing any vibrator. The peak-to-peak voltage across the vibrator transformer secondary is usually around 600 volts which will give considerably over full-scale deflection on the oscilloscope, even with the "vertical" amplifier switched "off." Consequently, an external voltage divider should be used. If desired the vertical amplifier can be used and the "Ampl. A Gain" control greatly retarded to attenuate the voltage sufficiently. This oscilloscope also has provision for synchronizing the "saw-tooth" oscillator with the vibrator, either at the fundamental frequency or at a sub-multiple, and for controlling the amount of synchronizing voltage.

(Continued on page 755)

Build Your Own Wheatstone Bridge For \$41.50

A simple, rugged, wide-range Wheatstone Bridge for resistance measurements. Operation identical with best laboratory instruments. Sensitive, accurate. Low cost. Kit easily assembled.



SHALLCROSS No. 630 Kit \$41.50
Assembled \$49.70

Built around a highly sensitive galvanometer and Shallcross Resistors. Range .01 ohms to 11.1 megohms. Send 6c in stamps for Bulletin 630-P.

SHALLCROSS MFG. COMPANY
Electrical Measuring Instruments and Accurate Resistors
700 MAC DADD BOULEVARD
COLLINGDALE, PA.

NOVEL IDEAS IN CAR RADIO

(Continued from page 717)

licensed amateur who has procured a mobile license) which acts as the "hare." The other cars—as many as can possibly be rounded up for the game—are equipped with portable receivers tuning to the same wavelength as the transmitter. The object of the game, of course, is for one of the "hound" cars to catch the "hare."

While considering the possibilities of auto radio, the sketch on the lower right may be of interest. This is a view of a police car of the future. In this car is an ultra-short-wave transceiver; a facsimile receiver (such as the one described in this issue of RADIO-CRAFT) for identifying criminals or missing persons; and a P.A. system for directing traffic or calling out to fleeing cars, etc. Thus, radio is used in three different ways to aid the police in preventing crimes and apprehending criminals. What is perhaps most interesting about this imaginative car is the fact that all the devices shown are practical and could, in fact, be installed today!

HOW TO INSTALL REPLACEMENT-"B" GENEMOTORS

(Continued from page 728)

externally if desired. The rectifier tube and vibrator are removed from the circuit.

If the set is equipped with filter chokes and condensers, then a separate filter system is not necessary. For interference of any type, a radio-frequency choke may be inserted in the circuit as shown in the diagram.

The choke consists of 150 turns of No. 33 S.C.C. wire, which is wound at random on a form 1/4-in. inside diameter and 1/4-in. long. An R.F. choke is used in each leg of the power supply, which is designated RFC 1 and 2. The choke RFC 3 which is in the leg of the "hot" side of the "A" circuit, is made with 50 turns of No. 14 cotton covered wire, 11/32-in. inside diameter and 3/4-in. long.

OBSCURE SOURCES OF CAR-RADIO NOISE

(Continued from page 729)

varies, which is usually the case, the resistance of the circuit thus formed may change sometimes slightly or even quite radically. The circuit formed will, of course, absorb some of the received energy, and when its resistance changes, the field intensity about the receiving antenna will change accordingly. If the automatic volume control mechanism does not have sufficient range to compensate for this effect, volume changes or intermittent reception may result. To remedy this a piece of mica or thin bakelite may be placed behind the latch receiver, thus breaking the continuity of the electrical circuit.

These troubles, of course, should be investigated only after a careful analysis has been made of the more common troubles arising from the ignition and lighting systems of the car and those existing within the receiver itself.

It is hoped that this information will be seriously considered by every Service Man detailed to work with automotive installations.

The All-Electric All-Wave Receiver



GREATEST VALUE ON THE MARKET
See Article Page 609 April Issue of Radio-Craft

A completely electrified all-wave receiver capable of world-wide reception. Circuit has been re-designed so as to be bigger and more powerful than ever. Uses 072 tubes in one bulb 75 & 1253 tubes as screen grid regenerative detector. 2 stage audio amplifier. rectifier & built-in power purpose tube, the 067, this

- KIT ASSEMBLED and ready to wire \$5.95**
- Wired & tested extra..... \$1.25
 - Matched Arcatuna tubes..... 2.25
 - Broadcast coils..... 0.95
 - Head of black enish metal cabinet, hinged lid... 1.00

simply. Due to the use of the dual circuit produces 4 tube performance from 3 tubes. No batteries. Simply plug into 110 volt house lighting circuit & operate. Sensitive & gives great volume. Works speaker on many stations. Covers 10,000 meters. Mounted on heavy black crackle finish metal chassis and panel. Cords for 110-200 volt stations included. **FOREIGN RECEPTION GUARANTEED.** SPECIAL: Cannonball headphones \$1.45. Magnetic speaker \$1.45. **\$1.00 Deposit on all C.O.D. orders. Prompt shipment.** **EILEN RADIO LABORATORIES** Dept. RC-6, 136 Liberty St., New York, N. Y.

Please Say That You Saw It in RADIO-CRAFT

A CAR-TYPE PORTABLE P.A. AMPLIFIER

(Continued from page 729)

mentioned require an average plate current of 46 milliamperes, total, while the filaments draw less than 0.8-amp. per tube.)

5. *Maximum Utility.* Ability to operate satisfactorily from either a 6 V. storage battery or from 110 V. A.C. power lines when it is necessary to operate the amplifier indoors or within range of commercial power lines. (See Fig. 4.)

6. *Unlimited Flexibility of Operation.* To meet the various acoustic conditions encountered in mobile P.A. work, it is essential that suitable provision be made to conveniently change from one type microphone to another so that a crystal microphone may be used while the automobile is in motion, for example. (Fig. 3 shows the circuit used to permit instantaneous change-over from one type microphone to another without making any wiring changes.)

7. *Adequate Gain.* Of course, low-level microphones (crystal, velocity and dynamic) are usually unsuitable for use with ordinary-type amplifiers unless suitable preamplifiers are used to bring their level up to that of an ordinary carbon microphone. (The overall gain of this amplifier is more than 124 db. so that any input device with a level as low as -90 db. may be used.)

8. *Ease of Installation and Removal.* In view of the fact that the maximum utility is desired of the entire system, it is particularly advantageous to utilize a system that can be quickly removed from the automobile and rapidly set up to meet special conditions of operation and then be easily assembled and reinstalled into the automobile. (The 12½ W. amplifier described can be removed from the auto in less than three minutes and reinstalled again in the same amount of time. This unusual feature is only made possible by the plug and cable arrangement used for interconnection of the various components.)

9. *Designed for Mobile Operation.* The ideal mobile P.A. outfit should not include an amplifier designed primarily for 110 V. A.C. indoor use. Many makeshift indoor P.A. systems have been awkwardly adapted for mobile use only to become burdensome and costly experiments in excessively high initial, maintenance and operating costs.

UNUSUAL CIRCUIT FEATURES

By referring to Fig. 4A it will be noted that the universal microphone input transformer (which is of the two section bilateral balanced winding type, to cancel out all extraneous noises) is connected to a 7-prong microphone socket (MP1) in such a fashion so that any type microphone may be appropriately wired to a seven-prong plug and inserted into the circuit. Unless a jumper is placed across terminals Nos. 6 and 7 of the microphone plugs, the secondary of the transformer T1 is out of the amplifier circuit. This open-circuit is necessary for use with a crystal microphone which is ordinarily connected across a 5 meg. resistor directly into the control-grid of the 6C6 pre-amplifier tube by connecting to terminals 1 and 6 of its seven-prong plug. A similar arrangement provides for automatic microphone current and proper matching for both single- and double-button carbon microphones. Figure 3 shows the connections to be made for various type microphones, and the position that the microphones assume when plugged into their respective input circuits.

The 6-prong phono. socket (PS2 in Fig. 4) likewise provides for universal phono. pickup or line coupling (200, 500, 3,000 or high impedance).

Fig. 3
Circuit permitting changeover of mikes.

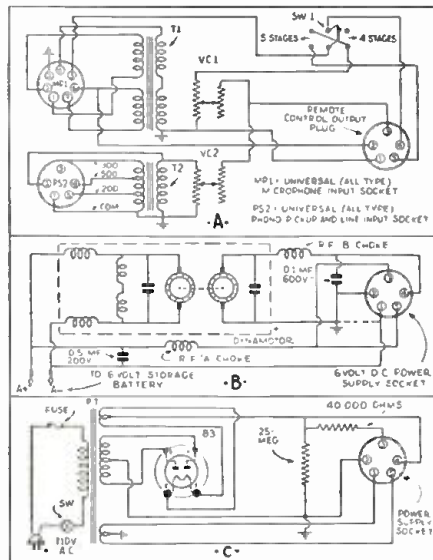
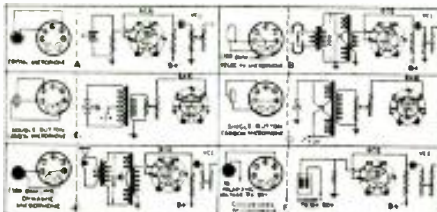

Fig. 4
Remote control and power supply circuits.

The "L" pad volume control VC2 attenuates all signals fed into sockets PS2 while another constant impedance control VC1 likewise attenuates all signals entering socket MS1. By varying both of these controls, while two signals are being fed into the input sockets, mixing and fading can easily be accomplished so that a phono. record may be used as a musical background for voice announcements, or vice versa.

The D.P.D.T., four-five stage selection switch S2 "cuts" the first 6C6 tube out of the microphone input circuit and lowers the overall gain of the entire amplifier so that carbon microphones may be used.

INSTALLATION PROCEDURE

The entire installation of this system is extremely simple, and the exact procedure is dependent upon the automobile and the type of installation desired. If a temporary installation is required, the speakers should be fastened to the top or hung inside and against the open windows of the touring or pleasure car. The remote control is strapped to the steering column and the amplifier proper strapped underneath the dash board. The 6V. power supply should be fastened inside the motor hood.

If a permanent type of installation is planned, the speakers should be securely fastened to top of auto or to the sides of sound truck.

The author will gladly answer all questions relative to the mobile system described.

CATHODE-RAY OSCILLOSCOPE FOR VIBRATOR-"B" TESTING

(Continued from page 754)

In the "oscillograms" on page 754, A shows the wave-shape when secondary contacts close after and open before primary contacts. At 1, the primary contact closes and since the secondary is unloaded its voltage builds up to the value of 2-3. At 3, the secondary contact closes and the voltage drops to the value of 4-5. At 5, the secondary contact opens and the higher voltage of 6-7 obtains until the primary contact re-opens at 7.

B shows the wave-shape when air-gaps are unequal. At 1, the contacts open and the curve between 1 and 2 represents the time during which the oscillatory transfer of energy takes place. At 2, the contacts close; at 3, they re-open; and at 4, they close. It is readily apparent that length 1-2 is not equal to 3-4.

C shows the wave-shape when the time of "break" is too long. At 1, the contacts open and the oscillatory voltage builds all the way up to that shown at 2 before the contacts close and the voltage returns to the normal value of 3-4. This is a dangerous condition, for, as the contacts deteriorate the time of break becomes even greater, and the oscillatory voltage may become high enough to sustain a continuous spark between the contacts.

D shows the wave-shape with properly adjusted air gap, length 1-2 being approximately equal to 3-4.

Please Say That You Saw It in RADIO-CRAFT

TAKE A TIP FROM AN OLD TIMER

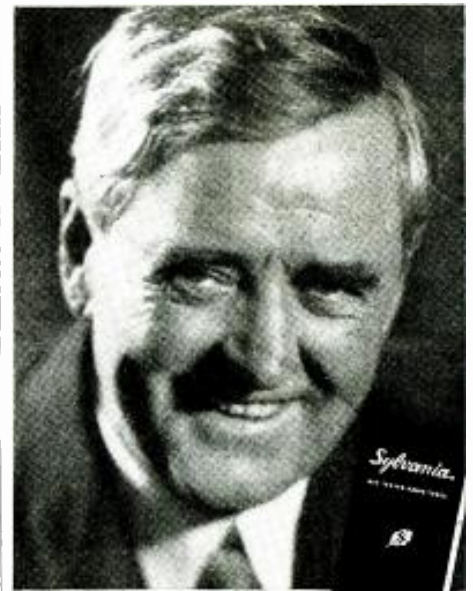

Send for this valuable book today!

You may be an old timer in radio or the field may be a new one for you . . . it doesn't matter. We believe this latest Sylvania Service booklet will help you a lot with your work.

It contains 104 pages of real information . . . descriptions of various tubes, each with its circuit application. It also includes diagrams showing plainly a lot of problems that come up in your work . . . and, more important,—how to solve these problems.

With the help of this pocket manual, you'll find fewer "blind alleys"; fewer times when you're up against it. That's why we say that this book will actually put money in your pocket, money that you wouldn't be able to get if you didn't know how to get around these everyday troubles.

Send for it today . . . you'll feel like patting yourself on the back, once you've seen how useful it is . . . how crammed with information that will help you take the guess work out of tube application. Don't wait! It's yours for 10c in stamps.

HYGRADE SYLVANIA CORPORATION
Makers of SYLVANIA TUBES, HYGRADE LAMPS
Factories Emporium, Pa., Salem, Mass., St. Mary's, Pa.
© H. S. Corp., 1935

Sylvania

THE SET-TESTED RADIO TUBE

10c- TECHNICAL MANUAL-10c

Hygrade Sylvania Corporation,
Emporium, Pennsylvania. (B.23)
Please send me the new Sylvania Technical Manual.
I enclose 10 cents in stamps.

Name

Address

City State.....

FACTS
You should know about
Condensers

WE PROVE IT!

FREE! You owe it to yourself to write today for a copy of this BOOKLET.

Just what does the Power Factor rating really mean in the condensers you buy?

... What is the truth and the whole truth about leakage claims—capacity and voltage ratings?

As serviceman or amateur, how can you be SURE you are getting the most filtering, the best performance for the least money?

These and many other bothersome condenser questions are clearly explained in our new free booklet illustrated above. It will show you that we not only claim Sprague Condensers are best—but explain exactly how we PROVE IT! Write for a copy.

SPRAGUE PRODUCTS CO.
North Adams, Mass.

SPRAGUE CONDENSERS
MADE RIGHT  PRICED RIGHT

Give the Audience a Break

WITH THE GENUINE

SILVER MARSHALL



A. C. Amplifier
USES 1-57, 1-50
AND 1-81

\$10.45
LESS TUBES

A COMPLETELY wired 3 tube, 7½ watt amplifier, for Microphone, Radio or Phonograph. Can be used for intercommunication, Public Address, Window Demonstrations, etc.

A. C. DYNAMIC SPEAKER TO MATCH \$4.75

MAIL ORDERS FILLED

THOR RADIO CORP.

167 GREENWICH ST. NEW YORK CITY

WHEN CHOOSING A RADIO SCHOOL

RCA Institutes, with its reputation established by 26 years service, is an institution recognized as an important factor in the radio industry. Whether elementary radio principles or advanced subjects, sound applications or practical radio engineering, RCA Institutes is prepared to give you the instruction you need.

RESIDENT SCHOOLS NEW YORK AND CHICAGO with modern standard equipment
EXTENSION COURSES FOR HOME STUDY under convenient "no obligation" plan
Illustrated Catalog on Request.

R. C. A. INSTITUTES, Inc. Dept. RT-35
75 Varick St., New York—1154 Merchandise Mart, Chicago

THE LISTENING POST

(Continued from page 735)

p.m. to 9:30 p.m. C.S.T. each Sunday, Tuesday, Thursday, and Saturday evening. This transmission is intended especially for listeners in western Canada.

A new Station XECW, "Del Caballero Santokan," Bajio 120 Mexico D.F., broadcasting on 5,970 kc., has been coming in with excellent strength nightly from 10:00-12:00 p.m. C.S.T. despite their very small power of 10 W.

YV6RV, the Voice of Carabobo, in Valencia, Venezuela, a new station reported for the first time in last issue of RADIO-CRAFT, has changed its wavelength from 49.75 (6030 kc.) to 46.01 meters, and 6.52 mc. This change was made on account of short-wave station HP5B, Mirimar Club, in Panama City, Panama, which was occupying the same channel. YV6RV broadcasts from 4:30-9:30 p.m. E.S.T., nightly. We are informed that HP5B has ordered a new 500 W. transmitter to take the place of the 100 W. one which they have been using.

A new short-wave station H11J has been reported by Mr. Edwin Hatch of Philadelphia, Pa. Mr. Hatch says H11J may be heard on 5,785 kc., the same frequency as OAX4D, in Lima, Peru. They are located in San Pedro Macoris, Dominican Republic.

According to Jack Watrous, San Mateo, Calif., station HVJ, Vatican City, reports the following schedule of hours and wavelengths: daily from 10:30 to 10:45 a.m. E.S.T., on 15,121 kc. On Mondays, the talk is in Italian, on Tuesdays in English, on Wednesdays in Spanish, on Thursdays in French, on Fridays in German, on Saturdays and Sundays in Italian. HVJ also broadcasts on a frequency of 5,969 kc., daily from 2:00 to 2:15 p.m., E.S.T. The tick-tock of a clock is heard for 10 minutes before the broadcasts start, and the bells of St. Peter sound the hour.

Russell Bills, of Elkhart, Ind., believes he has heard the very rare catch, VPD, in Suva, Fiji Islands. Russell believes he had VPD at from 11:36 to 11:45 p.m. C.S.T. on their wavelength of 22.9 meters. The announcements were in English but very weak. The music consisted of band numbers. Another night Russell heard this same "mystery station" at from 11:52 to 11:58 p.m. C.S.T. Russell has also been hearing the new Station CT1GO in Parede, Portugal. Sunday morning seems to be the best time to get them and he heard them from 9:14 a.m. C.S.T., until they signed off at 9:32 a.m. C.S.T. They were operating on or near their frequency of 24.2 meters (12,400 kc.). Continuous wave interference was bothering them badly. (This C.W. question is getting to be quite serious as the greatest majority of S.W. stations are bothered by C.W. at times, and some programs are completely ruined.—Ed.)

It is reported that "TFK, the Voice of Iceland" is on the air on a wavelength of 33 meters. Mr. Frank D. Andrews, of "KFI DX Chat" fame reports hearing them on their first test, and several times since. According to Hans Priwin of Copenhagen, Denmark, who recently had a talk with the Prime Minister of Iceland, the Icelandic government has actually purchased an 8½ kw. S.W. transmitter from the Marconi works at Chelmsford, England. The new transmitter will be used for telephonic communications between Iceland and Denmark, and for special musical broadcasts. Mr. Priwin also tells us that CT1AA, in Lisbon, Portugal, is now testing on 50.17 meters and 25.1 meters, and asks that reports be addressed to "Station CT1AA, Emisora Nacional, Lisbon."

The Norwegian Government has sketched a 7-years' plan for reorganizing the Norwegian broadcasting services. Mr. Priwin states, and there is to be a new short-wave transmitter included which will be built at Lamberstet near Oslo, with an energy of 25 kw., for the benefit of Norwegian listeners abroad. (As predicted by the DX Editor several months ago, it is only a question of time until every large country has an "empire" short-wave service modeled after Daventry and Zeesen for the benefit of its nationals in other parts of the World.—Ed.)

The "mystery station" in Santiago de Cuba which had us baffled for so long has turned out to be C09GC. They are on 6,150 kc., and according to Capt. Hall are on daily from 1:30-4:30 p.m. E.S.T.

WOR's new short-wave station will go under the call W2XHI, and according to reports from the Federal Communications Commission will

probably not be completed until the latter part of May.

CSL, the "Emisora Nacional," in Lisbon, Portugal, broadcasts on 6,140 kc., and can be heard in the East fairly well until W8XX in Pittsburgh comes on the air.

That very popular short-wave station DJB, Zeesen, Germany (15,200 kc.) is now being heard again in the mornings, irregularly, after an absence of several months, says Russell Bills, of Elkhart, Ind. (DJB was heard at full loud-speaker strength on Sunday morning, Mar. 10, broadcasting the Max Schmeling and Steve Hamas championship bout from Hamburg, Germany, between 10:30-11:00 a.m. C.S.T.—Ed.) We certainly hope that DJB will soon return to a regular morning schedule on the 19-meter band, as thousands of people miss this superb station in the mornings.

Station HJ4ABL "Echoes of the West," Manizales, Columbia, is now on the air on 6,100 kc., from 10:00 to 11:00 p.m. C.T.S., on Saturdays, according to many reports received from our readers.

Paul Dilg, of Evanston, Ill., reports hearing M37 talking to SB90 on Sunday from 10:00-10:30 a.m. C.S.T. on about 31.28m, They seem to be Fire Patrol planes in the Blue Ridge Mountains. Have you any dope?

WTR, Albrook Field, Panama Canal Zone, has been heard lately in the evenings talking to the other Army aviation stations on a wavelength of about 47m.

LV Bandoeng, Java (9,415 kc.) has been heard lately playing music, and calling phone stations at about 5:30 a.m. C.S.T.

SPECIAL BROADCASTS:

RKI and RNE, both of Moscow (15 and 12 mc. respectively) will dedicate an international good will broadcast to the DX-ers of North America on the morning of Sunday, May 5, from 1 to 2 p.m. G.M.T. (8:00-9:00 a.m. E.S.T.) The All-Union Radio Board in Moscow has gone to a great deal of trouble on this broadcast and asks all radio listeners hearing it to please report to them. Address communications to Mr. R. Siglin, c/o All-Union Radio Board, short-wave stations RNE and RKI, Moscow, U.S.S.R.

HP5B, "Emisora Mirimar" at Panama City, Panama, writes that they will put on a special international short-wave good will program for the short-wave listeners of the world on the evening of May 14. HP5B operates on 6,030 kc. Address communications to "Chief Engineer Enrique Linares, Jr., Emisora Mirimar, HP5B, Mirimar Club, Panama, Republic of Panama, Central America."

TIPS PERIODS

"Around the World DX Chat" with Frank D. Andrews featured weekly over radio station KFI, Los Angeles, Calif., (640 kc.) at 2:30-3:00 a.m. E.S.T., on Saturday mornings. Short-wave and broadcast-band tips, guest speakers, and other features of interest.

The "KDKA DX Club," weekly at 12:30-1:00 a.m. E.S.T. (Saturdays) over KDKA (980 kc.), W8XX (6,140 kc.), W8XX (11,870 kc.). This popular DX club has now been on the air about one year and features those inimitable DX commentators Ed Lips, the short-wave announcer, and Joe Stokes the broadcast-band tipster. The DX Club is eagerly awaited in all parts of the world.

WTCN, Minneapolis, Minn. (1,250 kc.) has now inaugurated a weekly DX tips period which comes on Sunday mornings from 12:45-1:00 a.m. E.S.T. This period features G. Morran Spencer, and M. Mickelson a well-known old-timer and vice-president of the Society of Wireless Pioneers. This period caters more to the ham and the pioneer than do either of the two first named clubs.

SERVICE MEN—

Don't fail to enter the contest sponsored by RADIO-CRAFT which will begin in the next issue.

This is the first time any contest has been held exclusively for the Service Man. It is open to everyone in the service field and there will be no cost involved in entering it.

The object of the contest is to determine what testing equipment a Service Man requires for his service shop. The prizes for the contest will be testing equipment which will increase the efficiency of your shop as well as increase your earning power. Watch for the details next month!

Please Say That You Saw It in RADIO-CRAFT

Aircraft Radio

JUST OUT!

Write for your Free Copy!

A new 28 page booklet describing the latest developments in Aircraft Radio—including the new Lear Radio Compass, Transmitters, Receivers and special equipment used by Turner and Pangborn in the London to Melbourne race.

LEAR DEVELOPMENTS, INC.
Aircraft Radio Engineers
123 West 17th St. New York, N.Y.

"SCOUT" SHORT-WAVE Receiver Kit



Accompanying prints and detailed instructions inform the builder the entire procedure as to how the receiver is to be assembled and wired.

Uses the low current consuming 230 tube.

Requires one 45 and two No. 6 dry cells for operation. Supplied complete with one plug-in coil.

Kit of parts.....	\$1.95
Wiring extra.....	.50
30 tube.....	.40
Extra 3 plug-in coils.....	.50

TRY-MO RADIO CO., INC.
85R Cortlandt St. 179R Greenwich St. City
New York City

RESISTOR SPECIALISTS

Featuring:

- QUIET VOLUME CONTROLS, built on an entirely NEW principle.
- VITREOUS RESISTORS
- TRUVOLT RESISTORS
- POWER RHEOSTATS

Write Dept. RC-6 for Catalog

175 Varick St., New York, N.Y.

ELECTRAD

Radio Dealers & Servicemen!

Large, Quick Profit

Sell Sound Equipment to theatres. We supply EVERYTHING! FREE CATALOGS!

S. O. S. CORP.
1600 B'way., N. Y. C.

A.C. CURRENT-ANYWHERE!

WITH Kato Light Plants



A little Gas and a Kato AC plant enable you to operate ALL radios, amplifiers, refrigerators and all other standard household appliances. Size: 300 watts and up. Write for interesting descriptive literature.

KATO ENGINEERING CO. Mankato, Minn., U. S. A.
Mfg's of AC Generators and Converters for operating AC Radios on 27 and 110 volt DC

TRANSFORMERS

MADE TO ORDER OR REWOUND

Write for Prices!

CARMI TRANSFORMER WORKS
202-204 Staley St., Carmi, Ill.

THE LATEST RADIO EQUIPMENT

(Continued from page 725)

more in circuits of conventional design. Suppressor-grid is brought out to a separate terminal. Excellent for use in vacuum-tube voltmeters.

Characteristics, as class A amplifier: plate, 250 V. and 0.5-ma.; sup.-G., 0.0; S.-G., 50 V.; C.-G., -2.1 V.; fil., 6.3 V.

(*The 955 "acorn" triode is described in the December, 1934 issue of RADIO-CRAFT—"Three New Tubes"; see also, "And Now—The 'Shoe-Button' Tube," October 1933.)

DASH-TYPE AUTO-RADIO CONTROL (720)

A VERY neat-looking and easily installed dash control unit has been designed for five leading makes of automobiles. It fits flush with the instrument panel, and looks like a factory-installed job. Finished in chromium, with black striping. Something for the car-radio Service Man to install on older car sets; a profitable touch of modernity.

CELLULOSE-COATED RECORD-BLANKS (721)

A NEW development in ungrooved record-blanks utilizes a cellulose coating over aluminum. Unusually high fidelity and low background noise are claimed. The records are to be cut with a regular sapphire point; use any needle for play-back. Use for program auditions, personal recordings, air checks, and for electrical transcriptions where only a few records of a single program are needed.

PLUG-IN CRYSTAL "MIKE" (722)

(Shure Bros. Co.)

NEWEST in inexpensive crystal microphones is a plug-in unit of the diaphragm-actuated type. A "cantilever" system of coupling affords matched mechanical impedance. Microphone is provided with a plug which permits instant removal from stand for use elsewhere, or for safekeeping. Feeds directly into the grid circuit; does not require a polarizing voltage. A single stage of low-gain amplification brings the level to that of a 2-button carbon mike.

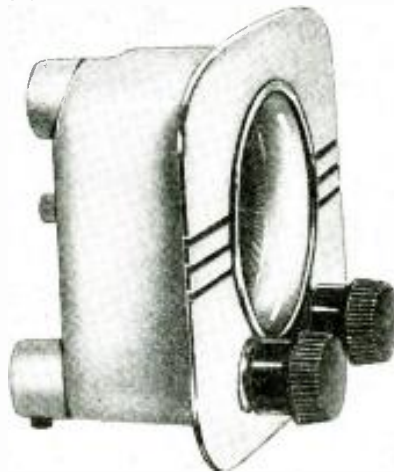

Above—No. 720. Below—No. 721.

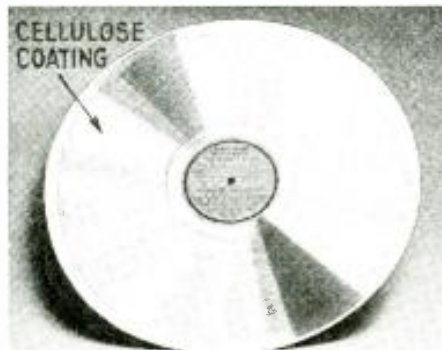

64,340 LETTERS

"I am writing to ALLIED because I know you have always been able to serve me better." That's the way thousands of letters begin that are addressed to us yearly. Last year, we answered 64,340 inquiries—completely and promptly, in a helpful, personal way. There were letters on technical radio problems and requests for replacement parts recommendations, letters asking for kit quotations for radio building, letters requesting advice and prices on public address installations—inquiries from thousands of Amateurs, Servicemen, Dealers and Experimenters. We, at ALLIED, welcome your letters always, and invite your correspondence on all types of radio problems.

A NEW CATALOG



The new ALLIED Spring and Summer Catalog is now off the press. If you haven't received your copy, write for it at once. This new book offers you the recent sensational tube price reductions and again makes available R C A - Radiotron tubes for outright purchase. The Spring and Summer ALLIED Catalog is devoted 100% to Radio. It features everything for the Serviceman, Set-builder, Sound Specialist and Experimenter. Lists thousands of exact duplicate standard replacement parts; up-to-the-minute test equipment; dozens of new set-building kits; new All-Wave Receivers—electric, battery, 32 Volt, and Auto Radios—the latest Sound Systems, everything for Short Wave Transmitting and Receiving. Write for this new Catalog now.

Mobile Sound



We offer an outstanding new type of Public Address system to meet the growing demand for mobile sound amplification. Develops full 20 watts output. Operates completely from a 6 volt storage battery. Has built-in electric 6 volt dual-speed phono motor. Input is for mike and phono; with mixer control panel. Only one of many new Sound Systems developed by ALLIED. Send your Public Address specifications to our Sound Engineering Division for valuable advice and attractive quotations. We can serve you better.

ALLIED RADIO

ALLIED RADIO CORPORATION.
833 W. Jackson Blvd., Chicago, Ill.
Dept. D.

Send me the following:

FREE Spring and Summer ALLIED Catalog

Detailed information on your new Mobile Sound System

Name.....

Address.....



No use doing a nose-dive under the service bench—or digging into a bunch of old cigarette tins for that unphumpy ohm resistor. . . .

Get this new CENTRALAB HANDY RESISTOR RACK that's FREE with an assortment of 40 CENTRALAB RESISTORS. You'll like the way you can instantly "spot" just the resistor you're looking for . . . or tell just what resistance values are missing.



**FREE!
CENTRALAB
HANDY FIXED
RESISTOR
RACK**

15 x 9½ inches . . . sturdy steel and includes an R M A Color chart in FULL COLORS.

NEW! Centralab Volume Control Guide

The new CENTRALAB VOLUME CONTROL GUIDE is now out . . . better than ever before . . . much low dope. Ask your jobber for a copy.

MAIL COUPON NOW!

CENTRALAB
900 E. KEEFE AVE.
MILWAUKEE, WIS.

Please send me information about your special deal which includes a FREE HANDY FIXED RESISTOR RACK.

NAME _____
ADDRESS _____
CITY _____ STATE _____
MY JOBBER IS _____ R. Craft

THE LATEST RADIO EQUIPMENT

(Continued from page 757)

RUBBER-JACKETED SHIELD CABLE (723)

NO MORE taping of the shielded control-grid wire in the radio set, or the lead from crystal microphone to amplifier input, if the new "rubber jacketed" conductor is used. The flexible conductor is covered with cotton, over which is placed the usual mesh shield; a serving of thick, soft rubber acts as protection against damage and corrosion, and prevents accidental short-circuits and grounds.

WATERPROOF "DOPE" (724)

(General Cement Mfg. Co.)

THIS waterproof "dope" is a chemical solution especially suitable for firmly holding coil windings in place. An unusual characteristic of the chemical is that it not only gives the coils a tough, moisture and weatherproof film, but also causes the windings to contract and thus more tightly hug the coil form. Recommended for waterproofing sets and speakers that are exposed to the elements—as in a car, or boat.

"CLUB ROOM" PHONO. AND P.A. UNIT (725)

(Federated Purchaser, Inc.)

THIS new 110 V., A.C. "phonograph table" is ideally adapted for use in clubrooms, small lecture halls, etc. Microphone connection permits use as a small P.A. unit. Incorporates a 2-speed phono. turn-table. Room capacity is about 250 people. Finished in black crackle, with chrome trimmings. Size, 20½ x 15 x 25 ins. high.

IMPROVED 5-TUBE SHORT-WAVE SET (726)

(Radio Trading Co.)

TWO interesting features are found in this new Doerle "de luxe" short-wave receiver. First, it is equipped with a 125-to-1 bandspread dial; two knobs, on concentric shafts, provide fast and slow tuning. Second, antenna circuit accommodates either standard or doublet antenna. A 6 in. dynamic reproducer is built into the set.



CRYSTAL "MIKE" PLUGS INTO STAND

The plug-in crystal microphone. (722)

SHIELDING

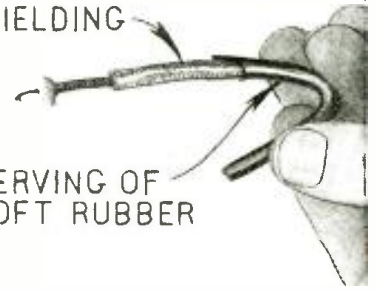

SERVING OF SOFT RUBBER

Rubber-jacketed shield cable for control-grid leads, etc. (723)

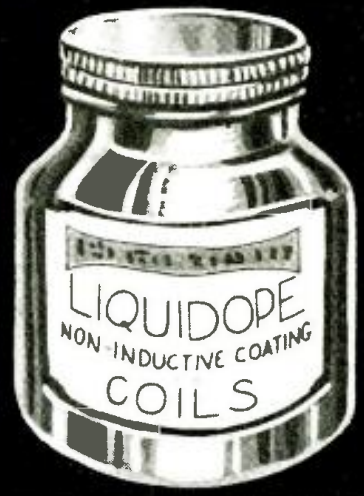

Waterproof "dope" for coils and speakers. (724)—above.

"Club room" phono. and P.A. unit. (725)—below.



**NEW!
Amplifiers
Complete
in One Unit!**

Series A-30 and B-50

Now! You can save time—effort—make more money—with these NEW Amplifiers, for large outdoor or indoor installations. High output! Tone quality! Performance! Power output—A-30, 30 watts; B-50, 50 watts.



**NEW
Catalog
Send
for
Copy**

More Jobs! More Profits!
No fuss. No bother. Webster advanced engineering design simplifies sale and installation. All accessories totally enclosed in well ventilated, attractive case. New products—new features of design—have been added to the Webster-Chicago line.

Write for Details—Today!

3825 West Lake St.
CHICAGO, ILL.

THE WEBSTER COMPANY



**A MAGAZINE WHICH NEEDS
NO INTRODUCTION
TO SHORT-WAVE FANS**

SHORT WAVE CRAFT

This popular monthly magazine, **SHORT WAVE CRAFT**, contains everything you want to know about Short Waves. The wonders of world-wide short-wave reception are clearly described and illustrated. Latest practical information for radio fans, experimenters and "hams" will be found. Tells you how to build short-wave receivers and transmitters; construct sets of one and two tubes or as many as seven, eight or more. Tells best foreign stations to log and when to tune them—includes newest and best circuits of the time. **SHORT WAVE CRAFT** is edited by Huto Gernsback.

NEW FEATURE RECENTLY ADDED—To the short wave fan who has logged and obtained verification of the largest number of short-wave stations from all over the world during one month, will be awarded a magnificent 24" silver trophy.

Special This Month Only!

For the month of May only, we offer readers of this magazine the opportunity to read radio's greatest short-wave magazine at a special saving. The regular subscription price is \$2.50 per year. You can now get **SHORT WAVE CRAFT** for the next

**8 MONTHS
FOR \$1.00**

4-Color Cover
Over 200 illustrations
9x12 inches in size

25c The Copy
ON ALL
NEWSSTANDS



Send remittance by check, money order or U.S. Postage Stamps. Register letter if it contains cash or currency.

SHORT WAVE CRAFT
99R Hudson St. New York, N. Y.

AIR CONDITIONING
is America's Next Great Industry

THE idea of electricians, radio service men and other mechanically inclined men servicing Air Conditioning and Refrigeration Units is self-evident and the thought has occurred to some untold thousands ever since air conditioning equipment has been installed in public auditoriums, theatres, studios, department stores, office buildings and manufacturing plants. The tremendously broad possibilities in this new industry are bound to give employment and success to men far-sighted enough to see its advancement and development.

Well-known Engineer Edits Manual

THE OFFICIAL AIR CONDITIONING SERVICE MANUAL is edited by L. K. Wright, an expert and a leading authority on air conditioning and refrigeration. In this Air Conditioning Service Manual nearly every page is illustrated; every modern installation and individual part carefully explained; diagrams furnished of all known equipment; special care given to the servicing and installation end. The tools needed are illustrated and explained; there are plenty of charts and page after page of service data.

CONTENTS IN BRIEF

History of Air Conditioning; Fundamental Laws; Methods of Refrigeration; Ejector System of Refrigeration; Compression System of Refrigeration; Refrigerants; Lubricating Oils; Liquid Throttle Devices; Servicing Expansion and Float Valves; Servicing Refrigerating Systems; Control Devices; Thermodynamics of Air Conditioning; Weather in the United States; The Field of Air Conditioning; Insulating Materials; Heat Transmission Through Walls; Complete Air Conditioning Systems; Estimating Requirements for the Home, Small Store, Restaurant; Layout of Duct Systems; Starting Up a System; Operating and Servicing Air Conditioning Systems; Air Filtration, Ventilating and Noise Eliminating Devices; Portable Electric Humidifiers and Room Coolers; Automatic Humidifiers; Air Conditioning Units for Radiator Systems and Warm Air Systems; Central Conditioning Units, etc.



**352 Pages
600 Illustrations**

9x12 Inches

Flexible, Loose-Leaf
Leatherette Cover

\$5.00 A COPY

(Send remittance by check, money order or unused U.S. Stamps. Register letter if it contains stamps or currency.)

GERNSBACK PUBLICATIONS, INC.
99R Hudson Street New York, N. Y.

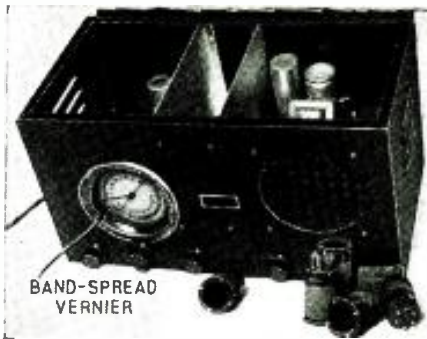

S-W. set has "second-hand" vernier. (726)

**VELOCITY MIKE MAGNETS OF
NICKEL-ALUMINUM-CHROME**

(Amperite Corp.)

I NCREASED output with reduced physical dimensions is the outstanding feature of a new velocity microphone. The "secret" lies in the use of permanent magnets made of a special nickel-aluminum-chrome alloy twice as strong as 36 per cent chrome steel. The output is thus increased 6 db.



A velocity mike with improved magnet system. Operates without background noise, and has wide frequency response. Acoustic feedback and hum pickup have been eliminated. (727)

OPERATING NOTES

(Continued from page 736)

the plate by the hinge of the door and attaching a new shielded lead-in to the old one, I pulled the new through by pulling the old one. Making sure that the shielding would not touch the antenna I soldered the new lead-in to the antenna and grounded the shielding to the frame as many places as I could, as shown in Fig. 4. Carefully replacing everything that was taken off, the job looked as good as new. On trying the set it was found to be O.K. except when the engine was running. The noise, noticed more at the high-frequency end of the dial, sounded like faulty suppressors. These tested up O.K. and upon turning on the dome-light while the set was operating and the car engine running I found that the noise was considerably reduced. By placing a choke (the series coil of an old cutout) in series with the dome-light wire and a .5-mf. condenser on the battery side of the choke, the noise was completely eliminated. (If an old cutout is not available a suitable choke may be made by winding about 30 turns of No. 18 enamel wire on a 1/2-in. form about 3 ins. long.)

JACK BALL

1935 PHILCOS

I N THE past several months we have had a number of complaints on all Philco volume controls, even those used in the Ford-Philco auto-radio sets. Here is the remedy:

Before replacing the entire unit, remove the control, and then carefully bend back lugs that hold the switch unit to the control. The slider is now exposed.

Next, carefully solder a small wire (about No. 30) as shown in Fig. 5. This pigtail contact within the rocker arm successfully eliminates a noisy and erratic volume control.

CHAS. EDW. HARRISON

Please Say That You Saw It in RADIO-CRAFT



J. MATHESON BELL
Radio
Manufacturer
for 15 years

**I Want Men
To Sell Radios-Spare Time**

Since 1921 I have sold radios through trained radio men. Not the type of "price cutting" radios generally sold in stores but radios of a quality which only radio men can appreciate.

I need more men in my organization, men who actually know radio values because no other could ever sell my quality of radio. Give me your spare time... evenings, and I'll show you radios which will sell... with a simple demonstration.

I'll guarantee that any eight year old child can actually tune in the European stations. It's one thing to tune in London but... quite another to tune them in as... easy as any local and... with real volume.

New Auto Radio only 17.95

Here is the sensation of the year—an Auto Radio you'll be proud to handle. No need to worry any more about installing or service difficulties for these are a thing of the past.

No vibrator trouble... no aerial trouble... Installation so simple that every job gives you an extra profit. At this unheard of low price you get amazing reception... distance and tone. Tubes and remote control included... or for those who want it... the very latest ash tray installation with panels to match all cars and any special length cables.

Special Offer to Radio Service Men

I can show you how to make money... big money out of Auto Radios... But... Start now. This will be the Big Year. Everyone wants an Auto Radio as proved by new car sales... Cash in on this demand NOW. I make a full line of radios... up to 12 tube radios in cabinets of 1 1/4 inch solid walnut. My line is complete, 2 volt air cell operated, 6 volt no "B" batteries, 32 volt, and in "AC" from five to twelve tubes and all of a quality you can sell and... make friends.

I know the radio service man's problem. There is real money to be made if... you get lined up right, but it never will be with the regular lines on which prices are slashed... Just where you least expect. My prices are never cut.

Send the coupon for fine illustrated literature and special offer. You'll find both very interesting.

J. MATHESON BELL, INC.

308 W. Randolph St., Dept. D Chicago

You may send me illustrated literature and details of your special offer which will help me make extra money.

Name
Address
City..... State.....

**WHAT DO YOU KNOW
ABOUT THE NEW
"HI-FORMATION"
ELECTROLYTICS?**

OUR CATALOG No. 128 WILL TELL YOU ALL ABOUT THEM

CORNELL-DUBILIER CORPORATION
4347 BRONX BOULEVARD
NEW YORK

The
World's
Finest
Radio
Receiver

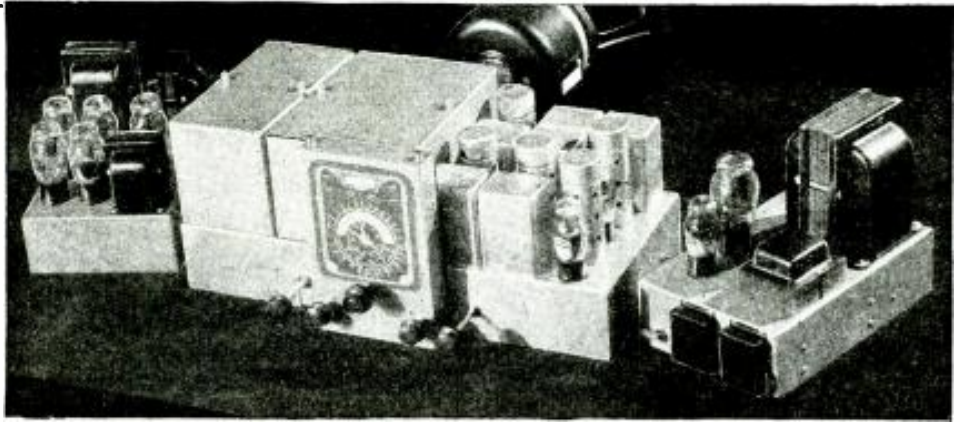

The 19-TUBE All-Wave HOWARD GRAND

MAIL THIS COUPON for complete details, pictures, descriptions, prices, etc.

It is a magnificent radio receiver with features fully a year ahead of the times. It has an altogether new type of Tone Control that lifts the bass instead of "cutting" the highs. It has High Fidelity; Band Spread tuning; covers every broadcast, short-wave and long-wave band; has superlative Sensitivity; a Choice of Selectivity; 20 watts output; Beat Oscillator for code reception; delayed Automatic Volume Control; Phonograph Jack; Headphone Jack; a new kind of dial and Band indicator; two R.F. stages on short wave; and a high signal-to-noise ratio. Every part is the finest obtainable. It is truly "THE WORLD'S FINEST RADIO." Yet it is surprisingly LOW PRICED. Write for details.

HOWARD RADIO CO., Dept. RC
1735 Belmont Ave.,
Chicago, Illinois, U.S.A.
Send me FREE details on the HOWARD GRAND

Name

Address

HOWARD RADIO

1735 BELMONT AVENUE, CHICAGO, ILLINOIS, U.S.A.

"AMERICA'S OLDEST RADIO MANUFACTURER"

Train Now for New RADIO Opportunities

Get Into a Line Where There's Action—Every Day—And a Payday Every Week—You Be the Boss!

Analyzer & Resistance Tester—Latest Design—YOURS Without Extra Cost

Right now while hundreds are looking for work where there isn't any, the radio service field can use trained men. With the proper training and the necessary equipment, you can enter this field and make a comfortable living. We include with our course this modern set analyzer and trouble shooter without any extra charge. This piece of equipment has proved to be a valuable help to our members. After a brief period of training, you can take the set analyzer out on service calls and really compete with "old timers." We show you how to wire short-wave receivers—analyze and repair all types of radio sets—and many other profitable jobs can be yours. Teaching you this interesting work is our business, and we have provided ourselves with every facility to help you learn quickly and thoroughly. If you possess average intelligence and the desire to make real progress on your own merits, you will be interested.

ACT NOW—MAIL COUPON

Start this very minute! Send for full details of our plan and free booklet that explains how easily you can now cash in on radio quickly. Don't put it off! Write today. SEND NOW!

RADIO TRAINING ASSN. of AMERICA
Dept. RC-56, 4513 Ravenswood Ave., Chicago, Ill.
Gentlemen: Send me details of your Enrollment Plan and information on how to learn to make real money in radio quick.

Name

Address

City State

A NEW HIGH-FIDELITY ALL-WAVE RECEIVER

(Continued from page 730)

entirely, since this section of the receiver in combination with the oscillator provides practically all of the selectivity which "cuts" the sidebands (resulting in poor tonal quality).

One of the most important prerequisites to high-fidelity reception is that the station received have a very high field strength, so that the normal background noise is blanketed out, otherwise the extended frequency range would unquestionably do more harm than good, in that the various undesirable noises would be amplified in proportion to the signal. This practically limits high-fidelity reception to local stations, or those within a radius of approximately 75 miles. Since local stations are separated at least 50 kc., the selectivity requirements of a high-fidelity receiving system are negligible. Measurements indicate that only three tuned circuits, even when stagger-tuned give the desired station separation. Since this is the case, why use the I.F. amplifier, as at its best it still

"cuts" sidebands.

The result of our reasoning, then, for "best" programs, is a T.R.F. receiver—with a simple switching arrangement to connect the I.F. amplifier and oscillator into the circuit when additional selectivity and sensitivity are desired. The schematic diagram in Fig. 2 shows how this is accomplished in a commercially-available receiver model.

For extreme distant reception it is only necessary to throw the switch to the other position and you have a receiver capable of picking up the weakest station, whether short-wave or broadcast. The frequency-converter stage, an exclusive feature (described in November 1934, RADIO-CRAFT) is then automatically connected into the circuit. This stage makes it possible to combine the enormous amplification of a low-frequency I.F. stage, (without the usual superheterodyne hiss) with the excellent image-rejection characteristic of a high-frequency I.F. stage, making the receiver ideal for both short-wave and broadcast reception. Without a frequency-converter stage the design of an all-wave receiver must be a compromise either favoring the short-wave or the broadcast band.

Fig. 2—The circuit of the T.R.F.—Superhet. receiver described above.

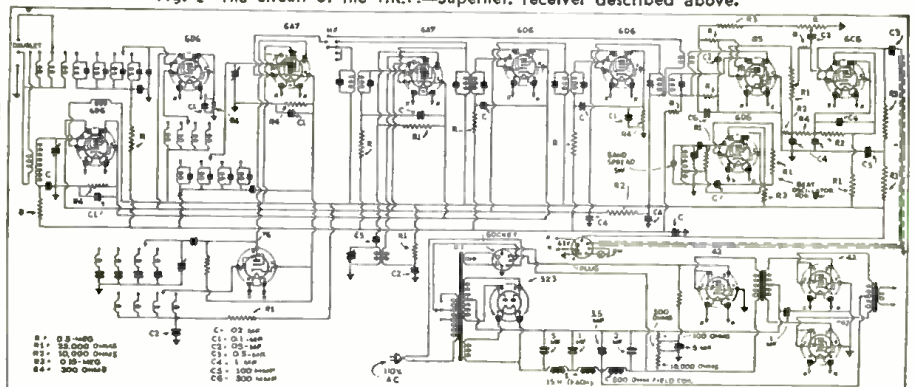

Please Say That You Saw It in RADIO-CRAFT

DEAF-AID EQUIPMENT— A SERVICE MARKET

(Continued from page 728)

customers will also bring relatives and friends with them that otherwise would not frequently attend because of the hard-of-hearing member of the family. Properly approached, such ammunition should sell the theatre owner.

Another good prospect is the churches. In most cases, the church organizations are too poor to even approach on the subject. A good beginning is to find a well-to-do member who, whether he admits it or not, has defective hearing and try to sell him on the idea of donating the system for the good of the community. If necessary to reduce the cost to him, you can suggest his donating the system *less the phones*, and each of the members having defective hearing buying their own receivers. Another suggestion is to contact a list of members having poor hearing and get them to pool their money together to get the equipment.

These are a few ideas and many more will suggest themselves to the radio man who is *actively* out creating his market for sound apparatus.

As for specific equipment for these installations, the diagram shows a reasonably priced group of well-designed apparatus, the installation of which the dealer or Service Man can be assured will result in trouble-free operation and whose performance will increase his reputation and bring him more sales.

In discussing hard-of-hearing "aids" with theatre owners who do not have any stage show presentation, the point is sometimes brought up by them that with all of the volume they have available, it should only be necessary to install the phones and connect them across their stage speaker line and that they, therefore, do not need any additional amplifier. Of course, a "bridging amplifier" is necessary as you can easily show them. Unless these phone circuits are isolated from the speaker line by some sort of bridging amplifier, clicks will be heard in the speakers as phones are added and removed, volume will be affected by the number of phones in use, and most serious of all, frayed cords causing short-circuits, mischievous patrons tampering with control boxes and innumerable other ways of causing short circuits mean stopping the show.

Regarding installations as a whole, the placement of control boxes is merely a matter of using good common sense, and the actual wiring and installation of the system neither complicated nor expensive.

The business is there for you if you will go out and get it. Every year is seeing a greater acceptance of sound amplification and the many ramifications and extended use of amplification equipment as so greatly demonstrated at the 1933-34 Chicago Fair has done much to make the public and "business" sound conscious.

NEW DATA ON AIRPLANE TYPE RECTIFIER TUBES

High altitudes where freezing temperatures prevail have developed problems that the old type rectifier could not satisfactorily solve. The mercury type rectifiers have well-known limits of ambient temperature in addition to the generation of R.F. noise. These same general limitations of mercury-type rectifiers exist in the operation of P.A. or amateur power supply equipment.

Raytheon—pioneer of the 83-V rectifier—now contributes to the solution of these problems by developing three higher voltage high-vacuum rectifiers known as RK-19, RK-21 and RK-22. These three new tubes are rated at 1250 V. R.M.S. per anode and 3500 V. maximum inverse peak voltage. Their peak current rating is 0.600 A. The RK-19 is a full-wave rectifier with a 7.5 V. 2.5 A. heater. The RK-21 is a half-wave rectifier with a 2.5 V. 4.0 A. heater, and the RK-22 combines the elements of two RK-21 tubes in a single envelope with the heater operating at 2.5 V., 8 A.

The 866-A rectifiers in airplane equipment are being replaced in many instances with the new RK-21 and RK-22 tubes. In general, where the R.M.S. voltage per anode does not exceed 1250 V., type RK-21 is interchangeable with the 866-A and two 866-A rectifiers can be replaced by a single RK-22.

"GENERAL" Auto-Radio "B" VIBRATORS

**Actual Size
Replacement
Unit**

**Mountings and Connections
to fit 156 Models of
Auto Radios**

To insure the most permanent and dependable service possible in equipment of this kind, the General full-wave vibrator is provided with the highest grade *Swedish* spring steel reed and with oversized tungsten contacts—assuring long life. The springs are firmly clamped between bakelite insulation supported with the coil on a rigid metal base to which is snapped a low resistance non-magnetic metallic enclosing case—no liability of mechanical injury to springs.

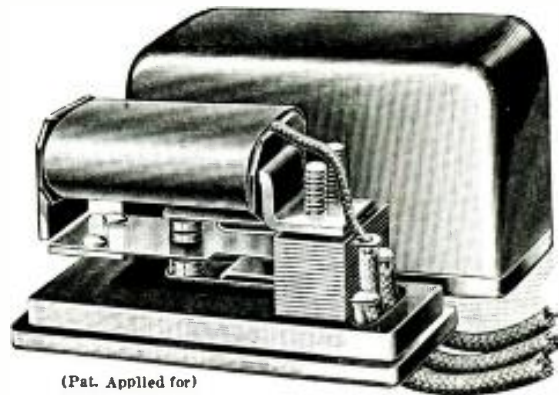

(Pat. Applied for)

MAIL THIS TODAY

General Transformer Corporation,
504 S. Throop St., Chicago, Ill.

Send me without charge a copy of "General" "B" Vibrator Guide for 156 Models Auto-Radio sets, with name of nearest distributor.

Name

Address

City..... State.....



THIS SERVICEMAN WON'T FAIL

But One Out of Four of His Competitors Will

He knows more than 25 percent of all servicemen fail EVERY YEAR. He knows, too, that thousands of eager but inexperienced beginners rush in to take their places, thus keeping competition at fever pitch. But he is not worrying. He knows, servicing will always be a good business FOR THE MAN WHO KNOWS HOW. And because this is so, his future is now secure. Through a small investment in Sprayberry's Practical Mechanics of

Radio Service, he has learned to do all kinds of work quicker, better and in THE MODERN WAY. He has discovered the knack of handling the most profitable jobs—of building a reputation for the finest work in his community.

Such a man is typical of hundreds of Sprayberry-trained servicemen throughout the world. Certainly you owe it to your own future to investigate a plan of offering so much for so little!

OSCILLOGRAPH DATA

Our three NEW lessons covering every service detail of the CATHODIC RAY TUBE or OSCILLOGRAPH may prove worth more to you than the surprisingly low price asked for the entire course.

F. L. SPRAYBERRY, 2548 University Place, N.W., Washington, D.C.

At no obligation to me, please send full details of your advanced training plan for radio servicemen.

Name

Complete Address

RC 6 35

SPRAYBERRY'S PRACTICAL MECHANICS OF RADIO SERVICE

22% Greater Signal Strength Efficiency!

WITH THE

WARD Magic Super Auto Antenna

ESPECIALLY DESIGNED FOR TURRET TOP CARS

Approved for all Turret Top Cars and many others

DEALERS! JOBBERS! SERVICEMEN! Write for Illustrated Catalog!

MFGD. BY THE **WARD PRODUCTS CORP.** WARD BLDG., 2135 SUPERIOR AVE., CLEVELAND, OHIO, U. S. A.

GOOD NEWS!! On page 708 of this issue appears an important announcement about the 1935 OFFICIAL AUTO-RADIO SERVICE MANUAL. Be sure to turn to this page now for full particulars.

Please Say That You Saw It in RADIO-CRAFT

Modern Testing Instruments that give Accurate Measurements, Longer Service and are Lower-Priced



DEPENDABLE MULTITESTER MODEL 403-A

Service men and dealers highly praised the Model 403 Multitester—and it deserved praise. But the new improved Model 403-A "DEPENDABLE" MULTITESTER insures even greater satisfaction at less cost. Embodying every feature of the former model, No. 403-A is more compact, having been designed as a companion instrument to the new Model 501 ANALYZER UNIT described below.

2,000 ohms per volt. Accuracy within 2 per cent in D'ARSONVAL type moving coil meter. 3-range 0-2,000,000 ohmmeter; 4-range 0-5-50-250-750 voltmeter; 0-500 microammeter.

COMPLETE, ready to operate..... **\$13.95 Net**
KIT \$10.65

DEPENDABLE A.C. - D.C. METER

UNIVERSAL SCALE—COPPER-OXIDE TYPE
D.C. Accuracy 2% A.C. Accuracy 5% 2000 ohms per volt

This sensitive microammeter, with D'Arsonval movement, is furnished in a black bakelite case. Designed particularly for use as a multirange instrument for accurately measuring A.C. and D.C. voltage and current. A separate ohmmeter scale, reading from 0-2000 ohms, can be used in circuits so as to read up to 20,000,000 ohms. Scales read 0-5-250-750, in volts and milliamperes.

Full-wave copper-oxide rectifier and its advanced circuit design, are protected by patent license. Leads are included for use in external circuits of all types. Universal meter has a 500 microampere movement giving a sensitivity of 2000 ohms per volt.

Diagrams included for building various A.C. and D.C. testing devices. Meter complete with rectifier **\$7.25**
Net to Dealers and Servicemen



FREE-REFERENCE-POINT TESTER New Model 502

Now, even greater convenience and accuracy in point-to-point testing. Saves time, temper, money and mistakes. Tests between any two tube elements, or chassis or ground. Automatic selector switches. No fusing with jumpers, plugs and jacks. Silver-plated moving arms, contacts and collector rings insure low resistance.

10-wire analyzer cable, with individual chassis-ground lead. Extra points on selector switches and extra socket space for future expansion. 5 3/4" x 8" etched panel.

Price, complete, including 5 "Sure-Pull-Out" Adapters..... **\$6.85**

DEPENDABLE CONVERTER UNIT

The DEPENDABLE CONVERTER UNIT permits any D.C. milliammeter to be used as a multirange A.C. Voltmeter. The meter can then be used as an output meter and will respond at all frequencies—A.F., I.F., and H.F. Four different A.C. voltage ranges are available. These correspond to the more popular multirange D.C. scales in use, as follows:

Model 601.....	5, 50, 250, 750	Style A—for 1 mil meters, 27 ohms resistance
Model 602.....	5, 50, 250, 1,000	Style B—for 1 mil meters, 50 ohms resistance
Model 603.....	3, 30, 300, 600	Style C—for 1/2 mil meters, 100 ohms resistance
Model 604.....	1, 5, 250, 750	

Specify both model number and style, as 601B, 602A, etc., to indicate range and type meter. **\$4.65 Net**



We Issue No Catalog All orders are F.O.B. New York. Terms: A deposit of 20% is required with every order—balance on delivery. DEDUCT 2% IF FULL AMOUNT IS SENT WITH ORDER

GRENPAK COMPANY

101 Hudson St. Dept. RC New York, N. Y.

INTERNATIONAL RADIO REVIEW

(Continued from page 734)

front of the cabinet and a speaker grille on the lower side. The cabinet is specifically designed to fit cars of small dimensions. The set is a superheterodyne and has an enclosed "B" supply.

At Fig. B3 is an idea which appeared recently in WIRELESS MAGAZINE, and shows an English idea for installing a radio set in the upholstery-covered arm rest found in the middle of the rear seat of some sedans. The details of this set are left to the constructor's ingenuity.

The set shown at Fig. B4 is a commercial British car set, removed from its cabinet. The receiver is completely self-contained having a "B" power unit (at the left) and a superheterodyne receiver (right). It is interesting to note that the "all-metal" Catkin tubes are used in this set. Figure B5 shows the same set in its metal box and the remote control with a modern airplane type dial. This set appeared in THE BROADCASTER AND WIRELESS RETAILER.

The last set is one from Australia, and has been called the Mickey Mouse because of its small size. It appeared recently in WIRELESS WEEKLY. This set contains all the refinements found in the latest American sets, such as A.V.C., dustproof construction, superhet. circuit, compact design, airplane-type remote control, etc.

These few samples of foreign auto radio sets will give the reader an idea of the progress made in these countries. A review through the International Radio Review pages of past issues of RADIO-CRAFT will reveal some of the earlier designs.

A NOVEL LAMP SET

THE LITTLE lamp shown in Fig. C is an ingenious example of novelty set design in Germany. The set is enclosed in the ornamental base, with a long shaft from the tuning condensers extending up through the shaft of the lamp. The lamp shade is marked with numerals and the long pointer which is attached to the condenser shaft serves both as dial and tuning control. The loudspeaker is concealed in the lamp shade which also holds a candelabra-type electric light bulb.

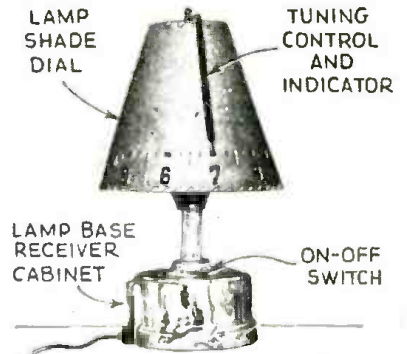

A German novelty in radio sets—a lamp-radio. (Radio Press Service)

Every SHORT-WAVE SET-BUILDER NEEDS THIS BOOK

Every experimenter who has ever tried to build a short wave set knows by experience the difference between a good and a poor receiver is usually found in the short wave coils. Often you have to hunt through magazines, books, etc., to find the information you require. The present book has been gotten up to obviate these difficulties.

In this book you find every possible bit of information on coil winding. Only the most modern "dope" has been published. Illustrations galore, giving not only full instructions on how to wind coils, but dimensions, size of wire, curves, how to plot them, by means of which any coil for any particular short wave set can be figured in advance, as to number of turns, size of wire, spacing, etc. There has never been such data published in such easy accessible form as this.

Sent to you up on receipt of **25c** in coin or stamps and U.S. Postage Stamps

RADIO PUBLICATIONS, 101C Hudson St., New York, N. Y.

Well Illustrated

POPULAR MEDICINE
SEX-HEALTH-BODY CARE

Send 25c for sample copy

KNOW THYSELF!

This new monthly magazine is also your own doctor. WHAT ALL YOU TOPULAR MEDICINE tells and advises you thoroughly. Written for you by doctors. Non-technical yet authoritative for all laymen. Many anatomical illustrations.

On All Newsstands
Special Offer!
8 Months for \$1
Send 25c for sample copy

Popular Medicine 97R Hudson St., New York, N. Y.

SHORT CUTS IN RADIO

(Continued from page 732)
HONORABLE MENTION

AUTOMATIC SENSITIVITY CONTROL. Figure 10 shows a satisfactory method of connecting variable volume control to end of gang condenser shaft to increase sensitivity of set at higher end of dial by automatically decreasing the fixed cathode bias resistance as the tuning condenser is varied.

The 50-ohm variable resistor, or volume control is ganged to the condenser shaft as shown. This will be found to be quite an interesting attachment on some of the less expensive sets that use a variable cathode type of volume control, and which have a tendency to oscillate at the lower dial setting.

CLAUDE KEFFLE

Please Say That You Saw It in RADIO-CRAFT

It's NOW

EVERYDAY SCIENCE AND MECHANICS is the finest scientific-technical-mechanical constructional magazine in the field. Up-to-the-minute with news flashes of scientific events. Dozens of constructional articles and many popular experiments. Ideas from which you can make things to sell.

10¢



A HOST OF INTERESTING SUBJECTS COVERED:
 Woodworking — Photography —
 Magic — Patents and Inventions —
 Book Reviews — Metal-working —
 Chemistry — Engineering — Mi-
 croscopy — Electrical Experiments —
 Household Helps — Astronomy —
 Prize Contests — and other
 subjects.

Get your copy today!
 On all newsstands

10c the copy

Over 150 Illustrations

Most Amazing TYPEWRITER BARGAIN

10 DAY FREE TRIAL OFFER EVER OFFERED



NEW REMINGTON PORTABLE only

10¢ A DAY

FIRST TIME! Remington's new purchase plan now lets you buy a genuine latest model Remington Portable No. 5 direct from the factory for only 10¢ a day. Not used or rebuilt. Not incomplete. A beautiful brand new remodeled Remington Portable. Standard 4-row keyboard, standard width carriage, margin release on keyboard, back spacer, automatic ribbon reverse; every essential feature found in standard typewriters.

With your machine we send you free a 18-page course in typewriting. Teaches touch system quickly, easily. Soon you dash off letters quicker than with pen and ink. You also get a handsome, sturdy carrying case free.

FREE Typewriting Course **BIG PRICE REDUCTION**

The amazing low price and easy terms now make it possible for you to buy this genuine complete Remington Portable for only 10¢ a day. But we cannot guarantee present prices long. Higher wage scales, rising cost of materials, everything points to higher prices. So we say, "Act now . . . while our liberal offer still holds good!"

FREE Carrying Case **You Don't Risk One Cent**

Try this typewriter in your home or office on our 10-day FREE TRIAL OFFER. Then, if you do not agree that it is the finest portable at any price, return it at our expense. You don't even risk shipping charges. Don't wait. Mail coupon now. It's the best chance you've ever had to own so complete a machine for so little money. So act NOW!

CLIP COUPON NOW

Remington Rand, Inc., Dept. 189-6
 205 East 42nd St., New York City

Please tell me how I can buy a new Remington Portable typewriter for only 10¢ a day. Also enclose your new catalog.

Name _____
 Address _____
 City _____ State _____

THE NEWEST IN CAR ANTENNAS

(Continued from page 721)

The new car-type dipole antenna has an overall length of 4 ft.; the distance between the two dipole sections is 5 ins. Rubber grommets are inserted in the brackets to completely insulate the antenna from all metal objects, and the antenna itself has been properly protected; first by copper plating, second by a dull gray baked crackle enamel, and third by dipping the complete antenna in a special wax. This process gives long life which normally would be reduced in areas near salt water. These special treatments provide sufficient insulation to prevent serious leakage to the car body as might be caused by dirt, grease, ice, water, etc. A special low-capacity transmission line is supplied with each antenna; one end of the line grounds to the car body, close to the antenna. Both runningboard positions should be tried, to determine which side of the car results in least noise pick-up.

The dipole is broadly resonant to a wavelength of about 7 meters, at which car-ignition interference is greatest. On most installations the antenna must be located parallel to the runningboard for minimum noise pick-up. With the antenna thus symmetrically located with respect to the body of the car, and with a set connected to the antenna, the antenna-to-car capacity of each leg of the dipole will be equal, and current flowing to the car from the antenna leg of highest potential will be equal and opposite to that flowing from the car to the antenna leg of lowest potential; as a result, these circulating currents will not flow through the receiver. This reasoning applies to all other points along the dipole, with relation to the car body.

That this is not just theory, but works out in practice, to really eliminate interference, may be demonstrated by moving the lead to the set off-center, in order to produce unbalanced voltages in the two legs of the dipole. Now, the capacity from the highest potential leg to car will be larger than the capacity from the lower-potential leg. The difference-current flow will then be through the receiver, as "noise," since all of the circulating current from the longer side cannot return to the shorter side through the smaller capacity couplings.

READERS' DEPARTMENT

(Continued from page 737)

the newest British Tompson-Houston pickup. We give below the table of output frequency and voltage published in the article and you can see that at the bass end the pickup gives an output in excess of 6 volts!

We hope that you do not mind our calling this to your attention but in view of the fact that it was a gross misstatement of fact, we thought that you would not object.

Audio Frequency	Voltage Output	Audio Frequency	Voltage Output
8,460	.2	1,362	1.4
7,720	.25	1,035	1.6
6,650	.25	993	1.7
6,120	.3	893	1.8
5,550	.25	773	1.9
5,160	.35	526	2.1
4,700	.2	445	3.5
4,450	.4	340	4.0
3,400	.7	261	4.7
3,540	1.2	205	4.4
3,015	2.2	150	5.5
2,512	1.3	104	6.1
2,075	1.5	79	6.2
1,788	1.3	52.4	5.4
1,579	1.4		

C. B. SCOTT,
 The Brush Development Co.,
 Cleveland, Ohio.

Far from objecting, Mr. Scott, we welcome your correction of the statement in our October 1934 issue. However, we are sure that the authors made the statement in good faith, keeping in mind only the magnetic type of pickup. Thank you for the correct information,



5- 10- 15- 20-Watt
RESISTORS

. . . smaller than a Cigarette!

Genuine wire-wound vitreous-enamelled units reduced to most compact dimensions. Nothing sacrificed except troublesome bulk. Another Aerovox engineering achievement!

Quality wire . . . crack-proof refractory tubing . . . precisely wound. Wire ends brazed to lugs . . . pigtail soldered to terminal bands . . . stiff wire leads. Heavily coated with vitreous porcelain enamel . . . permanent seal . . . moisture-proof, damage-proof. Conservatively rated . . . adequate heat dissipation . . . longest service life. Just install them and forget them!

Get the Facts! New 1935 catalog for complete resistor and condenser line. Also sample copy Research Worker. Remember **AEROVOX—MORE** quality for LESS money.



VARITONE



A new revolutionary variable fidelity audio transformer. Enjoy life-like reproduction in auto radios with the new UTC VARITONE.

The new UTC VT-1 VARITONE corrects or emphasizes high or low notes or both.

Distorted phono and radio reception can be brought back to pleasant high fidelity standards by using the VT-1 VARITONE. If you are troubled with too much lows, or too much highs, or with tinny quality, use the VT-1 VARITONE and notice the difference.

Type VT-1 designed to work from a single plate or low impedance pickup or mike to 1 or 2 grids. Net to servicemen or P.A. Specialists. **\$5.10**

See your local distributor for descriptive literature.

UNITED TRANSFORMER CORP.
 266-R Canal Street New York, N. Y.

FREE—Just off the press!

IMPORTANT BUYING GUIDE for Radio Servicemen, Dealers, Experimenters and Short-Wave Fans

SUPPLEMENT CATALOG NO. 29

1935 SPRING-SUMMER EDITION

LOWEST PRICES THIS BOOK WILL SAVE YOU MONEY
32 Pages Two Colors Profusely Illustrated

Packed between the covers of this new book is a huge array of modern radio equipment and other electrical and scientific merchandise—perhaps the very material for which you have been looking—and at prices which cannot possibly be any lower. A truly important buying guide for radio servicemen, experimenters, dealers, short-wave fans, biological and optical students, and other men following scientific professions.

Contains all-wave radio receivers, automobile sets, low-priced microscopes, field glasses, complete public address systems, official Doerle and other short-wave receivers, crystal radios, radio replacement parts and accessories, latest testing equipment, etc., etc.

Name the item—and it's in the book.

You can increase the value of your dollar by buying at the low prices contained in this buying guide. This amazing book will show you how to save money by buying economically. Why not start saving now? Don't delay. Write today for your free copy. You are not obligated in any way.

It's YOURS for THE ASKING!

WRITE TODAY — send postcard or letter, printing your name and address clearly. Your buying guide will be sent by return mail. IT'S ABSOLUTELY FREE.

RADIO TRADING COMPANY

97 Hudson St. New York City



TECHNICIANS' DATA SERVICE

(Continued from page 744)

receivers designed and built by Hallcrafters, Inc. Features: range of 13 to 200 meters (with broadcast or 10-meter band optional), automatic wave-change switch, continuous band-spread, built-in monitor, speaker and power supply (or batteries), high-fidelity audio, and other refinements.

73. HETRO HOME AND AUTO-RADIO RECEIVERS AND ACCESSORIES. A folder containing descriptions, illustrations, list and net prices of the Hetro Electrical Industries, line of console, phono-radio and table-model home radio receivers, auto-radio sets, phonograph automatic record changers and motors, antenna systems and D.C. converters.

74. SPRAGUE 1935 ELECTROLYTIC AND PAPER CONDENSER CATALOG. Gives specifications, with list and net prices on a complete line of wet and dry electrolytic, and paper condensers made by the Sprague Products Co. for radio Service Men, set builders, experimenters and engineers. Information on the Sprague Capacity Indicator, for making capacity tests on condensers and in servicing receivers, is included.

75. SPRAGUE TEL-U-HOW CONDENSER GUIDE. A valuable chart, compiled by the Sprague Products Co. which tells the proper types, capacity values and voltages of condensers required in the various circuits of radio receivers and amplifiers, and how to locate radio troubles due to defective condensers. Includes data on condenser calculations.

76. FACTS YOU SHOULD KNOW ABOUT CONDENSERS. A folder, prepared by the Sprague Products Co., which explains the importance of various characteristics of condensers, such as power-factor, leakage, capacity and voltage in determining the efficiency or suitability of a given condenser to provide maximum filtering and safety in operation.

RADIO-CRAFT'S INFORMATION BUREAU

(Continued from page 738)

leakage to the ground from the tires, or by direct radiation, equals the amount of the charge being generated.

The front-wheels, only, build up a sufficiently high charge to radiate to the radio antenna. The rear wheels do not radiate interference to any great extent because the charge built up by them is absorbed directly by the car body.

Better grounding of the brake shoes is the proper way to correct the difficulty. The illustration shows how a piece of braid may be connected from each brake shoe to the brake housing. Be sure to allow sufficient slack in the braid to insure proper functioning of the brakes.

SILENCING 32 V. PLANTS

(327) Mr. J. E. Lynaugh, Abington, Wash.

(Q) Is there any way to silence a 32 V. farm lighting plant so that a radio receiver can be connected to it?

(A) If a 32 V. receiver is to be operated in conjunction with a light plant in operation, it can be silenced with condensers and spark plug suppressors. In some cases the ignition parts must be shielded.

It is also advisable that the antenna be somewhere between 125 and 150 feet in length, and that the antenna be placed at exact right angles to the 32 V. lines.

It is also necessary to place a condenser (1 to 2 mf.) from each of the commutator brushes to the frame of the generator.

The breaker points of the distributor system are already shunted with a condenser, but in some instances it is necessary to shunt this with a mica condenser. A capacity of from 0.5 to 2.0 mf. should be tried between each of the low potential connections on the spark coil to ground. Experimentation is always necessary in order to determine the most effective position.

WONDER Stories

NOW

15¢ PER COPY

ON ALL NEWSSTANDS

THE GREATEST EVENT IN THE HISTORY OF SCIENCE-FICTION! This astounding reduction in the price of WONDER STORIES is the culminating step in our struggle to get on top and stay there! Science-fiction has always been an expensive luxury to lovers of action and adventure. NOW it can be enjoyed by everyone at the low prices of ordinary magazines!

If you have never read a science-fiction magazine before, due to their high cost, we heartily advise you to start now with the new popular-priced WONDER STORIES. We want you to buy one issue at your nearest newsstand—you can get the magazine everywhere—and read it thoroughly. We do not ask you to continue to buy it every month—we know you would not dare to miss an issue after reading the first!

Do yourself a favor—get acquainted with science-fiction now that you can afford it! Unlike most publications, the size and quality of WONDER STORIES is not reduced with the drastic price drop. You get as much for 15¢ as you could previously get for a quarter.

The June issue contains many unusual, "out-of-the-way," and thoroughly absorbing stories of super-scientific fantasy (nothing technical, boring, or hard-to-read) by the leading authors in the field, plus one of the greatest murder mysteries ever penned, by a "slick" writer.

Glance through these names: Eando Binder, J. Harvey Hancock, Laurence Manning, David H. Keller, M.D., Edmond Hamilton, W. Varick Nevins III, John Beynon Harris, Stanley G. Weinbaum, Philip James Bartel—if you have never seen them before, get acquainted with them—for they are about to become your favorite authors!

WONDER STORIES

99R Hudson St. New York, N. Y.

A GERNSBACK PUBLICATION

Please Say That You Saw It in RADIO-CRAFT

Many Auto-Radios Installed Last Summer Now Need Servicing!

Auto-radios installed during the past six months usually need some minor adjustment—new tubes, new suppressor- or other parts. Perhaps the job will even be more difficult—then you'll find how needy the Auto-Radio Service Manual is to repair the job quickly.

Volume I

\$2.50 LIST

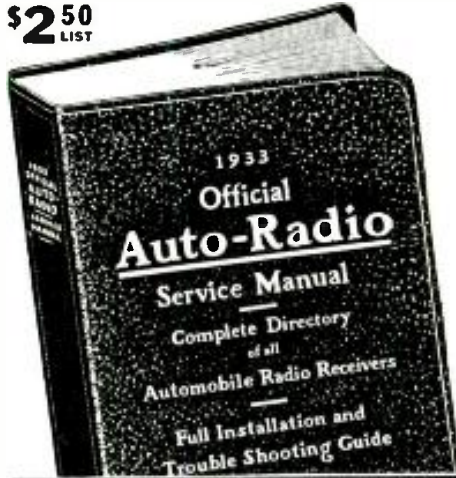

To everyone who now purchases the OFFICIAL AUTO-RADIO SERVICE MANUAL this big 48-page Supplement is issued FREE. Practically all of the latest sets, together with servicing information will be found in these new pages. The new Supplement does not increase the cost of the book to you, but gives you an Auto-Radio Service Manual that is right up-to-the-minute with service notes.

Good Money in Servicing Auto-Radios

If you are overlooking servicing auto radios, you're missing a great deal of business. The auto-radio business had its greatest boom last summer when thousands of sets were sold. By now many of these same sets require servicing and with hundreds of them right in your own community, you can build up a good auto-radio servicing business. In a short time you can easily add 25% profit or more to your regular servicing business.

List of sets covered in the Manual

- | | |
|-------------------------------|---------------------------------|
| Acme Radio Mfg. Co. | P. R. Mallory & Co. |
| Allied Radio Corp. | Melhorn Radio Mfg. Co. |
| Atwater Kent Mfg. Co. | Montgomery Ward & Co. |
| Audiotia Radio Co. | National Co., Inc. |
| Autocrat Radio Company | Noblit Sparks Ind., Inc. |
| Automatic Radio Mfg. Co. | Philco Radio & Tel. Corp. |
| Carrier Generator Corp. | Pierce-Alto, Inc. |
| Century Radio Prods. Co. | Premier Electric Co. |
| Chevrolet Motor Company | Radio Chassis, Inc. |
| Consolidated Industries, Ltd. | RCA-Victor Co., Inc. |
| Crosley Radio Corp. | Sentinel Radio Corp. |
| Deleo Amplifier Corp. | Sparks-Whitington Corp. |
| Detrola Radio Corp. | Stewart Radio & Tel. Corp. |
| Emerson Electric Mfg. Co. | Stewart-Warner Corp. |
| Fada Radio & Elec. Corp. | Stromberg-Carlson Tel. Mfg. Co. |
| Federated Purchaser, Inc. | Transformer Corp. of Am. |
| Ford-Majestic | United Amer. Bosch Corp. |
| Franklin Radio Corp. | United Motors Service |
| Galvin Mfg. Corp. | U. S. Radio & Tel. Corp. |
| General Electric Co. | Utah Radio Trade Co. |
| General Motors Corp. | Wells-Gardner Company |
| A. H. Grebe & Co. | Wholesale Radio Serv. Co. |
| Grigsby-Grunow Co. | Rudolph Wurlitzer Mfg. Co. |
| Chas. Hoodwin Company | Zenith Radio Corp. |
| International Radio Corp. | |

Over 200 Pages

Over 500 Illustrations

9 x 12 Inches

Flexible, Loose-Leaf Cover

MAIL THIS COUPON TODAY!

GERNSBACK PUBLICATIONS, INC. RC-6-35
99 Hudson Street, New York, N. Y.

Enclosed you will find my remittance of \$2.50 for which please send me One Copy of the OFFICIAL AUTO-RADIO SERVICE MANUAL with FREE 48-page Supplement. Send remittance in check or money order. Register letter if it contains cash or currency. WE PAY POSTAGE.

Name

Address

City State

RADIO MONTH IN REVIEW

(Continued from page 711)

PUPIN RADIO PIONEER DIES

MICHAEL Idvorsky Pupin, Professor Emeritus of Columbia University, died at Columbia-Presbyterian Medical Center, N.Y., from uremic poisoning, at the age of 77. Professor Pupin was born in Idvor, Banat, (formerly Hungary, now Serbia), Oct. 14, 1858. In the passing of Dr. Pupin radio has lost one of its founders and staunchest supporters.

Landing in America at Castle Garden, Pupin, then a lad of 16 years, emerged victor from a fist fight with Broadway "newsies" who thought to enjoy themselves at the expense of this emigrant in Turkish fez and carrying a piece of pie (and with only 5 cents in his pocket). Fifty-seven years later we find him professor emeritus, having been given degrees by 12 universities and 8 colleges.

"In the passing of Dr. Pupin, the world of science lost a great mathematical physicist, the world of engineering a great experimental inventor, and the world at large a great natural and spiritual philosopher." (Dean Joseph W. Barker, Columbia Engineering School.)



ORSMA MEMBERS' FORUM

(Continued from page 739)

piece of apparatus designed for 6 volts. This excess potential on the vibrator in a short time results in arcing and consequent carbonized points, loss of temper in the vibrator-contact spring and, finally, a vibrator that either sticks open due to flat springs or one that sticks shut due to the fusing of the carbonized points.

Due to the heat action on the springs it is decidedly inadvisable to attempt repairs on any vibrator unless the springs are to be replaced.

As for the reply to Mr. Smith, may the writer suggest that he install new vibrators after he has made sure that the generator on his customer's car is set to the manufacturer's specifications.

WILLIAM TODD,
Pittsburgh, Pa.

ELECTROLYTIC CONDENSER TESTER

RADIO-CRAFT, ORSMA Dept.:

Here is a diagram of my unit for testing electrolytic condensers for leakage. The parts needed consist of a D.C. milliammeter, a D.C. voltage supply and a resistor of proper value.

The resistor, R, is found by dividing the D.C. voltage by the maximum scale reading of the milliammeter.

Please Say That You Saw It in RADIO-CRAFT

Learn ELECTRICITY IN 12 WEEKS AT COYNE

The great Coyne Shops in Chicago have a world-wide reputation for training men in this big-pay field in only 12 weeks. Then they help you to success by giving you lifetime employment service. By my new plan YOU can take advantage of their wonderful method of learning by doing NOW—no need to lose time and money while you strive and save to raise the necessary tuition.

I WILL FINANCE YOUR TRAINING

You can get your training first—then I'll give you over a year to pay me back, in small monthly payments starting 60 days after your required training period is over. If you will write to me at once I will send you complete details of this sensational new plan, together with the BIG FREE Illustrated BOOK telling all about COYNE. It tells how many earn while learning and about the training you get there without book study or tuition charge.



COYNE ELECTRICAL SCHOOL
500 S. Paulina Street, Dept. A5-88, Chicago, Illinois

MR. H. C. LEWIS, President
500 S. Paulina St., Dept. A5-88, Chicago, Ill.
Tell me how you will finance my training at COYNE and send me the BIG FREE Illustrated Book on ELECTRICITY.

NAME.....
ADDRESS.....
CITY..... STATE.....

IS YOUR CAR A GAS EATER?



Replace your worn-out Auto - Radio Ignition Noise Resistors with New CONTINENTAL SUPPRESSORS . . .
Kit for 6 cyl. Cars, \$2.70
Kit for 8 cyl. Cars, \$3.30
Ask Your Auto Radio Serviceman

CONTINENTAL CARBON Inc.
13914 LORAIN, CLEVELAND, OHIO

Ken-Rad Radio Tubes

DEPENDABLE LONG LIFE
Ken-Rad Radio Tubes are made to give clear, dependable reception. They satisfy customers and build good will for dealers. Write for full information.

THE KEN-RAD CORP., Inc., Owensboro, Ky.
Division of The Ken-Rad Tube and Lamp Corp.
Also Mfrs. of Ken-Rad Incandescent Electric Lamps

WET AND DRY ELECTROLYTIC PAPER AND MICA CONDENSERS
RECOGNIZED FOR SUPERIOR QUALITY IN ALL CLIMATES THE WORLD OVER
SOLD BY LEADING JOBBERS EVERYWHERE

ASK FOR CATALOG OF EXTREMELY COMPACT TYPES HANDY FOR SERVICE

SOLAR MFG. CORP.
399 BROADWAY
NEW YORK

The **NEW**
RADOLEK 1935
1935
148
Page
RADOLEK CATALOG
Ready Now!

Hundreds of New Items!

RADOLEK'S Revised 1935 Radio Profit Guide contains all the new items recently brought out by leading manufacturers. This big book is a complete radio encyclopedia—accurate descriptions of thousands of radio parts, test instruments, tools, amplifiers, and receivers!

Valuable Information!

Diagrams, charts, illustrations! The Profit Guide is more than any ordinary catalog—it is a valuable reference book combining information with product data in such a way as to actually help you in securing more business and in doing your work more rapidly.

Sharp Price Reductions!

Lower prices than you have seen in several years! Take advantage of the hundreds of Specials and genuine bargains offered in this, the most complete Radio Servicemen's Profit Guide ever published.

If you have not ordered recently—

Send for this latest 1935 Profit Guide on your business stationery. RADOLEK restricts distribution to active and legitimate Radio Accounts.

Radolek Co.

606 West Randolph Street
 Chicago, Illinois

FULTONE V
NEW FIVE-IN-THREE SET

6F7
 76
 12A7
 AC-DC

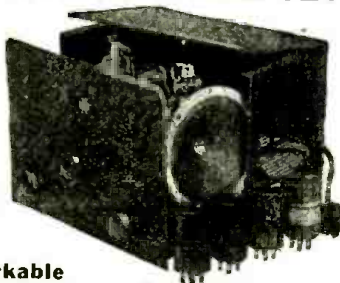

A remarkable receiver—at a remarkable price!

Sensitive—powerful—world-wide reception—all electrical—full five tube performance—compact—speaker or headphone operation—easy to operate—easy to build! A receiver you will be proud of!

Complete kit, including all necessary parts, crystal finished metal chassis with all holes, and complete, easily followed instructions—**\$7.45**
 Set of Sylvania Tubes—\$2.20. Metal cabinet—\$1.25
 Special loud speaker—\$1.45. 200-625 meter coils—\$1.25

SPECIAL COMBINATION OFFER
 Complete kit, speaker, cabinet, tubes, and broadcast band coils—only **\$12.75**

Kits wired and tested—\$1.85
At your dealer or order direct. Deposit required.

HARRISON RADIO CO., Dept. R-6 142 Liberty St. New York City

RIGHT OFF THE PRESS

NEW 92-PAGE RADIO CATALOG

Containing the greatest array of PUBLIC ADDRESS EQUIPMENT ever assembled between two covers.

If you are in the sound equipment field or intend to go into it, you will find this catalog indispensable.

WHOLESALE MERCHANTISERS, Inc.
 626 Broadway, Dept. R, New York City

Index to Advertisers

A	
Aerovox Corporation	763
Allied Radio Corporation	757
Amperite Corporation	750
Autopower, Inc.	749
B	
J. Mathewson Bell, Inc.	759
P. Blakiston Son & Company	768
C	
Capitol Radio Research Labs., Inc.	748
Carmi Transformer Works	757
Central Radio Laboratories	758
Classified Section	765
Coast-to-Coast Radio Corp.	746
Columbia Sound Systems	754
Continental Carbon, Inc.	767
Cornell-Dubilier Corporation	759
Coyne Electrical School	747, 767
E	
Hugh H. Eby, Inc.	762
Eilen Radio Laboratories	754
Electrad, Inc.	757
F	
Freed Radio Company	768
G	
General Cement Company	752
General Transformer Corp.	761
Grenpark Company	762
H	
Hammarlund Mfg. Company	749
Harrison Radio Company	768
Howard Radio Company	760
Hygrade-Sylvania Corp.	755
K	
Kato Engineering Company	757
Ken-Rad Corporation	767
Kenyon Transformer Co., Inc.	749
L	
Lear Developments, Inc.	757
Arthur H. Lynch, Inc.	768
M	
M & H Sporting Goods Company	748
Marlo Products Company	746
Mathews Radio	752
Midwest Radio Corp.	765
N	
National Radio Institute	705
National Union Radio Corp.	746
P	
The Plan Shop	768
Popular Book Corp.	759
Popular Medicine	762
R	
Radio Amplifier Laboratories	745
Radio Circular Company	765
Radio City Products Company	765
Radio Publications	762
Radio Trading Company	766
Radio Training Association	760
Radolek Company	768
Raytheon Production Corp.	743
RCA Institutes, Inc.	756
Readrite Meter Works	744
Remington Rand, Inc.	763
S	
Schwebel Press	768
S. O. S. Corporation	757
E. H. Scott Radio Labs., Inc.	751
Sexology Magazine	764
Shalleruss Mfg. Company	754
Shure Brothers Company	768
Solair Mfg. Company	767
Sprague Products Company	756
F. L. Sprayberry	761
Supreme Instruments Corp.	Back Cover
T	
Thor Radio Company	756
Toledo Sound Equipment Labs.	748
Triplet Elec. Instrument Co.	753
Try-Mo Radio Co., Inc.	757
U	
United Transformer Corp.	763
W	
The Ward Products Corp.	761
The Webster Company	758
Wellworth Trading Company	764
Weston Elec. Instrument Corp.	741
Wholesale Merchandisers, Inc.	768
Wholesale Radio Service Co., Inc.	745
Wright-DeCoster, Inc.	750

(While every precaution is taken to insure accuracy, we cannot guarantee against the possibility of an occasional change or omission in the preparation of this index.)

LYNCH
HI-GAIN
AUTO ANTENNAS
 ARE GUARANTEED TO IMPROVE RECEPTION IN ANY CAR—EVEN THE "TURRET TOP" THAT IS WHY THEY SELL SO FAST
 SEND FOR FREE BULLETIN FULL OF FACTS
ARTHUR H. LYNCH, INC.
 Dept. RC6, 227 Fulton St., New York, N.Y.
 Pioneer of the Noise-Reducing Antenna

for **RADIO ENGINEERS • ACOUSTICAL ENGINEERS • BROADCAST ENGINEERS • SOUND MOTION PICTURE ENGINEERS AND STUDENTS**
APPLIED ACOUSTICS
 The first American book to deal entirely with acoustical engineering principles. It covers the design, construction, operation and analysis of modern acoustical and electro-acoustical apparatus. Includes analysis of rooms, studios, theatres and operation of systems in modern environments and conditions. 228 Illustrations. 430 Pages. FabriKoid. \$4.50 Postpaid.
 By HARRY F. OLSON, Ph.D. and FRANK MASSA, M.Sc., Acoustical Research Engineers, R.C.A. Victor Co., Inc.
P. BLAKISTON'S SON & CO., INC.
 1012 Walnut Street Philadelphia

Stop GUESSING!
 WHAT IS WRONG
 WHAT TO CHARGE
 Famous RADIO CHUCKER, trouble-graph and repair-pricer, eliminates guess-work, puts servicing on a paying basis!
 Master Radio Co., Seattle, Wash., says: "If you can't estimate in the home, **no job!** If you guess, then, **no profit!** Use a Chucker! A St. Louis service man says: "Chucker knocks 'em dead" On one job, AK No. 60, other men claimed fault to be condenser block. Chucker localized trouble in the open voice coil. **Correct!**" W. J. Meale, Chicago, says: "Chucker is so business-like and convincing, the customer is not afraid of being overcharged." Since using Chucker business is **increasing right along!**
ANNIVERSARY OFFER! Regular \$1.00 price cut in half during MAY only. Send just 50c (no stamps) with this ad. We'll rush you a Chucker postpaid! Do it NOW!
PAUL G. FREED
 (Freed's Radio Co., Publishing Division R)
 5053 Baltimore Ave. Philadelphia, Pa.

SHURE
New CRYSTAL MICROPHONES
 None at Your Jobber (Licensed Under "Brush" Patents)
SHURE BROTHERS COMPANY
Microphone Headquarters
 215 WEST HURON ST. CHICAGO, U. S. A.

BUILD IT YOURSELF
 You can build this Trailer with ordinary tools easily from our step-by-step constructional sheets and large sized blueprints. Finest designed Trailer in existence, sleeps 4. Toilet. Shower. Electric Light, etc. Save 75% of the cost by building it yourself. Send 25c for plans sheet, illustrations and details.
THE PLAN SHOP, 910 Palmolive Bldg. Chicago, Ill.

BEAUTIFULLY LITHOGRAPHED FOLDING FANS
 with your advertisement attractively printed. These fans are very durable and smart looking. When closed, conveniently fits ladies handbag. Makes a wonderful advertising novelty or premium.
 PRICE 25c EACH PRINTED. MINIMUM QUANTITY 200 FANS. SHIPPED PREPAID. Sample if desired for 3c stamp.
SCHWEBEL PRESS
 526-R Van Sicken Ave., Brooklyn, N. Y.

Please Say That You Saw It in RADIO-CRAFT

SERVICE MEN'S ESSENTIALS FOR ALL MEMBERS OF THE

ORSMA

WHAT ARE THE SERVICE MEN'S ESSENTIALS?

THE OFFICIAL RADIO SERVICE MEN'S ASSOCIATION has arranged to supply a number of "Service Men's essentials" for its members and associate members only.

These essentials are priced at cost, plus a small additional fee which is the only source of income that the Association has. No one obtains any profit or benefit, except the Association itself. Whatever profit accrues, is reinvested for the furtherance and enlargement of the Association.

By using the letterheads, billheads, etc., you present the business-like appearance to your customers. In addition, the Association has made arrangements with most of the prominent manufacturers to allow special discounts to members, providing ORSMA letterheads are used when ordering.



No. 14—50c each
(Plus 10c for Postage)



No. 5—50c each



No. 6—75c per 100
\$4.00 per 1000

No. 1 ORSMA LETTERHEADS

These letterheads, shown on the right, are furnished with your name, address and telephone number. Printed on excellent paper. They are sold in lots of 100 or multiples thereof, with a distinct saving for single orders of 1,000 or more. Per 100, 60c; per 1000, \$3.00.

No. 2 ORSMA ENVELOPES

These are furnished to match the letterheads, printed with your name and address and seal of the Association. They go hand in hand with the letterheads and are usually ordered in the same quantity. Per 100, 60c; per 1000, \$3.00.

No. 3 ORSMA SERVICE RECORD CARDS

These serve a double purpose; whenever you complete a job you fill out the report-bill and hand it to the customer; this is the "psychological moment" to collect. By the use of carbon paper a permanent record is kept. Furnished with name, address and telephone number. Per pad of 50, 60c; per 10 pads, each of 50, \$3.00.

No. 4 ORSMA INSPECTION LABELS

The label is to be filled in with the proper dates, and pasted inside the set or cabinet where the customer will see it. It is a continuous reminder to him that when service is needed, he can call you again. The advantage is apparent. Per 100, 60c; per 1000, \$3.00.

No. 5 ORSMA LAPEL BUTTON

At the suggestion of many members a handsome lapel button bearing the name and emblem of the Association has been designed. It signifies that you belong to the ORSMA; and in addition it gives your customers a better appreciation of the professional nature of your work. 50c each.

No. 6 ORSMA BUSINESS CARDS

These are furnished on a fine grade of paper in two colors with a blotter back. Thus they present an incentive to customers to keep them in a prominent place. They are printed with your name, address and telephone and bear the official seal of the Association. Per 100, 75c; per 1000, \$4.00.

Nos. 9 & 10 ORSMA EMBLEM CUTS

These cuts for printing, advertising, etc., are furnished in two styles and sizes. They may be used for newspaper or telephone-book advertisements or for printing of any kind. Large size, 1 1/4 x 1 1/4 in., \$1.35 each; small size, 3/4 x 3/4 in., \$1.20 each.

No. 11 ORSMA MEMBERSHIP SIGN

A set of three signs, printed on heavy cards, and having holes punched in order to hang in office or store. These are sold to members and associate members. Large enough to be quite prominent and the two tone effect makes them attractive. Set of three, 50c.

No. 12 ORSMA ADVERTISING DISPLAY SIGN

A two color sign printed in large letters with your name, address and telephone, with the seal of the Association. This sign is sold in quantities of 25 or more and is ideal for hanging in stores, offices, etc., for advertising purposes. Set of 25 cards, \$3.00.

No. 13 RADIO SERVICE MEN'S ASSORTMENT PACKAGE

This includes one gold filled lapel button, 100 letterheads, 100 envelopes, 50 service record cards, and 100 labels printed with your name and address as described above. The whole assortment costs only—\$3.00—a worth-while saving. Complete, \$3.00.

No. 14 ORSMA MEMBER CERTIFICATE

A handsome diploma-like certificate engraved on stiff vellum-bond. The certificate is personally signed by the President and Executive Secretary and the corporation stamp of the Association is impressed on a red seal attached to it. Your name, certificate number and date of registration are lettered by hand and the Certificate is mailed in a cardboard tube to insure safe delivery. Each 50c. plus 10c for postage.



No. 4—60c per 100
\$3.00 per 1000

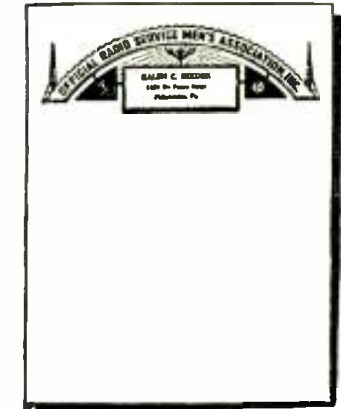

No. 1—60c per 100
\$3.00 per 1000

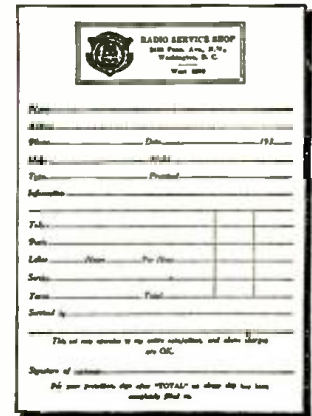

No. 3—60c per pad of 50
\$3.00 per ten pads, each of 50

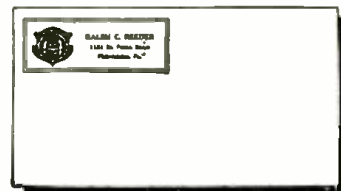

No. 2—60c per 100
\$3.00 per 1000

Application for Membership in ORSMA

Executive Secretary, ORSMA
99 Hudson Street, New York, N. Y.

Kindly send an application blank for

- Full Membership
 Associate Membership

Name

Street or Box

City..... State.....

OFFICIAL RADIO SERVICE MEN'S ASSOCIATION

99 Hudson Street, New York, N. Y.

Please send me the following RADIO SERVICE MEN'S ESSENTIALS which I have selected from this advertisement. My remittance for \$..... is enclosed. Send remittance in form of check or money order. Register letter if it contains cash, currency or unused U. S. Postage Stamps.

.....

 Name ORSMA No.
 Address City and State

SUPREME
INSTRUMENTS CORPORATION

GREENWOOD, MISSISSIPPI
U.S.A.

April 6, 1935

Supreme news-flash re new all-metal tubes:

The sudden announcement of new all-metal tubes having an entirely different base arrangement, and as many as 8 prongs, naturally grips the attention of professional radiomen whose policy it is to keep their service as modern as new set design.

So far as Supreme is concerned, it means the earlier announcement of new instruments on which our engineers have been constantly working during the past 8 months. Entirely new designs incorporating several interesting developments that were being held for Fall announcement will now be immediately available in instruments built for the new service.

This assures you, therefore, that we do not merely offer present models hastily revamped because of sudden tube designs, but, rather, finished products on which research, engineering and thorough field tests have already been completed. Adaptability to the new tubes and circuits will be but a minor feature of these new 1936 models. We are going to show you something absolutely new.

So expect a lot of these new Supreme instruments. An entirely new standard of value and engineering leadership. PLUS innovations galore. Your jobber will soon have these new 1936 instruments that are truly Supreme's greatest line of radio testers. Meanwhile, you will want to have immediately the inside technical story which is ready, awaiting your inquiry. Written by engineers who have done the radioman's work, who speak his language, and know his pride in up-to-date equipment. Write, right now, and learn all about your next Supreme.

Yours very truly,

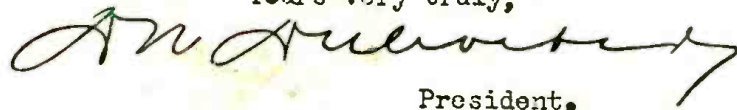

President.