

RADIO'S LIVEST MAGAZINE



June
25 Cents

Radio-Craft

HUGO GERNSBACK Editor

How to Build the
RADIO
"TREASURE"
FINDER

See Page 716

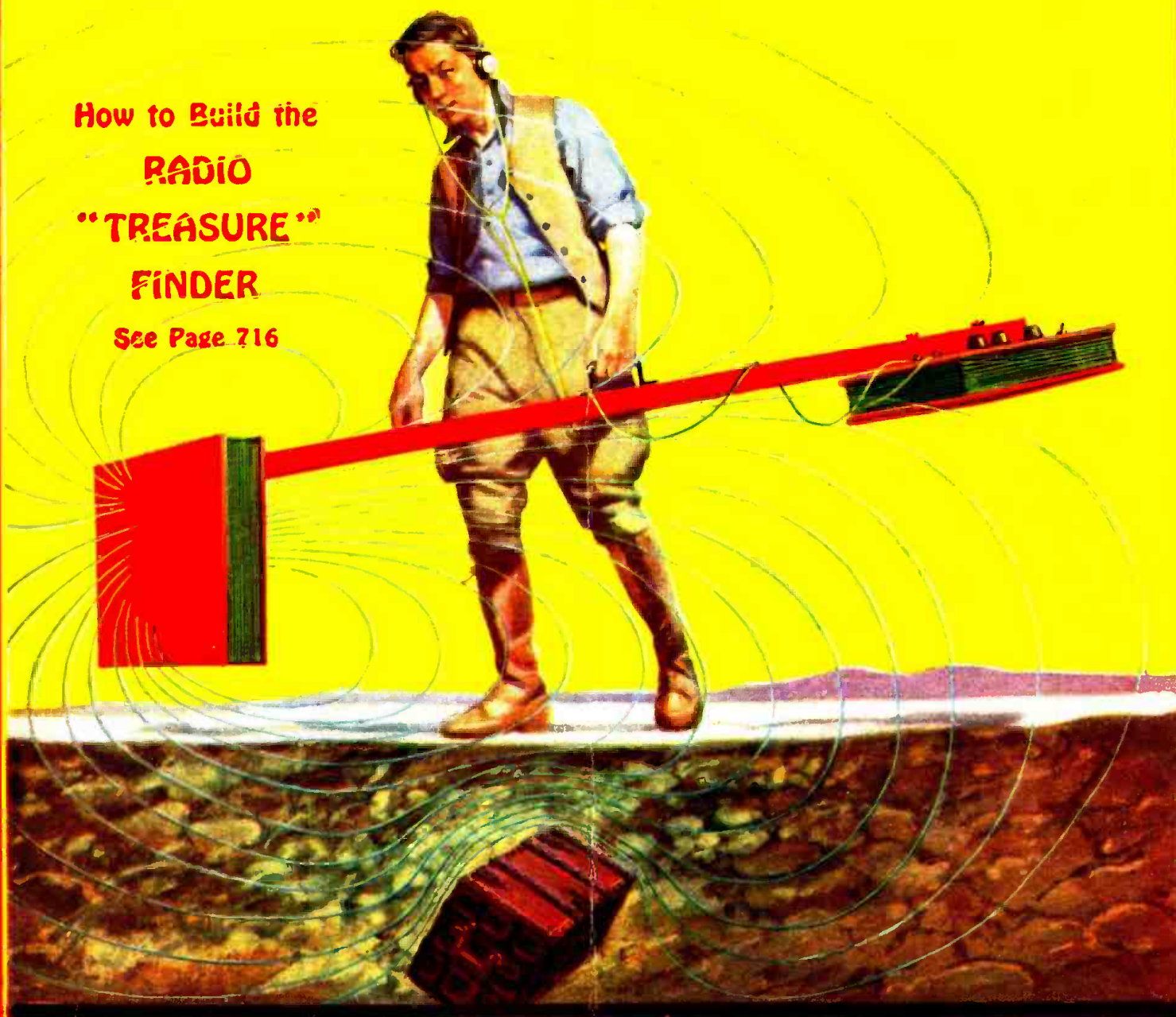

Making Modern Tubes—Copying Recordings—4-Pentode Set
Re-Ranging Meters — Superhet. Trouble Shooting — Kinks

SPEED

Radio Tubes—Foto-Lectric Tubes—Television Tubes

Economic conditions have given marked impetus to the development of several special-purpose tubes of increased efficiency. Three new SPEED types have been announced—several others are nearing completion in the SPEED laboratories.

TO THE RADIO TRADE: SPEED Radio Tubes will be displayed in Booth 40, Exhibition Hall, and in Demonstration Rooms 718, 719, 720, Stevens Hotel, Chicago; RMA Trade Show, May 23-26, Incl.

NEW TYPES

SPEED Type 256



is an AC General Purpose tube with 5-prong base, similar to SPEED type 227, with improved characteristics. This new fast-heater tube is in a small bulb measuring only 4 1/4" overall. This efficient tube, with the others in its series illustrated below, will be widely popular in new 1932 receivers.

SPEED

Types 257, 258

are designed to replace types 224 and 235 respectively in new equipment. SPEED type 257 is an AC Radio-Frequency Pentode with a 6-prong base; SPEED type 258 is an AC Variable-Mu Radio-Frequency Pentode with a 6-prong base. These fast heater tubes measure only 4 7/8" overall.



SPEED Triple-Twin, an exclusive development of the SPEED laboratories. Type 295 AC; type 291 DC; type 293 for automobile use.

REGULAR TYPES

Receiving Tubes

General AC Series	General DC Series	Automobile Series	Spartan Set Series
224	201A	236	S82B
235	199	237	S83
551	WD11	238	S84
226	WD12	239	S85
227	120		
245	140	Low Wattage Series	Rectifier Series
247	112A		
171AC	171A		
256	200A	230	280
257	222	231	281
258		232	282
	Triple-Twin Series	233	
Special Amplifier Series	291	234	
210	293		
250	295		

Other new important types will shortly be announced.

Foto-Lectric Tubes

Five types with several different basing arrangements. For use with DeForest Phonofilm, Kinoplay, Weber, Platter, Holmes, DeVry, RCA Photophone, Powers, Pacent, Royal, Universal, Gries, Western Electric and many other types of equipment.

Standard gas-filled types, red sensitive, caesium on caesium-oxide, silver-oxide base. Guaranteed against defects.

Television Tubes

One inch plate, Wall Electrode type for operation in plate circuit of type 171A tube and with plate current limitations in circuit of types 245 or 247.

Crater type, in standard diameters of .015", .020", .030", .040". Other sizes available on special order.

Send Coupon for Current Bulletins

CABLE RADIO TUBE CORPORATION,
Brooklyn, N. Y.

Send me current bulletins on items checked:

- SPEED Radio Tubes SPEED Foto-Lectric Tubes
 SPEED Television Tubes

Name

Address

City and State

CABLE RADIO TUBE CORP.
230-240 NO. NINTH ST. BROOKLYN, N.Y.



WORK FOR YOURSELF • SET YOUR OWN PAY BEGIN NOW • WE'LL HELP

If your pay has been cut—or, if you're slaving away on some hopeless job—here's your chance to get on your feet in a hurry! R. T. A.—one of the oldest, best known radio organizations in the world—offers you the opportunity to go to work for yourself—to name your own pay—and to start making money almost at once. R. T. A. is not just a school that teaches you and then lets you shift for yourself. Instead, R. T. A. makes you a Certified Radiotechnician and provides you with a wonderful service outfit that makes money for you just as soon as you get it. Real money too—up to \$20 a day! With R. T. A. Training and with the R. T. A. Set Analyzer and Trouble Shooter you should be the most popular radio service man in town, and have all the business you want to take care of. No pay cuts—no worry about losing your job—nobody to boss you but yourself.



SEND COUPON for NO-COST MEMBERSHIP PLAN

We have worked out a truly wonderful plan whereby R. T. A. membership, the R. T. A. Course, and the R. T. A. Set Analyzer and Trouble Shooter need not cost you a cent. The coupon will bring you full particulars. Clip—fill in—mail now! Today!

RADIO TRAINING ASSOCIATION OF AMERICA
4513 Ravenswood Ave., Dept. RCA-6 Chicago

Send me full particulars of your No-Cost Membership Plan.

Name.....
Street.....
Town..... State.....

RADIO TRAINING ASSO. OF AMERICA
4513 RAVENSWOOD AVE. Dept. RCA-6 CHICAGO, ILLINOIS

H. GERNSBACK, President
 S. GERNSBACK, Treasurer
 J. M. HERZBERG, Vice-President
 I. S. MANHEIMER, Secretary



HUGO GERNSBACK, Editor-in-Chief

R. D. WASHBURNE
 Technical Editor

LOUIS MARTIN
 Associate Editor

VOLUME III
 NUMBER 12

Contents of This Issue

JUNE
 1932

	PAGE		PAGE
EDITORIAL:		TECHNICAL RADIO TOPICS:	
Radio Converters and Adapters... By Hugo Gernsback	715	How to Build the Radio "Treasure" Finder	
NEW DEVELOPMENTS IN RADIO:		By Clyde J. Fitch	716
The Latest in Radio at the Radio Show.....	718	How to Make Copies of Instantaneous Recordings	
Making Modern Tubes..... By Arthur H. Lynch	722	By Geo. J. Saliba	726
Telephotography..... By Norman D. Buchling	724	Re-Ranging Meters..... By John C. Bank	728
SERVICE MEN'S DEPARTMENT:		The Quadruple Pentode Midget..... By H. G. Cisin	730
Dissecting a Modern Set Tester..... By Floyd Fausett	729	Police Radio Stations.....	734
Short-Cuts in Radio Service.....	731	Power for the S-W Converter..... By Louis B. Sklar	739
Operating Notes:		Using the V.T. Voltmeter..... By Beryl B. Bryant	740
By D. C. McCall.....	732	The Radio Craftsman's Page.....	741
By Bertram M. Freed.....	733	Information Bureau.....	742
The Service Man's Forum.....	734	RADIO-CRAFT KINKS	744
Modernizing the Jewell 199 Analyzer		Dry Electrolytic Condensers..... By Herndon Green	746
By Harry Schmidt	735		
RADIO SERVICE DATA SHEETS:			
No. 67: Silver-Marshall Model 727-DC Battery-Operated Superheterodyne.....	736		
No. 68: Majestic Model II Short-Wave Converter (No. 10 Chassis).....	737		
Superhet. Trouble Shooting..... By C. Bunting Moore	738		

In Forthcoming Issues

THE EDDY-CURRENT REPRODUCER. A development which bids fair to supplant the dynamic unit; and so sensitive it may be operated directly from a power-detector, is described by the author, an internationally famous engineer.

BUILDING THE UNI-PENTODE MAGNADYNE RECEIVER. Complete construction details for a one-tube loud-speaker set of entirely new design and remarkable simplicity of construction.

THE SERVICE MAN'S PORTABLE OHMMETER. All the data necessary to enable a Service Man to build for himself an ohmmeter with a range from a fraction of an ohm to several megohms.

A PRACTICAL FOUR-TUBE SUPERHETERODYNE. A story of absorbing interest which takes the technician inside one of the world's greatest laboratories and shows him just how the laboratorian has met the public's demand of "more for less money."

RADIO-CRAFT is published monthly, on the fifth of the month preceding that of date; its subscription price is \$2.50 per year. (In Canada and foreign countries, \$3.00 a year to cover additional postage.) Entered at the postoffice at Mt. Morris, Ill., as second-class matter under the act of March 3, 1879. Trademark and copyright by permission of Gernsback Publications, Inc., 98 Park Place, N. Y. C.

Text and illustrations of this magazine are copyright and must not be reproduced without permission of the copyright owners. We are also agents for WONDER STORIES and WONDER STORIES QUARTERLY. Subscriptions to these magazines may be taken in combination with RADIO-CRAFT at reduced Club rates. Write for information.

Copyright 1932. GERNSBACK PUBLICATIONS, INC.

Published by
TECHNI-CRAFT PUBLISHING CORPORATION

Publication Office: 404 No. Wesley Ave., Mount Morris, Illinois

Editorial and Advertising Offices 96-98 Park Place, New York City	Chicago Advertising Office 737 North Michigan Avenue, Chicago, Ill.	Western Advertising Office 220 No. Catalina St., Los Angeles, Calif.
L. F. McCLURE, Chicago Advertising Representative <small>London Agent: Hachette & Cie., 3 La Belle Sauvage, Ludgate Hill, E.C. 4</small>	LOYD B. CHIAPPELL, Western Advertising Representative <small>Paris Agent: Hachette & Cie., 111 Rue Reaumur</small>	<small>Australian Agent: McGill's Agency, 178 Elizabeth St., Melbourne</small>

OPPORTUNITIES *are many* for the Radio Trained Man

Don't spend your life slaving away in some dull, hopeless job! Don't be satisfied to work for a mere \$20 or \$30 a week. Let me show you how to get your start in Radio—the fastest-growing, biggest money-making game on earth.

Jobs Leading to Salaries of \$50 a Week and Up
Prepare for jobs as Designer, Inspector and Tester—as Radio Salesman and in Service and Installation Work—as Operator or Manager of a Broadcasting Station—as Wireless Operator on a Ship or Airplane, or in Talking Picture or Sound Work—HUNDREDS of OPPORTUNITIES for a real future in Radio!

Ten Weeks of Shop Training

We don't teach by book study. We train you on a great outlay of Radio, Television and Sound equipment—on scores of modern Radio Receivers, huge Broadcasting equipment, the very latest and newest Television apparatus, Talking Picture and Sound Reproduction equipment, Code Practice equipment, etc. You don't need advanced education or previous experience. We give you—**RIGHT HERE IN THE COYNE SHOPS**—the actual practice and experience you'll need for your start in this great field. And because we cut out all useless theory and only give that which is necessary you get a practical training in 10 weeks.

TELEVISION *and* TALKING PICTURES

And Television is already here! Soon there'll be a demand for THOUSANDS of TELEVISION EXPERTS! The man who learns Television now can have a great future in this great new field. Get in on the ground-floor of this amazing new Radio development! Come to COYNE and learn Television on the very latest, new-

est Television equipment. Talking Picture and Public Address Systems offer opportunities to the Trained Radio Man. Here is a great new Radio field just beginning to grow! Prepare NOW for these wonderful opportunities! Learn Radio Sound Work at COYNE on actual Talking Picture and Sound Reproduction equipment.

All Practical Work At COYNE In Chicago

ALL ACTUAL, PRACTICAL WORK. You build radio sets, install and service them. You actually operate great Broadcasting equipment. You construct Television Receiving Sets and actually transmit your own Television programs over our modern Television equipment. You work on real Talking Picture machines and Sound equipment. You learn Wireless Operating on actual Code Practice apparatus. We don't waste time on use!ess theory. We give you the practical training you'll need—in 10 short, pleasant weeks.

Mail Coupon Today for All the Facts



Many Earn While Learning

You get Free Employment Service for Life. And don't let lack of money stop you. Many of our students make all or a good part of their living expenses while going to school and if you should need this help just write to me. Coyne is 32 years old! Coyne Training is tested—proven beyond all doubt. You can find out everything absolutely free. Just mail coupon for my big free book!

H. C. Lewis, Pres. **RADIO DIVISION** Founded 1899
COYNE Electrical School
500 S. Paulina St., Dept. A2-8H Chicago, Ill.

H. C. LEWIS, President
Radio Division, Coyne Electrical School
500 S. Paulina St., Dept. A2-8H Chicago, Ill.

Dear Mr. Lewis:— Send me your Big Free Radio Book, and all details of your Special Offer.

Name.....

Address.....

City..... State.....

They say you CAN'T, but
 I say you
 get Enjoyable Programs
 Every day of



E. H. SCOTT

Pioneer Designer of 'round the world broadcast receivers.

Seven years ago, newspaper and magazine editors gave columns and columns of space to the amazing performance of a theretofore unknown receiver. They heralded the advent of transoceanic reception, on the broadcast band (200-550 meters) as the greatest radio achievement of the age. They named the receiver "World Record Super," because it brought in 117 programs from 19 stations, ALL OVER 6000 miles away, and WITHIN THE SHORT SPACE OF 13 WEEKS.

This receiver was the work of E. H. Scott, who believed that a radio set designed in accord with certain advanced ideas of his own, and engineered to micrometric precision, would do things no other receiver was ever able to do. These sets were built in the laboratory. Not even a screw was touched by an unscientific hand, and the radio industry was given a new target.

During the following years, E. H. Scott set still higher standards for radio's performance. Today, as the culmination of these efforts, he offers the Scott All-Wave, a hand-built instrument of scientific precision that is sold with a guarantee of regular, 'round the world reception, or YOUR money back.

MANY prominent radio engineers STILL contend that dependable daily reception of extremely distant foreign stations is impossible.

"It can't be done!" they shout. They insist that the distance is too great—that atmospheric conditions are too variable—that signal strength is insufficiently constant—that if foreign reception is to be obtained at all, an ideal location must be had—and, last, that there is no receiver generally available today that is sensitive enough to bring in foreign stations regularly.

Many of those making these statements are receiver manufacturers; men who have been forced to conclude that mass production methods cannot

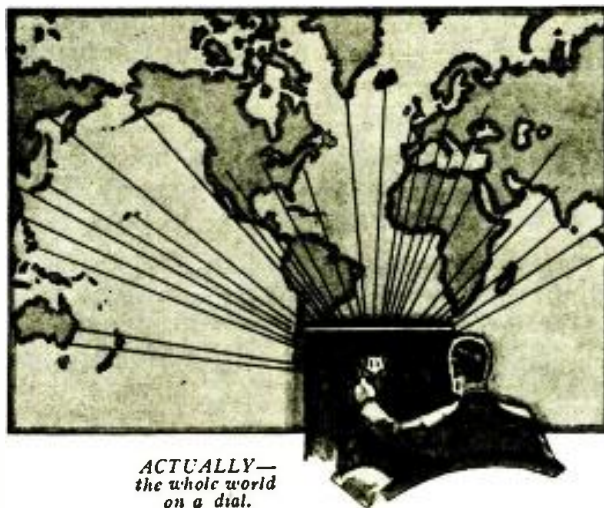

ACTUALLY—
 the whole world
 on a dial.

produce receivers capable of regular foreign reception. Seeming disbelief in the practicability of foreign reception is therefore the result of someone's failure. The only reason for sincere disbelief is ignorance of the facts.

You are entitled to the truth. It is your privilege to know the FACTS, because the most interesting—the most enjoyable world of radio is to be found

between 15 and 200 meters. Hence, I have written this answer to disbelievers and to the unadvised, and I am spending my own money to publish these four pages of FACTS.

You will find in them a full explanation of what foreign reception is; how regularly it comes in; what the programs are and how they sound. In addition—you'll find undeniable PROOF that the Scott All-Wave 15-550 meter Superheterodyne is certain to give you enjoyable round the world reception every day of every month of the year. Yes, EVERY day, even during the summer months! I say, "You CAN do it!" *E. H. Scott*

CAN



4 Pages of
PROOF

from dozens of Foreign Stations Every month of the Year



Reception from VK3ME sent back to Melbourne, Australia, by telephone from Chicago by E. H. Scott.

The AUSTRALIAN TEST *first proved regular reception possible*

For a considerable period, short wave broadcasts from England, France and Italy have been picked up by the broadcasting chains in this country, on highly developed laboratory-type short wave receivers and re-broadcasted on the 200-550 meter band to listeners in America. The fact that these broadcasts were always planned, weeks in advance, convinced us that their reception was contemplated with absolute certainty. Why, then, couldn't *all* foreign broadcasts be depended upon? To ascertain whether or not they could be, we selected the station farthest from Chicago that broadcasted regularly, and set out to see how many of its programs we could pick up with the Scott All-Wave.

All Programs Recorded

VK3ME at Melbourne, Australia, is 9560 air miles from Chicago. This station broadcasts two times a week on a wave length of 31.55 meters. The reception test was begun June 6th, 1931. Ten months have elapsed, and *every* broadcast (excepting three) was received with sufficient loud speaker volume to be clearly heard and logged. The three programs were missed only because an illegal code transmission interfered.

Each broadcast from VK3ME has not only been clearly heard, and its reception verified by the station, but they have all been recorded just as they came from the amplifier of the Scott All-Wave on aluminum discs. These recordings are available to anyone who wishes to hear them.

Program Returned to Australia by Phone

The engineer of VK3ME was curious to know with what quality his program was received in Chicago. He realized, of course, that clarity was sufficient to permit logging of details, but beyond that he was skeptical. So on January 23rd, 1932 Mr. Scott telephoned VK3ME from Chicago, and while VK3ME's program was being received, the telephone mouthpiece was pointed toward

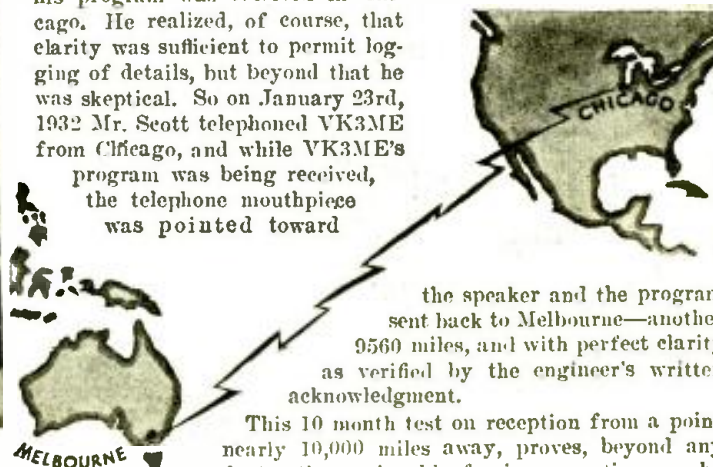

the speaker and the program sent back to Melbourne—another 9560 miles, and with perfect clarity as verified by the engineer's written acknowledgment.

This 10 month test on reception from a point nearly 10,000 miles away, proves, beyond any doubt, that enjoyable foreign reception can be depended upon, IF the receiving equipment is competent. It PROVES that DISTANCE is *no* obstacle! And it PROVES that variable conditions of the atmosphere are not insurmountable obstacles! To further substantiate our contentions we began a test of VK2ME at Sydney. VK2ME's acknowledgment of this reception is reproduced below. Both of these tests PROVE that there IS a receiver having more than enough sensitivity to detect and reproduce the broadcast from foreign stations regularly and with adequate volume!

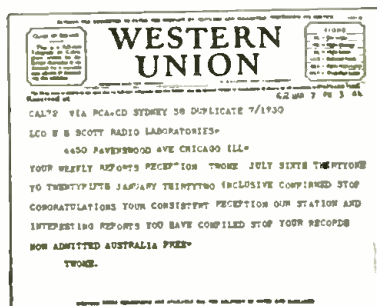

Other Owners Do Even Better

This remarkable performance was not a stunt. It was not a freak happenstance occurring to one

Scott All-Wave ideally located and installed. To the contrary, it appears as mediocre performance when compared to the 9,535 logs of foreign reception sent to us during January, February and March from Scott All-Wave owners located in all parts of the country! These logs, constituting further proof of the practicality of foreign reception, are discussed on the next two pages.

(Turn the page, please)

9535 Detailed Logs

by SCOTT

tell *What You hear*

and prove the absolute

Dependability of the Scott All-Wave



See preceding pages



Clarity

THE detail contained in this log, submitted by Mr. Roye Bilheimer of Pennsylvania, demonstrates the clarity with which the Scott All-Wave brings in foreign stations 10,000 miles away. This log was made Feb. 28, 1932, and while only 30 minutes of it are shown here, the log, as submitted, covered the entire 2 consecutive hours of the broadcast.

6:00 a.m. E.S.T.—Chimes are heard striking the hour of 9:00 p.m., and you say, "Just 9:00 o'clock. Sunday evening." You go on to say, "VK2ME, 17 York Street, Sydney, Australia, would be pleased to receive reports from those overseas relating to the reception of these programs. Our next record is rather an interesting broadcast. I am going to play for you, a record recorded in Chicago. This record was picked up by Mr. Scott of Chicago, an ardent listener of VK2ME. It was then recorded on his home recording set, on aluminum discs, and then sent to VK2ME, and we will now play this record over for you, which will give you some idea of the reception in the United States, especially in Chicago. This is a musical selection by the Band of His Majesty's Guards. Stand by a second, please."

6:05 a.m. E.S.T.—VK2ME, Sydney, Australia. The record you have been listening to was one made in Chicago by Mr. Scott, an ardent listener to VK2ME. The original recording was transmitted some time ago and Mr. Scott received that recording, and cut in the record on his home recording set, and forwarded this to VK2ME. That was the record which has just arrived in Sydney and we have just played it for you, to see how you will receive it. I shall now play for you the laugh of the "Kookaburra," that was also picked up in Chicago by the same gentleman.

6:06½ a.m. E.S.T.—Laugh of the "Kookaburra." Now you say, "That was the laugh of the 'Kookaburra,' reproduced in Chicago again after receiving the original recording from VK2ME. We should be glad to receive reports from other listeners as to how they receive these recordings." A talk of the day is entitled "Australia Commences the Travel Idea," prepared by Charles Holmes, Director of the Australian National Travelers' Association. Now you continue with the talk:

"Set in the sunshine of southern seas, Australia is the world's hottest continent. Australia is a continent that is different from other lands in its appearance, its geographic formation, and its strange animals, as well as its age-old peoples. Then, too, the remainder of the native race that originally inhabited Australia are a stone-age people, but now I wish you could see them in the Government Reservations, and in the far-back places of the continent, where many still lead their primitive lives.

6:12 a.m. E.S.T.—They were entertained by Australian aborigines who are located in a settlement there. They were amused to see them throw their boomerangs, that strange wooden weapon which, when thrown by a person, returns to the thrower, and the visitors had an amusing time practicing among themselves. Rudolph Friml gazed at a group of black fellows who were playing a tune with the leaf of the eucalyptus tree, "Rose Marie," from the famous play he had written.

6:14 a.m. E.S.T.—You are now speaking of native bears, and say: "Here the visitors saw the quaint and lovable little bears. 'Living toys,' one visitor called them. One gentleman wanted to buy them outright, so enthused was he by these little native animals. Some of the ladies brought honey and candy, and were greatly disappointed when their gifts were refused by the bears. They prefer to get their own sweets from the eucalyptus tree.

"Australia welcomes the visitor. We want the world to know us better, and we, ourselves, seek a greater knowledge of people of other lands. In these days, travel is more than a great pleasure maker—it is a great peace maker, and that is what the world today is most in need of. This concludes my short talk, entitled 'Australia Commences the Travel Idea,' prepared by Charles Holmes, Director of the Australian National Travelers' Association."

6:15 a.m. E.S.T.—The Band of His Majesty's Air Force will play "Washington Braves," arranged by Victor Herbert.

6:18 a.m. E.S.T.—VK2ME, Sydney, Australia. You now give the time as 18 minutes past 9:00 Sunday evening. Contralto solo, "God Shall Wipe Away All Tears," by Sullivan.

6:22½ a.m. E.S.T.—VK2ME, Sydney, Australia. An organ solo, "Just Imagine," by Leslie James. This is coming through with fine volume and clarity, although the weather here is very bad. It is very foggy and rainy.

6:25 a.m. E.S.T.—VK2ME, Sydney, Australia. The time is 26 minutes past 9:00 Sunday evening. You now announce the next selection, a waltz.

6:30½ a.m. E.S.T.—VK2ME, Sydney, Australia. The band of His Majesty's Guards directed by R. G. Evans, playing "Intermezzo," by Reeves

9,535 Detailed logs of foreign programs have been sent to us since January 1st, 1932. All of these logs are complete—proving that the reception was not only heard, but that the clarity was perfect. Two of these logs are reproduced (in part only, for lack of space) on these pages. Think of it! 9,535 logs from 186 stations in 40 different foreign countries! It is difficult to understand, how anyone after reading these logs, could believe that dependable, day in, day out foreign reception is anything but a complete, and thoroughly satisfactory actuality.

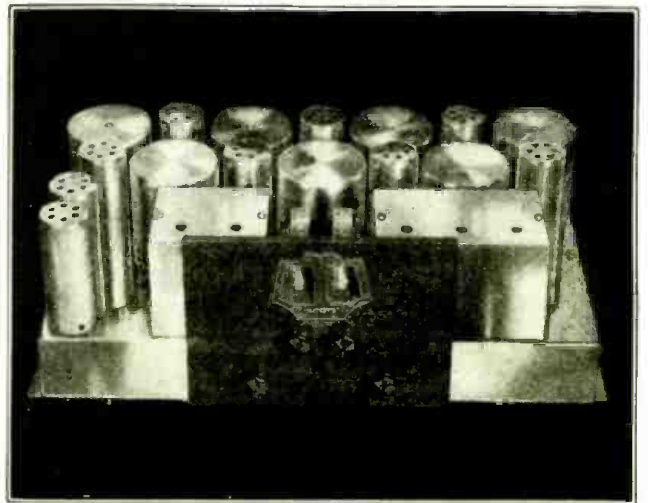

What Countries Will You Hear?

Any Wednesday, Saturday or Sunday morning you can tune in the Australian stations and listen to a three hour program, in English, of course. Then if you wish something with a decidedly foreign flavor, you can dial Saigon, Indo-China, and listen to the weirdest, Eastern music you have ever heard.

Right after breakfast, most any morning, you can tune in the Radio Colonial at Paris, France—or Chelmsford, England, from which station comes an English version of the World's latest news.

From 11:30 A. M. until 5 P. M. you have your choice of musical programs, talks, plays, etc. from Italy, France, Germany or England. In the late afternoon, the offerings from Portugal will be found very entertaining.

In the evening you may have your choice of a dozen or more different stations including Colombia and Ecuador in South America. Then, too, there is Spain, and Cuba.

Is this all?—Indeed not!—These are just a few of the many foreign stations that will be found on the dial of the Scott All-Wave. A complete list showing the exact time to tune dozens of foreign stations, is furnished with the receiver.

What Will You Hear?

From a large number of these foreign stations you'll hear news in English, and you'll delight in the variety of aspect the different countries give to an item of international interest.

You'll hear music from everywhere. Weird chants from Indo-China, and in contrast, a tango from the Argentine. From Rome you'll hear the real Grand Opera—you'll hear the voice of the Pope, the Vatican Choir and solo voices mellowed in Italian sunshine. From Germany you'll hear political speeches, music and news. From France, Spain and Portugal you'll hear a wonderful musical program that will thrill you hour after hour. From England you'll hear plays—drama—comedy and musicals: delightful presentations, refreshingly different from those to which you are accustomed. You'll never tire of foreign reception, because it never loses its novelty.

Will the Reception Be Clear?

Foreign stations are tuned easily and smoothly with a Scott All-Wave. As the dial is turned to the correct spot, the station comes on, in most cases, with the same naturalness, clarity, and roundness of tone that characterizes domestic reception.

of Foreign Reception Owners and *How You hear it*



Usually, you can have more volume than you wish, which means simply that the sensitivity may be lowered beneath the noise level, thereby permitting the program to come through with truly enjoyable bell-like clarity. There's no doubt about it. Dependable foreign reception is here; yours to thrill to; yours to enjoy as you have never enjoyed radio before.

Read These Logs*

The log reproduced at the right represents one day that E. B. Roberts of Massachusetts spent with his Scott All-Wave. During the day he journeyed from France to England, to Italy, back to France and in the evening to South America. The other log is that sent in by Mr. Roye Bilheimer of Pennsylvania who made a point of logging every word put on the air by VK2ME, Sydney, Australia, February 28, 1932. If you have any doubt concerning the authenticity of these two logs or the others sent to us, see the auditors' report herewith. Read these logs—then consider that 9,533 more detailed logs bear witness to the new world of radio pleasure opened to YOU by the Scott All-Wave 15-550 meter Superheterodyne.



THE SCOTT WELLINGTON

Typical of the many excellent models of Scott Consoles, the Wellington is a beautiful example of deluxe cabinet artistry. Fashioned from burl walnut and finished to go with the finest furniture. The center drawer contains the optional phonograph equipment, which, when wanted, is supplied with an automatic ten record changer.

Prove to yourself the practicability of Short Wave foreign reception

These four pages have told the story of short wave foreign reception in no uncertain terms. They have PROVED that clear, enjoyable reception of foreign stations can be enjoyed by anyone irrespective of the state or country in which he lives. And we want to prove to you, right in your own home—that YOU can tune 'round the world whenever you choose and enjoy every program you hear. To do that, we'll build a Scott All-Wave 15-550 meter superheterodyne to your order; we'll test it on reception from London, Sydney or Rome—and give you the exact dial readings. If you don't get enjoyable foreign reception from these stations—if the receiver does not eclipse every statement made for it, you may return it and your money will be refunded. The coupon below will bring full particulars of this offer—also the technical details of the Scott All-Wave. Clip the coupon—mail it now.

The E. H. SCOTT RADIO LABORATORIES, INC.
4450 Ravenswood Ave., Dept. C62 Chicago, Ill.

The E. H. Scott Radio Laboratories, Inc.,
4450 Ravenswood Ave., Dept C62
Chicago, Ill.

Send me full particulars of the Scott All-Wave Superheterodyne.

Name

Street

Town..... State.....

***AUDITORS' REPORT**

We hereby certify that we have examined and counted 9,535 logs of programs reported by purchasers of Scott All-Wave Receivers from 186 stations, foreign to the country in which received, during the months of January, February, March, 1932.

CHESNUTT, MURPHY, POOLE & Co.
Certified Public Accountants

News and Music From Four Foreign Countries Received in One Day

THESE logs, made March 7, 1932, and submitted by E. B. Roberts of Massachusetts, indicate the variety of foreign programs that may be heard with a Scott All-Wave. For lack of space, only a portion of each log appears here.

NEWS FROM FRANCE
STATION RADIO COLONIAL—PONTOISE

8:44½ a.m. E.S.T.—"This is Radio Colonial from Paris calling. Wavelength 19.68 meters."
News in English from the Continental Daily Mail. Great Britain—The financial recovery of Great Britain has aroused the interest of the world.

8:45 a.m. E.S.T.—Chimes.
From N. Y., Sunday—The U. S. view is that the world economic crisis is behind. Sterling reflected by rising to a new high.
From Geneva, Sunday—Small nations are not willing that the League's authority be haunted even if the larger nations are.
From N. Y., Sunday—Bulletin on the death of Bandmaster Sousa.

8:51½ a.m. E.S.T.—From Berlin, Sunday—Speeches regarding the election next Sunday. Will Hindenburg or Hitler be elected only question.

8:55 a.m. E.S.T.—From N. Y., Sunday—The Lindberghs have turned to the underworld for help as the authorities seem helpless.

NEWS AND MUSIC FROM ENGLAND
STATION G5SW—CHELMSFORD

1:15 p.m. E.S.T.—Chimes.

1:15½ p.m. E.S.T.—This is the British Broadcasting Corp. calling short wave listeners of the British Empire through G5SW. G5SW broadcasts on a wave of 17.550 kilocycles or 25.53 meters.

1:16 p.m. E.S.T.—Programs to be radiated today.

1:17 p.m. E.S.T.—Programs to be radiated tomorrow, March the 8th.

1:18 p.m. E.S.T.—News Bulletins for the Middle Zone. World copyrighted.
Briand died today. An ardent advocate of peace.
Bulletin regarding the Indian Budget.
Far East Bulletin—Dr. Yen announced that China is ready to enter negotiations to restore peace. The Japanese have no intention of advancing further.
Bulletin regarding the kidnaping of the Lindbergh baby—no news as yet.

NEWS AND MUSIC FROM ITALY—STATION I2RO ROME

2:49 p.m. E.S.T.—Telling in Italian of the results of the six-day bicycle race in Madison Square Garden, which was won by the team of McNamara-Pelen.

2:52 p.m. E.S.T.—Now talking about Primo Carnera and Young Stribbling.

2:54 p.m. E.S.T.—"Radio Roma-Napoli."
News bulletins from the U. S. A. Shanghai and Tokio.
News regarding the Lindbergh baby.

2:59 p.m. E.S.T.—Announcement.

3:01½ p.m. E.S.T.—Announcement. Gave names of Italian cities. Music by orchestra between announcements.

3:02 p.m. E.S.T.—Orchestra selection.

MORE MUSIC FROM FRANCE
STATION RADIO COLONIAL—PONTOISE

3:57 p.m. E.S.T.—"The Marseillaise."
3:59 p.m. E.S.T.—"Hilo, Hilo. Ici. Paree. Station Radio Colonial."
4:00 p.m. E.S.T.—Piano and violin selection.
4:06 p.m. E.S.T.—Announcement.
4:08 p.m. E.S.T.—Instrumental selection.
4:15 p.m. E.S.T.—Announcement.
4:16 p.m. E.S.T.—Cello solo.
4:21 p.m. E.S.T.—Announcement.

MUSIC FROM SOUTH AMERICA—STATION HKF BOGOTA, COLOMBIA

8:25 p.m. E.S.T.—Vocal solo. Man singing native selection.

8:28 p.m. E.S.T.—Announcement.
Baritone solo, with choruses singing.

8:33 p.m. E.S.T.—Announcement.
Vocal duet.

8:46 p.m. E.S.T.—Announcement.

8:47 p.m. E.S.T.—Native instrumental selection.

8:50 p.m. E.S.T.—Announcement.

8:53 p.m. E.S.T.—Dance music. Waltz.

8:57 p.m. E.S.T.—Announcement.
Baritone solo.

9:02 p.m. E.S.T.—Announcement.

9:03 p.m. E.S.T.—Native dance selection.

9:06 p.m. E.S.T.—Announcement.

9:09 p.m. E.S.T.—Station announcement. "HKF, in Bogota, Colombia, South America."

9:10 p.m. E.S.T.—Instrumental selection.
Volume very good. Some fading.

SEND NO MONEY--

Clip and mail to us the coupon below. We will send you either one or both books through the Express Company for your inspection. You have the privilege of keeping or returning them.

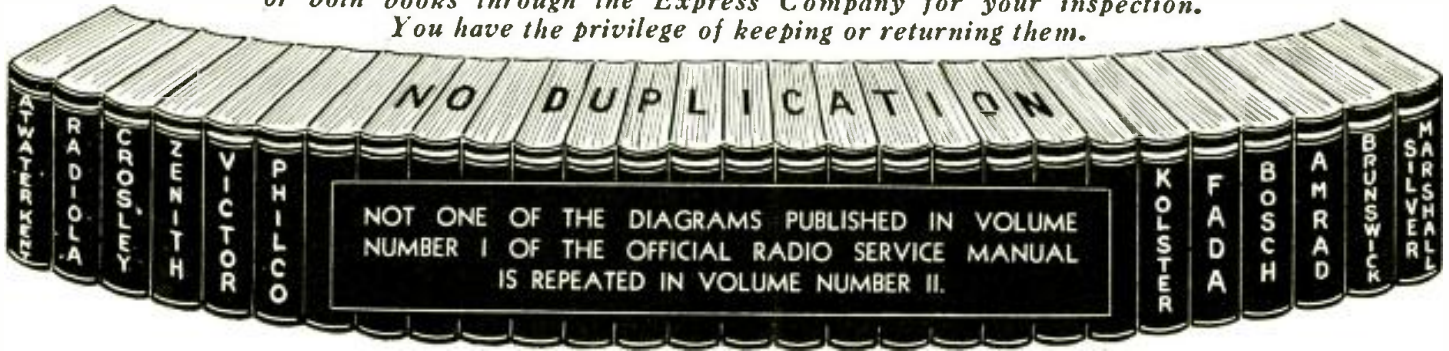

Volume I, 1931 Edition

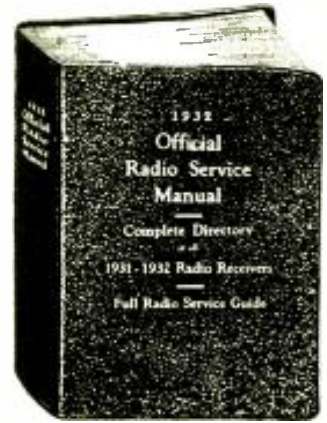

Volume II, 1932 Edition

If you want a complete set of all Radio Diagrams, you must have both volumes in your file

Both volumes of the OFFICIAL RADIO SERVICE MANUAL will give you the most complete set of circuit diagrams ever published for the Radio Industry. Every Radio Service Man and Dealer should have them available for immediate use in his business. Professional set-builders and amateurs will find them instructive and helpful.

Briefly outlined below are the "high spots" that are to be found in the 1931 Manual—the first complete radio service manual ever to be published. Over twenty-seven thousand copies of this edition were sold to members of the radio industry. This assures you of its importance to those engaged in radio and how valuable it is to them.

Partial Contents

Wiring diagrams of radio sets manufactured since 1927, and many earlier ones of which there is any record elsewhere.

650 pages of helpful radio-servicing material.

Complete course of instruction for Radio Service Men, dealers, manufacturers, jobbers, set builders and amateurs.

(Here are but a few of the subjects covered in the special course of instruction).

- | | |
|------------------|----------------------------|
| Amplifiers | Power-Supply Systems |
| Antennae | Radio Phonograph Equipment |
| Automotive Radio | Resistors |
| Condensers | Short-Wave Sets |
| Detectors | Speakers |
| Eliminators | Tubes |
| Meters | |

Get Supplements FREE with the NEW 1932 MANUAL

There is so much new material in this Manual, that a Service Man or dealer would be lost without it when called to service a set. Information about new models which have been on the market only a few weeks are contained in this book. The 1932 Manual makes the service kit complete. The 1932 Manual contains a Full Radio Service Guide and a Complete Directory of all 1931-1932 Radio Diagrams, also models of older design. Everyone in the Radio business should have a copy. Send for yours today!

Partial Contents of Volume II

A step-by-step analysis in servicing a receiver which embodies in its design every possible combination of modern radio practice; it is fully illustrated and thoroughly explained. It is the greatest contribution to the radio service field. Chart showing the operation of all types of vacuum tubes, whether new, old or obsolete. An exclusive résumé of the uses of the Pentode and Variable-Mu Tubes and their characteristics. Complete discussion of the superheterodyne and its inherent peculiarities. Also a special chapter on tools used on superheterodyne circuits. Schematic diagrams and circuits complete with color codings. Important chapters on commercial aircraft radio equipment; new data on commercial short-wave receivers and converters. Servicing and installation of public address systems and talking machine equipment. Standardized color-codings for resistors. Operation of old and new testing equipment; tube voltmeters, output meters, oscillators and aligning tools. A full section on Midget radios—their design, circuits, and types. How to service them most economically. Hundreds of schematic diagrams of older radio receivers which have never been published. Blank pages for recording notes, diagrams and sketches; these pages are transferable to any part of the book. Coupon page for free questions and answers.

\$4.50 Complete with Supplements

Mail Coupon TODAY!

\$5.00 Complete with Supplements

650 PAGES
(Complete with Supplements)
Over 1,500 Diagrams, Charts and Illustrations
Flexible, Looseleaf Binder,
9 x 12 inches

GERNSBACK PUBLICATIONS, Inc. RC-6
96-98 Park Place, New York, N. Y.
Please send me for FREE inspection the books I have checked below. I understand that I may examine them carefully, and should I decide to keep them, I will pay the full cost, plus the few cents for carrying charges. This offer is good only in the U.S.A.
() Volume I, 1931 Manual, with Supplements, \$1.50
() Volume II, 1932 Manual, with Supplements to be mailed Free every 60 days, \$5.00
() BOTH BOOKS FOR \$9.00
NAME
ADDRESS
CITY..... STATE.....

OVER 1,000 PAGES
(Including Supplements)
Over 2,000 Diagrams, Charts and Illustrations
Flexible, Looseleaf Binder,
9 x 12 inches

Some folks still climb
around on roofs and trees

Thousands and thousands,
though, have learned how much
easier it is just to connect—

this to the
ANT post—

this to the
GO post—

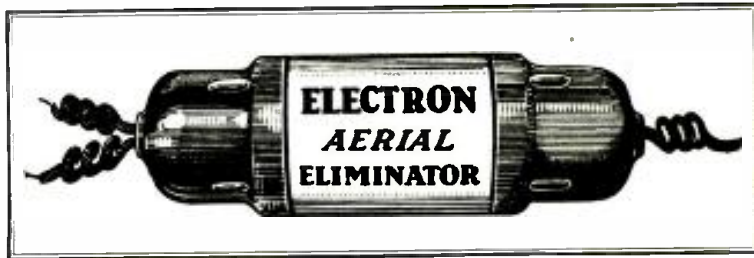

—and this long cord to
the nearest water pipel

THERE MAY not be any lightning hazard in a wire that leads from the roof straight down to your living room. (Try to get the Underwriters' Laboratories to say there isn't!) But you KNOW there isn't any in the ELECTRON AERIAL ELIMINATOR. So why take a chance?

More distance with an outside antenna? Maybe, sometimes—though it's hard to be so sure of that after talking to a few ELECTRON users. But even so—how much does Mr. Broadcast Listener of today care about getting a few more occasional stations, compared to the BIG satisfaction of getting his "regular" stations with less static and less interference? And that's what he can do with an ELECTRON ELIMINATOR. As far as reducing static is concerned, it is every bit as effective as the

"short inside antenna" that engineers have prescribed for years in static-infested neighborhoods.

Then there's the dealer who still worries over how he can either sell or give away an old-fashioned "installation" with sets selling as low as they are. Why do it? It's a rare set indeed that won't give more real satisfaction with an ELECTRON ELIMINATOR than with the most formidable 100-foot aerial-ground-lightning-arrester outfit that was ever "installed"!

Screen-grid tubes wrote the death warrant for the old aerial that straggled half across the block and made roofs look like a wireman's nightmare—and picked up a steady stream of static. Why not be modern and use the standard aerial eliminator that reduces static to the rock-bottom minimum?

The genuine ELECTRON AERIAL ELIMINATOR is sold at leading radio supply stores and departments all over the United States. If your dealer hasn't it, don't accept an inferior substitute, but send to the manufacturer direct. One sample, to anyone (note this protection) \$1.00 postpaid; to dealers and service men only, 1/2 dozen \$4.00, 1 dozen \$7.00 postpaid. Cash in advance; no accounts opened. Money promptly refunded on return of any sample in perfect condition within ten days.

COMPO MFG. CO.
1255 S. Michigan Ave.
Chicago

Compo Mfg. Co.,
1255 S. Michigan Ave., Chicago.

For enclosed \$..... (cash or check) you may send me..... genuine ELECTRON AERIAL ELIMINATORS. I am to be entitled to return them within ten days if not satisfied, and receive refund in full.

Name

Address

only \$37.50 11-TUBE Super-Het!



Completely Assembled with Large Dynamic Speaker

Pentode Variable-Mu and Real Automatic Volume Control

30 DAYS FREE TRIAL

New

13-Tube and 15-Tube ALL WORLD-ALL WAVE COMBINATIONS!

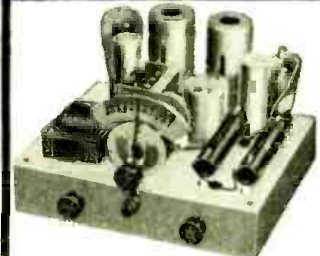

MID-WEST 4-TUBE SHORT WAVE CONVERTER

WORLD-WIDE SHORT WAVE RECEPTION

Converts any A.C. set of adequate sensitivity into a short-wave receiver for reception of police calls, airplane conversations, ships at sea, and, under conditions, broadcasts from foreign stations. This amazing new short-wave converter employs 4 tubes and is self-powered. It uses one 280, one 224, and two 227 tubes. In combination with a 9-tube Super-Het, it gives you a 13-tube ALL-WORLD, ALL-WAVE combination. When used with the very latest model Midwest 11-tube super-heterodyne, shown above, it gives you a total of 15 powerful tubes, and ALL-WORLD, ALL-WAVE reception unbeatable even in receivers costing several times as much.

Don't confuse this 4-tube self-powered converter with cheap one and two-tube converters that are not self-powered. The Midwest Converter actually gives better performance than many converters costing twice as much.

Now you may get SHORT-WAVE broadcasts—airplane calls—police signals—standard long wave broadcasts—all with one combination set. Hear U. S. stations from coast to coast, and from Canada to Mexico. Hear the Canadian stations, Mexico, Cuba, South America, ships at sea, foreign stations! A Midwest 13-tube or 15-tube combination gives you ALL that's desirable in radio. These wonderful new combinations are sold at amazingly low direct-from-factory prices. When you receive our big new catalog and note the low prices, 30 days free trial offer, terms as low as \$5.00 down, you'll be positively amazed. Mail the coupon right now—get the surprise of your life.



Deal Direct with Factory SAVE UP TO 50%

TERMS as low as \$5.00 DOWN

Never have such powerful sets been offered at Midwest's amazing low prices. You save the middlemen's profits. Your outfit will reach you splendidly packed, rigidly tested with everything in place ready to plug in. No assembling! Entertain yourself for 30 days absolutely FREE—then decide. And don't forget—every MIDWEST outfit is backed by an absolute guarantee of satisfaction. You take no risk. Mail the coupon now!

Read This Letter!

This is but one of many letters received from delighted Midwest buyers:

"During the past week I logged the following: FYA Pointoise, France; GBW Rugby, England; HVJ Vatican City, Italy; XDA Mexico City; VK2ME Sydney, Australia; VE9GW Bowmanville, Canada; 12 RO Rome, Italy; G5SW Chelmsford, England; CGA and VE9DR Drummondville, Canada. Also picked up many amateur and airport stations from all over United States. Numerous ship, shore and transatlantic phones from both sides and an Hawaiian Test Station came in clear and sharp. Several Spanish and German speaking stations have also been received but not yet identified. Have received every broadcast from FYA, morning and afternoon, for over a week with wonderful tone and volume. The Midwest Combination Set is certainly one to be proud of."

Wm. S. Teter, Winterpark, Fla., Mar. 2, 1932

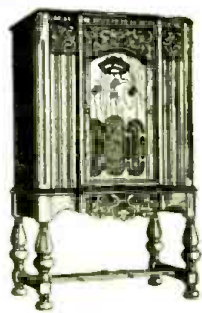

Complete Line of Consoles

The big FREE catalog beautifully illustrates the complete line of gorgeous Midwest Consoles "deLuxe," High-boy and Low-boy models.

Mail this Coupon for Complete Details and Big FREE Catalog!

Midwest Radio Corp. Dept. 73 Cincinnati, Ohio

() Send me SPECIAL USER AGENT'S PROPOSITION

Without obligation send me your new 1932 catalog and complete details of 13 and 15-tube All-World, All-Wave Combinations, 4-tube Converter, 9 and 11-tube Super-Heterodynes, low factory prices, easy terms and liberal 30-day free trial offer. This is NOT an order.

Name Address Town..... State.....

MIDWEST RADIO CORP. Dept. 73 (Est. 1920) CINCINNATI, O.

JUNE
1932
Vol. III—No. 12



HUGO GERNSBACK
Editor

"Takes the Resistance Out of Radio"

Editorial Offices, 96-98 Park Place, New York, N. Y.

Radio Converters and Adapters

By HUGO GERNSBACK

DURING the past year, an entirely new industry has sprung up in order to satisfy the avid demand made by the public for short waves. Every radio manufacturer, large and small, is rushing into this field, and the demand for this type of apparatus at the present time is very great and seems to be on the increase.

In order to receive short waves, one of three types of sets is required.

First (and also the most efficient one) is the straight short-wave receiver in which the short waves are received and amplified at the short wave lengths.

Second, the short-wave converter in which an ordinary broadcast receiver is used in conjunction with the converter. In this, the most popular combination today from the public standpoint, the broadcast receiver, generally speaking, is used in the role of an amplifier, and the short-wave adapter is used exclusively as the short wave end. The converter, in other words, is used to intercept the short waves, then pass on the result to the broadcast receiver and its loudspeaker. The short-wave converter has a power pack of its own and must therefore be connected to the light-line.

Third, the short-wave adapter, which is in many ways similar to the converter except that it has no power pack of its own, but uses the power supply from the broadcast set. The adapter as a rule is not as efficient as the converter, at least not in the present state of the art.

In addition to the three classes mentioned, we have, of course, the combination set where the short-wave converter is built directly into the broadcast set and where, by means of a switch, the user has the choice of receiving the usual broadcast reception on the long waves, or at his will, the shorter waves, through the converter.

An increasing number of radio broadcast sets are now being produced in the combination type, and the time is not far distant when a radio set will be considered out-of-date unless it can receive both long and short waves.

It is most fortunate for the radio industry and the art in general that radio manufacturers have taken to building short-wave combination sets, because it prepares the public for the time when all broadcasting will, without doubt, be transmitted on short waves. The trend is unmistakably that way. With television in the offing,—which will be entirely on short waves,—in the opinion of the best radio minds today, there is no question that broadcasting itself in the near future will be on short waves as well. Meanwhile, the public is getting used to the peculiarities of short waves and thus the radio manufacturers are unconsciously preparing the way for the wonderful possibilities inherent in the short waves.

Of course, much exaggerated nonsense appears in the short-wave converter advertisements of some radio manufacturers, who should know better. There are inherent peculiarities in the short-wave bands, and we have as yet to see the set which at the "twist of the wrist" brings in Rome, Italy or Sidney, Australia. In the first place, short waves cannot be received at their best during all hours of the day. Different wavelengths are received best during certain hours of the day or

night. And then again, location and local conditions have a lot to do with short-wave reception at the present time, and this holds particularly true for large cities, where man-made static frequently ruins good short-wave programs. Until such time as the art has progressed sufficiently to do away with such static, short-wave reception in the large centers will always be more or less unreliable.

I do not make these remarks with the idea of discouraging people from buying short-wave equipment. Quite to the contrary, for even if you cannot receive programs from the Antipodes, there are thrills galore which even mediocre sets can bring to their owners. To mention only one, which seems to have taken the country by storm—Police Radio. It is no trick at all to pull in exciting police reports from every point of the compass in the United States with a short-wave converter or short-wave adapter. There are at this time of writing about 70 police stations in the country, and these stations are audible practically everywhere over the length and breadth of the land, day and night. Murders, holdups, burglaries and other crimes, automobile collisions, and thousands of other interesting news items flash through the air almost every minute of the day.

Inasmuch as there are a number of such police stations operating on the same wavelength, it is not even necessary to tune your set once you have located the wave band. All you require is to turn on the set, lean back, and enjoy real excitement for hours at a time. Naturally, of course, if two stations on the same wavelength operating with equal power, transmit at the same time, they will interfere and it will be impossible to tune out one and bring in the other; but as a rule, one will drown out the other because two distant stations seldom come in with exactly the same volume.

As time goes on, there is no doubt that police radio will be extended so that practically every municipality in the country will have its own police radio. At the present time, the intelligence is intended only for police automobiles equipped to receive headquarters' reports, but there is no reason why diligent citizens should not help their police departments to curb crime; and it is here where short-wave converters and adapters become particularly useful.

Suppose there were several million short-wave instruments in the country and a large portion of the listeners were listening in. A good deal of crime could then be prevented because in the very nature of things, it is sometimes possible for a citizen to be on the scene quicker than the police automobile, which might be miles away from the scene of crime, accident, or what-not. Take the following case:

A murder has been committed and a citizen has reported to police headquarters a description of the criminals and the license number of their car as well as a description of it. Meanwhile, the car moves on. Within a few seconds a police alarm is given out and several thousand short-wave-set owners will hear the alarm and will be on the lookout for the car. It becomes, then, a simple matter for the citizens to report either to the policeman on the beat or to headquarters where the car has last passed, and in this way, the criminals can be apprehended far more easily and quickly than could be done in any other way. There are, of course, many other ways in which owners of short-wave sets can assist the police.

How to Build the RADIO "TREASURE" FINDER

A portable home-made radio transmitter and receiver which detects metal objects buried in the earth.

By CLYDE J. FITCH

FOR centuries the human race has combed the earth's surface in the search for precious metals, and their search has not been in vain; the earth has generously given up billions of dollars worth of gold and other precious minerals. It is obvious that if this mineral is found on the earth's surface it will also be found within the earth; and instances where it has been found within the earth have resulted in the exploitation of rich mines.

The problem of determining where precious minerals or other objects are concealed within the earth has absorbed human thought for ages. Various schemes have been proposed for locating this buried wealth. Some of them, whether based on superstition or not, which employ various forms of divining rods, are not within the scope of this article. We are chiefly interested at present in building a metal locator based on the known phenomenon of radio science.

We have received hundreds of requests from readers for information on a practical, electrical treasure finder. While the apparatus described in our June 1931 issue is entirely practical for the purpose for which it was designed, it is not very sensitive to the presence of small metal objects. Judging from the numerous requests received, many of our readers know the approximate whereabouts of some hidden treasure, which may be of very small physical dimensions but of enormous value. It is mainly to locate such objects that this apparatus has been designed. It will, however, in many cases, detect the presence of an ore deposit. *It must be thoroughly understood, however, that this device will not just detect gold or some other precious metal in preference to the base elements.*

It will indicate the presence of any substance which is a conductor of electricity. In other words, it will detect the pres-

ence of a buried tin can just as efficiently as it will respond to the presence of a hidden chest of gold. Furthermore a precious diamond or pearl may be directly under your feet and the apparatus will remain silent. Moist ground, especially if it contains acid or salts that will cause it to become a good electrical conductor, will register on the treasure finder. For these reasons you will no doubt have some disappointment and receive false alarms from the apparatus before you make a strike.

Practically all electrical treasure finders of the portable type operate on the Hughes induction balance principle. The induction balance is simply a Wheatstone bridge in two arms of which are connected induction coils. The coils are so balanced that when an alternating current is passed through the bridge no response is heard in a head-set connected to the bridge. If a piece of metal is brought within the magnetic field of one of the coils it absorbs energy (which is represented as eddy currents in the metal) and the coils are no longer in electrical balance. The effect is immediately manifested by a sound in the headphones.

The Hughes induction balance generally employs alternating currents within the audible range, and hence the extent of the magnetic fields radiated from the coils is somewhat limited. By using radio frequency currents, greater depths may be penetrated; and with proper design of the apparatus, great sensitivity will result.

We are all familiar with the early unshielded battery radio sets which produced a squeal in the loudspeaker whenever our hand approached any part of the circuit. This condition existed whenever the set was in an oscillating condition. It is partly upon this principle that the apparatus about to be described operates.

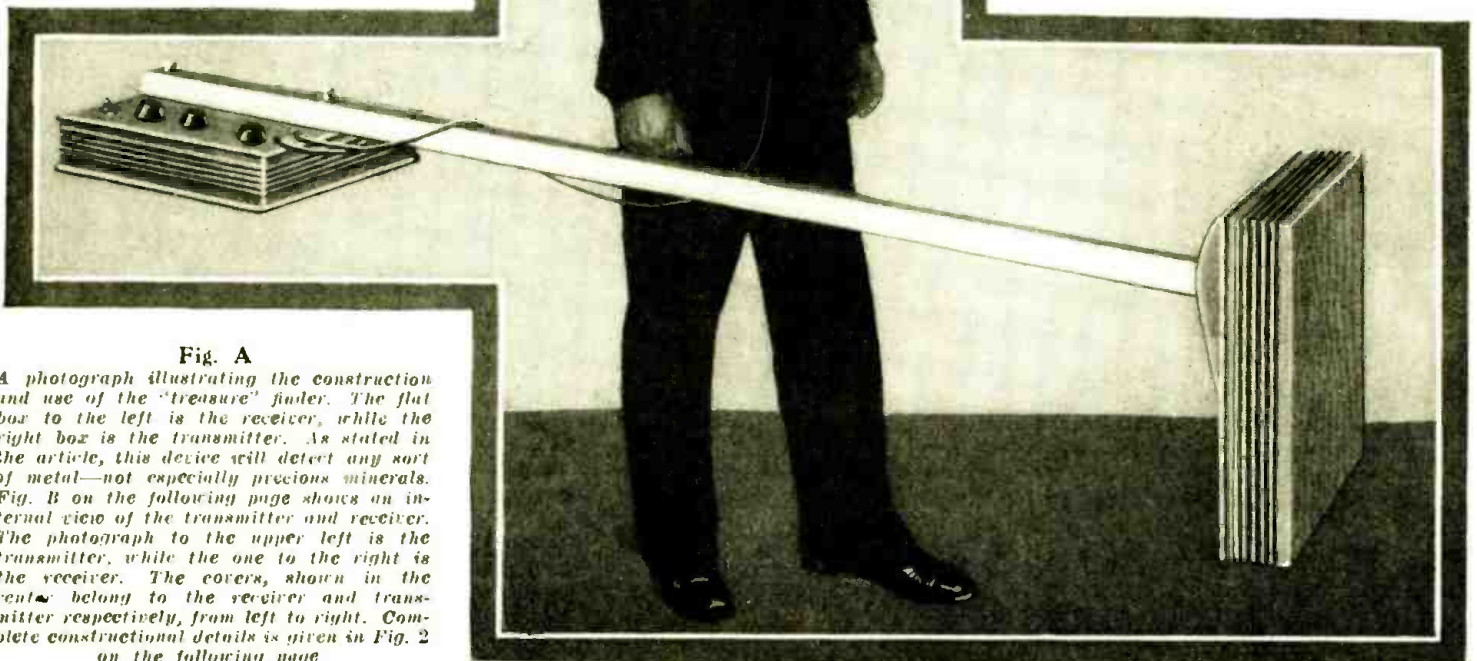

Fig. A

A photograph illustrating the construction and use of the "treasure" finder. The flat box to the left is the receiver, while the right box is the transmitter. As stated in the article, this device will detect any sort of metal—not especially precious minerals. Fig. B on the following page shows an internal view of the transmitter and receiver. The photograph to the upper left is the transmitter, while the one to the right is the receiver. The covers, shown in the center, belong to the receiver and transmitter respectively, from left to right. Complete constructional details is given in Fig. 2 on the following page.

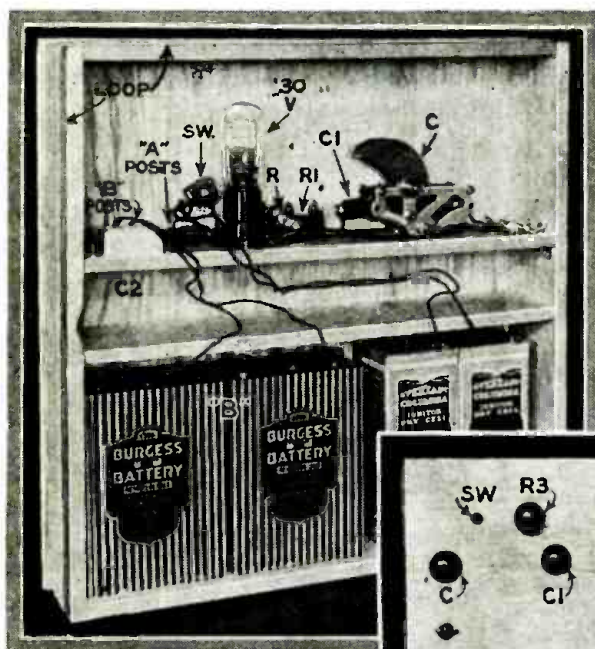
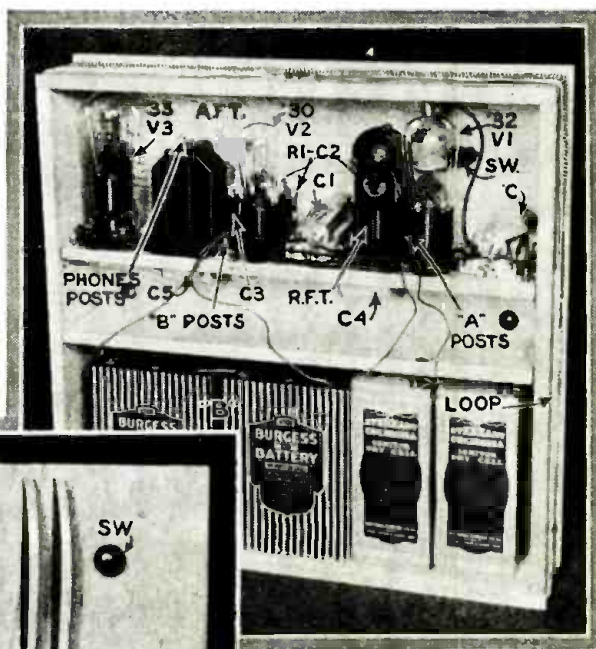

Fig. B
Photographs illustrating the placement of the parts in the transmitter and receiver. The numerals labeled in the photographs correspond to those given in the diagrams. Directly to the left is the transmitter; to the right, the receiver; below to the left, the receiver cover; and right, the transmitter cover.



General Description of Apparatus

The various illustrations show the general mechanical arrangement and design of the device. It comprises a miniature radio transmitter and receiver, each in a separate box connected to each other with a long wooden bar with a carrying handle attached at the center. The transmitter employs a single tube which sends out modulated oscillations from a loop aerial wound around the box.

The receiver (Figs. A and 1) employs a loop aerial wound around the receiver box and connected to a sensitive three tube set. The receiver is carefully tuned to pick up the signal radiated from the transmitter. It will be noted from Fig. 2 that the transmitter box is hinged to the carrying handle so that it may be set at any angle, and locked with a wing nut. The correct setting is determined by listening in on the headset and adjusting the transmitter angle until no sound is heard. Under this condition the receiver loop will be approximately at right angles to the transmitter loop. It may be necessary to use a long wooden stick to tilt the box to avoid body capacity. In free air, the radiated magnetic field will be approximately as indicated in Fig. 3A. Whenever a metallic object comes within the presence of radio waves it obstructs the waves and absorbs some of the energy. Those who have driven through the city while using an auto radio are well aware of this fact. Our treasure finder makes use of this phenomenon on a miniature scale; whenever it is brought within the vicinity of a metal object the radiated field of the transmitter is distorted as shown in Fig. 3B and a state of balance no longer exists; a signal will be heard in the headset.

In this apparatus the receiver is designed so that regenerative amplification may be employed. Also the set may be adjusted so that it will oscillate, and thereby produce a beat

note in the head-set by heterodyning the signal from the transmitter. Under these conditions a supersensitive state exists; the presence of a metal object within the field of the transmitter loop or the receiver loop will detune either circuit slightly and change the pitch of the beat note. This method of detecting an object should be carefully checked by previous methods in which the receiver is not oscillating, because it is so extremely sensitive that it may give erroneous readings. In either case it is important to maintain a uniform distance between the apparatus and the ground while carrying it along; otherwise the capacity to ground will change and affect the heterodyne whistle.

The Transmitter

The diagram of the transmitter is shown in Fig. 4. A Hartley oscillator circuit is employed. The tube is a '30 type operated from two dry cells for the filament and a "B" battery of 90 volts for the plate. The batteries are housed in the box with the transmitter as shown in Fig. B. The values of the parts are given in the list of parts. The grid condenser and the grid-leak are selected so as to produce an audio-modulated signal.

The loop aerials on both transmitter and receiver each comprise 10 turns of No. 18 bell-wire. The experimenter may try various wavelengths by increasing or decreasing the number of loop turns and the turns on the plug-in coil, R.F.T., Fig. 1, and by tuning the variable condensers. The wavelengths chosen are in the neighborhood of 100 to 200 meters. It is unlikely that a license to use the apparatus is necessary because of the low power of the oscillator. It is no more a radio transmitter than an ordinary test oscillator, such as is used by Service Men. It is interesting to note that the government has allotted the wave band of 175 to 188 meters (approximately) for geographical prospecting.

(Continued on page 749)

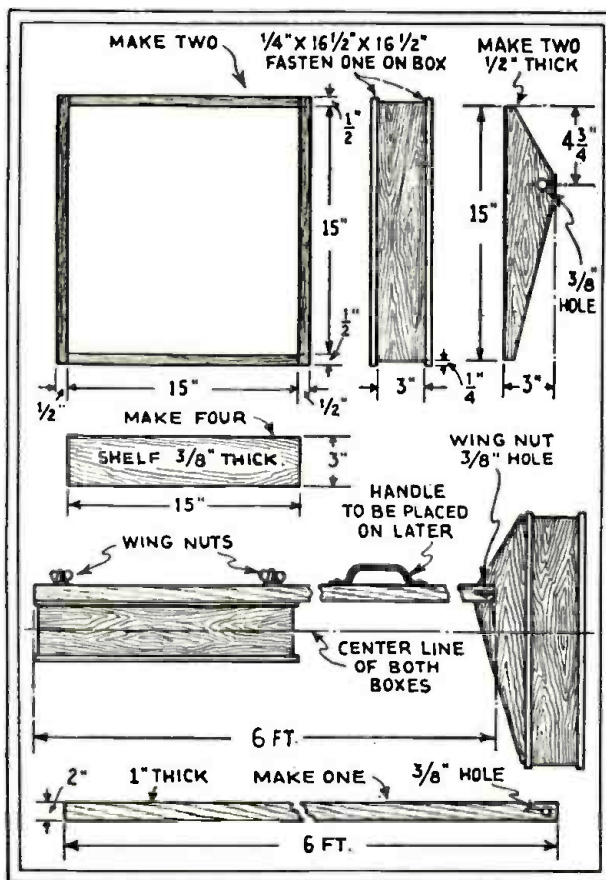
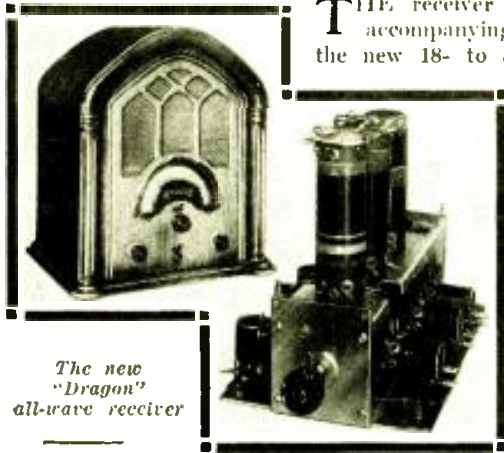

Fig. 2
Constructional details of the treasure finder.

The Latest in Radio At the RADIO SHOW

THE PILOT "DRAGON" ALL-WAVE RECEIVER



The new "Dragon" all-wave receiver

THE receiver illustrated in the accompanying photograph is the new 18- to 555-meter receiver manufactured by the Pilot Radio and Tube Corp. The features of the set are "one-hand" control, a 46-point band-selector switch, and catacomb construction of tuning units. A short-wave converter is interposed between the antenna and

broadcast receiver. Because of its unique design, no tone-control is necessary.

RCA-VICTOR MODEL RE-20

A DE LUXE ten-tube superheterodyne receiver, shown in the accompanying illustration has recently been announced by the RCA-Victor Co. It incorporates several features that are relatively new in radio receivers. It has a two-speed phonograph motor; an automatic volume-control in the phonograph circuit; a micrometer tone control; an automatic tone control; and a synchronous motor for the phonograph. The totally shielded chassis is mounted in a walnut-finished console cabinet, 43 inches high, 46 $\frac{3}{4}$ inches wide, and 16 $\frac{1}{4}$ inches deep. It uses 2-47's, 1-80, 1-24, 3-27's and 3-35's.



RCA-Victor's new RE-20

TRIAD'S CRATER LAMP



Triad's crater lamp.

A "COLD-CRATER" type neon lamp, designed for use in television receivers, has been announced by the Triad Television & Mfg. Co. The tube consists essentially of two electrodes mechanically mounted within a few thousandths of an inch of each other. One electrode is known as the "target" and has a hole approximately .025-in. in it, through which the intense beam of light is projected to a lens-type scanning disc. The tube draws from 20 to 40 milliamperes and the light intensity is sufficient to allow a picture approximately one-foot square to be obtained.

AUDIOLA SHORT-WAVE TABLE



New short-wave table.

THE Audiola Short-Wave Table, illustrated here, is a short-wave converter designed for use with a midget receiver which rests on top of the table as shown. The modern trend toward short-wave reception has manifested itself in many types of converters, but the one illustrated at the left is especially designed for midget sets, although it may be used successfully with any type of receiver. When a console-type set is used in conjunction with this converter, the table-top may be used to set ornamental articles upon.

This device is a product of the Audiola Radio Co.

The lightened area in the photograph merely illustrates the usual receiver designed for use with this "table."

THE SENTINEL ALL-WAVE "SUPER."

THE new Sentinel model 125 all-wave superheterodyne receiver is illustrated to the right. The broadcast band covered by this receiver includes those from 13 to 35 meters, 32 to 85 meters, 80 to 200 meters and 195 to 550 meters. Each band is completely calibrated in a single dial, and tuning is accomplished by operating only one control dual-speed dial. Band switching is done by a special multiple-gang selector switch operated by one of the knobs. An intermediate frequency of 507.5 kc. is employed in order to minimize image-frequency interference.

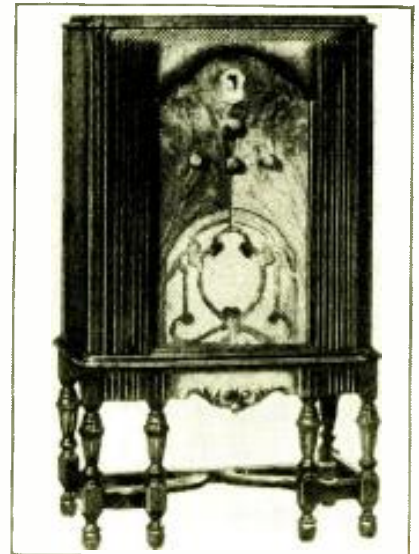

The Sentinel Model 125

This set has a sensitivity of better than 6 micro-volts while the selectivity is about 10 kc.

MACY'S ELECTRO-DYNAMIC UNIT

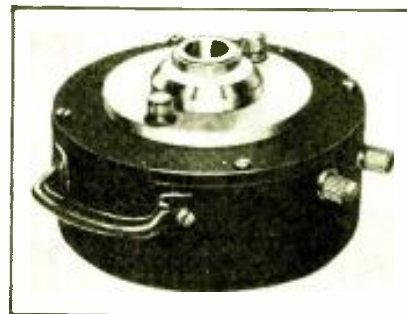

Macy's "Giant" 30-watt speaker unit.

FOR music reproducing systems the Macy Electrical Products Co., Inc., offer two new types of electro-dynamic speaker units; the junior type 3N operates on an output of 7-10 watts, and the giant, illustrated to the left, operates on an output of 10-30 watts. Both types require a field supply capable of delivering 1.6 amperes at 6-volts.

BLIC ADDRESS SYSTEMS

June, 1932



An Electrad P.A. System.

IN view of the increasing use of public address systems, Electrad Inc., announces a new line of complete equipment designed to cover this field. There are two types, that shown at the left known as the "500 series" and another known as the "1000 series." The "500 series" is 33 inches high, 29½ inches wide, and 18 inches deep. It is equipped with an automatic phonograph

record-changer for playing 20 records consecutively. Most any type Electrad amplifier may be used, from their "B-245" to their "E-250."

The main difference between the 500 series and the 1000 series is that there is no provision in the 500 series for radio music, as there is no tuner.

There are twenty-four different models in the 500 series and twenty different models in the 1000 series.

REVERE SUPERHETERODYNES

THE Revere Radio Corporation has just announced a six-tube superheterodyne receiver equipped with an auto-dyne detector, full automatic volume control, pentode output tube and variable-mu tubes.

This receiver is offered in four styles of cabinet. Model 47-S, a table model in a cabinet of rubbed walnut with a crotched walnut front panel, set off by an overlay of Mexican Marble Wood.

The Patrician Console, illustrated to the right, utilizes the space not required by the chassis to provide a convenient shelf for books and a handy stowaway space.



The Revere Patrician Console Receiver.

MAJESTIC "FAIRFAX"

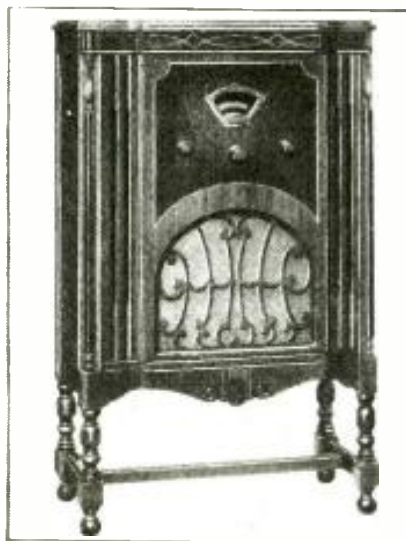

Majestic Fairfax Model 203

IN the May, 1932 issue of RADIO-CRAFT there was described (in a Data Sheet) the new Majestic models Fairfax and Sheffield receivers. A photograph of the Fairfax is shown to the left. As may be seen by reference to the above-mentioned issue, it is an eight-tube set employing four G-35-S tubes, one G-27-S, one G-2-S, one G-47 and one G-80, and is of the superheterodyne type. The model 200 chassis is used in the Sheffield model 201 receiver and in the Fairfax model 203 receiver.

S. M. 727-DC RECEIVER



S. M. 727-DC Receiver.

SILVER - MARSHALL, Inc. announces a new super-sensitive receiver designed to operate from batteries in the rural sections of country. It is an eight-tube set having a push-push output stage and uses two R.F. variable-mu pentodes. It is a broadcast receiver of low power drain.

RCA-VICTOR S.W. COMBINATION

THE RCA-Victor Co. has available for consumers' use a new combination short- and long-wave receiver known as the model RO-23. It is an eight-tube superheterodyne set with automatic volume control and a three-tube short-wave adapter. The short-wave range is from 13.8 to 200 meters, and any particular band may be selected by means of a seven-segment range switch.

It is 47 inches high, 27¼ inches wide, and 13 inches deep. The tubes used are one '80, one '24, three 27's, two '35's, and one '47. As may be seen by reference to the figure at the right, there are two sets of controls; one for the low and the other for the broadcast band.



RCA-Victor S.W. Combination.

CENTRALAB'S DUO-PURPOSE UNIT

DURING the past few years modern radio design has drifted toward compactness and versatility. In fact, the efficiency of radio apparatus has advanced to such an extent that the separate line switch, used to turn the radio "on" and "off," has been completely dispensed with. The Central Radio Laboratories has announced an extremely compact combination line switch and variable resistance.

As indicated by the photograph to the right, it is actually about 1½ inches in diameter, and therefore is suitable for use in present-day midget receivers where space is at a premium.

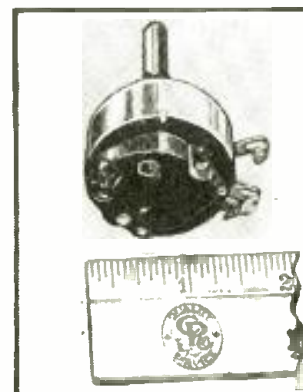

Centralab's Combination Unit

A PUBLIC ADDRESS AMPLIFIER

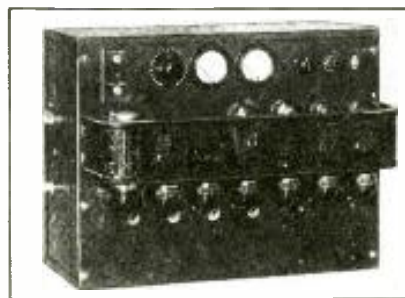

The Webster P.A. Amplifier

TO the left is shown an amplifier, known as the model 6048-R which is suitable for use in the smaller type of public address systems.

The model 6048-R is designed for a 115-volt A.C. line, while the 6049-R is designed for a 220-volt A.C. line. They are products of the Webster Electric Co.

WESTERN ELECTRIC MONITOR UNIT

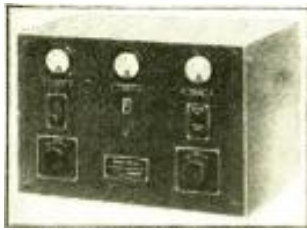

Above, front view of the Western Electric monitor unit. The schematic circuit of the device is shown below. It was designed by the Bell Telephone Laboratories.

BECAUSE the Federal Radio Commission issued General Order No. 116, compelling broadcasters to remain within 50 cycles of their assigned frequency, the monitoring unit illustrated was developed for the Western Electric Co.

The monitoring unit may be attached into any stage of the transmitter; it contains an oscillator working on the assigned frequency and a detector. The station's wave beats against the monitor oscillator, then detected.

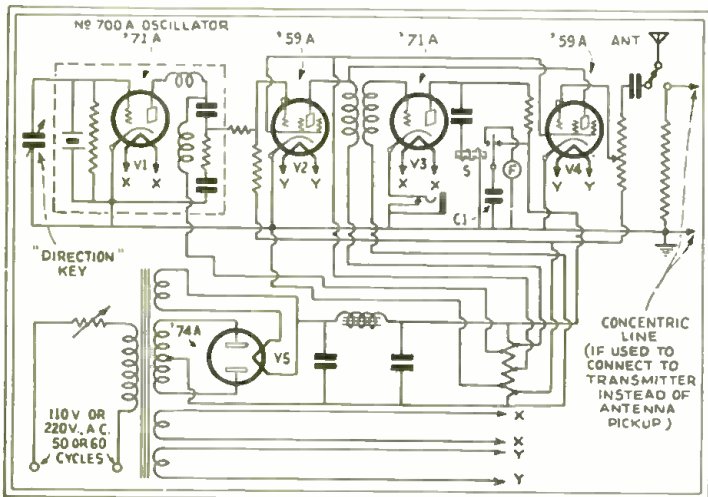

GLOBE TELEVISION RECEIVER



WITH the announcement of the Globe television receiver of midget construction, the public may now procure a set that is no larger than the broadcast midget.

The receiver comprises a metal chassis that is now employing two screen-grid '24 tubes for the R.F. stage, one '27 detector, one '24 first audio, one '27 second audio and two '45 power tubes for the third audio stage, together with an '80 rectifier. A power pack is included for full A.C. operation. The televisior consists of a quiet-running synchronous motor. Framing and synchronizing are accomplished by turning a single dial. A 60-line lens-disc is employed in combination with a erater neon lamp for projected images. A picture 4 x 5½ inches is secured.

The front and rear views of the set is shown to the left, and is a product of the Globe Television and Phone Co.

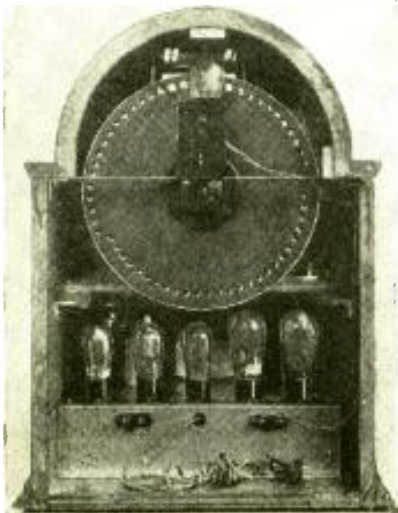

Above, front view of the Globe television set; left, a rear view of the receiver. The 60-line disc is clearly seen in the lower picture.

FADA "KY" CHASS.

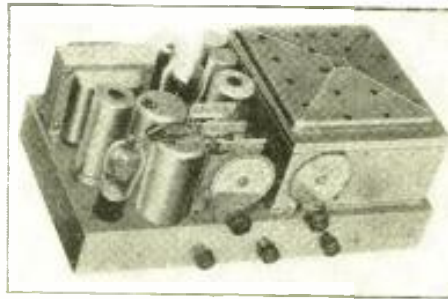

Photograph of the Fada "KY" receiver chassis.

left is F. A. D. and is their model 6. It is a ten-tube superheterodyne able for the short a broadcast bands. It 9½ inches deep, 2 inches high and inches wide. On the normal broadcast band it is a superheterodyne using one stage

of variable-mu amplification, one '24 used as a combination first-detector and oscillator, one stage of variable-mu I.F., one combination diode detector and A.V.C. using a '27 tube, a variable-mu first A.F. and a '47 pentode output tube.

The short-wave tuner of the multi-switch type is used. It consists of a '24 first detector, a '35 coupling tube acting as a 1525 kc. I. F. amplifier and a '27 high-frequency oscillator.

Past issues of RADIO-CRAFT contain data sheets on Fada receivers which should be consulted for a comparison between different models. It might also be advisable to check-up on other "double supers."

WOODRUFF RADIO WALL PLATES

SERVICE Men have not always found it convenient to install wall-plates in radio service installations because of the varied requirements of every different installation. There is an obvious demand for such a wall-plate, and consequently there has been developed the "Super-Thru" radio outlet illustrated.

With this device, wall thicknesses up to 15 inches may easily be spanned, regardless of whether they are of wood, plaster or any other material. The inside connection block shown to the right of the photograph is also a lightning arrester.

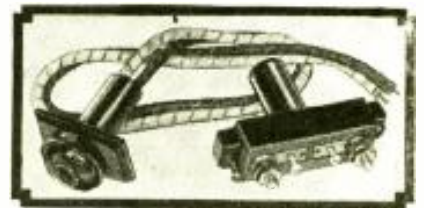

Photograph of the "Super-Thru".

An installation using this device conforms with the requirements of the National Electric Code, and therefore may be used with perfect safety.

This interesting and novel device is a product of Woodruff & Co.

READRITE EXPLORING COIL

THE exploring coil, illustrated below, was designed to assist the Service Man locate and detect R.F. circuit troubles. The coil is connected to an oscillator or broadcast signal by means of the shielded cable. The shield is connected to ground and the other terminal to the antenna terminal of the oscillator.

The explorer coil is then placed over one of the R.F. or I.F. tubes and induces the oscillator current into the grid of the tube.

The change thus brought about in the grid circuit makes a corresponding change in the signal output of the radio set under normal conditions. In order to localize R.F. circuit troubles, when the signal is noted, the stage just preceding the tube on which the exploring coil is placed is at fault.

It will localize troubles in R.F. and I.F. transformers and in band-pass filters. It will measure the efficiency of each stage by comparing the gain in output in the circuits between the antenna and first A.F. tube.

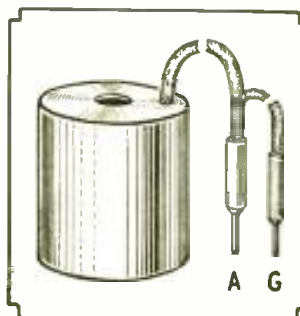

The explorer coil.

It is a product of the Readrite Meter Works.

CLAROSTAT "AD-A-SWITCH"

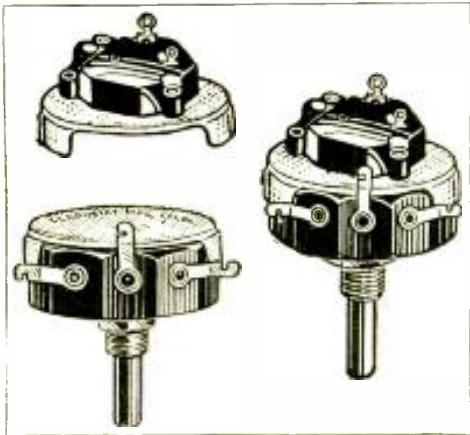

Clarostat's combination switch.

MANY times in the past a desire for a combination volume control and line switch has manifested itself. To meet this demand, the Clarostat Mfg. Co. announces a unit shown at the left. When the two units at the extreme left are snapped together, the final combination is obtained.

This should be especially suitable for the Service Man who specializes in modernizing "old" receivers.

The completed unit is shown to the right of the above illustration.

MICAMOLD CONDENSERS

THE type W wire lead condenser shown to the right is constructed of a fine grade of India mica and molded in genuine bakelite. At the extreme right is shown a completely dry electrolytic condenser sealed in a specially treated tube. They are products of the Micamold Radio Corp. It would be well for the Service Man to investigate the possibilities of small electrolytic condensers.

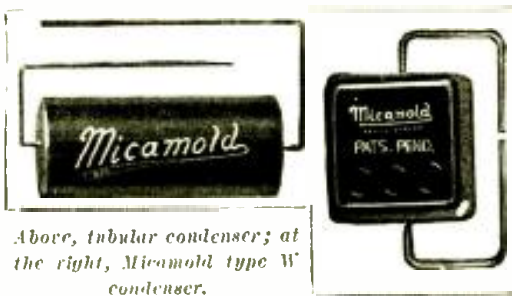

Above, tubular condenser; at the right, Micamold type W condenser.



External and internal views of the SWA-2.

RCA-VICTOR MODEL SWA-2

THE RCA - Victor short - wave converter SWA-2 is a three tube, single control short-wave unit designed to convert all short-wave signals from 13.8 to 200 meters to a single frequency so that they may then be amplified by means of the usual broadcast receiver.

One '24 is used as an R.F. amplifier, one '24 as the detector, and one '27 as the oscillator. Heater current for

these tubes is obtained from the small transformer which may be seen in the illustration to the left.

The photograph to the left is an internal view of the converter and the one above a front view. This converter is the same as used in the RO-23 described on a previous page. It is a product of the RCA-Victor Co.

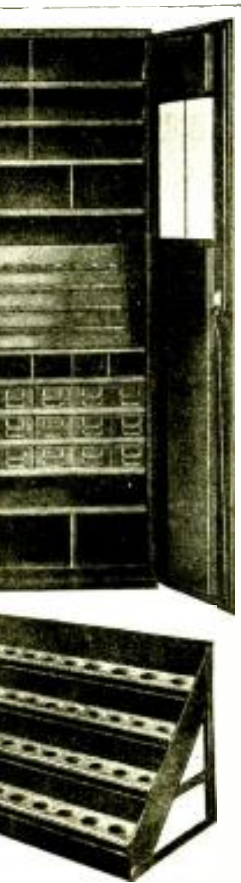
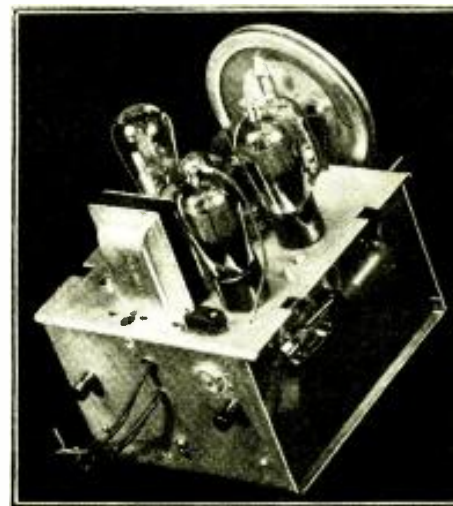

Storage cabinet and tube rack.

STORAGE CABINETS

A NEW steel storage cabinet for radio servicing — designed to save its cost by preventing breakage and damage to expensive test instruments and tubes—and to protect against loss and petty thievery.

It stores an average stock of new tubes, complete set of testing instruments, tools and small parts. The removable tube storage stand, shown at the lower left, is provided for test jobs on the work bench and is designed to store 50 tubes, including all the standard sizes.

The cabinet, shown at the left, is 36 inches wide, 12 inches deep and 84 inches high. The stand is 30½ inches wide, 11¾ inches deep and 15 inches high. The doors lock securely and are fitted with stock control-boards.

They are manufactured by Lyon Metal Products, Inc.

A NEW PORTABLE RECEIVER

A NEW receiver designated as the "P-31" is a portable eight tube battery-operated superheterodyne using three '34's, one '32, and four '30's. It is equipped with a diode detector, a triode audio amplifier, and a bias control automatic-volume control.

The portable receiver, shown at the right, is a product of the RCA-Victor Co.

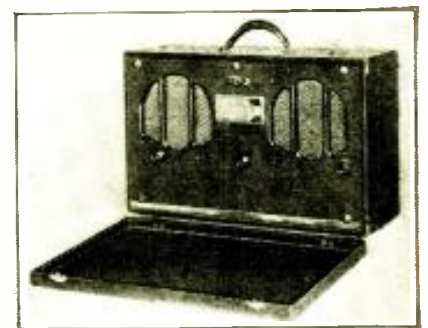

The RCA-Victor portable receiver.

AEROVOX CONDENSERS

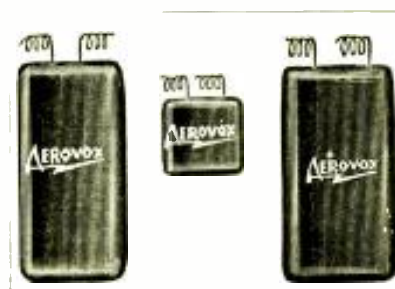

Left, type LU; center, type SU; and right LU condensers.

AT the left is indicated, from left to right, the type LU, SU, and LU Aerovox uncased replacement condensers. They are suitable for filter and bypass use and are non-inductively wound using a high-grade dielectric paper. In keeping with modern times, they are wrapped in moisture-proof cellophane.

They are available in working voltages up to 1000, and in capacity values to 2 mf. and are manufactured by the Aerovox Wireless Corp.

By ARTHUR H. LYNCH

in collaboration with

EDWARD

CARON

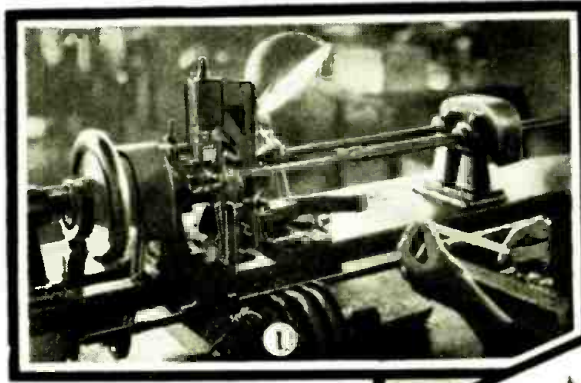

(1) This is an automatic grid winding machine. Two heavy support wires are run through a revolving head—at the extreme left of the pic-

ture. As these two support wires revolve, being driven by the motor which operates the revolving head, they pick up a fine wire which is run at right angles to the support wires and is equally spaced along the support wires. The spacing is automatically controlled for any particular type of tube for which the grids are to be used. This makes one long grid, the entire length of the support wires.



(2) *Cage Assembly*—The operator is using a foot-controlled electric welding machine. The upper arm of the welding machine makes contact with the metal elements which the operator is holding.



(3) *Cathode Assembly*—Here the operator is shown placing the special alloy filament wire into the Isolantite insulating sleeves.

(4) *Cathode Spraying*—After the operation shown in Figure No. 3, groups of the individual cathodes are placed in a spraying hood and given a coating of prepared chemicals by means of the spray gun which the operator holds in her right hand. The performance and the ultimate life of the heater-type tube depends, to a very large degree, upon the uniformity of the spraying mixture itself as well as the uniformity with which it is applied.

This is one of the most important operations of the cathode.

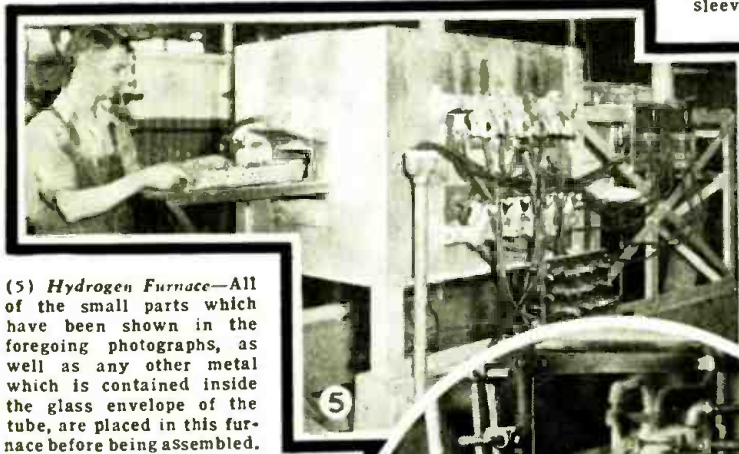
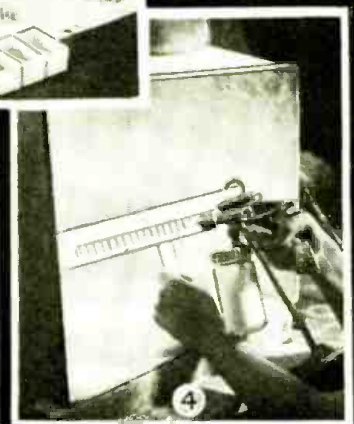

(5) *Hydrogen Furnace*—All of the small parts which have been shown in the foregoing photographs, as well as any other metal which is contained inside the glass envelope of the tube, are placed in this furnace before being assembled.

(7) *Stem Machine*—The operation shown in this picture is worked out in six different positions which are automatically rotated by the machine. The result is the inserting of the necessary lead wires which connect the elements of the tube to the prongs of the tube base, which in turn goes into the socket of the radio receiver. The small glass tube, which is shown in the operators hands, is used in a later operation for evacuating the entire tube. It joins the flare at a point where the lead wires are sealed into the glass.

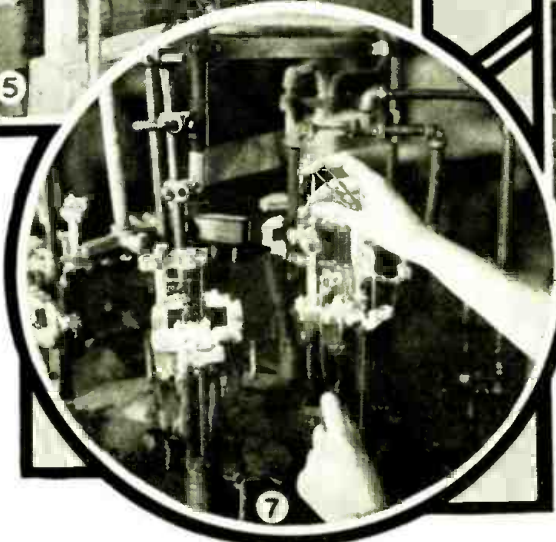

(6) *Automatic Flare Machine*—Long lengths of glass tubing are placed in the revolving chucks which are shown at the top of this machine. These chucks feed the glass tube, at a predetermined, desired length, into a number of gas flames. There are eight sets of gas flames which the tube passes through from the time the operation starts until the flare is finished. Each different position is accompanied by an increase of temperature of the flame acting upon the glass tubing as the process develops. At the position shown directly before the operator is a revolving steel flare cutting disc.

* Plant Superintendent, Triad Television Mfg. Co.

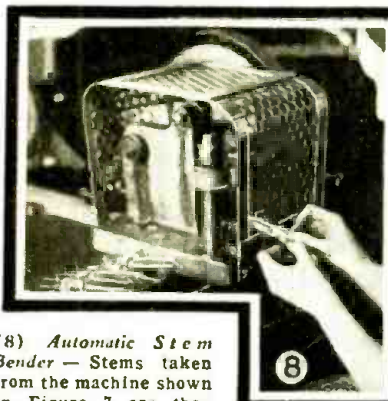

(8) *Automatic Stem Bender*—Stems taken from the machine shown in Figure 7 are then placed in this device which is controlled by a foot-operated clutch. When this machine is operated all of the lead wires are cut to the proper length.



(9) *Mount Assembly*—The operator in this picture is using a machine similar to the one shown in Figure No. 2. The difference lies in the fact that all of the assembly which has been finished by the process shown in Figure No. 2 is now joined to the rest of the elements, making a complete "Mount," ready for inserting into the glass envelope or bulb.
After the "Mount" is completed, the unit goes to the "sealing-in" machine.

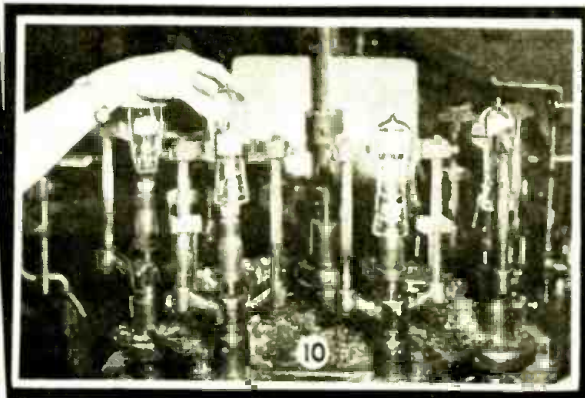

(10) *Sealing-In Machine*—The machine here is somewhat similar to the flare-making machine in that the operation includes passing the elements for the tube through a number of gas fires of gradually increasing temperatures.



(11) *Exhaust and Sealing Machine*—The entire tube assembly is run through this machine in such a manner as to drive off all of the gases and pump them out along with all the air in the bulb. The heavy coil of wire directly above the heavy insulated lead wires, is a high frequency coil, used for heating the elements within the tube, while it is being evacuated. The heat of the elements is produced purely by the inductive effect of the high frequency current passing through the coil. A "getter" explodes, giving a "silvery" appearance.

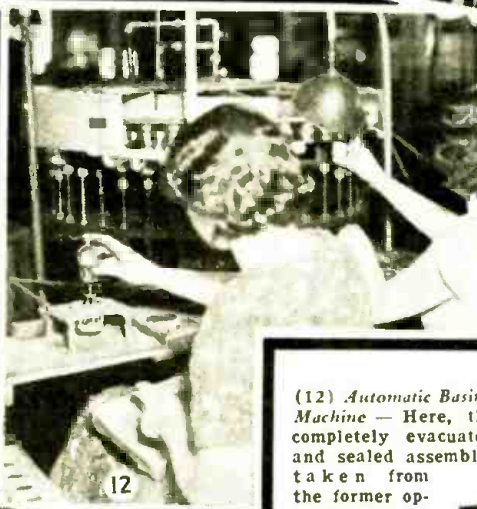

(12) *Automatic Basing Machine*—Here, the completely evacuated and sealed assembly, taken from the former operation, is attached to the base. The base is already fitted with the requisite number of tubular metal prongs. The lead wires are put through these tubular prongs, by the operator, before the tube and the base are placed in the basing machine. The base, itself, is filled with a specially prepared cement. These assembled units are then put through a circular oven, which is held at a constant temperature.

(13) *Aging Rack*—This highly interesting section of the production line indicates, by means of the banks of ordinary incandescent lamps, just exactly the condition of each tube as it comes through production. The finished vacuum tubes are placed in sockets which are connected to normal operating voltages. The current is then turned on and each tube has to be aged for a given period at specified voltages. If there is a short circuit between a plate and grid of one of the tubes, one of the lights in the bank to which that particular tube is connected indicates that fact to the operator. Other lights detect other troubles. This is true of any other flaws which might take place in the tube and the operator is therefore able to throw out those that are faulty.



(14) *Test Table*—A table, of this character, is at the end of each production line. It is fitted with nine delicate meters and is used to measure ten different characteristics of each tube. These test tables are of the very latest design and are the work of the Triad Engineering Staff.

(15) *Packing*—All of the highly developed Engineering work in a modern tube plant can be knocked into a "Cocked Hat" if the tubes are not satisfactorily packed. After shipping millions of tubes to all parts of the world the Triad Company has standardized on a system of wrapping.



TELEPHOTOGRAPHY

TRANSMISSION of PHOTOGRAPHS By WIRE

By NORMAN D. BUEHLING



An unretouched photograph of a picture transmitted by wire.

THE rapid advance of scientific knowledge has brought so many wonders within our grasp, that there is a tendency to take many of our present-day developments for granted. For every new discovery that is made today, there will be many applications tomorrow. Emission of electrons, caused by a ray of light on an active metal, a scientific novelty of yesterday, today finds endless uses. Without the photoelectric cell, who could dream of television or of the present telephotograph system? Every day photographs are being sent from coast to coast; the process is taken as a matter of course, but few know the methods employed in accomplishing this feat.

The system of transmitting pictures electrically over great distances has been a reliable, commercial accomplishment for a number of years. The Bell Telephone Laboratories have developed the system, which was originally invented by Professor Korn of Germany, and made it commercially possible. There are now eight stations in our most important cities scattered over the country, and photographs can be sent almost anywhere in a very short time. The quality of the transmitted picture is such that it is difficult to distinguish the telephoto, as it is called, from the original. We will discuss in detail each of the important factors.

Method of Transmission

Photographing the picture, diagram, or drawing, is the first step in sending it over the wires, and the result is a negative plate. As the positive film is used in the actual transmission, the negative is rephotographed and a positive film, 5 x 7 inches in size, is obtained. During the transmission, a photographic reversal usually takes place; that is, when a positive is sent, a negative is received, and vice versa. However, this is not necessarily so, for by reversing the photoelectric cell connections, a positive can be made to produce a positive, and a negative to produce a negative. It is a general rule, however, to send a positive and receive a negative. The actual time required to send a picture is seven minutes, but the associated photographic process take from one-half to three-quarters of an hour.

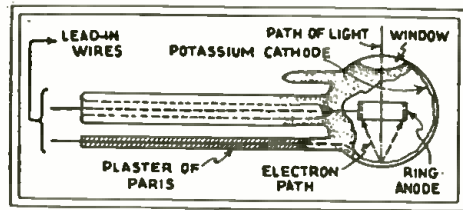

The photoelectric cell used in Telephotography

The transparent positive is fastened on a cylindrical form which only holds the film and does not interfere with light passing through it. Focused on the film, and shining through it, on to a photoelectric cell which is inside the cylinder, is a small rectangular beam of light. The film is rotated, and as it rotates it advances slowly parallel to its axis, like a screw, so that the beam of light, which is stationary, traverses the entire picture in a series of adjacent

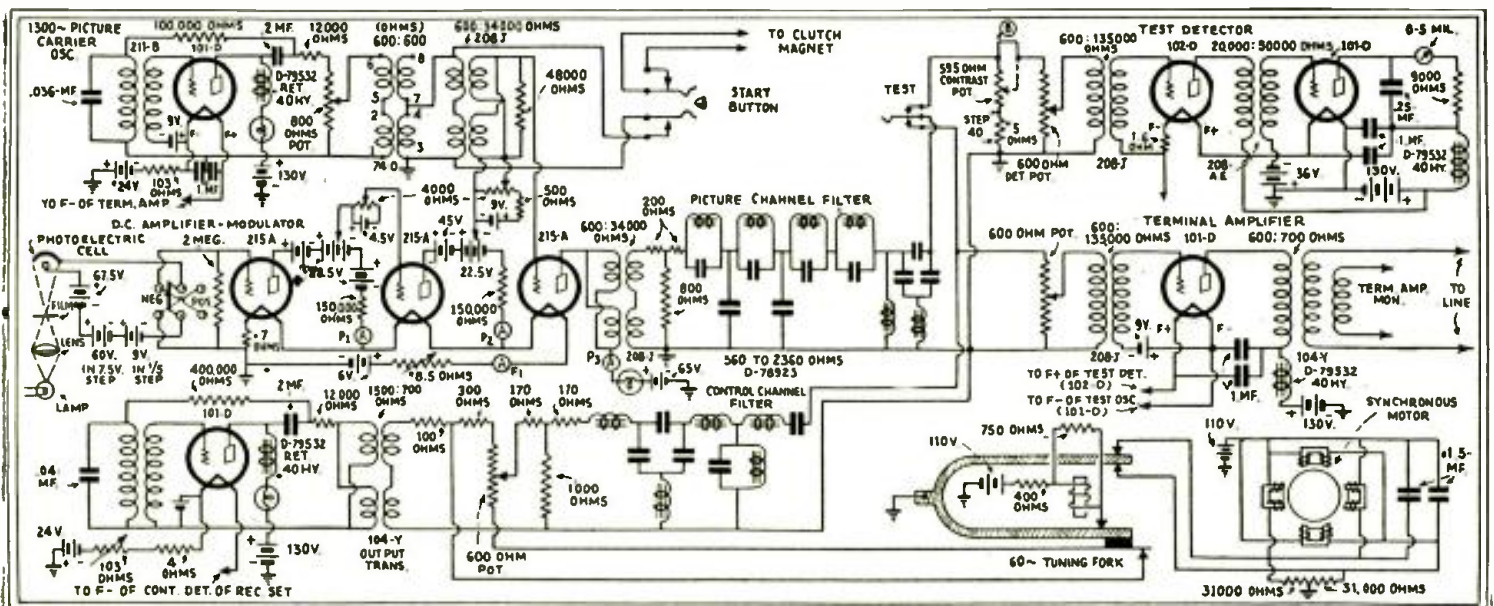

Complete schematic diagram of the transmitting station. All values are marked on the diagram for convenience.

lines. As the film rotates, the intensity of the light on the cell varies with the shade of the film at the point where the beam is focused. This variation of the light on the cell causes a variation of the current through it, and this current is amplified and used to modulate a 1,300-cycle carrier wave, which is sent over the telephone lines.

At the receiving end, an unexposed negative is rotated on a similar cylindrical form, in synchronism with the original picture. A light valve allows light to fall on the film, but with an intensity that varies with the strength of the current received from the telephone lines. The film is then developed and the transmission is complete.

The telephotograph system can be divided into two separate and distinct parts; the picture system and the control system. The picture system has to do with the transforming of light energy into electrical energy, its transmission over the lines, and the change back from electrical energy into light energy. The control system provides the means of starting both machines at the same time and maintaining synchronous speed.

The Picture System

The 5 x 7-inch positive film is placed over a cylindrical form which mounts on a rotating shaft. A motor drives the shaft at 90 R.P.M. and as it revolves, the film advances along a lead screw one-hundredth of an inch per revolution. Light from a stationary source is focused on the film, and covers it in a series of adjacent lines. A small lamp of constant intensity throws a beam of light through a small aperture and it is focused, by means of two lenses and a prism, on the film. The width of the image is equal to the lead of the screw or one-hundredth of an inch, and its height is two-thirds of its width. As the light passes through the film, it falls on the photoelectric cell, which is inserted into the film holder. With a change in shade of the film at the point where the image is focused, the intensity of the light on the cell also changes.

As a means of changing light energy into electrical energy a photoelectric cell is used. It consists of a long, evacuated tube, coated internally with a potassium cathode, and containing a metallic ring-shaped anode. A potential of approximately 100 volts is maintained between the two electrodes. Light passing through a window, falls upon the cathode, causing it to give off electrons. The number of electrons given off varies directly with the intensity of the light that falls upon it. These electrons are attracted to the positive anode, causing a small current flow of about 0.2-micro-ampere. Thus, a change in the density of the picture produces a change in the photoelectric cell



Left
Photograph of the receiving apparatus. The motor may be seen at the extreme right.



Right
Photograph of the transmitter. The motor may be seen at the left and the amplifier and oscillator at the extreme right.

current flow. Some of the advantages possessed by the potassium photoelectric cell over the selenium cell, are the absence of dark currents, and a lack of electrical inertia. This makes possible sharp, clear pictures.

Current from the photoelectric cell is run through a high resistance to give an appreciable voltage drop, and then sent through two stages of vacuum tube resistance-coupled amplification. The use of inductive or capacitive amplification is not possible in this case because the frequencies vary from a few hundred cycles per second to almost zero or direct current. Inductive or capacitive amplification would not operate on direct current. Resistance coupled amplifiers have an added advantage in that they amplify all of the frequencies equally.

A vacuum-tube oscillator, tuned to 1300 cycles, produces the carrier wave that flows over the lines. The output of this oscillator and the amplified output of the photoelectric cell are both impressed on the grid of a modulator tube, resulting in a 1300-cycle wave, modulated by the photoelectric cell current. To eliminate any stray frequencies or harmonics, a filter is provided at the terminal and then a final amplifier boosts the current higher.

(Continued on page 747)

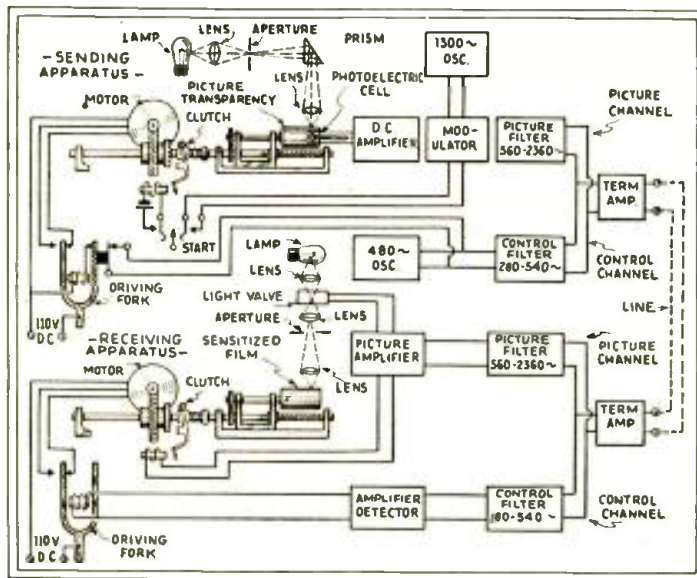

A block diagram of the receiving and transmitting apparatus.

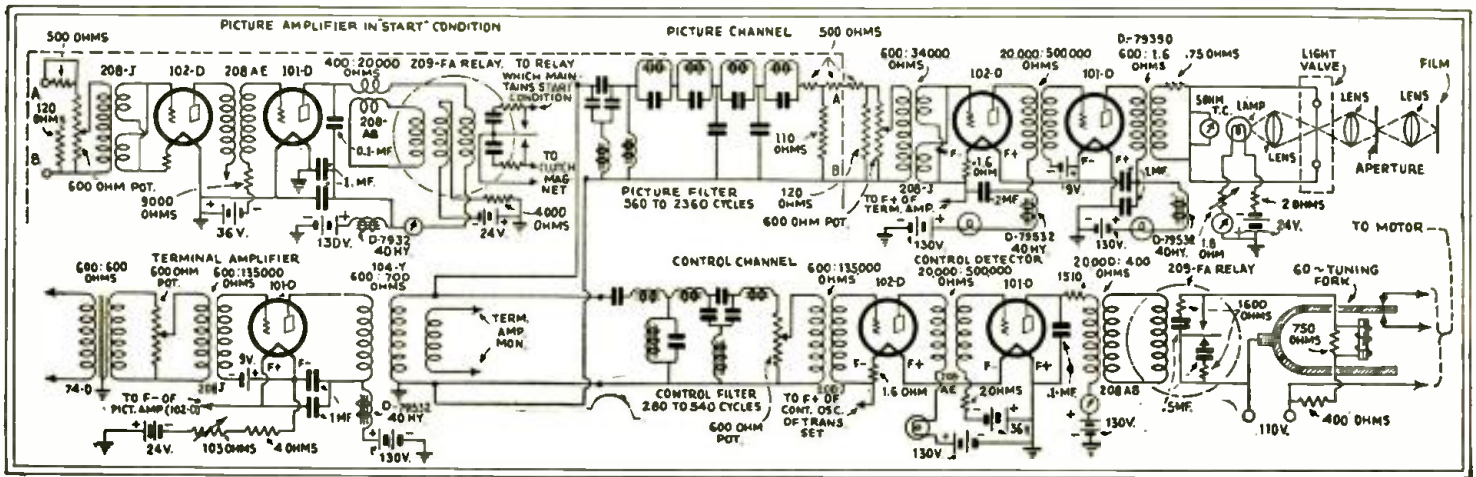

Complete diagram of the receiving station. All values are marked on the diagram for convenience.

How to Make Copies of Instantaneous Records

Past issues of RADIO-CRAFT have discussed numerous methods of making instantaneous records, but the methods of making copies of the original have not been given sufficient thought. The author describes several means which may be used by the home recordist.

By GEORGE J. SALIBA, B.S.

ONE of the great problems of the home recordist, judging from the volume of mail, seems to be his difficulty in obtaining duplicates of his recordings.

In photography, the amateur is obviously very fortunate in that at a very slight additional cost, his negative can be made the source of a great many pictures; and in the professional field of recording, the original *master* is also, at low cost, the source of many copies, through the modern application of the principles of electroplating. To the instantaneous-recording amateur, however, the problem is quite different and a trifle more expensive.

At the present time, there are two methods available whereby the recordist can obtain copies, the first being known as "dubbing," and the second as "processing." *Dubbing*, a word descriptive of the first of the two copying processes, is convenient for the home recordist, being derived from "doubling," an old term in the phonograph field; it means the direct production of one or more duplicate positives from a master positive.

In the days of soft-wax cylindrical records, direct duplicates were made by the use of a single reproducing machine, acoustically connected to several recording machines. Since this was before the days of the microphone and amplifier, the sound, reproduced mechanically from the original record, was "piped" to the cutters on the several recording machines. Another method of obtaining direct record duplicates was a mechanical *pantograph* arrangement. Today, we "pipe" our sound electrically over wires.

Duplication by "Dubbing"

A typical electrical "dubbing" layout for the home recordist is illustrated in block form in Fig. 1. The procedure in making a duplicate instantaneous recording is to play back the original record through an amplifier, the output of which is connected to the cutting head that is cutting the second or duplicate record. In other words, the set-up is the same as that used in making the original record, except that the microphone is replaced by the electric pickup, turntable and record.

The amplifier used must be the same one that was used in making the original record; although any good quality audio amplifier may be used. Since the output of the electric pickup is about one *volt*, whereas that of the microphone is in the order of *microvolts*, the gain required in dubbing instantaneous records is not nearly as great as that required in making the original recording.

For this reason, the sound level must be watched very carefully to prevent overloading. If, for instance, the feed-screw is cutting 92 lines per inch, the cutter may "double track"—cut over to the next sound track—with the result that the new record will not track. Of course, this condition is not so likely to occur when pre-grooved blanks (which, as stated in previous articles, are only 80 lines to the inch), are used; nevertheless, difficulty may be experienced in keeping the recording head on the record.

Quality of Recording

It must be borne in mind that to obtain good results a good

pickup is absolutely essential; and may be of either "high impedance" or "200 ohms" rating.

Since the primary impedance of the standard *microphone* input transformer used in the set-up for making the original record is 200 ohms, the 200-ohm *pickup* must be connected directly to the primary as shown in Fig. 2. If a high-impedance pickup is used, the connections are made across the secondary of the transformer; or, preferably, direct to the tube, as shown in dotted lines. For the latter connection, a pickup adapter may be used.

In "dubbing," the quality of the new, duplicate record will not be as good as the first record; or as good as duplicates obtained by "processing." In the first place, the question of needle scratch is to be taken into consideration. Since the original record had a certain amount of "surface" noise which is readily picked up and recorded, the dubbed record will have about twice the amount of scratch as the original. Of course, if exceptional care had been exercised in making the original and if the original record blank had been stamped from good material, then, the surface noise would be very small and the quality of the new record would very nearly approach the original.

Some people recommend the use of a scratch filter; in the writer's opinion this is detrimental to good quality, since the scratch frequency is in the neighborhood of 4000 cycles, and all frequencies above this figure must be cut out if the scratch is to be eliminated. However, for voice records *only*, the use of a scratch filter is permissible. These scratch filters may be obtained ready made; in reality they seldom are anything more than an ordinary tone control of the general type so popular on many radio receivers today; when adjusted for bass reproduction the high notes are cut out and the scratch disappears.

If several copies are to be made, the same "original" record must not be used, for after a few "dubs," it becomes too worn for good dubbing (although still sufficiently good for ordinary reproduction). The solution to this problem is to use each dubbed record as an "original" from which to make another. However, when it is realized that the scratch is additive, and the level of the surface noise after making a dozen copies is above the recording level, it becomes evident that the possible number of copies that can be made with the "dubbing" system is limited.

Obtaining Multiple Stampers

Processing, the second method of making copies of the original record, is costly and is the logical one to choose only where a great many records are desired; since it necessitates hiring the services of a commercial sound recording studio of the type which specializes in producing a limited number of records, say, in lots of a hundred.

The procedure followed is the same as that for the production of commercial phonograph records, in that a "master," "mother," and "stamper" are required before the pressing can be done.

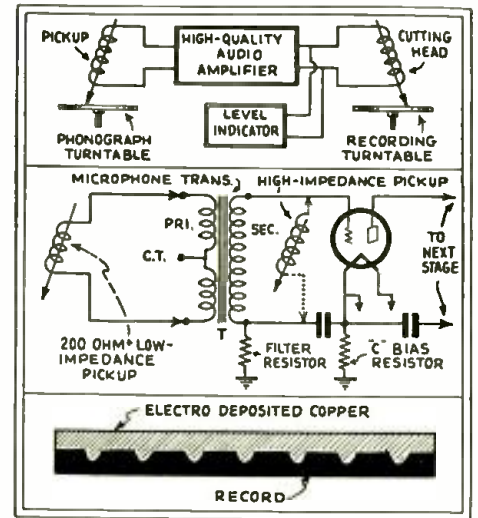

Fig. 1. above. A "dubbing" circuit layout.

Fig. 2. center. Connections of both high- and low-impedance pickups.

Fig. 3. below. Cross-section of copper and wax records.

THE THEORY *and* CONSTRUCTION of Attenuators, Line Filters *and* Matching Transformers

(PART II)

In this second of a series of articles, the author will discuss additional design considerations of attenuators, illustrating them with numerical examples.

LAST month, some of the more pertinent problems of transmission lines (with special reference to "pads" or "attenuators") were outlined. In this issue, we will continue with a discussion of actual design considerations.

The two extreme conditions that a transmission line could be subjected to are an open-circuit and a short-circuit condition; in which cases, the greatest reflection of energy will take place, and abnormal voltages and currents will be set up from small impulses originally sent into the line. This is the same as saying that *infinite* impedance terminates the line on open circuit, and *zero* impedance terminates the line on short circuit. These two conditions are very rarely encountered in practice, unless the line should accidentally become open or shorted at the far end.

Assume a transmission line in which the line conductors have negligible attenuation (zero losses) and in which the generator or source impedance is of known value. Then, if a terminating impedance is inserted at the far end of the line, and starting from the open-circuit condition of infinite impedance, this terminating impedance is gradually made smaller and smaller, the reflected energy will also become smaller, and as the terminating impedance approaches the value of the source impedance, the reflected energy rapidly decreases. At the point where the value of the terminating impedance exactly equals the source impedance, the reflected energy will be zero (no reflection losses), and maximum energy will be obtained at the load.

Likewise, starting with the short-circuit condition of zero terminating impedance, and increasing the load impedance, the reflected energy becomes smaller, so that when the point is reached where both the terminating and the source impedances are exactly equal, the reflected energy will be zero (no reflection losses), and maximum energy will again be fed to the load.

When the terminating or load impedance exactly equals the source impedance, the line has the same characteristics as a line of infinite length. If a line of infinite length could be constructed, any energy sent into this line would never be reflected back to the source. By inserting at the far end of a transmission line a load or terminating impedance equal to the source or generator impedance, the characteristics of a line of infinite length are immediately obtained (assuming zero losses in the circuit) and consequently no reflection losses are set up in such a circuit.

This entire discussion on reflection losses can be summed up by stating that the cause

By HY LEVY, B.S.

of these losses is *improper* impedance matching, and it is for this reason that the subject of *proper* impedance matching is so strongly stressed and observed in voice transmission circuits. In order to avoid reflection losses, care must be taken to see that, at any point in a transmission line where an impedance is to be inserted, this terminating or load impedance is made equal to the impedance working into it. Reflection losses, as previously stated, give rise to abnormal voltages and currents; harmonics are set up, and the wave form of the impressed original signals are distorted, with the result that straight-line frequency-response characteristics are not obtained from such a circuit.

If the load impedance Z_L (see Fig. 3) exactly equals the source impedance Z_s , then the source impedance Z_s is said to be working into its "image impedance," for in such a case, there is no reflection of energy from the load impedance back into the line.

If an attenuator is now inserted into the transmission line between the source and the load, it must be so

designed that the impedance of the attenuator must in no way upset the impedance match between the source and the load. If then, when the attenuator is working in the transmission line, the impedance "looking" into the source (from the line) exactly equals the impedance "looking" into the load (from the line), then the pad is said to be working between its "image impedances," and no energy will be reflected back at any point along the line, as the impedances looking in either direction along the line are exactly equal. In such a case, no reflection losses will occur at any junction points throughout the line, and practically ideal transmission characteristics are obtained, except for such losses as arise from the effects due to the length of line over which the energy is fed. (The losses due to length of line will not be considered in these papers. It is assumed that the voltage at the source is the voltage appearing across the 1-2 terminals, (See Fig. 7) of the pad, and the voltage at the 3-4 terminals is the voltage across the load).

Design Considerations

In order to maintain the same impedances in either direction, the pad must be designed in such a manner, that when looking into the 1-2 terminals, the combined (resultant) impedance of the attenuator and the load must exactly equal the source impedance. Also, when looking into the 3-4 terminals, the combined (resultant) impedance of the attenuator and the source must exactly equal the load impedance. These last two state-

(Continued on page 750)

TABLE-3

Decibels change	$\log \frac{V_1}{V_2}$	$\frac{I_1}{I_2}$	$Z_0 = 200 \text{ Ohms}$		$Z_0 = 500 \text{ Ohms}$		$Z_0 = 600 \text{ Ohms}$	
			Z_1 Ohms	Z_2 Ohms	Z_1 Ohms	Z_2 Ohms	Z_1 Ohms	Z_2 Ohms
1	.05	1.12	5.65	1760	14.3	4400	17	5280
2	.10	1.26	11.5	658	28.8	2150	34.5	2574
3	.15	1.41	17.0	571	42.6	1428	51	1714
4	.20	1.58	22.5	422	56.5	1056	67.5	1266
5	.25	1.78	28.0	328	70.0	820	84	964
10	.50	3.16	61.8	140.5	129.5	361.5	165	422
20	1.0	10.0	82.0	40.4	205.0	101	246	121.4
30	1.5	31.6	95.0	13.5	237.5	33.8	286	40.5
40	2.0	100.0	99.0	2.0	247.5	5.0	296	6.0
50	2.5	316.0	100.0	1.3	260.0	3.2	300	3.8

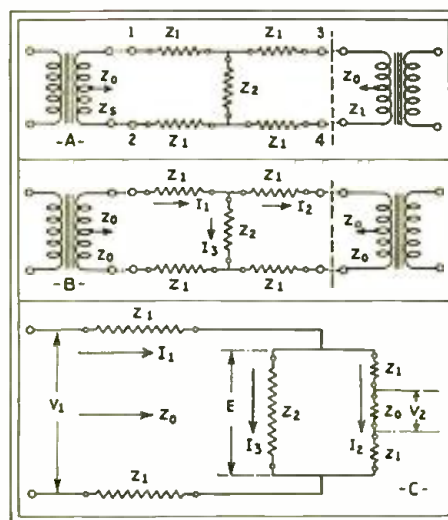

Fig. 7, above. Diagram of a pad.
 Fig. 8, center. A resistive network.
 Fig. 9, below. Equivalent circuit of Fig. 8.

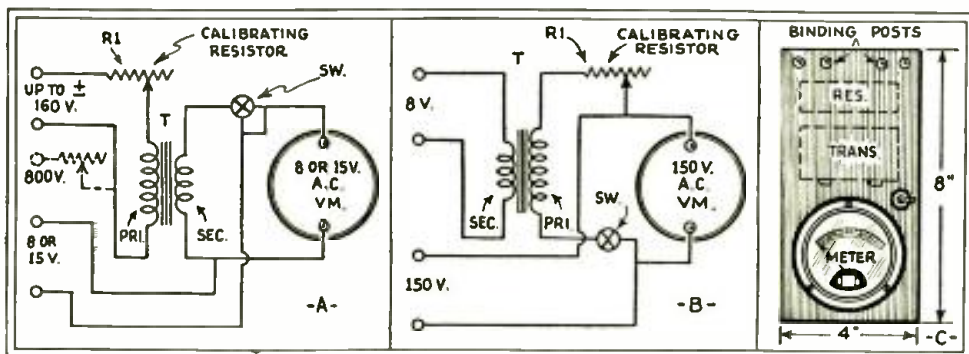

Fig. 1

At A, connections for using a low-range meter for measuring high voltages.
At B, connections for using a high-range meter for measuring low voltages.
At C, a suggested panel layout that is both simple and compact.

A unique method, described here by the author, for increasing the range of an A.C. meter without the use of resistors.

RE-RANGING METERS

ONE never seems to have enough meters for experimental or testing work. Either an A.C. milliammeter is needed, or the D.C. voltmeter scale is too coarse for the voltages to be measured. The object of this article is to help increase the usefulness of one's present equipment, or to assist in selecting the least number of meters required to give the greatest efficiency.

Very often one has a low range A.C. voltmeter and wishes to use it as an A.C. line voltmeter. The first thought is to put a resistance in series and increase the range to the desired value. In D.C. meters this is possible, but with low reading A.C. voltmeters, the series resistance method is not practical, and other means must be employed. Again, the meter on hand may be a 150 A.C. voltmeter and it is desired to measure A.C. filament voltages. We will show how either of the above meters may be utilized by employing a *small bell-ringing transformer*.

The transformer selected was, because of its small size and low cost, a 50-140 cycle General Electric, Type G.E. 2332. The voltage ratio is 110 to 8 volts, a ratio of 13.75 to 1. Thus, by connecting the transformer primary across the line and an 8- to 15-volt A.C. voltmeter to the 8-volt secondary terminals, we may determine the line voltage by taking the readings on the voltmeter and multiplying by 13.75.

Likewise if one possesses a 150-volt A.C. voltmeter and wishes to measure the filament voltage of a radio tube, connect the voltmeter to the transformer *primary*, and the filament terminals of the tube to the 8-volt secondary. But, in this instance, be sure to *divide* the voltmeter reading by 13.75, since we are using the transformer to step-up the voltage. It was found by experiment that *the ratio is not the same as when used for voltage step-down*; (the primary leads on this particular transformer are the stranded wires, whereas the secondary posts are the thumb nuts) consequently we must divide by 13 to obtain correct readings, due to the resistance of the primary.

Of course, the above method does not permit direct-reading (due to the odd ratio of the transformer windings). To accomplish this, the major part of this article will be devoted to means of making the meters read so that factors of 10 or 20 may be used to make easy the processes of multiplication or division.

Meter-Transformer Kit

To make a test meter for measuring filament and line voltages, one needs an 8-volt A.C. voltmeter (either Jewell Pattern 78 or Weston Model 476 will be satisfactory), and a General Electric, Type G.E. 2332 bell-ringing transformer; for housing them, a suitable wooden box, fitted with four insulated binding posts and a toggle switch should be used. A 3500-ohm adjustable resistance, R1 in Fig. 1A, is also necessary and should be mounted inside the box with the other equipment.

The adjustable resistor R1 in this circuit is connected in the primary leg, purposely, since it does not carry as much current in the primary as it would in the secondary, thus reducing the danger of overheating; in Fig. 1B the resistance is connected between the transformer T and the meter VM.

By JOHN C. BANK

The box mentioned should be no less than 8 x 4 x 2½ ins., which allows for wood up to ¾-in. in thickness, (although thinner material, making it lighter, would do much better). The sides and bottom may be held together with brads, and the top fastened by four oval-head wood screws. The meter, transformer, and all other parts should be mounted on the inner side of the top (preferably of bakelite) so that, by using the wood screws, this unit can be detached from the box for inspection. (If the stock used for this box is thin, it is best that a wooden block be glued or nailed at each corner to act as a "hold" for the screws.)

The best layout for the parts is shown in Fig. 1C; an arrangement which brings the meter close to the worker and also places the binding posts at the opposite ends. A hole must be drilled in the top of the box, the same diameter as the meter selected; and three additional holes (to coincide with those in the flange) for the small bolts that hold it to the panel. Drill the other holes for binding posts, switch, and if necessary, for mounting the transformer and resistance.

Note that the switch is placed in the meter circuit in order that the meter may be used by itself; otherwise, the current drawn from the circuit to be measured would be higher than necessary, since current would flow through the secondary of the transformer as well as to the meter. (See Fig. 1A.)

Calibration

After all the parts are mounted on the box cover and connections are made according to diagram, the combination must be calibrated. To obtain best results, a 150-volt A.C. voltmeter should be used to read the correct value of the test potential. This instrument must be connected directly across the line to which are connected the two high-voltage binding posts. In this way, we know the value of the voltage applied at the binding posts of our instrument to be calibrated. With this set-up, the 8-volt meter must be made to read one-twentieth of the 150 voltmeter indication by varying the value of adjustable resistor R1. Supposing, for instance, that the latter reads 114 volts, we divide 114 by 20 and have 5.7 as the voltage. Then we vary the value of R1 until the 8-volt meter reads 5.7 volts and fasten the sliding contact so that it cannot change—our outfit is now calibrated.

To some, it may not be possible to borrow, or have access to the 150-volt standard meter mentioned in the preceding paragraph, in which case it will be necessary to resort to another method, (although it is not as accurate as the one just described).

After all parts are mounted, connect a temporary switch across the adjustable resistance so that it may be shorted-out at will. Now, with the switch closed, connect the high-voltage binding posts leading to the transformer primary to a source of 60-cycle A.C. If the voltage on the secondary meter reads the 7.5 volts which we have been using for our example, we can *calculate* the line potential by multiplying 7.5 by 13.75 (the transformer ratio) giving 103 volts as the line potential. Wishing to make our multiplier 20, we must divide 103 by 20, obtaining 5.2, the value in volts which

(Continued on page 753)

DISSECTING A MODERN SET TESTER

(PART IV)

The Tube Tester

By FLOYD FAUSETT*

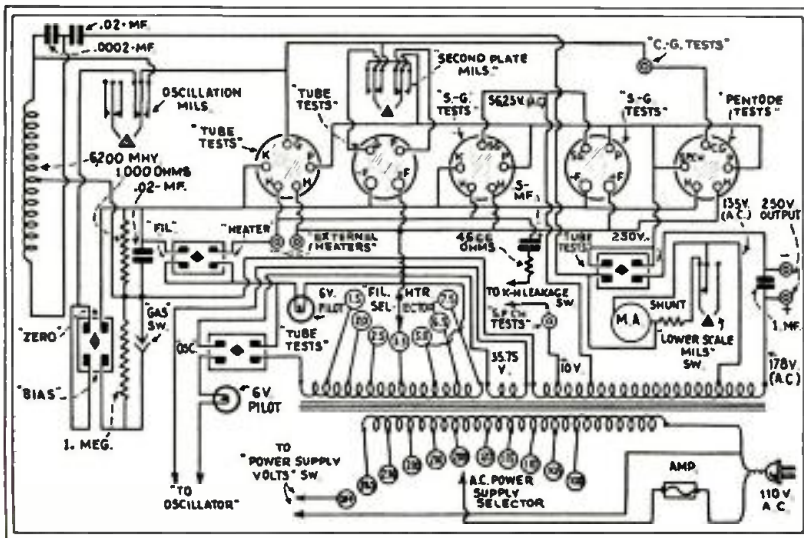

Fig. 5

Schematic diagram of the tube-tester incorporated in the Supreme A.A.1-1 Diagonometer.

IN the March and April 1932 issues of RADIO-CRAFT, the uses of a modern set tester as a tube-socket analyzer were discussed under the heading, "Dissecting a Modern Set Tester," (Parts II and III). This month's discussion relates to the *tube testing* functions of the same tester.

A 4½-volt flashlight battery is included in the tester (Fig. 5) for a comparative "grid-swing" test of tubes during analyses when radio power is utilized for the tube tests. This method is simple and has the advantage that noisy tubes may generally be detected "on the job." As a matter of fact, the "listening test" is the only practical service method for detecting noisy and microphonic tubes.

The Tube Tester

Service Men answering service calls often find, however, that the radio is completely inoperative, with the power supply from the power pack shorted or open circuited, so that the analyzer, which depends upon the radio power supply for its tube testing functions, is useless as a tube checker. Since customers usually expect an estimate of the cost of putting the radio back in operation, it is desirable that the Service Man have with him facilities for testing the tubes, so that he can include the cost of the necessary tube replacements in his estimate.

A tube checker which functions independently of the radio set is also advantageous in that it permits tests with predetermined power supply and circuit characteristics, so that "discard" limits can be established. Discard limits cannot generally be stated for tests from radio tube sockets because of the variations in circuit characteristics in different receivers or in different sockets of the same set.

Although reports of reliable radio service organizations indicate that less than 35 percent of service calls result directly from tube defects, some dealers have gained the impression from advertising estimates that 90 percent of radio troubles are due to this cause. This impression has brought about great interest in the comparative merits of tube-testing methods with a power supply independent of the radio chassis. Obviously, the most reliable method is that which most nearly approximates actual tube performance in the radio. Some very expensive tube testing equipment has been available for some time, and such equipment is probably capable of detecting 95 percent of tube deficiencies.

Some tube checkers which cost only about 10 percent as much as the more elaborate testers are capable of detecting about 90 percent of tube deficiencies. The Service Man must decide for himself whether his tube business warrants his investing five or ten times more money in an elaborate tester for detecting from five to ten percent more tube deficiencies than can be detected with a simple tube checker employing the principles incorporated in the AAA-1 Diagonometer, in which the alternating potentials applied to tubes during the tests are closely related to the potentials specified by tube manufacturers. All radio tubes in normal operation must respond to alternating or pulsating potentials, as all broadcast

carrier waves and modulated signals have alternating characteristics. Power supply variations are compensated by a tap switch arrangement for voltage ranges from 100 to 120 volts and from 200 to 240 volts.

Mutual Conductance Test

Since the "mutual conductance index" method is the most reliable of simple tube-checking methods, the principles involved are incorporated in the AAA-1 Diagonometer tube checking facilities. In addition to this method of comparative tube checking, provisions are included for, (1) indicating cathode-heater leakages; (2) comparative indications of the gas content of amplifiers; and (3) for indications of the plate current of tubes during oscillation. These three additional tests are for comparative purposes only, and no definite discard limits are prescribed for them. Discard limits for the "mutual conductance index" tests are tabulated on the inside top cover of the Diagonometer case.

Cathode-Heater Leakages

The "buzzing" noise sometimes emitted from radio loudspeakers is generally caused by intermittent cathode-heater leakage in heater-type tubes. The effect of this tube defect varies with different radio circuits, being most noticeable where the cathode biasing resistance is utilized in the volume-control circuit with the heater circuit grounded. A short circuit between the cathode and heater elements of a tube will be indicated by an approximate full scale deflection of the voltmeter needle during the test.

All radio tubes are more or less "gassy," but it is generally desirable that the gas content of tubes be at a minimum, especially for resistance-coupled circuits, in which the grid current resulting from the gaseous condition will tend to reduce the grid bias of the tube by the voltage drop of the gas current through the grid coupling resistors.

It may be found that new tubes will be indicated as "gassy" when first tested with the Diagonometer, but that the gaseous condition is less noticeable after they have been in service a few minutes. It may also be noticed that old tubes, after having served their expected period of usefulness, will test as very "gassy." If they develop a purplish glow between the elements during normal operating conditions, they should be replaced. A purple glow is sometimes observed on the inside glass surface of power tubes, but this is quite natural and should not be interpreted as an indication of a detrimental gaseous condition. However, if the purple glow surrounds the filament, the tube should be discarded.

The matching of tubes for tuned R.F. stages with the Diagonometer is accomplished by subjecting the tubes to a test of their ability to generate oscillations in a circuit having constant values of inductance, capacity, resistance and power-supply potentials. This test affords a very practical means for accurately tabulating comparative meter indications of the general operative merits of tubes under dynamic radio-frequency operating conditions, in which variations in inter-electrode capacities, as well as variations in

(Continued on page 755)

*Chief Engineer, Supreme Instruments Corp.

The QUADRUPLE PENTODE

MIDGET

A description of a new receiver that may be operated from either A.C. or D.C. without any circuit changes whatsoever.

By H. G. CISIN, M.E.

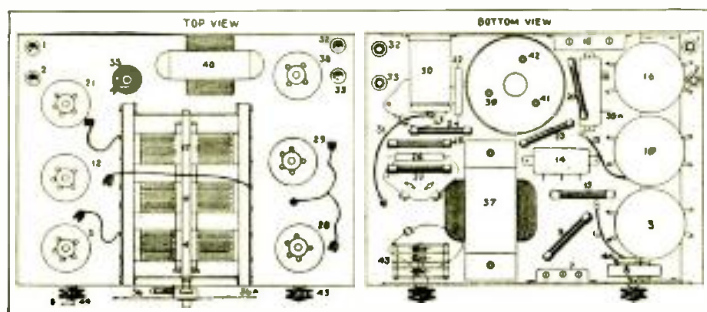

Fig. 2
Top and bottom views of the receiver.

THE "Quadruple Pentode Midget" possesses a number of novel features, all of which have been incorporated in the design for a single purpose—to produce superior results. There are two tuned R.F. stages which use two of the new 139A Arcturus variable-mu R.F. pentodes and are very effective in reducing cross-modulation distortion and various receiver noises. Furthermore, through the use of these tubes, easy control of volume is attained over a wide range of signal voltages, without the necessity of using a local-distance switch or a double preselector. A volume control in the cathode circuits of these two tubes gives wonderfully smooth control.

A "136A" tube functions as a screen-grid power (biased) detector. A single resistance-coupled audio stage employs two "138A" output pentodes in parallel. The use of the two tubes in this arrangement permits a larger power output without increasing plate voltage, and in addition, cuts the optimum load impedance in half. These tubes also give improved results when operated from a 110-volt D.C. source; as a result, they are ideal for use in the "Quadruple Pentode" set, since this set has been designed for use either on alternating or direct current, by means of an ingenious switching arrangement.

To make the change from A.C. to D.C. operation, it is merely necessary to turn the knob of a sectional rotary switch. This design, used in this set for the first time, eliminates changes in wiring, tubes, etc., and also does away with the necessity for special switching plugs. It is simple and convenient, and the inexpensive switch is the only additional part needed to make the set universally applicable to A.C. or D.C.

In this receiver, the filaments of the five tubes are in series. A pilot light and a resistor are also in series in the same circuit. This resistor has a value that permits the filaments of each of the five tubes to receive the rated potential of 6.3 volts.

On A.C., a full-wave rectifier (38), supplies direct-current for plates, screen grids and biases. (See Fig. 1.) The rectifier is switched out of the circuit when operated on D.C. On A.C., the speaker field is in series with the audio choke (10), thus supplying the extra filtering needed in this case; on D.C., however, the speaker field is switched directly across the 110-volt line, with the single choke taking care of the filtering. A triple-section electrolytic condenser forms an important part of the filter in either case. Metallized resistors are specified because of their permanent accuracy of rating. To obtain really fine results, all resistors should have values exactly as marked.

The automatic line-voltage control or

regulator, will give materially improved operation, and in addition, will protect tubes and other delicate parts against injury due to line-voltage surges. In case of short circuits, this valuable accessory also acts as a fuse, thus paying for itself many times over.

Mechanical Considerations

The chassis material is cut to size, drilled for the sockets and bent. (See Fig. 2.) Holes are drilled for variable condenser brackets, for the binding posts, the choke (10), the resistance mounting (35) and for mounting the parts on the chassis walls. The following parts are then mounted, preferably in the order given: Six wafer-type sockets and three shield bases; electrolytic condenser (39, 41, 42); transformer (37); electrolytic condenser (30); mica condensers (22, 26); bypass condensers (7), (14), (18), (19-35A).

The four binding posts are mounted, all being carefully insulated from the chassis. Then choke (10) and the three-gang condensers are fastened on top of the chassis. The sectional rotary switch (43) is mounted, then the combined volume control and "on-off" switch. Finally, resistor (35) is mounted on top of the chassis. The seven metallized resistors and the three flexible resistors are soldered in place while the set is being wired. The three coil

(Continued on page 755)

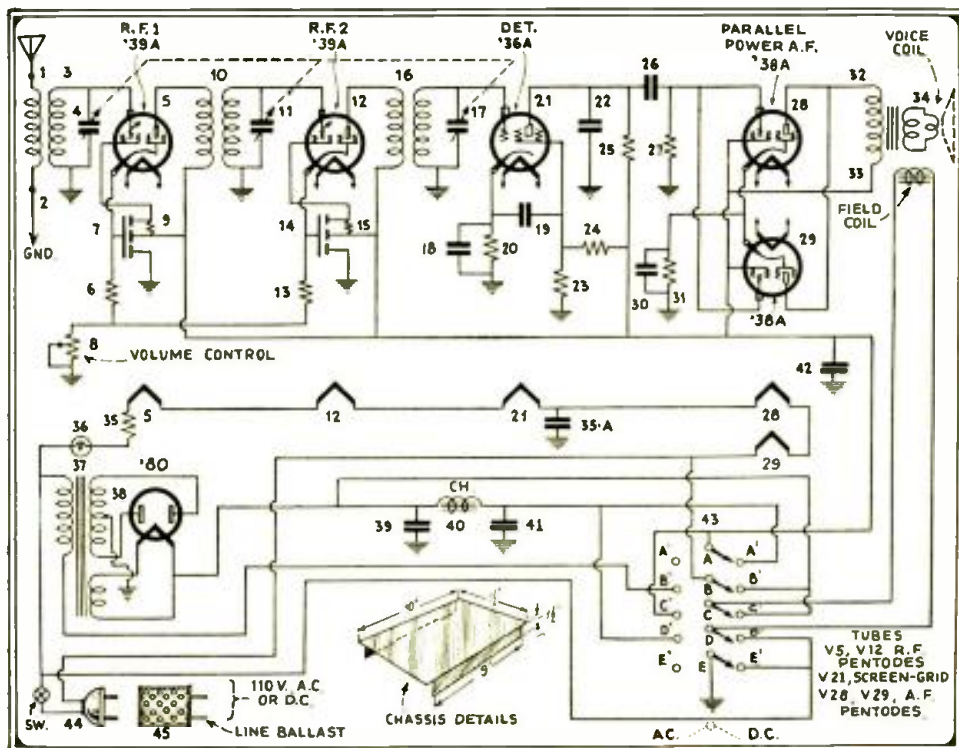

Fig. 1 Schematic circuit of the Quadruple Pentode A.C.-D.C. midget.

SHORT CUTS in RADIO SERVICE

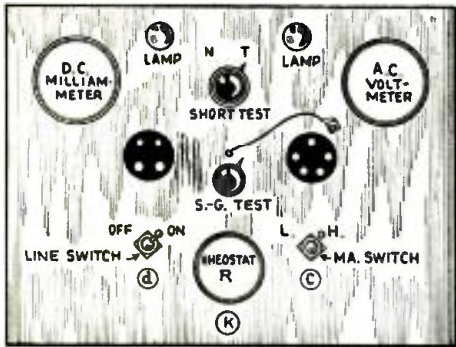

Fig. 1

Panel layout of Mr. Campbell's tester.

(PRIZE AWARD)

"SIMPLE TUBE TESTER"—NEWEST VERSION

By Vincent Campbell

I AM taking the liberty of sending you the enclosed data on the latest version of the "Simple Tube Tester" I have developed, details concerning which were published in the March and August 1931 issues of RADIO-CRAFT. The improved unit shown in Figs. 1 and 2, has the following innovations:

1. Similar to my original tube tester, this new version tests all types of tubes including rectifiers and the new pentode.
2. It has incorporated in it a "tube short indicator" that shows visually any short which would endanger the meter.
3. By the use of higher voltages, as developed through the use of a high-voltage winding on the power transformer, our tube voltages can be made to conform more nearly to the voltages employed, thus in-

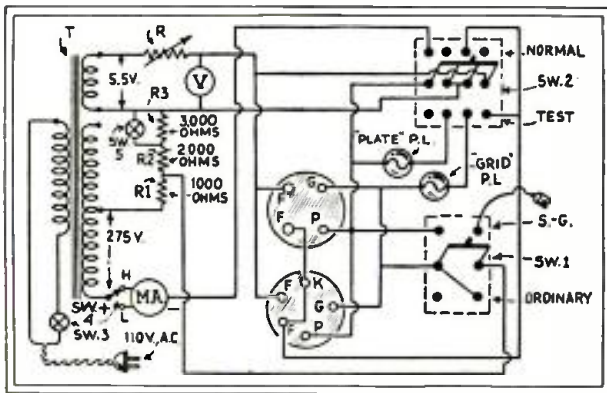

Fig. 2

Schematic circuit of Mr. Campbell's tester.

sure a better test, especially on our power tubes. Previously, they would test O.K., but when placed in operation, they would break down due to the actual working voltage in a radio set; but this new method gives us a real "breakdown test" on all tubes.

1. In the event that one does not wish to rebuild the old tester to function with the new high-voltage system, the "tube short indicator" can be incorporated into the old tube tester.

Operating Instructions and Parts List

Now for the material list and operating instructions. I am leaving the construction details to the individual builder, with the exception of a panel layout (Fig. 1) and of course the circuit diagram Fig. 2.

\$10 FOR PRIZE SERVICE WRINKLE

Previous experience has indicated that many Service Men, during their daily work, have run across some very excellent Wrinkles, which would be of great interest to their fellow Service Men.

As an incentive toward obtaining information of this type, RADIO-CRAFT will pay \$10.00 to the Service Man submitting the best all-around Radio Service Wrinkle each month. All checks are mailed upon publication.

The judges are the editors of RADIO-CRAFT, and their decisions are final. No unused manuscripts can be returned.

Follow these simple rules: Write, or preferably type, on one side of the sheet, giving a clear description of the best Radio Service Wrinkle you know of. Simple sketches in free-hand are satisfactory, as long as they explain the idea. You may send in as many Wrinkles as you please. Everyone is eligible for the prize except employees of RADIO-CRAFT and their families.

The contest closes the 15th of every month, by which time all the Wrinkles must be received for the next month.

Send all contributions to the Editor, Service Wrinkles, c-o RADIO-CRAFT, 98 Park Place, New York City.

stat R should be at the minimum or zero-resistance position during this test on all types of tubes. Thus we obtain the full 5.5 volt across our lamps.

4. Throw line switch SW. 3 off; throw the "short test" switch SW. 2 to the normal position; rheostat R to maximum or full resistance; SW. 4 to high or 100-ma. scale, the position of SW. 1 depends upon the type of tube (whether screen-grid or not). For a three-element tube, throw SW. 1 to ordinary; throw line switch SW. 3 "on" and adjust rheostat R to the proper voltage as read on our 0- to 10-volt meter. If we obtain a normal reading (below 15 ma.) we may throw the MA switch (SW. 4) to "low"

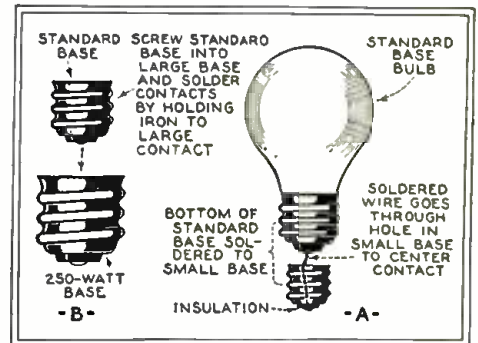

Fig. 3

A novel method of using a standard lamp in a mogul socket.

- One Pilot Universal "B" Eliminator Transformer or any transformer developing 5.5 volts at 2 amps., and 275 volts;
- One D.P.D.T. switch, SW. 1;
- One S.P.S.T. line switch, SW. 3;
- One S.P.D.T. switch, SW. 4;
- One Push-button switch, SW. 5;
- Two 6-volt pilot lamps and sockets, P.L.;
- One Giant Power variable 60-ohm rheostat, R;
- One 1,000-ohm resistor, R1;
- One 2,000-ohm resistor, R2;
- One 3,000-ohm resistor, R3;
- One 4-prong and one 5-prong socket;
- One Readrite double-scale milliammeter (0-20 and 0-100 ma.);
- One 0-10-volt A.C. voltmeter.

Operation

The operation of this tester is similar to other types. The procedure is as follows:

1. Insert the tube in the proper socket, leaving switch SW. 3 off;
2. Throw the "short test" switch SW. 2 to test position;
3. Throw the line switch SW. 3 on. Now if either or both of the "grid" and "plate" lamps light, there is a short and you should not continue further unless you wish to destroy the meter. In the event that they do not light, we may continue. The rheo-

or 20-ma. scale and proceed to take our mutual conductance readings, comparing them with a chart;

1. by not pressing SW. 5;
2. by pressing SW. 5.

These readings are similar to those in the chart shown in the March 1931 issue of RADIO-CRAFT.

(Continued on page 763)

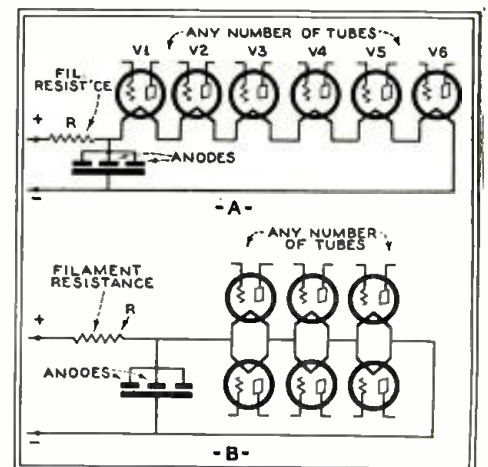

Fig. 4

At A, the original, and at B, the revised connections.

Operating Notes

The Analysis of Radio Receiver Symptoms

By D. C. McCALL

BUSINESS is good! A fist-full of service orders at the beginning of the day. With hot political speeches and the sensational news events of the day sizzling over the air, radio provides the only means of keeping up with the times. Service work promises to be an unusually attractive prospect for the summer of 1932. And "yours truly" certainly intends to get his share of this profitable trade. Public address equipment is



"Here, take this and go buy a new Chevrolet."

is coming into its own now that the public in general realizes its real worth in political campaigns, its use on sound trucks for stirring up trade, and in centralized installations for amusement and entertainment.

Sparton 593

Let's see, here's the first complaint of the day: "Sparton picks up local all over dial." Arriving at the address, I find this Sparton doing exactly that. This model 593 is generally fairly selective. Pulling out

the chassis I give it the usual visual inspection. This model has the antenna and ground post mounted on the end of the tuning condenser shield, and the common chassis ground is connected to this ground post by a flexible lead. I notice that this wire is disconnected. I replace this lead and "presto" the selectivity returns magically. Unless this lead is grounded the shielding is ineffective and the strong signal "skips" the tuned stages and goes directly to the detector stage giving extremely broad-tuning.

Apex 8B

Second order (and its a seven-mile jump to the address) says "rush" so with much coaxing and a high consumption of Ethyl the ancient "Chevy" of mine gets under way with lots of skips, misses, splutters and "cross-talk." However we finally get to our destination and give the bell a prolonged punch. "Come in," says the owner, when he recognizes the service kit and the baggy pants full of pliers, wrenches and what-nots, that indelibly marks the typical Service Man. "My Apex 8B gave a sputter and quit on me last night," he explains, "and I'm anxious to get that nine o'clock program." "O.K., won't be long now," I assure him and soon find, from my analyzer readings, that there is no plate voltage on the oscillator. Examination under the chassis shows an open fifty-thousand ohm resistor in the oscillator plate circuit. I replace this with a two-watt resistor of metallized construction and the set is back on the job. (This breakdown is a frequent one and invariably I replace with an extra good resistor that I can depend on to stay put).

Majestic 91

The next stop is to find out what is causing a Majestic 91 to cut-off. Everything checks O.K. and I find nothing wrong with the antenna system. After careful examination I find that the antenna wire from the lead-in-strip to the set is of No. 18 bell or annunciator wire with the usual unraveling of insulation at each end. I am sure this bare wire coming in contact with the metal chassis at the terminal post, grounded the antenna and caused the cutting off. And here's a kink worth knowing if you use this

kind of wire: tie a knot in the wire about a half-inch from the end, then scrape the insulation off this half inch for connecting, and the knot will prevent the insulation from unraveling.

Radiola 18

"Fix Radio" is the only information on the next customer, so when I am inside the house I recognize an "Oletimer," a Radiola 18. The customer had come in the store and bought a new set of tubes a few days before but said it had started "squealing" since he put in the new tubes. Those who have serviced this set in the distant past (way back in 1928), will remember that this set has an "R.F. compensator" located through a hole in the chassis below and between the second and third tuning condenser, which it is often necessary to adjust when tubes are changed or the antenna-length varied. So I gave this screw a small fraction of a turn, just enough to stop the oscillation in the set and then back again to a point where maximum amplification was obtained without the set oscillating. (An open volume control in this set will cause the same oscillation so I never fail to inspect this unit if oscillation is not stopped by the compensating screw).

"What on earth makes my Majestic rattle like that!" exclaimed my next customer as she turned on the set. "Sounds like something wrong with the cone," I answered as I removed the speaker. Upon removing the cone I found it had become loosened from the voice coil form and a thin coating of Auberoid applied here was all that was needed to stop the vibration which so annoyed this member of the fair sex.

"See if you can improve volume control on Public Address System" says my next order. The customer explained, when I asked him just what he wanted, that he was using a great many Operadio Portable 3-stage Amplifiers (model 3314) in a hook-up that required microphone phonograph pick-up or radio input and that he wanted a volume control that would be contained in the amplifier and serve to control either of the inputs without external wiring. Examination of this amplifier showed me that the input connections were attached directly to the grid and cathode of the first stage '27 tube. A switching arrangement made the necessary connections to the mike, pickup or radio. First I tried the customary potentiometer arrangement with the center tap or arm contact to grid. This was O.K. on phonograph records but on "mike" or voice the extremely high or "intelligence frequencies" seemed to be lacking, making the voice hard to understand.

The amplifier uses two stages of resistance coupling ('27 tubes) and a pair of '45's in push-pull. After thinking this over a few minutes, I proceeded to hook a 100,000-ohm potentiometer in the plate circuit of the first stage '27. The ends of the resistance element were connected so as to shunt the plate resistor and the variable arm contact hooked to the grid coupling condenser. See Fig. 1. Due to the high resistance of the potentiometer the shunting effect of the plate resistor did not change the plate load to any great extent and the volume control was smooth and produced no change in the clear crisp characteristic of this amplifier. "That's the stuff," said my friend enthusiastically, "here take this and go buy you a new Chevrolet."

And he handed me a "five spot."

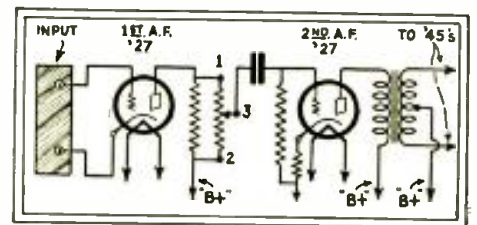

Fig. 1

Diagram showing the connection of the new volume control.

SERVICING RCA-VICTOR'S

By BERTRAM M. FREED

ALMOST every commercial receiver that has made its appearance recently has utilized the now very popular superheterodyne circuit. In discussing the common troubles and failures of some of the current models it will appear that, except in few instances, such defects have not been characteristic of the circuit, but on the other hand, may be traced to open-circuits, shorts, defective resistors and the like.

RCA-Victor Radiola Models

A large number of RCA-Victor model R-11 receivers have been sold. In this model there have been two major causes for complaints; among others, that of fading, and very weak and distorted reception. Upon examination it will be found that when the set is switched "on," the receiver will function normally for a few minutes, after which it will slowly fade, at the same time becoming distorted. Should the set be turned off and then on, it will operate normally again for only a few minutes, when the same condition will result.

This set employs an automatic volume-control tube, making necessary the use of a number of resistors of high value which, therefore, are very difficult to check with ordinary instruments at the disposal of the Service Man. Usually a faulty 5-megohm carbon leak in the A.V.C. circuit will be

found as the cause of the fading. One of the pigtails of the resistor is connected to the grid terminal of the A.V.C. tube. Repair is effected only by replacement. The value of the unit has not proved to be critical, either a three or four megohm carbon resistor serving satisfactorily.

If a careful analysis is made of the schematic of this receiver, it will be noticed that the primary and secondary of the second I.F. transformer are electrically shielded from each other. The only means of energy transfer is secured by a third, smaller, "coupling" winding, inductively coupled to the primary, but directly connected to the secondary. As shown in Fig. 2, the amount of energy transfer depends upon the setting of the volume control, which shunts this coupling coil. When the coil open-circuits the condition of very weak distorted reproduction will be noted. Since the use of an analyzer will not disclose the defect, a continuity tester or ohmmeter must be resorted to. Remove the volume-control leads, or an erroneous result (or reading) will be obtained. In most instances, the open will be found in the pigtail of the coil, which may easily be repaired.

Many of the RCA-Victor models R-50, R-55, and the more recent (Continued on page 751)

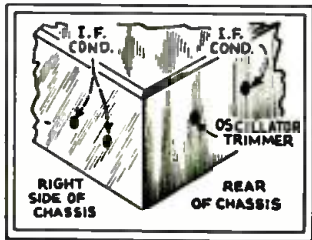

Fig. 5

Location of the trimmers in the Bosch 35 receiver.

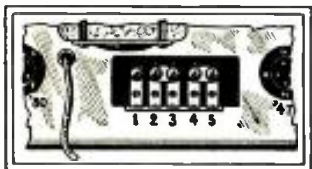

Fig. 3

Sketch showing the location of the terminal block.

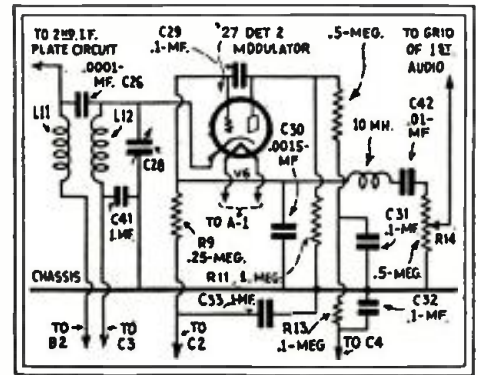

Fig. 4

Detail schematic of the Stromberg-Carlson model 22 second I.F. and detector stages.

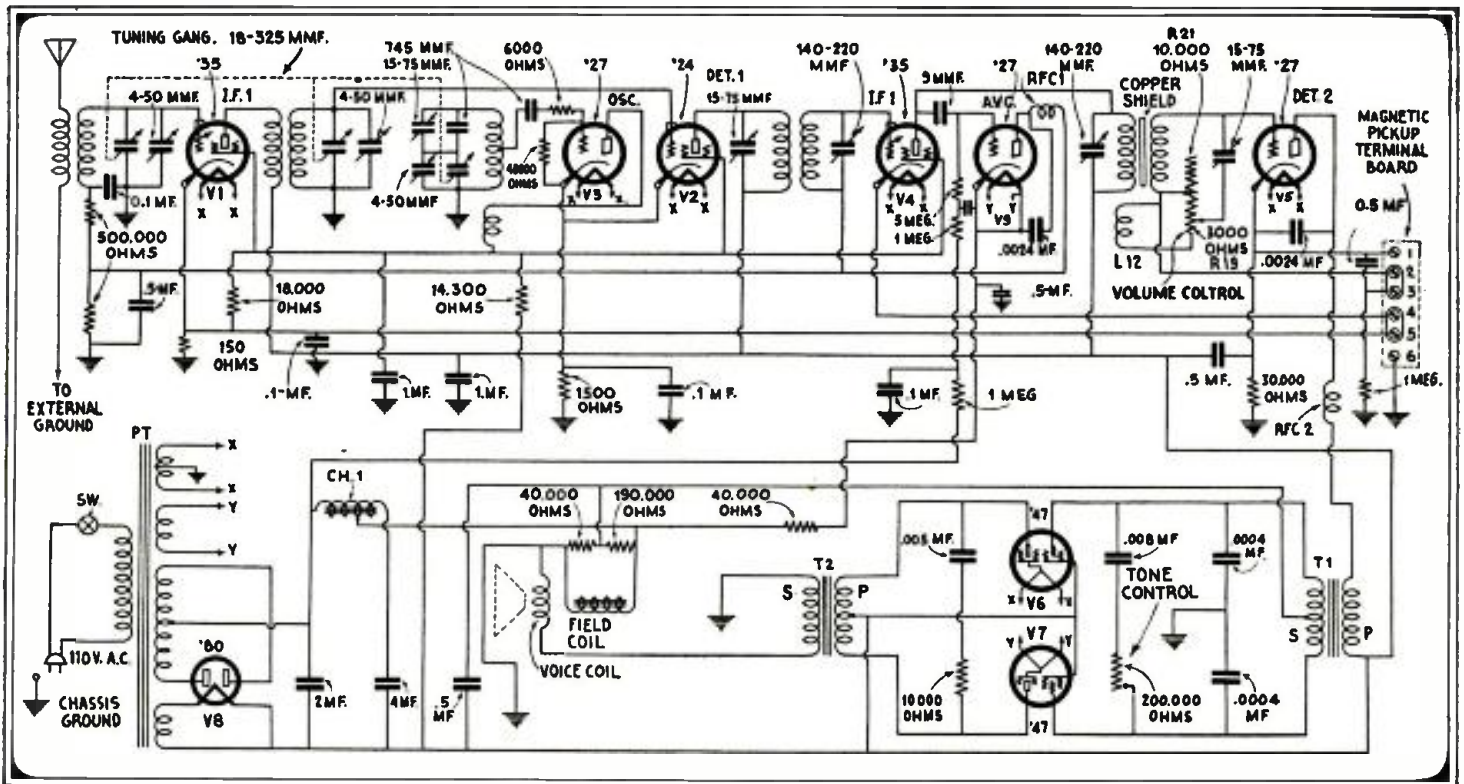

Fig. 2

Complete schematic circuit of the RCA-Victor R11 receiver. The transformer to the right of V9 has its primary and secondary shielded—coupling being effected via the coupling-coil L12.

The Service Man's Forum

“OPERATING NOTES”

We are in receipt of a letter from Mr. Floyd Fausett, commenting on “Operating Notes” section of RADIO-CRAFT. We reproduce the following with the permission of the Supreme Instruments Corporation.

“Personally, I feel that the most commendable feature of RADIO-CRAFT is its publication of reports of difficult service problems solved by good practical radio men. Almost every radio manufacturer's products develop some service peculiarities not anticipated by the manufacturer's service literature, and the published discoveries and solutions of such peculiarities make excellent reading and reference material for the radio servicing profession.

“For instance, the 1929-30 Edison (green chassis) radios frequently develop a trouble that, when first diagnosed, indicates a shorted filter capacitor, but which is generally found to be a grounded speaker field circuit; the ground resulting from leakage through the speaker terminal strip to the chassis. I searched for about an hour for this leakage when it was first encountered on this model, and probably other Service Men have done likewise. If the first man who discovered the weakness of this model had reported the peculiarity to you, knowing that it would be gladly published, many Service Men would probably have been saved much time when first encountering this particular difficulty.

“I would like to see more encouragement offered for such data from the field, to be classified and properly headed by manufacturer's names, and by models, as a sort

of national service data exchange. Your magazine has made a remarkable beginning in this direction, and I hope you will carry on with more practical service facts and less of the questionable imaginings of self-alleged Service Men who try to obtain the headlines with wild theoretical claims instead of contributing experimentally-acquired data of practical value. What do you think of this suggestion?”

SUPREME INSTRUMENTS CORPORATION,
FLOYD FAUSETT, Chief Engineer.

(The above question is self explanatory. All we can say is “Thank you, Mr. Fausett.” —Editor.)

“RADIO FOR ALL”

Editor, RADIO-CRAFT:

I am taking the liberty of writing to you personally regarding your book “Radio For All.” I wonder, sometimes, if the illustrations as used in your book wouldn't help others as well as myself. Most of the radio

I happen to be one who thinks that he can build anything he sees. Some time ago I happened on a library book of yours called “Radio For All.” I've had that four weeks now and it has done more to clear-up radio for me than anything else. My wife helped me the first evening we had the book, and in less than an hour we had an oyster container wrapped up with some other odds-and-ends and brought in WTAM (25 miles away) more than loud enough for ear phones, using an inside 40-foot aerial and a hot-air furnace pipe for a ground.

If you read this far, I can tell you that we got more kicks out of this set than from any other set we have ever had. All the blueprints in the world wouldn't have induced me to try it, but with the pictures I couldn't go wrong. I certainly hope you have published others since then that I may be able to obtain. Where can I get a copy for myself? “Radio for All” by H. Gernsback, published by Lippincott Co. and dated June 1922. I would sure love to have one.

Are there any other books you might suggest leading to one- or two-tube sets?

I am sorry to trouble you, but I hope you can help me get started in case you turn this over to some one to answer instead of the waste basket.

W. S. GUY,

Box 96, Hudson, O.

(Strange as it might seem,

there are still a great number of people who want to “tinker” with crystal or one- or two-tube sets. We regret to announce that while no pictorial diagrams are available at the present time, and no

(Continued on page 760)

THE Official Radio Service Mens Association, sponsored by RADIO-CRAFT, invites all Service Men who are not members of the Organization to write for an application blank. It is the official service organization of this maga-



zine and is maintained solely for the interests of Service Men. Membership cards are issued upon passing a written examination which is forwarded by mail. Write for yours today. The O. R. S. M. A., 98 Park Place, N. Y.

magazines are published, of course, for Service Men and dealers. As to their lines of puzzles we glance and pass on. The diagrams are as easy to read as code, but how many of us are far enough along in the art to puzzle them out as I have in the past?

POLICE and MARINE RADIO STATIONS

Wave-length (Meters)	Frequency (Kilo-cycles)	Call Letters	Location	Frequency	Call Letters	Location	Frequency	Call Letters	Location								
121.5	2470	KGOZ	Cedar Rapids, Iowa	123.4	2430	WPDE	Louisville, Ky.	180.5	1574	WRDS	East Lansing, Mich.						
		KGPN	Davenport, Iowa			KGPP	Portland, Ore.			WMP	Framingham, Mass.						
		WPDZ	Fort Wayne, Ind.			WPDH	Richmond, Ind.			KGPF	Shreveport, La.						
		WPDY	Kokomo, Ind.			WPDI	Columbus, Ohio			KGPR	Des Moines, Iowa						
		WPEC	Memphis, Tenn.			WPMJ	Berkeley, Cal.			WJL	Greensburg, Pa.						
		KGPI	Omaha, Neb.			WPEJ	Buffalo, N. Y.			WBA	Harrisburg, Pa.						
		WPDY	Philadelphia, Pa.			KGPE	Kansas City, Kan.			WMB	W. Reading, Pa.						
		KGPD	San Francisco, Cal.			KGPG	Vallejo, Cal.			WDX	Wyoming, Pa.						
		KGPM	San Jose, Cal.			WPDW	Washington, D. C.										
		WRDQ	Toledo, Ohio														
		KGPD	Salt Lake City, Utah														
		KGPK	Sioux City, Iowa														
		122.0	2458			WPDO	Akron, Ohio			124.1	2416	KGFB	Minneapolis, Minn.	685	438	WPY	New York, N. Y.
						WPDN	Auburn, N. Y.					WPDS	St. Paul, Minn.			WPF	New York, N. Y.
WPDY	Charlotte, N. C.					WBR	Butler, Pa.										
WRDH	Cleveland, Ohio					WJL	Greensburg, Pa.										
WPCR	Rochester, N. Y.					WBA	Harrisburg, Pa.										
WPEA	Syracuse, N. Y.					WMB	W. Reading, Pa.										
WPDG	Youngstown, Ohio					WDX	Wyoming, Pa.										
122.4	2450			WPKD	Milwaukee, Wis.	124.2	2414	WPDY	Atlanta, Ga.			187.81	1596			MARINE FIRE STATIONS	
				WPEE	New York, N. Y.			KGFS	Bakersfield, Cal.							WRDU	Brooklyn, N. Y.
				WPEF	New York, N. Y.			WCK	Belle Isle, Mich.							WKDT	Detroit, Mich.
		WPEG	New York, N. Y.	WPDY	Detroit, Mich.			WCF	New York, N. Y.								
		KGPH	Oklahoma City, Okla.	WRDR	Grosse Pointe Village, Mich.												
		KGPO	Tulsa, Okla.	WMO	Highland Park, Mich.												
		KGPN	Wichita, Kan.														
		122.8	2442	WRBH	Cleveland, Ohio			175.15	1712	KGPA	Seattle, Wash.			192.4	1558	WEY	Boston, Mass.
				KGPN	Denver, Colo.					WPGA	Tulare, Cal.					KGPD	San Francisco, Cal.
										WPDY	Dayton, Ohio						
				KGZA	Fresno, Calif.												
				KGPA	Beaumont, Tex.												
				WPDB	Chicago, Ill.												

MODERNIZING the JEWELL 199 ANALYZER

Complete construction details of the revised analyzer
which will test screen-grid and pentode tubes.

By HARRY SCHMIDT

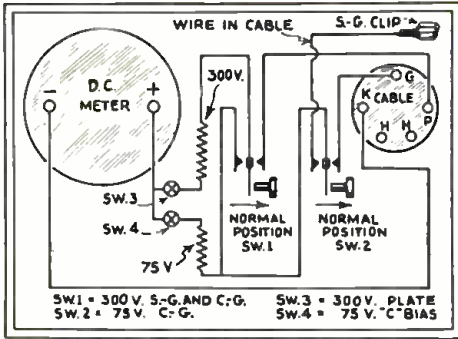

Fig. 7

Schematic diagram showing the connections of SW.1 and SW.2.

MANY Service Men have on hand, or are still using, one of the original Jewell 199 set analyzers. These analyzers are now obsolete and are of little use for testing sets using 24 and pentode tubes. As new set analyzers are

expensive, I decided to rebuild my old one. With the addition of a few parts and an afternoon's work it was brought up-to-date with extra equipment for testing screen grid and pentode tubes.

The parts necessary to make the change can probably be found in your junk box. The springs from an old jack, two UY tube bases, some hookup wire, two S. P. D. T. switches and two Pilot No. 215 subpanel sockets are needed. The switches may be of the midget-jack, Yaxley push-button or toggle type. If none of these are handy, you can make your own, as I did. A few jack springs and two inches of 1/4-in. or 3/8-in. bakelite rod is all that is needed.

All of these Jewell testers have two 7.5 volt filament switches, one marked "standard" and the other "reverse." For present-day testing, both are unnecessary although one of them, with a few alterations, can be used as the reversing switch for the D.C. meter.

A word of caution—Be very careful when making these changes. Rough handling, a wrong connection, a poorly soldered lead that may later come loose, may cause serious trouble and possibly burn

out some part of the tester. Have a clean bench to work on and a few small trays to put small parts in so they will not be mislaid.

Making the Changes

Disconnect the 4.5-volt test battery, remove the adapters, and take out the screws holding the panel. Lift the tester from its case and place it face down on the bench so that the socket and cable-terminal block are towards you. The D.C. switch-block is on the right-hand side. The switch to be altered is the second one from the bottom edge (the edge towards you).

Unsolder the two wires connected to the D.C. meter, tape and push them out of the way. Unsolder the wires connected to terminal Nos. 3 and 4 on the D.C. switch-block and bend them to one side so they cannot make contact with anything. Connect a lead from switch-block terminal No. 3 to the positive post of the D.C. meter; from switch-block terminal No. 4, connect a lead to the negative post of the meter.

Loosen the screws holding the switch to the panel. Insert two springs between the panel and switch supports; one on each side of the switch block. Solder a lead to each spring before they are put in place. Push them in just far enough to make contact with the switch blades, the spring on the right making contact with the

(Continued on page 756)

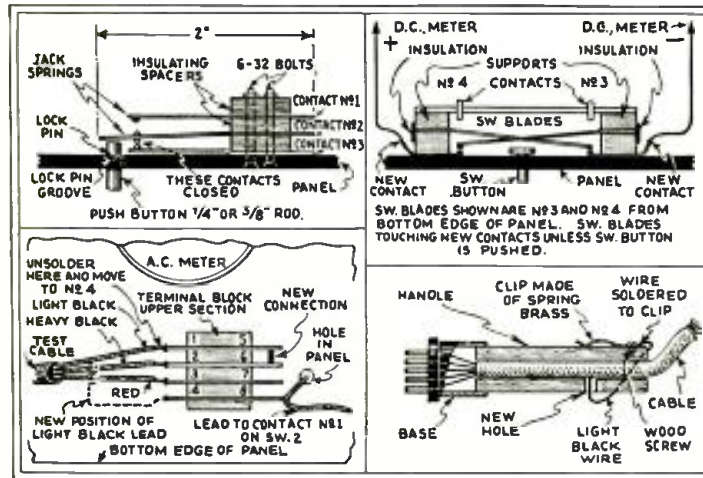

Fig. 1, upper right. Connections of the new switches.

Fig. 3, upper left. Construction of new jack switch.

Fig. 4, lower right. Construction of the analyzer plug.

Fig. 6, lower left. Cable connections to the switch.

spring on the right making contact with the

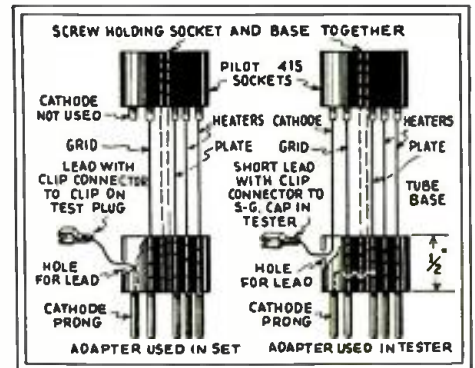
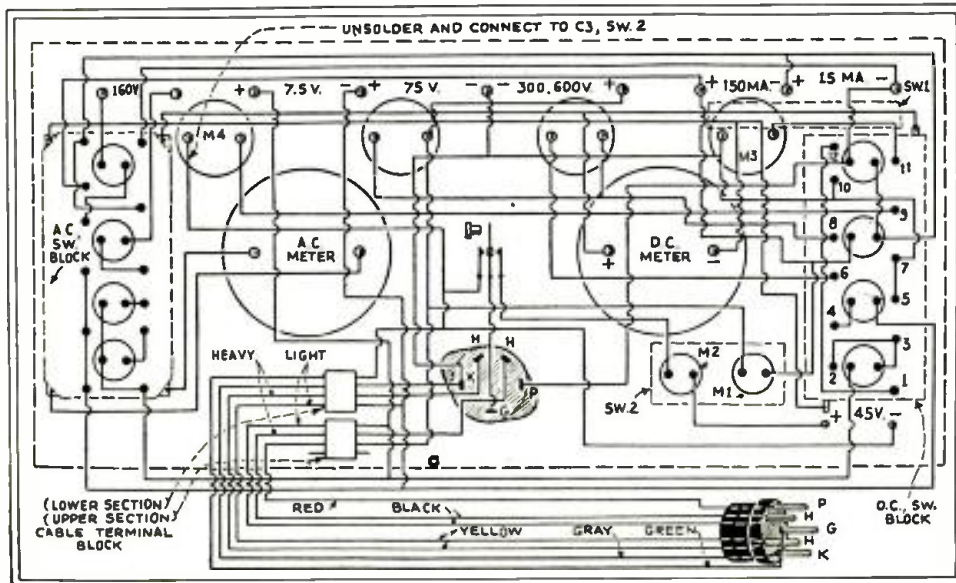

Fig. 5, above.

Diagram of connection and construction of the adapters used in the analyzer.

Fig. 2, left.

Complete schematic circuit of the analyzer after it is revised. The location and connections of the new units may be understood by carefully following the text and the diagram.

SILVER-MARSHALL MODEL 727-DC BATTERY-OPERATED SUPERHETERODYNE

(With push-push A.F. amplification and variable-mu '34 pentode I.F. amplification.)

This receiver, the S-M 727-DC "air cell" model, replaces the model 724-DC as an effective instrument for use in rural localities. The manufacturer is Silver-Marshall, Inc. Accompanying illustration shows the relative positions of the components on the underside of the chassis.

These components have the following values: Resistor R1, 0.5-meg.; R2, 0.15-meg.; R3, 0.5-meg.; R4, R6, 15,000 ohms; R5, 0.682-ohm; R7, 0.1-meg.; R8, 30,000 ohms; R9, 60,000 ohms; R10, 18,000 ohms.

Condensers C1, C2 are the tuning units; C3, 150 mmf.; C4, 0.1-mf.; C5, C6, C7, C8, C9, C10, I.F. trimmers; C11, C12, C13, C15, 0.1-mf.; C14, C21, 0.25-mf.; C16, 500 mmf.; C17, C18, .025-mf.; C19, .006-mf.; C20, .001-mf.

The filament current drain of this receiver is 0.48-amp.; during the condition of "no signal" the total plate current will be about 10 ma., with an increase to about 22 ma. during signal reception. The latter condition will be recognized as characteristic of "push-push" operation.

Features in the design of this receiver are the use of "push-push" or "class B" amplification, variable-mu R.F. pentodes as I.F. amplifiers, and an intermediate frequency of 465 kc.

There are eight tubes in the chassis, and to conserve current the instrument was designed to include a type of dynamic reproducer which would not require field current; a permanent-magnet unit met this requirement.

The use of variable-mu R.F. pentodes in the I.F. stages has made it possible to control volume by control-grid bias voltage variation without running into distortion, and without resorting to antenna potentiometers or local-distance switches. The sensitivity of this receiver ranges from 1.5 to 0.75-microvolt per meter. This high sensitivity can seldom be realized in radio sets located in towns, due to the prevailing high noise level; in rural sections, however, this degree of sensitivity is not only a convenience but a necessity.

The selectivity of this receiver is rated as 10 kc.; the resulting audio reproduction is exceptionally good.

The operating life of this receiver is approximately one year, using the "air-cell" type of "A" supply for which this set is

designed. Since the current drain from this type of "A" supply unit must not be permitted to exceed about 3/4-amp., extreme care should be taken when servicing this receiver to prevent short-circuiting the "A" connections in any part of the set.

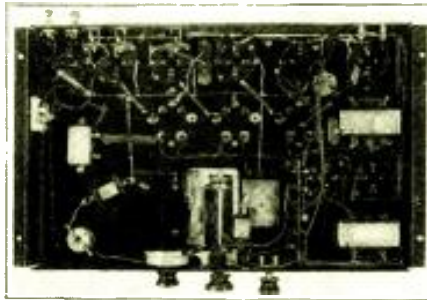

The voltage divider in shunt to the "B" supply is controlled by a switch which, operating in conjunction with the off-on "A" battery switch, serves to disconnect these divider resistors from the "B" supply when the receiver is not in operation.

Service Men desiring to check up the theory of push-push amplification are referred to the January, 1932 and subsequent issues of RADIO-CRAFT magazine. A feature of this circuit, in which the power tubes are biased to plate current cut-off, is that the power tubes draw considerable plate current only when a loud signal is being received.

Whereas, in push-pull operation the plate circuit milliammeter may be adjusted for a steady indication at normal signal volume by correct adjustment of the "C" bias, in push-push operation the meter reading should fluctuate.

A battery operated receiver connected for push-pull power output operates under rated "B" and "C" conditions only when the batteries are new, since the heavy plate circuit current "B" drain quickly reduces the available plate potential; the "C" drain, on the other hand, is slight, and thus the operating and shelf lives differ greatly. Consequently, a condition of over-bias gradually develops, (to a certain extent this can be corrected by the use of self-

bias resistors in a special compensating circuit).

However, in push-push amplification conditions are entirely different. Self-bias is not feasible since the grids draw current whenever the peak exciting voltage exceeds the bias, with the result that series resistance in the grid circuit must be kept at a minimum to avoid distortion. Thus, biasing batteries not only are an essential element in push-push operation, since every precaution must be observed to maintain the correct relation between grid and plate potentials throughout the life of the batteries, and since any appreciable over biasing would result in a certain range of grid swing without change of plate current, noticed as increased distortion—particularly at low volume—the rate of discharge of the "C" battery must be carefully matched to that of the plate "B" battery. This is accomplished by means of a resistance network in shunt to the current supply.

The batteries required in conjunction with this network to maintain an even rate of discharge are the Eveready Layerbilt No. 486 "B" batteries and the No. 768 22 1/2 volt "C" battery, or their equivalent.

Note that ground buses are used to prevent circulating currents in the chassis.

The use of the intermediate frequency of 465 kc. increases the separation of possible image frequencies from the desired carrier by a factor of 2.65 over the conventional 175 kc. system. Assuming that the desired station is at 550 kc., the corresponding image point would lie at 1480 kc. Evidently there are image points within the broadcast band for only three channels, namely 550, 560, and 570 kc. The wider separation of these points from the desired frequency means that for the same image response ratio as would be obtained under the 175 kc. system we must provide the same amount of attenuation as before, but at points which are 2.65 times as far off the resonance curve of the carrier-tuning circuit. Of course, exceptional care in the design of the receiver was necessary in order to realize good efficiency at this high intermediate frequency.

Transformers T1 and T2 are units specially designed for operation in a push-push circuit and in the event of burnout must be replaced with units of exactly the same type.

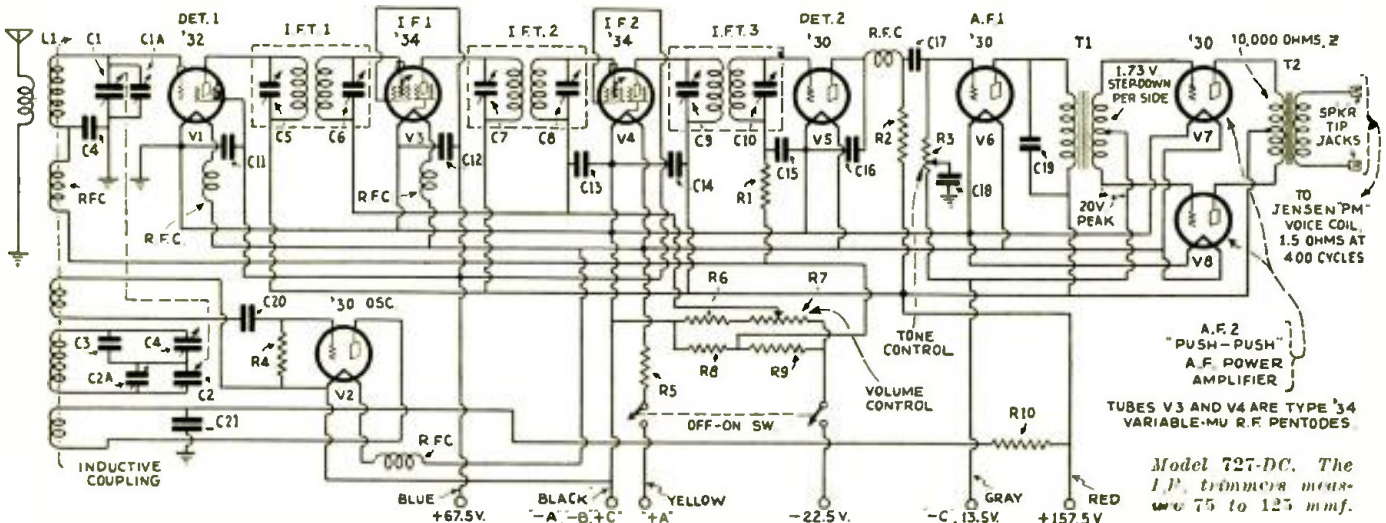

MAJESTIC MODEL 11 SHORT-WAVE CONVERTER (No. 10 CHASSIS)

(This chassis is incorporated in the Viking, Explorer and Number 11 all-wave receivers).

Short-wave reception has become the high-light of 1932 radio business; and among the foremost instrument designs with which the Service Man must familiarize himself are the Majestic models Viking, Explorer, and Number 11 all-wave receivers. These radio sets incorporate two chassis; one is a standard broadcast receiver, (No. 55 chassis), and the other is a short-wave converter (No. 10 chassis) whose output feeds into the broadcast receiver when it is tuned as an I.F. amplifier at 1,000 kc. (300 meters).

Volume is controlled by the volume control of the broadcast receiver operating in the usual manner.

The numbers on the dial of the converter give the frequency reading in "megacycles" (millions of cycles); therefore, to obtain a reading in "kilocycles" it is necessary to multiply the numbers on the dial by 1,000. The three sets of numbers on the dial of the converter indicate band frequencies as follows: outer circle, 37½ to 15 meters; center circle, 85 to 37½ meters; inner circle, 200 to 85 meters.

The values of the components of this converter are as follows: condenser C1, 100 mmf.; C2, C3, C4, 0.1-mf.; C5, .01-mf.; C6, C7, 360 mmf.; C8, C9, 5 to 30 mmf.; C10, C11, 50 to 100 mmf.; C12, C15, 200 to 600 mmf.; C13, .001- to .0015-mf.; C14, .0041- to .0047-mf.; C16, C17, .03-mf.; C18, C19, 4 mf.

Resistors R1, R7, 20,000 ohms; R2, R4, R6, 10,000 ohms; R3, 1,000 ohms; R5, 30,000 ohms.

Operating voltages read to ground (except A.C. potentials), with a 115-volt line and band-selector switch in "medium" position, are as follows. Filament potential, V1, V2, 2.5 volts; V3, 5 volts. Plate potential, V1, 250 volts; V2, 170 volts. Plate current, V1, 0.1 ma.; V2, 7.5 ma.; V3, 20 ma. (total). Screen-grid potential, V1, 135 volts; V2, 75 volts. Screen-grid current, V1, .02-ma.; V2, 1. ma. Filament-to-ground D.C., V3, 275 volts. Cathode-to-ground D.C., V1, V2, 8 volts.

For purposes of reference the variable condensers in the model 10 converter are given designations as follows: C6, oscillator tuning condenser; C7, R.F. tuning condenser; C7A, R.F. trimmer; C8, coil L1A "low frequency" padder; C9, L1B "medium frequency" padder; C10, coil L2A "low frequency" padder; C11, coil L2B "medium frequency" padder; V12, "low frequency" oscillator series-aligner; C13, "medium frequency" oscillator series-aligner; C14, "high frequency" oscillator series-aligner; C15, wavetrapping condenser.

If low sensitivity is encountered, check the condition of the tubes in the converter and the broadcast receiver. Do not realign the model 10 chassis except as a last resort; authorized Majestic dealers and distributors are best equipped for this service. Since the converter chassis does not in itself amplify, it is necessary to maintain the receiver chassis at maximum efficiency in order to realize the desired gain in signal strength. The model 10 chassis normally is selective.

In the model 10 converter chassis there are eight alignment adjustments; each of these must be made accurately in order to obtain maximum efficiency from the converter. To align these circuits it will be necessary to use two A.F. modulated service oscillators; one, the standard 350 to 1,500 kc. broadcast type of service oscillator, and the other a special 3,000 to 16,000 kc. "short-wave" type of service

oscillator. If realignment becomes necessary, every circuit of the converter should be adjusted.

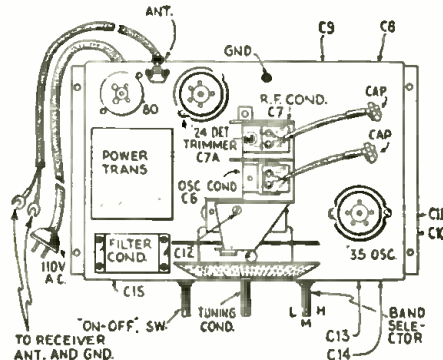

The first step in realignment is to tune the associated broadcast receiver (the I.F. amplifier portion of the complete short-wave superheterodyne) to 1,000 kc. and adjust the volume control to minimum position; then insert the receiver line plug into the receptacle provided on the converter chassis, and check the off-on switch to determine whether it correctly connects the antenna either to the receiver or the converter and at the same time controls the power line connection of the converter.

Now turn up the volume control on the broadcast receiver, adjust all the converter "padding" variable condensers C8, C9, C10, C11 and R.F. trimmer C7A to minimum position, and the series-aligners C12, C13, C14 to maximum position; then set the selector switch for "medium" range, adjust the converter tuning condenser for about 50% rotation, and connect to the input of the converter a broadcast service oscillator tuned to 1,000 kc. Turn this oscillator "on," and tune the wavetrapping condenser C15 for minimum indication on an output meter.

Next, readjust the converter tuning gang to an extreme right position, loosen the set screws on the hub of the dial and adjust for alignment with the indicator and long line at the extreme left of the dial.

Except for the final step, the remaining adjustments will require the use of the

short-wave service oscillator.

Set this oscillator at 16,000 kc. (modulation off), turn band-selector switch to "high frequency" position, and rotate the converter tuning control until a beat note is heard; then, turn the modulation "on" and adjust trimmer C7A for maximum output.

Proceed to tune the service oscillator to 9,000 kc. (modulation on), and tune the converter to this frequency. Turn the modulation "off" and adjust series-aligner C14 for zero beat.

Tune the service oscillator to 8,400 kc., place the band-selector switch in "medium" position (modulation on), and with the gang condenser on the converter turned all the way out first adjust padding condenser C11, and then padding condenser C9 for maximum output.

Next, tune the service oscillator to 7,400 kc. (modulation on), and tune in this signal; and then turn the modulation "off" and adjust padding condenser C11 for zero beat.

Tune the service oscillator to 4,900 kc. (modulation on), and tune in this signal; then, turn the modulation "off" and adjust series-aligner C13 for zero beat.

With the service oscillator tuned to 3,000 kc. (modulation on), and the band-selector switch in the "low" position, rotate the converter tuning condenser gang to the extreme left, and first adjust padding condenser C10 and then padding condenser C8 for maximum output.

The final adjustment requiring the short-wave service oscillator calls for a setting of 3,400 kc. (modulation on). Tune in this signal. Then, turn the modulation "off" and adjust padding condenser C10 for zero beat.

Finally, set the converter at 1.5, adjust the broadcast service oscillator for 1,500 kc. and start it operating, and adjust series-aligner C12 for maximum output.

Note that when adjusting for a peak with the modulation "on," the volume of the receiver (now the I.F. amplifier) should be kept low as possible—just enough to obtain a reading on the scale of the output meter. In this way the peak will be sharpest. Also, it will help to determine whether the signal heard is a harmonic or the desired fundamental.

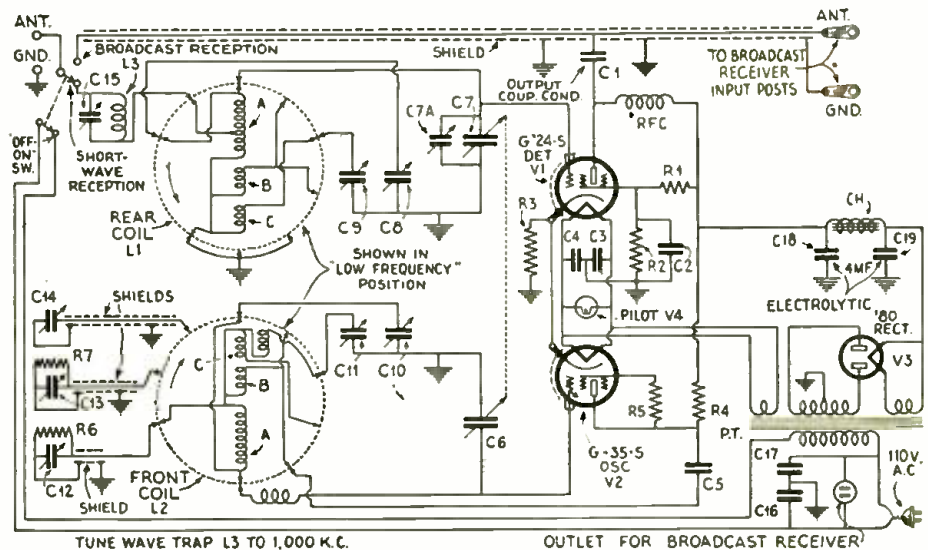

SUPERHET TROUBLE SHOOTING

A comprehensive discussion of the factors governing the theory and operation of superheterodyne receivers.

THE current popularity of the superheterodyne has brought the development of this highly efficient circuit to a point far beyond its status a year ago, with both manufacturers and builders; but, whereas the former have engineering staffs to keep them out of trouble, the man who builds his own finds many pitfalls along the road to success; which to the engineer, are comparatively easy to avoid.

It is the purpose of this article to endeavor to present solutions to many of these problems, together with an analysis of their causes, and what is more important, means of correcting them, in simple non-technical language.

Tracking

Probably the greatest mystery to the average layman is the "tracking" of the oscillator and tuning condensers. Assuming the frequency of the intermediate amplifier to be 175 kc., it is necessary for the oscillator circuit to be tuned at all times to a frequency 175 kilocycles *higher* than the R.F. circuits. (175 kc. lower would be equally good, but using a higher frequency is simpler from a constructional angle.) To illustrate the relation, a few points on the broadcast band are indicated as follows:

With the R.F. circuits tuned to

1500 kc.
1250 kc.
1000 kc.
750 kc.
550 kc.
500 kc.

By E. BUNTING MOORE

capacity of one section of the variable condenser can easily be accomplished by inserting in series with this section a fixed condenser of such value as to reduce the maximum capacity to $6\frac{1}{4}$ times the minimum. Since the minimum varies considerably, this condenser is usually made so that it may be adjusted with a screw driver. See Fig. 1.

Because the highest frequency of the oscillator is 1675 kc. for tuning-in a 1500 kc. signal, and the minimum capacity of both tuning and oscillator condensers are about the same, the oscillator coil must be sufficiently smaller than the R.F. coils to make this 175 kc. difference at the zero setting of the dial. Figuring again with the same data (with the same capacity, the inductance changes inversely as the square of the frequency) it appears that the oscillator coil should be a little more than 80 percent of the inductance of the R.F. coils.

Aligning the Tuning Condensers

Now we come to the actual process of aligning the tuning controls. To do this properly, an oscillator of the simplest kind is required. A suitable one is shown in Fig. 2. C1 and C2 may be ordinary 1 or 2 mf. bypass condensers. C3 can be any .00035- or .0005-mf. variable condenser that may be in the "junk box." T is any filter choke, audio choke, or even the

primary of an old audio transformer.

A modulated oscillator calibrated to 175 kc. is also an absolute necessity. Since this calibration must be very exact, it is hardly advisable for the experimenter to try to make this, but rather to either have one calibrated by a competent Service Man; to buy one of the many which are available for service work at a comparatively low cost; or to have the intermediate amplifier adjusted by a Service Man. The importance of exactly tuning the I.F. transformers to 175 kc. cannot be too strongly emphasized. The entire success or failure of the receiver depends upon this one point.

Now set the trimmers on the tuning condensers in about the center of their range; tune in a local station as nearly as possible to 1500 kc. and adjust the trimmers for maximum volume in exactly the same way as a T.R.F. receiver. If some of them tune too high or too low, change the oscillator trimmer up or down sufficiently, so that the R.F. tuning condensers will line up with it properly.

Tune in a station as near as possible to 550 kc. When it is brought in properly, take a small piece of wire and short circuit the oscillator section of the tuning condenser; the station will, of course, disappear. Now take the oscillator already described, and with one turn of insulated wire wrapped

loosely around its coil, connect one terminal to the grid cap of the first detector. Do not make a physical connection between the wire and the oscillator coil, just wrap it *once* around the coil.

Rotate the external oscillator dial until the station is again heard. Now, leaving the oscillator condenser in the set shorted, take off the wire leading to the external oscillator and turn the latter off. Do not touch the tuning dial on the set. Take the short off the oscillator condenser and readjust its padding condenser until the station again comes in at maximum volume.

(Continued on page 757)

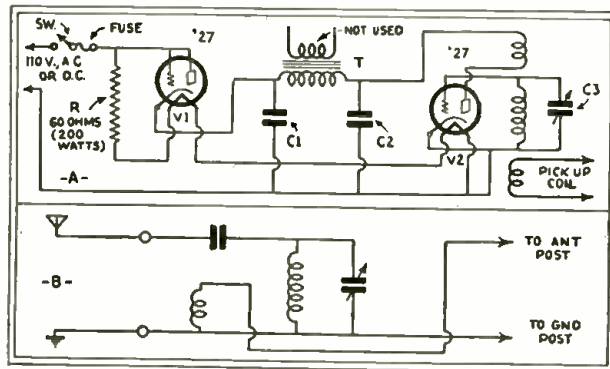

Fig. 2, above. A simple oscillator suitable for superheterodyne servicing.

Fig. 3, below. A band-pass filter that may be attached to a radio set.

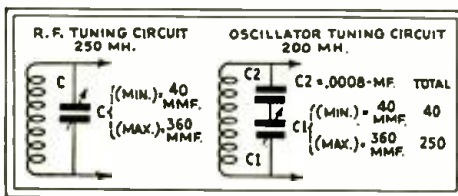

Fig. 1

Arrangement of tuning condensers in R.F. and oscillator tuning circuits.

The frequency to which a tuned-circuit resonates is a function of its inductance times its capacity, or LC. That is, a circuit with a .0005-mf. condenser and a coil of 200 microhenries, has an LC equal to .0005 times 200, or .1, and the circuit will tune to 600 meters; any change in the relative values of the coil or condenser, provided the other is changed oppositely, will result in LC remaining .1. A .00025-mf. condenser with a 400-microhenry coil or a .001-mf. condenser with a 100 microhenry coil would tune to 600 meters.

The LC product varies inversely as the square of the frequency. That is, for double the frequency, the LC drops to *one-quarter* its former value; for three times the frequency, LC is one-ninth its former value. Illustrating, if the LC for 600 meters (or 500 kc.) is .1, LC for 1000 kc. is .025, one-quarter as much; for 1500 kc. it is .0111, or one-ninth as much.

With a single coil, then, to cover the band from 1500 to 500 kc. a condenser is required, which, including all stray capacities in the set, has nine times as much maximum capacity as its minimum.

At the same time the oscillator, covering the band from 1675 kc. to 675 kc. (which is only a tuning range of $2\frac{1}{2}$ to 1) requires a maximum capacity equal to the *square* of $2\frac{1}{2}$ (which is $6\frac{1}{4}$) times its minimum capacity. The reduction of the maximum

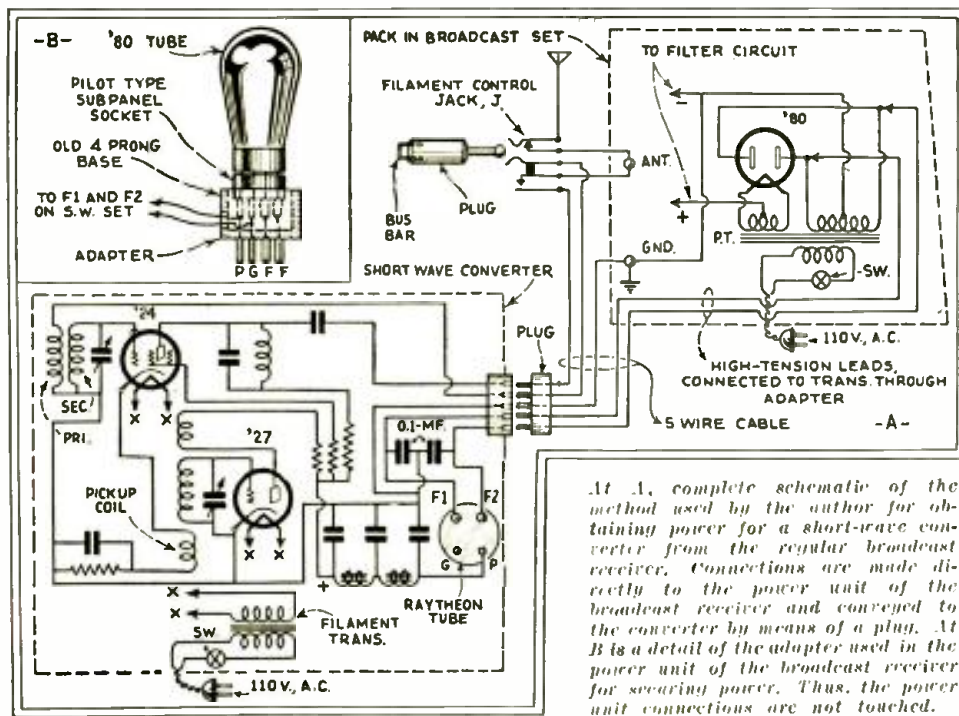

At A, complete schematic of the method used by the author for obtaining power for a short-wave converter from the regular broadcast receiver. Connections are made directly to the power unit of the broadcast receiver and conveyed to the converter by means of a plug. At B is a detail of the adapter used in the power unit of the broadcast receiver for securing power. Thus, the power unit connections are not touched.

One of the major objections to the use of short-wave converters is the source of power supply. In this interesting article, the author describes a very novel means of securing power from the broadcast receiver without changing its wiring.

By
LOUIS B. SKLAR

Power for the S. W. Converter

“THERE is no two ways about it,” as our friend Andy would say, the set of the future, which will, without doubt, dominate all other models at the next Radio Show, will be the combination long- and short-wave receiver,—simply a broadcast receiver and a short-wave converter housed in one cabinet.

The old type converter was equipped with an extension plug to one of the sockets of the broadcast receiver, to obtain plate and sometimes filament current for the tubes. The new “combination” receiver, however, is much more satisfactory, its filament supply being separate, and the plate-current supply being obtained from the common power-pack; correct plate voltage thus being delivered to the short-wave converter without decreasing the efficiency of the broadcast receiver.

This is all well and good in factory production, but the radio experimenter or Service Man who desires to build, as an adjunct to an “old reliable” broadcast receiver, a modern short-wave converter, is compelled to use a separate power transformer to energize it.

The writer will now describe his feat of obtaining without a separate transformer, plate supply for the short-wave converter without affecting the voltages in the associated broadcast receiver. This arrangement is illustrated by diagram in Fig. 1A.

Here, the power transformer performs a double duty: The secondary delivers current to the '80 tube of the broadcast receiver; also, it supplies current to the gaseous rectifier tube of the short-wave unit. Of vital importance is the fact that the power requirements of average short-wave receivers is so small, (6 to 10 ma.), that the changes in the plate voltages of the broadcast receiver, due to the extra drain on the main transformer, are almost negligible.

Extra wiring or rewiring is not necessary. All one has to do is make up an adapter with a 5-wire connection cable, as illustrated in Fig. 1B, take the '80 tube out of the socket, plug in the adapter and put the '80 tube into it. The circuits in the '80 tube have not been changed, all you have done is to bring the two main “B” leads from the big set over to the small one. There are no other power connections between the two sets.

There are, of course, the connections to ground and aerial; plus the wire to the change-over jack J. The purpose of using this filament-control type jack and short-circuited plug is to permit quick change-over from long-to short-wave reception, and vice versa. This unit, connected as shown in Fig. 1A, is permitted to

hang loose near the broadcast set, a little care being taken to prevent it grounding to either chassis.

The adapter shown in Fig. 1B is best made from a 4-prong tube base and a Pilot sub-panel type socket. However, connection can also be obtained by means of an insulating disc cut to the size of the tube base, four holes being punched into it for the tube prongs, and two contact eyelets being put in the “P” and “G” holes. Soldering the two cable leads to the eyelets completes the adapter.

Connection at the short-wave end of the cable is made by means of a 5-prong base and another Pilot type of sub-panel socket. Care must be taken to remove the 4-prong plug before removing the 5-prong plug, otherwise a severe shock will be experienced upon coming in contact with two of the prongs of the latter, between which there will be a potential difference of 700 volts or more.

The short-wave converter shown in Fig. 1A is of standard super-heterodyne type and uses the R.F. stages of the broadcast set as the I.F. circuit. The writer picked this combination for its efficiency. Any other type of short-wave converter together with any type of broadcast receiver may utilize the same system for obtaining the converter's power.

The Filament Transformer

In every case, a separate transformer will be required for energizing the filament of the two or three tubes in the converter, because the filament supply circuit of modern radio receivers are not designed to accommodate additional tubes.

Although a suitable filament transformer can be purchased at very little cost, this is not the thing that a “one-hundred percent” radio experimenter would want to do.

A transformer of such small capacity can be easily constructed from an old “filter” choke of 30- to 50-henries rating; or any choke whose core cross-section is about 1/2 in. The idea is to use the choke windings as a primary, and to wind enough heavy wire over this coil to form the secondary.

To construct such a transformer, first calculate its required capacity. We will take for example the converter design illustrated in Fig. 1, in which two tubes are used. Since each tube filament requires approximately 4 1/2 watts, the total output wattage of the transformer therefore will be 9 watts. Assuming an efficiency of 90%, the total input capacity must be about 10 watts. Its primary

(Continued on page 759)

USING the V. T. Voltmeter

(PART II)

The V.T. voltmeter in audio-frequency work.

By BERYL B. BRYANT

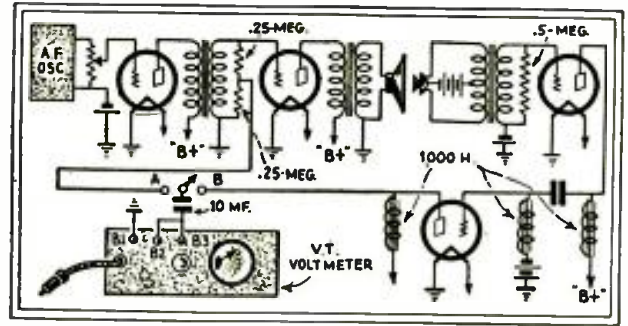

Fig. 8

Arrangement of apparatus for conducting loudspeaker response measurements. The characteristics of the microphone and its associated apparatus must have been previously determined.

THE vacuum-tube voltmeter is just as useful in A.F. as in R.F. measurement work. As a general rule, more accurate results may be obtained at audio frequencies, because the effects of stray and distributed capacities are reduced to a minimum.

As with radio-frequency measurements, the requirement for this work is an ample source of power of such frequency as is needed to determine the characteristics of the device to be measured.

Audio-Frequency Gain Measurements

The method of measuring the gain characteristics of audio-frequency amplifiers is the same whether one or more stages are to be measured. Naturally, the more stages of amplification to be measured, the lower must be the input to the amplifier.

The set-up for these measurements is given in Fig. 6. If the gooseneck type V.T. voltmeter is employed, the amplifier stage in the instrument is not used. The connections to the instrument are made to binding posts B1, B2 and B3 as shown. In order to isolate the D.C. component of the output of the amplifier under test from the meter, a large condenser of about 10 mf. is connected in series with the grid of the V.T. voltmeter; the grid leak for the voltmeter tube being already contained within the instrument, and is connected by shorting B2 and B3, A D.P.D.T. switch is used in order that the terminals of the instrument may easily be connected to either the input or the output of the amplifier under measurement.

The standard resistance in the plate circuit of the amplifier under measurement should have a value equal to twice the plate impedance of the tube. The procedure for determining the audio-response characteristics of the amplifier is to keep the input to the amplifier at a constant voltage as the impressed frequency is varied, recording the output (as read on the V.T. voltmeter) after each step. The input voltage may be kept constant at .5-volts and the frequency plotted in 50- or 100-cycle steps on logarithmic graph paper. The frequency, of course, might be varied in larger or smaller steps; when varied in larger steps, there is greater possibility of missing possible peaks which would be detected when the frequency is varied in smaller steps.

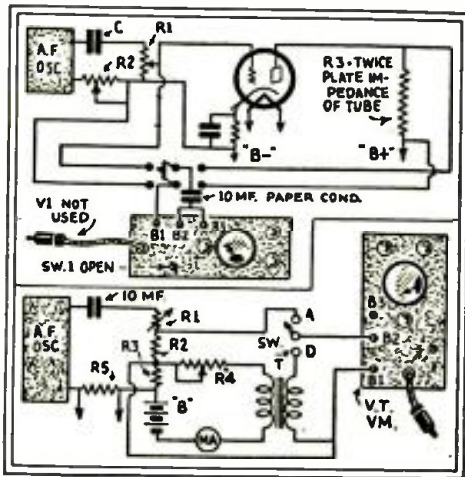

Fig. 6, above. Set-up for making A.F. measurements.

Fig. 7, below. Set-up for measuring the gain of audio-coupling units.

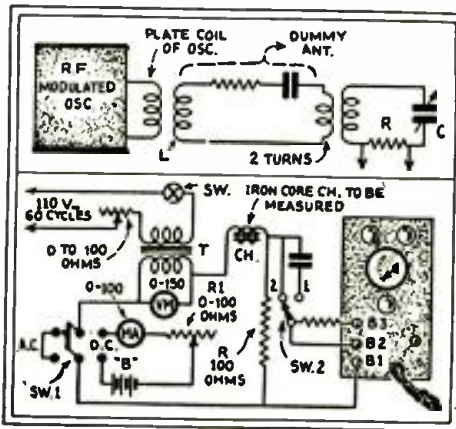

Fig. 9, above. Set-up for percentage modulation tests.

Fig. 10, below. Apparatus for measuring the inductance of iron-core coils.

Power Amplification

In measuring the power amplification of an audio system the set-up is the same as given in Fig. 6. The resistance R1 is 4000 ohms; R2 may be a variable resistance of 50,000 ohms, and is used to adjust the current flow through R1. From the voltage drop across R1, the current flow is calculated. The resistance R3, which has a value equal to twice the plate impedance of the tube, is measured for the voltage drop; the current through it being then determined by Ohm's Law.

If the resistance of both R1 and R3 are equal, the power gain in decibels may be determined by the following formula:

$$PA = 20 \log_{10} \frac{\text{Output current (Io)}}{\text{Input current (Ii)}}$$

If the resistance of R1 and R3 are not the same, the following formula is used:

$$PA = 20 \log_{10} \frac{Io\sqrt{R3}}{Ii\sqrt{R1}}$$

The source of power for the above measurement should be a suitable audio-frequency oscillator having a range of frequencies from 40 to 10,000 cycles per second and a sufficiently large output. The A.F. input to the receiver is adjusted to a value that will give the rated undistorted output from the power tube of the receiver. In this manner, the sensitivity of the amplifier is determined.

The power output may also be determined by measuring the current through R3. Having determined the effective value of current, and knowing the value of R3 in ohms, the power output in watts may be calculated by squaring the value of current and multiplying the result by the value of R3.

If the receiver has a large amount of hum or noise, it is necessary to first determine its value, which must later be subtracted from the total power, computed as described above, in order to secure the power due to the signal. The same procedure of measurement is followed when measuring receivers having a choke- or resistance-filter output system.

Gain of Audio Coupling Units

In measuring the gain of audio-coupling units, the set-up given in Fig. 7 is used. The resistance R1 is a variable 50,000-ohm unit; R2 and R3 are 250 ohms each; R4 is a variable resistance which is adjusted to a value equal to the impedance of the tube that would normally feed into the input of the coupling device. Once this latter resistance is adjusted to the proper value, it should not be disturbed. The battery "B" is adjusted to a value that would cause normal current to circulate through the primary of transformer T. The meter MA should be of such range as to suitably indicate the above current. R5 is a 500-ohm resistance, across which the A.C. voltage drop is measured by the V. T. voltmeter in order to determine the A.C. current in that circuit.

The procedure of measurement is to adjust the resistance R1 so that the voltage across the resistance R2 is kept at a constant value. This is indicated when the S.P.D.T. switch SW. is in position A. Since R2 and R3 are of the same value, the voltage drop across R3 will be the same as that across R2; the voltage across R2 is

(Continued on page 761)

Table Showing the Relation of Wave Length, Frequency, and the Product of Inductance and Capacity, in Oscillatory Circuits.

Wave length meters	Multiply values below by 1000	Multiply values below by 1000	CL C in μ L in cm	Wave length meters	Multiply values below by 1000	Multiply values below by 1000	CL C in μ L in cm
1	300000	1884000	0.0003	200	1500	9420	11.26
2	150000	942000	.0011	205	1463	9190	11.83
3	100000	628000	.0018	210	1429	8970	12.41
4	75000	471000	.0045	215	1395	8760	13.01
5	60000	377000	.0057	220	1364	8560	13.62
6	50000	314200	.0101	225	1333	8370	14.25
7	42900	269000	.0138	230	1304	8190	14.89
8	37500	235500	.0180	235	1277	8020	15.55
9	33330	209400	.0228	240	1250	7850	16.22
				245	1225	7690	16.90
10	30000	188400	.0282	250	1200	7540	17.60
15	20000	125600	.0635	255	1177	7390	18.31
20	15000	94200	.1129	260	1154	7250	19.03
25	12000	75400	.1755	265	1132	7110	19.77
30	10000	62800	.2530	270	1111	6980	20.52
35	8570	53800	.3446	275	1091	6860	21.29
40	7500	47100	.450	280	1071	6740	22.07
45	6670	41900	.570	285	1053	6620	22.87
				290	1035	6500	23.66
50	6000	37700	.704	295	1017	6380	24.50
55	5450	34220	.852				
60	5000	31420	1.014	300	1000	6280	25.33
65	4620	28970	1.188	310	968	6080	27.05
70	4290	26900	1.378	320	938	5890	28.83
75	4000	25120	1.583	330	909	5700	30.66
80	3750	23520	1.801	340	882	5540	32.55
85	3529	22120	2.034	350	857	5390	34.48
90	3333	20920	2.280	360	833	5230	36.48
95	3158	19830	2.541	370	811	5090	38.54
				380	790	4930	40.7
100	3000	18840	2.816	390	769	4830	42.8
105	2857	17940	3.105				
110	2727	17130	3.404	750	4710	4710	45.0
115	2609	16380	3.721	410	732	4590	47.3
120	2500	15710	4.05	420	714	4480	49.7
125	2400	15070	4.40	430	698	4380	52.0
130	2308	14480	4.76	440	682	4280	54.5
135	2222	13950	5.13	450	667	4190	57.0
140	2144	13450	5.52	460	652	4100	59.6
145	2069	12980	5.92	470	638	4010	62.3
				480	625	3920	64.8
150	2000	12560	6.34	490	612	3842	67.6
155	1935	12150	6.76				
160	1875	11770	7.20	500	600	3766	70.4
165	1818	11410	7.66	510	588	3692	73.3
170	1765	11090	8.13	520	577	3620	76.0
175	1714	10760	8.62	530	566	3552	78.9
180	1667	10470	9.12	540	556	3485	82.1
185	1622	10180	9.63	550	545	3422	85.2
190	1579	9910	10.16	560	536	3361	88.4
195	1538	9660	10.71				

Table Showing the Relation of Wave Length, Frequency, and the Product of Inductance and Capacity, in Oscillatory Circuits—Continued.

Wave length meters	Multiply values below by 1000	Multiply values below by 1000	CL C in μ L in cm	Wave length meters	Multiply values below by 1000	Multiply values below by 1000	CL C in μ L in cm
570	526	3302	91.4	1150	260.9	1637	372.1
580	517	3246	94.7	1200	250.0	1570	405
590	509	3193	98.0	1250	240.0	1506	440
				1300	230.8	1448	476
600	500	3140	101.4	1350	222.2	1395	512
610	492	3088	104.7	1400	214.4	1346	552
620	484	3038	108.2	1450	206.9	1298	592
630	476	2990	111.7				
640	469	2942	115.4	1500	200.0	1256	634
650	462	2896	118.8	1550	193.5	1215	676
660	455	2852	122.5	1600	187.5	1177	720
670	448	2810	126.3	1650	181.8	1142	766
680	441	2768	130.2	1700	176.5	1108	813
690	435	2730	134.1	1750	171.4	1076	862
				1800	166.7	1046	912
700	429	2692	137.8	1850	162.2	1017	963
710	423	2654	141.9	1900	157.9	990	1010
720	417	2616	145.9	1950	153.8	965	1071
730	411	2580	150.0				
740	405	2544	154.0	2000	150.0	942	1126
750	400	2510	158.3	2050	146.3	920	1183
760	394.8	2476	162.6	2100	142.9	898	1241
770	389.6	2443	166.8	2150	139.5	876	1301
780	384.6	2412	171.4	2200	136.4	856	1362
790	379.8	2382	175.6	2250	133.3	838	1425
				2300	130.4	819	1489
800	375.0	2353	180.1	2350	127.7	801	1555
810	370.4	2325	184.7	2400	125.0	784	1622
820	365.9	2297	189.3	2450	122.5	768	1690
830	361.4	2270	194.0				
840	357.1	2242	198.5	2500	120.0	753	1760
850	352.9	2214	203.4	2550	117.7	738	1831
860	348.8	2188	208.2	2600	115.4	724	1903
870	344.8	2162	213.2	2650	113.2	710	1977
880	340.9	2138	217.9	2700	111.1	697	2052
890	337.1	2116	222.9	2750	109.1	684	2129
				2800	107.1	672	2207
900	333.3	2092	228.0	2850	105.3	660	2287
910	329.7	2070	233.2	2900	103.5	648	2366
920	326.1	2047	238.1	2950	101.7	638	2450
930	322.6	2024	243.4				
940	319.1	2003	248.7	3000	100.0	628	2533
950	315.8	1982	254.1	3500	85.7	538	3448
960	312.5	1962	259.5	4000	75.0	471	4500
970	309.3	1942	264.7	4500	66.7	418	5700
980	306.1	1922	270.4	5000	60.0	377	7040
990	303.0	1902	275.9	5500	54.5	342.2	8520
				6000	50.0	314.2	10140
				6500	46.2	289.9	11880
1000	300.0	1884	281.6	7000	42.9	268.8	13780
1050	285.7	1794	310.5				
1100	272.7	1718	340.4	7500	40.0	251.0	15830

Fig. Q. 159

TABLE OF "L-C CONSTANTS," FREQUENCY AND WAVELENGTH—KENNEDY SHORT-WAVE CONVERTER

(159) Mr. James T. McGillicuddy, Akron, Ohio.

(Q. 1) In the article, "I. F. Coil Design," by Clifford E. Denton, which appeared in the April, 1932, issue of RADIO-CRAFT, mention is made, in the second paragraph, page 625, that "the condition of resonance is the same, no matter what the frequency may be, and the old L. C. chart is as useful as ever, as it gives the L. C. constants for all frequencies between 1,000 and 42 kc., thus taking in all of the frequencies used in I. F. amplifier design." What is the "L. C. chart" referred to in this article?

(A. 1) A table showing L. C. constants, wavelength and frequencies, appeared in the July, 1931 issue of RADIO-CRAFT, in the article, "How to Figure the R. F. Secondary," by Clifford E. Denton. A more complete table, arranged to cover the requirements of his later article on I. F. coil design, is reproduced as Fig. Q. 159.

(Q. 2) RADIO-CRAFT Data Sheet No. 63 describes the Kennedy Model 54 "Globe Trotter" Short-Wave Converter, but it does not suggest any way by which the Service Men

WAVE LENGTH TABLES.

Table Showing the Relation of Wave Length, Frequency, and the Product of Inductance and Capacity, in Oscillatory Circuits—Continued.

Wave length meters	Multiply values below by 1000	Multiply values below by 1000	CL C in μ L in cm	Wave length meters	Multiply values below by 1000	Multiply values below by 1000	CL C in μ L in cm
1000	37.50	221.4	18010	25000	12.00	75.4	176000
1050	35.29	231.4	20846	30000	10.00	62.8	233000
1100	33.33	243.2	22000	35000	8.57	54.0	264000
1150	31.58	256.2	23410	40000	7.50	47.1	300000
1200	29.90	270.4	25000	45000	6.67	41.1	340000
1250	28.30	285.8	26800	50000	6.00	37.7	390000
1300	26.80	302.4	28800				

can check the performance of this converter when operating it on any of the several tuning bands it covers.

(A. 2) A tabulation of short-wave stations which may be heard is available.

For reference of Service Men, the following representative list of short-wave stations, which under average good conditions may be received on the "Globe Trotter," is given, together with the approximate dial settings at which they may be received.

Dial	Identification	Meters
40	WSNK, Pittsburgh, Pa.	15-25
40	AGI, Nancem, Germany	15-25
60	WOO, Atlantic Phone, (N.J.) ..	15-25
74	Rugby, England, Phone	15-25
75	Amateur Phone	15-25
175	WSNK, Pittsburgh, Pa.	25-47
18	2RO, Rome, Italy	25-47
19	G5SW, Chelmsford, England ..	25-47
20	FTN, St. Assise, France	25-47
21	DHC, Berlin, Germany	25-47
28	KES, Bolinas, California	25-47
58	WJAZ, Springfield, Mass.	25-47
59	WXX, Pittsburgh, Pa.	25-47
59	W2NAF, Schenectady, N.Y. ...	25-47
60	WND-WOO, Deal Beach, N.J. ...	25-47
60	Trans-Atlantic Phone	25-47
90-100	Amateur Phone	47-85
10-15	Airplane Communication	47-85
25	VE9GW Bowmanville, Ont., Can.	47-85
26	VE9GW Bowmanville, Ont., Can.	47-85
30	HRB, Honduras, C.A.	47-85
29	WSXAL, Cincinnati, Ohio	47-85
26	HRB, Honduras, C.A.	47-85
26	WSXL, Bound Brook, N. J.	47-85
25	W2NE, New York, N.Y.	47-85
10	Amateur Phone	85-200
15	Airplane Phone	85-200
50	Television	85-200
30-35	Toledo, St. Paul, Buffalo, Detroit, Indianapolis, and St. Louis Police	85-200
70-75	East Lansing and Chicago Police	85-200

INTERMITTENT RECEPTION

(160) Mr. Joseph, Rock Center, New York.

(Q. 1) On several receivers that I was called upon to service, I noticed that the set would function normally for a few hours and then, for no apparent reason, would die out. A complete test of the receiver shows nothing wrong; what is the trouble?

(A. 1) This department has received a number of inquiries concerning this problem of "intermittent reception." As far as we have been able to determine, there is no fixed remedy that may be applied to all receivers. In one instance, it was found that the first audio transformer was defective. Now the peculiar thing about this transformer was the fact that according to analyzer readings it was perfectly OK, but when it was replaced by another, the set functioned normally. This defective transformer was removed to the shop for test, but nothing could be found wrong with it. However, it was found that when tested "hot," the primary was grounded to the core. The moral, then, is to test the audio transformers when "hot."

In another case, a defective resistor (incidentally, also in the audio circuit) caused the trouble. This resistor had an intermittent short that only manifested itself when warm.

(Q. 2) In certain models of General Motors receivers, the volume control does not seem to function properly. When low volume is desired, the adjustment is so critical that it is almost impossible to regulate it. Upon measurement, the correct value of volume control was found in the circuit. What remedy do you suggest?

(A. 1) Since you do not mention the particular model set you have in mind, it is rather difficult to answer your problem specifically. In general, however, the trouble is caused by too much pickup by the aerial. One solution that we have tried that worked successfully was to connect a fixed condenser of .0001-mf. in series with the antenna.

RADIO-CRAFT KINKS

Practical hints from experimenters' private laboratories.

(PRIZE AWARD)

A.C. "B" UNITS ON D.C.

By Vincent Kramer

EXPERIMENTERS do not seem to have struck upon the little kink illustrated in Fig. 1. It shows the manner in which an ordinary "B" eliminator designed for A.C. operation may be used to supply the various "B" potentials required for a radio set when operated on a 120-volt D.C. line.

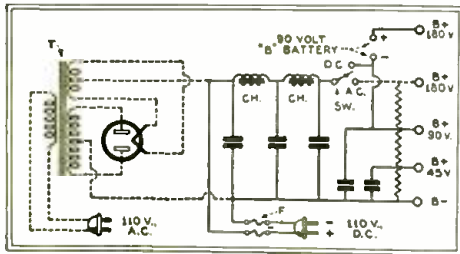

Fig. 1

Mr. Kramer's idea of a universal power unit.

Disconnect the A.C. portion of this circuit shown in dotted lines and run two leads for connection to the 110-volt D.C. power outlet.

A word of caution: Make sure that the radio set is not grounded; otherwise, something will blow out if this unit is plugged into the socket backwards, in fact, the author recommends the use of a fuse in each side of the line as shown by F.

A CHEAP "B" ELIMINATOR

By D. E. Black

THE experimenter may not be aware of the fact that a very simple "B" eliminator may be constructed at low cost through the use of a couple of ordinary bell-ringing transformers. As illustrated in Fig. 2 these should be of a type which delivers 12 volts at two of its terminals, with a third connection at 6 volts. The plate current requirements of small receivers will be met if a type 01A tube is used as the rectifier; its plate and grid are linked together, as shown.

The output voltage for the output audio-tube is the direct connection marked 150

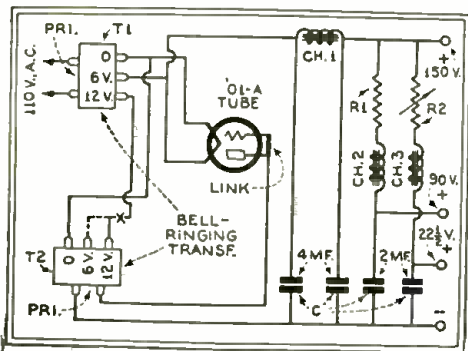

Fig. 2

The economical "B" power unit.

\$5 FOR A PRACTICAL RADIO KINK

As an incentive toward obtaining radio hints and experimental short-cuts, RADIO-CRAFT will pay \$5.00 for the best one submitted each month. Checks will be mailed upon publication of the article.

The judges are the editors of RADIO-CRAFT and their decisions are final. No unused manuscripts are returned.

Follow these simple rules: Write, or preferably type, on one side of the sheet, giving a clear description of the best radio "kink" you know of. Simple sketches in free-hand are satisfactory, as long as they explain the idea. You can send in as many kinks as you wish. Everyone is eligible for the prize except employees of RADIO-CRAFT and their families.

This contest closes on the 15th of every month, by which time all the Kinks must be received for the next month.

Send all contributions to Editor, Kinks Department, c-o RADIO-CRAFT, 98 Park Place, New York City.

volts plus; two additional, lower potential leads may be obtained through the use of a fixed resistor of about 15,000 ohms at R1, to deliver about 90 volts, and resistor R2, variable between 0 and .5-megohms may be used to adjust the detector plate potential to exactly the correct value.

As illustrated, the choke coil shown may be the secondary winding of a Ford spark coil; the fixed condensers from these coils may be connected in parallel to form the required filter capacity indicated at C.

Tracing through this circuit we find that the 110 volt A.C. fed into the primary of transformer T1 is stepped down; 6-volts output from part of the secondary drops to a little over 5 volts when it is applied to the filament of the tube.

The 12-volts output of this secondary may be connected as shown by the solid lines in Fig. 2, resulting in output voltages not exceeding the line potential; by connecting transformer T2 as shown by the dotted line, breaking the 12-volt lead at X, the output voltage may be doubled at a sacrifice in output current.

IMPROVING SUPERHETS' SELECTIVITY

By C. S. Culp

THE writer had a D.C. Victoreen superheterodyne which was not selective for present-day conditions and which did not bring in the high wave lengths; even with a potentiometer turned fully on, that is—towards the minus side, the circuit could not be made to oscillate. The writer pro-

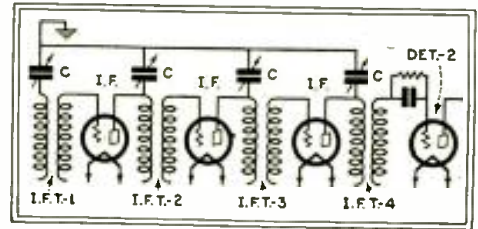

Fig. 3

Tuned I.F. Transformers

ceeded to work out the circuit arrangement illustrated in Fig. 3.

By a simple process of tuning the primary circuits of the I.F. transformers through the use of Pilot Capacigrads C it was possible to obtain sufficient selectivity to separate nearby broadcasting stations, regardless of the length of the aerial. At the same time, the circuit could be made to oscillate by variation of the potentiometer. These condensers have a range which varies roughly between the limits of 100 and 500 mmf.

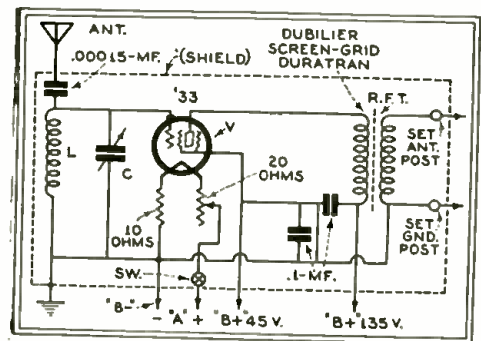

Fig. 4

A simple booster unit.

A SIMPLE BOOSTER UNIT

By Theodore R. Sayre

MANY radio receivers, particularly those which employ a blocking tube as the first amplifier in the set, lack sensitivity when used in localities remote from broadcasting stations. To meet this condition, the writer built up numerous booster units of the design shown in Fig. 4. Tube V may be a standard type 33, for operation on dry cells, or it may be of the A.C. type, its filament lighted by means of a small transformer. The entire unit must be shielded, as indicated by the dotted lines. All leads must be kept short, particularly the control-grid cap lead of tube V. The output R.F. transformer R.F.T. is an untuned unit such as the Dubilier Duratran. Coil L should be compact: It may be made by winding 125 turns of No. 28 D.C.C. wire in a single layer on a one-inch tube 1 1/2 inches long. Tuning condenser C may be a Cardwell type 407B Midway Condenser having a capacity of .000365-mf.; for other tuning condensers it will be necessary to slightly change the number of turns in coil L to match.

SM

Beat This Record!

31 Countries and 5 Continents in One Month—with a 727SW



For the First Time
in Radio History—
the Best AND the
Cheapest

\$ 58 51
NET

The Silver-Marshall all-wave 727SW (550 to 18,000 kilocycles) is a receiver that cannot be outperformed station for station. It has 10 tubes that all operate on both broadcast and short-wave. Automatic volume control that eliminates fading on distance tuning. Meter tuning. Fractional microvolt sensitivity. 10kc selectivity. And it has an EXCLUSIVE S-M feature—**COLOR TUNING**. It is a dial on which ALL the bands are accurately calibrated. It is as easy to find HRB, Tegucigalpa, Honduras, as it is to find KDKA.

The price of the 727SW chassis and speaker (factory wired and tested under the personal supervision of McMurdo Silver) is \$58.51 NET.

Tear out part of this page—pin a \$5 bill to it with your name and address, and the 727SW will be shipped balance C. O. D. Play with it for 10 days—give it every operating test. And if it is not the best receiver you ever tuned, return it and your money will be promptly refunded.

The 727DC (550 to 15 00 kc) chassis and speaker for operation with the new Eveready Air-Cell battery is \$40.87 NET. Write for details.



Let us send you a photo-static copy of the 6-page log G. H. Hanson, in Maine, got on his 727SW in less than 30 days. It covers every continent, very nearly every state, and 31 foreign countries! And he has just begun.

SILVER-MARSHALL, Inc.
6419 W. 65th St.
Chicago, U. S. A.

Enclosed find \$5. Send 727SW balance C. O. D. for ten day trial.

Please send me FREE a copy of G. H. Hanson's log.

Send 727DC details.

Name.....

Address.....

SILVER-MARSHALL, Inc.

6419 West 65th Street Chicago, U. S. A.

Short-wave MOLDED Coil Forms

- Four or five prongs 25c each
- Molded sockets with locator ring—Base mounting
- 481X 4-prong 25c
- 481Y 5-prong 25c
- 474 Laminated socket 4-prong 10c
- 474-5 475 Laminated socket 5-prong 10c
- Grips large or small wires easily. Guard keeps antenna from grounding on chassis. Binding nut cannot come off and become lost.
- Antenna-Ground Binding Posts 10c
- 949 FFP Disc adapter for bringing out filament and plate from pentode tube to provide filament and plate voltage for operating short-wave converters 60c
- Adapters to provide any type connections desired. New type for testing six prong '57-'58 tubes, the G-2 Diode and '82 Mercury Rectifier. Write your requirements.
- 3-4-5-6 Prong Speaker or Cable Plugs
- 905L and 906L Latch Lock Analyzer Plugs 5-prong with 5-foot cable \$3.00
- 6-prong 5.00
- with 5-foot cable 3.50
- 965DS Adapter for use with 906L, six prong top, five prong bottom 1.25
- 964DS same with four prong bottom 1.25
- 954DS Adapter to use with 905 center locking stud 1.25
- 954-KPC Pentode Adapter. Connects cathode to plate. Used for replacing 245's with 247 Pentode tubes 1.00
- 247 Pentode Tubes 1.00
- 954-FKP Pentode Adapter with resistance in filament reducing 5 volts to 2.5. For putting 247 Pentode tubes in 171 sockets 1.25
- 954-DS for 171 push pull, arc connected in series—pair 2.00

Send for Price Sheets—Dept. R
ALDEN
MANUFACTURING COMPANY
BROCKTON MASS.

AERO WORLDWIDE SHORTWAVE RECEIVER

\$6.45

Listen in DIRK (To London Paris, Berlin, Buenos Aires and other broadcasting stations throughout the world via short waves. Your ordinary receiver cannot tune in these low wave stations. WORLDWIDE RECEIVER gets 14 to 550 meters.

AERO SHORT WAVE CONVERTERS

Convert Your Present Set into a Short Wave Super-Heterodyne

A. C. MODEL \$12.50—D. C. MODEL \$11.50

AT LAST: The Perfect Auto Radio ONLY \$20.00

Built by pioneers in the manufacturing of Auto Radio. We guarantee 1000 miles radius of reception. A masterpiece of Radio Engineering. Latest model 6 Tube Aero Pentode Auto Radio. Price of set only \$20.00. Set complete with tubes, batteries, dynamic speaker, antenna equipment and noise suppressors. \$39.50. Send for complete Catalog.

CHAS. HOODWIN COMPANY

Dept. T-15, 4248 Lincoln Avenue Chicago, Illinois.

DRY ELECTROLYTIC CONDENSERS

By HERNDON GREEN

DURING the past year the dry electrolytic condenser received increasing attention from radio set manufacturers, radio experimenters and Service Men. The reason for this popularity is not hard to understand when we consider the relative sizes of paper condensers and dry electrolytics of the same capacity and voltage rating. A 4-mf., 400-volt paper condenser, as indicated by A in Fig. 1, averages about 14 cubic inches, while a dry electrolytic, B, of the same electrical characteristics, measure about 3½ cubic inches. To the manufacturer and set builder this small size means a saving of space and material; to the Service Man it means a considerable simplification of the problem of replacing bulky filter condensers that have gone defective.

Common belief to the contrary, the dry electrolytic condenser does not differ materially from the liquid type, which has been in widespread use for seven or eight years. It overcomes the main objection to the "wet" type—spilling of the electrolyte—but it contains an electrolyte just the same. It is dry in the same sense that a "dry cell" is dry; that is, the electrolyte has too low a viscosity to run or spill, regardless of the position of the container. A review of the fundamental theory of electrolytic condenser operation will undoubtedly help make the action of the "dry" type more clear.

The electrolytic condenser consists essentially of a so-called rectifying or "valve metal" immersed in an electrolyte together with an inactive electrode. The latter may be an additional bar or strip of metal, or may simply be the container holding the fluid electrolyte. Its only purpose is to form an outside connection for the electrolyte.

Several metals, under proper conditions and with the proper electrolytes, show "valve" action; that is, they allow current to flow only in one direction. For commercial purposes, however, aluminum and tantalum are the only satisfactory metals for the purpose. Of the two, aluminum is more widely used because it is cheaper and works with less corrosive chemicals than required for tantalum.

Fig. 2 shows the construction of an elementary electrolytic condenser, which consists merely of an anode of pure aluminum immersed in a solution of borax, boric acid or phosphates and water. The metal container, which is the cathode or inactive electrode, is usually copper, but aluminum that is not quite as pure as the anode is also used commercially with success.

A number of theories have been offered for the operation of the electrolytic condenser, but the most commonly accepted one will be given.

Suppose we connect the cell to a source of direct current, such as ordinary batteries, as

shown in Fig. 2, with the aluminum anode positive and the container-cathode negative.

The surface of aluminum is always coated with a thin film of oxide due to its exposure to the air. (This is why aluminum cannot be soldered by ordinary methods.) This natural coating of aluminum oxide is a poor conductor of electricity, but it is so thin that it does not appreciably limit the flow of current through the cell. Consequently, when a voltage is first applied to the cell there will be a comparatively heavy flow of current. Also, because of the porosity of the oxide coating, some



A photograph illustrating representative electrolytic condensers. The one in the foreground has a capacity of about 5 mf. suitable for bypassing purposes.

of the electrolyte may seep through the pores and attack the aluminum, causing the formation of more oxide. The flow of current "ionizes" the electrolyte, and negatively-charged oxygen "ions" are liberated at the negative container. These are attracted to the positively charged aluminum anode, which neutralizes the negative electrons. Oxygen gas is liberated, only to be entrapped in the aluminum oxide on the surface of the electrode. Because of the high electrical resistance of the gas, the current through the cell gradually decreases as more and more gas is entrapped, until finally the flow of current ceases altogether.

This process is called "forming" the cell. An insulating medium—the oxygen gas—is "formed" on the surface of the aluminum and

(Continued on page 758)

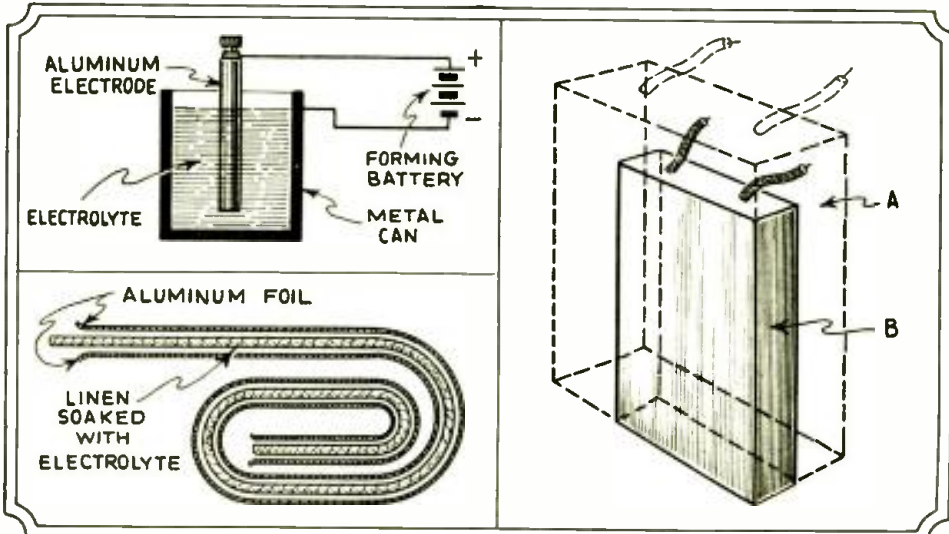

Fig. 1, right. Relative size of electrolytic and "paper" condensers.
Fig. 2, upper left. Forming an electrolytic condenser.
Fig. 3, lower right. A "rolled" dry electrolytic condenser.

TELEPHOTOGRAPHY

(Continued from page 725)

In order that the light and dark currents may be of the proper value so as to keep the picture of the proper shade, a test detector is provided. It compares the value of the output current, both light and dark, and provides a means of adjustment. On long distance telephone circuits, a certain amount of attenuation or loss of current strength takes place. To compensate for this loss, vacuum-tube repeaters are placed along the line at intervals of approximately 50 miles on cables and 150 miles on open wire. Repeaters are inductive coupled amplifiers, with a low amplification, and are used on all long distance telephone lines.

At the receiving end, the incoming currents are again boosted by a terminal amplifier, and a filter is provided to separate the modulated 1300-cycle wave from the 480-cycle wave that comes over the same wires to control the motor speed. Two stages of transformer-coupled amplification amplify the 1300 cycle current and it is terminated across the light valve.

As the name implies, the light valve acts as a valve or check on the amount of light passing through it. The amount of light it will pass varies as the strength of the current through it. The valve consists of a thin ribbon of duraluminum, one and one half inches long, held in mechanical tension in a strong magnetic field of constant strength. At rest, the face of the ribbon obstructs the passage of light which passes through an aperture to the film. If, however, a 1300 cycle current flows through the ribbon, a force is produced that causes it to vibrate 1300 times a second. As it vibrates, part of the aperture opens and light is allowed to pass. The greater the magnitude of the current, the greater is the displacement of the ribbon, and the greater the amount of light passing through the aperture.

The source of light is a small, high powered lamp of constant light intensity. Three lenses guide the beam through the light valve and focus it on an unexposed film. This film is of the same size as the transmitting film, and is rotating at the same speed and in the same manner. The image of the light on the film is of the same size as the original image and traces a series of adjacent lines just as the transmitting image does. When the film is developed, a negative of the original positive results.

The Control System

Motors of the phonic-wheel type are used to drive both the sending and the receiving machines. The rotor of the motor is of iron and has ten teeth, and the stator is composed of four magnets. The current applied to the magnets is one that pulsates in value. If the motor is brought to a speed of such value that when a tooth is approaching a pole that pole becomes magnetized, and when it is leaving the pole, it loses its magnetism, a pulsating torque is developed tending to turn the machine. A heavy flywheel, containing mercury, keeps the speed constant.

A large tuning fork, which vibrates at a natural frequency of about 60-cycles per second, controls the speed of both the sending and the receiving motors. This fork is located at the transmitter and there is a similar fork at the receiver. The control fork, like a buzzer, is kept in vibration by means of two magnets, the fork interrupting the current through them. Two other sets of contacts make and break connection when the fork is in vibration, one of which interrupts a 110-volt D.C. current through the motor causing it to turn at a certain speed. The other set of contacts short circuits the output of a 480-cycle vacuum tube oscillator which, passing through a filter and terminal amplifier, goes out on the line. Instead of a steady 480-cycle current being sent over the line, there is a 480-cycle current interrupted 60 times a second.

At the receiving station the interrupted 480 cycle oscillations are amplified by the terminal amplifier and directed into the proper channel by the control filter. They are passed through another amplifier and then into a relay. As the spurts of current enter the relay, it is caused to operate in synchronism with them, making and breaking a 110-volt

D.C. circuit that drives a receiving fork of the same type as the sending fork, in synchronism with it. A local 110-volt circuit is interrupted by the local fork contacts and drives the local motor at exactly the same speed that the motor at the transmitter is being driven.

It is absolutely essential that the two machines be started at the same instant if the picture is to be continuous. To insure such a condition, the operator at the sending station starts both machines together. Communication is first established by telegraph, mechanical printer or teletype, and then the transmitter operator sends the pure 1300 and the interrupted 480-cycle waves. Each man then brings his synchronous motor to speed by means of a hand crank. At the receiving station is a start key, which when operated, changes the picture amplifier into a detector by a change of grid bias. At the same time the output of the tube is transferred from the light valve to a relay that operates the clutch on the motor shaft.

The 1300-cycle carrier operates this relay which, by means of a local magnetic circuit, holds back the clutch. When ready to start, the operator at the transmitter presses a key, which releases his own clutch and at the same time short circuits the 1300 cycle wave for an instant. This short opens the receiving relay causing the clutch to be released by the magnet. A powerful spring engages the clutch so that it turns the film holder. This takes so little time that the two film holders start practically together.

The 480-cycle control system has the disadvantage that modulation often occurs between the picture carrier wave and the control oscillations, causing bands to appear on the picture. If the strength of the 480-cycle wave is considerably reduced, this modulation is eliminated, but in so doing, the effect of noise energy increases and results in poor control. To eliminate such difficulties an independent system, called the constant frequency control system has been inaugurated at some of the stations.

Various line conditions have different effects on transmitted pictures. A level change, that is, a sudden change in the strength of the line current, will cause a picture to change its shade. One part of the picture will be of a deeper, darker shade than the other. Noise will cause spots and streaks, and poor synchronism will give a ragged outline. Modulation of the picture carrier and the control carrier will cause a series of alternate light and dark bands across the picture.

Use of Telephotographs

Telephotographs are used, for the greater part, by the newspaper trade. Photographs can be sent swiftly and cheaply to all station points. Almost every daily paper has at least one or two telephotographs in it, although they are not always so labeled. Another large part of the business is in the form of brokers bond issues. It is necessary to have the advertisement or announcement in the papers of different large cities at exactly the same time. Time is valuable and instead of telegraphing lengthy and minute instructions, the ad is photographed and sent over the telephone wires. Pictures of criminals and their finger-prints can be quickly spread over the entire country.

Another use of the telephotograph is in sending written signatures. A man can send to his bank for money under his signature, or identification can be made by means of handwriting. In times of war, the apparatus should prove invaluable for transmitting maps and papers. Technical drawings and circuit diagrams as well as legal documents can be successfully transmitted. X-rays are often sent between cities when a doctor wants the diagnosis of another surgeon in a distant city.

While the mechanism for the transmission of photographs over extensive distances has been primarily developed for use on telephone lines, it would probably be suitable for the transmission of photos by radio if atmospheric conditions were such that steadiness of transmission and freedom from interference could be assured.

CROSLLEY

**7 TUBE
SUPERHETERODYNE
At an Amazingly
Low Price**



\$45.00
COMPLETE WITH 7 TUBES
AND TENNABOARD

The Crosley

FORTYFIVE

The Crosley FORTYFIVE is the last word in radio design and performance. The beautiful front panel is finished in Adam brown. A pleasing two-tone effect is accomplished by an overlay of stump walnut veneer which decorates the front panel. Fluted pilasters support the arch of "V" matched rose wood. The top and sides are finished in Adam brown.

The 7-tube superheterodyne chassis incorporates pentode output and variable mu tubes, continuous (stepless) tone and static control and on-off switch, illuminated dial, volume control. Full floating moving coil dynamic speaker is used. Never was there a greater radio value.

Prices subject to change. Any Federal or State taxes which may be levied must be added to this price.

Montana, Wyoming, Colorado, New Mexico and west, prices slightly higher.

THE CROSLLEY RADIO CORPORATION
Powel Crosley, Jr., President
Home of "the Nation's Station"—WLW
CINCINNATI

YOU'RE THERE WITH A CROSLLEY
**CROSLLEY
RADIO**

DEALERS and SERVICEMEN

Give to your customers the advantage of buying first-quality licensed R.C.A. tubes at prices that are exceptionally low. We carry the largest variety of tubes in the world, many for special purposes, and every tube is replaceable within 3 months, providing filament is not burnt out. We either have the tube you require or we will make it for you.

take advantage of our offer— 17 UY-227 Tubes FREE with every purchase of 100 Assorted Tubes

(This offer is good until June 7, 1932)

COMPLETE STOCK READY FOR IMMEDIATE SHIPMENT

Order from this page—Realt 20% with order, balance C.O.D. All prices are F.O.B. FACTORY, Newark. Shipments go forward express or parcel post. No order for less than \$3.00 accepted.

TYPE	DESCRIPTION	ANY QUANTITY
UX-201A	—Amplifier or detector	\$.30
UX-226	—AC amplifier	.30
UY-227	—AC amplifier or detector	.30
UX-171A	—Power output amp. for AC or DC operation, 1/2 amp.	.30
UX-171	—Same characteristics as 171A on tungsten filament, 1/2 amp.	.30
UX-240	—Designed for impedance and resistance coupling	.40
UX-120	—Power amp. used in last stage of audio freq.	.40
UX-199	—Detector and amp. tube, long prongs	.40
UY-199	—Same characteristics as UX-199 only short prongs	.40
UY-199	—Std. Base, has a 201A Base	.40
UX-112	—Power amplifier tube, 1/2 amp.	.40
UX-112A	—Power amp. tube for low cur. consump., 1/2 amp.	.40
UX-200A	—Detector tube recommended for weak signals and good reception	.40
UY-224	—AC screen grid amplifier	.40
UX-245	—Power amplifier	.40
UY-247	—Power pentode	.60
WD-11	—Detector Amp.	.60
WD-12	—Detector Amp.	.60
UX-230	—Dry cell amp. and detector, 2 volts	.60
UX-231	—Dry cell amp.—last audio stage, 2 volts	.60
UX-232	—Dry cell screen grid amp., 2 volts	.60
UY-233	—Power Amplifier Pentode, 2 volts	.60
UY-235	—Super control screen grid amp.	.85
UY-236	—Screen Grid Radio Freq. Amp.	.60
UY-237	—Detector Amplifier	.85
UY-238	—Power Amplifier Pentode	.85
UY-551	—Variable Mu	.60
UX-210	—For power amplifier, high voltage	1.10
UX-222	—Screen grid radio frequency amp.	1.10
UX-250	—Power amp. used in last stage of audio freq.	1.10
	Ballast tube to prevent tubes in set from blowing out	1.10
	Special super-sensitive 200A detector tube	.60
	Special super-sensitive Audio Freq. 201A	.60
	Special super-sensitive Radio Freq. 201A	.60
	Special 171 AC 1/2 amp. extra coated filament—good for electric sets.	.60
	T-14 (201A High Mu) high emission	.60
	Switch tube, 201A or 112 or 171 double life	.60
	Adapter tube 226, 227, 171A, to convert bat. sets to AC, each.	.60
	UY-227A—AC amplifier or detector, same as 227 (but quick heater)	.60
	UY-224A—AC screen grid amplifier, same as 224 (but quick heater)	.60

RECTIFIER AND CHARGER BULBS

125 Mil. rectifying tube (B. H.) (Raytheon Type)	1.25
6/10 amp. trickle charger bulb (Tungar Type)	2.00
2 amp. old and new type charger bulbs (list \$4.00) (Tungar Type)	2.00
5 and 6 amp. charger bulbs (list \$8.00) (Tungar Type)	3.75
15 amp. charger bulbs (Tungar Type)	7.50
Rectifying Tube especially designed for use with Freshman Master "B" Eliminators UV brass base, limited quantity	.30
UX-866—Hot Cathode Mercury Vapor Half-Wave Rectifier (Heavy Duty)	2.75
UX-280—Hot Cathode Mercury Vapor Full-Wave Rectifier as UX588	1.40
UX-281—Hot Cathode Mercury Vapor Half-Wave Rectifier	2.75
UX-871—Hot Cathode Mercury Vapor Rectifier	1.50
UX-280—Full-Wave Rectifier for High Emission	1.40
UX-281—Half-Wave Rectifier	1.10

PHOTO CELLS

Photoelectric cell, "Potassium" Type O	3.85
Photoelectric cell, "Caesium" Type A	7.90
Photoelectric cell, "Caesium" Type R	5.90

TELEVISION TUBES

Tellon Reflectron Neon Television Tube, 1" Cathode Square Type C	3.85
Tellon Neon Television Tube, 1 1/2" Cathode Square Type V	3.85
Tellon Neon Television Tube, 1" Cathode Square Type X	3.85

UX-182—Sparton Type	.85
UX-183—Sparton Type	.85
UY-484—Sparton Type	.85
UX-585—Sparton Type	2.10
UY-686—Sparton Type	.85
UX-401—Kellogg Type	1.50
UX-403—Kellogg Type	2.00

ARCO TUBE COMPANY, 38-40 Park Place, Newark, N. J.

HOME RECORDING

(Continued from page 726)

The following detail description will show why the home recordist will find it practically impossible to produce his own duplicates by the "process" system.

The instantaneous record is dubbed onto a soft-wax disc, the surface of which is then treated—usually, by dusting with very fine graphite to make its surface conductive.

An electrical connection is then made to this graphite surface and the soft-wax immersed in an electroplating bath. After a certain time, during which the plating solution is kept in motion, with respect to the wax, and the current densities are carefully controlled, there is deposited on the surface of the wax a layer of copper.

Since the graphite layer upon which this copper is built is very thin, and very uniform in character, the copper "plate" which has now been formed will fit tightly into each of the minute grooves on the wax.

In Fig. 3, for example, the dark portion represents the cross-section of the grooves on a soft-wax and therefore the shaded portion represents the cross-section of the copper which has been plated onto the surface of the soft-wax.

This copper layer when separated from the wax constitutes an exact copy of the original recording, except that it is "negative" in character—that is, bearing ridges where the original or positive record bore grooves. This thin layer of copper, only a few thousandths of an inch thick, is called a *matrix*, or sometimes a "master negative."

After being reinforced with a backing of thicker metal, it may be used in the record-press to make just a few of the familiar black pressings or finished records.

For the amateur who only wants a few copies, the production of this matrix will be as far as he need have his commercial studio go in the processing; but if several hundred copies are required, then it would be unwise to try to get along with this one matrix for there would be grave danger of losing the entire recording because of some accidental damage to it. Therefore, an additional electroplating process must be resorted to in order to provide enough stampers for use in making finished records.

Obtaining Multiple Stampers

The first of these steps is to electroplate the matrix or master *negative* to obtain one or more master *positive* records, sometimes known as "mother" records, which are in all respects similar to the finished record, except that they are composed of metal (instead of the familiar black compound); these become the new source from which are derived, by electroplating, as many (negative) stampers as may be required for use in producing the finished or positive records.

The final step in the process of producing a finished record is the pressing of the black compound, or "record stock," using a stamper as a die.

The record stock is heated on a steamtable until it becomes quite soft, rolled into a plastic ball, and then placed on the stamper, which is heated by steam inside the press to much the same temperature as the steamtable. The press is then closed and then the record material under hydraulic pressure of more than a ton per square inch, is pressed into the minute sound-grooves of the stamper. Cold water is then turned into the dies, and after a short interval the press is opened and the record separated from the stamper. It is then ready for immediate use if desired. This operation is repeated as many times as required to provide the desired number of copies.

An Alternative Recording Method

One method, whereby copies have been made fairly successfully, uses the home recordist's original metal recording as the wax master, the disc being treated the same as the wax by graphiting the surface and then electroplating it to obtain a copper negative. The process from here on is the same as described above.

The only objection to this method is the shallow groove, for in making the original cut the

(Continued on page 753)



TYPE O Potassium Photo Cell, 4" overall. \$3.85.



TYPE A Caesium Photo Cells, overall length 3 1/16". \$7.90



TYPE R Caesium Photo Cells, overall length 3-1/16". \$5.90.



TYPE V Television Tube 1 1/2" square cathode, overall size 2"x3 1/2". \$3.85



TYPE X Television Tube 1" square cathode, overall size 1 1/2" x 3 1/2". \$3.85.

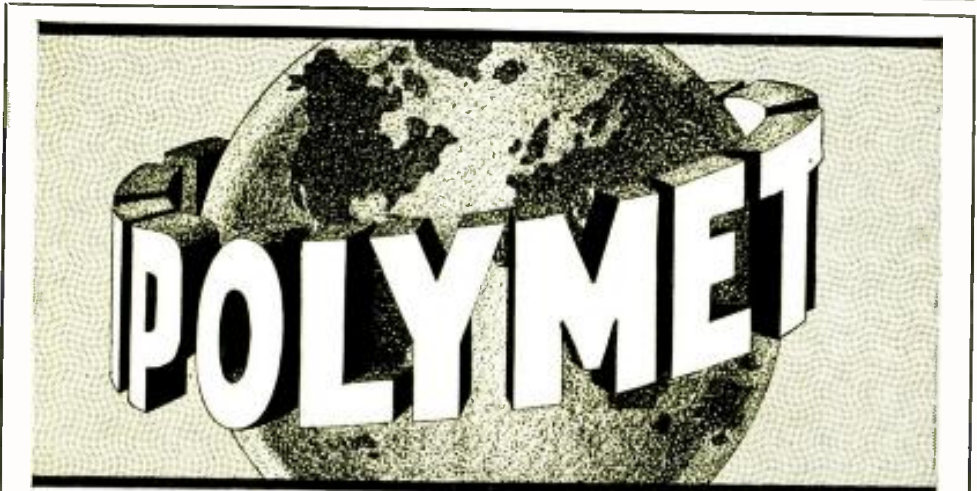

POLYMET PRODUCTS World—Known World—Accepted

POLYMET MFG. CORP.
834 E. 134th St., New York City

Send me your new and valuable catalog of quality replacement parts.

Name

Address

City State

Jobber Dealer Service-Man

The new 1932 Polymet Catalog gives complete dimension data and electrical specifications of the parts used by leading receiver manufacturers. You can purchase identical parts from your local jobber, and give "guaranteed" service work—a sure way to increase your business and your reputation.

MAIL COUPON FOR YOUR FREE COPY

THE RADIO "TREASURE" FINDER

(Continued from page 717)

The Receiver

The receiver is of conventional design, employing a screen-grid type '32 R.F. amplifier, a type '30 detector, and a type '33 pentode audio amplifier. The set is therefore very sensitive when used with a pair of headphones. The plate circuit of the screen-grid tube, as shown in the diagram of Fig. 1, comprises a tuned R.F. transformer of the plug-in tube base type, covering the 100-200 meter band. By proper tuning of the plate and grid circuits and by proper manipulation of the screen-grid potential by means of the series resistor R3 the circuit may be brought into a high state of sensitivity or it may be made to oscillate. The arrangement of the parts of the receiver are clearly shown in the photographs.

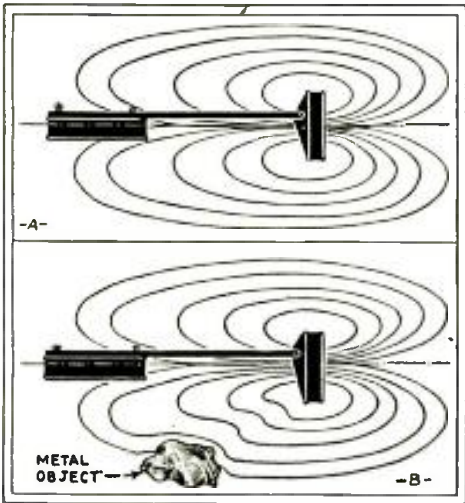

Fig. 3

At A, lines of force in free space. At B, the field when a metallic object is present.

Both transmitter and receiver units are built completely on shelves which are then mounted within the loop boxes on angle supports. Binding posts are included so that the batteries and loop can be quickly connected. It will be noticed that a center connection is made to the loop of the transmitter. A hole is drilled through the box for this connection.

The knob of the tuning condenser of the transmitter and the on-off switch are placed on the outside of the box so as to be accessible to the operator. Once properly tuned the only thing that need be touched again is the "on-off" switch.

The receiver box, however, has projecting through it the knobs of the two variable condensers, the screen-grid variable resistor and the on-off switch. Two binding posts are also mounted on this box for the headphone connections.

By following the dimensions given in Fig. 2 and the various illustrations, and the values given in the list of parts, little difficulty should be experienced in building the device and making it work. Tests should be made by walking

around some piece of metal of known location and carefully observing the effect of the signal in the headset. In this way you will become familiar with the apparatus and learn to interpret the meaning of the signal as regards the location and size of the hidden object. Radio Service Men throughout the country will find that treasure finders of this type can be built and sold for a large profit.

In testing this "treasure" finder, several precautions should be taken. First, the test should be constructed out in the open with no metallic objects near it. The transmitter and receiver should then be set up on two wooden chairs or boxes and the distance between them varied until the greatest sensitivity is secured. They should then be mounted on the carrying pole as illustrated in Fig. 2.

In giving the construction details we have stated that the length of this pole is six feet. This is the length that we have found to give best results, but it might change with slight variations in tube voltages, type of wood, etc.

List of Parts

The values of the parts necessary for the transmitter illustrated in Fig. 4 are as follows: C, .00025-mf. (variable); C1, .00025-mf. (fixed); C2, .5-mf.; R, 1 megohm; R1, 15 ohms.

The parts necessary for the receiver illustrated in Fig. 1 are as follows: Two Hammarlund .00025-mf. midjet variable condensers, C, C1; one Polymet .00025 mf. fixed condenser, C2; one Polymet .0005 mf. fixed condenser, C3; two Polymet .5-mf. fixed condensers, C4, C5; one 2-megohm resistor, R1; one 2½-ohm resistor, R2; one 0-100,000-ohm variable resistor, R3; one Air King plug-in type, 100-200 meters, R.F.T.; one audio-frequency transformer, A.F.T.; 1 switch, SW.

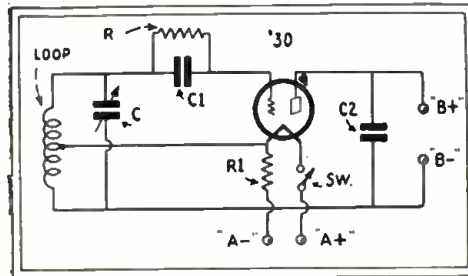

Fig. 4

Schematic circuit of the transmitter.

It might be well to emphasize at this time that good results might not be secured at first trial. After building the treasure finder, it would be well to check over the connections and the mechanical construction for errors. After this has been done, proceed with an actual test.

Some men, upon reading a description of a device in a magazine, decide that it would be better with a different arrangement of apparatus, either electrically, mechanically or both. To such men, the author suggests that the treasure finder be constructed as described, and if the results are not to their satisfaction, any and all devices may be tried—but not until the finder has been built as shown. However, I believe that when once constructed, there will be no need for any changes.

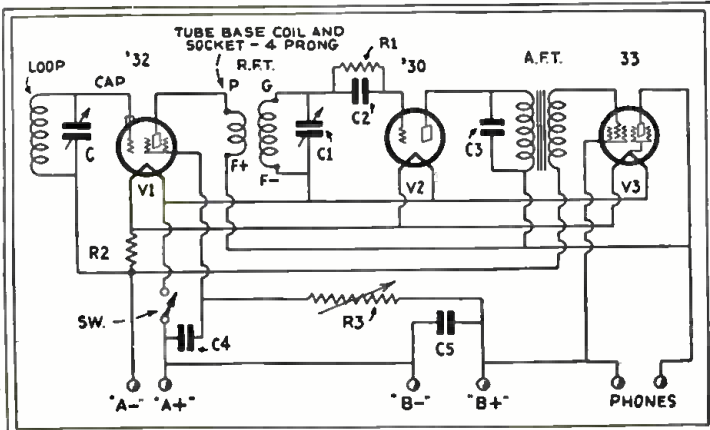

Fig. 1

Schematic circuit of the receiver. It is a three-tube receiver employing a screen-grid R.F. amplifier, three-element detector and a pentode output stage. An excellent control of volume is secured by varying resistor R3.



Readrite

No. 550

OSCILLATOR

Licensed by A. T. & T. Co.

\$18 Net to dealer
\$30 list

\$21 Net to dealer
with output meter

If not at your Jobbers we will ship direct when remittance accompanies order.

A sturdy modulated instrument carefully made. Completely shielded with separate battery compartment. Furnished with 22½-v. and 3-v. batteries and one '30 tube. Direct reading broadcast band (550-1500 kc.) and intermediate band (120-185 kc.). Sharp 2d and 3d harmonics for 260 and 475 kc. Operating instructions attached in case cover with shielded wire leads. Very compact. In leatherette case, 6x11½x5½ in. Weighs but 8 pounds. Built to high standards. Every serviceman should have the No. 550 oscillator to align r.f. gang condensers, locate defective r.f. transformers, adjust i.f. transformers, check oscillator stage and determine sensitivity of a receiver. A necessary instrument. Get yours today. Write for catalog of servicing instruments.

Readrite Meter Works
17 College Ave.
Bluffton, Ohio

Please send all information about Readrite Oscillator and other service instruments.

Name

Address

City..... State.....

Readrite Meter Works
Established 1904
17 College Ave., Bluffton, Ohio

THE THEORY AND CONSTRUCTION OF ATTENUATORS

(Continued from page 727)

ments described the "characteristic impedance" of the circuit when looking into both the source and load ends of the line.

In order therefore, to fulfill the circuit requirements for image impedance, and characteristic impedance, the two must be equal, and upon completion of the design of the pads, this will readily be seen.

Having discussed the various problems that must be considered from an impedance matching standpoint, our next problem is to analyze the various problems associated with the circuit, in the transmission circuit.

It is the purpose of the writer to lead up to the actual design of the pads by the method of "approach." For, having thrashed out the various problems associated with the circuit, the design of the pads is then reduced to the simple process of substitution into the working formulae for the pad under consideration.

Continuing now with an analysis on pads, it was stated in the first part of this paper, (May, 1932 issue) that pads are used to control the level of the energy entering the load. We are principally interested then, in determining the relative amount of current and voltage appearing at the load. In Fig. 8 is shown an "H"-type network working between a source impedance Z_0 and a load impedance Z_0 . Now, referring to Fig. 9, which is the equivalent circuit of Fig. 8, it can be seen that if we wish to keep the current I_2 and the voltage V_2 at the load at certain fixed values, with a constant voltage V_1 impressed across the input terminals of the pad, the values of the resistances used in the pad would have certain predetermined values in order to give the correct loss between the input and output terminals. The values of these resistances are determined by the impedances between which the pad is working and the ratio of the current or voltage on the input side, to the current or voltage on the output side of the pad.

Let us return now to our own problem under consideration, that of designing a pad to give a 20-decibel loss. We have determined that

if the voltage is reduced to $\frac{1}{10}$ of its original value, or in the order of 10 to 1, the voltage ratio is 10, and expressed logarithmically this loss is 20 decibels.

Suppose we wish to reduce the voltage only a small amount, or in the ratio of 1.12 to 1. We would then have only a 1-decibel loss in the circuit, which is comparatively small. Now suppose we wish to set up a large loss, in the order of 100 to 1. We then would have a 40-decibel loss. Taking these three cases of 1-, 20-, and 40-decibel losses, and impressing various values of voltage V_1 at the input terminals, let us see how the pads that we would have to design, would vary, in order to keep a constant voltage V_2 at the output terminals of the pad. In Table 3 are given the values of resistances as used in the series and shunt arms of "H"-type pads, when working between 200-, 500-, and 600-ohm impedances.

Now, using the 20-decibel loss as a reference level and referring to this table, it is seen that to obtain a 20-decibel loss the series arm, Z_1 is 82 ohms, and the shunt arm Z_2 is 40.4 ohms, when working between two 200-ohm impedances. With these constants, the output voltage would be $\frac{1}{10}$ the value of the input

voltage. Or, if the input voltage is 1.5 volts, the output voltage would be .15-volts, and the voltage would have been dropped 1.35 volts.

Now assume that the input voltage is .168 volts and we still wish to maintain the output voltage V_2 at .15-volts. The voltage ratio is .168

or 1.12; or, a 1-decibel loss is obtained

in the circuit. From Table 3, for a 1-decibel loss, the series arm Z_1 is only 5.65 ohms, whereas, the shunt arm Z_2 goes up to 1760 ohms.

From the simple laws of current flow, this can be understood; for to obtain only a 1-decibel loss, we do not wish to introduce a large amount of series resistance, as this would impede the current flow, which is what we wish to avoid. The voltage drop in this case is only .168 minus .15 or .018-volts. Therefore, the series arm Z_1 must be very small, and is but 5.65 ohms. Also, the shunt arm Z_2 must be very large, so that very little current will be bypassed or shunted from the load, and as can be seen, its value is large, being 1760 ohms.

Now comparing the 20-decibel loss to the 1-decibel loss, in order to obtain the same output voltage with different input voltages, the series arm Z_1 for a 1-decibel loss is only 5.65 ohms, and for a 20-decibel loss is 82 ohms. The shunt arm Z_2 for a 1-decibel loss is 1760 ohms, and for a 20-decibel loss is only 40.4 ohms. Therefore, to obtain a fairly large loss, (such as 20 decibels), the series arm is quite large and the shunt arm comparatively small (compared to the load impedance.) In this case, the current will be impeded by the large series arm, thereby dropping the voltage considerably, and at the same time shunting it from the load by the comparatively small shunt arm, thus creating the fairly large loss desired.

For a small loss such as a 1 decibel, the series arm is very small and the shunt arm very large as compared to the load impedance. In this case, very little voltage drop is encountered in the series arm, and since the shunt arm is very large, very little current will be shunted from the load. Therefore, practically all of the original current will enter the load, thereby obtaining the small loss desired.

(Continued on page 754)

Mr. SERVICE MAN



YOUR REPUTATION FOR DOING SATISFACTORY WORK IS YOUR GREATEST ASSET

Guard This Reputation!

GOLD SEAL Radio Tubes, RCA Licensed, are built to standard specifications—are double tested at the factory. The *second test*, under the supervision of GOLD SEAL Sales Engineers, assures you of that EXTRA "BIT"—THAT SATISFIES.

There's a GOLD SEAL Radio Tube for every radio receiver—for any television receiver—for that public address system

on which you are working. And, yes, there are photo electric cells ready.

GOLD SEAL Sales Engineers have developed a special "SELLING PLAN" for the Service Man. It's yours—if you will mail the coupon.

Mail Coupon TODAY!

GOLD SEAL MFG. COMPANY
5 Central Ave., East Newark, N. J.

Please send me by return mail Specifications on GOLD SEAL Radio Tubes and your "Sales Plan" for Service Men.

Name
Address
City State

PROTECT YOUR REPUTATION GIVE SERVICE THAT SATISFIES

OPERATING NOTES

(Continued from page 733)

model 99X, have given trouble owing to intermittent or no reception. Although the complaint has all the symptoms of an open voice coil, removing and re-inserting one or both of the pentodes will produce no click in the dynamic speaker. These chassis have a five-terminal strip, illustrated in Fig. 3, located in the rear of S.P.T., behind the reproducer. Due to vibration or other causes, the screws holding the connecting link across terminals 4 and 5 become loosened, which opens the voice-coil circuit causing the above complaint.

Another model, namely the 68 manufactured by the same company, presents a number of difficulties. This receiver is a radio-phono combination, with remote tuning. The remote control unit which is located in the front of the chassis is enclosed in a shield to service, which requires complete removal of the chassis. The most common troubles of the remote-control unit lie in the "off-on" switching mechanism, which is a relay composed of two coils, an armature and two contacts. The complaint will be that the set cannot be turned "on" or that it cannot be turned "off."

Normally, when the "on" button is pressed, the armature of the relay snaps to the right and engages two copper contacts, thereby closing the primary circuit. Due to the heavy current drain of the receiver, especially when the phonograph has been in operation, the arc (created by the engagement of the armature and the contacts) soon corrodes or burns away the ends of one or both of the contacts, preventing the set from being switched "on." On other occasions, the arc will cause the armature to spot-weld to the contacts, resulting in a condition where the receiver cannot be switched "off."

In some cases, where the contacts have not been burnt away and are only corroded and blackened, it is possible to clean the contacts with some very fine sandpaper or a magneto file; but in the majority of instances it will be necessary to replace the contacts.

Whenever this remote-control unit is serviced because of the foregoing failure, it is wise to connect across the two contacts a one or two mf. condenser, capable of working continuously at about 150 volts A.C., to absorb most of the arc when the switching takes place, thus avoiding future troubles.

Another service call concerning this model set may be a request to increase the length of the remote-tuning-unit cable, where the owner desires the unit placed at some distance from the receiver. The cables furnished for this extension work are obtainable in different lengths and are similar to those already used except in one detail. The terminals fanned out at one end of the extension cable may not correspond to the fanned terminals at the other end. In other words, right-side terminal No. 1, at one end, may be right side terminal No. 5, at the other. Every cable should be checked with some continuity device and marked before installation.

The pilot light used in the remote tuning unit is a miniature 2½ V. bulb. When any of the buttons are pressed, the glow should dim, due to the method of obtaining current for the bulb. However, should a 6 V. bulb be substituted, then instead of the light dimming, it will brighten considerably, when any of the buttons are pressed. This results in much shorter life.

The Kennedy 62

Only one serious complaint has shown up in the Kennedy 62 combination long- and short-wave receiver. When the tuning control of the broadcast receiver is rocked, or moved from one side to the other, or up and down, intermittent reception will result. The same defect that causes this complaint is also the reason for an inoperative receiver. The tuning condenser gang is mounted on rubber supports for obvious reasons. The lead soldered to the first stator section not being very flexible soon snaps off its connecting lug, because of the rocking of the gang, resulting in the two complaints. It will be necessary to remove the gang shield to remedy the cause of this trouble. To minimize the possibility of future recurrences, this lead may be removed and one that is more flexible installed.

Stromberg-Carlson 22

One of the new Stromberg-Carlson models, the superheterodyne 22, perplexed several Service Men, recently.

The receiver was inoperative. A thorough check revealed an entire lack of plate voltage at the second I.F. stage, with correspondingly lowered voltages on other tubes. The 1. mf. bypass condenser proved perfect. The ohmmeter indicated a resistance of over 10,000 ohms from the B+ side of the last I.F. intermediate primary, to chassis; at the plate side of the same winding it showed a reading of only about 1000 ohms. When the schematic was consulted and the circuit traced, it was found that the only possible source of trouble was in a shorted .0001-mf. mica condenser, coupling the plate of the second I.F. tube to the secondary of the last I.F. transformer or cathode of the second detector. This proved to be the situation when the suspected unit was tested. It is located at the base of the transformer within the shield, which is situated directly above the phonograph jack; its electrical connection in the circuit is shown in the detail illustration, Fig. 4.

The Bosch 31

In the Bosch 31 superheterodyne, the closely-coupled last I.F. transformer has been causing considerable annoyance. Here, as has been found with the untuned R.F. coils in previous Sparton models, the primary and secondary are wound together to obtain a high degree of coupling. The secondary is wound with cotton-covered enamel wire, while the primary has only the enamel for insulation. Break-down of the insulation at some point terminates in a shorted unit, which must be replaced. This condition will be known by properly checking the unit with all leads removed, but may be deduced from a lack of plate voltage not attributable to any other cause.

Fada Models

Several errors have been made by Service Men when aligning Fada Models 45, 48 and 49 superheterodynes. These have occurred due to the fact that the locations of the different trimmers have not been known. The I.F. in these models is 175 kc. The oscillator trimmer should be adjusted at 600 kc., the gang compensators, at 1400 kc. The four I.F. tuning condensers in the 48 and 49 models are located in the rear of the chassis; but the oscillator trimmer is found between the pentode '47 and the type '35 tubes within the main shield housing. In the 45 model, however, the trimmers are located as shown in the sketch, Fig. 5.

Sparton, Majestic and Zenith

Noisy reception on Sparton Model 591 receivers has definitely been traced, in many instances, to a faulty first A.F. transformer. This unit is situated under the chassis base-board with the first A.F. tube, which is inverted. It is best to replace the transformer, although a repair may be made by discarding the transformer and coupling the first A.F. tube to the detector by means of resistance coupling.

Many receivers, such as Majestic and Zenith, but especially Sparton models employing the band-selector, develop noisy tuning. As the condenser gang is rotated and tuned from broadcast band to broadcast band, the noise is heard. Examination will not reveal shorting plates. Cleaning all rotor friction contacts sometimes helps. However, the main reason for this trouble is due to tiny particles that peel from the plates and short to one another.

To eliminate this condition, all leads to the condenser sections should be disconnected and a high voltage applied to each section in turn. This voltage should be as high as possible and may be obtained from the receiver itself. All tubes but the rectifier should be withdrawn to raise the voltage. With the voltage impressed on each section, the gang should be rotated. Arcing at the shorted points will burn the particles and effectuate an efficient repair.



Order 5
Centralab
Replacement
Volume Controls
and get the new
50c Edition of our
Volume Control
Guide *FREE!*

This new Guide is just off the press . . . It is yours with an order of only FIVE (5) Replacement Controls at new low dealers' prices.

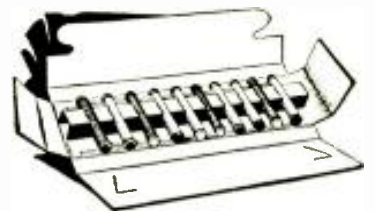

NOW!

A Service Carton
of 10 Centralab
Fixed Resistors

Your own choice of resistance values. Dealers list price \$3.00.

\$1.75

net

FREE: with every service carton we will include the **NEW QUICK REFERENCE WALL CHART** showing resistance combinations at a glance.

Centralab
CENTRAL RADIO LABORATORIES

930 E. Keefe Avenue
Milwaukee, Wis.

10 NEW BOOKS in the Radio-Craft

Presented on these two pages are the new books of the RADIO-CRAFT LIBRARY—the most complete and authentic set of volumes treating individually, important divisions of radio. Each book has been designed to give radio men the opportunity to specialize in one or more of the popular branches of the industry. The material contained in these books will increase your

knowledge; you will find them a real help in your work and they will contribute to your money earning capacity. Read these books during your spare time at home.

The authors of these books are well-known to everybody. Each one is an expert radio man; an authority on the subject—each is thoroughly familiar with the field which he represents.

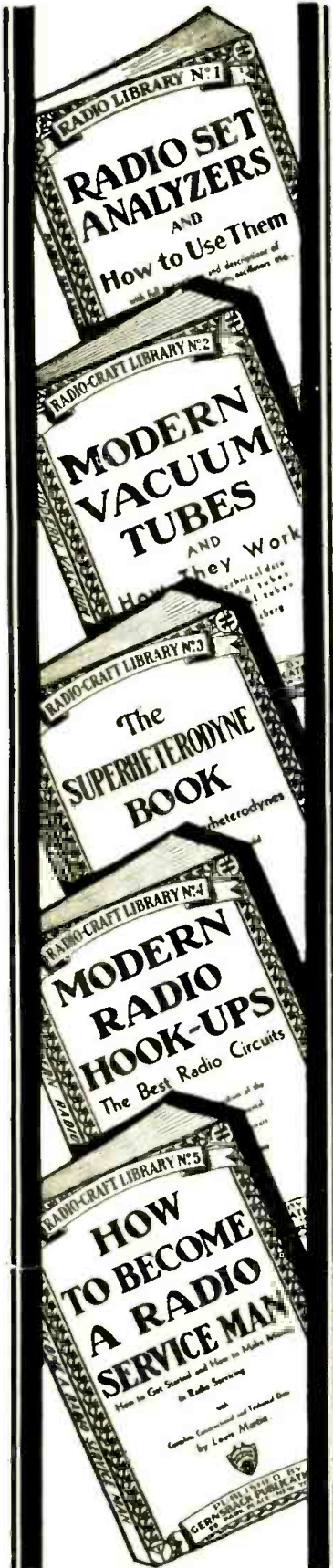

Book No. 1
RADIO SET ANALYZERS
 And How To Use Them
 With Full Instructions and Descriptions of Set Analyzers, Tube Checkers, Oscillators, Etc.
 By L. VAN DER MEL

This book explains thoroughly the operation of set analyzers, tube checkers, oscillators and other testing equipment. For every radio man this book is extremely helpful. It covers every phase of testing and gives you valuable short cuts; completely illustrated with photographs and diagrams to facilitate the use of modern testers.

The following chapters briefly outline the contents: INTRODUCTION; THE ANALYZER: Fundamentals, Switches, A.C. and D.C. Voltmeters, Calibration and Usage; TROUBLE SHOOTING WITH THE ANALYZER: Classification of Trouble, Analysis of Troubles, Uses of Various Analyzers, Care and Maintenance; CONCLUSION.

Book No. 2
MODERN VACUUM TUBES
 And How They Work
 With Complete Technical Data on All Standard and Many Special Tubes
 By ROBERT HERTZBERG

MODERN VACUUM TUBES describes the fundamental electron theory which is the basis of all vacuum tube operation, and goes progressively from the simplest two-element tubes right up to the latest pentodes and thyratrons. It is written in clear, simple language and is devoid of the mathematics which is usually so confusing. Valuable reference charts and characteristic curves of standard and special tubes are to be found, also diagrams of sockets and pin connections.

Here are some of the chapters: The Edison Effect and The Electron Theory; Electron Emitters and the Ionization Effect; The Three-Electrode Tube; Vacuum Tube Characteristics; Four- and Five-Element Tubes; Light Sensitive Cells and other Special Tubes.

Book No. 3
THE SUPERHETERODYNE BOOK
 All About Superheterodynes
 How They Work, How to Build and How to Service Them
 By CLYDE FITCH

There is no more fascinating a subject in the large array of radio circuits than the famous superheterodyne circuit. Whether you are a Service Man or experimenter, first-hand knowledge about the construction of superheterodyne receivers is very important. The book on Superheterodynes gives underlying principles of their construction, right from the very first set made.

The following is a short list of contents: Basic Principles of the Superheterodyne; The Detector; First Detector; Single Dial Tuning Systems; Intermediate Amplifier; Second Detector; Audio Amplifier and Power Supply; Commercial Superheterodyne Receivers; Servicing Superheterodynes.

Book No. 4
MODERN RADIO HOOK-UPS
 The Best Radio Circuits
 A Complete Compendium of the Most Important Experimental and Custom-Built Receivers
 By R. D. WASHBURNE

It is fascinating to the experimenter, or even to the up-to-date Service Man, to take a commercial set and to change it into one using a famous hookup that is not found in any manufactured set. Many excellent circuits have never been commercialized, but limited only to home-built builders. Thousands of these popular circuits have been requested from time to time, and in this book we have included over 150 circuits, which include the famous Perdyne, Cash-Box A.C.-D.C. Set and others.

The circuits cover the following: Broadcast Receivers; All-Wave Receivers; Short-Wave Receivers; Converters and Adapters; Television Receivers; Home Recording Apparatus; Automobile Receivers; Audio and Power Amplifiers, Power Units and Miscellaneous Equipment.

Book No. 5
HOW TO BECOME A RADIO SERVICE MAN
 How To Get Started and How To Make Money in Radio Servicing
 By LOUIS MARTIN

The ambition of many men in radio today is to become a first-grade Service Man. It is not as difficult as one might believe, but it cannot be done in a few short months. Following very carefully the advice of Mr. Martin, who has dealt with the problems of thousands of Service Men, this book deals very carefully with the essential steps in the preparation for qualifying as a Service Man.

Here are the chapters: The Small Independent Service Man; Advanced Commercial Aspects; The Radio Set; Semi-Technical Considerations; Advanced Service Data. Each chapter is again subdivided to bring out in minute detail every point of importance.

Book No. 6
BRINGING ELECTRIC SETS UP TO DATE
 With Pentodes, Multi-Mus, Dynamic Speakers—Complete Information How to Modernize A.C., O.C. and Battery Operated Receivers
 By CLIFFORD E. DENTON

In this country there are over ten million electrically operated receivers that could be modernized—by placing in them new type tubes, new speaker equipment and other modern improvements. This business of improving old sets can go to the experimenters and Service Men if they will quickly jump into action.

Read in this book by Mr. Denton, how easily you can modernize any obsolete set, and with little additional costs.

Here are the high lights of this book: Tubes Available for Replacements; Electrifying Battery Receivers; Use of the New 2- and 4-Volt Tubes; Operating Sets with Single Control; Conversion of A.C. sets into D.C. and D.C. into A.C.; Replacing Output Tubes with Higher Output Tubes; Improving Old Supers; Loft-White Amplifiers; Adapters and Their Use.

Book No. 7
RADIO KINKS AND WRINKLES
 For Service Men and Experimenters
 A Complete Compendium of the Latest Radio Short-Cuts and Money-Savers
 By C. W. PALMER

It often becomes necessary for experimenters and Service Men to call upon their memory for some short cut or radio wrinkle that will solve a problem quickly. In business, "short cuts" mean time and money saved, and to the Service Man "time saved" means money earned.

This book is a compilation of important radio kinks and wrinkles and discusses only such items as are constantly used today.

Here are some of the more important chapters: Introduction; Servicing Short-Cuts; Testing Equipment and Meters; Vacuum Tubes and Circuits; Volume-control Methods; Amplifiers and Phonograph Reproducers; Power Supply Equipment; Coils and Tuning Circuits; Short Waves; Loud Speakers; Tools and Accessories.

Book No. 8
RADIO QUESTIONS AND ANSWERS
 A Selection of the Most Important of 5,000 Questions Submitted by Radio Men During the Course of One Year
 By R. D. WASHBURNE

There has been collected a wide variety of questions which have come into our editorial offices during the past two years, and only those whose answers would benefit the majority of men engaged in radio have been incorporated in this amazing question and answer book.

The tremendously long list of topics better explains the subjects which are treated. Here are the titles: Radio Servicing; Receiver Design; Home Recording; Television; Sound Equipment; Short Waves; Antennas; Operating Notes; Test Equipment; Tubes; Ultra-Short-Waves; Police Radio; Reproducers; Superheterodynes; Automobile Sets; Power Packs; Automatic and Remote Control Devices; Aligning Procedure; Photoelectricity; Adapters; Measuring Apparatus; Band-Selectors; Converters; Public Address Equipment; Midset Sets; Oscillators; Phonograph Pickups.

Book No. 9
AUTOMOBILE RADIO AND SERVICING
 A Complete Treatise on the Subject Covering All Phases from Installing to Servicing and Maintenance
 By LOUIS MARTIN

Automobile radios are up and coming, and someone has to service them properly. It therefore behooves you to read this immensely important new book on the art of Automobile Radio. The book is concise, and full of illustrations, photographs, diagrams and hookups.

Here are only a few of some of the really interesting chapters: Introduction; Automobile Radio Installations; Complete Descriptions of Commercial Automobile Receivers; Servicing Automobile Receivers; The Ignition System; General Service Considerations; Effects of Temperature on Power Supply; Conclusion.

Clip Coupon and MAIL!

GERNSBACK PUBLICATIONS, INC. 96-98 Park Place, New York, N. Y.

I have circled below the numbers of books in the RADIO-CRAFT LIBRARY, which you are to send me, and have deducted 20% for ordering five (5) books or more. I have included my remittance in full, at the price of 50c each, when less than five books are ordered. The amount of my remittance is..... (Stamps, checks or money orders accepted.)

Circle numbers wanted: 1 2 3 4 5 6 7 8 9 10

Name Address

City State RC-632



Library

This is perhaps the first real opportunity that you have ever had to build a radio library of books that are authentic, right-up-to-the-minute and written so that they are easily digested and clearly understood. Mail coupon on the opposite page for your books.

Book No. 10

HOME RECORDING AND ALL ABOUT IT

A Complete Treatise on Instantaneous Recordings, Microphones, Recorders, Amplifiers, Commercial Machines, Servicing, etc.

By GEORGE J. SALIBA

If there is one subject that is fascinating to every radio man, it is that of Home Recording. Of course, this volume is not all on "Home" recording, but the information contained therein is important to commercial radio men, studio operators, engineers and others interested in this phase of radio.

The art of recording and reproducing broadcast selections is becoming more important every day to radio men, experimenters and Service Men. Equipping dance halls, auditoriums, churches, restaurants and homes with public address and amplifiers brings many extra dollars and often an excellent income.

In this book are found such topics as: Short History of the Art; Microphones; Recording Amplifiers; Cutting Heads; Types of Records; Commercial Machines; Adding Recorders to Receivers; Studio Layouts; Mechanical Filters for Turntables.

BIG DISCOUNT OFFERED

In order to make it possible for everyone to buy these books, the fifty (50) cents price has been made uniform for all volumes. You can buy these books separately, but you should take advantage of our special offer:

When Five (5) Books or More Are Ordered Deduct 20% from Your Remittance

Simply fill in the coupon below, and mail it to us together with your remittance. Checks, stamps or money orders accepted.

All Books Uniform

The books in the new RADIO-CRAFT LIBRARY are all strictly up-to-date, and written by men who know their subjects. The volumes are all uniform size, 4 3/8 inches, and contain on an average of 50 to 120 illustrations. Each book is printed on fine book paper, and no expense has been spared to make it an outstanding value, for its editorial contents as well as from the mechanical standpoint.



RE-RANGING METERS

(Continued from page 728)

the meter should read at that line potential. Finally, open the short-circuiting switch and vary the value of resistance R1 until the meter reads 5.2. (It might be well to repeat this to check our work in case the line voltage varied during the calibration.)

The same procedure may be used to calibrate a 150 V. scale line-voltage meter, using the transformer to measure the low A.C. calibrating potential. Connect as in Fig. 1B, placing a temporary short-circuiting switch across the variable resistance R1 which here is shown in series with the meter. From the two binding posts connected to the low-voltage winding of the transformer, run a pair of leads to some source of low-voltage A.C., such as the filament terminals of a radio tube socket. Turn on the current and read the 150 volt meter with resistor R1 shorted. Next, divide this reading by 13.0 and then multiply by 10. Finally, open the short and vary the resistance R1 until the meter reads this computed value. Run a pair of leads to some source of low-voltage A.C., such as the filament terminals of a radio tube socket. Turn on the current and read the 150 volt meter with resistor R1 shorted. Next, divide this reading by 13.0 and then multiply by 10. Finally, open the short and vary the resistance R1 until the meter reads this computed value.

Increasing the Range

After the step-down arrangement in Fig. 1A is calibrated as described (using either method), it may be further calibrated for a still higher value.

Add another binding post and between it and one of the high-voltage posts connect a resistor of about 30,000 to 35,000 ohms. This connection is shown dotted in Fig. 1A. A high-voltage meter will be temporarily required as a standard.

With the combination connected to some high-voltage source, such as the unrectified A.C. from a power pack, and the standard meter connected into the circuit, vary this new resistance (R2) until the 8-volt meter reads one-hundredth of that of the standard. For example, if the standard reads 320, the other should be made to read 3.2 volts by varying the value of resistor R2. On account of the high voltage, use extreme caution in this test; shut off the main supply when varying the value of resistor R2, which should be capable of dissipating about 10 to 12 watts. (It will be necessary to increase the length of the box to accommodate this extra resistance. Do not try to stuff it into the 8-inch box, as this will result in poor insulation and radiation.) With the above calibration the 8-volt meter will read 800 volts.

HOME RECORDING

(Continued from page 748)

groove was compressed into the metal, no material being removed. As a result, the groove is only about .0015-in. deep, as compared to the .003-in. deep groove that is cut into wax. Difficulty therefore might be experienced in playing back with a steel needle if the pickup and turntable are not level. This process is not recommended if many high-quality copies are desired.

In conclusion, it might be stated that the amateur must not expect too much from the "processed" records if his own original is not very good; while in "dubbing" even good records there is, as has been previously stated, a loss in efficiency which cannot be avoided; and if the original was only fair, the new record might be quite poor. The original record must be very good if the copies are to be good. Otherwise, money spent will be wasted—unless the copies are desired for sentimental reasons. As has been repeatedly stated, the making of very good records is not at all difficult if only care and patience in conjunction with good apparatus are used.

Inquiries concerning Instantaneous Recording are invited. Address these to the Home Recording Department of RADIO-CRAFT, enclosing a stamped, return-addressed envelope.

This Elaborate EXPERIMENTAL EQUIPMENT GIVEN TO ALL Students

AT NO EXTRA COST



Size of Cabinet: Height, 22 1/2", Length, 17 1/2"; Weight 25 lbs.

We give to every student without additional charge his chemical equipment, including fifty pieces of regular standard laboratory apparatus and supplies and forty-two different chemicals and reagents.

Opportunities in Chemistry



Dr. T. O'Connor Sloane

Chemistry offers those who are ambitious and willing to apply themselves conscientiously, the greatest opportunities of any vocation today. Industrial firms of all kinds pay tempting salaries to get the right men. Opportunities abound on every hand. You can study Chemistry under the well-known instructor, T. O'Connor Sloane, A.B., A.M., Ph.D., LL.D.

You Can Learn at Home

Our home study course, written by Dr. Sloane himself, is practical, logical and remarkably simple. It is illustrated by so many experiments that are performed right from the start that anyone can thoroughly understand every lesson. Dr. Sloane will, in addition, give you any individual help you may need in your studies.

Easy Monthly Payments

The tuition is very low, and includes your laboratory outfit—there are no extras to buy with our course. You can pay in small monthly amounts, and we show you how to earn the cost of the whole course as you go along.

CHEMICAL INSTITUTE OF

NEW YORK, Inc.

HOME EXTENSION DIVISION

19 Park Place New York, N. Y.

Mail the Coupon NOW!

CHEMICAL INSTITUTE OF NEW YORK.

Home Extension Division

19 Park Place, New York, N. Y.

Please send me at once, without any obligation on my part, your Free Book "Opportunities for Chemists," and full particulars about the Experimental Equipment given to every student. Also please tell me about the latest reduction in tuition price and your easy plan of payment.

NAME

ADDRESS

CITY STATE..... R.C.-632

ELECTRICAL ENGINEERING

BOOKS SENT FREE

New Edition Containing 100 Pages

A-C RADIO!

We're glad to send a set to your home to examine and use as your own for 10 days—to show you that here is the most up-to-date and complete work on Electricity ever published. Written by CROCKFORD of Columbia U.—MILLIKAN of Calif. "Tech."—HARRISON of General Electric and 26 other noted Electrical Engineers. Starts off with elementary Electricity in simple, non-technical language for the beginner and includes every Engineering branch for use of experts on the job.

8 FLEXIBLE MAROON VOLUMES
4300 pages, 3200 Illustrations, deluxe gold stamped binding, index in each book, general index in Vol. 8. Covers every subject in Electricity—Light, Power, Transmission, Generators, Motors, Switchboards, Radio, Telephone, House Wiring, Railways, etc.

Complete Electrical Reading Course

Electricity, the biggest industry in the world, continues to grow the most rapidly. And it offers better jobs, bigger salaries and a brighter future than any other field. Every dollar, every hour invested in learning Electricity will come back to you a thousand-fold. Learn in spare time with these books at one-fifth the cost of trade courses. Outline for organized study, quiz-questions and a year's free consulting membership in the American Technical Society included without extra cost, if you mail coupon immediately.

LOOK IT UP!
Thousands of these sets are used as REFERENCE books by men employed in electrical, building construction and allied lines. The JIPPEY INDEX puts the answers to 20,000 questions right at your finger tips.

AMERICAN TECHNICAL SOCIETY
Dept. EA-26
Drexel Ave. & 58th St., Chicago



AMERICAN TECHNICAL SOCIETY
Dept. EA-26 Drexel Ave. & 58th St., Chicago
Please send for 10 days' free trial 8-volume set of Electrical Engineering just off the press, subject to return if I wish to. (I pay the few cents express charges on receipt of books. You pay express if returned.) If I decide to keep them, I will pay \$2.00 after 10 days trial, then \$3.00 a month until \$34.80, special advertising price, is paid, after which books become my property. Year's Consulting Membership to be included free.

Name

Address

Employed by

Employer's Address

LISTENERS OFFICIAL RADIO LOG

World Short Wave Stations—Police—Aeronautical—Relay and Telephone Stations also Aeroplane and Amateur Bands—Cross Tabulated by Call, Frequency, Location and Time of Broadcast.

An accurate up-to-date 32-page call book. Contains all broadcasting stations from 15 to 550 meters with world-wide and United States time maps. Special illustrated short-wave features—contains just the information your customers demand—good for advertising or resale.

Jobbers, Dealers, Mrs., Service Men—write today on letterhead for sample and quantity prices. Others send 25c.

ALL AMERICAN SERVICE
5707 N. Clark St.
CHICAGO, ILL.



ATTENUATORS

(Continued from page 750)

Now if the input voltage is 15 volts and we want to maintain the output voltage V_2 at .15-volts, the voltage ratio is $\frac{15}{.15}$ or 100, and

the decibel loss is 40. This means we need to set up a very large loss, for the voltage is to be dropped from 15 volts to .15-volts, a decrease of 14.85 volts. To do this, we should need a very large series resistance and a very small shunt resistance, so that practically all of the current will be prevented from entering the load by (1) the large series arm, and (2) the very small shunt arm. Referring to Table 3, it can be seen that to cause a 40-decibel loss, the series arm Z1 is 99 ohms and the shunt arm Z2 is but 2 ohms, which exactly follows the reasoning as given above.

Comparing this 40 decibel loss to the 20 decibel loss, the series arms for the 20- and 40-decibel losses are 82 ohms and 99 ohms respectively, and the shunt arms 40.4 and 2 ohms respectively. The values for the series arms are such that a large series voltage drop is encountered in them, being greater in the 40 decibel case, as would be expected. The shunt arms are quite different.

In the 20-decibel loss, the shunt arm is practically $\frac{1}{5}$ of the value of the load impedance,

so that only a comparatively large bypass effect of current from the load is obtained; whereas, in the 40-decibel loss, the shunt arm is only $\frac{1}{50}$

of the value of the load impedance, thereby shunting practically all of the current from the load. For a very large loss then, the series arms are very large and the shunt arms very small in comparison to the load impedance. By inspecting Table 3, it will be seen that the various values of the series and shunt arms necessary to give certain losses follow the simple laws of current flow; in that large-decibel losses require large series arms and small shunt arms in comparison to the value of the load impedance, and that small decibel losses require small series arms and large shunt arms in comparison to the load impedance.

Whatever your **HOBBY** you'll find it in

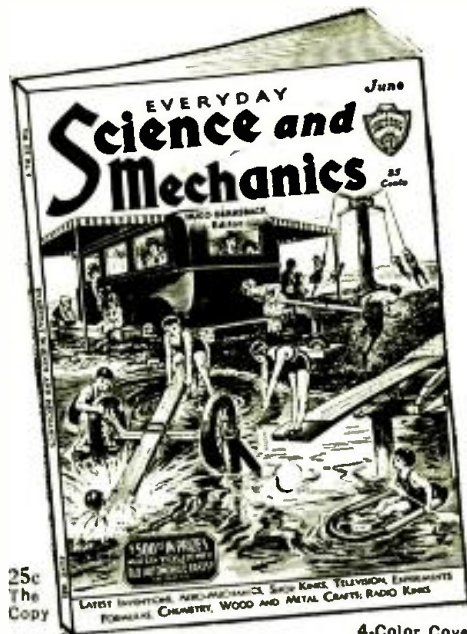

25c The Copy

4-Color Cover
Over 450 Illustrations
96 Pages—9x12 inches

M. R. HUGO GERNSBACH's latest magazine contains the most important and recent developments in Science, Mechanics, Radio, Television, Aviation and Chemistry. For everyone, regardless of age, **EVERYDAY SCIENCE AND MECHANICS** will be found to be useful and instructive. Thoroughly illustrated with scientific events from all parts of the world, and helpful to thousands of high school, university students and instructors who wish to advance their scientific knowledge.

Many excellent pages for the home workshop man who finds pleasure in building things; experiments in electricity, chemistry and formulas of all kinds.

- Just to Mention a Few Departments
- LATEST INVENTIONS
 - AERO-MECHANICS
 - SHOP KINKS
 - TELEVISION
 - EXPERIMENTS
 - FORMULAS
 - CHEMISTRY
 - WOOD AND METAL CRAFTS
 - RADIO KINKS AND OTHERS

Special Offer!
8 Months for \$1.00
ON ALL NEWSSTANDS
Mail Coupon Now!

EVERYDAY SCIENCE AND MECHANICS
100 Park Place, New York, N. Y. RC-5

I enclose herewith One Dollar for which you are to enter my subscription to **EVERYDAY SCIENCE AND MECHANICS** for the next Eight Months.

Name

Address

City State

STATEMENT OF THE OWNERSHIP, MANAGEMENT, CIRCULATION, ETC., REQUIRED BY THE ACT OF CONGRESS OF AUGUST 24, 1912.

Of **Radio-Craft**, published monthly at Mt. Morris, Ill., for April 1, 1932.
State of New York
County of New York

Before me, a Notary Public in and for the State and county aforesaid, personally appeared **Irving S. Manheimer**, who, having been duly sworn according to law, deposes and says that he is the business manager of **Radio-Craft** and that the following is, to the best of his knowledge and belief, a true statement of the ownership, management, etc., of the aforesaid publication for the date shown in the above caption, required by the Act of August 24, 1912, embodied in section 411, Postal Laws and Regulations, to wit:

1. That the names and addresses of the publisher, editor, managing editor, and business manager are: Publisher, **Techni-Craft Publishing Corp.**, 401 North Wesley Ave., Mt. Morris, Ill. Editor, **Hugo Gernsback**, 98 Park Place, New York City. Managing Editor, **R. D. Washburne**, 98 Park Place, New York City. Business Manager, **Irving S. Manheimer**, 98 Park Place, New York City.

2. That the owners are: **Techni-Craft Publishing Corp.**, 401 No. Wesley Avenue, Mt. Morris, Ill. **Hugo Gernsback**, 98 Park Place, New York City. **Shirley Gernsback**, 98 Park Place, New York City. **U. Manheimer**, 98 Park Place, New York City.

3. That the known bondholders, mortgagees, and other security holders owning or holding 1 percent or more of total amount of bonds, mortgages, or other securities are: None.

4. That the two paragraphs next above, giving the names of the owners, stockholders, and security holders, if any, contain not only the list of stockholders and security holders as they appear upon the books of the company but also, in cases where the stockholder or security holder appears upon the books of the company as trustee or in any other fiduciary relation, the name of the person or corporation for whom such trustee is acting, is given; also that the said two paragraphs contain statements embracing affiant's full knowledge and belief as to the circumstances and conditions under which stockholders and security holders who do not appear upon the books of the company as trustees, hold stock and securities in a capacity other than that of a bona fide owner; and that affiant has no reason to believe that any other person, association, or corporation has any interest direct or indirect in the said stock, bonds, or other securities than as so stated by him.

IRVING S. MANHEIMER
Sworn to and subscribed before me this 31st day of March, 1932.
MAURICE COYNE, Notary Public.
(SEAL)
(My commission expires March 30, 1934.)

THE PENTODE SET

(Continued from page 730)

bases are fastened on a strip of brass 1 3/4-in wide by 3/2-in long. This is bent so as to fit underneath the chassis between the front and the rear walls, and is put into place after the wiring is partially completed.

Wiring is started with the filament circuit. All heaters are in series. Resistor (35) and dial light (36) are also in series in this circuit. Next, the grid circuits are wired, care being taken to wire correctly to the caps of the pentodes, as indicated on the diagram. Screen-grid connections are made at the "G" terminals of the sockets. The cathode grids of the four pentodes are connected directly to the cathodes within the tubes, eliminating an extra external connection on each tube. The rest of the wiring is performed in the following order: Plate circuits; cathodes; volume control; bypass condensers; primary of antenna coupler; and secondary winding of transformer (37) to socket (38).

The sectional rotary switch is wired in next. Letters (A, B, C, etc.), marking contacts on the diagram, do not appear on the switch, but the constructor may pencil them in himself, if he requires this help. The choke (40) and the electrolytic condenser sections (39, 41, and 42) are wired in, thus completing the wiring.

In testing the set, the wiring is first checked over carefully, then the primary of the output transformer on the dynamic speaker is connected to posts (32) and (33). The wires from points C and D on the rotary switch are connected to the 2500-ohm field on the speaker. Aerial and ground wires are connected and tubes are inserted in their respective sockets, placing shields over tubes (5), (12), and (21). The 110-volt plug is placed in the line voltage regulator and this, in turn, is plugged into a 110-volt source. If the set is tested on D.C. first, it may be necessary to reverse the plug to obtain correct polarity, before the set will play.

If any difficulty is experienced in controlling R.F. oscillations, try substituting 1000- or 5000-ohm resistors at (6) and (13), in place of the 500 ohm values specified. In extreme cases, it may also be necessary to insert 5000-ohm flexible resistors between the stators of condenser sections (4) and (11) and the screen-grid clips going to the caps of tube (5) and (12) respectively. If the plate voltages are too high when set is used on A.C., they may be reduced by inserting a resistor between the center-tap of the high-voltage winding of (37) and ground. Thus, with a current of 28 ma. flowing, a 1000-ohm resistance will reduce the voltage 28 volts.

Parts List

- One Cardwell type 317-C (shielded) triple variable condenser, .00035-mf., (4, 11, 17);
- Two Aerovox type 161-31 triple section metal case condensers, .1-mf., (7, 14);
- One Aerovox type 260 bypass condensers, .5-mf., (18);
- One Aerovox type E25-25 electrolytic condenser, .25 mf., (30);
- One Aerovox type E5-248 triple-section electrolytic condenser, in can 2 1/2 in. high by 3-in. dia. (8 mf.—39) (4 mf.—41) (2 mf.—42);
- One Aerovox type 1460 mica condenser, .001-mf., (22);
- One Aerovox type 1460 mica condenser, .01-mf., (26);
- One Aerovox type 461-21 double section condenser, (19—35A);
- One Conoid (shielded) Antenna Coupler, (3);
- Two Conoid (shielded) R.F. coils, (10, 16);
- Two I.R.C. (Durham) type M.F.4, metallized resistors, 50,000 ohm, (20, 24);
- Two I.R.C. (Durham) type M.F.4, metallized resistors, 75,000 ohms, (9, 15);
- One I.R.C. (Durham) type M.F.4 metallized resistor, 10,000 ohm, (23);
- Two I.R.C. (Durham) type M.F.4 metallized resistors, 50,000 ohm, (25, 27);
- One Standard mazda dial light, 32 volt, .35-amp, (35);
- One Electrad type 2G-500 flexible resistor, (31);
- One Electrad type RI-202 volume-control potentiometer, (8), with switch, (44);
- Two Electrad type 2G-500 flexible resistors, (6, 13);

CONCOURSE

(DRY)

Electrolytic Condensers

Save Time and Profit for Service Men



Considerably smaller and lighter than wax paper condensers, yet same mfd. equivalent. Working voltage 450, peak voltage 600. 20% more capacity than rated; very low power factor. An established condenser with a solid reputation for performance. Replaces cumbersome paper blocks in a jiffy. Easier servicing; more profit for you; customer satisfaction assured. Types for every specification. Get the complete story at once . . . there's money in these Condensers for YOU!



Write or wire for our complete descriptive catalogue.

CONCOURSE
ELECTRIC COMPANY

389-409 Wales Ave., N. Y. C.



LECODE AT HOME
with Automatic
OMNIGRAPH

Has Helped Thousands To Better Positions
U. S. Govt. Dep'ts., Colleges, Scientists, and Schools use it
NOW! On Land, Ships, and Air—Your Career Future is Secure. Know Code. The Automatic Omnigraph teaches you easily and quickly. Learn by Listening. Models \$15-\$40. Catalog Free.
THE OMNIGRAPH MFG. CO., 810 E. 39th St., C-R, Brooklyn, N. Y.

- One Electrad type C-3 Truvolt fixed resistor, (35);
 - Five five-prong wafer-type sockets, (5, 12, 21, 28, 29);
 - One four-prong wafer-type socket, (38);
 - Four binding posts, (1, 2), (32, 33);
 - One Trutest power transformer, secondary center-tapped, with 5-volt filament for '80 tube, (37);
 - One Trutest 30-henry (200 ohm) choke (40);
 - One Best type 5X S32 sectional rotary switch, equivalent to 5-pole, double-throw, (43);
 - One Crowe moving light full vision dial, (36A);
 - One No. 16 gauge sheet-iron chassis, 10-in. long by 7 1/2-in. deep;
 - Three shields for tubes, (5), (12), (21);
 - Two Arcturus 139A, R.F. pentode tubes, (5, 12);
 - One Arcturus 136A, screen-grid tube, (21);
 - Two Arcturus 139A, R.F. pentode tubes, (5, 12);
 - One dynamic reproducer equipped with 7000-ohm (approx.) impedance output-transformer, 2500-ohm field, (34);
 - One Charostat 50-watt type automatic line voltage regulator, (45);
- Note: Numbers in parentheses refer to corresponding numbers marking parts on diagrams.

SET TESTER

(Continued from page 729)

filament emission and other factors, are readily reflected in the readings obtained. The conditions essential for the generation of oscillations with a vacuum tube are that the tube be capable of amplifying in a circuit having inductance, capacity and resistance, with feedback from the plate to the grid circuit, the feedback influenced by the inter-electrode capacity of the tube. A comparison of tubes with an average standard of oscillation test readings affords a method of tube matching which cannot be excelled for the practical Service Man. The tubes used in the tuned stages of a radio receiver should be of normal characteristics, and all such tubes should be matched as closely as possible with the oscillation test. All of the Diastrometer circuits are amply protected against the hazards usually experienced when testing short circuited elements.

No Reason for This!



Here's the Remedy

The cheapest and the best antenna for any set is the Improved Dubilier Light Socket Aerial. Plugs in any socket or outlet. Ideal with pre-ent-day radio sets. Consumes no current. No long leads or unsightly wires. Utilizes wiring and transmission line for long-distance signals. \$1.00 complete.



DUBILIER
Condenser Corporation
4377 Bronx Blvd New York

UNIVERSAL MODEL "X"

Startling! NEW! 2-BUTTON MICROPHONE \$10.00



Advanced 1932 superiority at today's rock-bottom prices. Same high standards, same exclusive features. Pure gold contacts. Duraluminaphragm. Is exceptionally rugged. Model X sets a new high standard for quality at a price that defies competition. For sale by dealers everywhere. New Catalogue with diagrams now ready.
Universal Microphone Co., Ltd.
424 Warren Lane
Inglewood, Calif., U. S. A.

The
PERRY
Karadio
THE DISTANCE GETTER

A SUPERHETERODYNE

Greater Volume and Distance

Easily Installed -- New Remote Control System

**MOST LIBERAL DISCOUNTS MAKE THIS
AUTOMOBILE RADIO THE LOWEST PRICED
EVER OFFERED TO THE TRADE**

\$57.50
List Price

Six Tube Super

The KARADIO, a superb new superheterodyne, is by far, different in every respect to others. Its unusual volume and distant-getting qualities are preeminent. Only 10 feet of aerial wire required. Compact and easily installed—chassis cadmium plated. New system of remote control makes tuning easier and more selective. The KARADIO Superheterodyne Automobile Radio employs six tubes (3-36's; 1-37; 2-38's) and measures $9\frac{1}{2} \times 6\frac{1}{4} \times 7$ inches. Shipping weight is 20 lbs. The complete set includes PERRY RCA licensed tubes, remote control unit, super-dynamic speaker, suppressors, by-pass condensers, battery cables and steel battery container.

Representatives everywhere can make big money this season selling the KARADIO. No matter what others may offer, you can be sure the KARADIO will outperform in every respect. Full details of complete selling rights and discounts will be sent immediately to servicemen, dealers and distributors. Write on your letterhead or send us your business card.

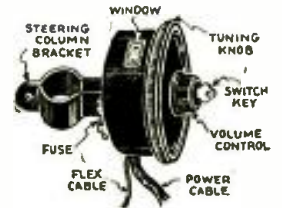

The Remote Control Unit shows clearly the dial, and how easy and accurate it is to tune. Illuminated dial makes station figures visible.

**EXCLUSIVE TERRITORY NOW BEING ALLOTTED
DEALERS, SERVICE MEN AND DISTRIBUTORS**

WIRE
OR
WRITE

PERRY PRODUCTS, INCORPORATED

(Legion Radio Mfg. Co., Direct Mail Division)

150 West 22nd Street

New York, N. Y.

MODERNIZING THE JEWELL 199 ANALYZER

(Continued from page 735)

third switch blade, and the left one with the fourth blade. The switch blades are Nos. 3 and 4 from the bottom, the edge towards you. See Fig. 1 for details. Be sure that there is no chance of the blades touching the upper contacts until connection with lower contacts has been broken. When the new contacts are in place, and when you are sure that they are O.K., tighten the screws holding the switch in place. The new contacts are connected to the D.C. meter as shown in Fig. 1.

For normal operation of the meter, leave the switch up. To reverse the meter for S.G. (screen-grid) readings on the 75 volt "C" bias scale or reverse the D.C. filament, push the button down.

Multipliers

To make room for the two new switch multipliers M1, M2 and M3 are moved to different positions. Remove the screw holding M1 to the panel. Lift M1 up about an inch from the panel, and bend the wires, making it parallel to the panel. As the connecting wires are not strong enough to hold it in place, additional support is provided by a piece of bus bar, one end of which is fastened under the screw holding the socket in place. Bend this so that its end goes through the hole in the multiplier. This will hold it in position; a little sealing wax on the wire will hold the spool in place.

Remove the screw holding M2 to the panel and unsolder the connecting wires. One of these wires goes to the upper spring of the grid-test switch. This wire is replaced with a piece of bus bar extending straight up for $1\frac{1}{4}$ ins., then bent at a right angle towards you for about an inch. Solder one contact of M2 to this bus bar. The other contact on M2 is connected to the positive post of the 4.5-volt test battery. The bus bar supports M2 in a vertical position between the two meters and just above the socket.

M3 is treated in the same manner as M1, the supporting wire going under the head of the screw holding the adjoining multiplier. As the holding screw of this multiplier will be too short, it should be replaced by one of the screws formerly used to hold one of the other multipliers. A piece of tape wound around M3 and over to the bottom of the D.C. meter will hold it in place.

Connect the new switches in the positions indicated in Fig. 2. These switches should be of such type that when released they will automatically return to normal position, that is, with the blade and one contact closed. Toggle or midget jack switches may be used, but as they do not operate automatically, special care must be taken to always return them to the normal closed position otherwise trouble will result. If you wish to make your own switches see Fig. 3 for details. The switch operates in the same manner as the regular Jewell type, a close study of which will reveal further details of the lock pin, lock pin groove, and operation. I used, for the lock pin, a No. 18 wire brad forced through a hole (slightly smaller) drilled in the push button. The groove is $3/32$ in. deep.

Drill all the holes from the front, if drilled from the back, the edges will chip and spoil the appearance of the panel. Mark the location of the holes with a scriber; use a small drill for drilling the guide holes; replace the tester in its case, and using the proper size drill, enlarge all the holes. In drilling the holes be very careful, when almost through, not to let the drill slam through and hit the wires and multipliers underneath the panel. Before mounting the switches, solder leads to them, as this will be hard to do afterwards. Switch No. 1 is mounted at the top of the panel in line with the other D.C. switches. Switch No. 2 is mounted at the bottom of the panel in the socket and the switch. See Fig. 2.

Providing a lead from the tester to the screen-grid tubes in the set is the next operation. Rather than have an extra wire loose on the cable, we should use one of those already in the cable. Examination of Fig. 2 shows seven cable-wires, plate, grid, cathode, and a light and heavy wire to each of the heater prongs. By making the following changes one of these wires, the light-black one, can be used as the control-grid lead.

Move the light-black wire from contact No. 1 to contact No. 2 on the upper section of the cable terminal block, Fig. 6. Connect contacts Nos. 5 and 6 together, drill a hole in the panel as indicated. A lead, with a clip long enough to reach the cap of a screen-grid tube in the tester, is passed through this hole. Tie a knot in the lead to prevent it from pulling out and solder the end to contact No. 8, upper section of the cable terminal block. From this same contact connect a lead to contact No. 1 on switch No. 2. The inside connections of the screen-grid lead are now completed.

The handle of the test plug should be carefully removed from the base by taking out the two screws holding it in place. Disconnect the wires from the base, making a note of the prongs to which they connect, and pull the cable out of the handle. About $\frac{3}{4}$ in. from the top of the handle drill hole about $\frac{1}{16}$ in. into the side of the handle. (See Fig. 4.) On the opposite side of the handle fasten a clip made of spring brass. Be careful that the screw does not hit the cable. Cut off the cable covering for about two inches and wrap some thread around it to prevent further unraveling. Take the light-black lead which has been disconnected from the heavy one and pass it through the new hole in the handle.

Push the remaining wires through the handle and connect them to the base in the original manner. Be sure that the wires are correctly connected and that there is no danger of short circuits inside the base. The wire which comes

(Continued on page 759)



3 Valuable New Books Formulas and Recipes Radio — Mathematics

Presented here are three brand new books, of diversified nature, which are most educational and instructive. Each book carefully treats a subject in full, and is prepared by an expert in the field. The books are well written and thoroughly illustrated to make the contents understandable. Get these books promptly—mail coupon below.

1. FORMULAS AND RECIPES for the Practical Man

This book has been compiled by S. Gerstback, a well-known author of practical instructional manuals in various scientific fields. It is extremely helpful and will show you how to save money by making in your own home, at a fraction of the regular cost, the hundred and one preparations which you now buy for use at home or business.

HERE IS A PARTIAL CONTENTS:

1. Adhesives; Glues; Cements; 2. Cleaning: Stain Removers, Bleaches; 3. Metal Craft: Coloring, Oxidizing, Plating, Polishes; 4. Paints: Colors, Stains, Varnishes; 5. Glass-Working: Cutting, Drilling, Boring, Etching, Engraving; 6. Wood-Craft: Fireproofing, Acid-proofing, Waterproofing, Furniture Polishes; 7. Inks: Sympathetic, Invisible, Hectograph; 8. Photography: Developers, Emulsions, Fixers; 9. Antidotes for Poisons, Remedies for Burns and Scalds; Disinfectants; 10. Preparation, Manipulation, Handling, Mixing, Tables of Weights of Measures; Useful Tables.

2. FUNDAMENTAL PRINCIPLES OF RADIO Radio Simply Explained—its Origin, Nature and Functions

The book, written by Louis Martin, has been prepared with special consideration given to young members in the radio profession, and those who have gained their experience in a haphazard fashion. This radio primer is a handy fundamental aid for "checking up" and systematizing your knowledge of radio. Regardless of how much you know about the subject, you should read this book.

HERE IS A PARTIAL CONTENTS:

Chapter I—Fundamental of Radio: Electricity, Resistance, Batteries, The Magneti Circuit, The Magnetic Field, Inductance, Condensers, A.C. Circuits, Propagation of Radio Waves; Chapter II—The Simple Radio Set, Single, Two, and Three-Circuit Tuners, The Battery Set, Vacuum Tubes, Electric Sets, Loud Speakers; Chapter III—Diagrams, How to Read Them; Chapter IV—Amateurs and Broadcast Stations, Talking Pictures, Televi-ion.

3. ELEMENTARY MATHEMATICS for the Technician and Craftsman

This manual has been especially prepared for the man who wishes to acquire a working knowledge of the elementary principles of mathematics. A complete treatment of the subject is given by the author, Mr. C. Shainmark, with special attention to the use of mathematics in Radio and other technical work for those who employ its formulas daily.

HERE IS A PARTIAL CONTENTS:

I—Arithmetic: Addition, Multiplication, Subtraction, Division, How to Use Decimals; II—Fractions, Percentage, Ratio and Proportions; III—Powers and Roots; IV—The Metric System; V—How to Measure Surfaces and Volumes; VI—Mathematics for the Manual and Technical Craftsman; VII—Special Mathematics for the Radio Technician; VIII—Commercial Calculations, Short-cut Arithmetic, Interest Calculation, Discounts; IX—Weights and Measures; X—Useful Tables.

All our books are of uniform size, 6 x 9 inches, and contain 64 pages. The books are printed on strong paper with stiff colored covers.

Clip and Mail Coupon TODAY!

PRESS GUILD INC., 16 Murray St., New York City, RC-6

Enclosed find \$.....for which mail me post-paid the following books:

- No. 1
- No. 2
- No. 3

50c each, Postpaid.

Name

Address

City and State.....

TROUBLE SHOOTING

(Continued from page 758)

Now, retune the set to a 1500 kc. station, or as near to it as possible. Readjust the trimmers on the R.F. condensers, do not touch the trimmer on the oscillator condenser, only very slight adjustments of the R.F. trimmers should be necessary here.

If the above instructions have been carried out properly, the set should now be in perfect alignment at all points on the dial, and changes in the trimmers at any point on the dial should not be necessary.

Poor sensitivity on one end of the band, as compared to the other end, or on both ends as compared to the middle, is almost invariably a sign of improper tracking, and can be corrected by making the adjustments already described. Lack of sensitivity all over the band, provided all other things are correct, is usually an indication that the intermediate transformers are not tuned accurately. As already stated, the adjustment of the intermediates to exactly 175 kc. is of extreme importance.

"Birdies"—sounds like a regenerative receiver passing stations at various points on the band—are caused either by the intermediates being tuned to some frequency other than 175 kc., or by insufficient selectivity in the R.F. tuning circuits. An easy way to find which is the cause is to short the oscillator tuning condenser, and then rotate the dial with the volume control turned well up. Under these conditions, no stations should be heard, in fact the receiver should be absolutely silent. If stations are heard at some points, without the oscillator tube operating, it is a certainty that the intermediates are not tuned properly. If the set is silent without the oscillator working, but whistling "birdies" are heard when it is working, the selectivity of the R.F. stations is insufficient. The simplest way of correcting this is to use a much shorter antenna, or to remove turns from the primary of the antenna coil. A very small condenser, of the order of .0005-mf., (a midget variable will do) inserted in the antenna lead, will very often eliminate the whistles without appreciably cutting down the sensitivity of the set.

Occasionally, on some supers, there will be found repeat points about 350 kc. off the proper place for a station. There are two remedies for this—either those already described for "birdies" (which will usually be found on sets having the repeat points) or by improving the shielding of the set from direct pickup; as, for example, mounting a set which has the chassis unshielded on the bottom, on a metal plate, so that the bottom will be shielded. Covering the top of the chassis with a grounded metal plate, so as to shield the variable condenser sections and grid caps is often very helpful.

Microphonic audio bowls will be found troublesome on some imperfect supers, and the builder, naturally attributing it to a bad tube, will hunt in vain for the tube that is causing the trouble. Actually, the howl may be caused by vibration in the plates of the variable condensers. It can usually be cured by mounting the entire chassis on a piece of sponge rubber, allowing the entire chassis to vibrate, instead of just the condenser plates.

Some sets will have ample selectivity so far as music is concerned, but on a station next to a powerful local, the loud notes of the local will "carry over" with a kind of scratching blast. This is a sign that the local is modulating a band more than 10 kc. wide, and inasmuch as the trouble originates in the air, it cannot be completely eliminated. It can, however, be considerably ameliorated by the addition of a hand-pass stage (see Fig. 2) ahead of the tuner. This will reduce the amount of signal from the local that reaches the grid of the first R.F. amplifier tube, but will not seriously affect the strength of the signal from the station to which the set is tuned.

Some sets will be found which work very nicely over a portion of the band, usually the high frequency end, but which stop working entirely on other portions. This is caused by the oscillator tube having incorrect voltages, so that it stops oscillating in spots. A check-up of the voltages supplied to the oscillator

(Continued on page 758)

He made it himself—easily—
from our instructions.



"I SAVED OVER
\$200 IN 1931 BY BUILD-
ING MY OWN TEST EQUIP-
MENT WITH YOUR
RESISTORS."

Excerpt from letter from Serviceman.

You can do the same. Write for FREE CHARTS giving complete instructions. Address Dept. C.



INTERNATIONAL
RESISTANCE CO.
2006 Chestnut St., Phila.
and Precision Wire Wound
RESISTORS

Make a
PROFIT

Service men make \$90 to \$110 extra per month installing AMPERITE. Send \$1.62, to Dept. RC-6 for dealers' sample AMPERITE and sales help.

AMPERITE Corporation
501 BROADWAY, NEW YORK

AMPERITE
Self-Adjusting
LINE VOLTAGE CONTROL

NEW Radio Handbook

CONTAINING: ——— Sent postpaid
Volume Control Guide. **25c**
Technical Information.
Transformer and Condenser Guide.
Radio Replacement Parts Catalog.

Hard to Get Parts—We have them.
Send us your repair work for estimate.

Grant Radio Laboratories
6521-R South Halsted St., Chicago, Ill.

**ELECTRIC REFRIGERATION
NEEDS SERVICE MEN**

Get into this big New Industry. Learn by doing practical shop work with tools; short course; all makes; low fee. Write for Free Bulletin, ESII, Herkimer Institute of Refrigeration, Inc., 1819 B'way., New York.

BIG HELP TO STUDENT IN RADIO COURSE

Dear Sir:
I must confess that this book has taken me by surprise. I did not expect to receive a book of such splendid material, and so conveniently put together; my first impression was one of admiration. Then after looking it over a while I was simply elated to find such a storehouse of valuable information, for the price. I feel that it is a gift, not a purchase.

You will understand what a book like this means to me, when I tell you that I am an active student of the National Radio Institute, and although the course is complete in every sense of the word, this second edition of your Radio Encyclopedia will always be of great assistance to me in my study, and always, after graduation. I feel that the N.R.I. should recommend a copy to every student enrolled for a course in Radio; whatever branch the student may want to specialize in, he will find this volume an asset worthy of the highest esteem.

To me it's worth its weight in gold; I'll NEVER part from it.

My feeling of satisfaction is such an elation, that I cannot thank you sufficiently for the valuable volume you have spent so much thought and labor in compiling, to put on the market at so low a price. But I beg you to be content with my poor expression of gratitude, and my sincerest wish for an enormous sale of your new edition Radio Encyclopedia.

BERT W. KELLEY,
La Lima, Hinduras, C. A.

What the New Second Edition Radio Encyclopedia Gives You

It gives you an explanation of every word used in radio. These explanations—or, rather, definitions—are not brief outline information like those of an ordinary dictionary, but they give in fullest detail, and at considerable length, the meaning and application of every word, phrase, general and special term used in the science of radio. They are written in plain, everyday English, easily understood by anyone.

Practically every definition in the book is illustrated by drawings, photographs, diagrams, or charts. All you need to do is to look up as you would in a dictionary, the word or phrase about which you are seeking information. Furthermore, each page is key-indexed, for greater convenience and speed in locating any definition. All the Subject-Matter is Arranged in Alphabetical Order.

This greatly enlarged Second Edition Radio Encyclopedia is an absolute necessity to everyone interested in Radio. It answers all radio questions, increases your knowledge and saves your time. It covers every known radio problem, and is a goldmine of practical information for every radio man.

- 2,201 RADIO DEFINITIONS
- 1,253 TECHNICAL ILLUSTRATIONS
- 34 TABLES AND CHARTS
- 24 PAGES OF APPENDIX
- Red Morocco-Keratol Flexible Binding
- Printed on strong ledger paper, Loose-Leaf Arrangement

352 pages
9 x 12 inches

Weight 3 lbs.

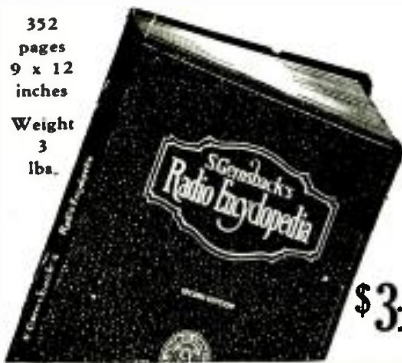

S. GERNSBACK CORPORATION,
98 Park Place, New York, N. Y.

Send me one copy of the new Second Edition S. Gernsback's Radio Encyclopedia. I enclose herewith \$3.98, check or money order preferred. (Foreign and Canada, add 35c extra for postage.) Money refunded in full if not satisfactory.

Name

Address

City..... State.....

RC-632

DRY ELECTROLYTICS

(Continued from page 746)

prevents a flow of current from the aluminum to the electrolyte. The great capacity of the electrolytic condenser is due primarily to the microscopic thinness of the gas film, which acts as a dielectric just as the paper or mica does in ordinary condensers. The greater the area of the active electrodes the higher the capacity.

It should be noted carefully that the electrolytic condenser must be "poled" properly in a circuit, with the aluminum anode always connected to the positive side. If the connections are reversed and the aluminum anode made negative, the oxygen is attracted to the cathode, which, having no porous coating to hold it, allows the gas to escape out into the air. Current flows through the cell and the capacity effect is not produced.

When an electrolytic condenser is used as part of the filter system of a "B" power pack, the transient A.C. from the rectifier naturally tends to break down the film, but the D.C. component is so much larger that it counteracts this action.

In the "dry" electrolytic condenser, the anode and the cathode, in one representative make, take the form of long strips of aluminum foil (one pure, the other slightly less so), separated by larger strips of cotton cloth soaked in electrolyte. In the Concourse condenser, illustrated in Fig. 3, the electrolyte is ammonium borate or phosphate dissolved in glycerine and gelatine. The glycerine, being hygroscopic, absorbs moisture from the air and keeps the active electrolyte properly moistened; it has no effect itself on the electro-chemical action of the condenser. The mixture has a jelly-like consistency, which is carefully adjusted during manufacture so that it is neither too thin nor too thick. It is thin enough to be absorbed by the pores of the cotton, but too thick to run out of the container. It is not affected by vibration, and the condenser is therefore ideal for automotive applications.

Besides the area of the plates, the capacity is determined by the forming voltage. The same condenser formed at 500 volts to have a capacity of 10 mf. will have 20 mf. if formed at 250 volts. The permanency of the oxide coating in the Concourse condensers is insured by slow and gradual forming, which takes about 36 hours. A peak voltage of 600 is allowable for short periods at a temperature not exceeding 125 degrees Fahrenheit. The normal high working voltage is from 350 to 450, with the temperature not above 130 or 140 degrees.

One of the interesting and less known facts about "dry" electrolytic condensers is their reaction to temperature changes. Low temperatures, from zero to 30 degrees below, reduce the effective capacity about 40% below the rated value, but this loss is only temporary and the full capacity is restored when the temperature returns to normal. Another fact not generally known is that the capacity of a condenser of this type may be increased if the working voltage is below normal. For instance, if a condenser is formed at 500 volts and has a capacity of 1-mf., this will increase in time as much as 60% if it is used continuously on 300 volts.

Capacity readings can be made on "dry" electrolytic condensers in the same way as on paper condensers. Leakage current, which flows in spite of the theoretical barrier of the gas film, can be measured with a milliammeter and a 500-volt D.C. source. The normal leakage current per mf. varies from .013-ma. for the 300-volt condensers to .1-ma. for the 500-volt sizes.

TROUBLE SHOOTING

(Continued from page 757)

tube, and the correction of these (if incorrect) will usually fix the trouble. Sets using dynatron oscillators are particularly subject to this trouble. In this case, trying out several tubes will result in one being found which will work properly over the whole band. Many '24 tubes will not oscillate at all as dynatrons, although they will function perfectly as detectors; and almost all tubes, so used, require very accurate settings of the screen and plate

(Continued on page 761)



GREATEST MAGAZINE IN TELEVISION



TIMELY developments in radio's latest wonder, Television, are published in every issue of TELEVISION NEWS—Mr. Hugo Gernsback's latest magazine. Rapid advancement in this art today is becoming a repetition of the radio cycles of years ago. Daily broadcasts are becoming more numerous and experimenters are following in quick order in building television sets for experimental purposes. Foresight of its development can be seen by the pioneers of radio—they are equipping themselves now with television experience.

The articles published in TELEVISION NEWS are of primary importance to experimenter—they are simple in construction, understandable and replete with diagrams, photographs and illustrations.

Interesting Articles in the Current Issue

- Latest Developments in Cathode Ray Tubes, Who Will Pay for Television?
- Building a Practical Television Receiver, Theory and Application of Color Television, Scanning Frequencies for Cathode Ray Tubes, 5 to 10 Meter Super-Regenerative Television Receiver,
- Better Optics for Lens Discs, Constructing Your Own Lens Disc, Crystal Detectors for Television, Television Course, Digest of Television Patents, Layout Data for 120, 80 and 60 Hole Discs.

SPECIAL OFFER COUPON

TELEVISION NEWS RC-632
100 Park Place, New York, N. Y.

[] As per your Special Offer, I enclose herewith \$1.25 (Canada and foreign \$1.50) for which enter my subscription to TELEVISION NEWS for One Year. You will also send me FREE the last two issues. I understand that the regular rate for such a subscription is \$2.00.

[] Mail me a sample copy of TELEVISION NEWS for which I enclose 15c (U. S. Stamps or coin accepted).

Name

Address

City..... State.....

THE JEWELL 199 SET ANALYZER

(Continued from page 756)

through the side of the handle is now connected to the clip on the other side of handle. Fig. 4 shows details.

This completes the connection for the screen-grid tubes. When making tests, the cap in the set slides under the clip on the test plug and the cap on the tester provides connection to the tube in the tester. Wrap some tape around the clip on the plug handle so as to prevent shocks if your hand comes in contact with the shields.

You are now ready to connect the switches. As one connection is already made to switch No. 2, start with that one. (See Fig. 7.) Unsolder the wire connected to C1 on M4 and connect it to contact No. 3 on switch No. 2. As the position of the multiplier contacts may not be the same on all testers, it is best to trace this lead. Reference to Fig. 2 will show that it connects to one side of the grid test switch, to the negative post of the 4.5-volt test battery and to contact No. 5, lower section of the cable terminal block. Connect C1 on M4 to contact No. 2, or switch blade of switch No. 2. Connect another wire from C1 on M4 to contact No. 1 on switch No. 1. Unsolder the wire connected to contact No. 7, upper section, cable terminal block and connect it to contact No. 2 on switch No. 1, which is the switch blade. Connect contact No. 3 on switch No. 1 to contact No. 7, upper-section of cable terminal block.

This completes the rebuilding of the tester. The engraving can be done with a sharp pointed instrument and engraver's wax or white lead.

Switch No. 1 is marked 300V., S.G. & C.G.
Switch No. 2 is marked 75V., C.G.
If push button type switches are used, mark the button with a line parallel to the lock pin in the same manner as the Jewell switches are marked.

Before replacing the tester in the case, clean

it carefully to remove all dirt and solder that may later get into the switches and cause trouble.

The pentode adapter is easy to make. Two UY type tube bases and two Pilot No. 215 subpanel sockets are needed. Cut off the tube base 1/2 in. from the bottom. Drill a hole in the center of the tube base large enough to pass a 6/32 in. machine screw. Drill a hole in the side of the tube base, opposite the Cathode prong, large enough to pass a lead through. Cut off the prongs of the sockets leaving just enough to solder a connection. Use insulated wire for connections. (See Fig. 5 for details.)

The changes made do not effect the normal operation of the tester except when testing '80 type tubes. Current can now be tested in both plates. Test the current in one plate in the usual manner. To test the other plate, press the "300V.S.G." button and the "150 MA." button.

Testing Tubes

Test plate and filament voltages as usual; plate current as usual, if the screen-grid voltage is less than 75 volts press the D.C., "Rev." button and "75C Volts" button. If it is more than 75 volts, press the "300V." and "Plate 300V." buttons. Screen-grid current can be tested by pressing the "300V.S.G." and the "15 MA." buttons. For control-grid voltage, press the "75V.C.G." and "75C Volts" buttons. For tube test, press "MA." button, connect a lead to the 300V binding post and touch it to the cap of tube.

Place the adapter with the long lead on the test plug and fasten the lead to the clip on the handle. The adapter with the short lead is placed in the analyzer socket and the lead connected to the screen-grid lead on the analyzer. Test plate and filament voltages as usual.

POWER FOR THE S. W. CONVERTER

(Continued from page 739)

current, in amperes, will be $\frac{10}{110}$, or 0.10 (approximately), or 100 ma.; the secondary current in amperes will be 2×1.75 or 3.50.

In order to pass 100 ma. through the "choke" winding at 110 V., A.C., it will be necessary to remove many turns before the impedance of the coil is reduced to the correct value for use as the transformer primary. The right way to do this is to remove several hundred turns (several layers), reassemble the choke, and put 110 volts across its terminals, measuring the current flow by means of an A.C. milliammeter. Since extreme accuracy is not required, it will only take about two trials to obtain the right number of turns for a current flow of 105 to 115 ma.

Having established the correct impedance for the primary, we are ready to start on the secondary.

Finding Secondary Turns

If we only knew the exact number of turns in the primary we could easily calculate the number of turns in the secondary. This, however, is unknown, and in order to find the number of turns on the secondary, the writer used the expedient of winding over the primary a "test secondary" of 100 turns, and measuring its voltage.

With this data on hand, the number of turns in the "primary" was calculated as follows:

$$N1 = \frac{E1 \times 100}{E2}$$

$$E2$$

Where N1 = number of turns in the choke coil or "primary";

E1 = 110V., A.C.;

E2 = secondary voltage (observed).

Knowing the number of turns in the primary, the number of turns in the secondary equals

$$N2 = \frac{2.5 \times N1}{110}$$

The next thing is to disassemble the choke unit, soldering leads to the two ends of the coil. Now tightly wind at least two layers of varnished cambric tape, or even ordinary friction tape over it to prevent a short circuit between this "primary" and the secondary.

The wire for the secondary should be No. 16, or even No. 14 A.W.G., enameled or cotton-covered copper, although ordinary "bell" wire may be used.

Now wind N2 turns over the primary; and solder leads to the resulting secondary. Place over this coil enough tape to keep the secondary from touching the iron laminations when they are reassembled. On account of the removal of many layers from the choke, there will be space for plenty of tape.

Reassemble the new transformer, *tighten the frame screws* to keep the core from vibrating, connect the primary cord and plug, and the transformer is ready for use.

The operation of the set is very simple, and by turning off the filament switch on the short-wave set you also disconnect the gaseous-remitter tube; as there is no load on this tube, it will be imperative even if there is an alternating E.M.F. between socket connections F1 and F2.

With few exceptions, no data is given on the various units used for the construction of the short-wave receiver, as this article is primarily intended to show the method used in obtaining the high-tension voltages from the power transformer in the broadcast receiver; the construction of the filament transformer; and a few of the other features—it is not intended to describe the construction of a short- and long-wave combination.

RADIO-CRAFT readers may find this information on a practical method of obtaining high voltages without the use of another transformer useful for other purposes, without reducing the efficiency of the broadcast radio set.

A New Service Kit

AND A NEW SERVICE

Resistor Assortment of one or two watt Metallized Resistors. The two formulas contained in each Handipak make possible hundreds of additional resistance values to meet every emergency. \$1.00 Lynch Resistor Replacement Manual FREE with each Handipak.



To Servicemen:
1 Watt Handipak, List \$3; Your Cost, \$1.80.
2 Watt Handipak, List \$4; Your Cost, \$2.40.

LYNCH Resistor Replacement Manual can be bought for \$1.00.

Send order today for Handipak, including the Manual, or write for FREE RMA Color Code Card and new, complete catalogue.
LYNCH MFG. CO., Inc., 1775-RC B'way., N.Y.C.

A NEW Money Making FIELD Instantaneous RECORDING

Make records of radio programs, banquet speeches, weddings, social functions, political meetings, singers, orchestras, etc. We carry a complete line of studio and portable recording equipment, also complete line of parts for home assembly.

Write for further information.

AMPEC ENGINEERING LABORATORIES
135 Liberty St. -:- New York, N. Y.

NEW 1932 HAND- LAPEL MIKES

No. 306—Single Button \$5.00
No. 501—Single Button 10.00
No. 503—Two Button.. 15.00
and 15 other types for every occasion.

Also Direct Manufacturers of Amplifiers, Horn Units, Trumpets and All P. A. Accessories

Send for Catalogue RC Now
MILES REPRODUCER CO.
26 East 22nd St., N. Y. C.



CATHODE RAY TELEVISION

Non-technical, non-mathematical course of instruction by correspondence in 10 lessons by Arthur H. Halloran, Instructor in Television for the Extension Division of the University of California. Any radio man can understand it. The course costs only \$10.00. Five dollars brings you the first five lessons. Enroll now. Cathode Ray Television is now on the air. It has revolutionized the art. ARTHUR H. HALLORAN, 130 Pacific Bldg., San Francisco.

SHORT WAVE SUBMARINER ACROCYCLE OSCILLATOR CONVERTER

\$12.50
\$17.50
AUTO-DIAL (Auto Radio) \$40.00
Send for Free Circular
J.-M.P. MANUFACTURING CO., Inc.
3355 Fond du Lac Ave., Milwaukee, Wis.

BUY THESE Great Books!

2 RADIO PHYSICS COURSE by Alfred A. Ghirardi . . . \$3.50
RADIO SERVICING COURSE by Ghirardi & Freed . . . \$1.50
Send for FREE Circular at once.
The Radio Technical Pub. Co.
80 Fifth Ave. RC-6, New York City

SERVICE FORUM

(Continued from page 734)

copies of "Radio For All" are available at the present time, nevertheless the book is being reprinted in revised form and will be announced shortly.—Editor.)

"LICENSED BY—"

Editor, RADIO-CRAFT:
Don't you think it is a crime to let these "Shunts Birds" put a big ad in a city publication that has a small "Licensed by" and a large "RCA" printed in one-inch type, followed by a picture of a midget and a price tag of \$17.95?

The people surely fall for that "line" and how.

I am just a small-town radio dealer and Service Man, so maybe I don't know all I should. I handle two standard lines, Graybar and Silver Marshall.

The other day a fellow came in to look at a small Graybar Model 4. He asked the price and I replied that it was \$37.50. He looked around a while and then said, "Well, I guess I'll go to the city and get one of those \$18.95 RCAs." I replied that there was no RCA set selling for \$18.95. Upon questioning him further, I found that it was an "RCA Licensed" set.

When I explained that nearly every set is licensed by RCA whether it be an "A.K.", or "Best Ever," he began to see light. I made the deal, but if I had not spoken to him, he would have bought the cheap outfit.

What do other radio men think of this? Of course, there may be some that have these sets at bargain prices, that think this type of business is O.K., but those that have a standard agency for a well-known set will agree with me, I am sure.

I have unloaded now. Will you please publish this letter so that I may know what other dealers think?

H. D. MILSTEAD,
Perry, Nebraska.

(The question raised by Mr. Milstead is a rather moot one. Here in New York City, where competition is the spice of life, price-cutting is an everyday occurrence, and no one seems to mind it, not outwardly, at any rate. The answer seems to be nothing more than gritting one's teeth and meeting the competition. If competition can't be met, then you're out of the running.—Editor.)

A TIMELY QUESTION

Editor, RADIO-CRAFT:
The inquiry that I am going to make will doubtless interest many aggressive radio technicians.

For the last five years, I have been employed by a prominent manufacturer, starting in the factory and subsequently, having qualified myself through training, being transferred to technical work in the laboratory. A few months ago I was the victim of a 75 percent reduction in the technical force, due to an unexpected decrease in production.

Now I desire to enter the service field as an independent, and would like to have your advice on the best procedure. I have both the practical and technical knowledge of current receivers, having previously been employed in service work. By reading RADIO-CRAFT monthly, I have found that you have been of assistance to other readers in similar enterprises, therefore I consider you one of the best sources of information in this matter. If you consider my query beneficial to others, you may publish this.

A. J. OLICK,
4382 Manayunk Ave., Phila., Pa.

It is difficult to answer this query in a short paragraph and therefore Mr. Olick is referred to one of our books "How to Become a Radio Service Man."—Editor.)

ADDRESS CHANGE

The replacement parts and service department of the Brunswick Radio Distributing Company has been taken over, according to a recent announcement, by the newly-organized United Radio Service with offices at 619 West Fifty-fourth Street in New York City.

I received your book, "How to Build and Operate Short Wave Receivers." I am very pleased with it, as I believe it is the best book that has been printed on short wave work. It is invaluable to builders of Short Wave receivers. Worth many times the price, my candid opinion.
E. H. BLADES,
Radcliff, Alberta, Canada.

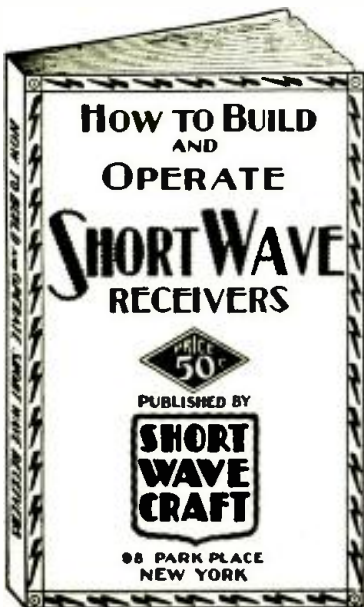

THE greatest book of its kind ever published. **HOW TO BUILD AND OPERATE SHORT WAVE RECEIVERS** is the best and most up-to-date book on the subject ever put between two covers.

The book has been edited and prepared by the editors of **SHORT WAVE CRAFT**, and contains a wealth of material on the building and operation, not only of typical short wave receivers, but short wave converters as well.

Dozens of short wave sets will be found in this book, which contains hundreds of illustrations; actual photographs of sets built, hook-ups and diagrams galore.

WE SAY—AND REPEAT IT—THAT NOTHING LIKE THIS HAS EVER BEEN PUBLISHED BEFORE.

The book comes with a heavy colored cover, and is printed throughout on first-class paper. No expense has been spared to make this the outstanding volume of its kind. The book measures 7½ x 10 inches.

This book is sold only at such a ridiculously low price because it is our aim to put this valuable work into the hands of 50,000 short wave enthusiasts during the first few months of 1932.

Published by the publishers of **SHORT WAVE CRAFT** magazine. This alone will be your guarantee that it is a really worthwhile publication.

We know that if you are at all interested in short waves you will not wish to do without this book. It is a most important and timely new radio publication.

76 Pages — 250 Illustrations — Stiff Paper Covers

NOT SOLD ON NEWSSTANDS
Mail Coupon At Left!

SHORT WAVE CRAFT RC-6
96-98 Park Place, New York City.

I enclose herewith fifty (50c) cents for which please send me a copy of your new book **HOW TO BUILD AND OPERATE SHORT WAVE RECEIVERS**. (Send money order, check, cash, or new U. S. Stamps. Register letter if it contains currency or stamps.)

Name
Address
City and State.....

CLASSIFIED ADVERTISEMENTS

Advertisements in this section are inserted at the cost of ten cents per word for each insertion—name, initials and address each count as one word. Cash should accompany all classified advertisements unless placed by a recognized advertising agency. No less than ten words are accepted. Advertising for the July 1932 issue should be received not later than May 9th.

CHEMISTRY

BECOME TRAINED CHEMIST. Thousands of opportunities—fascinating career. Learn at home. Complete experimental laboratory outfit given. Write for big free book. (Chemical Institute, 19 Park Place, Dept. RC, New York.)

INVENTORS

PATENT YOUR INVENTION: Send for FREE book, "How to Obtain a Patent," and "Record of Invention" blank. Consult us about how to protect your ideas. Victor J. Evans & Co., 620F Victor Bldg., Washington, D. C.

RADIO INSTRUCTION

LEARN Radio, television and talking pictures in Canada. Day, evening and home study classes. Free scholarship and trip to Toronto, all expenses paid. Booklet on request. Radio College of Canada, 310 Yonge St., Toronto.

RADIO

GUARANTEED "Pocket Radio," \$2.00. Catalogue, 10c. Neil Tasker, Shamokin, Pennsylvania.

TRANSFORMERS (Radio Power) rewind, special types made to order. Supreme Radio Laboratory, 16 Fulton Avenue, Rochester, N. Y.

SERVICE MEN, ATTENTION— Speakers rewind, magnetized, repaired, \$2.00 to \$2.75. Complete Power Pack Service—Transformers rewind, condenser blocks repaired, resistors duplicated. Guaranteed. Clark Brothers Radio Co., Albia, Iowa.

GUARANTEED MICROPHONE REPAIRS— Any make or model—24 hour service. Stretched diaphragm double button repairs, \$7.50. Others \$3.00. Single button repairs, \$1.50. Write for 1932 Catalog with diagrams. Universal Microphone Co., Ltd., Inglewood, Calif.

BACK ISSUES

of **RADIO-CRAFT** can be had at the price of 25c each. Address

RADIO-CRAFT
98 Park Place New York, N. Y.



\$5,000 WILL BE PAID TO ANYONE WHO PROVES THAT THIS IS NOT THE ACTUAL PHOTO OF MYSELF showing my superb physique and how the Ross System has increased my own height to 6 ft. 3 3-4 inches. Hundreds of Testimonials. Clients up to 45 years old gain from 1 to 6 inches in a few weeks!



First in 1907
First To-day

No Appliances—No Drugs—No Dieting. ROSS SYSTEM NEVER FAILS. Fee Ten Dollars Complete. Convincing Testimony and Particulars 6 cent stamp. "Allow time for return mails across the Atlantic." **G. MALCOLM ROSS, Height Specialist,** Scarborough, England, (P. O. Box 15).

USING THE V. T. VOLTMETER

(Continued from page 740)

usually adjusted to 1. volt.

After the input voltage has been measured, the switch is shifted to position 1 and the voltage across the secondary of the coupling device is measured. The frequency characteristic of the coupling device may be determined by plotting the applied input-frequency against the output voltage, keeping the input voltage into the device at a constant value. During the course of the measurement, the input voltage should be checked from time to time.

Loudspeaker Response Characteristics

Loudspeaker response characteristics may be determined by using the set-up given in Fig. 8. In addition to the amplifier normally used to supply the speaker, an additional amplifier is required. This amplifier is used to strengthen the feeble currents picked up by a microphone placed at a suitable distance from the loudspeaker.

The V.T. voltmeter is arranged in conjunction with the S.P.D.T. switch, as shown in the schematic, in order that the voltage applied to the speaker may be kept at a constant value, as well as providing a means for measuring the output of the microphone amplifier.

In order that some degree of accuracy may be obtained in this measurement, it is necessary that the microphone and its amplifier have as near a flat frequency-characteristic as possible from approximately 30 to 10,000 cycles. In addition, where greater accuracy is desired, it is advisable to place both the speaker and the microphone in a large cabinet or small room, whose walls have been lined with sound absorbing material.

The characteristic of speakers are usually plotted on logarithmic paper, frequency against voltage pickup. As a rule, the measurement is only comparative, unless the operator knows the frequency characteristics of the measuring apparatus and of the room in which the speaker and the microphone is contained.

Phonograph Pickup Frequency Characteristics

In measuring the characteristics of phonograph pickups the setup as given in Fig. 6 is used, with the exception that standard-frequency records are employed instead of the audio-frequency oscillator.

The standard-frequency records are rated in decibels gain or loss. Inasmuch as the input voltage will be known, it is not necessary to try to measure the input of the pickup, which at best, is a complicated procedure in itself. The D.P.D.T. switch is therefore eliminated. It may be necessary, however, to use a similar arrangement in order to switch in the amplifier stage of the gooseneck V. T. voltmeter, when desired. The gain or loss in decibels is determined in the same manner as described under Audio-Frequency Gain Measurements.

P.E.C. Frequency Characteristics

The set-up to determine the frequency characteristics of photoelectric cells is the same as used for loudspeaker response measurements, Fig. 8, with the exception that a suitable neon lamp is used instead of the loudspeaker, and the photoelectric cell to be measured is substituted for the microphone.

Measurement of Modulation Percentage

The percentage of modulation of a transmitter or modulated oscillator may be determined by many different methods. The method described here is simple and has an accuracy of 5% which is sufficient for ordinary purposes.

The I.R.E. definition of percentage modulation is the ratio of one-half the difference between the maximum amplitude and the minimum amplitude of the modulated wave, to the average amplitude (expressed in percent). As the modulated current amplitude will vary above and below the unmodulated radio-frequency amplitude by equal amounts (when of sinusoidal wave form) the percentage of modulation may be calculated from the following formula:

$$\text{Percent modulation} = \frac{I_m - I_c}{I_c} \times 100$$

Where the peak R.F. current, when modulated, is expressed as I_m , and the peak R.F. current, when unmodulated, is expressed as I_c ,

The set-up for the measurement is given in Fig. 9. The pickup inductance of the V.T. voltmeter (L) may be two or three turns of heavy insulated wire coupled to the plate inductance of the oscillator to be measured. The condenser C and the inductance together with the 100-ohm resistor R comprises a resonant circuit that is tuned to the frequency of the oscillator to be measured. The current through R is calculated (1) when the oscillator is modulated, and (2) when unmodulated.

Measuring Iron-Core Inductances

In measuring the inductance of iron-core coils, it is quite often desirable to know the inductance when direct current is circulating through the circuit in addition to the alternating current. The setup given in Fig. 10 provides a means of measurement whereby the inductance may be measured with only A.C. and with both A.C. and D.C. circulating.

To measure the inductance of the choke with only A.C. through the circuit, the D.P.D.T. switch is set to the A.C. position and the S.P.D.T. switch set to position 2. The voltage drop across the 100-ohm resistance R is now determined by the V.T. voltmeter. Having determined the current flowing through the circuit, and knowing the A.C. voltage as indicated by VM, the impedance is determined by dividing the voltage by the current. The inductance may now be calculated by the following formula:

$$Z^2 = (R_L + 100)^2$$

$$\text{Inductance (in henries)} = \frac{(6.28 \times \text{frequency})^2}{Z^2}$$

In the above formula the term R_L is given; it is the D.C. resistance of the choke and may be determined by any convenient method.

To measure the inductance of the choke with both D.C. and A.C. through the circuit, the inductance is first measured with only the A.C. as described above. After the A.C. current and voltage of the circuit have been determined, the S.P.D.T. switch (SW2) is set to position 1, and the equivalent indication on the V.T. voltmeter determined with the 10 mf. condenser in the circuit. This indication is recorded as being equal to the previous determined voltage drop across the resistance R.

The primary of the transformer is now opened, SW1 is set to the DC position, leaving SW2 on position 1. The potential of the tapped battery "B" and R1 are varied to give the desired D.C. through the choke. The current is indicated by a suitable D.C. milliammeter MA.

The transformer primary switch is next closed, the resistor in the primary circuit of T is adjusted until the indication of the V.T. voltmeter is the same as the value recorded in the first steps of the procedure, when the 10 mf. condenser was placed in the circuit. Now noting the new voltage value on VM, and the V.T. voltmeter indicating the same voltage drop, as was obtained without D.C. through the choke, the operator may calculate the impedance as for the A.C. measurement. From the impedance, having previously determined the D.C. resistance of the choke, the inductance in henries may be determined by the same formula.

TROUBLE SHOOTING

(Continued from page 758)

voltages to oscillate over the entire band.

Occasionally, a set will be found which has perfect quality on full volume, but when reduced, the quality "goes to pieces." If this is the case, examination of the tubes will probably disclose a '24 in a socket where a '35 or '51 should be. Proper placement of the tubes will make this right. This trouble applies to T.R.F. sets only; the use of a '24 in an amplifier socket in a set built for the multi-tube tubes will invariably produce this phenomenon.

No reference has been made here to account for poor results due to improper connections, wrongly placed parts, or similar troubles which would apply to any receiver. It is presumed that the correct hookup has been followed throughout, and the receiver is free from all defects in wiring, parts, or similar mistakes on the builder's part.

ANNOUNCING

We Are the Only Authorized Exclusive Service Bureau for

Brunswick

SERVICE REPLACEMENT PARTS

We carry a complete stock of parts for all Brunswick models. Write for free parts list.

UNITED RADIO SERVICE
619 West 54th Street New York, N. Y.
Big Discount to Dealers and Servicemen

Power Generator

FOR SHORT WAVE BROADCASTING
Reg. Price Was \$75

While They Last!
\$49.50

U. S. Gov. power generator for radio transmitting made by Westinghouse. Ideal for Amateur Broadcasting. Limited quantity purchased from U. S. Gov. Signal Corps. 250 to 500 meters 200 watts. 110 Volt R.P.M. 4500. Can be converted direct belt driven or wind propelled for Aeroplanes. Guaranteed new and perfect. Worth \$75.00, but while they last, only \$49.50, plus shipping charges. Send check or money order.

NATIONAL JOBBING & EXPORT CO.
109 W. Lake St. Dept. 186 Chicago, Ill.

Knowledge Pays Big

We teach you how to build and operate Radio Treasure Finders and how to locate Metals Underground, Fascinating, Scientific, Accurate. Full details for 2c stamp—Write TODAY.

Exchange, P. O. Box 607-W El Monte, Calif.

Every Service Man Needs

The ELECTRAD Resistor Replacement Hand Book

Write Dept. 125 Varick St. New York, N.Y.
RC-6 for **ELECTRAD**
Details

Build Your CUSTOMERS THE Revolutionary STENODE

The Receiver That Is NOISE FREE on SHORT WAVES or BROADCAST



STENODE selectivity curve makes 10KC selectivity, so-called, look like broad tuning.

STENODE selectivity is compared, at left, to that of ordinary receivers. All background noise is contained in outer curve. Stenode's curve, shaded, contains but 1-10 the total noise.



STENOTUBE. Only one required in each Stenode. This heart of the Stenode circuit consists of a quartz crystal ground to 175KC frequency and mounted in tube form for easy handling. Standard UX socket base. Price \$15.

Made in England

None genuine without the inventor's signature.

James Robinson

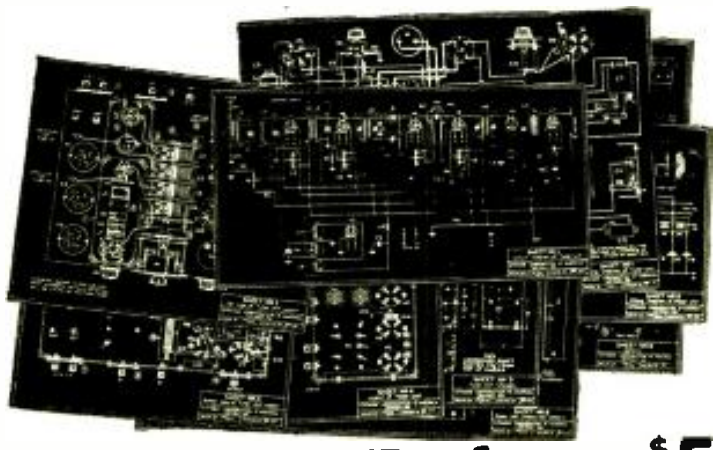

A STENODE demonstration will create more new custom set prospects than any radio receiver ever did before. People listen in amazement when they hear stations free of background noises and absolute silence between stations. When you tune out heterodynes and whistles and stations STAY IN strong and crystal clear, owners of all other sets gasp in astonishment. The former chief of wireless research of the British Royal Air Force, Dr. James Robinson has given an entirely new principal to radio in STENODE.

By the STENODE principal the highest selectivity ever attained as well as unprecedented tonal range is now made possible. All engineers agree that it is impossible with ordinary super-heterodynes.

STENODE amplifies signals most and static least. That's why YOU want to build an 11 tube STENODE to work with a SHORT WAVE adapter when it is not used to log and listen with enjoyment to more broadcasters than can be heard on any other type of radio. STENODE selectivity is 5 to 1 greater than that of so called 10KC Supers. The noise does not get in along with the high audio frequencies, and the STENODE reproduces perfectly higher frequencies than ever heard on any other receiver giving

500% BETTER SELECTIVITY
1000% MORE FREEDOM FROM NOISE
INFINITELY BETTER QUALITY

9 Blue Prints - Data Book - Direction Book Now \$5

Increased demand for Stenode Data Book, Instruction Book and Blue Prints permits our cutting former price in half. Those who have already sent in full price will receive our check for \$5. We are not interested in making profit from our engineering service. Our profits come solely from Royalties paid us by our licensees.

GERNSBACK PUBLICATIONS, Inc.
98 Park Place, New York, N. Y.

Enclosed find Money Order, Check, for \$..... Please forward me STENOTUBE, BLUE PRINTS, DATA BOOK and DIRECTION BOOK for building STENODE.
(Make all checks payable to Gernsback Publications, Inc.)

Name.....
Street.....
City..... State.....

The STENODE opens up new fields for short-wave and television work, as well as broadcasting. Full details of all sorts of applications are given in the STENODE Data Book. Nine full-sized diagrams show where to place every part. How to make every connection is clearly told in STENODE Book of Directions. Your finished STENODE will put you into a new field of radio. Fill in and mail the coupon with your money order for the biggest value ever offered custom set builders.

STENODE CORP. OF AMERICA
GERNSBACK PUBLICATIONS, Inc.
98 Park Place New York, N. Y.
SOLE SELLING AGENTS

IF IT ISN'T A STENODE IT ISN'T A MODERN RECEIVER

NOW
THE WONDER OF
MODERN SCIENCE

NEVER SOLD FOR
 LESS THAN \$50.00

COMPLETE KIT for \$10.00

There are hundreds of interesting electrical devices that you can make with a photo electric unit. It will turn on the parking lights of your car when the sun goes down or light the lamps in your house at dusk. It will open your garage door when the beam from the headlight is flashed against it—it will detect smoke in your home or protect your safe—there is no end of jobs that a photo cell unit can do in your home.

- PICTURES THAT TALK
- GARAGE DOORS THAT OPEN AT A LIGHT FLASH
- MECHANICAL MEN
- BURGLAR ALARMS, ETC.

all owe their origin to photo electric cells. It is now possible for you to buy a complete photo cell unit in a kit, ready to assemble, including an extremely sensitive photo electric cell, all necessary tubes, wire, resistances, relay, etc., with complete diagrams and an instruction book showing you how to assemble it in an hour—all for \$10.00.

We also furnish you with a book giving complete wiring diagrams and instructions on how to build a number of amazing devices and showing you many uses for your photo electric cell unit. The actual value of this complete kit is over \$50.00—we are making a special introductory price of \$10.00 to popularize experimental work with photo electric cells.

Clip check or money order to the coupon below and mail it today!



HERMAN A. DE VRY
 Inc.
 59 E. Wacker Drive
 Chicago, Illinois

CLIP THE COUPON BELOW... MAIL TODAY

Herman A. DeVry, Inc.
 59 E. Wacker Drive, Chicago, Illinois

Enclosed is \$10.00. Please send me the complete Photo Electric Cell Kit advertised in Radio-Craft.

Name.....
 Address.....
 Town.....State.....

LEGION 6-TUBE SET



The Legion Radio Mfg. Co. announces a new receiver of the T.R.F. family. It uses 2-248, 2-35's, 1-47 and 1-80. It is equipped with a full-vision dial, dynamic speaker, tone control, hum control and ball-bearing condensers. Cabinet of selected American Walnut.

SERVICE SHORT CUTS

(Continued from page 731)

To test the '47 pentode, follow the same procedure for the "short test" and "mutual conductance test" as described above, with these exceptions: Having inserted the '47 into our 5-prong socket; throw SW 1 to the S.C. side; the MA switch SW4 to the high side and leave it there—then take readings after throwing SW 5 on and adjusting rheostat R.

An "emission test" may be taken on tubes suitable for this test by using the High scale and throwing SW 1 to the S.C. side.

FIXING THE RCA VICTOR 52

By James Watson

THE R.C.A.-Victor receiver uses a pilot light which requires 110 volts on the filament. The writer wishing to replace this bulb, found the only lamp available was of the large standard-base type which would not fit into the light socket in the receiver. However, by breaking out the old bulb and its cement, it was possible to fasten the new base in the manner illustrated in Fig. 3 on page 731.

Again, while attending a light, for some unknown reason the large 250-watt bulb lighting the ring burned out, and the writer offered to tackle the job of fixing it.

At my suggestion, the management obtained a replacement bulb for me and upon examining it, I found that it was only rated at 150 watts, and that its standard base would not fit the large mogul socket of the big 250 watt bulb. However, it only required a few minutes to break the glass and cement from the old lamp, screw the standard base into the mogul base as illustrated in Fig. 3B on page 731 and replace it in the socket.

TAKING HUM OUT OF D.C. SETS

By George Van Velsen

SERVICE MEN, operating in the Metropolitan district, undoubtedly have encountered D.C. sets having a bad hum. The writer has found a simple solution which works very nicely where the receiver, as is usually the case, has its filaments connected in series, as indicated in Fig. 4A.

The remedy is to connect the filaments in series parallel, as shown in Figure 4B, increasing the value of emitting resistances R to compensate for the lower resistance of the filaments.

Connect electrolytic condensers in shunt with the filaments; whether they are connected in series as shown at 4A or in parallel as at 4B, these condensers must have a capacity between 25 and 50 mf.

MARQUETTE
AUTO RADIO
Sensational All Wave
6 TUBE SUPER-HET.

MARQUETTE SNAP ON MOUNTING STEERING POST MOUNTING
 NO TOOLS REQUIRED (PAT. APPL'D FOR) ELECTRICAL REMOTE CONTROL (MARQUETTE PAT. APPL'D FOR) ALL WAVE RECEPTION (15 to 55 METERS - PENTODE (RF AND AF) LATEST CUNNINGHAM TUBES - ELECTRO DYNAMIC SPEAKER - PUSH PULL PENTODE - AUTOMATIC VOLUME CONTROL - FULL VISION DIAL
 MONEY BACK GUARANTEE. 10 DAY FREE TRIAL
PRICE COMPLETE \$49.50
 WITH CUNNINGHAM TUBES AND EVERY READY BATTERIES

MARQUETTE RADIO INC.
 110 West 18th St. NEW YORK
 DISTRIBUTORS - DEALERS
 WRITE for TERRITORIES Now

Write for full details about the OFFICIAL REFRIGERATION SERVICE MANUAL. Gernsback Publications, Inc., 98 Park Place, New York, N. Y.

SERVICE MEN!
 Here Is A
Big Profit Opportunity.

Put Pentode Tubes in Old Sets



Replace the old 245's with the new 247's. There is a tremendous improvement in depth of tone and set sensitivity. The improved amplification strengthens weak signals, particularly in sets using 245 push-pull, and the improved tone turns sour old radios into new, sweet, musical instruments.

JUST INSERT ADAPTERS AND NEW 247 TUBES
 NO CHANGE IN WIRING

SPECIAL INTRODUCTORY OFFER:

2 Adapters, 2 RCA Licensed 247 Pentode Tubes—
 YOUR PRICE \$2.80 (postpaid)

You sell for \$6.00. It's a bargain for your customer and you double your money with 5 minutes work. Every owner of an old set can be sold. ACT NOW ON THIS FAST MOVING MONEY-MAKER!

2 Pentode Adapters Only (no tubes) \$1.20

MONEY BACK GUARANTEE! Try the two Pentode Tube outfit in a set! If not more than pleased with results, return your purchase anytime within five days and your money will be promptly refunded! If you do not have our new 1932 Radio Serviceman's Wholesale Price Guide, check in square below and it will be sent you.

FREE! The RADOLEK CO.
 601 W. RANDOLPH ST.
 CHICAGO, ILL.

Please send me.....
 of 2 Pentode Adapters, 2
 RCA Licensed 247 Pentode Tubes.
 \$2.80 (postpaid).
Sets of 2 Pentode Adapters (no tubes) \$1.20
 Copy 1932 Serviceman's Wholesale Price Guide. (Attach your letterhead.)

Name.....
 Street.....
 City.....State.....
THE RADOLEK CO., 106 Canal Station, CHICAGO, ILL.

Radio-Craft READERS' BUREAU

A FREE SERVICE

These booklets, pamphlets, etc., are obtainable FREE by mailing the accompanying coupon.

37. SOLA VOLTAGE COMPENSATOR

Variations of line voltage, which are very marked in many parts of the country, create objectionable results in radio receivers. If the voltage decreases the volume drops; if it increases, the power pack is overloaded and the life of the tubes threatened. The Sola Compensator automatically maintains the voltage to the set at a constant value even with wide fluctuations of the line voltage. This folder describes its operations and application. Well worth reading. *Sola Corporation.*

38. HOW TO PREVENT INTERFERENCE IN YOUR RADIO

This little folder is full of practical advice on the elimination of interference created by electrical machines of various kinds. The cures are applied at the source of the trouble, not at the radio set. Data are given on the use of filters designed for convenient connection to the power cords of electric fans, vacuum cleaners, sewing, washing and ironing machines, food mixers and motor-operated refrigerators. These are quickly installed without the use of tools. *Aerovox Wireless Corporation.*

39. ACCURATE HEAVY DUTY TEN WATT RESISTORS

Service Men and experimenters who wish to make multi-range instruments out of low-voltage A.C. and D.C. voltmeters will find this bulletin interesting and instructive. It describes the popular Akra-Ohm wire-wound resistors and tells how the proper sizes may be selected for meters of different internal resistance to cover various voltage ranges. These resistors are single layer wound on Isolantite tubes and are covered with a special insulating coating. They are accurate within 2% of their rated values, and are designed to fit conveniently in standard five-ampere fuse clips. *Shallcross Mfg. Co.*

40. THE LUXTRON "ST" CELL

The great drawback to the general adoption of light-sensitive devices by experimenters and constructors has been their high initial cost and their need for multi-stage audio amplifiers of special construction. With the introduction of the "Luxtron" cell this disadvantage seems doomed for elimination, as this new device is very inexpensive, yet sensitive enough to operate a relay directly. It is of the photo-conductive type, and functions by the reduction of its resistance when it is exposed to light. Its manufacturers claim it produces a current change of as much as 25 milliamperes in direct sunlight. This folder describes

On this page are listed booklets, catalogs, pamphlets, etc., of Manufacturers, Schools, Institutions, and other organizations, which may be of interest to readers of RADIO-CRAFT. The list is revised each month, and it will be kept as up-to-date and accurate as possible. In all cases the literature has been selected because of the valuable information which the books contain. If you are interested in subjects not listed on this page, write us and we will try to serve you.

This Service is absolutely free to all Readers of RADIO-CRAFT.

Fill in and mail the coupon below; make sure that your name and address are included and are plainly written. Order by number only.

the cell in detail and tells how it is used in conjunction with a small relay for various experimental and commercial applications. *Luxtron Mfg. Co., Inc.*

41. FAHNESTOCK SPRING BINDING POSTS

The average radio man does not realize that even a little thing like a binding post may be the subject of considerable design and manufacturing effort on the part of a large company. This 40-page catalog illustrates dozens of different models of the well-known Fahnestock connectors, which have wide application in both the radio and the general electrical fields. *Fahnestock Electric Co.*

42. RAWSON SINGLE AND DOUBLE PIVOT METERS

A new method of pivoting the delicate movements of electrical meters is described in an article prefacing the latest catalog of the Rawson meters. This discusses the features of older methods and tells of the advantages of the new system for highly

sensitive instruments. The catalog itself describes the Rawson line of high-grade portable meters of the following types: D.C. milliammeters and millivoltmeters, D.C. "Multimeters," fluxmeters, electrostatic voltmeters, and electronic multimeters. This is a valuable reference book. *Rawson Electrical Instrument Corporation.*

43. THE RECORDOVOX

The Amplion Recordovox is an instrument for speeding educational processes and measuring educational progress. It makes available for classroom work the arts of the phonograph and radio and provides public address facilities for the school auditorium. It consists of seven units, housed in a steel cabinet fitted with wheels. These units are: a microphone, a powerful audio amplifier, a loud speaker, an electrical phonograph, a radio receiver, a recording head for recording sound on phonograph records, and meters and switches for controlling all the apparatus. One of the most interesting uses of this instrument is for recording the speech of students, particularly those studying a language other than their native tongue, and then letting them hear their own voices through the loud speaker. *Amplion Products Corporation.*

44. CORNELL PAPER DIELECTRIC CAPACITORS AND RESISTORS

This is an engineering catalog of data on fractional capacity paper dielectric fixed condensers and various sizes of carbonized resistances for radio, television and ignition applications. A supplemental sheet describes two special kits of replacement filter and bypass condensers intended for use by Service Men and service organizations. *Cornell Electric Mfg. Co.*

45. ARCTURUS TRANSMITTING TUBES

The Arcturus company has added a series of power tubes of the transmitting type to its present line of receiving tubes. Five of the new tubes are fully described in a series of excellent folders now available to all radio men. The following tubes are listed: the E703A, a 50-watt R.F. oscillator and A.F. amplifier, interchangeable with the UV-203A; the E711 and E711E, a 50-watt oscillator, power amplifier and modulator, the first equivalent to the UV-211, the Navy type 1818A and the Army type VT4, and the second equivalent to the WE-211E; the E745, a 50-watt modulator and A.F. amplifier, interchangeable with the UV-845; the E766, a mercury vapor half-wave rectifier, similar to the UX-866; and the E772, another mercury vapor half-wave rectifier, equivalent to the UV-872.

37-45

RADIO-CRAFT
Readers Bureau
96-98 Park Place, New York, N. Y.

Please send me *free of charge* the following booklets indicated by numbers in the published list above:

No.

.....

Name

Address

City..... State.....

\$100,000 SPEAKER SALE!

Included in this tremendous speaker sale are the products manufactured by leading speaker makers. Every speaker is brand new and shipped in original factory sealed cartons. They are sold far below their regular list price because they were bought in exceedingly large quantities and our purchase price permits us to give you the benefit of low cost.



DUO MAGNETIC

Duo Magnetic Speaker — **\$3.95**
 Duo Inductor Dynamic Chassis **\$3.95**
 Similar to Farrand Inductor.

JENSEN

A.C.—D.8 Dry Rectifier **\$14.95**
 A.C.—D.7 Jr. Audit Tube Rect. **\$12.95**
 A.C.—D.15 Concert Jr. Tube Rect.... **\$8.50**
 D.9—2500 OHM D.C. Field **\$7.50**
 D.7—2500 OHM D.C. Field **\$8.50**
 D.15—Midget Concert Jr. 2500 OHMS — **\$4.75**

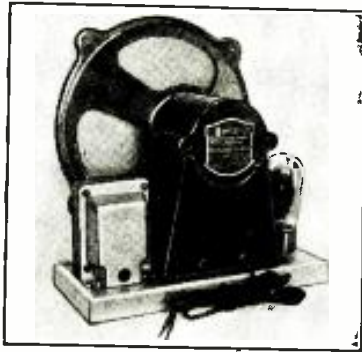

ROLA



A. C. Models
 Model O-90-C A.C. using 280 Rect. **\$9.95**
 Model K. Midget A.C. using 280 Rect. **\$8.50**
 D. C. Models
 2500 ohm P.P. Output Trans. } **\$4.25**
 1000 ohm P.P. Output Trans. } Each
 2500 ohm Single Pentode. } Model
 2500 ohm Push Pull 238.
 1000 ohm Single 238.
 1800 ohm Single Pentode 300 ohm Tap for Bias.

BALDWIN

A. C. using 280 Tube Rect. — **\$7.50**
 D. C. 2500 OHM—110 Volts **\$5.50**
 D. C. 2500 OHM—110 Volts Field Less Stand ... **\$4.00**
 D. C. 2500 OHM—110 Volts Field Less Output Trans. **\$3.25**



SANGAMO TRANSFORMERS

Sangamo transformers are offered to the public for the first time at these reduced prices.

Sangamo A. X. Audio Transformer. Price **\$1.75**
 Sangamo B. X. pp Input Transformer. Price **\$1.95**
 Sangamo H. X. pp Output Transformer. Price **\$1.95**



Do Not Write For Catalog!

All offers are F.O.B. New York, and subject to prior sale. Terms: A deposit of 20% is required with every order. Balance may be paid on delivery. Or, deduct 2% if full amount is sent with order.

HEADQUARTERS

for
 Materials and Parts
 for building

Treasure Locators

Radio, Audio, Ground Potential measurements, Hughes Induction Balances and other types; Oscillators and amplifying systems included.

We can supply all materials needed for building and operation of any of the recognized treasure finders.

WITH these apparatus you can locate buried treasures, metal war relics, mineral deposits, subterranean water veins, buried gas and water pipes, and lost objects, tools and treasures sunken in water, etc.

Write for pamphlet giving history and theory on this interesting subject. Twelve different circuits are described and explained. List of parts and prices included. (Price of pamphlet 10c.)

Mail
 Coupon
 TODAY!

GREN PARK COMPANY Dept. RC6
 245 Greenwich Street, New York, N. Y.
 Enclosed find 10c for which kindly send me pamphlet on Treasure Finders.

Name: _____
 Address: _____
 State: _____

GREN PARK CO., Dept. R. C., 245 Greenwich Street, New York, N. Y.

Hotel Directory of the Radio Trade

The Hotels on this page are Patronized by the Radio Trade. Make them your Headquarters.



THE HOTEL MONTCLAIR

LEXINGTON AVE., 49th to 50th STS.
NEW YORK

Directly Opposite the Waldorf-Astoria

800 ROOMS

Every Room With Bath
From \$3.00 per day

Attractive Rates by the Month

A RADIO IN EVERY ROOM

Short walking distance from Grand Central Terminal and B. & O. Motor Coach Station. Ten minutes by taxi from Pennsylvania Station.

American Home Cooking Served
in a Notable Restaurant

OSCAR W. RICHARDS, Manager

"The Gathering Place
of
Cosmopolitan New Yorkers."

The RUSSIAN VILLAGE
100 West 57th Street
New York City

Dining, Dancing, Russian and Gypsy
Entertainment.

LUNCH — TEA — DINNER

No cover charge at any time.

Broadcasting WOR Circle 7-9434



RENOWNED . . . FOR SUCCESSFUL CONVENTIONS

If you are responsible for a large or small Convention for your Industry or Business, consider these advantages. Overlooking Lake Michigan, with parklands, beaches and bridle path close at hand, Convention days here are pleasant and free from distractions which interfere with Convention sessions. When personal affairs are in order you are within a few minutes to Loop business . . . theatres and stores. The Drake Convention staff, available without extra charge, is trained in Convention detail, obtaining publicity, reduced railroad fares, entertainment, etc. Write us for further information.

THE
DRAKE
HOTEL, CHICAGO
Under Blackstone Management

A HOMEY HOTEL IN THE HEART OF NEW YORK

THE NEW FLANDERS

133 W. 47th Street through
to 48th Street

One of the Finest Hotels in
Times Square

Single Rooms with Adjacent
Bath \$1.50 and up
Single Rooms with Bath.... 2.00 and up
Double Rooms with Bath.. 3.00 and up
Suite—2, 3, 4 People..... 5.00

Special Weekly Rates

FRED W. BIZEL, Resident Manager

Important Announcement!

On pages 752 and 753 of this issue will be found a very important announcement telling of the RADIO-CRAFT LIBRARY. Be sure to turn to these pages NOW and learn of the ten new and interesting books which are being published.

THE SENSATIONAL
HOLLYWOOD
RESTAURANT
B'WAY. at 48th ST. N.Y.C.

NTG and his
NEW REVUE

Presents
the great-
est cabaret entertainment
the world has ever seen.
Broadway's Best Dinner
\$1.50 \$1.75 \$2.00
AFTER
THEATRE
Popular Prices.

NO COVER CHARGE

JUNE SPECIALS!!

EVERY month we list on this page certain **STAR** ★ items, which are NOT LISTED IN OUR CATALOG. These are all specials of which the quantities on hand are not sufficient to catalog them. *Once sold out, no more can be had.* First come, first served. Save yourself disappointment by ordering NOW.

STOP SHOPPING. The lowest prices are right on this page. No one undercuts us. We meet any price on ANY NEW Merchandise. Order direct from this page and save money. 100% satisfaction on every transaction. Take advantage of these special offers. **ORDER NOW, TODAY.**

NEW!

IMPROVED READRITE MODEL 700 ANALYZER

NEW!

MOST POPULAR LOW-PRICED ANALYZER ON MARKET

This new Readrite precision instrument embodies features which have always been desired in any instrument built for service work: (1) low cost; (2) simplicity of design; (3) accuracy of measurements; (4) ruggedness of the complete unit. It is needless to add that the kit is capable of testing anything from old battery models to the latest screen-grid, pentode, and multi-tube receivers.

EIGHT METER SCALES AVAILABLE

The Model 700 is an extremely compact device. The outside dimensions of the carrying case are only 10 3/4 by 7 3/4 inches. The analyzer contains a D.C. voltmeter, an A.C. voltmeter and a milliammeter. The D.C. voltmeter has three ranges: 0 to 60; 0 to 200; and 0 to 600 volts. The A.C. voltmeter has also three ranges: 0 to 10; 0 to 140; and 0 to 700 volts. The milliammeter has two ranges: one for 29-mill. reading and the other for 100-mill. This variety of ranges makes it possible to test every conceivable radio circuit; high voltage, secondaries of power transformers, current drain of all radio tubes, including the high power 250 and 210 tubes, etc.

CONVENIENT SELECTOR SWITCH

The instrument is equipped with a six-position bi-polar selector switch; by means of which readings may be obtained of "A" volts, "B" volts reversed, "K" volts, "K" volts reversed, plate voltage, and screen-grid voltage. A 1/2-volt battery is supplied



IN LEATHERETTE CASE—REMOVABLE COVER
The Model 700 now comes in a handsome black leather-

with the analyzer, to provide "C" bias, for grid tests, continuity tests, etc.

TESTS PENTODES — "MULTI-MUS" — & '80 RECTIFIERS

There are two sockets on the panel of the analyzer, one for four-prong tubes and the other for five-prong tubes. There is a "grid-test" push-button. Pin jacks are available for the individual use of all meters, externally, in every range. There is a screen-grid pin jack, and there are two pin jacks for connecting the external battery. A two-way toggle switch controls the testing circuit for either regular or pentode tubes. Both plates of the '80-type rectifier may be tested by use of a special adapter furnished. Charts are provided for measuring resistances and capacitances.

ette case, substantially constructed and equipped with nickel-plated corners and trimmings. By a novel hinge arrangement the cover of the case may be swung back and removed, thus affording a completely unobstructed view of the testing apparatus.

FREE with each Analyzer

We take pleasure in offering with the purchase of each analyzer—**ABSOLUTELY FREE OF CHARGE**—the latest radio publication to come off the press. **THE BOOK IS INTENDED FOR SERVICEMEN OF ALL CLASSES**, whether junior grade or expert. **NOTHING HAS BEEN LEFT TO YOUR OWN INGENUITY; EVERYTHING IS COMPLETE.** It contains detailed descriptions, photographs and circuit diagrams of all commercial set analyzers and testers. A real book! Contains information on every analyzer on the market. 64 big pages. Heavy cover. Profusely illustrated throughout.

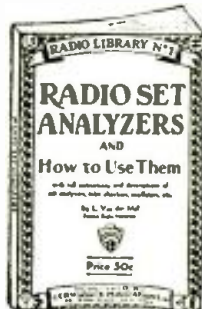

The Analyzer is furnished complete with test leads, connecting cables, Burgess 4 1/2 volt battery, several battery leads, 1Y to 1X adapter, '80 rectifier adapter and resistance and capacity charts. Shipping weight, 8 lbs. Model 700 Analyzer. List Price \$35.00. **\$14.70** YOUR PRICE

WORLD-WIDE SHORT-WAVE SET



Range 18 to 200 meters. Employs low current drain 230 tube. Requires but 1 1/4 volt "B" battery, 2 No. 6 drycells and earphones to operate. No. 1668—S.W. Set. Your Price **\$6.25**

A.C. SHORT WAVE CONVERTER KIT



Contains all parts and instructions to build a three-tube S. W. converter. Range 10 to 200 meters. Includes filament transformer for 110 volts, 60 cycles, A.C. Complete with set of 3 plug-in coils. Ship. wt. 8 lbs. No. 1617—Converter. Your Price **\$9.45**

SCREEN-GRID CAP CONNECTORS

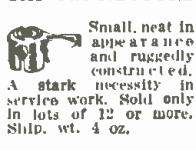

Small, neat in appearance and ruggedly constructed. A stark necessity in service work. Sold only in lots of 12 or more. Ship. wt. 4 oz. No. 1672—Caps. Per doz. Your Price... **\$0.12**

ADJUSTABLE VOLTAGE DIVIDER

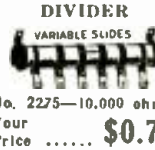

These guaranteed units will perform miracles in eliminating objectionable A.C. hum from A.F. and filter circuits. Easily mounted through use of bayonet socket. Ship. wt. 1 lb. No. SP 9054. Condenser. Your Price **\$0.49**

***8 MF. ELECTROLYTIC CONDENSERS**



AUTOMATIC BLOW TORCH



Heat intensity over 1200° Fahr. Requires no mouth-blowing. Entirely automatic. Used for heavy duty soldering, aluminum soldering, metal tempering, etc. Ship. wt. 1 lb. No. K1006—Torch. Your Price **\$0.60**

"245" POWER TRANSFORMER



For 110 volts 60 cycle A.C. operation. 5 v. at 2 a., 2 1/2 v. at 3 a., 1 1/2 v. at 10 1/2 a., 3/4 v. at 3a. 0.1, 310 V-340 V. No. 1450—Transformer. Your Price **\$3.84**

FREE 76 Page Radio Treatise



The new Winter edition, No. 24, of our **RADIO SERVICE TREATISE** is positively the greatest book in print—NOT JUST A CATALOG. It contains a large editorial section with valuable information not found anywhere else. Among the new technical information listed are the following: 1932 Complete Radiotron Characteristics Short Wave Tuners and Phone-Pickups.—Constructional Data for Servicemen's Test Oscillator—all about Tone Controls—Short Wave Adapters and Converters—Constructing a 3-tube Super-Het Short-Wave Converter—Modernizing old radio sets—Latest type Multi-Mu and Pentode Tubes—All about DC Receivers—Vacuum Tube Treatise.—And dozens of new radio experiments, hints to Servicemen, valuable tables of useful data, etc., etc.

100 New Hook-Ups, Etc. 675 Illustrations.

WRITE TODAY. Enclose 2 cents for postage. Treatise sent by return mail.



A.C. SUPERHET S.W. CONVERTER

Converts any broadcast receiver into a full-fledged superhet S.W. Receiver. Range 20 to 115 meters. Requires no plug-in coils. Has built-in filament transformer for 110 volts 60 cycle A.C. Employs 3 22" tubes. Single dial control. Instructions included. Shipping wt. 8 lbs. No. 1614—Converter. Your Price **NOW \$7.50**

RADIO MIRROR PENLIGHT



A clever device for looking around corners or other inaccessible spots on the radio chassis. Comprises pen flashlight and magnifying mirror. Complete with battery and bulb. No. 1695—Penlight. Your Price **\$0.85**

***POWER PACK-CHOKE UNIT**



Comprises power transformer for 5-226's, 2 227's, 2-171A's and 1 250, as well as 1-500-ohm filter choke. Put up in neat metal case. Ship. wt. 10 lbs. No. SP 9053—Power Pack Unit. Your Price... **\$2.75**

***MIDGET MICROPHONE**



A real microphone of single button type. Extremely sensitive. Excellent for P.A. work, etc. Standard resistance of 100 ohms. Responds up to 2500 cycles. Ship. wt. 1 lb. No. 1655—Mike. Your Price **\$2.25**

MIDGET DYNAMIC SPEAKER



A real dynamic speaker with surprising volume and tone. 6 1/2" overall, 1 1/2" diaphragm. Standard 2500 ohm field coil. Output transformer to match all type output tubes. Wt. 5 lbs. No. 1549—Speaker. Your Price **\$2.50**

SPEED "295" TRIPLE-TWIN TUBE



Equivalent to one 227 detector and one 245 P. o. w. r. tube. Constructive, substitutes a two-stage direct-coupled amplifier in itself. Filament, 2 A.C. 2 1/2 v.; plate voltage 250. Large undistorted output. Ship. wt. 12 oz. No. S699. Tube. Your Price... **\$2.10**

ELECTRIC CLOCK



Naval observatory time right from your light socket! No spring, no wind, no batteries. Never out of order. For 110 volts 60 cycle A.C. operation only. No. 1689—Clock. Your Price **\$1.00**

***UTAH A.C. DYNAMIC SPEAKER**



Operates from 110 volt 60 cycle A.C. line. 9" high by 9 1/2" wide by 7 1/2" deep. Ship. wt. 19 lbs. No. 1506—Speaker. Your Price **\$7.45**

WE ARE A WHOLESALE HOUSE AND CANNOT ACCEPT ORDERS FOR LESS THAN \$3.00. If C. O. D. shipment is desired, please remit 20% remittance, which must accompany all orders. If full cash accompanies order, deduct 2% discount. Send money order—certified check—U. S. stamps.

Radio Trading Co.
23 West Broadway
New York, N. Y.

ORDER FROM THIS PAGE. You will find special prices from time to time in this magazine. Get our big **FREE** catalog for the greatest Radio Bargains. Should you wish goods shipped by parcel post, be sure to include sufficient extra remittance for same. Any excess will be refunded.

I will train you at home to fill a **BIG PAY** Radio Job!



Here's Proof



\$100 a week

"My earnings in Radio are many times greater than I ever expected they would be when I enrolled. They seldom fall under \$100 a week. If your course cost four or five times more I would still consider it a good investment."

E. F. WINBORNE
1267 W. 48th St.,
Norfolk, Va.



Jumped from \$35 to \$100 a week

"Before I entered Radio I was making \$35 a week. Last week I earned \$110 servicing and selling Radios. I owe my success to N. R. I. You started me off on the right foot."
J. A. VAUGHN
Grand Radio and Appliance Co.,
3107 S. Grand Boulevard,
St. Louis, Mo.



\$500 extra in 6 months

"In looking over my records I find I made \$500 from January to May in my spare time. My best week brought me \$107. I have only one regret regarding your course—I should have taken it long ago."

HOYT MOORE
R. R. 3, Box 919,
Indianapolis, Ind.,

If you are dissatisfied with your present job, if you are struggling along in a rut with little or no prospect of anything better than a skinny pay envelope—clip the coupon NOW. Get my big FREE book on the opportunities in RADIO. Read how quickly you can learn at home in your spare time to be a Radio Expert—what good jobs my graduates have been getting—real jobs with real futures.

Many Radio Experts Make \$50 to \$100 a Week

In about ten years the Radio Industry has grown from \$2,000,000 to hundreds of millions of dollars. Over 300,000 jobs have been created by this growth, and thousands more will be created by its continued development. Many men and young men with the right training—the kind of training I give you in the N. R. I. course—have stepped into Radio at two and three times their former salaries.

Get Ready now for Jobs Like These

Broadcasting stations use engineers, operators, station managers, and pay up to \$5,000 a year. Manufacturers continually employ testers, inspectors, foremen, engineers, service men, buyers, for jobs paying up to \$6,000 a year. Radio Operators on ships enjoy life, see the world, with board and lodging free, and get good pay besides. Dealers and jobbers employ service men, salesmen, buyers, managers, and pay up to \$100 a week. My book tells you about these and many other kinds of interesting radio jobs.

Many N. R. I. Men Have made \$200 to \$1,000 in spare time while learning

The day you enroll I send you material which you should master quickly for doing 28 jobs, common in most every neighborhood, for spare time money. Throughout your course I send you information on servicing popular makes of sets; I give you the plans and ideas that have made \$200 and \$1,000 for N. R. I. students in their spare time while studying. My course is famous as the course that pay for itself.

Talking Movies, Television, Aircraft Radio included

Special training in Talking Movies, Television and Home Television experiments, Radio's use in Aviation, Servicing and Merchandising Sets, Broadcasting, Commercial and Ship Stations are included. I am so sure that N. R. I. can train you satisfactorily that I will agree in writing to refund every penny of your tuition if you are not satisfied with my Lesson and Instruction Service upon completion.

64-page book of information FREE

Get your copy today. It tells you where Radio's good jobs are, what they pay, tells you about my course, what others who have taken it are doing and making. Find out what Radio offers you without the slightest obligation. ACT NOW!

J. E. SMITH, President
National Radio Institute, Dept. 2 FX
Washington, D. C.

Our Own Home



Pioneer and World's Largest Home-Study Radio training organization devoted entirely to training men and young men for good jobs in the Radio industry. Our growth has paralleled Radio's growth. We occupy three hundred times as much floor space now as we did when organized in 1914.



Special Free Offer



Act now and receive in addition to my big free book "Rich Rewards in Radio" this Service Manual on D.C., A.C., and Battery operated sets. Only my students could have this book in the past. Now readers of this magazine who mail the coupon will receive it free. Overcoming hum, noises of all kinds, fading signals, broad tuning, howls and oscillations, poor distance reception, distorted or muffled signals, poor Audio and Radio Frequency amplification and other vital information is contained in it. Get a free copy by mailing the coupon below.

ACT QUICKLY!

.. NEW Radio Equipment for Broad Practical Experience Given Without Extra Charge

With the aid of this equipment you can work out with your own hands many of the things you read in our text books. From it you get the valuable experience that tells an expert from a beginner. In a short time you have learned what it would take years to learn in the field. It's training like this that puts the extra dollars in your pay envelope. Some of the many circuits you build and experiments you perform are: Measuring the merit of a tube, building an ohmmeter, tube voltmeter, and a grid dip meter for service work. You actually make experiments illustrating the important principles in the 2 best known sets.

I have doubled and tripled the salaries of many. Find out about this tested way to BIGGER PAY



FILL OUT AND MAIL THIS COUPON TODAY

J. E. SMITH, President
National Radio Institute, Dept. 2 FX
Washington, D. C.

Dear Mr. Smith: I want to take advantage of your Special Offer. Send me your two books, "Double Shooting in D.C., A.C. and Battery Sets" and "Rich Rewards in Radio."

This request does not obligate me.

Name.....
Address.....
City.....State.....

Lifetime Employment Service to all Graduates



In their own secluded laboratory, these engineers, with slide rule, meter and microscope are always making improvements and double checking Certified Triad production.



Hundreds of skilled young ladies find interesting and profitable employment, making "small parts" for Certified Triads.



Many "batteries" of sealing machines controlled by highly skilled co-workers make Triads great production possible.



At the end of every production line, the tubes are given their first check. Ten characteristics are checked here. Even this is more than is done with the average tube, but it is not enough for "Double-Checked," Certified Triads.

PROTECTION

For SERVICEMEN

CERTIFIED TRIAD TUBES are the result of many years experience. All the guess-work has been eliminated. They are designed, manufactured and tested by the most modern machinery. They are produced by skilled operators. No better tubes can be bought.

A complete study of the proper method of merchandising tubes, in order to protect the seller as well as the buyer has resulted in the adoption of an entirely new form of distribution. The CERTIFIED TRIAD SERVICEMAN is the key stone. You can become one of the agents, who are taking a handsome profit from these tubes, by filling in the coupon. The whole interesting story will come to you by return mail.

If you are selected to represent TRIAD, we will protect your territory, for you. Every Tom, Dick and Harry will not be competing with you.

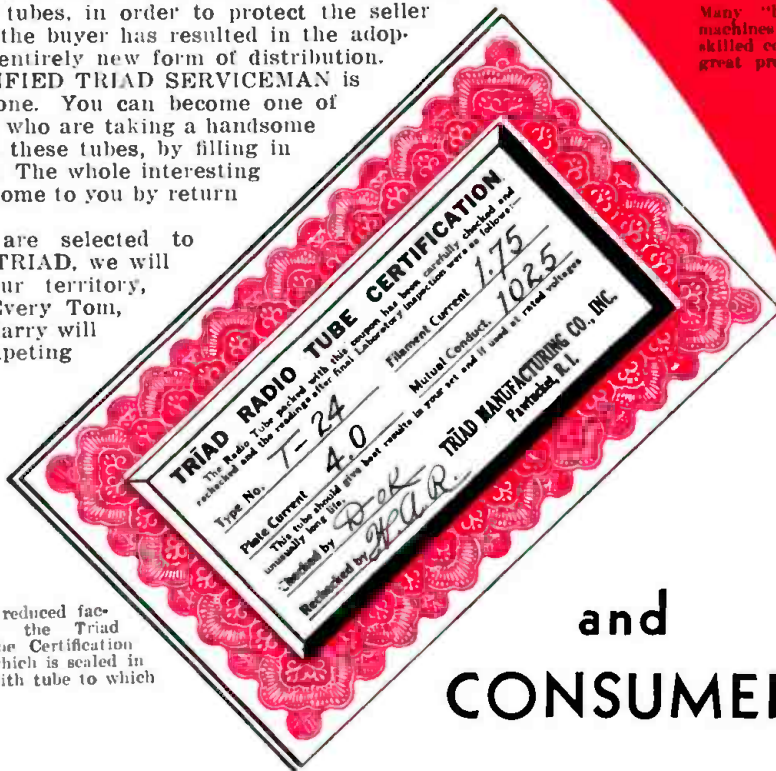

This is a reduced facsimile of the Triad Radio Tube Certification Coupon, which is sealed in the box with tube to which it refers.

and
CONSUMERS

Even a good radio receiver will sound like "nothing at all" if it is equipped with poor tubes. Most people realize that the radio tube is the heart of their receiver. Ordinary tubes can be bought for a song, but you usually get what you pay for. No one expects to get Cadillac or Lincoln service from an Austin. No one looks for custom-made shoes for three dollars. Those who expect the very best performance from inferior tubes are not logical and they are sure to be disappointed. No form of entertainment is as inexpensive as radio. Isn't it good business to keep it working at its best. You can be sure of doing so, by insisting on CERTIFIED TRIAD TUBES. A line to us will enable us to send you the CERTIFIED TRIAD SERVICEMAN, we have selected to serve your vicinity.

The TRIAD LINE is complete. It includes all types of standard Tubes as well as Photo-Electric Cells and Television Tubes

TRIAD TELEVISION & MFG. CO.
Pawtucket, R. I.

Gentlemen,
Please send me complete information about your new Sales Plan for servicemen.

I have been a serviceman for years.
I sell tubes per year. I belong to the Serviceman's Association.

Name

Address

City State

My letterhead or card is attached.

Your Ultimate Choice will be a *Super-Powered* LINCOLN

**Super Power Spans
Atlantic, on Broadcast
Band, in Broad Daylight**



St. Pierre and Miquelon.
I was surprised of the reception
we have obtained on the broad-
cast band of 200 to 550 meters
receiving by daylight many
American stations in full
strength as well as Radio Maroc,
Africa on 416 meters and also
as good results on the short
wave band.

15 to 550 meters.
Six screen grid tubes. Four
tuned I. F. stages deliver ex-
ceptionally high amplification.
Each band of short wave fre-
quencies is tuned through per-
manently placed coils and a
small non-capacity selector
switch on the front panel gives
instant access to the four short
wave and broadcast bands.

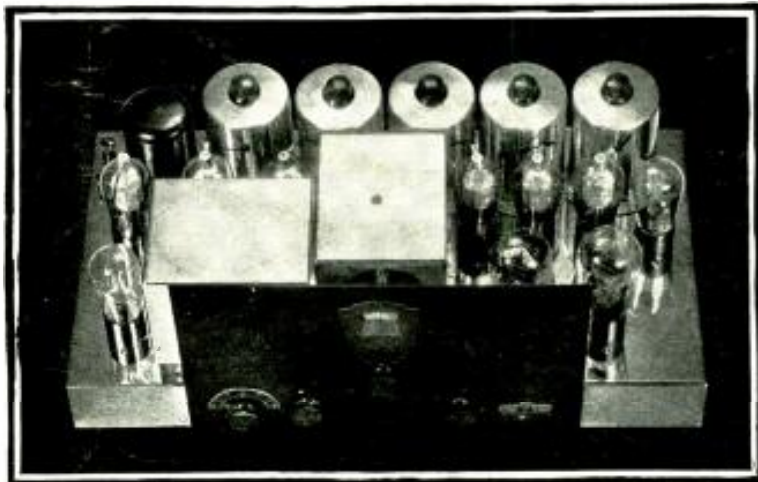

Lincoln DeLuxe Chassis
SW-32-110 V. 60 Cycles AC.—DC-SW-10-Battery Model
ALL-WAVE, WORLD-WIDE RECEPTION
WITHOUT PLUG-IN COILS—

LINCOLN'S PHENOMENAL RECORD OF SPECTACULAR ACHIEVEMENTS GUARANTEES SUPER PERFORMANCE

SPEAKING of records, read what Lincoln owners are actually getting . . . Three months of daily contact with Chicago from Baffin land, in the Arctic, by MacMillan expedition.

Exclusive news from Lindbergh Plane flying over Arctic, relayed to press by Lincoln Radio. Five continents tuned in two hours.

644 Verified stations on the Broadcast Band alone, by one Lincoln owner. JOFK, JOGK, JOCK, JOIK, JOHK, JOAK, JOBK (seven Japanese stations on broadcast band received by Lincoln owner in Oklahoma in one morning).

2YA Wellington, New Zealand; 2BL Sydney, Australia, brought in on broadcast band by Texas owner.

TELEGRAM: "Again congratulations this A. M. four to five logged 2 FC Sydney six eighty kilo JOBK Osaka eight hundred kilo KGMB Honolulu thirteen twenty kilo stop. This noon twelve CST logged WOP1, WLAC, WEHC,

WSVJ, WROL, WDOD, KRDL, WTAM, WOWO, WBT, WJAX, WENR, WABC, KWKII, WHAS, XED, WBAP, WJZ, WBBM, WSB, XER, WGN, WOR, WLW, WPTF, WFAF, WSM, WFAO, WSAZ, WWNC, WNOX, WKRC. How is that for broadcast Mr. Hollister?"

CHICKEN, ALASKA reports—"Under favorable conditions here in mid-winter we can pick up Germany, Sweden, England, France and Russia on the broadcast band. From ten to one P. M. in broad daylight they come in best."

SHORT WAVE RECEPTION

Enthusiastic reports of world-wide reception by Lincoln owners everywhere are too numerous to list in detail. One Lincoln owner has received 93 stations out of 131 stations listed in International Short Wave Club Log.

LINCOLN RADIO CORPORATION

Dept. RC-6 329 S. Wood St., Chicago, Ill.

LINCOLN RADIO CORPORATION
Dept. RC-6, 329 S. Wood St., Chicago, Ill.
Please send literature to

Name.....
Address.....
City..... State.....

LINCOLN
DeLuxe Receivers