



April  
25 Cents

*Con. let  
Bruch*

# Radio-Craft

579  
592  
612

FOR THE  
SERVICE MAN - DEALER - RADIOTRICIAN

HUGO GERNSBACK Editor



The  
Radio-Controlled  
Tank

See page 600

Tone Control, by John F. Rider

New Tube Types

A Home-Practice Set

D. C. - A. C. Current Conversion

Service Men's Test Equipment

Two-Volt Set Operation

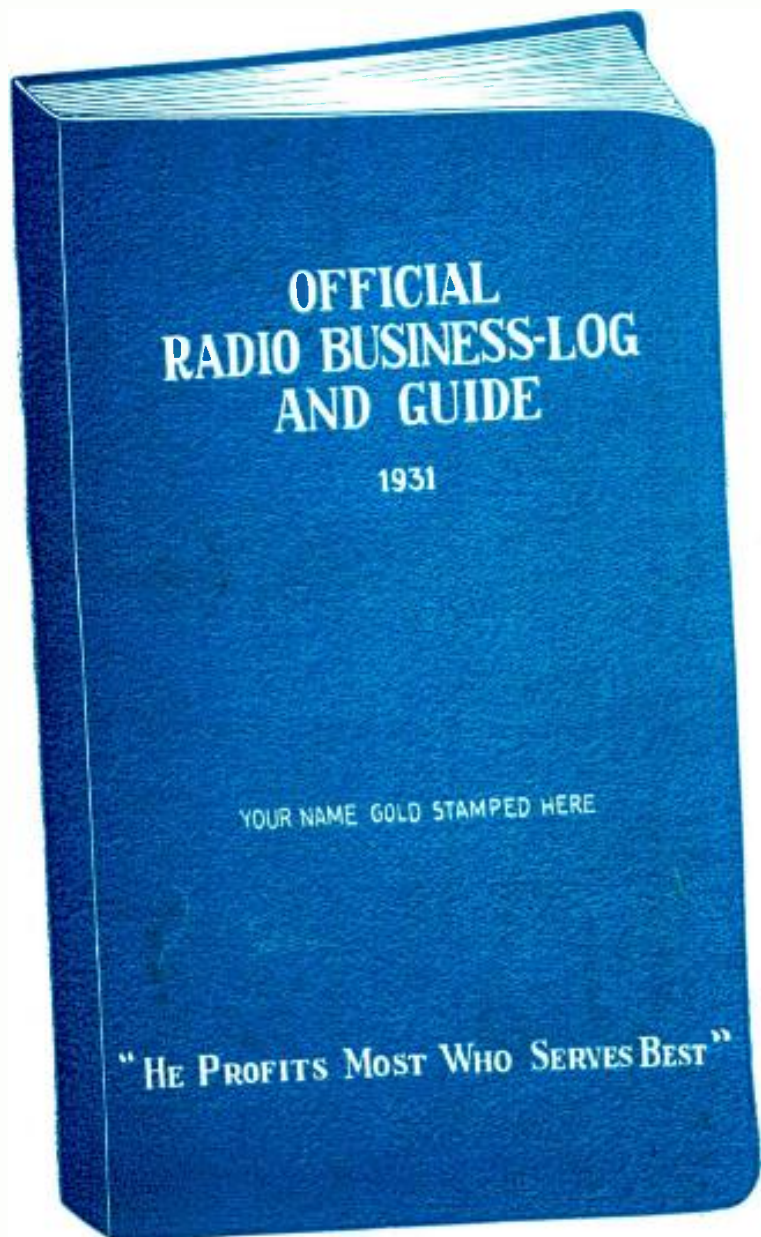

# Official Radio Business-Log and Guide 1931

**T**HIS book—containing over 300 pages—size 5 x 8½ inches, bound in green flexible leatherette, is a most useful desk tool for everybody connected with the Radio Trade.

The OFFICIAL RADIO BUSINESS-LOG AND GUIDE has been especially planned and laid out for the Radio Man—the Executive, the Engineer, the Radio Dealer, the Service Man.

A wide variety of radio data, of constant reference value to the man engaged in the radio business, has been compiled for this first OFFICIAL RADIO BUSINESS-LOG AND GUIDE. It contains, in addition, conveniently arranged spaces for listing appointments, engagements and personal records; business references; commercial information; diary and memoranda sheets, etc.

Here are a few of the features contained in the OFFICIAL RADIO BUSINESS-LOG AND GUIDE: Census of Radio Dealers—Population of States and Big Cities—Retail Store Operating Expenses—List of Radio Set Manufacturers—List of Vacuum Tube Manufacturers—List of Radio Parts Manufacturers—Bookkeeping Information for Radio Men—Underwriters' Rules—Code for Electrical Workers—Radio Service Man's Information—Useful Radio Reference Formulas—Tube Data Chart—Tables of Schematic Symbols and How to Use—Table of Broadcast Stations—Principles Underlying Receiver Designs—The Service Workbench and Test Table—The Service Car—The Business End of Servicing—Form Letters for Radio Dealers—The Radio Man's Credo—1931 Calendar—Important Holidays in 1931—Calendar of 1930—Calendar of 1932—

Postal Information—1931 Record of Engagements, Appointments, by Days (182 pages) Place for Keeping Tab on Things to be Done (Memoranda)—Alphabetical List of Customers' Names and Telephone Numbers—Record of Monthly Income and Expenses—Records of Notes, Dues and Future Expenses—Records of Insurances and Payments—Interest Calculations and U. S. Interest Laws—Cash Discount Savings—Table of Dozen and Single Prices—Table of Time Payment Plans—etc., etc.

There are sample advertisements that will give a professional tone to your advertising, and also a chapter on how to pep up business the year 'round.

No Radio Man can afford to be without the book. It will give him knowledge which he cannot get in any other way. It will help him in his business, through the commercial advice and information contained in its pages; and, most important of all, it will stop money losses by providing ample space for recording all business transactions day by day.

## Mail Coupon NOW!

GERNSBACK PUBLICATIONS, INC.,  
96-98 Park Place, New York, N. Y.

It's

As per your special offer, I enclose herewith \$3.00 for which you are to send me postpaid, one copy of the OFFICIAL RADIO BUSINESS-LOG AND GUIDE as soon as it is published, at the pre-publication price of \$3.00, with my name stamped in gold on the cover. I understand that the price will be \$4.00 as soon as the OFFICIAL RADIO BUSINESS-LOG AND GUIDE is published.

Name .....  
(Print name carefully)

Address .....

City..... State.....

Every item in the OFFICIAL RADIO BUSINESS-LOG AND GUIDE is compiled with the one thought in mind: How can the man engaged in the Radio Trade be assisted most efficiently? How can he make more money? and How can he save money?

The OFFICIAL RADIO BUSINESS-LOG AND GUIDE is a true assistant, a counsellor, and a silent partner to the man engaged in Radio activities. It eliminates account books; it becomes his private secretary, time-saver, business log and reference book.

The size of the OFFICIAL RADIO BUSINESS-LOG AND GUIDE—5 x 8½ inches—is such that it can be slipped in the pocket and carried around wherever you go—a real portable office.

The price of the OFFICIAL RADIO BUSINESS-LOG AND GUIDE is \$4.00 postpaid. It will be ready for shipment March 1, 1931.

### Special Offer!

We will accept your pre-publication order at the special price of \$3.00, and we will gold-stamp your name on the cover of the OFFICIAL RADIO BUSINESS-LOG AND GUIDE if you will mail your order at once on the coupon below. Once the book is published, its price will be \$4.00. You are saving \$1.00 by ordering now.



**RADIO NEEDS TRAINED MEN**  
*Let Us Train You at Home for a Big-Pay Job*

**G**ET into the rich field of Radio via the Radio Training Association. Radio manufacturers, distributors, dealers are all eager to employ our members because we train them right, and qualify them for the positions that require better trained men.

So great is this demand from Radio employers that positions offering good pay and real opportunity are going begging. If you want to cash in on Radio quick, earn \$3.00 an hour and up spare time, \$40 to \$100 a week full time, prepare for a \$10,000, \$15,000, \$25,000 a year Radio position, investigate the R. T. A. now.

**Special Attention to Radio Service Work**

Thousands of trained Radio Service Men are needed now to service the new all-electric sets. Pay is liberal, promotions rapid. The experience you receive fits you for the biggest jobs in Radio. The R. T. A. has arranged its course to enable you to cash in on this work within 30 days!

Would you like to work "behind the scenes" at Hollywood, or for a talking picture manufacturer? R. T. A. training qualifies you for this work. Television, too, is included in the training. When television begins to sweep over the country, R. T. A. men will be ready to cash in on the big pay jobs that will be created.

**Expert Supervision  
 Lifelong Consultation Service**

As a member of the Association you will receive personal instruction from skilled Radio Engineers. Under their friendly guidance every phase of Radio will become an open book to you. And after you graduate the R. T. A. Advisory Board will give you personal advice on any problems which arise in your work. This Board is made up of big men in the industry who are helping constantly to push R. T. A. men to the top.

Because R. T. A. training is complete, up-to-date, practical, it has won the admiration of the Radio industry. That's why our members are in such demand—why you will find enrolling in R. T. A. the quickest, most profitable route to Radio.

**Mail Coupon for No-Cost Training Offer**

Memberships that need not—should not—cost you a cent are available right now. The minute it takes to fill out coupon at right for details can result in your doubling and trebling your income in a few months from now. If you are ambitious, really want to get somewhere in life, you owe it to yourself to investigate. Learn what the R. T. A. has done for thousands—and can do for you. Stop wishing and start *actually doing something* about earning more money. Fill out the coupon and mail today.

**Radio Training Association of America**  
 Dept. RCA-4 4513 Ravenswood Ave., Chicago, Ill.

**Fill Out and Mail Today!**

**RADIO TRAINING ASSOCIATION OF AMERICA**  
 Dept. RCA-4 4513 Ravenswood Ave., Chicago, Ill.

Gentlemen: Send me details of your No-Cost Training Offer and information on how to make real money in Radio quick.

Name \_\_\_\_\_

Address \_\_\_\_\_

City \_\_\_\_\_ State \_\_\_\_\_

H. GERNSBACK, President  
 S. GERNSBACK, Treasurer  
 J. M. HERZBERG, Vice-President  
 I. S. MANHEIMER, Secretary

R. D. WASHBURNE,  
 Technical Editor



HUGO GERNSBACK, Editor-in-Chief

JOHN F. RIDER,  
 Editor Service Dept.

C. P. MASON,  
 Associate Editor

VOLUME II  
 NUMBER 10

## Contents of This Issue

APRIL  
 1931

	PAGE		PAGE
<b>EDITORIAL:</b>			
Radio Gadgets.....	By Hugo Gernsback 585	Radio-Controlled Tanks of the Future.....	600
<b>SERVICE MEN'S DEPARTMENT:</b>			
Tone Control?.....	By John F. Rider 586	Radio Equipment of Uncle Sam's Tanks.....	601
Operating Notes for Service Men		New Radio Devices for Shop and Home.....	602
	By Bertram M. Freed 587	Hints to Radio Manufacturers.....	603
Leaves from Service Men's Notebooks		<b>RADIO CONSTRUCTION AND THEORY:</b>	
	By RADIO-CRAFT Readers 588	The "Universal Super-Wasp" for All Bands.....	604
The Service Man's Open Forum.....	589	A Long-Wave Converter for the Broadcast Set	
<b>RADIO SERVICE DATA SHEETS</b>			
No. 39—Erla "Model 224".....	590	By Clyde J. Fitch and C. H. W. Nason 606	
No. 40—Bosch "Models 60 and 61".....	591	A Perfect-Quality Demonstration Receiver.....	608
Favorite Testing Equipment of Service Men—An Analyzer and Tool Kit.....	By H. Harrison and W. Green 592	Home-Made Intermediates for Supers..By John Ostlund	609
A Single-Meter Checker for All Tubes.....	By H. G. Cisin 593	Radio-CRAFT Kinks .....	610
<b>NEW DEVELOPMENTS:</b>			
Two-Volt Tubes Bring Back the Battery Set		The Radio Craftsman's Own Page.....	611
	By R. D. Washburne 594	A Home Telegraph and Phone Set	
Recent Advances in Radio Tube Design.....	599	By Milton E. Saunders 612	
		An Inexpensive D.C. to A.C. Converter	
		By R. W. Osland 613	
		Radio-CRAFT's Information Bureau.....	614

## In Forthcoming Issues

**RADIO-FREQUENCY TRANSFORMER DESIGN**, by Sylvan Harris. Some years ago Mr. Harris announced the result of exhaustive researches on R.F. transformers, in the most complete form then available to the constructor. There has been since that time no popular explanation of the general principles of coil design. Mr. Harris will discuss the subject in the light of the new tubes and new methods of construction which have since been introduced.

**THE DIODE DETECTOR**, by C. H. W. Nason. The cycle of radio has swept around again to the two-element rectifier, which Fleming introduced a generation ago. But modern radio circuits retain the theoretical advantages of this tube, while overcoming the difficulties which hindered its use back in the crystal days.

**AN A.C. BEAT-FREQUENCY OSCILLATOR**, by H. G. Cisin, M.E. This article, describing an apparatus which is so well built that it may be used for laboratory measurements and tests of the value of apparatus, will be valuable to Service Men, and of interest to every serious experimenter.

**A FIFTY-WATT AUDIO AMPLIFIER**. One of the most interesting features of this system, adapted to auditorium or open-air work, is the novel arrangement for correcting the frequency-characteristic, to give the proper balance of tones at great sound intensities.

And numerous articles for the Service Man, the constructor and the experimenter.

RADIO-CRAFT is published monthly, on the fifth of the month preceding that of date; its subscription price is \$2.50 per year. (In Canada and foreign countries, \$3.00 a year to cover additional postage.) Entered at the postoffice at Mt. Morris, Ill., as second-class matter under the act of March 3, 1879. Trademarks and copyrights by permission of Gernsback Publications, Inc., 98 Park Place, New York City.

Text and illustrations of this magazine are copyright and must not be reproduced without permission of the copyright owners. We are also agents for WONDER STORIES, WONDER STORIES QUARTERLY and EVERYDAY MECHANICS. Subscriptions to these magazines may be taken in combination with RADIO-CRAFT at reduced Club rates. Write for information.

Copyright 1931. GERNSBACK PUBLICATIONS, INC.

Published by  
**TECHNI-CRAFT PUBLISHING CORPORATION**

Publication Office: 404 No. Wesley Ave., Mount Morris, Illinois

Editorial and Advertising Offices  
 96-98 Park Place, New York City

Western Advertising Office  
 737 North Michigan Avenue, Chicago, Ill.

L. F. McCLURE, Western Advertising Representative

London Agent: Hachette & Cie.,  
 3 La Belle Sauvage, Ludgate Hill, E.C. 4

Paris Agent: Hachette & Cie.,  
 111 Rue Reaumur

Australian Agent: McGill's Agency,  
 179 Elizabeth St., Melbourne

Here are a few examples of the kind of money I train "my boys" to make

Started with \$5. Now has Own Business



"Can't tell you the feeling of independence N.R.I. has given me. I started in Radio with \$5, purchased a few necessary tools, circulated the business cards you gave me and business picked up to the point where my spare time earnings were my largest income. Now I am in business for myself. I have made a very profitable living in work that is play."

Howard Houston, 512 So. Sixth St., Laramie, Wyo.

\$700 in 5 Months Spare Time

"Although I have had little time to devote to Radio my spare time earnings for five months after graduation were approximately \$700 on Radio sales, service and repairs. I owe this extra money to your help and interest. Thanks for the interest shown me during the time I studied and since graduation."



Charles W. Linsey, 537 Elati St., Denver, Colo.

\$7396 Business in two and one-half Months



"I have opened an exclusive Radio sales and repair shop. My receipts for September were \$2332.16—for October, \$2887.77 and for the first half of November, \$2176.32. My gross receipts for the two and one-half months I have been in business have been \$7396.25. If I can net about 20% this will mean a profit of about \$1500 to me."

John F. Kirk, 1514 No. Main St., Spencer, Iowa.

My Free book gives you many more letters of N. R. I. men who are making good in spare time or full time businesses of their own



Rear view of 5-tube Screen Grid Tuned Radio frequency set — only one of the many circuits you can build with my parts.

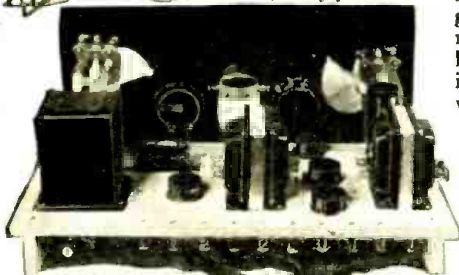

You'll get practical Radio Experience with my new 8 Outfits of Parts that I'll give you for a Home Experimental Laboratory!

My course is not all theory. You use the 8 Outfits I'll give you, in working out the principles, diagrams and circuits used in modern sets and taught in my lesson books. This 50-50 method of home training makes learning easy, fascinating, interesting. You get as much practical experience in a few months as the average fellow who hasn't had this training gets in two to four years in the field. You can build over 100 circuits with these parts. You experiment with and build the fundamental circuits used in such sets as Crosley, Atwater-Kent, Eveready, Majestic, Zenith, and many others sold today. You learn how these circuits work, why they work, how they should work, how to make them work when they are out of order.

I will show You too how to start a spare time or full time Radio Business of Your Own without Capital



J. E. Smith, Pres., National Radio Institute

The world-wide use of receiving sets for home entertainment, and the lack of well trained men to sell, install and service them have opened many splendid chances for spare time and full time businesses. You have already seen how the men and young men who got into the automobile, motion picture and other industries when they were young had the first chance at the key jobs—and are now the \$5,000 \$10,000 and \$15,000 a year men. Radio offers you the same chance that made men rich in those businesses. Its growth is opening hundreds of fine jobs every year, also opportunities almost everywhere for a profitable spare time or full time Radio business. "Rich Rewards in Radio" gives detailed information on these openings. It's FREE.

So many opportunities many make \$5 to \$30 a week extra while learning

Many of the ten million sets now in use are only 25% to 40% efficient. The day you enroll I will show you how to do ten jobs common in most every neighborhood, that you can do in your spare time for extra money. I will show you the plans and ideas that are making as high as \$200 to \$1,000 for others while taking my course. G. W. Page, 107 Raleigh Apts., Nashville, Tenn., writes: "I made \$935 in my spare time while taking your course."

Many \$50, \$60 and \$75 a week jobs opening in Radio every year

Broadcasting stations use engineers, operators, station managers, and pay \$1,800 to \$5,000 a year. Radio manufacturers continually need testers, inspectors, foremen, engineers, service men, and buyers for jobs paying up to \$15,000 a year. Shipping companies use hundreds of operators, give them world-wide travel at practically no expense and pay \$85 to \$200 a

month. Radio dealers and jobbers are continually on the lookout for good service men, salesmen, buyers, managers, and pay \$30 to \$100 a week. Talking Movies pay as much as \$75 to \$200 a week to the right men with Radio training. My book tells you of other opportunities in Radio.

I will train you at home in your spare time

Hold your job until you are ready for another. Give me only part of your spare time. You don't have to be a high school or college graduate. Hundreds have won bigger success. J. A. Vaughn jumped from \$35 to \$100 a week. E. E. Winborne seldom makes under \$100 a week now. The National Radio Institute is the Pioneer and World's Largest organization devoted exclusively to training men and young men, by correspondence for good jobs in the Radio industry.

You Must Be Satisfied

I will give you an agreement to refund every penny of your money if you are not satisfied with my Lessons and Instruction Service when you complete my course. And I'll not only give you thorough training in Radio principles, practical experience in building and servicing sets, but also train you in Talking Movies, give you home experiments in Television, cover thoroughly the latest features in sets such as A. C. and Screen Grid.

My 64-Page Book Gives the Facts

Clip and mail the coupon now for "Rich Rewards in Radio." It points out the money-making opportunities the growth of Radio has made for you. It tells of the opportunities for a spare time or full time Radio business of your own. The special training I give you that has made hundreds of other men successful; and also explains the many fine jobs for which my course trains you. Send the coupon to me today. You won't be obligated in the least.

Get my new book It points out what Radio Offers You



J. E. SMITH, President Dept. IDX. National Radio Institute Washington, D. C.

THIS COUPON IS GOOD FOR ONE FREE COPY OF MY NEW BOOK

mail it TODAY

J. E. SMITH, President, National Radio Institute, Dept. IDX. Washington, D. C.

DEAR MR. SMITH:—Send me your book. I want to see what Radio offers. I understand this request does not obligate me and that no payment will call.

Name..... Address..... City..... State.....

Get the facts on my Lifetime Employment Service to all Graduates

# LEARN ELECTRICITY

Without Lessons In  
90 Days

BY ACTUAL WORK  
GREAT COYNE

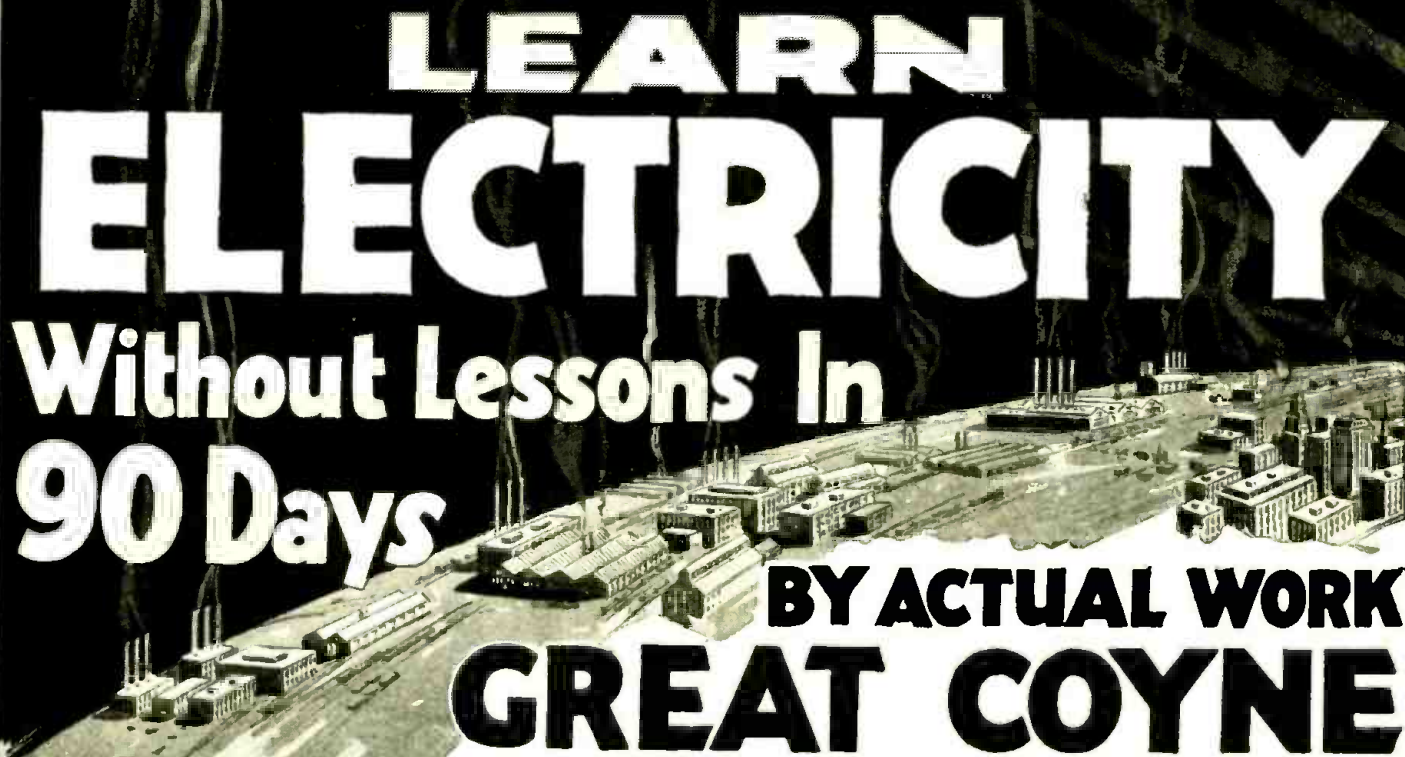

*Students working in our Alternating Current Department*



*Instructor explaining operation of modern airplane motor*

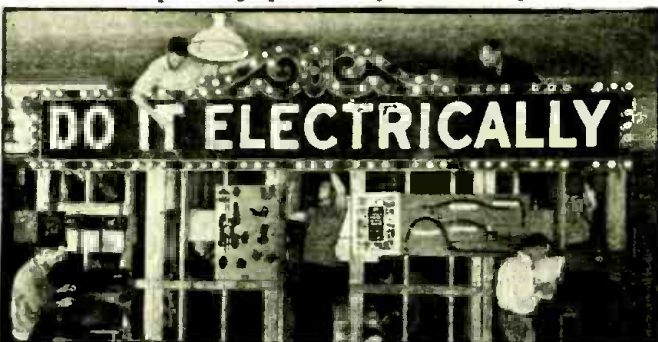

*Students getting actual experience on modern electric sign*

Don't spend your life in a dull, hopeless job! Don't be satisfied with a mere \$30 or \$40 a week! **You don't have to!** Electricity pays salaries of \$60, \$70 and even \$200 a week to thousands of fellows no smarter than you. And you can learn Electricity at Coyne in 90 days —**NOT BY CORRESPONDENCE**, but by actual electrical work.

## GOLDEN OPPORTUNITIES

**PAYING \$60 a Week and Up!**

In Power Plant work, Armature Winding, Auto Ignition, House Wiring, Radio Service, Refrigeration, Welding, Aviation Electricity, Illumination, etc. Thousands of Big Pay Opportunities for the Trained Man. And you can prepare for one of them in 90 days at Coyne!

## No Books - No Lessons

Coyne is not a Correspondence School. We train you by actual electrical work—on huge motors and generators, switch-

**H. C. LEWIS** **COYNE**  
President Founded 1899

**500 South Paulina Street,**

**MAIL COUPON FOR**

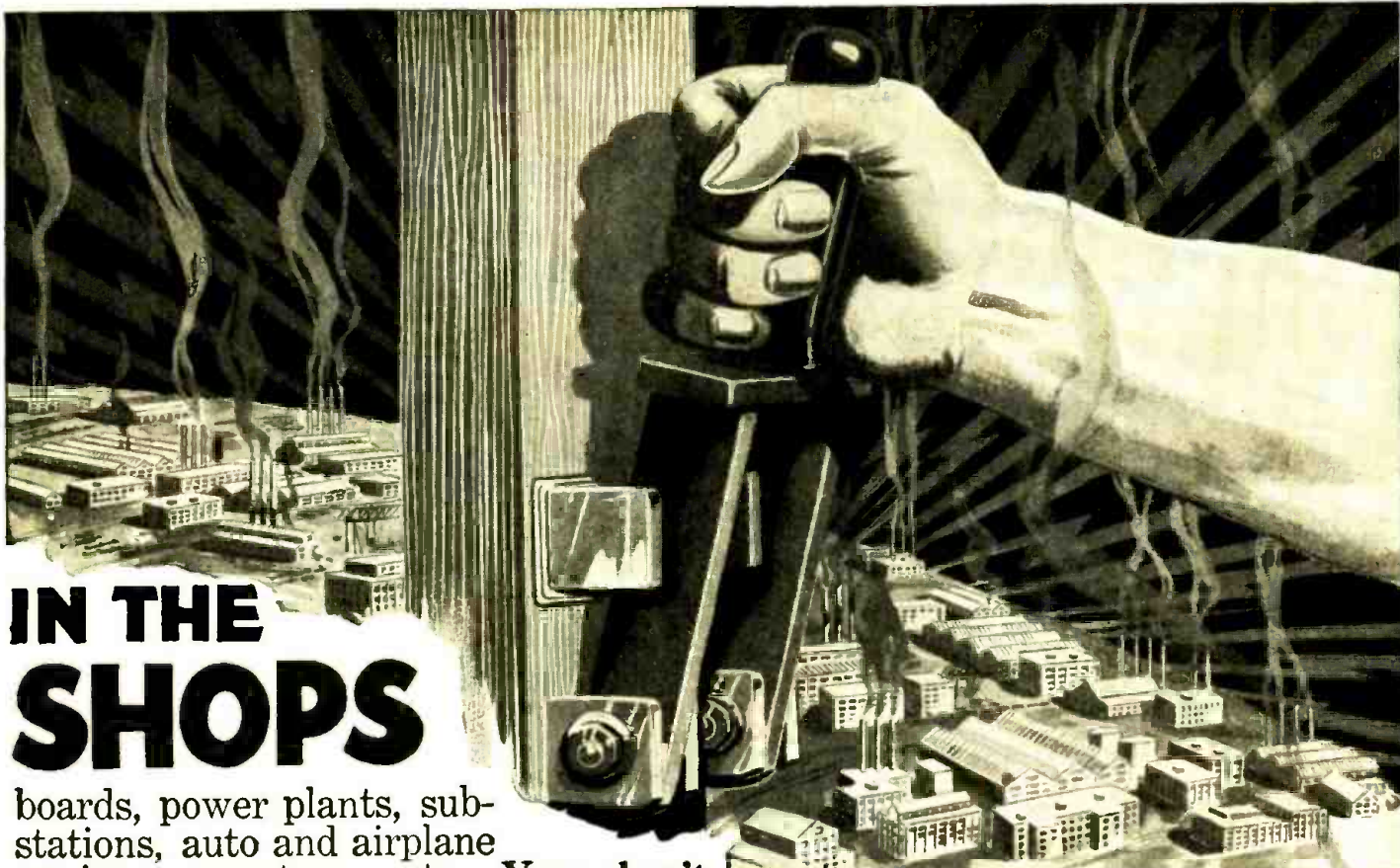

# IN THE SHOPS

boards, power plants, substations, auto and airplane engines, armatures, etc. You don't need advanced education or previous experience. Coyne has been placing men in Electrical Jobs since 1899. Let Coyne help YOU to a good electrical position!

## Free Employment Service EARN AS YOU LEARN

My Employment Department gives you a FREE lifetime Service. And if you need part-time work while at school to help pay expenses, we'll gladly help you get it.

## GET MY BIG FREE BOOK

But get the PROOF! Mail the coupon below for my BIG FREE BOOK—telling all about jobs, salaries, opportunities. Find out about my free Radio Service, Auto & Aviation Electricity offers. This costs you nothing and does not obligate you in any way. Just Mail the Coupon!

**Electrical School**  
Dept. 41-81 CHICAGO, ILL.

**MY FREE BOOK →**

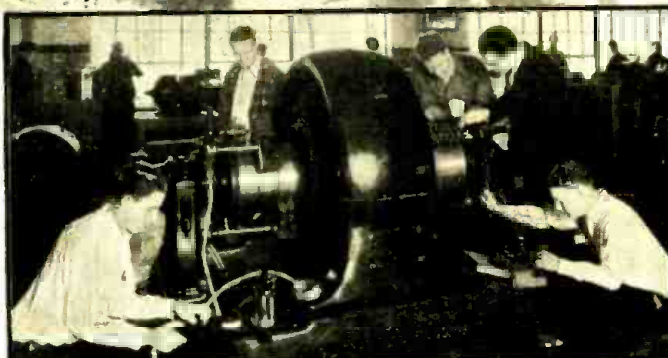

*Students working on a large synchronous Converter*

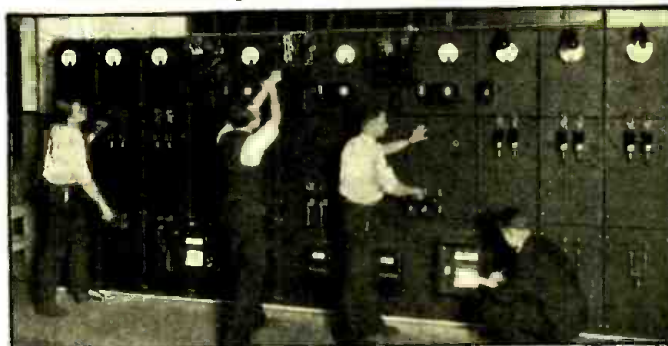

*Students learning switchboard work by actual practice*

H. C. LEWIS, President  
**COYNE ELECTRICAL SCHOOL, Dept. 41-81**  
500 S. Paulina St., Chicago, Ill.

Gentlemen: Please send me your big Free Electrical Book with 151 illustrations. This does not obligate me.

Name .....

Address .....

City ..... State .....

# THERE'S A BIG PAY For the Trained Man in **RADIO**

Dissatisfied with your job? Not making enough money? Then let me show you how to get into Radio, the liveliest, biggest money-making game on earth. **Thousands of opportunities for jobs leading to salaries of \$60 a week and up!** Jobs as Designer,

Inspector and Tester paying \$3,000 to \$10,000 a year; as Salesman and in Service and Installation work at \$45 to \$100 a week; as Operator or Manager of Broadcasting Station at \$1800 to \$5000 a year—as Wireless Operator on Ship or Airplane, as Talking Picture or Sound Expert. **Thousands of Big Pay opportunities for you to choose from!**

## LEARN RADIO TALKING PICTURES By Actual Work in Great Coyne Shops -

Come to Coyne and learn all branches of Radio in ten short, pleasant weeks. **NOT BY CORRESPONDENCE**, but by **actual work** on scores of modern Radio Receivers, huge Broadcasting equipment, the very latest Television transmitting and receiving apparatus, Talking Picture equipment, etc. **Broadcast yourself in our sound proof studio room!**

**Put on your own Television program!** Learn Radio the practical way—by **actual radio work on actual radio equipment!**

You don't need advanced education or previous experience. I don't care if you are 16 years old or 46. Come to Coyne and I'll prepare **YOU** for a good paying Radio job in **10 weeks' time!**



## TELEVISION IS NOW HERE!

And Television is already here! Soon there'll be a demand for thousands of Television experts. The man who learns Television now can make a fortune in this great new field. Get in on the ground-floor of this amazing new development! Mail coupon on the opposite page for full information—absolutely free!

**Radio Division**  
H. C. LEWIS, President **COYNE**  
**500 South Paulina Street,**



# JOB

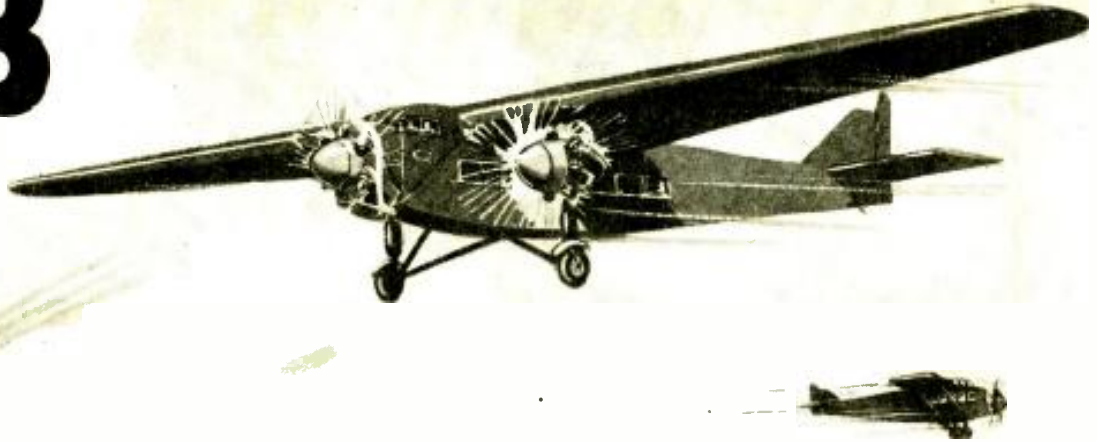

## Free Employment Service EARN AS YOU LEARN

You get free Employment Service as long as you live. And if you'll need part-time work while at school to help pay expenses, we'll gladly help you get it. Many of our students pay nearly all of their living expenses that way. Mail coupon below for full details.

# TELEVISION ♦♦ IN 10 WEEKS Not by Correspondence !!

Don't let anything keep you out of Radio! Start now, and after just ten short weeks of fascinating work in the great Coyne Radio Shops, you'll be all set for the best job and biggest pay you ever had in your life!

## Coyne is 32 Years Old!

Coyne Training is tested, proven beyond all doubt. You can find out everything absolutely free—how you can prepare for a good Radio Job or how you can go into business for yourself and earn \$3,000 to \$15,000 a year. It costs nothing to investigate!

## Mail Coupon for My Big Free Book

Fill in this coupon, tear it out and mail it to me at once. This will not obligate you in any way and positively no salesmen or agents will call on you. It will bring you—ABSOLUTELY FREE—a copy of my big Radio and Television Book, telling all about jobs, salaries, opportunities, etc. MAIL THE COUPON—NOW!

# Electrical School

Dept. 41-8H, Chicago, Illinois



H. C. LEWIS, President  
**Radio Div. Coyne Electrical School**  
500 S. Paulina St., Dept. 41-8H Chicago, Ill.

Send me your Big Free Radio Book and all details of your Special Introductory Offer. This does not obligate me in any way.

Name.....  
Address.....  
City.....State.....

# Make Your Old Radio (Electric or Battery)

## a 1931

### TONE CONTROL MODEL - IN ONE MINUTE

### with Vari-Tone TONE CONTROL

Read what two of the thousands of satisfied users have to say —

Gentlemen: I certainly want to congratulate you on the VARI-TONE Tone Control which I have been using on my 1928 model radio. I think it's just great. All my friends thought I had a new radio when they heard it. It brings out some musical notes I never was able to hear before, and it sounds so mellow and soft. It also seems to cut out some of the scratchy interference.

Several friends want me to get VARI-TONES for them. They were sold on this wonderful device from the first time I let them hear my set. All in all, I think it is the most wonderful radio contribution to people who want to bring their sets up to date that I have seen offered. Wishing you the best of success, I am, respectfully yours,

J. Frank Westerkamp,  
Bond Hill, Ohio.

Dear Sirs: I received my VARI-TONE and am very much pleased with it and every one who has tried it thinks it is a wonder. Enclosed find check for \$21.00 for which please ship 10 more at once. Yours very truly,

Donald Taylor,  
3638 So. Saginaw St.,  
Flint, Mich.



LIST PRICE, \$4.75

Your Price  
**\$2.95**

#### Have the BIG NEW Feature of 1931 Nationally Advertised Radio Without Having to Buy a New Set

Tone Control is the big, new radio feature this season on expensive radios. It is a fine thing.

People's ear-drums differ. Some folks like emphasis on bass notes. Some prefer high notes. Some like it somewhere in between these extremes.

Then, too, acoustics differ in different rooms. The same radio "sounds" better in one room than in another.

Occasionally the air may be "noisy" with high frequency interference. Such noises usually are on high frequency wave lengths.

Again, the broadcasting of certain programs or of certain stations may be a little off—too much stress perhaps on low or high notes.

Outside of regulating the volume loud, medium or soft with your set, you couldn't do much to correct these annoying conditions.

#### But Now! —

Now, merely by connecting in one minute the VARI-TONE Tone Control, with a slight turn of its knob, one way or the other, you can adjust the tone pitch to suit your ears.

You can adjust your radio to the acoustics of the room it is in.

You can "tune out" or counteract much of the "noise" in the air.

You can compensate to a considerable degree for any faulty broadcasting.

"Vary-the-Tone" of your radio to the way which suits YOUR ears and YOUR ideas of "what sounds good" in the room where you are. VARI-TONE is easily removed and carried with you to be attached on the radios of your friends.

The knob may be placed on top of your radio, or it may be permanently installed by screwing it to front panel or any other place on the cabinet. Merely remove audio amplifying tube from socket, insert VARI-TONE disc over proper prongs, re-insert the tube. That is ALL there is to it! Satisfaction or no sale! Positively cannot injure the finest radio in any way.

### RADIO AGENTS WANTED!

Write for Particulars

VARI-TONE is the newest, fastest money maker on the market. Connects in one minute. Carry in your pocket — demonstrate everywhere. Every radio owner wants his set to sound like latest 1931 Tone Control models. Low price — big profits easy. Valuable territory given — a few dollars starts you.

Send \$2.95 for sample or order C. O. D. Try it a week. Satisfaction or money back. (Lower prices in quantities.) Particulars free.

### VARI-TONE LABORATORY

Dept. 75, P. O. Box 700 • • • Cincinnati, Ohio

#### A Full Week's Trial

#### MAIL THIS COUPON TODAY

VARI-TONE LABORATORY  
Dept. 75, P. O. Box 700  
Cincinnati, Ohio

It is understood if I am not satisfied after my week's trial you will refund my money.

- Enclosed find \$2.95 for which rush one VARI-TONE (repaired).
- Rush one VARI-TONE C.O.D. I will pay price on arrival.
- Send me full particulars regarding agents' proposition.

Name .....

Address .....

Town..... State.....

“Takes the Resistance Out of Radio”

Editorial Offices, 96-98 Park Place, New York, N. Y.

## Radio Gadgets

By Hugo Gernsback

It would be most interesting, if someone of a philanthropic nature should erect a radio museum in which would be displayed all of the different radio appliances which, during the course of the years, have been put out by enterprising and hopeful manufacturers. For one thing, it would be most interesting from a historical standpoint; and, from many other standpoints, it would afford a good deal of amusement, aside from the instructive value.

Those who have had occasion to leaf through back-numbers of our radio publications, going back over a stretch of ten years or more, will be amazed at the tremendous amount of radio material that has been put out, and so much of which became obsolete very quickly. Of course, in an art that advances as rapidly as radio, this is a necessary evil; yet it is surprising how many radio accessories, that we could not do without at one time, are never heard of today. The newcomer, who is just starting in radio, often has not the slightest idea what the old gadgets were all about. A large catalog could be made of all of these obsolete items, many of which can no longer even be bought; while others, though obsolete so far as the experimenter is concerned, are built into a radio set as a regular thing. Very often it will be found that what once was an accessory, thought necessary to a radio set, is today no longer an accessory; for the manufacturer of the set builds it into the radio set as a matter of course.

Of the many gadgets that come to mind, only a few may be mentioned here.

For instance, there was the adjustable loud speaker. No one, some few years back, wanted to buy a loud speaker unless he could regulate it himself by means of an adjusting screw. Where can you buy an adjustable loud speaker today?

Then there was an epidemic of vernier dials. Fortunes were made and lost by a number of manufacturers, in just this one item alone. Yet a vernier dial today is almost obsolete, except in short-wave sets. Manufacturers of radio sets prefer to build their vernier arrangements, if they use any, right into the set.

Then we had the tube protectors, and there were a good many of these. Vacuum tubes were at that time fearfully expensive (costing as high as six and seven dollars apiece) and it was quite the thing to have a special fuse attached to every socket, to prevent the tube from blowing out, if the “B” battery should be actually shorted across the filament.

No radio set, six or seven years ago, could be sold unless it had anywhere from one to three jacks, into which you could plug in not only your loud speaker but your telephone receivers as well. We could plug into the detector circuit, if we wanted to, or into the first or second stage of the amplifier; and no set was considered complete without such gadgets. Where are the radio jacks today, and where do you plug in your telephone receiver, even if you want to, except perhaps in a few short-wave sets?

Then there was an outburst of adjustable grid leaks. A grid leak was considered so much junk unless you could adjust it to your heart's content. Dozens of manufacturers made grid leaks, from the simplest to the most complicated types, to take care of the demand. It is doubtful whether the new radio experimenter will be able to buy an adjustable grid leak today.

Then we had our tuned radio-frequency transformers. Some of the best tuned radio-frequency sets had to have tuned transformers, in order to get the last ounce of efficiency from the set. Today the tuned radio-frequency transformer is a museum attraction.

Then, for a while, we had a number of multiple tubes. The detector, radio-frequency and audio-frequency tubes were all incorporated into a single bulb. It was proposed to do away with all the other tubes in the set, and have just one. The idea did not go over, principally because of the great cost of such a tube; although it is inherently sound. I do believe that, in the future, we may have some of these multiple tubes again, provided they can be manufactured cheap enough.

At about the same time, we had a huge crop of tube rejuvenators. This was an interesting gadget; mainly for the reason that tubes were at that time very expensive and they could actually be somewhat rejuvenated by means of one of these appliances. Such electric tube rejuvenators sold from \$5.00 upwards. Go into a radio store today and ask for a tube rejuvenator; and the clerk will, most likely, not have the slightest idea of what it is all about.

Then we had the tube-howl arrestor, which was also an interesting little gadget at which we laugh, or at least smile, these days. Tubes were not as efficient then as they are today, and they were mostly microphonic. In those days it would have been impossible to manufacture a midget set; for the simple reason that the feedback of the loud speaker would have made radio reception impossible. Even five feet away from the set, a loud speaker produced enough audio feedback to start the tubes to howl. The tubes in those days were almost universally microphonic; hence the howl-arrestor gadget. It is doubtful whether there are any in the market today.

For the same reason, we had an epidemic of cushioned sockets, for these tubes; these were supposed to cure the howl evil and, incidentally, prevent filament breakage. The cushioned socket today is also an anachronism, for the reason that the modern tube no longer requires it.

Then there was the fad of wavetraps. Hundreds of thousands of these gadgets were sold; the most interesting points about them being the advertising claims, most of which were unwarranted. There was hardly a wavetraps manufacturer who did not make claims that his contraption also reduced or eliminated static. In some cases, this contention might have been true; because some of these wavetraps eliminated the signal as well, so you could hear neither static nor radio program. While there is still a limited market for wavetraps, the modern set has practically eliminated the wavetraps entirely.

What is the moral of all this? Simply that no one knows, ahead of time, what will or will not be successful in the radio art; and there is no way to find out except by the hit-and-miss system. No art can progress without this experience; and it is to be doubted that the radio industry would have achieved its present position had it not been for the activities of our inventors, big and little. There is always a market for a good gadget, and we have them today as we had them years ago. The future alone will tell which of these accessories will prevail.

# Service Men's Department

*This department is about the Service Man, for the Service Man, and largely by the Service Man. Its contributors are practical men, and we invite every Service Man in the country to tell about his own experiences of all kinds.*

Edited by JOHN F. RIDER

## TONE CONTROL?

By John F. Rider

**T**HERE has been a great deal of agitation about tone control. The principle is being discussed pro and con. Some receiver manufacturers favor its application, and others are against it.

What is tone control? What does it do? Questions of this type are heard daily.

Tone control, in the fullest sense of the word, denotes a means whereby the tone of a sound may be changed. Since the tone is a matter of pitch and, therefore, involves frequency consideration, "control of a tone" would seem to signify some means of varying the frequency. Obviously, such a procedure is impossible; but it is possible to vary the comparative amplitudes of the frequencies present in a sound, and thus to change the timbre of the tone. By increasing the amplitude of some frequencies, or the intensity of the sound, it is possible to create in the mind of the listener the same impression as if he had heard frequencies which were absent in the sounds issuing from the speaker.

While it is true that certain physiological reactions can be produced by means of a system which is of such design that the amplitudes of the frequencies can be varied, this does not signify that such a result is possible with the present-day systems of "tone control" which are employed in radio receivers. There are many reasons which indicate the need for a tone-control system; among them are the peculiarities of the human ear; the fact that the reproduction of the broadcast music must usually take place in a room which is much smaller than studios where the original music is being produced; the fact that the intensity of the reproduced music is much less than that of the original; the fact that the reproducing mechanism is far from being perfect; and several other similar considerations. However, the reader should not imagine that the average capacity-type tone control system produces such a control of the frequencies which are being passed through the audio amplifier. In short, the capacity-type, and similar simple forms of tone control, introduce distortion. Of that, there is no doubt; but the question arises, whether such distortion is or is not desired by the listener? Judging from all signs, distortion of the nature caused by the simple forms of tone control is desired by the radio public. That such a condition has been existent for a long period of time has been shown by the oft-suggested methods of producing "mellow tones."

"Mellow tones," as interpreted by the radio public, and as produced by several popular methods, means the loss of the

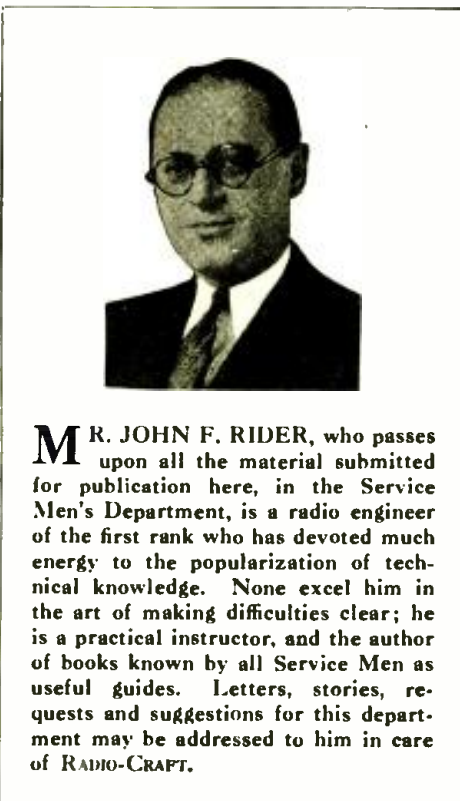

**M**R. JOHN F. RIDER, who passes upon all the material submitted for publication here, in the Service Men's Department, is a radio engineer of the first rank who has devoted much energy to the popularization of technical knowledge. None excel him in the art of making difficulties clear; he is a practical instructor, and the author of books known by all Service Men as useful guides. Letters, stories, requests and suggestions for this department may be addressed to him in care of RADIO-CRAFT.

higher audio frequencies. Anyone interested in the characteristics of speech and music will readily appreciate the significance of the high frequencies in speech and music; they mean brilliance and color in music, intelligibility and articulation in speech. But, if I do not care for the presence of the high audio frequencies in music, and I am satisfied with the speech-sounds which do not contain the frequencies above 2,000 cycles, who is there to tell me that what I hear is not what I *should* hear? Perhaps it is poor music in the ears of a music lover; but I like it just the same.

On the other hand, the introduction of the simple form of tone control defeats the efforts of that group of organizations who are true music lovers and are attempting to foster interest in musical appreciation. There is no doubt about the distortion introduced by the simple form of tone control, there is no doubt that it impairs the beauty of a symphonic orchestra—but one is tempted to ponder over the possibilities of satisfactorily reproducing a 125-piece symphonic orchestra in a living room (say, 14 x 17 feet), when the receiver is not equipped with tone control. Furthermore, one is tempted to ponder over the sensations of the average man or woman who is not a lover of symphonic music, and who would, when obliged to listen to perfect

reproduction, express an unfavorable comment. Many such individuals find pleasure in symphonic music when they can change the timbre of the complete sound. Whether or not such a viewpoint is correct, is beyond the point. The fact remains and it is glaring that the simplest of tone-control systems affords a means of satisfying the desires of the listener.

Perhaps we should qualify the last statement. The true music lovers who can appreciate good music, and whose auditory organs are such that they can appreciate the absence of certain frequencies, find no advantage in the tone control. Unfortunately, however, this group is a minority, and the majority must rule. Condemnation of the tone control is not in order. What is necessary is the design of a tone-control system which can be applied when desired, and disconnected when not desired. Of course such a system must increase the cost of a radio receiver. The design of the radio receiver without the tone control should be based along the ideal, theoretical lines, tending to produce music and speech of the highest calibre.

No one on earth can control the musical or gastronomic tastes of any other individual or, for that matter, any of the human desires. Radio manufacturers have known for a long time that the receiver-buying public has not been satisfied with the musical reproduction. It would be wonderful if all of us were music lovers; it would then be unnecessary for some of the rich men in this country to endow and finance musical organizations. The ticket sellers at concert halls greet many of their customers by the first names, because the same people come again and again. They are music lovers, but their numbers are few. We might just as well look the truth in the face; the major portion of the population desire "hot jazz" and not symphonic concerts.

The beauty of a symphonic rendition can be appreciated only when the listener is in the concert hall, or if the reproduction is of the original intensity. Musical composers attempt to create a picture in the mind of the listener. How can one visualize the march of countless men, the rumble of thunder or of cannon, and countless other images, when the intensity of the reproduction is so low as to cause the loss of many notes; and the crash of bass drums or the thunder of bass chords upon a piano sound like the flapping of wings?

It is indeed unfortunate that the majority of the listening public desire depth of low notes, and not the brilliancy of the high notes. It is also unfortunate that the zone of frequencies representative of noise includes the upper audio register. Efforts to

(Continued on page 623)

# Operating Notes for Service Men

*Hum, oscillation, irregular operation, and lack of selectivity or sensitivity have many causes; but a timely hint may save checking over a whole receiver in the shop*

By BERTRAM M. FREED

**H**UM, to an annoying extent, in the Bosch "48 A.C." chassis, may be due to one of the usual causes of such a complaint—bad tubes, an open section in a center-tapped resistor, or unmatched audio secondaries—but it has been sometimes found that the chassis has an inherent hum. At what time this condition developed does not matter; but it may be remedied by the addition of a 2-mf.

Electrical hum, in this model, may be caused by too much resistance in the hum control across the 2½-volt circuit of the heater-type tubes. This component may be removed, and one of about 15 ohms value substituted, to obtain more accurate and finer adjustment. Care should be taken to fasten this unit firmly to the chassis. An unbalanced condition of the secondary winding of the push-pull input transformer will

imperfect contact here may be a cause of much distress. Remove the gang shield, and bend the spring so that the tension on the shaft is increased.

### Phono-Radio Switches

Much time was wasted recently on a Radiola "47," and an account of the reason may save another Service Man a similar experience. This set operated correctly on the phono. side, but spasmodically on the radio side; which led to the conclusion that the trouble was in the R.F. end. Testing the parts and circuits showed a lack of screen-grid voltage on the R.F. amplifiers. The cable is hard to trace, because red and green wires lead to different components. (See Fig. 2). Finally, however, the defect was found in a badly-corroded transfer-switch prong, which made, apparently, good contact with the other terminal. The switch was carefully cleaned of the corrosion, which had acted as an insulation, and the prongs were bent to increase their tension.

A complaint, on the other hand, of spasmodic record reproduction on a Philco combination, was traced to poor contacts on the transfer switch. Care must be taken, however, not to bend the blades too far; or the elasticity and tension may be lost in this component.

A loud hum in the Radiola "67," which was not caused by any defect in the "B" supply, or any other component, was cured by placing wads of felt on the speaker cone, to prevent undue response to the 60-cycle note. This did not interfere with reproduction, and the customer was satisfied. On this model, when the local-distance switch is placed on the "local" side, the aerial is disconnected. In some localities, even with a sensitive super, reception is poor without an aerial; and the receiver will in some cases oscillate violently. In this set, the power pack is somewhat different from the

*(Continued on page 623)*

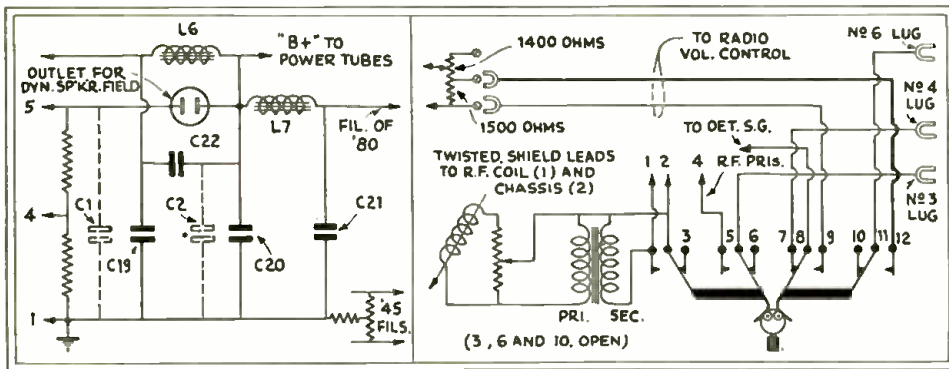

Fig. 1

Fig. 2

Left, Bosch "48 A.C." filter; right, transfer-switch and cable connections of the Radiola "47."

filter condenser, with a working rating above 300 volts, connected from one side of the speaker field's outlet to the chassis (Fig. 1). Trial will show from which side this bypass is most effective. This chassis is used in several models; the "16," "17," "18," "Jr.," etc.

Many Service Men forget the existence of the antenna aligning condenser which is located directly above the antenna and ground binding posts in the Bosch "58" and "60" series; this has a black knob for manual adjustments. Lack of sensitivity and, often, cross talk, are caused by an incorrect setting of this condenser; it should be adjusted when the receiver is tuned to 1,000 kilocycles.

### Transformer Hum

An elusive hum, in the Kolster "K43," may be caused by any of a number of defects; it must be determined whether it is due to the "B" supply, a faulty component, or is purely of a mechanical nature. Most frequently, its cause will be found in the vibration of a power transformer shield; placing the hand firmly on this shield will show whether the hum is due to it. If so, and no objection is made, the shield may be discarded; it is removed by straightening the lugs which hold it and pulling it out. Otherwise, the space between the transformer and the shield may be packed firmly with soft paper and the shield fitted back in position. The air space, which formerly amplified the hum from the transformer, is now occupied by the stuffing, and the vibration is greatly dampened.

result in hum which can be remedied only by replacement. All terminals of the power pack must be securely fastened down.

A cause of oscillation, in the Bosch "48," and certain Eveready models, is improper position of the variometer rotor, which should work with the condenser gang to provide equal sensitivity and stability over the whole tuning scale. When the latter is at 0, the rotor of the variometer should be at right angles to the stator. To align the rotor, loosen the two nuts which hold the variometer to the chassis, and adjust it. When replacing it in position, be certain that both sets of the insulating washers are in position between the frame of the variometer and the chassis. During the operation, and before the unit is fastened in place, it will not be amiss to bend the contact spring on the rotor to give better contact; for

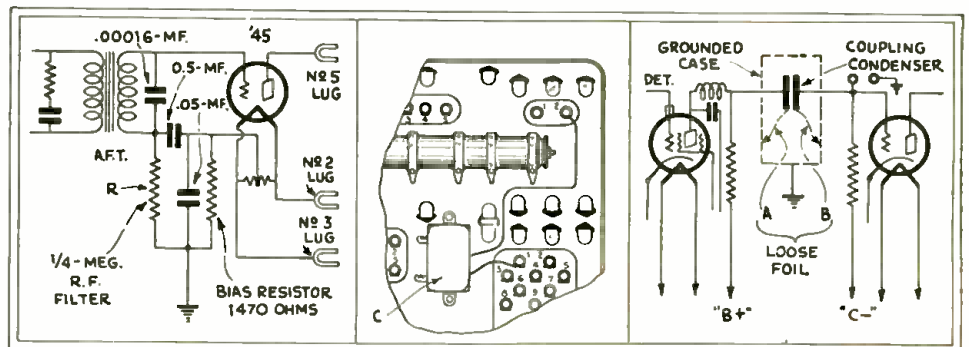

Fig. 3

Fig. 4

Fig. 5

Left, output of the Radiola "66"; center, an addition to early numbers of the Victor "RE-45" to reduce hum; right, a sensitive point in resistance-capacity coupling, as in the new Zenith "10," "11" and "12" (the latter not the old models similarly numbered.)

# Leaves from Service Men's Note Books

The "Meat" of what our professionals have learned by their own practical experiences of many years

By RADIO-CRAFT READERS

## NOISE IN A S.-M. SET

By James H. Mills

ONE of the Silver-Marshall sets was very noisy; this was traced, after several hours of testing, to the dial. By shaking the dial knob on the set, there was produced in the speaker noise which suggested a broken or loose connection somewhere in the set. I removed the chassis and found a filter condenser mounted and grounded to the base of the dial. In ninety-nine cases out of a hundred, this would be all right; but here was the hundredth, and it caused all the trouble. It is true that the dial was grounded; but only through a rolling contact, which was the noise producer. A wire direct from the filter can to the chassis cured the trouble.

## KYLECTRON "K-70"

By A. S. Cook

ABOUT 75% of the Kylectron "K-70" sets, manufactured by the United Reproducers Corp., which I have been called upon to service, have been troubled with a short in the .08-mf. condenser coupling the first A.F. '27 with the grids of the '45 tubes. When a replacement condenser is lacking, a speedy and oftentimes permanent repair can be effected by utilizing the unused primary of the push-pull transformer, the secondary of which acts as a grid coupling choke.

To do this, remove the defective condenser from the circuit, and break the plate connection of the '27 tube at the 20,000-ohm resistor. Then, connect one end of the unused primary to the plate and the other end to this resistor.

Many of my customers have said that this method of coupling the circuits gives

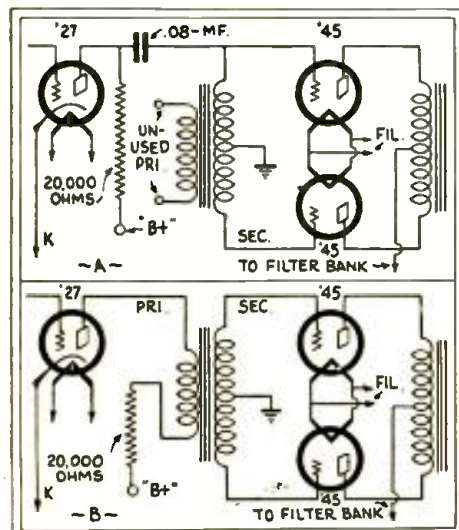

The resistance-impedance coupling in the Kylectron uses a push-pull transformer's secondary as a choke. A repair restores the original purpose of the transformer's primary.

a better tone to the set. Personally, I cannot tell any difference; but who am I to disagree with the customer?

## REVAMPING A.C. RADIOLAS

By John J. Nothelfer

FROM this method of improving the tone quality of Radiola "17," "18" and "33" receivers, I have had excellent results for many customers. Two changes in these receivers will result in greater tone quality and lessened hum.

The first is to install a 2,000-ohm resistor in series between the cathode of the detector tube and the ground or "B—" of the set; this resistance should be shunted by a 1-mf. condenser. The plate feed for the detector is taken off the 45-volt tap and put on the 100-volt connection of the voltage divider along with the plate supply of the R.F. tubes. This method will result in semi-power detection; although sensitivity is lowered, the tone quality will more than make up for this.

The second step is to take out the first audio-frequency socket and replace it with one of the UY type; the filament prongs of which are then wired to the detector filament connections. The cathode of this tube also should be wired with a resistor, say 2,000 ohms, and shunted in like manner to the detector.

This procedure may apply to any receivers designed along similar lines.

The advantage of changing the '26 to '27-type tube, in the first A.F. stage, is that the hum will be quite noticeably reduced.

## REPAIRING RADIOLA 25s

By J. J. Stancil

SINCE there are a number of the old R.C.A. "Model 25" supers scattered around, and since it has not been deemed practical for the average Service Man to open up the catacomb when any part of its interior goes wrong, I feel that some of my experiences with these might be worth noting.

I have found, quite often, that one of the A.F. transformers gives way—especially the primary of the last transformer. Some of the people who have lived with and enjoyed these old sets do not care to part with them; so I have replaced the audio transformers. The following applies, in this instance, to the last A.F. transformer but works equally well with the interstage one.

I took an R.C.A. audio transformer (ratio 3½-1) and, after cutting a hole through the front side of the catacomb can, directly in front of the last A.F. tube, I could readily solder the grid wire of the transformer to the grid terminal of this tube. I then connected the other secondary wire of the transformer to terminal No. 6 on the catswhisker back of the catacomb.

I then took a .002-mf. condenser; soldered

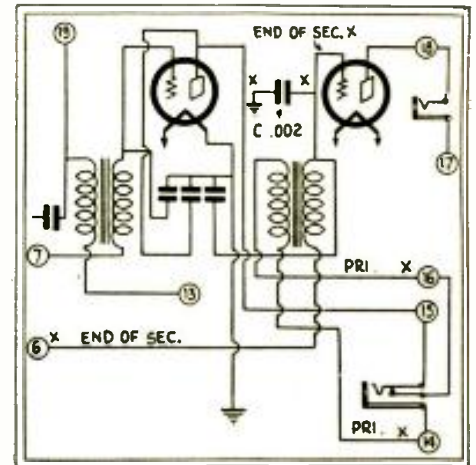

The Radiola "Model 25" is still popular with many users; transformer replacements may be made externally. The connections of the "cat" are shown in Data Sheet 16 (April, 1930, RADIO-CRAFT).

one terminal of it to the catacomb can and connected the other terminal to the grid end of the secondary of the transformer, in place of the condenser connected in this circuit inside of the catacomb. I connected one of the primary wires of the transformer to terminal No. 14 of the terminal strip, back of the catacomb, and the other primary to No. 16 terminal. After making the above connections, I bolted the transformer in an external position on the oval metal frame holding the catacomb, in a position as near to the original one in the catacomb as I could. The set worked fine and there was no drop-off from volume or general efficiency that I could discern.

The points marked X are the ones to which I made connections as indicated. I have replaced both the A.F. transformers in like manner in different receivers. The first transformer would, of course, be connected to different terminals on the catacomb; but these are readily found by checking up on the terminal strip.

## THE OHMIC SERVICE MAN—AND ZENITH SETS

By J. Rubenstein

WE often wonder, after the explanation has occurred to us, why we failed to find the seemingly obvious solution of a problem for so long a time.

I was recently called to repair a Zenith "De Luxe A.C."—a big eleven-tube job—and found on the detector plate an intermittent voltage which indicated poor contact or a loose connection. The trouble was finally traced to the plate resistor of that tube. The value of that resistor is 100,000 ohms; so, setting my Weston "547" tester to the high-resistance reading, I placed the prods on the resistor and watched. A reading of approximately 100,000 ohms was noted; and a second reading confirmed the first.

I then traced the circuit, but everything tested O. K.; I came round to the resistor and tried it again, but this time the meter didn't budge. Rechecked; same result.

A glance at the test prods, and the solution came to my mind; I verified my suspicion. I had inadvertently placed my fingers on the metal portions of the prods, and the meter recorded *the resistance through my body!*

In the same set, what appears to be a resistor cartridge near the detector plate is a bypass condenser for the latter. Also, a lot of noise, similar to static, was traced to corroded contacts in the pilot-light socket. The latter, in this set, is of the automobile type, using a 6-volt, 3-cp. bulb.

In a Zenith "33X" a bad hum, when the volume control was turned down, was traced to excessive voltage on the plate of the detector. This should not be greater than 45; the former reading was 54.

### "LOW VOLUME"

By Ruford W. Watson

OF all the problems that face the radio Service Man, the problem of low volume is perhaps the most perplexing, that is after the tubes and antenna installation check okay. The lack of ability to get the

stations "that we used to get every night" may be traceable to any one of a thousand things, ranging all the way from weak batteries to an audio transformer that is almost ready to kick off.

In one Crosley "Bandbox," the lack of wonted sensitivity was traced to the condition of the condenser gang. The set was several years old and had seen much service; the rotors are supported by only one bearing, and wear had thrown them out of alignment until the plates touched in spots as the dial was turned.

Corrosion in the condenser gang of an Atwater Kent electric caused the set to be weak, and extremely noisy when the tuning dial was rotated.

About the only thorough way, of correcting such troubles, is to completely dismantle the gang; while this work is being done it is well to make sure that the volume control is in quiet operating condition. The shaft of the volume control in a Crosley electric "Bandbox" was found so badly corroded that the set would not function properly. A little emery cloth corrected this difficulty.

Reducing the resistance of the grid suppressors in another set—a Zenith—that lacked "pep" solved another problem of low volume.

In certain Apex models the low-potential

end of the grid-bias resistor is grounded to the "Gnd" post of the set. In one case of low volume and intermittent operation, my client informed me that pressing firmly against the "Gnd" post oftentimes restored the set to normal operating condition. He surmised that the ground connection within the set was bad; the tone quality of the set led me to an entirely different conclusion, which was that of improper grid bias for the 45's. My Jewell analyzer confirmed my suspicion, and within ten minutes the set was in normal condition.

Sometimes I come upon a job that has been badly bungled by someone who professes to be a radio technician, but doesn't seem to realize that radio practice will not tolerate the use of acid in soldering.

As an example of the possible great extent of the damage, and the unexpected nature of the effects, I was once called upon to check up on trouble in an Apex screen-grid set. The dealer who sold the set, and who was having the service work done, informed me that the indications were that it was power-pack trouble. I found the voltages all low and fluctuating. Continuity tests for shorted condensers in the power-pack and by-pass condensers acquitted these parts, which were in good condition. There

(Continued on page 624)

# The Service Man's Open Forum

*His Opinions on Conditions and Practices in the Radio Business*

## SERVICING FOR PROFIT

Editor, RADIO-CRAFT:

I look forward with pleasure to the coming of each new issue of your helpful magazine.

I have been connected with radio since days of the old spark sets and loose couplers. Let me say, that I have subscribed or bought from news stands, practically all of the leading radio publications and, up to date, I think I get more genuine help from this paper than all the others combined.

I am service manager for one of the largest music houses in Nebraska and, of course, have my ups and downs in the routine of service work. The shop is very complete, with all necessary equipment such as test panels, tube checkers, oscillators and analyzers. Radio servicing is a business with our firm, and was installed as a means of making money and keeping our customers satisfied, not as a necessary evil.

Our line of sets are the Majestic, Atwater-Kent, R.C.A. and Victor, and we service all new sets free for the first thirty days and guarantee the tubes for six months; but we do not believe in free service. The public know that they will not receive anything for nothing; so why kid them to believing that they might? The satisfied customer pays his hard-earned money for service and, if the machine is not satisfactory with him, he has room to complain and the business man can afford to make it right. He is being paid for it.

I notice a good many comments on the midget receivers. In our part of the country, the midget has not cut a very big figure.

Only the people, who could not otherwise own a radio, buy them; and we use the midget radio as a football to roll our customer to higher-class merchandise. I think



A typical example of the arresting advertisements which have caused so much comment in recent letters to the Open Forum. Obviously, the purpose is introductory; some Service Men have even advertised free first calls for the purpose.

that the midget radio, used the proper way, will make the dealer money.

I have a suggestion to make for the boys who are installing the automobile type of radio. The majority of autos that are being equipped with radios, are the larger types; many have two wire wheels in fender wells on the side. By slipping insulating materials between the metal supports that hold the wheels in place, and drilling two small holes about one-eighth of an inch in diameter in the running board of a car, it is possible to connect the wheels in series and gives the

automobile plenty of unshielded aerial; the wheel, being mounted on rubber, gives the aerial plenty of insulation.

On my own car it was only necessary to put one piece of inner tube under each of the tire-lock arms, to completely insulate the wheels from the rest of the metal body; and this system works very well, besides eliminating plates and excess wire. The valve-lock nuts can be used for a connecting link.

EVERETT A. SIEMAN,  
Gaston Music & Furniture Co.,  
Hastings, Nebraska.

## ESPRIT DE CORPS

Editor, RADIO-CRAFT:

In all probability, Mr. R. Douglas Clerk can handle that "Skeptical Bunch" in just as short order as he serviced (?) those receivers. I believe, however, that there are two sarcastic replies from Maine and Iowa that could just as well have been left unsaid. If some of these Service Men had other things to do except find fault with a brother Service Man and his methods, I frankly believe there would be more harmony and less friction among us.

'Tis well said, "United we stand, divided we fall," and so be it. Fellows, let's pull together and we will win!

I have been a Radio Service Man since the days when helping a fellow put that "Catwhisker" on "The Spot" was all in the day's work. With stacks and mgodly piles of magazines, and books now more or less obsolete, not to mention those unrecorded hours of circuit experimentations to

(Continued on page 628)

ERLA MODEL 224 A.C. SCREEN-GRID RECEIVER

This receiver is manufactured by Electrical Research Laboratories, Inc., Chicago, Ill. The following values are used in this circuit:

Condensers C1, C2, C3, C4 are the tuning capacities; C5, C15, 0.5-mf.; C6, C7, C8, C12, C13, 0.25-mf.; C9, C10, .001-mf.; C11, C19, 1. mf.; C14, 0.1-mf.; C16, C17, 2 mf.; C18, 3 mf.

Resistors R1, R6, R7, 70,000 ohms; R2, 5,600 ohms; R3, R12, 6,000 ohms; R4, 80 ohms; R5, R8, 100,000 ohms; R9, 1,000 ohms; R10, R11, 10,000 ohms; R13, R14, 20 ohms.

Average current readings for this set are as follows: filament potentials: V1, V2, V3, V4, V5, 2.4 volts; V6, V7, 2.5 volts; V8, 5 volts. Plate potentials: V1, V2, V3, 175 volts; V4, 70 volts; V5, 95 volts; V6, V7, 245 volts; V8, 350 volts. Screen-grid potentials: V1, V2, V3, 80 volts. Ground-to-cathode: V1, V2, V3, 1.5 to 2 volts; V4, 6 to 7.5 volts; V5, 4.5 volts. Grid-to-filament, V6, V7, 50 volts.

This chassis is well shielded and normally does not oscillate. However, if a tube shield is left off, or if the aerial lead is allowed to dangle in around the tubes or control-grid leads, oscillation may occur. If the bottom shield of the chassis is removed, oscillation is generally encountered. It is likewise important that the ground and the aerial leads be connected as oscillation may occur if these are left unconnected. It is also important that all the shielding, particularly on the gang condenser, be in place and fastened securely. Changing the screen-grid tubes around may correct oscillation or tendency to motorboat.

Considerable heat and loud humming of the transformer should be investigated for short circuits across one of the windings of the transformer. A piece of wire or solder may have become loose, or the insulation of one of the leads may have been cut through, and short-circuited one or more of the transformer's windings. In any of these cases, if the transformer has not been allowed to remain in this short-circuited condition too long, correction of the short or separation of the shorted leads and the insertion of new leads will correct this and, usually, the transformer will again operate satisfactorily.

If the switch leads of the "high-low" voltage switch become shorted, considerable heating and danger to the power transformer will result. If one of the plates of the '80 should become quite red and its filament bright, whereas the other filament and plate are comparatively cool, the trouble is due to improper connection of the high-voltage winding to the plates of the '80 tube. Voltage tests will generally show a considerably higher reading on one plate than on the other. This is due to the connection

of the tap on this winding to one plate, instead of the tap's being connected to its proper circuit connection. Filter chokes of this power-supply unit generally will give very little trouble; however, if either should be shorted, a considerable increase of hum, as well as abnormally high plate voltages, will result. An open circuit of either choke coil will result in absence of voltage across this coil, as well as the circuits to which it supplies. The filter condenser used in the power supply is considerably oversized, and there should be very few cases of breakdown of these units. Excessive hum may be due to an open resistor, which will require replacement.

The volume control-and-switch combination is a particularly rugged unit; the resistor being rated considerably above its operating value. The possible troubles from this unit are an open circuit, due to cutting of the resistor wire, or improper operation of the phono-radio switch. The cutting may be caused by hitting with a sharp tool or the like. Care should be exercised in working on this unit, in order not to injure the resistor element. If this resistor is open at one end, there will be no control of volume on weak or strong signals. This, of course, should not be confused with the somewhat abrupt variation of control when attempting to control strong local volume in the "distance" switch position. If this resistor is open at the other end, there will be no signals received, since no voltage is then impressed on the screens of the screen-grid tubes. A check for either of these conditions may be made by connecting a voltmeter from the screen to the cathode; and varying the volume control should show variation of the screen-grid voltage.

If the single-pole switch, governed by the shaft of this control does not operate, when the control is turned toward the extreme left in the "off radio and on phono" position, no phonograph operation will be had. An examination of this switch will generally reveal either condition, and the method of its correction by re-adjustment. A little roughness in the volume control will be overcome by applying a touch of light oil with the finger tips across the resistor element. It should be noted that the shaft and body of this control must be insulated from the chassis frame.

Distorted signals may be due to poor '27's or '45's, but there are a number of other possible causes of this trouble. Low "B" voltages resulting from a defective '80 will, of course, cause distortion. If the distortion is due to rattles in the speaker, this may be defined by substituting another speaker. Generally a speaker which rattles will have its moving coil rubbing on the center pole-piece. This can

generally be felt, by slightly pressing the diaphragm in and out, and noting whether any rubbing exists. Another cause of distortion, which is generally very bad, is caused by either reversed connections in the speaker transformer or by an open or shorted connection at this point. Open grid-biasing resistors, or shorted bias condensers in the first audio or push-pull stage will result in distortion and increase in the hum level. An open field connection will also result in distortion and weak signals. Voltage readings across the field connections will be abnormal and, also, no magnetic pull will be felt on touching an iron or steel tool to the center pole-piece. An open winding on one side of the push-pull transformer will also result in some distortion, principally on strong signals; this latter condition will bring about some increase in the hum level.

The field coil of the reproducer in this receiver has a resistance of 1,000 ohms and is designed to carry 100 milliamperes.

Mounted on top of the condenser shield is the pilot lamp and receptacle. On looking at the front side of the condenser shield, the four aligning condenser adjusting nuts will be seen; these serve to align the tuned stages, and seldom require readjustment. To make adjustments in the alignment of the tuning condenser, the receiver must first be removed from the cabinet and connected up on a bench with antenna and ground as for receiving. By looking to the left of the tuning dial, four holes will be seen along the shield can of the tuning condensers. Through three holes can be seen four hexagonal nuts, which are to be adjusted for aligning the tuning condenser. Any wrench which will fit these nuts whether insulated or not may be used. Proceed as follows, to align the circuits: Tune in an oscillator signal between 220 and 240 meters; use an indicating meter. Set the "local-distance" switch on the "distance" position. Turn down the volume control until station can just be heard. With the No. 4 Spintite wrench turn the adjusting nut (nearest the tuning dial) first to the right and then to the left. If this section of the tuning condenser is properly aligned, the signal will get weaker whichever way the nut is turned; however, adjust for strongest signal. Follow this procedure with the remaining circuits.

It is important that the proper polarity in connecting the pick-up leads to the chassis be observed. One jack is marked "R," meaning red or grid side of cord; and the other is marked "B," for the ground side of cord. Connection to the incorrect terminals may result in hum, or lack of phonograph volume.

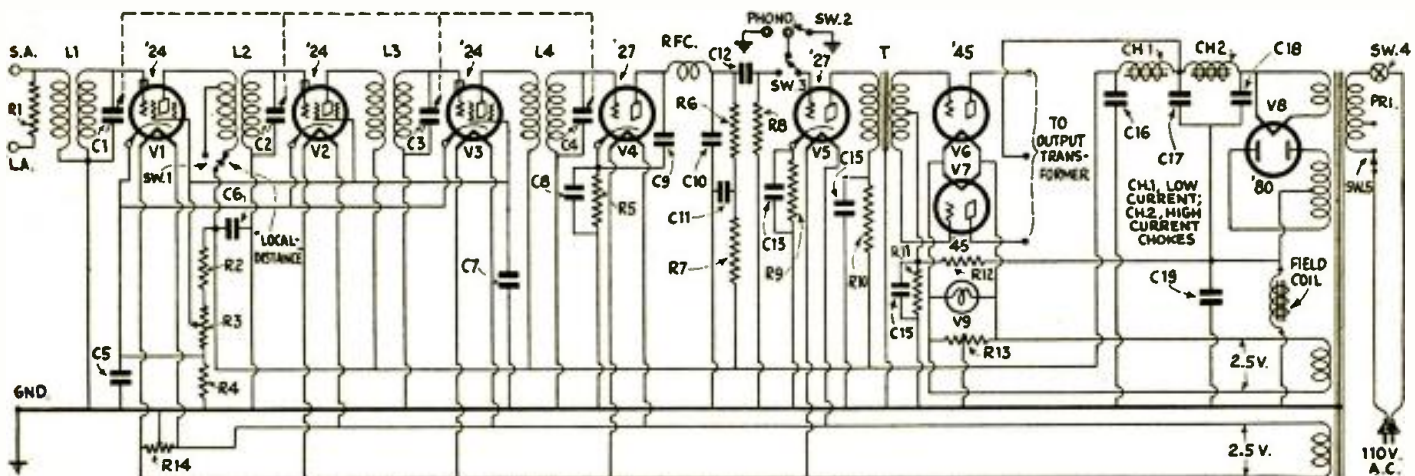

Schematic circuit of the Earl "Model 224 A.C." screen-grid receiver. Note that the field coil of the reproducer is in series with the "B-" lead of the power pack; and the phonograph pick-up connects to the input of the first audio tube, V5. A novel "local-distance" switch, SW1, is part of the design.



BOSCH MODEL 60 VOLUME-CONTROL RECEIVER

This receiver, the "Model 60" chassis with automatic volume control, is manufactured by the American Bosch Magneto Corp., Springfield, Mass.; the following parts values are used:

Condensers C1, C2, C3, C4, C5 are the usual tuning capacities; C6, an antenna trimmer; C7, C11, C14, .04-mf.; C8, C10, .25-mf.; C9, C12, C13, C17, 0.5-mf.; C15, C20, C26, .006-mf.; C16, 1.0 mf.; C18, C19, .0001-mf.; C21, C22, C27, 2 mf.; C23, C24, 4 mf.; C25, 0.75-mf. (exact).

Resistors R1, 500 ohms; R2, R4, R6, R8, R9, 1,000 ohms; R3, R11, R12, R13, R26, 1/2-meg.; R5, 20,000 ohms; R7, 10,000 ohms; R10, R28, 50,000 ohms; R16, 900 ohms; R17, R19, 5,000 ohms; R18, 25,000 ohms; R20, R21, 2,000 ohms; R22, 1,300 ohms; R23, 2,380 ohms; R24, 160 ohms; R25, 950 ohms.

The "Model 60" and the "Model 58" are very similar in general arrangement. The "60," however, is equipped with automatic volume control, a "mute" switch, and a larger reproducer. On the side of the cabinet is the tone control. In addition to the tubes required for the "58," the "60" requires a type '24 tube for the volume control, V8. An automatic "radio-phono" switch is operated by simply turning the tuning dial to zero. The "Model 61" corresponds to the "60," but is designed for use on 25-cycle, 100 to 130 volt A.C. supply. The chassis is the same, and the power pack differs only in the power transformer and filter condensers. Letters D and E refer only to the style of cabinet.

Lack of sensitivity may be due to incorrect connection of the three leads to the "local-distance" switch. It may be advisable, in some localities, to operate the set without a ground connection. Check the alignment of the tuning condensers.

Poor tone quality may be due to a defective '45 (which is ionized). Check also the remaining tubes in the receiver. If the plate currents of the type '45 tubes differ more than 5 ma., the output transformer will be overloaded and some distortion will result.

Operating voltages for this receiver follow: Filament potentials; V1, V2, V6, V7, 2.4 volts; V3, V4, V5, V8, 2.3 volts; V9, 5.0 volts. Plate potentials; V1, 170 volts; V2, 180 volts; V3, 185 volts; V4, 60 volts; V5, 150 volts; V6, V7, 250 volts; V8, 30 volts. Screen-grid potentials; V1, 70 volts; V2, 80 volts; V3, 85 volts; V4, 10 volts; V8, 20 volts. Control-grid potentials; V1, V2, 2.0 volts; V3, 1.5 volts; V4, 1.0 volt; V5, 0.1-volt; V6, V7, 50 volts; V8, 0.2-volt. Plate currents; V1, V2, 3 ma.; V3, 2 ma.; V4, 0.1-ma.; V5, 6 ma.; V6, V7, 30 ma.; V8, 0.2-ma.

The condenser drive-belt consists of a heavy stranded phosphor-bronze cable having a small loop at each end. Correct tension is maintained by means of a spring. After replacing the belt it is necessary to reset the dial; to do which, loosen the small gear on the knob shaft. Turn the shaft to the left as far as it will go. Set the dial against the stop at "100" position, and re-tighten the small gear. The procedure in replacing the belt is as follows: turn the condensers to the position of minimum capacity. Place the loop at one end of the drive-cable over the pin at the top right hand side of the large drive drum. Lead the belt along the groove and downward to the small grooved drum. Turn the condenser gear to the "100" position (condenser fully engaged). Start the belt at the center groove of the small drum and wind on 6 1/2 turns in a clockwise direction (to the right), toward the front of the receiver. Bring the belt up and over the idler pulley. Follow down the groove of the large drum and hook the loop over the drum's tension spring. The spring can most easily be pulled into the correct position by looping a length of wire or strong cord around the spring hook.

The field coil of the dynamic reproducer has a resistance of 2,000 ohms; and the voice coil, one of 10 ohms. A copper shield ring over the core prevents feed back between voice and field coils and the "B" supply. The only adjustment consists in centering the moving coil in the air gap. Do this as follows: loosen the holding screw. Insert in the air gap, around the moving coil, four gauges made of paper strips 0.01-in. thick. The strips should be about 6 in. long and 3/16-in. wide. Retighten the screw and remove the gauges. The connections to the reproducer are made at the terminal strip located under the name plate. The red and brown leads run to the voice coil; and the black lead to a terminal.

On the "Model 60" is a meter M which may be used in aligning the tuned stages. The meter will swing to the right as alignment is reached.

A grounding spring on one of the tuning condensers, in the third R.F. stage, grounds this condenser in the "phono" position, or dial zero setting, and in this position prevents circuit oscillation.

The operation of the automatic volume control circuit is as follows: When the signal being received increases in volume (as in tuning in a more powerful station) it results in a higher signal voltage on the detector tube. This higher voltage is applied to the grid of the automatic volume-control tube, by direct connection through one lead. A higher voltage on the grid of the automatic volume-control tube results

in the tube drawing greater plate current through R3, which controls the grid bias on the first and second R.F. tubes. The increased plate current through R3 causes a greater increase in the voltage drop across this resistor. This change increases grid bias on the first and second R.F. tubes and thereby cuts down the signal. The tuning meter M is in the plate circuit of these two tubes; it also indicates, therefore, the action of the automatic volume control, swinging further to the right (low plate current) as the signal level rises on a powerful station. It will be noted that the filament, cathode, and grid circuits on the first two R.F. stages are separate from those of the rest of the receiver, and are at approximately the same voltage (above ground) as the plate of the automatic volume control tube.

It is necessary, for the proper functioning of the receiver, that there shall be no points in the coils or wiring where leakage to ground may occur. It is also important, for proper operation, that the automatic volume-control tube should have proper characteristics. Such a tube can easily be selected as follows: have all the tubes in place except the automatic volume control, and switch the receiver "on"; but do not tune in a station. If the tubes are all operative, the meter needle will swing to the left from 3 1/2 to 5 divisions. Insert the automatic volume-control tube, V8, and note the action of the needle. The automatic volume-control tube tested is suitable if the needle remains in the same position.

The various resistors in the receiver have the following color code: 250 ohms, white; 500 ohms, yellow; 900 ohms, black-brown; 1,000 ohms, white-red; 2,000 ohms, brown-yellow; 5,000 ohms, black-yellow; 10,000 ohms, blue-yellow; 20,000 ohms, green-yellow; 25,000 ohms, blue; 50,000 ohms, green-white; 0.1-meg., blue-white; 0.25-meg., brown; 1.0 megohm, black; 2 megohms, black-white.

R.F. transformer L3 is untuned, and signal amplification through this stage increases in the low-frequency region (100 on the dial). The antenna input system is so designed that one setting of the antenna trimmer condenser C6 will maintain the antenna in tune over the entire broadcast band. This condenser is provided with a small adjusting knob, and need be set only when it is installed or when subsequent changes are made in the aerial. It is recommended that this condenser be adjusted in the following manner: tune in a semi-distant station which comes in at some point between 40 and 60 on the dial. Reduce the volume until the station can barely be heard; then turn the adjustment knob until it is at the point of loudest reception.

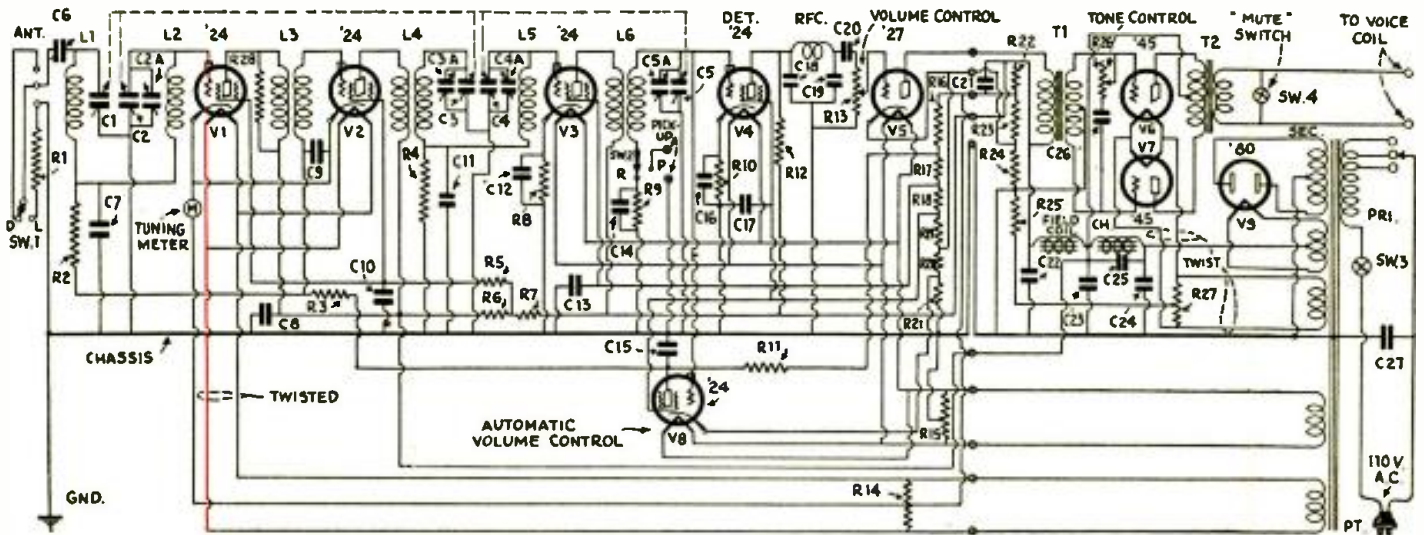

# Favorite Testing Equipment of Service Men

*And methods for its use to the best advantage in and out of the shop*

## ANALYZER AND TOOL KIT

By H. Harrison and W. Green

**T**HE test analyzer described embodies features which have always been desired in any instrument built for service work: (1) low cost; (2) simplicity of design; (3) accuracy of measurements; (4) ruggedness of the complete unit. It is needless to add that the kit is capable of testing anything from old battery models to the latest screen-grid receivers.

The total cost is extremely low; approximately \$25.00, including the carrying case, panel, two Jewell meters, and all other parts. The diagram is of very simple design, toggle switches being used to obtain the various meter readings instead of the usual push-button or bi-polar arrangements. Accuracy was found to be within 1% limits, after competitive tests with commercial instruments had been made.

The carrying case is ideally suited for service use. There are two large compartments for tubes and tools. A dozen tubes may be easily carried in the tube compartment. In the tool drawer may be placed the pliers, screwdrivers, soldering irons, replacement parts, and other usual service aids. The over-all height of the carrying case is 16.5 inches; the width and depth are 12 and 7 inches respectively. The total weight with all accessories is 18 pounds; the analyzer itself is only 8 pounds.

### Finding Resistor Values

Two Jewell meters are used to obtain the necessary test readings. They are an 0-1 milliammeter, and a 0-3-15-150 triple-range A.C. voltmeter. Since a 0-1 milliammeter is used for all direct-current measurements, it is a very simple matter to calculate the resistors necessary to convert the meter into a voltmeter of various readings. It is needful to multiply the full-scale voltage wanted by 1,000, to get the size of the resistor directly in ohms. For example—the resistance necessary for a 0-100-volt scale is 100,000 ohms.

Be sure to use accurate resistors, since the accuracy of the meter readings depends upon the resistances. Such resistors are made by various manufacturers and are very easy to procure.

To find the resistance value of the shunts

used for the 10- and 100-milliamperere scales, it is necessary to know the internal resistance of the milliammeter. In this particular case a Jewell "Pattern 88" was used. The shunts for this meter are 3 1/3 ohms for the 10-mill. scale, and 0.3-ohm for the 100-mill. scale. The internal resistance of the meter is 30 ohms. If other types of milliammeter are used, it is necessary to divide the internal resistance of the meter by the full-current reading desired *less one*. For example: if a Weston No. 301 is used, and the 10-ma. range is wanted, divide the internal resistance of 27 ohms, by 10, (current range desired) less one or 9. The shunt in this case is 3 ohms.

### Resistance and Capacity Tests

Resistance and capacity tests are now important features of every testing device. In this analyzer, a 4.5-volt battery, in series with a 1,500-ohm resistor and the milliammeter, is used to test unknown resistances. The same test can be used to test continuity and short circuits. For measuring resistances, the following formula is used:

$$R_x + R = E/I.$$

E is the battery voltage; I is the current reading obtained when testing; R is the resistance in circuit; and  $R_x$  the resistor under test.

Assume a current reading of 0.6 on the milliammeter; this equals .0006-ampere (all values must be expressed in terms of volts,

amperes, and ohms). Substituting in the equation given above: we find that  $R_x$  plus 4,500 equals 4.5 divided by .0006, which is

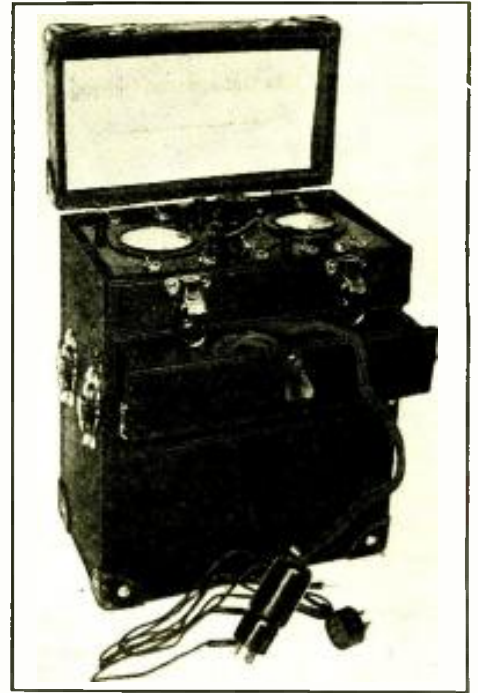

The finished tool kit, with analyzer above, and compartments for tubes and tools.

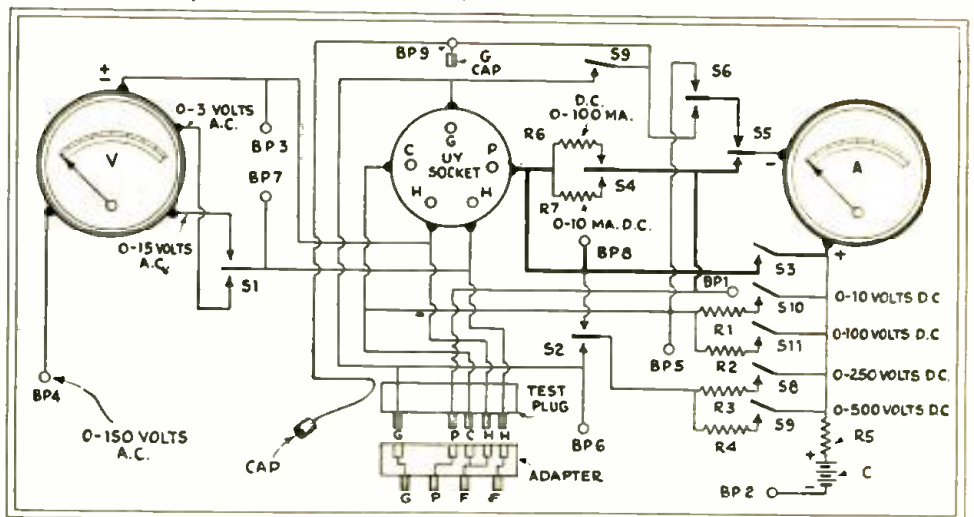

Fig. 1 (above)

The schematic circuit of the analyzer, in which two good meters are used, together with shunts and series resistors which make possible a very wide range of tests on tubes and circuits.

Fig. 2 (left)

The appearance of the panel, showing the relative positions of the meters, socket, toggle switches and binding posts. With a little practice, readings can be taken very rapidly.

7,500. Since  $R_x$  plus 4,500 equals 7,500, therefore  $R_x$  is 3,000 ohms. The capacity of condensers may be determined from previous calibration. The 120-volt A.C. line, in series with the 150-volt meter and the condenser under test, will give readings depending on the capacity under test. A graph or chart is drawn, after standard condensers have been tested to obtain the readings. Be sure that the line-voltage is always the same when testing; for the readings will vary if the line-voltage is different, and the graph will be of no use.

Having computed the resistances and shunts for the voltage and current scales, we can now proceed with the actual con-

(Continued on page 625)

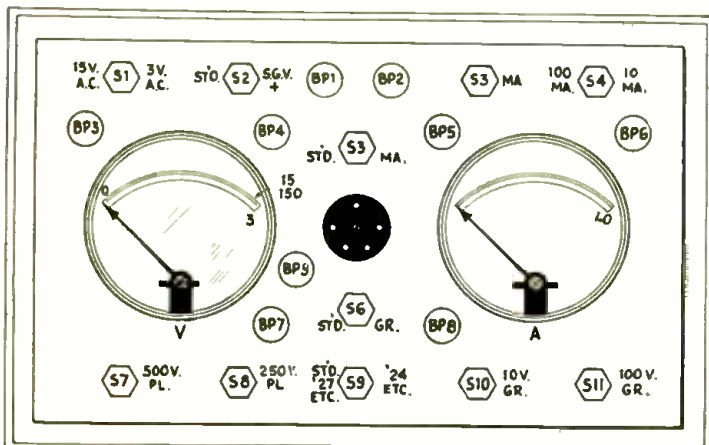

# A Modern Single-Meter Tube Checker

*The circuit and arrangement of a new instrument, designed by a maker of precision testing equipment, for use of dealers and Service Men*

By H. G. CISIN

SOME men get along splendidly during boom periods but, at the first sign of a depression, they give up in despair and fade out of the business picture. Others refuse to accept defeat and, when times are bad, they expend extra effort, try out new ideas, and often make more money than they ever made before.

This point is strikingly illustrated by the experience of radio dealers and Service Men who have adopted the use of a tube checker to pep up their business. The explanation is found in the very nature of radio. The action of a radio receiver depends fundamentally upon the action of its vacuum tubes. Considered in this light, every radio receiver consists essentially of a collection of parts designed to connect a group of tubes in a certain predetermined manner, and to supply these tubes with definite voltages. When these functions are properly performed by the radio set, it will operate satisfactorily, provided that the tubes themselves are normal.

Modern tube checkers are highly refined instruments, and bear little resemblance to the earlier devices bearing the same name. A fitting instance of this trend in test equipment design is the "Supreme Model 19" tube checker; this test instrument, embodying many unique features, is illustrated in Fig. A, and its schematic circuit is shown in Fig. 1.

### Layout of the Instrument

It tests at the correct filament voltage every type of tube, including the new 2-volt, the 3-volt and the 7½-volt tubes. This matter of proper filament voltage, while testing, is of the utmost importance; if improper voltages are used, readings obtained are meaningless. The "Model 19" also tests both plates of full-wave rectifiers, and offers a positive test on screen-grid tubes. This last is another important feature, in view of the constantly-increasing use of screen-grid tubes in modern radio receivers. The "Model 19" is so advanced in its design that it will even test pentodes.

Six separate sockets, plainly marked, provide for every type of A.C. or D.C. (battery) tube in general use; since each tube has its own testing socket, no switches are required and hence maximum speed in testing tubes is attained. An ingenious arrangement is provided for testing 2½-volt power tubes in the 3.3-volt socket. The circuit characteristics are such that the current-resistance drop introduced by the 2½-volt tubes is exactly correct for reducing the applied potential to the 2½ volts required.

The various pin jacks used have insulated heads to prevent accidental short-circuits and shocks. In addition to the "control-grid" jack, mentioned in connection with the screen-grid test, there is a space-charge "Sp Ch" jack, which provides an effective potential of 10 volts for the space-charge

connection of pentodes. There are also two other pin jacks, marked "11," which furnish a 3.3-volt filament potential for overhead-(top-)heater filament tubes. Suitable leads are included with the checker for making the various pin-jack connections.



Fig. A  
The appearance of the "Model 19."

The meter employed is a large 3½-inch D'Arsonval-type G. E. direct-current milliammeter, in a full bakelite case. Both the 80- and the 8-mil. scales are fully calibrated. The 80-mil. scale is normally in the circuit, but, when the 8-mil. button is pressed, a shunt is taken out of the circuit (see schematic wiring diagram Fig. 1), making the 8-mil. scale effective. When the "Screen Grid-80" button is depressed, an effective positive screen-grid potential of 70 volts is applied to the screen-grid and pentode sockets. When the "Grid Test" button is depressed, the normal zero-bias control-grid potential is changed to an effective negative potential of 3 volts.

The difference between the two plate-current readings, with a fixed difference of 3 volts applied to the grid, constitutes the mutual conductance index of the tube. This method gives the readings a definite value unobtainable by the frequently-used methods of employing an uncontrolled variable voltage with free grid.

The Supreme checker utilizes a large-capacity transformer supplying secondary potentials of 125, 70, 10 and 3 volts and filament potentials of 7½, 5, 3.3, 2 and 1½ volts. The size and the quality of the transformer employed assure adequate filament current.

### Principle of Operation

To determine the condition of a tube under test, it is necessary merely to check the meter readings with the ideal limits, which are plainly marked on the instrument panel beside each socket. This eliminates waste of time in referring to charts, curves, or other data sheets.

The "Model 19" can be used by anyone, since it is extremely easy to operate. In fact, written instructions are hardly necessary; observing a few simple precautions makes it impossible to injure this tester. In fact, positive protection is afforded to the meter against damage through the attempt to test short-circuited tubes.

The tube readings, used as reference indices, have been developed in co-operation with a number of the largest manufacturers of vacuum tubes. In compiling them, thousands of tubes were tested; comparisons were made on the most elaborate factory

(Continued on page 626)

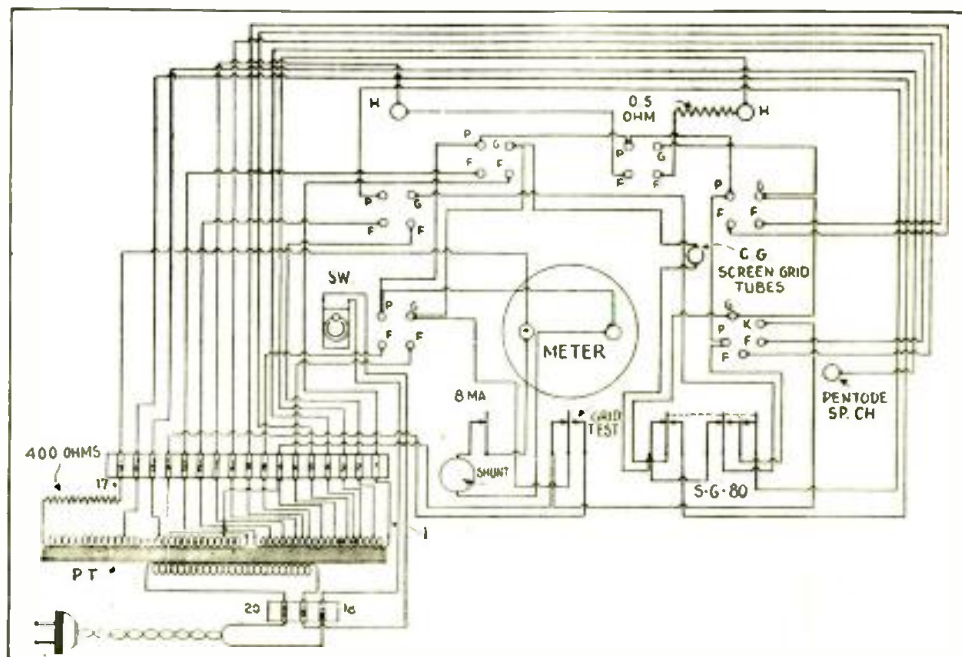

Fig. 1  
The internal connections of the checker, which is arranged to take any type of tube, with the minimum of switching. The central D.C. meter is automatically connected to any tube which is plugged into the appropriate socket.

# Battery-Operated Sets--New 2-Volt Styles

*The introduction of the two-volt tubes marks another period in Receiver Design*

By R. D. WASHBURNE

**M**ANY radio programs have winged their speedy way through the ambient ether since our radio manufacturers last gave any really serious thought to ameliorating the sad plight of the man without a standard light-line connection in his home.

"What is Radio's Greatest Need for 1930?" was the heading of a page, in the December, 1929, issue of RADIO-CRAFT, in which one radio dealer stated:

"There are approximately 7,000,000 farm homes in the United States. In this vicinity, (Minnesota), about 21% have battery-operated sets, and only about 2% A.C. sets.

"This year all-electric sets have had their boom in city and small-town sales. The great majority of farm homes are not equipped with electric-light current. About 90% of the farmers who have electric-light plants have radio sets already.

"Basing my assumption on the foregoing facts, there are between five-and-one-half and six million farm homes that are in the market for battery-operated radios and, in view of this, I consider the most urgent requirement of the radio industry today is the creation of a battery-operated radio working at peak efficiency with a minimum number of tubes and a minimum consumption of battery current."

Suddenly, there comes a loud knocking at the door, and lo, we find demanding entry a radio receiver completely self-powered; and combining every feature the heart could desire. Selectivity, sensitivity, volume and quality are there. So too are automatic volume control, tone control, superheterodyne circuits, combined long- and short-wave tuning, illuminated dial, dynamic reproducer (also, the "inductor dynamic" reproducer), single-dial control, chassis construction, screen-grid tubes, push-pull power amplification, dual volume control, complete shielding, frequency-calibrated dials, low

current consumption, power detection, resistance-coupled audio, handsome console cabinet designs; and many other desirable qualities.

Figuratively and almost literally, there have been developed by many manufacturers of fine electric receivers, "over night," superlative radio sets designed to operate with self-contained current supplies.

### Freedom from Line Limitations

And the light of this bounty shines on the radio enthusiast who lives in the "D.C." districts; where only direct-current lighting lines have penetrated, and the pleasures of the "A.C." set owner seldom are found. Also graced by this visitation are the residents of districts where "25-cycle," or "32-volt" are the prevailing current supplies; and, to a much less extent, 220-volt circuits (as, for instance, in New York City where certain hotels are generating their own current).

Although it is only recently that factory wheels have started to turn out this new type of radio receiver, the laboratories of



Fig. A

The panels on the top of this 2-volt battery protect the carbon electrodes from the air, until it is ready to use.

7 in. high; weighs, without electrolyte, 25 lbs.; and its current-capacity rating is 600 ampere hours at a normal current drain of a little over half an ampere.

At this point we may call attention to an interesting graph (Fig. 1) which shows the comparative lives of several banks of

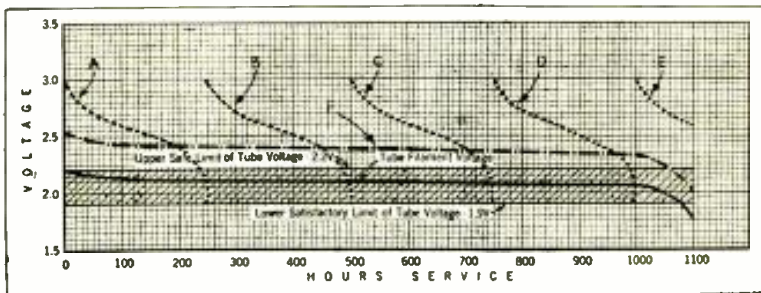

Fig. 1

A-B-C-D-E, working lives of dry cells, compared with the air cell (horizontal broken line). Below, limits of tube voltage compared to the cell's effective supply.

many radio companies have been working for a long time to perfect their design.

Foremost among the essentials is the 2-volt tube. Like the old UX-199 and the CX-399, the new standard, type '30 "general purpose" tubes consume only 60 milliamps. for operation of their filaments. Another tube of the 60-ma. type, not comparable with any of the '99s, is the '32 screen-grid tube. Next we consider the power tubes; and find that the new type '31 consumes 130 ma.—approximately the same amount as the old type '20 which drew 120 ma.). The main differences between the old tubes and the new may be summed as follows: filament potential for the '30, '31, and '32 is only 2 volts—whereas, the '99 and the '20 require 3 volts. Then, too, the new tubes are more uniform in characteristics; they have higher amplification factors, greater undistorted power output, and more rugged construction.

### The Air-Cell "A" Battery

Another and startling development of the laboratory is the "Air-Cell" battery illustrated in Figs. A and B.

Continuing our comparative analysis, we find that the new source of filament current has the outside dimensions of 13½ x 10 x

ordinary "No. 6" dry cells of the usual rating, working on the same receiver, in direct comparison with an air-cell battery. Intermittently discharging these batteries through a 7-tube set using three screen-grid '32's, two "general purpose" '30's, and two type '31 power tubes, it required 36 dry cells, used in a series-multiple connection of the correct type (to obtain maximum performance from the dry cells) to equal the operating life of 1,000 hours, at the rate of three hours per day, obtained with the single air-cell.

It will be noted from Fig. 1, that the maximum output potential of an air-cell battery is 2.5 volts; and the minimum, 2.0 volts.

The operating voltage of the air-cell battery, as shown in Fig. 1, is of great interest because of its constancy throughout the life of the battery; note the life-line of the air-cell plotted against the upper and lower working limits of the new 2-volt tubes. This graph is obtained by the use of a series resistor to drop the 2.5-volt potential of the air-cell battery to the operating voltage of the tubes.

Considering the new battery from the cost angle, we find that this unit, listing for a little less than nine dollars, is much less expensive, judged on the basis of its total operating life, than dry cells.

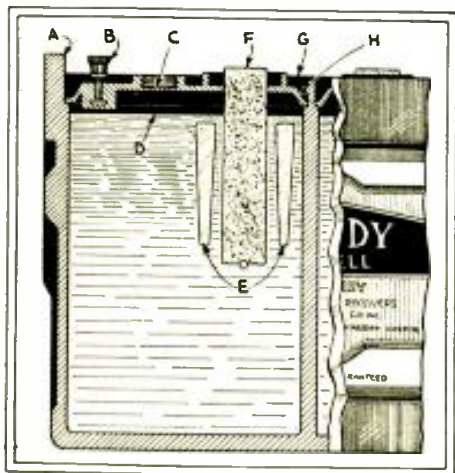

Fig. B

Cross-section of an "air-cell": A, case; B, terminal; C, filling vent; D, level of electrolyte; E, zinc electrode; F, carbon electrode; G, seal; H, partition.

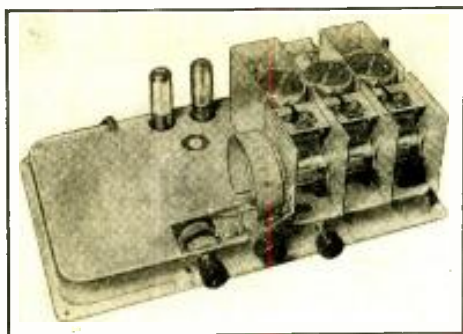

Fig. C

The Lyric "B-94" chassis, showing dual volume control and compensating condensers; a 6-volt battery is used.

It is difficult to draw a cost comparison between the air-cell battery and a 2- or 6-volt storage battery; since in each instance the factors involved have different values. However, sufficient information has been given above to enable the reader to make his own computations.

Theory of Operation

Like the regular dry-cell, the air-cell uses zinc and carbon electrodes. Unlike the "dry" cell, which uses a depolarizer in the form of a paste to prevent hydrogen (an insulator) from forming on the carbon electrode and thus reducing the voltage of the cell, the new air-cell uses an electrolytic solution; in conjunction with a plate formed of a special grade of carbon which is highly porous to oxygen.

The electrolyte-forming chemicals, in solid form, are placed in the battery at the time of manufacture. To prevent them from losing some of their strength by possible contact with moist air, while waiting to be placed in service, the battery is hermetically sealed at the time of manufacture by thin rubber membranes under the filler holes, and by a transparent sheet of Cellophane placed over the tops of the special "breather" carbon electrodes. Thus sealed, no change can take place in the chemicals; the battery can be placed in service at any time after manufacture, and still be as "fresh" as the day it was made.

To place the battery in service, all that need be done is to remove the covers from

the electrodes so they can "breathe" oxygen, punch out the membranes in the bottoms of the filler holes, and fill the two compartments with cold drinking water; about six quarts, total, being required.

This battery has a very definite overload point beyond which it is unsafe to go. This overload point is determined by the maximum rate at which the carbon electrodes can extract oxygen from the surrounding air, and amounts to approximately 0.75-ampere.

At current drains below this figure, the porous carbon is able to replenish the oxygen as rapidly as it is consumed within the battery; and as long as the carbon contains oxygen it repels water and remains dry. As the chemist would say, there is a "meniscus" or capillary effect downward, instead

never recovers. (Hence, the extreme care with which the radio sets, arranged for this battery, have been designed.)

The most practical application of this condition is that, under no circumstances, should an air-cell operated receiver be equipped with a pilot light which draws its current from the air-cell "A" battery; except where lamp makers supply special bulbs. Standard panel lamps consume from 0.40 to 0.45-ampere; and this lamp load, in addition to the tube load of the receiver, is sufficient to overload the battery and ruin it.

The electrolyte used in the air-cell "A" battery is a solution of sodium hydroxide (caustic soda), the active ingredient is zinc. Now, as the zinc dissolves in the electrolyte, a reaction takes place which produces, as a waste product, sodium zincate which, being heavier than the electrolyte, sinks to the bottom of the battery, and thereafter plays no part in the production of current. It will be seen, from an examination of Fig. B, that there is almost as much room below the zinc electrodes, which is provided to make room for the sodium zincate, as there is above them.

The passage of current through the cell dissociates the water in the electrolyte into its principal constituents, oxygen and hydrogen. The hydrogen ions migrate toward the carbon electrode, where they discharge themselves against the oxygen which the electrodes draw in from the surrounding air and by this combination produce water. Inasmuch as the oxygen in the electrode is freely available all over the surface of the electrode, there can be no accumulation of the voltage-reducing hydrogen at current drains below the overload point; and, as a consequence, the working voltage of the air-cell "A" battery remains practically at its full initial strength throughout the life of the battery.

From consideration of the facts above stated, it may have dawned upon the technician that accurate meters will be a mighty necessary part of the equipment of the man who, for pleasure or profit, is building receivers to use 2-volt tubes and the air-cell battery; or any kind of current supply, for that matter. To the Service Man, of course, they are indispensable.



Fig. D

A Brunswick 2-volt set from the rear: A, air-cell battery; B and C, dry-cell batteries; D, inductor-dynamic reproducer; E, shields of '32 tubes.

of upward. Once the oxygen content is exhausted, however, the water in the electrolyte rushes into the pores of the carbon and produces a condition closely analogous to lung congestion. Under such conditions the battery dies of "suffocation." Any load on the battery, therefore, amounting to more than 0.75-ampere will bring about the premature death of the battery; and, once it has been subjected to this treatment, it

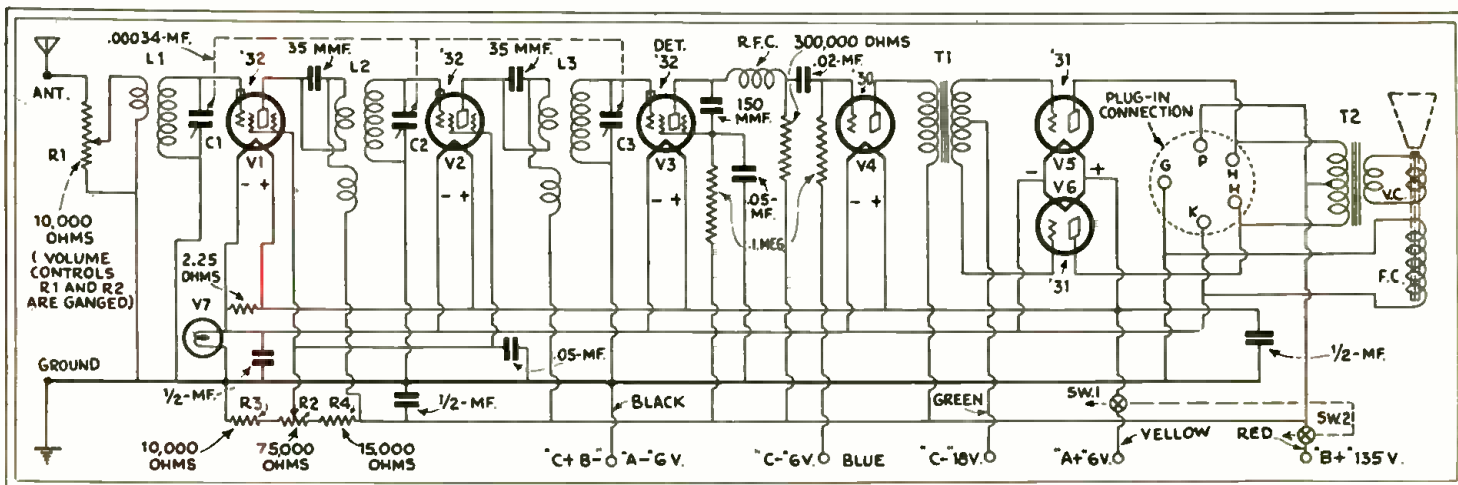

Fig. 2

The schematic circuit of the All-American Mohawk "Model B-94" Lyric, the chassis of which is illustrated above: it comprises a screen-grid power detector. The field coil of a dynamic reproducer is also operated from the six-volt storage battery which operates this receiver.

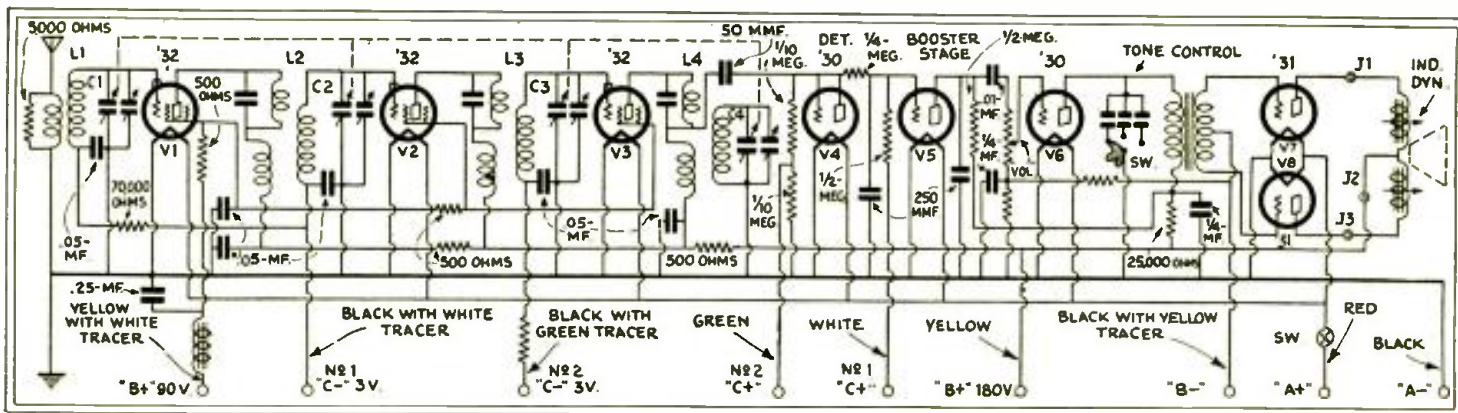

Fig. 3

The circuit of the Philco "Model 30" receiver, illustrated at the lower left, which is designed for operation from a two-volt source. It incorporates automatic volume control and tone control; and operates an inductor dynamic which requires no field current

**Practical Circuits**

Now that we know something about the accessories to the "2-volt-receiver," let us find out what the laboratory of the manufacturer has produced for the man who wants a radio receiver having low up-keep cost; either because of a desire for economy in light-line operation, or lack of standard light-line facilities. (Our English cousins have a name for it, "mains supply.")

**Brunswick 2-Volt Models**

One of the foremost receivers to incorporate advanced design in battery receivers is the "Model B-15" Brunswick radio set manufactured by Brunswick Radio Corporation. It is one of the models of their "Uni-Control" line of receivers.

By reference to the schematic circuit of this receiver, Data Sheet No. 38, in the March issue, it will be noted that a resistor R6 of 0.6-ohm is used to reduce the output voltage of the air-cell to the correct value for the filaments of the tubes.

Other points of interest are the capacity control of volume, condenser C5. Four tuned stages of screen-grid amplification, using a tuned-grid and choke-coupled plate circuit, assure high selectivity. Both sides of the filament circuit are grounded to the chassis; which is connected to the 3-volt "C—" potential. There are a screen-grid power detector, a resistance-capacity-coupled first audio stage, and push-pull second audio.

As indicated in the schematic circuit, and

shown pictorially in Fig. D, three "B" battery units are required. In this figure is an excellent illustration of the relative size of the air-cell "A" battery and the remainder of the compact installation.

Another Brunswick design intended for

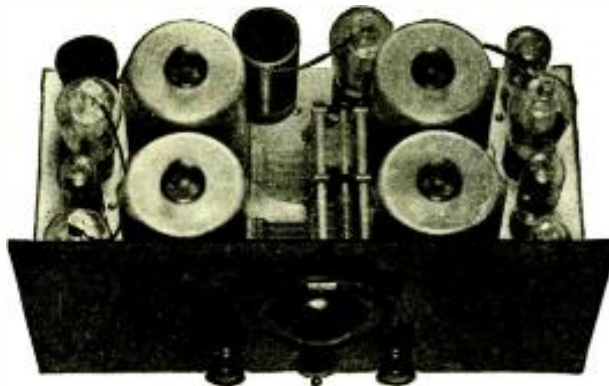

Fig. F

The chassis of the Lincoln 2-volt superheterodyne, which has tuned intermediates, and covers several wavebands.

110-volt D.C. circuits (manufactured as the Models "DC-15," "DC-22," and radio-panatropé "DC-32") uses four '32's, a '30, and a power stage with four '71A's in double-push-pull, feeding a dynamic reproducer.)

**Philco 2-Volt Receiver**

Automatic volume control is one of the features of the "Model 30" Philco radio set, a product of the Philadelphia Storage Battery Co., shown in Fig. E. A schematic circuit of the receiver is Fig. 3.

As in the all-electric "big brothers" of this set, the distinguishing characteristics of the "screen-grid plus" line are retained. Of these, the most novel is the "diode" or two-element detector, V4, with grid and plate connected together. This is the "linear" detector by which the "screen-grid plus" receivers are recognized. The "booster stage"

V5 detects a bit of the R.F. not rectified already by V4 and, in addition, acts as an audio amplifier. These two detectors also are part of the automatic volume control in the "Model 30." By checking over the circuit an odd condition will be noted; "C" batteries Nos. 1 and 2 "float," so far as the "A" circuit and chassis are concerned; the positive returns of these batteries being to points in the circuits of the volume-control tubes.

In the "30," there are three screen-grid tubes and four tuned circuits; the last unconnected at the high-potential end. The total "B" voltage is 180, and a 2-volt Philco storage cell, type "Dynamic 92-R," supplies the "A" potential; no series resistor is used in the "A" circuit. The total plate current drain of this set is about 25 ma.

The current readings obtained on the "Model 30" Philco, using an average set checker, are as follows: Filament potential, all tubes, 2.0 volts (the readings of tubes V7 and V8 being reversed in polarity with respect to the others). Plate potentials, V1, V2, V3, V7, V8, 150 volts; V5, 15 volts; V6, 90 volts. Control-grid potentials, V6, 1 to 4 volts; V7, V8, 24 volts. Screen-grid potentials, V1, 60 volts; V2, V3, 58 volts. Plate currents, V1, V2, V3, 1.5 ma.; V6, 2 ma.; V7, V8, 8 ma.

**Lincoln 2-Volt Super**

The latest in superheterodynes uses 2-volt tubes; and tunes in stations on the 80-meter band—in addition to the usual broadcast stations. This receiver, the Lincoln

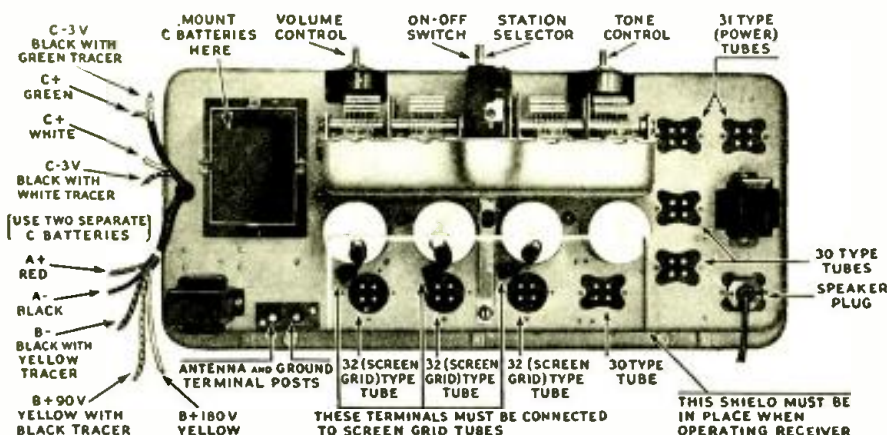

Fig. E

The arrangement of the Philco "30," the circuit of which appears above. As in the "screen-grid plus" models described in last month's Data Sheet, it uses a two-element "linear" power detector, and a booster stage described in the manual as a detector-amplifier.

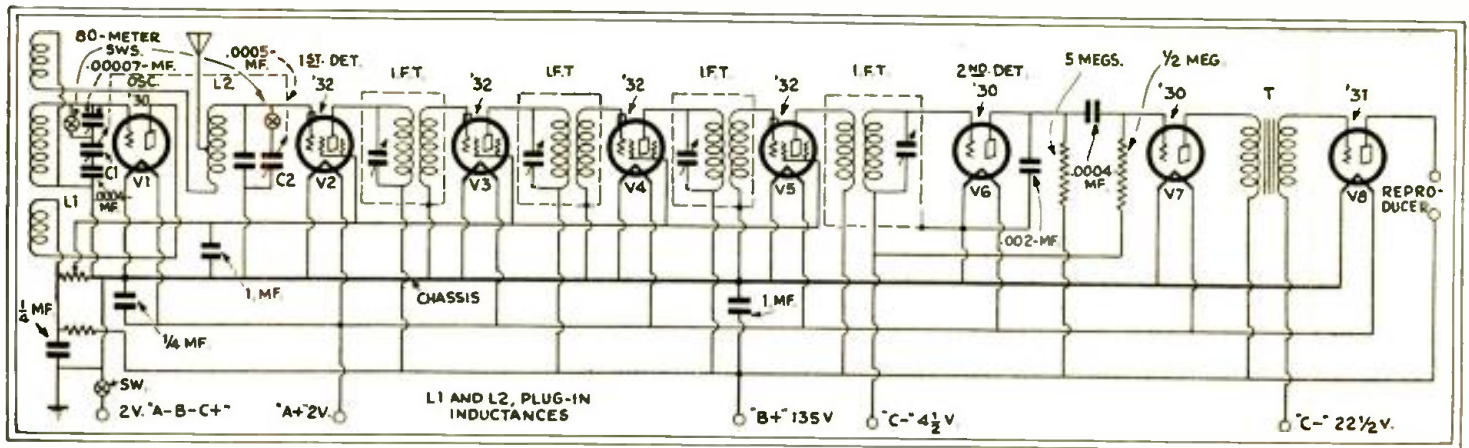

Fig. 4

The Lincoln "DC-8" superheterodyne not only works on two volts, but gives a choice of two wavebands, which may be extended by the use of plug-in coils. This specially powerful set may be operated from an air-cell battery; or a storage battery may be used. The filament-voltage control is external to the circuit shown.

"Model DC-8" made by the Lincoln Radio Corp., is shown in Fig. F; the diagram of connections is given in Fig. 4. It is recommended particularly to the experimenter.

This receiver also is designed to use the air-cell "A" battery; total plate potential required, 135 volts. Volume control is obtained by varying the bias on the screen-grids of the '32's. It is observed that there is no provision for reducing the output potential of the air-cell to match the filaments of the tubes. The plate circuit drain is only about 16 ma.

Special high-gain intermediate-frequency transformers are used; these are tunable by means of the knobs which may be seen in the picture, Fig. E. The oscillator and tuning condensers, C1 and C2, are under single-dial control.

Short-wave stations may be tuned in by turning the wave-change knob; this operates the dual switch, changing the circuit connections in the manner shown. Coils L1 and L2 are of the plug-in type and may be changed for others at the will of the experimenter.

**Pierce-Airo Midget**

The inhabitant of a "D.C." district, where the supply is 120 or 240 volts direct current is not to be left out in the cold. Instead, we present for his consideration the circuit and details of the Pierce-Airo, "De Wald, Model D.C. 632" midget radio receiver, Fig. G and Fig. 5.

In this single-dial, mantel-type radio set we find two stages of tuned screen-grid R.F. amplification and a screen-grid detector



Fig. G

A midget, operating its two-volt tubes from the D.C. house line, which is still found in many residential districts of cities.

using type '32 tubes; a single stage of resistance-capacity coupled A.F. amplification, using the type '30 tube; and a stage of transformer-coupled push-pull amplification using two type '31 tubes. The filaments of

all these tubes are wired in series; and the filaments of tubes V1 to V4 are shunted by individual resistors to pass the excess current from the 130 ma. required by the power tubes.

Lighting-circuit "strays," or "X's," are effectively choked by the 1:1-ratio transformer, which is functioning as a filter in the incoming line circuit. The Mazda lamp acts as both a panel light and a safety resistor; the specified type must be used.

A caution to be observed, when testing most D.C. lighting-circuit receivers, and particularly this "De Wald," is to refrain from removing tubes while the set is operating. Failure to follow this caution will probably result in burning out the filament shunt of the tube removed.

**All-American Mohawk "Lyric"**

The owners of 6-volt batteries will be interested in the radio set illustrated in Fig. C; the "battery set" chassis of the Rudolph Wurlitzer Mfg. Co.'s "Model B-94" 2-volt tube radio set. The schematic circuit is shown in Fig. 2.

Referring to this diagram, we find that the 6-volt "A" supply is reduced to the required two volts by the pilot light, V7, which passes just the required amount of current for the new tubes. Special R.F. transformers, designed to obtain even transfer of energy throughout the broadcast band, and similar in circuit arrangement to

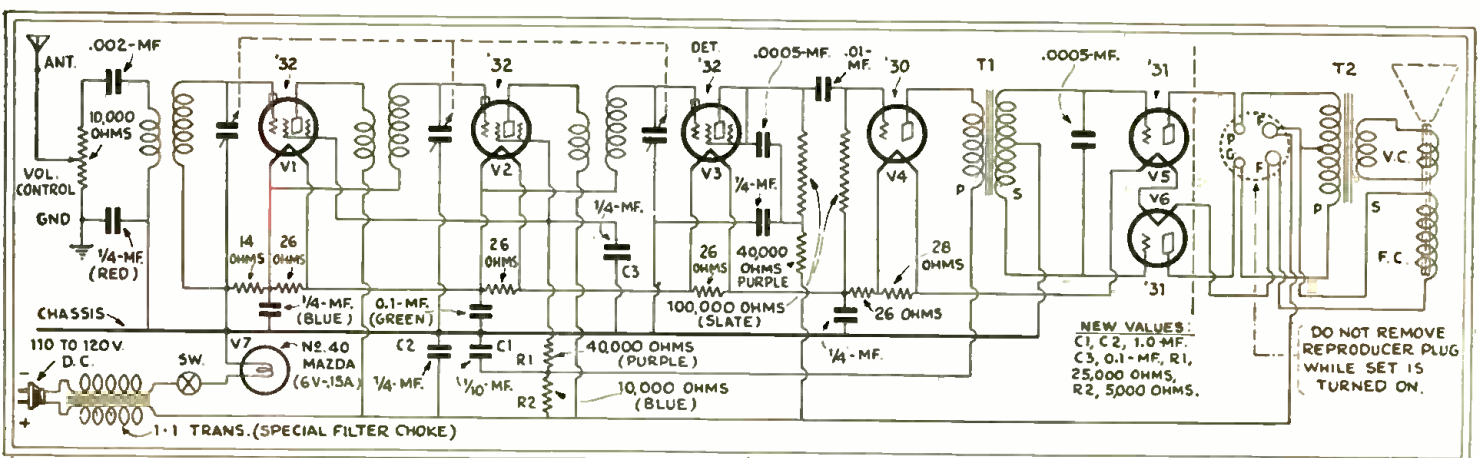

Fig. 5

The schematic circuit of the Pierce-Airo "DeWald Model DC 632" midget illustrated above. It is designed for 110-volt D.C. operation; but may be connected to a 220-volt line through a series resistor; the Mazda lamp ballasts the circuit. Note the dynamos field coil is in series with the filaments.

those used in the Philco "Model 30," are part of the tuning system; and a single dial controls the three tuning condensers. Resistors R1 and R2 constitute a dual volume control. A special dynamic reproducer, deriving its field current from the "A" supply, is part of the equipment. To prevent exceptional drain from the "B" supply, the plate circuit, including resistors R2, R3, R4, is opened by switch Sw2 at the same time the filament switch Sw1 is operated.

Space for the batteries is evident in the illustration of the set chassis, Fig. C.

**The Home-Builder's "DeLuxe" Two-Volter**

At this point we bid adieu to the manufacturer and the B.C.L. and, through the courtesy of Mr. H. G. Cisin, present to the radio experimenter wishing to construct his own 2-volt-tube receiver, the "DeLuxe Two-Volter." The diagram of connections is Fig. 7; the parts layout followed in the original receiver is Fig. 8; in Fig. 6, we see the arrangement of the completed chassis.

In addition to the three type-32 screen-grid R.F. amplifiers, of the two-volt type, there are two general-purpose '30's and two type-31 power amplifier tubes of the 2-volt filament type in push-pull. A "bass-treble" tone-control switch (48) shunts a fixed condenser across the primary of the first A.F. transformer for tone control.

Since the "A" supply may be a 6-volt storage battery, or an "A" eliminator, resistors are required to drop this potential to the required two volts for the new tubes. These are Amperites (9, 20, 32, 44, 55, 61 and 61A in Fig. 7.)

If an Eveready air-cell "A" battery is used, the wiring of the filament circuit will be somewhat different. First of all, the Amperites are omitted; the wiring then going direct from the switch (69) to the positive filament terminals of the various sockets. Instead of connecting the "A—" post (68) directly to the chassis, this post is insulated in the same way as the positive post; and a 1/2-ohm fixed resistor (Carter,

**Fig. 6**  
The front appearance of the chassis of the completed single-dial "DeLuxe Two-Volter," intended for the home constructor. This set was designed by Mr. H. G. Cisin, well known to our readers, to use standard parts generally available.

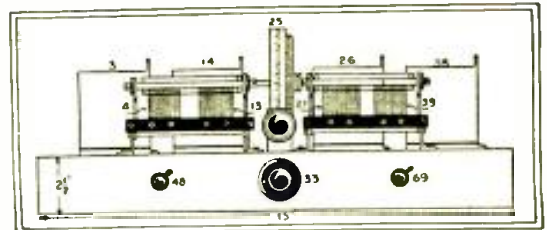

Yaxley, or equivalent) is connected between the negative post and the chassis. This serves the purpose of lessening the voltage of the air-cell "A" output from 2.5 volts to 2.2 volts; which reduces the initial voltage applied to the tube to the maximum allowable. At the same time, it is necessary

to 2.00 volts (as against 2.1 to 1.7 volts for a single lead-plate cell). This resistor must be variable; the filament supply is to be checked accurately with a voltmeter, or an ammeter.

Note the thorough by-passing of the circuits of this receiver. A list of recom-

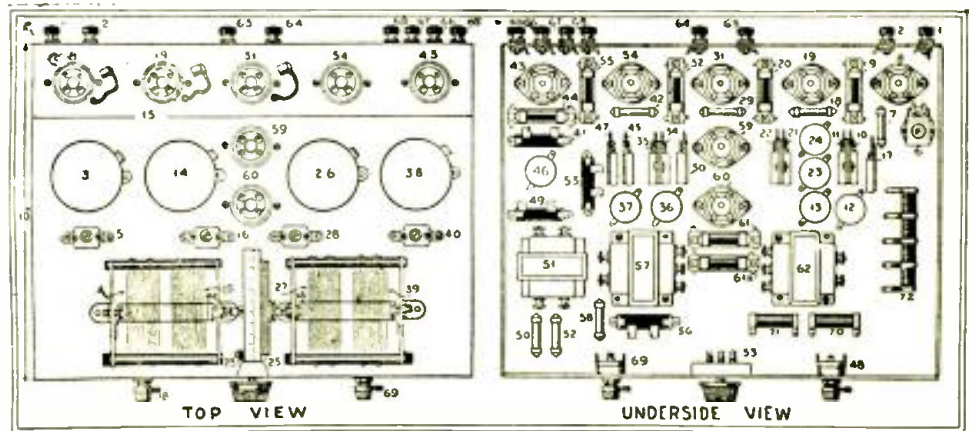

**Fig. 8**  
Left, the top view of the chassis, illustrated above; right, a view from beneath. The constructor may easily shield the screen-grid tubes, the positions of which are indicated by sockets 8, 19 and 31.

to dispense with the pilot light; because the smallest 2.5-volt lamp consumes 0.3-amp.; which, added to the 0.6-amp. requirement of the remainder of the set, would overload the air-cell "A" battery by the amount of 0.15-amperes.

If a 2-volt storage cell is used, no resistor will be required. And, if two Edison cells are used, a 1/2-ohm resistor is needed; since the operating-potential range of two of these nickel-iron cells in series is from 2.40

mended parts, as used in the original model, is given below:

**List of Parts**

- Two Cardwell "dual" variable condensers, type "217-CI," (4, 15), and type "217-CR" (27, 39); capacity, each section, .00035-mf.;
- One Silver-Marshall R.F. shielded coil, type "124" (3);

(Continued on page 617)

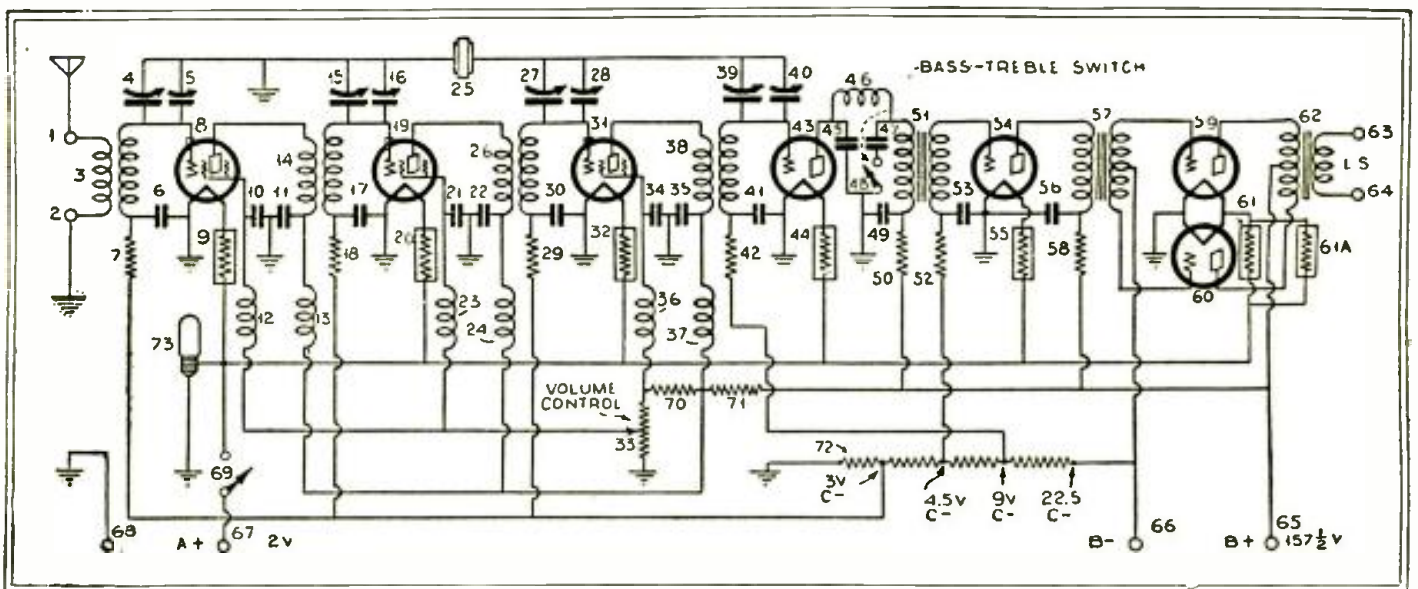

**Fig. 7**

The schematic circuit of the "DeLuxe Two-Volter," a set of high selectivity and amplification, but very low current consumption. It may be operated from either an air-cell or a storage battery coil; the only changes in the design necessary would be in the Amperites or filament-ballast resistors used.



# Recent Advances in Radio Tube Design

EVERY advancement in technical appliances brings with it additional and oftentimes unsuspected practical problems; and further experiments and inventions are at once required. This is one of the reasons why patents have continued to increase in number for a hundred years after the date when a commissioner of the Patent Office foresaw the end of its usefulness, for lack of anything further to invent.

So it has been in radio: every addition to

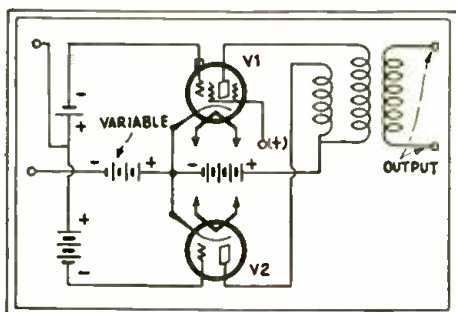

Fig. 1

In parallel, two tubes (one high-mu and one low-mu) would change the amplification factor automatically with the grid bias applied.

the apparatus which has been available to radio workers has suggested something new. The vacuum tube was a revolutionary step forward, for the owner of a crystal; before the possibilities of a single tube could be exhausted, the multi-stage R.F. amplifier was indicated. The problems which it introduced were almost innumerable; then the four-element, or screen-grid, tube emerged from the laboratory in which it had been hiding for years. Before the newcomer could make its mark commercially, the growing demand for light-line current supply revolutionized the radio industry. Electric sets went rapidly through the process of refinement; and, when the A.C. screen-grid tube appeared, it might seem that the ultimate of which early radio experimenters talked had been reached. The modern electric receiver has practically unlimited R.F. amplification, sufficient to bring up to full volume any signal, however distant, which an aerial can catch out of the etheric turmoil; and it has audio amplification sufficient to fill any room with sound. At last the radio listener, it might seem, has all that he can hope for.

Nevertheless, even a millionfold amplification has its drawback. While the tuned circuits of a receiver, one after another, may create a ten-kilocycle separation at the detector, there is no such sharpness in the early stages. A signal, unwanted by the listener, may be ten thousand—perhaps a million—times as strong as that for which he is tuning. And it will come into the early stages of the receiver with power so terrific that it plays the very deuce with the tubes' characteristics. Therefore, we have overloading, distortion, cross-talk, etc.

The old advice to the annoyed listener, to move away from the interference, will hardly do. The majority of listeners, at

least in the urban districts whose consolidated buying power dictates the design of commercial A.C. receivers, have nearby one or more stations from which one or at most two screen-grid R.F. stages would give overpowering volume. In a receiver with four such stages of amplification, something must be done to deal with the locals; their presence cannot be ignored, no matter what selectivity is provided.

We have been provided with, first, the manual volume control and, then, the automatic volume control which, by altering the biases on the R.F. amplifiers, reduce the amplification of the set. Yet even these are insufficient to solve the problem in the face of strong interference; for if the tube is, so to speak, throttled down too tightly, the goblin distortion pops up.

To meet the problem presented by multi-stage amplifiers, utilizing tubes of very high amplification factor (or "mu"), a new type has been devised. A very brief explanation of its action may be given here.

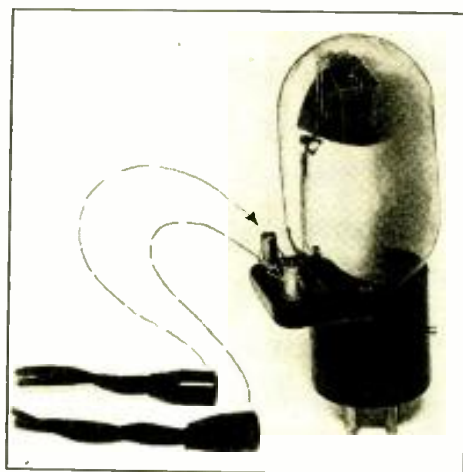

Fig. A

A "Leatron" adapter tube, taking filament current direct from the light-line, without alteration in the wiring of the set.

When the grid bias of a "high-mu" tube (of which class the screen-grid tubes are the extreme examples) is made too high, to prevent the output from overloading the following stage, the characteristic of the tube is altered; its shape, as shown on a graph, is curved, signifying that the output must be distorted. One of the results is that the percentage of modulation of the signal is increased, as the plate current falls; and this effect, carried through several tubes, may be serious when it reaches the detector.

In the old days, experimenters were fond of working with stages of R.F. amplification which could be switched in and out; and some distance fans would perhaps be still willing to welcome a gadget of this kind. Modern conditions call, however, for something automatic which only the Serviceman need worry about.

The solution was reached through a process of reasoning something like this: suppose a circuit, as in Fig. 1, where a tube of high amplification factor and low grid

bias (V1) is put in parallel with one of low amplification factor and high grid bias (V2). A small signal is put upon the two grids; the greater part of the voltage output comes from V1. As the signal increases in strength, we steadily increase the bias on both tubes. Because of the greater effect of grid voltage on plate current in the high-mu tube, the amplification of V1 is cut down much more rapidly than that of V2; and the latter assumes a more and more important part in the circuit. Finally we have increased the bias so much that V1 is blocked; no plate current flows; only the low-mu tube V2 is working, but on a strong signal it is giving ample output.

### The "Variable-Mu" Tubes

To construct a receiver on this plan, however, would double the number of tubes, as well as increase the number of parts and the possibility of trouble. The solution which has been found by the Radio Frequency Laboratories, under the direction of Stuart Ballantine, is the design of a "variable-mu" tube, which shall combine the characteristics of the two tubes shown in Fig. 1. After a great deal of research, the tube has reached the commercial stage, being made standard equipment in a new Majestic superheterodyne; and it is being produced by the Raytheon and Areturus tube factories as well.

The principle of the variable-mu tube is that its elements are not arranged symmetrically, as in previous tubes; for instance, at certain places, the voltage on the grid exercises less control on the flow of plate current than at others. In Fig. 2, let us say, the control grid is more open in the center than at either end. A voltage may be put upon it such that at either end no electron can pass through the mesh; and the two ends of the grid present an impassible barrier to plate-current flow. In the center, however, the mesh is more open, and a considerable number of electrons can pass. The tube, therefore, still operates with a greatly-reduced amplification factor.

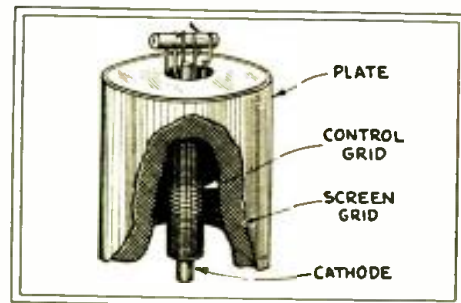

Fig. 2

A control-grid, unevenly spaced, passes plate current at one point while it is cut off at others by the grid bias. This varies the amplification factor, or "mu."

Two tube types, resembling greatly the '24 in normal characteristics, have been designed. The "550" is capable of handling an input voltage fifty times as great as that which can be applied to the '24 before the same degree of distortion is reached. However, since this entails the application of a

(Continued on page 630)

# Radio-Controlled Tanks of the Future

*Is it possible to make war with robot armies in moving forts operated by remote control?*

**W**RITERS of war stories, peering into the future, predict an approaching era when fighting will be done by machinery under remote control. Guns automatically operated will fire from deserted fortifications and from tanks which contain no living operators. Airplanes without human pilots will observe positions through televisors, and drop projectiles guided from a post at headquarters, many miles away. The casualties will be solely among robots of steel and copper, whose orders are conveyed to them by radio, or other subtle signalling methods. Such is the picture which is painted upon the drop curtain which conceals the next war—if it be true that war has not been abolished along with the dips in the business cycle.

A picture which appeared recently in one of our English contemporaries is reproduced here; the original, it is said, was taken at a public demonstration in Tokio of a tank which was operated entirely by radio from the post in the foreground. The tank went through numerous maneuvers, under full command of its operators, to the enthusiasm of a great crowd of spectators. While the picture does not seem to be of an official type, it is evidently genuine; the tank itself seems rather small and not too war-like.

## Radio Remote Controls

The feasibility of remote control of a vehicle has been known for many years. John Hays Hammond, Jr., some years ago demonstrated wireless control of automotive torpedoes; and he exhibited, as an amusing toy, his "Wireless Dog," whose movements were guided without physical connection to the controls.

At the World's Radio Fair of last season, in New York City, the most spectacular exhibits were undoubtedly those of various "robots" and other examples of the use of

photoelectric cells and electric relays. There were a knight in armor, and a winsome lady, and other mechanical devices which seemed almost human in intelligence and activity.

## A Photoelectric Control

One of the most interesting demonstrations of this kind was given under the

in the photograph reproduced at the lower left, was operated by the spoken command, directed into a telephone receiver. The pitch and tempo of the words selected the proper relay at the other end of the telephone line, to light a lamp in one or the other eye of the grotesque face. This lamp was, in actual operation, turned toward the



*This picture, which appears to be a somewhat retouched enlargement of a snapshot, shows a radio-controlled tank going through its paces in Japan. (From Popular Wireless.)*

auspices of the Museum of the Peaceful Arts, by the engineers of the Westinghouse company. The miniature automobile, shown

rear of the little car; where its rays were picked up by the photoelectric cell to which it corresponded. The photoelectric cell, in turn, operated one of the relays under the car; and this, according to the spoken word, made the car start forward, stop, back up, or sound its horn. There was no other connection between car and operating lamps than the beam of light.

In one sense, this might be classed with radio remote control. Light waves may be considered as radio waves, only about  $1/2,000,000$  of a meter long. The photoelectric cell forms a receiving system and detector of these waves; it is not, however, as sensitive as a tuned radio circuit at a considerable distance.

## War Conditions

The method illustrated, of the exhibits we have described, might readily be applied to the operation of a tank, however, which received signals by radio; to the extent that the movements of the tank could be electrically controlled. Tanks, however, are now driven by explosion engines, rather than batteries; and considerable energy is required in their guidance. We may picture the future tanks, however, as equipped



*The apparatus used in the control of an automobile by word of mouth, at the Radio World's Fair of 1930. The signals were in this case given by light at short-range, instead of radio, but the principle is similar. (Photo by Westinghouse Elect. & Mfg. Co.)*

with shock-proof batteries delivering great amperage to their motors; and thus being capable of starting, stopping, and steering under the control of radio-operated switches. Other points, however, enter into the problem of operating a tank by radio under

conditions of actual warfare; which would indicate that, while the technical feat is possible, under peace conditions, it would be difficult at the front under the conditions imposed. For instance, the tank normally carries a

crew, who are able to observe and direct its course to avoid, or overcome, local obstacles. The only substitute for them would be not one, but several televisors, of great efficiency. Each of these would require a  
(Continued on page 631)

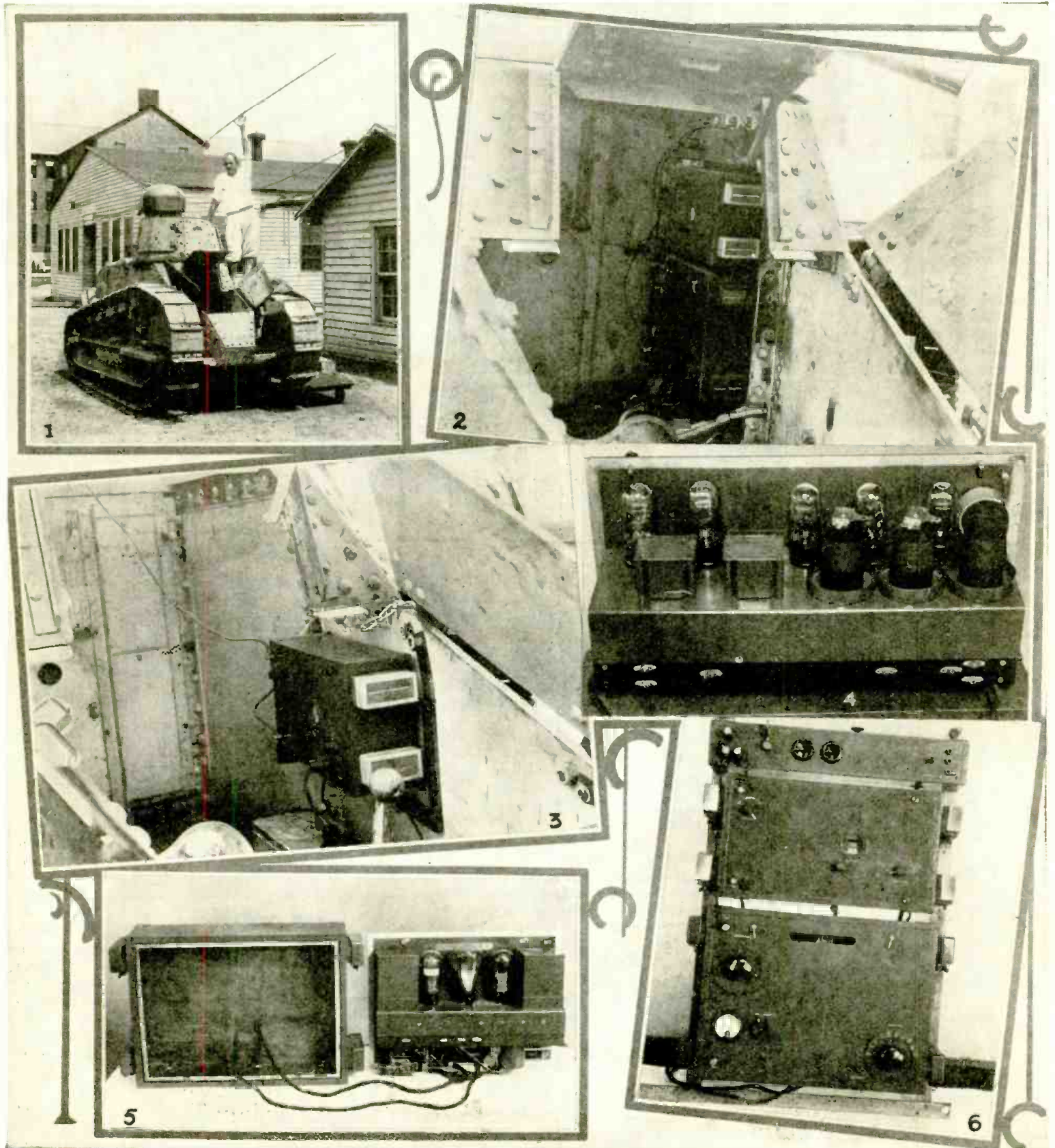

Radio equipment of Uncle Sam's tanks is shown above: the tank in (1) is an old-timer, used for these experiments. Observe its flexible aerial. (2) Receiver and transmitter in position; (3) receiver alone with battery case below; the oblong end-pieces are buffers. (4) Chassis of the receiver which uses five UX-864 tubes; (5) transmitter removed from its case. (6) The assembly of Fig. 2 removed from its mountings. (Photos by Signal Corps; U.S.A.)

# New Radio Devices for Shop and Home

In this department are reviewed commercial products of most recent interest. Manufacturers are requested to submit descriptions of forthcoming developments.

## THE SKYSCRAPER RECEIVER

WHAT is unquestionably a forerunner in radio cabinet set design is the pattern of the Westinghouse radio receiver bearing the trade name of "Colonnaire." Illustrations of this departure in cabinetry and equipment are Figs. A, B, and C.

The tendency toward forms slimmer and higher, as manifested in the architecture of the modern skyscraper, was found to be borne out in the entries submitted in the Westinghouse company's recent "\$10,000 Radio Idea" contest, many of whose entrants stressed the desirability of the future radio sets taking up less room. It is here exemplified in a high degree by this receiver.

The "Colonnaire," occupying a very small floor area, 10 x 12 inches, will fit in a corner or flat against the wall of the home. Consequently, it is particularly adapted to small apartments. The design is of no particular period, but leans slightly toward the modernistic and, therefore, will fit well with existing furniture. Its height is 59 inches.

Among the unique features in this newest design in radio receivers is the design of the reproducer. Instead of appearing on the front of the cabinet, the grille is placed on the top; it has sufficient strength to hold light articles, such as a small vase. The full length of the cabinet is utilized to obtain a five-foot horn; the directional effect of the average horn has been overcome, in this reproducer, by introducing at the opening a plug of special shape. It is this plug, too, which eliminates distortion due to the proximity of the walls and ceiling.

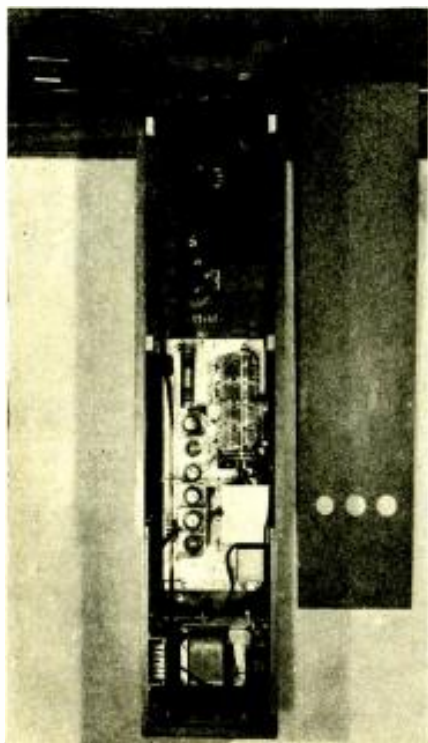

Fig. C

The vertical receiver from the rear, showing ease of access. The horn opens on top.

All controls and dials are flush-mounted on the sides of the instrument, as the illustration shows, and are readily operated from either a standing or a sitting position. The receiver chassis is that of a 9-tube screen-grid superheterodyne, in which is incorporated a tone control.

After this receiver has been in service for a sufficient length of time to require the customary special attention, the Service Man will find the necessary information available in a RADIO-CRAFT "Data Sheet." The service technician will be glad to learn that the requirement of servicing the set for tube replacement or adjustment has been given full consideration; the back of the cabinet is easily removed, and the horizontal arrangement of the tubes makes their replacement quite easy.

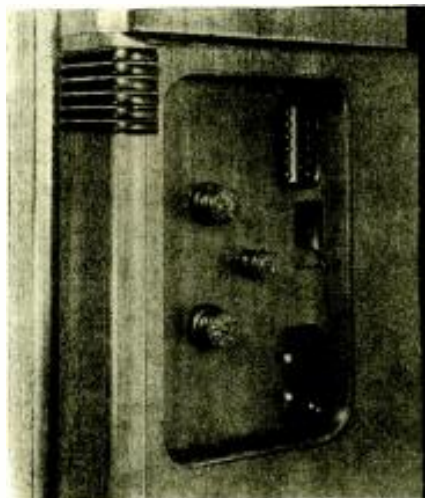

Fig. B

The panel of this superheterodyne looks like an ordinary one, unpeeled.

The suggestion of "grandfather's clock" in the columnar appearance of the cabinet is heightened by the presence of an electric time piece. Into the construction of this clock, the Westinghouse engineers have worked an "automatic control" which will continue to operate the clock mechanism for a time should the main current supply cease; as when a house fuse blows. Further, this auxiliary drive, when its power is expended, will not permit the time movement to operate upon re-application of the line supply until the drive is re-set.

Since the bulk of the weight of the instrument is in the base, the set stands solidly; while its small girth permits it to be conveniently transported by automobile.

The design of the chassis permits incorporating, at a later date, the newly-developed Westinghouse remote-control equipment.

## SMALL TUNING CONDENSERS

A SERIES of small-space tuning condensers ranging in maximum capacity from 19 mmf. to 322 mmf. have been developed in the laboratories of the Hammar-



Fig. A

This "grandfather's clock," 1931 edition, is a radio receiver for city apartments. A remote-control unit is on the table.

lund Manufacturing Company. The smallest condenser is 2 $\frac{3}{4}$ " long and the largest, 4" long. All "Midline" types are 2" wide, with plates fully extended. The "capacity" type is only 1 $\frac{1}{2}$ " wide.

No screws or nuts are used anywhere in the construction of these condensers, soldered eyelets being employed; thus all possibility of parts vibration is eliminated. This is an excellent feature for aeroplane and automobile sets.

The "Midline" type are known as the MC-(number of plates)-M type and the capacity as the MC-(number of plates)-S type. They are made in the following capacities: 19.2 mmf.; 34.2 mmf.; 49.2 mmf.; 78.6 mmf.; 93.6 mmf.; 100.2 mmf.; 138. mmf.; 198.6 mmf.; 242.4 mmf.; 294. mmf.; and 322 mmf. All are available in either clockwise or anti-clockwise types, and for base or single-hole panel mounting. The shaft is the standard  $\frac{1}{4}$ -inch size.

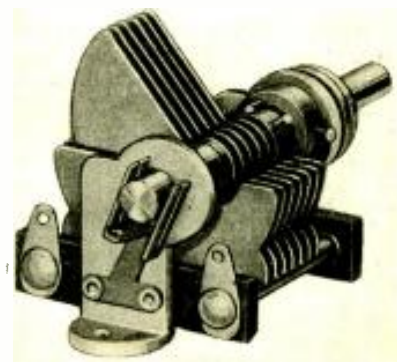

Fig. D

The newest condenser types are much more compact and smaller than instruments of the same capacities in previous models. They are strongly and precisely built.



Fig. E

The smallest of modern screen grid receivers is this Crosley "Wigit."

A SUB-MIDGET RECEIVER

PICTURED in Fig. E is the newest thing in small radio set design, the "Model 48" or "Wigit" midget radio receiver manufactured by the Crosley Radio Corp. Two interior views are Figs. F and G; the schematic circuit is Fig. 1. (See page 619.)

This selective receiver is probably the first screen-grid electric set, incorporating a sensitive reproducer, to list under forty dollars. It utilizes two screen-grid tubes as R.F. amplifiers, and a third as a power detector, which feeds into a type '45 power

Fig. F (left)

The tiny size of the "Model 48" ("Wigit") chassis is indicated by the tubes, part of whose shielding is removed.

Fig. G (right)

Under view of the same chassis.

tube. An earlier model of similar appearance, the "Elf," which used only two screen-grid tubes and lacked the sensitivity of the later sets, has been superseded by it. The cabinet has the appearance of carved wood; its material, however, being "Repwood," a composition which may be molded to present the appearance of carved wood.

A unique point in the design of the set is the manner of arranging the shielding. Because of the extreme compactness of the design, it was found necessary to devise some special means of reaching the tubes for replacement, without the necessity of removing all the shielding. The result was obtained by designing a "plug-in shield." It is difficult to arrive at a true conception of the size of this radio set by comparing the sizes of its components; since nearly every instrument is special and of proportions smaller than are found in previous radio sets; the exception being the tubes. The tuning gang, for instance, is extremely

compact. Filter requirements have been met by a single 8-mf. Mershon electrolytic condenser. The power transformer has been designed to occupy little more space than is required for an audio transformer. The variable resistor for volume control is of "small space" type; and the fixed resistors establish new standards of minuteness. Each R.F. transformer, of small size, is totally shielded.

The complete receiver (cabinet, reproducer, power and receiving equipment), weighs only 22 lbs.; of which about one-half is the cabinet.

The (discontinued) "Elf" was designed only for local reception; whereas the "Wigit" is designed both for local and distant reception. That it fully lives up to the expectations of its design engineers, this department, after careful test in the heart of New York City, is glad to affirm.

(Continued on page 619)

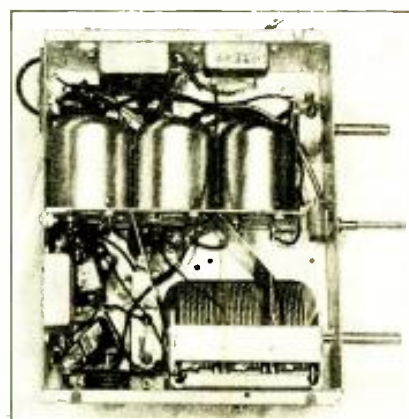
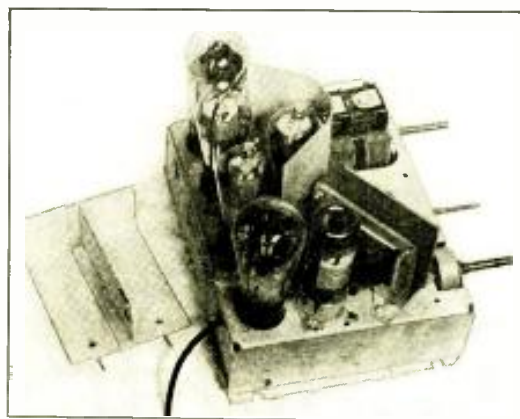

# Practical Hints to Radio Manufacturers

By Radio Users and Service Men

ADJUSTABLE TUNING SCALE

OFTEN a customer complains that the tuning dial, calibrated to kilocycles, reads incorrectly either at one end, or in the center. If the dial were made in about five sections, and held by six screws, the readings could be made to correspond to the positions of the stations, over the whole dial.

K. R. TANTLINGER,  
508 Boyd Avenue,  
Cumberland, Md.

REPLACEABLE CAPACITIES

PRESENT practice of many manufacturers is to assemble condenser blocks for filters in a large tin can "impregnated" with tar. Repairing one of these is the work of several hours. I am sure that these blocks could be assembled, without additional expense, and at a great saving of tar, to facilitate the work of servicing; to say nothing of saving to the customer and reduction of the time during which his set is laid up.

One concern in particular—and there are many more—makes a charge of \$17.50 for replacing a filter block. If only one of the filters goes west—\$17.50. I get lots of Majestic repair work, and I never get over the uneasy feeling that comes to me when I must tell a customer that the charges on

HINTS TO RADIO MANUFACTURERS

Until further notice, each "What the Public Wants" suggestion published here will be paid for at the rate of \$1.00; and their practical value, rather than their ingenuity or curiosity, will determine the selection, since this feature is intended to be of educational value to the radio industry. This means that we ask ideas from our readers, not for new inventions, but for simple details, often very small ones, which they have observed.

his power pack are from \$12.50 to \$22.50; for sometimes an old '80 goes with the condensers. Power transformers are easier, and replacements are made with less expense in the majority of cases. My opinion is that the condenser-block assembly could be simplified so that one or more damaged sections could be replaced.

Educating people to realize that radios do not have the stamina of the old spring-operated phonograph looks hopeless, at times. Allow me, in closing, to say "Darn the tar!"

B. M. ENLER,  
Ponca City, Oklahoma.

COMPLETE LINE PLUGS

MANY manufacturers are sending out their sets with only the cap part of the attachment plugs. This is often embarrassing when the Service Man goes out to hook-up a new set and forgets to take with him a screw-in plug; and the prospect is always amazed to think that the manufacturer of (often) expensive sets does not equip them with both parts of the attachment plug. It is just the lack of such little inexpensive things as this that gives the manufacturer the name of being "cheap," from both the customer and the Service Man.

G. B. GERMAN,  
411 American Exchange Bldg.,  
Duluth, Minn.

HANDIER CABINET TOPS

SERVICE MEN have often experienced difficulty in checking some of the receivers where the top of the cabinet is not hinged. The compartments are so small that it is necessary to grope in the dark to insert the analyzer plug or to change tubes. In some instances, time can be saved by taking out the chassis. It would seem that to provide a hinge for the cover, when

(Continued on page 629)

# The "Universal Super-Wasp" for All Bands

*A short-wave receiver with a frequency-range switch of novel character*

By ROBERT HERTZBERG

**I**N THE "Universal Super-Wasp" receiver, here presented in full detail to the readers of RADIO-CRAFT, a striking advance has been made in the technique of short-wave reception. Difficulties which have been experienced by the short-wave listener have been overcome, after a long period of experiment, by the final design of a waveband-control switch, whose operation will be explained below, as well as many novel circuit features which were evolved in the process of reducing the ingenious conception to practice. The completed receiver is one to which full justice cannot be done by mere illustrations; as the fine points of its construction can be appreciated only by thorough examination. It is, undoubtedly, the most advanced short-wave set yet presented for the public favor.

## Tunes from Long Waves to Short

The standard "Universal" now uses a total of six tubes, including the rectifier. Its big feature, its wavelength-changing switch, eliminates the plug-in coils that heretofore have been the greatest nuisance in short-wave work. The coils are fixed inside the set and are thrown in and out of the circuit by means of a very ingenious pair of rotary cam switches contained in molded bakelite housings. This switch, which is controlled by a small knob on the front panel, has seven positions, which cover seven wavelength ranges as follows: (1) 15 to 23 meters; (2) 22 to 41 meters; (3) 40 to 75; (4) 70 to 147; (5) 146 to 270; (6) 240 to 500; (7) 470 to 650.

This unusually wide wavelength range, probably the widest covered by any short-wave receiver, takes in not only all the short-wave channels, but also the entire broadcast band and even the calling waves used by commercial ship and shore telegraph stations. On the broadcast ranges it brings

**S**HORT-WAVE listeners have found, in the enormous breadth of this interesting field, one of their greatest problems in the past. In place of one tuning range, there were many. No single coil or tuning capacity, no matter what ingenious devices were used, could cover this whole vast radio field from 20,000 to 1,500 kilocycles—thirteen times the width of the upper broadcast band—at full efficiency. And the exchanging of coils, in sets with more than one tuned circuit, and with complete shielding, was a source of constant annoyance. Now, by a most ingenious mechanical and electrical arrangement, described here by one of the four collaborating radio authorities who are well known to our readers, this problem is so effectively solved that the receiver shown here covers, not only the short waves, but the broadcast band and beyond, into the region of long-wave signals. This receiver will be of interest to every prospective short-wave listener, and even more so to those veteran fans who have worked with its predecessors in turn; the "Wasp," the battery-operated "Super-Wasp" and its A.C. successor; which have become familiar throughout the world as successive steps making short-wave work easier and more satisfying.

in stations that are not at all audible on many regular broadcast receivers, the minimum settings of which are sometimes as high as 240 or so meters.

The complete schematic wiring diagram of the Universal is Fig. 1. At first glance this may appear somewhat complicated, but a close study will reveal it to be quite understandable. The set uses one stage of screen-grid tuned-radio-frequency amplification, a regenerative screen-grid detector, one impedance-coupled audio stage, using a '27, and a push-pull output stage using two '45's. For the sake of simplicity, the four antenna couplers permanently mounted inside the set are represented as a single coil (L1), and the four detector coils also as one (L2). Each of these coils has two windings; L1 has a primary and a secondary, and L2 a combination primary and tickler, and a secondary. One end of each winding is permanently grounded; either directly to the chassis or through a non-inductive condenser, as in the case of the primary-tickler. The other ends of the respective coils are

brought to contacts on the cam switches, and they are connected in the proper sequence as the switches are turned.

## Changing Wavebands by Switch

The antenna and detector tuning condensers (C1 and C2 in the diagram) are actually double units; one section of each has a maximum capacity of 130 mmf., and the other of 415 mmf. They have a common rotor connection but separate stators; the latter connections are also brought out to contacts on the cam switches, so that there are 15 contacts altogether on the switches. For the sake of convenience, I designate the small sections by A (as C1A and C2A) and the large sections by B (as C1B and C2B); there is also provided a fixed loading condenser of 0004-mf. capacity to shunt each variable instrument. The coils, in the upward order of their inductance value, may be numbered 1, 2, 3, and 4.

When the wavelength switch is set to the first range, coils No. 1 and condensers A are connected together in each tuned circuit;

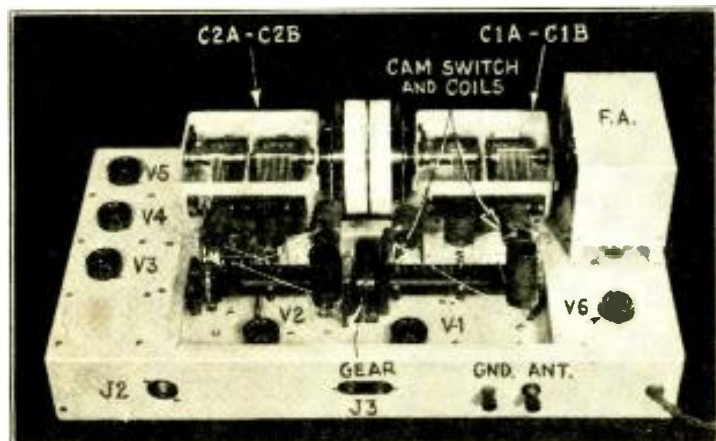

Fig. B

The chassis of the "Universal," from the rear, showing how the "pan" carrying the radio-frequency mechanism drops into the frame. The two waveband-switching coils run horizontally across the center of the picture; six short-wave coils, at right angles, are visible behind them.

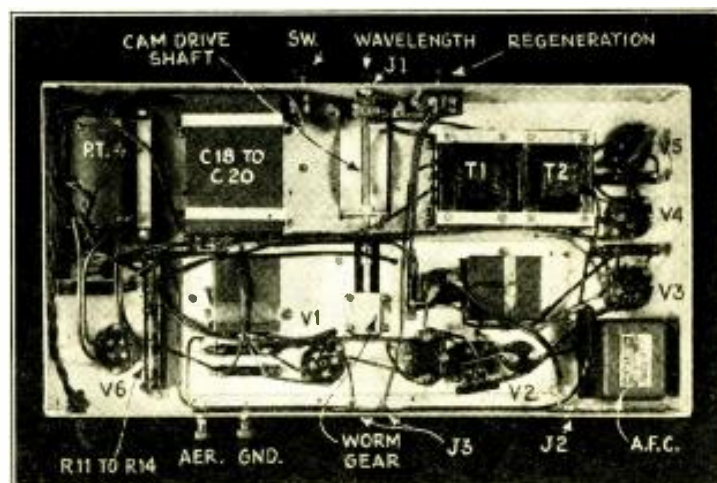
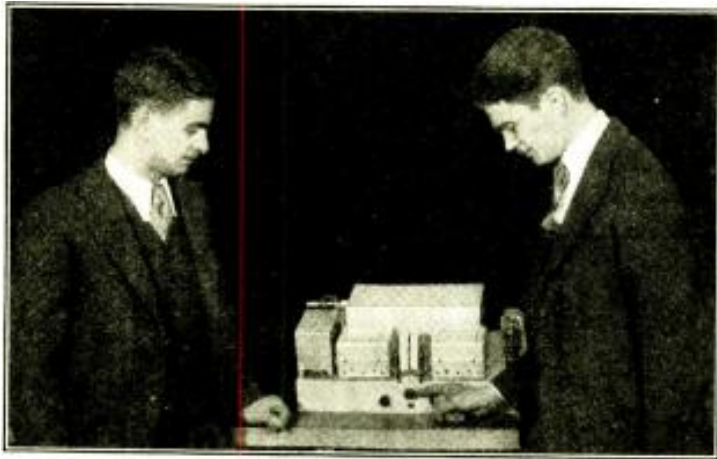

Fig. C

The "Universal" chassis inverted; power units at the left and A.F. components at the right of the tray; while the worm-gear driving the waveband switch appears in the center.



**Fig. A**  
The "Universal" chassis fully assembled, as it appears from the front. Mr. Geloso has his finger on the knob which drives, through a worm gear, the two rotary-cam switches which change the waveband covered by the tuning knob.

plate current from leaking off through the "B" circuit.

Because of the high amplification furnished by the screen-grid R.F. and detector tubes, headphone operation is comfortable only at the first audio stage, so the phone jack J1 is connected in the plate circuit of the '27. A shunt-feed arrangement is used for the plate voltage, in order to keep all

in range two, coils 2 and condensers A; range three, coils 3 and condensers A; range four, coils 3 and condensers A and B; range five, coils 4 and condensers A; range six, coils 4 and condensers A and B; range seven, coils 4 and condensers A, B and C. The shift from one range to another is made in an instant; and it is not necessary to open the set or disturb anything in it.

The primary and tickler windings, of both antenna and detector coils No. 3, are each tapped in one place; part of each winding being used for waveband three and all of it for range four. The primaries and ticklers of the No. 4 coils are tapped in two places, for use on ranges five, six and seven.

**Novel Regeneration System**

The method of coupling the R.F. stage to the detector and the system of regeneration through the combination primary and tickler was adopted after exhaustive investigations by David Grimes and Edgar Messing, radio engineers whose names are well known to readers of RADIO-CRAFT. It is the logical method of coupling for screen-grid operation on the short waves and provides very smooth regeneration, the control of which does not affect the tuning circuits. Thus it is possible to log stations very definitely and to duplicate the dial settings at any time.

**Fig. D**  
The two rotary-cam switches; that at the right is separated to show the parts.

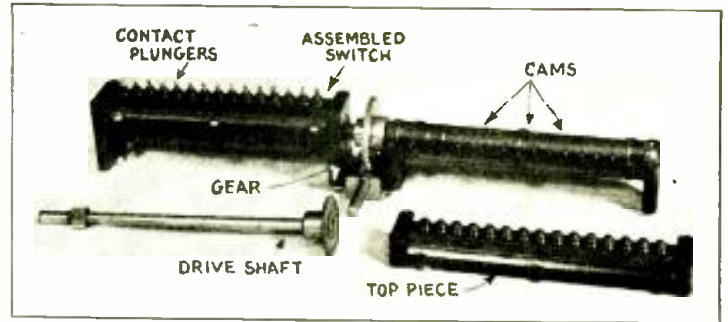

If you will follow the circuit carefully, you will see that the radio-frequency current from the plates of both tubes and the screen-grid of the detector tube V2 is led back to the tickler winding T through C10, (the .00004-mf condenser between the screen-grid and the plate) and C4 (the .0005-mf condenser at the lower junction of this circuit). The R.F. choke coils in the plate and screen-grid leads prevent the R.F. current from taking any other path. The control of regeneration is provided by a 50,000-ohm potentiometer (R10), regulating the screen-grid voltage.

Incidentally, a phonograph pickup jack (J2) is connected directly in the screen lead as shown, and the regeneration potentiometer thus acts as a volume control on the phonograph music.

The plate voltage for the detector tube is fed through a high inductance choke coil (A.F.C.), rather than through a fixed resistor. The choke coil allows the plate voltage to assume the value necessary for efficient operation and, at the same time, prevents the audio-frequency component of the

direct current off the jack. If the jack were made "live," the wearer of the phones would invariably shock himself when he touches the aluminum chassis. The push-pull output stage is of standard design and will operate a regular dynamic speaker at full efficiency. The terrific "sock" of this set can be appreciated only by a person who has actually tuned one.

The "Universal" is exceedingly quiet in operation, the hum scarcely being noticeable. The designers of the set benefited by their previous experience with the well-known "A.C. Super-Wasp," which has developed an international reputation. The entire power pack is built directly on one end of the chassis, this proximity having absolutely no bad effects.

It was discovered that the '80 rectifier tube is a prolific source of R.F. disturbance; so this part of the circuit is protected by buffer condensers (C21, C22), across the high-voltage winding of the power transformer and also by means of an R.F. choke coil R.F.C.3 in the "B+" lead.

(Continued on page 622)

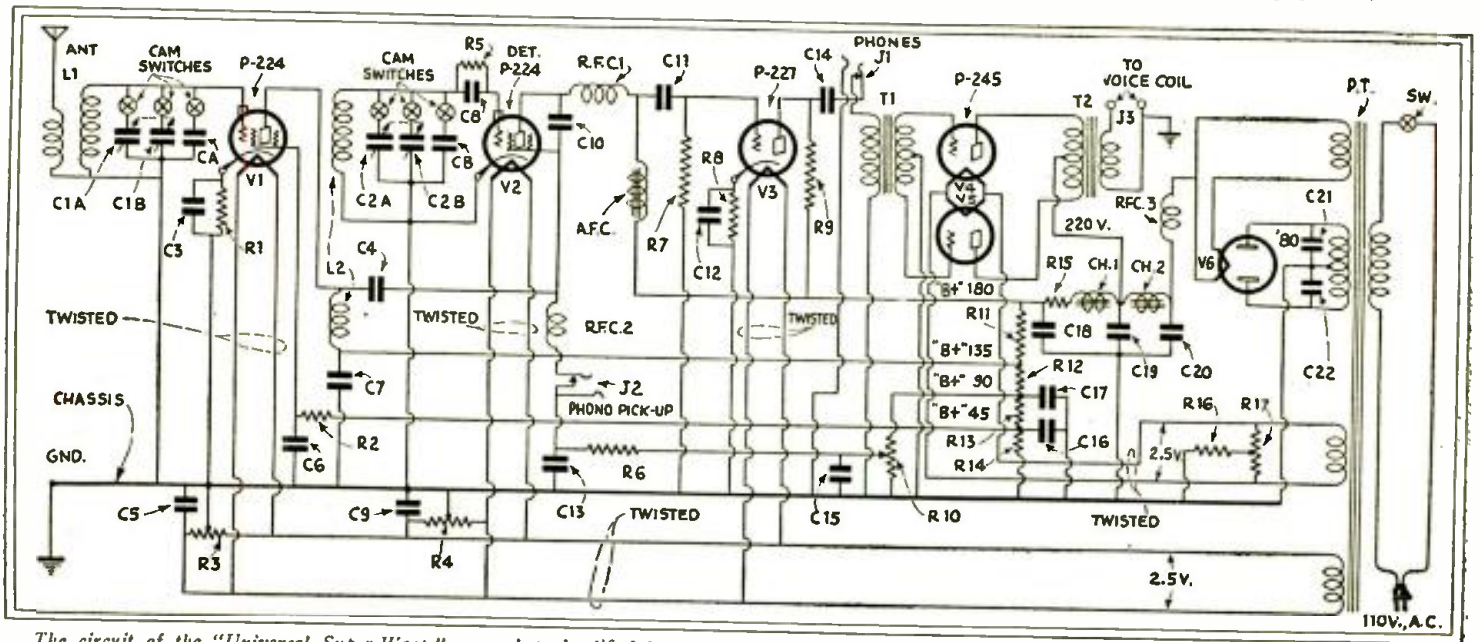

The circuit of the "Universal Super-Wasp," somewhat simplified by the representation of the four sets of R.F. transformers as one. The capacities CA and CB are fixed .0004-mf. condensers used only to tune the highest waveband, above 470 meters. Note the unusual regeneration method.

# A Long-Wave Converter for the Broadcast Set

*A new application of an old principle which presents some interesting possibilities in the way of distant reception, for the experienced set builder*

By CLYDE J. FITCH and C. H. W. NASON

WE are all familiar with short-wave reception of foreign broadcast stations; but few of us realize the great amount of broadcasting of exceptionally good foreign programs which is done with high power on wavelengths longer than those used in this country for broadcasting.

Whether or not these long-wave stations can be clearly received on this side of the Atlantic must depend upon the location and sensitivity of the receiving antenna and the weather conditions. The average broadcast listener does not want to invest in a special long-wave receiver for tuning in these stations—especially if he has already a sensitive broadcast receiver at hand. But the method of receiving them about to be described makes use of any standard broadcast receiver, and avoids the use of a special long-wave set. This system, which was first suggested by Mr. C. P. Mason of the editorial staff of *RADIO-CRAFT*, comprises a simple two-tube adapter unit with a heterodyning oscillator, as in any superheterodyne receiver, for changing the frequency of the long-wave station to a higher value suitable for reception on the broadcast receiver.

In this adapter, the "sum-frequency" (as in the well-known Infradyne system), rather than the "difference-frequency" is employed, in the manner explained below. Under favorable conditions, with a good sensitive receiver and a long aerial, preferably directional toward the northeast, a set owner should have little difficulty in tuning in some of the more powerful of these long-wave stations when using this simple adapter.

Back in 1924, one of the writers used to confuse his friends with the direct reception of programs from FL, in Paris, France, on the long waves. This was long before the advent of short-wave broadcasting.

The rather formidable list of stations accompanying this article is assigned to frequencies below—or waves above—the broadcast band, as it is known on this side of the Atlantic Ocean. The power used in some of these transmitters raises the question, just how many of the programs would be receivable over here with a sensitive receiver? Of course these same long waves are in use over here for ship traffic and for aircraft, radio beacons, weather services, etc.

A super-converter for receiving stations on the higher waves, incorporating advanced design data, is shown schematically in Fig. 1. The method of changing the frequency is quite the same as in any superheterodyne; except that the carrier frequency is beat or heterodyned "upwards" to meet the range of a broadcast receiver. In normal super practice, the signal is beat "downward," to a lower frequency, rather than to a higher one as in the present case. (See Fig. 2.)

When voltages of differing frequencies are superposed, one upon the other, the resultant wave is of a complex nature; it comprises, not only the original oscillations, but "beats" having frequencies representing the sum and the difference of the original components. Our problem is to take signals within the range from 600 to 2000 meters, and convert them into signals within the range of the ordinary broadcast tuner. Let us say that our apparatus must be capable

of accepting any frequency, within the range from 150 to 500 k.c., and "beating it up" (no pun intended) to produce a resultant oscillation which lies between 550 and 1500 kc. and therefore can be amplified by the R.F. system of any broadcast receiver.

If we generate an oscillation just below the broadcast band (let us say at 535 k.c.),

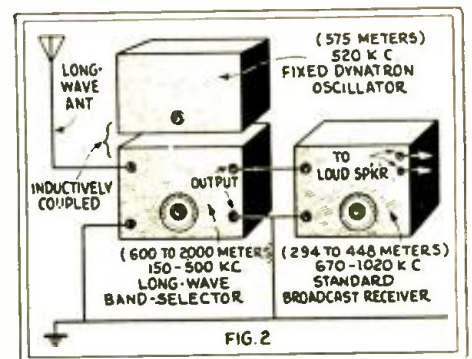

FIG. 2  
A substantial set-up like the above may be made where experiments have shown that receiving conditions are favorable. "B" voltage is supplied by batteries or a small power unit.

and superpose upon it a signal from a station at the low-frequency limit (150 k.c.) of our desired band, the sum of the two frequencies will be 685 k.c., which is within the broadcast band. At the high-frequency limit (500 kc.) of the desired band, the resultant will be 535 plus 500 or 1035 k.c., and still within the range of our broadcast receiver. We have disregarded as unimportant the fact that other frequencies result from the beating together of the signal and the local oscillation.

## Design of the Long-Wave Converter

For simplicity in operation, the converter device illustrated here has been made with a single tuning control, which tunes both windings of a coupled circuit or "band-pass" system. The oscillator adjustment is left fixed throughout the operation of the device; the tuning control of the broadcast receiver being varied to tune in the resultant oscillation, instead of using a fixed setting of the receiver and making the converter a two-control device.

Because of the natural capacity of the antenna, which is impressed across the first coil, a rather large equalizing condenser (C2A) is employed across the second tuning condenser. The tuning and ganging of these two circuits can be readily accomplished with the assistance of one of the long-wave American signals available in the band; as can the logging of the relative dial readings of the converter and broadcast receiver.

The tuning of the oscillator, so long as it is not disturbed after once being set, need

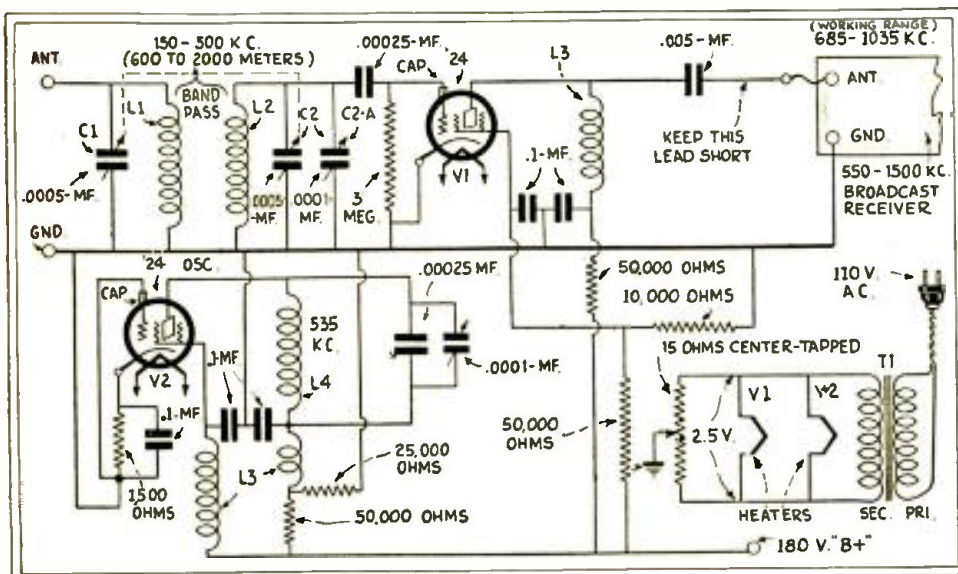
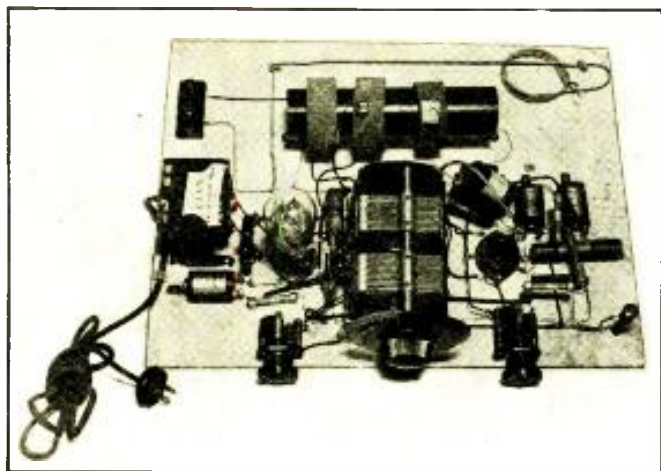

Fig. 1

A long-wave converter, arranged as above, creates a "sum-frequency" heterodyne between the R.F. signal and the oscillations of the dynatron tube V2; the modulator V1 passes this on, amplified, to the input of the broadcast receiver. A small filament transformer (lower right) lights the tubes.





A breadboard layout of the circuit shown on the opposite page, for experimental purposes. The type of oscillator is not essential, but only its frequency; which need not be of the exact value given; since the receiver's range covers three times the frequency range of the upper broadcast band, its tuning arrangement should be a sufficient control, after the converter has been adjusted with due regard to local reception conditions and interference, both on the broadcast band and above it.

airport, the search for the foreign broadcasters may begin. This is done by moving the C1-C2 dial of the converter very slowly across its range with one hand, while the other hand searches the range of the broadcast receiver. Needless to say, the antenna lead from the broadcast receiver to the converter should be as short as possible, to avoid pick-up from strong local stations within the broadcast band.

Values are given in Fig. 1; the coils used are Pacent duo-lateral (honeycomb) L1 and L2 having each 200 turns, and L4 75 turns. Each L3 is a Hammarlund 85-millihenry R.F. choke.

C1 and C2 are a Blan two-gang .0005-mf. bathtub condenser; a large capacity is needed for the long waves; C2A and the shunt across the oscillator fixed capacity are two Pilot 100-umf. midgets. T1 is a Silver-Marshall "247" transformer, of which only the 2.5-volt secondary is used. V1 and V2 were UY-224 Radiotrons, in Pilot five-prong sockets.

(Continued on page 635)

not be exactly to the frequency specified, so long as it is kept outside the broadcast band. In order to accomplish this, set the converter in operation but do not connect it to the antenna of the broadcast receiver. Then tune in some station near the long-wave limit of the broadcast receiver—WMCA at 570 k.c. is convenient for those located in New York City—and run a piece of wire from the antenna over to the converter. Place this bit of wire quite close to the oscillator winding, but do not connect it directly to the latter. Adjust the oscillator tuning until it interferes with the received signal. It will now be tuned to the approximate long-wave limit of broadcast assignments, and a slight further increase in the tuning capacity will place the oscillator frequency beyond the broadcast band. Aside from other considerations, it is necessary to keep the oscillator frequency outside the broadcast band, in order to avoid any possibility of causing interference in neighboring receivers.

Now, to turn to the physical characteristics of the unit we note one marked difference between this oscillator—a "Dynatron" circuit—and that employed in the usual superheterodyne receiver or converter. In the dynatron mode of operation, the screen-grid tube V1 is supplied with a screen-grid potential greater than its plate potential. In this voltage relationship, the tube becomes a "negative-resistance" device; that is to say, the plate current decreases with an increase in plate voltage. The natural negative resistance of the tube counteracts the resistance of the tuned circuit, and sustained oscillation results without the necessity for feedback by means of separate windings in the grid and plate circuits. This gives a remarkably stable oscillator which retains its adjusted frequency over long periods. (See Data Sheet No. 36 [Kennedy, Model 826B], in the February, 1931, issue of RADIO-CRAFT; wherein this type of oscillator—though working on a different principle—is used.)

The various voltages for the two '24 tubes employed are obtained by means of separate voltage dividers in each circuit as shown in Fig. 1. Since it is not advisable to take the "B" supply from the broadcast receiver, the experimenter may use "B" batteries or a small eliminator. Alternating current for the heaters is obtained from a small transformer T1 with a single 2.5-volt secondary.

In operation the coupling between the various windings should be as loose as possible—particularly between the oscillator and the tuning inductances. After aligning the tuning condensers (C1, C2) on some local station, such as a radio compass or

### LONG-WAVE EUROPEAN BROADCAST STATIONS

Kilo-cycles Fre- quency	Meters Wave- length	Location	Watts Rating
153	1961	Angora (Ankara) Turkey .....	2,000
155	1935	Kovno (Kaunas) Lithuania .....	7,000
160	1875	Huizen (sometimes announces "Hilversum"), Holland.....	*8,500
167	1796	Lahti (relays Helsinki [Helsingfors]) Finland.....	*54,000
174	1725	Paris ("Radio Paris") France.....	*17,000
183.5	1635	Konigswusterhausen (Zeesen or Berlin) Germany.....	*35,000
193	1554	Daventry ("5XX"—"National"—programs from London) England .....	*35,000
202.5	1481	Moscow (RAI—"Komintern") U.S.S.R. (Russia).....	40,000
207.5	1446	Paris ("FL" Eiffel Tower) France.....	*15,000
212.5	1411	Warsaw, Poland .....	160,000
222.2	1350	Tunis ("Kasbah") Tunisia, French No. Africa.....	500
222.5	1348	Motala (relays Stockholm) Sweden .....	*40,000
230.6	1304	Moscow ("Trades Unions"), U.S.S.R. (Russia).....	75,000
250	1200	Kharkov ("RV4"), U.S.S.R. (Russia) .....	25,000
250	1200	Istanbul (Constantinople) Turkey .....	5,000
250	1200	Boden, Sweden .....	*750
260	1153	Kalundborg (relays Kobnhavn—Copenhagen), Denmark....	*10,000
268.6	1116	Novosibirsk, U.S.S.R. (Siberia) .....	4,000
272	1103	Moscow ("Popoff") U.S.S.R. (Russia) .....	40,000
279.6	1073	Rostov-on-Don, U.S.S.R. (Russia) .....	4,000
283	1060	Oslo, Norway .....	*75,000
300	1000	Leningrad, U.S.S.R. (Russia) .....	20,000
320	938	Kharkov, U.S.S.R. (Russia) .....	
344.8	870	Tiflis, U.S.S.R. (Georgia) .....	4,000
357	840	Nijni Novgorod, U.S.S.R. (Russia) .....	1,800
375	800	Kiev, U.S.S.R. (Russia) .....	20,000
385	778	Petrozavodsk, U.S.S.R. (Russia) .....	2,000
389	770	Ostersund, (relays Sundsvall) Sweden .....	*750
395	760	Geneva ("Radio-Geneve") Switzerland .....	*1,500
416.6	720	Moscow ("Experimental"), U.S.S.R. (Russia) .....	20,000
428	700	Minsk, U.S.S.R. (Russia) .....	4,000
442	680	Lausanne ("Radio-Lausanne"), Switzerland .....	600
511	587	Hamar (relays Oslo), Norway .....	700
522	575	Ljubljana (Laibach) Yugoslavia .....	*2,800
527	570	Freiburg-im-Breisgau (relays Stuttgart), Germany .....	*300
530	566	Hannover (relays Hamburg), Germany .....	*300
531	565	Smolensk, U.S.S.R. (Russia) .....	2,000
536	560	Augsburg (relays Munich), Germany .....	300
545	550	Budapest, Hungary .....	*23,000

\* Input to Aerial

NOTE: Few of these stations announce by call letters. England and France are 5 hours ahead of New York; Central Europe, 6 hours; and Russia and Turkey, 7 hours—so that it is useless to listen in the late evening.

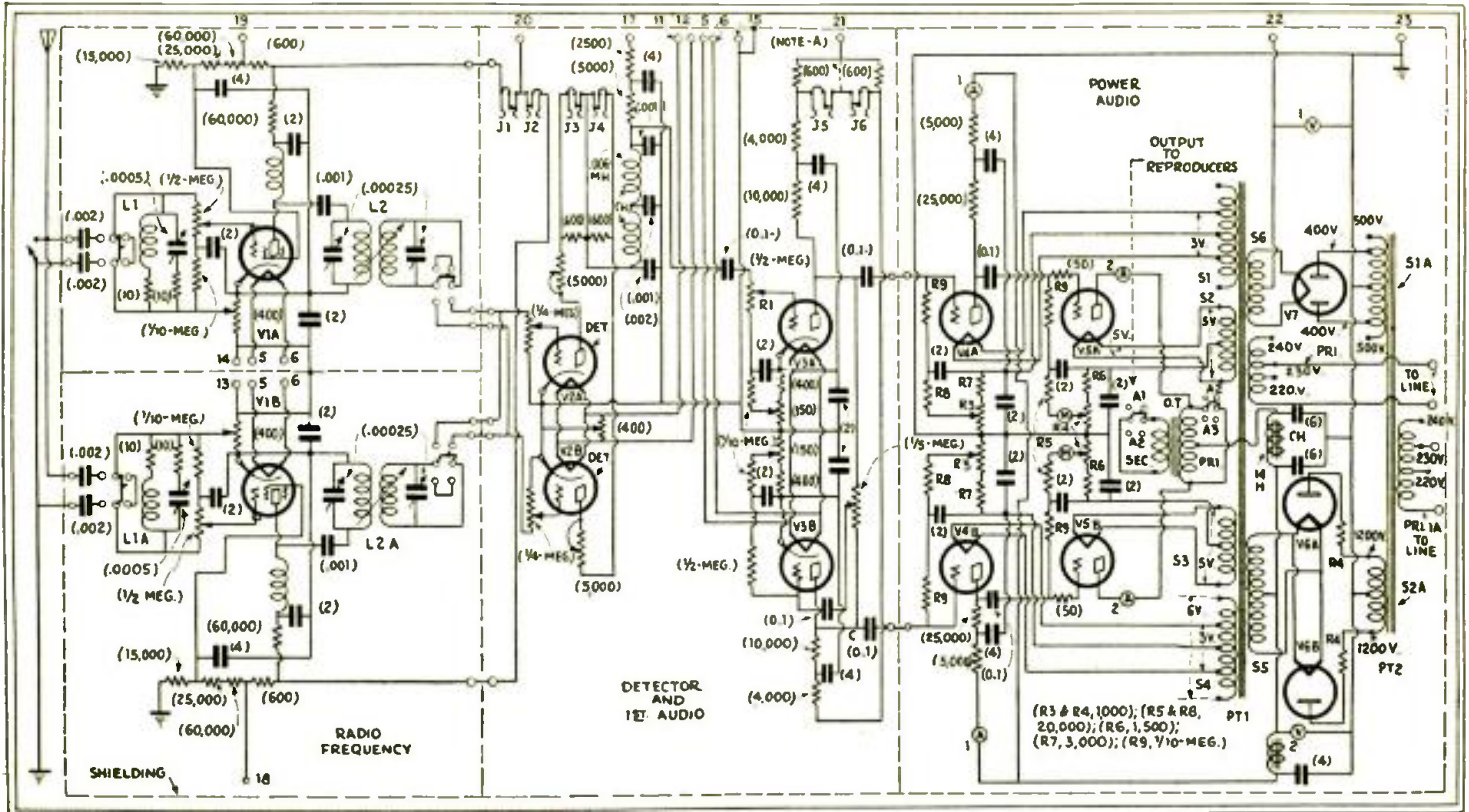

Fig. 1

This extraordinary arrangement is not as complex as it looks, though the degree of filtering used is very high; a portion of the power connections appears below. "Paraphrasing" takes place in the first audio stage, to avoid introducing transformers. The whole is a working exhibit in the Science Museum of South Kensington (London) England; and was designed with the technical advice of the British Broadcasting Co.; tubes are of British types and the design is not fitted for American conditions.

# A Perfect Quality Demonstration Receiver

**I**F YOU had a free hand to design, without regard to cost, a receiver that would give perfect reproduction—so far as any human ear could determine—with tremendous output, what would you build? It is probable that the very interesting design which is reproduced above would not occur to you; in fact, under American conditions, it almost certainly would not. But this is the actual circuit which was designed, after consultation with the engineering staff of the British Broadcasting Company, and which was installed in the Science Museum of South Kensington (London), England.

For the purpose of filling the museum's auditorium with reproduced programs, the receiver is arranged to work into a dynamic unit, connected to a straight exponential horn, 27 feet long, the bell of which is built into the wall of the room, from the outside. The horn itself was made of lead-covered sheet iron, covered with pitch and felt, to prevent any resonance of its own.

Since the primary purpose of the receiver is to reproduce the local transmissions of the two Brookman's Park stations, which afford a Londoner his choice of "national" and "regional" programs, two tuned circuits were provided, and a pair of switches choose between them. The transmissions are well separated—842 and 1,148 kilocycles; and the ten-kilocycle band selectors coupling the R. F. stage are (or should be) sufficient to keep out foreigners and other British stations which, after all, are on the same pro-

grams. While the amplification of the receiver is doubtless enough to pick up many of the more powerful continental stations, this is not its purpose.

## Extraordinary Fidelity

While the R.F. amplification, therefore, is much less than that of an ordinary American commercial set of late design, this receiver is designed for fidelity to the highest degree. The characteristic curve of its performance shows an amplification which is constant, from 9,000 to 300 cycles, within a single decibel; and which falls off from the 1,000-cycle standard less than two db. at the lowest point—around 60 cycles. However, it is necessary to use an output filter to compensate for the characteristics of the horn itself. The receiver, operated considerably below the ratings of its last tubes, therefore gives reproduction of perfect fidelity, with 40 watts undistorted output.

While the set is operated from alternating-current mains, the most elaborate filter systems are employed to isolate different circuits and prevent hum. An automatic switch is arranged to put the receiver on and off at predetermined times; it has a relay which turns on the filaments of the tubes, and permits them to heat, before plate voltage is applied.

It will be seen that every stage is double; though only one R.F. amplifier is used at a time, since one is tuned to longer waves, and the other to shorter. But the push-pull detector, with its highly-filtered plate leads, is novel for broadcast reception, at least (see page 476 of February, 1931, *RADIO-CRAFT*); and the "paraphrase" system of (Continued on page 633)

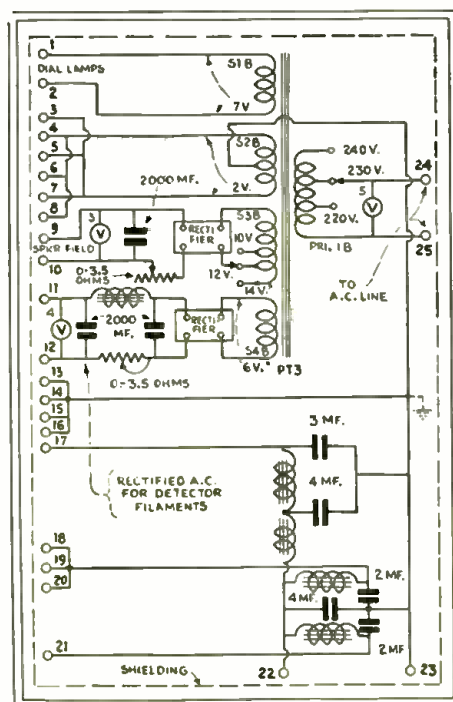

Fig. 2

The terminals connect to those correspondingly numbered in the large schematic diagram.

# Home-Made Intermediates for Supers

*A method of neutralizing these important components which will be of interest to all constructors who can match their circuits*

By JOHN OSTLUND

SOME years ago, when I first started to work with superheterodynes, I supposed that the intermediate-frequency transformers had to be made to peak at about 10,000 meters (30 kilocycles) in order to get good amplification and stable performance.

It did not take long, however, to find that the closeness of the two settings on the oscillator dial made this undesirable. Everyone, who is familiar with these low-frequency intermediates, knows how marked that effect is.

It was, however, easy to remedy this by using an intermediate frequency so high that the two settings are sufficiently separated to enable the R. F. tuning to eliminate the undesired signal.

Other shortcomings of the superheterodyne, however, were not so easy to remedy; at least, they seemed difficult at the time. One was that, although the set may be selective on a loop, it is exceedingly broad when ordinary aerial and ground are used.

However, I have been working for a long time on the development of a receiver which will use any antenna system. Instead of the potentiometer, I use a fixed "C" bias, with a control in the plate lead for regulation of voltage and volume. Squeal and radiation are quite eliminated.

My system is to use intermediates with both primaries and secondaries tuned, but with neutralization to prevent oscillation. I also neutralize the first tuned R.F. stage. The result is a receiver which is easy to handle, and gives distance, volume and good tone with a proper audio amplifier. For ordinary room volume, one stage of audio is sufficient.

It is possible to construct the I.F. trans-

formers in any of several ways; that I employ is to use three discs, 2 inches in diameter, the inner 1/16-inch thick, and the outer ones 1/8-inch thick, for convenience in counter-sinking the screws; with two others 1 inch in diameter and 1/4-inch thick.

These are then assembled on a 1/4-inch rod or bolt, as shown (Fig. 1) so that there is a form with two slots for windings. Two smaller holes, bored on either side of the

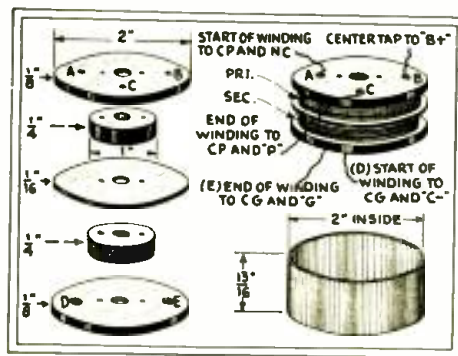

Fig. 1

*The very compact construction of these I.F. transformers is explained in the text.*

center, serve to fasten the whole more tightly.

It is easy to make a coil winder by bending a 1/4-inch rod for a crank. Thread the longer end of the rod so that a nut may be run over it to hold the transformer; a couple of uprights on a piece of board hold the rod while it is turned.

I countersink the two outer discs for small screws, to which soldering lugs for securing the wire are attached by the nuts on the outer side. Then I wind on 84 feet

of No. 32 D.C.C. wire in each groove, tapping one winding in the center. Since it is hard to wind the wire in regular layers, I measure it instead of counting the turns; and I like to take all the wire from the same spool, to be sure that it is of the same size.

The center tap (on the primary) will lead to "B+": the inside or start to the tuning and the neutralizing condensers CP and NC; and the outside lead to the tuning condensers CP and the tube plates. On the secondary, the inside lead will run to the grid tuning condenser CG and the 4 1/2-volt "C" battery lead; the outside lead to the tuning condenser CG and the tube grid. Two-inch bakelite tubing, cut to the right size, will fit nicely over the transformer.

I used Hammarlund 35-mmf. midgets for neutralizing at NC, because they fit nicely to the grid posts of the tube sockets. For tuning, Pilot "Micrograds," with a range from .0001- to .0005-mf., are suitable at CP and CG, as they will compensate readily for differences in the coils. If it were not for the differences of inductance and capacity in the coils, smaller condensers, even as low as 70 mmf., might be used; however, this might necessitate lengthening the wire.

The tuning condensers are fastened to the shields; though smaller components might be attached to the transformers. Individual S.-M. shields are used for these stages. It may not be necessary to shield each stage of the receiver separately, if proper spacing and position is employed; but the whole chassis must be well spaced.

It is very easy to neutralize the intermediate amplifier. Just tune in a strong signal (or use a modulated oscillator); take

*(Continued on page 634)*

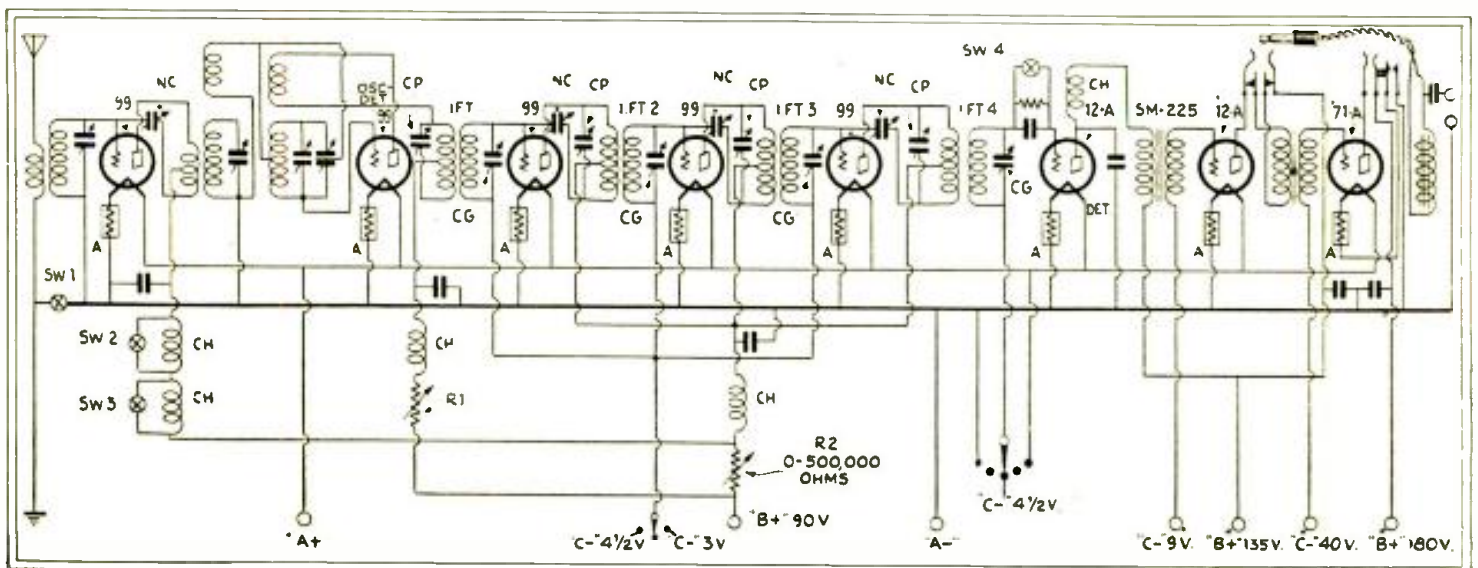

Fig. 2

*One of Mr. Ostlund's experimental models, designed for plug-in coils; the switches Sw2 and Sw3 select the proper R.F. choke for the waveband used. The frequency-changer is a strobodync; a receiver of this kind should be attempted only by a set-builder with much experience.*

# RADIO CRAFT KINKS

## TEST PANELS AND PRODS

By Luther C. Welden

NOT long ago, battery kit-sets were put on the market with drilled front and sub-panels, some 30 inches long. These are now out of date, and the panels can be bought of some salvage stock houses very cheap. By using one of these panels, an efficient test panel can be built without a great outlay of money, especially if a few meters are on hand.

That the panels are drilled does not matter since, with a little care in arranging the meters and switches, etc., these holes may be used or hidden. A tube tester may be included; also an inexpensive ohmmeter for continuity testing. By using Falmestock clips at the bottom for antenna, ground, and battery connections, a receiver may be quickly "hooked up" for test.

The panel may be set away from the "back board" of the workbench by using 2-inch pieces of bakelite or fibre tubing and long screws. Phone-tip jacks may be used at the meters and elsewhere for outside use through flexible leads and test prods.

Good test prods may be made by taking No. 8 insulated wire, (used on light and power lines) and cutting it into the desired lengths; leaving the insulation on except for about 1/2-inch at each end. One end is filed to a point, to the other are soldered the flexible leads and then taped.

Another way is to use hollow bakelite rods of proper length, through which you may pass a No. 12 or 14 insulated light wire. File the tips and connect as the above.

## TUBE-BASE TICKLER COIL

By Louis E. Fay

IN winding tube-base coils for 80 meters or above, it is impossible to wind both secondary and tickler on the outside. A method that I use is to wind the tickler

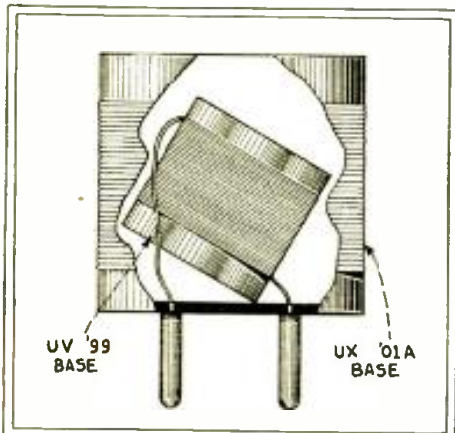

Fig. 1

A tickler for a UX tube-base coil, with fixed coupling, is obtained with a smaller (UV) base.

on an old V 199 base instead of the usual jumble wound coil.

Wind the secondary on the X base as usual. Then take an old V 199 and remove the tube, contacts, and pin. This base will fit inside the large X base nicely. Wind the approximate number of turns on the V 199 base and solder leads to X base contacts. Then vary either number of turns or coupling until proper regeneration is obtained. Then pour in melted wax or paraffin to hold tickler in place.

## A MOVIE ADDRESS SYSTEM

By Russell L. Woolley

A "TALKIE" operator uses the method shown herewith, to make short announcements over his Western Electric sound equipment without cutting into, or breaking the seals of the theatre apparatus. The only equipment needed to do this is a

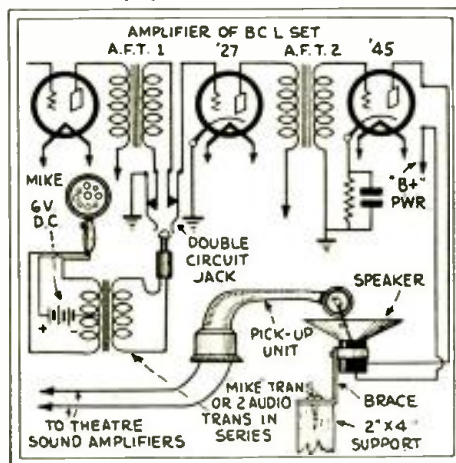

Fig. 2

The mechanical coupling of a pickup to a magnetic speaker gives an input for an audio amplifier.

portable broadcast set, with a double-circuit jack connected across the grid-circuit of the first audio stage of the receiver; a good "mike," a center-tapped transformer; and four dry-cell batteries. Two old audio transformers, with their windings connected in series, may be used in place of the microphone transformer. The broadcast receiver acts as a speech amplifier; the speaker—a magnetic one—is mounted near the pick-up unit of the "talkie" system. When it is desired to make an announcement, the needle of the pick-up is centered on the diaphragm of the speaker unit.

## ADAPTER FOR POLICE BROADCASTS

By P. L. Pennock

MANY set owners have asked me, time again, if it were possible to get the short wave broadcasts of the local police stations on their present broadcast receivers. This may be done sometimes, when the receiver is very close to the transmitter,

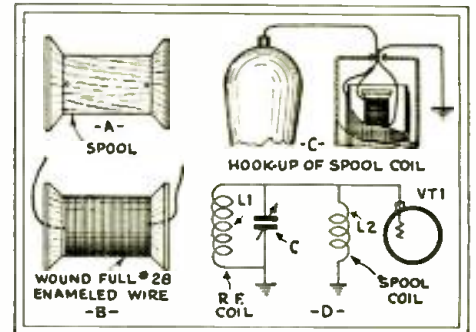

Fig. 3

An additional inductance in shunt across a coil lowers the wavelength, if there is not too much self-capacity.

which works only a little ways below the broadcast band; but, as a rule, a short-wave converter or adapter will be required. However, the method described here involves practically no cost and very little time; though it is true that the arrangement is not very efficient.

Procure some empty thread spools (of the ordinary type) and, at each end, drill a small hole to the center, just inside the flange. (Fig. 3A). Then insert one end of a No. 28 enamelled wire through this hole, leaving at least three inches for a lead; and wind a layer completely to the other end, passing the lead through the other hole (as at Fig. 3B). One of these inductors will be needed for each tuned R.F. circuit in the broadcast receiver, whether R.F. or detector; but none for the antenna coupler, if it is untuned.

If the receiver has screen-grid stages, lift the cap of the connecting lead from each tube until you can slip a terminal lead, from one of these chokes, under the cap and make an electrical contact with both tube and grid lead. Connect the other lead to some grounded point on the chassis or tube shields (See Fig. 3C) and set the spool on top of the regular coil; do this with each tuned stage. In any stage which does not use a screen-grid tube, the spool is connected between the grid prong of the tube socket and the filament side of the tuned circuit. These terminal wires should be polished with very fine sandpaper, until they will make good metallic contacts.

It will be found, when this has been done, that broadcast stations will tune much higher on the dial; and the short-wave stations on police, amateur, television and experimental waves will have come up among the lower readings of the scale. On a Crosley "42S" located here (Canton, Ohio), Louisville, Cincinnati, Akron, Cleveland, Richmond, Youngstown, Detroit and Buffalo have been heard. I would suggest that the local station be expected, but the distant ones merely hoped for.

(Continued on page 616)

# The Radio Craftsman's Own Page

*What our experimental readers have found out for themselves*

Letters concerning hookups asking further details, etc., should be addressed to the writers of these letters, directly

## A RESISTANCE-COUPLED SET

Editor, RADIO-CRAFT:

I have been a reader of this magazine since its birth, and have found no other with so much value to the Service Man and to the experimenter. (I speak in both capacities). I am sending a diagram of the short-wave receiver I have built, because I think it will be useful to some experimenter. I think that it is performing in A1 shape, considering that I use no R.F. or screen-grid tubes. As you see, the amplifier has three resistance-coupled stages; after experimenting with two stages of transformer coupling, one transformer and

C1 is a 7-plate, C2 an 11-plate instrument (capacities not specified); C3, .00025-mf.; C4, .002-mf.; C5, C6, C7, each .006-mf.; C8, 1 mf. R is 5 megohms; R1, R3, R6, 100,000 ohms; R2, 1 meg.; R4, 1/2-meg.; R7, 1/4-meg., R5 is a 100,000-ohm volume control and R8 is a 1-ohm filament ballast. The jack J is used for tuning in with phones. An aerial of about 50-foot length is used.

While the use of screen-grid R.F. amplifying stages before a short-wave detector may not add as high an amplification factor as in the case of long-wave broadcast receivers, it not only gives greater freedom from troubles due to antenna harmonics,

inches square and 7 inches deep, mounting a very heavy unit. The tone from this combination is very beautiful and without noises.

I will be glad to try and help out anyone who wants to know more about this super, and also on a good loud speaker.

GUSTAVE SIMMONS,

228 Wyoming Ave., Billings, Montana.

(Mr. Simmons, like a good many other open-hearted craftsmen, has an idea that he will receive about three letters. He will probably be rather surprised at the number who are willing to enter into unlimited correspondence with him, and perhaps lose interest at the fiftieth. Incidentally, we may say, the least that any inquirer can do is to enclose a stamped and self-addressed envelope; and to make his questions short, so that they can be quickly answered.—Editor.)

## MEASURING SMALL RESISTANCES

Editor, RADIO-CRAFT:

I see some complaints about Mr. Watson Brown's converter from those who could not get it to work well. Well, I was in the same boat; I tried it on a 110-volt A.C. set with a '26 input. No results; I then tried a "B" eliminator and got no results. I then took some "talking tape" aerial ribbon and wound it around every wire; filament leads, "B" leads, aerial and ground. I then mounted the converter and eliminator right alongside of a Crosley "Gembox." Then the fun began; and I must say it has beaten any short-wave set I have yet built.

I am waiting for an article on a super that will give 10-ke. separation in the congested district here; I think there are many other fans who would like to hear more from Mr. Hatry.

Another thing which would come in handy is an ohmmeter with a range from 1 to 5 ohms, to measure shunts for meters and also for dynamic voice coils. RADIO-CRAFT is getting better all the time, and I hope it keeps on till it has all the others put together beat.

CHARLES PRINCE,

329 Seventh Ave., Astoria, L. I.

(Ohmmeters and the recalibration of meters have frequently been discussed in RADIO-CRAFT. See page 564, May 1930 issue; page

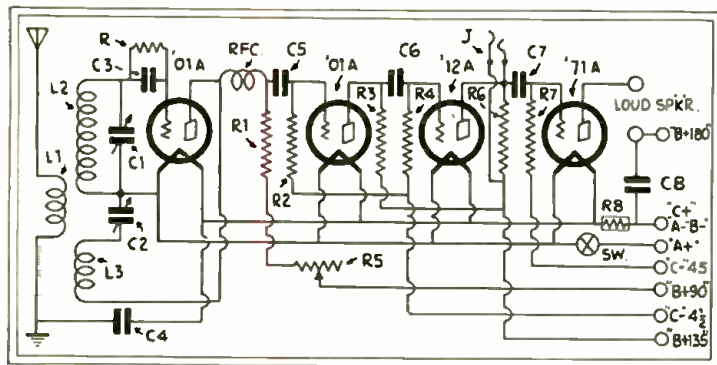

Here is a standard regenerative short-wave detector, to which is coupled an audio channel giving a very good characteristic. However, in short-wave work, just as in broadcast work, advantages of R.F. amplification are appreciable; especially from screen-grid tubes, working into and out of tuned circuits.

one resistance stage, etc., I have found that the set works more smoothly, clearly and strongly as shown. With a stage of resistance coupling following the detector, I can control regeneration more easily. The stations slide in smoothly, instead of hanging in with a squall, as they did with transformer coupling. I think that, if other short-wave fans will try this, they will find their sets working smoother, and will tune in more stations.

I use a "B" eliminator to supply plate current to the amplifier, and two 45-volt batteries, for the detector supply. The set does not work so smoothly when using the power unit for detector plate voltage. With a '71A in the last stage, very good tone is obtained on a Temple dynamic speaker; on which I receive W2XAF, W8XK, W9XF and VE9CI, very loud.

I have 83 short-wave stations logged, in addition to some television stations; letters of verification from PCJ, G5SW, LSX, HRB and XDA; have received GBW, WNC, GBS, WND, CMA, FTF, and some other stations whose calls seem foreign (DFT, LQA, RXC, etc.) but which I have no way of locating. Yours for better short waves.

WAYNE STORCH,

Beecher, Ill.

(The values of Mr. Storch's receiver are as follows: coils are wound on three-inch forms with No. 18 wire, spaced its own thickness; the primary L1 has 9 turns in each case. For 25 to 40 meters, L2 has 5 turns, L3 has 3; 40-80 meters, L2, 10, L3, 5; 70-100 meters, L2, 23 turns, L3 6. Secondary and tickler are separated 1/8-inch in each case.

but prevents radiation from the oscillator. As short-wave receivers become more common, the detector coupled into the aerial will doubtless go, as it has done from broadcast-receiver practice.—Editor.)

## AMONG THE "PROS"

Editor, RADIO-CRAFT:

It is of interest to read the arguments for and against the "Stenode" which you recently described. It has, in my mind, surpassed the best superheterodyne of today, because of its sharpness of tuning and control, for distance getting and picking up noises. As far as its construction is concerned, it is not, nor can it be, more complicated than some of today's manufactured receivers. The whole is yet in the experimental stage; but I am sure that in three years the whole radio system of today must be rebuilt around it; as the only solution to the crowded conditions of today.

M. J. REEF,

Alton, Iowa.

## A LARGE CONTRACT

Editor, RADIO-CRAFT:

I built the "Roll-Your-Own" with a few changes; used Amperites instead of rheostats, .0005-mf. single condensers, and push-pull. The three tuned circuits are in aluminum boxes, the screen-grid tube and coil in a smaller can. For an aerial, I use a five-wire eze, fifty feet long, which I first erected in 1924. For reproducer, I have a large one which I made a couple of years ago from plain airplane cloth; it is 24

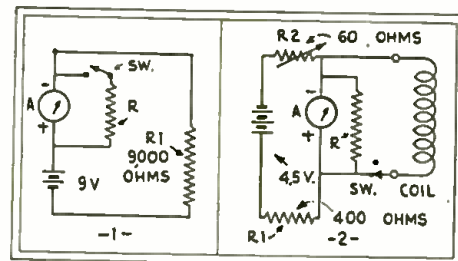

Left, a circuit which shows the ratio of the meter's internal resistance to the shunt resistor R. Right, method of measuring a low D.C. resistance.

177, Sept. 1930; page 266, Nov. 1930; page 482, February, 1931 for a resistance bridge; etc.

In the determination of a shunt for a meter, the meter itself is the calibrating instrument. In the illustration (at 1) the reading of the meter *A* when the switch *Sw* is open, divided by its reading when the switch is closed, is the ratio between the two scales. [This assumes that *R*1 has a

resistance so much greater than that of the meter itself that the latter may be neglected, in considering the whole circuit.] From this ratio subtract 1, to determine the ratio between *R* and the meter's resistance.

For instance, suppose the meter has a resistance of 30 ohms, and a scale of 0-to-1 milliamperes; a shunt *R* is put across it, and the reading drops to 0.25-ma. The ratio of readings is four to one; and it will

take four milliamperes through the parallel circuit of *A* and *R* to produce a reading of one milliamperes on the meter. The ratio of 4, minus 1, gives 3; the meter *A* has exactly three times the resistance of *R*, and *R* is therefore ten ohms.

To prove the calculation, we add the *conductance* of the meter (1 divided by the resistance, as explained in the preceding (Continued on page 616)

## A Home Telegraph and Phone Set

By MILTON E. SAUNDERS

THE hardest part about communication by code is the receiving it; learning to send is comparatively easy, but to understand a message when someone else is sending is another matter. To get the necessary practice, a simple arrangement like that diagrammed here is a valuable assistant. Two circuits, such as are shown in Fig. 1, are connected by a pair of wires. It should be easy to find a neighbor who will be interested in the idea and cooperate.

The features of this system are that a bell on one set can be rung from the other, by means of the double switch; and then, by turning on the set, conversation by phone as well as telegraphic communication is made possible. Voice and code may be transmitted and received, alternately, without changing any controls. The sound of the code messages is just like that of those received out of "the air."

The set-up illustrated herewith was built on the panel of a discarded radio hookup; and covered with black table oilcloth, after new holes had been drilled and the transformer and socket mounted. The panel carries all the parts; it is set into a shallow case, which supports it at the corners.

The "B" supply used is a 12-volt home-made storage battery; but six or eight dry cells would serve as well. This furnishes power for ringing the bell; a heavy-duty battery is not needed, as very little current is required, and for but a short time.

A single earphone is used for the "mike"; being arranged on a suitable support and

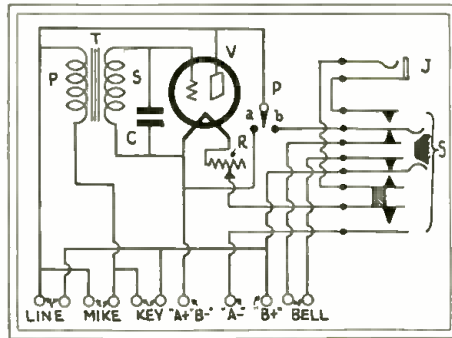

Fig. 1

Circuit of the home practice set, one of which is required at each end of the line; it is simple and easy to operate.

connected to two nickel-plated binding posts which are designed to receive phone tips.

The switch *S* was obtained from a second-hand dealer, having come from an old telephone box; however, any D.P.D.T. switch, with an added make-and-break contact, will serve the purpose. Any suitable junk-box parts may be used for the rest of the outfit.

To operate the set, plug the headphones into the jack *J*, and connect in the batteries, the bell and the key. Before connecting the "Line" wires, joining this set with its companion at the other end, set the switch-blade *P* in position *b*; turn the set on, by the switch *S* and the rheostat *R*; and see if a buzz results when the key is pressed down. If not, reverse the terminals leading to one winding (either the primary or the

secondary) of the transformer *T*. Connect the single earphone at "Mike" in the diagram, and adjust the pitch of the set's note by varying the rheostat *R*.

Then, with the "Line" wires connected, and both sets turned off, the bell of either set may be rung from the other by moving the switch-blade *P* to position *a* for an instant; then return it to *b*. No buzz will result from pressing the key until both sets are turned on.

When leaving the set, turn off the tubes at *S*; this switch also takes the phones off the line and puts the bell on.

The parts used in the set illustrated are: one A.F. transformer (*T*), an All-American type "R-21"; a "peanut" tube and socket (*V*); a rheostat *R* of suitable value; a fixed condenser (*C*) of .001-mf. capacity; a switch-blade and two contacts (*P*); a D.P.D.T. jack switch, with make-and-break (*S*); phone jack *J*; and eleven binding posts.

The accessories are, for each set, a bell or buzzer; a microphone (for which a single earphone may be used, as explained above); a pair of headphones; a telegraph key; a 1½-volt dry cell for the "A" supply; and about 12 volts of "B" supply.

(The "peanut" tube is not readily available in the United States; but constructors on this side of the line, who have no Canadian correspondent, may use '99s or, if they are available, '30s, for the purpose. The batteries and the rheostat value required must be determined by the tube used.—Editor.)

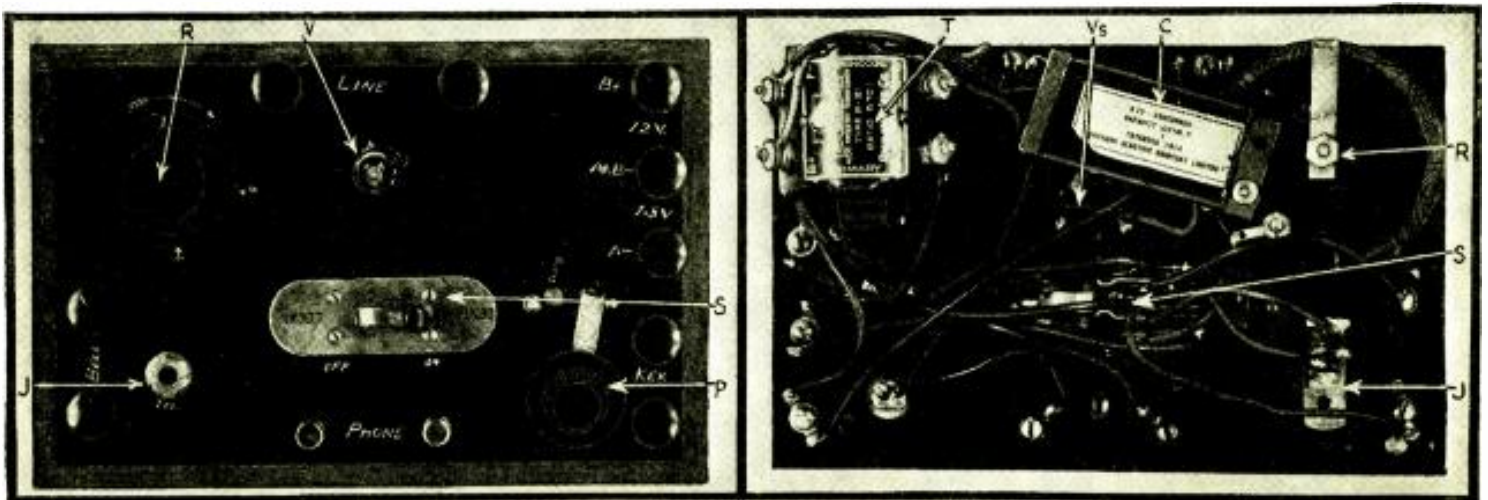

Left, front view; and, right, the back of the panel salvaged from an old receiver, which mounts the home practice set. The key is mounted on the front, which is normally horizontal, and set into a shallow case; any junk-box parts will serve the purpose. The phone communication will prove an added convenience for students.

# An Inexpensive D. C.-to-A. C. Converter

By R. W. OSLAND

FOR the last twenty years, it has been the lot of the writer to build special machinery for special purposes. One of the most pleasurable assignments was a recent one which necessitated harking

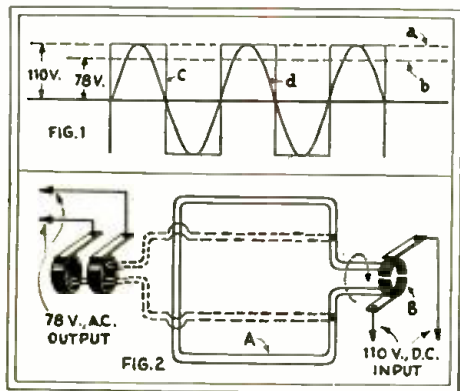

Above, "shapes" of currents; below, how an A.C. potential of 78 volts R.M.S. is derived from 110-volt direct current.

back to almost-forgotten lore on the design of electrical motors, generators, and transformers. Briefly, it was necessary to build a device which would make it possible to operate an A.C. radio set from a D.C. line supply; but the prime requisite was *low construction cost*. The solution to the problem was interesting, simple, effective, and inexpensive.

### Selecting the System

The most common method of obtaining alternating current from a direct-current

in a magnetic field; this coil, the armature, is shown in the figure as a single turn of wire A. The action of this construction is reversible; that is, we may turn the armature A and generate alternating current, (the current being drawn off by means of "collector rings"), or apply alternating current to the armature and cause it to turn. In the latter instance, we have produced an A.C. motor.

However, we are interested in a D.C. motor operable from a light line of 110 volts. And, by reversing the connections at the proper instant it is possible to make our single-turn armature rotate as a D.C. motor; or, by rotating this loop (in a magnetic field) with the aid of a separate motor, direct current may be drawn from the circuit-reverser, or "commutator," B.

Having progressed so far the question arose: "Why not make, to work on D.C. a motor provided with connections to the armature terminating in collector rings, so that the A.C. generated as the D.C. motor armature rotates can be drawn off?"; somewhat in the manner illustrated, by means of our single-turn example. In the answer lie the constructional data to follow. For we have found within the direct-current motor a source of alternating current which, having sine-wave form, is easily filtered.

### The Converter's Components

Our equipment, then, would seem to consist of a D.C. motor specially equipped with collector rings and, perhaps, a small filter

system. An insect in the ointment, however, is discovered upon recollection that it is not possible to take a direct current of, say, 110 volts, change it into an alternating current of sine-wave form, and still have 110 volts. This is made clear by reference to Fig. 1, which shows the "peak" voltage available at A and the "root-mean-square," or average value obtainable after alternating the polarity of the current, at B. For a peak value of 110 volts, an "R.M.S." potential of 78 volts is obtained. Therefore, we find that either a transformer or an auto-transformer will be needed to step the 78 volts up to 110 (or, 115) volts. The completed set-up is shown in Fig. 3.

The D.C. motor must have a removable shaft; and now comes the dirty work—the shaft must be drilled for nearly its entire

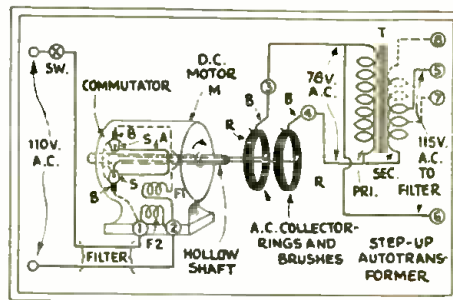

Fig. 3

Interior and exterior connections of a converter. A 15-watt lamp is placed in series with the shunt field of the motor specified, to raise its speed from 1725 to 3600 r.p.m.

length to make a conduit large enough to accommodate two No. 18 cotton-enamelled wires. (See your local machinist.) Refer again to Fig. 3, note that there are two brushes, B; the armature, A (shown, for clarity, as a single turn); field coils, F; and armature segments, S. The two new

(Continued on page 621)

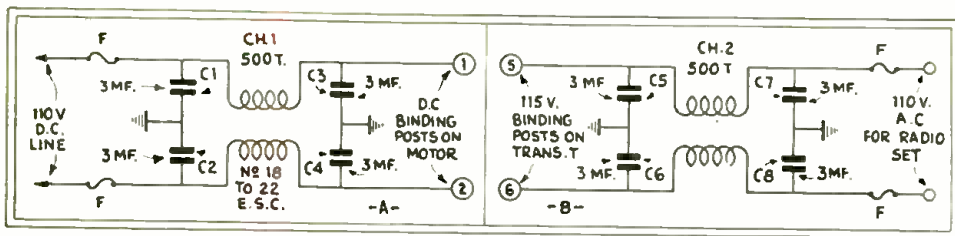

Fig. 5 (above)

Input (C1) and output (B) filters; the former may not be needed. The chokes are wound in the same direction, one winding over the other, on an air-core, 1 inch in diameter, 1 inch long; and taped.

source is to gear an A.C. generator to a D.C. motor.

Although the output of the generator has a *sine-wave* (that is, smoothly variable in amplitude, D, Fig. 1) its output must have a filter in addition to that which follows the rectifier in the radio set. The cost of the three units, motor, generator, filter, was considered to be too great.

The next idea to present itself was an adaptation of the system described in the article, "Obtaining 'B' Power from a Storage Battery," in the July, 1930, issue of *RADIO-CRAFT*. However, a "square-topped" waveform (C, Fig. 1), is obtained by this means and, with such a high-voltage D.C. source (110 volts), it would require a very expensive filter system. Something else had to be thought of.

The next idea, and the one finally adopted, is made clear by reference to Fig. 2. We find that alternating current may be obtained by revolving a coil of wire placed

Fig. A (right)

A breadboard model of the converter; a lamp receptacle, not shown, is required for a "Type SD" motor, as explained above. The apparatus need not be shielded, but should be placed at a distance from the receiver, and its leads twisted.

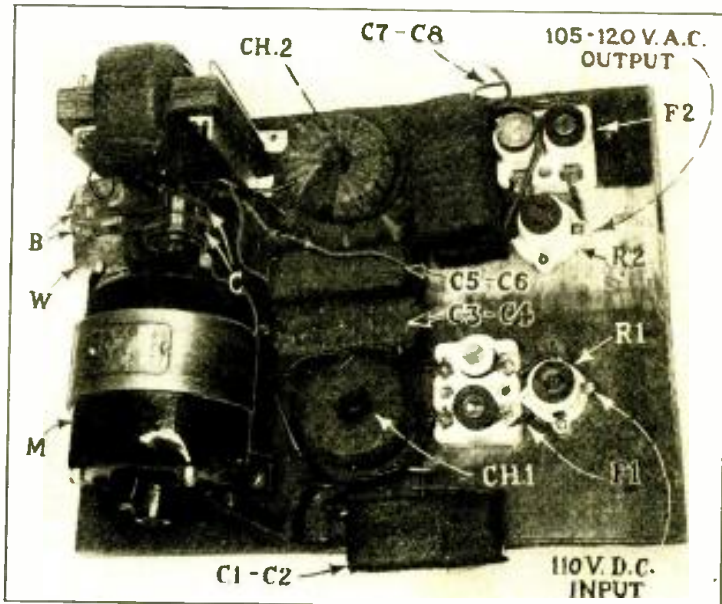

# INFORMATION BUREAU

**SPECIAL NOTICE TO CORRESPONDENTS: Ask as many questions as you like, but please observe these rules:**

Furnish sufficient information, and draw a careful diagram when needed, to explain your meaning; use only one side of the paper. List each question. Those questions which are found to represent the greatest general interest will be published here, to the extent that space permits. At least five weeks must elapse between the receipt of a question and the appearance of its answer here. Replies, magazines, etc., cannot be sent C. O. D. Inquiries can be answered by mail only when accompanied by 25 cents (stamps) for each separate question. Other inquiries should be marked "For Publication," to avoid misunderstanding.

**HOME-RECORDING "STROBOSCOPE"**

(113) Mr. Newton B. Parks, So. Norwalk, Conn.

(Q.) In the article, "Home Recording of Radio Programs and Speech," in the December, 1930 issue of RADIO-CRAFT, the statement is made (page 341), that the "stroboscope" makes possible a satisfactory solution of the problem of maintaining the correct speed of disc rotation for recording and reproduction. How does such a device work; and how can it be made?

(A.) The stroboscope is a mechanical device which depends for its effectiveness upon the "inertia" of the optic nerve, or, more familiarly, the "persistence of vision." By courtesy of the Marconi Radio Co. of Canada, we are able to reproduce two stroboscope discs; one for use where the lighting circuit alternates at 25 cycles per second; and one for use on 60-cycle installations. These are shown in Fig. Q 113, on page 636.

When discs of this type are rotated at the correct speed by a phonograph turntable, the lines appear to stand still when the disc is illuminated by an electric bulb which is lighted by an A.C. supply of the stated frequency.

main trunk. In those cases where the encircling wire is used, no immediate harm will result aside from a certain amount of chafing which may or may not damage the living bark tissue. But, as the trunk or branch grows in diameter, the wire begins to press against the bark. In a relatively short time it becomes deeply imbedded and stran-

"The system suggested will not interfere with the life functions or normal growth of trees. It will prevent much of the needless injury that has often been done to fine shade trees in the past."

Certainly this is valuable data for the Service Man who wants his installation to be as good as possible. We might add that it is well to keep

**Fig. Q.114**

It is much more satisfactory to attach an aerial to a tree by a pulley, as shown, than by winding the wire around the trunk or a limb. Either a spring or a weight may be used to keep the aerial at its proper tension.

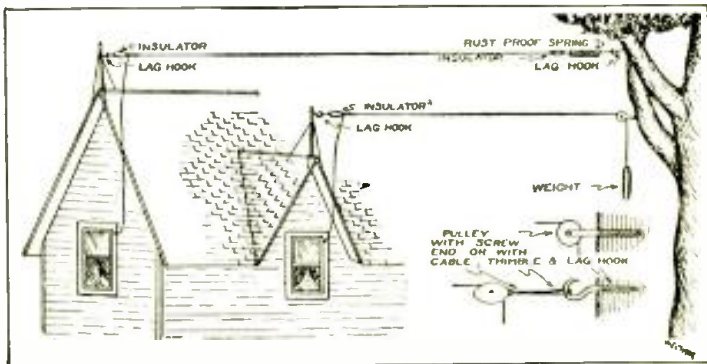

**ATTACHING AERIAL TO TREE**

(114) Mr. Nelson G. Haas, No. Plainfield, N. J.

(Q.1) Is there a "correct" way of "hanging" an antenna between a house and a tree? It seems those installed without due regard for the swaying of the tree do not stay up very long.

(A.1) A propos of this subject we are privileged to quote some interesting information gleaned from the Davey Tree Expert Co., as follows:

"Where radio antennas are attached to trees, the manner in which the attachment is made may determine whether the tree or part of it will be killed. Too often the antenna is fastened by means of a wire that encircles a branch or perhaps the

gulation results, for the sap that flows in the inner bark is cut off by the wire barrier. The death of the branch or trunk quickly follows.

"To avoid the possibility of injury, the safe method is to use either a lag hook or a pulley with a screw end. These should be attached in the manner shown in the illustration." (Reproduced here as Fig. Q. 114). "using first a bit to make the holes in which threaded attachments are to be turned. The hole bored by the bit should, of course, be a little smaller than the diameter of the lag or screw, in order that the threads will hold firmly.

the aerial itself about ten feet from the leaves of the tree; this may necessitate the use of an insulator at this distance from the tree end of the antenna. Of the two methods illustrated above, the weight seems preferable; as most springs, through the action of strong winds, gradually lose their elasticity and are then no longer effective.

**DAYRAD SERVICE OSCILLATOR**

(115) Mr. Manual Smith, Bennington, Okla.

(Q.) Are there any data available on the use of the Dayrad "Type 180" test oscillator; and its circuit connections? What type of tube is used in the 4-prong socket?

(A.) The Dayrad "Type 180" portable test oscillator is a relatively new instrument and there are few service data available in this connection. As shown in the diagram of connections, Fig. Q. 115, a type '30 tube is used as the oscillator.

The procedure to be followed in using this modern service oscillator may be of interest:

First, the black lead of the shielded dummy antenna is connected to the sliding rod just below the unit marked "output control"; the red wire being connected to "ground." (The jack switch marked "550-1,500 kc." and "175-180 kc." should be turned till its pointer is in the former position.) The other end of the dummy antenna is to be connected to the set; the black wire attached to the antenna post and the red wire to the ground. Turning the line switch on now will put the oscillator in operation.

The output meter ( Weston "Model 30" type 653) is removable for observation in the most convenient position. The "output meter connector," with its adapter, serves as the connection between the set and the meter. The latter is connected to the receiver by removing the output tube and placing this in the adapter's tube socket; the plug of the adapter is then inserted into the power-tube socket of the set. The two leads from the adapter are connected to posts C and 3 on the output meter; posts 1 and 2 are used if connection is made, where necessary, directly to the voice coil of a dynamic reproducer or a magnetic, respectively.

(Continued on page 635)

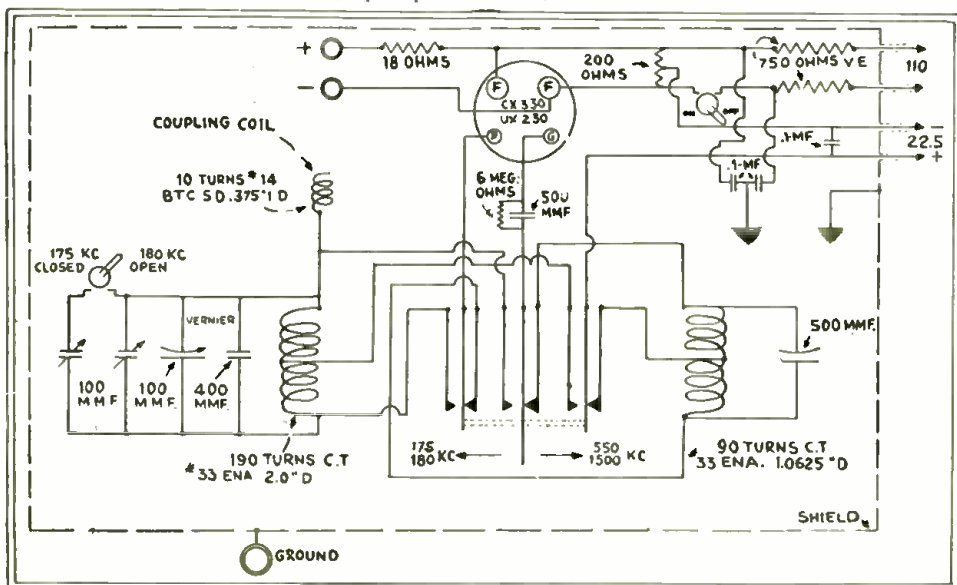

**Fig. Q.115**

The schematic circuit, with values, of the test oscillator illustrated on page 620, which may be operated from either the light line or batteries. A sliding rod is used to adjust the output until the set receives the proper signal.



THE BIGGEST RADIO VALUE IN AMERICA TODAY!

# Official RADIO SERVICE MANUAL

## and Complete Directory of all Commercial Wiring Diagrams

### IN LOOSELEAF, FLEXIBLE, LEATHERETTE BINDER

HUGO GERNSBACK, *Editor*  
CLYDE FITCH, *Managing Editor*

Over 1,000 Illustrations, Diagrams, etc.  
352 Pages — 9 by 12 inches — Weight 3 lbs.

**N**EVER in the history of radio has there ever been published a manual so complete as this new OFFICIAL RADIO SERVICE MANUAL. It is a veritable encyclopedia of service information — worth several times its regular price. It is invaluable not only to the Service Man, but to everyone interested in radio.

For this Manual there has been collected available wiring diagrams and data of nearly every commercial set, of which there is any record, manufactured since 1927, and many earlier ones.

Additional service data for new receivers, as they appear on the market, will be supplied at a trifling cost so that the Manual might be kept up-to-date at all times. But that is not all.

### Service Information

The OFFICIAL RADIO SERVICE MANUAL contains a comprehensive instruction course for the serviceman, giving practical information from every angle on how to service the set. Here are only a small number of the articles mentioned:

- |            |                    |                  |
|------------|--------------------|------------------|
| Antennas   | Eliminators        | Radio-Phonograph |
| Amplifiers | Meters             | Equipment        |
| Automotive | Radio Power Supply | Resistors        |
| Condensers | Systems            | Short Wave Sets  |
| Detectors  | Tubes              | Speakers         |

You simply cannot realize what a tremendous work this is until you have held a copy in your hands and have gone through the 352 pages.

### What They Say

#### NOTHING CAN COMPARE WITH IT

I have received my copy of the OFFICIAL RADIO SERVICE MANUAL. I expected it would be good for I think you know as much as any of them what the average radio man wants, but I'll wager not very many expected to receive a book comparable to this one. I think you deserve a lot of credit for being the first to put out a real service manual that the amateur or professional can make good everyday use of. It's a good practical book and one that every service man will be proud of.—E. D. HANA, Haslett, Mich.

#### BEST BOOK IN THE FIELD

I received your book OFFICIAL RADIO SERVICE MANUAL and I find it is as yet the best book I have found in this field of radio. You are well justified in that this is the peer of service manuals. I wish you all the success possible in the publishing of future books on radio which are sure of great necessity.—WILLIAM R. BROWN, Brown Radio Service, 1110 Buckingham Street, Toledo, Ohio.

#### WORTH A GREAT DEAL MORE

Received your copy of OFFICIAL RADIO SERVICE MANUAL and am greatly pleased with same. It is worth a great deal more than it costs.—HAROLD ARGIER, 41 Butland Ave., Arlington, N. J.

#### A VERITABLE GOLD MINE

I received the OFFICIAL RADIO SERVICE MANUAL. I am well pleased. It is a veritable gold mine for the Service Man.—EUGENE HINFORD, Arkansas City, Kansas.

#### MAGNIFIQUE

Received my copy of the OFFICIAL RADIO SERVICE MANUAL this A.M. "She is what you call him? Magnifique! Exquisite!" A timely aid for the troubled sets. Thanks.—E. BOLCE, 1118 W. Dauphin, Philadelphia, Pa.



**\$3.50**  
A COPY

MAIL COUPON  
TODAY!

GERNSBACK PUBLICATIONS, Inc. R.C.-431  
96-98 Park Place, New York, N. Y.

As per your special offer, I enclose herewith \$3.50 for which you are to send me, postpaid, one copy of the OFFICIAL RADIO SERVICE MANUAL.

Name .....  
Address .....  
City ..... State.....

Prepared Especially for the Radio Service Man!



## Dr. T. O'CONNOR SLOANE Will Teach You at Home!

**A**NYONE WHO CAN READ AND WRITE can study Chemistry through our simply prepared course. You don't need a higher education, and you don't need any previous experience or preparation. Chemistry is not harder to understand than electricity or radio. Just plain sense and ordinary observation powers.

### Laboratory Outfit Free

THE COMPLETE CHEMICAL OUTFIT and APPARATUS supplied to you as part of your course, without extra charge, makes you the owner of a laboratory, containing all the materials and instruments used by a full-fledged chemist. This working kit, which is shipped to you at the outset of the course, becomes your permanent property. It is a sturdy fitted wooden cabinet containing over 100 pieces of laboratory apparatus and chemical supplies.

### We Can Teach You At Home

Our faculty knows just how to mold you into a skillful laboratory worker. THE HEAD OF OUR STAFF IS DR. T. O'CONNOR SLOANE, scientist, engineer and author of wide repute. He has had more than fifty years of teaching experience. Our course fits you for an immediate position in a chemical laboratory, and you do not have to give up what you are doing now to learn it. During evenings and week-ends you can work at home on the fascinating experiments and the delightfully simple but comprehensive lessons.

### Big Money in Chemistry

CHEMISTS ARE WELL PAID MEN. Not only will our training help you to get a better job, but a worthwhile start on a new level. You can patent the work of your hands and your brain, and perhaps make millions of dollars on a new chemical discovery. Every day the newspapers and magazines are full of new items reporting new chemical discoveries—in mining, in electricity, in foodstuffs, in sanitary and medicinal appliances, in paper-making, rubber, steel, iron, dyestuffs, textiles, in fact in every well known industry—and behind each of these discoveries stands a well-trained chemist who knew how to take advantage of opportunity!

### No Exaggerated Claims

THE INSTITUTE DOES NOT CLAIM that every chemist makes millions, nor do we guarantee that you will immediately get a job paying \$10,000 a year. But many have done it and there is no reason why you can not do it too. Often enough you read or hear about men who have found the highest recognition, from small, inconspicuous beginnings, and you wonder how they got the "lucky break." Why, you wonder yearningly, couldn't you be such a "lucky" fellow? You can be—but you have to meet luck half way.

### Get Started Today!

IF YOU WOULD LIKE TO KNOW MORE ABOUT CHEMISTRY, and if you are sincere in your desire to get out of the treadmill of job anxiety and wage dependence, if you have ambition enough to want to become a chemist, and perhaps a famous one some day, you will not wait until tomorrow to find out how to go about it. MAIL the coupon below today. There is no charge and no further obligation. You will be simply asking us to write you about something that you want to know.

Chemical Institute of New York, Inc.  
Dept. RC-431  
19 Park Place, New York, N. Y.

Please send me at once, without any obligation on my part, your Free Book "Opportunities for Chemists" and full particulars about the Experimental Equipment given to every student.

NAME .....

ADDRESS .....

CITY..... STATE.....

## The Radio Craftsmen

(Continued from page 612)

issue) to the conductance of the shunt, to obtain the conductance of the parallel circuit:

$$\frac{1}{30} + \frac{1}{10} = \frac{4}{30}$$

The total conductance of the parallel circuit is four times that of the meter alone; so, while 1.0 milliamperes flows through R1, 0.75-ma. is carried by R and 0.25-ma. by the meter A.

However, while we can adjust shunts to any meter in this manner, we do not learn the resistance of the shunt unless we know that of the meter. To find this out by measurement, we must have some precision standards: a source of voltage of known value, a resistor of known value, or another milliammeter of similar precision. With any two factors known, Ohm's law permits us to calculate the third.

Given, however, a meter the resistance of which is known, we may use it as an ohmmeter [as shown at 2] by the rule which has been given above. It may be necessary, however, to use a shunt on our meter to bring up its scale to a point which permits accurate determination of a low resistance, such as that of a voice-coil.

Let us say that we have put across our original meter a shunt (as at 2) of the value of 3 1/3 ohms; the scale of the 30-ohm movement is multiplied by ten. The effective resistance of the parallel circuit of the meter A and its multiplier R is 3 ohms. Putting a 4 1/2-volt battery in series, by means of the 400-ohm resistor R1 and the rheostat R2, we bring up the current through the entire circuit to 10 ma.; we read 1 ma. on the meter's scale. We then close the switch Sw and put the coil in shunt across the milliammeter; the needle of the latter falls back to 0.4 ma.

By our previous rule, the shunted coil has acted as a multiplier to raise the conductivity of the circuit 2 1/2 times (1 divided by 0.4 equals 2.5). Subtracting 1, again, the resistance of the meter and multiplier is 1.5 times that of the coil. The shunted meter had a total resistance of 3 ohms, we know; consequently, that of the coil is 2 ohms.

It will be observed that we have used a resistance (R1-R2) to lessen errors which would be caused by the internal resistance of the battery, and by the internal resistance of the meter. Out of 450 ohms in the series circuit, only 3 are due to the shunted meter, and the error is less than one per cent. No calculation of this kind, of course, is more reliable than the readings of the meter over its scale; and only with a precision instrument can certainty of any such degree be obtained.

We trust that this will be of help to some of our readers. The little table following may be useful. It shows the ratios of the value of the external resistance R to that of the meter [in circuit 1] as the needle drops from full scale [1 ma.] to the given readings, on R being shunted across the meter.

When Needle of Meter Drops from 1.0 to	Obtain Value of R1 Multiplying Meter's Resistance by
0.95	19.00
0.90	9.00
0.85	5.67
0.80	4.00
0.75	3.00
0.70	2.33
0.65	1.86
0.60	1.50
0.55	1.22
0.50	1.00
0.45	0.82
0.40	0.67
0.35	0.54
0.30	0.43
0.25	0.33
0.20	0.25
0.15	0.18
0.10	0.11
0.05	0.05
0.00	Short

For the value of the meter's resistance in the last column, of course, it is necessary with the arrangement of [2] to take the effective value of the parallel circuit A-R which includes both the meter's movement and the last shunt previously used for resistance calibration—that is, in Fig. 1, R is determined by multiplying A alone by the ratio above; but, in Fig. 2, the coil's resistance is found by figuring from the combination of A and R—a resistance less than that of either alone. It will be seen above that a measurement of this kind is most accurate when the value of the external resistance is nearly equal to that of the meter in combination with its multipliers.—*Editor.*)

## Radio-Craft Kinks

(Continued from page 610)

(The principle of this kink, shown schematically in Fig. 3D), is that two inductances in parallel with each other have an effective value lower than that of either. Our readers may find other ingenious adaptations of the same principle.—*Editor.*)

### ABSENT TREATMENT

**B**ODY-CAPACITY has been dealt a telling blow by an English experimenter who writes *Popular Wireless*: "If there is trouble about"—his short-wave regenerative detector, obviously—"I tune it, right up, even to squealing point; then, at suitable distance, I set an absorption wavemeter, tune it to cut out the transmission, recline at ease, leave the set alone and then revolve the wavemeter alone."

Another form of "losser" which may interest the short-wave fan who likes to recline at ease while tuning in Hajji Hassan's Hennaed Houris, broadcasting from the Hedjaz.

### BLOW-OUT INSURANCE

**I**N England, the radio dealer who sells a set on the installment plan, with a year's guarantee, must keep the tubes in working order or replace them, say the courts.

Evidently the law agrees that "the tube is the heart of the set."

## DeLuxe Two-Volter

(Continued from page 598)

- Three *Silver-Marshall* R.F. shielded coils, type "121" (14, 26, 38);
- Seven *Silver-Marshall* R.F. chokes, type "275" (12, 13, 23, 24, 36, 37, 46);
- One *Silver-Marshall* illuminated drum dial, type "810-R" (25), with pilot light (73);
- One *Electrad* "No. 3 Super-Tonatrol," 50,000-ohm potentiometer type (33);
- One *Electrad* "Truvolt" resistor, type "B-250" (70);
- One *Electrad* "Truvolt" resistor, type "B-30" (71);
- One *Electrad* "Truvolt" resistor, type "C-8," with three extra adjustable taps (72);
- Two *Electrad* filament switches (48, 69);
- One *Flechtheim* midget condenser, .001-mf., type "M-E" (45);
- One *Flechtheim* midget condenser, .006-mf., type "M-J" (47);
- Nine *Flechtheim* midget condensers, .01-mf., type "M-K" (6, 10, 11, 17, 21, 22, 30, 34, 35);
- Three *Flechtheim* by-pass condensers, 1.0-mf., type "B100" (41, 53, 56);
- One *Flechtheim* by-pass condenser, 2-mf., type "B200" (49);
- Five *Durham* "Powerohm" metallized resistors, 50,000 ohms, type "M.F.F" with pigtail terminals (7, 18, 29, 42, 52);
- One *Durham* "Powerohm" metallized resistor, 40,000 ohms, type "M.F.F" (58);
- One *Durham* "Powerohm" metallized resistor, 60,000 ohms, type "M.F.F" (50);
- Seven sockets, "UX-type" (8, 19, 31, 43, 59, 54, 60);
- Five *Amperites*, "No. 631," with mountings (9, 20, 32, 44, 55);
- Two *Amperites*, "No. 630," with mountings (61, 61A);
- Four *Muter* or *X-L* midget variable condensers, 3 mmf. to 50 mmf. (5, 16, 28, 40);
- One *Thordarson* A.F. transformer, type "R-260" (51);
- One *Thordarson* A.F. transformer, push-pull input, type "T-2922" (57);
- One *Thordarson* A.F. transformer, push-pull output, type "F-2903" for dynamic reproducer; or type "T-2880" for magnetic reproducers (62);
- One *Eveready* "Air-Cell" "A" battery;
- Four *Eveready* 45-volt, large size "Layer-bilt" "B" batteries, "type 486";
- One roll of *Corvico* solid-core hook-up wire;
- Eight binding posts (1, 2, 63, 64, 65, 66, 67, 68);
- One aluminum sheet, 14- to 16-gauge, size 15 x 20 in.; cut and bent to form the chassis, which measures 10 x 15 x 2½ in. high.
- Two *DeForest* "Type 430" tubes (43, 54);
- Two *DeForest* "Type 431" tubes (59, 60);
- Three *DeForest* "Type 432" tubes (8, 19, 31).

Diagrams of the "DeLuxe 2-Volter" may be obtained by writing to Mr. Cisin, in care of RADIO-CRAFT, and enclosing a 2c stamp.

### WAVELENGTHS FOR THE MOVIES

JUST below the broadcast band, in the region of experiments, the movies have been granted two wave channels, of 1552 and 1556 kilocycles, for use in facilitating the communications necessary during filming expeditions.

# Groping . . . . Groping . . . .

AGAINST A BLANK  
WALL OF TROUBLE



THE chances are it's resistor trouble—but he doesn't know. And besides, there's nothing to tell him what types and values this particular set requires.

An I.R.C. Replacement Guide in his service kit would make it clear as day. He would be through with this set and on to the next in one-tenth the time he now takes groping in the dark.

Thousands of successful Service Men have speeded up their work with this wonderful Manual—and permanently cured resistor trouble by using I.R.C. Metallized Resistors. You can get the Guide FREE with the purchase of ten Metallized Resistors—or it may be bought for 50c. Loose-leaf sheets are mailed periodically to every holder of the Guide—and keep it constantly up to date. Fill out and mail coupon today.

INTERNATIONAL RESISTANCE CO., Philadelphia  
Makers of I.R.C. Precision Wire Wound Resistors

INTERNATIONAL RESISTANCE COMPANY  
2006 Chestnut Street, Philadelphia  
Gentlemen:—

(CHECK OFFER YOU ARE INTERESTED IN)

- I enclose 50c., for which send me Replacement Guide.
- Please send price list of Metallized Resistors. I wish to purchase assortment of ten, which will entitle me to Replacement Guide free.

Name \_\_\_\_\_  
Address \_\_\_\_\_  
City \_\_\_\_\_ State \_\_\_\_\_

Note:—All orders for Resistors referred to territorial Jobbers.

# The 2nd Supplement

to the

## OFFICIAL RADIO SERVICE MANUAL

# Is READY for Distribution

# NOW!

*SUPPLEMENTS No. 1 and No. 2 to the OFFICIAL RADIO SERVICE MANUAL are obtainable —*

ONE of the most important achievements in recent radio book publishing comes with the completion of the first and second Supplements to the OFFICIAL RADIO SERVICE MANUAL. These Supplements, now ready for distribution, are the beginning of a series which will be published every sixty days during the year. The pages of the Supplements are printed exactly like those in the OFFICIAL RADIO SERVICE MANUAL, and as each Supplement is added periodically it will be kept uniform with the original book in paper stock, (loose-leaf form) and in make-up.

The second Supplement to the Manual brings that useful book right up-to-the-minute with the diagrams and schematic circuits of the latest radio models which have been placed on the market during the past few months, as well as with new information of sets for 1930 and 1931.

With each set of Supplements a new index is supplied. The pages are numbered to enable one to include the new additions in their logical places in the original OFFICIAL RADIO SERVICE MANUAL.

Every owner of the OFFICIAL RADIO SERVICE MANUAL will be sure to be up-to-date in radio if he becomes a subscriber to the Supplements. The cost—only \$3.50 a year—is trifling, when it is considered that it is our intention to publish enough Supplements during 1931 to make the present SERVICE MANUAL more than twice the size it is now!

### Some of the features in the second Supplement

- Completely revised index for the entire OFFICIAL RADIO SERVICE MANUAL.
- Table of trade names in alphabetical order—listing the corresponding manufacturers.
- List of Amperite line voltage regulators for standard receivers.
- Canadian circuits—circuits for which we have had many requests since the original publication of the Manual.
- Technical data of a practical testing oscillator.

#### LIST OF CIRCUITS PUBLISHED IN SUPPLEMENT No. 2

Canadian Marconi	Splitdorf	Priess
Canadian	A.C. Dayton	Garod
Westinghouse	Majestic	Grimes
Sears-Roebuck	Kennedy	R.C.A.-Victor
Amertran	Sparks-	Fada
Knapp "A" Power	Withington	Silver-Marshall
Edison	Robertson-Davis	Telephone
	Lincoln	Maintenance

MAIL  
COUPON  
TODAY!

GERNSBACK PUBLICATIONS, Inc., RC-4  
96-98 Park Place, New York, N. Y.

I enclose \$3.50 for which you are to enter my subscription for the Supplements of the OFFICIAL RADIO SERVICE MANUAL. It is understood that the Supplements will be mailed to me at least six times during the year. No Supplement will be sold singly.

Name .....

Address .....

City..... State.....

SUBSCRIPTION PRICE FOR SUPPLEMENT SERVICE

# \$3.50 A Year

EACH SUBSCRIPTION STARTS WITH SUPPLEMENT No. 1.

This is a very small cost when you consider that for the whole year a Supplement will be mailed to you every other month. Those who already own the OFFICIAL RADIO SERVICE MANUAL have concrete evidence of what can be expected from a \$3.50 investment in the Supplements to the original book.

If you are one who has not yet recognized the importance of owning a copy of the OFFICIAL RADIO SERVICE MANUAL, turn to page 553 in this issue and learn more about this valuable book.

Future issues of the Supplements will be ready at the following dates:

February 1st    April 1st    June 1st    August 1st    October 1st

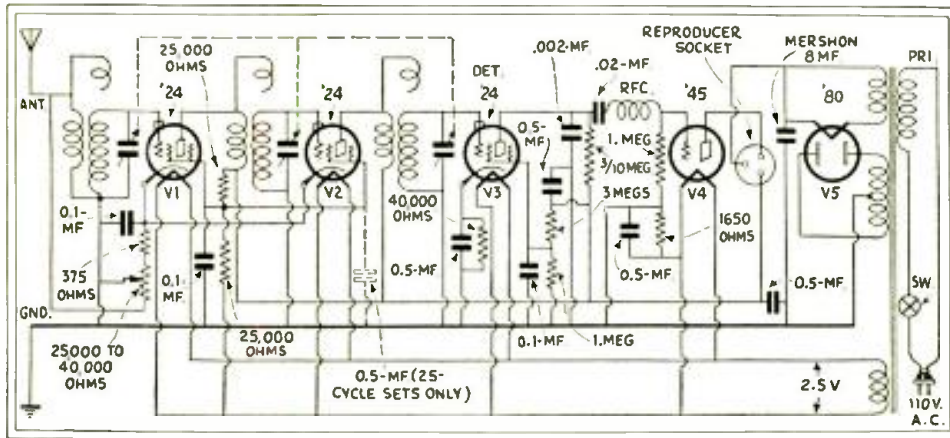

Fig. 1

Circuit of the Crosley "Model 48" or "Wiggit" illustrated on page 603; the small coils attached to the primaries are single turns around the grid ends of the secondaries

## New Radio Devices

(Continued from page 603)

### LINE-VOLTAGE CONTROL UNIT

SO far as we are aware, the "Compensator" illustrated in Fig. 2 is the first device put on the market in such shape as to be adaptable to existing receivers by simple

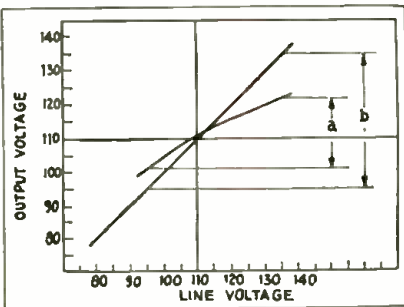

Fig. 3

Input, horizontal; output, vertical.

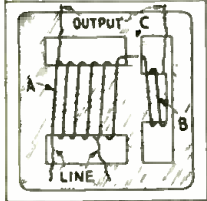

Fig. 2

The "Compensator's" winding is arranged thus on the core.

plug connections, while actually adding voltage to the radio set when the line voltage drops. It is manufactured by the Sola Corporation and is manufactured along sound engineering lines.

The principle of its operation may be comprehended by reference to Fig. 2; the unit

operates as a special type of auto-transformer shunted across the A.C. light line (it will not work on D.C. circuits). Referring to Fig. 2, winding A functions as a standard step-up auto-transformer when the line-voltage drops below predetermined limits; this action builds till normal voltage is reached at this point.

Now, the section C of the core functions slightly under the "saturation knee" of the iron's permeability and, when the line-voltage rises, the increase of saturation in the core section C forces a great portion of the flux through the higher-reluctance path B. This causes an auxiliary coil of opposite polarity to counteract the excess voltage; and the unit thereby functions to deliver a smoothly corrected and steady flow of current. Its characteristic is shown in the graph of Fig. 3.

With an input potential of 95 to 135 volts, the Sola "Compensator" has a capacity of 100 watts. Its installation consists of simply inserting the radio set's plug into the "Compensator," and the plug of the latter into the power-supply receptacle. The unit weighs 7 1/4 lbs. and its dimensions are 3 1/4 x 4 x 3 1/2 in. deep.

### DUPLEX RADIO OUTLET

THE unit shown in Fig. 1 is the "No. 2115" radio outlet manufactured by the Arrow-Hart & Hegeman Electric Co. One-half the receptacle is for the power connection of the radio set; the other the antenna and ground connections for the input circuit of the radio receiver.



.. Get the  
**RADIO TRAINING**  
you need at home  
in your spare time

IN order to help you learn radio in the shortest possible time, RCA Institutes, Inc., was established. You may study radio at home in your spare time . . . or at any one of the Institute's resident schools throughout the country.

It is not hard to study radio the way it's taught by RCA Institutes. You learn radio by actual experience on the latest type of radio equipment. And you need not give up the position you now hold. You can study an hour a day or any number of hours a day at home in your spare time.

The RCA Institutes Home Laboratory Training Course teaches you in a most thorough manner. You learn about servicing and selling, operating, radio telephony and telegraphy...also instruction in sound motion picture installation, maintenance and repairs. And you receive at no additional cost the complete RCA Institutes' home laboratory equipment, a modern outlay of apparatus furnished to every student, enabling you to easily solve radio problems.

### Home Training Course by America's Finest and Foremost Radio Training Organization

This home training course and free laboratory equipment are backed by more than twenty years' experience.

Send for our FREE BOOK Today!

Everything you want to know about radio . . . describes in detail the home training that has placed thousands of men in good paying positions.



### RCA Institutes, Inc.

RCA INSTITUTES, Inc.  
Dept. NP-4,  
75 Varick St., New York, N.Y.

Gentlemen: Please send me your FREE book which tells about the many opportunities in Radio and about your famous laboratory method of radio instruction at home.

Name.....

Address.....

Occupation.....

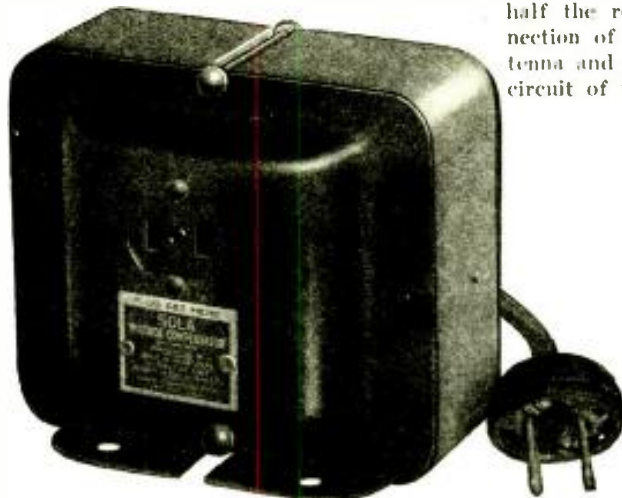

Fig. 1 (above)

The duplex convenience outlet.

Fig. 2 (left)

Appearance of the "Compensator," an automatic line-voltage regulator.

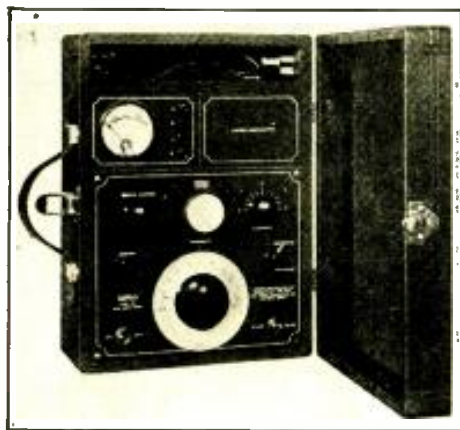

Fig. J

A complete oscillator-meter combination for receiver adjustments and tests.

It presents a neat appearance, due to the use of moulded bakelite. A scored metal dividing plate renders it quite impossible for one-half the unit to short to the other; the scorings make the plate fit properly in the outlet box. Its mechanical proportions are such as to enable it to be mounted in standard outlet boxes, like other electrical fittings; its design has received the approval of the Underwriters' Laboratories.

This two-gang outlet is clearly lettered "power," "aerial," and "ground." However, nothing is left to human error; a "polarized" plug is furnished as part of the equipment.

COMPACT SERVICE OSCILLATOR

IN Fig. J is shown the "Pyrad Type 180" test oscillator, developed by the engineers of The Radio Products Co; its design is particularly flexible and compact. Among its attributes may be mentioned its use as, (a) self-modulated broadcast-frequency oscillator; (b) self-modulated intermediate-frequency oscillator; (c) output indicator; comparator; sensitivity-indicator.

It is a portable unit, using the type '30 2-volt-filament tube. The lighting current may be obtained from either two dry cells in series, or a 110-volt light-line. A 17-ohm limiting resistor is required when the "A" supply is a 4-volt storage battery. A Burgess "B" battery, which completes the current supply, connects to two leads in the battery compartment.

Included in the case are a dummy antenna, an output meter connector with adapter, an I.F. amplifier connector, and warranty and registration cards.

A "TALKING PILLOW"

ALTHOUGH not a new idea, the head-phone-equipped pillow recently put on the market by RCA Victor Co., Inc., and shown in Fig. K, has aroused considerable interest by its novel appearance. It is of regulation hospital size, and made of specially selected sponge rubber in which a sensitive radio reproducing unit is concealed. It is so constructed that, although the sound permeates the pillow, it cannot



Fig. K

There is a radio reproducer in this pillow.

be heard except by resting the head on the pillow.

The new pillow may be sterilized like an ordinary pillow, and the pillowcases changed at will. A long cord is supplied to connect the "singing" pillow to the radio output connections.

It was especially designed for use in hospitals, to replace ordinary headphones which become irksome and chafe when worn for any length of time. The use of a loud speaker is not a solution to the problem; since its operation may be disturbing to patients in various stages of illness. It is useful for insomniacs, or to relieve the tedium of long journeys.

# How Would You Like to Know!

- 1—Where you can save money by purchasing at bargain prices mail order radio merchandise?
- 2—How you can keep posted on "Whats New in Radio?"

## This Hand Practical Portfolio FREE!



Every subscriber to our service receives a 10 by 12-inch accordion portfolio made of a durable material, in which to save the valuable data we send you.

NATIONAL RADIO TRADE DIRECTORY  
303 Fourth Avenue, New York, Dept. RC.

Gentlemen:  
Enclosed please find \$1.00 for one year's subscription to your "Big Mail" and "Radio" Information Service. It is understood that you are to put my name on your stencil list to receive mailings, including catalogs, bulletins, price lists, samples, etc. I am also to receive free a 10 by 12-inch accordion portfolio.

NAME .....

ADDRESS .....

CITY..... STATE.....

- 3—How to receive mail from leading radio mail order houses, manufacturers, jobbers, etc.?
- 4—How to have your radio problems answered; where to locate the manufacturer of a certain product; the name of a jobber handling an item you wish to secure; the manufacturer of a trade-marked product?

Your name is placed on our stencil list to receive for a year's time a constant supply of advertising matter, catalogs, circulars, price lists, samples galore.

You are privileged to write us at any time, questions pertaining to radio trade matters and receive a prompt and detailed reply.

No live radio dealer, fan, amateur, experimenter or professional can afford to be without our comprehensive service. Our business is the nerve center of the radio industry, reaching out everywhere, collecting data from every available source, maintaining the most complete service of its kind in the world.

You will realize that the amount we spend for postage alone does not cover the charge for our service. The \$1 subscription fee barely pays the necessary expenses entailed in mailing.

all \$1  
for

A subscription to our service will actually save you many times the small cost of \$1.00.

If there is any additional information you may require before subscribing, write for further details.

## D. C.--A. C. Converter

(Continued from page 613)

leads through the shaft connect at one end to collector rings; at the other they connect to armature segments.

If the motor is of the "bi-polar" type, the leads are to be carefully soldered to two armature segments diametrically opposite each other, as shown at A, Fig. 4; but, if it is of the "4-pole" type, to four equidistantly-spaced armature segments, as at B. This will result in obtaining approximately 60-cycle A.C., at 78 volts, if the motor has 24 to 28 segments and is a bi-polar unit rotating at about 3,600 r.p.m.; or a 4-pole one rotating at 1,700 to 1,800 r.p.m. The available power output will depend upon the size of the motor; that shown in Fig. A, as M, is rated at 240 watts and delivers sufficient current to operate average 8-and 10-tube electric sets.

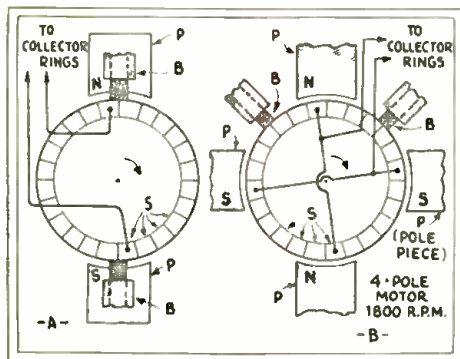

Fig. 4

Collector-ring connections of a bipolar motor (3600 r.p.m.) at A; for a 4-pole motor at B.

The autotransformer used in this installation (T, Fig 3) was made by winding a primary of 400 turns of No. 21 cotton-enamelled copper wire over a form 1 1/4 inches square and two inches long. About 72 silicon-steel laminations, 1/65-in. thick, will fit into this space. Over the primary are wound three layers of Empire cloth, and then, in the same direction, the secondary. (The inside end of this secondary is to be connected to the outside of the primary.) The secondary consists of 225 turns of No. 18 cotton-enamelled wire, tapped at the 150th, 175th, 200th, and 225th (outside end) turns; the latter lead bringing the available output potential to 120 volts (or the same value as the lighting service in most sections of New York City). Lengths of "angle-aluminum," drilled and bent into shape, bolt the core laminations together.

### The Filter System

Adequate filtering was obtained by following the construction and wiring details for the input circuit A of the motor, and the output circuit B of the autotransformer as shown in Fig. 5.

Note that four fuses, F, guard the input and output of the D.C.-A.C. converter. The exact values of the filter condensers will vary in every installation. They depend upon the motor used and the efficiency of the construction, and are to be determined by trial. The writer used individual 1-mf. units of the "replacement" type designed for radio service; building up each bank by paralleling the condensers until the correct degree of filtering was obtained. Each bank

is to be taped. Whether it is desirable to ground the core of the autotransformer and, perhaps, the motor frame, to reduce hum, is to be determined by trial. The motor must be carefully balanced on a heavy baseboard supported on sponge rubber (such as four bath sponges); since any unbalance may cause hum!

### The Collector Rings and Brushes

The details of the collector rings R are shown in Fig. 6. The exact specifications will vary in each instance. The particular construction followed is shown. The flanges F are screwed to the wood pulleys on which the copper rings R are fastened; and set screws hold the flanges in place on the hollow motor shaft (through which run the two No. 18 leads from the motor segments S to these two collector rings.

The brushes are graphite blocks, having the dimensions shown; they are to be curved slightly on the inside surface to fit closely the curvature of the collector rings. The phosphor-bronze springs holding them in place do so only by friction—they are not otherwise fastened to the graphite brushes. These springs, seven in number for each brush, are 3 1/2 inches long, and are soldered at one end. At this end they are to be drilled for two wood-screws; and then are they to be mounted on top of a wood post W, of the correct height for the particular set-up.

The author will be glad to answer inquiries regarding this inexpensive and effective D.C.-A.C. converter, provided return postage is enclosed. Good Luck!

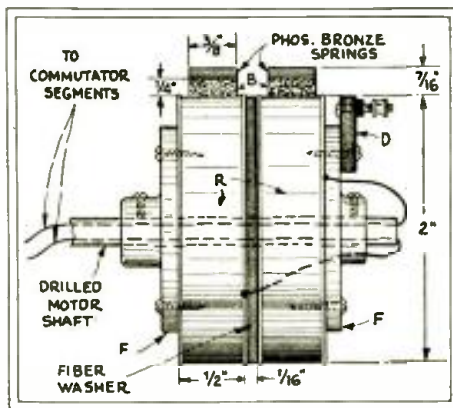

Fig. 6

Details of collector ring and brushes, connection strip D is optional. The dimensions, of course, may be altered to suit the apparatus used

### Equipment Required

One *General Electric* 115-volt Type SD, compound wound motor, 1,725 r.p.m., (28 segments) 1/6-h.p., 2 amps.;

Twenty-four *Radio Trading Company*, No. 1703 replacement condensers, 1 mf. each;

Two *General Electric* porcelain fuse blocks, F1, F2; and two 2-amp. fuses;

Two *General Electric* porcelain screw-type plug receptacles, R1, R;

Four pounds No. 21 cotton-enamelled copper wire (for filter chokes and autotransformer primary);

One pound No. 18 cotton-enamelled copper wire (secondary of autotransformer T);

One roll, friction tape, 1/2-lb. size.  
See text for descriptions of the following material; collector rings, core-iron; collector brushes; baseboard.

## IT'S EASY TO IDENTIFY 1931 TUBES

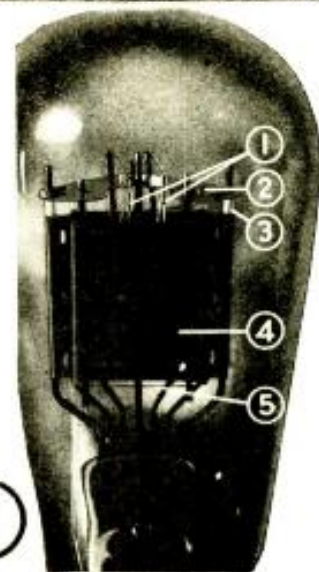

## Look for Power Tube Refinements

The loud-speaker voice can be no better than its power tube lungs. That is why De Forest engineers have spared no efforts in refining power tube design. In the De Forest 445 Audion:

1. Special alloy filament insuring intimate contact between coating and base metal. Extreme ruggedness. Uniform resistance throughout life.
2. Mica spacer maintaining proper spacing of elements for positive characteristics.
3. Ceramic spacers keeping mica spacer clear of grid.
4. Ribbed or reinforced plate insuring uniform operation at all temperatures. Buckle-proof.
5. Molybdenum grid wire—20 times the cost of usual nickel—with extreme melting point permitting complete degasification.

These and many other advanced features found in every type of fresh De Forest Audion, insure the 1931 performance of the 1931 radia sets.

*de Forest*

AUDIONS  
RADIO  
TUBES



DE FOREST RADIO CO.  
PASSAIC, N. J.



# Experienced Service Men!

Have YOU  
had enough  
Experience  
in Radio  
to appreciate  
the need for  
**ENGINEERING  
TRAINING?**

*If so, mail coupon TODAY!*

CAPITOL RADIO ENGINEERING  
INSTITUTE, INC.

3166 Mt. Pleasant St., N. W., Washington, D. C.  
Please send me, without obligation, your new issue  
of "Modern Radio" explaining your advanced  
course in Practical Radio Engineering.

Name .....

Address .....

Position ..... RC-4

*More  
Pleasure  
From  
Your  
Radio  
Receiver*

At last you can retire and relax or read while listening to your radio without the inconvenience of getting up to shut it off or worry of falling asleep and having it turned on all night. Just set the—



## X-L SENTINEL

for the time you wish the receiver to run and—presto—off goes—the music and the light—for thoughtful designing has provided a socket in the Sentinel for your reading lamp as well as one for the receiver.

Used also on window displays and signs, hall lights, night lights, etc. Fully guaranteed.

SEE DEALER—OR SEND DIRECT  
LIST PRICE \$6.75

## X-L Radio Laboratories

1224 Belmont Avenue Chicago

Service men and setbuilders—Write for attractive agency proposition.

# The "Universal Super-Wasp"

(Continued from page 605)

## Assembly on Rugged Chassis

The "Universal" is a marvelous piece of mechanical engineering, being an exceedingly simple set to assemble in spite of its apparent complexity. The chassis is made of one piece of heavy aluminum, so formed that all the radio-frequency units are on top and the incidental power and audio units underneath.

The general appearance of the completed set, without its cabinet, may be observed in Fig. A, showing Jolin Geloso, (chief engineer of the Pilot Radio and Tube Corporation, to whom the perfection of this versatile switching arrangement is due) and the writer. Mr. Geloso is pointing to the wave-changing knob, the indicating scale of which is mounted on a small disc directly above it. The two tuning condensers are controlled by individual vernier dials of the drum type. On the left side of the chassis is the choke-coil assembly, and just behind it the rectifier tube. On the right side are the three audio tubes.

Behind the tuning condensers is the complete R.F. and detector unit; this is mounted on a tray which slips into a large rectangular opening, cut out in the top of the chassis itself. The construction of this tray, which holds the coil and switch assembly, is made plain in Fig. B, which shows the set with the covers of both the condensers and the coils removed. The entire tray unit is supplied with the coils and switches already assembled in place and wired; since these parts are the heart of the set and the wiring must be done properly.

Fig. C shows the under side of the chassis of a completely-wired set. The arrangement of the parts has been worked out very carefully, all the connections being as short and as direct as possible. All the power units are on the left side, and the audio amplifier units on the right, with the R.F. tray between. The entire tray assembly slips very nicely into place, where it is held by machine screws passing into threaded holes. The worm-gear driving the cam switches is coupled to the control knob on the front of the set by a universal joint; the connecting shaft being plainly visible between the white indicating scales of the variable condensers.

## Ingenuity of Switch Design

A close up of the interesting cam switches is Fig. D. The split bakelite housing, a beautiful example of the die-makers' art, is shaped out in the center to accommodate a bakelite rod on which are mounted thin cams or washers, which are slightly eccentric in shape; only small sections of their periphery protruding beyond the surface of the insulating material. These cams make contact with a series of fifteen tiny plungers which are set in the top half of the housing, like the cylinders of an automobile. As the switch is turned by the worm gears, operated from the front panel, the cams make contact with the plungers; the combinations having been laboriously worked out to connect the double tuning condensers to the four fixed coils in the proper order to give the seven wavelength ranges mentioned. This switch idea is the result of

more than a year's experimentation with every imaginable kind of switching device, and is the simplest, most reliable and most efficient scheme yet conceived for the purpose. The capacity between contacts has been reduced to a minimum, and the losses are so slight as to be negligible.

The effectiveness of this switching stunt is simply great. You sit down to the "Universal" and snap on the switch; then you can sweep back and forth from low waves to high waves quickly and comfortably, without wrestling with recalcitrant coils and loose shield cans. If one waveband seems dead, you turn in a second to another; there is always something to be heard, at any time.

The eight coils used in the "Universal" are wound in the factory, assembled in place on the edges of the switch housings, and wired properly to the contacts. The rest of the wiring, to be done by the individual purchaser, is no more complicated than that of an ordinary plug-in coil outfit. The set is a sure-fire outfit, and will work the first time it is turned on. So long as the cams are not disturbed, no trouble will develop, for the sequence of the connections is worked out very thoroughly and exactly.

The following parts values are used in this chassis: C3, C5, C6, C7, C9, 0.2-mf.; C4, .0005-mf.; C8, .00025-mf.; C10, .0001-mf.; C11, .01-mf.; C12, C13, 0.6-mf.; C14, .06-mf.; C15, C16, C17, 1.0-mf.; C18, C19, 3 mf.; C20, 2 mf.; C21, C22, 0-1-mf., buffer condensers. The resistors measure: R1, R2, 450 ohms; R3, R4, R17, 20 ohms; R5, 2 megs.; R6, R8, 2,000 ohms; R7, 1/2-meg.; R9, R10, 50,000 ohms; R11, R12, R13, R14 comprise the regular voltage divider; R15, output loss; R16, 1,000 ohms. Resistor R10 is the regeneration control.

The "Universal" is available with or without a cabinet. The cabinet that is regularly supplied is a plain, handsome walnut affair, and will not detract from the appearance of any home. It might be said that the advent of this receiver marks the graduation of the short-wave set from the cellar or attic to the respectability of a living-room accessory. It is a really fine broadcast receiver and, though it does not have the sensitivity or knife-like selectivity of regular broadcast sets using multi-stage screen-grid R.F. amplification, it is satisfactory for average home entertainment. It has an excellent audio system, which may be used with a phonograph pick-up, as explained before. It is a set that will produce endless hours of diversion, for the possibilities of the short waves are unlimited. There are many hundreds of stations of different kinds to be listened to, and a new thrill awaits the owner every time he tunes in.

Initially, the "Universal Super-Wasp" will be an all-A.C. job, for various line-voltages between 110 and 240 and for 50-60 cycles only. A battery model is definitely scheduled for production, however, and will be designed to use either 601A type tubes lighted from a storage battery or 30 type tubes on dry cells. The battery set will have all the distinctive features of the A.C. model.

On Page 618 you will find an interesting announcement of the Supplements to the OFFICIAL RADIO SERVICE MANUAL. It takes but a few minutes to read of the full particulars about this announcement.



## Tone Control?

(Continued from page 586)

remove noise have resulted in the elimination of some of the high frequencies. The sideband limitation has also resulted in the minimization of the upper audio frequencies. The musical instruments within the knowledge of the average individual are those which produce fundamental tones below the upper limits of the normal audio range. The popular type of music, listened to by most people for many years, has been that in which the low tones predominate. The telephone has caused people to comprehend speech despite the absence of the very high audio frequencies, and to appreciate the presence of the low tones. In fact, everything has favored the low tones and the majority of the people are not conscious of the highs.

Whether or not the present form of tone control can be classed as an improvement, is a subject open to discussion. The tone-control system, wherein the amplitude of the upper or lower audio register can be increased or decreased at will, constitutes an improvement. The present-day form of tone control by capacity or capacity-resistance units, was used back in 1925 and 1926, and is therefore not new. It introduces distortion, but it offers the advantage of permitting a change in reproduction to satisfy the desires of that tremendous number of people who prefer low tones and dislike high tones. Certain types of cheese may seem too odoriferous to many people and offend their fine sensibilities while hundreds of thousands find such cheese pleasing to their palates.

(And the moral is, we presume, that the successful cheese merchant makes his profit by furnishing his customers with the flavors and odors which they prefer, without regard to the brands which he puts on his own table. Or, as the old Roman said, *De gustibus non est disputandum*; that is, tastes are not to be disputed about, but satisfied. —Editor.)

## Operating Notes

(Continued from page 587)

usual arrangement; a filter choke is used in each side of the line, in addition to the speaker field, which is in the negative line.

An open 250,000-ohm leak resistor, between the secondary of the last audio transformer and "B—" in the Radiohn "66" super, has been found the cause of irregular reproduction; its position is indicated by R in Fig. 3.

In the Victor "RE-45" phono combination model, a hum which is exceedingly difficult to contend with may be encountered. The fact that '26-type tubes are used may furnish the average Service Man with an alibi; however, the hum due to these tubes should be hardly noticeable, and may be considered negligible. The first step is to be sure that every tube is perfect; the '45s or the '27, if of low emission or gassy, will cause a loud hum. The hum balancer should be regulated in the usual manner. Some receivers of this model were released without the bypass condenser connected across the first filter choke, which appears in the later

# THE NEW 1931 TROUBLE SHOOTER'S MANUAL

By JOHN F. RIDER

is now being printed and will be ready for distribution early in March.

The tremendous ground covered by this book cannot be described in an advertisement. It is the most complete that is possible to compile. It includes practically all receivers, power amplifiers, eliminators and public address systems produced since 1920. The majority of popular kit receivers manufactured since 1920 are also included.

A feature of this book is that trouble shooting data is complete with electrical values, color code, socket data and voltage data!! Chassis layouts!!

More than 800 pages and more than 1500 diagrams. Loose Leaf. Mounted in a beautiful leatherette binder.

Nothing that we can say in this advertisement will show the value of this book. It will save you many hours and dollars or labor. Send for descriptive literature.

800 pages. More than 1500 diagrams. Size 8½ x 11 in.  
Price, \$5.00

### OTHER BOOKS BY JOHN F. RIDER

Practical Testing Systems. 147 pages. 5 x 7½ in. \$1.00  
Practical Radio Repairing Hints. 262 pages. 6 x 9 in. 2.00  
Mathematics of Radio. 127 pages. 8½ x 11 in. 2.00

### TWO NEW BOOKS NOW BEING PRINTED

Ohm's Law. 96 pages. 5 x 7 in. \$1.00  
Peculiarities in Commercial Receivers. 128 pages 1.00

## RADIO TREATISE CO., Inc.

1440 Broadway - - - New York City

**Makes Your Radio BEHAVE!**

Free Bulletin

The New AMPERITE for electric radio improves reception—makes tubes last longer. Eliminates disturbing line voltage fluctuations. No radio can be modern without it.

AMPERITE Corporation  
301 BROADWAY, NEW YORK

**AMPERITE**  
Self-Adjusting  
LINE VOLTAGE CONTROL

## New, Complete ELECTRAD CATALOG

36 pages of helpful information on Radio Resistors, Voltage Controls and Amplifiers — for manufacturers, service men and experimenters.

Address Dept. RC-4. Enclose 10c. (stamps or coin) for mailing cost.

175 Varick St., New York, N.Y.  
**ELECTRAD**

# And Now!



Television — radio's latest and greatest wonder — **IS HERE** — not tomorrow, not next year, **but right now** — **TODAY** — 27 STATIONS IN THE UNITED STATES ARE BROADCASTING TELEVISION DAILY. In London, plays are being broadcast by television. In Berlin, television shows are on the stage. In New York, the National Broadcasting Company has its television studios, while the Columbia Network is about to broadcast television. **THESE ARE FACTS, NOT THEORY.** Sometime this year, the long awaited television boom will break. Fortunes will be made. There will be opportunities untold for every wide-awake Radio Enthusiast. Whether you are an engineer, you must keep up-to-date in television that you cannot afford

50c The Copy On All Large Newsstands

just a "looker-in" fan, a Service Man, a professional or an authority, So much is happening daily in television that you cannot afford to be out of the picture. **WILL YOU BE READY WHEN THE BOOM COMES?** TELEVISION NEWS is the answer. Edited by Hugo Farnsworth, Editor of RADIO-CRAFT and SHORT WAVE CRAFT; you just know what to expect from him. Look at the list of contents of the first issue—TELEVISION NEWS. Mr. Hugo Farnsworth's latest and greatest, ultra-modern magazine, is in a class by itself. There never was anything like it. Look at the list of contents of the first issue—TELEVISION NEWS. Mr. Hugo Farnsworth has imported articles from German, English and French authorities as well.

### PARTIAL CONTENTS OF THE MARCH-APRIL ISSUE

- And What of Television? by Dr. Alfred S. Goldsmith, Vice-President and General Engineer, Radio Corp. of America
- A Word on the Future of Television, by Dr. E. F. W. Alexanderson
- Television Images in Natural Colors, by Dr. Herbert E. Ives, of the Bell Telephone Laboratories
- What Shall We Do for Television? by Harold A. Latham, of the Federal Radio Commission
- The Newest Television Program, by Austin C. Cockaday, Famous Radio Expert
- Television in the Theatre, by C. Francis Jenkins, Emeritus of the Jenkins Television Corp.
- A New Electrical Scanning System Without Discs, by D. E. Knight, National Known Authority on Television
- Complete Television Hints, by Philo T. Farnsworth
- Television in Twelve Colors, by C. H. W. Nason, E.E.
- Solving Some Television Problems, by Clyde J. Eltch, Well-Known Radio and Television Writer
- Practical Television Hints, by H. Wulheid Seeger, Radio and Television Specialist
- How to Build an A.C. Television Receiver, by C. H. W. Nason, E.E.
- The Future of Television, by E. E. Shumaker, President of R.C.A. Victor Company

Beginning in this number **COMPLETE TELEVISION COURSE** By C. H. W. Nason — Nationally Known Television Authority

Besides these features, TELEVISION NEWS is chock-full of how-to-build and constructional articles on television transmitters and receivers. Then there is a question and answer department which you will cherish. TELEVISION NEWS is not technical. It contains articles that can be understood by all. It brings television down to earth.

Over 175 Illustrations, Hook-ups, Circuit Diagrams, Sketches, Dozens of Actual Photographs of Television Receivers, and a Wealth of "Meat."

**MAIL COUPON TODAY!** RC-431

TELEVISION NEWS, 96-98 Park Place, New York, N. Y.

Gentlemen: As per your special offer, I enclose herewith \$2.00 for which enter my subscription to TELEVISION NEWS for one full year.

Name..... Street..... City..... State.....

**PUBLISHED ON THE 15th OF EVERY OTHER MONTH**

**March-April Issue Now On Sale**

**SPECIAL OFFER! Void After April 15th**

The regular price of TELEVISION NEWS is \$3.00 a year (\$3.50 foreign). Up to April 15th—if you use this coupon—we will accept \$2.00 (\$2.50 foreign) for a full year's subscription. **THIS OFFER WILL NOT BE MADE AGAIN.**

product; if this is lacking, it should be supplied (Fig. 4). A capacity of one-half to one microfarad will do. If the hum still persists, examine the phono-radio switch; the two screws holding the fiber washers and the contact springs together may have loosened under vibration. If so, tighten these screws firmly.

Intermittent reception, in Zenith "Models 10, 11 and 12," was formerly very perplexing to some Service Men. One set would work well for some hours and then, seemingly without cause, it would start and stop spasmodically. As soon as it was touched, reception became normal again. For this reason, it seemed impossible to locate the trouble. Every component tested correct; tubes were changed to no avail, condenser plates were checked for alignment, and all bypass condensers were tested for leaks. Bouncing and striking the set would not cause the trouble to reappear; and the trouble continued to be mysterious. Then the chassis was placed on the floor and all wires were pulled, in an effort to locate the loose contact. At last, when a hold was taken on the set to turn it to another position, a Service Man unintentionally laid hold of the blocking condenser of the resistance-coupled stage; and the set began to act spasmodically again.

This condenser is riveted to the chassis; when it was removed, it was found that part of the foil was not completely covered with pitch, and vibration of the chassis would short the condenser. On some sets, while this took place, the reception was only impaired by the shorting of the grid side of the condenser. With the plate side shorted, reception was entirely cut out. The remedy is replacement with an 0.1-mf. condenser, or taping and insulating the original component so that a short cannot occur again. (See Fig. 5).

## Service Men's Notebooks

(Continued from page 589)

was, however, a short between high potential and ground, which was traced to the socket of the power tube—one of the sub-panel type, universally used by manufacturers. And someone had used acid-solder when replacing a socket which he had deemed defective.

### UNUSUAL INTERFERENCE

By R. W. Watson

"INTERFERENCE" noises can be traced to unexpected places. Such was the case with a new Victor which I was called in to service; a terrific noise had suddenly developed in what was usually a very quiet location. A quick preliminary check of the set revealed that the trouble was not in the instrument itself, while a portable super-het very quickly determined that the interference was extremely local. Following the routine indicated by my findings, I began a check of the light bulbs which were burning at the time. The trouble was in almost the first one turned out; it was on the point of burning out and was arcing. A new bulb—and everything was okey.

In an Audiola screen-grid set, which the owner said might operate properly for an

indefinite period, but would cut out; the peculiar fact was that it would come on loud and normal when the electric refrigerator in his home switched on. Meter readings of all voltages were taken in my laboratory and tubes were carefully checked; no abnormal condition could be detected. After a minute inspection of each and every piece of apparatus had systematically proceeded to the third R.F. coil, the low-potential end of the secondary winding was found to be entirely severed; the ends of the broken wire were held in place, and in partial contact, by the collodion with which the coil was coated.

The owner of a Zenith set reported that it faded badly, but snapping electric switches in the room might bring it back to normal volume. The fault was found in a defective grid suppressor.

**POLICE SIGNAL INTERFERENCE**

By J. R. Steen

I WAS told by a member of the police force, on electrical maintenance duty, that he had a blinker, on a certain corner, which kept a woman awake at night by flashing through her window. I did not see any way to remedy this, if she did not wish to pull down her shade; but he went on to say that other families complained the blinker interfered with their radios.

I tested the motor, with a receiver in the same room: connected a 1/2-mf. condenser across the make-and-break contacts; connected two 1-mf. condensers across the line in series, with the common terminal to ground; shielded the motor's input leads and the motor. All this decreased the interference only slightly.

A little more experiment showed that a single 1-mf. condenser across the line, if the condenser leads were not more than about an inch long, would completely cut out interference from the blinker motor. It was also found that 1/2-mf. was just as good as the larger capacity across the make-and-break contacts.

**Testing Equipment**

(Continued from page 592)

struction of the tester. A complete schematic drawing (Fig. 1) and panel layout (Fig. 2) are given. Of particular importance are the exact locations of the toggle switches, which will be described at greater length. The following parts are needed to construct the analyzer: carrying case; panel; 0-1 D.C. milliammeter A; 0-3-15-150 A.C. triple-range voltmeter V; six toggle switches; five S.P. D.T. three-contact toggle switches; necessary resistors (see diagram); a UY socket; UX and UY adapters; ten feet of 6-wire cable; a test plug composed of holder and UY tube base; nine binding posts, test leads, hardware, hookup wire, etc.

As stated before, the toggle switches are the heart of the circuit. Close observance must be given to the panel layout and the schematic diagram, in order to wire the switches in their proper terminals and positions. When all toggle switches are thrown to the left, all the meters are in the "off" or standard position; this is indicated in the diagram as the top position. Throwing the toggles to the right, and in certain

combinations with each other, produces the proper circuit connections. When they are thrown in the proper sequence, it is possible to obtain the desired readings.

For example, we wish to test a socket using a '27 tube; for filament voltage, we throw S-1 to the right (that is, the 3-volt meter tap). For plate current indication, we throw S-5 to the right, and then S-4 to the left for the 100-mill. scale, and close S-3. If the tube draws less than 10 mills., then S-4 may be thrown to the right side.

For all plate-current readings, be certain that S-5 is thrown first; for otherwise the full plate voltage will be impressed on the milliammeter and the meter may be seriously damaged. Before making other grid or plate voltage tests, return switches S-3 and S-5 to the left or standard positions; being careful that S-3 is returned first.

To obtain grid-voltage readings, move S-6 to the right; then use S-10 for the 10-volt range or S-11 for 100-volt scale. As cautioned before, return all switches to the "off" position before proceeding with further tests.

For plate-voltage readings, throw either S-8 or S-7; choice depending on whether the 250- or the 500-volt scale, respectively, is required.

For screen-grid voltage tests, throw S-2 to the right and use the plate-voltage switch S-8 for indication. Before inserting a screen-grid tube, open S-9, so that the control grid will not be shorted to the screen-grid.

For continuity and resistance tests, test leads are connected to BP-2 and BP-5. For external milliammeter connections, use BP-1 and BP-8, throwing the milliammeter switches as previously described. In fact, for all external measurements the proper toggles must be put in the correct positions before tests can be made.

External voltage measurements can be made by using BP-5 and BP-6, with grid switch thrown, for 10 and 100 volts. For 250 and 500 volts, throw plate switches, and connect to BP-5 and BP-8. The binding posts for 3 or 15 volts A.C. are BP-3 and BP-7. The A.C. line voltage can be tested by terminals BP-3 and BP-4 which are connected to the 150 A.C. volt range. A flexible wire, with a control-grid cap connector is attached at BP-9, when testing with 224 or 222 tubes.

Remember to throw all switches back to the "off" position before making other tests; and you need not fear burning out the meter. The switch arrangements are only a matter of practice and are soon performed automatically.

The authors have constructed several of these instruments which are now in service, and performing in a very satisfactory manner. Service Men who construct this analyzer will be well pleased with the results.

The values of the parts indicated in Fig. 1 are: R1, 10,000 ohms; R2, 100,000 ohms; R3, 250,000 ohms; R4, 500,000 ohms; R5, 4,500 ohms; R6, shunt for 100-ma. scale (see text) 0.3-ohm; R7, shunt for 10-ma. 3 1/3 ohms; the arrangement of the switches listed is obvious.

The leads represented by the bold black lines in the diagram, which carry heavier current, should be of No. 14, or larger wire.

**—building, testing and repairing radio sets**



THE three volumes of this Library cover the entire field of building, repairing and "trouble-shooting" on modern radio receivers. The Library is up-to-the-minute in every respect and is based on the very latest developments in the design and manufacture of equipment. The rapidly-growing interest in short-wave reception is thoroughly covered in a complete section which deals with the construction of this type of apparatus.

**Radio Construction Library**

By JAMES A. MOYER and JOHN F. WOSTREL

Faculty, University Extension, Massachusetts Department of Education

Three Volumes — 993 Pages, 6x9  
561 Illustrations

VOLUME I: presents the fundamental principles of radio so clearly and simply that anyone of average training will be able to read, understand and apply them. In one chapter alone, it gives actual working drawings and lists of materials for the construction of eight typical sets.

VOLUME II: fully discusses all of the elementary principles of radio construction and repair. An explanation of the necessary steps for "trouble-shooting," repairing, servicing and constructing radio sets successfully. Practical data is also given on antenna systems, battery eliminators, loud speakers, chargers, etc.

VOLUME III: covers the essential principles underlying the operation of vacuum tubes in a non-technical a manner as is consistent with accuracy. It discusses the construction, action, reactivation, testing and use of vacuum tubes; and an interesting section is devoted to remote control of industrial processes; and precision measurements.

**EXAMINE these books for 10 days FREE**

This Library is not only a thorough home-study course, but a handy means of reference for the more experienced radio experimenter, repair man, and radio shop-owner. To these men, as well as to those who desire to advance in the radio profession, this offer of a 10 days' Free Examination is made.

Simply clip, fill in, and mail this coupon

**McGraw-Hill**

**FREE EXAMINATION COUPON**

McGraw-Hill Book Company, Inc.,  
370 Seventh Avenue, New York.

Gentlemen:—Send me the new RADIO CONSTRUCTION LIBRARY, all charges prepaid, for 10 days' Free Examination. If satisfactory I will send \$1.50 in 10 days, and \$2.00 a month until \$7.50 has been paid. If not wanted I will return the set at your expense.

Name .....

Home Address .....

City and State .....

Position .....

Name of Company..... RC-4-31

(WRITE PLAINLY AND FILL IN ALL LINES)

# MAKE Your Own Home-Recording Outfit



USE A SKINDERVIKEN BUTTON

## This Microphone Unit is the Heart of Home-Recording

With a SKINDERVIKEN microphone button you can make a powerful HAND-MICROPHONE — one of the essential parts in any home-recording outfit.

The HAND-MICROPHONE will faithfully pick up your voice and translate it into electrical current variations.

These variations may be amplified — simply by connecting the HAND-MICROPHONE, through a plug-in adapter to the detector or first audio circuit of a radio set.

The amplified currents will powerfully vibrate the recording needle in a phonograph pick-up connected to the "loud speaker" binding posts of the set, and thus may be made to register on any pre-grooved phonograph record.

The "play back" is accomplished by connecting the pick-up in place of the HAND-MICROPHONE, and attaching a loud speaker to the proper binding posts.

If you wish to dispense with the radio set amplifier, you may connect the SKINDERVIKEN HAND-MICROPHONE direct to the recorder (the "pick-up" with a recording needle) through a transformer.

Full details supplied with every SKINDERVIKEN button, including diagrams, drawings and instructions.

These wonderful little SKINDERVIKEN microphone buttons may be used for hundreds of uses, such as:

- |  |  |
|--|--|
| RADIO AMPLIFIER<br>DETECTAPHONE<br>STETHOSCOPE<br>MICROPHONE | PHONOGRAPH AMPLIFIER<br>TELEPHONE AMPLIFIER<br>LOUD SPEAKER AMPLIFIER<br>CRYSTAL SET AMPLIFIER |
|--|--|

**95c EACH**      Two for **\$1.75**  
**12-PAGE INSTRUCTION BOOKLET**  
 containing suggestions and diagrams for innumerable uses, furnished with each unit.

EVERY AMATEUR SHOULD HAVE TWO OR THREE OF THESE AMPLIFIERS IN HIS LABORATORY

WE PAY \$5.00 IN CASH for every new use developed for this unit and accepted and published by us.

## SEND NO MONEY

When the postman delivers your order you pay him for whatever you have ordered, plus a few cents postage.

(Canada and Foreign: cash with orders)

PRESS GUILD, Inc., R.C.-131  
 16 Murray St., New York, N. Y.

Please mail me at once as many of the following items as I have indicated.  
 ...Skinderviken Transmitter Units at 95c. for 1; \$1.75 for 2; \$2.50 for 3; \$3.20 for 4.

When delivered I will pay the postman the cost of the items specified plus postage.

Name .....  
 Address .....  
 City ..... State .....

# Supreme "Model 19" Tube Checker

(Continued from page 593)

testing equipment available, and the tubes were tested under actual operation. Through this procedure, fairly definite limits for operative tubes have been made available.

The table reproduced here gives the panel markings for all tubes on which three readings are employed. The first column gives plate current, which is read on the 80-mil. scale of the meter unless the value is less than 8 mils.; in which case the 8-mil. scale button is depressed for a closer reading. If the plate current reading (at zero grid) is not greatly in excess of the first figure shown in the readings on the panel (Col. I), the tube may be classed as operable, if it will conform to the other test reading limits. The plate current with negative bias (about 3V.) is read on the meter when the "Grid Bias" push-button is depressed. If this reading is not less than the second figure shown in the markings on the panel (Col. II), the tube under test is operable, provided it conforms to the other two limits.

The third figure shown in the panel readings, opposite the type of tube (Col. III) is the "Change," representing the difference between the "Plate Current" and the "Plate Current with Negative Bias." If this change is not less than the limiting figure given, the tube under test may be classed as operable, provided it conforms to the other two limits.

### A Typical Test

To make the above still clearer, an actual test will be given as an illustration. Suppose that it is desired to test a '24-type screen-grid tube; this is placed in the 5-prong socket, designated for '24, '27, and 484 tubes. The tube checker is connected to any ordinary 50-60 cycle 100-120-volt A.C. power supply, by means of a detachable rubber-covered cable furnished for this purpose. A short connector, with pin plug on one end and control-grid clip on the other, is then plugged into the jack on the panel marked "Cont. Grid," and the clip is fastened to the cap of the tube.

The "On-Off" toggle switch is thrown to the operating position, and the tube is allowed to attain its full working temperature. In order to read the plate current of the screen-grid tube, it is necessary to press the red push-button marked "Screen-Grid-80." Since the reading obtained is less than 8 mils., the "8-mil. Scale" button is also depressed.

In the case of the tube under test, a reading of 2.6 is obtained. Comparing this with the ideal "Plate Current" reading of 3, it is seen that the obtained reading does not exceed the ideal; and hence the next test is made. This is obtained by holding down both "Screen Grid-80" and "8-mil. Scale" buttons while depressing the "Grid Test" button. The reading obtained on the tube being checked is 1.3; since this is greater than the second ideal reading, the tube again conforms to requirements.

By subtracting the second reading from the first, we obtain 1.3 as the "Change." Since this is greater than the ideal limiting figure, the tube has conformed to all requirements and is accepted as a satisfactory tube.

Tube Type	(I) Plate Current	(II) Current with "—" Bias	(III) Change in Current
'01-A	8.0	2.0	0.4
'10	10.0	5.0	1.6
'12-A	14.0	4.0	1.5
'20	6.0	3.0	0.1
'22	3.2	1.0	0.3
'24	3.0	0.8	1.0
'26	8.0	3.6	1.0
'27	8.0	3.0	1.4
'30	6.5	2.4	0.3
'31	13.0	5.0	0.2
'32	3.0	1.0	0.8
'40	1.0	0.5	0.1
'45	24.0	12.0	1.4
'50	26.0	12.0	1.0
'71-A	30.0	12.0	1.0
'99	3.0	1.0	0.1
182-B	25.0	12.0	1.5
183	30.0	22.0	2.0
484	7.0	2.5	1.0
		Second Plate	
'80	40.0	40.0	
'81	35.0		

While the foregoing description may seem somewhat involved, the actual performance of the test is simplicity itself and, ordinarily, takes less than a minute to complete. The current is snapped on, the two required readings are taken as soon as the tube is warmed up, comparison is made with the readings stamped on the panel—and the test is finished.

In the case of a '71A or a similar tube, having a comparatively high plate-current reading, the only push-button used is the "Grid Test" button. In testing an '80 type tube, the reading on the meter after the tube reaches operating temperature is the plate current of one plate. The other plate reading is obtained by pressing the "Screen Grid-80" button. The readings of both plates of full-wave rectifiers should not be less than the panel markings "40." This represents a minimum; and higher readings indicate proportionately better - quality tubes. A marked difference between the readings on the two plates may account for hum or distortion; and such tubes should be carefully observed in actual operation.

### The Checker as a Salesman

A number of methods have been suggested and are being used for increasing sales with the tube checker. Among these are free testing of tubes for customers, prominent display of the tester on the counter to create interest and inspire confidence, combination sales-service calls to check up the condition of tubes in use in the customers' home, etc. Many other sales-producing plans are constantly being evolved.

One dealer has adopted the plan of using his "Model 19" to educate his clientele to the fine points of tube purchasing; he displays above his counter a large chart showing the ideal limiting readings contained in the table. When a tube is purchased, the readings obtained on the tube checker are plainly marked on a dated label, which is

.. your copy is ready ~

# RADIO

## Service Man's HANDYBOOK

### WITH ADDENDA DATA SHEETS

**T**HIS new book contains a tremendous amount of the most important data of every kind — several hundred illustrations, wiring diagrams, charts, on every conceivable subject pertaining to radio sets, tubes, etc. The book is live "meat" from start to finish, and contains only *practical information* on which every radio man can cash in immediately.

Just to give you a few subjects contained in the book, we mention the following:

- Prescriptions of a radio doctor
- Modernizing old receivers
- Servicing obsolete sets
- Operating notes for Service Men
- Service Men's data
- Servicing automobile radio installations
- Curing man-made static
- Causes and cure of radio interference
- Notes on repairing "B" power units
- Constructional data on laboratory equipment

- A portable radio testing laboratory
- Servicing with the set analyzer
- What and how the Service Man should sell
- Helping the Service Man to make money
- How to become a Service Man
- Servicing broadcast receivers
- All about vacuum tubes, and vacuum-tube data
- Special radio Service Man's data
- Dozens of radio service data sheets
- And hundreds of other similar subjects

**\$2.00 PER COPY**

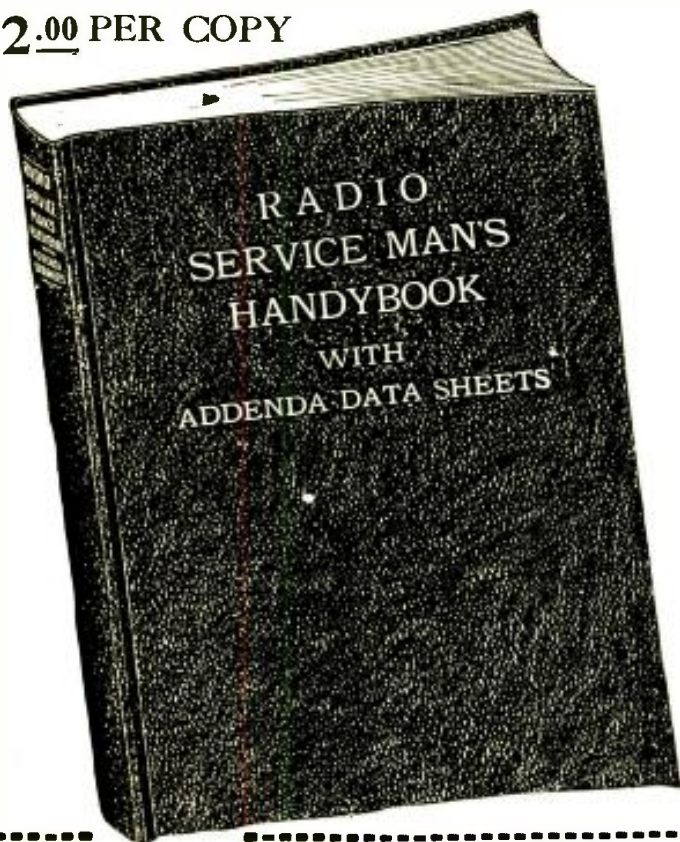

*The Foremost Radio Service Authorities Have Contributed to This Book*

- |                  |                  |                 |
|------------------|------------------|-----------------|
| C. W. PALMER     | GEO. C. MILLER   | H. WEILER       |
| LEON L. ADELMAN  | JULIUS G. ACEVES | J. E. DEINES    |
| SYLVAN HARRIS    | C. W. TECK       | F. R. BRISTOW   |
| BERTRAM M. FREED | PAUL L. WELKER   | and many others |

### A NEW DEPARTURE

**E**VERY Service Man, every radio man, every radio experimenter and every radio professional makes his own notes, draws his own circuits and writes down his own observations and his own data. For these reasons, the RADIO SERVICE MAN'S HANDYBOOK has been made in loose-leaf form. There are supplied with this book 48 special ledger paper pages, square ruled on both sides so that you can take a leaf and place it wherever you wish, and write on it your own data. If you wish, you can also cut out data from other publications and paste it on the sheet—placing it in its proper position in the loose-leaf book.

The total number of pages is 200 and the book contains such a wealth of radio material as you have never seen before between two covers. *Nothing like it has ever been produced.* The book is of the large size, 9 x 12 inches, and is in the same loose-leaf form as the OFFICIAL RADIO SERVICE MANUAL. It has a semi-flexible cover with gold stamping.

GERNSBACK PUBLICATIONS, INC.,  
96-98 Park Place, New York City, N. Y.

R.C.-431

Gentlemen:

As per your special offer, I enclose herewith remittance of \$2.00 (Canada and foreign \$2.25) which pays the entire amount on your new book entitled RADIO SERVICE MAN'S HANDYBOOK with Addenda Data Sheets, in loose-leaf form, as described in RADIO-CRAFT.

Name .....

Street .....

City and State .....

**MAIL COUPON TODAY**

# Hotel Directory of the Radio Trade

The hotels on this and opposite page are patronized by the Radio Trade. Make them your headquarters.

## A HOTEL AUDITORIUM

Opposite Cleveland's  
\$15,000,000  
Public Auditorium

300 CLEAN MODERN ROOMS

Each with bath

\$2.00 \$2.50 \$3.00



NO PARKING  
WORRIES  
HERE  
2 GARAGES  
AT THE HOTEL  
W.H. BYRON  
Manager

EAST SIXTH AT ST. CLAIR AVE.  
**CLEVELAND**

*Around the corner from the  
Little Church around the Corner*

# HOTEL SEVILLE

MADISON AVENUE  
& 29th Street

A hotel of distinction and comfort,  
within walking distance of shopping  
and amusement centers. Five minutes  
from Times Square, Pennsylvania Sta-  
tion and Grand Central Terminal.

Room and Bath **\$3.00** Per Day Up

Convenient to all  
points of interest

pasted on the tube. The customer is then able to check these readings with those on the chart. As a result of this frank method of doing business, this dealer's average weekly tube sales have increased 100 per cent. since the installation of the tube checker. In fact, tube sales in one chain of stores have been so stimulated that the owner is rapidly clearing out his stock of radio sets and specializing on tubes only; and the most prominent display is a tube checker!

The "Model 19" is available in two types: a counter model and a portable model; the latter comes equipped with a lid, carrying handle and detachable cable. The lid is mounted on slip hinges, so that it can be readily removed; hence the portable model can also be used as a counter instrument. The mechanical construction of both types is identical. The "Model 19" checker weighs only 6 pounds; its dimensions are 3 1/4" x 9 7/8" x 6 1/16". It is housed in a selected hardwood walnut-finished case, which is practically indestructible. In the event of accident, this rugged housing offers maximum protection to the instrument assembly.

## Service Man's Forum

*(Continued from page 589)*

find the One, I believe I can prove what seems to be lacking in some of our self-adopted brethren.

I certainly believe in every word Mr. Poli said under "Good Business Methods." Mr. Poli, let's hear more from you.

RADIO-CRAFT is certainly covering a much needed field and I, for one, appreciate its services. May it continue on and on.

NEWBURN C. KEY,  
Rockdale, Texas.

## HARD TO SWALLOW

Editor, RADIO-CRAFT:

I have just read the February issue, and I would like to say a few words in regards to the letter shown, from The General Motors Corp. First of all, isn't it funny how some of these large corporations try to "hog" everything they can? As soon as I had read the letter and their way of looking at the situation, I came to the conclusion that they were all wet.

Suppose that you wanted a G.M. Radio and nothing else would do. You purchase the set from your local dealer, have it installed, use it for a period of about six or eight months, then trouble develops. You send for the dealer's Service Man. He may do the job, because he had been instructed by the G.M. service book; but, this man may do other things that are to the dislike of the customer (things that I have run across, such as rough handling, and letting tools scratch the cabinet, or the soldering iron may accidentally fall upon a nice new rug, all through careless working). No matter how well a man may know his work, I have seen them get careless. Then, right off the "bat," the customer turns "sour" and usually another independent Service Man of good reputation is the next one called. The first thing he will say, if he wants to be truthful, is: "I have no notes on your particular set, as the G.M. Corp. holds on to them." He may say that he

will try to locate the trouble, but at a greater expense to the customer than if he were able to go to work on the set with notes for each model and circuit.

Now I do not know whether or not I have taken the right attitude or not; but it is my way of looking at the situation. I started in radio when crystal sets were the "rage," and have always tried to keep up with the newer things in Radio. I am a proud owner of the Official Radio Service Manual; and also a subscriber to the supplements, and a regular reader of RADIO-CRAFT. This magazine certainly has the Service Men at heart, and I know that many of them benefit by your wide variety of articles. This is the first letter that I have written to you because as a rule I try to slum writing letters; but this just stuck in my "Craw," and I thought you might like to hear someone's opinion on the matter.

PATL W. MEYERS,  
407 Walnut Street  
Philadelphia, Penna.

### Hints to Manufacturers

(Continued from page 603)

the chassis fits the compartment so tightly, would add very little expense.

DONALD MAXWELL,  
112 Fayette Street,  
Charleston, W. Va.

### DESIGNATED SOCKETS

WITH the advent of the multi-stage superheterodyne, additional problems are presented to the Service Man and trouble-shooter in sub-panel endeavors. My hint is for the indication of the tube numbers at the bottom of the socket, as an aid toward rapid work. Moreover, additional help would be given by marking the stages (1RF, Mod., Osc. 2IF, etc.) at the top as well as the bottom of the socket.

FRANK DE MARCO,  
63 Oak Street,  
Yonkers, N. Y.

### EASIER CONNECTIONS

MANUFACTURERS of radio parts could make bigger holes in the lugs of rheostats, potentiometers, condensers, etc., so that a nut and bolt can be used, if desired, instead of soldering. If the hole be 11/64", a No. 6 dry-cell terminal can be used as a binding post. I have found this handy in experimental hookups and also of use when servicing. In a "battery-operated" district, facilities for soldering are not always available.

J. E. KIRCHS,  
Alert Bdg., B. C., Canada.

### BATTERY SETS—EXTERNAL AUTOMATIC CONTROL

I SUGGEST that all radio manufacturers tin the ends of the hook-up cables used on battery sets; also that they fasten the instructions, for connecting the batteries inside the set, so that they will not be lost.

That some radio manufacturer put out an automatic volume control which can be connected to any of the sets now in use.

PALMER STADUM,  
Baker, No. Dakota.

## Hotel Directory of the Radio Trade

# NEW KENMORE HALL

145 EAST 23<sup>rd</sup> ST. New York City

*Free!* GYMNASIUM  
SWIMMING POOL  
SOCIAL ACTIVITIES  
SPACIOUS LOUNGES

SINGLE ROOMS \$1.50 UP  
with BATH \$2.00 *1. per day*

SPECIAL WEEKLY RATES

SINGLE \$8.00 UP  
DOUBLE \$16.00 UP

GEO. TURKEL-MGR.

NEW YORK'S  
*Smartest*  
700 ROOM-  
CLUB HOTEL  
*for Men & Women*



"SOUTH OF THE MASON-DIXON LINE" is but another way of saying "Hospitality"

### HOTEL LUDY

South Carolina Avenue at the Boardwalk  
'Atlantic City's Newest Centrally Located Fireproof Hotel  
IS South of the Mason-Dixon Line  
Its RATES are as PLEASING as its hospitality  
\$5 up Daily — American Plan — \$30 up Weekly  
\$2.50 up Daily — European Plan  
Fireproof Garage Attached  
R. B. LUDY, M.D.

# The HOTEL LUDY

ATLANTIC CITY, N.J.

### SERVICE MEN — DEALERS

A few minutes of your time NOW, spent in reading the interesting announcement of the OFFICIAL RADIO SERVICE MANUAL which appears on page 615 of this issue, might save you hours of time in servicing in the future. Every dealer, Service Man and custom set builder should have a copy at his disposal.

## Hotel Directory of the Radio Trade

### HOTEL CUMBERLAND

54th Street and Broadway

New York City

3 Minutes to Times Square

*Close to Everywhere—but Removed  
from the Noise and Clamor*

A modern fireproof hotel with every modern hotel convenience. Within walking distance of theatres, shops and business sections.

**DAILY RATES: Room and Bath, \$2 and \$3 per day**  
Special Weekly Rates

Under the Personal Management of Joseph Goulet  
formerly of Hotel Woodstock, New York City  
**FREE CATALOG FROM ANY RAILROAD DEPOT**



**CINCINNATI'S  
SMARTEST**

Right on Fountain Square... Noted for fine food, reasonably priced, and a rare and distinctive type of service... 1000 rooms, each with bath, \$3 and up... five famous restaurants... Ideal convention facilities... Teenage sample rooms.

**THE GREATER  
HOTEL GIBSON**  
E. C. SCHIFFERLE, MANAGING DIRECTOR  
CINCINNATI, O.

### WELCOME to NEW YORK and The HOTEL GOVERNOR CLINTON

31<sup>ST</sup>. ST. AND 7<sup>TH</sup>. AVE.  
opposite PENNA. R.R. STATION



1200 Rooms each  
with Bath, Servitor  
and Circulating Ice Water,  
also Radio  
Provisions

**ROOM AND BATH 3<sup>00</sup> UP**

### Recent Tube Design

(Continued from page 599)

grid bias higher than is convenient in most receivers, a compromise was effected by the design of the "551," which may be used as a replacement for the '24, with a higher grid bias (15 to 30 volts), obtained as before by the use of a proper resistor value in the cathode return lead. It is estimated that, in a receiver employing automatic or remote volume control, the range of control over the amplification of the received signal will be multiplied by a factor of 25. With such equipment, the use of a "local-distance" switch should be superfluous.

The "551," with a plate voltage of 180 and screen-grid voltage of 90, has normally the same plate resistance and mutual conductance as the '24. Its plate current is about a third higher (5.3 milliamps). It will, however, endure twenty-five times as much signal voltage, before 20% distortion is reached, as the '24; and its "cross-talk" factor, at the maximum, is but 3% of that of the latter tube. The fear that this action, permitting limited emission from the heated cathode, might shorten the life of that element, has been negated so far in the endurance tests of the tube.

#### Direct-From-Line Heating

In the light-socket type of receiving sets, which has been standard for the past few years, the principal effort has been devoted to obtaining maximum results from the 110-volt, 60-cycle A.C. mains, which serve the majority of customers in the United States. The step-up transformer, supplying plate current through a rectifier, and the step-down transformer, furnishing low-voltage, high-current filaments with unrectified current for heating, have been practically universal. Tubes have been designed for raw A.C. operation on 15, 7½, 5, 3, 2½ and 1½ volts, with different types of connection. However, a large number of prospective electric set owners, whose house-lighting facilities are not always in accordance with the above standard, have profited comparatively little by the advance in receiver design.

For some years, however, one laboratory has been prosecuting researches in the idea of producing tubes for operation from the house current without the intervention of a transformer; and it is now announced by the makers, the Lestain Corporation of America, that three such types are ready for the market, with others to follow. These may be operated from either A.C. or D.C. mains, as the heating effects are practically equivalent.

As in the 2½-volt tubes now so extensively used, the cathode is heated indirectly by a tungsten filament, which is electrically isolated from an oxide-coated cathode. The arrangement of the electrode is, of course, standard—heater, cathode, grid and plate. The filament is wound upon an insulating core in non-inductive fashion to lessen hum. The parts are substantial in formation, and somewhat larger than in the usual tube design (Fig. 3.). While this increases inter-element capacity, it also reduces the plate impedance and increases the mutual conductance; this may be seen by comparing the average values below with those of the standard '12A and 45 tubes:

**O**N Page 627 you will find an interesting announcement of the RADIO SERVICE MAN'S HANDY-BOOK with addenda data sheets. It takes but a few minutes to read of the full particulars about this new book.



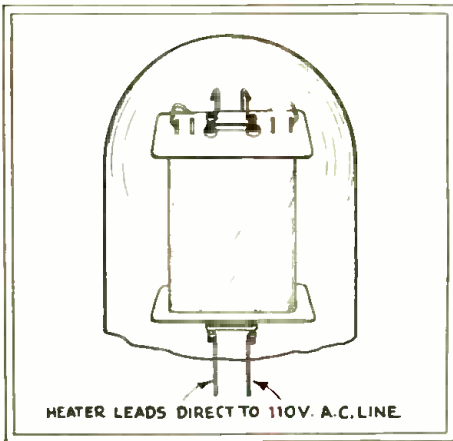

Fig. 3

Appearance of the assembly in a 110-volt tube; there are two heater elements in the center.

"Type 1012" (general purpose): amplification factor 8.5; plate impedance, 4,000 ohms; mutual conductance 2,000. Undistorted output in milliwatts, at 90 volts, 80; 135 volts, 190; 180 volts, 500.

"Type 1018" (power tube): amplification factor 3.5; mutual conductance from 2,600 to 3,000. The output at 180 volts plate, with a 34.5-volt grid bias, is 1,250 milliwatts; at 250 volts plate, with 50 volts on the grid, it is 2,900.

A full-wave rectifier, also employing an indirectly-heated cathode, is being put in production, and it is stated that a screen-grid tube with a "mu" of 500 (theoretical) and a mutual conductance from 1,500 to 1,800 micromhos, is undergoing laboratory tests. Since the only value to be changed for operation from higher or lower voltages is that of the heater filament, 32- and 220-volt tubes will also be available.

One of the most interesting possibilities, for city dwellers, is that of the development of a receiver operable equally well on D.C. or A.C. light lines supplying 110 volts. With the latter, it would be necessary, of course, to employ a rectifier and filter in the plate voltage lead; but tubes of such high mutual conductance, particularly in the power stage, will readily furnish good output volume. A high line-voltage, in this case, would be an asset.

The tubes described are regularly manufactured with standard UY bases. For the purpose of electrifying battery-model sets, however, the adapter type illustrated in Fig. A is also made, with a four-prong base, and the heater connections at one side. The harness, the insulating sleeves of which appear at one side, affords the necessary connections from the tube to the light socket without disturbing the set's wiring; only one filament prong is connected into the receiver's circuit. Thus any of the tubes (especially the power stage) may be wired for socket operation without disturbing the others.

**A SELENIUM DRY RECTIFIER**

THE copper-oxide type introduced by Westinghouse ("Rectox," etc.) is the best known of the dry-metallic rectifiers, used in radio work to obtain direct current from an alternating source. Another, however, which has just been introduced by a German inventor, employs the non-metallic element selenium for the purpose.

As in other dry rectifiers, a stack of compound discs is built up on a central bolt, and compressed by a nut (Fig. 1). Each unit contains two metallic layers between which is deposited a layer of selenium, which has been specially treated until it acquires a crystalline structure; in which state it has high unilateral conductivity.

The units, shown in cross-section in Fig. 1, are flared for greater strength, and to aid in cooling; washers separate them and help to give more uniform tension. The selenium is protected from the air by the metallic covering on each side; and the action of the rectifier will not be weakened by exposure for a considerable time to temperatures up to 212° F. As the temperature rises, so does the resistance, furnishing automatic protection against overload.

Each element will support readily a voltage of 20 without breaking down; but in practice the rectifier is designed for 5 volts on each disc. The discs may be large or small; and the assembly may be wired, like other rectifiers, for half- or full wave rectification. Fig. 2 shows two elements connected to a transformer secondary, for charging a small storage battery. For plate supply and grid bias, it is necessary only to use a sufficient number of elements with the proper filter system.

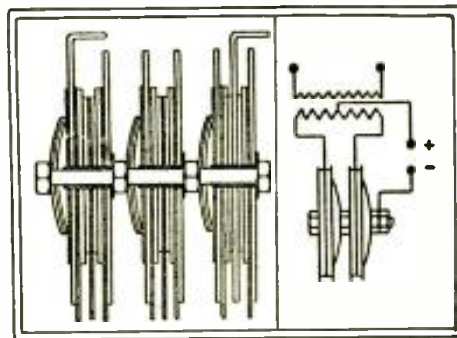

Fig. 1

Fig. 2

The selenium rectifier is a foreign novelty.

**Radio Tanks**

(Continued from page 601)

transmitting channel of far greater width than that needed for the actual relay signals. The complexity of the controls would be greatly increased if it were necessary to train and sight guns by television.

However, for the purposes, say, of tearing down obstacles such as wire, the positions of which were known, or of serving as land torpedoes to convey explosives to designated spots, we may suppose that such machines might readily be made; and that they might be operated over comparatively short ranges, by observers who were able to follow their courses directly. The whole resolves itself, from the military standpoint, into a question of values; in which men are considered as supplies to be expended, and in which their cost may be less than that of complicated machinery, while their ability to function under the most trying conditions is less delicate. At present prices of robots, the soldier is somewhat less expensive, as well as more rugged and versatile.

Certain other problems arise, in the multiplication of radio transmitters which would

**Clarostat Tone Control Panel Mounting Type**

Service Men install tone control right on panel of any receiver, drill one hole, run two wires—that's all.

Regularly supplied without wire or adapters—List Price \$1.80.



Extra for pair of adapters and flexible wire 50c.

CLAROSTAT MFG. CO., Inc.

285 No. 6th St. Brooklyn, N. Y.

**ELECTRIFY YOUR RADIO FOR ONLY \$6.85 COMPLETE**

Why discard your present good set when you can electrify it for only \$6.85, and banish the annoyance and expense of buying new "B" batteries?



**Over 150,000 Townsend "B" Power Units in Use**

Hooked up in a few minutes. Use same tubes—no changes. Works on A.C. (any cycle) or D.C. You'll be amazed at the improvement in reception. Send name and address today for full details, proof and Free Trial Offer.

TOWNSEND LABORATORIES

423 W. Superior Street

Chicago, Illinois

**Study RADIO in CANADA**

CANADA'S PIONEER COLLEGE, endorsed by leading radio manufacturers, offers DAY, EVENING, HOME STUDY and SPECIAL TRADE COURSES with free scholarships and trip to Toronto (all expenses paid). Write for booklet to Principal.

RADIO COLLEGE OF CANADA Limited

310 Yonge Street - - - Toronto

**ALUMINUM BOX SHIELDS**

Beautiful silver dip finish—5 x 9 x 6, \$1.87; 6 x 10 x 7, minor size, \$3.25; 5 x 5 x 5, knocked-down coil shield, \$1.00. We make any size to order.

Three contact toggle switch, 29c; resistance wire for multipliers and shunts accurately made and checked on Wheatstone Bridge—price reasonable.

**"BUDDY" Test Prod**

Always sharp pointed, using phonograph needles, 4-ft. wires, spade or phone tips. Colored nipples identify each lead, 75c. each.

We specialize in radio parts exclusively—parts furnished for any kit in any magazine.

Please include sufficient postage for parcel post.



BLAN, THE RADIO MAN 89 Cortlandt St. Dept. RC-431

New York, N. Y.

**Bronze Dial Cable**

Keep a supply on hand—save time and money. Special low prices for Service Men and Dealers. 50-ft. coil 7c, foot 100-ft. coil, 5c, foot 250-ft. coil, 4c, foot 500-ft. coil, 3c, foot

Standard size used by leading manufacturers of radio sets having drum type dials. Mailed C.O.D. Address

MULLINS DIAL CABLE

134 So. Mason Ave.

Chicago, Ill.

**PATENTS — TRADE MARKS**

All cases submitted given personal attention by members of the firm. Information and booklet free.

Patent Office and Federal Court Practice

Lancaster, Allwine & Rommel

Patent Law Offices

475 OURAY BLDG., WASHINGTON, D. C.

**PATENTS** Write for Free Guide Book, "HOW TO OBTAIN A PATENT" and Record of Invention Blank. Send model or sketch and description of your invention for our Free Opinion whether it comes within Patent Office Rules. RADIO and ELECTRICAL Cases a Specialty. Prompt, Efficient Service. PAYMENT OF FEES IN INSTALLMENTS. VICTOR J. EVANS & CO., 923 - 9th, Washington, D. C.

# 39,000 RADIO MEN CAN'T BE WRONG!



In every Home  
every Repair Shop  
every Radio Store  
every Laboratory  
every Library

2ND EDITION

## S. Gernsback's Radio Encyclopedia 2d EDITION

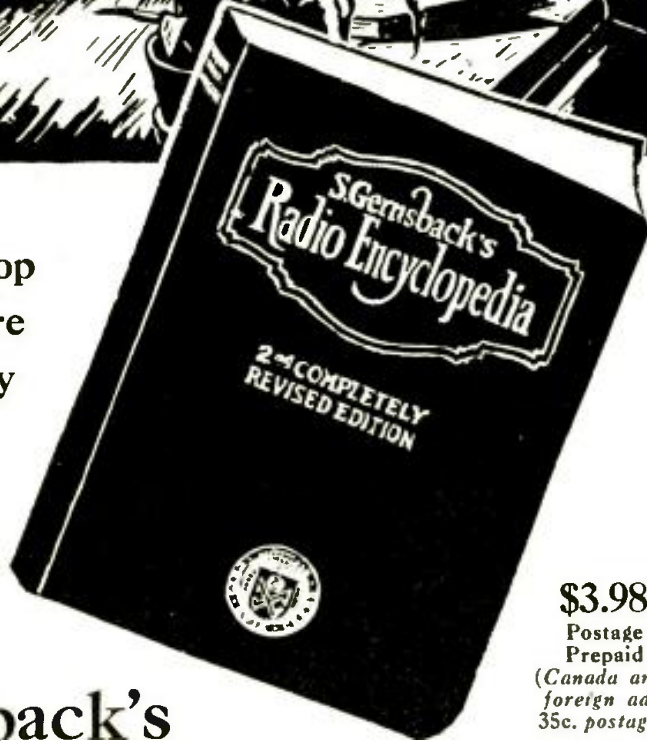

**\$3.98**  
Postage  
Prepaid  
(Canada and  
foreign add  
35c. postage)

**T**HIS book is not a dictionary, but a true Radio Encyclopedia, covering Radio from A to Z. It is the first standard work ever published in America attempting to classify alphabetically the countless words used in this highly specialized science of Radio. The Encyclopedia was first issued in 1927. The volume offered now is the **SECOND EDITION**, greatly enlarged and improved.

Every page is replete with illustrations; a vast number of tables and charts have been added. In many instances, the definitions have been rewritten to conform to new developments and new material has been added which makes the book twice the size of the first edition.

The Encyclopedia contains definitions of every word and phrase used in the entire Radio art—every circuit, part and apparatus, formula, abbreviation, outfit, accessory, etc., is thoroughly explained. The entire book is written in everyday English, easily understood by anyone.

The Radio Encyclopedia is published in one volume, bound in semi-flexible red morocco keratol, size 9 x 12 inches and gold-stamped cover. Heavy ledger stock is used and the loose-leaf construction enables new material to be added periodically.

**39,000 men bought the first edition!**

be required. Modern radio equipment for armies comprises an enormous number of units. A field army concentrates, into a limited area, more transmitters than there are broadcasters in the whole United States. To increase the number, even by the use of ultra-short waves, creates additional problems of interference.

It is true that the ultra-short waves—below five meters—have myriads of channels, and that their interference area is limited. Nevertheless, these waves are so sharply reflected, by the surface of the ground and other obstacles, that they can hardly be received out of the direct line of vision. We may, of course, assume, for each radio tank so controlled, an airplane which would keep it in the focus of a directional guiding beam; but the airplane, so tied down, would be limited in its movements and a target for high-angle artillery fire as well as for speedy combat planes.

### Design of Tank Radio Sets

Nevertheless, radio work is being carried on with tanks and motorized artillery and special services in all armies, including our own. We are enabled to present, by courtesy of the Signal Corps of the U. S. Army, pictures of the equipment which it has designed for work in tanks.

As to the apparatus itself, technical details of the circuits have not been released, though the radio man may quickly guess a few of the more evident points. The equipment shown is subjected to what is, perhaps, the severest test which any radio material will undergo in actual service. We may compare conditions to those of a transmitter and receiver which are being operated while being rolled from the top of a staircase to the bottom and back. The containers are heavily cushioned with rubber on the outside to take up the successive shocks, which are violent even where a tank has smooth going.

The wavelength range covered is not stated; but it is probable that more than one short-wave band may be used. It is not customary to equip every tank with a transmitter, since they usually move in fleets or squadrons under united command, when employed in maneuvers or action.

The shortness of the flexible aerial, protruding from the turret's cap in the first picture, indicates a wave possibly around ten meters (it is stated that the British army uses approximately an eight-meter wavelength in recent equipment).

The tank is, by its nature, completely shielded; so that an external aerial is needed, while the body of the machine serves as a counterpoise or ground. The aerial is made flexible, so that it will not be broken or swept away by obstacles overhead. Long-range reception is not necessary, or even desirable, since most of the signalling is intended only for the unit under one command.

An interesting feature of the apparatus shown is that it serves also for phone communication between different compartments of the tank where, it may be imagined, a high volume of sound is necessary to make itself heard above the continual banging, jarring and crashing attendant on operation under even the most favorable circumstances.

**S. GERNSBACK CORPORATION**  
98 Park Place, New York, N. Y.  
Kindly send me one copy of the Second Edition of S. Gernsback's Radio Encyclopedia. I enclose herewith \$3.98 for which you are to send me the book postpaid. (Foreign and Canada add 35c. extra.) If the book does not come up to my expectations, or is not as represented, I can return it, and have my money refunded in full.  
Name .....  
Address .....  
City..... State.....  
RC-4

## Perfect Quality

(Continued from page 608)

amplification, used in the audio channel, produces an effect similar to push-pull in each stage.

The receiver itself presents little similarity to the ordinary home radio apparatus in appearance; though it is not unlike the installations used with the power-amplifier public-address systems here. The entire apparatus is mounted in a large, high metal rack, fitted with shields, which serves also for protection against the high voltages developed; and it is fitted with automatic safety switches. Any unit may be removed for adjustment. A separate rectifier is provided for the power stages, which take the high-voltage output of two half-wave mercury-vapor tubes. The set is fused, in about twenty leads; and flexible metal tubing shields the wiring thoroughly.

### The Circuit Itself

The receiver and the power supply themselves are shown in Fig. 1; for convenience, and to avoid a maze of lines, the intermediate connections are shown in Fig. 2. Though the whole is far from simple, it is not so complicated, after all, as the reader's first impression. Let us analyze it:

At first glance, this circuit will seem to consist of nothing but tubes, resistors, and condensers. Some of these components are coupling units; but most of them are used for filtering. Each filter resistor is bypassed by a fixed condenser of the correct value to meet engineers' specifications.

If the reader will carefully examine the diagram, it will soon be found that the circuit resolves itself into no more than a receiver incorporating a single stage of screen-grid R.F. amplification (tubes V1A and V1B) and a detector circuit (tubes V2A and V2B), followed by three stages of resistance-capacity coupled A.F. amplification. The first of these uses tubes with a "mu" of 10 (V3A, V3B), followed by a stage of low-gain amplification using 10-watt tubes (V4A, V4B), and a power stage comprising two high-power (75-watt) tubes. The last have a "mu" of 5, and require a plate potential of 1,000 volts (tubes V5A and V5B).

### Methods of Checking

The plate current to V1A may be checked by plugging a milliammeter into the jack J1, and noting the reading as the 400-ohm cathode bias potentiometer is adjusted; the performance is repeated for tube V1B, jack J2 then being called into service. The two grid-circuit potentiometers control the inputs of these tubes, to prevent overload due to the great strength of the locals.

A similar balancing procedure may be followed for the detector tubes V2A and V2B. Jacks J3 and J4 indicate currents, as determined by the settings of the plate circuit's variable resistors (since the grid leak return is directly to the cathodes of the heater-type tubes, there is no cathode resistor available to control the plate current; hence the use of these plate-circuit series resistors). The cathodes of these tubes are returned to a center-tapped potentiometer in shunt across their filaments.

The A.F. outputs of the detectors are

# RADIO CIRCULAR CO. 225 VARICK ST. NEW YORK, N. Y.

THESE MONEY SAVING BARGAINS ARE TYPICAL OF THE MANY SENSATIONAL RADIO VALUES THAT WE OFFER IN OUR MONTHLY BARGAIN BULLETINS. SEND FOR YOUR FREE COPY NOW. USE COUPON BELOW.



## KOLSTER 245 Push-Pull POWER AMPLIFIER and MATCHED KOLSTER DYNAMIC SPEAKER

CAN BE USED WITH ANY TUNER

LIST PRICE, \$98.00

Our Price **\$19.95** Less Tubes

Original Factory Sealed Cartons

For radio, phonographs, public address systems for lecture and concert halls and small auditoriums. Reproduces speech and music with marvelous fidelity of tone. The amplifier has two stages using the 227 in the first and two 245 tubes in the push-pull stage with a 280 rectifier. Kolster Dynamic Speaker to match. For 115 volts, 60-cycle alternating current.

## KOLSTER SPEAKER

Equipped with a highly sensitive oversize magnet and a driving unit that is one of the finest, the Kolster responds instantly to the faintest impulse. It faithfully reproduces both voice and orchestra from the faintest whisper to the fullest volume of a brass band. Dimensions: Height, 11 inches; width, 11 inches; depth, 6 1/2 inches.

LIST PRICE, \$35.00

Our Price **\$4.50**



## MISCELLANEOUS BARGAINS

Sprague Electrolytic Condenser	\$.95	Brandes Phones	1.25
Thordarson R-171 Power Compact	4.95	RCA Loud-speaker 103	4.25
A-Box Filter Unit	1.95	Kolster Magnetic K6 Sp. Chassis	2.45
Telerad	1.80	Atwater Kent Replacement Transformer	1.50
Peerless A10 Power Transformer	4.75	Sprague Midget Condenser, 001	.08
Melofonic Speakers	2.50	A.K. 37 Condenser Block Replacement	3.95
Zenith Power Transformer	2.95	Majestic B Eliminator Condenser Block	2.95
Shield, Cap and Base (set of 3)	.10	Victor Resistor	.95
Centralab Twin Potentiometer	.50	Baldwin Ideal Unit	.75
Soldering Iron	.60	F. & H. Capacity Aerial Eliminator	.75
Automatic Voltage Control	.50	I.C.A. Res-stovolt No. 99	1.05
United Electric Motor and Turntable	7.95	Patler 1/2-Mfd. By-Pass Condenser	.25
Philco Power Transformer	2.95	Crosley 1/2-Mfd. By-Pass Condenser	.25
RCA Condenser Block (Part No. 8133)	1.50	<b>All prices are F.O.B. New York City, transportation charges extra. Specify whether you desire shipment by Freight, Express or Parcel Post. 20% cash must accompany all orders, balance C.O.D. Where full cash remittance is sent with order 2% discount may be deducted. All merchandise guaranteed to be exactly as represented.</b>	
Victor Replacement Condenser Block	2.25	<b>USE THIS COUPON AND RECEIVE OUR BARGAIN BULLETINS PACKED FULL OF TREMENDOUS BARGAINS.</b>	
General All-Purpose Condenser	.25	<b>Bargain Bulletin Coupon</b>	
Phil Dynamic A.F. Power 33A Sp.	6.50	RADIO CIRCULAR CO. RC-4	
Victor A10 Power Transformer	2.75	225 Varick St., New York, N. Y.	
A. F. Kelford Shielded Transformer (ratio 2-1)	.75	Send me your bargain bulletins free of charge.	
Antenna Kit Complete	.55	Name .....	
7-Strand Copper Aerial Wire	.16	Address .....	
General Filament Switch	.20	City .....	
Yaxley 2000-ohm Volume Control	.45	State .....	
Indoor Ribbon Antenna	.36		
Thordarson Power Transformer (for sets using 226, 227, 245, 260)	2.75		
Frost Twin Volume Control	.39		
Naald Bakelite Sockets	.10		
Eby Twin Field and Sp. Posts, each	.20		
Freed-Elsomann 8-Point Switch	.20		
Centralab Volume Control (6000 and 9000-ohm)	.30		
Freshman Basket Weave T.H.F. Coils (set of 3)	.30		
Freshman Output Transformer (ratio 1-1)	.30		
Extension Cord for Dynamic Speaker (20 ft.)	.50		
Aluminum Shields, per doz.	.75		
Kurz Kasch Port Dials	.40		
Franklin Power Trans., Type 17A	2.65		
Radart Power Transformer, 17A and 215	3.95		
Victor Input and Output Push-Pull Transformer	1.50		
Crosley Dynacone Speaker Chassis	2.75		
Bosch Speaker	3.50		
General Replacement Transformer	2.75		
Dumont AB Bone Dry Eliminator	15.50		
Dumont 180-volt B Eliminator	8.95		
Dumont Silent A Eliminator	9.50		
Stewart-Warner Rotary Snap Switch	.15		

# RADIO CIRCULAR CO. 225 VARICK ST. NEW YORK, N. Y.

## SERVICE MEN WANTED EVERYWHERE

**T**O install and service all makes of sound reproducing systems, public address systems, etc. NATIONAL SOUND SERVICE BUREAU is an organization of manufacturers of sound equipment, users of sound equipment and hundreds of electro-acoustical engineers located everywhere to install and service this equipment. If you are competent now, our organization needs you; if not, we can arrange to have you trained. Write us your present qualifications.

**USERS OF SOUND EQUIPMENT,** write us. We have an electro-acoustical engineer near you available now to help you.

**MANUFACTURERS OF SOUND EQUIPMENT,** you can join our organization and reap the advantages of the largest and most comprehensive sound service men's organization in the world.

**NATIONAL SOUND SERVICE BUREAU**  
723 Seventh Avenue Dept. RC New York, N. Y.

## CLASSIFIED ADVERTISEMENTS

Advertisements in this section are inserted at the cost of ten cents per word for each insertion—name, initial and address each count as one word. Cash should accompany all classified advertisements unless placed by a recognized advertising agency. No less than ten words are accepted. Advertising for the May issue should be received not later than March 7th.

### DETECTIVES

**DETECTIVES Earn Big Money.** Excellent opportunity. Experience unnecessary. Particulars Free. Write, George Wagner, 2190B Broadway,

### FORMULAS

**MAKE AND SELL** your own products. We will furnish you any formulas. Write for our literature. Chemical Institute, 19R Park Place, New York, N. Y.

### PERSONAL

**ESCAPE** from your lonely existence! Valuable information free. Write today! Box 128-M, Tiffin, Ohio.

### RADIO

**SERVICE MEN, ATTENTION** — Speakers re-wound, magnetized, repaired, \$2.00 to \$2.75. Complete Power Pack Service—Transformers re-wound, condenser blocks repaired, resistors duplicated. Guaranteed. Clark Brothers Radio Co., Albia, Iowa.

**RESISTANCES, Condensers, Transformers, Choke Coils, etc.** Write for sensational low price list. Bronx Wholesale Radio Company, 5 West Tremont Avenue, New York.

**SERVICE MEN**—a plan that will boost your earnings. Send 25c. Radio Service, Colville, Washington.

## SONG WRITERS

**Advance Royalty Payments,** New Talking-Picture Song requirements, etc., fully explained in our Free instructive book. Writers of *Words or Music* for songs may submit their work for free examination and advice. Past experience unnecessary. We revise, compose, arrange music and secure Copyrights. Our modern method guarantees approval. Write Today—Newcomer Associates, 1678B Broadway, New York, N. Y.

**\$5,000 WILL BE PAID TO PROVES THAT THIS IS** not the actual photo of myself showing my superb physique and how the Ross System has increased my own height to 6 ft. 3-4 inches. Hundreds of "Testimonials." (Gents up to 45 years old gain from 1 to 6 inches in a few weeks!)

**No Appliances—No Drugs—No Dieting. ROSS SYSTEM NEVER FAILS.** Fee Ten Dollars Complete. Convincing Testimony and Particulars 5 cents stamps. Allow time for return mails across the Atlantic. G. MALCOLM ROSS, Height Specialist, Scarborough, England, (P. O. Box 15).



First in 1907 First To-day

**SOMETHING DIFFERENT**  
**Mystery Cigar Lighter**  
**MAKE UP TO \$25 A DAY**

Showing this Scientific Marvel to Men. New Principle of Ignition. What Makes it Light? No Flint or Friction. All Guaranteed. Sample with Sales Plan, 25c. Sample Gold, Silver or Chromium Plated. \$1.00. Agents. Write for Proposition. **NEW METHOD MFG. CO.** Desk SF-4, New Method Bldg., Bradford, Pa.



**WE MATCH PANTS**  
**To Any Suit!**

Double the life of your coat and vest with correctly matched pants. 100,000 patterns. Every pair hand tailored to your measure; no "readymades." Our match sent FREE for your O. K. before pants are made. Fit guaranteed. Send piece of cloth or vest today. **SUPERIOR MATCH PANTS COMPANY** 115 So. Dearborn Street, Dept. 579, Chicago



On Page 627 you will find an interesting announcement about the **RADIO SERVICE MAN'S HANDY BOOK with Addenda Data Sheets.** It takes but a few minutes to read of the full particulars about this announcement.

combined in the output circuit, filtered by a couple of R.F. chokes, by-passed; and then this A.F. energy is fed through a coupling condenser to the A.F. amplifier V3A; potentiometer R1 preventing tube overload.

The plate currents to these tubes determined by the settings of two grid-bias potentiometers are indicated on milliammeters plugged into the jacks J5 and J6. (Note A: the dotted lead is not shown in the official diagram of the circuit, but seems desirable.—*Technical Editor.*)

(To be continued in May RADIO-CRAFT.)

## Home-Made Intermediates

(Continued from page 609)

out the Amperite, or in some other way keep the tube from lighting in that stage. Adjust the condenser until you cannot hear the station, or, if it is a very strong one, till the signal is weakest. This must be done right; since the setting for best results is very critical.

If the owner of a superheterodyne wishes to try my method, after making the transformers, let him take out the potentiometer, and replace this control with a 500,000-ohm variable resistor (R2) in the plate lead. The grid lead which formerly ran to the potentiometer now connects to "C—D."

If the intermediate frequency is changed greatly, however, it may be necessary to alter the number of turns on the oscillator coil.

I say nothing about the frequency-changing system; so much has been written about the superheterodyne, the Stroboddyne, the Ultradyne, etc., that it seems unnecessary to go into a discussion of that. The receiver which I use has three Remler condensers with separate dials and plug-in coils for experimental purposes; though it would be easy to make one with but two dials, and it can even be reduced to one station selector. I would not have a receiver of this nature without a stage of tuned radio frequency ahead of the first detector. When reception conditions were good, I could tune in stations almost anywhere in the country on ground alone; this is better than using the aerial alone without a ground. The set, however, is so thoroughly shielded that even static cannot be received without antenna connections.

Even with 125 feet of aerial, it is possible to separate the strongest stations one receives here, on their 10-ke. channels, without distortion. (The writer is located in central Minnesota). I can tune out WCCO for either WHAS or WBAP.

Since I am working on low wavelengths, I employ two R.F. chokes in the plate lead of the tuned R.F. stage, and a variable plate resistor R1 in the frequency-changing stage. The switch Sw1 shorting the grid condenser and leak, and the top switch giving a choice of positive or negative bias are convenient, for use with different tubes. In all but the detector and audio stages, '99 tubes may be used for economy of batteries; I employ '12As for detector and first audio. (The article was written before 2-volt tubes became available; these might advantageously be used instead.) While the volume might not be so strong, with the '99s, I do not use the second stage of audio for my house, as it gives too much volume.

## Long-Wave Converter

(Continued from page 607)

The fixed condensers, the values of which appear in the text, are Aerovox cartridge-type by-pass condensers, for the larger capacities, and "Micamold" for the smaller; the fixed resistors are "Service" units, which are equipped with convenient pigtails for soldering them into circuit.

### An Optional Arrangement

For the experimenter with only two screen-grid tubes on hand, there is given, as an alternative another circuit, Fig. 3; this is offered by Mr. R. D. Washburne in consideration of the fact that not all screen-grid tubes exhibit the dynatron characteristic to an extent sufficient to drive the long-wave tuned oscillatory circuit. Without recourse to the connections shown in Fig. 3, the experimenter in many cases may be compelled to try a number of screen-grid tubes in the oscillator position. The remainder of the circuit remains the same.

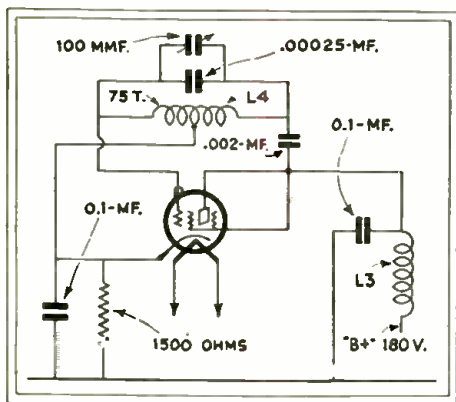

Fig. 3

A rearrangement of the circuit of the oscillator V2; L3 and L4 are the same as in Fig. 1.

A Hartley oscillator connection has been selected here for the circuit of V2. There is no need to change the socket, if it is desired to use the '24 in this position; it is necessary only to "strap" the screen-grid to the plate, as shown, with a jumper. It is equally easy to use a type '27 tube at V2; in this case, the "G" post of the tube socket replaces the "cap" connection; the strap from socket post "G" to post "P" will not be employed. The honeycomb L4 is shown center-tapped; there will be little difficulty in approximating the position of this connection, and making the tap. (The only essential to observe is to scrap the insulation off only one turn, to tap. If soldering paste, or insulation char, is permitted to extend to two or three turns, the resulting losses may prevent circuit oscillation.)

If batteries are used as the "B" supply, it will be unnecessary to supply over 100 volts to the screen-grid of the dynatron oscillator.

## INFORMATION BUREAU

(Continued from page 614)

The intermediate frequencies calibrated on the oscillator are 170, 172.5, 177.5 and 180 kilocycles. The I.F. output of the oscillator may be smoothly varied; the vernier must be set at 50 to obtain the exact fundamental frequencies. This variation feature permits "flat-topping" tunable I.F. transformers.

# JUST WHAT YOU WANT AND FREE!

**R**ADIO WORLD, the first and only national radio weekly, now in its ninth year, is published every week, dated Saturday. Subscribers get their copies well in advance of Saturday. RADIO WORLD publishes illustrated technical articles about broadcast and short-wave receivers, short-wave converters, audio power amplifiers and midjet sets. It also publishes lists of short-wave and broadcast stations and every week prints news of radio events in broadcasting and of station activities. Published weekly, RADIO WORLD prints news of radio while it is news. Keep yourself posted on the timely doings in the field of radio, both technical and popular branches, by becoming a subscriber for RADIO WORLD. The regular subscription rate is \$6 per year (52 issues, one each week).

## Ohmmeter-Voltmeter



**E**VERYBODY who does any radio work whatsoever, whether for fun or for pay or for both, needs a continuity tester, so he can discover opens or shorts when testing.

A mere continuity tester is all right, but—often it is desired to determine the resistance value of a unit, to determine if it is correct, or to measure a low voltage, and then a continuity tester that is also a direct-reading ohmmeter and a D.C. voltmeter comes in triply handy.

So here is the combination of all three: A 0-4 1/2-volt D.C. voltmeter, a 0-10,000-ohm ohmmeter and a continuity tester. A rheostat is built in for correct zero resistance adjustment or maximum voltage adjustment. The unit contains a three-cell flashlight battery. Supplied with two 5-foot-long wire leads with tip plugs. Case is 4-inch diameter bakel enamel. Weight, 1 lb. Sent free with an order for one year's subscription for RADIO WORLD (52 weeks) at the regular rate of \$6. Order Cat. PR-500.

## Power Transformer



**I**N building a receiver or a B supply you will be delighted with the performance of the type K power transformer. This has 105-120 volt A.C. primary, 50-60 cycles. Secondaries on one side are for the 280 rectifier (F-C-F for filament of 280, with C as the positive B lead and both F's to the 280 filament) and 0-1-0 for the high voltage, with both 0's to the respective plates of the 280 and 1 to B minus, usually ground. The secondaries on the other side are: two marked 1 1/2 volts, one marked 5 volts, one marked 2 1/2 volts. The 5-volt winding may be used for one or two 171 or 171A output tubes or for the heaters of two 227 or 224 tubes in series. The 2 1/2 volts may be used for one or two 245 output tubes and, besides, two heater type tubes, or for four heater type tubes. Each of the 1 1/2-volt windings may be used for three 226 tubes, or for one heater type tube on each such winding, when the actual voltage will be 2 volts, which is enough. Sent free with one year's subscription for RADIO WORLD at the regular subscription price, \$6 (for 52 issues). Order Cat. PR-KPT.

## Shielded Coils for Screen-Grid Circuits

**T**HESSE shielded coils are especially suitable for screen-grid circuits, but are adaptable also to other circuits.

They consist of a secondary wound on a 1 3/4-inch diameter bakelite tubing, a layer of moisture-proof insulating fabric, and primary wound over the secondary.



**T**he bakelite tubing of the coil is firmly embedded in a veneered base, to which an aluminum plate is attached at bottom, punctured to pass outleads and to coincide with mounting holes of the aluminum shield. The shield size is 2 11/16 x 2 11/16 x 3 3/8 inches. The mounting method keeps the walls of the shield equi-distant from the coil.

**T**HE outleads of the coils are: shielded wire lead to plate, red lead to B plus, dark blue lead to grid and yellow to ground. When the coil is used as antenna coupler a fixed condenser of .00025-mfd. or smaller capacity should be in series with the aerial. The connections would be: shielded wire to fixed condenser, red and yellow both to ground and dark blue to grid. The coils are packed in matched sets of four. Thus they are of precision type, necessary for full effectiveness from gang tuning. The primaries are of high impedance and the coupling to the secondary is very tight. These features are desirable for high gain in multi-stage screen-grid circuits. However, for circuits using other tubes, the primary turns may be easily reduced by the user to 10 turns, by cutting the primary wire near where it enters the insulating cloth, and unwinding all but 10 turns, cutting and then soldering the two wires together. Set of three coils sent free with an order for a one-year subscription for RADIO WORLD, at \$6, the regular rate. For .00035-mfd. order Cat. PR-SGC-3. For .0005-mfd. order Cat. PR-SGC-5.

RADIO WORLD, 145 West 45th Street, New York, N. Y.

Enclosed find \$6.00 for one-year's subscription for RADIO WORLD (52 issues, one each week) and please send me free the premium checked off below:

- Cat. PR-500 (direct-reading ohmmeter-voltmeter)
- Cat. PR-KPT (power transformer for 300-v. D.C. output, etc.)
- Cat. PR-SGC-3 (set of three shielded coils for .00035-mfd.)
- Cat. PR-SGC-5 (set of three shielded coils for .0005-mfd.)

YOUR NAME .....

ADDRESS .....

CITY .....

STATE .....

# Over the Mountains from Los Angeles

559 Miles

on  
**11**  
Gallons of GAS



Think of it FIVE HUNDRED FIFTY-NINE MILES over rough mountainous country burning only ELEVEN GALLONS OF GASOLINE. Imagine more than FIFTY MILES TO THE GALLON. That is what the WHIRLWIND CARBURETING DEVICE does for D. R. Gilbert, enough of a saving on just one trip to more than pay the cost of the Whirlwind.

## THE WHIRLWIND SAVES MOTORISTS MILLIONS OF DOLLARS YEARLY

Whirlwind users, reporting the results of their tests, are amazed at the results they are getting. Letters keep streaming into the office telling of mileages all the way from 22 to 59 miles on a gallon, resulting in a saving of from 25% to 50% in gas bills alone. Mark A. Estes writes: "I was making 17 miles to the gallon on my Pontiac Coupe. Today, with the Whirlwind, I am making 35 5-10 miles to the gallon." P. F. Goerzen writes: "34-6-10 miles with the Whirlwind, or a gain of 21 miles to the gallon." R. J. Tulp: "The Whirlwind increased the mileage on our Ford truck from 12 to 26 miles to gallon and 25% in speed." Car owners all over the world are saving money every day with the Whirlwind, besides having better operating motors. Think what this means on your own car. Figure up your savings—enough for a radio—a bank account—added pleasures. Why let the Oil Companies profit by your waste? Find out about this amazing little device that will pay for itself every few weeks.

### FITS ALL CARS

In just a few minutes the Whirlwind can be installed on any make of car, truck or tractor. It's actually less work than changing your oil, or putting water in your battery. No drilling, tapping or changes of any kind necessary. It's guaranteed to work perfectly on any make of car, truck or tractor, large or small, new model or old model. The more you drive the more you will save.

### SALESMEN AND DISTRIBUTORS WANTED TO MAKE UP TO \$100.00 A WEEK AND MORE

Whirlwind men are making big profits supplying this fast selling device that car owners cannot afford to be without. Good territory is still open. Free sample offer to workers. Full particulars sent on request. Just check the coupon.

### GUARANTEE

No matter what kind of a car you have—no matter how big a gas enter it is—the Whirlwind will save you money. We absolutely guarantee that the Whirlwind will more than save its cost in gasoline alone within thirty days, or the trial will cost you nothing. We invite you to test it at our risk and expense. You are to be the sole judge.

■■■■■■■■■■ **FREE TRIAL COUPON** ■■■■■■■■■■  
Whirlwind Mfg. Co., Dept. 315-A, Sta. C., Milwaukee Wis.  
Gentlemen: You may send me full particulars of your Whirlwind Carbureting device and tell me how I can get one free. This does not obligate me in any way whatever.

NAME .....

ADDRESS .....

CITY .....

COUNTY..... STATE.....

Check here if you are interested in full or part time salesman position.

## Become a Reporter!



Thousands of opportunities for young men to enter the Newspaper field. Fascinating work. You will meet interesting people; interview celebrities. A famous New York reporter with twenty years of practical experience has written a whole course of journalism and reporting in six easy lessons. He shows you the short-cut to success. He tells you what to do and what not to do, to become a successful reporter. Send today for the "PRACTICAL COURSE IN JOURNALISM," by Henry John Brockmeyer of *The New York Evening Post*. Just drop us a Postal Card—no need to send money. We will mail you the whole set of six books and you pay the Postman \$3.00 plus a few cents for postage. No more to pay. Money absolutely refunded if not satisfied.

**PRESS GUILD**  
16-E Murray Street Dept. D-431 New York

## A New Member of "QRQ"

### the Universal Family

**ONLY \$5 COMPLETE**  
Including 3-ft. Cord

Just what the amateur and experimenter has been praying for. Genuine carbon single button microphone, 200 ohms resistance. Bronze case with suspension eyelet. Life-like voice reproduction. Built by microphone specialists! Only \$5 complete.



**UNIVERSAL**  
Microphone Co.  
(LIMITED)

1163 Hyde Park Blvd. • INGLEWOOD, CALIF.  
Other models \$7.50, \$15, \$25, \$50, \$75. Also cables, plugs, transformers, mountings, etc. Get catalog.

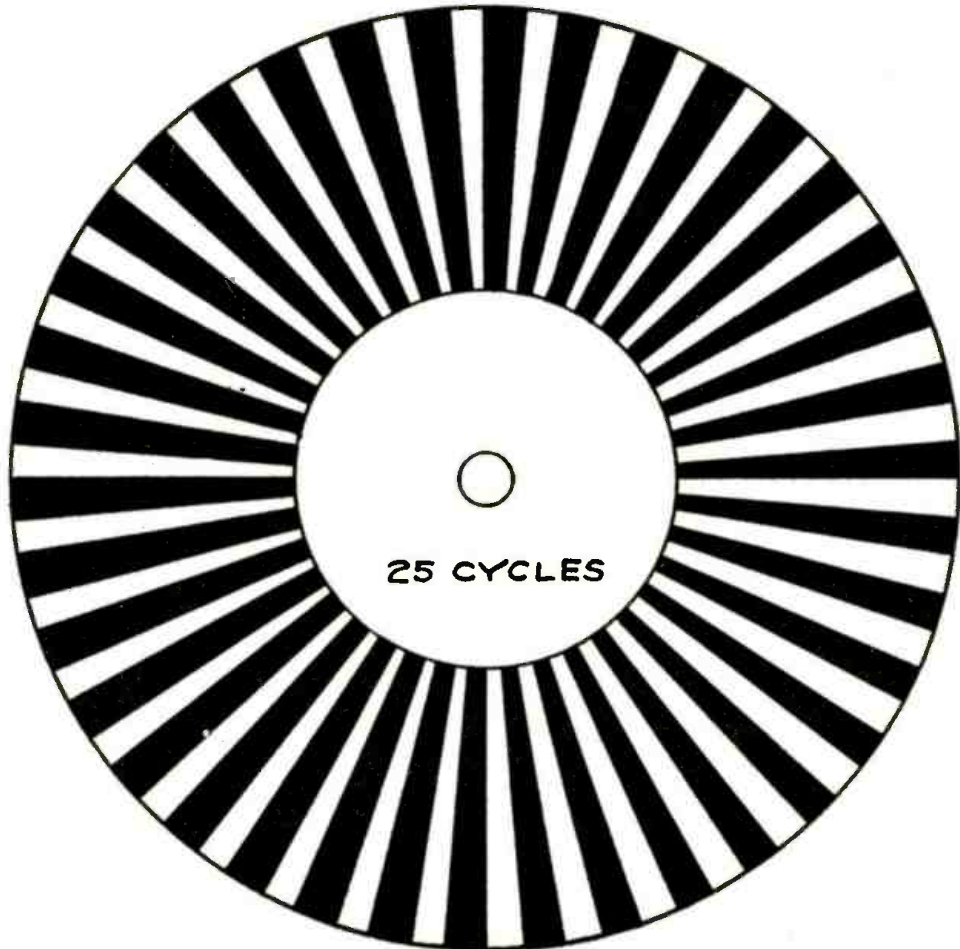
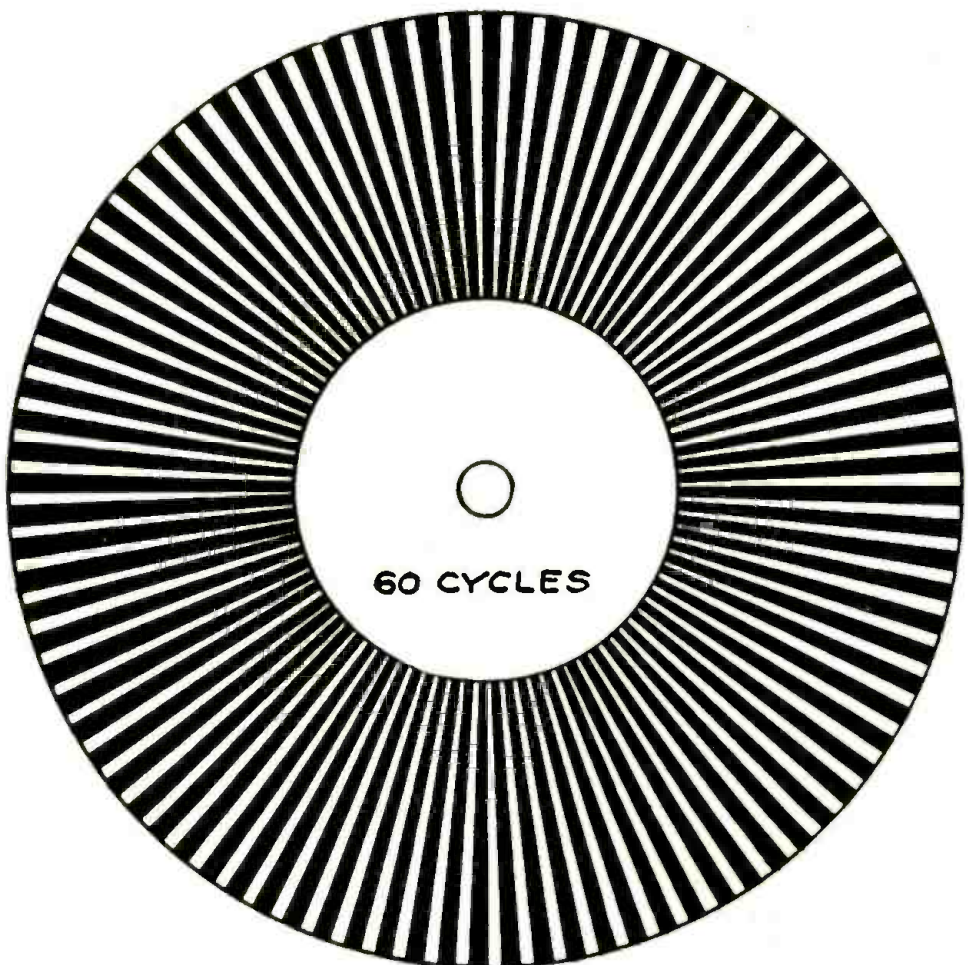

Fig. Q113. Discs of this pattern, rotated on a phonograph turntable at the standard speed of 78 r.p.m. under a lamp varied by A.C. impulses of the stated frequency, seem to stand still. This "stroboscopic" effect would be strongest with a neon lamp. (Marconi Radio Co. of Canada.)

**NOTHING IN RADIO EVER APPROACHED THESE VALUES!**

**SONORA!** Known everywhere as **QUALITY** Radio. Now offered to you in **LIMITED QUANTITY** at Prices **LESS** than the Actual cost to manufacture. A ready market awaits your sale of these famous sets.

These Sonora Chassis are of the very latest design and construction—Screen Grid — 245 Push Pull Amplification. Totally shielded. Battleship Construction, with oversized transformers and condensers assuring long, faithful performance. Chassis measures 21 in. long, 8 in. wide and 8 in. high. **NOTE:** Do not confuse this genuine Sonora built Radio chassis with similar type models offered elsewhere.

**Sonora**  
CLEAR AS A BELL

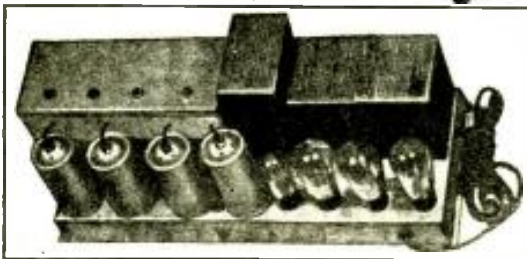

**RADIO CHASSIS  
WITH MATCHED  
ELECTRO DYNAMIC  
SPEAKER**



**LATEST MODELS  
SCREEN GRID  
45's IN PUSH PULL**

**SONORA Model A31**  
7 TUBES—3 SCREEN GRIDS

**SONORA Model B31**  
8 TUBES—4 SCREEN GRIDS

Uses:  
3—224, 1—227,  
2—245 & 1—280 Tubes

OUR  
PRICE

**26.50**  
Net

Uses:  
4—224, 1-22  
2—245 & 1—280 Tubes

OUR  
PRICE

**29.50**  
Net

**Sonora**  
CLEAR AS A BELL

**Super  
Power**

**245 and 250**

**Push Pull  
Amplifiers**

And "A-B-C" Power Supply



**SONORA CONCERT  
Power Amplifier**

**2 STAGE  
245 Push Pull  
With "ABC" Supply  
POWERFUL**

**Faithful Reproduction**

Here is a truly fine amplifier affording volume galore with astonishing faithfulness and realism. Constructed of the highest quality parts, to give long life and the finest performance.

**PHONOGRAPH AND RADIO INPUT**

The Concert Power Amplifier supremely efficient for reproduction of phonograph records, radio programs and speeches. Operation requires: Two x 245 Power Tubes, one Y227 AC tube, and one X280 Rectifier tube.

Regular Value **\$85.00**

OUR  
PRICE

**22.50**  
Net

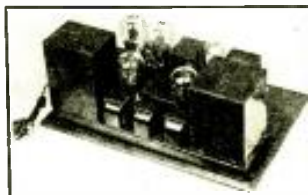

**SONORA  
AUDITORIUM  
Theatre Amplifier**

**2 STAGE  
250 Push Pull  
With "ABC" Supply  
Enormous Volume**

QUALITY OF REPRODUCTION IS AS NEAR PERFECT AND LIFE-LIKE AS POSSIBLE! ITS POSSIBILITIES CAN BE SUMMED UP IN THREE WORDS: ABSOLUTELY DISTORTIONLESS VOLUME! The full benefit of the 450 volts produced is obtained, using this as a **PHONOGRAPH AMPLIFIER—PUBLIC ADDRESS AMPLIFIER SYSTEM—RADIO TUNER AMPLIFIER.** Self-contained unit. Supplies all necessary A, B and C power to its own tubes. Operation requires two type X250 power tubes, one Y227 A.C. tube, and two type X281 rectifier tubes.

Regular Value **\$145.00**

OUR  
PRICE

**29.50**  
Net

**Genuine TUNG-SOL  
HANG-UP REPLACEMENT  
CONDENSER SECTIONS**



FOR  
**GENERAL REPAIR  
AND POWER-PACK  
WORK**

Every Service Man should always have on hand several units of each capacity and voltage to meet every emergency!

Working Capacity	Voltage D. C.	Our Price
1/2 Mfd.	500 V.	\$0.35
1 Mfd.	300 V.	.40
1 Mfd.	450 V.	.45
1 Mfd.	500 V.	.50
1 Mfd.	600 V.	.60
1 Mfd.	700 V.	.70
1 Mfd.	800 V.	.80
1 Mfd.	1000 V.	.90
2 Mfd.	300 V.	.60
2 Mfd.	400 V.	.70
2 Mfd.	500 V.	.80
2 Mfd.	600 V.	.90
2 Mfd.	700 V.	1.00
2 Mfd.	800 V.	1.10
2 Mfd.	1000 V.	1.25
3 Mfd.	300 V.	.85
3 Mfd.	400 V.	.95
3 Mfd.	500 V.	1.05
3 Mfd.	600 V.	1.15

**ISN'T THIS WHAT YOU'VE  
BEEN WANTING?  
At Last A Real Noise and Hum  
Eliminator**



No More  
Hum-m!

**CUT DOWN USELESS SERVICE CALLS:** You will find this article to be a money-saver, as well as a money-maker, for you. The majority of your service-calls are due to line-noises. How much time and material has been wasted by your Service-Department making special apparatus to cut down line-noises? Now a simple installation of the "MAXIM FILTERAD" and your troubles are over. Works on all currents—Automatic—Requires no adjustments—Take advantage of this offer now!

**Heavy Duty Model**

OUR PRICE

**2.65**  
Net

**SONORA ABC  
POWER TRANSFORMER  
For Models A-31 and B-31**



For 5—224 or 227, 2—245 and 1—280 Tubes. For Models A-31 and B-31, 6 3/4 in. wide, 6 3/4 in. long, 4 in. tall. Also Furnished for 25 Cycle Current for \$5.50.

OUR PRICE

**3.75**  
Net

**KODEL STEP-DOWN  
TRANSFORMERS**



**HEAVY DUTY**  
Primary 110-120 Volts, 50-60 Cycles AC current. Output 14 Volts AC at 2 1/2 Amp Suitable for A Eliminators, Dynamic Speakers, Truckle Chargers, Bell Ringing and Toy Transformers.

OUR PRICE

**75c** Net

All offers are F.O.B. New York, and subject to prior sale. Terms: A deposit of 20% is required with every order. Balance may be paid on delivery. Or, deduct 2% if full amount is sent with order.

**DO NOT WRITE FOR CATALOG!**

**GRENPARK CO., Dept. R C 245 Greenwich Street, New York, N.Y.**

If It's A  
Replacement Part

# Hudson Radio Co. HAS IT

## SANGAMO QUALITY AUDIO TRANSFORMERS



"X" Line Type Only

A type for every purpose.

Never sold at these prices before.

Cat. No.	Type	Description	List Price	Our Price
3560	AX	Straight Audio	\$6.00	ALL ONE PRICE
3561	BX	Push-pull Input	6.50	
3563	HX	Push-pull Output for 250 or 271 power output tubes to match the impedance of moving coil of dynamic speaker	6.50	\$2.25 Each
3565	E	Output choke to match impedance of the various type power tubes	5.00	



## AT A SENSATIONAL PRICE! TYPE 227 ONLY

Lots of 6	25c Each
Lots of 12	22c Each
Lots of 25	20c Each
Lots of 50	15c Each

No Less Than 6 Sold

Packed in Original Factory Cartons and Guaranteed to Light and Play.

## VICTOR REPLACEMENT CONDENSER BLOCK

10½ MFD., 600 VOLTS

For replacement in All Victor Sets  
Total capacity 10½ Mfds., 600 working voltage.  
Housed in metal can.  
Size: 5½ in. long, 5 in. high and 4 in. wide.

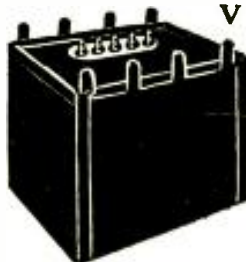

Cat. No. 2709

Our Price, **\$2.25**

## Radiart Step-Down Transformer



Primary 220 to 250 Adjustable  
Secondary 110-125  
Cap. 160 Watts  
Cat. No. 2576  
LIST PRICE \$10.00  
Our Price, **\$4.50**



We Carry a Complete Line of Microphones, Turntables, Pick-ups and Amplifiers for Public Address Systems and Theatres.

Universal Baby Mike. A real microphone, single button, with covers and 25 ft. of cable. List, \$7.50. Our Price \$4.50.

## Carryola Synchronous Motor

Complete with turn-table. Silent, sturdy and compact, only 1¼" thick. No brushes. Only \$3.25.

## STANDARD REPLACEMENT POWER TRANSFORMERS



Cat. No.	Type	Price
2615	Peerless Kylectron	\$2.25
2572	Midget sets using 224, 227, 245 & 280 Tubes	2.85
2603	Sonora A-31, B-31	4.50
2655	Kolster K24 (210-250)	4.75
2656	Kolster K20, 22,	
2618	Sonora with 600 V. C.T. 2-7½V. 1-2½V., and 1-15V. with 85V. primary for voltage regulator tube	3.75
2558	Victor using 245's	2.75
2626	Freshman Q	3.85
2628	Freshman QD	4.50
2522	Earl 21, 22, 55, 56	3.95
2557	G. T. C. 1½, 2½, 5 & III	2.75
2608	Dongan 2½, 5, 15 & III	2.75
2602	Thordarson T-3187 for Sparton 600, 5, 5, 3 V	4.50
2250	Anrad BelCanto Series	4.50
2580	Franklin 210-250-281	3.85
2600	Phileo all sets	3.90
2664	Zenith 33, 34, 35, 35A	2.95
2527	Zenith 0, 11, 12	5.00
2551	R C A 17, 18, 33, 51	3.95
2573	R C A 44, 46	4.25
2566	R C A 60, 62	5.95
2630	Loftin-White 600, 2½, 2½, 5	4.25

## PEERLESS 600 VOLT CONDENSERS



### IN CARDBOARD BOXES

Cat. No.	Size	Price
3004	1 Mfd.	\$0.35
3005	2 Mfd.	.65
3006	4 Mfd.	.80

## UTILITY CONDENSERS

### IN METAL CANS

3150	1 Mfd.	450V.	.50
3152	2 Mfd.	450V.	.75
2925	1 Mfd.	1000V.	.75
2926	2 Mfd.	1000V.	1.45

Set	Model	Item No.	Part No.	Cat. No.	Price
Atwater Kent	37	Filter Block	5001	4.95	
Brandes	B-15, B-16	Filter Block	5004	5.00	
Columbia-Kolster,	C-6	Filter Block	5005	2.00	
Eveready and Bosch	1928-29	Filter Block	2988	3.95	
Earl	A2	Filter Block	5006	4.00	
Fada	D	Filter Block	5008	3.75	
Freed-Eisemann	NR57	Filter Block	5010	3.75	
Freshman	H-5	Filter Block	5012	7.00	
Freshman	M12 (171 tube)	Filter Block	5013	5.00	
Freshman	N11 (250 tube)	Filter Block	5014	6.00	
Kolster	K-22, K-20, K-40, K-42,	Filter Block	2805	2.50	
Columbia-Kolster	920, K-43	Filter Block	WS3626A	2963 2.95	
Kolster	6-H and K-5	Filter Block	2316	2815 2.75	
Kolster	6J, 6K	Filter Block	5022	3.50	
Kolster	K20, 22, 25, 48A, 48B	Condenser Block	2624	2805 2.50	
Majestic	171 Sets	Filter Block	5026	5.00	
Majestic	250 Sets	Filter Block	5027	5.00	
Majestic	245 Sets	Filter Block	5028	5.00	
Majestic	Master B, Super B	Filter Block	5029	2.95	
Majestic	Special Master B	Filter Block	5030	3.25	
Majestic	A Eliminator	Filter Block	5031	3.75	
Peerless	All Courier Sets	Filter Block	2855	1.50	
R C A	18, 33, 51	Filter Block	8333	2710 1.50	
R C A	41	Filter Block	5033	4.25	
R C A	17	Filter Block	8289	2711 4.95	
R C A	44, 46	Filter Block	3346	2711 4.50	
R C A	60	Filter Block	3346	2726 4.95	
R C A	62	Filter Block	2659	5.95	
Sonora	Using 250 tubes,	Filter Block	2914	1.85	
Sparton	69, 79, 89,	Filter Block	4049	4.75	
Steinite	45	Filter Block	5037	5.00	
Steinite	40	Filter Block	5028	6.00	
Temple	8-60, 8-80, 8-90	Filter Block	2754	.95	
Zenith	ZE11, 12, 14, 18	Filter Cond.	PL1145	2800 3.25	
Zenith	ZE18	Filter Cond.	35Px, 35APX, and 37A	2701 3.25	
Zenith	ZE17	Filter Cond.	333X, 353X	2700 3.25	

MAIL  
ORDERS TO

# Hudson Radio Co.

16 Murray Street - - New York, N. Y.

TERMS:—20% with order, balance C.O.D. 2% discount allowed for full remittance with order only. No orders for less than \$2.00 accepted.



# THIS MONTH'S SPECIALS!

ALL merchandise listed is BRAND NEW and is shipped in the original, factory sealed cartons and carries the same guarantee of ABSOLUTE SATISFACTION! Due to the demand for this seasonable merchandise actually exceeding the available supply, ACT IMMEDIATELY! In most

instances, our SALE PRICES ARE LOWER THAN THE ACTUAL MANUFACTURER'S COST! Join the ever swelling ranks of our 100 per cent SATISFIED CUSTOMERS. ORDER DIRECT FROM THIS PAGE TODAY. NEW LOW PRICES.

## Dry Electrolytic Condensers

Mount in any position! Guaranteed never to blow out! Remarkably compact and very inexpensive, permitting generous use of filtering systems. The greater the mfd. capacity employed, the less A.C. hum remains. 500 volt peak rating. Ideal for all 171A - 245 power packs—use two of each capacity desired for 250 power packs (1,000 volt peak thereby assured).



No.	Mfd.	Diameter	Length	YOUR PRICE
1801	1	3/4 in.	2 1/2 in.	\$0.28
1802	2	1 in.	2 1/2 in.	.45
1804	4	1 1/2 in.	2 1/2 in.	.85
1808	8	1 3/4 in.	4 1/2 in.	1.25
1816	16	3 in.	4 1/2 in.	2.12
1824	24	3 in.	4 1/2 in.	2.75
1832	32	3 in.	4 1/2 in.	3.33

## Cavalier Model 159 Console With Peerless Speaker



This beautiful and distinctive cabinet is sold with the built-in Peerless Speaker. It is designed to provide a maximum cabinet at a minimum price. veneers of figured Walnut with attractive carvings and unusual turnings. Set Compartment, 21 3/4 in. wide x 10 1/2 in. deep x 8 in. high. Height, 38 in. Shipping weight 65 lbs. Packed in original crate. Complete with speaker.

No. 159—YOUR SPECIAL PRICE **\$9.95**

## Thordarson Standard Replacement Power Transformer 70 WATTS

This transformer may be used in building up inexpensive chassis; or for replacement in such standard combinations as three '21's, two '27's, two '71A's or two '45's, and an '80 rectifier. Suitable for the home-built rack-and-panel public address amplifier, or cabinet-type phonograph power amplifier. Just the foundation unit for an audio amplifier to be used as a standard of comparison. Well designed. Connections are made to soldering lugs on the two end plates. Dimensions: 3 1/4 x 3 1/2 x 4 inches. For 110-120 volts, 50-60 cycles. Shipping weight 5 1/2 lbs. List Price, \$12.50.



No. 1405—YOUR PRICE..... **\$2.55**

## Kolster Speaker Chassis



May be connected directly in the plate circuit of type '12A tubes; or to higher-power tubes through an output device. In push-pull circuits, speaker may be connected from plate to plate. "9 inch cone" type. Paper-plate is prevented by a flange diameter; bass notes are well reproduced due to the "free-edge" effect. Its small dimensions make it eligible for use in home-constructed midget sets.

Comes with 6 ft. cord. Dimensions: 10 x 5 1/2 x 2 1/4 inches. Shipping weight 6 1/2 lbs. List Price, \$18.00.

No. 1500—YOUR PRICE..... **\$2.85**

## Short-Wave Converter



Build a short-wave converter at lowest price on record, but with which excellent results are obtainable nevertheless. The voltage for the three 227 tubes used may be obtained from an external filament transformer or from a secondary winding of 2 1/2 volts in a power pack. Wavelengths from 30 to 110 meters. No plug-in coils; coil switch is used to cover wave band. Single dial tuning, no grunting, no hilly capacity, no squeals. Leak condenser modulation. Converter consisting of all parts (less filament transformer) including cabinet, panel, diagram and 1-page instruction sheet (less tubes).

No. 1619—YOUR PRICE..... **\$4.85**  
No. 1615—6-Volt Battery Model, same price.

## R.C.A. Double Filter Chokes

This heavy-duty, extremely strong, double filter choke can be used for all types of filter circuits, experimental work, power amplifiers, receivers, eliminators, power packs, converted sets, etc. Known as R.C.A. replacement part for all Radiola models, particularly Nos. 33, 17 and 18. Each choke D.C. resistance, 500 ohms. Connected in parallel, these double filter chokes have a rating of 15 Henries at 160 Mills; connected in series, 60 Henries at 80 Mills. Fully shielded in heavy metal case with special insulating compound. Size 5 1/4 x 3 1/2 x 2 1/2. Shipping weight 6 lbs. List Price \$10.05.



No. 8336—YOUR SPECIAL PRICE... **95c**

## "250" A.C. Power Transformer



This power transformer supplies current for five 15-volt Arcorpus tubes drawing 6 Ma. and 1/2 amp. on filaments; one 2.5 V. tube; two '50's, and two '81's. Two 227 or 221 (if suitable resistance is used) and 750 volts. Full wave 'B' and 'C'. A line ballast resistor, such as the Amperite, in conjunction with the special 85-volt primary, will maintain even voltage over 105 to 125 volts. Entirely shielded in metal. 4 3/4 x 4 3/4 x 6 1/2 inches high. Weight 15 lbs. For 110-120 volts, 50-60 cycles. List Price, \$20.00.

No. 1412—YOUR PRICE..... **\$3.75**

## 2.5 Volt Filament Transformer 60 WATTS

Has 2 center-tapped windings. Both deliver 2.5 volts. One winding gives 3 amperes; the other, 11 amperes. Pistal leads. Heavy iron case, beautifully finished in brown crackle. 1 1/2 to 1 3/4 inches. 50 to 60 cycles. Dimensions: 3 1/4 x 5 x 1 1/2 inches. Shipping weight 9 lbs. List Price, \$6.00.



No. 1414—YOUR PRICE..... **\$3.45**

## Earl Power Transformer 70 WATTS

Make money reamping the old battery set. This power transformer used in Earl Model 122 receiver supplies "A," "B" and "C" potentials for: two '27's (or screen-grid '21's), three '26's, two '71A's and one '80 rectifier; total current output of high-voltage winding at maximum output (about 200 volts) is 80 ma. High-voltage secondary filament winding for '27's, and for '71A's are center-tapped. May be used in any number of combinations. Suitable resistors, a couple of 4-in. filter condensers, two 30-henry chokes and by-pass condensers complete fine power pack. Size 3 3/4 x 3 x 2 1/4 inches. 16 long leads and full wiring directions. Shipping weight 5 lbs. List Price \$7.50.



No. 1410—YOUR SPECIAL PRICE **\$1.75**

## Shielded "A" Transformer



Modernize storage battery receivers by replacing '01A's with '26's and '27's heated by this filament transformer. Supplies 1.5, 2.5, and 5 volts; 2.5-volt winding center-tapped. Heats three '26's, two '27's, and two '12A's or '71A's. 3xxx1 inches. For 110-120 volts, 50-60 cycles.

Weight 3 1/2 lbs. List Price, \$4.50. No. 1400—YOUR PRICE..... **\$1.75**

## A.K. 37 Filter Choke Condenser

Contains two filter chokes, a speaker output choke, two high-voltage filter condensers, a detector by-pass condenser, and an R.F.-A.F. by-pass condenser, each connecting lead being identified by colors. To make up efficient power pack for a receiver using a type '71A output tube you need only a rectifier tube socket, a voltage divider, a power transformer, and this filter block. 3 1/4 x 4 1/2 x 5 inches. Shipping weight 6 lbs. List Price, \$7.50.



No. 1800-283—YOUR PRICE... **\$4.95**

## Utah Dynamic A.C. Power Speaker—Model 33A

110-volt, 60-cycle A.C. light socket supply for field excitation with Westinghouse dry rectifier. 9 in. high, 9 1/2 in. wide, 7 1/2 in. deep. Speaker comes packed in wooden crate. Weight 19 lbs. It is one of the most powerful as well as best producers in the market. 9-inch cone. List Price \$50.00.



No. 1506—YOUR SPECIAL PRICE **\$7.50**

## Kolster Power Transformer 85 WATTS



Will supply sufficient current and voltage for push-pull '10's, in conjunction with type '81 half-wave rectifiers. The 2.25-volt secondary output is just below the rated maximum for type '21 and '27 tubes; tubes will last much longer than when heated from a higher-voltage transformer. Four secondaries are rated as follows: Secondary S1, 7.5 V., 1.25 A.; S2, center-tapped, 7.5 V., 1.25 A.; S3, 1.5 V., 1.25 A.; S4, 2.25 V., 1.65 A.; S5, 7.25 V., 90 Ma. Primary is tapped for low line voltage. Has eight feet drilled for mounting to base of park. Generous iron core assures cool performance under heavy load. For 110-120 Volts, 50-60 Cycles. Dimensions: 1 1/2 x 4 1/2 x 4 1/2 inches. Shipping weight, 12 lbs. List Price, \$19.50.

No. 4336—YOUR PRICE..... **\$5.75**

## The SONOLA 1931 A.C. Model Midget Receiver RCA LICENSED

This Midget Receiver will outperform many of its larger brothers. Uses 5 tubes: 3 screen grid, 215 power tube, 250 rectifier, Rola dynamic. Large capacity filter. Perfectly shielded. Selectivity obtained by use of three tuned stages. High amplification is assured by screen grid RF, screen grid power detector and '45 output. Rola Dynamic gives wonderful reproduction. So small you can put it anywhere yet it will fit. There may be cheaper midgets on the market. We are fully aware of this. That's exactly why you should have a SONOLA. There is NO GRIEF with this high grade set. For 50 to 60 cycle, 110 volts. Dimensions: 14 x 9 x 18 inches high. Shipping weight 30 lbs. List Price, \$59.50.



No. 2500—Your Price (less tubes) **\$29.85**

## Genuine Magnavox Microphone Do Your Own Home Phonograph Recording

Made by the world-famous Magnavox Co. While originally made to strap on the head, it is easy to screw a handle onto one of the side brackets. The side brackets are covered with soft rubber and place the microphone at the best speaking distance from the mouth. Comes with 6 feet of cord. The biggest mike bargain in America! Complete with straps and buckle to fit around head. Brand new, in original factory packing. Shipping weight 1 lb. List Price, \$10.75.



No. 1610—YOUR SPECIAL PRICE **\$1.55**

## "RTC" High-Voltage "Puncture Proof" Filter Condenser Units

We guarantee these condensers unconditionally. They are ideal for general replacement purposes and can be installed in any new power-pack. All condensers are furnished with 8-inch lengths of lined "push-back" wire.



600 VOLTS			800 VOLTS		
Cat. No.	Mfd. Capac.	Your Price	Cat. No.	Mfd. Capac.	Your Price
1702	1/2	\$0.25	1706	1	\$0.45
1703	1	.30	1707	2	.75
1704	2	.40	1708	4	1.10
1705	4	.60			

## 6 MONTHS GUARANTEED NEONTRON TUBES

Sold on a 6 MONTHS FREE REPLACEMENT GUARANTEE BASIS, PROVIDING THE LIGHTS! All tubes are carefully meter-tested before shipment, and carefully packed. Do not confuse these HIGH QUALITY tubes with any other "low priced" tubes—our low prices are possible because we do a VOLUME business!

Choice of	Choice of	Choice of	Choice of
226	112A	245	222
227	200-A-199UX	240	210
171A	199UV-120	171	250
201A	221		281

63c each      70c each      80c each      \$1.60 each

FREE

We have just issued our new "RADIO SERVICE TREATISE". It's red hot all the way through. 52 new bookups and circuit diagrams, 110 illustrations.

Partial contents: Modernizing old radio sets. How to convert battery to power sets. Selection of tubes. The detector tube. The power tube. Changes in grid or "C" bias circuits. Push pull amplifiers. Replacing audio transformers. Phono attachments. How to choose power transformers. Voltage dividers. Wattage of power transformers. Selecting and installing replacement parts in radio sets. Filter condensers. Repairing "44 eliminators. ALL BRAND NEW BOOKS—NOT A REPRINT. A book full of REAL radio information all the way through. Even the catalog section has dozens of bookups—never found anywhere before.

WRITE TODAY. Enclose 2 cents for postage. Treatise sent by return mail.



**RADIO SERVICE TREATISE**  
AND  
**RADIO BARGAIN CATALOG**  
FOR RADIO SERVICEMEN—RADICIATIONISTS—RADIO DEALERS  
**RADIO TRADING CO.**  
25 WEST BROADWAY  
NEW YORK CITY

WE ARE A WHOLESALE HOUSE AND CANNOT ACCEPT ORDERS FOR LESS THAN \$3.00. If C. O. D. shipment is desired, please remit 20% remittance, which must accompany all orders. If full cash accompanies order, deduct 2% discount. Send money order—certified check—U. S. stamps.

Radio Trading Co.  
25 West Broadway  
New York, N. Y.

ORDER FROM THIS PAGE. You will find special prices from time to time in this magazine. Get our big FREE catalog for the greatest Radio Bargains. Should you wish goods shipped by parcel post, be sure to include sufficient extra remittance for same. Any excess will be refunded.

# Headquarters For Replacement Parts For All A. C. and D. C. Sets

We can replace any A. C. Power Transformer, Condenser Block, etc.,  
WITH AN EXACT ELECTRICAL DUPLICATE!

## SEND FOR OUR FREE CATALOG

### Semi-Assembled Peerless 9 Tube AC 3 or 4 Screen Grid Receiver

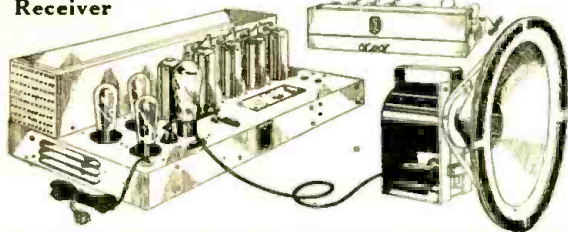

Set of 8  
R. C. A.  
LICENSED  
TUBES  
Included  
FREE!

Uses THREE SCREEN GRID TUBES! LINEAR POWER DETECTION! PUSH-PULL 245 AMPLIFIER! PHONOGRAPH ATTACHMENT! TUBE VOLTAGE REGULATOR! TOTALLY SHIELDED! IMMENSE POWER PACK! Requires 3-224, 2-227, 2-245, 1-280 and AMPERITE VOLTAGE REGULATOR. Operates with a 15 foot aerial—even picks up 2,000 miles on same. Furnishes field current to any D. C. DYNAMIC SPEAKER (we sell a very excellent MATCHED DYNAMIC for \$8.95. This receiver can also be used with any A.C. type dynamic, or magnetic speaker (\$2.50 additional cost.) Self explanatory diagram and blue-print included assures rapid and accurate assembly! 21" x 9 1/2" x 12" deep. FULLY GUARANTEED!

Leas Speaker, but including 8 FREE TUBES. **\$22.50**

(FULLY WIRED RECEIVER (Less Speaker but including FREE Tubes) **\$32.50**

### Semi-Assembled Three Stage, Double Push-Pull Auditorium Super-Amplifier and ABC Power Pack

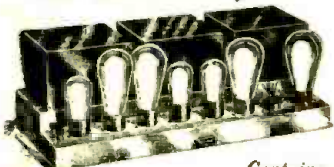

Contains

### Thordarson Power Units

Here is the very last word in power amplifiers. Use with any Radio Tuner—as a PHONOGRAPH AMPLIFIER of exceptional efficiency—or as a PUBLIC ADDRESS AMPLIFIER. Input feeds into a 227 1st A.F. stage, followed by a PUSH-PULL 2nd A.F. stage using two 227's followed by a 3rd A.F. PUSH-PULL STAGE, using TWO 250 super-power tubes. Amplification produced ample for huge auditoriums or outdoor gathering. AMPLIFIES WITHOUT DISTORTION! Requires 2-281, 2-250, 3-227 tubes. Furnishes 45, 67, 90, 135, 180 volts "B" for tuner, as well as choice of 2 1/2 volt or 1 1/2 volt and 2 1/2 volt A.C. filament current for any tuner. Also furnishes 110 volt field current for any D.C. dynamic for exceptional results. Use the 15" 110 volt D.C. PEERLESS DYNAMIC! Can be assembled by any novice—detailed diagram included. For 110 volt, 60 cycle A.C. 21 1/2" x 8" x 7" high. **\$39.75**

Wired, ready for use **\$47.50**  
Set of 7 R.C.A. LICENSED TUBES **\$12.50**

### 2 Stage Audio Amplifier

Encased in an aluminum box (with cover) 13" long, 3 3/4" high. Parts alone are worth twice our price!

FULLY ASSEMBLED **\$2.95**

### Loftin-White Direct Coupled Amplifiers and "A-B-C" Supply

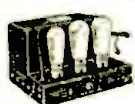

Affords more than sufficient volume, sufficient for most dance halls, schools, small auditoriums, etc. The very finest of parts only are used—contains THORDARSON A. C. Transformer. Tube Condensers!

Also furnishes all ABC voltages to any 2 1/2 volt A.C. tuner. Easily connected by any novice. **\$13.90**

250 MODEL Requires 1-250, 1-281, 1-224 **\$24.50**

### Peerless 15 inch Dynamic Speakers

110 v. D.C. MODEL Contains double field: 900 ohms and 4000 ohms! Use either or both fields! Produces super auditorium volume, with uncanny perfection of realism of reproduction. Contains push-pull output transformer. Can be used with any set. **\$15.95**

12" 110 V. A.C. **\$14.50**  
12" 110 V. D.C. **\$10.50**  
9" 110 V. A.C. **\$10.95**  
9" 110 V. D.C. **\$10.00**

### Peerless Dynamic Speaker

110 v. A.C. MODEL—15" Diam. Model Uses a 280 Rectifier tube—more superior than metallic disc rectification. No finer speaker made! **\$18.75**

### Semi-Assembled Radax

3 or 4 SCREEN GRID A.C. TUNER Most compact made—only 9" long, 6 1/2" deep, 6" high. Produces enormous, distortionless volume—with amazing fidelity of reproduction! Furnishes all A.C. voltages to any tuner, and furnishes field current to a D.C. type dynamic speaker. Can be used with any tuner! An ideal PHONO. amplifier. Blue Prints included **\$12.75**  
Less Tubes **\$12.75**

### Semi-Assembled Radax 245 Push-Pull Power Amplifier and AC "A-B-C" Supply

Most compact available only 9" long, 6 1/2" deep, 6" high. Produces enormous, distortionless volume—with amazing fidelity of reproduction! Furnishes all A.C. voltages to any tuner, and furnishes field current to a D.C. type dynamic speaker. Can be used with any tuner! An ideal PHONO. amplifier. Blue Prints included **\$14.50**  
Less Tubes **\$14.50**  
FULLY WIRED **\$18.50**

### Thordarson Power Transf.

All types listed below furnish all plate and filament voltages for any A. C. set.

MODEL 171 PUSH-PULL For 4-226, 1 or 2-227, 1 or 2-171A, 1-280. **\$2.55**

MODEL 245 PUSH-PULL For 3 or 4-227 or 245 2-227, 2-245, 1-280 **\$3.25**

MODEL 250 PUSH-PULL For 5 or 6-227 or 224, 2-250, 2-281 **\$5.55**

### FILTER CONDENSER AND FILTER CHOKE BLOCK FOR ATWATER KENT 37-38 SERIES SETS

Contains four filter condensers AND THREE FILTER CHOKES! Same size and placement of leads as on original! **\$4.95**

A.C. TRANSFORMER for same sets \$4.25.

### REPLACEMENT POWER PACK FOR Atwater-Kent 40-42-43-44-45-46-47-52-53 A.C. Sets

Contains the necessary A.C. Power Transformer Unit and a Filter Condenser-Choke Block Unit, both contained in one common case. An exact electrical and mechanical duplicate of the original!! **\$9.00**

### Radax General Replacement A.C. Power Packs

Can be connected in 30 minutes. Detailed instructions and diagrams included. 171-A "B" ELIMINATOR. 200 volt output, and 45, 67, 90, and 135 volt terminals. Requires 280 Rectifier. **\$6.75**

Same as above, but also furnishes A.C. filament current for 5-226, **\$8.25**

245 "B" ELIMINATOR. Output 250 volts, and 45, 67, 90, 135 and 180 output terminals. Also furnishes 3 amps., 2 1/2 volts A.C. for lighting TWO 245 tubes. Provides "C" bias for these tubes also provided. Requires 1-281 **\$10.45**

Same as above, but also furnishes A.C. filament current for 6-224 or 227 tubes, 2-245 tubes, 1-280 tube. MAKES AN IDEAL ENTIRE A.C. POWER PACK REPLACEMENT UNIT **\$12.45**

Any of the above sold FULLY WIRED for \$2.50 additional.

### Semi-Assembled Radax 3 Tube Short-Wave Receiver

Uses 1-222 SCREEN GRID TUBE, 1-112A and 1-171A. Can be wired in very little time! Complete with 4 plug-in coils, 10 to 225 meters. Enclosed in handsome FULLY SHIELDED ALUMINUM BOX, 13" long, 3 3/4" deep, 6" high. **\$13.50**  
Less Tubes **\$13.50**

### Semi-Assembled Midget 8 Tube---4 Screen Grid---245 Push-pull AC Receiver

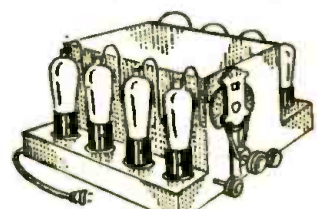

Midget proportions (13" long, 9" deep, 6" high) but MIGHTY PERFORMANCE! Duplicates (and even exceeds!) results generally obtained on very large and very costly A.C. sets. 1931 design! Self-explanatory blue prints and wiring instructions included. Designed for use with MATCHED D.C. DYNAMIC SPEAKER, to which it furnishes suitable field current. (We can furnish one for \$7.75) Can also be used with an A.C. dynamic or magnetic speaker—\$2.00 additional! **\$19.75**

Set of 8 R.C.A. LICENSED TUBES **\$3.75**

### Columbia-Kolster Phono. Pick-Up

None finer made. Does full justice to manufacturers' high reputation! Removable head! Extremely SENSITIVE! (4-224, 1-227, 2-245, 1-280) Reg. \$19.75 **\$5.95**

### Diehl A.C. Phono. Motor

Guaranteed not to interfere with Radio reception! HUM-FREE and QUIET in operation. Speed regulation! High torque! 12 inch felt table (included) does NOT Wobble! Uniform speed! **\$9.75**

### Radax Push-Button Model Set Analyzer and Tube Tester

Makes every possible test, with speed and ACCURACY generally associated with \$70.00 to \$100.00 type instruments. TREMENDOUS SALES WARRANT OUR LOW PRICE! FULLY GUARANTEED! **\$18.75**

### Peerless Magnetic Speaker

Do not confuse this HIGHEST QUALITY speaker with any other low priced speaker! Regardless of terrific volume imposed on it, this SPEAKER WILL NOT DISTORT! Handsomely finished wood mantel cabinet **\$5.75**

### Elkon M-16 Rectifier

Ideal for ANY "A" ELIMINATOR or MOST ANY A.C. DYNAMIC SPEAKER. Furnished as illustrated, or with base with 5 heavy brass strip lugs **\$2.95**

### ORDER FROM THIS PAGE!

We accept checks, money orders, and stamps in all denominations. In absence of postage allowance, shipment will go forward, express collect. Deduct 2% CASH DISCOUNT if you send remittance with order! C.O.D. Shipments require 20% deposit remittance with order. We guarantee complete satisfaction!



### ORDER FROM THIS PAGE!

SEND ALL ORDERS AND CATALOG REQUESTS TO  
Coast to Coast Radio Corp.  
142-R Liberty Street  
New York City

# There are Two Ways to go about getting yourself **A BETTER JOB**

**1** Stick to your job. And work. Know theory as well as practice. Study the jobs of the man alongside you, and the man above. Know the *how* and *why*.

**2** Decide that you are up against a stone wall. Consider what you do best; what you like to do; whether it pays well; offers a future. Then *get ready*.

*Opportunity will knock at your door when you are ready*

**With a working knowledge of**

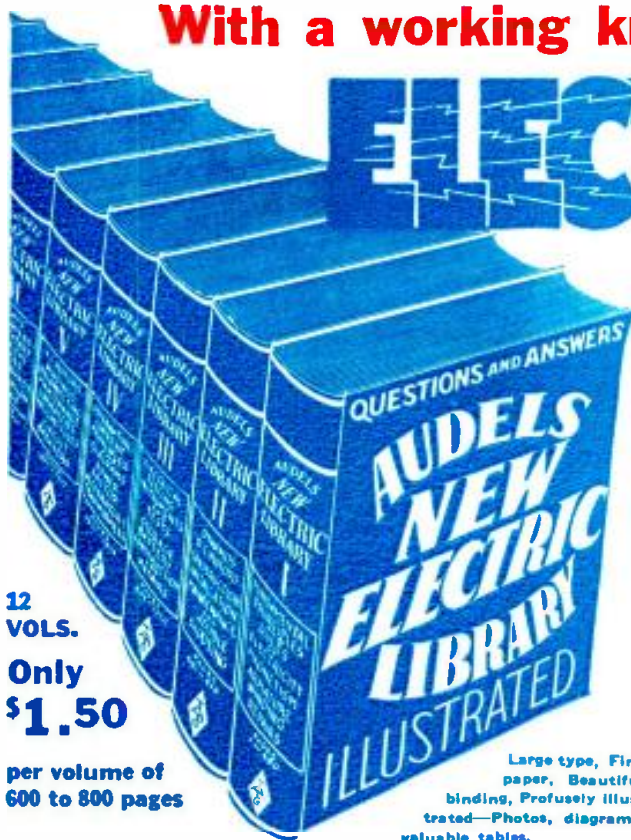

12  
VOLTS.  
Only  
\$1.50

per volume of  
600 to 800 pages

# ELECTRICITY

you can find a job in a field that never will be overcrowded. For Electricity does most of the world's work today; will do more tomorrow. There will always be good jobs for good men in Electricity . . . and at good pay. The work is interesting! You put your heart and soul into it—get somewhere.

**AUDELS NEW ELECTRIC LIBRARY** makes Electricity as easy as ABC for beginners; interesting as fiction; engineers carry in pocket for spare time reading and reference; questions, answers, diagrams, calculations, underwriter's code; design, construction, operation and maintenance of modern electrical machines and appliances. FULLY COVERED, in twelve (12) handsome, flexible covered volumes. (Nine ready, three in work.)

**THESE SUBJECTS—Hundreds of Others**

Dynamos, D-C Motors, Armature Winding, Maintenance, Tests, Batteries, Transformers, Condensers, A-C Motors, Alternating Current, Meters, Power Station Practice, Wiring, Diagrams, Electric Railways, Elevators, Auto and Aero Ignition, Radio, Telephone, Telegraph, Motion Pictures, Talkies, Refrigeration, X-Ray, Welding, Domestic and Farm Appliances.

**QUESTIONS AND ANSWERS**

You remember what you read **THE AUDEL WAY**. Every paragraph is written simply and logically so as to answer the "test questions" at the end of each chapter. This makes facts stick.

Large type, Fine paper, Beautiful bindings, Profusely illustrated—Photos, diagrams, valuable tables.

## **AUDELS EASY BOOK-A-MONTH STUDY PLAN**

The newest, easiest way to study. Only one book a month to read. Every subject made as simple and clear as ABC. Even poor students

find it intensely interesting, are amazed at the ease of it and the speed with which they learn. What you start *the Audel Way* you can finish.

**COSTS 6¢ A DAY**

**BUT SEND NO MONEY**

The *money cost*—the price of one mild cigar per diem—is nothing. The price in *time* is a few hours per week, spent as enjoyably as in reading fiction.

**PLUS NOT TOO MUCH SWEAT**

The cost in *effort* is something. No one ever got anywhere without lifting a finger. But—we have been helping men to overcome the handicaps of education for FIFTY YEARS. Let us help you!

**MAIL COUPON TODAY**



THEO. AUDEL & CO., 66 W. 23rd St., N. Y. City  
Mail Vol. I, Electric Library on 7 days' free trial. If O. K. I will remit \$1.50, otherwise return it. I also request you to mail one book each month on same terms. No obligation unless I am satisfied.

Name .....

Address .....

Occupation .....

Employed by..... R.C.

## FOR WORLD RECEPTION Short and Long Waves (14 to 500 Meters)

In two years this wonderfully efficient and economical "kit" receiver has not only established itself as the favorite of all real DX fans but is rapidly becoming the favorite of Licensed Amateur Operators. They receive relay messages with it from every place in the world where short wave communication originates.

**BATTERY SET KIT  
\$29.50**

**KIT K-110:** The battery operated Super Wasp. Batteries and tubes extra.

**A-C KIT SET  
\$34.50**

**KIT K-115:** AC Super Wasp. Use own ABC Pack or Pilot K-111, specially designed for the Super Wasp.

## PILOT SUPER WASP



## The "QUALITY" MIDGET

People can't believe they are hearing a Pilot Midget unless they see it! Its clarity, volume and range of tone makes the owners of most big consoles, wonder what they paid big money for. In its beautiful, NEW, two-tone walnut cabinet, it delights all who see it as much as it delights all who hear it. Illuminated Dial Knob Control, Tone Control and Phonograph Connection.

**AC MODEL:** 2-224 Screen Grid TRF, 1-224 Screen Grid Power Detector, 1-227 1st Audio, 1-245 Output Audio, 1-280 Rectifier.

**DC MODEL:** 4-201-A's and 2-271-A's.

Less Tubes **\$59.50**

## PILOT MIDGET

## PILOT'S NEWEST

A gem in cabinet design, this charming little two-tone walnut Queen Anne Model is coveted by every home loving woman the moment she sees it.

It has double sliding doors. Baffling area of cabinet is ample to bring out lowest tones of the special electro-dynamic speaker. Illuminated Dial, Knob Control, Tone Control and Phonograph Connection.

2-224 Screen Grid TRF, 1-224 Screen Grid Power Detector, 1-227 First Audio, 1-245 Audio Output, 1-280 Rectifier. (The DC Model uses 4-201-A's and 2-271-A's.)

Dimensions: Height, 33 inches; width, 19½ inches; depth, 13 inches.

Less Tubes **\$79.50**

## PILOT De Luxe CONSOLETTA

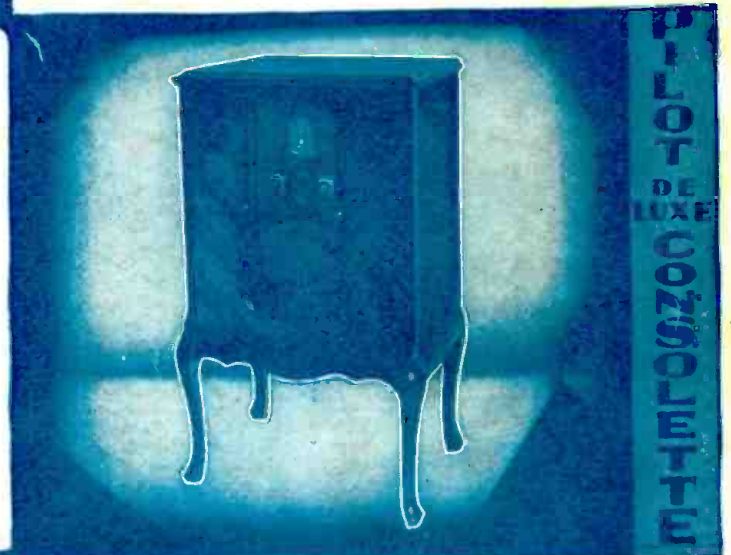

PILOT'S SERVICE TO ALL LOVERS OF RADIO GROWS! Broadcast Listeners, Short Wave Enthusiasts, Licensed Amateurs, Service Engineers, Professional Custom Set Builders, Amateur Set Builders and Sound Distribution Experts, now find all their needs met by Pilot Products. The New Pilot Plant at Lawrence, Mass., is the largest in the world owned and operated by a radio manufacturer.

See the Pilot Receivers at your dealer or write for description folder to

# PILOT RADIO

LICENSED UNDER



RCA PATENTS

## PILOT RADIO & TUBE CORPORATION

LAWRENCE, MASS.

New York Office: 525 Broadway

OFFICES IN PRINCIPAL COUNTRIES OF THE WORLD

San Francisco Office:  
1278 Mission Street

Chicago Office:  
234 S. Wells Street