



May
25 Cents

Radio-Craft

for the
Professional-Serviceman-Radiotrician

HUGO GERNSBACK Editor

A REVOLUTIONARY
NEW SHORT-WAVE
RECEIVER!

See Page 572

IN THIS ISSUE

Articles by
L. M. COCKADAY
SYLVAN HARRIS
GEORGE LEWIS
JOHN F. RIDER
DAVID GRIMES
And Many Others

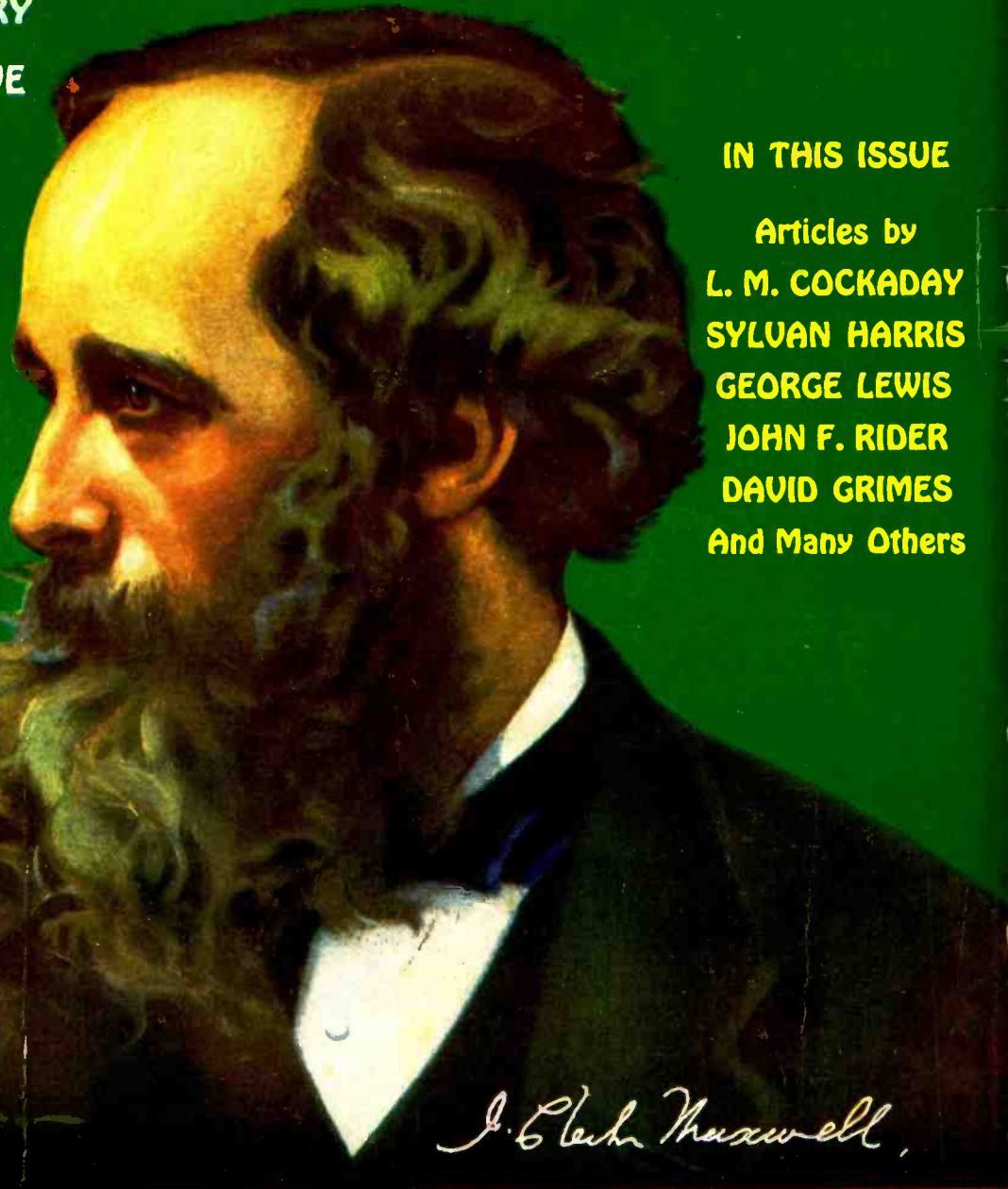

James Clerk Maxwell

Men who have made Radio: James Clerk Maxwell

R. T. I.

R. T. I. QUALIFIES YOU TO MAKE MONEY AND ITS SERVICE KEEPS YOU UP-TO-THE-MINUTE ON THE NEWEST DEVELOPMENTS IN RADIO, TELEVISION, AND TALKING PICTURES

R. T. I.



RADIO CALLS FOR MORE TRAINED MEN

Big Money quick—the chance to more than double your salary—is offered to you now. RADIO has leaped from the experimental stage to a gigantic industry, employing many, many thousands and loudly calling for MORE TRAINED MEN to fill the Big-Pay jobs.

TALKING PICTURES have taken the larger cities by storm and will sweep the entire country, opening up many new good jobs everywhere. TELEVISION now comes with even greater promise of a large number of good paying jobs and big profits for those who are prepared.

Big Money Now! More to Come

Here is an entirely new field of profitable employment—Big-Money Jobs—\$2500—\$3500—\$5000 and up, right now—lots of money easily made in spare time—increasing pay for you and more and more money as this new industry grows bigger and bigger.

Answer the Call—Get Into This Money-Making Industry Now!

The "R. T. I." famous "3 in 1" Home Training in Radio, Television and Talking Pictures makes it easy for men, young men and boys to get into this new field quickly. R. T. I. home training is practical and easy to understand. It trains your head and hands at the same time. Your opportunities for money-making are unlimited. Your age, amount of education, or experience make no difference.

If you are interested and ambitious you can succeed. Are you willing to use a little spare time at home? That is all you need to quickly start making money with R. T. I. material and home training. You will be ready for a good job or profitable business of your own, even before you finish the training. Remember—you learn at home in your spare time on actual equipment included in fine, big outfits sent you by R. T. I. R. T. I. with all its connections in the industry, keeps you up-to-date and pushing forward all the time.

R. T. I. Wonderful Free Book Nothing Like It Ever Published

No one can fully realize the amazing size and future growth of the Radio, Television, and Talking Picture industries unless they know all the facts revealed in this R. T. I. book. No exaggeration is necessary—the plain truth is astounding. It will open your eyes to the dawn of the greatest development in the history of the world—the vast number of new money-making jobs—enormous spare-time profits—all within easy reach of ambitious men. Send for your copy before this edition is exhausted.

Big R. T. I. Book Free—While They Last



Let F. H. Schnell and R. T. I. Advisory Board Help You

Mr. Schnell, Chief of the R. T. I. Staff, is one of the ablest and best known radio men in America. He has twenty years of Radio experience. First to establish two way amateur communication with Europe. Former Traffic Manager of American Radio Relay League. Lieutenant Commander of the U. S. N. R. Inventor and designer of Radio apparatus. Consultant Engineer to large Radio manufacturers. Assisting him is the R. T. I. Advisory Board, composed of men prominent in the Radio industry.



Is Now Radio Engineer Through R. T. I. Training

Today I am able to class myself as a Radio Engineer along with the leaders, and this is all due to the help of R. T. I. I have been able to handle efficiently every radio problem with which I have come in contact. I cannot say too much in praise of R. T. I., and any man desiring to improve himself can do nothing better than find out what this institution has to offer, and get started with their training.—H. F. SATTERFIELD, Chief Radio Engineer, Western Air Express, Amarillo, Texas.

RADIO & TELEVISION INSTITUTE
Dept. 765 4806 St. Anthony Ct., Chicago



\$500 In 2 Months
Hasn't Finished the Course
Your radio course enabled me to earn over \$600 in two months spare time work.—
J. Noffsinger, R. I. Box 37, Greenville, Ky.



\$60 a Week—Through R. T. I. Training
I am earning \$60 per week and another \$20 a week in spare time. Radio Work Your Course was the best investment I ever made.—W. W. Mead, 915 W. 28th St., Indianapolis, Ind.



STEP UP QUICK TO A BIG MONEY JOB THROUGH R. T. I. Training in Broadcasting, Sales, Service, Manufacturing, Repairing, Ship and Station Operating, Installing, in business for yourself.

R. T. I. R. T. I. TRAINS YOU AT HOME FOR A GOOD JOB OR A PROFITABLE PART TIME OR FULL TIME BUSINESS OF YOUR OWN



RADIO & TELEVISION INSTITUTE
Dept. 765 4806 St. Anthony Court, Chicago

Send me Free and prepaid your BIG BOOK "Tune In On Big Pay" and full details of your three-in-one Home Training (without obligating me in any way).

Name.....
Address.....
City..... State.....

ARE YOU INTERESTED IN MOTION PICTURES WITH SOUND?

JUST OFF THE PRESS

SOUND PICTURES
AND
TROUBLE SHOOTERS MANUAL

By CAMERON and RIDER

OVER 1200 PAGES . . . 500 ILLUSTRATIONS

Sound Recording and Reproducing Equipment
How It's Constructed — How It Works
Why It Works — Troubles to be Expected
How to Locate Source of Trouble — How to Remedy Trouble

The Whole Question of Sound Motion Pictures Treated from an Entirely New Angle
Explains in Detail the Construction, Operation and Care of All Sound Recording and
Reproducing Equipment

A COMPLETE GUIDE FOR TROUBLE SHOOTING

Vitaphone—Movietone—W. E. Systems— R.C.A. Photophone—Pacent—Tone-O-Graph, etc., etc.

THE MOST COMPREHENSIVE WORK ON THE SUBJECT PUBLISHED

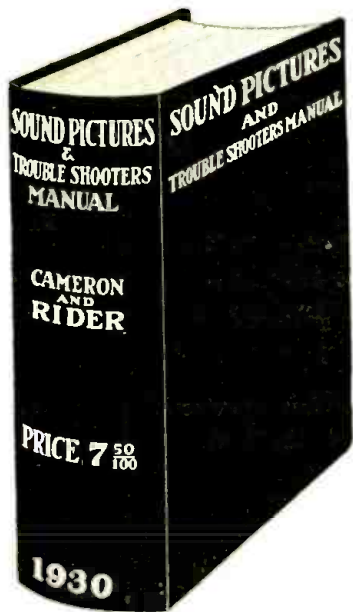

WHAT DO YOU WANT TO KNOW
ABOUT SOUND PICTURES?

YOUR ANSWER IS IN THIS ENCYCLOPEDIA

Cameron's Books have been used in the motion picture industry throughout the world for the past 12 years, and are universally recognized as THE STANDARD AUTHORITY on the subject. They have been endorsed by every trade paper in the industry.

DEPT. OF COMMERCE, Washington, D. C.:

"These books should be in the possession of every projectionist, theater manager and everyone interested in receiving first-hand authentic information regarding the application of sound to motion pictures. Cameron's books are a very worth-while contribution to the motion picture industry."

DEPT. OF PUBLIC INSTRUCTION, Washington, D. C., Says:

"There is no series of books on Motion Pictures in the whole library of Congress as much useful as those by Cameron. We recommend them as a complete guide to the Motion Picture Industry."

YOU CAN'T GO WRONG WITH A CAMERON BOOK

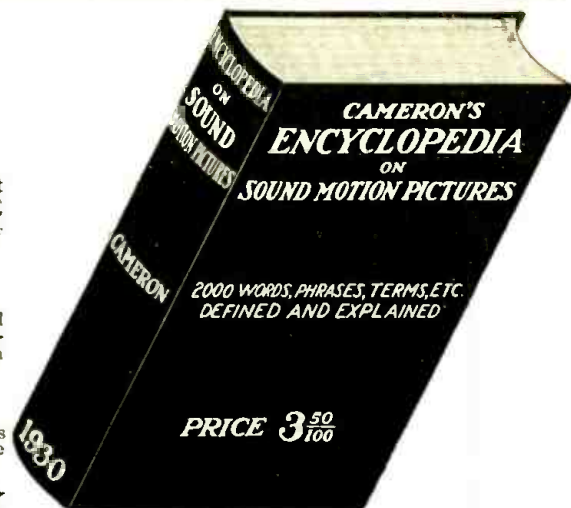

MOTION PICTURES WITH SOUND

By JAMES R. CAMERON

Introduction by WILLIAM FOX (Fox Film Corp.)

This book covers the subject from A to Z in such a manner that the subject is easily understood—400 pages of nothing but "Talkie" information—fully illustrated

Price, \$5.00

MOTION PICTURE PROJECTION

By JAMES R. CAMERON

Introduction by S. L.ROTHAFEL ("Roxy")

1280 Pages . . . 500 Illustrations . . . 4th Edition . . . 12th Year

Used Throughout the Motion Picture Industry as THE STANDARD AUTHORITY

Price, \$6.00

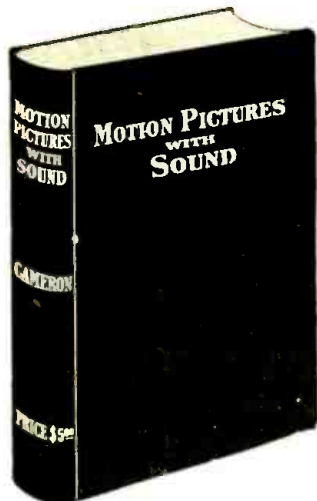

CAMERON PUBLISHING CO., Manhattan Beach, Brooklyn, New York

H. GERNBACK, President
 S. GERNBACK, Treasurer
 J. M. HERZBERG, Vice-President
 I. S. MANHEIMER, Secretary

R. D. WASHBURNE,
 Technical Editor



HUGO GERNBACK, Editor-in-Chief

JOHN F. RIDER,
 Editor Service Dept.

C. P. MASON,
 Associate Editor

VOLUME I
 NUMBER 11

Contents of This Issue

MAY
 1930

	PAGE		PAGE
EDITORIAL		NEW RADIO DEVICES FOR SHOP AND HOME.....	
What About Auto Radio?.....By Hugo Gernsback	553	How to Start an Anti-Noise Association?.....	570
SERVICE MEN'S DEPARTMENT:		Automotive Radio Grows in Efficiency.....	571
Tube TestingBy John F. Rider	554	SHORT WAVE CRAFT:	
Leaves from Service Men's Notebooks		A Revolutionary New Short-Wave Receiver.....	572
		List of Short-Wave Stations of the World.....	576
		SOUND PROJECTION:	
		The Problem of Color in Films.....	577
		The Pentode as a Service Problem...By George Lewis	578
		The "Hi Q-30" for Custom Builders...By Lewis Martin	580
		Adapting Screen-Grid Sets for the Pentode	
		By F. S. Huddy	581
		CURING "STATION INTERFERENCE" IN THE	
		RECEIVERBy Sylvan Harris	582
		Selling Radio to the Schools.....By J. E. Smith	583
		THE COOPERATIVE RADIO LABORATORY:	
		The Direct-Coupled Amplifier.....By David Grimes	584
		\$100 for a Slogan for RADIO-CRAFT.....	586
		Information Bureau	588
		RADIO-CRAFT Kinks	602
		Letters from Short-Wave Listeners.....	603
		RADIO-CRAFT'S Opportunity Column.....	605
RADIO SERVICE DATA SHEETS			
Atwater Kent "30," "33," "35," "48" and "49".....	558		
Crosley "AC-7" and "AC-7C"	559		
The Radio Manufacturer Has His Say.....	560		
Operating Notes for Service Men..By Bertram M. Freed	562		
More About Man-Made Static.....By J. E. Deines	563		
Neutralizing and Screen-Grid Problems			
By K. R. Tantlinger	564		
MEN WHO HAVE MADE RADIO (VIII)			
James Clerk Maxwell	565		
"National List of Service Men" Questionnaire.....	565		
NEW DEVELOPMENTS IN REPRODUCERS			
By Laurence M. Cockaday	566		

In Forthcoming Issues

SOLVING TELEVISION PROBLEMS. By Clyde J. Fitch. This well-known radio authority presents a very interesting discussion of the present condition of the art, and the possibilities of applying new principles to the technique in order to produce larger and clearer images.

A SCREEN-GRID SUPERHETERODYNE. By H. G. Cisin. A complete constructional description of a sensitive receiver which the home builder may readily adapt to his car. Today, automotive radio is the feature of this year's market, and the custom builder should be awake to the

possibilities of getting into the bandwagon of this big movement.

MODERNIZING OLD RECEIVERS. At the present time, a large number of very high-class receivers are obtainable for small sums. They contain the best of material, housed in fine cabinets; and the custom builder and Service Man who can adapt them to modern demands has an excellent opportunity to profit by this condition. A series of articles will deal with what may be done along this line.

And many other practical and instructive articles.

RADIO-CRAFT is published monthly, on the fifth of the month preceding that of date; its subscription price is \$2.50 per year. (In Canada and foreign countries, \$3.00 a year to cover additional postage.) Entered at the postoffice at Mt. Morris, Ill., as second-class matter under the act of March 3, 1879. Title registered U. S. Patent Office. Trademarks and copyrights by permission of Gernsback Publications, Inc., 98 Park Place, New York City.

Text and illustrations of this magazine are copyright and must not be reproduced without permission of the copyright owners. We are also agents for SCIENCE WONDER STORIES, AIR WONDER STORIES, SCIENTIFIC DETECTIVE MONTHLY and SCIENCE WONDER QUARTERLY. Subscriptions to these magazines may be taken in combination with RADIO-CRAFT at reduced Club rates. Write for information.

Copyright 1930, GERNSBACK PUBLICATIONS, INC.

Published by
TECHNI-CRAFT PUBLISHING CORPORATION

Publication Office: 404 No. Wesley Ave., Mount Morris, Illinois

Editorial and Advertising Offices
 96-98 Park Place, New York City

Western Advertising Office
 737 North Michigan Avenue, Chicago, Ill.

L. F. McCLURE, Western Advertising Representative

London Agent: Hachette & Cie.,
 16-17 King William St., Charing Cross, W.C. 2

Paris Agent: Hachette & Cie.,
 111 Rue Reaumur

Australian Agent: McGill's Agency,
 179 Elizabeth St., Melbourne

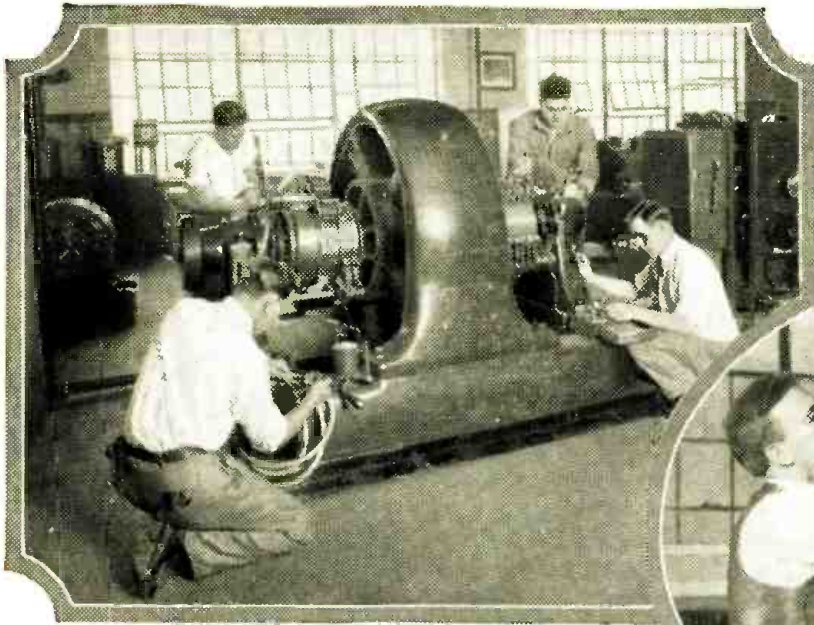

Learning about the converter used to change alternating to direct current at the great Coyne Shops

Coyne men working on the valves and timing of a Velle Radial Aircraft Engine

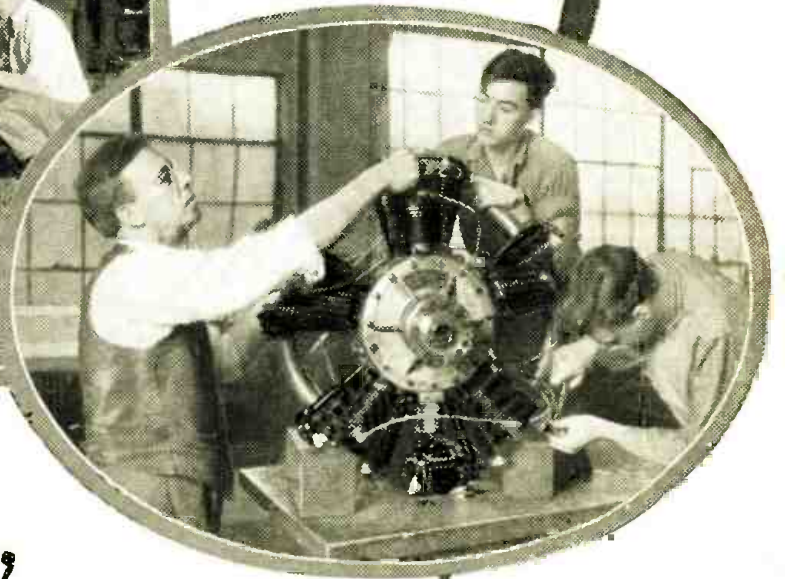

Follow this amazingly easy way into

ELECTRICITY

-and you're through in 90 DAYS!

SAY good-bye to 25 and 35 dollars a week. Let me show you how to qualify for jobs leading to salaries of \$50, \$60 and up, a week, in **ELECTRICITY** — NOT by correspondence, but by an amazing way to teach, **RIGHT HERE IN THE GREAT COYNE SHOPS**. You become a practical electrician in 90 days! Getting into Electricity is far easier than you imagine!

LEARN—by doing the work with your own hands IN 90 DAYS

The secret of Coyne-training is that it is ALL PRACTICAL work. No books—no dry lessons—no useless theory. In the great shops of Coyne you learn the "ins and outs" of Electricity by actual work on real electrical equipment—the finest outlay in the country. And best of all—experts work right with you every step of the way, showing you all the electrical secrets that are essential to your success!

NO BOOKS—NO PRINTED LESSONS

COYNE ELECTRICAL SCHOOL
500 S. Paulina St., Dept. 50-85
Chicago, Ill.

Experience not required I don't care if you don't know an armature from an air brake—I don't expect you to! I don't care if you're 16 years old or 48—it makes no difference! Don't let lack of money stop you either. Most of the men at Coyne have no more money than you have.

Big pay jobs are waiting Our employment bureau gives you lifetime service. Two weeks after graduation, Clyde F. Hart got a position as electrician for the Great Western Railroad at over \$100 a week. That's not unusual. We can point to Coyne men making up to \$600 a month. You can go into radio, battery, or automotive electrical business for yourself and make up to \$15,000 a year.

Railroad fare allowed Make up your mind today to get into one of these big pay electrical jobs. If you act now—I'll allow your railroad fare to Chicago and give you these courses free! **AVIATION ELECTRICITY, RADIO and AUTOMOTIVE ELECTRICITY!** And besides that, I help you to a part time job while learning! Don't lose another minute—make this the turning point in your life. Send this coupon **RIGHT NOW**.



Get this FREE BOOK

This school is 30 years old—endorsed by many large electrical concerns. Simply mail the coupon and let me tell you all about it in the big, free Coyne book.

USE THE COUPON

Mr. H. C. Lewis, President
COYNE ELECTRICAL SCHOOL, Dept. 50-85
500 S. Paulina St., Chicago, Ill.

Dear Mr. Lewis:

Without obligation send me your big free catalog and all details of Railroad Fare to Chicago, Free Employment Service, Radio, Aviation Electricity, and Automotive Courses, and how I can "earn while learning."

Name.....

Address.....

City..... State.....

5,000 Radio Service Men Needed Now!

The replacing of the old battery-operated receivers with all-electric Radios has created a tremendous country-wide demand for expert Radio Service Men. Thousands of trained men are needed *quick!*

\$40 to \$100
a week
Full Time
\$3.00 an hour
Spare Time



THIS WILL ESTABLISH YOU

30 Days of R.T.A. Home Training enables you to cash in on this latest opportunity in Radio

Ever on the alert for new ways of helping our members make more money out of Radio, the Radio Training Association of America now offers ambitious men an intensified training course in Radio Service Work. By taking this training you can qualify for Radio Service Work in 30 days, earn \$3.00 an hour and up, spare time; prepare yourself for full-time paying \$40 to \$100 a week.

If you were qualified for Radio Service Work today, we could place you. We can't begin to fill the requests that pour in from great Radio organizations and dealers. Members wanting full-time positions are being placed as soon as they qualify. 5,000 more men are needed *quick!* If you want to get into Radio, earn \$3.00 an hour spare time or \$40 to \$100 a week full time, this R. T. A. training offers you the opportunity of a lifetime.

We furnish you with all the equipment you need to become a Radio ServiceMan!

Mail Coupon on Opposite Page for No-Cost Training Offer

Cash in on Radio's latest opportunity! Enroll in the Association. For a limited time we will give to the ambitious man a No-Cost Membership which need not . . . should not . . . cost you a cent. But you must act quickly. Filling out coupon can enable you to cash in on Radio within 30 days, lift you out of the small-pay, no-opportunity rut, into a field where phenomenal earnings await the ambitious. You owe it to yourself to investigate. Fill out coupon NOW for details of No-Cost Membership.

Radio Service Work a Quick Route to Big-Pay Radio Position

Radio Service Work gives you the basic experience you need to qualify for the big \$8,000, \$10,000 to \$25,000 a year Radio positions. Once you get this experience, the whole range of rich opportunities in Radio lies open before you. Training in the Association, starting as a Radio Service Man, is one of the quickest, most profitable ways of qualifying for rapid advancement.

If you want to get out of small-pay, monotonous work and cash in on Radio quick, investigate this R. T. A. training and the rich money-making opportunities it opens up. No special education or electrical experience necessary. The will to succeed is all you need.

THE RADIO TRAINING ASSOCIATION OF AMERICA
4513 Ravenswood Ave. Dept. RCA-5 Chicago, Ill.

WITH THIS R. T. A. TESTING OUTFIT you will be able to service all types of radio receivers. As the instruction book which accompanies it gives individual data on most commercial sets on the market, its operation can be quickly mastered. This outfit does the work of testing outfits that cost over \$100.00. Just owning the set and being able to use it will make you a welcome addition to the staff of the harassed radio dealers who are being driven almost crazy trying to properly service the new all-electric sets. With this outfit it will be a simple matter for you to take a radio set that has gone wrong and by means of a few simple tests locate the trouble. We are speaking of all types of sets—the old battery set, A.C. receivers, and the new screen-grid sets. Tubes also can be tested with this outfit.

This R. T. A. Testing Outfit is housed in a well-constructed case measuring eleven inches long, eleven inches wide, and four inches high. The instruments and switches are mounted on an engraved bakelite panel, behind which is a spacious compartment for carrying tools, etc. The case is covered with a durable keratol and all external fittings are highly nickel plated. A large leather handle makes the Outfit easy to carry.

You will find this testing outfit very easy to assemble and wire, and equally simple to operate.

With it you can make all the important tests such as for plate voltage, plate current, filament voltage, grid bias, cathode bias, screen-grid voltage, control-grid bias, etc. You can also use it as a continuity tester for testing circuits, transformer windings, shorts, etc. It is a portable radio laboratory—a laboratory in a box!

When you become a Radio Serviceman you will absolutely have to have such a testing outfit. The one we offer you is equal to the best commercial test sets on the market. When you walk into a customer's house with an impressive outfit like this, it gives you prestige and inspires confidence. When a customer sees you starting to work with this equipment, he's bound to feel that you know your stuff.

Bear this in mind—if you choose this testing outfit you can start cashing in on your training by following our spare-time money-making plans. In a very short time we'll have you in a position where you will be a full-fledged Radio Doctor able to earn \$3.00 an hour servicing sets. When that time comes you will need an outfit such as this. Think it over. This R. T. A. Testing Outfit meets every requirement of the radio industry. It is a triumph of constructional perfection—a marvel of completeness, which when coupled with your training will give you a firm hold on the lion's share of the radio servicing business in your community.

AS A BETTER SERVICEMAN..



This Testing Outfit has been especially designed for Radio Servicemen. It is the latest word in Radio Testing Outfits.

Similar outfits sell for as high as \$100.00.



Included with this training is this Elaborate TESTING OUTFIT

Within thirty days after you start taking our course and with the professional outfit, illustrated above, you will be on the road to make real money.

No necessity to give up your present position, if you do not wish to do so. Many of our students have started in as Radio Servicemen in their spare time until they have become convinced that they can make far more money from Radio Servicing than they ever dreamt of doing before.

Be sure to fill in the adjoining coupon and send it in today. It may well prove to be the turning point of your life.

THE RADIO TRAINING ASSOCIATION OF AMERICA
4513 Ravenswood Ave., Dept. RCA-5, Chicago, Ill.

Gentlemen: Please send me details of your No-Cost training offer by which I can qualify for Radio Service Work within 30 days. This does not obligate me in any way.

Name

Address

City..... State.....

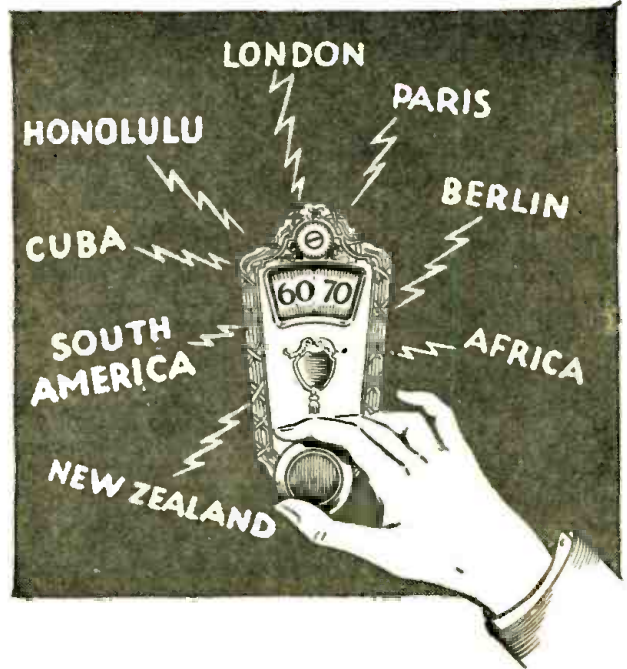

Parade of International Radio DIRECT from Foreign Stations

See Nearest Dealer or
Write Direct for Details

Kit K-115: The A.C. Super Wasp. Use your own ABC pack or Pilot K-111 at \$16.50, specially designed for the Super-Wasp. Power Pack and Tubes Extra .

\$34⁵⁰

Kit K-110: The battery-operated Super-Wasp. Batteries and Tubes extra

\$29⁵⁰



**Without Dependence On
Local Re-Broadcasting!**

PILOT SUPER-WASP

Short Wave and Broadcast Receiver
RANGE 14 TO 500 METERS

In Kit Form for A. C. or Battery Operation

Widen Your Circle of Entertainment!

Your broadcast receiver is useless below 200 meters, but the Super-Wasp, swooping down to 14 meters, and up to 500, unlocks a new world of trans-oceanic radio you never heard before! And you get it directly from the foreign station and not from a local rebroadcast. Enthusiasts report European, African, South American and Australian stations. Music amazingly new! Welcome variety for listeners "fed up" with domestic radio programs! To assure consistently satisfactory operation, Pilot engineers developed the Pilotron P-227, which naturally makes it a splendid tube for broadcast receivers.

PILOT RADIO & TUBE CORP.

323 BERRY STREET
BROOKLYN
N. Y.



Chicago Office: 234 South Wells Street
San Francisco Office: 1278 Mission Street

JOINING THE RADIO INTERNATIONAL GUILD

A Costs only 50c and includes lapel pin, certificate and "Radio Design" Construction Quarterly Magazine, the Guild's Official Organ. Enclose 50c coin or stamps to Radio International Guild, 103 Broadway, Brooklyn, N. Y.



Name.....
Address.....
City..... State.....



MEN!

Get Your Copy of My *New* Book

It shows you

How to get a good job in the Radio Industry

Hundreds of Jobs paying \$50, \$60, \$75, \$100 a week are opening in Radio every year.

J. E. SMITH, Pres.
NATIONAL RADIO INSTITUTE

I showed these men how to get *Big Pay* jobs like these



Seldom Under \$100 a Week

"My earnings in Radio are many times bigger than I ever expected they would be when I enrolled. In November I made \$577, December \$645, January \$465. My earnings seldom fall under \$100 a week. I merely mention this to give you some idea of what a Radio man can do who has the training."

E. E. WINBORNE,
1414 W. 48th St., Norfolk, Va.



\$3000 a Year in Own Business

"I cannot give N. R. I. too much credit for what I have been able to do in Radio. I can safely say that I averaged \$3000 a year for the past three years. I am in the Radio business here. Any man who really wants to advance cannot go wrong in Radio. There is certainly a lack of trained men."

FRED A. NICHOLS,
P. O. Box 207, Eaton, Colo.

If you are earning a penny less than \$50 a week, send for my book of information on opportunities in Radio. It is free. Radio's amazing growth is making hundreds of fine jobs every year. My book shows you where these jobs are, what they pay, how I can train you at home in your spare time to be a Radio Expert.

You have many Jobs to choose from

Broadcasting stations use engineers, operators, station managers and pay \$1,800 to \$5,000 a year. Manufacturers continually need testers, inspectors, foremen, engineers, service men, buyers for jobs paying up to \$15,000 a year. Shipping companies use hundreds of operators, give them world-wide travel with practically no expense and \$85 to \$200 a month besides. Dealers and jobbers (there are over 35,000) are always on the lookout for good service men, salesmen, buyers, managers and pay \$30 to \$100 a week for good men. Talking Movies pay as much as \$75 to \$200 a week to men with Radio training. There are openings almost everywhere to have a spare time or full time Radio business of your own—to be your own boss. Radio offers many other opportunities. My book tells you about them. Be sure to get it at once.

My New 8 Outfits of Parts give you extensive Practical Radio Experience

With me you not only get the theory of Radio—you also get practical Radio experience while learning. You can build over 100 circuits—build and experiment with the circuits used in Atwater-Kent, Majestic, Crosley, Eveready, Stewart-Warner, Philco, and many other sets. These experiments include A. C. and screen grid sets, push pull amplification and other late features. When you finish my course you won't need to take "any old job" just to get experience—you will be trained and experienced ready to take your place alongside men who have been in the field for years.

Back view of 5-tube A. C. screen grid tuned Radio frequency set—only one of many circuits you can build with the parts I give without extra charge.



I Will Train You at Home In Your Spare Time

Hold your job until you are ready for another. No need to leave home. All I ask is part of your spare time. I have doubled and tripled the salaries of hundreds through my practical home-study training. You don't have to be a high school or college graduate. My course is written in easy, simple terms that most anyone can understand.

My course includes Talking Movies, Wired Radio, Television

My course is up-to-date with Radio's latest uses and improvements. It includes Radio's application to Talking Movies, Television and home Television experiments, Wired Radio, Radio's use in Aviation, in addition to fitting you for many other lines. When you finish you won't be a "one job" man. You will be trained for many jobs.

Money Back If Not Satisfied

I will agree in writing to refund every penny of your tuition if you are not satisfied with my Lesson Texts and Instruction Service when you have finished my course. This agreement is backed by the Pioneer and World's Largest organization devoted entirely to training men and young men for good jobs in the Radio industry, by correspondence.

Find out what Radio offers you Get My Book

This book gives you the facts on Radio's opportunities and the many features and services of N.R.I. training. It gives you 100 letters from actual students who have proved that my methods are successful. Get your copy today. There is no obligation.

J. E. SMITH, President,
National Radio Institute, Dept. OEY
Washington, D. C.

THIS COUPON IS GOOD FOR ONE FREE COPY OF MY NEW BOOK

mail it NOW

J. E. SMITH, President
National Radio Institute, Dept. OEY
Washington, D. C.

DEAR MR. SMITH:—Send me your book. I want to see what Radio offers and what you offer in Radio training. This request does not obligate me in any way.

Name.....

Address.....

City.....State.....

Lifetime Employment Service to all Graduates

NATIONAL APPROVAL

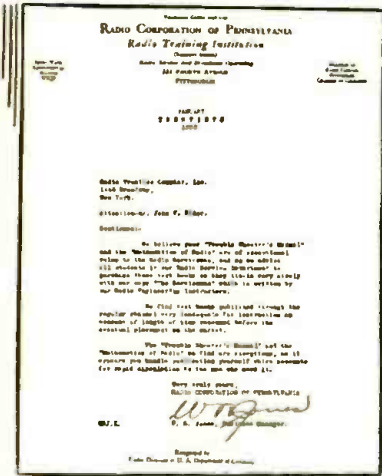

JOHN F. RIDER'S "TROUBLE SHOOTER'S MANUAL"

is the accepted text book in the best radio schools. It is the acknowledged source of service data and trouble shooting information for many thousands of service men in this country. Besides 22 chapters thoroughly covering the field of trouble shooting, this volume contains the wiring diagrams of more than 200 models of radio receivers covering the period between 1924 and 1929.

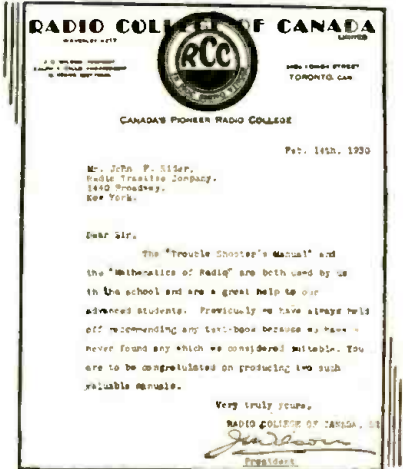

HERE ARE THE 22 CHAPTER HEADINGS

- Service Procedure
- Practical Application of Analysis
- Vacuum Tubes
- Operating Systems
- Aerial Systems
- "A" Battery Eliminators
- Troubles in "A" Eliminators
- Trouble Shooting in "A" Eliminators
- "B" Battery Eliminators
- Troubles in "B" Battery Eliminators
- Trouble Shooting in "B" Battery Eliminators
- Speakers and Types
- Audio Amplifiers
- Trouble Shooting in Audio Amplifiers
- Troubles in Detector Systems
- Radio Frequency Amplifiers
- Trouble Shooting in R.F. Amplifiers
- Series Filament Receivers
- Testing, and Testing Devices
- Troubles in D.C. Sets
- Troubles in A.C. Sets

**ORDER
YOUR
COPY
NOW!!**

WIRING DIAGRAMS OF THESE COMMERCIAL RECEIVERS

- Radio Corp. of America
- Atwater-Kent
- Zenith
- Fada
- Stewart-Warner
- Philco
- Freed-Eisemann
- All-American
- Colonial
- Amrad
- DeForest
- Garod
- Operadio
- Magnavox
- Federal
- Crosley
- Majestic
- Stromberg-Carlson
- Grebe
- Freshman
- Kolster
- Day-Fan
- Workrite
- Spartan
- Ware
- Kennedy
- Sleeper
- Grimes

240 PAGES 8" x 11", BLACK STURDITE BINDING

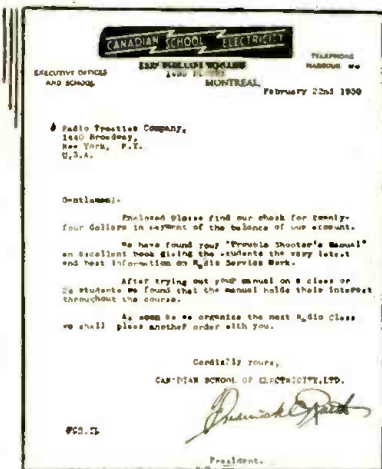

SUPPLEMENTARY DIAGRAMS OF 1929-1930 RECEIVERS

WIRING DIAGRAMS of receivers manufactured during 1929 and 1930, as a supplement to the "Trouble Shooter's Manual," are now available. The first group numbers 115 diagrams and includes screen-grid receivers manufactured by Grebe, Brunswick, Radiola, Silver-Marshall, Steinite, Stewart-Warner, Edison, American, Bosch, Crosley, Stromberg-Carlson and others. Approximately 20 manufacturers are represented in Supplementary Package No. 1. These diagrams are 8 x 11 inches, black on white. Here is an opportunity to secure wiring diagrams of the new receivers at a price slightly greater than 2 cents each. The diagrams are suitable for loose-leaf binding.

115 Diagrams for \$2.50
Combination Offer 5.50

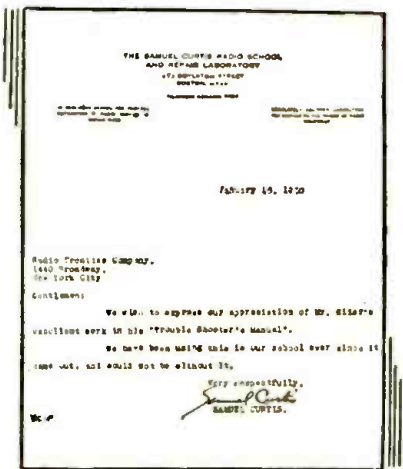

COUPON

RADIO TREATISE CO.,
1440 Broadway, New York, N. Y.

- Send me John F. Rider's "Trouble Shooter's Manual" and I will pay postman \$3.50 plus a few cents for postage on delivery.
 - Send me John F. Rider's "Supplementary Wiring Diagram Package No. 1" and I will pay postman \$2.50 plus a few cents postage for delivery.
 - Combination offer. Send me John F. Rider's "Trouble Shooter's Manual" and "Supplementary Wiring Diagram Package No. 1" and I will pay postman \$5.50 plus a few cents postage on delivery.
- It is understood that my money will be refunded if I am not satisfied.

Name

Address

City..... State.....

What About Auto Radio?

By Hugo Gernsback

IN an editorial entitled "The Future of Wireless," which appeared in the March, 1916, issue of one of my former publications, *The Electrical Experimenter*, I made the following remarks:

"We prophesy that in less than 15 years every automobile, whether pleasure or commercial, will carry its small radiophone outfit. Its occupants will thus be in constant touch with their homes or offices and *vice versa*; a convenience much needed today. Imagine the immense usefulness of such a device. Nor is this an idle dream. There is at least one company in existence today capable of filling an order to equip autos with radiophones having a 20-mile range. Nor will there be much confusion of voices becoming mixed up in transit; our tuning apparatus is becoming more accurate each day and it will be an easy matter to tune out unwanted voices. It will take considerable capital and a host of trained men to turn out enough radiophones to equip several million automobiles, aeroplanes, motorboats, yachts, and large vessels; but it will be done nevertheless, and soon at that. Every farmer will have his wireless telephone to talk with his neighbors. Every train will have its radiophone enabling passengers to talk to their homes or offices. The radiophone will link moving humanity with the stationary ones, as the wire telephone linked humanity together before. To us there is nowhere a brighter future than in the vast possibilities of the Radiophone."

These remarks were made fourteen years ago, when broadcasting was unknown and when there was no such thing as a real radiophone.

With one year more to go in my prediction of 1916, I believe indeed that in 1931, pretty near every automobile will carry its own radio.

Of course, we are not going to use the radio set for the ambitious purpose which I outlined in 1916, and we are as yet a long way off from telephoning to our friends from our own cars; yet it is technically possible to do so today. Indeed, it is being done every day in airplanes and, only as late as the middle part of March of this year, two airplanes conversed with each other while both in the air.

In this respect, my prediction of 1916 came true one year ahead of the time set.

But today we are faced with an altogether different sort of problem, so far as automobile radio is concerned.

Automobile radio has arrived; and thousands of cars have already been equipped with efficient radio sets.

From a technical standpoint, radio on your car is perfect. But from the human angle, cloudy days seem ahead.

It seems that three well-meaning but misguided states (namely, Massachusetts, New Hampshire and Maine) are threatening to pass laws banning radio from automobiles.

The reason in all cases is identical; that some of the authorities contend that radio in an automobile tends, not only to distract the attention of its own driver, but to draw as well the attention of other drivers and thus make for collisions and accidents.

So far, there are no laws about this, except where a registrar of motor vehicles makes the statement that he will refuse to license cars that carry radio sets. This has been the case in Massachusetts. It seems that in this state the registrar has the right to prepare such rules without an act of the legislature. Similar steps were taken by the vehicle commissioner of New Hampshire.

No one likes to see any more motor accidents; and certainly the radio industry does not wish to be liable to criticism on this score, and invite the displeasure of the public as well as government officials. Yet we believe that radio on automobiles is here to stay and that, during the next few years, practically all cars will be equipped with radio.

We believe the present troubles are insignificant and can be easily overcome.

We, ourselves, believe that it is not good business for the driver of a car to operate a radio set while it is in motion. There is, however, no good reason why a parked car, or a car running on a country road where there is little traffic, should not operate its set.

In the first place, a tremendous amount of good can be done by having automobilists listen in on police alarms and aid in apprehending criminals. Secondly, important news, such as fires, disasters, etc., should be broadcast to the public with as little delay as possible. Sometimes (in the case, for instance, of a broken dam or a railroad accident) it is of the greatest importance that the news should be broadcast instantaneously, and this will often cause the saving of hundreds, if not thousands of lives. Here is where automobile radio will do its best.

We wish to present here also a most excellent idea, suggested by Mr. Louis Berkowitz of Dorchester, Mass., who presents a really practical suggestion. He suggests that a law could be passed compelling the replacement (in automotive radio) of the ignition switch with a double-throw ignition switch; which, in one position, would turn on the ignition and in the other shut off the motor and turn on the radio. If such a switch, which is not expensive to install, were used, so-called "bootleg listening" would be impossible, and no car could operate its radio set while in motion. We believe that this is a most excellent suggestion and one which will no doubt be adopted, if its real use is understood by the authorities.

The publishers of RADIO-CRAFT invite comment on this and on other phases of automobile radio as well.

There is no question that the problem can be solved, and solved to the satisfaction of everyone concerned.

Service Men's Department

This department is about the Service Man, for the Service Man, and largely by the Service Man. Its contributors are practical men, and we invite every Service Man in the country to tell about his own experiences of all kinds

Edited by JOHN F. RIDER

TUBE TESTING

By John F. Rider

WITH due consideration of the economical aspect of tube testing and the effort to make all tests with the minimum expenditure of time and money, it is still necessary to give thought to the fact that all forms of testing devices are not equally applicable.

Take as an example a small tester designed to show plate current and emission current. The usual range of emission current and output current of rectifying tubes extends as high as 200 mils. In many cases one meter without shunts or multiple ranges is employed. Such a meter will be found satisfactory for high values of current; but it is extremely difficult to satisfactorily interpret small values of current, such as 5 mils, or the difference between 5 and 10 mils. The significance of this condition can best be illustrated by an incident in the writer's recent experience.

A number of tubes tested on an accurate tube tester, known to be in perfect condition, were placed into the hands of a group of men. They were told to test the tubes and to report upon their suitability for use in radio receivers.

One man employed a combination set and tube tester with a 0-to-50 D.C. milliammeter arranged with a 250-mil shunt. He rated the tubes as fair, checking plate current and grid swing on the 50-mil scale. An investigation showed that the meter was off approximately 3.5 mils at the zero point. In other words, the zero adjustment was not accurate. Such a small discrepancy was considered negligible, yet it amounted to almost 33% on a 10-mil reading. Of course the 3-mil difference was negligible when testing the current output of a rectifier such as the 280 or the 281; but it did influence small current readings. . . . When reminded of the discrepancy, he merely shook his shoulders.

Another man condemned the tubes and said that the emission current was low. Investigation showed correct readings, but incorrectly comprehended. The meter was a 0-1 D.C. milliamper instrument equipped with 10, 20, 50 and 200 mil shunts. The scale was the 1-mil range and it was necessary to calculate the values according to the shunt in the circuit. The man thought that the 10-mil shunt was in use, whereas the 20-mil shunt was being used. The fact that all the tubes showed lack of emission did not arouse the slightest suspicion and he was so certain that the correct scale was being used, that an examination was not deemed necessary.

The third man reported satisfactorily, but his test figures did not conform with the



MR. JOHN F. RIDER, who passes upon all the material submitted for publication here, in the Service Men's Department, is a radio engineer of the first rank who has devoted much energy to the popularization of technical knowledge. None excel him in the art of making difficulties clear; he is a practical instructor, and the author of books known by all Service Men as useful guides. Letters, stories, requests and suggestions for this department may be addressed to him in care of RADIO-CRAFT.

initial accurate measurements. His figures were slightly lower in every case. An investigation showed that the filament voltage was not the exact value stipulated in the manufacturer's bulletins. He used 4.75 volts instead of 5 volts and approximately 1.39 volts instead of 1.5 volts.

The fourth man likewise reported satisfactory performance. His figures on the other hand were high. A check-up of the system showed that the voltage output from the filament supply transformer was in excess of the rated value. He employed a filament winding designed for six tubes of certain type and was applying only one tube at a time. In addition the line was in excess of the rated 115. A test upon the transformer showed that the rated output was available with 110-volt input. The line voltage at the time was 121.4 volts.

The fifth man found the tubes erratic. No two tubes seemed to provide similar readings. An examination of his set-up showed everything to be normal. When the writer made the regular routine test, the figures were satisfactory; but when the man made the tests the figures were again erratic. He did not read the meters with any regard to precision.

The ninth reported one tube normal and

all the rest deficient. A detailed test showed that his readings were correct. The tubes were again checked upon an elaborate layout and found normal, yet plate current tests showed low readings. The meter was checked and found defective. The fact that one of the tubes was classed as satisfactory provided an interesting point for investigation. This tube was rechecked upon the defective tester and showed up identical with the rest. To all appearances the meter was perfect. A verbal cross examination of the operator brought to light the fact that after completing the test upon the first tube, which showed normal condition, the current meter was accidentally subjected to a heavy overload, but fortunately did not burn out. All readings thereafter showed low readings. The meter was damaged and all of the tubes tested with the defective meter showed poor condition.

We admit that such procedure does not seem normal; yet the above facts are, without a doubt, the exact conditions present in thousands of set and tube testers—not because the meters were poorly designed or manufactured, but because they are carelessly handled. Tube manufacturers are very reluctant to provide definite standards for testing; to provide stipulated figures and tolerance values, because the testing is not carried out along the proper lines. A tube test in order to be satisfactory need not be elaborate, but it must be accurate; the meters must be in good condition and the operator must be meticulous in his work.

We do not mean to imply that tubes are not defective. Hundreds of thousands of tubes are found defective each year and the tests are accurate; but, at the same time, other tens of thousands are unjustly classed as unfit for use. If you are going to test tubes, see that the tests, the meters are accurate. The average meter is a delicate instrument. It should not be subjected to heavy overloads, or as a matter of fact to overloads of any kind. Physical shock will damage the mounting and meters should be handled with care.

If you are going to test tubes, see that the operating voltages are correct: 20% difference in the filament voltage of the 326 will cause 50% difference in emission. Filament and plate voltages must be according to the manufacturers' ratings. If you are going to work with meters, read accurately. Do not read the deflection from one or the other side; look right down upon the meter, so that a line drawn from the meter deflection towards the face is perpendicular to the plane of the scale. Only by complying with the above conditions will you feel secure when you accept or condemn a tube.

Leaves from Service Men's Note Books

The "Meat" of what our professionals have learned by their own practical experiences of many years

By RADIO-CRAFT READERS

A MODULATED OSCILLATOR

By L. J. Lansa

"USE a modulated R.F. oscillator" is a common instruction. How many radio men can make one without a circuit diagram? Here is the one which I use for a great many purposes, with power supplied from "A" and "B" eliminators.

With a variable resistor properly adjusted in the grid circuit of the tube, this oscillator may be used to match condensers: the same capacity gives the same note. In a similar manner, resistors may be matched, R.F. transformers, impedances, etc. This may be used as a wavemeter, and calibrated from the beat notes of stations of known frequency. It can be used as either an R.F. or an A.F. oscillator separately. It produces a very sharp, powerful signal, and is very useful.

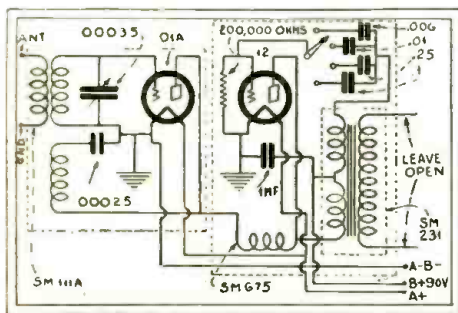

Fig. 1

We can assure the contributor that uncounted Service Men can make an oscillator, from the letters we receive. However, this is a good one.

MEASURING SMALL RESISTANCES

By E. Witherstone

DYNAMIC speakers, which gave poor volume or none at all, were a recent problem of mine. Those which wouldn't work were easily repaired, because a circuit tester would locate the trouble. On the other hand, the first weak one tested all right; but by patiently unwinding the voice coil (which was in two layers) I found that part of it was shorted out. It took me a long time to find this out; so for the rest of them, I decided to find some easier way of measuring the resistance. As this is normally but three ohms, a dead short made no difference in the reading of the circuit tested.

I have, however, a Jewell thermocouple galvanometer, which I hooked up as per the diagram herewith. This meter has an internal resistance of only 2.5 ohms; so a very small resistance should be used for the meter shunt. When the right value is found, the meter will read full scale for a dead short and half-scale for three ohms. I use one good voice coil as a standard and check the rest by it. The five parallel lamps shown are 6-volt pilot lights, but could be replaced by a fixed resistor of 10.5 ohms. The source of power is a 6-volt storage bat-

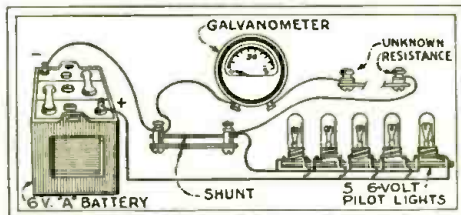

Fig. 2

The galvanometer must be protected by a line ballast and a shunt of very small resistance; so used, it will measure extremely low resistances.

tery. The shunt I used was a six-inch length of No. 20 solid copper wire.

This instrument is very sensitive; a difference of half an inch in the shunt will show a difference of two or three degrees on the meter. If the meter is calibrated with standard resistors, it will be found to read accurately from 0 to 25 ohms. From five ohms down to zero, there is a reading of ten degrees per ohm.

SPEAKERS AND GRILLES

By Harry Schmidt

EVERY time a magnetic speaker is brought into the shop for repairs, the armature must be spaced and adjusted before the speaker will work properly. To space it by sight is not easy; for the thickness of a paper out of the way will throw the speaker out of tune.

The only way to space an armature correctly is by using a set of spacers, which may be made as shown in the diagram. Get a piece of brass shim stock .01-inch thick, 5 inches long and 1/4-inch wide; bend it double, about 3/8-inch off center, as shown. Then bend the two ends at an angle so that they will easily fit into small spaces. Two of these are needed, one for each side of the armature.

Often the owner of an old and valued cabinet of some kind would like to have a radio set and speaker installed in it. For this purpose, there are speaker grilles to be cut out, as well as openings for the dials. This work cannot be done satisfactorily with a scroll saw. The dial openings may be made by drilling holes around the edges and smoothing them with a file; but this is a tedious job.

The next time you have a job of this kind, lay out the design of the grille and the shape and size of the openings in the panel. When you are positive that everything is correctly

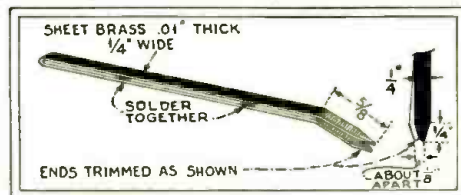

Fig. 3

The tool indicated is convenient for spacing speaker armatures, which require careful adjustment.

marked, visit your local sign shop (or the artist of your local theatre). If it is up-to-date, it has a machine known as the "Cutawl," used for cutting out fancy and complicated designs in beaver board for display purposes. With small chisels and special saw blades, it will cut out anything up to 5/8-inch thick. For a small sum you can have your work done in half an hour, with a smooth edge.

A little smoothing of the edges with some very fine sandpaper, and you are ready to put on the grille cloth, which may be obtained in various designs from the larger radio supply houses. I have found it a good practice to iron this with a very hot iron; as this takes out the wrinkles and makes it stiffer and easier to put on.

REDUCING HUM BY NEUTRALIZATION

By Boris S. Naimark

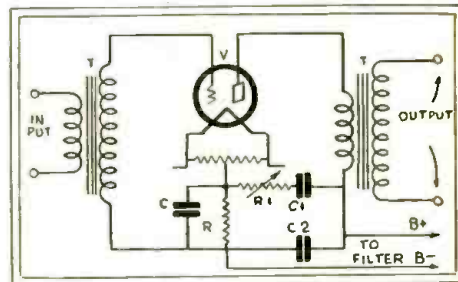

Fig. 4

The combination of C1 and R1, properly adjusted, will balance out hum from '26-type amplification stages and improve many a high-priced receiver of an early A.C. model.

EVERY once in a while the Service Man is called upon to service some of the earlier electric receivers which employ type '26 tubes, in all but the detector and last audio sockets and are now notorious for their A.C. hum.

When the first all-electric receivers employing A.C. tubes appeared, a slight residual hum distinctly audible in the loud speaker (particularly when no signal carrier was being received) was never strenuously objected to. The Service Man always had that universal alibi: "You know, all electric sets do hum somewhat." That was his story and he stuck to it.

To-day, with a predominance of all-electric receivers utilizing heater-type tubes, audible hum in the speaker is the exception rather than the rule; and so the owners of the older receivers, judging by comparison, are brought forcibly to the realization that their sets do hum, and quite noticeably at that.

What can the Service Man do about it? He can reduce that hum to a negligible value by the use of a minimum of apparatus—not in the filter, which is his customary line of attack, but in the receiver itself.

The method employed by this writer was found effective in the greater number of

cases and is essentially one of hum neutralization.

The circuit arrangement shown in Fig. 4 is quite simple and, I understand, was originated by Mr. B. F. Miessner, the well-known radio engineer, who described it before a meeting of the Rochester Section of The Institute of Radio Engineers. It is applicable to either a single tube or a number of tubes; provided all obtain their plate and grid potentials from the same points, such as first audio and all radio stages which have the same "B" voltage and use a single grid-bias resistor.

The required material consists of a 1/2-mf. condenser C1 and a 0- to 5,000-ohm variable resistor R1; these are connected as shown and the variable resistor is adjusted for a minimum hum. R is the biasing resistor previously employed in the receiver; C is the by-pass condenser; and C2 is the usual by-pass and filter condenser found in the conventional filter circuit.

Without going into lengthy detail suffice it to say that the addition of R1 and C1, as shown, sets up in the grid and plate circuits of the tubes voltages which are opposite in phase to the normally-present hum voltages; and the audible hum is thus effectively neutralized.

While the values suggested have proved quite effective, the Service Man may find others better in different receivers; these can be very simply determined by experiment and trial.

"ZENITH 16E"

By Andrew J. Cook

I WAS called in lately to service a Zenith "16E" which was performing unsatisfactorily. The set, after a few minutes' operation, would stop playing and start to hum. A few of the locals could still be received, but with a very blurred tone. After a few minutes of tube testing, I found a defective '26 tube in the first audio stage, and thought that I had finished then and there; but more was to come. The owner complained that several '26 tubes had burned out in the first two audio stages, and that, quite often, several of the filament circuits would not light. Furthermore, since the visit of the last Service Man, the performance of the set had not been quite up to standard.

An examination of the set revealed that the filament voltage of the '26 tubes used in the first and second audio stages was

1.65; which was obviously too high. The plate voltage of the '27 detector tube was 150, about that of the R.F. and A.F. amplifiers. The other defect was uncovered by moving the plug from the power pack sideways in its chassis receptacle: this caused the tube filaments either to grow dimmer, to grow brighter, or to go out, according to the position of the plug.

I learned from the owner that the previous service man had discovered a defective 1-megohm resistor in the detector plate circuit and, instead of replacing it, had merely shorted it out of the circuit. The insertion of a new resistor in this circuit brought the plate voltage down to the normal 50, used in the grid-leak system of detection.

The 1.65 filament voltage of the two audio tubes was cut down to 1.45 by the insertion of 3 1/2 inches of No. 22 German silver wire in each leg of the filament circuit of these two tubes. Current is furnished to these tubes from the same transformer tap that supplies the '27 with current. However, the resistance wire used to cut the voltage down to the proper potential for the '26 tubes was insufficient; hence the addition of the extra wire.

My method of guaranteeing constant filament current to all circuits was tedious but effective. I soldered six four-inch pieces of wire to the filament terminals of the chassis receptacle, and did the same to the corresponding terminals of the plug from the power pack. I then tied together each pair of the corresponding wires and taped them. Soldering the connections might have made a better contact; but it would have been inconvenient, in case the set had to be moved.

The set has worked well since and the customer is satisfied. A lot of work, but a good result.

DETECTOR TROUBLES

By Jack H. Boykin

MY observations are that most troubles in the detector circuit, which cannot be cured by changing the grid leak, are caused by the fact that the tube itself is not a good detector. Test the tube for filament emission and oscillation; a tube which is a good oscillator is usually a good detector. A simple test circuit is shown herewith.

A tube when oscillating should show from three to five times as much plate current

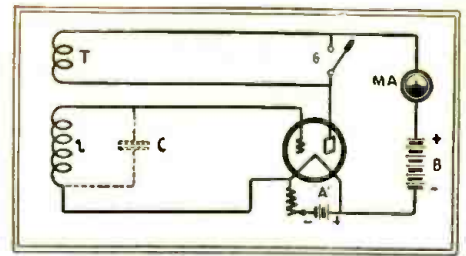

Fig. 6

The simple circuit used forms a test of a tube's oscillating, and consequently its detecting powers.

as when it does not. From 6 to 25 milliamperes is a common ratio for '01A and similar tubes. If tubes test O. K., the filament, grid and plate voltages are right at the socket, and all connections are secure, try swapping tubes with another socket to find a good detector. Tubes are not uniform, and not all good amplifiers are good detectors.

In some of the older models of receivers, poor contacts at the sockets are common; so it is a good idea to examine this point closely. Wagging the tube in the socket will show a bad contact by a noise in the speaker.

A Service Man will do well to select a good detector of each of the common types of tubes, paste a sticker on them for identification, and carry them with his tools. Substitution will then show if the tube is bad.

Distortion in the detector circuit is usually caused by wrong operating voltages or by overloading. The voltages can easily be checked by meters; and the test for overloading is to reduce the volume of the R.F. circuit.

If the condenser is of the grid-leak type, it may be worth while to take out the condenser and leak and wire the grid return to the negative filament.

Most of these remarks apply equally to battery or A.C. receivers; though I have, myself, never seen any trouble in the detector circuit which was not caused by a faulty tube or by something which would show up in the voltages at the socket.

In the tester circuit shown, L is 60 turns on a 2-inch tube; spaced one inch away is T with 20 turns. The condenser C, if required, is .00025-mf. The meter MA should have a range from 0 to 25 milliamperes. The switch S is normally closed, shorting out the tickler. When S is opened, the circuit should oscillate, and the meter reading should jump to from three to five times its former reading.

DEMAGNETIZING THE WATCH

By H. B. Brand, EE.

MAGNETIZATION of watches by a dynamic speaker's field coil, as described by Mr. Haby in the March issue, recalls some interesting experiences. Bi-polar D.C. motors and generators, of the old type, and the induction type alternator were the cause of many watches being magnetized.

To demagnetize your watch, tie a string to the ring of the watch and twist the string until it is linked. Suspend the watch by the string and let it revolve near a strong magnet. While it is still revolving, move the watch out of the magnetic field. It will be found that the watch is demagnetized. Of course, holding the watch in an A.C. field is the better way.

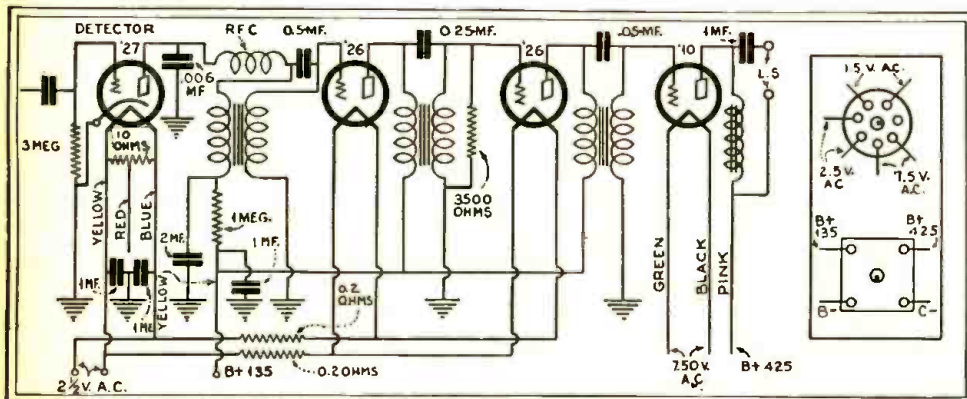

Fig. 5

Above, the schematic of the detector and audio circuits of the Zenith "16E" in which the '26 filaments are fed from the detector 2.5-volt winding. At the right, the arrangements of the plugs connecting the chassis with the power pack of this model.

The Service Man's Open Forum

RADIO IS NOT A "GAME"

I KNOW RADIO-CRAFT better than you know me; I have been a reader since it was first published, and find it as good an instructor as I have ever found. I have read every book on radio, science and electricity that I could secure in the past seven years; and my advice to many would-be Service Men is to do likewise.

"Get the facts before you ruin the works." There should be a restriction against a lot of the fellows who are going into "the radio game," as they call it. It is not a game; it is an art, and should be termed such.

Should an amateur go into the field with a little knowledge of radio, and be allowed to work on sets which he knows very little about? Repairing a receiver does not consist merely of checking it with a test set. Pleasing the customer is half the work, and also half the advertising that you get. I believe in the younger generation's learning the radio art; but let them *learn* it first, and then constantly study what is going on.

I keep notes and index files up to the minute in radio; I spend an hour a day in reading and compiling radio literature—and I can say truthfully that I have not yet lost a customer.

So let us get more men in the radio art who have a good common sense, and ability to study each day and play square with the public who have faith in us and give us a return call every time they need service.

I close by saying again: "It is not a 'game'; it's an art."

ALBERT A. SADDLER,
Canton, Ohio.

LOCAL OFFICIAL PROHIBITS RADIO SET BUILDING

LAST June there appeared in our local newspaper an advertisement to the effect that after Jan. 1, 1930, no radio could be installed in Richmond, Va., unless it had the approval of the Underwriters and their label thereon. I wrote to the newspaper and inquired in its "Forum" who started this thing and why. I received a letter from the Chief Electrical Inspector of the city, who had signed the advertisement, and later a visit.

He assured me that it was done to protect us, and the main idea was "to break up these fellows who buy 'five-and-ten' store parts, build radios and sell them around most everywhere." He continued to advertise the same thing, and I wondered why he told me one thing, and advertised exactly opposite. I waited and watched developments.

In January, I wrote the inspector, advising him that I had on hand two custom-built sets which I built last year and had left over, and wanted to know what was expected of me, in order to sell and install them.

In reply, he stated that I should send those sets to 109 Leonard St., New York City, the nearest Underwriters' Laboratories, and have them test, approve and stamp same.

His ruling is that a set cannot be installed without the Underwriters' label on it. A man cannot install an aerial unless he is a

OPPORTUNITIES

The "Opportunities" column of this month's issue of RADIO-CRAFT will be found on page 605 of this issue. The Service Man who desires to take advantage of this feature may do so without cost, as explained there.

licensed electrician. A fee of \$10 must be paid extra to install aerials, and the man must be examined by the inspector first.

As long as the present owner cares to use his set, it is O. K.; but he cannot install it elsewhere, even if he moves his residence.

The city code covering electrical work is dated 1924 and references are made to "electrical apparatus, electrical appliances and electrical devices"; but there was none to radio. I consider radio too big a thing to be passed by under miscellaneous devices.

NORMAN WILLIAMS,
1307 E. Franklin St., Richmond, Va.

(If the chief electrical inspector of the city of Richmond instructed Mr. Williams to send his receivers to the Underwriters' Laboratories in this city to receive a label of approval, he required an impossibility. These laboratories do not undertake to approve individual pieces of apparatus, but only the design of articles in factory production; also, they do not label such pieces, though they have an approved list of a limited number of radio receiver models which have been submitted to them for approval by the manufacturers. No kit receivers are approved by them, even though the individual components might be; for a kit carries no guarantee of the assembly. The Underwriters' Laboratories are established under the auspices of the fire insurance companies of the country, for the purpose of reducing fire risk through the use of ill-designed material; they decline to mix into local controversies.

We cannot undertake to pronounce upon the legality of the ordinances of the city of Richmond or the authority of the electrical inspector in prohibiting the use of home-built radio receivers. That is a matter of the constitutions of the United States and the state of Virginia, and the laws of that state. However, we may say that in the past cities have passed local regulations laying restrictions upon radio amateurs, and have been compelled to rescind them by the prompt action of the A. R. R. L., the amateur's national organization. The situation in Richmond points to the lack of similar organizations of parts manufacturers, custom set builders, and Service Men.—*Editor.*)

The latest printed list available shows that the Underwriters' Laboratories have approved, up to the end of November, 1929, the following commercial sets: Atwater Kent Models 55 C and 55 FC, 60C, 66; Crosley 40S, 41S, 30S, 33S, 34S, 42S, 82S; Brunswick 5NO and 5KR; Graybar 310, 311, 320, 330, 340, 500, 550, 600; Eveready 31, 32, 33, 34, 42, 43, and 44; Philco 52, 65, 82, 83, 86, 87, 95; Radiolas 18, 33, 44, 46, 60, 62, 64, 66; Stromberg Carlson 635A, 635B, 636A, 638B, 641A, 641B, 642A, 642B. In addition, there are several "B" power units, amplifiers, loud speakers, battery chargers, etc., and numerous switches, lightning arresters, and other components and electrical fixtures carried on the list of inspected and approved appliances.

DISAPPROVES PART-TIMERS

THE letters and comments by Service Men show more dissatisfaction with compensation and lack of cooperation by manufacturers than anything else.

As for the pay, I have never found the concern that would not pay if you can deliver the goods. As for cooperation, I cannot understand why any man wants service notes and data on all receivers. I also disapprove of part-time repairmen. Every day we hear that this is the age of specialists.

We handle R.C.A. Radiolas, Victors and Majestics; and I find that those three manufacturers back me up with all the data that can possibly be of any assistance in servicing their machines. We can do justice to this work, and this would not be possible if we were taking all kinds of jobs.

What hurts worse than anything else is the fact that the part-time Service Man often does not know what is wrong when he goes out on a call; but he bluffs the customer into believing that it is something serious. He then takes the entire machine to his shop and, after several days, finds a condenser broken down or a resistor open. Then he replaces it with something else, that he thinks will do as well, takes the set back and charges a big price.

Is that right? EDWARD H. OLSON,
Chief Technician, Kahn & Levy,
Galveston, Texas.

OTHERWISE IT WAS O. K.

IN view of the fact that manufacturers expect all servicing to be done by their dealers, and turn the cold shoulder to independent Service Men, I am reminded of a rather amusing incident. I was called to service a "Model 30" Atwater Kent, which a dealer had sold. When I arrived, the owner told me that the dealer had been out several times to fix it, but had failed in the attempt.

On examining the set in general, I found a 71A tube, drawing about 15 milliamperes, in the detector socket; while the 700A detector was in the last audio socket. There were two dead "B" batteries, one dead "C" battery and three dead tubes in the set; the condensers were out of alignment; and the speaker diaphragm was stuck.

That goes to show what many dealers know about the sets they sell. Yet the manufacturers don't know enough to realize that it is the Service Man who keeps their radios sold; and they refuse to furnish service manuals on the sets they make. They never stop to think that we Service Men fix them, regardless of whether or not we have service manuals on them.

ARTHUR PAGLES,
Clarksville, Iowa.

TOO SHORT A TEST

By Willis Werner

WHILE I am not a Service Man myself, I am interested in such things. As I have not heard of this particular brand of trouble elsewhere, I am passing on this bit of information, hoping it may solve some Service Man's problem.

We had a Sparton "931" a few months
(Continued on page 595)

ATWATER KENT MODELS 30, 33, 35, 48 AND 49

These receivers are six-tube sets of the single-dial, battery-operated type. They are often referred to by their factory catalog numbers, to wit: Model 30, No. 8000; Model 35, No. 8100; Model 48, No. 9840; Model 33, No. 8930; Model 49, No. 9860.

The models 33 and 49 have a tuned input (four tuned circuits); the models 30, 35 and 48 have an untuned input (three tuned circuits). Models 48 and Model 49 are coil numbers showing that a gold-finished panel is used. Models 33 and 49 are so wired that R5 limits the current to V5 and V6 only while V4 is controlled by the additional variable resistor Rx. R in the first stage of these two circuits has the same value as equivalent resistors R1 and R2. C is the regular tuning condenser, in shunt to which is the circuit-balancing variable condenser Ca.

The purpose of the untuned antenna input of the 30, 35 and 48, shown in the larger diagram, is to eliminate the detuning effects of aerials of different constants.

If it becomes necessary to change a variable-condenser bank, make certain that the pulleys turn easily on the shafts; if they do not because of a damaged condenser shaft, replace the entire condenser group.

Each belt must be arranged with the eyelets, which clamp the two ends together, at the bottom of the belt loop. Each belt has two small holes; one to fit over a pin on the dial-condenser pulley and the other to fit over the pin on the pulley which is controlled by that belt.

Loosen screws in the outer condensers and move them toward the dial-condenser, so that the belts will fit easily over the pulleys. In moving condensers, hold them by the heavy frame of the stator plates, as this avoids strain on the different parts of the condenser assembly.

To arrange the belts on the 30, 35 and 48, first put on the belt which fits over the inner of the two pins on the dial-condenser pulley, and over the pulley of the third (right) condenser. Then, put on the belt that fits over the outer of the two pins on the dial-condenser pulley, and over the pulley of the first (left) condenser.

A bit different procedure must be followed in arranging the belts on the 33 and 49. Put on the belt that fits over the inner of the two pins on the dial-condenser pulley, and over the third pulley, as the first step. Then, put on the belt that fits over the inner of the two pins on dial-condenser pulley (this will bring it on top of the first belt) and continue on over the pulley of the fourth right condenser. The last step is to put on the belt that fits over the outer one of the two pins on the dial condenser pulley and over the pulley of the first or left condenser.

After the belts are in position the next step is to adjust the belt tension. See that the three

screws holding the dial-condenser to chassis are tight, and that the three screws in each of the other variable condensers are slightly loosened. Note that the holes through which these latter screws pass are slotted, allowing the condenser to be moved horizontally a fraction of an inch toward or away from the dial condenser. Two pins projecting from the front of the condenser fit into two horizontal slots and serve to keep the condenser properly aligned. It is important to see that the pins of the condenser are not jammed outside but are in the slots. The frame of the metal-frame variable condensers will be found to partly cover a hole (on the side of the condenser nearest to the dial-condenser) that is provided in the front of the chassis and at the edge of each condenser for the purpose of tightening the belts. By inserting the blade of a screwdriver in this hole and twisting the blade, the condenser may be moved away from the dial-condenser; this motion tightens one belt. A little dexterity is required when the correct belt tension has been obtained; for the next step is to keep the condenser in the correct position while, with the right hand, a second screwdriver is used to tighten the three screws that pull the condenser to the chassis. Screws must be pulled up tight as soon as the tension is such that the variable condensers all move at the same instant, forward or backward, when the dial is adjusted, without any slack in the belts.

Following are a few details that relate specifically to the 30, 35 and 48. Adjust right-hand belt first; insert the blade of a screwdriver in the chassis hole at the left-hand edge of the third condenser and twist the blade, slowly. This will force the third condenser toward the right and increase the tension on the belt. When it seems to be at about the right tension, as judged by pressing the belt, tighten the three screws with a second screwdriver.

Special notes in connection with the 33 and 49 are as follows: the dial-condenser and third condenser belt should be adjusted first. Following this is the adjustment of the belt passing over the pulleys of the dial-condenser and fourth condenser. (Tension is tested by pressing down the belt between the third and fourth pulleys.) The left-hand belt is the last to adjust.

As it is necessary, in making certain replacements, to know the general classification of the R.F. inductance group of each model as regards its serial number, these data are included herewith. The identifying washer is found under the nut on the second R.F. transformer mounting; the colors of the washers are as follows: Model 30, 635,001 to 644,351, black; above 644,351, red. Model 35, below 900,000, no washer; 900,001 to 955,700, yellow or amber; above 955,701, gray. Model 33, Unit No. 9220: antenna coil has five leads (one red), L1 has one

green lead, L2 has one yellow lead, and L3 has one blue lead.

To reduce inter-stage coupling to a minimum, the three R.F. inductances L1, L2 and L3 in the 30, 35 and 48 are so arranged that the axis of each is at right angles to that of the others. (The R.F. choke Ch is only about 1/4-in. long and has a negligible field); however, the 33 and 49 incorporate four tuned circuits and, to reduce interstage coupling, the coil design was entirely changed to "binocular" or "astatic" (non-inductive) windings. If, after carefully balancing the variable condensers, it is found that the variable condensers cannot be kept in tuning alignment throughout the tuning range, it is probable that one or more of the R.F. inductances is out of balance; it is then advisable to replace the entire set with a new unit.

The A.F. output of any of these sets may be fed to a Weston "Model 424" thermocouple galvanometer, through an additional, or third, stage of A.F. amplification, to determine the alignment of variable condensers when the A.F. modulated output of an R.F. oscillator is picked up by the set. The oscillator should be coupled to the set to a degree which results in an approximate reading of 50 on the galvanometer, at about 50 on the tuning dial (as each stage is brought into resonance the meter reading will rise, and the oscillator coupling should be reduced to compensate for this.) First, resonate all the circuits for maximum deflection at about 40 on the dial; repeat performance at 80; then drop to 20 on the dial. After the condensers have been locked in position, the meter readings at 20 and 80 should not drop more than 30% below the reading at 40; a lower reading shows either a defective condenser gang or defective R.F. inductance bank. Inspection of both should then enable a decision to be made.

These sets are wired for a power tube in the last A.F. socket except for early types of the 30. To change the wiring of these, determine by continuity test the grid return lead of T2 which connects to the blue lead in the cable. Break this grid return lead, and attach a length of wire sufficient to reach the "C" battery. Then, connect the positive lead of the speaker (black and red, for Atwater Kent models) to the highest "B+" instead of the connection post on the set.

The A.F. transformers have the following color code for the leads: green to plate; yellow to "B" plus; black to grid; blue to "A—" or "C—". T1 has a ratio of 4:1; T2, 2 1/2:1.

Approximate values for the parts used in these radio sets are as follows: C4, 0.5-mf.; C5, 0.00025-mf.; C6, .006-mf.; R1, R2, R3, R, 800 ohms; R4, 20 ohms; R5, 4 ohms; R6, 30 ohms, center-tapped; Rx, 20 ohms.

In the earlier diagrams "A+" is connected to "B—"; in later models, "A—" to "B—." This is purely external, however.

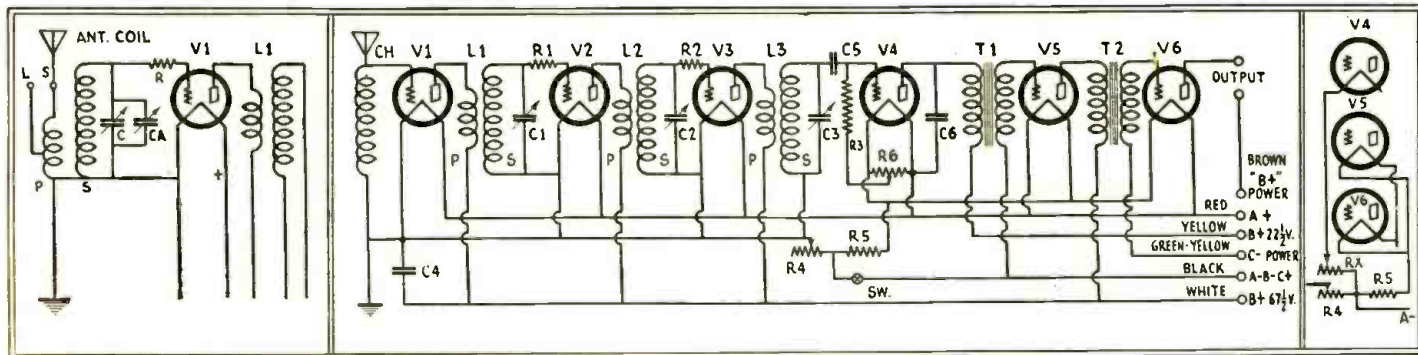

Left panel: R.F. input circuit of "Models 33 and 49"; right panel, their A.F. filament circuit. They are otherwise as shown in the large diagram.

CROSLY AC-7 AND AC-7C

This receiver employs one (first) stage of tuned "push-pull" R.F., a second stage of R.F. amplification (in which circuit oscillation is prevented by a "losser" resistor R12 of 750 ohms and the reversed tickler winding T of L2), a regenerative detector, and the usual two stages of transformer-coupled A.F. amplification.

The tubes used are as follows: V1, V2, V3, V4 and V5, X-99s; V6, '12; V7, BH-type gaseous rectifier. (The specified tubes must be used.) The filaments of the amplifier and detector tubes are connected in parallel, and the filament current is obtained from the rectifier V7 and high-voltage winding S1 of the power transformer PT. The manner of obtaining grid bias for these tubes is indicated in the detail circuit.

The constants of the components are as follows: R1, 700 ohms (variable); R2, 49 ohms; R3, 1,500 ohms; R4, 63 ohms; R5, 750 ohms; R6, 76 ohms; R7, 500 ohms; R8, 88 ohms; R9, 375 ohms; R10, 1000 ohms; R11, 500 ohms (center-tapped); R12, 750 ohms; R13, 8,750 ohms; R14, 90,000 ohms; R15, 2,400 ohms; R16, 500 ohms (variable). C6-R17 constitute the usual grid-condenser-and leak combination; C1 and C2, .00042-mf. (variable); C3, .00046-mf. (variable); C4, .06 to 1.0 mf.; C5, C8 and C9, 1.0 mf.; C7, .003-mf.; C10 and C12, 15 mf.; C11, 5 mf.; C13 and C14, 0.2-mf. A.F. choke Ch1 is rated at 50 henrys; Ch2, 15 h.; Ch3, 100 h. T1 and T2 have a ratio of four-to-one.

Condensers C10, C11 and C12 are contained in a single case and constitute the Mershon electrolytic condenser in one corner of the "ABC Supply Unit."

An insulating film on the plate of the Mershon condenser is built up at the factory; but this gradually breaks down if the receiver is not in use for some time. To build up a film on the plates the receiver is put into operation with all tubes in their respective sockets. At the start of the re-conditioning process, resistor R16 should be turned to extreme left, and resistor R1 set mid-way. Operate the set for ten minutes to half an hour, noting the current reading on the milliammeter MA; the value for correct operation of the set is between 55 and 60 milliamps. As the current increases, R16 should be adjusted to maintain this reading. A greater length of time than fifteen minutes is seldom required before the set begins to play well. If C10-C11-C12 is defective, the Mershon unit should be replaced.

As the filament supply of V6 is alternating, there is no polarity for the (white) supply leads.

Meter MA is polarized and each of its connection posts must be connected to the lead wire, from the set, directly below it.

The tertiary (third) winding T of L2 is a fixed negative feed-back coil used to prevent oscillation in the circuit of V3, while the wind-

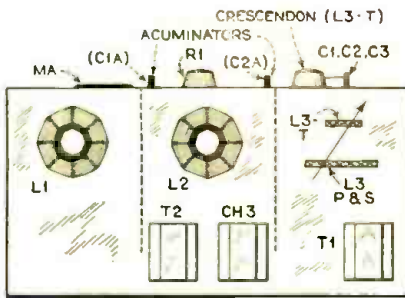

Approximate position of certain R.F. and A.F. units in the Crosley "AC-7" and "AC-7C" receivers. L3T is a tickler coil arranged for variable coupling to the primary and secondary inductances of L3. In this set, the filament supply for the battery-type tubes is obtained from the high-voltage output of the power pack.

ing T of L3 is a variable positive feed-back or regeneration coil; the latter is called the "Crescendon" control. C1 and C2 are shunted by the balancing condensers C1A and C2A, which are controlled from the panel and termed the "Acuminators"; C3A, in shunt to C3, is adjusted from the bottom of the chassis.

R2, R4, R6, R8 and R10 are biasing resistors. If the A.C. line voltage is low, the fuse should be changed over from the pair of clips at the right (in which position it is shipped) to the left pair (as seen from the control-knob

First, however, determine whether the leads to the electrolytic condenser are making good contact.

Special care must be taken to insure that the proper tubes are in the sockets designated for them.

Ch1 and Ch2 are mounted above the electrolytic condenser in the power unit. With the electrolytic condenser at the left and V7 at the right, Ch1 is at the rear and Ch2 is mounted in front of it. The buffer condensers are mounted below V7.

Since the arrangement of the circuit of this receiver is unusual, it is necessary to give care and attention to details when servicing. A wrong value for a replacement unit will change the voltages across the various resistors. The line-voltage should be determined if Ma seems to read too high.

A '71 tube should not be substituted at V6, or the rectifier will be overloaded. However, this or a larger tube may be used if it is included in a separate power unit; an adapter, or a change in circuit wiring, is then required in order to transfer the output of V5 to the external power tube.

The power unit, contained in a metal case, is designed to supply "A" current only for type '99 tubes—except at V6, which is marked "UX-112"—and only in the manner shown in the diagram. For this reason it must not be connected to a set in which the tubes are wired differently; or where the filament requirements are different.

If the "A" current drops to 20 to 35 milliamps, despite all adjustments, and consider-

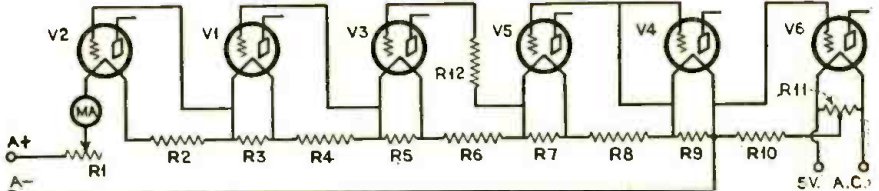

Grid-bias voltages for one type of Crosley receiver are derived from resistors in the "A" circuit, as this illustration shows. The milliammeter MA is provided to indicate when, through adjustment of R1, the correct current is being supplied to the filaments of the tubes.

end of the power unit.)

Condenser C4 completes the R.F. circuit, while at the same time it insulates the D.C. circuits of V1 and V2. If C1, C1A, or C4 short-circuit, the filament of V1 will not light.

Hum in the "AC-7" receiver may be due to an open in one side of hum-balancer R11, or to an open in one or both buffer condensers (C13-C14).

able hum is noticed, try another tube in place of V7.

Ch3 together with C8, is designed to eliminate interference due to line pick-up of outside disturbances.

The shunts across the filaments of V1, V3, V4 and V5 help to by-pass the "B" current, which must go through the filament circuit in completing the "B" current supply circuit.

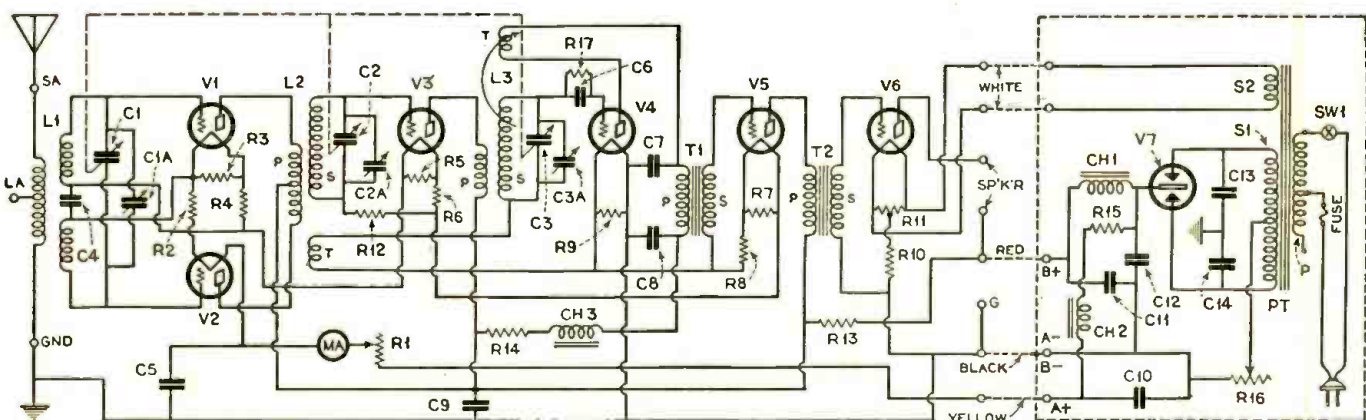

Schematic circuit of the Crosley "Models AC-7" and "AC-7C" radio receivers. A novel arrangement may be noted in the push-pull R.F. input; L1 (although in two sections mechanically) is equivalent to a center-tapped inductance. In fact, if it were desired to obtain grid bias from a separate battery, it would not be necessary to use other than a center-tapped coil. The circuit of V3 is neutralized, while detector V4 is arranged to be regenerative.

The Radio Manufacturer Has His Say

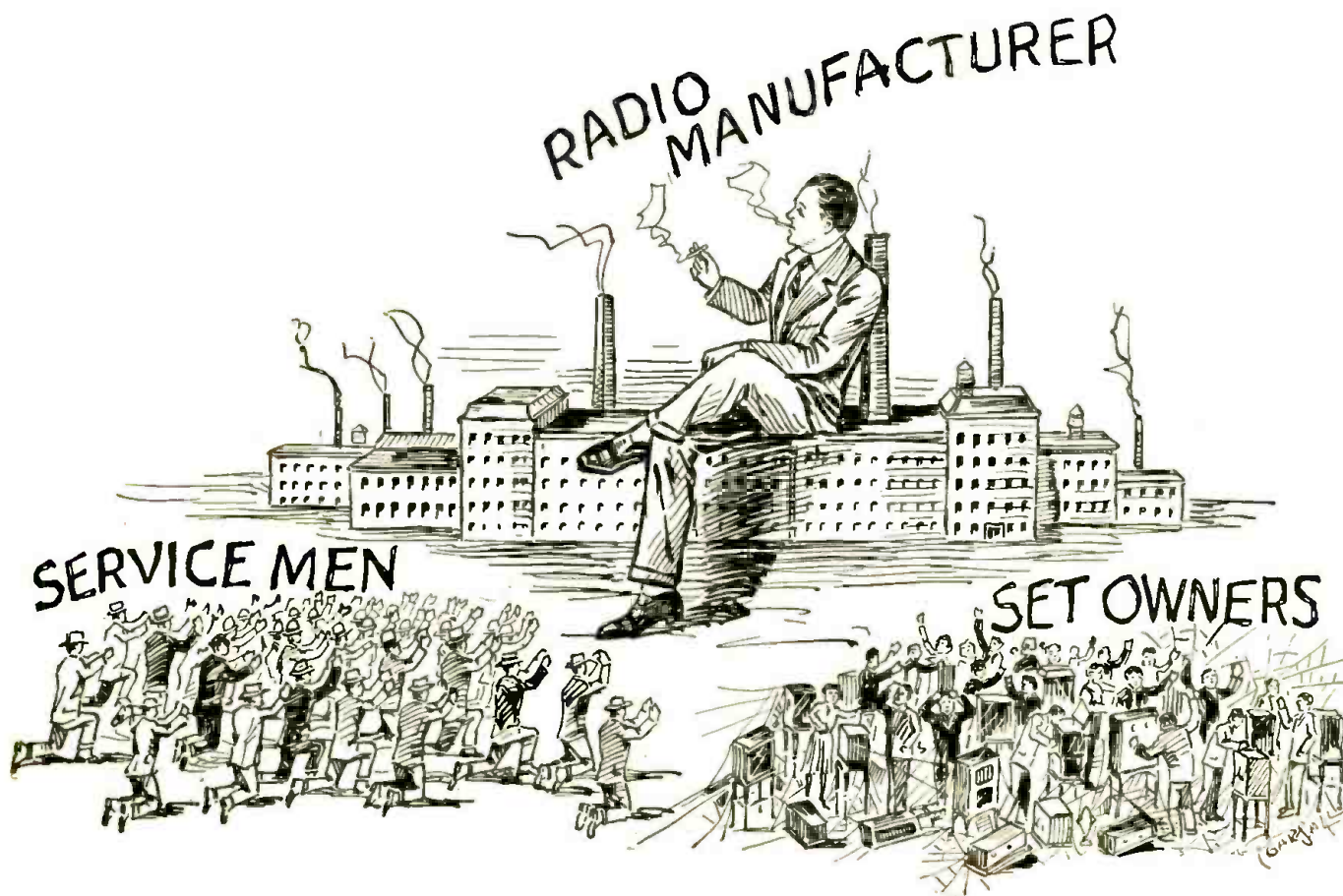

Stewart-Warner

THE writer cannot let go unchallenged your invitation to the radio industry to produce a radio manufacturer who has been giving conscientious service to the purchasers of his radio receivers. We have always prided ourselves on just that point, and we must therefore take exception to your statements. A careful analysis of your editorial ("Frenzied Radio," in the February issue of *RADIO-CRAFT*) discloses quite a few claims that do not coincide with our own views on how we have been doing business since our first set was sold.

Early in our radio manufacturing history, it became necessary to lay down a definite policy for stocking radio repair parts. We felt then, as we do now, that any individual who invests a considerable sum in a radio receiver is justly entitled to expect service on it for its natural life. A careful survey of the life of the average set was, therefore, made with the result that we laid down the ruling that we would continue to stock all parts in any way necessary toward the complete repair of any Stewart-Warner radio receiver for a period of three years after the introduction of the subsequent model. Furthermore, we would continue to stock indefinitely all parts for which there was any demand as evidenced by our sales records for the previous year. To live up to this policy, it has been necessary at times to go to extreme measures in securing repair parts. Manufacturing schedules have often suffered, night shifts have been instituted, our distributors' stocks have been searched,

and often special machinery built. Quite often, as a result, we were compelled to sell parts considerably under our manufacturing costs. Our only reason for such action was to insure consumer service that had been promised.

Realizing that the Service Man plays a very important part in keeping a customer satisfied, we have always given our fullest co-operation to anyone requesting service information. We even went to the trouble some time ago of preparing a special correspondence course in radio for the benefit of the Stewart-Warner dealer or his Service Man. Since requests were received for extra copies of this course, our radio service department made up a quantity of reprints which were mailed to any Service Man requesting this material, regardless of his affiliations, until the course became outdated and was discontinued.

At the present writing, we keep on hand circuit diagrams of all sets we have ever made, and will furnish them to anyone without question. As a further help to Service Men, we have reprinted all these diagrams in our latest service manual, just off the press.

Our own policy is to supply all service information and instruction books without charge; and we have kept all service data reasonably simple, so that this may be done without entailing an expense entirely out of proportion to the benefits derived. We can, nevertheless, see the viewpoint of the manufacturer who gets out elaborate manuals that are in reality textbooks on radio, and then feels justified in charging a nominal

price to insure that he will not be imposed upon by any individual who may happen to be sufficiently curious about his sets to write for a service manual. We use as a guide the letter-head on which the request is written or, if a plain piece of paper is used, we judge by the general tone of the letter whether the individual really needs a service manual or is only in need of our instruction book.

The apparently excessive selling price of radio repair parts for old models at first glance may often seem out of reason; yet a closer analysis will show this conclusion to be ungrounded. In our own case, parts are priced after they have been in manufacture for a sufficient length of time for us to know exact costs. Once that price is set, it is seldom changed. Obviously, every year manufacturing costs drop considerably; so that a transformer that must be sold at \$6.00 one year can be made to sell for not more than \$4.00 a year or two later. Nevertheless, the older transformer must still sell for \$6.00, even though it is not as good as the later model; since its manufacturing cost was the higher figure. Following this line of reasoning, which is the only correct one, the price of repair parts must necessarily bear a direct relationship to the original selling price of the radio—not to any subsequent close-out price. The dealer should, in all fairness, point this out when he sells any set below its normal value. A good second-hand Cadillac may be bought for \$300, yet the repair parts cost as much as for a new machine.

Your claim that only in the last year or

two have radio set manufacturers been supporting broadcasting, is not borne out by facts. We announced our own entrance into the radio industry by leasing a broadcast station (WBBM) for two years; and we still tie up indirectly with broadcasting through our distributors in many cities throughout the country. In addition, you will find the following outstanding manufacturers who have been actively sponsoring broadcasting prior to 1929: Atwater Kent, All-American, Amrad, Crosley, De Forest, Federal, Grebe, Philco, R. C. A., Zenith. We have purposely refrained from listing any manufacturer who has been broadcasting, directly or indirectly, for less than one year.

We believe that RADIO-CRAFT is sufficiently widely read to command attention, and any editorial it features deserves consideration. With this in mind, we are sure that you will agree with us when we ask you to devote space in the pages of your magazine for

giving trouble take it back to the dealer from whom purchased; and, if this dealer cannot repair it, he will return it to the wholesaler, but never to the factory.

It has been our experience that a big majority of all Service Men who are working on all makes of receivers never get enough training on any one to become proficient. The exceptions to this can get in touch with the nearest Philco jobber and I am sure he will give them all possible cooperation.

PHILADELPHIA STORAGE BATTERY COMPANY,
ROBERT F. HERR,
Service Engineer.

R. C. A.-Victor

WE feel that the successful dealer must be organized to serve his customer and keep him enthusiastic about his purchase. The customer is certainly entitled to receive merchandise that operates satisfactorily, and

upon independent service organizations to accept a responsibility that is our own.

R. C. A.-VICTOR COMPANY, INC.
W. A. GRAHAM,
General Service Manager.

Crosley

OUR service information is published in a little paper that is sent twice a month only to authorized dealers, distributors and distributor's salesmen. About twice a year this service information is compiled and put out in pamphlet form, called the *Crosley Service Manual*, and this pamphlet is sent to all Service Men requesting service information. Although it costs money to prepare this, we do not charge for it, nor do we think a charge should be made.

However, we must have some kind of ruling covering the distribution of service manuals; therefore any man claiming to be a Service Man must write in on his business

"**FRENZIED RADIO**," the leading editorial by Mr. Hugo Gernsback in the February issue of RADIO-CRAFT, aroused more heartfelt comments than any other expression of the Editor's views which he can recall from more than twenty years' publishing experience. This office was literally swamped by thousands of fervent communications from Service Men and other readers in all branches of the radio trade, as well as from consumers who voiced their interests in the matter.

In that editorial, we promised to publish any comment which radio set manufacturers desire to make, with regard to their policies on servicing in relation to their dealers, other Service Men and

the public. The letters presented here give the widely-differing viewpoints of the leading manufacturers; which we print here in their essentials, leaving to our readers all deductions from them, and comments thereon.

We only ask whether, since the radio industry is still at odds as regards its relations to the Service Man, the radio set manufacturers would not do well to agree among themselves on a policy to which all of them can subscribe? Such action would certainly tend to clear away a tremendous amount of the dissatisfaction which exists at present among radio dealers and Service Men.

the refutations submitted by responsible radio manufacturers who are sincere in their belief that they are handling their service problems in an eminently fair manner.

STEWART-WARNER CORPORATION,
J. N. GOLDEN,
Radio Service Department.

Philco

EVERY time a new model Philco radio is put on the market, a complete service manual covering that model is sent free of charge to all authorized Philco dealers. We also supply copies of these manuals to radio editors of newspapers and reliable magazines on request.

All service problems and the distribution of repair parts for Philco receivers are handled by the jobber. It is, of course, impossible for the factory to fill any orders for parts when they are sent in by unknown people. Quite often when parts are sent out in this way, they are used incorrectly, due to lack of knowledge, and the owner will then blame the trouble on us. However, if any Service Man is established in this business, and can show that he is well trained in this kind of work, I am confident that he can go to the nearest Philco wholesaler and buy the parts needed by him. We leave this entirely up to the wholesaler, because he has a much better knowledge of service conditions and can investigate the Service Man's ability a lot better than we can here in Philadelphia. We would prefer to have a user of a Philco receiver that is

it is the responsibility of the dealer to make certain that this is the case. All successful enterprises are built on this principle. If the merchandise does not operate satisfactorily, the dealer must be in a position to make repairs either through his own organization or the organization of the manufacturer. Certainly the success of any manufacturer's products must depend upon the degree of satisfaction they give their owners.

The fact that no radio manufacturer yet enjoys a popular reputation for excellence of service through his dealers must be due to the relative youth of the radio dealer system, and that it takes considerable time to build up a dealer organization that is reasonably perfect in this respect. I have no doubt, however, that this desirable condition will be eventually attained, particularly as we recognize this as our ideal and are striving to accomplish it.

This is one of our reasons for not desiring to support the independent service organization, but to concentrate our efforts in an attempt to perfect service through our dealer organization. I agree that the dealer service organization is far from perfect at the present time; but I do not feel that the condition will be permanently improved by sacrificing principle to expediency. We want our customers to feel that we are 100% behind our product, and it is our humble opinion that this can best be accomplished by having control over the organization that serves the customer, rather than depending

letterhead. We require that they have some sort of letterhead showing that they are engaged in the repair business; or in some business such as garage, automobile accessories, hardware, music store, electrical or music house.

When a Service Man writes in on a postal card or an ordinary piece of paper, requesting a service manual, we immediately write him, telling him that his request must come on a business letterhead, otherwise we cannot send him the information requested. If we are included in some complaints, our refusal is due simply to the fact that the party writing in did not show evidence that he was in the service business.

There have been some cases where we received requests at a time when we were out of service manuals; but these people received letters, telling them to write again within two or three weeks, at which time we expected to have a new supply.

We have also had requests from Service Men for information on certain obsolete sets, and (as the models had been out of production four or five years or more) no service information was available, and we therefore informed them to that effect.

THE CROSLLEY RADIO CORPORATION
D. J. BUTLER.

Stromberg-Carlson

OUR business is built largely on a foundation of loyal dealers. In fairness to
(Continued on page 597)

Operating Notes for Service Men

There are a good many useful ideas in the service manuals with which many Service Men are provided; other kinks are picked up only in the school of experience. Here are some of a scholar's reminiscences.

By BERTRAM M. FREED

SOME receivers, such as the "Radiola 64" and the Brunswick models using the same circuit, incorporate a reversed-scale milliammeter for visual adjustment of the tuning selector. The needle of this meter will often waver and fluctuate, because of R.F. current; the condition may be corrected by shunting it with a condenser of .0001-mf. capacity, as indicated in Fig. 1. A larger capacity seems to be less satisfactory.

It is sometimes necessary to balance and neutralize the superheterodyne; a procedure which, as remarked in the preceding article, has often been looked upon with apprehension. Undoubtedly, audio oscillators and 180-ke. oscillators are great helps in such a procedure; however, the job may be done without other apparatus than an insulated rod with a screwdriver tip, and a dummy UX-227 (a tube of the proper internal capacity must be selected). It will be necessary, first, to remove the chassis and its shelf from the console. The meter should be removed with its bracket, for easy replacement. Care must be taken not to disturb any connections to the power pack.

In Brunswick models, which employ a phonograph pickup, it will be necessary to remove the five-wire cable which is attached to the connectors on the chassis. After this, short the three middle connectors on the chassis. Then unsolder the wires to the condenser gang and free the gang from the chassis by removing the three screws that hold it. Place the gang several inches from the chassis, lengthen the leads from the

chassis to the gang, and resolder. Switch set to "on" position and tune in a station at about 30 on the scale.

Referring to Fig. 2, adjust (with the

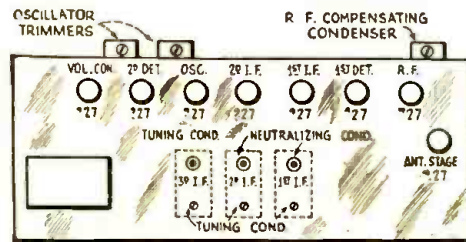

Fig. 2

Chassis layout of the "Radiola 64" and combinations of this popular superheterodyne.

insulated screwdriver) the third I.F. tuning condenser for maximum signal; repeat the procedure with the second and the first I.F. condensers. Now, place the dummy 227 in the first I.F. socket, and adjust the neutralizing condenser of that stage for minimum or no reception. Neutralize the second I.F. stage in like manner.

We still have the two oscillator trimmers and the R.F. compensating condenser to take care of: but that must be done with the condenser gang back in position, and the chassis back in the console. Tighten the adjusting screws on the trimmers and the R.F. compensator, and then loosen one full turn.

When Radiola "44" and "46" sets oscillate, it is a sign that either the shield cans

are not making proper contact, or the tuning condensers must be adjusted.

Give the Speaker Air

Some console cabinets, into which customers have had modern sets built, are not well adapted to the powerful dynamic reproducers used with them. This is because the back of the console is entirely closed; and, no matter how good a baffle is used in front, the speaker will rattle and vibrate. This may be remedied by cutting a circular hole, about the diameter of the cone, in the back of the console, directly behind the dynamic.

Causes of Bad Contact

Complaints of noise, made to Service Men, may often be traced to the strip which brings the aerial lead-in through the window to the set. The Falnstock clips on these strips lose their tension by exposure to corrosion; this causes the outside lead-in to become loose in its clip. It is desirable, when making an installation, to tape this contact thoroughly.

In the Zenith "50" series, it is sometimes very difficult to locate the breaks in an open R.F. coil. The wire on these coils is wound very tightly, and a break usually comes at the lug to which the end is soldered.

Abnormal hum in this model, when not caused by any electrical or mechanical defect, will be found to arise in the screen-grid tube in the detector circuit, which will test O.K.

Variable condensers in the Colonial "32-
(Continued on page 596)

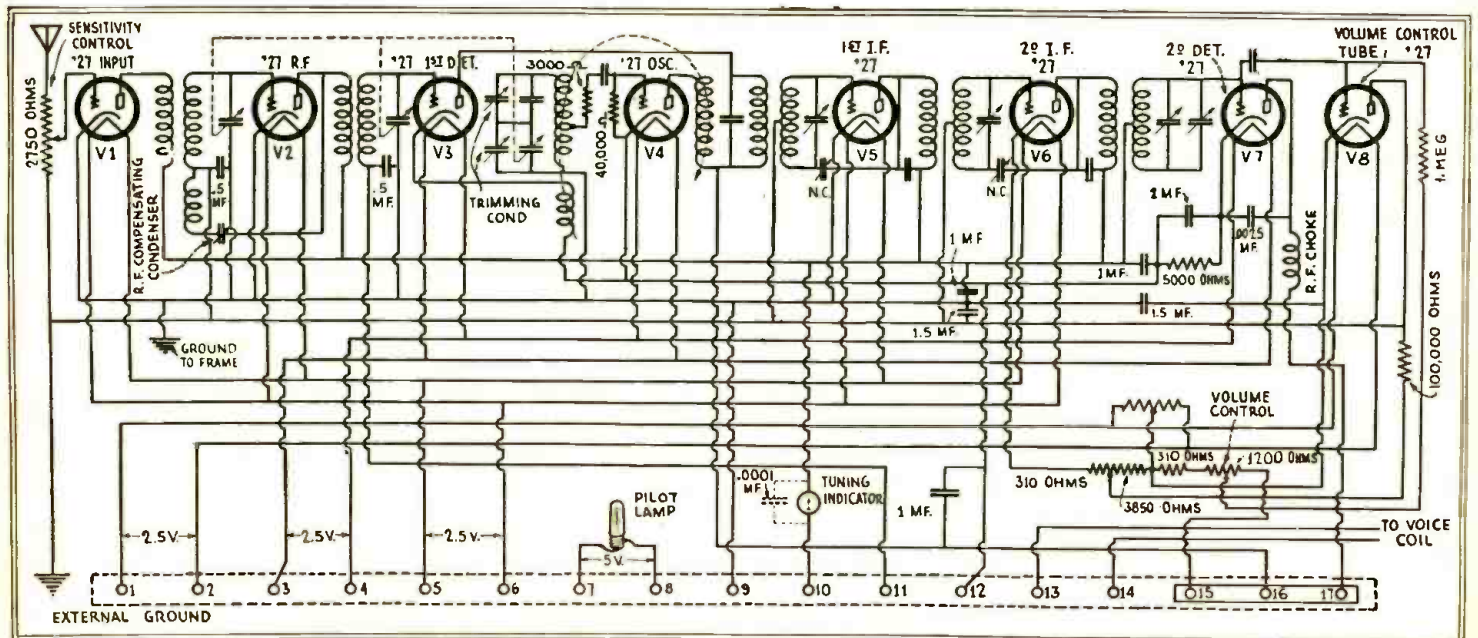

Fig. 1

Receiver circuit and terminal connections of the "Radiola 64." If radio-frequency current causes trouble in the tuning indicator, the very small capacity shown is an effective by-pass, Mr. Freed has found.

More About "Man-Made Static"

A Trouble-Shooter tells of some sources of interference which he has found in his regular work of checking radio noises

By J. E. DEINES, W9CU

MUCH has been said about electrical apparatus that interferes with radio reception, about methods of location, the kind of set to use in this work, and all that—but still there is that puzzling case that makes you scratch your head and wonder what it is all about. Perhaps some of these ideas will help you.

We all agree that the noise travels back on the electric line, much in the manner of "wired radio"; and that the way to look for it is to keep the loop parallel and directly under the line, then reduce the volume and try—first in one direction and then the other—until the loudest spot is found. This is usually a pole. If it is secondary distribution that you are working on, the trouble is probably in some one's home. There are two things that you can do in this case. Either walk under the "services" (lighting lead-ins to houses) one at a time, and pick the loudest; or ask everyone connected to that pole what they are using and, if it sounds suspicious, have them shut it off to prove your case.

In this day and age of powerful and sensitive receivers, interference seems to be on the increase. A check of the electric light companies' records shows that about 65% of the trouble located is in consumer's ap-

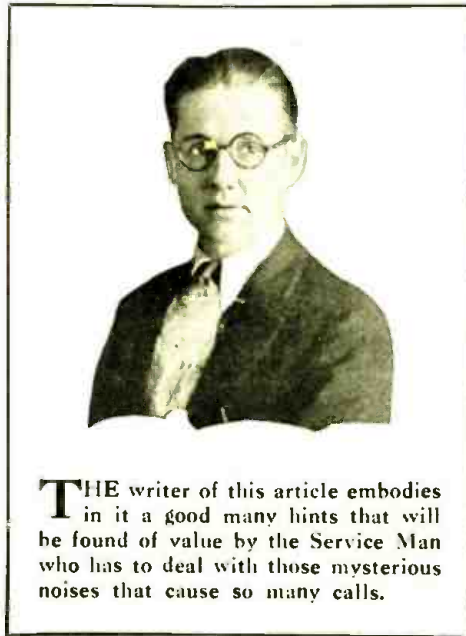

THE writer of this article embodies in it a good many hints that will be found of value by the Service Man who has to deal with those mysterious noises that cause so many calls.

set when a station is tuned in. It creates a background roar and spoils the tone quality. The reason for this is that the electric set is more closely coupled to the line than

Fig. 1

The high-voltage lines, which in some systems are used for "wired wireless" distributors, also carry unwanted R.F. noises from one house line to another, sometimes a long ways off—as from No. 1 to No. 3 here.

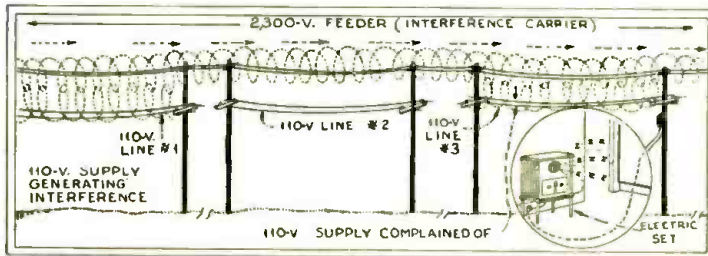

pliances; while the owners of these do not seem to realize the importance of applying filters, and usually make the statement that they use the appliances only for a few minutes.

But consider a number of these appliances used at alternate intervals, and we have a chain of interference that will last for hours.

Radio has a peculiar place in the electrical industry, due to its rapid growth in the last ten years. It has grown to a giant ranking next to the automobile, and we have only "scratched the surface." Too much time has been spent selling radio and not enough spent in making a place in which to use it.

We are now facing the problem of working over and filtering all our old equipment (which is, otherwise, operating normally) to make the world, speaking from a radio standpoint, a better place in which to live.

Some noises which can be heard on the electric sets can not be heard on the trouble shooter's set, even under the house "service"; that is, interference which is not a major noise, that would spoil reception entirely, can be heard on a sensitive A.C.-operated

the portable; and a careful inspection of the electric lines in the vicinity will soon get you on the right track. It can readily be seen from Fig. 1 that interference set up in one secondary line will in turn set up an interference in a parallel line; the intensity of the transfer depending on the length of exposure. The noise will be weaker, to be sure; but nevertheless it is there and can be found if looked for in the proper manner.

Troubles in House Wiring

We all know that any arc or spark causes radio interference, and we can no longer tolerate loose connections. An easy way to find troubles from this source in house wiring is to turn on the radio set at full volume, shake all fixtures and pound all the wall switches, listening for cracks and pops that you will no doubt hear. Many of the older houses throughout the country were once piped for gas lights and, in some cases, combination gas and electric fixtures are still in use. Others have the pipes capped off under the new light and fixtures. Here is a place for a lot of trouble. In an in-

stallation of this kind it is very seldom that the fixture is free from grounds. (See Fig. 2.)

When lightning strikes in the vicinity of the electric line, the induced current usually runs into the house and jumps off at the most likely spot—the gas-pipe ground—and the result is damaged insulation. If it is on the live side a fuse goes out; but, if it is on the ground side of the line, nothing happens until the fuse (X) goes out. Then the fun begins. The current flow is now from X to the transformer ground in the alley and, because contact is poor in the fixture, an arc is the result. Several cases of this kind were found where a loud buzz was set up with the set turned on only about sixty watts. The greater the load, the louder the buzz.

It seems to be a habit with the electricians, when they cannot find a ground in the wiring, to reverse the circuit; thus putting the grounded wire on the neutral or ground side of the electric line. This is all right where there are no neutral fuses but, if there happens to be one and it blows, then the noise starts. Therefore, if in doubt as to the origin of the noise look at the neutral fuse.

In a fixture of the type shown in Fig. 2, where the wire is woven through the chain, a static charge is set up in this chain and, as long as everything is quiet, there is no trouble. But walk across the floor, or otherwise move or jar the chain, and a crackling or popping noise will be set up. The cure here is to tape the eyelet (Z) and thus insulate the chain from the canopy.

Another spot in house wiring that will near watching is the entrance switch at the meter; here is a likely place for loose connections. (Fig. 3). All places marked X are likely places and, if the meter switch and fuse box happen to be located near a door, the vibration due to constant opening and closing of the door will loosen all screws and fuses. These loose connections can be found by the method used above.

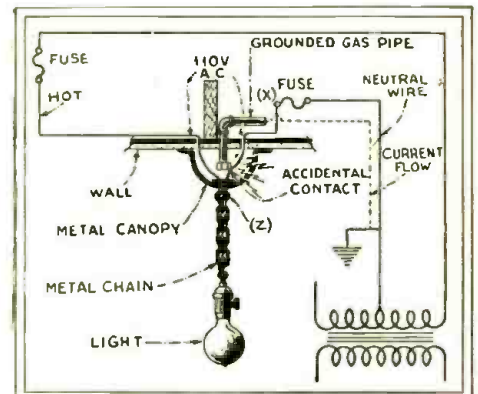

Fig. 2

One side of an A.C. line is grounded; if a fuse in this line blows, a ground in the wiring will cause all kinds of radio disturbance.

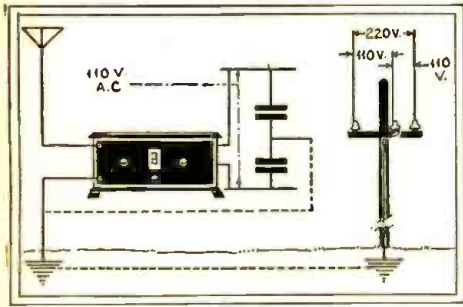

Fig. 4

A bad ground furnishes a coupling for line noises, even though there is a filter in the input of the set. The reason may be easily seen above.

Even the lowly electric lamp comes in for its share of the blame. Investigation of one complaint showed that the noise was coming from a neighbor's home; but only a 100-watt lamp was turned on that time. Turning it off stopped the noise, and it was found that the lamp filament had parted and was holding an arc that did not go out until the lamp was turned off.

Troubles in Receivers

One day we received a complaint of a humming noise which came in at one spot on the dial. During the course of the evening it would move from place to place. Upon investigation it was found that a neighbor was using a superheterodyne he had built from a kit. By a mistake in wiring, the antenna was coupled to the oscillator, and it would radiate at double the frequency the set was tuned to.

The heater-type tube causes a number of complaints, for it sometimes emits noises

that imitate most any interference. All are caused by a static discharge from heater to cathode. Many sets are found with defective power packs. Small arcs in the condensers, due to loose connections or high-resistance short circuits, cause many of the unusual growls heard in the listener's sets. Also some voltage-divider resistance units have a broken wire caused either by corrosion or by breakage due to contraction or expansion. This will show up only when the set gets good and warm; and many other complaints of this type, that appear after the set has been for use for hours, will account for the large number of cases found clear at the time of inspection.

Strict attention should be paid to the ground wire and its connections. When it is connected to the antenna post trouble starts. With such a connection, the light line acts as an antenna and, since interference travels on the line, we can readily see what will happen. In districts where street cars are used or direct-current lines exist such connection makes the noise about 30% louder.

It always pays to put up a good antenna.

Loose connections in ground wires always cause trouble; because any number of electric receivers use by-pass condensers on the line side of the power transformer. Since even a small condenser will pass alternating current, and since the electric company's lines have a grounded center or neutral wire, a small arc will result at the point of poor connection. (Fig. 4.)

Another condition that will produce a loud hum is a lamp sitting on top of the set over the detector tube or cord stuffed inside the set too near the tube.

Key click from telegraph offices some-

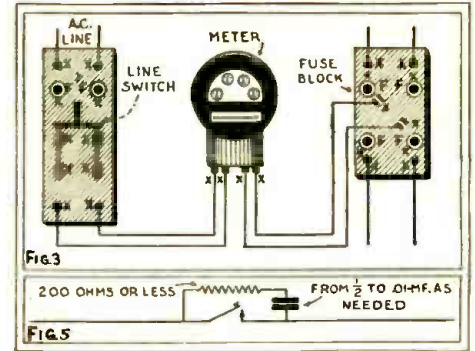

Above, we may see how many opportunities for a loose contact are afforded in a meter installation: Count the Xs. Below, a filter for telegraph interference.

times causes severe interference in the form of a loud popping or thumping noise and, when other lines parallel the circuit, it will spread over a large area. This is not so hard to find, but the cure may be a little harder. Use a 1/2-mf. condenser with about 200 ohms in series across the key. The resistance of condensers may be tried until the noise is stopped and the key does not arc too much at the contact. (Fig. 5.)

One piece of electrical apparatus emits a noise that sounds like the ticking of a clock; it is licensed under the Abrams patents and used for electrical treatments. The same filter will apply to this.

The trouble shooter's life is not all roses. He is usually a much cussed and discussed man and, if every owner of an interfering device would apply a filter, it would save him many a gray hair and many a cold ride.

Neutralizing and Screen-Grid Problems

By K. R. TANTLINGER

TO balance a neutrodyne receiver similar to the Philco "87," Brunswick "14" and "21," etc., an output meter should be connected across the speaker terminals, as shown in Fig. 2. The R.F. oscillator (such as that shown in Fig. 1, which may be operated conveniently from the light socket) is set in operation at about 1250 kilocycles, and a wire coupled to its oscillator coil is attached to the "antenna" post of the set. Then after adjusting the volume control for full meter reading, start with the last stage of R. F., and balance each of the neutralizing condensers until the reading is at minimum. Turn the volume control till a reading

of about half the scale of the meter is obtained at 1500 kc., with the receiver tuned to the oscillator signal. Then balance each of the aligning condensers until the highest reading is obtained. Repeat the latter procedure at 600 kilocycles, and the receiver is now balanced. If any difficulty is encountered in preventing oscillation after balancing, check all the filter and by-pass condensers for a partial leak; the defective one should be replaced.

In checking a Radiola "44," if a rasping noise is heard between stations when turning the dial, don't look for a shorted variable condenser, but clean the shield cans

at the contact edge. If the condition persists, balance the set as above.

When checking a screen-grid receiver whose response is weak, place a good screen-grid tube in the detector socket, and the reception will usually improve remarkably. Also, watch for those shorted screen-grids; because they are often the cause of no reception.

In case of a serious hum in a Zenith "50" or "60" series receiver, which cannot be eliminated by changing tubes (often the '24 detector will cause hum), remove the chassis from the cabinet and reverse the two black leads. If lack of selectivity is encountered, the receiver should be tuned to about 1195 kc. when the oscillator is set at 1200. After balancing the receiver with a hexagon No. 5 1/2 wrench, the selectivity should be better. If it is not, then tune the receiver to about 1205 kc., leaving the oscillator at 1200, and rebalance. One of these procedures should obtain greater selectivity. The second and fourth aligning condensers (from the left) will be found critical to adjust. This chassis need not be taken from the cabinet for rebalancing.

If a Philco speaker seems to be dead, pull the chassis out of the cabinet, and remove the bottom plate; then make sure that the
(Continued on page 595)

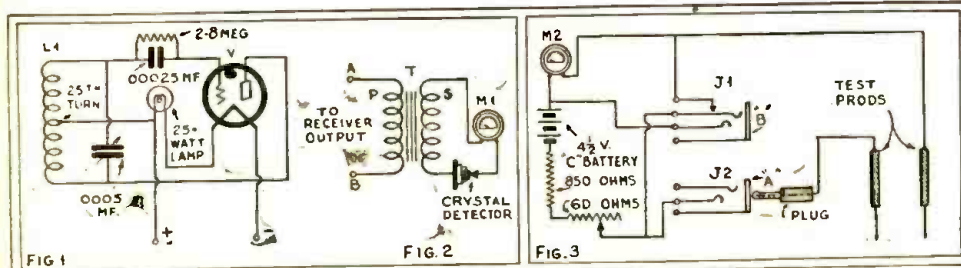

Left, a convenient R.F. oscillator; center, an output meter which will be found very handy in balancing work, as more accurate than the ear. Right, an ohmmeter which will read high or low values. (The Brunswick manual should be credited with this.)

Men Who Have Made Radio-J. C. Maxwell

THE EIGHTH OF A SERIES

IF you seek his monument, look about you," is written on the tomb of the architect of St. Paul's. The whole of earthly space, vibrant with the countless messages that are incessantly hurrying to and fro with the speed of light, has become a memorial to the scientist who first directed the attention of mankind to the unknown and unsuspected possibility of radio.

If Columbus, before he set sail from Palos harbor for the New World, had drawn a map of America—*islands, coasts, rivers and mountains*—which his voyage proved true in every detail, such a feat would have resembled that of Clerk Maxwell. The latter conceived, and laboriously computed, the existence and the laws governing an infinite range of electromagnetic "waves" imperceptible to our senses, except for the narrow spectrum of light. He thus declared the certainty that there must be what we today call "radio waves." Eight years were to pass after Maxwell's death before the genius of Hertz actually demonstrated the truth of Maxwell's calculations, and the world found awaiting it a new activity.

Today, fifty-seven years after their promulgation, the laws of Maxwell are still the fundamental basis of the science of radio. It is not easy to describe his work in popular language. "The object of these experi-



ments," said the modest Hertz, announcing their striking results, "was to test the fundamental hypotheses of the Faraday-Maxwell theory, and the result of the experiments

is to confirm them. I know no shorter or more definite answer to the question, 'What is Maxwell's theory?' than the following: 'Maxwell's theory is Maxwell's system of equations.'

James Clerk Maxwell was born in Edinburgh, Scotland, November 13, 1831. Though his eccentricities of expression as a boy were to win the nickname of "Dafty" from his schoolmates, he was yet a lad when his mathematical abilities attracted the attention of his elders. At fifteen, he devised a method of drawing certain curves which was deemed worthy of publication by the Royal Society of Edinburgh. At sixteen, he was introduced to Nicol (the inventor of the Nicol prism) and led to make a study of light, and particularly its polarization, which was to shape his future scientific course. In 1850 he entered the University of Cambridge, noted for the long line of great mathematicians it has produced. Here he graduated; and here his post-graduate work was to be most important. In 1855 appeared his paper on "Faraday's Lines of Force," containing an analysis of the actions which take place in electrical and magnetic fields.

Maxwell became professor of natural philosophy—or, as we now say, physics—at (Continued on page 594)

Attention: Radio Service Men

RADIO-CRAFT is compiling an international list of names of qualified service men throughout the United States and Canada, as well as in foreign countries.

This list, which RADIO-CRAFT is trying to make the most complete one in the world, will be a connecting link between the radio manufacturer and the radio service man.

RADIO-CRAFT is continuously being solicited by radio manufacturers for the names of competent service men; and it is for this purpose only that this list is being compiled. There is no charge for this service to either radio service men or radio manufacturers.

We are hereby asking every reader of RADIO-CRAFT who is a professional service man to fill out the blank printed on this page or (if he prefers not to cut the page of this magazine) to put the same information on his letterhead or that of his firm, and send it in to RADIO-CRAFT. The data thus obtained will be arranged in systematic form and will constitute an official list of radio service men, throughout the United States and foreign countries, available to radio manufacturers. This list makes possible increased cooperation for the benefit of the industry and all concerned in the betterment of the radio trade.

NATIONAL LIST OF SERVICE MEN,
c/o RADIO-CRAFT, 98 Park Place, New York, N. Y.

Please enter the undersigned in the files of your National List of Radio Service Men. My qualifications are as set forth below:

Name (please print)

Address (City) (State)

Firm Name and Address

(If in business for self, please so state)

Age Years' Experience in Radio Construction?

Years in Professional Servicing?

Have You Agency for Commercial Sets? (What Makes?)

What Tubes Do You Recommend?

Custom Builder (What Specialties?)

Study Courses Taken in Radio Work from Following Institutions

Specialized in Servicing Following Makes

What Testing Equipment Do You Own?

What Other Trades or Professions?

Educational and Other Qualifications?

Comments

(MAY) (Signed)

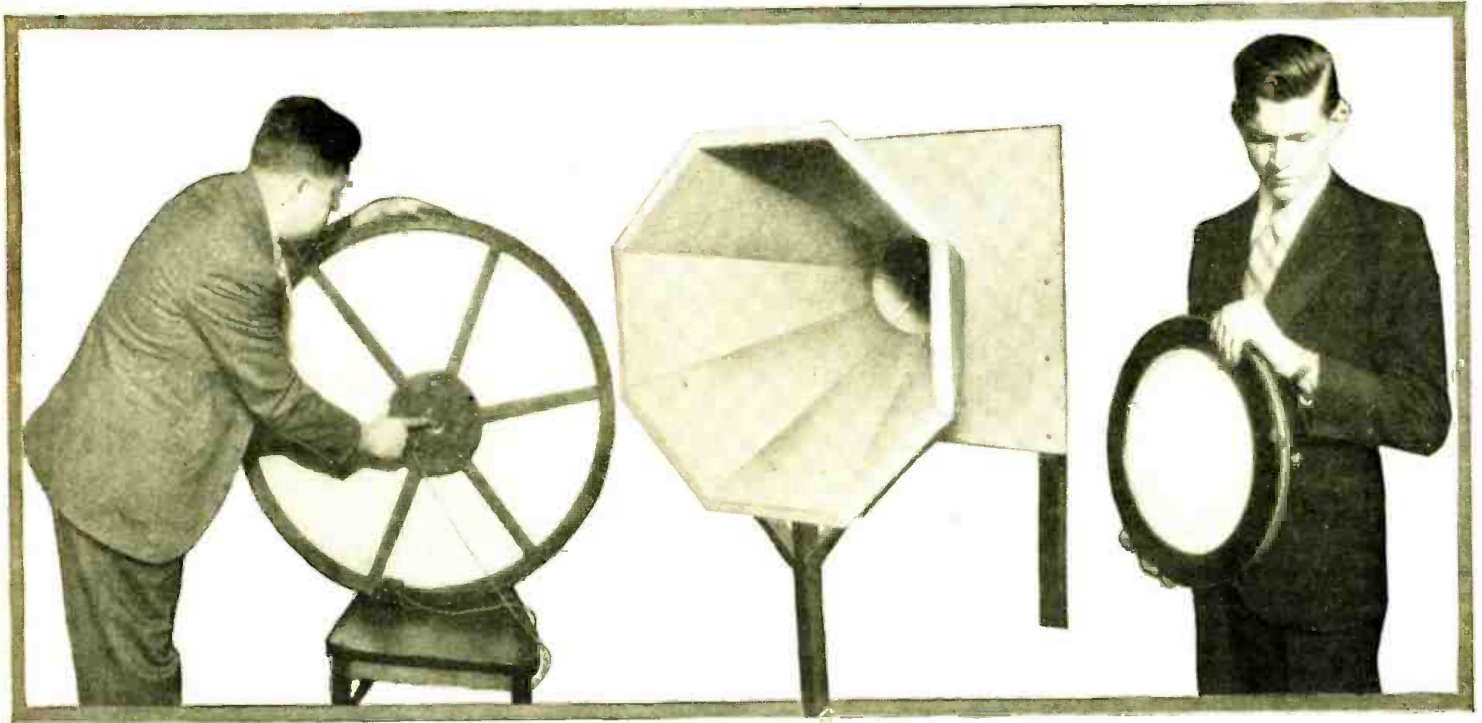

Fig G

Fig. H

Fig. D

At the left, the author pointing to the magnet core of the Thomaston stretched-disc reproducer; this is a dynamic speaker with the voice coil attached to the diaphragm. In the center, the new Celotex baffle, designed for auditorium sound projection, and exemplifying horn and cone principles. Right, the Myers-Delatre electrostatic speaker, removed from its baffle.

New Developments in Reproducers

Some of the new devices which are bringing about sound amplification of a fidelity hitherto unapproached, and with volume suitable for present-day entertainment demands

By LAURENCE M. COCKADAY

THE art of making loud-speaking devices is really one of the oldest scientific endeavors of man and goes back at least thousands of years into dim history. The ancient Sumerian priests used the principles of the speaking tube and of

enlarged mouthpieces, comparable to our modern loud-speaker horns, to make "talking" idols with which to sway and control the hordes of semi-civilized peoples to their will and bidding. It is interesting to note that the same general kind of speaking tube or loud speaker, using air waves, is now a part of almost every home and that people are still being guided and informed in much the same manner by the radio broadcasting "priests."

Nearly all the more primitive tribes still in existence today have made use of some form of loud-speaking apparatus; sometimes hollowed out of logs; sometimes molded out of clay, but at any rate serving to throw the voice with greater intensity to a distance.

It is only in the last seventy-five years, however, that any serious attempts have been made to do this electrically, or at least to accomplish anything like a satisfactory result.

At the present time all loud speakers are terribly inefficient in actual conversion factors; although the last two years have seen great strides in making electro-acoustical devices which could accomplish the conversion from electrical energy to acoustical energy without undue discrimination between the frequencies within the range of audibility. These modern devices produce radio rendition that sounds far more natural than that from any of the previous instruments; although the power necessary to operate them is still many times greater than

would be required if anything like good efficiency were attained. This is the reason why power audio-frequency amplifiers are still necessary for loud speakers of most types. Some of the newer loud speakers, however, work on a fluctuating voltage of rather high potential; and these offer opportunities of considerable value in the future search for efficiency.

Early Atrocities

The earliest types of speakers were of the magnetic, horn type and, although the horns used were too small for reproducing the lower notes, they were used almost exclusively during the first five years of broadcasting.

During the latter part of that period, the design of audio-frequency amplifiers was developed until further improvement in them would have been useless without a corresponding betterment in the loud speaker.

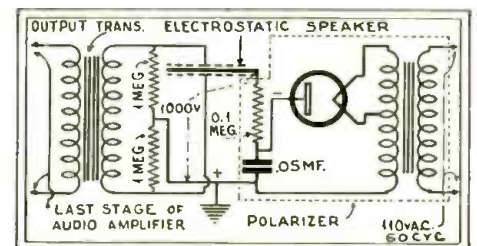

Fig. 2A

The electrostatic speaker derives a high negative charge from the floating plate of the rectifier.

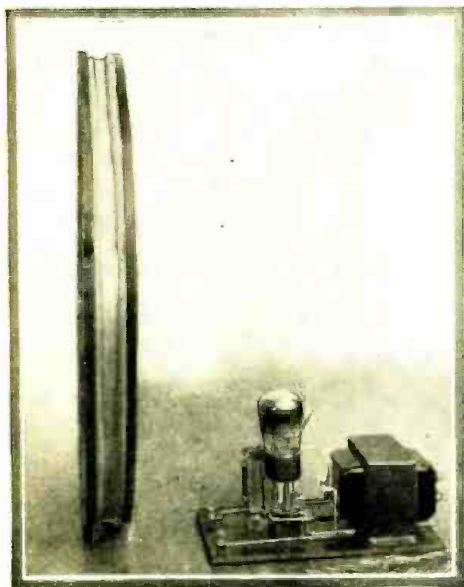

Fig. C

The new French electrostatic speaker has a polarized central diaphragm, enclosed in a mesh cloth.

The radio and acoustic engineers then began searching around for a more suitable type of reproducer and, finally, the large-cone type made its appearance. Its use did increase the low-frequency response to quite a noticeable extent; but was soon followed by a better understanding of the functioning of the horn, and the development of the exponential type of horn reproducer. The last is still used, almost exclusively, in public-address work and in the talking-moving picture field. The necessary length and size of these horns, for wide-frequency response, is so great, however, that they are not used very much for radio installations in the home.

New and Improved Types

Next in line came the applications of the dynamic-motor principle, which allowed longer swings for the moving surface and made possible the modern types of dynamic-cone loud speakers. These utilize small, light-weight cones, which are capable of swinging back and forth a much greater distance, and thus not only give the added power necessary for the lower notes but respond more to the higher frequencies in the harmonic ranges of sound. These cones were a great improvement over the earlier types and capable of delivering much greater volume than the others, because their movements are free, and not limited by the swing of the armature up to the pole pieces.

In the dynamic-type reproducer, no armature is used; but a moving coil, through which the signal currents circulate, is employed to give the mechanical energy.

Another development that has recently been gaining notice is the electrostatic- or condenser-type reproducer, whose principle has long been understood but only recently put into practical use; this is the force of static attraction and repulsion occurring, successively, between two plates upon which the alternating-current sound signal is impressed. No motor is used; but the output of the set is delivered directly to the diaphragm of the speaker, without passing through coils placed in magnetic fields, at all.



MR. COCKADAY, well known to all our readers as a radio authority and publicist, will contribute to each issue of RADIO-CRAFT an article reviewing the latest developments in applied radio, during the coming year. We know that they will be among the most valued features of this magazine.—*Editor.*

Important Service Items

It is advisable, for anyone interested in the problem of radio in the field of servicing work, to follow closely the newer developments which were and are being made in this most difficult branch of radio research and endeavor. There are, probably, more possibilities for improvement in the reproducing apparatus than in any other phase of radio-receiver design. At any rate, the reproducing end of radio is lagging far behind other developments in the receiver, such as circuit work and the adaptation of the new vacuum tubes, tuning systems and power-supply problems.

The newer developments in speaker design are now beginning to come thick and fast, both in this country and abroad, and what is being done in this field should be of striking importance to the Service Man if for no more than what it promises for the simplification and improved quality of the future radio installation, for home use.

In all our loud speakers up to the present we have yet to realize the requirements for a perfectly-driven diaphragm as outlined by Professor W. C. Sabine of Harvard University, a noted authority. This definition gives the moving element "the characteristics of infinite rigidity without mass, freely suspended in air without mechanical friction, tension or stress. Such a diaphragm would have perfect damping; no natural period; no flexural, reflected or standing waves; in other words, no distortion. It would act with a pure plunger, or piston, action." Of course this would be the perfect solution; but it is believed to be almost impossible of realization unless the air could be set in motion, directly, by some ionizing or electrostatic process so far unknown. However, progress is being made, and let us see how the various coming developments are being worked out.

Some of the world's experimenters, along electro-acoustical lines, are working on the idea of the flat-piston reproducer with suitable baffle-board arrangement to give the waves the proper grip on the air. Some others are working on the principle of the taut diaphragm, stretched to a natural

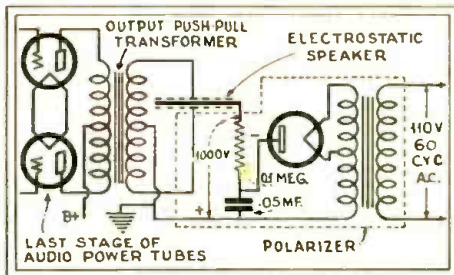

Fig. 2B

The electrostatic speaker illustrated below, as it is used with a push-pull audio output. The high negative voltage is impressed on the diaphragm, which is screened on both sides by plates at ground potential.

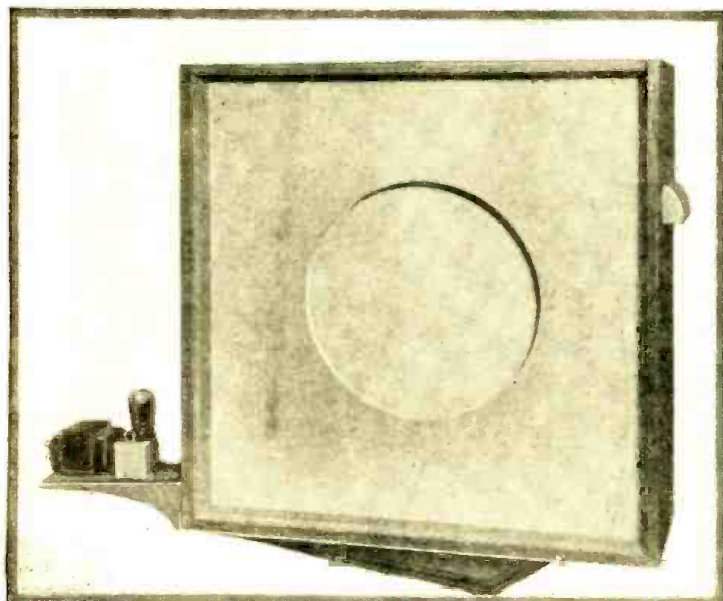

Fig. A

The baffle shown is necessary with the electrostatic speaker, in order to preserve low-note reproduction; it may be a part of the radio console.

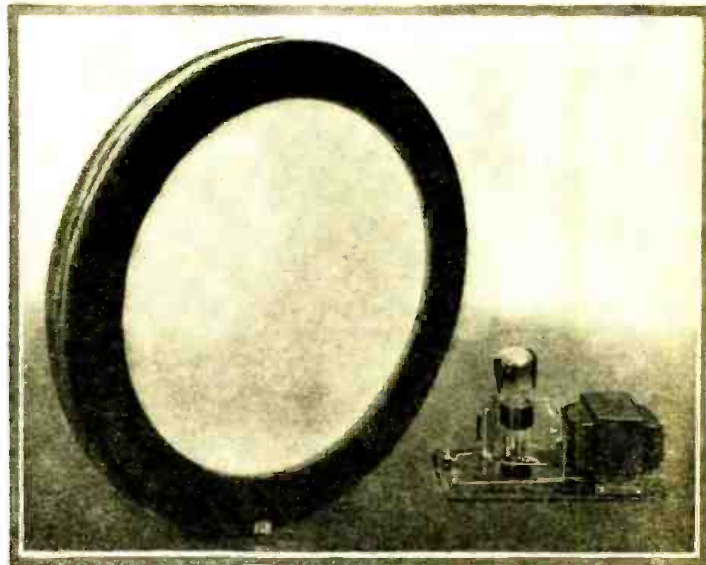

Fig. B

The size of the electrostatic speaker is indicated by the amplifier unit beside it. This device, with suitable connections, becomes a very sensitive condenser microphone which responds with great fidelity to all frequencies which are impressed upon it.

period of vibration well above the highest audible frequency. Some are utilizing the principles of "poly-resonance," based upon the discoveries of Helmholtz. Others have been combining already-known principles to get a newer and better effect.

New French Condenser Speaker

From France comes the development of a new type of electrostatic device, without motor, incorporating "differential" operation. This new speaker uses a tightly stretched diaphragm suspended between two outer discs. The dielectric used is elastic and actually changes shape or thickness when the signal from the amplifier is working into it.

The device was developed in the laboratories of the General Electrostatic Corp. of Paris and is the invention of MM. A. J. Myers and Paul Delattre. As will be noticed from the diagram (Fig. 1) the sound waves are given off through a series of large holes in the outer discs. In the photographs reproduced here (Figs. A, B, C and D) the device shows up as a narrow circular frame, while the moving part or diaphragm is enclosed in a meshed cloth; it is used with a suitable baffle, which may be a part of the cabinet design of the radio receiver with which it is used.

This new speaker is used with a polarizing power unit which supplies the 1000 volts fixed potential necessary for operation. The unit goes well up into the high-frequency end of the audible spectrum, with good reproduction on the lower notes when baffled efficiently. It may be connected to either a standard single-tube output circuit or a push-pull power stage, as shown in Fig. 2.

This device, which is of simple construction, offers a number of advantages over the earlier types of electrostatic speakers and

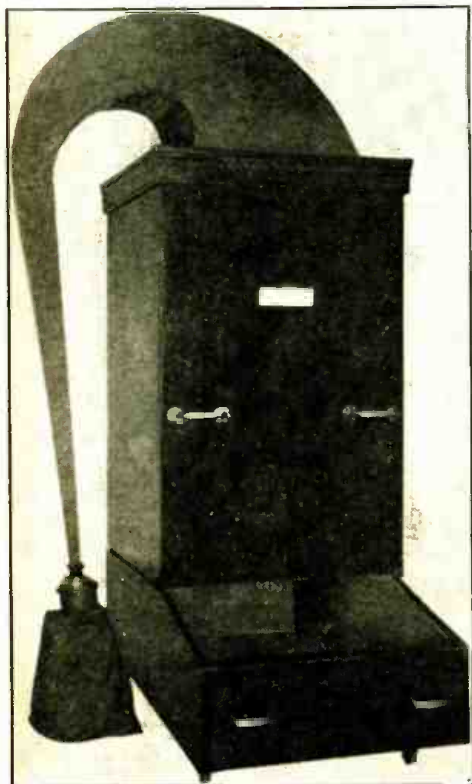

Fig. E

External appearance of the Volf auditorium speaker. The chamber at the bottom is adjustable, to reflect sounds at any desired angle.

may also be used successfully as a condenser microphone. Its future development will undoubtedly make it popular as an outstanding type of its class.

A Unique Development

Another development, which is the outcome of the work of a Danish acoustical worker, Christian A. Volf, Jr., employs the principle of the exponential horn with a poly-resonator and a projection chamber working from a water surface. This device is attracting much attention in acoustical circles for public-address and talking-picture possibilities. It is capable of great volume; and it is claimed that it will greatly simplify reproduction problems in large auditoriums and theaters.

The Volf apparatus is quite large, standing about eight feet high (Fig. E). It works out of the standard type of horn dynamic unit with an exponential air column deflected downward through a series of separately tuned tubes, clearly shown in Fig. F. Bottom

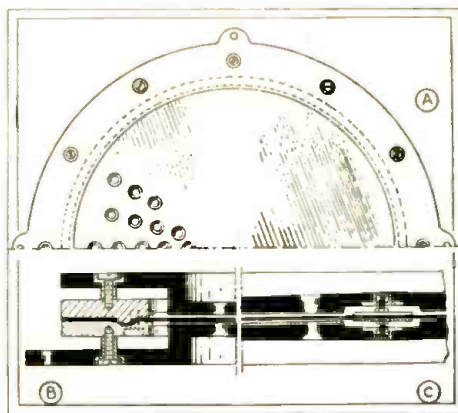

Fig. 1

The Myers-Delattre speaker, showing the perforations of the housing in part. The enlarged cross-sections below show the manner in which the diaphragm (the heavy center line) is suspended.

and side elevations of the tube arrangements are given in Figs. 3 and 4. In this manner, each tube is said to separate its own particular frequency from the rest and cause it to resonate as it is thrown down against the water trough located at the bottom of the cabinet. From here the sound vibrations are projected outwards; and the angle of reflections can be controlled so that it may be redirected to any portions of an auditorium which would, ordinarily, be considered "dead spots."

A series of tests, now being run in theatres, are demonstrating just what there is to this interesting principle and how it may help to overcome what has been found one of the stumbling blocks that have long puzzled and baffled the installation engineer who deals with these large acoustical systems.

The Thomaston Stretched Disc

A powerful reproducer, having a very wide frequency-response from the lowest notes of the organ to the highest harmonics that give quality and character to broadcast sounds of all descriptions, has recently been developed in the Thomaston Laboratories of New York and Thomaston, Conn. It consists of a combination of a disc of large size, made of a very light metal and only a mil or two in thickness, stretched over a heavy steel frame in the form of an offset cartwheel (Fig. G). The diaphragm, tight-

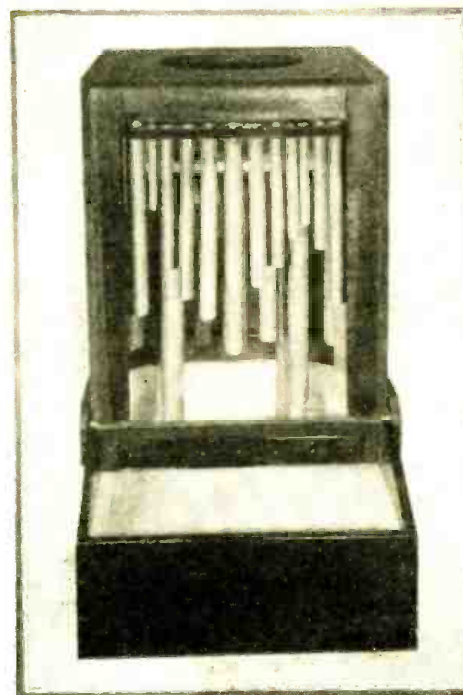

Fig. F

The "poly-resonator" of the Volf speaker opened; plan- and cross-sections will be found on another page. The large exponential horn works into this manifold chamber.

ened to a natural period well above the audible frequency range, approximately 20,000 cycles, resembles a greatly-enlarged condenser diaphragm from a high-quality condenser microphone. For a motor, the new loud speaker employs a new dynamic unit which has a hollow "pot" magnet of the electromagnetic type and externally excited with a potential of six volts D.C. The field windings of this unit are enclosed within the magnetic material of the magnet proper. The unit is contained at the axis of the six spokes of the frame; the moving coil is attached directly to the diaphragm and swings back and forth with the diaphragm, as the signal currents cause it to vibrate in accordance with the interfering magnetic fields of both the coil and the magnet.

This speaker has a flat response with very great volume capabilities and, although the construction is necessarily expensive, further production developments should reduce this cost considerably and give the art a combination of two inherently worthwhile principles in a new instrument of still improved characteristics.

In a recent test of this instrument, I was surprised at the depth in frequency to which it would respond without the familiar booming rendition so common to over-accentuated bass resonance in many types of speakers now being used. A pure sine-wave 60-cycle tone was played with high efficiency on this device, without the production of harmonics; and high frequencies were reproduced with less attenuation than with the regular contemporary dynamic-cone speakers now on the market.

Modern Horn Baffles

I would like to mention one more development, which is not exactly a loud speaker but combines the characteristics of both the horn and the baffle board in a new form of projector, designed for attachment to a
(Continued on page 593)

New Radio Devices for Shop and Home

In this department are reviewed commercial products of most recent interest. Manufacturers are requested to submit descriptions of forthcoming developments.

THE AUTOMOBILE-TYPE REPRODUCER

By W. L. Woolf

Directing Engineer, Amplion Radio Corp.

NOW that the automobile has adopted radio, the loud-speaker manufacturer has been on the job to adapt his product to automobiles. The dynamic type so popular at the present time because of its excellent range and tone quality requires an extra supply of direct current to excite the field, thus adding an additional load to the storage battery; it is unduly heavy, requiring very heavy fittings to strap its mass securely to a rapidly-vibrating tonneau; and it is not extremely sensitive. Since the compactness and low current consumption required in an automobile receiver allow it no volume to spare (if it is to be operated below the point of objectionable distortion), while good engineering can, and no doubt will, adapt the dynamic speaker to motor use, it is a task the accomplishment of which it yet to be announced.

The first speaker to find its way into cars was the magnetic horn; which is both light and efficient; though good quality is obtainable only when the horn employed is much larger than that for which space is available in a car.

The magnetic cone, which holds the lead in automobile installations to date, is light-weight, compact, efficient, and requires no field-excitation current. With careful design, it has been found, efficiency, volume, wide frequency-range and excellent quality can be produced from a magnetic cone with a base six inches in diameter, while not more than 3 7/8 inches in depth are required.

The manner in which one well-known automobile manufacturer uses this speaker is shown herewith. The case is octagonal, nine inches across and three and a half inches deep. The weight of speaker and case is approximately 2 1/2 pounds. The motor, which is itself very compact, is housed within the cone and mounted on an aluminum bar. A very light armature, restoring spring, and drive-rod, constitute the only vibrating parts in addition to the cone.

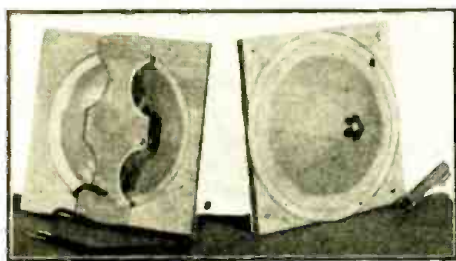

Fig. A

The size of this "automotive" speaker is shown by the pen at the right. A low-frequency baffle is formed by the sides and partitions of the car in which it is installed.

Vibration, shaking and dropping tests prove the speaker to be very rigid. Its light components are less inclined to pull away from their moorings under vibration than speakers made of heavier parts.

Efficiency tests show that, with a two-stage A.F. amplifier employing either a '12A or '71A tube on 180 volts, the speaker gives satisfactory volume.

A good automobile speaker must reproduce high frequencies efficiently if speech is to be distinct and natural, or if one would distinguish clearly the characteristics of high-pitched instruments. For when the speaker is placed under the dash-board the reproduction is highly muffled, since a "sound chamber" with a natural low frequency period is produced by the front portion of the car, unless special precautions are taken. This "sound chamber" consists of rubber-covered floor boards, leather sides, upholstered seat and padded top, a combination of circumstances which naturally absorbs the high notes.

Thus, while much remains to be done, much has been accomplished toward producing a speaker that meets the requirements of automobile use with respect to size, weight, durability, efficiency, frequency range and tonal quality.

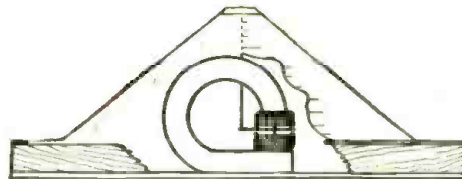

Fig. 1

A cross-section of the speaker shown in Fig. A reveals the compactness obtained by the method of mounting the driving unit.

"MICALEX"-INSULATED CONDENSERS

THE laboratories of National Company, Inc., Malden, Mass. have developed a new line of efficient variable condensers which employ a new insulator, a mixture of ground mica and lead borate, compressed at high temperature under five tons-per-square-inch pressure. At 50 meters the dielectric

Fig. C

The new tube checker shown at the right is a precision instrument, suitable for laboratory work, as well as for servicing organizations and others who have to check and match tubes. It contains a new-type transformer which insures a constant voltage supply from A.C. lines.

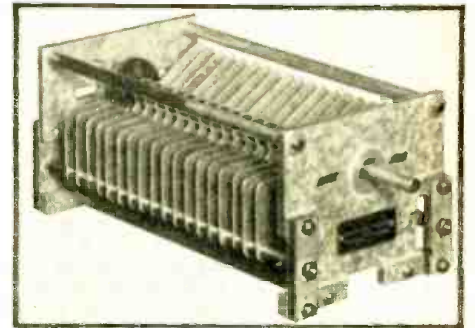

Fig. B

The widely-spaced condenser shown above, which is designed for transmitting under high voltages, employs a new low-loss dielectric.

losses are but a small fraction of those with glass or porcelain (quartz has lower losses but is more brittle).

Type TMU condensers, "Micalex" insulated (through R.C.A. agreement), are designed to meet the demand for a moderate-priced stock transmitting condenser for higher-powered work than the "DXT" permits; yet smaller than the Navy Type.

A 3/8-in. shaft rotates in conical and ball bearings, machined with the cast aluminum end plates. The high-current-capacity rotor contact brush used has low impedance at high frequencies. Both rotor and stator plates have rounded and polished edges.

NEW SUPREME TUBE TESTER

THE Supreme Instruments Corporation of Greenwood, Mississippi, announces the "Model 50" tube tester, a precision instrument especially designed for particular value to the testing laboratory, higher grade service station and large dealers and distributors, for checking returned tubes. It will also find a most extensive field in checking and matching tubes for address systems and sound pictures.

The unit is self-contained and requires no batteries, drawing its supply from any 60-cycle, 110-volt A.C. line. A unique feature



of great value is the constant-voltage transformer with which the instrument is equipped, manufactured under license from the Ward Leonard Electric Company. (This is an entirely new development which maintains a constant output, irrespective of load, within the limits of the transformer. By this means the output is maintained at fixed predetermined voltages, drawing on input line supply, ranging from 100 to 130 volts, and keeping all readings constant irrespective of line fluctuations).

Two testing sockets are provided to take care of all four-prong and five-prong tubes, including screen-grid tubes. By means of a voltage-selector switch, filament voltages 1.1, 1.5, 2.5, 3.2, 5 and 7.5 may be applied to either of these testing sockets.

An indication of the amplification factor is obtained by a direct reading on a dial; and the mutual-conductance indication in like manner on a separate dial. A gas test is made by pressing a button, obtaining a direct indication of the gas content. The emission qualities are ascertained by pressing a button, securing a direct reading on the meter.

By pressing a button, a direct reading is secured also from the second plate of full-wave thermionic rectifier tubes.

The instrument is equipped with the highest standards of laboratory instruments; the assembly being contained in a hand polished case made of selected black walnut, surmounted with a 3/8-inch bakelite panel which carries the motor, testing sockets and operating switches and dials. Rugged construction is employed in the assembly. The size is 7-5/16 x 10-9/16 x 5-1/8 inches, and the weight approximately 14 pounds.

FIXED R.F. TRANSFORMERS

TO the older experimenter "Duratran" will recall an R.F. transformer that was famous a few years ago. The new unit

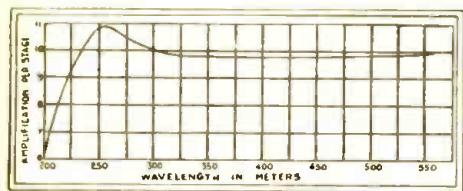

Fig. 2

The very flat "characteristic" of the new fixed R.F. transformer for screen-grid tubes.

of that name, designed especially for complying type '22 or '24 screen-grid tubes, bids fair to attract as much favorable attention as the old unit for use with '01A tubes.

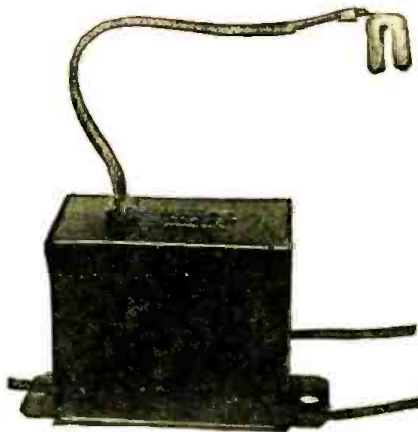

Fig. D

The screen-grid "Duratran," complete with its clip for the tube to which it is coupled.

For instance, substituting this fixed R.F. transformer in the "1930 Electric Receiver" described in the November, 1929, issue of RADIO-CRAFT, will considerably increase the volume obtainable from this exceptionally fine set. The commercial use of fixed R.F. transformers also has been shown in Data Sheets in past issues of RADIO-CRAFT. The characteristic curve of the screen-grid "Duratran" indicates that with 135 volts on the plate, 88 volts on the screen-grid and 2 volts, (negative) on the control-grid a high degree of amplification per stage may be expected throughout a wavelength range 200 to 550 meters; a rising characteristic being shown at 250 meters and an appreciable falling off at wavelengths below 230 meters.

The unit measures 1 5-16-in. x 1 5-16-in. x 3 in. overall. Four leads, six inches long, are provided for connection to the circuit; the screen-grid lead being shielded. The core consists of L-shaped laminations of special "R.F. iron" .002-in. thick. The metal case of the device constitutes a complete shield.

By the use of adequate shielding, four stages of amplification, requiring four of these fixed units, may be used. The gain per stage is said to be about one-half that of an efficient tuned R.F. design; while all tuning is preferably at the input and in the form of a hand selector. If a simple loop set is desired, no other tuning than that afforded by the loop and tuning condenser is ordinarily required.

AUTOMOBILE INTERFERENCE REDUCERS

THERE is now available, for the man who would have radio while he motors, an aid toward reduction of the "static" interference caused by spark plugs, in the form of a special, sturdy 25,000-ohm "Automobile Resistor" made by The Allen Bradley Co., Milwaukee, Wis.

One unit is required for each of the high-voltage leads to the spark plugs; thus, connecting 25,000 ohms in series. The convenient manner in which this is accomplished is illustrated herewith (Additional effectiveness is obtained by connecting another unit in the main high-voltage lead, as shown).

The action of the resistor is to "damp" the oscillations that follow the initial igniting spark. It is said that dynamometer tests indicate that the power output of engines is unaffected; and cold-weather starting is not affected by this procedure. When used in other parts of a radio installation and by-passed the resistors form effective filters, and may be used to reduce radio interference wherever spark plugs are used.

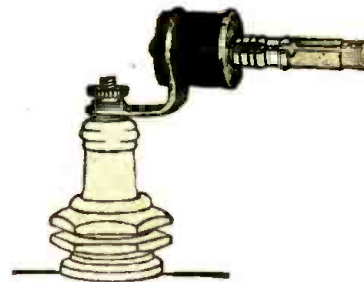
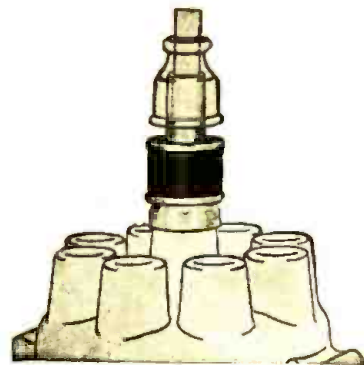

Fig. E (above) Fig. F (below)

The need of interference suppressors on a car equipped with radio is met by such devices as this. Above, an "automobile resistor" is shown in the main ignition lead; below, one connected to an individual spark plug.

How to Start An Anti-Noise Organization

WE are cursed here with myriads of howls, roars, growls, squeals, hisses, etc., etc. There has been no concerted action taken, up to this time, to overcome this combination of waste and petty annoyances.

I have chased down several bad cases of radio interference in this locality. However, no one paid me for my trouble, or even thanked me, for that matter. The owner of the offending electrical noise maker usually seemed to feel that I was assuming too much responsibility in hunting down his "pet," and asking him to spend some money on it. He wondered why I picked on him when the power lines, rail-

road shops, old battery-operated receivers and other sources of disturbance continued to make din and roar unmolested.

I am writing you for information concerning the methods of organization and operation followed by listeners' clubs.

I am in the radio game to make a profit, naturally. It seems to me that backed by an organization of some kind, I could render a real service, which would be worth dollars and cents to the radio listening public in this vicinity. Would you be willing to give me some helpful ideas along this line?

R. H. JENSEN,
Green River, Wyoming.

(While the nucleus of every radio club must be one or more men who are willing to give some time and enthusiasm to cleaning up local conditions, once the ball has been set rolling, it should gather support from all set owners. Manufacturers of interference-suppressing devices will give valuable hints; notably the Tobe Deutschmann Co. of Canton, Mass., which has been doing very extensive work along the lines of organization against interference. We will be glad to hear from radio listener's clubs as to their success in dealing with the conditions Mr. Jensen describes.—Editor.)

Automotive Radio Grows in Efficiency

New developments in receiver and antenna systems add to the effective sensitivity and quality obtainable en route. The receiver described incorporates late advances on previous automotive radio design.



Fig. A

The position of the Bosch radio control unit is shown at the right of a standard auto instrument panel. The knobs are tuning and volume controls.

MOTOR-CAR radio, or "automotive radio," as it is now known, is rapidly coming to the fore. Indications are that the summer of 1930 will find thousands of cars of standard make factory-equipped with radio receiving sets that closely approach the average home receiver in volume, sensitivity and quality. As emphasized in the articles on automotive radio that have appeared in past issues of RADIO-CRAFT, it is necessary to consider the installation and servicing of these special automobile radio sets as a distinct branch of the radio art; and one that is

receiver pictured in these columns. The finer details of design and construction are too numerous to be described in this article, but will be explained in detail in forthcoming stories.

housed in the control unit. A balanced-armature magnetic-type reproducer with a 6-inch cone has been developed for this set; a baffle effect is obtained through mounting the reproducer, in its metal housing, on the chassis of the receiver. The reproducer is "pitched" with particular regard to the requirements of the interior of cars and the usual noises of a car in motion.

To the technician the schematic circuit of this receiver, shown in these columns, presents many points for conjecture. Probably the first will be that some form of generator or converter is required to supply alternating current for the filaments, as well

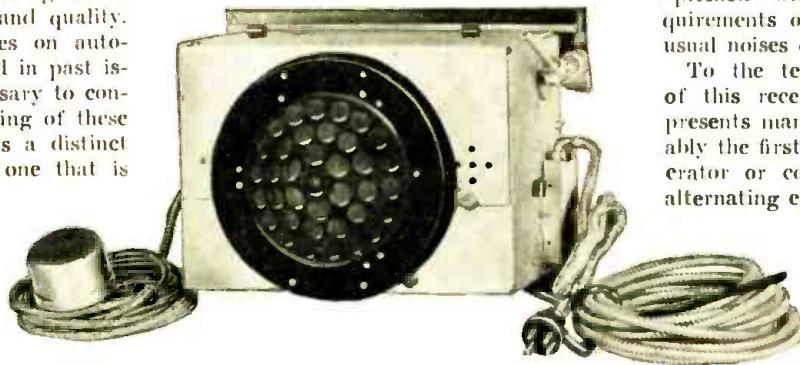

Fig. B

The extension at the left of the Bosch automotive receiver, shown here, is the R.F. transmission line, ending in the pickup device which takes the signal from the "earth capacitor." The battery cable is opposite.

On the upper right side of the receiver chassis is the tube which receives the flexible shaft from the control unit and rotates the condensers. The reproducer shown is connected to the front of the shield can, which lifts off with it.

opening up an entirely new service technique apart from past service work. The successful, and well-paid, automotive radio Service Man must possess a high degree of specialized knowledge involving automobile mechanics and radio technicalities.

Another evidence of the activity in automotive radio is the new Bosch motor car

Sponge-rubber mountings are provided to support the receiver chassis in position behind the instrument board. A steel shaft with universal joints couples the tuning-knob control unit (shown in the reproduced photograph) to the shaft of the ganged tuning condensers. The off-on key-switch, fuse, pilot light and volume control also are

as "B" and "C" potentials for the type '24 A.C. tubes. The answer is that the set is entirely battery-operated; the '24s are used in preference to '22s to obviate a condition of noisy reception due to fluctuating "A" potential as battery load and engine speed vary. True it is that considerable current is drawn from the storage battery; but there is no more difficulty in following this design than in planning the current supply for any other power requirement; the hardest thing to overcome is the mental inertia of custom against the fact that the storage battery is perfectly suited to the requirements. The maximum "B" potential required for this set is obtained from a bank of "B" batteries that delivers 180 volts.

Two outstanding technical advances in car radio are noted in an "earth capacitor," as Bosch engineers call it (this is a plate, insulated from the chassis but slung thereunder, which functions as the signal pick-up or antenna) and an "R.F. transmission line" which connects the earth capacitor to the set.

Further values for parts used in the Bosch screen-grid radio set are as follows: R1, 18,000 ohms (variable bias for the control grids of tubes V1, V2 and V3); R2, 500 ohms; R3, 25,000 ohms; R4, 500,000 ohms; R5, 500,000 ohms; R6, 2 megs.; R7, 250,000; R8, 1.3 ohms; R9, 1.1 ohms; R10, 1,000 ohms; C5, C6, C8, C9, 0.5-mf.; C10, C11, 0.0001-mf.; C12, 0.002-mf.; C13, 1-mf.

We invite criticism, comment and suggestion on the subject of automotive radio. Service Men will find RADIO-CRAFT a clearing house for technical difficulties in this field.

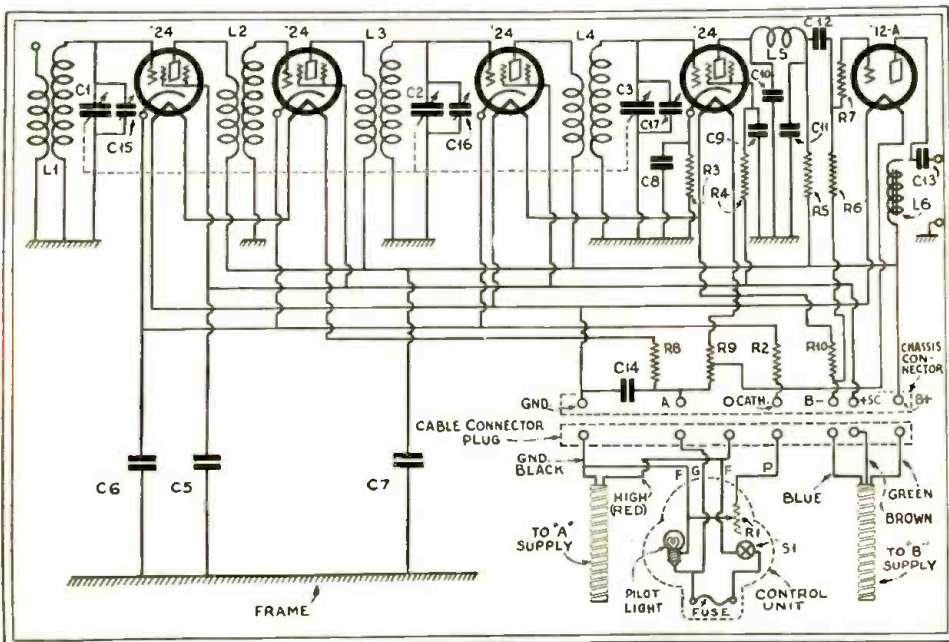

Fig. 1

The schematic circuit of the Bosch Motor Car Radio receiver, made by the American Bosch Magneto Corp.; it includes four tuned-input, battery-operated, '24-type screen grid tubes, as R.F. and detector stages, and a single audio output tube, operating the built-on magnetic speaker.

SHORT WAVE CRAFT

A New Revolutionary Short-Wave Receiver

AUTOMATIC waveband shifting, obtained by the ingenious system of variable inductance and capacity units illustrated here, makes it possible to cover a tuning range up to five times the lowest frequency. This invention marks another milestone in the development of short-wave radio to the stage where it will be convenient for the public as long-wave broadcast tuning, and consequently of universal commercial value.

By the combination of variometer and dual condenser shown, which was worked out by W. H. Hoffman and D. H. Mix, and has now become available to the experimenter, it is possible to obtain an enormous tuning range by the use of two dials, entirely without the changing of coils which has hitherto been necessary and, with completely-shielded receivers, highly inconvenient.

The first, or "shift-frequency" dial, rotates the shaft designated as L1 in the front view (Fig. A) and operates, as will be seen, one set of plates (C1SF Fig. B) in the peculiar double-rotor condenser which is prominent in all rear views of the unit. By its motions, synchronized with those of the rotors of the coil L1 and the condenser C2A, the desired waveband in which the receiver is to operate is selected.

The second dial, rotating shaft C1R, governs the other set of rotors of the large con-

denser; and thereby selects stations in the waveband to which the set is adjusted by the first dial. The shift-frequency dial, therefore, does not require continual adjustment; it produces an electrical change equivalent to that obtained, say, by moving a "fan" switch over a bank of condensers. The tuning range thus may be extended, for instance, from a minimum of 20 meters (15,000 kc.) to a maximum wavelength of 100 meters (3,000 kc.). By slipping a switch a built-in, fixed two-inductance coil of greater dimensions may be connected into circuit and higher wavelengths up to 200 meters may be then tuned in; a larger inductance unit would raise this maximum still more. (Fig. 5.)

New Condenser Design

This extraordinary range is obtained by the fact that the variable inductance of the input circuit (the "variometer" shown as L1) is shunted across a variable capacity obtained from two condensers, one of which has an extremely low minimum value because of its unusual design. While one condenser (C2A) is of ordinary low-capacity type, the other has no stators, but two sets of rotors, operated by different dials, and separated completely by a considerable distance when unmeshed. Their position of minimum capacity is shown in Fig. B; Figs.

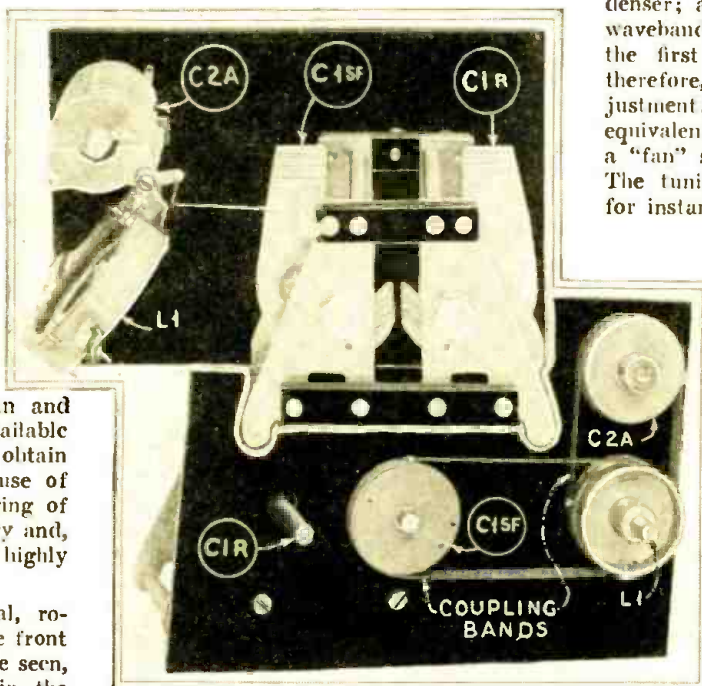

Fig. A (below)
Fig. B (above)

These two views show: below, the front of the new "Automatic Tuner," whose circuit is Fig. 2C; and, above, the components operated by the two controls, as they appear in the position of minimum setting (compare Fig. C) corresponding to a wavelength of from 15.25 up, as determined by the circuit and tube used.

has an extremely low minimum value because of its unusual design. While one condenser (C2A) is of ordinary low-capacity type, the other has no stators, but two sets of rotors, operated by different dials, and separated completely by a considerable distance when unmeshed. Their position of minimum capacity is shown in Fig. B; Figs.

The Dawn of a New Short-Wave Era

WE are happy to present to our readers one of the greatest (if not the greatest) recent developments in the evolution of short-wave receivers.

Heretofore short waves were a sealed book to the public, because of the inability of the average man to tune a short-wave set. It took an expert to tune such a set successfully, and even he would frequently pass over many stations.

Imagine the following:

Take a wide rubber band and place across it a number of fine lines very close to each other—so close in fact that your eye can no longer separate them. This corresponds to the tuning dials of short-wave sets before the advent of this new tuner.

Now take the same rubber band and stretch it to about ten times its original length. Immediately, the former lines which ran into each other become widely separated and can easily be distinguished. A corresponding separation of stations is the accomplishment of the new short-wave receiver presented in this article.

It becomes now possible for anyone to tune-in on the short waves, just as easily as he tunes-in on his broadcast set.

No more passing over stations because the tuning, unbelievable as it seems, is so broad on one of the dials that it is well-

nigh impossible to go over any station that comes in with any amount of audibility.

Nor is this all:

The second and greatest objection to short-wave receiving, at the present time, is the plug-in coil bugaboo. Heretofore, the average short-wave set has required at least four such coils to take in a range from 16 to 200 meters.

With the new receiver this is a thing of the past. In the new tuning unit described here, no plug-in coils whatsoever are used, yet the range of the set can be made from 16 to 200 meters.

It is certain that this evolutionary accomplishment will make it possible to interest the public at large in short waves, just as broadcasting in 1921 created a wave of immediate popular enthusiasm.

No doubt, as time goes on, the present system will be improved, until it will take in all short waves from 3 meters up; and in years to come we will have a single-dial short-wave set of this range as well.

But the important point is that radio has taken a big leap forward, once more, and the seemingly impossible has been accomplished.

C and D and Fig. 1 at A, B, and C illustrate increased degrees of meshing at different adjustments, until a maximum is seen in Fig. E. Here the plates mesh to the extent of the largest shaded area in Fig. 1C.

By reference to Fig. A, it will be seen that a system of belts, such as are used in well-known makes of single-dial broadcast receivers, enables the right-hand dial (which we will call the "shift-frequency dial") to turn, not only the movable plates C1SF of the double condenser, but also the rotors of the variometer L1 to the shaft of which it is directly attached, and the standard 135-mmf. variable condenser C2A. The left-hand dial, on the other hand, turns only the

set of plates C1R, and thereby, in effect, produces a vernier effect over the widened frequency-range. This dial, therefore, we shall call the "station selector."

Now that the somewhat intricate mechanical arrangement of this tuning unit has been considered, and found to be a combination of old and new elements to produce a system that is quite new, we may consider the electrical actions brought about by their interaction under their dual controls.

A Fundamental Circuit

Before we come to the application of the unit, let us consider a typical regen-

erative circuit, such as that shown at A in Fig. 2. Coils L1 and L2, of fixed inductance, may constitute the tuned "secondary" (grid) and the tickler (plate) windings and, in short-wave sets, are usually wound on one plug-in form. C1 is the standard variable tuning condenser, of any convenient design and capacity. In most short-wave receivers an aerial coupling condenser, C2B, is required to prevent direct conductive connection of L1 with the aerial; for the latter would introduce a high damping effect, and cause erratic tuning and regeneration. Often this condenser (C2B) is connected to a tap on the tuned coil (as at L.A) when a particularly long aerial is be-

In Fig. 1, at the right, we see represented the effects of the dial settings pictured below. Fig. C (upper left) corresponds to Fig. 1A: the inductance and capacity controlled by the "shift-frequency" dial are at a minimum: consequently, the very small capacity change permitted by the tuning dial gives a sufficiently wide station channel. (The plates of the tuning rotor are between positions R1A and R2A.)

In Fig. D, as shown also by Fig. 1B, at the middle of "shift" dial's range, the tuning dial also effects a correspondingly great capacity variation, with a frequency-band no wider. (Position R3B)

In Fig. E the "shift" dial is at maximum, and, since the tuning dial is also at 100, we have the top of the wavelength range. (This is position R3C in Fig. 1C.)

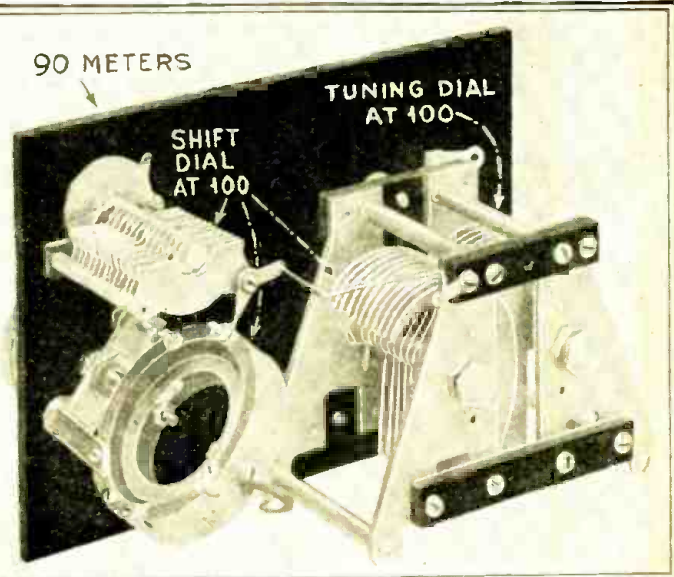
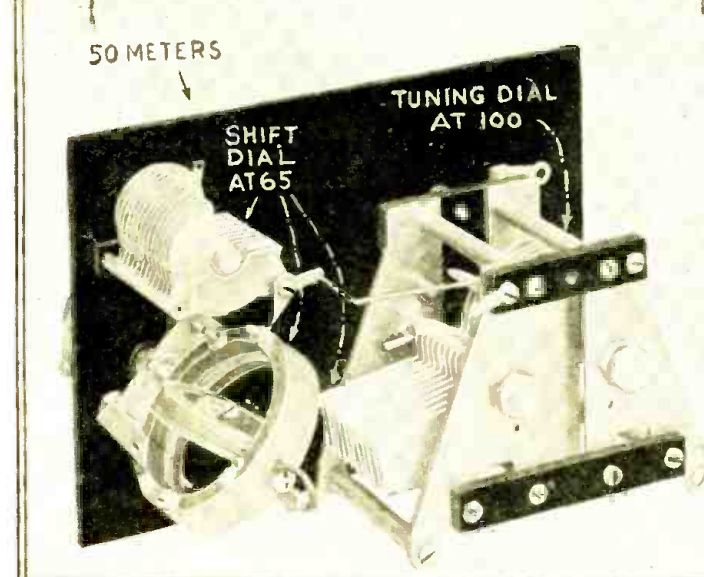
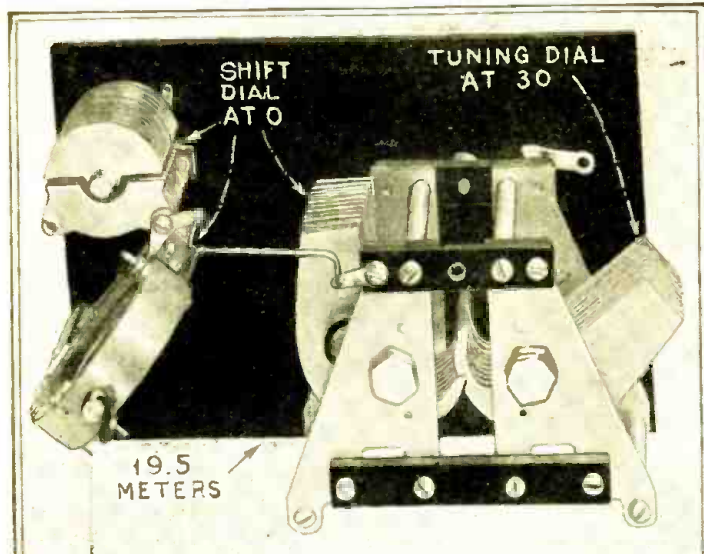
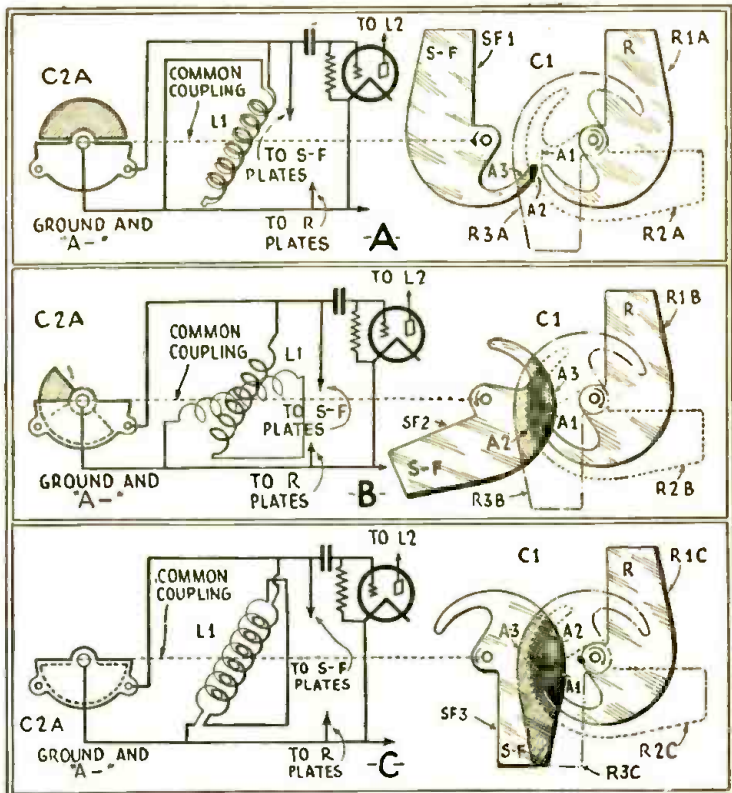

Fig. C (upper left)

Fig. D (lower left)

Fig. E (lower right)

The upper tuning condenser, the variometer rotor, and one set of plates of the large condenser are turned together by the shift dial, and left at any setting which the operator desires. This determines the band, say 1500 kilocycles wide, which the tuning dial covers over its full scale. The actual minimum and maximum, and consequently the calibration of the receiver (see Fig. 3, page 574), are determined by the hookup and the characteristics of the tube used. (Photos courtesy Aero Products, Inc.)

ing used; its capacity is best determined by trial. For short-wave work a variable of 135-mmf. maximum capacity may generally be recommended. For short-wave reception, the grid condenser C4A may have a capacity of .00015-mf. or 150 mmf.; the grid leak, for this work, has usually a resistance between the values of 3 and 10 megohms. Whether the grid leak should return to the positive or negative side of the filament circuit depends upon the characteristics of the tube V1, used as a detector. All simple short-wave receivers follow the general lines of this fundamental design.

Yet it is possible to tune-in different stations without resort to a variable condenser. Tuning-in is changing the resonance-peak, or fundamental frequency of the circuit, to correspond with that of the received wave. The formula for determining a circuit's frequency shows that this is inversely proportional to the square root of the product of the capacity by the inductance. In other words, whether we vary the inductance or the capacity, we affect equally the frequency and wavelength of the circuit. Therefore, in place of a variable condenser, a variometer may be used.

To explain this instrument, it may be said that when two coils, connected in series, are placed in such inductive relation that their magnetic fields act in the same direction, they "aid" each other, and the inductance of the combination is at a maximum. By changing their relation to each other, the fields are made to "oppose" or "buck"; and the inductance will be then at a minimum. The variometer is commonly made by rotating one winding within—and very close to—the other; and was a familiar device in the early days of radio.

A circuit arrangement whereby tuning is accomplished by substituting a variometer L1 in place of the L1-C1 combination, is given in Fig. 2 at B; the wavelength range remains the same.

The "Automatic" Tuner

Now, let us add a variable condenser across the variometer L1; in fact, let's add two variable condensers in shunt with this inductance. We thus rearrange the circuit as at C in Fig. 2. Two variable condensers (C1 and C2A) are used to obtain the desired tuning range in the most satisfactory manner, for a reason to be explained below.

In Fig. 2, at B and C, regeneration is obtained through the use of L2, a feed-back or tickler winding placed over the stator-coil of the variometer, L1. In the tuning unit pictured, the stator tube of the variom-

eter, 1 7/8 in. in diameter, is wound with 4 3/4 turns of No. 24 D.S.C. wire, and the rotor, 1 11/16 in. in diameter, with 4 1/2 turns of the same wire. The tickler inductance consists of 5 turns of No. 28 D.S.C. wire.

(It is convenient to indicate here the new design for condenser C1, with its non-stator and two-rotor construction, by two arrowheads instead of only one.)

The dotted lines at C (Fig. 2) show that variometer L1, the "shift-frequency" or SF half of the variable condenser C1, and the 135-mmf. variable condenser C2A are

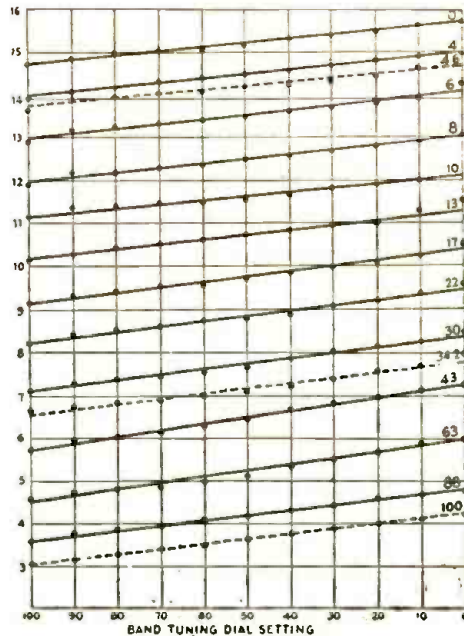

Fig. 3

This log shows how completely the short-wave bands may be covered. Each heavy sloping line represents the tuning range obtained with the "station selector" at one setting of the "shift-frequency" dial; the latter may be set, however, to give any intermediate range. (From QST)

ganged together and operated by one dial; while the other dial controls the other rotor section R of C1, for station selection.

Turning the master dial (controlling C1SF, L1, and C2A) determines where, in the range between approximately 15 meters and 100 meters, stations may be tuned in. A wavelength frequency table for the tuning components described above is given herewith.

On a panel about 8 1/2 in. x 5 in., an "Automatic Tuner" may be built comprising only L1, C1 and C2A, to tune approximately as follows (the degrees indicate the settings of the shift dial):

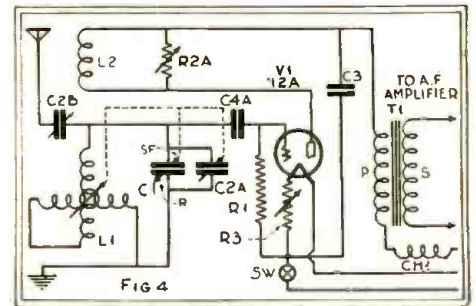

In this diagram, the simplest method of connecting the Automatic Tuner unit for short-wave reception; the details of the audio amplifier are purely optional.

S. D. Degrees	Wavelength Meters	Frequency Kilocycles
0	15.25—16.2	19672—18519
3	15.7 — 17.0	19048—17647
5	16.5 — 18.5	18182—16216
7	17.6 — 19.9	17045—15075
9	19.1 — 22.6	15707—13274
13	21.9 — 25.7	13699—11673
18	25 — 29.5	12000—10169
24	28.25—34.1	10619—8800
32	32.9 — 40.5	9120—7407
45	39.4 — 50.5	7610—5941
65	48.7 — 65.	6160—4615
85	59.3 — 79.	5059—3797
100	69.7 —100	4304—3000

Tuning Made Even

A major difficulty, in the design and operation of short-wave sets, has been the manner of tuning to stations at extremes of the range for which the receiver is designed. If stations are not crowded on the dial at the adjustments for the higher frequencies, it is usually found the low-frequency stations are not logged close enough on the dial for convenient searching. In the new tuning unit this lugaboo no longer exists; for the tuning dial cannot cover much more than 1,500 kc. at any setting of the shift-frequency dial. This is clearly shown in Fig. 3. Settings for the shift frequency or SF dial appear at the right of the vertical scale (the circuit's resonance-frequency is given at the left in megacycles); while settings for the tuning dial, controlling C1R through a 1,500 kc. swing, are shown along the base-line. Although a simple variometer and condenser design will not show a straight-line characteristic, the graph indicates that a remarkably flat one is obtained.

Just how it is possible for control C1R to tune the circuit through only 1,500 kc. becomes very evident upon carefully studying Fig. 1. The positions taken by rotors of the three instruments, for different settings of the dials, are approximately equivalent to those illustrated by the photographic reproductions, Figs. C, D, and E.

We have C2A, L1, SF represented as set for the lowest wave-band in Fig. 1A; the lowest wavelength in this band is then obtained with R set at R1A (the plates of SF and R being spaced the distance indicated as A1). Advancing R to position R2A meshes the 21 plates of SF and R over the area A2; and the balance of the 1,500-ke. tuning is accomplished with R turned to position R3A (SF- and R-plates are meshed for the area A3). All this time C2A and L1 have not changed position; but

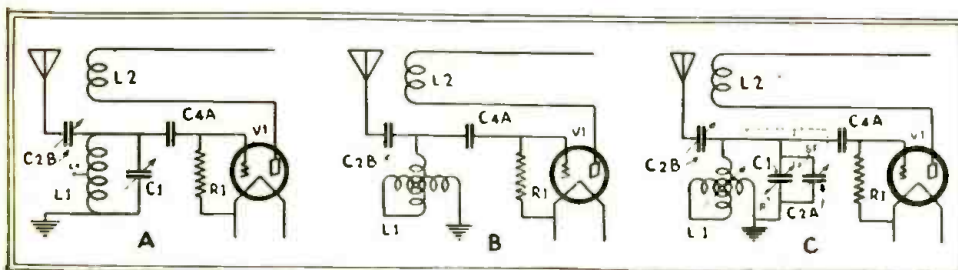
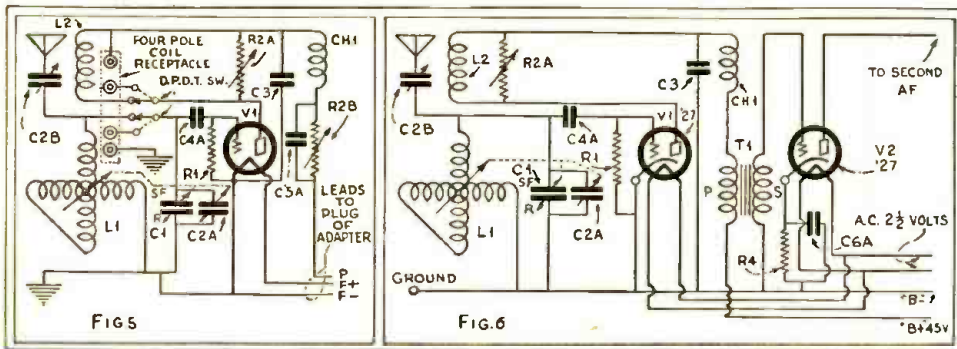

Fig. 2

The first two diagrams show the variable-condenser tuning method which is now usual, and the variometer much used in long-wave sets in the old days. By combining the two, we arrive at the much more finely-adjustable system indicated at C; which is the heart of the short-wave "Automatic Tuner" illustrated on the two preceding pages.



At the left, the circuit of an adapter constructed with the "Automatic Tuner" for use with the audio channel of a broadcast receiver. A plug-in receptacle is provided for a 100-200 meter coil, switched in when desired. At the right, a short-wave receiver, using the same tuner, with one or two A.F. stages as desired.

the maximum frequency established by the self- and distributed-capacities and inductances of all the instruments and the wiring has been diminished through a band of only 1,500 kc.

After we have scoured this first tuning-band (which is only about one meter wide at about 19 meters) SF is shifted to a position SF2, a considerably higher wavelength-band, as shown in Fig. 1B; and the 1,500-kc. tuning process is repeated by obtaining mesh-areas A1, A2 and A3 through turning R to positions R1B, R2B and R3B. (Thus deriving a tuning band from about 50 meters to about 65 meters.)

Fig. 1C is a repetition of this procedure, with SF at 100.

Alternate Circuit Arrangements

A better idea of the manner in which the "Automatic Tuner" may be wired into a circuit may be had from Fig. 4, which shows a simple one-tube circuit, in which regeneration is controlled by the variable resistor R2A. For code reception, greater selectivity to a single tone is obtained by using a very high-ratio, or else a "tuned," transformer at T1.

An adapter is readily made by following a different circuit. (See Fig. 5.) Condensers C1 and C2A may be connected to a regular solenoid inductor of the plug-in type (a convenience for 200- to 550-meter tuning) if desired, instead of L1 and L2, by wiring the usual coil-receptacle as shown in the diagram; a low-capacity D.P.D.T. switch changes the connections. The rotor of L1 will continue to turn as before.

Of course, the fundamental ideas in the circuit of this adapter may be adapted to any other amplifier or detector arrange-

ment. The approximate wavelength range afforded by the longer-wave inductance unit (which may be arranged either as a plug-in unit or permanently wired in) is given in the following table:

S. D. Degrees	Wavelength Meters	Frequency Kilocycles
0	88—92	3410—3265
16	92—115	3265—2610
33	115—146	2610—2050
60	146—185	2050—1620
100	185—204	1620—1460

The schematic circuit for an easily-built A.C. short-wave receiver using the "Automatic Tuner" is Fig. 6; any A.F. channel design may be followed.

Use of a Screen-Grid Coupler

The question, whether a stage of screen-grid amplification really improves reception at the shorter wavelengths (higher frequencies) is still a good starting point, in short-wave circles, for some hot pros and cons. Yet (and with no desire to cause any casualties) the diagram shown in Fig. 7 is proposed. When the best results are obtained from this wiring arrangement, chokes Ch1 and Ch2 will be found to have different constants from Ch3. Whether R1 will be required depends considerably on the insulation-resistance of C4A. The use of R8 is recommended where smooth control of regeneration is found difficult to obtain. Tubes of different types should be tried in position V1. The idea of regeneration control by using R2 may be retained, unless the experimenter has a different preference. Even though the input be untuned, the use of a blocking-tube V4 is recommended.

Shielding the set is not recommended, in ordinary locations; unless a second Automatic Tuner is used, to tune the input of V4 and increase its selectivity and amplification. Without this, shielding may cause broadening of tuning or loss of sensitivity. The idea of two stages so tuned is still experimental.

Preceding the new tuning unit with such a tube may alter the tuning slightly, as the following table shows:

S. D. Degrees	Wavelength Meters	Frequency Kilocycles
0	19.00—20.35	14750—15750
4	20.00—21.42	15000—14000
6	21.05—23.07	14250—13000
8	23.07—25.00	13000—12000
10	24.00—26.65	12250—11250
13	26.65—29.90	11250—10125
17	28.55—32.86	10500—9125
22	31.56—36.34	9500—8250
30	35.25—42.58	8500—7125
43	41.35—52.14	7250—5750
63	49.97—66.63	6000—4500
88	63.62—83.28	4750—3600
100	70.59—99.94	4250—3000

An A.C. 4-tube short-wave receiver is shown in Fig. 8; a circuit variation worth special mention is the manner of connecting the return leads of the Automatic Tuner (L1, C1, C2A) to a point of low potential. This will reduce hand-capacity effects.

The following constants are suggested for the various circuits that appear in this article:

C1, 150 mmf.; C2A, C2B, 135 mmf., variable; C3, .0005-mf.; C4A, C4B, .00015-mf.; C5A, C5B, 1.0 mf.; C6A, C6B, C6C, C6D, C6E, C6F, C6G, .002-mf.; R1, 10 megs.; R2A, R2B, 10,000 ohms ("Bradleyohms"); R3, 20 ohms; R4, 600 ohms; R5, 15 ohms; R6 2-tube ballast; R7, 100,000 ohms; R8, 400 ohms; R9, 2,000 ohms. Ch1, Ch2, Aero No. C-60 low-impedance R.F. chokes; Ch3, Aero No. 65 high-impedance R.F. choke. L1-L2, special short-wave variometer (described in text). T1, T2, Aero AE-300 (peaked for code reception), or Thordarson R300 (for phone reception) A.F. transformers.

In Fig. 5 is shown the use of a panel-mounted (Yaxley No. 760) switch to connect an Aero "INT-104" inductance into circuit to increase the wavelength range to 200 meters.

We shall be glad to hear from experimenters as to their success with this type of construction.

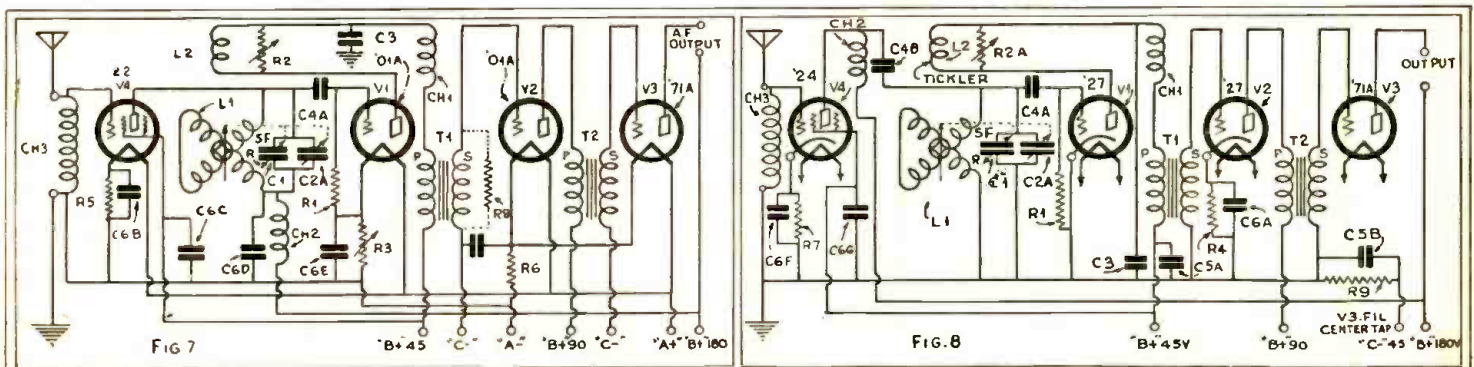

Above, alternative arrangements of four-tube short-wave receivers using the "Automatic Tuner" after an untuned or blocking stage of screen-grid amplification. The latter practice is coming into increasing vogue; as increasing short-wave reception makes it desirable to minimize radiation.

Short-Wave Stations of the World

Meters	Kilo-cycles	Stations
4.97-5.35	60,000-56,000	Amateur Telephony.
8.57	35,000	W2XCU, Ampere, N. J.
12.48	24,000	W6AQ, San Mateo, Calif. (Several experimental stations are authorized to operate on non-exclusive waves of a series, both above this and down to 4 meters.)
13.04	23,000	W2XAW, Schenectady, N. Y.
13.97	21,460	W2XAL, New York.
14.06	21,320	DIV, Nauen, Germany.
14.50	20,680	LSH, Monte Grande, Argentina, after 10:30 p. m. Telephony with Europe. FMB, Tamatave, Madagascar. PMB, Bandoeng, Java.
14.62	20,500	W9XF, Chicago, Ill. (WENR).
14.84	20,200	DGW, Nauen, Germany, 2 to 9 p. m. Telephony to Buenos Aires.
15.03	19,950	LSG, Monte Grande, Argentina, From 9 a. m. to 1 p. m. Telephony to Paris and Nauen (Berlin). DIH, Nauen, Germany.
15.10	19,850	WMI, Deal, N. J.
15.12	19,830	FTD, St. Assise, France.
15.40	19,460	FZU, Tamatave, Madagascar.
15.45	19,400	FRO, FRE, St. Assise, France.
15.50	19,350	Naney, France, 4 to 5 p. m. VKZME, Sydney, Australia.
15.55	19,300	FTM, St. Assise, France, 10 a. m. to noon.
15.60	19,220	WNC, Deal, N. J.
15.85	18,920	XDA, Mexico City, Mex. 12:30 to 2:30 p. m.
15.91	18,850	PLE, Bandoeng, Java, Broadcasts Wed. 8:40 to 10:40 a. m. Telephony with Kootwijk (Amsterdam).
16.10	18,620	GBI, Bouhlin, England, Telephony with Montreal.
16.11	18,610	GBU, Rugby, England.
16.30	18,400	PKK, Kootwijk, Holland, Daily from 1 to 6:30 a. m.
16.35	18,350	WND, Deal Beach, N. J. Transatlantic telephony.
16.38	18,310	GBS, Rugby, England, Telephony with New York, General Postoffice, London. FZS, Saigon, Indo-China, 1 to 3 p. m. Sundays.
16.50	18,170	CGA, Drummondville, Quebec, Canada, Telephony to England, Canadian Marconi Co.
16.54	18,130	GBW, Rugby, England.
16.57	18,120	GBK, Rugby, England.
16.61	18,050	KQJ, Bolinas, Calif.
16.70	17,950	FZU, Tamatave, Madagascar.
16.80	17,850	PLF, Bandoeng, Java ("Radio Malabar"), Works with Holland.
16.82	17,830	PCV, Kootwijk, Holland, 3 to 9 a. m.
16.88	17,770	PHI, Hulzen, Holland, Beam station to Dutch colonies, Broadcasts Mon., Wed., Thurs., Fri. 8 to 11 a. m. N. V. Phillips Radio, Amsterdam.
16.90	17,750	HSIPJ, Bangkok, Siam, 7-9:30 a. m. 1-3 p. m. Sundays.
17.20	17,440	AGC, Nauen, Germany.
17.34	17,300	W2XK, Schenectady, N. Y. Tues., Thurs., Sat. 12 to 5 p. m. General Electric Co. W2XCU, Ampere, N. J. W9XL, Anoka, Minn., and other experimental stations.
18.40	16,300	PCL, Kootwijk, Holland, Works with Bandoeng from 7 a. m. Netherland State Telegraphs. WLO, Lawrence, N. J.
18.56	16,150	GBX, Rugby, England.
18.75	15,990	SXG, Saigon, Indo-China.
18.80	15,950	PLG, Bandoeng, Java, Afternoons.
19.56	15,340	W2XAD, Schenectady, N. Y. Broadcasts Sun. 2:30 to 5:40 p. m., Tues., Thurs. and Sat. noon to 5 p. m., Fri. 2 to 3 p. m.; besides relaying WGY's evening program on Mon. Wed., Fri. and Sat. evenings, General Electric Company.
19.60	15,300	DXV, Lyngby, Denmark, Experimental.
19.63	15,280	W2XE, Jamaica, N. Y.
19.66	15,250	W2XAL, New York, N. Y.
19.70	15,220	W8XF (KDKA) Pittsburgh, Pa. 4:30 p. m. on; Saturday from 6. Sundays, entire program.
19.99	15,000	CMGX, Central Tulum, Cuba. LSI, Monte Grande, Argentina.
20.00	14,990	TFZSH, Iceland.
20.80	14,420	VPD, Suva, Fiji Islands.
20.90	14,340	G2NM, Caterham, England.
20.97-21.26	14,300-14,100	Amateur Telephony.
22.20	13,500	Vienna, Austria.
22.38	13,400	WND, Deal Beach, N. J. Transatlantic telephony.
22.69	13,050	W2XAA, Houlton, Me. Transatlantic telephony.
23.35	12,850	W2XAD, Schenectady, N. Y. Antipodal program 9 p. m. Mon. to 3 a. m. Tues.; noon to 5 p. m. on Tues., Thurs. and Sat. General Electric Co. W6XN, Oakland, Calif. Relays KGO from 8 p. m., Mon., Thu., Sat., to 2:45 a. m. Tues., 3 a. m. Fri., 4 a. m. Sunday, General Electric Co. W2XCU, Ampere, N. J. W9XL, Anoka, Minn., and other experimental relay broadcasters.
24.41	12,280	GBU, Rugby, England.
24.46	12,250	FTN, Ste. Assise (Paris) France, Works Buenos Aires, Indo-China and Java. On 9 a. m. to 1 p. m., and other hours. KIXR, Manila, P. I. GBX, Rugby, England.
24.63	12,180	Airplane.
24.68	12,150	GBS, Rugby, England, Transatlantic phone to Deal, N. J. (New York). UOR2, Vienna (Hosenhugel) Tues., Thurs., 9-11 a. m.
24.89	12,045	NAA, Arlington, Va. Time signals, 8:55-9 a. m., 9:55-10 p. m.
24.98	12,000	FZG, Saigon, Indo-China, Time Signals, 2-2:05 p. m.
25.10	11,945	KKQ, Bolinas, Calif.
25.10	11,940	Zeelen, Germany, Tests of new Super-power broadcasters.

All Schedules Eastern Standard Time: Add 5 Hours for Greenwich Mean Time.

Kilo-Meters	Kilo-cycles	Stations
25.31	11,840	W2XE, Jamaica, New York (WABC).
25.40	11,800	W8XK (KDKA) Pittsburgh, Pa. 4:30 p. m. on; Saturdays from 6 on; Sundays entire program, Television Ann. and Fri. 2:30 p. m. 60 lines, 1200 r. p. m. W2XAL, New York (W2XY).
25.53	11,750	G5SW, Chelmsford, England, 7:30-8:30 a. m. and 2-7 p. m. except Saturdays and Sundays, Also 7-9 p. m. Mondays and Wednesdays, Tests with W2XO 12-1 a. m. Mondays and Thursdays.
25.68	11,670	KIO, Kahala, Hawaii.
26.00	11,530	CGA, Drummondville, Canada.
26.10	11,490	GBK, Rugby, England.
26.22	11,430	DHC, Nauen, Germany (Berlin) Weekdays after 6, Sun. after 9 p. m. DHE, Nauen, Germany. DHE, Nauen, Germany, "Leviathan" and A. T. & T. telephone connection.
26.70	11,230	W3BN, "Leviathan" and A. T. & T. telephone connection.
27.00	11,100	EATH, Vienna, Austria, Mon. and Thurs., 5:30 to 7 p. m.
27.75	10,800	PLN, Bandoeng, Java.
27.88	10,760	PLR, Bandoeng, Java, Works with Holland and France weekdays from 7 a. m.; sometimes after 9:30.
28.00	10,710	VAS, Glace Bay, N. S., Canada 5 p. m. to 9 p. m. Canadian Marconi Co.
28.50	10,510	FDRL, Leningrad, U. S. S. R. (Russia).
28.50	10,510	VK2BL, Sydney, Australia.
28.80	10,410	VKZME, Sydney, Australia, Irregular. On Wed. after 6 a. m. Amalgamated Wireless of Australia, Pennant Hills, N. S. W. KES, Bolinas, Calif.

(NOTE: This list is compiled from many sources, all of which are not in agreement, and which show greater or less discrepancies; in view of the fact that most schedules and many wavelengths are still in an experimental stage; that daylight time introduces confusion and that wavelengths are calculated differently in many schedules, in addition to this, one experimental station may operate on any of several wavelengths which are assigned to a group of stations in common. We shall be glad to receive later and more accurate information from broadcasters and other transmitting organizations, and from listeners who have authentic information as to calls, exact wavelengths and schedules. We cannot undertake to answer readers who inquire as to the identity of unknown stations heard, as that is a matter of guesswork; in addition to this, the harmonics of many local long-wave stations can be heard in a short-wave receiver.—EDITOR.)

Meters	Kilo-cycles	Stations
31.50	8,690	W2XAC, Schenectady, New York.
31.68	8,650	W2XCU, Ampere, N. J.; W9XL, Chicago. W3XE, Baltimore, Md. 12:15-1:15 p. m., 10:15-11:15 p. m. W6XN, Oakland.
34.74	8,630	WOC, Deal, N. J.
35.00	8,570	HKC, Manizales, Colombia.
35.48	8,450	W3BN, SS, "Leviathan."
36.00	8,330	3KAA, Leningrad, Russia, 2-6 a. m., Mon., Tues., Thurs., Fri.
37.02	8,100	EATH, Vienna, Austria, Mon. and Thurs., 5:30 to 7 p. m. HS4P, Bangkok, Siam, Tues. and Fri., 8-11 a. m., 2-1 p. m. Tuesdays.
37.36	8,030	NAA, Arlington, Va. Time signals 8:55-9 a. m., 9:55-10 p. m.
37.43	8,015	Airplanes.
37.80	7,930	DOA, Doberlitz, Germany, 1 to 3 p. m. Leipzig-Stralsund, Berlin.
38.00	7,890	VPD, Suva, Fiji Islands.
38.30	7,850	PCV, Kootwijk, Holland, after 9 a. m.
38.80	7,770	PCL, Kootwijk, Holland, 9 a. m. to 7 p. m.
39.70	7,550	SS, "Bremer."
39.98	7,500	TFZSH, Ierkiavik, Iceland. EK4ZZZ, Danzig (Free State).
40.20	7,460	YR, Lyons, France, Daily except Sun., 11:30 a. m. to 12:30 p. m.
41.00	7,310	Paris, France ("Radio Vitus") Tests.
41.46	7,230	DOA, Doberlitz, Germany.
41.50	7,220	Zurich, Switzerland, Sat. 3 to 5 p. m.
41.70	7,190	VK6AG, Perth, West Australia, Between 6:30 and 11 a. m.
42.12	7,120	OZ7RL, Copenhagen, Denmark, Irregular, Around 7 p. m.
43.00	6,870	EAR 110, Madrid, Spain, Tues. and Sat., 5:30 to 7 p. m., Fri. 7 to 8 p. m.
43.50	6,900	IMA, Rome, Italy, Sun., noon to 2:30 p. m.
43.57	6,880	O4AFF, Coethen, Germany.
43.86	6,835	VRY, Georgetown, British Guiana, Wed. and Sun., 7:15 to 10:15.
44.00	6,820	XC 51, San Lazaro, Mexico, 3 a. m. and 3 p. m.
45.00	6,800	Berlin, Germany.
45.20	6,835	W3BN, SS, "Leviathan."
46.05	6,515	WOC, Deal, N. J.
46.70	6,425	W2XCU, Ampere, N. J.; W9XL, Anoka, Minn.; and others.
47.00	6,380	CT3AG, Funchal, Madeira Island, Sat. after 10 p. m. VAS, Glace Bay, Canada, Tests.
47.35	6,335	W10XZ, Airplane Television. VE9AP, Drummondville, Canada.
48.35	6,200	HKT, Bogota, Colombia.
48.74	6,155	W9XAL, Chicago, Ill. (WMAC) and Airplanes.
49.80	6,140	KFR, Manila, P. I. 3-4:30, 5-9 or 10 a. m., 2-3 a. m. Sundays.
49.85	6,140	KDKA, East Pittsburgh, Pa. 6:30-7 a. m., 11-4:30 p. m., Holidays, 5 a. m.-5 p. m.
49.96	6,120	Notala, Sweden, "Rundradio," 6:30-7 a. m., 11-4:30 p. m., Holidays, 5 a. m.-5 p. m. ARI, Hongkong, China.
49.92	6,120	W2XE, New York City, Relays WABC, Atlantic Broadcasting Co.
49.15	6,100	W3KL, Round Brook, N. J. (WJZ, New York), 12 midnight on.
49.20	6,040	W2XAL, New York.
49.31	6,080	W2XCX, Newark, N. J. Relays WOR.
49.40	6,070	W9XAA, Chicago, Ill. (WCFL).
49.40	6,070	UOR2, Vienna, Austria, 5-7 a. m., 5-7 p. m.
49.50	6,060	W8XAL, Cincinnati, Ohio, Relays WLW. W9XU, Council Bluffs, Iowa, Relays KOIL. W3XAU, Byberry, Pa., relays WCAU. HKT, Bogota, Colombia, 8 to 11 p. m., ex. Sun. and Mon.
49.67	6,040	W9XAD, Chicago, Ill. (WMAQ).
49.80	6,020	W9XF, Chicago, Ill.
49.97	6,000	W2XBR, New York, N. Y. (WBNT). ZL3ZC, Christchurch, New Zealand, 11 p. m. midnight. EAJ25, Barcelona, Spain, Sat. 3 to 4 p. m. RFN, Moscow, Russia, Tues., Thurs., Sat. 8 to 9 a. m. SAJ, Karlsborg, Sweden. Eiffel Tower, Paris, France Testing 6:30 to 6:45 a. m., 1:15 to 1:30, 5:15 to 5:45 p. m. among this wave. HRD, Tegucigalpa, Honduras, 9:15 p. m. midnight, Mon., Wed., Fridays.
51.70	5,800	HK7, Barranquilla, Colombia, 8:30 to 10:30 p. m., ex. Sun.
52.00	5,770	AFI, Berzdorf, Germany.
52.42	5,720	VE9CL, Winnipeg, Canada, Jas. Richardson & Sons.
52.72-54.44	5,690-5,510	Aircraft.
54.51	5,500	W2XBH, Brooklyn, New York City (WBRC, WCGH).
56.70	5,300	AGJ, Nauen, Germany, Occasionally after 7 p. m.
58.00	5,172	Praha, Czechoslovakia.
60.90	4,920	LL, Paris, France.
61.22	to 62.50	meters-4.800 to 4.900 kc. Television. W8XK, Pittsburgh, Pa.; W1XAY, Lexington, Mass.; W2XBU, Beacon, N. Y.; WENR, Clevean, Ill.
62.56	4,795	W5AM, Elgin, Ill.
62.69	4,785	Aircraft.
65.22	to 66.67	meters-4.500 to 4.600 kc. Television. W6XC, Los Angeles, Calif.
67.65	4,430	DOA, Doberlitz, Germany, 6 to 7 p. m., 2 to 3 p. m. Mon., Wed., Fri.
70.00	4,280	OHK2, Vienna, Austria, Sun., first 15 minutes of hour from 1 to 7 p. m.
71.77-72.98	4,180-3,100	Aircraft.
72.87	4,116	WOC, Deal, N. J.
74.72	4,105	NAA, Arlington, Va. Time signals 8:55-9 a. m., 9:55-10 p. m.
80.00	3,750	F8KR, Constantine, Tunis, Africa, Mon. and Fri.
84.24	3,560	OZ7RL, Copenhagen, Denmark, Tuesday and Fri. after 6 p. m.
84.46-85.66	3,550-3,500	Amateur Telephony.
86.50-86.00	3,190-3,160	Aircraft.

(Continued on page 606)

Modern Sound Projection (IV)

THE PROBLEM OF COLORING IN FILMS

IN sound-on-film projection, just as in television, the characteristics of the photoelectric cell, or "electric eye," are of the greatest importance. In the latter process, they determine the appearance of the transmitted image; while, in the "talkies," the sounds heard by the audience must depend upon the depth and distinctness of the markings on the sound track, as they are "seen" by the photoelectric cell.

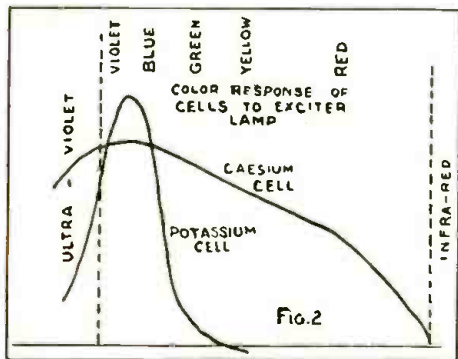

The rays of the "exciter lamp" of the projector affect cells differently at different wavelengths. It is evident that the blue light from the lamp is more necessary than the red; which is more plentiful, but less effective.

(The workings of this device have been explained in the articles on Modern Sound Projection in the February, March and April issues of RADIO-CRAFT; and are repeated here only as necessary to introduce the present subject.)

The photoelectric cell depends for its efficiency on the emission from the lining of its bulb of electrons, which flow to the center ring, or anode, which corresponds to the plate of a two-element thermionic (rectifier) tube. The lining of the bulb corresponds to the tube's filament, but is excited to electron emission by light, not heat.

The substances which are most suitable for the purpose are the "alkaline" metals—lithium, sodium, potassium, rubidium and caesium. These, under the influence of light, throw off electrons; and thus create a feeble current which may be amplified to any desired value. Since the emission of electrons, and therefore the current, is proportional to the light received, we have thus a means of converting light fluctuations into electrical fluctuations of corresponding amplitude.

Differences of Color Response

However, like the human eye, the photoelectric cell does not respond equally to equal intensities of light, if they are of different colors. The eye sees most clearly a given amount of light if the latter is yellow—corresponding nearly to the principal color of the sunlight which diffuses down to us through the "blue" sky. An equal amount of energy in the form of deep red or deep violet light is less perceptible.

The color sensitivity of the photoelectric cell varies also with the metal used as its electron-emitter or cathode. In Fig. 1 the respective color sensitivity of the average eye and of two principal types of photoelectric cells (the Western Electric potas-

sium cell and the R. C. A. caesium cell) is indicated. The curves are not indicators of absolute sensitivity; but only of the proportional response to a given color of light.

(The color of light, the reader probably is aware, is determined by its frequency; just as a musical tone is identified by its pitch. All light which human eyes can see has wavelengths running from about .00039- to .00077- millimeter, or from 1/64,300 to 1/32,600 of an inch. The colors and wavelengths of the visible spectrum are indicated in Fig. 1.)

It will be seen that the photoelectric cell can "see" quite plainly ultra-violet light which is invisible to the eye—just as does the camera. On the other hand, the eye is more efficient in the range of red light.

Fig. 2 shows the result obtained by focusing the standard tungsten-filament exciter lamp of the projector into the photoelectric cell. It is obvious that the total effect on the coil is that of all the light which it receives, and is, in other words, proportioned to the area under the curve (shown here for the visible spectrum alone). This type of lamp, however, gives little of the violet and ultra-violet light to which the cells are most sensitive.

Now, if we insert between the lamp and the cell a piece of film which is not perfectly transparent, we weaken the light which is received through the clear areas of the sound track (See page 457, of the March issue of RADIO-CRAFT, and page 519 of the April issue) and consequently the strength of the reproduction of sound.

This introduced a difficulty in the way of producing colored films with sound; while a color process was available, and sound reproduction had been achieved, the former interfered with the latter.

One method of getting around the difficulty was to prepare film in such a manner that the picture area alone is chemically treated for color, and the sound track is clear. This is a highly-expensive process of manufacture, however; but machinery has been made for the purpose.

New Tinted Films

On the other hand, tinting the entire film with a dye which will interfere least with the activity of the photoelectric cell is much less costly; and research work along this line has resulted in the production of many types of tinted films.

The difference, however, between eye and photo-cell sensitivities has its influence. A yellow color filter hardly produces any lessening of light to the eye, while it may be almost dark to the photo-cell, which misses its favorite blues. On the other hand, blue scenes may be very dark to the eye, yet affect the film's sound volume but little.

It was decided that 30% density—corresponding to that absorption of energy by a tinted film, in comparison with clear base film—could be allowed. This may be compensated on the volume control by advancing it two or three steps.

The contrast in visual and photoelectric densities may be illustrated thus, the percentages being those of light lost by the eye and by the two types of cells. (K represents potassium, and Cs caesium, in the chemical table.)

Film Tint	Eye	K	Cs
Fleur de lis (blue purple)....	75	14	30
Clear	0	0	0
Rose Dorée (deep pink)....	43	19	15
Afterglow (orange)	43	27	15
Candleflame	25	24	9
(orange-yellow)			
Verdante (green)	43	28	18
Turquoise (blue)	54	10	24
Nocturne (violet-blue)	72	9	28
Inferno (fiery red)	64	18	22

The psychological aspects of the use of these and many other tints in projection, for their effect on the spectators, as well as these photoelectrical problems, were discussed at length in a paper from which many of these data were abstracted, and which was presented to the Society of Motion Picture Engineers by Loyd A. Jones of the Kodak Research Laboratories.

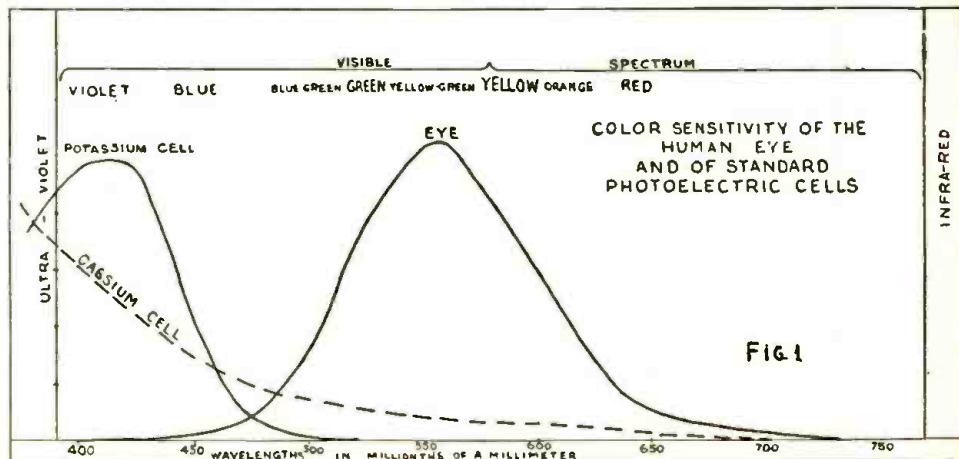

The photoelectric cells used in sound-film reproduction are more sensitive than the eye to violet and blue light; less so to yellow and red. The film must pass rays which will operate the photo cell, as well as those which form the image on the screen.

The Pentode as A Service Problem

Advance data on probable three-grid-tube circuits and their operation

By GEORGE LEWIS

(Vice-President, Arcturus Radio Tube Co.)

THE advent of the Pentode brings forth two interesting radio conditions—a new tube for the experimenter and new problems for the Service Man. While, at the present writing, no pentode receivers are being manufactured for distribution in America, many experts believe such a tube will be shortly in common use; and it is worth while at this time to consider just what this tube is, and what will be its probable effects on the industry and the radio listening fan.

wherein changes in plate power no longer follow proportionately the grid variations. As the grid swing increases, the time comes when the variation in plate conditions is out of step with the variations at smaller grid swings; and the result may be noticed as distortion. This condition is familiar to all who have studied the action of the simple *triode* (three-electrode tube); and it is the effect to be expected when the grid swing strays from the *straight portion of the characteristic curve*.

THE Pentode described in this article, while utilizing the same advanced construction principles as that introduced to our readers in the April issue of RADIO-CRAFT, is a tube of different characteristics and designed for an entirely different purpose. Mr. Lewis describes a power amplifier with a "Mu" so high that a single stage of audio alone is required, and discusses the possibility of making the detector also the output stage.

As generally known to the radio profession, the use of pentodes has been revolutionary in European radio practice. They not only economize in the number of tubes, but they cut down the distortion which is necessarily increased in geometrical progression through the coupling devices of a multi-stage amplifier.

We may therefore look forward to the development of receivers, for battery as well as house-current operation, in which from two to four pentodes will be employed to give volume, sensitivity and quality equal to that obtained by older models with double the number of tubes.—*Editor*.

The pentode has recently been brought into prominence by two factors—an effort to condemn it as useless, and a general ripening of the situation as the tube actually became useful! The situation may be clarified by the consideration of several simple facts regarding this *five-electrode* (three-grid) tube; and the reader may draw his own conclusions.

Distortion and Its Causes

The efficiency, with which power variations in the plate circuit are controlled by fluctuations in the grid circuit, is the ultimate criterion of a vacuum tube's excellence. Unfortunately, so far as we are concerned, this definition is limited by the possible introduction of distortion—the condition

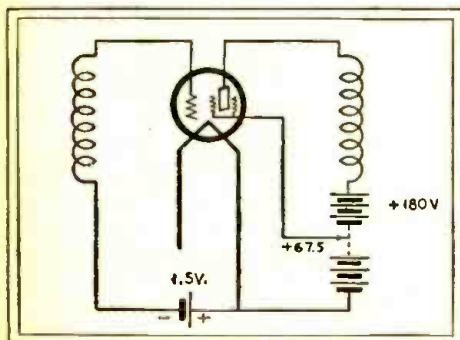

Fig. 1

The fundamental circuit of a screen-grid (four-element) tube, omitting isolating components.

It is the distortion accompanying relatively small grid swings in the ordinary screen-grid (two-grid) tube that limits the utility of this device; which nevertheless from the point of view of the agreement of plate variations with grid fluctuations, is a highly-efficient tube.

The operation of a vacuum tube—the effectiveness with which it amplifies—depends upon the effectiveness with which the potential changes on the grid control the plate current, which is an electron stream flowing between the cathode (or filament) and the plate. This variation in the plate current is caused by a variation in the voltage existing between the (positive) filament and the (negative) grid. As this charge on the grid is increased, for instance by adding additional negative bias or by applying the negative half of an alternating-voltage cycle, the plate current is decreased; since the augmented negative charge repels more of the electrons seeking a path, through the grid, to the plate.

Space-Charge Effects

The negative charge existing between the filament and the grid of an ordinary vacuum tube has two components: the useful control-charge, imposed on the grid, and the "space charge," which, in the '01A tube for instance, is useless but inevitable. The space charge is an accumulation of electrons, relatively constant in effective potential, which are

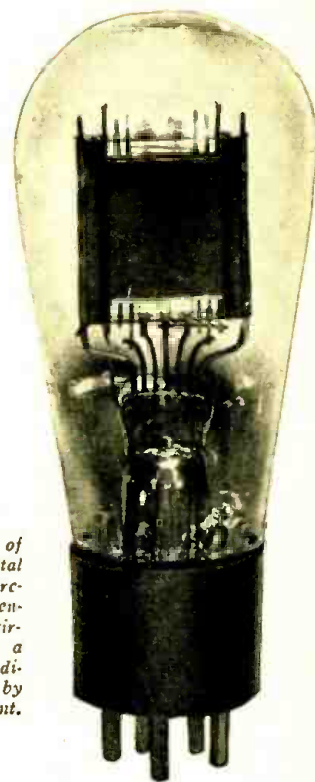

Fig. A

The appearance of an experimental model of the Arcturus power pentode for output circuits. It has a heavy filament directly heated by alternating current.

more or less permanently parked between the cathode (filament) and the grid.

Returning to the problem under consideration, it is fairly obvious that, if we could eliminate this negative space charge, the effect of grid-potential variations on the plate current would be considerably increased. In other words, the effectiveness of the tube would be raised. This is exactly what the fourth element, or the screen-grid, accomplishes, by introducing a counter-acting *positive* charge. A few of the electrons, of course, stick to this screen-grid; but the majority of them, traveling some twenty thousand miles a second, pass through the mesh and continue on to the plate.

At the same time, the effectiveness of the plate potential in the "tetrode" or screen-grid tube, is increased. In the "triode," or standard three-element tube, a rather excessive plate voltage is required to overcome the effect of the space charge, and to create sufficient plate current for the satisfactory operation of the tube. However, with the space charge eliminated, we find we can achieve the same effect at much lower plate potentials or (in general practice) we can obtain the usual increase in efficiency by operating the tube at a plate potential in excess of the minimum requirement of the tube (as by operating the '24 at the normal '01A plate voltage).

Secondary Emission

Unfortunately the effectiveness of the screen-grid tube, particularly as a power amplifier, is limited by "secondary emission." This phenomenon is to be observed in practically all forms of electronic devices; it is the emission of electrons by the anode (plate) caused by the bombardment of the original cathode ray. As the electrons strike the plate at extremely high velocities, they knock off additional electrons. Also, the bombardment of the plate often heats it to an electron-emitting temperature. In the ordinary triode, these electrons may float

around for a fraction of a second and either return to the plate or join other electrons in the space charge. However, in the screen-grid tube, because of the presence of another highly positive charge on the screen-grid, many electrons leave the vicinity of the plate and travel to the screen-grid. These, by taking a direction exactly opposed to that of the electrons leaving the filament, partially nullify the effect of the original electrons which form the plate current.

This reduction of the plate current by secondary emission becomes particularly effective when, as very often happens, the screen-grid is at a higher positive potential than the plate itself! An inspection of Fig. 1, which shows the regular fundamental screen-grid tube circuit, will show how this is possible. The output of the tube is generally connected to an inductive load, the voltage drop across which (with A.C. grid variations) will momentarily oppose the plate-battery charge on the plate. When this voltage drop is in excess of the difference between the voltage of the plate battery and that on the screen-grid, the screen-grid must have a higher momentary voltage than the plate of the tube. It is then that the effect of secondary emission is most marked; and we have a condition where the plate current varies in a manner which is not at all consistent with its normal changes under grid fluctuations. In other words, we have run up against the limiting factor of distortion.

This is the reason why the screen voltage is always less than the plate voltage.

Functioning of the Pentode

The construction of the pentode effectively reduces this secondary emission, making it possible to take full advantage of the screen-grid amplification in power circuits. The third grid is connected to the cathode inside the tube, and is commonly termed the "cathode-grid." This grid is obviously at the same potential as the cathode and has just left the cathode en route to the plate. However, its negative potential (with reference to the plate) is that of the instantaneous plate voltage; with the result that the secondary electrons prefer returning to the plate rather than passing through the cathode-grid back to the screen-grid.

Fig. 2 shows a typical pentode arrangement while Fig. A is a photograph of an experimental Areturus pentode.

The internal construction of the pentode is shown in Fig. 3, with its prong arrangement in Fig. 3A.

In the pentode we have something approaching the ideal vacuum tube, in which the maximum amount of plate power is controlled by a minimum amount of grid-voltage fluctuation. The pentode illustrated is a screen-grid tube adapted to power purposes, and intended for use in circuits where, with the four-element tube, the grid swing would be sufficient to introduce distortion through secondary emission.

The future popularity of the pentode will undoubtedly lie in its use as a power tube, as it is here that its advantages are most manifest.

Experimental models in our laboratory indicate that a good commercial pentode will deliver about 2.5 watts of undistorted power output, dissipating about 8 to 10 watts on

the plate, at a plate potential of 250 volts, with a grid swing not exceeding 15 volts. Contrast this with the output of a '45 power tube which dissipates some 8 watts, with a 50-volt grid swing which delivers 1.6 watts to the load or speaker circuit.

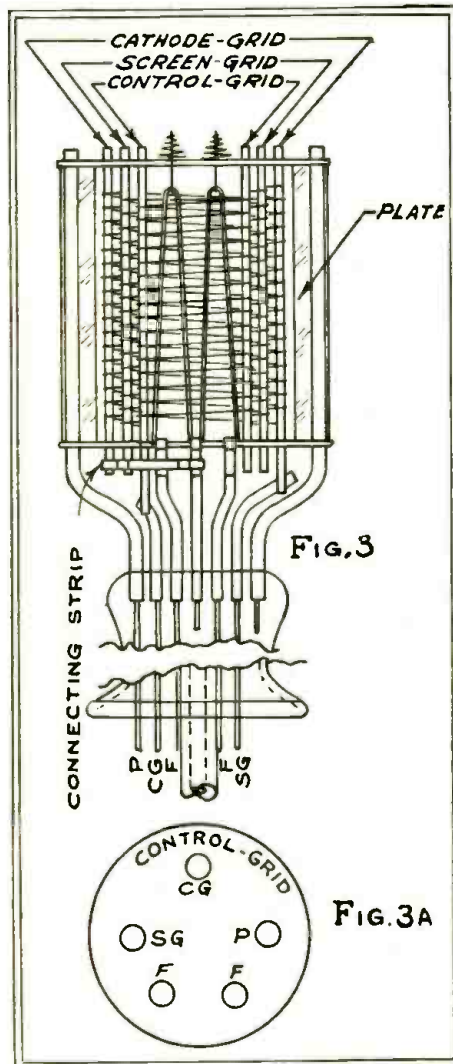

The interior arrangement of the elements of a pentode with directly-heated filament; the cathode-grid is connected internally to the midpoint of the filament. Below, prong arrangement of the pentode base.

In other words, a good pentode, properly operated, will be more efficient than a '45 tube, for the same power employed (in the power tubes); but it possesses so high an amplification constant that it definitely eliminates the first audio stage and in many instances will function as both detector and power amplifier, with obvious and added economies. The elimination of previous stages automatically eliminates the hum and incidental distortion associated with the discarded tubes.

It is difficult at this time to venture a guess at the commercial probabilities of the pentode, aside from those suggested by the engineering considerations already described. The possibilities of such a tube are too great to be suffocated under the desirability (from the manufacturer's point of view) of continuing in the rut of present receiver designs. The type that will be marketed will be a high-amplification power tube, selling for a price somewhat in excess of that of the present screen-grid tubes.

An Experimental Circuit

The fundamental circuit is shown in Fig. 2, in which the pentode is resistance-coupled to the detector tube. The potentials indicated are not necessarily those to be specified in final production types, but are proportionately logical.

A peculiar thing about the pentode is that the greatest undistorted output can be secured at load impedances considerably below the plate impedance of the tube, rather than at twice the plate impedance (which is correct for the triode.) Experimental models require a load impedance of about 6000 ohms for maximum undistorted power output. The pentode, which favors high frequencies slightly, should be used in conjunction with a dynamic speaker. The coupling transformer should, therefore, have a primary impedance of about 6,000 ohms at 100 cycles and a secondary impedance matching the voice-coil of the reproducer.

So far as present-day receivers are concerned, the advent of the pentode should have no great effect on the popularity of the better designs. One of the finest receivers obtainable today and another big seller in the popular class do not employ screen-grid tubes, despite the ballyhoo and the genuine screen-grid possibilities. The exact utility and economic field of the pentode will be determined by the engineers designing receivers for the set manufacturers—which is as it should be.

However, in D.C. districts, such as midtown Manhattan (New York City) the improvement is radical. The pentode should make direct-house-current receivers really practical, by effecting an improvement in output at low plate voltages over standard-type power tubes.

Servicing the Pentode

While the pentode is an excellent power tube, I doubt if it will be readily adaptable to receivers already employing a three-element tube in the output stage. As tubes capable of handling higher powers have heretofore been brought out, it has often been the Service Man's job to improve his customers' receivers by making the relatively simple changes necessary to accommodate the new tube.

In the case of the pentode, the game will seldom be worth the candle. The output of a good modern receiver is well-nigh perfect. The function of the pentode will be to make possible better sets for the money, rather than to improve the actual quality output

(Continued on page 601)

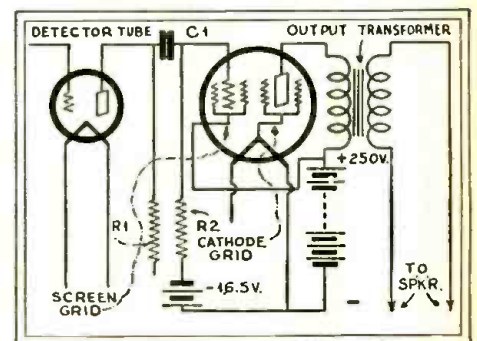

Fig. 2

The elements of a circuit in which the output stage is a pentode, resistance-coupled to the detector. The values used are subject to modification, as the tube design is still experimental.

The "Hi Q-30" for Custom Builders

The latest of a distinguished series of receivers which have been noted for their high amplification and extraordinary selectivity and quality, the "Hi Q-30" embodies new principles of design.

By LEWIS MARTIN

Hammarlund Manufacturing Company

WHAT is the difference between the 'HiQ-30' and the 'HiQ-29?' This is the first question that arises when the latest of this distinguished series of receivers is announced. The answer is that the latest "HiQ" has three stages of screen-grid R.F. amplification instead of two, an improved system of tuning, an improved volume control, "unit construction" or seven basic units, push-pull '45s, a new type of condenser-gang (called the "battleship" design), and single-dial control.

The "HiQ-30" is a receiver in which the gain raises a threshold signal strength of 1 microvolt (per meter) to the output standard of 50 milliwatts in an optimum load (A.F. output device). Where such extreme degrees of amplification are developed, good circuit operation requires exceptionally selective tuning circuits. A band-pass "pre-selector" comprising L1, L2, L3, and a tuning-condenser gang C1 (Fig. 1) and an interstage tuned-transformer-coupled amplifier, incorporating L4, V2, L5, V3, L6 and V4, and controlled by a second condenser gang C2, together give extreme selectivity with full sideband reproduction. The volume is controlled by adjusting R12, which varies the grid bias of V1 and V2.

The chassis of the "HiQ-30" measures 7 x 12 3/4 x 24 inches, giving a wide choice of consoles. A phonograph pick-up may be connected as provided for. A control on the panel is mechanically linked to Sw. 1 on the subpanel.

Selectivity "Squared"

The selectivity of the "pre-selector" filter is such that, even with fixed R.F. transformers in the subsequent stages, it would hold the tuning width to not more than 15 kilocycles under ordinary reception conditions. On the other hand, without it, the

tuned-transformer coupling of the "Hi Q" would give sufficient selectivity. The combination of the two systems is intended to eliminate an undesirable condition—"cross modulation" or "cross talk"—which might otherwise exist. In the laboratory, many commercial receivers demonstrate 10-ke. selectivity; but they are found woefully lacking in this essential when "on the field." The difference between broad tuning and "cross-talk" becomes evident when the station to which the set is tuned goes off the air—for in the latter case, the interfering station disappears simultaneously.

(A discussion of "cross-modulation" and the reason for it will be found on page 582 of this issue.—*Editor.*)

The manner in which station signals "snap in," rather than "slide in," is characteristic of band-selector tuning circuits. A point which cannot be stressed too greatly is that care must be taken to obtain a good tube for every stage in the set; and exceptional care must be given to obtaining exact balance of each tuned circuit. Apropos of this, the "kitchen-table constructor" will find it a discouraging proposition to wind twelve coils with the expectation that they will "track" throughout the tuning band when used in conjunction with six variable condensers, all adjusted by a lone knob. However, for the constructor who fully appreciates these and kindred technicalities there are given below details of the coils used.

Design of the Units

A variation from an older practice, that of fabricating a working radio set from individual parts, is observed in the assembly procedure for the "HiQ-30"; it has been found that faults in assembly and wiring are reduced to a minimum by supplying to the constructor a lesser number of units, com-

pletely wired and balanced. Each "basic unit" (of which there are seven) comprises a number of tested components.

Each of the radio-frequency inductance units included in the tuning circuits is encased in a copper shielding can; while each of the triple-gang variable condensers (.0005-mf. "Midline") is housed in an aluminum can, and its sections are individually shielded by partitions. Both units are controlled by the single drum dial.

The balancing condensers in shunt to the tuning condensers constituting unit C1 have a minimum capacity of 2 mmf. and a maximum capacity of 35 mmf.; the balancing condensers that complete tuning unit C2 have a minimum capacity of 2 mmf. and a maximum capacity of 70 mmf. The "polarized" R.F. chokes Ch1, Ch2, Ch3, and Ch4 are also housed in aluminum shield cans.

The first audio transformer T1 has a ratio of 1 1/2 to 1; the input push-pull transformer T2, of 2 to 1 on each side; while the output push-pull unit T3 is selected with reference to the characteristics of the reproducer, as shown by the list of parts.

The line-voltage regulator R18 is designed for use with a power transformer whose primary is tapped for an 80-volt A.C. input. Ch5 and Ch6 are 30-henry choke coils, contained in the shielded case of the power transformer PT.

The voltage divider consists of five resistor-windings on a vitreous tube 3/4-in. in diameter and 5 in. long, enameled. They have the following values: R13, 850 ohms; R14, 2,500 ohms; R15, 1,500 ohms; R16, 3,000 ohms; R17, 2,000 ohms.

List of Parts

One Hammarlund "HiQ-30" cadmium-plated foundation unit (including two 25,000-ohm resistors R2 and R5) No. QFU-30;

(Continued on page 592)

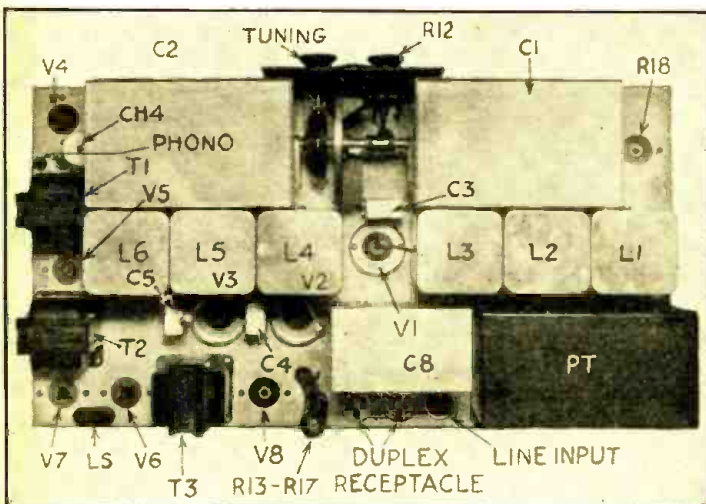

A view from above of the "HiQ-30" chassis with its power pack at the rear; the circuit is at the top of the opposite page. C1 and L1, L2, and L3 house the "pre-selector" unit, which feeds into the first screen-grid tube V1.

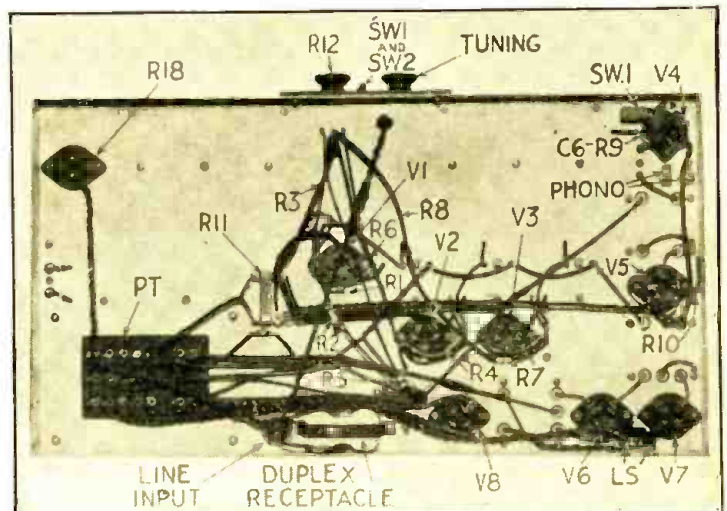

A bottom view of the "Hi Q-30" chassis, showing all the wiring connections of this A.C. receiver. The parts shown may readily be identified by comparison with the schematic circuit and the accompanying list of components.

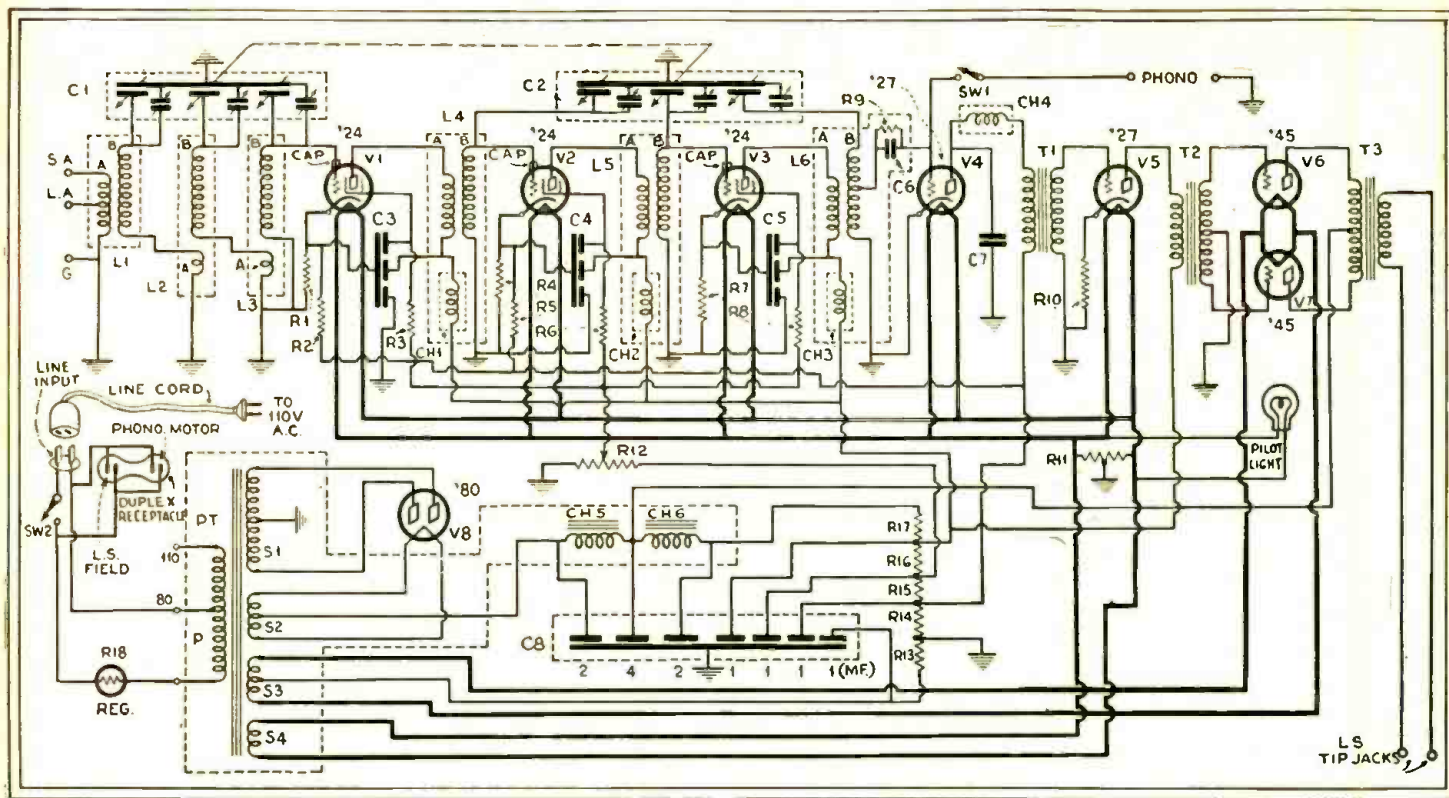

Complete schematic circuit of the new Hammarlund "Hi Q-30," embodying the newest refinements in set design. The power pack is shown below, with its external connections. This receiver is designed for the set owner who wishes something more than can be obtained from mass-production, factory-assembled receivers.

Adapting Screen-Grid Sets for the Pentode

By F. S. HUDDY

Assistant to Chief Engineer, CeCo Mfg. Co.

THE changes necessary to make possible the use of the type "P-1" pentode in sets designed to operate with '24 tubes are neither difficult nor expensive. Tests have shown that, although the optimum plate voltage for this pentode is 250 and the optimum screen voltage is 135, it will work satisfactorily with 180 volts on the plate and 75 on the screen. The last-named voltages are those most commonly found in present day sets and, in general, it is not advisable to attempt to change them. Where '45's are used in the last audio stage, it is a simple matter to connect the plate returns from the pentodes to the 250-volt tap on the voltage divider. All the pentodes in a set will operate at the same plate and screen voltages.

The outstanding difference in construction between the pentode and the '24 is the

presence of a space-charge grid in the former. Hence, the first consideration in changing a set is the provision of a potential of 13.5 volts positive for application to the space-charge grid. This may be done in two ways: the simpler is to provide a battery of nine small dry cells, connected from the space-charge-grid terminal on the side of the tube base to the cathode terminal on the socket. The other is to connect the space-charge terminal through a resistance of 8200 ohms to the 75-volt screen-grid tap on the voltage divider or 16,500 ohms to the 135-volt tap. Where it is possible to secure an extra tap on the voltage divider, the space-charge terminal may be connected to a tap giving a voltage equal to 13.5 plus the control-grid bias (which is usually one and one half volts.) In any one of these connections, the space-charge grid should be held at ground potential, with respect to any radio-frequency voltages, by the connection of an 0.5-mf. condenser from its terminal on the base to the ground. When these connections have been properly made, a high-resistance D.C. voltmeter will read 13.5 volts between the space-charge connection and the cathode terminal. Voltages in excess of 13.5 shorten tube life; while voltages less than 13.5 will cause somewhat inferior reception.

The correct voltage to be applied to the control grid is 1.5 volts negative with respect to the cathode; this is most commonly done by inserting a resistor in series with the "B-" return to the cathode. The plate current of the tube causes a voltage drop

in the resistor, and makes negative (with respect to the cathode) the grid connected to the terminal of the resistor nearest to the negative terminal of the "B" supply.

The plate current of the pentode is somewhat higher than that of the '24 and, for this reason, the grid will be made too negative because of a greater drop in the bias resistor. The current will be different if a separate battery is used to furnish space-charge-grid potential; and a different value of bias resistor is needed.

With a separate battery, for the space-charge grid, the plate current of the pentode is 3.5 milliamperes, the screen-grid current 0.5-ma.; a total of 4 ma. To obtain a biasing potential drop of 1.5 volts, a 375-ohm resistor is needed.

If the space-charge grid is to be given its potential from the power pack, the total
(Continued on page 597)

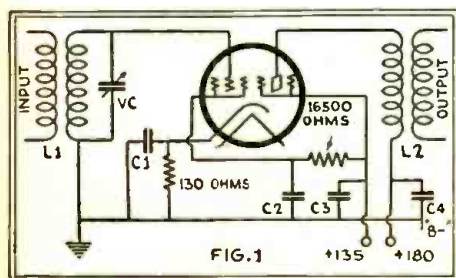

The pentode as shown here, drawing space-charge current from the voltage divider of the power pack, requires less biasing resistance in its cathode return than the circuit of Fig. 2.

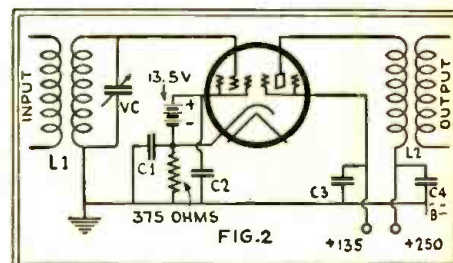

When the pentode takes its space charge current from a battery connected to the terminal on its base, the circuit is as shown. C1, of 1/2-mf. capacity, is needed, as well as the proper resistor value.

Curing "Station Interference" in the Receiver

A discussion of the cause for a considerable amount of the difficulty of "cross-talk," experienced with even very selective apparatus

By SYLVAN HARRIS

THERE is no doubt that many of you have experienced a lot of interference which you attributed unwittingly to lack of selectivity, or to condensers out of alignment, or to high-resistance circuits, or what not. At any rate, let it be known at the start that there are several other sources of interference.

One other kind is what we may call "set pick-up," since we have no better name for it. This is merely the effect of the energy of the passing radio wave on the wiring of the set, and it can generally be identified by simply pulling the first R.F. tube out of the socket. After you do this, if you still hear the signals, it is clear that what you heard has been "picked up" by the wiring of the set. The obvious cure for this is to completely shield the whole receiver. Since this is generally being done nowadays, this cause of interference is rapidly passing into the limbo of forgotten things; except under the worst conditions, where the receiver is located near or "under the eaves" of the broadcaster.

Interference which results from power-line pick-up is also gradually disappearing, with the introduction of buffer condensers, R.F. chokes in the power lines, grounding condensers, and what not.

But the kind of interference we are going to discuss in this article is more difficult to handle than those which we have mentioned. Its cause is the same principle that permits us to use an electron tube as a detector, or rectifier, of radio-frequency signals: we refer to the rectifying properties of the tubes.

Effect of Untuned Coupling

This form of interference is known as "cross-modulation;" it is the same kind of modulation that we have in the detector tube—or should we call it de-modulation? It is both, as we shall see. And we call it cross-modulation to distinguish it from the useful forms of modulation which we require in both transmitting and receiving.

Remember the untuned or "aperiodic" couplings we used to use in the antenna circuit? These consisted merely of a choke

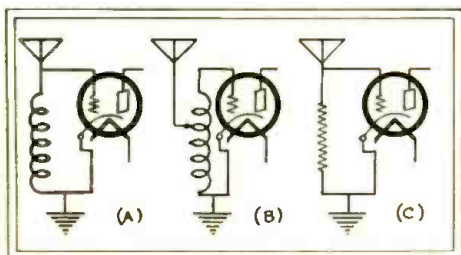

Fig. 1

Three typical "untuned" antenna couplers, which accept all R.F. frequencies, used to eliminate a panel control and produce a single-dial set.



MR. HARRIS, well known as a radio editor and as a designer of commercial receivers, here presents the fruit of some technical researches, designed for the guidance of engineers, in a form which will appeal more to the Service Man and the experimenter who are trying to demonstrate the combination of sensitivity with quality.

coil, or an auto-transformer, or even a simple resistor, placed between the grid and cathode of the first R.F. tube; the grid end of the coupler being connected to the aerial, and the cathode end connected to the ground. (These arrangements are shown in Fig. 1.) Let us see what is likely to happen, and what actually does happen, when the signals are strong, and when the R.F. amplification is very great, as it is nowadays.

All signals in the vicinity of the antenna are impressed simultaneously on the input of the first R.F. tube, for the antenna circuit is untuned, and is supposed to be an acceptor circuit for all signals. Of course, the strength of the signal voltage reaching the first grid depends upon the frequency-characteristic of the coupling device, but this is generally a pretty good one.

Let us suppose that we usually tune in WEAJ (660 kilocycles) at 80 on the dial, and WGCP (1250 kilocycles) at 20 on the dial. Then we find that, by turning our dial to about 95, we can hear both of these stations together. What is happening?

The same thing that happens in a superheterodyne: the two stations "beat" together. One beat-frequency, the sum of the two, is outside the tuning range of our receiver, and so does not cause us any trouble;

but the other—the difference-frequency, or 590 kilocycles ($1250-660=590$), is just within the upper limit of our tuning range.

Now, the mere presence of the two signals upon the input of the first tube would cause us no trouble if this tube did not act as a rectifier and permit one signal to modulate the other, thus producing the beat-frequency in its plate circuit. The tube acts this way because its plate current-grid voltage characteristic curve is not exactly straight, but has a slight curvature, even when we operate well up on the curve.

So, in the plate circuit of the first tube, we have current of a frequency different from the frequencies of the signals, and which is within the tuning range of our variable condensers. This exotic frequency is then amplified by the R.F. amplifier in the usual manner; and we therefore hear both stations simultaneously at a point on the dial where we shouldn't hear them.

We can pick out dozens of combinations of stations which will produce this effect. All that is necessary is that either the difference or the sum of the two frequencies should lie within the tuning range of the receiver. There is one short interval in the whole tuning range in which no beat-frequencies can be obtained. This is near the middle of the range, from about 950 to 1060 kilocycles. A chart, showing the various possible combinations of frequencies which can produce beat frequencies within the broadcast band, was included in the writer's paper on cross-modulation in the *Proceedings of the I. R. E.*, February, 1930.

Use of Push-Pull Input

The obvious way of curing this form of cross-modulation is to tune the antenna coupling; but it may be of advantage, sometimes, to keep the antenna untuned. In this connection it is worth while to note that we can make the acceptance-characteristic of the coupling device almost anything we want; and so boost up the gain on the long waves, where we often need it so badly. In any event, it is possible for us to retain the untuned circuit and eliminate the cross-modulation, by using a push-pull circuit as the first radio-frequency amplifier stage. Such a circuit is shown in Fig. 2.

There are several things to notice in this diagram. In the first place two of the coils must be wound in opposite directions, in order to place signal voltages of opposite polarity on the two grids; this is necessary in all push-pull stages. In the second place, because the two tubes are so closely coupled together, it is almost impossible to prevent them from oscillating unless a neutralizing scheme is used. The two capacities (C1 and C2), connected cross-wise between the tubes, are the neutralizing condensers. A very strong modulation signal, to which the set

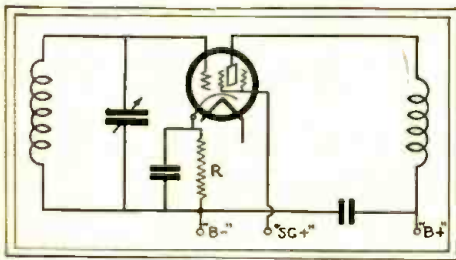

Fig. 3

In the usual grid-biasing arrangement, the bias falls off as the plate current decreases, until the grid draws current.

is tuned, can be made to disappear completely by adjusting the neutralizing condensers until the circuits are correctly balanced.

The fact, that this form of modulation can be corrected by using a push-pull circuit, indicates that it is due to curvature of the grid-plate characteristic curve.

Screen-Grid Problems

Another form of cross-modulation occurs when tubes are operated at such voltages that grid current flows. Many people have called this condition "overloading"; it was not overloading in the most serious case we have had to contend with lately. Most screen-grid tubes have such characteristics that grid current flows—even when there is no signal at all—when the grid voltage is made less than about 1.5 volts negative.

Under such conditions, when the signal comes on, even though it has a voltage considerably less than the bias, it produces a variation in this grid current (just the same thing that happens in our grid-leak grid-condenser detector) and the signal is rectified.

Now, suppose we have two signals applied to the grid of the first screen-grid tube, while grid current is flowing; the one signal will then modulate the other and, when we tune to either of them, we will hear the intermingled programs of both stations. In this case we tune, not to the heat frequency, but to one or the other of the interfering signals. This phenomenon occurs when we have two strong signals fairly close together in frequency.

Furthermore, it generally occurs on reduced volume. As you are aware, it is customary to obtain the biasing voltage for the grids of screen-grid R.F. amplifier tubes by placing a resistor in the cathode circuits, and connecting the grid return below this resistance. (The arrangement is shown in Fig. 3.) The plate current of the tube flows through this resistor R, and the voltage drop

in it creates the grid bias. Now, when the volume is controlled by reducing the voltage of the screen, the plate current decreases—and, consequently, the bias decreases. So, when we reduce volume on a strong signal and thereby reduce the bias, we soon come to a point when the grid begins to take current, and the modulating process begins.

Maintaining Grid Bias

The obvious methods of curing this are twofold; the first is, of course, to make the input of the first tube so selective that only

grid bias from getting so low that grid current can flow in the circuit; this can easily be done by adopting the arrangement (Fig. 4) in which the grid-return or ground is connected to the voltage divider of the power pack at a point 1.5 volts below that where the cathode circuit is connected. Then, even when the cathode current (or plate current) of the tube is as low as zero in value, the grid will be still 1.5 volts negative with respect to the cathode; and no grid current can flow.

There is one objection to this method however; because it is often necessary, when receiving very strong local signals, to reduce the screen voltage so far (in order to make the listening comfortable) that the plate current is reduced to perhaps 30 microamperes or less. This means that we are operating near the "cut-off" of plate current, which is obviously a bad thing in amplifiers; since it permits only the stronger bursts of signal voltage to get through, and the quality suffers considerably thereby.

The set designer, therefore has had to resort to other expedients in order to overcome these troubles. A practical answer has been found in the use of two volume controls. One of these is the usual potentiometer (R1 in Fig. 5) which controls the screen voltage. The other is the potentiometer (R2) connected across the primary of the first R.F. transformer (i.e., in the antenna circuit and forming a well-known form of volume control.

Both these controls are operated simultaneously by a single shaft. On reducing volume, therefore, by the time the screen voltage has been so reduced that grid current begins to flow, or we approach the cut-off of plate current, the volume control at the antenna has simultaneously diminished the signal. In other words, by the time we approach a condition where the signal begins to suffer, the signal is no more.

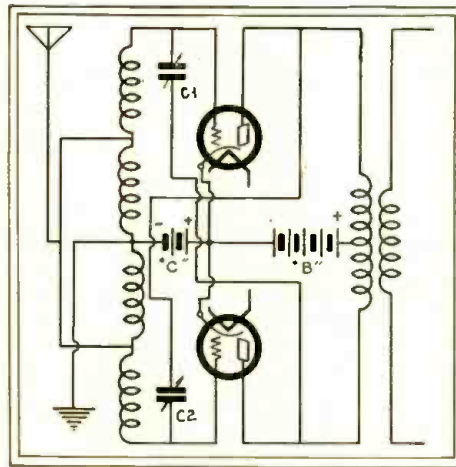

Fig. 2

This tuned push-pull R.F. input is designed to eliminate cross modulation; it must be neutralized, as with the condensers C1 and C2, to prevent oscillation.

one signal can get to the grid at any one time. There is, however, a limit to this, which is found in the impairment of quality due to side-band cutting when we use the simple tuned circuits. Here is an obvious use for the "pre-selector" band-pass circuit. The other obvious cure is to prevent the

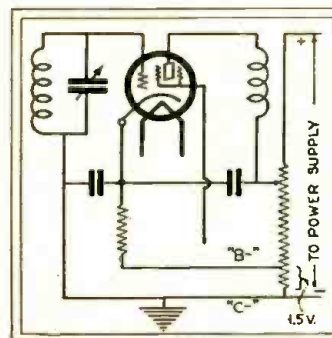

Fig. 4

The connection at the left keeps the grid bias much steadier than that of Fig. 3. At the right, dual volume control. When R1 and R2 are operated together, distortion is minimized.

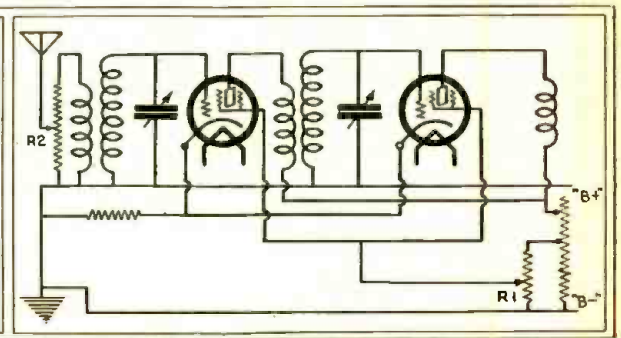

Fig. 5

Selling Radio to the Schools

By J. E. SMITH

President National Radio Institute

IF ever there was a case of the "vicious circle," it is the problem of introducing radio in schools. School boards decide against radio installations for the reason that there is insufficient educational material available during school hours in the present broadcast programs. Broadcasters, on the other hand, refuse to provide more educational material during school hours on the ground that there are not enough schools equipped with radio to make the effort

worth while. A perfect vicious circle. Yet the problem is not quite as hopeless, I believe, as it might seem. It so happens that the centralized radio installation may be employed quite independently of radio programs. By means of a microphone, it becomes possible for the principal to address the students at their own desks, without calling for an assembly. The physical-culture instructor can order "windows up," and proceed with brisk setting-up exercises,

without having the students leave their classroom. The visitor to the school can say a few words to the students at their desks. Or, with a phonograph pick-up, it becomes possible to provide any desired musical program, language lesson, and so on. A radio installation, fortunately, has other uses besides the interception and distribution of radio programs. That is the idea which radio Service Men should sell to school authorities at this time.

The Cooperative Radio Laboratory

The Director gives an impartial summary of the advantages and disadvantages of the "direct-coupled" amplifier, in which a principle familiar to radio engineers has been applied successfully to electric sets

By DAVID GRIMES

THE first series of articles which appeared in the Cooperative Laboratory department discussed various types of detection circuits, and dwelled at considerable length on the technical advantages of crystal rectification. Several crystal detector combinations were presented, featuring the now famous "Crystal-Hybrid" circuit. (This met with great success, apparently, for one of the experimenters, Mr. Thomas of Louisiana, sent us a large bag of pecans. On second thought, there may have been an ulterior significance in the fact that he sent us nuts. Anyway he swears he's satisfied).

Then we branched out into the direct-current field and described a complete D.C. electric receiver in which simplicity and economy were considered foremost. This led to some unusual filament and "B" supply connections in which, however, the R.F., detector, and A.F. circuits were more or less standard. Anyone living in a D.C. light-mains district, and enthusiastic over the "Crystal-Hybrid," could easily adapt the crystal rectifier to this D.C. set.

The last two articles have been devoted to a novel system of radio-frequency amplification in which regeneration by means of an automatic, electrical, feed-back-filter circuit is employed to boost the R.F. gain at the longer wavelengths. We have made a conscientious effort to work this circuit out for possible operation on the crystal system; but, so far, this has not been accomplished. We state this because it is our policy to work out various parts of the radio set in such a manner that definite advances made in certain parts of the circuit will not have to be discarded when we come to developments in other portions of the receiver. We can imagine nothing more discouraging than becoming enthused over a new radio-frequency hook-up, only to be obliged to drop it because it can not incorporate some revolutionary audio scheme. It would seem, at



MR. GRIMES has for many years been well known not only to the engineering profession, but also to constructors and experimenters. In these pages, each month, he describes the latest circuit developments in simple language.

first thought, that the various portions of a radio receiver could be segregated, and that any audio system could be matched up to most any radio circuit; but this is not the case. Special consideration must be given these problems. All of which leads us up to the present discussion.

Coupling Methods

Some of you have undoubtedly already read about the "direct-coupled amplifier" (sometimes called the non-reactive amplifier) which goes under the name of "Loftin-White," from the two eminent engineers who have done considerable work on the circuit layout. We dare say that some of you have already tried it and, possibly, have had trouble and blamed the circuit. Nevertheless, the principle is fundamentally sound, adverse experiences notwithstanding! In fact, this is one of the most interesting problems that has arisen in radio in many a day and, so far, "the surface has hardly been scratched." Some of our contemporary publications would have you believe that the present circuit is in its final form, with nothing to do but buy the parts and obtain Utopian results.

Perhaps it is this impression that has led to so much grief. From past experience, we think it unwise to consider any presentation of a new circuit as its final form; and in any case, no development should be considered as the great panacea of radio troubles. The direct-coupled amplifier has been a little oversold; its introduction has been a trifle premature, for the experimenter has not been properly prepared regarding the true

merits of the system. It really has a use, however, and really accomplishes a good and valuable purpose. Let us inquire into it further.

About the first thing in order is a hasty classification of different types of audio coupling. This is necessary in order to place direct coupling in its proper category, and more fully to appreciate just what it will and will not do. Fig. 1 should here be consulted.

At A we have the conventional transformer coupling between two audio tubes. The transformer consists of the primary P and the secondary S, between which energy is transferred because the magnetic flux set up in the primary, induces voltages in the secondary winding. Such a device actually boosts the voltage, as the secondary is usually wound with more turns than the primary. The two separate windings not only accomplish the step-up in voltage just mentioned, but also effectively insulate the plate and grid circuits; so that the "B" supply on the plate does not reach the grid to upset the grid bias on the following tube. These two features have made this type of coupling by far the most popular.

At B, in contrast, is indicated the regular, so-called "resistance" system of coupling. (In the strict sense of the word this is not resistance coupling; the condenser C, really, couples the two circuits.) The reason for this makeshift is that in the past it has been imperative to insulate the grid from the previous plate circuit, so that the "B" supply will not affect the proper grid bias. It is the A.C. voltage drop across the resistance R1 which is impressed on the grid of the following tube, through the coupling condenser C. The condenser merely insulates, while the resistance R2 merely supplies the negative grid bias to tube No. 2. There are two advantages of this system of coupling; first, the necessary apparatus is quite inexpensive, as compared with transformer circuits. Secondly, the amplification at all frequencies in the musical range is remarkably good. The latter advantage has been, perhaps, the strongest consideration of those who have advocated it in spite of everything.

Troubles of Resistance Coupling

And now for the disadvantages of "resistance" coupling. There are three that stand out quite prominently. There is, obviously, no possible voltage step-up, such as in the transformer combination; only the gain obtained from the tube is available. This limits results or compels us to use tubes of special types, whose high internal amplification is usually offset by a correspondingly-reduced "C" bias, which limits the possible grid swing to a very small amount. Then there is the need for a very high-voltage "B" supply, to offset the excessive direct-current voltage drops in the

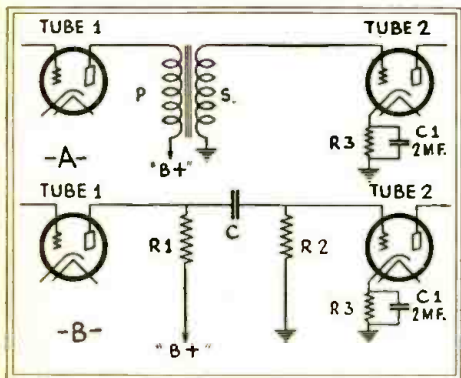

Fig. 1

The standard transformer and "resistance" couplings used in A.F. amplifiers. The latter system gives no voltage step-up, and on strong signals introduces the effect of a blocked grid.

coupling plate resistors. This always ruled out resistance coupling when "B" batteries were the only source of power. Now, with "B" eliminators, this problem has been pretty well solved.

The third factor, and the one that is less generally appreciated, is the tendency for the grid to "choke up" when only a reasonably strong signal is applied thereto.

Not only is this last point least understood, but it forms the whole point to our discussion of direct-coupled amplifiers. It is in this respect—and this respect only—that the direct-coupled system excels the standard resistance-coupled amplifier with its coupling condenser. A detailed study of

(such as from a bass-drum beat or tuba blast) the added energy pushes the grid way over into the "plus" region where distortion does occur; but it occurs only at that particular instant. As soon as the surge is over, the grid immediately returns to its normal condition and the normal music continues unmolested. This favorable condition enables us to fool the amplifier and ourselves, as the instantaneous distortion is not objectionable. We thus are able to get full measure out of the circuit on normal music and the surges take care of themselves.

Not so with the standard resistance coupling shown in Fig. 1B. Here we cannot tolerate the grid's running "plus" even for an instant; for during that time it will attract sufficient electrons to charge the condenser "C" to an excessive negative value. Then this excessive negative value will hang over for many seconds; since the condenser cannot readily discharge itself because of the necessarily high resistance of R2. Thus the momentary distortion on the bias surges, which we could tolerate in the transformer system, is extended over an appreciable period of time, and therefore they are highly objectionable in the "resistance" system. This precaution, which we must exercise in standard resistance coupling, greatly limits our output; because we must keep the gain so low that not even the bass surges will overload the grid. This is really the reason for the failure of standard resistance coupling, even after special tubes became available and the "B" eliminators made the extra voltage easily obtainable. Figs. 2 and 3 show this effect of momentary grid swing and the time required for the choked grid to clear.

The Direct-Coupled Amplifier

We are now ready to consider Fig. 4. This shows the new direct-coupling system, which incorporates only a single resistance between the plate of the audio amplifier and

the power tube. An arrangement of this kind is startling, to say the least. Wasn't the whole object of the coupling condenser, in the standard resistance-coupling system, to insulate the plate from the succeeding grid? And here we deliberately connect them together! Have we changed all of our preconceived notions of grid bias, or has some trick circuit permitted us to do this without upsetting the bias? The latter is actually the fact. We can actually make this direct connection without disturbing the bias on the grid of the power tube; and it is not such a trick circuit, either! The stunt is made possible by the use of A.C. tubes whose filaments are heated by separate windings on the filament transformer.

A simple tracing of the circuit in Fig. 4 will suffice to explain the principles on which this new circuit is based. A "B" potential of about 425 volts is applied to the plate circuit of the power tube in the standard manner. Current then flows from this source to the plate of the power tube, thence through the tube to the filament, and back to ground through the resistance R3. This resistance, however, is much higher than that with which we are familiar in the grid-biasing resistor usually placed in this position. Actually, this resistance is made so large that it places the power tube filament about 165 volts above ground, instead of the usual 50 volts. Since the power tube requires only the normal 250 volts, it is this excessive voltage between filament and ground that demands the original high "B" supply of 425 volts. Then, it must be remembered, this 165 volts is positive with respect to ground, and so the filament is really 165 volts positive; though it is 250 volts negative with respect to the plate. The resistor R3 which does this trick is of about 5500 ohms. You will recall that the ordinary resistor used in this position for a grid bias has only about 1500 ohms.

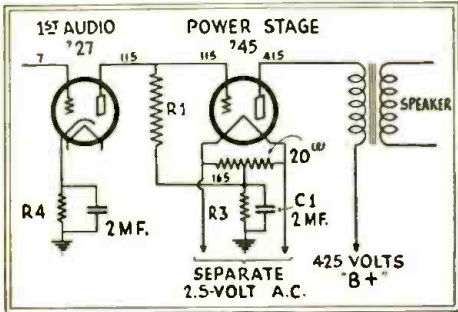

Fig. 4

The new "direct-coupling" system uses the principle of the old laboratory "battery-coupler" to give very uniform amplification at all frequencies.

this phase of the subject is therefore justifiable, here and now! Theoretically, the amount of possible signal strength that an amplifier can pass without distortion is limited by the value of grid bias on the power tube. Thus, with any given negative "C" bias, we are limited to a signal that does not swing the grid positive. The instant that the grid is stretched beyond this point, distortion of the signal occurs. Fortunately we can go considerably further than this in practice; because excessive surges do not exist for any length of time during the rendering of normal musical orchestrations.

Effect of Grid Overload

You see, in the transformer-coupled system shown in Fig. 1A, the grid bias given by the cathode resistor R3 permits ample volume without distortion for the ordinary run of music. It a sudden surge takes place

Too high a signal on "resistance" coupling runs the grid positive as at B (Fig. 2). The grid draws electrons until it is too negative, as at C. It remains so for a time indicated in Fig. 3—the period of the condenser's discharge through the grid resistor.

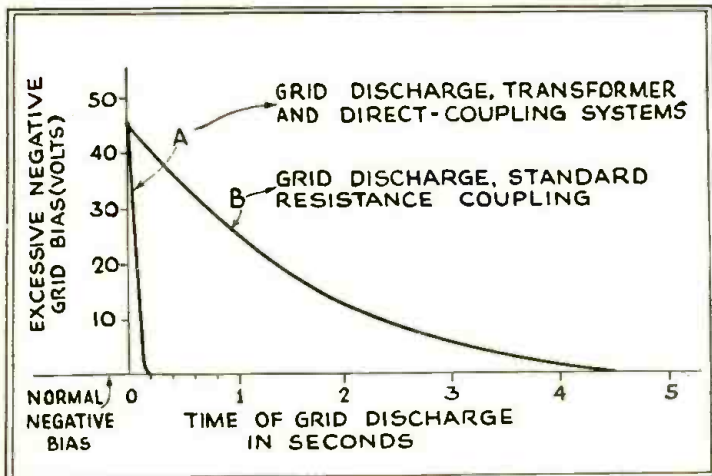

Fig. 3

Comparative periods of grid blocking.

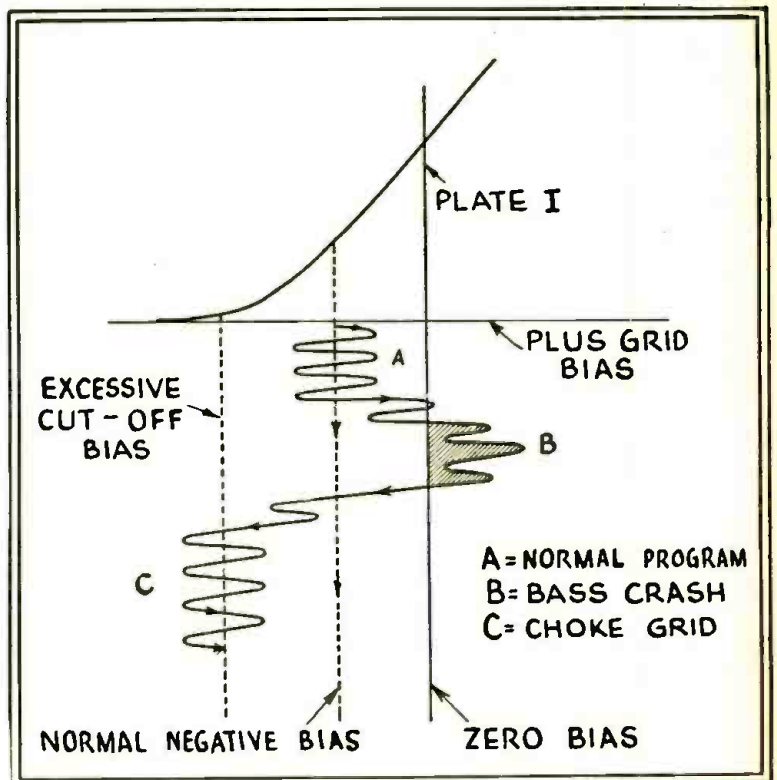

Fig. 2

Effect of a bass-note surge on grid bias.

Division of Voltages

Since the filament of the power tube is 165 volts positive, it may be used as the plate supply for the preceding amplifier, and R1 may be looked upon as the plate resistor of the first audio tube. So far, so good! The only unusual thing, up to this point in the circuit tracing, is the very high filament-resistance bias, and the use of this for the plate supply of the preceding tube.

Now, we will consider the grid circuit. It is necessary that the permanent grid bias on the power tube shall be about 50 volts negative with respect to the filament. How do we get this when we connect the grid directly to the plate, as in Fig. 4? It is too simple! The plate circuit of the first audio tube naturally draws current through resistor R1, when this resistor is connected to the mid-tap of the filament of the power tube (this point being 165 volts positive). When current flows through this resistor R1, there is a drop of potential, so that the original 165 volts is materially reduced; and, by properly determining the value of the resistance, we may make this drop about 50 volts. Hence, we find that the grid will have a potential, with respect to filament, about 50 volts less than the mid-tap of the filament. The grid will, therefore be 50 volts negative with respect to filament!

A little study will show that the same cir-

cuit condition which gives the 50 volts negative to the grid of the power tube will, at the same time, give 115 volts positive (with respect to ground) to the plate of the preceding audio tube. We can therefore connect these two points directly together and eliminate the necessity of the insulating coupling condenser (C, in Fig. 1B) which was the source of choking in the standard resistance system. It is now easy to see that we have overcome the most serious defect of resistance coupling; and we can run the amplifier up to full volume on normal music, without fear of choking it on the bass surges. This new direct-coupled amplifier simply will not choke. In this respect, it is every bit as good as the transformer hook-up.

On the Other Hand

And now for the disadvantages, so you won't dash off half-baked! It should be perfectly apparent that this new system will not deliver audio volume, on weak signals, such as you are accustomed to with transformer coupled circuits. There is nothing inherent in the direct amplifier to boost the voltage step-up, other than the tubes themselves. In this respect, it is not one whit better than standard resistance coupling. True, it will deliver as much volume on locals as the transformer system; and it is here that it exceeds the regular resistance circuit.

All of the hue and cry about this direct-coupled amplifier being cheaper than the standard resistance amplifier, because it eliminates the coupling condenser and the grid leak, is just pure bunk. This is many times offset by the cost of the special power pack required to give the 425 volts to the plate of the power tube; and this must be an extra pack, too, because it is not possible to use this high-voltage unit on the rest of the set. (Two things are against it: first, the rectifying tube will not stand the load; and secondly, the direct audio amplifier is also a good R.F. amplifier, and both systems can be fed from the same power pack only with difficulty. Of course, this latter point is only a minor one, for the same statement applies also to the regular resistance system.)

Perhaps the most serious handicap is that the system cannot be carried through more than one stage without an initial voltage on the power tube beyond all reason and safety. Even if this were possible, still the direct-resistance amplifier cannot be placed directly on the output of the detector without introducing a lot of complications which more than offset its simplicity.

In the next article, we will continue this discussion and show some very practical circuit arrangements whereby this startling contraption can actually be made to work directly from your present detector circuit.

One Hundred Dollars in GOLD

for a SLOGAN for

A few moments of
your spare time NOW may
bring you \$100.00 in GOLD!

WE want a catchy slogan for this magazine. Slogans are now used universally in many different lines of business, and we believe that this magazine should be known by its own slogan.

Such slogans as "NOT A COUGH IN A CARLOAD"; "GOOD TO THE LAST DROP"; "SAY IT WITH FLOWERS," etc., are well known. A number of magazines have already adopted slogans; such, for instance, as "Popular Mechanics," with "WRITTEN SO YOU CAN UNDERSTAND IT."

We are offering \$100.00 for a novel, as well as descriptive, catchy phrase which we shall use after the end of the contest as a permanent slogan of this magazine.

REMEMBER, THERE IS NOTHING TO BUY OR TO SELL!

You have an equal chance to win this prize, regardless of whether or not you are a subscriber. The contest is open to all. Get your friends in on this and, if they give you suggestions, you may split the prize with them, if you so desire.

To win the \$100.00 prize, you must submit only a single slogan, ONE ONLY. It must be an original idea. It makes no difference who you are or where you live, whether in this country or not; anyone may compete in this contest and you may be the winner.

Look this magazine over carefully and try to find out what it stands for, what its ideals are, and what it tries to accomplish. Then try to put all of your findings into a slogan which must not, under any circumstances, have more than seven words.

After you have the idea, try to improve upon it by shortening the slogan and making it sound more euphonious; but always remember that it is the idea which counts. The cleverer the slogan, and the better it expresses the ideas for which this magazine stands, the more likely are you to win the prize.

No great amount of time need be spent in the preparation of slogans. Start thinking right now and jot down your thoughts. Also, tell your friends about it, and get them to submit slogans of their own; or compose one in partnership with them.

Radio-Craft
for the
Professional-Serviceman-Radiotrician

Here are a couple of sample slogans; which are given as mere suggestions, AND NOT TO BE USED AS ENTRIES:

"WAVES OF RADIO INFORMATION"
"IT HOOKS UP THE RADIO MAN"

RULES FOR THE CONTEST

- (1) The slogan contest is open to everyone except members of the organization of RADIO-CRAFT and their families.
- (2) Each contestant may send in only one slogan; no more.
- (3) Slogans must be written legibly or typed on the special coupon published on page 595 of this magazine. (If you do not wish to cut the magazine, copy the coupon on a sheet of paper exactly the same size as the coupon.) Use only ink or typewriter; penciled matter will not be considered.
- (4) Each slogan must be accompanied by a letter stating in 200 words, or less, your reasons for selecting this slogan.
- (5) In case of duplication of a slogan, the Judges will award the prize to the writer of the best letter; the one which, in their opinion, gives the most logical reasons for the slogan.

This contest closes on May 1, 1930, at which time all entries must be in this office; and the name of the winner will be announced in the July, 1930, issue of RADIO-CRAFT, on publication of which the prize will be paid.

Because of the large number of entries which may be expected, the publishers cannot enter into correspondence regarding this contest.

Address all communications to:

Editor, Slogan Contest

Care of RADIO-CRAFT

96-98 Park Place

New York, N. Y.

SUCCESS IN RADIO

Depends Upon Training

... You Get that Training
with RCA Institutes, Inc.

REGARDLESS of who you are... how old you are... where you live or what you do... You, too, can make a success in radio because RCA Institutes *trains you for success*. This is the *only* school backed by the Radio Corporation of America... the foremost radio organization in the world today!

"A Serious Shortage of Trained Men Exists Right Now"

Thousands of men are needed. Broadcasting stations, manufacturing plants, retail and wholesale dealers, as well as ships at sea and planes in the air are now waiting for men like you... men who have the will as well as the knowledge to make good. They know that the graduate of RCA Institutes has the knowledge and ability to hold a good position in radio.

Inside Information about Radio... Quickly and Easily Yours

See how easy it is to learn at home in your spare time... Mr. Lawrence A. Aicholtz says:

"Your course is without a doubt the very best of its kind and the training I received has enabled me to work up to the position of Chief Remote Operator of WSAI."

We have received hundreds of letters similar to this... each letter a "true story" of success in radio. You get your lessons and criticisms direct from RCA... the very source of radio achievement... the organization that made Radio what it is today... that sponsors every lesson in this course.

Remarkable Outlay of Apparatus Included with this Famous Laboratory Training Course

You learn radio by actual experience with the famous RCA Institutes outlay of apparatus... A complete assortment of parts assembled for your help and instruction by RCA experts. See for yourself how easy it is to solve every radio problem such as repairing and servicing fine sets. Here is



*Radio Inspectors
\$2,000 to \$4,500
a Year*

*Radio Repair
Mechanics
\$1,800 to \$4,800
a Year*

*Radio
Operators
\$90 to \$200
a Month
(Board Free)*

the training that you cannot duplicate elsewhere, at any price. Students learn by actual experience, under the direction of nationally known instructors.

RCA Graduates Find it Easy to Fill Good Radio Jobs

For more than 20 years there has been a radio job for practically every graduate who wished one. RCA Institutes students are actually *trained for success in Radio*... That is the *only purpose of this organization* and that is why students make such rapid progress in Radio. Every student receives an agreement signed by the president of this school assuring absolute satisfaction upon completion of the course... or money refunded.

RCA INSTITUTES INC.

Formerly Radio Institute of America



Clip this Coupon NOW!

RCA INSTITUTES, Inc.
Dept. RC-5 75 Varick Street
New York, N. Y.

Gentlemen: Please send me your FREE 40-page book which illustrates the brilliant opportunities in Radio and describes your laboratory-method of instruction at home!

Name.....

Address.....

INFORMATION BUREAU

SPECIAL NOTICE TO CORRESPONDENTS: Ask as many questions as you like, but please observe these rules:

Furnish sufficient information, and draw a careful diagram when needed, to explain your meaning; use only one side of the paper. List each question. Inquiries can be answered by mail only when accompanied by 25 cents (stamps) for each separate question. We cannot furnish blueprints or give comparisons of the merit of commercial products. The reader asking the greatest number of interesting questions, though they may not be all answered in the same issue, will find his name at the head of this department.

Highest for the current month: **GEORGE IVES** with four interesting questions.

EARLY CROSELY MODELS

(58) Mr. Carroll A. Perrine, Philadelphia, Pa.

(Q.) If they are available, please print the diagrams of the following Crosley units: "3R3 Trirdyn" (one stage of tuned R.F., regenerative detector, two stages of transformer-coupled A.F.—with three tubes); "Type V" (a one-tube regenerative receiver); "Model 51" (regenerative detector and single audio); "Model 3B" and "Model 3C" (regenerative detector and two A.F.); the Crosley two-tube A.F. amplifier; "Model XJ" and "Model XL" (each with one stage of tuned R.F., a non-regenerative detector, and two A.F.)

(A.) These circuits, the earliest commercialized by Crosley, are diagrammed here. Except for the "Trirdyn," these receivers include the famous "book" condensers, consisting of two sheets of foil on maple blocks, one of which was movable by means of an eccentric cam; tapped spiderweb inductances; and UV-type sockets.

The "Type V" uses spiderweb inductances for L1 and L2 (Fig. 58A); C2R2 is the usual grid-condenser-and-leak combination, of .00025-mf. and 2 meg. values, respectively; V1 may be any tube having a "UV" base; C1 is the "look" condenser; and R1 is a rheostat with three resistance-windings (approximately 1 ohm, 10 ohms, and 20 ohms, in series) across which slides the contact-arm; a type of construction which makes it convenient to control circuit performance under widely-varying "A" battery voltages for type '99 or '01A tubes. A "double" binding post affords connection of one side of the headphones and "B+." Looser coupling between L1 and L2 (called the "Varind") is obtained by pushing L2 from L1. Headphones may be connected to the posts marked "phones."

A companion unit for "Type V" is the two-stage unit shown in Fig. 58B. Sw.2 controls both the tuner and the amplifier when the two are connected through the posts provided. V2 and V3 may be of any type of low-power tube, with corresponding "A," "B," and "C" potentials. (When a "C" battery is not used the grid return circuit is completed as shown by the dotted line.)

"Model 51," as may be seen, is a regenerative detector followed by a single stage of A. F. amplification. (Fig. 58C.)

The "Crosley XJ" (and "XL") are next diagrammed. Parts of the same types described above are used to construct the circuit; V2 is the detector. (Fig. 58D.)

The models "3B" and "3C" employ the spiderweb-inductance arrangement described above for the detector circuit, which is followed by a 2-stage A.F. amplifier in which a jack is used to reduce

OBTAINING A LICENSE

(59) Mr. George Ives, Congress Park, Ill.

(Q.) What is the fee for a license to operate a code transmitting station?

(A.) No government fee is charged for either the station or the operator's licenses required for operation of a transmitter of any type. It is neces-

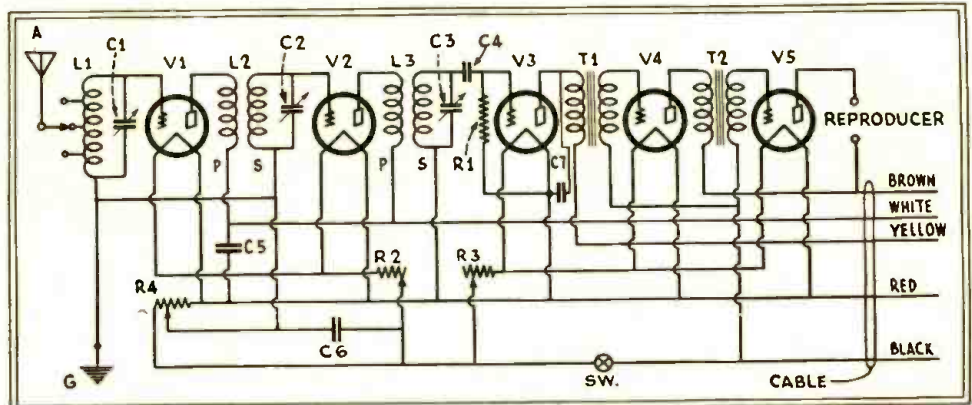

(Fig. Q60) The Atwater Kent "Model 10B," a very early "breadboard" receiver. The circuit is quite simple, and the controls numerous. It is designed for storage-battery tubes, and has potentiometer R.F. control. It may be readily altered to use a power tube.

the amplification to one stage of A.F. (Fig. 58E.)

A departure from the previous circuit design is observed in the "Trirdyn" circuit (Fig. 58F.); which is also catalogued as the "Model 3R3." This receiver comprises a stage of tuned R.F., a regenerative detector, and two stages of A.F. amplification, in a three-tube arrangement, by means of the reflex principle. The headphones may be plugged into the jack, to use one audio stage. In this receiver, regular interleaving plates supplant the earlier "look" design of the 0.00035-mf. variable condenser.

sary to pay the small fee of the notary who witnesses the signature of the applicant and affixes a seal.

(Q.) What is the fee and what are the requirements for operating an amateur short-wave station transmitting voice?

(A.) See the answer given to the first question (above).

The required forms may be obtained from the office of the Supervisor of Radio in the Inspection District where the applicant resides; the correct address may be determined from the following list:

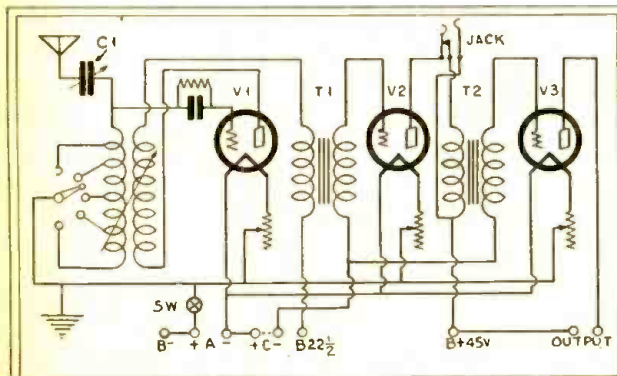

(Fig. Q58E) Above, the schematic of the Crosley "Model 3B" and "3C," which, like the "Type V," uses a variocoupler in the two-circuit regenerative detector stage.

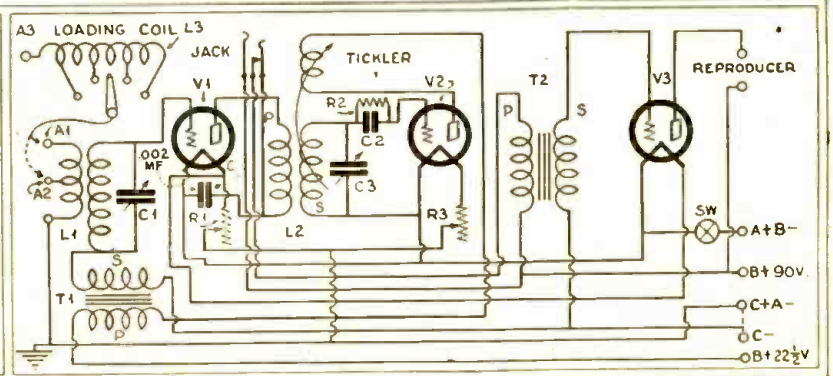

(Fig. Q58F) The famous Crosley "Trirdyn" (Model 3R3) which incorporates a reflexed stage of R.F. and first A.F. Unlike earlier models, this receiver used a condenser with meshing rotor plates.

CENTRALIZE YOUR BUYING!

Every Radio Accessory that is necessary and profitable for Jobbers and Dealers to carry can be furnished in Bud Radio Products

AERIAL EQUIPMENT

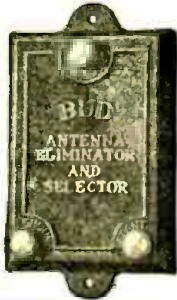

BUD ANTENNA ELIMINATOR AND SELECTOR
A device that can be fastened into Cabinet of Set, and takes the place of an outside aerial.
Price - \$2.50



BUD ANTENNA OUTLET
Used for installation in new homes and apartments in place of outside aerial.
Price - \$4.00

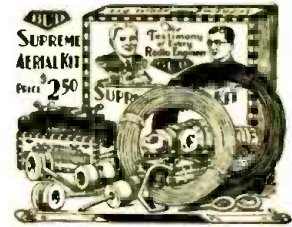

BUD SUPREME AERIAL KIT
Includes all of the best materials necessary for a complete outside aerial.
Price - \$2.50

BUD RADIO CONVENIENCE OUTLETS MADE OF BAKELITE



No. 105-B
For Aerial and Ground Connections.
Price - \$1.10



No. 106-B
For Loud Speaker or Head Phone Connections.
Price - \$1.00

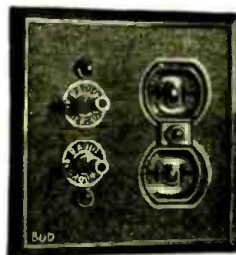

No. 158-B. D.
Combination for Aerial, Ground and Electrical Connections.
Price - \$2.10

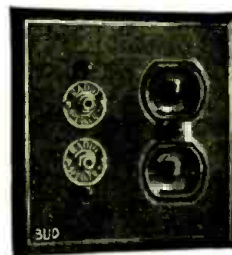

No. 168-B. D.
Combination for Speaker and Electrical Connections.
Price - \$2.00



No. 157-B
Speaker Outlet with Volume Control.
Price - \$2.85



No. 166-B
For two Loud Speaker or Head Phone Connections.
Price - \$2.00



No. 156-B
Aerial, Ground and Speaker Connections.
Price - \$2.10



No. 108-B
For Electrical Connections. Will Harmonize with Bud Radio Convenience Outlets.
Price - 85c



No. 104-B
A four-way toggle switch for turning on and off radio set and power speaker at three points distant from radio set.
Price - \$3.35

No. 103-B

A three-way toggle switch for turning radio set off and on at two points distant from radio set.

Price - \$1.00



BUD OUTPUT ADAPTER

Designed so that additional speakers can be connected to any of the newer radio sets that are using push pull amplification without having to disconnect any of the wiring of radio set or solder any connections.

Packed 2 in a box—Price 65c each—\$1.30 for pair



BUD LOCK-TITE GROUND CLAMPS
Price - 15c

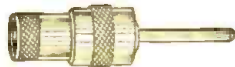

BUD SOLDERLESS PLUG
Price - 10c



BUD SURE-GRIP JACK
Price - 15c



BUD LIGHTNING ARRESTER

Made of Bakelite—Includes \$100.00 Free Insurance.

Price - \$1.00



BUD VISE-GRIP GROUND CLAMP

Price - 25c

Jobbers and dealers are requested to write us for discounts on this profitable line of merchandise

BUD RADIO, INC. - - - - - Cleveland, Ohio

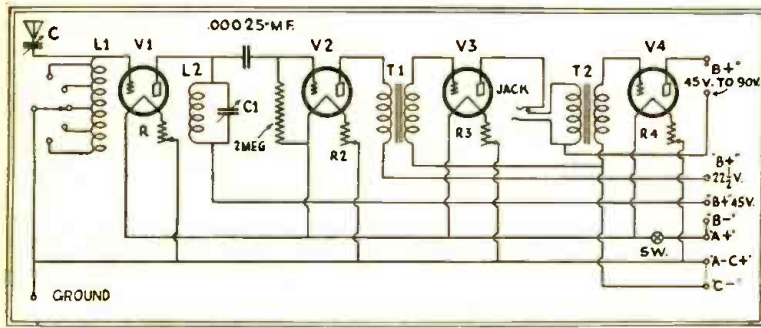

(Fig. Q58D) In the Crosley "Model XI" (and "XL") a stage of impedance-coupled R.F. amplification precedes the non-regenerative detector. Note that the antenna coupler L1 is without the adjustable coupler of previous models.

Fig. Q60. Approximate electrical values are as follows: R1, 2 to 4 megs.; R2, 15 ohms; R3, 10 ohms; R4, 400 ohms. C1, C2, C3, .0005-mf.; C4, .00025-mf.; C5, 0.2-mf.; C6, 0.2-mf.; C7, .006-mf.

If an A.F. transformer must be replaced, it is necessary to melt the sealing compound carefully, before the defective unit can be removed. The by-pass condensers are mounted in grooves under the baseboard, and held in position by a sealing compound. As the set was originally wired, type '01A tubes must be used throughout, with the exception of the two stages of A.F. amplification. In these it is possible to use two type '12A tubes, if the "C" bias is increased to 9 volts (with 135 volts "B"); but this procedure is not recommended unless the last A.F. transformer is replaced by one with a primary winding capable of carrying the increased plate current of V4.

(Q.) What is the circuit arrangement of the "Bud Antenna?"

(A.) The schematic circuit of this unit is shown in Fig. Q. 60 B on page 606.

C1 and C2 have negligible values; the operation of the instrument centers around fixed condenser C, of the tin-foil and mica type, which has a capacity of about .01-mf. "Pri." and "Sec." are the

First District: Maine, New Hampshire, Vermont, Massachusetts, Rhode Island and Connecticut. (Supervisor of Radio, Custom House, Boston, Mass.)
 Second District: New York (New York City, Long Island, and the counties on the Hudson River to and including Schenectady, Albany, and Rensselaer) and New Jersey (counties of Bergen Passaic, Essex, Union, Middlesex, Monmouth, Hudson and Ocean).

(Supervisor of Radio, U. S. Sub-Treasury Building, Wall, Pine and Nassau Sts., N. Y. C.)

Third District: New Jersey (all counties not included in Second District), Pennsylvania (counties of Philadelphia, Delaware, all counties south of the Blue Mountains, and Franklin County), Delaware, Maryland, Virginia, and the District of Columbia. (Supervisor of Radio, Room 13, Custom House, Baltimore, Md.)

Fourth District: Alabama, Tennessee, North Carolina, South Carolina, Georgia, Florida and the Territory of Porto Rico. (Supervisor of Radio, Room 524, Post Office Bldg., Atlanta, Ga.)

Fifth District: Mississippi, Louisiana, Texas, Arkansas, Oklahoma, and New Mexico. (Supervisor of Radio, Custom House, New Orleans, La.)

Sixth District: California, Nevada, Utah, Arizona and the Territory of Hawaii. (Supervisor of Radio, Custom House, San Francisco, Calif.)

Seventh District: Oregon, Washington, Idaho, Montana, Wyoming and the Territory of Alaska. (Supervisor of Radio, 2116 L. C. Smith Building, Seattle, Wash.)

Eighth District: New York State (all counties not included in the Second District), Pennsylvania (all counties not included in the Third District), West Virginia, Ohio and Lower Peninsula of Michigan. (Supervisor of Radio, 504 Commerce Building, Detroit, Mich.)

Ninth District: Indiana, Illinois, Wisconsin, Michigan (Upper Peninsula), Minnesota, Kentucky, Missouri, Kansas, Colorado, Iowa, Nebraska, North Dakota and South Dakota. (Supervisor of Radio, 2022 Engineering Building, Chicago, Ill.)

(Further procedure is explained on the forms.)

Amateur transmitting stations licensed to operate in any of these districts may be permitted to use any or all of the available amateur frequency bands; amateur phone stations must transmit only on the 1715-2000, 3500-3550 and 56000-60000 kilocycle (150-175, 84.5-84.7, 5-5.36 meter) bands. Transmission is prohibited, in the United States, between the hours of 8:00 and 10:30 p.m., local standard time; and also, during local church services on Sundays if interference to other services exists. This subject is thoroughly covered in the 16-page chapter, "Getting Started," in "The Radio Amateur's Handbook," obtainable from The American

Radio Relay League, Hartford, Conn. The prospective "ham" should write to the Government Printing Office, Washington, D. C., for a copy of "Regulations Governing Radio Communication," (10c per copy); and "The Radio Law of 1927," (5c per copy).

(Q.) What is the proper length and height of an antenna for proper short-wave operation? We are located about thirteen miles west of the downtown district of Chicago.

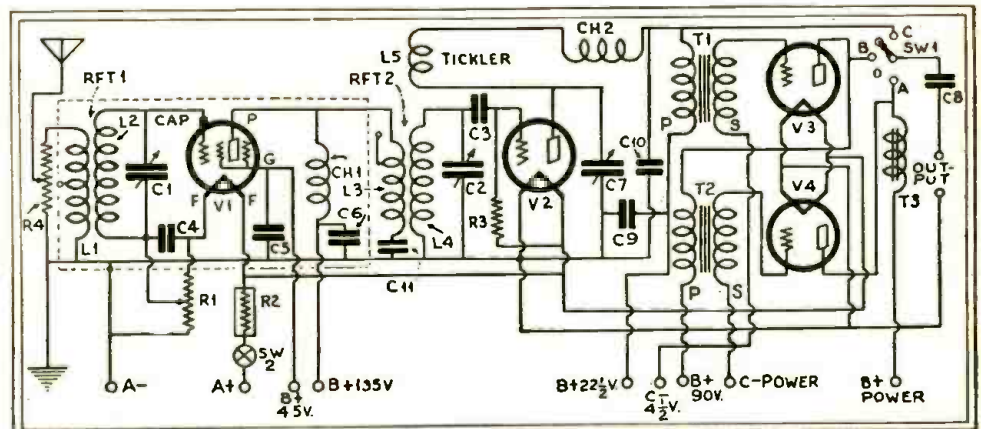

(Fig. Q61) An old-style regenerative set will be much improved by a tuned screen-grid stage. The audio end looks like push-pull, but isn't; the switch SW1 selects the detector, first or second A.F. output for the reproducer, which may be headphones.

(A.) The proper design of the antenna for a short-wave transmitter is determined by local conditions, as well as the wavelength, or wavelengths, at which the transmitter is to operate, and the circuit design of the transmitter.

primary and secondary coils of the input R.F. transformer of any standard radio set.

It is claimed that the device is equivalent in signal input to a 50-foot outside aerial. It is obvious, from a study of this diagram, that the results the user will obtain from this antenna substitute depend almost entirely upon the radio set with which it is used, and the length, location and efficiency of the ground available.

ATWATER KENT 10B

(60) Mr. Herbert Dudley, Back Bay, Va.

(Q.) What is the circuit of the earliest Atwater Kent receiver? One of these sets is in for repair. A potentiometer is used for volume and circuit-oscillation control. Five tubes are required for the set, which is of the "breadboard" type. The detector and A.F. are combined in a single unit.

(A.) This receiver is the "Model 10B," Nos. 4550 and 4560. The schematic circuit of this battery-operated "Open Mounted" set is shown as

HOME-MADE FOUR-TUBE SETS

(61) Mr. G. Kenworthy, Qu'Appelle, Sask., Can.

(Q.) Your constructional articles are so plain and easily understood that I am encouraged to write for the schematic circuit and constructional details of a receiver which I know would be very popular with radio fans on the Canadian

(Continued on page 605)

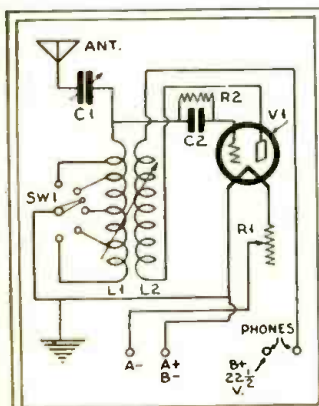

(Fig. Q58A) The single-tube Crosley "Type V"; the red tickler lead runs to the plate of the tube.

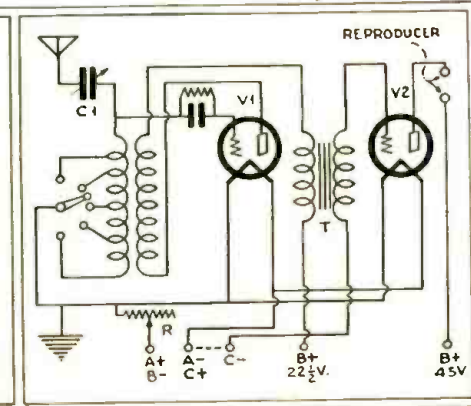

(Fig. Q58C) The Crosley two-tube "Model 51," in which there is a "C" lead for the single stage of A.F. amplification. Replacing C1 with a .0005-mf. condenser will increase the tuning range.

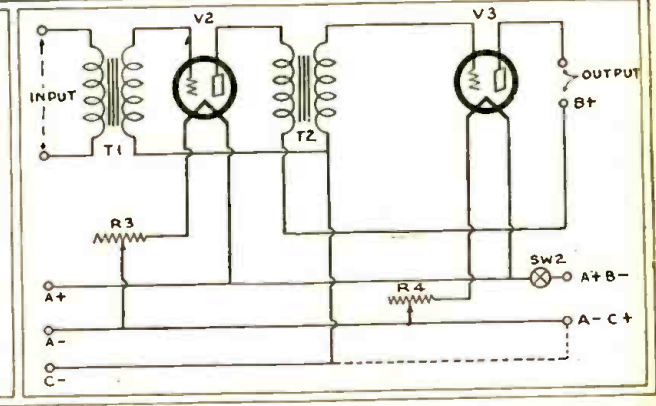

(Fig. Q58B) This two-stage Crosley A.F. amplifier was designed for use with the single-tube "Type V" tuner diagrammed at the left. The "B-22 1/2" double post of the tuner affords a connection with the battery and across the primary of T1.

4th RMA Trade Show

ATLANTIC CITY

AUDITORIUM

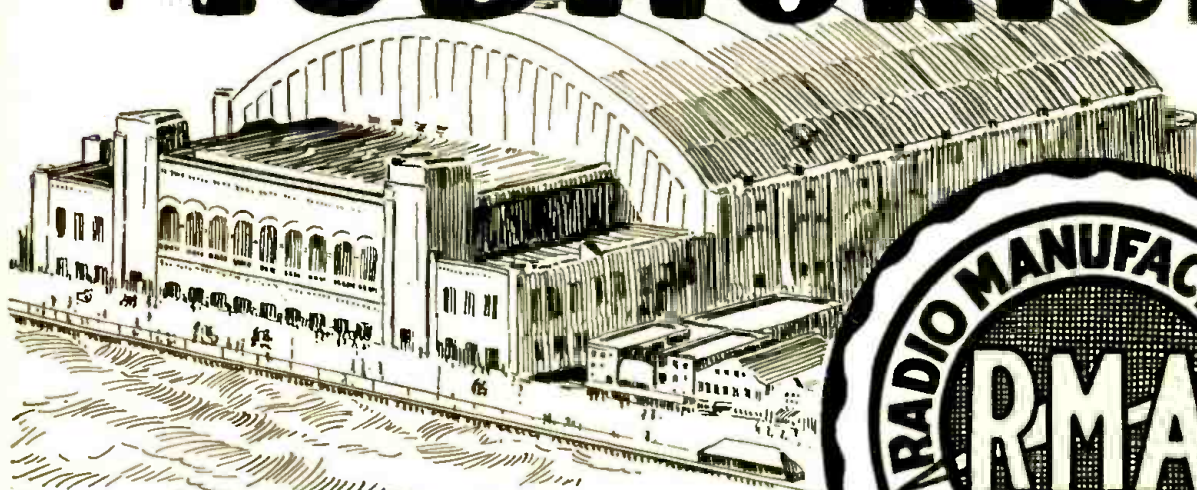

JUNE 2 to 6th

ALL indications are that the 4th Annual R. M. A. Trade Show to be held in Atlantic City June 2nd to 6th will be the largest as well as the most important Trade Show in the industry's history.

In addition to the latest receiving set models and accessories, which will be exhibited and demonstrated in the Atlantic City Auditorium, many important subjects of interest to everyone in the industry, from dealer to manufacturer, will be discussed.

During the same week as the Trade Show, the Sixth Annual R. M. A. Convention, the National Federation of Radio Associations, the Radio Wholesalers Association, and the Institute of Radio Engineers will convene in Atlantic City.

Atlantic City abounds in first-class hotels. The visitors to the Trade Show can be assured that an average of \$10.00 per day will well cover all expenses except transportation. For your information, we give the round trip railroad rates to Atlantic City from the principal cities.

The Radio Trade Show immediately follows the opening on Decoration Day of Atlantic City as the "Playground of the World." All of the attractions of Atlantic City, piers, golf courses, bathing, fishing, etc., will be in full swing, affording you an ideal opportunity to combine business with pleasure.

Make your hotel reservations through the Atlantic City Convention Bureau, Atlantic City, N. J. Invitation credentials for the Trade Show will be mailed to the trade about May 1st.

Round Trip Railroad Rates to Atlantic City

All railroads are offering special fare and one-half rates for the round trip to Atlantic City. Following are the round trip rates from the cities indicated:

Pittsburgh	\$22.50
Cleveland	29.06
Toledo	34.83
Detroit	37.94
Columbus	32.28
Dayton	36.09
Cincinnati	38.75
Louisville	45.21
Indianapolis	42.03
Chicago	47.28
Milwaukee	51.87
St. Louis	55.32
Kansas City	70.38
Minneapolis	69.27
Omaha	74.18
Denver	103.20
Los Angeles	162.89
San Francisco	162.89
Portland and Seattle	163.10

Radio Manufacturers' Association Trade Show

ROOM 1904, TIMES BUILDING

NEW YORK

Under Direction of U. J. Hermann and G. Clayton Irwin, Jr.

The "Hi Q-30"

(Continued from page 580)

- One Hammarlund three-stage band-filter unit (comprising L1, L2, L3 and C1) No. BS-3;
- One Hammarlund three-stage screen-grid amplifier unit (comprising L4, L5, L6, C2, .00025-mf. grid condenser C6, 1-meg. grid leak R9, and three polarized R.F. chokes, Ch1, Ch2, Ch3) No. RF-3;
- One Hammarlund knob-control drum dial No. SD;
- One Hammarlund shielded polarized R.F. choke (Ch4) No. SPC;
- One Hammarlund first-stage A.F. transformer (T1) No. AF-2;
- One Hammarlund push-pull input A.F. transformer (T2) No. AF-4;
- One Hammarlund push-pull output A.F. transformer (T3) No. AF-M if for use with magnetic reproducers, or AF-D for use with dynamics;
- One Hammarlund power supply unit for push-pull '45s (comprising power transformer PT and A.F. chokes Ch5 and Ch6) No. PS-45;
- Three Hammarlund screen-grid tube shields, No. TS;
- One Aerovox filter-condenser block (seven capacities, values indicated on diagram, C8) No. CHQ-30;
- Three Aerovox by-pass condenser units, each triple 0.1-mf. (C3, C4, C5) No. BP-3;
- One Yaxley 10-ohm center-tapped fixed resistor (R11) No. 810-C;

- One pair Yaxley insulated phone-tip jacks, No. 422;
 - One Yaxley twin-tip speaker jack, No. 401-S;
 - One Electrad voltage divider (comprising R13, R14, R15, R16, R17) No. R11Q-30;
 - Four Electrad flexible grid resistors—one 2,000-ohm (R10), two 400-ohm (R1, R4), one 800-ohm (R7)—No. 3;
 - Three Electrad 5,000-ohm flexible filter resistors R3, R6, R8) No. 3;
 - One Electrad 25,000-ohm "Royalty" volume-control potentiometer (R12) special-taper;
 - One Eby two-prong tube socket (for voltage regulator R18) No. 6-11;
 - Three Eby four-prong tube sockets (for V6, V7, V8) No. 6-11;
 - Five Eby five-prong tube sockets (for V1, V2, V3, V4, V5) No. 6-11;
 - One Eby triple binding-post strip;
 - One Hart & Hegeman phono-toggle switch (Sw1) No. 20510;
 - One Hart & Hegeman line toggle switch (Sw2) No. 20510;
 - One Sangamo .001-mf. "Illini" mica fixed condenser (C7);
 - One Beaver-Arrow handle cap, cord connector and silk cord ("Line Cord");
 - One Beaver duplex receptacle No. L-14;
 - One Arrow plug-type midget receptacle ("Line Input") No. 8339.
- The operating voltages at the tube sockets are as follows: Plates V1, V2, V3, V5, 180 volts; V4, 50 volts; V6, V7, 280 to 300 volts; Screen-grids V1, V2, V3, 20 to 30 volts; Cathodes V1, V2, V3, 1 to 2 volts; Con-

trol-grid voltage, V1, V2, V3, 1½-volts; V4, 0.0 volts; V5, 13 volts; V6, V7, 80 volts; Filament voltage, V1, V2, V3, V4, V5, 2.4 volts; V6, V7, 2.6 volts. The total current consumption is 130 watts.

Coil Data

The coil constants for this receiver are as follows: L1A, 30 turns, tapped at the tenth turn and wound alongside L1B; L2A, L3A, one turn each; L4A, L5A, L6A, each 40 turns of wire, over the grid end of each corresponding secondary. L1B, L2B, L3B, L4B, L5B and L6B consist each of 63 turns of No. 31 enameled wire wound on threaded bakelite tubes 1½-in. diameter, and for a winding length of 11/16-in. L1A has a winding width of 5/16-in.; L4A, L5A and L6A, 7/32-in. L6B is tapped at the 40th turn from the filament end. L1A, L2A and L3A are wound with No. 31 enameled wire; L4A, L5A and L6A with No. 36 enameled wire. R.F. units L1, L2, L3, L4, L5 and L6 are centered in cans measuring 3 x 2⅞-in.

WHAT RADIO NEEDS

THE importance of the Service Man was one of the themes of importance considered by the various conventions of the radio industry at their recent gathering in Cleveland; and the necessity of examination and classification of technical qualifications was generally acknowledged. Less obtrusive advertising over the radio, and more truth in advertising of radio, were also seen by the industry to be desirable in its campaign for "a billion-dollar year."

EVERY
SERVICE MAN
SHOULD OWN
THIS BOOK!

S. GERNSBACK'S RADIO ENCYCLOPEDIA

The First Real Radio Encyclopedia Ever Published

Regular Price \$2.00

Our Special Price \$1.49



(1930 Definitions)
FULLY ILLUSTRATED
Size 9 x 12 in.
Over One Inch Thick
168 Pages
Written in Plain English

EDITED by SIDNEY GERNSBACK, Author of "Wireless Course in Twenty Lessons" — "One Thousand and One Formulas" — "Practical Electricity Course" — "The Radio Educator," etc.

S. GERNSBACK'S RADIO ENCYCLOPEDIA is the only standard work ever published in America attempting to classify alphabetically the countless words used in the highly specialized science of RADIO. The ENCYCLOPEDIA is written in plain English so that everybody can understand the definitions and descriptions.

No expense has been spared, covering over two years in compilation, to make it worthy a place in your library.

It is published in one volume—168 pages—size 9 x 12 inches, over an inch thick and nicely accommodates the beautiful illustrations and the large, easy-to-read type.

The work contains 549 photographs, drawings and diagrams.

REMEMBER THIS IS A REAL ENCYCLOPEDIA — NOT A DICTIONARY — and very few of the things described and illustrated in this volume can be found in any diction-

ary, or any other encyclopedia.

The book contains as a supplement a classified cross index designed to bring together radio references under one heading having relations in common.

All circuits new and old are described by word and picture and every part and apparatus used in Radio is explained and made understandable by means of photographs and drawings.

The volume is printed upon fine paper—bound in full black Keratol, marbled paper fly leaves and end sheets, with the title stamped in gold.

SEND NO MONEY

Just Pay Postman

(Canada or Foreign send Check or Money Order for \$1.75)

ISKOR PRESS, Inc., R-5-30
286 Fifth Avenue,
New York, N. Y.

Send me one copy of Sidney Gernsback's First Radio Encyclopedia in one volume as advertised. I will pay postman \$1.49 plus postage on delivery.

Address

Town and State.....

Name

New Reproducers

(Continued from page 568)

well-known make of auditorium dynamic cone reproducer.

It is a development of the Celotex Baffle-board Co. and comprises a large octagonal projector of the straight-sided wide-throat variety, made of thick heavy celotex (Fig. 11). It takes up much less space than the ordinary large baffle used with auditorium installations, and is said to have the ability to throw the sound with higher efficiency directly through the movie screen of the "talkies"; so that even the farthest corners of the theatre are easily reached.

Later on, I shall tell my readers of some other reproducer developments, now in process of research, which are expected to lift the standard of rendition of the electro-acoustical field some added notches higher and hasten the day when radio reproduction will be completely undistorted and at the same time as efficient as other mechanical and electrical devices have become.

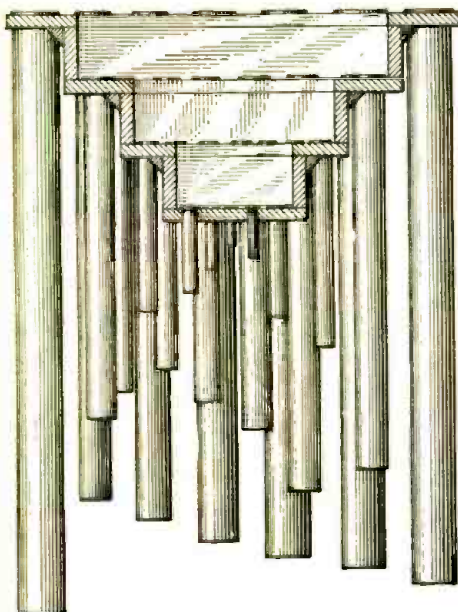

Fig. 3

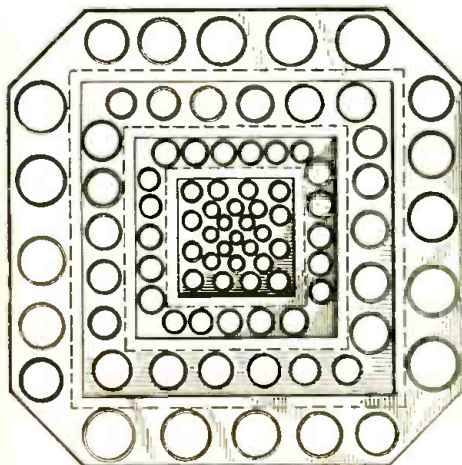

Fig. 4

Above, the elevation and the plan view of the resonators used in the Volf system, in the acoustic train of a large exponential horn. The tones, each concentrated by the resonator nearest its own frequency, are recombined in a chamber below from which they are reflected into the auditorium.

PATENTS INVENTORS

**Write for these
FREE BOOKS!**

MY PATENT
LAW OFFICES
OPPOSITE
U. S. PATENT
OFFICE

At the left is a view of my drafting and specification offices where a large staff of experienced experts is in my constant employ. All drawings and specifications are prepared in my offices.

Protect Your Ideas

Take the First Step Today

If you have a useful, practical, novel idea for any new article or for an improvement on an old one, you should communicate with a competent Registered Patent Attorney AT ONCE. Every year thousands of applications for patents are filed in the U. S. Patent Office. Frequently two or more applications are made for the same or substantially the same idea (even though the inventors may live in different sections of the country and be entirely unknown to one another). In such a case, the burden of proof rests upon the last application filed. Delays of even a few days in filing the application sometimes mean the loss of a patent. So lose no time. Get in touch with me at once by mailing the coupon below.

Prompt, Careful, Efficient Service

This large, experienced organization devotes its entire time and attention to patent and trademark cases. Our offices are directly across the street from the U. S. Patent Office. We understand the technicalities of patent law. We know the rules and requirements of the Patent Office. We can proceed in the quickest, safest and best ways in preparing an application for a patent covering your idea. Our success has been built on the strength of careful, efficient, satisfactory service to inventors and trademark owners located in every state in the Union.

Strict Secrecy Preserved— Write Me in Confidence

All communications, sketches, drawings, etc., are held in strictest confidence in strong, steel, fire-proof files, which are accessible only to authorized members of my staff. Feel free to write me fully and frankly. It is probable that I can help you. Highest references. But FIRST—clip the coupon and get my free book. Do THAT right now.

No Charges for Information on How to Proceed

The booklet shown here contains valuable information relating to patent procedure that every inventor should have. And with it I will also send you my "Record of Invention" form, on which you can sketch your idea and establish its date before a witness. Such evidence may later prove valuable to you. Simply mail the coupon and I will send you the booklet and the "Record of Invention" form, together with detailed information on how to proceed and the costs involved. Do this NOW. No need to lose a minute's time. The coupon will bring you complete information entirely without charge or obligation.

Clarence A. O'Brien
Registered Patent Attorney

Member of Bar of Supreme Court of the United States; Court of Appeals, District of Columbia; Supreme Court, District of Columbia; United States Court of Claims.
Practice confined exclusively to Patents, Trademarks, and Copyrights



Mail this Coupon Now

CLARENCE A. O'BRIEN
Registered Patent Attorney

3502 Security Savings and Comm'l Bank Bldg.,
Washington, D. C.

— or —
Suite 1106, Woolworth Bldg., New York City

Please send me your free book, "How to Obtain a Patent," and your "Record of Invention" form without any cost or obligation on my part.

Name

Address

(Important: Print or Write name clearly
and address office nearest you)

10 Tools in One

A SMALL but handy article which serves for every possible need of the all-round mechanic. Invaluable in any emergency.

An excellent combination of utilities for the household—every necessity featured: HAMMER — KNIFE-SHARPENER — NAIL-PULLER — BOTTLE-OPENER — SCREW-DRIVER — CORK-SCREW — CAN-OPENER — WEIGH-SCALE — RULER — TABLE OF WEIGHTS AND MEASURES

Just glance at the illustration and you will see how really useful this article is. The "Ten in One Tool" is 10 inches high and finely nickel-plated.

The new tool is not only handy in the household, but every TOURIST, AUTO-IST, CAMPER, PICKNICKER, BOY-SCOUT, FISHERMAN, CANOEIST, etc., should carry in his bag one of these indispensable combination tools. No SHOP, OFFICE, STORE, GARAGE, FARM, BOAT, should be without one. PRICE \$1.00, POSTAGE PAID.

Be the first one to own the "Ten Tools in One" in your own town.

Send your order today, pin a dollar bill to coupon below and the shipment will go forward to you the same day order is received.

GRENPKARK COMPANY

245 Greenwich Street
New York, N. Y.

Grenpark Company, FG-5
245 Greenwich Street,
New York, N. Y.

Enclosed find \$1.00 for which please send me prepaid your "Ten Tools in One."

Name

Address

Town..... State.....

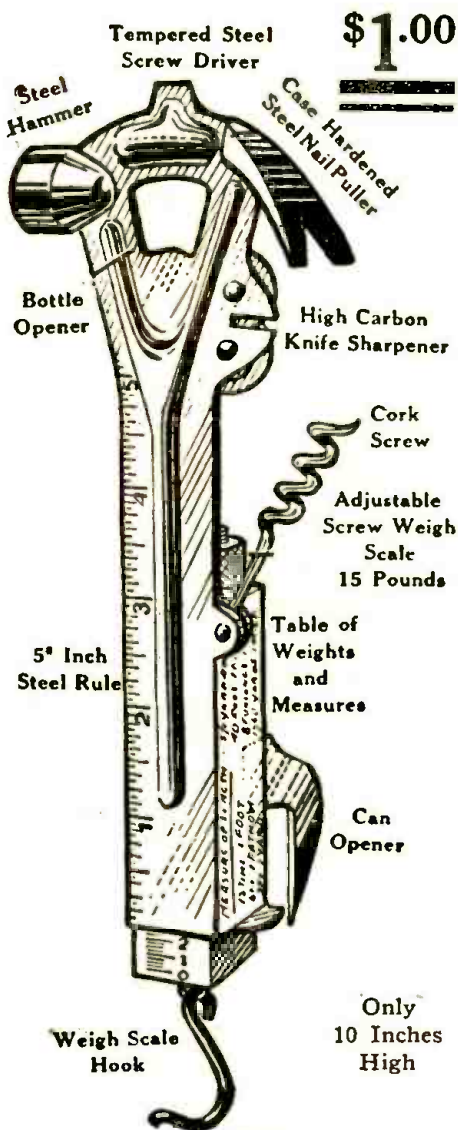

\$1.00

Mail
Coupon
Send for Yours
TO-DAY

James Clerk Maxwell

(Continued from page 565)

Aberdeen, Scotland, in 1856; and after four years accepted a similar chair at King's College, London. During this time he issued a classic paper which proved that the rings of Saturn must be composed of separate solid particles. He published in 1860 a treatise on the "Kinetic Theory of Gases"; and in 1864 the "Dynamical Theory of the Electromagnetic Field," advancing the proposition that light is but a manifestation of magnetism.

In 1865 ill health caused Maxwell to retire to the family estate at Glenlair, in southwestern Scotland, where he remained until called in 1871 to Cambridge to organize the Cavendish laboratory, as the first professor of experimental physics. Here, among his other labors, he edited the notebooks of Cavendish, the eccentric chemist and physicist of the eighteenth century, who had anticipated many of the later discoveries of science, but indifferently neglected to publish them to the world. Here, too, Maxwell published "The Theory of Heat," a book for the beginner, and his great work on "Electricity and Magnetism." In this he not only united the scientific theories of light and electricity, but showed the necessity of the existence of waves both longer and shorter than those of light, in unending ranges; and thus laid upon the world of science the task of finding them.

Maxwell's own time was short. His work was interrupted by illness; and, at the early age of forty-eight, he died at his Scotch home, on November 5, 1879. Yet, brief as was his life, it had revolutionized the outlook of science upon the world; and, though his own labors were in the field of mathematics and pure science, they have led directly to the development of radio and many other applications of electricity. He is the creator of modern mathematical physics; in the words of Sir Joseph Larmor, "Maxwell unified physical science, by connecting light and radiation with electricity so as to form one interlocked, systematic whole."

The comparison which has been made most often, perhaps, is that of Maxwell and Newton. Newton advanced mankind's conception of the unity of the universe by bringing the whole of it under the scope of one physical law; Maxwell brought all the fundamental phenomena into a single law—except that the task of fitting gravitation into the electromagnetic scheme was not to be accomplished by him. Whatever modifications the science of the future may find necessary in the system of Maxwell, and whatever additions it may make to his calculations, he has, like Newton, the glory of bringing about a new era in human thought; and by those who live in the Day of Radio, he must be remembered as its Morning Star.

BE A RADIO DOCTOR



Radio servicing offers the biggest opportunity for the man interested in radio. About 10,000,000 receivers need service some time or other, many are naturally inefficient and can be improved on.

The Radio Doctors, Inc., is the only institution teaching exclusively radio repairs, having specialized on this phase of radio for a number of years.

\$3,000 to \$5,000 per year

The professional "Radio Doctor" receives \$2.00 or \$3.00 per visit and is welcomed in the best of homes—may I tell you more about this new, fascinating and extremely profitable business? Write now for free booklet, "Why the Radio Doctor." (Early inquiries will receive a blueprint of a recent well-known manufactured superheterodyne.)



E. W. PARKER, Pres. RADIO DOCTORS, INC., Dept. C10, 131 Essex Street, Salem, Mass.

AUTOMATIC LE CODE AT HOME RADIO AND TELEGRAPHY

Has Helped Thousands — Your Future Will Be Secure

Every day sees new openings for men who know CODE. You can easily learn in short time. All schools use this method. Opportunities in aviation, on ships and on land. No other profession has so many young men holding BIG PAY jobs. The AUTOMATIC OMNIGRAPH will teach quickly and cheaply, \$15-\$40; CATALOG.



OMNIGRAPH

THE OMNIGRAPH MFG. CO., 810 E. 39th St., N.C.2, Brooklyn, N. Y.

THEATRE TELEVISION

IT is stated that a private showing of I auditorium television was recently presented at Proctor's 58th Street Theatre in New York City; the image reproduced was much smaller than the moving-picture screen. While the process is yet far from perfection, it was predicted that 1932 will see television an entertainment feature for theatrical audiences.

Neutralizing Problems

(Continued from page 564)

speaker plug contacts are O.K. When a hum is heard, check the '45 tubes. If no screen voltage is obtained while testing the set, check the volume control and the fixed condensers in the screen-grid circuit. Even though the volume control checks O. K. in a continuity test, try another and see what happens.

In a Zenith "41," the resistor which feeds screen-grid current may be found defective. Take out the two 25,000-ohm resistors and replace with a small 50,000-ohm Ward-Leonard resistor; this will make a permanent job.

If no plate current is found when checking a Zenith "30," the voltage divider is probably burnt out; look also to the cathode resistor of the first audio tube in this model. On a Zenith "11E," "15E" or "18," look to the power condenser.

When going out on a call, the Service Man should have a reliable set tester (I use a Weston "547") an oscillator and output meter, similar to those shown. An ohmmeter, such as that in Fig. 3, should prove valuable to determine whether a component is shorted, or whether its resistance is correct. Adequate tools include several sizes of screwdrivers and pliers, soldering iron, assorted lugs, nuts and bolts, wire and a line of tubes of different types.

TABLE I

(Plug in position "A")

Reading ma.	Ohms	Reading ma.	Ohms	Reading ma.	Ohms
0.0	Infinite	1.7	1,745	3.4	423
0.1	36,000	1.8	1,600	3.5	385
0.2	26,000	1.9	1,465	3.6	350
0.3	14,100	2.0	1,350	3.7	316
0.4	10,350	2.1	1,240	3.8	284
0.5	8,100	2.2	1,145	3.9	253
0.6	6,600	2.3	1,055	4.0	225
0.7	5,530	2.4	975	4.1	198
0.8	4,725	2.5	900	4.2	171
0.9	4,100	2.6	830	4.3	146
1.0	3,600	2.7	766	4.4	122
1.1	3,190	2.8	707	4.5	100
1.2	2,850	2.9	651	4.6	78
1.3	2,560	3.0	600	4.7	57
1.4	2,315	3.1	551	4.8	37
1.5	2,100	3.2	518	4.9	18
1.6	1,915	3.3	460	5.0	0

TABLE II

(Plug in position "B")

Reading ma.	Ohms	Reading ma.	Ohms	Reading ma.	Ohms
0.0	0	2.7	13	4.0	47
0.5	1	2.8	14	4.1	54
0.8	2	2.9	16	4.2	63
1.1	3	3.0	18	4.3	74
1.3	4	3.1	19	4.4	90
1.6	5	3.2	20	4.5	110
1.8	6	3.3	23	4.6	140
2.0	7	3.4	25	4.7	210
2.1	8	3.5	27	4.8	370
2.2	9	3.6	30	4.9	1,000
2.4	10	3.7	33	5.0	Infinite
2.5	11	3.8	37		
2.6	12	3.9	42		

The Open Forum

(Continued from page 557)

ago which commenced to chatter; in general, it went "haywire." We called in the Spar-ton Service Man, who thought a condenser in the power pack was out. We were therefore surprised when, a short time later, the set was returned in normal condition, and the Service Man told me the following:

One time they had to service a set which

N.Y. ELECTRICAL SCHOOL Men

Graduate into many fields...



AVIATION
ELECTRICITY

AUTOMOBILE
ELECTRICITY

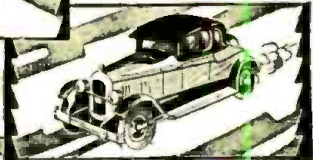

NAUTICAL
ELECTRICITY



ELECTRICAL
ENGINEERING



A full knowledge of electricity, as taught in the New York Electrical School, makes you independent, gives you your choice of either a **BIG PAY** job with one of the world-famous electrical companies, or a business of your own. **ELECTRICITY** is also a stepping-stone to Aviation, Automobile Engineering and other highly paid professions.

Here at the New York Electrical School you learn, not by correspondence, but by **ACTUAL PRACTICE** on full-size standard equipment. **NO BOOKS** used. Individual instruction—you can start any day. This School owns and occupies two seven-story buildings in New York—the city of most opportunities. It is widely known as the country's oldest and foremost institution for trade training. That's why big companies eagerly demand our graduates.

THE NEW YORK ELECTRICAL SCHOOL

21 West 17th Street, New York



FREE

This big 64-page booklet gives full information about the New York Electrical School courses and picture of the equipment available for your personal use. Send for it TODAY. It's free.

MAIL TODAY

The New York Electrical School
21 West 17th Street, New York

Please send me **FREE** your 64-page booklet. It is understood that this request puts me under no obligation.

Name

Address

Editor, SLOGAN CONTEST,
RADIO-CRAFT,
96-98 Park Place, New York City.

SEE PAGE 586
5-30

Gentlemen:

I have written below my entry in your \$100.00 Prize Slogan Contest.

Name

Occupation Age

Street Address

City State

ALLERTON HOUSES

NEW YORK CITY, N. Y.

SO located they offer the social value of a distinctive address with the air and service of the select club; lounge, library, billiards, squash courts and hand-ball courts.

\$15 to \$25 Weekly

38th St., corner Madison Ave.
39th St., near Lexington Ave.
55th St., corner Madison Ave.

57th St., cor. Lexington Ave.
for women only

Chicago Cleveland
Allerton Houses, for Men and Women

CLASSIFIED ADVERTISEMENTS

Advertisements in this section are inserted at the cost of ten cents per word for each insertion—name, initial and address each count as one word. Cash should accompany all classified advertisements unless placed by a recognized advertising agency. No less than ten words are accepted. Advertising for the June 1930 issue should be received not later than April 7th.

CHEMICALS

BOOKLET OF EXPERIMENTS and chemical catalog, 15c. General Chemical Company, Box 397, Reading, Penna.

DETECTIVES

DETECTIVES Earn Big Money. Excellent opportunity. Experience unnecessary. Particulars Free. Write, George Wagner, 2190B Broadway, N. Y.

INSTRUCTION

BE THE LICENSED RADIO DOCTOR of your community. Earn \$7.00-\$10.00 spare time evenings. Write now for free booklet, "Why the Radio Doctor?" Radio Doctors, Inc., Dept. C, 131 Essex Street, Salem, Massachusetts.

LEARN TATTOOING. Instruction catalog, dime. Miller, N431 Main, Norfolk, Virginia.

MEDICAL

LOST VITALITY — The Specific Pill and Winchester's Hypophosphites, \$1.00 per box or bottle, postpaid, literature free. Winchester & Company, Established 72 years, Box 237, Mount Vernon, New York.

OLD MONEY WANTED

\$5 to \$500 EACH paid for Old Coins. Keep ALL old money. Many VERY valuable. Get Posted. Send 10c. for illustrated Coin Value Book, 4x6. Guaranteed Prices. We buy and sell. COIN EXCHANGE, Room 10. Le Roy, N. Y.

RADIO

SERVICE MEN, ATTENTION — Speakers re-wound, magnetized, repaired, \$2.00 to \$2.75. Complete Power Pack Service—Transformers re-wound, condenser blocks repaired, resistors duplicated. Guaranteed. Clark Brothers Radio Co., Albia, Iowa.

ALUMINUM BOX SHIELDS

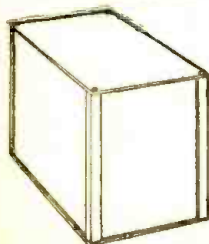

Beautiful silver dip finish, 5" x 9" x 6"—\$1.89. We make any size to order in 24 hours.

No. 1424 Federal Anti-Cap Switches, \$1.95.

Genuine Baldwin Type "C" phones, a necessity for short-wave reception, \$3.65 a pair.

BLAN THE RADIO MAN, Inc.
896 CORTLANDT ST. NEW YORK

TO NEW READERS

A few back issues of RADIO-CRAFT from July 1929 through April 1930 may still be had at the regular price of twenty-five cents each.

Send stamps, check, cash or money order to

RADIO-CRAFT

98 Park Place New York City

acted exactly like ours. They tore it down, checked everything, to no avail. Meanwhile, another set came in minus tubes. They put the tubes out of the balky set in the second set, and it acted the same way. Yet they had tested all the tubes, and they checked O. K.

One by one, they replaced each tube in the receiver till they came to the one that was causing the trouble. Yet it registered all right. They decided to make a careful study of that tube, and found the reason. The elements were just a trifle out of line; so that, when the heater became warm, it expanded sufficiently to cause a short-circuit in the tube. This little internal short was the source of all the trouble; but it did not register in the tester, because under the short test, the heater did not expand as greatly as it did after it had been in the receiver for a few minutes.

Operating Notes

(Continued from page 562)

AC" and "DC" models may be easily damaged by excessive shock and vibration. The stator plates are soldered together and to a bracket which is fastened to a porcelain arm. In some cases, the bracket snaps, and in others the stator plates loosen from the bracket. This defect will cause the complaint, "No stations below 30," broad tuning and, especially, insensitivity.

D.C. Receivers

The Atwater Kent "41DC" may be made to tune more sharply and become more sensitive if the condensers are lined up. They are fastened by two set screws to the tuning belts. However, care must be taken in using a screwdriver; for if the stator plates are accidentally grounded, one or two burnt-out tubes may result and, possibly, a burnt-out grid resistor.

In many instances, faulty reception is caused by incorrect wiring of the "C" battery in the installation of D.C. commercial sets. The table gives the correct color combinations of the more important models.

Service Men are often confronted by the problem of neutralizing a D.C. set in which the tube filaments are wired in series. To insert a dummy '01A or '12A would break the filament circuit. To overcome this difficulty, use an adapter in which a 20-ohm resistor has been shunted across the "F" terminals; and insert the dummy tube in this.

With the Colonial D.C. sets, never allow the ground wire to touch the chassis in any way while the set is operating. This precaution will prevent burning out tubes.

GRID RETURN COLOR CODE

	"C" Voltage
RCA 18 and 51 D.C.—Black.....	-22½
RCA 18 and 51 D.C.—Green.....	+
RCA 33 D.C.—Brown.....	-18
RCA 33 D.C.—Black and Yellow.....	-12
RCA 33 D.C.—Red.....	+
RCA 41 D.C.—Green.....	-22½
RCA 41 D.C.—Brown.....	-16½
RCA 41 D.C.—Black.....	+
RCA 46 D.C.—Black and Brown.....	-18
RCA 46 D.C.—Black.....	-12
RCA 46 D.C.—Green.....	+
Sparton D.C. 931 and 301—Black.....	-22½
931 and 301—Red.....	+
Brunswick D.C.—Black.....	-22½
Brunswick D.C.—Blue.....	-16½
Brunswick D.C.—Red.....	+

Adapting Screen-Grid Sets for the Pentode

(Continued from page 581)

current draw is increased to 11.5 milliamperes by the 7.5 which the space-charge grid draws. The biasing resistor for the control-grid needs to be but 130 ohms.

Owing to the fact that the inter-electrode capacities of the pentode are about double those of the 224, some small difference in tuning may be noticed; but if pentodes are used throughout the alignment of the set will not be disturbed.

In some sets using '24 tubes, some means of neutralizing are employed. When pentodes are substituted, it may be necessary to re-adjust the neutralizing condensers to prevent oscillation.

It may be found that when pentodes are used in a set previously adapted to '24s, some oscillation will occur at advanced settings of the volume control. This is entirely natural; since the tremendous amplification obtainable from the pentode requires that the set shielding be even more complete than that usually found in sets using '24's. It will be found, however, that it is unnecessary to advance the volume control to the point of oscillation; since the greater sensitivity of the pentode will permit excellent reception at lower settings.

The Radio Manufacturer Has His Say

(Continued from page 561)

the dealer, we cannot furnish instruction sheets indiscriminately to Service Men working independently of our dealers.

You are aware of the possibilities of careful servicing by the dealer with respect to the good will it builds up for him. It is fully established that much of his new business is obtained from recommendations brought to him through servicing. It will be seen that helping to build up a large number of independent servicing units would not be to his interest.

Frankly, we haven't much faith in the ability of the majority of independent Service Men. We are not referring to the established servicing concerns, but to the independent Service Man who in many cases is making a side issue of the job of servicing, and practices it after a regular day's work. The present tendency of numbers of young men setting up to do service work on their own responsibility is economically unsound, and we do not wish to encourage it. The situation will, of course, adjust itself in due time.

We have no desire to hold back any ambitious young man who earnestly desires to make servicing his livelihood; but the proper procedure for him is to obtain first of all a basic training at evening school or some other institution. Then to start in with a reputable dealer, later to branch out for himself if he so desires.

Undoubtedly there is rivalry between the independent Service Man and the authorized dealer. This is evidenced by the tone of the letters you submit which have been received by you from Service Men. But we are not persuaded that we are wrong in our present policy of furnishing instructions only to our authorized dealers. Where an

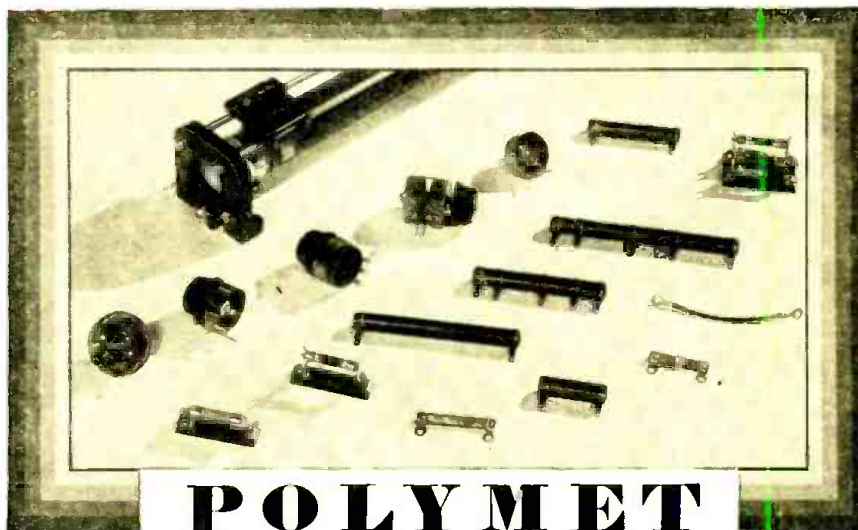

POLYMET RESISTANCES

Built to those high standards which have led 80% of the leading radio set manufacturers to adopt

POLYMET PRODUCTS

- CARBON VOLUME CONTROLS
- WIRE-WOUND VOLUME CONTROLS
- DUAL VOLUME CONTROLS
- SLIDING CONTACT TUBE RHEOSTATS
- TAPPED VOLTAGE DIVIDERS
- WIRE-WOUND TUBULAR RESISTORS
- FLEXIBLE RESISTORS — FLAT STRIP RESISTORS
- GRID LEAKS — POLYTROLS

Ask for leaflet CL-1 giving diagrams of popular circuits including automobile radio receiver. A catalog of Polymet parts is available on application.

POLYMET MFG. CORP.

Paper and Mica Condensers — Resistors
Electrical Coil Windings — Magnet Wire

831-A East 134th St.
NEW YORK CITY

For Exact Radio Tube Voltage

With micrometer accuracy, AMPERITE automatically controls each tube. Lengthens tube life. A type for every tube. \$1.10 with mounting (in U. S. A.).

AMPERITE Corporation
661 BROADWAY, NEW YORK

FREE—"Amperite Vest Pocket Tube Chart."
Write Dept. R, C. 5

AMPERITE
REG. U.S. PAT. OFF.

The "SELF-ADJUSTING" Rheostat

Be a BETTER Radio Man

MORE than 1000 members of the ELECTRAD FORUM exchange technical and service ideas for improvement of the profession. Join the ELECTRAD FORUM and be a BETTER radio man. Dues, \$5 per year, include a unique monthly magazine of inestimable value. WRITE DEPT. RC-5 FOR DETAILS AND APPLICATION BLANK.

ELECTRAD FORUM

John F. Rider
DIRECTOR

1440 Broadway, New York

SKINDERVIKEN Transmitter Units

95¢



Two for \$1.75

Have hundreds of uses. Every amateur should have two or three of these amplifiers in his laboratory
A FEW USES FOR THESE UNITS

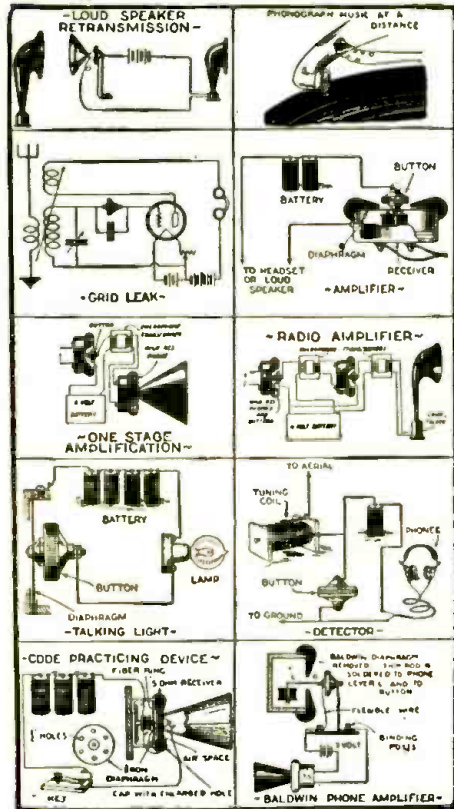

12-PAGE INSTRUCTION BOOKLET

containing suggestions and diagrams for innumerable uses, furnished with each unit.

WE PAY \$5.00 IN CASH

for every new use developed for this unit and accepted and published by us.

P. G. Microphone Transformer

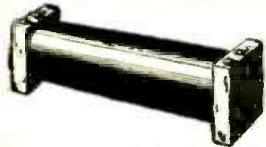

A Modulation Transformer specially designed for use with the Skinderviken Transmitter Unit. Has many other uses. Primary resistance, 1/2 ohm; secondary, 55 ohms. **\$2**

FOR SALE AT LEADING DEALERS

Or Order Direct, Using Coupon Below

SEND NO MONEY

When the postman delivers your order you pay him for whatever you have ordered, plus a few cents postage.

PRESS GUILD, Inc. R-5-30
16-18-R—East 30th St., New York, N. Y.

Please mail me at once as many of the following items as I have indicated.

...Skinderviken Transmitter Units at 95c. for 1; \$1.75 for 2; \$2.50 for 3; \$3.20 for 4.

...P. G. Microphone Transformers at \$2. When delivered I will pay the postman the cost of the items specified plus postage.

Name
Address
City..... State.....

outside Service Man can be of help to the dealer, the dealer will be only too glad to let him have instructions and data books. There are a number of good servicing concerns, and these firms will find no difficulty in obtaining the information that they desire; but it must come to them through the dealer with whom they are working. We invariably make this recommendation to concerns requesting this information, and we write the dealer in his vicinity at the same time.

The great majority of our dealers are doing a splendid service job and we are well satisfied with our present method of servicing of our Stromberg-Carlson receivers. **STROMBERG-CARLSON TELEPHONE MFG. CO.,**

ERNEST S. BROWNING,
Chief of Service Department.

Graybar

It is contrary to our policy to broadcast I service bulletins on our radio receivers; likewise it would be contrary to our policy to offer them for sale to various radio Service Men. Inasmuch as we have only a few dealers across the country and do not desire many dealers, it is much better for us to have our radio sets serviced by our own dealers. Also, we give a very substantial guarantee with each set and, in order that the owners of our receivers may receive the full benefit of this guarantee, it is much better that they have our own dealers do service work.

GRAYBAR ELECTRIC CO., INC.,
WALTER NYE,
General Merchandising Department

Majestic

It is our policy to furnish to radio servicing organizations the necessary blueprints and diagrams for the use of their service departments. We do not furnish a complete manual for any one except our authorized dealers and distributors. Each distributor renders factory service; and, if the dealer wishes to avail himself of service instructions, he has but to apply to his jobber, and they will issue instructions to him to come in and stay just as long as he likes, to secure the information.

It has been our policy in the past, to furnish service information to no one except our own authorized representatives. Of course, where we know that the company requesting this is so trained that they can render service, we furnish information in the form of diagrams, etc., for their aid. **GRIGSBY-GRUNOW COMPANY,**

L. G. WILKINSON,
Service Manager.

Grebe

WE are glad at any time to furnish complete service data to any individual service representative requesting this information, and without charge. The writer has been in charge of service problems of this organization since its inception, and does not recall that we have ever refused to supply individuals or owners of our product with internal wiring diagrams and complete service data pertaining to particular sets on request.

NOW ON ALL NEWSSTANDS

Look for the **GOLD COVER!**

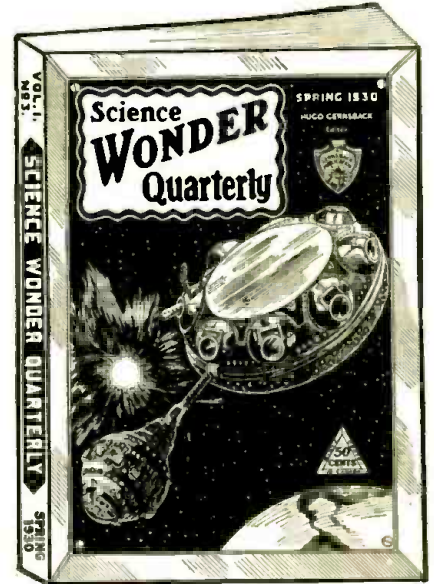

144 Pages 4-Color Cover

THE STONE FROM THE MOON

By Otto Willi Gail

In this sequel to the "Shot Into Infinity," Mr. Gail gives us a full-length novel of the most amazing romance, adventure and interplanetary travel. The mad dashes from planet to planet to solve an age-old secret of the world will thrill the most cold-blooded reader.

OTHER CONTENTS OF THIS ISSUE

THE APE CYCLE

By Claire Winger Harris

WITHIN THE PLANET

By Wesley Arnold

VIA THE HEWITT RAY

By M. F. Rupert

And several other stories.

50¢ The Copy

Special Offer!

The regular price of the QUARTERLY is \$1.75 per year, single copy 50¢. To new subscribers a special price of \$1.25 is now available.

MAIL COUPON

SCIENCE WONDER QUARTERLY RC-5
98 Park Place
New York, N. Y.

Enclosed find \$1.25 for which please send me the next four issues of the QUARTERLY.

Name

Address

City..... State.....

(Canada and foreign \$1.50)



At the present time we are unable to supply complete data on our products manufactured prior to 1924, due to the fact that our stock has become depleted. We likewise are not making a practice of repairing or furnishing parts for sets manufactured prior to 1924; because the demand does not warrant the expense involved.

A. H. GREBE & CO., INC.,
F. B. OSTMAN,
Asst. Sales Manager.

Kellogg

WE are not interested in selling our service manual to any one. We supply same through our regular distributing channels, free of charge.

KELLOGG SWITCHBOARD & SUPPLY CO.

J. K. Utz,
Manager Radio Sales.

Amrad

IT has been in the past, and probably will continue to be in the future, the policy of this company to send service data to independent service stations when they desire it. We make a charge for this material merely sufficient to cover the cost of production and distribution. The attached form letter this office uses to answer any requests from independent service stations.

There is much that can be said for and against the attitude of some manufacturers in distributing their service literature only to authorized dealers. However, this company has felt that service stations interested enough in their library to purchase the books they desire should have consideration.

THE AMRAD CORPORATION,
L. D. TREERY,

Manager Service Department,

(The form letter offers the Amrad Service Data Book at \$1.50, postpaid, with a supplement in the form of blueprints of receivers for the past two years—Editor.)

Steinite

ANY Service Man in the United States can obtain a service manual on any model Steinite set ever made by going to the local distributor of Steinite products in his vicinity.

It has always been our policy to issue circuit diagrams and complete service data; as we feel that if the trade is properly informed, we will have less merchandise coming back to the factory for service. We shall be very glad to receive a copy of your survey and its analysis and, if we can assist you in your work in any way, we are at your command.

STEINITE LABORATORIES CO.,

O. R. COBLENTZ,

Asst. General Sales Manager.

Day-Fan

IN order to protect the original purchaser against the possibility of sacrificing their 90-day factory guarantee, by having other than our authorized agents make the repairs, we have adopted a policy of releasing service data on current models to authorized Day-Fan distributors and dealers only.

We have been mailing service manuals which do not include data on current models,

ELECTRICITY OFFERS BIG PAY



NOW YOU CAN LEARN AT HOME

HUNDREDS OF COOKE TRAINED MEN ARE MAKING \$60 to \$100 A WEEK

\$12 A Day
When I enrolled I was a laborer at small pay. Now I make \$12 a day in Electricity. Wm. J. Wynn, 203 S. Maple, New-Blick, Okla.

\$65 A Day
But for your Course I would still be on small pay. Instead of making a high day in as \$65 a day in Auto Electricity. Jacob Lentz, 1223 1st Av., Hillsboro, Oregon.



Why don't you get into Electricity, too? It's today's great Opportunity for you and every other man who is sick and tired of struggling along on small pay. Hundreds of "Cooke Trained Men" who were no smarter than you when they started now make \$3,000 to \$5,000 a year—and some make even more.

LEARN AT HOME IN SPARE TIME

Learn with the famous L. L. COOKE "Work Sheet and Job Ticket" Method. It's simple, it's thorough, it's practical. It's just like actual shop experience, yet it's all done right in your own home with the Big Complete Outfit of Tools and Apparatus given to you without extra cost. And it's done in your spare time, without quitting your present job or losing a single hour's pay.

PREVIOUS EXPERIENCE NOT NEEDED

You don't need previous experience—you don't need higher education to learn Electricity the L. L. COOKE Way. If you can read and write, that's enough. This great Training is amazingly clear and simple. There's nothing like it anywhere. It's the Training with hundreds of successful graduates; it's the Training that has put many men on Easy Street; it's the Training for you.

GET STARTED—MAIL COUPON

"Cooke Trained Men" are the "Big Pay Men" everywhere. \$60 to \$100 a week is what many of them are making. That's the kind of a job for you. Get started under the famous L. L. COOKE Money Back Agreement. Act today to increase your pay. Send coupon for Big FREE Book, "Secrets of Success in Electricity." Mail coupon now.

L. L. COOKE SCHOOL OF ELECTRICITY
Dept. 305, 2150 Lawrence Ave., Chicago, Ill.

FREE BOOK COUPON!

L. L. Cooke School of Electricity,
Dept. 305, 2150 Lawrence Ave., Chicago, Ill.
Send me entirely free and fully prepaid, your book "Secrets of Success in Electricity," with particulars about your Home Study Course in Electricity.
Name.....
Address.....
City..... State.....
Residents of Canada may send coupon to R. A. Farrow, Special Rep., 7 Medbury Lane, East, Windsor, Ont., Canada.

The "Cooke" Trained Man is the "Big Pay Man"

DO YOU WANT TO STOP TOBACCO?

Banish the craving for tobacco as thousands have. Make yourself free and happy with Tobacco Redeemer. Not a substitute, not habit forming. Write for free booklet telling of injurious effect of tobacco and dependable, easy way to relieve the craving many men have. **FREE BOOK**

Newell Pharmacal Co.
Dept. 928 Clayton, Mo.

WE MATCH PANTS
To Any Suit!

Double the life of your coat and vest with correctly matched pants, 100,000 patterns. Every pair hand tailored to your measure; no "readymades." Our match sent FREE for your O. K. before pants are made. Fit guaranteed. Send piece of cloth or vest today. **SUPERIOR MATCH PANTS COMPANY**
115 So. Dearborn Street, Dept 376, Chicago

SONG WRITERS!

Substantial Advance Royalties are paid on work found acceptable for publication. Anyone wishing to write either the words or music for songs may submit work for free examination and advice. Past experience unnecessary. New demand created by "Talking Pictures", fully described in our free book. Write for it today—Newcomer Associates
751 Earle Building, New York, N. Y.

RADIO BARGAINS

Short-Wave Sets, 1 tube; receives from 30 to 550 meters \$ 6.45
7-Tube A.C. Sets 26.50
A B C Power Packs 8.75
Power and Filament Transformers 4.00
Tubes: UX type, Fully Guaranteed. No. 250, \$2.35; No. 281, \$2.00; No. 215, \$1.25; No. 224, \$1.75; No. 227, 75c; No. 226, 65c; No. 171, 75c. Audio transformers, 75c. Variable condensers, 50c.

CHAS. HOODWIN CO.
4240 Lincoln Ave. Dept. E-15 Chicago, Ill.
DEALERS IN BANKRUPT RADIO STOCKS

No Wind Can Blow It Out

SOMETHING DIFFERENT
No Flint, No Friction.
MAKE UP TO
\$40 A DAY

Showing My Mystery Lighter to Men. What Makes It Light? All Guaranteed. No Flint or Friction. New Principle of Ignition. Sample with Sales Plan, 25c. Sample Gold or Silver Plated, \$1.00. Agents write for proposition. **NEW METHOD MFG. CO.**
Desk SF-5, New Method Bldg., Bradford, Pa.

BRAXTON-KING
SCREEN GRID
A. C. Superheterodyne Tuner will work with any two-stage amplifier

Write for Information
MISSISSIPPI VALLEY RADIO CO.
914 Pine St., Dept. A, St. Louis, Mo.

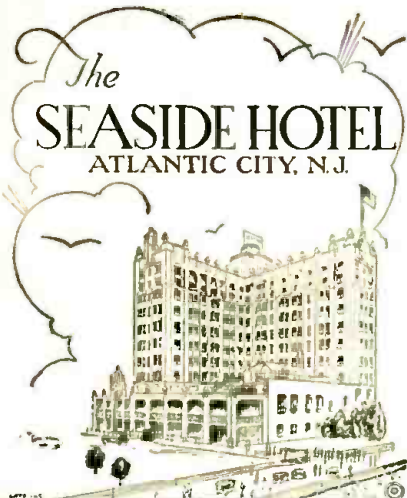

The
SEASIDE HOTEL
ATLANTIC CITY, N. J.
1873-1930

NEW in construction and furnishings.
OLD in hospitable traditions.
Famous for its home-like atmosphere.
The SEASIDE is a rare combination
of a thoroughly modern hotel and a
great private hotel with your friends
about you. The mildest weather north
of the southern resorts, open golf
throughout the year and no snow.

**COOK'S SONS
CORPORATION**

NEW
**BISMARCK
HOTEL**

RANDOLPH AT LA SALLE
**YOUR VISIT
TO CHICAGO**

Will be a pleasant memory if
you select the right hotel. The
New Bismarck welcomes you to
a hostelry where good food,
superior service and cheerful
comfort await you.

Easily accessible to all the high
spots of the city.

Rooms, \$2.50 and up—
With Bath, \$3.50 and up



at a nominal cost, in response to all in-
quiries which indicate that the writer is a
legitimate radio Service Man.

Where we do not have authorized distribu-
tors, who carry parts in stock, we make
shipment on parts direct to the individual
or service organization placing their order
with us. In case the order or letterhead
indicates that the parties concerned are legiti-
mate dealers or service organization, a dis-
count is allowed on all parts purchased.
However, if we have an authorized distri-
butor, our contract gives them exclusive
rights to sell all parts within their terri-
tory. If they do not carry sufficient parts
to make immediate shipment, that auto-
matically and temporarily cancels their con-
tract, and we make shipment direct.

GENERAL MOTORS RADIO CORP.,
C. E. GREENE,
Service Manager.

Kennedy

WHEN we appoint a new dealer, we
send him as many service manuals as
he thinks he will need; but we have never
taken any steps to supply the independent
Service Man with information about serv-
icing Kennedy sets.

This, however, is not due to a lack of
desire to cooperate on our part. Whenever
we receive a request from someone for a
service manual, it is sent to them without
charge, regardless of whether they are con-
nected with a Kennedy dealer or not.

However, if we were to go into supply-
ing service manuals to Service Men not
connected with any Kennedy dealer, I think
we would have to make a small charge just
to prevent them from being ordered by Ser-
vice Men who are inquisitive rather than in-
terested. Our service manuals cost us about
30c. each; but we would supply them to
anyone, upon request, for say 10c. We are
glad to cooperate with radio Service Men
anywhere and everywhere at all times.

COLIN B. KENNEDY CORPORATION,
LARRY WALL,
Asst. Advertising Manager.

Hammarlund

WE are always glad to supply complete
information regarding our line to any-
one requesting it. We have instruction
sheets and diagrams covering all models and
these are supplied at a cost of 25c net per
copy. As our business is tied up very
closely with custom builders and service
stations, we probably cooperate with them
closer than most manufacturers. We have
even prepared and published at considerable
expense a Sales and Service Course. This
is supplied complete at a cost of \$5.00 and
those subscribing also receive a mass of in-
formation which is sent out from time to
time, covering matters of interest to set
builders and Service Men.

HAMMARLUND MFG. CO., INC.,
L. A. HAMMARLUND.

Name Withheld

ONE manufacturer's service department
writes as follows, in reply to our quo-
tation of a paragraph in the letter of a
Service Man who had commented on their
courtesy:

"The point we are driving at is that, if



The MADISON

ILLINOIS AVENUE
Overlooking Boardwalk and Ocean

**"A Hotel Distinctively
Different"**

JUST COMPLETED IN

Atlantic City

Unexcelled Colonial
Hospitality

Now Ready for YOU

From \$4.00 daily
European Plan

From \$7.00 daily
American Plan

FETTER & HOLLINGER, INC.
Eugene C. Fetter
Managing Director

**HOTEL
EMBASSY**

BROADWAY AT 70TH ST.
NEW YORK

400 LARGE LIGHT ROOMS
ALL WITH BATH

\$2.50 A DAY FOR ONE PERSON
\$3.50 A DAY AND UP FOR TWO

*Special Rates for Permanent
Guests*

FINE RESTAURANT
REASONABLE PRICES
Club Breakfast, 30¢ to 50¢
Luncheon, 75¢
Table d'Hote Dinner, \$1.00

EDMUND P. MOLONY
Manager

*If you are a service man, profes-
sional or radiotrician, you should
receive RADIO-CRAFT each month.
Turn to page 603 of this issue and
read the special offer to those who
are actively engaged in radio.*

The Big 3

always in the SPOTLIGHT
of Scientific Fiction

*A Scientific Education While Reading
the Most Marvelous Fiction*

Once you have read your first magazine of scientific fiction, you will never let a month pass without making every effort to read the next issue. Hours of pleasant pastime are well spent in reading stories that you like—stories that are entertaining and educational as well. In the Science Fiction Group you will read stories of the H. G. Wells, Jules Verne and Arthur B. Reeve type with a techni-scientific background.



SCIENCE WONDER STORIES exploits the present and the future by giving you the most marvelous stories—interplanetary trips, space-flyers, talking to Mars, death rays, gravity-nullifiers, transmutation of elements, trips to other worlds, are some of the subjects treated.



AIR WONDER STORIES presents solely flying stories of the future, strictly along scientific-mechanic-technical lines, interspersed with exploration and achievement.

THEY ARE ALL DRAMATIZED MECHANICS OF THE AIR.

In addition to this, AIR WONDER STORIES publishes interplanetary stories by which you visit strange worlds and strange races and find strange adventures.



NOW—for the first time, advanced thought on scientific crime detection is published in a profusely illustrated monthly magazine. SCIENTIFIC DETECTIVE MONTHLY is truly the most amazing publication ever issued. 100 pages—every one chock full of gripping revelations and stirring situations—all based on newly discovered scientific facts.

25c *The Copy* On All Newsstands

THE NEXT 8 MONTHS
ANY ONE MAGAZINE \$1.00

STELLAR PUBLISHING CORP.,
98 Park Place, New York, N. Y.

Enclosed find \$....., for which enter my subscription to

SCIENTIFIC DETECTIVE MONTHLY
 SCIENCE WONDER STORIES
 AIR WONDER STORIES

for eight months. Check which you prefer.
(Canada and foreign \$1.25.)

Name

Address

City..... State.....
RC-5

you were to publish the fourth paragraph of your reader's letter, which reads as follows: 'In reply I received a very nice letter from their Service Department, together with blueprint and book of instructions, and discount offer for any parts needed,' we probably would be swamped with requests from all over the country for free information, and it would cause us considerable trouble in correcting the impression that the public received. We appreciate your offer to publish the letter praising our co-operation, and ask that you correct this one part.'

Pentode Service Problem

(Continued from page 579)

at high amplitudes. However, in some cases (and we leave it to the Service Man's good judgment) the alteration may be justified.

The procedure is obvious. When necessary, transfer the power output connections to the plate circuit of the first audio tube (the pentode). In the majority of instances, a five-prong socket will be found already provided in this stage. The required changes should be made to provide the correct "B" and "C" potentials; generally by bridging over the plate supply to the old power tube, and replacing the original biasing resistor with a one-watt, 800-ohm component.

The pentode should be coupled to the speaker by a transformer approximating the characteristics already given.

Trouble shooting with the pentode will be along the general lines of present practice. Check the filament (or heater) and the "B" and "C" potentials. A good pentode should be no more microphonic than a good screen-grid tube. However, some of the less perfect varieties may offend in this respect. In the case of repeated complaints of short life, suspect a filament or heater voltage in excess of normal. A low plate current with normal voltages and a high screen-grid current (showing proper emission) indicates a broken connection inside the tube between the case of repeated complaints of short life.

When the pentode is finally available for general use, the writer will be most interested to learn from readers of RADIO-CRAFT their experiences with this new tube.

NEW STEPS IN TELEVISION

TELEVISION signals were sent on February 18 from Schenectady, New York, to Sydney, Australia, and back again, on short waves; and they completed their 20,000-mile round trip badly disfigured, but at times recognizable. The image was a black rectangle on a white background, transmitted by W2XAF and rebroadcast by VK2ME; it was reproduced in the General Electric receiving laboratory.

The effect of atmospheric conditions and many reflections is described by Dr. E. F. W. Alexanderson, who directed the test: "as though an image seen in one pail of rippled water had been reflected in another pail of rippled water. Many times during a five-minute period the lines of the rectangle were distinct enough for the observers to distinguish the picture."

At the same time, a two-way conversation between the stations was recorded on film for future reproduction and transmission.

Radio Inspectors
\$2000 to \$4000
a Year



Radio Repair
Mechanics
\$1800 to \$2600
a Year!

SUCCESS IN RADIO

Depends upon Training

...You Get that training
with RCA Institutes Inc.

REGARDLESS of who you are... how old you are... where you live or what you do... You, too, can make a success in radio because RCA Institutes trains you for success. This is the only school backed by the Radio Corporation of America... the foremost radio organization in the world today!

"A serious shortage of Trained Men Exists Right Now"

"Thousands of men are needed. Broadcasting stations, manufacturing plants, retail and wholesale dealers, as well as ships at sea and planes in the air are now waiting for men like you... men who have the will as well as the knowledge to make good. They know that the graduate of RCA Institutes has the knowledge and ability to hold a good position in radio.

Remarkable Outlay of Apparatus included with this famous Laboratory Training Course

You learn radio by actual experience with the famous RCA Institutes outlay of apparatus... A complete assortment of parts assembled for your help and instruction by RCA experts. See for yourself how easy it is to solve every radio problem such as repairing and servicing fine sets. Here is the training that you cannot duplicate elsewhere, at any price. Students learn by actual experience, under the direction of RCA, the world-wide organization that made Radio what it is today.

RCA Graduates Find It Easy to Fill Good Radio Jobs

For more than 20 years, there has been a radio job for practically every graduate who wished one. RCA Institutes students are actually trained for success in radio... That is the only purpose of this organization and that is why students make such rapid progress in Radio. Every student receives an agreement signed by the president of this school assuring absolute satisfaction upon completion of the course... or money refunded.

RCA INSTITUTES INC.

Formerly Radio Institute of America



RCA INSTITUTES, Inc.
S. R. A. - 5, 75 Varlek Street, New York.

Gentlemen: Please send me your FREE 40-page book which illustrates the brilliant opportunities in Radio and describes your laboratory-method of instruction at home!

Name.....
Address.....

Over the Mountains from Los Angeles



Think of it! FIVE HUNDRED FIFTY-NINE MILES over rough mountainous country burning only ELEVEN GALLONS OF GASOLINE. Imagine more than FIFTY MILES TO THE GALLON. That is what the WHIRLWIND CARBURETING DEVICE does for D. R. Gilbert, enough of a saving on just one trip to more than pay the cost of the Whirlwind.

The Whirlwind Saves Motorists Millions Of Dollars Yearly

Whirlwind users, reporting the results of their tests, are amazed at the results they are getting. Letters keep streaming into the office telling of mileages all the way from 22 to 59 miles on a gallon, resulting in a saving of from 25% to 50% in gas bills alone. Mark A. Estes writes: "I was making 17 miles to the gallon on my Pontiac Coupe. Today, with the Whirlwind, I am making 35 5-10 miles to the gallon." P. H. Goerzen writes: "34-6-10 miles with the Whirlwind, or a gain of 21 miles to the gallon." R. J. Tulpe: "The Whirlwind increased the mileage on our Ford truck from 12 to 26 miles to gallon and 25% in speed." Car owners all over the world are saving money every day with the Whirlwind, besides having better operating motors. Think what this means on your own car. Figure up your savings—enough for a radio—a bank account—added pleasures. Why let the Oil Companies profit by your waste? Find out about this amazing little device that will pay for itself every few weeks.

FITS ALL CARS

In just a few minutes the Whirlwind can be installed on any make of car, truck or tractor. It's actually less work than changing your oil, or putting water in your battery. No drilling, tapping or changes of any kind necessary. It is guaranteed to work perfectly on any make of car, truck or tractor, large or small, new model or old model. The more you drive the more you will save.

SALESMEN AND DISTRIBUTORS WANTED FREE SAMPLE AND \$100.00 A WEEK OFFER

Whirlwind men are making big profits supplying this fast selling device that car owners cannot afford to be without. Good territory is still open. Free sample offer and full particulars sent on request. Just check the coupon.

GUARANTEE

No matter what kind of a car you have—no matter how big a gas eater it is—The Whirlwind will save you money. We absolutely guarantee that the Whirlwind will more than save its cost in gasoline alone within thirty days, or the trial will cost you nothing. We invite you to test it at our risk and expense. You are to be the sole judge.

FREE TRIAL COUPON

Whirlwind Mfg. Co., 999-246-A Third St., Milwaukee, Wis. Gentlemen: You may send me full particulars of your Whirlwind Carbureting device and free trial offer. This does not obligate me in any way whatever.

NAME
 ADDRESS
 CITY
 COUNTY STATE

Check here if you are interested in full or part time salesman position.
 Check here if you are interested in full or part time salesman position.

UNIVERSAL NEUTRALIZING and ALIGNMENT KIT

FOR SERVICE MEN

Hundreds of radio Service Men have already added the No. 10 Universal Neutralizing and Alignment Kit to their servicing equipment. Neutralizing, balancing and condenser alignment of standard manufactured sets are made easier, accurate and more quickly.

Made of highest grade insulating material with nickel-plated metal nibs—ready for long use. Easily clipped into the pocket as a fountain pen in a single unit—smaller tool fits into the larger. Quadruple tools make it useful for (1) Amrad, Bosch, Crosley, Earl, Fada, Freed, Freed-Eisemann, Majestic, Philco, Spanton, Stromberg-Carlson; (2) Zenith; (3) Brunswick, Garod, Radiola and Victor; (4) Magnetic end for picking up and placing small parts.

Indispensable to Service Men and guaranteed for the sets mentioned above. ORDER YOUR KIT TODAY. Sent anywhere in the U. S. upon receipt of \$2.00—postage prepaid.

\$2.00 Patent Applied For

SERVICEMENS SUPPLY CO. 55 DEAN STREET BROOKLYN, N. Y.

Radio-Craft Kinks

HOME-MADE BATTERY CABLE

By M. W. Johnson

MOST battery sets employ for the battery leads a cable, one end of which is soldered to the receiver. This arrangement therefore presents several disadvantages.

For one thing, it is not convenient to move the set to a position beyond the limit of the cable's slack, without first removing all the battery connections. Also, it is inconvenient to make tests on the receiver without the battery potentials, unless it is desired to remove battery connections.

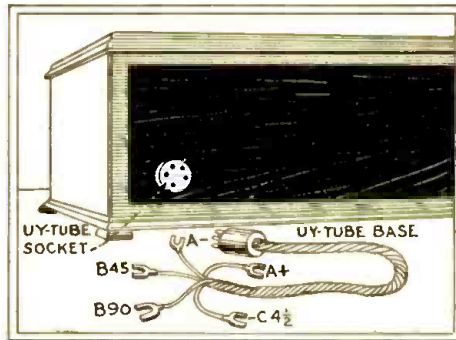

Fig. 1

The set builder who is working over an old battery set can use the connecting method shown to provide a 5-lead cable which will facilitate connecting and disconnecting.

Electric sets and the more expensive battery sets overcome this situation by arranging the current-supply cable to plug into a receptacle on the receiver.

This idea may be applied to any receiver requiring not more than five leads in a single cable, as shown by Fig. 1. A 5-prong UY socket is mounted on the rear of the set cabinet, the cable ends are soldered to the prongs of the old tube-base. The cable may be held in place with sealing wax poured into the ex-base. If desired, another plug and socket may be "rigged up" for the opposite end of the cable.

A KINK FOR THE CAREFUL SET-TESTER

By Alvin Porter

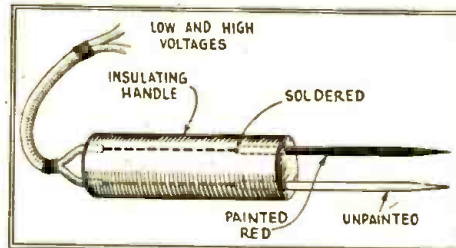

Fig. 2

The tester shown here will make the routine shorter for the Service Man; but it is not to be recommended for the absent-minded; as an application of the wrong point is hard on the meter.

THE tester who is careful in his work will find no difficulty in using the double-prod unit for circuit testing that is illustrated in Fig. 2.

RADIO NOISES

vanish the moment you install a TOBE FILTERETTE! Over 64 different models for every type of interference. Your radio or electrical dealer can tell you which model you need. Or write us a personal letter, telling in detail all you can about the noise or interfering apparatus, and you will receive a personal reply.



TOBE Filterette Junior Price \$3.50

Filterettes are sold by all lse dealers. If your dealer has not yet stocked them, he can obtain them from any Westinghouse, General Electric or Graybar jobber.

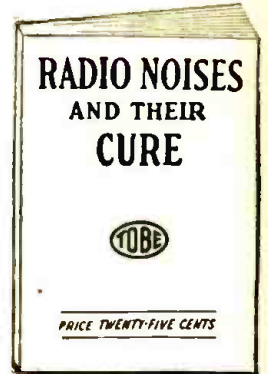

64 pages. Crammed full of photographs, diagrams and pictures showing how the noises start and how to stop each type of interference. Twenty-five cents, postpaid. You'll need this book near your radio set.

TOBE DEUTSCHMANN CORP.

Filterette Division CANTON, MASS.

Pioneer and Leader in Eliminating Radio Interference of Every Description

START to PLAY Very First Day!



Pleasant, Easy Lessons Show You How!

A lifetime of rich, wholesome fun. 5 days' free trial in your own home. A year to pay.

THE whole world seems different when you learn to play and now you can play the most spectacular of all instruments—the Deagan Xylorimba. No long waiting. No finger or lip exercise. No tiresome practice. Start to play very first day even if you can't read a note of music right now. Soon you'll be the "hit" of every party. Maybe, like the Musical Hallmans (Reading, Pa.) you'll make \$65 a week spare time.

Our Big Free Book tells all about the free lessons, the wonderful payment plan. No cost or obligation—send in coupon today.

J. C. Deagan, Inc., Dept. 1938, 1770 Berceau Ave., Chicago.

Send me, without obligation, full details of Free Trial offer and easy-payment plan of the Deagan Xylorimba.

Name
 Address

ELECTRIFY YOUR RADIO FOR ONLY \$6.85 COMPLETE

Why discard your present good set when you can electrify it for only \$6.85, and banish the annoyance and expense of buying new "B" batteries?



Over 100,000 Townsend "B" Power Units In Use

Hooked up in a few minutes. Use same tubes—no changes. You'll be amazed at the improvement in reception and distance getting. Send name and address today for full details, proof and Free Trial Offer.

TOWNSEND LABORATORIES 723 Townsend Street Chicago, Illinois

A Special Courtesy to

Radiotricians
 Professionals
 Engineers
 Mechanics
 Consultants
 Designers
 Service Men
 Contractors
 Manufacturers
 Dealers

IN ORDER to make it possible for all Radio Technicians to read RADIO-CRAFT regularly, each month, we have put into effect a special subscription price.

The regular price of RADIO-CRAFT is \$2.50 per year (12 issues). The newsstand rate is 25 cents a copy.

Any radio professional, sending in a subscription on his letterhead, showing that he is engaged in some capacity in radio work will receive as a special courtesy

EIGHT ISSUES OF



Just pin a dollar bill to the coupon below and forward it with your letterhead or business card.

CLIP COUPON—NOW!

RADIO-CRAFT,
 RC-5, 98 Park Place,
 New York, N. Y.
 Enclosed find \$1.00 for which please enter my subscription to RADIO-CRAFT for next eight months.

Name

Address

City..... State.....

In testing the voltages of electric sets, two test points, usually, are needed for testing "B" and "C" voltages, or any other circuit voltages requiring extremes of meter reading.

The writer uses only one prod; but it is "duplexed" in the manner shown. A wire from the high-voltage binding post of the meter is connected to one prod; while the low-reading side of the meter has its lead connected to the other prod, which is in the same handle. The negative side of the meter is connected to the set through a flexible lead and a clip, the latter connecting to the negative terminal of the set.

The prods may be driven into the wooden handle, and the flexible leads soldered to them, or the unit may be made in any other convenient manner.

BROADCASTING MIRTH

ANOTHER use for a public-address system is found by a theatre on Broadway, New York, which advertises a comedy by broadcasting the laughter of the audience through a speaker on the front of the building.

Letters from Short-Wave Listeners

HE GETS 'EM ALL!

Editor, RADIO-CRAFT:

I have come to believe that there is no such thing as "skip-distance," except in the first few miles. As a beginner in short-waves, I used to believe in it; but now that I know how to tune in, I have no faith in it at all. When I learn that a station is being heard in the U. S. at a certain time and try on the exact wave, I nearly always run into it after a few trials. Results others are having prove my theory. Reception depends on the operator, his knowledge of what to tune for, and his ability to bring the set up to the point below regeneration.

CM2MK, Havana, on 32.6 meters, is heard on Sunday near 6 p. m. G2IV (the *Majestic*) is heard at night near 65 meters and in the mornings near 18, talking to WOO and G2AA (London) on a telephone circuit; I heard them also say they were on 24 and 35 meters. Barranquilla, Columbia, on 51.7 meters was overheard saying that they have but 7½ watts and are on the air every night from 8:30 to 10:30 (E.S.T.). HKT, Bogota, is on almost every night from 9 till 11, just under KDKA. IIRB has moved down till they are almost on the wave of W3XAU; they expect to have a 1000-watt transmitter on the air April 1. VRY announces a proposed change to between 46 and 48 meters, to overcome code interference. They will also add power. HS2PJ, Bangkok, Siam, is back on 29.5 meters; this is the station which was taken for ARI, Hongkong. VE9AP, Drummondville, was on 46.7 meters testing, and will be on 33 meters soon. Up to the present time, my log shows 87 stations heard on voice out of our own country, including telephone stations and the ships.

The call letters of the French phones, often referred to as FW3, etc., are as follows: FTD 15.12 meters; FRO and FRE, 15.45; FTM 15.55; FTO, FTE 16.44; FTN 24.46; FOO, FOE 24.67; FTL 30.15; FTF 38.61. The letters E and O in pairs indicate beams to the east and the west. (*Ouest*, in French).

Fans wishing sample copies of the Short-Wave Club's bulletin may obtain same by sending me a dime.

ARTHUR J. GREEN,
 Box 713, Klondyke, Ohio.

(Mr. Green, whose duties as president of the International Short-Wave Club have evidently been keeping him increasingly busy, is endeavoring between other activities to prepare for RADIO-CRAFT an article of practical instruction on short-wave broadcast reception for the fan. While he him-

The World's Premier Custom-Built RADIO



NO radio produced in mass can even approximate the skilled perfection of the new Custom-Built "HiQ-30." Here is the newest, most efficient model by Hammarlund — the climax of five years of unequalled custom designing and famed throughout the world for power, selectivity and tone. A great opportunity for custom-set builders. Choice of magnificent cabinets and speakers. A.C., D.C. and Battery Models. List, \$139.50 to \$1,175 complete, less tubes.

Mail Coupon for 48-page "HiQ-30" Manual

HAMMARLUND-ROBERTS, INC.
 425-438 W. 33rd St., N. Y.
 Enclosed 25c. (stamps or coin) for "HiQ-30" Manual.
 Name..... Address.....

FREE! RADIO BARGAIN CATALOG

ALSO FREE RADIO GIFT

Send now for this new free radio catalog which saves you many dollars on radio outfits, kits, parts, tubes and accessories! Also TIME CONVERSION CHART FREE. Tells you instantly what time it is in any part of the world! Given free if your request for catalog reaches us this month.



NO JOKETO BE DEAF

—Every Deaf Person Knows That I make myself hear, after being deaf for 25 years, with these Artificial Ear Drums. I wear them day and night. They stop head noises and ringing ears. They are perfectly comfortable. No one sees them. Write me and I will tell you a true story, how I got deaf and how I make you hear. Address Medicated Ear Drum
GEO. P. WAY, Artificial Ear Drum Co. (Inc.)
 74 Boffman Bldg., Detroit, Mich.



PATENTS

Protect Your Ideas

Write for Instructions, free on request - - or send drawing or model for preliminary examination of Patent Office records

Promptness Assured with Best Results

Carl Miller

PATENT ATTORNEY

Former Member Examining Corps, U. S. Patent Office
265 MCGILL Building, Washington, D. C.

PATENTS TRADE-MARKS

DO NOT LOSE YOUR RIGHTS TO PATENT PROTECTION

Before disclosing your invention to anyone send for blank form "EVIDENCE OF CONCEPTION" to be signed and witnessed.

LANCASTER, ALLWINE & ROMMEL
(Registered Patent Attorneys)
475 Ounay Bldg., Washington, D. C.
Originators of forms "Evidence of Conception"

PATENTS

TRADEMARKS - COPYRIGHTS
Before showing your idea to anyone, send for new - "Duplicating Invention Record" - you keep a copy for evidence and send me a copy for advice and exact cost of patent. Prompt Personal Service. Advice and Record free on request.

JOHN J. LYNCH, Registered Patent Attorney
41-F Park Row, International Building, New York City Washington, D. C.

PATENTS

Write for Free Guide Book, "HOW TO OBTAIN A PATENT" and Record of Invention Blank. Send model or sketch and description of your invention for our Free Opinion whether it comes within Patent Office Rules. RADIO and ELECTRICAL Cases a Specialty.

PAYMENT OF FEES IN INSTALLMENTS
VICTOR J. EVANS & CO., 923 - 9th, Washington, D. C.

AUTO RADIO

Designed specially for operation in automobiles, motor boats and airplanes. Compact. Tremendous volume. Wonderful tone. Single dial control. Will fit any car. Easily installed by anyone. Fully guaranteed. Be among the first to have an auto radio. Price, including tubes..... \$39.50

CHAS. HOODWIN CO.

4240 Lincoln Ave. Dept. E-40 Chicago, Ill.

Write for Information about the NEW
H-F-L MASTERTONE
LABORATORY MADE RECEIVER
The Year's Outstanding
Radio Achievement
HIGH FREQUENCY LABORATORIES
28 N. Sheldon St. Dept. 76 Chicago, Ill.

self is favored by extraordinary location, we can hardly believe that the skip-distance does not manifest itself in some cases at his location. Ohio, however, seems especially favored in this regard.—
Editor.)

NEW STATIONS TO THE SOUTH

Editor, RADIO-CRAFT:

A new station is FRT, Fort de France, Martinique, West Indies, on a wave of 48.25 meters; they were heard here about 11 p. m. Jan. 23, with about R6 signal. G2AA of the Radio Communications Co., Ltd., Slough, England, can be heard regularly about 10 or 11 p. m. with G2GN.

Senor Cespedes of the famous NRII states that a station at Barranquilla, Colombia, is working nightly on different waves from 30 to 50 meters; one at Santiago de Cuba, one at La Vega, Dominican Republic, and one at Cali, Colombia. This may help to identify some of the gang of Spanish-speaking stations on waves from 43 to 55 meters; this place is hot with stuff about 7 or 8 p. m.

CHARLES J. SCHROEDER.

3125 N. Spangler St., Philadelphia, Penna.

We acknowledge numerous other reports of stations heard, many of which duplicate each other's facts. What presents difficulty is that hearers catch different letters and estimate wavelengths differently; it is then impossible to make a notation in the station list. Among those sending in short-wave information are: John W. Campbell, Francis Walczak, George Harrold, Mander Barnett (England), Robert Rogers (Canada), E. F. Henning, Allan R. Eurich, Ralph Wymer, and George A. Nitsche. The last reports LSN testing on Feb. 17 on 9.890 kc. at 11 a. m. This is obviously Monte Grande, Argentina.

CORRESPONDENTS WANTED

Editor, RADIO-CRAFT:

I have shielded the detector components of my Pilot "Wasp" with parts taken from a Crosley "Band-Box," eliminating body capacity and interference to a great extent. Have received 121 broadcasts and 51 short-wave stations. Have heard an Australian on 55 meters giving the call 3AR. I would appreciate and answer letters from any short-wave fans, especially constructors of this set.

JOHN DEBB.

3rd & Walnut St.,
Cressona, Penna.

I have had a station on 90 meters giving the call W10XX and would appreciate further information about this station. (This is one of many airplanes licensed to operate on this wave experimentally). I would like to correspond with other short-wave fans, especially in foreign countries.

BRUCE GREEN,
1355 Caroline Ave.,
Clinton, Iowa.

On Feb. 22. WOO was testing with G2RZ (the *Majestic*) from 1 to 10 p. m.; the first on 75 meters and the other about 60. I would like to hear from any other reader as to their reception, as I did not get the location. I am using an Aero converter.

W. GOSCH,
24 Peck St.,
New Haven, Conn.

I am going to build a transmitter and would be glad to hear from "hams" about constructing a good transmitting antenna; and from short-wave fans about receiving conditions in their vicinities. Will be glad to give advice on the "Wasp" and "Super-Wasp" to inquirers.

FLOYD SWEET,
92 North 5th St., Hudson, N. Y.

Could you put me in touch with an amateur within twenty-five miles? I would also like one or more correspondents.

EARLE SAGE,
41 Birdsall, Norwich, N. Y.

A RECORD IN BROADCASTING

Between 207 and 260 broadcast stations of regular wavelengths, it is estimated by *World Radio*, relayed the opening speech of King George at the international naval limitation conference. One long-wave station (Rugby) and six short-wave stations outside the United States, besides the several short-wave transmitters in this country, were linked together by wire circuits and radio relays to this unprecedented group of stations on all continents.

A new 12-kw. station on about 80 meters, it is announced, will relay the program of the 441-meter, 50-kw. broadcast transmitter which was put in operation a few weeks ago at Rome, Italy.



Summer Days Are Comfortable... Here

SUMMER days in Chicago are comfortable... at THE DRAKE. Pleasant... spacious... airy rooms and an ideal location... overlooking Lake Michigan... Beach, bridge paths... Lincoln Park... and other attractions immediately accessible. Rates begin at \$5 per day. Permanent Suites at Special Discounts.

THE DRAKE HOTEL, CHICAGO
Under Blackstone Management

"AN ADDRESS OF DISTINCTION"

Orders - Inquiries

60 pages
Send for FREE Copy
Can be Secured by MAIL

POLK'S REFERENCE BOOK and Mailing List Catalog

Gives counts and prices on over 8,000 different lines of business. No matter what your business, in this book you will find the number of your prospective customers listed. Valuable information showing how to use the mails to secure orders and inquiries for your products or services is given.

Write for FREE Copy
R. L. POLK & CO., Detroit, Mich.
Largest City Directory Publishers in the World. Branches in Principal Cities
Mailing List Compilers—Business Statisticians
Producers of Direct Mail Advertising

QUIT TOBACCO

No man or woman can escape the harmful effects of tobacco. Don't try to banish unaided the hold tobacco has upon you. Join the thousands of inveterate tobacco users that have found it easy to quit with the aid of the Keeley Treatment.

KEELEY Treatment For Tobacco Habit Successful For Over 50 Years

Quickly banishes all craving for tobacco. Write today for Free Book telling how to quickly Free yourself from the tobacco habit and our Money Back Guarantee.

THE KEELEY INSTITUTE
Dept. L-701 Dwight, Illinois

ATTENTION—Radio Service Men

Leading manufacturers often consult us for the names of competent service men who are actively engaged in radio work. We want every reader of RADIO-CRAFT who is engaged as a service man to read page 665 of this issue. You will find the few minutes reading this page well worth while.

Radio-Craft's Opportunity Column

TO make this magazine of additional benefit to Service Men, RADIO-CRAFT has instituted a new feature, of which advantage may be taken, free of charge, by any Service Man who has enrolled himself in the NATIONAL LIST OF RADIO SERVICE MEN (by filling out in full the blank which is printed in every issue of this magazine). We will print short notices of the same nature as those which follow; and will forward to the writer of any of them the replies which may be addressed to him (by the number given) in care of RADIO-CRAFT.

We must reserve the right to condense all letters into their most essential details; and we urge all our correspondents who use this service to be as concise, though thorough, as they would be in the composition of a paid advertisement which would cost them several dollars.

Service Men seeking employment should give, at the beginning, the important details which an employer will first ask; and anyone offering employment to a Service Man should be equally specific.

It is desirable that references be given in all letters seeking employment, etc.—not for publication, but in order that RADIO-CRAFT may verify the statements made, if requested to do so, by parties interested in replying to the advertisement.

Please give all information for publication on a sheet of paper separate from the questionnaire, which is filed by us. Age, years' experience, domestic affairs, etc.; and do not forget to put your name and address on each sheet. We have several requests lacking these important details, which we cannot publish as yet. A period of at least one month must elapse between receipt of letters and publication; as the forms of RADIO-CRAFT close several weeks ahead.

We cannot publish under this heading any advertising of a commercial nature—for the sale of goods, or instruction, etc.; or for an employment agency. We cannot publish offers of general servicing for the public, or general representation of a manufacturer in a district. For the former, local advertising mediums are available, and as to the latter, a manufacturer requesting such information will be given it directly from the files of the NATIONAL LIST OF RADIO SERVICE MEN. Announcements seeking or offering regular employment, however, will be accepted under the conditions stated above.

The writers of any of these requests may be addressed as Opportunity No. (number given below), in care of RADIO-CRAFT, 98 Park Place, New York City.

(Opportunity 32) Inquiry for a Service Man by a music store in a New Jersey suburb of New York City. Must be well qualified.

(Opportunity 33) N. R. I. graduate, high-school education, desires position in factory or broadcast station with opportunity to work up. (Iowa.)

(Opportunity 34) Service Man, C. E. W. graduate, eight years' experience, desires position with manufacturer with opportunity to specialize. Will go anywhere. Age 24. Married. (Washington, D. C.)

(Opportunity 35) Physicist, at present superintendent of schools, with fourteen years' experience in radio, six in servicing, bachelor's degree and post-graduate credits in radio and audio work from Iowa U., desires to obtain laboratory connection or position teaching radio and kindred subjects. (Iowa.)

(Opportunity 36) Service Man, experienced, with a following, desires laboratory position. R. C. A. Inst. graduate, engineering student, Junior I. R. E. (Brooklyn, N. Y.)

(Opportunity 37) Service Man, nine years' ex-

perience, short-wave amateur, former railroad mechanic (15 years) desires to make change. Interested in aviation radio. Will go anywhere. Married. (North Carolina.)

(Opportunity 38) Service Man, six years' radio experience, specialist in short waves, Asso. R. T. A., desires position with manufacturer. (Ontario.)

(Opportunity 39) Service Man, owns business, wishes to make connection with jobber or manufacturer. (Indiana.)

(Opportunity 40) Service Man, owns business, desires connection with manufacturer to learn line, or in sound field. (Ohio.)

(Opportunity 41) Electrical Engineer, employed by telephone company, eight years' radio experience, desires position as sales and Service Man. (Indiana.)

(Opportunity 42) Service Man, own car, employed store chain, seeks change for personal reasons. (New York City.)

(Opportunity 43) Service Man, two years' experience, three years' office work, desires connection with distributor or manufacturer. Age 25. (Maine.)

(Opportunity 44) Service Man, seven years' experience radio, theatre and public-address systems, desires service and installation position with manufacturer sound equipment. N. R. I. graduate. (South Dakota.)

(Opportunity 45) Naval Radio Man, seventeen years' service, seeks shore position on discharge this spring, as broadcast or aviation operator, etc.

(Opportunity 46) Service Man, eight years' experience, desires permanent place with jobber or dealer, north or east Florida. Has own full equipment. Age 24. Married. (Florida.)

(Opportunity 47) Service Man, in business as electrician, Signal Corps (British) and Service experience in New York City and elsewhere, desires position in any electrical field; preference for sound. Age 27. Single. (Pennsylvania.)

(Opportunity 48) Electrician, twelve years' experience, nine as chief, desires position with manufacturer, or electrical and radio maintenance, such as hotel. Will go anywhere east of Mississippi. Opportunity for advancement more important than salary to begin. (Pennsylvania.)

(Opportunity 49) Service Man, radio factory, film development, phonograph and speaker laboratory experience; head of service department large store; desires place with manufacturer affording opportunity for study of line and advancement. Will go anywhere. Age 23. American. (Suburb of New York City.)

(Opportunity 50) Radio Man, negro, seven years' experience, two college engineering, will consider position of any kind with electrical firm. Age 21. (Kansas.)

(Opportunity 51) Service Man, one year's experience, one in telephone servicing. Good mechanic. High-school graduate, R. C. A. Inst. student, seeks any position in radio or electrical work offering advancement. Age 19. (Iowa.)

(Opportunity 52) Service Man, partner in firm; Signal Corps service in France; Veterans' Bureau training; ten years' subsequent radio experience; two years' college. Has designed, built and operated broadcast station. Would appreciate opportunity to "grow" and learn more. Age 37. Married; two children. (South Carolina.)

(Opportunity 53) Service Man, six years' experience construction and repair, five years' commercial operating, one year broadcast station, desires connect manufacturer or reliable retailer, Connecticut or New York. (Connecticut.)

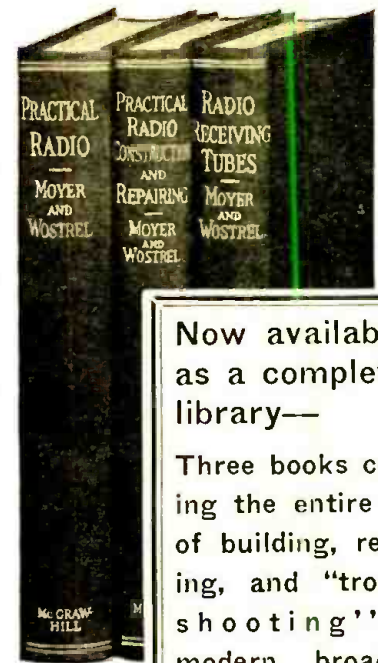

993 pages
5 1/2 x 8 inches
fully
illustrated

Now available as a complete library—
Three books covering the entire field of building, repairing, and "trouble-shooting" on modern broadcast receiving sets.

This Library serves alike the needs of the commercial radio dealer, installer and serviceman, and the amateur who keeps abreast with the latest trend in radio by building his own sets.

RADIO CONSTRUCTION LIBRARY

By JAMES A. MOYER

Director of University Extension, Massachusetts Department of Education

and JOHN F. WOSTREL

Instructor in Radio Division of University Extension, Massachusetts Department of Education

THESE three books embody not only a thorough home-study course, but a ready means of reference for the experienced radioer. "Step-by-step" information is given on wiring, "trouble-shooting", installation and servicing to get the best tone quality, distance and selectivity in broadcast reception in all types of sets.

Practical data is given on radio equipment such as antenna systems, battery eliminators, loud speakers, chargers, vacuum tubes, etc., etc.

A section is devoted to the identification of common faults in receivers and methods of making workmanlike repairs.

The three books are profusely illustrated with understandable diagrams of hookups, connections, loud speaker units, installation work and antenna erection—as well as numerous photographs, tables and charts which clarify the text.

See this Library for 10 Days Free
No Money Down — Small Monthly Payments

It is your privilege to examine this Library for 10 days without cost. If they prove satisfactory, send an initial payment of only \$1.50 and \$2.00 a month until \$7.50 has been paid. Otherwise return the books.

McGRAW-HILL
FREE EXAMINATION COUPON

McGRAW HILL BOOK COMPANY, INC.,
370 Seventh Avenue, New York.

You may send me the Radio Construction Library, three volumes, for 10 days' free examination. I agree to remit an initial payment of \$1.50 at the end of 10 days and \$2.00 a month until the price of \$7.50 has been paid—or I will return the books.

Name

Home Address

City and State

Position

Name of Company..... R. C. 5-30

Radio Craft's Information Bureau

(Continued from page 590)

prairies. We are very free from interference here, in the Northwestern portion of Canada, and I think the following would be a suitable hook-up: one stage of screen-grid R.F., an '01B detector, and two stages of A.F. amplification. Home-wound coils should be considered.

(A.) The arrangement suggested is a "stand-by" with the constructors who have been following the adaptation of the new equipment that has appeared in the radio field. Apparently our inquiring correspondent has not noticed that four-tube circuits of this sort have already appeared in the following issues of Radio-Craft:

July, 1929, p. 16; August, 1929, p. 82; October, 1929, p. 174; December, 1929, p. 260. We wish to call particular attention to "The Moore-Daniels Receiver," a five-tube set described in detail on page 56 of the August, 1929 issue.

The U.X.201B tube is not generally available to experimenters in the United States; the 201A is the American standard.

For those who wish specific instructions for a receiver that will operate particularly under the conditions outlined by Mr. Kenworthy, there is given here a schematic circuit for a four-tube set of exceptional sensitivity and fair selectivity;

DON'T GUESS!

Radio satisfaction is based on knowing and doing the right thing. Don't guess at line voltage! You may call it 110 volts, but it may be anything from 85 to 140 volts. That spells poor radio results—and often costly replacements. But—

When you employ the LINE BAL- LAST CLARO- STAT, such as the Type 2179 for the Silver-Marshall or the Hammarlund HiQ sets, you eliminate line voltage guesswork. Your set works at the correct, uniform, safe input voltage at all times.



Likewise, don't take a chance on resistance values! It takes an experienced engineer with meters and slide rule to determine correct plate, grid, voltage divider, bleeder and other resistances. But when you employ—

CLAROSTAT variable resistors, you can instantly adjust resistance values for best results, with meters or mathematics. And when you know the exact resistance values, you can employ CLAROSTAT strip or flexible resistors.

Remember **CLAROSTAT** for Every Purpose
Here's a

WRITE for data regarding the complete line of CLAROSTAT products. Or if you prefer, ask your most progressive dealer to show you the CLAROSTAT products and to explain their use.

Clarostat Mfg. Co.

Member R.M.A.

Specialists in Variable, Fixed and Automatic Resistors

295 North Sixth St., Brooklyn, N. Y.

The Place to Prepare!



Study All the Phases of Radio Work in One School

Commercial Radio Radio Service
Radio Broadcast Navigation
Radio Mathematics Laboratory
Vitaphone-Movietone

Dormitory - Laboratory - Workshop

LITERATURE ON REQUEST

COMMERCIAL RADIO INSTITUTE
FOUNDED 1920
38 W. BIDDLE ST. BALTIMORE, MD.

and "loud-speaker volume" on most stations.

The values of the parts are as follows: R1, 20-ohm "hum adjuster"; R2 is a suitable filament ballast, or 6-ohm rheostat (In the latter instance a voltmeter should be connected across the filament terminals of the screen-grid tube V1, to indicate the maximum allowable potential of 3.3 volts); R3 is the usual grid leak, which may have a value between 2 and 6 megohms; R4, a 2,000 to 5,000-ohm potentiometer, is the volume control (if one is not available, a variable resistor of this value may be used); C1, C2, 0.0005-mf.; C3, .00025-mf.; C4, C5, 0.25-mf.; C6, 2 mf.; C7, 0.00025-mf.; C8, 2 mf.; C9, 4 mf.; C10, 0.001-mf.; C11, 0.004-mf.; Ch1 and Ch2 are standard 80-mh R.F. chokes; T1 and T2 are standard A.F. transformers of any standard make; while T3 is an output unit of any convenient design; V7 is a battery-model screen-grid (type '22) tube; V2 and V3 are standard '01A, and V4 is the power tube (of whatever type is dictated by the available "B" and "C" supply).

The design of RFT1 and RFT2 is as follows: L2 and L4, 58 turns of No. 22 insulated wire on a 2 1/4-in. tube of high insulating value (card-board impregnated with paraffin, or painted with shellac or collodion, to prevent moisture absorption will do.) Primaries L1 and L3 are wound on 2-in. forms and placed at the filament ends of the corresponding secondaries; L1 has ten turns of wire center-tapped; L3 30 turns of wire, tapped at the 10th turn. The tickler coil L5 is 30 turns of wire wound on a rotatable form 1-in. in diameter and mounted at the grid end of L4. The tap on L1 affords increased selectivity when desired; while the tap on L3 enables a standard '01A to be used as V1, or to increase the selectivity when a '22 is used as V1.

By placing Sw1 on contacts (a), (b) or (c) a flexible control of the audio output is obtained, for choice of high-volume reproducers or headphones.

The correct grid bias for V1 is obtained by adjustment of the movable arm on R1. Shielding should be used as shown in the diagram; the degree of shielding depends upon the parts used and their placement, the proximity of broadcast stations, and the ambition of the constructor.

SULPHATED BATTERIES

(Q.) In the July 1929 issue of Radio-Craft is an article on page 34 entitled "Reclaiming Sulphated Storage Batteries." My storage battery was sulphated to quite an extent and took a long time to charge. I obtained the articles specified and proceeded as per instructions. After getting the job completed, and leaving the battery on charge for the periods specified, I cleaned it out, rinsing it with several lots of water and charging it with the last filling for about twelve hours. I put in the new acid solution, which then had a specific gravity of 1300. After letting it stand several hours, the specific gravity dropped quite low; then, after putting the battery on charge for several hours, it seemed to rise quite rapidly to 1200, but nearly a week's steady charge has failed to raise it much over 1225. What is the matter and how can I remedy it?

When I looked in the battery, before I started putting in the new acid solution, the sulphate

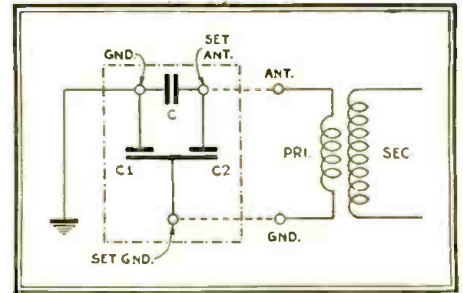

(Fig. Q60B) The schematic circuit of the Bud Antenna. This provides a receiver with a capacity-coupled pickup, connected as shown.

seemed to have disappeared; but, upon inspecting it today, I notice quite a lot more formed; also some down in between the plates, which seems to have never been removed. I am anxious to get it fully charged, as the radio set does not work up to par with the battery in the condition that it now is. Do you think I should have left the battery on charge longer when considering the charging rate?

(A.) The author of the article in question states that there is no reason why the battery in question should remain sulphated, after receiving the treatment described in his article. Sometimes, however, with a large battery container, enough acid may remain so that it will not be completely neutralized by the alkali used to clean it before desulphation. In this case, a second treatment with the alkali should be given; then charge the battery as described. The complete elimination of the sulphate from the plates should be indicated by the voltmeter's registering the ability of the battery to stand a full charge.

Then the cleansing operation should commence, and be carried out thoroughly. After this, the usual sulphuric acid solution is poured into the cells, and the charging continued until the battery is fully charged. Its ability to retain its charge is the best indication of its condition, and this is largely due to the skill with which it has been handled. The size of the containing cells and the active metal surface of the plates govern the best specific gravity for the solution to be used.

Our correspondent is recommended to disregard the hydrometer test, for the present; charge the battery at a greater rate—say three amperes—and, when each cell shows 2.5 volts while charging, remove the battery. Discharge it slowly—that is, through a suitable load, equivalent to a radio receiver. When the voltage drops to 1.5 per cell, recharge it without losing any time; so that it will have no opportunity to sulphate. Repeat this until the battery is as nearly normal, to all indications, as may be judged from its working condition. Then, when it is fully charged, if it gives an incorrect hydrometric reading, pour out all the acid electrolyte and refill with a standard acid solution. It will be best to watch the voltage indicator till the battery begins to work normally.

Short-Wave Stations of the World

(Continued from page 576)

Kilo-Meters	Cycles	Station
92.50	3,256	—W9XL, Chicago, Ill.
94.76	3,166	—WCK, Detroit, Mich. (Police Dept.)
95.48-97.71	3,142-3,070	—Aircraft.
96.03	3,121	—WOO, Deal, N. J.
97.15	3,088	—W10XZ, Airplane Television.
97.53	3,076	—W9XL, Chicago, Ill.
98.95	3,030	—Motala, Sweden. 11:30 a.m.-noon, 4-10 p.m.
101.7 to 105.3	2,850 to 2,950	ke. Television. —W3XK, Silver Springs, Md., 8 to 9 p.m. except Sunday; —WPY, Allwood, N. J.; —W2XR, New York, N. Y.; —W3XL, Round Brook, N. J.
104.4	2,870	—6WF, Perth, Australia.
105.3 to 109.1	2,750 to 2,850	ke. Television. —W2XA, Newark, N. J., Tues. and Fri. 12 to 1 a.m.; —W2XCL, Brooklyn, N. Y.; —W8XAU, Pittsburgh, Pa.; —W1XB, Somers, Ill., Mass.; —W7XAO, Portland, Ore.; —W9XAP, Chicago, Ill.; —W2XCR, Jersey City, N. J. 8:15 and 9 p.m.
109.1 to 113.1	2,650 to 2,750	ke. Television.—W9XR, Chicago, Ill.
110.2	2,722	—Aircraft.
124.2	2,416	—Seattle, Wash., Police and Fire Depts.
125.1	2,398	—W9XL, Chicago, Ill.; —W2XCU, Ampere, N. J.
128.0-129.0	—	—Aircraft.

Kilo-Meters	Cycles	Station
129.0	2,325	—W10XZ, Airplane Television.
136.4 to 142.9	2,100 to 2,200	ke. Television. —W8XAU, Pittsburgh, Pa.; —W1XB, Somerville, Mass.; —W2XCW, Schenectady, N. Y.; —W1XAU, Boston, Mass.
142.9 to 150	2,000 to 2,100	ke. Television. —W2XCL, Brooklyn, N. Y., Mon., Wed., Fri., 9 to 10 a.m.; —W9XAA, Chicago, Ill.; —W2XBS, New York, N. Y., frame 60 lines deep, 72 wide, 1,200 R.P.M.; —W1XAE, Springfield, Mass.; —W8XAU, Pittsburgh, Pa.; —W6XAM, Los Angeles; —W2XBU, Beacon, N. Y.; —W3XAK, Round Brook, N. J.; —W3XK, Washington, D. C., daily except Sun., 8 to 9 p.m.; —WPY, Allwood, N. J.; —W10XU, Airplane.
149.9-174.8	2,000-1,715	—Amateur Telephony.
175.2	1,712	—WKDU, Cincinnati, Ohio. (Police Dept.) —WRB, Cleveland, O. (Police Dept.)
178.1	1,684	—WDKX, New York, N. Y. (Police Dept.)
186.6	1,608	—W9XAL, Chicago, Ill. (WMIAC) and Aircraft Television.
187.0	1,601	—W2XCU, Wired Radio, Ampere, N. J.; —W2XCD, DeForest Radio Co., Passaic, N. J. 8-10 p.m.
187.9	1,596	—WKDT, Detroit, Mich. (Fire Dept.) (Standard Television scanning, 48 lines, 900 R.P.M.)

The Most Complete Radio Book Service!

Your Opportunity to Obtain Any of the Outstanding Volumes from One Source

"AUDIO POWER AMPLIFIERS"

By J. E. Anderson, M.A., and Herman Bernard, LL.B.

The First and Only Book On This Important Subject

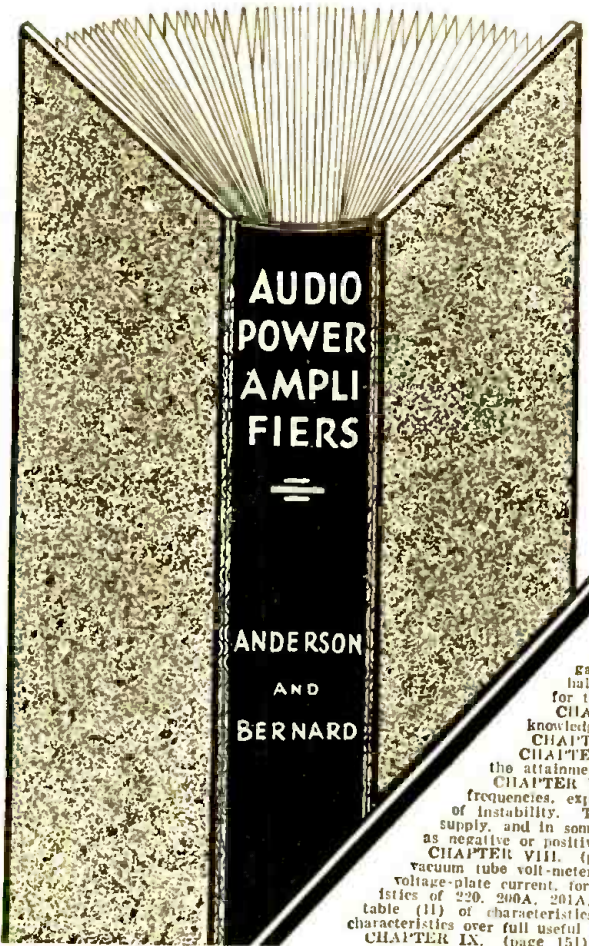

IN radio receivers, separate audio amplifiers, talking movies, public address systems and the like, the power amplifier stands out as of predominant importance, therefore a full and authentic knowledge of these systems is imperative to every technician. "Audio Power Amplifiers" is the book that presents this subject thoroughly. The authors are: J. E. Anderson, M.A., former instructor in physics, University of Wisconsin, former Western Electric engineer, and for the last three years technical editor of "Radio World."

Herman Bernard, LL.B., managing editor of "Radio World." They have gathered together the far-flung branches of their chosen subject, treated them judiciously and authoritatively, and produced a volume that will clear up the mysteries that have perplexed many. The book begins with an elementary exposition of the historical development and circuit constitution of audio amplifiers and sources of power, including Ohm's laws and Kirchhoff's laws. The determination of resistance values to produce required voltages is carefully expounded. All types of power amplifiers are used as examples: AC, DC, battery operated and composite. But the book treats of AC power amplifiers most generously, due to the superior importance of such power amplifiers commercially.

"Audio Power Amplifiers" is for those who know something about radio. It is not for novices. But the engineers of manufacturers of radio receivers, power amplifiers, sound installations in theatres, public address systems and phonograph pickups will welcome this book. Engineers—even chief engineers—of the Bell Telephone Laboratories, Radio Corporation of America, Westinghouse Electric & Mfg. Co., Western Electric, Phonophone, Vitaphone and the like needn't be afraid they won't learn something from this little book.

Details of Chapter Contents

CHAPTER I. (page 1) General Principles, analyzes the four types of power amplifiers, AC, DC, battery-operated and composite, illustrates them in functional blocks and schematic diagrams, and treats each branch in clear textual exposition.

CHAPTER II. (page 20) Circuit Laws, expounds and applies Ohm's laws and their special form known as Kirchhoff's Laws.

CHAPTER III. (page 35) Principles of Rectification, expounds the vacuum tube, both filament and gas-filled, electrolytic and contact rectifiers, and explains why and how they work. Full-wave and half-wave rectification are treated, with current flow and voltage derivation analysis. Regulation curves for the 280 tube are given. Voltage division, filtration and stabilization are fully illustrated and dissected.

CHAPTER IV. (page 62) Practical Voltage Adjustments, gives the experimental use of the theoretical knowledge previously imparted. Determination of resistance values is carefully revealed.

CHAPTER V. (page 72) Methods of Obtaining Grid Bias, enumerates, shows, and compares them.

CHAPTER VI. (page 90) Principles of Push-Pull Amplifier, defines the push-pull relationship, with keys to the attainment of desired electrical symmetry.

CHAPTER VII. (page 98) Oscillation in Audio Amplifiers, deals with motorboating and oscillation at higher audio frequencies, explaining why it is present, stating remedies and giving expressions for pre-determination of regions of instability. The treatment is definitely assigned to the feedback through common impedance of load reactors and B supply, and in some special instances to the load's relationship to the C bias derivation as well. The feedback is shown as negative or positive and the results stated.

CHAPTER VIII. (page 118) Characteristics of Tubes, tells how to run curves on tubes, how to build and how to use a vacuum tube volt-meter, discusses him in tubes with AC on the filament or heaters and presents families of curves, plate voltage-plate current, for 240, 220, 201A, 112A, 171A, 227 and 245, with load lines. Also, plate voltage-plate current characteristic (11) of characteristics of Rectifier and Voltage Regulator Tubes, and individual tables, giving grid voltage, plate current characteristics over full useful voltage ranges for the 220, 201A, 112A, 171A, 222, 240, 227, 245 and 224.

CHAPTER IX. (page 151) Reproduction of Recordings, states coupling methods and shows circuits for best connections. A rectifying detector, designed by one of the authors, is expounded also.

CHAPTER X. (page 161) Power Detection, explains what it is, when it should be used, and how to use it.

CHAPTER XI. (page 131) Practical Power Amplifier, gives AC circuits and shows the design of a sound reproduction system for theatres. A page is devoted to power amplifier symbols.

CHAPTER XII. (page 183) Measurements and Testing, discloses methods of qualitative and quantitative analysis of power amplifier performance. Order Cat. APAM.

ANDERSON AND BERNARD

"Elements of Radio Communication"



The latest book by Prof. John H. Morecroft, of the Engineering Department of Columbia University, and past president of the Institute of Radio Engineers, is his "Elements of Radio Communication." We regard this as the best elementary book to inform you authoritatively on the technical phases of radio in plain language, provided you have some foundation knowledge of radio. The book is a complete course on the elements of radio, containing much material never before published. It has 226 pages, 170 illustrations and a complete index. Cloth bound. Order Cat. ME.

By the same author: "Principles of Radio Communication," second edition. This book is for advanced students. It is the standard of excellence in its field. Cloth bound. Order Cat. MP.

"Radio Receiving Tubes"

The need for an up-to-date book on radio tubes that answers all the important questions has been filled by James A. Moyer, Director of University Extension, Massachusetts Department of Education, and John F. Westrel, instructor in radio engineering, Division of University Extension, Massachusetts Department of Education. This book is a complete discussion of tube principles, functions and uses. The essential principles underlying the operation of vacuum tubes are explained in a non-technical manner as is consistent with accuracy. The book covers the construction, action, reactivation testing and use of vacuum tubes as well as specifications for vacuum tubes and applications for distant control of industrial processes and precision measurements. 297 pages, cloth bound. Order Cat. MWT.

By the same authors: "Practical Radio" including the testing of radio receiving sets. 378 pages, 223 illustrations. Cloth bound. Order Cat. MWPR.

"Practical Radio Construction and Repairing," 319 pages, a companion volume, new second edition. Order Cat. MWPRC.

(NOTE: The standard book on tubes for advanced students is "The Thermionic Vacuum Tube," by Hendrik Von der Bijl. Order Cat. VDB.)

RADIO WORLD, the first and only national radio weekly, eighth year, publishes all the latest circuits and news of radio. Its technical presentations are highly authoritative. Construction of ultra-sensitive and selective circuits is featured regularly. Subscribe for RADIO WORLD and follow the developments on pentodes, Loflin-White amplifiers, band pass filters, pre-tuners, Superheterodynes, screen grid tubes, push-pull, etc.

Two Other New Books by the Same Authors

"The Superheterodyne," a new volume, deals with the theory and practice of this receiver in a detailed and pertinent manner, fully illustrated. The theoretical discussion proceeds to a receiver embodying the theory stated. Full constructional data. Order Cat. ASH1.

"Foothold on Radio," for the sheer novice, the only book published that is really for the person who knows nothing about radio. Fully understandable by any one. Freely illustrated. Order Cat. FOH.

"Trouble Shooter's Manual" — "Mathematics of Radio"

The three books by John F. Rider, Institute of Radio Engineers, are "Mathematics of Radio," "Trouble Shooter's Manual," and "Treatise on Testing Units for Service Men."

"Mathematics of Radio," 128 pages, 8 1/2 x 11", 119 illustrations, bridges the gap between the novice and the college professor. It gives a theoretical background so necessary for a proper understanding of radio and audio circuits and their servicing. Flexible cover. Order Cat. MOK.

The first comprehensive volume devoted exclusively to the topic uppermost in every service man's mind is "Trouble Shooter's Manual," just published. It is not only a treatise for service men, telling them how to overcome their most serious problems, and fully diagramming the solutions, but it is a course in how to become a service man. It gives all the details of servicing as they have never been given before. Finding the right mode of attack, applying the remedy promptly and obtaining the actual factory-drawn diagrams of receivers always have been a big load on the service man's chest. But no more.

This book is worth hundreds of dollars to any one who shoots trouble in receivers—whether they be factory-made, custom-built or home-made receivers.

MORE THAN 100 WIRING DIAGRAMS OF RECEIVERS MADE BY MORE THAN FORTY DIFFERENT SET MANUFACTURERS ARE PUBLISHED IN THIS BOOK, INCLUDING OLD MODELS AND LATEST MODELS! RCA, ATWATER, KENT, FROLEY, MAJESTIC, ZENITH, STROMBERG CARLSON, KOLSTER, FEDERAL, FADA, ETC. 240 pages, size 8 1/2 x 11"; 209 illustrations. Imitation leather cover. Order Cat. TSM.

"Treatise on Testing Units for Service Men," is a 43-page, liberally illustrated book on testing units and circuits. Tells what equipment a service man should have and how to use it most effectively and quickly. Rapidity of operation is one of the points stressed throughout this valuable book, as a service man's time is his chief stock in trade. Order Cat. TTH.

Other Books

"ABC of Television," by Raymond Francis Yates, tells the whole story and gives data on construction of a television receiver. 210 pages, 100 illustrations. Cloth bound. Order Cat. TEL.

"The Radio Manual," by G. E. Sterling of U. S. Dept. of Commerce and Robt. S. Kruse, formerly technical editor of QST. Nearly 900 pages, 369 illustrations. Bound in flexible fabricoid. Order Cat. MAN.

"Drake's Encyclopedia," new edition, 2 1/2" thick, weighs 3 1/2 lbs., 920 pages, 1,025 illustrations. Order Cat. DRA.

"Experimental Radio," by R. R. Ramsey, Ph.D., Prof. Physics, Indiana University. 255 pages, 168 illustrations. Cloth cover. Order Cat. REX.

"Fundamentals of Radio," by Ramsey. 372 pages, 402 illustrations. Order Cat. RFM.

"Principles of Radio," by Keith Henney, M.A., director, laboratory, Radio Broadcast. 477 pages, 305 illustrations. Order Cat. PRK.

"Radio Telegraphy and Telephony," by Rudolph L. Dunne and Charles C. Dreyer, of Radio Institute of America. Order Cat. RTT.

"The Superheterodyne," by R. E. Lavault, 93 pages, 68 illustrations; cloth cover. Order Cat. REL.

Radio World, 145 West 45th Street, New York, N. Y. (Just East of Broadway.—Phone BRYant 0558.)

Enclosed please find \$..... for which please enter my subscription for RADIO WORLD for specified period and send free (postpaid) the one premium book designated by my cross in square.

- REL \$1.00 for 8 weeks (8 issues)
- ABSH \$2.00 for 16 weeks (16 issues) TTU
- FOR \$3.00 for 6 months (26 issues)
- MOR \$4.00 for 34 weeks (34 issues) MWPRC
- MWT \$5.00 for 42 weeks (42 issues) MWPR
- APAM \$6.00 for 1 year (52 issues) ME
- TEL REX PRK
- RFM \$7.00 for 60 weeks (60 issues)
- VDB \$10.00 for 86 weeks (86 issues)
- MAN \$12.00 for 2 years (104 issues) RTT

Name.....
Address.....
City.....State.....

Radio's Greatest Bargains!

THESE are the greatest radio set bargains that have ever been offered. The radio sets listed here are standard sets made by the greatest and best known radio set companies in America.

All of these sets are battery sets (with the exception of the Freshman All-Electric A.C. Set); but this is only one reason why they are sold at such ridiculously low prices.

The other reason is that these sets are mostly demonstration and display models from New York's largest radio and department stores.

We have been able to make connections with a number of houses in New York City, and we secured these fine sets at remarkable prices. Due to these circumstances, we are enabled to sell them to you at only a fraction of their original cost.

IMPORTANT—SET BUILDERS, CONSTRUCTORS AND EXPERIMENTERS TURN THESE SETS INTO BIG MONEY!
There are still many families and many houses not equipped with radio today. At the

prices at which we are selling them, it will pay you to install these sets and sell them at an excellent profit.

A number of our customers have made as much as \$20.00 and \$30.00 on each one of these sets by installing them, incidentally making a profit on tubes, loud speakers, etc.

Remember, we do not sell you these sets as brand new. They all have been used somewhat, but they are all in excellent condition, and, by going over the cabinets with some furniture polish, or otherwise renovating them, they will make a first-class appearance and, in most instances, you will not be able to tell the set apart from a new one. This is your great opportunity to make a few extra dollars, and we trust that you will not let this opportunity go by.

We promise reasonably prompt shipments. We have a large supply of these sets on hand, and, in most cases, can ship within 24 to 48 hours.

ALL SETS ARE TESTED BY OUR EXPERTS AND WE GUARANTEE THEM TO WORK SATISFACTORILY.

STROMBERG-CARLSON 523 RECEIVER



ONLY
\$
24.95

This model of the famous "Treasure Chests" was one of the first to introduce the idea of electrification. Four 201A tubes and one 200A were recommended; all operating voltages to be supplied from an external power unit operating from the light socket, such as the No. 403 Audio Power Unit. (Of course, regular batteries may be used.) A beautifully-grained slanting wood panel carries the well-known phosphor bronze tuning and control escutcheons. The panel controls include a "Long-Short Antenna" switch, and a Weston 0-7 voltmeter. Jack on panel is for phonograph pick-up. Neutrodyne circuit is used. Weight is 40 lbs. Cabinet is 26 in. long x 14 in. deep x 13 in. high. Its appearance is unusually attractive. Makes a fine appearance in any home. The chassis of this set is the same as the one used to complete the No. 524 Console that listed for \$230.00. Circuit will accommodate either a 112A or a 171A without any changes in wiring. List price is \$160.00.

RADIOLA 20



ONLY
\$
12.50

Two stages of tuned radio frequency amplification, a regenerative detector, and two stages of A.F. amplification, using 4 type 189 tubes and a 120 for the last audio stage, is the arrangement of this receiver. A marvel for sensitivity. Made by Radio Corporation of America. Like the Dix superheterodynes of the same make, drum dials are used. Three variable condensers are used and these are ganged, and adjusted by the left-hand or "station selector" dial. The two H.F. stages are NEUTRALIZED. Two jacks are provided; a choice of one A.F. or two is obtainable. Two small black knobs on the lower right are controls which vary the filament circuit resistance, and two similar knobs at lower left are controls for 3-plate balancing condensers. Cabinet is mahogany. The tube sockets are moulded in a single strip of bakelite. This strip is supported on sponge rubber. A terminal strip is provided, to which is fastened one end of a 7-wire battery cable 5 ft. long. The clever constructor can adapt this chassis to short-wave operation by mounting sockets for plug-in coils and by doing a bit of engineering with the variable condensers. Overall dimensions are: 19 x 16 x 11 inches high. It weighs 29 pounds. List price is \$102.50.

FRESHMAN "MASTERPIECE" TYPE E



ONLY
\$
11.95

This is a single-dial receiver (what everyone wants) and, like the A.K. 35, it uses a phosphor bronze "bell" to couple the three 19-plate brass variable condensers. Six tubes are required for this set. Easy to turn over at a big profit. Its overall dimensions are: 20 x 10 x 10 inches high, and the slanting panel measures 7 x 18 x 1/32 inch. It is of brown crackle-finish metal. Weight of set is 21 pounds. The escutcheon in the middle of the panel has an opening through which the dial setting may be seen; a semi-circular rheostat for volume control is adjusted by the small knob to be seen below the tuning knob. At the extreme left is a little 13-plate condenser connected from grid to filament of the first R.F. tube, for obtaining distant station programs. The first R.F. is untuned, while the second and third are tuned; circuit oscillation being prevented by the use of grid suppressors. This set is designed to be used with five type 201A's and a type 112 tube. The cabinet is of two-tone mahogany veneer, with a nickel-plated, full-length piano hinge. List price is \$89.50.

Send for FREE RADIO SET CATALOG—
A Postal Card Brings It

FRESHMAN ALL-ELECTRIC RADIO FOR 110-VOLT A.C. OPERATION



ONLY
\$
31.95

This is a brand new and unused set. It comes in the original factory case. The latest and best of the famous Freshman all-electric radio sets. It is a 1929 model. This set uses 1 type 227 tube, 4 226s, a 250 and a rectifier of the 281 type. The power pack is contained in a small shielded case at the rear of the chassis and within the cabinet; thus, it is an entirely self-contained electric receiver. All equipment is housed in a gold and crystalline olive finished metal cabinet 19 in. long x 10 in. high x 12 in. deep; set weighs approximately 35 lbs. The Freshman Electric Radio supplies the demand for a simple, neat-appearing, illuminated single-dial control, entirely self-contained, shielded, all-electric radio set. List price is \$90.00.

ATWATER KENT MODEL 35



ONLY
\$
14.95

One of the most compact receivers ever offered to the public. It is of the tuned radio frequency type. The first stage of R.F. is untuned and acts as a "blocking" tube. Circuit oscillation is prevented by the use of grid suppressors, of which two are provided. There is a total of three stages of R.F. amplification and two of A.F. Three variable condensers are used. Overall dimensions are: 17 1/2 x 8 x 5 1/2 inches. The chassis is housed in a brown crackle-finish pressed metal cabinet. This is a "one-dial control" receiver. A "full vision" moulded bakelite dial controls the variable condenser gang; another moulded control varies the filament heat. It weighs 12 pounds. Incorporated in this set is a 6-wire cable, each wire of which is rubber insulated and "color coded." A power tube may be used in the last stage. Phosphor bronze "belting" couples the two side condensers to the central one, upon the shaft of which the tuning dial is fastened. This shielded receiver has very high "gain" and may be used with antennas of any length. The variable condensers are of the "single bearing rotor" type. This set takes the following tubes: 5 type 201A and one type 112A or 171A tubes. List price is \$65.00.

FRESHMAN 3-DIAL "MASTERPIECE"



ONLY
\$
5.00

This is distinctly a Custom Built set. Where it was thought that a change of parts would improve the performance of the receiver, the change has been made. Although, in the main, the circuit is that of the famous "Masterpiece." There are three standard R.F. coils, and three standard Freshman variable condensers (19 plates) made with brass plates. The panel is mahogany hard-rubber, 7 x 18 x 3/16-inch thick; the baseboard is the same size and material. A Cutler-Hammer push-pull snap switch is used. Ample volume control is obtained with the two panel-mounted rheostats. One is 25 and the other is 10 ohms. Two phone jacks are provided for loud speaker connection to first audio or second audio output. Seven battery connection binding posts are mounted on the rear of the baseboard. The dials are black, moulded. This set takes five type 201A tubes. Total weight is 12 pounds. The overall dimensions are: 20 1/2 x 9 x 9-inches high. The cabinet is finished in mahogany, to match the panel. The set lists for \$60.00.

HOW TO ORDER

Remit amount by money order, cash or certified check (personal checks occasion delay). Order direct from this page at prices quoted. No. C.O.D. orders on this sale accepted.

RADIO SPECIALTY CO.

BUY FROM RADIO'S OLDEST MAIL ORDER HOUSE

98C Park Place
New York City

WHAT EVERY ELECTRICIAN WANTS TO KNOW!

JUST OUT!—Latest Exact Information from A to Z!

We take pleasure in announcing: "AUDELS NEW ELECTRIC LIBRARY"

New and More Uses for Electricity offer great opportunities to men who can handle this power correctly. Modern electrification of industry calls for trained men who know how to handle electricity accurately.

Simple as A. B. C.—"Audels New Electric Library" gives latest, exact information from foundations of electrical practice to latest modern applications. This is a NEW practical and theoretical course in electricity for home study and ready reference.

Here are the answers to your questions, giving you the real dope that every electrician must know. They chart your knowledge, taking away the uncertainty of guess work.

NEW!

As Easy As ABC



Latest information, fully illustrated, covering:—

Fundamental Principles and Rules of Electricity, Magnetism, Armature Winding, Repairs, Dynamos, D.C. Motors, Construction, Installation, Maintenance and Trouble Shooting, Tests and Testing Instruments, Storage Battery, Construction and Repairs, Alternating Current Principles and Diagrams, Power Factor, Alternators, Transformers, A.C. Motors, Windings, Reconnecting, Converters, Switches & Fuses, Circuit Breakers, Relays, Condensers, Regulators, Rectifiers, Meters, Switchboards, Power Station Practice, House Light & Power Wiring, Circuits, High Tension, Transmission, Plans, Calculations, Code, Electric Railways, Signals, Elevators, Hoists & Cranes, Gas Engines, Auto & Aero Ignition, Starters, Radio, Telephone, Telegraph, Bells & Signals, Motion Pictures, Talkies, Lighting, Illumination, Electric Refrigeration, Heating, X-Ray, Plating, Welding, Pumps, Compressors, Domestic & Farm Appliances, An Electric Calculator for Engineers and Mechanics, Practical Mathematics for Ready Reference, A New Electric Dictionary & Encyclopedia of Words.

7 Books Now on Sale
5 in Preparation

The Library contains 12 books—the first 7 books containing 3600 pages with thousands of diagrams and illustrations are now ready; the remaining 5 books are in preparation. A pocket-size, flexibly bound series that is valuable wherever electricity is used.

Beautiful, timely books for service—pocket size; completely illustrated with diagrams and charts; simplified, easy to read and understand. No electrical man can afford to pass up this opportunity. Extremely low price; buy on your own terms.

QUESTIONS AND ANSWERS
AUDELS NEW ELECTRIC LIBRARY ILLUSTRATED

NEW!

SATISFACTION GUARANTEED! "Audels New Electric Library" is backed by our 50-year record as helping hand publishers. Satisfaction always guaranteed.

Beautiful, Timely Books

POCKET SIZE

Read for Profit

BUY ON YOUR OWN TERMS

- PLAN 1—ONE BOOK A MONTH**
Please enter my subscription to "Audels New Electric Library" to consist of twelve volumes, price \$1.50 a volume (\$10.50 for the seven volumes now ready). Mail one volume each month and as they are received, I will mail you \$1.50 promptly.
- PLAN 2—PAY 50c OR MORE A WEEK**
Please ship me for one week's free trial the first seven volumes of "Audels New Electric Library," \$1.50 each (\$10.50 for the seven volumes now ready). The remaining five volumes to be mailed as issued at \$1.50 a volume. If satisfied, I will mail you 50c or more each week as payment for the first seven books and I will pay for the last five volumes as I receive them at \$1.50 each.
- PLAN 3—CASH PRICE \$9.98**
Please ship me postpaid "Audels New Electric Library" for which I enclose remittance \$9.98 in full payment for the seven volumes now ready. You are to ship me on one week's trial the remaining five volumes as they are issued for which I will either pay \$1.50 each as received or return to you. This price is based on 6% cash discount.

THEO. AUDEL & CO.,
65 West 23rd St., New York, N. Y.

Please ship me the NEW "Audels Electric Library" on the plan marked (X).

NAME

ADDRESS

OCCUPATION

EMPLOYED BY

SM

"S-M 722 a Knockout" —Setbuilders Demand D.C. Design—It's Here!

\$200-\$300 Radio Reception at \$50-\$75 Cost

Experienced setbuilders have learned to expect big results from any screen-grid custom design that S-M offers—but the 722 Band-Selector Seven has broken all records. And no wonder—a custom receiver that is sold, completely wired, at \$74.75 net, topping the performance of widely advertised factory sets selling at twice the price. Yet there is nothing mysterious about it—just the long experience of S-M engineers applied to the job of producing those essential receiver parts whose quality spells the difference between the performance that "gets by" and the performance that an S-M fan demands. Everything that is the "last word" is in the S-M 722—the '24 power detector, the band filter—the uniform gain all over the dial—single dial tuning—all electric with built-in power supply. Tubes required: 3-'24, 1-'27, 2-'45, 1-'80. Wired, less tubes, \$74.75 net; parts total \$52.90.

The new 722DC for battery use (illustrated) gives every advantage of the a. c. design—big volume, DX ability, and uniform amplification at all frequencies, just like the a. c. set—truly the ideal battery receiver. Tubes required: 3-'22, 3-'12A. Wired, less tubes, \$57.50. Parts total \$38.50.

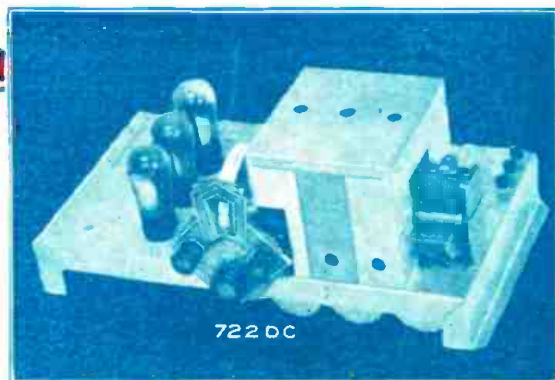

722 DC

Do You Want Absolutely the Best There Is?

It doesn't cost an awful lot more than the 722, but this S-M 712 tuner, in its neat innocent-looking all-metal shielding cabinet, is absolutely guaranteed to out-distance and out-perform all competition regardless of circuit or price—just as its famous predecessor, the Sargent-Rayment 710, did last year. Read, in last month's issue of this magazine, how one listener living only a mile from the powerful WSM tunes in regularly a station 400 miles away with only 20 kc. separation! That's performance—and with one-dial tuning—no verniers. Tubes required: 3-'24, 1-'27. Wired as shown, less tubes, \$64.90 net. Parts total \$40.90.

Any good amplifier can be used with the 712; ideal tone quality and perfect convenience are secured by using the S-M 677—or, with slightly less power, but absolute freedom from hum, by using the new S-M 677B. The 677B uses 1-'27, 2-'45, and 1-'80 tubes. Wired complete, less tubes, \$56.20. Parts total \$41.00. For 25-40 cycle current, \$70.20 wired.

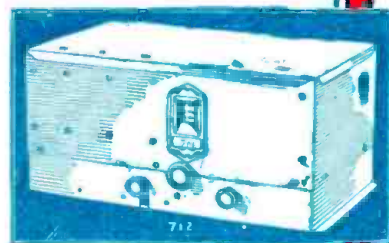

712

And a "Bearcat" for the Short Waves

"The little 735 is a 'bearcat'. The way it will pick up stations is nobody's business. You want to see the hams come in and play with it. First one I wired I got 5SW Chelmsford, England, also a Dutch station and a lot of others . . . this was around 2 P. M."

That's the verdict of R. G. Sceli of Hartford, Conn.—one of the most expert setbuilders in New England, and remember he is speaking of the first completely-a.c.-operated short-wave sets ever brought out! The new S-M 735 Round-the-world seven is carrying all before it this year. On same chassis as the 722; tubes required: 1-'24, 2-'27, 2-'45, 1-'80; wired \$64.90, parts total \$44.90. 735DC for battery use, using 1-'22, 4-'12A, wired \$44.80. Parts total \$26.80.

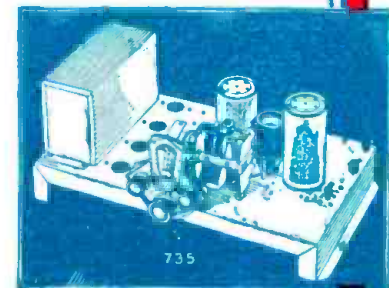

735

Beautiful Cabinets

A full line of beautiful cabinets is available for all these S-M receivers. The 735, 722 and 722DC fit perfectly in the 707 table cabinet, which, in rich crystalline brown and gold, is only \$7.75 net. Any of these sets, or the 712 with 677B amplifier, fit perfectly into the beautiful line of furniture cabinets shown in the S-M catalog—use the coupon if you haven't it.

Detailed information about the new 692 and 677B Amplifiers were printed in the extra-big issue of THE RADIOBUILDER for March 1st. No setbuilder who wishes to be informed about the latest in radio should be without this "mouthpiece of the S-M laboratories". Use the Coupon!

Over 3,000 Authorized S-M Service Stations cover the United States and Canada. Many are profiting handsomely! Write us for the address of the nearest one if you wish a custom-built set. Setbuilders write us regarding a franchise in your territory.

SILVER-MARSHALL, Inc.

6419 West 65th Street Chicago, U. S. A.

Silver-Marshall, Inc.
6419 West 65th Street, Chicago, U. S. A.

-----Please send me, free, the latest S-M Catalog; also sample copy of The Radiobuilder.

-----Please send me, without obligation, name of nearest Service Station.

For enclosed -----In stamps, send me the following:

-----50c Next 12 issues of The Radiobuilder

-----\$1.00 Next 25 issues of The Radiobuilder

S-M DATA SHEETS as follows, at 2c each:

- No. 3. 730, 731, 732 Short-Wave Sets
- No. 4. 255, 256, etc., Audio Transformers
- No. 7. 675ABC High-Voltage Power Supply
- No. 9. 678PD Phonograph-Radio Amplifier
- No. 12. 669 Power Unit
- No. 14. 722 Band-Selector Seven
- No. 15. 735 Short-Wave "Bearcat"
- No. 16. 712 Tuner (Development from the Sargent-Rayment)
- No. 17. 677 Power Amplifier
- No. 18. 722 DC Band-Selector Six
- No. 19. 692 Power Amplifier (50 Push-Pull)
- No. 20. 677B Power Amplifier for use with 712

Name -----

Address -----