

# Radio-Craft

for the  
**Professional-Serviceman-Radiotrician**

Nov  
25 Cents

HUGO GERNSBACK Editor

**Men who  
have made  
Radio:**

C. FRANCIS JENKINS



*C. Francis Jenkins*

WALTER  
EDWARD  
BLYTHE

You Fellows  
Who Want

**BIG  
PAY**

Get Into

**WHY** earn \$15 or \$20 or \$30 a week, when in the same six days as an Electrical Expert, you can make \$70 to \$200 — and do it easier—not work half so hard. Why, then, remain in a small-pay, no-future job that offers no chance for big promotion — no chance for big income? Fit yourself for a real job. **Get Into Electricity.** That's where the big money is being made, and always will be made.

**Electricity — The Big Pay Field**

Today even the ordinary Electrician — the "screw driver" kind — is making money—big money. But it's the trained man—the Electrical Expert—who makes the really big money — \$12 to \$30 a day — \$70 to \$200 a week. Be a Big-Pay man, yourself. Get in line, now, for one of these "Big-Pay" Jobs.

**I'll Train You At Home**

I'll train you at home—in your spare time. You work just as you are working now — at your same job. My now famous "Work-Sheet and Job-Ticket" method guarantees you simplified, practical training along work-shop lines. In a few short months you can step out of your old job into a new job—into electrical work where you can be a Big-Pay man in this Big-Pay field.

**You Earn As You Learn**

To learn Electricity my way you don't have to be a College man, or even a High School graduate. You can read. You can write. That's enough. With me, you get experience as you go along and make good money while learning. I'll show you how—and I'll give you, without extra cost tools and apparatus to work with — 6 Big Outfits in all.

**Money Back If Not Satisfied**

That's what I agree to do. And back of me in this agreement stands the Chicago Engineering Works, a \$2,000,000 Illinois Corporation. There's nothing like "Cooke" Training, anywhere. It's the Training that big Electrical men are praising; it's the Training that employers recommend; it's the Training that one of our greatest Engineering societies, has endorsed 100 percent. **It's the Training for you.**

**If You're Earning Less Than \$70 A Week — Investigate**

Don't wait a minute! Find out today why "The Cooke Trained Man is the Big-Pay Man", everywhere! Find out how "Cooke" Training will help you boost your pay! Mail coupon right now for my **6 FREE Book of Facts.** See the Six Big Working Outfits I give you without extra charge. See the hundreds of pictures, the proofs, the Big-Pay letters of other "Cooke" Trained Men. Get this great free Book. Send for it today. Clip, sign, and mail coupon **RIGHT NOW!**

L. L. COOKE, Chief Instruction Engineer

**L. L. COOKE SCHOOL  
OF ELECTRICITY**

Dept. 308

2150 Lawrence Avenue  
Chicago, Illinois

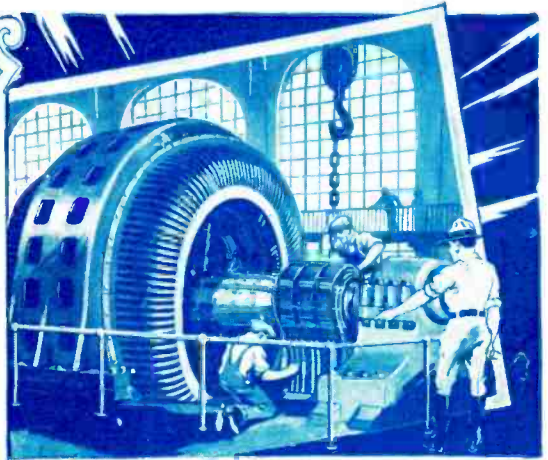

**ELECTRICITY**

*Hundreds of Men  
I have trained are  
now earning*

**\$60 <sup>to</sup> \$100  
A WEEK**

Why don't you?

If you  
earn less  
than \$70  
a week—  
**INVESTIGATE**

**ACT  
NOW**



I'll train you  
at home in  
a few short  
months!

Use this **FREE BOOK COUPON**

L. L. COOKE, Chief Instruction Engineer,  
Dept. 30 2150 Lawrence Avenue, Chicago, Illinois

Send me at once without obligation your big illustrated book "The Secrets of Success in Electricity" and complete details of your Home Training Course in Practical Electricity, including your outfit and employment service offers.

Name \_\_\_\_\_  
Address \_\_\_\_\_  
City \_\_\_\_\_ State \_\_\_\_\_  
Residents of Canada may send coupon to R. A. Farrow, Special Representative,  
7 Medbury Lane, East, Windsor, Ontario, Canada.



**PROOF**

**GETS \$12,000 JOB**  
Dear Mr. Cooke: Since finishing your Course I have been doing very well in my own electrical business. But recently I was offered the job of Chief Electrician for a Big Coal Mine. I took the job, at \$12,000 a year.

F. M. HUGHES  
1506 2nd Avenue  
Terre Haute, Ind.



**MORE PROOF**

**\$65 A DAY**

Dear Chief: If it wasn't for your wonderful course I wouldn't now be making as high as \$65 a day. It makes me proud to have your Diploma, and believe me I am a booster for your Course. JACOB LENTZ  
1223 1st Avenue  
Hillsboro, Oregon



**MORE PROOF**

**\$150 A WEEK**

Dear Mr. Cooke: My new shop is going strong, paying me now over \$150 a month above expenses. I must thank you again for my success, because it was your wonderful course and method of instruction that put me where I am. W. E. FENCE,  
Box 921, Palo Alto, Calif.

**6 BIG  
OUTFITS  
TOOLS APPARATUS  
GIVEN**



**The "Cooke" Trained Man is the "Big Pay" Man**

# WHOLESALE PRICES



## FREE RADIO CATALOG

**T**HIS new "1930"-148 page radio catalog is now ready, with all the latest radio improvements and all at wholesale prices. Hundreds of specials at remarkable figures, including the new

# SCREEN GRID RADIO

From the first page to the last this book is crowded with values that will please and astound you—every radio need and requirement fulfilled in this greatest of all Radio Books.

**Standard Sets as low as  
\$15.95**

Marvelous offerings in new, Humless, Screen Grid A. C. all-electric and battery operated sets; a wide range of beautiful consoles, from the small table model types to the most ornate and artistic of radio furniture; dynamic speakers of tremendous volume and richest tone; accessories, parts and kits in wide variety—in fact, everything that is standard, as well as everything that is new, in Radio. Get this book *today!* Supply your every Radio need at rock-bottom wholesale prices, and pocket the saving. Such startling values have never before been offered at like prices.

**Write for This Catalog Now!**

**CHICAGO SALVAGE STOCK STORE**  
**World's Largest Radio Store**  
**509 So. State St. Dept. 130 Chicago, Ill.**

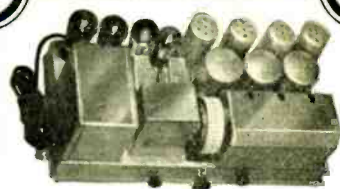

### The New Screen Grid Receivers

The outstanding Screen Grid Receiver of the year featuring advanced engineering practices and a new perfection in circuit design—that is establishing a new standard in radio performance.

#### Humless

The use of the new heater type tubes assures freedom from hum and all extraneous noises assuring unusual tone quality.

#### A. C. Operated

Practical A. C. operation assures consistent performance operates directly on 110-125 volt. 50-60 cycle A. C.

#### Power Detector

A tuned detector stage in keeping with modern radio engineering imparts unusual power to the receiver.

#### "245" Push Pull

The use of two "245" super power tubes assures faithfulness in reproduction without danger of overloading.

#### Screen Grid Tubes

Three screen grid tubes in this famous chassis assure extreme sensitiveness and remarkable distance range.

#### Super-Sensitive

Power detector coupled with Screen Grid R. F. efficiency imparts unusual sensitivity to the circuit assuring extreme distance range.

#### Dynamic Tone

Two stages of audio frequency the last employing two "245" power tubes with oversize transformers assures finest tone quality.

#### Tremendous Volume

Perfection in audio circuit design makes possible tremendous undistorted volume from a whisper to the full blare of an orchestra.



VOLUME I.

November

NUMBER 5

HUGO GERNSBACK, Editor-in-Chief

R. D. Washburne, Technical Editor.

C. P. Mason, Associate Editor

Contents of This Issue:

	PAGE		PAGE
EDITORIAL—HOW TO BECOME A SERVICE MAN,	197	RADIO SERVICE DATA SHEETS.....	208
SERVICE MAN'S DATA		LIST AND SCHEDULES OF SHORT-WAVE STATIONS	210
ELECTROLYTIC CONDENSERS IN POWER PACKS,		THE RADIO CRAFTSMAN'S OWN PAGE.....	211
Bertram M. Freed	198	AT THE 1929 RADIO WORLD'S FAIR.....	212
SERVICING THE FRESHMAN "G".....	Harold Weiler 199	LATEST THINGS IN RADIO.....	214
MEN WHO MADE RADIO—C. Francis Jenkins.....	201	VACUUM TUBES FOR RADIO RECEPTION.....	C. W. Palmer 216
NATIONAL LIST OF SERVICE MEN REPLY BLANK.....	201	RADIO-CRAFT KINKS .....	219
SHORT WAVE CRAFT		INFORMATION BUREAU .....	220
AIRPLANE STATION KIK.....	Glenn Dale Bronner 202	RESISTORS IN RADIO.....	Charles E. Golenpaul 239
THE RADIO CONSTRUCTOR			
THE 1930 ELECTRIC RECEIVER.....	Clyde J. Fitch 204		

In The December Issue

- More About Resistors..... Charles Golenpaul
  - Further information about the application of resistors in radio.
- Experiments with 14-Centimeter Waves ..... Ernst Gerhard
  - A series of investigations with ultra-high frequencies which act like light.
- Servicing the Freshman "N" and Other Sets.... Harold Weiler
  - Where and how to service well-known radio receivers.
- The Development of the Modern Reproducer..... Oscar Roos
  - Reproducers of past and present design are discussed, and new laboratory developments are described.

RADIO-CRAFT is published on the 5th of the preceding month. 12 numbers per year. subscription price is \$2.50 a year in United States and its possessions. In Canada and foreign countries, \$3.00 a year. Single copies 25c. Address all contributions to Editor, RADIO-CRAFT, 96-98 Park Place, New York. Publishers are not responsible for lost Mss. Contributions cannot be returned unless authors remit full postage.

RADIO-CRAFT—Monthly—Entered as second class matter in the Post-office at New York, N. Y., June 24, 1929, under the act of March 3, 1879. Title registered U. S. Patent Office. Trademarks and copyrights by permission of Gernsback Publications, Inc., 98 Park Place, New York City, owner of all trademark rights. Copyright 1929 by G. P., Inc. Text and illustrations of this magazine are copyright and must not be reproduced without permission of the copyright owners.

RADIO-CRAFT is for sale at all principal newsstands in the United States and Canada. European agents: Brenano's, London and Paris. Printed in U. S. A.

IF YOU WISH TO SUBSCRIBE TO RADIO-CRAFT, make out all remittances to the Techni-Craft Publishing Corp., 96-98 Park Place, New York City. Be sure to mention the name of magazine you wish to subscribe for, as we are also agents for the following magazines: SCIENCE WONDER STORIES and AIR WONDER STORIES, subscription price of which is the same as RADIO-CRAFT. Subscriptions can be made in combination with the above publications, at a reduced club rate. Ask for information. Subscriptions start with current issue. WHEN YOUR SUBSCRIPTION EXPIRES, we enclose a renewal blank in the last number. No subscriptions continued unless renewal remittance received. Change of Address. Always give us old as well as new address and notify us as far in advance as possible.

This magazine is published by

TECHNI-CRAFT PUBLISHING CORPORATION

H. GERNSBACK, President S. GERNSBACK, Treasurer JOSEPH M. HERZBERG, Vice-President IRVING S. MANHEIMER, Secretary

Chicago Advertising Representative: L. F. McClURE, 737 North Michigan Avenue

Editorial, Advertising and General Offices . . . . . 96-98 Park Place, New York City

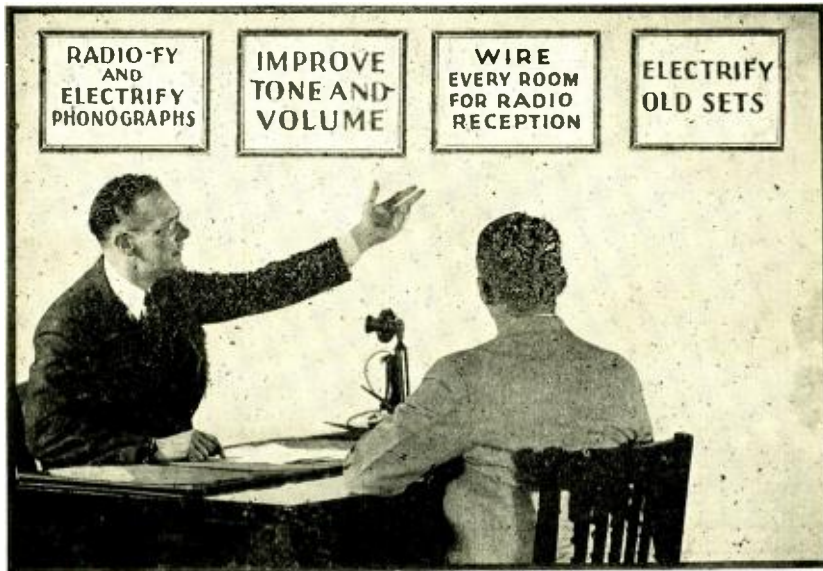

# "That's But the Third of the 40 Easy Ways

— to make \$3<sup>00</sup> An Hour Spare Time In Radio"

Wiring rooms for Radio—as usual, our members are among the first to cash in on it, because the Association was on the job in advance of the trend, preparing its members for this newly developing easy way to make money in radio. It is but one of the many easy ways by which Association-trained men are making \$25 to \$75 a week in spare time, \$50 to \$200 a week full time—easy ways you, too, can follow.

## Join with 100,000 Ambitious Men—Cash in on Radio Now

Join the Radio Training Association and take advantage of the proven ways by which you can make \$3.00 an hour upwards from the day you join. Our members are cleaning up on them and at the same time preparing for the \$10,000 to \$25,000 openings in Radio. The Association is helping men start businesses without capital, finance inventions, increase their pay, pass licensed operator's examinations, get better positions. No matter what you want out of Radio, the Association can help you get it easier and quicker. Learn what the Association has done for others and can do for you.

## Act NOW...for No-Cost Membership!

A limited number of these memberships now available! Write for one today! It need not—should not—cost you a cent. Write for the inspiring story of what the Association has

done for other ambitious men. Learn how it can help you make more money now and later. Fill out and mail in the coupon now—right now—without fail.

**RADIO TRAINING ASSOCIATION OF AMERICA**  
4513 Ravenswood Avenue     ▲     ▲     Chicago, Illinois

### Do You Know That —

- 20,000,000 sets are waiting to be modernized?
- over \$200,000,000 will be spent on them by their owners?
- every phonograph owner is a prospect for the services of an Association member?
- our Free Radio Hand-book will open your eyes?

Mail Coupon for **FREE Radio Hand-book**



### In 2 Months Made Factory Manager at 300% Pay Increase

H. L. Schweber, Ill. — "After graduating I secured a position with a large Radio manufacturer. In two months I was given complete charge of a factory. My income has increased 300% since I joined the Association."

### Clears \$3,000.00

Frank J. Deutch, Pa. — "Since joining the Association I have cleared nearly \$3,000.00. I don't see how a man can fail, no matter how little education he has, if he follows your easy ways of making money."

### \$1,100.00 In 6 Weeks

J. R. Allen, Calif. — "Have done over \$1,100.00 worth of business in the last 6 weeks. Next month I'm going to open a store. Never knew money could come so fast and easy."

### \$32.00 In 2 Days

F. G. Gentner, Pa. — "I thought I was doing well last month in spare-time work, but the first two days of this month I have made \$32.00. Since joining I have started a bank account."

Radio Training Association of America  
Dept. RCA-11, 4513 Ravenswood Ave., Chicago, Ill.

Gentlemen: Please send me full details of your special No-Cost Membership Plan, and a copy of your Radio Handbook.

Name .....

Address .....

City ..... State .....



### Are You Caught Behind the Bars of a "Small-Time" Job?

Why be satisfied with a "small-time" job at low pay? Why grind along at tiresome, uninteresting work with long hours and no future? Why take orders all your life from every Tom, Dick, and Harry who happens to be your boss?

Right now—this very minute—you hold the key to REAL SUCCESS in your hand. Hundreds of other

men before you have read of COYNE just as you are doing now—and are making \$50—\$75—\$100 a week as a result. This is your BIG CHANCE to get friendly help and practical training that will enable you to climb out of the rat, and EARN REAL MONEY! Don't miss it! Today may be the big turning-point in your whole life!



# LEARN ELECTRICITY Without Books or Correspondence IN 12 WEEKS

By Actual Work—in the Great Shops of Coyne

SOME kinds of jobs ought to be labeled with a big sign that says "Man-killer." They are either so heavy, dirty and hard that they sap a man's strength and keep him dog-tired all the time—or else they are so disagreeable, uninteresting and poorly paid that they kill his ambition in almost no time. And AMBITION is the most valuable thing a man can have!

### Fascinating Work—Real Pay!

That's why so many men are turning to ELECTRICITY, which offers unlimited rewards and opportunities—with ordinary salaries of \$50—\$75 and up a week! Right now big electrical jobs are actually going begging! Electrical experts are in demand—and the need is growing every day! The situation is one that spells O-P-P-O-R-T-U-N-I-T-Y in letters a foot high for the man who is wide-awake enough to see it!

### Learn Quickly

Let me make you a master electrician—the Coyne way. I've done it for thousands of others—farmers, laborers, factory men, and hundreds who haven't had more than 8th grade education! I can do it for you—and start you off on the road to independence and big earnings in just 90 days!

### Not by Books

The secret of Coyne-training is that it is ALL PRACTICAL work. No books—no dry lessons—no useless theory. In the great shops of COYNE you learn the "ins and outs" of Electricity by actual work on real electrical equipment—the finest outlay in the country! And best of all—experts work right with you every step of the way, showing you all the electrical secrets that are essential to your success!

### No Advanced Education or Experience Needed

With a personal, practical method like this, is it any wonder I say I can make any man into a master electrician in 12 happy weeks? You don't need a bit of previous experience or advanced education. Many of our most successful graduates are fellows who never went to high school and hated "book learning." The Coyne method is different!

### Special Offer Now

Make up your mind today to get into one of these real-pay electrical jobs. If you get now—I'll pay your railroad fare to Chicago and give you these courses free! AVIATION ELECTRICITY, RADIO and AUTOMOTIVE ELECTRICITY! And besides that, I help you to a part-time job while learning! FREE employment service for life after graduation, too. We place dozens of men in wonderful jobs every week.

### Send for FREE Book

Just give me a chance to tell you about the unlimited opportunity that awaits you. Let me send you this big book free, containing over 150 photographs and listing and telling you how you can qualify for the kind of jobs that lead to \$75 to \$200 a week. If you really want more money and a wonderful future, send for this book now! No obligation. Simply mail the coupon.

Mail This FREE BOOK Coupon To-day

### Big Pay Jobs

are common in electricity. Our free employment bureau puts you in touch with openings to choose from. The following are only a few of the kind of positions you fit yourself for in the Great Shops of Coyne:

- Farm Lighting Experts \$60 to \$100 a Week
- Armature Expert \$50 to \$100 a Week
- Power House Operator \$50 to \$75 a Week
- Auto Electrician \$50 a Week and up
- Inventor - Unlimited Income
- Maintenance Engineer \$60 a Week and up
- Service Station Owner up to \$200 a Week
- Radio Expert \$20 a Week and up
- Contractor, \$3,500 to \$15,000 a Year

### Special Reduced Tuition Offer

NOW—For a short time I am making a Special 30th Anniversary Offer. You can now get a real money-making training at the lowest price.

# COYNE ELECTRICAL SCHOOL

500 S. Paulina St., Dept. 89-95, H. C. Lewis, Pres., Chicago

COYNE ELECTRICAL SCHOOL  
H. C. LEWIS, Dept. 89-95  
500 South Paulina Street, Chicago, Ill.

Dear Mr. Lewis:—I want the facts, so without obligation, send me your free illustrated catalog and details of your R. R. fare.

Name \_\_\_\_\_  
Address \_\_\_\_\_  
City \_\_\_\_\_ State \_\_\_\_\_



HUGO GERNSBACK.

Editor

EDITORIAL AND GENERAL OFFICES, 96-98 PARK PLACE, NEW YORK

# How to Become a Service Man

By HUGO GERNSBACK



Are in receipt daily of dozens of letters from former set builders and experimenters who desire to become service men, and who wish to know how to go about it to enter the ranks.

"Poets are born, not made"; but it requires a good deal of experience and hard work to become a good service man. Yet any intelligent young man, who has a good radio foundation, and knows something about radio and the use of its instruments, should have no trouble in becoming a first-class service man.

The first requisite is that he must have a fundamental knowledge of radio and circuits, with actual experience in the handling of meters and various other radio instruments. The theoretical knowledge of radio is most important; without it, no real results can be achieved because, nine times out of ten, a service man so handicapped will not be able to delve into the intricacies of the radio circuit.

The service man must be familiar with tubes, their characteristics, their amplification-factors, and practically everything that is to be known about tubes. Of course, there are on the market today a number of testing sets by means of which it becomes a simple matter to test the characteristics of the tubes—merely by plugging them into the socket of the testing set. This makes the work very much easier; but many service men do not understand the fundamental tube characteristics, with which they must be familiar for a better insight into radio receiver operation.

We can think of nothing better as a practical course for an embryo service man than to get hold of some discarded old radio sets, take them apart and put them together again. This practice will be most valuable; because in the dissection and building of radio sets a multitude of practical points are discovered, which not ten volumes of radio manuals can possibly give.

Nine times out of ten, a radio set that is to be serviced has failed, not for any radio reason at all, but because of some mechanical defect. Perhaps the most usual cause of failure of a radio set is a burnt-out transformer; that, of course, requires only a replacement of the transformer which, as a rule, proves to be a simple job.

Frequently, other failures have to do with a loose connection within the set, which may or may not be located readily. Here is where a testing set, equipped with the right meters, will save a tremendous amount of time; and, if the service man knows something about the hook-up (as he should), then the open circuit can be traced rapidly as a rule.

The sources of peculiar noises are not located so readily, unless the service man has had some experience and knows how to differentiate the different sounds which come out of the loud speaker. There may be heard high whistles due to faults in the radio-frequency circuit. There may be grinding noises due to loose contacts. And there may be "microphonic" noises, due to microphonic tubes, making poor contacts and thus becoming doubly microphonic.

All of these points can be found out only by actual practice. Reading books and instructions may help, but it is not a sufficient education in itself, because every trouble has not the same cause. Very frequently there develop freak troubles which it takes a certain amount of native ingenuity to explain. Practically every service man will tell you that, in a number of set experiences, it took him a long time to classify the trouble; and even a good experienced service man, who has been at it for a long time, is likely once in a while to stumble across such a "sticker" that may take anywhere from half an hour to several hours to locate.

The service man most successful in the end is the one who is best informed of the various circuits and characteristics of different sets; the service man who owns a versatile testing equipment that he understands thoroughly; the service man who is a good mechanic and a good electrician as well.

And, finally, one of the most important attributes of a successful service man—that is, one who makes more money than his fellows—is that he does careful and clean work, and is not content simply with a rush job. We have seen too many service men who, instead of soldering an important connection, were content to wrap a wire around a piece of metal and let it go at that, or who did not take the trouble to sandpaper the tube prongs which they knew were in need of cleaning. Such service men are a menace to the industry and will never get anywhere; because in the end they fool only themselves.

Sloppy, careless work has never benefitted anyone because, sooner or later, a set thus serviced will get out of order again and the blame will fall on the man who "fixed" it last.

And finally, a good service man does not take advantage of the ignorance of his customer. Too many service men, so called, are in the habit of trying to sell their customers all sorts of "tidbits" to "improve" a so-called "sick" set, in their desire to make a few dollars. The public is becoming wise to such tactics, and is beginning to shun men of this sort. Sooner or later such men forfeit the good will of their customers, and in the end, the real loss will be their own.



## Electrolytic Condensers in Power Packs

Being a record of some of the experiences of the author.

By BERTRAM M. FREED

SEVERAL manufacturers (including Amrad, Crosley and Zenith) use "Mershon" electrolytic condensers, for filtering purposes, in the power packs of their receivers. They thereby effect a considerable economy, as may be seen when we consider the filtering effect which takes place around these condenser units.

Since the electrolytic condenser has a much higher capacity than a paper-dielectric condenser of the same dimensions and voltage rating—in addition to being much simpler in its construction—it is possible to use choke coils of less inductance and, consequently, a greatly-reduced number of turns. As magnet wire is expensive, the economy is evident.

The electrolytic condenser is much more rugged than the paper variety, and has a considerably longer life. This is due to the fact that it is "self-healing"; and consequently a break-down of the insulating film on its plates, due to an unusual voltage-surge, will not cause permanent damage. The manufacturers above named, therefore, find that the use of this condenser effects a reduction in the number of service calls.

The writer has observed that, in the few instances known to him where electrolytic condensers had broken down in what seemed to be normal service, the trouble originated in the fact that the receiver had been installed

by an inexperienced service man. What is meant by this, is that certain necessary operations had not been performed when the installation was made.

On all these condensers there is a small rubber-stoppered "vent hole"; its purpose is to permit the escape of gases formed during the normal operation of the device. If this rubber stopper is not removed, the gases cannot escape and the resulting chemical action causes the unit to break down. When this stage is reached (the plates having become covered with a film) the only remedy is an expensive one—replacement of the unit.

It will be noted that the newest Zenith job has been cleverly designed to eliminate this "human element." A board which covers the electrolytic condenser unit has been so packed with the receiver that it is necessary to remove this board to complete the installation. Now, when it is removed, the rubber stopper comes out with it; since the stopper is glued to the board!

The Crosley radio set uses two 12-mf. sections (one on each side of a single choke coil); while the Zenith set calls for 16-mf. on each side, and Amrad uses 8-mf. on each side.

### Direct-Current Precautions

On a Crosley D.C. receiver, if the set's power cable is plugged into the light line

in the reverse direction, the Mershon condenser will certainly be ruined if it is left in long enough; for this condenser is distinctly different from the paper type in that it is "polarized" (that is to say, it blocks a current from flowing in one direction, but permits it to pass in the other, like an electrolytic rectifier, which is very similarly constructed). Therefore, a Mershon unit must be connected with its positive lead to the positive side of the filter, and its negative lead (copper can) to the negative connection of the filter.

To find out whether such a D.C. set is properly connected to the light-line, simply turn the set switch to "on," before the cable-plug is inserted in the house-current receptacle. If the dial-light ("pilot" light) glows dimly, the plug is wrongly inserted; reverse it at once. The explanation of this peculiar effect is that these polarized condensers pass a current when their connections are reversed, as stated above; and that the power unit, when thus improperly connected, is loaded by the condensers to such an extent that insufficient current reaches the filament circuit.

Mentioning this fact calls to mind a certain student service man who, when one of these series-filament D.C. sets showed "no voltage" across one of the tube filaments (because one of the tubes in series with it had gone bad) reported that the power-transformer winding had burned out!

(Incidentally, the quick way to test for open filaments in D.C. electric sets is to short each tube filament, successively, with a piece of copper wire. When the burn-out tube is reached, the others will light with slightly more than normal brilliancy.)

Although the electrolytic condenser incorporates a very high capacity in very small dimensions, the "old-reliable" screwdriver test will not give the enlightening information as to its condition that would be obtained from a large paper condenser. Because the internal resistance of the electrolytic unit is very low, compared with that of a paper dielectric, there exists always a leakage-current which effects a rapid discharge of the condensers. A heavy spark, therefore, is not obtained from the electrolytic condenser, notwithstanding the high capacity of the unit, when the terminals are shorted.

A shorted electrolytic condenser, however, may be tested with any device which will indicate a short circuit. One which is defective will usually be recognized by a greenish (perhaps yellowish or reddish) chemical deposit on the walls of the condenser. When this deposit is seen, we need not bother to test the unit; but must replace it immediately.

(Continued on Page 226)

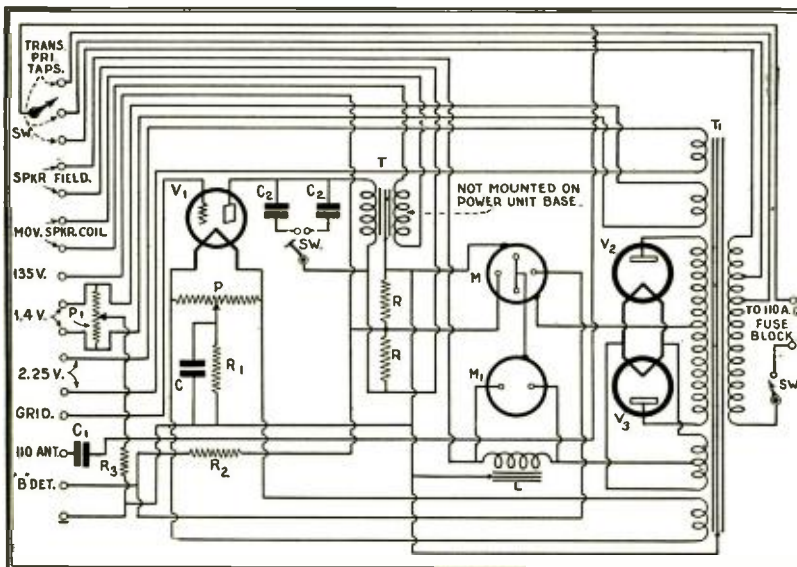

Schematic Circuit of the Amrad Type 7191 Power Unit designed for the Model 7100 receiver. The Model 7100 receiver is designed to operate without an outside aerial, the radio frequency pick-up of the light line being sufficient in most localities to bring in the signals of distant stations. Units M and M1 are Mershon electrolytic condensers.



# Servicing the Freshman "G"

This is the first of a series of articles, describing the troubles, both common and uncommon, and their remedies in both early and late model radio receivers.

By HAROLD WEILER

### The "G" Chassis

**B**EFORE going into detail about the receiver model which this article deals with, we will describe the various units used in testing for trouble. It is quite likely the reader has the equivalent of at least one of these units; many will have all of them. However, the construction of these simple testing devices are described here because they will be repeatedly referred to in succeeding service reports, and those who pass by this elementary information will find it impossible to pick up the thread later on, where we use a single letter (A, B, etc.), to designate a test-unit connection.

### Test Units

The first and most-used item is a device for testing high-and low-resistance continuity. We need an 0-6 voltmeter, a 22½-volt battery and a single-pole, double-throw switch, connected as in Fig. 1. For low-resistance testing, switch to 4½ V. tap; for high, to 22½ V. tap. Mark the test leads "A" and "B"; this is important as will be seen later.

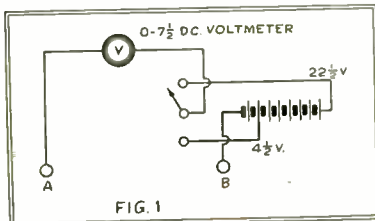

FIG. 1  
Circuit of the first test unit.

Next, we have one which is not used much, but is worth the trouble required to make it. This unit is for testing noisy resistances; it will also test continuity, but we will only use it for the former purpose. Connect a battery and a pair of phones in series as in Fig. 2 (Make sure the battery itself is not noisy).

trated in Fig. 3, which will solve this problem for us. It is a tube with ¼-inch cut off the filament prong. When inserted all the way into the socket, it acts as an ordinary tube, all

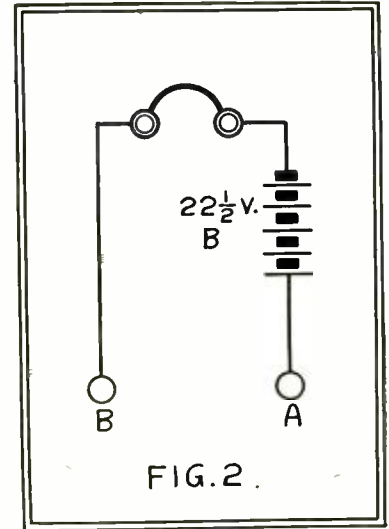

FIG. 2.

Arrangement of the second test unit.

Now we get to the set itself. It is a Freshman "G" which consists of three stages of tuned radio-frequency, a tuned detector, and two stages of straight audio-frequency amplification.

This receiver is designed to operate from a 110-volt, 60-cycle line. A small toggle switch on the front panel of the power supply has two positions; marked "110 V." and "120 V." This switch should, normally, be in the "120 V." position.

Lack of selectivity can be attributed to one of three things:

- (1) Antenna is too long (figure the lead-in as part of the antenna);
- (2) Radio-frequency tubes are defective;
- (3) Set was improperly neutralized originally.

The first thing that should be done to a set, for service, is to test the tubes. The majority of trouble in sets today is with the older A.C. tubes. Like all new things, the earlier A.C. tubes underwent a series of changes before the present accuracy of production was attained. These older tubes are an almost certain source of many set troubles; while the newer tubes of reliable make work very well, as a rule.

The tubes testing O.K. leave only the two remaining causes for loss of selectivity.

Antennas vary greatly in their electrical constants, and it is well to examine this item next. If the aerial is too long, take the insulator from the end and insert it in about the center of the span, if convenient; this will cut off from 25 to 50 feet, depending upon the length of the wires. In nine cases out of ten, this will help a great deal.

### Re-neutralizing

All that remains now is to re-neutralize the set. On the A.C. sets we cannot disconnect a filament-post connection, as of old; so, because "necessity is the mother of invention," we take recourse to the "kink" illus-

prongs making contact; but pull it out ¼-inch and you have the same effect as though you disconnected a filament wire on that socket.

To neutralize, put tube (X) in first R.F. socket. This is the first on the left-hand side of the row nearest the panel. Then, tune to a station—preferably, one in the center of the broadcast band. Now you will find a stabilizer exactly in line and to the right of the first R.F. tube. With the (X) ¼-inch out of the socket, adjust stabilizer until signal

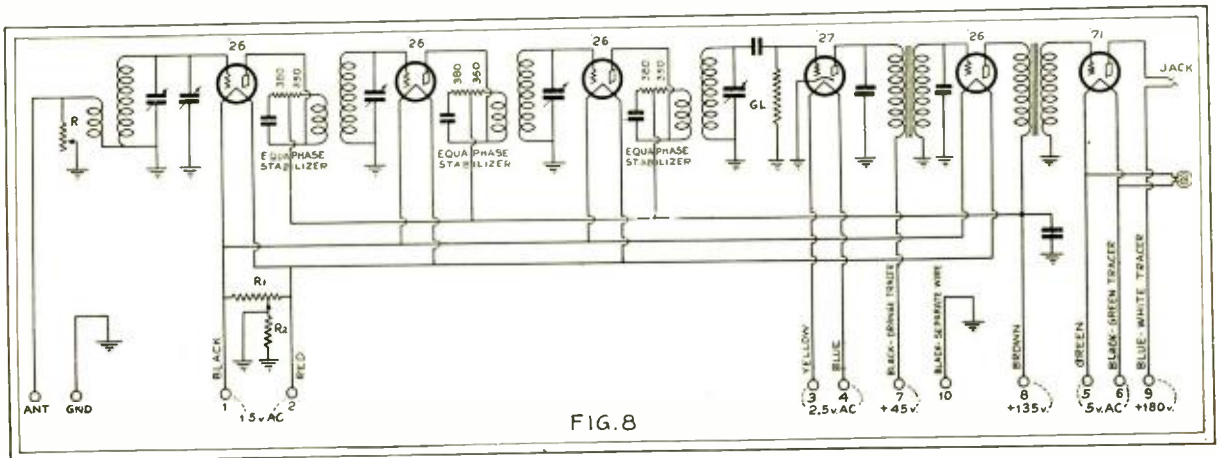
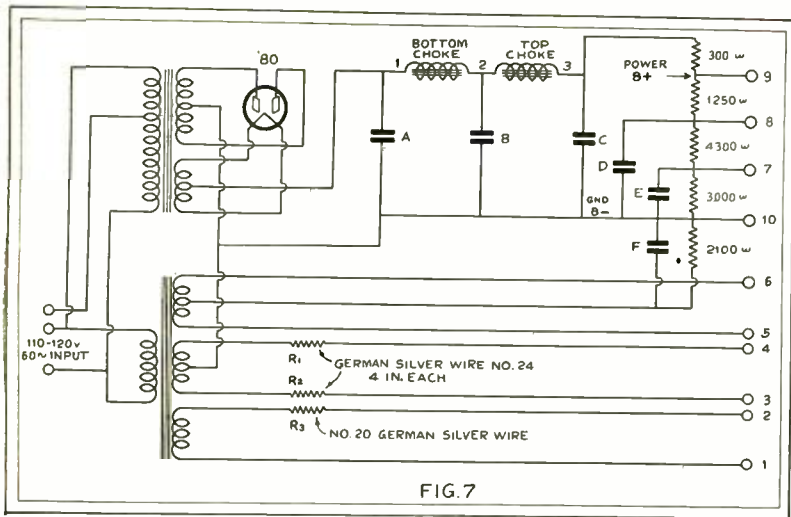

FIG. 8

Schematic circuit of the Freshman Model "G" receiver.



Wiring of Model "G" power pack. The values of the condensers are as follows: A, 2-mf. (2,000); B, 2-mf. (2,000); C, 6-mf. (2,000); D, 4-mf. (1,000); E, 2-mf. (1,000); F, 1-mf. (1,000). The numerals in parentheses indicate the break-down potentials.

is at a minimum. Do the same with the second and third R.F. stages, and then try your selectivity. Also, see that the balancing condenser in parallel with the first tuning condenser is not shorted.

**Hum Controls**

The next thing we encounter very often is the hum; most of this is due to the dynamic reproducer. The one I have in mind is used in only about twenty-five thousand Freshman 65 and 66 receivers in and around New York (As most of the metropolitan service men will recall, they were flooding the market last season). There is a remedy for this hum. Get a 1,500- or 2,000-mf. condenser for just this purpose, and shunt it across the terminals of the field coil of the reproducer. As it is sometimes difficult to locate the field, this condenser may be connected across the rectifier output. The condenser is shown as C in Fig. 4.

Then there is the hum control at the upper right-hand corner of the set. Place the dial in a position at which there are no signals, and adjust the control to minimum sound. If hum is still objectionable, change the '27 and the

'71s. This will almost certainly take out the hum completely, if it is not due to a fault in the pack.

If the set is noisy, use the device shown in Fig. 2. Put "A" lead on antenna post and "B" lead on ground post. Now try the volume control. If a scratchy noise is heard in the headphones, clean the resistor and arm with alcohol. To test grid leak, leave "B" lead on ground and put "A" lead on grid terminal of detector socket. If noisy, replace the leak.

The other troubles one may encounter in this receiver usually resolve themselves into a burnt-out transformer, a shorted variable tuning condenser, or a shorted trimmer condenser.

Here are where our troubles start. For additional hum trouble and repairs, we have to open the power-supply case. Take a 5-inch bare wire and, short leads 1 and 2. If hum increases, the bottom choke is O.K.; if not, it is bad. Do the same to leads 2 and 3. (These tests are made with set in operation; so take all precautions to avoid touching any chassis or lead points, other than the test contacts.) Next, check all condenser-bank

leads and re-solder any broken connections.

**Resistors and Condensers**

To test resistors, use the circuit of Fig. 1. With switch in lower position, put "A" lead on No. 10 binding post and "B" lead on No. 6. This and the following connection should show continuity. If there is no indication of continuity between posts 10 and 6, replace the 2,100-ohm resistor. Then, put "B" lead on No. 7 post; the resistor value is 3,000 ohms. Test next with "A" lead on No. 8 post (resistor value, 4,300 ohms, between posts 7 and 8). Now change "B" lead from No. 7 post to No. 9; here the resistance is 1,250 ohms. Again change "A" lead from No. 8 to No. 3 lead on the choke assembly; the resistance is 300 ohms. So much for the resistance tests.

If you do not get any voltage from the detector tap, condenser E is probably shorted. If you do not get voltage from any but the power tap, condenser D is probably shorted. No voltage from any "B" tap, providing everything else is O.K., may be due to faulty condensers A, B or C. Disconnect from rest of circuit, switch on tester to position 1, and test. If they are bad, install new condenser or pack.

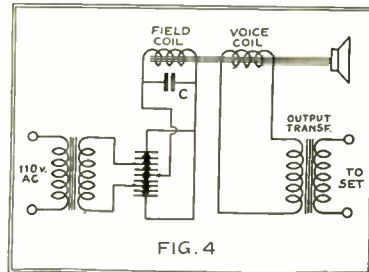

Wiring of the dynamic reproducer components.

**Voltage Conditions**

To test high-tension secondary, put "A" and "B" of continuity tester on grid and plate contacts of socket in pack; the meter should read.

The filament transformer is next; posts 1 and 2 should show 1.60 volts, A.C.; 3 and 4, 2.25; 5 and 6, 5.00 to 10.00 (This is without a load and using an A.C. 0-7½ volt-meter. Of course, it will not accurately indi-

(Continued on Page 239)

**RADIO SET ANALYSIS**

OWNER \_\_\_\_\_ DATE 7/24-'29

ADDRESS \_\_\_\_\_

NAME OF SET FRESHMAN 'N'

TUBE NO. IN ORDER	TYPE OF TUBE	POSITION OF TUBE	TUBE OUT				TUBE IN TESTER				PLATE CHANGE	REMARKS	
			A VOLTS	B VOLTS	C VOLTS	VOLTS	W/THRESHOLD	NORMAL PLATE	PLATE TEST	PLATE			
1	226	1 <sup>st</sup> RF	1.45	100	1.35	90	6	—	3.2	7.4	4.2	—	—
2	226	2 <sup>nd</sup> RF	1.45	100	1.35	90	6	—	3.2	7.4	4.2	—	—
3	226	3 <sup>rd</sup> RF	1.45	100	1.35	90	6	—	3.2	7.4	4.2	—	—
4	227	DET.	2.40	65	2.25	50	0	—	2.2	2.2	0.0	—	—
5	226	1 <sup>st</sup> AF	1.45	100	1.35	90	6	—	3.2	7.4	4.2	—	—
6	250	2 <sup>nd</sup> AF	7.40	350	7.20	300	50	—	36.0	43.5	7.5	—	—
7	281	RECT.	7.50	—	7.20	—	—	—	46.0	—	—	—	—

LINE VOLTAGE 119 SET ON 120 VOLT TAP \_\_\_\_\_ VOLUME CONTROL POSITION \_\_\_\_\_

SUGGESTIONS OR CHANGES MADE \_\_\_\_\_

By J. H. White

Fig. 5. An analysis of the Model "N" characteristics.

**RADIO SET ANALYSIS**

OWNER \_\_\_\_\_ DATE 7/24-'29

ADDRESS \_\_\_\_\_

NAME OF SET FRESHMAN MODEL 'G'

TUBE NO. IN ORDER	TYPE OF TUBE	POSITION OF TUBE	TUBE OUT				TUBE IN TESTER				PLATE CHANGE	REMARKS	
			A VOLTS	B VOLTS	C VOLTS	VOLTS	W/THRESHOLD	NORMAL PLATE	PLATE TEST	PLATE			
1	226	1 <sup>st</sup> RF	1.45	140	1.35	135	9	—	5.0	9.0	4.0	—	—
2	226	2 <sup>nd</sup> RF	1.45	140	1.35	135	9	—	5.0	9.0	4.0	—	—
3	226	3 <sup>rd</sup> RF	1.45	140	1.35	135	9	—	5.0	9.0	4.0	—	—
4	227	DET.	2.30	70	2.00	50	0	—	3.0	3.1	0.1	—	—
5	226	1 <sup>st</sup> AF	1.45	140	1.35	135	9	—	5.0	9.0	4.0	—	—
6	171	2 <sup>nd</sup> AF	5.50	200	5.10	175	37	—	16.0	18.0	2.0	—	—
7	280	RECT.	5.50	—	5.10	—	—	—	20.0	—	—	—	—

LINE VOLTAGE 120 SET ON 120 VOLT TAP \_\_\_\_\_ VOLUME CONTROL POSITION \_\_\_\_\_

SUGGESTIONS OR CHANGES MADE \_\_\_\_\_

By J. H. White

Fig. 6. A chart for checking the Model "G."

# Men Who Made Radio—C. Francis Jenkins

THE SECOND OF A SERIES

**W**HILE other great inventors have devoted their attention successfully to the problems of converting sounds into radio waves and back again, or dispersing these waves over the earth and finding them again, the subject of our cover illustration this month has specialized upon a task which differs from all the above. It has been his purpose to extend the range of human sight, rather than of hearing, by radio. And no man has spent more effort, or succeeded so well, in the endeavor to widen the vision of mankind, than C. Francis Jenkins. It was he who by his invention of the "Phantascope," the parent of all motion-picture machines (the patent rights of which were sold to Thomas A. Edison for the trifle of \$2,500) prepared the way for the eighth wonder of the modern world, and made the human race movie-wise, from Alaska to Antarctica.

Logically, then, the man who put "motion" into motion pictures may eventually succeed in putting "eye-appeal" into radio—in transforming homes into miniature motion-picture theaters! His new 5,000-watt transmitting station in Maryland; his laboratory experiments in the development of radiovision transmitting and receiving apparatus, such as drum scanners and television-image boards; the transmission and reception of weather maps at sea by radio; the sending and receiving of photographs by radio; broadcasting visual images from an airplane; development of a radio or capacity altimeter for landing aircraft; and eventual attempts to broadcast images of living

subjects—all of these efforts were designed to make radio's message available to the eye. For this reason, he has been described as the "Father of Radiovision,"—just as Dr. de



A characteristic study of C. Francis Jenkins, America's Television Pioneer.

Forest is known as the "Father of Modern Broadcasting."

Born 61 years ago in a rural district north of Dayton, Ohio, C. Francis Jenkins with his

Quaker parents moved to a farm near Richmond, Indiana, where he spent his boyhood. He attended a rural school, a high school, and Earlham College—and, quite recently, he flew from Washington to Indiana in his own airplane to receive an honorary degree from his *alma mater*, in recognition of his inventive accomplishments. His youthful days on the farm were marked by their curiosity as to the "innards" of a watch, the workings of farm machinery, and other things mechanical. Affected with wanderlust, he migrated to the wheat-fields and timber regions of the Northwest and, subsequently, to mining camps and sawmills of the Southwest; where he had further opportunity to familiarize himself with the whys and wherefores of machinery.

In 1890, Mr. Jenkins, tiring of the lure of the mining camps and the uncouthness of sawmill operations, came to the National Capital and accepted a position as secretary to Sumner I. Kimball of the "Life-Saving Service," now known as the Coast Guard. It may seem a far cry from the position of a government stenographer to invention as a lifetime profession; but in 1895 Mr. Jenkins embarked on this seemingly precarious undertaking. While boarding near the Capitol he had received inventive inspiration from the behavior of a crude box-camera and, without knowledge of photography, he began construction of the prototype of the motion-picture projector, now used in theaters all over the world. That marked the beginning of his inventive career—one of such cumulative proportions as to in-

(Continued on page 226)

## Attention: Radio Service Men

**R**ADIO-CRAFT is compiling an international list of names of qualified service men throughout the United States and Canada, as well as in foreign countries.

This list, which RADIO-CRAFT is trying to make the most complete one in the world, will be a connecting link between the radio manufacturer and the radio service man.

RADIO-CRAFT is continuously being solicited by radio manufacturers for the names of competent service men; and it is for this purpose only that this list is being compiled. There is no charge for this service to either radio service men or radio manufacturers.

We are hereby asking every reader of RADIO-CRAFT who is a professional service man to fill out the blank printed on this page or (if he prefers not to cut the page of this magazine) to put the same information on his letterhead or that of his firm, and send it in to RADIO-CRAFT. The data thus obtained will be arranged in systematic form and will constitute an official list of radio service men, throughout the United States and foreign countries, available to radio manufacturers. This list makes possible increased cooperation for the benefit of the industry and all concerned in the betterment of the radio trade.

### National List of Service Men,

c/o RADIO-CRAFT, 98 Park Place, New York, N. Y.

Please enter the undersigned in the files of your National List of Radio Service Men. My qualifications are as set forth below:

Name (please print) .....

Address ..... (City) ..... (State) .....

Firm Name and Address .....

(If in business for self, please so state)

Age ..... Years' Experience in Radio Construction. .... In

Professional Servicing .....

Have You Agency for Commercial Sets? ..... (What Makes?) .....

What Tubes Do You Recommend? .....

Custom Builder ..... (What Specialties?) .....

Study Courses Taken in Radio Work from Following Institutions. ....

Specialized in Servicing Following Makes .....

What Testing Equipment Do You Own? .....

Other Trades or Professions .....

Educational and Other Qualifications .....

Comments .....

(Signed) .....



## Airplane Station KIK

An Airplane Radiotelegraph Set designed by the writer of this article for the plane "City of Tacoma," with which Lieut. Harold Bromley is attempting a flight across the Pacific to Japan.

By GLENN DALE BRONNER

LATE in April of this year, Lieut. Harold Bromley, the aviator, who was planning a trans-Pacific flight to Tokio in June, called upon the writer at his house in Glendale, Calif., and explained his desire to obtain instruction in radio operation, sufficient to serve his purpose during the hop. At that time his special "ship," the *City of Tacoma*, was under construction at the Lockheed aircraft plant at Burbank, about five miles away.

The task proposed was cheerfully undertaken by the writer. Lieut. Bromley proved a ready pupil; and quickly picked up the code and fair operating speed. After taking his instructor on a visit to the aircraft works and exhibiting the low-winged monoplane, then under construction, he suggested that a transmitter and receiver for the ship might be constructed by the writer. This proposal was accepted and the work of planning the necessary equipment began. After many changes in the designs, it was determined to lighten the apparatus by the use of a '10-type tube in the transmitter, in place of the fifty-watt at one time specified. After many fits and starts, and much exchanging of the parts which had been first procured and then eliminated from the specifications, work in earnest began.

We had wired to the Radio Commission for a call and a wavelength suitable for airplane transmission. After a few weeks, we received our call of KIK and a wave of 36.19 meters. We also wired to the Burgess Battery Company for a specially built waterproof battery supplying 450 volts of "B" and seven and one half volts of "A"; and the writer proceeded to the construction of the set.

### Design of the Sender

The frame of the transmitter is made of 3/8-inch angle brass, bolted and soldered together at the corners. The front and bottom panels are made of 1/8-inch aluminum, and

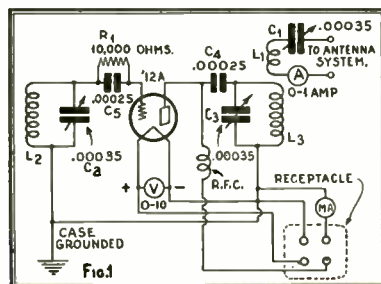

Schematic circuit of the transmitter of station KIK.

the other six sides of 1/16-inch stock. All eight sides are bolted and lock-washed to the brass frame.

The circuit employed, of the tuned-grid, tuned-plate type (Fig. 1 is the schematic) was chosen because of its steadiness of emitted signals and its low plate-current consumption. The grid and plate tuning condensers mounted on the front panel (C2, C3) are two National .00035-mf. receiving type. The coils are of quarter-inch, hard-drawn copper tubing, silver-plated and buffed, bolted directly to the backs of the condensers and so mounted that their magnetic fields are at right angles to each other. The grid and plate coils (L2, L3) consist of eight turns each, two inches in diameter; the antenna coil (L1) has four turns and is spaced about an inch and a half from the plate side of L3.

The circuit operates with high capacity and

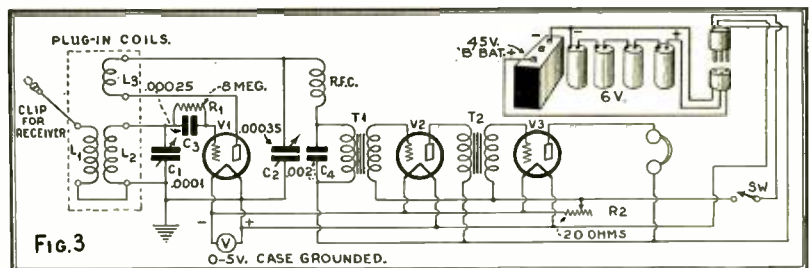

Schematic circuit of the receiving equipment constructed by Mr. Bronner for use in an airplane specially built for a trans-Pacific hop. Both the transmitter and receiver were designed by him with particular regard for the service to which they were to be put.

low inductance; for the tuning condenser must be about three-quarters meshed for use on 36.19 meters; and almost all in, to work in the bottom of the American amateur band.

Sangamo .00025-mf., 5,000-volt mica condensers (C4, C5) are used for both grid and plate blocking capacities. The grid leak (R1) is 10,000 ohms; this particular value being chosen because of the fact that, the higher the grid resistance, the lower the plate current.

The set requires 450 volts of "B" batteries and 7 1/2 of "A" dry cells. The plate circuit draws about twenty milliamperes when oscillating with no antenna coupling, and forty-five to fifty milliamperes when antenna resonance is reached; the amount of current depending on the type of radiating system used.

The antenna resonance, or series, condenser C1 is a .00035-mf. Cardwell receiving-type instrument mounted on three General Radio wall-stand-off insulators; this condenser operates from the top of the set and is the only adjustment, besides the filament switch, neces-

sary to put the set in operation. A Weston 0-1-ampere, two-inch, radio-frequency meter (A) is used to determine antenna resonance; a 0-100 milliammeter (MA) for plate current; and a 0-10 voltmeter (V) in the filament circuit. The radio-frequency choke (RFC), which is wound on 3/8-inch bakelite tubing, is a 3-inch winding of No. 28 D.C.C. wire.

### Operating Connections

The top of the case may be removed by loosening six thumb screws and taking off the antenna condenser knob. Battery and key connections are made to the set by means of a four-pronged plug which fits into the right side of the transmitter (Fig. 2). From this plug, two double rubber-covered cables run to the "A" and "B" batteries. The key is cut in series with the negative "B" lead.

It was found in the test flights of the *City*

of *Tacoma* that gas fumes were very bad; which necessitated having an air-tight system of keying to prevent a possibility of the sparks from the key contacts igniting the gas. A rubber compartment was constructed around the key and vulcanized all around (as indicated in Fig. 2) making it safe to send with gasoline fumes around. Plugs were also fitted on the battery ends of the cables, and handles for the batteries provided, for their removal in case of a landing in the water and the abandonment of the plane for the rubber life boat.

For the same emergency, slots in the sides of the fuselage were provided to insert two jointed bamboo poles, one fourteen and the other fifteen feet long. The antenna to be used in this case was a current-fed Zeppelin; the thirteen-foot feeder running along the fourteen-foot bamboo pole, and a 28 1/2-foot antenna extending from the top of the feeder system to the end of the fifteen-foot pole. This same radiating system could be transferred to the rubber life boat, in case the ship-

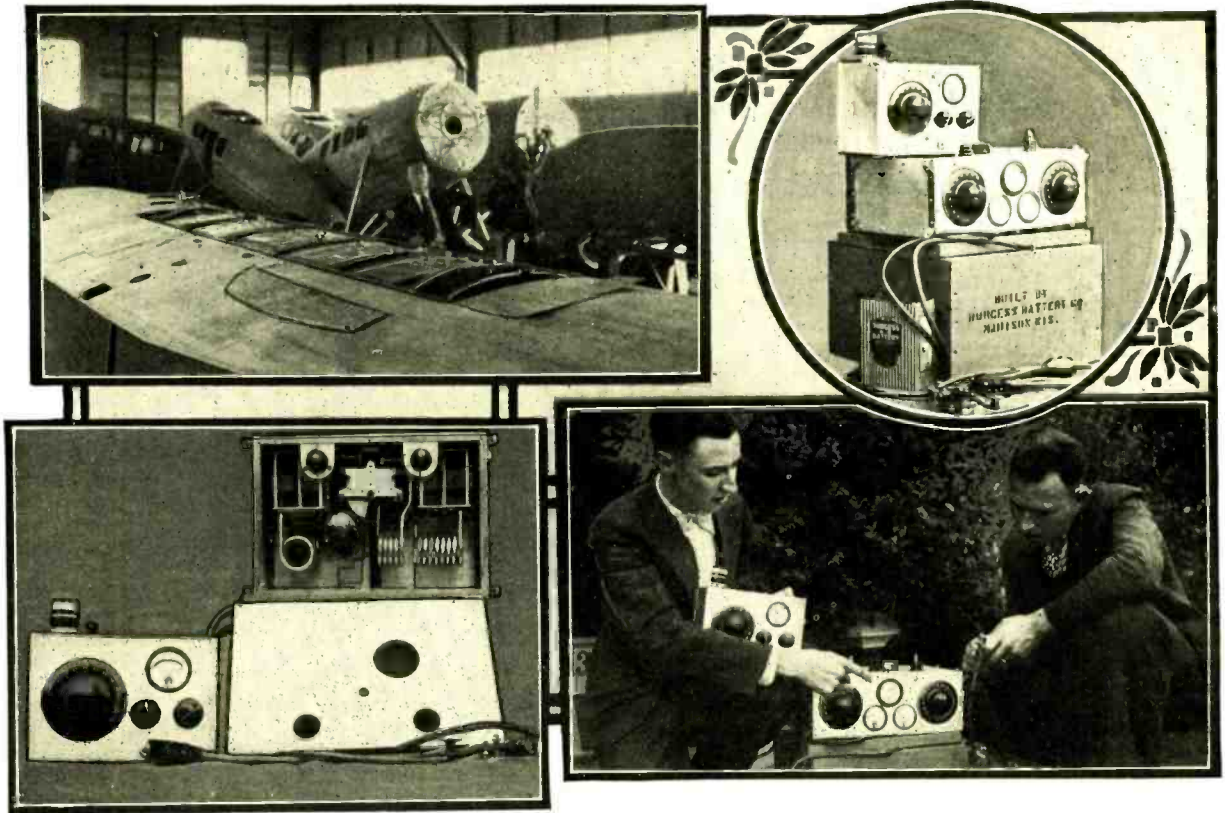

At the upper left appears the *City of Tacoma* in the course of construction. The complete transmitter and receiver are shown in the circle at the right; they include the special battery supply mentioned by the author. At the lower left is seen the interior of the transmitter, and, at the lower right, a comparative appreciation of the sizes of transmitter and receiver is obtained. Positive-contact plugs eliminate the possibility of arcing, due to binding posts loosening; an arc igniting gas vapors would prove disastrous.

failed to float. Vulcanized slots in the boat were provided for the poles, and waterproof rubber sacks for the transmitter and receiver.

**The Compact Receiver**

The receiver was designed for reception on both long and short wavelengths by means of plug-in coils, two of which were provided; one with a range of 500-650 meters for ship and commercial stations, and another with a range of from 30 to 50 meters.

The set is built into an aluminum case 9 x 6 x 5 inches, of 3/32-inch stock. The regular three-circuit-tuner hook-up is used; with a .00035-mf. *shuttle condenser* (C2) for regeneration control and a .0001-mf. Cardwell (C1) for tuning. Two stages of audio were used, and '01A tubes throughout. Transformers T1 and T2 have a 3 1/2-to-1 ratio. The tuning condenser was supplied with a National vernier dial, while an ordinary knob was used for regeneration control. A 0-6 Weston voltmeter (V) is mounted on the panel to indicate the correct filament voltage and, also, enable the operator to know something of the condition of his "A" batteries. Six volts of dry cells and a small 45-volt Burgess battery supplied the current for the receiver.

At first, brackets on the sides of the sets were employed to hang them from shock-cords and keep them free from vibrations; but a five-ply board to which the sets were bolted was later substituted. The transmitter and receiver were bolted together and mounted on pieces of sponge rubber glued to a base board, which was in turn mounted directly under the plane's instrument board and in

front of the pilot. By loosening two wing-nuts, the transmitter and receiver could be removed from the plane on short notice.

**Experimental Work**

The transmitter had its first try-out in the 40-meter amateur band. A separate set of test batteries, sent us also by Burgess, were employed. Several CQ signals had been sent out when the filament of the '10 went out for some unknown reason. An '01A was therefore substituted and the writer continued his CQ and signed his call. An eighth-district amateur answered and gave a very encouraging report that the signals were very steady, "pure direct-current and crystal-controlled." He said they came in QSA 3 (on the new scale of 5, "fairly good; readable but with difficulty."—EDITOR), which is very good reception for that distance (from Glendale to New York State, nearly three thousand miles). Many other stations throughout the country were worked and very favorable reports received.

The set was mounted in the writer's "Lizzie" for about two weeks. Eastern stations were worked with two wires used as a radiating system, only five feet above the ground at the Ford and running to stakes driven in the ground.

It was found later that an '01A tube worked just as well as the '10, giving the same radiation, drawing the same plate current, yet only one fifth the filament current; thus making the batteries last a much longer time. The '01A was later exchanged for a '12A which was found to give a more steady signal and a little more radiation.

When the time came to install the set in the *City of Tacoma*, just prior to the test flights, the transmitter and receiver were given their final testing and very carefully looked over for defects.

During test flights in the Mojave Desert, about sixty miles from Glendale, very satisfactory tests were made between station W6-EGX and Lieur. Bromley in the plane. Tests were also made with W7AFO, located in Tacoma, Washington, and NEJZ, then located in the harbor at Vancouver. After returning to the Metropolitan Airport, the sets were taken out, completely checked over, and found to be in perfect shape. The night before the final departure from Southern California, the sets were again installed and everything made ready for the hop to Tacoma.

The operation of the sets is very simple. The antenna is first released and the filament switch closed and, while the key is held down,

(Continued on page 227)

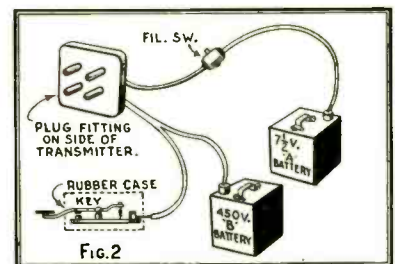

Detail of the plug-in arrangement connecting the current supply to the transmitter.



## Building a 1930 ELECTRIC Receiver

A super-sensitive set of simple construction incorporating the latest principles in radio design.

By CLYDE J. FITCH

**T**HE modern factory-built radio set is so far advanced in design that one hesitates now to construct his own; yet with a little care and patience a commercial-looking job can be turned out at home that will excel the latest commercial models. The receiver shown in the accompanying illustrations was designed for sensitivity, tone quality, and ease of operation; while it incorporates new features not found in other receivers. It was built for installation on the Florin Lenox estate in the Adirondack Mountains, a location which is immune from interference of any kind except an occasional thunderstorm; consequently unusual selectivity was not required. However this set compares with the best in selectivity.

### Engineering Features

It comprises a *Vreeland-band-selector* system which feeds into a three-stage *untuned R.F. amplifier* using A.C. screen-grid tubes and iron-core untuned radio-frequency transformers. A *screen-grid detector* is used with one stage of resistance-coupled audio amplification and one of push-pull using type '10 power tubes. This makes seven tubes in all, four screen-grid type '24, one type '27, and two '10's; not counting the '81 *rectifier* and '74 *voltage regulator* used in the power pack.

The band selector, the theory of which is explained below, passes a *10-kilocycle band* of wavelengths at any location in the broadcast spectrum, depending upon the adjustment of

# NEW

LOCALS with a 2-foot aerial! Absolutely no batteries about which to think twice. The power of two '10s in push-pull at the flick of a switch and turn of a knob! All station selection obtained by the turn of another knob. "Wind-your-own" selectivity! Three stages of screen-grid amplification (guaranteed non-whistling) and a screen-grid "power detector." And audio quality with a realism which will startle the critical ear. When we heard that our old friend Clyde J. Fitch had built, at moderate cost, a receiver which met these qualifications, we asked Mr. Fitch to tell you all about it. And so—WE NOW TAKE PLEASURE IN PRESENTING

## "The 1930 Electric Receiver"

the tuning dial. This allows the *carrier-wave* with its accompanying "sidebands" (which

represent the music), to pass through from the antenna to the amplifier uniformly, giving distortionless reception in this part of the set. This is true also of the radio-frequency amplifier, which employs the old Acme iron-core transformers, used several years ago in that company's reflex sets. These transformers give very efficient amplification over the entire

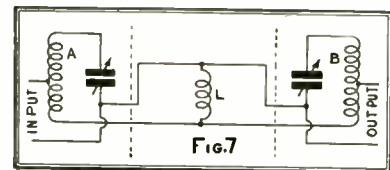

The "band-selector" detail. Varying the number of turns in L determines the selectivity of the receiver.

broadcast band, and associated circuits do not oscillate ("whistle," howl, etc.) at any point on the dial when used with screen-grid tubes. Two type-R3 transformers, (RFT1 and RFT2 in Fig. 1) with one type-R4 (RFT3), gave the best results; the type-R2 was found unsatisfactory. No doubt there are other iron-core radio-frequency transformers that may be used instead, in case the constructor has difficulty in finding the Acmes.

The use of a screen-grid detector with a stage of resistance-coupled audio amplification is another feature that gives high, distortionless amplification.

Here (in New York City) the set picks up locals with an indoor antenna two feet long; with no antenna it picks up nothing, since it is well shielded. Quality is unusually good, for the reasons mentioned above, and operation is simple, as the illustration (Fig. A) shows; one knob (C2-C3) being used for tuning, and the other (R5) for a volume con-

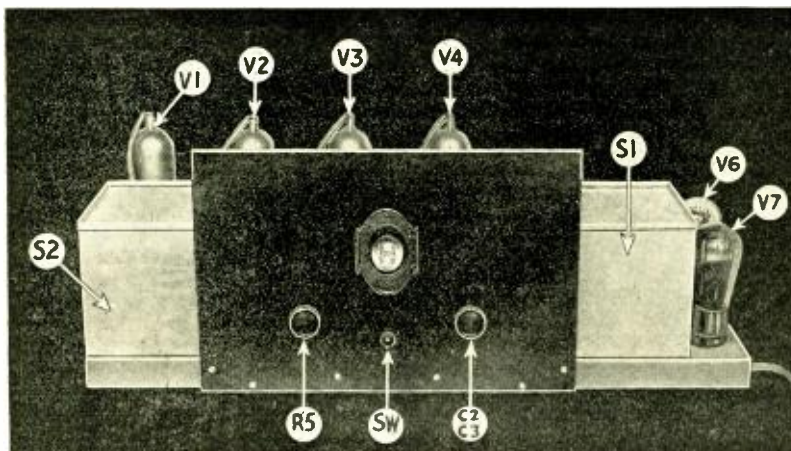

Fig. A.

Front of set, showing panel layout; note convenient adaptability to any panel size. The "volume control" is R5; while C2-C3 is the "station selector" or tuning knob. A light, rigid, monel-metal sub-panel is used.

trol (which is easy to regulate because it does not detune the set or cause it to oscillate and squeal or howl).

In the illustrations, Fig. A shows the front view; Fig. B the top with the covers of the shield cans removed; Fig. C the rear, and

Fig. D the power pack. The panel was cut to the size shown, merely to fit a special cabinet.

Construction of the Set

The metal base should be made first; that illustrated here was a sheet of monel metal

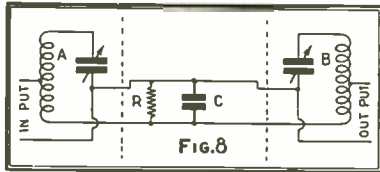

An optional but experimental design of the "band-selector." Selectivity is governed by C; R closes the circuit.

13½x29½ inches and 1/32-inch thick with the corners cut out to a depth of an inch each way and the sides bent down and soldered at the corners, making a "pan" 11x27x1¼-inch deep. This work should be done by a tinsmith. Aluminum may be used instead, but it should be at least 1/16-inch thick, as it is mechanically weaker than monel metal; since aluminum cannot be soldered easily, the corners should be strengthened with brass angles bolted in place. Even a good wooden base-board may be substituted.

Dimensions for drilling the base are not given, as these will depend upon the particular parts used. The general layout shown in Fig. B can be followed without difficulty. The sockets are mounted with their terminals underneath; so that practically all the wiring is below, out of sight and well protected. With the exception of the socket holes, the drilling of the base may proceed as the set is being assembled, by the use of a hand drill.

The Band Selector

The band-selector coils L1 and L2 consist each of 85 turns of No. 28 wire wound 2 inches in diameter, with a center tap, as detailed in Fig. 2. (Hammarlund space-wound coils were used.) They are clamped by two strips of bakelite, which carry the three terminals for the two end connections and center tap. Brass angles are used to mount them in the proper relation to the metal base, inside the shield cans as shown.

The two .00035-mf. tuning condensers C2, C3 are mounted on the shield cans as illustrated; both on the same shaft and with a single-dial control.

The 23-plate "midget" antenna coupling condenser C1 is mounted on an insulating strip of bakelite which is fastened to the upper left-hand corner of the right-hand can, (Fig. B). The 9-plate "midget" trimming condenser C4 is mounted directly on the other shield can, as shown in the same figure.

The coupling coil L3 consists of 4½ turns of wire wound on a vacuum-tube base. This is plugged into a standard socket, mounted on the set base as shown. The two ends of the coil are connected to the filament prongs of the tube base. This completes the band-selector parts; wiring and adjustment will be described later.

Many explanations have been published about this new method of radio tuning, but the practical man wants more practical data and a clearer understanding of the theory without wading deeply into mathematics; therefore, let us begin at the beginning and explain why band-pass tuning is necessary for undistorted reception.

Suppose we start at the transmitter, but forget the old idea of modulated carrier waves, and look at the situation from a different viewpoint; a viewpoint where even the layman can get a clear insight into radio transmission. From our method of heterodyne reception (as used in the superheterodyne receiver) we know that when two alternating currents of different frequencies,  $F$  and  $F_1$ , are combined, two other frequencies are produced, equal to  $(F + F_1)$  and  $(F - F_1)$ ; making four distinct frequencies in all. (Harmonics of these will also appear, but they are useless for our purpose.)

"Modulation" Simply Explained

Since radiation of electric energy from the transmitting antenna must take place at very high frequencies to be efficient, a high-frequency generator is used at the transmitter. For broadcasting, frequencies from 500,000 to 1,500,000 cycles per second are used, each station having its own assigned operating frequency. This frequency is called the carrier-frequency, or "carrier wave." We will call

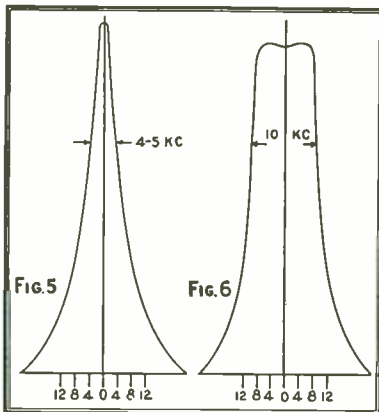

At left is illustrated the sharp "cut-off" by which "volume distortion" is caused in ordinary "tuned-radio-frequency" sets; at the right, the desirable "flat-top" effect which may be obtained by proper "band-selector" design.

this frequency  $f$ . Now, suppose we combine with this carrier frequency,  $f$ , the sound-frequencies (or music- and speech-frequencies produced in the studio) and see what happens;

keeping in mind that the music- and speech-frequencies range from about 50 to 5,000 cycles per second. We will call these the audio-frequency band, or just "AB."

From the above heterodyning action, we learn that four distinct frequencies will result; namely, the carrier-frequency  $f$ , the audio-frequency band  $AB$ , and the bands  $(f + AB)$  and  $(f - AB)$ .

The audio-frequency band  $AB$  will not be radiated from the antenna, because its frequencies (50 to 5000 cycles) are too low for efficient radiation. The carrier frequency,  $f$ , will be radiated as will also the frequencies  $(f + AB)$  and  $f - AB$ . These latter two are called the sidebands, and they contain all the music and speech, because they contain the audio-frequency-band component  $AB$ .

In explaining radio transmission to a layman, we can simplify this still further and merely state that radiation takes place at very high frequencies; therefore at the transmitter we add a high frequency, say a million cycles, to the sound frequencies, so that they can be radiated, and later remove the high frequency at the receiver. The ordinary person will grasp this heterodyne idea much quicker than he can grasp the modulated-carrier-wave idea.

We see from the above that a group of frequencies (namely,  $f$ ,  $f + AB$ , and  $f - AB$ ) are radiated from the broadcast transmitter, having a maximum difference of  $f$  plus and minus 5000, or a total separation of 10,000 cycles, or 10 kilocycles. For example, using a carrier of 1,000,000 cycles, a band of frequencies from 995,000 to 1,005,000 cycles will be radiated. Our receiving set must therefore tune in all these frequencies at once in order to receive all the music; or the sopranos will be lost in the ether, and this might not always improve the programs. Hence, the use of a band-pass or selector.

The ordinary radio set must be selective in order to tune in a single station without interference from others. Tuning must be sharp. But sharp tuning cuts the sidebands; it weakens or eliminates the higher audio frequencies, and causes the music to sound deep and muffled. Instead of tuning in the complete ten-kilocycle band of waves, it covers a band of only about four or five. This is shown in the response curve of Fig. 5, which only has good response over a 4-kc. band. Each tuned circuit in the

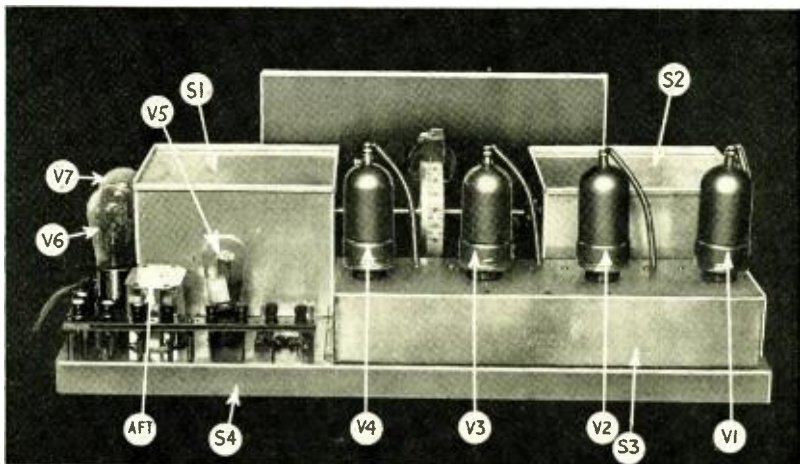

Fig. C. Rear view. The arrangement of the binding posts is clearly shown in this illustration. Tube shields which thread on were used to prevent noisy contacts. Note the neatness of this powerful screen-grid-type radio receiver. The parts used are standard.

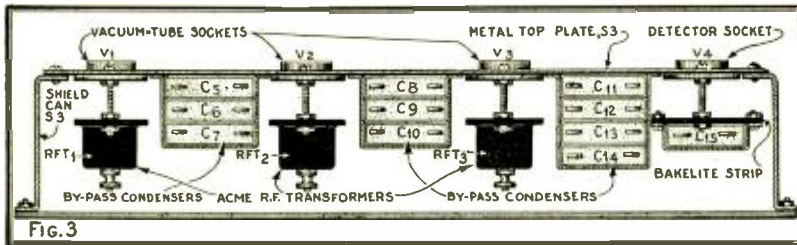

FIG. 3

A view of the interior of S3, looking from the front of the set. The fixed condensers are soldered to each other. To obtain maximum efficiency from the R.F. transformers, they are mounted away from all metal work. There is no interaction between these units.

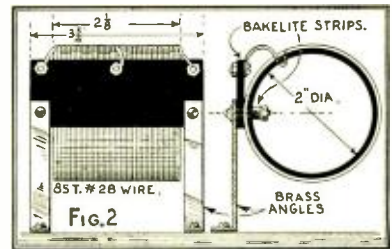

FIG. 2

Details of "band-selector" coils. (Two are required.) The use of different tuning condensers will necessitate a different number of turns.

receiver has one definite "peak" where the response is maximum, and this is adjusted to be in resonance with the carrier-frequency.

Design of the Selector

The band-pass selector has two tuned circuits, loosely coupled together. The two circuits give two peaks, adjusted so as to be close together, making a somewhat flat-topped graph 10 kilocycles wide, as shown in Fig. 6. The curve has two small humps at the top caused by the two peaks of the two circuits. The sides slope down about as in the curve of Fig. 5, but the width at the base, using carefully-designed circuits, is no greater than in the former curve. Therefore, selectivity is as good when using the band selector as it is with the ordinary method of tuning, and it responds to the entire band of transmitted frequencies more evenly.

Fig. 7 shows the circuit diagram of a band selector; this is the system used in our complete schematic, Fig. 1. The two tuned circuits are indicated at A and B, and are coupled together by the common inductance L. The circuits A and B have each the same sizes of coils and condensers, and are designed to cover the broadcast range; therefore any good broadcast coils and condensers may be used. Magnetic coupling must not exist between the coils; therefore they must be thoroughly shielded.

The degree of coupling is determined by the value of the inductance L; this, also, determines the spacing between the peaks of the two resonance curves, and consequently the width of the band of frequencies that it will

pass. If L is increased, coupling is increased and the width of the curve, Fig. 6, is increased. If L is decreased, the width of the curve is decreased. The correct value of the coupling inductance L will give us the desired 10-kc. width. 4½ turns, wound on a tube

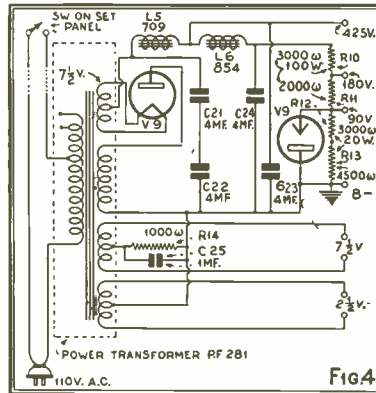

FIG. 4

The power unit. Figures 709, 854, and PF2B1 are parts numbers. The power-transformer primary is provided with taps for line-voltage compensation. One voltage regulator, V9, is used.

band, is about the correct number. Several such coils may be made, ranging from 2½ to 6 turns, and are easily interchangeable by mounting them in a standard socket. The smaller the coil, the greater the selectivity. You can therefore adjust the selectivity to suit your particular requirements.

The width of the curve (Fig. 6) does not remain constant over the entire broadcast band, but varies with the frequency. Using the circuit of Fig. 7 with inductive coupling, the width increases with increase of frequency; because the reactance of the inductance L is greater at the higher frequencies, and the degree of coupling is greater. Hence it may pass only the correct 10-kc. band at the upper wavelength settings, but a 20-kc. band at the lower. As this will be objectionable in some localities, the system shown in Fig. 8 may be employed instead.

The only difference is that the two circuits are coupled by a common capacity C, instead of by an inductance. (When using the coupling condenser C, the grid circuit of the first tube in the R.F. amplifier will be open. The resistor R, of about 2 megohms, should be connected across the condenser C.) This gives just the opposite effect to that obtained with the inductance; the larger the capacity, the less the degree of coupling, and vice versa. A coupling condenser of .025-mf. is about the correct size. This also may be mounted into a tube base, together with the resistor R, and plugged in the socket in place of the coupling coil.

With capacitive coupling, the coupling decreases with increase of frequency. Therefore the selectivity is greater at the lower wavelengths than at the higher, which is just the opposite effect to that obtained with the inductance. Different sizes of condensers may be tried to get the correct balance. (Perhaps a combination of capacity and inductance may be found to give a 10-kc. curve through the entire broadcast band.)

Summing up, the receiving aerial picks up all the stations on the air, but the band selector allows only the band of frequencies transmitted by any one selected station to pass through it and into the R.F. amplifier.

R.F. Amplifier and Detector

The radio-frequency amplifier and detector is a complete unit in itself and wired independently. The mounting of the apparatus is indicated in cross-section in Fig. 3, and the reproduced photographs clearly show the unit and its location on the base. The copper shield can (S3) of a Remler "Infradyne" intermediate amplifier was used by the writer, and was just the correct size for inclosing the parts; a metal top was required, however, measuring 4 by 16 inches. All the parts are mounted on this top, so that it can be removed for inspection or repair without removing the can from the base. The can is 2¾ inches deep inside, and can easily be made up of sheet copper.

The sockets are equally spaced on the metal top, as shown, while the radio-frequency transformers are mounted below them and away from the can. Below the detector socket is

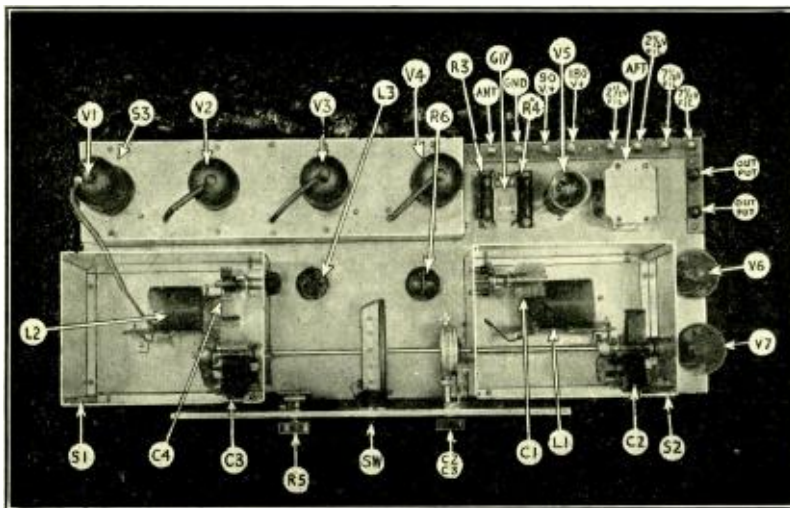

Fig. B.

An airplane view of "The 1930 Electric Receiver." Simplicity is a key-note. A convenience is socket L3 into which the coupling coil of the "band-selector" is plugged. Condensers C1 and C4 are mounted on the ends of the aluminum shield cans.



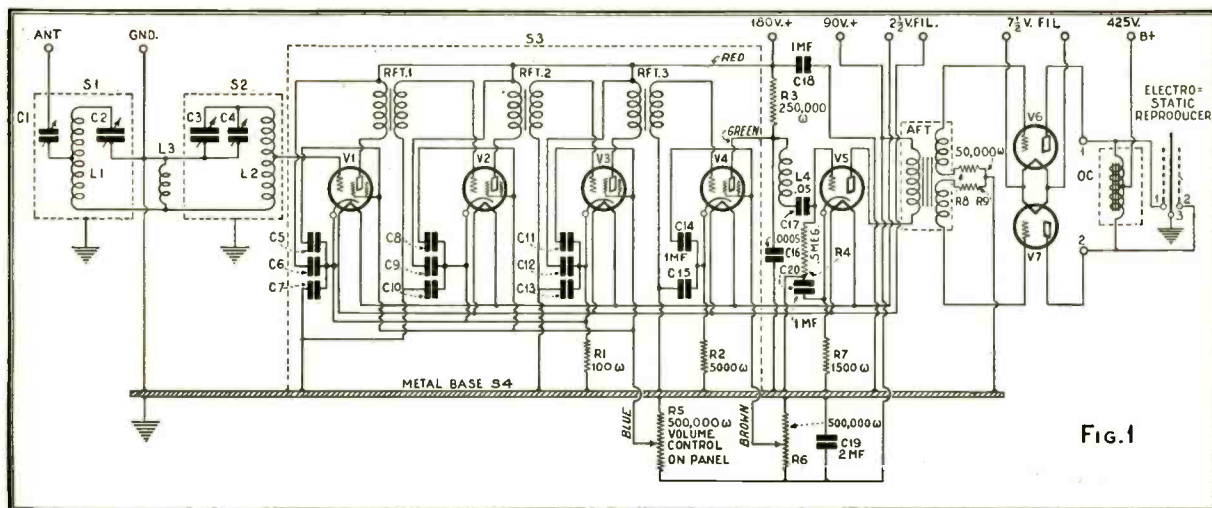

FIG. 1

Schematic diagram of the "1930 Electric Receiver." The shield cans for the various units are indicated by dotted lines. Resistor R6, once adjusted, need not be changed unless the characteristics of V4 change appreciably. A dynamic reproducer may be substituted for the electrostatic reproducer indicated. Resistors R8, R9 prevent undesirable oscillation in the push-pull stages. Every by-pass condenser shown should be used.

fastened a strip of bakelite supporting one of the *by-pass condensers*; the other condensers are soldered together and mounted between the sockets. Eleven one-microfarad condensers in all are used in this unit. Condensers of this capacity were selected to by-pass thoroughly all the connections in each stage, so there would be no tendency to oscillate due to coupling of the common connections. In ordinary sets this effect is negligible; in "high gain" receivers using screen-grid tubes "common coupling" becomes a serious problem.

The wiring of this amplifier is clearly shown in the complete schematic diagram, Fig. 1. The space enclosed by dotted lines S3 indicates the connections inside this unit.

The 100-ohm resistor R1, between the R.F. cathodes and ground, gives a 1½-volt "C" bias on the R.F. control grids. The 5000-ohm resistor R2, connected between the detector cathode and ground, gives 5 volts bias on the detector control grid. These resistors are mounted in the amplifier unit but are not shown in Fig. 3.

Connections to the amplifier unit are brought out through holes in the bottom. There will be two heavy leads for the 2½-volt A.C. supply to the heaters. Large flexible wire should be used for these, as the current for the four tubes will be 7 amperes.

There are four other connections to the amplifier, colored preferably as indicated in the diagram; blue for volume control (R5) regulating the screen-voltage of the R.F. tubes; brown, for detector screen-voltage control (R6); green for the detector plate; and red for the 180 volt "B" supply. The shielded control-grid leads are brought out through the top, as shown in the photographic illustrations. The first one comes from the hand-selector shield can, as will be seen from Fig. B.

Hand-Made "R.F.T.'s."

Suitable untuned transformers for the R.F. amplifier can be constructed according to the illustration, Fig. 9. The core consists of strips of very thin *silicon steel* transformer laminations ½" wide by 2¾" long, stacked up to a thickness of 3/16", as shown. On each side of this is placed a wooden form 5/32" by ½" by 2¾" long, so that the finished core assembly is ½" square. It is

bound together with a few wrappings of waxed paper.

The primary winding is "random wound" over one half of the core length. No. 38

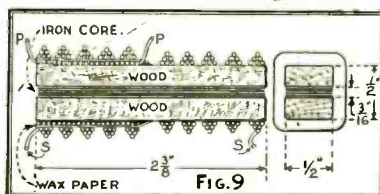

FIG. 9

Construction of the R.F. transformers. The secondary is arranged in "pies" to reduce self-capacity to a minimum. "Flat" response is obtained by variation of the number of primary and secondary turns.

S.C.C. wire is used. (This is indicated in the illustration for clearness as a single layer.)

The secondary is also of No. 38 S.C.C. wire wound in ten sections, or "pies," equally spaced over the entire length of the core as

shown. A layer of waxed paper is placed between the two windings.

The wavelength band which the transformer efficiently covers depends upon the number of turns in the primary and secondary. For the first and second stage units, RFT-1 and RFT-2, the primary should have 35 and the secondary 83 turns.

For the third stage, RFT-3, the primary should have 26 and the secondary 43 turns. As there will be some variation in these transformers due to different qualities of iron, it may be necessary to add or subtract wire from both primary and secondary to obtain the best results. This can easily be done experimentally after once operating the set to determine if it amplifies uniformly over the entire broadcast range.

The Audio Channel

The audio amplifier comprises one stage (Continued on Page 228)

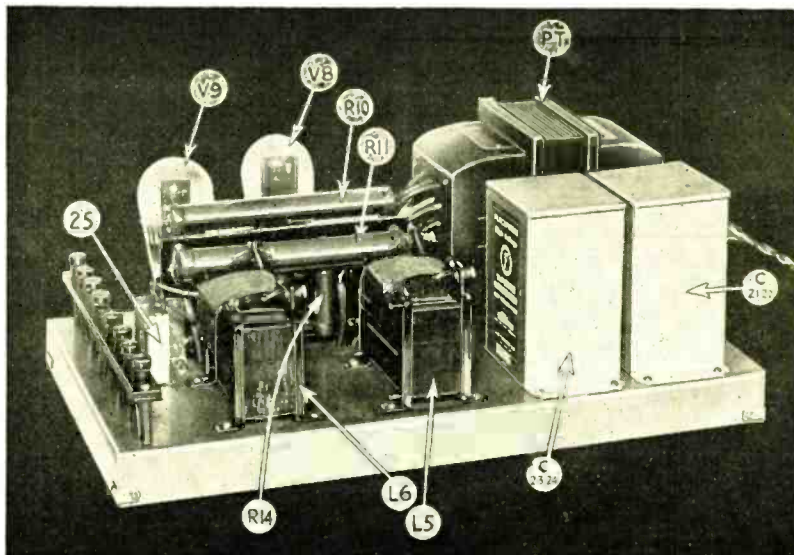

Fig. D.

Perspective view of the power pack, which should be mounted at a distance from the set chassis. Power transformer PT should be at the point most distant from audio transformer AFT. Filter chokes with generously-proportioned cores greatly help to obtain humless operation.

FEDERAL MODEL K

In the Model K receiver the volume control is a 700,000-ohm variable resistor R6, in shunt to the secondary of T6. The plate-supply resistors are mounted in the set chassis, instead of the power unit.

The first consideration is the line-voltage. Having noted its value, plug the 3-amp. fuse F into the pair of clips marked with the nearest corresponding voltage. Continuity tests are made with cable disconnected from the power unit and all tubes removed from receiver. The terminal blocks of the receiver chassis and power pack are illustrated. When testing connections on latter, remove all cable leads from the chassis and also the fuse, and plug into the A.C. line. Connect a 0-150 V., A.C. meter between 1 and 7, or between 1 and 16 (note in some units 7, 8 and 9 are the incoming common terminals, in others 16, 17 and 18 are common). The meter should read the A.C. line voltage, or the cord is defective. Next, replace the fuse in the proper clips and, if the meter reads the same between 1 and both sides of the fuse, fuse is good. Short posts 1 and 2 with a piece of wire, and put the type '80 tube in the socket. Immediately take the readings between the following posts on a 0-250 v. high-resistance D.C. voltmeter: 14 to 6, 14 to 15. Both readings should be off scale. (Note 14 is the negative post.) Using a 0-5 A.C. meter, check the filament voltages. 3 to 12, approx. 3.3 volts A.C.; 4 to 13 off scale. Shut off power by pulling the plug as soon as the readings are taken; because this test subjects the condensers to very high voltages. If the power unit fails to deliver the rated voltages the entire unit should be exchanged.

When checking the receiver chassis, make sure cable is properly connected; then turn receiver switch "on." Contact to socket terminals is easily obtained as the heads of the spring-holding eyelets are above-panel.

Special note: operating voltage of screen-grid to frame should not rise above 70 volts. A defective screen-grid tube can be easily identified by the fact that its low emission causes the screen-grid potential to frame to rise above 70 volts.

The troubles that are found from the sequence test must be located with the aid of the schematic circuit. Remove the cable from the power unit, and follow through any faulty circuits with the aid of a high-resistance voltmeter (50-volt connection) and a 2 1/2-volt battery in series. Shorts in the plate circuits will show up as readings on the voltmeter when one lead is touched to frame and one to the plate. If opens are indicated by previous voltage readings, the circuit must be traced and each piece checked until fault is located. If VC rotors and stators rub, set will operate on low wavelengths when plates come out of mesh. High hum level usually due to defective '27, V3 or V4. Hum control is located in power unit and between fuse slips. Keep the two cables to "On-Off" switch far from V3.

In the K41 type, high hum in isolated cases may be due to loose step-down transformer laminations in dynamic reproducer assembly; tap laminations lightly with hammer to reset them and reduce hum level.

In rare instances, high hum may be occasioned by high-frequency radiations originating in the dry rectifier in the reproducer power assembly. To check this, disconnect the reproducer leads and attach a

separate reproducer. If hum is heard through the latter disconnect A.C. leads to the dynamic reproducer at the power unit. If hum disappears it may be assumed that the rectifier is defective and should be replaced. Looking at chassis from front, VC3 is at left. Use middle VC as pilot when reganging,

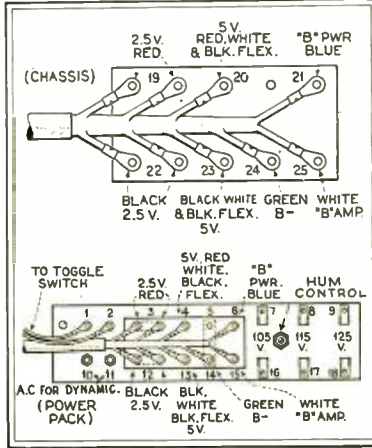

though rarely necessary. Turn volume control "Full On" and loosen two locking screws on left-hand VC, reaching through the slot left in the VC shield. Turn eccentric back and forth until weak signal is loudest and tighten. VC1 has panel vernier and need not be touched.

If changing tubes, and all other efforts, does not stop circuit oscillation, tune in station near 210 meters and, with a non-metallic screwdriver adjust NC1, NC2 and NC3. NC2 (upper left-hand) adjustment not critical. Re-check on 360 meters and seal. Under load, rectifier transformer secondary

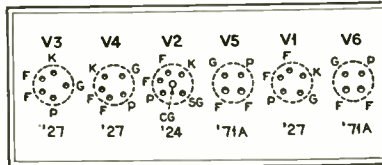

(dynamic reproducer) should read close to 11 volts; rectifier output should be 5.5 to 6 volts.

Continuity Test

Terminals	Correct	Cause if Wrong
24-frame	full	Open in cable
V3F-22 or 19	full	Do.
V3P-25	17.5	Do., T1 pri. or R8
V3G-fr.	0.5	Open or shorted R7
V3K-fr.	full	Open Gnd. lead

V4F-22 or 19	full	Open in cable
V4P-25	full	Do., or T2 pri.
V4G-fr.	20	Open in T1 sec.
V4K-fr.	full	Open R9
V2F-22 or 19	full	Open in cable
V2P-25	20	Do., R5, or T6 pri.
V2CG-fr.	full	Open in sec. of T3
V2SG-25	13	Open R4
V2K-fr.	full	Open R3
V5F-23 or 20	full	Open in cable
V5P-21	full	Do., or T3 pri.
V5G-fr.	21	Open T2 sec.
V1F-22 or 19	full	Open in cable
V1P-25	20	Do., R2, or T5 pri.
V1G-fr.	full	Open T4
V1K-fr.	full	Open R1
V6F-23 or 20	full	Open in cable
V6P-21	full	Do. or T3 pri.
V6G-frame	21	Open T2 sec.
Any rotor-fr.	full	Open fr. lead
VC1 stator-fr.	full	Open T4 or T4 leads
VC2 stator-fr.	full	Open T3 sec. or leads
VC3 stator-fr.	full	Open T6 sec. or leads
Anr. post-fr.	no r'd'g.	Shorted C13
L.S.L.S.	full	Open T3 sec. or leads
V8F-23 or 20	full	Open in cable
Any Plate prong-fr.	no r'd'g.	Sh't'd bypass or pl. lead
V1F or V2F-fr.	Do.	Sh't'd bypass or fil. lead
V3F-fr.	Do.	Shorted heater lead
V4F-fr.	Do.	Shorted fil. lead
V5F or V6F-fr.*	full	Open R10 or R11*

(\*Tubes and dial lamp out of sockets.)

Transformer Tests

T1 P1-P2	full	Open pri.
T1 S1-S2	full	Open sec.
T2 P1-P2	full	Open pri.
T2 S1-S2	full	Open sec.
T3 P1-P2	full	Open pri.
T3 S1-S2	full	Open sec.

Operating Voltages of Set

(Turn volume control to off position.)

V3P-F, 2.5 A.C.; V3P-fr., 65.0 D.C.; V3G-K, below 1 D.C.; V4P-F, 2.5 A.C.; V4P-fr., 135.0 D.C.; V4G-K, 7.5 D.C.; V2P-F, 2.5 A.C.; V2P-fr., 110.0 D.C.; V2CG-K, 1.5 D.C.; V2SG-fr., 60.0 D.C.; V5F and V6F-F, 5.0 A.C.; V5P and V6P-fr., 205.0 D.C.; V5 and V6G-F, 40.0 D.C.; V1F-F, 2.5 A.C.; V1P-fr., 120.0 D.C.; V1G-K, 7.5 D.C.

Values of Parts

Receiver: C1 to C9, inclusive, 0.25-mf.; C10, C12, .0002; C11, .001; C13, .0001; R1, R9, R10, 1,500 ohms; R2, 6,000; R3, 300; R4, 40,000; R5, 6,000; R6, 700,000; R7, 2-meg.; R8, 13,000 ohms; R11, R12, 40 ohms.

Power unit: R, 1,300 ohms; L1, 15-henry, 285-ohm; L2, 60-henry, 1,570-ohm; C16, C17, 1-mf.; C18, 2 mf.; C19, 0.1-mf.

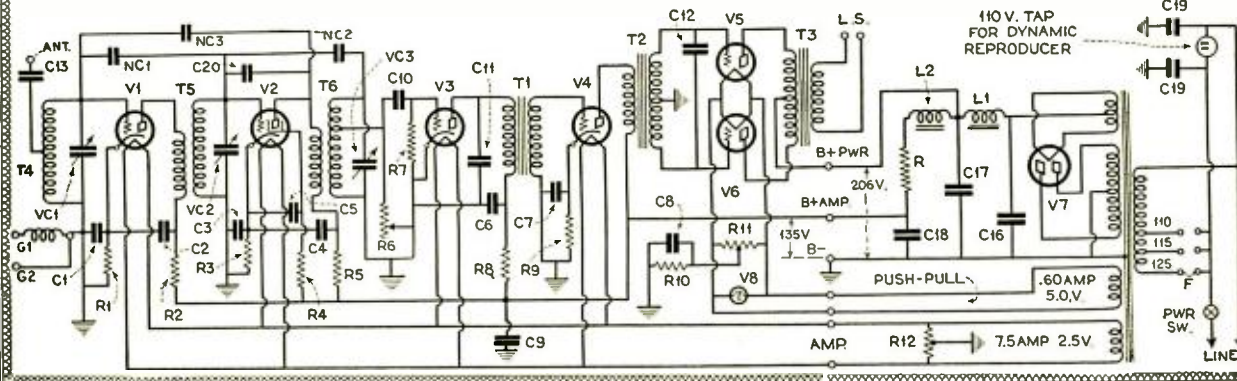

GREBE SYNCHROPHASE—7

Several models of Grebe instruments are available under the name of "Synchrophase"; the 7-tube receiver is described and diagrammed this month. In the coupling chain controlling the left-hand dial there is play to permit condenser variation, to compensate for differences in antenna capacities. This should be about two or three degrees. Between center and right-hand dials, only one-half degree is allowed as compensation for variation in parts and tube manufacture.

Condenser C1 has a capacity of .00022-mf. Units a, b, c, d and e ("Tonecolor") have a capacity of 1750, 1450, 950, 600 and 175 mmf., respectively. Resistors R1, 2, 3, 4, are 400 ohms; X is a "dummy" cartridge having a copper wire in place of a high resistance. Resistors R5, 6, 7, 8 and 9 are 5 to 7 megohms.

39-"C4½"	none	"C4½" grounded	
41-"90v."	about ¾	Lead or T2 pri. open	
19-"C4½"	about 1/3	Lead or T1 sec. open	
39-"C40"	none	"C40" grounded	
20-40v.	about 1/3	T2 sec., or lead open	
20-39 (rotate "Tonecolor")	none	"Tonecolor" grounded	
39-"A—"	full	Lead open	

Inside Receiver

C8, C9, C10, C11, C12, to 30, 31, 32, 33, 34, respectively	Shorted C2, C3, C4, C5, C6, respectively
30-35	none
31-36	Almost full R1 open
	Almost full R2 open

CONTINUITY TEST

Beneath Aluminum Deck

Test Leads	Correct	Fault, if Otherwise
1-39	full	L1 open
1-2	none	C1 shorted
3-39	none	C14 shorted
4-39	none	C13 shorted
5-6	about 1/3	T1 sec. open
7-8	about ¾	T1 pri. open
7-39	none	T1 pri. grounded
5-39	none	T1 sec. grounded
5-7	none	T1 pri. short to sec.
9-10	about 1/3	T2 sec. open
11-12	about ¾	T2 pri. open
11-39	none	T2 pri. grounded
9-39	none	T2 sec. grounded
9-11	none	T1 pri. short to sec.

Test of Cable Leads

39-"180v."	none	Lead grounded	21, 22, 23, 24,
13-"180v."	full	Lead open	25, 26, 27, respectively, to
39-"90v."	none	Lead or R.F. pri. grounded.	"A—"

32-37	Almost full R3 open
33-38	Almost full R4 open
full	"A—" circuit open

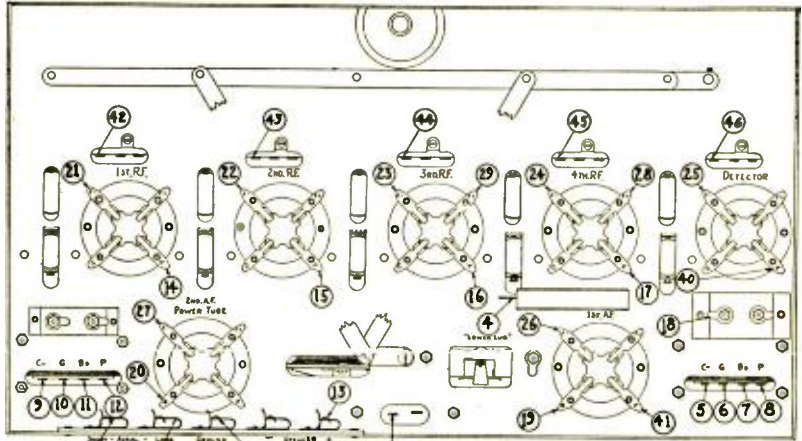

BOTTOM VIEW: Set turned on its back, bottom panel facing operator.

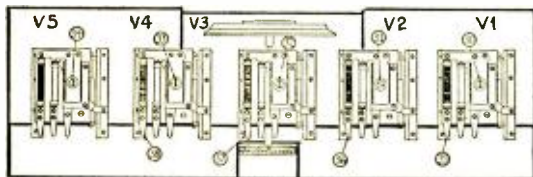

14, 15, 16, 17, in turn, to "90 v."	full	Open pri. in respective R.F.T.	42, 43, 44, 45, 46 to "A—"
39-"Det."	none	Lead grounded	39—"A+"
40-"Det."	about ¾	Lead or T1 pri. open	28—"A+"
18-"Det."	none	Shorted C7	(rotate rheostat)
39-"C+"	full	"B—" open	29—"A+"

The heavy black bar at the left of the unit marked V5 is the dummy bus referred to in these columns. Each block comprises a coupling condenser, grid leak, and grid suppressor.

full	L2, L4, L6, L8 or L10, respectively, open
none	Lead grounded
full	Rheostat or contact bad
full	As above

In any receiver it may occur that an audio transformer primary open-circuits. The service man may conveniently apply to T1 and T2 the same test used in production. Referring to bottom view of chassis, the north-seeking pole of a compass placed over 5-6-7-8 or 9-10-11-12 should point to the right (with plate current flowing). Both primaries and secondaries may be tested through use of the current in the average continuity-test kit; provided the polarity of the prods is known. With "plus" test lead to 7 or 11 and "minus" lead to 8 or 12, the compass should swing to the right; and also to the right when "+" lead of prod is connected to 6 or 10 and "-" to 5 or 9.

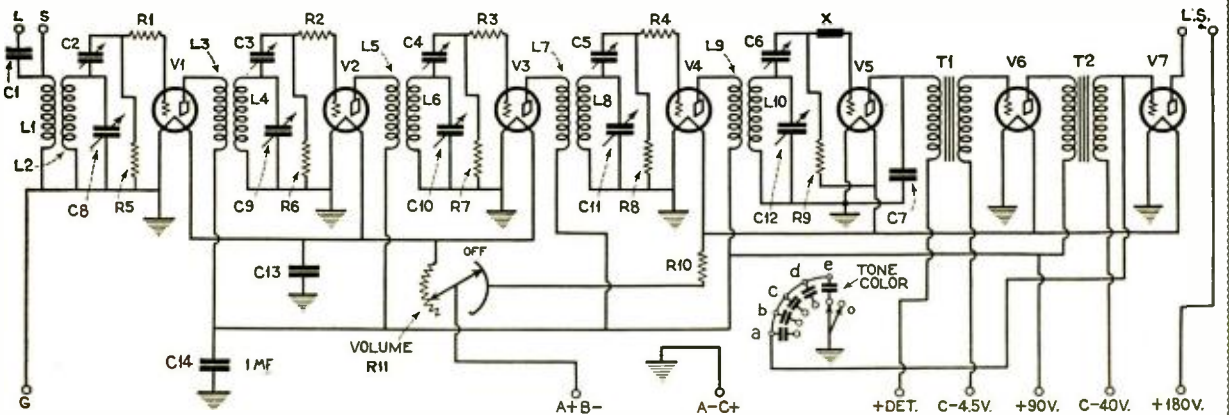

# Short-Wave Stations of the World

All Schedules Eastern Standard Time: Add 5 Hours for Greenwich Mean Time

Meters	Kilocycles	Station	Meters	Kilocycles	Station	Meters	Kilocycles	Station
14.50	20,680	Monte Grande, Argentina, after 10:30 p.m. telephony with Europe.	28.50	10,510	RDRL, Leningrad, U.S.S.R. (Russia).	39.98	7,500	AFK, Doberitz, Germany.
14.84	22,220	DGW, Nauen, Germany, 2 to 9 p.m. Telephony to Buenos Aires.	28.80	10,410	VKZME, Sydney, Australia. Irregular. On Wed. after 6 a.m. Amalgamated Wireless of Australia, Pennant Hills, N. S. W.			TFZSH, Reykjavik, Iceland.
15.02	19,970	LP3, Monte Grande, Argentina. From 9 a.m. to 1 p.m. Telephony to Paris and Nauen (Berlin).	30.50	9,830	NRH, Heredia, Costa Rica. 10:30 to 11:30 p.m. Amando Cespedes Marin, Apartado 40.	40.20	7,460	YR, Lyons, France. Daily except Sun., 11:30 a.m. to 12:30 p.m.
15.50	19,350	Nancy, France. 4 to 5 p.m. FW3, Paris, France. From 10 a.m. Telephony to Monte Grande (Buenos Aires).	30.75	9,750	Agén, France. Tues. and Fri., 5 to 6:15 p.m.	41.00	7,310	Paris, France ("Radio Vitus") Tests.
15.74	19,060	PLE, Bandoeng, Java. Broadcasts Wed. 8:40 to 10:40 a.m. Telephony with Koorwijk (Amsterdam)	30.91	9,700	W2XAL, New York, N. Y.	41.50	7,220	Zurich, Switzerland. Sat. 3 to 5 p.m.
16.10	18,620	GBJ, Bodwin, England. Telephony with Montreal.	31.00	9,680	7LO, Nairobi, Kenya, Africa. 11 a.m. to 2 p.m. Relays G5SW, Chelmsford, frequently from 2 to 3 p.m.	41.70	7,190	GAG, Perth, West Australia. Between 6:30 and 11 a.m.
16.30	18,390	PKC, Kootwijk, Holland. Daily from 1 to 6:30 a.m.	31.23	9,600	LGJ, Hilversum, Holland. English programs Thurs. and Fri. from 7 to 9 p.m., Sat. from 5 to 7 a.m. Other languages, Thurs. 1 to 3 a.m., Fri. midnight to 4 a.m.; Sat. 1 to 7 a.m. N. V. Philips Radio, Eindhoven, Holland.	42.12	7,280	7RL, Copenhagen, Denmark. Irregular. Around 7 p.m.
16.35	18,350	WND, Deal Beach, N. J. Transatlantic telephony.	31.26	9,590	PCJ, Hilversum, Holland. English programs Thurs. and Fri. from 7 to 9 p.m., Sat. from 5 to 7 a.m. Other languages, Thurs. 1 to 3 a.m., Fri. midnight to 4 a.m.; Sat. 1 to 7 a.m. N. V. Philips Radio, Eindhoven, Holland.	43.00	6,970	EAR 110, Madrid, Spain. Tues. and Sat., 5:30 to 7 p.m.
16.38	18,310	GBS, Rugby, England. Telephony with New York. General Postoffice, London.	31.28	9,580	VK3LO, Melbourne, Australia. Irregularly after 4 a.m. N. S. W. Broadcasting Co. VPD, Suva, Fiji Islands.	43.50	6,900	IMA, Rome, Italy, Sun., noon to 2:30 p.m.
16.50	18,170	CGA, Drummondville, Quebec, Canada. Telephony to England. Canadian Marconi Co.	31.38	9,550	Zeesen, Germany. Projected new station.	43.86	6,830	FRY, Georgetown, British Guiana. Wed. and Sun., 7:15 to 10:15.
16.80	17,850	PLF, Bandoeng, Java ("Radio Malabar"). Works with Holland.				44.00	6,820	XC 51, San Lazaro, Mexico. 3 a.m. and 3 p.m.
16.88	17,770	PHI, Huizen, Holland. Beam station to Dutch colonies. Broadcasts Mon., Wed., Thurs., Fri. 8 to 11 a.m. N. V. Philips Radio, Amsterdam.				45.20	6,635	WSBN, SS. "Leviathan."
16.90	17,740	HS1PJ, Bangkok, Siam. Broadcasts 9 to 11:30 a.m.				47.00	6,380	CT3AG, Funchal, Madeira Island. Sat. after 10 p.m.
17.20	17,440	AGC, Nauen, Germany.				49.02	6,120	W2XE, New York City. Relays WABC, Atlantic Broadcasting Co.
17.34	17,300	W2XK, Schenectady, N. Y. Tues., Thurs., Sat., 12 to 5 p.m. General Electric Co.				49.34	6,080	W2XCX, Newark, N. J. Relays WOR.
18.40	16,300	PCL, Koorwijk, Holland. Works with Bandoeng from 7 a.m. Netherland State Telegraphs.				49.40	6,070	UOR2, Vienna, Austria. Testing Tues. and Thurs., 8:10 to 9:10 a.m. Wed. and Sat. after 6 p.m.
18.80	15,950	PLG, Bandoeng, Java. Afternoons.				49.50	6,060	W8XAL, Cincinnati, Ohio. Relays WLW.
19.56	15,340	W2XAD, Schenectady, N. Y. Broadcasts Sun. 2:30 to 5:40 p.m., Tues., Thurs. and Sat. noon to 5 p.m., Fri. 2 to 3 p.m.; besides relaying WGY's evening program on Mon., Wed., Fri. and Sat. evenings. General Electric Company.						W9XU, Council Bluffs, Iowa. Relays KOIL.
19.60	15,300	Lyngby, Denmark, Experimental.				50.00	6,000	EAJ25, Barcelona Radio Club. Sat. 3 to 4 p.m.
20.00	14,990	TFZSH, Iceland.						RFN, Moscow, Russia. Tues., Thurs., Sat. 8 to 9 a.m.
22.20	13,500	Vienna, Austria.						SAJ, Karlsborg, Sweden.
22.38	13,400	WND, Deal Beach, N. J. Transatlantic telephony.				52.00	5,770	AFL, Bergedorf, Germany.
22.99	13,050	W2XAA—Houlton, Me. Transatlantic telephony.				56.70	5,300	AGJ, Nauen, Germany. Occasionally after 6 p.m.
23.35	12,850	W2XO, Schenectady, N. Y. Antipodal program 9 p.m. Mon. to 3 a.m. Tues. noon to 5 p.m. on Tues., Thurs. and Sat. General Electric Co. W6XN, Oakland, Calif. Relays KGO Tues., Wed., Fri., 12:30 to 4 p.m. Antipodal program 9 p.m. to 3 a.m. Tues. Also after 9 p.m. General Electric Co.				60.90	4,920	LI, Paris, France.
24.50	12,240	FW, Ste. Assize (Paris) France. Works Buenos Aires, Indo-China and Java. On 9 a.m. to 1 p.m., and other hours.	31.48	9,530	W2XAF, Schenectady, New York. Mon., Tues., Thurs. and Sat. nights, relays WGY from 6 p.m. General Electric Co. W9XA, Denver, Colorado. Relays KOA.	62.50	4,800	W8XK, Pittsburgh, Pa. Relays KDKA after 6 p.m. Works with 5SW 5 to 7 p.m. Tues. and Thurs. Westinghouse Electric Co.
24.68	12,150	GBS, Rugby, England. Transatlantic phone to Deal, N. J. (New York).						62.50 to 61.22 meters—4,800 to 4,900 kc. Television. W8XK, Pittsburgh, Pa.; W1XAY, Lexington, Mass.; W2XBU, Beacon, N.Y.; WENR, Chicago, Ill.
25.10	11,940	Zeesen, Germany. Tests of new Super-power broadcaster.						65.22 to 66.67 meters—4,500 to 4,600 kc. Television. W6XC, Los Angeles, Calif.
25.40	11,800	W8XK—East Pittsburgh, Pa. Relays KDKA after 6 p.m. Tues. and Thurs. from 5 to 7. Westinghouse Electric Co.				67.65	4,430	AFK, DOA, Doberitz, Germany. 6 to 7 a.m. 2 to 3 p.m. Mon., Wed., Fri.
25.53	11,750	G5SW—Chelmsford, England. Relays 5XX, Daventry 2 to 7 p.m., experimental transmission from 7 to 9 p.m. and 7:30 to 8:30 a.m., and tests with W2XO 12 to 1 p.m. Mon. and Thurs. Silent Sat. and Sun. British Broadcasting Co.				70.00	4,280	OHK2, Vienna, Austria. Sun., first 15 minutes of hour from 1 to 7 p.m.
25.60	11,710	CRX, Winnipeg, Canada. 5:30 to 8 p.m. daily. Sun. 1 to 2 p.m. Relays CJRW. James Richardson & Sons, Ltd.				70.20	4,270	RA-19, Khabarovsk, Siberia. Daily except Wed. from 4 a.m.
26.22	11,430	DHC, Nauen, Germany (Berlin) Weddays after 5, Sun. after 9 p.m.				80.00	3,750	F8KR, Constantine, Tunis, Africa. Mon. and Fri.
26.70	11,230	WSBN, SS. "Leviathan" and A. T. & T. telephone connection.				84.24	3,560	OZ7RL, Copenhagen, Denmark. Tuesday and Fri. after 6 p.m.
27.00	11,100	EATH, Vienna, Austria. Mon. and Thurs., 5:30 to 7 p.m.				101.7 to 105.3 meters—2,850 to 2,950 kc. Television. W3XK, Silver Spring, Md., 8 to 9 p.m.; WPY, Allwood, N. J.		
27.27	11,000	Posen, Poland. Mon. and Thurs. 5 to 6 p.m. New station testing.	31.56	9,500	VK3LO, Melbourne, Australia, irregular. Broadcasting Co. of Australia.	104.4	2,870	WFF, Perth, Australia.
27.80	10,780	PLR, Bandoeng, Java. Works with Holland and France weekdays from 7 a.m.; sometimes after 9:30.	32.00	9,375	CGA, Drummondville, Canada. Irregular. Canadian Marconi Co. EHOS, Berne, Switzerland. Mon., Tues., Sat. 3 to 4 p.m. JB, Johannesburg, South Africa, 2 to 6:45 p.m. 7MK, Copenhagen, Denmark. Irregular after 7 p.m.	105.3 to 109.1 meters—2,750 to 2,850 kc. Television. W2XBA, Newark, N. J., Tues. and Fri. 12 to 1 a.m.; W2XCL, Brooklyn, N. Y.; W8XAU, Pittsburgh, Pa.; W1XB, Somerville, Mass.; W7XAO, Portland, Ore.		
28.00	10,710	YAS, Glace Bay, N. S., Canada. 5 a.m. to 2 p.m. Canadian Marconi Co.				136.4 to 142.9 meters—2,100 to 2,200 kc. Television. W2XCR, Jersey City, N. J. 3 to 5 p.m., except Sat. and Sun.; 8 to 10 p.m. Mon., Wed., and Fri. W8XAU, Pittsburgh, Pa.; W1XB, Somerville, Mass.; W2XCW, Schenectady, N. Y.		
28.20	10,630	PLE, Bandoeng, Java. Tests with Australia.	32.50	9,230	FL, Paris, France (Eiffel Tower) Time signals 3:56 a.m. and 3:56 p.m. VK2BL, Sydney, Australia.	142.9 to 150 meters—2,000 to 2,100 kc. Television. W2XCL, Brooklyn, N. Y., Mon., Wed., Fri., 9 to 10 p.m.; W9XAA, Chicago, Ill.; W2XBS, New York, N. Y., frame 60 lines deep, 72 wide, 1,200 R.P.M.; W1XAE, Springfield, Mass.; W8XAU, Pittsburgh, Pa.; W6XAM, Los Angeles; W2XBU, Beacon, N. Y.; W2XBF, Bound Brook, N. J.; W3XK, Washington, D. C. Daily except Sun., 8 to 9 p.m.; WPY, Allwood, N. J.		

(NOTE: this list is compiled from many sources, all of which are not in agreement, and which show greater or less discrepancies; in view of the fact that most schedules and many wavelengths are still in an experimental stage; that daylight time introduces confusion and that wavelengths are calculated differently in many schedules. We shall be glad to receive later and more accurate information from broadcasters and other transmitting organizations, and from listeners who have authentic information as to calls, exact wavelengths and schedules. We cannot undertake to answer readers who inquire as to the identity of unknown stations heard, as that is a matter of guesswork; in addition to this, the harmonics of many local long-wave stations can be heard in a short-wave receiver.—Editor.)

(Standard Television scanning, 48 lines, 900 R.P.M.)

# The Radio Craftsman's Own Page

In these columns will be found letters of RADIO-CRAFT readers from every quarter of the globe. Here old friends will renew acquaintances of long standing.

## GOOD LUCK ON SHORT WAVES

Editor, RADIO-CRAFT:

As I have not seen many reports from owners of short-wave converters, I thought you might be interested in the results I have obtained. I have a Dresner short-wave converter, and I find it very satisfactory. So far I have received Chelmsford, Eindhoven, Winnipeg, and Sydney (Australia) as well as several U. S. stations. I plug the converter into a seven-tube super-her; in the audio end I use a 112, and for operating a three-foot cone also a 210. It may be of interest to some to know that I use a "B" power unit as well, and have no trouble with hum. I have heard one station on about 32 meters, but they spoke a foreign language, and I could not understand them. I hope to see more letters from short-wave fans.

BOB PATERSON,  
North Lawrence, N. Y.

(Not all short-wave fans, it is true, have had such encouraging results with the use of power units; and sometimes local or circuit reasons cause the short-wave beginner to be quite baffled. We therefore would especially like to receive letters about methods which have proved successful in overcoming the troubles first experienced by broadcast listeners with short-wave sets and converters.—Editor.)

## WILL HELP OTHER BUILDERS

Editor, RADIO-CRAFT:

I have received my second issue and am very much pleased. I have recently constructed the Pilot "Wasp" and am getting wonderful results with it. Last week I tuned in W6XAX, Oakland, Calif., and PCJ, Eindhoven, Holland; and if there had not been so much fading, I could have put them on the loud speaker. Will you please inform me of the air mileage? (About 2750 miles to Oakland and 3500 to Eindhoven). If any of your readers are thinking of constructing the "Wasp" and would like some information concerning it, I will be glad to answer any letter addressed to me; I think we should all get together and exchange ideas and I will be more than glad to swap experimental data with anyone who cares to write me. I am going to construct the "Super-Wasp" in the near future.

I think your magazine is the best in the field, even at the start, and hope you will have plenty of success.

JOSEPH D. COPELAND,  
85 Main St., South Portland, Me.

(Our correspondents' kind offer is the first of many, we believe. Incidentally, we may remark, a reader who sends an inquiry asking for free information would show courtesy in enclosing a stamped envelope; the number of letters attracted by a communication of this kind is often unexpectedly large.—Editor.)

## SHORT-WAVE ENTHUSIASM

Editor, RADIO-CRAFT:

I built the "Super-Wasp" described in your first issue, and it sure is a fine set. I have pulled in PCJ, 5SW, 2ME, 2FC, CJRX, W6XN, W8KK, W8XAL, W2XAF, and W2XAD, all loud-speaker volume. I use an aerial about 85 feet long and a 112A in the last stage. I would like to hear of the results others are getting from this receiver, and any articles about short waves in future issues will be welcomed. RADIO-CRAFT is just the magazine I have been waiting for.

EDWARD MARKETTE,  
Box 75, LaBelle, Florida.

## FOR THE NEIGHBORS' GOOD

Editor, RADIO-CRAFT:

Experiments of the most simple kind sometimes work out the hardest problems. To be brief, we purchased one month ago the improved Majestic. We lived in a down-town section (as they say, "right under" KPO and KYA). We could not cut out either station; when one was on both were on. We discontinued a part of our outdoor aerial and, since that seemed to improve reception, we then discontinued the entire outside connections; having connected only two short wires that ran from

the set to the window casing, about six feet. When the interference subsided with this arrangement, we discontinued one of these; simply hung a piece of wire out of the window, and this did more to reduce the interference than any thing we had done.

**T**HE letters of encouragement and praise which our readers have been showering on us have been very welcome to the Editors of RADIO-CRAFT, and they take this opportunity of acknowledging the great number to which it has been impossible to reply personally, much as they would have liked to do so. Bouquets, however, are not all they are looking for. This is YOUR magazine, and it will welcome every letter which expresses a definite wish for a certain line of editorial information. It is only in this manner that we can know just what You want and what will be of most use to You. Our readers realize, and so do we, that there is still much room for improvement in RADIO-CRAFT; and, with YOUR cooperation, it will be forthcoming.

We especially invite letters telling of your experiences with sets, circuits, and practical radio problems, as they come up in your work. We know that our readers like to know what others are doing, as much as to read the more formal articles available from those who are active in industrial development of radio; and we trust to make this Experimenter's page the stamping ground of those who like to follow out their own ideas and do something a little different. What have you found out for yourself that will help along other experimenters? Write to the Editor of RADIO-CRAFT and tell your story in your own words.

Then the folks who lived under us complained about hearing our radio so loud that it interfered with their rest. The discarding of the aerial seemed to allow the sound to sink or penetrate the floor to the discomfort of our neighbors downstairs. Then I went to the five-and-ten store and purchased

ラジオセット (七球Aセット)

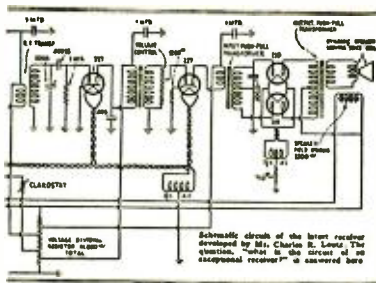

も思はれる。省くが、低周波の部は、R3が加はると、R3の比のて、テックラフIは、低周波電流のC1又はC2の一次線に少ないクリングングの

Radio-Craftmanship in the Orient. Our readers will recognize the audio end of the "Seven Seas" receiver described in our first issue; but not, perhaps, follow the comment of our Japanese contemporary, the "Radio Experimenter."

four glass dishes (called "berry dishes") and placed one under each leg of the console. Now we have no interference, from either the assembled stations or our neighbors.

This is a simple thing; but if you will think it out there's something to it which I don't understand but will work good for the radio owners as well as all concerned.

MORGANTHALL BUSH,  
378 Golden Gate Ave., San Francisco, Calif.

(There is no apparent reason why discarding an aerial should cause the sound to manifest greater penetration; but more volume from the speaker would account for this phenomenon. It is probable that changing the input (antenna) values resulted in a condition of electrical resonance (in the input circuit) in the broadcast band with the result of increased output from the reproducer. It may be remarked that one of our contributors has found a solution of localized interference in a longer aerial and turned-down volume. No general rule can be given for solving antenna problems; for they are different in every location. The suggestion as to insulating the legs of the receiving set may be blessed by many residents of lower floors. It is suggested dishes of rubber, cut from a discarded inner tube, also be tried.—Editor.)

## RESULTS WITH INEXPENSIVE SETS

Editor, RADIO-CRAFT:

I constructed a four-tube set as an experiment, on the plan of a Browning-Drake receiver, except that no tuning condenser is used across the R.F. transformer secondary. On tests with this set using two tubes (without the audio) I received programs from 32 states, ranging from Schenectady to Oakland; Texas, Florida, and two Canadian stations in two evenings.

It is easily tuned and gives good volume on detector tube with 22 volts through a 50,000-ohm Electro adjustable resistor.

I do not believe any of the older readers will build it; but it is a fine set for a beginner who has limited finances to work with. I used UX-199 tubes with the set and it worked fine. A three-circuit tuner run by a .00035-mf. Pilot condenser, an R.F. coil to match (without its usual tuning condenser), and two A.F. transformers were the principal parts. I would like to hear from anyone who has built a set like this; as I would like to collect data on its operation in various places.

JOHNNIE BABILLUS,  
Box 104, Sraunton, Indiana.

(With a simple set like this, good work has been done in many localities; though it is not suitable for the neighborhood of a broadcast station, as a rule. The untuned blocking stage gives a little amplification. However, it is impossible to obtain the same results, locations and other things being equal, without the devices which engineers find necessary for modern receivers; but painstaking tuning and operation have no mechanical substitutes. That is why the DX record is not always to the owner of the most costly set.—Editor.)

## HIS FEARS WERE BASELESS

Editor, RADIO-CRAFT:

I have no "Kink" to send in, but am writing on a subject that might already be settled in the reader's mind. Yet it is information for which I would have been very thankful, when I needed it.

When the CX-322 first came out, I heard all about its good qualities; but I also heard that it used the CX-320 filament. My worry was, what will the life of the tube be? Will it act like the others of the '99 family and go dead in a few months? Well, I took a chance, and the result is that these tubes which I bought in March, 1928, seem to be just as good as new. There are three of them, so it is not just luck. What is more, I have been an invalid for two years; and I am always lying alongside of my radio set and playing it.

BRUNO CZARRA,  
1386 Orchard St., Milwaukee, Wis.

(There is no doubt that tube design is steadily improving; and that when a new type is offered to the public, it has been tested in the laboratories for a long time, and the individual tubes have been tested repeatedly by automatic machinery before they are sent out. Occasionally, of course, one may be short-lived; but faulty operating conditions are in most cases the reason for any trouble with standard tubes.—Editor.)

# At The 1929 Radio World's Fair

Some of the New Things Displayed at Madison Square Garden

## THE EVEREADY "30" RECEIVERS



The Eveready "Model 34" Console.

The National Carbon Co.'s line of Eveready receivers presents the same chassis, the "Model 30," in a choice of consoles. The receiver, a R.F.L. design, has variometer tuning in the antenna circuit, and six stages, using four '27s and push-pull '71s. All console models have the Eveready dynamic reproducer built in.

## SILVER A.C. SHORT-WAVE "735"



Chassis of the "Round-the-World Six," a 17-meter factory assembled receiver.

This receiver is designed to take short-wave reception off the breadboard and into the parlor. Its circuit is similar to that of the D.C. "735" which is also available; the latter uses one '22 in an untuned R. F. stage, and four '12As. The A.C. model uses a '24 with its superior characteristics in the first stage, and has a '45 push-pull output. The audio channel and power unit are the same as in the "Model 722" — "Band Selector Seven". The "735" A.C. model lists at \$64.90, factory assembled, with or cabinet or long wave plug-in coils.



The Weston "Model 533" Counter Checker.

## SET TESTER AND CHECKER

Thirteen ranges are combined in the new Weston "Model 547" Set Tester, which measures both A.C. and D.C. voltages up to 750, by means of its two selector switches. Three 3/4-inch meters are incorporated in the panel. The instrument, with the necessary tools and testing accessories, weighs ten pounds and fits in a carrying case 12 3/8 x 9 x 3 3/4 inches. Its net (dealer's) price is \$93.75.

The counter tube checker is adapted for operation from any standard A.C. lighting circuit, with considerable tolerance of input voltages; and is designed to test quickly all the latest A.C. as well as D.C. tubes for their characteristics.

## BRANDES AND KOLSTER REMOTE TUNERS



The Brandes "Model B15," with its selector tuner above. The Kolster and Brandes receivers of this season incorporate a new method of automatically-selective tuning.

The Kolster "K-45" has no knobs or dials on the front; its dial may be seen through a small window in the top, and the tuning buttons are on the side. In addition, there is a remote-control box, led by a cable to the set, which has six buttons for as many stations, volume control, switch and pilot lights. The list price of this de luxe set is \$500; other models range down to \$200.

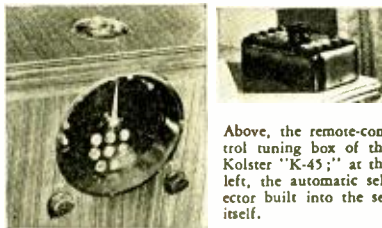

Above, the remote-control tuning box of the Kolster "K-45;" at the left, the automatic selector built into the set itself.

By modern house-wiring methods, any room can be equipped with a receptacle, thus allowing a convenient disposition of the tuning box wherever desired.

The Brandes brings the selector tuning system into a lower price range. This line has also four tuned circuits and '45 push-pull amplification. The "Model B-15" illustrated lists for \$125.50; the line covers the field from \$85 to \$165.

## DE FOREST AUDIONS

In the line of new tubes presented by the DeForest Radio Co., an improved heater design has been incorporated to reduce the hum of the A.C. filament current. The heaters now used are made of "crolite," a new synthetic ceramic; and the filament is completely shielded from the cathode. In the 410 power tube, as in the new D.C. screen-grid audion (the 422), oxide-coated filaments are used to give longer life than with the thoriated-tungsten commonly used. In the new 424, the A.C. screen-grid audion, other characteristics have been retained, but the grid bias has been doubled.



## CROSLY MONOTRAD



The Crosley "Monotrad" in a table-type metal cabinet, designed to take the speaker as shown or on top.

In the Crosley line of mass-production price receivers, the newest arrival is the Monotrad, a seven-tube A.C. screen-grid receiver, listing at \$62 without accessories. Its chassis, illustrated below, has the new Crosley triple-range control, a completely-shielded gang condenser, carbon-type amplification control and Mershon condenser. It is intended for use in any of the many cabinets designed for the Crosley line.



The chassis of the Crosley "Monotrad."

MAJESTIC RECEIVER MODELS



The post-colonial console design of the "Model 181".

The Majestic line incorporates, in its "Models 91 and 92," the latest type of power detection. These receivers, with built-in super-dynamic reproducers, list at \$137.50 and \$167.50. The "Model 181," illustrated above, is a striking accomplishment in cabinet work, and reproduces either radio or phonograph records through a '50 push-pull amplifier. List, \$316.50.

ZENITH REMOTE-TUNER SYSTEM

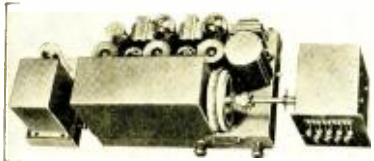

The Zenith "50 Screen-Grid" Chassis (above) and Automatic Tuner (right).

The newest Zenith designs incorporate the "Model 50" chassis, with its five tuned R.F. circuits, and two push-pull audio stages, with '45 output. All embody the Zenith automatic tuning system, to which has just been added (in the "Model 55") the remote tuner illustrated. This operates at the turn of a button, its pilot light automatically indicating the station which is on; and gives also volume control. The set operates a 12-inch dynamic reproducer. The "Model 55" is priced at \$700 in its Italian Renaissance cabinet; others down to \$175.



CHAMPION RADIO TUBES

A new method of merchandising of interest to buyers, as well as sellers, is utilized in the packing of Champion tubes. Not only is there the new system of packing the complete tube equipment for a given receiver in one carton; but the individual tube is in a stout container of a design which permits a demonstration test of its characteristics without removing it or breaking the seal by means of a test adapter furnished by the manufacturers.

HAMMARLUND AMPLIFYING UNITS AND TRANSFORMERS

The Hammarlund Manufacturing Co. has just added to its extensive list of radio components several important units; among them a three-stage R.F. band-selector, known as "BS-3," to work ahead of an amplifier; a three-stage screen-grid R.F. amplifier, "RF-3," to follow the former; a shielded, polarized R.F. choke, SPC, and a family of audio-frequency transformers.

The band filter comprises a three-gang "Midline" condenser and matched filter coils; this affords pure 10-ke. selectivity ahead of the amplification. The amplifier also contains a three-gang condenser and matched, shielded coils. Both units are factory assembled and sealed.

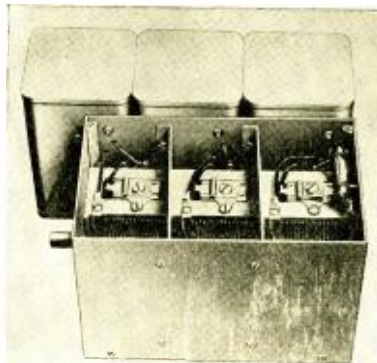

In front, the "Battleship" condenser of the band filter; behind it, the coils in their shields.

The first-stage A.F. transformer, "AF-2," has a ratio of 1 1/2-1; the push-pull input type, "AF-4," 2-1 on each side. Both have very large primaries, and cores of special-alloy laminations to insure a flat characteristic. The output transformer types are "AF-M" for magnetic reproducers and "AF-D" for dynamics.

A complete power supply unit, "PS-45," is designed to operate a receiver with push-pull '45 amplification. It comprises two heavy chokes and a power transformer with primary tapped at 80 volts for use with an automatic voltage regulator. The high-voltage secondary is a center-tapped 750-volt winding with a rating of 100 milliamperes; and there are a 5-volt and two 2 1/2-volt windings. The new voltage divider is "RHQ-30" and the condenser block "CHQ-30."

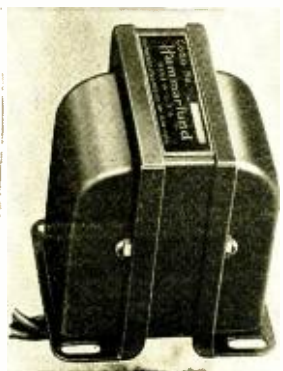

The new A.F. transformer in its steel housing for sub-base mounting.

JEWELL "581" TEST PANEL

The Jewell Electrical Instrument Co. has designed a laboratory panel, suitable for shop or jobber's use, to facilitate complete testing of receivers and other radio apparatus in the shortest time. It is furnished with high-resistance precision meters and gives in addition to tube readings, condenser capacities and high-voltage secondary readings. Dealer's price \$159; with work bench, \$208.87.

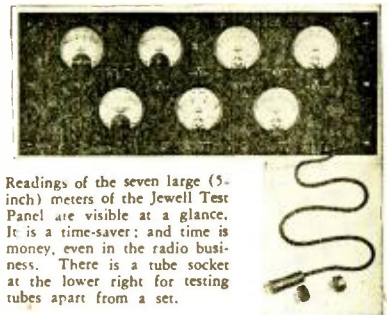

Readings of the seven large (5-inch) meters of the Jewell Test Panel are visible at a glance. It is a time-saver; and time is money, even in the radio business. There is a tube socket at the lower right for testing tubes apart from a set.

"GENERAL" WOOD CABINETS

The increasing vogue of individuality, in cabinets to take standard receiver chassis, has promoted the production of many very artistic designs. The Wood Cabinet Corporation presents a line, of which the "Model 108" is illustrated; it is designed to accommodate any popular set, with speaker above.



An attractive and somewhat modernistic piece of cabinet work.

BEST ELECTRIC MOTOR CHASSIS

The "BBL" electric motor, designed for small-cone reproducers, incorporates a tapped winding with a switch, which matches the output impedance of the receiver without resorting to a special transformer, as well as a separate volume control. It is now available in a separate cabinet, at \$35 list, as well as in chassis form at \$22.50.

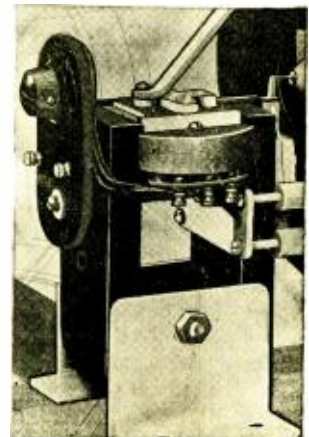

The magnetic reproducer unit of the "BBL" motor will drive a 12-inch fixed-edge diaphragm.

# LATEST THINGS IN RADIO

*Manufacturers are invited to send to this department photos and descriptions of new apparatus*

**I**N the new tube tester, Types VT1 and VT2, made by Ferranti, Incorporated, New York City, and illustrated in these columns, is included a large-scale meter, with direct-current ranges of 0-10-100 milliamperes, and D.C. voltage readings from 0-10-100-300 volts (in the Type VT1 unit; Type VT2 has a maximum reading of 500 volts instead of 300). The resistance of the instrument is 1000 ohms per volt.

The case is of polished bakelite eliminating any possibility of grounds to other equipment; upon its face is a switch to select connections to the meter, for its different purposes. A plug fitted with a flexible lead makes it convenient to determine the characteristics of a tube while in operation; the plug being inserted into the proper tube socket in the receiver, while the tube is inserted in a receptacle on top of the plug.

It is worthy of note that provision has been made for its use with receivers of such compact design as to prohibit the use of an ordinary plug, such as described above, because of the lack of space. For such conditions an "extension plug" with an extension cable is supplied; the tube may then be placed outside the receiver, while connected to the end of the cable.

Another accessory is an intermediate plug. The purpose of this is to reverse the meter connections; so that the correct grid-potential indication will be obtained when testing receivers in which the "B—" connects to "A+" (for otherwise the meter should read "off-scale"). The makers refer to this connection as used in "certain obsolete receivers." It is true that this method of connection has become *passé*; but it will be found in use in thousands of sets now in operation.

Rotation of the selector switch of the tester, when the plug is inserted in the tube sockets

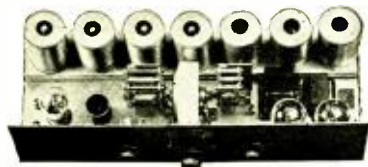

Above is pictured the new H-F-L chassis of the latest.

of the receiver under test, enables the service man to determine instantly:

- (1) "A" potential (0-10 volts);
- (2) "B" potential (optional scales, 0-100 and either 0-300 or 0-500 volts);
- (3) "C" bias potential (optional scales 0-10 and 0-100 volts);
- (4) Plate current (optional scales of 0-10 and 0-100 milliamperes);
- (5) Polarity;

(6) Circuit continuity and approximation of value of resistance in "A," "B" or "C" circuits;

(7) In the case of screen-grid tubes, the "grid" circuit readings will be those of the "screen-grid;" for it is necessary to connect a flexible lead (supplied with the meter) to the



Single-meter test unit made by Ferranti.

tube-cap to obtain "control-grid" indications.

In addition to these specific tests, the instrument may be used with test-prods to determine values in various parts of any circuit in which a potential is available. This potential may be supplied by the set equipment or it may be a separate test battery; depending upon the particular test to be made.

That service man is a rarity who has not had the thrilling experience of burning out at least one milliammeter. It happens in the best of families, when, during testing, a short-circuit develops. In the Ferranti unit, a replaceable fuse prevents such expensive incidents.

The usual "zero adjuster" is included in the design.

To call this ingenious unit a mere "tube tester" is an error; the device has a testing scope too wide to be limited by such a name. For example, "Radio Set Tester" might be suggested.

The meter, designed for precision as well as sturdiness, comprises a d'Arsonval moving-coil galvanometer action, swung on highly-polished steel pivots in sapphire bearings. The torque of this instrument is very high, as required by engineering specifications for laboratory instruments; and the damping is exceptionally good to correspond. On a half-scale reading, the pointer comes to rest a fifth of a second after the current is switched on. A compensating

adjustment for the pointer is provided to reset it to zero mark, should this ever become necessary from long use or rough handling.

The entire design incorporates maximum strength with minimum weight. The instrument is 4½ inches long by 3¼ wide and 1¼ thick. For the purpose of use as an ordinary milliammeter or voltmeter, it is connected (with leads provided which slip over the pins of its cable plug) to the external current supply. Its accuracy at full scale is guaranteed within 1 per cent.

The aluminum pointer having both knife-edge and flag-indicator design, and being designed for strength and lightness, like a miniature girder.

Complete with all equipment, the list price of the model VT1 Tester is \$60.00; Model VT2 at a higher price.

## H-F-L MASTERTONE AND POWER MASTER

**I**T is rather unusual to find production designing under custom construction standards; but, we are advised by the High Frequency Laboratories of Chicago that everyone of their sets is assembled and wired under the personal direction of the two distinguished engineers who developed the circuit of the latest receiver sponsored by this concern.

To list the features of this receiver is to indicate, in a few lines, the design data that enables the radio man to judge, in a general way, his possible need for the set. This data follows:

- 11 tubes (5, type '24 tubes; 3, '27; 2, '45; and 1, '80);
- Superheterodyne circuit;
- Single dial tuning;
- All A.C. operation;
- Five tuned R.F. circuits;
- Compact (panel 7"x21" and chassis depth 7½");
- Screen grid tube as a power detector;
- Automatic line-voltage fluctuation control;



The "Power Master" designed for the H.F.L. receiver.

100 volt D.C. dynamic reproducer field supply incorporated;

- 3-stage phonograph pickup amplifier;
- Self-healing Mershon condensers.

Describing this receiver in somewhat greater detail, we start at the aerial. Right here we





The Ultratone "Model T" auditorium electric-dynamic reproducer

find this need not be more than a sheet of metal on the cover of the cabinet, in most localities. The input is aperiodic and consequently it makes no difference what the aerial conditions are, insofar as circuit tuning is concerned; and the sensitivity (a few tenths of a microvolt) is sufficiently great to enable a small size pickup to be used. A ground connection is not necessary or recommended.

In the antenna, at the low potential side, the heterodyne frequency is introduced and the difference frequency is amplified by four stages, using screen-grid tubes. The intermediate frequency amplifier output feeds a screen-grid detector upon the plate of which a potential of 175 volts is impressed. A 10-kc. filter design is incorporated in the I.F. amplifier unit.

The first audio stage is followed by a stage of push-pull '45 amplification. The output of this stage couples to any type of reproducer with equal efficiency and has been termed the "inter-space" type; there is no direct current in the audio output coupling to the reproducer. The output design includes a high frequency cut-off characteristic.

Provision has been made for the connection of a phonograph pickup, the current of which is amplified by three stages of audio amplification.

The power pack, called the "H-F-L Power Master" has a filter system using large chokes and 24-mf. Mershon condensers. A full-wave, or '80 tube is used as the rectifier. As a D.C. type dynamic reproducer is used, it has been found convenient to supply its 50 milliamp. field current at 100 volts. Reproducers having 2200- to 2500-ohm field coils are required.

The fact that a superheterodyne circuit is used makes it convenient to use four stages of screen-grid amplification. Since the intermediate frequency at which these operate is unaffected by tuning operations, a constant condition is obtained which makes stable performance possible.



The Nova "Electric-Switch" clock turns the radio on or off at any hour selected.

### ULTRATONE DYNAMIC REPRODUCER

The new 10-inch super-power reproducer illustrated at the left is the product of the Ultratone Manufacturing Co., Chicago, and designed solely for auditorium and outdoor address systems. It has a 16-volt field coil weighing 15 pounds.

A smaller model, the "A1," which takes the output of any domestic audio amplifier, operates an 8-inch cone. The characteristics are designed for fidelity, rather than the bass accentuation often found. It is listed at \$35 in a walnut cabinet, and \$20 for the chassis alone.

### NOVA RADIO-CONTROL CLOCK

The electro-switch clock made by the Nova Electric Corporation of New York is designed to govern the on-turnings and off-shuttings of a radio receiver; thus serving to announce the hours in a diplomatic fashion. Its purpose is not thus narrowly limited, however; for it will operate the switch of any electrical device. No current is consumed in its operation. In the art-bronze finish shown, it is listed at \$10, in a walnut cabinet at \$10.50. It breaks a circuit up to 300 watts at 250 volts; a heavier-duty switch lists at 50 cents additional. Size 6 inches high, by  $5\frac{1}{2}$  by  $2\frac{1}{2}$ .



A close-up view of the Carter "Electro-Automatic" tuning selector.

### BEEDE TUBE AND SET TESTER

An inexpensive and highly useful portable test set is manufactured by the Beede Electrical Instrument Co., of Penacook, N. H. and illustrated here.



The "No. 250" Beede Improved tester.

It is designed to meet the demand where a low-priced instrument is required for service or experimenter's use, and to furnish a comparison of the performance of tubes and sets which will be sufficient for ordinary purposes. It contains both A.C. and D.C. meters, and gives readings up to 500 volts and 100 milliamperes. The list price is \$25, with a dealer's discount.



The Carter automatic radio control, built into a standard receiver console.

### CARTER AUTOMATIC TUNER

The device illustrated at the left and above has just been perfected by the Carter Radio Co. of Chicago; and was designed for engineering into a set's design, rather than for sale as an accessory. It operates automatically on the pressure of a selector button, which sets its tiny motor in operation until the desired reading is reached. The mechanism lends itself also to remote-control operation. It does not return to neutral in tuning; but turns, like a human operator, directly to the wanted setting.

### THE RADIO LITE-TENNA

The advantages of indoor-aerial operation are known to comparatively few set owners, though readily appreciated on a moment's consideration; a loop, however, lacks compactness, and its pick-up is small. By the use of the device shown at the right, both objections are overcome. The attractive lamp shown connects on one side to the light socket, on the other to the radio "Ant." posts; a fixed condenser supplies the link between the pick-up, which is furnished by the power wires, and the receiver. The "Lite-Tenna" is manufactured by the Aerial Insulator Co. of Green Bay, Wis.; its list price is \$7.50. The lamp is ten inches high; its shade is amber and the frame old gold.



### A RUGGED TUNING CONDENSER

A sturdy piece of apparatus is the "B.T." armored condenser produced by the United Scientific Laboratories of New York City. (Continued on Page 238)



A component designed for permanent efficiency

# Vacuum Tubes for Radio Reception — Part II

By C. W. PALMER

**L**AST month we gave a number of details about the construction of tubes, and also the characteristics of some of the more common types. Rules were also supplied for determining the characteristics of tubes. These data are intended for the dealer and service man who is interested in the technical side of the tube problem.

There is another test which is particularly useful in comparing the operation of tubes, when the complete characteristics are not necessary; such as in the case where a number of tubes are to be tested for a customer or where the tubes are received from the jobber. This method of testing involves the measurement of the *gas-content* in the tube, and also of the *leakage-current* between the elements.

A knowledge of the *gas-content* of a tube provides a good indication of the probable life and the permanency of its characteristics. While the actual characteristics of the tube depend upon the positions of the elements and their size, as mentioned last month, a common cause of short life is an excessive amount of air or other gas in the envelope of the tube.

### Operation of the Tester

Fig. 1 is the diagram of the test apparatus: this consists of a plate voltmeter, a filament voltmeter, a grid voltmeter, a plate-current meter and (last but not least) a microammeter. The plate, grid, and filament voltmeters and the plate milliammeter are used for the purpose of checking the currents supplied to the various elements, and a single voltmeter may be used for all three voltage tests. The voltages should be adjusted to the normal values as specified by the manufacturer. The tube is then operated for about

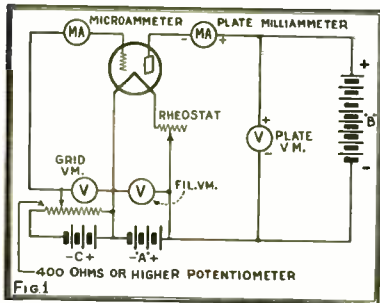

The schematic circuit of a tube tester which will indicate the quality and probable life of tubes of a given type.

five minutes with normal currents on the elements. The potentiometer across the grid battery will allow the current flowing in the plate circuit (indicated in the plate milliammeter) to be adjusted to normal. This value is more important than the plate voltage, in this case; but both should be adjusted as closely as possible. The potentiometer should have a value of 400 ohms or more, so that the current drawn from the "C" battery is not excessive.

After the tube has been operating for some time, the reading of the microammeter should be noted. Next the tube should be turned

off and allowed to cool. Then the reading of the microammeter should be taken with the plate battery connected, but the filament turned off. This reading is the *leakage-current* between the plate and grid.

Filament voltage should be applied again and the needle of the microammeter should be watched carefully. In its first swing, the inertia of the moving parts will carry it beyond a certain point; to which it will drop back momentarily, before it begins to climb again. The reading at this pause should be taken. The reading of the leakage current should be subtracted from this value and the resultant is the true "gas reading" of the tube under normal operating conditions. After a few tubes have been tested in this way, a chart of good values for a certain type of tube can be made.

### Problems of Tube Construction

Although modern methods of tube manufacture reduce the gas-content to a very small degree (later, when we describe the methods of making vacuum tubes, we will give more information about the actual degree of vacuum attained, and the values used to compare different gas pressures) it is not possible to remove all the gas. In a rarefied gas some of the electrons are parts of atoms and some are "free," or not connected with any atom. The free electrons move with such velocity that, if one hits an atom, another electron may be knocked off. This action of an electron on an atom is known as *ionization by collision*. These stray electrons are influenced by the plate voltage; since all electrons are charged negatively, and according to the law of like and unlike charges, are drawn toward a positive charge.

The electrons detached from the gas atoms thus move toward the plate with the other electrons which are sent out by the filament. The remainders of the gas atoms, from which the electrons have been removed, being positively charged thereby, move toward the filament. Thus, both parts of the atom cause an increase in the flow of current through the gas.

The difference between the actions of two tubes, one with a high vacuum and the other with some gas, is shown in the graph of Fig. 2. The increase in the flow of current in the gassy tube is indicated at Y. It may be considered that the ionization of the gas tends to neutralize the space-charge in the tube, and thus a larger current is permitted to pass.

Offhand, one might think that there would be an advantage gained from ionization, because the plate current is increased; but, unfortunately, under this condition the filament deteriorates very rapidly. The reason is that the positively-charged ions are attracted forcibly to the negatively-charged filament, and (since they are much heavier than electrons) their impact breaks down the filament surface. Also, if a high plate voltage is applied to the tube, a "blue-glow" discharge may result. In this condition, the tube is very erratic, and is less sensitive than normal; because the plate current is so high that it is not affected by variations of the grid potential. The in-

creased plate current heats the elements excessively, and results in a total breakdown of the tube structure within a short time.

Certain gases, such as caesium vapor, are purposely introduced into tubes designed for detection purposes, as in the case of the 200A; but here the gas is used for a somewhat different purpose and, since very low plate potentials are employed, the effects mentioned above are not encountered. The gas-filled special detector tube is more sensitive to slight changes in the grid voltage, with the correct plate voltage, and this makes it more efficient as a detector.

Before describing the various special-duty tubes, it might be well to dispel some of the common misunderstandings about the popular screen-grid tube.

### The Meaning of Tube "Amplification"

The screen-grid tube has attracted more interest from both manufacturers and amateurs, during the past few months, than any other development. Contrary to common belief, the screen-grid tube is not a new invention. In

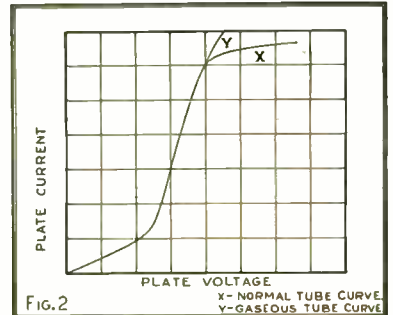

The presence of too much gas in a tube increases the plate current, as at Y, and will shorten the effective life.

a recent engineering bulletin the Fada Radio Corp. reveals the fact that the first screen-grid tube was developed in Germany over ten years ago. This type of tube is being used increasingly at present in both receivers and transmitters.

A very common misconception about this tube is in the amount of amplification that is obtained. Although the *amplification factor* of the tube is between 200 and 400, the actual amplification obtained is considerably lower. This is shown by applying several well known mathematical formulas; that for the *impedance* of a "parallel-tuned circuit" at resonance is

$$R = \frac{L^2 \times (6.283 \times F)^2}{r}$$

where L is the inductance in henries; F, the frequency in cycles; and r the "radio-frequency resistance" of the coil. Applying this equation to a common case, consider a coil of 240 microhenries, a coil resistance of 10 ohms and a frequency of 545 kilocycles. The formula then becomes

$$R = \frac{.00024^2 \times (6.283 \times 545,000)^2}{10}$$

or R=67,500 ohms, approximately.

The amplification obtained from the tube is equal to the *effective resistance* times the *mutual conductance*. (More will be said about this valuation later). The mutual conductance of one of the popular screen grid tubes is 560 micromhos; this is equivalent to .000560 mhos. The result of substituting these values in the above formula is an answer of 37.80; which is the approximate "gain" for the stage in which the tube is used.

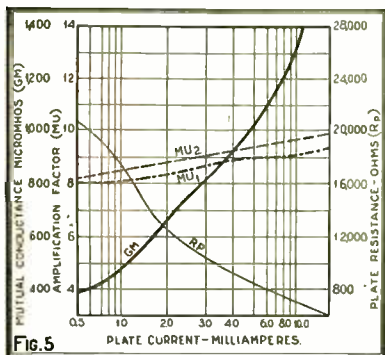

FIG. 5 The characteristics of a '27-type tube, calculated as described last month. The amplification factor Mu varies with the grid bias.

The "High-Mu" Tube

Last month we gave the characteristics of some of the older types of tubes, many of which are still in general use. This month we will continue with the listing of the later designs following a logical sequence in their purpose and popularity.

Another type of special-duty battery tube is the "high-mu" tube, known as the '40 and similar designations; this tube was developed especially for impedance- and resistance-coupled amplifiers. It is found that the tube is also a very good detector, especially when followed by a resistance- or impedance-coupled amplifier. The plate and grid coupling resistors for this tube are somewhat different from those of the 201A tube in a resistance-coupled amplifier. The plate resistor should have a value of 250,000 ohms, and the grid resistor one from 50,000 to 75,000 ohms.

When used as a detector, the grid return should be tried on both the positive and negative terminals; although the best results are usually obtained with the negative connection.

Filament voltage, 5; filament current, 0.25-ampere.

Plate voltage, 135 to 180; plate current, 0.2-ma. as an amplifier, 0.3- to 0.5-ma. as a detector.

Grid bias, 3 volts at 135 volts; 4½ at 180. Plate resistance, 150,000 ohms. Amplification factor, 30.

Screen-Grid Tubes

As will be explained, the screen-grid tube is designed to have an extremely small capacity between the input or "control" grid and the plate and, because of this characteristic, the elements may be so constructed and placed that an extremely high amplification-factor is obtained. The reduction in the grid-plate capacity is obtained as follows:

In an ordinary tube, such as the 201A, the electrons emitted by the filament are not all absorbed by the plate, even though the correct filament and plate potentials are used.

As a matter of fact, some electrons are held up in the space between the two electrodes. In the screen-grid tube, an extra grid is placed between the regular control-grid and the plate. This extra grid is then connected to a source of direct current at a sufficient potential to take up the electrons which would otherwise be suspended between the grid and plate.

Besides the effect of carrying away the cloud of electrons, the screen-grid has another purpose, which is explained in Fig. 7. The capacity between the grid and the plate of the ordinary three-electrode tube is shown at A in dotted lines as a condenser between the elements. In the screen-grid tube shown at (B), it will be seen that there are two capacities instead of one.

It is well known that the capacity of two condensers in series is less than the actual capacity of either one. Because of this effect, the actual capacity between the elements of the screen-grid tube is considerably reduced below that of the ordinary tube. The virtual capacities are shown at C and D to simplify the diagram. The effective capacity of the '01A tube is in the neighborhood of 9 mmf.; while that of the '22 is 0.1 mmf.

By proper spacing of the tube elements as mentioned before, a very high amplification factor (mu) is obtained. In actual practice, the amplification given by this tube is three to five times that obtained from the '01A type when used on the broadcast band. This variation is due to the plate impedance, which is somewhat limited at the higher frequencies.

When constructing a set to use this tube, several precautions must be followed. It is not necessary to use any neutralizing or stabilizing devices with a screen-grid tube; since the capacity which allowed the set to oscillate is reduced to a very low value. However, in order to prevent a feedback through some other source, such as interstage coupling between the coils and wiring, it is necessary to use extreme precaution in shielding each stage from the others. Because of the high plate resistance, a high impedance must be used in the plate circuit in order to maintain the high amplification. This necessitates the use of special coupling coils with very large primary windings or the employment of tuned-impedance coupling.

The Space-Charge Circuit

The screen-grid tube is also adaptable to audio-frequency amplification; although it was designed as a radio-frequency amplifier. When

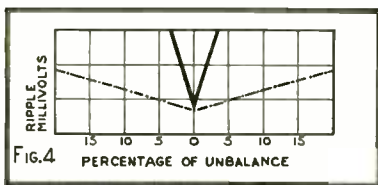

FIG. 4 The unbalanced current in which there is an A.C. component causes less hum in a '27 tube, as shown in the heavy line, compared with a '26, shown in the dotted.

used as an audio-frequency amplifier, the connections to the grid and screen-grid are reversed.

The connections for the screen-grid and space-charge tube circuits are shown in Fig. 8. In the circuit at the right the normal control grid (which is at the top of the tube) is connected to a source of positive potential to give the space-charge effect; while the screen-grid instead is used as the control-grid

and connected (usually) to an A.F. input. Since the grid-plate capacity of a tube is not very important at audio frequencies, the larger electrode may thus be used as the control grid; this produces a tube with a high amplification factor, which also has a fairly large current-carrying capacity. The smaller grid at the top of the tube (the ordinary control-grid) serves to stabilize the action of the tube; allowing the high amplification factor to be more fully utilized. Its effect is a slight reduction of the number of electrons which reach the plate; this action limits the plate current and, thereby the amplification. Its terminal (the cap at the top of the tube) is connected to a positive potential of about 22 to 45 volts. The use of a variable control of the voltage at this point will regulate the amplification obtained from the tube, and also allow the stability to be controlled; so that the greatest amplification can be obtained with stable action.

When the screen-grid tube is used as a space-charge amplifier, because of the high plate resistance, it is necessary to use a very high value of impedance in the primary coil. The use of resistance coupling between the screen-grid (space-charge) tube and the succeeding tube is advisable in order to fill the above requirements.

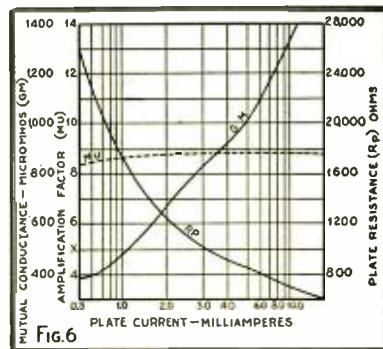

FIG. 6 The characteristics of an '01A tube, for comparison with the '27 graph opposite. It will be seen that there is a considerable similarity in these tubes, for general purposes.

The screen-grid tube has a filament designed for 3.3 volts and it draws 0.132 ampere. For this reason, a higher value of filament resistance is required than normal (with the '01A etc.). Usually a tapped resistor of about 15 ohms with a tap at 5 ohms is employed. This resistor is connected in the negative filament lead of the tube, permitting the grid return to be connected to the tap and, in this way, the voltage drop in the resistor is used as the grid bias.

Filament voltage, 3.3 volts; current 0.132-ampere.

Plate voltage, 135 as radio-frequency amplifier. Plate current 1.5 ma. with 1.5 volts grid bias, 1 ma. with 3 volts of grid bias.

Plate voltage 180 as space-charge audio amplifier. Current 0.3-milliamper with 1.5 volts grid bias.

Screen-grid voltage, 45 maximum.

Space-charge voltage, 22½ (on inner grid). Plate resistance, 850,000 to 1,100,000 depending on grid bias. 150,000 ohms as space-charge tube.

Amplification factor 300 (limited by circuit constants). As space-charge audio amplifier, 60.

(Continued on Page 232)

# Characteristic Data of Radio Vacuum Tubes

MANUFACTURER	Trade Name	Type Number	Radio-Craft Designation	Base	Filament Supply		Plate Supply		Plate Resistance OHMS	Amplification Factor MU	Mutual Conductance MICRORMHOS	Neg. Bias VOLTS
					VOLTS	AMPS.	VOLTS	MILLIAMPS.				
Radio Corporation of America.....	R.C.A.	UX240	'40	Large Std.X	5.0	0.25	135	0.3	150,000	30	200	1.5
E. T. Cunningham, Inc.....	Cunningham	CX 340	"	"	5.0	0.25	180 180	0.4* <sup>1</sup> 0.2	150,000 150,000* <sup>3</sup>	30 30	200 200	3.0 3.0* <sup>2</sup>
Sonatron Tube Co.....	Sonatron	X240	"	"	5.0	0.25	180 180	0.2 0.2	150,000 150,000	30 30	200 200	1.5 3.0
"	"	X30	"	"	5.0	0.25	90 155	1.0 1.7	40,000 35,000	32 32	800 315	8.0 4.5* <sup>2</sup>
"	"	X20	"	"	5.0	0.25	90 155	1.0 2.5	30,000 24,000	20 20	670 835	3.0 4.5
Cable Radio Tube Co.....	Speed	X140	"	"	5.0	0.25	155 180	0.3 0.2	150,000 150,000	30 30	200 200	3.0 4.5
Champion Tube Co.....	Champion	UX240	"	"	5.0	0.25	180 135	0.2 0.1	150,000 150,000	30 30	200 200	1.5 1.5
Sylvania Products Co.....	Sylvania	SX240	"	"	5.0	0.25	180 180	0.3 0.2	150,000 150,000	30 30	200 200	4.5 3.0
Gold Seal Electric Co., Inc.....	Gold Seal	GSV240	"	"	5.0	0.25	155 180	0.2 0.2	150,000 150,000	30 30	200 200	1.5 1.5
Arcturus Radio Co.....	Arcturus	32(A.C.)	"	"	15.0	0.35	135	1.5	32,000	30	940	3.0
Ken-Rad Corporation.....	Ken-Rad	240	"	"	5.0	0.25	180	0.65	75,000	30	400	3.0
French Battery Co.....	Ray-O-Vac	RX240	"	"	5.0	0.25	180	.....	.....	30	.....	3.0
Marvin Tube Co.....	Marvin	UX240	"	"	5.0	0.25	155 180	0.2 0.2	150,000 170,000	30 30	200 200	3.0 4.5
Ce Co Manufacturing Co.....	Ce Co	G	"	"	5.0	0.25	60	0.8	25,000	20	800	0.0
"	H	"	"	"	5.0	0.25	80	6.0	14,000	14.3	1030	0.0
"	K	"	"	"	5.0	0.25	80	4.8	11,000	12.5	1130	0.0
Triad Manufacturing Co.....	Triad	T40	"	"	5.0	0.25	115 180	0.2 0.2	150,000 150,000	30 30	200 200	3.0 4.5

<sup>1</sup> Through coupling resistor of 250,000 ohms. <sup>2</sup> Reduce dial 1.5 volts when using 1/2 meg. plate resistor. <sup>3</sup> With resistor (see <sup>2</sup>); without, 60,000 ohms.

Radio Corporation of America.....	R.C.A.	UX222	'22	"	3.5	.132	135 180* <sup>1</sup>	1.5 3.0	850,000 150,000* <sup>1</sup>	300 60	350 400	1.5 1.5* <sup>4</sup>
E. T. Cunningham, Inc.....	Cunningham	CX322	"	"	3.5	.132	90 135	1.5 1.5	500,000 850,000	175 290	340 350	1.5* <sup>2</sup> 1.5* <sup>2</sup>
Sonatron Tube Co.....	Sonatron	X222	"	"	3.5	0.132	135 135	1.5 1.5	1,100,000 850,000	300 300	280 350	3.0* <sup>2</sup> 1.5* <sup>1</sup>
Sylvania Products Co.....	Sylvania	SX222	"	"	3.5	0.132	135 180	1.5 1.5	170,000 850,400	60 300	400 350	1.5* <sup>1</sup> 1.5
French Battery Co.....	Ray-O-Vac	RX222	"	"	3.5	0.135	180	.....	.....	300	.....	1.5* <sup>2</sup>
Gold Seal Electric Co., Inc.....	Gold Seal	GSX222	"	"	3.5	0.132	135 180	1.5 0.3	850,000 150,000	300 400	350 666	1.5 1.5* <sup>2</sup>
Ce Co Manufacturing Co.....	Ce Co	RF22	"	"	3.5	0.132	135	.....	600,000	400	666	1.5* <sup>2</sup>

<sup>1</sup> Through 1/2 meg. coupling resistor. <sup>2</sup> Potential of 5 G<sub>1</sub> + 45 V<sub>2</sub> at 0.15 ma. <sup>3</sup> S. G<sub>1</sub> potential, 22V<sub>2</sub> V<sub>1</sub> at 0.6 ma. <sup>4</sup> As "space charge" tubes. Control grid (cap lead) 22.5 V<sub>1</sub> plus and screen grid 1.5 V<sub>1</sub> minus.

Radio Corporation of America.....	R.C.A.	UY227	'27	3 pr. Std.	2.5	1.75	45 90 135	3.2 5.5 9.0	8,500 10,000 9,000	8.0 9.0 9.0	1050 900 1000	0.0 4.5* <sup>1</sup> 9.0* <sup>2</sup>
E. T. Cunningham, Inc.....	Cunningham	C-327	"	"	2.5	1.75	45 90 135	3.2 5.5 9.0	8,500 10,000 9,000	9.0 9.0 9.0	1000 900 1000	13.5* <sup>1</sup> 6.0 9.0
Sonatron Tube Co.....	Sonatron	Y227	"	"	2.5	1.75	45 90 135	2.0 7.0 5.5	10,000 8,000 9,000	8.0 8.0 9.0	800 1000 1000	9.0 13.5
Pilot Radio and Tube Corporation.....	Pilatron	C-227* <sup>4</sup>	"	"	2.5	1.75	90 155	7.0 5.5	8,000 9,000	8.0 9.0	1000 1000	4.5 9.0
Cable Radio Tube Co.....	Speed	227	"	"	2.5	1.75	90 180	5.0 6.0	10,000 9,000	9.0 9.0	1000 1000	13.5 6.0
Champion Tube Co.....	Champion	UY227	"	"	2.5	1.75	45 90	.....	.....	9.0 9.0	1100 9.0	13.5 0.5
Sylvania Products Co.....	Sylvania	SY227	"	"	2.5	1.75	90 90	.....	.....	9.0 8.2	1050 9.0	4.5 6.0
Gold Seal Electric Co., Inc.....	Gold Seal	GSY227	"	"	2.5	1.75	180 90	7.5 .....	10,000 10,000	8.2 8.0	900 800	13.5 6.0
Arcturus Radio Co.....	Arcturus	127* <sup>3</sup>	"	"	2.5	1.75	90	7.5	8,000	8.0	1000	13.5
Ken-Rad Corporation.....	Ken-Rad	227	"	"	2.5	1.75	180	3.6	9,000	9.0	1000	9.0
French Battery Co.....	Ray-O-Vac	RY227	"	"	2.5	1.75	180	.....	8,800	8.8	1000	.....
Eveready Carbon Co.....	Eveready Raytheon	RayX227(1)	"	"	2.5	1.75	90 155 180	3.0 5.0 6.0	10,000 9,000 9,000	9.0 9.0 9.0	900 1000 1000	6.0 9.0 13.5
Ce Co Manufacturing Co.....	Ce Co	N27	"	"	2.5	1.75	90	3.0	11,300	8.2	725	6.0
De Forest Tube Co.....	De Forest	427	"	"	2.5	1.75	180 135	5.0 5.0	11,300 10,000	8.2 8.2	725 820	6.0 9.0
							180	6.0	9,400	8.2	870	13.5

<sup>1</sup> (Undistorted output in milliwatts) 30. <sup>2</sup> 7b. <sup>3</sup> 16c. <sup>4</sup> designed with special regard for use in short wave circuits. <sup>5</sup> Also efficient in short wave work.

Radio Corporation of America.....	R.C.A.	UX226	'27	4 prong large Std.	1.5	1.05	90 155 180	3.7 6.0 7.5	9,400 7,400 7,000	8.2 8.2 8.2	875 1100 1170	6.0* <sup>1</sup> 9.0 13.5
E. T. Cunningham, Inc.....	Cunningham	CX326	"	"	1.5	1.05	90 135 180	3.5 6.0 7.5	9,400 7,400 7,000	8.2 8.2 8.2	875 1100 1170	6.0* <sup>1</sup> 9.0 9.0
Sonatron Tube Co.....	Sonatron	X226	"	"	1.5	1.05	90 135 180	3.5 6.0 7.5	9,400 7,400 7,000	8.2 8.2 8.2	875 1100 1170	6.0* <sup>1</sup> 9.0 13.5
"	"	X401	"	"	3.0	1.0	45 100 135	4.0 5.0 5.0	7,400 8,000	8.2 10	1170 1250	6.0* <sup>1</sup> 3 9
Cable Radio Tube Co.....	Speed	X225A 226	"	"	Same characteristics as "X401," except heater prongs are on side-of base.		90 155	3.5 6.0	7,400 7,400	8.2 8.2	875 1170	6.0 6.0
Champion Tube Co.....	Champion	UX226	"	"	1.5	1.05	90 135 180	7.5 6.0 7.5	7,400 7,400 7,000	8.2 8.2 8.2	1170 1100 1170	13.5 6.0 9.0
Sylvania Products Co.....	Sylvania	SX226	"	"	1.5	1.05	90 135	3.5 6.0	7,400 7,400	8.2 8.2	1100 1170	13.5 4.5
Gold Seal Electric Co., Inc.....	Gold Seal	GSX226	"	"	1.5	1.05	180 135 180	7.5 6.0 7.5	7,400 7,400 7,000	8.2 8.2 8.2	1100 1170 1170	15.0* <sup>1</sup> 6.0 9.0
Arcturus Radio Co.....	Arcturus	28	"	"	15.0	0.35	90	7.5	9,000	10.5	1165	1.5
"	"	48	"	"	15.0	0.55	90	4.5	9,200	10.9	1185	4.5
"	"	126	"	"	1.5	1.05	135	6.2	7,800	8.2	1050	9.0
Ken-Rad Corporation.....	Ken-Rad	226	"	"	1.5	1.05	180	5.2	7,800	8.2	1050	9.0
French Battery Co.....	Ray-O-Vac	RX226	"	"	1.5	1.05	180	.....	.....	8.5	.....	.....
Eveready Carbon Co.....	Eveready Raytheon	RayX226	"	"	1.5	1.05	90 135 180	3.5 6.0 7.5	9,400 7,400 7,400	8.2 8.2 8.2	875 1100 1170	6.0 9.0 13.5
Ce Co Manufacturing Co.....	Ce Co	M26	"	"	1.5	1.05	90	3.7	9,400	8.2	875	6.0
De Forest Tube Co.....	De Forest	426	"	"	1.5	1.05	135 180	3.0 3.8	9,400 9,400	8.2 8.2	870 870	6.0 12.0 16.5

\* Measured from mid-point of filament.

Radio Corporation of America.....	R.C.A.	UY224	'24	9 pr. Std.	2.5	1.75	180 180	4.0 4.0	400,000 400,000	420 420	1050 1050	1.5* <sup>1</sup> 1.5* <sup>1</sup>
E. T. Cunningham, Inc.....	Cunningham	C324	"	"	2.5	1.75	180 180	4.0 4.0	400,000 400,000	420 420	1050 1050	1.5* <sup>1</sup> 1.5* <sup>1</sup>
Sonatron Tube Co.....	Sonatron	222AC	"	"	2.5	1.75	180 180	4.0 4.0	400,000 400,000	420 420	1050 1050	1.5* <sup>1</sup> 1.5* <sup>1</sup>
Cable Radio Tube Co.....	Speed	224AC	"	"	2.5	1.75	180 180	4.0 4.0	400,000 400,000	420 420	1050 1050	1.5* <sup>1</sup> 1.5* <sup>1</sup>
Champion Tube Co.....	Champion	UY224	"	"	2.5	1.75	135 180	5.0 4.0	200,000 400,000	150 150	650 1000	1.5 1.5
Sylvania Products Co.....	Sylvania	SY222AC	"	"	2.5	1.75	180 180	4.0 4.0	400,000 400,000	420 420	1050 1050	1.5* <sup>1</sup> 1.5* <sup>1</sup>
Gold Seal Electric Co., Inc.....	Gold Seal	GSY224	"	"	2.5	1.75	180 180	4.0 4.0	400,000 400,000	420 420	1050 1050	1.5* <sup>1</sup> 1.5* <sup>1</sup>
Arcturus Radio Co.....	Arcturus	22	"	"	15.0	0.35	135 180	1.0 3.8	700,000 400,000	120 420	1000 1050	1.5* <sup>1</sup> 1.5* <sup>1</sup>
Ken-Rad Corporation.....	Ken-Rad	124	"	"	2.5	1.75	180	3.0	400,000	420	1050	1.5* <sup>1</sup>
French Battery Co.....	Ray-O-Vac	RY224	"	"	2.5	1.75	180	4.0	400,000	420	1050	1.5* <sup>1</sup>
Eveready Carbon Co.....	Eveready Raytheon	RayAC22	"	"	2.5	1.75	180	4.0	400,000	420	1050	1.5* <sup>1</sup>
Ce Co Manufacturing Co.....	Ce Co	AC22	"	"	2.5	1.75	180	4.0	400,000	420	1050	1.5* <sup>1</sup>
De Forest Tube Co.....	De Forest	424	"	"	2.5	1.75	180	4.0	400,000	420	1050	3.0

<sup>1</sup> Screen-grid potential 75 volts positive. <sup>2</sup> Screen potential, 50 volts positive.

# RADIO CRAFT KINKS

## RADIOCRAFTSMEN:

**H**OW good are you at remembering the thousand and one little things that occur during a day, a week, or a month of experimenting, designing, constructing, wiring and testing of radio sets and parts for yourself or your friends?

Everyone has an equal chance to be awarded one of the two copies of "The Radio Amateur's Handbook" (A Manual of Amateur Short-Wave Radiotelegraphic Communication; contains 200 pages chock-full of the things you want most to know; right up-to-date and absolutely the best book of its kind obtainable), which are to go to the two readers of Radio-Craft who send in the greatest number of contributions to this department in one month.

All accepted material, will, in addition, be paid for at space rates.

The correct address is:

Radio-Craft Kinks Department,  
c/o Radio-Craft Magazine,  
98 Park Place,  
New York City.

## AN EFFECTIVE INTERFERENCE ELIMINATOR

By Ernest V. Amy\*

**M**OST service men are familiar with the use of a choke coil for the suppression of artificial "static" radiations. However, it is generally believed that a successful unit must be purchased. The construction and application of the unit pictured in these columns will explode that fallacy.



At left is pictured an effective "static" radiation reducer, for use on sparking devices, wired as described by the author. It is quickly and inexpensively constructed and easily applied; and will give relief from the "man-made static" generated by so many installations. The closer it is to the sparking device, the better.

In practically every instance of interference from motors it is usual to apply a palliative at the point where the motor line connects to the power line. This materially reduces interference conduction into the light lines; but, it does not prevent interference radiation from the current lead between socket and motor.

The design of this device is based on the fact that all motors of any real size have "fused switches" close to them.

To install this air-core choke (Fig. 1A), a fuse is removed from this switch box, the choke inserted, and the fuse screwed into the choke. The opposite side of the line is tried; one in each side may be necessary—in extreme cases.

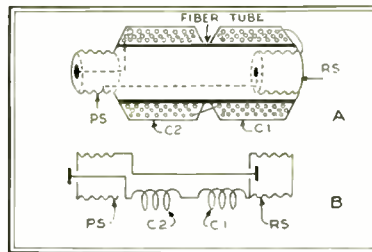
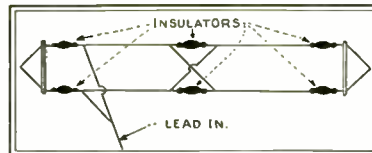

Fig. 1. "Skeleton" and schematic circuit of the radio-frequency choke coil illustrated at the left.

Fig. 1B illustrates the series circuit so formed. This is schematically indicated in Fig. 2A (the fuse box without the choke); and in Fig. 2, below (the unit in use).

A brass shell is arranged in one end of a fiber tube, as shown in Fig. 1A. This is the receptacle shell, R.S. for the fuse. In the opposite end is fastened the plug-in shell P.S. On the tube are two windings; each of which consists of 140 turns of No. 18 D.C.C. wire, plain layer-wound. They are spaced as shown to reduce self-capacity which would act as a high-frequency by-pass and nullify the reactive effect of the choke.



"Phasing" an antenna to reduce the effects of interference pick-up.

## ELIMINATING HUM FROM NEARBY LIGHT LINES

By J. H. Mills

When your antenna must be placed parallel and close to high tension lines, a great deal of hum is picked up by it.

To eliminate the biggest proportion of this hum, put up a two-wire antenna, as shown in the drawing above.

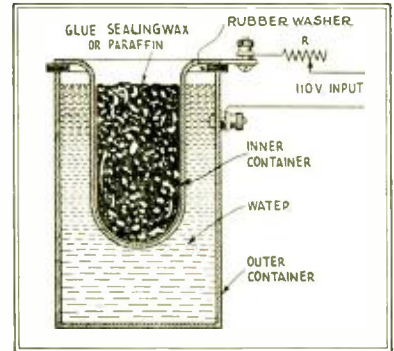

An easily-constructed glue pot, recommended as an emergency construction design. It may be used regularly for light work.

The wires cross in the center of the span and they must not come in contact with each other.

## A HOME-MADE ELECTRIC GLUE POT

By C. M. Parks

**S**OME time ago a glue pot was needed in a hurry. There was none around, so a serviceable one was made as illustrated.

Resistor R may be any unit having the required value, which must be determined by experiment. If the water is too conductive, too much current may flow for the resistor to carry safely, and it will burn out. It is therefore suggested that a lamp bank be used.

The water serves a dual purpose, as the resistor required to develop the requisite heat, and to isolate from direct contact with a localized heat (known as the "water-bath" method) which is a requirement for properly heating glue, sealing wax, paraffin and similar plastics.

The rubber washer is required to insulate the inner metal container from the outer metal can.

The outer container is an ordinary metal can of convenient dimensions; the inner one is of proportionate size and the top is slit to form two ears which are bent over to rest on the rubber washer.

Of course, the line supply may be either direct or alternating current.

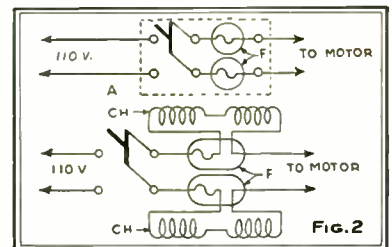

Above is diagrammed the method of applying the radio-frequency choke coil described by Mr. Amy.

\* Consulting Engineer, Amy, Aceves and King, Inc.

# INFORMATION BUREAU

## SPECIAL NOTICE

When writing to the Information Bureau, correspondents are requested to observe the following rules:

- (1) Ask as many questions as desired, but furnish sufficient information to permit a proper diagnosis. Carefully drawn schematic diagrams are often desirable.
- (2) Inquiries (not too involved) to be answered by mail must be accompanied by 25c in stamps, per single question. Blueprints are not available.
- (3) Use only one side of paper and LIST each question.
- (4) We cannot furnish comparisons between commercial instruments.

*(The reader with the greatest number of interesting questions each month, although they may not all appear in the same issue, will find his name heading this department.)*

## Highest for the Month: HARRY EICHLER with 8 Interesting Questions

### NOISY RECEPTION—PHONOGRAPH PICKUP—FILTER

(27) Mr. Harry Abish, Brooklyn, N. Y.  
 (Q.) Is there such a thing as a microphonic socket? An explanation of a peculiar situation may be in order. Only one socket in the receiver seems to be causing trouble; the effect produced is a very loud howl. However, this cannot be caused by a microphonic tube, since changing tubes around does not make any difference; it is still possible to produce this howl by lightly tapping a particular socket. "Howl arresters" have been tried without success. Please suggest a remedy.

(A.) Despite the change of tubes mentioned, the fact remains that the trouble mentioned is due to a microphonic tube, in all probability; it is probable that all the tubes tried had loose "elements." The socket mentioned is the detector socket; the one most "sensitive" to this effect, for the reason that maximum audio amplification is measured from detector to output.

There is also the possibility that the tubes make poor contact in the detector socket. The remedy may lie in changing the socket; or the wiring may have been insecurely soldered to the socket.

(Q.) Is it practical to make a phonograph pickup by soldering a phonograph needle to a telephone receiver diaphragm; connecting the receiver to the radio set; and arranging the needle to rest on the record?

(A.) We admire your ingenuity, but it would be almost a waste of time. The reason is that such a combination is very resonant; that is, it is more responsive to some notes than to others. The result would be amusing but not musical; for certain notes would be heard loudly and others not at all. (That is, providing it were possible to solder to the diaphragm without warping it.) For experiment, it would be best to use an adjustable type of reproducer, to compensate for the bending of the diaphragm due to the weight and pressure of the reproducer on the record. For highest volume, the reproducer-winding leads should be connected to the grid and minus filament terminals of the detector tube.

(Q.) What is a "brute-force" filter?  
 (A.) This type of filter is illustrated in the accompanying diagram. Only a single choke and two filter condensers are used; upon them depends the success of the filtering. By making sufficiently large the inductance of L and the capacities of C1 and C2, it is possible to achieve almost any degree of filtering. The "brute-force" filter is so called to distinguish it from the band filter, which is more sharply resonant to the frequency to be suppressed.

### SHIELDING—DETUNING—STATIC

(28) Mr. Harry Eichler, New York City.  
 (Q.) What is the recommended distance between tuning inductances and shields, for short-wave operation?

(A.) This depends considerably upon the operating wavelength. For very short waves, it has been suggested that special wire screening be used to overcome certain losses which result when even the best of shields are used at very short wavelengths. In general, copper shielding may be placed no

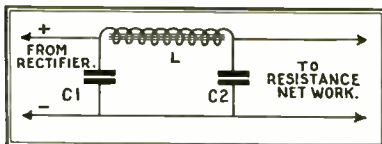

(Q. 27) Schematic circuit of the "brute-force" filter referred to in the query.

closer than one to one and one-half inches from the sides of coils, and not closer than two to three inches from the ends. However, such figures are a matter for discussion, as many factors enter into the situation. For example, certain coil shapes produce magnetic and electrostatic "fields" with different arrangements of the lines of "flux"; and each type of coil, therefore, is best used with shields of a certain pattern.

(Q.) Why does removing a stage-shield cover result sometimes in increased volume; while at other times the same operation may result in a reduction of volume?

(A.) This is readily understood when we consider that pieces of metal in the "field" of a coil change its inductance. Going one step further, we find that where there are several tuned stages and a shield cover is removed, the removal may either cause that stage to come into tune with the others or, perhaps, throw the "gang" out of tune. The first condition would cause an increase of volume and the latter would cause a reduction.

(Q.) It seems that static is greatly reduced on the short-wave station settings, signals often being more clear on 40 meters than on 200. Is this an "acoustic illusion," or an actuality? And if so, why?

(A.) The effect is quite as described; that is one reason why the tropical countries are so greatly interested in short-wave installations. Often, contacts may be made on short wavelengths which would not be possible on longer waves, because of the excessive static. The reason is still obscure. It seems plausible to suggest that lightning flashes are more sharply "resonant," or "tuned," than has been believed.

### INCREASING "B" VOLTAGE—LOOP—ATWATER KENT MODEL 12

(29) Mr. W. C. Miller, Elgin, Ill.

(Q.) What is necessary to rebuild a Timmons "B" eliminator to deliver 180 volts instead of 90?

(A.) The solution of that problem is to buy another eliminator. A shiftless and inadvisable scheme sometimes employed to increase voltage (and the writer admits having tried it) is to change the rectifier for one of higher output rating. However, this puts an added strain on the transformer, granting that the condenser pack has been changed for one having a higher break-down rating; and a burn-out transformer may result. These are only a few of many reasons why "B" eliminators should be operated only as designed.

(Q.) Is the enclosed symbol the correct one to indicate a von Ardenne shielded loop?

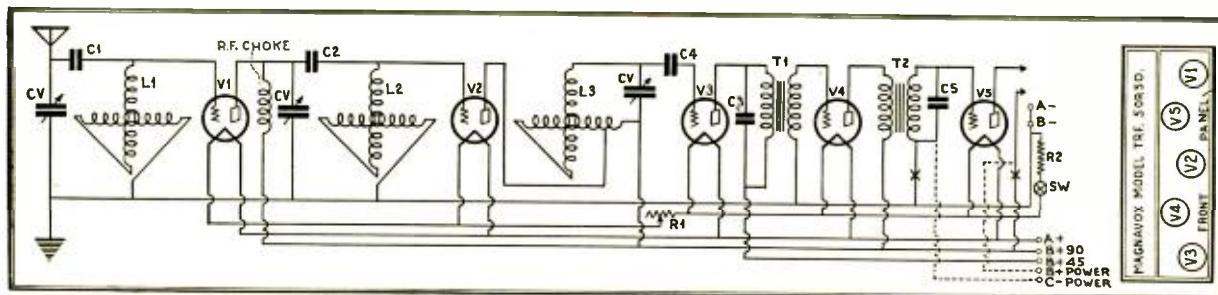

(Q. 30) Circuit arrangement of the Magnavox Types TRF-5 and TRF-50 receivers; Note that this single-dial set is tuned by variable inductances (variometers) instead of the more usual variable condensers. Servicing one of these receivers requires treatment different from that which would obtain when the more usual type of receiver is being serviced.



*This handsome blue and gold pin furnished free as part of your membership which is included with your subscription to Radio Design at 50c for four issues.*

# **E**XTRAORDINARY **A**NNOUNCEMENT..

## Radio Design Magazine Designated Official Organ of Radio Inter- national Guild....

The same 50c per year which formerly covered a subscription to Radio Design Magazine *now includes* one year's membership in the Radio International Guild.

The Guild is a world-wide organization of radio engineers, custom set-builders, research workers and experimenters.

The Guild's objects include the encouragement of independent amateur experimentation, research and interchange of new ideas, cooperation among Guild members, promotion of international amity via radio and allied arts, maintenance of a technical advisory board and reference library to assist in the solution of

technical and construction problems. Suitable awards will be established for outstanding original work by Guild members.

*Now*, more than ever you will want Radio Design, jammed from cover to cover with vital new developments in radio, short-wave, airadio, television—all written concisely and authoritatively by recognized radio experts—profusely illustrated with photos, drawings and diagrams.

Send 50c and your subscription will start with the current issue of Radio Design, including one year's membership in the Radio International Guild with the Guild Pin, Certificate and Membership Card.



NAME  
ADDRESS  
CITY

RADIO DESIGN, Dept. X  
103 Broadway, Brooklyn, New York

Enclosed please find 50c covering one year's subscription to Radio Design including one year's membership in Radio International Guild.

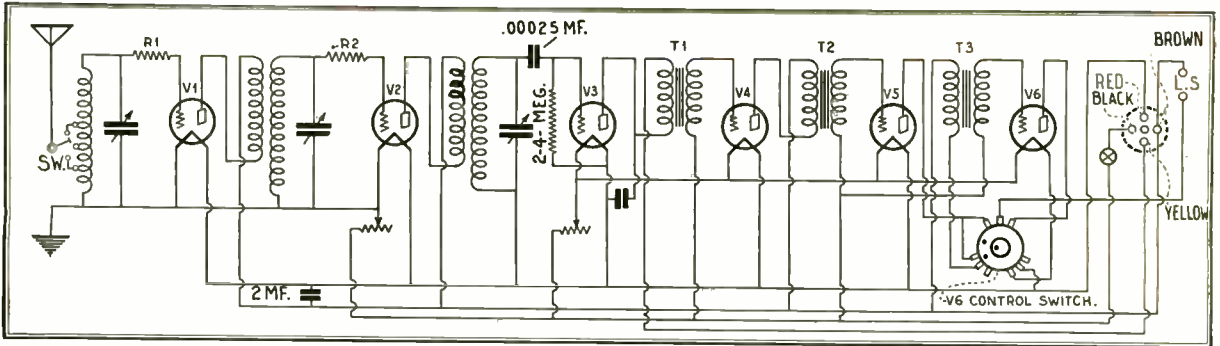

(Q. 29) Schematic arrangement of the Atwater Kent Model 12 receiver; this set is popularly referred to as the "breadboard" type of construction. The Model 12 set was one of the very first ones to incorporate "grid suppressors" to prevent circuit oscillation. The most usual complaint by owners of this receiver is that the tubes will not light. A check-up would indicate that one of the rheostats had burned out; because someone in the family had connected one side of the storage battery to ground. This put the full storage-battery current across the rheostat controlling the first two R.F. tubes.

(A.) The correct figure appears in these columns. (Q.) If possible, I would like to see in the columns of RADIO-CRAFT, a schematic circuit of the Model 12 "breadboard" receiver made several years ago, each part of which was exposed on the base-board. This is an Atwater Kent model.

(A.) This circuit is shown in these columns. Circuit oscillation was controlled by the grid-suppressor method, which is not purely a "losser" one. The filament temperature of the two radio-frequency stages was controlled by a rheostat.

**AUDIO OSCILLATION—MAGNAVOX TYPE TRF-5**

(30) Mr. Carl B. Dedrick, Kansas City, Mo.

(Q.) A Victrol "super," wired exactly as specified by the manufacturers and using specified parts, with the exception of the audio transformers, has decided to develop a loud howl. When two stages of audio are used the set starts to howl, not at a high pitch, but with a low, deep whistle like a steamboat in the distance, growing louder until it turns to a deafening roar. This action does not occur when only a single audio stage is used.

I am using a 6-volt "A" battery, Majestic "B" eliminator, and "C" batteries, and have tried different audio transformers having the same and different ratios (they work well in other sets). A resistance in shunt with the secondary of the first audio transformer reduces the howl, but also reduces the signal volume. An R.F. choke and a by-pass condenser in the second-detector plate circuit do not change the operation. Inserting an audio choke coil in the "B" lead to the detector and by-passing it to "A—" does not stop howl.

Changing the resonant period of the transformers by shunting the secondaries with fixed condensers has been tried. I have grounded the transformer shells, changed sockets, tried different tubes, and even removed the entire audio unit to a distance, connecting the circuit with lengthened leads. The "A" and "B" potentials test O.K. with set in operation.

(A.) Although the "B" potential may seem to be correct by meter test, we believe that the trouble lies in the output of the particular Majestic "B" eliminator you are using. One designed to deliver a heavier current should enable you to operate the "super" without trouble.

The entire trouble is due to audio regeneration; there is a feed-back coupling in some part of the

set which is "common" to both the grid and plate circuits.

The "C" battery may have sufficient "internal resistance" to cause this; a 2- to 4-mf. condenser around this battery is recommended here.

However, we believe that it is the "internal resistance" of the "B" unit that is causing the trouble. Although the meters indicate a steady current supply to the tubes, there is a rapid fluctuation of the potential at an audio-frequency rate, too rapidly for the meter to indicate it. Very large by-pass condensers across the several voltage-output posts of the eliminator will stop the howl; but it will probably be impractical to use the high capacities called for. Changing the eliminator for one having a heavier current-output capacity (lower internal resistance) is the better plan.

Changing the reproducer is sometimes a convenient remedy.

(Q.) Is the Magnavox model TRF-5 tuned by variable condensers; and if so, where are they located?

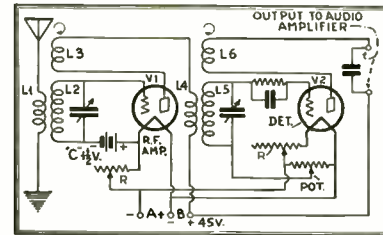

(Q. 31) "Double regeneration," obtained by incorporating tickler coils in plate circuits of both the detector tube and the stage of radio-frequency amplification preceding the detector.

ated? Please state what the tube "sequence" is. Can this set be modernized?

(A.) The schematic circuit of the Magnavox type TRF-5 (and TRF-50) receiver, which appears in these columns, indicates that variometers and not variable condensers are used to tune in stations.

By extremely careful design it has been possible to obtain substantially maximum resonance at all points in the tuning range, with one-dial control. This was the most difficult part of the receiver design.

The values indicated are: C1 (antenna coupling condenser), .001-mf.; C2, .001-mf.; C3 (by-pass condenser), .001-mf.; C4 (grid condenser), .00025-mf.; C5 (audio by-pass), .0005-mf.; CV, (circuit-balancing units, called "ratio" condensers), 10 to 150 mmf.; R1, (volume control), 10 ohms; R2 (filament resistor), 0.8 ohms; the variometers, all on one shaft are V1, V2 and V3.

The tube sequence is shown in the same illustration. The "ratio" condensers are controlled by the white knobs inside the receiver. It is necessary to use a "soft" detector, as there is no grid leak in the circuit; the detector is therefore dependent upon the leakage within the tube.

The word "modernizing" covers a big territory. A very desirable improvement (which we show) is the use of a power tube in the last audio socket, V5. If a '12A is selected, use a nine-volt "C" battery (positive terminal to "A—" and negative terminal to "C—" power) and use 135 volts at the power "B" terminal; for a '71A use 30 to 40 volts "C" and 180 volts "B." In the figure SW is the battery switch.

To connect these added batteries into circuit, the grid and plate circuits of tube V5 are broken at

X, and connections made as shown by the dotted lines.

**DOUBLE REGENERATION—GRID RETURN—SHIELDING**

(31) Mr. Edison Barker Leeds, Atlantic City, N. J. (Q.) Does shielding a set help to reduce the pick-up of "background" reception?

(A.) If a sensitive radio set is located in a district in which one or more stations are operating, shielding is usually necessary to prevent the coils of the set from picking up energy from one of these powerful locals, when tuned to a different station. This pick-up gives the effect of the local "riding in" on the signals of the desired station.

(Q.) Would the sensitivity of a tuned-radio-frequency receiver be increased by adding regeneration to the radio-frequency stage, as per marked diagram?

(A.) This circuit, which we reproduce in these columns, is quite practical, if the operator does not object to the difficulty of tuning. This circuit is only for those who have infinite patience, and due appreciation of what happens in a neighbor's radio set when circuits such as this are adjusted.

As to the sensitivity; it is no greater than that of the standard circuit would be if the number of turns in L4 were increased to the point of oscillation, and some oscillation control incorporated in the set. As the rotors L3 and L6 unbalance the tuning of circuits L2 and L5, a critical condition obtains; varying L3 or L6 disturbs the stability of the system again, and everything will be out of adjustment.

(Q.) Is there any advantage in having a potentiometer shunting the "A" supply, with the detector grid-return connected to the moving arm?

(A.) If there is a filament resistor in the "A—" lead, it will be possible to obtain a variation in the grid's polarity and potential, thus determining the best operating voltages. Without the filament-lead resistor, the voltage variation will be only positive in polarity.

**REGENERATION—A.C. SCREEN GRID BOOSTER COUPLING**

(32) Mr. Leonard Childs, Speed, Mo.

(Q.) What are the general causes for an increase of feed-back in a regenerative set, after it has been in use some time?

(A.) If batteries are used, the batteries have probably depreciated too much and should be replaced.

(Continued on Page 237)

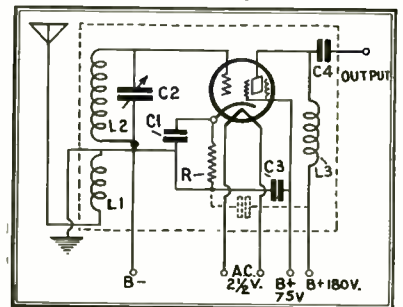

(Q. 32) An A.C. screen-grid booster unit designed to connect to the aerial and ground posts of the average receiver, to increase its sensitivity.

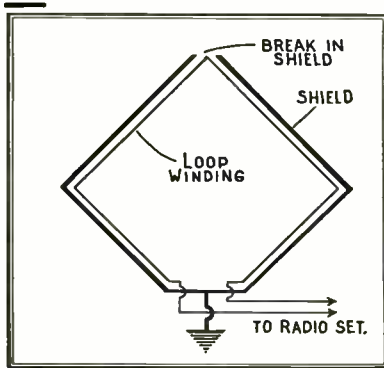

(Q. 29) The symbol for a shielded loop antenna.



# Science Wonder Stories

25c  
The Copy

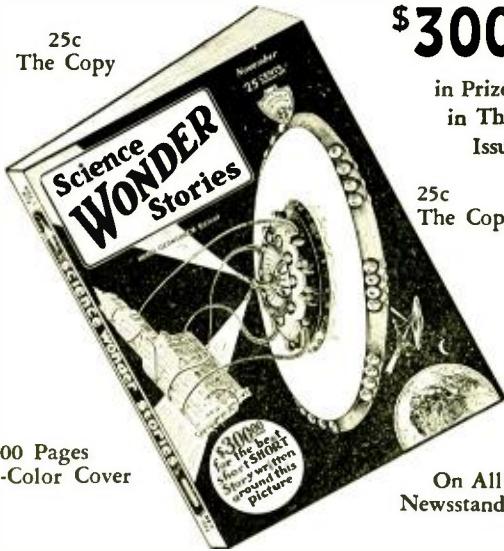

100 Pages  
4-Color Cover

**\$300**

in Prizes  
in This  
Issue

25c  
The Copy

On All  
Newsstands

*the wonders of modern science  
in fiction —*

**DRAMATIZED  
MECHANICS!**

Once you have read your first science fiction story magazine, you will never let a month pass without making every effort to read the next issue.

Hours of pleasant pastime are well spent in reading stories that you like—stories that are educational and entertaining—written by men with great imaginations and a vision of future flying.

In SCIENCE WONDER STORIES you will find creative ideas that touch beyond the world of human civilization, stories of interplanetary trips, discourses on transmutation of the elements, and the operation of machine men by perfect mechanism.

# Air Wonder Stories



100 Pages  
4-Color  
Cover

25c  
The Copy

On All  
Newsstands

*flying stories of the future —  
aviation a thousand years  
hence —*

In AIR WONDER STORIES you will read stories that reach beyond present day aviation methods—future warfare—gravity nullifiers — atomic rays — fourth dimension and gripping revelations of what to expect of aviation a thousand years hence.

Begin with the November issue of AIR WONDER STORIES or SCIENCE WONDER STORIES and you will find a new delight in future reading.

### Regular Subscription Rates

\$2.50 in U. S.      \$3.00 in Canada and Foreign

## SPECIAL PRICE

8 ISSUES OF  
EITHER FOR **\$1.00**

STELLAR PUBLISHING CORPORATION Dept. RC-11  
98 Park Place, New York.

Enclosed find \$....., for which enter my subscription to

Air Wonder Stories     Science Wonder Stories

Name .....

Address .....

City and State .....

# an Analysis of

SEPTEMBER 1929



# Radio-Craft

## READERS

A MAGAZINE

for the Professional—  
Service Man—  
Radiotician—

Submitted by  
**RADIO-CRAFT**

96-98 PARK PLACE NEW YORK, N. Y.

Reproduced below is the questionnaire sent out to 5,000 readers of RADIO-CRAFT

QUESTIONNAIRE

No. 1036

Name \_\_\_\_\_

Address \_\_\_\_\_

City \_\_\_\_\_

State \_\_\_\_\_

Profession \_\_\_\_\_

Age \_\_\_\_\_

How long have you been interested in radio? \_\_\_\_\_

How much money do you spend on radio materials annually? \_\_\_\_\_

What other radio publications do you read now? \_\_\_\_\_

Is there any waste in RADIO-CRAFT circulation? \_\_\_\_\_

1,063 Readers or 21% answered this QUESTIONNAIRE

86.5% of Our Readers Are Engaged in Radio in a Professional Manner

**ALL** figures presented in this report have been checked by the firm of Homes and Davis, certified public accountants, and the statement of their findings is attached herewith.

All the original letters, as well as the envelopes in which they were mailed to us, are conserved in our offices and may be inspected by anybody who so desires.

In view of the fact that the questionnaire was mailed out in the midst of the summer heat, it is remarkable that July 21 per cent. of readers should have made the effort of sending in answers—and quite a number of replies are still coming in from day to day.

**THE QUESTIONS ASKED, AND THE TABULATION RESULTS FROM THE ANSWERS, WERE:**

**"My interest in radio is as follows":**

The returns are tabulated by number of registrations within each of the classifications designated, and by percentage of the whole group which the respective classifications thus constitute:

Classification	Number	Per Cent.
Service men	440	42.3
Radio engineers	49	4.6
Radioticians	115	10.9
Professional set-builders	87	8.2
Mechanics	53	5.0
Radio consultants	9	0.8
Radio designers	6	0.6
Radio contractors	2	0.2
Radio dealers	120	11.0
Radio manufacturers	2	0.2
Radio hobbyists	3	0.3
Radio experimenters	95	9.0
Non-professional set-builders	49	4.6
Radio factory employees	3	0.3
<b>Total</b>	<b>1,063</b>	<b>100.00</b>

Taking the average circulation of RADIO-CRAFT conservatively as only 65,000 readers, these percentages applied to actual readers would give the following figures for occupational distribution of our reader public:

Service men	28,145
Radioticians	2,390
Professional set-builders	7,985
Mechanics	8,330
Radio consultants	585
Radio designers	390
Radio contractors	130
Radio dealers	7,150
Radio manufacturers	130
Radio hobbyists	195
Radio experimenters	5,785
Non-professional set-builders	2,990
Radio factory employees	195
<b>Total</b>	<b>65,000</b>

**NOTE:**—Hundreds of answers have checks in more than one square. A majority of readers who checked the "Service Man" classification also checked the "Radio Dealer" square.

**"If none of the above classifications describes you, please state here your profession"**

Among the answers received, we reproduce here the most frequently recurrent:

Patent attorney; chemist; instrument maker; instructor in physics; toolmaker; science teacher; physician; civil engineer; inspector; patternmaker; instructor; garage owner; factory superintendent; teacher; draftsman; mechanical engineer; talking-machine installer; radio-necessary dealer; consulting engineer; special repair work to dealers and jobbers; electrician; medical chemist; chemical engineer; electrical engineer; radio salesman, etc.

**"How long have you been interested in radio?"**

Only 1,063 readers have answered this question. The total is 6,531 years, or an average of 6 1/2 years per reader. Many of our readers report fifteen and twenty years of "radio activity."

**"Approximately how much money do you spend on radio materials annually?"**

Only 767 readers have given us data on this subject. The total reaches the staggering sum of \$443,742, or an average of \$578.54 of yearly expenditure per reader. One reader (a radio jobber) reports a business of \$100,000 per year; another, a dealer, \$40,000; and still two others, \$20,000 each.

These sums are not included in the computation of the average given above, as we want the latter to represent only the sums spent by our average reader on radio material, testing apparatus, tubes, sets, etc.

**"What other radio publications do you read now?"**

177 readers, or 16%, report that they read no other magazine except RADIO-CRAFT. 631 readers, or 59%, report that they read RADIO NEWS besides our magazine. 236 readers, or 23%, report that they read RADIO WORLD besides our magazine. 252 readers, or 23%, report that they read RADIO besides our magazine. 150 readers, or 14%, report that they read Q. S. T. besides our magazine. 148 readers, or 13%, report that they read RADIO ENGINEERING besides our magazine. 90 readers, or 8%, report that they read CITIZENS RADIO CALL BOOK besides our magazine. 52 readers, or 4%, report that they read RADIO RETAILING besides our magazine.

**There is no waste in RADIO-CRAFT circulation.**

At our low rate (\$234. per page) you can reach the cream of the entire radio industry, plus 16% additional who do not read any other radio magazine.

**NOTE:** Besides the magazines cited above, some of our readers also occasionally read the following: RADIO DIGEST; RADIO DESIGN; RADIO RETAILER AND JOBBER; RADIO BUILDER (SILVER-MARSHALL); LEFAX; DATA SHEETS; W. F. C. L. MAGAZINE; N. Y. SUN RADIO SECTION; PROCEEDINGS OF INSTITUTE OF RADIO ENGINEERS; RADIO SELLING (ATLANTA); NEBERS; RADIO RESEARCH TELEVISION; THE FILTERETTE; STEVENSON'S RADIO GUIDE; TALKING MACHINE WORLD; NATIONAL RADIO NEWS (R. I.); RADIO MANUFACTURERS MONTHLY.

I certify herewith that all the above figures have been compiled from the questionnaires sent in by our readers and are to the best of my knowledge and belief absolutely correct.

**RADIO-CRAFT**  
(Sig.) S. Gernsback,  
in Charge of Advertising,  
New York, N. Y.  
August 24, 1929.

Above is a reproduction (reduced in size) of a two-colored broadside giving an analysis of RADIO-CRAFT readers. If you want to reach the PROFESSIONAL Radio Man—advertise in RADIO-CRAFT.

# WHOLESALE PRICES

## For Dealers, Service Men, General Repairmen and Set Builders!

**F  
R  
E  
E  
C  
A  
T  
A  
L  
O  
G**

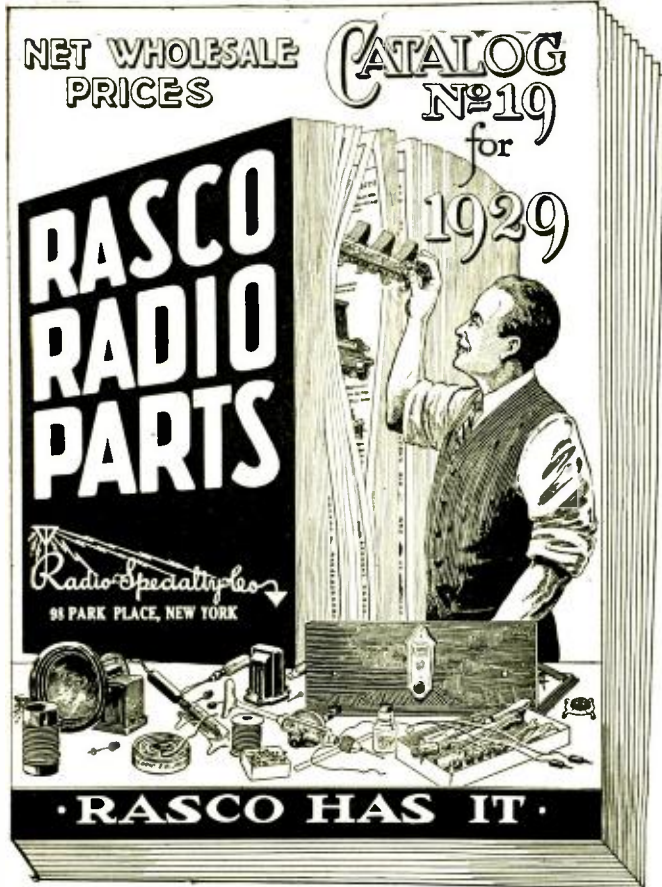

Our new, HUGE LARGER PAGE SIZE (8" x 10 1/4") WHOLESALE CATALOG No. 19, 2nd Edition, enjoys the enviable distinction of being universally accepted by the RADIO TRADE in the same manner that a school treasures the Dictionary and Encyclopedia Britannica—or the home, the Bible and Almanac!! Those "in the know" regard our catalog AS THE OFFICIAL ORGAN OF THE 1929 RADIO SEASON!!!

This FREE CATALOG is literally a most valuable ENCYCLOPEDIA—YOU cannot well afford to be without one—and, you do not have to. Your request for one is all that is needed! In these many years we have been in the Radio Mail Order Business, we have learned to GAIN AND RETAIN THE GOOD WILL OF OUR CUSTOMERS. In this, our DETERMINED GOAL, RADIO SPECIALTY COMPANY OFFERS TO SHIP PRACTICALLY ALL ORDERS IN FROM 6 to 24 HOURS—OFFERS YOU 100% MERCHANDISE ON A STRICT MONEY-BACK BASIS IF NOT SATISFIED—AND OFFERS YOU ALL MERCHANDISE AT ABSOLUTE ROCK BOTTOM NET PRICES!

Our Catalog Lists More  
**Completely Assembled**  
**All-Electric A. C. Receivers**  
 than any other Radio Catalog!  
 Available in chassis form, or mounted in table or console cabinets, with and without built-in loud speakers.  
**OUR ROCK BOTTOM NET PRICES FOR THESE SETS WILL ASTOUND YOU!**  
 In this new catalog there are also listed large assortments of CAMERAS, HOUSEHOLD ELECTRICAL APPLIANCES AND ELECTRICAL TOOLS OF EVERY DESCRIPTION.

**HERE ARE TWO OF OUR BIG BARGAINS**  
 Order From This Page—Send Money Order—Check—or Postage Stamps

### RASCO REPLACEMENT AUDIO TRANSFORMERS

Can be mounted in either of three positions, that is, lying down, or standing up with the core parallel with the base on which it is resting, or standing up with core perpendicular to the base. Other replacement transformers can only be mounted two ways. There are six specially designed feet to provide this most convenient choice of mounting, and any of them can be removed at will, should you so desire. Thus, it is logical to conclude that our Replacement transformers can be installed in ANY receiver, either custom or factory built, no matter how small a space there may be available, whether such mounting is to be above, or beneath, a sub-panel, or baseboard. The coils themselves are of the first quality, and are only found on the most costly Transformers. The core is the highest grade silicon steel, and of ample proportions. A happy combination of electrical values in both the core, and coil, assure maximum amplification possibilities—more than sufficient volume, yet with no trace of distortion! The silicon steel stampings are very rigidly bolted together by a generous size bar which is attractively nickel plated. 2 1/2 in. long by 1 1/2 in. high by 2 1/4 in. wide.

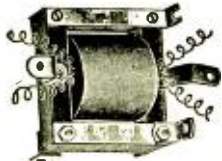

No. 7900. Your net Cost..... **\$0.80**

### TERMINAL STRIP MODEL

The primary and secondary leads are spaghetti covered, and unusually well soldered to generous size lugs. Strip is bakelite and properly lettered. No. 7950. Your Net Cost..... **\$1.01**

### DUO-MAGNETIC CONE SPEAKER CHASSIS

No other magnetic speaker chassis is so strongly constructed! Note the heavily ribbed, sturdy "spider leg" white-lead casting! The entire frame work is one piece—a beautifully molded job! A Duo-Magnetic cone speaker unit is bolted to the rear mounting plate of the chassis, and the Burex "ribbed" cloth cone is fastened between two heavy rings of cardboard—these rings are held in place by either screws and nuts, bolted to the frame of the chassis, or by being pressed up against a baffle mounting board. Although this speaker can be used as illustrated, it is strongly recommended that it be used in conjunction either with a baffle board or mounted within a box, a cabinet, or speaker compartment space in any console. *The tone quality is comparable to any speaker selling for many times its trivial cost. Will stand all the volume any radio set can "give it."* Will work satisfactorily with a D.C. or an A.C. set—with 90 volts applied through it, or even as high as 500 volts! No blasting! No distortion! No rattling! You will be most impressed with its splendid performance! Overall dimensions: Diameter 9 in. width of mounting ring 1/2 in., depth (rear of unit to mounting baffle board plate) 6 1/4 in.; diameter of unit mounting plate 4 1/2 in.



No. 6850. COMPLETELY ASSEMBLED. Including DUO-MAGNETIC UNIT and cord. AS ILLUSTRATED. Your Special Price **\$6.75**  
 Net Cost No. 6852. MOUNTED IN A CABINET OF EXTRAVAGANT BEAUTY. Your Net Cost **\$9.44**

# RADIO SPECIALTY CO.

BUY FROM RADIO'S OLDEST MAIL ORDER HOUSE

**98C Park Place  
 New York City**

## Electrolytic Condensers

(Continued from Page 198)

### Test the Rectifier

Service men should be instructed to check the rectifier tube whenever a filter condenser is serviced; for this tube is almost certain to be "shot," because of the excessive current the shorted condenser passes. A burnt-out transformer winding, also, may check back to a shorted pack condenser (whether paper or electrolytic), because its windings are not designed to carry the excessive current which flows in a shorted circuit. For this same reason, a burnt-out resistor in the pack portion of a set may have been caused by a shorted pack condenser; the resistor acting as a "fuse," and perhaps saving some more expensive device.

While on this subject note that, so far as the author is aware, only one separate "B" eliminator is using the Mershon condenser; this is the "Velvet," made by National. However, if the service man gets a call on one of these jobs, he should first check for continuity the resistor which connects between the detector tap and "B—," as this has been the real offender in all cases which have come to the attention of the writer. The customer usually reports "low volume on all stations."

A high-resistance meter, connected from detector plate to "B—," will read almost the total voltage of the pack; and this excessive voltage may have damaged the detector tube, necessitating its replacement.

## C. Francis Jenkins

(Continued from Page 201)

clude more than 400 domestic and foreign patents. Perhaps the most profitable of these is the simple but universally used spiral-wound paraffin all-paper container—the kind in which you may take ice-cream from the drug-store to your home.

The interest of Mr. Jenkins in radio has extended over only a brief period—hardly exceeding five years—yet it has been eventful and crowded with one development after another, in quick succession. He (who had made the first electrical transmission and reception of a recognizable moving image, in his laboratory in 1922), gave the first public demonstration of the transmission and reception of motion pictures by radio on June 13, 1925: the images being broadcast from NOF, the naval air station at Anacostia, D. C., and received in the Jenkins Laboratories, at a distance of about 7 miles. He has broadcast and received "still" photographs, between Washington and Philadelphia; and, on July 2, 1928, he inaugurated a regular schedule of broadcasts of motion pictures by radio. Quite recently, Mr. Jenkins opened his new 5-kilowatt visual transmitting station and, in connection with this formidable effort, it is well to quote a proverb found in his laboratories, "They said it couldn't be done; but he, poor fool, didn't know it, and went ahead and did it." To this may be added a witicism of Mr. Jenkins: "If I stay poor enough long enough, I may be able to accomplish something really worth while."



400 Large Rooms

Only Hotel in Philadelphia with a subway entrance from main lobby.

Most Moderate Rates!

Single Room, running water.....	\$2.00
For Two .....	\$3.50
Single Room, private bath.....	\$3.00
For Two .....	\$5-\$6

Garage Connected with Hotel

Wire at our expense for Reservations.

JNO. C. GOSSLER, Mgr.-Dir.

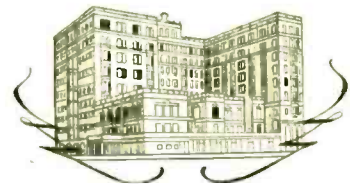

# FREE! Course in Radio and Television

EIGHT CONCISE LESSONS Interestingly Presenting

- Theory of Radio and Television Transmission and Reception
- Principles of Radio and Television Construction
- Step-by-step Instructions on Building Your Own Radio and Television Receivers
- Directions for Making a Short-wave Adapter for Your Radio Set
- Sources of Common Radio Troubles and How to Find Them
- How to Service Your Own Radio Set, and Other Helpful Information

## Just the Thing for Beginners and for Boys

This splendid course in Radio and Television comes to you ABSOLUTELY FREE through courtesy of WCFL RADIO MAGAZINE, the only radio magazine fighting for the preservation of the freedom of the air—the most important question before the American public today. WCFL RADIO MAGAZINE also always features the latest things in radio and television invention and construction. One dollar and twenty-five cents per year.

**WCFL Radio Magazine**  
621 South Wabash Ave., CHICAGO

Editor WCFL RADIO MAGAZINE,  
623 South Wabash Ave., Chicago:

Send me your Free Radio and Television Course. For these lessons there is to be no charge.

Name .....

Street .....

Post Office .....

Age..... Occupation.....



**SHORT WAVES  
THE SUBMARINER**

will convert your receiver into a short wave receiver without any changes. Enthusiastic owners have written us from all parts of the world. Stations broadcasting music 8000 miles away have been received. Very little static on short waves. Latest improvements—shielded—vernier dial 64 to 1 ratio—a quality product—on the market over three years.

**Many Models**

16-32 meters, AC or DC, \$17.50. Interchangeable coil. 12-160 meters, AC or DC, \$22.50. "J" model gives five times volume of other adapters. Price. 16-32 meters. \$22.50. Interchangeable coil. Model. \$27.50. Sent postpaid upon receipt of price or C.O.D. if \$1.00 accompanies order. Give name of set and tubes used, when ordering.

**J-M-P MFG. CO., Inc.**

3332 Fond du Lac Ave., Milwaukee, Wisconsin.

**LIFE-TIME DX AERIAL**



**Guaranteed Double Volume and Sharper Tuning**

**DESCRIPTION OF LIFETIME DX AERIAL**  
No. 30—LENGTH 30 FEET: Assembled ready to string up. Brings in volume of 150-ft. wire but retains the selectivity of a 30-ft. aerial. Rings are heavy gauge solid zinc. Duplicates in design and non-corrosive materials the aeriels used by most of largest Broadcasting Stations. Design permits using this powerful aerial in 30-ft. space, (preferably outside). Sharpens tuning of any receiving set because of short length but has enormous pick-up because 150-ft. of No. 14 enamelled wire is used. Made for owners of fine radio sets who want great volume on distance without destroying sharp tuning (Also used by many owners of short-wave outfits.) "Makes a good radio set better."  
PRICE \$ 1 0 . 0 0

No. 60—LENGTH 60 FEET: Assembled ready to string up. "BIG BOY" Size. (same description as above except that 300-ft. of wire is used making this the most efficient and powerful aerial possible to manufacture.)  
PRICE \$ 1 2 . 5 0

Manufactured by  
**THOROLA RADIO PRODUCTS**  
1014 So. Michigan Bl'vd.  
Chicago — Illinois

WHEN it comes to making sick radios well, or good radios better just

Remember **CLAROSTAT** for Every Purpose there's a

For literature, write **CLAROSTAT Mfg. Co.**  
295 N. 6th St., Brooklyn, N. Y.

**TO NEW READERS**

A few copies of the July, August, September and October issues of

**RADIO-CRAFT**

can still be had at the regular price of 25c each. Send stamps, cash or money order to:

**RADIO-CRAFT**

98 Park Place New York, N. Y.

**Radio KIK**

(Continued from Page 203)

the antenna condenser is varied from minimum to maximum until reading of the radiation meter A is at maximum. The receiver is operated in the usual manner. The antenna, made of stranded copper wire, was weighted down by a 29-ounce lead sinker, shaped to make the wind-resistance as low as possible. When resonance is reached, the antenna current is about six tenths of an ampere (using a '12A tube), and the set draws about fifty-five milliamperes of plate current. When the ship is in flight the trailing antenna extends 28½ feet; the frame of the ship is used as the other radiator, or "ground."

**Delay in the Flight**

The "B" batteries used for test purposes, which were identical with those installed in the plane, showed very little voltage drop after a month of testing; and a slight drop in the "A" batteries was noted. The length of sending time was estimated at 36 hours of intermittent work, and the sending range at 5,000 miles.

A little trouble was encountered by the navigator when he installed the plane's compasses. This necessitated a little construction work, as the magnets in the meters affected the compasses.

W6CNN and the writer were out at the Metropolitan Airport the whole night prior to Lieut. Bromley's take-off for Tacoma, making sure that all was in readiness for the big flight. At ten the next morning, the ship was loaded up with gasoline and was off for Tacoma.

No tests were made during this flight to Tacoma, but later tests proved to be a success. W6EGX and W6CNN were in direct communication with either KIK or W7AFD until the lieutenant made his disastrous run down the mile-and-a-quarter runway, ending in a crack-up after he had gone about 1500 feet. Gasoline from over-filled tanks blinded the daring aviator, causing him to leave the runway and smashing up the ship.

The old "ship" was shipped back to Lockheed and is being rebuilt for a new flight. Designers and builders are working night and day rushing to complete it before weather conditions become too hazardous for Lieut. Bromley to attempt such a flight. The radio sets were undamaged and will be used on his next attempted flight to Tokio, Japan, late in September.

**RECORD-POWER BROADCASTS**

STATION WGY has received permission from the Federal Radio Commission to operate experimentally between midnight and morning (Eastern Standard Time) on 545, 454, 261 and 200 meters (in addition to its regular wave of 380) and with the full power of the transmitter—two hundred kilowatts! With previous experimental transmissions of half that power WGY was heard with unusual clearness in many foreign countries. Theoretically, with a receiver of high sensitivity and amplification, it should be possible to receive this station from any point in the world which has only darkness between itself and Schenectady. Failure to do so, however, might readily occur on account of "location," as well as atmospheric conditions.

**FREE  
PROOF YOU  
CAN MAKE  
BIG MONEY  
in  
RADIO!**



A GLORIOUS future awaits you in this huge industry. Millions of sets need servicing, thousands of ships require radio operators...manufacturers and broadcasting stations throughout the land are eagerly seeking trained men. By means of this marvelous, simplified home-training course, sponsored by the Radio Corporation of America...you can now prepare for success in every phase of Radio. The remarkable outlay of apparatus given to you with this course enables you to learn by actual practice how to solve every problem in radio work.

**Money Back If Not Satisfied**

As a student you will receive an agreement signed by the president of this school assuring you of complete satisfaction upon completion of your training—or your money will be instantly refunded.

**FREE!**

This fascinating book on Radio's glorious opportunities...written by one of America's well-known radio experts.



**RADIO INSTITUTE OF AMERICA**  
Dept. RC-11  
326 Broadway, New York, N. Y.

Gentlemen: Please send me your FREE 50-page book which illustrates the brilliant opportunities in Radio and describes your laboratory-method of instruction at home.

Name .....  
Address .....

**RADIO INSTITUTE OF AMERICA**



Radio Operator \$90—\$200 per month with all expenses paid. Broadcast Operator \$1,800—\$4,800 a year. Radio Repair Mechanic \$1,800—\$4,000 a year. Radio Inspector \$2,000—\$4,500 a year.

# Can You Outguess O. Henry

Can you look ahead in an O. Henry story and see the unexpected denouement, the strange twists of plot, the breath-taking finish? Try it! If you succeed you can out-think the best minds in the world, for the genius of O. Henry sees the wits of the brilliant people of all lands working at top speed—and still be amazed them all! He is the supreme master of the "trick" ending, luring you into sudden laughter while a lump still lingers in your throat—making you gasp by a sudden vivid flash of horror in the midst of a smoothly flowing tale.

## Stories of Wit and Pathos

Gentle is O. Henry, but manly strength glows in every virile sentence; tender with the suffering; ever kind to the underdog; chucking with the light-hearted—drawing always from his unplumbed depths of understanding the sparkling crystal of sincerity. A great writer, yet the most entertaining and thrilling companion. Reading his stories is like



## The Master Story Teller

listening to a more brilliant story-teller than you ever knew. His works immeasurably enrich the limited library, and grace the shelves of the most crowded.

**Why DO YOU READ?**

For entertainment? For escape from daily drabness? For romance, adventure, thrills? To sharpen your wits or exercise your emotions? Whatever your reason, O. Henry scores on every point.

53 BEST STORIES

Less than 4 cents each **\$1.97**

You are now offered for the first time 53 enthralling, living, selected stories, handsomely and durably bound in leatherette, stamped with gold. 500 pages, all for the price of only one ordinary short novel.

### CUT PRICE COUPON

Greenpark Company, Dept. R.C.-11  
245 Greenwich St.  
New York, N. Y.

Please send me O. Henry's Best Stories at the cut price of \$1.97. I enclose stamps, check or M. O. for the amount. (Check which).

Name .....

Address .....

City and State.....

# Stop Using A Truss

STUART'S ADHESIF PLAPAO-PADS are entirely different—being mechanico-chemico applicators—made self-adhesive purposely to keep the muscle-tonic called "Plapao" continuously applied to the affected parts, and to minimize danger of slipping and painful friction. The fabric is soft as velvet, and being adhesive



clings closely to the body without straps, buckles or springs. Easy to apply, comfortable, inexpensive.



For almost a quarter century stacks of sworn testimonials from many different countries report success—without delay from work. The epidermatic absorption of Plapao and the utilization of "plaster therapy" tend toward a natural process of recovery, after which no further use for a truss. **FREE** Test of factor "PLAPAO" sent Mail Coupon below TODAY—

Plapao Laboratories, Inc.

397 Stuart Bldg., St. Louis, Mo.

Gentlemen: Send me a Free Trial Plapao and 48-page book on Rupture. No charge for this now or later.

Name.....

Address.....

# The 1930 Receiver

(Continued from page 207)

using resistance-capacity coupling (V5) and one with push-pull (V6-V7). Resistance-capacity coupling was selected for the first stage, because it is the most efficient method when used with a screen-grid detector. The plate-circuit resistor R3 used at a plate voltage of 180 is 250,000 ohms, which allows about one milliamper to pass through the detector with a grid bias of 5 volts and a "screen" voltage of 75. The screen voltage is adjusted by the 500,000-ohm potentiometer, R6, mounted on the base. When once set, this requires no further adjustment.

The plate resistor R3, grid leak R4, and .05-mf. coupling condenser C17 are mounted on the base, as shown. The locations of the '27-type A.C. tube, the two '10s, and the input push-pull transformer AFT are clearly illustrated.

Underneath the base are mounted the detector R.F. choke L4; the .0005-mf. by-pass condenser C16; the 1500-ohm "C" bias resistor R7, for the first audio tube; the two 50,000-ohm stabilizing resistors R8 and R9, in the push-pull grid returns; and the by-pass condensers. A 1-mf. condenser C18 shunts the 180-volt and ground terminals; 2-mf. (C19) is the by-pass capacity for the 90-volt output; and 1-mf. (C20) by-passes the first-audio "C" bias resistor.

The two plate terminals 1 and 2 of the output tubes are mounted on a bakelite strip at the right end of the base, while the other terminals are along the back, arranged as indicated in Fig. B.

## Parasitic Oscillation

The center tapped output choke used with this set is mounted in the cabinet with the reproducer. It has a value of 400 henries and a carrying capacity of 60 ma. (To prevent parasitic oscillation the halves are balanced at the factory for absolute electrical symmetry on both sides of the center tap.)

It is fitting to observe at this moment that a primary fault in average push-pull circuits is that malady variously known as "feedback," "interference," "harmonics," etc.; in plain words, parasitic oscillation. It manifests itself in an above-normal plate current; and it may, or it may not, be accompanied by a high-pitch whistle, and distortion. It does not make any difference whether it causes distorted reception, the idea is that a fault exists which is going to cost the owner some money unless it is remedied. As exceptional precautions have been taken in the design of this receiver to prevent parasitic oscillation in the push-pull stage, there is almost no likelihood of trouble from this source. In addition to measures mentioned above, the author points out the use of two stabilizers or oscillation suppressors, R8 and R9, in the "grid return" lead of each power tube. This connection is possible only when the input transformer secondary has a balanced, two-section winding. (To by-pass these resistors would be to defeat their purpose. The "grid bias resistor" R14 serves an entirely different purpose and it is necessary that this unit be properly by-passed,—the purpose of C25.) A single resistor in a single return lead would be "common" to both tubes and the "isolation" desired would not be obtained.

By carefully following the diagram, Fig. 1, you should have no trouble in wiring the

# NOW On All Newsstands

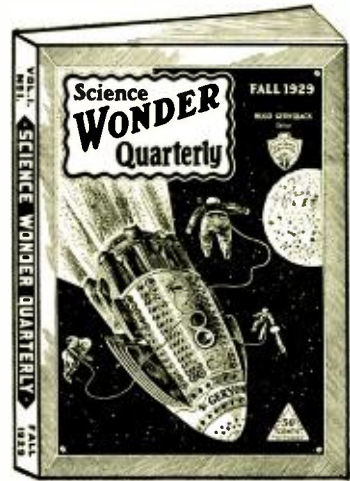

LOOK FOR THE GOLD COVER

144 PAGES  
4-COLOR COVER

50c  
THE COPY

We are pleased to announce that the first issue of the SCIENCE WONDER QUARTERLY is now on the newsstands.

We have secured for the first issue, the American rights of a complete new novel by the famous German science fiction author, Otto Willi Gail. Far from being fantastic, this story has the very vitals of reality in it. Interplanetary problems become those serious things that are part and parcel of our everyday life. You will be stunned by the truths that this powerful writer gives you. This is one of the most unusual interplanetary stories ever published. The title of the story is

## "The Shot Into Infinity"

Among the other stories are:

THE HIDDEN WORLD  
By Edmond Hamilton

THE GRAVITATIONAL DEFLECTOR

By Harry D. Parker

THE ARTIFICIAL MAN  
By Clare Winger Harris

The subscription price of the QUARTERLY is \$1.75 per year, single copy 50c.

To all charter subscribers, a special rate of \$1.25 per year is available now.

## Use This Coupon for Convenience

STELLAR PUBLISHING CORPORATION,  
Dept. R.C.-11, 98 Park Place, New York, N. Y.

Enclosed please find \$1.25 for which send me the next 4 issues of SCIENCE WONDER QUARTERLY. (Canada and foreign \$1.50)

Name .....

Address .....

City .....State .....

set. Be sure to use large cable connections for the  $7\frac{1}{2}$ -volt filament and the  $2\frac{1}{2}$ -volt heater supply. The practice of transposition is followed with all filament leads; that is, they are twisted to eliminate any possibility of an induction hum. The metal base is grounded, also the "B—" lead from the power pack. The band-selector connections should be as direct as possible. The leads should be well insulated and securely soldered. After the panel is put in place, the condenser shaft lined up and dial mounted, the set is ready for operation.

#### Type '45 or '10 Power Tubes?

During the early stages of the design, the question arose as whether type '45, type '10 or type '50 tubes should be used. Each has its advantages and disadvantages. (The constructor is recommended to experiment with the necessary power equipment for type '45 tubes, where the power-handling ability of the type '50 tube is not needed for driving dynamic reproducers.) Type '10 tubes, however, were selected because it was intended to use an electrostatic reproducer, the polarizing potential for which would be available with the operating voltages of type '10 tubes; whereas the use of type '45 tubes, which do not operate at such high plate potentials, would necessitate a special "polarizing" unit for the electrostatic reproducer. (The "undistorted power output" of two '10s is about the same, at the voltages shown, as that of two '45s at 250 volts, plate.) The question of single or push-pull operation was settled almost instantly; as the push-pull arrangement, on many counts, is far superior to a single tube. It will be noticed that coupling condensers have been dispensed with; this arrangement is possible only when the output is push-pull, for the direct current (which would ordinarily circulate through the reproducer winding or matching transformer primary, when contact is made directly to the plate—in the case of "dynamic" and "electro-magnetic" reproducers), is balanced out by this connection. What the constructor is most interested to know is that the frequency-discrimination of coupling condensers has been eliminated and better reproduction results.

Where "electrostatic" reproducers are used, it will be an advantage to connect directly to the plate, as will be observed from consideration of the output connections of Fig. 1. Of course, the use of a dynamic reproducer is optional; its two leads being connected to output posts 1 and 2.

#### The Power Pack

The power pack (Fig. D) is also mounted on a metal base. This base (when shaped) is  $10'' \times 18'' \times 1\frac{1}{2}''$  deep. Only one illustration, besides the diagram (Fig. 4) is given as this unit is comparatively simple to build. The list of parts gives the details of the apparatus used in the power pack, all of which is mounted on top of the base.

Each of the filter condensers (C21-22, C23-24) consists of two 4-mf. units. Two of these are connected in series, giving a total capacity of 2 mf. across the highest-voltage side. One of the other 4-mf. sections is connected across the 425-volt lead and the fourth across the resistance bank.

The latter consists of one 3000-ohm, 100-watt, resistor R10; one 2000-ohm, 100-watt, resistor, R11; one 3000-ohm, 20-watt, R12; and one 4500-ohm, 20-watt resistor, R13; all connected in series as shown and mounted on

# The NEW H-F-L Mastertone Laboratory Made Receiver

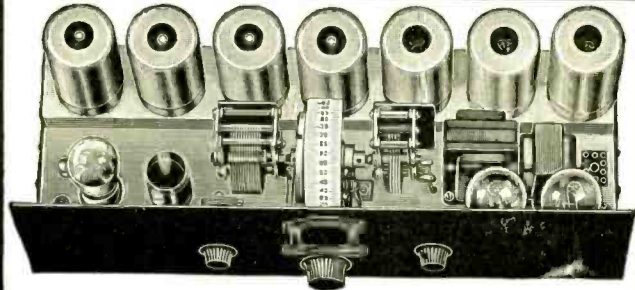

## Completely Built and Assembled by H-F-L Engineers—Shipped ready to Operate

All metal completely shielded chassis:  $7'' \times 21'' \times 7\frac{1}{2}''$ . Fits nearly all consoles. 11 tubes operating at peak efficiency [5-224; 3-227; 2-245; 1-280.] Single dial positive one-spot tuning; Humless AC Operation; Uses 5 Screen-Grid tubes, 5 Tuned R. F. Circuits; High Power Screen-Grid detector, with 175 volts impressed on plate; Automatic line voltage control inbuilt holds voltage against fluctuating; 100-Volt DC Dynamic field supply incorporated; 3 stage Phonographic amplifier; Finest quality precision made parts.

#### Amazing Power

Startling realism! Unfailing accuracy! Its great power and sweet tone awe and thrill, setting new standards of performance achieved by H. F. L. engineers after two years of tireless research and tests under all conditions.

#### Keenest Sensitivity

Unlike any ever known! Gets distant stations clearly, sharply, distinctly with only wire screen or metal plate aerial built in cabinet.

#### Highly Developed Circuit

Intermediate employs 4 screen-grid tubes with 5 tuned filter circuits, easily adjustable to peak of tuned frequency. Positive 10 Kilocycle selectivity. Most highly engineered receiver ever built.

#### The New Audio System

Uniform amplification over entire musical scale. Operates with dynamic, magnetic or horn speakers without a bit of hum.

#### The H-F-L Power Master

Not an ordinary power pack, but a specially developed unit of the Mastertone, built separately to simplify installation. Has oversized transformer, full wave type 280 rectifier tube.

#### Built by Hand—Yet Low in Price—

Quality—not quantity—the H-F-L Mastertone standard. One demonstration will convince you that its the master receiver of all times. Fully guaranteed.

Write today for complete description and price.

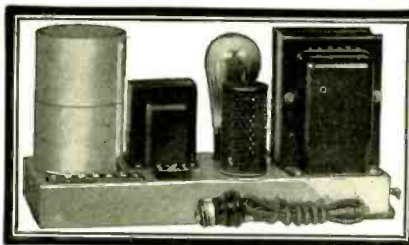

## HIGH FREQUENCY LABORATORIES 28 North Sheldon St. Dept. 70 Chicago, Ill.

#### ALUMINUM BOX SHIELDS

Beautiful silver dip finish,  $5'' \times 9'' \times 6''$ —\$1.75. We make any size to order in 24 hours.



Hammarlund .00035 Cond Special \$3.00; Midge 23-plate \$1.75; 9-plate \$1.55

Drum Dials SDB1—\$3.00 Acme R3 and R4 Transformers

Remler Tube Shields \$9.00 Full Stock of Amertran

Genuine Baldwin Type "C" phones, a necessity for short-wave reception \$3.65 a pair.

BLAN THE RADIO MAN, Inc.  
89C Cortlandt St. EST. 1923 New York

## A Special Courtesy to all

Radiotricians  
Professionals  
Engineers  
Mechanics  
Consultants  
Designers  
Service Men  
Contractors  
Manufacturers  
Dealers

In order to make it possible for all Radio Technicians to read RADIO-CRAFT regularly, each month, we have put into effect a special subscription price.

The regular price of RADIO-CRAFT is \$2.50 per year (12 issues). The newsstand rate is 25 cents a copy.

Any radio professional, signing in a subscription on his letterhead, showing that he is engaged in some capacity in radio work will receive as a special courtesy

Eight Issues of

**Radio-Craft**  
for the  
Professional Serviceman-Radiotrician

for One Dollar

Just pin a dollar bill to the coupon below and forward it with your letterhead or business card.

a small bakelite panel. A 1000-ohm, 100-watt, "C" bias resistor R14 is also mounted on this panel, and by-passed by the 1-mf. condenser C25. Be sure to use well-insulated wire for making all connections.

Resistor R10 functions as an over-all voltage control, "absorbing" the potential-difference between 180 and approximately 400 volts.

Choke L5 has a greater current carrying capacity than L6. Its rating is 120 ma., 20 henries, and D.C. resistance of 210 ohms; L6 being rated at 60 ma., 50 henries and 600 ohms. It will be seen that the power tubes derive their plate supply through L5, but not through L6. This connection results in absolutely humless operation (so far as the filter is concerned) when the output tubes are in push-pull; a little more filtration being desirable for a single-tube-output design.

The 110-volt A.C. connection to the power transformer passes through the switch SW on the panel of the set. *The filament connections between the power pack and the set should be made with large wire; so that there will be no appreciable voltage drop.* The pack should not be placed too close to the set; because A.C. hum may be picked up by the set if it is placed in the magnetic field of the power transformer.

This completes the assembly of the parts, with all the apparatus mounted, the radio-frequency amplifier unit all wired and its leads coming out the bottom through holes in the base.

### Adjustment and Operation

With everything hooked up properly, simply turn on the switch and the set is ready for operation. To adjust the band selector, tune in a station and turn the volume down. Then set the antenna-coupling condenser C1 at maximum and retune the station while changing the trimming condenser. For maximum sensitivity, the two tuned circuits *must* be in resonance; and this condition is obtained by carefully adjusting the trimming condenser C4. A screwdriver may be used to adjust the two "midjet" condensers by cutting holes in the shields and slotting the shafts of the condensers.

If the set is broad in tuning, decrease the capacity of C1 and readjust C4. In this way, the correct capacity for your particular antenna can be found. A trimming condenser for the first tuned circuit has been found unnecessary; but one may be used to facilitate the adjustment. The adjustment should be tried at both upper and lower ends of the scale.

The tubes also may be shifted around, for they vary slightly, and some work better as a detector than others. The detector screen voltage should also be adjusted for maximum sensitivity.

Using a good electrostatic or dynamic reproducer, this set will give unusually good tone quality with very little A.C. hum; and you will be well pleased with the ease in operation and sensitivity. With the '10 push-pull amplifier you can obtain sufficient volume for any occasion. If preferred, '45 tubes may be substituted by making changes to suit in the power pack.

Acknowledgement is made here of the courtesy of Mr. R. H. Siemens, chief engineer of the Radio Construction Laboratories, who kindly provided laboratory facilities and technical aid during the design and construction of the "1930 Electric Receiver."

(List of parts on opposite page.)



### AMERICAN PLAN

Single rooms—running water—\$5.00, \$6.00, \$7.00 per day.  
Single rooms—running water—\$30.00, \$35.00, \$42.00 per week.  
Double rooms—running water—\$10.00, \$12.00, \$14.00 per day.  
Double rooms—running water—\$56.00, \$63.00, \$70.00 per week.  
Single rooms—private bath—\$7.00, \$8.00, \$10.00, \$12.00 per day.  
Single rooms—private bath—\$42.00, \$49.00, \$63.00, \$77.00 per week.  
Double rooms—private bath—\$14.00, \$15.00, \$16.00, \$18.00, \$20.00, \$22.00 per day.  
Double rooms—private bath—\$70.00, \$80.00, \$98.00, \$112.00, \$126.00, \$140.00 per week.

OLD in hospitable tradition  
NEW in construction and furnishings

COOK'S SONS  
CORPORATION

### Orders - Inquiries

60 pages  
Send for FREE COPY  
Can be Secured by MAIL

### POLK'S REFERENCE BOOK and Mailing List Catalog

Gives counts and prices on over 8,000 different lines of business. No matter what your business, in this book you will find the number of your prospective customers listed. Valuable information showing how to use the mails to secure orders and inquiries for your products or services is given.

Write for FREE COPY  
R. L. POLK & CO., Detroit, Mich.  
Largest City Directory Publishers in the World. Branches in Principal Cities  
Mailing List Compilers—Business Statistics Producers of Direct Mail Advertising



Parts Required for "1930 Electric" Receiver

- 1—metal sheet, 13½x29½x1/32 to 1/16-inch thick (S4);
- 2—Hammarlund shield cans, 6x8x5¾ inches (S1, S2);
- 1—Copper shield 4x16x2¾ inches (S3);
- 1—Insuline panel, 10x13x3/16 inches thick;
- 1—Hammarlund dial, illuminated, 0-100, type SDB-1;
- 2—Electrad 500,000-ohm (type E) potentiometers (R5, R6);
- 1—Carter power switch (SW);
- 2—Hammarlund .00035-mf. "Midline" condensers (C2, C3) and extension shaft;
- 1—Hammarlund 23-plate midget condenser (C1);
- 1—Hammarlund 9-plate midget condenser (C4);
- 2—Band-selector coils, special (See text);
- 1—4-prong tube base (for L3);
- 5—Eby 5-prong sockets;
- 3—Eby 4-prong sockets;
- 4—Remler screen-grid-tube shields;
- 4—Type '24 tubes;
- 1—Type '27 tube;
- 2—Type '10 tubes;
- 1—Amertran input transformer, Type 151 (AFT);
- 2—Electrad 50,000-ohm resistors (grid leak type) (R8, R9);
- 1—Electrad 250,000-ohm (plate) resistor (grid leak type) (R3);
- 1—Flechtheim .05-mf. (coupling) condenser (C17);
- 1—Daven 0.5 megohm grid leak (R4);
- 1—Electrad 100-ohm ("C" bias) "Truvolt wire grid" resistor, (for R.F. amplifier) (R1);
- 1—Electrad 5000-ohm ("C" bias) "Truvolt wire grid" resistor, (for detector) (R2);
- 1—Electrad 1500-ohm ("C" bias) "Truvolt wire grid" resistor, (for first audio) (R7);
- 1—Silver-Marshall 85 mh. R.F. choke (for detector plate) (L4);
- 1—Flechtheim .0005-mf. by-pass condenser (C16);
- 13—Flechtheim 1-mf., 250-volt condensers (C5 to C15, C18, C20);
- 1—Flechtheim 2-mf., 250-volt condenser (C19);
- 8—Eby binding posts;
- 2—Acme Type R-3 radio-frequency transformers (RFT1, RFT2);
- 1—Acme Type R-4 radio-frequency transformer (RFT3);
- 1—Amertran output choke, No. 641.

FOR POWER PACK

- 1—metal sheet, 13x21x1/32 to 1/16-inch thick (S5);
- 1—Amertran power transformer, type PF 281 (PT);
- 1—Amertran choke, type 709 (L5);
- 1—Amertran choke, type 854 (L6);
- 2—Flechtheim 1000-volt condensers, two sections 4-mf. each (C21-22, C23-24);
- 1—Flechtheim 250-volt, 1-mf. condenser (C25);
- 1—Aerovox 3000 - ohm 100 - watt resistor (R10);
- 1—Aerovox 2000 - ohm 100 - watt resistor (R11);
- 1—Aerovox 3000-ohm 20-watt resistor (R12);
- 1—Aerovox 4500-ohm 20-watt resistor (R13);
- 1—Aerovox 1000-ohm 10-watt resistor (R14);
- 2—Eby 4-prong sockets;
- 1—'81 rectifier (V8);
- 1—'74 voltage-regulator glow tube (V9);
- 8—Eby binding posts.

# N.Y. ELECTRICAL SCHOOL "Men Graduate into many fields..."



AVIATION ELECTRICITY

AUTOMOBILE ELECTRICITY



NAUTICAL ELECTRICITY



ELECTRICAL ENGINEERING



A full knowledge of electricity, as taught in the New York Electrical School, makes you independent, gives you your choice of either a **BIG PAY** job with one of the world-famous electrical companies, or a business of your own. **ELECTRICITY** is also a stepping-stone to Aviation, Automobile Engineering and other highly paid professions.

Here at the New York Electrical School you learn, not by correspondence, but by **ACTUAL PRACTICE** on full-size standard equipment. **NO BOOKS** used. Individual instruction—you can start any day. This School owns and occupies two seventy-story buildings in New York—the city of most opportunities. It is widely known as the country's oldest and foremost institution for trade training. That's why big companies eagerly demand our graduates.

**THE NEW YORK ELECTRICAL SCHOOL**  
21 West 17th Street, New York



**FREE** This big 64-page booklet gives full information about the New York Electrical School courses and picture of the equipment available for your personal use. Send for it TODAY. It's free.

MAIL TODAY

The New York Electrical School  
21 West 17th Street, New York  
Please send me **FREE** your 64-page booklet. It is understood that this request puts me under no obligation.

Name .....

Address .....

**PATENTS TRADE-MARKS**

DON'T LOSE YOUR RIGHTS TO PATENT PROTECTION

Before disclosing your invention to anyone send for blank form "EVIDENCE OF CONCEPTION" to be signed and witnessed

LANCASTER & ALLWINE  
475 OUBAY BLDG., WASHINGTON, D. C.  
Originators of forms "Evidence of Conception"

**Choice of 1200 Newest RADIO VALUES**

SEND for our 1930 catalog. Filled with amazing values in screen grid radios, push pull audio, consoles, kits, parts. All standard makes and guaranteed merchandise. **FREE**

**WESTERN RADIO MFG. CO.**  
124 W. LAKE ST. CHICAGO ILL.

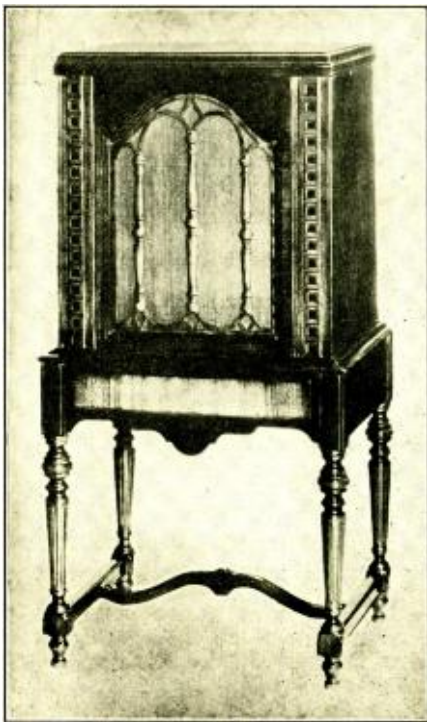

# SPECIAL

The speaker enshrined in this beautiful SONORA A-50 cabinet designed by Master Craftsmen is the PEERLESS 12 in. A.C. SUPER DYNAMIC speaker. Operates from 110 volt, 60 cycle A.C. current.

**\$37.50** OUR PRICE

LIST PRICE **[\$155.00]**

**B. C. L. RADIO SERVICE CO., Inc.**

177 GREENWICH STREET  
NEW YORK, N. Y.

## Vacuum Tubes

(Continued from Page 217)

### Alternating-Current Tubes

This concludes the battery tubes with the exception of the semi-power tubes such as the '20 and '12A which will be considered with the other power tubes. Next we come to the A.C. tubes which obtain their filament current from a step-down transformer connected to the electric light line.

The first of these A.C. tubes is one which has a filament very similar to the battery-operated tubes, but uses a very low voltage. This tube is being used less than at first when it was introduced, because of certain advantages in the use of the '27 and the new '45 tubes as amplifiers. The '26 tube is not suitable for use as a detector of radio signals because of the loud hum that would be heard. The lines of Fig. 4 show the relative amount of hum-voltage or "ripple-voltage" introduced in the '26 and '27 tubes for a given percentage of "unbalance" in the filament circuit. It will be seen that a 10% unbalance in the '27 produces an entirely negligible increase in the output ripple. With the '26 tube, however, the ripple voltage is increased tremendously.

Filament voltage 1.5 A.C.; current 1.05 amperes.

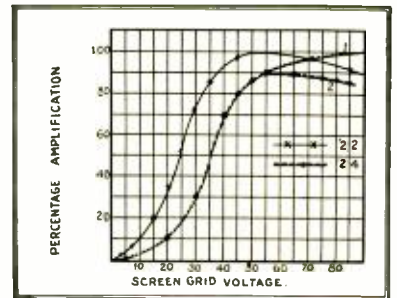

Fig. 3. A graph showing exactly what happens when the screen-grid voltage is varied in D.C. and A.C. Screen-grid tubes.

Plate voltage, 90 to 180; current 3.5 ma. at 90 volts; 7.5 at 180.

Grid bias 6 volts at 90 plate, 13.5 volts at 180 volts.

Plate resistance, 9,400 at 90 volts; 7,000 at 180 volts.

Amplification factor, 8.2.

Undistorted output, 160 milliwatts at 180 volts.

The contrast between the '26 and '27 types in Fig. 4, as to exclusion of A.C. hum, is due to the construction of the two tubes. The '26 tube uses A.C. on the filament, while the '27 uses an indirect method of filament operation. In the latter method, the filament is merely used to heat a small cylinder surrounding it and does not enter into the electrical operation of the tube at all. The small cylinder, or "cathode" as it is known, is coated in such a way that it emits electrons when it is heated to a red heat. In this way it takes the place of the regular filament and also serves as a common connecting point for the plate and grid circuits.

The '27 tube was originally designed as a detector tube, but it was found to be much more satisfactory, in many cases, as an amplifier than the '26 type, and it is fast replacing this tube in modern sets. This is due to the

**44<sup>TH</sup> ST. HOTEL**  
Just East of B'way

*One of New York's  
New Hotels at Right Prices*

A high class hotel in the very center of Times Square and within walking distance of all Shops, Theatres, etc.

**300 Rooms—300 Baths,  
\$2.50 & \$3.00 per Day**

A Restaurant of Unusual Excellence

*Special Weekly Rates*

**ATTENTION: Radio Service Men**

Leading manufacturers often consult us for the names of competent service men who are actively engaged in radio work.

We want every reader of RADIO-CRAFT who is engaged as a service man to read page 201 of this issue. You will find the few minutes reading this page well worth while.

THE  
**OMNIGRAPH  
AUTOMATIC**



TRANSMITTER

## CODE AT HOME RADIO AND TELEGRAPHY

Has Helped Thousands to Better Positions

The best, easiest, quickest way known for over 20 years. U. S. Govt., Schools, Colleges, and Scientific Institutions use it. Becomes an Operator, Broadcaster, Railroad Official, etc. Interesting positions everywhere on land or sea.

JUST LISTEN! The short waves are speaking.

No other profession offers so much for your Future or Pleasure, and awaits the young man WHO KNOWS, in its many different branches.

The OMNIGRAPH Automatic Transmitter will teach you to receive and send Code. Experts approve it. START NOW. Catalog Free.

Other Scientific Apparatus also supplied. Write your requirements.

OMNIGRAPH MFG. CO., N.C., 810 E. 39 St., Brooklyn, N. Y.

characteristic of the tube, as well as the lower hum-voltage introduced into the circuit by its use. The cathode's emission of electrons is almost entirely unaffected by the change in the filament current.

The graph in Fig. 5 shows the measured amplification factor (Mu), plate resistance (Rp) and mutual conductance (Gm) for a normal '27 tube of well-known make. It will be seen by referring to Fig. 6, that the characteristics of this tube are very similar to those of the '01A, except for a slightly higher amplification factor in the A.C. tube. The horizontal scale has been taken as the plate current instead of the usual method of using plate voltage. This was done because the plate and grid voltages are apt to vary (with line changes in the case of the A.C. tube) and they are also apt to vary under the load supplied by measuring instruments, even though instruments of high resistance (high

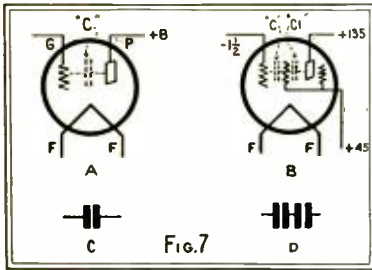

Just "why" a screen-grid tube has a low grid-to-plate capacity is illustrated above.

resistive-sensitivity) are employed. The use of plate current overcomes these errors. It will be noticed that there are two values of Mu given for the '27. The first of these corresponds to a negative grid bias of 9 volts (Mu 1) and the second to a grid bias of 4½ volts (Mu 2).

The curves made with the '27 tube are the result of measurements made according to the methods explained last month for determining the characteristics of tubes. It will be noticed that a logarithmic graph paper was used to plot the curves. This was done to show the values more clearly at low plate currents. An ordinary graph paper could be used, but the results would not be shown as clearly.

Filament voltage, 2.5 volts A.C.; current 1.75 amperes.

Plate voltage, 45 volts as detector, 45 to 180 as amplifier.

Plate current, 3 milliamperes at 45 volts; 3 milliamperes at 90 volts and 6 milliamperes at 180 volts.

Grid bias, 0 at 45 volts; 6 volts at 90 plate volts; 13.5 volts at 180 plate volts.

Plate resistance, 8,500 ohms at 45 volts; 10,000 at 90 volts and 9,000 at 180 volts.

Amplification factor, 9.0.

Undistorted output, 164 milliwatts, at 180 volts.

#### Grid Bias for A.C. Tubes

Although the method of using the voltage drop in the plate circuit of a tube for grid bias and the way to figure the resistance value are simple, there may be some who are still puzzled by this system. The resistance used for the "C" bias voltage is connected between the plate circuit and the filament or cathode (depending on the type of tube). This connection between the plate circuit and the cathode completes the plate circuit. If

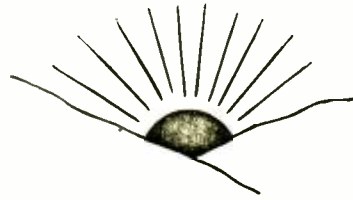

## Television is here..

Through the efforts and inventions of Mr. C. Francis Jenkins and his associates in the Jenkins Television Corporation, Television for the home is already an assured fact.

Home Televisors have reached so practical a stage that they will shortly be placed on general sale.

Television arrives at an opportune time. Its possibilities defy the imagination.

The year 1930 will be a television year. Write for a copy of

*"Television—the eye of Radio"*

JENKINS TELEVISION CORPORATION

Jersey City

New Jersey



## Ex Libris Beautiful Bookplates

DO YOU TAKE PRIDE IN YOUR LIBRARY?

A PERSONAL bookplate, with your name on it insures you against loss of your cherished volumes. The friend who borrows your book can't fail to be reminded that *it belongs to you!*

A bit of the feeling of the great Old Masters is captured for you in our artistic *Duo-Tone Bookplates*, reproducing old woodcuts and engravings, on antique-tint vellum paper. \$2 up per hundred, your name imprinted. Send 10c for specimen and illustrated catalogue of our unique new series.

ISKOR PRESS, Inc.

286 Fifth Ave. (Dept. 9) New York

# Tube Tester and Set Analyzer \$6.50

Service men, experimenters, teachers, students need a handy meter test set to determine voltages, shorts, opens, continuity, etc. With the three-meter outfit you can do this completely.

Cat. 215, consisting of two meters in one noire metal case, with UY and UX sockets built in, also built-in cable with 5-prong UY base and 4-prong UX adapter; changeover switch, bias switch and posts for high resistance voltmeter. The two built-in meters are: (a) 0-20, 0-100 m. a., controlled by changeover switch, and (b) 0-10 voltmeter, reading BOTH A.C. and D.C. Price, less high-resistance plate voltmeter, Cat. 215, size 8x3 3/4 in. **\$6.50**

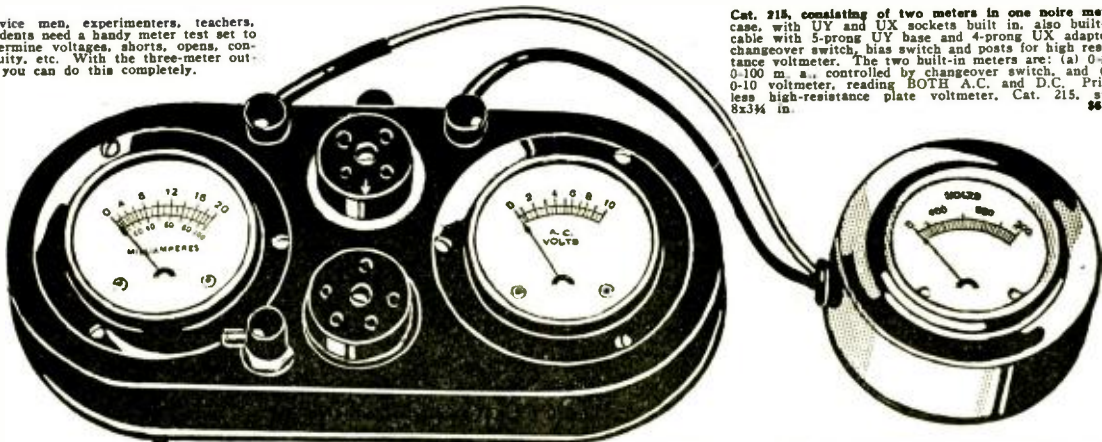

SEND NO MONEY!

### EXTRAS

- 0-300 high resistance voltmeter, Cat. 3M \$3.00
- 0-600 high resistance voltmeter, Cat. 5M \$6.00
- 0-600 high resistance voltmeter, reads A.C. and D.C., Cat. 6M \$7.00
- Cable to enable tests of screen grid tubes, A.C. or D.C., Cat. SGC \$0.35
- Two adapters for UV tubes, Cat. UVA \$1.10
- Leatherette carrying case, Cat. LCC \$2.00

The 215, with the high resistance meter of your choice added thereto, will test any tube or circuit, with suitable adapters, as listed under "Extras." It will make thirteen vital tests in 4 1/2 minutes, as described in free construction sheet, sent with each order for a 215.

You can test screen grid tubes by connecting the special cable, with clip to control grid (cap of tube) and other end of special cable to the clip in the set that went to the cap before the tube was transferred to the tester. Disregard what the instruction sheet says about not being able to test screen grid tubes. A later improvement made this test possible.

NOTE: If you want Cat. 215, Cat. 6M, Cat. SGC, Cat. UVA and Cat. LCC, order "Jiffy 600" at..... **\$15.90**

**GUARANTY RADIO GOODS CO. - - - - - 143 WEST 45th STREET**  
(Just East of Broadway) New York, N. Y.

# S. GERNSBACK'S RADIO ENCYCLOPEDIA

THE FIRST RADIO ENCYCLOPEDIA EVER PUBLISHED

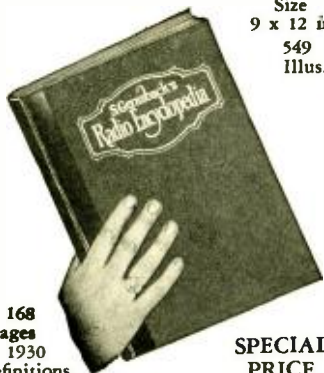

Size 9 x 12 in.  
Pages 549  
Illus.

168 Pages 1930 Definitions

**SPECIAL PRICE \$1.49**

PEDIA is written in plain English so that everybody can understand the definitions and descriptions.

No expense has been spared, covering over two years in compilation, to make it worthy a place in your library.

It is published in one volume—168 pages—size 9 x 12 inches, nearly an inch thick and nicely accommodates the beautiful illustrations and the large, easy to read type.

The work contains 1,930 definitions, 549 photographs, drawings and diagrams.

**REMEMBER THIS IS A REAL ENCYCLOPEDIA—NOT A DICTIONARY**—and very few of the things described and illustrated in this volume can be found in any dictionary, or any other encyclopedia.

The book contains as a supplement a classified cross index designed to bring together radio references under one heading having relations in common.

All circuits new and old are described by word and picture and every part and apparatus used in Radio is explained and made understandable by means of photographs and drawings.

The volume is printed upon fine paper—bound in full black Keratol,

marbled paper fly leaves and end sheets, with the title stamped in gold.

### SEND NO MONEY

Just forward the Coupon below and the Encyclopedia will be sent you at once. You pay the Postman \$1.49 plus postage on delivery and if the book is not satisfactory return it and your money will be paid back at once without any questions.

**ISKOR PRESS, Inc.**

*286 Fifth Ave., New York*

ISKOR PRESS, Inc., R-11  
286 Fifth Avenue,  
New York.

Send me one copy of Sidney Germsback's First Radio Encyclopedia in one volume as advertised. I will pay postman \$1.49 plus postage on delivery.

Name .....  
Address .....  
Town and State .....

Edited by **SIDNEY GERNSBACK**, Author of "Wireless Course in Twenty Lessons"—"One Thousand and One Formulas"—"Practical Electricity Course"—"The Radio Educator," etc.

**S. GERNSBACK'S RADIO ENCYCLOPEDIA** is the only standard work ever published in America attempting to classify alphabetically the countless words used in the highly specialized science of RADIO. The ENCYCLO-

**AGENTS WANTED**

**FREE BOOK.** Start little mail order business. Hadwil, 27A-74 Cortlandt Street, New York.

Get our Free Sample Case—Toilet Articles, Flavorings, Soaps, Specialties. Wonderfully profitable. LaDerma Co., Dept. SC, St. Louis, Mo.

IMPORT your own goods; German export magazine published in English, offers numerous bargains, latest novelties; opportunity for obtaining profitable agencies; copy 60c. Square Deal Supply, K246 5th Ave., New York.

**AIRPLANE SUPPLIES**

**MODEL AEROPLANE Supplies.** Write for free bundle of sample stock. Aero Shop, 3050 Hurlibut Ave., Detroit, Mich.

**BUSINESS OPPORTUNITY**

**SELL BY MAIL!** Books, Novelties, Bargains! Large profits. Particulars FREE! D. Elfco, 525 South Dearborn, Chicago.

**CHEMICALS**

**BOOKLET OF EXPERIMENTS** and chemical catalog, 15c. General Chemical Company, Box 397, Reading, Penna.

**DETECTIVES**

**DETECTIVES Earn Big Money.** Excellent opportunity. Experience unnecessary. Particulars Free. Write, George Wagner, 2190B Broadway, N. Y.

**INSTRUCTION**

**f CATCH** from 45 to 50 foxes from 4 to 5 weeks' time. Can teach any reader of this magazine how to get them. Write for particulars. W. A. Hadley, Stanstead, Que.

**BE THE LICENSED RADIO DOCTOR** of your community. Earn \$7.00 - \$10.00 spare time evenings. Write now for free booklet. "Why the Radio Doctor." Dept. C, 131 Essex Street, Salem, Massachusetts.

**MISCELLANEOUS**

**TOBACCO OR SNUFF HABIT Cured** or No Pay. \$1.50 if cured. Remedy sent on trial. Superba Co., T28, Baltimore, Md.

**PERSONAL**

**LET ME READ** your character from your handwriting. Sample reading 12c. Graphologist, 2309-EH Lawrence, Toledo, O.

**PATENT ATTORNEY**

**PATENTS**—Time counts in applying for patents. Don't risk delay in protecting your ideas. Send sketch of model for instructions or write for free book, "How to Obtain a Patent" and "Record of Invention" form. No charge for information on how to proceed. Communications strictly confidential. Prompt, careful, efficient service. Clarence A. O'Brien, Registered Patent Attorney, 343-A Security Bank Building (directly across street from Patent Office), Washington, D. C.

**SONG WRITERS!**



Substantial Advance Royalties are paid on work found acceptable for publication. Send sketch of model for instructions or write for free book, "How to Obtain a Patent" and "Record of Invention" form. No charge for information on how to proceed. Communications strictly confidential. Prompt, careful, efficient service. Clarence A. O'Brien, Registered Patent Attorney, 343-A Security Bank Building (directly across street from Patent Office), Washington, D. C.

a resistance is introduced in series with this circuit, there will be a voltage drop through the resistor, according to Ohm's Law— $E=IR$ , or the voltage drop is equal to the current in amperes multiplied by the resistance in ohms.

The value of the resistor is determined by using Ohm's Law and is quite simple. By reversing the equation shown above, we have

$$R = \frac{E}{I}$$

or the resistance is equal to the re-

quired voltage divided by the current in amperes flowing in the plate circuit. If we have a tube which draws 3 milliamperes and requires 6 volts of grid bias for a certain plate voltage, the resistance is equal to 6 divided by .003 (the current in amperes) or the resistance value is 2000 ohms. When more than one tube is used on the same biasing resistor, the resistance is equal to the required voltage divided by the sum of the plate currents.

**Fifteen-Volt Tubes**

Besides the two standard A.C. tubes, the '26 and '27 which have been described, there are several special types of tubes which are in use. The first of these is similar to the '27 in the purpose for which it was designed. It differs from the '27 in several respects. In the first place, it utilizes a four-prong socket. Second, the electron-emitting element or cathode is connected to the filament and is part of the filament circuit.

The filament of the tube is designed to operate on a voltage of 15 instead of the usual 2.5. The current used by this filament is much lower than the regular '27, being 0.35 ampere. The tube is similar in its characteristics to the other '27 tubes, except for the differences mentioned. The grid return for this tube is made to the side of the filament circuit which connects to the cathode.

Another special duty tube is one similar to the '40 high-mu tube, but designed for A.C. operation. This tube has a filament similar to the '26 tube, and the same precautions must be exercised when using it. There are several other special-duty tubes on the market, but their use is so limited that it is not worth while considering them here.

**The A.C. Screen-Grid Tube**

The next tube in the list is one which is attracting interest everywhere. This tube is being used in practically all the new manufactured sets and it promises to become a favorite in A.C. operation. This type includes the '24 and similar screen-grid tubes designed for A.C. operation.

The operation of the A.C. screen-grid tube is similar to the '22 type, but there are a number of differences in the construction and the characteristics. In the first place, the amplification factor of the '24 tube is higher than that of the '22 tube. Although the theoretical amplification factor cannot be reached in actual practice, as shown elsewhere in this discussion, the higher value of this factor has some effect on the actual amplification of the tube. Also, the mutual conductance is much higher than that of the D.C. tube, and gives a very desirable characteristic from the standpoint of amplification.

In order to obtain stable operation in circuits designed to give normal gain per stage it is necessary to use shielding to separate the input from the output circuits. The internal construction of the tube makes it unnecessary to use neutralization providing external couplings are eliminated by correct

**CORWICO VULCAN Lightning Arrester**

**\$1**

**\$100 Guarantee Against Lightning Damage Enclosed in Each Box At Your Dealer or Direct Upon Receipt of Price.**

**CORNISH WIRE COMPANY**  
36 Church Street, New York City  
Makers of Corwico BRAIDITE Hook-Up Wire

**TRI-STATE HEADQUARTERS**  
Pennsylvania—Ohio—West Va.  
**WHOLESALE RADIO**

To DEALERS and SET BUILDERS we offer the most prompt and efficient service. We handle only the best merchandise and give MAXIMUM DISCOUNTS.

**GET OUR CATALOG**

**CAMERADIO**  
430 WOOD ST.  
at Diamond St.  
PITTSBURGH PA.

**MAKE GOOD RECEPTION EASY**



Thousands of users marvel at the difference in reception with a Townsend "B" Power Unit. Full, sweet tone, clarity, volume and greater distance are among the many advantages reported daily.



**TOWNSEND "B" POWER UNIT**  
Hooked up in a few minutes; just plug into the light socket and forget it. Delivers up to 100 volts on any set—D.C. or A.C.—any cycle.

Approved and passed by the field laboratory tests of "Popular Radio" and "Radio News."

**Over 150,000 Now in Use!**

There's no longer any reason for putting up with the expense and dependable performance of "B" Batteries—when you can own a good "B" Power Unit for \$6.85. Over 150,000 Townsend "B" Power Units now in use—a substantial proof of satisfaction.

**Send Only \$1.00**  
Send name and address with only \$1.00. On arrival of Townsend Power Unit pay postman \$5.85 plus postage. Try out ten days, then, if it fails to do everything we say, return it and money paid us will be refunded. Make a REAL receiver of your set.

**"Results Equal to 180 Volt Power Unit!"**  
I have used my Eliminator for a year and it is giving just as good service now as the time I bought it. I am using it on a Sylvania 8 tube set that calls for 180 volts, and I noticed no difference when I connected the set to a 150 volt "B" Eliminator than when I used your 90 volt one.  
Harry Metz,  
Evanston,  
Pittsburgh, Pa.

**TOWNSEND LABORATORIES**  
723 Townsend St. Chicago, Ill.

When writing to advertisers, please mention RADIO-CRAFT

# Your Choice of One to Nine Meters



## Cash in on this Astoundingly Liberal Offer At Once!

### CHOOSE THE METERS YOU WANT FROM THIS LIST

- |                                |                              |                               |
|--------------------------------|------------------------------|-------------------------------|
| □ 0-6 Voltmeter D.C. No. 326   | □ 0-10 Amperes D.C. No. 338  | □ 0-100 Millamp. D.C. No. 390 |
| □ 0-50 Voltmeter D.C. No. 337  | □ 0-25 Millamp. D.C. No. 325 | □ 0-300 Millamp. D.C. No. 399 |
| □ 0-Vt Chge Tester D.C. No. 23 | □ 0-50 Millamp. D.C. No. 350 | □ 0-400 Millamp. D.C. No. 394 |

Put a cross in the square next to the meter you desire, and fill out and return coupon below.  
All meters except No. 23 are panel mount types; size of hole, 2 5/64"

### WHAT RADIO COMPANIONSHIP DO YOU ENJOY?

ARE you meeting weekly the best minds of radio? Do you keep abreast of all the new circuits, the intimate details on perfecting existing sets, and get the inside track on sensitivity, distance reception, tonal quality, and how to achieve them? Do you keep fully abreast of the news of radio, technical and non-technical? If not, here is your chance to enjoy the writings of McMurdo Silver, J. E. Anderson, Herman Bernard, Capt. Peter V. O'Rourke, James H. Carroll, Herbert E. Hayden and a host of other radio engineers who contribute their knowledge to you through the medium of Radio World, the first and only illustrated national radio weekly (eighth year!)

#### LATEST CIRCUITS AND NEWS

You will find Radio World specializes in most intimate revelations of the ins and outs of the best circuits, with technical accuracy second to none. Enjoy the weekly companionship of Radio World's famous contributors, and glean the news of radio, from the four quarters of the earth. Short waves? Radio World will tell you all about them. Extremely sensitive broadcast receivers? Their construction and operation are fully discussed with confident regularity. Power supplies—push-pull or otherwise? AC receivers? Screen grid tubes? Large receivers that give a super-abundance of performance—small, economical receivers that give performance out of all comparison to their size? Automatic volume controls? Band-pass filters? New tubes? Are you interested in these? Then you're interested in Radio World.

#### RADIO WORLD

145 West 45th Street, New York City  
(Just East of Broadway)

Enclosed please find \$..... for which send me Radio World for ..... weeks (one copy each week), and also send me FREE, at once, the meters checked below.

- |                                  |                                  |                                  |
|----------------------------------|----------------------------------|----------------------------------|
| <input type="checkbox"/> No. 326 | <input type="checkbox"/> No. 338 | <input type="checkbox"/> No. 390 |
| <input type="checkbox"/> No. 337 | <input type="checkbox"/> No. 325 | <input type="checkbox"/> No. 399 |
| <input type="checkbox"/> No. 23  | <input type="checkbox"/> No. 350 | <input type="checkbox"/> No. 394 |

Name .....

Street Address .....

City..... State.....

6-DAY MONEY-BACK GUARANTEE

See the list of nine meters above. Heretofore we have offered the choice of any one of these meters free with an 8-weeks subscription for RADIO WORLD, at \$1, the regular price for such subscription. Now we extend this offer. For the first time you are permitted to obtain any one or more or all of these meters free, by sending in \$1 for 8-weeks' subscription, entitling you to one meter; \$2 for 16 weeks, entitling you to two meters; \$3 for 26 weeks, entitling you to three meters; \$4 for 35 weeks, entitling you to four meters; \$5 for 44 weeks, entitling you to 5 meters; \$6 for 52 weeks, entitling you to 6 meters; \$7 for 61 weeks, entitling you to 7 meters; \$8 for 70 weeks, entitling you to 8 meters; \$9 for 79 weeks, entitling you to all 9 meters. Return the coupon with remittance, and check off desired meters.

**The Season Is Now Opening! Keep  
in Touch With Latest Circuit  
Developments!**

RADIO WORLD, 145 W. 45th St., N. Y. C.  
Published Weekly — All Newsstands — 15c copy —  
\$1.50, 3 months — \$3, 6 months — \$6 a year.

Buy a copy at the newsstand to-day!

shielding. The need of plenty of shielding to separate the coils, tubes, condensers and chokes cannot be emphasized too much. A single flaw in the isolation of the various circuits will often result in complete failure of the set.

The manufacturers recommend that the screen-grid voltage be varied to control the volume. The curves in Fig. 3 show the relative amplification with different screen grid voltages. In cases where more than two stages of radio-frequency amplification are used, it is often difficult to prevent some grid current from flowing. The result of this current on the amplification is shown in the curve for the '24 tube. It will be seen that the amplification falls off after a certain value, and that the further increase in the screen-grid voltage causes a reduction rather than an increase in the volume. This condition is not a good one for several reasons. In the first place, the presence of grid current results in very broad tuning; also, the plate current increases over its recommended value and the

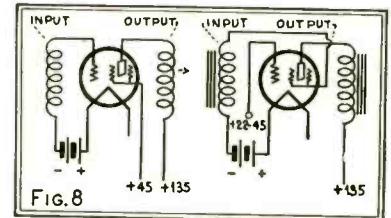

"Screen-grid" and "space-charge" connections are diagrammed above.

over-all performance of the tube is affected.

In order to overcome the difficulties encountered by the flow of grid current, one of the large manufacturers (the de Forest Tube Co.) has changed its '24 specification so that the normal grid bias is 3 volts instead of 1.5. This allows a larger grid swing and in many cases entirely cures the trouble. In order to limit the amplification in sets using several of these tubes, some manufacturers limit the screen-grid voltage to a value lower than the rated maximum. In the new Radiola 44 receiver, the maximum screen-grid voltage is 45.

By referring to the curve again, it will be seen that the amplification increases rapidly up to a value about 50 volts and tapers off after that point. Because of this bend in the characteristic, the use of a higher screen-grid voltage does not increase the amplification to any great extent.

The '24 tube is an excellent bias detector either with small or large signal inputs. When small R.F. inputs are obtained, the screen-grid voltage should be kept at 35 to 45 volts and the control-grid at minus 3.5 or 4.5 volts. The output in this condition feeding into a 200,000-ohm load choke fed with a one-volt radio-frequency input modulated 22% is 5½—both voltages Root-mean-squared values. This handling value is more than sufficient to operate a '45 at full output with direct coupling or two '45 tubes in push-pull with a low-gain audio transformer.

Filament voltage, 2.5 volts; current 1.75 amperes.

Plate voltage, 180 maximum and recommended value.

Plate current 4 milliamperes at 180 plate volts.

Grid bias, 1.5 volts; screen-grid voltage 70 (positive).

Plate resistance 400,000 ohms.

Amplification factor, 420 (theoretically).

# SKINDERVIKEN Transmitter Units

95c



Two for \$1.75

Have hundreds of uses. Every amateur should have two or three of these amplifiers in his laboratory.

## A FEW USES FOR THESE UNITS

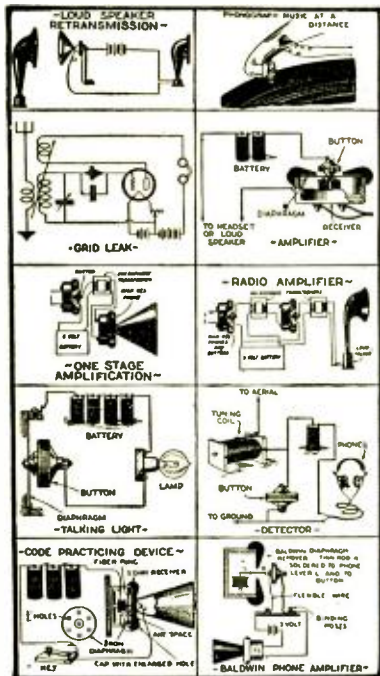

12 PAGE INSTRUCTION BOOKLET containing suggestions and diagrams for innumerable uses, furnished with each unit.

**WE PAY \$5.00 IN CASH**

for every new use developed for this unit and accepted and published by us.

### P. G. MICROPHONE TRANSFORMER



A Modulation Transformer specially designed for use with the Skinderviken Transmitter Unit. Has many other uses. Primary resistance, 1/2 ohm; secondary, 55 ohms.

**FOR SALE AT LEADING DEALERS**

Or Order Direct. Using Coupon Below

**SEND NO MONEY**

When the postman delivers your order you pay him for whatever you have ordered, plus a few cents postage.

PRESS GUILD, INC. R. 11-29  
16-18-R—EAST 30TH ST., NEW YORK, N. Y.

Please mail me at once as many of the following items as I have indicated.

...Skinderviken Transmitter Units at 95c for 1; \$1.75 for 2; \$2.50 for 3; \$3.20 for 4.  
...P. G. Microphone Transformers at \$2.

When delivered I will pay the postman the cost of the items specified plus postage.

Name .....  
Address .....  
City ..... State .....

## Information Bureau

(Continued from Page 222)

If an eliminator is used, the rectifier tube should be replaced.

If the "A" and "B" potentials are O.K., check the "C" batteries.

An infrequent cause of this trouble is a defective tube.

Corroded connections may cause this effect; also, a ground connection which has become imperfect because of corrosion or drying of the earth nearby. Some sets will work with nothing more than a lead-in. If the regeneration is a suddenly-acquired one, check over the aerial installation. Open by-pass condensers will also cause this effect suddenly.

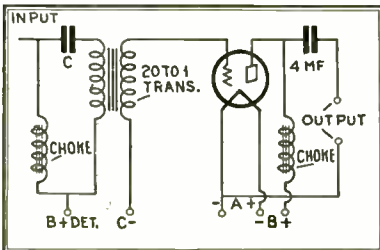

(Q.32) A convenient circuit for getting the most out of transformers of odd size.

(Q.) Please show the circuit for an A.C. screen-grid booster unit to be added to the average receiver, for use on broadcast wavelengths.

(A.) The circuit requested appears in these columns; connect its "output" to the grid post of the first R.F. tube in the set. The tuning condenser C2 will not "track" closely with the radio set dial unless it is of the same capacity and design of plates.

The constants are as follows: L1, 10 turns of No. 26 D.C.C. wire on a tube 2 inches in diameter; L2, 80 to 85 turns of the same wire on a tube of the same diameter; L3, standard R.F. coil; C1 and C3, 1-mf. fixed condensers; C2, .00035-mf., variable; C4, .00025-mf., fixed; R, 1200 ohms. Resistor R is for biasing the tube.

Over-all shielding, grounded, is shown in dotted lines. The coils should not approach the can more closely than two inches at any point. It is a good idea to connect a 1-mf. condenser as shown in dotted lines.

(Q.) Is it possible to employ an audio transformer with a twenty-to-one ratio, by using "parallel-plate-feed"? The sketch illustrates the idea.

(A.) The circuit shown will work in some fashion, but it will be necessary to experiment with condensers to arrive at the correct value for C. It is probable that the response will be very "peaked"; that the high notes will be weak, and that very "drummy" reproduction will be obtained.

## DON'T BLAME THE RECEIVER— ALWAYS

A PROFESSIONAL pianist, residing on Long Island, wrote to F.A.D. Andrea that she desired to play the piano in conjunction with piano concerts over the air, adding: "I find that the loud speaker of my radio is not in true pitch; for I have had my piano tuned by a well-known piano tuner."

The lady was informed that speakers are absolutely true to pitch and the chances were that the piano had been tuned by a tuner who used a tuning fork of discontinued pitch. At the National Music Trades Convention, four years ago, it was decided to change "International Pitch" to 440 A.

The tuner was called in again, at the suggestion of the radio company, and when the tuning fork was examined it bore the figures 435 A. That explained why the piano in the home was lower than the reception via the ether.

The case resulted in the discovery by the pianist of great variances of tone and pitch in other residences.



A Beautiful New PANEL PLATE

for the Famous

## HAMMARLUND DRUM DIAL

RICHLY embossed, pebbled bronze in the modern mode. It has grace and charm appropriate to the superb dial mechanism back-panel that delighted thousands of set builders last season.

The control knob can be mounted anywhere on the panel. Illuminated scale.

Write Dept. RC11 for Details

HAMMARLUND MFG. CO.

424-438 W. 33rd St., New York

For Better Radio  
**Hammarlund**  
PRECISION PRODUCTS

By an *Amperite* for every tube. *Dr. Radio Engineer*

The Prescription for Better Radio Reception

AMPERITE automatically delivers the RIGHT voltage for efficient tube operation. Improves tone, sensitivity, volume. A type for every tube. \$1.10 with mounting (in U.S.A.) At all dealers.

AMPERITE Corporation  
561 BROADWAY, NEW YORK

Free — "Amperite Test Pocket Tube Chart". Write Dept. RC-11

**AMPERITE**  
"SELF-ADJUSTING" Rheostat

Choice of 1200 Newest RADIO VALUES

SEND for our 1930 catalog. Filled with amazing values in screen grid radios, push pull audio, consoles, kits, parts. All standard makes and guaranteed merchandise.

**FREE**

WESTERN RADIO MFG. CO.  
124 W. LAKE ST. CHICAGO ILL.



**A LEADING Hotel of this Popular Resort.** Rooms—Single—Double or en-suite with private baths. Unexcelled cuisine and service. American plan. Ownership-Management MARY L BIOREN Also under same management The Boscobel and Ocean Avenue Hotel, Ocean Grove, N. J.

**MARLBOROUGH HOTEL**  
ASBURY PARK, N. J.  
"ON THE ATLANTIC"

LATZ, INC.

**New Apparatus**

(Continued from Page 215)

These, available in standard tuning capacities (350, 250 and 150 mmf.) in single units and gangs up to four, insure precision in their calibration, reduce capacities except those which are useful, and lend themselves electrically and mechanically to any circuit.

**RADIO CONSOLE—SECRETARY**

While the radio set owner nowadays is less inclined to sit up to his set and fish for stations than in the old days, the combination of a receiver and a desk is an attractive one, for many households; and the console illustrated meets this purpose.



International "No. 444" Secretary

The piece of furniture illustrated is of walnut of a size for standard receivers, such as Crosley, Atwater Kent, Arborphone and Apex. It is manufactured by the International Equipment Co. of Kansas City.

**Ten Tools in One**

A SMALL but very handy article which serves for every possible need of the all-round mechanic. Invaluable in any emergency.

An excellent combination of utilities for the household—every necessity featured: HAMMER—KNIFE—SHARPENER—NAIL - PULLER—BOTTLE-OPENER—SCREW-DRIVER—CORK-SCREW—CAN-OPENER—WEIGH-SCALE—RULER—TABLE OF WEIGHTS AND MEASURES. Just glance at the illustration and you will see how really useful this article is. The "Ten in one Tool" is 10 inches high and finely nickel-plated.

The new tool is not only handy in the household, but every TOURIST, AUTOIST, CAMPER, PICNICKER, BOY-SCOUT, FISHERMAN, CANOE-IST, etc., should carry in his bag one of these indispensable combination tools. No SHOP, OFFICE, STORE, GARAGE, FARM, BOAT, should be without one. PRICE \$1.00 POSTAGE PAID.

Be the first to own the "Ten Tools in One" in your town.

Send our order today, pin a dollar bill to coupon below and the shipment will go forward to you the same day as received.

**GREN PARK TOOL CO.**  
245 Greenwich St.,  
New York

Grenpark Tool Company, R-11  
245 Greenwich Street,  
New York, N. Y.

Enclosed find \$1.00 for which please send me prepaid your "Ten Tools in One."

Name .....

Address .....

Town ..... State .....

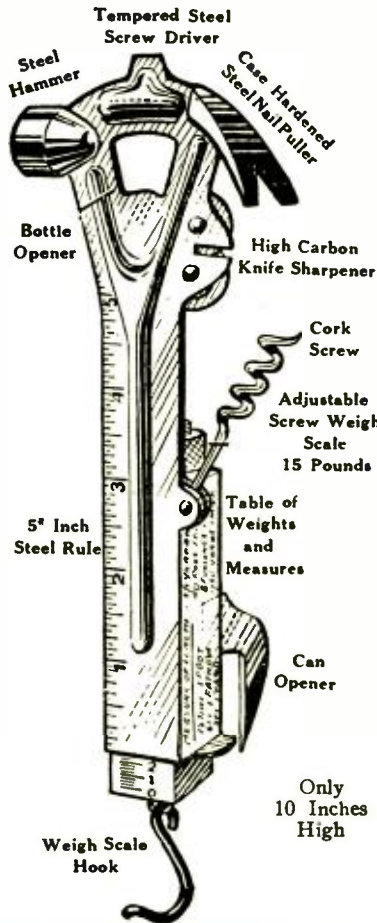

This little condenser is called the "Cub"; its terminals may be wrapped round the leads of a resistor to be bypassed, and soldered direct.

**A SELF-MOUNTING CONDENSER**

The little device illustrated here is ingeniously designed to expedite production in radio. It is made by the Cornell Electric Mfg. Co., of Long Island City, N. Y., in capacities from .0001- to .02-mf.; is non-inductive and rated at 1,500 volts.

**ATWATER-KENT "MODEL N"**

A SERVICEMAN writes that in an Atwater-Kent "Model N" battery set there are three tests to make that will almost always locate the trouble;

- (1) Symptoms, "B" shorted out; signals practically a whisper; test by-pass condensers.
- (2) One of audio transformers burnt-out—usually second stage.
- (3) The .002-mf. condenser across primary of first audio leaky; continuous noise in speaker with aerial off and set on. Test with "C" battery and headset. If the grating of rheostats is heard in speaker when filament is increased or decreased, they need cleaning. Use sandpaper or a soft lead pencil.

If a noise is heard in speaker with aerial disconnected, scrape tube contacts and aerial taps; spring tube-socket prongs from bottom of chassis up toward set. Clean grid leak and holder.

In ninety-nine out of a hundred of these sets, he has found only these ailments; and only one out of all he has ever seen failed to be corrected by either treatment.



# RESISTORS IN RADIO

By Charles Golenpaul\*

LAST month we considered the resistor in the role of a voltage divider; and its direct relation to sensitivity. However, its applications are many and varied.

In one instance we may mount, on the panel, a one-half- to one-megohm variable resistor with its two leads connected to the secondary terminals of either the first- or the second-stage A.F. transformer. In this position the resistor acts as both volume control and quality control. It is pleasing to observe that bass notes are reproduced best when a local station is being received. The reason is that the resistor is then adjusted to a position of low resistance. This results in *by-passing* the higher frequencies, in addition to adjusting many of the input conditions to those which result in good reproduction of low notes.

Now, when a distant station is being received, the resistor is adjusted until it is practically out of the circuit; it has, in fact, the highest resistance value to which it can be adjusted.

### The Audio Filament Rheostat

The volume control which a rheostat affords is known to practically every radio worker. In series with the current supply to the filament, it acts as a "gate" to the filament supply current.

However, it must be pointed out that considerable distortion may result when rheostats are resorted to for controlling volume. This is particularly true in the audio-frequency stages; where any variation in the filament heat is reflected in the grid and plate circuits by changes which are quickly evident, acoustically, as distorted reproduction. Correct meters give an even quicker indication.

### The Detector Rheostat

In the detector circuit, filament control may result in obtaining phenomenal results in distance reception; this is almost a certainty when soft or gaseous tubes are used as detectors. (It is to be noted that "soft" and "gaseous" are not here used in an unfavorable sense.) Soft tubes are those having a low degree of vacuum, but not necessarily any considerable quantity of atmospheric gases. Tubes of these special detector types are very erratic in performance, for that matter; but it is just this instability which results in that desirable condition we refer to as "sensitivity." (More about this anon.)

When tubes which are critical in this respect are used, it is not uncommon for the owner to report that he "tuned in several stations merely by varying the rheostat setting." At one time this was a puzzler in the radio game. One faction contended that it is impossible for anyone to tune in stations by adjustment of the rheostat; that the tube filaments could have nothing to do with tuning in stations. The other crowd, composed of those who had "been there," argued differently.

As it is seldom, in sets having less than three stages of T.R.F. (a sensitivity of approximately five microvolts per meter) that high-quality audio reproduction goes hand-in-hand with sensitivity, the technician will do well to decide which is preferable.

### Rheostats for R.F. Tubes

Although, as stated above, a detector or audio-stage rheostat will control volume (but probably at the expense of audio quality), it must be remembered that the radio-frequency filament control functions in a different matter. In this position the rheostat may be used, with little effect on tone, until a very low filament heat is reached.

However, this again is a matter in which every factor must be taken into consideration before one can say definitely that so-and-so happens when such-and-such a thing is done. The average person is inclined to make snap judgments and such judgments are of no value in technical work—there must be an observed reason for every statement, and it should be clearly shown just what are the limitations of those reasons.

If the reader will pardon this digression, we will now return to the subject of resistors and the thought which occasioned the above philosophy.

### Detection to be Avoided

To quote, "—The rheostat may be used with little effect on tone." This will be true if the grid bias and plate potentials do not fall below a certain value. For, below a certain "safety level," detection will readily take place and detection in a radio-frequency circuit designed to amplify is an unpardonable fault. A glance at a family of

"characteristic graphs" will show why detection can occur.

From the above we are led to believe, and rightly, that manufacturers were wise in finally abandoning the use of the filament rheostat as a volume-control unit.

Although some manufacturers have incorporated low-resistance rheostats in their new electric receivers, their purpose is simply reduction of the filament heat. A very noticeable difference in the characteristics of the A.C. tubes is the time (rather considerable) which it takes for temperature variations in their filaments to make a noticeable variation in the audio output quality.

It would not be right to wipe off the slate all mention of the rheostat as a volume-control device, for there are times, as hinted in the bit of philosophy above, when a rheostat may be used in the proper circuit to very good advantage.

### Design Hints

For example: suppose we are able so to design the set as to keep the filament heat within certain defined limits, still obtaining good volume control. Is this a point worthy of consideration? The answer is in the affirmative, of course; for we are not interested in the filament heat for its own sake, but only for the audio effect which we obtain through it. It now remains to select a circuit combination which will meet the conditions required.

At least one answer to this is the use of a fixed resistor in series with the variable instrument; the resistance can never drop below the minimum value which the fixed resistor establishes. This prevents putting more than the rated potential on the tube filaments.

A single variable resistor of the proper value, in series with the "A" lead to two or three tubes, will effect a great control over the volume of a receiver which has several stages of radio-frequency amplification. If the exact value is not available, a rheostat having a higher resistance may be used with a stop-pin placed at a point determined by experiment, to prevent the filament heat dropping to a point at which detection will take place in one or more of the radio-frequency tubes. Add a limiting fixed resistor, and you have a good method of volume control.

## Servicing The "G"

(Continued from Page 200)

cate 10 volts, but an approximation may be arrived at by observing the manner in which the needle swings across the scale. This overload is within the safety limits of the meter design; but only experience will enable the service man to handle his

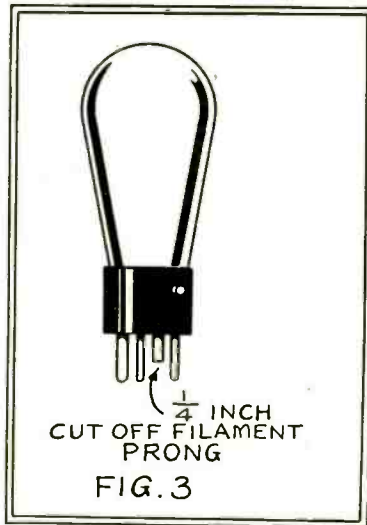

A device (x) used when balancing neutrodyne.

meters with proper discretion). Plate voltage, without load, from posts 10 to 7 should be 45 to 60; 10 to 8, 130 to 155; 10 to 9, 155 to 200, using a high-resistance voltmeter with a 0-250 scale. These voltages should be obtained with a 120-volt A.C. line supply, and the "120-V" tap on the transformer in use.

The grid bias on the '71 should be about 37 volts, at 170 volts "B."

In Fig. 6 we have a list of readings taken from a Jewell "Type 199 Analyzer."

# "Trouble Shooter's Manual"

By JOHN F. RIDER

## Wiring Diagrams of All Well Known Receivers!

Besides 22 chapters covering thoroughly the field of trouble shooting, this volume contains the wiring diagrams of models, as obtained direct from the factory, a wealth of hitherto confidential wiring information released for the first time in the interest of producing better results from receivers. You will find these diagrams alone well worth the price of the book. The wiring diagrams are of new and old models, of receivers and accessories, and as to some of the set manufacturers, all the models they ever produced are shown in wiring diagrams! Here is the list of receivers, etc., diagrams of which are published in this most important and valuable book:

- |  |   |
|--|---|
| <b>R. C. A.</b><br>60, 62, 20, 64, 30, 105, 51, 16, 32, 50, 25 AC, 28 AC, 41, Receptor S.P.U., 17, 18, 33.   | <b>ZENITH</b><br>39, 39A, 392, 392A, 40A, 35PX, 35APX, 35ZPX, 35ZAPX, 37A, 35P, 35AP, 35ZP, 35ZAP, 34P, 34ZP, 33, 34, 35, 35A, 34Z, 35Z, 35ZA, 36Z, 31, 32, 333, 353A, power supply ZE17, power supply ZE1Z.                        |
| <b>FEDERAL</b><br>Type F series filament, type E series filament, type D series filament, Model K, Model H.  | <b>MAJESTIC</b><br>70, 70B, 180, power pack 7BP3, 7P6, 7P3 (old wiring) 8P3, 8P6, 7BP6.   |
| <b>ATWATER-KENT</b><br>10B, 12, 20, 30, 35, 48, 32, 33, 49, 38, 36, 37, 40, 42, 52, 50, 44, 43, 41, power units for 37, 38, 44, 43, 41.  | <b>FRESHMAN</b><br>Masterpiece, equipbase, G, G-60-S power supply, L and LS, Q15, K, K-60-S power supply.   |
| <b>CROSLLEY</b><br>NJ, Tridyn 3R3, 601, 401, 401A, 608, 704, B and C supply for 704, 704A, 704H, 705, 706.   | <b>STROMBERG-CARLSON</b><br>1A, 2B, 501, 502, 523, 524, 635, 636, 403AA power plant, 404 RA power plant.  |
| <b>STEWART-WARNER</b><br>300, 305, 310, 315, 320, 525, 500, 520, 525, 700, 705, 710, 715, 720, 530, 535, 750, 801, 802, 806.   | <b>ALL-AMERICAN</b><br>6 tube electric, 8 tube 80, 83, 84, 85, 86, 88, 6 tube 60, 61, 62, 63, 66, 6 and 8 tube AC power pack.   |
| <b>GREBE</b><br>MU1, MU2, synchrophase 5, synchrophase AC6, synchrophase AC7, Deluxe 428.  | <b>DAY FAN</b><br>OEM7, 4 tube, 5-5 tube 1925 model, Day Fan 8 AC, power supply for 6 tube AC, B power supply 5524 and 5525, motor generator and filter, 6 tube motor generator set, 6 tube 110 volt DC set, 6 tube 32 volt DC set. |
| <b>PHILCO</b><br>Phileo-electric, 82, 86.  |   |
| <b>KOLSTER</b><br>4-tube chassis used in 6 tube sets, tuning chassis for 7 tube sets, power amplifier, 7 tube power pack and amplifier, 6 tube power pack and amplifier, rectifier unit K23. |   |
- There are also wiring diagrams of Pada, Freed-Eisemann, Colonial, Workrite, Amrad, Sparton and others.
- Size of Book 8 1/2" x 11"—234 pages. Profusely illustrated with charts and full page diagrams.

## RADIO TREATISE CO.

1440 B'way, N. Y. C.

Send No Money

RADIO TREATISE CO.,

1440 Broadway,  
New York City.

Send me John F. Rider's "Trouble Shooter's Manual" and I will pay postman \$3.50 plus a few cents for postage on delivery. It is understood that my money will be refunded if I am not entirely satisfied.

Name .....

Address .....

City..... State.....

\*Clarostat Mfg. Co.

# Barawik - the Old Reliable RADIO SERVICE



## Another Big Bargain Book —ALL READY for You

The new Barawik Radio Guide presents some of the most outstanding bargains you have ever seen. Your money goes far here. You'll be pleased with the many new things contained in our new catalog.

This big new Radio Guide tells how to take advantage of the new things in radio. It shows how to get the best results from A.C. and D.C. Screen Grid sets and tubes, how to use remote control, how to get reception on front or back porch and lawn, while playing bridge, etc.; how to save money on tubes, speakers, supplies; how to make radio-phonograph combinations and public address systems, etc. Many new ideas with pictures, full descriptions and new low prices on anything you want in radio—sets, kits, parts and supplies—besides hundreds of necessities for your auto, for home, camp and outdoor use. Fill in the handy coupon below. It will bring you the latest edition. Be sure to send at once. Get the facts before you. Write today—NOW!

### Special Service to Set-builders, Short Wave Experimenters and "Hams"

The BARAWIK COMPANY is the pioneer radio house in supplying set builders' supplies and short wave equipment, parts, receivers and transmitters, to amateurs and fans. Order the various parts, kits and accessories used in building sets, converters, transmitters, etc., from us. We make shipments to all parts of the world.

The following Short Wave Circuits are some that are available from us:

- |                                     |  |
|-------------------------------------|--|
| Aero Coil Kits                      | Walker's Multi-Unit  |
| Aero Short Wave Receivers           | National Parts and Receivers                               |
| Aero Transmitters                   | Karas Parts and Receivers                                  |
| R.E.L. Receivers and Transmitters   | Short Wave Converters                                      |
| Hammarlund Kits                     | Public Address Systems                                     |
| Portable Receivers and Transmitters | Television Equipment.                                      |
| Cardwell Parts                      | Parts for AC, DC, Screen-Grid and other Broadcast Circuits |
| Pilot Kits Etc., Etc., Etc.         |  |

**MAIL THIS COUPON FOR FREE COPY**

BARAWIK CO., 341 Canal Station, Chicago, U. S. A.  
 You may send me, free, the big new Radio Guide, set-builder's encyclopedia and catalog of newest radio sets, kits, parts, supplies and home necessities, showing illustrations, descriptions and giving me advantage of new low prices.

Name .....

Address .....

City .....

State .....

E.C.11

Mail coupon for latest Radio Guide. It is free.

*The Barawik Co.*

341 Canal Station

Chicago, U. S. A.



# Now PILOT'S ELECTRIC SUPER-WASP

Short Wave  
PLUS Screen Grid  
PLUS A. C. Operation



10,000 Mile Range  
—Covers all bands  
14 to 500 Meters

**Employs Super-Sensitive Screen Grid Tube and New 227 PILOTRON especially developed for A. C. Super-Wasp**

Now you can enjoy the thrill of international short-wave radio from your electric light socket! Utterly uncanny is the A. C. Super-Wasp's ability to jump 10,000 miles, "pulling in" novel short-wave broadcasts from all over Europe, Central and South America, Canada, South Africa and Australia! Easily assembled in single evening.

The Pilotron 227 used as detector is a new type tube developed especially for the critical requirements of short-wave reception! Precisely because of this it is an eminently superior tube for any broadcast receiver!

  
**A. C. Operated SUPER-WASP**  
(Catalog No. K-115)  
Custom Set-Builder's  
Price in U. S. A.

**\$34<sup>50</sup>**

*Slightly Higher West of the Rockies*  
Power Pack extra  
(Pilot K-111 ABC Power Pack is recommended)



**Battery-Operated SUPER-WASP**  
(Catalog No. K-110)  
Custom Set-Builder's  
Price **\$29<sup>50</sup>**  
in U.S.A.  
*Slightly Higher West of the Rockies.*

## Special Notice to Owners of BATTERY-OPERATED SUPER-WASPS

Some S. W. fans will continue to prefer a battery-operated Super-Wasp. However those who desire to change over to A. C. operation, will find full details in Pilot's Special Data Sheet, obtainable free from your Pilot dealer or direct from the factory.

## Join the Guild!

50c brings you four quarterly issues Radio Design, official organ of Radio International Guild. Subscription also includes one year's Guild membership with membership pin and certificate furnished without charge. Timely construction articles include full story on new A. C. Super-Wasp. Radio Design, Department 5, 103 Broadway, Brooklyn, New York.

## Qualified Dealers!

Financially responsible and technically informed dealers are invited to secure details of Pilot's authorized Agency Plan.

# PILOT RADIO & TUBE CORP

WORLD'S LARGEST RADIO PARTS PLANT — ESTABLISHED 1908

323 BERRY ST.

BROOKLYN, N.Y.

Trade Mark



Registered

# A NEW SCREEN GRID RECEIVER

Engineered to a new  
Height of Perfection

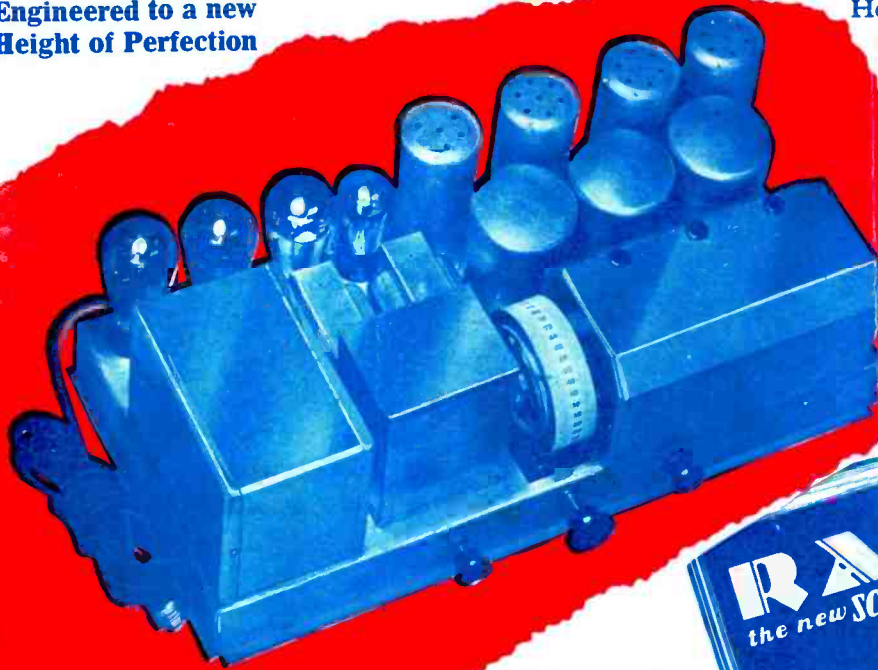

Here is a new receiver featuring a Screen Grid circuit—  
245 push-pull power audio  
—power detector—8 tubes  
—with A-C. All electric  
humless operation. A  
tuned detector stage  
imparts unusual power to  
the receiver. Ultra selective—  
sturdy construction  
—R C A licensed.

## FREE RADIO CATALOG

Send for this new, big catalog—196 pages full of the very latest in radio, such as this new Screen Grid Chassis, as well as many other special features. All priced to you at wholesale—offering remarkable values on everything in radio.

Our recent purchases totaling over one million (\$1,000,000) dollars in standard radio receiving sets coupled with our tremendous stock of standard accessories, parts and kits has enabled us to make startling price reductions. Write today for the complete story as given in this large 196-page catalog of radio bargains.

## EVERYTHING IN RADIO AT UNHEARD OF PRICES

New Screen Grid A. C. Humless All-Electric sets—standard A-C sets as well as battery operated receivers in an attractive array of consoles ranging from small table model types to gorgeous pieces of radio furniture. They represent the finest offerings of the season. The price range is especially attractive presenting unusual values as low as \$15.95.

Get this Allied catalog. Buy low so you can make more profit. Deal with an organization of experts who are trained to render real service in radio.



# \$15.95

A  
Reliable,  
High-grade  
Radio House

# ALLIED RADIO CORPORATION

711 W. Lake Street Dept. 1-1 Chicago

Backed by  
Resources  
totaling over  
\$3,000,000