

MARCH 1930

RADIO BROADCAST

ENGINEERING • THE LABORATORY • SERVICING



SPECIAL FEATURES IN THIS ISSUE

Characteristics of the New Pentode Tube

Volume Control In Broadcasting

High-Frequency Measuring Methods and Circuits

High-Efficiency D.C.-A.C. System » Grebe Method of Rating Receivers » Auto-Radio Installations » 3 Years of the Federal Radio Commission » A Phonograph Record-Changing Device » Engineering Review Sheets » Magnetic Circuit Design

THIRTY FIVE CENTS

WILEY, DORAN & CO., INC. ♦ GARDEN CITY, NEW YORK

COMING!!!

A NEW RADIO TUBE

IF this were merely the announcement of another new radio tube, it would not command your interest. New radio tubes arrive all too frequently.

But this is *the* new radio tube, long awaited. It is the radio tube which had to come, as the natural result of the formation of the National Union Radio Corporation.

It was to be expected that this huge \$16,000,000 combine of resources and engineering genius would result in a radio tube new in quality, new in sales appeal, and new in its possibil-

ities for profit to dealer and jobber.

This new tube will represent a high water mark of present-day radio tube engineering. It will offer evidence in its tone, its performance and its long life, of the untiring efforts of a famous group of engineers. It will take its place among the more noteworthy achievements of American industry.

It will be produced in plants that are modern-to-the-minute, equipped with the newest and most remarkable developments in automatic machinery and manned by the finest workers in the field.

NEW IN QUALITY

So much painstaking care will be lavished on the production of this new tube, that it will create a new conception of how good a radio tube can be. A Sales Inspection Department, without responsibility for speed

or cost-of-production, will double-check the daily output. There is little question in the minds of dealers and jobbers as to the very tangible effects of radio tube quality on radio tube sales. We have built our new tube with that thought in mind.

NEW IN SALES APPEAL

We have clothed this new radio tube with an idea which will make it a star of the first magnitude in the radio sky. The most brilliant of merchandising, the most effective of advertising will be employed in its behalf. To the dealers and jobbers who will be entrusted with the presentation of this tube to the American public, we offer these assurances of a prosperous business relationship.

WAIT!

NATIONAL UNION RADIO CORPORATION

400 Madison Avenue

» » » »

New York City

RADIO NEEDS YOU

Let RCA Institutes show you the way to SUCCESS in this fast-growing industry

REACH out for a big-pay job in Radio... Tie-up to the fastest-growing industry in the world today... See for yourself what other men have done... You, too, can do the same! Hundreds of fellows just like you are now earning from \$2,000 to \$25,000 a year in RADIO. J. H. Barron, Radio Inspector of the U. S. Department of Commerce says that a most serious shortage in trained Radio men exists right now. Thousands of trained men are needed. Broadcasting stations, manufacturing plants, retail and wholesale dealers, as well as ships at sea and planes in the air, require trained Radio men.

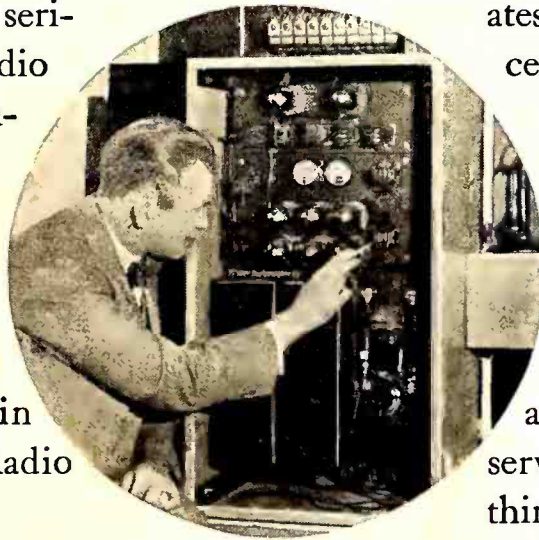

Radio Mechanics earn up to \$4,800 a year.

*Learn Radio at Home...
RCA Institutes Will Train
You for Success!*

RCA sets the standards for the entire radio industry. The RCA Institutes Home Laboratory Training Course gives you the real, inside, practical training in Radio, quicker than you could obtain it in any other way. It's easy to learn at home in your spare time. You get your lessons and criticisms direct from RCA... the

very source of radio achievement... the vast world-wide organization that has made Radio what it is today... that sponsors every lesson in this course.

RCA Graduates Find it Easy to Fill Good Radio Jobs

There has been a radio job for practically every graduate of RCA Institutes. Graduates are actually *Trained* for Success because they learn radio by actual experience with the RCA Institutes famous outlay of apparatus given to every student of this course. You learn to solve every radio problem such as repairing, installing, and servicing finesets. Here is everything you need know in order to fill a well-paid position in Radio.

*Send for this Free Book
"Radio... the Field of
Unlimited Opportunity"*

Read these 40 fascinating pages, each one packed with pictures and text that tell you everything you want to know about the many brilliant opportunities in Radio and about RCA Institutes, the world's oldest and largest radio training organization. Tune in on Radio. Send for this free book today and speed up your earning capacity!

Clip this Coupon NOW!

RCA INSTITUTES, INC.

Formerly
Radio Institute of
America



RCA INSTITUTES, Inc.
Dept. RB-3, 326 Broadway, New York

Gentlemen: Please send me your FREE 40-page book which illustrates the brilliant opportunities in Radio and describes your laboratory-method of instruction at home!

Name

Address

Contents for March, 1930

Review - - - - -	-W. K. W.	251
Important Events Distribution New Models Broadcast Advertising	In Lawyerland New Tubes? Revelation The Service Gospel	
A D.C. to A.C. "Converter" - - - - -	Frank G. Logan	252
Characteristics of Pentode Tubes	Keith Henney and Howard E. Rhodes	254
Automobiles With Radio - - - - -		256
The March of Radio - - - - -	-An Editorial Interpretation	258
The Jellyfish Commission	"A Patent Pool for Public Service"	
Volume Control in Broadcasting - - - - -	O. B. Hanson	260
High-Frequency Measuring Equipment - - - - -	H. D. Oakley	262
Magnetic Circuit Design - - - - -	E. A. Uehling	265
"Radio Broadcast's" Engineering Review Sheets - - - - -		267
No. 31. Radio Galvanometers	No. 32. Radio Galvanometers (continued)	
The Serviceman's Equipment - - - - -	J. H. Miller	269
Three Years With the Federal Radio Commission	Louis G. Caldwell	270
Strays From the Laboratory - - - - -	Technical Shorts	273
Square-Law Detectors Capacities of Coils Changes in Stations	Quartz Crystals A Correction Recent Articles of Interest	
Production Testing Equipment - - - - -	J. A. Callanan	274
Rating Radio Receivers - - - - -	Alfred H. Grebe	276
Tricks With Set Testers - - - - -	Herbert M. Isaacson	278
Professionally Speaking - - - - -	Keith Henney	281
Regarding Pentode Articles Are Technical Salesmen Needed?	Improvements in Monitoring	
The Serviceman's Corner - - - - -		284
Artificial Q R N 245 Tubes in Radiolas Sales Dope for Servicemen	Getting Acquainted With A K Points on Installation	
"Radio Broadcast's" Service Data Sheets - - - - -		288, 290
Crosley Models 40S, 41S, 42S, 82S	The Erla Model 224	
Book Review - - - - -	Robert S. Kruse	291
News of the Radio Industry - - - - -		294
In the Radio Marketplace - - - - -		298
Radio Broadcast Laboratory Information Sheets	Howard E. Rhodes	300, 302, 304
No. 328. Loud Speaker Bibliography	No. 333. Calculating Power Output	
No. 329. Loud Speaker Bibliography	No. 334. Calculating Power Output	
No. 330. Loud Speaker Bibliography	No. 335. Undistorted Output vs. Dynamic Range	
No. 331. Modulated Oscillator and Output Meter	No. 336. Undistorted Output vs. Dynamic Range	
No. 332. Modulated Oscillator and Output Meter		

. . . among other things

C FRANK G. LOGAN, who describes the Ward Leonard "Adaptoron" in this issue has been connected with the radio division of the company for many years. Mail reaches him at Mt. Vernon, New York. . . . O. B. Hanson, writing on volume levels in broadcasting, has been active in the technical side of broadcasting since "way back when." Mr. Hanson was with WEAJ when its towers dominated 24 Walker St., New York, followed its fortunes to 195 Broadway, and when the National Broadcasting Company took WEAJ unto its heart from the Telephone company, Mr. Hanson was made manager of plant and operations. . . . Edwin A. Uehling's article on magnetic circuit design in this number is one of those unusual articles which you may expect to find in RADIO BROADCAST. Mr. Uehling is a graduate of Wisconsin and has been with the Bell Laboratories, Grebe, and Fada. He is now in the Graduate School, University of Michigan. . . . For the past five years, H. D. Oakley, while he has been employed by General Electric, has been engaged in the invention and development of high-frequency measurement apparatus. Associated with Mr. Oakley are H. J. Schrader and G. S. Jacobs. Their enthusiastic interest and ability for this sort of work is responsible for much of the advancement which has been made in the creation of measurement tools and technique, Mr. Oakley tells us.

C IN APRIL, the story about phonograph record-changing mechanisms by Thomas Piazza, promised for this issue, will appear. Other articles will include: E. L. Brown, aircraft radio development; Jesse Marsten, high-frequency response; Von Ardenne, use of the cathode-ray tube to measure percentage of modulation; Mancill, describing construction of a laboratory and testing apparatus used; Oakley, input and output audio-frequency measuring apparatus; and an article from American Bosch describing the design and characteristics of their automobile radio receiver. All the regular departments for service and practical workers will appear, as usual.

C THROUGH ONE of those often unexplicable and always embarrassing typographical errors, the formula appearing in the article by Ernest Amy and J. G. Aceves on page 206 of our February issue was made to read $\frac{1}{\sqrt{LC}}$. This, as most readers know, should be $f = \frac{1}{\pi\sqrt{LC}}$

TERMS: \$4.00 a year; single copies 35 cents; All rights reserved. Copyright, 1930, in the United States, Newfoundland, Great Britain, Canada, and other countries by

DOUBLEDAY, DORAN & COMPANY, INC., Garden City, New York

MAGAZINES
COUNTRY LIFE WORLD'S WORK THE AMERICAN HOME RADIO BROADCAST SHORT STORIES LE PETIT JOURNAL EL ECO WEST

BOOK SHOPS (Books of all Publishers)

NEW YORK: <LORD & TAYLOR, JAMES MCCREERY & COMPANY, PENNSYLVANIA TERMINAL, 166 WEST 32ND ST., 848 MADISON AVE., 51 EAST 44TH STREET, 420, 526, and 819 LEXINGTON AVENUE, GRAND CENTRAL TERMINAL, 10 WALL STREET> ATLANTIC CITY: <2807 BOARDWALK> CHICAGO: <75 EAST ADAMS STREET> ST. LOUIS: <310 N. 8TH ST. and 4914 MARYLAND AVE.> CLEVELAND: <HIGBEE COMPANY> SPRINGFIELD, MASS: <MEEKINS, PACKARD & WHEAT.

OFFICES

GARDEN CITY, N. Y. NEW YORK: 244 MADISON AVENUE. BOSTON: PARK SQUARE BUILDING. CHICAGO: PEOPLES GAS BUILDING. SANTA BARBARA, CAL. LONDON: WM. HEINEMANN, LTD. TORONTO: DOUBLEDAY, DORAN & GUNDY, LTD.

OFFICERS

F. N. DOUBLEDAY, Chairman of the Board; NELSON DOUBLEDAY, President; GEORGE H. DORAN, Vice-President; RUSSELL DOUBLEDAY, Secretary; JOHN J. HESSIAN, Treasurer; LILLIAN A. COMSTOCK, Ass't Secretary; L. J. McNAUGHTON, Ass't Treasurer

THE NEW HOME OF SPRAGUE CONDENSERS • NORTH ADAMS, MASS.



F. W. MCNAMARA
PURCHASING AGENT

R. U. CLARK
SALES ENGINEER

W. L. DUNN
CIRCUIT ENGINEER

C. SHUGG
PRODUCTION MGR

DR. P. ROBINSON
RESEARCH ENGINEER

A. B. AYRES
GENERAL SALES MGR.

F. D. SPRAGUE
MECHANICAL ENGINEER

J. K. SPRAGUE
VICE PRESIDENT

R. C. SPRAGUE
PRESIDENT

GENTLEMEN

**HAVE YOU A
CONDENSER
PROBLEM** *in your
lab?*

IF SO *we can
help you.*

WE HAVE
very extensive

RESEARCH LABS
headed by

CAPABLE ENGINEERS
*specializing in the
application and production
of*

**ELECTROLYTIC and
PAPER CONDENSERS**

**TO
HELP DESIGN AND
PRODUCE A-1**

**FILTER SYSTEMS
AT A LOWER COST.
HOW ABOUT
PRODUCTION?**

120,000 SQUARE FEET
in our new

PLANT *devoted entirely
to the manufacture of
condensers.*

WE ARE ONE SPECIALIST
it costs nothing

TO CONSULT.

YOU ARE both

JUDGE and

JURY.

HOW ABOUT

A TRIAL?

SPRAGUE SPECIALTIES COMPANY QUINCY, MASSACHUSETTS

SOME SPRAGUE ELECTROLYTIC OR PAPER CONDENSER
WILL SOLVE YOUR CONDENSER PROBLEMS





ONE conspicuously successful radio manufacturer, whose name is a by-word in America, has risen to the position because he insists upon building his product as well as he know how to build it. In that plant any suggestion that a few cents can be saved, by buying parts or materials not thoroughly approved, is quickly frowned upon.

Permanency in a fast-changing industry can be attained only by building a genuine and accumulative good will over a period of years.

You will secure in Dongan Power Parts the most recent developments that will stand the acid test of performance. Not the lowest in price—but the finest Power Parts that can be made by an organization which has devoted twenty years to the single purpose of designing and building fine transformers.

*Exclusively Mfr's
of Parts for the
Set Manufacturer*

*Transformers
Chokes
Condenser Units*

Dongan Electric Manufacturing Co.

2991-3001
Franklin Street



Detroit
Michigan



Big
Profits
in it with
Reliable
Equipment

"A penny saved is a penny earned" is not true in purchasing instruments for radio servicing work. The small difference in cost between the best obtainable meters and those of secondary value comes back to you many times over in the money you can make and the business reputation you acquire through the use of reliable equipment.

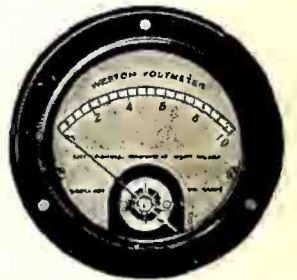

Shown herewith are two designs of miniature panel instruments—2" and 3 1/4" diameter—for use in the repair shop and in portable testing work. These are the instruments selected by Commander Byrd for his Polar expeditions. Preferred for their nicety of construction and superior electrical characteristics.

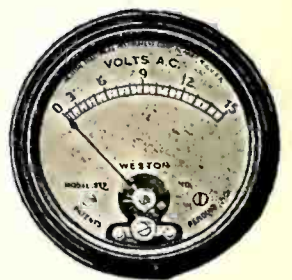

Made in A. C., D. C. and Thermo-Couple Types, and in all the required ranges. Open scales almost to zero position. Designed for flush panel mounting. Write for Circular JJ, containing complete descriptions and prices.



WESTON ELECTRICAL
INSTRUMENT CORPORATION

604 Frelinghuysen Ave. Newark, New Jersey

Fulco RADIO COVERS



"FULCO" covers are used by those dealers who realize the importance of making deliveries in perfect condition — without scratches or mars. For they know that complaints mean dissatisfied customers and loss of business.

"FULCO" covers are a real service feature that helps sales and holds trade. Substantially constructed, heavily padded, box-shaped, providing perfect protection. Give us the dimensions of radios handled and let us quote special prices on your individual needs. Write our nearest house.



Fulton Bag & Cotton Mills
Manufacturers Since 1870
ATLANTA · NEW ORLEANS · DALLAS · ST. LOUIS
MINNEAPOLIS · BROOKLYN · KAN. CITY · KAN

**ON AND OFF
IN A JIFFY**

REVIEW

◀ **IMPORTANT EVENTS**—National Carbon retires from receiving set field, unloading sets throughout the country at less than half of list price. List of Radio Corporation tube licensees mounts to 12 with addition of Triad, of Pawtucket. (Others: Allen, CeCo., Champion, Hygrade Ken-Rad, La Salle, National Union, Sylvania, Raytheon, Tung-Sol, and United Radio). Revelations continue in Washington before Senate Interstate Commerce Committee with B. J. Grigsby, of Majestic, saying that the industry is badly hampered by the clouded and unhappy patent situation and the effect of the RCA licensing policy, and Oswald F. Schuette revealing list of 54 members of the Radio Protective Association. (RADIO BROADCAST, February, p. 199.) International broadcasting renewed on January 21 with great success. Four more companies reported in receivership proceedings, increasing the total to thirteen. New companies Temple, Kolster, DeForest, Balkeit. (De Forest receivership petition was dismissed on February 5.) Others; Earl, Freed, A. C. Dayton, Marti, Neonlite Tube, Buckingham, United Reproducers, Erla. McGraw-Hill announces new magazine, *Electronics*, to appear in April. The publication will cover technically, the entire field in which the vacuum tube is used.

◀ **DISTRIBUTION**—RCA-Victor Corporation is reported planning exclusive distributor policy with merchandising of Victor sets to continue as before. The Camden plant of RCA-Victor will produce both Victor and RCA sets, the latter to be marketed under four trademarks: Radiola, Greybar, General Electric, and Westinghouse. Brunswick reported returning to the jobber system.

◀ **NEW MODELS**—In spite of the unhappy position of some manufacturers who are moving present stocks of merchandise announced about the middle of last year, five manufacturers have announced new models; Majestic, Philco, Silver, Zenith, and Stromberg. Several other makers may follow soon.

◀ **BROADCAST ADVERTISING**—President Aylesworth, N.B.C., states to Senate Committee that broadcast advertising while successful must be carefully guarded against excesses. Excesses reported from the West Coast. (RADIO BROADCAST January, p. 126.) Writes our private detective from Los Angeles:

[SOME OF the events in the world of radio in recent weeks may have escaped you. A few of the more important, to our way of thinking, are presented on this page.]

“If you think some East Coast advertisers lay it on thick, you should hear some of the three-minute, wheedling, direct-selling discourses which the announcers here put on between about equal intervals of canned music. However, a reaction may be setting in.” Evidence: advertisement of Silverwoods, Los Angeles, from a recent issue of the *Los Angeles Times*. “Listen to Silverwoods ‘No-Advertising’ program over KHJ. . . . We have determined upon a change of policy in our radio programs. Beginning to-night, there will be *no advertising* . . . When you extend to us the courtesy of listening to our program . . . we become a *guest* in your home. . . . We think there is too much intrusion of advertising over the radio to-day and are pleased to do our small part toward correcting this situation.”

◀ **IN LAWYERLAND**—The Supreme Court refuses to review the decision of the Circuit Court of Appeals, Second district, in *Wildermuth vs. Hazeltine Corp.* case (Atwater Kent-Hazeltine). Hazeltine brought suit on patent No. 1,538,858 said to cover grid circuit neutralization. The decision favored Hazeltine. Atwater Kent is now moving to reopen the case on the ground of new evidence. RCA sues De Forest and Universal Wireless Communication in the Federal Court at Wilmington on certain communications patents. DeForest sues Grigsby-Grunow on their Coyer patent relating to the winding of grid electrodes in tubes.

◀ **NEW TUBES?**—Considerable interest evidenced in the pentode tube. Three American makers have produced experimental models: Arcturus, Champion, and CeCo. January 15th meeting of the Radio Club of America addressed by Keith Henney and Howard Rhodes of RADIO BROADCAST with a paper describing measurements on experimental American tubes and probable receiving set application. The meeting was well attended by tube and set makers. Appearance of a tube in commercial quantities is practically certain but its probable influence on set design of 1930 is not.

◀ **REVELATION**—Fifty four companies made up Oswald Schuette's very vocal Radio Protective Association. Of the fifty four, twenty three companies have now merged, resigned from the Association, or are in the hands of receivers. Of the thirty one remaining, seven are set manufacturers: Advance Electric, Los Angeles; Metro Electric, Chicago; Premier Electric, Chicago; Shamrock Mfg. Co., Newark; Sparks-Withington, Jackson; Tyrman, Chicago; Wilcox Laboratories, Charlotte, Mich. The other active members are: Callite Products, Union City, N. J.; Cardon Phonograph Corporation, Jackson, Mich.; Davis Industries, Chicago; Diamond Electric, Newark; Duovac, Brooklyn; Dura-tron Products, Union City, N. J.; Eisler Electric, Newark; Gold Seal, New York; Halldorson, Chicago; Oxford, Chicago; Parker-McCrory, Kansas City; Perryman, New York; Pilot Radio and Tube, Brooklyn; Polymet, Brooklyn; C. H. Quackenbush, Cleveland; Radio Electric Works, New York; Schickerling Products, Newark; Scranton Button Works; Sonatron Tube, Chicago; Specialty Appliance, Cleveland; Transformer Corp of America, Chicago; Triad, Pawtucket; United Scientific Laboratories, New York; Van Horne Tube Company, Franklin, Ohio; Vesta Battery Corporation, Chicago; Western Coil and Electrical Company, Racine, Wisconsin.

◀ **THE SERVICE GOSPEL**—Substitute “radio” for “car” in the following: “In the Ford Motor Company, we emphasize service equally with sales. It has always been our belief that a sale does not complete the transaction between us and the buyer, but establishes a new obligation on us to see that his car gives him service. We are as much interested in your economical operation of the car as you are in our economical manufacture of it. This is only good business on our part. If our car gives service, sales will take care of themselves. For that reason we have installed a system of controlled service to take care of all Ford car needs in an economical and improved manner. We wish all users of Ford cars to know what they are entitled to in this respect, so that they may readily avail themselves of this service.”—From a full-page newspaper advertisement of the Ford Motor Company. How many radio manufacturers are there who could sign such a statement?

A D.C. TO A.C. "CONVERTOR"

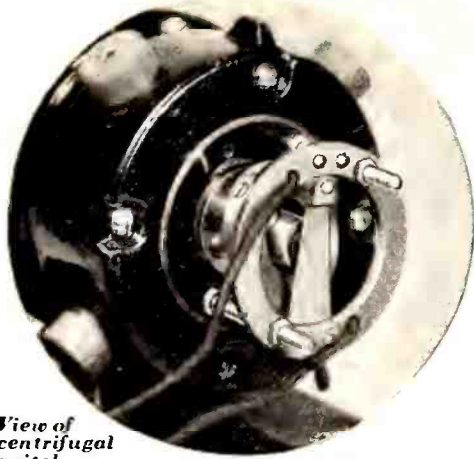

View of centrifugal switch

By **FRANK G. LOGAN**
Ward Leonard Electric Company

The engineering problems associated with the design of radio receivers for operation on d.c. have always been serious—the available voltage is limited, line noise has been hard to eliminate completely, and a d.c. receiver giving good results in one district may not give satisfactory operation in another location. On the other hand, the development of a special receiver for 110-volt d.c. operation is costly, and, since production is comparatively small, tool and production costs are higher. The power output is very limited in designs suitable for public use and the owner of a d.c. set who moves to an a.c. district must purchase an entirely new receiver.

In rural homes equipped with 32-volt farm-lighting systems either battery-operated receivers or a.c. sets with motor generators or rotary converters have been used in most cases. Motor generators or rotary converters in sizes suitable for use with radio sets which require only about 100 watts are quite inefficient, generally being not more than about 40 per cent. efficient. Therefore, a 100-watt a.c. set powered from a convertor connected with a 32-volt system places a load on the line of about 0.25 kVA.—which is undesirably large for such systems are seldom rated at more than about 1 kVA.

There is an obvious need for some device which will make it possible to build efficient sets for 32-, 110-, and 220-volt d.c. systems which will not cost much more, and which will give, in every way, a performance equivalent to that obtained from a standard a.c. receiver. Considerable work on such a device has been in progress at the laboratories of the Ward Leonard Company and a very satisfactory final design has been produced. This device is known as the Ward Leonard Adaptoron. A most important feature of this device is economy; the cost of an alternator or converter to supply 0.25 kVA, is much in excess of the cost of an Adaptoron for equivalent duty.

A Device to Permit the Operation of A.C. Radio Receivers From a 32-, 110-, or 220-volt D.C. Supply. Efficiency Approximately 80 Per Cent.; Automatic in Starting; Quiet in Operation.

Briefly, the Ward Leonard-Adaptoron consists of a specially designed rotating reversing switch which reverses the flow of current from the direct-current line 120 times per second. This gives the effect of a 60-cycle alternating current as it requires 1/60th of a second to go through a complete cycle, or reversal in both directions. The switch is in the form of a commutator with four brushes, the commu-

frequency ratio may be altered as desired.

The efficiency of this device is approximately 80 per cent. as compared with 50 per cent. delivered by the average motor-generator for radio and 40 per cent., or less, with the average rotary converter for radio use. The standard model is designed to carry loads of 0.125 kVA., or less. This, roughly, is the equivalent of a radio receiver consuming 120 watts.

The output voltage is dependent upon the voltage of the direct-current line but, unlike motor-generator sets and converters is independent of motor speed. A variation of loads, within limits, causes little change in output voltage. On the average direct-current line of 115 volts ample a.c. voltage is supplied to the receiver using the low-voltage tap. For those who live in a district where the d.c. line voltage is low a booster transformer is supplied at slight additional cost. Such a transformer is also supplied with the 32-volt model.

Filters Prevent Interference

The design of the device not only includes adequate filters but the housing itself forms a double shield which prevents the radiation of electrical disturbances. A filter circuit is included in both the input and output circuits. This effectively prevents any disturbance arising in the device itself and a majority of the "line noises" from reaching the receiver and interfering with reception.

The small driving motor rotates at the comparatively low speed of 1800 r.p.m. This low speed reduces vibration and lessens bearing wear and brush loss. On the other hand, many motor-generators and rotary converters operate at speeds of 3600 r.p.m.

The motor of the Adaptoron is suspended from helical springs inside the case, thus preventing all motor vibration from being transmitted to the case. The freedom from noise due to this arrangement

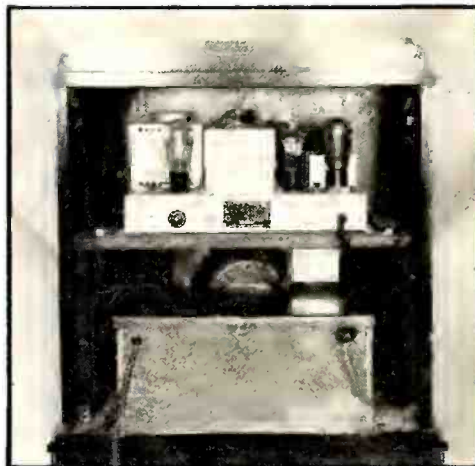

The Adaptoron installed in the battery compartment of a radio console cabinet.

tator being rotated by a small direct-current motor similar to those used in small hair driers, vacuum cleaners, and other household appliances.

By using a motor with fairly good speed-regulation characteristics, a frequency may be pre-selected and maintained within limits. The relation between motor speed and the frequency of the output voltage is—

$$f = \frac{\text{r.p.m.}}{30}$$

By other arrangements of the commutator segments and brush, this motor speed-

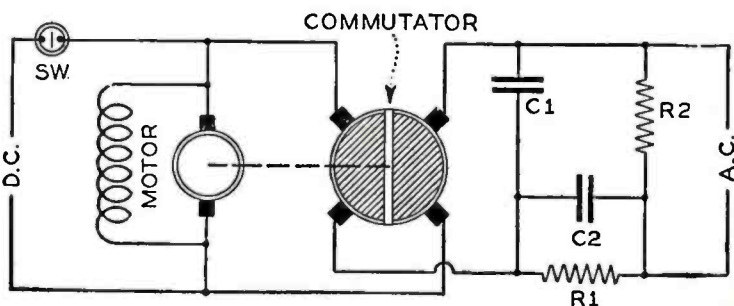

Fig. 1—The neon-tube Adaptoron circuit.

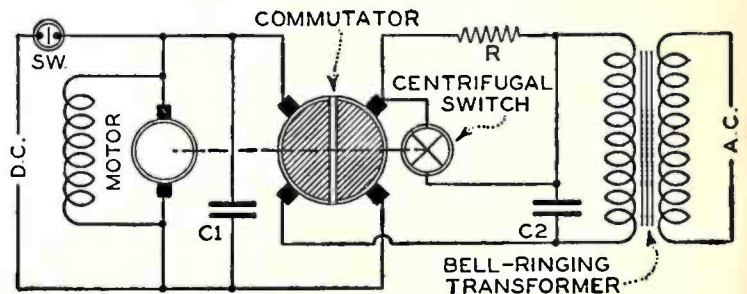

Fig. 2—The bell-ringing Adaptoron circuit.



Adaptoron equipment of the type used for purposes other than radio, that is, neon-light and bell-ringing circuits.

permits it to be placed near the radio receiver. In fact, it has been designed for placement in the console type cabinet which houses the receiver and loud speaker. As the driving motor may be wound for any direct-current voltage, models are furnished for operation upon 32-, 115-, and 230-volt direct-current lines.

The direct-current motor used has only one function in the circuit: To drive the special commutator at a constant speed. The power consumed in this service is small and it represents practically the entire inefficiency found in the device.

Centrifugal Switch

This device is self-starting. It requires only a simple switch as compared with the accessories required with motor-generators and converters. Since, if the d.c. supply to the special commutator were closed with the motor at standstill or rotating at a very slow speed, the d.c. line would be shorted across the primary of the power transformer, a small centrifugal switch is connected to the shaft of the motor. This switch does not close until the motor reaches about normal speed and as a result prevents the line from being shorted across the transformer primary.

The final design of the device was based on a number of measurements to indicate the effect of varying the length of the commutator segments and of varying the constants of the filter circuits associated with the input and output circuits. In

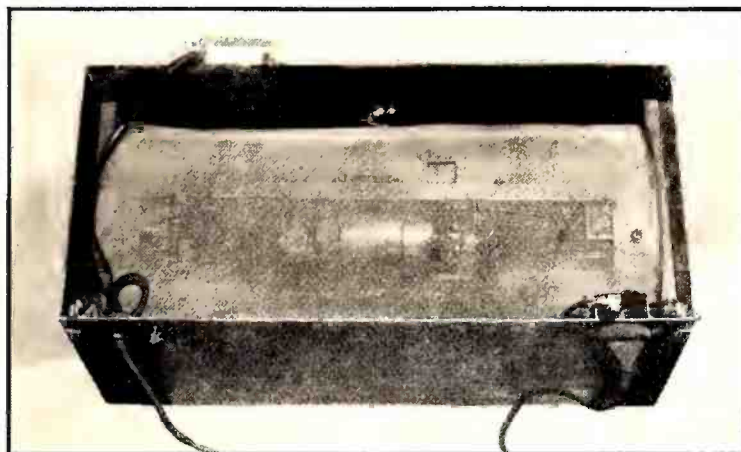

View of Adaptoron with front shield removed.

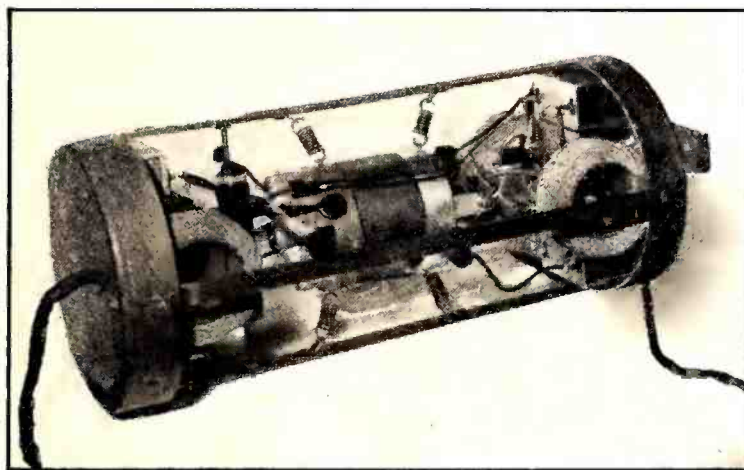

The Adaptoron chassis with both shields removed.

all cases the output of the device was connected to a step-up transformer with a turns ratio between the primary and the high-voltage secondary of 3.5 to 1. Across the secondary a 9800-ohm load resistor was connected. The measurements taken were the d.c. input voltage, the a.c. output voltage, the a.c. voltage across the secondary, and the wave form across the primary.

The first tests were made with a simple commutator system to determine the effect of varying the length of the commutator segments. Some of the wave forms obtained are indicated in Fig. 4 (page 302). It should be noted that the lengths of the segments are

given in electrical degrees. Since there are four segments, giving two complete cycles per revolution, the total electrical degrees in the circumference is 720°. Since all the segments are of equal length the maximum number of degrees per segment is 180°. The wave forms shown in curves 1, 2, 3, and 4 of Fig. 4 were obtained with segment lengths of 110, 130, 140, and 150 electrical degrees.

The area of the curves increases as the commutator segments are lengthened because of the greater length of time the circuit is closed. Increasing the segment length to 160 or 170 degrees caused the commutator to flash over. The sharp sides of the curves indicate the presence of a large number of harmonics and the succeeding experiments were made to determine the effect on the wave form of various filter circuits. A commutator length of 150° was chosen since it gave high efficiency without any tendency for the segments to flash over.

Filter Systems

Placing a condenser across the primary terminals (points 1 and 2 in Fig. 4) or a choke in series with the primary circuit caused excessive sparking at the commutator. Much better results were obtained by the use of filters containing both types of reactances. In Fig. 5 are some data and curves obtained by the use of the filter system indicated. A series of curves made with a choke in both legs instead of only one leg (as indicated in Fig. 6) gave a somewhat purer wave form, especially if the condenser had a capacity of more than 8 mfd. The wave form corresponding to a C of 16 mfd. approximates that of the final design for radio use. The short horizon near the beginning of each cycle is due to a defect in the commutator, and is, therefore, not present in the wave forms of the commercial units.

A double-section filter was next tried. The circuit, voltage readings, and wave forms are shown in Fig. 7. Various capacities were placed at the input and output of the filter circuit, and, as indicated, they had quite an effect on the wave form. The lowest curve for capacities of 8 mfd. at input and output evidently contained a large third harmonic (180 cycles) but not much of any other harmonics.

Variation of the load will, of course, (Continued on page 302)

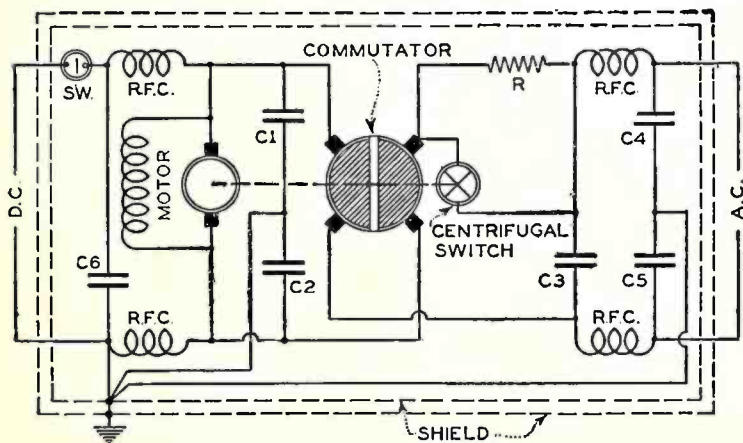

Fig. 3—The Adaptoron for radio use.

CHARACTERISTICS OF PENTODES

A Discussion of the Pentode With Particular Reference to the Characteristics of Some Experimental American Tubes. The Curves Given Include Static and Dynamic Characteristics, Power Output, etc.

By **KEITH HENNEY*** AND **HOWARD E. RHODES†**

*Director of the Laboratory and †Technical Editor, Radio Broadcast

Mention of the pentode tube first appeared in English and Continental radio publications in 1928 and 1929. Essentially it is a power output tube which, compared to a triode, delivers more a.c. power output per watt d.c. expended in heating the plate. At the same time it is more sensitive than triodes, i.e., it delivers more a.c. power output per a.c. volt input squared. The tube may have resulted as a natural development of tetrodes where secondary emission is bad or it may have been the result of the search for more economical power tubes. In this country there are already two kinds of five-element tubes. One is a power pentode and the other (CeCo) is a screen-grid pentode for r.f. or a.f. circuits.

Until very recently foreign pentodes delivered about 500-750 milliwatts when operated with 150-180 plate volts and with plate currents of the order of 10-15 milliamperes. The grid excitation required is roughly one tenth that required to deliver the same amount of power from a triode. Recently more powerful tubes have been developed; i.e., those using 300 volts on the plate and delivering 2000 milliwatts. Such tubes are made by Mullard, Philips, Marconi, etc.

In the United States the desire is not so much for greater economy as it is for greater power output. Hence the trend in experimental tubes so far is to increase the possible power output from a 250-volt tube. At the same time the

superior sensitivity of the pentode is a distinct advantage. It will eliminate the very large grid swing necessary to load up a push-pull amplifier using low- μ triodes.

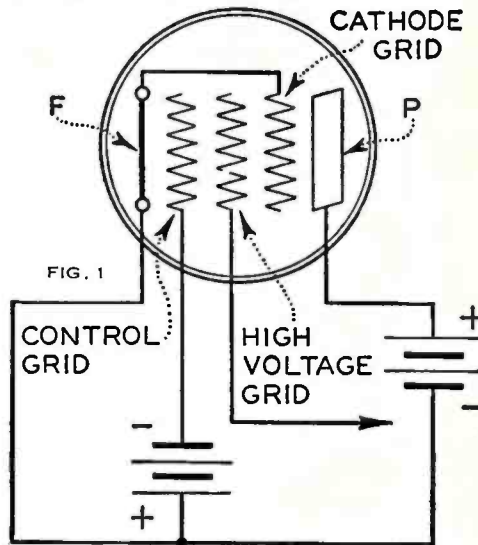

The pentode is a three-grid tube (See Fig. 1). One grid is the usual signal or control grid. The second grid, situated between the control grid and the plate, is a high-voltage grid. It has the effect of moving the plate nearer the filament and reducing the plate resistance. The third grid is very near the plate and is permanently connected to the filament. It is, therefore, at zero potential with regard to the d.c. and a.c. voltages within the tube. It is called the cathode grid and its purpose is to return to the plate any secondary emission from the plate. The arrangement of the five elements is indicated clearly in the diagram on the left.

Secondary emission is due to high-energy electrons striking the plate and knocking other electrons out of the latter element. The fact that a high-potential grid is in the path of the electrons speeds them up considerably and hence increases their kinetic energy. If, as in the screen-grid tube, there were no retarding influence between the plate and the positive or accelerating grid, these secondary electrons would find themselves in the field of the positive grid and would represent a decrease of plate current. The cathode grid which is at zero potential represents a wall over which the secondary electrons cannot or prefer not to jump. Therefore, they return to the plate.

The curves presented here are largely from an experimental tube developed in Arcturus laboratories. It

TABLE I

COMPARISON OF PRESENT POWER TUBES AND THE PENTODE FROM THE STANDPOINT OF SENSITIVITY, D.C. POWER INPUT, AND EFFICIENCY.

Tube	E_c	E_p	I_p	Output M_w	$\frac{M_w}{E^2}$	D.C. Power (Watts)	Eff. ($\frac{P_{a.c.}}{P_{d.c.}}$)	I_f Power
112A	9	135	7	120	2.9	0.945	12. %	1.25
171A	40	180	20	700	0.47	3.6	19.5 %	1.25
210	31	400	18	1325	2.73	7.2	18.4 %	9.4
250	84	450	55	4050	1.12	24.7	16.3 %	9.4
245	50	250	32	1600	1.27	8.0	20 %	3.75
PE 7	12	250	42	2200	30.5	10.5	21 %	3.75
150-Volt Pentodes	10	150	12	500	10.0	1.8	28 %	0.6 to 0.8

Eff = output power \div input d.c. power

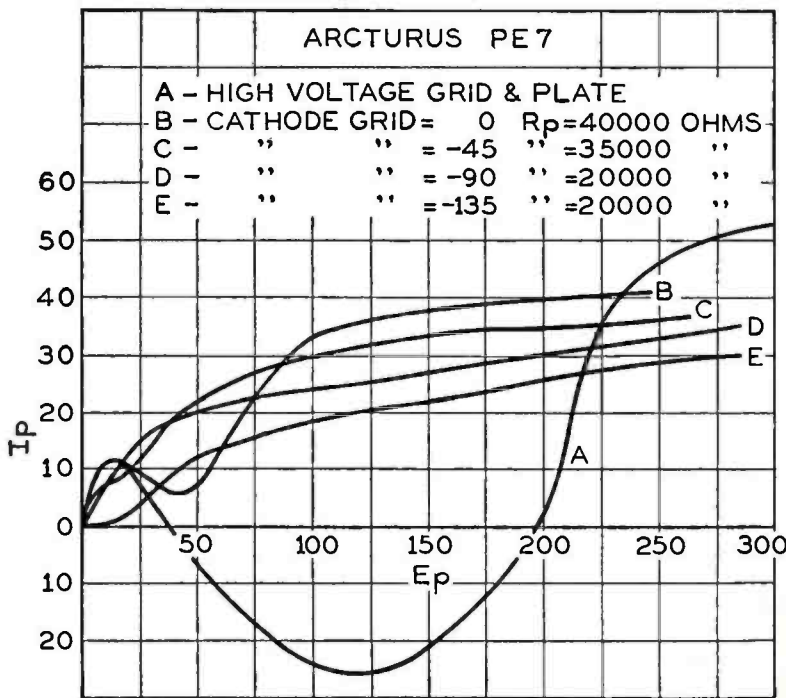

Fig. 2

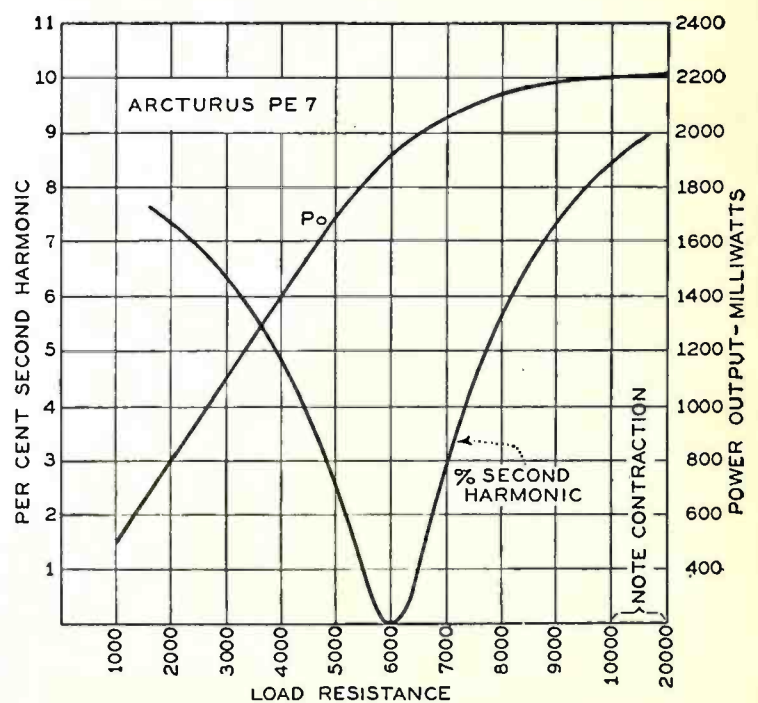

Fig. 3

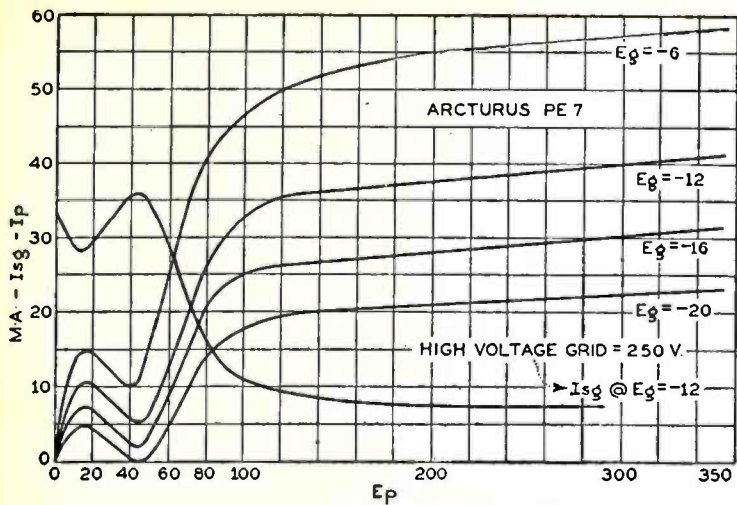

Fig. 4

will deliver about 2000 milliwatts with a plate current of about 40 milliamperes at 250 volts, and requires a grid voltage (a.c.) of only 12 volts peak. This may be compared to a 245-type tube which delivers 1600 milliwatts on approximately the same amount of d.c. power and with a grid voltage of 50 volts.

Characteristic Curves

Plate current-plate voltage characteristics of the Arcturus PE-7 tube are shown in Fig. 4. There is still some secondary emission at low plate voltages. The effect of varying the potential of the cathode grid is shown in Fig. 2. At high negative voltages on this grid, all the electrons are speeded back to the plate and there is no secondary emission.

While it is probably not correct to use the usual method of laying out load lines on the E_p - I_p curves to determine the proper load resistance and the second harmonic distortion, some idea of the respective values can be discovered by so doing. These data are presented here with the knowledge that they may mean very little indeed. Thus it may be calculated that the Arcturus experimental tube with an internal resistance of about 40,000 ohms will work best into a load resistance of from 4000 to 8000 ohms. Within these two values the second harmonics (according to usual methods of calculation) will be less than 5 per cent., the usual criterion for distortionless amplification. At the same time the power output does not increase appreciably for values of load resistance in excess of 8000 ohms. (Fig. 3).

It is probable that the third harmonics are the worst offenders in the pentode and at the present time there seems to be no generally accepted and easily worked method by which the percentage of third harmonics can be calculated from the characteristic curves.

Use of the Pentode

In Europe the pentode has been worked with magnetic loud speakers whose well-known impedance characteristics are anything but straight flat lines. As a rule the impedance of these loud speakers increases rapidly with frequency. Since greater and greater distortion is the result

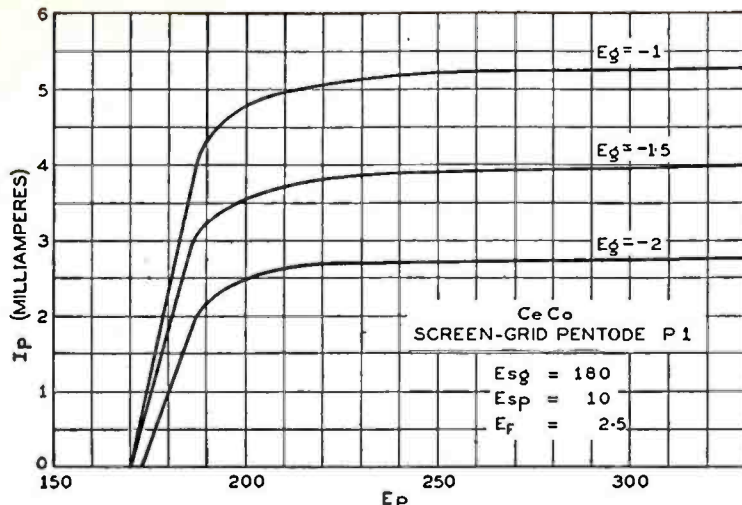

Fig. 5

of using a high-resistance load with the pentode, the fidelity of response is not very good. The high frequencies develop very high voltages across the load and within the tube, and are reproduced all out of proportion to the low tones.

In this country the magnetic loud speaker is practically on the shelf in favor of the

electrodynamic type which has a flatter impedance characteristic. Since the pentode should be worked into a load lower in resistance than itself, it can be coupled to an electrodynamic loud speaker through the same transformer which usually couples it to a 4000-ohm tube. In the Laboratory the fidelity from such a tube and a Peerless loud speaker compared very favorably with that obtainable from a 245-type tube, and with a given grid voltage input the output was some 15 db higher. In other words, feeding 12 volts into a 245-type tube produced about 100 milliwatts but the same voltage fed into an Arcturus pentode produced about 2000 milliwatts. This is a very appreciable difference in volume.

Practical Applications

One of the important applications of this tube may be in the detector socket as a true power detector. Thus it may be used with the loud speaker in its plate circuit. However, whether it will make a good power detector tube has not been determined by experiment. A glance at its grid voltage-grid current curve (Fig. 6) indicates that it will make a good grid-circuit detector. The problem then becomes one of obtaining sufficient power from it. Development of more efficient loud speakers will make it possible to eliminate the audio-frequency amplifier entirely and to use only the pentode as a power detector working directly into the loud speaker.

It has been suggested that the tube in this capacity might serve in automobile radio receivers and in other places where the space limitations are severe. The fidelity obtainable from a small loud speaker under the best conditions cannot be extremely good, and so the use of a small magnetic or electrodynamic loud speaker in connection with a pentode detector supplying perhaps 500 milliwatts may be an important application.

In this particular tube, which may not

TABLE II

Name	E_f	I_f	R_p	M_u	G_m	E_p	E_s	E_c	I_p	P_o	I_s
Cossar 230	2	0.3	20×10^3	40	2000	180	120	9	14		1.6
415	4	0.15	20	40	2000	180	120	9	14		1.6
Marconi PT 240	2	0.40	55	90	1650	150	150	9	16	500	6.0
PT 625	6	0.25			1850	250	200	15	26.5	2000	7.0
Mullard PM 24	4	0.15	28.6	65	2300	150	150	12	12	500	3.0
PM 24A	4	0.275			1550	300	200	21	18	2000	5.0
PM 22	2	0.3	62.5	80	1300	150	150	10	13	350	3.5
Six Sixty ss 230 pp	2	0.3	64	80	1250	150	150	10	13	350	3.5
415	4	0.15	27	60	2200	150	150	12	12	500	3.0
4pen	4	0.275			1550	300	200	21	18	2000	5.0
Mazda 425	4	0.25			2000	150	150	12	18	750	5.0
Philips C443	4	0.25	40	60	1500	300	200	15	28		
PE 7	2.5	1.75	40	80	2000	250	250	12	40	2200	10.0

E_f —filament voltage
 I_f —filament current
 R_p —plate resistance
 M_u —amplification factor
 I_s —current to high-voltage grid

G_m —mutual conductance
 E_p —plate voltage
 E_s —high-grid voltage
 E_c —control-grid bias
 I_p —plate current
 P_o —power output (milliwatts)

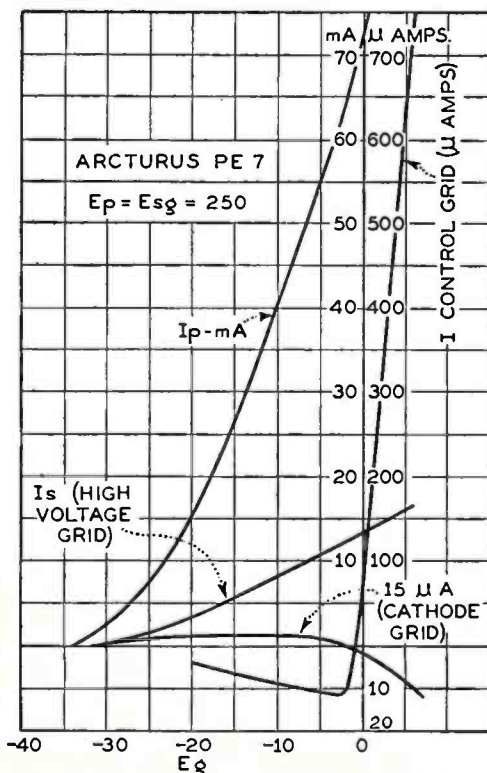

(Note change in grid current scale below abscissa.)

Fig. 6

TABLE III

	New CeCo Screen-Grid Tube	Present Screen-Grid Tube
Filament volts	2.5	2.5
Filament amperes	1.75	1.75
Control grid bias	(-) 1.5	(-) 1.5
Space-charge grid volts	(+) 10	(+) 10
Screen-grid volts	(+) 180	(+) 75
Plate volts	250	180
Mutual conductance	2300	1050
Plate resistance	250,000	400,000
Amplification factor	575	400
Plate current	3.9 ma	4.0 ma
Screen current	1.5 ma	
Space charge current	5.0 ma	
Maximum amplification (into 100,000 ohms)	164	84

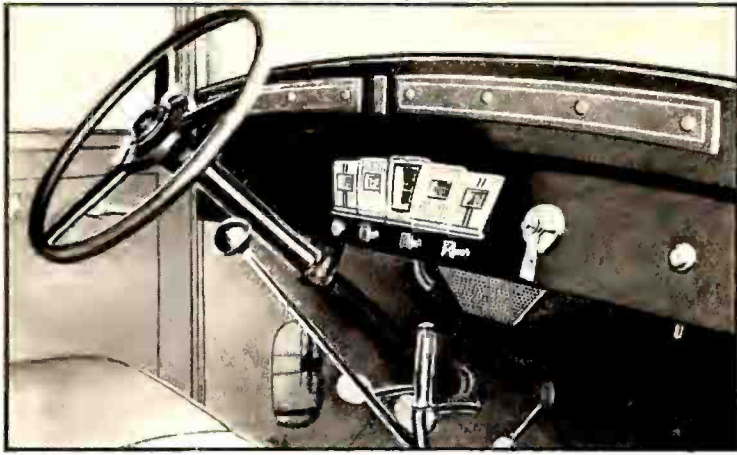

A Chrysler car equipped with a Transitone radio.

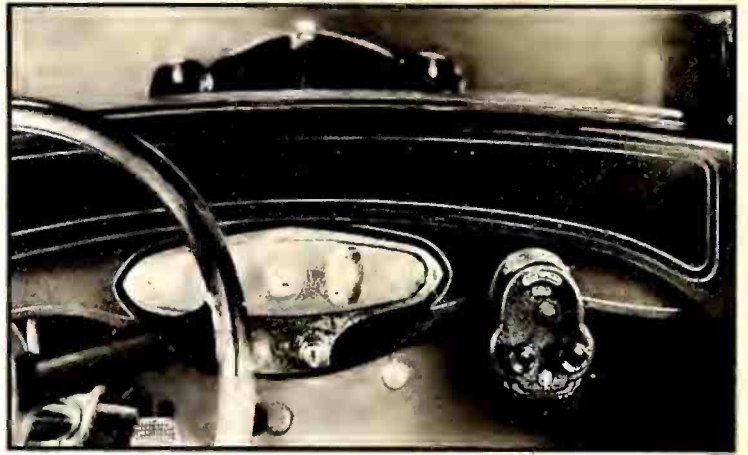

The Bosch radio control on the dash of a car.

AUTOMOBILES WITH RADIO

This Development, Which is Rapidly Gaining Headway, is Being Exploited by a Number of Manufacturers; Several Are Selling Cars With Radio as Standard Equipment While Others Provide Wiring to Facilitate Installation at Time of Sale. Three Manufacturers Make Suitable Equipment.

Opinions on the desirability of radio as a standard accessory in the automobile differ widely among passenger car manufacturers, but the question commands some consideration in practically all quarters where automotive topics are discussed.

Quite recently a number of automotive executives, whose interest in the radio-equipped car previously had been rather indifferent, have displayed a decided curiosity. There are a number of executives representing some of the largest automobile manufacturers, on the other hand, who admit doubt about the future of radio equipment, and who feel that the public should be given more time to manifest its attitude.

Since radio receiving sets first gained popularity in American homes, some seven or eight years ago, there have been individual cases of radio-equipped automobiles. These early examples, however, proved more of a novelty than anything else, and their use was restricted more or less to purposes of advertising. There were too many technical difficulties to be overcome and the cost of intensive experimental work was not recognized as commensurate with the likelihood of immediate demand by the public.

In recent years the radio has developed from a novelty and a luxury to something closely approaching the indispensable. The phenomenal expansion of the radio industry is something unmatched except by the amazing development of the automobile industry. The product of each has become an item of paramount importance to the American family, and the possibility of combining the advantages of radio and the automobile has been considered by far-visioned car manufacturers for some time.

In some quarters argument has been advanced that a radio set in an automobile must necessarily act as a distraction to the driver. There has even been some discus-

sion of the possibility of adverse legislation, or at least legislative control of the use of radios in cars. However, *Automotive Industries* (from which much of this material is abstracted), states that it has not learned of any definite move on the part of any group to place legislative limitations on the use of radio in motor cars. The informal argument to the effect that a loud speaker would tend to claim too much of the driver's attention, has been met with the opinion that conversation between the driver of a car and his passengers also

might be termed a distraction, and one which is offset by the presence of the receiving set.

Within the past several weeks Alfred P. Sloan, Jr., president of the General Motors Corp., and Walter P. Chrysler, president and chairman of the Chrysler Corp., have expressed the attitudes of their companies on this subject in no uncertain terms. Mr. Sloan said in part: "Not only do we believe that there is a great opportunity for

the development of the radio business as an adjunct to the automobile, but the radio field in general is one that is closely related to the automobile and electric business, in which General Motors is engaged."

Mr. Sloan's statement said further: "New Cadillac and LaSalle cars have been designed for radio installation and thousands of installations already have been contracted for by dealers. As quickly as possible the same facilities will be available for other makes of General Motors cars."

A survey among major automobile manufacturers just completed by *Automotive Industries* has revealed that in the near future a number of other companies will introduce cars either with radio as optional equipment or with the installation already made for the provision of receiving sets. However, the number of manufacturers who have taken no steps for the installation of radio in their products is probably larger. Several automobile executives stated positively that they could see no indication of public demand of sufficient strength to warrant any measures for the provision of radios in their cars, at this moment.

For several weeks Transitone automobile receivers, the radio receiving sets manufactured by the Automobile Radio Corp., of New York, have been incorporated as standard equipment on Dodge Brothers Senior Six models and on Dodge Brothers motor coaches. More recently Walter Chrysler announced

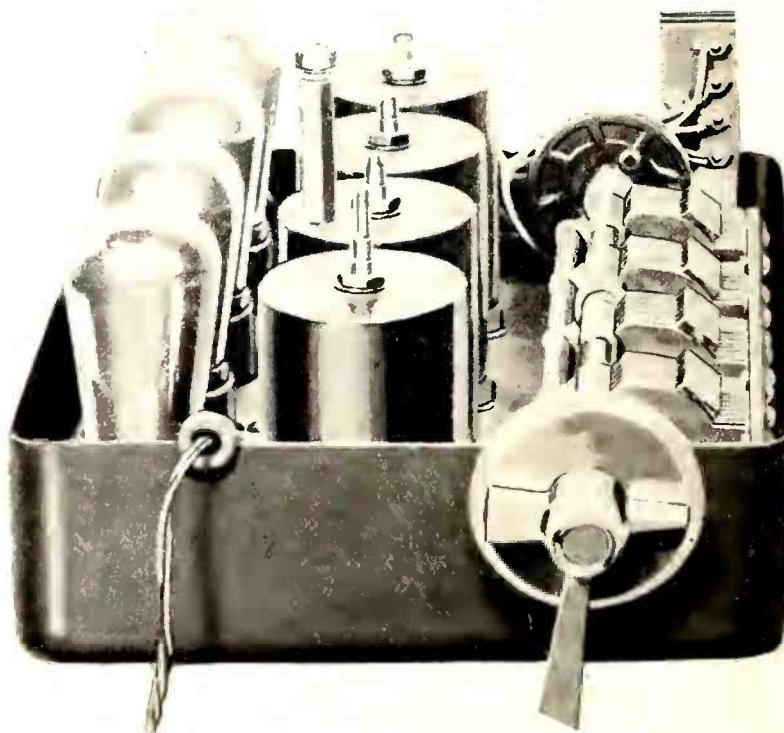

Interior view of the tuning unit of a Transitone automobile radio receiver.

that the closed models of the Chrysler "70" and "77" lines were being wired for the installation of radio receiving sets at the owner's option. Mr. Chrysler's statement said in part:

"After exhaustive tests on the road and in the laboratory by engineers of the Chrysler Corp., the Transitone radio was found to provide perfect reception under all conditions imposed by motor car installation. Its inclusion as an engineered unit in Chrysler cars was immediately directed."

The Transitone is a six-tube set built integral with the car so that only the tuning dial and switch are visible on the instrument board. The antenna is concealed in the top of the body, the lead-in wire running through the right windshield post. The entire set is composed of four units; loud speaker, receiver, audio-frequency amplifier, and batteries. These, with the exception of the batteries, are enclosed in metal boxes, held in place by heavy steel brackets under the cowl.

Type of Circuit Used

The receiver has three stages of tuned-radio-frequency amplification, a detector, and two stages of transformer-coupled audio-frequency amplification. Three 201A-type tubes are used in the radio-frequency sockets; one 112A-type tube in the detector socket; one 201A-type tube in the first

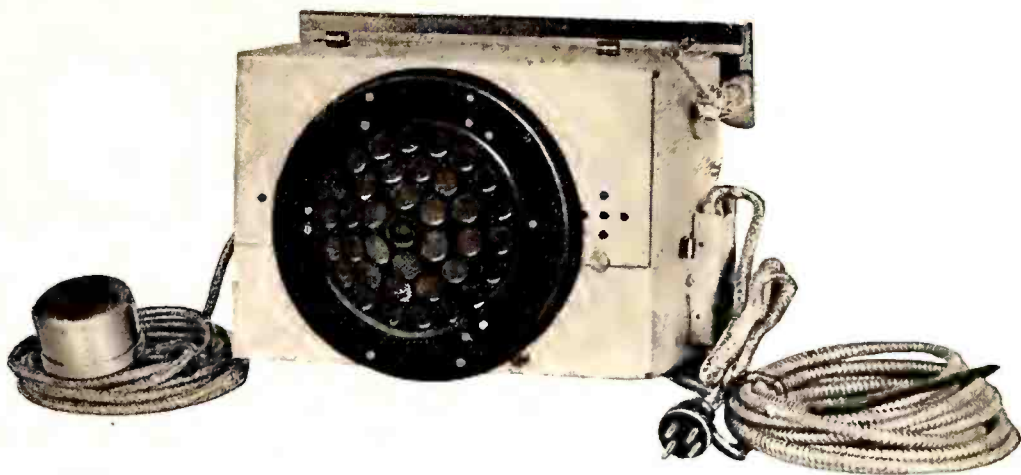

The complete chassis of the Bosch automobile radio.

and an automatic volume control, so that the driver does not have to readjust his volume control each time he passes behind a steel building or under overhead wires. A volume control knob is provided to allow the driver to set the volume to the desired level where the automatic control holds it as long as the station signal strength does not become too weak.

The set uses two stages of screen-grid radio-frequency amplification, a power detector, and two stages of resistance-coupled

wires strung lengthwise between the outer covering of the car top and the upholstering inside the top. The lead-in wire connecting the antenna to the set is covered with a copper braid to prevent it picking up spark noise.

The Bosch Motor Car Set

The American Bosch Magneto Corporation announced and displayed the Bosch Motor Car Radio for the first time during the New York Automobile Show. The receiver utilizes screen-grid tubes and is thoroughly shielded from outside interferences and from the electrical system of the automobile. The receiver and the cone-type electromagnetic loud speaker are contained in one small compact unit which is mounted out of sight on the dash, behind the instrument panel. A solid shaft operates the receiver from the tuning control unit which can be mounted in any convenient position on the dash.

This control unit, no larger than a man's hand, contains a key switch to prevent unauthorized operation in the absence of the owner. One knob controls the tuning and the other controls volume. The station selector dial is electrically lighted and tuning is made easier through the use of the Bosch "Line-O-Lite" dial.

The receiver operates from the storage battery of the car and from dry-cell batteries which are carried in a weather-proof steel container mounted underneath the car. No mutilation of the dash, top, or upholstery is necessary in the installation of Bosch Motor Car Radio. The antenna is not located in the roof of the car but consists instead of a metal plate fastened under the car.

The list price of Bosch Motor Car Radio, complete in every way with tubes, B batteries, shielded wiring, etc., including installation, will be \$140.00. All Bosch distributors and some automotive distributors will handle the receiver.

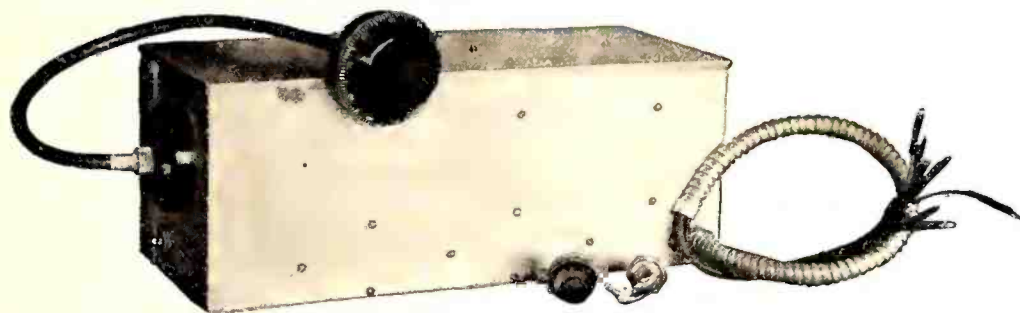

Chassis view of the Delco-Remy automobile radio.

audio-frequency socket, and one 112A-type tube in the last a.f., or power stage. These sockets are cushioned to prevent the transmission of road shocks, and, under normal driving conditions, the tubes are said to last virtually the same length of time as those in a regular set.

To facilitate installation of Transitone equipment at the time of sale, a number of leading motor car manufacturers are building antennas in the roof of their 1930 models at the factory and in other ways specifically designing their products to accommodate radio receivers. Among these are: Chrysler Models 70 and 77, Desoto, Franklin, Gardner, Hupmobile 8's, Jordan Airway Models, Moon, Packard, Peerless 8 Series 3, and Pierce-Arrow. Arrangements have also been concluded whereby the Willard Storage Battery Company's nationwide system of service stations will sell, install, and service Transitone receivers.

The receiving set for automobiles introduced by the Delco-Remy Corp., of Anderson, Ind., and being used in Cadillac and La Salle cars is now being manufactured by the recently organized General Motors Radio Corp., of Dayton, Ohio, which also manufactures the Day-Fan radio receiving sets for home use. The entire manufacturing and engineering work has been transferred from Anderson to Dayton.

Automatic Volume Control

Ease of control is essential because the driver does not have time to adjust several dials and controls while he is driving. The Delco-Remy set has a single dial control

audio-frequency amplification. Three variometers are mounted in line on the same shaft to tune the radio-frequency stages.

The set is mounted between the instrument board and dash to the left of the middle of the car and is out of sight. The tuning dial is connected to the set through a flexible shaft similar to a speedometer drive cable, to prevent any disturbance to the tuning adjustments, which might be caused by a slight weaving of the car. A gear reduction is used at each end of this flexible shaft, in order to give a vernier action on the dial as well as to reduce the effect of twisting the flexible shaft. The set is connected by flexible leads to a terminal box on the loud speaker.

The antenna consists of five parallel

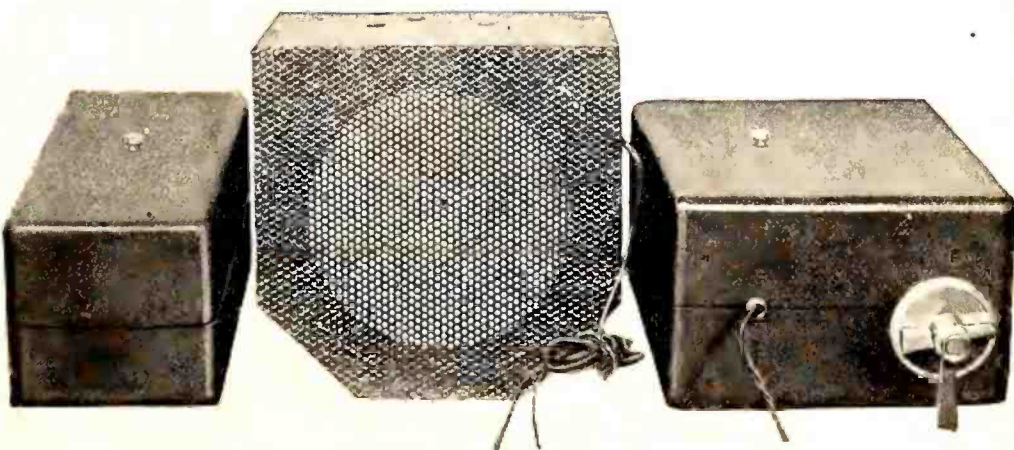

Transitone automobile radio, model RN 109, in the position in which it is installed beneath the cowl.

The MARCH

Reviewing the Commission's Reign
Too Much Politics in Radio Licensing

The Jellyfish Commission

The Federal Radio Commission, after a reign of nearly three years over broadcast allocation, stands nervously before the bar of public opinion. Its only notable action in three years of broadcast regulation was the adoption of General Order 40 and the allocation accompanying it. This action was preceded by a year and a half of purposeless bungling and alibis. Only the passage of the Davis Amendment forced the Commission from its initial policy of dilly-dallying and compromise, almost uninfluenced by the demands of the listening public. Many acceptable reasons may be advanced to account for the delay in adopting a general plan of allocation, but the principal and only important one was lack of courage to face the issues involved. Improvement, of course, was effected before General Order 40 but, so chaotic were conditions when the Commission started work, that a committee of high school seniors could have brought about improvement.

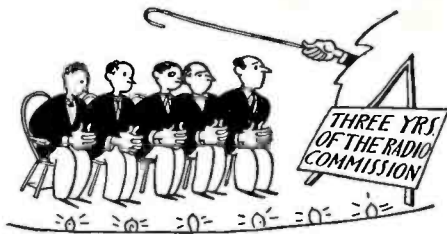

From the moment of its inception, the Commission was aided by sound engineering advice. Within 30 days of its formation, it had in its hands a complete allocation plan based on thoroughly demonstrated engineering principles. Had it acted promptly, the Commission, aided by the backing of public opinion and, if required, additional power of confiscation through legislative action, could then have accomplished a wholesale reduction in the number of stations. During the first few days of its operations, the owner of every pirating broadcasting station expected hourly announcement of the cancellation of his license. But the Commission feared to test its powers. It sought to do "gradually" what could be done only on a wholesale basis.

Station managements soon discovered the temper of the Commission. It has been yielding to individual pleas ever since, each a further narrowing of service to a specially favored area.

The most important action, as we have stated, taken by the Commission in its long history, was the adoption of General Order 40. But it has failed to stand behind this order with the vigor necessary to insure its success. The value of the regional channels has been almost nullified by power increases and excessive loading so that they are to-day little better than local channels. The invaluable cleared channels, on the other hand, have been occupied very largely by stations of such small power that they should be on regional channels. The few really powerful stations on cleared channels have abundantly proved that their assignment represents the most efficient possible allocation. But allocation to cleared-channel operation has not been considered an obligation to render a rural service. Instead, the wide-spread use of cleared channels for regional service only has been construed as evidence that cleared channels are unnecessary.

Yieldings to political pressure in behalf of particular stations have become more and more difficult as conditions have become more and more crowded. It has been inevitable, therefore, in absence of firm resistance to compromise of engineering principles, that the standards set up in General Order 40 should be gradually lowered. Regional assignments are supposed to give the stations allocated to them the opportunity to serve the audiences within their high-grade and regional service areas an interference-free signal. There were to be no more than 125 regional stations operating simultaneously, but the number has been progressively and substantially increased. The power assigned to regional stations has, in many instances, been increased beyond the point that permits other stations on the same channel to serve their intended range. For example, WTMJ, worthy of a cleared assignment, if one is available, finds itself operating in the face of WFLA-WSUN, Florida, which pumps a strong signal into its territory, while WLBZ, in Maine, on the same channel, has had a power increase to 500 watts. WJAY, in Ohio, in response to vigorous protest, has recently been shifted to another channel, but now Philadelphia stations are being interfered with by that station. Its new assignment has effectively converted the 610-kilocycle Philadelphia channel from a regional to a local one.

The requirement that 50-kilocycle separation be maintained among stations within the same area now appears slated for abandonment. This essential principle should be rigidly supported, not only to avoid cross-talk trouble on average receivers but also to prevent undue concentration of stations in populous areas. In spite of the clutter of stations operating simultaneously in the New York area, WGBS, apparently through political influence, has secured a so-called "experimental" license for 600 kc., only 30 kilocycles from WMCA and WNYC. It is authorized to use 250 watts at night in total disregard of WCAO, in Baltimore, less than 170 miles away, attempting



to serve that area with Columbia programs.

Perhaps the most reprehensible feature of such jellyfish yielding to political importunities is the fact that most of these arbitrary licenses are secretly granted. Stations which suffer from these disastrous assignments are not notified in advance nor are they given opportunity to present formal evidence showing the effect of such assignments. All one must do, apparently, is gather unto himself a couple of Congressmen, visit the most weak-kneed commissioner available, make a few grand statements about service to the public, and some way, regardless of the general good of the listener, will be found to accommodate the pleading station. Without the political support, however, pleading is of little avail for the very practical reason that the ether is hopelessly overcrowded.

With increasing frequency, the Federal Radio Commission is making adjustments and reassignments without notifying affected stations or giving them opportunity to

OF RADIO

The R.C.A. on the Griddle at Washington
Has the R.C.A. a Monopoly of Radio Patents?

have their protests heard in advance of such assignments. The unfortunate wording of the Radio Act makes it practically impossible for stations adversely affected by such political pandering to bring their cases before the Court of Appeals because that privilege is accorded only to those who initiate an application which is denied by the Commission. Most of the peculiar assignments are made without hearing and the listening public, as nearly as it can be represented by stations imposed upon, has no opportunity to make itself heard or to secure review of unwise and arbitrary decisions of the Commission.

We should not be too ready to put all the blame on the present Commissioners. The greatest blame should be attached to those who formed the original Commission. They had the whole situation in their hands with full support and confidence of public and politician alike. But, with crass disregard of the listening public, they adopted the attitude of the broadcast station owner and spent much of their time in discussing his property rights. But the present Commission must take the full blame for permitting the progressive devaluation of the benefits conferred by the adoption of General Order 40 and for its extraordinary failure in grasping, or rather selling, through public education, the merits of allocation based on engineering principles.

"A Patent Pool for Public Service"

The hearings before the Senate Interstate Commerce Committee for the purpose of guiding the destinies of the Couzens Bill have not been particularly helpful to the prestige of the Radio Corporation of America. In fact, every interest not directly affiliated with the RCA in one way or another has taken the opportunity to issue some withering blasts. Newcomb Carlton of the Western Union told the Senators that the British cable-radio threat claim is "one of the most fantastic bogies that has ever been dressed up." He pointed out that the message business across the Atlantic during the past nine months, consisting of 51,100 messages daily, was divided as follows: Western Union 44 per cent.; Commercial I. T. & T. 29 per cent.; French cable 7 per cent.; merger cables 2.9 per cent.; merger beam radio 1.8 per cent.; RCA with the British merger 3.5 per cent.; and RCA with all other European countries except Great Britain, 10.2 per cent. In other words, this allegedly all-consuming merger does less than 5 per cent. of the total business and shares but 3.5 per cent. with RCA.

Joseph Pierson, president of Press Wireless, Inc., before the same committee, described his difficulties in procuring apparatus from the RCA to operate on the channels assigned the newspaper group by the Federal Radio Commission. The newspaper men were asked to pay the base cost of the apparatus charged by the General Electric Company to the Radio Corporation, plus a 45 per cent. profit to the RCA, plus 5

per cent. royalty on gross message business, plus a surrender without any charge to the RCA of all patents held by Press Wireless, plus the requirement that Press Wireless must charge its clients with a view to earning a profit and not as a mutual company, plus a prohibition against using the facilities for anything else but telegraph code work and specifically not for transmission or reception of facsimile pictures and the like. For a benevolent monopoly (if we interpret the high-sounding phrases of Messrs. Young and Harbord correctly) the RCA is exceedingly jealous of prospective competition.



B. J. Grigsby, president of the Grigsby-Grunow Company, revealed that his company has paid

\$5,302,879.15 in royalties in a year and a half to the Radio Corporation of America for patents which he does not consider worth this amount of royalty. "But the radio combine has so terrorized the industry and so intimidated the jobbers and dealers everywhere that they were afraid to handle what they called 'unlicensed' sets. Our bankers said they would not finance us unless we took out a license." . . . "When the Radio Corporation fixed this royalty of seven and a half per cent., it did so on the pretext that it had a complete monopoly of the radio patent situation and that its patents covered every part of the radio receiving set. This is untrue. We are now paying royalties to three other patent owners and are being sued by five additional companies for infringement of seven patents. In no

case has the Radio Corporation protected us against these patentees or helped us in the suits which have been filed against us."

Mr. Grigsby, like Mr. Pierson, has become impatient with the patent pool "formed at the urgent request of high Government officials." One of the unfortunate features about the RCA license situation is the fact that their royalty rate is such

a burden upon manufacturers that independent inventors have had the greatest difficulty in securing recognition. The RCA, on the other hand, collects huge royalties on patents, many of which have not been adjudicated.

The industry has paid a toll of tens of millions for patent rights to the RCA group. The companies from which the RCA has procured its patent structure have spent substantial sums for research which have been handsomely returned in commercial and manufacturing advantages and, what is more unusual, have also yielded immense royalty returns although only a very minor proportion of these patents have withstood the test of the courts. If radio had not been such a bonanza at the start, its executives would not have been so ready to pay royalties on unadjudicated patents and would have driven a much harder bargain. Under these conditions, many an independent patent, now out in the cold, would now be receiving the recognition intended by the protection of the patent law.—E. H. F.

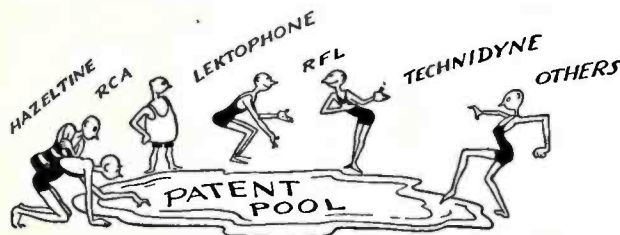



Walter Damrosch and the National Orchestra.

VOLUME CONTROL IN BROADCASTING

Factors Which Limit Range of Volume that Can be Handled by Broadcast Circuits. Effect of Cross-Talk and Repeater Overloading, Frequency Characteristic of Tie-Lines, Limitations Imposed by the Receiver, etc.

By O. B. HANSON

Manager Plant Operation and Engineering
Dept., National Broadcasting Co.

All mechanical and electrical devices have their limitations as man has not yet constructed a machine or a piece of apparatus that is known to be able to operate at 100 per cent. efficiency under all conditions.

In broadcasting less than ten years have been required to develop the present equipment, and the progress which has been made in this direction may be classed as remarkable. The reception enjoyed by radio listeners to-day is in marked contrast to the early days when it was thrilling to receive any signal at all, whatever might be its quality.

Nevertheless, we have *not* yet reached the point of saying, "Well, that's about as good as we can do." Every day we are working, experimenting, discovering, and refining. And each step we take leads to another step. It is probable that the progress has been so gradual that each succeeding stride has not been generally recognized by the average listener.

Pioneers among radio listeners will undoubtedly recall many of the undesirable noises that marked early broadcasting. There was, for instance, a raucous vibrating rattle when volume increased beyond a certain point, and it could not be eliminated by adjustment of the radio receiver. This was the result of faulty production, transmission, or volume control in the studio. To-day we have little of this trouble from properly

constructed and operated equipment, but our improvement has required years of study.

We have learned something of the relation of volume control to other factors, such as size of the broadcast studios and their acoustic properties, "balance" of producing units such as orchestras,

volume range of primary amplifiers, etc. We have learned many of the limitations of the radio transmitter itself, and of the receiving sets in use.

In our study of volume control, we have found important limitations imposed by the avenues over which the signal transmitted reaches the radio receiver—the ether itself and the wire over which the sound must be sent.

There has been established a scale of energy level in order that the limitations in these various stages may be compared

with volume variations of program material being transmitted. The unit of measurement of electrical energy in audio-frequency circuits is the transmission unit, which has recently been christened the "decibel." And the basis to which all levels are compared is known as "zero level." Originally, zero level was established by the telephone companies in the early days of the telephone. It was the level of the average electrical energy developed by the average speaker talking into the ordinary telephone carbon transmitter. This energy level in standard electrical terms is approximately twelve milliwatts. In broadcasting circles, when engineers speak of "zero level" they usually refer to the maximum peaks which are their most serious consideration. These maximum peaks in most cases do not exceed twelve and one half milliwatts.

The instrument used to

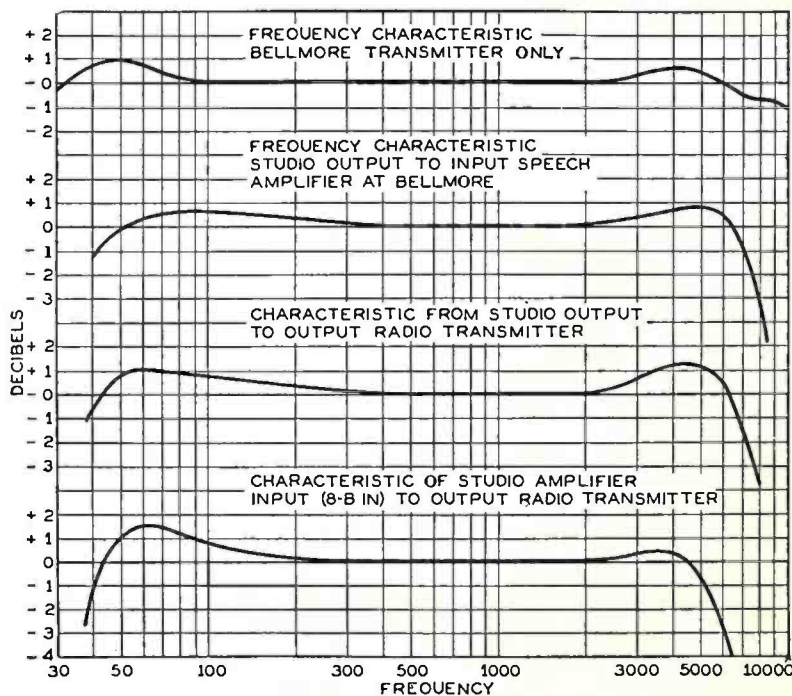

Fig. 1

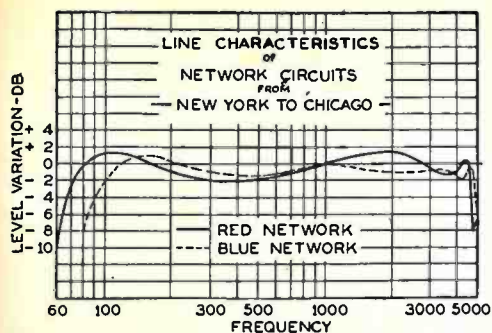

Fig. 2

measure energy level in broadcast equipment is known as the volume indicator, which in reality is a vacuum-tube voltmeter. The scale of the instrument runs from 0 to 60, 30 in the center of the scale being the calibrating point to represent the peak level. This is chosen, of course, to permit the needle to swing freely past this point without hitting the back stop.

There are two major sources which impose limitations on volume variation—the wire lines and the ether. Under the present conditions of broadcasting, with only a limited amount of power permitted, the ether cannot be depended on as a certain medium beyond rather definite limits. Therefore, in nationwide distribution of programs, it becomes necessary to use wires.

Wire Lines in Broadcasting

Telephone lines in the United States are designed primarily for the transmission of speech from city to city. When these existing lines were built there was no thought of transmitting music as it is done to-day. The lines were designed for the transmission of voice only and the quality of the speech was not so important as the intelligibility. It is this transmission system which is used to-day for the transmission of music, and music imposes more stringent requirements for its transmission than does intelligible speech.

To obtain intelligible speech it is only necessary to transmit frequencies between 250 cycles and 2500 cycles, whereas to obtain satisfactory transmission of music it is necessary to transmit frequencies of from 100 to 5000 cycles.

To change a telephone system over to meet these requirements requires considerable engineering and is after all somewhat unsatis-

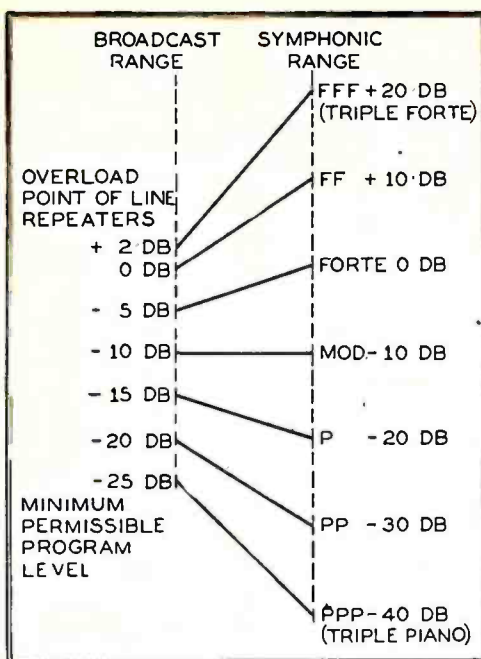

Fig. 3

factory. More repeaters must be introduced, and these amplifiers must have better frequency characteristics than those required in the transmission of ordinary speech.

Music, unlike telephone conversation, varies considerably in its volume. We have the range from triple pianissimos to triple fortes. This variation, when expressed in transmission units, is approximately 60 decibels in the case of a symphony orchestra. The average long telephone circuit

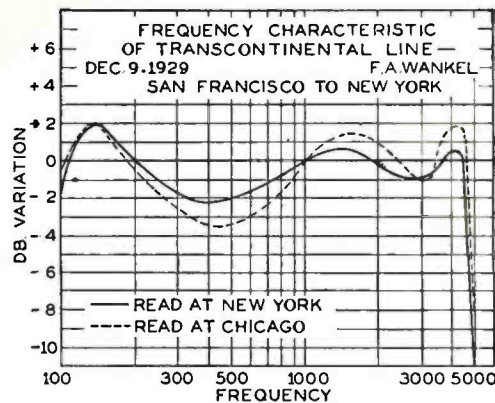

Fig. 4

is not capable of satisfactorily handling such a variation in volume. There is a limitation placed on the maximum energy level which can be transmitted over telephone lines. The maximum safe level is something of the order of plus six decibels and this is imposed primarily by the cross-talk factor.

Cross-Talk Problems

Hundreds of telephone circuits run parallel to each other for many hundreds of miles, and even though these wires are carefully insulated from one another, and transposed in an attempt to reduce the cross-talk effect, the electrical energy being transmitted on one pair will induce small currents to flow in adjacent wires. Everything has been done, of course, to reduce this effect to its economic minimum. The higher the frequency the greater is the possibility of this phenomenon.

The greater the energy in one circuit, the more cross-talk to another circuit, and experience has indicated the maximum permissible level on a telephone circuit to be plus six decibels. This, therefore, is our limitation on the output.

This means that our triple fortes must not be transmitted to the line at a greater level than plus six decibels. We also have our limitation at the bottom of the volume range. The telephone circuit running for miles adjacent to another circuit carrying a program will receive from that circuit by induction a certain energy level of cross-talk. If an amplifier with considerable gain is connected to the end of the dead circuit, cross-talk can be amplified to a point where it is clearly

(Continued on page 292)



The monitor while seated in front of his controls may view activities in the studio through a sound-proof glass window but he listens to the program from a loud speaker.



A glimpse of the monitor in front of his controls from a studio at WEAf.

Some Developments in HIGH-FREQUENCY MEASURING EQUIPMENT

By H. D. OAKLEY

General Electric Company

During the past few years there have been developed systems of telemetering, remote control of apparatus, wire and wireless carrier communication, etc. As these systems come more and more into use their complexity increases and the conditions which the apparatus of a system must satisfy become more exacting. And so it becomes necessary to supplement the design of such apparatus with measurements made on the apparatus itself, not only for the purpose of improving its design but also to determine its performance characteristics before being put into service.

The systems mentioned make use of modulated high-frequency current. Therefore, in order to make measurements on apparatus built for these systems there must be available equipment with which it is possible to generate and control modulated high-frequency current and to fix the characteristics of this current so that they meet the needs of the apparatus upon which measurements are to be made.

There has been developed in the General Engineering Laboratory of the General Electric Company equipment—signal generators, a.f. oscillators, etc.—to provide facilities for this class of measurements. This article, and those that are to follow, will describe this equipment and show its main electrical and operating features. Although the particular apparatus which is the subject of this article generates currents whose frequencies lie in the broadcast band and modulates them with frequencies in the audio-frequency band, still its design is adaptable to other ranges of high frequencies and modulating frequencies. This article describes the signal generator equipment.

The Signal Generator

An inspection of the two pictures on this page of the signal generator will supply one with information concerning its appearance, construction, and arrangement. The signal generator generates a current of a particular high frequency,

The signal generator apparatus described in this article was developed in the laboratories of the General Electric Company. The second article of this series will describe the audio-frequency voltmeter circuits used. These have a range of from about 0.2 volt up to 200 volts. The third installment will describe a voltage attenuator system using mutual inductors.

Additional information on these instruments can be obtained from the Engineering Products Division of the RCA-Victor Corporation of America through whom the apparatus is available.

—THE EDITOR.

modulates it, amplifies it, and delivers it to the output terminals. The signal generator must in addition indicate the absolute value of the frequency of the current it is generating and the degree to which it is modulated.

The circuits and units of the signal generator have been arranged in six groups, and as far as practicable each group has been restricted to the performance of a single function. There are thus six panels and any one of these may be removed for inspection or adjustment without disturbing the other groups. This panel type of construction also provides the additional advantage of making it possible to change units to meet special conditions; for instance, the high-frequency oscillator panel can be removed and replaced by another, enabling the signal generator to cover another band of high frequencies.

The circuit of the r.f. oscillator (Fig. 1) is of the tuned-grid, self-biasing type. The plates of the variable condenser are shaped

so that the frequency of the oscillator changes in proportion to the angle through which the condenser is turned. The scale is marked directly in kilocycles (500-1500) and an additional scale permits reading frequency differences down to 200 cycles. In parallel with the main tuning condenser is a small vernier condenser. This vernier makes it possible to set the frequency of the oscillator so that it agrees with the frequency value marked on the scale. The tuned circuit of the oscillator is inductively coupled to the grid of the modulator tube.

The Modulator

The high-frequency voltage supplied to the grid of the modulator by the oscillator is of constant amplitude. This constant voltage or current is of relatively little use in the systems we are considering. It is necessary to arrange the system so that this r.f. voltage can be modulated. There may be required, for instance, a 500-kc. voltage modulated with 500 cycles. This means that there is required a voltage whose frequency is 500 kilocycles, but the amplitudes of successive cycles instead of being the same value rise and fall about some mean value and go through this series of values 500 times a second.

The modulator is a device which when supplied with a high- and a low-frequency voltage combines them in such a manner that in its output circuit appears the high-frequency voltage modulated by the low. In the signal generator a screen-grid tube is associated with the proper voltages and circuits to make it act as a modulator. The process of modulation in this case is briefly this: The control grid of the tube is supplied by the oscillator with a high-frequency voltage of constant amplitude. So long as the screen-grid voltage is held at some constant value there appears in the output of the modulator a high-frequency, constant-amplitude voltage. Now

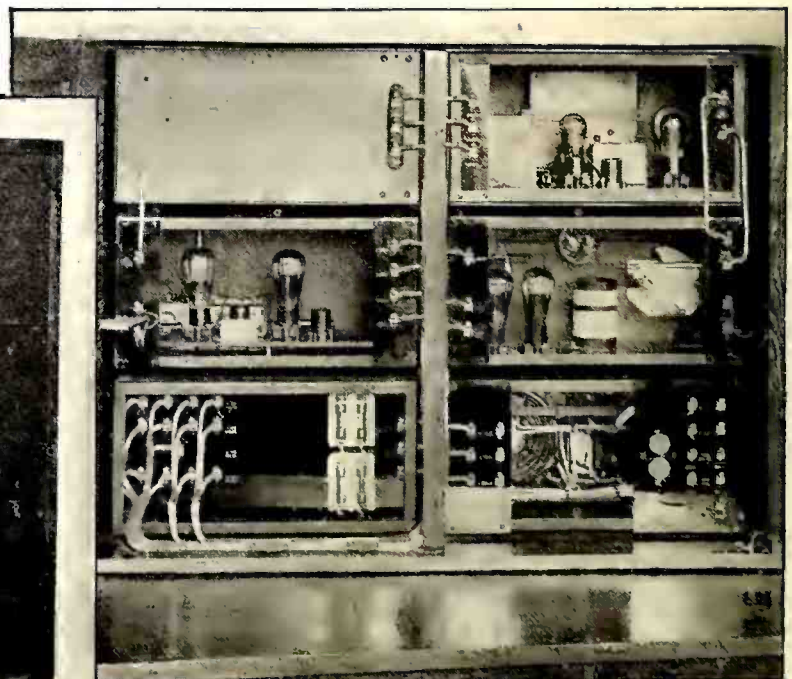
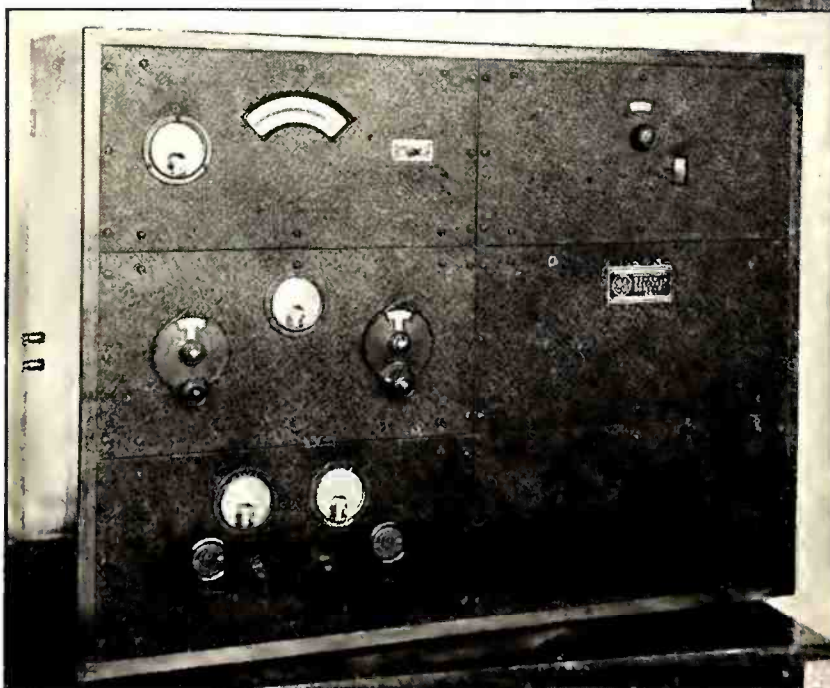

Two views of the signal-generator equipment developed in the laboratories of the General Electric Company.

PART I—

A Description of General Electric Signal Generator Equipment. This Installment Deals with the Design of an Oscillator, Modulator, and Indicator of Depth of Modulation. Subsequent Articles on Associated A.F. Voltmeter and Attenuator.

if the screen-grid voltage be raised and lowered about its original value, the amplitude of the high-frequency voltage in the modulator output will also rise and fall, and thus there will be generated a modulated high-frequency voltage. Therefore, to effect modulation it is merely necessary to supply the screen grid with the proper modulating voltage. This may come from a microphone, a magnetic pick-up unit and phonograph records, or some sort of audio-frequency oscillator. One of the pictures shows a type of audio-frequency oscillator which has been used in some installations for supplying the modulating voltage. This oscillator will generate a voltage of any frequency within the range of from 30 to 10,000 cycles, and the frequency of the voltage generated can be read directly from a scale. The wave shape throughout the entire range is usually good. The output voltage of the modulator excites the grid of a one-tube, resistance-coupled amplifier. This amplifier simply increases the voltage to a value sufficiently large to control the grids of the output tubes.

The Output Circuit

The output circuit consists of a single tuned circuit and milliammeter. The circuit is designed to be used with low-impedance apparatus connected to its output terminals. The meter indicates the amount of current flowing in the circuit. Variable mutual inductance coupling exists between the output circuit and the modulation meter. The coupling between the output circuit and output tubes is inductive and quite loose. The output tubes are connected in parallel and the inductance in their plate circuit is large enough to make them operate as a linear amplifier under all possible conditions of the output circuit.

In making measurements with modulated voltages it is not only necessary that this voltage be generated but also the degree to which it is modulated must be known. The degree of modulation is usually expressed in terms of percentage. For example, if the amplitude of a modulated voltage rises to 110 per cent. and falls to 90

Parts Used in Generator

HIGH-FREQUENCY OSCILLATOR

1. Grid condenser, 0.00025 mfd.
2. Grid leak, 100,000 ohms
3. Frequency correcting condenser, 15 mmfd. maximum
4. Main tuning condenser, 0.0006 mfd. maximum
5. Oscillator inductance, 150 μ h. (approximately)
6. Coupling coil, 4 μ h.
7. Plate by-pass condenser, 0.005 mfd.
8. Plate choke, 60 mh
9. Plate resistor, 12,000 ohms

MODULATION METER

10. D.C. plate meter scale, 0-10 mA.
11. A.C. plate meter scale, 0-50% modulation (thermocouple heater 700 ohms resistance)
12. Load resistor, 12,000 ohms
13. Condenser, 4 mfd.
14. Plate current limiting resistor, 50,000 ohms
15. Choke, 60 mh.
16. Battery, 22.5 volts
17. Resistor, 100,000 ohms

MODULATOR

18. Coupling condenser, 0.00025 mfd.
19. By-pass condenser, 0.1 mfd.
20. By-pass condenser, 0.00025 mfd.
21. Choke, 60 mh.
22. Coupling condenser, 0.0005 mfd.
23. Resistor, 5300 ohms
24. Choke, 60 mh.
25. Coupling condenser, 0.00025 mfd.
26. Resistor, 12,000 ohms
27. Resistor, 12,000 ohms

OUTPUT CIRCUIT

28. By-pass condenser 0.012 mfd.
29. Primary coil, 900 μ h. (approximately)
30. Tuning condenser, 0.001 mfd. maximum
31. Thermo-ammeter, 0-350 mA.
32. Output circuit coil, 60 mh.
33. Modulation meter coupling coil, 100 μ h.

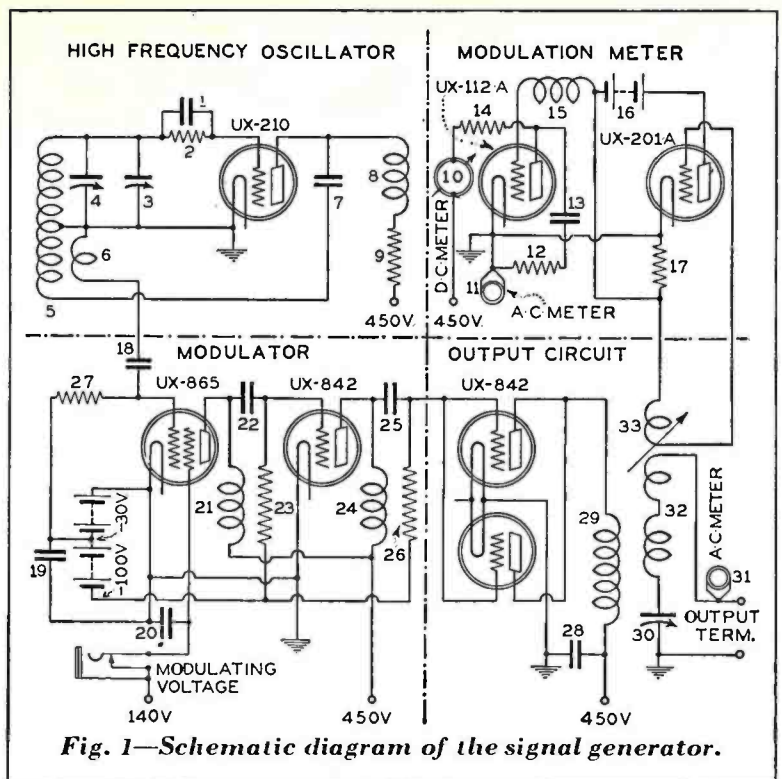
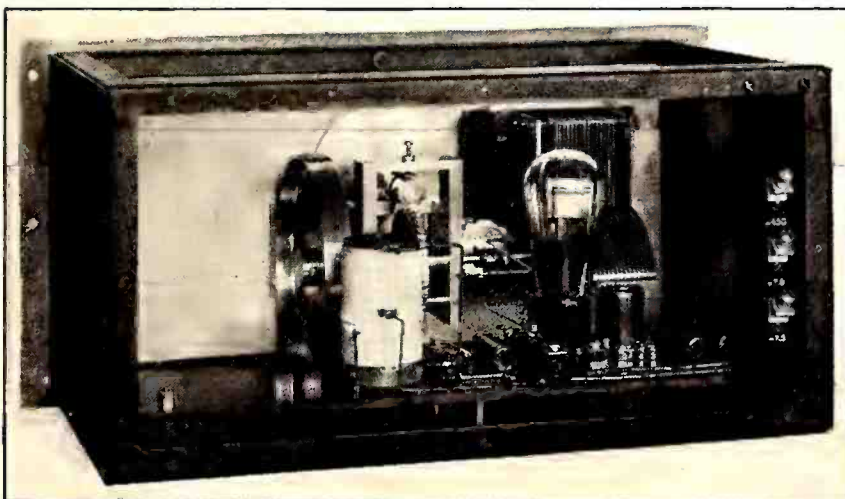

Fig. 1—Schematic diagram of the signal generator.

per cent. of its mean value the voltage is said to be modulated 10 per cent.; and again, if the values were 150 and 50 per cent., the degree of modulation would be 50 per cent. The modulation meter is a device for determining the percentage of modulation of the current flowing in the output circuit of the signal generator.

This meter consists of two main parts, a linear rectifier and an audio-frequency voltmeter. The rectifier is of a type that was devised and used by Dr. A. W. Hull and is strictly linear over its operating range. To understand the action of the modulation meter assume for the present that there is current of constant amplitude flowing in the output circuit of the signal generator. By induction this current produces a constant-amplitude voltage in the grid circuit of the rectifier and this voltage, in turn, causes a current to flow through that resistor which is common to the grid and plate circuits of the rectifier. This is a direct and not an alternating current. The explanation is that although the voltage applied to the rectifier grid is alternating, and because of the rectifying action of the tube, one would expect that the current in the resistor would be pulsating; yet it is not, because connected to the resistor is the grid circuit of another tube which acts as a condenser in shunt with the resistor. This condenser smooths out the current pulses giving rise to a flow of direct rather than pulsating current. The other tube just mentioned is the voltmeter tube of the modulation meter.

An inspection of the circuit diagram (Fig. 1) seems to show that no bias has been provided for the voltmeter tube but actually there is a bias resulting from the flow of the direct current through the resistor. It is evident that the value of this bias can be controlled by varying the voltage supplied to the grid of the rectifier. This can be effected either by varying the coupling to the output circuit of the signal generator or by varying the current flowing in the output circuit. There then exists means by which it is always possible to set the bias to a predetermined value provided there is cur-



Rear view of the high-frequency oscillator panel.

rent flowing in the output circuit. Should there be no current there would be no bias and ordinarily the plate current of the voltmeter tube would rise to an excessive value, but in this case the current is limited to a safe value by the resistor in the plate circuit.

When a measurement of percentage modulation is to be made the operator adjusts the coupling of the modulation meter until the needle of the d.c. meter (which is in the plate circuit of the voltmeter tube) rests on a predetermined scale division. After this operation has been performed the following conditions exist. The values of the voltmeter plate current, grid bias, and the high-frequency voltage across the grid of the rectifier have the same values as they did have at the time the modulation meter was calibrated. Also the values of grid bias, plate current, and plate circuit resistance are such that the tube will operate as a linear audio-frequency amplifier. The external plate circuit is made up of two parallel branches. One consists of a d.c. milliammeter and a resistance; the other of a condenser, resistance, and the heater of a thermocouple. The first carries the d.c. plate current of the tube. Should there be set up in the grid circuit of this tube an audio-frequency voltage, there would appear in the plate circuit a corresponding alternating current, and nearly all of this current would flow through the second circuit rather than through the first. The magnitude of this current could be determined from the indication of the thermocouple microammeter.

So far the following conditions have been assumed: A constant amplitude current in the output circuit, the coupling between this circuit and the modulation meter set so that a predetermined set of conditions exist, and the voltmeter tube operating as a linear audio-frequency amplifier. Let all the conditions remain unchanged except the first. Instead of a constant-amplitude current assume a modulated one. Now the conditions in the grid circuit of the voltmeter tube have changed. The grid-bias voltage is still the same but in addition there is an audio-frequency voltage whose frequency is the same as that which is modulating the output current. The magnitude of this voltage is dependent upon the degree of modulation of the output current; the higher the degree of modulation the greater the amplitude of this voltage. Obviously there will be in the plate circuit an alternating current whose frequency is the same as the modulating frequency and whose ampli-

tude is dependent upon the degree of modulation of the output current. Therefore, the indications of the thermocouple microammeter can be interpreted in terms of percentage of modulation of the signal-generator output current. There is one more requirement that the voltmeter must meet. Since the modulating frequency may have any value in the range

potential of the filament generator is 7.5 volts and that of the plate generator 450 volts. The currents from both generators pass through filters which suppress the commutator ripple. The controls and indicators for the motor generator are on the power panel. There are a field rheostat and a voltmeter for each generator, a line switch for starting and stopping the motor, and a pilot lamp which, when lighted, indicates that the motor is connected to the line. There is another switch which in one position connects the filaments and plates of the signal-generator tubes to the power supply and in the other position disconnects the tubes but still supplies power to any auxiliary apparatus which may be connected to the power panel. Behind the panel are located the motor line fuses and a safety switch. When the rear doors of the cabinet are open the safety switch opens the field of the high-voltage generator and so it is impossible to get at the signal generator circuits while the high-voltage circuits are alive.

The distribution panel receives power from the power panel and distributes it to the four panels of the signal generator proper. In the distribution panel are a voltage-dividing resistor and by-pass condensers, and the filament and high-voltage fuses. From the voltage divider are obtained the plate and the modulator screen-grid voltages.

Calibrations

Three calibrations are required: the scale of the high-frequency oscillator, the modulation characteristic, and the modulation meter scale.

In calibrating the high-frequency oscillator scale the dial is turned until the 1500-kilocycle mark appears. The frequency generated by the oscillator is beaten against the fifteenth harmonic of a 100-kilocycle crystal oscillator. If there is a beat note the vernier condenser of the oscillator is adjusted until zero beat is obtained. The oscillator scale reading and frequency then agree. The dial is then set on 1400, 1300, 1200 kilocycles, and so on and at each setting a beat is obtained between the oscillator frequency and the corresponding crystal harmonic frequency. The beat is brought to zero by turning the dial of the oscillator. The amount that the oscillator frequency differs from the scale readings can then be immediately determined. For instance, suppose a zero beat is obtained between the tenth harmonic of the crystal and the oscillator and say the oscillator dial scale read 1002 kilocycles.

(Continued on page 300)

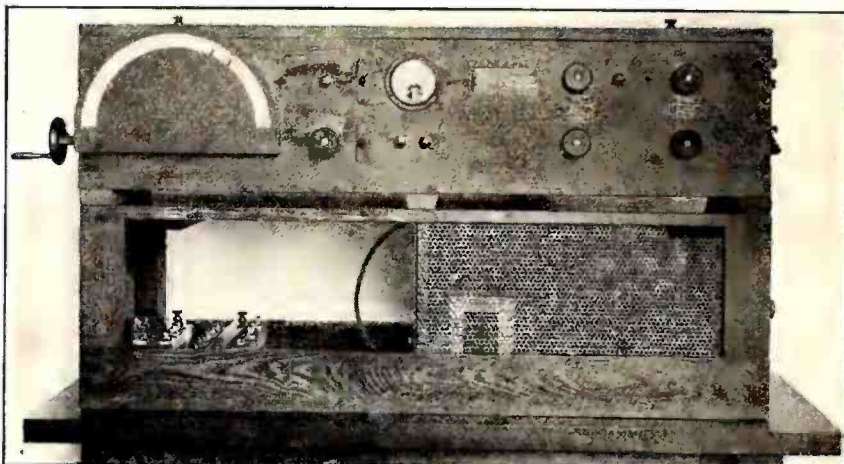

The audio-frequency oscillator for generating modulating voltage.

of from 30 to 10,000 cycles, the ratio between the a.c. voltage across the grid of the tube and the alternating current flowing through the thermocouple must remain unchanged throughout this range of frequencies; otherwise percentage modulation determinations will be in error.

Table I

Variations between the high-frequency oscillator scale readings and the generated frequencies are indicated in the figures below.

Scale Reading Kilocycles	Oscillator Frequency Kilocycles
500	501.0
600	611.6
700	714.2
800	812.4
900	908.6
1000	1004.2
1100	1103.6
1200	1202.0
1300	1299.0
1400	1393.5
1500	1500.0

The Power Panel

The filaments and plates of the tubes of the signal generator are supplied with power by a three-unit motor generator. The motor is a single-phase, 110-volt, 60-cycle induction type. It possesses the desirable feature of running at constant speed over quite a range of line voltage fluctuations and so the generated d.c. voltages are remarkably free from variations due to line-voltage fluctuations. The

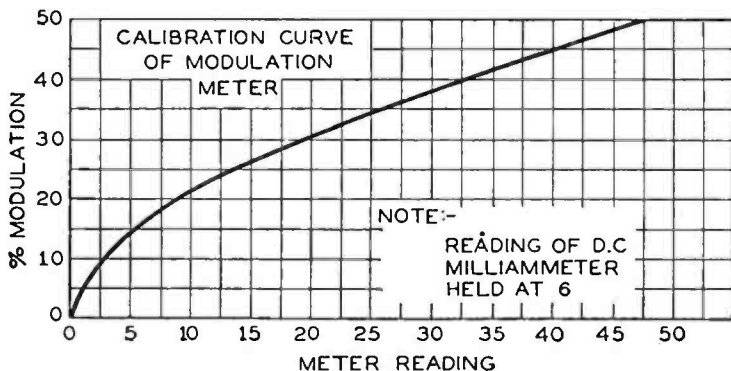

Fig. 3—Modulation meter calibration curve.

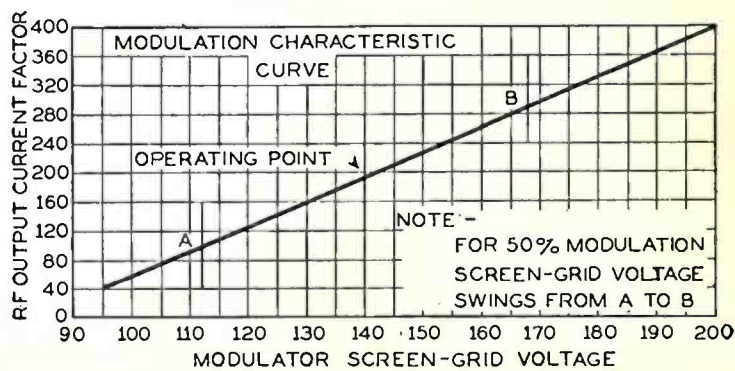

Fig. 2—Modulation characteristic curve.

MAGNETIC CIRCUIT DESIGN

By E. A. UEHLING

Theory and Practical Design of Magnetic Circuits; Air-Gap Flux Density as a Function of the Length and Area of the Magnet; Factors Influencing the Choice of Magnetic Material.

Magnetic fields of high concentration are of importance in many instruments and machines in which energy of one form is converted into that of another form. Among the most important of such instruments in radio engineering is the electromagnetic and the electrodynamic loud speaker. The magnetic fields in the air gaps of these instruments are spoken of as having a high concentration because the flux density in these fields is usually of the order of the magnetic saturation point of the highest flux-carrying-capacity material known. Such densities are in the neighborhood of 10,000 to 20,000 lines per square centimeter. Magnetic fields of this character are not always easily obtained, and when they are obtained it is not always with the greatest economy. It will be of great value to consider the properties of such circuits, and to discuss empirical formulas that greatly simplify the design of many types of magnetic structures. First of all we will consider magnetic circuits in their more general aspects.

Analogous to Electricity

Magnetic circuits are closely analogous to the more familiar electrical circuits, and many of the principles of electrical circuits can be used in the design of magnetic structures. There are, however, many important differences, and it is these variations in the behavior of electricity and of magnetism that is quite largely responsible for the surprising results that engineers sometimes have when testing a carefully designed structure. Among the most

important of the differences in the properties of electricity and of magnetism, and the properties which are responsible for the more or less general belief in the elusiveness of much of the subject of magnetism are: (1) The static nature of magnetism as compared with electricity; (2) The smaller differences in the permeability of various media which accounts for the difficulty of insulating magnetic flux and of causing it to flow in definite paths; and (3) The distributive nature of the motivating force; i.e., of the magneto-motive force.

These conceptions will become evident as we proceed with the discussion of actual design formulas, and they need not be discussed further. Much that we shall say regarding magnetic circuits can be attributed to electromagnetic and permanent-magnetic structures equally well, for there is essentially no difference in the two types of magnetism.

The Fundamental Formula

Corresponding to the Ohm's Law of electrical circuits there exists a relationship of a similar nature between the magneto-motive force of the circuit, the reluctance, and the magnetic flux. The magneto-motive force is expressed in *Gilberts*, the unit of which is defined as the force required to force one line of magnetic flux through a reluctance of one Oersted. The *Oersted*, which is the unit of reluctance, is defined as the reluctance to magnetic flux that is offered by a centimeter cube in air. The reluctance of an air-gap may then be expressed as the ratio of the air-gap length in centimeters to its area in square centimeters. If the magnetic structure to be designed is of the electromagnetic type, the required magneto-motive force necessary in the electrical circuit will be given by the relation

$$\text{MMF} = R\phi$$

where the available magneto-motive force is

$$\text{MMF} = 0.4\pi NI$$

and, where R is the reluctance of the air-gap computed as already shown, and ϕ is the total flux desired in the air-gap. Then

$$NI = \frac{R\phi}{0.4\pi} = \frac{L\phi}{0.4\pi A} = \frac{LB}{0.4\pi}$$

L being the length of the path and B the flux density

With this relation ends practically all that can be borrowed directly from our knowledge of the analogous electrical circuit. From this point magnetic circuits must be designed as such, and our failure to do so is largely responsible for many strange results obtained in the laboratory.

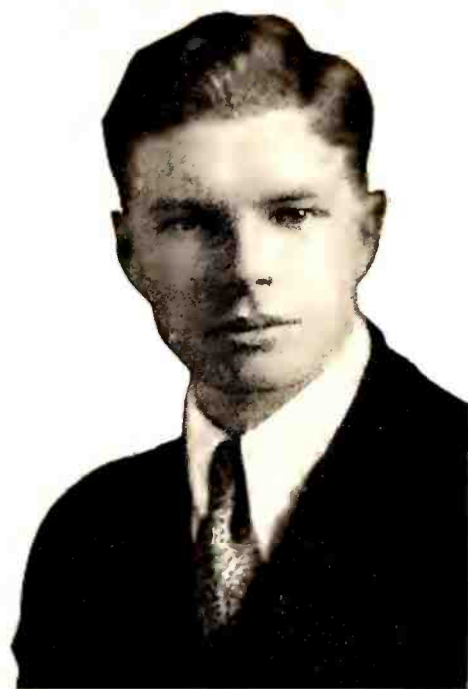

The distinct nature of magnetism becomes more obvious when we consider that in the magnetic flux as such no energy exists. A magneto-motive force may be required to hold an established condition of magnetism, but once established no further energy is given to the magnetic circuit. Energy is given, of course, to the electrical circuit, the coil of the electromagnet by which the magnetic field is maintained, but all of this energy is dissipated in the form of heat in the winding itself. Once this conception becomes established much of the apparent difference between electromagnetic and permanent magnetic structures disappears.

Permanent Magnetic Circuits

For purpose of design it is of considerable importance to consider magnetic circuits that depend upon a permanent magnet for the maintenance of the magnetic condition. Such circuits have a very great importance in nearly all of the various types of electromagnetic loud speakers. They have not yet become important in the electrodynamic loud speaker where an electromagnet is usually used to supply the required magneto-motive force. However, many laboratory models of the electrodynamic loud speaker with permanent magnets have been made. Experiments of this nature have been in progress for some time, with what might seem to be encouraging results, in view of the rather difficult problem involved. Before discussing this subject, however, it will be necessary to discuss the formulas relating the magnetic circuit with the flux that

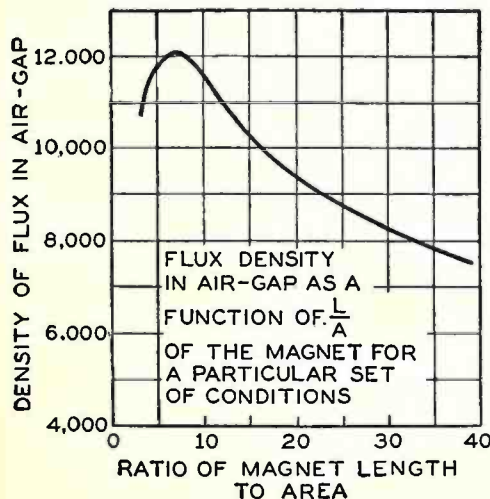

Fig. 1

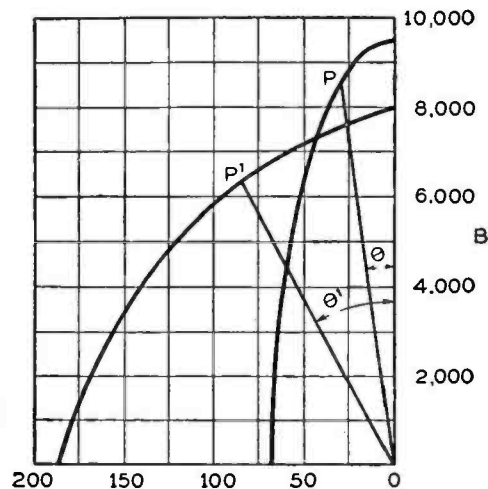

Fig. 2

can be obtained from a given permanent magnet.

In designing magnetic circuits using a permanent magnet to supply the magneto-motive force, the reluctance in the permanent magnet must be considered as well as that of the air-gap. This reluctance is, however, unknown, and the design formula desired should not contain reluctance as a factor in the equation. Such a formula is easily developed. We will assume a well-designed magnetic circuit of negligible leakage flux, and attempt to allow for leakage flux when it exists in another manner. We have the preliminary relation—

$$\frac{MMF}{R} = \phi$$

where MMF is that part of the total magneto-motive force used to force the total flux through the air-gap, R is the reluctance of the air-gap alone, and ϕ is the total flux in the magnet and in the air-gap. If B is the flux density in the permanent magnet, and A' is the area of the magnet cross-section—

$$\frac{MMF}{R} = BA'$$

But R is equal to L/A, the length of the air-gap in centimeters divided by the area of the air-gap in square centimeters. Making this substitution, and dividing by L', the mean length of the permanent magnet in centimeters, and finally, representing MMF/L' by MMF', the magneto-motive force of the permanent magnet in Gilberts per centimeter length available at the air-gap is—

$$\frac{MMF'}{B} = \frac{A'L}{AL}$$

The B-H Curve

The left side of this equation requires interpretation before the equation can be used in a practical design problem. It can be interpreted in terms of the B-H curve of the material of the magnet, giving a very convenient and practical relationship between quantities the values of which are easily ascertained. A typical B-H curve for tungsten steel is shown in Fig. 3. This portion of the entire B-H curve is all that is used when considering the properties of permanent magnets. The coercive force of the material of the permanent magnet multiplied by the length of the magnet represents the total magneto-motive force in the circuit.

If no demagnetizing force exists in the magnetic circuit, the value of the flux density is given by the highest point of the curve of Fig. 3, which is the retentivity value. If demagnetizing force exists, as, for example, the demagnetizing force or counter magneto-motive force of an air-gap, the flux density in the magnet will be less than the retentivity value, and is determined when the value of the right-hand side of the above equation is determined. We can consider this value of the flux density as the operating point, P and draw a line from it to the origin making an angle θ with the vertical through the origin. Drawing another line through the operating point perpendicular to the line of coercivity we divide the coercivity per centimeter length of the magnet in two parts. The interval between this vertical line and the origin represents the magneto-motive force per unit length of the magnet used in overcoming all demagnetizing forces in the circuit, as, for example, that of the air-gap, and that of the free poles of the magnet. The interval between the vertical line and the coercivity value for the material represents the magneto-motive force per unit length used in overcoming the reluctance of the material of the magnet. Only the former value enters into the above design equation. It

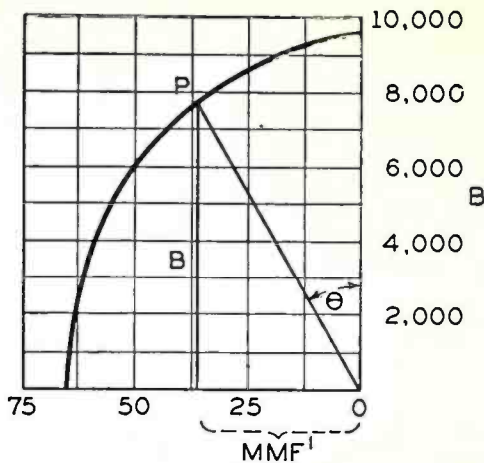

Fig. 3

is the term MMF' given in this equation, provided the magnet is long enough so that the demagnetizing effect of the poles of the magnet is negligible, which is usually the case. The other factor, B, of the left

Table I

TABULATION OF DATA IN DESIGN OF A PERMANENT MAGNET*

(Volume of magnet—357 cm ³)						
A _m	L _m	tan θ	B _m	φ	B _a	
3.225	110.6	.001554	8300	26,800	7530	
4.031	88.5	.002193	8000	32,300	9075	
4.838	73.8	.003152	7600	36,800	10340	
5.645	63.3	.004285	7100	40,100	10940	
6.450	55.3	.005615	6500	41,900	11770	
7.256	49.2	.007095	5900	42,800	12030	
7.655	46.6	.007900	5600	42,850	12050	
8.062	44.3	.008765	5250	42,350	11900	
8.869	40.3	.010585	4600	40,800	11480	
9.675	36.9	.012620	4000	38,700	10870	
10.482	34.0	.014820	3600	37,700	10580	

*Chrome Steel Magnet
Air-gap Dimensions—(3.56 cm.² x 172 cm.)

side of the above equation is the ordinate to the operating point of the B-H curve. Then—

$$\frac{MMF'}{B} = \tan \theta$$

and accordingly

$$\tan \theta = \frac{A'L}{AL}$$

In other words, the product of the air-gap length and the area of the cross-section of the permanent magnet, divided by the product of the area of the air-gap and the length of the permanent magnet, is equal to the tangent of the angle between a line drawn from the origin to the operating point and the vertical through the origin. This is a very useful equation, and one that greatly simplifies the problem of de-

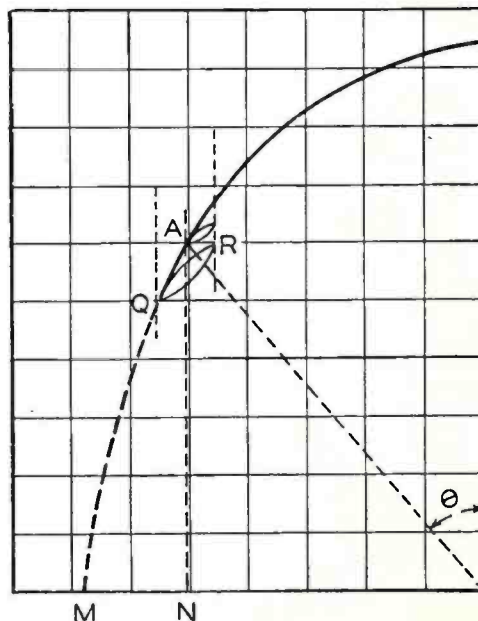

Fig. 4

signing a permanent magnet to supply the required flux density in a given air-gap.

Air-Gap Determinations

The nature of the air-gap is determined, of course, from other considerations. In the electrodynamic loud speaker, for example, it is determined by the size and type of voice coil used. Having the air-gap completely determined, two of the factors of the design equation are determined. A third factor, the area of the steel, may be given a definite convenient value as a preliminary trial in the calculations. This value of the area of the steel together with the value of the desired flux in the air-gap determines a fourth quantity in the equation, the tangent of the angle θ , provided that the leakage flux is small. The fifth and last quantity of the equation, the required length of the magnet, is then determined.

A permanent magnet satisfying all the requirements of the air-gap has then been determined, but the magnet may not and generally will not be the most economical possible. It is obvious that for a given air-gap, an optimum ratio of the area of the magnet steel to the magnet length exists, for an increase in this ratio without limit would only increase $\tan \theta$ without limit, and reduce the flux density in the steel to a negligible value. Consequently the area of the magnet cross-section is not completely arbitrary, and should not be given any one of the many possible convenient values.

The Complete Determination

A convenient method of making the complete determination and the one used by the author for some time is as follows: Determine from considerations of cost and the reasonable limits of weight and size the total volume of steel to be used in the magnet. Then tabulate for successive values of magnet cross-section the corresponding values of magnet length, and continue this tabulation using the design equation given above to include corresponding values for $\tan \theta$, the flux density in the magnet, the total flux, and finally, the flux density in the air-gap. The length and cross-section corresponding to the maximum flux density in the air-gap is that of the most economical magnet. A typical tabulation of this kind is shown in Table I and as a curve in Fig. 1. If the maximum value of the flux density in the air-gap found in this way is larger than required, a smaller value for the volume of steel in the magnet should be chosen, and all the values retabulated. If this value of flux density is less than that required a greater volume of steel will have to be used.

The reluctance of the soft iron parts in the circuit may not always be neglected. Another reluctance that is often of importance is that of the partially saturated soft iron parts in the neighborhood of the air-gap. These reluctances may be taken into account by assigning to them an equivalent air-gap length, determined from the dimensions of the soft iron parts and the estimated permeability at the flux density at which these parts will be used.

Magnetic Materials

The three principal materials of which permanent magnets are made are chromium magnet steel, tungsten steel, and cobalt steel. The latter can be obtained in several different percentages of cobalt alloyed with chromium, and in castings or forgings, each type having magnetic properties different than the others. The B-H curves for each of these materials are necessary to facilitate any determination of the best possible magnet to satisfy a

(Continued on page 282)

RADIO GALVANOMETERS

Probably the most easily constructed form of sensitive galvanometer is that in which the magnet is suspended by a fiber removed from a silk thread. A rather long pointer of very fine wire is attached to the magnet and at right angles to it. The coil is in two sections, as shown in Fig. 1, to provide space for

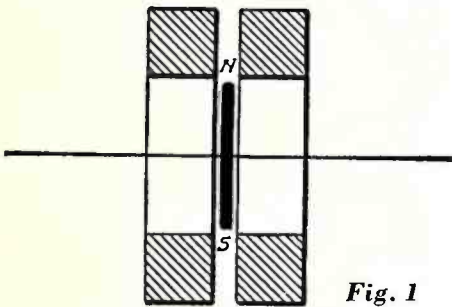

Fig. 1

the suspension fiber. Another form of makeshift galvanometer may be contrived by using a high-resistance coil, such as one half of the secondary winding of a Ford spark coil, and suspending the magnet therein by means of a fine wire yoke, as shown in Fig. 2. In either case, the whole must be enclosed in a glass container, such as a Mason fruit jar or lamp chimney.

Such galvanometers are not satisfactory for radio work as they are disturbed by the slightest jar, and when used, considerable time must elapse before the needle comes to rest. For general purposes, therefore, it is more practicable to support the magnet on a pivot, as in a pocket compass.

A Practical Instrument

A satisfactory magnet may be constructed from two pieces of bicycle spoke three fourths of an inch long, which have been heated to a bright red and plunged into water. Across the center of these a small brass block is neatly soldered, as indicated in Fig. 3. Take the end of a sixteenth-inch drill and make a small center punch with a sixty-degree point. With this, the bearing may be formed in the brass block. The depression should be about $\frac{1}{32}$ " deep, in order to prevent the magnet from being jarred off the pivot. The magnet is now placed on the point of a sewing needle and carefully balanced, by grinding off the heavier end.

The pointer should be of very fine wire, No. 40 nichrome, preferably, as

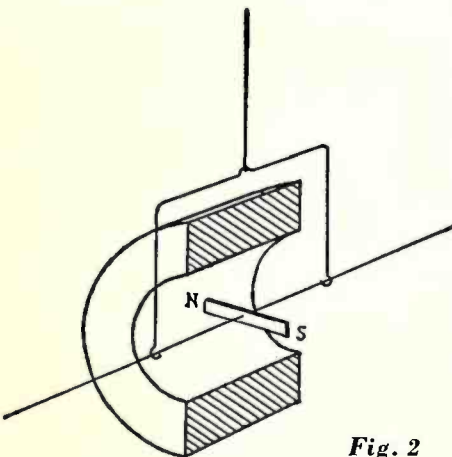

Fig. 2

it is quite stiff. Care must also be taken to have it quite straight, after which it is soldered to the brass block with the merest speck of solder, applied by using the end of a piece of tinned copper wire as a soldering iron.

The supporting pivot is soldered to a piece of No. 30 soft sheet brass, shaped as shown in Fig. 4. This form readily permits of adjusting the plate so that it may be snugly pushed into the inside of the bobbin on which the coil is wound. The sewing needle to be used as a pivot should be let down into a block of wood, with the end projecting just enough to permit the magnet to swing clear with a safe amount of space above the small brass block. This clearance on top need not be more than about a hundredth of an inch, otherwise the magnet might slip off the pivot if the instrument were turned upside down. After soldering, the lower portion of the sewing needle is to be cut off and ground flush with the bottom of the brass plate. Two brass pins are now to be soldered, heads down, to the plate to limit the swing of the needle to 90°. Without these, any excess of current would cause a violent deflection, throwing the delicate indicating

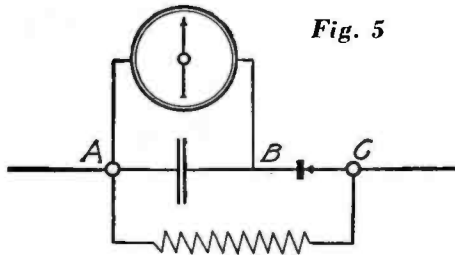

Fig. 5

pointer against the coil and probably bending it.

Mounting the Instrument

Such a galvanometer was built in one of those cases in which the works of a watch are received by the jeweler. The upper rim was removable, and contained a plain glass top. The magnet was about three quarters of an inch long, and was made and supported in the manner just set forth. The coil was wound on a brass bobbin, made by neatly forming a thin brass rectangular tube, just large enough to accommodate the magnet, and soldering two rather heavy end plates to it. The latter, of course, each had a suitable rectangular opening just large enough to slip over the ends of the tube. After lining the bobbin with paper, it was filled with No. 40 enameled wire. (A coil of 6000 ohms resistance makes a fairly sensitive galvanometer.) The end of the wire was soldered directly to the metal bobbin, using a non-corrosive flux, thus avoiding the necessity of bringing out a loose end.

After the magnet and needle have been inserted into the bobbin, the latter may be secured to the bottom of the case by means of a couple of drops of solder, applied with a very small iron. A small block of hardwood or fiber should be fastened in position to support the paper scale. This may be accomplished by the use of two slender

rivets. The metal case forms one terminal, and the other end of the magnet winding is soldered to the end of a brass pin run in through the block that supports this scale. A hole somewhat larger than the pin is made in the metal case, so that it will not make contact with the pin.

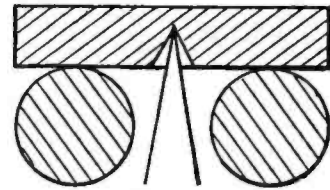

Fig. 3

Such a galvanometer should show a full-scale deflection with the minute current generated by dipping the end of a fine iron wire into a little saliva placed on a dime.

In Fig. 6 is a completed galvanometer and when placed directly in a radio circuit, the instrument should be connected as shown in Fig. 5. Across the galvanometer coil is an 1.5-mfd. fixed condenser. In series with this combination is a crystal of galena to rectify the high-frequency current. R is a non-inductive variable shunt with a range from about 2 to 25 ohms. The introduction into an oscillatory circuit of a galvanometer connected in this manner will add no more resistance than the resistance of the shunt. The small amount of current that finds its way through the crystal rectifier, however, is sufficient to operate a sensitive galvanometer. The large fixed condenser increases the effect on the galvanometer.

The base is simply a wooden box in which the fixed condenser is placed. The upper portion consists of a wooden frame, having a glass top, for which a Kodak plate was used.

The experimenter should have no difficulty in contriving a suitable crystal detector, preferably of the inclosed type. By providing three binding posts, A, B, and C Fig. 5, the instrument may be used as a regular direct-current galvanometer by connecting to posts A and B.

In constructing a shunt for a radio galvanometer it is very necessary that it be non-inductive, variable, and susceptible to measurement. Fig. 7 illustrates one way of providing such a shunt. A strip of hardwood about three fourths of an inch wide is provided, and on this is stretched a length of No. 36 nichrome wire, which has a resistance

(Continued on next page)

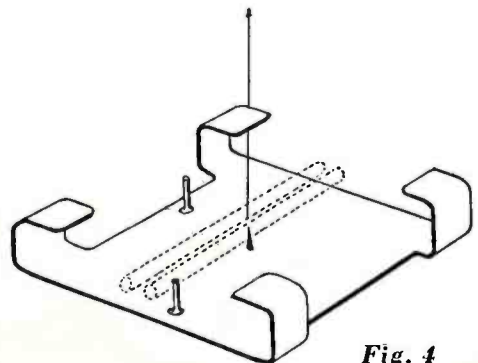

Fig. 4

RADIO GALVANOMETERS

(Continued)

(Continued from preceding page)

of over 25 ohms per foot. Along the underside of this runs a piece of bus-bar wire, so that a small spring clip may be snapped on at any point along the strip in order to connect the resistance wire and the bus wire together at that point. In this manner the resistance is readily varied, and by providing a paper scale, the resistance being used will always be known. The heavy projecting wires, No. 14, are set in suitable holes drilled edgewise through the strip. These serve to make connection with the binding posts of the galvanometer, and are spaced accordingly. In the shunt illustrated, the length was a little over eight inches, and it contained over sixteen ohms.

How to Use the Galvanometer

While a telephone receiver and crystal detector provide a more sensitive method of detecting a minute radio current, it is often desirable to provide some visual indication of the current strength that will not only accurately indicate when the current is at a maximum, but will also enable one to determine the relative value of the current. This feature is particularly important when measuring high-frequency resistance. In a commercial laboratory, the thermo-element galvanometer provides such a means. As such an instrument does not lend itself to amateur construction, a galvanometer such as has been described may be used, and if it has been properly constructed, will be equally, if not more, sensitive.

The action of the galvanometer in this connection may be tested by the experiment as illustrated in Fig. 8. The galvanometer with the crystal rectifier and shunt is placed directly in the oscillatory circuit. As the condenser C approaches the point of resonance, the galvanometer will indicate the fact, even when the shunt resistance is reduced to a few ohms.

What actually goes on in the circuit is as follows. When the condenser of the circuit under test is adjusted so that the circuit is roughly in tune with the buzzer-driven oscillatory circuit, current at the frequency of the driver will flow in the test circuit. This radio-frequency current flows through the crystal detector in series with the condenser across the galvanometer. If the condenser is sufficiently large to offer little reactance to the radio-frequency current, the galvanometer will have no effect upon the a.c. current flowing. This radio-frequency current will be rectified by the crystal detector. In this process a direct current will be produced which will flow through the galvanometer and its shunt resistance.

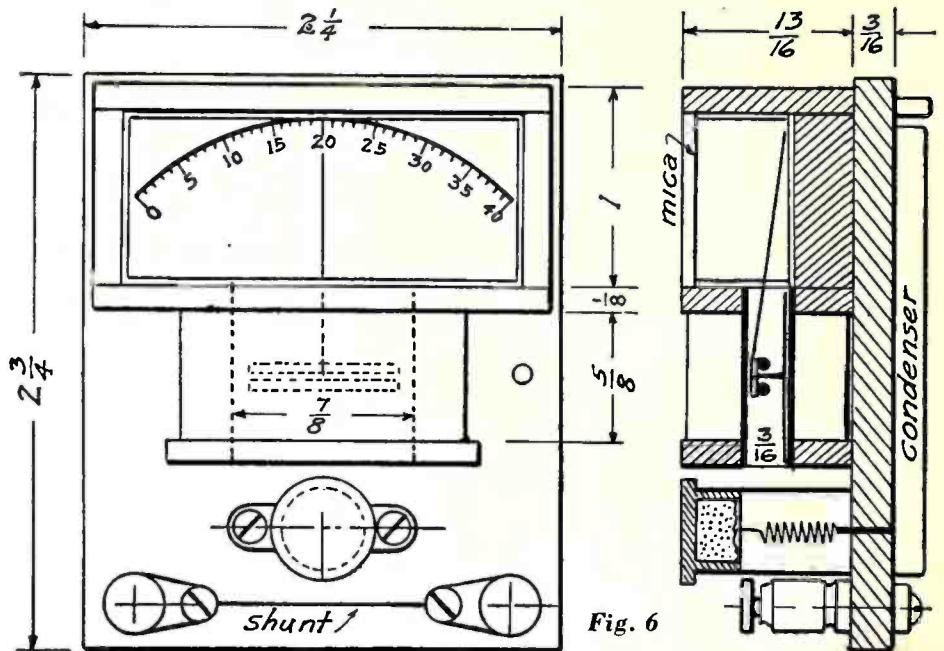

Fig. 6

If the proper position of the two circuits with respect to each other is determined so that the galvanometer needle will not go off scale at resonance, a resonance curve can be plotted

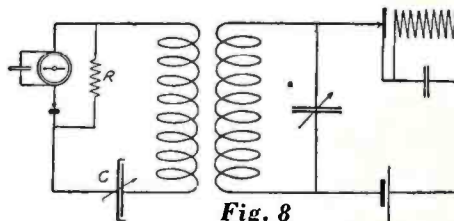

Fig. 8

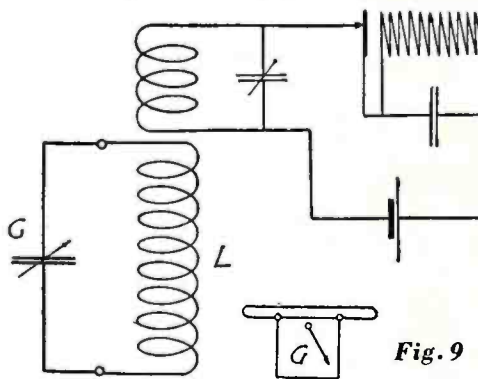

Fig. 9

by noting the deflection at each degree setting of the tuning condenser.

It will be observed that when the distance between the primary and secondary circuits is increased, the point of resonance is more sharply defined, and if the coupling is made sufficiently loose, the point of deflection can only be maintained by the most careful manipulation of a sensitive vernier condenser.

It will also be noted that if additional

resistance is added to the circuit, and the resistance of the shunt R is increased to bring the deflections up again, the point of resonance is not so sharply defined, thus verifying the important fact that in a radio circuit the resistance should be kept as low as possible if selectivity is desired.

The detector circuit in Fig. 8 embraces all the elements of a good wavemeter, assuming that the coil is of low resistance (say 1 layer of No. 18 d.c.c.) and that the galvanometer is sensitive.

The galvanometer may be used as a resonance indicator if it and the crystal are shunted with a single turn of wire about five inches in diameter. In this case the shunt running between the binding posts should be disconnected.

Fig. 9 indicates a method of using a galvanometer in this manner. On one side of the circuit LC is the generator (a buzzer connected to an oscillatory circuit), and on the other is the galvanometer with its single turn of wire.

When measuring the distributed capacity of inductance L, the condenser C is disconnected. As soon as the generator is adjusted to the natural wavelength of the coil, relatively strong radio currents will flow in the latter, and as a result sufficient current will be induced in the turn of wire to deflect the galvanometer after rectification by the detector. The arrangement is very advantageous as it necessitates no connection whatever with the coil, the distributed capacity of which is to be measured.

This method of using a galvanometer also has considerable application in connection with vacuum-tube oscillators. In such cases it is only necessary to bring up the instrument to determine whether the circuit is oscillating. Further use of the galvanometer may be made when the measurement of high-frequency resistance is undertaken.

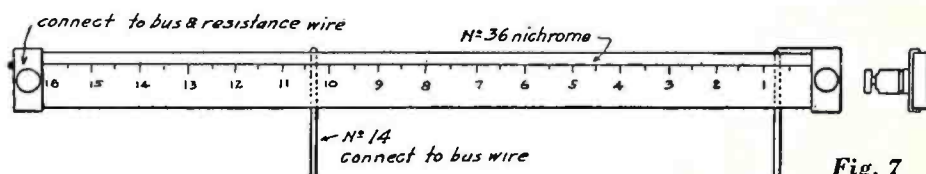

Fig. 7

THE SERVICEMAN'S EQUIPMENT

By J. H. MILLER

Chief Engineer, Jewell Electrical Instrument Co.

Importance of Service Equipment; Details of Two Types of Jewell Radio Set Testers, Models 409 and 199.



Model 409
Set Tester.

The fundamental purpose of any device for testing receivers is to make possible a quick and accurate measurement of the voltages and currents supplied to the various tubes in the receiver. Practically all the important circuits in a receiver finally end at the terminals of the various tube sockets; accordingly if measurements are made at the tube socket terminals of all

but attention should also be paid to the speed with which tests may be conducted. A set analyzer with four instruments, such as the Jewell model 409, is more rapid in operation than the Jewell Model 199 which utilizes only two instruments.

button, the maximum B voltage may be measured. Having the various instruments available at separate binding posts also makes it possible to make measurements to determine the value of resistors,

The two additional meters on the Model 409 are available for continuous reading of plate voltage and plate current, an obvious advantage since these two quantities can be noted at any time during the test. By using all four meters simultaneous readings can be taken of filament or heater voltage, grid voltage, plate voltage, and plate current. The adapter plugs supplied with the instrument have five prongs so that measurements may be made on tubes which have their cathodes biased with respect to the filament. Four-prong adapters are also supplied so that measurements may be made on all types of four-prong tubes.

In these Jewell set analyzers all of the instrument terminals are also brought out to separate binding posts so that the instruments may be used separately to make other measurements. For example, if the maximum voltage from the B supply is to be determined two leads can be run from the B-power unit to the two binding posts that connect to the high-range voltmeter, and, by pressing the appropriate push



Model
199
Set
Tester.



Model
210
Tube
Tester.

the voltages and currents it is not difficult to determine in what circuits defects exist. If when checking any particular socket a defect is indicated, a good tube can be substituted and if the defect disappears the fault was obviously due to a bad tube, whereas if the defect remains some circuit in the receiver is evidently at fault.

Good instruments for servicing radio receivers are made by a number of manufacturers who have spent considerable time and effort to make such equipment complete, accurate, and rapid in operation. In selecting service equipment the cost is, of course, a factor

condensers, etc. Proper testing apparatus is obviously essential in the servicing of radio receivers and any serviceman who knows something about the circuits of sets can double his efficiency with the proper kind of servicing equipment.

If records are kept of all of the readings on an analysis chart of the type illustrated, the logic of the method cannot be questioned. If a carbon copy of the analysis is left with the set owner, it is just as much of a receipt as a prescription which the physician leaves, if only for sugar-coated pills. And, in the long run, the service (Continued on page 297)

RADIO SET ANALYSIS													
OWNER		Mr. A. B. Smith										DATE	July 3, 1929
ADDRESS		3000 Madison St., Chicago, Illinois											
NAME OF SET		Atwater-Rent, Model 55 A. C.											
TUBE NO. IN ORDER	TYPE OF TUBE	POSITION OF TUBE 1ST R.F. DET., ETC.	READINGS, PLUG IN SOCKET OF SET										
			TUBE OUT					TUBE IN TESTER					
			A VOLTS	B VOLTS	A VOLTS	B VOLTS	C VOLTS (CONTROL GRID)	CATHODE - HEATER VOLTS	NORMAL PLATE M.A.	PLATE CHANGE M.A. TEST	PLATE CHANGE M.A.	SCREEN GRID VOLTS	
1	224	1st R.F.	2.15	182	2.1	140	3	-3	2.6	5.6	3	76	
2	224	2nd R.F.	2.15	182	2.1	140	3	-3	2.6	5.6	3	76	
3	227	Det.	2.15	84	2.1	82	14	-14	1	-	-	-	
4	227	1st Aud.	2.15	140	2.1	80	3	-3	2.1	3	8	-	
6	245	2nd Aud.	2.4	228	2.45	208	38	-	2.2	2.6	4	-	
6	245	2nd Aud.	2.4	228	2.45	208	38	-	2.2	2.6	4	-	
7	280	Rect.	4.3	-	4.1	-	-	-	32	-	-	-	
9													
10													

LINE VOLTAGE 106 SET ON VOLTS 50 VOLUME CONTROL POSITION Full on

SUGGESTIONS OR CHANGES MADE Set O.K.

BY _____

THREE YEARS OF THE FEDERAL RADIO COMMISSION

By **L. G. CALDWELL**

Formerly, General Counsel, Federal Radio Commission



*Admiral
W. H. G.
Bullard*



*O. H.
Caldwell*



*Col. J. F.
Dillon*



*Harry A.
Bellows*



*Judge
Eugene O.
Sykes*

The third anniversary of the enactment of the Radio Act of 1927 fell on February 23, 1930. With the enactment of that law radio regulation, which for fifteen years had been entrusted to the Department of Commerce under the Radio Act of 1912, was given over to a commission of five members for a temporary period of one year from the date of the first meeting of the commission. Certain important responsibilities, however, such as the examination and licensing of operators, inspection and investigation services, the filing of applications, the assignment of call letters, and the like, were left in the Department of Commerce. The law provided that at the end of the first year the Department of Commerce should again become the licensing authority, subject to revision of its decisions by the Commission in controversial matters which were appealed or referred to the Commission. Further provision was made for appeals from decisions denying applications for construction permit, license, renewal of license, or modification of license, to the Court of Appeals of the District of Columbia.

Commission Becomes Permanent

The Commission held its first meeting on March 15, 1927. If there had been no amendment to the law, it would have become an appellate tribunal on March 16, 1928. By virtue of three successive amendments to the law, however, the Commission has been continued as the licensing authority and, as matters now stand, it seems virtually certain to continue indefinitely as such (subject to being replaced by a Commission on Communications if Congress should act favorably on the bill now pending before it for that purpose.)

The very recent third anniversary of the formation of the Commission offers an appropriate occasion for a brief discussion of the advantages and shortcomings of the commission form of regulation of radio as they appear from the experiences of the past three years.

It would be unfair to enter upon such a discussion without reference to facts and circumstances which are not *necessary* incidents of commission regulation but which nevertheless have played an important rôle in shaping conditions as we find them in radio to-day. Judgment cannot be rendered on the commission form of regulation abstractly; account must be taken of the peculiar nature of the subject matter to be regulated, of the character, ability, and experience of the men to whom the regulation is confided, and of the problems and difficulties which have been imposed from without. The limited scope of this article will not permit more than passing mention of such considerations which are, however, generally known to the industry.

Ten Men in Three Years

Ten men have filled the five positions on the Commission in three years, and only one of the original appointees still holds office. Because of delays of the Senate in confirming appointments, there have been

considerable periods in which the Commission has had three members and even less. The terms of office, which under the original law were to have been on a six-year basis, have twice been cut down to one year, and at the end of each year the commissioners have been subjected to grueling inquisitions as to their conduct and their views by Congressional committees. During the first year the Commission had no appropriation at all and during the last few months its appropriation has been grossly inadequate. Two men have filled the office of secretary. In the last eighteen months three men have filled the office of general counsel, and two (both borrowed from other governmental departments), the office of chief engineer.

The subject matter of radio regulation is difficult enough, merely from the point of view of its complicated engineering and economical aspects taken together with the rapid advances in the art. These have had their counterpart in legal problems which are unique in the history of jurisprudence, for the solution of which analogies fail and precedents are dangerous.

Other Problems

In addition, however, to the difficulties which are unavoidably inherent in the subject matter, the Commission at the outset found an intolerable situation of congestion in the broadcast band which has been its most perplexing problem and which was not of its making. Its solution of the problem has been hampered by the unscientific Davis Amendment and by a host of engineering and economic heresies which have found formidable advocates in Congress, among the public, and, sad to relate, even in the radio industry itself. Witness the hue and outcry against cleared channels, the complaint against the so-called duplication of chain programs, the condemnation of "high power," the advocacy of "synchronization," and the like. To the foregoing must be added the problems created by a complicated patent situation, the alleged existence of a "radio trust" and the anti-monopoly provisions of the statute, the inadequacy of existing international agreements, the political pressure constantly exercised (usually by Senators and Congressmen) in all manner of cases, the flood of mail and protests from the public (usually uninformed) and many others.

If the Commission has failed to accomplish all that was expected of it, the blame cannot be laid entirely upon its shoulders or upon the commission form of regulation generally; Congress, the public, and the industry must share the responsibility. Whether, under the circumstances, a single executive officer would have done better is impossible to say; much would have depended, of course, upon the character, experience, and ability of such an officer, just as much has at all times depended upon the character, experience, and ability of members of the Commission. While there has been a difference of opinion as

The Former Counsel of the Commission Discusses the Advantages and Shortcomings of Our Present Form of Radio Regulation as They Appear From Experiences of the Past Three Years.

to virtually every appointment made to the Commission, it must be conceded that the average quality of the appointments has been very high, in fact surprisingly so in view of the unattractive prospects and the uncertainty of tenure which go with such an appointment.

Defects in Administration

The foregoing should not be taken as indicating the writer's belief that defects have not developed in the form of regulation provided by the Radio Act of 1927. Serious defects have developed, both in the provisions of the law itself and in the administration of that law. Except as to a very few controversial matters, however, (such as the zone system, the Davis Amendment and the anti-monopoly and anti-merger provisions of the statute), there is remarkably little difference of opinion as to what the defects are or as to the manner in which they should be corrected. The industry generally can be of service in informing itself of the nature of the necessary changes and in supporting the recommendations so far as it finds itself in agreement with them. Already bills are in course of preparation which follow a large proportion of the recommendations of informed persons on noncontroversial matters.

With respect to the fundamental question of the form of regulation, it must be remembered that the issue is not one purely between a single executive officer on the one hand and a commission on the other. If the Radio Act of 1927 had been allowed to take its course, there would still have been a commission to which virtually every controverted matter would have been referred or appealed almost automatically; Section 5 of the Act gave the Commission plenary power (subject to review by the Court of Appeals) to reverse or revise "any decision, determination, or regulation of the Secretary of Commerce." In the years immediately preceding the enactment of the Radio Act of 1927 there was no bill pending which contemplated lodging regulation solely in the Secretary of Commerce; the most that was urged in this direction was what would have been the situation to-day if the original powers of the Commission had not been extended from time to time by Congress.

Needed Amendments

Space will not permit discussion of necessary amendments to the Radio Act which do not have some relation to the nature of the licensing authority. No discussion will be entered into, therefore, of the Davis Amendment, the inadequate procedural provisions with respect to hearings before the Commission and appeals, the undue rigidity imposed by the cumbersome provisions as to construction permits, licenses, and renewals of license, the unnecessarily drastic restrictions on the issuance of licenses to corporations with alien stockholders, officers, or directors, the anti-monopoly and anti-merger

provisions, and the penal provisions. Leaving these aside, let us inquire into what defects have developed that have more or less direct bearing on the nature of the licensing authority.

In the first place, the present form of regulation has proved defective in not giving the Commission any latitude in delegating purely administrative matters to a subordinate officer. As matters now stand, the Commission must go through the form of making a finding and a formal entry in its minutes before any license, renewal of license, or modification of license can be issued. This is a tremendous and unnecessary burden with respect to such matters as amateur, ship, and airplane licenses and, in the great majority of cases, with respect to renewals of license of any character. A single executive officer can unquestionably perform such duties more efficiently than a commission. If the law were amended so as to permit the Commission to delegate such purely administrative and routine matters to a subordinate (e. g., its secretary or a "Director of Radio"), the Commission to reserve to itself a decision on any controverted matter, the situation would not be very different from that originally provided by the Radio Act of 1927 and the law could be made to work even more efficiently than under the ambiguous and almost unintelligible provisions of Section 5 of that Act.

Lack of Stability

A second defect has been the lack of stability in the Commission manifested in an inconsistency of decisions, in its tardiness in arriving at definite policies in accordance with engineering principles in the broadcast band, and in the amount of political pressure which is constantly exercised upon it. It is significant that after nearly three years of existence, it has not yet adopted any rules and regulations other than a rather heterogeneous lot of "General Orders"; that it has established no standards on such comparatively elementary matters as the proper geographical separation between broadcasting stations of a given power on regional and local channels, or as between stations given daylight assignments on any channels (including cleared channels); that it still refrains from adopting and announcing definite policies with respect to the desirability of cleared channels and the use of high power; that it called an engineering conference for January 17, 1930, to obtain the views of engineers on such questions as synchronization and antenna construction; that it has not yet come to any conclusion as to whether the alleged unnecessary "duplication" of chain programs really exists; that, with the exception of the unsuccessful venture made in the summer of 1928 to eliminate stations, it has done virtually nothing to decrease what every one concedes to be an excessive number of stations and, on the contrary, has made the situation worse by allowing many stations of the regional

Harold A. La Fount



Judge Ira E. Robinson



Sam Pickard



William D. L. Starbuck



Maj. Gen. C. Mck. Saltzman



class to increase in power. On the other hand, it did, by its General Order 40 and its allocation of November 11, 1928, introduce a substantial measure of improvement in the broadcast band. Whether a single executive officer would have done any better in the face of similar difficulties is at best doubtful. It is obvious that it is precisely in those matters in which Congress and its individual members have been most vocal that the Commission has



Thad H. Brown, general counsel of the Federal Radio Commission.

fallen somewhat short of following the mandates of radio physics.

The Good Points

By way of contrast the Commission has accomplished a creditable, efficient, and reasonably speedy performance of its duties in various fields of radio communication other than broadcasting. The inherent difficulties of these fields, particularly in the high frequencies, have certainly been no less than in the broadcast band but, with minor exceptions, pressure from Congress and its individual members has been absent. Opinions may differ as to the correctness of certain of the Commission's decisions on particular applications but there is virtually no criticism of the soundness of the engineering structure and standards which it has set up or as to the allocation of frequencies as between the various services. When it is considered that virtually every available frequency between 1500 kc. and 23,000 kc. has been assigned, that the applications for these frequencies were many times greater than the available facilities, and that many complicated and lengthy hearings have been held, it must be conceded that the job has been well done. For this, of course, no small share of the credit must go to the engineering advice which the Commission had from experts loaned to it by the United States Navy. In general, the Commission has followed the recommendations of engineers in all fields other than broadcasting, and has not had to contend with advice from Congress as to what is or is not sound engineering.

International Agreements

The Commission has also played its part well in maintaining the interests of the United States in international conferences. The United States delegation to the first

meeting of the International Technical Consulting Committee at The Hague in the fall of 1929 was ably headed by a member of the Commission and the results of the meeting were a matter for congratulation to the delegation. There was some complaint that the agreement entered into with Canada on March 1, 1929, covering the high frequencies from 1500 to 6000 kc., was unduly generous to Canada but one of the strongest proponents of this point of view was one of the two members of the Commission who formed part of the delegation which negotiated the agreement. There has been no criticism of the engineering aspects of the agreement.

The defects in the law and in the Commission's administration of the law which have contributed most signally to the lack of stability seem now in a fair way to being remedied. It is true that the terms of the present members of the Commission expired on February 23, 1930, and that each of the appointments to be made by President Hoover (whether of the present incumbents or of new members) will probably be subjected to close scrutiny in the Senate, with the possibility of either delay or refusal of confirmation. On the other hand, the amendment enacted by Congress in December, 1929, which extended the present powers of the Commission indefinitely "until otherwise provided by law," for the first time gives a measure of assurance of a substantial term of office, a stability of organization, and a continuity of policy. Unlike the two previous amendments, the most recent one does not shorten the terms of office to one year, and the new appointments may henceforth be made on a six-year basis. Engineers and lawyers may be employed without fear that at the end of a year their positions will cease to exist by reason of a reversion of radio regulation to the Department of Commerce.

In March, 1929, generous provision was made for employment of competent attorneys to handle the Commission's legal



Louis G. Caldwell, the author of this article and formerly general counsel of the Federal Radio Commission. Mr. Caldwell is also Chairman of the Committee on Communications (formerly the Committee on Radio Law) of the American Bar Association and Chairman of the Executive Council of the American Section of the International Committee on Wireless Telegraphy.

problems; by the recent amendment similar provision was made for engineers. It is unlikely that there will be further difficulties on the score of appropriation. It is to be hoped, therefore, that within a few months we shall have a Commission which is freed from many of the handicaps of the past three years and in a position to act with full judicial independence on controverted issues, aided by the advice of competent lawyers and engineers employed



Carl H. Butman, secretary of the Federal Radio Commission.

on a permanent rather than a temporary basis. In the meantime, the Commission is gradually freeing itself from such undesirable practices as the zone system of administration (under which system each member of the Commission gave little or no attention to matters concerning zones other than the one from which he was appointed).

The industry can contribute a great deal to the achievement of a stable, efficient licensing authority. Its various branches (and particularly broadcasting stations) can and should refrain from bringing any pressure, political or otherwise, upon the Commission, particularly where universally recognized engineering principles are at stake. They can and should refrain from misrepresenting scientific facts and principles either to Congress or to courts. The strongest support should be given the Engineering Division of the Commission in its endeavor to bring about the observance of engineering principles; the same degree of support should be given to the Legal Division in its endeavor to prevent the injustice which inevitably results from failure to observe the fundamental requirements of due process of law (which require notice and a fair hearing to all interested parties in every matter where interests other than those of the applicant are concerned).

Conclusions

There is ground for optimism, for, if the defects pointed out are remedied and if the industry cooperates as it should, the commission form of regulation will be successful. It must, however, have a fair trial. Those who, while placing every obstacle in the way of its success, point to the results of their conduct as evidence that it cannot succeed, are not serving the best interests of either the radio industry or the public.

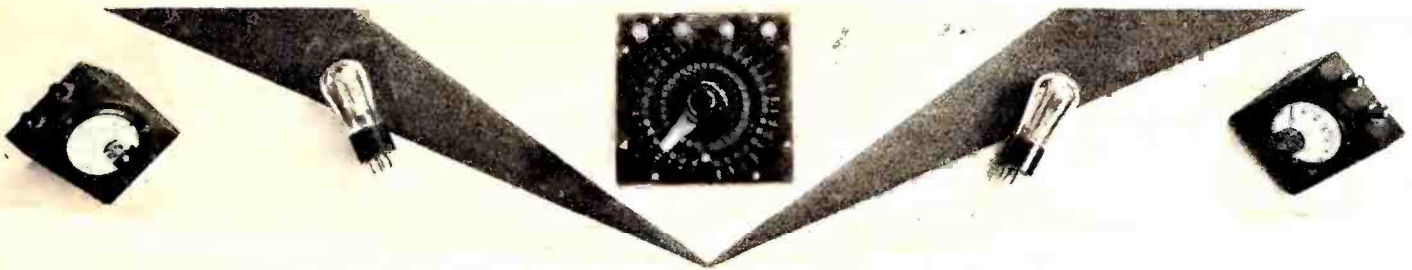

STRAYS FROM THE LABORATORY

Square-Law Detectors

ONE OF THE disadvantages of detectors which operate according to a square law, that is, where the a.f. output is proportional to the r.f. input squared, is that the stronger the a.f. input to the broadcasting station microphone, the greater is the distortion occurring in the detector. Audio tones which completely modulate the transmitter (100 per cent. modulation) produce in the plate circuit of a square-law detector a second harmonic which is 25 per cent. of the fundamental. Thus, if a 1000-cycle signal of 10 volts is produced in the output of a square-law detector, there will also be a 2000-cycle voltage of 2.5 volts in this output. Such distortion is distinctly audible to the trained ear. The greater the signal (a.f.) the greater the distortion. The actual value of the second harmonic is proportional to M^2 where M is the modulation percentage.

A graphical representation of this distortion may be constructed according to Fig. 1. Let us look at this illustration in which is plotted the relation between r.f. input to such a detector and the a.f. output. Now let us assume a fully modulated input of 2 volts. This means that at some instants the r.f. voltage is 4 volts and at some other instant it is zero. The a.f. voltage output corresponding is 16 when the r.f. is equal to 4 and zero when the r.f. is equal to zero. Now looking at the *Cunningham Tube Book*, page 19, we find a method of calculating the second harmonic distortion in such circumstances. It is equal to—

$$\frac{\frac{1}{2}(I_{\max} + I_{\min}) - I_0}{(I_{\max} - I_{\min})}$$

and substituting the above figures in this equation we get—

$$\frac{\frac{1}{2}(16 + 0) - 4}{16 - 0} = \frac{4}{16} = \frac{1}{4} = 25 \text{ per cent.}$$

The output a.c. voltage would look like that in Fig. 2 if a fully modulated wave

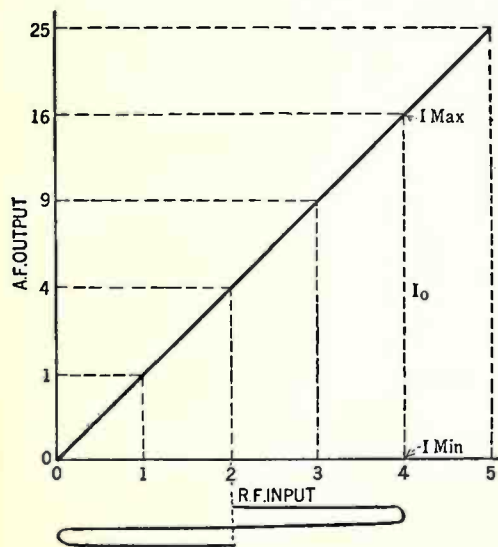

Fig. 1

of 2 volts (r.f.) were placed on a square-law detector.

Capacities of Coils

Various attempts have been made to calculate the distributed capacities of radio-frequency coils. Out of such calculations and experiments have come several interesting facts.

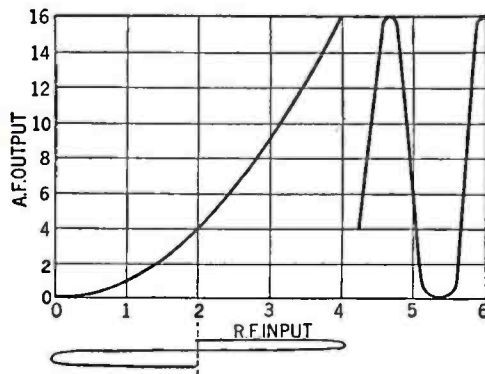

Fig. 2

In the *Journal of the Institute of Electrical Engineers*, (England) vol. IX, p. 63, Howe shows that the capacity in mmfd. of coils with a length of winding equal to half the diameter is equal to $0.6 R$ where R is the radius of the coil in centimeters. If the diameter is half the length of winding, the distributed capacity in mmfd. is equal to $0.64 R$ where again R is the radius of the coil in centimeters. In other words, the ratio of length to diameter does not change appreciably this empirical relation between radius of coil and distributed capacity.

Another interesting relation is that of Drude which states that the natural wavelength of the coil in meters is equal to 2.54 times the length of wire on the coil in meters.

Changes in Stations

The following data are taken from *The Voice of Columbia*, a publication of the Columbia Broadcasting System, Inc. They give changes in station power, etc., among members of this important broadcasting chain. The changes are prefaced with the statement that installation of crystal control and 100 per cent. modulation increases a station's signal strength by three or four times.

In Philadelphia, WCAU has increased its power from 1000 to 10,000 watts, and KMOX in St. Louis has received a permit to set up a 50,000-watt transmitter. In Detroit, WGHP is preparing to have new 1000-watt, 100 per cent. modulation equipment in operation at an improved location within the next two months.

With the installation of new equipment, WMAK in Buffalo becomes a 1000-watt station with 100 per cent. modulation, as does WSPD in Toledo with its power increased from 500 to 1000. In Boston, WNAC has installed a new 1,000-watt, 100 per cent. modulation transmitter at a loca-

tion which gives good New England coverage. Within the next few weeks, when its new equipment is installed, WKRC in Cincinnati plans to increase to full time and operate at maximum efficiency. Installation of 1000-watt, 100 per cent. modulation equipment is completed for KOIL in Council Bluffs. At Fort Wayne, WWO has a 50,000-watt transmitter which is all set to go when the word is given. KMBC in Kansas City and WLBL in Oil City have installed 100 per cent. modulation facilities and an order for similar equipment has been placed by WJAS of Pittsburgh.

About a month or so from now, WHK of Cleveland should have its new 5000-watt, 100 per cent. modulation transmitter replacing its present 1000-watt equipment, and in a more advantageous location.

Quartz Crystals

Quartz crystals may be obtained from the Crystal Grinding Laboratories, 215 West Cook St., Santa Maria, California, at the following rates: 3500-3650-kc. band, \$7.50; 1750-1825-kc. band, \$5.00; Oscillating blanks, \$3.50. The Laboratories offer immediate service; frequency to within 0.1 per cent.

A Correction

An unfortunate error occurred in the article in January, 1929, RADIO BROADCAST, entitled "A Radio Dealer's Tube Tester." Fig. 2, a circuit diagram, was incorrect. The correct diagram is given in Fig. 3 on this page. The lamp, B, should be connected to the grid terminals of the tube sockets and not to the plate terminals as indicated in the January issue.

Recent Articles of Interest

An analysis of the design and applications of beat-frequency oscillators is contained in the *General Electric Review*, October, 1929. The article, by M. S. Mead, Jr., describes not only the construction of an instrument built by the General

(Continued on page 302)

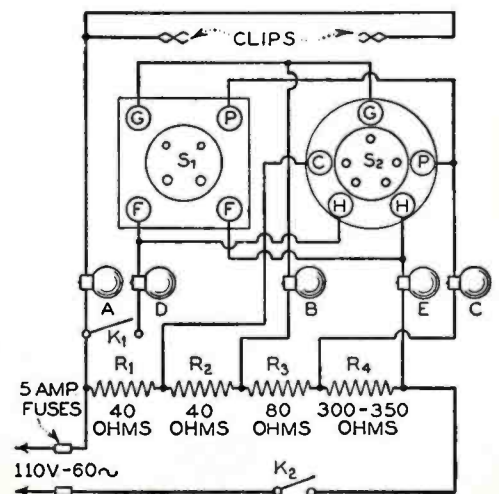
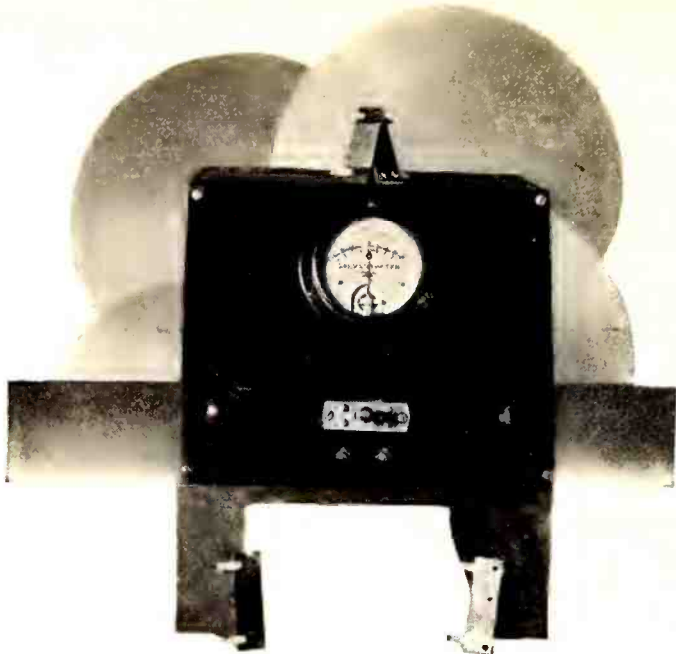

Fig. 3

PRODUCTION TESTING EQUIPMENT

By J. A. CALLANAN
Stewart Warner Corporation



This device for measuring the resistance of wire-wound resistors within 1 per cent. is attached to each winding machine.

In this, the third of a series of articles dealing with production testing of radio appurtenances, the discussion centers around the testing of a miscellany, which, while just as important as either capacitances or iron-cored items, does not come under either group. For example, the testing of r.f. coils is, in the writer's opinion, secondary in interest only to the testing of gang condensers. The acceptance limits must, of course, be held just as closely as those of gang condensers as they are used in conjunction with one another.

Testing R. F. Coils

In testing r.f. coils we have tried a number of systems, including matching sets of coils, adjusting turns, etc., but have found that all of these resulted in manufacturing difficulties which made them impractical. Several years ago we tried the matched-set system in which every coil is graded according to the position of a condenser dial at which the tuned circuit resonates. The coil is then marked high, medium, or low and is used with a condenser conversely marked. Our manufacturing, repair, and service stations branches soon protested, and, while we operated with this method

that year, the system was more costly than either the turn-adjusting system or our present one. The turn-adjusting method was very good, but it was not very fast and therefore required more labor. From these experiences our present system was evolved; it is neither costly nor slow and has been entirely satisfactory to all concerned. For those who may be interested in a similar procedure a detailed description of our coil-winding and inspection system is given below.

Upon receipt from the factory the coil forms are first dried to prevent a possible variation in size due to the absorption of moisture in shipping. They are next placed in a double split ring gauge which measures the circumference at either end of the coil form. A dial indicates the average circumference to the thousandth part of an inch. The gauge is necessarily constructed so that even if the shape of the coil form is distorted a true circumference reading is obtained. In our particular case we find that a difference in size of 0.003 inch makes a $\frac{1}{2}$ -turn difference in winding so we have made our factory acceptance limits plus and minus 0.003". This makes a difference of one full turn in apparent inductance, or,

in other words, gives us three possible groups of coils, viz. minus $\frac{1}{2}$ turn of 150 turns (our standard), 150 turns, or $150 + \frac{1}{2}$ turns, and each is interchangeable in the completed receiver.

The tested coil forms are first punched and wound with the required number of turns as shown by the inspection ticket, the coils being space wound to prevent error due to varying wire diameter. The coils are then doped and soldered after which endless belts or conveyors carry them along until they are placed in the receiver.

Our coil test equipment consists of two types of machines, one for the "A" coils with relatively few primary turns and the other for "B," "C," and "D" coils which have sufficient primary turns to resonate below the broadcast band when connected in parallel with the tube capacity. The schematic diagram of the "A" coil machine is given in Fig. 1, while the machine for testing B, C, and D coil is shown in Fig. 2 and the accompanying picture. These test fixtures consist of a crystal oscillator to which is coupled the coil under test, resonance being indicated by a V.T. voltmeter connected across the coil.

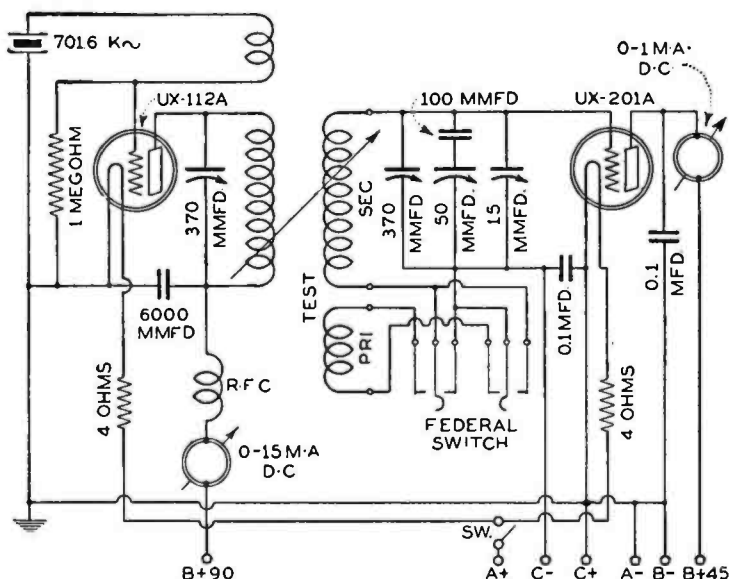

Fig. 1—Circuit for checking low-inductance r.f. transformers. A crystal oscillator supplies the power and the coil under test is connected in the grid circuit of the V.T. voltmeter tube. The secondary is first checked alone and then primary and secondary are connected, series aiding, to test both windings and the mutual inductance between them.

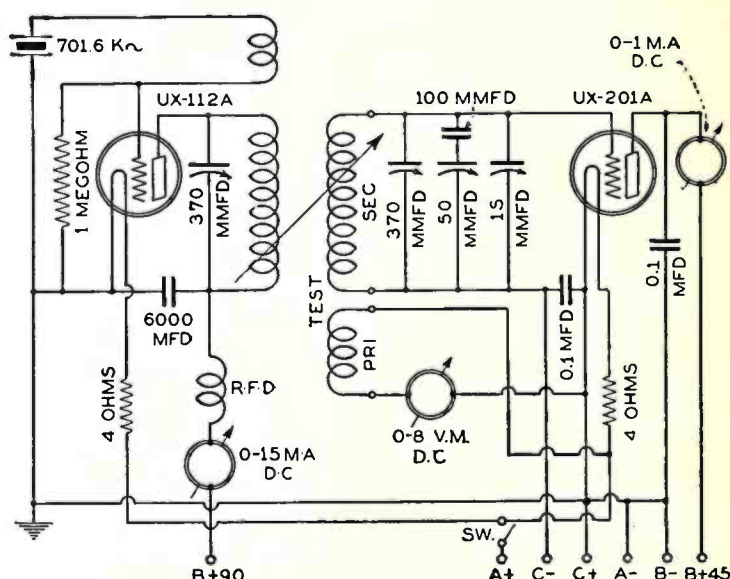

Fig. 2—This circuit for checking high-inductance r.f. transformers operates in a similar fashion to Fig. 1 except that only the secondaries are tested, the limits being plus or minus one half turn. All primary coils are tested for resistance and only a small percentage of the production receives an inductance test. The rejects run about 1 per cent.

PART III—

Apparatus Designed and Used by the Stewart-Warner Corporation for Testing Radio-Frequency Coils and Chokes, Loud Speakers, and Wire-Wound and Fixed Resistors.

The calibrated condenser is of the transmitter type and is equipped with special bearings to resist wear. The "A" coil machine (Fig. 1) is made so that the secondary is first tested alone and then by a throw-over switch the primary and secondary are connected in a series-aiding circuit. In our particular case where a variable antenna compensating condenser is connected across the "A" coil secondary, the inductance limits are rather broad, plus and minus one turn for the secondary winding and two turns for the primary and secondary in a series-aiding circuit.

The "B", "C", and "D" coil machine differs only in that the secondaries alone are tested for inductance with limits of plus and minus $\frac{1}{2}$ turn, the primaries being tested for d.c. resistance with a simple ohmmeter. We have found this d.c. reading to be just as satisfactory an indicator of the primary as an inductance test, though, as in other branches, an inductance test is run on a percentage of the primary windings. Our production department reports that rejections run approximately 1 per cent. with this system. The 0-15-mA. meter indicates the condition of the crystal oscillator while the 370-mmfd. variable condenser in the tank circuit controls the power output. The condensers in the V.T. voltmeter are to adjust the circuit to

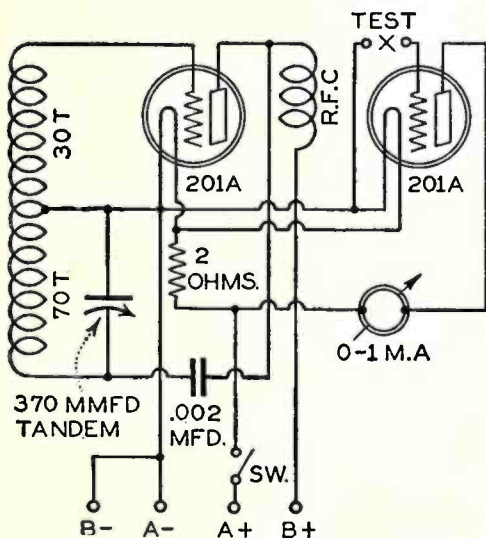
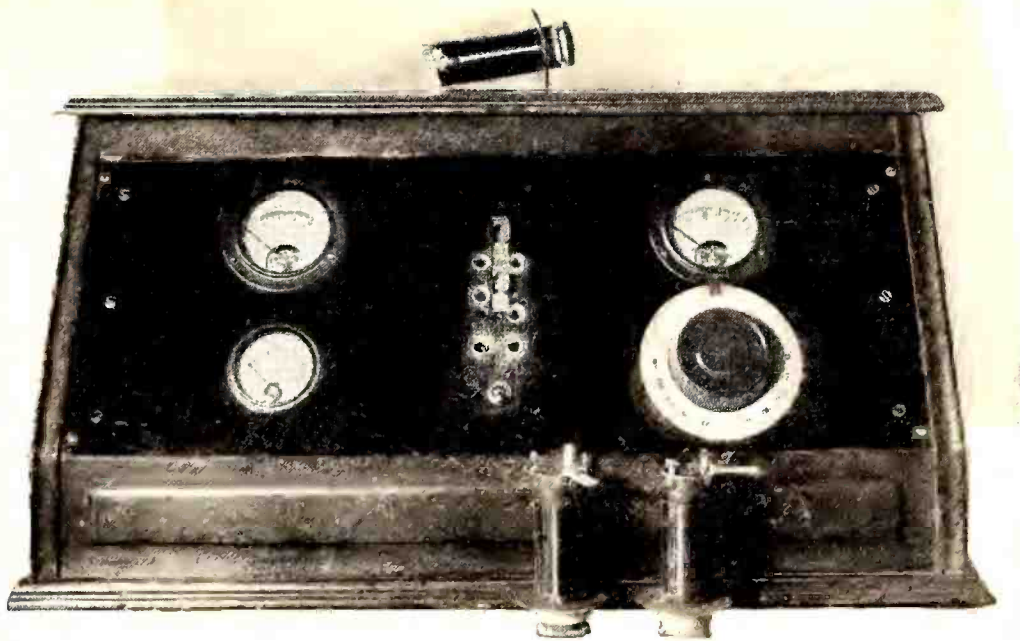

Fig. 3—In testing r.f. chokes with this apparatus the resonant frequency is checked by adjusting a 750-mfd. condenser. All chokes resonating in or near the broadcast band are rejected.



High-Inductance r.f. transformers are tested with this device. It contains a crystal oscillator coupled to the coil under test and a V.T. voltmeter to indicate resonance. The circuit is given in Fig. 2.

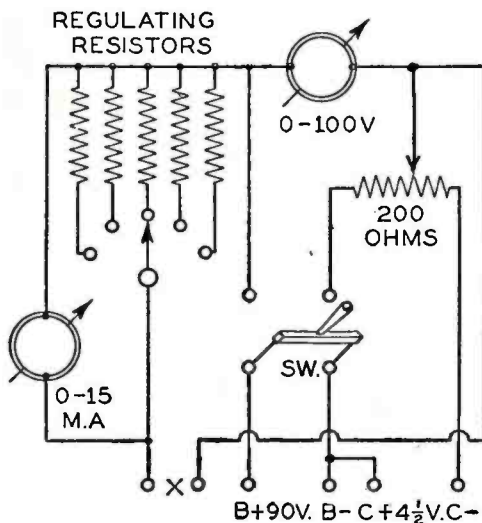

Fig. 5—Carbon resistors are tested by passing through them a current approximating normal and measuring this current with a milliammeter and the voltage across the resistor with a voltmeter.

resonance when a standard coil is connected, while the arrangement for connecting the coils in the circuit is shown in the picture. These test sets use one 6-volt A battery and two 45-volt B batteries.

Testing R.F. Chokes

The testing of r.f. chokes is very similar to the testing of r.f. coils except that, as the limits are broader, we do not find it necessary to use a crystal oscillator. As shown in Fig. 3 the coil under test is coupled to an oscillator whose frequency is made variable by means of a 750-mmfd. tandem variable condenser. Resonance is indicated by a simple V.T. voltmeter and limits are painted on the dial. The operator rejects chokes which resonate near or in the broadcast band while those resonating between 300 and 500 kc. are accepted. This test set uses one A battery and one 45-volt B battery.

Loud speaker coil testing is accomplished by first testing for shorted turns with the test fixture described in last month's article and then measuring the resistance with an ohmmeter. Very little trouble is experienced here because automatic counters are used in winding.

The testing of wire-wound resistors on a production basis is not difficult as far as

testing is concerned but is often an expensive item because of the quantity used in the average receiver. A good bridge or ohmmeter costs from \$50.00 to \$100.00 and can only be used by one operator, so where there are 25 to 50 girls winding resistors, if each were to have a tester this would become quite an item. We have designed a simple bridge circuit costing about \$10, one of which is attached to each winding machine. As this enables the operator to wind exactly the right amount of resistance wire our resistor rejections are less than one per cent. and this is due to breakage and not to incorrect resistance.

As may be seen by referring to Fig. 4 and the picture, the test fixture consists of a bridge with two standard legs and a high and low-limit arm, either of which may be inserted by a throw-over switch. This switch also serves to break the battery circuit. The binding posts in the front of the fixture are so that it may be connected to the winding machine while the contact points are used in testing completed resistors directly. The arrangement is sensitive to differences in resistance of 1 per cent. and is not affected by battery poten-

JEWEL PTRN
N° 54 — 50-0-50
GALVANOMETER

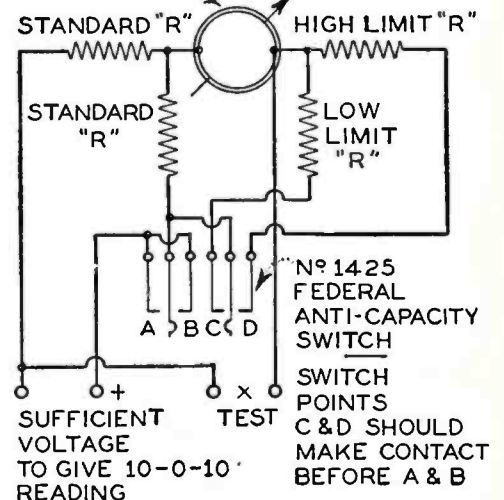

Fig. 4—Wire-wound resistors are checked within 1 per cent. by means of this bridge system which is attached to the winding machine. Changes in battery potential do not affect its accuracy.

RATING RADIO RECEIVERS

By **ALFRED H. GREBE**
President, A. H. Grebe & Company, Inc.

A Method Offered by A. H. Grebe & Company, Inc., as a Solution to the Problem of Describing to the Non-Technical Public the Merits of a Particular Broadcast Receiver.



The author in the laboratory checking the work of Grebe engineers.

Newspaper and magazine advertising of radio receivers consists mostly of high-sounding adjectives. It was our feeling that performance claims backed by definite quantitative measurements would form a better basis of advertising than vague claims of superiority. This desire to find a reasonable basis upon which to write

Grebe copy has been responsible for the use of a new type of advertisement by our company.

Our present series of advertisements have been based on a series of measurements on a number of standard makes of radio receivers. The technical data which forms the background of these tests are described in the following paragraphs.

In the rating of receivers there are three factors of major importance—sensitivity, selectivity, and fidelity. Stating these factors in engineering terms such as so many microvolts per meter, or a loss of so many dB at 5000 cycles is understandable to engineers but means little to the layman. We have, therefore, endeavored to work out formulas for these various factors which will permit their expression in percentages so that a set has a fidelity of say 50 per cent., a selectivity of a certain percentage, and so forth.

and there is a great variation between sets. We are therefore using the selectivity at 1400 kc. as a basis for comparison of sets, and are taking the width of the selectivity curve at 100 times the input at resonance. Therefore, if a set has a band width of 40 kc. it means that if our signal were 20 kc. off resonance on either side, the input to the set would have to be increased 100 times to give the same loud speaker output that we would have obtained with the set tuned to the signal. Since the sides of the selectivity curve are fairly straight, a set with a band width of 40 kc. at 100 times input would have a band width of about 20 kc. at 10 times input. This means that a station of equal strength on an adjacent channel (10 kc. off) would only produce one tenth the signal in the detector, and this is not enough to interfere with the station to which the set is tuned.

Therefore, a set with a band width of 40 kc. can be said to have "10-kc. selectivity" over the entire broadcast range. As a matter of fact, a set having 40-kc. band width will give 10-kc. channel selectivity even though the interfering signal on the adjacent channel is twice as strong as the desired signal. A set having 50- to 55-kc. band width is still capable of giving 10-kc. channel selectivity provided the interfering signal is no stronger than the desired signal.

We have given a set with a band width of 40 kc. at 1400 kc. a rating of 100 per cent. in selectivity. The curve of per cent. rating against band width has been made steeper in the neighborhood of 40 kc. because a 1 kc. improvement in band width here is more difficult to obtain, and is also worth much more than the same improvement at a band width of, for example, 100 kc.

Selectivity

The ability of a set to receive the desired station without interference from another signal on an adjacent or nearby channel is indicated by the selectivity curves. The selectivity of all sets is roughly the same at the lower broadcast frequencies, but on higher frequencies the selectivity becomes much worse

Sensitivity

The sensitivity of a set is expressed in terms of the voltage input to antenna required to give a fixed output to the loud speaker.

The figures used are in microvolts per meter. The actual input to the antenna of the set is four times this figure, since a standard antenna is assumed, having an effective height of 4 meters.

The lower the figure for sensitivity the

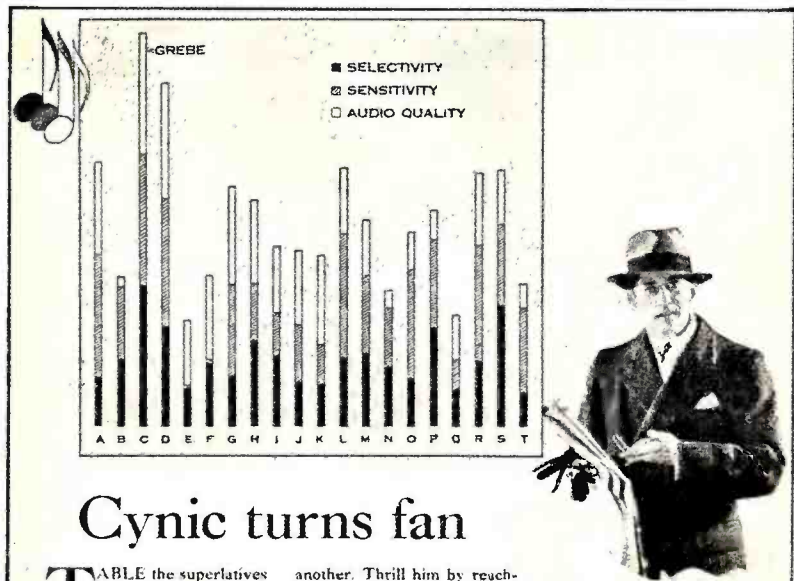

Cynic turns fan

TABLE the superlatives when he comes in; don't bear down with sales talk; this hardened cynic wants evidence. And on this chart he finds the facts that show him exactly what to expect of the Grebe—clear-cut comparisons that shatter his shell. Now let him listen to the set that is newer than screen grid and watch him turn fan.

He is critical but his demands are not unreasonable when put to the Grebe. This set satisfies them with plenty to spare for it is at least a year ahead of the field. Show him how sharply the Grebe separates one station from

another. Thrill him by reaching out for weak, distant broadcasts. Close the sale with the lifelike tone that enables him to identify every instrument, every voice.

Then, after he has signed on the dotted line, be sure you deliver on time. You know how it is with this type of buyer; once you have sold him, you cannot get the set to his home quickly enough!

There is extra profit in the Grebe franchise. In addition to getting normal business, it sells those who would not otherwise be ready for another year.



Alfred H. Grebe—"In the new folder being distributed to the public by our dealers we prove the uniformly high quality of this new set in every important characteristic of radio reception. We support the statement that Grebe prices will not be reduced with the pledge that Grebe quality will not be reduced. To franchise-holders this means that profits will not be reduced—that every sale will continue to yield a worth-while return."



Grebe radio

A. H. GREBE & COMPANY, Inc., Richmond Hill, New York
Western Branch, 443 So. San Pedro Street, Los Angeles, California

The advertisement above is indicative of the way in which Grebe explains the merits of its product to the non-technical public.

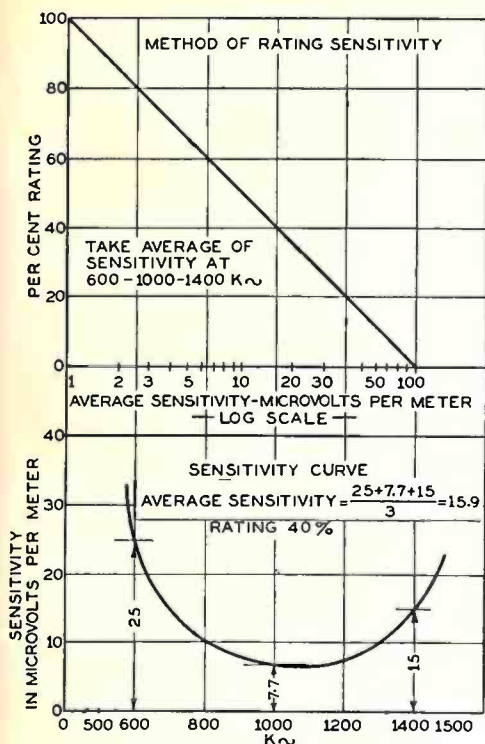

Fig. 1

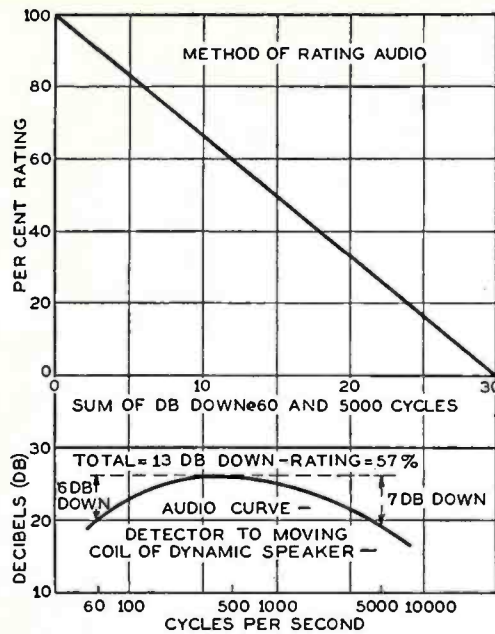

Fig. 2

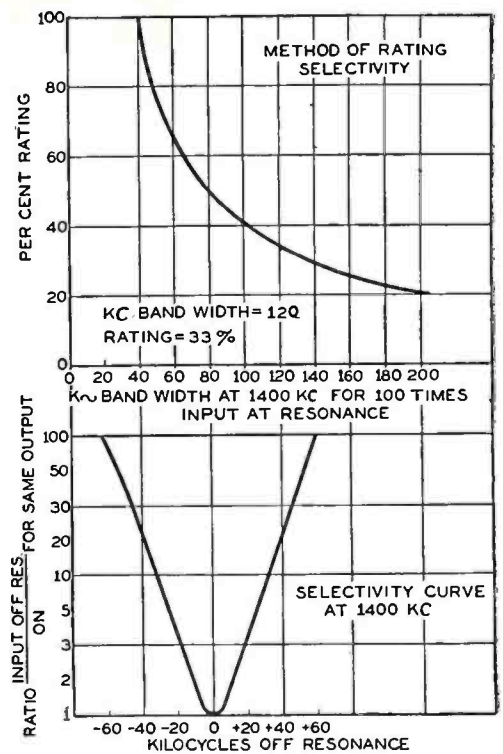

Fig. 3

more sensitive is the set. We have given a sensitivity of 1 microvolt per meter 100 per cent. credit. No set has been found that is quite this sensitive. A sensitivity of 100 microvolts per meter has been given zero credit since a set having such a sensitivity would only be able to get a few distant stations, and would be unable to get some of the weaker local ones.

In order to penalize those sets whose sensitivity varies widely over the broadcast range we take the average of the sensitivity at 600, 1000, and 1400 kc. The curve of per cent. rating against sensitivity uses a log scale since the response of the ear is logarithmic. Fig. 1 shows how average sensitivity is determined and the relation between average sensitivity and the per cent. rating.

Fidelity

The a.f. curve of the set is taken from the detector

to the moving coil of the speaker. The amplification is expressed in decibels, which is a logarithmic unit. The useful frequency range taken as from 60 to 5000 cycles per second, and the set is given a 100 per cent. rating if it amplifies equally all frequencies between these values. Most sets have maximum amplification at 500 cycles per second and fall off somewhat as the frequency is either increased or decreased. As an in-

dication of how much it varies we take the difference between the amplification at 60 and 600 cycles per second expressed in decibels, and add to this the difference between the amplification at 5000 and 500.

This gives the total decibels variation from uniform amplification.

A set with a total variation of 30 decibels has been given a rating of zero.

In the three charts on this page will be found examples which indicate quite clearly the method used in indexing the selectivity, sensitivity, and fidelity characteristics of radio receivers. In addition, the table on the left shows the ratings which have been assigned to twenty standard receivers and the method of converting band width, microvolts per meter, and total decibels loss into corresponding percentage ratings. The overall rating is the average of these three ratings.

SET	SELECTIVITY		SENSITIVITY		FIDELITY		TOTAL %	OVERALL %
	Band Width at 1400 kc.	Band Width $\times 100$ (% Selectivity)	Average $\mu V/m$ 600, 1000, and 1400 kc.	(1-1 log Saver) $\times 100$ (% Sensitivity)	Sum of DB loss at 60 and 500 cycles	$30 - \frac{\text{Sum}}{30} \times 100$ (% Fidelity)		
1	43	93	1.75	88	5.5	82	263	87.6
2	61	66	2.	85	7.	77	228	74.0
3	120	33	2.3	82	11.7	61	176	58.7
4	88	45	2.2	83	16.4	45	173	57.7
5	50	80	7.9	55	18.8	37	172	57.3
6	90	44	2.6	78	15.6	48	170	56.7
7	122	33	5.7	62	10.1	66	161	53.7
8	70	57	29.1	38	12.9	57	152	50.7
9	61	66	6.66	59	23.9	20	145	48.3
10	81	49	9.	52	18.8	37	138	46.0
11	124	32	3.5	73	22.6	25	130	43.3
12	83.6	48	26.2	29	16.7	44	121	40.3
13	136	29	16.2	39	14.9	50	118	39.4
14	154	26	29.4	27	11.7	61	114	38.0
15	95	42	89.	03	13.3	56	101	33.6
16	90	44	10.3	49	28.	07	100	33.3
17	185	22	7.4	57	25.1	16	95	31.6
18	102	39	15.9	40	26.4	12	91	30.3
19	156	25	41.3	19	20.6	31	75	25.0
20	176	23	110.	2	16.1	46	71	23.6

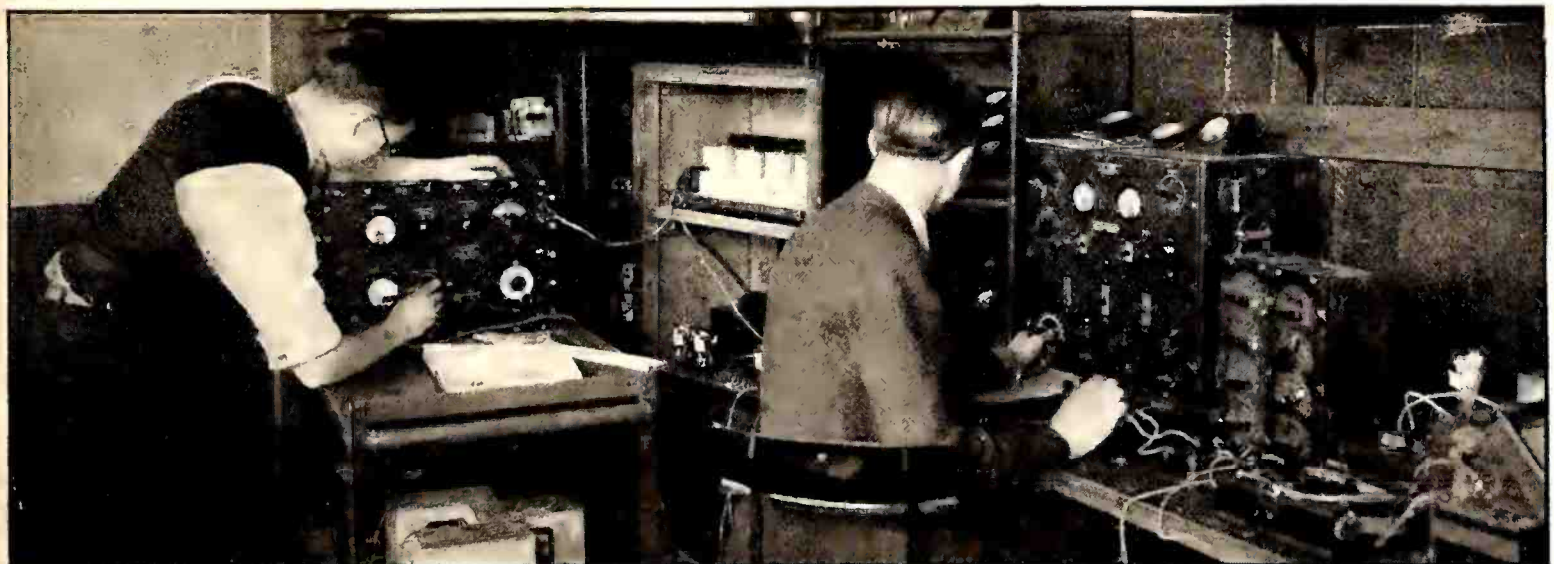

Two Grebe engineers at work in the laboratory measuring the characteristics of a broadcast receiver.

TRICKS WITH SET TESTERS

By HERBERT M. ISAACSON

Engineering Dept., Colonial Radio Corp.

Using a Trouble Diagnoser to Measure Inductance, Capacity, and Resistance.

In the November, 1929, issue of RADIO BROADCAST the writer described a radio set diagnoser of his design. As explained in the first article this instrument is capable of performing all the tests which may be made with a standard set tester and in addition it may also be used for measuring resistance, capacity, and inductance. As interest in the diagnoser has been so great it has been decided to give data on making the latter measurements. Also, certain omissions occurred in the wiring diagram which accompanied the original article and therefore a revised circuit will be found on this page.

Resistance Measurements

The usual method of measuring resistors is to read the current with a known voltage impressed across the resistor. This method does not lend itself readily to the measurement of resistors of large value, since an unreasonably high voltage would have to be used to secure a readable deflection on the 10-milliamper meter scale. However, for measuring resistors which have a value comparable to that of the voltmeter multiplier resistors there is a very simple method which may be used. Using a voltage that gives a large-scale deflection on the voltmeter range selected, take a reading with the resistor under test in series with the voltmeter and a reading without the resistor. If V is the voltage reading without the resistor, v the reading with the resistor in series, R the resistance of the voltmeter range used, and r the unknown resistor value, then $r = \frac{(V-v)R}{v}$. For instance, if the resistance value of a grid leak were to be determined, and the voltage as indicated on the 100-volt scale without the grid leak in series was 90 volts, and with it in series was 5 volts, then $r = \frac{(90-5) \times 100,000}{5} = 1.7 \text{ megohms}$.

Measuring Capacity

The capacity of a filter or by-pass condenser may be measured by either of two methods. The first makes use of the fact that the reactance of a condenser is inversely proportional to its capacity and with this method it is necessary to know the impedance of the a. c. voltmeter. Its impedance, which can be considered equal to its resistance without introducing an appreciable error, can easily be determined by either of two

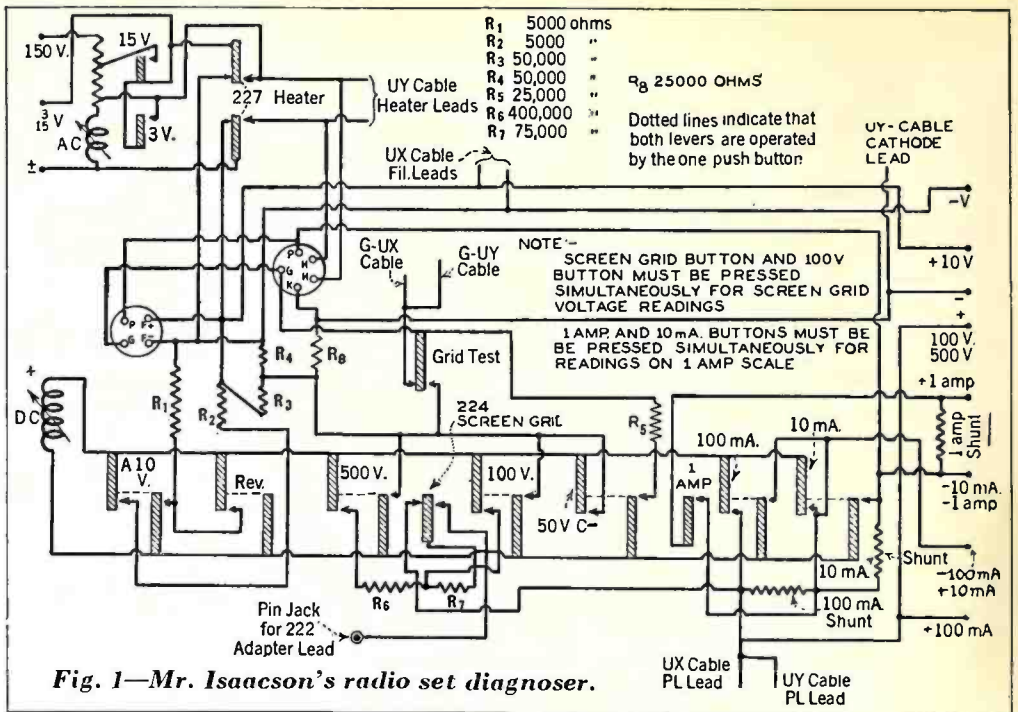

means. When direct current is available a measurement of the current through the meter when a known voltage is impressed across it will give the resistance by dividing the value of voltage by the value of current. The other way is the "half-current method." It calls for inserting in series with the voltmeter a resistor of such value that the meter reading is reduced to one-half of that obtained without the resistor. Either a.c. or d.c. may be used and the resistance of the meter is considered equal to the resistance of this external resistor. To ascertain the unknown value of a capacity, take a reading of the a.c. line on the 150-volt a.c. scale and call it V . Take another reading with the condenser under test in series with the meter, and call it V_1 . Then the value of capacity in mfd. is $\frac{2652.5}{KR}$ where R is the voltmeter resistance and K is a constant, the value of which depends on the ratio $\frac{V_1}{V}$ and is given in the table.

For illustration, suppose the line voltage reading on the 150-volt scale of a 40-ohm-per-volt meter were 120 volts. With the capacity in series with the meter, the reading would fall to 84 volts. The ratio $\frac{V_1}{V}$ is $\frac{84}{120}$ or 0.7. Consulting the table we find a value of 1 for K when $\frac{V_1}{V} = 0.7$. Then $C = \frac{2652.5}{6000} = 0.44 \text{ mfd}$.

The second method, the so-called ballistic-galvanometer method, is based on the fact that the charge in a condenser is directly proportional to its capacity. Charge a condenser of known capacity at a convenient voltage (90 volts is handy). Connect the 100-volt d.c. scale of the diagnoser across the condenser and note the highest reading of the pointer (with the supply voltage disconnected, of course). Now charge the condenser under test at the same voltage and observe the reading when it is discharged through the voltmeter. If C is the first capacity, c the unknown, V the first voltmeter reading, and v the reading with the unknown capacity, $c = \frac{Cv}{V}$.

The first method is by far the easier, but where a.c. is not available, it is necessary to fall back on the ballistic-galvanometer method.

Measuring Inductances

Inductances of large values such as are used for filter chokes may be measured in a manner similar to the first one described for capacity measurements. A line voltage reading, V , and a reading with the choke in series with the meter, V_1 , are taken. The inductance, in henries, is then equal to $\frac{KR}{377}$ where R is the voltmeter resistance and the value of K depends on the ratio $\frac{V_1}{V}$ as before, and is given in the table. For example, assume a line voltage reading of 115 volts, using a 6000-ohm meter. With the inductance in series, the reading falls to 51 volts. $\frac{V_1}{V} = \frac{51}{115} = 0.44$. From the table we find $K = 2$. Then $L = \frac{2 \times 6000}{377} = 31.8 \text{ henries}$.

This formula is more "vigorous than rigorous," since it assumes that the reactance of a choke equals its impedance. However, for practical purposes the error introduced is negligible.

(Continued on page 282)

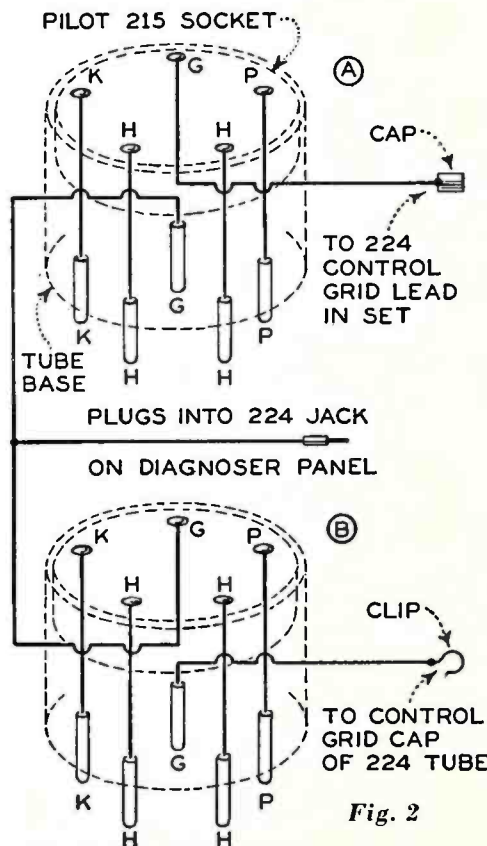



What does *your* set say
to
"the man who knows"?

"Who really buys your set?"

"What points actually sell it?"

THE success of today's manufacturer and builder depends upon how well he knows the answers to these two questions.

The man who knows enough about radio to understand causes as well as results is becoming an increasingly important sales factor in the receiver market. Those who are not radio-wise hesitate to purchase sets without relying upon the advice of an acquaintance who has some knowledge of radio. To this man, Sangamo Transformers stamp your set as O.K. Sangamo in

the "audio end" means true TONE.

TONE QUALITY is the magic key that finally opens the purse and closes the sale.

Transformer building is a science in itself—best left to an organization like Sangamo, whose research, experience and precision manufacturing facilities guarantee results. Sangamo "A" Line Transformers are built for the custom set maker or manufacturer who wants a "tone" advantage over competition. They cost a little more, but the set is easier to sell.

SANGAMO ELECTRIC CO.

SPRINGFIELD, ILLINOIS, U. S. A.

Manufacturers of Precision Electrical Apparatus for 30 years

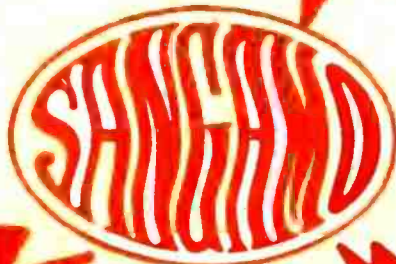

See Reverse
Side

"A" Line Transformers

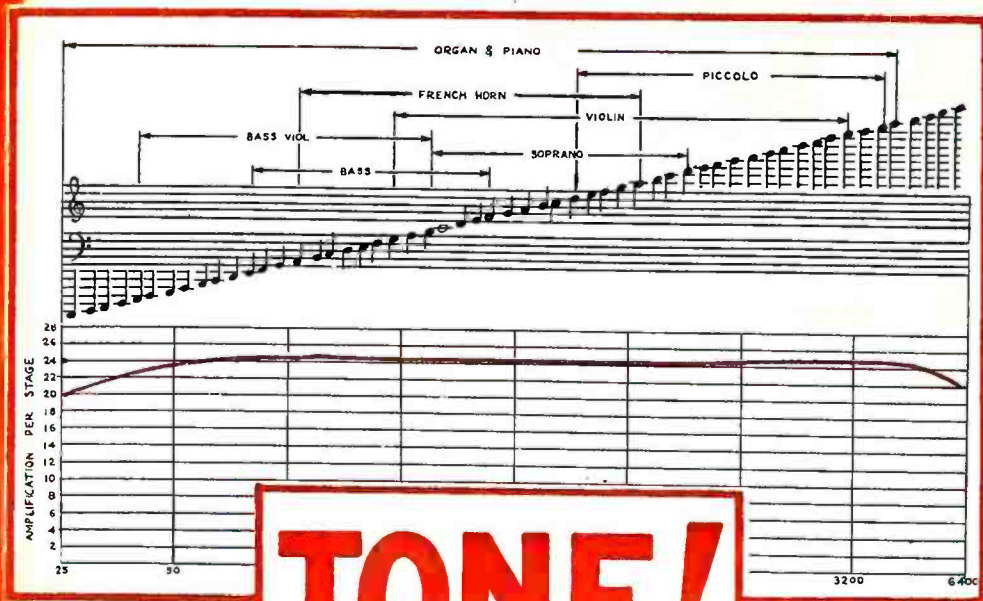

TONE!

Curve of Type "A" Sangamo Straight Audio Transformer showing uniformity of amplification at all audible frequencies.



Type "A" straight audio amplification. List price..... **\$10**

Type "B" Push-pull Input Transformer for all tubes. List price..... **\$12**

Type C-171 Push-pull Output, for 171 or 250 type power tubes with cone speaker. List price..... **\$12**

Type D-210, same as C, except for 210 and 112 power tubes. List price..... **\$12**

Type H-171, Push-pull Output for 171 or 250 power tubes for Dynamic Speaker. List price..... **\$12**

Type G-210, same as type H, except for 210 and 112 power tubes. List price..... **\$12**

Type F Plate Impedance for use as a choke to prevent oscillation and for impedance coupled amplifiers. List price.... **\$5**

Unusual facilities for furnishing transformers with or without cases ready for mounting and quick assembly with the receiver. Prices on application.

SANGAMO Type "A" Condensers



No item can cost so little and cause so much trouble in a receiver as a fixed condenser. This fact is especially appreciated by the manufacturer with an eye to the service problem. Likewise, experience has shown that a fixed condenser is not necessarily a good condenser just because it is molded in Bakelite.

The immunity to thermal changes and to mechanical damage rendered by the Bakelite enclosure is supplemented in Sangamo Condensers by accurate rating and sound construction of the mica condenser within the Bakelite casting.

The standard line of Sangamo Fixed Condensers leaves the factory tested to maximum variation of 10%. Also furnished with closer ratings and in high voltage types.

SANGAMO "Illini" Condensers



"Illini" Condensers are standard with those manufacturers who insist on ratings being actually what the specifications call for. Manufactured by exclusively designed equipment, held to the tolerances your engineering department demands, Sangamo Condensers will reduce to a negligible quantity inspection department rejects and "re-assembly" losses in profit.

CUT THIS TO YOUR LETTERHEAD AND MAIL

SANGAMO ELECTRIC CO.
Springfield, Illinois, U. S. A., Dept. S

(For manufacturers) I am interested in engineering data regarding your transformers and condensers.
 (For set builders) Please send circulars describing your apparatus and latest audio hook-ups. I enclose 10c to cover cost of mailing.

Name _____

Prices on request

PROFESSIONALLY

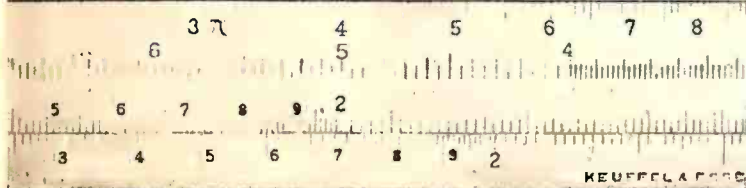

SPEAKING

REGARDING PENTODE ARTICLES

A number of articles have been published in RADIO BROADCAST, and also in several foreign radio periodicals, on the pentode, a new five-element tube designed for power output purposes. It is a tube which, with less grid excitation, will deliver as much power output as present-day tubes—in other words, it is more sensitive. On the other hand, there are other types of pentodes which will deliver the same power output as present tubes on a smaller consumption of plate power. The new tube is therefore more efficient.

A few set manufacturers do not like the appearance of such notes and articles on new tubes. They say the industry is already bothered with too many tubes; that new tubes come along faster than the set manufacturers can get ready for them, they appear sooner than they can engineer good sets for them, and are put on sale before the tubes themselves are fully developed. Therefore, any announcement of a new tube tends to unsettle the industry. They believe, therefore, that the thing to do is to keep quiet, brag up present-day sets, and beat the drum in the band wagon.

The Editors of RADIO BROADCAST have no desire to upset the industry, but they do not feel flattered at being part of an industry that is so unstable as to be unsettled by publication of news of a new foreign tube which may or may not have to be reckoned with in this country.

On the other hand, the Editors feel an obligation to present the most complete and authentic information on the latest technical developments to the several thousand engineers who read RADIO BROADCAST.

Many of these engineers have flattered the Editors into believing that the tube articles (the first appeared in 1925 and were widely reprinted by tube and set manufacturers) which have appeared in this magazine were timely and useful. It may be remembered that the first laboratory data on the screen-grid tube, except that published by Dr. Hull in the *Physical Review*, were published in RADIO BROADCAST. Unfortunately not many radio engineers read the *Physical Review* or the foreign technical papers, and, therefore, until the technical articles appeared in this magazine only a few radio engineers knew much about this tube which has come into such favor within the past year. Similarly the first articles on the pentode published in the United States were in the technical columns of RADIO BROADCAST.

Engineers may expect in RADIO BROADCAST as much material as it is possible to get on pentodes or on any other technical matter of interest or importance to them.

The Editors do not believe that publishing technical data about impending developments will accelerate the growth

of gray hairs in any manufacturer's head and regret that any manufacturers feel that such articles will impede the sale of present models. They do not believe that the fault is with releasing information on technical developments—progress, some call it.

You can pull down the shades in the morning if you want to sleep after sunrise—but you cannot prevent the sun from coming up.

Attention—

A promise to keep engineers informed of progress and technical developments.

Should radio salesmen be informed of what's under the lid?

Let's be thankful that we do our radio listening in America.

ARE TECHNICAL SALESMEN NEEDED?

How much technical knowledge a salesman or dealer should have seems to be a question that occasionally agitates manufacturers of radio receivers. In general the question is or has been dismissed with the thought that the public knows nothing at all about what is inside the box, and the salesman need know but little more.

We believe that this attitude is not conducive to selling the maximum possible number of radio receivers. It is true that the general public knows and cares but little about linear detectors, microvolts per meter, or milliwatts output, and that a salesman seldom finds it necessary to drag such terms into the conversation prior to closing the deal. But on the few occasions when a salesman finds a customer who wants an explanation of linear detection or screen-grid amplification, the dumb salesman cannot help being dumb and probably finds that his commonplaces about superior sensitivity or selectivity do not help him to fill the dotted line.

The dealer's salesman who is best equipped to talk about the set he is trying to install in a prospect's home, has, in our opinion, the best chance of removing that radio from his employer's storeroom. The salesman who persists in talking grid leaks and C bias to non-technical customers is not a good salesman anyhow, but the salesman who is poorly equipped to sell a technical product may find himself in the unenviable position of knowing less about his product than does his customer.

It is our opinion that the manufacturer should make every effort to interpret to his dealers what is under the lid; why it is technically better than others; what technical terms really mean to the consumer, etc.

Perhaps the greatest contribution of the screen-grid tube is greater freedom from annoying hum—yet we have not heard of a dealer who mentioned this advantage.

IMPROVEMENTS IN MONITORING

One of the outstanding achievements of the radio year 1929 was the broadcasting of the Philadelphia Symphony Orchestra under the baton of Mr. Stokowski. The Philadelphia Storage Battery Company deserves commendation for sponsoring programs of such merit, and the National Broadcasting Company's engineers who carried the symphony to the radio audience must share in the credit, too.

In these days when any aggregation of musicians that someone pays to go on the air is a symphony orchestra; when anyone who wields a baton is a maestro; in these days of severe monitoring of symphonies so that fortissimo and pianissimo sound alike in a rather deadly monotone; in such days it means something for a listener to be able to hear Mr. Stokowski's orchestra because of the excellence of this organization—and because Mr. Stokowski was his own "monitor."

The leader of this famous orchestra had apparently listened to the broadcasting of full symphonies in which the peaks and hollows of volume were electrically leveled off for radio; he had heard the audible manipulation of the gain control; and, like many careful listeners, had been disgusted. Hence he had the volume level indicator mounted where he could see it, and conducted his orchestra so that the volume was kept between the desired limits.

Normally as soon as the orchestra goes up in volume, the monitor operator cranks the volume down so that the differences of level are ironed out. The effect of Mr. Stokowski's monitoring was one of listening to an orchestra which turned out much greater volume differences of level.

Conditions in this country are not as bad as they seem to be in England where one listener complains that "efforts of monitors to vary the volume inversely to the conductor of the orchestra have reached such a pass that they have almost attained the engineer's dream of transmitting a pure sine wave of unvarying frequency and amplitude as a means of musical entertainment."

Another British listener complains that announcers come on so loud after a musical selection that they must be toned down at the receiver. Then, when the music comes back, it is so weak it cannot be heard and the listener must again adjust the volume control. He describes a piano recital in a studio beginning in such a fashion as to suggest that the pianist with his opening chords had broken 80 per cent. of the strings of the piano. Then a monitor reduced the volume about 300 per cent. and only about 10 per cent. of the strings seemed to have been damaged.

Let us be thankful we listen in America and that occasionally someone like Philco broadcasts something like the Philadelphia Symphony Orchestra. Let us be thankful for Mr. Stokowski's monitoring and for the excellence of transmission made possible by the NBC engineers.

MAGNETIC CIRCUIT DESIGN

(Continued from page 266)

given condition. Several of these curves are shown in Fig. 2. Determining $\tan \theta$ from a knowledge of the air-gap and magnet dimensions will in general determine the material of which the magnet is to be made. If all considerations except that of maximum flux density are neglected, the choice of the magnet material will rest on that which gives the highest intersection on the B-H curve with the line drawn from the origin making an angle θ with the vertical through the origin. Two cases are shown in Fig. 2. In the first case the air-gap dimensions and the arbitrary values for the magnet dimensions determine the angle θ . In this case quite clearly tungsten or chrome steel gives a higher flux density in the air-gap than 15 per cent. cobalt steel. In the second case the reluctance of the air-gap is considerably higher than before and a larger angle θ is determined. If the maximum flux density in the air-gap is again the primary consideration, it is obvious that cobalt steel is a more desirable choice than tungsten or chrome steel.

Other Considerations

Unfortunately there are also other considerations. If the magnet is necessarily very short because of limited space or limitations of weight, as in a telephone receiver or phonograph reproducer, tungsten steel may not be capable of withstanding the ageing and demagnetizing effect of the free poles of the magnet, and cobalt steel would have to be used regardless of the results determined as shown above. Another consideration that may vitiate these results is that of cost. Cobalt steel is considerably more expensive than tungsten steel in forging and heat treating, in the operation of magnetizing, and particularly in first cost. Thus the engineer in designing a magnet must study these conditions, simultaneously attributing to each condition its relative importance.

The value of $\tan \theta$ in certain designs of magnetic structures may be rather large. In such cases it may be well to observe the extent of the demagnetizing effect of any alternating magneto-motive forces, if any such demagnetizing forces exist. A method of making such an observation is shown in Fig. 4. Tangent θ is determined in the usual way, and drawn on the B-H curve determining the operating point A. The alternating magneto-motive force about the point A is then determined as follows: Determine the maximum amplitude of the counter magneto-motive force due to the signal current in any coils directly connected with the permanent magnet system, and due to any changes occurring in the length of the air-gap. Divide the maximum amplitude of the counter magneto-motive force by the length of the magnet. This quantity should have a lower order of magnitude than the coercivity value MN of Fig. 4 determined by the value of $\tan \theta$. If it does not have a considerably lower value than MN, the permanent magnet may eventually be demagnetized. The flux cycle due to the alternating component of magneto-motive force is shown in Fig. 4. The initial flux density in the magnet is that of point A. If the alternating magneto-motive force has an initial positive swing the flux density of the magnet will follow the curve as shown and eventually trace the curve QR. The length of this loop should be small compared with MN.

Limitations in Practice

A permanent magnet may be used to supply the magnetic field in the air-gap

of an electrodynamic loud speaker. The earliest attempts of accomplishing this result made use of many comparatively short magnets in parallel. That the required conditions would be difficult to satisfy by this method becomes quite obvious when one considers the equation for the angle θ drawn on the B-H curve,

$$\theta = \arctan \frac{\text{air-gap length} \times \text{magnet area}}{\text{magnet length} \times \text{air-gap area}}$$

The numerator of this fraction is already very large, because the air-gap length of an electrodynamic loud speaker is comparatively large, and, therefore, the angle θ tends to be large. Using a number of magnets in parallel increases the angle θ to still larger values with the result that the flux density in the magnets has a very low value, and negligible increases in the flux density in the air-gap are obtained as the area of cross-section or the number of parallel magnets is increased.

If the magnet is designed more nearly in accord with the design equation for permanent magnets using tungsten or chromium steel as the material in the magnet, the magnet will have to be made very long. Leakage flux in a long magnet may be considerable, and it is not inconceivable that the leakage flux over the complete assembly consisting of the magnet, pole pieces, and connecting parts may actually amount to more than the total number of maxwells in the air-gap itself. Such results are not uncommon.

A shorter magnet may be used, however, if the magnet is made of steel of very high coercivity. Steels can be obtained having coercivities of the order of 250 gilberts per centimeter length. This value is, of course, a considerable improvement over that for tungsten steel which has a value of about 63 gilberts per centimeter. Let us consider a permanent magnet made of 15 per cent. cobalt steel. This material has a coercivity of about 185 gilberts per centimeter. If the air-gap of the electrodynamic loud speaker for which the magnet is intended has a length of 0.17 centimeters and an average area of 4 square centimeters, a magnet that will provide a field of 12,000 gauss in the air-gap can be made in a length of about 20 centimeters. This is approximately one-third the length that would be required were the magnet made of tungsten steel instead of 15 per cent. cobalt steel, with the very considerable added advantage that because of its shorter length leakage flux may be considerably reduced. It is the necessity of reducing leakage flux to smaller values than are generally obtained that may be the deciding factor regarding the possibility of ever producing an entirely satisfactory electrodynamic loud speaker with a permanent magnet. The use of high coercivity steel and the design methods for magnetic circuits which we have just discussed may be an aid in accomplishing this important result.

Short-Wave Journal

The only journal devoted to short-wave reception exclusively is the organ of the International Short-Wave Club, Klondyke, Ohio. A. J. Greene is running the organization and those who are interested in joining the club and receiving the publication may write directly to Mr. Greene. The present fee is \$1 per year. Two copies of the official organ of this club have been received by RADIO BROADCAST and the amount of timely data on the ever-changing short-wave spectrum is surprising. Those who are interested in reading reports of what is going on in the short-wave field will find the publication invaluable.

TRICKS WITH SET TESTERS

(Continued from page 278)

In order to test sets using 224-type tubes an adaptor is necessary. Fig. 2 shows the wiring scheme. The author used Pilot type 215 sub-panel sockets, which nest right into a tube base if the ridge on the socket base is filed away. The adaptor end, "A," fitted on the diagnoser test plug, is inserted in the set. The tube is inserted in end "B" which in turn plugs into the diagnoser socket. The adaptor leads are connected as in Fig. 2. Readings are taken in the same manner as with three-element tubes. The switch shown between the 500-volt one and the 100-volt one in the diagram (Fig. 1) is the one that is pressed for measurement of screen-grid voltage.

The Oscillator

The oscillator has proved itself to be a tremendously useful component of the diagnoser; in fact in a great many instances it has been found possible to locate the trouble in a receiver without the aid of anything else. It is a great help in neutralizing sets and it furnishes an easy means of checking the overall sensitivity of a set. For example, the average loop-operated set will pick-up the signal from the oscillator at a distance of 20 feet, and if the set under test does this but fails to bring in stations properly, the indication is very definite that the receiver is being operated in a shielded location. It is also particularly useful in checking the antenna-ground systems of receivers. By coupling the oscillator closely to a concealed indoor antenna, for instance, it is possible to determine the exact point of a break in the wire. A frequent trouble is the breaking of a rubber-covered lead-in wire inside its insulation, or the shorting of a lightning arrester, and in such cases the diagnoser oscillator locates the faults easily.

With the oscillator it is also possible to tell quickly whether the trouble is in the set proper or in the pick-up system; a determination that otherwise often requires considerable time. It is useful as a means of testing the sensitivity of loud speakers. A bit of experience will enable one to know what volume to expect from a loud speaker when there is sufficient coupling between the oscillator and the set to cause slight overloading of the power tube as evidenced by a plate milliammeter. It is helpful in aligning tandem condensers by noting when maximum deflection occurs on a detector plate circuit milliammeter as the condensers are tuned to resonance with the oscillator. Loose coupling should be used.

The plane of the radiated wave from the oscillator is parallel to the front and back of the diagnoser carrying case. By rotating the carrying case and thus varying the coupling to the set, the oscillator signal as reproduced by the set can be made inaudible at the position of minimum coupling and then brought up to tremendous volume by turning the carrying case a couple of inches.

Table 1

$\frac{V_1}{V}$	K	$\frac{V_1}{V}$	K
0.025	38	0.44	2
0.035	28.5	0.47	1.8
0.05	19	0.5	1.7
0.08	12.5	0.55	1.5
0.1	9.8	0.6	1.3
0.13	7.6	0.64	1.2
0.15	6.5	0.7	1
0.18	5.4	0.75	0.9
0.2	4.9	0.8	0.7
0.23	4.2	0.85	0.6
0.26	3.7	0.89	0.5
0.29	3.2	0.95	0.3
0.32	3	0.97	0.25
0.35	2.7	0.98	0.2
0.39	2.3	0.99	0.14
0.42	2.1		

SM

Here's a New Amplifier With a Wallop You'll Never Forget!

The New S-M 692

Power, and more power—more gain than you ever imagined could come out of a three-stage amplifier. Tone quality—a flat curve (within 2 DB) from 60 to 12,000 cycles—within 4 DB from 44 to 13,000 cycles. Set one up—try it—and you'll know why we feel so proud of it!

You'll notice the difference in the "highs"—the usual falling off around 6,000 cycles simply doesn't start till up around 11,000. Voltage amplification totals 4,000—three times the usual three-stage total! With proper input transformer there is plenty of gain—as high as 90,000—even for "distant" microphone pickup—or 20,000 from a standard phonograph pickup. High resistance input—operate the 692 out of any source of impedance up to 100,000 ohms. Operate it directly into any speaker system—sixteen combinations give output impedances from 8 to 125 ohms—eliminating any possible distortion in speaker transformer.

Test the 692 just once on your oscillator—and you'll use it thereafter as a standard to test your speakers!

Tubes required: 1—'24, 1—'45, 2—'50, and 2—'81.

Price, completely wired, less tubes, \$147, net.

And the S-M 712—the Ideal Tuner

Just the radio tuner you've been looking for as a feed for that power installation. And what a tuner! All-electric, single-dial (no verniers), pre-selector, power detector, battleship shielding cabinet, individually shielded r.f. coils, and all r.f. circuits individually by-passed and isolated—making the 712 absolutely stable and free from oscillation. And it's absolutely guaranteed to out-distance and out-perform all competition regardless of price.

Tubes required: 3—'24, 1—'27. Wired, less tubes, \$64.90 net. Parts total \$40.90.

The 712 requires separate power supply (2½ volts A, 180 volts B) if used with 692 amplifier. Or S-M 677 amplifier ('45 push-pull, 2-stage) supplies all ABC power required; price, \$58.50 net.



Curve of 692

This curve was not taken at plates of output tubes, but includes output transformer. If input transformer of the speaker is removed, curve shows frequency characteristic as fed direct to speaker.

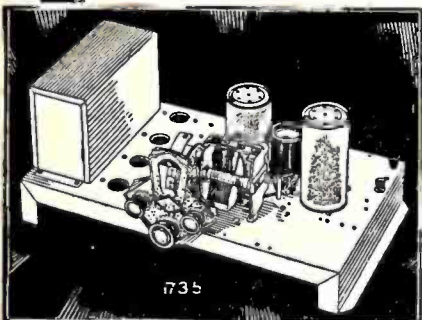

The S-M 735—Short-Wave "Bearcat"

The first all-electric short-wave set on the American market, the S-M 735 is easily the "bearcat" of them all. Four plug-in coils cover a wave-length range including both amateur and American and foreign short-wave broadcasting (16-6 to 200 meters). Two extra coils extend the wave-length range to cover all American broadcasting. The 735 presents astonishing quality in a remarkably inexpensive receiver. Price, wired, less tubes, \$64.90. Parts total \$44.90. Tubes required: 1—'24, 2—'27, 2—'45, 1—'80.

The Radiobuilder, a monthly publication telling the very latest developments of the S-M laboratories, is too valuable for any setbuilder to be without. Send the coupon for a free sample copy, or to enter your subscription if you want it regularly.

Over 3,000 Authorized S-M Service Stations are being profitably operated. Write for information on the franchise.

SILVER-MARSHALL, Inc.
6403 West 65th Street Chicago, U. S. A.

Silver-Marshall, Inc.
6403 West 65th Street, Chicago, U. S. A.

-----Please send me, free, the latest S-M Catalog; also sample copy of The Radiobuilder.

For enclosed ----- in stamps, send me the following:

-----50c Next 12 issues of The Radiobuilder
-----\$1.00 Next 25 issues of The Radiobuilder

S-M DATA SHEETS as follows, at 2c each:

- No. 3. 730, 731, 732 Short-Wave Sets
- No. 4. 255, 256, etc., Audio Transformers
- No. 6. 740 "Coast-to-Coast" Screen Grid Four
- No. 7. 675 ABC High-Voltage Power Supply
- No. 8. 710 Sargent-Rayment Seven
- No. 9. 678 PD Phonograph-Radio Amplifier
- No. 12. 669 Power Unit
- No. 14. 722 Band-Selector Seven
- No. 15. 735 Short-Wave "Bearcat"
- No. 16. 712 Tuner (Development from the Sargent-Rayment)
- No. 17. 677 Power Amplifier for use with 712
- No. 18. 772 DC Band-Selector
- No. 19. 692 Amplifier

Name -----

Address -----

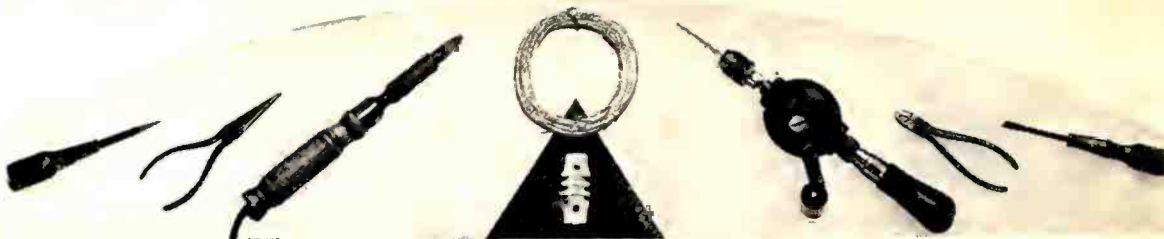

THE SERVICEMAN'S CORNER

Artificial QRN

Artificial static is a problem that confronts the serviceman much more often than he realizes due to the difficulty of distinguishing between artificial strays and natural static. The almost universal test of disconnecting the antenna, and convincing oneself that, if the sound stops, it is bona fide static, "is all wet." Disconnecting the antenna, particularly if there is a station tuned-in, will lessen the effect of all extraneous sounds, even those emanating from the receiver and power supply itself. The only real way of discriminating between artificial and atmospheric static, is by comparing reception between the offending receiver, and a set located in a district known to be free from power leaks and other forms of man-made QRN. Once a determination has been made, the notes below will be helpful:

TRACING ELECTRICAL INTERFERENCE

C. Washburn, Jr., radiotrician of Florida, veteran contributor to the Serviceman's Corner, and associated with the Electric Distribution Department of the City of Jacksonville, sends us the following notes:

"A few weeks ago WJAX, the municipal station of Jacksonville, Fla., was authorized to hire a man for the express purpose of tracing down electrical interference throughout the city. Up until that time this work was done by Superintendent F. H. Koerber, of the City Electric Distribution Department, assisted at different times by other members of the department, among them myself.

"The first trouble of any great magnitude to be run down was radiation from the mercury-arc rectifier tubes. This interference went out on the street-lighting circuits all over the city. The rectifier tubes are used with constant-current transformers to supply high voltage d.c. to the street lights. This was referred to the General Electric Company who submitted the design of a coil to be constructed and connected to the offending tubes, and this practically eliminated the trouble from this source.

TREE GROUNDS

"The principal trouble we have encountered is tree grounds on the street-lighting wires carrying up to 7000 volts. Where a limb touches one of these wires arcing takes place and interference

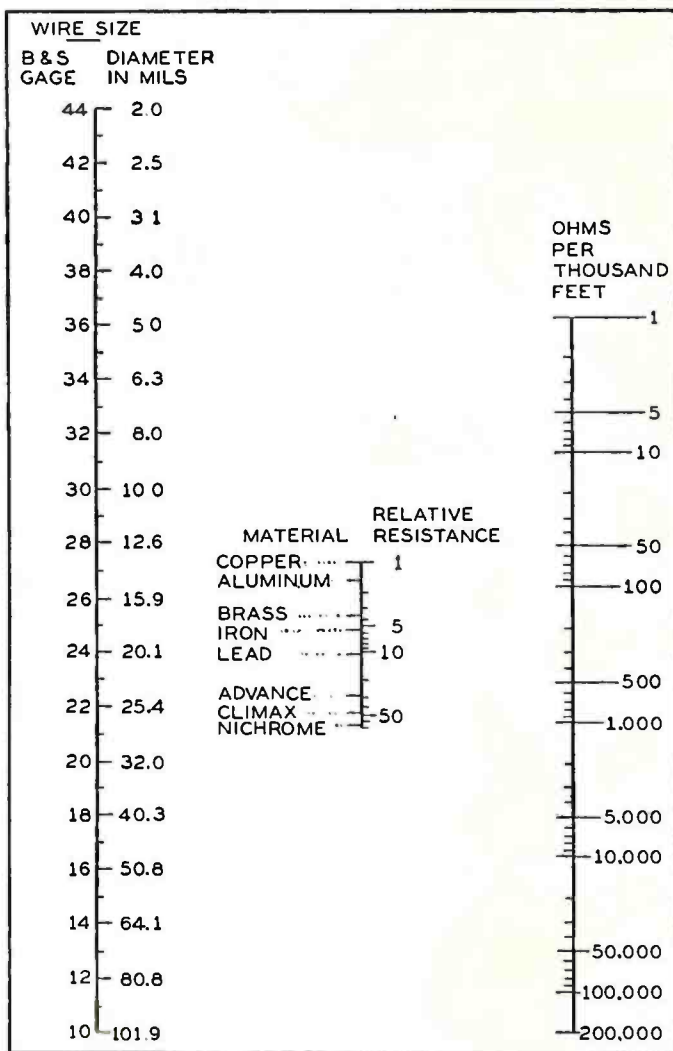

A useful chart prepared by the Radio Corporation of Pennsylvania. An extended straight edge intersecting the kind of wire and the size of wire will indicate on the right-hand scale the resistance per 1000 feet.

is transmitted all over the circuit and is also induced in parallel wires which may carry it into sections away from the original area.

"Contrary to many writers, we have not been able to locate these troubles

fixture we used a Radiola III, with a short antenna. The lamps were about 150 feet apart yet a superheterodyne would not distinguish the one causing the trouble but the Radiola III indicated a louder response

for one than the others when the antenna pole was held up to the lamps. However, the Radiola III is not sensitive enough for ordinary use.

"In conclusion I would say that it takes great persistence and patience to run down these troubles as they do not seem to follow any consistent theory."

GUILTY STREET LIGHT

James A. Robinson, radiotrician of Methuen, Mass., and a

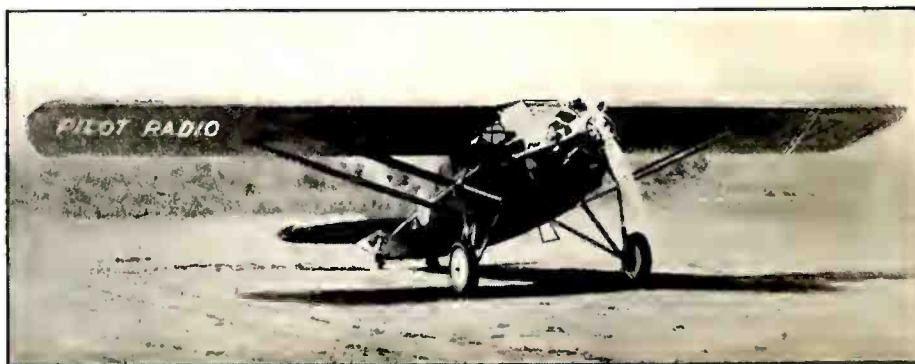

The Pilot Radio and Tube Corp. is owner of the first radio service plane. Their flying laboratory has been fitted for answering rush service calls on public-address and talking-movie apparatus.



YOU NEED SELF-EVIDENT QUALITY TO SATISFY YOUR CUSTOMERS

Today's critical buyers want the facts before they buy. Show them, with these simple tests, that Arcturus Blue Tubes give exceptional service in every radio set . . .

Here are three tests that accurately measure the merit of any tube.

You can easily make these tests, in a few minutes, in your own store. When you do, you definitely answer three questions about tubes that your customers are asking:

"How quick do they act?"

Ask your customer to hold a watch on any set equipped with Arcturus Tubes. There's the program in 7 seconds.

"How clear is the tone?"

Let your customer listen to the clear, pure tone that is characteristic of Arcturus Blue Tubes. There's no annoying

hum, no outside noise, to mar the smooth reception of any station.

"How long do they last?"

Show your customer, on the meter, that Arcturus Tubes withstand exceptional overloads. This kind of stamina has given Arcturus the world's record for long life.

These three Arcturus tests convincingly prove Arcturus' superiority. Thousands of Arcturus dealers and hundreds of thousands of Arcturus users know by actual comparison that Arcturus performance is unmatched by any other tube on the market today. If you have not checked Arcturus quality ask your jobber for a demonstration. See why Arcturus is the fastest growing tube in the radio industry.



7 seconds by your customers' watch! That's how fast programs come in when Arcturus Tubes are used.

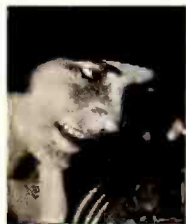

Clear, pure tone, free from hum, is a certainty when sets are equipped with Arcturus Tubes.

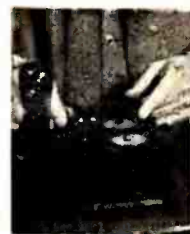

Exceptional ability to withstand overloads, easily proved on your meter, explains the long life of Arcturus Tubes.

ARCTURUS RADIO TUBE COMPANY
NEWARK, N. J.



ARCTURUS

Quick-Acting

RADIO TUBES



The Aldrich Radio Service, Minneapolis, make their service wagon do double duty—advertising and transportation.

(Continued from page 284)

Radiola dealer, has had similar trouble with street lamps. He writes:

"A trouble breeder is the street light. While going over a Radiola No. 62 for noises of an intermittent variety I was unable to locate any defect. By chance I was facing the window at the time the street lights went on. The street light in front of this house is the regular Mazda variety. As soon as the street light began to glow a regular barrage of noise came through the loud speaker which disappeared when the street lamp had warmed up. For some time I watched this phenomenon, and at times the light would flicker with an accompanying series of sputters in the set.

"Another trouble of this type I noticed at a Legion whist party where I had installed a Radiola 66. On the stage with the radio there were a number of lamps to be used as prizes for the winners. Upon lighting the lamps the radio had to be shut off until we found the trouble—a lamp with a loose filament."

245 Tubes in Radiolas

Greater undistorted output can be secured from many receivers by substituting the 245-type power tube for lower power types, such as the 210 or the 171. The changes necessitated are those providing for the correct A, B, and C potentials. The correct filament potential may be secured either by placing a resistor in the 7.5- or 5-volt winding, or by switching the filament leads over to a 2.5-volt winding. As a rule nothing can be done about stepping up the B voltage, and when the C bias is secured through an IR drop, the C voltage generally adjusts itself to approximately the correct potential.

RADIOLA 41

The only circuit change is the addition of a resistance in series with the 7.5-volt winding to reduce the filament voltage to 2.5 volts. The changes necessary are indicated in Fig. 1. They are:

1. Fasten an Electrad 3-ohm B resistor to the edge of the baseboard directly above the power pack.
2. Disconnect one of the yellow filament leads from the power pack.
3. Connect this lead to one terminal of the 3-ohm Electrad resistor. The remaining resistor terminal connects to the binding post on the power pack to which the yellow lead was previously connected.

RADIOLA 33

A noticeable improvement in volume and quality of reproduction can be obtained in Radiola 33, 110-volt, 60-cycle, by substituting the 245-type tube for the

171A. To use the 245-type tube in place of the 171A-type tube the following wiring changes are necessary in the socket-power unit only:

1. Unsolder the two red leads attached to one terminal of the filter condenser

Pictures often speak louder than actions. Psychologically we are more interested in what the other fellow has than in what he does. In this connection "The Serviceman's Corner" is particularly interested in photographs of service equipment, from complete laboratories and shops to test sets—from service staffs to individuals. Photographs of unusual installations and service jobs will also be most welcome on these pages.

We shall pay an attractive price for service stories accompanied by photographs, and in many instances we can use photographs alone.

—THE EDITOR

bank. Solder the two leads together and tape up securely.

2. Solder a wire to the condenser bank terminal just left and connect the other end of the wire to the filament terminal

of the 280-type tube socket having two yellow leads.

3. Unsolder the two green leads running from the receiver chassis (filament 171A) at their connection to the centertapped resistor. Connect these two green leads to the outer terminals of the centertapped 227 resistor.

4. Unsolder the three leads connected to the center tap of the centertapped 227 resistor. Solder and tape these three leads together.

5. Solder a jumper between the two center contacts of the 227 and 171A centertapped resistors.

The above arrangement requires no additional parts. The grid bias is slightly high for the available plate voltage, although by reducing the bias to standard specifications no material change is noted in the output. With the changed connections the 245-type tube is operated on a plate voltage of 165 volts, a plate current of 18 mA., and a grid bias of 34 volts.

The power transformer under test for eight hours with this conversion showed no appreciable increase in temperature.

RADIOLA 60

The Radiola 60 may be adapted for use with the 245-type tube in the following manner:

1. Remove the Radiola 60 S.P.U.
2. Remove the two green filter reactor leads from the condenser bank and tape them up, being sure that they are soldered together.
3. Provide a small piece of insulated wire and connect one end of it to the condenser bank terminal to which was previously connected the green leads from the filter reactor. The other end of the lead connects to one of the rectifier socket filament contacts—the socket contact having the single yellow lead already connected is most convenient.

4. Replace the S.P.U. in the cabinet. Reconnect the leads from the receiver assembly to the S.P.U. terminal strip in the normal way except that the two green leads that formerly connected to terminals 8 and 9 are now brought to the two blue leads already connected.

The Radiola is now returned to normal operation except that a 245-type tube is used in place of the 171A.

Electrically the change is to place the 2-mfd. condenser connected between the center point of the two filter reactors and minus B to the filament of the 280-type tube and minus B. The change at the terminal strip places the 245-type tube on the same filament winding as the 227. No drop in the voltage of this winding was noted with the increased load.

The change of the condenser increases



C. Heyd, Milwaukee, Wis., camouflages an electrodynamic loud speaker in a neat installation job. The loud speaker is mounted against a partition between the pantry and the living room, and is hidden by the table.

the initial rectified voltage from the 280-type tube by about 60 volts which causes the 245-type tube to have a plate voltage of 200, a grid voltage of 40, and plate current of 21 milliamperes. The second detector plate voltage is also increased to about 200 and the grid bias to 25, thus providing sufficient output to obtain the desired increase from the 245-type tube. The plate and grid voltages to all the other tubes are increased about 15 per cent. but are all within limits for the tubes.

Points on Installation

Adjusting Line Voltage: H. J. HALSTRICK, of Philadelphia, Pa., suggests an old but good method of either raising or lowering the line voltage for a.c.-operated

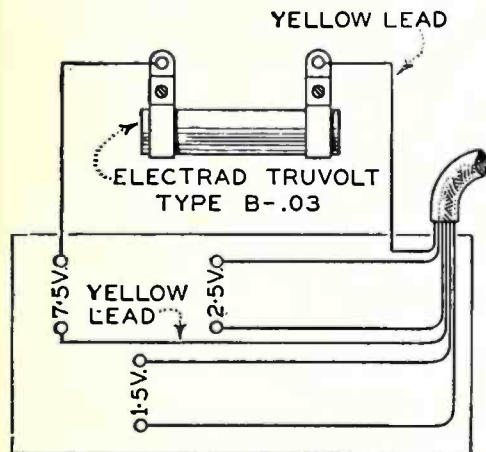

Fig. 1—A simple method of rearranging the Radiola 41 for operation with the 245-type power tube.

receivers, where the variation from normal is fairly constant.

“An efficient and inexpensive method of lowering or raising the line voltage to a.c.-operated radio sets is shown in Fig. 2 (page 289). A Jefferson bell-ringing transformer is interposed between the line and the load as shown. Then, by connecting the two leads to the secondary terminals of the transformer in either of two ways, variations from the line voltage are effected. The effect is that of an auto-transformer with a tapped primary.

“Two advantages of this method over inserting a resistor in the line circuit in order to reduce voltage are: first, that the voltage regulation with various drains is considerably better, and second, that there is no heat dissipation of energy.

“The secondary of the bell-ringing transformer will carry up to one ampere continuously, equivalent to approximately a 110-watt drain. In order to keep the secondary binding posts of the bell-ringing transformer at low potentials, the bottom lead of Fig. 1 should be made the ‘hot’ side of the line. (Or the transformer can be suitably inclosed.)”

With the two windings connected so as to assist each other, this arrangement can be employed to increase the voltage output of a B-power device.

ANTENNA INSTALLATION

“I am chief serviceman for a concern operating three large stores in central Nebraska.

“In installing radios we put our antennas around the eaves of a house in a good many cases. The split knobs are often driven into the metal roofing cornices or edges and the antenna wire is put on the cross sections of the knob. If the wire touches the nail and the metal roofing strip supports the drain pipes, which in turn touch the ground, you can readily see the result is an antenna that is a ground.

“This type of antenna is very popular
(Continued on page 289)



New!
the **PF 245A**
AmerTran Power Transformer

Continuing its progress in the development of power transformers for all radio receiving sets the American Transformer Company announces the perfection of the new type PF 245 A. This new power transformer operates a radio receiver equipped with 2½ volt heater for heater type A. C. tubes and 2½ volt filament for a power tube (UX245 or CX345) which closely approaches the 210 in undistorted watts output.

The AmerTran Power Transformer Type PF 245 A is designed for a 60 cycle 115 volt line source, and has a continuous rating of 100 VA. with primary taps for 100—108—115—120 volts. A four point radial switch regulates the operation for different primary voltages. There are five secondary windings. Because of its lower maximum voltages, all secondary connections terminate in solder lugs attached to a bakelite terminal board.

This new, heavy duty power transformer is compact, sturdy, beautifully machined and mounted in cast iron end clamps provided with mounting feet. Like all AmerTran Transformers the PF 245 A is built to deliver sufficient excess voltage for maximum requirements.

Fill out and mail the coupon for AmerTran Bulletin No. 1088 giving complete description of the PF 245 A Power Transformer.



AMERTRAN
TRADE MARK REG. U.S. PAT. OFF.

AMERICAN TRANSFORMER CO.
Builders of transformers for over 29 years
178 Emmet St., Newark, N. J.

List Price \$22
East of the Rocky Mountains

AMERICAN TRANSFORMER CO., 178 Emmet St., Newark, N. J.

Please send me complete information on the new PF 245A Power Transformer.

Name.....

Address.....

R-B-3-30

CROSLY MODELS 40-S, 41-S, 42-S, AND 82-S

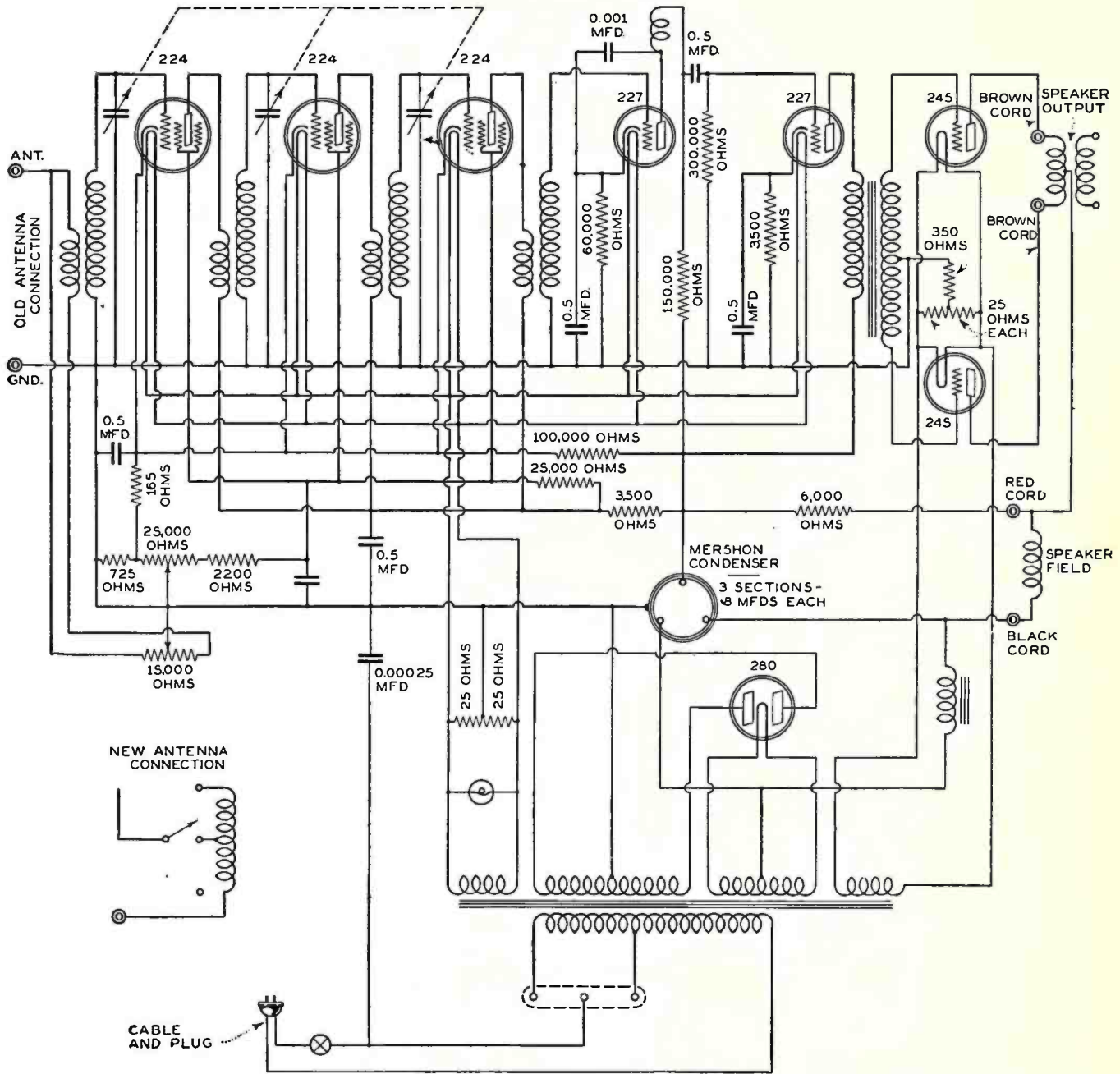

THIS RECEIVER incorporates an eight-tube (including rectifier tube) circuit which employs three stages of tuned radio-frequency amplification, an untuned detector stage, and two stages of audio-frequency amplification, the second of which is a transformer-coupled push-pull stage. The first audio-frequency stage is resistance coupled to the detector stage. Screen-grid tubes are used in the radio-frequency stages.

Receivers having serial numbers prefixed with "GC", "GCA", "GCB", or "GCC" have volume controls composed of two rheostats operated simultaneously. One of these is shunted across the antenna coupling coil primary so as to regulate the strength of signal passing through this coil. The other is used to control the potential of the screen grids in the radio-frequency tubes. Receivers of serial numbers other than above have a volume control consisting of but one rheostat, controlling the potential of the screen grids.

The filament supply for the heater-type tubes (that is, the 224-type tubes used in the radio-frequency stages, and the 227-type tubes used in the detector and first a.f. stages) is obtained from a winding on the power transformer. A 50-ohm potentiometer is shunted across the filament supply leads for these tubes, and the middle tap of the potentiometer is connected to the chassis. The dial light is also shunted across these leads. The filaments of the 245-type output tubes are supplied from another winding on the power transformer. The 50-ohm potentiometer shunted across these leads has its mid-point connected through an 850-ohm resistance

to the chassis. A third winding on the power transformer supplies current to the filament of the 280-type rectifier tube. The high potential plate supply taps on this winding.

A center-tapped high-voltage winding on the power transformer supplies power to the plates of the 280-type tubes. Each end of this winding is connected to one of the plates of the 280-type rectifier tube, so that full-wave rectification is obtained. The tap of this winding is connected to the chassis, which thus acts as the low-potential side of the plate supply. As stated above, the high-potential lead of the plate supply is connected to the transformer secondary supplying power to the filament of the 280-type rectifier tube. This lead is connected through

an iron-core choke coil to the "Black" terminal on the receiver. Two sections of the Mershon condenser are connected to the terminals of the choke coil so that the condenser and choke act together as a filter system. When the Dynacoil loud speaker is connected to the receiver, its field coil is placed between the terminals marked "Black" and "Red." Thus the entire plate current from the high-potential lead of the plate-supply circuit passes through the field of the Dynacoil. The plate supply for the two 245-type output tubes is obtained through a connection inside the Dynacoil loud speaker from the field coil of the loud speaker to a mid-tap on the primary side of the built-in output transformer.

READINGS WITH JEWELL ANALYZER MODELS 198 AND 199

Type of Tube	Position of Tube	Tube Out		Readings With Plug in Socket of Set and Tube in Tester					Plate Change mA.	Screen Grid Volts	
		A Volts	B Volts	A Volts	B Volts	C Volts	Cathode-Heater Volts	Normal Plate mA.			Plate Grid Test
224	1st R.F.	2.60	180	2.40	175	1.5	1.5	1.5	4.0	2.5	70
224	2nd R.F.	2.60	180	2.40	175	1.5	1.5	1.5	4.0	2.5	70
224	3rd R.F.	2.60	180	2.40	175	1.5	1.5	1.5	4.0	2.5	70
227	Dct.	2.60	100	2.45	100	12.0	12.	0.2	0.3	0.1	
227	1st A.F.	2.65	220	2.45	180	15.0	12.	4.0	5.0	1.0	
245	2nd A.F.	2.55	265	2.30	240	48.0		26.0	30.0	4.0	
280	Rect.	5.60		5.00				100.0			

Line voltage = 117.5. Set on high voltage tap. Volume control position maximum.

(Continued from page 287)

and a little care on the part of the serviceman will be a worthwhile ounce of prevention."

E. A. SHERMAN, Hastings, Nebraska.

SHORT ANTENNAS FOR S-G SETS

"An antenna longer than 60 feet with sets using two or more screen-grid tubes is undesirable. After installing an AK-55 with a short antenna it could pick up both coasts any night. A few weeks later the customer came into the store with the complaint that the music was distorted on low volume. Riding up to the house, I noticed an antenna much longer than

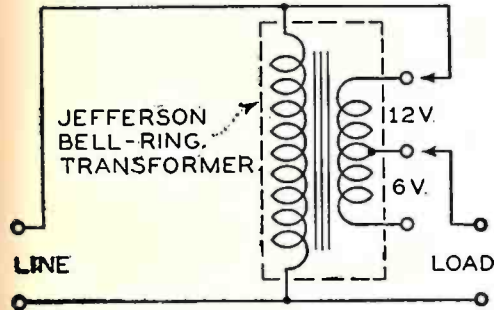

Fig. 2—A somewhat familiar but always practical method of compensating a consistent line variation.

I had installed. Nothing was wrong with the set. I put a condenser in series with the antenna and the distortion cleared up."

WALTER STRAUSS, JR., W9CMX, Chicago.

Getting Acquainted With AK

Defective Resistors: WALTER STRAUSS, who specializes in Atwater-Kents, contributes the following:

"I am one of those fellows who are loath to drag the set analyzer from the car when an Atwater-Kent set is a bit below par. All the sets below the AK No. 55 employ glass voltage-dividing resistors in the power pack, and if the first a.f. tube is pulled out and put in without a click, it is a reasonably sure sign that the first a.f. resistor is gone. To make sure I put a new a.f. resistor across the terminals and if music comes through, then that's the one."

MODEL 55

A serviceman in Eutaw, Alabama, bids us beware of high-voltage shorts:

"If the set hums see if the rectifier tube shows a blue glow. If it is dead, look for a burned-out filament. In either case remove the base cover from the set and inspect the left-hand or outside plate lead—it may be shorted or arcing to the filament prong on the same side of the set. This will not show up in a continuity test if it is only arcing over. The trouble is caused by rough handling in nearly all instances."

SERIES CATHODE RESISTORS

An Atwater-Kent dealer in Mount Vernon, N. Y., keeps the ball rolling: "The last Atwater-Kent we received for servicing was a new one that had just arrived from the factory. The set would work all right for a while then it would burst out in loud crashes. We were at a loss as to the trouble, so we sent it back to the factory. They returned it saying nothing was wrong with it. However, the noise was worse than ever. We suspected the first a.f. transformer, but upon replacing it, no improvement was noted. Then we thought the by-pass condenser was punctured. However, tests showed nothing wrong here. I happened to be tapping around the set when I hit the series cathode resistor (the set was turned on and removed from the cabinet). The crash was heard in the loud speaker. When we re-

(Continued on page 291)

PROOF

In order to meet the acid test of big theatre sound reproduction requirements, any reproducer must represent the last word in efficiency. The verdict of Mr. E. C. ZRENNER, Sound Engineer of the great Publix theatre interests is overwhelming proof of the satisfaction given by the

Wright-DeCoster Reproducer

Read what Mr. Zrenner says:

January 1, 1930

WRIGHT-DECOSTER, Inc.
2233 University Avenue, St. Paul, Minn.

Gentlemen:—After using several of your Wright-DeCoster speakers and No. 9 horns, I am writing to let you know that they are giving very satisfactory results. Very truly yours,

E. C. ZRENNER, Publix Sound Engineer.



"The Speaker of the Year"



Write for
Complete
Details



Model 117
Junior Console

WRIGHT-DECOSTER, Inc. 2213 University Ave., St. Paul, Minn.

Export Dept.: M. Simons & Son Co., 220 Broadway, New York City

Cable Address: Simontrice, New York

Are You Experimenting With the New Pentodes?



Laboratory and home experiments with the new pentode tubes require a reliable source of high voltage. And successful experimentation with the recently announced direct-coupled amplifiers depends on the proper power-supply.

The National Velvet-B Power Supplies, in two popular models, give reliable power tube and accurately adjustable intermediate voltages with minimum hum and a high current output. They are licensed under R. C. A. patents. Priced at \$26.50 and \$39.50 (Less rectifying tube.)

NATIONAL

VELVET—B

POWER — UNIT

NATIONAL CO., INC., Malden, Mass.

Est.  1914

National Co. Inc. also make a full line of power and filament transformer and choke coils. Write us for full information today, mentioning Radio Broadcast.

ERLA MODEL 224 A.C. SCREEN-GRID RECEIVER

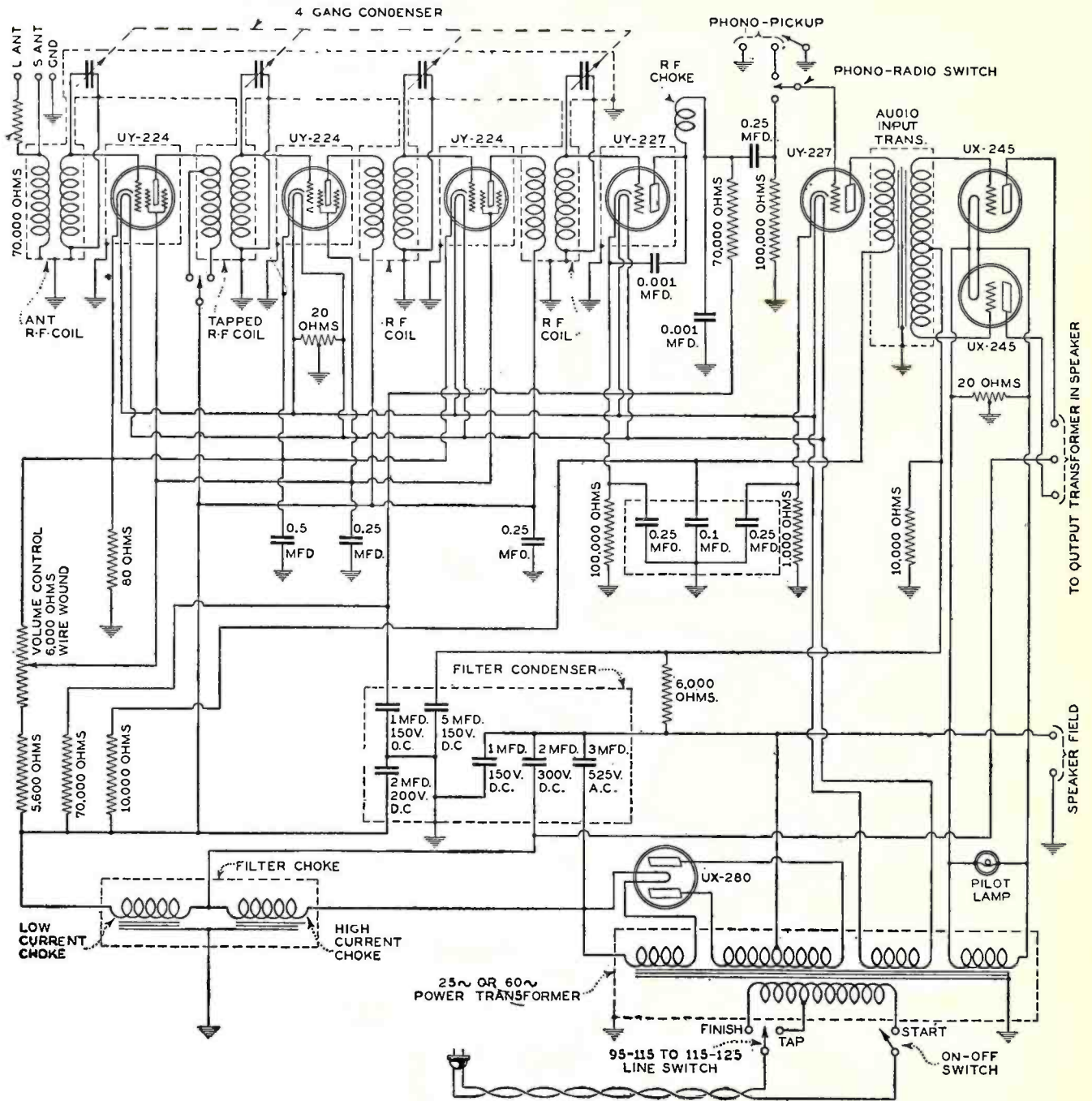

THE CIRCUIT of this receiver chassis employs three stages of tuned-radio-frequency amplification with four tuned circuits and uses three 224-type screen-grid tubes. The detector is a 227-type tube operated in a grid-bias or plate-rectification circuit. In the first audio-frequency stage a 227-type tube is employed with resistance-coupled amplification. In the output stage two 245-type tubes are used in a push pull. Reference to the diagram will show that two antenna connections are provided. For most purposes the "S. Ant." connection should be used as it provides the greatest sensitivity, but if a very long antenna is used, connection should be made to the "L. Ant." post. It will be noted that the "L. Ant." connection consists of a resistor (attenuator) in series with the "S. Ant." connection. This serves to cut down the signal pickup and consequently the noise level when a very long antenna is used.

The local-distance switch functions to tap the primary coil of the first r.f. transformer. When in the tapped or "local" position the amplification is decreased. This setting is best for most local stations as that proper control of volume is obtained. By moving

this switch to the distance position extreme sensitivity is obtained, but if powerful local stations are tuned-in improper volume control action is obtained for these strong signals tend to overload the screen-grid tubes.

The volume control consists of a 6000-ohm wire-wound potentiometer connected so as to vary the screen voltage on the screen-grid tubes. In combination with this volume control a single-pole, double-throw toggle switch is employed to throw the receiver from "phonograph" to "radio." When the control is turned all the way to the left the input to the resistance-coupled a.f. stage is switched from the output of the detector circuit to the phonograph pick-up

jacks on the rear of the chassis. It will be noted that a small clip-type switch is connected across one of the jacks and the chassis frame. This clip should be connected in this manner when the pick-up unit is not inserted in the jacks, as otherwise a hum will be evident when the volume control is set so that the receiver is in the phonograph position. This hum results from having the input circuit of this first a.f. tube open.

A small toggle switch located alongside of the 280-type rectifier tube is used to tap the primary of the power transformer. The approximate line voltage ranges for the two positions of this switch are shown. It is well to keep this switch in the 115-125-volt position wherever possible.

The loud speaker used with this receiver is of the electrodynamic type and contains in its assembly the output transformer for coupling the output of the two 245-type tubes to the moving coil of the loud speaker. The field of this loud speaker has a d.c. resistance of 1000 ohms and is designed to carry 100 milliamperes. All connections from the loud speaker are made by means of a five-conductor cable and the special five-prong plug which avoids any danger of improperly connecting the loud speaker to the receiver.

AVERAGE VOLTAGE READINGS

Position of Tube	Type of Tube	Fil. Volts (A.C.)	Screen-grid to cathode volts	Plate to cathode volts	Ground to cathode volts	Grid to filament volts
Rectifier	280	4.8 to 5		340 to 360		
2nd A.F.	245	2.4 to 2.5		240 to 250		45 to 50
1st A.F.	227	2.35 to 2.4		90 to 100	4.5	
Det.	227	2.35 to 2.4		60 to 75	6 to 7.5	
R.F.	224	2.35 to 2.4	75 to 80	160 to 170	1.5 to 2	

(The above are based on a line potential of 110 volts and the switch in the 95-115 position, no signal and volume control at maximum.)

(Continued from page 289)

placed the series cathode resistor the noise cleared up."

Sales Dope for Servicemen

BRUCE J. WOODWARD, service chief with Burcher's Battery and Electrical store in Honesdale, Pa., sends the following tip on how to replace antiquated receivers with the help of diplomacy:

"In this territory most of our customers are people of limited means and it is very difficult to sell a new set to a person who already has a set. No matter how obsolete the set may be they will not trade as long as the set will pick up stations. If a salesman calls on a person who has one of these old sets he will be told that the present set is satisfactory and sounds better than many of the new sets. It is a fact that a person will become accustomed to a peculiar kind of distortion and believe it to be perfect reception.

"As soon as something goes wrong with one of these obsolete sets and a serviceman is called in, he has a good opportunity to make a sale without entering into any argument with the customer as to the relative merits of radio sets.

"When I am called in to service an obsolete set and find something wrong which cannot be fixed in a few minutes, I always

take the set to the shop and loan the customer a modern set until the old one is fixed. In many cases this results in a sale.

"To illustrate, here is a typical example—A lady owned a Model 20 Atwater-Kent set. She called me in to service it. I found that her storage battery was worn out. She had electricity so I suggested that she buy an up-to-date electrified receiver. She told me she could not afford a new set and anyway she was well pleased with her old set. I sold her a new battery and forgot the incident. Less than two months later I was called to service the set again. This time I found the by-pass condenser shorted and the 'B' batteries ruined. Without saying anything about a new set I told her how much the job would cost. She said fix it. I told her I was very busy and would not be able to fix it for a few days, but that I would loan her a set while hers was being repaired.

"I brought her a late model electric set, explaining it was much easier and quicker to hook up than a battery set. I showed her how to operate the set and left without giving any sales talk at all. Two days later the lady called the store and said she wished to see the serviceman. I called and sold her the set. She told me she had not dreamed there could be so much difference in radio receivers.

BOOK REVIEWS

PRINCIPLES OF RADIO, By Keith Henney. Published by John Wiley & Sons, New York, 1929. 477 pages, 306 illustrations. Price: \$3.50

Speaking as an occasional reviewer of radio books, the opinion is offered that adverse criticism does not necessarily arise from the mean motives which fill the yellow papers and the green magazines. Some books are so badly written that comment must be either adverse or dishonest, and most of us prefer not to lie publicly.

It is, therefore, very pleasant when one is so lucky as to come upon a book which permits speech that is both honest and favorable. The writing of this review of the *Principles of Radio* is accordingly a pleasure.

The author's viewpoint from the laboratory and editorial desk of RADIO BROADCAST seems to have been unusually favorable for he has avoided altogether those standard defects which vitiate the usefulness of nearly all radio books. Thus we are spared the customary platitudes; we need not yawn through a rehash of the wonders of radio, we are spared an introduction, and the preface is 16 lines long. Even more! We are not (this is really very hard to believe) dragged to the edge of the traditional frogpond and made to observe the ritual ripples on its ancient and scummy surface.

Having decided to speak of radio—which is electronic—the author forthwith does so. The electron appears in the second sentence and remains through the entire performance, not in an unseen chorus behind the scenes but as an active member of the cast, along with the rheostat, the ammeter, the tube socket, etc.

Plainly, a moderate amount of well-explained mathematics can replace a huge quantity of talk about radio theory. Most books have instead slunk swiftly through the subject under cover of a thin fog of generalities called a "non-mathematical treatment," or else have solemnly buried the subject past all hope of resurrection under a ponderous mass of obscure calculations. The present book is mercifully free from either extreme. The mathematics are as simple as is expedient. Where it is convenient to show the derivations that

is done; where it is better to show only the final formula as a working tool that is done without apology and *with the meaning of the symbols clearly stated*, a practice so novel in the troubled literature of the art as to be almost heretical. Furthermore, the same system of electrical units is used throughout the book, the author not finding it necessary to demonstrate either erudition or indolence by the usual unprofitable variety of standards.

The illustrations are numerous, clear, pertinent, and (again your credulity is to be taxed) placed adjacent to that part of the text which discusses them. For this alone many sins could be forgiven, although there is no need.

The problems and examples are alive and not fossiliferous. One meets the ux-227, not the obsolete vt-14 or the obscure p-20. There are a great many such problems and examples, nor are they of the variety sometimes used as filler.

Where there is a curve it relates to something existent, not to the customary unknown or "purely illustrative" device.

It is hard to express the elevation of the spirit which results from this transfer out of the area of the academic and bygone to that of the actual and existent. Indeed, if adverse criticism were to be offered it would be in the mild form that the title of the book might well have been extended to read "Principles of Radio and their Practical Application."—ROBERT S. KRUSE.

New York-Chicago Circuit

The Universal Wireless Communication Company announced late in January the opening of a New York-Chicago circuit. The New York Office is located at 130 West 42nd Street. Rates are arranged on the same basis as domestic telegraph companies with the exception that the minimum is 15 rather than 10 words.

Service Companies Merge

QRV Radio Service, Inc., 155 West 72nd St., New York City, recently purchased the service business of Rossiter, Tyler & McDonnell, Inc., of 136 Liberty St., New York City. The business and good will of Factory Radio Service in New York City has also been acquired by QRV.

NO [REDACTED]
NOTE [REDACTED]
CAN [REDACTED]
ESCAPE
Thordarson
POWER ▲▲▲▲
AMPLIFICATION

Realistic reproduction for all occasions . . . and in every circumstance . . . that's what Thordarson's new line of complete Audio Amplifiers means to the listening world. And nothing short of actuality in sound reproduction will be accepted today.

Thordarson Amplification Equipment Means Consistent Audio Excellence

The engineering laboratories of Thordarson . . . with years of research and experience behind them . . . have succeeded in solving the problems of sound reproduction. And with the utmost in manufacturing facilities, the most exacting

specifications are faithfully and efficiently fulfilled.

Why not make use of Thordarson engineering service in your work? We can give you installation suggestions that will make your work easier and more profitable.

THORDARSON
Transformer Specialists Since 1895

THORDARSON ELECTRIC MANUFACTURING COMPANY
Huron, Kingsbury and Larrabee Streets
Chicago, Illinois, U. S. A. 4416

Extra Money! For Service Men

Extra
Enjoyment
for
Construction
Fans



RETURN COUPON
FOR FREE BOOKLET!

You know dozens of people who cannot (or will not) buy a 1930 receiver, but who will spend a reasonable amount to secure 1930 tone quality. This free booklet tells about the profit possibilities of modernizing old sets with new Pilot transformers.

PILOT RADIO & TUBE CORP.
323 BERRY STREET, BROOKLYN, N. Y.

PILOT RADIO AND TUBE CORP.
323 Berry Street, Brooklyn, N. Y.

Send me without obligation "A 1930 Voice For Old Sets"

NAME.....
ADDRESS.....
CITY..... STATE.....

Stop A.C. Noise!

Improve Selectivity!

PLUG in a Falck Claroceptor between wall socket and radio set and eliminate "static" from motors, street cars, telephones and electrical appliances. This new improvement by a pioneer radio parts manufacturer grounds and thus blocks out line interference noise and radio frequency disturbances. Also improves selectivity and distance. Requires no changes in set. Measures just 3½ x 5½ x 2½ inches. Thousands now all over America use the Claroceptor for clearer A. C. reception. Get one right away—at radio parts dealers. Write for descriptive folder.



\$7.50 complete with cord and plug

Falck CLAROCEPTOR

Built by ADVANCE ELECTRIC CO.
1260 W. Second St. Los Angeles, Calif.
JOBBERs and DEALERS, GET OUR PROPOSITION

VOLUME CONTROL IN BROADCASTING

(Continued from page 261)

audible, and, as amplifiers are used on all circuits, it is readily understood that cross-talk becomes a serious factor in transmission over telephone wires.

Experience has shown that the cross-talk level on a circuit is something of the order of minus thirty-five decibels. To express this differently it might be said that if an amplifier having a gain of thirty-five decibels were placed across a dead circuit and its output connected to a loud speaker or pair of headphones, a jumble of cross-talk from adjacent circuits would be clearly audible.

This means, of course, that if we permit the energy level of the program being transmitted over the circuit under discussion to fall to a level of minus thirty-five decibels the jumble of noise and cross-talk in the circuit will be as loud as the program being transmitted at that particular instant. It is necessary, therefore, to maintain a ratio in favor of the program transmitted.

Inasmuch as this cross-talk level varies considerably with open wire circuits, depending on weather conditions, the margin between the lowest levels of the transmitted program and the cross-talk must be kept wide enough to prevent the cross-talk being heard by the radio listener. Cross-talk does not always consist of jumbled conversation and music but very often is induction produced by adjacent power lines, resulting in what is commonly called "line hum."

Total Volume Range

Experience has taught us that if we are to transmit a program over a telephone circuit in a satisfactory manner that we must not permit its minimum energy level to fall below minus twenty-five decibels. Of course, there are cable circuits where this minimum can be dropped to a minus thirty and sometimes minus thirty-five, but this latter condition exists chiefly in cities where underground lead-covered cables are used exclusively. We, therefore, find that the volume variation permissible over a telephone circuit is from plus six to minus twenty-five DB, a volume variation of approximately thirty decibels. However, the full range of 30 DB cannot be utilized as it is not possible to operate at the maximum level plus six decibels in practice.

To prevent too high a level being transmitted on the telephone circuits, the repeating amplifiers equipped with vacuum tubes will not pass energy levels in excess of plus six decibels peak level. Volume in excess of this merely overloads the vacuum tubes, producing harmonics and distortion. Inasmuch as several hundred of these telephone repeaters are used in the networks of the National Broadcasting Company, a margin of safety must be allowed at the top to prevent overloading on repeaters whose gain setting is such that they may more than compensate the loss introduced by the telephone line. This condition is not brought about by the repeater changing its gain but by the telephone circuit changing its characteristic due to the weather conditions. For instance, when the circuit is lined up prior to a program it may be bright daylight with an intense sun shining on the open wire lines, causing the resistance of telephone circuits to be at a maximum and, therefore, the transmission loss the highest. After sundown, the temperature of these wire lines is reduced materially and some of the transmission loss is removed, bringing up the input levels to all subsequent repeaters on that circuit, thus increasing the output level to a point in excess of the allowable maxi-

mum. Of course these conditions are watched closely and attempts at correction are made while the programs are in progress.

Practical Limits

Experience has taught us that it is necessary to leave a margin between the absolute maximum and the practical operating maximum. Therefore, our programs are transmitted with a maximum energy level of plus two decibels, reducing the possible volume variation that can be transmitted to twenty-seven decibels.

In transmitting a full symphony orchestra whose volume variation is approximately sixty decibels between its minimum pianissimos and maximum fortes, it is absolutely necessary for an experienced control man to reduce the maximum energy level to plus two decibels and raise the minimum energy level to minus twenty-five decibels. This can be done successfully if the volume control man, whose training makes it possible for him to visualize these problems, is assisted by a musical director who can interpret for him the score of the symphonic music several bars in advance of the playing in order that he may smoothly control with accuracy the gain settings of his amplifier.

If this man did not function, the radio audience would listen to a badly overloaded and distorted transmission on the fortissimos and would be unable to hear the minimum pianissimos because they would be over-ridden by cross-talk. This explanation is not written in any criticism of these limitations placed on radio broadcasting by the wire lines, but it is a compliment to the engineers who have made the present facilities as satisfactory as they are for the handling of radio programs. At the present time every effort is being bent to improve these line facilities not only with respect to volume variation that can be handled, but also to widen the band to transmit more bass and more harmonics.

Characteristic Curves

Several curves showing the line characteristics of network circuits will be found accompanying this article and an explanation of the data they contain may be of interest.

The four curves in Fig. 1 show the audio-frequency characteristic of transmission through WEAf, Bellmore. The output curve shows frequency characteristic of the radio transmitter alone which is even from 30 to 10,000 cycles within plus or minus 1 DB. This, of course, covers a range of frequencies considerably greater than the average receiver and loud speaker will reproduce.

The second curve shows the characteristic of the telephone line from New York to Bellmore, including the line amplifier at New York and the speech amplifier at Bellmore. It will be noted that there is a slight drop at the lower end which is of no consequence and at the upper end of the curves it will be noted that the telephone line cuts off sharply at 8000 cycles. The telephone line from 711 Fifth Avenue to Bellmore is a cable circuit of latest design and unlike the usual run of broadcast circuits, is passing frequencies from 30 to 8000 cycles. By reference to one of the other curves showing the typical network circuit, a comparison of the two line characteristics may be noted.

The third curve is the addition of the first two curves, showing the radio transmitter and line together.

The bottom curve shows the overall characteristic of the transmission system from the microphone to the air, including all speech input equipment at 711 Fifth Avenue; considering that this includes the entire broadcasting system, a variation of 6 DB is still acceptable to the average radio receiver and the average ear, so it

can be stated that frequencies between 35 and 7000 cycles are successfully transmitted in this system.

The audio-frequency characteristic of a typical network circuit is shown by the two curves (Fig. 2) representing the red and blue network circuits from New York to Chicago. Considering the length of this circuit, and the fact that it is made up of varying types of transmission facilities and involves a number of telephone repeaters, the frequency characteristic from 100 to 4500 is flat within plus or minus 2 DB. This condition, of course, varies somewhat with temperature and weather conditions but in general it is typical of the circuit.

Low-Frequency Cut-Off

Generally speaking, both of these circuits cut off quite sharply at 90 cycles, and, as stated before, this cut-off point varies from day to day within a few cycles as shown by the difference between the red and blue network in the particular curves. Two or three years ago this cut-off at 100 cycles was not noticeable to the average listener but with the advent of electrodynamic loud speakers and amplifiers which will handle the bass in the later radio receiving set models, this loss of frequencies below 100 cycles is now more serious. The cut-off at the upper end in the vicinity of 5000 cycles is extremely sharp but this end of the spectrum is not so serious at this time as most radio receivers cut off quite sharply at 3000 cycles.

Much work is being done by both the Telephone company and the National Broadcasting Company to extend the range of the present telephone facilities to make the general transmission of network circuits comparable with that shown in the curve for the Bellmore circuit.

Fig. 4 shows a typical frequency characteristic of the transcontinental circuit from San Francisco to New York. It will be noted that the added line facilities and the additional repeaters make the cut-off at 100 and 4500 cycles much more definite. Considering that this represents 3000 miles of cross-continent circuits the frequency characteristic over the range transmitted is reasonably stable.

Another Problem

Another factor enters into this problem, and that is the volume variation which the average radio receiver can handle. The more modern sets are now constructed so that they can handle considerably more volume than was possible two years ago, but the problem of background noise brought in by the radio receiver and introduced by the vacuum tubes and the power supply is a limiting factor.

As conditions stand to-day, the average radio set operating at some distance from a radio transmitter has a higher noise level to contend with than that which is found on telephone wires, so that even if greater volume ranges could be transmitted over telephone circuits, the ether medium through which the program must be transmitted eventually, introduces a problem which is not as readily overcome as our first difficulty.

The cure for static and interference by electrical machinery operating in the neighborhood of receiving sets is a further increase in power of the radio transmitter, thus increasing the ratio of signal strength to noise at the listener's antenna.

The first condition we have some control over—that is, the energy levels transmitted over telephone wires to the radio transmitters; but the broadcaster has no control over the manner in which the broadcast listener operates his radio set. All the care taken by broadcasting companies and the telephone companies in maintaining energy levels and preventing overloading in any of the equipment under their control, is completely

offset by the listener when he overloads his amplifier.

Conclusions

I still feel that, perhaps, the real limiting factor which makes volume control necessary is the ether medium and the radio receiver where the margin is even less than exists in telephone circuits. The amplifiers and the radio transmitter in use by broadcasters have been designed so that the volume variation that can be handled by this equipment is as great as that of the symphony orchestra itself. I use the symphony orchestra in this explanation because it probably has the greatest volume range that we have to consider. A jazz orchestra, for example, which plays almost at the same tempo and volume at all times, for dancing purposes, presents no problem. In most cases volume control is not necessary during the playing, as the orchestra maintains its dynamic range within a volume variation of twenty-seven decibels. The diagram on page 261 (Fig. 3) shows the limitations on a decibel scale as compared with the volume variations of a symphony orchestra.

CHARACTERISTICS OF PENTODES

(Continued from page 255)

be representative of the final tube in several respects, there is a step-up of 8 to 1 between the high-voltage grid and plate. Hence any a.c. hum reaching to the high-voltage grid will be amplified by a factor of 8 by the time it gets to the plate. At the same time the superior sensitivity of the tube indicates that hum appearing in the plate circuit of the preceding stage will reach considerable proportions in the loud speaker circuit. For this reason it may be that greater filtering than is now necessary will be required.

Similar experimental tubes are being built by other tube manufacturers. Those made by Champion have been tested in the Laboratory and are not appreciably different from the Arcturus tubes.

Screen-Grid Tube Developments

If another grid will improve a power tube and get rid of secondary emission, tube manufacturers reason that an extra element may improve a screen-grid tube. CeCo has spent considerable time in experimenting with such tubes and some characteristics of such a screen-grid pentode tube are given here (Fig. 5). Table III compares it and present-day screen-grid tubes.

The greater possible amplification from such multi-element tubes is obvious. Whether or not receiver manufacturers prefer to get a lot of r.f. gain per stage or to get the total amplification in several stages is a matter that time only will indicate. At present it seems more economical to use several stages and to get the total amplification by cascading. The problem of shielding a stage in which there is a voltage gain of 100 is different than that of preventing stray fields from a stage in which the gain is only 30 times. On the other hand, the economy to the consumer of operating fewer tubes and the sales value of a physically smaller set may indicate use for this new high-gain screen-grid tube. As an a.f. amplifier tube, it should prove to be quite valuable. It represents a gain of 6 DB over present screen-grid tubes.

Tube manufacturers working on power-output and screen-grid pentodes will welcome suggestions from manufacturers and designers of receiving sets. At the same time the Editors of RADIO BROADCAST will welcome communications on this interesting subject.

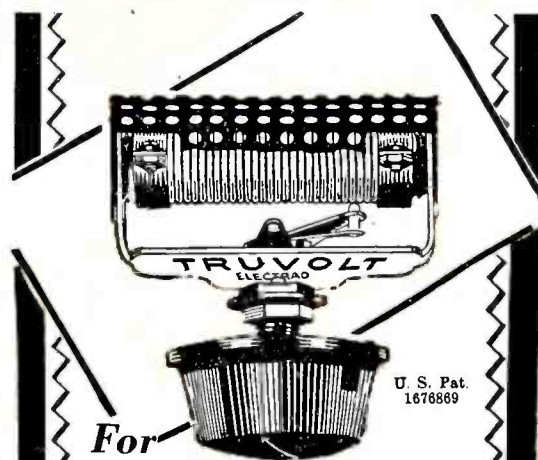

U. S. Pat. 1678869

For

SATISFACTION Sell ELECTRADS

SINCE the birth of radio, the name ELECTRAD on a resistance has stood for highest quality at right prices—the unbeatable combination that spells increased profits and good-will for your parts department.

TRUVOLT

Safest for Eliminators

Distinctly different air-cooled winding gives greater accuracy and longer life. Variable model (illustrated) with knob control and panel mounting. 22 sizes. List \$2.50.

Fixed types have exclusive sliding clip for adjustment of resistance values. Made in all usual sizes.

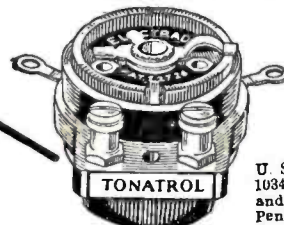

U. S. Pat. 1034103-04 and Pat. Pend.

TONATROL

The Expert's Choice

The TONATROL line of volume controls is characterized by superior workmanship and longer life. Made in a variety of sizes and resistance values, with or without filament switch attached. List \$1.50 to \$3.00.

Super-TONATROL

For Power Receivers

New type resistance element permanently fused to an enameled metal plate with pure silver floating contact insures smoother action, longer wear and rapid heat dissipation up to 5 watts. 7 types for all usual requirements. List \$2.40 to \$3.50.

175 Varick St., New York, N. Y.

ELECTRAD
INC.

ELECTRAD INC., Dept. RB3
175 Varick St., New York, N. Y.

Please send data on TRUVOLT and TONATROL Line to

Name.....

Address.....

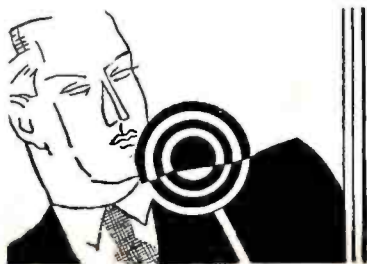

RADIO

Grigsby-Grunow Paid Huge RCA Royalty

During the eighteen months that the Grigsby-Grunow Company has been in the receiving set business RCA has received \$5,302,879.15 from them, stated Mr. Grigsby before the Senate Commerce Committee recently. Describing the present patent situation as intolerable Mr. Grigsby said that when he accepted the RCA license he understood that RCA enjoyed a complete patent monopoly and that these patents covered every part of the radio receiving set. "This is not true," continued Mr. Grigsby. "We are now paying royalty to three other patent owners and have been sued by five additional companies, claiming infringement of seven patents. In no case has the Radio Corporation protected us against these patents or helped us in the suits which have been filed against us.

"The patent licenses we were thus compelled to take out include one under the RFL patents. We also had to take out a license under the Lektophone patent. This is a patent on the loud speaker cone. When we manufactured our loud speaker under the RCA patents we copied directly the 104-A type of Radio Corporation loud speaker.

"When Lektophone Company charged us with infringement we tried to get some help from the Radio Corporation but they refused to give it because they had taken out a personal license from the Lektophone Company and thus acknowledged the validity of its patents. The radio combine did not take out a license to protect its licensees and so we had to pay additional royalties to Lektophone on the same loud speaker which we are making under the RCA patents.

"We also have a license under the Lowell and Dunmore patents which have recently been upheld in the suit against RCA. Further, to show that the members of the radio combine, individually or as a group, do not own patents covering even standard types of sets we are also being sued at present by the following: Magnavox, Hazeltine Corporation (two patents), Latour (two patents), Federal Telegraph Company (Kolster patent), Edelman, and DeForest. Beside this we have been threatened by at least a dozen other patent owners.

"The distinction between the licensing policy of the radio combine and that of other patent owners is that the combine is seeking to dominate the industry and create a monopoly while the others are simply trying to collect revenue from their patents."

Columbia Finances Improved

"Revenues for the Columbia Broadcast System in 1929," said William S. Paley, president, recently, "were approximately \$3,500,000. Columbia serves," said Mr. Paley, "71 affiliated stations, is absolutely independent, and depends for its earnings solely on the sale of time for sponsored programs." In 1928 Columbia showed a loss of \$172,655. Prior to January 1, 1928, the loss was \$205,424.

Annual Trade Show and Convention in Atlantic City



The new mammoth \$15,000,000 civic auditorium on the boardwalk at Atlantic City where the Annual Convention and Trade Show of the Radio Manufacturers' Association will be held during the week of June 2. The building is the last word in convention hall construction. It is 350 feet wide by 650 feet deep and provides 85,000 sq. ft. of exhibition space.

Supreme Court Refuses to Act in Radio Patent Suit

The decision of the Circuit Court of Appeals for the Second Circuit in the radio patent case of Wildermuth vs. Hazeltine Corp., No. 532, will not be reviewed by the Supreme Court of the United States, that court on Jan. 13 having denied a petition for a writ of certiorari.

The respondent is the owner of the Hazeltine patent in suit, No. 1538858, covering "grid-circuit neutralization," while the petitioner, a resident of New York, is engaged in the sale of radio broadcast receivers.

The petition for a writ of certiorari pointed out that among the fundamental rules of construction, as related to patents, is the principle that a limitation introduced into the specification to obtain allowance cannot be ignored, and that the patent cannot be interpreted as if such limitation did not exist.

It was the contention of the petitioner that the respondent's patent was deliberately limited to "close coupling," because of rejection by the Patent Office. However, it was pointed out, the Circuit Court of Appeals for the Second Circuit held that the petitioner's "loose coupling" did infringe the respondent's patent, thereby disregarding the disclaimer filed by the respondent.

The respondent took the position in his brief that in describing a particular embodiment of the invention it described ideal conditions—"close coupling" and "substantially equal to unity coupling"—but this was not intended as a limitation of the invention nor of the scope of the patent."

Audio Research Foundation Organized

Oswald F. Schuette, active in the affairs of the Radio Protective Association, is also involved in the Audio Research Foundation, Inc., 134 South LaSalle Street, Chicago. Organization of the group represented is said to be due to the feeling of manufacture of amplifier and associated equipment for radio and sound picture use that mutual protection from the legal thrusts of the American Telephone and Telegraph Company and others of the radio group was a growing necessity. While no membership list is available and none has been announced, C. C. Colby, president, Samson Electric, is chairman of the new organization, J. M. Stone (Operadio) is secretary, and John R. Howell, of Chicago, is executive secretary.

The Foundation intends, it is said, to follow two courses of action, according to *Exhibitors Herald World*, a motion picture trade paper. First they will seek to undermine the validity of basic patents on which such companies as Western Electric are alleged to base their exclusive right to manufacture certain radio and sound system parts. The second method of attack to be adopted by this group will be publicity. This publicity will attempt to show, it was said, that a monopoly in public entertainment exists as far as the use of amplifiers for public address and sound motion work is concerned.

The twelfth RCA tube licensee is the Triad Manufacturing Company, Pawtucket, R. I.

R-3

INDUSTRY

New Officers Elected

Dr. Lee DeForest was elected president of the Institute of Radio Engineers and L. G. Pacent of the Radio Club of America, in elections announced during January. Other officers of the I.R.E. are: Colonel A. G. Lee, vice-president; Melville Eastham, treasurer; John M. Clayton, secretary, and Alfred N. Goldsmith, Editor of *Proceedings*. Other officers of the Radio Club of America are: C. E. Maps, vice-president; Joseph Stantley, treasurer, and Willis K. Wing, corresponding secretary. Messrs. Amy, Armstrong, King, Burgard, Sadenwater, Grinan, and McMann were chosen for the Board of Direction.

Sarnoff, RCA Head

David Sarnoff is now president of the Radio Corporation of America at the age of 39. He succeeds General James G. Harbord who has been elected chairman of the Board. Owen D. Young, formerly chairman of the Board, RCA, will become the chairman of an executive committee of the company.

Maine Passes Radio Law

According to *Editor and Publisher*, Harold S. Dockam, radio editor of the *Augusta-Kennebec Journal*, is the author of a radio bill recently passed by the Maine legislature. This act makes it unlawful to operate a radiating receiver.

Personal Notes

W. L. Dunn, formerly chief engineer of the Colonial Radio Corporation, has joined the staff of Sprague Specialties Company as head of the engineering department. He will be in charge of research work.

Arthur T. Haugh, former president of the Radio Manufacturers' Association, has been elected vice-president in charge of merchandising of Valley Appliances, Inc.

Harry A. Beach has been appointed manager of the Radio Department of Stromberg-Carlson Telephone Manufacturing Company. Mr. Beach has been associated with Victor Talking Machine Company for more than twelve years, Brunswick-Balke-Collender Company for three years, and Earl Radio Company for three years.

Three promotions in the plant operation and engineering departments of the National Broadcasting Company were announced recently. G. O. Milne, former operations supervisor, was named New York division engineer; E. R. Cullen, former field supervisor, was named staff engineer of the entire system, and Max Jacobson, formerly assistant to Mr. Cullen, was named field supervisor.

L. Warrington Chubb, manager of the radio engineering department of the Westinghouse Electric and Manufacturing Company has been appointed first assistant to the vice president in charge of engineering of the Radio-Victor Corporation of America, Camden, New Jersey.

D. E. Replogle has been appointed treasurer of the Jenkins Television Corporation, Jersey City.

Henry H. Murray has resigned as manager of the Victor technical service department. As yet no

RCA Radiotron Co. Organized

Effective January 1st the RCA-Radiotron Company, Inc., Harrison, N. J., began to function. This organization has taken over all of the manufacturing, sales, engineering, and research activities in the tube field formerly scattered among the various members of the "Radio Group."

Factories, five in number, are located at Harrison, Newark, Cleveland, and Indianapolis. Total production can be 210,000 tubes daily, 5500 people will be employed, and the buildings provide 1,147,000 square feet of floor space. Warehouses are located in New York, Atlanta, Dallas, Chicago, and San Francisco. The complete roster of officers follows:

President, T. W. Frech
Vice-President, sales, George C. Osborn
Vice-President, manufacturing, W. T. L. Cogger
Sales Manager, Meade Bruuet
Advertising and sales promotion, J. W. Melver

successor to Mr. Murray has been appointed but until further notice J. F. McGarrey will be acting manager of the technical service department of the Victor Division of the RCA-Victor Company, Inc.

F. A. La Baw, formerly general sales manager of the Marvin Radio Tube Corporation, Irvington, N. J., has resigned. He is now sales manager of the Standard Tank and Seat Company, Camden, N. J.

The Atwater Kent Manufacturing Company has announced several important changes in sales personnel: J. W. Hitchcock has been appointed assistant sales manager; George H. Jaud, Northeastern sales manager; J. Harry Heikey, Southeastern sales manager; E. E. Rhoads, Central sales manager; H. T. Stockholm, West Central sales manager; L. M. Willis, Pacific Coast sales manager. Announcement has also been made of the appointment of John McCoy to the position of head of the statistical department to succeed E. H. Kester who has resigned.

Kenneth W. Jarvis, formerly chief engineer of The Sterling Manufacturing Company, Cleveland, Ohio, is now radio engineer with Sears, Roebuck and Company, Chicago, Ill.

The Zenith Radio Corporation announces a change in its factory and production management. Frank A. Whiting has been made general factory manager; George Knott has been appointed production manager. Paul E. Anderson has been named manager of the cabinet factory, and Howard A. Gates has been made chief engineer.

William Lawall Jacoby, president of the Kellogg Switchboard and Supply Company, Chicago, passed away after a short illness at Chicago on January 11th.

L. C. F. Horle, formerly chief engineer of the Federal Radio Corporation, has established his own business as consulting engineer at 50 Church Street, New York City.

Charles M. Blackburn, formerly with the Marathon Tube Company, has been appointed chief engineer of National Union Radio Corporation.

A. F. Murray, formerly assistant chief engineer of Wireless Specialty Apparatus Company, Boston, has joined the engineering staff of the RCA-Victor Company, Camden, N. J.

Cyril M. Jansky, formerly assistant professor of electrical engineering at the University of Minnesota, has opened an office as consulting engineer in the Munsey Building, Washington, D. C.

The Directors of the Radio Corporation of America at their meeting held recently elected an Executive Committee consisting of the following Directors: Owen D. Young, chairman of the Executive Committee; General James G. Harbord, Chairman of the Board; David Sarnoff, president; Gordon Abbott; Edward W. Harden; Andrew W. Robertson; James R. Sheffield; Frederick Strauss; and Gerard Swope.

(Continued on page 296)

Radio Entertainment the Latest Service on Trains



Those traveling on the "crack" trains of this country and Canada are no longer out of touch with national events. The difficulties presented by steel cars, electric signals, and myriads of power lines have been successfully overcome and as a result passengers are now able to enjoy radio and electric phonograph entertainment while in route. This picture shows a group listening to a radio installed on the Pioneer Limited, a "crack" train of the Chicago, Milwaukee, St. Paul, and Pacific railroad.



Precision

De Forest Audions are laboratory products of precision—that's why they're better.

DE FOREST RADIO CO.
PASSAIC NEW JERSEY



de Forest AUDIONS



The World's Premier Custom-Built RADIO



Band-Filter Tuning
Screen-Grid Amplifier
Six Tuned Circuits
World-Wide Range

COMPLETE
FACTORY
WIRED
AND
TESTED
UNITS

NO radio produced in mass can even approximate the skilled perfection of the new Custom-Built "HiQ-30." Here is the newest, most efficient model by Hammarlund—the climax of five years of unequaled custom designing and famed throughout the world, for power, selectivity and tone. A great opportunity for custom-set builders. Choice of magnificent cabinets and speakers.

List, \$139.50 to \$1,175 complete, less tubes.

Mail
Coupon
for
48-page
"HiQ-30"
Manual



HAMMARLUND-ROBERTS Inc.
424-438 W. 33rd St., N. Y.
Enclose 25c (stamps or coin) for
"HiQ-30" Manual. RB 3

Name.....
Address.....

R.C.A.-Victor Distribution

Those particularly interested in current activities in the field of distribution found something to think about in the announcement made by E. E. Shumaker, president RCA-Victor Company, late in January. President Shumaker said, "The RCA-Victor Company . . . will distribute its products not only through the distributing channels of the Radio Corporation and the Victor Talking Machine Company, but also through the distributing channels of the General Electric and Westinghouse Companies." Since for the last two years Graybar Electric has been distributing under their trade mark the same chassis as found in the entire Radiola line, this in effect promises that every chassis in the Radiola line this year will be available under Westinghouse, General Electric, Graybar, and Radiola labels. It is understood that the Victor receiver, although made in the Camden plant, will retain its individuality in the same degree as during the selling season just past.



T. W. French,
RCA-Radiotron

Supreme Service Stations

B. F. Dulweber, president, Supreme Instruments Corporation, announces that the following organizations have been appointed authorized service stations equipped with parts and laboratory facilities for servicing Supreme Radio Diagnostics and that they have been appointed authorized service stations.

- Harrison Sales Company, 314 Ninth Ave., North Seattle, Washington.
- Arthur Honeychurch, 682 Mission St., San Francisco, Calif.
- Illinois Testing Laboratories, Inc., 141 West Austin Ave., Chicago, Ill.
- Instrument Service Laboratories, 3645 McRee St., St. Louis, Missouri.
- Professional Radio Service, 429 Penn Avenue, Pittsburgh, Pa.
- QRV Radio Service, 1400 Broadway, New York, N. Y.
- Rubicom Company, 29 N. Sixth St., Philadelphia, Pa.
- Standard Laboratories, 1334 Oak St., Kansas City, Missouri.

Stromberg Buys Patent

Stromberg-Carlson has arranged a working agreement with Blutworth, Inc., of New York, designers and builders of special amplifying and remote-control systems. Stromberg-Carlson, it is understood, secures the rights to all inventions and laboratory work of Blutworth, Inc., prominent among which is the radio remote-control system, developed by T. F. Blutworth and Arthur P. Davis, which is fully perfected and has been in service in the field for several years. Under this agreement Blutworth, Inc., also receives the rights to use certain patents held by the Stromberg-Carlson Company.

Blutworth, Inc., will have the advantage of additional working capital, to meet the demands of a rapidly expanding business. It will also receive the benefit of the Stromberg-Carlson's sales and services organization.

A-C Dayton in Receivership

B. A. Ducasse was appointed equity receiver for the A-C Dayton Company on December 20. The action was requested by practically all of the creditors and approximately 90 per cent. of the stockholders. The receiver will undertake to unloose certain frozen assets and will plan for the continuance and further expansion of the business.

Financial Notes

RADIO CORPORATION: The following dividends were declared for the first quarter of the year 1930:

On the "A" Preferred stock—1½% (87½¢. per share)

On the "B" Preferred stock—\$1.25 per share.

These dividends are payable on April 1st, 1930, to stockholders of record March 1st, 1930.

PERRYMAN: This Company reports sales of \$1,121,016 for 1929, compared with \$672,338 in 1928, an increase of 67 per cent. In the last year the company produced 1,142,939 radio tubes, compared with 437,500 in the preceding year.

SPARKS-WITHINGTON: This company reports for the six months ended on Dec. 31, 1929, earnings of \$1,639,365, equivalent to \$2.40 a share on the 684,606 shares outstanding, against \$2.05 a share on the same basis in the previous year. Current assets were shown at \$5,583,646, with total assets of \$8,254,026. Current liabilities were shown as \$544,680 and surplus as of Dec. 31, 1929, \$3,655,988.

RADIO-VICTOR CORPORATION: Sales of radio instruments, records, and record-reproducing instruments, as reported by Radio-Victor for 1929, amounted to \$121,000,000. The total exceeds Victor's 1928 business by \$22,600,000, and its best previous year, 1920, by \$16,000,000.



W. L. G. Cogger,
RCA-Radiotron

as any previous year. On December 10, 1929, manufacture of Zenith "50" line of receivers stopped with no manufactured inventory on hand in December. New "60" series production begun January 2nd. Zenith dealers total 6000, distributors 55.

GRIGSBY-GRUNOW: Report for six months ended November 30, 1929, showed net income, after deducting depreciation, Federal taxes, and all other charges, of \$3,989,717, equal to \$1.99 per share on the 1,997,897 shares of no-par-value stock outstanding. Total assets as of November 30, 1929, equal \$35,537,128 compared with \$10,093,418 for previous year. Cash in hand was \$3,387,031. Production reached in October, 6000 sets and 65,000 tubes per day. The radio tube business of the company will shortly be transferred to a separate corporation, operating under an RCA license. In 1930 Majestic will enter the electric refrigeration field says President Grigsby: "Because of the fact that this field is opposite in its seasonal aspect to radio and the adaptability of the company's equipment to its manufacture we are optimistic as to the results."

Production Notes

HY-GRADE: Daily capacity of 10,000 tubes; will soon be increased to 15,000, it was announced late in December.

NATIONAL UNION: President Chirelstein states National Union plans to sell more than 15,000,000 tubes during 1930.

QRV Radio Service, Inc., formerly located at 1400 Broadway, New York City, has removed to 155 West 72nd St., New York City. John S. Dunham is president.

R-5

Recently Issued Patents

Wireless Telegraph and Telephone System. Lee De Forest, New York, assignor to DeForest Radio Telephone and Telegraph Co., Jersey City, N. J., corporation of Delaware. Filed July 1, 1924, Serial No. 723,488. Renewed May 11, 1929. No. 1,740,577.

Constant Scanning Disc, Charles Francis Jenkins, Washington, D. C., assignor to Jenkins Laboratories, Washington, D. C. Filed Nov. 5, 1928. Serial No. 317,286. 10 Claims. No. 1,740,654.

System of Secret Radiant Telephony and Telegraphy, John Hays Hammond, Jr., Gloucester, Mass. Filed Feb. 21, 1924. No. 1,740,859.

Controlling Phase Relations Between Stations. Harry Nyquist, Milburn, N. Y., assignor to American Telephone and Telegraph Co., Filed Oct. 19, 1927. Renewed Sept. 13, 1929. 5 Claims. No. 1,740,867.

Exclusive Radio Transmission and Reception. Frederick K. Vreeland, Montclair, N. J. Filed Sept. 13, 1922. Serial No. 587,909. 6 Claims. No. 1,740,964.

Piezo-Electric Interference Eliminator. Herman A. Affel, Ridgewood, N. J., assignor to American Telephone and Telegraph Company. Filed July 17, 1926. No. 1,739,494.

Radio Receiving Circuits. Ralph K. Potter, New York, N. Y., assignor to American Telephone and Telegraph Company. Filed December 4, 1926. No. 1,739,520.

Electrical Transmission Circuits. Horace Whittle, Maplewood, N. J., assignor to Bell Telephone Laboratories, Inc., New York, N. Y. Filed August 30, 1926. No. 1,739,699.

Wired Radio System. Albert H. Taylor, Washington, D. C., assignor to Wired Radio, Inc., New York, N. Y. Filed January 23, 1926. No. 1,739,773.

Tuning of High-Frequency Circuits. Wendell L. Carlson, Schenectady, N. Y., assignor to General Electric Co. Filed October 4, 1928. No. 1,740,331.

Light Valve Transmitter. Charles Francis Jenkins, Washington, D. C., assignor to Jenkins Laboratories, Washington, D. C. Filed June 25, 1927.

Split Switching Gear. Charles Francis Jenkins, Washington, D. C., assignor to Jenkins Laboratories, Washington, D. C. Filed September 6, 1928. No. 1,740,354.

Arrangement For Eliminating Atmospheric Disturbances. Abraham Esau and Friedrich Lange, Berlin, Germany, assignors to Gesellschaft für Drahtlose Telegraphie m.B.H. Hallesches Ufer, Berlin, Germany. Filed July 28, 1925, and in Germany Aug. 12, 1924. No. 1,743,124.

Picture-Transmitting System. Leonard G. Abraham, Brooklyn, N. Y., assignor to American Telephone and Telegraph Company. Filed August 18, 1926. No. 1,743,180.

Method and Apparatus for Determining the Properties of Acoustic Materials. Edward C. Wente, New York, N. Y., assignor to Western Electric Company, Inc., New York, N. Y. Filed July 13, 1926. No. 1,743,414.

Vacuum-Tube Circuits. Sidney E. Anderson, Maplewood, N. J., assignor to Western Electric Company, Inc., New York, N. Y. Filed December 24, 1923. Renewed March 16, 1929. No. 1,743,701.

Picture Transmission. Herbert E. Ives, Montclair, N. J., assignor to Western Electric Co., Inc., New York, N. Y. Filed August 20, 1925. Renewed Jan. 13, 1928. No. 1,743,856.

Photo-Amplifying System. Richard Howland



Harry A. Beach, Stromberg



C. M. Blackburn, National Union

Ranger, Newark, N. J., assignor to Radio Corporation of America. Filed November 18, 1924. No. 1,738,315.

Method of and Arrangement for Stray Elimination in Radio Communication. Julius Weinberger, New York, N. Y., assignor to Radio Corporation of America. Filed August 17, 1923. No. 1,738,337.

Thermionic Amplifier, Edward Herbert Trump, London, England, assignor to Radio Corporation of America. Filed Dec. 24, 1926, and in Great Britain Jan. 9, 1926. No. 1,738,408.

Adjudicated Patent

(C. C. A. N. Y.) Hazeltine patent, No. 1,533,858, for method and means for neutralizing capacity coupling in audions, claims 1, 2, 5, 9, 11, 12, 14, and 16 held valid and infringed. Hazeltine Corporation v. Wildermuth, 34 F. (2d) 635.

Patent Suits

1,128,292. E. H. Colpitts, Electric wave amplifier; 1,432,022, R. A. Heising, Circuit connections of electron-discharge apparatus; 1,483,273 D. G. Blattner, Circuit for heating the filaments of audions; 1,493,595, same. Amplifying with vacuum tubes; 1,504,537, H. D. Arnold, Power-limiting amplifying device; 1,514,943 E. O. Scriben, Electric wave repeater for multiplex transmission, D. C., N. D. Ohio (W. Div.), Doc. E 997, Western Electric Co., Inc., et al. v. Silverphone Corp. Decree pro confesso (notice Sept. 20, 1929)

1,173,079. E. F. Alexander, Selective tuning system; 1,251,377, A. W. Hull, Method of and means for obtaining constant direct-current potentials; 1,313,094, I. Langmuir, System for amplifying variable currents, D. C., N. D. Ohio (E. Div.), Doc. 2692, Radio Corporation of America, et al. v. The Sparks-Withington Co. Discontinued without prejudice Sept. 19, 1929.

1,183,875. R. V. Hartley, Electrical circuit; 1,231,764, F. Lowenstein, Telephone relay; 1,319,252, H. D. Arnold, Method of and means for utilizing thermionic currents; 1,403,475, same, Vacuum-tube circuit; 1,432,022, R. A. Heising, Circuit method connection of electron-discharge apparatus; 1,465,332, same, Vacuum-tube amplifier, D. C., N. D., Ohio (E. Div.), Doc. 2691, Radio Corporation of America, et al. v. The Sparks-Withington Co. Discontinued without prejudice Sept. 19, 1929.

1,231,764 (b) F. Lowenstein, Telephone relay; 1,493,217, R. C. Mathes, Vacuum-tube circuit, D. C., N. D. Ohio (W. Div.), Doc. E 1000, Western Electric Co., Inc., et al. v. Silverphone Corp. Decree pro confesso (notice Sept. 20, 1929).

1,244,216. I. Langmuir, Electron-discharge apparatus, and method of preparation; 1,244,217, same, Electron-discharge apparatus and method of operating same; 1,529,597, same, electron-emitting device and method of preparation, C. C. A., 3d Cir., Doc. 3800, General Electric Co. v. The DeForest Radio Co. Decree affirmed Oct. 3, 1929.

1,244,217, I. Langmuir, Electron-discharge apparatus and method of operating same, C. C. A. 3d Cir., Doc. 3801, The DeForest Radio Co., v. General Electric Co. Decree affirmed Oct. 3, 1929.

1,558,436. I. Langmuir, Electrical discharge apparatus and the process of preparing and using same, C. C. A., 3d Cir., Doc. 3799, General Electric Co. v. The DeForest Radio Co. Decree affirmed Oct. 3, 1929.

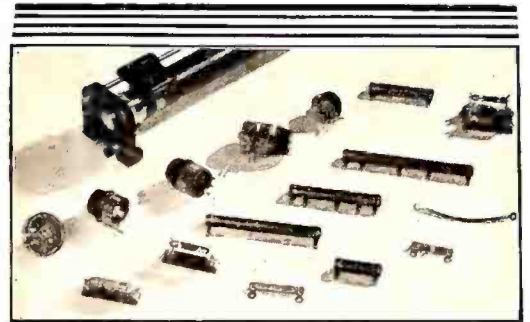

POLYMET RESISTANCES

Built to those high standards which have led 80% of the leading radio set manufacturers to adopt

POLYMET PRODUCTS

CARBON VOLUME CONTROLS
WIRE-WOUND VOLUME CONTROLS
DUAL CARBON AND WIRE VOLUME CONTROLS
SLIDING CONTACT TUBE RHEOSTATS
TAPPED VOLTAGE DIVIDERS
WIRE-WOUND TUBULAR RESISTORS
FLEXIBLE RESISTORS
FLAT STRIP RESISTORS
GRID LEAKS POLYTROLS

Ask for leaflet No. CL-1, giving diagrams of popular circuits including automobile radio receiver. A catalog of Polymet Parts is available on application.

POLYMET MFG. CORP.

Paper and Mica Condensers — Resistors
Electrical Coil Windings — Magnet Wire

837 East 134th Street
NEW YORK CITY, N. Y.

A Radio Parts Guide

THE NEW

YAXLEY

Catalog

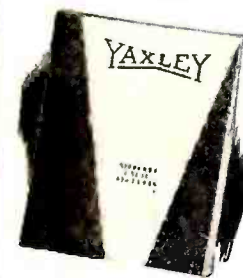

Send for it today for complete listings of Radio Convenience Outlets, Connector Plugs, Rheostats, Fixed and Grid Resistances, Jacks, Jack Switches, Phone Plugs, etc.

YAXLEY MFG. CO.

Dept. B, 1528W Adams St., Chicago, Ill.

THE SERVICEMAN'S EQUIPMENT

(Continued from page 269)

stations which file these records will find them to be of inestimable value in following up such service calls, since a record is available of the kind of set which was serviced and how it functioned at that time, and a call in six to eight months will frequently result in a second request for service, which will probably result in the sale of a new set of tubes, at least.

One must not forget the psychology of a serviceman entering a home with proper equipment. Shooting trouble, as we did in the old days with a screwdriver and a pair of pliers, pulling this and pushing that to see what happened, simply is not accepted to-day by the consumer who knows he will later be billed several dollars for the operations of the so-called expert. However, when the serviceman shows up with a kit of instruments and proceeds to make an

analysis of the entire radio set in a logical and methodical manner, it cannot help but react on the man who pays the bills and cause him to feel he has received his money's worth, even though all that was needed was a set of tubes.

The serviceman who is making money to-day is the man with proper equipment. The service department may be an asset or a liability. It is sure to be a liability if much time is spent analyzing minor defects. But, if the serviceman can make eight to ten calls a day, analyze the trouble rapidly and accurately, and display his equipment to such advantage that the customer senses his knowledge of the facts, then sales of new tubes should result in velvet in addition to a net profit when the accounts of the service department are totalled at the end of the year.



In a school with a reputation for graduating competent men

Dormitory—
Laboratory—
Workshop

Subjects Taught:

COMMERCIAL RADIO RADIO SERVICE
RADIO BROADCAST NAVIGATION
RADIO MATHEMATICS LABORATORY
VITAPHONE-MOVIETONE

Write for further information

COMMERCIAL RADIO INSTITUTE

38 W. BIDDLE ST. FOUNDED 1920 BALTIMORE, MD.

R-6

IN THE RADIO MARKETPLACE

News, Useful Data, and Information on the Offerings of the Manufacturer

Stewart-Warner Console

STEWART-WARNER CORPORATION: The Stewart-Warner screen-grid eight-tube receiver is available in a Tudor period console. The set (illustrated below) is priced at \$131.50.



Arcturus D.C. Tubes

ARCTURUS RADIO TUBE COMPANY: This company will make d.c. tubes of the following types: 012A, 101A, 099, 122, and 071A. Arcturus previously manufactured only a.c. tubes.

New A.F. Amplifier Manual

RADIO RECEPTOR COMPANY: For the purpose of guiding servicemen and dealers in the proper planning, selection, and installation of various types of amplifier equipment this company has issued a booklet containing considerable data on amplifiers. It covers such matters as gain, loud speakers, transformers, microphones, etc. The booklet also contains complete data on the various products manufactured by this company.

Timing Device

TIMING DEVICES INCORPORATED: This unit is designed for use with a standard radio receiver, the electrical connections being such as to place the timer in series with the circuit between the radio receiver and the light socket. The unit is operated by means of a coin which causes the radio receiver to be turned on for a certain length of time.

Utah Loud Speakers

UTAH RADIO PRODUCTS COMPANY: This company manufactures a number of electrodynamic and magnetic loud speakers. The various models are priced at from \$15.00 to \$55.00. The chassis may be secured separately or the unit may be obtained in a cabinet.

Weston Tube Checker

WESTON ELECTRICAL INSTRUMENT CORPORATION: The Model 533 Tube Checker is designed for use by dealers in checking tubes as they are sold. The tube is checked by noting the reading



of the meter and then pressing a button and noting a second reading. From these two readings a direct indication of the worth of the tube is obtained. Price \$50.63 net.

Durham Fixed Resistors

INTERNATIONAL RESISTANCE COMPANY: Modifications in the coating material and in the size of the filament have made it possible for this company to design resistor units with three or four times the safety factor of present units. Units rated at 1 watt have been placed on loads up to 15 watts at which load the heat became so intense as to melt off the end cap but the conducting filament was not damaged.

Wright DeCoster Speakers

WRIGHT DECOSTER, INC.: A number of reproducers for use in connection with radio receivers but similar in design to those supplied in the sound-movie field are now being manufactured by this company. The loud speakers are available in various types of cabinets.

Volume-Control Resistors

RADIO RECEPTOR COMPANY: This company is manufacturing a new line of volume controls for various uses. The controls will be made in all ranges and sizes. In addition the company recently announced a line of microphones, electric pick-up units, electrodynamic loud speakers, and other apparatus used in a.f. amplifying systems.

New Westinghouse Charger

WESTINGHOUSE ELECTRIC AND MANUFACTURING COMPANY: The new battery charger manufactured by this company uses a Rectrox recti-

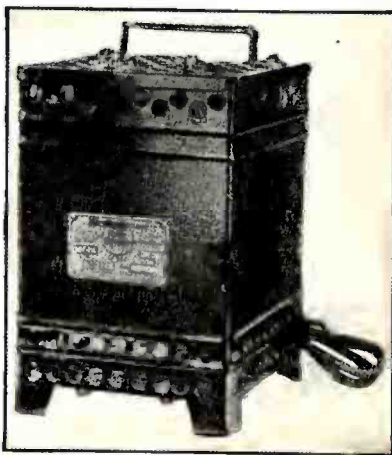

fier. This rectifier has a long life and is perfectly dry. The unit is ideal for charging radio and automobile batteries.

DeForest Dry-Cell Tube

DEFORREST RADIO COMPANY: The 499-type audion differs from the 199-type tube mainly in its filament construction. The 499 uses an oxide-coated filament of about three times the cross sectional area of the usual thoriated tungsten filament while emission from the 199-type filament is about four times that obtained from the thoriated tungsten type. The tube has a mutual conductance of 415.

An oxide-coated filament is also used in the 422A, the DeForest d.c. screen-grid tube. Emission from the filament averages 50 milliamperes and the filament current is only 60 mA. at 3.3. volts.

Automatic Phonograph

HOLCOMB AND HOKE MANUFACTURING COMPANY: This company manufactures a number of continuous-playing, automatic, electric phonographs. The unit uses a three-stage audio-frequency amplifier with a ten-inch electrodynamic loud speaker. The units are made with or without a coin-operated mechanism.

Atwater Kent Model 100

ATWATER KENT MANUFACTURING COMPANY: A new walnut lowboy cabinet, Model AK-100, has been added to the regular line of cabinets available exclusively for Atwater Kent



screen-grid receivers. The dimensions of the new cabinet are: height 38 1/2", width 24 1/2", and depth 15".

Flechthelm Fixed Condensers

A. M. FLECHTHEIM AND CO., INC.: This company manufactures a complete line of by-pass condensers, filter condensers, high-voltage transmitter condensers, and grid and plate blocking condensers for use on potentials up to 2000 volts d.c. By-pass condensers are available in various capacities from 0.1 to 4 mfd., and filter condensers in capacities up to 4 mfd. and in blocks.

Clarostat Volume Control

CLAROSTAT MANUFACTURING COMPANY: To meet the requirements of receivers in which the volume control must operate simultaneously in two circuits the dual-type wire-wound resistor has been designed. It is made up of two standard units mounted in tandem. Each unit may be wound to any resistance and a power switch may also be included in the assembly.

Wall Type Loud Speaker

BEST MANUFACTURING COMPANY: A loud speaker has been designed especially for installation in hotels, schools, and other buildings where programs are distributed by a centralized amplifier. It is 10 1/2" square, is equipped with a magnetic unit, and is designed to be installed in the wall of a room.

New Philco Models

PHILADELPHIA STORAGE BATTERY COMPANY: The Model 95 is a nine-tube receiver with automatic volume control using three screen-grid tubes, two 227-type tubes, two 245-type, and one 280-type. It is available in various models priced from \$67 to \$195. The model 76 is a seven-tube receiver using two screen-grid r.f. amplifiers, a screen-grid detector, a 227-type a.f. amplifier in the first stage, two 245-type tubes in the second a.f. stage, and one 280-type rectifier. Prices range from \$97.00 to \$225.00



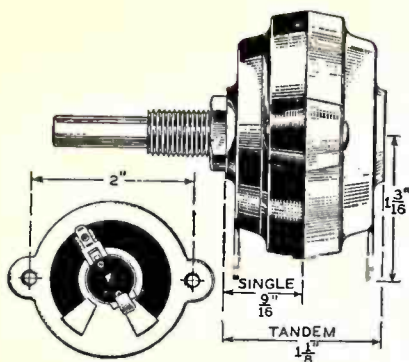

Electrad Super-Tonotrol

ELECTRAD, INC.: The Model B Super-Tonotrol combines two volume control resistors into a single unit. The advantage is that a tapered resistor can be used in the antenna circuit while a uniform resistor operated by the same shaft can be used to control the screen-grid voltage. Resistance variation in the antenna circuit is quite small during the first half of the shaft's rotation. The Model B is bakelite covered and dissipates three watts. It is available in usual sizes of resistances of practically any desired taper.

Hickok Service Instruments

HICKOK ELECTRICAL INSTRUMENT COMPANY: The Hickok Radio Set Tester, Model SG-4600, uses five meters as follows:

Plate voltmeter, double scale, 300 and 600 volts, resistance 400,000 and 800,000 ohms.

A.C. filament voltmeter, scale 3.3, 15, and 150 volts.

D.C. filament voltmeter, scale 15 volts, resistance 20,000 ohms.

Grid voltmeter, scale 100-0-80 volts, resistance 200,000 ohms.

Plate milliammeter, double scale 20 and 200 milliamperes.

By means of these five instruments it is possible with this testing device to obtain simultaneous indications of all voltages and currents, even in the case of the four-element screen-grid tube. List price \$140.00.

The Hickok Radio Tube Tester, Model B-47, is designed especially for use by manufacturers of tubes. With it all static constants can be measured and characteristic curves plotted, and by means of a.c. meters it is possible to obtain dynamic characteristics of tubes. The standard model lists at \$350.00 and the laboratory model at \$400.00.

Jenkins and Adair Apparatus

JENKINS AND ADAIR, INC.: This company manufactures a complete line of transformers, retards, gain controls, mixing controls, and amplifier accessories, such as condenser microphones, microphone amplifiers, low- and high-voltage generators for plate supply attenuators, level indicators, etc. The transmitter condensers can be obtained in sizes for use in 3000-volt circuits.

Zenith New 60 Series

ZENITH RADIO CORPORATION: This series includes the model 60, 61, 62, 64, 67, and 503. All except the latter use the Zenith nine-tube screen-grid chassis. The model 60 (\$145.00 list), designated as the "Super-Midget," is a small receiver designed especially to fit between twin beds! The 61 is a lowboy console priced at \$155.00 less tubes. Other models in the 60 series range in price from \$145.00 to \$495.00.



New Electrodynamic Speaker

RADIO-RECEPTOR COMPANY: The new Powerizer electrodynamic loud speaker is stated to have an effective frequency range of from 40 to 6000 cycles and to be capable of handling up to 10 watts of undistorted power. The loud speaker was originally designed for use in the Powerizer public-address and theatre-sound systems. It is now being sold as a separate unit.

Radio-Phonograph Combination

STROMBERG-CARLSON TELEPHONE MANUFACTURING COMPANY: The Model 654 Combination uses a receiver chassis with three screen-grid tubes, a linear power detector, and a single 245-type power tube. In the upper compartment is the turntable powered by an electric motor. The pick up unit is of the low-impedance flexible-armature type. The combination is very compact measuring 46 1/2" high, 27 1/2" wide, and 17 1/2" deep.

This company also has a new lowboy console, the model 652. The model 25A electrodynamic



loud speaker has been inspected by the Underwriters Laboratories and has received their approval. The model 641, 642, and 846 receivers have also been approved.

A.C. Tube Checker

JEFFERSON ELECTRIC COMPANY: A new and simplified tube checker for a.c. tubes has been



designed. Each tester is provided with a scale to indicate whether the tube is good, fair, or poor. The tester has six sockets, one each for the 226-, 227-, 224-, 245-, 171A-, and 280-type tubes. Price to dealers: \$13.50.

Samson Transformers

SAMSON ELECTRIC COMPANY: The Type 0-11 impedance-adjusting transformer consists of two identical primary and four identical secondary windings. Each primary will carry 150 mA. and each secondary 350 mA. By proper connection of the primary the transformer may be worked out of 2000 ohms or 500 ohms. The 0-12 transformer is designed especially for use in coupling a number of loud speakers or headphones in multiple to the output of an audio-frequency amplifying system. The transformer is designed to work out of 500 or 2000 ohms and into secondary loads of from 2 ohms to 1000

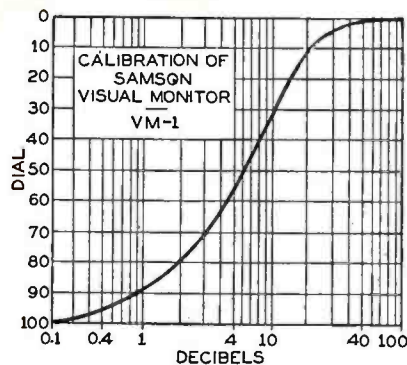

ohms. The Samson Visual Monitor, VM-1, has been developed to meet the need for an accurate indicator of volume level in power amplifier systems. It is completely a.c. operated and is arranged for standard rack mounting. It consists of a vacuum-tube voltmeter and a gain control, the action of the meter being slightly damped so that the voltmeter tends to indicate the mean levels rather than peaks. A sample calibration of the monitor is given. It will be noted that it has a total range of 100 db.

Service Instruments

THE BURTON-ROGERS COMPANY: This company manufactures a number of service instruments. The Model B Tube Checker is completely a.c. operated and will check all types of a.c. and d.c. tubes, including screen-grid tubes and rectifiers. The instrument is equipped with a standard Hoyt milliammeter with a D'Arsonval movement. Models are available for operation on 25 and 60 cycles. The 110-volt, 60-cycles model is priced at \$22.75 net. The Model C Counter Checker is also an a.c.-operated instrument and with it quick tests may be made on all types of tubes and also tests may be made on dry-cell batteries, B-power units, transformers, choke coils, resistors, etc. It is equipped with a three-range instrument, 0-20mA. and 0-20-200 volts. Price: \$27.75 net. The Radio Analyzer is an instrument for testing receivers by means of adapters. The instrument is equipped with a d.c. volt-milliammeter with ranges of 0-20, 0-100, milliamperes and 0-20, 0-100, 0-200 and 0-600 volts. The a.c. voltmeter has ranges of 0-4, 0-8, 0-16, 0-160 volts. The various meter ranges are connected into the circuit by means of a rotary selector switch. Price complete with full instructions, \$58.50 net. The Direct Reading Ohmmeter, \$35.00 net, is designed to measure resistors of from 0.5 to 50,000 ohms. The instrument is operated from two flashlight cells connected inside the case.

Victor Cameras

VICTOR ANIMATOGRAPH COMPANY: This concern manufactures a complete line of home motion picture cameras and projectors. The Model 3 camera has the following features: half-speed adjustment giving 8 pictures per second, normal speed, 16 pictures per second, upper speed, 68 pictures per second, for slow-motion work; spring motor, one winding of which is sufficient for 28 feet of film, and interchangeable lenses. The Model 3 T in addition to these features has a multiple lens turret making it possible to instantly change from a close-up to a long-distance shot. Both models can be obtained in a variety of lenses. Various models list at from \$125.00 to \$200.00. The Model 3 B projector is designed for the projection of 16-mm film. In addition this company manufactures a number of accessories such as tripods, rheostats, etc. for use with their cameras and projectors.

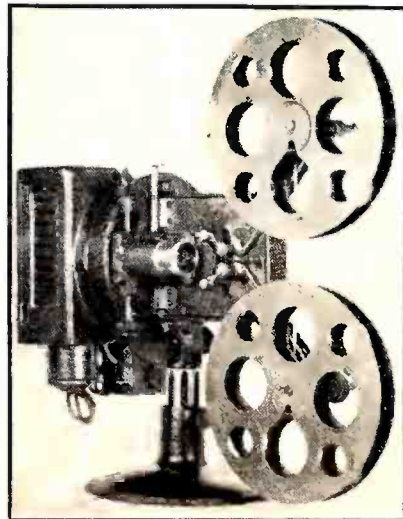

Loud Speaker Bibliography

THE FOLLOWING short bibliography on the theoretical development of electrodynamic loud speakers was prepared by F. V. Hunt, Cruft Laboratory, Harvard University.

THE DEVELOPMENT OF A HORNLESS TYPE OF LOUD SPEAKER: (This is the definitive paper that lays the foundation for subsequent design. Consulted at this date it seems incomplete, but one cannot be "in the know" without a grasp of these fundamentals.) Rice and Kellogg. *A.I.E.E. Journal*, Sept., 1925.

LOUD SPEAKERS: (A lecture delivered before the Radio Society of Great Britain in January, 1926, that greatly stimulated the discussion and development of electrodynamic loud speakers in England.) McLachlan. *E.W. & W.E.* (London), March, 1926.

A SERIES OF ARTICLES ON LOUD SPEAKERS: (General discussion of electrodynamic loud speaker design, with notes in the first on the influence of diaphragm diameter on interference effects at high frequencies. Many details of interest to the home constructor.) McLachlan. *Wireless World*, March 23, March 30, April 13, 1927.

THE OUTPUT STAGE AND THE MOVING COIL: (Report of some measurements on the impedance

of electrodynamic loud speakers and discussion of its influence on the response curve.) McLachlan. *Wireless World*, Aug. 8, Nov. 28, 1928.

RESONANCE PHENOMENA: (Consideration of the factors producing and affecting the resonant frequencies, especially the low-frequency 'boom' resonance due to the diaphragm-supporting membrane.) McLachlan. *Wireless World*, Oct. 10, Oct. 17, 1928.

OUTPUT POWER MEASUREMENTS ON A MOVING-COIL LOUD SPEAKER: (Practical measurements of loud speaker output, using the method of bridge measurement of the motional resistance. In addition the equivalent electrical circuits of the electro-mechanical loud speaker system are developed in an appendix and offer a powerful approach to the design problem for one familiar with electrical filter theory.) Clark and Bligh. *E.W. & W.E.*, Sept., 1928.

LOUD SPEAKER TESTING METHODS: (Description of what is still the best method available for obtaining loud speaker response curves: condenser microphone, equalized amplifier and vacuum-tube voltmeter, and semi-automatic recording.) Wolff and Ringel. *I.R.E. Proc.*, May, 1927.

Loud Speaker Bibliography

(Continued)

Continuation of foregoing paper, showing several actual curves and discussing their interpretation. Wolff. *I.R.E. Proc.*, Dec. 1928.

A HIGH-EFFICIENCY RECEIVER OF LARGE POWER CAPACITY FOR HORN-TYPE LOUD SPEAKERS: (This is a detailed description of the Western Electric 555-w unit now being used chiefly for "talkie" installations. One hesitates to use the superlative but it is probably the best loud speaker now made, yielding honest efficiencies of 25-50 per cent. from 50 to 5000 cycles and with no resonance peaks. Unfortunately the horn required to do the unit justice makes it unsuitable for home use. Wentz and Thurax. *Bell System Tech. Journ.*, Jan., 1928.

NEW MOVING-COIL LOUD SPEAKER. *Journ. Scient. Instr.*, June, 1929, V. 6, pp. 197-198.

THE ACOUSTIC PERFORMANCE OF A VIBRATING RIGID DISC DRIVEN BY A COIL SITUATED IN A RADIAL MAGNETIC FIELD. N. W. McLachlan. *Phil. Mag.*, June, 1929, V. 7, No. 46, pp. 1011-1038.

DESIGN DATA ON THE MOVING COIL: (Some notes on the most efficient coil and its correct design.) L.E.T. Branch. *Wireless World*, May, 1929, V. 24, pp. 561-564.

THE MOVING COIL LOUD SPEAKER: H. M. Clarke. *E.W. & W.E.*, July, 1929, V. 6, pp. 380-384.

MOVING-COIL LOUD SPEAKERS, WITH PARTICULAR REFERENCE TO THE FREE-EDGE CONE TYPE. C. R. Cozens. *E.W. & W.E.*, July, 1929, V. 6, pp. 353-368.

SOUND RADIATION FROM A SYSTEM OF VIBRATING CIRCULAR DIAPHRAGMS. I. Wolff & L. Malter. *Phys. Review*, June, 1929, V. 33, pp. 1061-1065.

THE "BREAKING UP" OF LOUD SPEAKER DIAPHRAGMS. N. W. McLachlan. *Wireless World*, July 10 & 17, 1929, V. 25, pp. 33-35 & 62-64.

MESSUNG DER GESAMPTENERGIE VON SCHALLQUELLEN: (Measurement of Total Energy of Sound Producers.) E. Meyer & P. Just. *Zeitsch. f. tech. Phys.*, Aug., 1929, V. QP, No. 8, pp. 309-316.

Loud Speaker Bibliography

(Continued)

UBER NEUERE AKUSTISCHE: (New work on acoustics and in particular electro-acoustics.) F. Trendelenburg. *Zeitsch. f. Hochfreq. Tec.*, Oct., 1928, Vol. 32, pp. 131-135.

PRESSURE DISTRIBUTION IN A FLUID DUE TO THE AXIAL VIBRATION OF A RIGID DISC. N. W. McLachlan. *Proc. Roy. Soc.*, Feb. 4, 1929, V. 122A, pp. 604-609.

THE EFFECT OF A FINITE BAFFLE ON THE EMISSION OF SOUND BY A DOUBLE SOURCE, M. J. O. Strutt. *Phil. Mag.*, March, 1929, No. 43, V. 7, pp. 135-158.

APPARENT EQUALITY OF LOUD SPEAKER OUTPUT AT VARIOUS FREQUENCIES. L. C. Hector & H. N. Kozanowski. *I.R.E. Proc.*, March, 1929, V. 17, pp. 521-535.

TRANSIENTS ALIAS "ATTACK": (Natural oscillations of loud speaker diaphragms.) N. W. McLachlan. *Wireless World*, April 3 & 10, 1929, V. 24, pp. 346-348, 385-388.

DOES A VIBRATING DIAPHRAGM CARRY A MASS OF AIR WITH IT? G.W.O.I. (Editorial) *E.W. & W.E.*, March, 1929, V. 6, pp. 117-118.

ON THE SOUND WAVES RADIATED FROM LOUD SPEAKER DIAPHRAGMS. *E.W. & W.E.*, April, 1929, V. 6, pp. 175-177.

A.E.G. COIL-DRIVEN LOUD SPEAKER: (Rice-Kellogg) F. A. Fischer and H. Lichte. *A.E.G. Mitt.*, Jan. 1929, No. 1, pp. 25-31.

THE INDUCTOR DYNAMIC: (Farrand Loud Speaker Movement.) H. P. Westman. *QST*, Aug., 1929, Vol. 13, pp. 29-30.

TRANSIENTS IN LOUD SPEAKERS AND AMPLIFIERS: (How sudden changes in sound intensity affect the amplifier: the important effect of a choke-filter output.) N. W. McLachlan. *Wireless World*, Aug. 7 & 14, 1929. Vol. 25, pp. 118-121, 154-157.

ACOUSTIC PRESSURE AND VELOCITY RELATIONS ON A CIRCULAR DISC AND IN A CIRCULAR ORIFICE. A. G. Warren. *Phys. Soc. Proc.* 40, pp. 296-298. Disc. 299 Aug. 1928.

THE ELECTRODYNAMIC LOUD SPEAKER: (Good brief discussion of motional impedance with some notes on practical design.) E. A. Uehling. *RADIO BROADCAST*, Dec. 1929, pp. 113-115.

MEASURING EQUIPMENT

(Continued from page 264)

The actual frequency being generated is 1000 kilocycles, but the scale says 1002 kilocycles, so in this part of the scale the reading is 2 kilocycles too high. Points are checked every 100 kilocycles over the range of the oscillator. A table appears here which shows the scale readings and the corresponding frequencies. In no case is the variation greater than two per cent.

Modulation Characteristic

The modulation characteristic is a curve which shows the relation between the voltage on the screen grid of the modulator and the current flowing in the output circuit of the signal generator. The shape of the curve rather than the absolute values associated with it are of interest, so the current scale instead of representing actual current values represents a factor proportional to the current. When obtaining the calibration data the factor is more easily obtained than is the actual current value. The characteristic should be a straight line over the operating range of the modulator. This generator was built to modulate from zero to 50 per cent. and over this range the characteristic is very nearly a straight line.

Calibration

There are several ways by which the modulation meter may be calibrated but only one will be explained here. From the modulation curve (Fig. 2) the value of a.c. voltage that must be supplied to the screen grid of the modulator for a given percentage of modulation can be obtained. For instance, in this case the normal operating point of the modulator screen-grid potential is 140 volts and the corresponding output current factor is 200. Suppose it is desired to set the modulation at 50 per cent. The current factor must increase to 300 and decrease to 100. The curve shows that in order to effect this variation the screen-grid voltage must rise to 168 and fall to 112 volts, or considering 140 as the zero axis of an alternating voltage the peak value of the voltage must be 140-112 or 28. All that then remains to be done is to supply the screen grid with an alternating voltage of any convenient frequency and adjust its peak value until it is 28. After the modulation has been fixed the modulation meter coupling is set so that the d.c. milliammeter reads the correct value (in this case it is 6 mA.). The reading of the thermocouple microammeter is then noted. Thus a point on the calibration curve has been determined. To find other points the modulation is set at say 40, 30, 20 and 10 per cent. and the corresponding readings of the microammeter are recorded. From these data the calibration curve (See Fig. 2) is plotted.

Other Considerations

These are the calibrations ordinarily made but to be considered a dependable unit in the measurement equipment the generator must possess other characteristics. The oscillator frequency must not drift with time nor must it be subject to variations due to changes occurring in the output circuit of the generator. The generator was run steadily for four hours and it was found at the end of this period that the frequency had drifted less than 200 cycles. The extremes of conditions that can exist in the output circuit are first with maximum current flowing (the output terminals short circuited and the circuit tuned to the oscillator frequency) and second with the output circuit open (no current flowing). Under these extremes of conditions the frequency of

the oscillator varied less than 20 cycles. This freedom of the oscillator frequency from output circuit conditions results from the use of the screen-grid tube as the modulator. That is, the screen-grid tube prevents the succeeding tube circuits from reacting upon the oscillator circuit.

Neither the degree of modulation nor the shape of the modulating wave must be affected by circuit conditions. Both the output tubes and the amplifier preceding them operate as linear devices under all circuit conditions and so the degree of modulation cannot be affected. The screen grid of the modulator is practically a voltage-operated device so the modulating oscillator is at all times operating under substantially open-circuit conditions. Consequently the modulating wave shape is good under all operating conditions.

The output current must not fluctuate. The motor-generator supplies power at constant voltage independently of normal line-voltage fluctuations so the output current is not subject to undesired variations.

The output current must be reasonably free from harmonics. In this generator the amplitudes of the harmonics that may be present are so small that their effect upon measurements being made is negligible.

Conclusions

Criticisms have at various times been directed against the use of these larger tubes in this equipment. The argument being that the same results could be obtained with the smaller tubes (201, 171, 224) and reductions could be made in the size of the equipment and the expenses of maintaining it. But experience has demonstrated that with the larger tubes the generator characteristics remain constant for long periods of time and the maintenance expense in general is not excessive. When batteries constituted the power supply there were important considerations in favor of the smaller tubes, but the motor-generator eliminates these considerations and actually reduces the original cost and subsequent maintenance expense.

In the next article in this series there will be described measurement apparatus which is used in conjunction with the signal generator.

PRODUCTION TESTING EQUIPMENT

(Continued from page 275)

tial except that the galvanometer deflection is lessened as the battery voltage decreases.

Carbon Resistors

In testing carbon resistors where the resistance varies inversely with the current flow it is necessary to test them under very nearly their normal load condition. We find that by applying the necessary potential and measuring the current flow a satisfactory test can be made on these carbon items.

As can be seen by referring to Fig. 5 the test fixture consists of a voltmeter and milliammeter connected so that the voltmeter measures the drop across the resistor and the milliammeter the current through it. The C battery and potentiometer adjust the applied potential while the milliammeter shunts make it possible to test a number of different resistor values on the same test fixture. Limits are indicated on the scale of the milliammeter and, of course, are of the same width for all carbon resistors where the acceptance limits are similar.

a smooth start and a steady pull

The giant electric locomotive starts with velvet smoothness and pulls the heaviest loads over steep mountain grades with steady, unflinching power.

It's all a matter of proper control.

The increased sensitivity of your radio demands the s-m-o-o-t-h control that only Centralab can give. Noiseless, free of inherent sputtering—self inflicted static. For smooth, quiet, velvety radio reception your radio must be CENTRALAB equipped.

Write Dept. 218 E, for free booklet "Volume Controls, Voltage Controls and Their Uses."

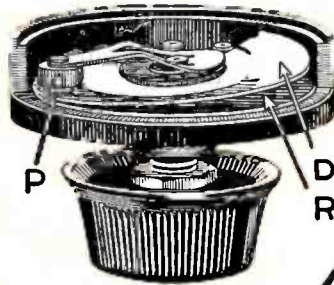

THIS shows the exclusive rocking disc construction of Centralab volume control. "R" is the resistance. Contact disc "D" has only a rocking action on the resistance. Pressure arm "P" together with shaft and bushing is fully insulated.

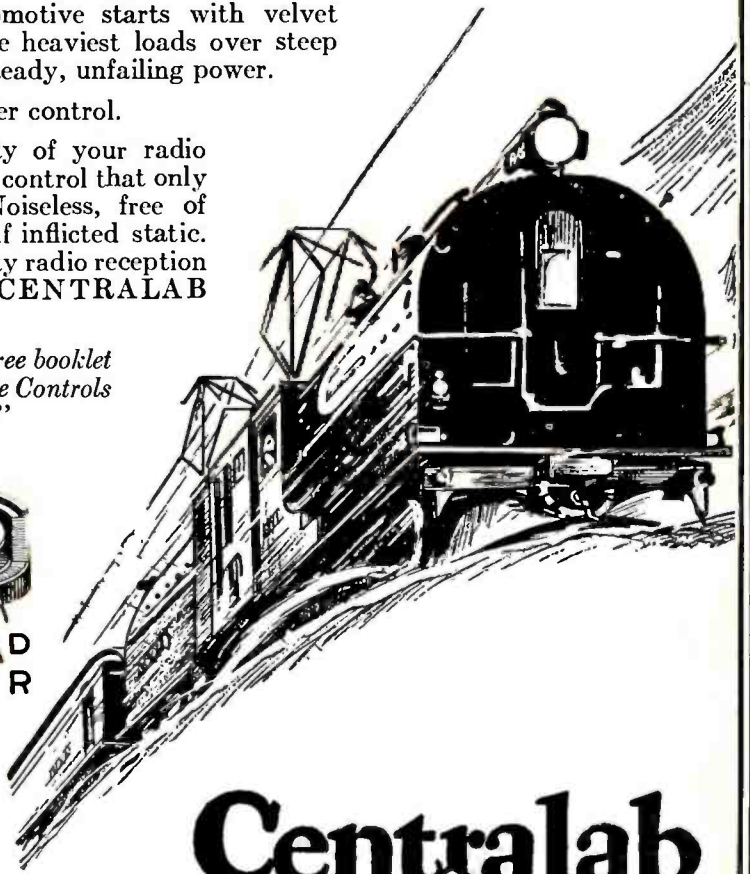

Centralab

CENTRAL RADIO LABORATORIES

Dept. 218-E, Keefe Ave., Milwaukee, Wis.

TYPE 360 TEST OSCILLATOR



One of the new test oscillators for the radio service laboratory is now ready. It will deliver a modulated radio-frequency voltage at any point in the broadcast band (500 to 1500 kilocycles) and at 175 and 180 kilocycles. The tuning control is calibrated with an accuracy of 2 per cent.

The Type 360 Test Oscillator is intended to be used for neutralizing, ganging, and tuning of the radio-frequency stages in a receiver, and it is fitted with an output voltmeter for indicating the best adjustment. This voltmeter is of the copper-oxide rectifier type, and by means of a switch it may be connected across a 4000-ohm load or across the dynamic speaker of the receiver when making tests.

Price \$110.00

GENERAL RADIO COMPANY

30 State Street

Cambridge, Massachusetts

Modulated Oscillators and Output Meter

ONE of the most important tasks in the servicing of radio receivers is the accurate alignment of the tuning condensers and the accurate adjustment of the neutralizing condensers. Although these operations may be carried out by tuning the set to some local station and making the necessary adjustments while listening to the a.f. output, this method is not very accurate. It is much better to set up a local oscillator and an output meter so that the input to the set and the a.f. output are reasonably constant and so that slight changes in the adjustments can be detected readily.

On "Laboratory Sheet" No. 332 are given the circuits of two simple modulated oscillators and two output meters that may be used in checking a receiver. Oscillator No. 1 is designed for operation on a.c. and oscillator No. 2 for operation from batteries. The a.c.-operated oscillator uses a 226-type tube supplied from a filament transformer and plate potential is obtained by connecting the plate lead to the primary of the power transformer. The oscillator will then have 110 volts a.c. on its plate and will be modulated by the a.c. The battery-operated oscillator uses a 199-type tube and the grid leak and condenser values are such that

they will function to modulate the output. It is, essential, of course, that the oscillator be modulated so that a note will be audible in the output of the loud speaker connected to the set under test.

The output meter No. 1 uses a 226-type tube as a rectifier in series with an 0-10 milliammeter and a 1-to-1 output transformer. The output meter of oscillator No. 2 simply uses a 1-to-1 transformer to whose secondary an a.c. milliammeter is connected. If an a.c. milliammeter is available this is, of course, the simplest circuit but if a d.c. milliammeter must be used it is necessary to rectify the output by some circuit such as is indicated by circuit 1.

In use the output meter terminals marked "to set" are connected either directly across the moving coil of the electrodynamic loud speaker or, if necessary to get sufficient reading, across the primary of the transformer supplying the loud speaker. The oscillator is set up near the set and located at such a point that a satisfactory deflection is obtained on the output meter when the set is tuned to the frequency being generated by the oscillator. The various condensers can then be accurately aligned until maximum deflection is obtained on the meter.

STRAYS FROM THE LABORATORY

(Continued from page 273)

Electric company and used in their laboratories (and probably for sale), but takes considerable space to describe how it is used, the importance of the shape of condenser plates, how to get good wave form at low frequencies, etc. It should be digested by every engineer engaged in radio- and audio-frequency laboratory work.

Despite the fact that *QST* is edited primarily for the audience whose interest and activities lie in the frequencies higher than 1500 kc., we are continually surprised and pleased with the amount of material of interest to broadcast-frequency engineers. In the November (1929) issue will be found an article on the use of an interesting mechanical rule for determining the proper load resistance for power amplifiers, and to simplify power output and distortion calculations. This article is by K. S. Weaver, Westinghouse Lamp Co., Bloomfield, N. J. Another article by Technical Editor James J. Lamb describes the uv-845, a low-impedance linear power amplifier and modulator tube of the 50-watt type. A third article on "Operating Characteristics of Vacuum Tube Oscillators," by H. A. Robinson, belongs with the engineer's file of vacuum tube circuit articles.

Modulated Oscillator and Output Meter

THE CIRCUITS on this sheet show arrangements that can be used to supply a constant modulated signal to a receiver for testing purposes and also output meter circuits that can be used to in-

dicate qualitatively the output of the set. All specifications are given on the circuits and some notes on their use will be found in "Laboratory Sheet" No. 331.

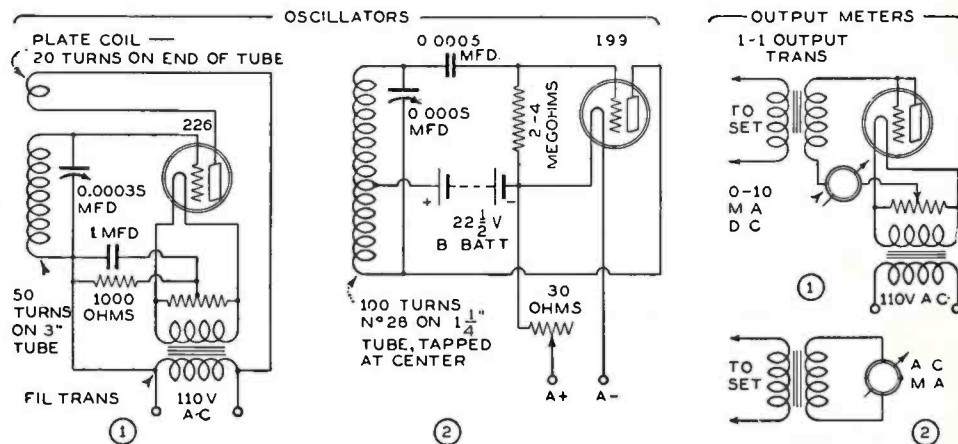

Calculating Power Output

ONE of the simplest and most effective ways of calculating the power output of an ordinary three-element power tube is by the use of "load lines" plotted across a group of characteristics showing the relation between the plate current and plate voltage for various grid biases. A group of plate current-plate voltage curves for the 171A-type tube are given on "Laboratory Sheet" No. 334 and the following notes indicate how the load lines are determined.

It should be noted that these curves show the plate current obtained for various plate voltages at grid biases corresponding to from 0 to -80 volts. The first thing to do is to pick out the normal operating point of the tube, which in this case is -40 volts and 20 milliamperes. The tube has a plate resistance of 2000 ohms and for maximum undistorted output the load resistance would therefore be 4000 ohms. We now have to lay off the line to indicate the manner in which the plate current will change with grid voltage. This is not difficult. With no signal on the grid the plate current will be 20 milliamperes. Now assume that the plate current changes from 20 milliamperes to 40 milliamperes. This means that there will be a change of 20 milli-

amperes in the current flowing through the 4000-ohm resistor. By Ohm's Law the resistance, 4000 ohms, multiplied by this current, 20 milliamperes, gives the change in voltage across the 4000-ohm resistance, or in this case 80 volts. We, therefore, mark on the diagram point B at a plate current of 40 milliamperes and a plate voltage of 100 (80 volts less than the normal operating potential of 180 volts). A line is then drawn from the operating point at 20 milliamperes and 180 volts so as to pass through the point B. This is the load line corresponding to a load resistance of 4000 ohms.

Load lines for values other than 4000 ohms can be calculated in this same manner. For example, if the load resistance is 2000 ohms then a 20-mA increase in plate current will produce a 40-volt change across the load resistance. This gives us point C at a current of 140 milliamperes and a plate voltage of 40 volts. Drawing a line between C and the operating point A gives the load characteristic corresponding to 2000 ohms.

In future Sheets we will show how these load lines may be used to determine the power output of the tube and also the percentage of second-harmonic distortion.

THE ADAPTORON

(Continued from page 253)

have some effect on the wave form, but, as indicated in Fig. 8, load resistance of from about 6000 ohms up to about 40,000 ohms does not have a serious effect. The effect of changing the length of the commutator segments for a constant load and a specific filter system had a somewhat greater effect. Fig. 9 gives the data for this case. Second and third harmonics are

(Continued on page 303)

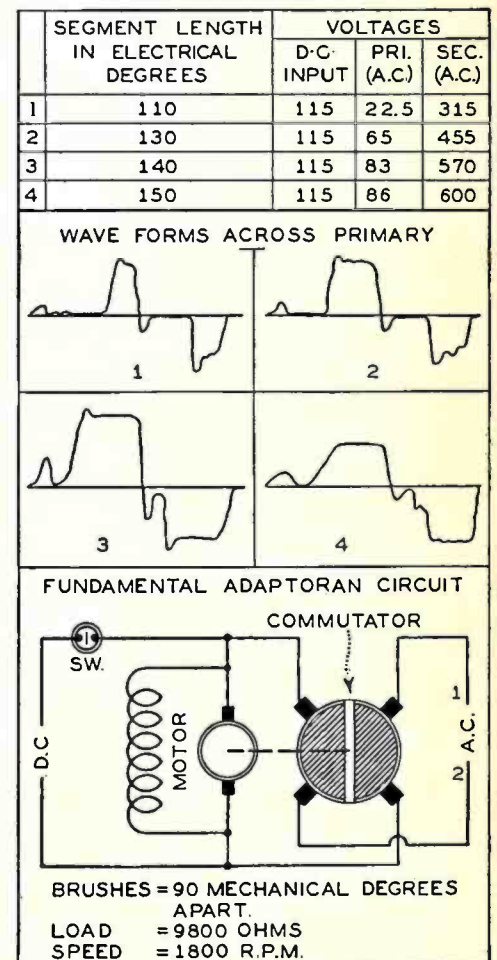

Fig. 4—Effect of varying length of commutator segments.

(Continued from page 302)

largely responsible for the shape of these curves. The third curve for a segment length of 160 degrees seems to indicate a third harmonic with a value of about 25 per cent. of the fundamental.

Practical Uses

The wave shapes indicated in the various figures shows that from this device one can obtain a number of different forms, some quite peaked and others quite flat relative to the effective value.

The application of this device is, of course, not limited to that of permitting the operation of a.c. radio receivers from d.c. lines. It has application wherever low-power devices that function best on a.c. must be operated in d.c. districts. In many of these applications somewhat better results are obtained with wave forms other than sinusoidal, and by the proper choice of the segment length and the filter system these special wave forms can be obtained.

Special Adapteron circuits are necessary when the unit is called upon to supply

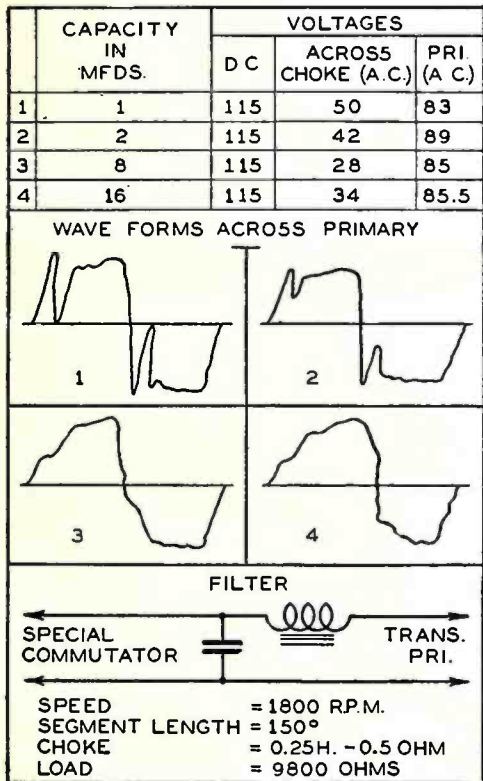

Fig. 5—Effect of parallel capacity and series inductance.

loads of low power factor. As a matter of interest two special circuits are shown. Neon tube circuits are designed with a transformer which has very high secondary leakage reactance in order to maintain a constant secondary current; consequently the power factor is usually poor—40 per cent. being unusually good and from 17 to 30 per cent. being average.

In designing an Adapteron for these circuits, a condenser feed was decided upon and the circuit utilized is shown in Fig. 1. Resistors, R_1 and R_2 , are placed across the condensers to limit the voltage across them. As, if a condition of resonance is reached, the current in the circuit is very high and some care must be taken in the circuit design to prevent such a condition from occurring in practice.

The bell-ringing circuit is shown in Fig. 2. As bell-ringing circuits are similar, it is possible to design a more simple filter to take care adequately of the conditions met with in this type of service.

In the use of this device in the consoles of standard a.c. receivers several points, such as the location and grounding of the elements of the filter circuit, the shielding, etc., are very important.

The complete circuit of an Adapteron of the type used with radio receivers is shown in Fig. 3. Technically, the circuit

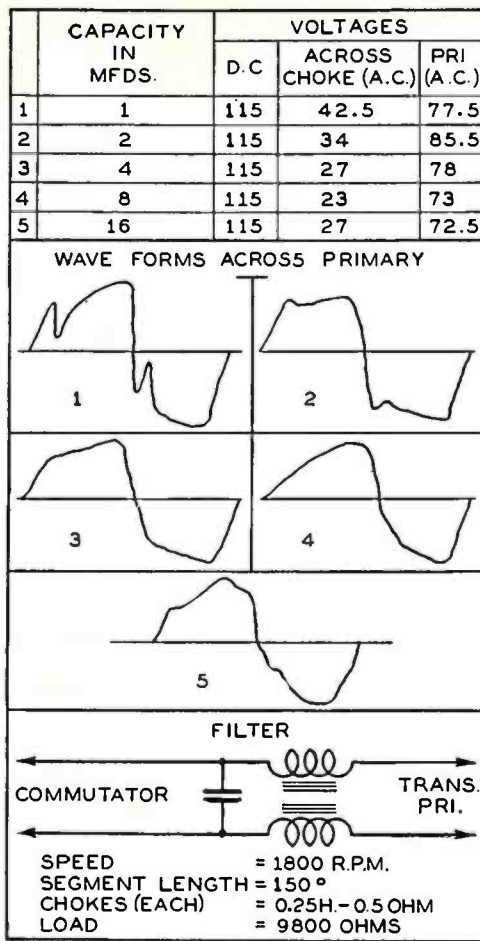

Fig. 6—Effect of parallel capacity and choke in both sides of line.

is quite interesting. The problem of preventing the radio-frequency oscillations generated by commutation from reaching either the d.c. lighting mains or the a.c. output leads was solved by the filter circuits shown.

During the tests it was found that although no appreciable r.f. energy was reaching either power line, the signal reaching the set from the antenna was distinctly annoying, particularly at certain frequencies. Later tests proved that the unwanted energy was being picked up from the single shield then employed around the entire equipment. The ground lead, too, was decidedly "hot." This condition was remedied by the introduction of a double shield, the two shields being insulated from each other. All radio-frequency leads (Continued on page 304)

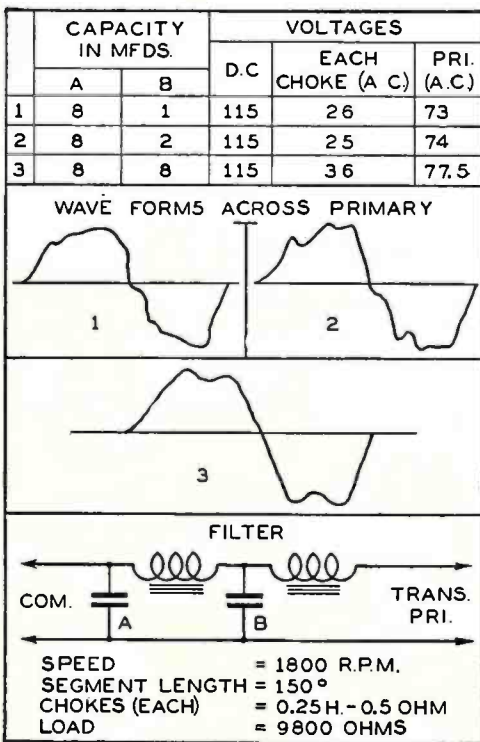

Fig. 7—Effect of different capacity combinations.



PILOTRONS

These tubes, built to satisfy professional radio engineers and custom set-builders, will surely satisfy your customers. "Good Sets Deserve Pilotrons, Others Need Them!" Pilot Radio and Tube Corporation, 323 Berry Street, Brooklyn, N. Y.

RADIO Isn't Modern Without Automatic VOLTAGE CONTROL

See that the electric radio you buy or build is equipped for the AMPERITE Self-Adjusting LINE VOLTAGE CONTROL. Prevents noisy voltage fluctuations. Improves Reception—Saves Tubes.

Write for Useful Bulletin. Address Dept. RB 3

AMPERITE Corporation
561 BROADWAY, NEW YORK

AMPERITE Self-Adjusting LINE VOLTAGE CONTROL

ROBERT S. KRUSE

Consultant and Technical Writer

103 Meadowbrook Road, West Hartford, Conn.

Telephone Hartford 45327

Wanted:

Representative in each town for new easy selling proposition to home-makers. Generous commissions, bonus and sales helps supplied. Especially attractive offer to club or civic workers. Apply

Box R. B. % The American Home Garden City, N. Y.

Calculating Power Output

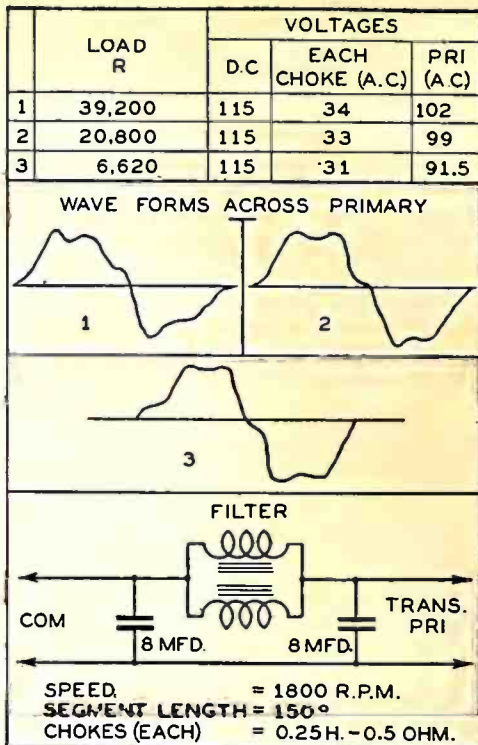
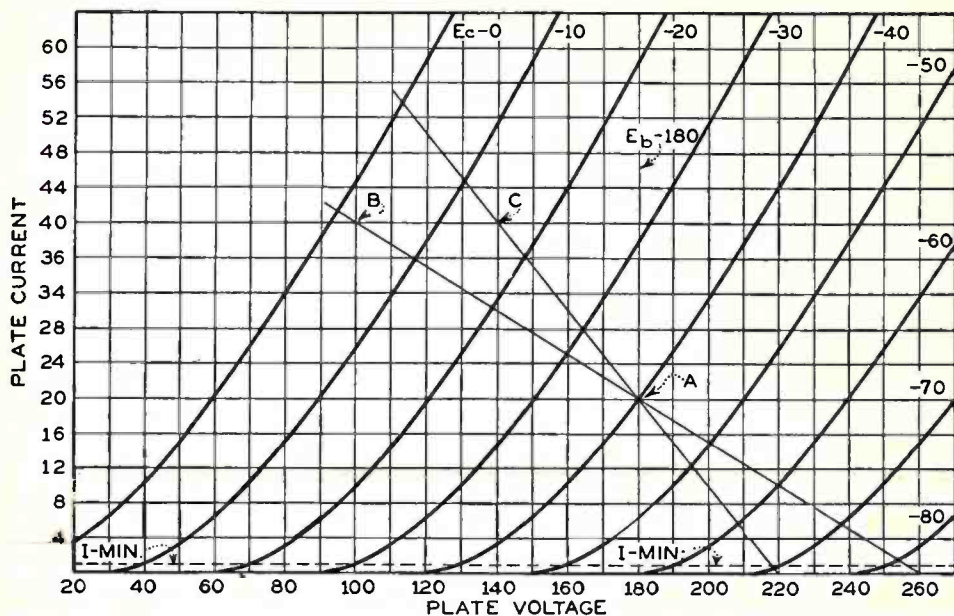

Fig. 8—Effect of varying load resistance.

(Continued from page 303)

were returned to one common point and this point was grounded to the outer case at one point. The point on the outer case also formed the ground connection.

Experimental models of the Adaptoron have been in actual use for some time operating standard a.c. sets in d.c. districts. They have functioned entirely satisfactorily. The line noise audible from the loud speaker has generally been much less with an a.c. set powered from the Adaptoron than from an ordinary standard d.c. receiver.

One of these units has been in continuous operation, except for short examination periods, in New York City since November 19, 1929. All components are in perfect condition and operation is more satisfactory now than originally.

The circuits shown are developments of the Ward Leonard Electric Co., Mount Vernon, New York, and are being produced under their patents and patent applications.

Undistorted Output vs Dynamic Range

THE DYNAMIC range in volume which a radio receiver can handle depends largely on the maximum undistorted power output from the power tubes, upon the minimum acoustic power output, and upon the efficiency of the loud speaker. In this sheet and the following some figures are given which serve to give some idea of the maximum undistorted power output required with loud speakers of various efficiencies for dynamic ranges of 20 to 60 db, all the figures being based on the assumption that the acoustic sound output from the loud speaker at minimum volume is 5 microwatts. Some relative idea of this power may be appreciated from the fact that the average power in speech is about 10 microwatts.

An example will clearly indicate the basis on which these figures were determined. Assume that the sound output power at minimum volume is to be 5 microwatts, that the loud speaker has an efficiency of 3 per cent., and that the ratio between maximum and minimum volume is 40 db, corresponding to 10,000 to 1 in power. If the minimum sound output is 5 microwatts then the power input to the loud speaker for minimum volume is equal to the sound output divided by the efficiency which gives 0.167 milliwatts input to the loud speaker.

If the ratio of maximum to minimum power is 10,000, then the maximum power input to the loud speaker must be 10,000 times 0.167 or 1670 milliwatts which is equal to 1.67 watts. The figures used in this example correspond to those given in the second line of the data on "Laboratory Sheet" No. 336.

As will be noted the table on the following sheet is worked out for loud speaker efficiencies of from 2 to 10 per cent, and for dynamic ranges of from 20 to 60 db. Each 10 db increase in dynamic range, of course, requires a ten-fold increase in the maximum power output from the receiver. The maximum power output required for any given dynamic range is an inverse function of the efficiency of the loud speaker so that doubling the efficiency halves the power output required. The maximum output requirements also depend naturally upon what sound output at minimum volume is decided upon. In the table 5 microwatts is assumed but, of course, if this level is cut in half the power output for maximum volume is also halved. The power outputs indicated under the columns 20, 30, 40, and 50 db are expressed in milliwatts. The power outputs under 60 db are expressed in watts.

Undistorted Output vs Dynamic Range

THE TABLE below serves to indicate what dynamic range in volume can be handled with a certain loud speaker efficiency and some definite value of acoustic power output at minimum volume.

The basis for the figures and a brief explanation of their meaning will be found on "Laboratory" Sheet No. 335. Note: The figures under columns 20, 30, 40, and 50 represent power output in milliwatts.

Efficiency of Loud Speaker	Power Output for Minimum Volume	Maximum power output in milliwatts required for a DB difference between minimum and maximum volume of				
		20	30	40	50	60
2 %	0.250	25	250	2500	25000	250 watts
3 %	0.167	16.7	167	1670	16700	167 "
4 %	0.125	12.5	125	1250	12500	125 "
5 %	0.100	10.0	100	1000	10000	100 "
8 %	0.062	6.2	62	620	6200	62 "
10 %	0.050	5.0	50	500	5000	50 "

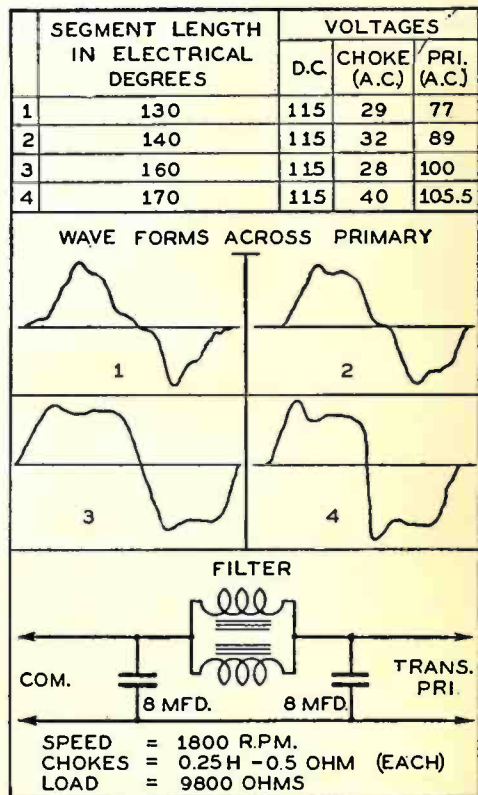

Fig. 9—Effect of changing segment length.



When they phone you . . . *“My radio set won't work”*

Be in a position to give the sort of service that makes friends and profits for your service department. Equipped with Sterling Testers, your service man goes out on the job, spots the trouble *instantly*, without fussing around; makes the necessary repairs and is back in your shop in half the usual time. One call—and you send out your bill to a satisfied customer. That's what Sterling Testers mean to you.

SERVICE TESTER

Sterling R522 All-Purpose Testers are neat, compact, efficient. In a handsome leather-grained case, weighing but 7½ pounds complete.

Simply plug in the tube sockets of the set. Instantly the meters register the filament and plate voltage, “C” bias and milliamperage drain, and definitely locate the trouble. Tests tubes, too—all types, including the new screen-grid tubes.

COUNTER TUBE TESTER

The Sterling R511 Tube Tester instantly shows the condition of every type of tube. Reactivates, too. It's small, good looking and never fails. No batteries. Simply plug it into the light socket to operate.

Write to Sterling of Cleveland for full information.

**R511
 Tube
 Tester**



**R522
 All-
 Purpose
 Tester**



LOWEST PRICE RELIABLE TESTING DEVICES ON THE MARKET

List Prices: Sterling All-Purpose Tester, \$67.50; Sterling R511 Tube Tester, \$35.00.
 Slightly more in the Far West and Canada. Liberal dealer discounts.

Sterling

THE STERLING MANUFACTURING COMPANY CLEVELAND, OHIO

MAKERS OF STERLING CONCERTONE RECEIVERS



Features of the Jewell 199

- 1 Makes every essential field test.
- 2 Endorsed by manufacturers and engineers.
- 3 Used by largest radio service organizations.
- 4 Simple to operate.
- 5 Backed by the most complete data service.
- 6 The most popular radio set analyzer.

Dealers' Price
\$73¹²
 List Price. \$97.50

Good Service Equipment Pays

It Is the Correct Foundation for Good Service

THE Jewell Pattern 199 Set Analyzer is built to the specifications of service men. It is a marvel of simplicity—easy to operate—yet it provides every essential test for checking receivers in service.

Instruments, switches, binding posts, panel, case, and plugs are of the best. The Jewell 199 is built to the highest standards throughout, yet it is the lowest priced complete radio service kit on the market.

The price of the Jewell Pattern 199 is so reasonable that no good service man can afford to be without it. In the hands of a good service man it quickly pays for itself many times over.

But the service man who does not have a 199 pays for it over and over again in wasted time, costly service, troublesome complaints, and loss of business due to dissatisfied customers.

Order a Jewell Pattern 199 from your jobber and pave the way to increased sales as well as service profits through the superior performance it provides.

THE Jewell Pattern 199 is backed by the most thorough and complete radio data service. Revised instructions books containing data on new sets are furnished the owners of Jewell Pattern 199's at frequent intervals. This data plus the Jewell Chart Method of Set Analysis takes the guesswork out of set servicing. That is why America's most successful sales and service organizations have adopted Jewell Set Analyzers.

FREE

To Service Men

The latest edition of the Jewell booklet, "Instructions for Servicing Radio Receivers" contains data on 139 of the most popular sets. Mail the coupon for your copy.



Jewell Electrical Instrument Company
 1642-H Walnut Street, Chicago, Illinois

Please mail free a copy of your Instruction and Data Book together with descriptive literature on Jewell Set Analyzers.

Name.....
 Address.....



30 YEARS MAKING GOOD INSTRUMENTS

JEWELL

199 Set Analyzer