

J A N U A R Y 1 9 3 0

RADIO BROADCAST

PUBLISHED FOR THE RADIO INDUSTRY



SPECIAL FEATURES IN THIS ISSUE

Stewart-Warner Test Methods

What Service Charges Are Fair?

A Review of Technical and Merchandising Progress in 1929

Engineering Review Sheets • Can Cabinet Resonance Be Avoided? • Considerations In Remote Control • RCA Model 21 •
What Radio Can Learn from Automotive Service Methods • Making Service Departments Pay • Directory of Price Changes

T H I R T Y F I V E C E N T S

DOUBLEDAY, DORAN & CO., INC. ♦ GARDEN CITY, NEW YORK

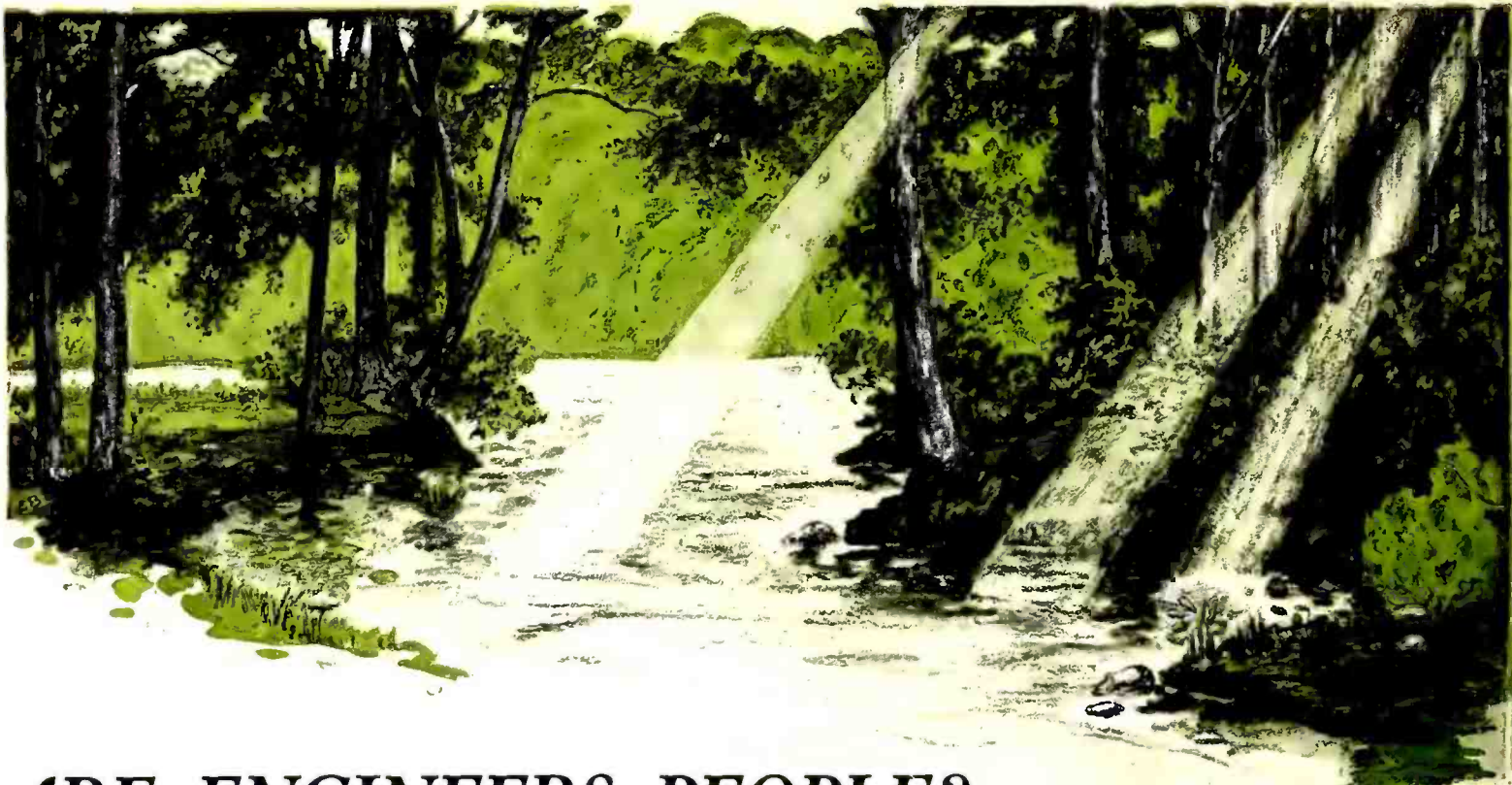

ARE ENGINEERS PEOPLE?

The engineer is supposed to be a hard boiled human with a slide rule mind—a man whose blood has become acid in arteries of lead. A suspecting man. A doubter.

We hope this may be at least partly true, for Sylvania Radio Tubes are winning and keeping the friendship of foremost technicians of the radio industry—without printed shoutings or extravagant arguments.

This much is certain—the nature of his job makes it impossible that an engineer should take any statement for granted—

Even the statement that the much more slowly made Sylvania Tubes are just a little better than the average.

There Is An Open Door To Any Open Mind.

SYLVANIA PRODUCTS COMPANY, Emporium, Penn.

The home of the Sylvania Foresters who are heard each week over WJZ, KDKA, KWK, KYW, WBZ, WBZA, WBT, WHAM, WJR, WLW, WREN, WRVA, KGRC, KPRC, WFAA, WFYR, WCCO, WHK.

Sylvania

RADIO TUBES

Licensed Under RCA Patents



W. R. Jones, Sales Engineer
Sylvania Products Co.
Emporium, Penna.

Mine is an open mind.
Name.....
Company.....

Position.....
Address.....
City and State.....

R.B.-1-30

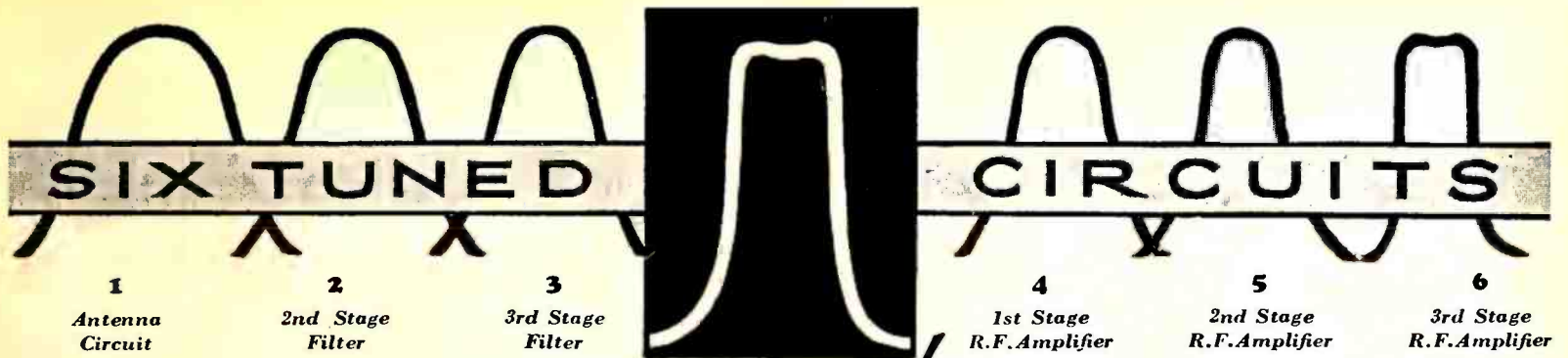

Tuned
BAND-FILTER
 FLAT-TOP - STRAIGHT-SIDE
10-KILOCYCLE SELECTIVITY

HAMMARLUND once again has put over a screen-grid, band-filter radio with six tuned circuits, so amazingly efficient that professional radio men by the score are building it for their own use.

The "HiQ-29" was a startling revelation, but in the words of Al. Jolson, "You ain't heard nothin' yet" like the "HiQ-30" performance—or the "HiQ-30" tone.

It is the only circuit that makes screen-grid tubes really do a day's work and the marvelous "HiQ-30" power amplifier with push-pull '45's takes all they can give it.

Pre-selected signals—ten-kilocycles apart—with no side-band cutting means *Selectivity* with a capital "S" and T-O-N-E that talks.

The easiest of all "HiQ's" to build too, with complete, factory-wired and tested units. No adjustments—no troubles. It percolates from the start.

A. C. or battery chassis fits standard cabinets, or your choice of nine special "HiQ-30" cabinets including phonograph combinations, \$139.50 to \$1175 complete, less tubes.

You should have a copy of the 48-page "HiQ-30" Manual. Price 25c. Use the coupon.

WORLD'S PREMIER **30** CUSTOM RADIO

Complete Factory-Built Units—Wired and Tested, ready to install.

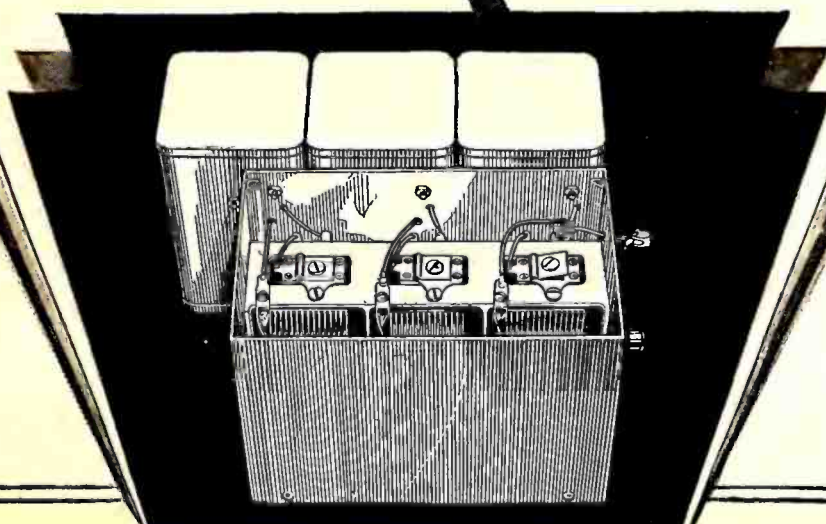

HAMMARLUND-ROBERTS, INC.
 Dept. RB 1,
 424-438 W. 33rd St., New York
 Enclosed 25c (stamps or coin)
 for HiQ-30 Manual.

Name

Address

RADIO BROADCAST

WILLIS KINGSLEY WING Editor
 KEITH HENNEY Director of the Laboratory
 HOWARD E. RHODES Technical Editor
 EDGAR H. FELIX Contributing Editor

VOL. XVI. NO. 3



PUBLISHED FOR THE RADIO INDUSTRY

Contents for January, 1930

Don't Give Service Away	129
What Happened in Radio in 1929?	
In Merchandising	Edgar H. Felix 130
In Engineering	Keith Henney 131
A Service Department That Pays	Harry P. Bridge 132
Tested Sales Ideas	Merchandising Kinks 134
Bringing Them in Your Store	Unusual Advertising
Band Wagon Advertises Radio	Tying-in With Sports
Boosting Tube Sales	Coöperate With Your Theatre
Another Angle on Service	136
Professionally Speaking	Keith Henney 138
What About Independent Service Men?	How the Industry Feels About Radio
Regarding Advertising Claims	
A Few Interesting Radio Pictures of the Month	139
A Modern Radio for the Country Home	140
The March of Radio	An Editorial Interpretation 142
Reaching the Mass Market	7 1/2-Kilocycle Channels Proposed
Cleared Channels Threatened Again	Station Distribution
New RCA-Victor Set Up	
A Radio Dealer's Tube Tester	James W. Blackwood 144
How We Look at Service Problems	Milton B. Hager 146
"Radio Broadcast's" Engineering Review Sheets	147
No. 27 Matching Impedances	No. 28. Electrons and Tube Testing
The Kinematic Remote Control	M. B. Sleeper 149
Clippings	What Radio Men Say 150
Strays From the Laboratory	Technical Shorts 151
A Novel Wavemeter	A "New" Recording System
An International Broadcaster	Two New Booklets
An Interesting Formula	
A Production Testing System	J. A. Callanan 152
Resonance and Reverberation	Howard E. Rhodes 154
The Tube Business	News of the Tube Industry 161
The Serviceman's Corner	164
A Symposium on Noise	A Useful Output Meter
"Radio Broadcast's" Set Data Sheets	168, 170, 172
Apex Model 36	The Majestic Model 90
Fada Models 10, 11, 30 and 31	The A.C. Dayton Navigator
A Reflex Vacuum Tube Voltmeter	173
News of the Radio Industry	174
General News	Financial Notes
Personal Notes	Production Notes
Distributors Appointed	Recent Patents
In the Radio Marketplace	Offerings of Manufacturers 180
Directory of Recent Price Changes	181
Radio Broadcast Laboratory Information Sheets	
Howard E. Rhodes 182, 184, 186	
No. 310. Factors Considered in Receiver Design	No. 314. Selectivity in Radio Receivers
No. 311. Effect of Reflections and Echos	No. 315. C-Bias Resistor Values
No. 312. Measurements of Sensitivity	No. 316. Range of Frequencies Required
No. 313. Fidelity in Radio Receivers	No. 317. Range of Frequencies Required
	No. 318. 60- and 120-cycle Hum Measurements

The contents of this magazine are indexed in *The Readers' Guide to Periodical Literature*, which is on file at all public libraries

. . . among other things

THIS MONTH, we give over this forum to a communication from the peripatetic Carl Dreher, who, having deserted the eastern seaboard, is now director of sound for RKO in Hollywood. Mr. Dreher, let it be said before we give him the floor, as author of "As the Broadcaster Sees It" was for many years a regular contributor to RADIO BROADCAST.

To The Editor:

Although I am now in the moving picture business, I still burn with solicitude for the poor broadcasters. For the Eastern members of the fraternity I have no fears; except for the irreparable loss which they sustained when I left their ranks, they seem to be getting on all right. But in the West I think the boys are headed for a bad time, aside from the stock market, gassy tubes, and their sweeties running around with fellows who don't have to work at night.

The California stations, I find, are laying on the advertising with a trowel. Not only that, but half of it is downright fraudulent. Maybe the listeners will continue to stand for it, but one day they may rise and throw receivers out of the windows by thousands. Then the poor ops will be out of their jobs.

Something had to be done and I have done it. By careful observation I discovered that the Coast announcers, while they recite the virtues of the local chiropractors, second-hand clothes shops, swamis, patent medicine dispensers, and other fakers, invariably use the word "folks" at least once in each sentence. I have accordingly invented a speech-operated, selective relay, known as the *folkstopper*. As soon as the announcer says "folks" it automatically opens the antenna circuit. After a ten-second interval, controlled by a dashpot, the circuit closes again, but if the announcer is still selling, "folks" shuts him off again.

The precise form to be taken by this latest wonder of science is unimportant. I don't bother with technical details. Mr. Grace, the lecturing vice president of the American Telephone and Telegraph Company, could design an efficient *folkstopper* in ten minutes. He has lots more intricate and less useful machines in his bag right now. Just give him the idea; and he'll elaborate on it.

You will probably object that as soon as the *folkstopper* gets into extensive use the announcers will stop saying "folks". That only shows you know nothing about California announcers. They can no more stop calling listeners "folks" than they can stop breathing.

Sincerely yours,
 CARL DREHER.

TERMS: \$4.00 a year; single copies 35 cents; All rights reserved. Copyright, 1929, in the United States, Newfoundland, Great Britain, Canada, and other countries by

DOUBLEDAY, DORAN & COMPANY, INC., Garden City, New York

MAGAZINES
 COUNTRY LIFE WORLD'S WORK THE AMERICAN HOME RADIO BROADCAST SHORT STORIES LE PETIT JOURNAL EL ECO WEST
 BOOK SHOPS (Books of all Publishers)

NEW YORK: <LORD & TAYLOR, JAMES MCCREERY & COMPANY, PENNSYLVANIA TERMINAL, 166 WEST 32ND ST., 848 MADISON AVE., 51 EAST 44TH STREET, 420, 526, and 819 LEXINGTON AVENUE, GRAND CENTRAL TERMINAL, 10 WALL STREET> ATLANTIC CITY: <2807 BOARDWALK> CHICAGO: <75 EAST ADAMS STREET> ST. LOUIS: <310 N. 8TH ST. and 4914 MARYLAND AVE.> CLEVELAND: <HIGBEE COMPANY> SPRINGFIELD, MASS.: <MEEKINS, PACKARD & WHEAT.

OFFICES

GARDEN CITY, N. Y. NEW YORK: 244 MADISON AVENUE. BOSTON: PARK SQUARE BUILDING. CHICAGO: PEOPLES GAS BUILDING. SANTA BARBARA, CAL. LONDON: WM. HEINEMANN, LTD. TORONTO: DOUBLEDAY, DORAN & GUNDEY, LTD.

OFFICERS

F. N. DOUBLEDAY, Chairman of the Board; NELSON DOUBLEDAY, President; GEORGE H. DORAN, Vice-President; RUSSELL DOUBLEDAY, Secretary; JOHN J. HESSIAN, Treasurer; LILLIAN A. COMSTOCK, Ass't Secretary; L. J. McNAUGHTON, Ass't Treasurer

LET RCA INSTITUTES START YOU ON THE ROAD TO . . . SUCCESS IN RADIO

Radio needs you . . . That's why the entire Radio industry is calling for trained men . . . That's why thousands of men who answered these advertisements are now earning from \$2,000 and up a year. Radio is thrilling work . . . easy hours, too, vacations with pay and a chance to see the world. Manufacturers and broadcasting stations are now eagerly seeking trained RCA men . . . Aviation and radio in the movies also provide innumerable opportunities . . . Millions of sets need servicing . . . thousands of ships require experienced operators . . . Never before was there an opportunity like this.

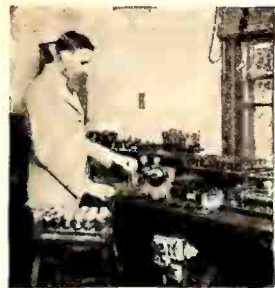

Radio Mechanic and Inspector \$1800 to \$4000 a Year.

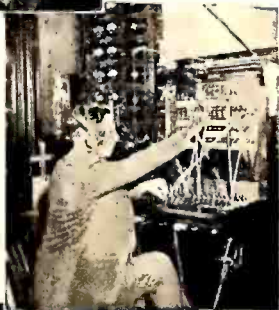

Broadcast Station Mechanic \$1800 to \$3600 a Year.



Land Station Operator \$1800 to \$4000 a Year.



Broadcast Operators \$1800 to \$4800 a Year.

has the experience, the ability and the confidence to hold a big-money Radio job.

Graduates of RCA Institutes Find It Easier to Get Good Jobs

They are closest to the source of Radio's greatest achievements because the progress of Radio is measured by the accomplishments of the great engineers in the huge research laboratories of the Radio Corporation of America.

Students of RCA Institutes get first-hand knowledge, get it quickly and get it complete. Success in Radio depends upon training and that's the training you get with RCA Institutes. That's why every graduate who desired a position has been able to get one . . . That's why graduates are always in big demand.

Study Radio at the Oldest and Largest Commercial Training Organization in the World

Send for our Free Book . . . or step in at one of our resident schools and see how thousands of men are already on the road to success in Radio. Remember that you, too, can be successful . . . can speed up your earning capacity . . . can earn more money in Radio than you ever earned before. The man who trains today will hold down the big-money Radio job of the future. Come in and get our free book or send for it by mail. Everything you want to know about Radio. 40 fascinating pages packed with pictures and descriptions of the brilliant opportunities in this gigantic, world-wide money-making profession.

See for yourself why graduates of RCA Institutes now occupy thousands of well-paid positions. These positions are usually available in from 3 to 10 days after graduation for men who can qualify. RCA Institutes will back you up to the limit. Our catalogue is yours free . . . SEND FOR IT TODAY!

This is the Only Course Sponsored by Radio Corporation of America

RCA sets the standards for the entire Radio industry . . . The RCA Institutes' Home Laboratory Training Course enables you to quickly learn all the secrets of Radio . . . In your spare time, in only an hour or so a day, you can obtain a thorough, practical education in Radio . . . You get the inside information, too, because you study right at the source of all the latest, up-to-the-minute developments. RCA, the world's largest Radio organization sponsors every single detail in this course.

You learn Radio by actual experience with the remarkable outlay of apparatus given to every student. You learn the "How" as well as the "Why" of every Radio problem, such as repairing, installing and servicing fine sets. That's why every graduate of RCA Institutes

For the added convenience of students who prefer a Resident Study Course, RCA Institutes, Inc., has established Resident Schools in the following cities:

- New York 326 Broadway
- Boston, Mass. 899 Boylston St.
- Philadelphia, Pa. 1211 Chestnut St.
- Baltimore, Md. 1215 North Charles St.
- Newark, N. J. 560 Broad St.

Graduates of both the Home Laboratory Training Course and the Resident Schools receive exactly the same training and enjoy the same privileges so far as jobs and salaries are concerned. And every Home Study graduate may also attend any one of our resident schools for post-graduate instruction at no extra charge.

Clip this Coupon NOW!

RCA INSTITUTES, INC.

Formerly Radio Institute of America

SPONSORED BY



RCA INSTITUTES, Inc.
Dept. RB-1, 326 Broadway, New York, N. Y.

Gentlemen: Please send me your FREE 40-page book which illustrates the brilliant opportunities in Radio and describes your laboratory-method of instruction at home!

Name

Address



YOU ARE WANTED

at the

Fourth Annual Convention

of the

National Federation of Radio Associations

and the

Radio Wholesalers Association

at the

Hotel Statler ☪ Cleveland, Ohio

February 10 and 11, 1930



THIS INVITATION

is extended to all Individual Radio Dealers, Wholesalers, Manufacturers, Broadcasters and the Press, as well as to all State and Territorial Radio Trade Associations.

THIS WILL BE

a "down-to-facts" convention that will get at the vital problems of our industry. Retailers and Wholesalers will all have their round-table sessions at which problems pertinent to the group concerned will be discussed.

THE MEN WHO SET THE PACE

the very leaders of our industry will all be there. Do not miss this opportunity to meet them "man-to-man" and talk it over.



This space donated through the courtesy of Radio Broadcast

DON'T GIVE SERVICE AWAY

HOW MUCH is good service worth? What will the customer pay? These are questions which are not yet solved by the radio trade. Service charges vary from \$1.00 an hour to \$2.50 or \$3.00, and so does the quality of the work. The quality may always vary, but collecting a fair price for service rendered will do much to improve service, stability, and profits of all radio dealers.

Out of the experience of the trade in service matters, acquired by inexorable experience, some degree of standardization of methods, charges, accounting, and general administration is developing. Service workers tinker less with sets in the customers' living rooms and solve problems presented by balky sets more and more in well-equipped service laboratories. Here and there, far-seeing dealers and servicemen are practising—to their eternal success—the undeniably successful plan of increasing their business by answering customer-demands promptly, and by keeping to the letter every promise they make. Where a service clinetetele is treated in this fashion one hears little complaint that "service work doesn't pay." Customers will pay for good service, but before they pay, good service must be given.

Few customers in search of service shop around here and there to get their maintenance or repair work done at bargain prices. Yet many dealers and independent servicemen are giving service—literally giving it—at bargain prices. In this situation, both customer and dealer suffer. Is there any guide to which dealers and servicemen can turn? We think there is in the Suggested Code of Business Practices for Radio Dealers, issued by the National Federation of Radio Associations.

The sections of this Code relating primarily to service work suggest that the dealer's free service be limited to sixty days, or after a limited number of calls specified at the time of sale. After the free-service period, not less than \$2.00 per hour should be charged for service required. A standard charge for antenna erection and installation is suggested. The recommendations in full follow:

Limiting Free Service. No free service to be rendered after 60 days, or after a

New Code of Business Practice, if Followed, Will Help Dealers in Making Service Calls Pay.

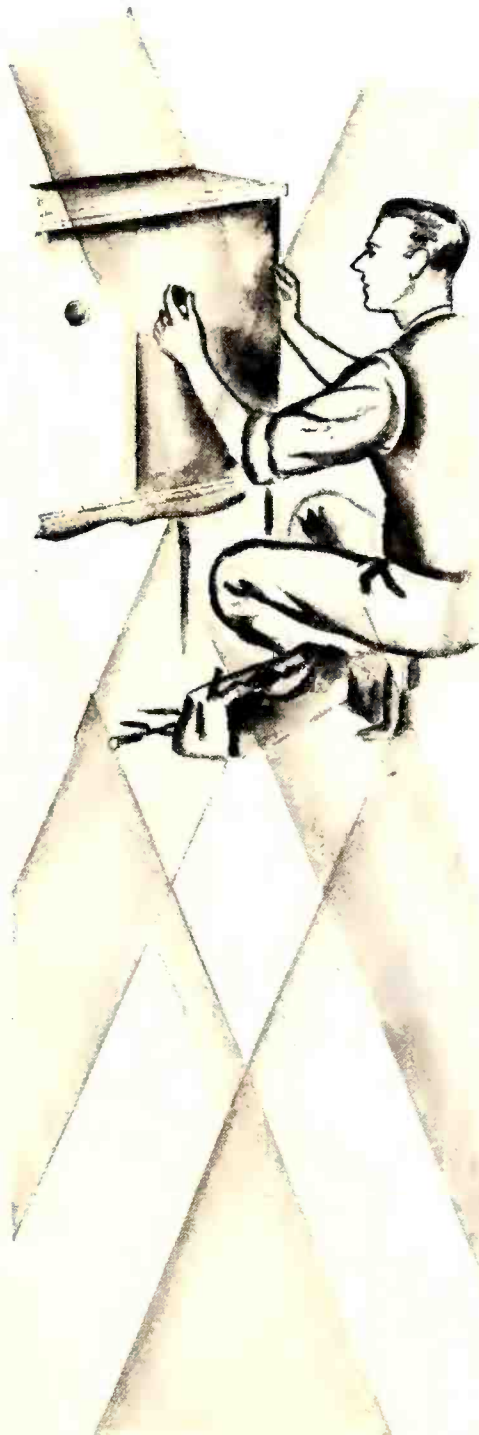

certain number of calls specified at the time of sale. In case of defective parts in the radio receivers after the 60-day free-service period, if the manufacturer's warranty covers free replacement and if the instrument has not been tampered with, the dealer should replace these parts, charging only for the labor involved.

Minimum Service Charge. If the free-service period has expired, a minimum service charge of \$2 should be made. If the call is of half-hour, or more duration, a specified rate per hour, plus cost of material should be charged.

Antenna Installations. If an outside antenna must be put up when a set is installed, a charge of \$7.50 should be made to meet the cost of labor and materials. If an inside antenna must be put up when the set is installed, a charge of \$5 should be made to meet the cost of labor and materials. If no antenna is necessary, but ground connections, lead-ins, etc., must be checked, at least \$2 should be charged to meet the cost of labor.

Advertising Policy. Truth in advertising must be observed to preserve the good reputation of the individual dealer and the entire trade. The code of ethics of the National Better Business Bureau on radio advertising should be followed.

Servicemen who are independent, or dealers with service departments may see some reason for service practices in their own cases different from those suggested. However, we believe that the practices and charges suggested by the Federation are the lowest, the very minimum with which the dealer or serviceman can be content if he desires to render real service and stay in the business at a profit.

Other items in the Suggested Code of the Federation follow:

Home Demonstrations. Prospective customers should be allowed a free trial or home demonstration for forty-eight hours.

Time Payments. An adequate interest charge should be made on all time-payment contracts and contracts should not extend beyond one year. These are standard practices in all other forms of time-payment selling.

Allowance for Trade-Ins. Considering the advertised list price as the cash price, the allowance on instruments offered for trade-in should be based only on their fair cash market value. This applies to the receiving set only, and does not cover tubes, batteries, and other accessories.

Many articles in past issues of this magazine have treated the question of good service at fair prices and a list of these articles will be sent to any reader requesting it.—THE EDITOR

WHAT HAPPENED

By EDGAR H. FELIX

MERCHANDISING



UNLIKE every other industry of equal magnitude, radio cannot report attaining any outstanding success during 1929, either through unusual and aggressive merchandising methods or the exploitation of a new engineering principle or invention, the reorganization of a major unit by consolidation or financial expansion, or the impelling influence of genius in executive management. Nor can the radio industry chronicle a new or difficult merchandising situation faced, met, or overcome, a colossal merger, or a great failure.

The large producers have maintained their relative positions but greatly increased their manufacturing facilities. Only one new name of consequence appears, Radio-Victor. It arrived there entirely by conventional methods, an advertising campaign of superlatives and the exploitation of a technical mystery word for dealers to conjure with. Without the accumulated good will behind the name Victor, it is doubtful whether the sales-promotion plan would have attracted any great attention.

New Developments? The industry cannot boast of any departures from the conventional console. In previous years, a leader has stood forth whose product was slavishly copied by the entire industry. This year, the industry is thrown into confusion because there is no outstanding success to copy. Where is the clarion call to sales around which a cheering public shall rally? Remote control? Automatic tuning? Condenser speakers? None of these have excited the public.

Screen-Grid Radio: If we analyze the dominant sales point for the year 1929—screen-grid radio—it is easy to determine why it failed to bring an enthusiastic response. Screen grid is merely accepted; it has not made obsolete previous production as did the appeals of other seasons, such as a.c. operation, electrodynamic loud speakers, power output tubes, and single-control radio sets.

The outstanding capability of the screen-grid tube is its potentially greater amplification. The consumer expected tremendously greater sensitivity or else the previously accepted standard of sensitivity with less tubes and at much lower cost. But the gain in sensitivity has been almost imperceptible because noise level limitations make it a disadvantage rather than an advantage. Nor have substantially cheaper sets using less tubes appeared. Instead, the customer must pay just as much as before and use just as many tubes, more expensive tubes at that.

Price cuts: The failure of the industry to confer any substantial benefit through technical progress or reduced prices has resulted in a failure to absorb the greatly increased production capacity of the leaders in the industry. Faced with overproduction, the industry has wisely adopted a widespread series of price cuts, led by Atwater Kent, Majestic, R. C. A., Kellogg, and Colonial. Some financial writers attributed these price cuts to fear of reduced luxury purchases as a result of the stock market debacle but this conclusion is entirely erroneous. The price cuts were decided upon before the big break by failure of the industry to enlarge its service to the public.

A trend toward lower prices is bound to broaden the radio market. As radio reaches into lower and larger market levels, economy of maintenance becomes increasingly important. This may force the production of sets of greater efficiency to sell at \$50 and \$60, approximating the performance of sets now selling for \$125. Such sets may use but a single stage of screen-grid, radio-frequency amplification and a single output tube. Only with such sets available will the radio industry sell more units than the automotive industry.

Novelty appeal: In the attempt to find a new appeal with which to sweep the market, many expedients were tried. Most were obvious clap-trap which have as much appeal as an automatic wiper for the bathroom mirror. The public has not found turning a dial to a desired setting, the correctness of which is easily checked by ear, such a trying operation that a mechanism of adjustable buttons, locking clamps, and flashing lights is anything to excite its enthusiasm. The public has recognized so-called automatic tuning of 1929 as the invention of despairing sales managers.

Remote-Control Tuning: This has possibilities, but the entire conception of radio installation must be modified before it means anything to the public. Dealers report that the public estimate of remote control is that it is a \$300 device enabling particularly

lazy persons to press buttons at the end of a six-foot cord rather than to reach for the tuning knob.

We are only at the beginning of this development. It will be a different story when remote control is intelligently merchandised. An enterprising manufacturer will have vision enough to market a complete radio installation: four to six remote-control points spread conveniently throughout the home—in living room, dining room, kitchen, and master bedroom—a compact metal chassis to be installed in cellar

(Concluded on page 16?)

The Radio Year Just Closed Was Notable Not so Much for any Large Accomplishments Either in Engineering or in Sales as for Steady Progress in Many Small Ways. There Were Mistakes, Advances, and Shortcomings. But the Year Bubbled with Action. These Articles Weigh the Twelvemonth Interestingly. On this Page Edgar H. Felix Considers Conditions from the Merchandising Viewpoint and on the Facing Page Keith Henney Reviews the Engineering Progress of the Past Year.

IN RADIO IN 1929?

By KEITH HENNEY

ENGINEERING

ENGINEERING advance in 1929 centers around the development and introduction of new tubes. The most important of these is the a.c. screen-grid tube; others are the humless-heater and quick-heater types; finally the 245-type tube which has already been adopted by the industry.

The advantages of the screen-grid tube are two, greater inherent stability, and greater inherent amplification. Strangely enough neither of these advantages, nor the two together, is sufficient to produce an entirely new type of set or to make new receivers incomparably better than old. Before the introduction of the new tubes there were stable, high-gain, neutralized receivers.

Screen Grid Sets: The advantages of these sets lie in other directions than in greater sensitivity and stability. The by-products of the new tube are more important than the chief *raison d'être*. These by-products of the screen-grid tube were discovered; not thought out in advance.

The greater stage gain of the tube led some to believe a radio set could be made with less stages of amplification than was possible in 1928. Unfortunately just as many stages were required for selectivity's sake, and so the r.f. amplifier of 1929 has at least two screen-grid tubes, just as the 1928 set had at least two stages employing 227-type or equivalent tubes. This made a set which had much greater overall amplification than the set of previous years, but this amplification was not necessary; receivers already went down to the noise level in the average locality. And so some manufacturers reduced the a. f. amplification — and gained considerably thereby.

Low Hum: The receiver with one stage of a.f. needs less care in design to prevent undue hum. This is probably the greatest single advantage of the high gain r. f. amplifier—it makes possible a humless receiver which has good low-frequency response. Here it must be said that receivers with but a single a.f. stage (and hence a "power detector") were in use before the advent of screen-grid tubes, but not in general use in standard radio circuits.

Circuit Changes: This single a.f. stage and a high-gain r.f. amplifier made other changes in design which are advantageous. The volume control in some sets, for example, may now be made to operate on the a.f. end of the circuit so that when the volume is down, the hum is down too. Thus the ratio between signal and hum is constant and does not decrease when the volume is turned down as in the older sets where all the volume control was in the r.f. amplifier.

Screen-grid receivers may be somewhat more selective than

triode sets with the same number of stages. However, these receivers are still not selective enough, or rather, they are not selective in the proper manner. They are too sharp at 5 kc. off resonance, too broad at 10 kc. off resonance.

In some sets sensitivity has been sacrificed in favor of reducing the cost of shielding; in some sets the newer tubes have been used for benefit of the sales department, or for some mechanical reason.

Linear Detectors: High-output r. f. amplifiers have required detectors with a high overload limit. Such detectors have some portion at least of their characteristic which is linear, the advantage being less distortion on high modulation and somewhat greater selectivity. More research is necessary either to make truly linear detectors or to extend the range over which the detection is linear, or to develop new detectors which are more linear or more efficient.

Power: The 245 tube in pushpull makes possible a power output of about 3 watts which is sufficient for the average home. Some users require more power output and can get it from the few sets which use 250-type tubes in push pull. It is probable that power output will not change greatly in 1930. It may be secured somewhat more efficiently by the use of new tubes but it will not be lowered—unless vastly more sensitive loud speakers make their appearance—and power output need not be appreciably increased.

The new heater type of tube which does not crackle or hum is a distinct advantage; the quick heater is an advance provided life, or freedom from noise, or both, are not sacrificed. At present the 5–10-second tube seems a good compromise between all the essential and desired characteristics.

Volume Control: This year saw two developments in volume control, the local-distance switch which changed the sensitivity of

the receiver in a big jump, say 40 to 1 in voltage, and the variable type which reduces the coupling or gain to the antenna at the same time the sensitivity of the receiver is decreased. Either of these seems satisfactory but those which vary the coupling alone or the sensitivity alone are not generally satisfactory due to cross talk, overloading, etc.

Greater use of the automatic volume control circuits was evidenced during the year. A control of about 300 to 1 in voltage due to automatic control, and a 40-to-1 control due a

(Concluded on page 162)



Behind the scenes of

A SERVICE

By HARRY P. BRIDGE, JR.

Two points of particular interest stand out in connection with the generally interesting service department of the Universal Radio Corporation, Juniper and Arch Sts. Philadelphia, Penn. In the first place, this department has shown a profit from the start. Secondly, it has been largely divorced from the store proper as a means of putting it "on its own" to rise or fall according to its merit.

To an outsider, these facts might hold little or no significance. "Just good business," he might say and let it go at that. To one initiated into the mysteries of selling radio at retail, however, a glance behind the scenes might prove both interesting and enlightening. He has probably seen all too many service departments operating at a loss. And he has probably known many more stores where this work is regarded as a necessary evil—a mere sideline to the main issue which is the sale of new sets.

In the Universal Radio Corporation, the service department is *not* a sideline. Service Manager C. A. McCrork has been charged with the production of a worth-while profit on his regular service work and has come through with flying colors. To him, and to those who work with him, the service department is a bread-and-butter business. No sidelines, no sidestepping the issue which is so plainly told in red or black figures on the ledgers. In this organization it is the work of the sales department to produce sales. The work of the servicemen lies in keeping customers satisfied and, equally important, in proving their department's right to existence where only the fees collected from the service work can be taken into consideration in computing profit or loss.

Separated From Sales Department

Housed in the basement of the company's retail store, the service department's records are kept separate and distinct. The work of servicing sales free of charge for 90 days is regarded as part of the department's expense of doing business.

C. A. McCrork says—

Keep Service Records Separate and Distinct

Make 24-Hour Service Your Rule

Do All Work on a Cash Basis

Make Definite Appointments for all Outside Calls

Charge a Minimum of \$2.00 for Every Outside Call

Employ Men Who Will Provide Their Own Cars, Tools, and Test Sets

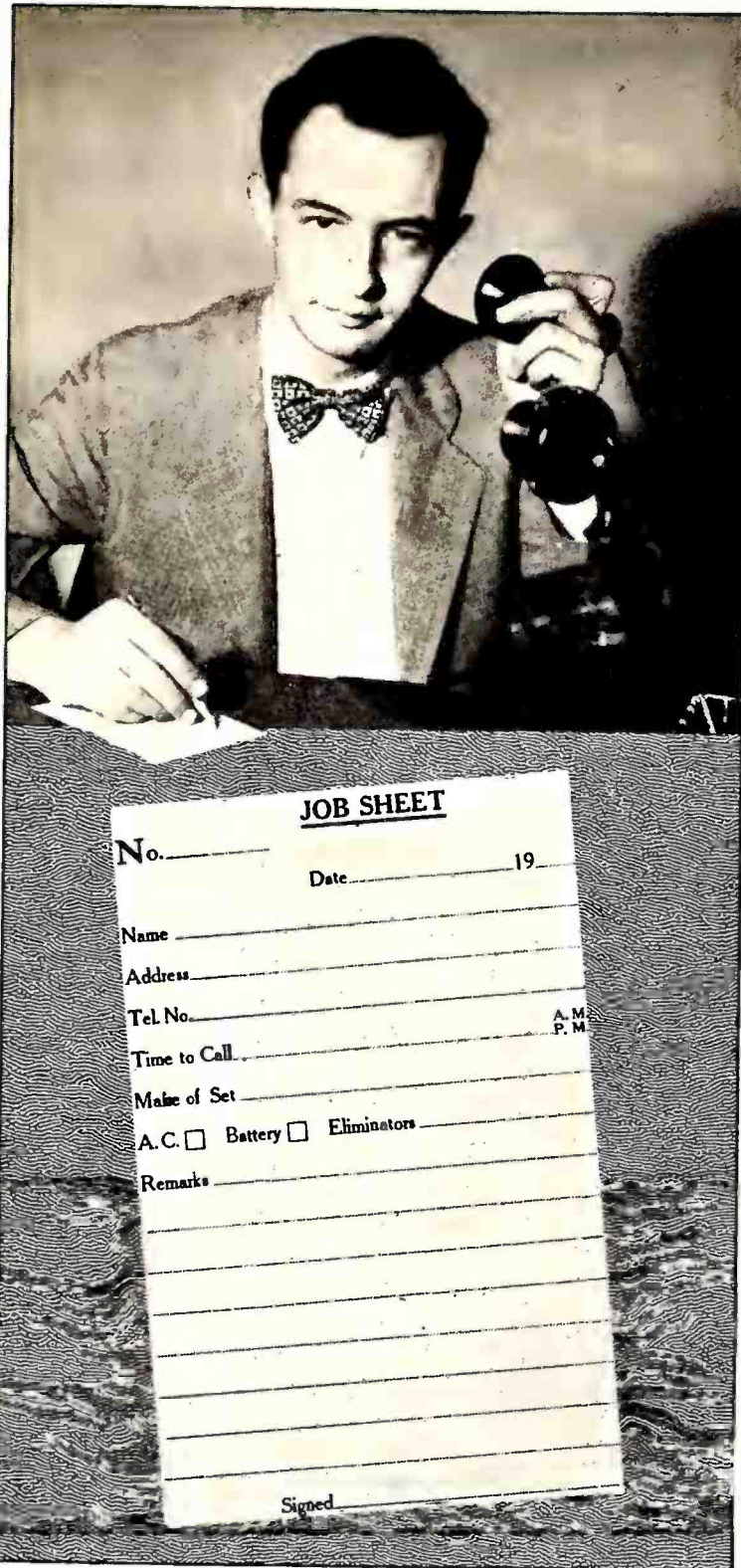

UNIVERSAL RADIO CORPORATION 1321 ARCH STREET PHILADELPHIA, PA.					No. 1450	
NAME				DATE		
ADDRESS				PHONE		
Set				Work to be done		
TYPE	CONDITION OF	REPAIRED OR REPLACED	PRICE			
Tubes						
Batts "A"						
" " "B"						
" " "C"						
Elim A			ACCESSORIES			
" B			LABOR			
Speaker			TOTAL			
Ant.			Terms	Charge to		
Gnd.						
REMARKS.						
We Shall Consider Work Satisfactory, Unless Notified to the Contrary Within Two (2) Days						

DEPARTMENT THAT PAYS

Out-and-out service calls are relied on to produce a regular profit—and do.

“Service is the Supreme Commitment of Life” reads an inscription which hangs near Mr. McCrork’s desk. Everything possible is done to sink the significance of this motto into the minds of those connected with the department.

“When a radio goes bad, the person who calls wants service—not a promise,” says Mr. McCrork. “Consequently, when we say a man will be there to fix it at such and such a time, we mean exactly what we say. ‘Service’ is a much abused word, but we’re working hard to give it a real meaning as far as this business is concerned.”

Universal service rates are \$2 an hour with this figure also representing the minimum. Charges are figured from the time the man starts for the job until he is ready to go on to the next one. There are no charge accounts in this service department, collections being made by the men when sets are repaired in the home. If it is necessary to bring an outfit to the shop, it is repaired with equal promptness and delivered C. O. D.

Not only has this system done away with a great deal of bookkeeping, but it has also eliminated annoying losses from bad accounts. The serviceman gives the customer a receipt and turns the money with his report on the job over to the cashier at the store. Then, to provide a check on the transaction, a card thanking the customer and expressing the company’s wish that the work prove satisfactory is mailed from the office. The amount paid is mentioned on each card.

Twenty-four-hour service is an invariable rule with Universal. Servicemen are required to have their own automobiles, the operating expenses of which are paid by the company. Philadelphia covers a vast expanse and quick trans-

portation is essential to the economical conduct of the work. The increased cost of having men use automobiles has been more than made up by the greater number of calls they are able to make.

How Jobs are Handled

When a service call comes in, it is registered on a job sheet which immediately goes to Mr. McCrork. In addition to the customary name and address, the girl at the phone desk gets the customer to set a time when it will be convenient to have the serviceman call. She also gets the customer’s full name, address, and telephone number, and the make and type of set to be repaired.

As far as possible, service work is routed. Calls are grouped according to the various sections of the city. In selecting his men, Mr. McCrork endeavors to get men who live in different districts. Thus, in many cases, it is not necessary for the men to come into the store in the morning and in doing so go many miles out of their way. A man may be given his route sheet the night before and instructed to go directly to the first job in the morning. Then, to round out this system, each man is required to report via telephone at least four times during the day. He tells the operator where he is and is given any additional calls from that territory which may have come in since he has left. Under this method surprisingly prompt service can readily be made the rule rather than the exception.

If a serviceman gets behind on his schedule—and this is sometimes unavoidable—he is required to call those whose sets are still to be repaired and inform them of the fact. He tells them just when he will be there and if they will not be at home at the time, he makes another definite appointment at their convenience. If the delay promises to prove inconvenient to the customer, the original date is kept by the simple expedient of sending a man out from the store in

(Concluded on page 183)

A view of the test bench in the service department of the Universal Radio Corporation, Philadelphia, Penn.

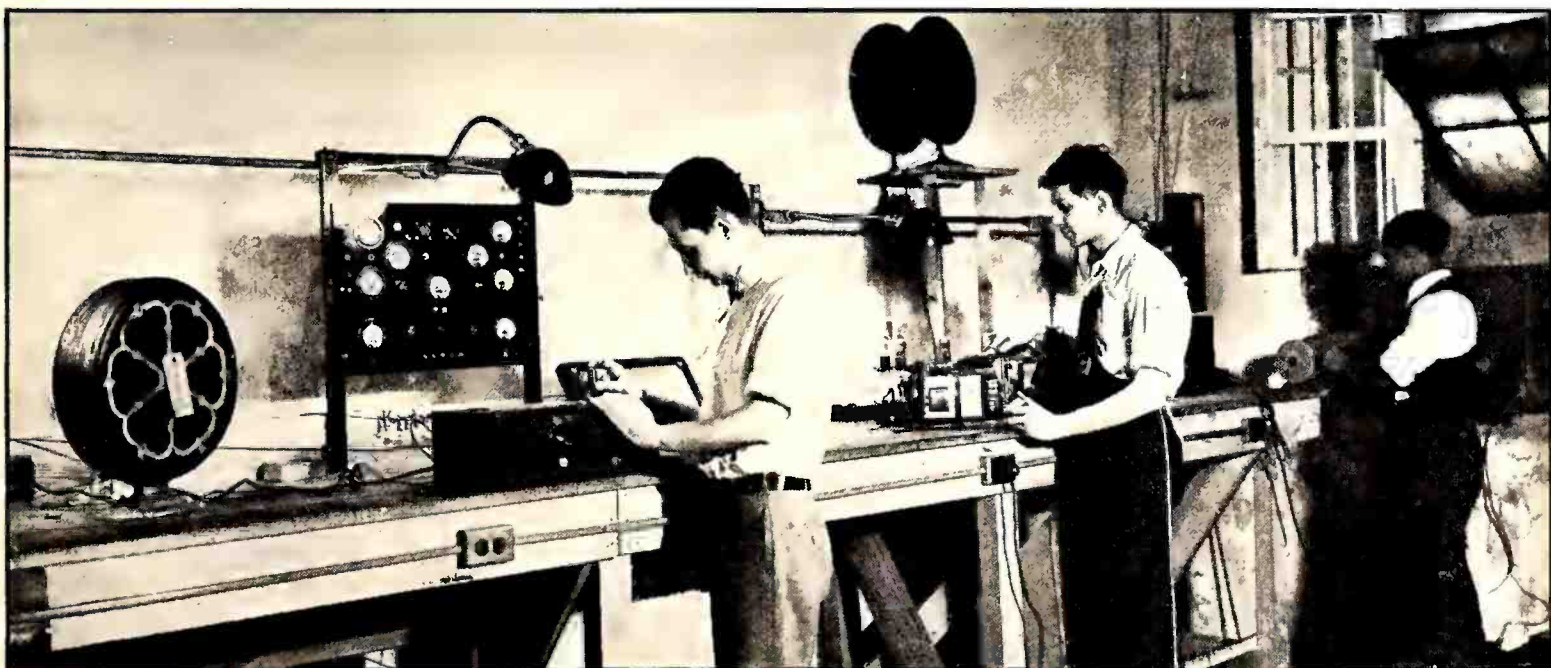

TESTED SALES IDEAS

Bring Them in Your Store

DO THE dulcet strains of your finest radio set fail to halt the crowds passing your windows on the way to your competitor's? Is your display equal to, if not superior to his, and are your prices cheaper? Is the trade his because of earlier establishment in the neighborhood?

Well, if any of these conditions apply, there is another way to cause people to stop at your window. You can even do more than that—you can make them enter your doorway, and perhaps buy. This is how to do it: *install a free scale in your doorway.*

Now let's see how the plan works. Everyone likes to get weighed. Scales are scattered along the streets of every city, in waiting rooms, in theatre lobbies, etc., and you'll always find somebody patronizing them. Few can resist a scale.

Why not capitalize on this desire? A store in Philadelphia adopted this method of advertising with the result that approximately 100 persons per hour enter their doorway to be weighed. And before they get on the scales, while they are on it, or before they get off they gaze around and discover the windows, which is the desired result.

LEO I. MOONEY, Philadelphia, Penn.

Band Wagon Advertises Radio

We have prepared for display purposes a rather unusual truck which we have christened "The Fada Band Wagon." This truck has been especially built to carry around our territory a complete display of radio apparatus and accessories of interest to the radio dealer. It is so constructed that the back unfolds, thereby providing a stairway which makes easy access to the display. The right side of the truck also unfolds, thus presenting to view a full-size room in which a complete line of receivers is on display.

With this equipment we are able to demonstrate the merits of each receiver for the dealer as the truck is completely wired and each receiver is connected. Power for the receivers is obtained with the aid of a long extension cord. We plan to use the truck exclusively for demonstrating Fada receivers to dealers in our territory.

C. C. BAINES, manager, Radio Department,
Peaslee-Gaulbert Company, Louisville, Ky.

Boosting Tube Sales

Mr. Boyd, manager of the Baldwin Piano Company, Indianapolis, Ind., is a man who knows human nature. He knows that the best way to remind and impress people is to show them; and that they will feel the urge to buy if buying

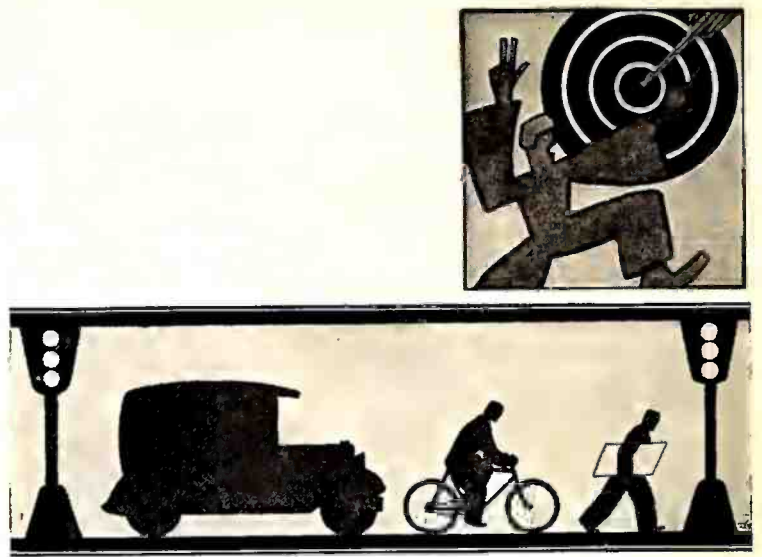

Each Month These Pages Serve as Our Clearing House for Merchandising Ideas of Proved Value. Every Radio Dealer Should Read Them Carefully

is made easy. If they see a product prominently and attractively displayed, they are reminded of a possible need. Otherwise they wait until the force of necessity makes them buy, and then possibly they buy elsewhere.

By placing these theories in practice and concentrating on tubes Mr. Boyd has been successful in selling \$1000 worth of radio tubes a month. This is how he did it. Mr. Boyd realized that radio tubes are constantly in demand and he decided to install a special tube counter near the front entrance of his store so that people coming in for other merchandise might see it. It was fully equipped with testing apparatus, display material, and a substantial stock. Tubes could be tested and bought quickly and in this manner a source of profits that had previously been untapped began to roll in. In addition, a campaign was mailed to radio owners throughout the city and this brought additional prospects to the store.

Unusual Advertising

In Del Ray, Calif., a small town having a population of only 110, there is a very unusual radio dealer. This dealer, Ira Fautz, sells Atwater Kent receivers exclusively and uses very novel advertising and merchandising





\$5.00 FOR YOUR PET SALES IDEA

methods to promote his business. The standing offer which he has made to the people of his town is that he will accept anything from raisins up to a ranch in exchange for a new radio receiver, providing the exchange does not exceed 40 per cent. of the cost of the set.

Fautz writes his own advertising copy and much of it is quite individualistic and unusual to say the least. He makes free use of similes and out-of-the-ordinary selling arguments. Here is a sample paragraph or so from one of his bulletins:

"We are continuing our special proposition—60 per cent. cash and balance in trade, if suitable.

"Wanted: Household furniture, roofing, bookcase, fencing, rugs, sewing machine, fan, poultry, livestock, etc. What have you?"

"See us for tubes, batteries, supplies, service calls, and repairs at reasonable rates. Ask for a demonstration on the Atwater Kent Screen-Grid Sets. Buy now and get all winter programs.

"Trade your raisins for a Radio!"

Tying-in With Sports

F. A. Tomlin, owner of the Tomlin Battery and Radio Shop, Havana, Ill., estimates that he attracted thousands of dollars worth of prospective sales by a publicity stunt which cost him exactly 34 cents. In this particular case the stunt was a tie-in with the World's Series, but the same plan could be followed during any important broadcast.

Mr. Tomlin equipped the store's delivery truck with a popular-priced screen-grid receiver and parked in the business district of his city every afternoon during the World's Series. Using two fishing poles as a support for the aerial and an electrodynamic loud speaker in a large baffleboard at the rear of the truck, radio programs could be heard at a distance of two blocks away. As a result thousands of people stopped to listen to the exciting games.

The cost of the whole publicity stunt was only the expense involved in buying cloth to make a display sign advertising the receiver used in the demonstration.

Coöperate With Your Theatre

The following idea which has repeatedly been carried out successfully and which will yield any alert dealer plenty of sales. It is not merely an experiment but has paid several dealers satisfactorily. All you need to do is to go to your local theatre manager and offer one of your receiving sets as a lucky prize. The manager will be only too glad to do this as it will increase his own business as well as yours. The

set is put in view in the lobby of the theatre for about a week before it is given away. Over the set is placed a placard giving the name of the dealer etc.

With every ticket sold at the theatre the patron receives a card. The stub of this card is filled out with the patron's name and address and a brief description of his radio and is dropped into the box. These stubs, after the lucky one has been picked out the night the set is given away, are saved.

On the half of the card retained by the patron it states that a discount of \$10.00 or so will be allowed on any set purchased within a given time. There are many people who do not own sets who will take advantage of this offer.

The stubs containing the names and addresses of the theatre goers are saved by the theatre for the dealer. In most cases there will be several thousand of these and they will be found to contain the names of hundreds of prospective customers. If the persons who do not own sets or who possess battery-operated models can not be personally interviewed by the dealer a personal letter should be sent describing his line of sets and the discount.

By sacrificing one set the dealer will be able to close a great many sales and will gain in the end.

EDWARD V. PIRANIAN,
Philadelphia, Penn.

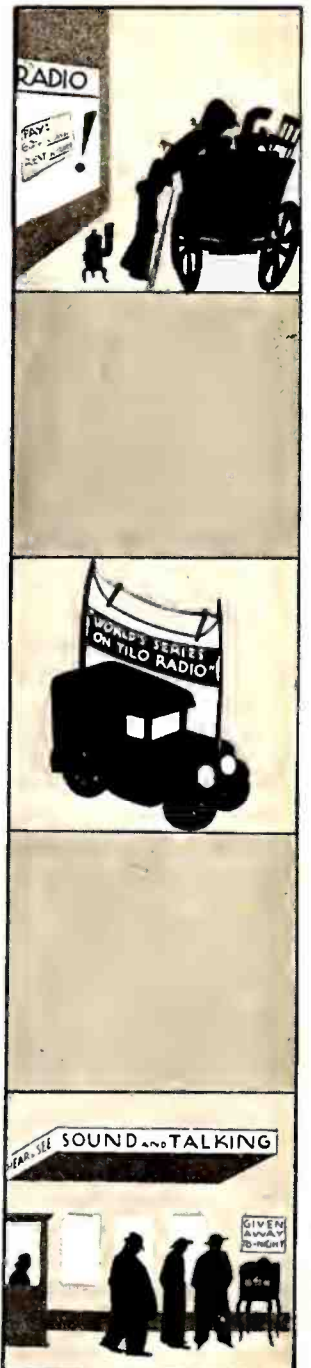

ANOTHER ANGLE ON SERVICE

*Ten Years Ago the Automotive Industry
Faced a Service Problem Similar to Ours.
The Way in Which These Difficulties Were
Overcome Should Therefore be of Great
Interest to the Entire Radio Industry.*

NO ONE in any way connected with the selling of radio receiving sets will question the statement that the servicing problem is the bugbear of the radio trade. A radio set, once sold, cannot be dismissed from the minds of manufacturer, distributor, and dealer; the purchaser keeps coming back, like Hamlet's ghost, to plague the dealer with awful mumblings of dissatisfaction. And, like Hamlet, the radio dealer, the distributor, and the manufacturer know no peace of mind until by proper servicing they have stilled the customer's hollow protests.

This matter of servicing the sold set has been studied and re-studied by the entire radio industry. Somewhere there is a median line on which a service policy can be drawn without eating up too much of the dealers', distributors', and manufacturers' profits on the one side, and without nibbling too annoyingly into the customers' pocketbooks on the other. Where that median line should begin and end has yet to be determined to the satisfaction of the radio industry.

The automobile industry has had much longer experience with just as bothersome a service problem, and has learned much that may be of value to the radio industry. At first glance, to be sure, there seems little resemblance between the servicing that an automobile requires and the servicing that a radio set needs. A faulty cylinder block is rather different from a bent condenser, no matter how you look at them. But in the fundamentals of merchandising, the automobile industry and the radio industry face precisely the same problem. There are some things which the automobile trade has done that should be of interest to the radio trade.

The First Step in Servicing

The first, and most natural, step in servicing automobiles came in the form of "repair garages," independently operated by more or less skilled mechanics. At the start, these garages did more or less satisfactory work on any and all makes of cars, and charged whatever they saw fit for doing so. They were in part responsible for the old catch-line, "It's not the cost, it's the upkeep," that so generally described the pleasures of automobile ownership prior to 1920.

It didn't take the automobile dealers long to realize that

they were the big losers under this repair-garage system. First, when the customer went to the repair-garage, the dealer lost contact with him, and when the customer was ready to buy a second car, he was quite as likely to go to another dealer as to return to the first one. Secondly, the repair-garage did not give the customer complete satisfaction, since, in handling all makes of cars, the mechanics could specialize in none. And thirdly, the dealer was losing a possible profit in repair work.

Specialists Enter the Field

So the next logical step was for the dealer to establish a service department of his own. There the customer was assured that trained specialists would diagnose and repair any trouble his car might develop, and there the dealer could chat with the customer whenever he drove in for repairs. The psychological advantages of that, when it came to selling the customer a new car, were obvious. And the customer was satisfied, for it is a proved fact that the customer prefers to do his repair transactions with the dealer who sold him the car; he naturally feels that the dealer is more interested in keeping his car running well than is the proprietor of an independent repair garage.

The manufacturers and distributors were quick to see that the dealer's service problem was also their problem. During the past ten years they have made great strides in the right direction; to-day every manufacturer has his own factory service shop, to which the dealer can send big repair jobs, and the large distributors have established remarkably efficient and well-equipped service shops to which dealers in their territory can turn.

The dealer service shop solves the problem for the dealer and the motorist in the large cities. There the dealer, and certainly the distributor, does a sufficient volume of business to warrant making a sizable investment in service-shop equipment, and the volume of repair business that comes to him from his customers is such that his shop pays for itself and a bit more. Also, in the large cities, trained mechanics are readily available.

But the dealer in the small city and the country town can't afford to establish his own repair-shop. The volume of

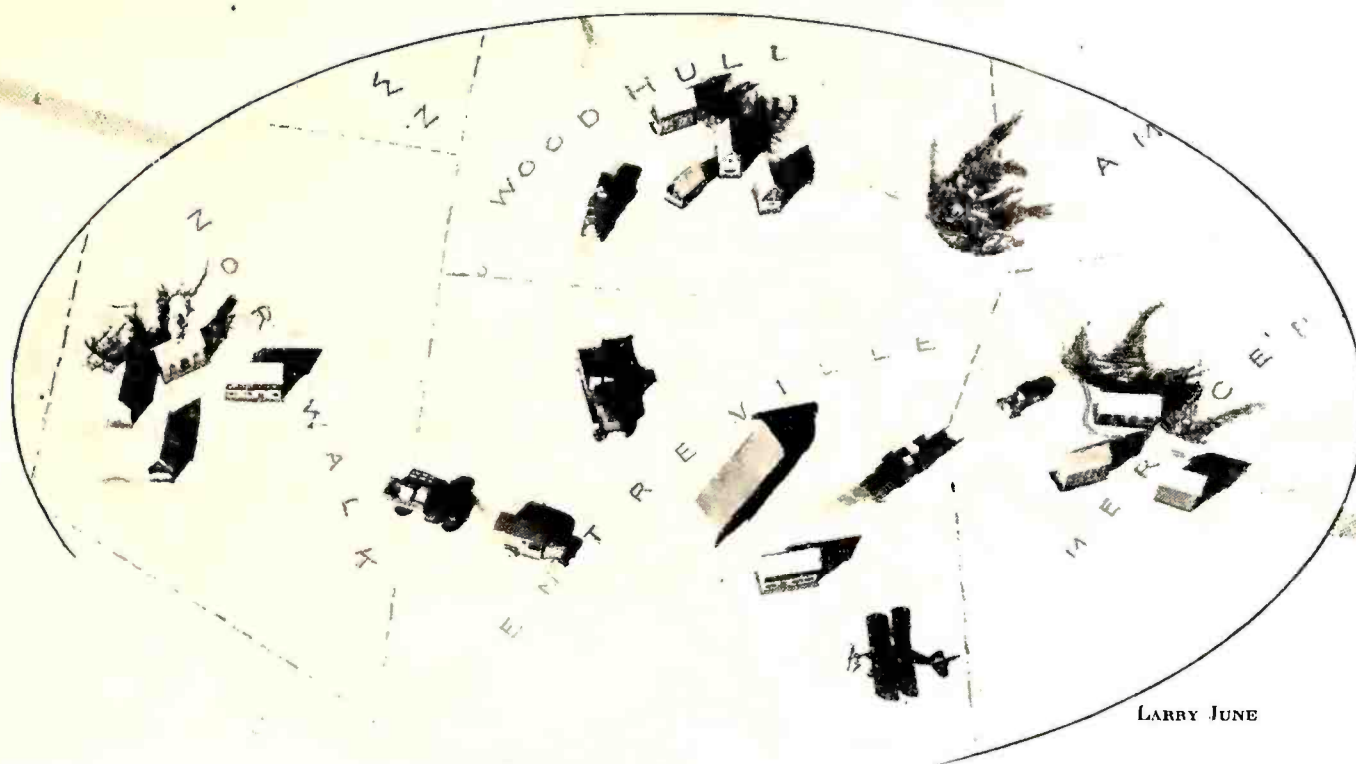

*Will a central repair
factory solve our rural
service problem?*

his repair business is so small that he can't justify the investment necessary to equip the shop with welding machines, machine-tools, etc; in many cases he can't even afford to keep a full line of spare or replacement parts. Now, 64 per cent. of the automobiles sold in the United States in 1928 were sold by small dealers—those in cities of less than 500,000 people, and more than half of that 64 per cent. were sold by dealers in towns of less than 25,000. There the service problem is still unsolved; the independent garages are getting the repair work, and the dealers are losing potential sales and profits.

The automobile industry divides service into two classes: *attentive maintenance*, which keeps cars in good running condition until repairs are necessary; and *corrective maintenance*, which repairs the ailments caused by accidents or wear. And, since the small dealer cannot handle the corrective-maintenance service, he has started to compensate by giving attentive-maintenance service.

For years the automobile dealers have given every car they sell a free overhaul at the end of its breaking-in mileage. These overhauls are attentive maintenance, and are now considered an integral part of the sales transaction. They are comparable to the "free call-back" which a few far-sighted radio dealers have instructed their servicemen to make within a week after a new set has been installed in a customer's home.

Super Attentive Service

The small dealer, and the "super-service" filling stations' which are now playing-up attentive maintenance with the backing of the oil companies and accessories manufacturers, have developed that attentive service to the point where the car-owner is relieved of all responsibility and mental strain. For a small annual fee, say \$15, \$20, or \$25, the dealer agrees to change oil, grease the transmission and rear-end regularly, keep the springs and body free from squeaks and rattles, see that the headlights are properly focussed, the wiring and battery in good condition—in short, to do all the little jobs that will keep the car running well. Furthermore, he agrees to notify the car-owner whenever any of those jobs should be done, so the owner doesn't even have to think of dates or mileage totals. The result is that the owner has a car which

runs better than it ever did while he was attempting to remember about those details, and he is only paying a nominal fee for it. In addition the dealer not only retains a close contact with the customer, but he sells him more gas, oil, and grease than he possibly could otherwise.

The possibilities that exist for the radio dealer who adapts this attentive-maintenance plan to his business are obvious.

In the field of corrective maintenance, or actual repair work, the small automobile dealer's position has already been stated. At present, the independent garages are getting his repair business and his profits, and he is losing out with his customers.

The automobile industry, however, has recently evolved what promises to be a complete solution of the small dealer's service problem. The idea has already been tried out on a small scale, and has been found to be completely satisfactory from the viewpoints of the customer and dealer alike. It also has many points which recommend it to the manufacturer and the distributor, and it is probable that within a few years it will be in general use throughout the country.

Regional Repair Factories

The plan is based upon a chain of "regional repair factories," each of which will handle all the repair business within a given territory. It is economically sound, and in actual practice it seems to be even more suited to the radio industry than it is to the automobile industry, since it is easier and less expensive to transport radio sets over great distances than damaged automobiles.

The regional repair factory, in brief, merely puts a number of specialists under one roof, and insures them sufficient business to make the factory profitable. It is estimated that, in the automobile industry, about one repair factory to a county will be sufficient. This one factory, handling all the repair business within a radius of ten to twenty miles, will operate on a purely wholesale basis, doing no work for customers direct.

The car-owner takes his car to the dealer from whom he bought it. If it is a major repair job, beyond the capabilities of the dealer's serviceman, the dealer sends the car to the regional repair factory. There, with the most complete repair

(Concluded on page 185)

PROFESSIONALLY



SPEAKING

WHAT ABOUT INDEPENDENT SERVICEMEN?

Servicemen who have no direct connection with sales organizations feel themselves handicapped and not squarely treated when their requests for service data from certain manufacturers are turned down. They feel that if they are to service receivers, even though they are not the manufacturer's authorized dealer, they ought to have all the available information. And we believe they are right.

It is certain that a manufacturer does not want every man who can wield a screw driver to have a detailed description of his receiver; but it is the serviceman's contention—and again we believe he is right—that it is no proof that a serviceman is a seven-days' wonder just because he is attached to some organization whose primary purpose in existing is to sell receivers and not to service them.

We believe it would be a much better plan to give as much helpful service data as possible to everyone who qualifies for this information. But we do not believe qualification should depend upon a willingness to invest some dollars in a few sets at wholesale prices. In other words, the qualifications for getting service data should be the ability to service a set and not to sell it. It is a serviceman's job to fix sets and to keep them sold; not to sell them in the first place.

Why would it not be a good plan to prepare an examination which a prospective recipient of service data could fill out, thereby either satisfying the manufacturer or damning himself in his eyes? It may be felt that permitting an independent service organization to fix a receiver works an unnecessary hardship upon the service department of the authorized dealer in the locality, but it is our idea that if this service department does its job better than the independent there will be no need to worry, especially if both servicemen have had to pass the same technical examination.

REGARDING ADVERTISING CLAIMS

Parks and Hull, Baltimore distributors for Atwater Kent, put an Atwater Kent Model 55 screen-grid receiver on life test. They tuned it to a local station at full volume, the voice coil of the loud speaker was removed from the field, and the set was left to its silent task. Day and night the set was connected to the a.c. mains, part of the time a.f. signals were coursing their way through the loud speaker and associated circuits.

At the end of 816 hours the set was turned off and the tubes were retested. It was found that the tubes were but little different from what the test indicated at the start of the experiment. Some had increased slightly in emission, others had decreased slightly. This test of 816 hours is equal to about 275 days of service, in the average listener's home.

Attention—

A plan for distributing service information to all qualified servicemen.

Our problem—to inform factory managers of the cure for man-made static.

Good and bad advertising claims, and which is which.

Let's have more life and performance tests.

Out in South Dakota something went wrong in a power house supplying an Indian school. In this school there was an Atwater Kent Model 60 receiver. Instead of delivering 110 volts to the set the power wires supplied 220 volts. Electric lights in the building began to pop and burn out. When the electrician arrived, a half hour after the ruckus began, he found the set playing with considerable volume, tube shields very warm, and everything going along at a merry clip.

After the power wires had been fixed up, the A.K. came back to normal without any bad effects and at this writing the receiver is operating as well as when it was new.

On August 3rd L. T. Breck, vice president in charge of merchandising, Kolster Radio Corporation, picked a Kolster, which is a medium-priced set, and a Brandes, which is a low-priced set, out of the production lines and put them on life test. Day and night they operated at full voltage and volume. At the end of 2000 hours they were still going strong. No tubes had been changed; no service had been required.

We believe that life tests which give actual hours of test, some reference to the conditions of the test, or any definite quantitative data make much better advertising or news copy than the vague generalities which are in common use.

Compare these three stories with the following statement which is quoted from a recent advertisement for a radio product, "Comparative tests show that our product stands up longer in life test than any similar product on the market."

HOW INDUSTRY FEELS ABOUT RADIO

There are many hundreds of listeners to radio programs in Hartford, Connecticut, just as there are in other manufacturing cities. Not a few of these listeners have been bothered by nightly man-made static emanating from an airplane factory. One of them had the temerity to write the factory manager protesting about the racket that spoiled reception. We did not see this letter but the factory manager's reply seems to be characteristic of many industrial plants:

"There is little or nothing we can do to help out this condition, and suggest that you refer the matter to the manufacturer of your radio set, as it can not be expected that the manufacturing industry is going to spend millions of dollars to radio shield their properties."

This letter indicates no desire to alleviate an annoying situation; it shows that no attempt had been made to find out what made the noise and how it could be eliminated. It proves that the factory manager did not know that a few dollars invested in an interference eliminator would inhibit all but the most virulent type of racket.

The name of this plant manager will be furnished any interference eliminator manufacturer who wants to take his life in his hands for the benefit of the radio industry.

A FEW INTERESTING RADIO PICTURES OF THE MONTH

The "Temple of the Air" cabin monoplane on the right has made a cross-country sales-promotion tour. Those with the plane are (left to right): Lieut. Frank Hoffman, pilot; Cliff Bellinger, sales-promotion director; Gabriel J. Tolan, publicity director; and Chas. Muntzer, Temple dealer.

Upper right in circle: During the trial trip of the recently completed U. S. Cruiser Salt Lake City radio and phonograph music was available to officers and men through the medium of a Victor Radio with Electrola installed in the ship's wardroom.

In the toll house (below) on the James River Bridge, Va., an Atwater-Kent receiver has been installed for the entertainment of the toll keepers. It operates perfectly with four large high-tension transformers all around it.

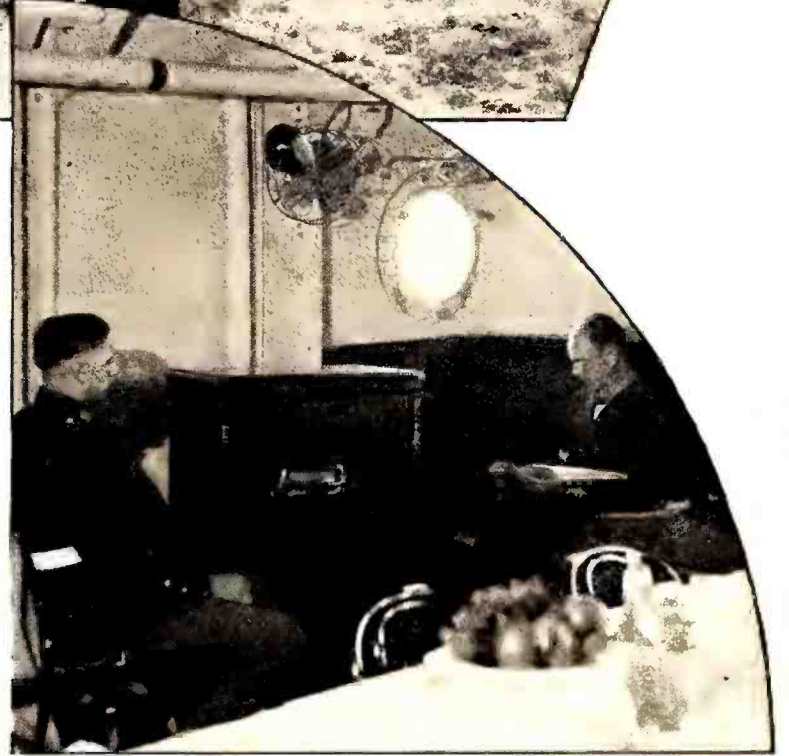
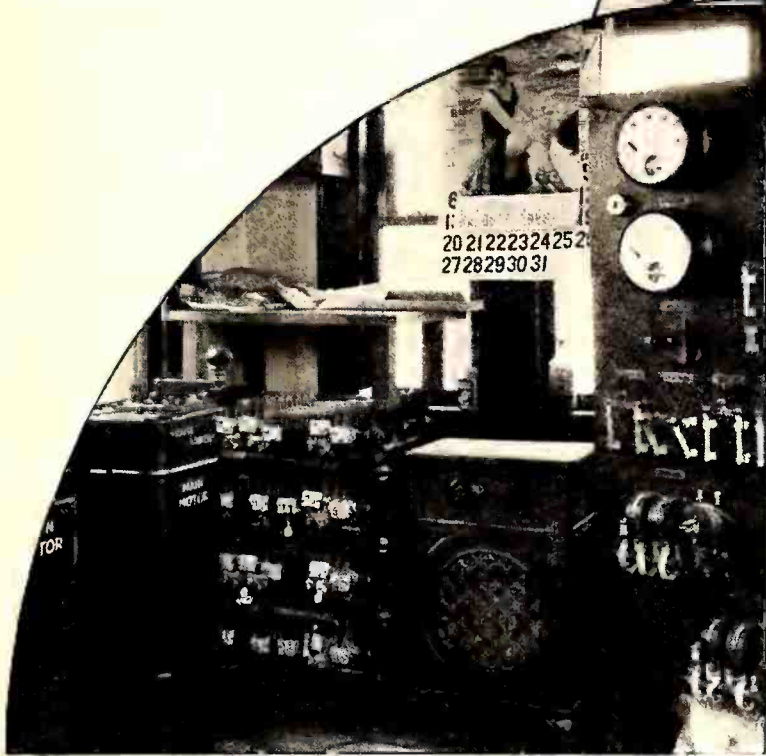

This youthful veteran (above) has tested 160,000 receiving sets since she started working for the Crosley Radio Corporation, in Cincinnati, O., eight years ago.

The view on the left shows one of the large vacuum tube assembly rooms in one of the factories of the Sylvania Products Company, Emporium, Penn.



Lower left in circle: After their perilous flight from Moscow to Oakland Cal., the Soviet Fliers heard felicitations for themselves pouring from a Grebe receiver especially installed for them by Ralph Weinstock, radio distributor in San Francisco.

A MODERN RADIO for the COUNTRY HOME

MANY OF THE loveliest homes in America are located far from cities, far from the sources of electrical power upon which larger communities depends." So reads the booklet describing the first Screen-Grid RCA Radiolas designed primarily for homes without electricity. RCA dealers, however, have an eye on the vast market among people who have electricity and who now possess a set of ancient vintage operating from batteries or from a socket-power unit which seems too good to throw away in favor of an electric set. These people will find that they can improve the results obtained from their radio by buying the new farm set and operating it with their old accessories.

The Radiola 21 is a battery-operated screen-grid set of good sensitivity and selectivity, and it possesses an up-to-date a.f. amplifier system so that excellent fidelity of response is possible. It must be used with an external loud speaker. When placed in a Queen Anne cabinet of the type illustrated and permanently connected to a Radiola 100B loud speaker mechanism, which is mounted in the large baffle formed by the front of the console cabinet, the receiver becomes Radiola 22.

The advantages of the receivers are briefly, modern equipment, low upkeep cost, and low first cost. A receiver for the home without power wires must operate satisfactorily on battery current of a comparatively low value. These receivers require about one ampere from the A battery, and, with a 171A-type power tube and 135 volts of B battery the total plate current drain, with volume control at maximum, is 35 milliamperes. The minimum drain is 25 milliamperes. With a 112A-type tube, and 180 volts of B battery, however, the current drain decreases to a maximum of slightly less than 30 milliamperes and the minimum of slightly less than 20 milliamperes. When using 112A power tube the volume is not appreciably less than with a 171A tube.

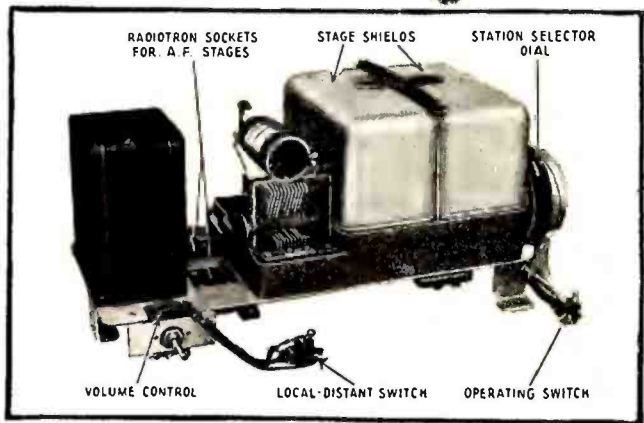
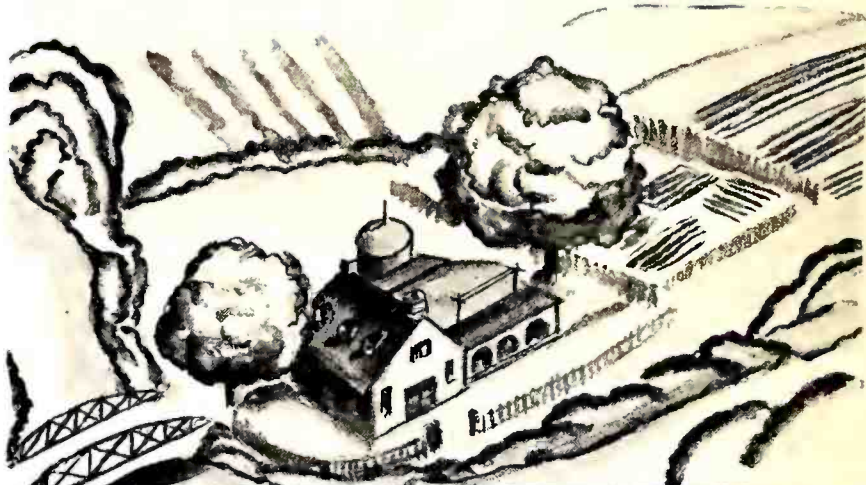

Describing One of the First Offerings of the Industry to Supply Users in Unwired Homes with a Set Comparing Favorably with Latest a.c. Models



Electrical and Physical Specification

Type of Receiver—Screen-grid, tuned r.f., battery operated.
Recommended Antenna Length—25–60 feet.

Type of Filament Power—Storage battery or A power unit.
Type of Plate and Grid Power—B and C batteries or B power unit

Number and Types of Tubes—Two UX-222, two UX-112A, and one UX-112A, or UX-171A—Total 5.

Number of R.F. Stages—Two.

Type of Detector—Grid condenser and leak.

Number of A.F. Stages—Two

Type of Loud Speaker (R22 only)—Magnetic.

	R21	R22
Height	10.5 inches	40.5 inches
Depth	10.0 "	22.0 "
Width	20.5 "	21.5 "
Weight, alone	27 lbs.	44 lbs.
Weight, packed	40 lbs.	105 lbs.
Price (less tubes)	\$69.50	\$135.00



A mechanical description will be found in the table, and the technical features are summarized below. The pictures give a good idea of the tuning mechanism and the arrangement of parts.

Features of Set

(a) Screen-grid battery receiver giving sensitivity and selectivity comparable to that obtained with a.c.-type screen-grid receivers.

(b) Circuit consists of two tuned r.f. stages, a tuned grid-leak-type detector, and the first and second a.f. stages with a choice of power tubes in the output stage.

(c) A local-distant switch provides best reception on both loud and weak signals. With the switch in the local position an 0.00023-mfd. condenser is connected from the antenna connection to ground. This condenser, or the antenna to ground capacity when the switch is at "distant," causes the circuit to resonate in the broadcast band at about 700 kc., thereby increasing the sensitivity of the low-frequency end. The result is that the receiver has about equal sensitivity throughout the tuning range.

(d) The use of screen-grid tubes together with proper shielding, eliminates the necessity of neutralizing or other method of stabilizing.

(e) The volume control varies the voltage on the screen grids of the two r.f. tubes. This provides a smooth means of control which, together with the local-distant switch, provides a positive cut-off even on loud local stations.

(f) In addition to disconnecting the filament battery the operating switch disconnects the B voltage from the volume control. This prevents unnecessary B battery consumption when the set is not in use.

(g) A fixed regenerative detector gives added sensitivity to that circuit with a resulting gain in overall sensitivity. This does not require any adjustment during operation.

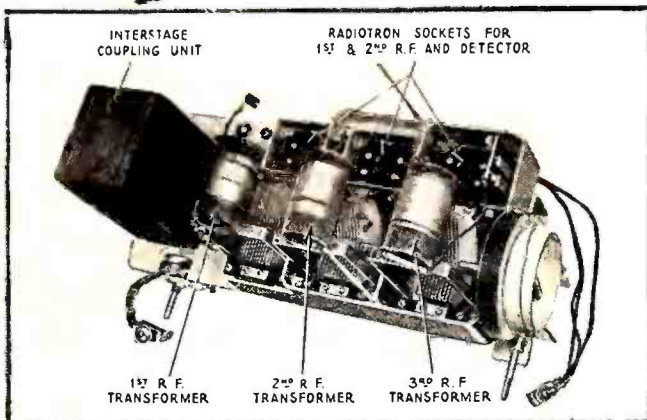

The MARCH

Let's Market a \$35 Radio Receiver
Have Radio Broadcasters Made a Profit?

Reaching the Mass Market

THE RADIO INDUSTRY is fighting for its share of the consumer's surplus dollar with a \$150 article. That is the real price of the cheaper modern radio receivers, fully equipped with tubes and reproducer, installed and ready to use. Some well-known brands are listed at a lower price, but when the extras are summed up, including furniture, reproducer, and tubes, the totals are almost invariably nearer the \$150 than the \$100 mark.

While \$150 does not seem to be an excessively large unit, the great mass of American families are still waiting for a less costly introduction to radio. We hardly seem to realize that 68.6 per cent. of American families earn less than \$2000 a year and that 33 $\frac{1}{3}$ per cent. earn less than \$1500 a year. The resistance to purchasing a \$150 article in competition with the numerous other demands for every dollar earned, accounts for the relatively slow growth of the radio family. Most of the increase in sales totals of the last two years has been replacement business.

Radio has never been as democratic as it was in its earliest days when practically all the parts for a radio receiver could be purchased in a ten-cent store. During this early period in radio's development, we were called to address the assembly of a continuation school, an audience of young working boys who were compelled by law to spend a part of their time in school, practically all of them members of families having a net income of less than \$1000 a year. Over half of these were faithful earphone listeners, having built their own receivers. The march of progress has left them behind; the industry has found no place for them. Every other industry, which reaches into every strata of society, has found it profitable to appeal to this, the largest market, by marketing goods within their reach. To do so requires an entirely different approach, different advertising, and a different type of outlet than the industry now addresses with its \$150 goods.

It has been abundantly demonstrated, by the automobile industry in particular, that progressive buying is characteristic of the mass market. A very large percentage of Packard owners made their initiation into the automotive fraternity by purchasing a Ford. The lower the price strata to which an industry reaches, the more rapidly progressive buying finds larger markets for better quality goods.

It requires more than suitable sets at low first cost and upkeep expense to make inroads into the mass market. Broadcast program services must also be made available which appeal to that market. We are inclined to delude ourselves that we have broadcasting services to appeal to all classes of persons because programs are satisfactory to the existing audience. We have never ascertained the program desires of the great unsold market. Perhaps we might profit from the example of certain newspaper and magazine publishers who have found new fortunes by reaching further and further into the

mass market. Every convert from this group to the printed page is only at the foot of the ladder, making a start toward progressive improvement and to higher standards of taste.

The radio industry is standardizing its market by the minimum price of reliable receivers which it offers and by the character of its principal broadcasting programs. We would not be surprised if radio's largest fortune is still to be made by a manufacturer who designs an ingenious three- or four-tube a.c. set, selling for less than \$35 complete, ready to use, a set offering reasonably good quality of reproduction, sensitivity not necessarily exceeding that of the crystal receiver, and only moderate volume through a fairly responsive loud speaker.

The progressive price reductions which have been made in radio receivers have greatly increased the purchasing power of the consumer's dollar in radio, but no manufacturer has yet dared to sacrifice sensitivity and volume to a degree which would enable him to reach the real mass market, the great two thirds of the American families which earn less than \$2000 a year.

Cleared Channels Threatened Again

The Bureau of Internal Revenue has published the first figures indicating the income of broadcasting stations and organizations during 1927. Ninety-seven broadcasting corporations reported an income of \$73,363,297. Of these, 30 grossed \$66,121,400 with a net of \$9,828,929. On the other hand, 58 reported a gross income of \$7,241,897, with a loss in their operations of \$1,181,127. The group of thirty organizations showing a profit earned almost 11 per cent.

Political dabbling is endangering the stability of the profitable group. If broadcasting is to expand, the operations of those engaged in it must continue to show a profit. But apparently, the Commission has learned very little by experience. Commissioner Sykes recently proposed that WAPI, Birmingham,

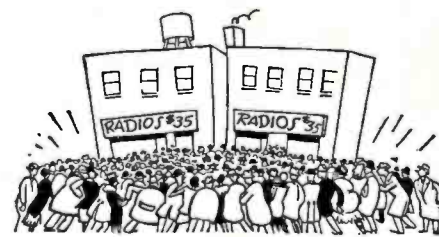

Ala., be permitted to operate experimentally on channels now occupied exclusively by KOA, KNX, KJR, and WBZ. Considering that WAPI delivers a fairly strong signal in Springfield, Mass., it is obvious that heterodyne interference would result. Very probably the same is true with respect to the service areas of KOA, KJR, and KNX, although we do not know the facts from actual experience in the latter cases.

During the radio chaos, which the Commission was appointed to cure, the reception of WBZ in Springfield was seriously interfered with by KTNT, Muscatine, Iowa, which is about the same distance from Springfield as Birmingham. Other similar cases of heterodyne complaint which are blithely overlooked by Judge Sykes are KFNF's interference with WJZ, WCFL's interference with WEAJ, KMA's interference with WOR. Why has nothing been learned from the bitter experience of the radio chaos of 1926 and 1927? Must we repeat all this again in order to teach the Commissioners the simple rudiments of allocation? The fact that the Commission voted down

OF RADIO

Less Separation For Our Stations?
50,000-Watt Transmitters Should Be Restricted

the proposal does not make the offense of flaunting experience in the face any less serious.

The Federal Radio Commission itself brought forward overwhelming evidence of the popularity of stations on cleared channels through its questionnaire circulated among farmers and radio amateurs. The 44,141 replies reveal that 72 per cent. indicated as their first choice cleared channel stations, including 100 per cent. of those replying from Connecticut, New Mexico, Vermont, and Wyoming; 99 per cent. from New Jersey; 90 per cent. or more from Delaware, Kentucky, Utah, Mississippi, Arizona, Louisiana, Illinois, Colorado, and Texas; and 85 per cent. from New York. It is notable that only 50 per cent. of those replying from California registered preference for cleared-channel stations. This is accounted for by the fact that the high-grade chain programs originating from the Eastern studios, which make cleared channels the most popular in practically every part of the country, do not reach the Pacific Coast with highly satisfactory quality or at the peak listening hours. Excessively long-distance wire transmission across the country robs the chain programs of their glamor and builds up preference for some of the minor stations, even those whose only good-quality broadcasts consist of phonograph records.

7½-Kilocycle Channels Proposed

The refusal to heed hard won experience is by no means limited to the Federal Radio Commission. We were surprised to learn of the proposal put forward by Louis G. Caldwell, former counsel, Federal Radio Commission, appearing before the Commission in behalf of a number of stations seeking and, no doubt, deserving cleared channels, that a part of the band be compressed to seven-and-one-half-kilocycle channels so as to make such assignments possible. During Hoover's administration of radio, the experiment of seven-and-one-half-kilocycle channels was tried on an exhaustive scale and found wanting. With modern radio receivers, responding to 4000- and 5000-cycle notes, the reception on seven-and-one-half-kilocycle channels would be nothing less than a hopeless bedlam. We are thoroughly in sympathy with the effort to increase the number of cleared channels, but that objective

can be attained only by reducing the number of stations occupying the broadcast band. Any proposal to attain additional cleared channels by rendering other channels useless is not worthy of consideration. We are

surprised that such an eminent and competent authority on radio allocation as Louis G. Caldwell should subscribe to such an extraordinary proposal. It could be consummated successfully only if receiving sets with a sharp cut-off at 3500 cycles were introduced. We cannot beg the question of more efficient utilization of the broadcast band by borrowing from Peter to pay Paul.

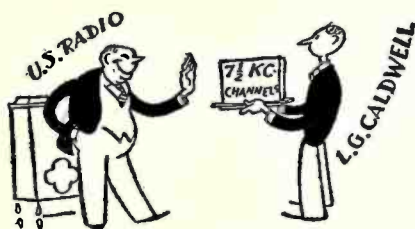

Very possibly a larger number of radio listeners would be served if ten additional channels were cleared and the entire band below 1200 cycles virtually destroyed, but the broadcast band is too valuable and restricted a territory to make tolerable any proposal which would destroy any part of it.

Station Distribution

While we observe with considerable enthusiasm the increase of 50,000-watt stations, the minimum power which makes for efficient use of a cleared channel, the commission should restrict the total number of 50,000-watt stations assigned to cleared channels in each section of the country before we have an unfortunate concentration of such stations in the New York and Chicago districts. Since the total number which can be accommodated

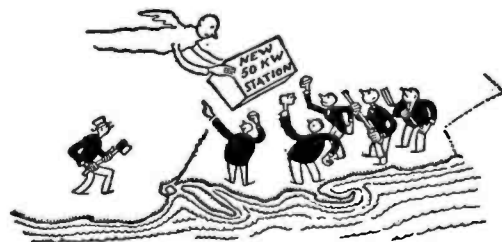

in our broadcast band is strictly limited, 50,000-watt stations should be carefully distributed in all parts of the country. We have, or rather should have, learned from experience the difficulties standing in the way of revocation of licenses and compulsory abandonment of broadcasting facilities to correct allocation errors. But with characteristic disregard of past experience, we are already approaching dangerously close to the saturation point in the northeastern section of the country.

Any limits which are decided upon should be on the basis of equalized geographical areas rather than the impractical five-zone demarcations so far unsuccessfully applied to equalization. The most practical foundation for equalization is to divide the country arbitrarily into 500-mile squares in three belts from north to south, as was proposed to the Commission at its first public hearings immediately after its organization by a representative of RADIO BROADCAST. This would divide the country into 13 equal zones, forming an excellent basis for equalization. The carriers radiated by broadcasting stations cover a specific area regardless of the cities or populations within them. A channel and power assignment is a grant to use a specific channel over a definite area. Consequently, equalized allocation is a matter of dividing channels among equally sized areas, the number of radio broadcasting stations per channel being determined by power and geographical separation.

New R.C.A.-Victor Set-up

The R. C. A-Victor Corporation will, after January 1, 1930, conduct the engineering, manufacturing and sales activities for all the Westinghouse, General Electric, and Radio Corporation of America interests in the broadcasting and talking motion picture field. The resultant increased efficiency in the operations of the radio group means still more intense competition in the quantity production market.—E. H. F.

A RADIO DEALER'S TUBE-TESTER

By JAMES W. BLACKWOOD

AN ESSENTIAL PART of the dealer's and serviceman's equipment has always been some simple tube-testing device. Such an instrument must be inexpensive, portable, and yet accurate enough to judge the quality of a tube. On the other hand, to test all types of tubes for all conditions which might affect their performance requires expensive and complicated equipment which is beyond the needs of the dealer, since he is primarily interested in whether the tube will perform normally in his customer's receiver.

What the dealer or serviceman needs is not some exhaustive test on tubes but a simple test to determine whether the tube will operate at all, and if so how well. He needs to know only three things:

- (1) Is the filament intact?
 - (2) Are any of the elements shorted?
 - (3) Is the tube satisfactory in other respects?
- Either (1) or (2) above cause non-operation; (3) may result in poor operation.

A testing arrangement which the dealer or serviceman can use to classify tubes on the basis of these three general divisions is described in this article. The apparatus can be divided into three circuits: the first, for testing short circuits and open filaments or heaters on all tube types; the second, for testing the operation of three- and four-element receiving tubes; and the third, for testing the operation of rectifier tubes. For convenience, each of these has been arranged to work directly from the 110-volt 60-cycle supply, available to dealers and servicemen everywhere.

Short and Filament Tester

The short-circuit test-set (Fig. 2) consists of two sockets to accommodate four- and five-prong tubes and a system of lamps to indicate when a short circuit occurs. The 110-volt a.c. supply, which is connected across a resistance-type voltage-dividing arrangement, provides the energy necessary to light the lamps when a short circuit occurs. The key, K_1 , in the circuit is for closing the filament or heater circuit through two 10-watt 110-volt lamps in series and gives an indication of open filament or heater circuits.

When key, K_1 , is pressed lamps D and E should both light with equal brilliance, proving the filament or heater circuit is complete. If they do not light, or if only one lights, or if one lights brighter than the other, a short or an open filament is indicated. It is suggested that the owner of the tester have available a convenient method of checking this circuit periodically. This can easily be done by providing old bases with short circuited grid-plate, grid-filament, plate-filament, etc.,

terminals and placing them consecutively in the socket to check the lighting of the proper lamp.

The list of equipment in Table I is offered as a suggestion for those who may wish to build the tester. Any equivalent apparatus, however, will give satisfactory results.

The tube is inserted in the proper socket and the clip attached to the external terminal, in the case of screen-grid tubes. For a normal tube no lamps should light

until the key is pressed after which the two 10-watt lamps D and E should light up with equal brilliance, their circuit being completed through the filament or heater circuit of the tube. If any one or more of the lamps light before the key is pressed, a short circuit is indicated. If, upon pressing the key the two 10-watt lamps are not of equal brilliance, a short circuit is also indicated. The 10-watt lamps will usually burn very dimly when the key is pressed since they are in series across the 110-volt circuit and have, therefore, only 55 volts each.

If, before either key is pressed, any lamp or lamps light the trouble may be found from the following table:

Lamps lit	Type of short
A only	Grid-cathode (control grid)
B	grid (control or screen)
C	Plate-cathode
A and B	Screen grid-control grid
A and C	Control grid-plate
B and C	Grid-plate (control or screen grid)
E only	Heater-cathode
A and E	Heater or filament-control grid
B and E	Heater or filament-grid (control or screen grid)
C and E	Heater or filament-plate

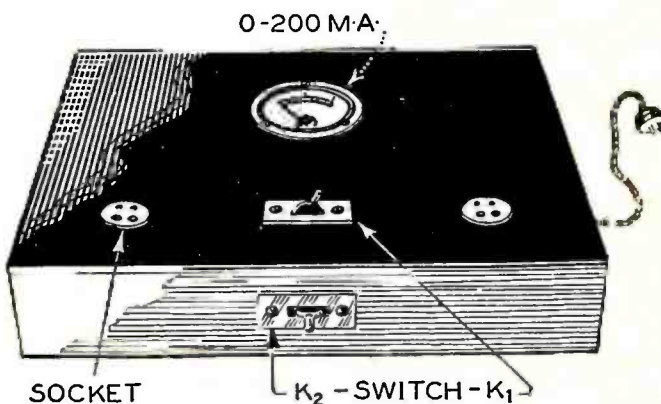

This drawing shows the layout of parts on the panel of the rectifier tube tester.

Table I

- R_1, R_2 —Two Carter resistors, type H, 20-ohm
- R_3 —One 80-ohm resistor (Two Carter type H were connected in series)
- R_4 —One 300-ohm Electrad resistor, type B
- A, B, C—Three dial illuminating lamps and sockets, 6-volt, 0.1-ampere
- D, E—Two lamps and sockets, 10-watt, 110-volt
- K_1 —One key or switch, S.P.S.T. (Push button will do)
- K_2 —One General Electric toggle switch, single-pole (Catalogue No. 269943)
- S_1 —One tube socket, X type
- S_2 —One tube socket, five-prong (Y type)
- One adaptor, c-199 (ux-199) tube to x-type socket
- One adaptor, c-11 (wp-11) tube to x-type socket
- Two clips for connecting to control grid
- Two fuses, five-ampere
- Box, panel or circuit board.

To test the actual operation of a tube, after it has been determined that there are no shorted elements or an open filament or heater circuit, the circuit shown in Fig. 1 is used. It is a modification of that published in January, 1929, RADIO BROADCAST.

The filament (or heater) is provided with raw a.c. from a transformer. At the same time a.c. voltage is put on the plate. On the positive half cycles the tube takes current which flows through resistors (R_2 and R_3) which puts a negative bias on the grid of the tube. Thus a certain plate current flows. When a key (K_1) is pressed part of this resistance (R_2) is shorted out of the circuit, thereby changing bias and changing plate current. This change in plate current may be taken as a measure of the value of the tube.

With a 15-milliampere full scale meter, M_1 , in the plate circuit, using bias resistors of approximately the values given, all types of tubes can be tested with satisfactory results. A 10-watt, 110-volt lamp, L_1 , used as a protective resistor is included in the circuit to protect the meter in case a shorted tube is accidentally inserted in the socket. A plate-filament or grid-plate short in a tube inserted in this tester will cause the 10-watt lamp, L_1 , to light and the meter M_1 to vibrate slightly about the zero adjustment, the needle following the 60-cycle current passing through the meter. However, it is recommended that in every case tubes be tested for short circuits before inserting in this tester.

The circuit requires a special transformer having a 100-volt primary and a secondary tapped at 1.1, 1.5, 2.5,

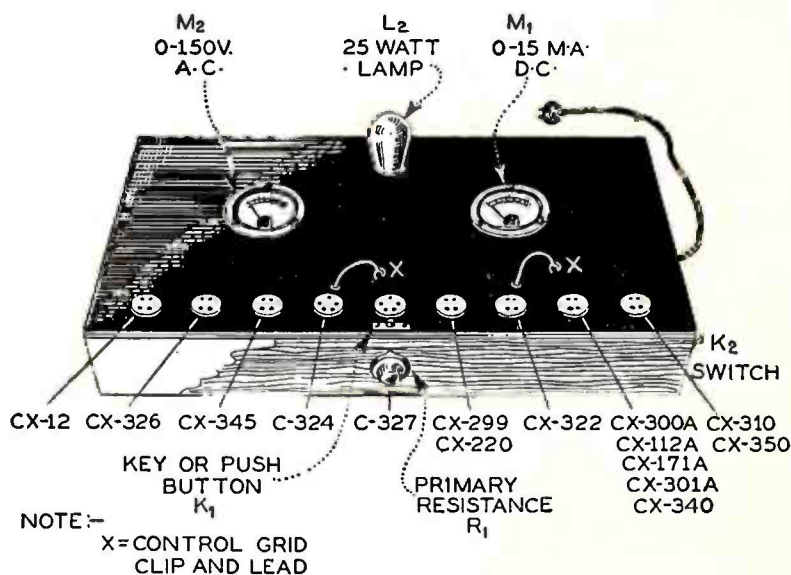

The arrangement of tube sockets, meters, voltage control, etc., of the tube-tester is indicated in this panel layout.

3.3, 5, and 7.5 volts to supply the various filament voltages to the different types of tubes. The American Transformer Company (Amertran) has manufactured such a transformer on special order and other transformer manufacturers are also equipped to do the same thing.

In operation the variable resistance, R_1 , in the 110-volt lead is varied until the a.c. voltmeter, M_2 , across the transformer primary reads 100 volts with the tube inserted in the socket. This insures correct filament and plate voltage on the tube being tested at various a.c. line voltages. The shunting lamp, L_2 , across the transformer primary is to reduce the size of the series resistor required for some of the low-filament-consumption tubes and also serves as a pilot lamp to indicate that the set is turned on.

An alternative method of filament lighting is shown in Fig. 4. All filaments are connected in parallel across the secondary of a transformer having a 110-volt primary and a 7.5-volt, 3-ampere secondary. In this case the primary voltmeter and resistance control change only the plate voltage to the tube, the filament voltage control being obtained from two series filament rheostats, R_4 and R_5 , and read on a two-scale voltmeter, M_3 . It is very important to adjust the rheostats R_4 and R_5 to maximum resistance before inserting any tubes. Two rheostats are provided, one for low- and the other for high-current tubes. Because of the voltmeter current the 50-ohm rheostat, R_4 , provides all regulation necessary even for 60-mA. tubes.

Operation of Tester

The operation of this tester will then be as follows: In the case of a tapped transformer, the tube is inserted in the proper socket and the resistance R_1 is adjusted so that voltmeter, M_2 , reads 100 volts. The plate current reading as shown on M_1 is then noted both before and after closing the key, K_1 . With the untapped transformer (alternative method), rheostats R_4 and R_5 are first set at maximum resistance value. The tube is then inserted in the proper socket and R_4 and R_5 are adjusted to give the correct filament voltage as shown on meter M_3 . Resistance R_1 is then changed to make meter M_2 read 100 volts and from then on procedure is just as in the first case.

It will be found that the tube readings are dependent of the way in which A and A_1 , the plate voltage supply connections, are made to the a.c. supply and filament transformers.

These leads should be reversed until the highest readings are obtained, in order to obtain results comparable to the following table. The difference is especially noticeable in the case of tubes with a 7.5-volt filament.

In testing the tubes with higher readings on the meter M_1 it will be found that as the

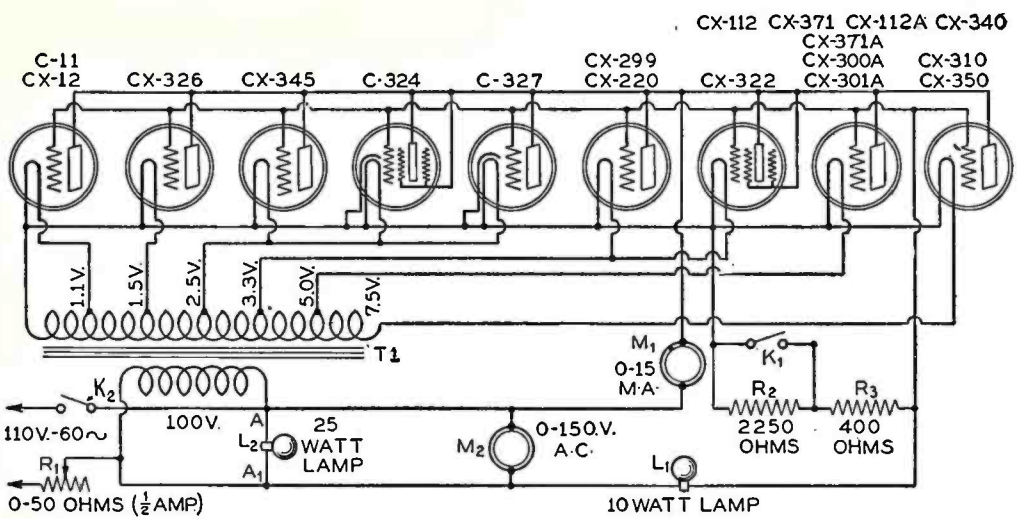

Fig. 1

10-watt lamp becomes slightly heated, the meter reading will decrease slightly. This is entirely caused by the lamp and

tained. Variations in the values of biasing resistor, transformers, meter calibration, etc., will cause some changes in the result.

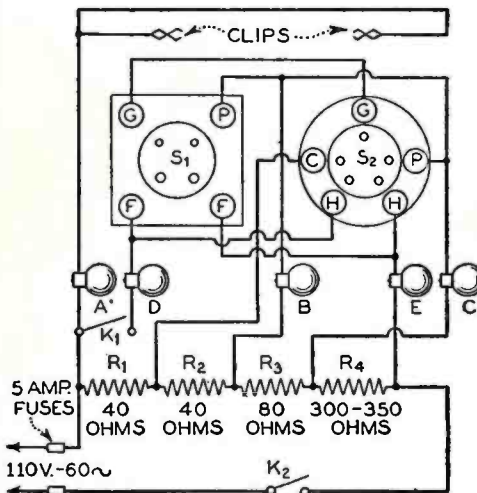

Fig. 2

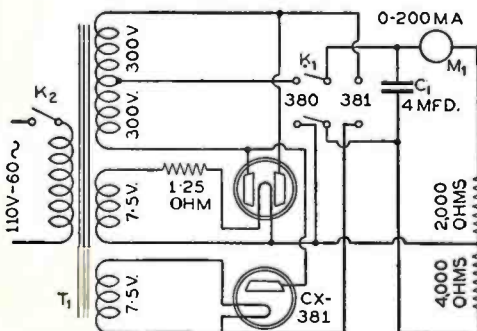

Fig. 3

should not be construed to mean any defect or abnormality in the tube being tested. A table of approximate changes in Cunningham tubes is given here, this table being by no means a criterion but merely to suggest the results to be ob-

Tube	Average Plate Current Values for Tubes	
	K_1 Open	K_1 Closed
c-11	1-1.5	2-2.5
CX-12	1-1.5	2-2.5
CX-326	1.5	4
CX-345	3	11
C-324	1	2.6
C-327	1.5-2	3-5.5
CX-299	1.5	3
CX-220	2.5-3	5.5-6
CX-322	2	4-6
CX-112	2	6.5-7.0
CX-301A	1.7	4.5-5.0
CX-340	.7	1.7
CX-371	3.5-4	12-13
CX-371A	3.5-4	12-13
CX-300A	1.5	3.5
CX-310	2	6
CX-350	3	10.5
CX-112A	2	6.5-7.0

For constructing the test set a suggested layout is drawn in perspective, For quick work and convenience it is essential to have one socket for each of the groups of tubes indicated on the diagram. It is seen that for the screen-grid tubes the screen grid is connected to the plate making it a three-element tube for purposes of this test. For this reason it is necessary to use a separate socket for screen-grid tubes since on them the control-grid connection is on top and the screen grid is connected to the usual grid terminal of the socket.

The equipment listed in Table II was used in the experimental model but any equivalent apparatus will give satisfactory results.

Table II

- T₁—one special filament transformer, 20-watt capacity and having a 7.5-volt secondary with taps at 1.1, 1.5, 2.5, 3.3, and 5.0 volts. Primary wound for a 100-volts 60-cycle supply and secondary delivering above voltages at rated primary voltage. (American Transformer Company.)
- R₁—One variable resistor, 50-ohm, 500-mA. (General Radio 50-ohm rheostat type 214)
- L₂—One lamp, 25-watt, 110-volt
- L₁—One lamp, 10-watt, 110-volt
- M₂—One Weston 476 a.c. voltmeter, 0-150 scale.
- M₁—One Weston model 301 milliammeter (d.c.) 0-15-mA.
- Six—Sockets, CX type
- Three—Sockets, five-prong
- K₁—One S.P.S.T. switch or key (push button will do)
- R₂—One Electrad resistance, type B, 2250-ohm
- R₃—One Electrad resistance, type B, 400-ohm
- Two—Clips for connection to screen-grid tubes
- K₂—One General Electric single-pole tumbler switch (Catalogue No. 269943)

For the alternative method of filament supply, the following changes would be made in the apparatus requirements:

- T₂—One Thordarson type T2230 filament transformer having a 7.5-volt, 3-ampere secondary and a 110-volt primary
- M₃—One Weston model 528 a.c. voltmeter with two scales of 4- and 8-volt ranges
- R₄—One General Radio type 214 rheostat, 7-ohm, 2-ampere
- R₅—One General Radio type 214 rheostat, 50-ohm, ½-ampere

The rectifier test consists in operation of (Concluded on page 171)

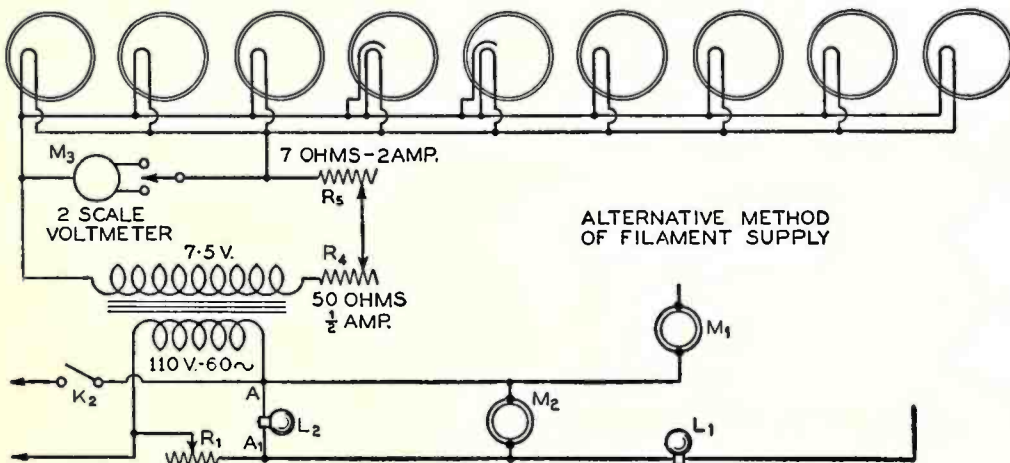

Fig. 4

HOW WE LOOK AT SERVICE PROBLEMS

By MILTON B. HAGER

MOST SERVICE articles which we have read in worth-while radio publications have been written either by a radio engineer or by an executive of a high-grade independent service organization. Although this article has been written by an engineer, the author has been actively engaged in radio installation and service work for one of the largest radio retail chains in the East. Therefore, an attempt will be made to consider service problems from a slightly different angle. On the other hand, it is not intended to lay down an iron-bound set of rules for dealers to follow, but rather to give them ideas which they may adapt to their own needs in their own localities.

Regarding Installation

First, the matter of installing sets will be considered. In this connection we have found that the most economical method of delivering receivers is to send out a light truck with as many sets as may be handled at one time, using two men on the truck. As it takes a good man to make more than four installations in an eight-hour day, the maximum load for the truck for a full day's work would be eight receivers. Throughout the day the men split up so that only one man works on the actual installation of any one set.

Some dealers fit up a special truck for installation work and equip it with all sorts of special apparatus for facilitating the work. However, we have found that this is not necessary. We carry a small kit which contains a few tools and the necessary accessories, such as antenna wire, insulators, ground clamps, etc. We also have a few odds and ends of lumber and some short lengths of bamboo, as these often simplify the work when erecting an antenna on the roof of an apartment house.

When working in an apartment house district a ladder is not always a necessary piece of equipment as a step-ladder, which may be borrowed almost anywhere at any time, will usually give access to the roof. Of course, one-, two-, and three-family houses present problems of their own but even here we have found that a convenient ladder appears with pleasing regularity. In the case of two- and three-family homes tall clothes poles are common. These make an excellent antenna mast and are usually fitted with spikes strong enough to permit the average able-bodied man to reach the top.



"A convenient ladder appears with pleasing regularity."

Above everything else our servicemen who work on installations are cautioned *not to drive nails in a roof*. Failure to follow this rule would cause considerable damage to customers' houses and would give the dealer a poor reputation. Our servicemen are also told not to solder joints in the antenna, lead-in, or ground wire. It is both difficult and inconvenient to make a good soldered joint out of doors and we have found that well-taped, clean, mechanical joints are just as satisfactory. For the



"Some people like company."

ground connection we usually use a radiator, but we make sure that all paint or rust has been removed from the pipe before applying the ground clamp.

The customer must be pleased and this means that the serviceman must watch his P's and Q's while working inside the house. He should keep his hands clean. He should treat the customer with courtesy and respect at all times. If it is found necessary to move furniture, he should ask permission, and then, when he is finished, things should be put back in the order in which they were found. Before leaving he should also instruct the customer in operating the set and at the same time make sure that everything is in good working condition. If it is a c.o.d. installation it is also necessary for the serviceman to watch the collection. In this case the best rule to apply is, "Be courteous but advise the office at once in the event of any misunderstanding."

Routine Calls

Every dealer has a great many service calls which of necessity must be scattered throughout the day to meet the convenience of the customers, noon and late afternoon calls being the most numerous. These calls can be made profitable only when they are handled with care. It is necessary to route your calls carefully to save time and mileage. Don't bunch your calls but spread them out over the week. One must be reasonably prompt, but remember that you can't have six servicemen on Tuesday, none Wednesday, and two on Thursday. It is also wise to concentrate on service calls in wet weather when it is unwise to attempt putting up antennas. Your men should be instructed to make all calls short but consistent with courtesy and service. On an average it will be found that calls do not take more than one half hour each and if care is taken in centraliz-

ing the work of each serviceman to a particular portion of the city very little time will be lost between calls.

From the viewpoint of efficiency it is highly important that the outside servicemen be properly equipped. Every man should be provided with a reliable set-analyser, and the dealer should make sure that he knows how to use it. We use one of the most inexpensive set-testers on the market but have found that it answers perfectly in ninety per cent. of the cases. Twenty-five dollars should cover the cost of the individual equipment that a serviceman uses when he is out of the shop. Besides the set-analyser and small tools each serviceman should carry a pocket voltmeter, a battery tester, and a complete set of tested tubes.

Another principle which we have found important in servicing receivers is not to attempt making any extensive repair in the customer's home. If a test indicates that the work could be performed best in the shop the serviceman should take the chassis, power pack, loud speaker, or the whole works, if necessary, to the shop for repair. Incidentally, what the customer doesn't see can't cause comment.

Servicemen should also be trained in the way they should talk to customers regarding their receivers. The customer should be told that most standard sets are good value at the time of sale and that he (the serviceman) intends to repair the set so that it is capable of giving as good service as when it was new. Most people appreciate good service, and good service begets confidence.

Free Service on New Sales

In addition to his regular service business the dealer must give equal consideration to another form of service which may seem less profitable but which is just as important—the free service on new sales. We back the manufacturer's guarantee and in many cases service both set and tubes for a period of six months without additional charge. We find that the tube service in particular is a big factor in making your set sales stick. All these free service calls, of course, should receive just as prompt attention as the paid calls.

Servicemen must be selected with care. RADIO BROADCAST published an article (April, 1929, issue page 405) giving a good stiff examination. Get a copy of this article and then find out how your men measure (Concluded on page 188)



"Before leaving he should instruct the customer in operating the set."

MATCHING IMPEDANCES

THE TRANSFER of electric power from one place to another, or from some source to a load is continually taking place and the phenomenon no longer excites any public interest. On the other hand, this transfer of power is the engineer's job; he spends his days and nights trying to get either more power from a given source, or the same amount of power at greater efficiency.

In a radio set power is taken from a tube and put into a loud speaker; in an oscillator the power is taken from the tube and put into an antenna.

What are the factors the engineer deals with? How can he adjust matters so that he improves the power output, or the efficiency?

Consider the circuit in Fig. 1. Offhand it looks like a very simple series circuit consisting of a generator, E, and two resistors, r and R. That is exactly what it is, but at the same time it is the fundamental power circuit and may represent not only a battery without resistance feeding current into two resistors, or a dynamo with an internal resistance, r, feeding power into R, or a vacuum tube with a plate resistance, r, feeding power into a load resistance R. When the switch is closed on this circuit, current flows from the source, E, into the two resistors. A certain amount of power is required to force this current through the resistors; this power is numerically equal to I^2r for the power in the resistor r, and I^2R for the power used up in the load.

Now if we could make a generator or a tube without internal resistance, all the power coming from it would be usefully employed in the load, R, but actually this is impossible. Some of the voltage, E, is used up in the internal resistance of the source, whether it be a battery, a generator, or a tube, and the remainder is used in the load.

The first thing to do is to calculate by Ohm's law the current in the circuit, $E/(r + R)$; then calculate the power used up in the two resistors, I^2r and I^2R ; then, in order to find out how efficient the system is, calculate the ratio between the power usefully employed (that in R) to the total power available. Thus, if all the power were used in R (no internal resistance), the system would be 100 per cent. efficient. Such is never the case. Finally we should calculate the voltage across the load and across the internal resistance (Ir and IR).

In the Data Table we have assumed a potential of 100 volts and a generator resistance, r, of 10. Using these values we filled in some of the values as the resistance of the load, R, varies from 1 to 50 ohms, i.e., from one-tenth to five times that of the load. The other values should be calculated and filled in and the data plotted against either load resistance or against the ratio between the load resistance and the internal resistance (R/r).

Analysis of Data

Such calculation and plotting of data is the first half of many experiments; the remainder must be devoted to an analysis of what has happened. One of the first things to note is that the power taken from the generator decreases as the load resistance increases, but that more and more power is used in the load, and less and less is wasted in heating the generator. Note that when the load resistance, R, is equal to the internal resistance, r, the greatest amount of power is taken by the load and that no further adjustment of the latter results in greater power being used in the load. At this point half the total power taken from the source is used in the load and half in the source; the efficiency is 50 per cent.

As the load resistance is increased beyond this point the power in both load and generator decreases—but the efficiency increases. In other words, the power usefully employed in the load rises from a low value to a maximum and then decreases; power wasted in the generator steadily decreases; of the total amount of power taken from the generator, more and more is usefully employed as the load resistance is increased, which means simply, that the efficiency of the system as a whole increases as the external or load resistance increases.

Now an engineer usually has one of two things in his mind when he designs power transfer apparatus. Either he wants the maximum possible power to be taken from a source and transferred to a load; or he wants the transfer of what power he gets to take place at the highest possible efficiency. Often he compromises between power output and efficiency. If he has control over the load resistance he can get maximum power into it by making it equal to

the generator resistance; he can get maximum efficiency by making it high in comparison to the load resistance.

Adjusting the Load

Suppose, however, that the engineer has no control over the load resistance. Suppose, for example, it is a 600-ohm telephone line which must be fed with audio-frequency power from a 6000-ohm vacuum tube. Clearly a loss in power will take place compared to the transfer possible if the tube were 600 ohms or the line were 6000. What can be done?

A transformer can be interposed between the tube and the line which will enable maximum power to be transferred provided it has the proper turns ratio. In this case the ratio of secondary (load side) to primary (tube side) would be $\sqrt{6000/600}$ or about 3.16. Then, so far as the load is concerned, the tube resistance is stepped down so that it could be re-

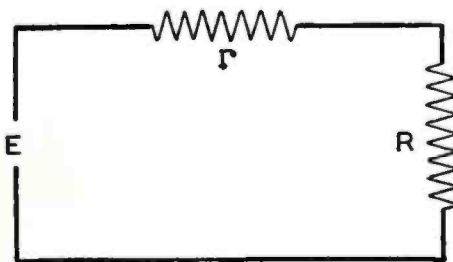

Fig. 1

placed by a 600-ohm tube and the transformer thrown away, and, so far as the tube is concerned, the line resistance is stepped up to 6000 ohms. The only loss in power in such a case is the loss in the transformer itself, which is small if the latter is properly designed.

Matching Impedances

The business of making the resistance of the load equal the resistance of the generator is called "matching impedances" and many thousands of transformers have been designed for this purpose. In the case above, the load and generator impedances were pure resistances. If the generator or load contain some reactance, due to capacity or inductance, the problem is more complex. Suppose the generator, for instance, had an inductive reactance of 10 ohms. To get maximum power into the load, it would be necessary to match the resistances, and to have the load have a capacity reactance of 10 ohms, to balance out the inductive reactance in the generator.

Generally speaking, when the power is small—a few watts, perhaps—engineers match im-

Data Table

$$E = 100 \text{ volts; } r = 10 \text{ ohms; Eff} = \frac{P_L}{P_L + P_g}$$

R	R + r	I	P _L	P _g	P _L + P _g	R _r	E _L	Eff
1	11	9.1	84	830	913	91	9.0	9.27
2	12	8.34	140	700	840	83	16.7	16.7
4	14	7.15	204	510	714	71	28.6	28.6
6	16							
8	18							
10	20	5.0	250	250	500	50	50	50.0
15	25							
20	30							
30	40							
40	50							
50	60	1.66	138	28	165	17	83	83

$$P_L = I^2R; P_g = I^2r; \text{Efficiency} = \text{Eff.} = \frac{P_L}{P_L + P_g}$$

pedances if possible. Maximum power transfer is of greater importance than great efficiency. When the power is high, however, as a generator supplying lighting and heating power to a city, the efficiency must be high or the generator will burn up. At 50 per cent. efficiency (maximum power output), as much power must be dissipated in the generator as is used in the load. When the power is small, efficiency does not matter so much.

Voltage vs. Load Resistance

The higher the load resistance the greater the proportion of the total voltage available that appears across the load, and the less

across the generator. When the load and the generator resistances are equal, there is as much voltage on the load as on the generator. The sum of the voltages across these two resistors must equal the total available voltage.

Power Output from Tubes

The greatest power is taken from a tube and used in a load, when the resistance of one is exactly equal to that of the other. The greatest undistorted power, however, is transferred from a tube to a loud speaker when the latter has twice the resistance (radiation) of the tube. After you have plotted the data in the table, note how little power is lost by making the loud speaker have twice the resistance of the tube compared to the power obtainable when the resistances are equal. Note how little power is lost if the load has even five times as much resistance. From this you can gather that many of the articles and statements in popular radio journals about the importance of properly matching impedances are exaggerated. As a matter of fact doubling, or halving, the power from a tube into a loud speaker is just about audible to the average ear.

In an amplifier which is designed to increase the voltage and not the power, the impedances are not matched. In order to get the greatest voltage out of a low-impedance device, it is necessary to work it into a very high resistance so that of all the voltage available, the greatest part will appear across the load resistance. Thus in an a.f. amplifier the plate circuit works into a very high impedance, sometimes a straight resistance, as in a resistance-coupled amplifier, or the primary of a transformer if a step-up in voltage between tubes is desired. This primary impedance is usually several times greater than that of the tube out of which it works. This impedance must be high at the lowest frequency to which the amplifier is required to transmit without undue loss. Then at all other frequencies, the impedance will be still higher.

If the load has twice the resistance of the tube, three-fourths of the total voltage available will be used up across the coupling device, and hence will be applied to the next tube. If a transformer has an inductance such that at 100 cycles its reactance in ohms is three times the resistance of the tube, nearly 90 per cent. of the voltage at that frequency will be impressed across the transformer because of the fact that the voltage across the transformer and that across the tube are out of phase by 90°. At any other frequency the difference of transmission can be no greater than 10 per cent. (because the maximum transfer is only 100 per cent.), and thus a good characteristic is possible.

Problems

1. A tube (171) has a voltage of 26 (r.m.s.) applied to its grid. This voltage is multiplied by the "mu" of the tube, 3, and appears in the plate circuit as 3×26 . The resistance of the tube is 2000 ohms. Into what resistance should the tube work to transfer the maximum amount of power to the load? What will be the power then? What will be the voltage across the load? Across the tube?
2. The maximum "undistorted power" is transferred from tube to load when the latter has twice the resistance of the tube. What then are the power, the voltages across tube and load, assuming same data as in Problem 1?
3. An amateur transmitter oscillator can put 100 watts into an antenna through an appropriate coupling transformer. If the antenna current is one ampere, what is the resistance of the antenna?
4. An electrodynamic loud speaker has a very low resistance (15 ohms). Suppose it is connected to a power tube capable of an output of one watt and that by means of a step-down transformer 90 per cent. of this power goes into the loud speaker. What is the current in the loud speaker winding?
5. A loud speaker is properly matched to a 2000-ohm tube so that maximum power is transferred. Now a 10,000-ohm tube is put in the socket. What proportion of this tube's power is being transferred to the load? A good way to solve this problem is to assume some voltage, calculate the power in the loud speaker and the total power taken at this voltage. The proportion of the power usefully employed is the power in the loud speaker divided by the total power.
6. What transformer ratio must be used to connect the 10,000-ohm tube to the loud speaker for maximum power transfer?

Answers to problems given on this sheet will be found on page 179.

ELECTRONS AND TUBE TESTING

EVERYONE KNOWS that the electron is what makes the wheels in a radio vacuum tube, and hence in a radio receiver, go around. But servicemen, engineers, and others who know a lot technically about radio, are only on hazy terms with the electron itself, even though they know it by name and talk about it as if they were the best of acquaintances.

What is the electron? How big is it? How many are there? How fast do they travel? When a tube gets older, do the electrons get tired, or what?

The electron and its positively charged companion, the proton, are the fundamental building blocks of the universe. For many years it was thought by scientists that all matter was composed of atoms which were more or less all alike. Then it was discovered that the atoms were not all alike, but that there were about 90 different kinds of them corresponding to the 90-odd elements like gold, hydrogen, mercury—to mention three elements existing commonly in the three states of matter, solid, gaseous, and liquid.

Finally it was learned that these 90-odd atoms were all made up of different numbers and arrangements of electrons and protons. The protons are all in the very heart of the atom; some of the electrons are there too, probably, and the rest are at some distance from the protons but held to them by the attraction existing between these two oppositely charged particles.

How large is the electron? Well, everyone has seen oil films on the street. It is possible to get an oil film about one half a ten thousandth of an inch thick. Atoms must be at least this small

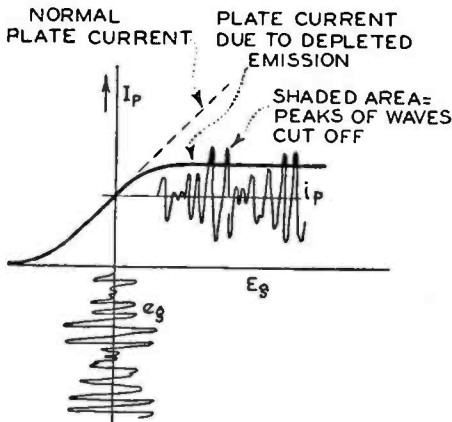

Fig. 2

and electrons must, of course, be much smaller yet. No microscope can see them; we are aware of the electron only when it migrates in company with many billions of its fellows.

If the atoms to which the electrons are attached, are agitated enough, by great heat for example, some of the electrons can escape much as the earth and the other planets escaped from the sun at some very remote time. Because these electrons are negatively charged they are attracted toward any positive body and the more positive the body is, or the nearer the electrons are to it, the faster the electrons go.

If an electron gets up a speed of about 600 miles per second it can escape from a metallic filament. If 10^{16} electrons per second arrive at the plate in a vacuum tube, a plate current meter would read one milliamperere. Now this number of electrons (it is actually ten thousand million million) may not seem like a very great number, but take out your watch, and for one minute count just as fast as you can. You may be able to count up to 300 in one minute. Then, if you like to juggle figures, calculate how long it would take all the people of the United States (110 million) to count out this number of electrons.

The milliammeter, then, is a machine for counting electrons in huge blocks. Instead of saying there are so many billion electrons per second flowing out of the plate battery and going through the tube, we bunch them (in motion) into very large groups called an ampere, or a milliamperere (one thousandth of an ampere).

The electrons in modern tubes come from paste or active material put on or in a wire which is heated by passing current through it. The idea is to get some material which will give off its electrons easily, so that not a great amount of power must be wasted in heating the filament. The 201A-type tubes and some others use thorium as the active element. Thorium is a relative of radium and gives up its electrons easily. It makes a very efficient filament. Some

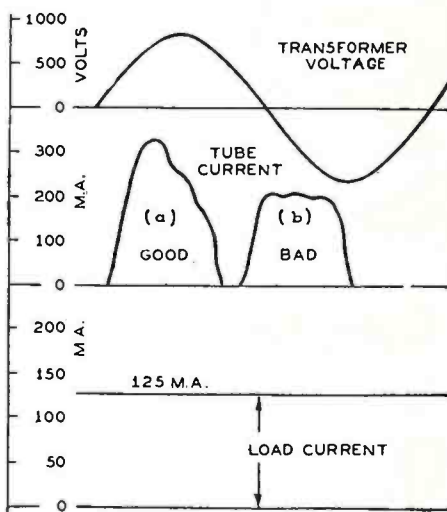

Fig. 1

tubes like the 280 and others which burn with a dull red glow are coated with oxides of rare earths of barium, cesium, etc. They require but little heat before the electrons go shooting off into space and looking for something positive to hang onto, so to speak.

The better the filament the more electrons; the more positive the plate the more electrons arrive per second, each carrying its negative charge or burden or electricity. When a tube gets old, its supply of electrons becomes exhausted, i.e., all the active material is used up.

Consider a single-wave rectifier tube which carries current when the plate is positive with respect to the filament. In some filter circuits the current taken from the tube at some instants may be as high as three times the steady current required by the radio receiver. If there are not enough electrons per second available to take care of this high drain, the curve of tube current output against transformer secondary voltage will flatten out and the output current curve will not look like the input voltage curve. Furthermore if you measured the resistance of the tube you will find that it has increased.

In Fig. 1 are the curves from a good and a poor rectifier tube. Now a flat curve like that in (b) is difficult to filter; therefore when the rectifier tube gets old, it not only refuses to supply the required voltage and current to the set because its resistance is high, but it also becomes difficult to filter and the loud speaker hums.

Now consider a power tube, a 245 for example. The steady plate current with no a.f. signal is about 50 milliamperes. Now if an a.f. signal comes along that has a peak voltage value equal to the C bias on the tube, the current at that instant may be twice the steady value or 100 milliamperes. Suppose, however, the tube is old and that, while it can supply 60 or 75 milliamperes, it cannot supply 100. Such a tube will function properly so long as the volume is not turned up to the point where the tube can no longer supply the peaks of plate current when the grid voltage becomes high. Then the output will begin to break down, and the loud

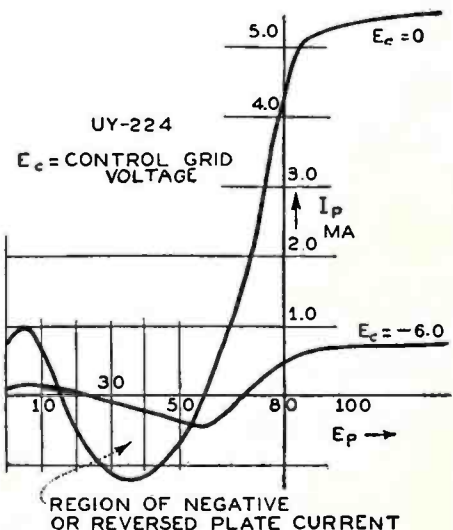

Fig. 4

passages sound as though they fell over themselves in trying to get through the system. They have a top-heavy effect. The trouble is that the source of electrons has been partly exhausted.

The effect is shown in Fig. 2 where e_g is the input grid voltage and i_p is the output a.c. plate current. Whenever this output current does not follow exactly the grid voltage, distortion enters the system. A magnified picture of this distortion is shown in Fig. 3.

Screen-Grid Tube

Many of the electrons which leave the filament never arrive at the plate. They either return to the filament or congregate out in the inter-electrode space. These electrons are negative and the little invisible cloud (called a "space charge") they form is negative. Therefore, they repel any electrons which come near them, and because they are between filament and plate they limit the plate current.

Now a second grid with a positive charge placed in the midst of this cloud will attract these stray and unhelpful electrons and thereby get them out of the way. Such is the second grid in the screen-grid tube. It is positive and attracts some electrons; there is some screen-grid current. If the plate voltage is high compared to the screen grid, the plate current will be high. Since the sum total of electrons taken from the filament and going to screen grid and plate is more or less constant, the greater the plate current the fewer the number of electrons that stop at the screen grid.

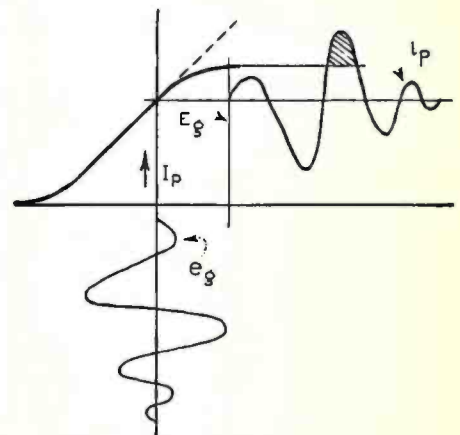

Fig. 3

Suppose, however, the screen grid and plate have about the same voltage. Now the currents will be approximately equal. An electron, speeded along by this positive grid will go through it and thump the plate. It may knock an electron out of the plate, perhaps one that has just arrived. This electron may go back to the screen grid and if enough of them return toward the filament the plate current will actually go backward; it reverses. This reversed current is said to be due to "secondary emission."

In Fig. 4 is the plate voltage-plate current curve of an a.c. screen-grid tube. Note that the plate current flows even though the plate voltage is zero. Why is this? It is because there is a stream of electrons going to the screen grid which is positive. Some of these go through the screen grid and form a plate current. As the plate voltage is increased, the plate current increases up to a certain point and then begins to decrease. When the two voltages are about equal the current to the plate is actually negative, this means that more electrons are leaving the plate than arrive at it. At higher plate voltages the secondary electrons are attracted back as fast as they leave the plate.

Pentode

If now still another grid is put into the tube and made positive, it will attract these reversing electrons and prevent the plate current going backward. Now we have the heart of the pentode. It is a tube with three grids, the usual signal grid which is maintained negative, a cathode grid which is the grid which cleans up the space charge or cloud of lagged electrons, and finally is the third grid which has about the same potential as the plate. It cleans up the electrons which are reversing their field.

A New Factor in Radio Construction

THE KINEMATIC REMOTE CONTROL

By M. B. SLEEPER

Sleeper Research Corporation.

ENGINEERS WHO have been working on remote control for radio sets have produced a wide variety of exceedingly clever devices. We, at the Sleeper Research Corporation, found that it would be difficult, perhaps impossible, to out-engineer some of the systems already in existence.

As a general policy, anyway, it is always well to forget others when you want to do something original. That was why we went back to pre-war times and set to work on a thirteen-year-old system, originally planned for airplane radio use, to make a piece of present-day merchandise.

There, briefly, is the story of Kinematic remote dial tuning. It isn't designed as a remarkable mechanism that does amazing things. It is only intended to meet a sales manager's requirements as a piece of merchandise. The only remarkable things about it are its simplicity, small size, and low cost.

What the Kinematic Does

Fig. 1 shows a Kinematic control box. There is a dial, the scale of which corresponds to the settings of the tuning condensers. This is rotated by the knob on the left of the box. The right-hand knob regulates the volume control which is mounted in the set. The volume control is the standard Yaxley device fitted with an a.c. toggle switch which is thrown over, when the volume is cut down to zero, to turn off the current supply to the set.

We feel that the proper place for the volume-control resistor is in the chassis—not inside the control box—because it is not good engineering practise to run long leads belonging to the radio circuits, here and there around the house. Moreover, when such an arrangement is employed, it limits the system to the use of only one control box.

Certainly any really useful system must be capable of controlling the set from two or three points, or up to a dozen if they are required.

How It Operates

In Figs. 2 and 3 are top and front views of a standard Sterling screen-grid chassis equipped with the Kinematic driving

mechanisms. The mechanism at the left is geared to the shaft of the four-gang condenser, while the one at the right moves the arm on the variable volume-control resistor. The contact arm, in turn, operates the toggle switch controlling the power.

These devices are referred to as driving mechanisms because, contrary to their

having started, inertia will cause it to turn the condenser too far. By eliminating inertia from the Kinematic device, and designing it to operate in synchronism with the control box dial, at any speed, the tuning condensers can be adjusted to an accuracy of greater than one-quarter of a division on the dial. Still finer settings can be obtained if it is considered necessary, but one-third or one-fourth of a division is sufficient for most sets.

Importance of Accuracy

The extreme accuracy of the Kinematic gives just as perfect and as close tuning at each box as can be obtained by hand at the set itself.

One of the great difficulties with pre-selection devices is the problem of stopping the condensers at a given setting, repeatedly over a period of months, right on the nose of each station. Any kind of contacts are subject to wear, and stops are moved slightly by repeated action, just enough to make a difference of plus or minus one-half the division or more. The result is that the adjustments require frequent re-setting. As this is a service which must be performed by a serviceman, and, as it is due to failure of the mechanism itself, the work must be done at the dealer's expense. As a result the cost of repeated re-settings may wipe out the profit from the installation.

Another thing, beyond the control of the manufacturers—a change in the antenna, the lead-in, or a ground connection—may throw out all the settings. Nor is the frequency of the broadcasting stations absolutely constant. The stations are only limited by Radio Commission regulations to an accuracy of one kilocycle, and, at that, many stations vary beyond this limit. Thus pre-selected settings, no matter how perfect, do not assure perfect tuning.

All these troubles are eliminated with synchronous dial tuning, but they are inherent with remote pre-selection. In this, remote pre-selection differs from hand-operated automatic tuning, for with the hand type of control no harm is done if the selectors do not bring in each station on the peak, for when the selector button is pressed the tuning knob is also within



Fig. 1—The Kinematic remote dial tuning unit.

appearance, they are not motors. They simply serve to actuate the condensers in perfect synchronism with the rotation of the dial on the control box, following not only in speed but in degree of movement.

This point is made because, although the driving mechanisms operate in both directions, they are not to be confused with the systems which employ constant-speed, reversible motors. Such motors are controlled by two buttons, one to make the motor turn left and the other to make it turn right. Stations are tuned in by juggling the buttons back and forth.

The disadvantage in this is due to the inertia of the armature. That is, if you want to make the condenser move only one-half a division, and you barely touch the button, the armature does not have time to start up. If you hold the button down long enough to start the armature,

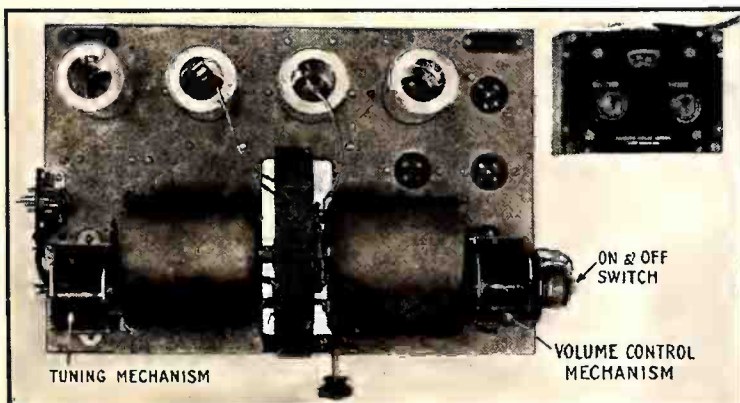

Fig. 2—Top view of standard Sterling chassis equipped with remote control mechanisms.

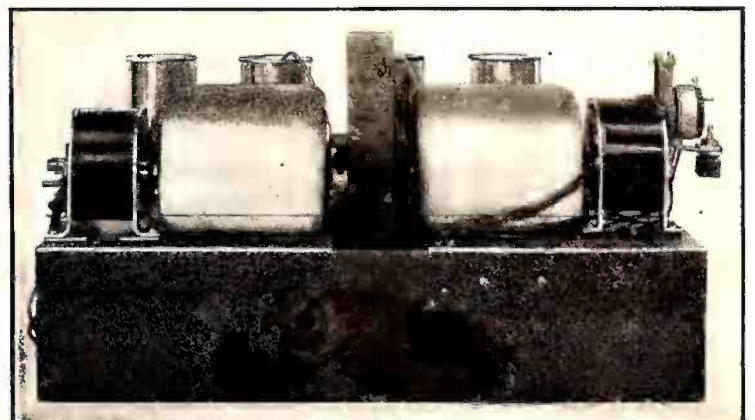

Fig. 3—Front view of chassis shows small size of tuning mechanisms.

reach for making more accurate adjustments.

Show a dealer a likely looking device, and listen for his first question—"How much does it cost?" He wants to know if it is a low-priced convenience for everyone or an expensive luxury for a few.

Discussing remote control, R. H. Langley, director of engineering for the Crosley Radio Corporation said, "Important improvements in the automotive field have not brought corresponding price increases. If remote control is to become a permanent feature of radio sets it must be possible for manufacturers to add it without substantial increase in the cost to the public." In this connection it is expected that the new models, equipped with Kinematics, to be brought out this spring, will cost only a little more—only ten or fifteen dollars—than hand-tuned models. On the other hand, remote control may bring about important changes, to be discussed in subsequent paragraphs, which will make it necessary to spend no more for the complete installation with remote control than for the present types of hand-tuned receivers.

The biggest feature of Kinematic is not seen as much as it is experienced. That is, the device is habit-forming. Just, as from habit, you open your front door at night, and reach for the switch to turn on the lights, so you reach, with little direct attention, for the tuning knobs of the Kinematic, changing the volume, tuning up or down to a program that is in keeping with your mood, or switching the set off altogether. When you have learned to depend upon the convenience of the control, you are conscious of what you accomplish, rather than of the means you employ.

There you have the difference between the gas water-heater which has to be lighted each time with a match, and the type which lights itself when you turn on the water. Kinematic removes the radio mechanism from your consciousness and leaves you with the sense of enjoying music from a source you need not consider.

What About Radio Furniture?

This season, most chassis cost less to manufacture than the cabinets which house them. To put it differently, and in a rather startling way, the companies that make sets and cabinets are more in the furniture business than in the radio business. If they do not make their own cabinets, they are supporting furniture companies larger than their own.

This is not a healthy development in the industry for, in order to permit a wider choice of good cabinets at reasonable prices, the radio equipment is being ruthlessly engineered to lower costs. There are many improvements which are now excluded from the radio chassis simply because their cost is put into the appearance of the cabinet.

The trend of design for 1930—and this will be most pronounced by 1931—is to eliminate the necessity for elaborate cabinets by putting the set, enclosed in a plain metal box, out of sight, operating it by remote control.

While it is true that the initial results obtained from 1929 model sets, equipped with screen-grid tubes, show some improvement over preceding types, and although the outward appearance of the new sets is generally more clean-cut and attractive, the result of cost reduction is apparent the moment you dig into the chassis to shoot trouble. This year parts are being hung together by the wiring. No attempt has been made to facilitate the finding of faults which develop all too rapidly. The wiring has simply been moved to the under side of the chassis

where, out of sight, it is done in a most haphazard manner. The coming season will certainly demonstrate the general

no need for furniture except to house radio and phonograph combinations. These instruments must be a part of the home furnishings, but the radio set should take its place with the other home electrical and mechanical devices, out of sight.

How It is Installed

The set manufacturer's first question concerning remote control is, "What changes must be made in the chassis?"

With thousands of dollars invested in manufacturing tools, dies, and fixtures, no company can afford to make sweeping changes in the current chassis designs in order to accommodate remote control, no matter how good it is. This is particularly true in the case of controls which require a considerable increase in the overall dimensions of the chassis, for then the chassis cost is increased also.

The driving mechanisms described in this article are so small, fortunately, that they can be fitted on as compact a job as the Crosley receiver. It is necessary to locate the tuning mechanism at one end or the other of the condenser shaft, but the volume and switching mechanism can be put anywhere that space can be found.

Nor is any complicated assembly problem introduced. To avoid the use of the flexible coupling, the large gear is mounted on the condenser shaft. Then, when the driving mechanism is in place, it is moved up until a pinion engages smoothly with the big gear, and the holding screws tightened permanently.

The volume and switching device is a complete unit in itself, so it does not require a special assembly on the chassis. Leads which, on hand-tuned sets, were brought to the volume control and power switch, are connected to these devices now mounted on the driving mechanism.

A separable connection or terminal strip is used for connections from the mechanism to the cable. This circuit is shown in Fig. 4. The wiring is very simple to do because all the control boxes hook on in parallel. Small terminal boxes are provided for the cable connections to the boxes, as it is safer to use this method than to employ ordinary splicing.

Much New Business Ahead

Every family that has bought a radio set to which remote control can be attached is a prospect right now. The first sale may include only one or two control boxes. Subsequent calls, after the people have become acquainted with this new device, will bring many sales of additional boxes. Spring and fall moving times will bring substantial extra business in re-installing the control equipment.

Already, many concerns which specialize in wiring new houses for radio are planning to sell Kinematic installations. When houses are wired for remote control, the cable will be led to seven-contact wall plates, into which a convenient length of cord, attached to a control box, can be plugged, just as wall outlets are provided for electric lamps.

New sets, Kinematic-equipped, open another field of sales and installation work for dealers. This can be developed most profitably for there is not only the initial work to be done, but follow-up sales of additional controls.

These are time-plus-profit jobs, requiring no subsequent free service. No routine inspection is needed. There are no brushes to be replaced, armatures to be rewound, grease cups to fill, or adjustments to be regulated—things which must be done free of charge—only clean-cut set sales and installation for which charges can be made legitimately.

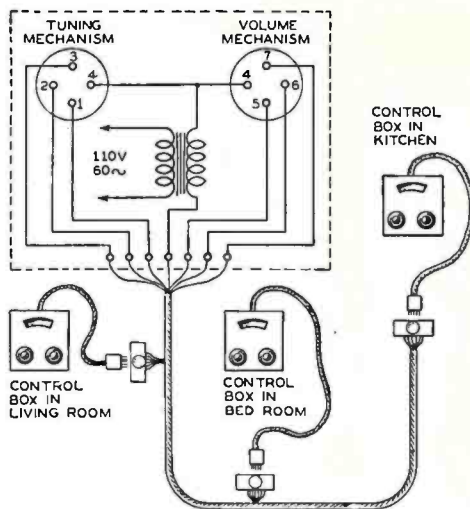

Fig. 4—Diagram showing how the remote dial tuning units are connected with the receiver.

fallacy of cheap construction where it has been carried to an extreme in radio receiver sets.

Scientific development has been brought to a standstill because improvements which would increase the cost of the chassis are prohibited. The use of remote control will permit a part of the present cost of cabinets to be put into better radio equipment. The overall cost to the public will be no higher, but the public will buy more radio and less cabinet. This is easy to understand when you realize that furniture companies entering the radio field buy standard chassis for less than twenty-five dollars, and retail these chassis, fitted into cabinets at two hundred and fifty dollars.

With remote control available there is



JOHN S. GORMAN (Gulbransen): "Although the stock market upheaval undoubtedly may cause a radical readjustment affecting many concerns, we are going full steam ahead."

MAJOR FROST (Radio Manufacturers' Association): "The era of suspicion and distrust among radio manufacturers is over."

HAROLD A. LAFOUNT (Federal Radio Commission): "Expressions from listeners throughout the nation concerning the character of the programs they enjoy should aid the Radio Commission in properly appraising the public service rendered by broadcasters."

J. L. RAY (Radio-Victor): "At no time in radio's short but spectacular history has it been possible to get so much for the radio dollar."

H. B. RICHMOND (Radio Manufacturers' Association): "Fortunately for the average pocketbook, radio receiver design has reached a point where to-day's set does not make yesterday's obsolete."

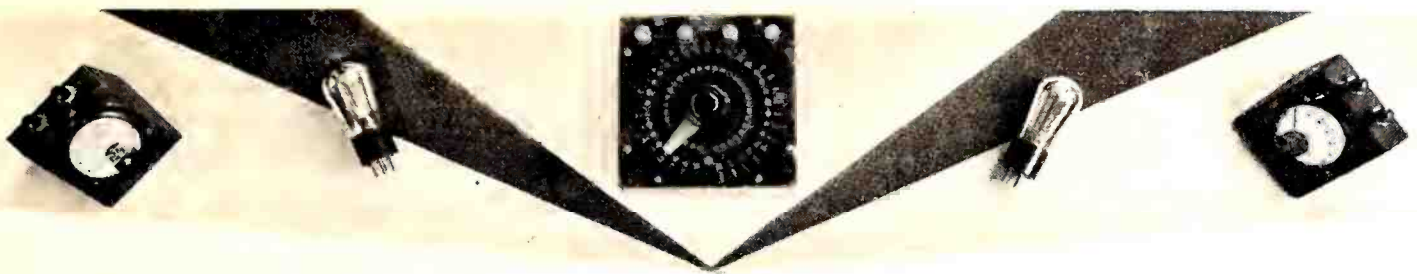

STRAYS FROM THE LABORATORY

A Novel Wavemeter

The picture in Fig. 1 illustrates an interesting and effective addition to the resonance type of wavemeter. This device, which was first described in the *General Radio Experimenter*, September, 1929, consists simply in a small fixed capacity which can be thrown across the variable tuning capacity by means of a push button, and is useful in getting an accurate setting of the meter. (See Fig. 2).

Suppose for example, as in Fig. 3, the variable capacity is equal to C_1 so that the current is indicated at I_1 . Then pressing the push button throws the fixed capacity into the circuit and makes the current equal to I_2 , which, in this case, is numerically equal to I_1 . In other words, at one point on the variable condenser dial, pushing the button will not cause a change in current. This point, C_1 , is taken as the calibration point. At any other setting of C pushing the button causes a change in current.

There is one disadvantage of this type of wavemeter—the tuned circuit is not exactly in tune with the circuit whose frequency is being measured. Therefore, the tuned circuit of the wavemeter has some reactance which will be reflected into the tuned circuit under test. This may change the frequency of the circuit with the result that the reading will not be accurate. This difficulty can be obviated by using very loose coupling, and by changing the coupling as the setting of the wavemeter is adjusted to the proper point.

An International Broadcaster

Down in Heredia, Costa Rica, "the center of America," is a patient amateur, Amando Cespedes Marin. For several years Sr. Marin, who has many medals for proficiency and artistry in photography, has maintained and operated a 7.5-watt amateur radio telephone station on 30.8 meters. Despite such limited power, Sr. Marin's voice and music have been heard all over North, South, and Central America and he has not only secured considerable favorable notice for his station but also for his city and his nation. For some time he has been making a plea for funds with which to enlarge his station and to increase its power.

Contributions have been received in small amounts from many of his listeners in the United States and elsewhere and one enterprising American manufacturer sent him a batch of tubes and a check for \$50. Now the Costa Rican city, Heredia, has given him \$150 and money for telephone lines to the municipal band stand. He has collected nearly enough to bring his power up to 150 watts which should fling his voice into the short-wave receiver of many hundreds of avid listeners. Con-

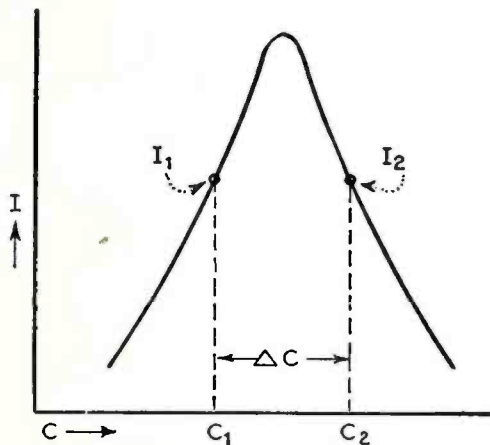

Fig. 3

tributions may be mailed to Sr. Marin and will be appreciated.

An Interesting Formula

An interesting expression in the next column gives the relation between stability in an r.f. amplifier and the circuit con-

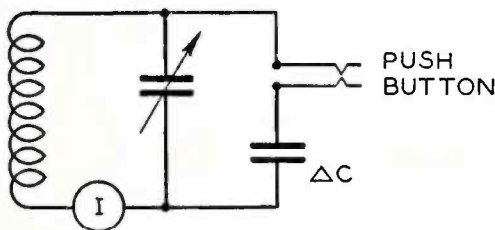

Fig. 2

stants, such as plate resistance, coil resistance, grid-plate capacity, etc. The lowest resistance the tuning coil can have may be found by substituting the circuit constants in this expression at the highest

frequency to be used, viz., 1500 kc. for the broadcast band. The circuit will be stable at all other frequencies. The plate of the preceding tube and the grid of the following tube are connected across the entire coil. Perfect shielding is assumed except that due plate-grid capacity.

$$\frac{C_{gp} \omega G_m}{r \left(r + \frac{1}{R_p} \right)} = 2$$

where C_{gp} = grid-plate capacity
 ω = $2 \pi f$
 G_m = mutual conductance in mhos
 r = high-frequency resistance of coil
 R_p = plate resistance of tube

A "New" Recording System

In October the public press in England was greatly excited by the report of a new invention, made in Germany, having an application in the talking motion picture industry and in the recording of sound for home entertainment. The method consists simply of impressing audio-frequency currents on a pair of electromagnets between which an iron or steel wire is drawn at a constant rate. The wire is magnetised according to the voice modulation, and when the process is reversed the sounds may be reproduced. The time interval between recording and reproduction may be as short as desired.

Some time after the disclosure of the principle and the general hurrah about it in the newspapers, someone discovered that the idea was not new at all but had been invented some thirty years before by Valdemar Poulsen, the Danish radio engineer of world-wide fame. This was then related in the papers and altogether there was quite a hullabaloo.

We remember discussing this method of sound recording with Theodore H. Nakken several years ago. He had worked with it and found it a successful method provided the wire could be made to retain the "sound," which, at the time of the discussion, had not been found possible.

Newspaper clippings about the affair were sent through the courtesy of Lawrence Corbett, formerly of the editorial staff of *RADIO BROADCAST* and now of London, England.

Two New Booklets

Research Papers Nos. 77 and 90 of the Bureau of Standards describe, respectively "A Course-Shift Indicator for the Double-Modulation Type of Radiobeacon" and "A Comparison for the Calculation of the Inductance of Coils and Spirals Wound With Wires of Large Cross Section." The former is by Harry Diamond, radio engineer, and F. W. Dunmore, physicist, and the second by Frederick W. Grover, consulting physicist.

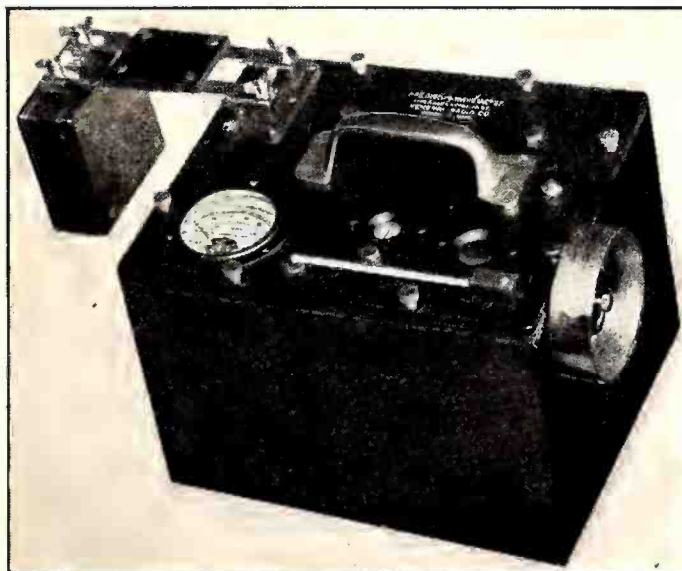
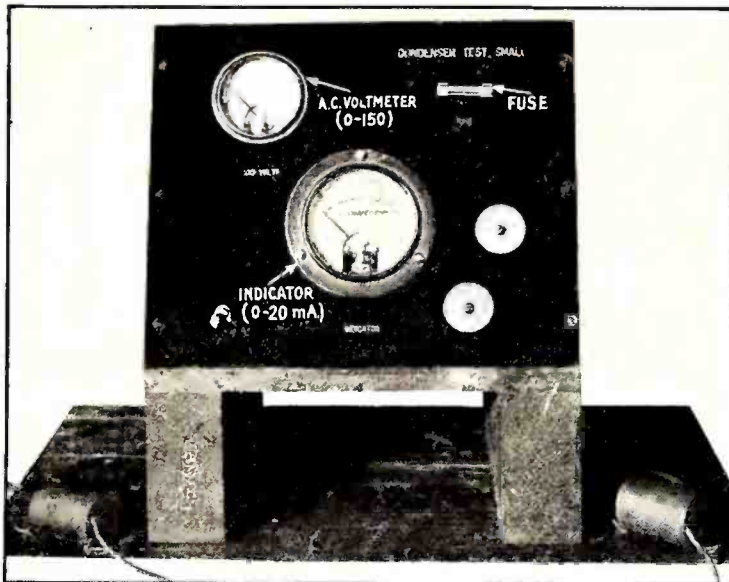

Fig. 1—General view of the new wavemeter developed by General Radio.

A PRODUCTION TESTING SYSTEM

By J. A. CALLANAN

Stewart Warner Corporation



This apparatus measures the capacity of small by-pass condensers. The schematic diagram is shown in Fig. 5.

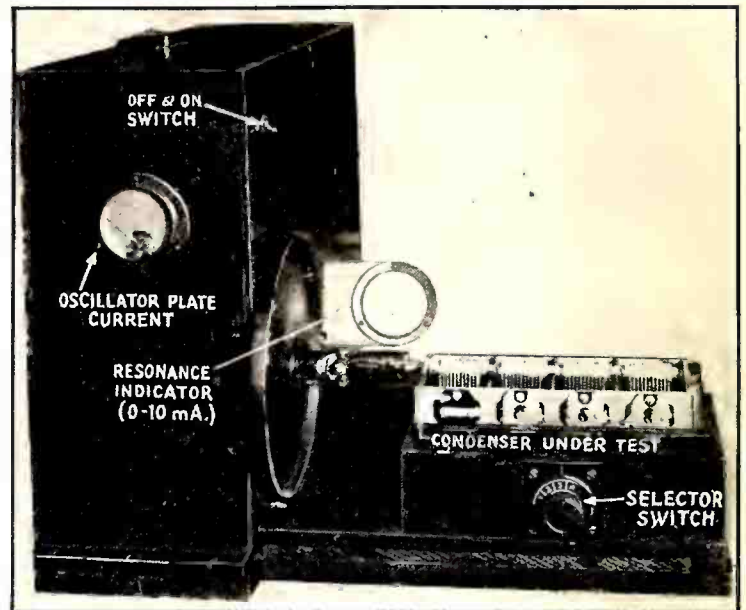

An instrument for rapidly testing gang condensers.

THIS is the first of a series of several articles which will consider the testing of radio parts and receivers from the production viewpoint. In this installment information is given on the method employed at the Stewart Warner Corporation for the testing of condensers used in radio receivers. Furthermore, in presenting these data it has been assumed that the reader is familiar with the more severe percentage tests which are run in the laboratory and from which the inspection department limits are derived.

Without further introduction we will enter into the discussion. To begin with the requirements of production testing are, as we find them, listed in the following table in the order of their importance:

- 1.—The test must be complete and accurate.
- 2.—The test must be quick.
- 3.—The test fixtures must be safe for the operator, as often potentials which might prove fatal are used.
- 4.—The cost of the test fixture should be reasonable.
- 5.—The test fixture must be made so as to be fool proof, and in case damage results to it, easily serviced.

With the above requirements in mind

we can consider the production testing of condensers of the type used in radio receivers. In Stewart Warner sets, which are nearly all of the single-dial a.c. screen-grid type, there are five types of condensers which must pass exacting tests before they are considered satisfactory for use as component parts of the completed receiver.

Of major importance is the testing of the gang variable condenser and the coupling condensers attached to it, and this is probably the most interesting as its requirements are the most exacting. After the condenser is received by the inspection department it is given a visual examination for bent or defective plates and defective construction. It is then placed on a conveyor belt, and upon reaching the first operator the coupling condensers are given a breakdown test at 500 volts a.c. This is accomplished by use of a small step-up transformer with a neon lamp connected in each side of the high-potential winding and two well-insulated circuit test pointers. In this case danger to the operator is guarded against by using a very small transformer which on direct short only consumes from 10 to 15 watts.

After the test described above the con-

veyor takes the condenser to the next operation, the setting of the coupling condensers by the beat oscillator shown in Fig. 1. The test apparatus for this operation consists of an oscillator, an oscillating detector and a conventional two-stage a.f. amplifier. Headphones are used on the output rather than a loud speaker because the operator is not distracted as easily by other noises in the room. In performing the test, the condenser is placed in a jig which has three stops, one opposite each coupling capacitor. The operation merely consists of tightening the set screw on each section, in turn, until its capacitance is correct to place the oscillating detector in resonance or zero beat with the standard oscillator. Standardizing is accomplished by throwing a switch from test to standard position, thus connecting a standard condenser of the desired capacity across the test position; variation is compensated by a small condenser connected across the detector. To sharpen the response and minimize coupling error, the oscillating detector beats against the second harmonic of the standard oscillator.

More accurate results could be obtained in this test by modulating one of the oscillating circuits with say a 1000-cycle

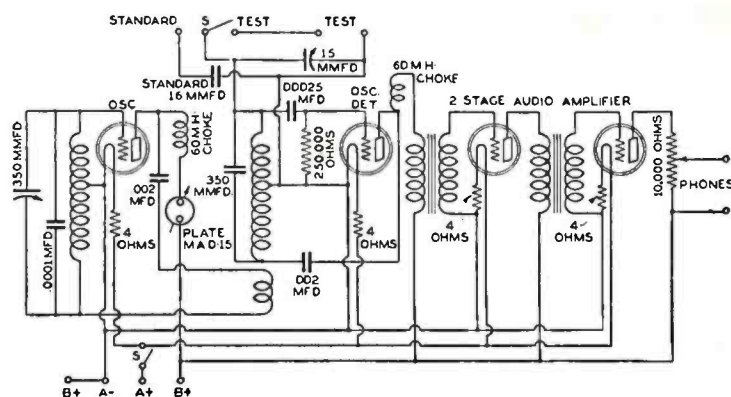

Fig. 1

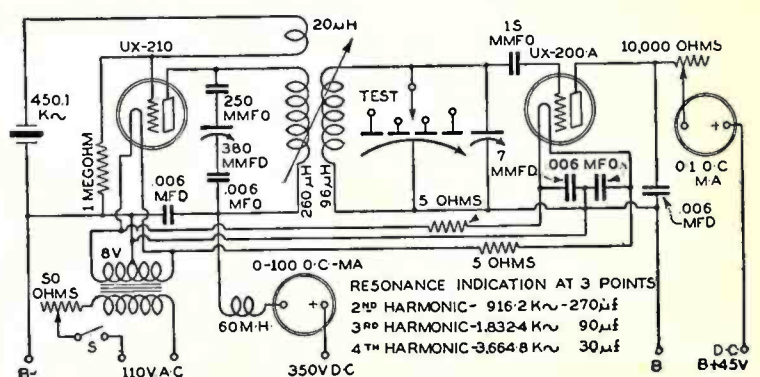

Fig. 2

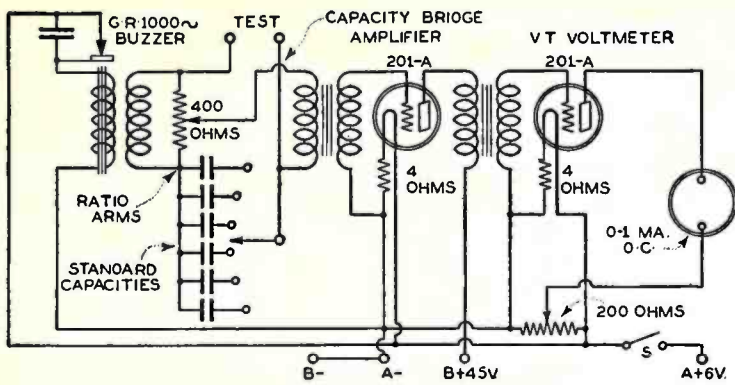

Fig. 3

source and beating against that. However, it was not found necessary because if the circuits are correctly adjusted differences of 0.1 mmfd. can be made to make a note of approximately 100 cycles in the headphones. Also, when using the 1000-cycle modulation there is the possibility of the operator beating either 1000 cycles above or below the standard. This is a 2000-cycle error compared to the more sure zero-beat method with possibly a 75-cycle error. Variation of these condensers in the following operations is prevented by applying a dab of ambrod cement to the adjustment screw. The test set-up uses one 45-volt B battery as a.c. operation has not been found practical.

The Third Operation

The third operation is the testing of the gang condenser sections. The test fixture consists of a 450-kc. crystal-controlled oscillator coupled to what might be termed a vacuum-tube voltmeter. As can be gathered from the picture on page 152 and the diagram, Fig. 2, the condenser with plates open is placed in a jig, a large dial is clamped to its shaft, and the plates are meshed until maximum deflection of the meter denotes resonance with the fourth harmonic of the crystal oscillator (3600 kc.). In our particular case this occurs when the condenser capacity is approximately 30 mmfd. The variation allowed at this point is 0.3 mmfd. or 1 per cent. The four sections are alternately tested at this point by use of the selector switch as may be seen by again referring to Fig. 2. The plates are then meshed further until the meter again deflects, this time at 1800 kc., the third harmonic, and the sections tested as before. The capacity of the condenser at this position is approximately 60 mmfd. and the limits 0.6 mmfd. or again 1 per cent. The plates are then interlocked almost completely, resonance being noted at the second harmonic of the oscillator (900 kc.) and each section is tested again. The capacity at this point is approximately 270 mmfd. and the limits 1.5 mmfd. or somewhat less than 1 per cent.

The potential for the oscillator is supplied by a motor generator and the oscillator output is controlled by the variable condenser in the plate tank circuit. As it is possible to touch this condenser when adjusting the fixture, series fixed condensers are used to guard against a possible shock. The 100-mA. meter is employed to indicate the condition of the oscillator. The 8-volt centertapped filament transformer supplies both tubes while the 10,000-ohm resistor makes possible control of the resonance reading. The small variable condenser paralleled with the test position allows for variation in the tube capacitance when replacements are made. The 15-mmfd. condenser in the grid lead of the vacuum-tube voltmeter provides an automatic control of the resonance dip. A setting is possible with

it that gives the same deflection for each position. This fixture uses a motor generator and one 45-volt B battery, high-potential rectifier systems having been found rather unstable.

Fixed Condensers

The testing of fixed mica condensers of 0.01 mfd. or less is not such a complicated matter. The condensers are first tested for breakdown under conditions similar to those used in testing coupling condensers.

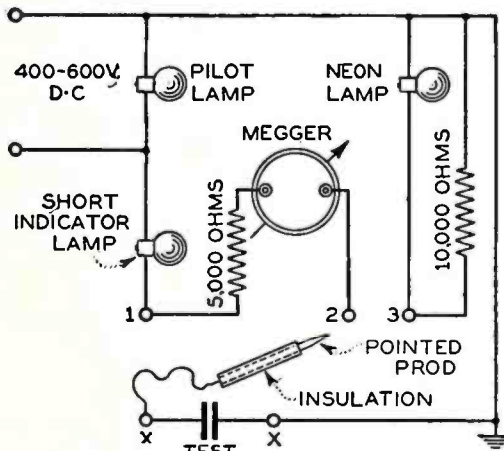

Fig. 4

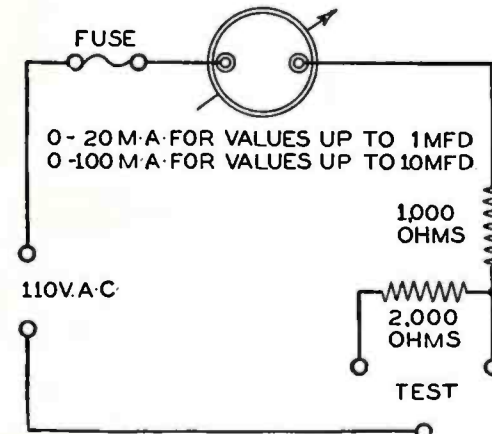
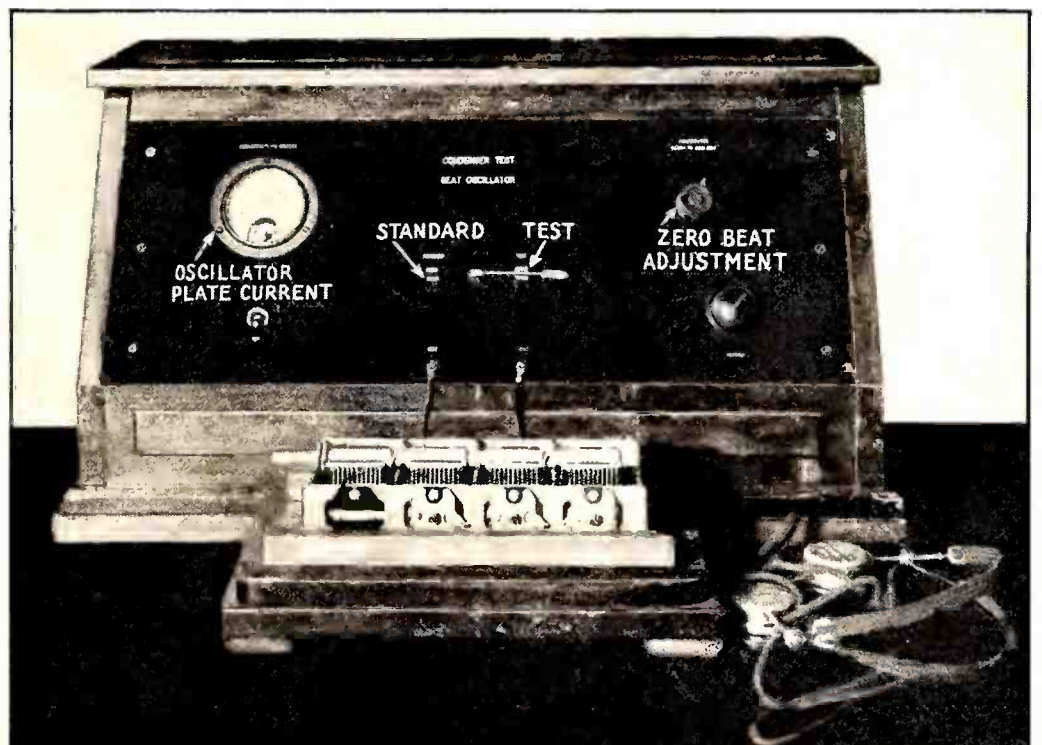

Fig. 5

The two fixed terminals take the place of the test pointers, and, as the condensers used are of the moulded bakelite type they are held in the bare hand while testing. The capacity test, as may be seen from Fig. 3, consists of a conventional bridge circuit actuated by a 1000-cycle source, the sound being amplified and then indicated by a vacuum-tube voltmeter. A dial is attached to the 400-ohm potentiometer with the desired limits painted on it. By selecting a standard of the same capacitance as that which is being tested, the bridge is always balanced at the center of the dial of the potentiometer. The limits are of the same width for all values. It is only necessary for the operator to note that the value marked opposite the selector switch corresponds to the value of the condenser being tested and that the minimum deflection is within the painted limits on the dial. The 200-ohm potentiometer is a sensitivity adjustment on the vacuum-tube voltmeter as, of course, much greater deflections are noted when testing 0.01-mfd. condensers than 0.00025 mfd. units. Operators soon become so accustomed to the deflections noted on this meter that they center the potentiometer dial and then are able to tell whether or not a condenser is within the required limits by the deflection of the meter. The test fixture uses a storage battery and a 45-volt B battery.

Filter Condensers

Filter and by-pass condensers differ only in their values and rated operating potentials in so far as testing is concerned, and so, of course, they are tested similarly. At the start of their journey through the inspection department they are placed on conveyor belts, depending upon whether they are filter or by-pass condensers and the type of set for which they are intended. They are given three tests; the first two, breakdown and insulation resistance are one operation, while capacitance measurement is another. The circuit used for the breakdown-insulation resistance test is shown in Fig. 4. The condenser is clipped into the test position and given a breakdown test by inserting a prod in terminal No. 1. This places twice the rated operating potential on it and should the condenser prove to be defective a red lamp lights, indicating a shorted condition. (Concluded on page 179)



A machine for production testing of coupling condensers.

RESONANCE AND REVERBERATION

By HOWARD E. RHODES

Technical Editor

EXCESSIVE low-frequency response of a loud speaker mounted in a cabinet may be due to one or a number of factors—reverberation, resonance of the cabinet, acoustic coupling between the tubes and the loud speaker, and so on. The subject is one which has been given no small amount of attention, and, to determine what methods are used in eliminating these effects, we asked a number of representative engineers for their comments. In sending out these questions the particular problem we had in mind was the practicability of using some type of sound-absorbing material as a lining in the cabinet. An analysis of the replies showed that the general consensus was that acoustic linings in cabinets are not very effective in eliminating low-frequency response.

What Six Engineers Say

The replies proved interesting. One engineer pointed out that, "The idea of using a cabinet lining seems to have little merit. If the chamber resonance is below the range of the loud speaker, or does not correspond to a peak in the response, no treatment is needed. All a lining can do is to absorb say 50 per cent. of the harmful sound, which is necessarily loud so close to the loud speaker. The remaining 50 per cent. will do practically as much damage, if the condition is noticeable, as all of the original energy."

The chief engineer of a large receiver manufacturing company wrote us, "In the attempt to find a suitable lining material for the cabinet it has been our experience that differential absorption exists with practically all materials which have an absorption coefficient sufficiently high to

prevent coupling from the loud speaker to the tubes by the absorption of the energy caused by resonance in the cabinet. This means that the loud speaker response is partially altered due to the fact in some materials the higher frequencies are absorbed much more readily than the lower frequencies, causing non-linear energy response with respect to frequency."

From another engineer we learn, "We have done very little work along this line but the results to date indicate that lining of offending cavities with sound-absorbing materials is not very effective. We have found that venting the walls or floor of the cavity is a far better solution. A reduction of 3 dB (50 per cent.) in energy at resonance, which is about as much as can be expected by lining cabinets with sound-absorbing materials, is barely noticeable and certainly is not a practical method of attack. I believe you will find that any information you may gather on this subject will be of considerable interest."

Another engineer says, "For small loud speaker cabinets, the use of absorbing material inside the cabinet is often advisable. For large size cabinets, I do not see any better way than leaving the back of the cabinet open."

From the chief engineer associated with a large radio receiver manufacturer we learn, "We have found that venting the walls or floor of the cavity is a far better solution than using sound-absorbing material. It frequently happens that a shelf or wall of the cabinet will vibrate and thus augment the hang-over due to cavity resonance. More rugged construction or breaking up of the vibrating surface by slits or holes is the customary remedy. We further find it very desirable to use a

large opening in the cabinet for the loud speaker, the gap between the edge of the opening and the diaphragm of the loud speaker

being closed by a baffle of sound-proofing material such as Celotex.

Another engineer stated that "In my estimation, there are several kinds of cabinet resonance. The first and simplest is the natural frequency of the air chamber itself. It is always quite pronounced and usually very easy to eliminate by making suitable openings in the cabinet. The second and much more harmful resonance is that of the wooden structure which is not simple. On the contrary it is very complex and interlinked with acoustic regeneration. Some manufacturers suspend the chassis on rubber cushions.

Data From Insulite Co.

With these and other replies as a basis we then made contact with several companies and individuals who were more directly concerned with the properties and uses of acoustical materials. From V. L. Larson and J. M. Osborne, of the Insulite Company, we received the following summary:

"The differences between reverberation, resonance, and cabinet vibration effects produced by the loud speaker operating under heavy loads are not clearly understood.

"Cabinet resonance is, of course, perfectly normal and easily handled. Resonance usually occurs in well-made radio cabinets at the lower frequencies if at all. In light-weight veneer cabinets resonance effects are much more pronounced, due to the mass characteristics of the cabinet system.

"Large area panels, especially when constructed of veneer stock, will have acoustical characteristics. However, panel vibration is not resonance, and should not be confused with resonance effects. The solution of this type of trouble is obviously one of rigidity and the proper cutting up of the large areas, capable of relatively large displacement amplitudes, into small

FREQUENCY	128	256	512	1024	2048	4096
WATSON		.36	.70	.76	.76	
KNUDSEN	.37	.50	.67	.74	.80	.77
SABINE		.38	.61	.70	.57	.46
BU. STDS.	.19	.42	.61	.72	.76	
AVERAGE	.28	.42	.65	.73	.77	.77?

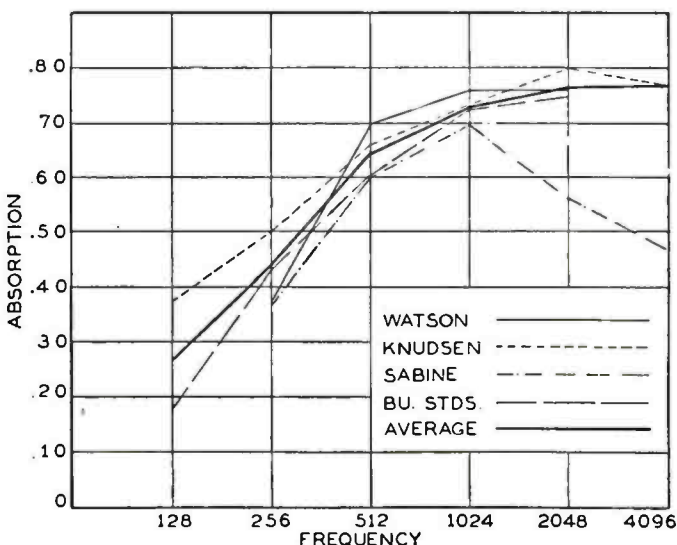

Celotex type B B

FREQUENCY	128	256	512	1024	2048	4096
WATSON		.24	.47	.49	.60	
KNUDSEN	.28	.32	.46	.56	.61	.62
SABINE		.27	.40	.46	.42	.42
BU. STDS.	.16	.26	.40	.62	.64	
AVERAGE	.22	.28	.43	.53	.62	.62?

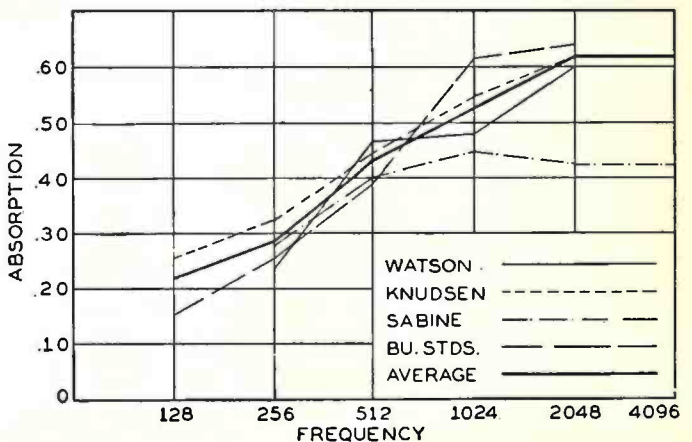

Celotex type B

Fig. 1

Fig. 2



A Rayleigh disc having a period of vibration of 15 seconds was housed in the box shown above. The disc was 1.2 cm. in diameter, 34 mg. in weight, and was suspended by a quartz thread about 15 cm. long.



The two pictures above and the one below show views of the apparatus used by F. R. Watson, of the University of Illinois, in his tests on acoustic material. The results of this work appeared in bulletin No. 172 published by the University. Above is shown the reverberation room.



Courtesy Temple Corporation

The sound-proof room pictured above is lined with type B Celotex. The sound absorption coefficient of the material is 0.7 and the thickness of the lining is 8 inches.

areas having low amplitudes. The result of proper rigidity and support is the reduction of amplitude displacement to a value where this effect becomes negligible. That rigidity and support are important may be seen from the fact that the limits of panel amplitudes, or displacements, necessary to produce a barely audible and an intense sound range from 5×10^{-3} (0.00000005) to 0.004 inch.

“Reverberation is the chief cause of trouble in radio cabinets, especially those types having appreciable depth. The cubical content is the governing factor in any radio cabinet. Optimum reverberation is that time value giving best acoustical results and can, for example, be accurately calculated by formula. We are now working on a formula suitable for use with very small volumes such as are encountered in radio applications. For large volumes, such as rooms, auditoriums, and theaters the equation is

$$t = \frac{0.05V}{a}$$

where t is reverberation time in seconds; V is the room contents in cubic feet; and a is the number of acoustical units (absorption coefficient times area in square feet).

“Acoustical units are calculated using an open window as a basis of 1.00 unit per square foot. In this respect Insulite has a value of 0.30 at 512 d.v. (double vibrations), the absorption values decreasing slowly at lower frequencies and increasing slowly as the frequency increases.

Open Back Cabinets

“We wish to point out one fact that governs the use of open back cabinets, especially those of appreciable size. This is the fact that while the sound-absorbing constant of an open space is unity, this value assumes infinite space behind the opening. When a radio cabinet is placed in a room and is set out at a varying distance from the wall, the open space does not act as an efficient absorber but becomes, in reality, the mouth of the horn formed by the cabinet. The wall behind the cabinet, therefore, must assume the duty of absorber, and since the absorbing coefficients of walls are of very small magnitude, the sound issuing from the cabinet is reflected into the room and back into the

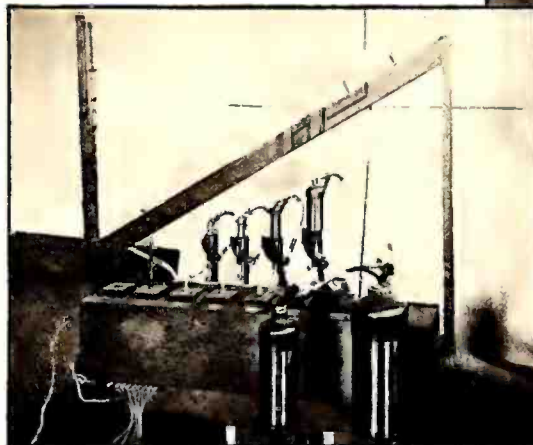

Watson's tone variators were adjustable Helmholtz resonators. They could be tuned easily and were practically free from overtones.

cabinet at practically the same intensity as when received.

“This reflection from wall to room results in greater efficiency since the input into the loud speaker may be much lower for a given sound intensity; it being assumed that no bad acoustical effects occur. Actually, however, the reflected wave and the wave emitted by the front of the loud speaker are not in synchronism; the result being a lack of clear cut articulation which may become very serious when the loud speaker is being operated at high sound levels. This reflection and secondary cabinet reverberation may be corrected in several ways; for example, by enclosing the back almost entirely but leaving a sufficient number of openings to equalize the air pressures within the cabinet. Large cabinets, having very bad reverberation and druminess effects, have been treated by a new method which cannot be disclosed at the moment so that the barrel effect was eliminated and clear cut audition obtained. Varying the adjustment beyond this point resulted in an ultimate total lack of quality, the entire system being so dead acoustically as to be lifeless and impractical. This method is, therefore, applicable to any size of cabinet and any type of loud speaker, since the practical results have proved that the optimum, or any other, degree of reverberation can be obtained for any such system. However,

it should always be kept in mind that a certain amount of reverberation is desirable in any enclosure in order that the esthetic aspect of pleasing, well rounded out tones be secured.”

There is one point in the preceding discussion about which a few more words might be said. The separation of cabinet resonance (vibration of the cabinet itself) and reverberation is desirable to clarify the discussion. It should be realized, however, that reverberation is actually resonance of the air activity.

Mr. Knudsen's Opinion

We asked V. O. Knudsen, of the University of California, well known for his work in sound, for his opinion on the subject and he answered with the following interesting comments:

“The resonant frequency of the average radio cabinet is very low. When used as a housing for an electrodynamic loud speaker which ordinarily is an efficient radiator of low-frequency sound, there is certainly a tendency to over-emphasize the low-frequency components. The loud speaker and cabinet may actually constitute a coupled system which would selectively enhance the low frequencies. Naturally, the lining of the cabinet with absorptive material will introduce resistance and loosen the coupling, both of which factors would tend to eliminate any sharp resonance. Since such resonance as may be developed by the cabinet has a low frequency, it is necessary to line the cabinet with material which has relatively high absorption at the low frequencies. This calls for a rather thick lining. For example, one half an inch of felt has a coefficient of sound-absorption of only about 0.08 at 128 d.v., which is not much more absorptive than wood which has a coefficient of about 0.06 at 128 d.v. Felt two inches

thick has a coefficient of about 0.20 at 128 d.v. This would be expected to reduce greatly the resonance at low frequencies, whereas a one-half inch thickness of felt may not be adequate.

"I have not conducted any research on

FREQUENCY	128	256	512	1024	2048	4096
WATSON		.12	30	48	55	
KNUDSEN	.19	23	32	39	52	50
BU. STDS.	09	14	22	47	63	
AVERAGE	14	16	28	45	57	55?

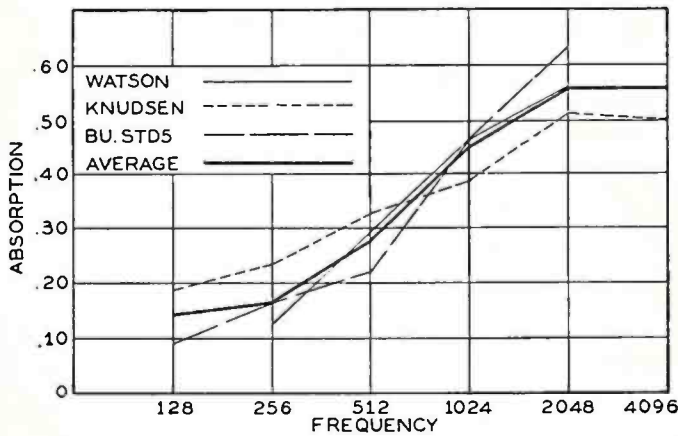

Fig. 3—Celotex Type C

this specific problem; but it seems to me that it is highly important that the subject be given a thorough investigation. It is certainly a subject which admits of both theoretical and experimental work, and it would seem to me that careful work of this nature would be handsomely rewarded. It is not improbable that a type of absorptive material could be developed which would supplement the loud speaker unit in such a way as to provide a more uniform radiation of energy at all frequencies in the sound spectrum. Certainly it does not seem feasible to use as a lining a thin felt which is probably five or six times more absorptive for high frequencies than it is for low frequencies."

Data from Celotex Co.

Wallace Waterfall, who has done considerable work for the Celotex Company, has given his opinion on the manner in which tests on this problem should be conducted. He says:

"The only way to answer the question is to make proper tests. When such experiments are made I believe that care must be exercised in setting them up in the proper way. The normal way of measuring the effect of absorption on resonance would probably be to place a loud speaker in some kind of a cabinet, actuate it with an oscillator, and determine the acoustic response both with and without an absorbent lining in the cabinet. This may be the wrong procedure. In actual practice the radio receiver is mounted in the same cabinet with the loud speaker and the vibration from the speaker is communicated to the receiver. At points of greatest cabinet resonance the vibration of the console is the greatest. This vibration is communicated to the tubes which, through microphonic action, still further amplify the resonance points. Celotex or Acousti-Celotex as cabinet lining should tend to reduce the loudness of the air sound at resonance, as well as to reduce the vibration. Therefore, I believe that a test should be set up on a standard radio set consisting of loud speaker, receiver and all. The source of sound used for the test purposes should be a radio-frequency oscillator modulated to the various test audio fre-

quencies. Such a test would be very difficult. It would require electromagnetic shielding as well as careful attention to the interference pattern in the room. It might be simplified somewhat by an investigation of the response near the resonance points only."

The effectiveness of any acoustic material in reducing so-called resonant effects is due not so much to its absorption characteristic at the particular frequencies at which excessive response occurs as it is due to a change in the resonant frequencies that an acoustic lining produces. Lining any enclosure with an acoustic material will generally lower the resonant frequency and in this way may lower it to a frequency below which the ear is sensitive so that even though the resonance does occur it is not objectionable. It would be hardly worth while to use some material with an absorption coefficient of say 0.5 if the only effect of the use of such material were to decrease the response at resonance by half. Actually, however, the use of a material with such an absorption coefficient

might prove effective because of the change in the resonant frequency which it produces—the absorption coefficient of such

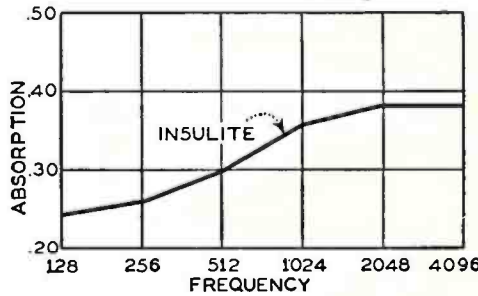

Fig. 4—Insulite Acoustile

material does not have to be 100 per cent. to render resonant effects negligible.

The data which must form the basis of any actual measurements are the absorption characteristics of the material to be used. In Fig. 4 are given such absorption characteristics for Insulite, a material made by The Insulite Company. In Figs. 1, 2, 3, and 5 are absorption characteristic curves of different types of Celotex made by the Celotex Company. All these curves were determined by the same method.

Whether the elimination of excessive response at low frequencies—the difficulty most generally met with in radio receiver design—will be by the use of cabinet lining is problematical. It is certainly true that the greater part of these effects has been eliminated by methods other than that of lining the cabinet. It is quite possible that the solution lies in the better design of the cabinet which houses the radio receiver and loud speaker. A loud speaker cabinet has three dimensions and therefore three natural periods of vibration, one corresponding to each dimension. Each of these

periods or all of them may cause considerable trouble depending upon where the resonance frequencies occur. Of course, the smaller the cabinet the higher will be resonant frequency, assuming that the material in both cases is the same. One engineer suggests the possibility of designing the cabinet so that there is no partition between the receiver itself and the loud speaker. This will effectively increase the area of the cabinet.

As Knudsen points out the disadvantage of some types of acoustic material as a cabinet lining is that it may have absorption characteristics that increase with frequency so there is a certain amount of differential absorption with respect to frequency, the greatest absorption usually occurring at the high frequencies—where it is not required. In fact, decreased response at the high frequency is found in altogether too many receivers, and it would hardly seem advisable to make use of a material that would tend to increase the high-frequency suppression. An engineer with whom we communicated pointed out that such an effect took place in some actual laboratory work which he conducted. The use of an absorbing material with a higher absorption coefficient at high frequencies than at low frequencies actually enhanced the low-frequency resonance due to the fact that the high frequencies were attenuated more than the low frequencies and as a result the low-frequency resonance stood out even more prominently. It seems likely, however, that such an effect would not be noticed except with a material having a relatively large ratio of high-frequency absorption to low-frequency absorption. As the curves given in this article indicate this is characteristic of some, but not all materials—for example Fig. 5 gives the characteristic of a special Celotex board which has essentially uniform absorption over the range indicated, and, assuming that the curve continues at the same slope, the absorption at 4096 d.v. will be about 0.35 or only 1.7 times the absorption at 128 cycles. If material of such characteristics were to be used, it should not produce excessive absorption of the high frequencies relative to the lows and might prove very effective in eliminating resonance by lowering the frequency at which such effects take place. In actual practice the two factors of cabinet vibration and reverberation are tied closely together and the use of acoustic lining should lower the frequency at which either effects take place.

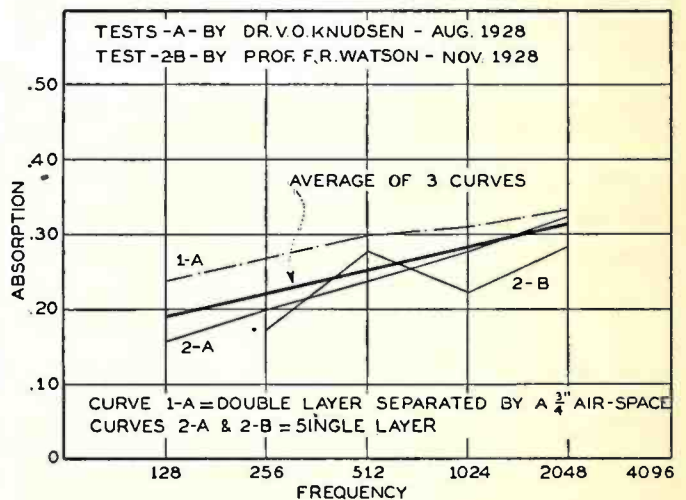

Fig. 5—Special Celotex

The final decision of whether or not the use of such materials has any place in radio receiver design is something that can only be answered by actual measurement. The final answer must come out of the laboratory.

TUBES

THE ONE THING IN RADIO

THAT EVERYBODY USES

YOU CAN SELL MORE TUBES IF THE TUBES YOU SELL ARE BETTER

The logo for Eveready Raytheon is presented within a dark blue, house-shaped frame with a white outline. The text "EVEREADY" is on the top line and "RAYTHEON" is on the bottom line, both in a bold, white, sans-serif font.

EVEREADY
RAYTHEON

Trade-marks

4-PILLAR TUBES

ARE A NEW AND

REVOLUTIONARY IMPROVEMENT

TELL YOUR CUSTOMERS TO PUT A NEW **E**VEREADY



TELL your customers not to miss the full enjoyment that radio can give in these winter months. Programs are at their best. The air is clear and free from static. Distant stations come in like locals when receiving tubes are new Eveready Raytheons—packed with power.

Have your service man put a new Eveready Raytheon in each socket of your customers' receivers and note the vast improvement. You can profit from this better performance. More power, increased distance, better tone and quicker action—these are reported by people everywhere, using Eveready Raytheons in their present receivers.

Improved performance means more sales for you, quicker stock turn, more pleased customers. Push Eveready Raytheons in complete sets for replacement.

EVEREADY RAYTHEON 4-PILLAR TUBES

RAYTHEON IN EACH

SOCKET

OF THEIR PRESENT RECEIVERS

YOU can *hear* the difference with Eveready Raytheons—and see the reason. Look at the diagram on this page. See the solid, four-cornered glass stem, supporting the four rigid pillars which hold the elements. Notice how this *4-Pillar construction* is braced at the top by a stiff mica plate.

Eveready Raytheons give better reception because they are stronger . . . immune to the hazards of shipment and handling which endanger the performance of ordinary tubes. The unusual precision with which Eveready Raytheons are built is safeguarded by their *4-Pillar construction*. With Eveready Raytheons only can you get all the advantages of this superior construction, for it is patented and exclusive.

Eveready Raytheons come in all types, for A. C. and battery-operated receivers.

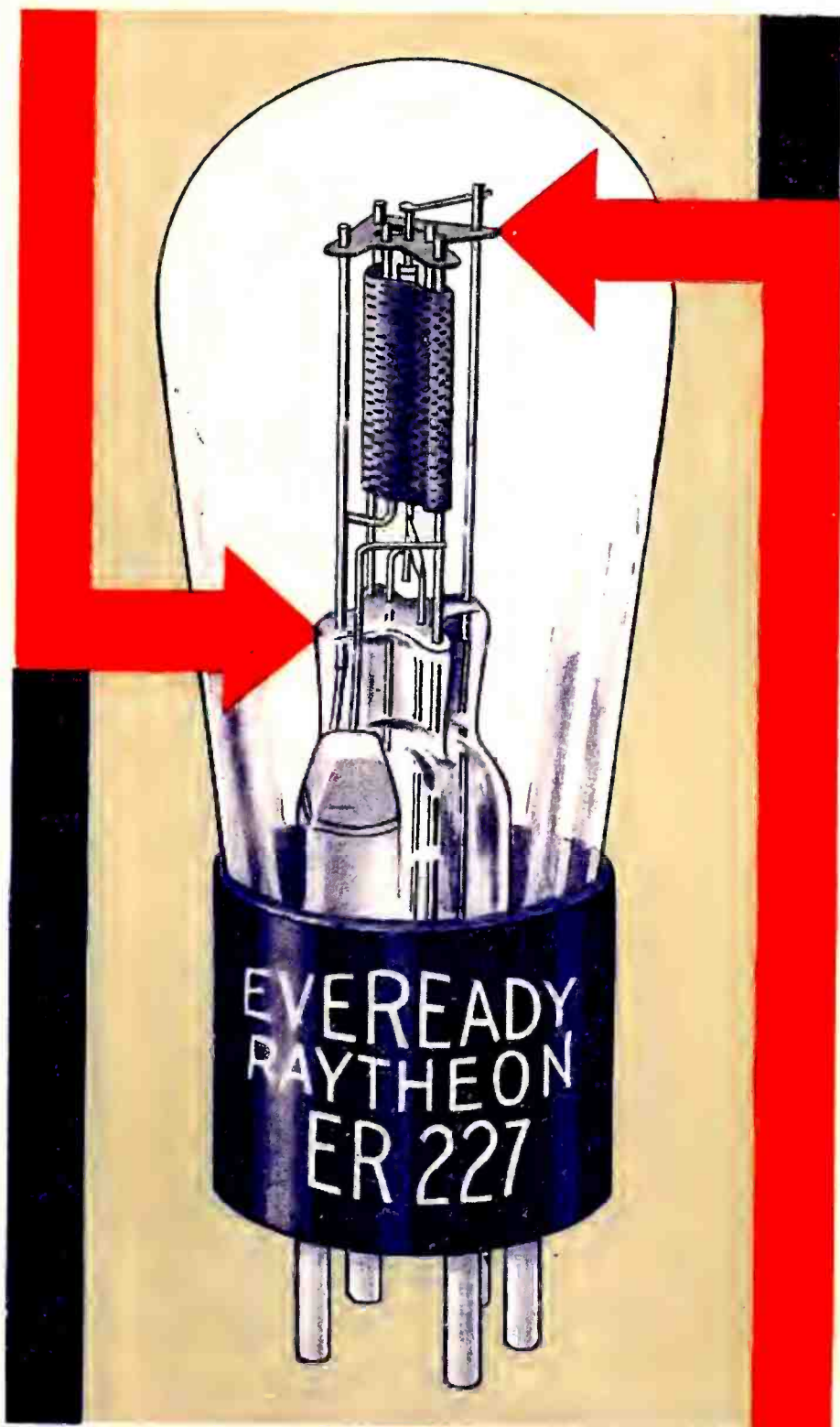

EVEREADY RAYTHEON 4-PILLAR TUBES

WRITE FOR THESE STRIKING EVEREADY RAYTHEON DISPLAYS

EVEREADY RAYTHEON

4-Pillar Tubes



4-Pillar
Construction



Anchored 4 Points
Top and Bottom

YOU can have this helpful counter display by writing to the nearest branch of the National Carbon Co., Inc. There is also a five-piece window display which tells your customers that you sell better tube performance—Eveready Raytheon performance. There is a muslin wall chart showing the characteristics of various types of tubes, and a tube register showing types of tubes required for various sets. You can hang this chart in a prominent location where it will help both you and your customers.

Eveready Raytheon Tubes are selling fast with distribution through a selected number of jobbers, conveniently located. Ask your jobber or write us now for the names of our jobbers near you.

NATIONAL CARBON COMPANY, INC.

General Offices: New York, N. Y.

Branches: Chicago, Kansas City, New York, San Francisco

Unit of Union Carbide  *and Carbon Corporation*

EVEREADY RAYTHEON

Trade-marks

4 - P I L L A R T U B E S

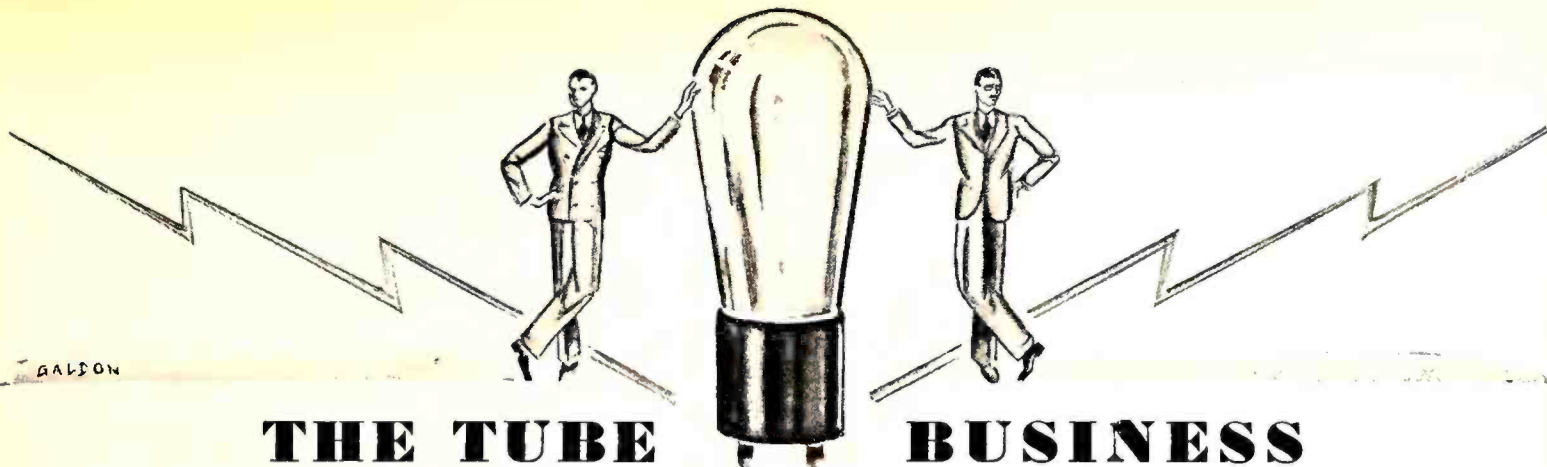

THE TUBE BUSINESS

FINANCIAL AND PRODUCTION NOTES

CeCo—Assets on Oct. 15, \$2,500,000. Same date 1924, assets \$24,000. Sales ten months ending October 31, \$2,168,902. Same period 1928, sales \$877,684. Earnings per share twelve months ending September 30, \$6.37.

PERRYMAN—Sales September \$176,602, October \$230,000. Sales October, 1928, \$126,000. Production in October, 15,000 per day. Production of screen-grid tubes in October, 5000 per day.

DeFOREST—Net profits six months ending September 30, \$261,109. Estimated profits third quarter 1929, \$900,000 to \$1,000,000.

Note: These data are taken from various sources, which we believe to be reliable, but the Editors cannot be responsible if errors occur. Unfortunately errors sometimes do occur. The most recent occurrence did an injustice to the CeCo Manufacturing Company. We are informed by Ernest Kauer, of CeCo, that at the end of July, 1929, business showed a 202 per cent. increase over the same period in 1928.

DeFOREST GETS LARGE CONTRACT

THE DeFOREST RADIO COMPANY has closed a contract with McKesson and Robbins, Inc., who control 17,000 retail drug stores in the United States, to sell DeForest tubes exclusively. An initial shipment of 100,000 tubes was made in October.

IMMUNITY TO SURGES

ONE OF ARCTURUS' talking points is "immunity to line surge." Not long ago a Fada receiver in Newark, N. J., was struck by lightning. Five tubes were Arcturus; three were not. After the fire department, etc., had done its work, it was found that the five Arcturus tubes were o.k. The others were burned out. Arcturus engineers feel that such a filament will take care of any normal line voltage surge.

EXCLUSIVE TUBE JOBBERS

ACCORDING TO Edward T. Maharin, CeCo, the volume of tube business is near the point where distributors will be justified in concentrating their entire efforts on this single item of radio merchandise. The volume of tube business approaches that done in complete sets, and, since there is no obsolescence in tubes, it begins to look as though a distributor could afford to handle no other item.

The Serviceman's Job

By F. D. WILLIAMS

Radio Tube Division, National Carbon Company



F. D. Williams

Mr. Clerk, Mr. Salesman, a window display, the printed page—these are usually the first contacts between a radio manufacturer and a consumer. Once the sale is made and the receiving equipment has been initially installed all these contacts are broken and it is you, Mr. Serviceman,

who carries on for us.

It is you who answers the distress signal, S. O. S. (service on sets or supplies), and the good will of our customer depends a great deal on your ability and conscientiousness. You have it in your power to help or hinder the progress of a manufacturer of sets or tubes.

You are in a position, when in the normal course of events a reliable make of tube needs replacing, to put in another tube of comparable value, and when you find a case in which a good set is handicapped by a poor make of tube you can be of real service to your client and to the reputable manufacturer by advising a change to the right brand of tubes.

Ever since our "BH" gaseous rectifying tube was developed we have found you rendering us loyal, intelligent support, and following the introduction of the complete Eveready Raytheon Radio Tube line reports from all sources indicate that you are again giving us the same consistent, valuable cooperation.



Ben Erskine, president, Sylvania Products Company, is often seen in the laboratory checking with his engineers.

NEW De FOREST TUBES

THE DeFOREST RADIO COMPANY, of Jersey City, N. J., announces a comprehensive line of transmitting tubes as follows:

Type	Tube	Price	\$
510	15-watt Oscillator	9.00	
503A	50-watt Oscillator	40.00	
511	50-watt Modulator	40.00	
545	50-watt Amplifier	40.00	
500	500-watt Oscillator	130.00	
520B	5-kilowatt water-cooled tube	250.00	

Other transmitting tubes are being placed in production, such as higher-power oscillators and mercury rectifiers, as well as various sizes of screen-grid, and general-purpose tubes.

The DeForest transmitting tubes are sold by the factory to consumer direct, and at the above net prices.

A NEW WORLD'S RECORD

THE SYLVANIA PRODUCTS COMPANY, are claiming a world's record for two Buffalo salesmen. O. J. Loersch, of the Buffalo Talking Machine Company, and Walter Dossert, of the Philco Buffalo Distributing Company, are the two men. They teamed together for a five-week drive and between them they sold 14,637 Sylvania tubes. "This," says Fred Strayer, the Sylvania sales manager, "we claim as a new two-man world's record, and we will consider it so until proof is furnished that will testify that the new world's record has been broken."

TWO INTERESTING QUOTATIONS

A quotation from the service department of one of the largest producers of radio receivers in the United States: "We know that the majority of service is caused by tubes and other accessories."

Quoting again from a set manufacturer, this time from the sales manual, "There are a number of fast-heating equipotential cathode tubes on the market to-day, including both the '27 and '24 types. Under no circumstances should any of these tubes be used in any of our receivers, since they are extremely noisy. The quick-heating type has insulating washers of white material at either end of the cathode, and the heater return (which is outside the tube elements since the heater itself is a spiral within the cathode) is covered with a glass tube between the mica support and the glass stem. A great deal of the hum in this tube is due to the magnetic fields from the multi-turn coil of the spiral heater and from the large single turn formed by the heater and its return."

p. 2

WHAT HAPPENED IN RADIO MERCHANDISING IN 1929

(Continued from page 130)

or on the top shelf of a closet, a loud speaker for wall mounting in foyer, stair landing, or hall, at enough distance from the dining room and living room so that music filters into them gently and pleasantly. By elimination of expensive cabinets, this remote control outfit will not be much more expensive than present-day receivers, although the dealer will have an opportunity to earn a good installation profit. That kind of remote control would greatly increase the average listening hours and would mean, in turn, larger tube sales.

Condenser loud speakers have not swept the market. Manufacturers are marking time to determine their life and performance qualities. If remote control ultimately eliminates the cabinet, decorative wall-type condenser loud speakers may become a possibility.

Tube Sales: An outstanding merchandising trend is the greatly increased proportion of tube sales to total sales. The cumulative effect of tube sales is helping materially to stabilize dealer turn-over. But the position of the average dealer has not improved greatly during the year because of the excessive number of radio outlets. The possibility of more active competition by automotive distribution channels as a result of the new Radio-General Motors alliance is causing some apprehension. The automobile salesman is trained to aggressive personal salesmanship. He may replace the type of radio dealer who does not begin to work on a prospect until he comes into the store to buy.

Too Many Outlets: The statistics distributed by the Department of Commerce through the cooperation of the National Electrical Manufacturers Association prove conclusively that the industry is suffering from a large proportion of inefficient outlets. One-third of the 39,153 outlets did a business of less than \$500 during the quarter ending July 1, 1929, the latest date for which detailed figures are available. On the other hand, dealers selling more than \$100,000 in that quarter, constituting less than 0.2 per cent. of the

total number, did 13.95 per cent. of the total business reported. More conclusive is the fact that the mere 4.22 per cent. of the dealers who did more than \$10,000 during that quarter accounted for 51.16 per cent. of the gross business. Obviously, a distribution system which does about half its business through one twentieth of its outlets is heavily laden with dead wood. Instead of improvement in the situation, however, the number of outlets increased by 20 per cent. during the year.

If radio sales fail to show marked gain, we may look to a substantial reduction of outlets, with the consequent disappearance of many lesser manufacturers depending upon them. This would be a desirable trend because the industry is burdened with altogether too many minor manufacturers. Most of them will take the merger route to oblivion. With one or two exceptions, all mergers to date have been of that character.

Chain Distribution: The trend toward chain distribution, which is progressing so markedly in other fields, has made slow but steady progress in the radio industry. The outstanding event of this character was the consolidation of the Atlas, Davega, Fanmill, City Radio, and Abe Cohen Exchange, forming a combination of 61 stores in New York, Newark, Chicago, Detroit, Cleveland, Cincinnati, and Akron. Chain distribution, however, requires high turnover, a condition obtaining in the radio field only in relatively few large broadcasting centers. In consequence, extension of chain distribution to radio's greatest unsold market, the rural districts, is not an immediate prospect.

Concentration of the industry's sales activities in urban centers is indicated by the continued decrease in percentage ratio of battery to a.c. receivers sold. The available figures are as follows:

Quarter Ending	Per cent.	
	d.c.	a.c.
July 1, 1929	6.8	93.2
April 1, 1929	10.0	90.0
January 1, 1929	10.4	89.6
October 1, 1928	19.3	80.8

The rural market is yet untapped. No manufacturer of standing is concentrating

upon the production of battery receivers of real capability giving results comparable to those secured with a.c. sets.

Television: If only for sentimental reasons, we mention television which, last year at this time, was arousing considerable attention. The public interest in television of a year and two years ago was the product of excessive premature publicity and the expression of an unfulfilled desire. But no longer is the public startled by announcements of magnificent achievements in television because such announcements have too often been unadulterated hokum. The public's idea of what constitutes television of entertainment value is based upon home motion pictures as a criterion. Home movies are so far ahead of the most magnificent television device which has been demonstrated that the available crudities can hardly be classed as commercial possibilities. The trade awaits with enthusiasm the appearance of a really commercial and salable television device because it knows the public to be ready to buy it. Laboratories and scientists are bending efforts toward the production of such a machine but they have still a long way to go. We are awaiting a fundamental development to make possible at least 100-line television of considerable reliability. Anything less than that has insufficient entertainment value to have public appeal and must be classed as an experimental device or a curiosity.

Conclusions: The year 1929 has been successful as far as volume is concerned, but the industry has failed to make much progress toward the inevitable adjustments which it faces; namely a radical reduction in the number of manufacturers and the elimination of inefficient outlets. The industry has yet to face a year of reduced consumer spending to demonstrate how small is its margin of selling power over production. One such year would have a salutary effect in eliminating weak units and in developing the industry's sales ability. We are still a long way from a set for every American family but are reaching the day when the industry must sell the individual prospect rather than wait for him to come and buy.

WHAT HAPPENED IN RADIO ENGINEERING IN 1929

(Continued from page 131)

local-distance switch provides a total control of about 10,000 to 1, which is sufficient for present conditions.

Remote control got a late start in 1929 and will come into much greater prominence in 1930. The ideal seems to be a device which gives the user perfect dial control over the receiver as distinguished from that type which permits reception of a number of stations by pushing various buttons.

The year saw few fundamental circuit changes. Uniform sensitivity was one of the biggest advances. So little of a quantitative nature on band-pass circuits has been published that it is difficult to state the extent to which these circuits, from which much has been expected, have been advanced. Another advance will be uniform selectivity. Perhaps the year 1930 will see it.

The year saw almost complete acceptance of the moving-coil electrodynamic loud speaker. Whether the balance in favor of these loud speakers as against the magnetic, the inductor dynamic, or the condenser type will be maintained de-

pends upon engineering development. If someone develops a more sensitive, less costly, lighter, and longer lived loud speaker, manufacturers will be quick to accept it. It is strange how little has been the general acceptance of the inductor speaker. It is sensitive, has a good characteristic, requires no field power, has a fairly high overload limit, and is inexpensive.

The fidelity characteristic of console receivers has been improved somewhat. The boomy effect has largely disappeared. There is still a dearth of high audio frequencies, but some manufacturers deliberately cut them out by means of filters for the benefit of users far from local stations who want as little static and other noise and as much program as possible. Some manufacturers have adjustable fidelity so the listener can have more or less high or low tones as he pleases. In some this is continuously adjustable: in others a switch throws in a certain definite loss at either end of the musical scale.

The fidelity obtained from phonograph pick-up units has improved, but, because of mechanical and electrical limitations, it is not up to par with the best broad-

casting. This deficiency is divided between record and pick-up. Electrodynamic loud speakers have improved both in frequency response and efficiency.

Many 100 per cent. modulation transmitters have gone into service during the year with consequent better service. Many manufacturers have engineered their receivers with the object in view of decreasing the possible mechanical or electrical trouble in service; many of them have improved the mechanical arrangement of parts so that the serviceman has less difficulty in getting at the trouble and fixing it. Unsightly antennas, some thousands in number, came down during the year as a result of two developments: one, the use in apartment houses of a single, high, well-insulated antenna connected by transmission lines to each listener who gets the impulses traversing this conductor but without annoying his neighbor by stealing the signal or sending out one of his own; the other cause for an early demise of overhead wires is the superior sensitivity of some receivers. A 100-foot antenna is no longer necessary; instead, the ice pick will do.

SM

“S-M 722 a Knockout” —Setbuilders Demand D.C. Design—It’s Here!

The Record-Breaking S-M 722

Experienced setbuilders have learned to expect big results from any screen-grid custom design that S-M offers—but the 722 Band-Selector Seven has broken all records. And no wonder—a custom receiver that is sold, completely wired, at \$74.75 net, topping the performance of widely advertised factory sets selling at twice the price. Yet there is nothing mysterious about it—just the long experience of S-M engineers applied to the job of producing those essential receiver parts whose quality spells the difference between the performance that “gets by” and the performance that an S-M fan demands. Everything that is the “last word” is in the S-M 722—the '24 power detector, the band filter—the uniform gain all over the dial—single dial tuning—all-electric with built-in power supply. Tubes required: 3—'24, 1—'27, 2—'45, 1—'80. Wired, less tubes, \$74.75 net; parts total \$52.90.

The new 722DC for battery use gives every advantage of the a. c. design—big volume, DX ability, and uniform amplification at all frequencies, just like the a. c. set—truly the ideal battery receiver. Tubes required: 3—'22, 3—'12A. Similar in appearance to 722 illustrated. Wired, less tubes, \$57.50. Parts total \$38.50.

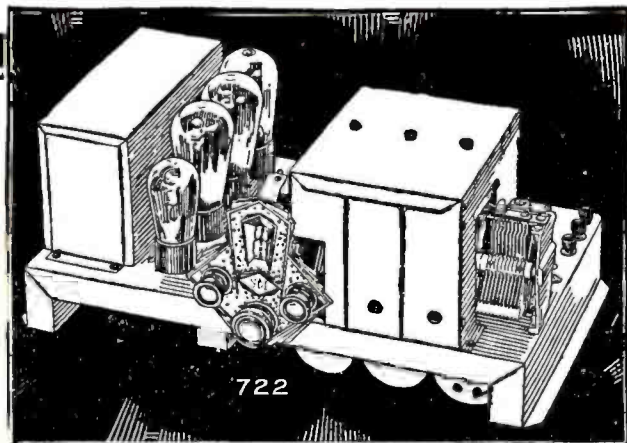

Do You Want Absolutely the Best There Is?

It doesn't cost an awful lot more than the 722, but this S-M 712 tuner, in its neat innocent-looking all-metal shielding cabinet, is absolutely guaranteed to out-distance and out-perform all competition regardless of circuit or price—just as its famous predecessor, the Sargent-Rayment 710, did last year. Read, in last month's issue of this magazine, how one listener living only a mile from the powerful WSM tunes in regularly a station 400 miles away with only 20 kc. separation! That's performance—and with one-dial tuning—no verniers. Tubes required: 3—'24, 1—'27. Wired as shown, less tubes, \$64.90 net. Parts total \$40.90.

Any good audio amplifier can be used with the 712; ideal tone quality and perfect convenience are secured by using the S-M 677. Uses 1—'27, 2—'45, 1—'80 tubes. Wired complete, less tubes, \$58.50. Parts total \$43.40. For 25-40-cycle current, \$72.50 wired.

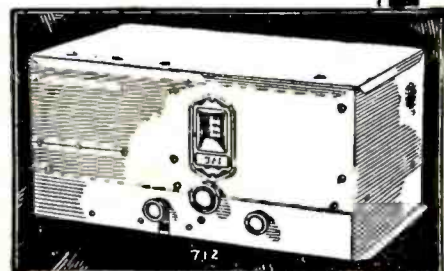

And a “Bearcat” for the Short Waves

“The little 735 is a “bearcat”. The way it will pick up stations is nobody's business. You want to see the hams come in and play with it. First one I wired I got 5SW Chelmsford, England, also a Dutch station and a lot of others . . . this was around 2 P. M.”

That's the verdict of R. G. Sceli of Hartford, Conn.—one of the most expert setbuilders in New England, and remember he is speaking of the first completely a.c.-operated short-wave sets ever brought out! The new S-M 735 Round-the-world seven is carrying all before it this year. On same chassis as the 722; tubes required: 1—'24, 2—'27, 2—'45, 1—'80; wired \$64.90, parts total \$44.90. 735DC for battery use, using 1—'22, 4—'12A, wired \$44.80. Parts total \$26.80.

A full line of cabinets is available for all these S-M receivers—the beautiful 707 table cabinet, in rich crystalline brown and gold,

is only \$7.75 net. The cabinets of remarkable charm are listed in the S-M catalog—see coupon.

“THE RADIOBUILDER” for December contained details of the 722DC; every issue gives advance technical information of great interest and profit to setbuilders. Use the coupon!

Over 3000 Authorized S-M Service Stations cover the United States and Canada. Many are profiting handsomely! Write us for the address of the nearest one if you wish a custom-built set. Setbuilders write us regarding a franchise in your territory.

SILVER-MARSHALL, Inc.

6403 West 65th Street
Chicago, U. S. A.

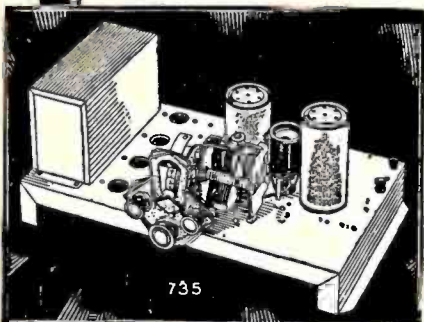

Silver-Marshall, Inc.
6403 West 65th Street, Chicago, U. S. A.

.....Please send me, free, the new fall S-M Catalog; also sample copy of the Radiobuilder.

For enclosed.....in stamps, send me the following:

.....50c Next 12 issues of The Radiobuilder

.....\$1.00 Next 25 issues of The Radiobuilder

S-M DATA SHEETS as follows, at 2c each:

-No. 3. 730, 731, 732 Short-Wave Sets
-No. 4. 255, 256, etc., Audio Transformers
-No. 5. 720 Screen Grid Six Receiver
-No. 6. 740 “Coast-to-Coast” Screen Grid Four
-No. 7. 675ABC High-Voltage Power Supply
-No. 8. 710 Sargent-Rayment Seven
-No. 9. 678PD Phonograph-Radio Amplifier
-No. 12. 669 Power Unit
-No. 14. 722 Band-Selector Seven
-No. 15. 735 Round-the-World Six
-No. 16. 712 Tuner (Development from the Sargent-Rayment)
-No. 17. 677 Power Amplifier for use with 712
-No. 18. 722 DC Band-Selector

Name.....

Address.....

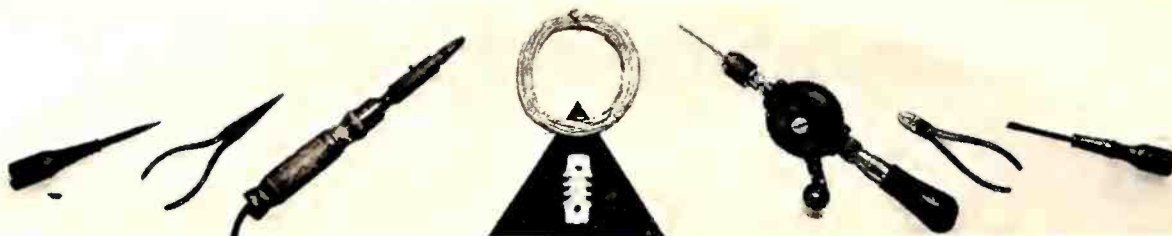

THE SERVICEMAN'S CORNER

A Symposium on Noise

NOISE continues to be a major service problem. Under the category of noise may rightfully be included motorboating, intermittent reception, hum, frying, and noise in general. The following servicemen have contributed the data on noise printed below:

PAUL WALLER, the Boren Biegele Company, Little Rock, Ark.

GEORGE GILLET, Bismark, N. D.

A. C. HOAG, West Allis, Wis.

CHARLES W. FOSTER, Rochester, N. Y.

HERBERT A. FISKE, Wareham, Mass.

R. F. SNYDER, Lakemore, Ohio.

J. E. BAINES, Kansas Power and Light Company, Topeka, Kans.

INTERMITTENT RECEPTION

In many cases it has been found that intermittent reception can be traced to tube trouble, as is indicated by the three instances which follow:

"One evening I was called upon to find the trouble in an electric set. When the set was first turned on and tuned to a local station it worked beautifully and with good volume for a short time, then the volume gradually diminished, and after a time began to pick up. While checking the tubes when the set was operating normally, I noticed that all the filaments were lit. Later when it was operating below normal I noticed that the heater of the detector tube was not lit, but the set would still work at reduced volume.

"The heater of this particular 6Y-227 was evidently cracked and when cold made perfect contact. However, when heated the metal expanded enough to open the heater and shut off the heating current in that tube. The set continued operating at low volume due to the fact that the heater was sufficiently warm to continue to operate until it had cooled down to a point where it made contact again.

WATCH FOR FLASHERS

"With the new 1930 receivers coming onto the market with either the 224- or 227-type tubes throughout, my advice to all my brother servicemen is to watch for flashers (the one that has the bright light on the top of the heater) and the oxygen generators which are indicated by the purple glow during operation. It has been found fading, buzzing, and intermittent noises are caused by these tubes. However, in some cases these tubes do not indicate the trouble until the receiver has been in operation for some time."

"An owner called and said his set kept going on and off. Sometimes it would operate for two or three minutes and then stop; then a slight jar would start it again. All indications suggested a loose connection, and so it was, but not where you would expect it. After all tests showed nothing wrong, the rectifier tube was examined and a cold soldered lead to the filament prong was discovered. It was just barely loose but the vibration of the loud speaker would jar it so it did not make connection. It was soldered again and there has been no more trouble."



The service laboratories of Clarke Laboratories, Danville, Va.

Mechanical imperfections are also at the bottom of numerous freaks of the intermittent type. "I recently ran into a trouble similar to the one mentioned by Mr. Glose in January, 1929, RADIO BROADCAST, but from a different cause," writes another serviceman.

ZENITH MODEL 14

"A Zenith Model 14 with a 4-gang condenser gave weak signals at times with the volume control turned on full. Sometimes a jar on the set or the floor would make it oscillate till the volume control was turned back, and then it would operate satisfactorily for an indefinite period of time.

"Indications pointed to something loose but the set tester failed to show anything. Taking out the chassis and attempting to adjust the little trimming plates did not do much good and the trouble came and went making it hard to find. Grasping the condensers and attempting to move them back and forth showed that one was apparently a little loose on the shaft, judging solely by the effect on the signal strength.

"The shaft of the condenser was iron and the castings which were of aluminium were held together by one taper pin in each unit. Drilling and tapping a 6-32 screw hole in the shaft at each unit, fastening with a flat-head screw, and then

putting in some longer taper-pins (so they could be removed more easily, in case of further trouble) has cured this case.

"I was called out to service one of the Stewart Warner 950 series a couple of nights ago. The set would play along and seemingly from no cause at all would cut out. A little jar would start it playing again. By shaking the first a.f. tube, which is resistance coupled, the set would act in the same way. I removed the bottom plate of the set expecting to find a loose socket spring or dirty tube prong. After cleaning contacts, etc., the set continued to act in the same manner. I found by shaking the by-pass condenser in the resistance-coupled stage it would play in one position or stop in the other. The solder lug is held in place by one brad. One lug of the condenser is soldered direct on the socket springs to hold it rigid with the result that the condenser, if pushed too far to one side, breaks loose from the tinfoil.

"This same trouble was found with the condenser bypassing the r.f. of the screen grids with the result that the set would oscillate over the whole dial range."

HIGH-PITCHED HUM

"It seems to me all the radio servicemen pick on center-tapped resistors or the shielding of the detector tube or something of the like to stop hum in a.c. receivers. I have found quite a bit of the above myself. In some cases, however, I have had to look elsewhere for the said hum.

"A Kolster developed a high-pitched hum which was stopped when a 1-mfd. condenser was connected from detector plate supply to ground. A bad hum in a Stewart Warner was also stopped by connecting a 2-mfd. condenser from the first a.f. supply wire to the ground. So I believe in capacity sometimes." (A Mershon condenser will often do the trick where everything else fails. *Editor.*)

MISCELLANEOUS NOISES

The noisy grid leak: "The resistor manufacturers did their best for some years to blame all noise on the grid leaks made by
(Continued on page 166)



This elaborate tube-tester was designed by Westinghouse. It is intended especially for manufacturers' use.

Now D-C Tubes

by **ARCTURUS**

AND 2 NEW A-C TUBES GIVING
ARCTURUS DEALERS A COM-
PLETE LINE OF TUBES
FOR EVERY SET



PROVED PERFORMANCE
Demonstrate Arcturus' quick action, clear
tone and long life... there will be no question
which tube your customers will buy.

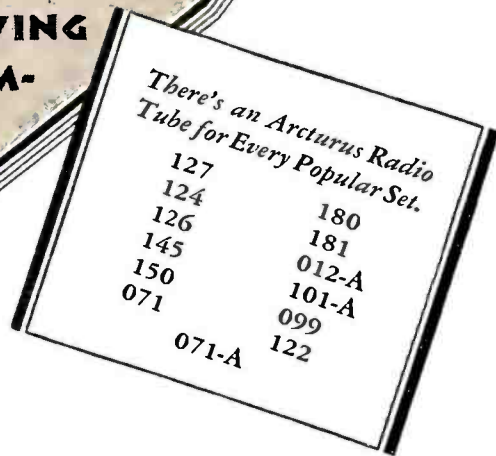

YOU know what the name Arcturus means on an A-C tube. Quick action, clear tone, long life. This kind of service has made Arcturus Tubes famous throughout the radio industry...a symbol of dependable tube performance wherever A-C sets are made, used or sold...Now we offer Arcturus *Direct Current* tubes, built to the same high standards that made possible Arcturus' A-C superiority. In addition, 2 *new* A-C tubes have been added to the Arcturus line, giving dealers complete Arcturus equipment for any popular radio set...Thousands of Arcturus dealers know that Arcturus A-C quality has helped them increase their set and tube sales. Now, with a complete line of Arcturus Tubes for D-C and A-C sets, Arcturus offers better profit possibilities than ever before. Your business, too, can benefit by Arcturus' *proved performance*. Stock and sell the entire Arcturus line.



ARCTURUS RADIO TUBE COMPANY
Newark, New Jersey

ARCTURUS

LONG LIFE
RADIO TUBES



Robert Mac Gregor, Assn't chief engineer, Temple Corporation, conducts a service school for Temple Dealers.

(Continued from page 164)

their competitors. But the noisy grid leak is not altogether ballyhoo. It is wise to look to grid leaks in noisy sets. An a.c. Marshall S. G. Six kept giving a frying noise like fish in a pan. At first it was thought it was interference from some outside source, but when the antenna was disconnected it kept right on frying. After some time spent, a new grid leak was put in and the noise stopped."

The ground wire offends: "The other day I was called out to cure interference on an expensive set. It had a roar or buzz that would start as a low-pitched roar, get very loud, and then die away. This set like many others had by-pass condensers across the 110-volt side of the power pack and when the ground wire was disconnected a faint spark could be seen. This gave me an idea. Inspection of the ground connection showed that it had been soldered to an outside water pipe and the man that did the job forgot to drain the pipe. Also he used some kind of acid flux solder. The result was this: when the job was new everything was satisfactory but when the weather got in its work the corrosion set in, and crept under this cold solder job, causing a poor contact that would arc or spark as the contact changed from poor to maybe none at all."

"A customer kept complaining of noise in the form of a put, put, put, of varying frequency and between wide time intervals. The set was a Radiola 62. Some time was spent waiting for the noise to start, which the customer insisted it would, in a few minutes. Sure enough it did, and it was, as he said, very annoying. I listened for several minutes. Again and again, the noise would start at low frequency and amplitude and increase in both and then die out. A bus 'stop' was right in front of the house, and it was soon found that the put, put, was the exhaust noise of a departing bus!

"A window strip lead-in, was broken in the center, and when it was replaced by a new one the trouble was ended."

MOTORBOATING

Rather unintentionally your editor has recently run into several very balling cases of motorboating, both in the labo-

ratory, and, in his own home! Without going into the theory of the thing, the possible cures are about four in number.

The mechanical arrangement in a home-made receiver may be responsible for motorboating. However, it is often difficult or expensive to change this, so all cases of motorboating may be considered on the basis of a commercial job.

It is seldom that motorboating will be encountered if the B and C potentials are correct. These should, therefore, be checked immediately. A variable by-passed resistor in the plate circuit (try in the order of, first a.f., detector, and middle r.f.) will often stop the trouble by virtue of one or both of two possibilities, i.e., establishing the correct B and C potential balance, and by reducing the plate voltage on an ionizing tube.

Ionizing tubes are almost a concomitant characteristic of motorboating—often in the power stage. Drop the voltage, with a by-passed resistor until the blue haze disappears or the motorboating ceases.

A bypassed a.f. choke coil, such as the primary of an amplifying transformer, in

the plate circuit of the detector or first a.f. stage will also often help matters.

The main point, in our own experience (which has been considerable as far as motorboating goes), is to watch out for ionizing tubes—tubes showing more than the slightest tinge of a blue haze.

An Output Meter

The serviceman's labors involve the pepping up of receivers that have lost selectivity and sensitivity due to loss of tuning alignment, and neutralization. These adjustments can be effected most rapidly and accurately with the aid of the vacuum-tube voltmeter—an inexpensive design of which is described below by S. S. TRIER, of the Chicago Radio Service Laboratory.

"We have found occasion to require an output meter for general use around the laboratory, being of great utility for neutralizing receivers, aligning gang condensers, checking overall gain and total output of receivers, where an accuracy greater than the usual headphone signal strength is desirable. Having investigated the market we found the cost of a suitable thermo-voltmeter far above the value of the instrument to us. Accordingly, the following apparatus was assembled and is now an indispensable article in our equipment.

"A simple vacuum-tube voltmeter was constructed using the conventional circuit, a 199-type tube, 0-1-mA. meter, and an a.f. transformer to supply the coupling between the receiver output terminals and the input (grid and filament) of the vacuum-tube voltmeter. The

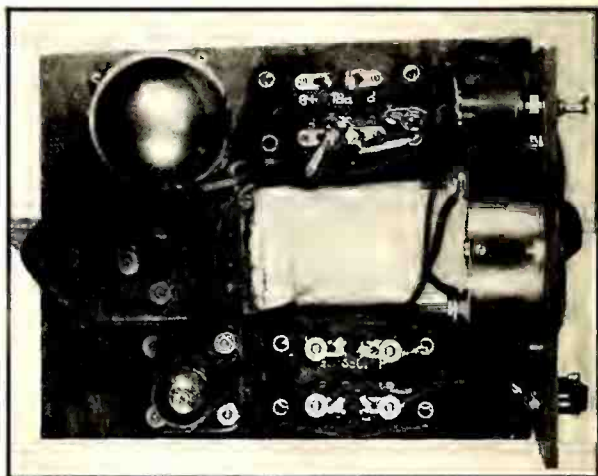

Baseboard view of output meter.

unit was constructed so as to be a.c. operated with the exception of the tube filament which was heated by means of a 4½-volt C battery. To supply the necessary plate voltage to the tube, another socket and tube was arranged as a B-supply unit. An old a.f. transformer having a burned out primary made a satisfactory choke, the secondary winding being used. The filter condensers were originally a 4-mfd. Dubilier 600-v. unit, which, having broken down, was opened and separated into four 1-mfd. sec- (Continued on page 167)



The servicemen of the Sun Radio Company, Akron, Ohio, are dressed as shown above. The uniform identifies them as legitimate representatives of the company employing them.

(Continued from page 166)

tions. Each unit was tested, and the defective section discarded.

"The circuit diagram is indicated in Fig. 1, while pictures on this page suggest the constructional points.

"In using the meter the output or loud speaker terminals of the receiver under test are connected to the two input posts of the meter and the receiver is turned on.

"For alignment of condensers, neutralization, or overall measurements, as described in L. M. Hull's article appearing in February, 1929, RADIO BROADCAST, an oscillator of some type, such as de-



Front view of output meter.

scribed by G. F. Lampkin in July, 1928, RADIO BROADCAST, is used to generate a constant modulated r.f. signal and the receiver is tuned to resonance. As the receiver approaches resonance, the meter will show deflection, maximum deflection being reached when the receiver is in exact resonance with the received signal. The condensers are then adjusted by means of the trimmers, where a gang condenser is used in the receiver, until the highest reading obtainable is reached on the meter. It is advisable to align the condensers first on a comparatively high frequency, say 1300 or 1400 kc. working back and forth over the trimmers until a maximum deflection is reached, then setting the oscillator for a lower frequency of 550 or 660 kc., retuning the receiver to this frequency, and again touching up the

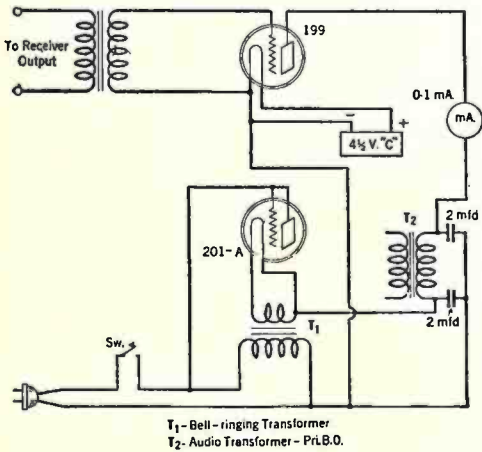

Fig. 1—Diagram of output meter with its simple B supply.

adjustments. In this way it may be discovered that the receiver does not give as great a deflection at one end of the dial as it does at the other, showing a lower over-all efficiency at a certain frequency. This may be due to poor design or assembly of the gang condenser and may be rectified by bending the plates of the rotor
(Continued on page 169)



Licensed under patents of the Radio Corporation of America and associated companies for radio, amateur, experimental and broadcast reception.

FULL VOLUME

OR THE MEREST WHISPER

With no distortion along the entire range

The Amertran Push-Pull Amplifier, Type 2-AP, is designed for radio listeners who truly appreciate fine music and its reproduction exactly as broadcast. With efficient loud speakers it will furnish ample volume for dancing in a large hall and agreeable rendition in a moderate sized auditorium. Or you can tune down a musical program to a faint, melodious background for an evening by the fireside.

There is no distortion at any volume. The shrill, bird-like treble of the flute has the same rich quality as the somber bass of organ or cello.

The Type 2-AP is a high quality two-stage transformer coupled audio amplifier with a push-pull power stage. It is designed for A. C. operation with a—27 A.C. tube in the first stage followed by standard power tubes in the push-pull stage, and is intended to be connected to the detector of any good receiver and operated from an A. C. power supply system, such as the Amertran Power Box, Type 21-D.

For complete information on the Type 2-AP Amplifier, write for Bulletin 1075-A.

AMERICAN TRANSFORMER COMPANY
172 Emmet Street, Newark, N. J.

AMERTRAN

Quality Radio Products

R B. 1-30 AMERICAN TRANSFORMER CO., 172 Emmet St., Newark, N. J.

Gentlemen:

Please send me Bulletin 1075-A containing complete information on Type 2-AP Amplifier.

Name

Street

Town

State

APEX MODEL 36

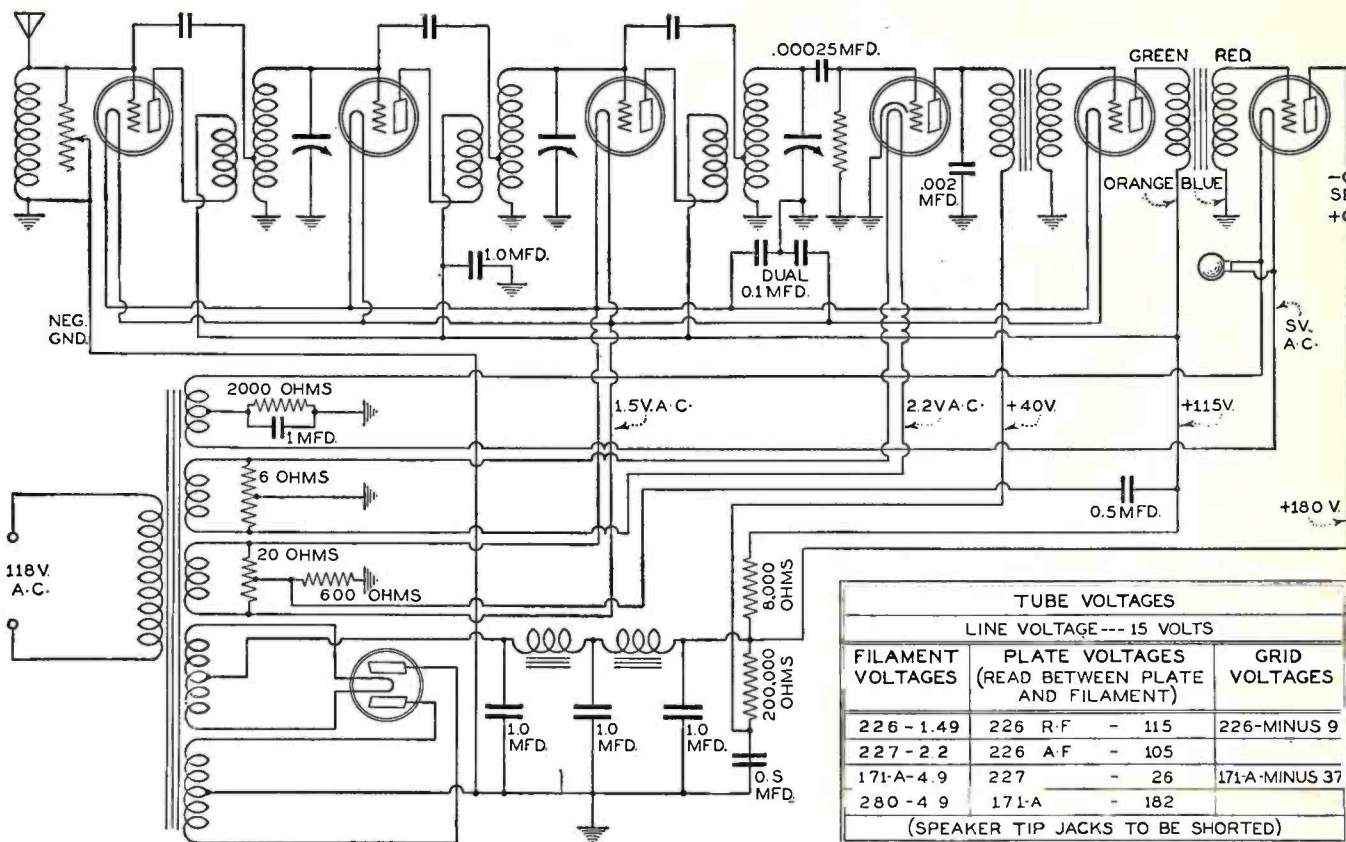

This is a six-tube a.c.-operated receiver consisting of three stages of tuned-radio-frequency amplification, a grid leak-condenser detector, and a two-stage transformer-coupled a.f. amplifier. In the r.f. and first

a.f. stages 226-type tubes are used. The detector is a 227-type tube. The power tube is a type 171A. Plate voltages are obtained from a 280-type tube in a full-wave rectifier circuit.

FADA MODELS 10, 11, 30, AND 31 RECEIVERS

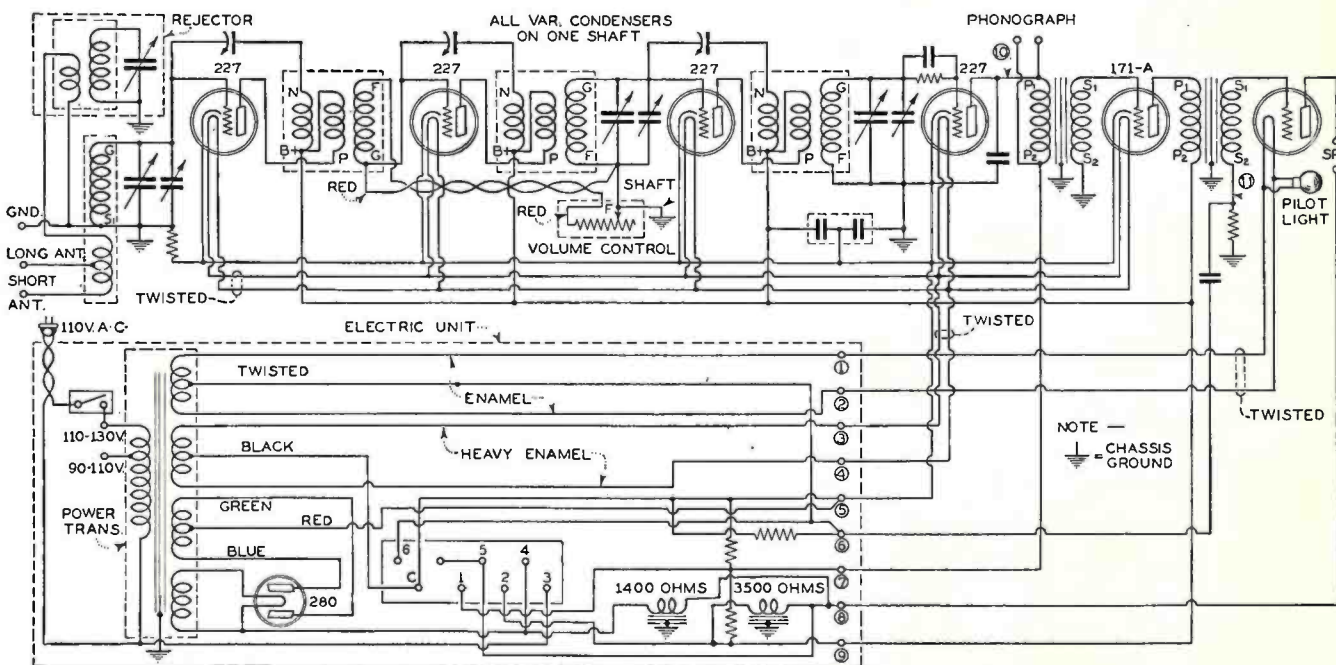

One of the unusual features about this Fada receiver is the use of a "rejector" circuit in the antenna stage. The primary of this rejector circuit is placed in series with the primary of the usual antenna transformer. The rejector circuit is not, however, tuned to the frequency of

the desired signals but is tuned so as to eliminate undesired signals. Another unusual feature is the use of an untuned r.f. transformer between the first and second r.f. amplifier tubes, the transformer being of such characteristics as to equalize the r.f. gain.

(Continued from page 167)

in whatever section the gang condenser does not tune accurately so that as the plates come into mesh the bent plate will have a closer spacing and so raise the capacity at the desired frequency setting.

"In neutralizing a receiver, the oscillator is set as for alignment of condensers and a dead or burned-out tube is placed in the first r.f. socket. The receiver is tuned to resonance, and the balancing condenser for that stage adjusted for *minimum* deflection of the output meter. Each r.f. stage is balanced in this way both on low and high frequencies.

"If an oscillator such as is described by Mr. Lampkin is a part of the shop equipment (and it certainly should be) some very interesting tests may be made on the efficiency of the a.f. systems of various makes of receivers. By changing the frequency of the a.f. oscillator and comparing readings or making graphs of the results obtained when the receiver's a.f. system is fed with frequencies ranging from the lowest to the highest a.f. note, the cut-off of the transformers, etc., may be determined.

"The human ear is very unreliable as a judge of volume in testing and fine adjustments of this nature as will be seen if a loud speaker is connected in parallel with the meter during tests.

"It may be necessary to insert a bias battery in the 199 grid return to reach zero reading with no signal input to the receiver."

Data on Atwater Kent sets: WALTER STRAUSS, JR. describes his experiences with A.K. screen-grid receivers:

"On one Atwater-Kent 60, three screen-grid tubes employed, it was necessary to hold down on the detector tube to hear signals, and when the hand was taken off the voice was distorted and weak with all the volume turned on. After taking off the base cover, an investigation revealed the grid leak touching the frame so that when the tube was pressed, the socket bent sufficiently to break the connection between the ground and the grid leak. The grid leak was raised a little with a piece of paper placed under it.

"Another quite similar incident occurred on the same model. In this case the music was weak and distorted, and tappings and knocks could not make the set play louder. So again the search was directed to the sockets of the 227 tubes in the detector and first a.f. stages. The analyzer showed something wrong in the grid circuit of the first a.f. stage. The secondary of the first a.f. transformer was o. k. and so was the resistor across the secondary of the transformer. With the continuity tester it showed that the resistor was grounded on both sides instead of only one. The other ground was found where solder on a wire was also making contact to the rivet nearby which held the sockets. The excess solder was removed. Another thing to watch for is that this resistor is not grounded to the frame as with the detector resistor. Don't always blame the 224's!"

Repairing a burned-out transformer: J. P. KENNEDY, radio serviceman of South Bend, Ind., and a student in E. E. at Notre Dame, suggests changing over to capacity coupling, with resistance or impedance in the plate circuit, for burned-out a.f. transformers not easily accessible for repair—the Radiola supers being an example.

"If, instead of going to the bother of repairing, let us say, a break in the plate circuit of the first a.f. stage, he simply binds a small wire around the plate terminal of the tube and solders the other end of it to one side of the 0.25-mfd. condenser and one end of a 50,000-ohm resistor, it is only necessary to attach the other

(Concluded on page 171)



DONGAN

*Looking Ahead
in
Radio Design*

WHILE your production line is turning out sets or amplifiers for this season's market your engineers are looking ahead. Decided improvements in Transformer design for the season to come is already an accomplished fact. Engineers in the Dongan Laboratories have developed innovations and refinements during the past six months which will unquestionably be accepted for the new models.

Exclusive devotion to the design and construction of Transformers, Chokes and Condensers over a period of 19 years has won for Dongan a leadership in Radio Parts. That, plus unfailing reliability for deliveries, has won for Dongan the patronage of the larger and better set and amplifier manufacturers.

New designs and engineering coöperation for the new models are available to any manufacturer.

*Exclusively M'fr's
of Parts for the
Set Manufacturer*

*Transformers
Chokes
Condenser Units*

Dongan Electric Manufacturing Co.

2991-3001
Franklin Street



Detroit
Michigan



Fulco RADIO COVERS

"FULCO" covers are used by those dealers who realize the importance of making deliveries in perfect condition — without scratches or mars. For they know that complaints mean dissatisfied customers and loss of business.

"FULCO" covers are a real service feature that helps sales and holds trade. Substantially constructed, heavily padded, box-shaped, providing perfect protection. Give us the dimensions of radios handled and let us quote special prices on your individual needs. Write our nearest house.

Fulton Bag & Cotton Mills
Manufacturers Since 1870
ATLANTA · NEW ORLEANS · DALLAS · ST. LOUIS
MINNEAPOLIS · BROOKLYN · KAN. CITY · KAN.

ON AND OFF
IN A JIFFY

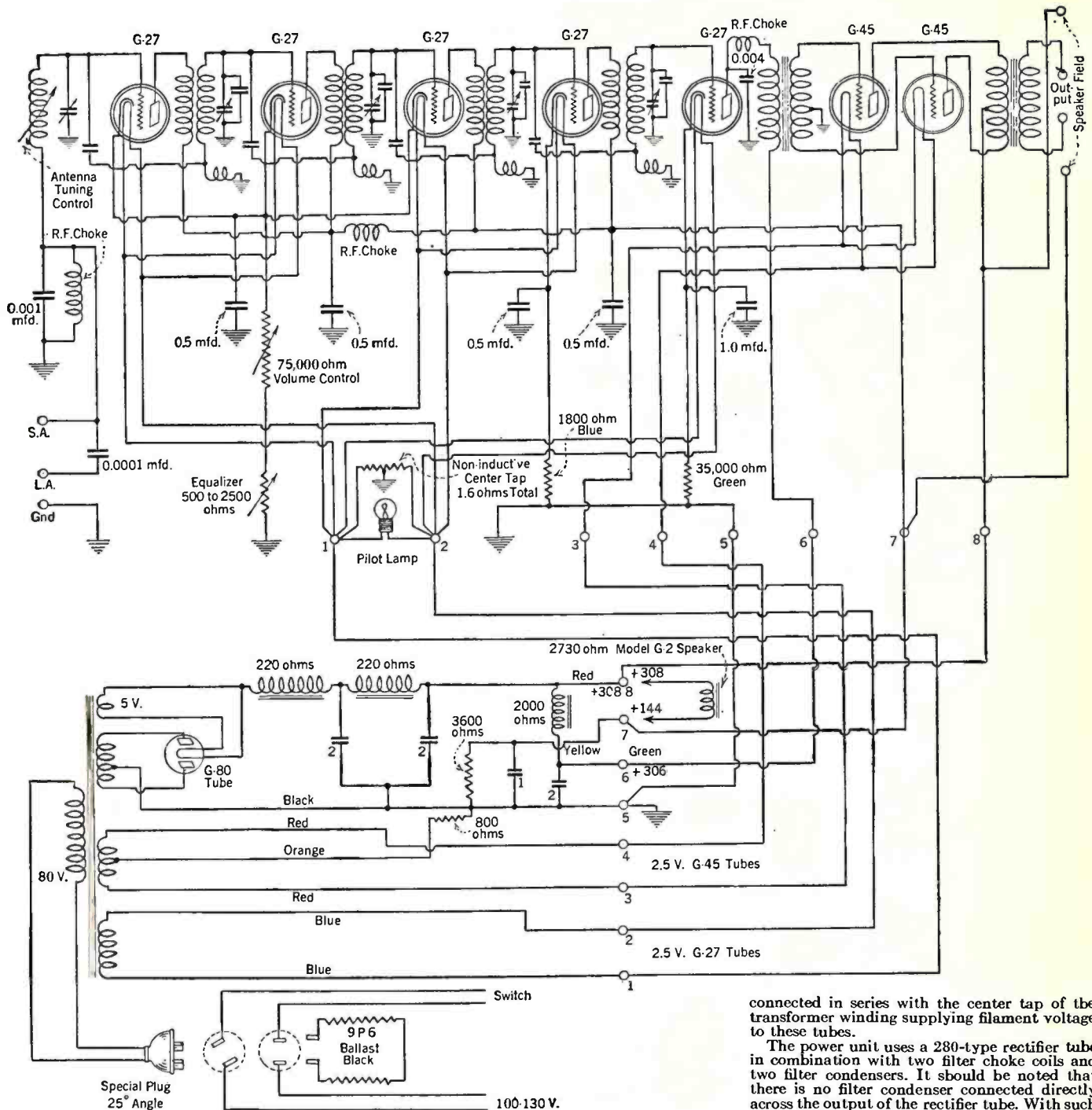

THE MAJESTIC MODEL 90 receiver uses the same fundamental type of radio-frequency amplifier circuits as did the previous Majestic receivers, Models 70, 70B, and 180. This set uses four stages of tuned-radio-frequency amplification followed by a C-bias detector and a single stage of audio-frequency amplification. There are five tuned circuits in the receiver, all of them controlled by the same tuning dial. Across the second, third, fourth, and fifth tuned circuits small compensating condensers are connected so that all the stages may be accurately tuned to resonance. The inductance of the antenna tuning circuit can be varied slightly so as to compensate the effect of the antenna circuit.

The volume output of the receiver is controlled by varying the grid bias applied to the first, second, and third r.f. amplifier tubes. For this control a variable resistor of 75,000 ohms is connected in series with the cathodes of the r.f. amplifier tubes. Increasing

the value of this resistor increases the bias on the tubes and thereby decreases the gain, causing a reduction in volume.

To make the receiver uniformly sensitive over the entire broadcast band, an equalizer circuit is used. This equalizer consists of a variable 500-2500-ohm resistor connected in series with a 75,000-ohm volume control. The shaft of this equalizer is mounted on the rotor shaft of the gang condenser so that as the rotor is turned in tuning the movable arm on the resistor unit moves correspondingly. The result is that an automatic variation in grid bias is obtained which is sufficient to compensate the normal variation in r.f. gain of the receiver.

Grid bias for the fourth r.f. amplifier tube is obtained by the use of a fixed resistor of 1800 ohms connected in series with the cathode of this tube. Bias for the detector tube is obtained by the use of a 35,000-ohm fixed resistor in the cathode circuit of the detector. The two 45-type tubes obtain their bias from an 800-ohm resistor

connected in series with the center tap of the transformer winding supplying filament voltage to these tubes.

The power unit uses a 280-type rectifier tube in combination with two filter choke coils and two filter condensers. It should be noted that there is no filter condenser connected directly across the output of the rectifier tube. With such a circuit it is necessary to use somewhat higher voltages across the secondary of the power transformer to obtain sufficient output voltage, but the advantage of such a system is that the load on the rectifier tube is much lighter than it would otherwise be and as a result the rectifier tube will have a long life. The full output of the filter circuit is used to supply grid and plate voltages to the two power tubes. This voltage is decreased for application to the other tubes in the receiver by connecting the field of the electrodynamic loud speaker in series with the high voltage tap so that the plate current of all the tubes except the power tubes must flow through the field winding. The resistance of the field winding is 2730 ohms.

The primary of the power transformer is wound for an input potential of 80 volts so that an automatic line voltage ballast may be used. This automatic ballast functions to supply approximately 80 volts to the primary of the power transformer even though the line voltage fluctuates between 100-130 volts.

READINGS WITH THE WESTON SET-TESTER MODEL 547

Type Tube	Tube Position	"A" Volls	"B" Volls	"C" Volls	Cath. Volls	Nor'l mA.	Test mA.
27	1 R.F.	2.3	150	14	19	3.4	6
27	2 R.F.	2.3	150	13	17	3.5	6
27	3 R.F.	2.3	150	13	18	3.6	6
27	4 R.F.	2.3	158	12	12	6.6	8
27	Dct.	2.3	290	29	28	.8	1
45	P.P.	2.4	285	50		35	40
45	P.P.	2.4	285	50		35	40
80	Rect.	4.8				60	

VOLTAGE READINGS WITH SUPREME DIAGNOMETER

Tube Type	Use	Fil. V.	Plate V.	Grid V.	K.	P. Cur.
27	1 RF	2.35	130	8	8	5.5
27	2 RF	2.35	130	8	8	5.5
27	3 RF	2.35	130	8	8	5.5
27	4 RF	2.35	130	9	9	5
27	Detector	2.35	270	30	30	1
45	Power	2.45	250	50		32
46	Power	2.45	250	50		32

All readings under full load. Line voltage 115 volts.

(Continued from page 169)

end of the resistor to the 90-volt positive B terminal and the other side of the condenser to the grid terminal of the following tube to get results.

"If the break is in the grid circuit of an a.f. tube, a 150,000-ohm resistor should be bridged from the grid of the tube to the negative end of the 4.5-volt C battery wire and the same sized condenser should be connected, as in the previous case, from the plate of preceding tube to the grid of the tube in question."

Nuts and Bolts and Antennas: "When going on service trips, I always carry a light-socket antenna with me. Its use is obvious. If you suspect that the outdoor antenna is in any way contributing to the set's defect, your suspicions may be verified easily or refuted by a temporary substitution. True, many of the modern sets are equipped with such socket antennas but it must be remembered that a majority of the sets one is called on to repair give the impression that they are the radios which accompanied Noah on his famous personally conducted tour.

"I have always made it a point to carry a varied assortment of radio hardware; nuts, bolts, screws, lugs, etc. Just a few of each in a small cardboard box will be sufficient. This seems rather obvious yet I have seen numerous repair kits which neglected such necessary equipment. The radio man will be getting a reputation such as the plumber has earned through his forgetfulness and frequent trips back to the shop, if he doesn't watch out.

"One summer I was called upon to service an Atwater-Kent 35 which I had installed the previous winter. Inspection proved the antenna to be guilty. One end had been

attached to a tree and newly grown branches and leaves were rubbing against it, creating the disturbance. A little emulation of the lumberjack and a peaceful silence reigned where had been chaos and discord. Moral: Use a little forethought in erecting an antenna."

BERNARD CANNON, Pittsburgh, Pa.,
Majestic and S-M.

More Dope on Hum Elimination: The following letter has been in our files for some time. Our first impulse was to include it in one of our symposiums on hum reduction. On second thought that was not quite the place for it. But it certainly deserves publication somewhere—so here it is:

"I present the following as a matter of interest and not because it presents the solution of a particular problem. Many a serviceman may get a laugh from it.

"A most drastic method of removing hum from an a.c. set just came to my attention. A friend of mine, a plumber by trade, had an Atwater-Kent. After being in service some time a wire became disconnected. It caused a buzz or hum and was very annoying. Upon inspection he discovered the loose wire and saw immediately that a little solder was all that was necessary to make the set operate as it should. He had no iron at hand so got out his blow torch, fixed the flame as small as possible and turned it on the bad connection. Have you in all your experience heard the beat of that? The wire was difficult of access. More flame, more heat, and then the metallic clank of various small members falling on the chassis. The hum was removed and so was everything else that makes radio, radio.

"I certainly enjoy your magazine."
BYRON E. LAIDLAW, Crestwood, N. Y."

A RADIO DEALER'S TUBE-TESTER

(Continued from page 145)

a standard circuit using the rectifier tube to deliver current to a fixed load resistance. A low current through this resistance shows a defective tube. The circuit (Fig. 3) is arranged to use a standard center-tapped transformer delivering 600 to 700 volts and having a 5.0- and a 7.5-volt filament winding. A switch is provided to change connections from 380 to 381 tubes, this change consisting of changing the load resistance as well as the transformer connections. As can be seen from the circuit, the 380 tube is used with 300 to 350 volts on each plate and delivers current to a 4-mfd. condenser and a 2000-ohm load resistance which has a 0-200-scale milliammeter in series with it. The 381 tube is used with 600 to 700 volts at 60 cycles on the plate and delivers current to the 4-mfd. condenser with a 6000-ohm load. The test consists of inserting the tube in the proper socket, making sure the switch is thrown to the correct side. The milliammeter should read something over 100 mA. for the 380 and something over 60 mA. for the 381, though these readings depend on whether a 600-volt or a 700-volt transformer is used. For the higher voltage the limits can be raised 10 mA. and for intermediate voltages, allowances made.

In the drawing a typical layout of this circuit is shown. It is preferable to keep the tube socket terminals beneath the panel to avoid shocks. A conventional double-pole double-throw tumbler switch is shown. The 4-mfd. condenser must be a good one capable of working continuously at 1000 volts. d.c. The load resistor must have a high current carrying capacity, the Electrad type C or D being satisfactory.

The equipment listed in Table III was used in the original model but any equivalent parts will give satisfactory results.

Table III

- T₁—One Amertran PF52A transformer, 110-115-V. 60-cycle primary having 300 volts each side of center of secondary (capable of delivering at least 85 milliamperes in each half of the high winding) and having two 7.5-volt windings, both insulated for 1000 volts from other windings. This particular transformer, since it has two 7.5-volt windings, required a 1-ohm and a 1/2-ohm Carter type H resistor in series with the filament terminals of the 380 socket to reduce the voltage to 5 volts. A transformer having two 5-volt windings and a 2.5-volt winding could also be used, one five-volt winding being used for the 380 and the other two (the 5 and the 2.5 volt) connected in series to provide 7.5 volts for the 381.
- C₁—One Acme Parvohm condenser, 4-mfd. 1000-volt
- M₁—One Weston model 301, 0-200 milliammeter.
- R₁—One Electrad type D, resistor, 2000-ohm
- R₂—One Electrad type D, resistor, 4000-ohm
- Two tube sockets, cx-type
- K₁—General Electric switch, double-pole, double-throw (Catalogue No. 289739)
- K₂—General Electric tumbler switch, single-pole (Catalogue No. 269943)

[For those dealers and servicemen who prefer to buy ready-made apparatus, there are a number of tube-testers as well as apparatus designed for overall measurements on receivers, which will perform some of the measurements which the apparatus described in this article will do. Some commercial equipment will carry out all the tests, including short-circuit tests, etc. The circuit which includes a C-bias resistor part of which can be shorted to get the worth of the tube is covered by a patent issued to the Weston Electrical Instrument Co. Other tube-tester manufacturers are licensed under this patent. Efficient and inexpensive apparatus for testing tubes may be purchased from the instrument makers, a number of whom may be found advertising in RADIO BROADCAST. This article is published for those who already have some of the apparatus available (meters etc.), and for those who enjoy making their own equipment.—The Editor.]

"Here at last is The Book that we of the Radio profession have needed for a long time. It is the best and most complete handbook ever published," says J. H. Bloomenthal, Chief Radio Operator, U. S. S. B. Steamship "East Side,"

THE RADIO-MANUAL

A New Edition

Complete new chapters on aircraft radio equipment; Practical Television and Radiomovies with instructions for building a complete outfit; radio interference; 100% modulation; latest equipment of the Western Electric Co.; the Marconi Auto-Alarm System; and many other developments of the past year. All this information is added in the new edition and, besides, the entire book has been brought right up to date with much new material. The Radio Manual continues to be the one complete and up-to-the-minute handbook covering the entire radio field.



A Handbook for Students Amateurs Operators Inspectors

20 big chapters cover: Elementary Electricity and Magnetism; Motors and Generators; Storage Batteries and Charging Circuits; The Vacuum Tube; Circuits Employed in Vacuum Tube Transmitters; Modulating Systems and 100% Modulation;

Wave-meters; Piezo-Electric Oscillators; Wave Traps; Marine Vacuum Tube Transmitters; Radio Broadcasting Equipment; Arc Transmitters; Spark Transmitters; Commercial Radio Receivers; Marconi Auto-Alarm; Radio Beacons and Direction Finders; Aircraft Radio Equipment; Practical Television and Radiomovies; Eliminating Radio Interference; Radio Laws and Regulations; Handling and Abstracting Traffic.

An immense amount of information never before available including detailed descriptions of standard equipment is presented.

Prepared by Official Examining Officer

The author, G. E. Sterling, is Radio Inspector and Examining Officer, Radio Division, U. S. Dept. of Commerce. The book has been edited in detail by Robert S. Kruse, for five years Technical Editor of QST, the Magazine of the American Radio Relay League. Many other experts assisted them.

Free Examination

The new edition of "The Radio Manual" has just been published. Nearly 900 pages, 369 illustrations. Bound in Flexible Fabrikoid. The coupon brings the volume for free examination. If you do not agree that it is the best Radio book you have seen, return it and owe nothing. If you keep it, send the price of \$6.00 within ten days.

Order on This Coupon

D. Van Nostrand Co., Inc.,
250 Fourth Ave., New York

Send me the Revised edition of THE RADIO MANUAL for examination. Within ten days after receipt I will either return the volume or send you \$6.00, the price in full.

(Radio Broadcast 1-30)

Name.....
St. & No.
City and State.....

THE A. C. DAYTON NAVIGATOR

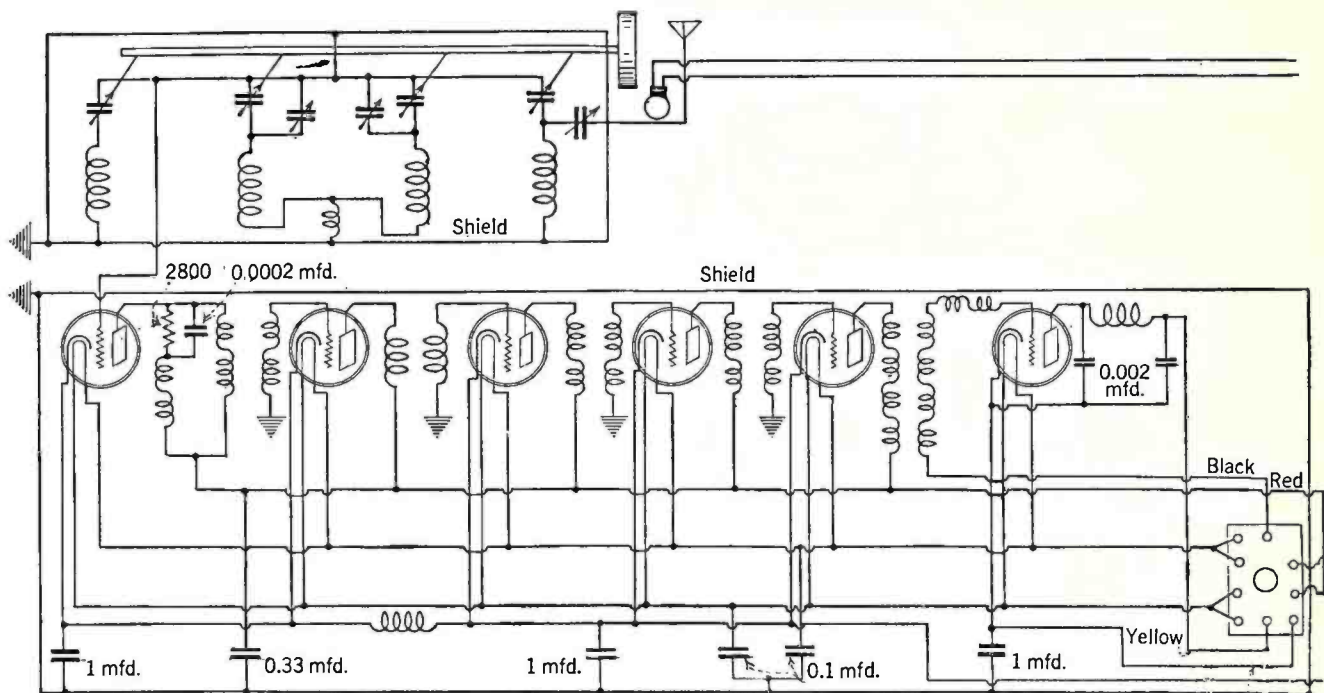

THE A-C DAYTON NAVIGATOR receiver, the circuit of which appears on this sheet, is an example of a set using a system of "pre-selection" in which the signals to be received are selected by several tuned circuits before they reach the first r.f. amplifier tube. Reference to the circuit diagram shows that the tuning dial controls the setting of four variable condensers, each of which functions to tune a circuit to resonance. There are, therefore, four tuned circuits between the antenna and the grid of the first r.f. amplifier tube. Induced in the antenna circuit are signals from all broadcasting stations, but in the process of passing through the various tuned circuits all of these except the desired one are eliminated. Although there are many different signals across the input, in the output of the selector there is only one signal—the desired signal to which the various circuits have been tuned.

THE R. F. AMPLIFIER

After this signal goes through the tuned stages it reaches the first tube of the r.f. amplifier. In the r.f. amplifier there are five tubes and each of these functions to amplify the desired signal. The r.f. amplifier is untuned, that is, it is designed to amplify a signal of any frequency in the broadcast band that is impressed on its input. Since the selector circuits weed out all but the desired signal, the amplifier functions to amplify this signal whether it be from a station transmitting on 500 kc., 1000 kc., or any other frequency in the broadcast band.

The difference between the system described above and that used in many other receivers should be noted. In most sets a tuned circuit is placed between each tube so that the processes of selection and amplification occur in the same circuit. In this receiver the functions of selection and amplification are separate, the signal is first selected and then amplified.

THE DETECTOR CIRCUIT

The output of the r.f. amplifier supplies voltage to a C-bias detector operated at sufficiently high grid and plate voltages (see table) so that it can supply enough a.f. output to operate the two 245-type push-pull tubes at

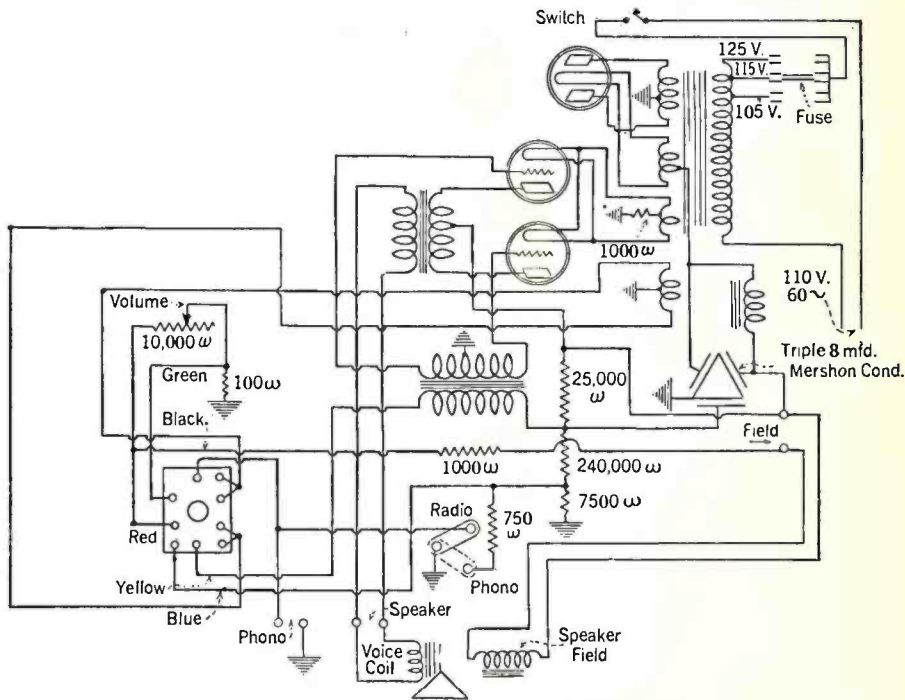

their maximum power. It should be noted that in the plate circuit of the detector tube there is an r.f. filter circuit consisting of r.f. chokes and two 0.002-mfd. condensers. This filter circuit bypasses to the heater of the detector all the r.f. currents in the plate circuit so that only audio-frequency currents will be applied to the primary of the a.f. transformer.

Plate voltage for all the tubes is obtained from the 280-type-rectifier tube which feeds into a filter circuit consisting of two chokes (one of which is the field of the electrodynamic loud speaker) and a three-section Mershon condenser

with a capacity of 8 microfarads per section. The primary of the power transformer is tapped for various line voltages from 105 to 125.

EASE OF SERVICING

In serving the receiver the fact that the set is made up of three separate sections—the selector, the r.f. amplifier, and the power amplifier and B supply—makes it possible to readily remove any one section and replace it with a new unit while the defective unit is being repaired. The chart of voltage and current readings given on this sheet will prove helpful in determining whether or not the various circuits are receiving the correct voltages and whether the plate current at these voltages is normal.

The fact that the r.f. amplifier is of the untuned type makes it possible to determine readily whether or not the selector unit is in proper working order. For example, if the set does not seem to have very much gain it might be due to some defect in the selector and this could be checked readily by removing the antenna from its usual location at the input of the selector and connecting it instead to the contact between the selector unit and the r.f. amplifier. If the signals from any local station then come in with tremendous volume it is a definite indication that the loss in gain is due to some defect in the selector which can then be removed and replaced with a new unit.

AVERAGE VOLTAGE READINGS OF THE A.C. DAYTON NAVIGATOR RECEIVER

Tube Number	Tube Type	Function of Tube	Heater Volts	"B"—Plate Min. Vol.	Plate Max. Vol.	"C" Bias Min. Vol.	Bias Max. Vol.	Normal Plate mA.
1	27	1st. r.f.	2.4	20	110	4.5	3.5	4.5 to 5.0
2	27	2nd. r.f.	2.4	20	110	4.5	3.5	4.5 to 5.0
3	27	3rd. r.f.	2.4	20	110	4.5	3.5	4.5 to 5.0
4	27	4th. r.f.	2.4	20	110	4.5	3.5	4.5 to 5.0
5	27	5th. r.f.	2.4	20	110	4.5	3.5	4.5 to 5.0
6	27	Detector	2.4	180	185	15	15	1.0
7	45	Audio	2.4	230	230	50	50	20 to 24
8	45	Audio	2.4	230	230	50	50	20 to 24
9	80	Rectifier	4.75	330	330			

Note: The above readings for "Detector" are given with the "Phono-Radio" switch in the "Radio" position. With this switch in the "Phono" position, the detector should have the following readings: Plate Volts = 120; "C" Bias = 4.0 volts; Plate current = 5.0 mA.

A REFLEX VACUUM-TUBE VOLTMETER

THE ORDINARY vacuum-tube voltmeter has the disadvantage that its range is quite limited, generally being not more than about 3:1 in voltage. By the use of an arrangement whereby the plate current is caused to flow through a resistance which functions to increase the bias on the grid of a tube, it is possible to increase the range of the instrument almost indefinitely. Such a device is called a "reflex" voltmeter.

The first reflex voltmeter which came to the attention of the writer was one described by W. B. Medlam and U. A. Oswald in the November, 1926, *Experimental Wireless and Wireless Engineer* (England). A description of a reflex voltmeter formed part of an excellent series of articles by these two engineers. In Fig. 1 is given a calibration curve of a reflex voltmeter taken from the previously mentioned article. On the curve is shown the circuit arrangement used. It should be noted that the plate current, in order to get to the filament, must flow through the resistance R, and that increases in the current through R will also increase the bias on the grid of the tube. The calibration curve of a reflex voltmeter is quite linear, in this particular case we find that from about 3 volts to 20 volts each increase of 10 microamperes in plate current corresponds to an increase of 2 volts on the input. The steady bias, E_c , is used so that the plate current will not be excessive when the a.c. input voltage is zero.

In Fig. 2 is given the circuit diagram of a reflex voltmeter using a 227-type tube. This should make a very useful instrument. It should be possible to supply the voltmeter from a rectifier and filter system so that the instrument could be entirely self-contained and light-socket operated.

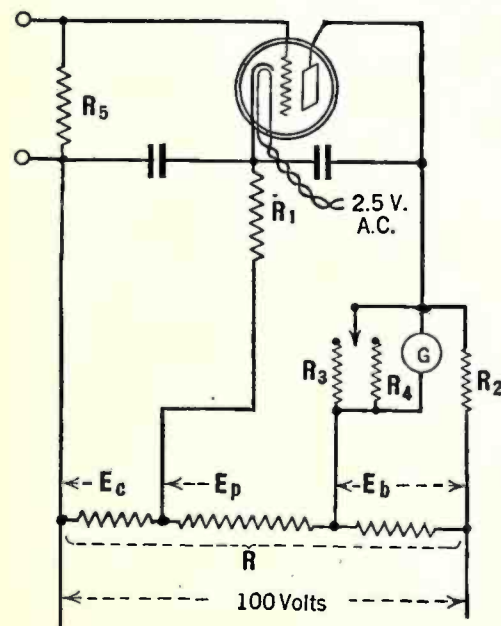

Fig. 2

To balance out the steady plate current flowing through the plate microammeter, when there is no input voltage, connection is made through resistance R_1 to the plate side of the meter and the potential E_b is adjusted so that the current through G is exactly equal and opposite to the steady

plate current. The value of resistor R_2 is not critical; its value should simply be much greater than the resistance of the galvanometer so that the entire increment in plate current will flow through the galvanometer and not through R_2 .

Vacuum-tube voltmeters are generally calibrated by connecting known a.c. voltages across their input, noting the corresponding plate current, and finally plotting the calibration curve showing the variations in plate current with input voltage. It is, however, possible to use a static characteristic curve to calculate

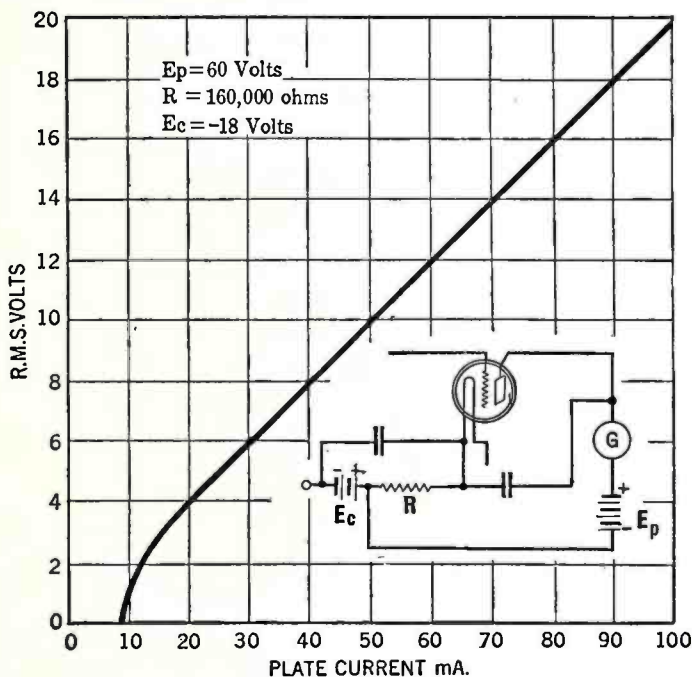

Fig 1

the calibration curve of a simple voltmeter by any one of several methods. Medlam and Oswald give a simple method in their article. To determine the calibration from the static characteristic curve, we must know the plate current corresponding to:

- E_c the steady bias on the grid
- E_F the steady bias plus the peak value of the a.c. voltage
- E_r the steady value minus the peak value of the a.c. voltage

Knowing these three quantities it is possible to calculate within two or three per cent. the mean plate current as read on the plate current meter, by means of the following simple relationship.

$$I_m = \frac{I_c}{2} + \frac{I_F + I_r}{4}$$

- where I_m = reading of the plate meter
- I_c = plate current corresponding to E_c
- I_F = plate current corresponding to E_F
- I_r = plate current corresponding to E_r

Consider the following example. We desire to determine what would be the reading of the plate meter if a peak a.c. potential of 1 volt were applied to the grid. Assume that the steady bias on the tube is minus 3 volts. Therefore,

$$\begin{aligned} E_c &= -3 \\ E_F &= -3 + 1 \text{ or } -2 \text{ volts} \\ E_r &= -3 - 1 \text{ or } -4 \text{ volts} \end{aligned}$$

From an accurately measured static characteristic curve, we determine that I_c is 10 microamperes, I_F is 34.1 microamperes and I_r is 1.7 microamperes. Substituting in the formula, we have

$$\begin{aligned} I_m &= \frac{10}{2} + \frac{34.1 + 1.7}{4} \\ I_m &= 13.95 \end{aligned}$$

By actually applying an a.c. voltage having a peak value of 1 volt to this tube it was found that the plate meter read 14 microamperes, which agrees very closely with the calculated result.

Just Out . . . Keith Henney's Book on Radio

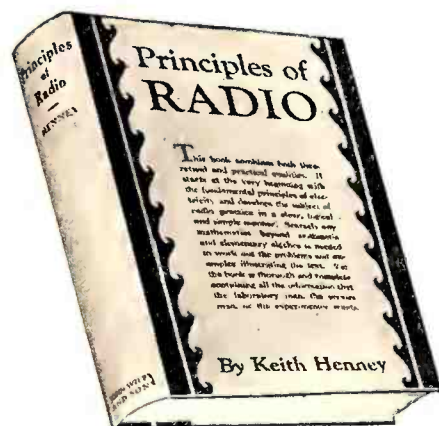

Principles of Radio

By KEITH HENNEY
Director of the Laboratory
Radio Broadcast Magazine

Readers of Radio Broadcast, long familiar with the work of Keith Henney in his capacity as Director of the Magazine's Laboratory, will be eager to secure his first book, just released from the press.

This book brings together within one cover the kind of information on radio which will appeal to the practical interest of every radio experimenter, technician, engineer, and fan. It contains the latest data and the most modern methods. It treats in a thoroughly practical way everything from the production of radio currents to their reception and transmission. Many problems, examples, illustrations, experiments, are here presented in book form for the first time.

Keith Henney, by reason of his wide experience as an operator, engineer, and writer, has the gift of making technical information readily understood by the reader.

See a Copy on Ten Days' Approval

Price \$3.50

A Wiley Book

ON APPROVAL COUPON

JOHN WILEY & SONS, INC. RB 1-30
440 Fourth Ave., New York City

Gentlemen: Kindly send me on approval Henney's "Principles of Radio." I agree to remit the price (\$3.50) within ten days after its receipt or return the book postpaid.

Name
Address
Reference

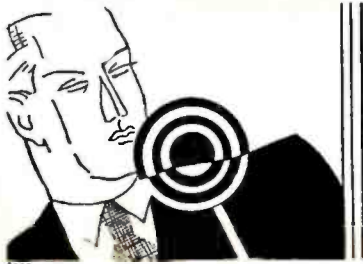

RADIO

De Forest Wins General Electric Co. Suit

The Court of Appeals of the Third Circuit, in a decision just handed down, has confirmed the right of the DeForest Radio Company to the use of high vacuum in its audions, and has discharged the suit brought against this company by the General Electric Company. This decision is held to be of outstanding importance, since it removes the sole remaining question regarding the enviable tube patents position of the DeForest Radio Company.

The suit for patent infringement was instigated by the General Electric Co. against the DeForest Radio Co. in April, 1925, charging infringement of the so-called Langmuir high-vacuum patent. The original trial lasted five weeks, with the District Court finally holding that the patent was invalid. The decision was appealed by the General Electric Company, and has now been confirmed by the Court of Appeals. If the so-called Langmuir high-vacuum patent had been sustained, it would have placed its owner in control of the radio tube industry.

The decision declares invalid three patents covering the use of a high vacuum in a vacuum tube, the use of thoriated filament in high vacuum, and the use of the magnesium flash in a high vacuum.

Receiver Appointed for Earl

Receivers were named on application of creditors late in November for the Earl Radio Corporation, New York. Principal creditors are the Klamer Furniture Company, Evansville, Ill., \$500,000; Westinghouse, \$56,000. Arcturus Radio, \$250,000; Scoville, \$150,000; and Erickson Manufacturing Company, \$31,000. Attorneys for Earl announce consent to the receivership as a protection to creditors and state that a reorganization to obtain larger working capital is under way.

Studebaker Enters Radio

The Studebaker interests, of South Bend and Chicago, have acquired substantial holdings in the Marvin Radio Tube Corporation, according to Thomas F. James, president. Col. George M. Studebaker will become chairman, with F. H. Wellington treasurer. The directorate will be increased to include Colin B. Kennedy, president of the Colin B. Kennedy Corporation; Hiram H. Maynard, of the H. H. Maynard Corporation; Col. Studebaker; and F. H. Wellington.

Rauland Returns to Radio

E. N. Rauland, formerly of the All-American Transformer Company, Chicago, Ill., is president of the Rauland Corporation, 3311 Belmont Ave., Chicago. All types of a.f. transformers will be made from a replacement transformer at \$2.25, to a standard shielded model at \$1.50, and the laboratory type at \$7.50. Special power amplifiers have been developed in collaboration with Jenkins and Adair. The company also makes ultra-violet sun lamps.

General Motors' Officials Attend Convention



"Building for the future by building right" was the keynote of the first convention of district managers of General Motors Radio Corporation at the company's plant in Dayton, Ohio, October 24 and 25, 1929, with John E. Grimm, Jr., vice president and director of sales, in charge.

Plans for fall selling were outlined and it was announced that the General Motors Radio Corporation would continue the manufacture of the Day Fan Radio receivers. Advertising plans were outlined by Mr. Rothman and W. A. P. John, vice president of the Campbell-Ewald Company, the company's advertising counsel. The company's advertising policy, it was announced, would be to handle all advertising on a controlled basis for both distributors and dealers, which met the

approval of all district managers and officials present.

At a banquet at the Van Cleve Hotel, Mr. Emmert outlined the engineering and manufacturing plans of the company. The convention was brought to a close with an address by R. H. Grant, who discussed the future of the radio business as seen by General Motors.

Officials of the company attending the convention are pictured above. They are from left to right: (upper row) Charles T. Lawson, general sales manager; E. E. Rothman, advertising manager; John F. Reeder, Campbell-Ewald Co., advertising counsel; (lower row) John E. Grimm, Jr., vice president and director of sales; R. H. Grant, vice president in charge of sales of General Motors; R. J. Emmert, president and general manager.

R. S. M. A. To Expand

Service managers outside of New York who are interested in forming branch service managers associations are urged to communicate with G. C. Kirchhof, executive secretary R.S.M.A., at their new address 324 West 42nd Street, New York. Branch associations will secure copies of the examination questions used by the parent organization in registering servicemen, necessary forms, including certification cards, office records, and copies of the new official publication of the R. S. M. A., *The Radio Service Man*.

N. F. R. A. Survey

A committee of the Radio Wholesalers Association is making a nation-wide survey on the handling of sets, tubes, and accessories by radio wholesalers. A report of findings will be made at the Cleveland Convention in February. Other committees of the Radio Wholesalers Association will investigate the handling of vacuum tubes and accessories.

Radio In Schools

South Dakota has announced plans to install radio in all the 5000 schools of the state within the next two years, with a regular semi-weekly broadcast by the State Department of Education as part of the regular educational program, in addition to broadcasts from other stations. The action is in line with developments in other states. Quinton Adams, vice president of the Radio-Victor Corporation, has announced that within the last few months thirty schools in the United States have installed built-in centralized radio apparatus for distribution of educational programs to classrooms and that between sixty and seventy other schools are planning similar installations.

New Experimental Station

The DeForest Radio Company will construct a five-kilowatt transmitter at its Passaic plant. The new station will be used for research and test purposes in the radio transmitter field.

p-3

500 Dealers Receive Dept of Commerce Questionnaire

Marshall T. Jones, of the Bureau of Foreign and Domestic Commerce, is mailing to four- or five-hundred representative dealers an unusually complete questionnaire covering all angles of retail trade. Among other fundamentals the survey asks the relation of parts business done by a dealer to all other business, facts on the dealer's service methods, whether part time servicemen are employed, number of sales made after 6 P.M., to whom sales are made, how shipments are forwarded from distributors, trade papers received, local interest in short-wave reception, etc.

A Book on Radio Law

A new book, *Radio Law*, by W. Jefferson Davis, published by Parker, Stone and Baird Co., Fourth and Wall Streets, Los Angeles, Calif., has just been issued. This volume is an excellent source for those who have occasion to follow the legal course of radio during recent years. The text covers decisions of the Federal Radio Commission and briefs of cases coming before the courts on state, national, and municipal regulation of radio. It also considers copyright, slander, world radio codes, the Washington Convention, and procedure before the Federal Radio Commission. It has a useful index and appendix.

Will Not Change Price

A number of manufacturers have reduced prices of 1929 models. Full details are given in this issue on page 181. The following manufacturers, however, have announced that no changes in prices will be made covering current models: Zenith, Philco, Edison, Grebe, Silver, Steinite, and Bosch.

Bosch Adds to Plant

An addition to Plant A of American Bosch at Springfield is now under way and is due to be completed early in January.

Personal Notes

G. J. Hallam, for the past three years assistant merchandise manager of the home furnishing division of the Associated Merchandising Corporation, has been appointed general sales manager of the De Forest Radio Company, Jersey City, N. J. Mr. Hallam succeeds Harry Holmes who recently resigned.

McMurdo Silver, president of Silver-Marshall, Inc., is now back at his desk after a month's absence due to injuries incurred in an automobile accident.

N. O. Williams, chief engineer and vice president of the CeCo Manufacturing Company, Providence, has been made works manager.

John E. Grimm, Jr., formerly with the Delco-Light Company, Dayton, Ohio, has been appointed vice president and director of sales of the General Motors Radio Corporation. He was formerly with the sales division of the Chevrolet Motor Car Company.

Charles J. Ross, formerly comptroller of R. C. A., has been elected executive vice president of R. C. A. Photophone, Inc. He succeeds E. E. Bucher who was recently appointed assistant vice president of the Radio Corporation of America.

W. R. G. Baker, has been selected to head the engineering division of the new RCA-Victor Corporation, with the title of vice president in charge of engineering. Mr. Baker will make his headquarters at Camden, N. J. He is at present in charge of radio engineering and manufacturing at the General Electric Company at Schenectady.

L. T. Breck, sales manager for the Kolster Radio Corporation for the past year, has been elected vice president in charge of merchandising to succeed Major Herbert H. Frost, who recently resigned.

Glenn Browning, has been retained by the Temple Corporation to work on special problems relating to radio development. Temple now has nineteen graduate engineers in the permanent staff.

LeRoi J. Williams has been appointed director of patents for the Grigsby-Grunow Company. Mr. Williams was formerly associated with the Raytheon Manufacturing Company, the General Electric Company, the Westinghouse Company, and the Radio Corporation of America.

James T. Bristol has been made General Manager and executive head of the Majestic Corporation which has been organized to finance installment sales of Majestic radios.

J. R. Aray has been appointed chief service engineer of the Grebe Sales Company. Mr. Aray

Edison Discontinues Making Records

Thomas A. Edison, Inc., has discontinued the manufacture of commercial phonograph records (including both diamond disc and needle types) in order to make available additional factories for the manufacture of radio and radio-phonograph combinations on an augmented scale, according to announcement by Arthur L. Walsh, vice president of the corporation. Mechanical phonographs of the portable type will be continued to be manufactured and sold as heretofore.

Minnesota Service Organization

The Associated Radio Service Engineers, 301 Tribune Annex, Minneapolis, Minn., was organized in May, 1929, with more than forty charter members. Meetings are held each Monday evening. The association is affiliated with the Northwest Radio Trade Association and all members have passed the registration examination for servicemen given by that organization. H. E. Knox is president, C. E. Graves, vice president, M. N. Flemming, secretary, C. L. Larson, treasurer, Earl Gibbs, director, and H. H. Cory, executive secretary.

was formerly chief sound technician at the Paramount Studios.

Nathan Chirelstein, of the Sonatron Tube Company, has been made president of the National Union Radio Corporation. Mr. Chirelstein, with his brother, Harry Chirelstein, embarked on his radio career in 1922 at which time Chirelstein's Radio Tube Corporation was formed. Three years later it became the Sonatron Tube Company.

Edward B. Newill has become affiliated with the radio manufacturing company being formed jointly by the General Motors Corporation and the Radio Corporation of America. Mr. Newill was formerly manager of the Control Engineering Department of the Westinghouse Electric and Manufacturing Company.

George M. Cook has been appointed director of public relations of the Grigsby-Grunow Company. Mr. Cook has held similar positions with the Stan-

(Continued on page 176)



The new eight story addition to the plant of the Crosley Radio Corporation is so spacious that as many as 600 employees can work on set assembly on a single floor.

(Continued from page 175)

dard Oil Company and Swift and Company and was connected with the Associated Press for fifteen years.

Lester Abelson, general production manager of the Steinite Radio Company, is developing several unique methods of checking and improving efficiency in the new Steinite plant. An automatic counter, similar to a taxicab meter, has been installed on his desk which clicks off the number of each completed radio set as it leaves the factory.

David Grimes has joined the research staff of the Temple Corporation in Chicago.

P. P. Huffard, formerly vice president and general manager of the National Carbon Company, a subsidiary of the Union Carbide and Carbon Corporation, has been elected president of that company. He succeeds W. J. Knapp who is now chairman of the board.

Curtiss Ahhott, formerly general sales manager of the Eveready Radio Corporation, has been appointed manager of the Pacific Northwest territory for Philco.

Ira B. Lamphier has been appointed a director of the Package Research Laboratory, Rockaway, New Jersey. In his new capacity, Mr. Lamphier will continue the work of package design and construction that he has been carrying on for several years.

J. J. Steinharter, president, Cable Radio Tube Corporation, left New York recently for a trip to the Pacific Coast in the course of which he will visit Los Angeles, San Francisco, Portland, and Seattle.

Lester Noble, formerly president of Federal Radio

Corporation, has been elected president of the United Reproducers Corporation, Springfield, Ohio. Arthur B. Hill, former president, has resigned.

Major I. E. Lambert is vice president and general counsel, RCA-Victor Company, Inc. E. C. Grimley is treasurer and comptroller. Both were former officers of the Radio-Victor Corporation.

A. H. Meyer, of Leo J. Meyberg Co., has been elected president of the Pacific Radio Trade Association. Other officers are Robert Eastman, vice president, Ernest Ingold, E. G. Arnold, H. R. Curtiss, Harrison Holliway, C. L. McWhorter, W. H. Quarg, and L. B. Quimby.

Byron P. Minnium, formerly chief engineer, Radio Division, Stewart-Warner Corporation, has joined the Baldwin Piano Company in Cincinnati, Ohio, as head of their Radio Division.

Carl Dreher, formerly chief engineer of RCA Photophone, Inc., prior to that staff engineer of the National Broadcasting Company, and for four years a regular contributor to RADIO BROADCAST as author of "As the Broadcaster Sees It," is now located in Hollywood, California as director of sound for RKO Pictures, producers of Radio Pictures.

The Northwest Radio Trade Association, at its annual election of officers held recently in connection with the Northwest Radio Show in Minneapolis, chose by a unanimous vote, J. W. A. Henderson as its president for the coming year.

Sylvan Harris, formerly with the Brandes Laboratories, Newark, New Jersey, has joined the engineering staff of F. A. D. Andrea, Inc., Long Island City, New York.

Complaint Against Freshman

Charging that the Charles Freshman Company, Inc., of New York, manufacturers and dealers in radio receiving apparatus, acquired control of a competing company, the Freed-Eisemann Radio Corporation, of Brooklyn, N. Y., the Federal Trade Commission has issued a complaint against the Freshman Company, according to information made available by the Commission on October 31.

More than 250,000 shares of the stock of the Freed-Eisemann Corporation were obtained by the Freshman company, the complaint alleges. "The effect of the acquisition by respondent of said capital stocks of Freed-Eisemann Radio Corporation or the use of such stocks by the voting or granting of proxies, or otherwise," it was stated in the complaint, "may be and is to lessen substantially the competition between respondent Charles Freshman Company, Inc., and Freed-Eisemann Radio Corporation."

Coming Events

February 10-11, 1930. Cleveland, Ohio. Fourth Annual Convention of National Federation of Radio Associations, Radio Wholesalers Association, Statler Hotel.

Week of June 2, 1930. Atlantic City. Annual Trade Show and Convention Radio Manufacturers' Association. Convention Hall.

Pilot's Flying Laboratory

A large new airplane, specially constructed for use as a flying radio laboratory and broadcasting studio, has been acquired by the Pilot Radio and Tube Corporation, radio parts manufacturers, of Brooklyn, N. Y. The cabin, which accommodates six passengers, is being fitted with experimental apparatus for the development of radio altimeters and aircraft radio equipment in general, and also with a powerful transmitter for aerial broadcasting. One of the features of the plane is its roof of transparent pyralin, which increases the visibility range for observation, refueling and photographic purposes.

The new craft, a Stinson monoplane powered with a Wright J-6 engine, replaces a smaller ship of the same make which has been maintained by the Pilot company for the past year and a half.

Kolster-Earl Deal Off

The Kolster-Earl consolidation deal has been declared off. A public statement by the Spreckels interests indicates that the Kolster organization withdrew from the negotiations.

Course For Servicemen

H. M. Leight, service manager, Williams Hardware Company, Crosley and Amrad distributors, Streeter, Ill., has prepared a course for dealers and servicemen. The course has been in operation for four years.



HiQ-30
The World's Premier Custom-Built RADIO
Built With WORLD FAMOUS PARTS

JUST like adding two and two to get four—the result is inevitable when you combine a most efficient circuit with parts the whole radio world respects.

The "HiQ-30" Receiver is Hammarlund-designed and Hammarlund-built. Eighteen years of producing precision telegraphic, telephonic and radio instruments is the insurance of quality which you get in every Hammarlund product.

Write Dept. RB1 for Circular

HAMMARLUND MANUFACTURING CO.
424-438 W. 33rd St., New York, N. Y.

For Better Radio
Hammarlund
PRECISION PRODUCTS

! ATTENTION! SERVICE MEN

Quality Replacement Blocks and By-Pass Units for Radio Receivers "B" Eliminators Power Supply Units

RB-1-30

THE POTTER CO.
1950 Sheridan Road, No. Chicago, Ill.

Please send latest condenser information for Repair and Service Work.

Name

Address

City State

Classification DEALER—SERVICE MAN

Party in Charge of Purchases



This picture shows the managers of Grebe's sales campaign in conference. From left to right they are: D. A. Betts, from New England territory; Major H. P. Disbecker of New York; George Rhodes, sales promotion manager; E. S. Hilber, from Middle West; A. W. Milleisen, Pennsylvania representative; and Ralph S. Viall, Chicago and Mid West manager.

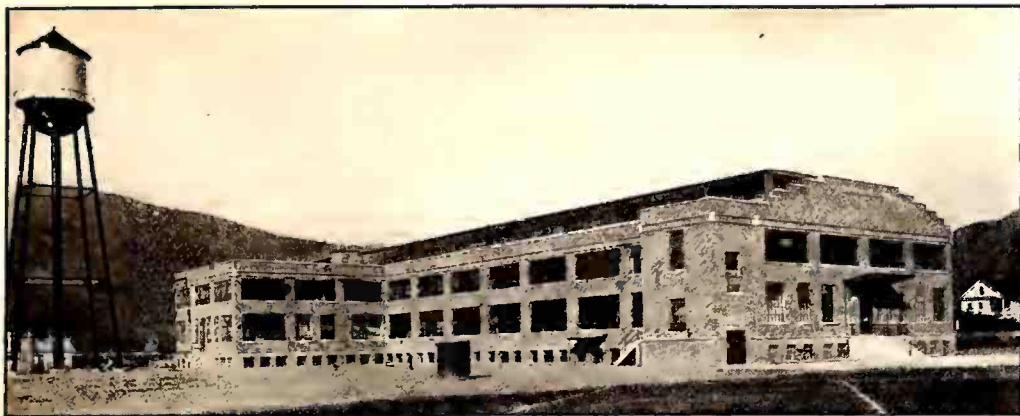

This modern plant located at Emporium, Pa., is the latest addition to the Sylvania Factories.

R.C.A. Earns \$1.47

A statement of operations of R.C.A. and subsidiaries for the quarter ending September 30th, 1929, shows a net income of \$13,725,876 for the nine months ending September 30th. Comparisons with earnings for 1928 cannot be made because 1929 earnings include operations of the Victor Talking Machine Division. The data follow:

GROSS INCOME from Sales, Communications, Real Estate Operations, and other Income	\$63,272,926.28
DEDUCT: General Operating and Administrative Expenses, Depreciation, Cost of Sales, Patent Amortization, Estimated Federal Income Tax and Accrued Reserve for Year-End Adjustments	54,513,536.67
SURPLUS PROFITS (for quarter ended September 30, 1929)	8,729,389.61
SURPLUS PROFITS (for 9 months ended September 30, 1929)	13,725,876.72

Experimenters Guild Formed

The Radio International Guild has been founded by the Pilot Radio & Tube Corporation, of Brooklyn, N. Y. Membership is of two classes: one for active members, including radio engineers, experimenters, custom set-builders, and the radio public; the other, trade members, including dealers and merchants engaged in the radio business.

The announced aims of the Guild are to encourage individual experiment in radio to the end that new devices may issue from the home laboratory and attic workshop. Prizes will be offered by the Guild for work of this character. The Guild will provide a source to which members may bring new developments of their own invention and receive the advice of competent engineers.

Dues for active members are 50¢ a year; for trade members, \$1. *Radio Design* is the official organ, published quarterly. Offices are at 325 Berry St., Brooklyn, New York.

New Atlas Officers

Atlas Stores Corporation, the new radio-phonograph combination, operates sixty-one stores located in the following cities: New York, Newark, Chicago, Detroit, Cleveland, Cincinnati, and Akron. In addition the company operates a mail order house in New York. In New York the stores operated by the merger include those of Davega, Fanmill, City Radio, and Abe Cohen Exchange.

H. M. Stein, of City Radio Stores, Inc., has been elected president of Atlas Stores; N. L. Cohn, chairman of the board of directors; A. Davega, vice president in charge of retail sales and advertising; Henry Benjamin, vice president and merchandise manager; Michael Cohen, vice president in charge of real estate and construction; and L. Cohn, vice president. O. D. Williams, of Davega, Inc., will continue his duties in the merchandise and advertising departments for the entire chain.

New Plant for Crowley

Henry L. Crowley & Company, manufacturers of Crolite, an insulating material widely employed in the radio and electrical field, announces the purchase of a new plant located at 1 Central Ave., West Orange, N. J. The old plant in East Orange is being dismantled, and the new one will be in operation by December 1, 1929, according to Henry L. Crowley, president of the company. There are 32,000 square feet of space at the West Orange factory, which will accommodate the offices, laboratory, shipping department, and production plant proper, all under one roof.

New Name for Federated

The Federated Radio Trade Association has changed its name to the National Federation of Radio Associations. The new name, it is said, more closely identifies the organization as a national group of local, state, and territorial radio associations. Plans are now under way, according to Michael Ert, president, for examination and registration of radio servicemen in every locality, and, when in final operation, this will increase the supply of adequately trained and competent servicemen.

Sprague Has New Factory

The Sprague Specialties Company, formerly located in Quincy, Mass., makers of high-voltage condensers, has purchased a factory in North Adams, Mass. Officers of the company are Robert C. Sprague, president and treasurer, Frank D. Sprague, plant engineer, and Julian K. Sprague, vice president and production manager.

Distributor Franchises Desired

This will be a regular feature of RADIO BROADCAST in which manufacturers can be kept in touch with reputable concerns who desire a jobber or dealer franchise.

Inquiry D-1

Gentlemen:

We are in the market for territory as distributors of a popular-priced screen-grid radio receiver. We wish to secure radio wholesaling for exclusive territory from a radio manufacturing concern which is not represented in our territory.

Please give us the addresses of such radio manufacturing concerns.

Very truly yours,
G. M Co.,
Vermilion, S. D.

New Members of P.R.T.A.

Sixty-four new members have joined the Pacific Radio Trade Association since January, 1929. On September 30th, the membership totalled 165, including 15 manufacturers, 21 jobbers, 17 manufacturers' agents, 69 retailers and 43 individuals.

(Continued on page 178)

**Today's Radio Demand
Thoroughly Trained Service Men and Reliable Testing Equipment . .**

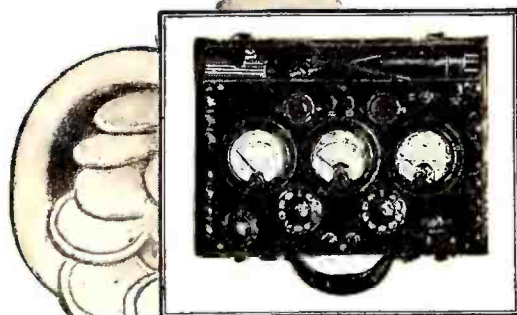

WESTON
Model 547 Set Tester meets every requirement of radio's demands. Its use is proof of conscientious servicing and high professional

standing, assuring manufacturer and dealer of prime set performance wherever it is periodically employed.

With the Model 547, the operator can quickly and positively check up any receiver made—locate and correct troubles without loss of time and add materially to his profits.

It is a triumph of constructional perfection and electrical completeness—a marvel of simplicity, its operation can be quickly mastered. Enclosed in a durable, abrasion-proof case of black bakelite with all external fittings of the same material, it offers a handsome appearance which will retain its newness in spite of hard usage.

A unique instruction book including individual data for most receivers on the market accompanies each outfit. Before purchasing any testing equipment carefully investigate the unusual merits of this tester. A fair and impartial comparison will convince you of its superior qualifications for service. Write for *free copy* of "Testing Instructions for Service Men."

**WESTON ELECTRICAL
INSTRUMENT CORPORATION**

604 Frelinghuysen Avenue Newark, N. J.



(Continued from page 177)

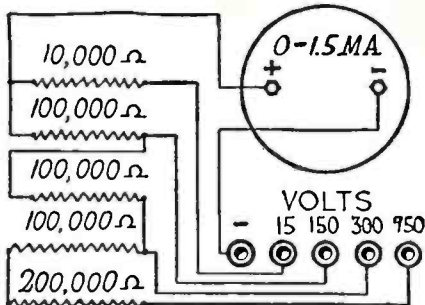

A Voltage Multiplier

The Super Akra-Ohm wire-wound Resistor is especially adapted for use as a Voltage Multiplier as shown in the above diagram. It is carefully designed to insure an accuracy of 1% and a constant permanency of calibration. Its use is also highly recommended for Laboratory Standards, High Voltage Regulators, Telephone Equipment, and Television Amplifiers and Grid and Plate Resistors, etc.

BULLETIN 62

contains the first complete chart for the use of accurate resistors with microammeters and milliammeters. If you will send us the name of your dealer or jobber, we will send you a free copy.

Shalleross Mfg. Company
 ELECTRICAL SPECIALTIES
 700 PARKER AVENUE
 Collingdale, Pa.
 ALWAYS ACCURATE Super AKRA-OHM WIRE WOUND RESISTORS

Financial Notes

CROSLLEY: A letter dated November 8 to stockholders from Powell Crosley, stated that from January to November 1, 1929, sales were \$13,509,188.08. Sales for the corresponding period in 1928 were \$11,409,430.78. Mr. Crosley has disposed of none of his stock and has recently been a heavy buyer of more. "I am," he says, "devoting my entire attention to the development of the business. I believe firmly in its future."



L. G. Pacent, Pacent Elec.

STEINITE: October sales were \$1,024,977. This is 62.5 per cent. above a year ago.

U. S. RADIO AND TELEVISION: This company earned \$3.01 per share in two months to September 30th.

POLYMET: The earnings of this company were \$2.02 per share for the first quarter on 180,000 shares capital stock outstanding. This compares with 50¢ per share for the same period last year.

TEMPLE CORPORATION: August shipments totalled \$712,836 against \$102,200 for the same period a year ago.

UNITED STATES RADIO AND TELEVISION: September sales were about \$1,500,000. Production beginning about October 1 totalled approximately 2000 sets daily.

POLYMET MANUFACTURING COMPANY: September sales were \$583,793 against \$96,157 for the same period a year ago.

UNITED REPRODUCERS: This company reported a net loss of \$477,990 in the five months ending September 30.

STEINITE RADIO: Earnings of this company were \$1.29 a share in the ten months ending July 31st.

AMRAD CORPORATION: Earnings of \$4.30 a share in the nine months ending September 30, in comparison with 82¢ a share for the same period a year ago, have been reported.

Production Figures

KOLSTER-BRANDES, LTD.: The English branch of the Kolster Radio Corporation has increased its daily set production by more than two-hundred per cent. over last year's figures. By the end of January it is expected that a combination phonograph-radio set will be added to the English line. At the present time Kolster-Brandes dealers in England number about 3500. The company is sponsoring a weekly broadcast feature over the Hilversum station at Holland and a two-hour program on alternate Sundays over the station at Toulouse, France.

TEMPLE CORPORATION: This company shipped \$1,100,000 worth of receivers between October 1st and 31st, making October the most successful month in the history of the company. Daily production is 1000 sets.

GRIGSBY-GRUNOW COMPANY: Plans have been announced for the construction of additional factory space to make possible a 50 per cent. increase in the production of Majestic products. The new factory is to be ready about April 1, 1930. It is to be built on some 34 acres of land in the vicinity of Chicago which the company recently acquired. Also a three-story addition will be constructed at the Armitage Ave. factory.

NATIONAL UNION RADIO TUBE CORPORATION: This company is producing 35,000 tubes a day and is planning to produce 100,000 tubes a day, according to President Chirelstein.



F. J. Kahn, Kolster

CROSLLEY: Cincinnati facilities enable production of 8000 radio sets per day. They include 222,000 additional square feet of floor space. Six floors are utilized for set manufacture.

ELECTRAD: Arthur Moss, president, announces the signing of a lease for additional manufacturing space at their present location, 173 Varick Street, New York. Electrad will introduce a new type of volume control as well as a full line of amplifiers.

Distributors Appointed

GULBRANSEN: The appointment of the following wholesale distributors has been announced by the Radio Division of Gulbransen: O. M. C. Supply Company, Pittsburgh, Pa.; Elliot & Waddington, New Castle, Pa.; Smith & Phillips Music Co., East Liverpool, Ohio; Greer & Laing, Wheeling, West Virginia; Ohio Battery & Ignition Company, Canton, Ohio; Geo. Byers Sons, Inc., Columbus, Ohio; Rich Electric Sales, Inc., Cleveland, Ohio.

BALKEIT: Balkeit Radio Sales Company have opened offices at 274 Chronicle Bldg., San Francisco. Arthur C. Maryon is manager.

CROSLLEY: Seven additional branches for the distribution of Crosley products have been established. The Consolidated Automotive Company, Jacksonville, Fla., have opened branches at West Palm Beach and Orlando. A new branch at 315 South Boston St., Tulsa, Oklahoma, has been established by the Ahrens Supply Company of Oklahoma City. The Fargo Motor Supply, Inc., Fargo, N. D., opened a branch at 137 E. Third St., Grand Forks, N. D. R. M. Peffer Co., Harrisburg, Pa., established a distributing point at Altoona, Pa. The Standard Battery & Electric Co. have added a fourth branch at Mason City, Iowa. The Davidson Radio Corporation established a distributing point at South Bend, Ind.

GULBRANSEN: The Alabama Electric Supply Company, Birmingham, Alabama, has been appointed state distributors for the Gulbransen radio.

EDISON: The appointment to an Edison distributorship of the Sprague Electrical Supply Co., Waterbury, Connecticut, was announced recently. The main office of the Sprague company is located

at Waterbury and a branch maintained at Bridgeport. A field force of seven salesmen operate from these two offices. The officials of the company are: president, Starbuck Sprague; treasurer, B. S. Coe; ass't. treasurer, H. A. Ashley; secretary, Walter W. Lowell.

STROMBERG-CARLSON: Thirteen retail outlets of the Atlas Radio Stores in Chicago, and thirteen associated stores in Detroit, Cleveland, and Cincinnati, are to handle the Stromberg-Carlson line. Each of the stores has been awarded a Stromberg-Carlson franchise.

PENRYMAN: Nine new distributors for the Perryman Electric Company have been announced: The Alliance Motor Corporation of Rochester, N. Y., with offices in Buffalo, Syracuse, Rochester, and Binghamton, will cover upper New York State. The New England Distributing Co., of Boston, Mass., with offices in Boston, Portland, Springfield, and Worcester will take care of Northern New England.

Weinberg and Co., Chicago, will serve the metropolitan district of this City. The Atlanta Sales Co., with offices in Atlanta, Ga., and North and South Carolina, will serve dealers in that territory.

Walter Ashe Co., and the Lance Electric Co., both located in St. Louis, Mo., will serve dealers there.

The Belmont Corp., Minneapolis, Minn., will cover the central part of the State, while the Hanson Duluth Co., of Duluth, will take care of the Northeast section of Minnesota.

The Atlas Player Roll Co., with headquarters in Newark, N. J., will serve the dealers in New Jersey, Philadelphia, and sections of Boston, where they have offices.

TRUVOLT

The SAFE Resistance FOR B-ELIMINATORS

QUICK sales and increased profits when you feature TRUVOLT All-Wire Resistances—satisfied customers, too, who appreciate PERFORMANCE.

TRUVOLT Variable (illustrated) simplifies eliminator construction. Lasts longer due to endwise travel of contact over wire. 22 stock sizes, \$2.50

TRUVOLT Fixed has convenient sliding clip for quick adjustment to desired values. All usual sizes.

U. S. Pat. 1678869 & pat. Pend.

175 Varick St., New York N. Y.
ELECTRAD
 INC.

ELECTRAD, INC., Dept. RH
 175 Varick Street, New York, N. Y.
 Please send full information and prices of TRUVOLTS.
 Name
 Address

p-4

Recently Issued Patents

Method and Apparatus for Testing Networks. Harry Nyquist, Milburn, N. J., assignor to American Telephone and Telegraph Company. Filed February 25, 1928. No. 1,732,311.

Method and Apparatus for Purifying and Charging a Gas into Vacuum Tubes or Other Containers. Ralph W. Lohman, Los Angeles, California. Filed November 1, 1926. No. 1,732,336.

Radio Installation for Moving Vehicles. Herbert Walters and Roman A. Hoerman, Detroit, Michigan. Filed December 5, 1928. No. 1,732,451.

Sound-Reproducing Apparatus. William Brower, Palo Alto, Calif., assignor to Federal Telegraph Company, San Francisco, Calif. Filed May 27, 1926. No. 1,732,495.

Telephonic Loud Speaker. Clair L. Farrand, Forest Hills, N. Y., assignor to Farrand Inductor Corporation, Jersey City, N. J. Filed July 9, 1928. No. 1,732,644.

Superheterodyne Signaling System. Arthur Edwin Leigh Scanes, Strathfield, England, assignor to Associated Electrical Industries, Ltd., Filed May 4, 1925, and in England May 28, 1924. No. 1,732,698.

Wireless Receiving System. Max C. Batsel, Wilkesburg, Pa., assignor to Westinghouse Electric and Manufacturing Company. Filed September 20, 1923. No. 1,732,710.

Directive Reception Microphone. Charles W. Horn, Swissvale, Pa., assignor to Westinghouse Electric and Manufacturing Company. Filed January 2, 1924. No. 1,732,732.

Duplex Radio Transmission System. Frank Conrad, Pittsburgh, Pa., assignor to Westinghouse Electric and Manufacturing Company. Filed May 4, 1925. No. 1,732,741.

Photographic Sound Recording. Vladimir K. Zworykin, Swissvale, Pa., assignor to Westinghouse Electric and Manufacturing Co. Filed May 26, 1927. No. 1,732,874.

Transformer and Coil System. Lester L. Jones, Oradell, N. J. Filed June 1, 1927. Renewed September 10, 1929. No. 1,732,937.

Sound-Reproducing Device. George Hibacsko, Schenectady, N. Y., assignor to General Electric Company. Filed January 25, 1924. No. 1,732,013.

Electrostatic Phonograph Pick-up. Humfrey Andrews, Highgate, London, England, assignor to Radio Patents Corporation, Bronx Boulevard, New York, N. Y. Filed April 6, 1928, and in Great Britain July 22, 1927. No. 1,732,393.

Multiplying Graphophone. Henry A. Koester, Norwalk, Ohio, assignor of two-fifths to Oscar D. Miller, Massillon, Ohio. Filed June 14, 1921. No. 1,732,756.

Sound System. Harry Harold Thompson, Kansas City, Mo., assignor to Radio Corporation of America, N. Y. C. Filed March 15, 1922. No. 1,735,095.

Support For Thermionic Tubes. Arthur Schmidt, Berlin, Germany, assignor to Gesellschaft fur Drahtlose Telegraphic m.b.H., Berlin, Germany. Filed November 22, 1924, and in Germany, November 27, 1923.

Means For Energizing Radio Apparatus. Cornelis Bol and Cornelis Hendrik Morel, Eindhoven,



D. E. Replogle, Jenkins Television.

Netherlands, assignors to Radio Corporation of America. Filed Sept. 7, 1928, and in the Netherlands Sept. 3, 1927. No. 1,735,152.

Apparatus for Amplifying Low-Frequency Speech Currents of Radio Receivers. Gustav Eichhorn, Zurich, Switzerland. Filed Jan. 6, 1927, and in Switzerland Sept. 11, 1926. No. 1,735,267.

Television Apparatus. Samuel Thomas Syphrit, Racine, Wisconsin, assignor to A. J. Carter, Chicago, Ill. Filed September 14, 1928. No. 1,735,553.

Low-Frequency Electric Amplifier Circuits. Philip H. Greeley, Washington, D. C. No. 1,735,750.

High-Frequency Oscillation Generator. Albert H. Taylor, Washington, D. C., assignor to Wired Radio, Inc., New York, N. Y. Filed December 22, 1928. No. 1,735,808.

Method of and Apparatus for Reducing Width of Transmission Bands. Allen Carpe, New York, N. Y., assignor to American Telephone and Telegraph Company. Filed August 12, 1926. No. 1,735,037.

Frequency Equalization Carrier System. Estill I. Green, East Orange, N. J., assignor to American Telephone and Telegraph Co. Filed October 22, 1927. No. 1,735,044.

Adjudicated Patents

- (D. C. Del.) Lowell & Dunmore patent, No. 1,455,141, for radio receiving apparatus, claims 3 and 4 held valid and infringed. Dubilier Condenser Corporation vs. Radio Corporation of America, 34 F. (2d) 450.
- (D. C. Del.) Dunmore & Lowell patent No. 1,606,212, for power amplifier, claims 204 and 6 held not infringed. Dubilier Condenser Corporation vs. Radio Corporation of America, 34 F. (2d) 450.
- (D. C. Del.) Dunmore patent, No. 1,635,117, for signal-receiving system, claim 9 held valid and infringed. Duhilier Condenser Corporation vs. Radio Corporation of America, 34 F. (2d) 450.

Patent Suits

- No. 1,158,123. R. A. Fessenden, Apparatus for generating and receiving electromagnetic waves, D. C., N. D. Ohio, (E. Div.), Doc. 2693, Radio Corporation of America et al. vs. The Sparks-Withington Co., Discontinued without prejudice Sept. 19, 1929.
- 1,333,298. Evershed & Kilroy, Sound emitter, filed June 25, 1929, D. C., E. D. Pa., Doc. 5245, Farrand Inductor Corp. vs. The R. Wurlitzer Co.
- 1,403,475. H. D. Arnold, Vacuum-tube circuit, D. C., N. D. Ohio (W. Div.), Doc. E 999, Western Electric Co., Inc., et al. vs. Silverphone Corp. Decree pro confesso (notice Sept. 20, 1929).
- 1,648,808. L. A. Hazeltine, Wave Signaling system, filed Aug. 19, 1929, D. C., E. D. Pa., Doc. 5359, Hazeltine Corp. vs. Atwater Kent Mfg. Co.
- 1,707,544. A. L. Thuras, Electrodynamical device; 1,707,545, E. C. Wente, Acoustic Device, D. C., N. D., Ohio (E. Div.) Doc. E 982, Western Electric Co., Inc., vs. Silverphone Corp. Consent decree for plaintiff (notice Sept. 5, 1929)



F. N. Rauland, Rauland Corp.

A PRODUCTION TESTING SYSTEM

(Continued from page 153)

The prod is next inserted in terminal No. 2 which connects a direct-reading "megger" in the circuit to indicate the insulation resistance of the condenser at the same potential as the breakdown test. The third position discharges the condenser through a resistor and neon lamp, the latter serving to show that contact is made to the discharging terminal. Various switching arrangements have been experimented with, but none as satisfactory as the above have been discovered. The high potential for this test is obtained from a motor generator, as ordinary B supply systems have not proved sufficiently steady for satisfactory "megger" readings.

After passing the test described above the condensers are conveyed to the operator who makes capacitance test. In this test each condenser is placed in a series circuit, the capacity of the condenser regulating the current flow through the milliammeter as shown in Fig. 5. We have found that two values of meters, 0-20 mA. and 0-100 mA. will accommodate values from 0.1 mfd. to 10 mfd. For accurate results with this fixture it is only

necessary to calibrate the meter in terms of capacity and then see that the 110-volt 60-cycle supply is kept constant.

A percentage of the condenser production is also given a life test. However, such tests do not come under the heading of this article and so descriptions of them are not included. [Mr. Callanan's next article will include a description of tests conducted on power transformers, audio-frequency input and output transformers, and a.f. chokes.—The Editor.]

ANSWERS TO PROBLEMS

The following are answers to the six problems which are given at the end of "Engineering Review Sheet" No. 27 on page 147 of this issue:

- (1) 2000 ohms; 760 milliwatts; 39 volts; 39 volts.
- (2) 680 milliwatts; 26 volts; 52 volts.
- (3) 100 ohms.
- (4) 245 milliamperes.
- (5) 16.7 per cent.
- (6) 2.25.

KOLSTER



MODEL K-45

... another leader who standardizes

on DURHAM RESISTORS and POWEROHMS

KOLSTER!—another great name in radio—another leader who has set the pace in quality receivers for many years—another leader who has long recognized the superiority of the metallized principle upon which DURHAM Resistors and Powerohms are manufactured. Yes, KOLSTER is another who standardizes on DURHAM resistance units . . . because they are absolutely un failing in accuracy and uniformity. DURHAMS may cost slightly more than average resistances, but their aid to quality reception is well worth the slight difference in price. Furthermore, their presence in a receiver is a guide to the quality of other parts.

Write for engineering data sheets, samples for testing and complete literature. Please state ratings in which you are interested.

Metallized



DURHAM Metallized RESISTORS and POWEROHMS are available for every practical resistance purpose in radio and television circuits, 500 to 200,000 ohms in power types; 1 to 100 Megohms in resistor types; ratings for all limited power requirements; standard, pigtail, or special tips.

THE LEADERS STANDARDIZE ON

DURHAM

RESISTORS & POWEROHMS

INTERNATIONAL RESISTANCE CO.
2006 Chestnut Street, Philadelphia, Pa.

IN THE RADIO MARKETPLACE

News, Useful Data, and Information on the Offerings of the Manufacturer

Crosley Model 82-S

CROSLY RADIO CORPORATION: This is a seven-tube receiver using three 224-type screen-grid tubes, one 227-type biased power detector, one 227-type first-stage a.f. amplifier, and two

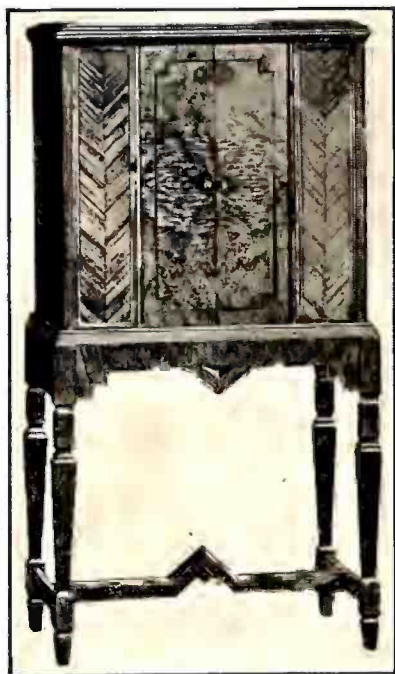

245-type power output tubes. The rectifier is a 280-type tube. Price: \$160.00.

Sound-On-Film Apparatus

RADIO RECEPTOR COMPANY: A special Powerizer power unit has been designed to eliminate the storage battery previously required with all sound-on-film apparatus to supply current for the exciter lamp as well as some of the amplifier tubes. The new Powerizer unit supplies this current as well as B voltage for the amplifier tubes from the light socket. A special voltage compensator is included in the device to compensate within less than 0.1 per cent. line voltage fluctuations between 100 and 130 volts.

Stromberg-Carlson No. 642

STROMBERG-CARLSON TELEPHONE MANUFACTURING COMPANY: This screen-grid receiver has been designed to have a high and uniform gain over the entire broadcast band. The de-



tor is of the power type with automatic grid bias. The bias adjusts itself automatically to the proper value for the strength of signal received. The receiver has three control knobs, the single station selector, the volume control knob, and an on-off switch. As in all Stromberg-Carlson receivers, provision is made for the use of a phonograph pick-up unit. Price, \$259.00.

Fada Models 35 B and 35 C

F. A. D. ANDREA, INC.: The 35B (same cabinet as model 35) uses three 224-type screen-grid tubes in a three-stage tuned-radio-frequency amplifier, two 227-type heater tubes in power detector, an a.f. stage with two 245-type power tubes in push pull, and one 281-type rectifier. Special features of this set are the hum adjuster to reduce hum to a minimum and adjustable sensitivity and selectivity to meet varying installation conditions and requirements. Price: \$225.00.

The 35C (same cabinet as model 35) chassis is the same as present Fada 25. It uses four 227-type heater tubes, one 224-type screen-grid tube, and two 245-type tubes. The 245-type tubes are used in push pull. Price, \$220.00.

Gulbransen Receivers

GULBRANSEN COMPANY: Features of these receivers are: uniform amplification, push-pull output circuit, screen-grid r.f. amplifier and power detector, large diameter electrodynamic



loud speaker, local-distance switch, and complete shielding. The highboy console is priced at \$149.50 and the lowboy at \$139.50.

Balkeitt Model C Radio

BALKEITT RADIO COMPANY: Five tuned stages and special features of design are to be found in this nine-tube neutrodyne-type receiver. The Model C is a console and is priced at \$175.00.

Kolster Model K-43

KOLSTER RADIO CORPORATION: The K-43 receiver uses screen-grid tubes, an "equipoised" electrodynamic loud speaker, a selector tuner, and push-pull amplification. Price less tubes: \$175.00.

Electric Phonograph Motor

STEVENS MANUFACTURING CORPORATION: The Stevens-Sibley electric phonograph motor has no gears or springs. The drive is against the outer rim of the turntable. It has a speed adjustment giving all speeds required for correct reproduction. There are no exposed parts, all elements being enclosed in a substantial metal housing which is dust and moisture proof. The motor requires no attention, not even lubrication.

Sonora Model A-31

SONORA PHONOGRAPH COMPANY, INC.: The Model A-31 Lowboy is a screen-grid receiver using three screen-grid tubes in the r.f. stages, a power detector, and a push-pull power ampli-



fier. The cabinet, which is of modified Gothic design, is paneled with lacewood and American walnut. Price: \$149.50.

Zenith Model 54

ZENITH RADIO CORPORATION: This is a new nine-tube radio receiver with automatic tuning and two stages of push-pull a.f. amplification. It is loop operated and is priced at \$370.00. Other Zenith receivers range in price from \$175 to \$700.00.

Freed Radio Model 90

FREED-EISEMANN RADIO CORPORATION: The Model 90 receiver utilizes a number of interesting features among which are automatic tuning, the use of a variometer in connection with the first tuned circuit to permit accurate tuning, and the use of four screen-grid tubes, three as r.f. amplifiers and one as a detector. Up to as many as ten stations can be tuned-in with the

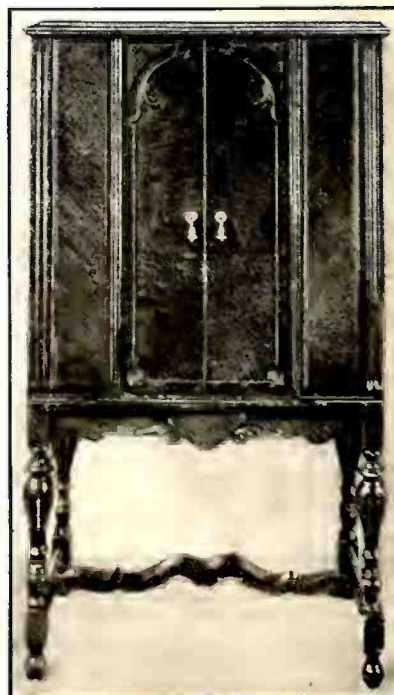

P-10

automatic tuning device by sliding along the indicator arm to the desired station and then pulling out the knob.

The Per-Con Ground

RICHMOND METAL PRODUCTS COMPANY: This company has designed a special ground in the form of a hollow steel tube made in three sections and containing special materials.

New Bosch Receiver

AMERICAN BOSCH MAGNETO CORPORATION: The Console Model 16 is one of the newest



Bosch receivers using the Bosch screen-grid chassis. Price complete with Bosch electro-dynamic loud speaker: \$198.50.

Two New Kits

PILOT RADIO AND TUBE CORPORATION: The Pilot kit K-113 contains all the parts necessary for the construction of an a.f. amplifier using two 245-type tubes in push pull. The kit includes an aluminum base already drilled for the transformers, sockets, resistors, etc., and a completely assembled and wired power pack. All the amplifying unit must be wired together.

The K-117 contains the necessary parts for the Pilot Twin Screen-Grid Eight. It uses three stages of screen-grid r.f. amplification, shielded coils, screen-grid detector, a push-pull a.f. amplifier, and a built-in power supply.

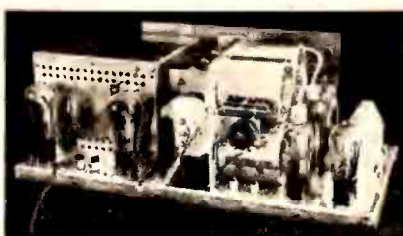

Ware Band Selector

WARE MANUFACTURING COMPANY: The Ware receiver uses the band selector circuits developed by Vreeland. In the r.f. amplifier are two screen-grid tubes. A unique switching arrangement is used to give four different operating characteristics, i.e., broad tuning, sharp tuning, sensitive (for distant reception), and insensitive (for local reception). This chassis is incorporated in a table model at \$195.00 and in various consoles ranging from \$280.00 to \$800.00 in price.

Thordarson Power Amplifier

THORDARSON ELECTRIC MFG. CO.: A new completely self contained power amplifier has been designed by this company. It has a maximum undistorted power output of 4650 milliwatts, a voltage amplification of 275, and is designed so that the hum has been reduced to a minimum. The amplifier is guaranteed for 90 days. Price \$89.50.

Bush & Lane Model 90

BUSH AND LANE PIANO COMPANY: The Model 90 houses a chassis using screen-grid tubes followed by a detector and two-stage a.f. amplifier. All grid, plate, and filament voltages,

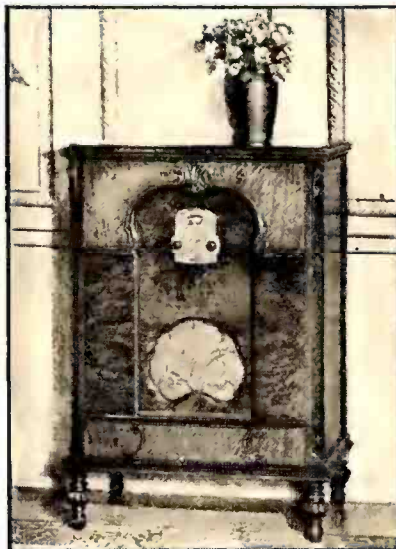

THE RADIO DEALER'S DIRECTORY OF RECENT PRICE CHANGES

Company	Model No.	Former Price	New Price	Company	Model No.	Former Price	New Price
All-American Mohawk Corp.	97 (New)		\$225.00	Atwater Kent Mfg. Co.	524	\$295.00	\$225.00
	98 (New)		235.00		526	260.00	185.00
	99 (New)		245.00		528	305.00	235.00
	94-6 (New)		105.00		55	88.00	68.00
F. A. D. Andrea, Inc.	35-B (New)		255.00		55 C	84.00	64.00
	35-C (New)		220.00		55 F	88.00	68.00
Colonial Radio Corp.	32 AC Cavalier	\$235.00	175.00		55 F-C	84.00	64.00
	32 AC Piccadilly	235.00	175.00		60	100.00	80.00
	32 AC Moderne	270.00	235.00		60 C	96.00	76.00
	32 DC Cavalier (New)		175.00		61	100.00	80.00
	32 DC Piccadilly (New)		175.00	61 C	96.00	76.00	
	32 DC Moderne (New)		235.00	66 C	135.00	110.00	
Crosley Radio Corp.	31-S	67.00	56.50	67	77.00	62.00	
	33-S	115.00	112.00	67 C	73.00	58.00	
	34-S	125.00	116.00	The Brandes Corp.	B-15	125.50	97.50
	41-S	85.00	65.85		B-16	165.00	136.00
	42-S	140.00	126.00	Pioneer Radio Corp.	100 chassis (New)		83.00
	A-C Dayton Co.	AC-9961 (New)			173.50	101 Lowboy	
AC-9971 (New)			193.00		102 Highboy		136.00
AC-99110 (New)			275.00	Radio-Victor Corp. of America	44	110.00	75.00
Grigsby-Grunow Co.	91	137.50	116.00		46	179.00	130.00
	92	167.50	146.00		60	130.00	98.00
Howard Radio Co.	Florentine (New)		275.00	Bremer-Tully Mfg. Co.	164		\$124.00
	Hepplewhite (New)		245.00		195		149.00
	Highboy (New)		210.00		134		164.00
	Consolette (New)		185.00		159		195.00
Kellogg Switchboard & Sup. Co.	523	250.00	175.00	Stromberg-Carlson Tel. Mfg. Co.	642	\$247.50	\$259.00

P-7

POLYMET
POLYMET
POLYMET
POLYMET



WE, too, can shout our name from the rooftops. & But — can such shouting be one-half so impressive as this truthful statement, quietly made: "Over 80% of the great radio set manufacturers of the country use



**CONDENSERS
TRANSFORMERS
RESISTANCES
CONNECTORS
COILS
PLUGS**

POLYMET PRODUCTS"

POLYMET MFG. CORP.
837 E. 134th Street, New York City

Don't Guess at Set Troubles

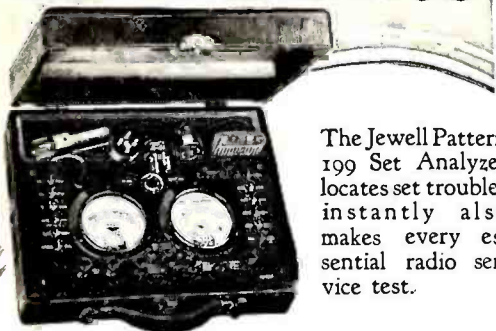

The Jewell Pattern 199 Set Analyzer locates set troubles instantly also makes every essential radio service test.

You can save time and build profitable business by using a Jewell Pattern 199 to locate set troubles. Pattern 199 is the lowest priced complete set analyzer on the market. Accurate and easy to use. Every service man should have one. Sold by leading radio jobbers.

Mail the coupon for a free copy of the Jewell Instruction and Data Book which contains data on 139 popular sets.



Jewell Electrical Instrument Co.
1642-H Walnut Street, Chicago, Illinois

Please mail Instruction and Data Book also complete information on Pattern 199 Set Analyzer.

Name

Address

No. 310

RADIO BROADCAST Laboratory Information Sheet

January, 1930

Factors Considered in Receiver Design

IN THE DESIGN of a radio receiver certain factors must be considered in order to determine the circuits to be used. Some of these important factors are:

1. The limiting values (maximum and minimum) of the field strength from the transmitting station.
2. The output obtained from the antenna at a given field strength.
3. The power output required from the receiver.
4. The r.f. frequency band to be received.
5. The a.f. frequency band to be amplified.
6. The nature and strength of the interference from other radio transmitters and from noise.
7. The selectivity required to permit the satisfactory reception of the desired signal and the elimination of all undesired signals.
8. The stability of the frequency transmission characteristic and the gain of the receiver.

With these facts decided, it is possible to proceed with the design and to determine how much r.f. and a.f. amplification is required, how selective the r.f. circuits must be, and what type of audio-frequency output circuit must be used to supply power to the loud speaker.

In the design of broadcast receivers the tendency has been toward the building of stable, high-gain r.f. amplifiers that are able to deliver sufficient voltage to the detector for satisfactory output at field strengths in the order of 1 to 10 microvolts per meter. This represents a very high order of sensitivity and it is probable that the average noise level in many locations is of the same order or greater than the above field strengths, thereby making it of no advantage to endeavor to increase further the gain of the r.f. amplifier since this would simply result in an excessive ratio of noise to signal.

No. 311

RADIO BROADCAST Laboratory Information Sheet

January, 1930

Effect of Reflection and Echoes

IN CONTEMPLATING the subject of fidelity in its relation to the problem of loud speaker reproduction there are many factors to be considered. In this connection one of the most important considerations is the condition under which the loud speaker is to be operated, whether it is to be operated in the open, in a large room with heavy drapes, in a room practically bare of furnishings, etc., for it should be realized that the naturalness of the reproduction will depend to a large extent upon these conditions.

When a loud speaker is operated in a room there is a certain amount of reflection of sound from the walls and standing waves are also generated. Both of these factors cause a change in response depending upon the position of the listener in the room. At one point we might hear a very intense sound at some particular frequency but, upon moving but a step or two away, the intensity of the sound will markedly decrease. If the loud speaker is supplied with a single-frequency tone this effect

will be quite noticeable but it is not as effective in producing a definite audible change in intensity when listening to music. In music or speech the frequency changes so rapidly that the effects of standing waves are not especially noticeable, if at all.

From the above remarks it should not be thought that the effects of reflection and echoes are always detrimental. In many cases a certain amount of echo effect improves the reproduction, adding an effective vastness and a richness to the tones which would otherwise be lacking.

It is frequently the case that the naturalness of the reproduction is greater if one listens in some room adjacent to the one in which the loud speaker is located, and if possible it is frequently advisable to locate the loud speaker in some room other than that in which one ordinarily sits when listening to a program. In such a case the increased naturalness is probably due to the effect of the reflection and echoes which occur.

No. 312

RADIO BROADCAST Laboratory Information Sheet

January, 1930

Measurements of Sensitivity

IT IS BECOMING quite common to read statements to the effect that a certain receiver has a sensitivity of so many microvolts per meter. As this method of rating the sensitivity of receivers is becoming so popular, in this "Laboratory Sheet" we indicate exactly what this term means.

When a receiver is to be measured for sensitivity it is generally done in the following manner. A receiver is set up and a resistor is connected across the a.f. output circuit of the set. This resistor has a value such as to give maximum power output per volt on the grid of the power tube. In most cases the resistor will have a value equal to twice the plate resistance of the output tube.

The next step is to apply to an artificial antenna a known r.f. voltage modulated 30 per cent. at 400 cycles and to increase the r.f. input voltage until 50 milliwatts of audio-frequency power is developed across the output resistance. We then determine the magnitude of the input r.f. voltage required to produce this output by dividing by the effective height of the artificial antenna which is usually four meters. This gives us the microvolts per meter input required to produce the standard output of 50 milliwatts.

Assuming that such a method is used in determining the sensitivity of the set, it is simply necessary to give the microvolts per meter input for standard output in order to define completely the sensitivity of the receiver. We can, therefore, say, for example, that a certain set has a sensitivity of 10 microvolts per meter. This means that if a thirty per cent. modulated r.f. signal is impressed across the input, then 50 milliwatts of power will be developed in the output at 400 cycles.

During the past few years there have been remarkable improvements in r.f. amplifier circuits and as a result receiving sets to-day are much more sensitive than past models. Whereas a sensitivity of 50 or 100 microvolts per meter was not uncommon during past seasons, more recent receivers have a much higher sensitivity, in many cases being of the order of 3 or 5 microvolts per meter.

In many sets the sensitivity varies widely over the broadcast band, generally being low at low frequencies and high at high frequencies. This is a disadvantage which is gradually being overcome and sets are being produced which have a more uniform high sensitivity throughout the entire broadcast wave band.

Philippine Radio Stations

E. T. Wilson, of the Radio Corporation of the Philippines, Manila, sends the following information on stations now operating in the Philippine Islands.

- KZRM—Manila, 485 Meter, 1000 Watts
- KTXR—49 Meters (also 41.5 and 31.6 Meters), 1000 Watts (transmits same programs as KZRM)
- KZIB—Manila, 260 Meters, 15 Watts
- KZRC—Cebu, P. I., 320 Meters, 1000 Watts

These are the only broadcasting stations in the Islands.

Jenkins Televisor Displayed

A commercial model of the Jenkins Televisor was shown at the Chicago Radio Show and also at a similar show at Trenton. The cabinet is 18 by 18 by 24 inches. Shadowgraphs are seen through an aperture in the front with the aid of a concealed magnifying lense.

Technidyne Licenses Ajax

The Technidyne Corporation, 644 Broadway, New York, has sold to the Ajax Electrothermic Corporation, Trenton, New Jersey, an exclusive license for the use of Banning patent No. 1,667,715 and Jonas patent No. 1,608,560 covering coil systems for use in high-frequency induction furnaces, Technidyne acquires the exclusive use or license in radio of the Northrup patent No. 1,378,187.

Sonora Has Canadian Factory

The Sonora Corporation of Canada, Ltd. has located a factory in Toronto at 345 Adelaide St., West. The new plant is already in production and W. B. Puckett, formerly treasurer of the American company, has been appointed vice president and general manager of the Canadian branch.

News of the N.F.R.A.

A model serial-number ordinance for consideration of local town councils is available from the officers of the National Federation of Radio Associations. Where serial-number abuses are serious and no state legislation has been passed, the association feels a local ordinance is helpful.

New members of the Radio Wholesalers Association are George H. Wann Company, Boston; Electric Equipment Company, Youngstown, Ohio; and J. V. Kane Company, Philadelphia.

The Traffic Committee of the Radio Wholesalers Association, working with the R.M.A. has effected a freight rate reduction on radio products which will reduce transportation costs \$1,500,000 annually.

A SERVICE DEPARTMENT THAT PAYS

(Continued from page 133)

response to an "S. O. S." from the fellow who has been delayed.

Mr. McCork attributes much of the success of his department to the fact that all service calls are made on definite appointments—also that, as a consequence, no not-at-home reports are accepted from servicemen.

Shop Work vs. Outside Work

Although the rapid rise of a.c. sets is steadily reducing the number of sets having to be brought into the shop for repairs, it is found advisable to remove approximately 40 per cent. from the homes of the owners. It has been found that the greater facilities available in the shop insure better work in many cases. No estimates are given in any case until the set has been carefully gone over in the shop. It has been found that so many faults can produce

(Continued on page 185)

Important Announcement

"A New" Wright-DeCoster Reproducer
—for the Home—

Now you can equip your radio so that it will have the same tone quality and truthful reproduction as the finest theatrical sound equipment, except in volume.



Model 117 Jr. Table Style

Write for Descriptive Matter and District Sales Office.



Model 117 Jr. Console Style

WRIGHT-DECOSTER, INC.
2213 University Ave., St. Paul, Minn.

TYPE 360 TEST OSCILLATOR



One of the new test oscillators for the radio service laboratory is now ready. It will deliver a modulated radio-frequency voltage at any point in the broadcast band (500 to 1500 kilocycles) and at 175 and 180 kilocycles. The tuning control is calibrated with an accuracy of 2 per cent.

The Type 360 Test Oscillator is intended to be used for neutralizing, ganging, and tuning of the radio-frequency stages in a receiver, and it is fitted with an output voltmeter for indicating the best adjustment. This voltmeter is of the copper-oxide-rectifier type, and by means of a switch it may be connected across a 4000-ohm load or across the dynamic speaker of the receiver when making tests.

Price \$110.00

GENERAL RADIO COMPANY

30 State Street

Cambridge, Massachusetts



Stop A-C Tube Troubles at the Source

Every A. C. set owner is a prospect for the Vitrohm Unit. It saves A. C. Tubes and insures full tube life. Cuts costly service calls and customer complaints due to tube failure. Send your order today for twelve units packed in three color counter display carton.

WARD LEONARD ELECTRIC CO.
MT. VERNON NEW YORK



Retails for \$2.00

VITROHM 507-109
For sets using 65 watts or less
VITROHM 507-109A
For sets using more than 65 watts and less than 130 watts



John H. Morecroft

Zeh Bouck says:

"*MORECROFT is the finest engineering interpretation of Radio's first quarter century we have.*"

Second Edition—Revised and Enlarged

Principles of Radio Communication

BY JOHN H. MORECROFT

Again Mr. Bouck says: "No radio book has ever been of greater utility to the engineer and student than this classic—the only reliable reference of its kind six years ago and today the most astounding collection of answers to technical questions from the analysis of radio frequency phenomena in terms of complex formulae to why a particular amplifier howls."

\$7.50

JOHN WILEY & SONS, Inc.

440 Fourth Ave., New York

Please send me Morecroft's RADIO COMMUNICATION for free examination. Within ten days after its receipt, I will either return the book or send you \$7.50.

Name.....

Address.....

Firm.....RB 1-30

No. 313

RADIO BROADCAST Laboratory Information Sheet January, 1930

Fidelity in Radio Receivers

RADIO ENGINEERS, in rating the performance of radio receivers, now make use of three terms, sensitivity, selectivity, and fidelity. These three factors completely define the essential characteristics of a set and make it possible to compare readily one set against another.

Sensitivity is determined, as explained in "Sheet" No. 312, by impressing an r.f. voltage on the input of the set, of a value such that normal output—50 milliwatts—is obtained. In this sheet we explain the meaning of the term fidelity and explain briefly how it is measured. "Laboratory Sheet" No. 314 gives similar data on selectivity.

Fidelity is the term used to indicate the accuracy of reproduction, at the output of a radio receiver, of the modulation impressed on the r.f. signal applied to the input of the receiver under test. A receiver having perfect fidelity would be one in which the form of the output current was exactly similar to the form of the current used to modulate the r.f. signal. Fidelity is determined by setting up the receiver to be tested and impressing on its input an r.f. signal modulated at 30 per cent., the input

signal having a value such that normal output is obtained. The frequency of the modulating signal is then varied (the modulation being held constant) over the entire audio-frequency band and the output power at each frequency is noted. From these data a curve can be plotted showing how the audio-frequency output power from the set varies with frequency.

Such curves are run at various radio frequencies—say 600, 1000, and 1500 kc.—in the broadcast band so that the variation in fidelity can be determined. In this way we can tell something regarding the characteristics of the r.f. amplifier system, for if the system tunes too sharply at some point in the broadcast band the sidebands will be suppressed partially and this will show up on the curve which we plot as a falling off in response at the higher audio frequencies.

In making such tests it is essential, of course, that the source of audio-frequency voltage used to modulate the r.f. input signal be quite pure, i.e., free from harmonics. Generally the total harmonic output from the a.f. oscillator should not be allowed to exceed five per cent.

No. 314

RADIO BROADCAST Laboratory Information Sheet January, 1930

Selectivity of Radio Receivers

PRACTICALLY speaking, the selectivity of a receiver is that characteristic which enables us to determine how well the set will tune-out one signal and tune-in another. Technically, it is defined in somewhat similar fashion, as the degree with which a radio receiver is capable of differentiating between signals of different carrier frequencies.

Selectivity is determined with the aid of an r.f. oscillator by means of which we are able to impress known r.f. voltages on the input of a radio receiver. There are various methods of carrying out the test but the one generally used is to impress a small known voltage on the input of the set, note the output of the set, and then to vary gradually the frequency of the r.f. oscillator, at the same time adjusting the voltage supplied to the receiver so as to maintain the same output. In this way we obtain a set of figures showing how the output of the receiver falls off either side of the frequency to which it is tuned. Generally the more rapidly it falls off the better is the selectivity.

Unfortunately a receiver's selectivity is, as has been pointed out many times, closely tied up with its fidelity, for if we make the selectivity too great the sidebands are suppressed and the high frequencies are partially suppressed. At least this is true of ordinary circuits.

Selectivity curves are, of course, made at various points throughout the broadcast band so that the variation in the receiver's selectivity at different points in the broadcast band can be

determined. The results are finally plotted in the form of curves, an example is given below.

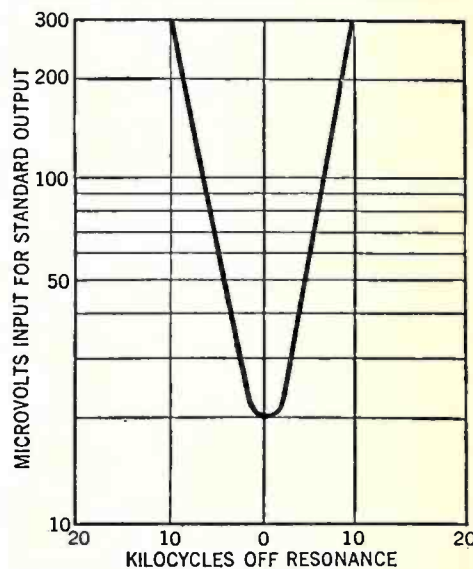

No. 315

RADIO BROADCAST Laboratory Information Sheet January, 1930

C-Bias Resistor Values

THE TABLE ON this sheet gives the values of C-bias resistor in ohms which must be used in conjunction with various types of tubes used in a.c. receivers to supply correct bias. It will be noted that the value of the resistor for use when the filament is operated on a.c. is slightly different from the value when the filament is on d.c. This is due to the fact that in the case of d.c. operation the returns are connected to the negative side of the filament and in a.c. operation they are connected to the mid point of the filament side. If the two tubes are connected in parallel, and obtain their C bias from a common resistor, then the value of the C-bias resistor should, of course, be half that indicated in the table.

TYPE OF TUBE	PLATE VOLTAGE	C-BIAS RESISTOR IN OHMS	
		FIL. ON D. C.	FIL. ON A. C.
227	90		2000
	135		1800
	180		2250
112A	90	850	1300
	135	1300	1650
	180	1350	1600
171A	90	1650	1900
	135	1700	1850
	180	2000	2150
210	250	1500	1800
	350	1700	1950
	425	1750	1950
250	250		1600
	300		1550
	350		1400
245	400		1300
	450		1550
	180		1250
224	250		1550
	180		350

TYPE OF TUBE	PLATE VOLTAGE	C-BIAS RESISTOR IN OHMS	
		FIL. ON D. C.	FIL. ON A. C.
226	90	1700	
	135	1500	
	180	1800	

(Continued from page 183)

the same unsatisfactory condition in a set that it is never safe to name a price for service work without a thorough examination. After the trouble has been determined the cost is communicated to the customer by telephone. A charge of \$3 is made for inspecting sets where the latter decides not to have the work done.

Mr. McCrork is insistent on thoroughness in service work. He believes that lack of this quality inspired by the inclination of many servicemen to hustle through jobs has been responsible for a great deal of unsatisfactory "service" work.

His men are carefully trained not only to look for the obvious faults but to probe deeply. It is not enough to get a set working. Like a fabled Chinese doctor of old, part of the job of those who work with him is to do everything in their power to insure sets staying in the best of health. Although the obvious fault may be only a burned-out tube, the serviceman does not necessarily stop there. The set is given a detailed examination to determine whether it merely happened or came as the result of some definite mechanical or electrical weakness.

High-Grade Men Employed

Because of this requirement, Mr. McCrork employs only experienced servicemen—men who recognize their responsibility in insuring the best possible entertainment in the "Theater of the Home." His requirements for a serviceman, given in the order of their importance are: ability, courtesy, appearance, and honesty. Care is taken to get men who measure up to these specifications. They are paid straight salaries to further insure that no work will be skimmed.

This service manager also prides himself, and justly so, on the fact that almost no sets are returned to the factory. No matter how complicated the work of repair, it can invariably be done in the shop, even though this should entail the winding of an obsolete transformer or the replacing of a condenser block or choke coil that would have to be made up. Naturally, this sometimes adds to the expense of the service department. On the other hand, it permits of the quickest sort of service and that is one of the features Mr. McCrork is stressing in building for the future. Thanks to the skill which makes such work possible, it has been found poor economy to carry a large stock of parts. Only those most frequently needed for the most popular sets are kept on hand. Others are ordered as needed or made in the shop.

In addition to the usual small tools, servicemen are required to have a set-tester (Jewell or Weston). These are supplied to them at cost when they are hired, the price being taken out of their monthly salaries in small amounts. Each man also carries a complete set of carefully tested tubes. This has been found to do away with much unnecessary traveling back and forth from homes to store.

Servicemen Do Not Sell

Incidentally, it is interesting to note that members of the Universal Radio department are not encouraged to do any selling. This is so for the obvious reason that their main work is to build up their department. Any unwarranted effort to sell a new set to a customer who merely wants an old one repaired might be misconstrued by the latter.

How natural it would be for the customer to think: "Oh well, it's this fellow's job to sell me a new set if he can. I'll get someone who doesn't feel that way about it to fix the old one and make it as good as new." Servicemen are only allowed to talk new sets when they are asked point blank by the customer whether or not it would

be to his advantage to make a change. Then they turn such leads over to the sales department.

Only broadcast advertising over station WCAU (which is under the same management) is used in featuring this service. This, plus the word-of-mouth advertising by satisfied customers has been found entirely adequate. With broadcast advertising there is little or no lost circulation, for every radio set owner who listens in is a potential service customer. A radio in need of repairs bringing imperfect reception on an announcement of a well-known radio service supplies plenty of incentive to the owner to go to the phone and call at once. The service department is open from 9 o'clock in the morning until 11 o'clock at night. Thus, to make 24-hour service infinitely more than an idle boast, some servicemen work from 9 A.M. until 6 P. M. while others work from 11 A. M. until the department closes. The greatest number of service calls come in on Fridays and Saturdays. Particular pains are taken to see that the latter are taken care of before Sunday. As a result of the broadcast advertising over WCAU not a few sets are received by express from people who want to avail themselves of the service of which they hear. These outfits are diagnosed and the estimated cost communicated to the owner for approval before the work is done.

Since entering the radio business in 1919, it has been Mr. McCrork's dream to have a service department that would pay for itself over and above the work of installing and servicing the sets sold by the store. Although, admittedly, his present department is not perfect in every respect, it has achieved this end and is progressing rapidly. This winter will undoubtedly find from 20 to 25 servicemen regularly employed in rendering a service that Philadelphians already recognize for its promptness and efficiency.

"The opportunities for the service department are limitless," said this service manager in closing. "Indifferent service has been so much the rule in the past that it would seem only a matter of sound common sense in the conduct of it to make this section of the business highly profitable. I'll repeat: service is *not* a sideline and the success of the fellow who regards it as a serious bread-and-butter business will be limited only by his ingenuity and managerial ability."

ANOTHER ANGLE ON SERVICE

(continued from page 137)

equipment possible and a staff of specialists in each make of car, the repair job is done as it should be done—as well, if not better than, it would be done if the car were sent back to the manufacturer's service shop at the factory.

The regional repair factory charges the dealer for the job; and the dealer charges a small commission for handling the transaction. Thus the factory makes its proper profit, and the dealer makes his. Because of the volume of repair business which the repair factory does, its rates are cheaper than those charged by independent repair garages.

Advantages of Wholesale Servicing

The advantages of the regional factory are almost self-explanatory. The manufacturer has the assurance that his cars are being properly serviced, so that the customer is satisfied. The manufacturer also has a larger market for spare parts, since the regional factories would use only regular or authorized parts. The dealer is relieved of the necessity of stocking a great

(Continued on page 188)

NEW AUDIOS for Old Sets



A profitable business for service stations is the installation of tone quality by replacing inferior units with THORDARSON REPLACEMENT TRANSFORMERS.

The chief difference between this year's sets and last year's, between high priced sets and cheap ones, is the difference in audio amplification. This is the difference which the OWNER HEARS.



R-100 Straight Audio, \$2.25
R-101 Input Push-Pull, 3.50

AT ALL JOBBERS

THORDARSON

THORDARSON ELECTRIC
MFG. CO.

Huron, Kingsbury and Larrabee Streets
CHICAGO, ILLINOIS



Give Your Radio Set a Chance
Install De Forest Audions in your
radio set and you will note the
difference right from the start—
purer tones, more volume and
hum-free reproduction.

DE FOREST RADIO CO.
PASSAIC NEW JERSEY



De Forest
AUDIONS



By the author of

**"Principles
of Radio
Communi-
cation"**

An independently
written introduc-
tion to the subject
of Radio

John H. Morecroft

**Elements of Radio
Communication**

BY JOHN H. MORECROFT

"We can highly recommend 'Elements of Radio Communication' to those of our readers who want a book that will give them a strong, elementary grounding in radio and leave them with few questions to ask save those which may be born of a desire for more knowledge."

Boston Post Radio Section

\$3.00

JOHN WILEY & SONS, Inc.

440 Fourth Ave., New York

Please send me Morecroft's "Elements" for free examination. Within ten days after its receipt I will either return the book or send you \$3.00.

Name.....

Address.....

Firm.....RB 1-30

No. 316

RADIO BROADCAST Laboratory Information Sheet

January, 1930

Range of Frequencies Required

PAST AND PRESENT improvements in quality of reproduction from radio receivers has been due in no small extent to the important research carried on by the laboratories of the Bell Telephone Company to determine the characteristics of the ear so that some rules might be laid down regarding the range of frequencies required for good reproduction and the range of pressure common in speech and music. A group of curves illustrating some of these important characteristics is given in "Laboratory Sheet" No. 317. These curves show how the sound pressure varies for sounds of constant volume over the entire band of audible frequencies. On the curve are also indicated some contour lines of equal volume which have been divided into three parts, the bass, the tenor or alto, and the soprano, corresponding to the range of notes produced by various instruments.

The vertical distance between the two limiting lines indicates the range in pressure and

shows that although the pressure is greater at the low frequencies, the range of pressure is not as great as at the higher frequencies.

The musical instruments producing the greatest pressures are the percussion type such as the traps and drums. Although the fundamental tones produced by these instruments are quite low they are very rich in harmonics extending sometimes up to 10,000 cycles.

Generally speaking, the fundamental and first three overtones are essential in order to distinguish the notes of various instruments and better reproduction is obtained if the fourth overtone is reproduced. The frequencies used most in music are contained in the octaves between 128 to 512 cycles. As the fourth overtone of 512 cycles is 8192, tones of this frequency and below frequently occur in music. The average individual, however, would probably find it difficult to detect the elimination of all frequencies above 6000. The letters "dv" on the curve mean "double vibrations."

No. 317

RADIO BROADCAST Laboratory Information Sheet

January, 1930

Range of Frequencies Required

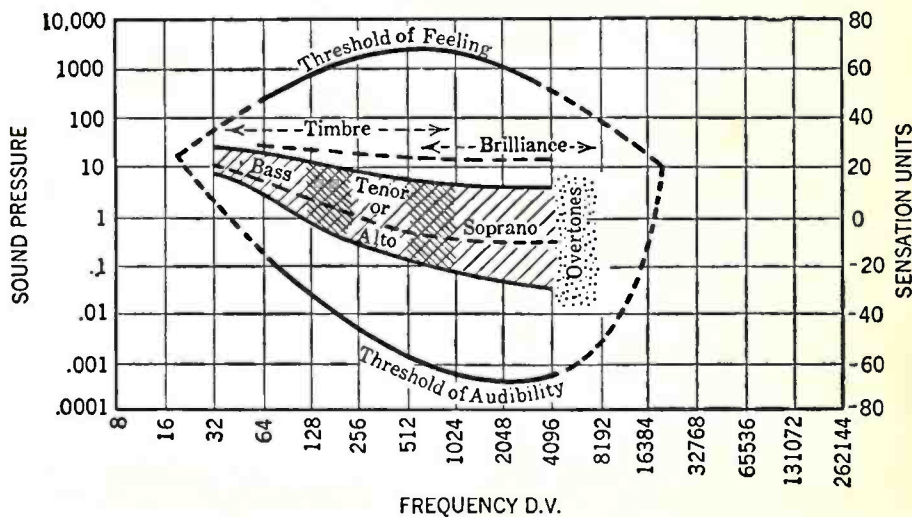

No. 318

RADIO BROADCAST Laboratory Information Sheet

January, 1930

60- and 120-Cycle Hum Measurements

IN THIS "Laboratory Information Sheet" are given some data on hum measurements made in the Laboratory some time ago. The measurements were made using an a.c.-operated Wright DeCoster electrodynamic loud speaker. These measurements were made to determine how much a.c. voltage at 60 and 120 cycles was necessary across the primary of the coupling transformer in the loud speaker to produce an audible hum output.

Two series of measurements were made. The first to determine what voltage would produce a just audible sound and the second to indicate what voltage was required to produce the maximum hum that might be tolerated. The figures are useful in indicating how much hum voltage in the output circuit of a radio receiver is permissible. It is interesting to note from the figures given below that the ratio of the voltage at 60 cycles to the voltage at 120 cycles is approximately 10, which ratio agrees quite well with the variation in sensitivity of the ear between 120 and 60 cycles.

JUST AUDIBLE HUM	
60 cycles	1.3 volts
120 cycles	0.15 volt
MAXIMUM TOLERABLE HUM	
60 cycles	5.2 volts
120 cycles	0.54 volt

If we assume that most of the hum arises in the detector circuit, it is a simple matter to calculate the maximum permissible value of this hum. We simply have to divide the voltage indicated above by the gain of the amplifier. For example, if an amplifier had a gain of 200, then the amount of 60-cycle voltage in the plate circuit of the detector tube to produce a just audible hum from the loud speaker would have to be 1.3 divided by 200 which gives 0.0065 volt or 6.5 millivolts. The maximum permissible 120-cycle voltage is 0.15 divided by 200 which gives 0.00075 volt or 0.75 millivolts.

READS VOLTS FILAMENT HERE READS VOLTS PLATE HERE READS GRID CONTROL HERE

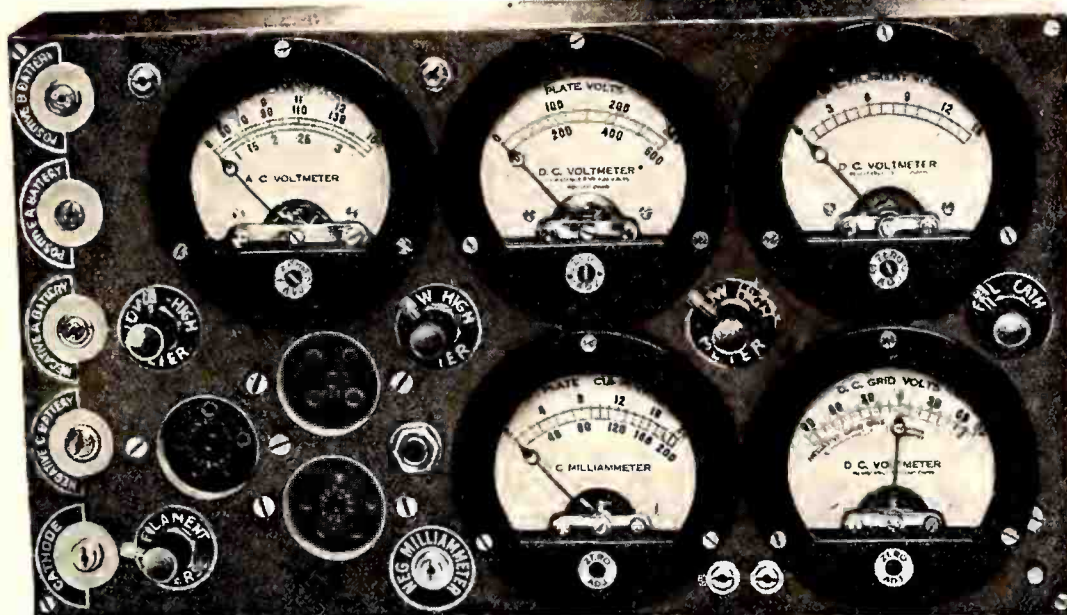

THE NEW
Type SG
4600
RADIO
SET
TESTER

Radio's
Most
Complete
Servicing
Equipment

Dealers' net price complete with carrying case

\$90.00

Write for FREE Bulletin No. 26

READS PLATE READS SCREEN
CURRENT HERE GRID VOLTS HERE
INDICATES SIMULTANEOUSLY ALL THE ABOVE VALUES

The Hickok Electrical Instrument Company
CLEVELAND, OHIO

**MEN ARE IN DEMAND
In All Branches of Radio**



Prepare through a school with a reputation for efficiency. Our courses are easy, interesting and effective.

We have large classrooms, laboratory, workshop, dormitory and many other new and unusual features.

Subjects Taught:

COMMERCIAL RADIO RADIO SERVICE
RADIO BROADCAST VITAPHONE-MOVIETONE
LABORATORY NAVIGATION
RADIO MATHEMATICS

Mid-Year Semester Begins January 20, 1930
Literature on Request

COMMERCIAL RADIO INSTITUTE
38 W. Biddle St. Founded 1920 BALTIMORE, MD.

A Radio Parts Guide

THE NEW
YAXLEY

Catalog

Send for it today for complete listings of Radio Convenience Outlets, Connector Plugs, Rheostats, Fixed and Grid Resistances, Jacks, Jack Switches, Phone Plugs, etc.

YAXLEY MFG. CO.
Dept. B, 1528W Adams St., Chicago, Ill.

**Add the Highest Quality of Radio
To Your Present Amplifier**

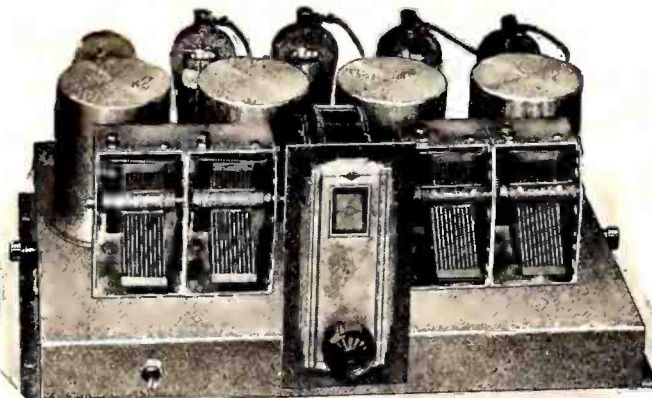

If you wish to add the most modern type of Radio Reception to your—

Electric Phonograph Public Address System
Auditorium Amplifier Power Amplifier

the NATIONAL Screen Grid MB-29 Tuner is especially adapted for such use.

Equipped with 4 Screen Grid A. C. tubes, it will give satisfactory reception on indoor antenna even in steel frame buildings. Has every modern feature, including power detection, Band Pass tuning, and heavy aluminum chassis.

NATIONAL CO. INC., Malden, Mass.

Est. 1914

Write today for full technical information mentioning Radio Broadcast.

**NATIONAL
SCREEN-GRID—MB-29**

HARNESSING A MIGHTY POWER

—your radio!

A delicate, intricate network of coils and transformers—cascading amplifications tube by tube.

Such power must be harnessed—if the result is to be a smoothly flowing, clear reception.

A CENTRALAB volume control in your radio does just that . . . and it does it smoothly . . . silently . . . surely. It means much if your radio is CENTRALAB equipped.

Write for free booklet "Volume Controls, Voltage Controls, their uses."

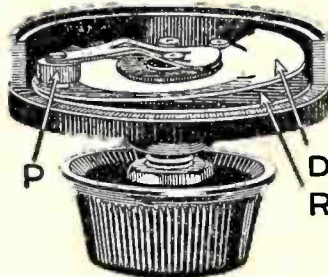

This shows the exclusive rocking disc construction of Centralab volume control. "R" is the resistance. Contact disc "D" has only a rocking action on the resistance. Pressure arm "P" together with shaft and bushing is fully insulated.

Centralab

CENTRAL RADIO LABORATORIES
20 Keefe Ave., Milwaukee, Wis.

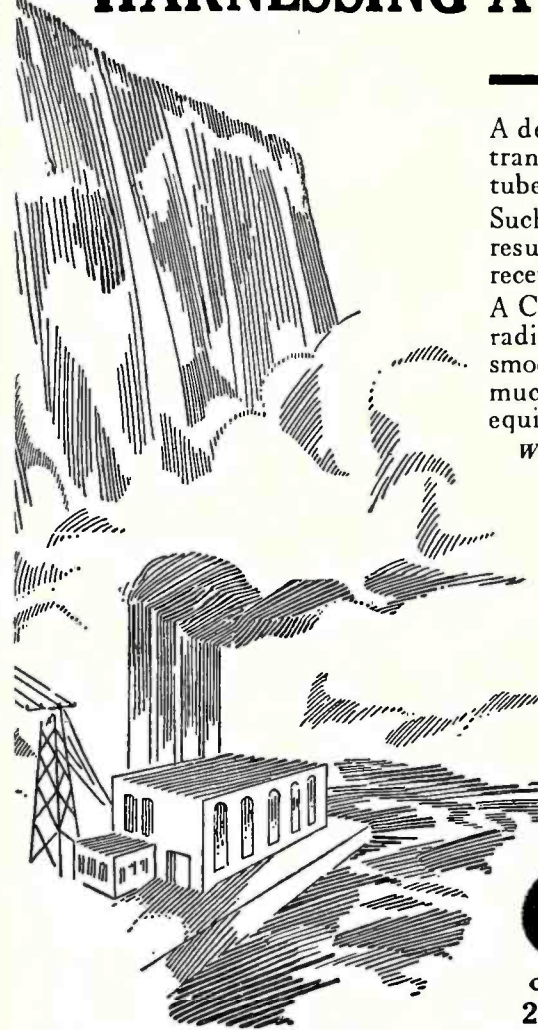

(Continued from page 185)

number of spare parts, so he has more floating capital upon which to operate. And the regional factory can train its own mechanics, offering them steady employment and good wages, so the skilled labor problem so bothersome to the small dealer is solved. All that the dealer has to employ is a good diagnostician and a general helper, to attend to the attentive-maintenance service.

The Financial System

The regional repair factory should be financed by a holding company, which could be formed by the manufacturers and in which distributors and dealers should in time be permitted to buy stock. In one Western state, the dealers themselves have financed such a factory, each buying stock according to the volume of his normal repair business. On principles, however, the automobile industry seems to feel that the original burden should be borne by the man with the most money, the manufacturers; and that the dealer will be doing his share at first by sending business to the factory, thereby making it profitable.

HOW WE LOOK AT SERVICE PROBLEMS

(Continued from page 146)

up. Remember also that technical knowledge and handiness with tools are important but that handling the customer is just as important. Don't employ a man that you wouldn't be willing to send to your own home. Get men with a good education, if you can, and men who have a real flair for radio. If these men intend to stay with the game a little overtime will not scare them. And when you get a good man give him a square deal. Pay a fair wage and a commission on sales.

A few experiences showing the nature of the problems that the serviceman is called upon to solve may be of interest. The following paragraphs describe average calls, picked at random, which show some of the things the author has run up against recently.

The other day I had a report marked "No reception." A Czecho-Slovak bought a QD Freshman and we installed the set and antenna. The Czech moved, and moved the set. At the new location what did I find? The set was properly grounded. The antenna lead-in went to a woven-wire fence—and the fence was grounded. I explained to the customer the need for a proper antenna.

About a week ago I delivered a neutrodyne console, complete with power supply and loud speaker. Shortly after I got another "No reception" report.

All the tubes were burned out except the detector tube. The set tester showed current at sockets o.k. with one exception. The set had apparently been taken out of the console, examined, and then put back by unfamiliar hands. I found, after some questioning, that one of the boys in the family was a radio "bug" and had worked in a radio factory neutralizing sets. He certainly neutralized that one.

Some people like company. I have had several calls where "No reception" was reported and an examination showed that set and connections were all right. The a.c. plug was connected too. Some of these people admitted that they just wanted someone to talk to. I suppose that the grocer and the ice man do get to be an old story at that.

WTRC changed its wavelength from the Back Bay to the North End, if you know your Boston. We got all sorts of complaints and inquiries as to how to separate wric, wbz, and wpg. An 0.00025-mfd. fixed condenser in the antenna lead-in fixed some of these.

Stop A.C. Noise!

Improve Selectivity!

PLUG in a Falck Claroceptor between wall socket and radio set and eliminate "static" from motors, street cars, telephones and electrical appliances. This new improvement by a pioneer radio parts manufacturer grounds and thus blocks out line interference noise and radio frequency disturbances. Also improves selectivity and distance. Requires no changes in set. Measures just 3½ x 5½ x 2½ inches. Thousands now all over America use the Claroceptor for clearer A. C. reception. Get one right away—at radio parts dealers. Write for descriptive folder.

\$7.50 complete with cord and plug



Falck

CLAROCEPTOR

Built by ADVANCE ELECTRIC CO.
1260 W. Second St. Los Angeles, Calif.
JOBBERs and DEALERs, GET OUR PROPOSITION

Makes Your Radio BEHAVE!

Free Bulletin
Write Dept. RB1

The New AMPERITE for electric radio improves reception—makes tubes last longer. Eliminates disturbing line voltage fluctuations. No radio can be modern without it.

AMPERITE Corporation
561 BROADWAY, NEW YORK

AMPERITE

Self-Adjusting
LINE VOLTAGE CONTROL.

ROBERT S. KRUSE

Consultant and Technical Writer

103 Meadowbrook Road, West Hartford, Conn.

Telephone Hartford 45327

- ADVENTURE
- EXPLORATION
- CURRENT EVENTS
- BIOGRAPHY — SCIENCE
- PERSONALITIES
- BUSINESS — EDITORIALS

The BEST of all these in

WORLD'S WORK

WORLD'S WORK Garden City, New York



Symington Precision Manufacture Begins Here

IN THIS modern tool room costly machines, skilled workmen fashion the accurate jigs, tools, dies and fixtures necessary for volume production at low cost. Here begins the precision which distinguishes the Symington product.

This tool room spells quick production on new designs, complete facilities for prompt design changes where a manufacturer's altered specifications so require.

Supporting this tool room is a million dollar plant geared up for large scale production of the Symington Reproducer—a quality speaker at the lowest possible price.

Write for illustrated folder showing this great one-profit plant in detail.

A view of the big Valley Plant. We invite executives and engineers to visit us in Rochester.



**VALLEY
APPLIANCES, Inc.**
*Manufacturers Symington Electro-
Dynamic Reproducers*
ROCHESTER, NEW YORK

U. S. S. WYOMING, PAM EQUIPPED

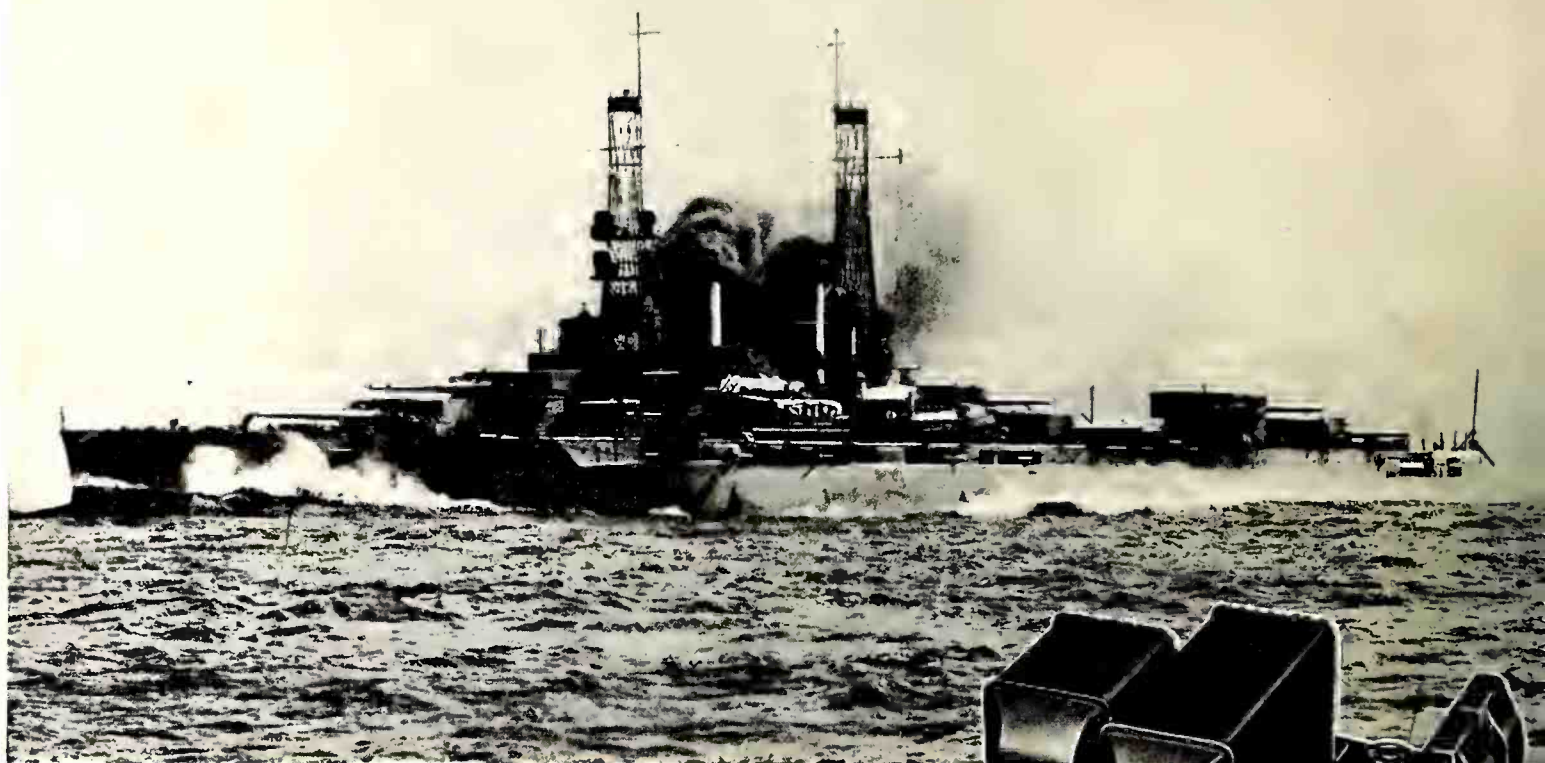

PAM

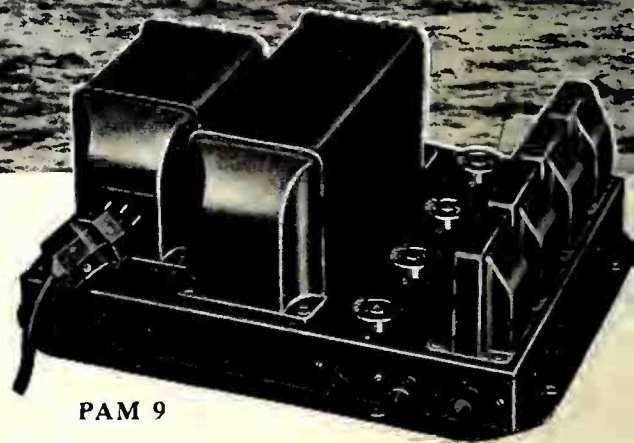

PAM 9

Accompanies the Big Guns

Where important events are staged, in this and many other countries, you will find Samson PAM Amplifiers providing entertainment and instruction through loud-speaker systems.

Not only on battleships, but on coast-wise vessels and excursion steamers—probably in your neighborhood—are opportunities for such installations.

Truly these are opportunities for worth-while profits from the sale of

PAMS and associated equipment, such as radio sets and loud speakers, phonographs and pick-ups, microphones and wiring.

A new 16-page bulletin giving mechanical and electrical characteristics, representative installations, and many new PAM Amplifiers will be sent upon receipt of 10c in stamps to cover postage. When writing ask for Bulletin No. RB14.

Main Office:
Canton, Mass.

Samson Electric Co.

MEMBER
RMA

Manufacturers Since 1882

Factories at Canton
and Watertown, Mass.