

CT. 1925 **RADIO** 35 CENTS  
**BROADCAST**

Notes on Chemical Plate Supplies

Single Control  
For Your Present Receiver

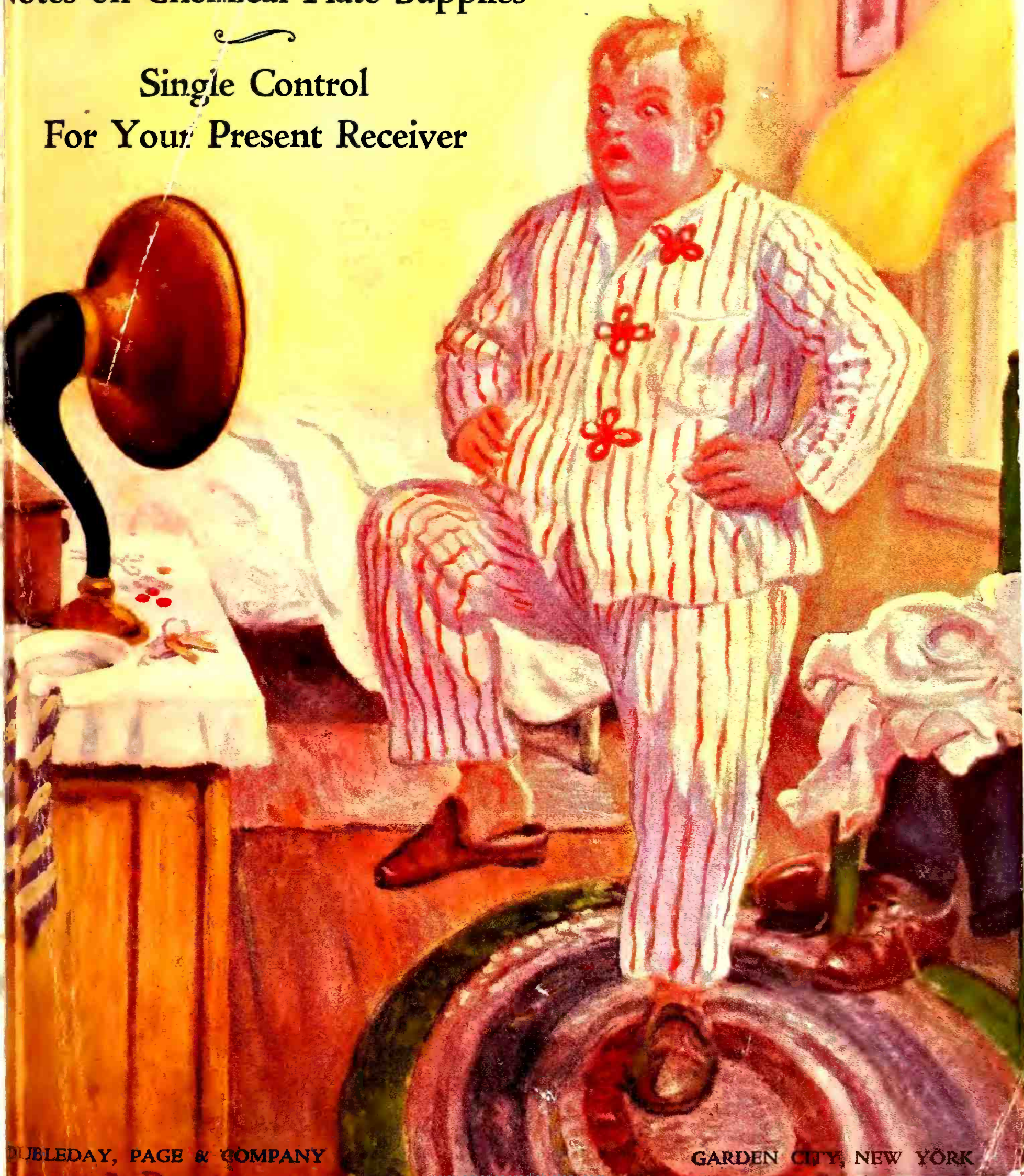

# MacMillan demands Cunningham RADIO TUBES

*For Life  
and Death  
Service*

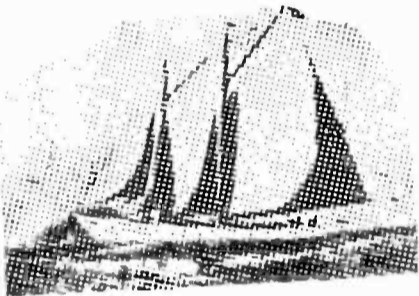

## THE MACMILLAN ARCTIC ASSOCIATION

HERBERT L. BRIDGMAN  
PRESIDENT

GEORGE F. CARY  
TREASURER

W. J. LOOK  
VICE PRESIDENT

EDWARD N. GODING  
SECRETARY

EDWIN W. SPARKS  
VICE PRESIDENT

DONALD B. MACMILLAN  
MANAGING DIRECTOR

626 TREMONT BUILDING, BOSTON, MASS.

April 19th, 1925

Mr. E. F. McDonald, Jr.,  
332 S. Michigan Avenue,  
Chicago, Illinois.

My dear Gene:

I have had so much success and long life with the Cunningham tubes in my set, and I have heard such favorable reports during my lecture tour throughout the United States, that I have decided that we should equip the Expedition with Cunningham receiving tubes exclusively.

You will therefore please arrange to purchase these tubes, per attached order, and have it shipped to the Bowdoin in time for the tests before the sailing at Wiscasset.

Sincerely yours,

*Donald B. Macmillan*



Home Office: 182 Second St.  
SAN FRANCISCO

CHICAGO  
NEW YORK

*E. J. Cunningham Inc.*

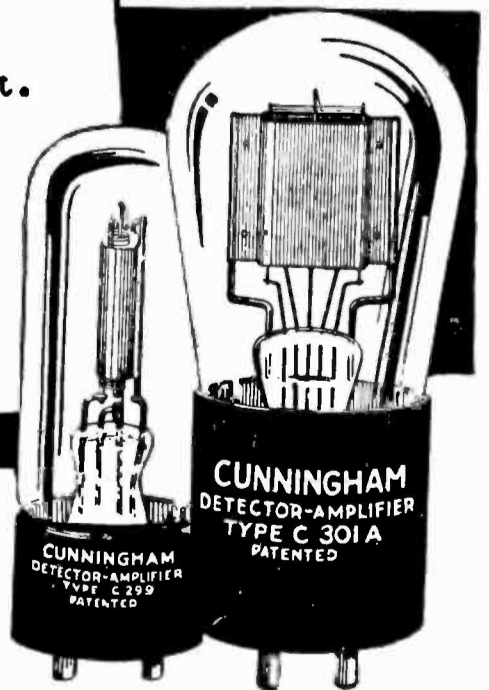

★  
Since 1915—  
Standard for  
all sets

Types C-301A  
C-299 : C-300  
C-11 : C-12

In the Orange  
and Blue Carton

In that white and silent Northland with its glistening ice, driving blizzards and endless, relentless cold, Cunningham Radio Tubes deliver the same efficient, well-rounded service that makes them valued so highly in the shelter of the American home.

MacMillan's  
choice  
may well be  
yours

★ Tested and approved by RADIO BROADCAST ★



## Don't cheat your radio set! —use a Beldenamel Aerial

### Important Facts about Beldenamel Aerial Wire

It is endorsed by leading radio engineers as the most efficient type of outdoor aerial.

It offers maximum surface to radio-frequency oscillations.

It is not a trick aerial, but a real, scientific development.

It is furnished in 100 and 150 foot lengths to provide sufficient length for lead-in without joint.

**T**HE volume and range of your radio set depends largely upon the condition of your aerial. An ordinary bare copper aerial wire soon corrodes, due to the smoke and fumes in the atmosphere, and its resistance increases rapidly. When this happens, less energy is transmitted to your detector and you lose volume and range. *It cheats your set!*

A Beldenamel Aerial is coated with many layers of baked Beldenamel, which protects the copper surface from corrosion, and the aerial resistance does not increase. A Beldenamel Aerial insures maximum range and volume, year in and year out. *It lasts indefinitely!*

*Mail the Coupon  
for Free Illustrated  
Booklet*



BELDEN MANUFACTURING CO.  
2312E South Western Ave., Chicago

Please send me your booklet entitled "Helpful Hints for Radio Fans."

Name.....

Address.....

*Belden*

★ Tested and approved by RADIO BROADCAST ★

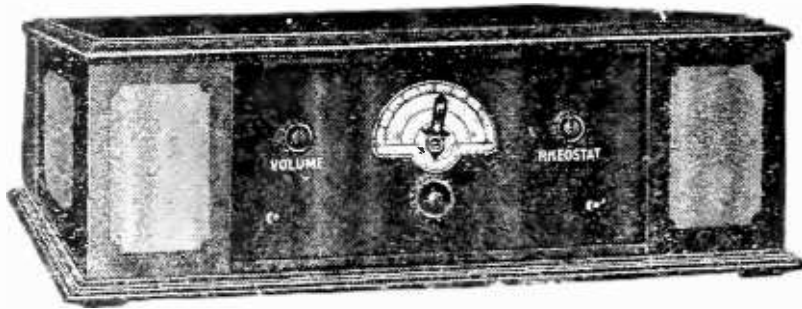

MODEL B                      PRICE \$125  
 SOCKETS FIT ALL NEW TYPE TUBES

## A Heart to Heart ★ Talk on Radio Receivers

The Radio Receiver *You* want must be able to bring in local and distant stations, at will, clearly, and with full, rich volume—and it must be so simple to tune and so reliable in operation that your child can tune it. You also want a Receiver that is so far advanced that it represents a *permanent* value when you buy it.

That is why you want the new Mu-Rad Transcontinental Receiver.

*Go To Your Nearest Dealer  
 See This Remarkable Receiver  
 Ask Him to Let You Tune It Yourself*

Write Dept. E-2 for Literature

**MU-RAD RADIO CORPORATION**

Factory  
 Asbury Park,  
 New Jersey

General Sales Offices  
 972 Broad Street,  
 Newark, New Jersey

*The*  
**MU-RAD**  
*Transcontinental Receiver*

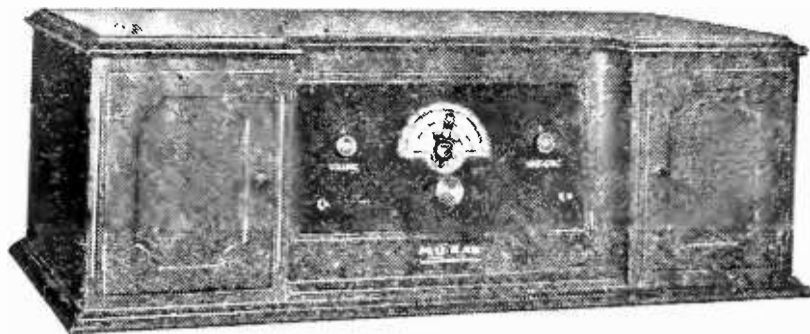

MODEL A                      PRICE \$175  
SOCKETS FIT ALL NEW TYPE TUBES

## ★ Far Ahead of the Times

THE new Mu-Rad Transcontinental Receiver is a distinct advance in the art of Radio Reception. It is the evolution of ten years progress and development in Radio and is the masterpiece of one of Radio's greatest engineers.

### ONE DIAL CONTROL

One Dial setting, the turning of *One* knob brings in local and distant stations with amazing clearness and volume and absolute selectivity. Once a station is logged it will always come in at the same dial setting. It's so simple a child can operate it.

Write Dept. E-2 for Literature

### MU-RAD RADIO CORPORATION

Factory  
Asbury Park  
New Jersey

General Sales Offices  
972 Broad Street  
Newark, New Jersey

The  
**MU-RAD**  
Transcontinental Receiver

# AMSCO

ANNOUNCES A  
SPACE-SAVING  
S.L.F. CONDENSER

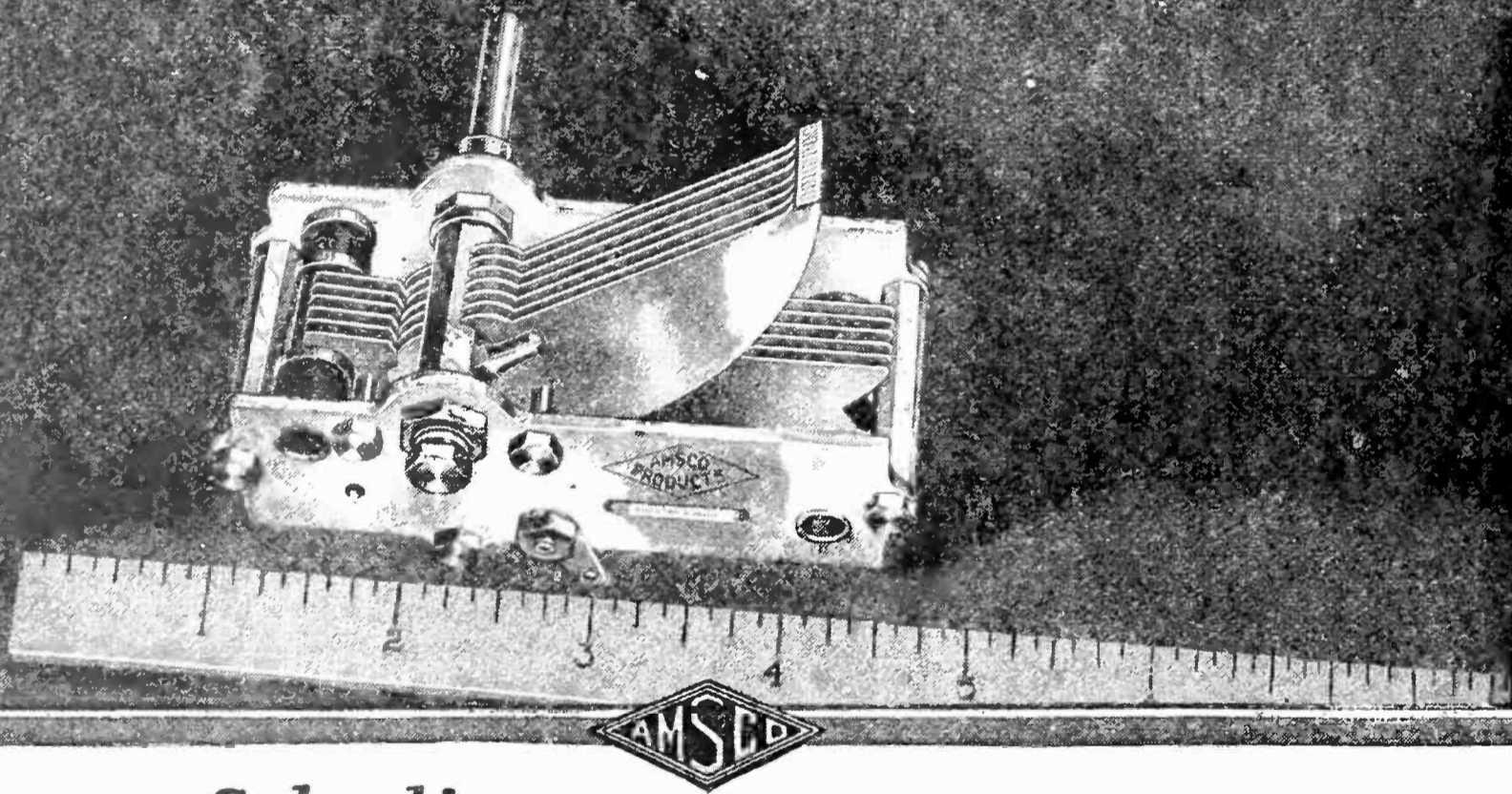

Half a Heart is  
the secret.



Half a Heart is  
the shape of the  
rotor plates.



Half a Heart is  
the new symbol  
for efficient S.L.  
F. variable con-  
densers.



**Solved!** The space problem of the straight-line frequency condenser. The new AMSCO Allocating Condenser is ingeniously designed to save room in the cabinet—yet spreads the stations evenly around the dial, according to frequency. Greatly improves the selectivity of the set—and simplifies tuning. Three sizes—Single or Siamese.

Ask your dealer—or write Dept. E

**AMSCO PRODUCTS, INC.**  
Broome and Lafayette Streets, New York City  
MAKERS OF MELCO SUPREME RADIO RECEIVERS

★ Tested and approved by RADIO BROADCAST ★

**AMSCO  
PRODUCTS  
ARE SPECIFIED BY  
STROMBERG-CARLSON FREED-  
EISEMANN PRIESS RADIO &**

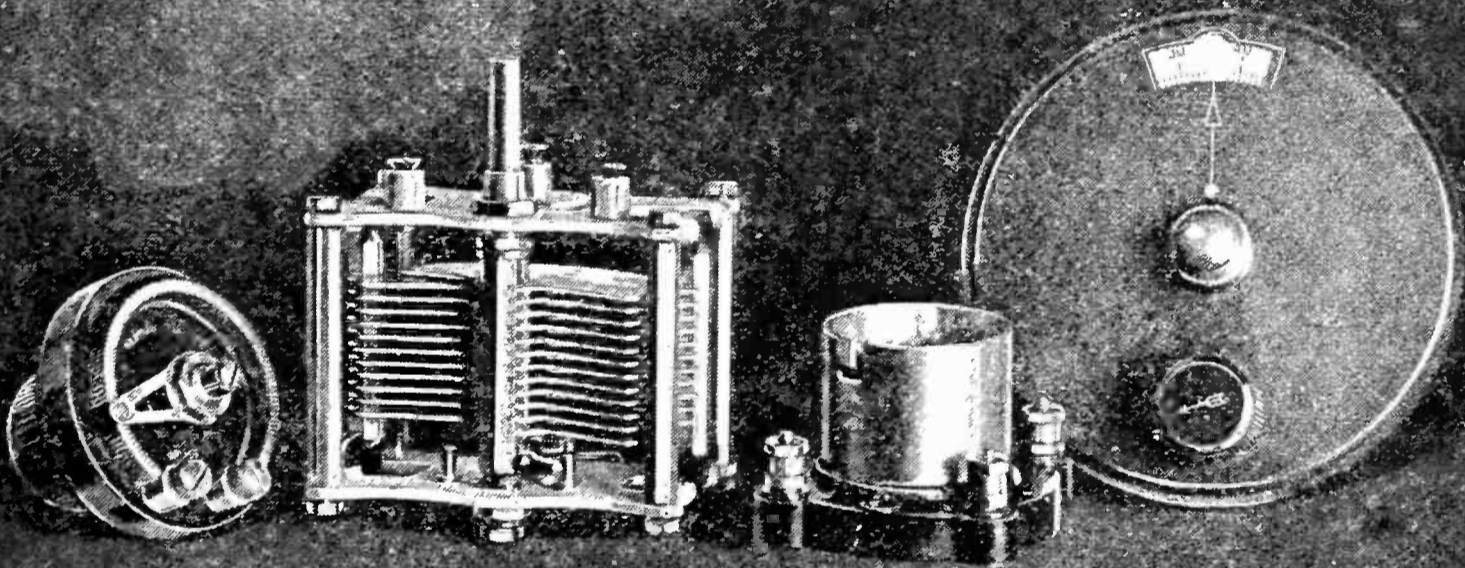

**Set builders** who strive for electrical and mechanical perfection inevitably come to AMSCO. Look behind the panel of the finest sets, and you will find the AMSCO trademark, the sign of *engineered* radio parts. Standardize on AMSCO Condensers, Vernier Dials, Rheostats, Potentiometers, Sockets and Binding Posts—each the best that can be made, and made to *match* each other.

Ask your dealer—or write Dept. E

**AMSCO PRODUCTS, INC.**  
Broome and Lafayette Streets, New York City  
MAKERS OF MELCO SUPREME RADIO RECEIVERS

NEW—The Amsco Vernier Dial—at a popular price. The right ratio for precision tuning.



★ Tested and approved by RADIO BROADCAST ★

**Valley**  
  
 Radio  
 Receiver



# Selectivity means more with the Valleytone

## Potential Balance exclusive in the Valleytone

The *potential balance* method of suppressing oscillation and preventing distortion is used for the first time and exclusively in the Valleytone Radio Receiver.

Reception is clear and mellow—free from the thin, hard, metallic sound and the howls and squeaks which have been the plague of radio.

## Valley Toroidal Coils

The Valleytone is the first manufactured set to use Toroidal coils. The Valley Toroidal winding allows a greater coupling ratio between primary and secondary. The result is an appreciable increase in volume over the old solenoid winding.

## Appearance

The Valleytone is mounted in a solid walnut cabinet, finished in two tones with inlaid gold stripes. It may also be procured in beautiful console models. Special Valley tables with built in loud speaker may be obtained for the cabinet model.

Finer tuning becomes a reality . . . selectivity means more with the Valleytone Radio Receiver.

For instance: The Valleytone has regularly received and separated clearly and distinctly, radio programs broadcasted simultaneously from stations on wave lengths from four to five meters apart.

Such selectivity is attained in the Valleytone because of the Toroidal coils. The Valleytone circuit brings in stations sharply, clearly, and free from distortion.

With the Valleytone, you can enjoy radio as never before. You can get a station if it is on the air and transmitting strongly enough to reach you. You can choose your stations by the clock and hear them with the Valleytone.

The Valleytone is a five-tube set. It is manufactured by an old established company with the experience and the resources to assure you always the utmost in radio value.

Before you buy a radio, see the Valleytone. Hear it. Let an authorized Valley dealer give you a demonstration.

VALLEY ELECTRIC COMPANY, *Radio Division*, ST. LOUIS, U.S.A.  
*Branches in Principal Cities*

**Valleytone**  
 Receiving Sets

**Valley**  
 Battery Chargers

**Valley**  
 B-Eliminators

# Valley Electric

★ Tested and approved by RADIO BROADCAST ★



# For radio at its best you need these, too



## Valley B-Eliminator

The Valley B-Eliminator is made for receiving sets of from one to eight tubes. Binding posts and control rheostats are mounted on Bakelite panel. The unit is enclosed in a handsome black case.

It costs less at the start than wet B batteries and less in the long run than dry cells, too. Much more satisfactory than either.

## Like new B batteries every night

Here is a new and better way of supplying B voltage for radio reception.

B batteries wear out. They cannot be the same two nights in succession. As they decrease in strength, volume decreases, too. Furthermore, they become noisy as they wear out. The absolutely ideal B battery current can be obtained only by the use of fresh new B batteries every night. The same ideal results can now be obtained by the use of the Valley B-Eliminator as your source of B voltage.

In its performance, the Valley B-Eliminator is like a new set of B batteries every time you tune in and every second you are tuned in.

The Valley B-Eliminator is more than a substitute for B Batteries. It is a new and better way of supplying B voltage for radio reception. It operates on the house lighting circuit and provides B current *at a constant voltage all the time.*

Hence reception is always at its best. There is never any decrease in the strength of signals and none of the frying noises or hum which are due to low B batteries. Volume is maintained. Reception is uniformly good.

## The charger with ten points of superiority

The Valley Battery Charger has a reputation for results. It is based on principles which were proven successful long before radio became popular. It is the only charger needed for all radio batteries:—6 volt A batteries; 24, 48, 72 or 96 volt B batteries; and 2 volt batteries.

### It has ten points of superiority

- |   |   |
|---|---|
| <ul style="list-style-type: none"> <li>1 No bulbs.</li> <li>2 No liquids.</li> <li>3 Quiet in operation.</li> <li>4 Cannot harm your battery.</li> <li>5 Efficient. Takes about a dime's worth of current for a full charge.</li> <li>6 Correct 6-ampere charging rate enables you to recharge your battery overnight.</li> <li>7 Ammeter mounted flush with panel shows if battery is receiving charge and if charging rate is correct.</li> </ul> | <ul style="list-style-type: none"> <li>8 Special switch for B Batteries. Voltages: 24, 48, 72, 96.</li> <li>9 Has only two wearing parts, the contacts, which can be replaced easily and cheaply. Average life of these contacts about two years.</li> <li>10 Built in handsome black case with grained and engraved Bakelite panel and clear glass top which shows simple patented working parts. Harmonizes with the finest receiving set.</li> </ul> |
|---|---|

These features are all essential. Be sure of them by getting only a Valley Battery Charger.

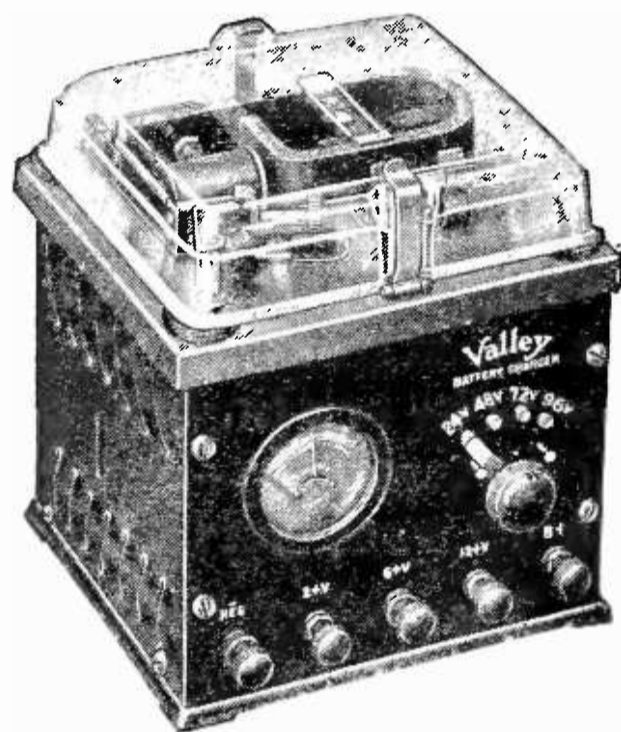

## Valley Battery Charger

VALLEY ELECTRIC COMPANY, Radio Division, St. LOUIS, U. S. A.  
Branches in Principal Cities

Valleytone  
Receiving Sets

Valley  
Battery Chargers

Valley  
B-Eliminators



# Valley Electric

★ Tested and approved by RADIO BROADCAST ★

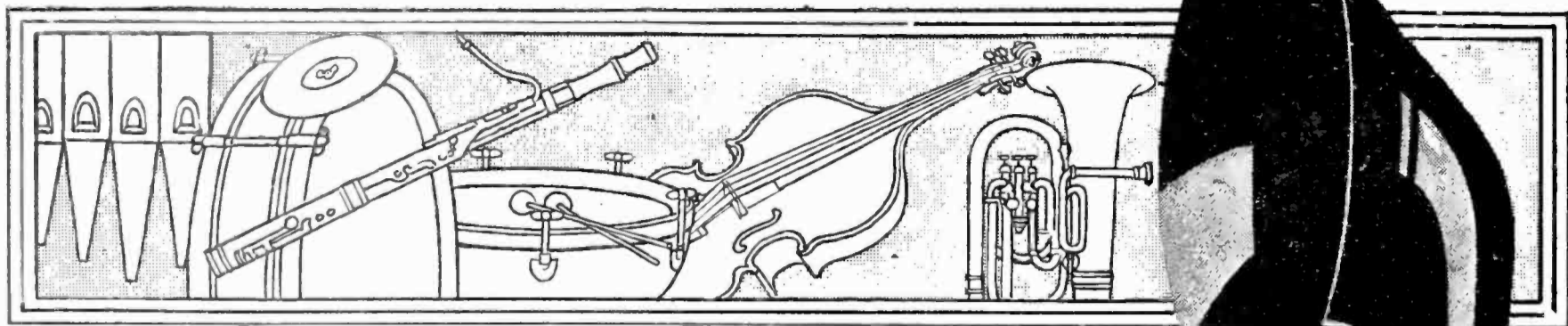

## The New Large Diaphragm



### Brings In The Deep Bass Notes

THE new Super Unit is a diaphragm of broad pitch range, especially designed by Bristol engineers. It reproduces the high and low notes with equal truthfulness, and, therefore, evens up the entire musical scale of either voice or instrumental music. Often the harmonies of a wonderful ensemble have been destroyed by the persistent loss of high or low notes, and the annoyance attributed to a faulty receiver when, in fact, the trouble lay wholly with the loud speaker. The Bristol Audiophone Loud Speaker with its new Super Unit of broad pitch range, and its exceptional voice of scientific development tells the whole tonal truth and nothing but the truth.

The are four Bristol Loud Speaker models, both horn and cabinet type, priced at \$15.00 to \$30.00.

If your dealer does not carry the Bristol line, send for our illustrated folder AH-3025. We will also send free a most instructive booklet, "How To Select Your Loud Speaker."

The Super Unit with the new Low Pitch Diaphragm.

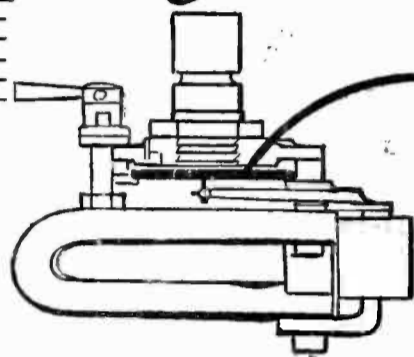

Model S Audiophone \$25.00

Rubber horn 14½ inches in diameter. Black mat finish with silvered base decoration.

Models S, and C (the cabinet Model), are equipped with the new Super Unit.



# BRISTOL TRADE MARK AUDIOPHONE REG. U.S. PAT. OFFICE Loud Speaker

THE BRISTOL COMPANY



WATERBURY, CONN.

★ Tested and approved by RADIO BROADCAST ★

# TRUE TONE QUALITY

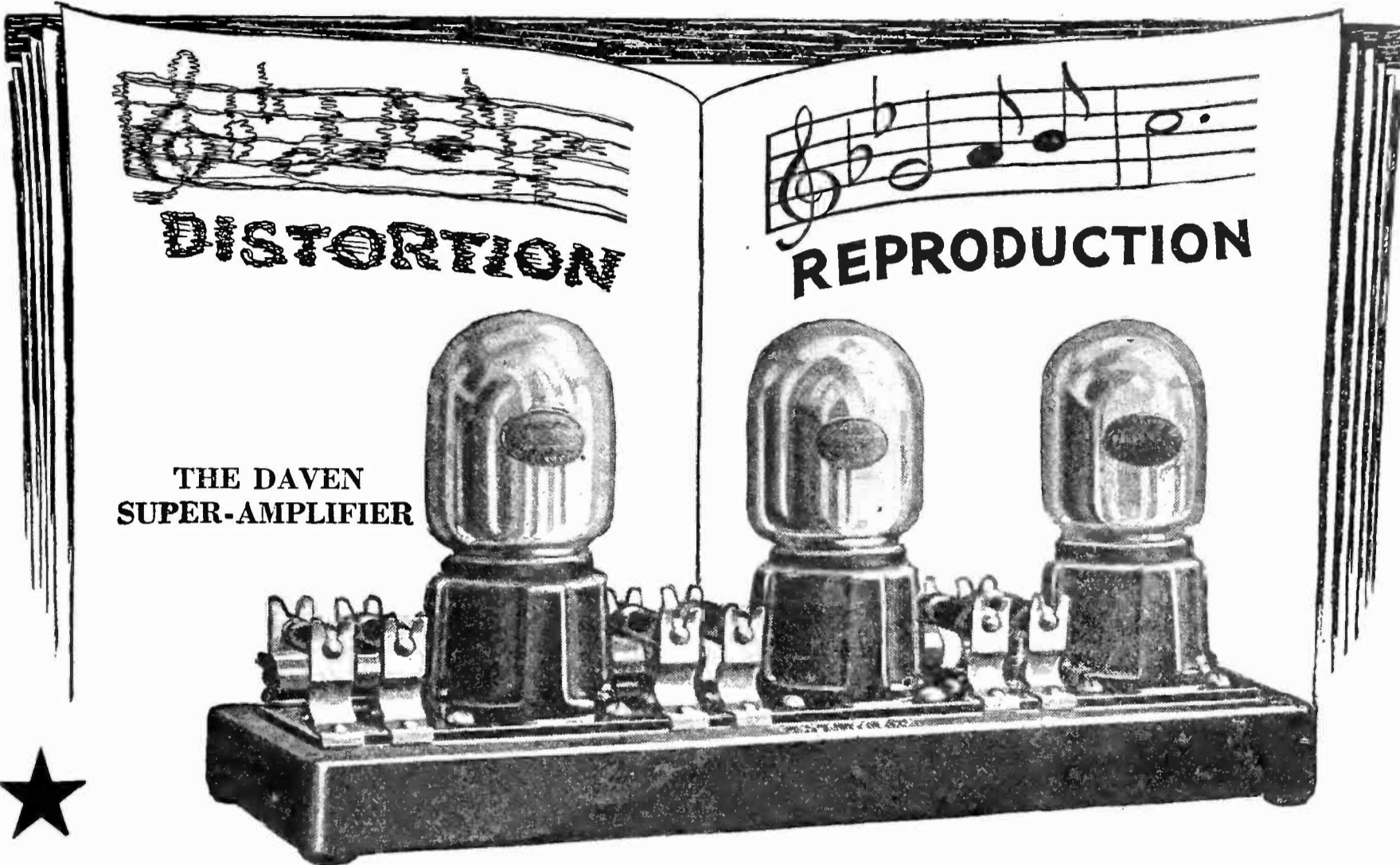

THE DAVEN SUPER-AMPLIFIER



**RESISTOR MANUAL**  
The Handbook of Resistance Coupled Amplification.  
At Best Radio Dealers 25c.  
Direct by mail, postpaid 30c.

**CLIP THIS COUPON**

E-10-25

**DAVEN RADIO CORPORATION**  
158-160 Summit St., Newark, N. J.  
Please send me the following on Resistance Coupled Amplification:

Check one

- Resistor Manual. 30c is enclosed.
- Complete Catalog (free).

Name.....

Address.....

**FOR DEALERS:** Send your letterhead or card, or this coupon and we will have our nearest distributor communicate with you.

**V**OLUME was formerly the goal of radio engineers. The blare of discordant trumpets succeeded the tinkling of the harp. The goal had been reached.

But true tone quality is the star we now are shooting at. This explains the phenomenal growth of the demand for resistance coupled amplification. The end of the era of distortion is in sight.

Daven engineers have pioneered in resistance coupled amplification. Daven Resistors and Mountings, Ballasts, Amplifier Kits and Super-Amplifiers are standard everywhere.

The Daven Super-Amplifier is the *aristocrat* of amplifiers. Absolutely no distortion. A revelation to music lovers. It is sold by dealers everywhere, complete, ready to connect with tuner and batteries, for \$15.00.

## DAVEN HIGH-MU TUBES

**MORE** volume of true tone quality is the latest achievement of Daven engineers. The new Daven Tube Type MU-20 increases the amplification of the Daven Super to equal or exceed that obtainable with transformers. 6 volt, 1/4 ampere—\$4.00 each. The Daven Power Tube Type MU-6 for the last, or output stage—\$5.00 each.

**DAVEN PRODUCTS ARE SOLD ONLY BY GOOD DEALERS**

*"The Sine of Merit"*

# DAVEN RADIO CORPORATION

*Resistor Specialists*

Newark

Reg. U. S. Pat. Off.

New Jersey

# THE BIG LITTLE THINGS OF RADIO

★ Tested and approved by RADIO BROADCAST ★

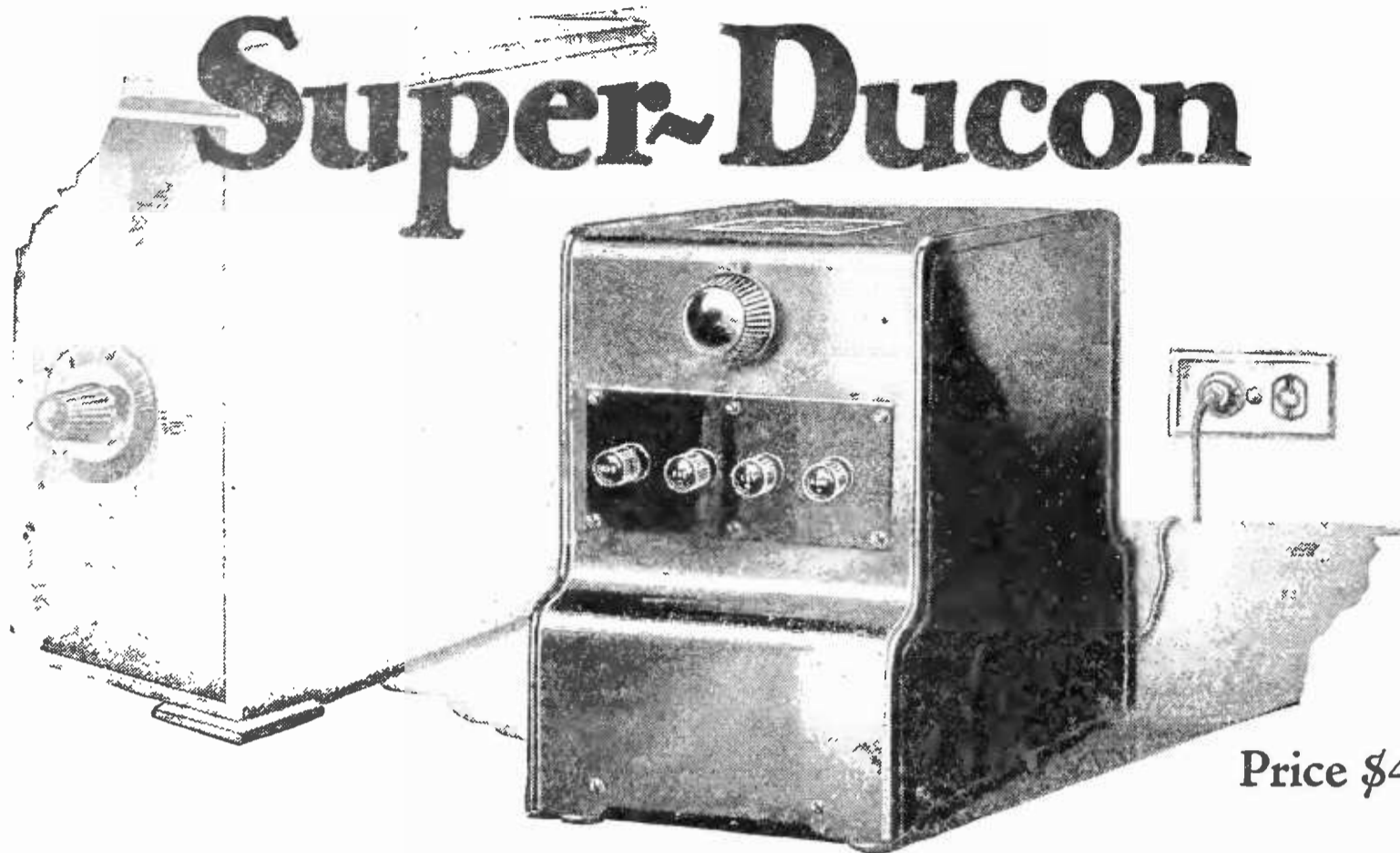

Price \$47.50

*Perfected with specially designed*  
**RCA Tube**

The Super-Ducon replaces the "B" battery, operates from the light socket (110 to 115 volts, 60 cycle A.C.) and is absolutely noiseless when properly installed.

Every radio man knows the results he gets when his "B" battery is at its best. The Super-Ducon gives him this top-notch volume *all* the time.

As now furnished, the Super-Ducon has a specially designed RCA tube—Rectron U.V. 196, which has an average life of more than 1000 hours.

*Tested and listed by the National Board of Fire Underwriters.*

Write for descriptive bulletin. Address—4377 Bronx Blvd.,  
 New York City



**Dubilier**

**CONDENSER AND RADIO CORPORATION**

★ Tested and approved by RADIO BROADCAST ★

Absolute freedom from all self-made noises makes Jewett performance a revelation. Due to the Jewett Clarifier (Patent applied for) there is no B-Battery current in the telephone circuit.

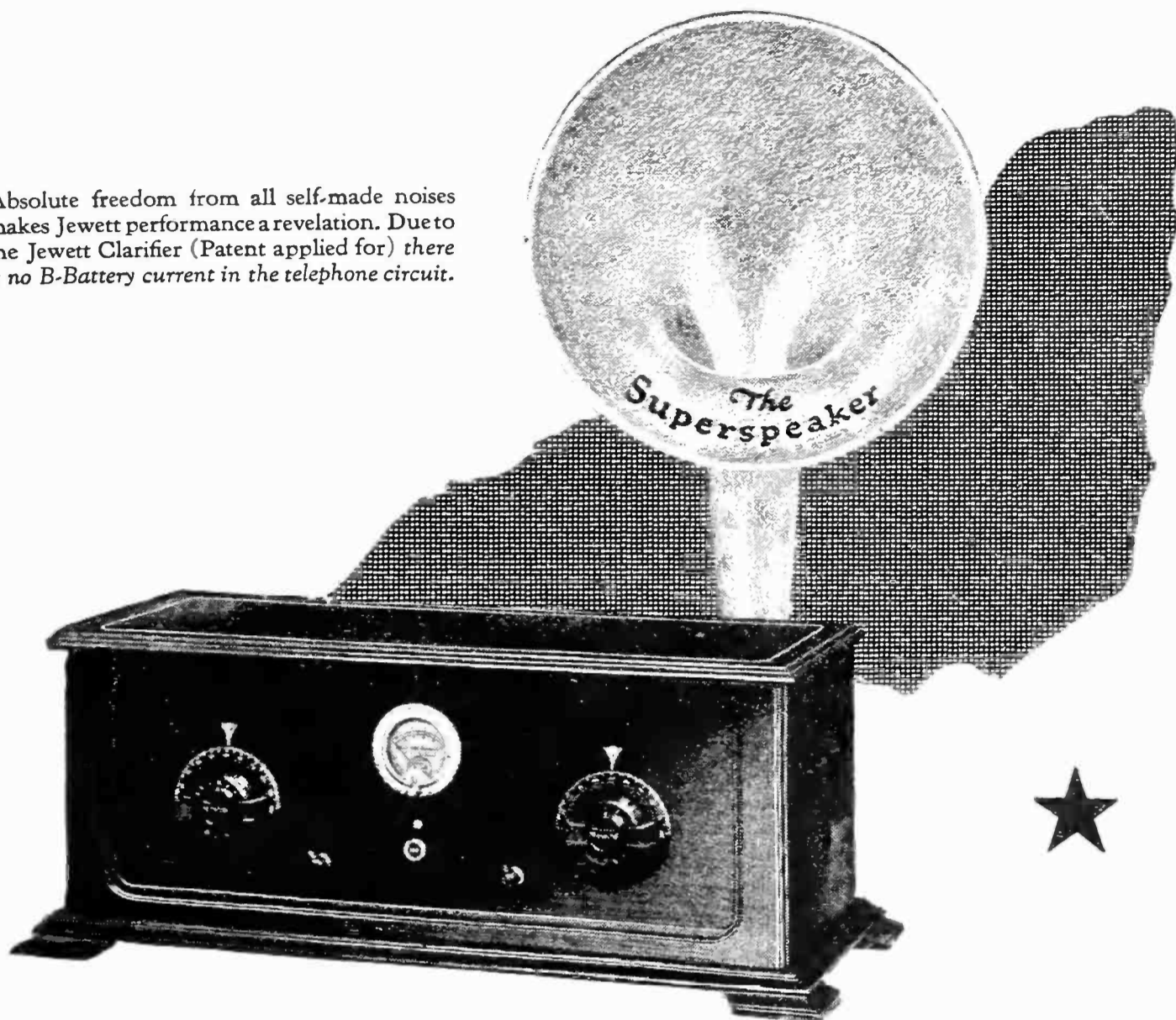

**P**ROCEEDING, step by step, along the path of deliberate and consistent progress, the Jewett Radio & Phonograph Company now offers a Receiver reflecting, in its every detail, that originality and close approach to perfection which you have so thoroughly enjoyed in the Jewett Superspeaker.

Deliveries are being made to pre-arranged schedule. Distribution is through wholesalers and retailers who are under direct contract, with full territorial protection.

**JEWETT RADIO & PHONOGRAPH COMPANY**

5672 Telegraph Road

Pontiac, Michigan

**JEWETT**

★ Tested and approved by RADIO BROADCAST ★

# CLARITY

THE OBEDIENT SLAVE TO YOUR DESIRES

FROM the mellow depth to the highest pitch of harmony—the improved APEX Receiving Sets bring in, with startling clarity and naturalness, all of the delicate gradations of the entire range of sound—whether the highest soprano or the deepest of bassos profundo.

The charm of naturalness, combined with greater distance getting ability, positive selectivity and full volume, plus the enchanting elegance of design and finish, present radio receiving sets that are most satisfactory in every element of operation and a real delight to all whose choice of home furnishings is guided by true appreciation of artistic and refined beauty.

Only a dependable merchant is given the APEX dealer franchise. *Your* APEX dealer will gladly make personal demonstration of APEX Quality Radio Apparatus.

**APEX ELECTRIC MFG. CO.**  
1410 W. 59th St. Dept. 1004  
Chicago

Also makers of the famous APEX Vernier Dials and APEX Rheostat Dials, which are sold by every good dealer in Radio.

*Upon request, we will gladly mail you descriptive folder.*



**Apex Utility Radio Table**  
Price \$75

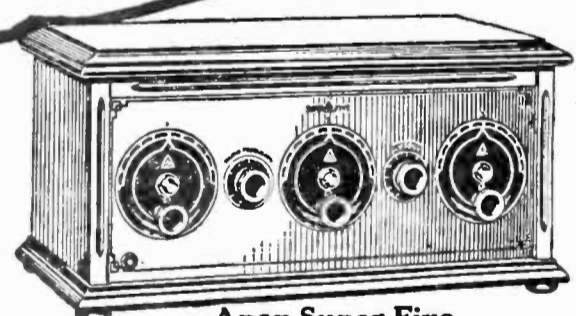

**Apex Super Five**  
Price \$95  
without accessories

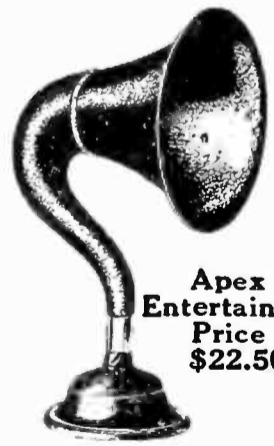

**Apex Entertainer**  
Price \$22.50

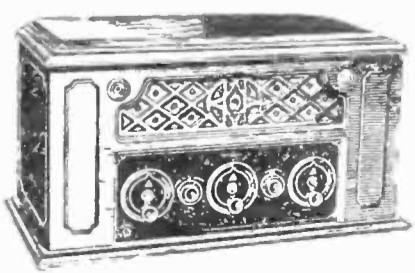

**Apex De Luxe**  
Price \$135



**Apex Baby Grand Console**  
Price \$225

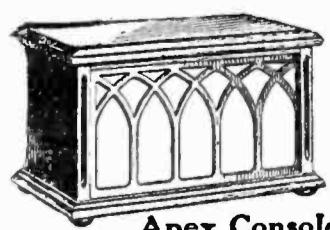

**Apex Console Entertainer**  
Price \$27.50

Prices West of Rockies slightly higher.  
Canadian prices approximately 40% higher.

★ Tested and approved by RADIO BROADCAST ★

# Quality Sells Them - Not Price!



## BRIGHTSON TRUE BLUE RADIO TUBES

**T**O those who hold quality above price in making a purchase True Blue Radio Tubes tell a story of values which continue to mark them **The Finest Radio Tube in the World.** Evidence of their value is given in their remarkably rapid increase in sales to thousands of radio fans, amateurs and engineers whose friends use and recommend True Blue Tubes.

### *Exclusive Qualities of True Blue Tubes*

1. Every True Blue Tube is like every other True Blue Tube — there is no need of switching tubes to get best results.
2. All True Blue Tubes are

- non-microphonic; they operate noiselessly without shock absorbers.
3. Special Filament gives True Blue Tubes two to three times longer filament life.
4. All True Blue Tubes have silver contacts. There are no corrosion losses.
5. Every tube is handsomely safety cased — singly or in sets.

True Blue Tubes are sold with a 60 day written guarantee against defects. Users can return them in 10 days if unsatisfactory. True Blue Tubes are 6 volt  $\frac{1}{4}$  ampere storage battery tubes, made with standard base and small base. Ask your dealer to show them to you.

**BRIGHTSON**  
Waldorf Astoria Hotel

**THE FINEST RADIO TUBE**



**LABORATORIES, Inc.**  
16 W. 34th Street, New York

**IN THE WORLD**

★ Tested and approved by RADIO BROADCAST ★

# BRANSTON RADIO

## The Latest Achievement!!

Whether you give your present Tuned R.F. set the advantage of this forward step in radio, or build a new receiver, HETORUS Coils will afford results in keeping with the newest radio developments of 1926.

**HETROLA** tuned radio frequency sets equipped with the new HETORUS (Doughnut) Coils.

**HETROLA V**  
Model  
R-45

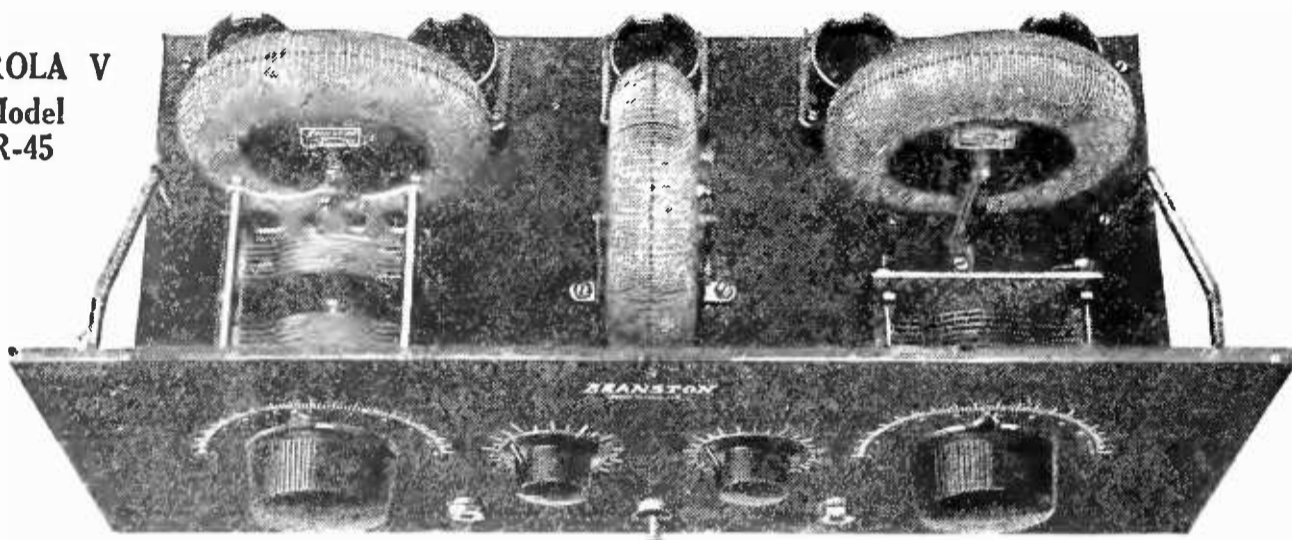

A new and improved type of tuned R.F. transformer with isolated-field coils. Designed to make radio reception a pleasure under all conditions.

### *It Will:*

1. Increase selectivity, affording a new and better means of separating closely allocated stations.
2. Improve tone and volume of distant stations, bringing in a wider choice of programs.
3. Reduce static and other interference to a minimum. Undesired impulses are eliminated.
4. Enable the builder to design a more compact receiver layout, disregarding critical angles, etc.

**HETORUS COIL**

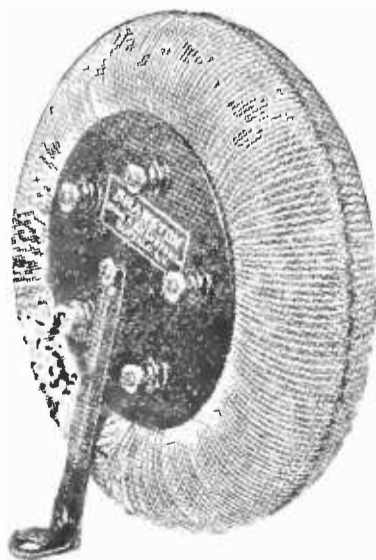

### *Why It Is Better:*

The HETORUS Coil has no pick-up qualities of its own, due to the inherently isolated field. It responds to and amplifies only the signals to which the antenna circuit is tuned. Being fieldless there can be no interaction either between the coils themselves or adjacent apparatus. They can therefore be mounted in any position or angle.

### *Prices:*

- HETROLA V** Model R-45 Completely Wired Kit ..... \$55.00  
 Model R-46 in combination with handsome walnut cabinet ready for tubes and batteries .... 75.00  
 Model R-47 Table Console Type with self-contained loud speaker and battery compartment 120.00  
**HETORUS COILS**—for tuned R.F. receivers  
 Set of three matched coils carefully boxed \$7.50  
 Single coil \$2.50

*Write at once for full information on this outstanding sensation*

## CHAS. A. BRANSTON, Inc.

813 MAIN ST.

BUFFALO, N. Y.





## One Tuning Control— Calibrated in Meters!

**T**HIS, the fondly sought, generally abandoned dream of every radio engineer has, at last, found fulfillment in the Ferguson "Eight," and without a sacrifice of any of the sensitivity, selectivity, tone quality or volume that have, since the pioneer days, been outstanding characteristics of every Ferguson Receiver.

Milady will acclaim the Ferguson "Eight" for its graceful beauty, its unequalled simplicity, its full, crystal-clear reproduction. The man who knows radio will choose it because he appreciates excellence, permanence and dependability in design and craftsmanship.

*Authorized Ferguson Dealers sell Ferguson Receivers. If there is none in your locality, write us.*

**J. B. FERGUSON, Inc.**  
41 East 42nd Street, New York

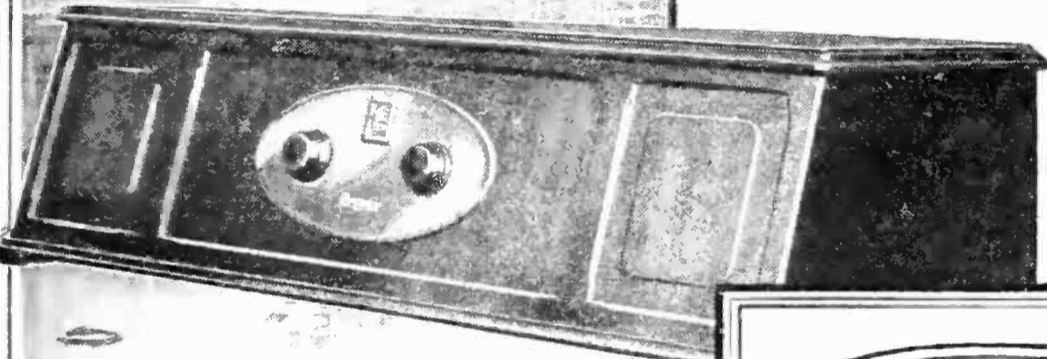

The Ferguson "Eight" is a six-tube tuned radio frequency Receiver.  
Cabinet Model, (Illustrated) . . . \$226  
De Luxe Console Model with built-in Amplion loudspeaker . . . \$348

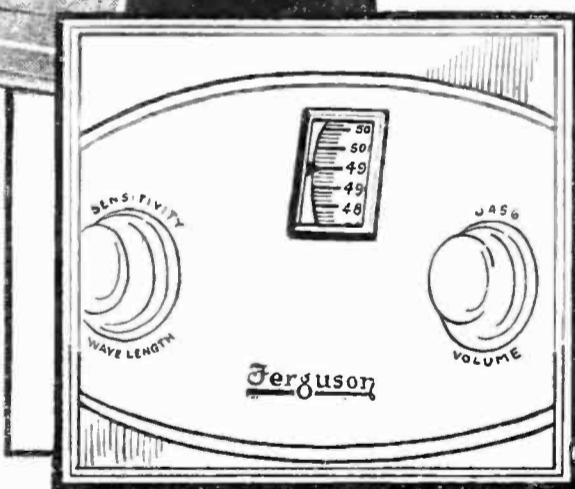

*To operate, simply light the tubes; select your program, noting its wavelenght; set indicator and adjust vernier and volume. Simplicity itself!*



# Ferguson

J. B. INCORPORATED

*The Gold Standard of Radio Receivers*

Brigham

★ Tested and approved by RADIO BROADCAST ★

# ANNOUNCING

the

new

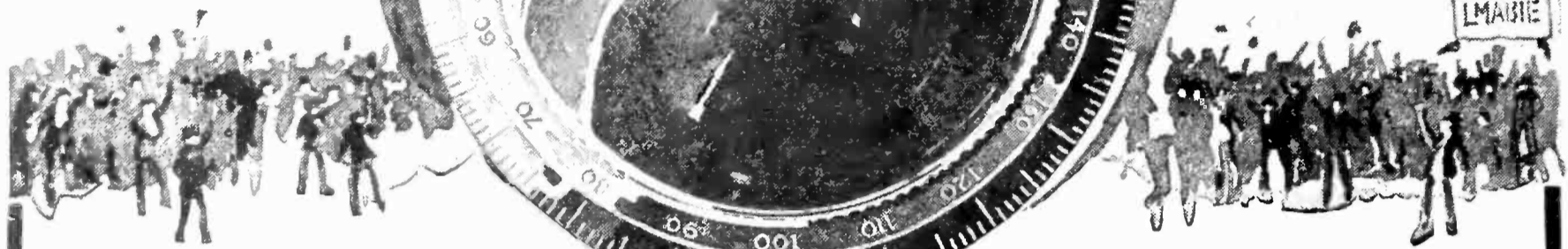

## RATHBUN ★ STRAIGHT LINE FREQUENCY CONVERTER

THE modern radio receiver has abundant tone, volume and power—now it may have *perfect, simplified control.*

The Rathbun Straight Line Frequency Converter is adapted for use on your receiver

—every receiver—without change of equipment—except the condenser dials. Each station is given a distinct reading at a uniform distance from the next. Real logging becomes a fact. The stations are distributed with flawless precision over 360°—one complete revolution of the Dial. There is no limitation or crowding as on controls using only half a dial. Radio control *is* simplified.

The Rathbun Straight Line Frequency Converter provides straight line frequency tuning with ordinary capacity condensers. It is interchangeable with any condenser—on any receiver. It is sold with the guarantee of reliability and satisfaction attached to all Rathbun Radio Apparatus.

**See and Try it - at Your Dealer's**  
*If your dealer cannot supply you, send Money Order (\$3.50 each) and your order will be shipped promptly by Parcel Post prepaid.*

**Rathbun Manufacturing Co. Inc.**  
Jamestown New York

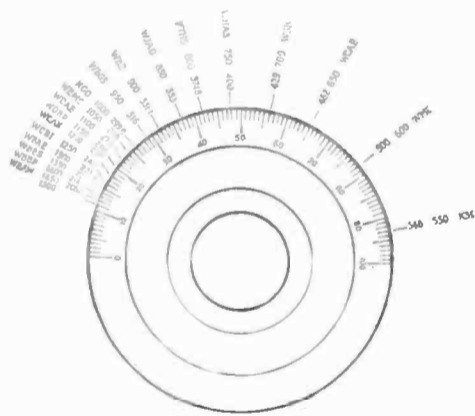

Stations indicated in kilocycles and wavelengths showing crowding with an ordinary capacity condenser.

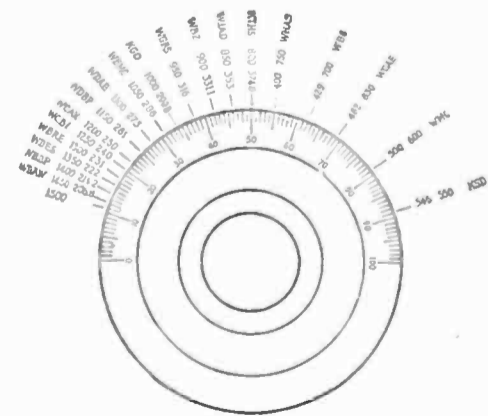

Stations partially separated and tuning slightly improved with a Straight Line Wave Length Condenser.

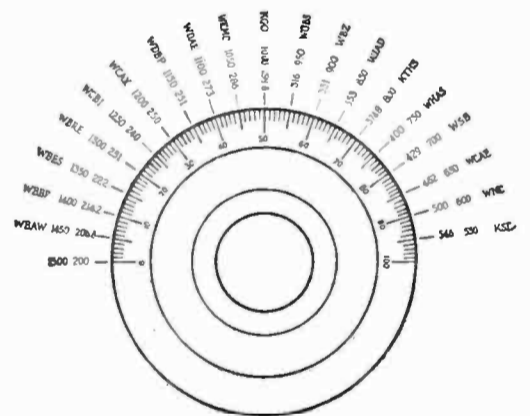

Practically even separation over half the dial with a Straight Line Frequency Condenser.

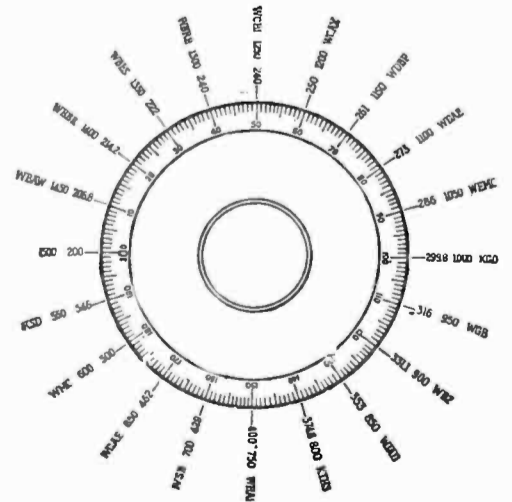

Complete and equal separation of stations over the entire dial with the Rathbun Straight Line Frequency Converter.

★ Tested and approved by RADIO BROADCAST ★

# The latest developments in low-loss parts

*Built of this special insulation  
made to order for radio*



*Ask for Radion Panels  
by name; look for the  
stamp on the panel and  
the name on the en-  
velope.*

**N**OW you can get a *complete line* of low-loss parts made of Radion, the special insulation which our engineers created for radio purposes exclusively.

These parts embody the very latest developments in radio. They are as efficient as the well-known Radion Panels and have the same high-resistant characteristics.

Radion Panels, made in black and Mahogany, come cut in 18 standard sizes for whatever set you wish to build. And in addition, you can have Radion Sockets, Radion Loud Speaker Horn, Radion Tubing, Radion Binding Post Strips, Insulators, etc.

### *New sockets for both new and old tubes*

Of particular interest are the new Radion Sockets. Nos. 4 and 5 are for the new-style UX tubes exclusively. Nos. 2 and 3 are designed to take *both* new and old-style tubes.

All Radion Sockets are highly efficient, due to the principle of their construction and the low-loss characteristics of Radion. Ask your dealer to show them to you.

### *Send for Booklet*

OUR booklet, "Building Your Own Set" gives clear, complete directions for building the most popular circuits. Mailed for 10 cents (stamps). Send the coupon to-day.

**AMERICAN HARD RUBBER COMPANY**  
Dept. C-10, 11 Mercer St. New York City

*Chicago Office:*  
Conway Building

*Pacific Coast Agent:*  
Goodyear Rubber Company  
San Francisco Portland



*This is the Radion No. 2  
Socket, designed for both old  
and new tubes.*

# RADION

*The Supreme Insulation*

AMERICAN HARD RUBBER COMPANY  
Dept C10, 11 Mercer St., New York City

Please send me your booklet, "Building Your Own Set" for which I enclose 10 cents in stamps.

Name \_\_\_\_\_

Address \_\_\_\_\_

\_\_\_\_\_

★ Tested and approved by RADIO BROADCAST ★

*Guaranteed*  
**Airline**  
**RADIO**  
*Sets and Parts*



**MONTGOMERY WARD & CO.**  
Baltimore Chicago Kansas City St. Paul Portland, Ore. Oakland, Calif. Fort Worth

## Ward's New Radio Catalogue Is Yours Free

Yours Free—the newest, most interesting book published on Radio. A book prepared by Radio experts—a complete Radio manual.

52 fully illustrated pages showing what is new in Radio and what has been approved by the best experts.

It shows sets from one tube to five tubes, the new one dial control, parts and supplies, batteries and cabinets. It gives a list of stations, a radio log for recording stations.

### Headquarters for Radio

Ward's is today one of the greatest Radio stores in the world—selling

everything in Radio without the usual Radio Profits. And besides, we sell only the tested and approved equipment—selected and tested by our own experts, who are up to the minute in Radio. Thousands of customers write us of their delight and saving on Ward's Radio sets.

### Our 53 year old Policy

For 53 years we have sold only quality merchandise under a Golden Rule Policy. You can rely absolutely upon the quality of everything shown in this Radio Catalogue.

Write for your free copy of Ward's new Radio Catalogue  
Address Dept. 27-R

ESTABLISHED 1872  
**Montgomery Ward & Co.**

*The Oldest Mail Order House is Today the Most Progressive*

Baltimore Chicago Kansas City St. Paul Portland, Ore. Oakland, Calif. Ft. Worth

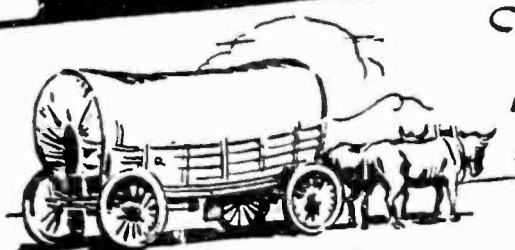

The covered wagon has gone;  
like the old-fashioned charger  
with the slow 2-ampere rate  
it is obsolete!

Buy nothing but an up-to-date 5-ampere charger!

The New Improved  
**5 AMP. A & B  
GOLD SEAL  
HOMCHARGER**  
**\$19.50**



Over 500,000 already in use

★  
**Get This Modern Fast Charger!**

**Better Because:—**

New micrometer adjustment, hinged lid, and carrying handle.

No bulbs to buy or break.

Can be used anywhere—contains no acids or other harmful liquids to spill.

Approved by underwriters—trouble-proof, shock-proof and fireproof.

Beautiful cabinet in maroon and gold.

When you buy a charger don't let anybody sell you an obsolete, slow 2-ampere model.

The New Improved GOLD SEAL HOMCHARGER, with its full 5-ampere rate, charges your battery overnight! Does away with the long bothersome waits that were necessary when the slow inefficient chargers of last year were the best that radio offered.

And the New Improved GOLD SEAL HOMCHARGER charges both A and B batteries without additional equipment.

Be sure when you buy that you get a modern, fast charger, with a 5-ampere rate. To be absolutely sure, insist on the GOLD SEAL HOMCHARGER.

**Free**

Write for new edition of our instructive booklet on radio operation "The Secret of Distance and Volume in Radio"

**The Kodel Radio Corporation**

505 East Pearl Street

Cincinnati, Ohio



Owners of Kodel Broadcasting Station WKRC on the Alms Hotel. Send for program.

★ Tested and approved by RADIO BROADCAST ★

# Greater selectivity, range, power, beauty and simplicity—*at lower cost!*\*

Built like—  
looks like—  
performs  
like a \$200  
set

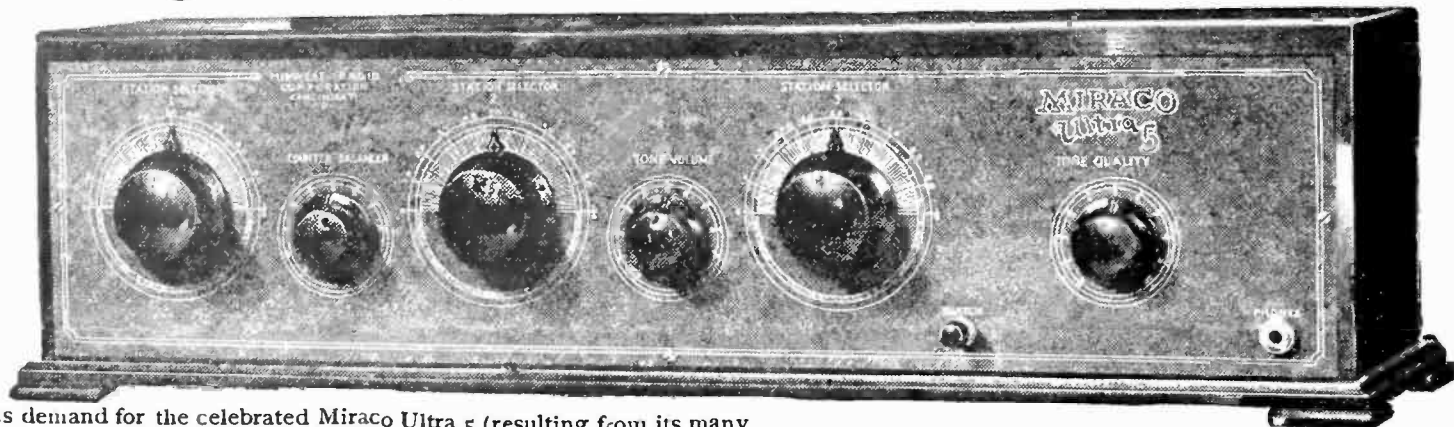

\*NOTICE! Enormous demand for the celebrated Miraco Ultra 5 (resulting from its many enthusiastic users so highly recommending it to their friends) has enabled us to add hosts of costly new features, latest refinements and up-to-the-minute improvements such as you might expect to find only on the newest sets selling at much higher prices. So the Improved New Ultra 5 for 1926 is even a better set—more beautiful set—a more selective and more powerful set—incredible as this may sound!—for less money than ever before.

now only \$59<sup>50</sup> retail

SEND FOR SPECIAL OFFER!

## The Powerful New MIRACO Ultra 5

[FIVE TUBE OUTFIT IN BEAUTIFUL MAHOGANY CASE]

**MIRACO  
RADIO  
GETS 'EM  
COAST to  
COAST**

our files and which we receive daily.

Reports from Ultra-5 users everywhere leave little for us to add. These letters are typical of the many in

**HEARS CALIFORNIA TO EUROPE**

Enclosed is a partial list of the stations I received with the Miraco Ultra-5: KSD WEBH WBAV WEAF WLW WCBW WHB WOR WJAZ WOC WHAS WWJ CKAC KFIX WCK WHAZ KFAB WHAA WASI WCAP WTAS WQJ KFKX WAW WTAM WOAI WSOE WCCO KDKA WBAP WMC CNRO WLS WHJ WBZ WMH KFNF KFI WEEI WWL WFAA WAF WGY CKY WRR WCAE WEO WRC FFDW WJJD WGR WABN WCAL WEB WHN WMAQ WJZ WLS WOAW WOO WOS CFAC Sheffield, (Eng.); Paris (France). Carl H. —, Waukesha, Wisc.

**MONTANA HEARS CALIFORNIA TO IRELAND**

I am more than pleased with the Ultra-5 Receiver. I have 90 stations on my record in 20 days time including KDKA WCAL KFLE WFC WCC WIAM WEAF WEM WGM WCAL WLW CAM CFCF WJJ WAE KAKE KOOW WCCO WOC WCAZ WHO WCCA WOA CFA WOAI WOS WCKF KFPU KBB KPO KFAA WMCR CKY WCCF WMAQ WBAP WGN KJR WHJ WOS WMC WJJ WGAN KKW WGW WLW WOOI WHB WFAI WJAZ KGO WCAF KSAC WTAP KSKI KFKA. On February 16th at 12:15 o'clock I received Ireland—the distance between seven thousand miles. Richard —, Comertown, Montana.

**WEST VIRGINIA HEARS AUSTRALIA**

Got 2-XB Wellington, Australia, plain last night at 12:45 A.M. over the Ultra-5 Miraco you sold me. I am delighted and would not trade for any instrument in town. Geo. B. —, Glen Ferris, West Va.

Mail Coupon Today!

The amazing coast to coast reception (on the loud speaker) and international receiving range of the famous Miraco Ultra-5 in the hands of its multitudes of pleased users—as voluntarily reported by them to us in writing—offers proof of performance which makes claims by us superfluous. Send for plenty of this proof—and our remarkable Special Offer—at once.

Remember that one of America's oldest and most reliable manufacturers of quality sets completely builds, thoroughly tests and factory guarantees each Miraco. That longer experience and immense production make possible such money-saving prices. Bear in mind that this big, beautiful, powerful and clear-toned Miraco Ultra-5 is the latest, improved model. That it has a beautifully gold-etched genuine Formica panel with large Bakelite knobs equipped with gold filled indicators for very fine tuning. That

it is even more selective, more powerful and is capable of getting greater distances due to exclusive use of "Duofomers" (ultra low-loss inductance coils—the newest achievement in radio engineering). "B" battery consumption is minimized and oscillations are controlled on all wave-lengths by a new patented feature, the "Counter-Balancer." Flexibly wired (to prevent broken connections). Has an adjustment for different length aerials, only two rheostats, a cut-out switch, concealed wiring and other features of costliest sets.

Comes in a handsome hand-rubbed mahogany cabinet. An instrument thoroughly tested and approved by radio's highest authorities and one which anyone can easily connect, operate and "log." Works on storage or dry batteries. Literature describes other latest improvements—use coupon.

### Other Miraco Long Distance Sets \$13<sup>75</sup> up retail

Wonderfully improved new models in one-tube and three-tube Miraco Long Distance Sets also ready at lower prices! Powerful new Miraco R-3 at only \$27.35 (retail) operates loud speaker on distant stations.

All Miraco sets work on storage or dry batteries. Approved by Radio's highest authorities. Unmatched values! Let testimony of users convince you. Write for literature and Special Offer—use coupon.

### All the Proof you want is waiting for You!

Reports from their hosts of users in every state prove Miraco sets—at rock-bottom factory prices—outperform sets costing much more money. Send for latest literature, SPECIAL OFFER and plenty of additional testimony from users leaving no doubt that "Miraco Radio Gets 'em Coast to Coast." SEND COUPON FOR SPECIAL OFFER!

**Dealers! Jobbers!**

Write for the new Miraco proposition.

**Agents!**

The wonderful tone, volume and distance-getting ability of Miraco Sets makes them easy to sell. Send coupon for proposition: good territory open.

Send coupon for free bulletins! or order direct from this ad

**MIDWEST RADIO CORPORATION**  
Pioneer Builders of Sets 604 E. Eighth St., Cincinnati, O.  
Send free literature, SPECIAL OFFER and all particulars regarding Miraco Sets. ( ) Dealer ( ) Agent ( ) User

NAME.....  
ADDRESS.....  
.....

★ Tested and approved by RADIO BROADCAST ★

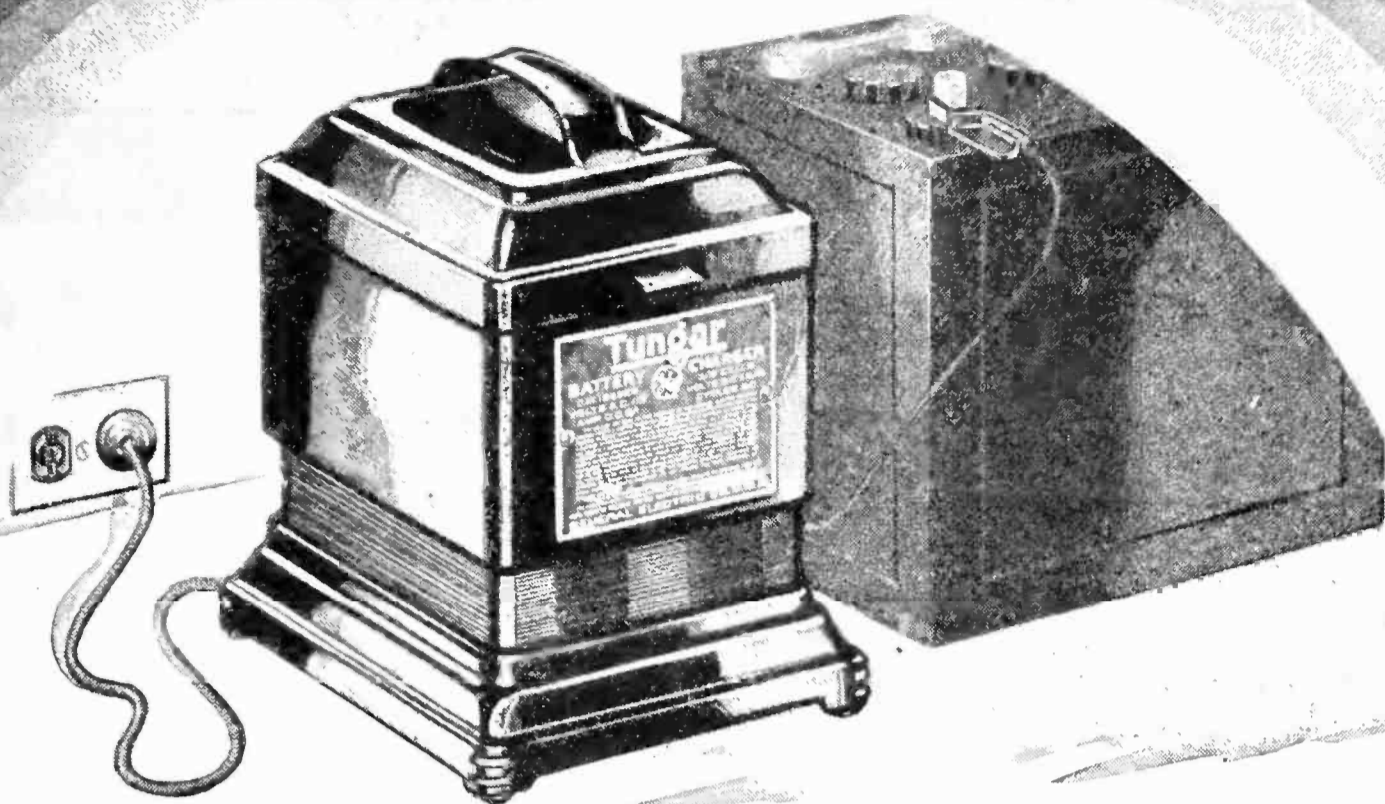

# Partners for Power

If you want distance and clear tone from your radio set, your storage battery must have its partner—the Tungar Battery Charger.

Two clips and a plug to connect to the house current. That's all there is to it. Or you can make permanent connection and *just throw a switch*.

The Tungar charges while you sleep—it makes no disturbing noise—keeps your batteries at top notch. For power there is nothing like a good storage battery—with a tungar to keep it good.



The Tungar is a G-E product developed in the great research Laboratories of General Electric.

The new Tungar charges 2, 4, 6 volt "A" batteries, 24 to 96 volt "B" batteries; in series; and auto batteries, too. No extra attachments needed.

Two ampere size (East of the Rockies) . \$18.00

60 cycles—110 volts

# Tungar

REG. U.S. PAT. OFF.

## BATTERY CHARGER



*Tungar—a registered trademark—is found only on the genuine. Look for it on the name plate.*

Merchandise Division

General Electric Company, Bridgeport, Conn.

# GENERAL ELECTRIC

# Perfect Simplicity!

# NO-DIAL

(Patented)

## 5-Tube Receiver using storage or dry batteries

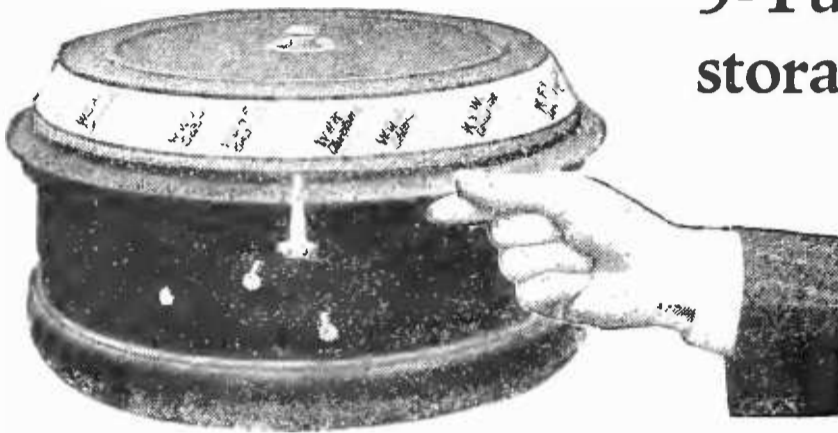

Licensed under Blackmore Patents and Patents Pending.  
Hogan Patent No. 1014002.

A touch of the finger brings 'em in! Think of a receiver *without dials*—so simple that any child can operate it; so sturdy that he cannot break it! That's NO-DIAL, the newest thing in radio.

## Features You Have Waited For!

**Utmost Simplicity** without sacrifice has been attained by NO-DIAL engineers through the most careful correlation of all parts. Adjustments which the listener himself, in ordinary sets, must make are in NO-DIAL completed at the factory.

**Better tuning** is made possible because the condensers are permanently kept in step. Rotating the cover brings in station after station loud and clear, far and near. The entire edge of the cover is your permanent visible Station Register. Stations always come in at the same places where you locate and mark them.

### OUR GUARANTEE

We guarantee NO-DIAL Receivers against defects in workmanship or material, and will promptly replace any receiver which in our judgment is defective, or refund the purchase price.

**THE OHIO STAMPING &  
ENGINEERING CO.**  
DAYTON, OHIO  
U. S. A.

**Sensitivity of NO-DIAL** is equal to that of higher-priced receivers. In many tests it has received stations from coast-to-coast with loud speaker volume and fine tonal quality. Tube for tube, it recognizes no superior. NO-DIAL does not re-radiate.

**Cabinets of NO-DIAL** Receivers are of spun aluminum, finished in mahogany brown crystalline, matching the most beautiful loud speakers and harmonizing with distinctive furniture in any home.

**Circuit of the five-tube NO-DIAL** is the latest and newest radio hook-up, a most remarkably efficient combination of tuned radio frequency and resistance coupling.

*Use this coupon for detailed information*

The Ohio Stamping & Engineering Company  
Dayton, Ohio, Dept. RB-10

I am a (distributor).....(dealer).....(agent).....  
(user).....without any obligation on my part, send  
me full details of NO-DIAL Receivers.

Name.....

St. and No.....

City..... State.....

★ Tested and approved by RADIO BROADCAST ★



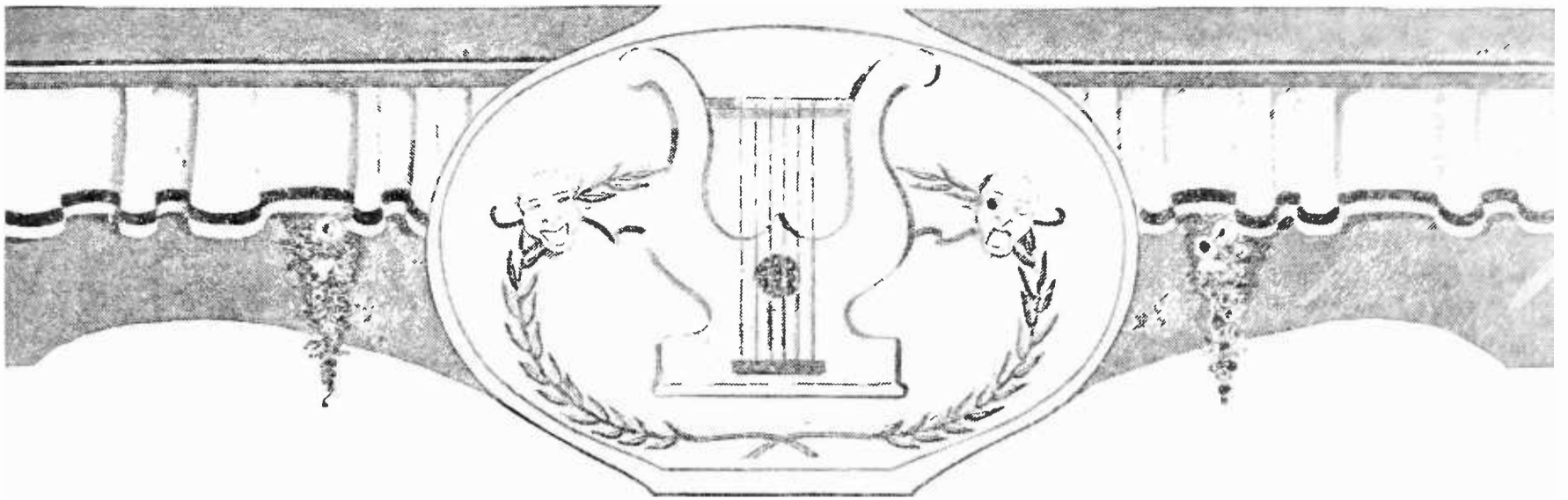

## WITHOUT EXAGGERATION!!

You can buy radio apparatus on the strength of exaggerated statements or you can be guided in your purchase by the reputation of the manufacturer and the actual performance of the article itself.

The Holtzer-Cabot Electric Co., has just celebrated its fiftieth anniversary. A half century spent in building a reputation for quality electrical products equalled by few and surpassed by none. The experience gained through this period has enabled us to produce a remarkable loud speaker about which we could say much without exaggeration.

We prefer, however, to let the instrument speak for itself, knowing that its performance will convince you of its merits. Before you buy a loud speaker at any price, ask your dealer to demonstrate the Holtzer-Cabot, National.

**National  
Loud Speaker**  
\$12.00  
*Adjustable Control*



**1875-1925**  
For  
**FIFTY YEARS**  
*manufacturers*  
of  
*Quality*  
*Electrical*  
*Apparatus*



The  
**HOLTZER-CABOT  
ELECTRIC CO.**  
125 Amory St.,  
Boston, Mass.

# Holtzer-Cabot

★ Tested and approved by RADIO BROADCAST ★

# Radio Broadcast

WILLIS K. WING  
ASSOCIATE EDITOR

ARTHUR H. LYNCH  
EDITOR

JOHN B. BRENNAN  
TECHNICAL EDITOR

OCTOBER, 1925

COVER - - - - -	<i>From a Painting by Henry J. Peck</i>	
THE ROUTE OF THE MACMILLAN ARCTIC EXPEDITION - -	<i>Frontispiece</i>	718
AND NOW—THE RADIO LIGHTHOUSE - - - - -	<i>James C. Young</i>	719
NEW DEVELOPMENTS AND EXPERIMENTS WITH RECEIVERS -	<i>Keith Henney</i>	725
THE MARCH OF RADIO - - - - -	<i>J. H. Morecroft</i>	732
GUIDING THE GOOD SHIP RADIO - - - - -	<i>Dwight K. Tripp</i>	743
<i>An interview with W. D. Terrell</i>		
SOME REMARKS ON AUDIO AMPLIFICATION - - - - -	<i>George C. Crom, Jr.</i>	745
THE LISTENERS' POINT OF VIEW - - - - -	<i>Kingsley Welles</i>	751
IN WHICH SOME DISCREPANCIES ARE CLEARED UP - - - - -		759
AS THE BROADCASTER SEES IT - - - - -	<i>Carl Dreber</i>	761
NOTES ON CHEMICAL PLATE SUPPLY UNITS - - - - -	<i>James Millen</i>	774
SINGLE-CONTROL FOR YOUR PRESENT RECEIVER - -	<i>Allan T. Hanscom</i>	781
THE NEW SIZE OF "RADIO BROADCAST" FOR NOVEMBER - - - - -		787
HIGH RADIO ADVENTURE ON SHORT WAVES - - - - -	<i>Keith Henney</i>	789
FOR THE RADIO BEGINNER - - - - -	<i>Zeh Bouck</i>	795
The Construction of a Simple Audio-Frequency Amplifier		
Describing the Action of the Vacuum Tube		
References to Standard Text Books		
Ionization, Filament, Plate, Tungar Bulb, Plate Current, Space Current, A Battery, B Battery and Rheostat Defined.		
HOW TO JUDGE RADIO TUBES - - - - -	<i>The Laboratory Staff</i>	802
"NOW, I HAVE FOUND" - - - - -		807
A Lead-in Kink		
A Self-Supporting "D" Coil		
A Tube Life-Saver		
Removing Insulation from Wire		
THE GRID - - - - -		809
What Care Does a Receiver Ordinarily Require		
Using the Beers' Charger for Storage B Batteries		
Adding Resistance-Coupled Amplification to the Roberts Set		
The Inclusion of Regeneration in the Neutrodyne Circuit		
W. E. Transformers for the Roberts Circuit		
A Table of Screw Sizes, Drill Gauges and Tap Sizes		

Copyright, 1925, in the United States, Newfoundland, Great Britain, Canada, and other countries by Doubleday, Page & Co.  
All rights reserved. TERMS: \$4.00 a year; single copies 35 cents.

F. N. DOUBLEDAY, *President*  
ARTHUR W. PAGE, *Vice-President*

NELSON DOUBLEDAY, *Vice-President*  
RUSSELL DOUBLEDAY, *Secretary*

S. A. EVERITT, *Treasurer*  
JOHN J. HESSIAN, *Ass't. Treasurer*

<p><i>Doubleday, Page &amp; Co.</i> MAGAZINES</p> <p>WORLD'S WORK COUNTRY LIFE GARDEN MAGAZINE &amp; HOME BUILDER RADIO BROADCAST SHORT STORIES EDUCATIONAL REVIEW LE PETIT JOURNAL EL ECO THE FRONTIER</p>	<p><i>Doubleday, Page &amp; Co.</i> BOOK SHOPS</p> <p>NEW YORK: LORD &amp; TAYLOR BOOK SHOP PENNSYLVANIA TERMINAL (TWO SHOPS) 38 WALL ST. GRAND CENTRAL TERMINAL ST. LOUIS: 223 NORTH 8TH STREET 4914 MARYLAND AVENUE KANSAS CITY: 920 GRAND AVENUE 206 WEST 47TH STREET TOLEDO: LASALLE &amp; KOCH CLEVELAND: HIGBEE CO. SPRINGFIELD, MASS.: MEEKINS, PACKARD &amp; WHEAT</p>	<p><i>Doubleday, Page &amp; Co.</i> OFFICES</p> <p>GARDEN CITY, NEW YORK NEW YORK: 120 WEST 32ND STREET BOSTON: PARK SQUARE BUILDING CHICAGO: PEOPLES GAS BUILDING SANTA BARBARA, CALIFORNIA LONDON: WM. HEINEMANN, LTD. TORONTO: OXFORD UNIVERSITY PRESS</p>
---	--	---

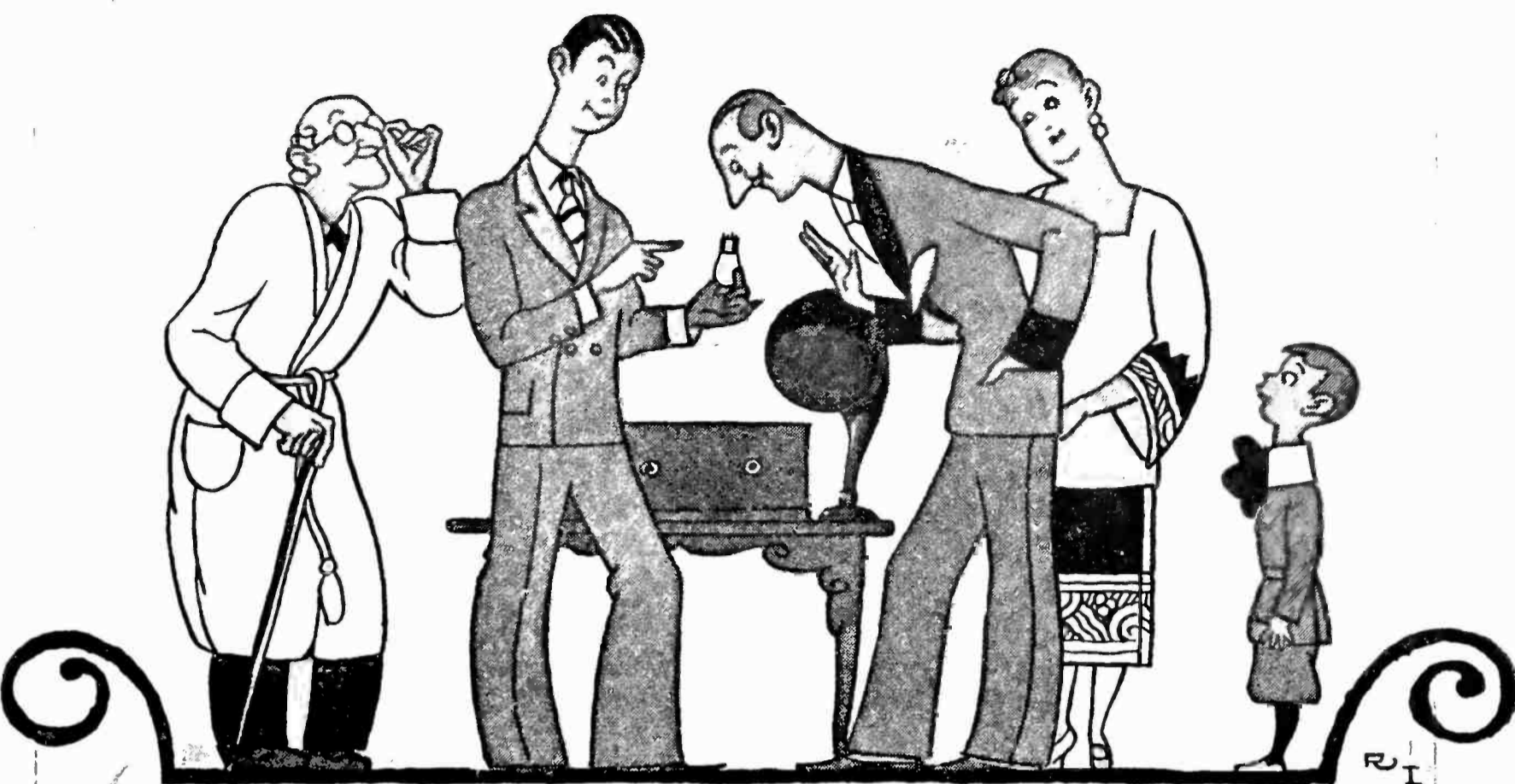

It's a *genuine* UV-201-A  
 only when it bears  
 the name Radiotron  
*and* the RCA mark



WD-11, WD-12, UV-199, UV-200, and UV-201-A are the type names of Radiotrons. They belong to Radiotrons only. To be sure you are buying the genuine, look for the name Radiotron and the RCA mark on the base. Then you are sure of quality.

Radio Corporation of America

Chicago

New York

San Francisco



**Radiotron**

REG. U.S. :PAT. OFF.

AN RCA PRODUCT

★ Tested and approved by RADIO BROADCAST ★

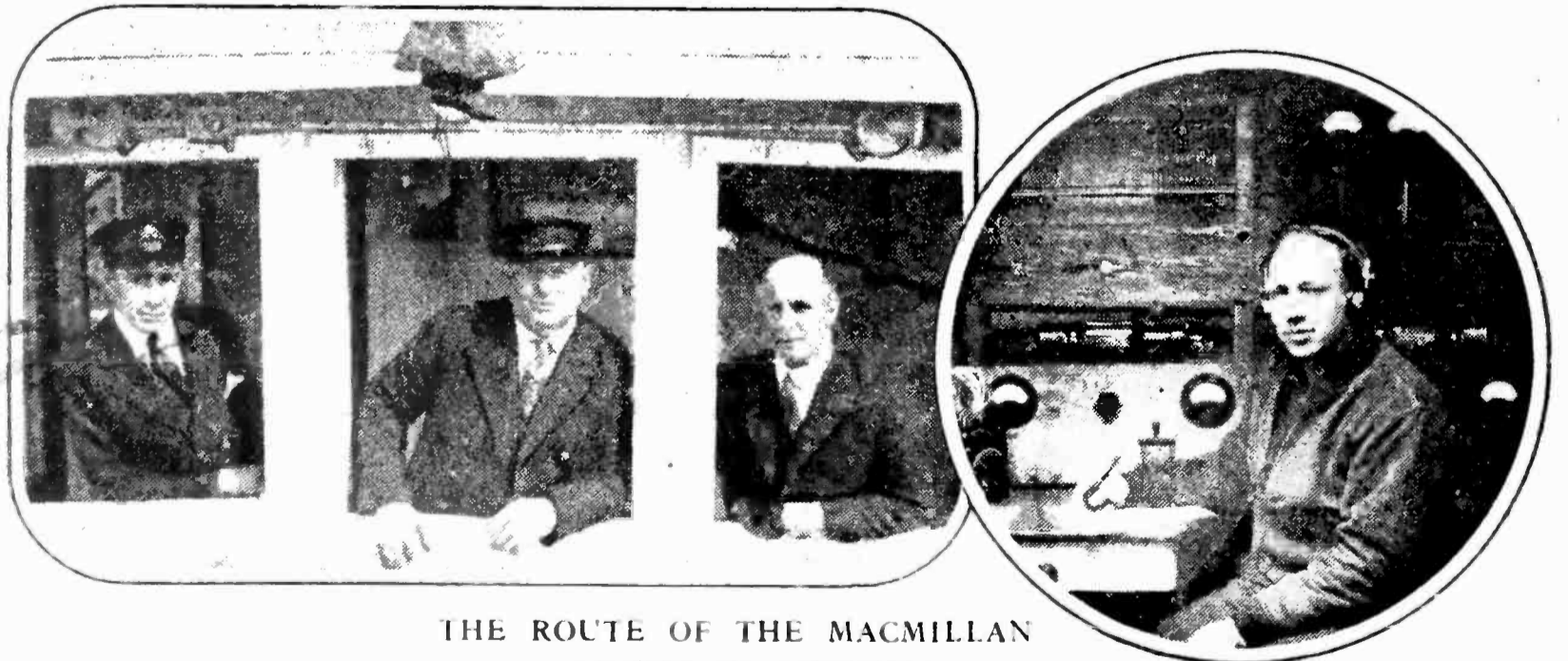

THE ROUTE OF THE MACMILLAN ARCTIC EXPEDITION

At present in Arctic waters. The map shows the route of the two ships, the *Peary* and the *Bowdoin*. The cut at the upper left shows the command of the expedition in the pilot house of the *Peary*. At the left is Lieut. Commander E. F. McDonald, Jr. (U. S. N. R. F.), in command of the *Peary*, next is Captain George Steele of the *Peary*, and at the right is Commander Donald Macmillan, in charge of the expedition. The insert at the right shows John L. Reinartz, radio operator in his cabin aboard the *Bowdoin*. Radio communication with the 40- and 20-meter transmitters aboard both ships has been established with amateur operators in the United States, Canada, and England from the Greenland base. Short waves are used because they are less subject to attenuation in daylight. The expedition during its entire time in northern latitudes will be in constant daylight. 2 CY, the short wave station maintained by RADIO BROADCAST has been in communication with the *Peary*, WAP, using a wavelength of 40 meters at her Etah, Greenland base

SEP 25 '25

© 18668025

# RADIO BROADCAST

Vol. 7 No. 6



October, 1925

## And Now—The Radio Lighthouse

The Navy and the Lighthouse Service Have Joined Hands to Make Going Down to the Sea in Ships Increasingly Safer—How Ships Make Port, Guided by Invisible Radio Stations

BY JAMES C. YOUNG

**I**N ALL the drama of radio, nothing equals that stirring call for help which sometimes comes from the sea. Since the first sos flashed word of peril afloat, the imagination of mankind has responded. Many a follower of the nightly programs, seated quietly at home beside his own comfortable hearth, has heard this sudden, vivid call, when the voice of every station is hushed as a tense audience awaits word of what goes on upon the far reaches of the deep. Surely no other experience quite compares with this waiting for the next message from a stricken ship, the message that may report her sinking with all hands, or convey the cheering news that another ship is standing by.

Radio has developed rapidly, and now hardly a passenger vessel re-

mains on the high seas without its protection. From the moment that a ship leaves Europe until she ties up at her pier in New York, the

long arm of radio guards the passengers aboard. Throughout the voyage it makes possible accurate reports on weather conditions, the movement of icebergs and ships, and any chance developments that fortune may bring.

In the open sea there is relatively little danger to a ship, unless she encounters weather of the worst sort, but on approaching the coast her safety diminishes. There are other ships on all sides, reefs ahead, and a thousand possibilities bound up in fog and storm. This is the point where the lighthouse service of the United States takes charge of the ship's destiny.

This service, estab-

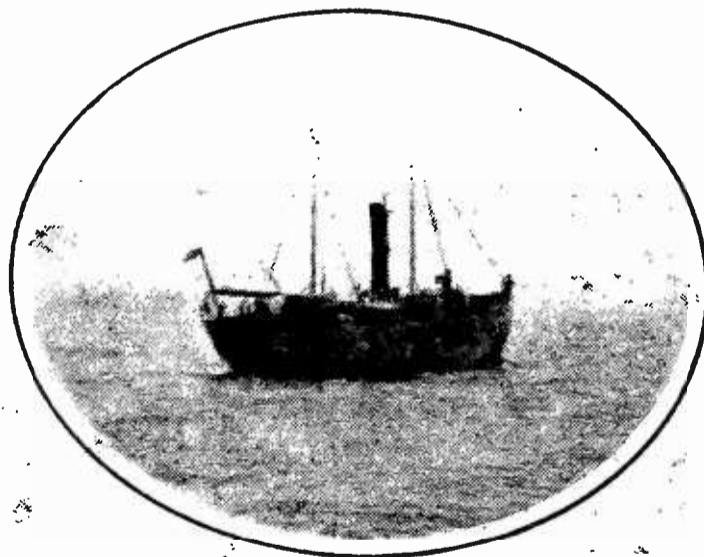

AMBROSE CHANNEL LIGHTSHIP

Stationed outside New York harbor. Within the past year, radio equipment has been added to the other devices aboard this ship, which mark another step in the constant march of progress in making life safer at sea. The light at the masthead, the outside and the submarine bells, and the radio, all do their share to make the task of the navigator an easy one. During thick weather, day and night, a radio transmitter aboard this vessel sends out radio beacon signals on 299 kc. (1000 meters). The Government has installed similar transmitters on many important lightships on the Atlantic and Pacific coasts and on the Great Lakes



ROBERT GRAEME

Radio operator aboard the *Ambrose*. The radio equipment of this important light vessel serves probably a greater number of ships, totalling a larger tonnage, than similar equipment near any port in the world

lished in Colonial times, is the oldest branch of the Federal Government, antedating even the army and navy. And no government service has a finer record of brave deeds and high loyalty. During two hundred years of operation it has lighted the way of countless men and ships through dark waters. Boston Light, the oldest in the country, was destroyed by Indians when first built, and the Sandy Hook lighthouse, erected in 1764, was considered a particularly dangerous point. Redskins were all around and they showed small friendliness for lighthouses.

These ancient beacons of the sea have served to guide all kinds of ships. First came the high-prowed English frigates with ornamented forecastles, and brass cannon gleaming in the sun; stately Spanish galleons, prowling down the coast ready to seize any unprotected settlement; and graceful French corvettes, sails billowed in the wind. Then came our clipper ships to hang up records in the seven seas, the fastest things afloat.

The steadfast lights also guided the whaling ships, now almost a lost race of the sea, that brought home wealth in oil and bone for their New England skippers. They pointed the way for slave ships, the scourge of the seas. And who knows but Captain Charles Gibbs, the dread pirate who roamed the Long Island shore, set his compass by the Sandy Hook light?

But gone now are the frigates and the gal-

leons; slave ships and pirates have fled the seas, and in their stead we have ocean liners and submarines. And though the lighthouse service still goes on, time has wrought great changes in it.

A new feature of the service is the lightships, which lie along the coast year in and year out in positions which ships can determine within a few feet. Every ship from Europe lays a direct course for Ambrose Lightship, anchored fifteen miles off the port of New York, and thus acting as the outpost of the harbor.

#### RADIO SIGNPOSTS FOR NAVIGATORS

IF THE weather is bad on nearing the coast the master of an incoming vessel is anxious to know if he is steering a correct course. He may also have doubt about his position at sea. Of course, every ship keeps a daily log of speed and progress, by means of which her navigator can, theoretically, determine his position at any time. But navigators, log books, and theories have a way of working at variance. Therefore, if the weather is thick and the coast not many miles away, the captain will look to the lighthouse service for help. Now, it might seem to any one not versed in nautical matters that the captain should be able to learn with little trouble just where his ship rides through the night and fog. But it is really a complicated problem. The captain will listen by radio for an automatic



CAPTAIN AUGUST LANGE

Of the Lightship *Ambrose*, a familiar "watermark" to all marine travelers in and out of New York harbor. Captain Lange says that broadcast programs do yeoman service in breaking the solitude of months of sea duty

signal sent out from several points off the Atlantic coast. These signals are transmitted as a part of the radio compass service, which joins vessels at sea with the lightships anchored near to shore. In the case of the Ambrose Lightship, her transmitter sends forth an automatic signal which continues for sixty-five seconds and is then silent twenty-five seconds, a sequence maintained as long as the weather continues bad. A similar signal also will be sent out from Fire Island lightship and another from the ship at Five Fathoms, near Cape May, New Jersey.

The captain who is trying to get his bearings has on board a receiving apparatus which makes these signals audible. This apparatus is operated by means of a dial placed in the center of a circle on which appear the 360 numbered degrees of the compass. In order to take the position of the Fire Island lightship the operator on the incoming vessel turns the dial of his radio compass to the point where the Fire Island signal becomes the faintest. If we assume that this point is on the right hand, or landward side of the ship, the master then knows that he has Fire Island at just about the point desired. But this signal alone will not provide him with an accurate bearing. In order definitely to determine his position, he must take what is known as a three-point bearing. And the lighthouse service once more is the means of assistance. Again turning the compass dial,

another point is found where the Ambrose signal sounds the faintest. This should be somewhere directly ahead. Then the operator endeavors to locate the ship at Five Fathoms, once more turning his dial until the automatic signal from that point is fainter than anywhere else on the compass. In a general way the Fire Island signal represents East, the Ambrose signal stands for West and that of Five Fathoms for South. When the three lightships are thus linked with the incoming vessel her captain draws a line on his chart from each one to a point of latitude and longitude where the three lines meet. That point represents the position of his ship. This is a highly scientific and extremely accurate method of navigation, so that the master can be sure he is on the right course, and where his ship speeds through the night.

#### “FINDING” SHIPS AT SEA

**I**N BAD weather the radio compass service would be put into operation without request, but it is also possible for the master of a ship nearing New York—and this is true in many other American ports where the Navy has installed compass stations—to get his bearings in another way, namely, by making use of station NAH. This is the navy plant on Fire Island and has no connection with the lightship at sea. A master using this second method would flash a message of inquiry to NAH (probably the international

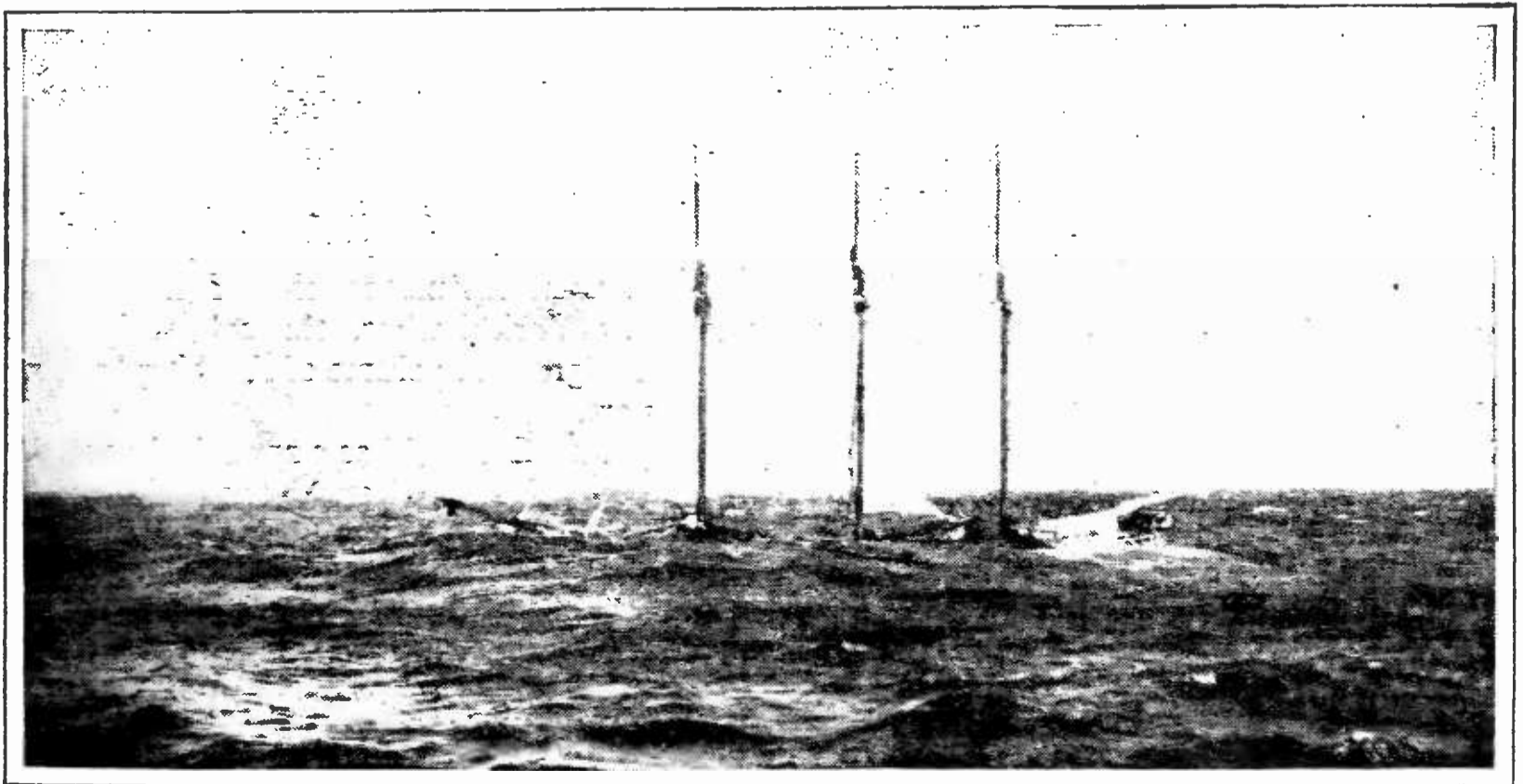

A TYPICAL DERELICT

Awash and abandoned. Government radio services are doing much, through the radio beacons and radio compass service furnished at many important United States ports, to prevent wrecks. In addition, warnings of these menaces to navigation are broadcast to ships through the agency of the Coast Guard. Last year, notice of 75 such partially submerged wrecks was broadcast by radio telegraphy

signal QTE, "What is my bearing?") to which the navy station would answer, QRX "Stand by." Then the radio operator at sea would begin sending a conventional signal, usually the letter "m," repeated many times, followed by his own call. While this message was in the air, NAH would call the lighthouse shore stations at Sandy Hook and Manasquan, New Jersey, by land lines, asking them to take the call of the ship and send back the results. NAH could then figure a three-point bearing for the vessel by a reverse of the process used by the master when determining his bearings by means of the lightship. Once determined, this bearing would be flashed to the vessel and she could lay her course accordingly.

The radio compass represents the greatest advance in navigation since man first invented the compass itself. Before the introduction of this new aid to navigation some few years ago, ships were steered in much the same manner as they had been centuries ago. From the beginning of man's adventure upon the water, he depended in large measure upon the old and honored lead for his enlightenment about shoals and his general position. Within the last century almost every coast in the world has been extensively charted. Each navigator has a map which shows the approximate depth of water along any coast that he may be sailing. By means of the lead line, thrown overboard at frequent intervals, it is possible to keep a check on the progress of the ship and determine whether or not she is getting into dangerous water. But a lead line at night, in a fog or heavy weather is sometimes deceptive and difficult to operate. Yet it was the only indicator approaching reliability that could be used by navigators of large and small steamships alike until the advent of the radio compass made it possible to obtain land bearings even when still at sea or in bad weather. The benefit of this invention to shipping the world around surpasses all estimates. It has brought a new measure of science into the always hazardous enterprise of steering a ship safely into port.

The Ambrose lightship is a dangerous station. Captain August Lange, her master, remembers more than one vessel which loomed up out of the night and fog and almost ran her down. At least one of these troublesome visitors struck the lightship head on, because the man at her wheel was headed directly for the exact spot where the lightship rides at her chain. But such incidents are fortunately not common, owing to various

devices used by the lightship for self-protection. One of these is a submarine bell, dangling over her side, which sends out warnings at intervals. This bell has a deep, ominous tone. Each clang of its brazen tongue resounds underneath the surface of the water and is caught up by means of a receiving instrument on the bow of the approaching ship. Before the coming of the radio compass, the submarine bell was looked upon as a great advance in the science of navigation. Although the bell has a distinct value, it by no means compares with the method of communication from ship to shore.

Another means of warning the advancing vessel is the dependable steam whistle mounted alongside her single stack. In foggy weather this whistle blows loud and long, a mournful, warning blast, that can be heard miles away. The whistle is also regulated automatically and experienced mariners lend sharp ear on approaching the coast for this sturdy friend.

The last defense of the lightship, for her own protection and for that of all who travel the sea, is the two winking lights at her mastheads, burning brightly all the year round. In clear weather they can be seen for miles, the first signal of home that greets the returning sojourner from foreign lands. They have been the object of anxious regard for many an eye long denied the sight of home. Every soldier who went to France looked back to the Ambrose lightship as the goal of his hopes.

Once past this first beacon of the harbor, the navigator will usually turn his ship toward shore and steer for the sea buoy, three miles nearer land. This buoy has a winking gas light of its own, a whistle operated by the motion of the sea, and a submarine bell. From the buoy it is two and a quarter miles to the entrance of Ambrose channel, the highway of New York harbor, through which must pass the greatest volume of shipping known to any port.

Ambrose Channel has a spread of 2000 feet. It takes a nice eye to strike the middle of that channel at night, but many ships pass in and out, under the hand of pilots picked up from the pilot boat at the mouth of the channel. Along both sides of the way a string of buoys keeps guard over the course. Those upon the right are called nuns of the sea because of their red cones, like the headdress of religious women in the Middle Ages. The buoys upon the left are black cans with white lights. The Channel runs at an angle toward the coast of Staten Island and the man at the



wheel is guided by the West Bank Light, with the Staten Island Light further off. These are known as ranges, and by keeping his ship's head directly on the ranges, a pilot reaches the point in the Channel where he must put over his wheel and turn in toward the Narrows. If it is night he drops anchor at Quarantine and waits for the doctors to come aboard the next morning. Some hours later he will carry his charge up the bay, under the glory of the morning sun, to her dock. And thus with the aid of the lighthouse service ships come safely in from the sea.

HOW THE COASTS ARE GUARDED

**A**LTHOUGH this service is the most important and, perhaps, the most dramatic rendered by the men of the lighthouses and their fellows afloat, it by no means comprehends the entire operation of their depart-

ment. The United States has a larger number of lighthouses and a coast better protected by sea buoys than almost any other country. There are also many inland waters, such as the Great Lakes, that require protection.

Throughout the service, a high degree of skill is needed, and the men who follow this trade have the loneliest vocation in the world. They spend twenty-one days on duty in the lighthouse or lightship with nine days shore-leave. On such posts as the Diamond Shoals lightship, off Cape Hatteras, it requires stout hearts to resist melancholy. This ship is anchored about 300 miles from shore and has virtually no communication with the world outside or passing craft. Shore leave from a post like that is a matter of first importance and it is almost the only thing that breaks the monotony of existence. However, during the war, men serving on the Diamond Shoals light-

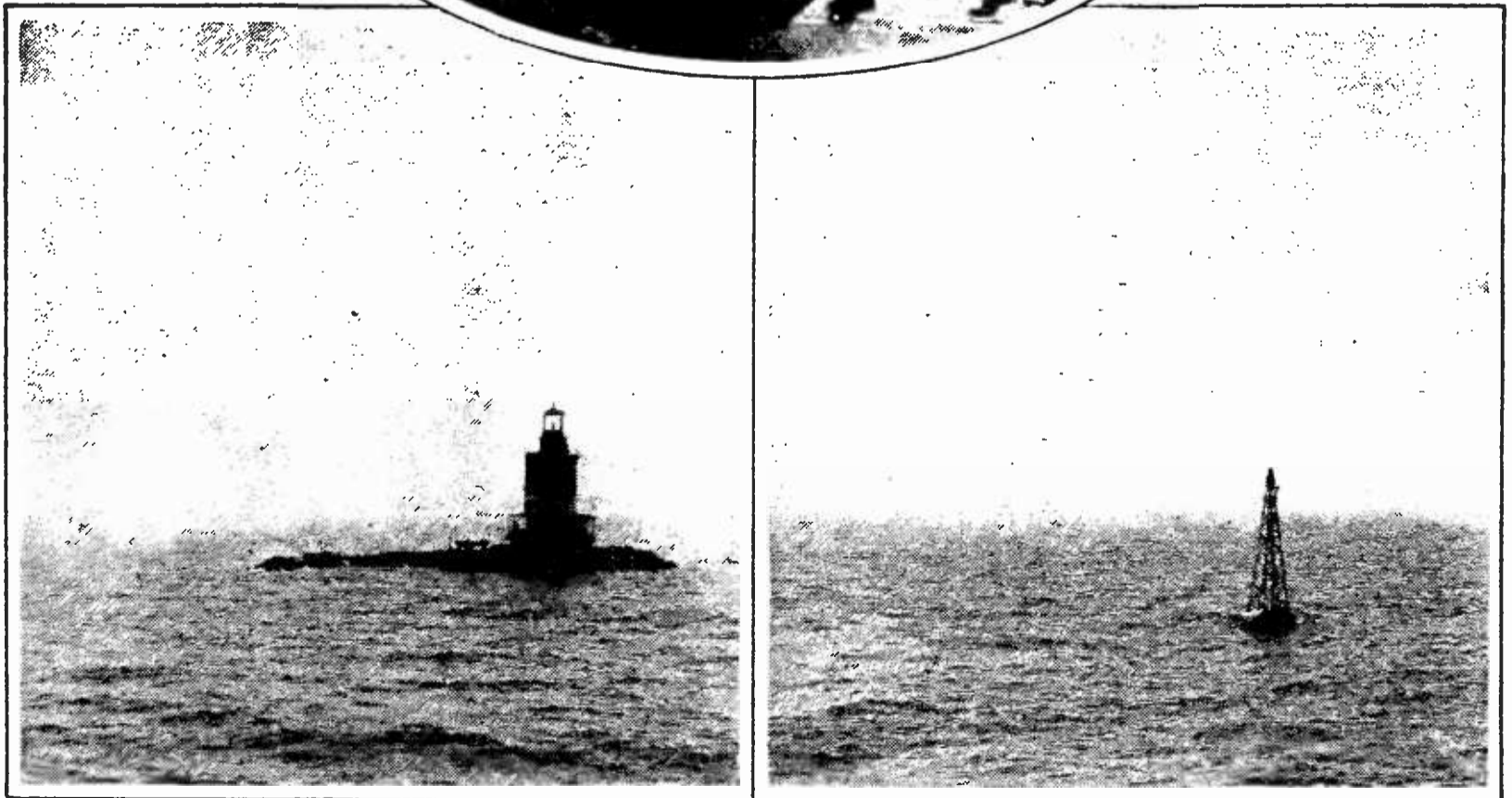
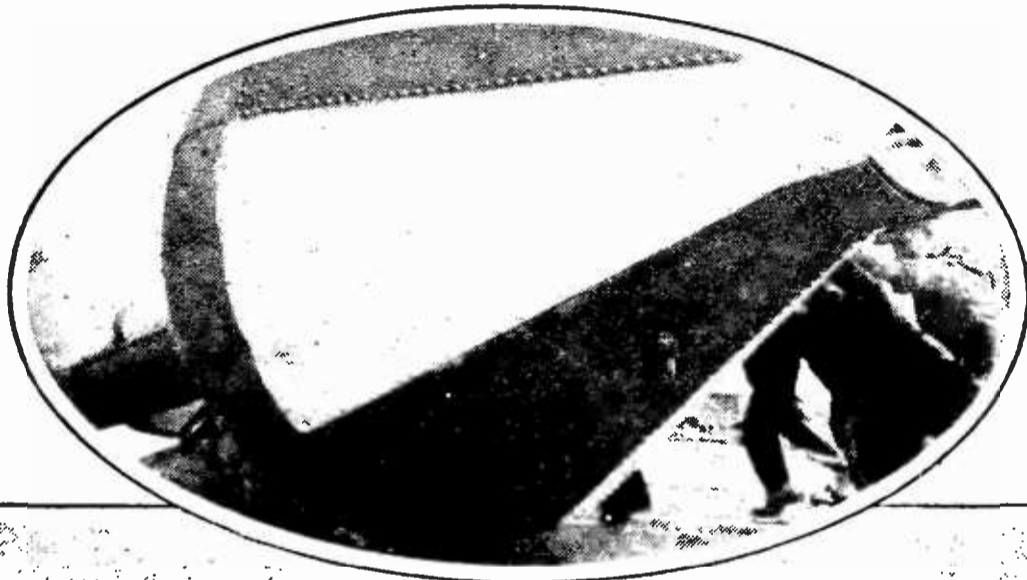

PROTECTION AT SEA

On the left is a lonely beacon of the sea, familiar and important to ship masters. It is interesting to note that radio, which has been turned so successfully to the aid of the navigator, through the sending of radio beacon signals from important marine outposts such as this, has also been applied to the good service of decreasing the loneliness of the crew at these outposts. Broadcast programs bring the life of the outside world to the crews at these stations. At the right the sea buoy at the entrance to Ambrose Channel. Above: dropping a four-ton "toy" buoy at its station

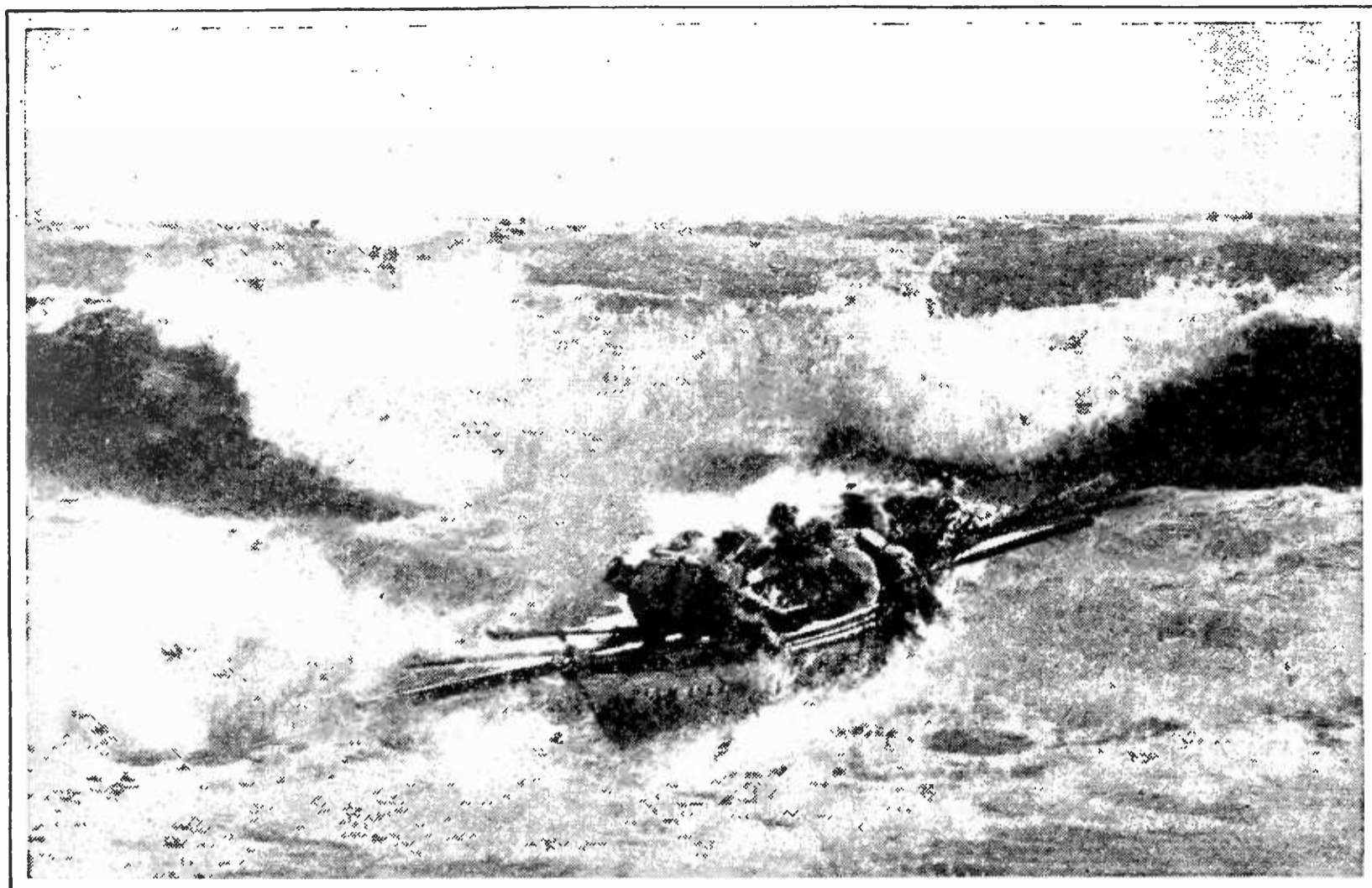

©Charles A. Harbaugh

#### A COAST GUARD SURFBOAT

Bucking a heavy sea to aid a distressed vessel. The dangers of navigation are constantly being lessened through the good offices of radio, now compulsory on most ships

ship had enough excitement to make up for days of dullness, when the ship was sunk by a German submarine. But all hands got safely to shore.

Most radio operators on the lightships have an interesting and often eventful life. They are expert men whose duties require a technical skill and a measure of intelligence of the first order. Robert Graeme, relief operator on the lightship at Fire Island and Ambrose Channel, is only twenty-three years old, but is looked upon as one of the ablest operators in the service. He has had six years of experience with radio operation, having learned his vocation in one of the navy schools, and he has conducted a number of experiments with radio transmission. "It's a great job," he told the writer, "and I get a lot of fun out of it." Mr. Graeme serves a month on each ship and then has a month ashore.

#### RADIO BREAKS SOLITUDE AT SEA

**T**HE Ambrose Lightship is manned by a crew of old sailors, men who served before the mast in the days of the square-riggers when those with the hardest heads lived to be the

oldest. That was long before radio helped to brighten the tedium of voyages around the Horn and through the far seas. But, as Captain Lange said, "The sea was the sea then. We had wooden ships and iron men. Nowadays they are mostly iron ships and wooden men. . . . You know," he continued reminiscently, "when I listen to radio programs I imagine myself ashore at the theater or a concert. And Sunday afternoons at three-thirty there is a program that reminds me of the days when I was a boy and used to sit in the village church, long before I ran away to become a cabin boy and finally an old sailor. But some of us have got to stay out here and keep the lights going. I have been forty-six years out of port and I suppose I would be lost at a land station. The sea is a hard master, but it's not easy to quit the sea once a man has sailed it."

He looked off to port with a wave of his hand over the stretches of heaving water, gray as a tern's wing. Just then the fog settled down and the mournful steam whistle broke into its sad refrain.

# New Developments and Experiments with Receiving Circuits

BY KEITH HENNEY

**I**N this article, Mr. Henney has some interesting things to say about reflexing and discusses the design of a five-tube receiver without the reflex. The analysis of radio and audio amplification, and in especial the recommendation of the use of power tubes in the last audio stage, will be found of great interest. Innumerable radio constructors have built the Roberts set, in the two-, three-, or four-tube layouts, and it is not breaking any confidences to say that the Roberts Knockout receiver is the most popular ever designed for home construction. In April, 1925, Mr. Henney's article, "Progressive Experiment With the Roberts Circuit," told of his experiments in our Laboratory on improvements and alterations in certain individual parts of the set. This entire article is, we think, a distinct contribution to the best current thought on radio design. The author is interested in hearing from readers who follow his recommendations, or who feel they have made helpful discoveries during the course of their work.—THE EDITOR

**F**OR the dyed-in-the-wool experimenter, there are few radio circuits that offer him more possibilities than the type of which the RADIO BROADCAST Knockout is a well known example. Here is a radio-frequency amplifier, a regenerative detector, a reflex, and an audio amplifier. Each of these component parts needs development, and offers fields of experiment for those so inclined.

In the April RADIO BROADCAST, a number of experiments were cited which were designed to improve the selectivity of the receiver as well as several features upon which the home constructor might work. Letters from readers

have suggested other experiments, and the present article deals with what is going on in the Laboratory on this famous circuit and suggests other arrangements of apparatus upon which readers can experiment.

The business of making coils for this receiver has occupied the attention of many, and judging from the questions that have arisen on this point, it is a fertile field of work. Contrary to general opinion, there is no reason why the old fashioned solenoid coil cannot be used in this circuit. In fact it is quite probable that if the coils are well made, with a thought toward "low-loss", better over-all results will be

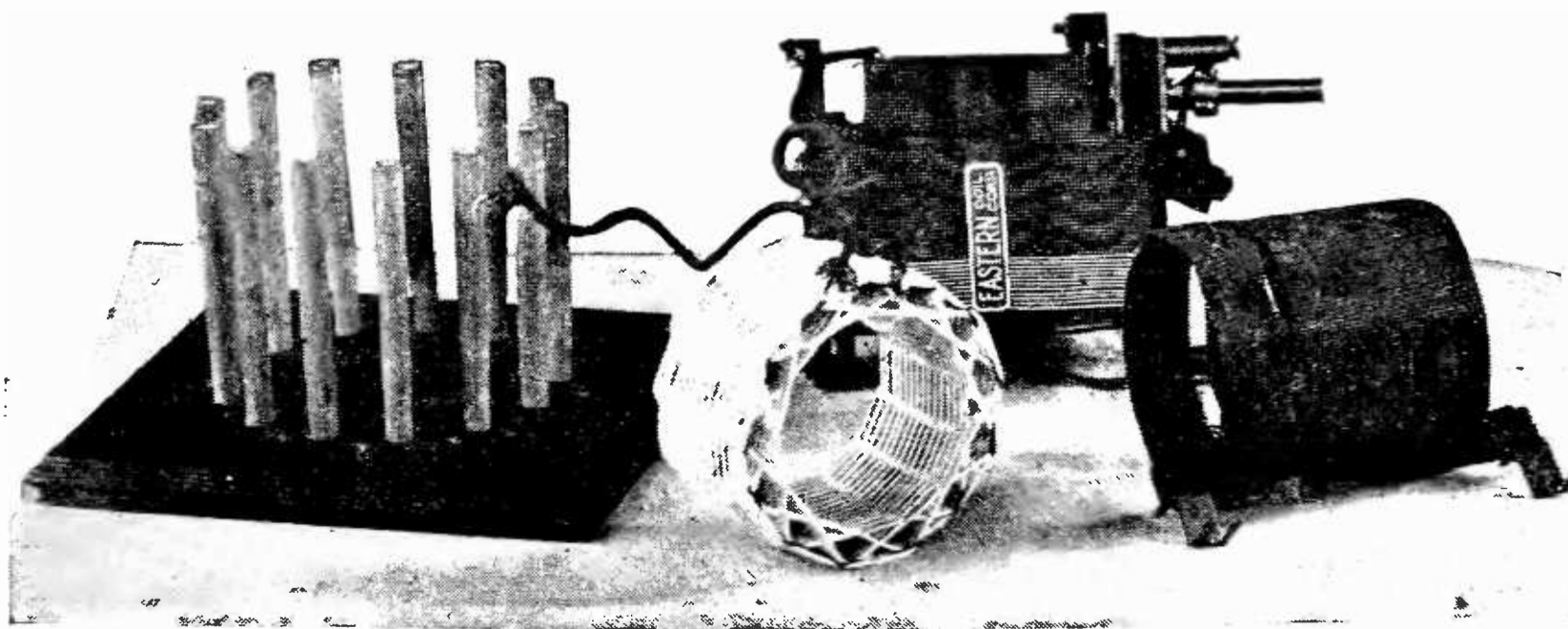

FIG. 1

Two types of coils that may be used in the Knockout receivers. The solenoid coils are wound on a form and the winding bound with passe-partout. The basket-weave coil form has an uneven number of pegs—and the more pegs the nearer the coil approaches a solenoid. The number of turns is four times the number that can be counted on a side. The coil illustrated has 64 turns and the mean diameter is three inches

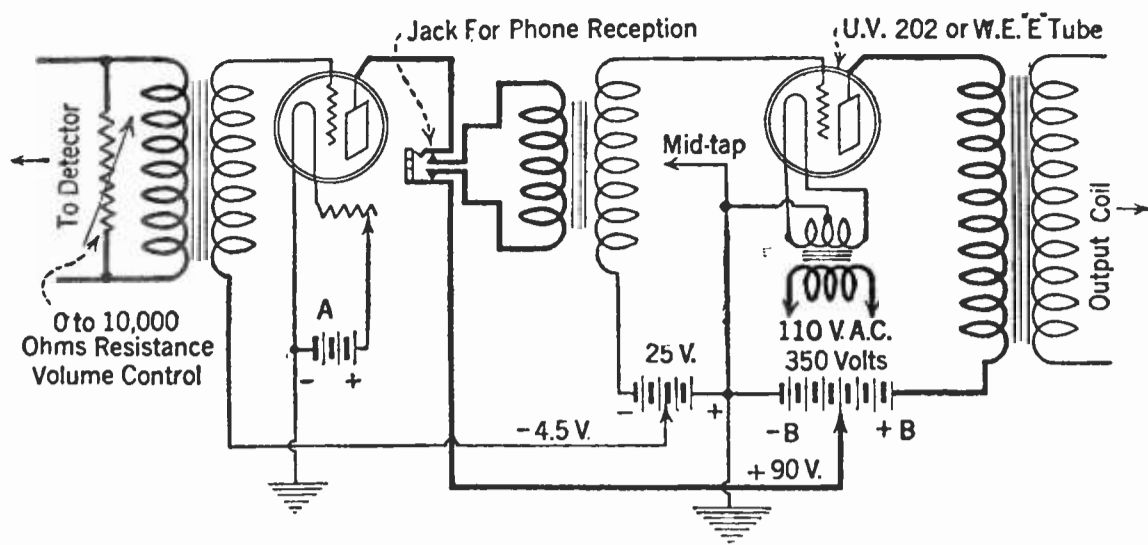

FIG. 2

A power amplifier to be added to a radio-frequency amplifier and a detector. The last tube is one that will handle at least 300 volts on the plate, and whose filament may be operated by alternating current by means of a step-down transformer. The quality of music transmitted by such an amplifier is a function of the transformers only since high enough C battery voltage may be applied to prevent overloading. The output transformer referred to in the diagram as an "output coil" is important since it keeps the heavy plate current from the loud speaker windings

obtained than by the use of other forms of inductances. Typical solenoid coils are shown in Fig. 1. and have the following dimensions to work with condensers of .0005 mfd. capacity.

Antenna coil, 50 turns No. 22 d.c.c., 2 inches in diameter,  $2\frac{1}{2}$  inches long.

Detector coil, 45 turns No. 22 d.c.c.,  $3\frac{1}{4}$  inches in diameter, 2 inches long.

If other sizes of wire and tubing are used, the constructor should consult the inductance-capacity chart given in the May RADIO BROADCAST, page 46.

In winding low-loss coils, the points to be remembered are these; use fairly large wire say No. 22 to No. 18; use as little dielectric as possible; space the wire about the diameter of the copper; and use solder sparingly.

Basket weave coils are illustrated in Fig. 1 together with a home made form upon which they may be wound. It pays to use rather large, well insulated wire here. The coils are stronger mechanically if the larger wire is used.

#### A FIVE-TUBE KNOCKOUT

**M**ANY readers have requested information regarding the addition of an extra tube to the four-tube set. There are two places

where this additional tube may be used, either as a stage of radio frequency amplification, or in the form of a separate audio amplifier by eliminating the reflex part of the original circuit. The first arrangement requires an additional coil and condenser but it is somewhat of a trick to attain successful operation due to the numerous feed-backs which result when two "high-powered" radio amplifiers are hooked together. This use of an extra tube is explained in the March RADIO BROADCAST, page 939.

By eliminating the reflex, the constructor gains several worthy points. The radio amplifier is free to give its maximum output, which is considerable if that amplifier is correctly designed; there is greater selectivity; the quality is somewhat improved—though the average loud speaker and the average untrained ear will not detect the difference—and the rumbling noises peculiar to reflex receivers disappear. The receiver will then consist of a straight radio amplifier, a detector with regeneration, and as much audio amplification as the builder desires to use.

On the other hand the receiver on two tubes will not operate a loud speaker, which is one

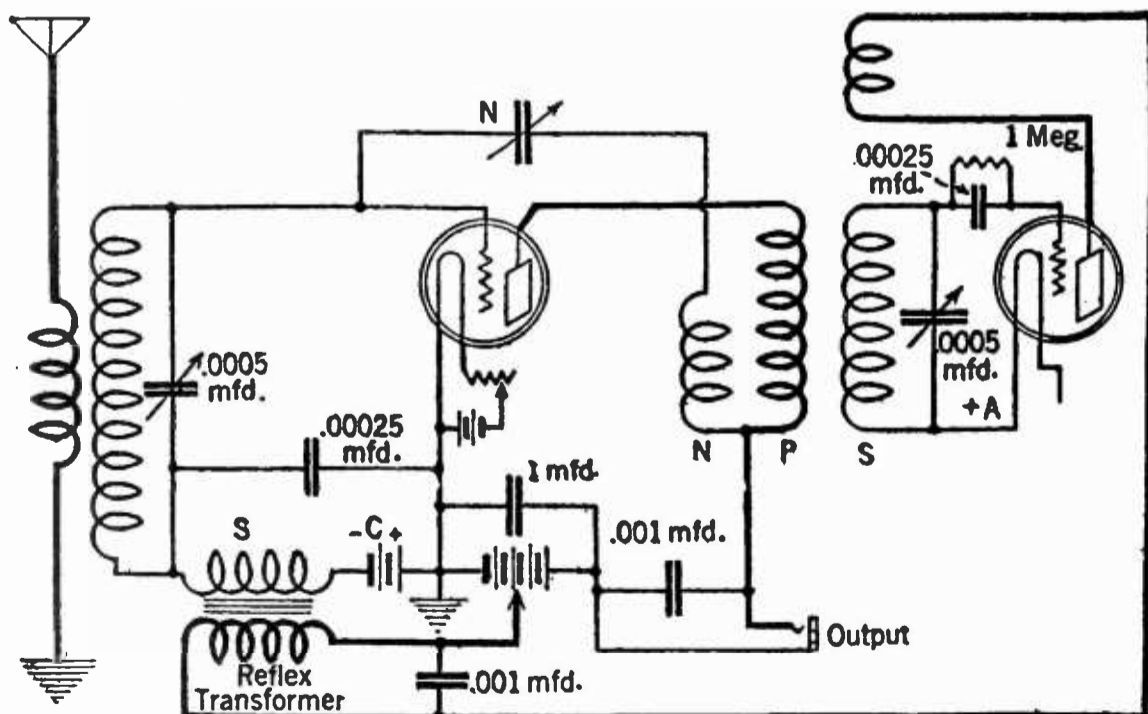

FIG. 3

The original and to date most popular reflexed radio amplifier. The bypass condenser from tuning coil to filament tends to eliminate the higher musical tones, and the iron cored inductances in both grid and plate circuits of the first tube make an excellent audio oscillator at certain adjustments of tuning condensers

of the greatest advantages of Dr. Roberts's original design. The elimination of the reflex involves the additional cost in upkeep.

The English expert, Scott-Taggart, for many years the champion of reflex circuits, has changed his opinion recently on this subject. Quoting from *Wireless Weekly* for Feb. 25, 1925, one of Scott-Taggart's papers:

I can foresee a fairly . . . distinct tendency to depart from reflex circuits altogether. I think the reduction in price of valves and the development of the dull emitter will do more than anything else to oust the reflex circuit from popular favor. The reflex is popular simply because the great demand is for signal strength with a minimum number of valves. Economy . . . is the one and only reason for the use of a reflex arrangement, and if we have the advantage of improving the selectivity and the range and generally making the set more effective, then an extra valve will probably be cheerfully added. A straight circuit will give better results in nine cases out of ten, than the same circuit condensed so as to use one less valve, the reflex principle being introduced.

In the opinion of the writer, the future set will require but four tubes, the last of which will be a power or semi-power tube whose filament will be lighted from alternating current and which will deliver enough output to operate the best loud speaker without overloading. Such tubes and the devices for operating them will be on the market as soon as home constructors have created a demand for them.

At the present time input push-pull coils are not so good as our best types of audio frequency transformers. A four-tube set would get around this difficulty. We would then no longer be troubled with much of the distortion now present in two-stage amplifiers and noticeable when low impedance cone type loud speakers are used.

An amplifier of this type is shown in Fig. 2.

It is a simple matter to eliminate the reflex in the Roberts receiver and Figs. 3 and 4 show the differences between the reflexed and the straight radio amplifier. The correct connections are indicated.

The increase in gain of the radio amplifier is quite noticeable and may be cause for trouble unless certain precautions are taken to prevent feed-backs. The

coils, especially if low-loss, must be on the same plane and at right angles to each other. A good radio-frequency amplifier will oscillate if the grid and plate coils are an inch out of line. This is, in fact, a good test to see whether one has an amplifier that is giving full gain or not.

The gain in quality over the reflexed arrangement is due to the fact that the reflexed transformer secondary must be shunted with a rather large condenser which causes this secondary coil to resonate at lower frequency and naturally to lose those audio notes above about 3000 cycles.

The increase in selectivity is due to the decreased losses in the radio amplifier circuit which are large when an iron core coil is placed nearby, as in the reflex.

It is probable that the average voltage gain of the first tube with its accessory apparatus in a radio amplifier circuit will be about seven or eight, while the average neutrodyne has a gain of about three—which explains why these receivers have two stages of radio! If an amplifier is well constructed with plenty of plate inductance and is properly neutralized, it is possible to have a voltage gain of more than ten.

In the RADIO BROADCAST Laboratory, a five-tube receiver, without antenna or ground, gave comfortably loud signals on New York City stations 20 miles away, and on a short antenna equalled any receiver that was compared with it. A laboratory model is shown in Fig. 5

NEUTRALIZING THE ROBERTS

PERHAPS the most distinctive feature of the original Roberts circuit is the method of neutralization, namely, the double wound

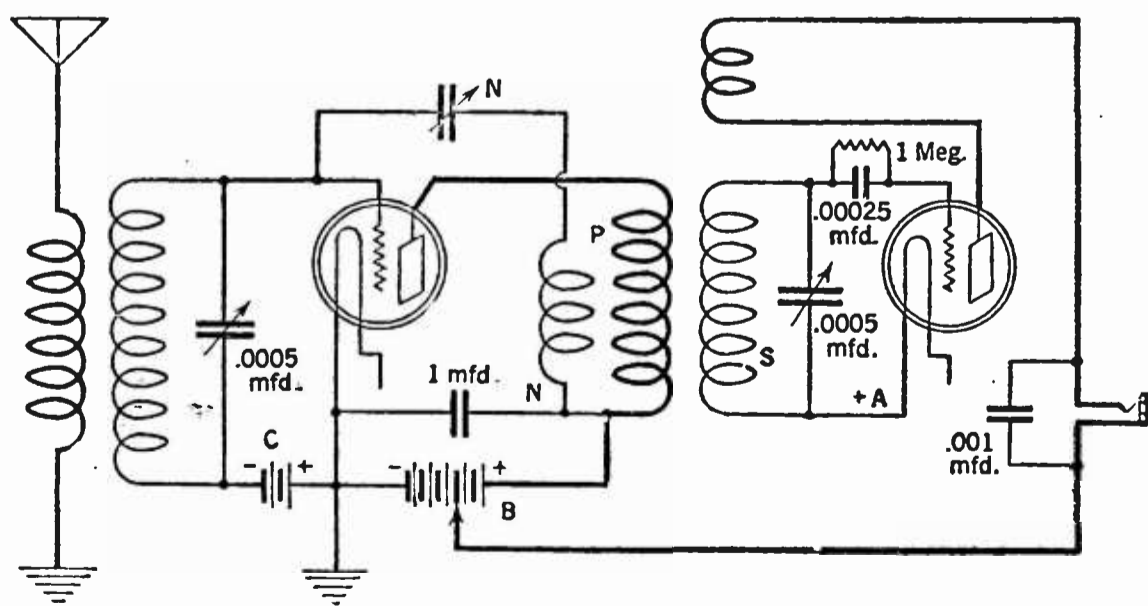

FIG. 4

The non-reflexed Knock-out circuit. The radio amplifier is now freed from audio frequency currents which occasionally modulate the incoming highfrequencies with considerable distortion as a result. The gain of this tube is increased over the reflexed arrangement—but one more tube is required

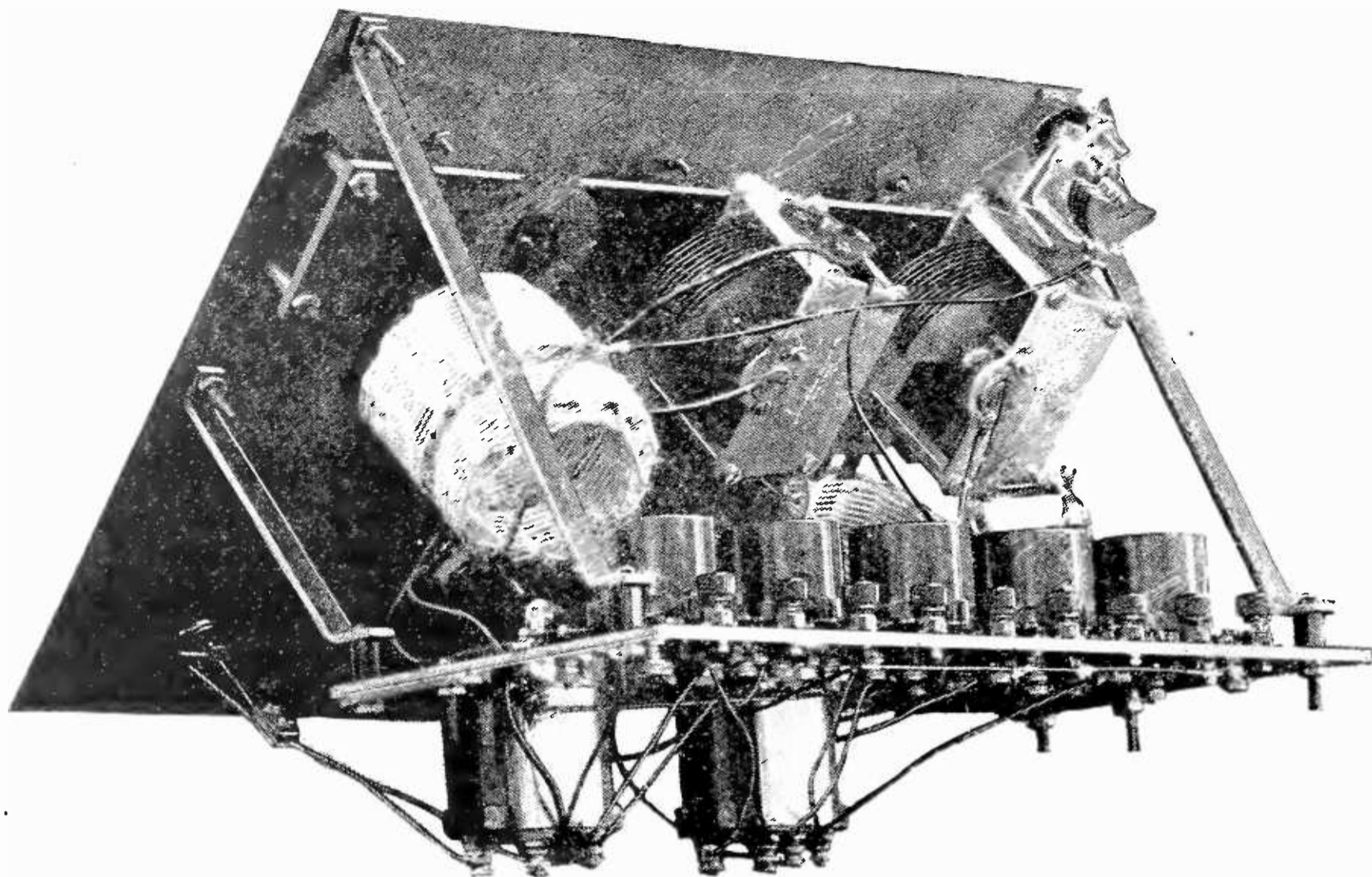

FIG. 5

A Laboratory model of a five-tube Knockout receiver

NP coil, or as it is used now, the mid-tap coil. If the audio frequency currents are removed from the first tube, as in the unreflexed set, neutralization becomes increasingly important, and experimenters will do well to investigate the various methods of capacity balancing illustrated in Fig. 6.

The double wound NP coil has one serious fault, especially when collodion is used as a binder. These two parallel wires have a large capacity which tunes with the inductance to give the coil a natural wavelength somewhere in the broadcasting band. The effect is immediate and obvious—the receiver refuses to tune to the lower wavelengths, it tunes broadly, and makes peculiar and irritating noises at certain positions of the two tuning condensers. One coil, whose high-frequency resistance was found in the Laboratory to be 300 ohms at 300 meters, was quite worthless, but became a highly efficient inductance when the midtapped arrangement was used. The resistance then dropped to less than 30 ohms, which is about average. The most satisfactory commercial coil sets now made for the Roberts receiver are equipped with mid-tap coils.

#### NEUTRODYNE NEUTRALIZATION

**T**HERE is one advantage in the neutrodyne method of balancing out grid-plate capacity in that it eliminates the double sized NP

coil. The presence of the large primary tends to broaden the detector tuning, due to capacity coupling and the mass of the metal in the coil being near the detector inductance. The neutrodyne method will not give any measurable gain over the Roberts. The tap on the detector coil should be near the filament end of the coil, and the neutralization will not be independent of frequency—contrary to general opinion.

#### THE RICE METHOD

**T**HE Rice method as well as the Roberts system, possesses a distinct advantage over the neutrodyne method of neutralization in that all of the balancing apparatus, the inductance and neutralizing condenser, are kept within the amplifier circuit itself and are not carried on to the detector. The Rice method has another advantage because the neutralizing condenser is not attached to the grid but to the less critical plate, and if the exact center of the input coil is found, neutralization will be independent of frequency. The antenna-ground connections must be placed symmetrically with respect to the mid-tap if correct neutralization is to be maintained.

#### REGENERATION IN THE AMPLIFIER

**A**N INTERESTING point was discussed about a year ago in radio technical comment, regarding the policy of completely neu-

tralizing a radio amplifier It was argued by some writers that a little regeneration in the amplifier was advantageous. Dr. L. M. Hull published an article on this subject in *Q. S. T.* January, 1924, which the experimenter should read and digest.

Dr. Paul Ginnings, of Greensboro College, North Carolina, has sent a useful device to the

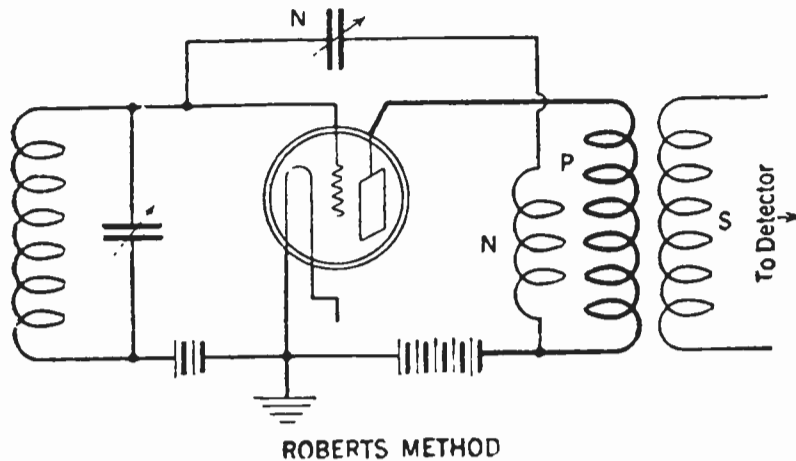

ROBERTS METHOD

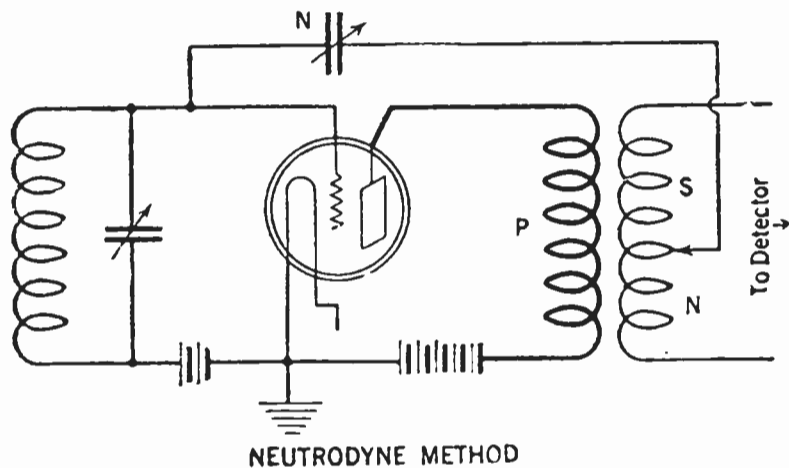

NEUTRODYNE METHOD

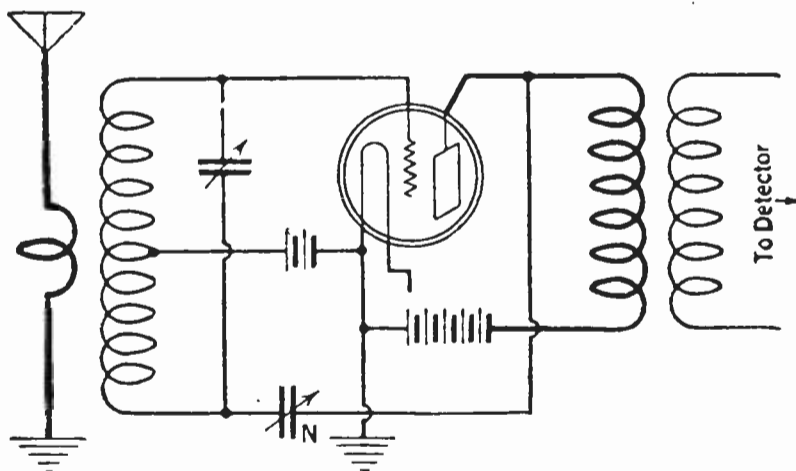

RICE METHOD

FIG. 6

Methods of neutralizing the radio-frequency amplifier of the Roberts receiver. The original N-P arrangement of Roberts is contrasted with the Hazeltine and Rice methods. The advantages of these three systems are outlined in the text

Laboratory which is designed to introduce a given amount of regeneration into the first tube of the Roberts set. A diagram of the connections is shown in Fig. 7 and a photograph in Fig. 8. What Dr. Ginnings condenser does, is to add a constantly increasing amount of regeneration to the amplifier so that the longer wave stations will be received with greater strength than ordinarily. In practice, the device consists of an additional

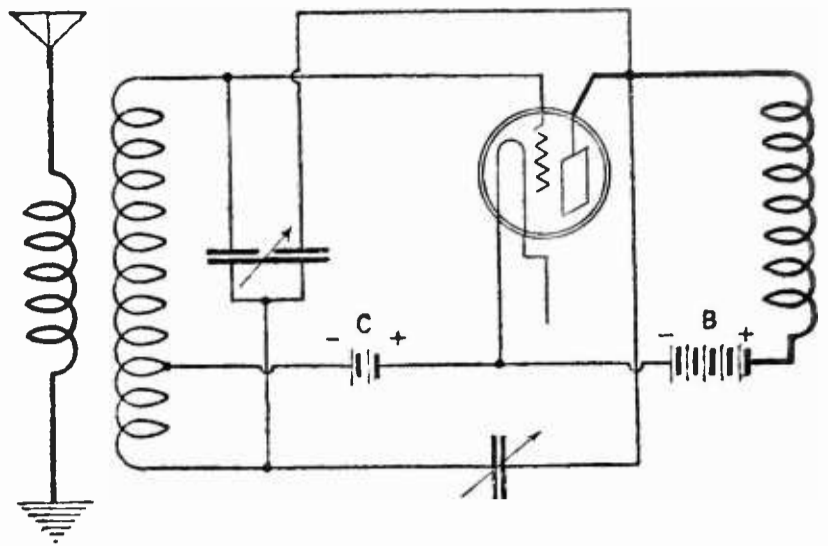

FIG. 7

Dr. Ginnings's method of introducing regeneration into the radio amplifier of the Roberts receiver. The reception of the longer wavelength stations is improved by this method. The double condenser shown is the tuning capacity to which is attached a single plate which is connected to the plate circuit. The tap is placed so that the ratio of turns is about 6 to 1

plate attached to the amplifier tuning condenser which is so adjusted that oscillations are just prevented at the lowest wavelength to be received. Then as the tuning condenser is adjusted to the longer waves, more and more unbalance is attained through the extra condenser.

DETECTOR REGENERATION

SEVERAL interesting methods of introducing and controlling regeneration in the detector circuit have been used recently in

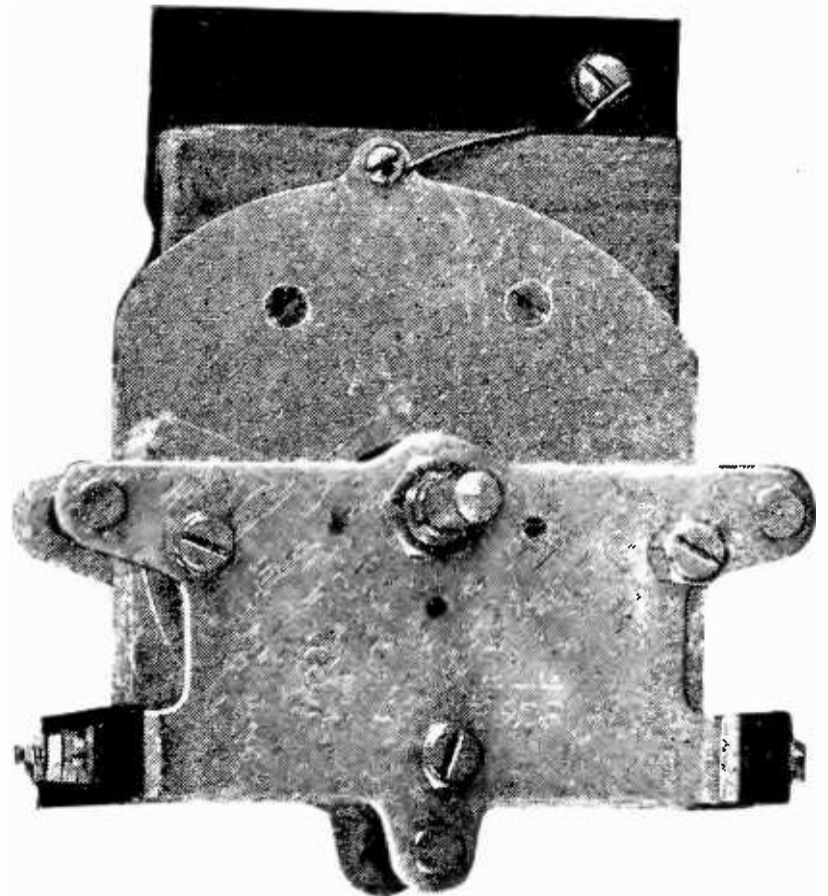

FIG. 8

A photograph of Dr. Ginnings's device. The method of attaching the feedback condenser is shown

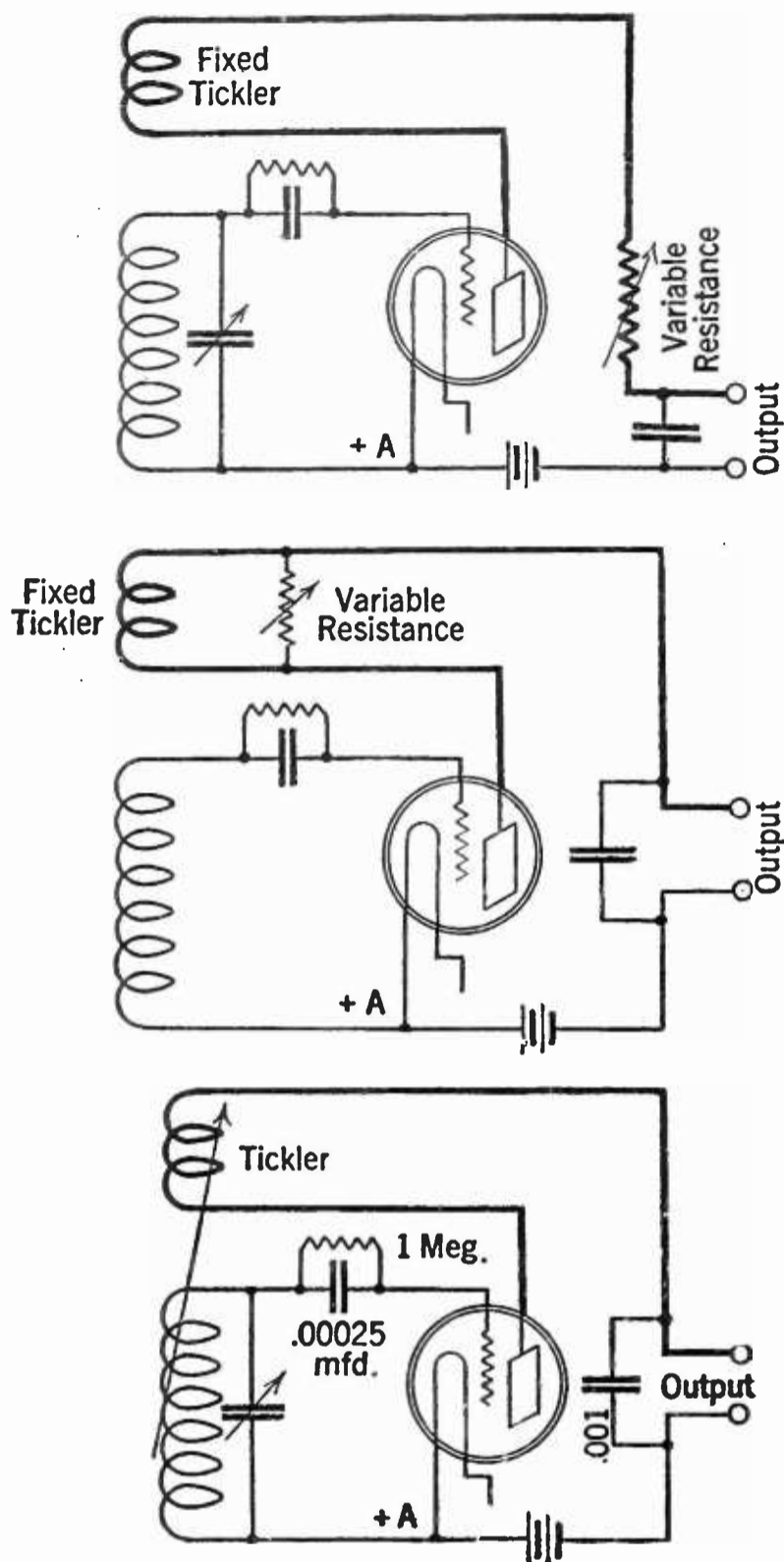
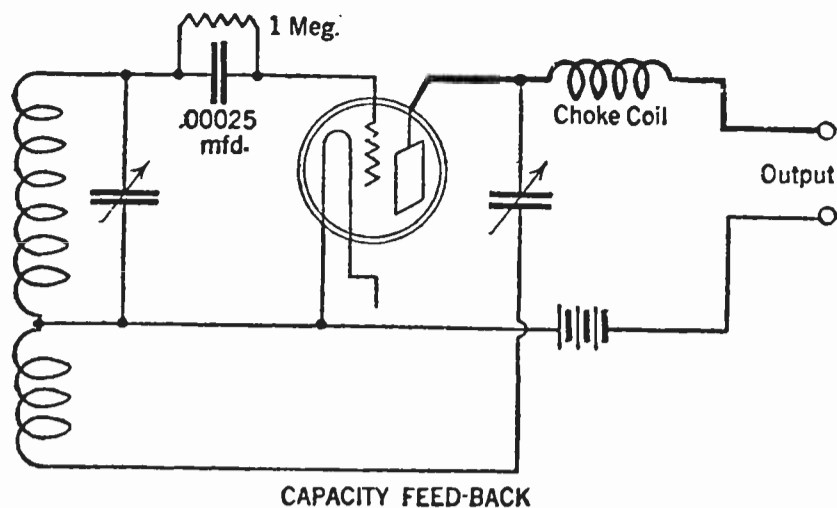

FIG. 9

Methods of introducing regeneration into the detector. The familiar tickler is contrasted with two methods of avoiding the mechanical difficulties incident to a variable inductive feedback. A Bradley-ohm, a Clarostat, or any resistance variable from a few ohms to a few thousand may be placed across a fixed tickler and affords a smooth control

the Laboratory. Fig. 9 shows the conventional tickler feedback and two systems for avoiding the variable coupling between tickler and detector coils.

In practice, the tickler is fixed in position so that oscillations will occur on the longest wave to be received without resistance control. Then, by adjusting the resistance, either shunt or series, oscillations may be secured on other wave-



CAPACITY FEED-BACK

FIG. 10

A condenser may be used to introduce regeneration in connection with a fixed tickler coil. Here again the control is more even than with the conventional "floppy" tickler

lengths. This regeneration is fairly independent of frequency—which is not true of the usual "flopping" tickler system—and should not affect the tuning of the detector circuit. In the five-tube receiver, this is particularly valuable since there is less danger of unwanted coupling back to the amplifier than with the moving tickler coil.

## CONDENSER FEED BACK

A VARIATION of the resistance control is the condenser feedback, probably due to Weagant and used commonly in the Reinartz circuit. A fixed coil is placed near the detector secondary and coupling to the plate is effected by means of a series condenser. The condenser and coil is then a shunt path for the radio frequency currents, and a choke coil may be necessary to keep these currents from escaping through the phones or amplifier primary. The circuit is shown in Fig. 10 and a drawing of a choke in Fig. 11. There should be no condenser across the output in this

Hard Rubber  
or Bakelite

FIG. 11

A drawing of a choke coil to be used in connection with condenser feed back. Fine wire may be used and up to 100 turns may be placed in each slot. The number is unimportant, and the choke itself may be eliminated if oscillations occur without it. Possibly the radio frequency currents will be kept in the feedback circuit by the impedance of the telephones or audio transformer in which case the choke is unnecessary

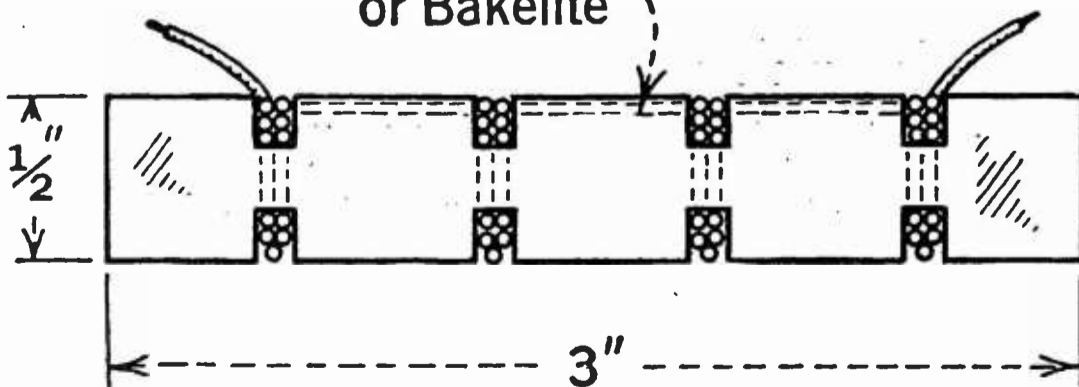

arrangement. This method of adding regeneration is particularly smooth in operation, and it avoids the movable tickler with its varying field.

#### TUNED PLATE FEEDBACK

**A**NOTHER effective method of adding regeneration is shown in Fig. 12. This is the tuned plate scheme popular with amateurs for many years. The coil and condenser may be of the same dimensions as the detector tuning elements, and if this is the case, the dial readings will be about the same at various frequencies.

This system is particularly effective when using toroid coils since it obviates the necessity of tapping the inductances—which would destroy the toroid effect.

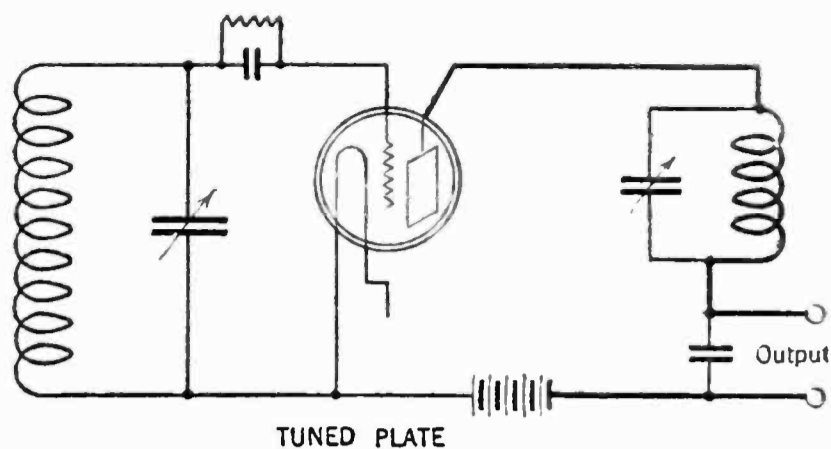
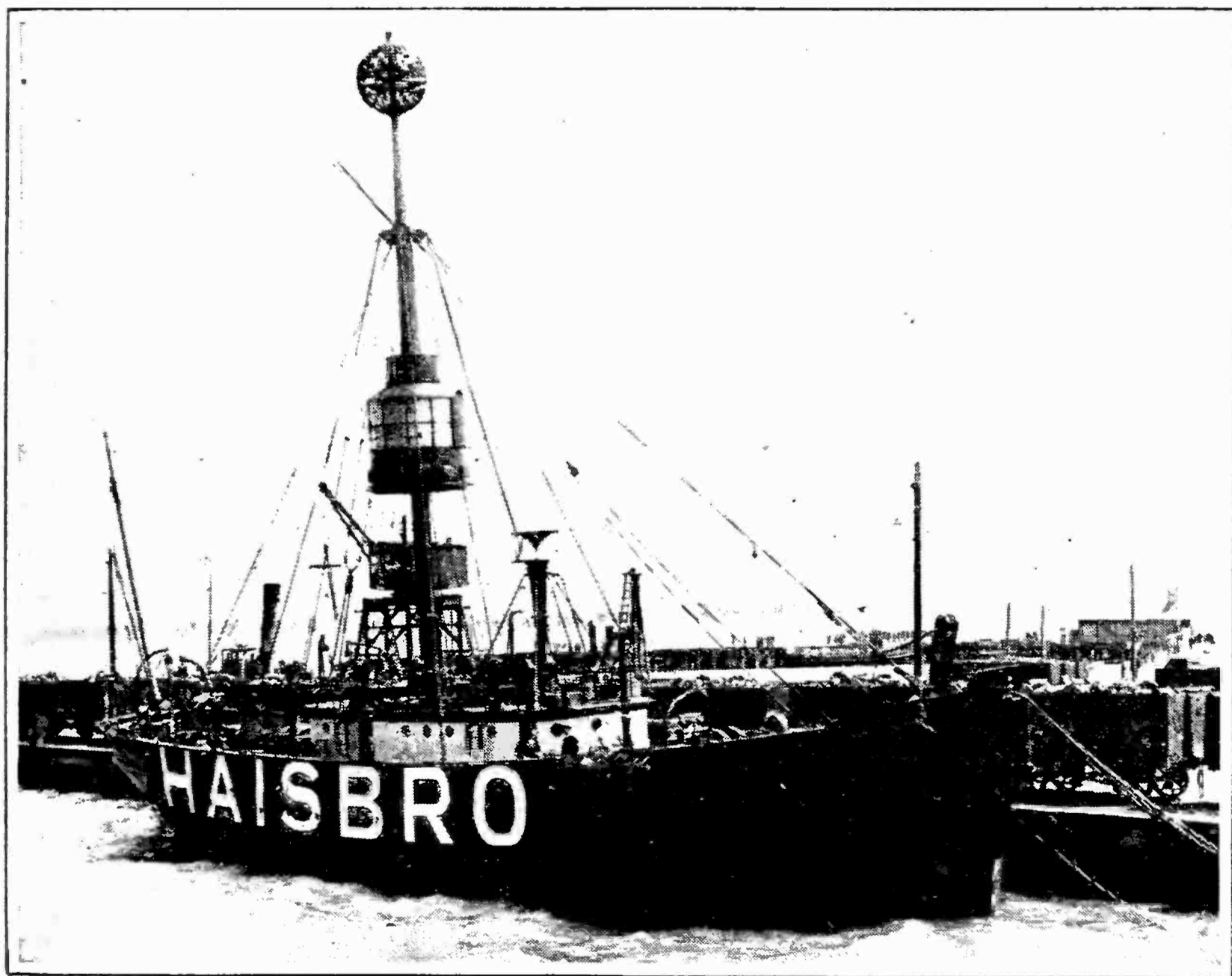

FIG. 12

The old method of tuning the plate circuit to the same frequency as the grid circuit. Oscillations will occur, and if this plate circuit has somewhat higher resistance than ordinary, oscillations will be controlled very easily. It is possible with this arrangement to have the tickler dial read like the tuning dials



#### WIRELESS COMES TO THE LIGHTSHIP

The English lightship No. 67 at Haisbro is one of many in the British and other services to be equipped with radio receivers to entertain the crews while they are anchored at their lonely stations. Many of these ships are equipped with automatic radio transmitters which transmit radio fog signals on 299 kc (1000 meters). The United States has particularly led in this respect, and many lightships on the Atlantic and Pacific coasts and the Great Lakes have "radiophares" or directional wireless signals for ships

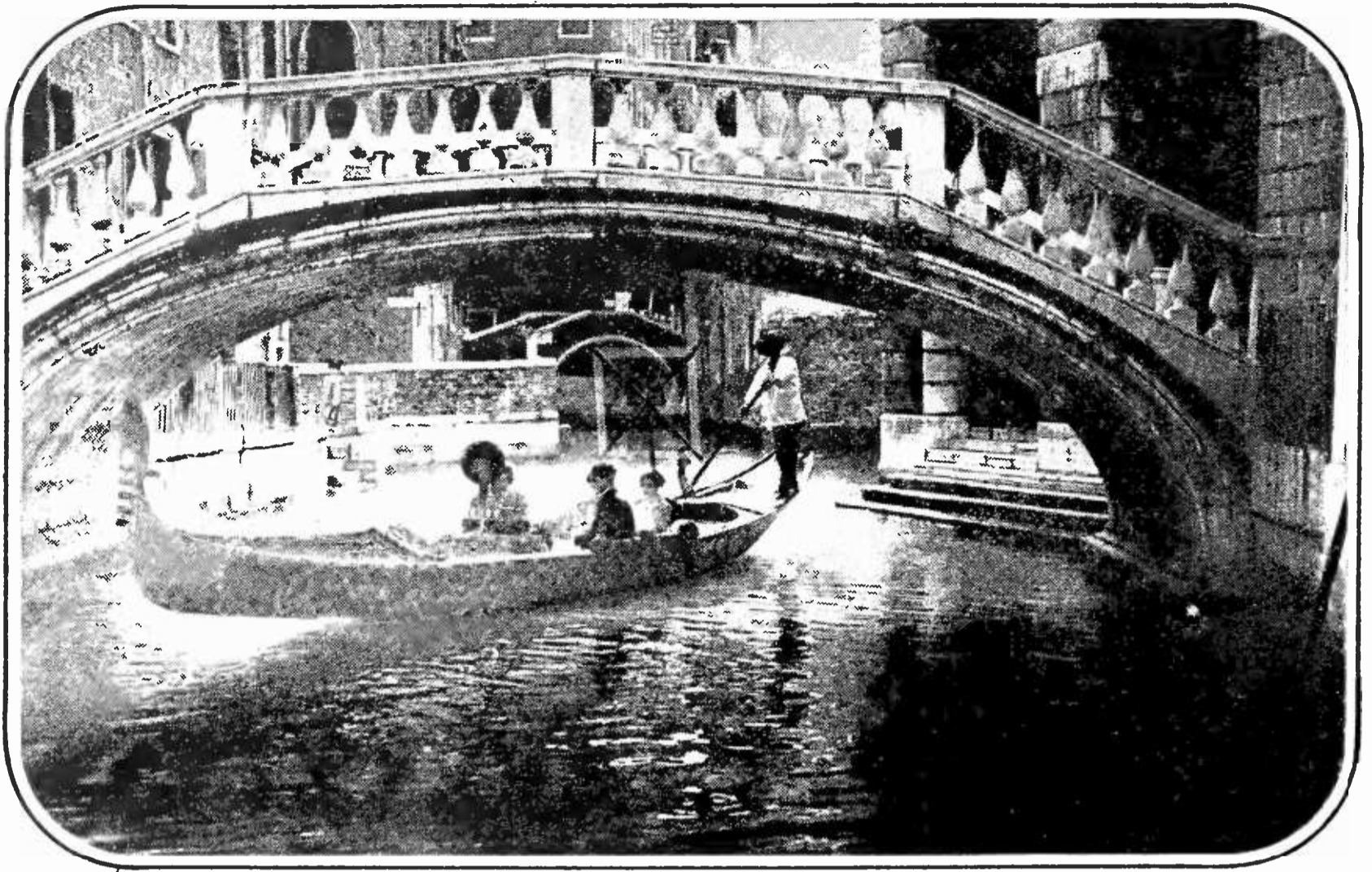

SO THIS IS VENICE!

The directorate of the Venetian "Rapid Transit Company" is equipping all of its conveyances with radio receivers. Patrons will in future be provided with timely entertainment in the event of a tie-up

## THE MARCH OF RADIO

By

*J. J. Morecroft*  
Past President, Institute of Radio Engineers

### The Horizontally Polarized Wave—Another Radio Bombshell

**W**E HAVE all become familiar with the vagaries of energy transportation by radio waves and have practically schooled ourselves into the idea that fluctuation and fading of signals is one of their characteristics and thus not to be remedied or be done away with. But also we have learned that scientific attack on many of radio's problems has frequently yielded valuable results in the past, so when a recognized authority puts forth a new idea or radio theory we are ready to accept it, strange and odd as it may sound at first.

As an illustration of how our radio ideas have been upset, we have only to think of the

directions in which radio waves are supposed to travel. Textbooks tell us that these waves travel out from a station in a straight line, becoming less intense with increasing distance. But many features are now known to affect this. Measurements of signals from WEAJ, for example, in the vicinity of New York City show that at many places the signals come from directions at right angles to the expected one and further, that signals may increase in intensity with increasing distance instead of diminishing as they should. So we have to be ready to accept other odd ideas if they are based on experimental fact.

Engineers of the General Electric Company

and the Bell Telephone Laboratories have recently been carrying on some most fascinating work to determine exactly what happens to radio waves as they travel along. We can see a water wave as it goes over the ocean surface, see it twist and turn around a projecting pier or rear itself and fall over on a sand bar, but to find what happens to radio waves, our eyes are not very helpful. Delicate vacuum tube apparatus and wonderful oscillographs are necessary to show photographically the electric currents which tell us definitely of the action of the radio waves.

Interpreting the pictures they have obtained, the research engineers now tell us that the radio waves twist and turn as they travel outward from the station—that in some places a vertical antenna will pick up more power than the usual horizontal kind. Furthermore, at some instance the horizontal antenna may be better than the vertical one and then, as the amount of twisting of the waves changes, the reverse may be true.

According to E. F. W. Alexanderson, consulting engineer of the Radio Corporation, this haphazard twisting accounts for much of the rapid fading to which some signals are subject and he suggests a possible remedy. To use two transmitting antennas is appar-

ently his idea, one of them to be a horizontal one and the other a vertical one. Then as these two waves travel out from the broadcasting station, their total effect on the receiving antenna will be about the same no matter how much twisting the wave has suffered. In his opinion, a scheme of this kind will do much to lessen fading. At the same time, it should increase the ratio of signal strength to static; which is the same as though static had been to some extent eliminated.

Mr. Alexanderson refers to this second, and aiding radio wave as horizontally polarized. It is interesting to note, in this connection, an article by Walter Van B. Roberts, "Can Static Interference Be Eliminated?" in RADIO BROADCAST for December, 1924. Mr. Roberts, in that article, reviewed methods for the elimination of static interference and suggested, among other things, that horizontally polarized waves might offer a solution to the difficulty.

### Radio, the Handmaiden of Explorers

**C**ERTAINLY no explorer ever started on a polar expedition with the assurance reasonably assumed by Mr. Donald MacMillan on his latest venture into

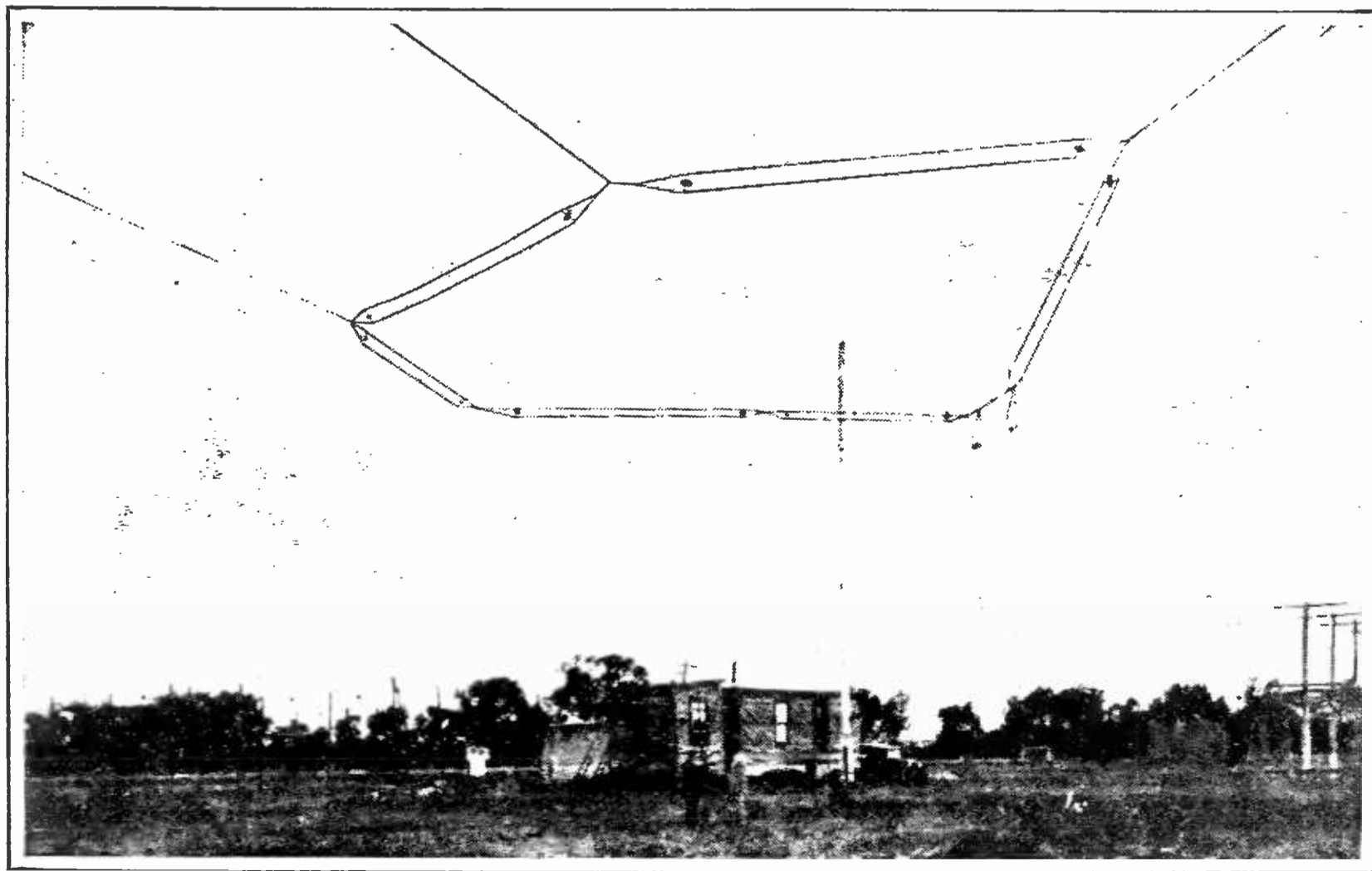

E. F. W. ALEXANDERSON'S ANTENNA

With which he is carrying on extensive experiments in his laboratory at Schenectady in radiating horizontal polarized waves. It is possible that his and others' experiments will result in the diminution of static and fading, two of the listeners' deadliest foes

the unknown seas around the North Pole. A few years ago he would have left civilization with the reasonable certainty that he would not hear white men again for perhaps two years; all that time his triumphs and disasters would be known to him alone, those at home blindly trusting to his ability to return when his self imposed task was finished. If he was not heard from after a year or two a relief expedition might start out with the slim hope of picking up his trail and giving what aid they might.

On the present expedition, radio is keeping the explorer's friends constantly advised of his progress; both ships of the expedition are well equipped with apparatus designed specifically to best maintain the polar radio channels open. The experience with radio gained by MacMillan and his operator, Donald Mix, on the previous expedition was such that short waves are to be largely depended on during the present trip. Frequencies from about

2000 kilocycles up will be used, the highest being 15,000 kilocycles (150-20 meters). Only specially designed receiving sets will pick up such high frequency signals, for even the lowest of these frequencies is very far beyond the highest useful frequency of broadcast receivers.

Already the peculiar conditions discovered on the last trip have been re-encountered. As this is written, the *Bowdoin* and the *Peary* are in the Greenland ice fields, not isolated as previous explorers have been, but in easy communication with those at home. Instead of reaching the eastern coast of the United States, however, the radio messages are already veering west, and again the operators in Washington, British Columbia, and Iowa, are the ones who have to relay MacMillan's messages to us. His compass pointed due west—a fact that makes us well appreciate how far from usual are the experiences through which these northern explorers pass.

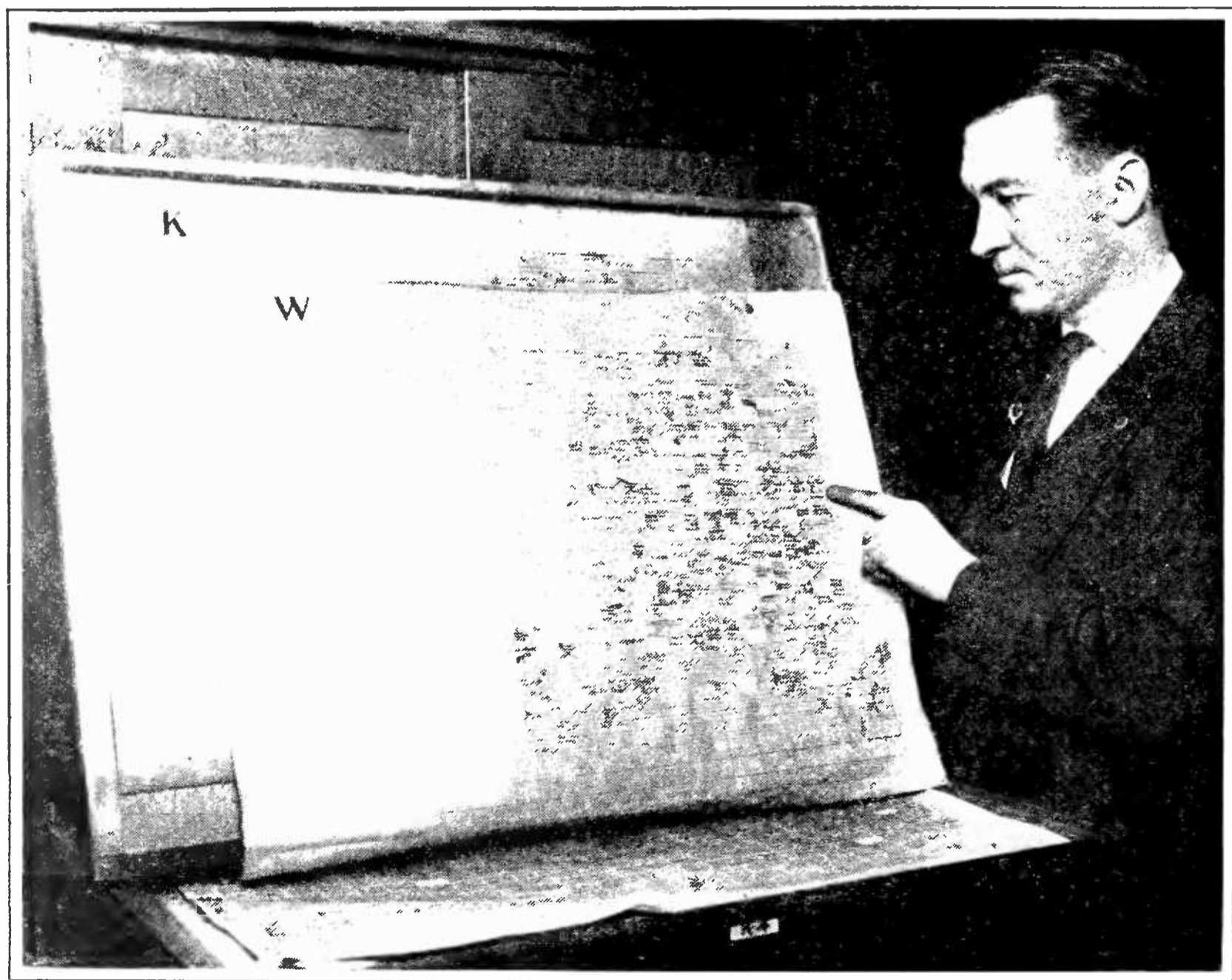

© Harris & Ewing.

#### L. A. CORRIDON

Of the Department of Commerce who is responsible for the selection of all new call letters for broadcasting and telegraphy stations. The fact that he is tied down to the initial letters, N, K and W, makes this no simple matter

## How the League of Nations Aids Radio

**I**N SPITE of the assertions of many of our politicians that the League of Nations is dead, it seems to be gradually working out problems which, without the international coöperation the League guarantees, might be the cause of much bad feeling. Of especial interest to us is the attack being made on the radio broadcast problem. With our 561 broadcasting stations, the interference problem is by no means as important and difficult question as it is in Europe with its fifty odd stations.

With the possible exception of a small part of our northern border, the interference between various stations in America is national rather than international. Hard feelings, if any are really engendered, are not of international significance and can lead to no serious trouble. In Europe, however, the fifty odd stations may cause a tremendous amount of international dis-sension. The countries are so small, and so close together, that a station of any

one country is very apt to reach out into all the others. The band of frequencies available for broadcasting in Europe permits of only forty-two channels, so that with the fifty-seven stations operating, some interference is almost sure to occur.

The technical committee of the International Radiophone Union acting under the auspices of the Communication Section of the League of Nations, has just met to discuss and act upon the European broadcast situation. Taking up the interference question in a reasonable and amicable manner, the com-

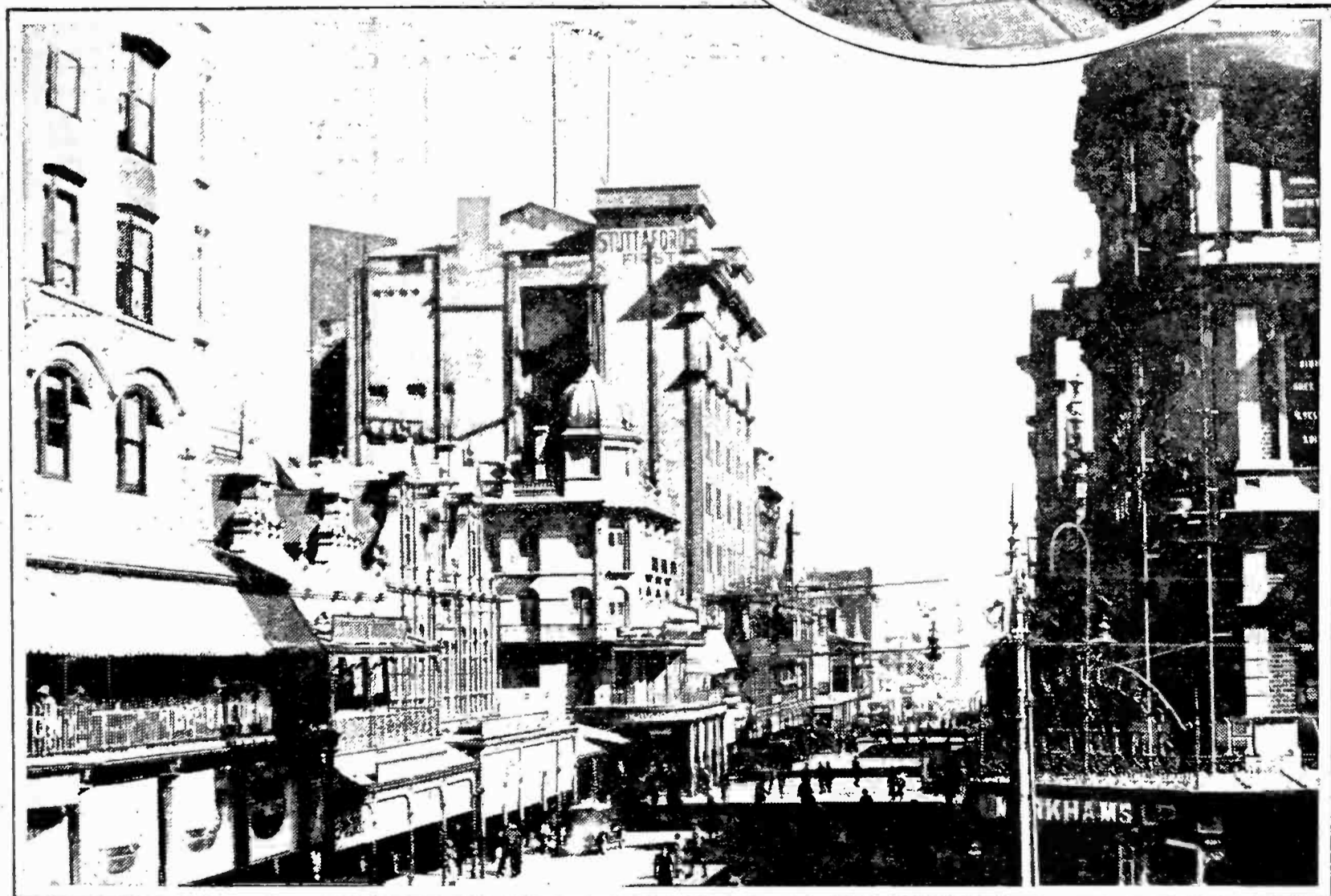
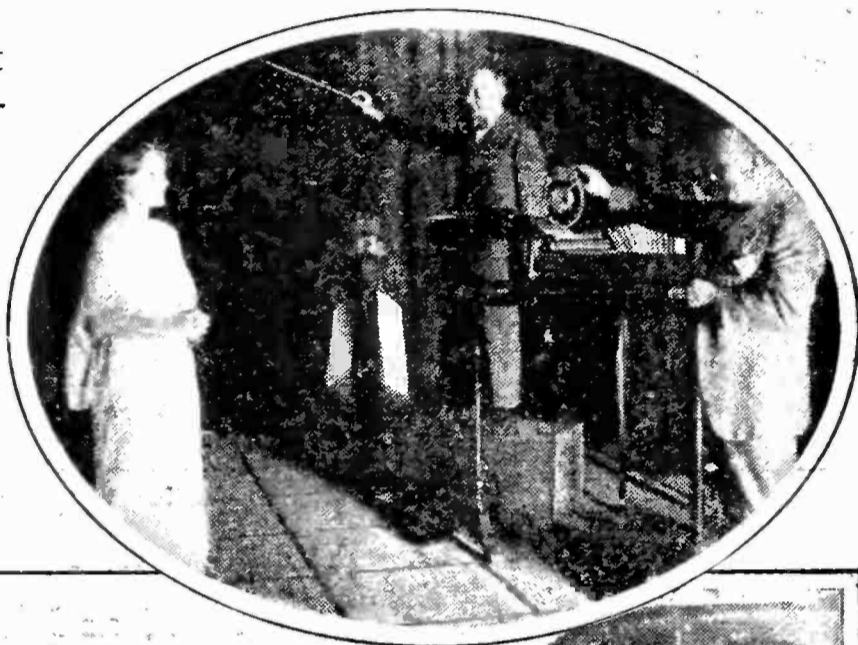

THE JOHANNESBURG BROADCASTING STATION

Showing the antenna atop Stuttafords Buildings in Pritchard Street. Transmissions from KDKA at Pittsburgh are often re-radiated from this antenna after being picked up at a distance of about three miles from the studio and then carried by land line to the transmitter. The smaller picture shows Miss Peggy Cook giving a recital from the station, JB. The floor of the studio, it will be noticed, is squared off to enable the director to place the artists to best advantage

mittee decided that with the amount of information available, a proper solution of the problem was not possible. It was decided that during the next two months, extensive testing would be taken up, on regular schedules after the broadcasting hours, to accumulate the necessary data on the interference effects. Two months experimenting are necessary in the committee's opinion and so the session was adjourned for about this length of time, after which another meeting will be called to further analyze the question. We are glad to see that, to all appearances, European interference will be settled in a friendly manner in spite of the international, and therefore vexatious, questions involved.

### The News Value of Broadcasting

**P**ROBABLY never before has radio performed such a countrywide service as when the news about Mr. Bryan's death was broadcast. Whether for or against him there was none of us who could help being interested in the passing of this noted American. His death came so suddenly and

unexpectedly that it made the service of radio seem even more striking than it has been on other occasions, when a previously announced event has been spread over the country.

On Sunday evening, the radio audience is probably larger than at any other time and, as every important broadcasting station was at once notified by telephone, telegraph or radio of Mr. Bryan's death in the obscure Tennessee village, it seems not at all unlikely that within a few hours of its happening, from five to ten millions of his countrymen had been notified of the sad event.

### "Weeding Out" in the Radio Trade

**A** RECENT summary of the midsummer conditions of the radio industry shows that although many of the smaller companies must succumb as a result of over production, and consequent cut price disposition of their stock, many of the companies, by pooling patents and credits, consolidation of manufacturing facilities, etc., are putting themselves on a reliable and trustworthy basis for the resumption of trade in the fall.

When we consider the extraordinarily rapid growth of the radio business, it seems remarkable that even more business failures have not occurred. In 1920, the radio business was estimated at two million, in 1921 five million, 1922 sixty million, 1923 one hundred and twenty million, and in 1924 three hundred million dollars. The estimates for the radio business for the present year go as high as four hundred and fifty million.

A short time ago the stock exchange saw a new radio stock practically every day, and during this year about five million shares of radio stock were sold to the public. The advertisements of this stock were generally worded to indicate that reliable business regarded them as a gamble, but the public was willing to take a chance, and did so. Comparison of the original selling price of



#### WHAT ARE THEY LISTENING TO?

Or are they merely resting between "paddles"? The photographer tells us that the two youngsters are enjoying the music provided by their radio, but we fail to detect any antenna and we hardly suspect that an enclosed loop would give satisfactory results with a neutrodyne receiver



#### TWO PROMINENT BRITISHERS

On the left is J. C. Reith, who is the managing director of the British Broadcasting Company and a popular figure among the British listening public. The Right Hon. F. G. Kellaway is shown in the second photograph. He succeeded Godfrey Isaacs as managing director of the Marconi Wireless Telegraph Co. Ltd. and the Marconi International Communication Co. Ltd.

the stock with the present quotations show that the trusting public has already suffered a paper loss of more than \$100,000,000. Probably this loss will be a real one and of even greater magnitude before the radio business is completely stabilized.

Present estimates—all of them founded on no especially reliable facts—place the number of radio sets in the hands of the public at 2,500,000, and as we have about 9,000,000 phonographs in our homes, and 12,000,000 automobiles, it is evident that for those companies which make reliable apparatus and which are properly financed to stand the periods of depression, there is still plenty of market left to absorb their products.

#### Radio in Foreign Countries

**F**ROM the Department of Commerce comes a summary of the radio situation in foreign countries, compiled for the benefit of American manufacturers who are seeking to do export business.

In Austria, where broadcasting began a year ago, much interest is displayed, and it is estimated there are at present fifty thousand receivers in use; most of which are of home manufacture due to the high tax imposed on imported sets. The broadcast listener must obtain a license before using a receiving set. The license costs at the present rate of exchange about fifty cents a year.

In Czecho-Slovakia, a broadcast station of

five kilowatts capacity is about to be erected in Prague. If receivers of the type common in America are used, this station should reach over most of the country.

In Spain there is a considerable demand for radio apparatus, due largely to the operation of two broadcasting stations in Madrid. Although most of the receiving apparatus is of British and French origin, the American manufacturer can well afford to go after this market. In the first quarter of 1925 more than \$100,000 worth of American apparatus was imported.

In South America, Argentina continues to lead, possibly because the government has not as yet put any restriction on the use of radio receivers. It is claimed that practically all the radio apparatus used there is of American manufacture.

New Zealand has just put in several broadcasting stations and the number of radio receivers is rapidly on the increase. It seems that most of this apparatus must be of home manufacture or else of British origin as the imports from America for the first quarter of 1925 totaled only \$23,700.

Our commercial attaché in London reports that although but little American apparatus is as yet used in England he believes that there will be a considerable market for highly sensitive sets which will be sought only by the "distance hound" because those who listen only to local stations do not require multi-tube receivers. There are twenty-two stations on

the mainland, only as large as New York and Pennsylvania combined, so that no listener is very far from his closest station.

### Is Canada Showing Us the Way?

**W**E ARE glad to notice that some of our Canadian friends have earnestly taken up the fight against radiating receivers. The position of this magazine on the question has been stated repeatedly and we are glad to commend our northern neighbors for the attack they have started.

The Victoria Radio Club of Victoria, British Columbia, have sent their views on the question to the Dominion government in the following letter:

Honorable, the Minister of Marine and Fisheries,  
Dominion Government,  
Ottawa.

SIR:

Whereas in the opinion of the members of the Victoria Radio Club, the use of radiating sets has become a public nuisance, it is the opinion of this club that some government action must be taken.

We believe that the manufacture and sale of radiating sets in Canada should at once be stopped by law, that on all licenses the type of receiving set used should be specified, and, in reasonable time, the use of all radiating sets absolutely prohibited by law. Also that all radio inspectors be given full power to act at once in case of persistent interference.

Yours truly,  
Victoria Radio Club.

### The Month in Radio

**T**HE Bureau of Foreign Commerce in Washington reports the successful transmission of energy by radio, the feat having been accomplished by an Italian inventor. The radio waves he used were so short that the kilocycle becomes an inconveniently small unit for expressing their frequency. In wavelength, so the dispatch states, the radio wave resembles a light wave rather than a radio wave, the length being only about one hundred millionth of a meter. Remembering the "achievement" of another Italian inventor, who, during the war, was to explode submerged bombs from great distances by the use of a ray much the same as this, we would not even mention the present dispatch if it had not come to us in a Department of Commerce communication. It is only a

short time ago that the inventor of a wonderful "death ray" had headlines in all of our newspapers but to the best of our knowledge he never showed a single experiment to back up these claims.

**C**ONGRESSMAN SOL BLOOM of New York has just announced that he is about to lead a battle to purify the ether from the taint of radio advertising. At the next session of Congress he will introduce a bill abolishing all advertising through the broadcast channels. He denounced the exploitation of the radio public by advertisers in no uncertain terms. We hasten to point out to him that he would be wise to proceed slowly. The public will never get something for nothing and so if they are to get a good musical program without paying a cent for the artists, it will probably be necessary to listen to the name of the donor of the hour's entertainment. This indirect advertising, if well done, is not at all disagreeable. If Mr. Bloom is successful, he will legislate away our best radio entertainments.

**J**UST why the police should permit a demonstration of a radio controlled car on crowded New York streets is a mystery, yet just that did happen. On one of New York's busiest thoroughfares an automobile, controlled by radio from another car a few yards away from it, was allowed to careen its way against traffic, making other cars climb up on the sidewalks to avoid collisions, narrowly missing a fire engine, and finally plunging into a photographer's car.

There is nothing remarkable about such a demonstration except the foolishness of the police in permitting it. The remote control of vehicles, boats, and even aeroplanes has been accomplished many times before, but never before on a crowded city street.

**T**HE Navy Department, which is temporarily carrying on commercial radio business across the Pacific, announces that traffic to Tahiti is now possible. From our west coast to Hawaii, then to the Samoan Islands, and so to Tahiti, the radio reaches over the expanse of the Pacific.

**A**T THIS year's commencement of Union College, the Bailey prize, given each year to that senior who contributes most to the college, went to Edward B. Redington, who had carried on experiments in the generation of very high frequency oscillations by



vacuum tubes. By using very short connections for inductances and in place of an ordinary condenser utilizing the capacity between the grid and plate of the tube, he was able to obtain frequencies as high as 80,000 kilocycles (3.8 meters) using fifty-watt tubes. Those who have tried to make large tubes oscillate at very high frequencies realize the difficulties which the young researcher encountered and feel that he well deserved the prize.

**I**N LONDON, a bill has just passed Parliament which makes it illegal to make phonograph records from radio signals. It is said that many well known artists have refused to sing over the radio because of the possibility of records being made in this way, and quite naturally the artists are not anxious to "stand for" the indifferent quality the average radio set gives.

**T**HE city of Philadelphia has just awarded William G. Housekeeper of the Bell Telephone Laboratories, the John Scott medal for his contribution to technical progress. The award carries with it a \$1000 prize.

By this public award, Mr. Housekeeper is recognized as the one responsible for the development of the metal-glass seal which was the one step required to increase the capacity of triodes from one kilowatt to one hundred kilowatts or more. As previously explained in these columns, to seal successfully a large copper thimble to a large glass tube was impossible until Mr. Housekeeper discovered that if the edge of the copper tube was made very thin where it met the glass, the joint would not crack, as was always the case when this simple expedient was not resorted to. Copper and glass contract to different degrees on cooling so that the joint has always cracked as the glass cooled down, thus spoiling

the vacuum tube. If, however, the copper tube is drawn to a thin edge where it meets the glass it becomes sufficiently elastic that as the cooling glass tries to pull away from it the copper yields and thus permits the joint to stay air-tight.

### The Misuse of a Municipal Broadcast Station

**A**BOUT a year ago, when the mayor of New York City was contemplating the installation of a municipal broadcasting station, we pointed out the very likely misuse to which such a station could be put by unscrupulous politicians. We don't yet appreciate either the importance of a broadcasting station of this stripe nor yet its proper economic classification.



PREMIER STANLEY BALDWIN

Delivering an address which was simultaneously broadcast from every one of the British broadcasting stations. The occasion was the recent rally of more than 100,000 persons at Welbeck Abbey, celebrating the signal victory of conservatism under Premier Baldwin. Note the two microphones which are enclosed within the boxes in front of him



GOVERNOR ALFRED E. SMITH

—Of New York State—

*"The American democracy covers so vast a territory that we must heartily welcome an art that brings its executives and legislators into the most immediate contact with the public they have been elected to serve. The advantage is double. Radio expedites the sending of an intimate message to the whole body of citizens and it secures to the speaker a more prompt and frank expression of personal opinion than he could obtain in any other way. Thus there is preserved a mutual relationship that is of especially high value as new problems arise which can best be solved by a renewed meeting of minds.*

*"Recent experiences in broadcasting matters of public moment through the medium of WGY have given me a new sense of close fellowship with my fellow citizens; their many replies have been an inspiration in seeking a solution to the questions which an executive can conscientiously answer only in the full light of the common thought."*

Is it a proper use of public funds to establish such a publicity medium, which can so easily be used to wage warfare on those who incur the disfavor of the temporary municipal rulers? This question has been brought up in the case of WNYC, New York. A citizen claimed that the establishment and maintenance of the station was a misuse of the city's funds. In the suit against the city authorities, the plaintiff's attorney states that:

the City of New York, and the defendants are without authority to expend or use the funds of the City of New York for the purchase, construction, or operation of the station. That there is no authority in law for broadcasting official reports by radio, the publication of such reports being otherwise provided

for. That there is no authority for the use or expenditure of city funds for the broadcasting of political propaganda on behalf of the defendant or any other person or persons.

That unless restrained the illegal acts of the defendants will continue. . . .

More than a year ago, Mr. Grover Whelan, then Commissioner of Plants and Structures, through whom the Mayor's orders regarding the station were carried out, made a public statement of what the station's activities were to be. Said he, when the station was being installed,

editorial writers are now concerning themselves with the possible misuse of the municipal station. Let me assure these gentlemen that no administration would be foolhardy enough to invade the sacred precincts of the homes of its people with any political propaganda. . . .

The complaint states that "the purpose and use of this broadcasting station have been utterly different from what was indicated in the above statement and it has been used repeatedly and continuously for grossly improper political propaganda."

The city officials have given out reports which are supposed to show that the material sent out over the broadcast channel was entirely non-partisan. Any listener who has heard the political "news" broadcast from station WNYC knows the facts to be otherwise. Fulsome praise of the city's mayor has always been a dominant note of the so-called "news of the day" and violent attacks on any who dared question his actions have always been used to accentuate his wisdom and his thoughtfulness for the city's dwellers.

The actual situation is readily made clear when one recalls that any talk to be sent out over WNYC's channel has to be written out beforehand—as is true of almost every first-class station—and submitted to the mayor or his hirelings for criticism and correction before being delivered. The Mayor or his commissioners are quite free to say what they want to on any subject uppermost in their minds.

Supreme Court Justice Churchill denied the injunction asked by the Citizen's Union, the body behind the movement, to confine the use of the station to proper activities. In his decision, he states that "it was within the discretion of the legislative bodies (of the city) either to confine the use of the station to the administrative work of the city's officials or to permit a wider use." The court also asserted that it was "a question which no court

has a right to consider." So that evidently the taxpayer in New York has no redress; if he doesn't want to hear what a wonderful mayor the city has had for the last seven years and reasons for putting him back in office, his only recourse is to tune-in on other channels.

The course of events following the opening of this municipal station is exactly as we predicted it would be when discussing its installation; while ostensibly of service to the police and other departments its most important function may be to spread political propoganda for those in office.

### The Radio Corporation Announces a Deficit

FOR the first time in its history, the Radio Corporation of America has reported a deficit. Its expenses for the second quarter of the year exceeded its income by nearly \$400,000. This is the first check in a remarkable growth, and one almost without parallel in financial circles.

Up to 1921, the Radio Corporation retained its original character. Founded during the war to improve the overseas communication channels for the government, for several years it was essentially a transoceanic communication company with a comparatively small business. Even the total transoceanic communication business is not very large and of course the radio channels got only a resonable fraction of the total. In 1921, when radio broadcasting began, the total business of the Corporation was less than \$1,500,000. Last year, its business totalled \$50,000,000. Such a rapid growth has seldom been seen in the industrial world.

During the first quarter of this year, the earnings of the company were \$15,229,923, which, with expenses of \$13,301,594, left a comfortable surplus for dividends. But the second quarter showed earnings somewhat less than \$4,600,000, and the expenses were nearly \$5,000,000, leaving a deficit for the quarter of \$391,053. This report shows the high seasonal character of the radio business and serves to emphasize the fact that a company must have a good deal of financial reserve or else carry on at the same time some other business which fills in the slack periods of the radio season.

It is quite evident that the Radio Corporation is feeling the pressure of competition and the tremendous unloading of sacrificed stock which many of the smaller companies were forced to carry out this summer. Unlike the



EDWARD H. JEWETT

Detroit; President Jewett Phonograph  
and Radio Company

*"There is no question about the public's having purchased a terrible lot of junk in the past years, believing, of course, that they were buying reliable radio apparatus. It has not given them any satisfaction and it certainly has done the radio industry harm.*

*"Be sure to go to a dealer in whom you have confidence and then add the caution of comparison. Gear your actions to what you hear demonstrated, not to what you are promised. I am sure that if any one of you were out to purchase a trotting horse, for example, and the seller said the horse could make a mile in two minutes flat, you would not make the purchase on such hearsay. More likely you would say, 'Is that so? Let's see the bound do it.'*

*"Approach your radio purchases the same way. Remember that you are buying something you will want for a long time and apply that thought to the measure of what you spend. The difference between cheapness and economy is almost the same as the difference between disgust and satisfaction."*

smaller companies, however, this great corporation has sufficient reserve power to stand several such temporary setbacks.

### Where is the Channel Cable?

NOT long ago we enthusiastically reported the success of an experiment which, although not belonging strictly in the radio realm, was sufficiently close to it to be classed by many as a new conquest for radio signalling.

On many occasions the traffic in our im-

portant harbors is held up for hours and sometimes days, by heavy fogs. Where the channels are narrow and winding, the cautious pilot generally holds up his ship until he can see the familiar landmarks. These delays of course are very costly to steamship companies and aggravating to homecoming passengers so that the public hailed with delight some months ago the announcement of a new scheme for piloting ships into harbors in spite of fog.

An insulated electric cable laid on the bottom of the channel, carrying alternating current of about 500 cycles frequency, was to act as a guide to the fog-bound ship; large coils carried on the ship's sides were to be used to pick up the alternating magnetic field surrounding the cable and by suitable setting of these coils, as the received signal was heard in a pair of head phones, the ship could be held on a course right over the top of the submerged cable. As this was laid in the center of the channel, the scheme (at least on paper) seemed sure to permit the pilot to bring his vessel up the harbor no matter what the weather conditions might be.

After the successful experiments were reported, it seemed certain that the scheme would be put into operation. The cable installation could not be very expensive and the apparatus required on board ship was so cheap and simple that its immediate application in important harbors seemed almost certain. But either the reporter responsible for the story of the successful tryout was too optimistic or else the pilots refused to accept newfangled ideas, otherwise we should not read in a current paper that "fifteen steamers, including eight passenger liners, lie off Ambrose Light waiting for the fog to lift." The Ambrose channel is exactly the place where the successful cable tests were carried out.

### Interesting Things Interestingly Said

**SULTAN CHINEY** (Bombay; interviewed during his recent visit to this country): "At present there is no commercial wireless in India but we have recently started the India Radio Telegraph Company, Ltd., and obtained all the rights of the Marconi Wireless Telegraph Company with their affiliations in America, Germany, and France,

and are putting up beam stations to connect in the first instance with England and then America and gradually with the rest of the world. The Government of India is going to give a single license to one company, such as the British Broadcasting Company has received for England. Interest in radio has become tremendous in India and there are many radio sets in use, some of them of American origin. But we have a large population and one difficulty that confronts us is that if we wish to make everybody understand what we are broadcasting, we shall have to use about nineteen languages. I rather think we shall have to concentrate on two—the Hindu and English.

**DR. J. H. DELLINGER** (Washington, D. C.; Chief, Radio Laboratory, Bureau of Standards): "There has been considerable discussion over the question of regulating the character of programs sent out by broadcasting stations. The Government has consistently opposed censorship, and the result is that the stations are entirely free in their choice of material. The radio broadcasting system of the United States can be characterized as one of extreme freedom. Any one is free to erect a broadcasting station and no license or regulation other than patent right is imposed upon the sale, purchase and use of receiving apparatus. This accounts in large measure for the remarkable growth of radio broadcasting. It is also responsible for the principal difficulty in which broadcasting finds itself at present, the existence of too many broadcasting stations."

**BISHOP JAMES E. FREEMAN** (Washington; National Cathedral): "More and more am I coming to the conviction that, through the medium of radio, we are to bring about, among all types and classes of our people, not only a better understanding, but a finer spirit of unity and comradeship. In the course of a ministry covering thirty-one years I have never had a greater evidence of the widespread interest in religion—and that from all types of people—than during the year and a half in which we have been broadcasting our services from the National Cathedral in Washington."

**MARTIN P. RICE** (Schenectady; manager of broadcasting for the General Electric Company): "Radio programs are slowly but surely improving. The listening public is becoming more discriminating and exacting. The advertising program is being weighed in the balance of public favor and it is doubtful if it will be accepted. More skill, art and talent are needed to make advertising by radio successful. Good music is appreciated everywhere, and the stations broadcasting it are always popular. Jazz still has a place on programs especially for dancing, but it is not so noisy as it used to be and it is more melodious."

# Guiding the Good Ship Radio

An Interview with W. D. Terrell, Chief Supervisor of Radio, Department of Commerce—The Radio Inspector's Relation to Broadcasting—The Amateur's Service to Radio—Elimination of Interference by Coöperation

BY DWIGHT K. TRIPP

**M**ANY people think that the amateur is a boy playing with a toy, and that he serves no useful purpose," says W. D. Terrell, Chief Supervisor of Radio, Department of Commerce. "This is a mistaken idea. The licensed amateurs of this country number in their ranks doctors, lawyers, business men, engineers, and, in fact, men and boys of all ages and of all walks of life. Many of our amateurs are men who are seriously interested in the development of radio, and the boys, through their amateur training, develop into the most successful commercial operators. As amateurs these boys learn to adjust their sets properly, make repairs, receive messages under the most difficult conditions, and become generally self-reliant. They proved their value to this country as a reserve force during the late war. As a rule, they are law-abiding, unselfish, and anxious to coöperate with our branch of the government service to the fullest possible extent. This country has long appreciated their worth and it has extended to them privileges not enjoyed by the amateur of any other country. Recently, I am glad to say, other countries have begun to take a more liberal view of their activities."

Through the energies of the radio amateur, many new and wonderful discoveries have been made, among the most important of which was the discovery a short time ago that short wavelengths are more efficient than the longer ones. Through the use of wavelengths as low as three-quarters of a meter, amateurs have recently conducted two-way conversations over hitherto unheard of distances.

"The radio inspection service," says Mr. Terrell, "has done much for the amateur, by explaining that much of the interference attributed to the amateur by the broadcast listener, is, in fact, caused in some other way. Last winter, many complaints of amateur interference through the Middle West and in the Great Lakes region were received. Investigation by

the inspection service disclosed the fact that nearly all of this interference was caused by commercial ship stations operating in the Atlantic Ocean and in the Gulf of Mexico. At that time, ship stations were permitted to use 666 kilocycles (450 meters) well within the broadcasting band. The situation was serious, and when it was brought to the attention of the Secretary of Commerce, a regulation was issued prohibiting the use of that wavelength by ships, assigning to them instead a wavelength of 706 meters (425 kc.)."

The first radio regulation was inaugurated in June, 1910, for the purpose of enforcing the installation of wireless equipment on certain passenger-carrying vessels. Since that time the Radio Inspection Service has developed into one of the most important branches of the Department of Commerce. Under the Act of 1910, the Secretary of Commerce and Labor organized on July 11, 1911, the Radio Service of the Bureau of Navigation. A subsequent Act, approved in 1912, stipulated that all vessels navigating the ocean or the Great Lakes and carrying fifty or more persons, including passengers and crew, be equipped with radio. An Act to Regulate Radio Communication was approved in August, 1912. Under this Act, transmitting



© Harris & Ewing

W. D. TERRELL

stations and radio operators are licensed by the Department of Commerce.

#### THE RADIO POLICE

JUST as Ariel, in the fables of the Middle Ages, was a spirit guardian of the air, so in this day of wireless, the Radio Inspector, a modern Ariel, stands a silent watch over the ether. But though he may be silent and, indeed, an angel, he is far from a fable, as those who attempt to dispute his wavemeter soon find out. For the Radio Inspector, ready at all times to be of assistance to those who need him, is essentially a traffic officer of the air, and to him falls the tedious duty of directing the myriad of amateur, commercial, experimental, and broadcasting stations under his jurisdiction.

"The Radio Inspector's work," Mr. Terrell continues, "enables the broadcast listener to receive programs without unnecessary interference. This is accomplished in part by the careful adjustment of broadcast transmitters to their assigned frequencies and to a constant inspection of these transmitters to insure their remaining so adjusted.

"The careful adjustment of commercial and amateur transmitters accomplishes the same results. Readjustments are necessary whenever it is found that one station is heterodyning another because of a slight change in the adjustment of the transmitter.

"Investigations of complaints of inter-

ference caused by electrical devices other than radio transmitters, such as, for instance, leaky power lines, magnetos on telephone lines, x-ray and violet-ray machines, electrical precipitation plants, and so forth, are not controlled by the present radio law, but many of such sources of interference are eliminated through coöperation.

"Radio Inspectors frequently give short talks to audiences in the cities which they visit concerning the problems which they encounter in their work, as well as the problems of the listeners-in.

#### AND WHAT ABOUT THE FUTURE?

THE Radio Inspection Service has helped the commercial operator to maintain a high standard of excellence by providing examinations for commercial operators which only well qualified men have been able to pass. The results have been gratifying, for in the many cases of disaster to ships at sea, not one case has been reported where the commercial operator has failed to observe the orders of the master of the vessel, has failed to show the highest courage, or has failed to remain at his post until his duties have been fully performed."

No, the task of the Radio Inspector is not an easy one nor does it promise to be easier in the future. But as for the radio future, we can safely say that it will take care of itself, for it is in exceedingly competent hands.

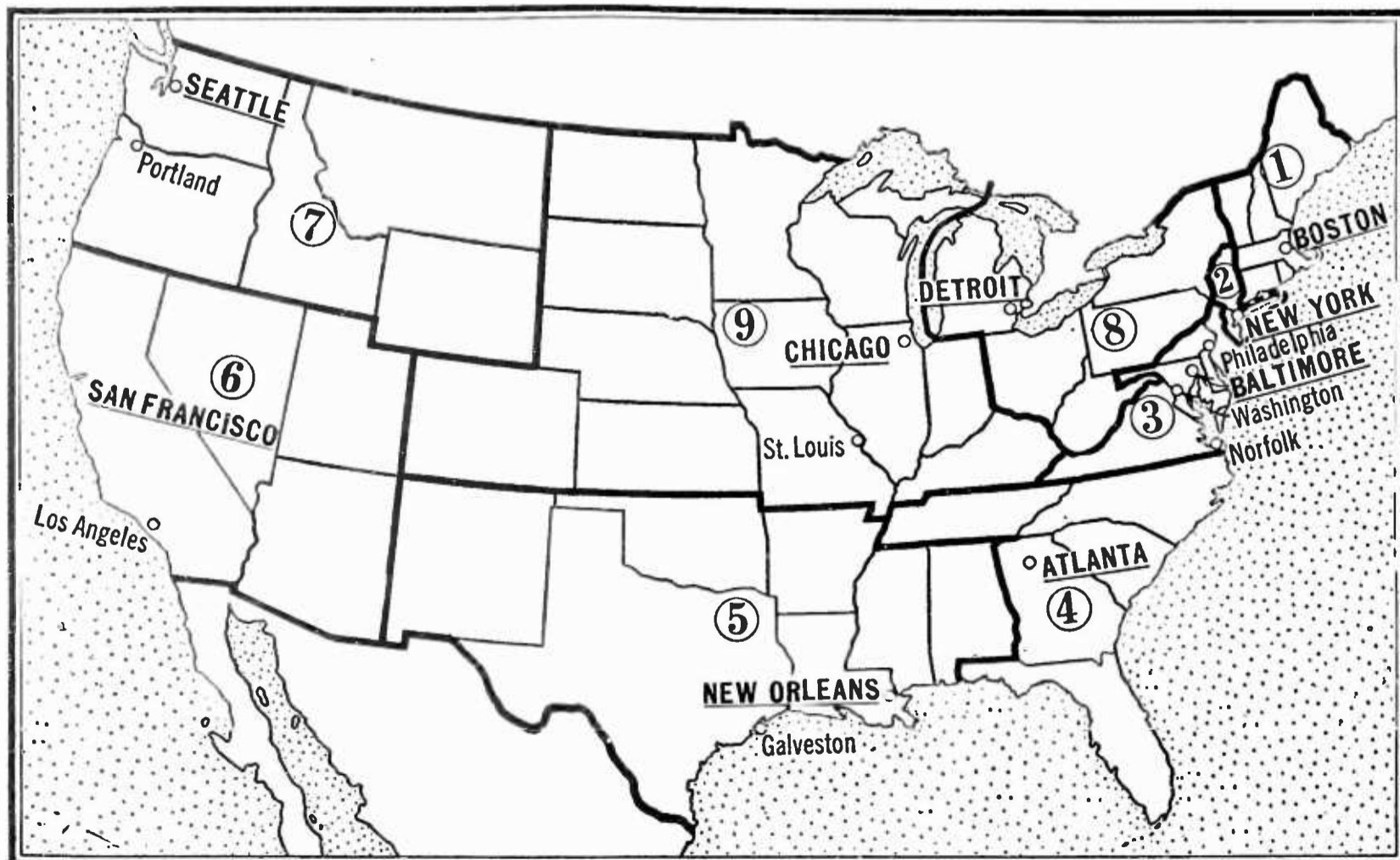

RADIO INSPECTION DISTRICTS OF THE UNITED STATES

# Some Remarks on Audio Amplification

If You Aim at High Quality in Radio Reception, Here Are Some Suggestions on Improvement Through the Use of High Plate Voltage and a Special Use of By-Pass Condensers—A Discussion of What Occurs in the Audio Circuit

BY GEORGE C. CROM, JR.

**T**HE search for high quality in the audio circuit of the radio receiver is growing more general and more popular every month. In the August, 1925, RADIO BROADCAST an article by John B. Bremman appeared describing the construction of a two-stage audio amplifier of very high quality. This article by Mr. Crom, while in no sense a construction article, contains some interesting ideas on methods for securing better quality. These suggestions, as far as we know, have not been formulated by any other writer. The Crom amplifier demands a high plate voltage, which is best supplied from alternating current and Mr. James Millen will describe an amplifier unit, practically embodying Mr. Crom's suggestions, in an early number of this magazine.—THE EDITOR

**O**NE of the most common of all radio devices is the two-stage amplifier; which, common though it may be, is often not constructed or operated in the most satisfactory manner. Insufficient thought is given to each of the components and their relation to each other and this results in the production of sound in the loud speaker utterly different from that imposed on the input circuit of the audio amplifying arrangement. The faults of design are made very evident when the audio amplifier output circuit is fed to a good loud speaker of the cone type. In some instances, poor reproduction has been blamed on the speaker instead of on the audio amplifier, where it actually belongs.

## THE PROBLEM OF GOOD AMPLIFIER DESIGN

**A**N AUDIO amplifier must be capable of raising a weak audio signal of rapidly varying frequency to the required strength without materially changing the relative value of each frequency.

It should, if it is to be an ideal amplifier, be easy to build and operate and should be low in first, and upkeep cost. The latter requirements, if the others are not to be sacrificed, are very difficult to realize.

In order to visualize the problem more completely, let us consider the functions of each part in the amplifier circuit, assuming that the tone quality being received on the detector is sufficiently good for most purposes. The small currents in the detector circuit must be fed into the primary of the trans-

former and converted by the transformer into a voltage variation on the grid of the first amplifying tube.

Although, perhaps, this process does not seem to be particularly difficult, it is well to remember that these small currents are composed of three entirely distinct forms. We have a direct current which is supplied by the detector B battery, a radio frequency current derived from the carrier wave of the broadcasting station, and the audio frequency current resulting from the rectifying action of the detector tube. It is this last current which we wish to amplify.

Fig. 1 shows the paths of the various currents in the detector circuit. The radio frequency or carrier current is by-passed directly to ground by the condenser placed between the plate and the negative filament terminal. The usefulness of this path is directly proportional to the size of the condenser, and if this part of the circuit were considered alone, a very large condenser would give best results. But a practical difficulty arises in that a large by-pass condenser here will also by-pass some of the audio frequencies which we wish to amplify, that is, the upper audio frequencies, approaching the lower radio frequencies. So in practice, the size of this condenser is limited by the necessity of conserving the audio frequency voltages present in the plate circuit, and sizes between .001 and .006 mfd. are generally used. The exact sizes that give best results for a particular layout are found by experiment.

The effect of the direct current in the plate circuit does not pass beyond the transformer itself, as only fluctuating current or voltage will pass through a transformer.

The audio frequency current passes through the primary, and through the large by-pass condenser (1 or 2 mfd.) back to the filament of the detector tube. This large by-pass condenser is a necessity for quality reproduction, as it prevents this audio current from flowing through the leads to the B battery and the B battery itself, and conducts it through a short path to the filament. The B battery and its leads have resistance and inductance. If the audio currents flowed through these leads, it would couple the circuit of the detector path to the plate circuits of the other tubes using the same B batteries and leads, by means of this common resistance and inductance. The majority of squeals and audio howls in an amplifier are caused by common circuits and by capacity couplings.

The audio current, in passing through the primary of the transformer, induces a voltage in the secondary by means of the magnetic flux induced in the iron core of the transformer, and this voltage is impressed between the grid and filament of the first audio tube. The plate current of the audio tube is controlled by this voltage, and variations exactly similar in form to those of the grid voltage will follow

in the plate current if the operating conditions of the tube are correct.

#### GOOD QUALITY OF RECEPTION MEANS GOOD TRANSFORMERS

IN CHAPTER VII of *The Thermionic Vacuum Tube*, by Van der Bijl, a complete discussion of the action of the vacuum tube when used as an amplifier is given, and the reader is referred to this book for complete information, some of which is too involved or too technical for presentation in this article. Proof of most of the statements made in this article can be found by the careful reader in this book.

Before discussing operating conditions of amplifier tubes it is necessary to make one further statement about transformers. Good quality of radio reproduction—to which more attention is constantly being given—can not be obtained with cheap, poorly designed transformers. In order to obtain amplification of the lower audio frequencies, such as those of a drum or bass viol, it is necessary that the impedance of the primary winding of the audio transformers shall be, at that particular low frequency, at least two and one half times the impedance of the tube connected to the primary of the transformer. Transformers made by most of the reliable manufacturers have this necessary primary impedance.

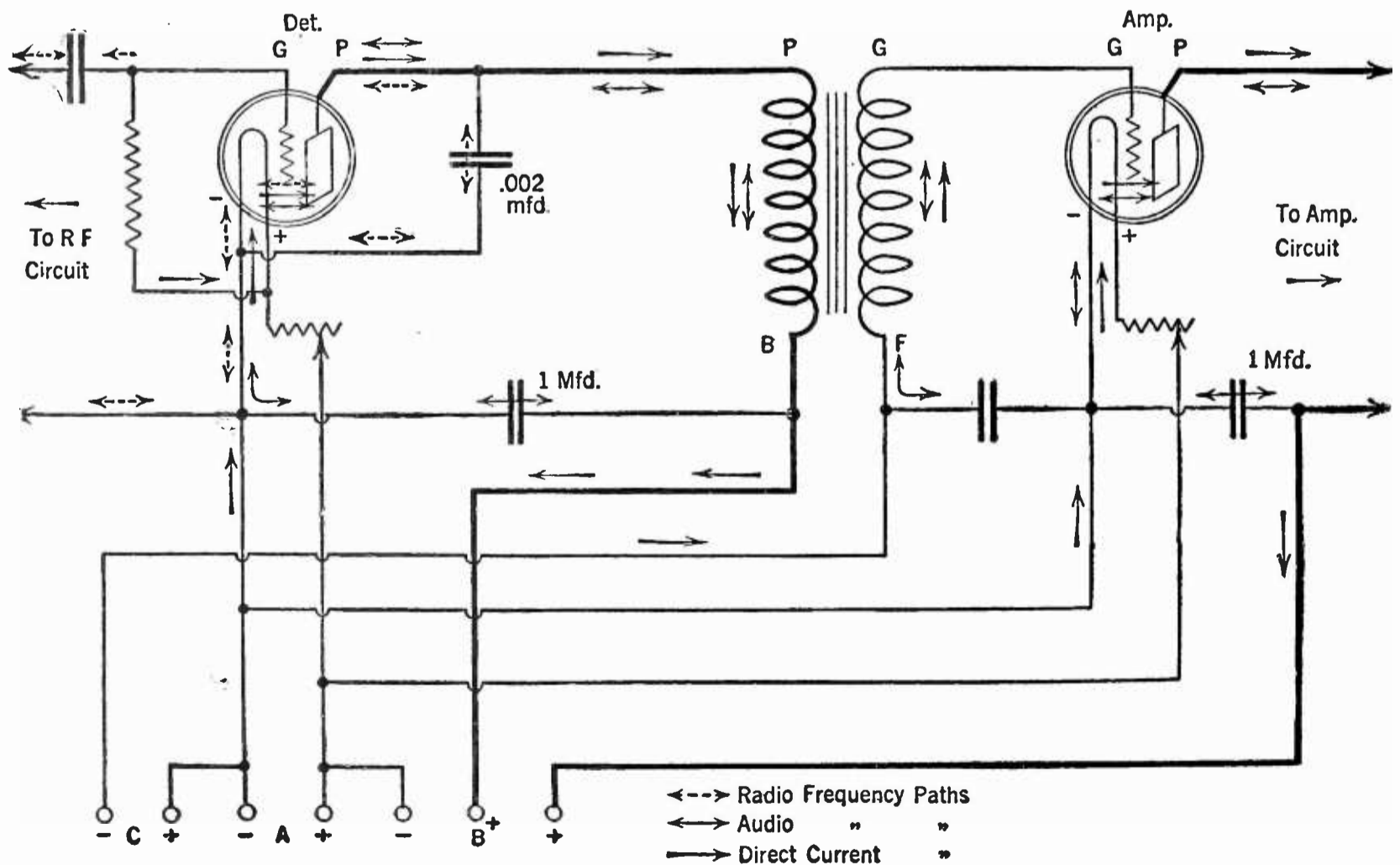

FIG. 1

The paths which must be followed by the different currents in a good audio frequency amplifier. The author tells how to keep them on the right path



DISTORTIONLESS AMPLIFIER OPERATION

THE conditions for distortionless amplification in the amplifier tube itself are as follows:

1st—The filament must be operated at a temperature high enough to supply all the electrons resulting from the sum of the direct plate current and its audio frequency component. The majority of good tubes give this necessary electron emission at low temperatures such as that resulting from 4.5 to 5.5 volts across the filament of a five-volt tube.

2nd—The plate circuit should have sufficiently high impedance. This high impedance straightens out the curve which is usually referred to as the operating characteristic, and is explained in Paragraph 60 of Van Der Bijl's book. This is too involved a discussion for this article.

3rd—The grid must be maintained negative with respect to the filament so that at the positive peaks of the signal-voltage wave, appreciable current does not flow to the grid. If current does flow to the grid, it pulls down the plate current and causes a bend in the operating characteristic curve, that is, the positive peaks of the plate current waves are cut off. As current flowing to the grid must pass through the transformer secondary with its many turns, it may saturate the transformer core, pull down its amplification and thus cause distortion in the transformer. The value of the C battery necessarily depends upon the structure of the tube

used and upon the signal voltage. Most tubes can be operated one or two volts positive at the peak signal voltage. This is not necessarily true, for individual tubes vary widely.

4th—The plate voltage must be high enough so that the plate current can faithfully follow the grid voltage. The plate voltage must force the plate current through the resistance of the apparatus in the plate circuit and still apply enough voltage to the tube, so that at the maximum negative signal voltage on the grid some plate current will still be flowing. In other words, the negative peaks of the plate current waves must not be cut off.

These conditions sound complicated but they are not when stated simply. The first is: use good tubes and keep your A battery charged. The second is: Use good transformers. The third and fourth are: Use the proper value of C battery for the signal voltage at the grid of each tube, and the plate voltage which corresponds to this C voltage.

One way to check up on these last two conditions, is to measure the signal voltage at the grid of each tube with a vacuum tube voltmeter, which measures peak voltages, and use the value of the voltage measured as the amount of the C battery voltage, and increase the plate voltage to the value given by the tube manufacturers for this C voltage. This is

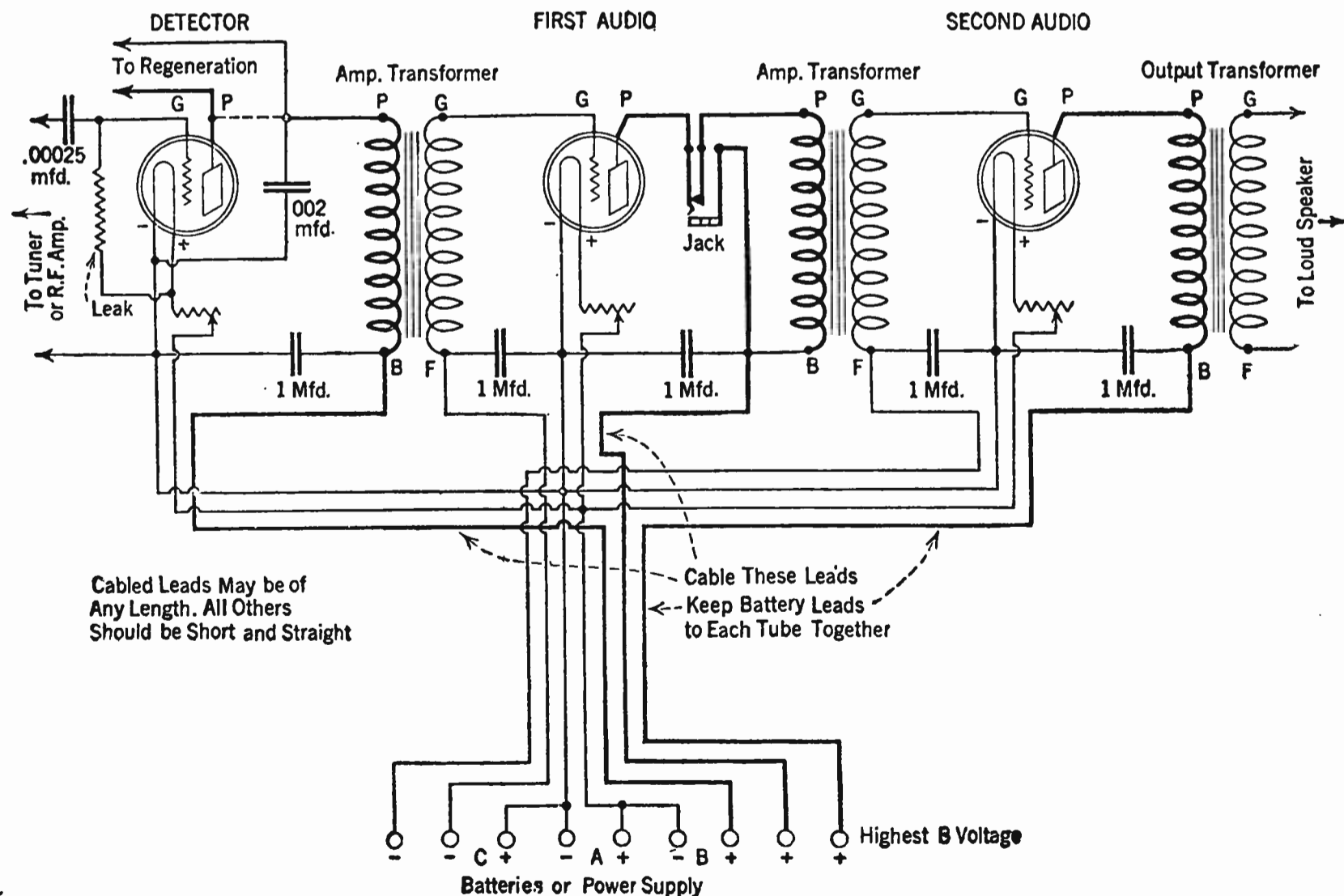
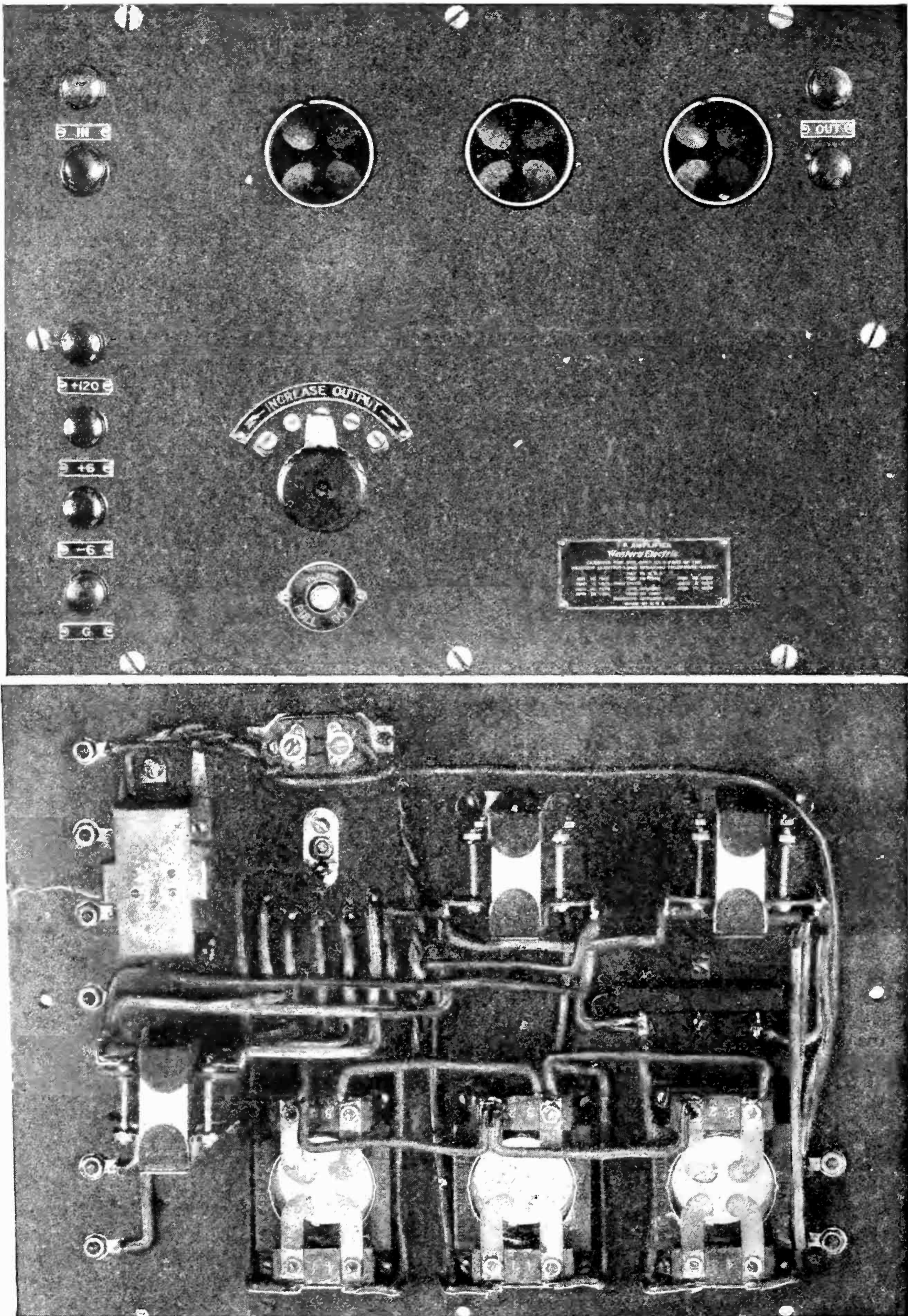

FIG. 2

The circuit diagram of a high quality audio frequency amplifier. Note in particular the output transformer, by-pass condensers, and cabled leads



AN EARLY TYPE OF HIGH QUALITY PUSH PULL AMPLIFIER  
 A front and rear view of one of the first high quality amplifiers to be put on the market. It is of the push-pull type, and made by the Western Electric Company

beyond the usual fan, because vacuum tube voltmeters are expensive and scarce.

The most satisfactory method, and also the easiest, of determining these last two conditions is to put a milliammeter (d. c. of, say, 0-15 milliamperes) in the plate of the amplifier tube under investigation and observe the plate current, while the strongest signal that is to be received, is going through the amplifier. If the C battery voltage is not high enough and positive peaks of the plate current are cut off (and current is flowing in the grid circuit), the plate current will decrease with a strong signal. Increasing the C battery will prevent the grid going too much positive.

If the plate voltage is too low (in the opinion of the writer, it usually is) and the negative peaks of the plate current are being cut off, the current will rise on a strong signal. Increasing the plate voltage will remove this difficulty.

Both of these effects may be, and often are, present at the same time so the needle of the milliammeter may fluctuate violently.

For quality amplification, the plate current should not vary, so it is necessary to

increase the C battery and the plate battery, until there is no appreciable variation of the plate current of each tube on the strongest signal that will be received. Most of the better grade filament voltmeters now on the market can be used as milliammeters as they usually have a full scale deflection for about 15 mA. The milliammeter (or filament voltmeter) can be best put in the lead to the B battery near the battery where its capacity will have no effect on the operation of the amplifier.

#### CHECKING THE CIRCUIT FOR QUALITY

**A**FTER the first stage amplifier is checked up in this manner, the same method may be applied to the second stage. It is easily seen that the signal voltage on the grid of the second stage will be higher than that on the first, so it is necessary that the C battery voltage applied to the second amplifier should be higher than on the first and its plate voltage should be correspondingly higher. The milliammeter test will show by its fluctuations if these voltages are not right.

The signal voltage on the grid of each am-

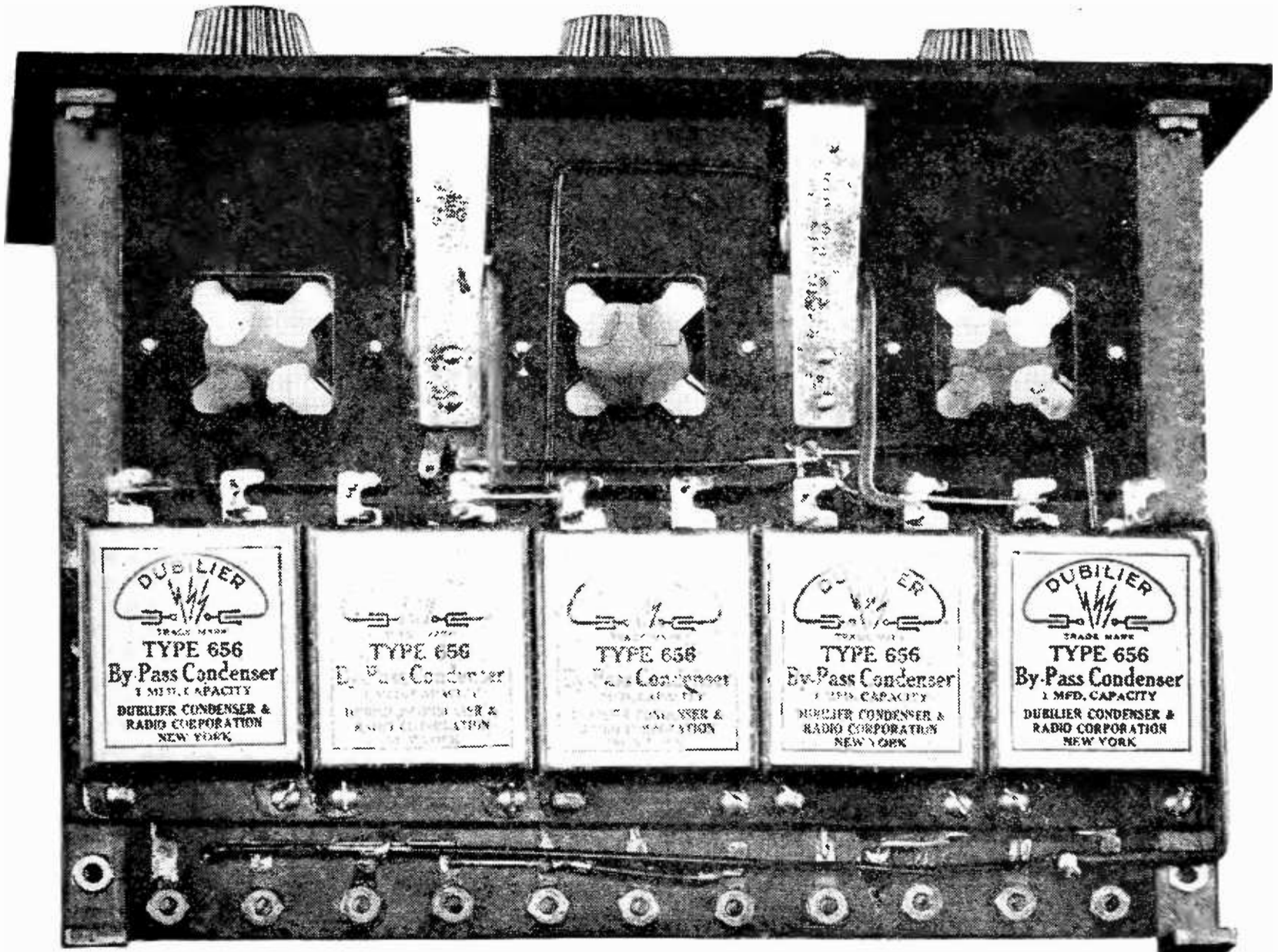

#### IMPROVING QUALITY IN A TWO-STAGE AMPLIFIER

How by-pass condensers whose value is suggested in this article, may be added to the Quality Amplifier described by Mr. Brennan in the August RADIO BROADCAST

plifier tube determines the amount of C battery to be used. The signal voltage and the C battery voltage fix the plate voltage required. The C battery voltage and B battery voltage can be higher than necessary but cannot be lower, without overloading the grid of the tube and causing distortion in the tube itself.

The average receiving set, regenerative or neutrodyne, or other circuits of equal merit, require much higher C and B voltages on the first and especially on the second stage, than are usually supplied.

A large number of tests have shown that these voltages should be, depending on signal voltage, tubes, and transformers:

1st-Stage	C-4.5-9 Volts	B-90-120 Volts
2nd- "	C-12-30 Volts	B-200-450 Volts

Where plate voltages such as these last values are not available or are not desired for economic reasons, even though the second audio tube is overloaded, the signal voltage can be decreased by using a low ratio transformer, or by putting a grid leak of less than one tenth of a megohm across the secondary. A push-pull amplifier allows appreciable distortion in each half of the circuit, but as the two audio currents are 180 degrees out of phase, the distortion cancels out; so the push-pull amplifier can be used with a limited plate voltage to give amplification without distortion.

Perhaps the best way to obtain good quality is to obtain the required B voltage from a plate supply system operated from the a. c. electric light socket. Such a system permits using a 5-watt tube in the last stage, as its filament may be operated from the same transformer that supplies the plate power. But that is another story.

#### A SUGGESTED HIGH-QUALITY AMPLIFIER

**I**N FIG. 2, a diagram of a two-stage amplifier is shown. Attention is called to the way in which by-pass condensers are used to

shorten the audio frequency paths, and to keep these frequencies in their separate circuits. Also note the way in which all the battery leads are grouped closely together in a cable, thus avoiding closed loops, which might cause coupling between stages. Grid and plate leads should be kept short and straight. The leads to the by-pass condenser should also be kept short as they are part of the audio circuit.

More than two audio stages are unnecessary except where more than one loud speaker is to be operated. Two well built audio stages, with proper grid and plate voltages, will operate two cone type loud-speakers so that they may be heard for several blocks without distortion.

The general purpose five-volt tubes will hold up under continuous operation at plate voltages of 250 to 300 with a C battery of 16 to 22 volts. Sometimes, however, it is necessary to pick out of several tubes, the one which will stand up best under this load. Several of one make of five-volt tubes were operated for six months with 350 volts on the plate and were still going strong when the test was ended.

In using such high plate voltages on the last stage it is essential that the direct plate current be kept out of the loud speaker. This can be done either by using an output transformer, or by using a choke coil of 75 to 100 henries in the plate circuit with a condenser of two to six mfd. between the loud speaker and the plate. The audio current will pass through the condenser to the loud speaker and then return to the filament, while the d. c. passes through the choke coil to the battery.

Now that good loud speakers (such as the cone type) are available, and broadcasting stations are transmitting signals of high quality, distortion of the signal in radio receivers is absolutely unnecessary, and can and should be prevented.

---

**C**The material appearing in this magazine is fully protected by copyright, and editors of periodicals are advised that unauthorized publication of circuit diagrams, technical descriptions, and parts or the whole of articles, without due permission and credit, is an infraction of the law. Those who wish to reprint material appearing in these pages are asked to communicate with the editor.



## The Listeners' Point of View Conducted by Kingsley Welles

# Do We Need "Silent Nights" for Radio Stations?

**T**HOSE two letters "DX" have caused as much radio joy and sorrow as any others known in the vast and mystic terminology of the science. To radio widows, the term is anathema; to radio fans, it represents a high form of enjoyment. To build or buy a set which will bring in the call letters of some broadcaster two or three thousand miles removed is better than being elected to Tammany Hall, or fathering the prize baby in the annual exhibition at Atlantic City. Those captious souls who sneer at radio like to say that broadcast listeners have installed their radio merely to indulge this passion for distance.

Well, that portion of the radio audience whose religion is DX come by that honestly. The very terms comes from the vocabulary of the intent amateur whose constant lust has been to project signals from his own little transmitter to some listener equally intent a great distance away. In the prehistoric wireless times of about 1909, his cup of joy fairly bubbled if reports of reception came from a paltry twenty miles.

Now your amateur speaks calmly of communication with Australia. The alluring possibility of being able to send signals six or seven thousand miles is the chief force which makes the experimenter an "amateur" and keeps him up indecently late o' nights.

And a very large body of radio broadcast listeners, who differ very little essentially from the "transmitting amateurs," gain their chief pleasures from searching out the elusive carrier wave of a broadcaster terrifically far away. The publicity writer for station KFI, Los Angeles, has put the lure well:



OLIVER SAYLER

Who presents, through WGBS, New York, one of the most interesting features given by any broadcasting station in his talk every Thursday evening at 8:30 called "Footlight and Lamplight." Mr. Saylor never fails to bring his listeners something worth hearing

For the Atlantic Coast to hear the Pacific Coast or vice versa is to journey into the unknown and come back with a new lease on life. DX is the home run, the hole-in-one, the six-pound trout, the twelve-point buck, the royal flush of the radio game, and those who seek to discourage it are striking at the very well-springs of the go-getting national spirit. Earle C. Anthony says, "Let the DX'er take for his motto, 'We will fight it out along these lines if it takes all summer', and continue to burn the midnight tubes. After all, who wants to tune-in when you can see the whites of their eyes?"

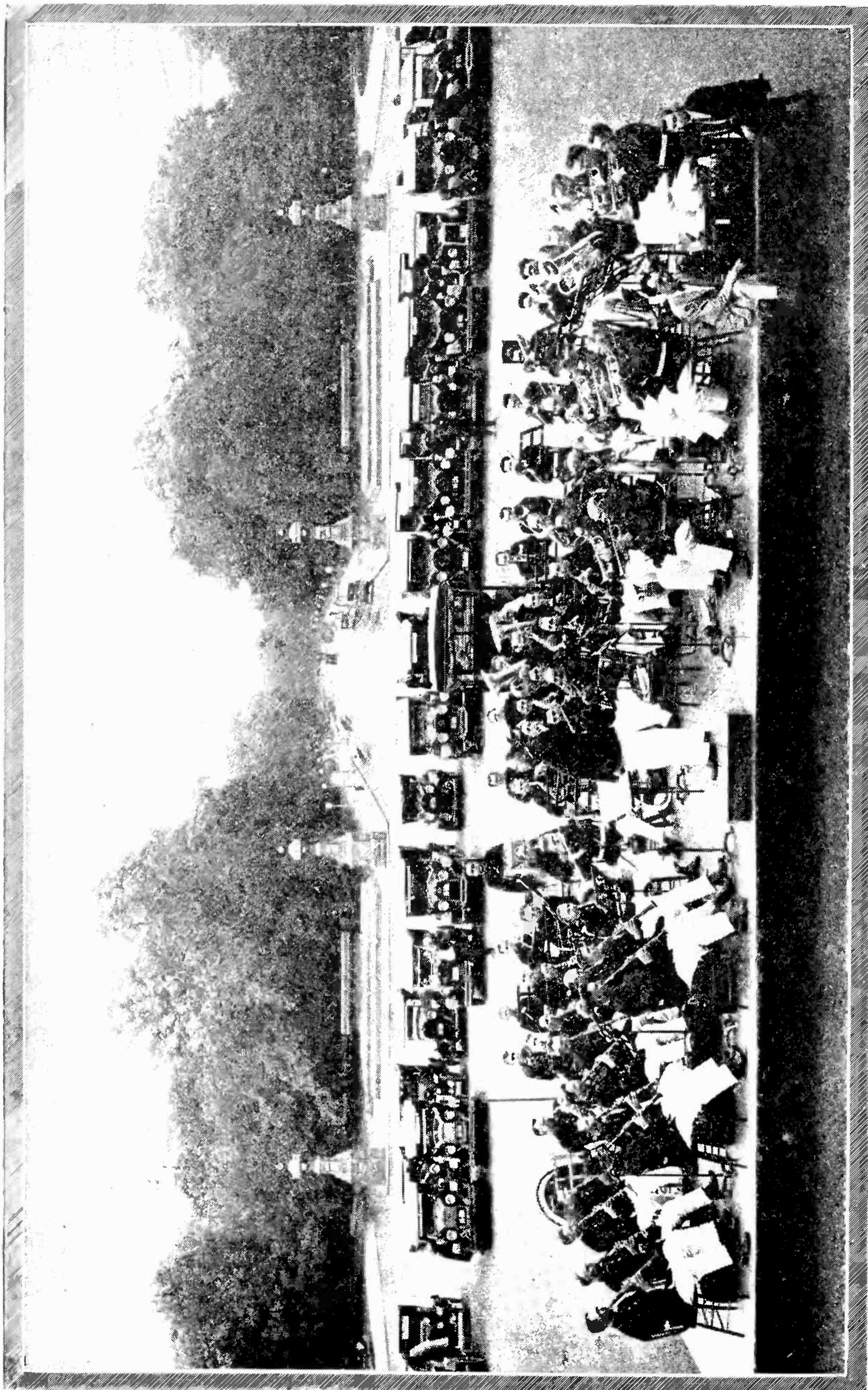

#### THE UNITED STATES MARINE BAND

Captain William H. Santlemann, conducting, playing one of two weekly concerts which are broadcast by WRC, WJZ, and WGY. The band is shown on the special platform erected in front of the steps of the Capitol building at Washington. The audience is seated in motor cars nearby and on the steps of the Capitol. Norman Brokenshire, whose excellent announcing is familiar to radio listeners in the East is seated at the left of the control apparatus.

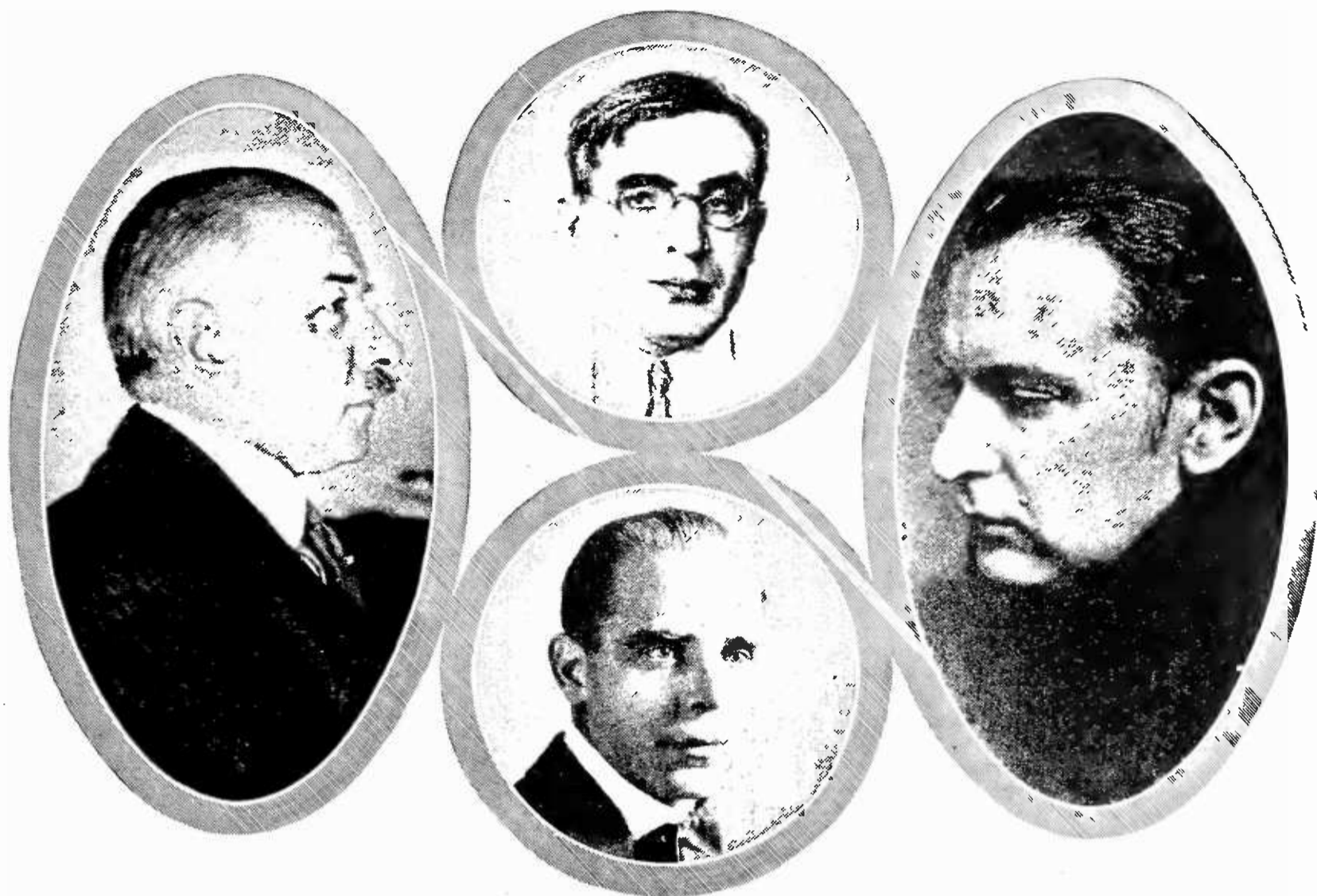

CONDUCTORS OF THE NEW YORK PHILHARMONIC ORCHESTRA

Whose programs have been beautifully transmitted by wjz, wgy, and wrc. At the left is Rudolph Ganz, conductor of the St. Louis Symphony Orchestra. In the upper center circle is Nikolai Sokoloff, conductor of the Cleveland Symphony Orchestra. Fritz Reiner (right) is the conductor of the Cincinnati Symphony Orchestra. In the lower circle, center, is Willem Van Hoogstraten, conductor of the New York Philharmonic Orchestra. Mr. Ganz, Mr. Sokoloff, and Mr. Reiner were invited to act as guest conductors of the Orchestra

This ether fishing is no chore for the listener located at a moderate distance from stations of large power. But for the unfortunates in large cities where broadcasters keep their tubes glowing from the setting-up exercises in the morning until the last dance orchestra has folded up its drums and silently stolen away, the job is not so easy. No matter how selective a receiver is, it is hard to get through the strong waves of the locals and to hear the elusive DX broadcaster.

By a kind of gentleman's agreement during the past year, Chicago broadcasters have kept off the air on Monday nights to allow the natives to indulge their urge for distance. Lately, the news has quietly leaked out through the medium of the Associated Press that there is dissention among the broadcasters in the Chicago area and the listeners in same. Those broadcasters who have studios in Chicago and transmitters in the suburbs feel, it seems, that since they are not local in a very strict interpretation of the word, there is no reason why they should keep to the silence agreement. So the local stations have been silent on Monday nights and the subur-

ban transmitters have been whacking away at the ether.

Mr. Frank H. McDonald, president of the Broadcast Listener's Association, has announced that a canvass of radio listeners in Chicago shows that 98 per cent. of the canvassed listeners are in favor of a silent night. He further says his Association is planning to have a bill submitted to the next Congress which would divide the country into six radio areas and assign a different quiet night to each. Sunday, according to this proposal, would be open night.

Mr. McDonald's Chicago broadcast listeners are doing well to organize in order to express their opinions, but the mere fact that a large and powerful Chicago group want to indulge in DX fishing is no reason for making national silent nights legally compulsory on the entire country. We have no quarrel with DX hunting, or with the silent night idea, but the matter is manifestly one for local option.

One cannot help but suspect that, when there is so strong a demand from listeners to hear programs from other localities, there are

serious lacks in the local programs. There has never been, in the New York area, for example, any similar widespread desire for a silent night. If one judge the signs in that territory aright, in the main, the local programs have proved quite satisfactory for every taste. And since WEA F has linked itself through the long lines of the Bell system regularly to representative stations in the East and Middle West, programs of the highest quality and of great variety of appeal have been made available to a larger number of listeners than ever before.

We might as well call things by their right names. If radio is really entertainment, then the program is the important thing. If that is true, the source matters less than, in a manner of speaking, the bone and sinew of the program itself. But, on the other hand, if radio reception is a kind of elaborate animated geography lesson, then every effort ought to be bent to give those devotees the chance to hear distant names whisked through the microphone.

### Brooms for Symphonies

YOU excellent folk who live in civilization don't know and can't realize what a wonder first-rate broadcasting is to those who live in distant places. Oh yes, we are civilized—we have in some homes modern



COUNT ALEXANDER SKRZNSKI

Foreign Minister who spoke recently over WEA F and a chain of eight others. His address came at the end of an excellent hour of Polish music. When the WEA F announcer described the program, he made the startling statement that Count Skrznski would be "accompanied by a Polish orchestra"

plumbing, and electric lights in most, and that's more than Bach ever had or dreamed of. We have stations of our own which do their best . . . with *n*th rate singers (why *will* they sing?). But perhaps it is unkind to look at gift horses.

"Last night," continues Mr. P. H. Russell, of Red Deer, Alberta, from whose recent letter we have taken the liberty to quote, "I turned the switch on my home-made Haynes superheterodyne, and was more than thrilled to hear faintly through the midsummer heat—you'd not guess unless you heard it—Bach's double sonata!"

This is a small place. There are 2400 people of all ages, sizes, conditions, and sorts. There is one pianist who is such, and is a sort of prodigy. He is good, too. There are also one or two others who don't know anything about music but who know what they like. So you will gather that the standard is high for a town in the wilds. Sitting with me were the top local fraulein and a friend, appointed masculine associate for the nonce, smoking cigarettes with me.

My office has a forgery of George Clausen on the wall, and a Raeburn copy, and a print of Praxiteles' "Hypnos." My walls are covered with books ranging from Gibbon's *Decline and Fall* to detective stories. There are a few law books, of course. So I can smoke cigarettes with the stenographer freely (when no Methodists infest with their accustomed severity.)

"Believe me," continues Mr. Russell, "when that music came winding in, a wonderful, faint thread of beauty, then a latter-day (and really rather charming) flapper and her youth, a railway fireman, ceased from talking and listened. They didn't say so, but I knew, for they looked it—they had never heard anything like it before. Then the thread faded into mutterings of static and I never heard whence it came. But it sounded like the music of the spheres."

Those stranded souls who live in the territory rather vulgarly called the sticks depend much on what the broadcasters offer, and how much more worth while radio must make life! Fortunate are those rural inhabitants who like jazz and non-musical programs of like level. For radio stations are really making the ether one huge vaudeville performance, with the emphasis on ultra-popular music, quite in the manner of the variety theatre. All stations, with the exception of those operated by religious organizations, are trying to be all things to all men. Here a child prodigy on the violin, there a famous boxer, giving his opinions on how to become a famous boxer; a politician casting pearls of partisan wisdom; an actress



whispering secrets of temporary beauty; a returned traveler confiding the curious customs of the Senegambians; and jazz orchestras, jazz orchestras, and jazz orchestras.

The impression of many listeners that radio programs are too much devoted to jazz is heightened by the fact that of necessity, all distance reception is carried on at night and everybody knows that the later evening slices of programs are invariably devoted to the local currently popular jazz orchestra.

Not even the most rabid demanders and defenders of jazz hardly insist on a steady radio diet of it. And those listeners who are in range of the Bell System wire tie-up who can hear the "pop" concerts, the Eveready Hour, the Goldman Band, and the WEA F opera company, have the opportunity to hear good music, played as it should be played. These are some breaks in what some months ago appeared to be an endless evening radio barrage of jazz. Considering this purview to be only moderately

accurate, one can sympathize with Mr. Russell's concluding plea: "Tell the broadcaster, to feed us provincials Bach, Beethoven, and Brahms, then Mozart and—but you know them all as well as I used to when I lived in London. That seems ninety years ago. Won't you give me a job sweeping your office, so that I can hear a symphony concert now and then?"

### The Popular Dinner Concert

THE dinner concert has come to be one of the most popular of radio features. The term is rather inclusive, for while many of the concerts are produced by musical organizations innocent of any saxophone and associated evils, not a few are out and out dance orchestras. The best dinner music on the radio is that furnished through WEA F by Joseph Knecht's Waldorf Astoria Rose Room orchestra and the Commodore Hotel concerts from WJZ. The Benjamin Franklin Hotel



THE "HOOT OWLS" OF KGW, AT PORTLAND OREGON

A popular organization heard frequently from the Portland *Oregonian* station. The members are business and professional men of the vicinity and their breezy entertainment is eagerly tuned-for, out where the West is. Left to right, Ashley C. Dixon, himself a broadcaster (KFJR); Allen Greeb; R. G. Calvert, Grand Skidoo; Charles F. Berg, Grand Screech; Henry W. Metzger, Grand Slam; Barnett Goldstein, Grand Schmoos; Tige Reynolds (cartoonist of the *Oregonian*), Grand Sketch; Frank J. Sardam, Grand Scream; and William R. Boon, Grand Skipano, at the piano

Concert orchestra, heard through WIP, Philadelphia is also deservedly popular. KHJ, Los Angeles, occasionally sends out the excellent concert orchestra of Art Hickman, playing at the Biltmore Hotel. The dinner organ recitals, played by Phyllis Griswold at the Rialto Theatre and broadcast through WOAW, Omaha are worth hearing, as well.

In Cleveland, WTAM frequently offers the popular music played by the Golden Pheasant orchestra. At WWJ, in Detroit, they have the curious custom of alternating selections played by a dance orchestra with classical music by an instrumental trio. The effect is highly disconcerting when one hears an old classical favorite immediately followed by "Collegiate," or "Don't Bring Lulu." That WWJ dinner program assures one that the wise individual who, in the dim rhetorical past, asserted that it was impossible to be both flesh and good red herring, had a great weight of truth on his side. There is something radically wrong with the microphone placing at WWJ's pick-up at the Hotel Statler, because the harp in the instrumental trio comes through like the fabled falling bricks, while the piano and violin do their best to form a melodic background.

The dinner programs from WTAM, Cleveland, WCX, and WWJ, Detroit are also distinguished

by a glaring, and what should be an unnecessary fault in broadcasting—that of long pauses between individual numbers. One can almost progress from the soup to the salad course during some of the Detroit program hiatuses.

### Station KSD's Fine Record

STATION KSD, of the St. Louis *Post-Dispatch* has long held its place among the best of our broadcasters. On June 26, 1925, the station celebrated its third anniversary, and a review of its activities show that its programs entitle it to the high esteem it has gained. During the three years, 1434 programs have been arranged, and 1383 individuals took part. The artists represented fifteen different nationalities, twenty-five states of the Union, and 115 cities of the United States. During the three-year period, 379 pianists and 310 vocalists appeared on their programs. There were also 71 children who appeared before the microphone, and a distressing total of 41 readers. The large number of the latter strikes us as curious, because radio listeners seem to be united in their dislike of readers.

The address of the late President Warren Harding was broadcast when he spoke at the St. Louis Coliseum on June 21, 1923. This was

the first time that the voice of a President of the United States had been broadcast. KSD has broadcast practically all of the important national radio political and non-political addresses which have been sent out over the long lines of the A. T. & T. Company.

During the first International radio broadcast tests, KSD was reported by a representative number of listeners in England. The station is under the capable direction of Miss V. A. L. Jones. One wishes the station, in that good old fashion of speaking, a long life and a merry.

### Reading of Applause Telegrams is Unnecessary

BY THE time this number of the magazine is published, station WJR of the Jewett Phonograph and Radio Company at Pontiac, Michigan, will be on the air with 1500 watts, transmitting at a fre-



JOE NOVAK

Giving one of his weekly lessons on golf from KGO, Oakland, California. Mr. Novak is a professional golfer and instructor and goes on the air at KGO, at 7:15, Pacific Coast Time every Thursday evening

quency of 579.9 kilocycles (517 meters). Corley W. Kirby, formerly director of station WWJ, of Detroit, is the director of the new station, and if he succeeds as well with his new charge as he did with the old, station WJR will leap into immediate favor. WWJ was licensed in September, 1921, which makes it the first American broadcaster. Mr. Kirby was associated with the station during its pioneering days.

Telegrams and greetings directed to WJR will not be read or acknowledged over the air during the inaugural program or later on, Mr. Edward H. Jewett, president of the operating company announces. He goes on, to say very sensibly: “Telegrams and greetings do not entertain those who are listening. They please only those persons who are mentioned in them. We want WJR to please the public, not ourselves.”

The number of first-class stations who read telegrams, whether they be from listeners in the next block or half way across the continent, is pleasantly small. No listener should be discouraged from sending his telegrams of appreciation to a station whose offerings please him. But it is hard to find an excuse for reading them over the air. And, we might add, the listener who feels a deep throb at hearing these telegrams read is probably the same person, who, in the cruder electrical days, spent much time in listening-in on party lines.

### The WGBS Prize Play Contest

**N**ANCY BANCROFT BROSIUS of Cleveland, Ohio, won the \$75 prize in the radio play contest conducted by station WGBS, New York in conjunction with WIP, Philadelphia and WGY, Schenectady. Hers was a one-act play entitled *Sue 'Em*. The play will be produced on the air through the three stations by the well known Province-

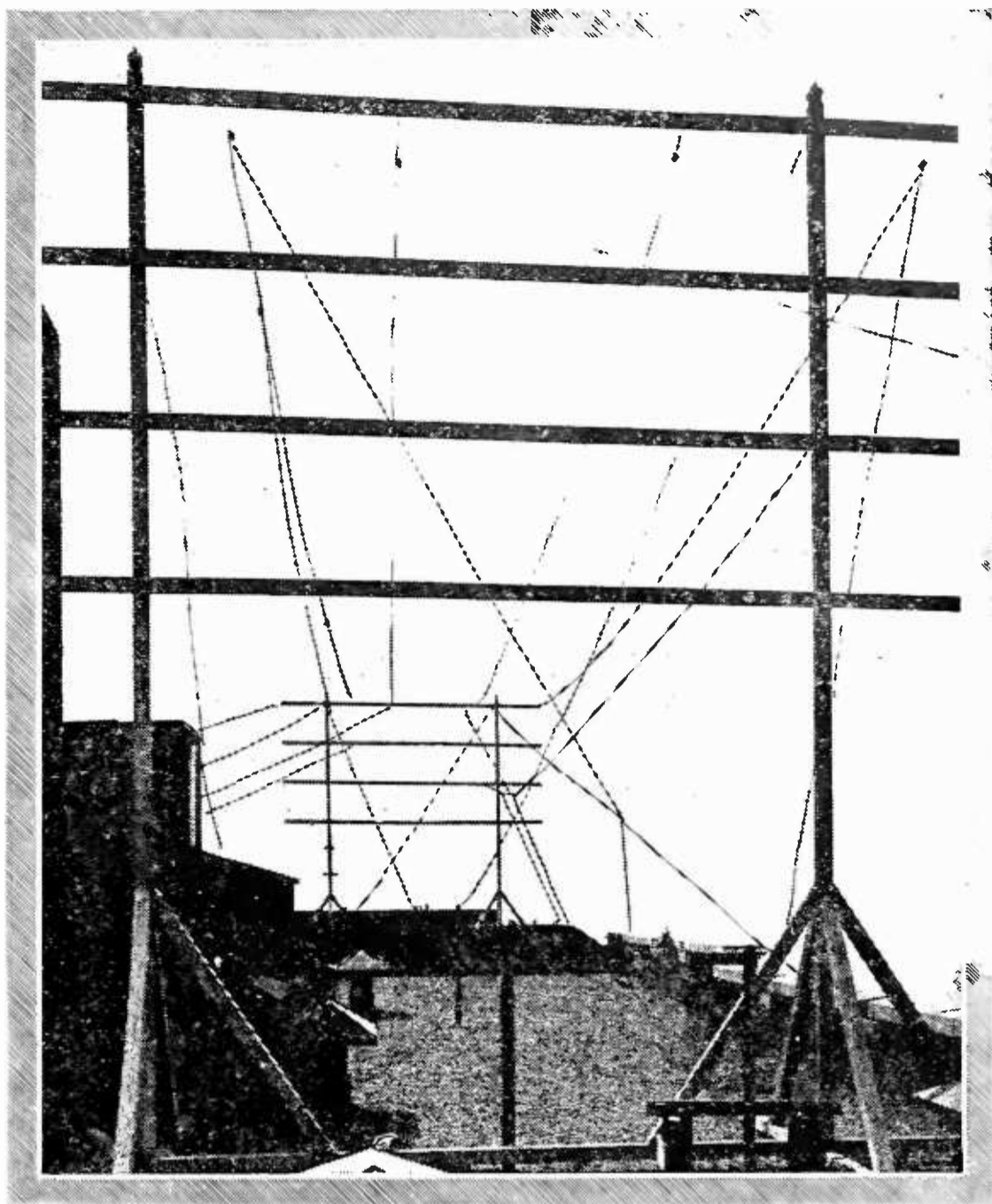

A RADIO APARTMENT IN SEATTLE

A picture of the roof of the Biltmore Apartments in that city. Provision has been made for twenty-four antennas—one for each apartment. The owner and architect, Mr. Stephen Berg, is an enthusiastic radio devotee himself. The local KFOA supplies the tenants with much of their radio enjoyment, but distant stations are heard as well

town Players of New York. Mr. Oliver Saylor, in making the announcement from WGBS during his charming “Footlight and Lamplight” period on a recent Thursday evening, said:

The most frequent fault which the judges found among the manuscripts was a failure to remember that radio drama, unlike good little children, is heard but not seen. A number of plays were submitted which might interest a Little Theatre, but the dependence on the eye was too great. Still another fault which was frequently encountered was the choice of a subject so fantastic that all the methods by which illusion is gained in an actual theatre would be necessary to make the play convincing.

Good plays are becoming more frequent over the air. Station WGY has produced a number of Mr. Cosmo Hamilton’s plays which have rightly met with enthusiastic approval. KOA and KGO have also been active with plays dur-

ing the summer months. Elliott Nugent's *Kempy* was recently produced by KGO with great success.

### Broadcast Miscellany

THE Sunday evening programs of WJZ and WGY are of unusually high standard. The Lakewood Farm Inn Ensemble, a Joseph Knecht group, led by Mr. Jan Weber, furnishes the first part of the program—from 7:45 to 9, Eastern Summer Time—and the delightful solo work of Godfrey Ludlow, violinist, the second half, which continues from 9 until 10. The Lakewood Farm Inn Ensemble never fails to present a program of varied interest, and their work shows that good music need not necessarily be boring or “high brow”—frightful term. Godfrey Ludlow, the staff violinist of WJZ, is an artist of very much more than ordinary talent and those in reach of the radio emanations of WGY and WJZ are missing a delightful feature if they do not hear his recitals. The accompanying verbal program notes of Mr. Milton J. Cross, the veteran announcer of WJZ are well presented, informative, and in excellent taste.

AND now to chronicle the temporary passing of “Roxy,” the impresario of the Capitol Theatre, New York, whose Sunday evening programs are heard over WEAf, WEEL, WJAR, WCAP, WCTS, WCAE, and WWJ. Mr. Rothafel will have a theatre of his own in New York and has severed connections with the Capitol, but the Capitol programs will continue as before with Major Edward Bowes, managing director of the Theatre, in charge. The “Gang”—excellent group of musicians that they are—are maintaining the standard of their programs quite as before. The musical quality of this very popular feature we have never questioned, but it must be admitted that the drooling sentimentality of the presentation spoils what would otherwise be an almost perfect program of its type. Mr. Rothafel deserves much credit for devising a genuinely new type of radio presentation, but why that presentation had to be constantly weighted with expressions of almost tearful sentiment and side remarks which somehow are invariably weightily saccharine—we could never understand.

STANLEY W. BARNETT, known to woc listeners as “BWS” has resigned his post as chief announcer at that station to assume similar duties at a new station now under construction at Baltimore, Maryland. His place at woc will be taken by L. E. Wass, a native of Davenport, Iowa.

OVER at WJZ, New York, they have started a feature which is great delight to a large number of invalids and those afflicted with blindness. At 4:10 P. M., Eastern Summer Time, J. B. Daniel, a staff announcer, reads short stories, novels, works of history, and general selections from good literature. It is dangerously near a bromide to say that radio has taken an almost irreplaceable part in the lives of those who are shut in. Radio stations receive more mail from persons who can not actively join in the life of the world than from any others. This feature could well be adopted by many other stations who desire to expand their field of service.

ON AUGUST first, there were 561 broadcasting stations in the United States, ten less than on July first, 1925. WEAf, New York, is now using 5000 watts, and WORD, Batavia, Illinois is now operating on 5000 watts. Among the long range stations, WGY has been testing recently with 50,000 watts, chiefly after midnight. WJZ expects to have 40,000 watts “in the air” about the time this magazine appears, although unexpected delays may retard this date a week or so more. KGO, Oakland, California is now using 3000 watts, WBBM, Chicago, and WTAS, Elgin, Illinois are using 1500 watts. In England, the Daventry station of the British Broadcasting Company (5XX) is now transmitting on a frequency of 187.4 kilocycles (1600 meters), using 15,000 watts (7500 watts, American rating), which brings the total of British stations to 22, of which eight are relay stations. 5XX should be heard in this country by listeners whose receivers can tune to that frequency. . . . Among those broadcasters gracefully retiring from the field are WDM, Church of the Covenant, Washington, D. C.; WWAo, Michigan College of Mines, at Houghton; WVAy, The Milwaukee Civic Broadcasting Station, Milwaukee, Wisconsin, and WRAA, The Rice Institute, Houston, Texas.

# In Which Some Discrepancies Are Cleared Up

Some Interesting Correspondence Relating to an Article by E. T. Flewelling in Our Friendly Contemporary, *Radio in the Home*

**W**E WERE surprised to find in the July number of our contemporary *Radio in the Home*, for which we have had a lot of respect, an article by E. T. Flewelling, one of the Associate Editors, in which a very severe criticism of a circuit appearing in RADIO BROADCAST for June was made. The attack was made on the Frequency-Changer or Super-Heterodyne Converter described by Mr. A. O'Connor of Cleveland, Ohio.

The various letters passing between Mr. O'Connor and the Editor of *Radio in the Home*, as well as our own office, point out quite clearly that we were perfectly justified in bringing the Frequency-Changer to the attention of our readers.

It did violence to some of our ideals of professional ethics to find that the Associate Editors of *Radio in the Home* find it advisable to criticize the technical articles appearing in RADIO BROADCAST. Some of our old readers will remember that Kenneth Harkness' first claim to fame came as a result of the publicity he received in connection with the single-tube reflex receiver described in RADIO BROADCAST in November, 1923. Following his connection with *Radio in the Home*, Mr. Harkness maintained, in an article appearing in that magazine, that resistance-coupled amplification was of no practical value. He seemed to forget that one of the principal objections to resistance-coupling had been overcome when the dry cell tube and the quarter-ampere storage battery tube had been developed. If there are any among our readers who have a notion that resistance-coupling is not worth while, we shall be delighted to demonstrate a resistance-coupled receiver for their benefit at any time they would like to visit our laboratory.

The situation with regard to the O'Connor Frequency-Changer may well be understood by reading the letters which follows:

June, 26 1925.

Mr. Henry M. Neely,  
% Henry M. Neely Pub. Co.,  
608 Chestnut St.,  
Philadelphia, Pa.

DEAR SIR:

The writer has just read with a great deal of interest the article entitled "Why Not a Super-Het Converter" in July issue of *Radio in the Home*. Your "word of explanation" was particularly interesting.

I am glad to see that Mr. Flewelling was finally clever enough to "tackle it right" and got the circuit working. He may be interested in knowing

that numerous BCL's have had wonderful success with the circuit in June RADIO BROADCAST, (to which he referred.)

The writer has read your magazine from the beginning with a great deal of interest and while not always agreeing with you, has admired you for having the courage of your convictions. I am, however, very much surprised in this issue to notice that your magazine allows a direct slam at such a high class magazine as RADIO BROADCAST. Mr. Flewelling by this time should know that RADIO BROADCAST will not publish a circuit until they are absolutely sure that it is correct. I don't think that Mr. Arthur Lynch is going to like Mr. Flewelling's remarks in your "word of explanation."

Very truly yours,  
A. O'CONNOR.

June 30, 1925.

Mr. A. O'Connor,  
9702 Euclid Ave.,  
Cleveland, Ohio.

DEAR MR. O'CONNOR:

It was with something like a shock that I learned from your letter of June 26th that the magazine to which Mr. Flewelling made unfavorable reference was RADIO BROADCAST. I thought at the time of publication that the magazine was . . . and that is why I let the Flewelling remarks go as they were. If I had known that they referred to RADIO BROADCAST, I should not have printed them because I can assure you that no one in the whole radio field has a higher respect for RADIO BROADCAST nor a greater personal liking for Arthur Lynch, Editor, than I have.

Yours very truly,  
HENRY M. NEELY.

July 7, 1925.

Mr. H. M. Neely, Editor,  
*Radio in the Home*,  
608 Chestnut St.,  
Philadelphia, Pa.

DEAR FRIEND NEELY:

A few months ago you took RADIO BROADCAST for a rather severe ride concerning resistance-coupled amplification, and Kenneth Harkness, one of your Associate Editors, said that resistance-coupling should never have been taken from the grave in which it was peacefully reposing, or words to that effect. I cannot refrain from putting you on the pan this morning for a little roasting and trust that you will take what I have to say in good part, as I know you will.

On page 14 of the July, 1925, number of *Radio in the Home* we find a rather interesting disserta-

tion by Flewelling on "Why Not a Super-Het Converter?" Among other things Mr. Flewelling says: "In discussing the subject with H. M. N., I started a line of thought that appealed somewhat to both of us as one that should prove of very great value to the public as a whole so far as its selectivity problems are concerned. The thought is not entirely new, because more than one engineer has probably given time to it, but, so far as we know, it has never been given to the public."

In the editorial box accompanying this article we find the following statement also credited to Mr. Flewelling: "The Super-Het converter is working great. I see that another magazine hit at it in their June issue. The thing doesn't work, however. I know several good men who have tried it and found it a dud."

With regard to the first statement that the super-het converter is not entirely new, Mr. Flewelling is entirely right. A similar idea was described by George J. Eltz, Jr., in RADIO BROADCAST for December, 1923, and another arrangement of the same general character was described by Zeh Bouck in RADIO BROADCAST Lab Department for January, 1924. A wave-changer described by Mr. A. O'Connor employing the same principle was published in RADIO BROADCAST for June, 1925, and it is evident from what Mr. Flewelling has said that it is our frequency-changer which has been characterized by him as a dud since we have not been able to discover an article on the frequency changer in any of the other periodicals in their June number.

Mr. Flewelling is wrong, impossible as that may seem. The O'Connor wave-changer is anything but a dud. We have used it in our laboratory for months and have tried it in connection with all kinds of receivers. It works in an extremely satisfactory fashion and we know definitely that a great many readers of RADIO BROADCAST have built this Frequency-Changer and are finding that it works as well for them as it does for us.

Now, we don't mind having somebody grab off our ideas, and put a new face on them and call them new, but we do hate to have our competitors publish statements which in themselves are untrue—and the statement that our frequency-changer is a dud is untrue—and if you don't think so, come over to Garden City and I will

be delighted to show you how well it works. In fact, I will go further than that if you think it is necessary, and drop in at your own laboratory with the Frequency-Changer under my arm.

We, as you know, are trying to do a good job on RADIO BROADCAST and we feel sure that you are attempting the same thing in your field. We feel that the attack on our technical accuracy is entirely uncalled for, and in this instance, entirely unjust. We believe that in fairness to us, a statement from you and one from Mr. Flewelling appearing in your paper concerning the O'Connor Frequency-Changer described by us should be made.

I have not overlooked your magnanimity in proclaiming RADIO BROADCAST's Roberts Knock-out the most popular circuit of the season. And for this statement I am duly grateful.

Cordially yours,  
ARTHUR H. LYNCH, *Editor*,  
RADIO BROADCAST

July 29, 1925.

Mr. Arthur H. Lynch, *Editor*  
RADIO BROADCAST,  
Doubleday, Page & Company,  
Garden City, N. Y.

DEAR ARTHUR:

As I told you during the chat we had at Atlantic City, I am extremely sorry that the attack made by Flewelling on your Frequency-Changer should ever have been made, and I am equally to blame for having published it without having made a thorough investigation.

It was an error, and you may be sure we will make every effort to coöperate with you in repairing any damage it may have done.

Cordially yours,  
HENRY M. NEELY, *Editor*,  
*Radio in the Home.*

The letter above is characteristically a Neely letter. Mr. Neely is broad-minded enough and honest enough to admit a mistake and make every effort to try to rectify it. Which should close the subject.

---

**A** COMPLETE receiver has been designed by RADIO BROADCAST with two aims in view—high quality in the audio side of the circuit, and operation of the audio amplifier tube, and the plate supply of the radio, detector, and first audio tube directly from the alternating current house supply. The receiver circuit is a tried and true design. Overloading—that general fault in audio circuits is avoided by the use of a power tube, entirely operated from a. c. This receiver for home construction will arouse a great deal of interest because it takes the lead in current receiver design—a sensitive circuit, used with an audio amplifier whose quality is irreproachable. An article fully describing this receiver will appear in an early number.

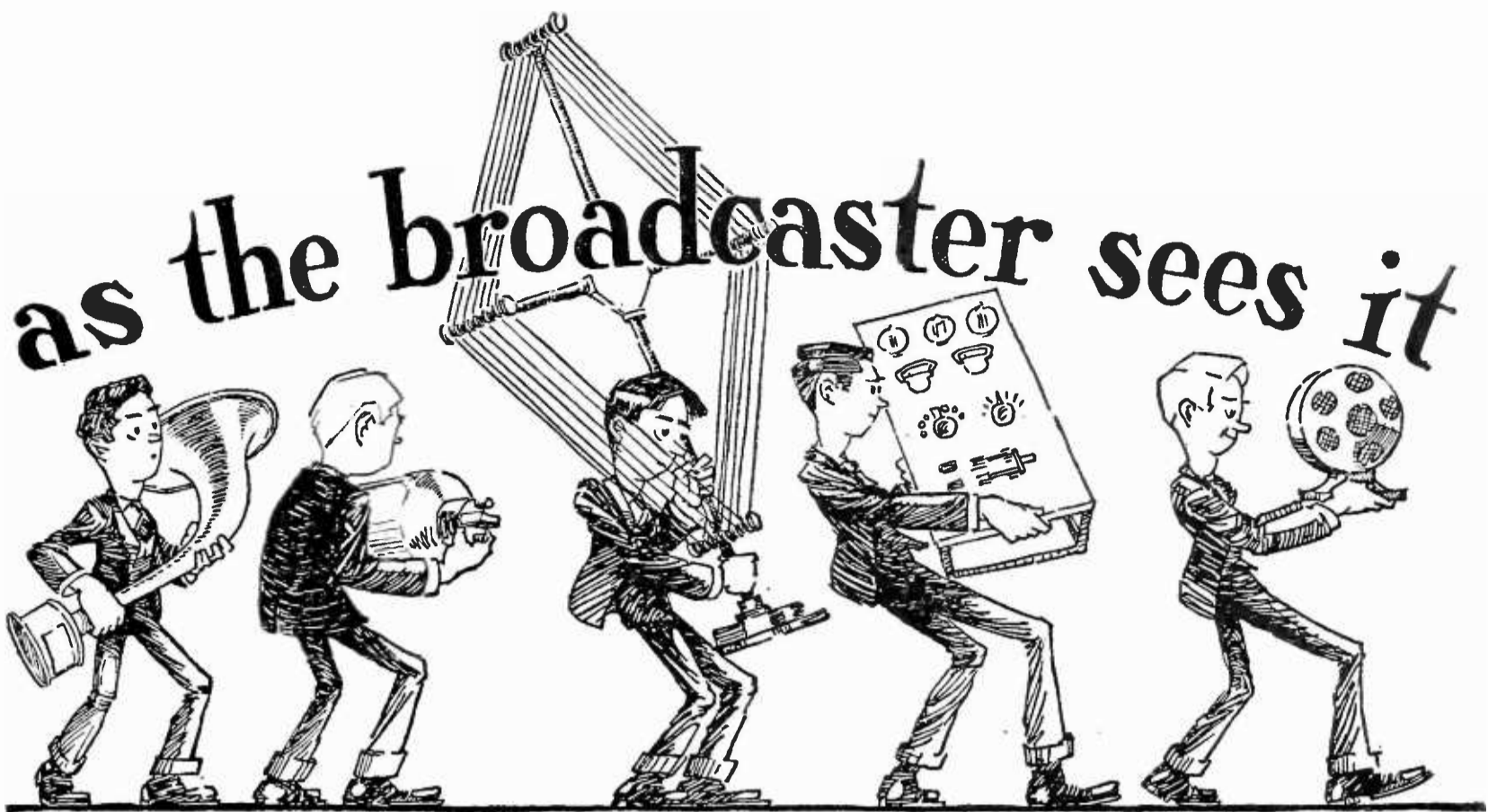

by CARL DREHER

F.F. STRATFORD

Drawings by Franklyn F. Stratford

## A Debate: Resolved, That 500-Watt Stations Are Not Sufficient for Program Service

*Affirmative:* Mr. Dreher

*Negative:* Professor Williams, WHAZ

**I**N ANSWER to your article on "Radio Power and Noise Level" in your September issue, which I have read with great interest," writes Professor Williams of Rensselaer Polytechnic Institute, "I must confess surprise at finding an article in your magazine written on such a high noise and such a low power level.

"As stated in your article, I do object to raising the power level of broadcasting stations for the same reason that I object to increasing the time assignments of existing broadcasting stations, and the addition of new broadcasting stations. All these changes increase the amount of interference

**R**EGULAR readers of this department will recall that Mr. Dreher took exception to statements made by Professor Williams of Rensselaer Polytechnic Institute in a recent address at Hartford. Professor Williams contended, in brief, that the proposal to permit the operation of long range broadcasting stations was technically unnecessary and that the familiar 500-watt broadcaster produced a satisfactory signal under most conditions. Mr. Dreher particularly took exceptions to Professor Williams' remarks about power level. Professor Williams has been good enough to amplify his ideas and they, together with Mr. Dreher's reply, are printed below. The subject is important, for it concerns every broadcaster and every broadcast listener. Intelligent discussion of the subject can do a great deal to clarify opinion on this much-discussed question of "super-power" and we believe that the remarks printed below do precisely that.—THE EDITOR.

experienced by radio listeners. It is strange, but true, that while the electric light and power companies, the telephone companies, the radio amateurs, and, in fact, all users of electrical energy who have been causing radio interference, have done everything within reason to eliminate interference, the broadcasters have done everything possible to increase interference. They act as if they want to make conditions so bad that the Government will have to step in with drastic governmental regulation. No doubt some of the more influential broadcasters might gain a material advantage through such a procedure, but the

great majority of broadcasters would find themselves in a position much worse than that which they previously enjoyed.

“In order to make my position on the question of power level perfectly clear to your readers, I will quote exactly what I said on this subject in my talk on interference at Hartford, Connecticut. ‘The other limitation, which is the more important, that must be imposed upon radio broadcasting is that of intensity or power level. If we allow a large variation in power level, we make it extremely difficult to design and construct receiving equipment which can be operated by the average radio listener with equally good results over the whole intensity range. We in Troy have experienced more trouble from this source than from any other in the whole field of radio broadcasting. Radio listeners have constructed for themselves or bought so-called super-sensitive sets with which they hope to hear the Pacific Coast and European stations; also the Troy and Schenectady stations. It has been our experience that it is impossible for the majority of these people to receive satisfactorily either the distant or the near-by stations. The near-by stations have an intensity which is too high to be received without distortion. The distant stations have a power level which is so low that they cannot be received in many locations without sufficient noise to make the reception unpleasant. You may think that this condition is the fault of the radio listener, and that he can be educated to use his set in such a way that these difficulties will be overcome. This is undoubtedly true in most instances regarding the reception from near-by stations, but it is not true regarding the distant stations. There is no place—at least I have been unable to find a place—where there is a zero noise level. The noise level does vary greatly at different locations, and a sensitive set which may function satisfactorily at one location will prove to be entirely unsatisfactory at another location. It is therefore evident, that at each location, there is a minimum signal strength which can be satisfactorily received on the most sensitive receiving set and if we attempt, at this location, to receive a program from a station which has a signal strength below this minimum, we receive so much noise along with the program that for all practical purposes the program is ruined. At first sight, it would appear that we could lower this minimum signal strength to any desired value by eliminating, in the territory considered, the various sources of noise. Theoretically this is possible, but practically and economically it is impossible. If the radio listeners require the Public Service Corporations operating in their territory to reduce the noise level produced by them, they would require these corporations to spend vast sums of money in changing equipment, improving insulation, etc. Eventually the public, which includes the broadcast listeners, would have to pay for these improvements. This would mean that the cost to the consumer of the services he receives from these corporations would increase proportionately. If the broadcast listeners carried their demand to the limit of no, or

nearly no noise, it would mean that the public could not afford to pay for the service rendered by our public utilities, and the broadcast listeners would be, in fact, sacrificing the benefits they now receive from these corporations for the sake of improving and extending the range of their broadcast reception. As stated earlier in this talk, no one, when he realized what he was doing, would be willing to make this sacrifice. It is, therefore, necessary to establish a reasonable lower power level limit. Then if any particular broadcast listener wishes to construct or buy a sensitive receiver, which will receive programs below this power level, he should do it with the knowledge that, in general, he will not be able to use the extreme sensitivity of his set without experiencing disagreeable interference. If he is made to understand that what he is doing is, in every way, equivalent to placing a symphony orchestra in a boiler shop, very few will be foolish enough to do it, and our troubles from interference will be very materially reduced.

“‘With regard to the upper power limit, there is room for considerable difference of opinion. Our experience in Troy has convinced us that there is no necessity for these superpower broadcasting stations. When we know that a 500-watt station can be consistently heard throughout the cool weather all the way across this continent in one direction, and in Europe in the other direction, we can hardly be criticized for taking the stand that a power level of approximately this value is sufficiently high to meet the needs of the radio audience. When it is necessary to lift the power level all over the country, when something of national importance is being broadcast, it can be done very satisfactorily by linking by wires several broadcasting stations, chosen on account of their location.’

“Comparing the above with your remarks in the September RADIO BROADCAST, it is evident that we are in substantial agreement with regard to the necessity for a low power level limit. If this level is established sufficiently high so that ‘static’ interference is not disagreeable, we can unquestionably keep man-made interference at the same level as ‘static’ interference, and thus also avoid this form of interference.

#### SUPER-POWER VERSUS SUPER-BROADCASTING

“WITH reference to the upper power level, we agree that this should be maintained as high as practicable, and differ only in our methods of obtaining this high power level over large areas. Your method is to use a super-power broadcasting station; my method is to use a super-broadcasting system, by which I mean, as stated above, several broadcasting stations of approximately 500 watts connected by wires. With your system you would have an excessively high power level in the neighborhood of your super-power station, and this power level would fall off rapidly with distance from your station. With my method you would not have an excessively power level at any point, and you would have a more uniform power level over the



area to be covered by the program. By my method an average power level could be maintained at a higher value than by the one you suggest.

"You use the electrification of our railways as an illustration of the centralization of power production, which you think should be followed in the case of radio broadcasting. Do you propose a super-generating station at the central points of our transcontinental railway systems to feed energy over the entire line? Do you not know that it is the intention of those who are considering the electrification of our railway systems to take the power required from our super-power systems? And what is a superpower or giant power system in the minds of those who are forming them? It isn't a super-power plant, but a relatively large number of generating stations connected by transmission lines. In such a system, the electrical energy consumed in a given locality is, under ordinary operating conditions, produced at the power plants originally designed and constructed for supplying the energy to that part of the system serving the given locality. This system is interconnected by transmission lines with its neighboring systems so that, when necessary, there can be an interchange of energy between the distributing systems by means of the connecting transmission lines. The general opinion of power engineers on this subject is stated, as follows, on page 438 of the July 1925, *National Electric Light Association Bulletin*:

During the past decade, the rapid growth of the industry has required the greatest amount of attention to a development which was marked at every step by notable increases in size and capacity of the individual components of our physical plants. In studying the trend of growth for the future, it is quite likely that the necessity for a continuing increase in capacity of equipment will be far less than we have been forced to meet during the past decade. Further increases will be largely determined by the economics of the situation, and while estimates of future growth indicate that the total energy demand will treble during the next ten years, there is little likelihood that unit capacities of equipment for generation and distribution will increase in anywhere near the same ratio.

I have been intimately associated with the electric light and power industry for the past twenty years, and am not aware of any tendency in the direction of super-power plants, but am entirely in sympathy with the trend toward the consolidation of transmission systems, and the ultimate establishment of the so-called super-power systems.

#### LINKING A DEVELOPMENT IN THE POWER AND COMMUNICATION FIELDS

"IN THE communication field we have a similar development. The local telephone exchange gives the community which it serves local telephone service. The American Telephone and Telegraph Company, with its long distance lines interconnects these local telephone exchanges into a super-telephone system, which gives national telephone

service. The writer has studied the development of the telephone industry in this country for the past fifteen years and is unaware of any tendency toward the development of a super-telephone office, but is aware of the fact that the interconnection of these offices by telephone transmission lines has produced the super-telephone system.

"In your article you endeavor to show by computation, the advantages of a 50 kw. broadcasting station from the point of view of economy. Let us carry your argument a little further, and see what conclusions we arrive at. On Page 117 of the November, 1922, *Bell System Technical Journal* we find the following:

Economy of transmission requires the handling of messages at as low an energy level as possible and, as the author points out, wire transmission satisfies this requirement much better than radio. Referring to the transcontinental line with radio extensions, which was used recently to talk from Catalina Island in the Pacific Ocean to a ship in the Atlantic Ocean, it is stated that, had all of the necessary energy been introduced at one end of the circuit, there being no intermediate amplification, the total power required would have been  $1.8 \times 10^{29}$  kilowatts, an amount unavailable in the world. In the actual system, distributing the amplification along the transmission line, the power required sums up to something less than 1 kilowatt.

This statement needs no amplification by me. I have used it for the reason that the data have been taken from an actual transmission problem and is, therefore, not academic. If your readers will write down 18 with twenty-eight zeros after it before they come to the decimal point, they will have some idea of what will be required in the way of a super-power station if you wish all the amplification to be transferred from the receiving set to the transmitting set, which is the development suggested in your article.

"The super-broadcasting system, suggested in my article, operates on exactly the same principle as that used on this transcontinental line. It would be operated between perfectly definite power level limits and for the same reason that the transcontinental telephone line is operated between perfectly definite power level limits. In telephone transmission, the power level must be maintained above the noise level so that the noise does not interfere with articulation. The upper power level is maintained as low as practicable so as to reduce the interference between the various telephone circuits. The electric light and power engineers in this country are very anxious to have the communication systems increase their power level, as it would reduce very materially the interference produced by the light and power systems in the communication systems. The telephone engineers object to raising their upper power level because they know, from experience, that increasing this upper power level increases the interference from one telephone circuit into another. Increasing the upper power level for broadcasting by the use of super-power stations produces practically the same

kind of interference between stations in the receiving sets, and when broadcasters have had a little more experience they will be no more anxious to increase their upper power levels than are the telephone engineers.

#### LOCAL BROADCASTERS AS OPPOSED TO "SUPER" ONES

“CONTRARY to the statements made in your article, if we wish to take advantage of the past experience of power and telephone engineers and develop broadcasting along similar lines, we must have local broadcasting stations for local service, which may be interconnected, thus forming super-broadcasting systems when we wish important programs to cover large areas efficiently, economically and with minimum interference.

“We are at a loss to understand why your magazine has completely reversed its opinion with reference to 500-watt stations. Two years ago this winter you asked WHAZ to cooperate with you in your transatlantic tests. At that time we were using a little less than 500 watts in our antenna and yet, according to your own report, we made a very creditable showing in spite of the fact that a larger powered station operating on the same wavelength, occupied approximately one half of our broadcasting period, leaving approximately only eight minutes for the broadcast listeners on the other side of the Atlantic to tune-in station WHAZ. These and other long distance listeners were not, as you say, ‘batted in the ear by crashes of static, violet ray machines, electric bells, door-openers, and other miscellaneous natural and artificial noise makers.’ If you will procure and read a copy of the National Electric Light Association’s serial report of the inductive coordination committee, technical national section, *Radio Interference* published July, 1925, you will find that arrangements have been completed for making the noises you refer to part of radio’s ancient history. Why resurrect this corpse and use it for an argument in favor of super-power stations?

#### WHY WHAZ ISN’T HEARD OFTENER?

“THE real reason why fewer long distance listeners are unable to pick out ‘the mystic letters WHAZ’ is because they are ‘batted in the ear’ by their so-called local superpower and the squealing produced by the heterodyning of carrier waves from too many stations broadcasting simultaneously.

“You say that ‘a large station costs a pile of money and all that one gets from the disbursement, besides the ability to address the populace, is the privilege of spending a lot more cash to keep the thing going.’ This statement would lead one to believe that the scramble one witnesses at a radio conference for more time, more stations, and more power is due to the anxiety of the broadcasters to spend their money for nothing. This is absolutely false. The reason why our present broadcasters are asking for more time and more power, and new broadcasters wish to enter the field, is because they know ‘it pays to advertise.’ What sense is there in telling the public that radio broadcasting

stations are philanthropic organizations, when anyone who has sense enough to read knows it isn’t so? Can any one imagine the stockholders of a radio manufacturing concern voting large sums of money to be spent for entertaining the public without any money return to the corporation? The groaning broadcasters referred to in your article are as hard to find as the missing link which would have been of so much value recently at Dayton, Tennessee.

“You say that ‘among all the sounds heard in broadcasting studios, the jingling of the cash register is the least frequent.’ Do you not know that no one expects to find cash registers in the advertising department of any business, and that they are found in the sales department? Any one who has purchased radio apparatus has heard the cash register jingle more than once. The stores that operate broadcasting stations have their cash registers behind the counter or in the cashier’s cage. The hotels that operate broadcasting stations have their cash registers in the cashier’s cage, etc. If the cash register manufacturers are losing business through broadcasting, the writer doesn’t know it.

“In your enthusiasm for those who have money to spend on super-power stations you say ‘If Mr. Williams wants to reduce station interference, he should advocate a reduction in the number of poor transmitters by enforcing decent standards of service, instead of opposing the sound engineering adjustments of organizations with the resources and determination to maintain the progress of the art. And, if he will ponder a little on the difference between the ‘I-think-I-heard-your-station-last-night’ range, and the effective service range of a station, he will perhaps reconsider an argument which is reminiscent of the early days of automobilism, when it was decreed that a flagman had to walk ahead of each automobile to prevent it from scaring horses.’ Let us look into this matter and see if it is as foolish as it sounds. Bringing the idea of your flagman up to date, are you not aware of the fact that the 1925 flagman is represented by our various State Motor Vehicle laws, with the required personnel for enforcement? And why is the 1925 model flagman necessary? It is because automobilists, with resources in the form of automobiles and determination in the form of a well filled gas tank, have attempted to use our public highways without due appreciation of the rights of others to use these same highways unmolested. Are you asking me to advocate the construction and operation of super-power stations by those organizations which have the necessary financial resources and influence, to mislead them into believing that they may ride rough-shod through our ether highways, without any regard for the rights of those localities that wish to operate lower powered broadcasting stations, and use the same ether highways unmolested? We agree that there are too many 500-watt stations operated simultaneously at the present time. We also know that conditions will be worse than they are now, if all these stations

increase their power. This is why I refuse to advocate the use of super-power. I know that each section of these United States has as much right to the use of the ether as any other section, and I do not believe the American people will ever stand for a monopoly in broadcasting, either by one section of the country or by one corporation.

LIMITATION OF POWER NECESSARY

“SINCE each section of the country has an equal right with every other section to broadcast, we must expect to have a relatively large number of broadcasting stations, and the only possible way of operating them simultaneously, without annoying interference, is to limit their power. The separate stations can then operate independently for local service and can be linked together by land wires for national service. If this method were followed, there would be less necessity for a flagman of the ether and I am of the opinion that the fewer laws required to regulate broadcasting the better for everyone. This is a question, however, which must be eventually settled by the radio audience, so let us see who they are.

“In your article you ask ‘What is the radio audience and what are its demands?’ You indicate your answer as follows: ‘We shall be surprised, indeed, if the members of this WHAZ audience do not send us loads of poisoned cigars, live tarantulas, and infernal machines.’ We will have to part company with you on this subject also, as we have found the radio audience intellectually on a par with the broadcasters and we are very grateful to them for the manner in which they have shown us their appreciation of our endeavors in the broadcasting field. They believe in free broadcasting as thoroughly as they believe in free speech. They have indicated in the past that they can recognize a monopoly in the forming and that they have no intention of standing for a radio monopoly. We believe that the radio audience are intelligent and that if they decide to have a radio broadcasting station of any size in a certain locality and are told that the cost will be prohibitive, they have back-bone enough to start an investigation to determine why powerful radio broadcasting equipment is so expensive, and determination enough to carry the investigation through to a conclusion, and thus put the skids under that argument.

RADIO AT WHAZ

NOW I wish to say a few words regarding the broadcasting activities of this Institution. The Rensselaer Polytechnic Institute has had broadcasting equipment since the winter of 1909-10. It was procured at that time because we believed it had a great future, although it was known then by the unpretentious name of a wireless telephone. We believe that, in the future, innumerable practical applications will be found for high frequency electrical energy and for that reason we are, at this time, designing and constructing an addition to our radio laboratory, which will give us approximately 3000 square feet of addi-

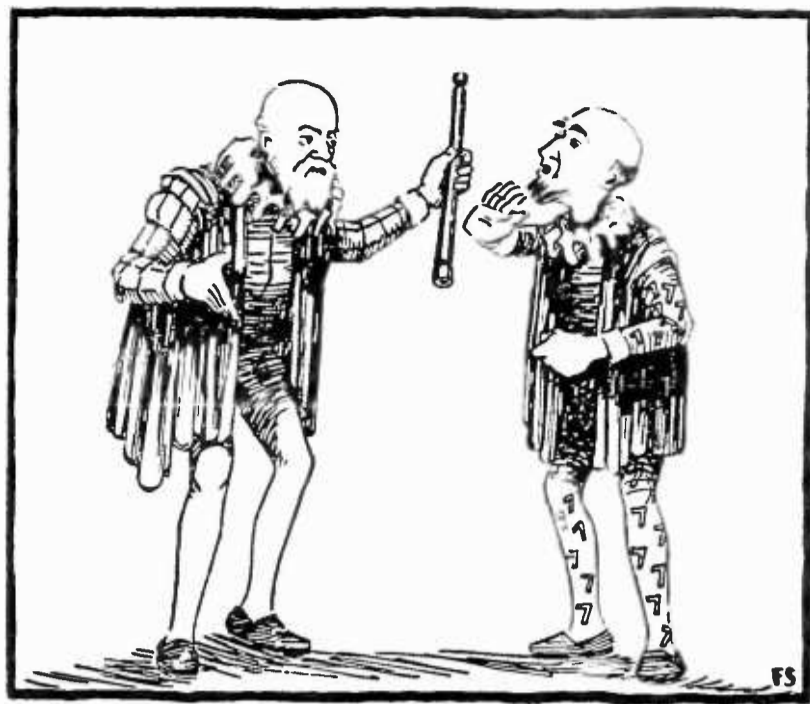

Sizzi wouldn't have those moons

tional floor space. Educational institutions are not made of money but some of them have an uncanny way of looking into the future. This Institution intends to use this additional laboratory space for laying the foundation for our part in this future development. As soon as we find it necessary for our purpose to have a 5 kw. or a 50 kw. transmitter, we will have it. You may rest assured on that point. We have been drawn into this broadcasting controversy because we had the audacity to use our laboratory equipment for part of one evening each week for broadcasting. Practical engineers, to say nothing of academic ones, never start anything they can't finish, so you are quite likely to find this station interested in this controversy until a solution is found which meets the needs of the American public.

“In closing, I wish to restate what everyone knows, who has anything to think with and uses that God-given power:

- (1) The American people are worthy of, and will have, the best local, national and international broadcasting, and they will have this service with a minimum amount of interference.
- (2) In order to reduce interference, upper and lower broadcasting power levels must be established.
- (3) There are too many Class B Stations operating simultaneously, and to allow these stations still further to increase their power can only result in making conditions worse.
- (4) The most economical, efficient and satisfactory system will limit the power used by stations for local broadcasting, and will unite these local stations into a super-broadcasting system for national service.
- (5) There can be no private broadcasting monopoly, either by a section of this country or by a corporation.
- (6) It pays to advertise—broadcasting at present is advertising, therefore, broadcasting pays.
- (7) The radio public pays for broadcasting and what they pay for they will control.”

## Mr. Dreher's Reply

**A**LONG in the very early part of the seventeenth century, Galileo, having devised a sufficiently effective telescope, was able to view the four moons of Jupiter. When he announced his discovery, all the Aristotelian astronomers of the day, who had their jobs and were satisfied with the heavens as they knew them, rose in horror. One Sizzi, a learned star-gazer of Florence, declared that as there were only seven apertures in the head: two eyes, two ears, two nostrils, and one mouth; and as there were only seven metals (he was sure of that), and seven days in the week, so there could be only seven planets. Being persuaded that the four satellites were actually visible in the telescope, the scholarly Sizzi shifted his position a trifle. He now argued that as the circumjovian planets were invisible to the naked eye, they could exercise no influence on human beings, they were useless; finally, therefore, they did not exist. In short, Sizzi just wouldn't have those moons, and that was all there was to it.

With apologies, I must confess that Professor W. J. Williams' remarks regarding my article on "Radio Power and Noise Level" in the September RADIO BROADCAST affect me much like the arguments of the staunch conservative Sizzi in his day. It is true that I have not invented a telescope, nor made any celestial discoveries. With touching modesty, I confess that I see no resemblance between Galileo and myself, but I do feel that a comparison between Professor Sizzi and Professor Williams is not too far fetched. As Sizzi clung desperately to the mystic number *seven*, so Mr. Williams will never abandon *five hundred*. Five hundred watts, that's the power for a good honest broadcasting station! It was good enough in 1922, and why shouldn't it serve now? *In youth it sheltered me, and I'll protect it now!* as we used to declaim in the high school elocution classes. As for any higher power, Professor Williams simply won't see it.

At no point in his argument is Professor Williams courageous enough to discuss, simply and without obfuscations my contention that the addition of a stage or two of audio amplification to the listener's

signal, *without a proportionate rise in the noise level*, would improve broadcasting as a public service, stabilize the industry, free it to a great extent from seasonal variations, and benefit everyone concerned except, perhaps, the owners of a few antiquated and unprogressive broadcasting stations. Instead, he begins with a restatement of his dicta on noise level. He has apparently never heard of an effective volume control on a receiving set, for he repeats his entirely erroneous notion that it is not feasible to design receiving equipment capable of distortionless reception from powerful near-by stations as well as distance work. Such a sensitivity control costs about twenty cents, and there are almost as many ways of doing the thing. His attitude toward radio noise is apparently quite fatalistic, as in his Hartford address, where he declared that the radio art, being in its infancy, must be expected to be noisy! This is like saying that there is no reason why men should wear belts or suspenders, for they can hold up their trousers with their hands. He compares distance reception to placing a symphony orchestra in a boiler shop, and says that it is a very foolish thing to do. There we agree. But it is not half so foolish as continuing to suffer noisy reception when one can overcome these disturbances. I do not understand Mr. Williams's supine and complacent attitude with regard to this problem. An engineer is not expected to turn his back on difficulties; he is supposed to be trained to overcome them. By increasing transmitter power, we can proportionately reduce amplification at the receiver, thereby riding over disturbances without any increase in station interference whatsoever. Professor Williams, who is not a radio engineer, and whose talk, to which I took exception, was not delivered before an audience of radio engineers, persists in dragging all sorts of bogeys into the field which it has pleased him to invade at this late date. Finally, when he does come down to figures, he quotes the computations of a telephone engineer, which I used myself in an article for *Radio* two years ago, to the effect that, if one tried to get as much voice power at the receiving end of a line, without repeaters, as one can get with them, the required input to the line would be  $1.8 \times 10^{29}$  kilowatts. This is glorious, but what is its relevancy? This is what Professor Williams calls carrying my argument for a 50 kw. station "a little further." By what right? I gave my figure, and I knew what I wanted to say. If I want to ride from Boston to Providence, must I go on to Washington, because the conductor of the train goes that far?

Apparently Mr. Williams sees some antithesis between wire line transfer of programs and superpower. He devotes several hundred words to arguments in favor of linking up stations by wire lines. Every radio engineer will agree with him heartily. We know the advantages and disadvantages of wire lines, and use them whenever it is expedient and we have the money to pay for the lease. But if all the 500-watt stations in the country—to name the power which has become Professor Williams's fetish—were to be linked up by wire lines, there would still

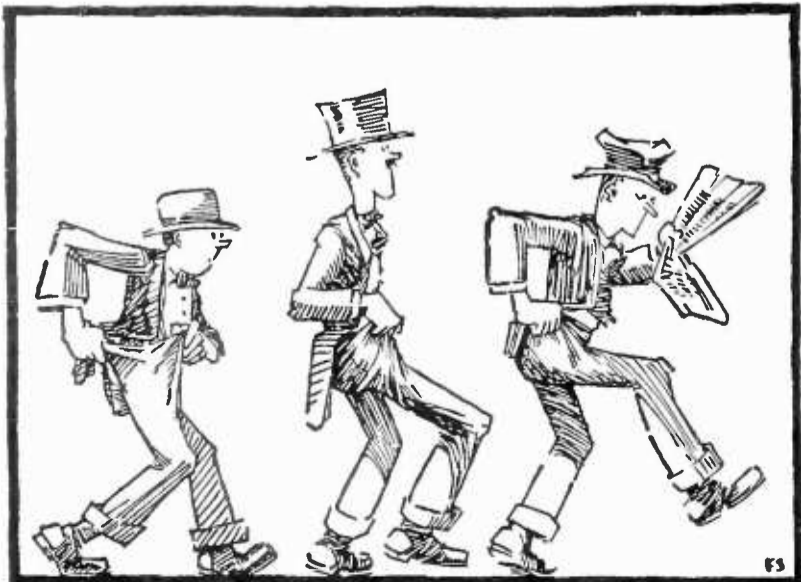

why wear belts or suspenders?

be vast areas unprovided with program service, and every time a lightning storm came up (static has remarkably little respect for 500 watts in the antenna) all the listeners who lived more than a mile from one of those stations would encounter a certain amount of unnecessary interference. By all means, when we have stations of adequate power, let them get their modulation as best they can—by bringing their artists to the studio in airplanes, or by the use of wire lines empty thousand miles long, or in any other way that works.

#### CONTINUOUS PROGRESS IS NEEDED IN RADIO

PROFESSOR WILLIAMS' complete insensitivity to the need for continuous progress in a field like radio broadcasting amazes me. I should like to know, for example, what he would do about transoceanic or international broadcasting. Would he permit the erection of a super-power station or two for that purpose, or would he forbid that also, on the ground that it might interfere with reception in the rural location in which it would naturally be placed, or that it might encourage the growth of, the nefarious monopoly which agitates Professor Williams's imagination so violently? Would he try to send a program over to France for re-broadcasting there, or get one from England, with his all-encompassing  $\frac{1}{2}$  kw.? His predilection for that power reminds me of nothing so much as the sacred decretals of the pious Bishop Homenas in Rabelais, with which he hoped to redeem mankind, and to accomplish all things good. It is not at all certain that the Professor would not attempt this, for he says flatly, in his reply to my article, that the European listeners to WHAZ in the transatlantics

two years ago "were not, as you say, 'batted in the ear by crashes of static, violet ray machines, electric bells, door-openers, and other miscellaneous natural and artificial noise makers.'" Heaven, then, intervened with a miracle, and the European listeners heard WHAZ against a quiet background. Has the man ever listened to DX at all, or is he only writing about it? Luckily for the radio business, a lot of radio listeners are situated so close to broadcasting stations that they are able to get quiet reception, by virtue of the powerful fields that Professor Williams can't abide, even in prospect; but before we get through there is no reason why everyone who wants to buy a radio set, should not be able to enjoy freedom from disturbances practically all of the time.

Professor Williams is an optimist. He says artificial inductive noises have been eliminated. He quotes a report. Well, then it must be so. Only, someone should inform the noises that they have been eliminated. With all due credit and encouragement to the men working on this problem, I am bound to say that considerable noise is still getting by them. Besides, Professor Williams himself points out that there is a limit below which it is not practicable to go in electrical noise suppression. The remedy lies only partly in attacking artificial noise at the source; the signals of broadcasting stations should be brought up to a level where every cat rubbing his back against a fence will not interfere with reception.

In the matter of the electrification of railroads, and giant power, I will yield the field to my opponent. There I freely acknowledge that he knows more than I do, and it is therefore proper that

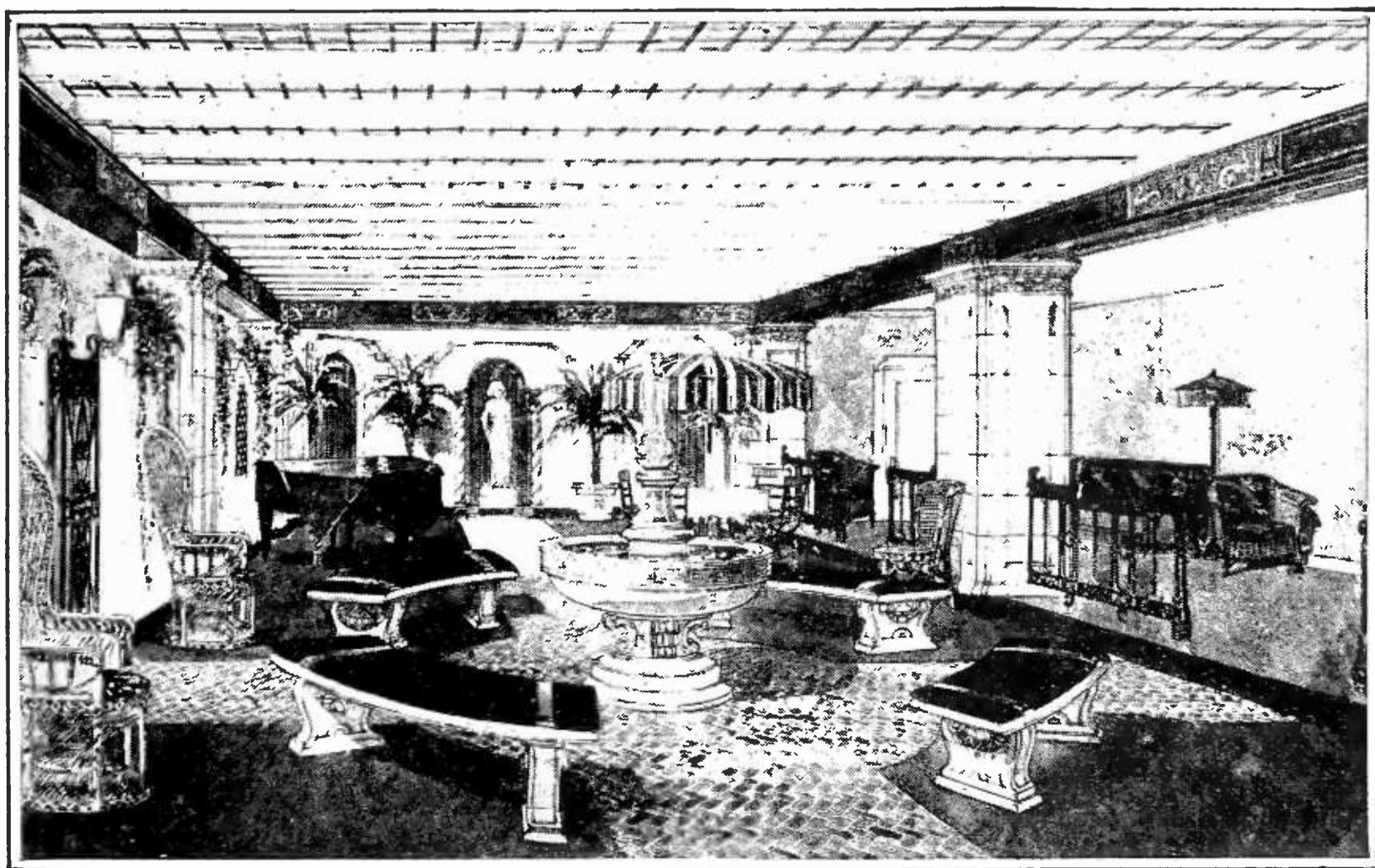

ARCHITECT'S DRAWING OF THE NEW WJAZ STUDIO AT CHICAGO

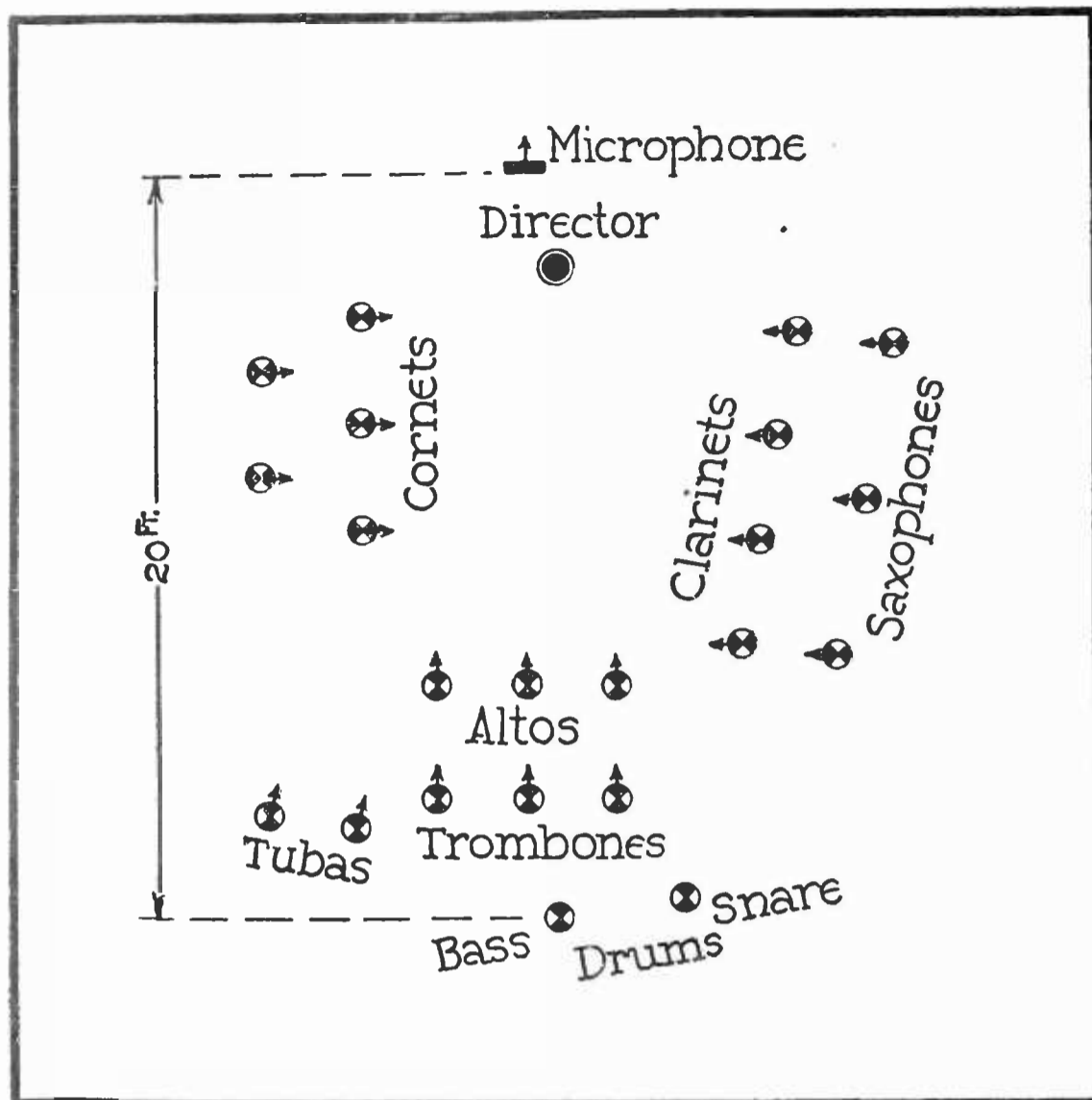

FIG. 1

An effective studio set-up for a brass band in a small broadcasting studio, twenty-five by nineteen feet. In this particular case, a typewriter cover was placed over the microphone to lessen volume

I should defer to him. I used this process as an illustration. If it was not an apt illustration, I am glad to be corrected.

Professor Williams' treatise on the location of cash registers is really too absurd. All I have to say is that the editors and readers of this magazine do not encourage dull writing in their contributors. They understand a bit of sarcasm and do not write a homily about it. Of course the broadcasters are not altruists. They are working for the same two ends that Professor Williams strives to attain: to earn a living, or better; and to be useful in the world, if possible.

#### THERE IS NO MONOPOLY IN BROADCASTING

**M**ONOPOLY! Already about twenty stations in this country are going up in leaps and bounds to the 5 kw. level, including department stores; electrical, radio, and phonograph manufacturers, schools of chiropractic, newspapers, churches, and communication companies. Where is the monopoly? And the 50 kw. and 100 kw. broadcasting stations built or building in England and Germany, are they a part of the world-girdling octopus? Stuff and nonsense! Everybody is increasing power who has the money, because it is the next sound technical step. Professor Williams tries to put me in the position of traducing the radio audience. Why should I? I earn my living through it. I refuse, however, to flatter the listeners by attributing to them technical knowledge which both they

and I know they do not possess. This sort of playing to the galleries is deplorable in a teacher of science and technology. We want engineering data, not rhetoric. We can get the latter on any street corner around election time.

Professor Williams seems to think it necessary to defend WHAZ. I have no doubt that WHAZ is a good station. I wish I could hear it on those Monday evenings when I am told it is on the air. I can't, with any degree of pleasure, although I'm not 150 miles away. If R. P. I. intends to get the 5 kw. or 50 kw. station that the Professor hints at, all I have to say is: "Congratulations! Welcome to our city! But in the meantime, gentlemen, don't obstruct traffic. You may join the parade when you are ready."

By the time this gets into print, genuine super-power stations will, I hope, be audible on the air. I believe it will not take many months of use of these transmitters to convince Mr. Williams that he was wrong in his views, honestly

mistaken, no doubt, but mistaken. After all, he and I can talk ourselves dry and in the end the issue will be decided by performance. So I am content to leave the ultimate decision to the future.

#### WJAZ's New Studio

**T**HE photograph on page 767 shows one view of the new Zenith broadcasting studio located on the twenty-third floor of the Straus Building in Chicago. The call letters of the transmitter are WJAZ, the same that were used by the earlier station of the same company at the Edgewater Beach Hotel.

The new broadcasting parlor does away with drapes and Monk's Cloth for purposes of keeping down reverberation, but accomplishes the same object by suitable acoustic treatment of the walls and ceiling, an expedient which is not novel in this field, but seldom employed because of the increased expense. However, it looks much better and is worth the expenditure.

There is a large reception room with tapestry and rugs and period furniture, and from this an artistic archway leads one into the studio, laid out to suggest a garden, with stone seats, statues, and a real fountain in which Japanese goldfish are permitted to listen to the broadcasting. The floors are tiled; potted plants and an awning may also be seen. The only way you can tell that it's a studio is by the piano.

According to reports, lighting effects are to be introduced for the inspiration of the artists. Some of the dear things need inspiration, heaven knows. For instance, let one of them sing of love, and the garden will be bathed in moonlight, etc. Quite an idea. We have been advocating the use of symbolic microphone stands ourselves, be it remembered. But what will happen to the operator of the lights at WJAZ when he gives some nervous soprano a spot which doesn't suit her complexion!

### More About How to Place the Microphone

**C**ONTINUING with our technical series for broadcasters, we show in Fig. 1 a very successful studio set-up for brass band, due to Mr. F. D. Leslie. This was a Naval band playing with great energy to a carbon microphone in a 25 by 19 studio, so that it had a decided tendency to blast. The microphone was turned back to the orchestra, with its sensitive side toward a fairly dead surface, and a typewriter cover was slung over it. The typewriter cover was a rather barbarous expedient, but if it took out the higher frequencies, as theoretically it might be expected to do, the difference was not noticeable on the air, and there was certainly no blasting. This set-up should be compared with the arrangement for brass band shown in Fig. 3-B last month. The principal difference, aside from the reversing of the microphone, is in the position of the cornets, which in the present case are ranged on one side of the room on a line perpendicular to the plane of the microphone.

Fig. 2 illustrates the outdoor pick-up of the New York Philharmonic Orchestra of 110 men, conducted by Willem van Hoogstraten, at the Lewisohn Stadium in New York City. This is full stature symphonic material, all the Brahms symphonies being played during the season of about two months, most of the Tchaikowskys and Beethovens, and others by Schubert, Mozart, Schumann, Dvorak, Rachmaninoff, Respighi, and Rimski-Korsakoff. The popular overtures and light classics find no place. The management is rather proud of the fact that in the last few years the programs have been built "without concessions." Nevertheless, audiences as high as 11,000 a night attend these open-air concerts.

The orchestra plays on a stand surmounted by a huge reflector, and flanked by sounding boards. The spread of the orchestra over a front of about sixty feet makes the pick-up somewhat complicated. Using carbon microphones, a combination of close and overhead pick-up is found suitable. It is clear from Fig. 2 that the two overhead microphones, receiving sound directly from the orchestra as well as from the reflector, may be made to do the bulk of the work. They are far enough away to obviate blasting, and near enough to handle loud and medium passages. At a pinch they will also do for pianissimo portions, single instruments, etc., but the gain must be brought up to a point where the hiss is objectionable and such disturbances as automobile horns on nearby streets come in faintly. For first-class pick-up, therefore, a third microphone is placed on a stand two or three feet from the conductor and concert master. This microphone has its individual gain control and it is kept throttled

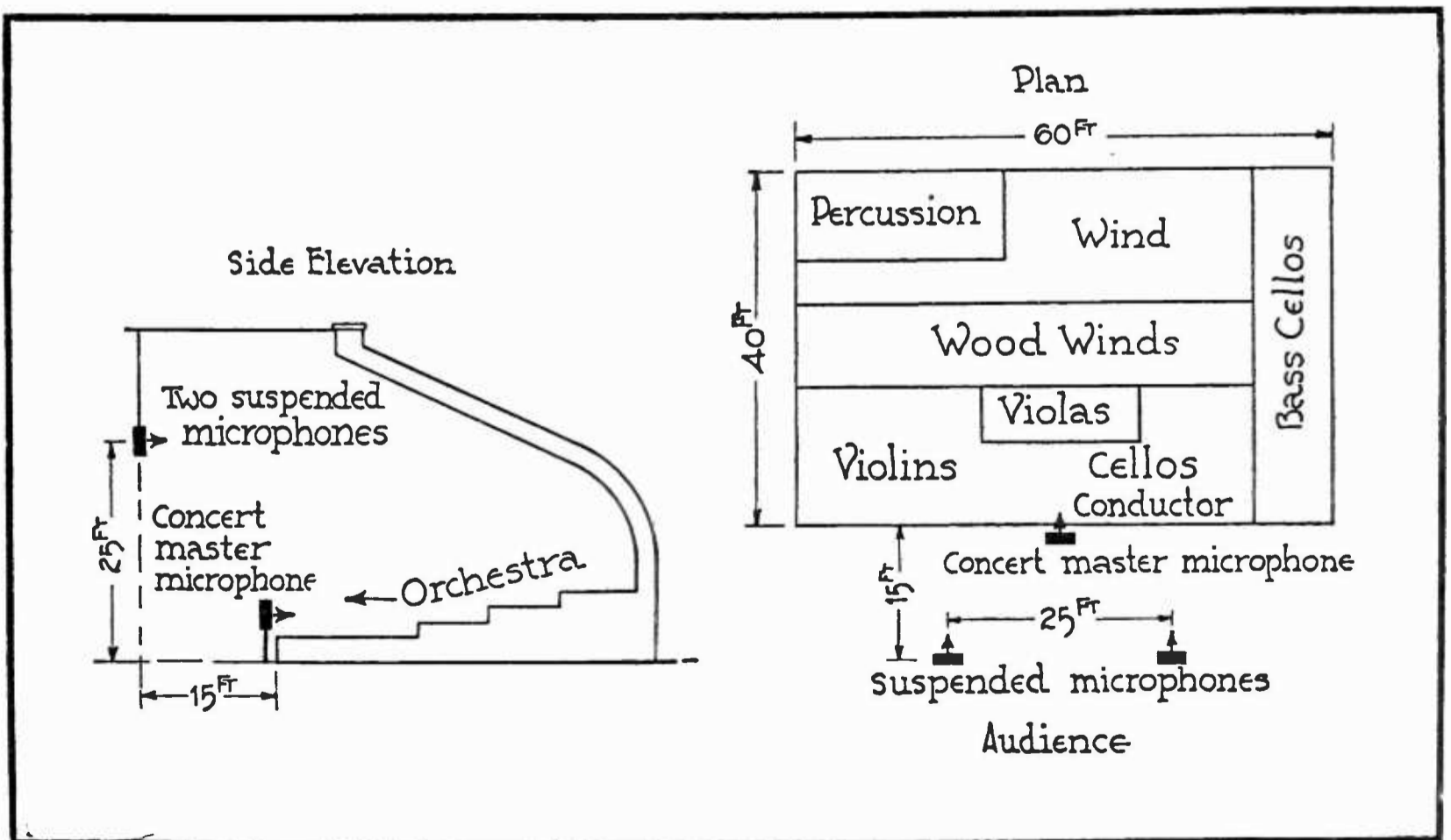

FIG. 2

The Lewisohn Stadium at New York, where the New York Philharmonic Orchestra presents its famous Stadium Concerts. This concert, in common with many others of its type, presents some genuine problems. Mr. Dreher discusses in the accompanying article the way in which they are solved

down much of the time, for it is so close to the players that full orchestra will cause it to blast. During low passages, however, it is swung in noiselessly and it will pick up single instruments with great detail and no hiss to speak of. This requires some finesse, of course, on the part of the man operating the amplifier.

The job might be done with only a single microphone suspended about fifteen feet in front of the orchestra stand and twenty-five feet high, together with the concert master's microphone for the low portions, but two suspended transmitters give somewhat better reproduction over the wide front of the orchestra seating. As Philharmonic audiences are perfectly quiet during the performance, there is no need to watch out for crowd noise, and the fact that part of the audience sits under the suspended microphones is of no consequence, except that the suspension must be made as safe as possible. The cables are good for 800 pounds ( $\frac{5}{16}$ -inch galvanized steel rope); and as two carbon microphones weigh five pounds, it is unlikely that accidents will occur. This is a rather important factor in field broadcasting; one must look out for the artistic features, of course, but care should be taken not to jeopardize the audience. A two-and-a-half-pound lump of steel does not have to fall very far to crack a man's skull.

Fig. 3 is a photograph of the general lay-out at the Lewisohn Stadium, showing the microphone suspension and the orchestra stand. The broadcasting of the Philharmonic Concerts is by wjz, wgy, and wrc being connected to it by land lines.

A very similar job, technically, is the transmission of the Goldman Band, which plays on the campus of New York University. Fig. 4 shows the disposition of the microphones. This orchestra is strong in brass, with the addition of a string section, and the number of players is considerably less. The selections are largely marches and popular classics. The broadcasting company in this case erected a frame of two-inch iron pipe for the overhead suspension, and did not find it necessary to spread the two microphones; they are angled off somewhat, however, to face the two halves of the band. There is also a microphone near the conductor for the close work. The pick-up in this case is done by WEAf and the modulation is sent on to a long chain of stations.

The radio critic of the New York *Herald-Tribune*, "Pioneer", says of these two summer features:

There are two downright perfect examples of microphone placement and balanced pick-up of large orchestras which this summer has produced. WEAf's pick-up of the Goldman Band and wjz's ditto of the Philharmonic Orchestra, achieve effective reproductions of the entire orchestras, which have never before (to our ears, at least) been equalled and between which there is little to choose.

Well, *perfect* is an elastic word, and what is perfect this year will be in the garbage can next summer, for electrical reproduction of music has this characteristic—anything at all good sounds fine . . . until you have something better to compare

it with. Only then do its faults stand out. However, on a good flat receiving set and loud speaker, these two jobs really appear to get quite close to the actual performance of their respective orchestras. The details of the simple pick-up used may be of interest to other broadcasters at this time.

## The Memoirs of a Radio Engineer. V

RELATED, in the preceding issue, the melancholy story of how wireless urchins were persecuted in 1909, resulting, in our case, in the loss of our four-wire flat top antenna. We continued our experiments without an antenna. By some means we secured a small induction coil of the type used for home "medical" treatment of rheumatism, a "shocking coil" with electrodes gripped in the hands which would impart quite a "wallop" when the apparatus was adjusted to give maximum voltage. By using excessive primary voltage on this coil we were able, at times, to draw a  $\frac{1}{8}$ -inch spark between needle points across the secondary. We made a spark gap out of tin cracker cans, the electrodes being cut to very sharp points. This was a sort of radio transmitter, capable of producing a buzzing sound in the telephone of the steel-carbon detector, at distances of six or eight feet, when the vibrator was not sticking, and the spark gap not in excess of the  $\frac{1}{8}$  inch which was its absolute limit.

Near the end of 1909 I made an inventory of our possessions in a small memorandum book, which I still possess. Some of the items are as follows:

- Alarm, burglar, made home, good.
- Battery, about run out.
- Buzzer, made home.
- Bottles, numerous.
- Catalogues, useful.
- Carbon, powdered, from dry battery, also in chunks.
- Foil, tin.
- Galvanoscope, small, very sensitive to weak currents.
- Junk, of every kind and description.
- Jar, Leyden, unbreakable.
- Magneto, Etheric Co., good.
- Magnet, large, powerful. Increased power of the magneto.
- Mercury, very little.
- Motor, Gem, power and speed. Runs fine.
- Press, printing, for printing laboratory literature.
- Resonator for the telegraph, small.
- Saw mill, toy.
- Shaft, counter.
- Wood, under closet.

The printing press, it should be stated, was merely one of those small wooden forms in which rubber type could be inserted to print more or less legible sentences in red ink. With it we printed the following report, dated December, 1909.

Red Seal batteries have been pronounced run out and have had binding posts removed. The ever ready's are of no more use. Have bought an X ray, very good. Motor and Mesco Engine run fine. Have built during the past month a winding gear for the motor, and a key for the telegraph, also



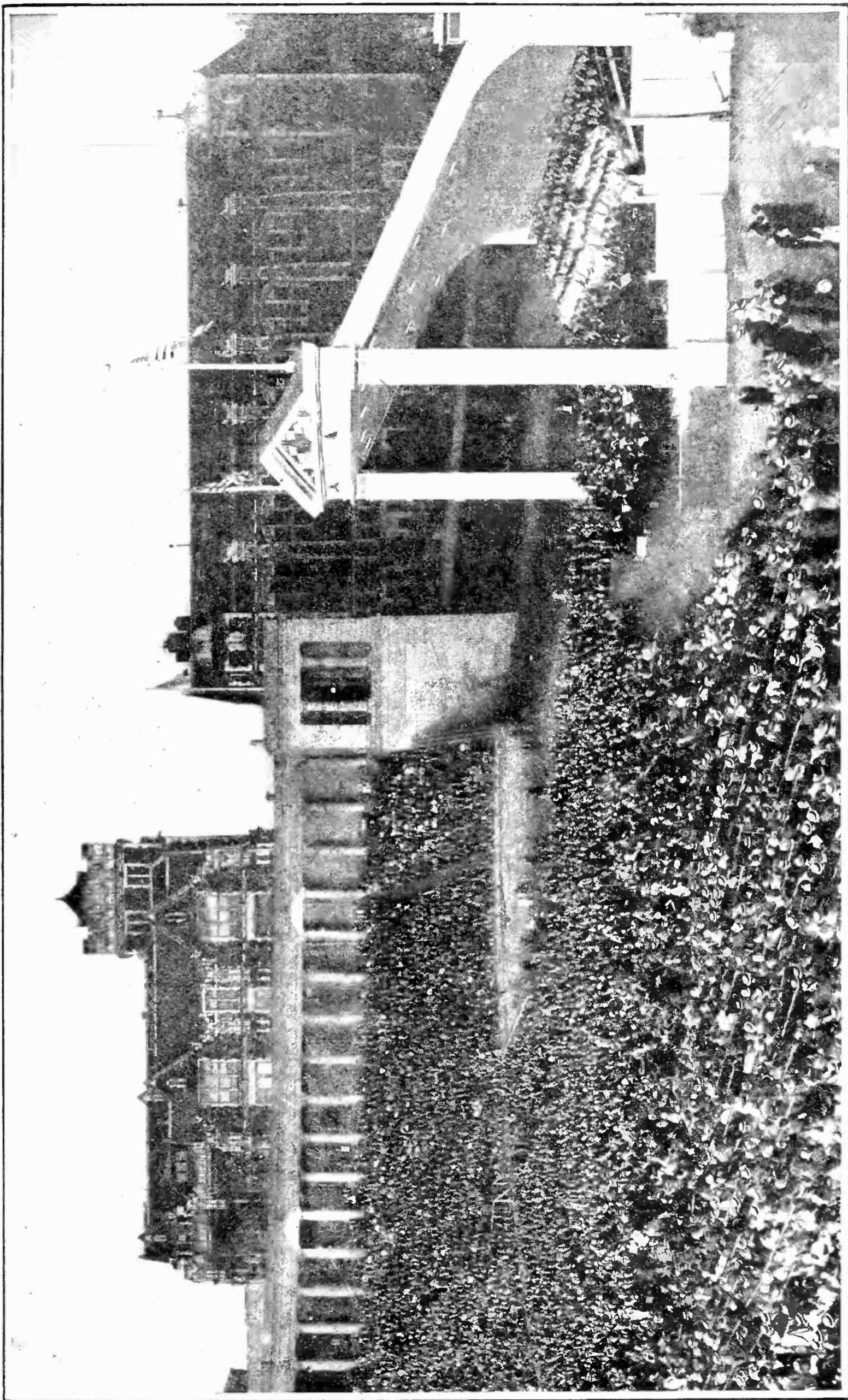

FIG. 3

The complete arrangements for broadcasting the New York Philharmonic Orchestra from the Lewisohn Stadium, New York. Note the placing of the various players. Three microphones, well placed and controlled, are sufficient for the pick-up, which has been rated as one of the best bits of broadcasting ever done. WJZ, WGY, and WRC do the broadcasting

a buzzer. Good quantity of wood in stock. Have made this new index book. Now for 1910.

The X Ray, bought after the batteries had been *pronounced* run out and subjected to removal of binding posts and no doubt evisceration for the salvaging of the powdered carbon, was also a dry cell, not, as the report might be taken to mean, a Roöntgen outfit or anything else so elaborate. It will be noted, also, that I had not reached the stage of quantitative exactness. There was the galvanoscope, "very sensitive to week currents,"—but no one knew just how "week" those currents were, and the magnet, "large, powerful," which increased the power of the "good" magneto. A similar uncertainty manifests itself in the spelling. In fact, the book exhibits two individualistic spellings of "catalogue,"—"catalouge" and "cat-alougle"; and I was in some uncertainty as to whether an engine ran "fine" or "finely." But these were small matters. In the words of a popular play, we knew what we wanted.

What was the status of commercial radio in 1909, is a question that may occur to some readers while I devote so much space to the infantile floundering of our group of boy radio wonders. As I have stated previously in these articles, there were many amateurs ahead of us, and the commercial interests were leading the amateurs by a very comfortable margin, such investigators as Stone, Fessenden, De Forest, Massie, Pickard, Shoemaker, and numerous others having been at work in this country for some time. In 1901, Marconi had succeeded in transmitting the letter "S" across the Atlantic from Poldhu, Cornwall, to St. John's, Newfoundland, a distance of 1,800 miles, and in 1909 the Glace Bay-Clifden circuit had already been in commercial operation for two years. In England the year 1902 saw the invention of the Fleming valve, to which the grid electrode was added in 1906 by De Forest in the United States. In the same year Professor R. A. Fessenden was working at Brant Rock, Massachusetts, on his high-frequency alternator and numerous other inventions. Even radio telephony, or aërophony, as it was frequently called at the time, had made appreciable progress, although the quality of transmission had not yet attained any celestial heights. In 1907 De Forest made experiments in wireless telephony on various naval vessels and succeeded in transmitting, on occasion, over distances up to sixty miles, using arc sets. The Poulsen arc was fairly well developed by 1908, and Marjorana telephoned with an arc modulated by a water microphone from Rome to Sicily, a distance of 300 miles.

In 1909, the great Nauen station was already in operation in Germany, and preparing for communication with the United States. It had a 330-foot tower, an umbrella antenna, and a 25 kw. alternator. Messrs. Slaby and Arco, the chief engineers of the Telefunken Company, working on the inventions of Wien and others, had produced a complete and efficient quenched spark transmitter, which was as far ahead of the straight gap sets of the day as the

modern tube transmitters are ahead of it now. In the neighborhood of New York things were lively enough. The 42 Broadway station of the United Wireless Company, call letters NY, erected in 1904, was in full operation, and many operators still remember its snappy 250 cycles calling AX (Atlantic City) in American Morse, under the capable fist of Mr. J. B. Duffy. The Waldorf Astoria roof bore two towers, and Mr. Pickerill presided over the station, which had the call letters WA. There was also a 2 kw. transmitter on the Hotel Plaza, with the spark gap placed in a wooden "safe" to prevent it from disturbing the slumbers of the guests. Its call letter was "P" and that was all it needed; the day of four-letter calls was still far in the future. Whether "DF," the Manhattan Beach station, was still in operation, I do not recollect at this instant, but De Forest had been making experiments on the incompleting Metropolitan Tower, and in 1909 he declared, "I feel certain that within a short time we will be able to be in wireless communication with the Eiffel Tower in Paris," a prophecy which was not fulfilled until 1915, and then by the American Telephone and Telegraph Company. There was also a fine antenna on the 71st Regiment Armory in New York. I recollect seeing it, but the call letters escape me. Nor were other sections of the country much behind. On the Great Lakes, there were stations at Port Huron, Detroit, Toledo, Cleveland, and Buffalo. In California there were stations at San Francisco, Mare Island, Sacramento, and Santa Barbara. On Cape Cod, MCC, operated by the Marconi Wireless Telegraph Company, was in operation not much later, and the Navy had a station at Key West. These are only a few among many deserving mention, and no doubt many of the old operators will feel aggrieved and write me, "What about Cape Race, and this, that, and the other station?" Radio was still in its days of struggle, and there was little money, and a vast amount of ignorance, but it was moving, here was no doubt of that.

### Microphone Miscellany

*A Free Bath.* Advertisement of a manufacturer of condensers: "By-Pass Condensers do a double job. They filter the fluctuating B battery current. They provide a free *bath* for the radio frequency currents. . . ." Yes; it was printed that way in at least two magazines.

*Imagination Is a Great Thing.* Ingenious blurb issued by the press agent of a chain of stations:

Those who are not fortunate enough to be able to spend their summers by the sea at least can have some compensation Sunday nights during July and August when programs are broadcast direct from the Steel Pier at Atlantic City.

The refreshing sounds of the surf beating on the shore will be relayed from the famous resort and sent out to keep the radio fan cool in sultry weather, a specially constructed microphone being housed under the furthest point of the Steel Pier, directly over the surf, for that purpose.

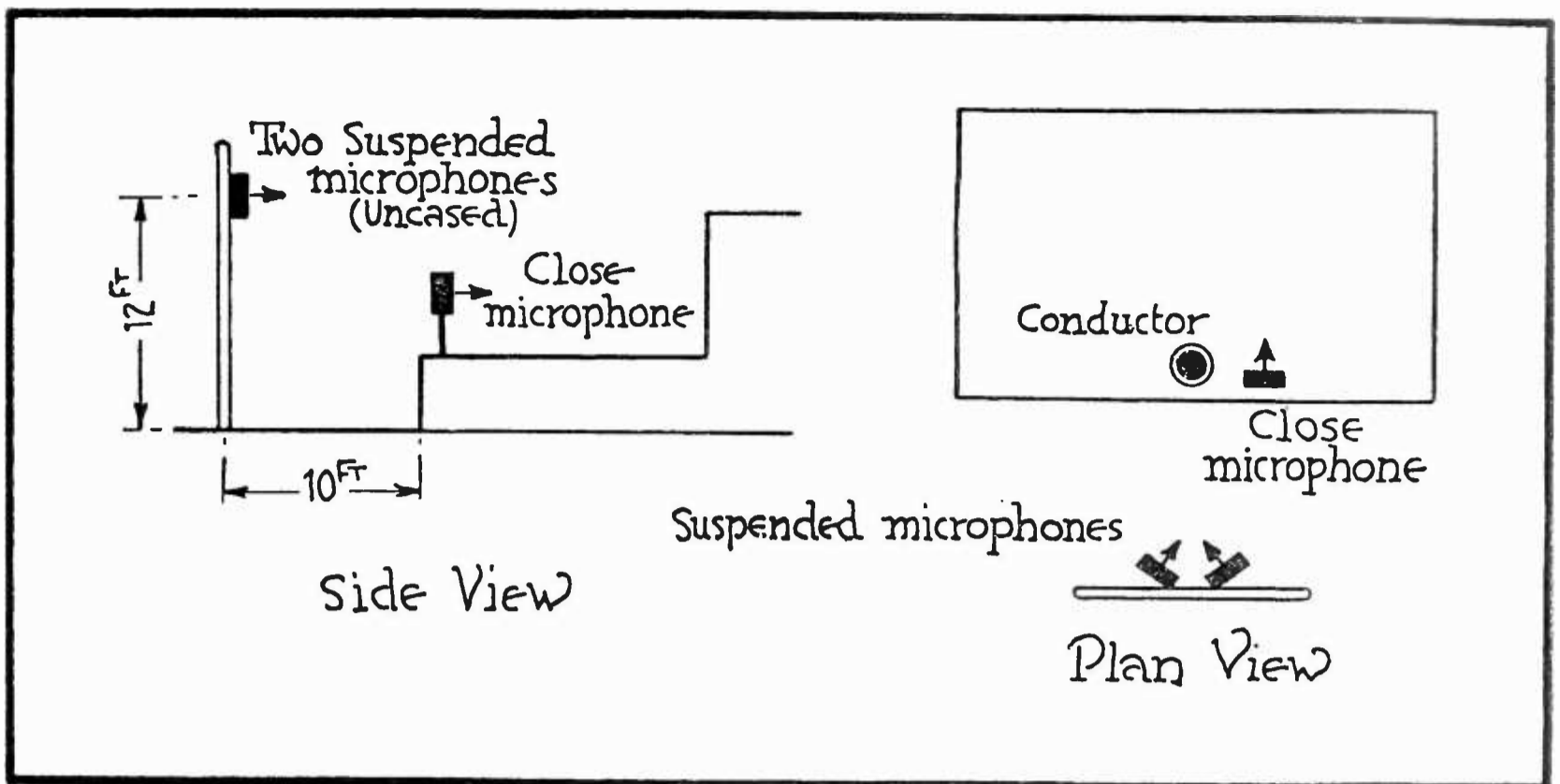

FIG. 4

The microphone set-up used by the American Telephone and Telegraph Company in picking up the Goldman Band, playing at the stadium on the campus of New York University. The WEAf engineers have done the work of installation and the programs are broadcast through a chain of stations

Thus refrigeration by radio has become a reality. Can one take one's baths that way also? Will not a microphone suspended in some lobster palace, carrying the sounds of mastication and imbibition to the radio audience, satisfy the hunger of the listeners and save heads of families several kopeks a day? Must we breathe, when an air-compressor can be set up to make respiratory sounds for everybody with a radio set? Go to it, boys, the idea has endless possibilities.

*The Age of Radio News Items.* A woman, by the expedient of not telling her age, need never grow old; and as long as journalists know little about radio, the same holds true for news items in this field. In the last few days the papers have carried headlines telling about two German ships which communicated by radio telephony over a few hundred miles; the phonograph recording of radio signals in Vienna, and the use by the New York Edison Company of a radio storm detector operated by static disturbances. The last named is about 12 years old, and the other two achievements are not so much younger.

*Radio and Audio.* An unfortunate man was trapped in a Kentucky cave. It was found possible to run an electric light close to him, but later the crevice through which the wires had been passed closed up, and communication with the entombed man ceased. Two newspaper men connected a two-stage audio amplifier to the wires leading into the cave, and, hearing a noise in the head-phones connected to the output of the amplifier, concluded that the captive was still alive. Although the ex-

periment had absolutely nothing to do with radio, all the newspapers referred to the two reporters as "radio experts."

Again, an announcement appears in the papers that during an outdoor opera production at the Polo Grounds, a "radio amplification system" is to be installed. A public address system is also radio, therefore; in short, everything that comes out of a horn is radio.

*Further Stirring Up of a Delicate Subject.* This is written on a night in July when static is in evidence, and I have to take it just like any common listener. What we should get into our heads is that static does not accompany heat, but *changes in temperature*, and in general, those conditions that make for lightning storms. During the extreme hot wave starting June 1st, and lasting about a week, there was little static on medium distance stations, and none on locals, although temperatures far up in the nineties were the rule. It is when hot changes to cool, or when the humidity is very high, that the static tends to become rambunctious.

Statement of a manufacturer of audio transformers: "Static is diminished in proportion to the amount of volume which a radio set delivers, experts agree." This is awarded the grand prize for the month's most brilliant climax in the dissemination of radio piffle—a fresh pretzel, four and a half inches inside diameter, stuffed with highest quality garlic. An unspecified reward is also offered to every "radio expert" who will come forward and publicly "agree" with the above contribution to technology.

# Notes on Chemical Plate Supply Units

An Unusually Complete Discussion of the Problems of Building and Operating a Chemical Unit for B Supply

By JAMES MILLEN

**T**HIS article should be of great interest to the large number of constructors who are experimenting with the chemical rectifier, for it is full of the experimental "dope" which delights the heart of every genuine experimenter. While the author has given his attention especially to the problems presented by the rectifier he described, the general remarks on the chemical type of rectifier have never been presented so completely and helpfully before. The Chemical Plate Supply Unit, described in RADIO BROADCAST for June, has been assembled by many readers and their many letters have echoed their great satisfaction with the device. That unit can be built for about \$20 and will furnish as much as 120 volts and plenty of current for any receiver.—THE EDITOR

**T**HE question of rectifying but half of the a. c. cycle by means of a single rectifier cell instead of the four cells for double wave rectification as described in connection with the Chemical Plate Supply Unit in June, 1925, RADIO BROADCAST, has arisen. It can be done, but the complete outfit is, in the end, larger and more expensive. Furthermore, such an arrangement will only be satisfactory when used with radio sets drawing little plate current, the upper current limit being about ten milliamperes. The increased cost and size of a single-cell plate supply over the four-cell outfit described in the June RADIO BROADCAST is due to the very much larger and more effective filter system required. In an experimental model, a total capacity of thirty microfarads and an inductance of thirty henries was used. There was no hum present in a set drawing twelve milliamperes and perhaps a slightly smaller filter might

have been satisfactory. The point to be emphasized is that the filter used in connection with the four-cell outfit is not effective enough for use with a single-cell outfit. Much more capacity must be added. For the benefit of those who might care to experiment with a one-cell device, the hook-up is given in Fig. 1. The rectifier cell is identical with those used in the four-cell B battery substitute.

Another limitation to the use of a single-cell outfit is that the voltage supplied by it must not exceed about seventy volts. To increase the voltage, it is necessary to connect two cells in series as shown in Fig. 2. The double rectification four-jar unit will supply an output d. c. voltage as high as 110 or 120 volts. The reason for the higher voltage being permissible in the four cell outfit is because the total a. c. voltage is always divided between two cells. Consequently, the voltage per cell never exceeds the practical maximum limit of about eighty volts a. c.

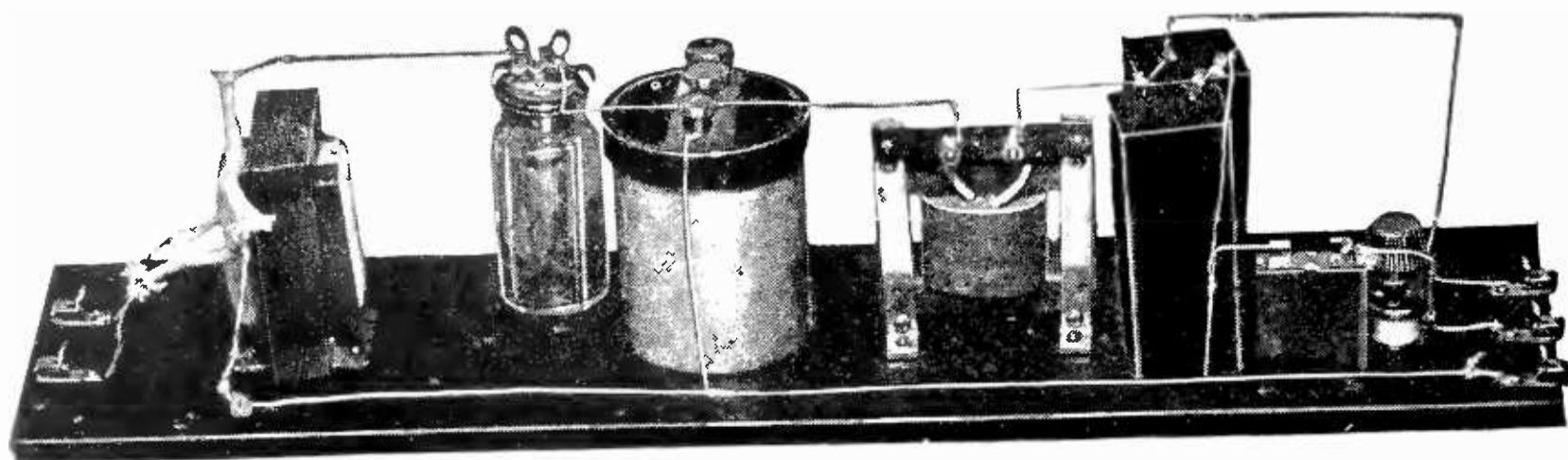

FIG. 1A

An experimental model of a current-tap with single wave rectification

## INCREASING THE VOLTAGE OF THE CHEMICAL PLATE SUPPLY UNIT

A NUMBER of the readers of this magazine who are using resistance-coupled amplifiers have inquired of the writer about ways in which to increase the voltage supplied by the original unit from 110 to 150. A current-tap supplying 150 volts will require eight rectifier cells in place of four. Fig. 3 shows how they are connected. The number of turns on the transformer secondary (using  $\text{NH}_3 \text{H}_2 \text{PO}_4$  electrolyte in rectifier jars) must be increased from 1035 to 1300. The construction of the cells, the choke, and, in fact, all other parts remains the same.

It is also possible to raise the output d. c. voltage by adding capacity to the line side of the filter. As filter condensers are rather expensive, it will be found more practical in this case to employ the method of voltage raising suggested above.

## THE AMMONIUM BORATE RECTIFIER

IT HAS been found that, when a cell with ammonium borate electrolyte stands idle for a long period (a month or so), its internal resistance increases to such an extent that the output voltage of the current-tap, when again put into use, is somewhat lower than originally. This voltage will increase to normal again after about three hours' use. This phenomenon does not occur when an electrolyte of primary ammonium phosphate is used. Should the experimenter have any difficulty in securing CP primary ammonium phosphate, CP secondary ammonium phosphate may be used with equally satisfactory results.

## IMPROVING THE CATHODE

ANOTHER peculiarity of the rectifier cell using an electrolyte of ammonium borate which can not be observed when one uses the ammonium phosphate electrolyte

is the deterioration of the lead electrode, whose surface is oxidized to lead peroxide which crumbles off and falls to the bottom of the jar. This action is readily prevented by removing the lead electrodes after they have been used for five or ten hours, and hammering them. An old flat-iron makes an excellent anvil for this purpose. The round shape of the electrodes may be retained by rotating them on the anvil during the hammering process, or, they may be hammered until they have a square or slightly rectangular cross-section. The reason for this treatment is to force the first coating of lead peroxide into the surface of the metal and thus form a protective coating for the rest of the electrode. No more trouble will then be had with lead electrodes which have been treated in this manner. As previously stated, this deterioration takes place only when the ammonium borate electrolyte is used.

Of course this process is not necessary as it will take a long time for an untreated lead rod to be completely changed to lead peroxide powder. The real objection to the lead peroxide is that it settles to the bottom of the jar and may, in time, short circuit the two electrodes.

## THE ANODES

THERE is no satisfactory substitute for CP aluminum rod for use as the anode. If one cares to take a chance with commercial rod, he may, or may not, secure a good set of electrodes the first time. The chances are that he will not. Some parts of a commercial rod are almost (but seldom) quite as good as the CP rod, while other parts of the same rod are worthless as rectifier anodes. The strange part about the commercial rod is that it appears to improve slightly with use, but it is rather poor during the first few hours. The CP rod is good from the very start.

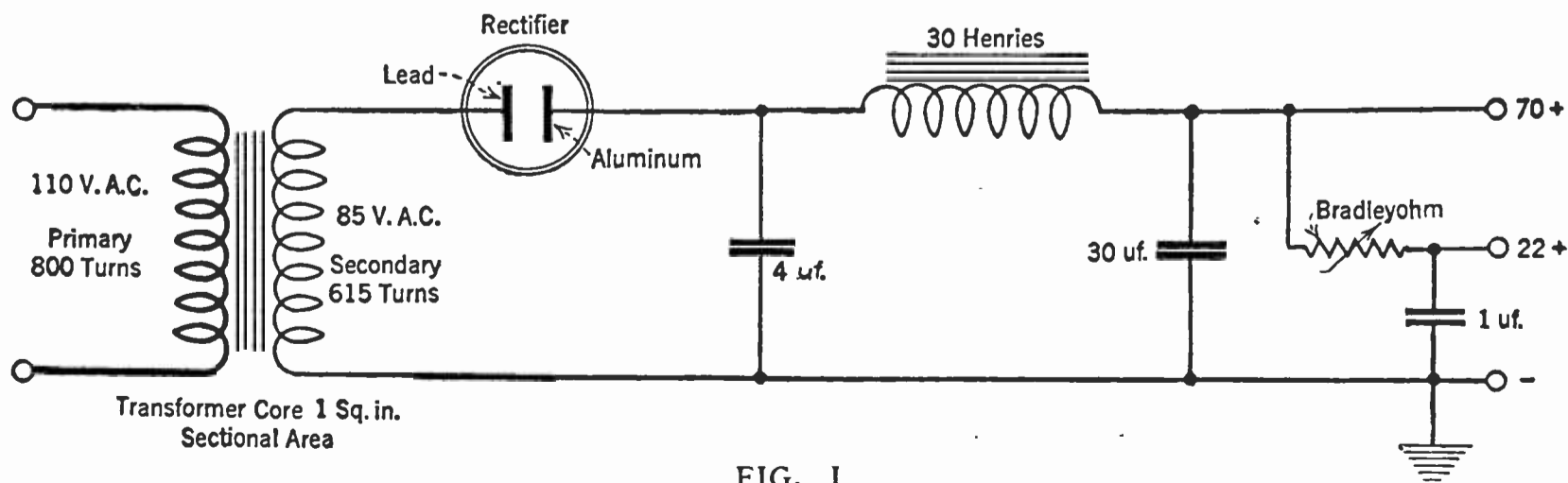

FIG. 1

The fundamental circuit diagram of the current-tap illustrated in Fig. 1 A. The transformer is not, from an engineering point of view, essential, but is required by the fire underwriters, as if it were not used and the connection to the 110-volt line reversed, a short circuit of the 110-volt line would result

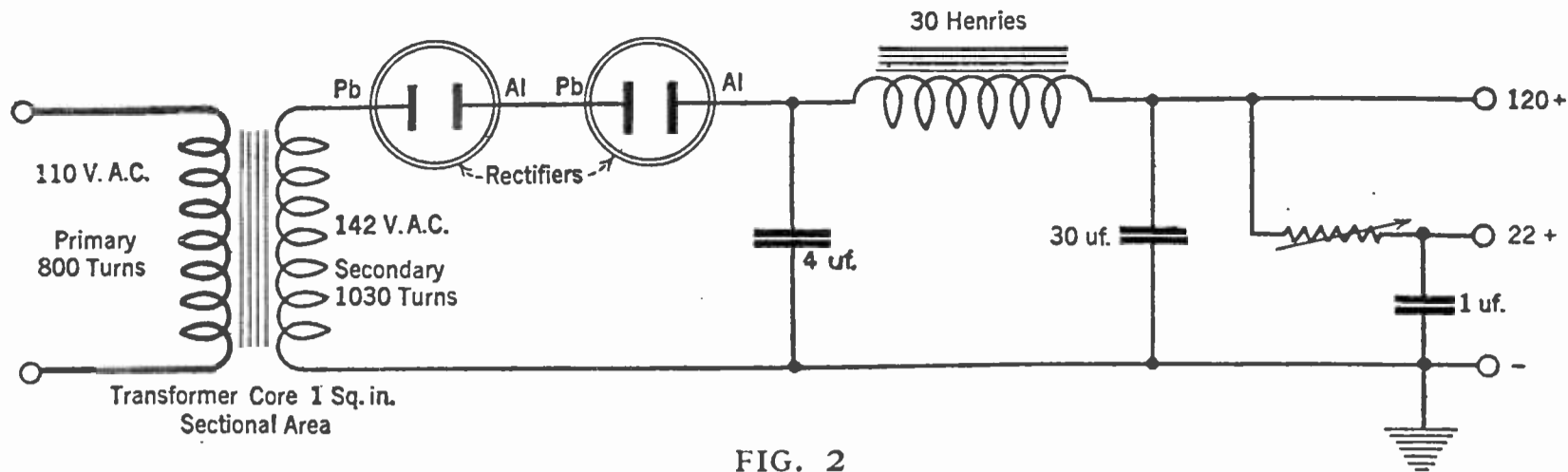

FIG. 2

When higher voltages than those supplied by the single cell outfit illustrated in Fig. 1A are required, two cells must be connected in series and the number of transformer secondary turns increased

Some tests were made using aluminum welding rods (aluminum alloyed with about 2 per cent. copper) as anodes. These electrodes were very much more resistant to corrosion when used with high currents, as in rectifiers for battery charging, but the cells employing them had quite a leakage current when used in a current-tap device. Leakage current was determined from oscillograms. The oscillogram of the output of an unfiltered chemical rectifier with CP aluminum electrodes never dropped down to the zero line, due, probably, to the filter action of the high inherent electrostatic capacity of the rectifiers. As would be expected, the d.c.-a.c. current ratio was very much better for the CP rods. Welding rods are certainly not suitable for a current-tap device.

Sheet aluminum electrodes have been used quite successfully but are not as satisfactory as CP rods. A sheet of supposedly CP aluminum obtained from a large chemical supply house was found to be impure and unsatisfactory at one end and not a bit better than the purer grade of commercial sheet.

In any event, poor electrodes are easily detected when put into use. Either the current-tap will not work properly (There is a "hum," or the d.c. voltage is much lower than theoretically calculated) or, if it appears to

work properly at first, the cells will soon over-heat and then the unit will cease performing. The presence of a very soft white cloudy precipitate which seemingly floats around in the bottom third of the jar generally denotes the presence of impurities. I have never seen it in cells using distilled water and made from good materials. It nearly always occurs when tap water has been used in place of distilled water in preparing



FIG. 4

A pair of electrodes, showing the rubber insulating sleeve on the anode

the electrolyte. As a rule, however, it does not cause much trouble, although the cells containing such a precipitate seem to run warmer than others. Always use distilled water.

This precipitate should not be confused with the solid crystalline deposits which are due to an excess of ammonium phosphate or borate in the electrolyte. Such precipitates are not injurious in any way whatsoever. It might be well again to warn against impurities in the electrolyte. Even the smallest quantity of ordinary table salt (NaCl) will seriously interfere with proper rectifier action.

Properly operating cells made from good materials are easily detected by observing them when operating in a dark room. The aluminum electrodes will

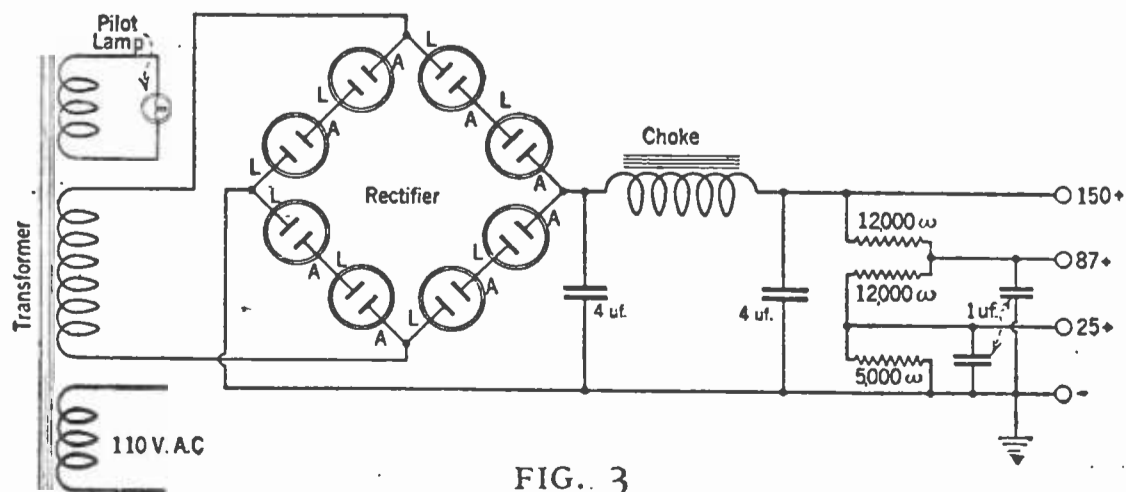

FIG. 3

The Plate Supply Unit described in the June issue may be altered so as to supply 150 volts to resistance-coupled amplifiers

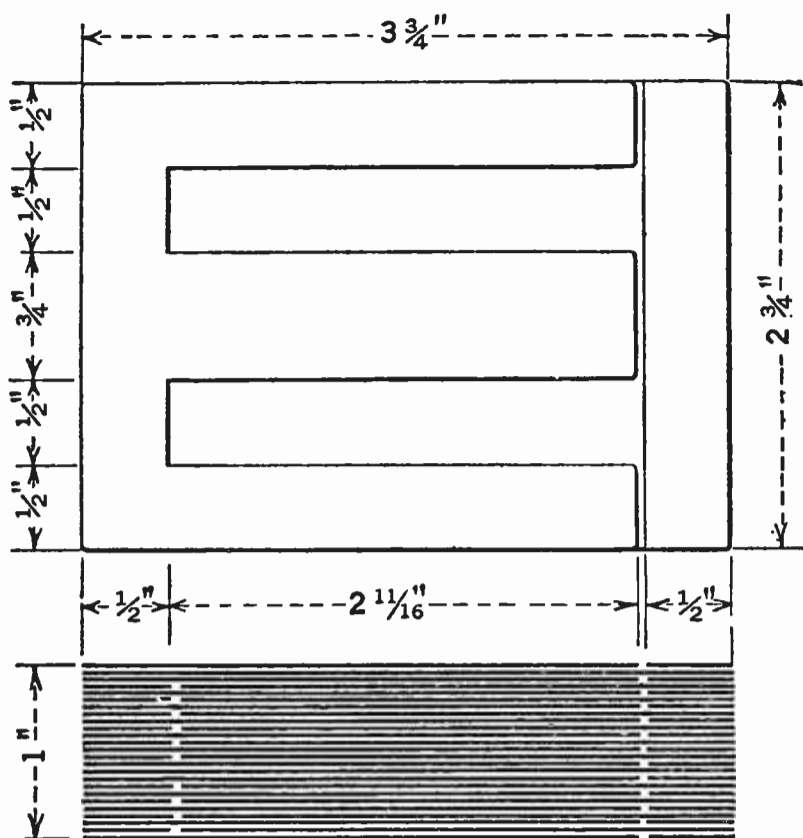

FIG. 5

Details of the shell type power transformer core

glow with a pale yellowish green light. Cells which do not so glow should be replaced.

Overheating of the cells is generally due, as previously mentioned, to the use of impure materials, but may also be caused by trying to get too high a voltage out of the unit (by increasing transformer secondary turns, etc.). The maximum filtered d. c. voltage from a four-jar unit must not be over 120 volts and should preferably be between 90 and 100 volts. The greatest allowable temperature of the electrolyte is about 50° centigrade or 122° F. As this is above body temperature, a properly operating cell may at times feel rather warm when touched.

#### ANODE INSULATION

**A**N IMPROVEMENT over the collodion film insulation for the anode as described in the RADIO BROADCAST for June is a film made from modified aeroplane wing "dope." This "dope" is prepared by dissolving some celluloid (secured from old photographic negatives, etc.) in acetone. Acetone is the solvent used by motion picture operators for joining film together. It may also be obtained from any druggist. Very little is required.

A still better insulation is obtained by the use of short lengths of live rubber tubing. The inside of the tube, which should be somewhat smaller than the aluminum rod is coated with vaseline and is then stretched over the upper end of the aluminum rod and pulled down to the proper position. This insulation is, of course, put on before the rod is fitted

into the stopper. The length of the electrode exposed to the solution should be one and one-half inches and the rubber insulation should extend below the surface of the liquid.

#### ADDITIONAL TRANSFORMER AND CHOKE DATA: THE CORES

**T**HE transformer and choke coils are cut from silicon steel sheets or from ten to seventeen mils (thousandths of an inch) in thickness. Fig. 5 gives the shape and dimensions of the toy transformer core recommended in the previous article. As it is almost impossible to cut such shape laminations by hand, the type of core illustrated in Fig. 6 may be used. The sectional area of the magnetic circuit of the manufactured core (Fig. 5) is .75 square inches, but if a home-cut core of the type illustrated in Fig. 6 is used, the sectional area had better be one square inch. Each lamination should be given a thin coat of shellac and allowed to dry before assembling.

#### TRANSFORMER WINDINGS

**F**OR either type of core, the transformer primary winding consists of 800 turns of No. 26 enameled copper wire and the secondary of either 1030 or 1125 turns of either No. 28 or No. 30 wire.

The primary is layer wound on a square cardboard tube which fits snugly on the core. Use thin, waxed or glassine paper between layers. Several layers of heavy paper or Empire cloth are wrapped over the primary

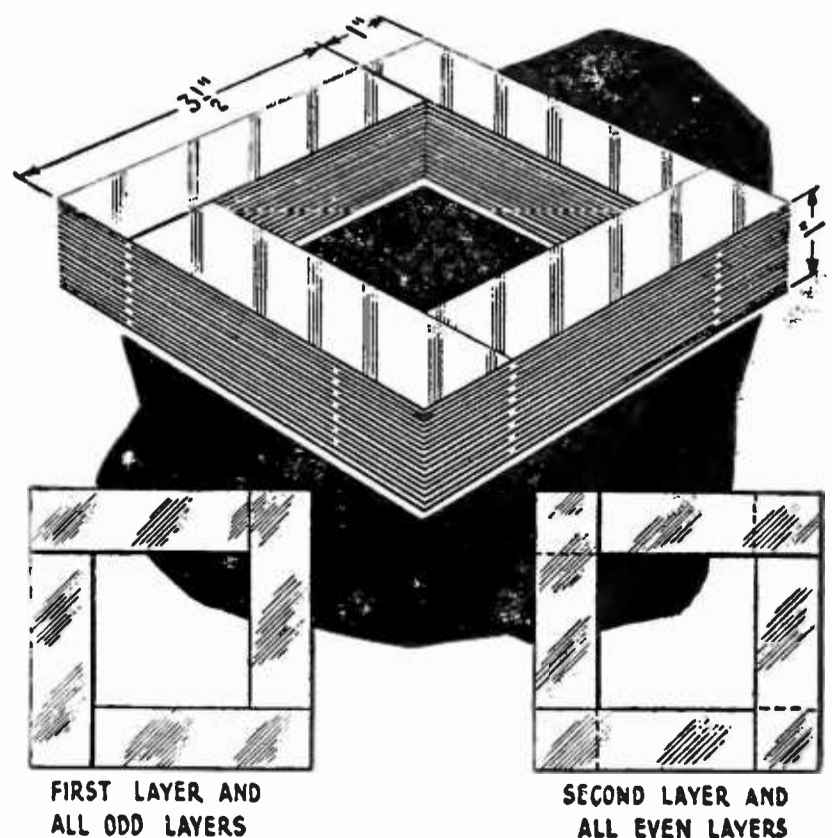

FIG. 6

If the power transformer core is to be hand-cut, the type of core illustrated in this Figure is recommended

before starting the secondary. Care should be used in bringing out the lead wires to see that they are well insulated from each other and from the core.

The choke coil core requires no air gap, as, due to the low current used in current-tap devices, the core is operated well below the saturation point.

It might interest some to know that at this time the particular current-tap shown in the illustrations in the June RADIO BROADCAST is still being used every day and as yet, after six months, has required absolutely no attention, not even the addition of distilled water.

The oscillogram shown in Fig. 7 was made of this same current-tap under the exceedingly heavy load of 60 milliamperes. Fig. 8 shows the effect of insufficient capacity in the filter system.

#### WHAT AN OSCILLOGRAM IS

**A**N OSCILLOGRAM is a visual indication of how current or voltage, as the case may be, varies with time.

A variation in the output of a double-wave rectifier, which is operated from 60 cycle a. c. would be very noticeable in the loud speaker of a receiving set, in the form of a 60-cycle "hum." This "hum" would usually be indicated by the periodic variations in current as indicated by the curved line in Fig. 11. The time interval between peaks is  $\frac{1}{60}$  of a second. Current at any instant is proportional to the vertical distance of a point on the curve from the straight horizontal "zero" line.

In Fig. 7, the current is steady, as shown by the upper horizontal straight line, and as a result, no hum is heard in the "loud speaker."

The allowable periodic variations in the current is about 1 per cent. although some people do not object to a "hum" caused by as much as 5 per cent. current variation. This latter condition is approximated by Fig. 8.

Oscillograms, such as those accompanying this article, are made by a photographic process in which a fine beam of light is caused to move up and down with variations in current on a strip of photographic paper mounted on a revolving drum, thus tracing the white lines shown in Figs. 7, 8, and 11.

The neat and compact arrangement of the rectifier jars shown in Fig. 9 was made by one of the readers of RADIO BROADCAST, Mr. F. A. Dede. The jars and electrodes are similar to those used in the original outfit. The straps around the top and bottom are made of

zinc, although any other material would have been just as suitable. The top is sealed with battery wax, which may be obtained from any storage battery service station. Four Fahnestock automobile ignition cable clips are used on the four electrodes to which connections are made. All wires between cells as well as the tops of the four electrodes not fitted with clips are concealed in the wax. Two small glass vent tubes are provided for each cell, one for filling and the other for the escape of air in the jar while it is being filled. The electrodes were held in place by means of cardboard discs fitted into the necks of the salt-mouth bottles. The hot wax was then poured over and allowed to harden. The cardboard discs also preventing the melted wax from running down into the bottles. The Fahnestock clips facilitate the easy removal of the rectifier as a unit from the current-tap cabinet for occasional inspection and addition of distilled water.

While describing unit arrangements of cells, it is well to emphasize the fact that the jars must not be completely sealed in a small box or other such container which would seriously reduce the heat radiation and thus cause the temperature of the electrolyte to rise. The arrangement shown in Fig. 9 does not violate this rule as air can circulate around each cell.

The majority of commercial B battery substitutes, especially those employing vacuum tubes as the rectifying units, show an unfortunate drop in voltage with increased loads. Thus the voltage supplied to a single-tube set by such a device might be nearly one-hundred volts whereas the voltage supplied by the same unit to a superheterodyne without proper C batteries might be but thirty or forty volts.

Such trouble is not had with the Chemical Plate Supply Unit as the drop in voltage due to increasing load is slight owing to the relatively low internal resistance of the chemical rectifiers. This phenomenon is illustrated by the curves in Fig. 9. Curve A is for a commercial B battery substitute using a UV201A tube, while curve B is for the Chemical Plate Supply Unit described in the June RADIO BROADCAST.

#### THE EXPERIENCE OF A READER

**M**R. R. E. GRAVES, in the following letter, gives some information which may be of value to those who have built the Chemical Plate Supply Unit described by the author.



Referring to the B battery substitute described in your June issue, I have recently made one, and the results it gives are excellent. However, for your information and to help you in answering inquiries, I will give you the following information. Instead of following out your transformer specifications, I had the Thordarson Elec. Mfg. Co. of this city, make the transformer which steps 110 volt a. c. up to 150 volts, but I found that with this high voltage the aluminum will not hold its film and it was necessary to put a resistance in the input to give me an output of about 125 volts.

The transformer has an extra winding for a 6-volt automobile lamp.

These people carry a 30-henry choke coil wound with large wire which I found very good. Instead of purchasing salt mouth bottles I bought four B battery chargers at the ten cent store. These come complete with rubber screw tops and the lead and aluminum rods.

Below is the cost of the special parts:

Thordarson Transformer . . . \$6.00  
 " Choke . . . . . 4.00

Rectifier jars complete . . . . . 25 each

Primary ammonium phosphate can be purchased in Chicago from Schaar & Co. 556 W. Jackson Blvd.

The transformers specified in your June issue are not to be found in Chicago.

The price of salt mouth jars and accessories if purchased here would put the rectifier cost to about \$3.00 as compared to \$1.00 if bought at the ten cent store while the primary ammonium phosphate can be purchased at only two places in Chicago and

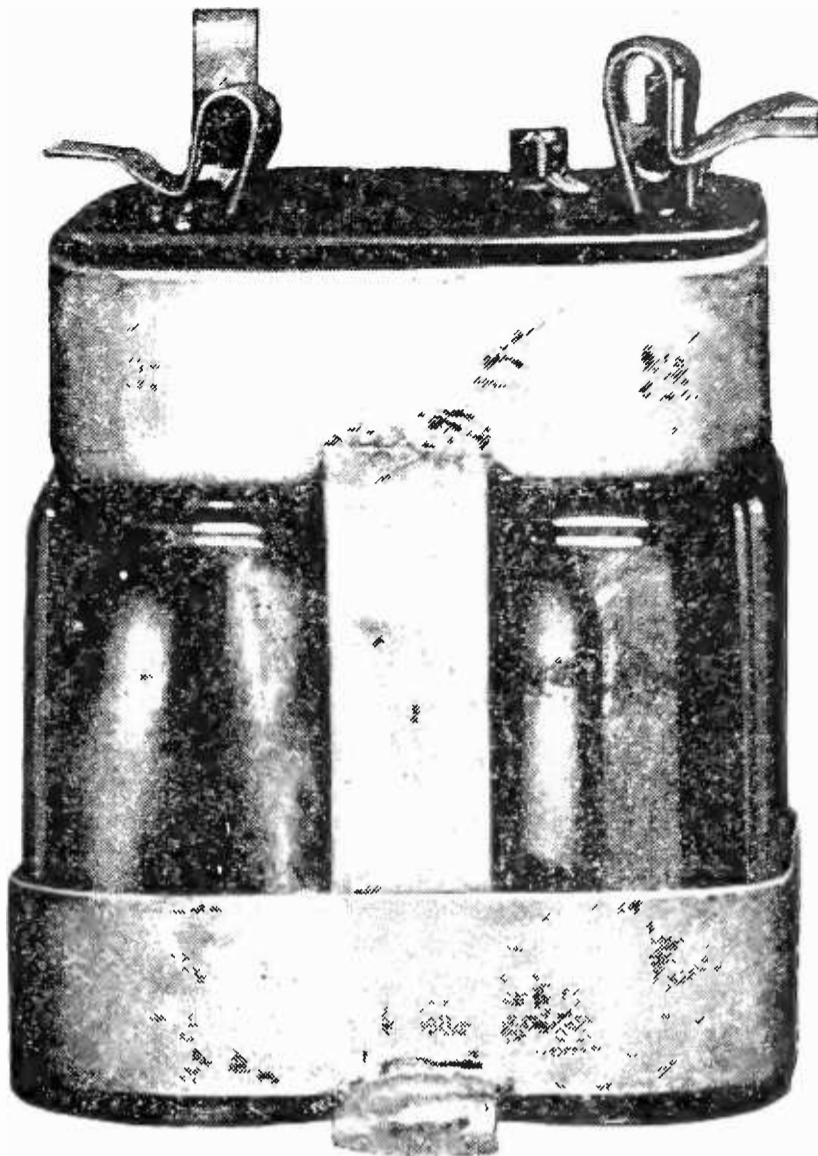

FIG. 9

A compact way in which the four rectifier cells may be combined into a single unit

I might add that the amount of phosphate as specified in your article did not make a fully saturated solution.

I am very pleased with the outfit, although from the start I knew that it would work or it would not have been published in RADIO BROADCAST.

Respectfully yours,  
 R. E. GRAVES.  
 Chicago, Illinois.

WHERE SUPPLIES FOR THE UNIT CAN BE SECURED

AS MANY of our readers have written that they have been unable to secure the chemical supplies listed in the June RADIO BROADCAST at reasonable prices, we have investigated the situation further and found that the material may be obtained from the following concerns:

Empire Laboratory and Supply Co., Inc.,  
 218 East 37th Street, New York  
 Strahs Aluminum Co.,  
 48 Franklin Street, New York  
 Aluminum rods only

The prices for the complete set of parts as listed below range from a high value of \$2.61 to a low value of \$1.75:

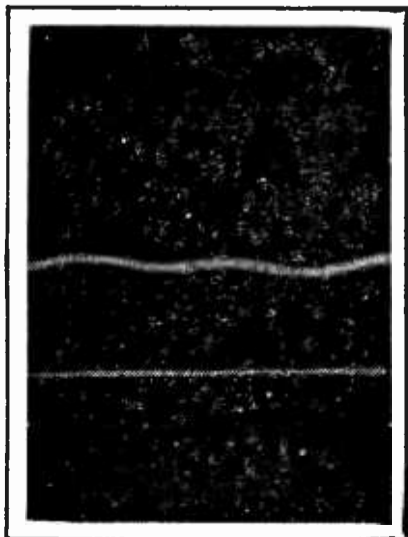

FIG. 7

Even when an exceedingly heavy current (50 milliamperes) is taken from the Chemical Plate Supply Unit described in the June RADIO BROADCAST, the output is very well filtered as shown by the smooth oscillogram of the output

FIG. 8

This oscillogram is a visual indication of what occurs when the constructor attempts to economize in the construction of the filter by using a total electrostatic capacity of 4 microfarads rather than eight. The load here is adjusted for a current of 60 milliamperes



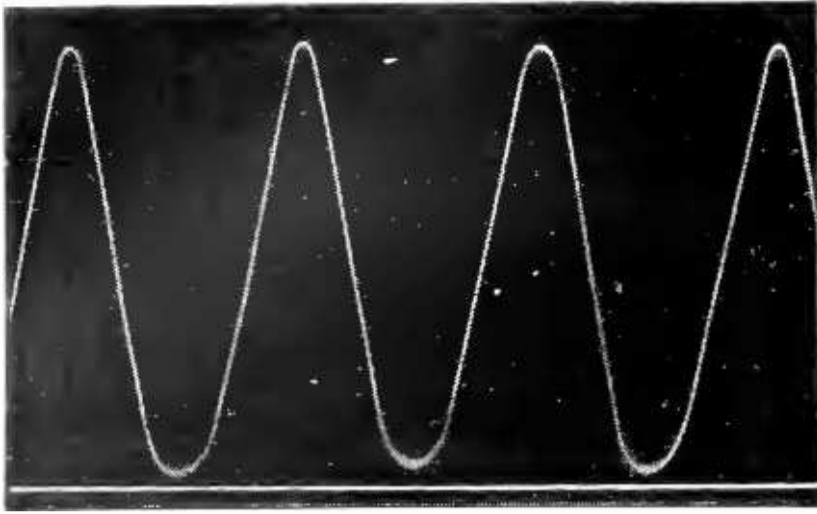

FIG. 11

Due to the high inherent electrostatic capacity, the unfiltered current supplied by a double-wave electrolytic rectifier does not drop to zero

- 4 3 oz. salt mouth bottles.
  - 4 No. 6 rubber stoppers
  - 1 2-ft. length  $\frac{5}{16}$ " diameter CP Aluminum rod.
  - 1 2-ft. length  $\frac{5}{16}$ " diameter lead rod.
  - 1 6-inch length glass tube for vent
  - 1 oz. primary or secondary ammonium phosphate.
- Any of the individual items may also be obtained separately.

As the price of lead rods still seems most unreasonable when obtained from chemical supply houses, the cathodes should be made from sheet lead which is readily obtainable at a very much lower price from your local plumber. Such lead should be cleaned with sand-paper before using.

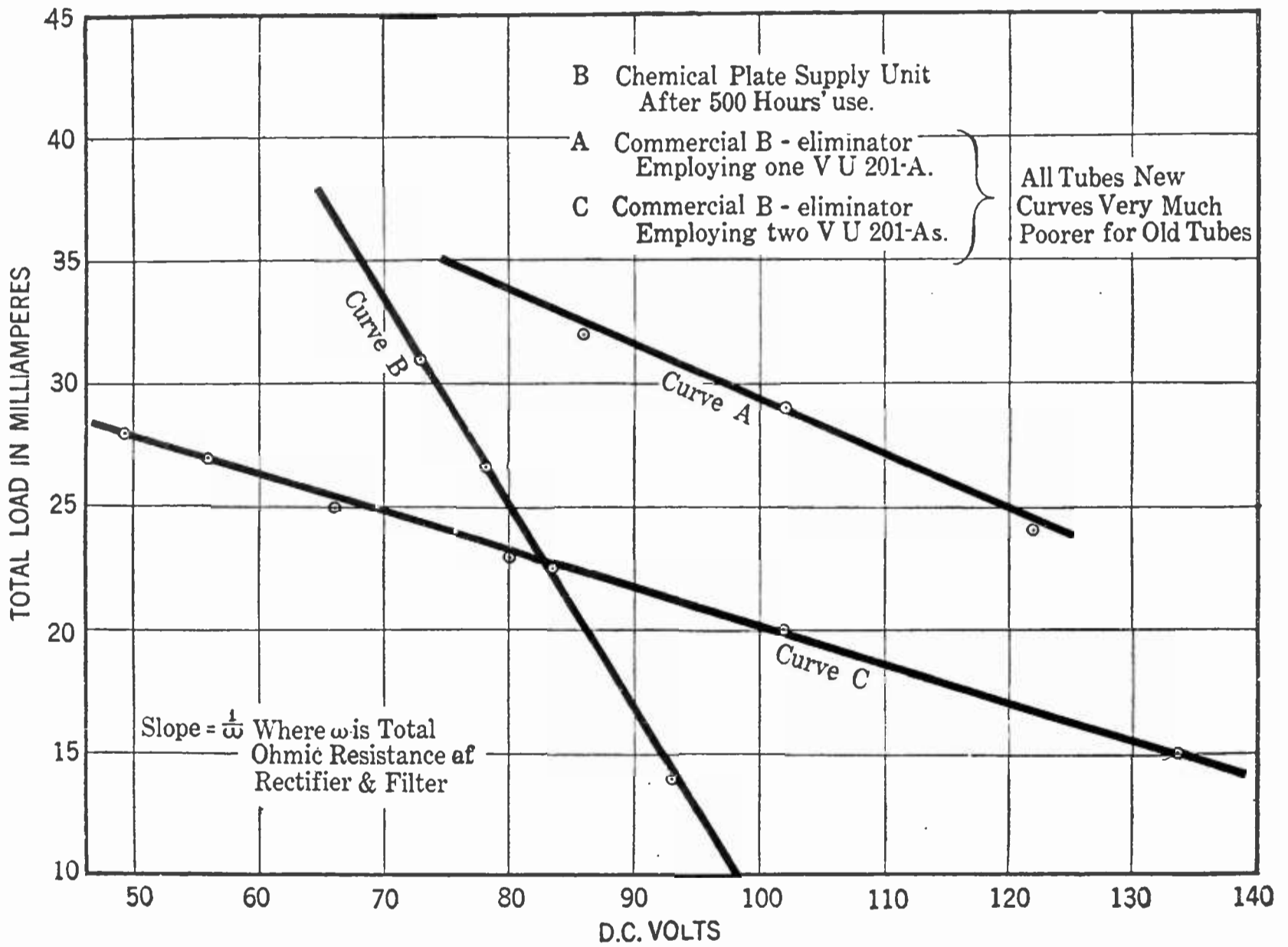

FIG. 10

These curves show how the voltage supplied by several different types of current-taps, drops as the load is increased

# Single-Control For Your Present Receiver

A Geared Condenser Unit Which Can Be Applied to the Roberts Knockout, the Phonograph Receiver, the Browning-Drake, the Super-Heterodyne, and Many Other Popular Receivers

BY ALLAN T. HANSCOM

**T**HE methods so far brought out for single-control of radio receivers have all been those which used a group of condensers all tuned by one dial—which simultaneously varied the frequency (wavelength) of each circuit in which the various condensers were connected. This method, due to Hogan, is quite workable, but it allows nothing for variations in the individual coils in the circuits. The unit described here may be applied to any circuit in which two coils of approximately the same value are tuned by condensers. Due to the ingenious cam arrangement on the first condenser of the single-control unit described in this paper, any irregularity in the first secondary coil of the circuit to which this unit is applied, may be compensated for by a preliminary adjustment of the first condenser. This is not a how-to-make-it article but the elements of the device are standard. The mechanical features of the complete unit could only be made by a constructor with more than ordinary mechanical ability and a good machine shop at his command. The single-control element should prove so helpful to the home-assembler that we feel no hesitancy in publishing this article, although the unit cannot be made, but must be bought.—THE EDITOR

**T**HE necessity for selectivity in radio receivers is becoming more evident as more stations take the air, and radio listeners will probably welcome a more simple method of tuning which will not in any sense detract from the efficiency of their receivers.

The ultimate in receiver design should have one station selector, one control for volume and one control to turn the set on and off. The old single-circuit receiver approached these requirements but did so at the expense of the selectivity which is an urgent requirement nowadays. The single-circuit set radiates most distressingly and so it has been gradually superseded by sensitive receivers of more desirable types.

Practically the only possible way to secure selectivity in the receivers in general use today, is by means of two or more tuned circuits. Now, since each circuit must be tuned separately, we have two or three tuning controls on most of the receivers now popular. It was early apparent that this difficulty could be overcome, provided the two or more tuned circuits could be controlled simultaneously with a single knob or dial. To do this successfully required laboratory methods which can not be adopted by the average constructor, and—more important—do not go hand in

hand with quantity production in manufacturing.

With these ideas in mind, the writer has developed a method which permits of the simultaneous tuning of two circuits, and at the same time makes possible a slight variation of one circuit without disturbing the other, in order to compensate for slight variations in the two.

This makes the reduction of one tuning control possible, and in the case of the standard neutrodyne or other tuned radio frequency receivers, the number of controls is thus reduced from three to two. In sets using a single stage of tuned radio frequency, such as the RADIO BROADCAST three- and four-tube Knockouts, the Browning-Drake, etc., as well as most super-heterodynes, the number of tuning controls is reduced to one, and the simplicity of the tuning is a pleasant surprise to a person operating one of these sets for the first time.

The essential feature of this assembly consists of two Remler condensers mounted in such a manner that their capacities may be simultaneously varied with a single Marco dial reading through 180 degrees. In addition, one of the condensers may be varied through 20 degrees of dial movement without disturbing the setting of the other condenser. At the mid-point of the vernier setting, the two con-

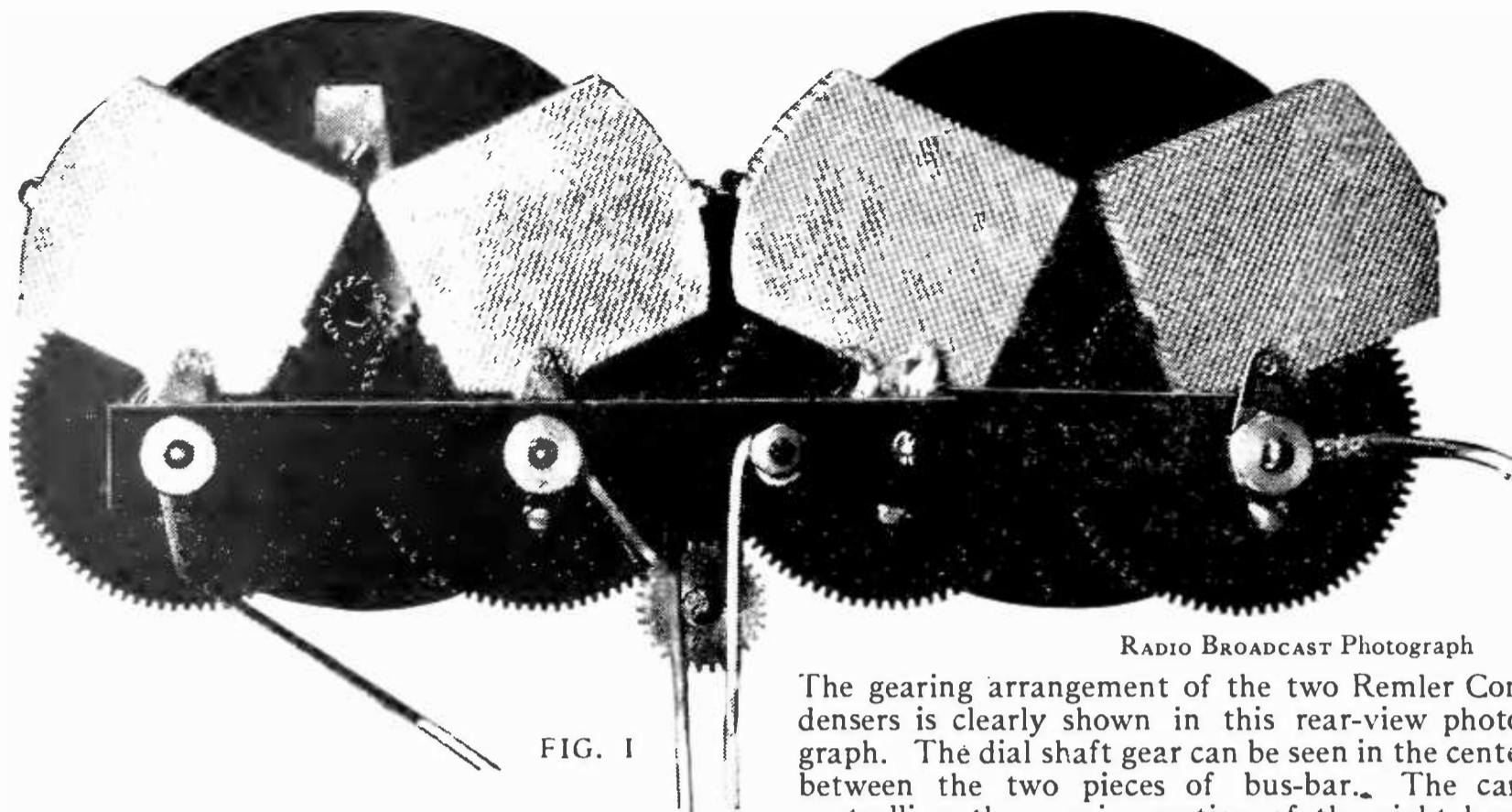

FIG. 1

RADIO BROADCAST Photograph

The gearing arrangement of the two Remler Condensers is clearly shown in this rear-view photograph. The dial shaft gear can be seen in the center between the two pieces of bus-bar. The cam controlling the vernier motion of the right hand condenser is not included in the photograph

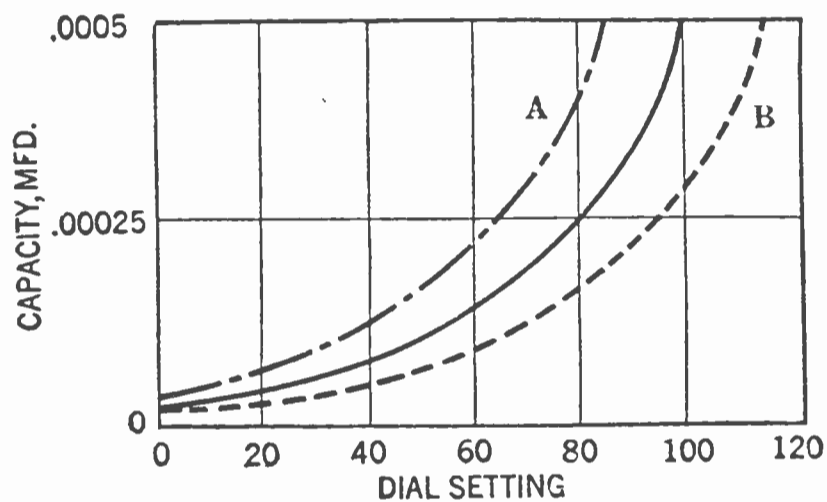

FIG. 2

The curve in the center shows how the capacity for one condenser will increase or decrease with respect to the dial readings. The dotted curves, A and B, depict how the values vary as the vernier is adjusted between maximum and minimum points

condensers have equal capacity at any dial reading and the vernier gives a plus or minus variation sufficient to cover the ordinary inequalities of tuning. This arrangement has the following important advantages:

1. Dial may be logged.
2. Straight line wavelength curve of the condenser spreads stations evenly on the dial.
3. Vernier variation at any setting is proportional to wavelength.
4. The main dial and vernier not electrically connected, thereby avoiding hand capacity effects.
5. Condensers each have separate terminals and may be connected independently.

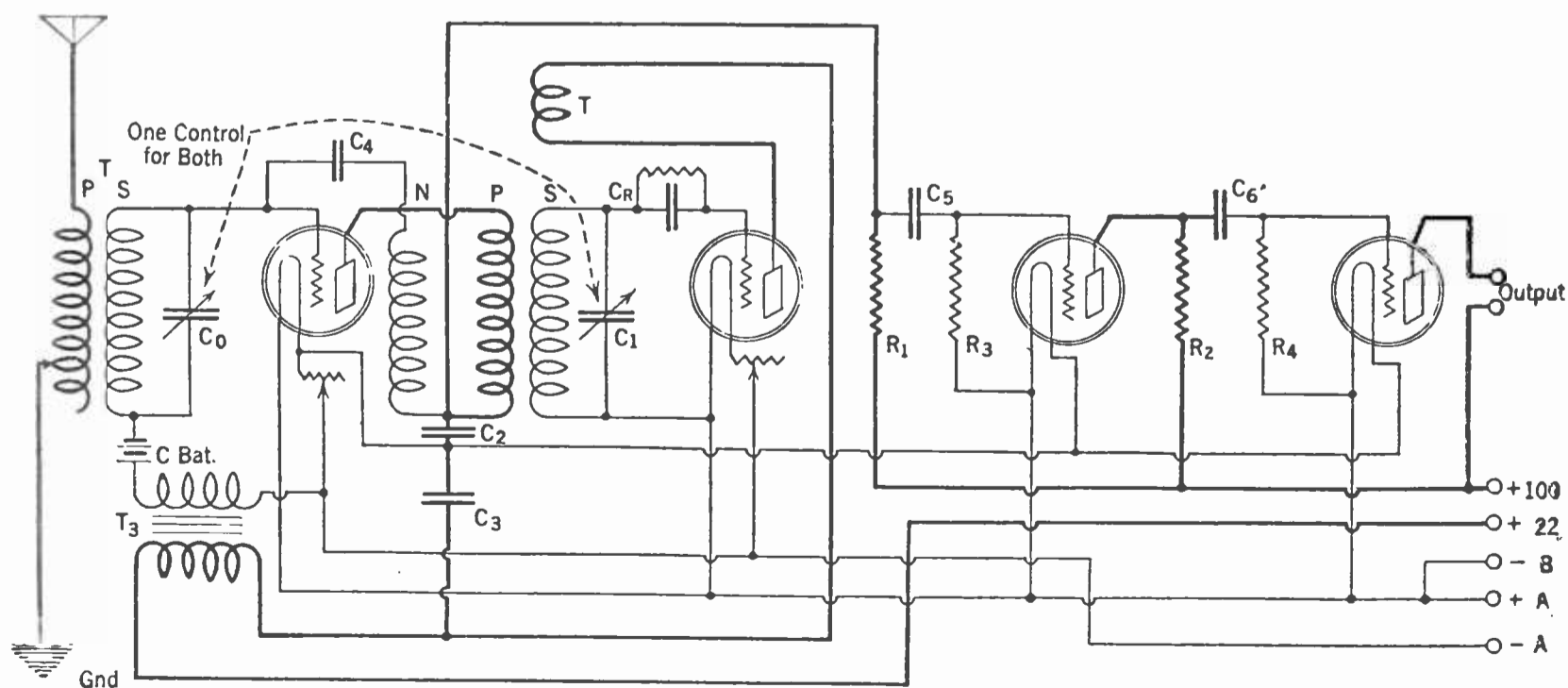

FIG. 3

The application of the single-control feature described in this article, may readily be applied to the Roberts Knockout receiver, a diagram of which appears above

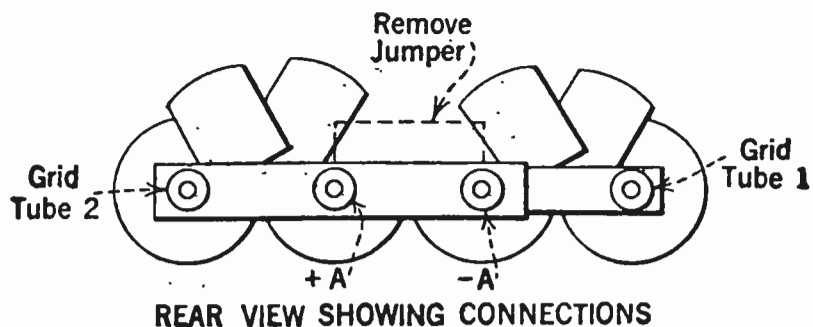

FIG. 4B

If the idea suggested in Fig. 4A. is tried out, the fan can follow the connections marked in this diagram for the two condensers

- 6. Side-by-side mounting saves space and conforms to layout of set.

The applications of the single control capacity element to various circuits will be taken up at length, and a description of the device is first presented in order that the details may be made clear. From the photographs we see that the two condensers are mounted so that the gears will engage with each other and consequently the rotation of one condenser will affect the other one simultaneously. The dial shaft gear is shown in Fig. 1. This drives the left hand condenser which in turn is geared to the one on the right. The cam which controls the vernier motion of the condenser on the right can be seen in the photograph of the back of panel view of the four-tube RADIO BROADCAST phonograph receiver. The condenser is mounted so that it may be raised or lowered by the motion of the cam and yet the position of the gear which engages with the left hand condenser remains

fixed. If the main dial shaft is rotated, both condensers will be affected, but the motion of the shaft containing the cam will vary the capacity of the right hand condenser but will in no way affect the one on the left. Fig. 2 represents the curve of one condenser and if the vernier is set at the mid-point, the other condenser will have an identical curve. In Fig. 2, A represents the curve of the right hand condenser with maximum adjustment of the vernier, while B in Fig. 2 represents the minimum adjustment.

In the application of this device to a receiving set, it is necessary to bear in mind certain

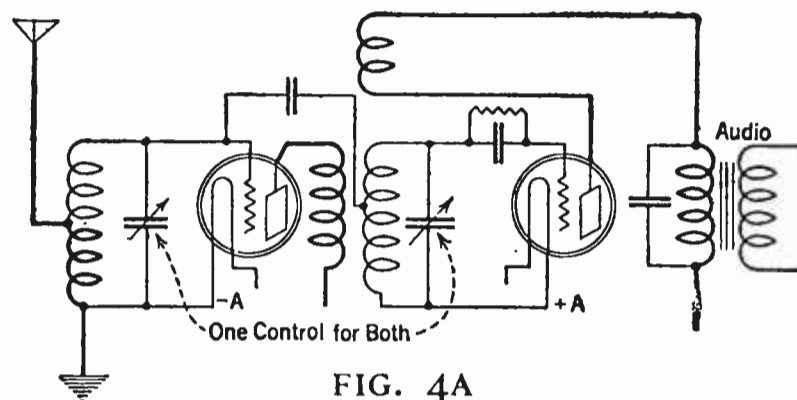
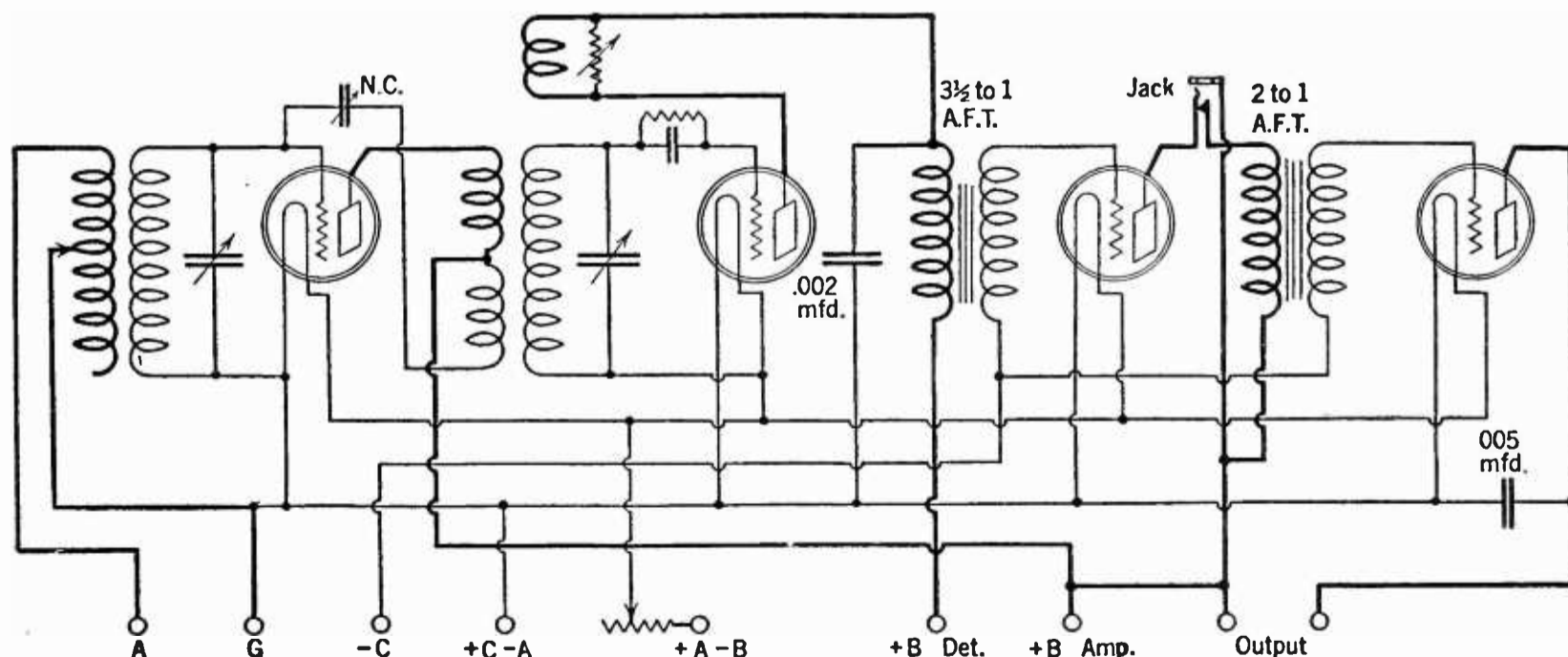

FIG. 4A

The Browning-Drake and Silver circuits, which are almost identical, have two variable condenser controls, and it is possible to cut this down to one control by employing the system outlined by Mr. Hanscom.

fundamentals which apply to tuned circuits. For a given frequency (wavelength), a certain value of C (electrostatic capacity) must have a definite value of inductance, the frequency, (wavelength) being a function of the product of these two. If we increase the



NOTE: 6  $\omega$  Rheostat Between + A - B Post and + A of all Tubes

FIG. 5

The single control unit may readily be applied to the RADIO BROADCAST Phonograph Receiver. In this way only one control will be necessary for the condenser shown across the secondary tuning coil and that across the secondary of the r. f. transformer. The connections in Fig. 4B apply in this instance also.

inductance we must decrease the capacity in order to tune to the same frequency (wavelength) value. It should therefore be apparent that, if two circuits are going to be tuned with this capacity element, the inductance of each circuit should be approximately equal. When these inductances are equal, it will be found that the adjustment of the vernier is unnecessary throughout the entire frequency (wavelength) range, but the vernier makes possible the necessary correction for differences in inductances and distributed capacity of the circuits.

#### APPLICATION TO THE ROBERTS KNOCKOUT RECEIVER

FIGURE 3 represents the Roberts circuit, which consists of a stage of tuned, neutralized, radio frequency amplification and a tuned detector with tickler feed-back together with a stage of reflexed audio amplification. As applied to this circuit, this single-control capacity element should be connected so that the condenser which is controlled by the vernier will tune the first radio frequency stage. It is suggested that a small fixed condenser be connected between the antenna and the tap on the first tuning coil, particularly if the set is used with a long antenna. If the single-control device is applied to a Roberts Knockout set which is already in use, it is well to make the necessary adjustment in order that the two dials will read alike before the element is installed. If you find, for instance, that the antenna tuning dial is always lower than the second dial, this should be corrected by inserting a small fixed condenser, from .0001 to .00025 mfd. in the antenna lead. If the dial still tunes low, this may be corrected by removing a few turns from the antenna tuning coil. This is necessary only in extreme cases, and if the dials can be made to read within four or five points of each other, you may install the single-control without any change in the set. In most Knockout receivers this change is brought about by means of the antenna switch, which compensates for antennas of various lengths.

It is suggested that the plates of the two condensers which are nearest each other, should be connected to the filament end of the respective coils to avoid coupling effects. The single-control capacity element has a flexible connection between these two sets of plates, and in the case of a positive return to the detector filament, this connection may be removed and the wiring then made in the usual manner care being taken to supply flexible

leads to the left hand condenser. The single-control capacity element is mounted on the rear of a panel by means of three screws and nuts, and the template gives the location of all the necessary holes.

#### SINGLE-CONTROL FOR THE BROWNING DRAKE RECEIVER

THE Browning-Drake receiver (completely described in RADIO BROADCAST for December, 1924), is deservedly one of the most popular circuits in use to-day, and it has earned this popularity through the excellent results which are obtained with it. This circuit differs from the Roberts only in the method of neutralization and in its lack of reflexing. Some of the kits which are on the market for its construction are provided with a .0005 mfd. variable condenser for the first stage and a .00035 mfd. condenser for the second stage. This results in the left hand dial reading lower than the right, particularly on the lower frequencies (longer wavelengths). In most cases however, the single-control capacity element can be installed in the regular manner. If it is found that the vernier must be turned to the extreme position so that the first condenser has more capacity than the second for any given setting, this may be corrected by lengthening the antenna or by connecting it to a tap on the coil a few turns nearer the grid end of the winding. If it is found that the vernier works best in the other extreme, where the first condenser has less capacity than the second, it can be corrected in one of three ways. One can shorten the antenna; connect a fixed condenser .0001 to .00025 mfd. capacity between the antenna and the tap on the first coil, or move the tap on first coil nearer the filament end. It will be found that the original inequalities can be taken care of with the vernier, but bear in mind that the proper adjustment of these inductance and capacity values will make the vernier almost superfluous, leaving only one, frequency (wavelength) control.

#### SINGLE-CONTROL FOR THE SUPER-HETERODYNE

THE super-heterodyne circuit consists essentially of two tuning controls, one to adjust the loop or antenna coupler and the other to vary the oscillator frequency, the latter to produce the proper beat for the intermediate amplifier. The single-control capacity element lends itself admirably to this type of circuit, because the proper value of loop inductance may be obtained by using the proper size and number of turns on the loop. To do

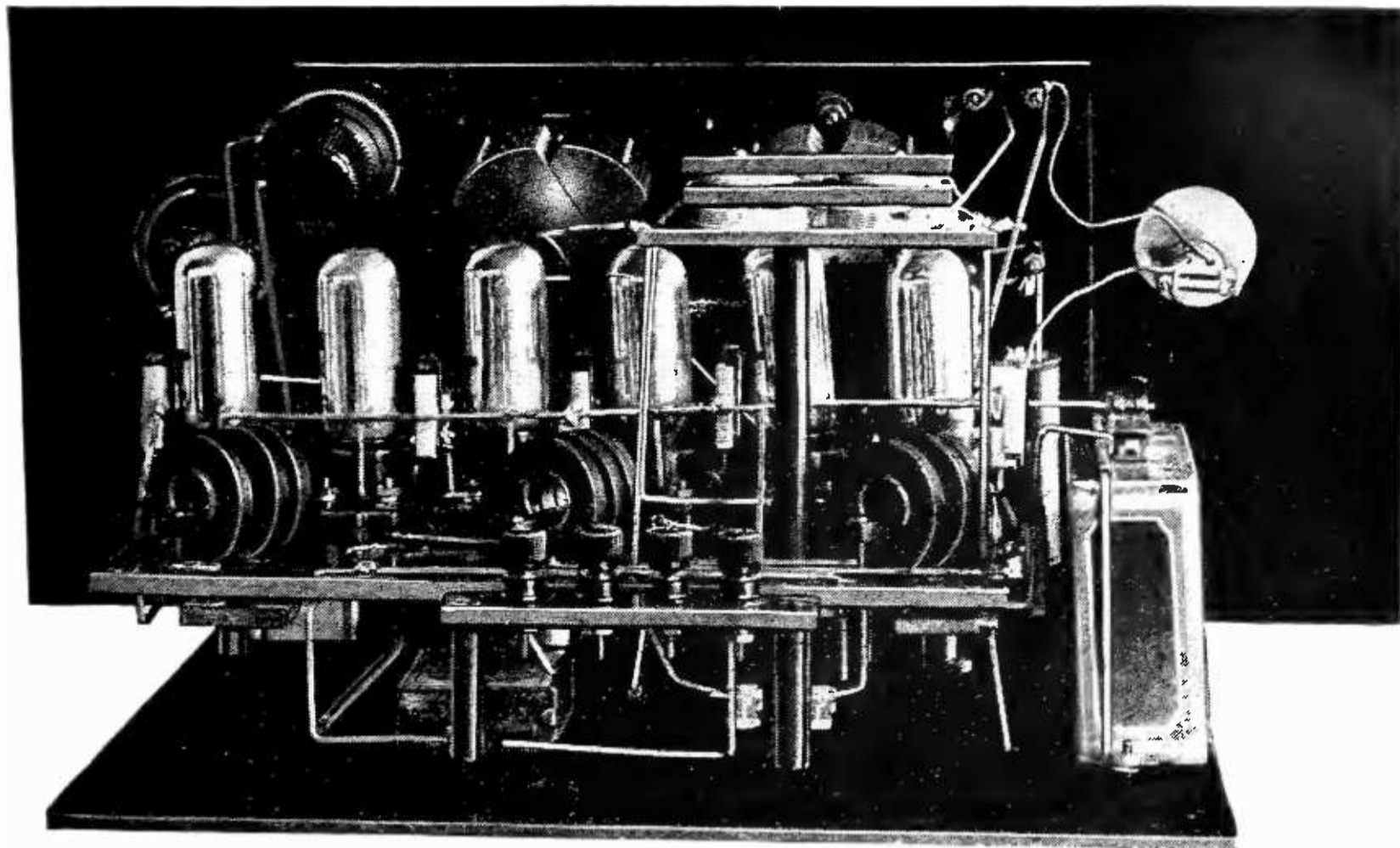

RADIO BROADCAST Photograph

FIG. 6

This illustration depicts the second harmonic super-heterodyne described by Mr. Hanscom in the November, 1924, RADIO BROADCAST. The single-control capacity element has been found ideal under actual working conditions, in this type of receiver

this, it is only necessary to vary the loop turns until a point is reached where the desired frequency (wavelength) range can be covered with the least possible variation of the vernier. The super-heterodyne is different from the tuned radio frequency set in the respect that it depends for its proper action on the constant difference of frequency between the two tuned circuits. It is, therefore, only necessary to provide the same tuning range in each of the circuits and the vernier can be set so that one condenser will always provide more capacity than the other, thereby providing the desired beat frequency. It is possible to calibrate a super-heterodyne for either the upper or lower setting of the oscillator. Below is given the dial settings of a two-dial super-heterodyne with a given loop.

	LOOP	OSCILLATOR
1199 kilocycles (250 meters) . . . . .	8	11½
999 kilocycles (300 meters) . . . . .	16	24
833 kilocycles (360 meters) . . . . .	27	38½
750 kilocycles (400 meters) . . . . .	33½	48
600 kilocycles (500 meters) . . . . .	51	73

This shows a total dial movement between the limits specified, of 43 points for the loop tuning and 61 for the oscillator. To correct this, three turns were removed from the loop after which the readings were as follows:

	LOOP	OSCILLATOR
1199 kilocycles (250 meters) . . . . .	13½	11½
999 kilocycles (300 meters) . . . . .	24½	24
833 kilocycles (360 meters) . . . . .	39	38½
750 kilocycles (400 meters) . . . . .	50	48
600 kilocycles (500 meters) . . . . .	75	73

It will be noticed that there still exists a considerable difference in the dial readings, but the total scale movement for each condenser is the same, and the vernier adjustment may be set at a position which will give uniform results throughout the entire scale. On practically all super-heterodynes the oscillator tunes sharper than the loop, and the single-control capacity element should be connected so that the right hand condenser will tune the oscillator, leaving the vernier for the fine tuning adjustment on the loop.

#### SINGLE-CONTROL FOR THE RADIO BROADCAST PHONOGRAPH RECEIVER

THE popular Roberts Knockout circuit is the basis of the set which has been featured by this magazine as being the best receiver for the money that can be built by the home constructor. By utilizing the capacity element, a phonograph receiver can be constructed as a true one-control set. A simple receiver, made to specifications supplied by RADIO BROADCAST and incorporating this de-

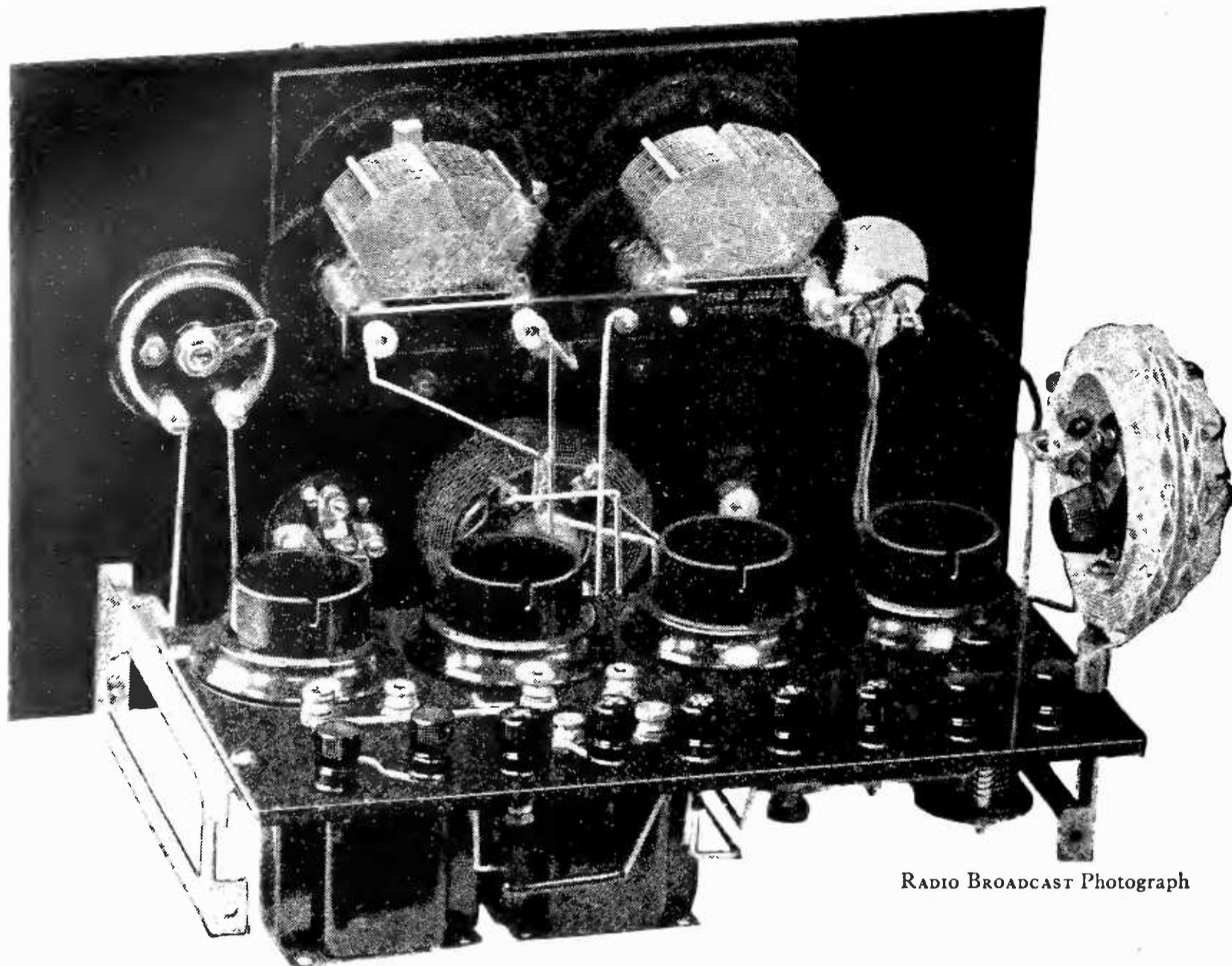

RADIO BROADCAST Photograph

FIG. 7

A variation of the RADIO BROADCAST Phonograph Receiver employing the single control capacity element. The cam which controls the vernier action of the condenser on the right, is shown beneath that condenser and is partly hidden by the detector tube socket. A Claratuna unit is employed for the r. f. coupling. This unit comprises a radio frequency transformer to which is tightly coupled the tickler coil. Regeneration control is accomplished by a variable resistance incorporated within the Claratuna

vice, is shown in the photograph. There are four tubes, consisting of one stage of tuned radio frequency, detector, and two stages of audio. The front panel measures only  $12\frac{3}{8}$  by 8 inches and the sub-base measures 5 by 10 inches. This is supported to the front panel by means of Benjamin brackets. The binding posts are mounted along the rear of the sub-panel and the Thordarson audio transformers are fastened beneath it. The Sickles antenna coupler contains a four-point switch to compensate for various lengths of antennas, and the coupling element between the radio frequency tube and the detector is a coil with fixed tickler, known as the Claratuna, mounted beneath the tuning element. The regeneration is controlled by a carbon resistance shunting the tickler coil. This gives a smooth even control without the necessity of moving coils, the space required for the radio frequency unit being reduced to minimum. This receiver gives excellent volume, distance and

selectivity, and the simplicity of tuning is a revelation.

Fig. 5 shows the wiring diagram of this phonograph receiver. The negative filaments of all tubes are connected together and to the ground. Use of the complete antenna coupler and the coupler between the first and second tubes, makes the wiring of the set a simple matter. The audio transformers are mounted with the cores in line and not at right angles, and the metal shieldings of the transformers are connected together and to the ground. A Chelton Midget condenser is used for neutralizing and its position is not critical. It is located on the sub panel at the end nearest the antenna coupler, which is clearly shown in the photograph.

## EDITOR'S NOTE

THE opinion is prevalent among some broadcast listeners that the use of straight line frequency, or wavelength, condensers will relieve most of the present difficulties in tuning. There are cer-



tain things that these condensers will do, and naturally others that they cannot do. What the phrase, straight line condenser means is that a given number of degrees on the condenser dial represents a certain number of kilocycles, or wavelengths, regardless of which end of the scale is being used. This is of distinct value at the higher frequencies (lower wavelengths) and will enable the user

to distinguish many of the stations now in class A. Condensers of this type will not eliminate the heterodyning of two stations that stray from their assigned frequencies; they will not separate two stations that are on the same frequency, as many in Class A are, and they will not eliminate any of the tuning troubles that arise at the transmitting station.

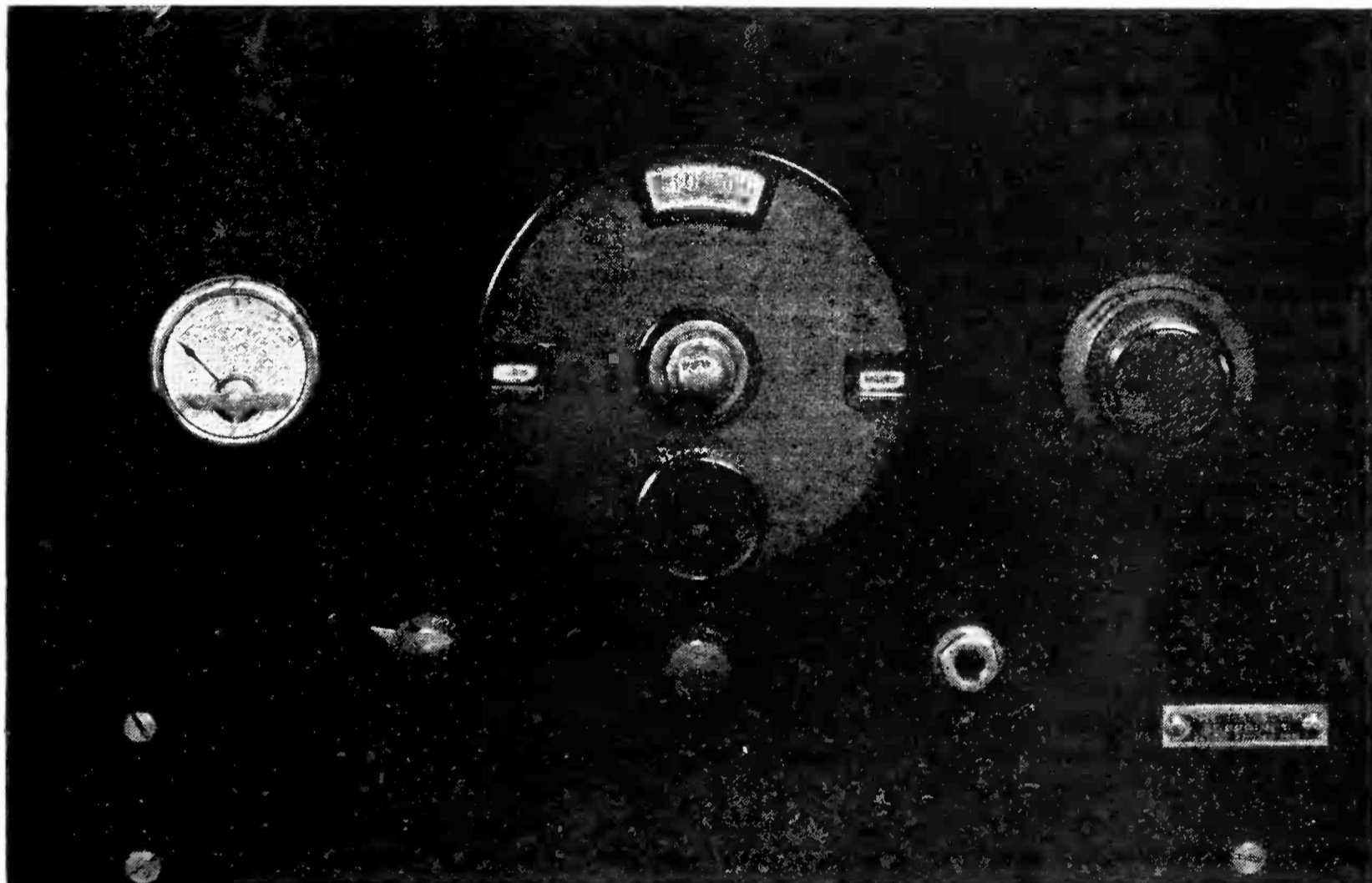

RADIO BROADCAST Photograph

FIG. 8

A front-of-panel photograph of the receiver shown in the preceding diagram. The apparatus on the panel, reading from left to right, include a voltmeter, the single-control dial, rheostat, and (bottom row) vernier control knob, resistance control and phone jack. A Hoyt filament voltmeter is included, and the use of filament meters is recommended in all receivers. Operating tubes above their rated voltage very materially decreases the life of a tube

## The New Size of "Radio Broadcast" for November

**W**ITH the November number, RADIO BROADCAST will be three and a half years old. During its career the publishers have tried, through every means in their power, to produce a magazine which, from the reader's point of view, should take the leading place in the radio field. Judging from letters which from time to time trickled into our office—letters of gratitude from our readers, backed up by healthy circulation figures, it appears that we have not failed altogether in this respect. It has been our constant endeavor to make the word "quality" synonymous

with both our editorial and advertising contents. Now, it is not our custom to celebrate a birthday every six months, but nevertheless it happens that in November, we shall signalize the occasion by introducing RADIO BROADCAST in a new form. The public support and approval of the magazine has been so unqualified that its physical size and appearance must be improved in addition to the improvements which from time to time we are constantly effecting in the editorial pages. November fifteenth, 1925, will be our red letter day then, and we hope that our readers will, by their universal

approval, help us to celebrate the occasion when the new RADIO BROADCAST appears. We contend, and that is only because our readers contend too, that our contents are exactly what the readers desire, and it is for this reason that every one of the popular features of the present magazine will be retained in the larger size.

Our constructional articles, as most of our readers know, are not printed merely because they provide another way to build a receiver, or worse still—because they afford another outlet for parts. The criterion by which we judge our construction articles is: *first*, are they authoritative? *second*, are they helpful? *third*, do they provide information on construction which is not available elsewhere? *fourth*, are they complete? These aims, we think we have attained. Our readers tell us we have done so, and after all is said and done, it is the reader who is in the most advantageous position to judge.

The authors who write for RADIO BROADCAST are men who know what they are writing. They are in the best positions to obtain information . . . shall we call it dope? . . . which is most interesting to our readers. Their names are veritably ones to conjure with in the vast field of radio. Ever since the first number of the magazine was placed on sale, it has contained, month by month, that engrossing article "The March of Radio" specially prepared by Professor J. H. Morecroft, of Columbia University. This editorial record of radio progress, which nearly everyone of importance in the radio industry reads, will naturally continue in the new RADIO BROADCAST. Mr. Morecroft occupies a high position in radio; a Professor of Electrical Engineering at Columbia, a Past President of the Institute of Radio Engineers, and author of a standard text on radio, *The Principles of Radio Communication*, Mr. Morecroft has a weight of knowledge and authority behind his editorial comment, which is nationally quoted every month.

Then there is Carl Dreher, one of the most able broadcasting engineers in the country. He tells us monthly what the broadcasters are doing and how they are doing it, and in his inimitable fashion—which has won him recognition in other fields than his chosen one—relates the opinions and comments that are prevalent, about the latest developments in the radio field.

The broadcast listener is represented in that popular feature "The Listener's Point of View," which has, again judging from correspondence alone, a very large following. We aim to cater to the fan of every stage, from the veriest of embryos to the most technical of them. For the former, Zeh Bouck conducts a department calculated to interest the beginner but written interestingly

enough to be followed by the more technical man. He sets out to guide the beginner sympathetically and carefully through the early and confusing mazes of radio, and in this he succeeds admirably.

And as regards advertising. The high standard of admissibility to our columns is the reader's assurance that everything advertised is exactly as it is described. Our policy is first to be sure and then go ahead. For that reason the star of approval, appearing on all the advertising pages, was established many months ago. It is a way of telling our readers that the apparatus advertised has been given a thorough test by the laboratory and was found satisfactory. The man not behind the editorial scenes cannot realize what an effort it has to maintain strictly this advertising policy under all conditions, but we feel sure that we have not failed in this respect. Our laboratory, we might add, is, in technical equipment and staff, second to none in the country.

In addition to its new size, which, by the way, will be eight and five eighths by ten and a half inches, the magazine is to be printed on a more expensive paper, a heavy white paper, which will greatly enhance the appearance of the illustrations and make the diagrams even clearer than is possible at present.

#### A NEW COVER

A PRIZE of \$500 was offered for the best cover design for the new magazine, and one has been chosen by the judges, which we think our readers will agree is particularly pleasing and attractive. It was painted by Mr. Fred J. Edgars of Tenafly, New Jersey, and was picked from innumerable others submitted from cities all over the United States.

In the November RADIO BROADCAST we are planning some features of particular interest. Robert H. Marriott, the first president of the Institute of Radio Engineers, has written a fascinating story of radio development, which will be run serially. Keith Henney will continue his engrossing articles on "What Is to Become of the Home Constructor," and there will be more phonograph radio receivers for those interested, in future issues. There will be an article on a high quality audio amplifier which operates direct from the a. c. mains; latest information on short wave work, gleaned from the operators of RADIO BROADCAST station 2 GY; plans for the third International RADIO BROADCAST Tests, and a host of important constructional material exclusively written for this magazine.

In November, RADIO BROADCAST will greet you, bigger and, we are sure, better than ever.

# High Radio Adventure—On Short Waves

The Romance of Code Communication Far Below the Broadcast Channels—  
Something About RADIO BROADCAST'S Experimental Transmitting Station 2 GY

BY KEITH HENNEY

Director, RADIO BROADCAST'S Laboratory

*FOR some months, the RADIO BROADCAST Laboratory has been hard at work—among its many other activities—in installing a high frequency (short wave), low powered transmitting station to operate in the communication bands assigned to amateur experimenting. The field of high frequency (short wave) transmission offers one of the most fascinating fields for experiment in all radio—as any amateur operator will tell you with a sympathetic optical twinkle. We have no desire to encroach on the field already well covered by our excellent contemporary, QST, and on the work we expect to do will be along somewhat different lines—although none the less fascinating. In an early number of the magazine we shall have an announcement of very great interest about this work and our station, 2 GY. A goodly number of advanced broadcast listeners, if we are any judge, are becoming more and more interested in what is being done on other communication bands than the broadcasting and this article presents some of the romance and interest of that new territory for radio exploration.—THE EDITOR*

**A**DVENTURING into the radio region below about 1500 kilocycles (200 meters) is like exploring unknown territory. It is impossible to say what will be found there and no guess is too wild. From this frequency, 1499 kilocycles to be exact, down to goodness-knows where, is a region so vast that all existing stations could be placed in it without crowding. "DX" exists there that is undreamed of on the longer waves, and it is a territory into which any one may venture with the certainty that he will discover interesting things.

A few years ago there were no stations working between the amateurs and the commercial stations operating on 1499 and 499.7 kilocycles (200 and 600 meters) respectively. Then the broadcasters filled the gap and gradually moved down toward the "hams" until they are now next-door neighbors. The amateurs, by government fiat, moved down into the "no man's land," employing frequencies of from 1499 kilocycles up (200 meters down).

Leon Deloy of Nice, France, an enthusiastic amateur experimenter, is one of the individuals who really started the short wave affair going on a grand scale. Sporadic attempts had been made to entice amateurs into this territory, but when this Frenchman established communication across the Atlantic on a fre-

quency of about 3000 kilocycles (100 meters), it was the signal for great amateur activity with the short waves that had once been thought useless. Now the amateurs not only occupy a band from 1999 to 1499 kilocycles (150 to 200 meters), as of old, but they are working in bands around 3748, 7496, 14,991, 59,964, 428,314 kilocycles, (80, 40, 20, 5, and .7 meters).

After Deloy's success it was not long until England, Denmark, and The Netherlands amateurs had communicated with America, and now there are few civilized nations whose radio citizens are not in personal touch with other foreign countries.

Below 1499 kilocycles (200 meters) is a paradise in which nationality, language, and distance are of no importance, nor is a limited pocketbook an excuse for staying away from the most interesting region of radio. There is the record of the Massachusetts boy who spoke with a fellow amateur in Australia with a lone 5-volt receiving tube which cost him \$3.

Remember how few stations you can hear on your broadcast set in the summer time at night—and how very few in the day time. Now suppose you sit in with the operator of 2 GY, the experimental transmitting station operated by the RADIO BROADCAST Laboratory.

## AN AIR TOUR

IT IS Saturday, June 27th. The weather is not particularly favorable. At 9:40 A. M. we tune the receiver to 7496 kilocycles (40 meters) and at 9:43 we hear 8 NX, Walter J. Barnwell, Lansing, Michigan, calling. We converse with him until after 10 o'clock when he says that our signals are somewhat wobbly, probably due to weather conditions between the two stations. At that time we hear 9 EK, the Burgess Laboratories Station at Madison, Wisconsin, calling us, and for the next hour we try to get together without success. He can-

not hear us and his signals waver too much for comfortable reception.

At 10:58 we hear WNP, S. S. *Bowdoin*, Commander MacMillan's vessel sending a long message to 1 NT, Norman C. Theobald, Attleboro, Massachusetts. We copy all but two words and when the *Bowdoin* has difficulty in hearing 1 NT, we step in and call him ourselves. He is troubled with near-by interference and finally replies 2 NY instead of 2 GY so we are not sure that we worked him after all.

Not long after, 9 EK calls us again, and after some attempts to get together he broadcasts

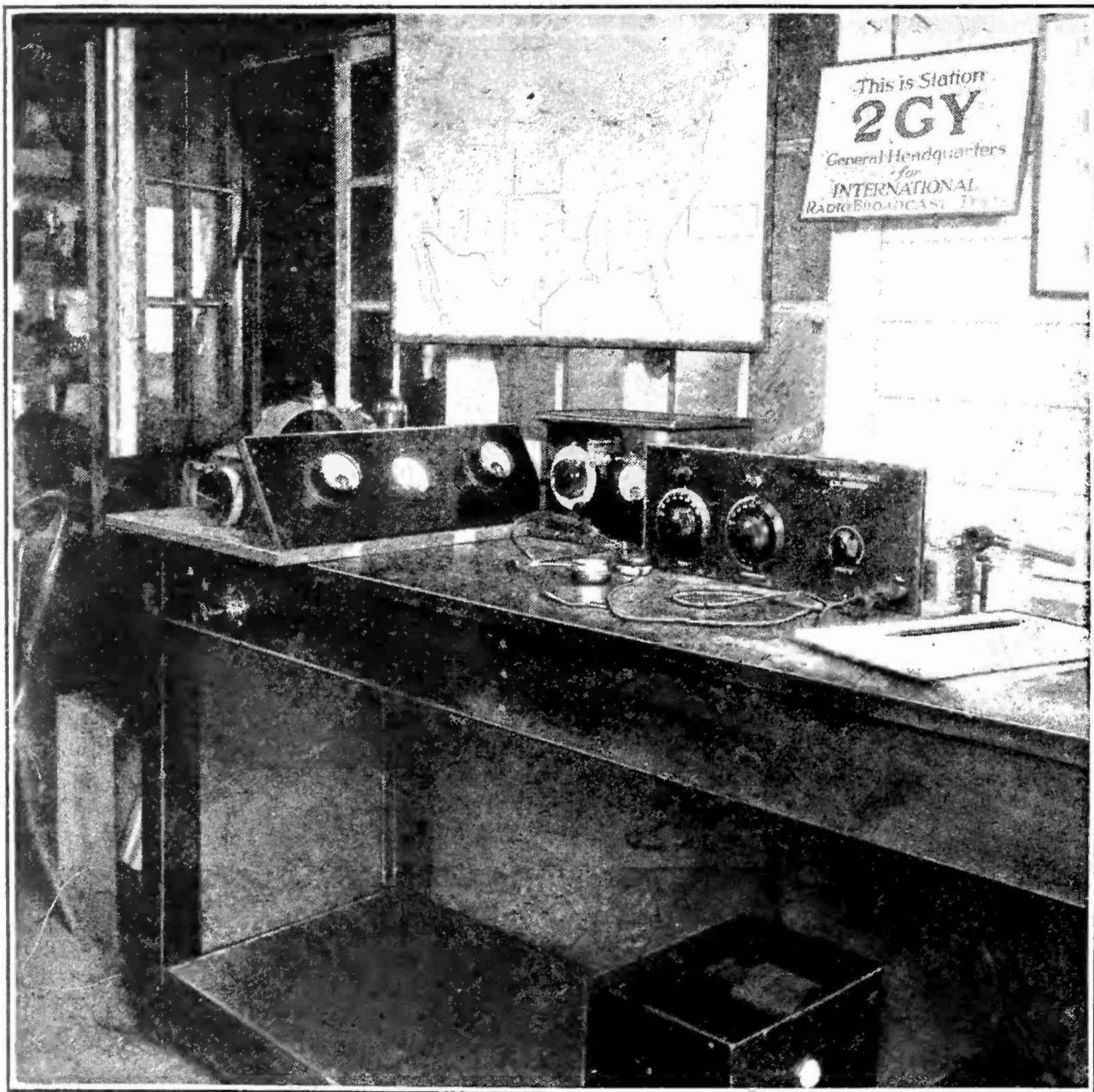

FIG. 1

The installation at 2 GY showing the 50-watt transmitter, receiver, wave-meter, and batteries for plate voltage. Strangely enough the "5 watter" transmitter operating entirely from batteries so far has done about as good work as the big transmitter. The big set requires 130 milliamperes, the small one, 60 mils. The receiver was made by U. B. Ross of 2 UD, and the wavemeter constructed to Bureau of Standards specifications. Although the map doesn't show it, there are pins in California and Dakota

a message to our Chief, Mr. Frank N. Doubleday. It says:

Greetings from Burgess Organization via our two stations. Hope to cooperate with Lynch to aid short wave work.

After telephoning the MacMillan message to the Western Union for transmission to the National Geographic Society at Washington, we sign off for luncheon. MacMillan, at that time, had just left Nova Scotia, and was on the second lap of his polar journey.

The next day, Sunday, June 28, we arrived at the station at 6:25 A. M. to see what was going on at that hour. It is raining slightly and there is some static. The first thing we hear is 6CHZ, Wallace S. Wiggins, Los Nietos, California, calling NPO. Now NPO, if you please, is Guam Island, in the Northern Pacific (6000 miles from California). At 6:39 we hear 6BUR, L. E. Smith, Whittier, California, 6CGW, K. L. Riedman, Long Beach, California, and 5UK, Charles A. Freitag, New Orleans, all working. A minute or so later we hear a strange note pounding away at great rate

working with 2MU, William Schick, Brooklyn. It turns out to be NVE, U. S. S. *Utab*, bound from Panama for San Pedro and now off the coast of Lower California. He has a load of Annapolis midshipmen aboard. Turning the tuning dial a bit we stumble into NPM, Honolulu, calling NPN, Cavite, Phillipine Islands. At 7:25, one hour after we arrived at the station, we hear 9DED, Ralph R. Williams, Denver, Colorado, calling NPO. In that short space we have heard three amateurs on the Pacific coast, we have heard the U. S. S. *Utab*, a cool 2500 miles away, and we have heard Honolulu approximately 5000 miles distant. Not bad for one hour! It has been broad daylight all the time—traditionally bad for radio work.

#### AUSTRALIA—IN ONE JUMP!

FRIDAY, July 10, we come to the station early again, and at 6:30 A. M. we send a message to our home via 8GZ, Loren G. Windom, Columbus, Ohio. We also have a message for Australia, but do not have the nerve to transmit it to this amateur in Ohio, only 800

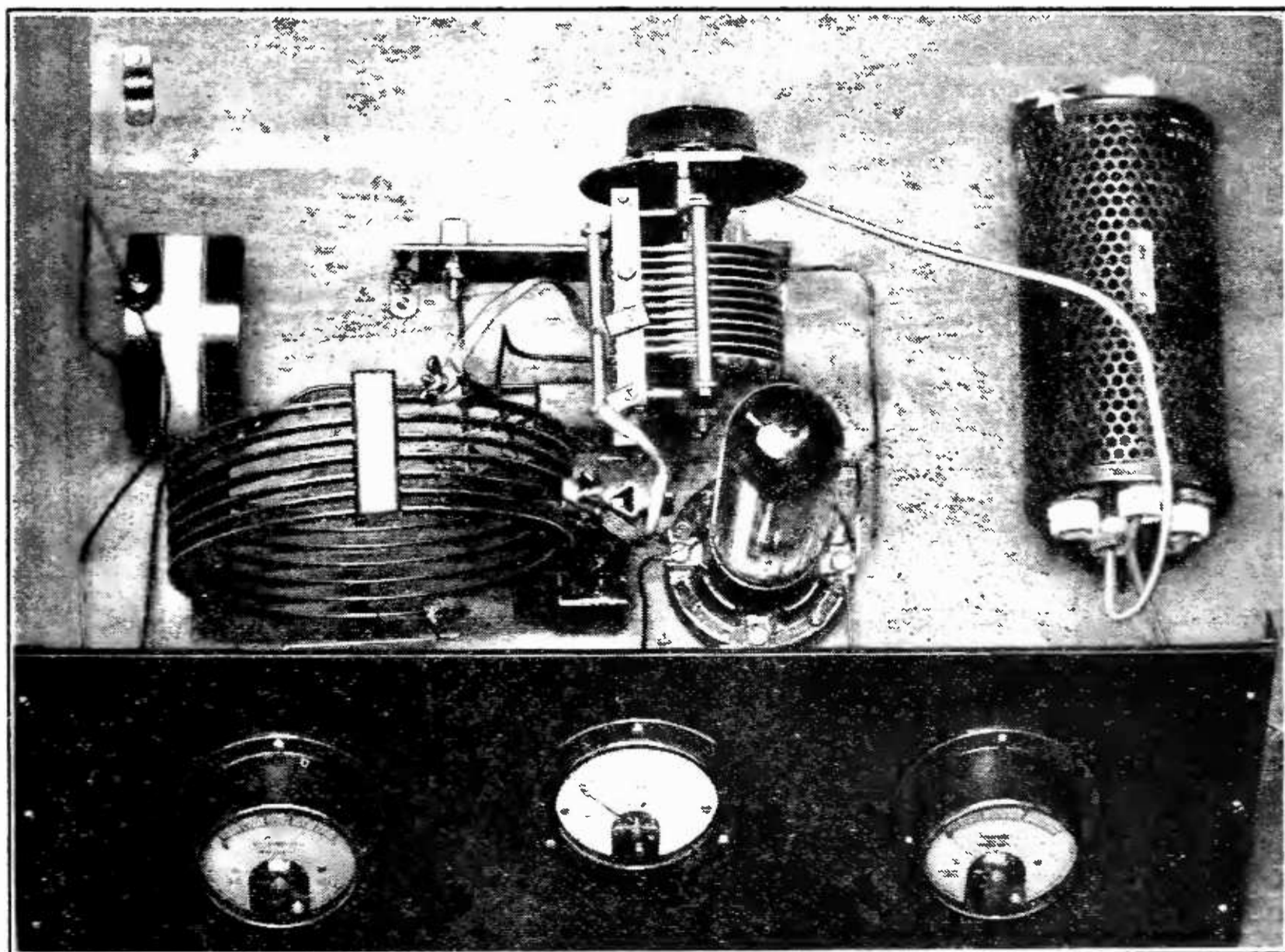

FIG. 2

A close-up of the 50-watt transmitter and the 40-meter inductance. The small coil on the left is a choke coil to keep radio frequency voltages out of the plate supply, and the mouse trap arrangement on the right is an external shunt for the kilovolt meter. A double-spaced Cardwell condenser is used for tuning

miles away. A half hour later we hear Australian 2CM working 8GZ. What hard luck! Had we given the message to the Columbus operator, it would have been in Australia in one half hour, better than any cable could do. It is 9 P. M. in Australia, 5 o'clock Central Standard Time in Ohio, and 7 o'clock Eastern Daylight Saving time in Garden City.

Honolulu is on again this morning as well as 4RL, Mario Castro Fernandez, Santurce, Porto Rico.

The next time we listen is on July 29 at 9:20 P. M. We hear 1CKP, George H. Pinney, South Manchester, Connecticut, calling WNP. There are thousands of amateurs on the frequency band of about 7500 kilocycles (40 meters), all pounding away, working, or trying to work, with each other. In this bedlam of signals it is difficult to pick out any particular one. We call several, but not until 10:30 do we raise any one. It is 1BQU, Alden C. Eldridge, Buzzards Bay, Massachusetts, and we converse for a half hour. At 11:52 we connect with 8AMS, Albert H. Buch, Tawas City, Michigan. This is better and we have hopes of reaching out. Nearly an hour later we communicate with 9MN, Robert C. Berry, Louisville, Kentucky, and then with 9EK, our friends at the Burgess Laboratories, Madison, Wisconsin. We feel pretty good over this communication, for we have been trying for a week to get together. We give him a message from Mr. Doubleday.

It is now 2:00 o'clock and our ears hurt from wearing the phones so long so we take a brief rest. A half hour later we listen in again and note that many stations have dropped out of the hunt for "dx." It is possible that we shall work the coast. Our signals are answered by 9NN soon. He is Chas. R. Jarosewicz at Chicago and a few minutes later we connect with 9AMM, James Gwynn, Shenandoah, Iowa. This is "out west" from Garden City and our hopes rise again.

Seven minutes elapse before we touch the key again and then we send out a general call, "cq." Who should come back but 6TX, R. M. Thacker, Baldwin Park, California! We have worked the coast. In twenty minutes, 3:24 A. M. to be exact, we click with another Californian, 6JP, Oscar Roediger, San Francisco. He says "FB," which in amateur language means "fine business."

At 4:25 we get a long message from 4ASK, Florida, which we try to phone to the Waldorf Astoria Hotel. The telephone operator there says she is not in the habit of getting telegrams phoned to her, especially telegrams that relate

to Florida real estate and a young lady who wants to marry somebody now at the Waldorf. If it were not illegal we would pass this whole message on, for it is a good one, but that is impossible, since it would violate the oath of secrecy assumed by every licensed operator.

It is now 5 o'clock and we are hungry, sleepy, and happy. We have worked two stations in California and many at less distance.

#### THE RESTRICTED BRITISH AMATEUR

THIS night's work was so successful that we try it again, the next evening, July 30. At 10:00 we get in touch with 9BBJ, James R. Freyermuth, South Bend, Indiana, with whom we have talked before. At 10:20 we work with 8DOO, Robert L. Miller, Royal Oak, Michigan. We now sweep all the amateur wavelengths for WNP, for we have messages for MacMillan. We do not hear a sign of him, but hear British 2SZ calling WNP. In a half hour this Britisher is working WNP and telling him that British regulations would not permit him to take messages. Stupid regulations, we think.

It is not a good night and it is after 1 o'clock before we connect with 8CCM, Eugene Rupprecht, Grand Rapids, Michigan. Not much later we click with 9CCA, Kurt T. Johnson, Chicago, Illinois, and finally work 6CPF, Bryson Walker, Hollywood, California. There are many Californians on the air and also 7IT, A. C. Dixon, Jr., Stevensville, Montana. Finally 9EFS, Lee Jensen, Marshalltown, Iowa, tells us that a bad thunder storm is raging out his way which explains why so few Western stations answer calls from 2GY. NVE, the *Utah*, is on again and working a number of Eastern stations. The Zenith station, 9XN, at Chicago, is working with WAP, S. S. Peary, the second MacMillan vessel now in the Arctic.

The next night, July 31, we have fair success with the transmitter, working down into several Southern states. The receiver, however, is doing remarkably well, for we log New Zealand, 2KF, British 2NM, Chilean 1EG, Australian 3BD, and Mexican 1AA, and 1B. All of this is around 40 meters—and is only an extremely small part of the frequency spectrum above 1490 kilocycles (below 200 meters).

The station operated by the RADIO BROADCAST Laboratory came on the air for the first time June 18, 1925, and by August 10th had worked amateurs in twenty states and two provinces of Canada. Many of these stations were worked in the daytime, feats of transmission and reception that would be impossible on the lower frequencies (longer waves). The power required to carry on these communica-

tions has never exceeded 130 watts, and together with that required to heat the filament of the "50 watter", totals less than 200 watts. The average electric iron requires 400 watts of energy. The cost of the apparatus has been about \$200, a sum required for a good receiver with its accessories. At the time this is written, in August, very successful communication is being maintained over 800 miles with a power totaling less than 40 watts, and some very good results have been secured with ordinary 5-volt receiving tubes used for transmitting purposes.

THE B. C. L. IS MISSING SOME GREAT RADIO SPORT

IMAGINE sitting in your home with apparatus as inexpensive as that of 2GY and conversing with fellow amateurs in England, or Australia, or South America! Is it any wonder that the 17,000 licensed amateurs in this country think that broadcast listeners have something yet to learn before they have tapped the greatest source of radio interest?

The transmitting tube is somewhat different from those with which broadcast listeners are familiar. Its filament requires 10 volts and burns up 6 amperes! Its plate battery requires 25 of the ordinary 45 volt B batteries, 1100 volts in all. The average plate current is 100 milliamperes, or about that required by five average broadcast receivers. Another source of high voltage that has been used successfully is an "S" tube rectifier also shown in the photograph below.

The antenna system has suffered many vicissitudes. It has consisted of nearly everything from a brass gas pipe to a fan of wires stretched between the two 85-foot masts. At the present time it consists of a single vertical wire one-half wavelength (65 feet) long. It is "fed" from the transmitter, which is actually some distance away, by a single wire, and although one half ampere of current flows in the center of the antenna, there is very little energy in the "driver" wire itself. It is a curious arrangement, but it works.

At the time this is written, plans are being

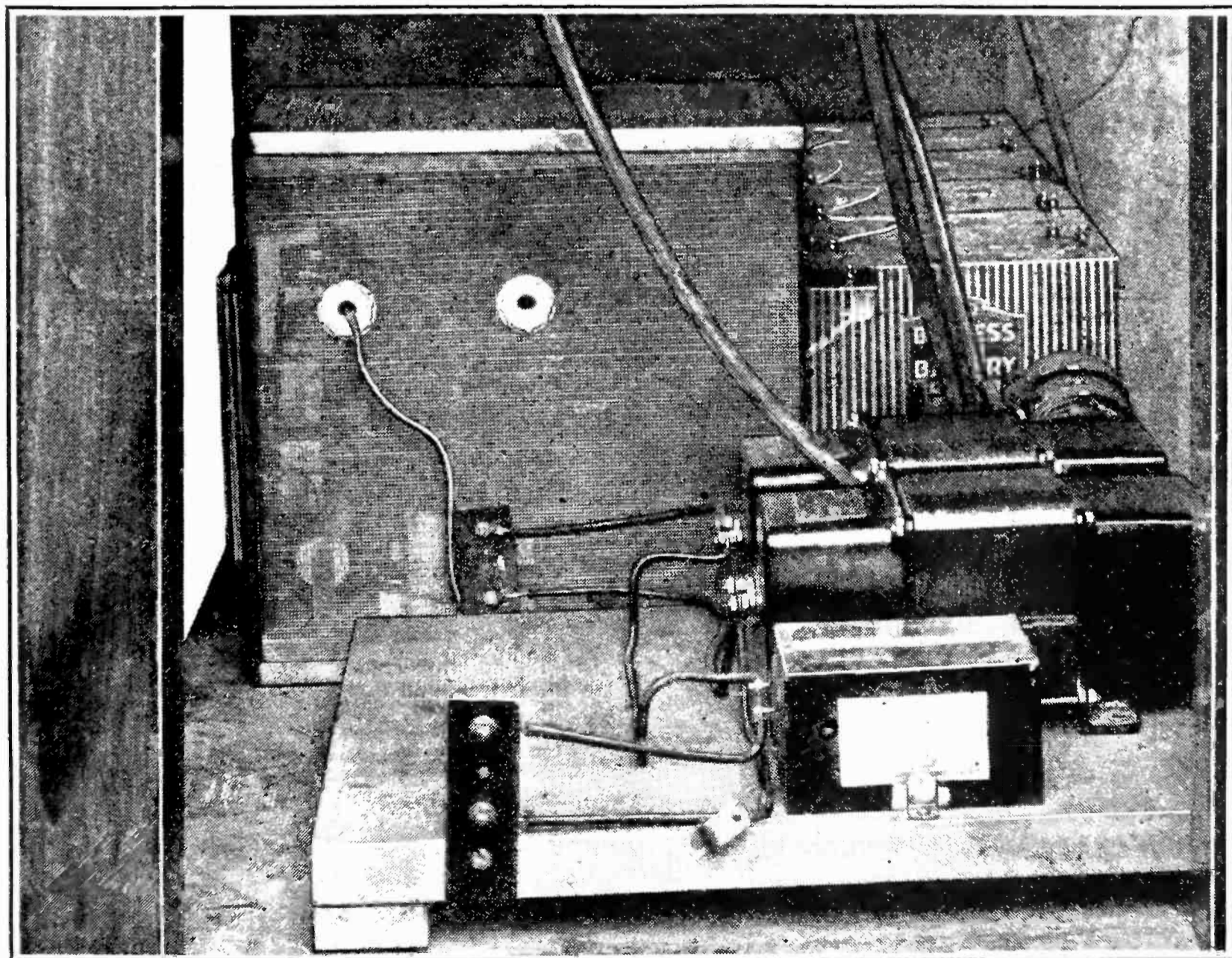

FIG. 3

An S tube rectifier and filter. The S tubes are in the cage together with an Acme 1500-volt transformer and control resistances. The filament transformer, behind the R. C. A. filter coils, is a home-made affair. The filter condensers are high voltage paper condensers

formulated for a complete investigation of the phenomena underlying transmission in this very high frequency (short wavelength), region. It is an adventure into unknown fields. There are many amateurs on their narrow bands down there, and a few commercial and naval stations are carrying on long distance communications down there also. Marconi is experimenting with "beam" transmitters, and there are a few broadcasters like KDKA and WGY who have high frequency (short wave) channels. There are many harmonics from broadcast stations down there too—but there are thousands of wavelengths and only a few to use them at present.

This experimental work will be carried out jointly by the Laboratory of RADIO BROADCAST and the National Carbon Company and will include the building of accurate frequency meters, short wave transmitters and receivers, especially low-powered, battery-operated af-

fairs. The interesting things that occur down in this strange territory are too many for the broadcast listener to pass up entirely, and from time to time the Laboratory will conduct a small pictorial and verbal tour for our readers.

For the benefit of amateur readers it may be said that 2GY has an operator on duty all day and night. The station will be glad to communicate with any amateur on any wavelength at any time, to relay, or deliver messages or to carry out tests that may be mutually interesting. The station will be glad to check amateurs on their transmitting frequency (wavelength), and it is possible that a calibrating service will later be organized so that wavemeters or receivers may be accurately calibrated for amateurs who desire the service.

Reports of the reception of signals from 2GY will be greatly appreciated. They should be sent to the Director of the Laboratory, RADIO BROADCAST, Garden City, New York.

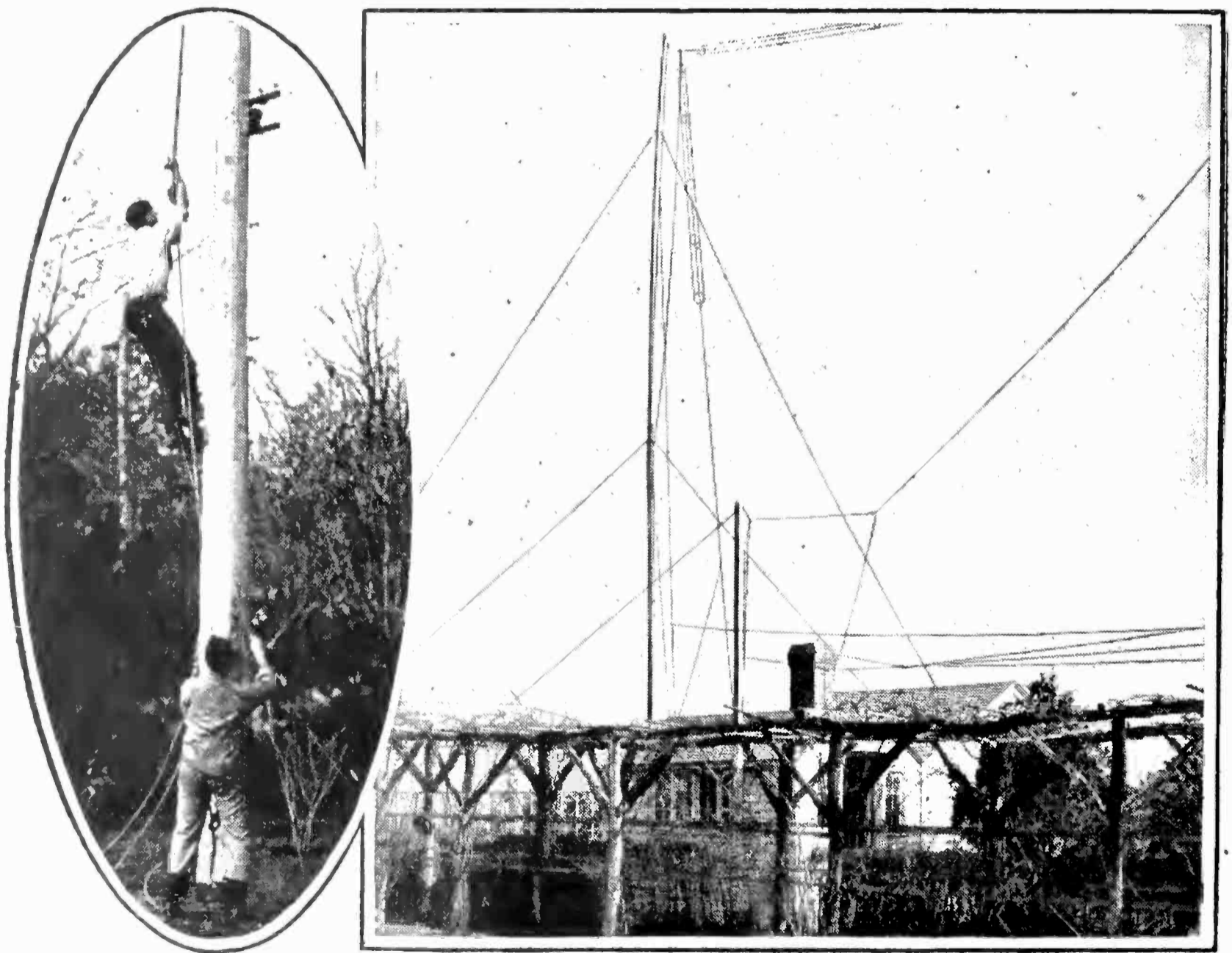

FIG. 4

The "shack" which houses 2GY. This was built originally for the International tests, but is now used for short wave transmission and reception entirely. In the spring the arbor is covered with roses and wisteria—but they have little to do with short waves. The insert shows some of the effort which has been expended on the masts and gives an idea of their size. The cage has been replaced by a single wire receiving antenna and a variety of transmitting antennas are used, strung from a rope between the two 85-foot masts 150 feet apart. A single wire 40 meters long, hung vertically downward, seems to be as efficient a radiator as any other



# For the Radio Beginner

## How to Build a Simple One-stage Amplifier

**T**HE "Radio Beginner" this month guides the newcomer through the construction of a simple one-stage audio frequency amplifier. The addition of this amplifier will add no little bit to the possibilities of the crystal and single-tube receiver, while its construction will contribute a valuable fund of practical knowledge to the experience of the builder.

In the elementary theoretical section of this department, Zeb Bouck, its editor, discusses the fundamental action of the vacuum tube in preparation for future articles on its action as a detector and amplifier. References for outside reading, treating on the material covered in "The Radio Beginner" this month, are suggested to the student reader.—THE EDITOR

**T**HE output of any of the receivers we have so far described in the past numbers of this magazine (for July, August, and September) can be amplified, or made louder, by the addition of a simple audio-frequency amplifier. The conventional amplifier consists of some means of coupling the output of the radio receiver proper (a transformer in this case) to an extra tube, where it is amplified by means of the well-known relay characteristics of the tube.

The following illustrations and text show how such an amplifier can be built up on a baseboard. The task is well within the experience and ability of the beginner.

### LIST OF PARTS

**T**HE electrical parts necessary for the construction of the amplifier are photographed in Fig. 1 and are as follows:

IN FIG. 1	DESCRIPTION	APPROXIMATE PRICE
No. 1	Standard socket . . . . .	\$ .25
No. 2	10-ohm rheostat (base mounting type) . . . . .	.25
No. 3	6 binding-posts at 5 cents each . . . . .	.30
No. 4	Audio-frequency amplifying transformer . . . . .	4.00
	Total	4.80

The parts designated are designed for use with a standard five-volt tube. If it is desired to use a three-volt tube, which is quite satisfactory in a single stage of audio amplification, a thirty-ohm rheostat and a socket for the small-based three-volt tubes should be substituted for the parts listed.

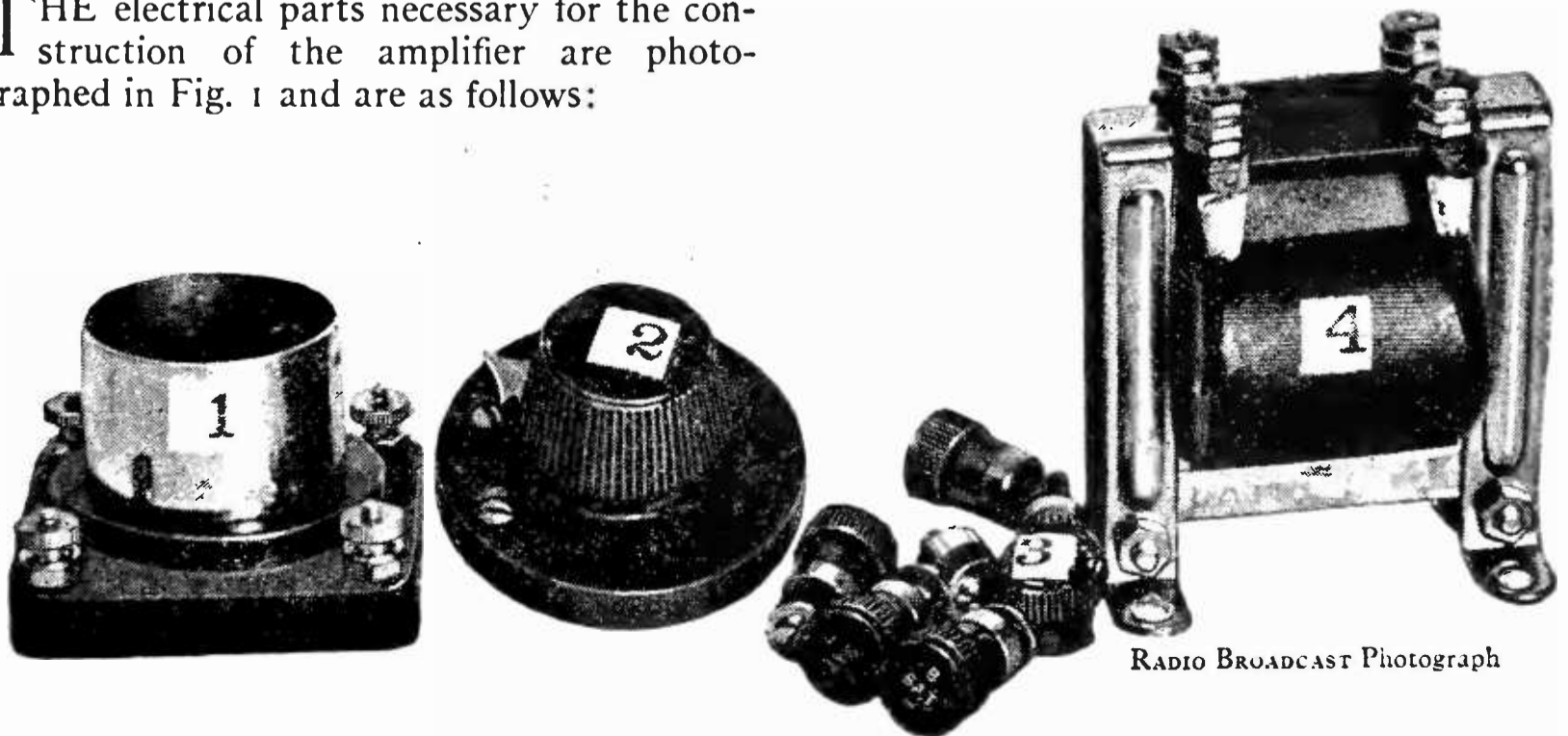

RADIO BROADCAST Photograph

FIG. 1

The electrical parts used in the construction of the simple amplifier

Any reliable make of amplifying transformer will give satisfaction. A Jefferson transformer was employed in the amplifier photographed and described. When purchasing the parts specify a three-to-one ratio transformer. This means that the secondary winding will have three times as many turns of wire as the primary, a ratio the writer recommends for all around amplification. A higher ratio, however (up to six to one), will work satisfactorily in the first stage of amplification.

The parts are mounted on a wood base five and one half inches long by five inches wide, according to the layout suggested in Fig. 2. The radio beginner will find it worth while to sandpaper the base, bevel the upper edges slightly, and to stain it a dark green.

#### WIRING IS THE NEXT PROCEDURE

FIGURE 3 shows the wiring diagram in two forms. Diagram A is the standard schematic arrangement employing the usual electrical and radio symbols. Diagram B is a pictorial layout of the same hookup which may be of greater significance to the beginner. Comparison of these two sketches will explain Fig. 3A. The reader should familiarize himself with this system of circuit diagramming.

Examination of the transformer will show four binding posts or connecting terminals. These are generally grouped into two on each

side, one group marked P (indicating the primary winding), and the other S (designating the secondary winding). One post in group P is marked "P," which indicates that this terminal should be led through to the plate of the preceding tube. The remaining primary binding-post will be marked either with a plus sign, or "B" or "B Bat," meaning that this post should connect with the positive terminal of the B battery. The secondary posts will be marked "G" and "F" or "G" and a minus sign, signifying respective connections to the grid of the amplifying tube and the minus side of the filament lighting or A battery.

There will be four posts on the socket marked "P" for plate, "G" for grid, and two marked "F" for filament. Occasionally plus and minus signs are substituted to indicate the filament binding-posts. The rheostat will have two binding-posts, unmarked.

Binding-posts 1, 2, 3, 4, 5 and 6 (Fig. 3) are wired respectively, by the shortest possible routes, to the "P" transformer connection; the "B Bat" transformer terminal; one filament post on the tube (plus if marked), to the rheostat and "F" terminal on the transformer; and to the plate of the tube. Post 6 is left blank.

The remaining post on the rheostat is wired to the second filament terminal on the socket.

The "G" post on the transformer is wired to the similarly marked socket post, completing the wiring of the amplifier.

Bare No. 18 copper wire, covered by black spaghetti, lends a neat appearance to the finished amplifier, shown in Fig. 4.

#### HOW THE AMPLIFIER IS CONNECTED

THE amplifier we have described is designed for operation immediately after a crystal or bulb detector, or following the single tube on the RADIO BROADCAST One-Tube Reflex receiver and similar sets. It should not be used as the last step in a multi-stage amplifier.

The principle of connecting the amplifier is the substitution of the input posts, 1 and 2, for the telephone receivers in the original circuit by phone plug or binding-posts. The telephone receivers, or loud speaker, are then connected at the output posts, 5 and 6.

Fig. 5 shows how the amplifier is

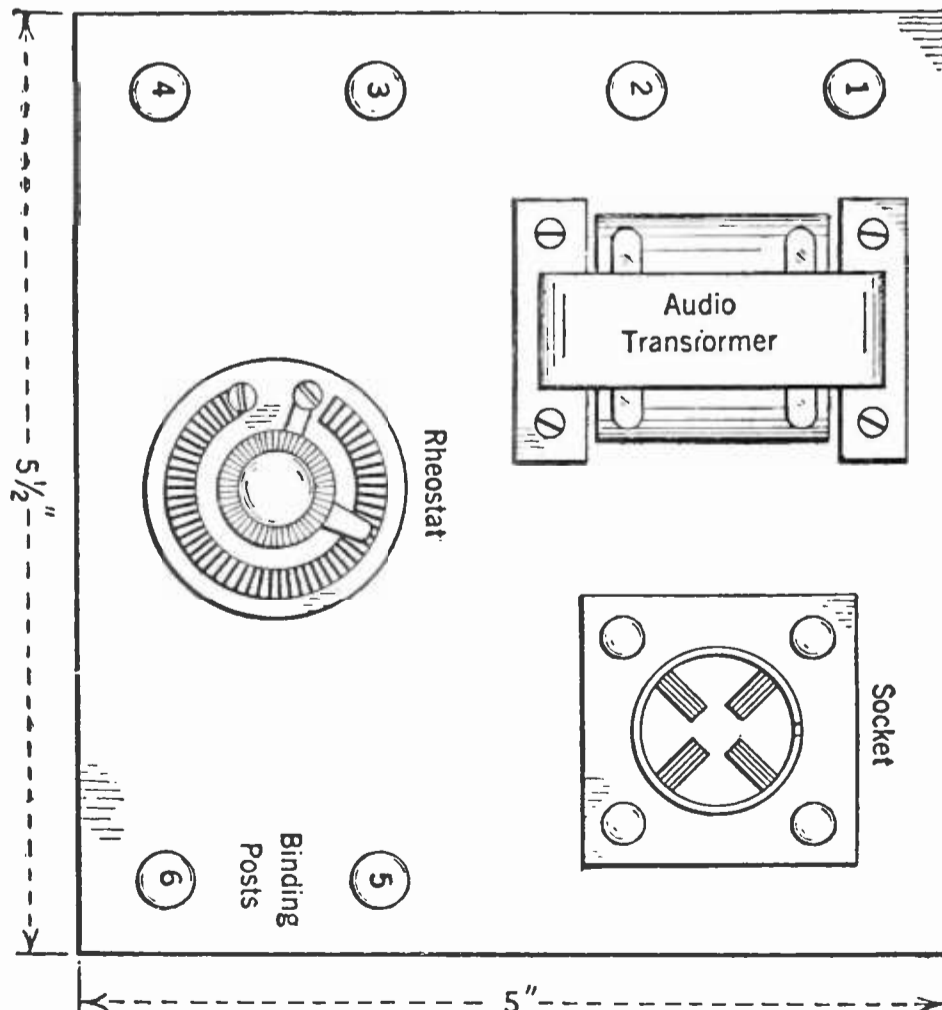

FIG. 2

Dimensions of the baseboard, indicating the positions of the various parts

connected to a crystal receiver, such as that described in "The Radio Beginner" for July.

A suitable A battery for the tube used—six volts for a standard five-volt tube or 4.5 volts for a three-volt tube—is connected with the positive terminal to post 3 and negative to post 4. The minus side of a 90-volt B battery (built up of two 45-volt blocks or four 22.5-volt blocks connected in series) is connected to the plus terminal of the A battery. The positive side of the B battery is led to post 6, thus completing all connections to the amplifier.

The connections to a single-tube receiver are fundamentally the same. The A battery that lights the detector tube can also be used to light the amplifying tube. In order to simplify this, the same type of tube should be used both in detector and amplifier. The battery connections to the amplifier, when inputted from a bulb set, are shown as heavy lines in Fig. 6. If a tube detector is employed, it is probable that only 22.5 volts will be used on the plate of that tube. A larger battery is therefore added to the detector B battery, to supply plate current to the amplifier *only*. If the one-tube reflex tuner is used, the plate battery will probably already have a voltage of 90, and the extra battery will not be required.

In both crystal and bulb receiving sets, the amplifier will function best when the primary of the transformer is connected in a certain electrical direction (when P is connected to the plate of the preceding tube in the case of a bulb set), and the connections to posts 1 and 2 should be reversed experimentally.

If any reader of "The Radio Beginner" is in doubt as to how his amplifier should be connected, the technical editor will be pleased to indicate the connections, if a diagram of the tuner is submitted to him.

OPERATION

**T**HERE is no tuning or other adjustment on the amplifier. The filament should be turned up to the proper brilliancy, as evidenced by satisfactory operation, after which the amplifier functions without attention.

Used with a bulb detector set, the one-stage amplifier will give fair loud speaker signals. In conjunction with the one-tube reflex, the signal strength will be sufficient for dancing in a small room. Inputted from a straight crystal detector, volume will seldom be sufficient for loud speaker operation, but will give comfortable ear phone reception on signals that are very weak unamplified.

The intensity with which distant stations

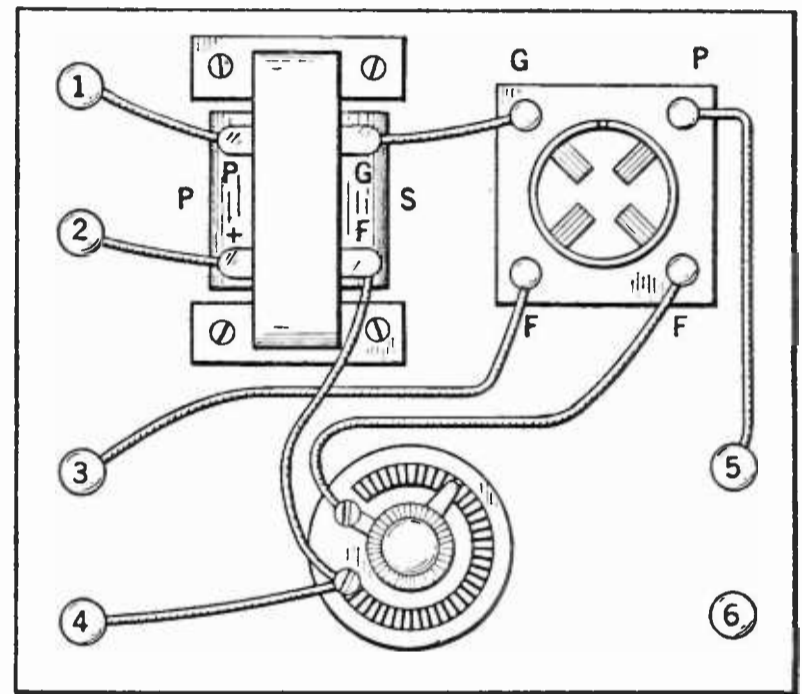
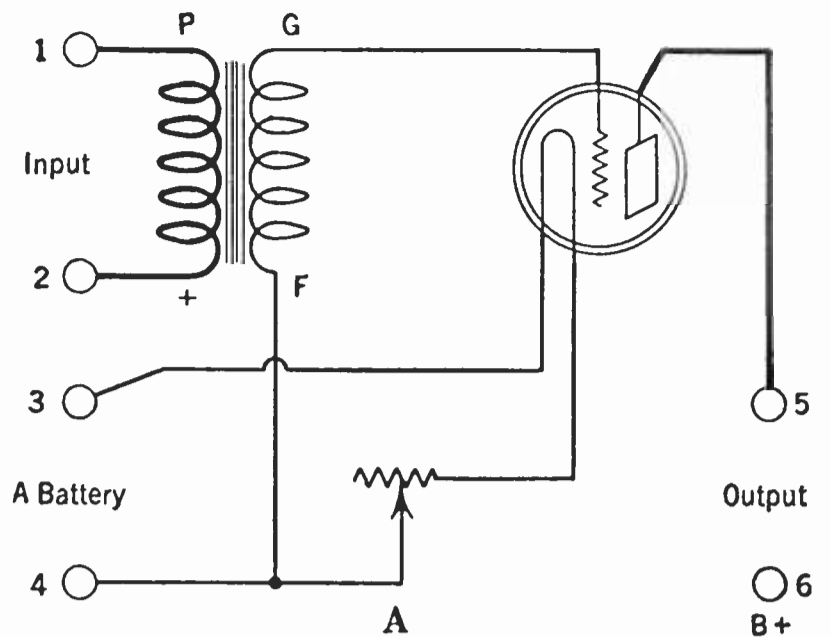

FIG. 3

How to wire the amplifier. Diagrams A and B are identical. The reader should endeavor to familiarize himself with the schematic system (A) of circuit diagramming

can be heard, is increased slightly by the addition of the RADIO BROADCAST Beginner's Amplifier.

THE RADIO PRIMER

Fundamental Ideas behind the Vacuum Tube

**A**S WE analyze matter—going down through the molecule, atom, and ion—we arrive at what appears to be "the thing itself," the fundamental component of all matter further than which science of to-day has been unable to guess or travel. All matter, from bricks to sewing machines, is apparently built of these tiny philosophical bricks known as electrons, which, so evidence

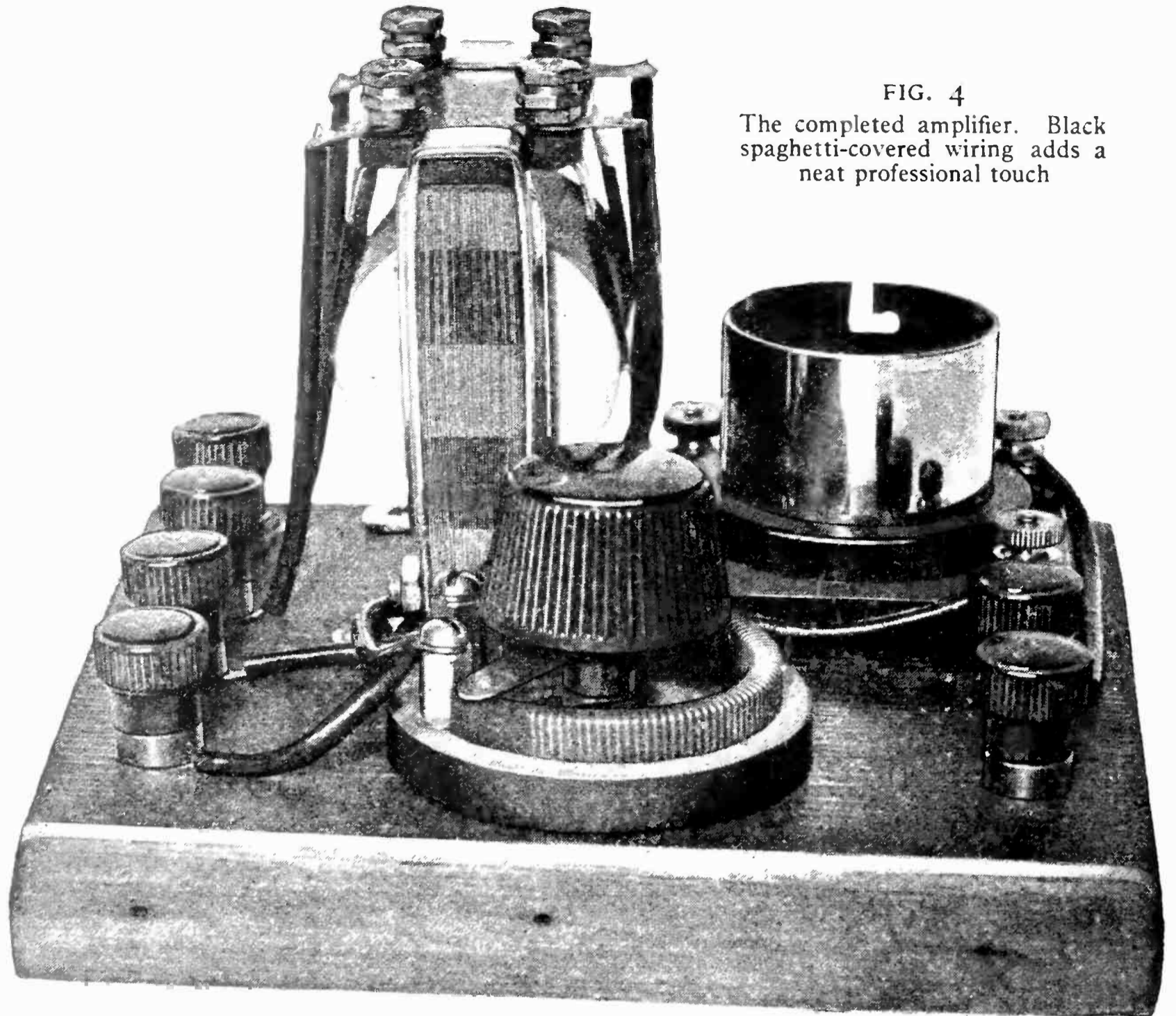

FIG. 4  
The completed amplifier. Black spaghetti-covered wiring adds a neat professional touch

RADIO BROADCAST Photograph

tells us, are infinitely small charges of negative electricity.

We have reason to believe that whenever electrons move in a coöperative motion away from the atoms with which they have been associated, their movement is evidenced as a current of electricity. A haphazard motion, or a regular movement within the atom does

not give rise to this phenomenon; for electrons are continuously moving about in this manner—in the paper on which I write, in the magazine which you are reading, and in millions of other things that at this moment exhibit no electrical characteristics. This perpetual activity of electrons within the atom is stimulated by temperature. The higher the tem-

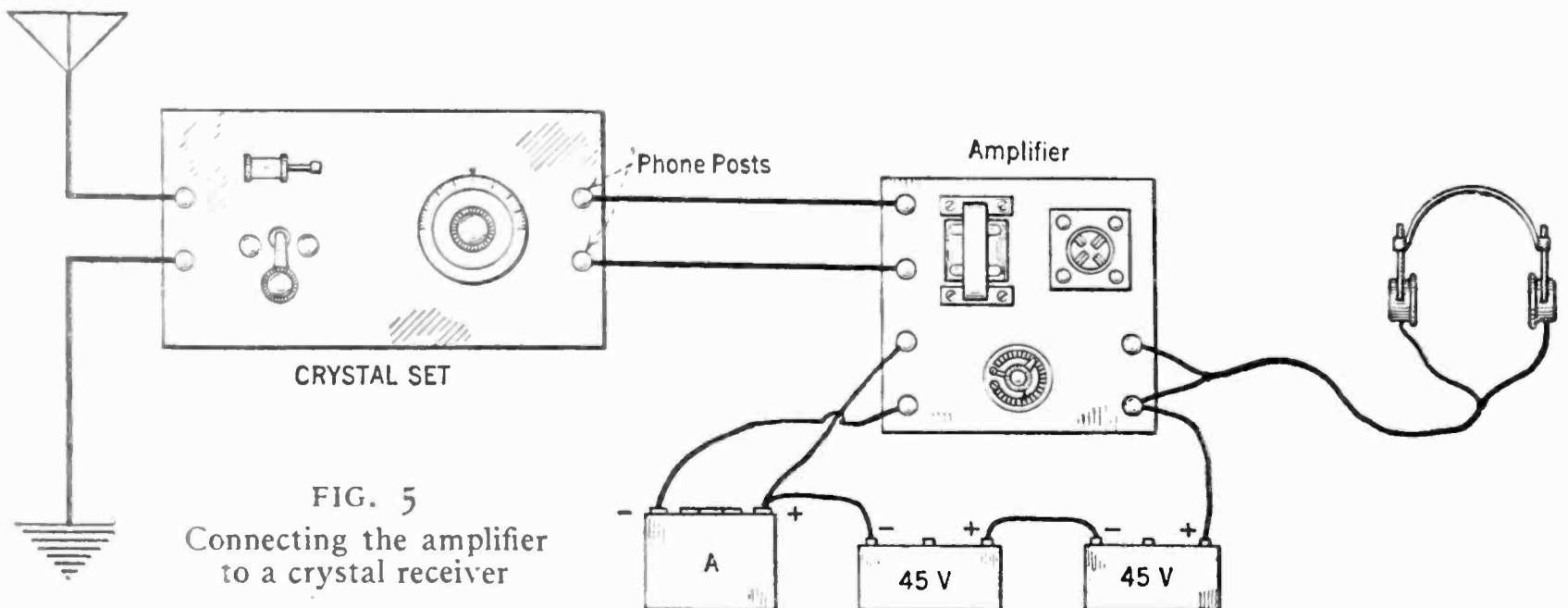

FIG. 5  
Connecting the amplifier to a crystal receiver

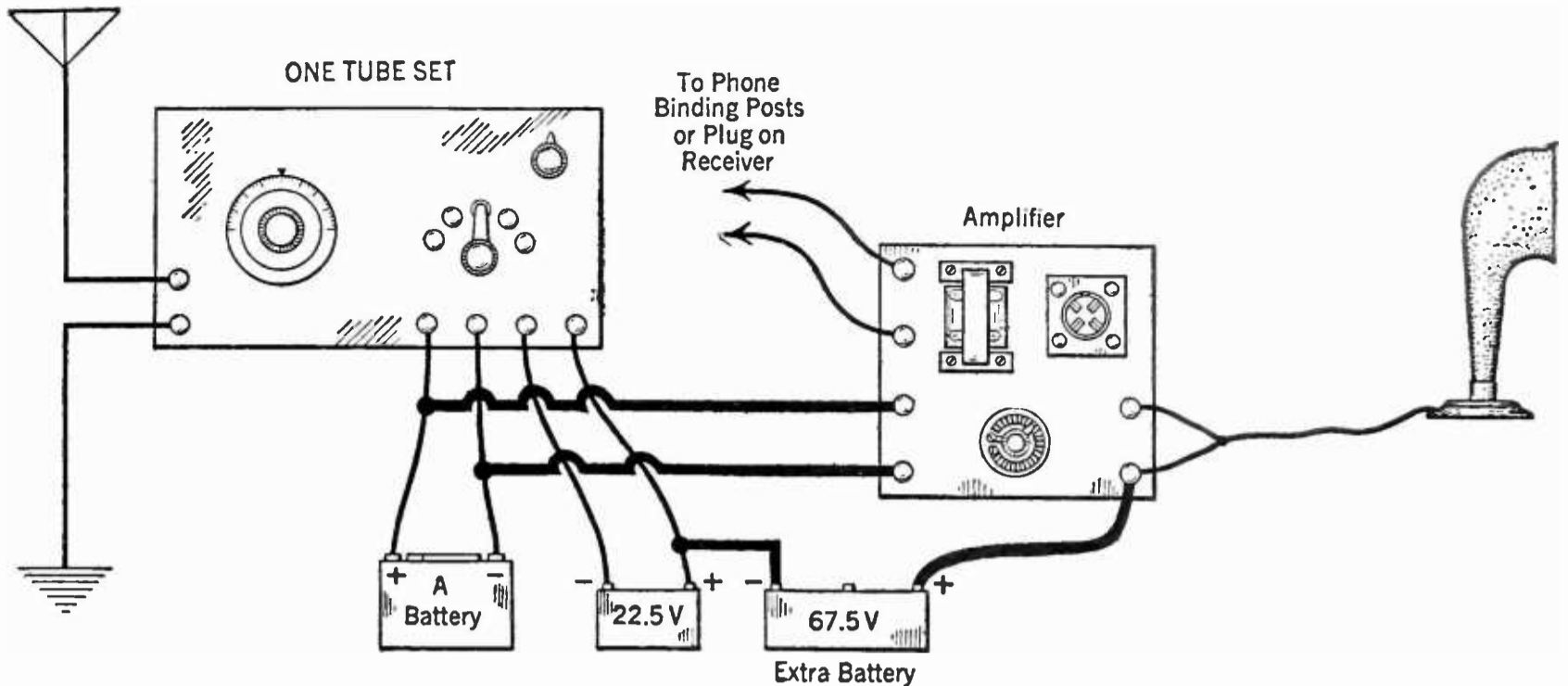

FIG. 6

The amplifier connected to a bulb set. The heavy wires indicate the battery connections to the amplifier

perature, the faster these unimaginably tiny negative charges move. If the temperature is made sufficiently high, the electrons will move so rapidly that many of them will fly away from the atom—like mud from a rapidly revolving wheel.

For instance, the sun, hotter than anything of which we know on this earth, is throwing off electrons in vast trillions. Many millions pass the earth each second. Above ground they "occasionally" (countless times per second) hit atoms of air. The collisions are visible as light; we see it thousands of miles away. We call it the aurora borealis. The reason the air below is not ionized (which is the scientific term for this generation of light) is that the atoms of dense atmosphere down where we breathe are too close together and would merely stop the motion of the electrons, instantly lowering their velocity below the high speed required for ionization.

If we heat a wire sufficiently by holding it over a candle flame, it will give off electrons. If a plate, or sheet of metal, is placed close to the heated wire, and a powerful electrical positive charge is applied to it as shown in Fig. 7, the electrons will be attracted over to the plate (remember that unlike charges attract each other). In other words, an electric current will flow through the circuit. The current will be a very small one due to the obstructing effect of the atoms of air. However, if the plate and hot wire are sealed up in a vacuum, the electrons will have a free path to the plate and comparatively high currents can be passed. This is done in the vacuum tube whose constructional principles are sketched in Fig. 8.

It is impossible now to heat the wire with a candle flame, so it is made hot by passing through it a current of electricity, just as a similar current heats the filament of the electric bulb in your reading lamp. This current is supplied by the filament or A battery. The positive charge is applied to the plate or "anode" (positive electrode), by the B battery.

When the filament is heated, generally to fair brilliance, electrons will be freed to fly to the plate through the vacuum and a current will pass through the tube.

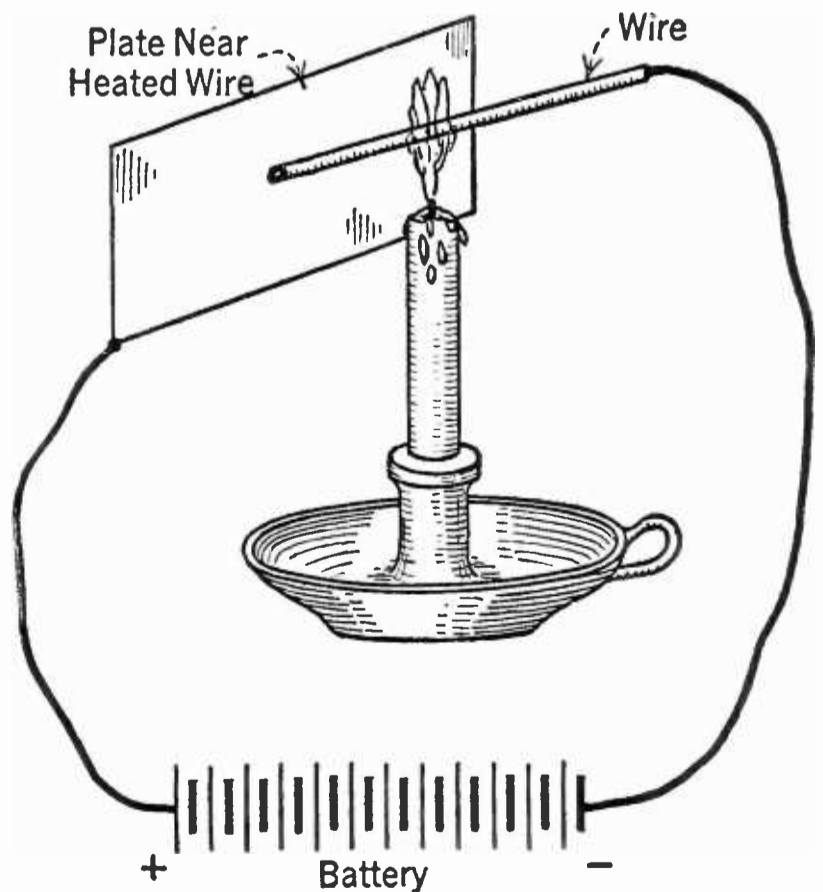

FIG. 7

The principle of the filament in a vacuum tube. The filament battery is applied to heat the filament to a high temperature

“UNILATERAL CONDUCTIVITY”: WHAT THE TERM MEANS

IT WILL be observed, in the arrangement we have sketched and described, that electrons will flow only from filament to plate, because there is no reversal of conditions to make them go backward. In other words, the vacuum tube can pass electricity in *only one direction*. Thus, if an alternating e. m. f. (electromotive force) were applied to the plate of the tube, current would flow through the circuit only when the plate was positively charged—that is, one half of the time. In this respect the bulb is similar to the crystal detector that we discussed in this department for August, and it can be substituted for the crystal.

It is readily understood that this rectifying action is comparable to a valve, which shuts off the current on one half of the cycle and passes it on the other. This type of tube—a two-element (filament and plate) bulb—has been named the “Fleming Valve” after Dr. J. A. Fleming, the English scientist who first applied it to the detection of signals. Modifications of the Fleming Valve have several uses to-day, the most common among which is the “Tungar” bulb used to rectify alternating current in battery chargers.

Mr. Lee De Forest gave us the vacuum tube used in modern radio when he inserted a third element, the grid, which is a wire screen looking something like its diagram symbol shown in Fig. 9, between the filament and plate.

But it is another matter when an electrical

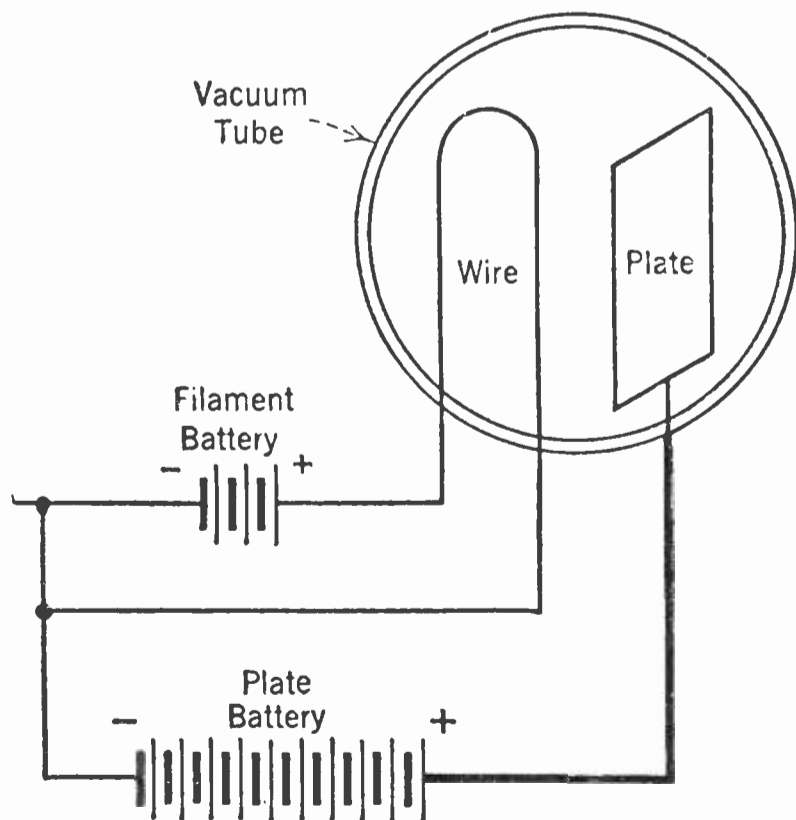

FIG. 8

The two-element vacuum tube, sometimes called the “Fleming valve” after its inventor, Dr. J. A. Fleming

charge is placed upon this grid. If a negative charge is applied to this third element, it will repel the electrons (it is an old electrical axiom that like charges repel each other) and none can pass through to the plate. Thus the cur-

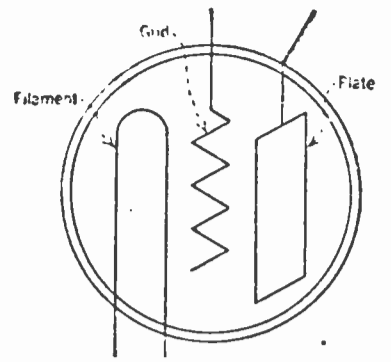

FIG. 9

How the usual three-element tube is indicated

rent through the tube—or “plate current” as it is called—will be decreased or stopped. On the other hand, if a positive charge is imposed on the grid, more electrons would be drawn from the filament, and by the time they travel as far as the grid, most of them are attracted by the greater positive potential on the plate and will pass through to it. The

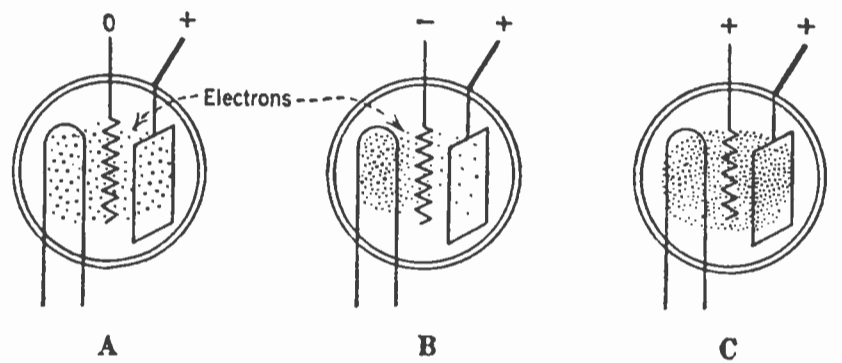

FIG. 10

result is an increased plate current in the circuit plate to B battery to filament. The sketches in Fig. 10 serve to illustrate this interesting action.

In A, the grid is at zero potential and an average number of electrons flow to the plate. As the grid is given a negative bias, in B, the flow of electrons (which causes the current in the plate circuit) decreases, to change to a comparatively large current with the plus charge in C.

The commercial tubes with which you are familiar have these three elements—and function in the manner we have described.

They can be obtained in various types having minor differences in electrical characteristics such as filament potential and current, but the fundamental action—the control of the plate current by the grid charge—remains the same. This control action is often referred to as a “trigger” or relay action, for like the trigger in a pistol or a relay in any electrical circuit, a variation in the charge on the grid can be made to control or set loose much greater power in the form of plate current variations. It is also a relay action in

the sense that the current in one circuit can be shut off by the impulses in another and totally different circuit. For instance, in Fig. 11, in which A is a magnetic relay circuit and B is a vacuum tube circuit, the closing of key K, in either system, will break the circuit through the telephone receivers. In A, the lever will be pulled down, opening the circuit at S, and in B, the high negative charge supplied to the grid will open the circuit at S.

## THE RADIO LIBRARY

**T**HE fundamental action of the vacuum tube is explained in almost every modern radio book. The student reader will find the following bibliography of interest and assistance:

*The Outline of Radio*, by John V. L. Hogan, Chapter eight. An easily understood exposition of detection.

*The I. C. S. Radio Handbook*, pages 216 to 237. This is less elementary but should be easily followed by the reader who comprehends most of what he has so far read in "The Radio Beginner."

*Vacuum Tubes in Wireless Communication*, by Elmer E. Bucher. Parts One and Two. Less elementary.

*Principles of Radio Communication*, by J. H. Morecroft. Pages 364 to page 467. This particular book is recommended to the engineering student. While starting with the simple elements of the vacuum tube, it rapidly develops into a mathematical exposition of the subject.

*Vacuum Tubes*, by H. J. Van der Bijl. A similarly exact but perhaps more thorough research than the excellent chapters by Professor Morecroft.

## THE RADIO LEXICON

**IONIZATION:** A phenomenon caused by the passage of current through gases—generally rarified. Mechanically, it is the result of repeated collisions between the infinitely small particles of which we believe matter to be composed. It is usually evidenced by a visible glow or haze.

**FILAMENT:** The wire in a vacuum tube which is heated, generally to incandescence, and which in this condition throws off electrons.

**PLATE:** The metal "anode" or element in a vacuum tube upon which a positive charge is placed to attract the electrons from the filament. **TUNGAR BULB, RECTIFYING TUBE, FLEMING VALVE:** Trade and technical names for a two-element, plate and filament, vacuum tube.

**GRID:** The third "element" introduced between the filament and plate by Mr. Lee De Forest. It controls the flow of electrons from filament to plate by means of the electrical charge placed upon it.

**PLATE CURRENT:** The current through a vacuum tube which flows from filament to plate.

**SPACE CURRENT:** Generally the same as plate current, but occasionally used in reference to a current between grid and filament or plate.

**A BATTERY:** The cell or battery supplying the filament lighting potential to a vacuum tube.

**B BATTERY:** The battery applying the high positive potential to the plate of a vacuum tube. (Usually of from 22.5 to 135 volts).

**RHEOSTAT:** A variable resistance of comparatively low maximum ohmage. In radio, it is generally used to regulate the voltage applied to the filament.

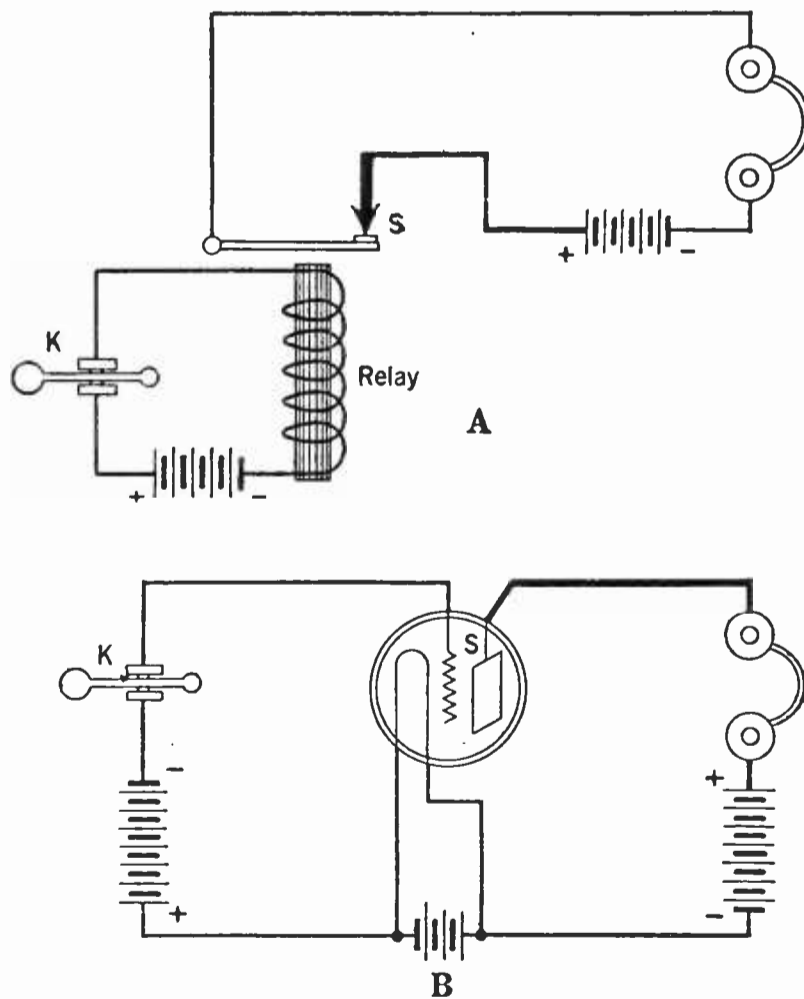
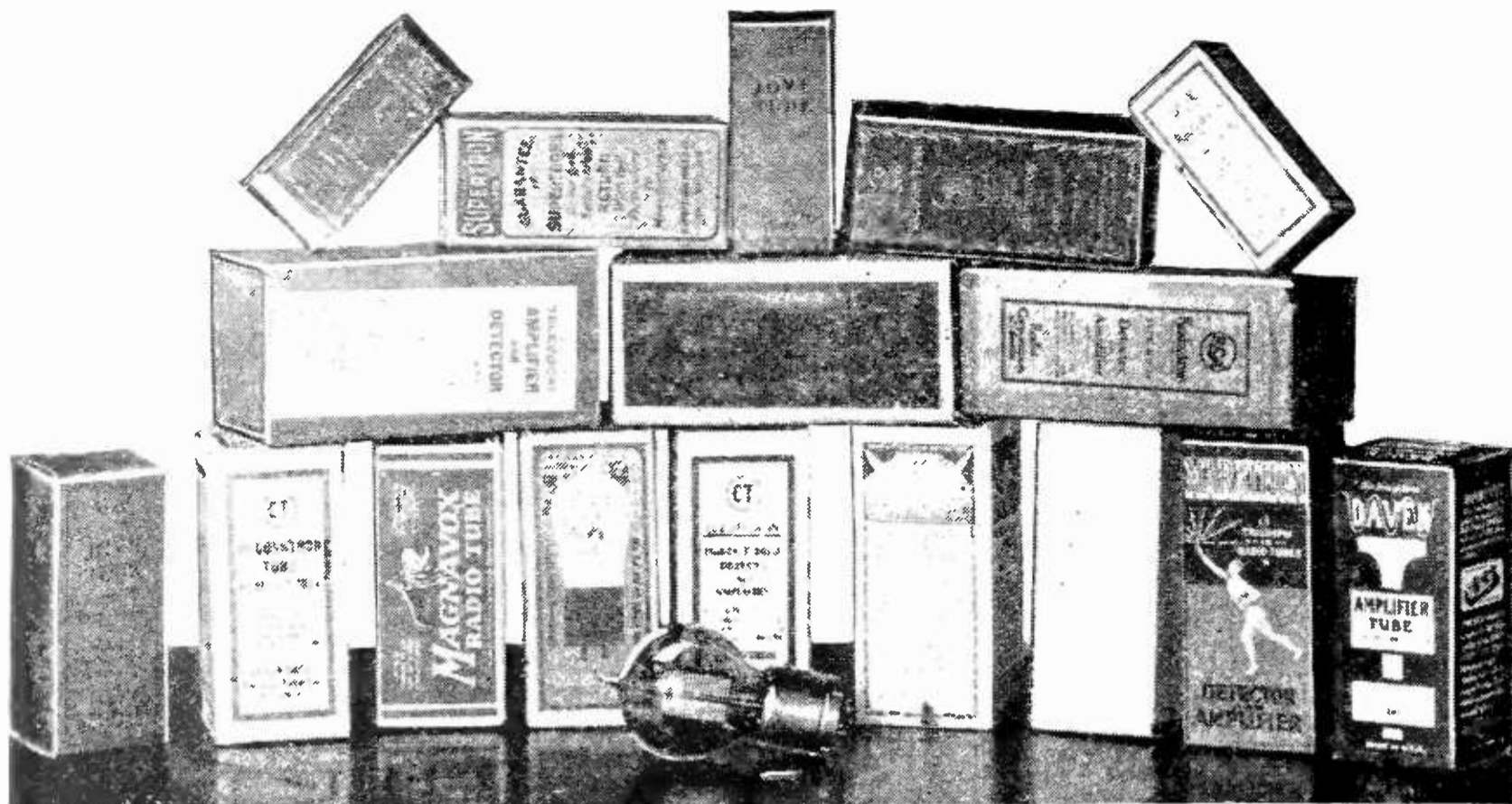

FIG. 11



RADIO BROADCAST Photograph

FIG. 1

Tubes of many manufacturers. The round one in the foreground is a Western Electric 216-A, particularly adapted for use in the last audio amplifier. Two "high-mu" tubes are shown, one from the Cleartron Tube Company and the other sold by the Daven Radio Corporation. The others are standard 3- and 5-volt tubes

# How to Judge Radio Tubes

Signposts to Tell What Factors Make a Good Tube—  
Results of Laboratory Tests on Many New Tubes—Two  
New Batteryless Receivers—A New Current Supply Device

BY THE LABORATORY STAFF

**T**HE tube and its batteries are the only things that should wear out in a modern radio receiver, and the economics of the tube is an important consideration when the broadcast listener is on purchasing bent.

In the usual five-tube set the vacuum tube performs the functions of radio frequency amplifier, detector, and audio frequency amplifier. In some receivers, such as the super-heterodynes or the regeneratives, the additional task of oscillation is placed on the tube, and in reflex sets, some of the tubes do two tasks at the same time. It is no wonder, then, that broadcast listeners should be careful of the tubes that they buy.

Within the last few months, the RADIO BROADCAST Laboratory has received samples of receiving tubes manufactured by many of the 100 manufacturers now in this business. Some of these tubes have been worthless, some very good. The data printed this month represents 71 tubes from 11 manufacturers and are the best of the many that have been tested. The average of these figures is an interesting and useful standard by which tubes

may be compared. One assumes that in both manufacturing and purchasing a tube, the most important question which arises is "what is a good tube?"

The answer involves two factors, the electrical characteristics of the tube and the factor of economics. How long will the tube last?

Electrically speaking, there are three factors which completely define any particular tube: the amplification constant, the plate impedance, and the mutual conductance. These terms may not mean as much to the radio buyer as "stroke," "bore," "wheel base" and other similar ones do to the automobile purchaser, but they are tremendously important to the shopper for tubes.

All three indicators are bound up in the mechanical construction and placing of the elements, and the efficiency of the filament. The construction and location of the elements are really a manufacturing detail; the efficiency of the filament is, then, the vital factor upon which the value of the tube depends. Unfortunately, the production of filament wire, especially modern oxide coated or thoriated wire, is not a simple task. It is said that much of



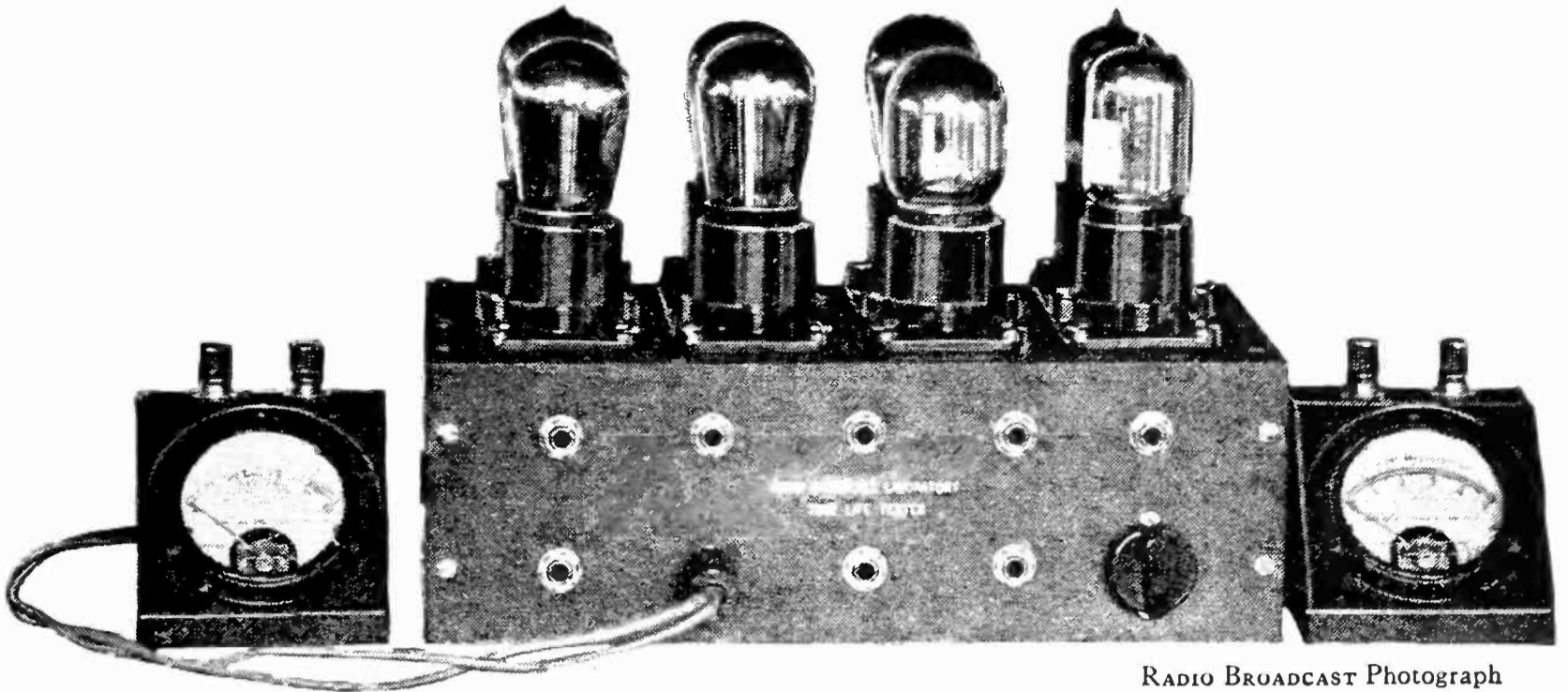

RADIO BROADCAST Photograph

FIG. 2

Tube life tester used in the Laboratory. Meters are provided for maintaining the filament voltage at proper value and for reading the plate current at regular intervals

the wire in present tubes is said to be stolen from the large manufacturers who own the patents and processes for making the wire. Some of the wire in tubes not made by those who control the manufacture of this filament wire is imported, some of it is made for independent concerns by men who

have been enticed away from the larger laboratories. One spool of wire will make hundreds of tubes.

The amplification factor of a tube is a measure of the voltage amplifying ability of the tube and should, in an amplifier, be high; the plate impedance is the electrical impedance which it places in the circuit

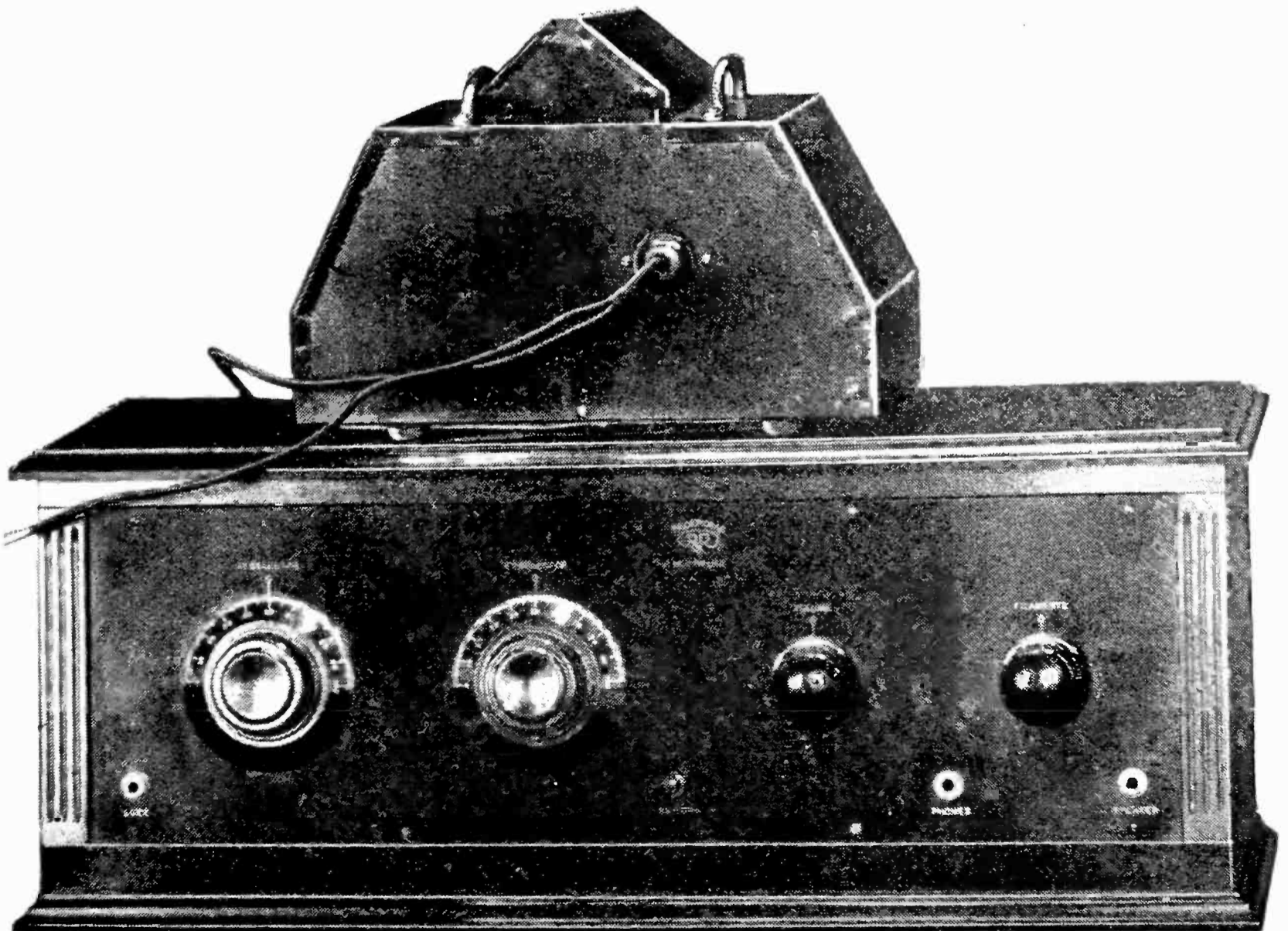

RADIO BROADCAST Photograph

FIG. 3

The Radio Receptor Company's batteryless receiver. This receiver will operate from a loop. The rectifier tubes are in the compartment on top of the receiver

in which it is used, and should be low; the mutual conductance relates to the importance of the grid in controlling plate current. It is also the ratio between the amplification factor and the plate impedance, and should be as high as possible.

In general there is no object in a tube of high "mu" (amplification constant), if the plate impedance increases correspondingly, although for resistance and impedance amplifiers there is much to be said for tubes with high voltage amplification.

For audio amplifiers, it is highly important that tubes of low impedance be used from the standpoint of quality and power amplification while in radio frequency circuits, tubes of low impedance will give greater gain and more stable operation. The future trend of tube development seems to be toward lower impedance tubes that may be used as power amplifiers with plenty of grid bias and a high B battery voltage. The new Radiotrons will do much to fill in the gap between the ordinary 5-volt tube and the 5-watt power tubes. Several independent tube manufacturers have realized the need for semi-power tubes and it is probable that the early winter will see high power, high quality amplifiers in more general use than has been possible up to this time.

#### GOOD FILAMENT WIRE MEANS GOOD TUBES

THE heart of the tube is the filament, and those manufacturers whose filament wire is good can make good tubes. Otherwise they can make only mediocre products whose characteristics will be erratic and whose life will be uncertain. Many

tubes have excellent characteristics when placed on test, but after a few hours of service the supply of electrons has been exhausted and the tube is dead.

For a given number of watts expended in heating the filament, the user should get a certain number of plate milliamperes. The filament efficiency, on the table shown as "mils per watt," is a measure of the value of the filament. Tubes with high filament efficiency will usually have a higher mutual conductance, as the table plainly shows.

It is probable that all of the tubes listed will give comparable results, and although measuring instruments will show that some give greater amplification than others, the ear will not be able to distinguish the difference. None of the poor tubes has been listed in this table. Since the customary practice is to run amplifiers at 90 volts on the plate and negative 4.5 volts on the grid, the data given was taken under those conditions.

In the Laboratory, these characteristics are measured and the tubes are then placed on a life test. They are run at normal filament voltage with the grid connected to the negative filament and with about 120 volts on the plate. At the end of 200 hours, if the tube is still "alive," the characteristics are again measured and another 200 hours test is run through. For this reason it takes considerable time before the Laboratory is certain of the qualities of any given tube.

Fig. 1 is a photograph of some of the tubes that have been tested and Fig 2 shows a tube life tester in use in the Laboratory.

### RADIO BROADCAST LABORATORY REPORT ON TEST OF 5-VOLT TUBES

TUBES	NO. TESTED	FIL. CURRENT	FIL. WATTS	PLATE CURRENT	MILS PER WATT	PLATE IMPED.	AMP. CNST.	MUTUAL COND.
Ceco . . . . .	2	.25	1.25	5.6	4.5	14,800	7.2	508
Cleartron . . . . .	8	.27	1.35	7.03	5.0	10,800	7.3	650
R. C. A. . . . .	10	.25	1.25	6.0	4.8	13,000	7.0	550
Diatron. . . . .	5	.27	1.35	5.83	4.3	14,500	7.8	550
Jove. . . . .	6	.27	1.35	6.7	4.95	10,000	5.6	603
Marathon . . . . .	9	.25	1.25	8.45	6.75	9,600	7.0	700
Sea Gull . . . . .	12	.23	1.15	6.7	5.83	10,000	6.6	660
Silvertone . . . . .	5	.22	1.1	7.0	6.35	10,700	7.2	650
Van Horne . . . . .	5	.23	1.15	5.8	5.05	13,600	8.33	615
Elektron . . . . .	4	.25	1.25	4.6	3.68	17,400	8.45	483
Goode . . . . .	5	.24	1.20	6.8	5.67	12,000	8.32	704
TOTAL . . . . .	71	Avg. .244	1.22	6.0	4.93	12,400	7.7	606

#### CONDITIONS

FILAMENT VOLTS      PLATE VOLTS      GRID VOLTS  
5                              90                              -4.5

Plate Current is at Zero grid

With each tube of the Van Horne Company of Franklin, Ohio, the purchaser gets complete data such as the characteristic curve, the plate impedance, amplification constant and mutual conductance. This gives the user an unusual check on each tube he buys.

#### BATTERYLESS RECEIVERS

IT HAS long been the dream of radio listeners to possess a receiver that required no batteries which would run from a lamp socket. Two receivers of this type have been tested recently in the Laboratory. One is known as the Multiflex and manufactured by the Radio Receptor Co., Inc., New York City, and the other is called the Powerola and is manufactured by the Terminal Electric Co., New York City. Neither of these receivers requires batteries of any kind, and both may be run from either direct or alternating current, both use standard tubes.

The development of receivers of this type has been interesting. It is a comparatively simple matter to secure proper plate potential from either direct or alternating current. The many B substitutes now on the market attest to this fact. It is not difficult to operate the filaments of amplifier tubes from alternating current either. The great obstacle in the way of a batteryless set, however, is the detector filament which must be fed from pure direct current.

Tungar tubes, such as are used for charging stor-

age batteries, are one solution to this problem. If two of them are used to rectify both sides of the alternating current and if the output is sufficiently filtered, the detector and amplifier filaments may be run without A batteries. In receivers utilizing this means of filament supply, it has been customary to run the filaments in series to lower the current flowing. If 3-volt tubes requiring but 60 milliamperes filament current are used, it is possible to use as rectifiers two of the B battery substitute tubes. In this case the entire current requirements are about 70 milliamperes, which two rectifier tubes should be able to supply for considerable length of time without deterioration.

Both of these receivers, which were previously mentioned operated successfully in the Laboratory. The Radio Receptor set operated quite satisfactorily on a loop.

#### THE A. C. TUBE

THE A. C. Tube, which is attracting considerable attention, has several advantages. In the first place its filament—which is not really a filament at all—is heated by alternating current. This means that no A battery is required and that a person who has a.c. in his house needs only a small toy transformer to operate the filaments. No rheostat is required. This tube is the outcome of a great deal of work by many engineers on a “uni-potential” cathode tube, which means little or nothing

FIG. 4

An excellent neutrodyne which, in the middle of the summer, picked up several Chicago stations and Miami Beach from Garden City. It is made by the Howard Radio Company, Chicago. With it is the Stewart Warner loud speaker, which is a very good horn, and an interesting power supply unit from Balkite

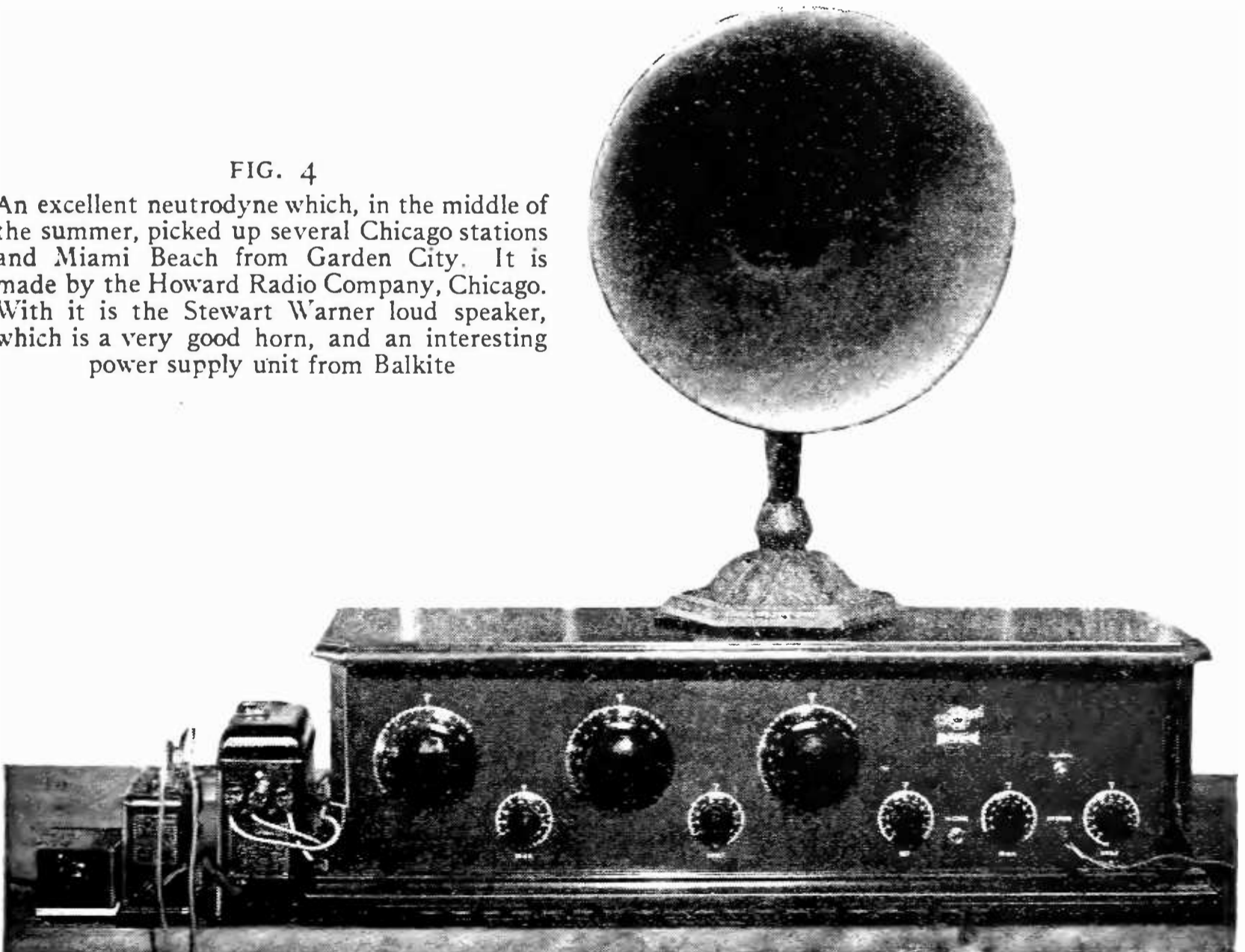

RADIO BROADCAST Photograph

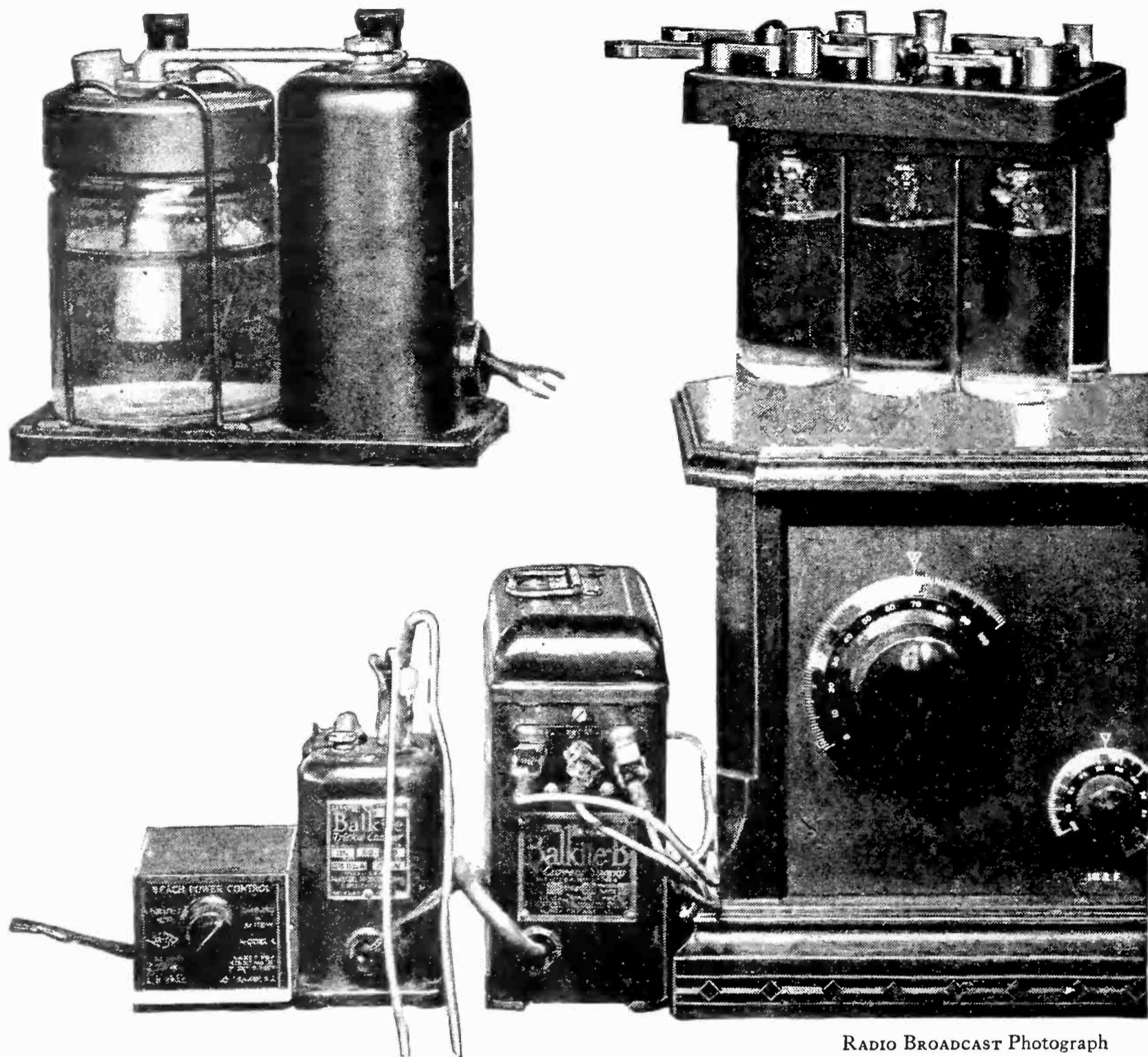

RADIO BROADCAST Photograph

FIG. 5

A close up of the Balkite B-current supply and trickle charger. These units are very compact and are neat adjuncts to modern radio sets. The B current supply takes the place of B batteries and employs a chemical rectifier. The trickle charger may be left on the storage battery at all times when the set is not being used. In this way the battery is always operating at top efficiency. The Brach switch is a device to switch the A battery from "on-charge" to the receiver, with very little effort on the part of the user. The component parts of the B-current supply of the trickle charger and tantalum elements are clearly shown

ing to most of us, and is an important step in a proper direction. With such a filament heater, it should be possible to get very high filament emission with consequent high mutual conductance. This should be a great advantage, since mutual conductance is a direct indication of the value of a tube.

A. C. tubes tested in the Laboratory have worked sporadically. Sometimes excellent results have been secured, sometimes no results at all. The chief trouble has been noise from the a. c. hum. This can be ironed out, and a receiver brought to the Laboratory by the Pathé Radio and Phonograph Company worked beautifully with no batteries at all. The filament emission of the A. C. tubes may be some-

what higher than that obtainable from standard 5-volt tubes, but the mutual conductance of a number of these was about equal to that of the average 5-volt tube, although they were not so uniform.

At present it is difficult to say what the A. C. Tube will mean to radio. They have many possibilities, and may prove to be one of the most important contributions to modern reception. On the other hand, they will be useless to thousands of listeners who do not have a.c. At the present time it is believed that they have not reached the acme of development and the future must promise a great deal for this new tube.

# "NOW, I HAVE FOUND . . ."

A Department Where Readers Can Exchange Ideas  
and Suggestions of Value to the Radio Constructor and Operator

## A SIMPLE SOLUTION TO A COMMON PROBLEM IN ANTENNA CONSTRUCTION

**R**ADIO fans who live in apartment houses or in densely populated areas are often confronted with almost insurmountable problems in the matter of erecting an antenna, and especially in the matter of bringing the lead-in down to a suitable window. A receiving set capable of operating on a loop is usually either too expensive or lacking in distance-getting qualities to be satisfactory in such locations, so an antenna is almost a necessity, undesirable though it may be.

The writer recently encountered and solved the problem of bringing a particularly difficult lead-in down the side of a large building.

The antenna was strung between two large electric signs over the center of the roof of the building and the lead-in brought down to an insulator on the end of a 2 x 2 inch piece of pine projecting a few feet (as far as was permitted) over the cornice of the building. It was secured with lag-screws. The wire was dropped down and brought in through a window frame. This is where the usual snag

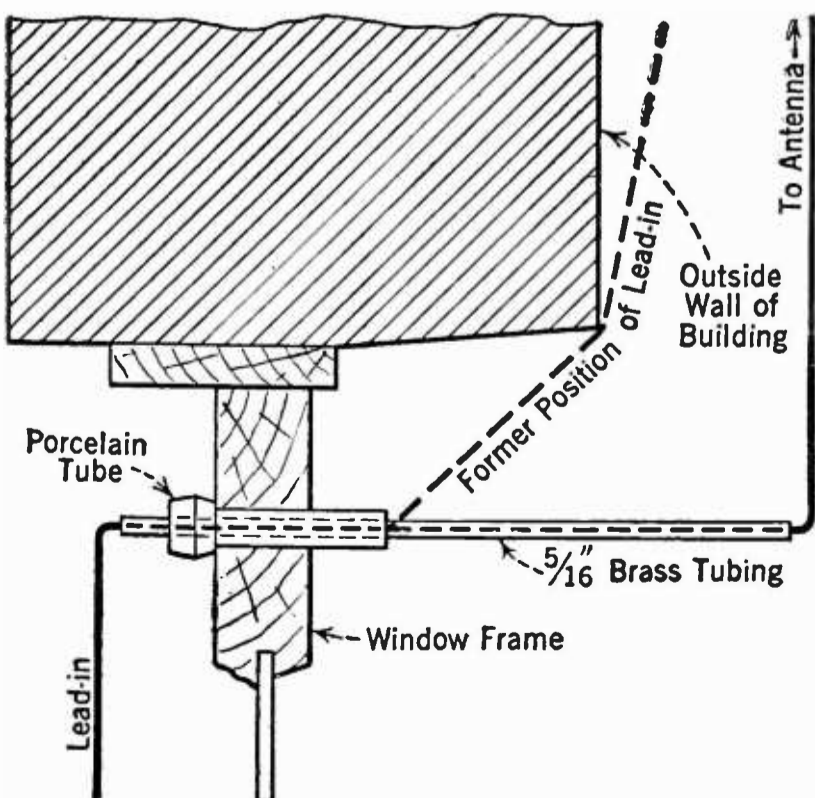

FIG. 1

was struck. The trouble lay in the fact that the window was recessed in the usual manner, being about fourteen inches in from the face of the building. Directly over the top of the window was a tin channel bearing a series of electric lights running the length of the story. The wire, dropping vertically and then inward at a sharp angle, of course made contact with the channel and swayed back and forth between two of the sockets, at times also brushing across the upper portion of the structure.

To carry the wire out away from the building with a stick was not to be considered, because the window faced a busy thoroughfare only a few feet below, and the unsightly conglomeration of braces, guy wires, etc., necessary to such a method would not have been tolerated by the company for which the antenna was being erected.

The problem was at last solved in the following manner: A porcelain tube was run through a hole in the window frame of a size to make a very tight fit. Through the center of the porcelain tube was forced a three-foot piece of  $\frac{5}{16}$  inch outside diameter brass tubing, so that the greater part of the latter protruded outside of the room into the open air. The hole in the brass tubing was large enough to allow the antenna wire to pass through. In this manner the lead-in was carried several feet out from the face of the building and entirely away from the electric light sockets, making a very neat and satisfactory job. The details are shown in Fig. 1.

H.A. HIGHSTONE,  
Oakland, California.

## A SELF-SUPPORTING "D" COIL

**A**LTHOUGH the toroidal coil is perhaps a trifle more efficient, the ease of construction together with its adaptabilities in the coupler and the variometer, make the D coil preferable in many cases, and the self-supporting feature adds to its efficiency.

A good wound-on-air coil of the D type may be constructed as follows: The nails or wooden pins which serve as a form on which to wind

the coil are inserted in a soft wood board in the same manner as that used for making low-loss solenoids, but are arranged as shown in the accompanying diagram, Fig. 2. The first turn is started by passing the wire inside pin 1 and outside pins 2 and 4 and then over 11, 9, 7, 5, 12, 14, 1, 3, 12, 10, 8, 6, 4, 13, 15. At this point, two turns have been completed and the third turn is wound over the first and the fourth turn will come directly over the second and so on.

It will be noticed from the diagram that pins 5 and 3 and pins 11 and 13 are relatively near to and equidistant from pins 4 and 12 respectively. That part of the circumference between pins 5 and 11 must be divided into some convenient number of equal parts of even number (6), and the portion of the circle between pins 3 and 13 is correspondingly divided into an odd number of divisions (5).

After the desired number of turns have been wound on, the coil is slipped up on the pins far enough to be tied at the intersections of the wire, with a strong linen thread. The pins are now removed and a very firm, efficient coil is the result.

HERMAN M. PATRIDGE,  
Newfields, New Hampshire.

### A TUBE LIFE-SAVER

WHEN, after having built a new set, a test is made to determine whether the plate battery is accidentally connected with the filament circuit, one procedure is to try a regular tube in the different sockets,

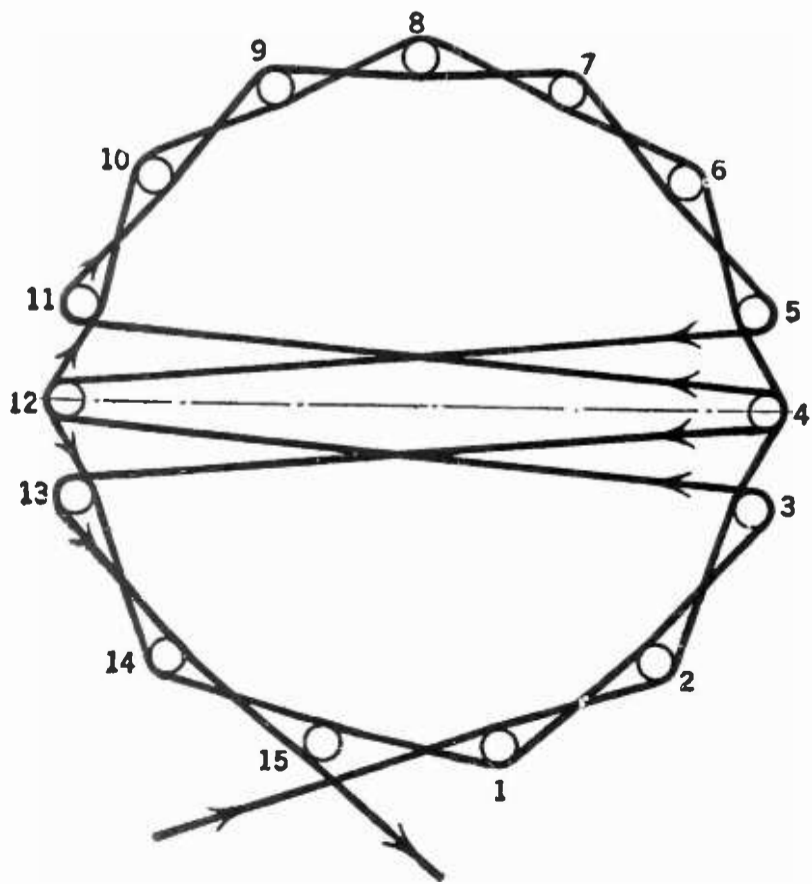

FIG. 2

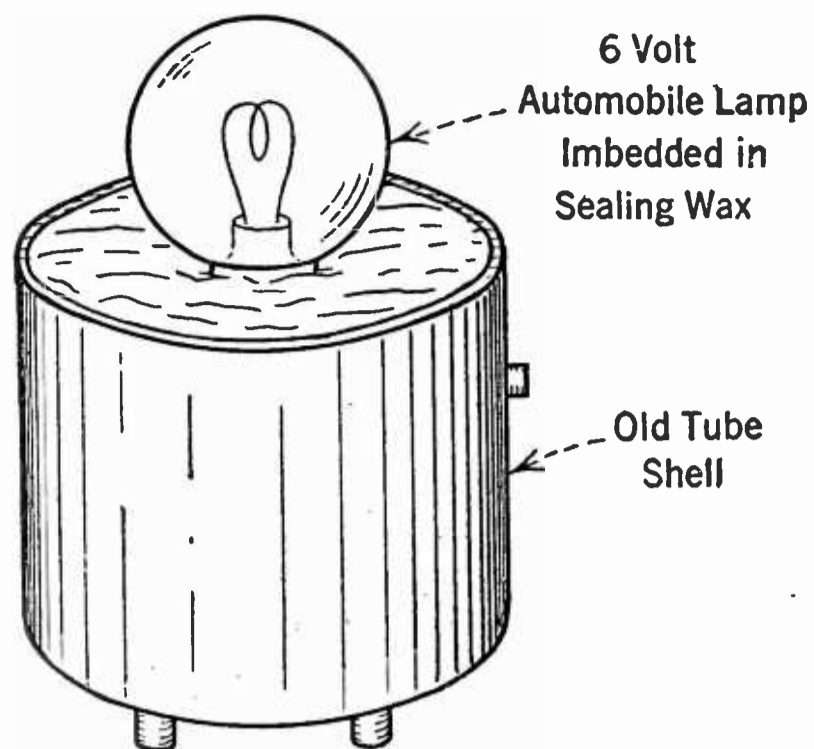

FIG. 3

and if it doesn't burn out in any of them, it is safe to put all tubes in their sockets, and go ahead with other testing. If, however, the plate battery *has* been wrongly connected, the cost of the test is a new tube, \$2.50, or thereabouts.

Take an automobile lamp socket, either single or double contact, as preferred, and solder two leads to it, connecting this lamp in an old tube base with its two leads connected to the regular filament terminals of the base. Fill around the socket, in the base, with sealing wax. Thus, using one of the small automobile lamps, as in Fig. 3, the cost of the test, in case of a wrong connection, will be reduced to the cost of the small automobile lamp, about 30 cents. This will no doubt appeal to set builders who have had to replace the "test tube," as I have had to do.

W. H. MAYFIELD, Miami, Arizona.

### A METHOD OF SCRAPING WIRE

A KINK that I have never seen in publications, and therefore may be of use to this department, is a method of removing insulation (either cotton or silk) from magnet wire. Until recently, when I had this to do, the only tool that occurred to me was a knife. One day when I had a couple of feet of wire from which to remove the insulation, I had no knife handy, but seeing a piece of emery cloth lying on the bench, I folded it and drew the wire through it a couple of times, and since then have never used a knife for this work. Try it.

W. H. MAYFIELD,  
Miami, Arizona.



**W**hat is this radio service which we claim is so necessary?  
 Do you drive a car?  
 Do you ever have little things go wrong with it?  
 You have become so used to minor troubles that you don't condemn the car on which they occasionally occur.  
 No—  
 You go right to a service man—a man who knows your make of car. You don't go to a handy man who claims he can fix any car.  
 That's automobile service, and is one of the main reasons for the auto being the success it is today.  
 The same service condition exists in radio—the only difference being that people don't yet understand it.  
 The radio instrument which never requires service has never been built—it never will be.  
 Like automobile manufacturers, the better radio manufacturers do all within their power to make their instruments mechanically perfect. Nevertheless, like the auto, little things will sometimes go wrong—they are serious to the radio owner but very simple to a factory trained service man.

The handy man who can fix any radio simply experiments until he locates the trouble—such a method was disastrous to the auto in former days—disastrous and expensive in radio today. It is not sound.  
 Ozarka instruments are sold only by Ozarka factory representatives, men who are factory trained in sales and service, men who sell no other radios but Ozarka.  
 These men don't pretend to know all about radio but they do know all there is to know about Ozarka—isn't that the kind of radio service you want?  
 Ozarka instruments are sold under a very definite plan. An Ozarka representative will gladly set up an Ozarka in your home—he won't tune it—he won't tell you what it will do—you must operate yourself. If the results you receive by your own operating won't convince you that the Ozarka gives you the distance, volume, selectivity, tone and ease of tuning that you demand then don't buy it.  
 Ozarka instruments are built to sell themselves but no Ozarka is sold without factory-trained service behind it.

**Openings for a Few More Ozarka Factory Representatives**

**O**ZARKA Incorporated, is now entering its 4th year. From a beginning with one engineer, one stenographer, one salesman—our present president, the Ozarka organization has grown to over 3,100 people. There must be some good reason for this growth.  
 Ozarka instruments have made good—they have more than met competition. Ozarka representatives have made good not only because Ozarka instruments were right, but because they have been willing to learn what Ozarka engineers were willing and capable to teach them—Ozarka unusual salesmanship and Ozarka service.

**Send for FREE Book**

Radio offers a wonderful opportunity to men who are willing to start at the bottom and build. You need not know salesmanship, but will you learn what we will gladly teach you? You may not know radio, but we can and will teach you if you will do your part. With such knowledge and willingness to work, it doesn't seem possible that you cannot make good. Sign the coupon below, don't fail to give the name of your county. Better still write a letter, tell us about yourself and attach the coupon. If interested in our salesman's plan ask for "Ozarka Plan No. 100."

**OZARKA**

122 Austin Avenue B  
 Chicago, Illinois



**INCORPORATED**

122 Austin Avenue, B  
 Chicago, Illinois

Gentlemen: Without obligation send book "Ozarka Instruments No. 200" and name of Ozarka representative.

Name.....  
 Address.....City.....  
 County.....State.....

**YOU'LL KNOW THE MAN BY THIS BUTTON!**

Gentlemen: I am greatly interested in the FREE BOOK "The Ozarka Plan" whereby I can sell your instruments.

Name.....  
 Address.....City.....  
 County.....State.....



## QUERIES ANSWERED

WHAT CARE DOES A RECEIVER ORDINARILY REQUIRE?

R. J. L. Lincoln, Nebraska.

HOW MAY THE BEERS CHARGER BE USED TO CHARGE STORAGE B BATTERIES?

T. C. N.—Hempstead, New York.

WHEN I ADD RESISTANCE-COUPLED AMPLIFICATION TO THE ROBERTS SET THE VOLUME IS LESS THAN ORIGINALLY ON TWO TUBES. WHY?

M. L. C.—Zion City, Illinois.

HOW MAY REGENERATION BE ADDED TO MY NEUTRODYNE?

T. C. R.—Butte, Montana.

HOW ARE THE W. E. TRANSFORMERS USED IN THE ROBERTS CIRCUIT?

I. K.—Brooklyn, New York.

WILL YOU PUBLISH A TABLE OF SCREW SIZES, DRILL GAUGES AND TAP SIZES?

C. B.—Philadelphia, Pennsylvania.

### RECEIVER RENOVATION

A RECEIVER, like any other piece of intricate machinery, needs frequent overhauling and renovation. It is just as unfair to assume that a motor will function without oil as it is to assume that a receiver will operate satisfactorily without frequent cleanings.

Look over your condensers. If they have a pig-tail connection so much the better for them. If they have not, then it should be observed whether a thin film of grease produced by moisture and dust has got into the bearings. Never use oil to lubricate a hard-turning condenser. Rather, try to loosen up on the pivots—or get a new condenser.

If your condenser is composed of a section of stator plates which are cut out of, or assembled into, a solid block, it is absolutely essential that every so often the spaces between the plates be cleared of collected dust. A pipe-cleaner is well suited for this work, and it is not a bad stunt to clean all condensers irrespective of their peculiar assembly.

How are your coil units? Is the wire merely wound on the bakelite or cardboard tubing without any binder? If so, and the coil is loosening owing to shrinkage and drying, put the wires back into place, tighten the turns and then, at the start and finish of the coil, put a dab of collodion, shellac or varnish—this to keep the winding permanently in place. Do not coat the whole coil with this binder as the resistance will materially increase affecting the overall efficiency of the receiver in which it is employed.

Take a look at your sockets. Have the binding posts on them become loose? If so, you can credit them with causing some of the scratchy noises which you have undoubtedly heard. Also look at the

contact blades of the sockets and see that they have not been bent down so far that there is no contact between them and the tube prongs. Brighten the surface of the tube prongs and be sure none are loose.

If, in the construction of your receiver, there has accumulated between the battery terminals, or any other contacts in the receiver, a deposit of soldering paste, remove it with a washing of alcohol.

Don't let your batteries get dusty, especially between the terminals, and be sure to coat the terminals of your A battery with vaseline to prevent corrosion. Phone and loud-speaker cords often become wet or if they have come in contact with the top of the A battery the insulated cotton covering becomes rotted and soon a short circuit between the tinsel wires occurs.

### CHARGING A AND B BATTERIES

THE Beers universal battery charger described in the September RADIO BROADCAST may, with the addition of a lamp and a few wires, be made to conform with its name and be employed as both A and B battery charger.

No change in the original circuit is necessary and it was found by experiment that both A and B batteries could be charged simultaneously. Of course, when a 6-volt battery is charged at the same time as a B battery, the amount of current passed into the B battery is lower than when only the latter battery is on charge. The output charging rate of 2 amperes will be divided proportionally between the two batteries.

With a 200-watt bulb it was found that a charging rate of .7 amperes was obtained on a 48-volt B battery, and with a 50-watt lamp, .18 amperes.



# new **ULTRADYNE** MODEL L-3

## *No Dials-No Panel Built-in Loud Speaker*

All Ultradyne are guaranteed as long as Mr. Lacault's monogram seal (R.E.L.) on the assembly lock bolts remains unbroken.

**I**F the Ultradyne Model L-3 were merely another new receiver, its influence in the industry would be little felt.

But it is in reality the first step in the general revision of radio receiver design which is bound to follow its advent.

For the new Ultradyne Model L-3, is an entirely new type of receiver—radically different in appearance and method of operation—gives finer results from finer engineering. Employs six tubes—is completely assembled and wired, ready for the tubes and batteries.

It has no dials—no panel—no needless controls. Two levers, an exclusive Ultradyne feature, give you control of the entire broadcast program. Its operation is practically automatic—simply slide the pointer to the station you want and adjust the volume control, soft or loud as you like it. Loud Speaker and "B" Batteries self enclosed in a beautiful cabinet that is far from mechanical in design and is an ideal mahogany furniture piece for the most charming home. Ask your dealer for a demonstration.

*Write for descriptive folder*

★  
\$ **135**

**PHENIX RADIO CORPORATION**  
116-C East 25th St.  
N. Y. CITY



★ Tested and approved by RADIO BROADCAST ★

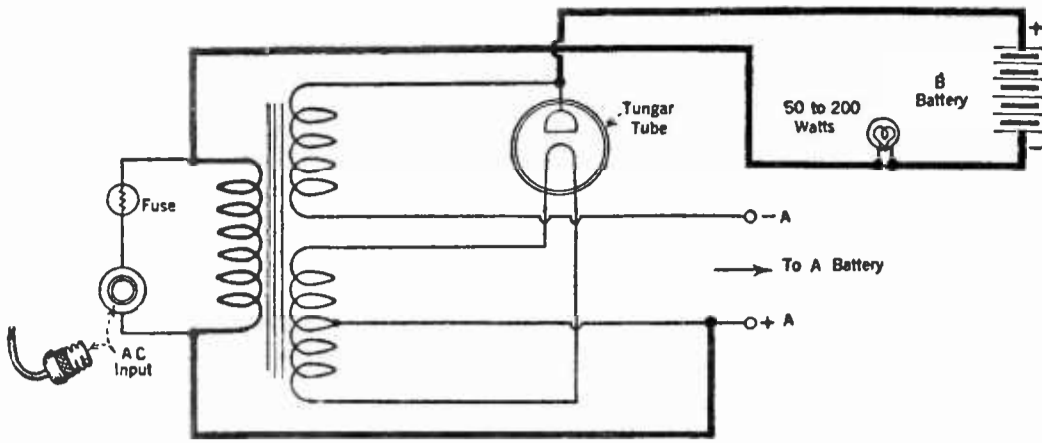

FIG. 1

With the A battery on charge at the same time, the current in the B battery circuit was cut to about one third its former value.

To charge B batteries it is only necessary to connect the positive terminal of the battery to the graphite electrode of the tungar tube, i.e., the lead coming out of the top of the tube.

The negative side of the battery connects to one side of the a. c. line. The other side of the a. c. line connects to the positive output terminal of the A battery charger. In the circuit diagram Fig. 1, the heavy lines indicate the new connections for B battery charging. It is obvious that by varying the size of the lamp in the charging circuit, within the limits specified, the charging rate may accordingly be varied.

The above specifications hold good only for a 48-volt B battery. Do not try by this method to charge a 96-volt or larger bank of B batteries.

RESISTANCE COUPLING IN THE ROBERTS KNOCKOUT

**M**ANY constructors have endeavored to add resistance-coupled amplification to their two-tube Roberts receivers with varying results. Some were successful, others not. If the circuit is observed and analyzed, it will be noted that the input connections to the first resistance coupler are not like that of a transformer-coupled amplifier. The detector-plate resistance, having B-battery current flowing through it, is isolated from the grid of the next tube by an isolating or blocking condenser. These points are brought out in Fig. 2.

Now supposing a pair of leads are brought from the output of a tube, such as at 1-2 Fig. 2, and are connected to the plate resistance of the resistance

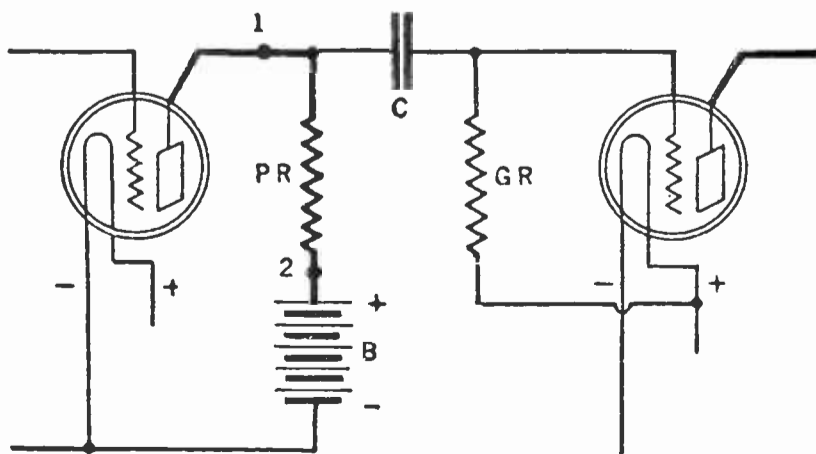

FIG. 2

coupler. If by any chance these connections are so reversed that the plate lead of the first tube connects to the end of the resistance not common to the isolating condenser, then a circuit such as in Fig. 3 will result.

Here, a B-battery potential will be applied to that end of the plate resistance connected to the isolating condenser and the effective voltage drop across the plate resistance will not be realized.

Those who employ resistance-coupled amplification in their receivers are cautioned to check over the connections to this part of the amplifier as satisfactory operation of the receiver is entirely depend-

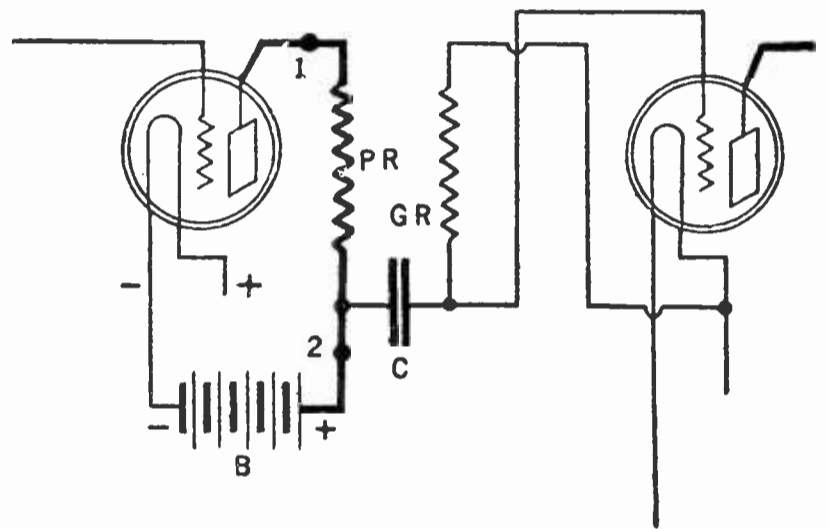

FIG. 3

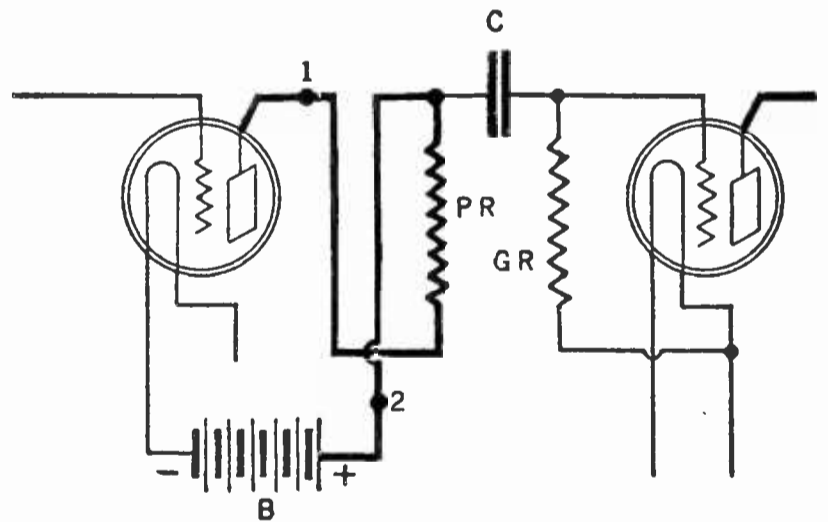

FIG. 4

ent upon the correct hookup of the plate resistance. In Fig. 4 the incorrect circuit is shown in another form and as it would be recognized in a receiver.

While on the subject of resistance amplification, it is well to state that the output amplification of the unit may be unquestionably increased with the use of the new high-mu tubes especially designed for use in resistance-coupled amplifiers.

ADDING REGENERATION TO THE NEUTRODYNE

**I**T HAS generally been assumed that the addition of regeneration to a receiver was theoretically equal to the addition of a stage of radio-frequency amplification. Furthermore, in the use

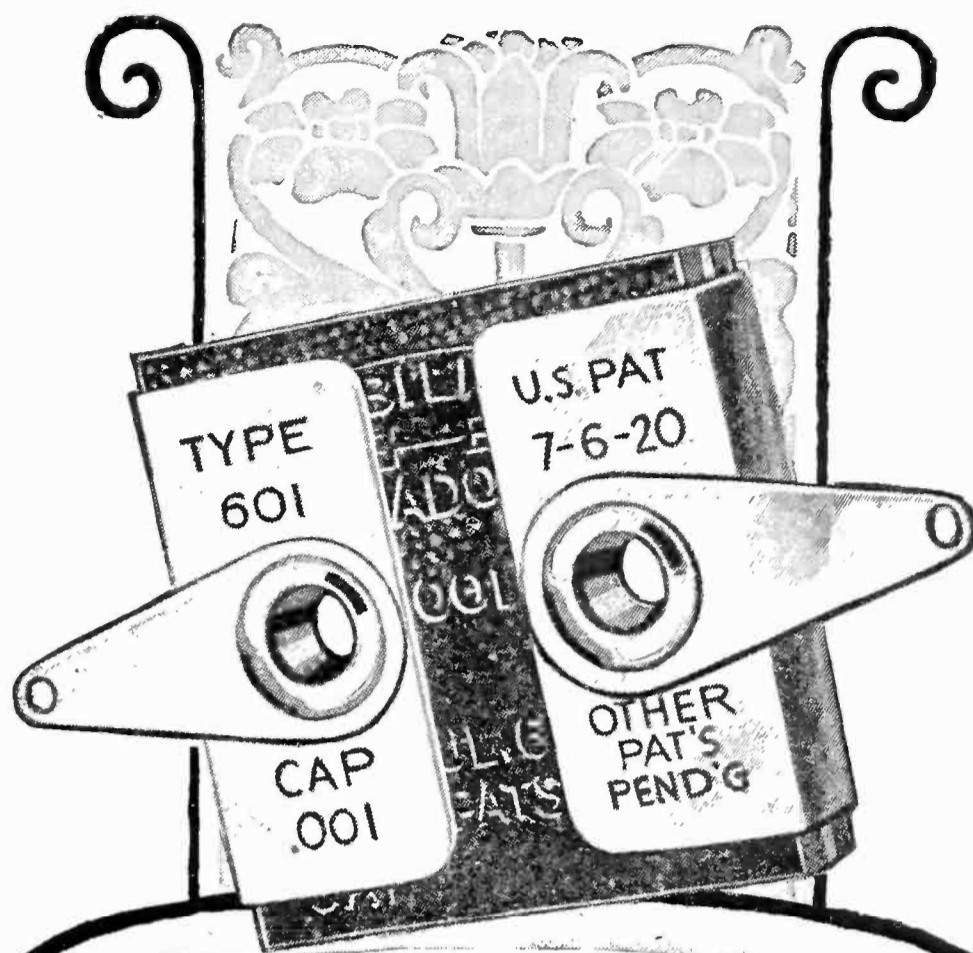

# Micadons

## standard fixed radio condensers

NEARLY all of the leading manufacturers of radio sets have adopted the Micadon as their standard.

A layman might be fooled—not so these manufacturers. They need fixed condensers with *accurately matched* and permanent capacities, and they know which are the best. Year after year, they buy millions of Micadons. This overwhelming preference is your assurance of *quality*.

*Send 10 cents for 32-page booklet "applications of Dubilier Condensers in Radio Circuits." Address Dept. H-2, 4377 Bronx Boulevard, New York City*

# Dubilier

**CONDENSER AND RADIO CORPORATION**

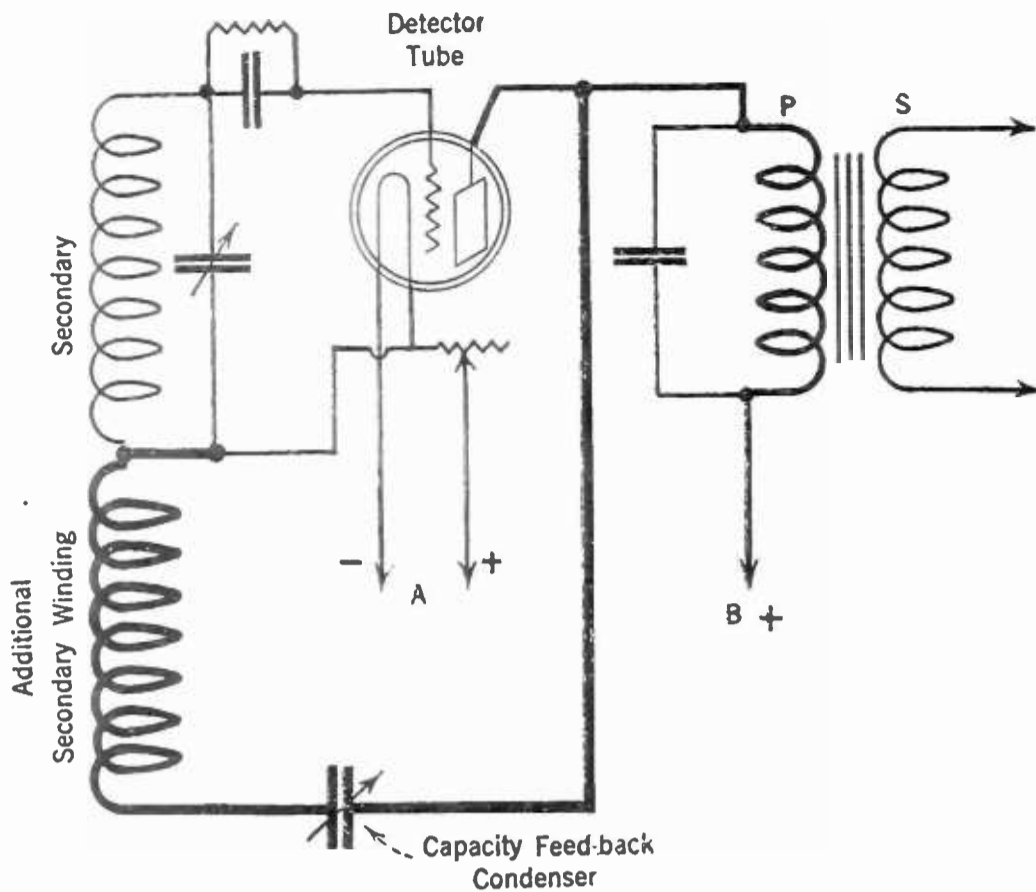

FIG. 5

of regeneration, it is possible to tune a receiver by the squeal method which is admitted to be practically the easiest system in use. In the standard neutrodyne, unless the receiver be improperly neutralized, it is not possible to realize the benefits from such a system of tuning, and often a station is passed by simply because the peculiar whistle is not present.

To include regeneration in a receiver of this type, it is possible to choose from two systems—namely capacity feedback or inductive feedback, otherwise recognized as “tickler regeneration.” The former has the advantage over the latter system in that the adjustment of regeneration is independent of wavelength and does not affect the tuning properties of the receiver.

In tickler control a readjustment usually throws out the main tuning control a trifle. Inductive feedback is, however, the more common form in use to-day and usually consists of a coil of wire located in the plate circuit of the detector tube. It is coupled to the detector secondary. Another method of doing the same thing is to employ a variometer in the plate circuit of the detector.

The capacity-feedback system has only lately come into extensive use and is the one described here.

The usual secondary coil in a neutrodyne consists of about 60 turns of wire wound on a cylindrical form. To this coil, at the filament end, must be added from one third to one half the number of turns already on the secondary. Then at the new lower end of the entire coil is connected one terminal of a variable condenser the other contact of which connects to the plate of the detector tube. The circuit is shown in Fig. 5. The heavy lines indicate that part of the circuit which is new, comprising the capacity-feedback system.

For individual receivers it may be necessary to experiment with additional coils having various

turn-values. Also the experimenter will find that with some coils a small condenser is satisfactory where in other cases only a larger condenser will do.

The most satisfactory and successful arrangement is that where, with a given number of turns, regeneration over the whole wavelength range of the receiver will be obtained over the whole scale of the capacity-feedback condenser dial.

The experimenter may wind the additional coil in any way convenient, according to the mechanical and physical limitations of the particular part of the receiver where the coil is to be placed. It may be bank wound, random, or in any of the concentrated forms such as basket weave, diamond weave, or spiderweb. The latter offers greatest possibilities because of the space saved in its use. One important thing to remember is to wind the

new coil in the same direction as the original secondary.

#### WESTERN ELECTRIC PUSH-PULL TRANSFORMERS

SINCE the publication, in the July “Now I Have Found Department,” of the article by Mr. H. Q. Horneij, describing the construction of a four-tube Roberts receiver employing a brace of Western Electric power-amplifier transformers, we have been asked where the transformers might be purchased and why, from a “new idea” standpoint, the article appeared in the above-mentioned department.

To answer the last question first, the article was presented to our readers because the use of Western Electric transformers guaranteed nigh on to perfect loud-speaker reproduction of voice and music.

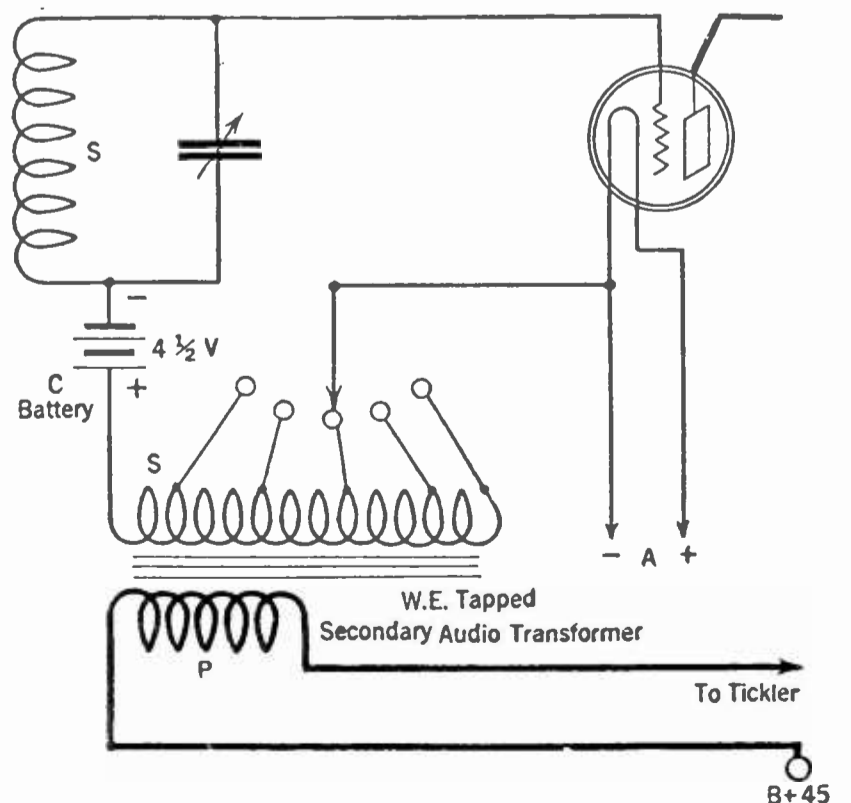

FIG. 6

**EVEREADY HOUR**  
**EVERY TUESDAY AT 9 P. M.**  
*Eastern Standard Time*

For real radio enjoyment, tune in the "Eveready Group." Broadcast through stations—

WEAF	New York	WCAE	Pittsburgh
WJAR	Providence	WSAI	Cincinnati
WEEL	Boston	WWJ	Detroit
WFI	Philadelphia	WCCO	Minneapolis
WGR	Buffalo	WCTS	St. Paul
WOC	Davenport		Worcester

# ECONOMY

No ONE size or type of battery can be economical on every type of receiving set. That's why Eveready Radio Batteries are made in different sizes and types —so that every radio user can enjoy the economy that is to be had by fitting exactly the right Eveready Battery to his receiver. For owners of sets with five, six, eight or more tubes, and power amplifiers, there is the extra-large, powerful and unusually long-lasting Eveready "B" Battery No. 770. There is an Eveready dealer nearby.

Manufactured and guaranteed by  
**NATIONAL CARBON CO., Inc.**  
 New York San Francisco

Canadian National Carbon Co., Limited  
 Toronto, Ontario

# EVEREADY

## Radio Batteries

-they last longer

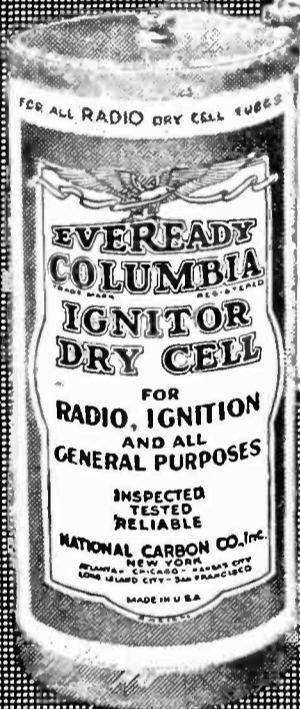

Eveready Columbia Ignitor "A" Battery, the proven dry cell for all radio dry cell tubes 1½ volts



No. 766  
 22½-volt  
 Large Horizontal  
 Price \$2.00



No. 770  
 45-volt  
 Extra-Large Vertical  
 Price \$4.75

Many owners of receivers already had in their possession the old Western Electric power amplifier and here was a good chance to incorporate it in a receiver of the highest type.

The tapped secondary of the first stage presented an opportunity to use this transformer for the control of volume in the Roberts receiver, when used in the audio-reflex stage. This application is embodied in the circuit diagram Fig. 6.

Naturally, the use of the W. E.-216-A tubes is essential to undistorted output inasmuch as the use of UV201A tubes with the Western Electric transformers would be a poor combination resulting somewhat in a loss in volume and clarity of output.

#### SCREW THREADS COMMONLY USED IN RADIO

**T**HE fan who makes his own must often rely upon the data contained in radio publications for the correct sizes of drills, taps and screws, to use in the assembly and general construction of his receiver and other radio apparatus.

Many can boast of a steel tap and drill gauge in their collection of tools, and with this handy adjunct to the constructor's shop, it is possible at a glance to know the proper size drill to be used by merely inserting the screw to be used in the hole in the gauge in which it properly fits.

However, not all have these gauges and so in Fig. 7 is shown a table which lists the screws and threads most commonly used in radio apparatus construction, with the corresponding clearance drill hole sizes and tap drill sizes.

The column on the left lists the screw sizes. The center column shows the tap drill sizes which naturally are smaller than the clearance holes, which are listed in the last column.

SIZE OF SCREW	TAP DRILL SIZE	CLEARANCE DRILL SIZE
2-56	48	42
3-48	44	37
4-36	41	31
5-40	36	29
6-32	33	27
7-32	30	22
8-32	28	18
9-32	24	13
10-32	20	9
10-24	23	9
11-24	19	3
12-24	15	1
14-24	6	$\frac{1}{4}$
14-20	10	$\frac{1}{4}$

FIG. 7

If it is desired to tap a piece of brass or bakelite for a 6-32 machine screw then a No. 33 drill is used.

If the screw is to be used to clamp two pieces together, then a clearance hole is drilled to allow the screw to pass through and into the hole with ease. In this instance a No. 27 would be used for the drilling.

Where a hole to be threaded does not go through the material but only is drilled for part of the way, then a tap having a blunt end with a uniform diameter is more satisfactory because if a tapered tap were used the threading would not be complete at the bottom of the hole. Where the hole does go through, then a tapered drill may be employed.

In all tapping operations, only work the tap for two or three threads, working it back and forth and then remove it so that chips or dust may be taken out. Repeat the operation which will insure a clean thread.

*When writing to the Grid, please use the blank printed below.*

#### GRID INQUIRY BLANK

Editor, The Grid,  
RADIO BROADCAST,  
Garden City, New York.

Dear Sir:

Attached please find a sheet containing questions upon which kindly give me fullest possible information. I enclose a stamped return envelope.

(Check the proper square)

I am a subscriber to RADIO BROADCAST. Information is to be supplied to me free of charge.

I am not a subscriber. I enclose \$1 to cover costs of a letter answering my questions.

My name is \_\_\_\_\_

My address is \_\_\_\_\_  
G. O.

# ATWATER KENT RADIO



*"We don't open the box"*

DEALERS have been telling us what they most like about Atwater Kent Radio.

"This sums it up," one of them said: "We send the sets to our customers' homes without opening the boxes in which they come from the factory. We know they're all right. 'Inspected' means inspected when Atwater Kent says it."

The word "Inspected" on the pink tag attached to the bottom of every Atwater Kent set is truly a certificate of character. It means that every set, before we will let go of it, has been subjected to no less than 140 gauge and physical inspections and nineteen electrical tests. The smallest defect is a death warrant.

Visitors at the factory sometimes think we're too fussy. That we regard as a great compliment. Every dealer knows that "fussiness" at the plant relieves the customer from fussing in the home, and therefore makes Atwater Kent Radio easy to sell.

We believe in being fussy and shall continue to be.

*Write for illustrated booklet telling the complete story of Atwater Kent Radio.*

**Dealers, did you know—**

that the farmers of the country have set down in writing their preference for Atwater Kent Radio?

The Meredith Publications and the Capper Publications recently asked the farmers: "What make of radio set do you expect to buy?" In the answers Atwater Kent was FIRST.

If you have prospects in rural districts, there's a tip for you.

**ATWATER KENT MANUFACTURING COMPANY**

*A. Atwater Kent, President*

4726 WISSAHICKON AVENUE · PHILADELPHIA, PENNSYLVANIA

**Every Thursday Night**—the potential audience of the Atwater Kent Radio Artists, who broadcast from ten stations every Thursday evening from 9 to 10 (Eastern Standard Time) is estimated at more than 10,000,000. These are the stations:

- |                       |                                     |                       |
|-----------------------|-------------------------------------|-----------------------|
| WEAF . . . New York   | WFI . . . Philadelphia              | WWJ . . . . . Detroit |
| WJAR . . . Providence | WCAE . . . Pittsburgh               | WSAI . . . Cincinnati |
| WEEL . . . . . Boston | WGR . . . . . Buffalo               | WOC . . . Davenport   |
|                       | WCCO . . . . . Minneapolis-St. Paul |                       |



Model H, with 9' flexible cord, \$22

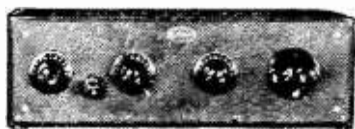

Model 20, without tubes \$80



Phonograph Attachment with 9' flexible cord, \$8



Model 24, without tubes \$100



Model 10, including battery cable but without tubes \$80



Model 20 Compact, including battery cable, but without tubes, \$80



Model 12, built on special order, including battery cable but without tubes, \$100



Model L, with 9' flexible cord, \$17

*Prices slightly higher from the Rockies west, and in Canada.*

★ Tested and approved by RADIO BROADCAST ★

*"The Speaker That Speaks for Itself"*

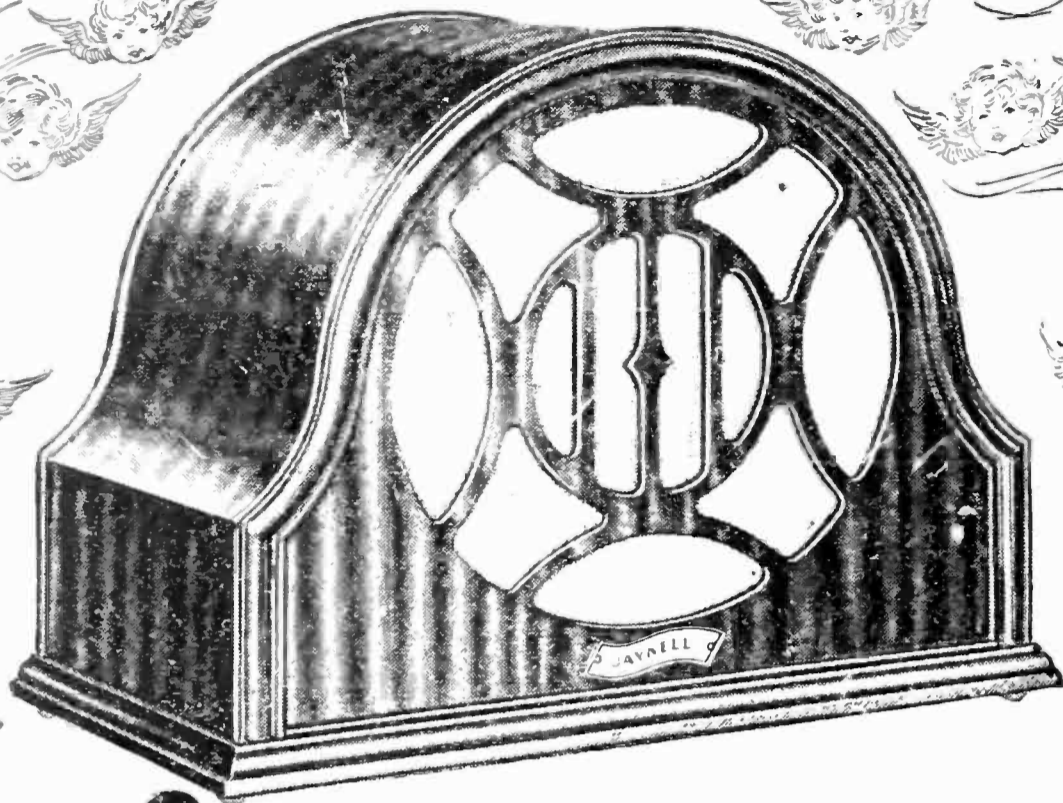

# Jaynell

**RADIO SPEAKER**

**Mellow and Clear as a Bell in Tone**

Now the real, natural beauty of music—as it is originally sung or played by radio artists—is yours. Tantalizing, toe-tickling tunes or the charming, bell-clear songs of a coloratura-soprano—the Jaynell re-creates them all, with all of their natural, triumphant beauty. Its tones are as delicate as a harp's—as sensitive as a violin to every zephyr-like note. Resonant and mighty when an organ plays—sweet and crystal-clear, bringing out all delightful modulations, when some renowned singer carols to the radio world.

In volume and tone-power the Jaynell is incomparable.

Back of every Jaynell Radio Speaker is an unconditional guarantee—beginning with a ten days' free trial upon a *money-refunded-if-not-absolutely-satisfied* basis.

Let radio in your home be delightful and entertaining—as true and pure in tonal qualities as if all the broadcasting stations were in the same room with you. Hear the Jaynell! At all good radio dealers—\$30.00, or order direct, sending name of your dealer with your remittance to

**Jaynell Manufacturing Co.**

217 No. Desplaines St.  
Chicago, Ill.





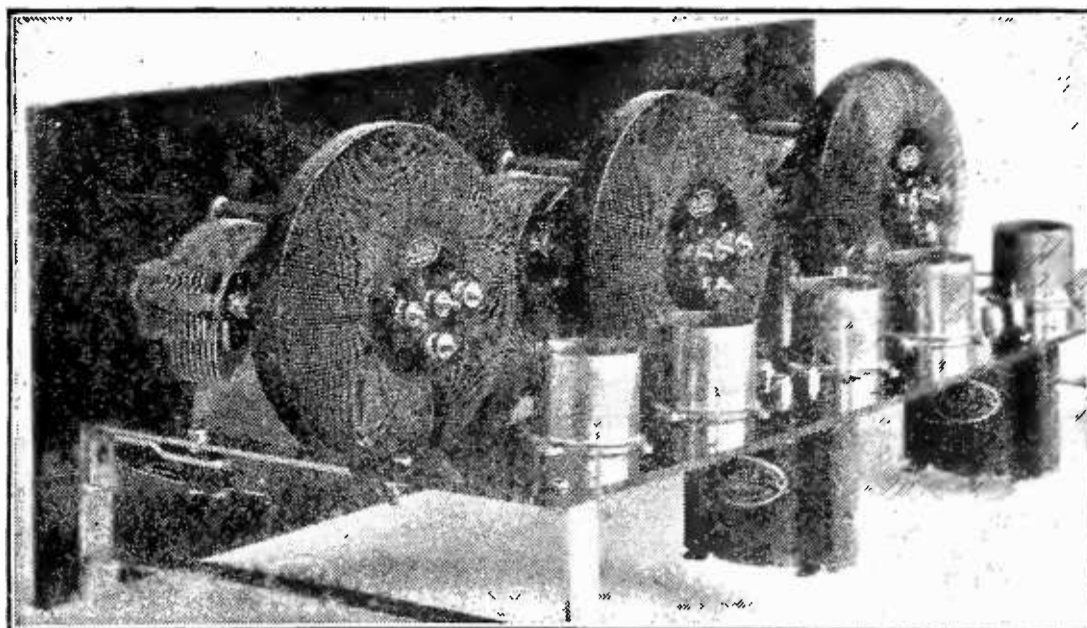

# Amazing new receiver

★ **NOW** anyone can build it in an amazingly short time this new easy way. Experts assemble it at factory. You simply wire. Note revolutionary new principle it contains.

**N**O excuse now for not having a fine radio. At a surprisingly low cost, too. For a remarkable plan is showing thousands a new way to build their own. It is so easy that anyone can do it in an hour's time. So fascinating that many continue to build them for others. No wire bending or soldering. Merely attach a few ready-cut, flexible eyeletted leads, and the job is done.

And in addition to the fun and pride of building your own, the finished receiver actually contains a phenomenal feature not yet found in the most expensive sets; that brings results otherwise impossible.

This feature follows the discovery of a new inductance principle that overcomes many vital weaknesses of present day sets. It is based on an entirely new type coil—the Erla \*Balloon \*Circloid.

Circloids are the backbone of the Erla kit and are largely responsible for the striking improvements this kit alone offers. Note these four advantages in particular:

**1. Greater distance.** Circloids have no measurable external field to affect adjacent coils or wiring circuits. This makes possible higher amplification in each stage, with increased sensitivity and greater range.

**2. More volume.** Higher r. f. amplification enables Circloids to bring in distant stations scarcely audible in ordinary sets with volume enough on the loud speaker to fill an auditorium.

**3. Increased selectivity.** Circloids have absolutely no pick-up qualities of their own. Only signals flowing in the antenna circuit are built up.

**4. Finer tone quality.** The self-enclosed field positively prevents stray feed-backs between coils. Hence no blurring or distortion. Tones are crystal clear.

Circloids are sold singly and in sets of three; also in kits containing three Circloids and three .00035 condensers.

*Write for free information on kit—also book.*

See how a few minutes of fun will give you the newest and most nearly perfected set known to radio science. Examine it at any Erla dealer's, or send the coupon for full information, illustrations and diagrams contained in the remarkable new book, "Better Radio Reception," describing the sensational new Circloid principle. Enclose 10c for mailing and postage on book.

\*Trade Mark Registered.

ELECTRICAL RESEARCH LABORATORIES, 2500 Cottage Grove Avenue, Dept. 10-A, Chicago, U. S. A.		
<input type="checkbox"/> Send me free information on kit.	<input type="checkbox"/> Enclose 10c for postage for book "Better Radio Reception."	
Name.....		
Address.....		
City.....		State.....

**Dealers:** Exclusive franchises are available to high class dealers in localities still open. Write or wire immediately.

# KARAS HARMONIK

AUDIO FREQUENCY

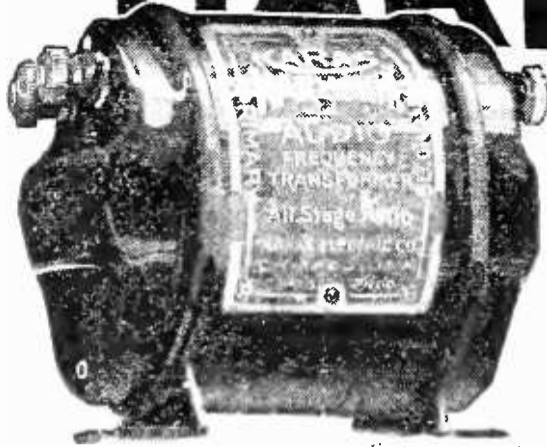

AMPLIFYING TRANSFORMER

## The Triumph of a Masterpiece!

—A Marvel of Transformers that Brought Real Musical Quality to Radio Reception

**J**UST one year ago the Karas Harmonik Audio Frequency Transformer took the radio world by storm.

Nothing like it had ever been known before. For the first time, scientific study had been devoted to perfecting an audio transformer for the reception of broadcast music. The problem of amplifying high, low and medium frequencies to equal degree was finally solved. Bass notes were poured from the speaker in full strength and rich tone quality. The vital harmonics in rich overtones, formerly lost, were brought out in their full beauty by this marvel of audio transformers.

Music critics, who had always condemned radio music as false and distorted, approved the results of Karas Harmonik amplification with great enthusiasm.

Prominent radio engineers subjected Karas Harmoniks to exhaustive laboratory tests—and pronounced it a technical masterpiece. Technical editors who promoted the season's most successful hook-ups specified Karas Harmoniks in their circuits. The triumph of the Karas Harmonik was complete.

But, for all of this, the enjoyment of Karas Harmonik amplification was too greatly confined to one class of radio enthusiasts. Home set builders bought Karas Harmoniks by the tens of thousands. They were free to pick and choose. They were most exacting in their demands for the newest and best developments.

It was the owners of factory-built sets who missed the delightful pleasure of real, true radio music in their homes. Set manufac-

turers were prevented by price from adopting Karas Harmoniks for their sets. So the ready-made set-buyer unless he undertook to switch transformers, had to do without Karas Transformers.

Today there are in use, hundreds of thousands of sets—good sets—which could be vastly improved in musical quality by the simple operation of replacing the old transformers with Karas Harmoniks. Perhaps you own one of these sets. It may be all you desire from the standpoint of selectivity of range, and other tuning qualities. But, if it is not equipped with Karas Harmonik Audio Frequency Transformers, you are NOT getting nearly the musical

quality you can just as well enjoy. Are you going to be content with anything short of the best?

You can install Karas Harmoniks yourself. It's a short, easy job. Or, any radio repair man can do it for you. Make up your mind to do it now—at once. Get a pair of Karas Harmoniks TODAY!

In large cities, most good dealers carry Karas Harmoniks—and in many small towns. If your dealer is out of them, order direct from us. Send no money. Just send the coupon now!

**Karas Electric Co.,**  
4042 N. Rockwell St.,  
Chicago, Ill.

### The Distinctive Features that Elevate Karas Harmonik Transformers to the Highest Pinnacle of Success in the Radio World.

1. Many thousands of turns of wire
2. Low ratio of turns
3. Extra large quantity of special formula iron in core
4. Controlled air gap
5. No core saturation
6. Minimum of Reluctance
7. Least Hysteresis and Eddy Current Loss
8. Low Distributed Capacity
9. Scientifically circular shielding preventing intercoupling of electrostatic and electromagnetic fields.
10. Very High Primary Impedance
11. Extremely High Inductance
12. High and Even Amplification of all Audio Frequencies.

**Karas Electric Co.,**  
4042 N. Rockwell St., Chicago, Ill.

Please send me \_\_\_\_\_ pairs of Karas Harmonik Audio Frequency Transformers. I will pay the postman \$7 apiece, plus postage, on delivery. It is understood that I am privileged to return the transformers any time within 30 days if they do not prove entirely satisfactory to me, and my money will be refunded at once.

Name.....

Address.....

★ Tested and approved by RADIO BROADCAST ★

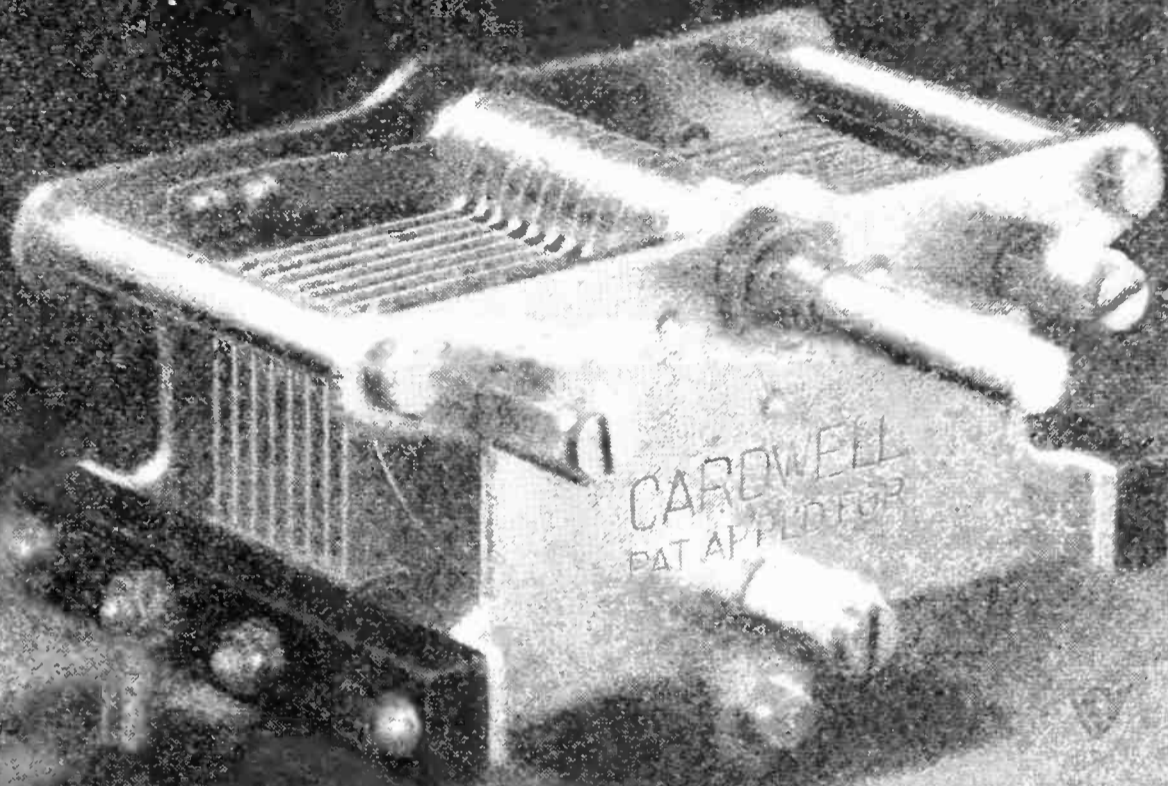

# Insist on **CARDWELLS**

## The *first* "low-loss" condensers

★

**C**ARDWELL invented the original *low-loss* condenser, using metal end plates and a grounded rotor. The phrase "low-loss" was in fact first applied to Cardwell Condensers by engineers to distinguish these highly efficient condensers from the ordinary varieties.

Cardwell Condensers have been universally adopted by radio editors, experts, and professionals. Cardwells have become the standard of comparison.

Performance is the only real test of a condenser. And Cardwell Condensers have proved their superiority because of their scientifically correct

design—small area of contact between insulation and stator supports, rigid three-point frame, permanent alignment, accurate adjustment, etc.

Such details permit exceptional distance records, smooth tuning free from noise, and prevent changes in capacity at given settings.

Use Cardwell Condensers in all receivers. There's a Cardwell Condenser for every requirement—seventy-six different types. A post-card brings you an education on condensers.

**Allen D. Cardwell**  
*Manufacturing Corporation*  
 81 Prospect St., Brooklyn, N. Y.

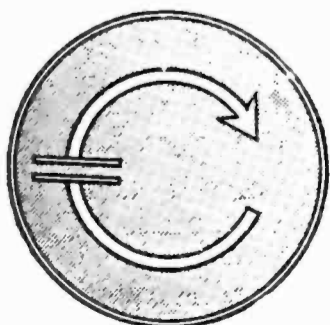

TRADE MARK  
 Registry applied for

★ Tested and approved by RADIO BROADCAST ★

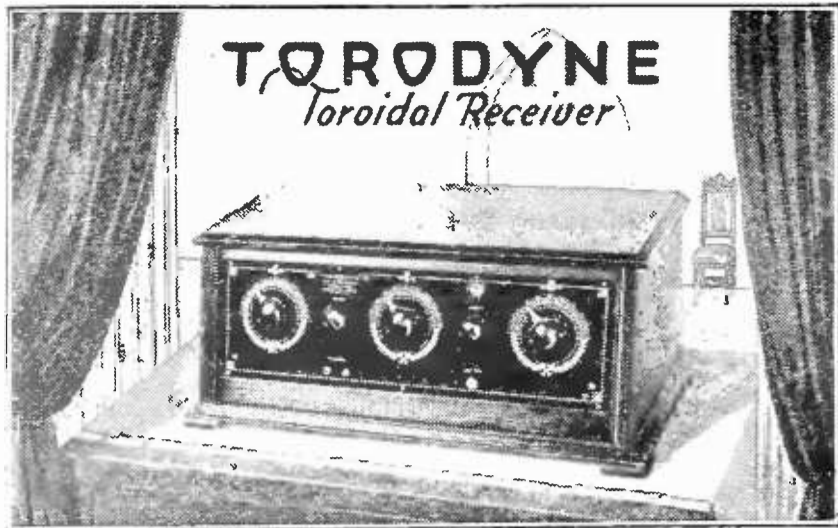

# 58 Stations in One Evening

IN ONE EVENING (two and one half hours actual time) 58 stations from Los Angeles to Boston, Calgary, Alberta to Ft. Worth and from Ottawa to Miami, Florida, were received with good volume and equal clarity of tone through a loud speaker. The time includes waiting for the announcement of call letters.

This is but one of the records of the TORODYNE, the latest AINSWORTH Receiver. It is a five-tube, tuned radio frequency receiver with Toroidal (doughnut type) transformers, which greatly increase the scope of radio frequency amplification. The TORODYNE will bear comparison favorably with any set and the difference can be quickly and easily distinguished.

## Why the TORODYNE is Superior in Performance

One of the leading features that places the TORODYNE ahead of the field is the use of Toroidal Transformers, which give it:

1. **GREATER SELECTIVITY** due to the fact that these coils do not pick up outside interference. Only the signal to which the set is tuned can be picked up as it must come through the antenna.

*Toroidal transformers will not pick up signals themselves.*

2. **MORE VOLUME** without oscillations. These coils permit this by minimizing interstage coupling.

3. **DISTANCE.** The greater amplification increases the sensitivity, bringing in distant stations with more volume. This naturally increases the range of the set.

4. **SUPERIOR TONE QUALITY** is secured through the elimination of distortion and foreign noises by preventing stray feed-backs.

Ask your dealer or write us

PRICE \$100.00



The Ainsworth Radio Co.

404 Main St.

Cincinnati, Ohio



## The TOWN CRIER Radio's Most Beautiful Speaker

YOU will be delighted with the gorgeous colors . . . the stippled finish, and the novel design of the TOWN CRIER—the "SPEAKER WITH THE VOICE THAT THRILLS."

Ask your Dealer to show you a Town Crier Speaker. Write to-day for beautifully illustrated circular, describing the Golden Polychrome and Green Polychrome models.

LIST PRICE \$17.50 West of the Rockies \$18.50

GALE RADIO LABS.

2510 Irving Park Blvd.

Chicago, Ill.



"a new 5-Tube Set with all the power and none of the grief of the Supers"—so wrote Henry M. Neely, Editor of Radio in the Home, Philadelphia.

## How to Build the SUPER-FIVE

Write to-day for the QUADRAFORMER BOOK. It will bring you a new radio experience. Profusely illustrated with photographs, drawings. It takes you step-by-step through the making of the SUPER-FIVE, an exceptional 5-Tube Receiver developed by engineers of the Gearhart-Schlueter Radio Corporation.

Inclose 25c and you'll have it by return mail

Gearhart-Schlueter Radio Corp'n.  
712 Voorman Street, Fresno, California

★ Tested and approved by RADIO BROADCAST ★

# Amplions chosen to reproduce Papal Ceremonies throughout Saint Peters, Rome

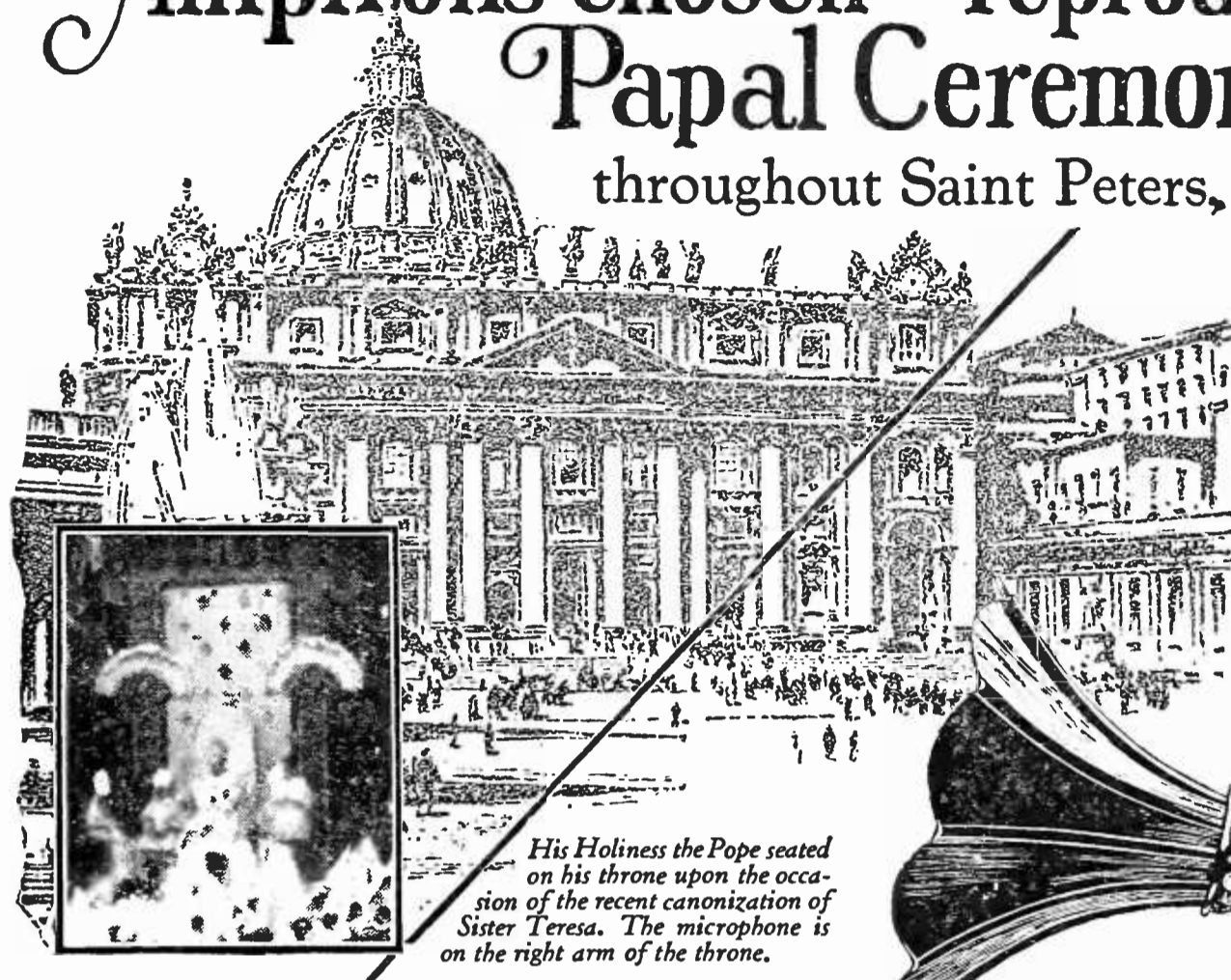

*His Holiness the Pope seated on his throne upon the occasion of the recent canonization of Sister Teresa. The microphone is on the right arm of the throne.*

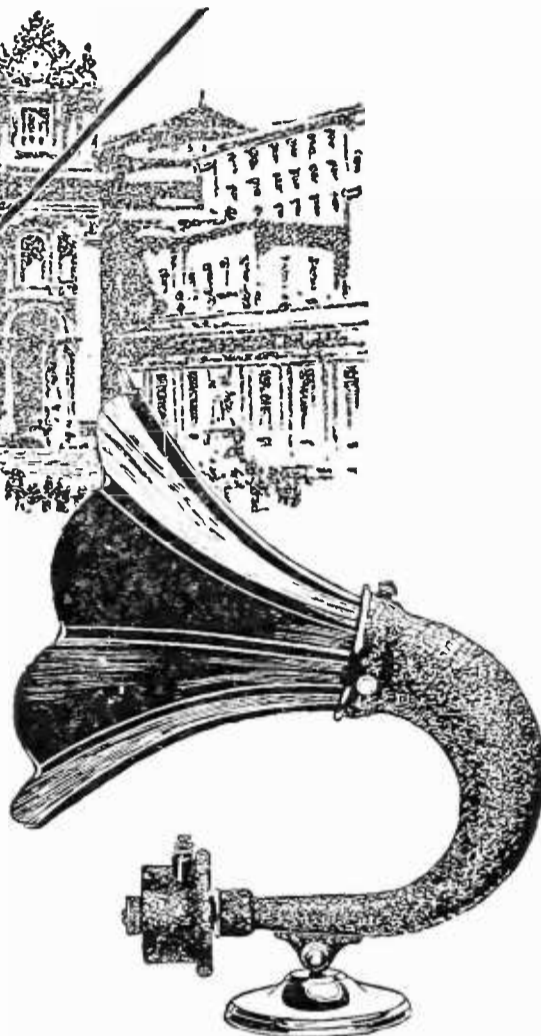

Of ALL loud speakers, Amplions enjoy the honor and high compliment of having been installed throughout the famous Cathedral of Saint Peters, Rome, that important ceremonies conducted by His Holiness the Pope may be clearly audible to great multitudes of people.

Supreme clarity of reproduction was the prime requisite. It is only logical that The Amplion—creation of the actual originators and oldest makers of loud speakers—should have been chosen. Amplions outsell any other loud speaker throughout the world, chiefly because of unrivaled clarity of tone. "The clearness of the reproduction of the Pope's voice was an outstanding feature," writes a witness to the first ceremonies.

Hear The Amplion in comparison with any or all other reproducers. Prove to your entire satisfaction that it is the world's finest loud speaker. Amplion Loud Speakers, \$12.00 up. Phonograph units in two sizes. Write for interesting literature and dealer's address.

**THE AMPLION CORPORATION OF AMERICA**

*Executive Offices: Suite L, 280 Madison Ave., New York City  
Canadian Distributors: Burndep of Canada, Ltd., Toronto  
Alfred Graham & Co., London, Eng., Patentees*

★ **AMPLION**

*The World's Standard Loud Speaker*

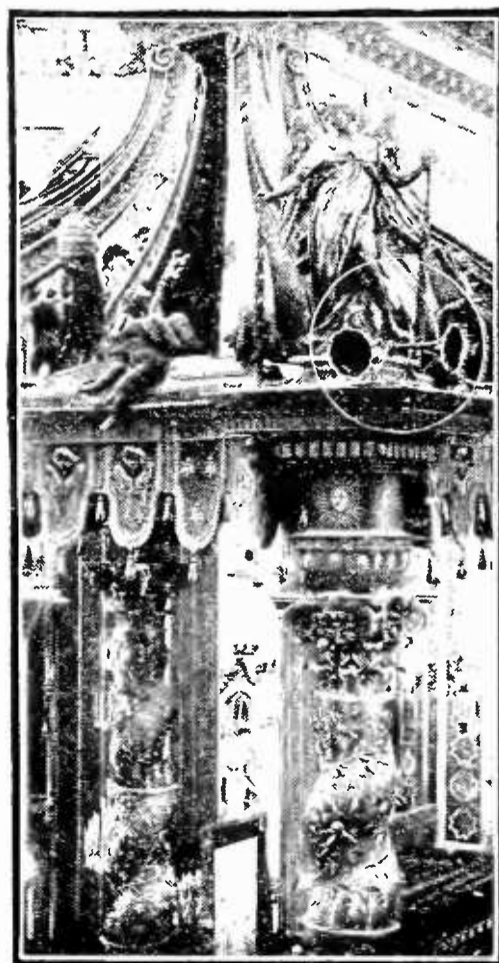

*A portion of the magnificent canopy over Saint Peter's Tomb, showing two of many Amplions installed for amplifying Papal services to vast assemblages of pilgrims.*

★ Tested and approved by RADIO BROADCAST ★



## Lullaby

Through the air of the evening, calm and sweet comes a cradle song from a distant city. Then, as never before, we feel the need of radio amplifiers which will bring out, strong and clear, just the pure beauty of music. For such moments is the joy of owning the one amplifying instrument selected by world-famed musical authorities for the purity of its tone: Rauland-Lyric.

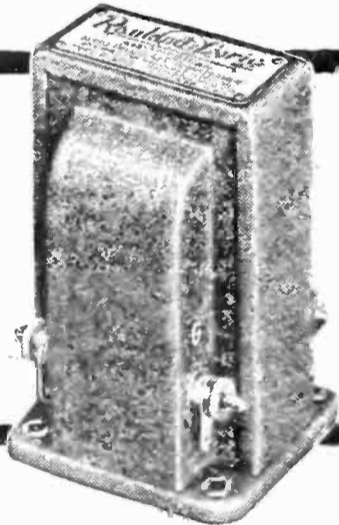

Rauland-Lyric is a laboratory-grade audio transformer designed especially for music lovers. The price is nine dollars. Descriptive circular with amplification curve will be mailed on request. All-American Radio Corporation, 4201 Belmont Ave., Chicago.

**Rauland-Lyric**  
AN

**ALL-AMERICAN**  
TRADE MARK

**TRANSFORMER**

*The Choice of Noted Music Critics*

# EBY

PATENTED

## BINDING POSTS

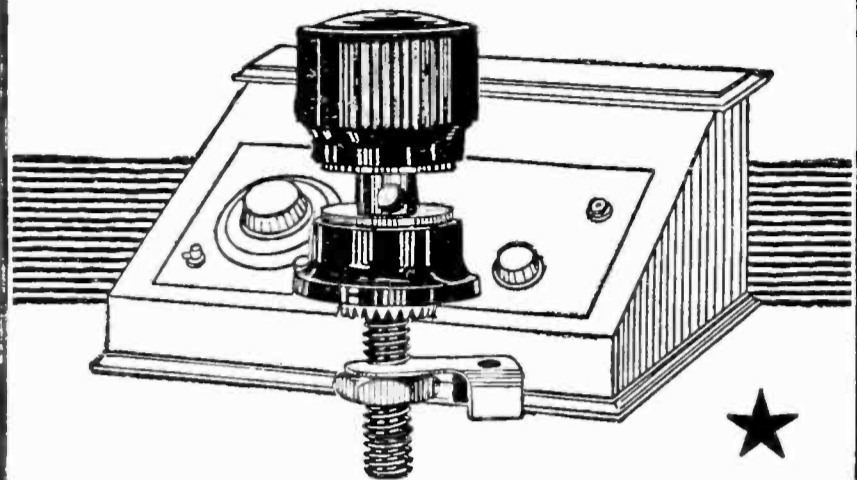

### Standard Equipment On 150 Manufacturers' Sets

Unvarying, built-in superiority made them select EBY posts. They are *your* logical choice, too. Furnished either plain or engraved in twenty-five different markings and the base of every post is clearly marked EBY.

*The Tops Don't Come Off*

**15c - At All Dealers - 15c**

**The H. H. EBY MFG. CO., Phila., Pa.**

**WRITTEN 2-YEAR GUARANTEE**

## Battery Prices SMASHED!

**To Consumers Only**

Here is a real battery quality, guaranteed to you at prices that will astound the entire battery-buying public. Order Direct From Factory. Put the Dealer's Profit in your own pocket. You actually save much more than half, and so that you can be convinced of true quality and performance, we give a *Written 2-Year Guarantee*. Here is your protection! No need to take a chance. Our battery is right—and the price is lowest ever made. Convince yourself. Read the prices!

<b>Auto Batteries</b>	<b>Radio Batteries</b>
6Volt, 11 Plate, \$9.50	6Volt, 100 Amp. \$9.50
6Volt, 13 Plate, 11.50	6Volt, 120 Amp. 11.50
12Volt, 7 Plate, 13.00	6Volt, 140 Amp. 13.00

**Buy Direct—Send No Money**

We ask no deposit. Simply send name and address and style wanted. Battery will be shipped same day we receive your order Express C.O.D. subject to your examination on arrival. Our guarantee accompanies each battery. We allow 5% discount for cash in full with order. You cannot lose! Send your order today —NOW!

**ARROW BATTERY CO.**  
Dept. 10. 1215 So. Wabash Ave., Chicago

# Plays No Favorites

## Amplifies both Low and High Tones



You want more from your loud speaker than noise, distortion, howls and squeals.

You want pure tones, clear and mellow whether high, low or of medium pitch. You expect faithful reproduction.

Such reproduction is made possible by resistance coupling amplification. Lower initial and operating costs, simpler assembly, and superior results make this method of amplification most popular.

**"Electrad" 3-Step Resistance Coupled Amplifier Kit No. 1-C**—A big \$6.75 value. Contains the necessary Resistor Couplers, Certified Mica Condensers, Condenser mounting, Grid Leaks and Resistors. Nothing else needed except sockets, rheostat and busbar.

*Ask your dealer or write for FREE Resistance Coupled Amplification Folder*

Variohms, Audiohms, Lightning Arresters, Lead-Ins and many other "Electrad" radio products are on sale at your dealer's. Send direct if he can't supply.

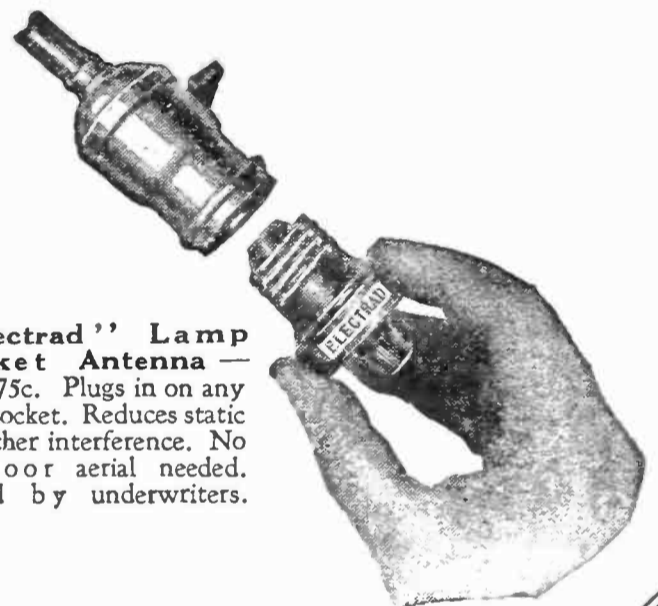
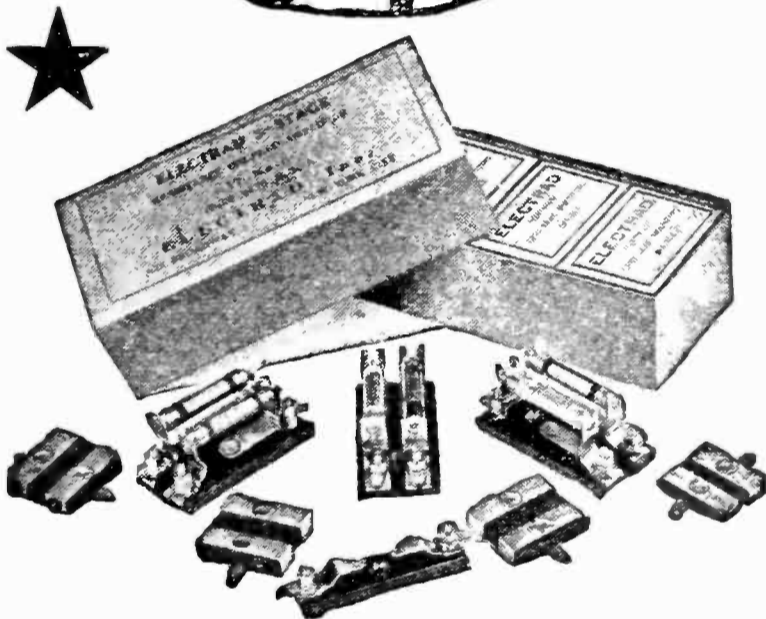

**"Electrad" Lamp Socket Antenna** — Price 75c. Plugs in on any light socket. Reduces static and other interference. No outdoor aerial needed. Passed by underwriters.

# ELECTRAD

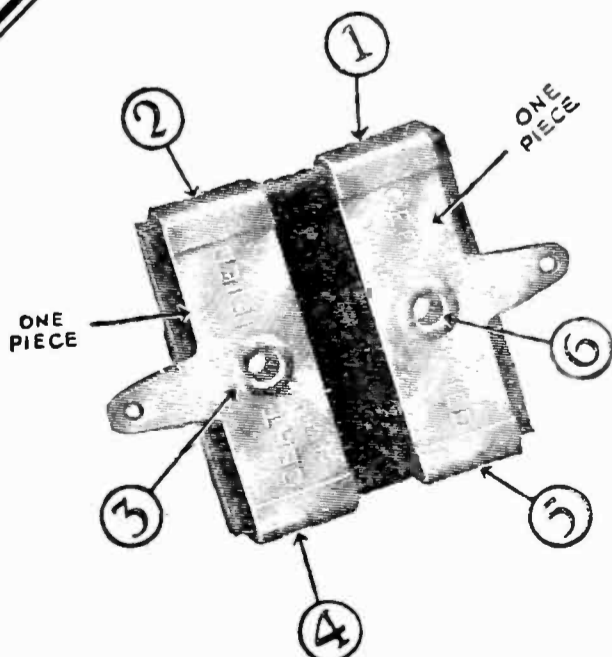

**The Six Point Pressure Condenser**

THE "Electrad" Certified Fixed Mica Condenser is a revelation in accuracy and design. Ingenious, rigid binding and firm riveting fastens parts securely at six different points insuring positive electrical contact. Impervious to temperature and climatic variations. Exerts even pressure upon the largest possible surface—can't work loose. Binding strap and soldering lug in one piece. Accuracy and quietness assured always. Value guaranteed to remain within 10% of calibration. Standard capacities, 3 types. Licensed under Pat. No. 1,181,623, May 2, 1916 and applications pending. Price 30c to 75c in sealed dust and moisture proof packages.

**ELECTRAD Inc.**  
428 Broadway,  
New York City

# HOYT METERS *Insure Reliable Radio Reception*

This HOYT  
2 INCH  
MILLIAMMETER  
TYPE 17

*with accurate moving-coil action attached to your radio set will save its cost in B batteries many times over because it checks continuously your B battery consumption; and possible short circuits.*

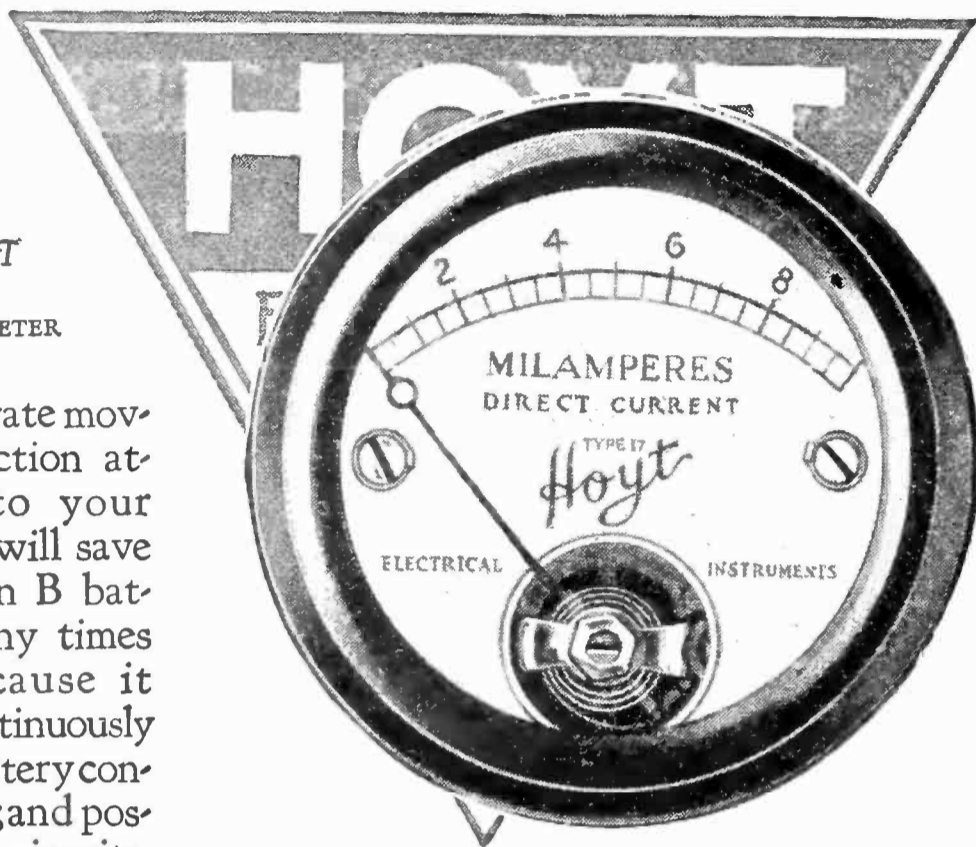

HOYT builds a full line of Radio Meters in all sizes and types. These are described in our book "Hoyt Meters for Radio." A request will bring it to you.

## BURTON-ROGERS • COMPANY

26 BRIGHTON AVE., BOSTON, MASS. . . . . National Distributors

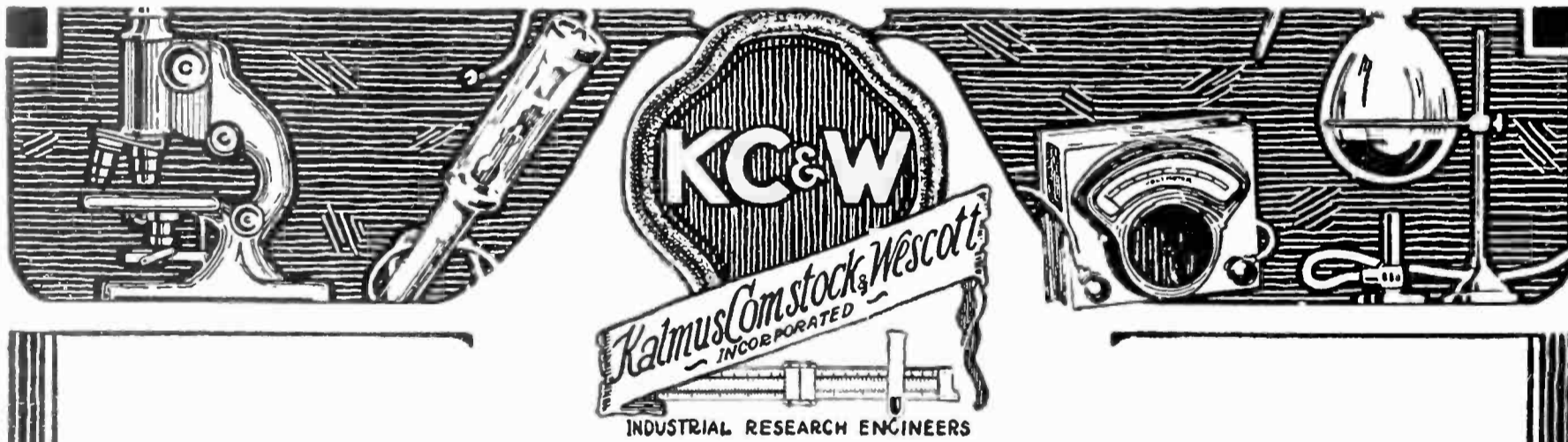

# Scientific Research for Radio Manufacturers

Radio Manufacturers are constantly faced with scientific problems due to the discovery of new principles and the necessity for keeping their product in the front rank in Radio's rapid advance. Kalmus, Comstock & Wescott, Inc. offers to the Radio industry resources, equipment, and trained scientific skill necessary to solve these problems.

We maintain a staff of highly trained scientists and engineers with years of practical experience in the various fields of industrial research.

Our Laboratories, personnel and experience are available to Radio Manufacturers for a reasonable compensation. It will pay you to write for complete information.

## KALMUS, COMSTOCK & WESCOTT Inc.

110-114 BROOKLINE AVE. *Industrial Research Engineers..* BOSTON, MASSACHUSETTS

★ Tested and approved by RADIO BROADCAST ★



1 — better color  
— lasting luster

2 — lower free sulphur  
— no discoloration

3 — higher softening point  
— no warping

# RUBBER is the best Material electrically for Radio Panels!

This is a known fact, but—

Due to discoloration in certain makes of hard rubber panels after a period of time, some people have the idea that age impairs their high electrical qualities.

An excess of the sulphur necessary in compounding hard rubber will cause discoloration and does ultimately lower electrical efficiency.

*Goodrich Silvertown Hard Rubber panels will not discolor or lose their electrical efficiency. They contain less than one per cent of free sulphur.*

Distinctly superior to other hard rubber panels. Specify them for maximum range and selectivity. Also the following for greatest all around satisfaction—

Goodrich V.T. Sockets—Goodrich Variometers unwound—Radiophone Ear Cushions—Spaghetti Tubing—Battery Mats.

THE B. F. GOODRICH RUBBER COMPANY  
ESTABLISHED 1870  
Akron, Ohio



# Goodrich

## Rubber Radio PRODUCTS

“Best in the Long Run”

★ Tested and approved by RADIO BROADCAST ★

[www.americanradiohistory.com](http://www.americanradiohistory.com)



**CABINET NO. 29**

Set Up Complete  
 Battery Compartment 10"x11"x29" open back with shelf compartment for "B" Battery. Panel front to conceal batteries, over all measurements 11 1/2"x32"x29". Set up complete in carton .....\$7.50



**RADIO TABLE NO. 31**

With Shelf for Battery. The Best Made, rigid substantial table 29" high, 15" wide by 31" long. Packed securely, one each in a carton.....\$3.50

# Get a Good Radio Cabinet

A large part of the pleasure in owning a radio set lies in an attractive cabinet to house it. Get an M B G Cabinet to-day.

All models are made from beautifully grained Douglas fir, thoroughly seasoned, ready for you to finish in any desired manner. Simple instructions for 24 standard wood finishes will be supplied you with the cabinet.

Radio has become decorative. Here is an opportunity to supply harmony or contrast to your present furnishings. Note the low prices, and send us your order at once.

## RADIO CABINET DEPARTMENT EXPRESS BODY CORPORATION

44 Lake St., Crystal Lake, Ill.

Made in all sizes from 7"x9" to 8"x40"  
 7"x18" ..... \$2.40  
 7"x21" ..... 2.50  
 7"x24" ..... 2.60  
 7"x26" ..... 2.70

All 7" deep.

Shipped, knocked down, one each in a carton. All holes bored; screws, hinges and lid support furnished. Easily set up by driving ten screws.



**NEAT-FIT CABINETS**

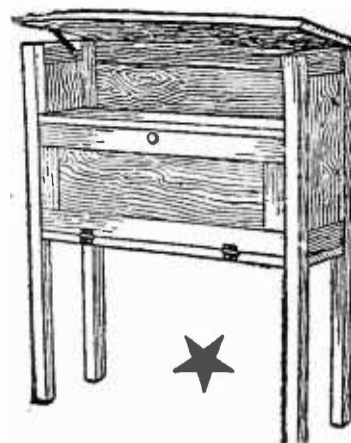

**CONSOLE CABINET NO. 37**

Set up complete packed 1 each in carton.

Panel Size	Dep.	Bat. Comp.
7"x18"	9"	10"x11"x18" \$10.50
7"x24"	9"	10"x11"x24" \$11.50
7"x26"	9"	10"x11"x26" \$11.50
7"x28"	9"	10"x11"x28" \$11.50

Additional door makes shelf in front of panel when open, extra .....\$3.00

### NO. 37 TWO-DOOR CONSOLE

Panel Size	Dep.	Bat. Comp.
8"x30"	10 1/2"	10"x11"x30" \$17.50
8"x36"	10 1/2"	10"x11"x36" \$20.50
8"x32"	12"	12"x11"x32" \$22.50

For Wet "B" Batteries

# NATIONAL Transmitting CONDENSER

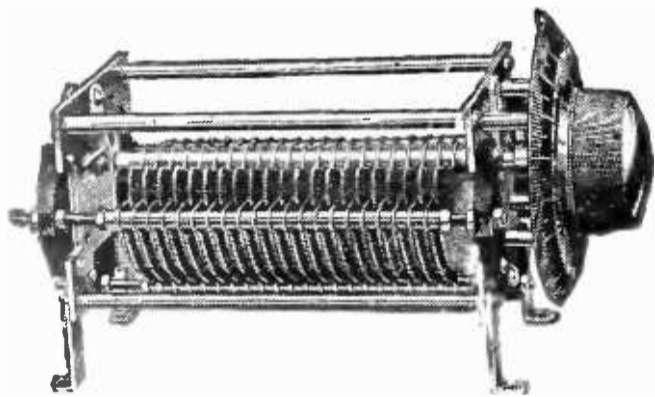

Built to amateur specifications for the amateur

Ideal for Short-Wave Experimentation Used by Lieut. Frederick H. Schnell, Traffic Manager, American Radio Relay League, for communication with amateurs during the Pacific Fleet cruise in Australian waters. Prices

Type 150—3000 150 MMFd. (.00015 MF). 3-16" spacing (ordinarily known as double spacing), 3000 volt flash-over. Fine for 5W and normal 50W sets. Proper size for Primary circuits. Price \$7.50  
 Type 450—3000 450 MMF (.00045 MF) 3-16" spacing, like those NATIONAL supplied to N. R. R. L. (Lieut. Schnell.) Price \$16.50  
 Type 100—6000 100 MMF (.0001MF) 3-8" spacing, 6000 volt flashover, for the overloaded "50" and the "250" W. Plenty big enough for the primary, too. All prices include 4" Velvet Vernier Dial. Price \$12.50  
 "NATIONAL" can furnish you with 5 or 3 plate Receiving Variables for that short wave receiver. Send for Bulletin 106 R. B.

**NATIONAL COMPANY, INC.** ★  
 ENGINEERS AND MANUFACTURERS  
 110 Brookline Street Cambridge, Mass.

OUR Midget By-Pass Condensers in Capacities of .005 to .1 will effect a saving of more than half of what you are now paying.

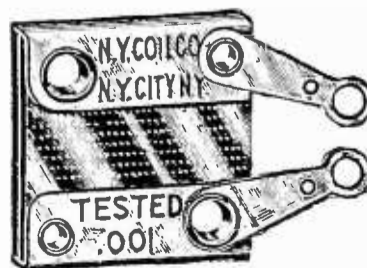

Of course our Precision Mica Fixed Condensers in capacities of .0001 to .006 are still the Standard of Comparison.

**NEW YORK COIL COMPANY**  
 338 Pearl Street NEW YORK CITY  
 Pacific Coast:  
 Marshank Sales Co., 926 Ins. Exch. Bldg., Los Angeles, Cal.

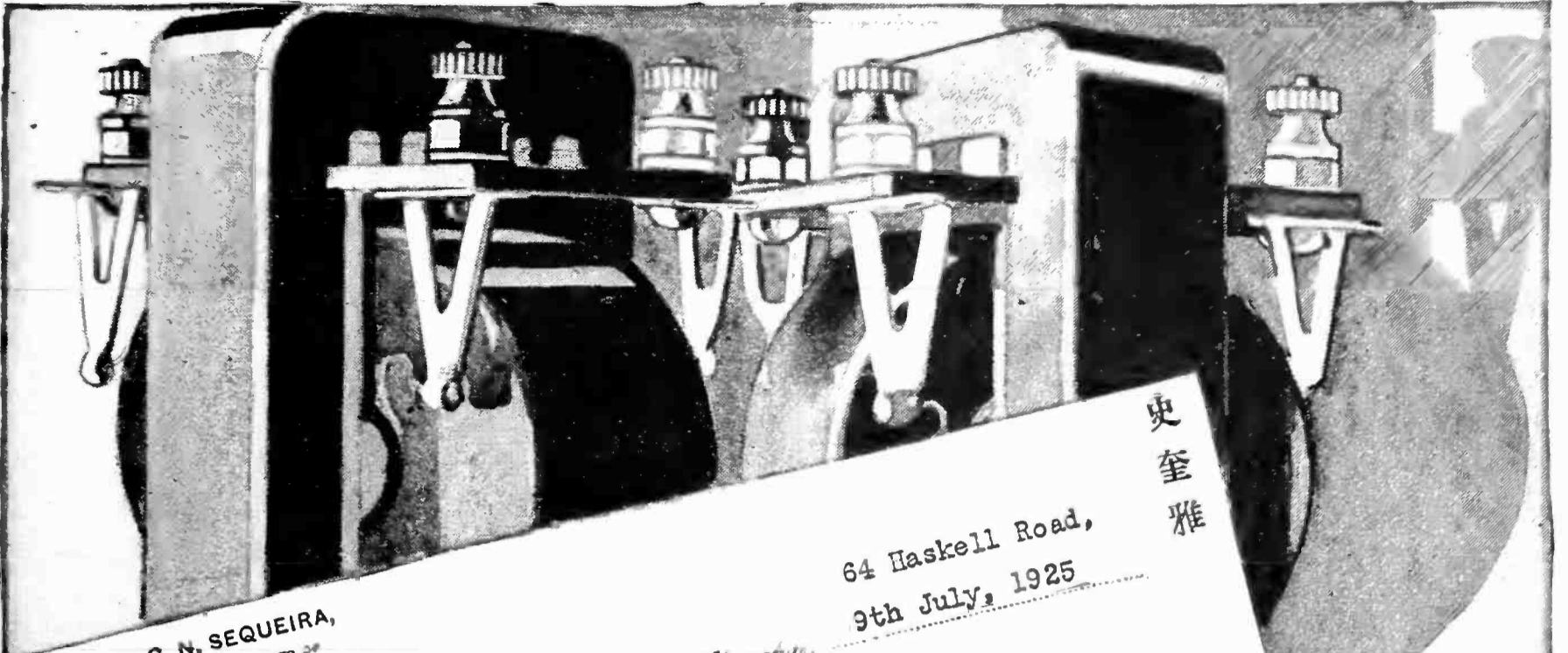

史奎雅

64 Haskell Road,  
9th July, 1925

Shanghai,  
(China)

F. X. C. N. SEQUEIRA,  
COMPILER & PUBLISHER OF  
THE FAR EASTERN EXCHANGE TABLES  
THE FAR EASTERN INTEREST TABLES  
THE FAR EASTERN DESK VADE MECUM  
THE FAR EASTERN FREIGHT CALCULATOR  
THE UNIVERSAL EXCHANGE TABLES ETC., ETC. ETC.  
TELEGRAPHIC ADDRESS FEETABLO  
TELEPHONE C. 2238

American Transformer Company,  
175 Emmet Street,  
Newark, N. J.

Dear Sirs:

I have the very great pleasure to inform you that on April 17 last I ordered some Radio goods from ----- Company of Chicago amongst which was a pair of

The Very Best Obtainable Audio Frequency Transformers  
irrespective of price

and they sent me a pair of AmerTrans.

Although I have tried and seen a lot of Audio Frequency Transformers, the pair of AmerTrans is certainly superior to them all. With these AmerTrans in my 3-tube Double Regenerative set, I can not only get Japan and the Philippine Islands, but the amplification is so very beautiful and clear that when I listen in to a Violin Solo it seems that the player was inside the room, every note clear and distinct.

This letter is written to show you my appreciation of your wonderful Audio Frequency Transformers and you are at liberty to use it or any part of it in any way you like.

With best wishes for your continued success and sincerest thanks to you for being the means of making me the proud possessor of such a pair of beauties,

Yours very truly,  
*F. X. C. N. Sequeira*

P.S. I need hardly tell you that all my Radio friends envy me the possession of my Transformers.



★ Tested and approved by RADIO BROADCAST ★



# ACME WIRE RADIO PRODUCTS

## Celatsite Battery Cable

For connecting A and B Batteries (or current supply) to radio set. Silk braid covering 5 flexible Celatsite wires—5 feet long—a different color for each terminal. Prevents messy wiring and "blown" tubes. Adds greatly to the appearance of your set.

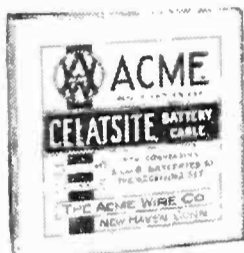

## Enamelled Antenna Stranded

The best outdoor antenna you can put up. 7 strands of enamelled copper wire; maximum surface for reception. Enameling prevents corrosion and consequent weak signals. 100, 150 or 200 foot coils, boxed.



## Loop Antenna Wire

You can make a good loop with Acme wire made of 65 strands fine copper wire, green silk covered. Flexible; non-stretching, neat.

## The New Celatsite Wire

Flexible stranded wire for "point to point" and sub-panel wiring—latest method of wiring sets. 5 colors, black, yellow, green, red and brown, one for each circuit.



## The Original Celatsite Wire

Celatsite is a tinned copper bus bar wire with a *non-inflammable* "spaghetti" insulation in five colors. Supplied in 30-inch lengths.

## Flexible Varnished "Spaghetti"

A perfect insulation tube for all danger points in set wiring. Costs little more and is worth a lot more than the cheaper substitutes offered. Black, yellow, red, green, brown; for wires No. 10 to No. 18. 30-inch lengths.



Send for folder

**THE ACME WIRE CO.** ★

Dept. B New Haven, Conn.

Also makers of fine enamelled magnet wire and coil windings for Audio Transformers, Battery Chargers, "B" Battery Eliminators

# DUPLEX



## CONDENSERS

Made according to Bureau of Standards specifications for lowest losses and best electrical characteristics.

Specially shaped-out stator plates space the stations over the dial, while keeping the condenser as small as a straight-line capacity model.

Aluminum stator plate, exactly the same as used in the new DUPLEX Straight Line Frequency condenser, sent on request. Write for one to-day. Learn the secret of DUPLEX superior construction.

**Duplex Condenser & Radio Corp.**  
46 Flatbush Avenue Extension  
Brooklyn, N. Y. ★

## Wonderful Results with HARPER METALOID

*"The Original Canned Coil"*

### A Shielded Radio-Frequency Transformer

Lowest resistance of any shielded radio frequency transformer, effective electromagnetic and electrostatic shielding, reduces interference from strong local signals, permits compact construction; eliminates inter stage coupling, which prevents stray feed-back and allows better control of regeneration. Space wound solenoid inductance. Mechanical precision in construction insures perfect matching. **No critical angle for mounting.** Primary tapped for all tubes. Easily substituted in your present set. Mounting base  $3\frac{1}{2} \times 4\frac{1}{2}$  inches.



From dealers or sent direct postpaid. **Free** technical circular especially prepared by W. W. Harper, designer of the Metaloid.

Price \$5.00

**CRIBBEN RADIO CORPORATION**  
967 Montana St. Chicago, Ill.

# What Is the Radio Dealer to Do?

**T**HAT is a question thousands of radio dealers, —real business men, all over the country are asking themselves to-day. They are wondering, and they have a right to wonder, if the radio business is a fair one—whether it is safe—whether it is honest.

The dealer works hard all Fall and Winter,—makes some money only to find, in the Spring, that the sets he recommended to his friends are now dumped on the market at prices much less than his cost. Not only does he lose on his inventory, but the sets sold on time come back, and, what hurts an honest dealer more, his friends lose confidence in him, because the sets he sold them only a few weeks before at a certain price may now be bought at half off or more.

What is the dealer to do? How can he guard against this?

Ludwig Hommel & Company has always felt the dealers' troubles very keenly, because our Company sells only to dealers, and radio is a main line with us,—not a side line.

We urge the dealers, for their own safety and profit, to watch the lines they carry. Be guided by the past performance of the manufacturers and jobbers. That is what we do and how we determine the lines we carry.

Ludwig Hommel & Company carries only lines that are quick moving, that have reputable factories behind them, and that will make most money for the dealer—with the firm promise to him that we will not knowingly carry a line or recommend any item on which he will lose money because of factory dumping, price drop or obsolescence.

It is to the advantage of every dealer to tie up with Hommel. Our illustrated catalogue 366B is free. Ask for it.

WHOLESALE

EXCLUSIVELY

# LUDWIG HOMMEL & CO

929 PENN AVENUE



PITTSBURGH, PA.

# A NEW HI-MU TUBE

## THE HI-CONSTRON TUBE



Model 101A

A Cleartron Product

For resistance coupled amplifiers, also intermediate steps super-heterodyne and in Radio Frequency receivers.

**GREATER VOLUME**

**BETTER QUALITY**

The Hi-Constron is a Hi-Mu tube with an amplification constant of 20 that has been especially designed for resistance coupled amplifiers. The Hi-Constron was the first Hi-Mu tube offered for sale to the general public and is the result of years of research work. Others may imitate the Hi-Constron in appearance, but none surpass its quality.

**CLEARTRON VACUUM TUBE CO.**

28 WEST FORTY-FORTH STREET, NEW YORK, N. Y.  
Factory: West New York, N. J.

*We also manufacture:*

C-T 201A

C-T 400 Rectron Tubes for B Battery Eliminators

C-T199 Standard Base

C-T199 Small Base

**Above Types \$2.50**

(Except the HI-CONSTRON, Which Sells for \$3.00)

# CLEARTRON

GUARANTEED RADIO TUBES



Building  
Better Service  
into RADIO PARTS



Aside from recognized radio uses in which no other metals can be substituted, COPPER and its alloys help you to make good radio sets *better* sets.

For instance, binding posts are superior posts, and battery nuts give best service and satisfaction when made of dependable free-cutting BRASS rod. And—

★ their speedier production makes labor costs lower.

**COPPER & BRASS**  
RESEARCH ASSOCIATION  
25 Broadway, New York

**SAVE A LIFE**  
OF A FAILING TUBE WITH THE  
**BURTON & ROGERS**  
TUBE  
**FLASHER**

**\$7.50**

ONE MODEL D.C. OR A.C. ANY CYCLE  
UTMOST SIMPLICITY OF OPERATION  
WILL BRING BACK TO FULL EFFICIENCY ANY TUBE  
OF TYPE 201A OR 199 NOT ACTUALLY RIPPED  
RESULTS WILL EXCEED YOUR EXPECTATIONS

**BURTON & ROGERS MFG CO**  
755 BOYLSTON ST BOSTON MASS

★ Tested and approved by RADIO BROADCAST ★

**Last Year—  
Bad Crowding of Shorter-  
Wave Stations**

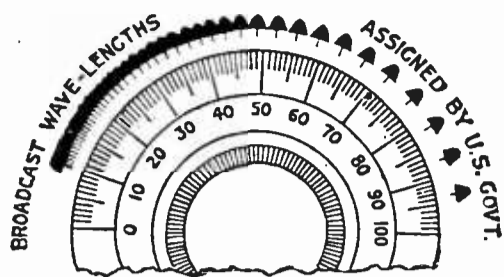

**This Year—  
Better, But Crowding Still Troublesome**

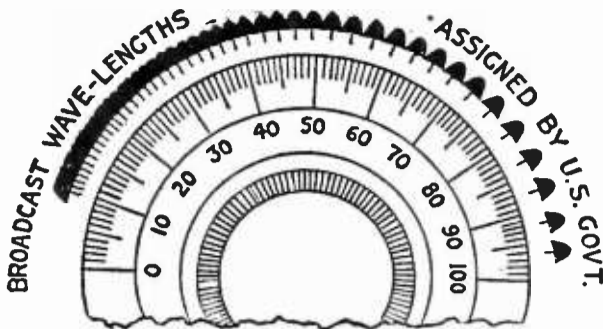

**Next Year—  
No Crowding!**

**Straight-Line Frequency Means—**

That the distance on your dials from one station to the next adjacent one is uniform—throughout the short-wave stations, as well as the longer waves.

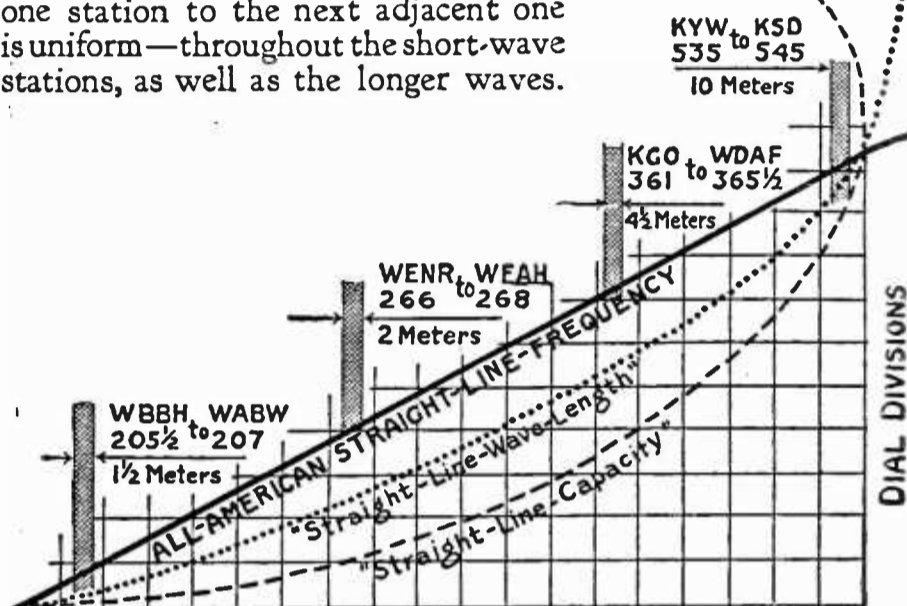

WAVE CHANNELS AS ASSIGNED U.S. STATIONS (BY FREQUENCY)

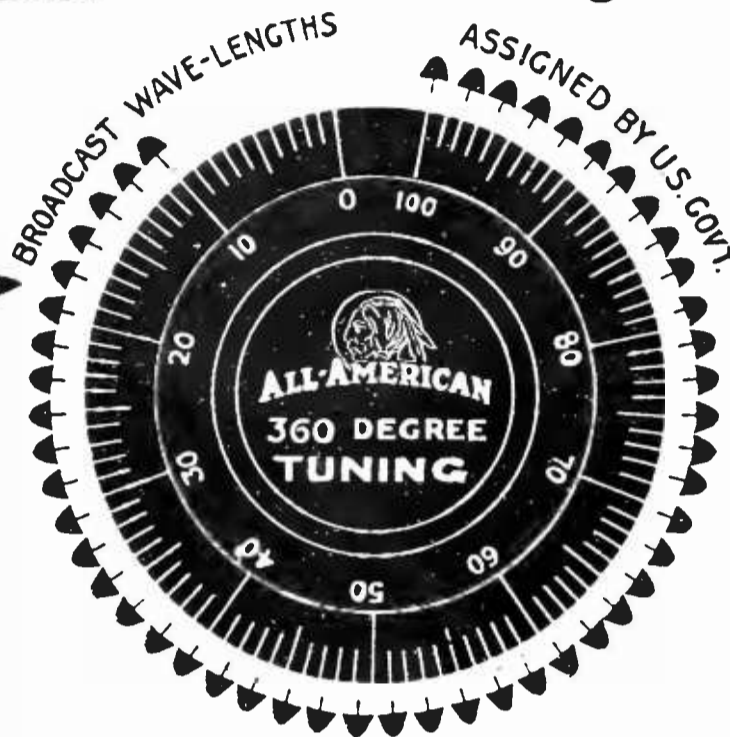

20-KILOCYCLE INTERVALS ARE SHOWN:  
ALTERNATE CHANNELS OMITTED  
FOR CLEARNESS

# ALL-AMERICAN STRAIGHT-LINE-FREQUENCY TUNING

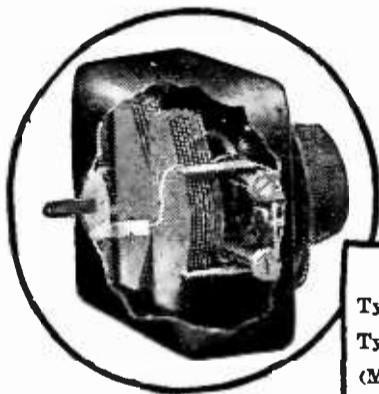

**ALL-AMERICAN Straight-Line-Frequency CONDENSERS**  
Type C-35 Max. 350 Micromicrofarads (Min. 10.5 mmf.) \$4.50  
Type C-50 Max. 500 Micromicrofarads (Min. 11.8 mmf.) \$5.00  
(Min. Capacity is measured at 400 meters)

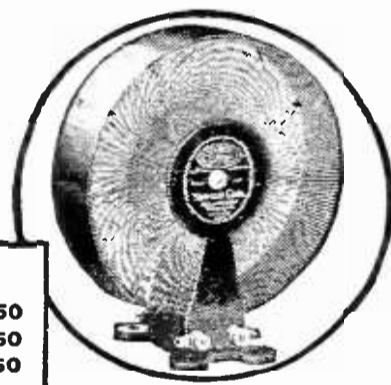

**ALL-AMERICAN Toroid Coils**  
Type T-1 Antenna Coupler . . . \$ 3.50  
Type T-2 R. F. Transformer . . . 3.50  
Set of 3 Coils Complete . . . 10.50

Ease and certainty in tuning—no more crowding of short-wave stations—no need to buy vernier dials—no gears or other back-lash makers—body capacity absolutely *not distinguishable*—electrical efficiency unsurpassed—on one-half the panel space: that is the ALL-AMERICAN Straight-Line-Frequency Condensers.

New power for distance reception through close coupling—tuning of arrow-like sharpness—elimination of all oscillation worries through the self-enclosed endless magnetic field—non-radiating reception: that is ALL-AMERICAN Toroid Coils—Antenna Coupler and Radio Frequency Transformers. See them at your dealer's.

A new edition of the famous RADIO KEY BOOK, together with complete information about the new ALL-AMERICAN Straight-Line-Frequency TUNING, is yours for 10 cents, coin or stamps. Send for it today sure!

ALL-AMERICAN RADIO CORPORATION, E. N. RAULAND, *President*, 4213 Belmont Ave., CHICAGO

**RMA** OWNING AND OPERATING STATION WENR—266 METERS

# ALL-AMERICAN

*Pioneers in the Radio Industry*

★ Tested and approved by RADIO BROADCAST ★

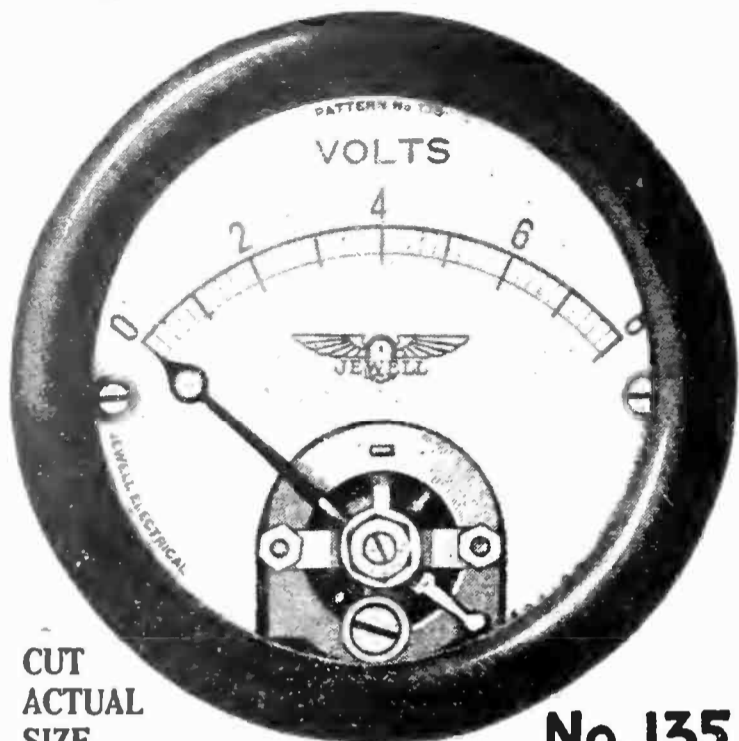

CUT  
ACTUAL  
SIZE

No. 135



★  
**NEW!**

Jewell continues to lead in the development of new radio instruments. Every set owner should send for circular No. 776 describing our new line of 2-inch instruments for radio sets.

Save your tubes:—  
Watch your batteries:—  
Use a Jewell High Resistance Voltmeter.

The leading radio engineers and amateurs prefer Jewell Radio Instruments. Broadcasting stations all over the world use them.

|| Ask your dealer for a Jewell ||  
|| 15-B Radio Catalogue . . . ||

**Jewell Electrical Instrument Co.**  
1650 Walnut St., Chicago, U. S. A.

26 Years Making Good Instruments



Red  
Stripe

## The Red Stripe A Radio Guide Line

For your protection, throughout the center of every Dilecto radio panel is a Red Stripe. You can see it along the edge of every panel.

If you buy or build a set look for the Red Stripe—and you'll be sure of the finest, strongest radio panel that can be made. Dilecto is a Phenolic condensation material.

**THE CONTINENTAL FIBRE COMPANY**

Factory: Newark, Delaware

Service on Dilecto, Conite, Contex and Vulcanized Fibre from:  
New York, 250 Park Ave. Chicago, Wrigley Bldg.  
San Francisco, 75 Fremont St. Los Angeles, 307 S. Hill St.

Seattle, 1041 Sixth Ave., South  
Pittsburgh, Farmers Bank Bldg.

★  
**Dilecto** ★



Five HILCO Condensers, installed in 18 minutes, will make a 3-tube circuit equal a 5-tube reflex—and then some!

But don't expect it from any other make. It takes the dynamo-tested, watch-built HILCO thus to clear frequency paths, stop battery clack and make low-loss a verity. You never knew a fixed condenser like it—yet HILCO Condensers cost no more than makeshifts.

★  
Reliable dealers and jobbers will get HILCO Condensers for you from

AE. HILL <sup>Mfg</sup> Co. ATLANTA

★ Tested and approved by RADIO BROADCAST ★



THE TUBE WITH A SENSIBLE GUARANTEE

REG. U.S. PAT. OFF. SUPERTRON A GOOD TUBE.

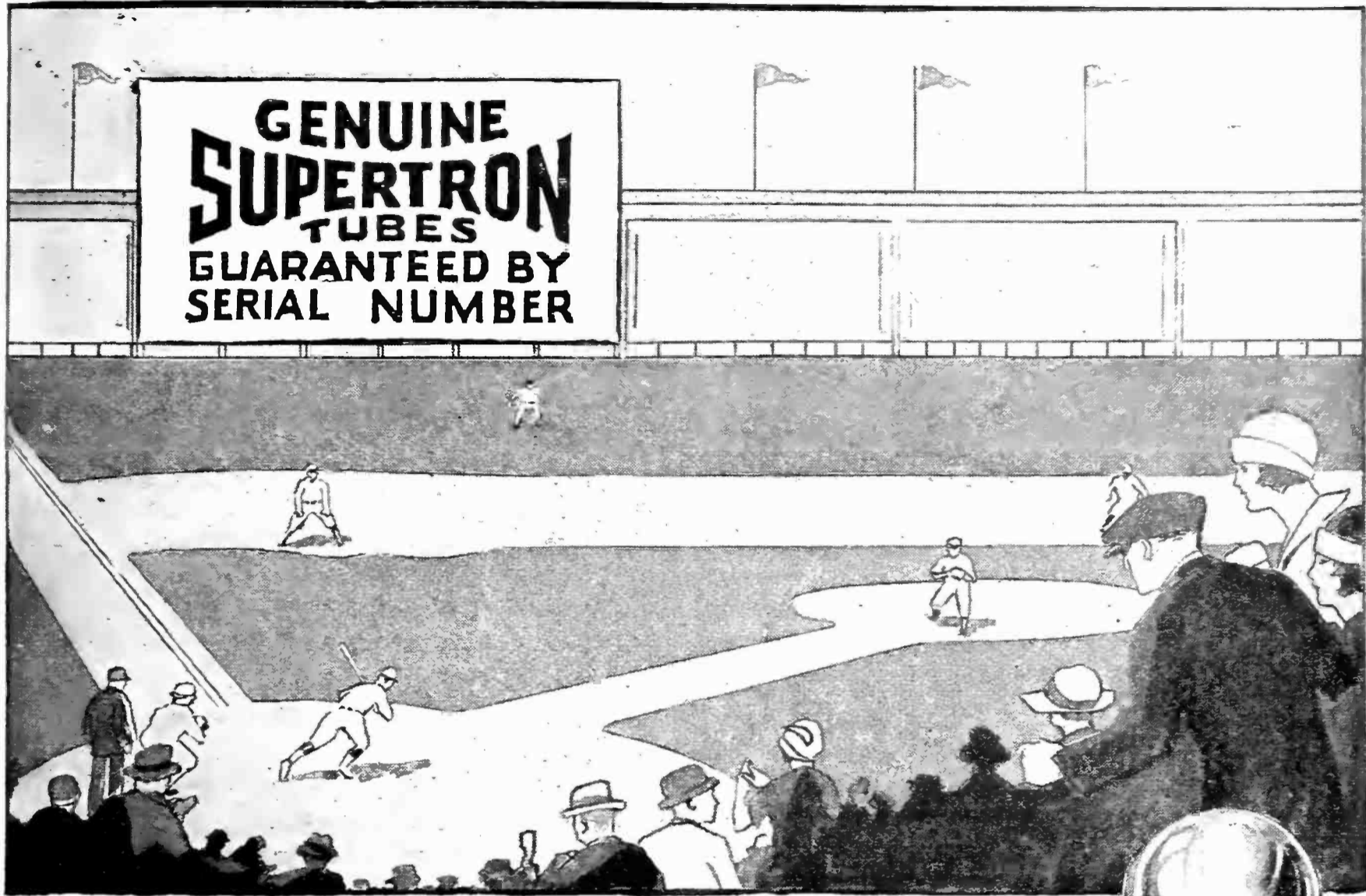

# That moment!



The last inning—tie score—and the bases are full you hear the crowd yelling !!!—then you hold your breath, for that moment—Alas! You are disappointed, reception has *ceased* due to faulty tubes.

ALL \$2.00  
TYPES 2—  
Canada \$2.75

### SUPERTRONS PLAY RIGHT THROUGH TO THE END OF THE GAME

Insist on Supertrons—at your dealer. Each Supertron tube is serial numbered for your protection.

#### Distributors

- |                             |               |                                 |                 |
|-----------------------------|---------------|---------------------------------|-----------------|
| FIRESIDE RADIO SET CO ..... | Chicago       | M. H. JOHNSON ELECTRIC CO.....  | Utica           |
| YAHR & LANGE DRUG CO.....   | Milwaukee     | HINSDILL ELECTRIC CO. ....      | Troy            |
| THE ROYCRAFT CO .....       | Minneapolis   | AMERICAN PHONOGRAPH CO. ....    | Albany          |
| SORENSEN LAMP CO. ....      | Des Moines    | ROSEN TALKING MACHINE CO.....   | Boston          |
| HIPPEE-STATES AUTO SUP. ..  | Des Moines    | BALT. HUB WHEEL & MFG. CO. .... | Baltimore       |
| ORR BROS .....              | Cedar Rapids  | CYCLE AUTO SUPPLY CO.....       | Buffalo         |
| RADIO DEALERS SUP. CO....   | San Francisco | H. D. TAYLOR CO. ....           | Buffalo         |
| WESTERN LIGHT & FIX. CO. .  | Los Angeles   | HAMBURG BROS. ....              | Pittsburg       |
| FRANKLIN ELEC. SUP CO. .    | Philadelphia  | REYNOLDS RADIO CO. ....         | Denver          |
| KEYSTONE RADIO DIST. CO.... | Philadelphia  | RADIO SERVICE, INC. ....        | Denver          |
| ALLENTOWN RADIO DIST. CO... | Allentown     | BURR-FOWLER .....               | Syracuse        |
| GOODLIN AUTO SUP. CO.....   | South Bend    | ED. J. GOETZ CO. ....           | Cincinnati      |
| FORT WAYNE IRON STORE....   | Ft. Wayne     | ELGIN RADIO CORP. ....          | Elgin           |
| SWANSON ELECTRIC CO. ....   | Evansville    | TURNER-LIPPE .....              | Newark          |
| M. A. BAKER & SON.....      | Elmira        | ALBERTA RADIO CO. ....          | Alberta, Canada |

SUPERTRON MFG. CO. Inc. Hoboken, New Jersey  
Export Dept. 220 Broadway, New York

#### Branch Offices:

- BUFFALO  
228 So Elmwood Ave.
- SAN FRANCISCO  
Rialto Bldg.
- DENVER  
1641 Stout Street
- KANSAS CITY  
410 East 14th Street
- MINNEAPOLIS  
229 So. 4th Street
- INDIANAPOLIS  
19 Arcade
- PHILADELPHIA . . . .  
353 No. 4th Street
- DALLAS  
2006 1/2 Commerce Street
- ATLANTA  
Georgia Savings Bank Bldg.
- CHICAGO  
21 East Van Buren St.



# SUPERTRON

A SERIAL NUMBER GUARANTEE

★ Tested and approved by RADIO BROADCAST ★

AT LAST YOU CAN TELL WHAT YOUR TUBES WILL DO

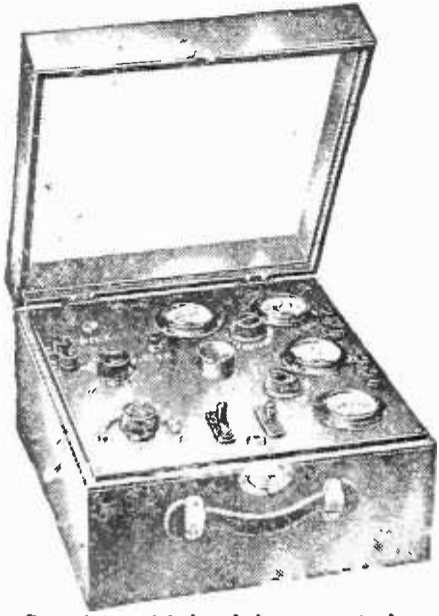

Complete with headphones and plug

# SUPERADIO VACUUM TUBE DYNAMOMETER

This revolutionary Meter measures easily, with positive accuracy, the power of any vacuum tube on the market. No more do you have to buy a "pig in the poke." Now, you can get that "best" audio or radio frequency amplifier or that "right" detector tube. And you can always duplicate your tubes when it comes to renewals. Insist on TESTED Tubes.

Every Set or Tube Manufacturer, every Jobber and Dealer will want this necessary Meter. Reliable Representatives wanted. Write for details.

## SUPERADIO KIT only \$17.50

Here is the ideal Kit to build, the new Super-heterodyne. Marvelous results. Contains 1 Antenna Coupler, 1 Oscillator Coupler, 1 Special Variable Condenser, 1 Tuned Filter Transformer, 3 Matched Intermediate Transformers and all necessary hardware with diagrams, layouts, and complete Super-heterodyne Treatise by Louis C. Billotte. Write to-day for information.

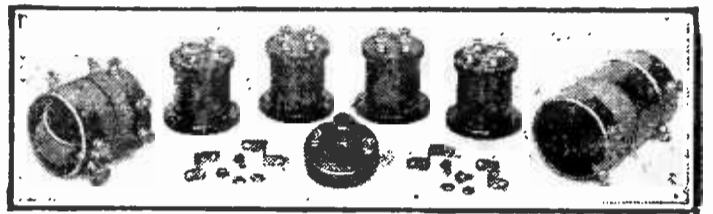

## DeWITT-LaFRANCE CO. INC.

54 Washburn Ave., Cambridge, Massachusetts

*Boston Representative:*

Martin, Hartley & Dewitt Sales Co., 99 Bedford St.

*Chicago Representative:*

William A. Welty & Co., 36 So. State St.



## Burns SPEAKER with CONCERT UNIT

### The Heart of the Speaker

Large size and scientific construction of the Concert Unit gives the remarkable tone values which combined with the special amplifying properties of the BURNS horn produce remarkable results.

Burns horn is of distinctive design with pyralin flare in several handsome finishes.

Manufacturers

*American Electric Company*

STATE AND 64TH STS.  
CHICAGO, U. S. A.

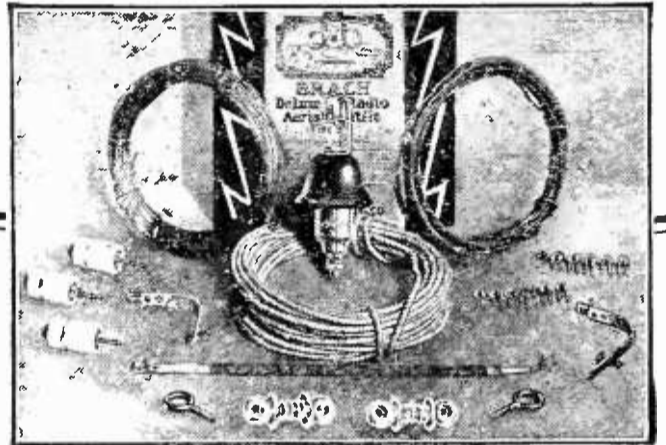

The Highest Form of Aerial Obtainable

## BRACH De Luxe Complete Aerial Outfits

Here you have every needed part to the last screw for an antenna—all in one package—in one purchase—everything of the highest class, including

*Brach Vacuum Lightning  
Arrester*

\$5.00 and \$5.50

L. S. BRACH MFG. CO.  
NEWARK, N. J.

★ Tested and approved by RADIO BROADCAST ★

# "Simplify Radio"

says

# Daven



## Daven Engineers Blaze Another Trail

THE biggest of all the little things in radio is the grid leak. The Daven Grid Leak is known the world over as the grid leak of permanent, constant value. It is standard.

Almost as important is the condenser. But grid condensers change with temperature and humidity. The mica in condensers lacks uniformity or is impure. The tin foil plates melt or change their capacity.

In their constant efforts always to simplify and to improve, Daven engineers have made a remarkably effective combination of grid leak and condenser.

### TWO-IN-ONE!

THE DAVEN LEAKANDENSER is so simple, so effective and so sturdy that you will wonder why it was not thought of before.

Similar in size to the Daven Grid Leak, it takes the place of the usual grid condenser which has shunted around it the usual grid leak. Made with five different values of grid leak resistance, 2, 3, 4, 5 and 7 megohms. The grid condenser capacity is fixed and correct for all makes of detector tubes.

With every Leakandenser a pair of new fastener clips that do not permit it to shake out. Precision-built. Price \$1.00 each.

*Manufacturers are invited to send for a sample.*

THE RESISTOR MANUAL is the handbook of Resistance Coupled Amplification. At your dealer's 25c. By mail postpaid 30c.

DAVEN PRODUCTS ARE SOLD ONLY BY GOOD DEALERS

*"The Sine of Merit"*

**DAVEN RADIO CORPORATION**  
*Resistor Specialists*

NEWARK Reg. U. S. Pat. Off. NEW JERSEY

### CLIP THIS COUPON

DAVEN RADIO CORPORATION E-10-25  
158-160 Summit Street, Newark, New Jersey

Please send me the following on Resistance Coupled Amplification: —

*Check one*

- Resistor Manual. 30c is enclosed.
- Complete catalogue (free)

Name .....

Address .....

*For dealers: Send your letterhead or card, or this coupon and we will have our nearest distributor communicate with you.*



## The New Daven Tube

Type MU-20 increases the amplification of the Daven Super-Amplifier to equal or exceed that obtainable with transformer coupling. A one-purpose, three-element tube, 6-volt, 1/4 ampere—\$4.00 each. Daven Power Tube Type MU-6 is recommended for last or output stage—\$5.00.

**THE BIG LITTLE THINGS OF RADIO**

★ Tested and approved by RADIO BROADCAST ★

*New!*

*The biggest little thing in Radio*

*this season*  
Bring control of high resistance to the panel

**DURHAM Variables**



Panel Mount \$1.00    Standard 75c

Both types in three sizes  
No. 100-1000 to 100,000 ohms  
No. 101-0.1 megs. to 5 megs.  
No. 201A-2 megs. to 10 megs.

Always a one-finger control and now at your finger-ends—that's the new DURHAM Variable. The familiar ease and accuracy of these standard high resistance units in their latest form may be placed anywhere on your panel, preferably near the tube they control. Only a 1/4" hole required.

For most hook-ups, you'll need two DURHAMS—detector and audio; with resistance coupled amplifiers, one for each tube.

Look for the plunger  
The Patented DURHAM combination of sliding plunger and non-wear compound is your protection and guarantee for accurate, noiseless high resistance control.

**DEALERS: Get this!**

Order from jobber now specifying type, panel mount and standard.



This style fits any clipped condenser 75c or DURHAM Bases, 30c-45c

**DURHAM & CO., Inc.**  
1936 Market St., Philadelphia

**"THE TUBE WITH A PEDIGREE"**



A RADIO tube is only as good as its characteristic curve reading. We furnish with each MUSSELMAN CERTIFIED TUBE a curve sheet showing the exact readings for that particular tube. Both tube and curve sheet are serially numbered, so that you, or any engineer, can check our figures. Remember this point: That a characteristic curve reading is the only way anyone can measure the value of a radio tube.

List: \$3.00. If your dealer cannot supply you, order direct from this advertisement.

Jobbers, manufacturers, and dealers are invited to write for details as to sales franchise.

Manufactured by  
**The Van Horne Co., Franklin, Ohio**  
SALES OFFICE  
**A. J. MUSSELMAN**  
602 Machinery Hall - Chicago

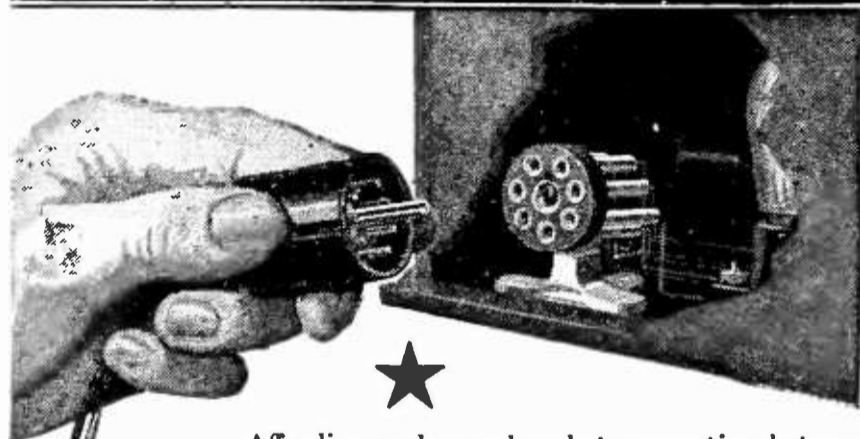

Affording a plug and socket connection between the radio set and all outside connections, Jones Multi-Plug is as essential to the radio as a cord and socket to the electric iron. For safety and convenience, leading set manufacturers have adopted this item as standard equipment. You, too, need a Multi-Plug for the set you are building or the set you now have. See your dealer or write direct for descriptive folder F.

TYPE BM — For set Building — \$4.50  
TYPE BP — Adaptable to any set — \$5.00

HOWARD B. JONES CHICAGO, ILL.



**Jones**  
**MULTI-PLUG**  
THE STANDARD SET CONNECTOR

★ Tested and approved by RADIO BROADCAST ★

AN ESSENTIAL ACCESSORY

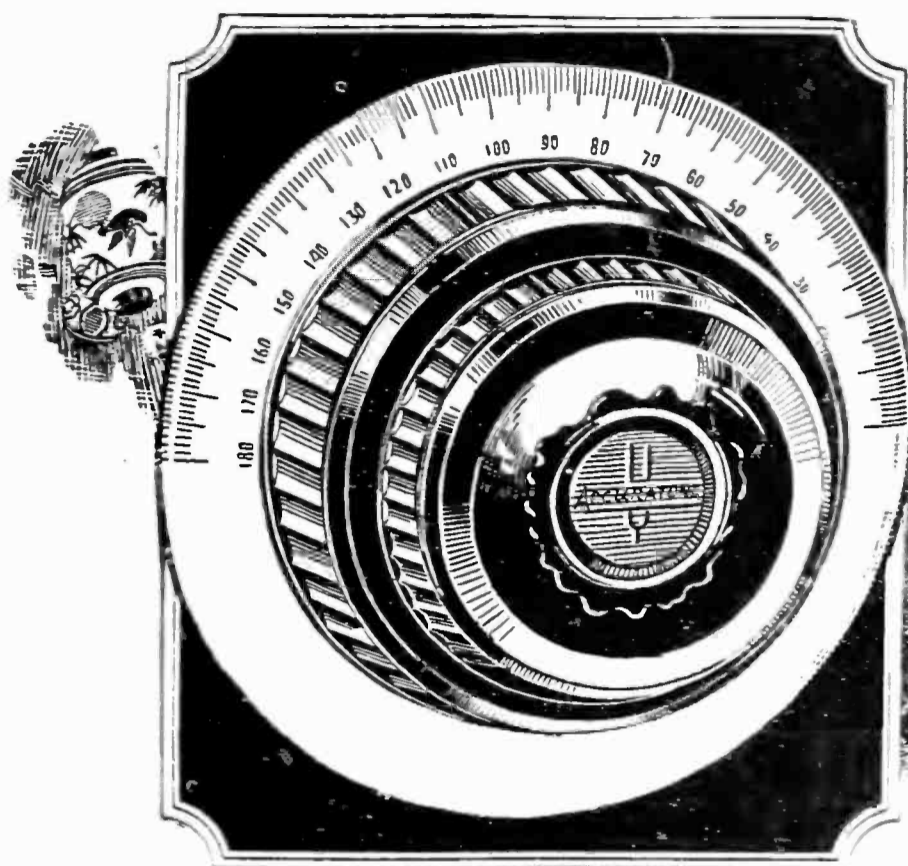

Pat. Apr. 21, '25  
Other U. S. & Fgn.  
Patents Pending

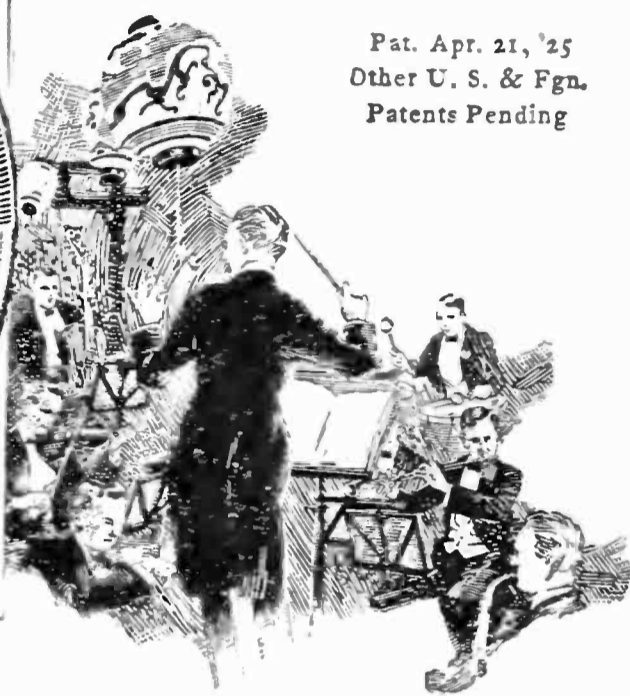

*When accuracy tuning counts—*

***ACCURATUNE***



WHEN there's a particularly fine program at one of the stations within the scope of your set, then if ever do you yearn for precision, and that's exactly what you can be assured of if your set is equipped with the Accuratune.

Geared on an 80-to-1 ratio for coarse or infinitely fine tuning, the Accuratune performs with uncanny precision at all times. Moreover, it's easily substituted for ordinary dials without altering your set.

MYDAR RADIO COMPANY  
3 CAMPBELL ST., NEWARK, N. J.

★ Tested and approved by RADIO BROADCAST ★

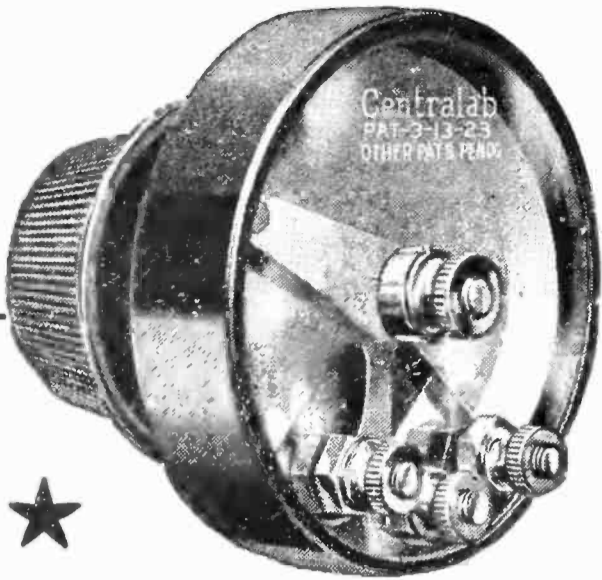

## Perfect Control— *from a Whisper to Maximum!*

THE CENTRALAB MODULATOR, used in audio circuits in connection with any ordinary transformer or with the new "Thordarson Autoformer," will give you perfect control of tone and volume, from a whisper to maximum volume! No need for interstage jacks, and eliminates the danger of transformer burn-outs. Has a total resistance of 500,000 ohms, smoothly variable from zero. Endorsed by Thordarson Electric Mfg, Co.

**\$2.00 at Your Dealer's  
or Mailed Direct**

*Write for literature and circuits describing this and other Centralab patented controls.*

**Central Radio Laboratories**  
16 Keefe Ave. Milwaukee, Wis.

# Centralab



# Pathé

REG. U.S. PAT. OFF.

## CONE LOUD SPEAKER



*Grecian  
Model*

**Exquisite in tone  
Exquisite in design  
Exquisite in work-  
manship**

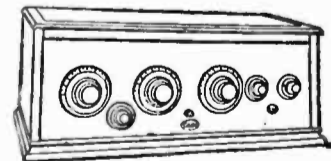

*Some territories for both jobbers and retailers  
still open. Write*

**PATHÉ PHONOGRAPH AND  
RADIO CORPORATION**

20 Grand Avenue, Dept. 18  
Brooklyn, N. Y.

★ Tested and approved by RADIO BROADCAST ★

# THORDARSON

UNCONDITIONALLY GUARANTEED

*Super*

AMPLIFYING TRANSFORMERS

*Standard on the majority of quality sets*

K E N N E D Y



## Says Thordarsons Are Best

"We are cranks on audio-frequency transformers and our engineers are constantly running comparative tests on them. The fact that we continue to use Thordarsons exclusively, in ever increasing numbers, simply means that we believe that they are the best available at this time."

*—From a letter signed by Colin B. Kennedy, President of Colin B. Kennedy Corporation, St. Louis.*

## Follow the Lead of the Leaders! Build or Replace with Thordarsons

Leading set builders have scientific laboratory apparatus to test, compare and prove the facts about transformers. They continue to use more Thordarsons than all competitive transformers combined. Doesn't this answer the amplification question?

Daily we hear from fans who paid high prices for musically named, fancy-looking trans-

formers only to discover that their old standbys—Thordarsons—were the real musical instruments." For the benefit of others we therefore repeat "when better transformers can be bought they will be Thordarsons." Few, if any, transformers actually cost as much to make as Thordarsons. Why, then, pay more? Any store can supply you. If dealer is sold out, order from us.

Write for latest Thordarson Bulletins on Amplification. Thordarson dealers everywhere

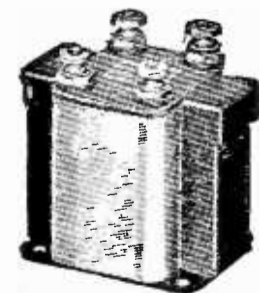

Thordarson Super Audio Frequency Transformers. Standard on majority of quality sets. Sub-panel or top mounting types: 2:1, \$5; 3½:1, \$4; 6:1, \$4.50

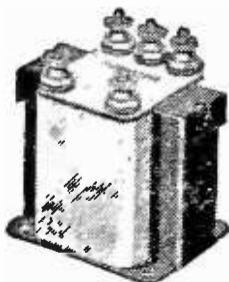

Thordarson power Amplifying Transformers give best results when preceded by two 3½:1 Thordarson A. F. Transformers. Pair \$13.



Thordarson INTER-STAGE Power Amplifying Transformer. Provides two stages of POWER amplification. Each \$8.

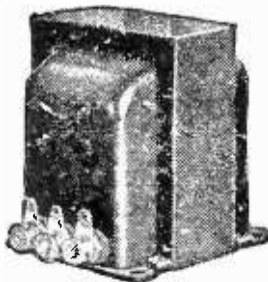

Thordarson -Autoformers amplify clearly the lowest notes as perfectly as the highest. \$5 each. Write for Autoformer Hookup Bulletin.

**THORDARSON ELECTRIC MANUFACTURING CO.**  
*Transformer specialists since 1895*  
**WORLD'S OLDEST AND LARGEST EXCLUSIVE TRANSFORMER MAKERS**  
**Chicago, U.S.A.**

ZENITH  
 KENNEDY  
 Radiodyne  
 Planstiehl  
 Howard  
 Thermodyne  
 GLOBE  
 Deresnadyne  
 ADLER-ROYAL  
 MURDOCK  
 MU-RAD  
 Valley  
 Silver-Marshall  
 OZARKA  
 ULTRADYNE  
 Newport  
 LEICH  
 NUNN-LANDON  
 KUSTOMBILT and  
 many others

Also the choice of the MacMillan Arctic Expedition

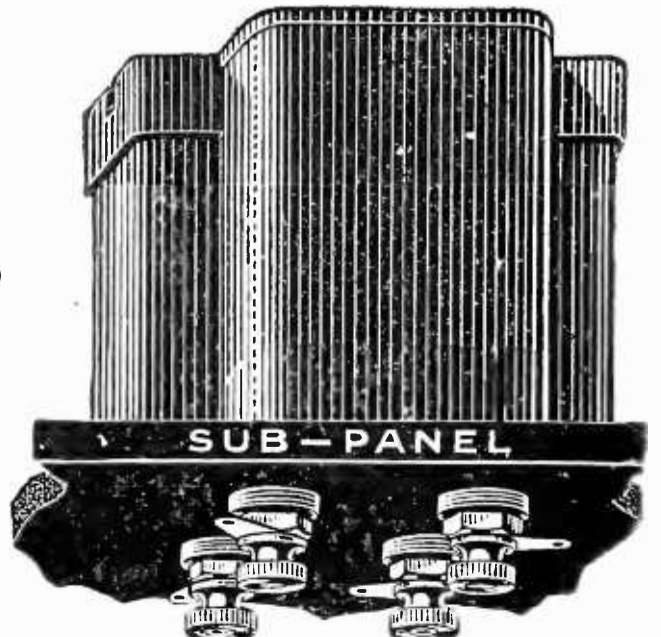

★ Tested and approved by RADIO BROADCAST ★

*The Loud Speaker Sensation!*

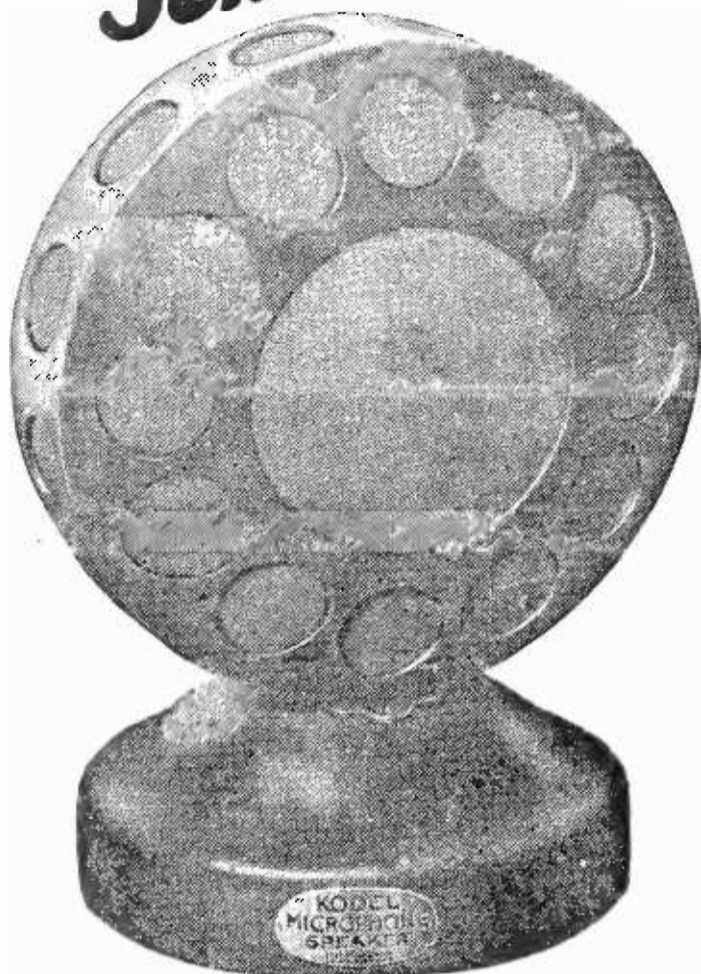

*The* KODEL  
**MICROPHONE  
LOUD SPEAKER**

You can't tell the KODEL MICROPHONE LOUD SPEAKER from the microphone the broadcasting stations use—they are exactly alike in size and appearance.

The efficient Kodel Sound Unit, with an ingenious new snail-shell horn, mounted inside the microphone case, produces a remarkably clear, full-toned volume. Non-vibrating tone chamber eliminates distortion.

\$15 model incorporates Kodel, Jr. unit; equipped with large Kodel unit \$20

**\$15<sup>00</sup>**

Radio dealers everywhere have them. ★

**THE KODEL RADIO CORP.**  
505 E. Pearl St., Cincinnati, O.

RECEIVERS :: SPEAKERS  
HOMCHARGERS

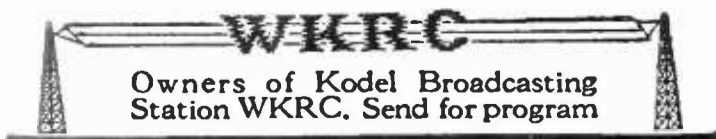

**Make your set  
a Super-Het**

The circuit described in Radio Broadcast for June and August will change any set into a super-heterodyne. It is particularly applicable to five tube neutrodyne and tuned RF sets. It changes these two circuits into super-heterodynes as good as most, and considerably better in some respects than any super-heterodyne circuit ever devised.

Stations come in at but one point on the oscillator dial. There is mathematically no possibility of harmonics. Full scale blue-prints with reprint of article \$1.00.

- Eastern Coil antenna coupler \$6.00
- O'Connor oscillator coupler . . . 6.00
- Special fixed condenser . . . .60
- Complete parts including panel drilled and engraved, special formica bushings, screws, and wire, blue prints and reprint 37.50



**A. O'CONNOR & COMPANY**  
SUPER-HETERODYNE HEADQUARTERS SINCE 1923  
9702 Euclid Avenue, Cleveland, Ohio

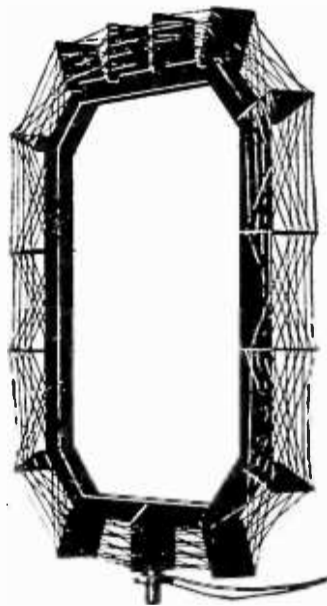

**A REMARKABLE  
LOOP**  
Exceptionally Directional  
Increases Volume

Users of the "ERIE" Loop say it is the most efficient Loop they have used.

If your Dealer cannot supply you, enclose Money Order for \$9.00 and we will make immediate shipment. Attractive proposition for Radio Dealers.

**ERIE RADIO COMPANY**  
Incorporated  
23 East 8th St. Erie, Pa.

**VICTOR COILS  
FOR  
Roberts circuit**

Endorsed by RADIO BROADCAST

Price **\$8<sup>00</sup>** per set ★

**VICTOR RADIO CO.**  
2915 Lehigh Ave., Philadelphia, Pa.

Distributed by

Franklin Electric Co., 50 N. 7th St., Philadelphia, Pa.  
Pacific Radio Specialty Co., 17 S. Orianna St., Philadelphia, Pa.

Correspondence invited from distributors

★ Tested and approved by RADIO BROADCAST ★



**RESULTS!**

**Laboratory Data**

THE following laboratory tests were made with the Penetrola on April 30, 1925. Measurements for volume and selectivity were taken with a General Radio Co. type 164 Audibility Meter, a precision instrument giving comparative values of signal intensity (the effect on the human ear is less than the actual differences recorded on the Audibility Meter). Standard regenerative, tuned R. F., neutrodyne, super-heterodyne, reflex, etc., sets were tested.

**SELECTIVITY TESTS**

Receiver	Desired Station	Interfering Station
Tuned R. F. Receiver 5 tube	WCAL Northfield, Minn.	WCBD Zion
Without Penetrola	35	29
With Penetrola	2,000 +	0
2 tube Regenerative set	WOC Davenport	WMAQ, WEBH, KYW, Chicago
Without Penetrola	0	2,000 +
With Penetrola	300	0
5 tube Tuned R. F. Receiver	CNRW Winnipeg	WGN Chicago
Without Penetrola	0	150
With Penetrola	1,300	0

Without the Penetrola Unit, CNRW, for example could not be heard, while WGN had a signal intensity of 150. With the Penetrola CNRW could be heard with a signal intensity of 1,300 while WGN was inaudible. Interference entirely eliminated.

**VOLUME TEST**

Receiver	Desired Station	Interfering Station
5 tube Tuned R. F. Receiver	WOAI San Antonio	None
Without Penetrola	11	—
With Penetrola	2,000 +	—

These figures show an actual increase of energy in the 'phone circuit of 188 times.

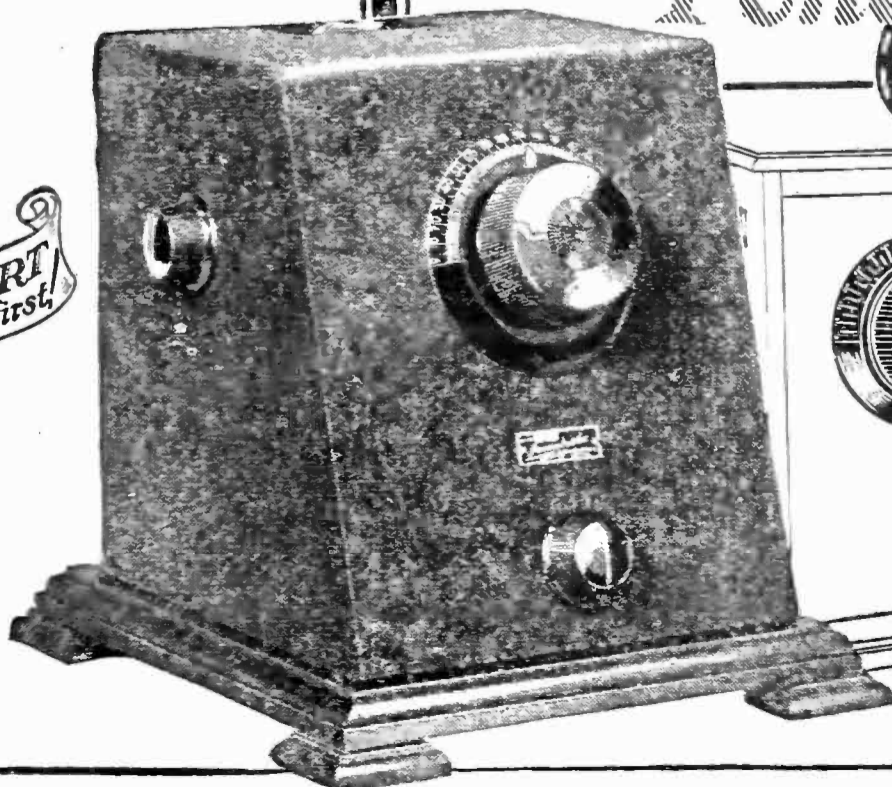

All Walbert Products protected by Pats. or Pats. Pend. U. S. and Foreign.

*Pep-up  
your present Receiver!*

**Its performance through the use of the Penetrola will astound you!**

The following results are guaranteed on even the best sets:

1. Increase selectivity. A powerful aid in penetrating interference from local stations. Will positively bring in stations you can't get without it.
2. Increase range and volume.
3. Reduce static by permitting use of short aerial while actually increasing signal intensity.
4. Improve quality by making it unnecessary for you to operate your set close to the oscillating (howling) point.
5. Positively stop your set from radiating to the annoyance of neighboring fans.

See laboratory tests in column to left

The Penetrola will add more in performance than many times its cost invested in a new set. In most cases your new combination will out-perform the best set on the market.

*Jobbers and Dealers: Write for discounts*

**WALBERT MANUFACTURING CO. ★**  
927 Wrightwood Ave., CHICAGO, U. S. A. ★

*The new*  
**WALBERT**  
*Penetrola*

Two types: (a) for antenna sets, (b) for loop sets, Easily installed—no alterations whatever. Equipped with standard Walbert parts: Univernier, Univernier-Condenser, Low-loss Socket, Low-loss Inductance, Isodon, Colored Connection Cords. Finished in black crystalline enamel blending with any cabinet. Price \$35.00.

**FREE** Write for laboratory bulletins describing any *Walbert* product in which you may be interested.

★ Tested and approved by RADIO BROADCAST ★

# ARE YOU HEARING EUROPE—

on the "All Wave Tuned Radio Frequency Receiver" as described by Zeh Bouck in the September Issue of this Magazine? Read what Mr. Bouck says about this Wonderful Receiver and order from us TO-DAY the parts that you require:

## ALL WAVE TUNED R. F. RECEIVER

Three Coil Branston Mounting .....	\$4.50
N-Ald Sockets .....	.75 ea.
Cotocoil Mounting Brackets .....	.60 ea.
General Instrument .0005 Mfd., Var. Con.....	5.50 ea.
General Instrument .001 Mfd., Var. Con.....	6.50 ea.
Marco Midget Ver. Condenser .....	1.25 ea.
Jones Series Parallel Anti-Cap. Switch .....	1.50 ea.
Cutler-Hammer Pull Switch .....	.60 ea.
General Radio 10 Ohm Rheostat .....	1.25 ea.
General Radio 400 Ohm Potentiometer .....	3.00 ea.
.00025Mfd. Dubilier Micadons with Grid Leak Mtg. ....	.45 ea.
.006Mfd. Dubilier Micadons .....	.75 ea.
.0025Mfd. Dubilier Micadons .....	.40 ea.
Daven Grid Leaks .....	.50 ea.
Daven 100,000 Ohm Resistors .....	.75 ea.
Daven Resistor Couplers .....	1.50 ea.
Daven High Mu 20 Tube .....	4.00 ea.
Daven High Mu 6 Power Output Tube .....	5.00 ea.
Yaxeley Pilot Light (with bulb) .....	1.10 ea.
Bakelite Panel 7 x 21 .....	2.95 ea.
Bakelite Panel 7 x 21 Drilled and Engraved ...	4.50 ea.
Eby Binding Posts .....	.12 ea.
Pacent Closed Circuit Jack .....	.55 ea.
Pacent Single Circuit Filament Control Jack....	.70 ea.
Honeycomb Coil 35 Turns .....	1.15 ea.
Honeycomb Coils 50 Turns .....	1.20 ea.
Honeycomb Coils 75 Turns .....	1.25 ea.
Honeycomb Coils 100 Turns .....	1.30 ea.
Honeycomb Coils 125 Turns .....	1.35 ea.
Honeycomb Coils 150 Turns .....	1.40 ea.
Honeycomb Coils 200 Turns .....	1.45 ea.
Honeycomb Coils 250 Turns .....	1.50 ea.

### SILVER-MARSHALL Super Autodyne Parts

2 S. M. 305A—S-L-W. Condensers .....	\$5.00 ea.
2 4in Bakelite Kurz Kasch Dials .....	.75 ea.
1 U. S. L. 6 ohm Rheostat.....	.80
1 U. S. L. 240 ohm Potentiometer .....	1.25
3 Insulated top binding Posts .....	.05 ea.
1 Carter 101 Jack .....	.70
1 Carter 102A Jack .....	.80
1 S. M. 211 Filter (with matched tuning cap.)	8.00
2 S. M. Charted intermediate Transformers ...	8.00 ea.
1 S. M. 101B Coupling Unit .....	2.50
1 S. M. 6 gang Socket Shelf (536-201A—537-U. V. 199) .....	10.80
2 Thordarson 3 1/2-1 Transformers .....	3.25 ea.
2 .002 Condensers .....	.40 ea.
1 .0075 Condenser .....	.75
2 .000025 Balancing Condensers .....	1.25 ea.
1 Daven S. M. 25 Meg. Leak .....	.50
1 Daven S. M. 2 Meg. Leak .....	.50
1 Carter No. 3 Jack Switch .....	1.15
1 Benjamin 8630 switch .....	.30
1 Belden color Cable .....	.85
1 Pair—Benjamin 8629 Shelf Brackets .....	.70
1 Bakelite Panel 7in. x 18in. x 3/16 in. drilled, grained and engraved .....	6.00
Spaghetti, bus wire, lugs, screws, etc.....	1.00

## TWO BIG SPECIALS

### ROBERTS RECEIVER

Complete parts for the knock-out 4 tube ROBERTS RECEIVER with the new type Sickles Coils exactly as specified **\$41.50**

### BROWNING-DRAKE

Complete parts for the Browning Drake 5-tube Receiver exactly as specified **\$44.50**

1926 CATALOG NOW READY—Write for our new 100-page catalog listing all the latest developments in Radio for 1926

HEINS & BOLET

46 Park Place, New York City

## The MOLLIFORMER "B" UNIT REPLACES "B" BATTERIES

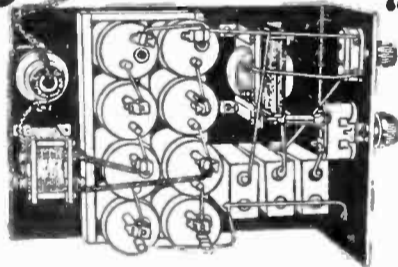

SEND FOR complete description of this powerful B Unit, that you can build in an hour, at most reasonable cost. Uses the current from the light socket. Excellent for Supers and all TRF sets. Assures greater clarity, DX and volume—noiseless, no tubes or acids—utilizes full wave rectification. **GUARANTEED TO GIVE COMPLETE SATISFACTION OR YOUR MONEY REFUNDED.**

### PRICE

COMPLETE KIT 60 Cycle Unit.....\$22.50  
COMPLETE KIT 25 Cycle Unit..... 24.50

Kits include Rectifiers  
Parts sold separately if desired  
DEALERS write for discounts

★ **C. E. JACOBS,** SOLE MNFR.  
2804 N. Kedzie Ave. Chicago



**\$3.25**  
30D

## RADIO Storage "B" Battery

32 Cells 24 Volts **Lasts Indefinitely—Pays for Itself**

Economy and performance unheard of before. Recharged at a negligible cost. Approved and listed as Standard by leading Radio Authorities, including Pop. Radio Laboratories, Pop. Sci. Inst. Standards, Radio News Lab., Lefax, Inc., and other important institutions. Equipped with **Solid Rubber Case**, an insurance against acid and leakage. Extra heavy glass jars. Heavy, rugged plates. Order yours today!

SEND NO MONEY Just state number of batteries wanted and we will ship day order is received. Extra Offer: 4 batteries in series (96 volts), \$12.75. Pay expressman after examining batteries. 5 per cent discount for cash with order. Mail your order now!

### WORLD BATTERY COMPANY

1219 So. Wabash Ave., Dept. 78 Chicago, Ill.  
Makers of the Famous World Radio "A" Storage Battery  
Prices: 6-volt, 100 Amp. \$11.25; 120 Amp. \$13.25; 140 Amp. \$14.00.  
All equipped with Solid Rubber Case.

**World**  
STORAGE BATTERIES

Set your Radio Dials at 210 meters for the new 1000 watt World Storage Battery Station, WSBC, Chicago. Watch for announcements.

KDIA—WEAF—WGN—WJS—KHJ—KGO—KFAF—WJY—KOP

## LEARN THE CODE AT HOME with the OMNIGRAPH

"Just Listen—The Omnigraph will do the teaching"

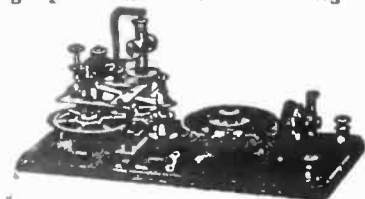

THE OMNIGRAPH Automatic Transmitter will teach you both the Wireless and Morse Codes—right in your own home—quickly, easily and inexpensively. Connected with Buzzer, Buzzer and Phone or to Sounder, it will send you unlimited messages, at any speed, from 5 to 50 words a minute.

THE OMNIGRAPH is not an experiment. For more than 15 years, it has been sold all over the world with a money back guarantee. The OMNIGRAPH is used by several Depts. of the U. S. Govt.—in fact, the Dept. of Commerce uses the OMNIGRAPH to test all applicants applying for a Radio license. The OMNIGRAPH has been successfully adopted by the leading Universities, Colleges and Radio Schools.

Send for FREE Catalogue describing three models. DO IT TO-DAY.

★ **THE OMNIGRAPH MFG. CO., 13K Hudson St., New York City**

If you own a Radio Phone set and don't know the code—you are missing most of the fun

★ Tested and approved by RADIO BROADCAST ★

# KODEL RADIO

The Emblem of  Worth in Radio

## Setting a New Radio Standard

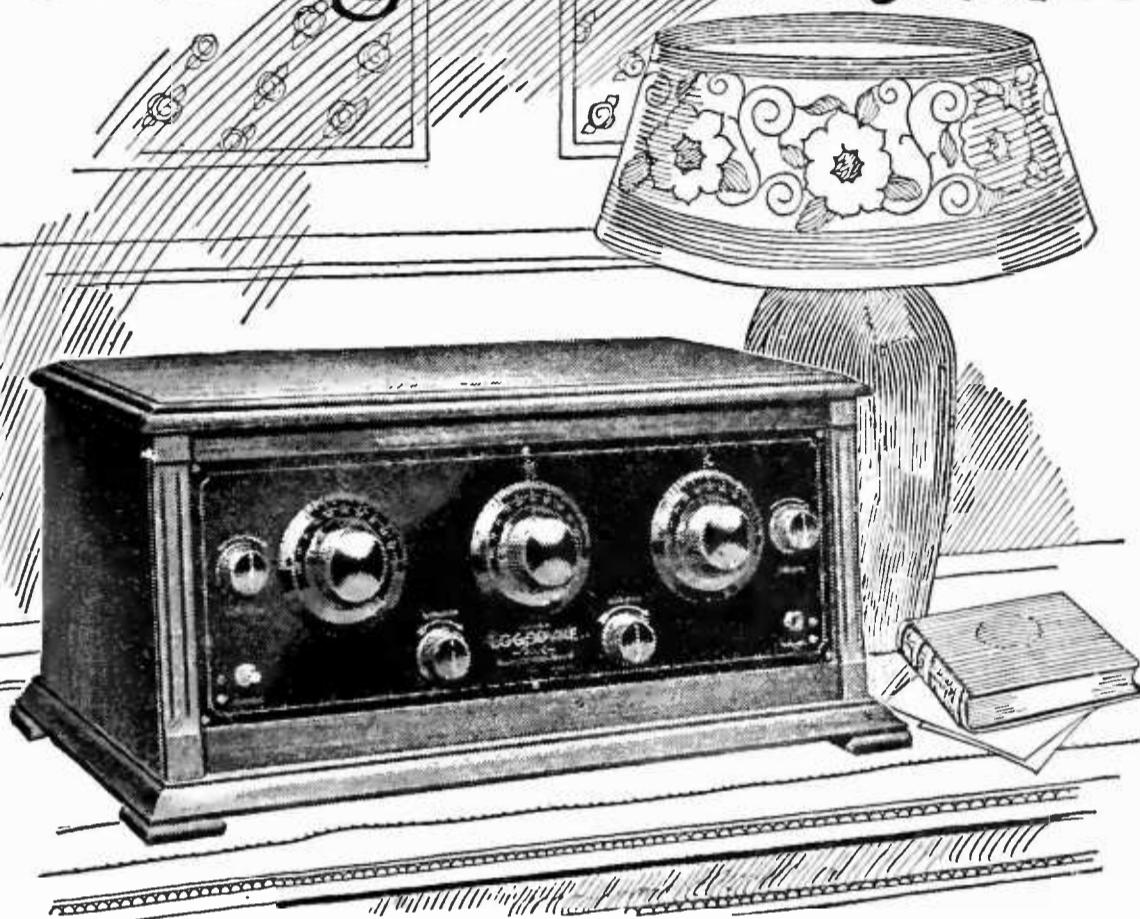

**LOG·O·DYNE** \$90<sup>00</sup>  
"BIG FIVE"



Five tubes, self-balanced tuned radio frequency; sloping panel gold engraved; beautiful, massive, Adam brown mahogany cabinet; compartment for batteries: stations already logged for easy tuning.

Radio for years to come will not offer a better receiver than the LOGODYNE Big Five. Combining the utmost in performance with striking beauty of cabinet design, the LOGODYNE Big Five represents a triumph in radio engineering and artistry of manufacture.

No receiver could better express or exemplify the high standard to which the entire KODEL RADIO line is built—for KODEL RADIO is, without a doubt, the best that radio offers.

**Free** Send for the new edition of our free booklet "The Secret of Distance and Volume in Radio". Gives helpful interesting information on radio operation.

**THE KODEL RADIO CORPORATION**  
505 East Pearl Street Cincinnati, Ohio

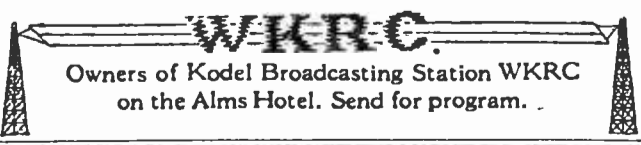

LOGODYNE "Big Five" Console Model—the Aristocrat of Radio; built-in loud speaker; compartment for batteries and charger a masterpiece in furniture design. \$275

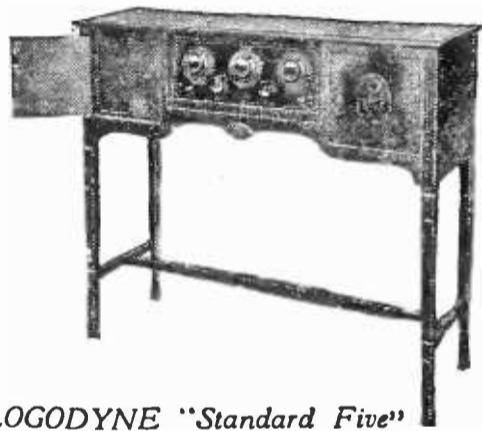

LOGODYNE "Standard Five" Console Model—beautiful brown mahogany; built-in loud speaker; compartment for A and B batteries and charger..... \$165

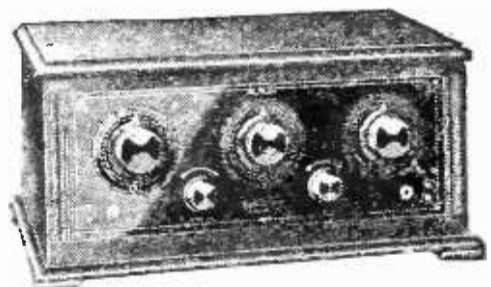

LOGODYNE "Standard Five"—five tubes self-balanced tuned radio frequency; gold engraved panel and sub-panel; battery compartment; handsome brown mahogany cabinet..... \$70

KODEL "Gold Star" Models—Radio's greatest set values; Three Tube "Gold Star" Model. \$30

Two Tube "Gold Star" Model.. \$20

One Tube "Gold Star" Model... \$12

"Gold Star" Crystal Set..... \$ 6

★ Tested and approved by RADIO BROADCAST ★

**5.00**

CAP.  
.0005  
mfd



**ULTRA-LOWLOSS  
CONDENSER**

*Positive  
as Big Ben*

SET Big Ben at seven and at seven o'clock you're bound to get the alarm.

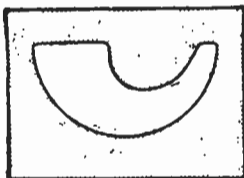

Cutlass Stator Plate exclusively an Ultra-Lowloss feature



A guarantee of satisfaction and Lacault design

Just so, the Ultra-Lowloss condenser can be set at any wavelength—the corresponding station will come in clear and sharp. You know instantly where to turn, once a station of known wavelength is located. Makes tuning easy—direct—positive. Special Cutlass Stator Plates spread wavelengths evenly over a 100 degree scale dial so that each degree represents approximately 3½ meters.

Ultra-Lowloss condensers are designed by R. E. Lacault, originator of the famous Ultradyne Receivers, and built upon scientific principles which overcome losses usually experienced in other condensers.

At your dealer's otherwise send purchase price and you will be supplied postpaid.

*Design of lowloss coils furnished free with each condenser for amateur and broadcast wavelengths showing which will function most efficiently with the condenser.*

**ULTRA-LOWLOSS  
CONDENSER**

**PHENIX RADIO CORPORATION**  
116-C East 25th Street - - - New York

*The Best Plug  
at a Better Price!*

**THE PACENT  
AUTOPLUG**  
*Now 60c*



THIS plug is entirely shock proof, for the entire length of the cord tips is encased by the plug shell and no metal parts are exposed. The shell is made of genuine Bakelite. No screws are used in its assembly, and there is nothing to work loose or cause trouble.

★ See your dealer, and write us for the Pacent Catalog of complete line of Pacent Essentials.

No. 60 Price 60c

**PACENT ELECTRIC COMPANY, INC.**  
91 Seventh Avenue New York City

Washington  
Minneapolis  
Boston  
San Francisco  
Chicago  
Birmingham

**Pacent  
RADIO ESSENTIALS**

Philadelphia  
St. Louis  
Buffalo  
Jackson  
Detroit  
Pittsburg

Canadian Licensees: White Radio Limited, Hamilton, Ont.

**DON'T IMPROVISE - PACENTIZE**

**Big Profits  
for  
DEALERS**

Make more money. Buy all your stocks from us. Prompt service. Complete line of newest merchandise.

**Get Big Free Catalog**  
of standard parts, sets, kits at big discounts. Write now!

**W.C. BRAUN CO.**  
32-52 S. Clinton St., Chicago

Dealers Catalog  
PARTS  
SETS  
KITS

**FAHNESTOCK CLIPS**

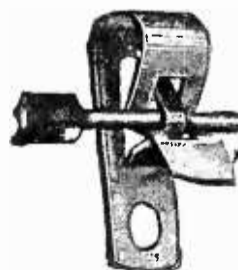

PRESS  
DOWN  
HERE

*"Popular Wherever Radio is Used"*

FAHNESTOCK Connectors are used by nearly every manufacturer of standard radio sets. All batteries made by the National Carbon Co. FAHNESTOCK makes connectors for every RADIO PURPOSE.

★ "THE IDEAL CONNECTOR"

**FAHNESTOCK ELECTRIC CO.**  
L. I. City New York

★ Tested and approved by RADIO BROADCAST ★

# NINETY CENTS

*May Solve the Problem of Your Set*

If you use leaky insulators on your antenna, most of the signal never reaches the set. Start without a handicap—a pair of genuine PYREX antenna insulators (45c each) will eliminate antenna losses.

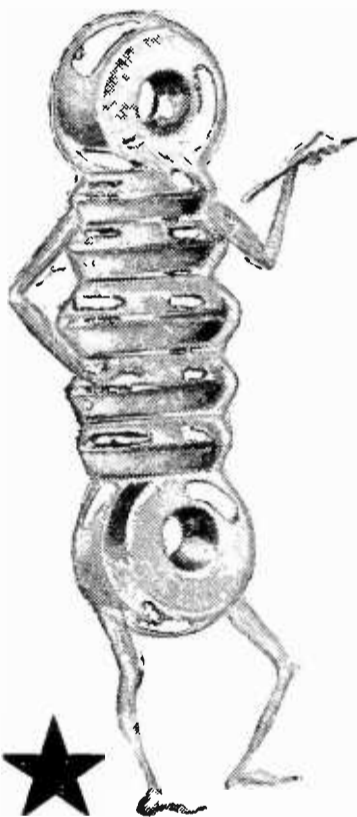

The sending and receiving antennas of the MacMillan Arctic Expedition are PYREX Insulated. 34 broadcasting stations have recently replaced other insulators with PYREX. The Navy, Coast Guard, Lighthouse and Air Mail Services specify and use genuine PYREX.

Be sure you get PYREX and not something "Just as Good."

Several makes of Variable Condensers can now be obtained insulated with PYREX.

*PYREX is Real Insulation*

## CORNING GLASS WORKS

*Industrial Division*

Corning

New York

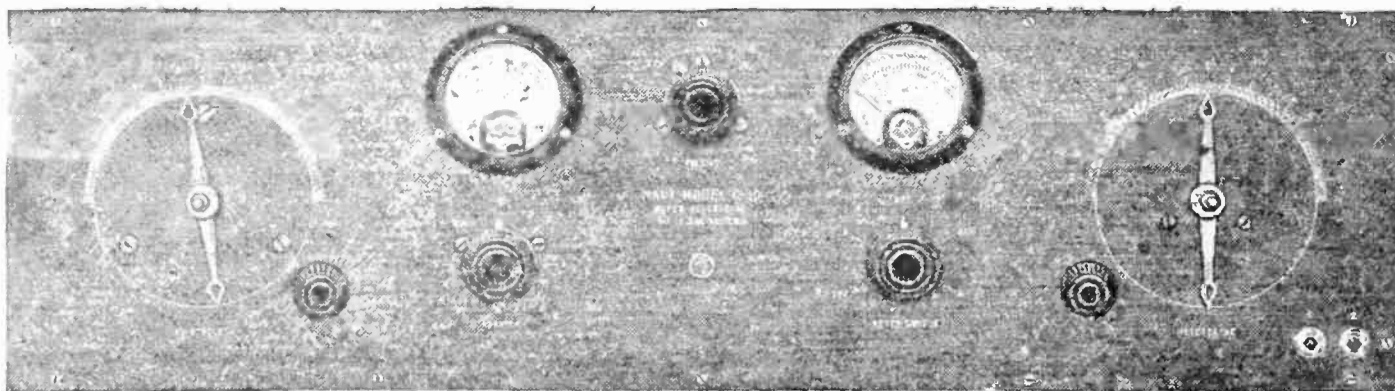

# NAVY MODEL C-10 Super-Heterodyne

*The Highest Class Receiver in the World*

## For any Circuit

Prompt shipment can be made on tested, standard apparatus of the following manufacture :

- E. I. S., Inc.
- General Radio
- Willard
- Benjamin Electric
- Allen Cardwell
- Dubilier
- Western
- Jewell
- Western Electric
- Radio Corporation
- Music Master
- Cutler Hammer
- Federal
- Formica
- Magnavox
- Amer Tran
- Acme
- Frost
- Kellogg

Wave length range 50-600 meters with removable Coils.  
 Panel Dimensions 28 3/16 in. x 8 in. x 1/4 in.  
 Only two major tuning adjustments.  
 Total amplification almost 2,000,000 times.

A high powered 10-tube Broadcast Receiver capable of receiving over 3,000 miles under favorable conditions, and having a degree of selectivity far in advance of others.

We believe the Navy Model C-10 represents final superiority over any receiver now being manufactured or even contemplated for broadcast reception.

Attractive illustrated literature gladly mailed upon request. Write direct to

**NORDEN-HAUCK, INC.**

*Engineers*

1617 Chestnut Street, Philadelphia, Penna.

# More Pep for Old Tubes!

WHY throw away your old tubes—The Rhamstine\* Tube Booster will renew life. It makes no difference whether you use 201-A or 199 type tubes, the Rhamstine\* Tube Booster will renew life and will give them new snap and pep.

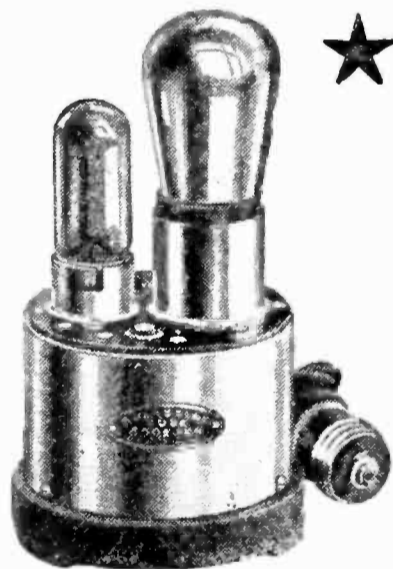

**Rhamstine★  
 Tube BOOSTER  
 Only \$6**

*Mail this Coupon  
 To-Day*

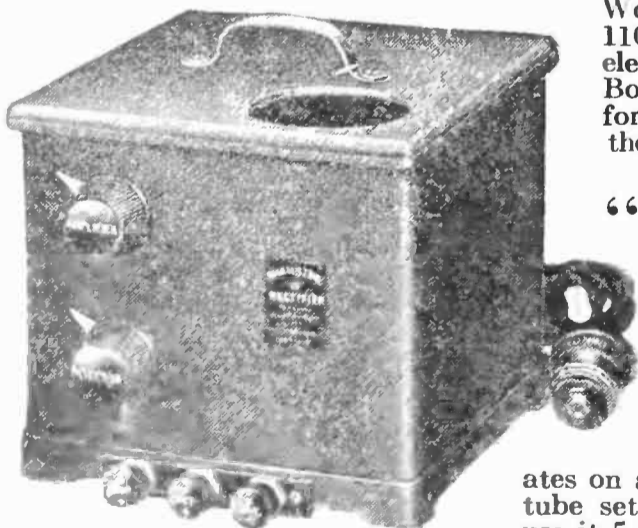

**Rhamstine★  
 "B" RECTIFIER  
 Only \$25**

**J. THOS. RHAMSTINE★**  
*Radio and Electrical Products*  
 506 E. Woodbridge St. Detroit, Mich.

Works equally well on alternating current 110-120 volts, 50 to 133 cycles—the ordinary electric light circuit. You can pay for this Booster in a short time by boosting old tubes for your friends. Send no money, just sign the coupon and mail it.

## "B" Rectifier for your "B" Power Service

gives you the finest, sweetest, most natural reproduction of any tone, always. Low in cost of operation, wonderful in results, attractive in appearance, a money saver and happy home producer. It's better than a "B" Battery. Operates on any 110 volt A C circuit. For use on any tube set. Send no money, pay when you get it, use it 5 days. If you're not entirely satisfied, purchase price will be refunded.

*Dealers Write for Our  
 Dealer Proposition*

J. Thos. Rhamstine\* (10)  
 506 E. Woodbridge St., Detroit, Mich.

Please send me your ( ) Tube BOOSTER at \$6; ( ) "B" RECTIFIER at \$25, by express C. O. D. subject to inspection. If I am not entirely satisfied with the "B" RECTIFIER, I will return it to you in five days and receive a refund of the full purchase price.

Name.....  
 Address.....

★ Tested and approved by RADIO BROADCAST ★

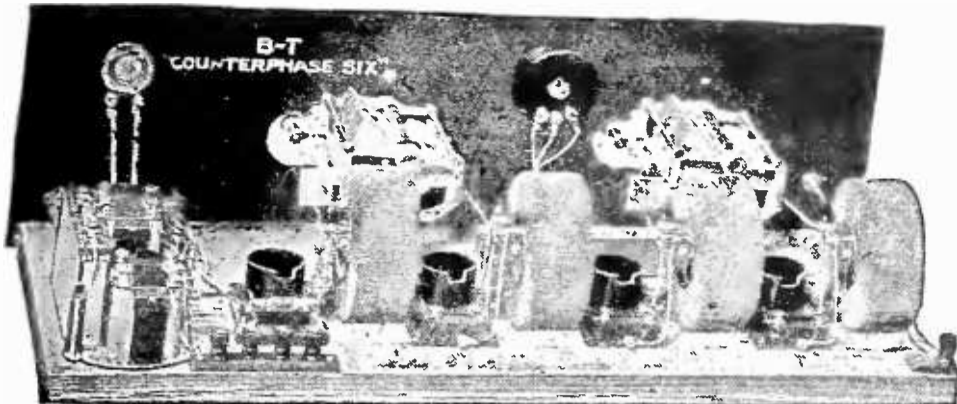

# The B-T "Counterphase-Six"

Since broadcasting began B-T have designed circuits and apparatus that have been continued successes.

To a long record of achievements is now added the B-T "COUNTERPHASE." The realization of a long cherished ambition,—the sixth tube where it belongs as a third stage of radio frequency. Sensitivity that gives distant reception on only a short indoor antenna. Selectivity to the point where added sharpness would cause distortion by cutting of the side bands. *And only two tuning controls.*

Nothing short of these improvements would satisfy B-T standards.

Kits containing essential parts for building the "COUNTERPHASE-Six" may be had at all reliable dealers. For those who desire only two stages of "radio frequency" kits may be had for building the "COUNTERPHASE-Five."

*Send for Literature.*

**B-T Variable High Resistances**  
Non-Inductive, variable high resistance, smooth, stepless and not impaired or changed in value through continuous service. High Resistances, Potentiometers, Modulators.

*Write for Descriptive Literature.*



**Keep in Touch with Radio**

A sane analysis of new ideas of the season, Straight-Line Frequency, "Toroids," AC-Tubes. Eliminators, etc, will be found in Better Tuning, 8th Ed. Out in Sept. Issued by-monthly. 10c per copy, 50c per year.

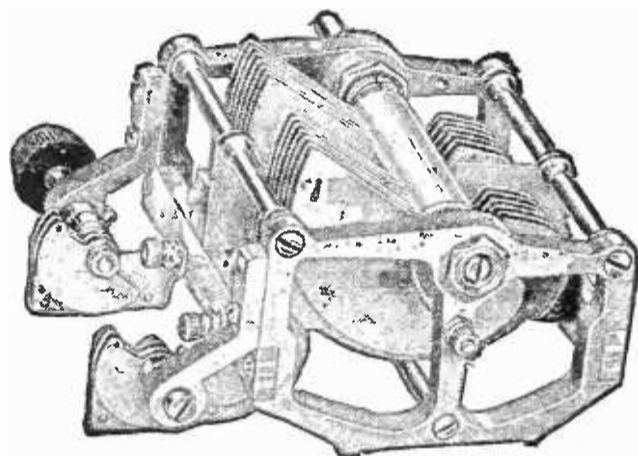

## B-T Tandem Condenser

Condenser experience that began when broadcasting was only a distant dream is behind the B-T Tandem Condenser. All the efficiency and sturdy construction of the famous B-T "Lifetime" Condenser with the added advantage of simultaneous control of two condensers.

The typical B-T touch is likewise evident in the B-T Straight Line Frequency Type. .00035-\$5.75; 00025 \$5.50.

*Write for Literature.*



# BREMER-TULLY MFG. CO.

532 S. Canal Street

Chicago, Ill.

★ Tested and approved by RADIO BROADCAST ★

# Biggest dollar's worth in RADIO

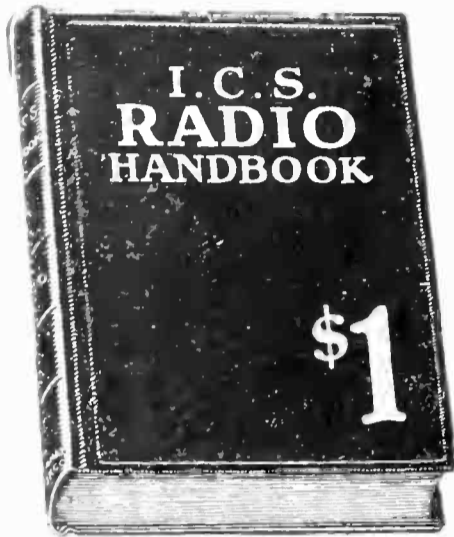

Compiled by HARRY F. DART, E.E.

Formerly with the Western Electric Co., and U. S. Army Instructor of Radio.

Technically edited by F. H. DOANE

514 PAGES—ONLY \$1

ONE of the most complete books of its kind ever published. Written, compiled and edited by practical radio experts of national reputation. Packed with concise, sound information useful to every radio fan—from beginner to veteran hard-boiled owl. Contents—

Electrical terms and circuits, antennas, batteries, generators and motors, electron (vacuum) tubes, most receiving hook-ups, radio and audio frequency amplification, broadcast and commercial transmitters and receivers, wave meters, super-regeneration, codes, license rules. Many other features.

Just mail the coupon with a dollar bill and your name and address, and this 514-page I. C. S. Radio Handbook will be sent to you by return mail. Note the other good books listed below at low prices.

**INTERNATIONAL CORRESPONDENCE SCHOOLS**  
Box 8300-D, Scranton, Penna.

I enclose \$....., for which send me, post-paid, the Handbooks marked X, at \$1 each. It is understood that if I am not entirely satisfied I may return them within five days and you will refund my money.

- RADIO HANDBOOK, 514 PAGES, - - \$1
- Automobile Handbook, 354 pages - - - - - \$1
- Electrical Handbook, 414 pages - - - - - \$1
- Chemistry Handbook, 348 pages - - - - - \$1
- Pharmacy Handbook, 324 pages - - - - - \$1
- Traffic Handbook, 386 pages - - - - - \$1
- Building Trades Handbook, 409 pages - - - - \$1
- Machine Shop Handbook, 335 pages - - - - \$1
- Salesman's Handbook, 352 pages - - - - - \$1
- Advertising Handbook, 445 pages - - - - - \$1
- Bookkeeper's Handbook, 302 pages - - - - \$1
- Civil Engineer's Handbook, 411 pages - - - \$1
- Steam Engineer's Handbook, 298 pages - - - \$1

Name.....

Address.....

Enclose \$1.50, instead of \$1.00, for each book if you want the Leatheroid binding. All of the above books can be had in this binding except the Traffic Handbook and the Building Trades Handbook.

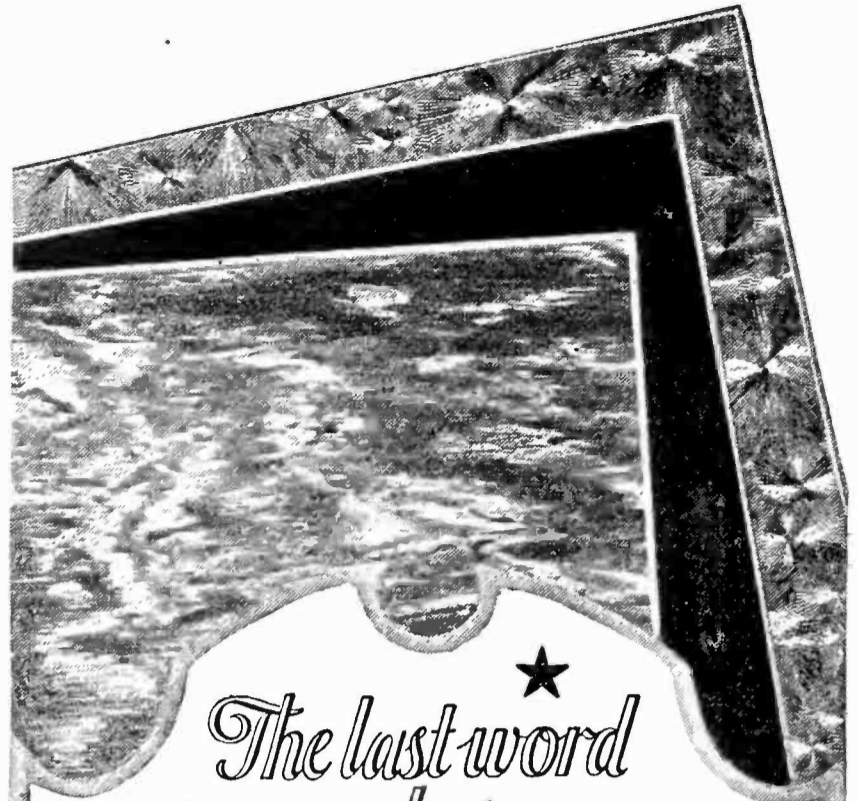

The last word  
in panel Beauty

## INSULINE

For sheer beauty, Insuline is in a class by itself. It imparts to your set a subtle touch of distinction that no ordinary panel material can give.

Insuline comes in three finishes, as shown: upper, "Frieze" art finish; center, Black; lower, Mahogany. The Mahogany outrivals the wood itself in richness of grain and color. Both Black and Mahogany are finished with a mirror-like surface which retains its lustre.

This standard insulating material does not discolor, warp, split or get soft. And—of vital importance—its high dielectric qualities and resistance to moisture are a barrier against leakage losses.

### Builders of "Home Sets"

can secure Insuline blanks in all standard sizes. You'll be surprised to find how easily it can be worked with ordinary tools. Also furnished drilled and engraved for nine well known circuits.

Insist on the genuine "Insuline" from your Dealer

### RADIO PANEL and PARTS CORP.

(Insulating Co. of America)

Insuline Bldg., 59 Warren St.  
New York

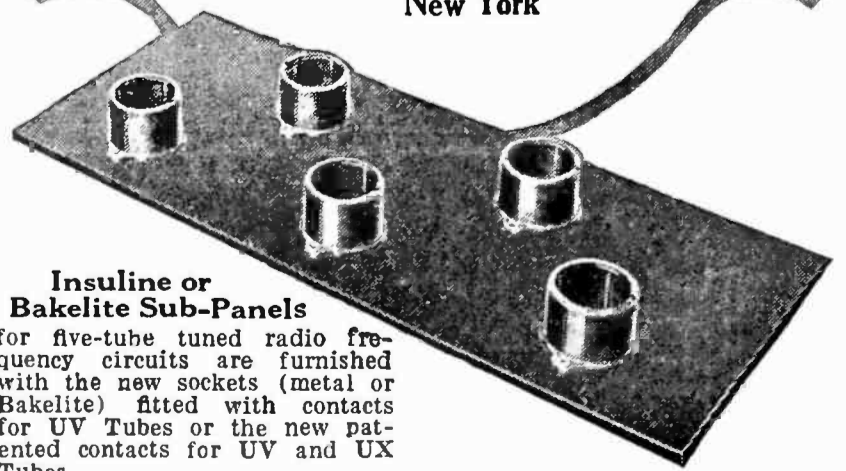

**Insuline or Bakelite Sub-Panels**  
for five-tube tuned radio frequency circuits are furnished with the new sockets (metal or Bakelite) fitted with contacts for UV Tubes or the new patented contacts for UV and UX Tubes.

★ Tested and approved by RADIO BROADCAST ★



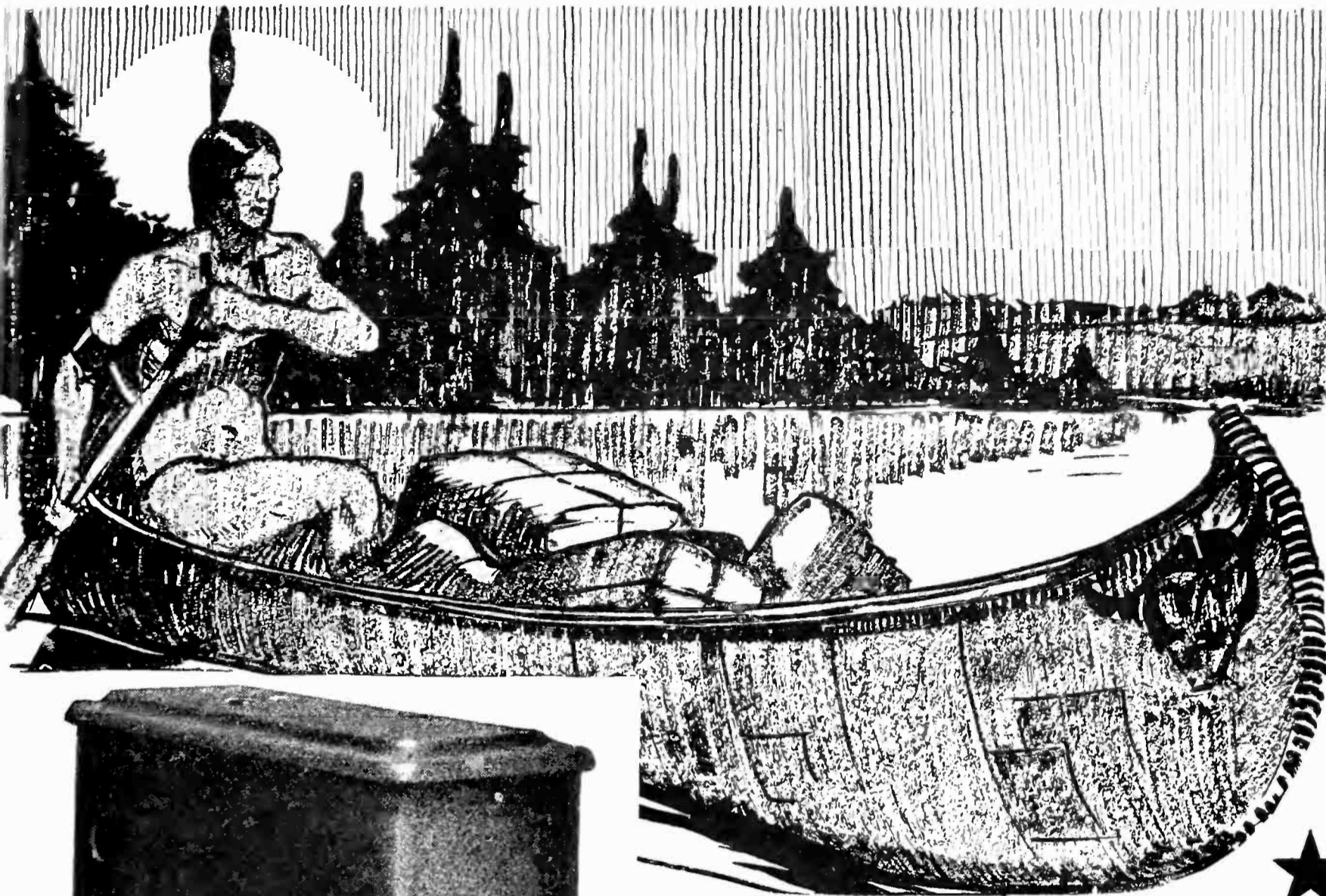

## SILENT POWER—

EPOM Engineers by their perseverance, untiring efforts and the uniting of the best electrical and mechanical principles have produced the EPOM "B" Battery Eliminator which parallels the silence of the wilderness solitude in operation. The EPOM "B" Battery Eliminator replaces unreliable and temporary "B" Batteries with constant "B" power direct from any convenient lighting socket. Once attached and adjusted to any radio receiving set it becomes as essential as the unseen parts and requires as little attention. Operated by an ordinary push pull switch. Five exclusive EPOM features make EPOM the best.

stant "B" power direct from any convenient lighting socket. Once attached and adjusted to any radio receiving set it becomes as essential as the unseen parts and requires as little attention. Operated by an ordinary push pull switch. Five exclusive EPOM features make EPOM the best.

### Distributors—EPOM "B" BATTERY ELIMINATOR

- |                 |   |                   |                            |                     |   |
|-----------------|---|-------------------|----------------------------|---------------------|---|
| <i>New York</i> | E. B. Latham & Co.<br>Sibley-Pitman Elec. Co.       | <i>Baltimore</i>  | Southern Electric Co.      | <i>Detroit</i>      | Electrical Specialties Co.                  |
| <i>Newark</i>   | Tri-City Elec. Co.                                  | <i>Pittsburgh</i> | Union Electric Co.         | <i>Cleveland</i>    | Erner Electric Co.<br>Republic Electric Co. |
| <i>Hartford</i> | So. New England Elec. Co.                           | <i>Atlanta</i>    | Carter Electric Co.        | <i>Columbus</i>     | Erner & Hopkins                             |
| <i>Boston</i>   | Pettingell & Andrews<br>Wetmore-Savage E. S.<br>Co. | <i>Chicago</i>    | Commonwealth Edison<br>Co. | <i>Cincinnati</i>   | Post-Glover Elec. Co.                       |
| <i>Phila.</i>   | Jones-Beach & Co.<br>F. H. Stewart Elec. Co.        | <i>Milwaukee</i>  | J. Andrea & Sons Co.       | <i>Kansas City</i>  | B-R Electric Company                        |
|                 |   |                   |                            | <i>Dallas</i>       | Southwest G. E. Co.                         |
|                 |   |                   |                            | <i>Indianapolis</i> | Indianapolis Elec.<br>Supply Co.            |

# EPOM

ELECTRICAL PRODUCTS OF MERIT

"B" BATTERY ELIMINATOR

EPOM CORPORATION 114 E. 47th St. N. Y. City

★ Tested and approved by RADIO BROADCAST ★

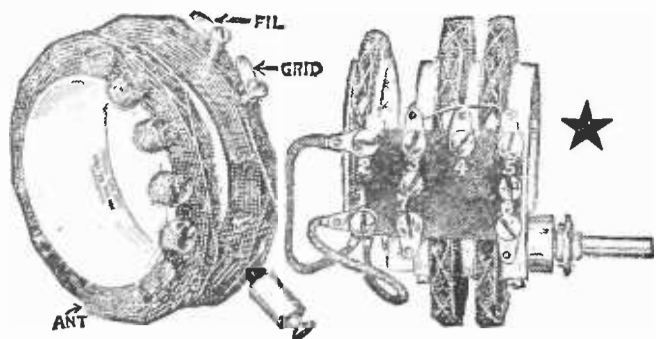

Sickles Coil Set No 18A for Roberts Circuit. \$8.00 per set.

# SICKLES

## DIAMOND-WEAVE COILS

(Trade Mark Registered Aug. 4, 1925)

*For Browning-Drake, Roberts, Craig, and Hoyt Circuits*  
(Patented Aug. 31, 1923)

**An entirely new system of Radio Reception**

*Sickles Diamond-Weave Coils have been specified for use in the Hoyt System of Signal Augmentation, by the inventor, Francis R. Hoyt. We have a limited number of blue printed copies of Mr. Hoyt's original laboratory notes on this new system of radio reception, together with nine circuit sketches, which will be sent free to you upon receipt of this coupon and four cents for postage.*

The F. W. Sickles Co.  
Springfield, Mass.

Please send information of Hoyt System

Name.....

Address.....

Radio Broadcast

Sickles Coils for the famous Browning-Drake Circuit are the latest Sickles achievement in efficient design for a particular use. They are priced at \$7.50 a set.

The New No. 18A Coils for any Roberts Circuit are absolutely standard equipment. They are priced at \$8.00 per set.

Coil Set No. 20, at \$4.50, is for use specifically with the New Reflex Receiver designed by Albert G. Craig using the Sodian detector.

Coils for the Hoyt Circuit at \$10.00 a set, for the Knock-out Reflex Circuit at \$4.00 a pair, and the Tuned Radio Frequency coils at \$2.00 each are other standard Sickles Coils. We manufacture also for manufacturers' special requirements.

*Send for descriptive catalog*

**The F. W. Sickles Co.**  
132 Union Street  
SPRINGFIELD, MASS.

# FROST-RADIO

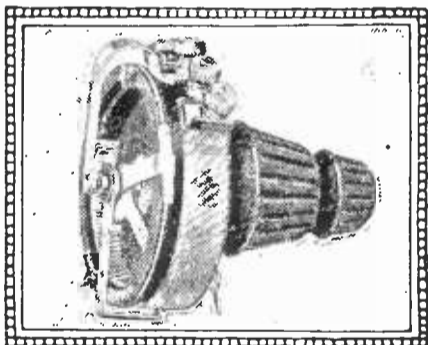

**Tube Control Units**  
Combines Vernier Rheostat and Potentiometer. Single hole mounting. 6, 25 or 35 ohm rheostat, 400 Potentiometer. Genuine Moulded Bakelite. List: \$1.75. Pacific Coast price slightly higher.



**HERBERT H. FROST, Inc.**  
314-324 WEST SUPERIOR STREET, CHICAGO  
NEW YORK CITY CLEVELAND KANSAS CITY LOS ANGELES



**CRESCENT LAVITE RESISTANCES**

*for Distortionless Amplification*

12,000, 48,000, 50,000, 100,000 Ohms. List \$1.50 each. Special Sizes to Order \$2.50 each. Dealers write for discounts. *When Better Resistances are made they will be Crescents.*

Crescent Radio Supply Co. 1-3 Liberty St., Jamaica, N. Y.

**Increase Distance, Volume, Clarity**

"Colytt" adjustable grid leak improves receiving. Gives proper value of leak in grid circuit, and holds it. Simple, compact, easy to install, only one hole in panel. Tunes any tube perfectly. Try the "Colytt" on Money-back guarantee. \$1.00 complete, with full directions. 3301

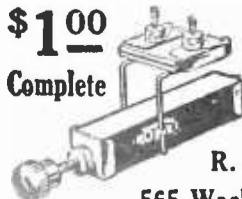

R. B. Colytt Laboratories  
565 Washington Blvd., Chicago



# ROBERTS'— "Supercoils" NEW TYPE

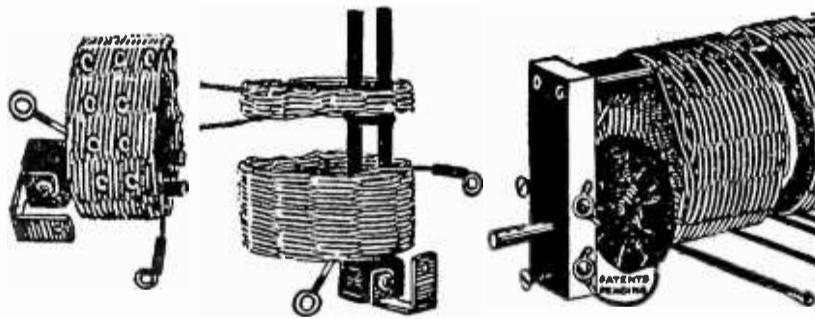

for Walter Van B. Roberts' "RADIO BROADCAST'S 'KNOCKOUT"

New "Supercoil" Antenna Tuning Circuit improves Volume tremendously, especially on high wave lengths.

**Complete Set** 6 coils in three mountings \$9.00 Postpaid

Basket weave windings. Large, duplex insulated wire. Adjustable couplings. Minimum dielectric. 180° tickler

Sent anywhere C. O. D. parcel post. Order shipped day received.

**PERFECTION RADIO MFG. CO.**  
Office 319-1520 Chestnut St. Philadelphia, U S.

★ Tested and approved by RADIO BROADCAST ★

# SM

## PARTS

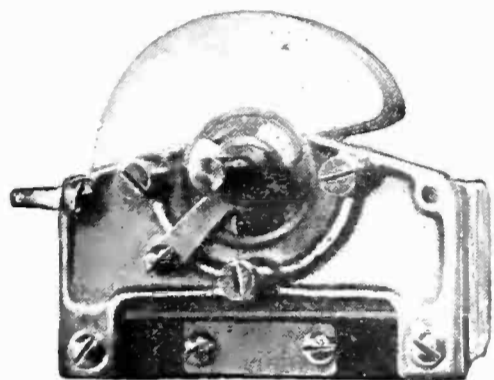

# NEW



## S L F CONDENSERS

Again Silver-Marshall leads with the lowest loss straight-line-frequency condensers yet produced. All metal parts are heavily silver-plated—Dielectric is highest grade hard rubber, and the instruments themselves are the smallest made—due to perfected S-M design.

### NEW TYPE S L F CONDENSERS

Type 310	.0005	-	\$6.00
Type 311	.00035	-	5.75
Type 312	.00025	-	5.50

### S L W CONDENSERS

*Effective Sept. 15, prices on S L W Condensers are reduced one dollar per size.*

Type 305	.0005	-	\$5.00
Type 306	.00035	-	4.75
Type 307	.00025	-	4.50

### ALL WAVE INTERCHANGEABLE COILS

The new 110, 111, and 112 coils are made as oscillators, antenna adapters, compensated R. F. Transformers etc. for all waves from 50 to 550 meters. They are interchangeable and fit the type 515 six-contact socket.

Price per Coil \$2.50

Price, Type 515 Coil Socket \$1.00

### CUSHIONED UX SOCKET

This type 510 cushioned spring socket, of moulded bakelite will fit all the new UX Tubes, as well as all existing makes excepting only UV199 and C299 tubes.

Price, Type 510 Cushioned UX Socket \$1.00

*See all these revolutionary parts at your Dealers  
or write direct for circulars.*

# SILVER-MARSHALL

103 S. Wabash Ave.  
CHICAGO

★ Tested and approved by RADIO BROADCAST ★

Guglielmo Marconi as he appears today. Signor Marconi is Honorary Chairman of the Radio Institute of America.



# There's a Position for YOU in RADIO

THE Radio Industry today holds forth more and better opportunities than ever before. Radio operating and manufacturing companies are constantly employing new radio operators, mechanics, assemblers, testers, repairmen and designers.

*Are you neglecting these opportunities?*

Start to prepare now for an interesting and profitable career in radio. The instruction offered by the Radio Institute of America has in the last sixteen years enabled 7,000 graduates to obtain lucrative positions in radio. A competent staff gives special attention to the requirements of each student.

Our Home Study Department permits those who cannot attend classes to study radio at home in spare time. Check the course in which you are most interested and mail the coupon to the

## RADIO INSTITUTE OF AMERICA

(Formerly Marconi Institute) Established in 1909  
328 Broadway New York City

.....CUT HERE.....

RADIO INSTITUTE OF AMERICA,  
328 Broadway New York City.  
Please send me full information about your Home Study Course of radio instruction.

I am interested in the complete course, including code instruction, which qualifies for the U. S. Government Commercial or Amateur Radio License.

I am interested in the technical course for radio dealers, jobbers and salesmen.

Name .....

Address .....

City..... State.....

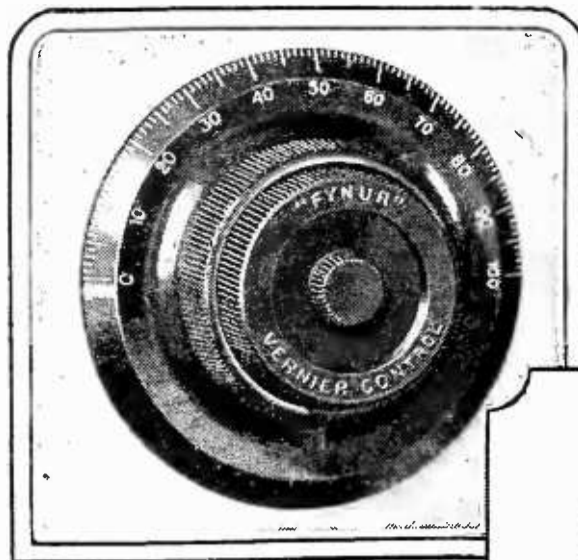

Price \$3.50

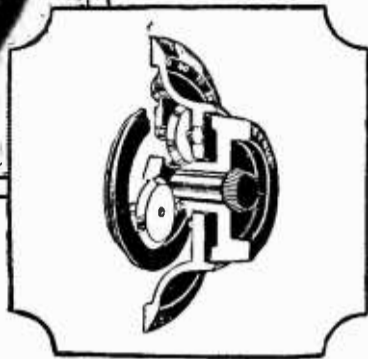

NO BACKLASH in this new dial

No backlash is possible in the new Fynur Vernier Control. There are no gears to mesh, so there can be no lost motion, and the movement is always smooth and free.

If you want the utmost accuracy in reception, and unless you have it you cannot expect the best results from your set, use Fynur dials.

*If your dealer cannot supply you, write to us.*

AUGUST GOERTZ & CO., INC.  
270-286 Morris Ave. Newark, N. J.

## FYNUR VERNIER CONTROL

# Get This Big Western Radio Catalog

Latest 1925 - 1926 Catalog. Contains highest quality standard parts, sets and kits.



Western Radio <sup>MFG</sup> CO.  
138 W. Lake St. Chicago, Ill

★ Tested and approved by RADIO BROADCAST ★

# The World Expected a Supreme Radio Set from **KELLOGG** *and here it is!*



## A Separate Circuit for Each 40 Meter Wavelength Band!

**K**ELLOGG — for 28 years makers of precision telephone instruments — producers of quality parts since radio began — Kellogg has perfected a radio receiver worthy to bear the Kellogg name.

In the new WAVE-MASTER there are nine separate circuits — one for each 40 meter wavelength band. Each circuit gives that maximum efficiency heretofore found only in one short section of the dials of ordinary radio frequency sets. Each circuit brings within the range of the tuning dial *a different group of stations.*

Merely set the pointer to the wave zone in which you are interested and tune in with the one dial.

This dial actually has a tuning

range of 540 degrees — over three times the range of any other set.

All other radio frequency sets have variable capacity which must be tuned, usually with three different dials, to balance with their inductance coils.

The WAVE-MASTER'S inductance is not fixed but variable and is easily and quickly tuned, with the one dial, to balance the fixed capacities

Write for full description. Please mention your radio dealer's name.

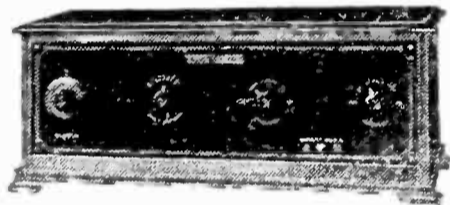

**WAVE-MASTER**  
Standard Model  
\$125.00



**WAVE-MASTER**  
Brown Walnut Console  
with inbuilt horn  
\$275.00



**Kellogg Switchboard & Supply Company**  
1032 W. Adams St., Dept. J, Chicago, Ill.

**KELLOGG**  
**WAVE MASTER**  
SWITCHBOARD & SUPPLY CO.

★ Tested and approved by RADIO BROADCAST ★

**Radio Dealers and Jobbers**  
The WAVE-MASTER franchise, backed by Kellogg resources and our powerful advertising campaign, is most valuable. Wire, or get into Chicago, quick, and see us.

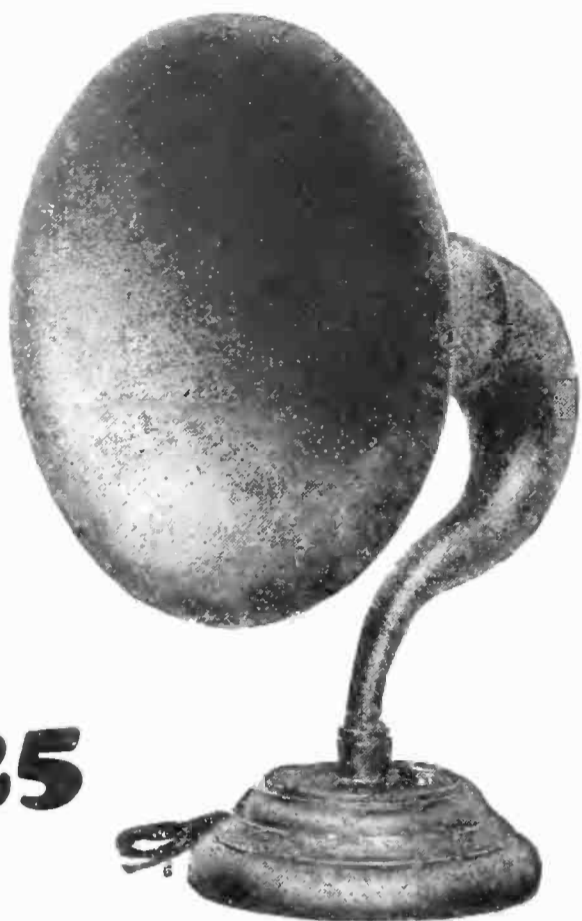

**\$25**

**TRIMM** Concert reproduces all the tones, from high of violin to low of organ, with perfect fidelity. Easily accessible adjustment permits control of tone and volume. Volconite horn eliminates scratchy overtones and noises.

TRIMM	
Superior Reproducers	
HEADSETS	
Professional - -	<b>\$5.50</b>
Dependable - - -	<b>4.40</b>
PHONODAPTERS	
Giant Unit - -	<b>\$10.00</b>
Little Wonder -	<b>4.50</b>
SPEAKERS	
Home Speaker -	<b>\$10.00</b>
Entertainer - -	<b>17.50</b>
Cabinette - - -	<b>17.50</b>
Concert - - -	<b>25.00</b>
Chello - - -	<b>30.00</b>

**TRIMM**

RADIO MANUFACTURING COMPANY

24 So. Clinton St.  
CHICAGO  
U.S.A.



**Oh boy**

**KESTER**

*Rosin Core*

**Radio SOLDER**

*Sure!* is Safe and Simple

APPROVED BY  
RADIO ENGINEERS

A GENUINE SOLDER

CHICAGO SOLDER COMPANY

4222 Wrightwood Ave., Chicago, U. S. A.

Originators and World's Largest Manufacturers of Self Fluxing Solder

YOUR DEALER CAN SUPPLY YOU

Surprise!—Read Radio Broadcast for November

**Potter**  
BY-PASS  
**Condensers**

- Prevent "B" voltage fluctuation
- Allow undistorted amplification
- Make possible full bass tones
- Improve reception with "B" Supply Units.

Made in  $\frac{1}{10}$ ,  $\frac{1}{4}$ ,  $\frac{1}{2}$ , 1, 2, 3 and 4 Microfarad sizes

Order from Your Jobber

POTTER MANUFACTURING COMPANY  
North Chicago, Illinois

★ Tested and approved by RADIO BROADCAST ★

# DAVID Grimes

**SUPER-SELECTIVE  
RADIO**



David Grimes  
Super-Tone  
**LOUD SPEAKER**  
with a mica diaphragm  
that eliminates  
distortion - - \$25

**ITALIAN RENAISSANCE MODEL**  
Utilizing 4 tubes with the efficiency of 6 tubes.  
Built in a Renaissance Cabinet of two-tone  
Mahogany and Walnut concealing  
all batteries. - - - - - **\$125**  
(without accessories)

*Ask a Grimes Dealer for Demonstration*

## More Stations On the Air

**Y**OU'LL want to hear them all—but one at a time. The Grimes Circuit in the Grimes Inverse Duplex receiver will give you the sharp tuning desired. Greater volume, distance range and a tonal quality you've never heard before are also yours in this remarkable instrument.

Dual operation of the tubes, providing two stages of radio frequency, vacuum tube detector and three stages of audio frequency amplification, gives you the energy of a six tube set with the economy of four tubes. A super power switch gives tremendous reserve power for distant stations.

A new form of inductance—the twin cylinder coils and straight line condensers allows you to tune in the desired programs and shut out the rest.

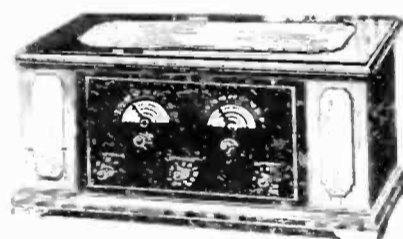

**BABY GRAND Duplex Model**, using  
3 tubes with the power of 4 tubes.  
In two-tone mahogany cabinet,  
housing all batteries. **\$59.50**  
(without accessories)  
West of Mississippi \$60.00

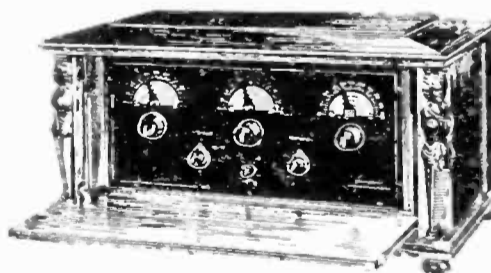

**EMPIRE MODEL**, in reality a 6  
tube set operating on 4 tubes. En-  
closed in 17th Century Solid Mahog-  
any French Cabinet, housing all  
batteries. - - - - - **\$125**  
(without accessories)

Products of ★  
**David Grimes Radio  
& Cameo Record  
Corporation**

1571 Broadway, New York, N. Y.

B  
R  
U  
N  
O  
B  
R  
U  
N  
O  
B

B  
R  
U  
N  
O  
B  
R  
U  
N  
O  
B

Hear MacMillan from the Arctic  
with the  
**LATEST "Bruno" PRODUCT**

*"Bruno"*  
**Short  
Wave  
Tuner**

*Dealers and Jobbers!  
Write us for Terms*

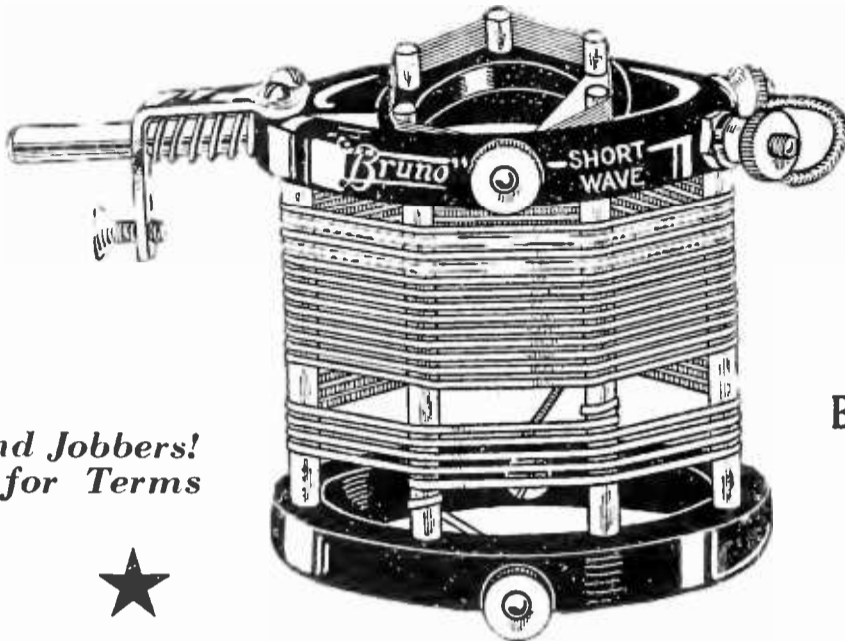

**\$5.50**

**BRUNO RADIO Corp.**  
221 Fulton St., N. Y.



*"Bruno"*

*Write in for Free Hookups and Pamphlets*

**SHORT WAVE TUNER**; tunes from 20 up to 110 meters. Distributed capacity losses are greatly reduced by the ribbon spaced windings on the quartzite rods. This coil mounts with one hole and is only 2½" over all.

B  
R  
U  
N  
O  
B  
R  
U  
N  
O  
B

B  
R  
U  
N  
O  
B  
R  
U  
N  
O  
B



Patented  
Mar. 31, 1925

**THE DOUBLETOROID COIL**

"Doubletoroids" can be mounted at any angle or spaced at any distance.

"Doubletoroids" make more selective sets possible, since they do not form miniature loop aerials.

"Doubletoroids" hold static and other disturbances to a minimum since no current from an external source can influence them.

**Outstanding Features of the "Doubletoroids"**

Both primary and secondary are true toroids.

The magnetic path is shortest.

It is the most compact.

**RADIO FOUNDATION, Inc.**

25 West Broadway

New York

Patented June 16, 1925



**It's Variable**

The Nonoise Gridleak improves reception because it can be adjusted for every station. Fits standard brackets. Absolutely noiseless. At all dealers and in the better sets.

**NONOISE GRIDLEAK**

★ Tested and approved by RADIO BROADCAST ★





**Earn \$50 to \$250 a Week in RADIO**

## Easy to Become a RADIO EXPERT at home in spare time

### Big Jobs Waiting in the Radio Business

If you are making less than \$50 a week—if you want to get into the big pay class in the world's fastest growing industry—get into Radio—NOW. Coupon brings you full information. Big Jobs are open for trained men in every section of the country. Radio manufacturers—distributors—broadcasting and receiving stations—railroads and steamship companies and branches of the government, need trained Radio Experts NOW! Opportunities are open everywhere for men to go into business for themselves as Radio Experts. The pay is big. Thousands are now making \$50 to \$250 a week in Radio. This new industry is making new millionaires almost overnight.

### Learn Quickly at Home by Tested Method

You can become a Radio Expert quickly, and easily, in your spare time at home, with the help of the National Radio Institute—America's first and largest home study Radio School. This famous, tested course makes Radio as simple as ABC—and so fascinating you will scarcely realize that you are mastering one of the world's most important industries. In a few short months you may become the Radio Expert of your town or wherever you wish to locate. You get the benefit of our years of experience and you learn Radio RIGHT when you learn our way!

### This is the Course That Pays For Itself

We mean every word of it! We have developed the famous method that makes it unnecessary for your training to be an expense. Instead of making any man "scrimp" to get his training, our system makes your course pay you returns practically from the start. When you learn our proven way your course will pay for itself and more—much more! Get the details of these amazing methods.

### Don't Worry About Age or Education

It makes no difference what your age is or what your previous training has been. Radio is a field in itself. It calls men of all ages from youth to settled middle ages. Success does demand training in Radio and the N.R.I. Course gives you the training necessary to Success.

### Up to date Receiving Sets Given With Course

You learn by doing—through the N.R.I. Course. All materials and equipment necessary are furnished you along with your course. You are sent receiving sets to build and install—real sets for experimental work and pleasure. This is a prac-

tical course that teaches you to get the practical results that big pay jobs demand.

### Helpful Employment Service

We are constantly in touch with openings for trained Radio men. The men we train get first chance at these fine jobs through our Free employment Department—at no extra cost. When you complete your training we help you until you get the job you want.

**Mail Coupon Quick for FREE BOOK and Special Offer**

The Coupon below will bring you the most amazing book on Radio ever written. It will open your eyes to the opportunities for you in this astonishing big pay field and tell you how to become a Radio Expert in your spare time at home. It has helped thousands of men to success in Radio. Important: We have Special Limited Offer for those who act quickly. Mail the coupon or write a letter Now.

## NATIONAL RADIO INSTITUTE

Dept. 31 M B  
Washington, D. C.

Get this  
Free Book



NATIONAL RADIO INSTITUTE, Dept. 31, MB  
Washington, D. C.

Without obligation send me your book "Rich Rewards in Radio" and full information on your practical, home-study Radio course.

Name..... Age.....

Street .....

City..... State.....

### Proof That Radio Pays

See what these N. R. I. men are doing

#### Buys new car with earnings



"I am at present employed as service Manager for the Geo. F. Dent Radio Service Co. and I am still taking the course.

I have great success selling, building, repairing and installing all kinds of Radios. At present I am getting a salary and commission which, although I have only been with the firm for 3 months, has enabled me to purchase a new car." Richard E. Jones, Bay City, Mich.

#### Makes \$50 to \$80 a week more

Your course leads so much further ahead than practical electricity that there is nothing left to say. Since I took your course I have earned from \$50 to \$80 a week more. Preston Fowler, Gordon, Nebraska.



#### Increases pay 160%



I was just receiving \$3.00 per 8 hours when I enrolled with N.R.I. and now I am receiving \$1.00 an hour (160% increase). That is where N.R.I. put me. The course has been worth \$2500 a year to me and in another year it will be worth \$3500 a year. Andrew M. Shurie, Latrobe, Pa.

**Earn \$50 to \$250 a week in Radio**

★ Tested and approved by RADIO BROADCAST ★

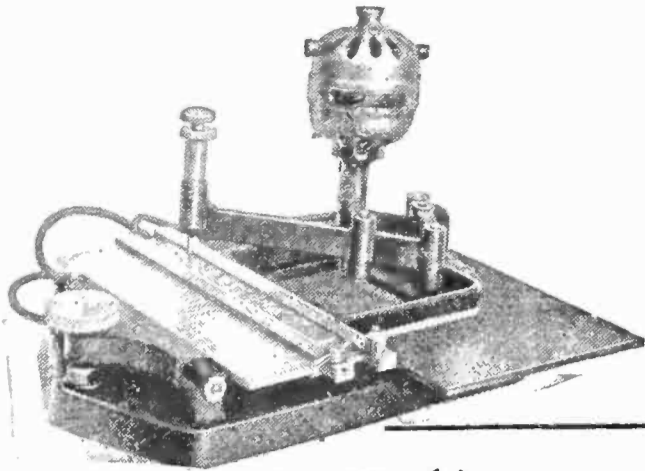

**Rapid Engraving Machine  
For Engraving Radio Panels**

*Easy to operate. Will increase Radio Dealers income*

A low price engraving equipment for engraving the words used on radio panels, trade-marks, and border and corner designs. Will engrave on Hard Rubber, Bakelite, Aluminum, and other soft metals. Price of complete equipment, \$135.00.

*Will earn several dollars an hour engraving panels for amateurs building their own sets.*

Branch Tool Co., Dept. G, Forestdale, R. I.

**NO AERIAL  
NO LOOP**

**THE Antennaphone**  
REPLACES THE AERIAL

INCREASES SELECTIVITY  
Gives wonderful results with any radio set. Not attached to, but merely placed under the telephone. Price One Dollar. Complete with insulated wire and simple instructions. At Your Dealer or Mailed C. O. D. on 3 days' approval.

ANTENNAPHONE CO. New York City

**FORMICA RADIO PANELS  
TUBES AND RODS**

WRITE TO-DAY for your copy of our new catalog listing and pricing 3384 different sizes and kinds of Formica Radio Panels, 126 different sizes of Formica Tubes, and 21 different sizes of Formica Rods.

**DRILLING—ENGRAVING**

Lowest prices consistent with good work.

**STARRETT MFG. CO.**

521 S. Green St. - Chicago, Ill.

22½ Volt

un-acid  
everlasting  
rechargeable

"B"

Storage Battery

**\$2.95**

including chemical



Does not lose charge standing idle. SPECIAL—2 22½ (45 volts) \$5.25; 90 volts \$10.00. Any special detector or amplifying voltage easily had. Very easily charged. Nearly 3 years sold on a non-red tape 30 day trial offer with complete refund if not thoroughly satisfied. Further guaranteed 2 years. Knock-down kits at still greater savings. Complete ready to run "B" battery charger \$2.75. Sample cell 35c. Order direct—send no money—simply pay expressman when delivered, or write for my free literature, testimonials, and guarantee. My large 36-page radio goods catalogue 10c. Same day shipments.

B. F. SMITH, 31 Washington Ave., Danbury, Conn.

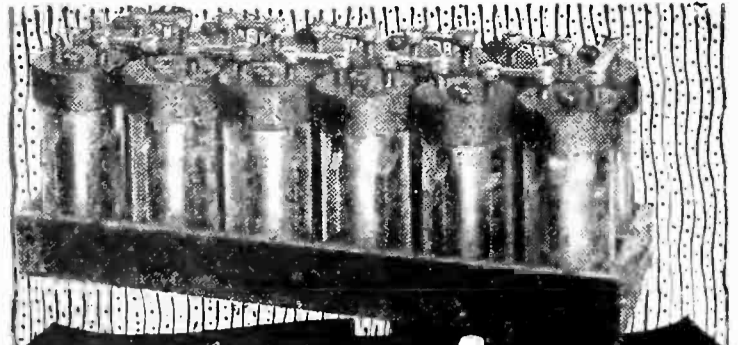

**FREE!**

**12-Cell — 24-Volt  
Storage 'B' Battery**

Positively given free with each purchase of a WORLD "A" Storage Battery. You must send this ad with your order. WORLD Batteries are famous for their guaranteed quality and service. Backed by years of successful manufacture and thousands of satisfied users. Equipped with Solid Rubber Case, an insurance against acid and leakage. You save 50 per cent and get a

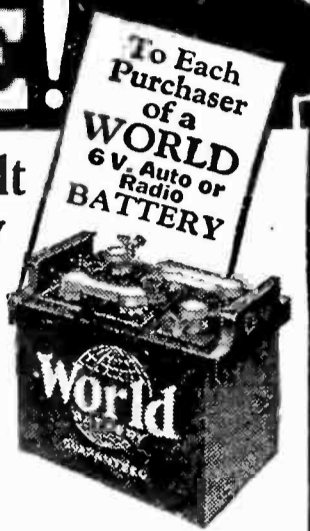

**2-Year Guarantee**

**Bond in Writing** WORLD Battery owners "tell their friends." That's our best proof of performance. Send your order in today. **Solid Rubber Case Radio Batteries**

- 6-Volt, 100-Amperes . . . . . \$11.25
- 6-Volt, 120-Amperes . . . . . 13.25
- 6-Volt, 140-Amperes . . . . . 14.00

**Solid Rubber Case Auto Batteries**

- 6-Volt, 11-Plate . . . . . \$11.25
- 6-Volt, 13-Plate . . . . . 13.25
- 12-Volt, 7-Plate . . . . . 16.00

**Send No Money** Just state battery wanted and we will ship day order is received, by Express C. O. D. subject to your examination on arrival. **FREE "B" Battery included.** **Extra Offer:** 5 per cent discount for cash in full with order. Buy now and get a guaranteed battery at 50 per cent saving to you.

**WORLD BATTERY COMPANY**  
1219 So. Wabash Ave., Dept. 24 CHICAGO, ILL.

**World STORAGE BATTERIES**

Set your Radio Dials at 210 meters for the new 1000 watt World Storage Battery Station, WSBC, Chicago. Watch for announcements.

(KDKA - WEAf - W6N - WJS - KHJ - KGO - KFAF - WJY - KOP)

Approved and Listed as Standard by Leading Authorities including Radio News Laboratories, Popular Science Institute of Standards, Popular Radio Laboratories. Radio in the Home and Lefax, Inc.

**No Library Complete Without Kipling Complete**

What they have done for others they will do for you.



**Improve Your Reception  
X-L VARIO DENSERS**

MAKE POOR SETS GOOD—GOOD SETS BETTER

Endorsed and Used by the Foremost Radio Engineers of the Country

MODEL N—Capacity range 1.8 to 20 micro-micro-farads, as used in Radio Broadcast's Phonograph Receiver, for balance in Roberts two tube, Browning-Drake, McMurdo Silver's Knockout, Neutrodyne and tuned radio frequency circuits.

Price \$1.00

MODEL G—Two capacity ranges, .00016 to .00055 and .0003 to .001 Microfarads, for the Cockaday circuits, filter and intermediate frequency tuning in super-heterodyne and positive grid bias in all sets.

Price \$1.50

**X-L PUSH POST**

A Binding Post that really does excel, looks, action, service and convenience. Just push it down—insert wire—cannot jar loose from vibration. No screwing or danger of shearing off wires. Furnished attractively plated with soldering lug and necessary markings.

Price Each, 15 Cents

**'X-L RADIO LABORATORIES**  
2424 Lincoln Ave. CHICAGO



★ Tested and approved by RADIO BROADCAST ★

# Radio drafted Bakelite

*so all could listen-in*



To make available for everyone, everywhere, the marvel of radio reception, radio engineers required an insulating material possessing a unique combination of properties.

Bakelite alone met the need. It combines high insulation value with strength and light weight. It is easily formed into the many shapes required and will not warp, shrink nor swell. It will not absorb moisture and is unaffected by extremes of heat and cold.

All of these properties and the beautiful color and finish of Bakelite are permanent—unaffected by time, use or climate. So "Radio drafted Bakelite," and to-day it is used by over 95% of radio set and parts manufacturers.

Make sure that the radio set or parts that you buy are Bakelite insulated, for good insulation is essential to clear reception.

*Write for Booklet 29*

## BAKELITE CORPORATION

247 Park Avenue, New York, N. Y.  
Chicago Office: 636 West 22d Street

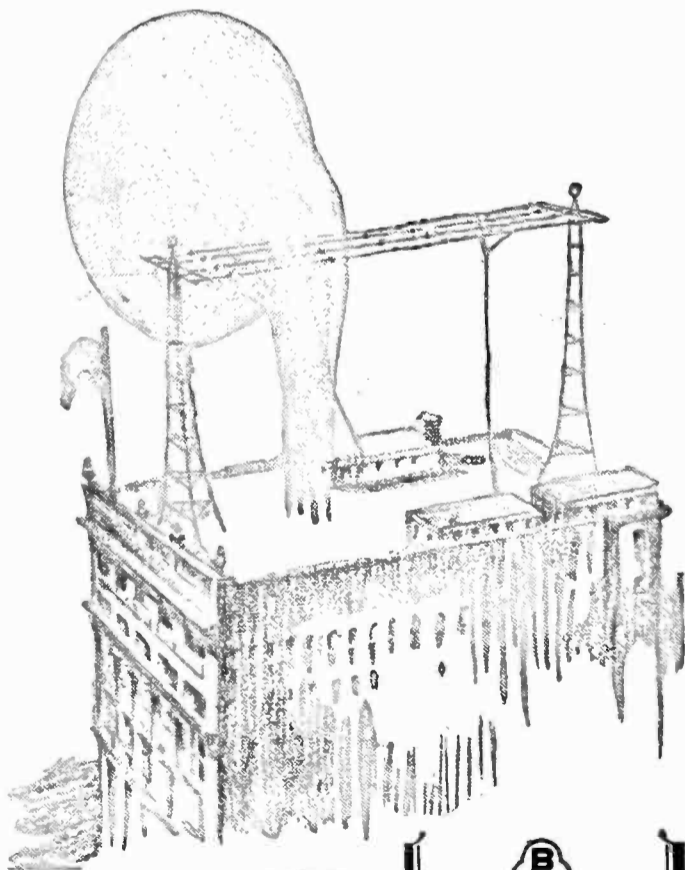



"Polyplug"  
Polymet Mfg. Co



Dial  
The Bell Mfg. Co.



Rheostat  
Yaxley Mfg. Co

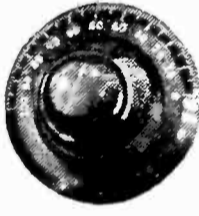

Aristocrat Dial  
Kurz-Kasch Company



Condenser  
Sangamo Electric Co

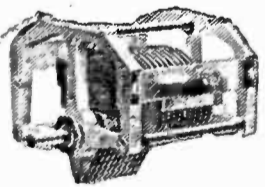

Condenser  
Bremer-Tully Co.



# BAKELITE

REG. U.S. PAT. OFF.



**BAKELITE**

is the registered trade mark for the phenol resin product manufactured under patents owned by the Bakelite Corporation.

Bakelite is an exclusive trade mark and can be used only on products made from materials manufactured by the Bakelite Corporation. It is the only material which may bear this famous mark of excellence

THE MATERIAL OF A THOUSAND USES

★ Tested and approved by RADIO BROADCAST ★

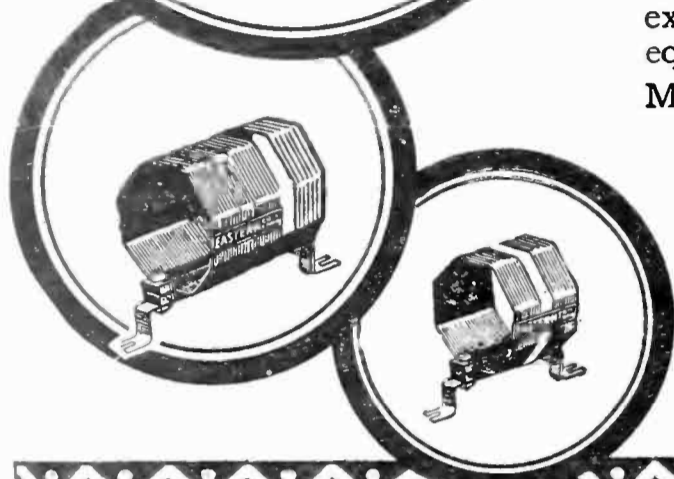
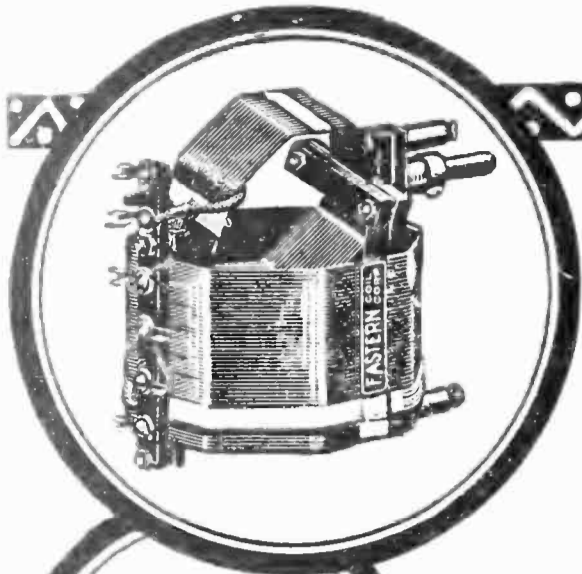

# EASTERN

## Make your set a Super-Het!

by adding the *new, revolutionary* O'Connor Frequency Changer as described in the June issue of Radio Broadcast. Only one extra tube is necessary. It's easy to build and the results obtained equal the best Super-Het.

Mr. A. O'Connor has *specified* the EASTERN PICKLE BOTTLE COUPLER (Type FC) for use in his remarkable Frequency Changer. Type FC Coupler \$6.00

EASTERN PICKLE BOTTLE COILS are also designed for perfect performance in the Roberts Circuit (\$8.50 per set), Browning Drake (\$8), DX Superdyne, (\$8 per set), 3 Circuit (\$6) and for Tuned R. F. for .0005 or .00035 condensers (\$2 per coil).

*At your dealers or direct, postpaid.*

EASTERN COIL CORPORATION

22 Warren Street Dept. R. B. New York



# *pickle bottle* COILS

## What You Save on Condensers You Lose in Reception!

The set builder who shops around for cheap parts is always the one to offer alibis for his receiver's performance. Especially is this true when "bargain" condensers are used, for they are the heart of the set; and its value as a fine instrument depends on the electrical and mechanical perfection of these devices.

Continental Lo Loss Condensers are used and approved by many of the biggest names in radio. Their extremely low dielectric losses, exact capacities, and mechanical precision make them invaluable to fine reception in high grade sets. Most reliable radio stores carry the complete line. If not write us direct.

**GARDINER & HEPBURN, Inc.**

611 Widener Building

Philadelphia, Pa.

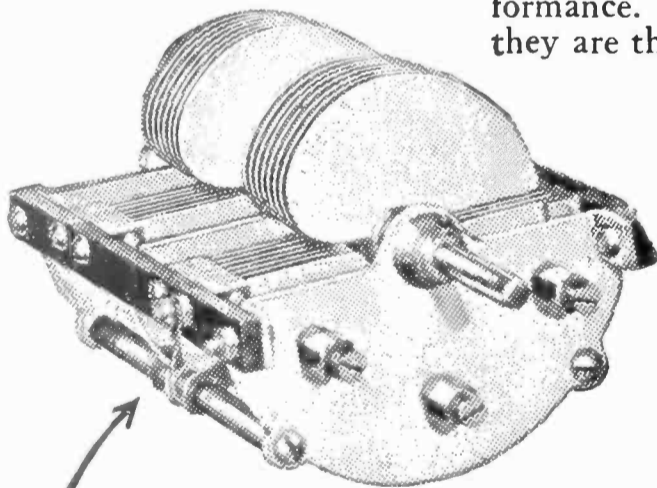

**UNITROL**  
Made under Hogan Pat.  
No. 1,014,012

The new UNITROL is a straight line wave length double condenser that is designed to separate low wave length stations and simplify the operation of quality receiving sets. *It will operate a four-tube set with one control.*

Notice the patented balancing plate feature illustrated above. This ingenious device is found only in Continental Unitrols.

14 Plate .00025 Capacity \$7.00  
18 Plate .00035 Capacity 7.50  
25 Plate .0005 Capacity 8.00

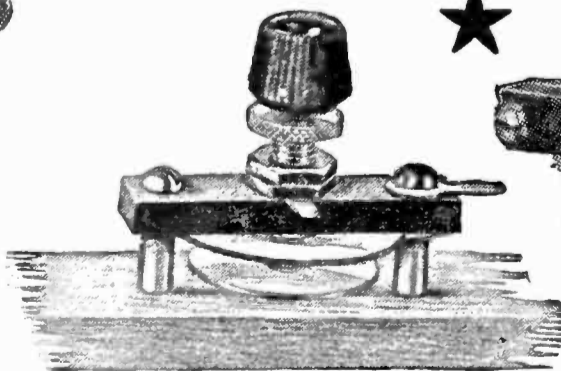

**CONDENSERETTE**  
The Neutralizing Condenser

has been found to be an excellent neutralizer in taking the squeal out of the Neutrodyne, Superheterodyne and other high frequency circuits.

Price, 50c.



**JUNIOR**  
The Perfect Vernier

Continental "Lo Loss" Junior does away with all friction and geared vernier devices. It is a miniature condenser designed with exactly the same low loss, rigid construction and precision workmanship as all Continental Condensers.

Price, \$1.25

★ Tested and approved by RADIO BROADCAST ★

# DISTON

AN ELECTRICAL INSTRUMENT  
REPLACING "B" BATTERIES and  
using ALTERNATING CURRENT

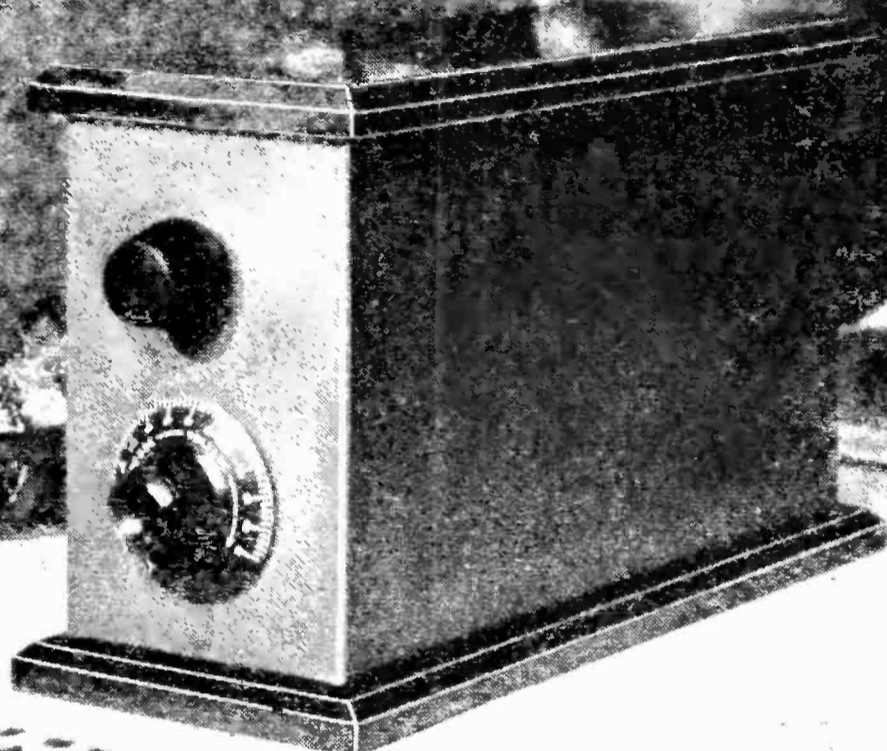

## For better reception with your present receiver

Diston makes good set operation better, more simple, reliable and satisfactory. It adds quality, volume, selectivity and distance.

You will never know real radio until you have used Diston on your receiver under your own local receiving conditions. You can confirm Diston Advantages in your own home without obligation. See your dealer or write us.

Diston Kits for Set  
Builders  
60-50-25 cycle  
\$28.50 to \$42.75

**RADIO PRODUCTS, INC.**  
Dept. RB      Richmond, Ind.

*Dealers: Write for the Diston User Judgment Sales Policy*

Diston Ready for  
Operation  
60-50-25 cycle  
\$40 to \$60



## Amplifier and Detector Tubes Improve Performance

Give your "set" a chance. Good tubes improve reception. Consider the points of SEA GULL superiority.

1. Non-microphonic
2. Uniformity—can be used interchangeably in any stage.
3. 10 % higher mutual conductance.
4. 50 % longer life.

The best workmanship, newest and most efficient equipment, and the finest material insure these properties.

When buying tubes have SEA GULLS tested on the meter, as well as in a "set". Compare with any other tubes—watch the oscillation factor—the constancy of which evidences "matched" tubes.



There is also a high capacity rectifier SEA GULL tube for B battery eliminators. These are equally as good as our other tubes. They sell for \$3.00.

If your dealer can not supply you, send his name and \$2.50 for each tube you want, plus p. p.

Dealers and jobbers write for information and discounts.



**ABERDEEN SPECIALTY CO., Inc.**  
1641 N. Hutchinson St. Phila., Pa.

**Obsolete**

**Take the "GUESS" Out of Tube Control**

**\$1.10 Everywhere**

**With**

Amperite automatically controls tube current, eliminates hand rheostats, filament meters, guessing and all tube worry. Simplifies wiring, tuning and operation. Permits the use of any type of tube or any combination of tubes. Tested and used by more than 50 set manufacturers and in every popular construction set

**RADIALL COMPANY**  
Dept. R.B-11: 50 Franklin St., New York City

★ Write for **FREE** Hook-ups

**AMPERITE**  
REG. U.S. PAT. OFF.

*The "SELF-ADJUSTING" Rheostat*

### The Wilson "B" Radiopower Unit

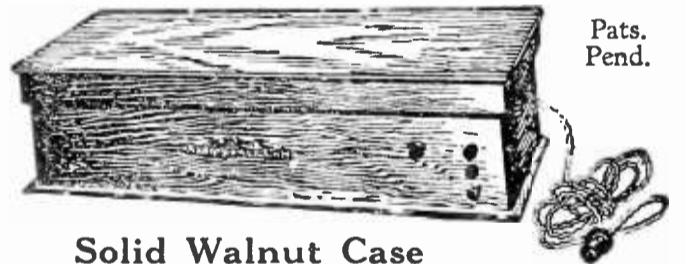

Pats. Pend.

#### Solid Walnut Case

Supplies plate current from light socket. Furnishes constant voltage at all times. Combines all the advantages of wet "B" batteries with none of their disadvantages. *Absolutely no hum during operation.*

No acid to spill. No moving parts to get out of order. Requires no attention after installation. The most dependable, economical, and convenient unit for supplying plate current.

*In handsome walnut case. Price \$35.00*

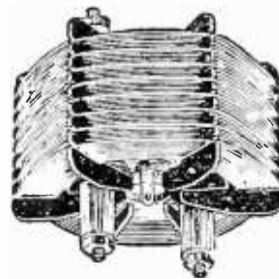

#### Paddlewheel-Coil

Has exceptionally high ratio of inductance to resistance. Losses are negligible. Increases range volume and selectivity. Improves tone. Used in high grade receivers such as DERESNADYNE and BUCKINGHAM. Can be used in nearly all standard receivers and circuits. Price, \$3.00. Secure constructional blue-prints from your dealer or write to our Technical Department.

*We also manufacture the famous DUO-SPIRAL Folding Loop in special models for every circuit. If your dealer cannot supply these standard products, write direct.*

## Radio Units Inc. ★

1304 First Avenue Maywood, Illinois  
Perkins Electric, Ltd., Montreal, Toronto, Winnipeg

# A real FREED-EISEMANN

*embodying many of the  
inventions of Marius C. A. Latour—  
for \$75!* ★

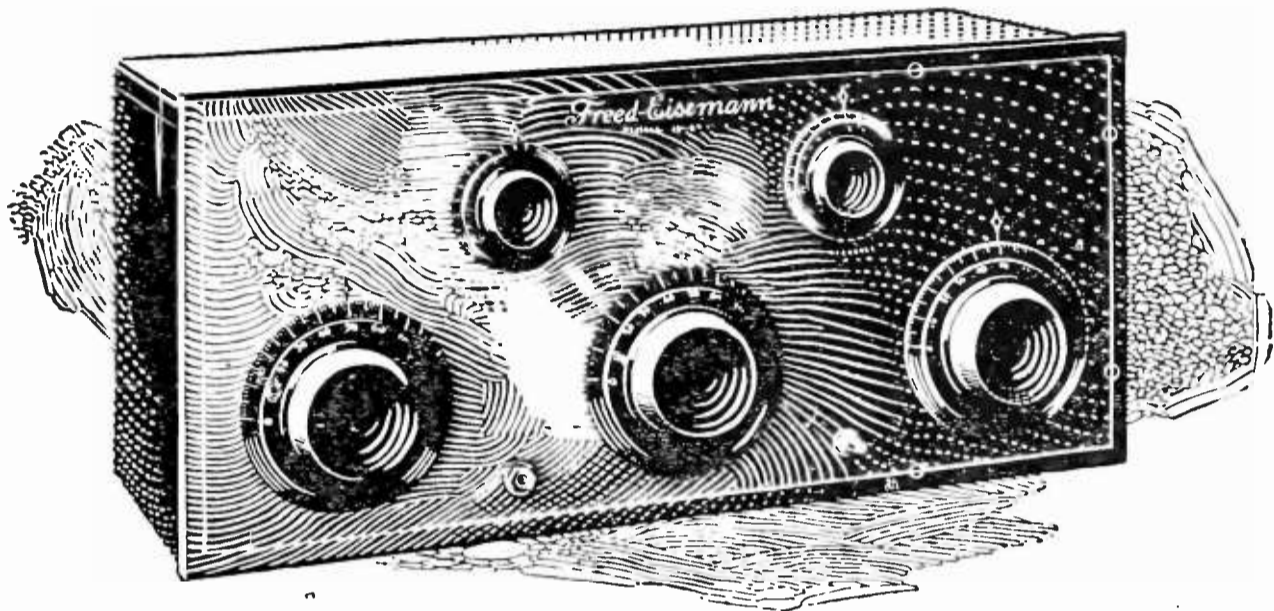

**W**HY not have the satisfaction of owning a set made by master craftsmen—

A set embodying advanced principles in Radio engineering—

In other words, the Freed-Eisemann FE-15.

This set at \$75 offers, we believe, the outstanding Radio value of today.

The receiver comprises two stages of tuned radio frequency (Latour arrangement); detector and two stages of quality audio frequency amplification. New radio and audio circuit design assures improved selec-

tivity and tone quality with minimum drain on B batteries.

It has five tubes, with a coupled antenna circuit which gives maximum selectivity. It is non-oscillating and non-radiating.

All connections are made to binding posts at the rear of the receiver. Shock-proof detector mounting.

Know the latest in Radio. Go to the Freed-Eisemann dealer and see this set!

*Freed-Eisemann Radio Corporation*  
MANHATTAN BRIDGE PLAZA, Brooklyn, N. Y.

# FREED- EISEMANN

*Mastery in Radio*

★ Tested and approved by RADIO BROADCAST ★



**\$25**

# The SAAL Soft SPEAKER

*combines volume with a velvet tone*



## SAAL Jr.

The same in every respect as the Saal Soft Speaker, except it measures 18½ instead of 21½ inches in height.

**\$20**

*West of Rockies, \$21  
In Canada, \$27.50*



The Saal Soft Speaker Unit is an example of the care with which the entire speaker is manufactured. The diaphragm is connected to the armature by a pin which transmits the action of the armature to the diaphragm as a push and pull movement. There are no springs to snap the diaphragm back into place. This explains why the unit cannot be blasted and cannot get out of order. In attaching the pin to the diaphragm it is threaded for a nut. These threads, 200 to the inch, are finer than a jewelers' standard.

**I**N buying a radio reproducer you need no longer choose between volume and tone quality. You can now buy a speaker with both. The Saal Soft Speaker combines volume with a velvet tone.

The Saal has no blare, no blast, no metallic ring. It is not a fad. It is a faithful reproducer of radio programs. It is properly constructed for the accurate reproduction of sound. It is not straight-necked like a trumpet. The neck is curved like a saxophone, the most melodious of all instruments.

The reproducing unit of the Saal Soft Speaker is of all-metal construction, and cannot be harmed or "blasted" by

the loudest receiver. It maintains its tone with any volume. There is no adjustment knob to complicate tuning.

The Saal Soft Speaker is made to last a lifetime. The neck is of aluminum. The bell is of genuine Bakelite. There is no wood, no tin, no composition. It has nothing to warp, crack, wear out or deteriorate. It is guaranteed to give you satisfaction.

In appearance the Saal, with its large black bell, black crackle throat and graceful lines, is the aristocrat of horns. Also furnished with a brown bell and gold or silver stippled throat at \$5 extra. Hear it at your dealer's today.

**SAAL** *Soft*  
**SPEAKER**  
VOLUME WITH TONE QUALITY

Manufactured and guaranteed by H. G. SAAL COMPANY, 1800 Montrose Ave., Chicago, Ill.

★ Tested and approved by RADIO BROADCAST ★



# Supremacy



★ **MAGNATRONS** have achieved supremacy in the vacuum tube field, but the constant vigilance which has brought these tubes to the fore has not for one moment been lessened. Every part, from contacts to filament, is tested, constantly tested.

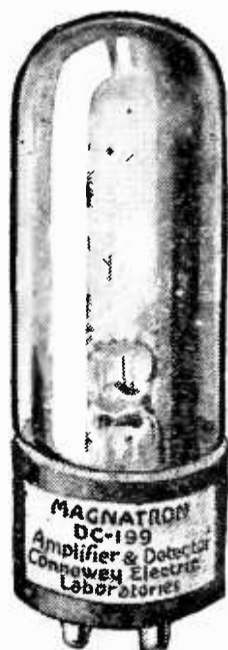

Magnatrons are made by the oldest exclusive manufacturer of thermionic valves. The Connewey plant has been turning out vacuum tubes long enough to know how—and rigid inspection makes certain that that knowledge is always being used.

*The Magnatron DC-201A, DC-199, and DC-199 (large base) now list for only \$2.50 each*



Connewey Electric Laboratories  
Magnatron Bldg., Hoboken, N.J.

# MAGNATRONS

★ Tested and approved by RADIO BROADCAST ★

**YOU**  
 don't need  
 "B" Batteries  
 if you use the  
**FRESHMAN MASTER "B"**  
 Battery Eliminator



★

A. C. Model illustrated  
 6 inches square; weighs 7½ pounds

Connects from any electric light socket right to your radio set;— that's all there is to it.

With the Freshman Master "B" Eliminator your set will always be supplied with constant and uniform power. Noiseless in operation; your reception will not be marred by the snap and crackle due to chemical action in "B" batteries.

*Costs less than one-tenth of a cent per hour to operate*

**A. C. Model \$20.00**  
 for alternating current

Freshman Rectifying Tube is required for operation of the A. C. Model. Price - - - - **\$2.50**

**D. C. Model \$17.50**  
 for direct current

Sold by AUTHORIZED FRESHMAN DEALERS only

**Chas. Freshman Co. Inc.**  
*Radio Receivers and Parts*  
**FRESHMAN BUILDING**  
 240-248 WEST 40TH ST.—NEW YORK, N.Y.  
 CHICAGO OFFICE — 327 S. LA SALLE ST.



UNIVERSAL  
 A Universal  
 Precision in-  
 strument that  
 meets ALL re-  
 sistor needs.

★

WHEN reception is so indistinct that you must use your imagination to get the sense, that's the time to install CLAROSTAT. CLAROSTAT across the transformer of your amplifier will clear up distortion. Installed in a moment and lasts a lifetime.

**\$225 LIST**

American Mechanical Labs., Inc.  
 285-287 No. 6th St. Brooklyn, N. Y.  
 Ask about the new CLAROTUNER; compact, efficient

**CLAROSTAT**

★

**SUPERTRAN**

**AUDIO TRANSFORMER**

**RATIOS**  
 3½ to 1—5 to 1

Fast becoming the world's most popular transformer, because of its unequalled ability to amplify without distorting and to bring in smooth, clean, clear-cut, reproductions of broadcasted programs.



**DISTRIBUTED BY**

L. W. Cleveland Co., Portland, Me.  
 E. P. Denham, Seattle, Washington  
 Waite Auto Supply Co., Providence, R. I.  
 Gray Sales Co., Philadelphia, Pa.  
 Rice-Hitt Co., San Francisco, Cal.

S. B. Darmstader, Chicago, Ill.  
 Whiting Radio Co., Bridgeport, Conn.  
 Paterson Radio Co., Paterson, N. J.  
 Buffalo Radiophone Co., Inc., Buffalo, N. Y.  
 The Jack L. Hirsch Co., Denver, Colo.

**FORD RADIO & MICA CORP.**  
 111 Blecker St. New York City

★ Tested and approved by RADIO BROADCAST ★

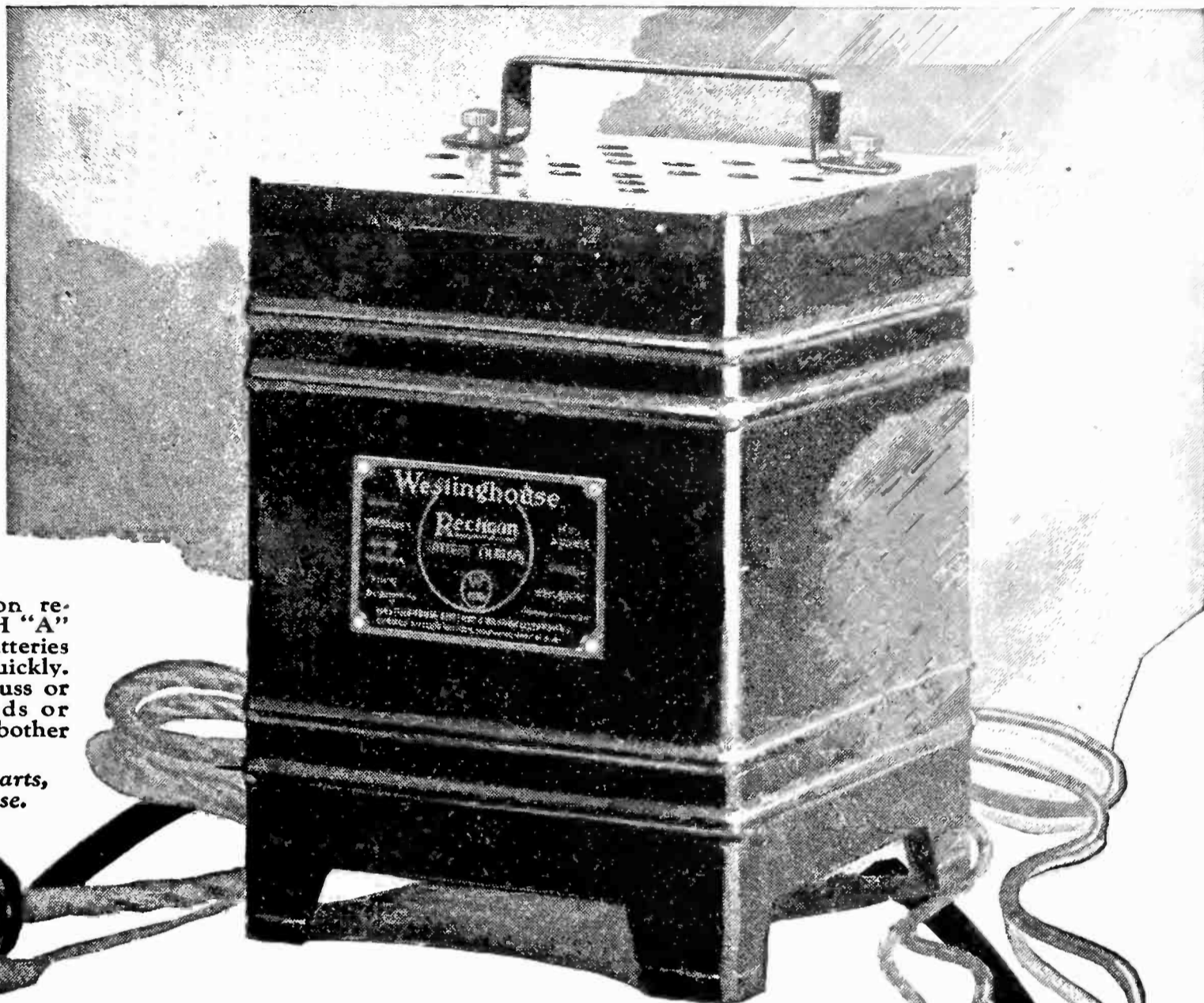

The Rectigon recharges BOTH "A" and "B" batteries easily and quickly. There's no muss or fuss; no acids or chemicals to bother with—

*No moving parts, and no noise.*

No storage-battery radio is complete without a **RECTIGON!**

★  
**Westinghouse**  
**Rectigon Battery Charger**

WESTINGHOUSE ELECTRIC & MFG. COMPANY  
 South Bend, Indiana



© 1925,  
 W. E. & M. Co.

★ Tested and approved by RADIO BROADCAST ★

**The Sun**  
**RADIO SECTION**  
 SECTION TWO NEW YORK, SATURDAY, JANUARY 24, 1925. 36 PAGES

**The Three-Tube Rasla Receiver**  
 How to Build This Remarkable Set, which Functions So Successfully That Many Distant Stations Become "Locals" Night After Night

**Volume, Selectivity and DX**  
 The Radio Sun sponsored the one tube Rasla and the two tube Rasla. The receiver was tested by the SUN staff. Tube for tube this three bulb receiver surpasses any home built set. Tests showed the volume far too sufficient for the locations fifty miles from the broadcasting station. **The Editors.**

**RASLA REFLEX**

Components and prices:  
 - Photo-Collector: \$1.25  
 - Rasla Transformer: \$4.00  
 - Rasla Tuner: \$1.75  
 - Rasla Speaker: \$4.00

**EDITORS** are notoriously "hard-boiled." Before they go into ecstasies over a circuit, it must really be exceptional.

You can draw your own conclusions from the fact that the Rasla Reflex was editorially boosted by The N. Y. Sun and by many others.

Write at once for FREE picture diagram.

DAVIDSON RADIO CORP.

★ Dept. B, 222 Fulton St. New York City

For 4 Tube Roberts Set Use **COMO DUPLEX**

The World's Standard Push Pull Transformer

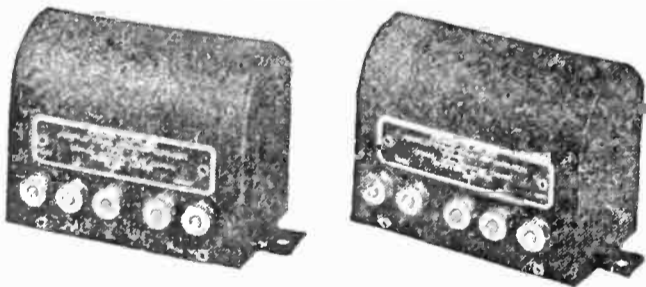

★ PRICE \$12.50 per pair

For maximum volume without distortion

What Prominent Writers on Radio Subjects say About Como

Arthur H. Lynch, Editor, *Radio Broadcast*: "The Push Pull System of Amplification usually results in overcoming the overload on the second stage Audio where transformer coupling is employed."

Lewis B. Hagerman, Technical Editor, *Chicago Post*: "Actual Tests show this transformer to be far superior to any others of similar makes."

R. J. Robbins, *New York Sun*: "After consideration of several well-known makes of push pull transformers which are available 'COMO DUPLEX' was selected as most satisfactory."

C. White, *Radio World*: "'COMO DUPLEX' is infinitely superior—most other push pull transformers seem to be ordinary transformers with a center tap brought out as a makeshift."

NEED WE SAY MORE?

**COMO APPARATUS COMPANY**

Manchester, New Hampshire  
 For Sale at Leading Dealers

★ **KORACH TUNED LOOP**  
**Multiple Switch Board Tuner**

Directional Base Compass for Logging. Collapsible



For Those Who Demand Superior Results

Leads the march toward perfect radio reception under all conditions. Not merely a "loop" but an ingenious arrangement of mechanical skill designed for superior results. L. M. Cockaday, using this loop, reached out across the Atlantic to audibly hear many trans-continental Stations.

**Selectivity Plus Distance**

unheard of with common loop aerials. The Korach excels on all sets designed for loop reception. Priced at \$16.50 and for sale by all good dealers. Full particulars sent for 2c stamp and name of local dealer.

**KORACH RADIO CO.**

20 E. Jackson Blvd. Dept. 8 Chicago, Ill.

Dealers and Jobbers: Write to-day for attractive proposition.

The **KORACH JUNIOR**

A modification of the "Senior" but possessing all its important features—\$12.50.

★ Tested and approved by RADIO BROADCAST ★

# What Kind of Variable Condensers will *You* use this Year?

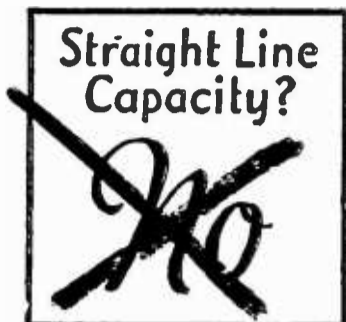

Why? Because out of 100 stations 85 of them come in below the first 50 points on the dial and of these 85 about 60 of them come in below the first 25 points. Hard to tune—only 15 stations on upper 50 points.

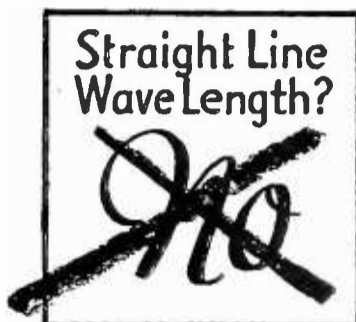

Why? Although somewhat easier to tune than the S. L. Capacity type, still 75 of 100 stations come in below the first 50 points on the dial and of these 36 come in below the first 15 points. Only 25 come in at over 50.



Why? Because every point on the dial means a different station. Points are 10 kilocycles apart. Because it is the most compact condenser made of its type, and the most efficient, all parts machined to 1-10,000 of an inch.

*Your Receiver's Selectivity depends largely upon the variable condensers used; so choose with great care.*

Before you build a new set or rebuild your old one, find out all there is to know about SAMSON Uniform (Straight Line) Frequency Condensers. Leading radio magazines have printed instructive articles about this latest improvement and valuable contribution to radio.

### Greater Selectivity

You know how more than half the stations crowd into the low points on the dial when ordinary condensers are used and how it is almost impossible to cut through local stations. SAMSON Uniform Frequency Condensers change all this. Each point means a different station; they're separated by kilocycles instead of by wave lengths.

### Most Compact

Samson Uniform Frequency Condensers are the most compact and efficient of their type. Just think—only 2¼ inches with the plates wide open and but 3¼ inches deep! See the space the use of these condensers saves. And, despite their compactness they are just as efficient as they could be were they three times as big. Capacity .0005 mfd. Single hole or three-hole mounting. Grounded rotor; low loss type.

### An Instrument

You must consider SAMSON Uniform Frequency Condensers as fine instruments and not merely a radio part. Machined to 1-10,000 of an inch. Silver-plated, with stator and rotor plates also gold-plated to prevent oxydization.

Write at once for Bulletin 33.  
Sent free on request.



The Government regulates broadcasting by kilocycles and separates the frequency at which stations may operate by 10 kilocycles. Therefore, with SAMSON Uniform Frequency Condensers on your set you get a different station for every point on your dial.

# Samson

Uniform Frequency

# Condenser

Made only by

## Samson Electric Company

Manufacturers Since 1882

Canton, Mass.

Sales Representatives in Principal American Cities

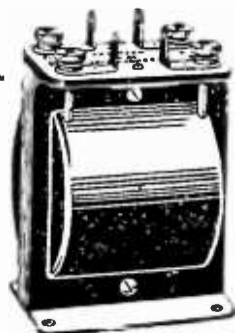

## Samson Helical Wound Audio Transformers

"The Standard for Comparison"

Amplify at all frequencies with practically no distortion. Choice of radio experts in sets for their own use. Only transformers with

famous SAMSON Helical Wound Coils. Two ratios—3 to 1 and 6 to 1. Price, either ratio, \$5.

★ Tested and approved by RADIO BROADCAST ★

VII

# Are You Looking for a Receiver

*That---*

1. Will Equal Superheterodyne Selectivity on Four Tubes?
2. Will Furnish Fine Quality Loud Speaker Volume?
3. Will Satisfy Your Desires for Distance?
4. Will Not Radiate?
5. Is Extremely Simple to Operate?

*Then Look No Further But Build Radio Broadcast's Knock-out Four-Tube Receiver*

*with the aid of our*

**Blue-prints and Sixteen-page Instruction Booklet**

RADIO BROADCAST'S Knock-out Four-Tube Receiver combines the advantageous features of:

1. **Neutralized, tuned radio-frequency amplification.** (which prevents the receiver from radiating.)
2. **Reflexed audio-frequency amplification.** (which saves one tube, transformer, socket, rheostat, etc.)
3. **Regeneration.** (which increases the selectivity and obtains the benefits of an extra tube.)
4. **Push-pull audio-frequency amplification.** (which secures great loud speaker volume and maintains fine quality of reproduction.)

The Blue-prints and instruction Booklet show you how to construct this remarkable receiver. A dollar and the coupon below brings them to you.

*DEALERS! Write to us and we'll outline to you a most attractive sales proposition which will be a distinct aid in moving the parts you now have on your shelves. We can help you make sales that stay sold.*

Doubleday, Page & Co.  
Garden City, New York

RBS

Enclosed find my dollar for the Blue-Prints and sixteen-page Instruction Book for building RADIO BROADCAST'S Four-Tube Knock-out. It is understood that my dollar will be returned if the material sent me does not come up to my expectations.

Name .....

Address .....

.....

# BOSCH BUILDS RADIO

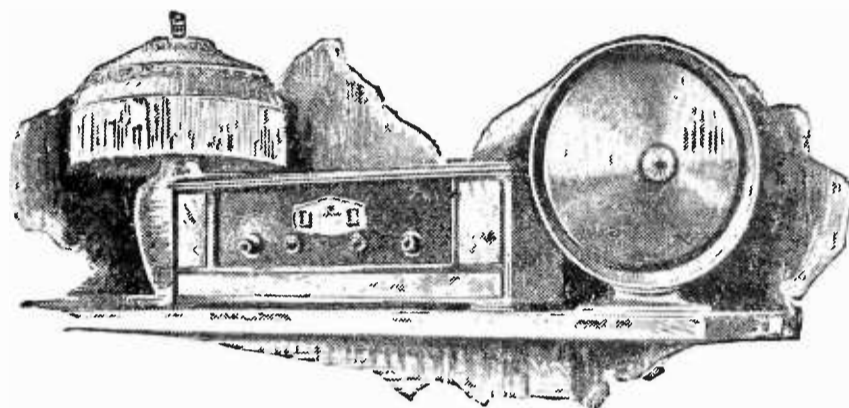

THE AMERICAN BOSCH  
MAGNETO CORPORATION PRESENTS "THE  
AMBOROLA," THE BOSCH  
RECEIVING SET AND "THE  
AMBOTONE," THE BOSCH  
REPRODUCER. THESE IN-  
STRUMENTS HAVE BEEN  
BUILT TO THE FAMOUS  
BOSCH LINE OF PRECISION  
AND ALL THE EXPERIMEN-  
TATION ON THEM HAS  
BEEN ACCOMPLISHED  
IN THE BOSCH LABORA-  
TORIES RATHER THAN  
IN THE HOMES OF THEIR  
PURCHASERS.



THE AMERICAN BOSCH MAGNETO CORPORATION  
SPRINGFIELD, MASS.

★ Tested and approved by RADIO BROADCAST ★

# INDEX OF ADVERTISERS IN THIS ISSUE

## A

Aberdeen Specialty Co. . . . . 864  
 Acme Wire Co., The . . . . . 830  
 Ainsworth Radio Co. . . . . 822  
 All-American Radio Corp. . . . . 824, 833  
 Allen-Bradley Co. . . . . Third Cover, 876  
 American Electric Co. . . . . 836  
 American Hard Rubber Co. . . . . 716-a  
 American Mech. Labs. . . . . 868  
 American Transformer Co. . . . . 829  
 Amsco Products Co. . . . . 704, 705  
 Amplion Corp. . . . . 823  
 Antennaphone Co., The . . . . . 860  
 Apex Electric Mfg. Co. . . . . 712  
 Arrow Battery Co. . . . . 824  
 Atwater Kent Mfg. Co. . . . . 817

## B

Bakelite Corp. . . . . 861  
 Belden Mfg. Co. . . . . 701  
 Brach Mfg. Co., L. S. . . . . 836  
 Branch Tool Co. . . . . 860  
 Branston, Inc., Chas. A. . . . . 714  
 Brann, W. C. . . . . 846  
 Bremer-Tully Mfg. Co. . . . . 849  
 Brightson Laboratories . . . . . 713  
 Bristol Company, The. . . . . 708  
 Bruno Radio Corp. . . . . 858  
 Burton, Rogers Co. . . . . 826, 832

## C

Cardwell Mfg. Co. Allen D. . . . . 821  
 Central Radio Lab. . . . . 840  
 Chicago SolJer Co. . . . . 856  
 Cleartron Vacuum Tube Co. . . . . 832  
 Colytt Laboratories . . . . . 852  
 Conneway Elect. Lab. . . . . 867  
 Continental Fibre Co., The. . . . . 834  
 Copper & Brass Research Ass'n. . . . . 832  
 Corning Glass Works. . . . . 847  
 Crescent Radio Supply Co. . . . . 852  
 Cribben Radio Corp. . . . . 830  
 Crosley Radio Corp. . . . . Fourth Cover  
 Cunningham Co., E. T. . . . . Second Cover  
 Como Apparatus Co. . . . . 870

## D

Daven Radio Corp. . . . . 709, 837  
 Davidson Radio Corp. . . . . 870  
 De Witt-La France Co. . . . . 836  
 Dubilier Condenser & Radio Corp. . . . . 710, 813  
 Dupix Cond. & Radio Co. . . . . 830  
 Durham & Co. . . . . 838

## E

Eastern Coil Co. . . . . 862  
 Eby Mfg. Co., H. H. . . . . 824  
 Electrical Research Lab. . . . . 819  
 Electrad, Inc. . . . . 825  
 Epon Corp. . . . . 851  
 Erie Radio Co. . . . . 842  
 Express Body Corp. . . . . 828

## F

Fahnestock Electric Co. . . . . 846  
 Ferguson, Inc., J. B. . . . . 715  
 Ford Radio & Mica Co. . . . . 868  
 Freed-Eiseman . . . . . 865  
 Freshman & Co., Charles . . . . . 868  
 Frost, Inc., Herbert H. . . . . 852

## G

Gale Radio Co. . . . . 822  
 Gardiner & Hepburn . . . . . 862  
 Gearhart-Schlueter . . . . . 822  
 General Electric Co. . . . . 716-e  
 General Radio Co. . . . . 875  
 Goertz & Co., August. . . . . 854  
 Goodrich Rubber Co. . . . . 827  
 Grimes, Inc., David. . . . . 857

## H

Heins & Bolet . . . . . 844  
 Holtzer-Cabot, Inc. . . . . 716-g  
 Hommel Co., Ludwig. . . . . 831  
 Hill Mfg. Co., A. E. . . . . 834

## I

International Corres. Schools. . . . . 850

## J

Jacobs, C. E. . . . . 844  
 Jaynell Mfg. Co. . . . . 818  
 Jewell Elect. Inst. Co. . . . . 834  
 Jewett Radio & Phonograph Co. . . . . 711  
 Jones, Howard B. . . . . 838

## K

Kalmus, Comstock & Wescott, Inc. . . . . 826  
 Karas Elect. Co. . . . . 820  
 Kellogg Switchboard & Supply Co. . . . . 855  
 Kodel Radio Corp., The. . . . . 716-c, 842, 845  
 Korach Radio Co. . . . . 870

## M

Midwest Radio Corp. . . . . 716-d  
 Montgomery Ward & Co. . . . . 716-b  
 Musselman, A. J. . . . . 831  
 Mu-Rad Radio Corp. . . . . 702, 703  
 Mydar Radio Co. . . . . 839

## N

National Carbon Co. . . . . 815  
 National Co. . . . . 828  
 National Radio Institute . . . . . 859  
 New York Coil Co. . . . . 828  
 Norden-Hauck Co. . . . . 848

## O

O'Conner Co., A. . . . . 842  
 Ohio Stamping & Eng. Co. . . . . 716-f  
 Omnigraph Mfg. Co., The . . . . . 844  
 Ozarka, Inc. . . . . 809

## P

Pacent Electric Co. . . . . 846  
 Pathé-Phonograph & Radio Co. . . . . 840  
 Perfection Radio Mfg. Co. . . . . 852  
 Phenix Radio Corp. . . . . 811, 846  
 Potter Mfg. Co. . . . . 856

## R

Radiall Co. . . . . 864  
 Radio Corp. of America. . . . . 717  
 Radio Foundation. . . . . 858  
 Radio Inst. of America . . . . . 854  
 Radio Panel & Parts Co. . . . . 850  
 Radio Products Inc. . . . . 863  
 Radio Units, Inc. . . . . 864  
 Rathbun Electric Co. . . . . 716  
 Rhamstine, J. Thos. . . . . 848

## S

Saal Co., H. G. . . . . 866  
 Samson Electric Co. . . . . 871  
 Sickles Co., F. W. . . . . 852  
 Silver-Marshall . . . . . 853  
 Smith, B. H. . . . . 860  
 Starrett Mfg. Co. . . . . 860  
 Supertron Mfg. Co. . . . . 835

## T

Thordarson Elect. Mfg. Co. . . . . 841  
 Trim Radio . . . . . 856

## V

Valley Electric Co. . . . . 706, 707  
 Victor Radio Co. . . . . 842

## W

Walbert Mfg. Co. . . . . 843  
 Westinghouse Electric & Mfg. Co. . . . . 869  
 Western Radio Mfg. Co. . . . . 854  
 World Battery Co. . . . . 844, 860

## X

X-L Radio Laboratories . . . . . 860



# From the Listener's Point of View

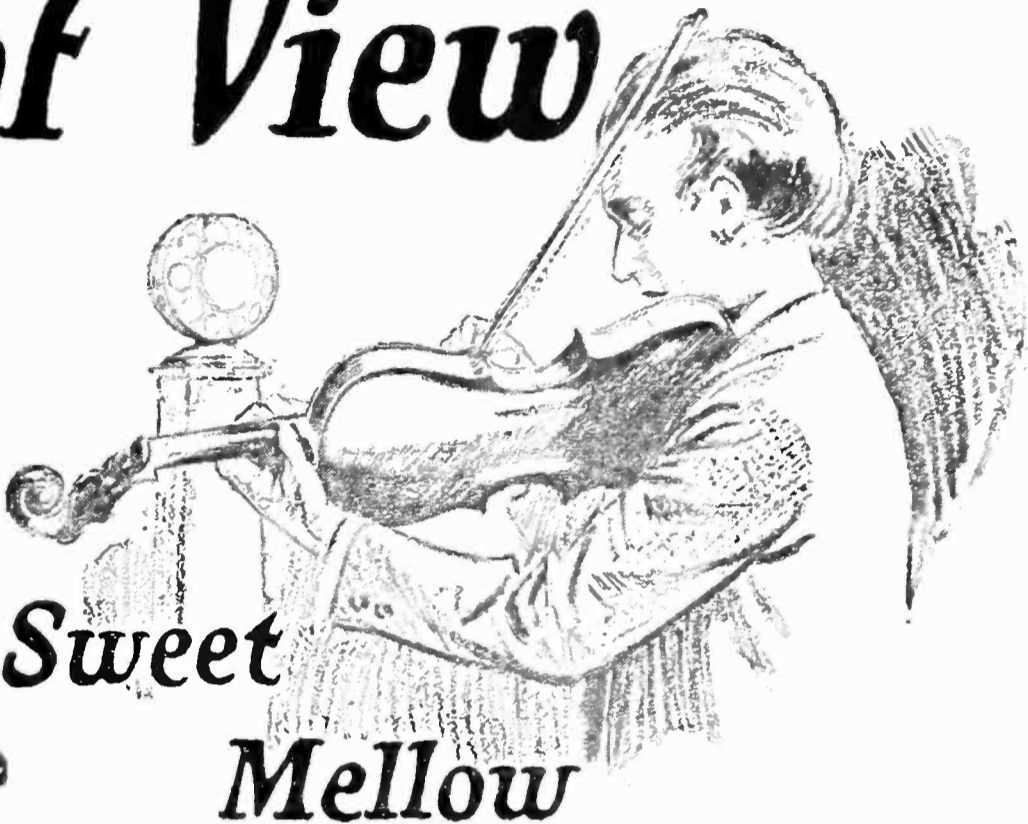

*Natural*

**G**ENERAL RADIO transformers are true mirrors of tone quality. They reproduce instrumental and vocal music as pure, full, and natural as it enters the microphone at the studio of the broadcasting station.

Due to the special design of the core and adjustment of the coil turns these transformers are capable of unusually high and even amplification of all tones common to speech and music.

In spite of their recognized superiority over other transformers they sell at a popular price.

Enjoy the programs of radio artists in unmodified form—Use a General Radio 6 to 1 ratio transformer in the first stage and a 2 to 1 ratio in the second.

Ask to see them at your local dealers or write for our descriptive folder No. 285-B showing amplification curves and wiring diagrams.

Type 285  
Audio Amplifying Transformers  
6 to 1 ratio for first stage  
2 to 1 ratio for second stage

\$ **6** each

GENERAL RADIO CO.  
Cambridge Mass.

# GENERAL RADIO

“Behind the panels of Better-Built Sets”

★ Tested and approved by RADIO BROADCAST ★



# There's a Real Thrill ★ in trying a New Hook-Up!

**E**VERYONE in the family is eagerly waiting to hear the new set! After hours and hours of drilling and soldering, the set is nearly ready for its first crucial test.

Will it meet with your expectations or will it be a disappointment? That depends upon two things—first your workmanship, and second, the quality of the parts used.

Good workmanship is the result of patience, but good parts are assured only by demanding well-known, guaranteed products, such as Allen-Bradley Perfect Radio Devices. Allen-Bradley Products are known the world over for exceptional performance and fine appearance. They eliminate the hazard and disappointment that follow the use of inferior radio products.

Ask your dealer for Allen-Bradley Perfect Radio Devices if you value your time and labor. *They always work!*

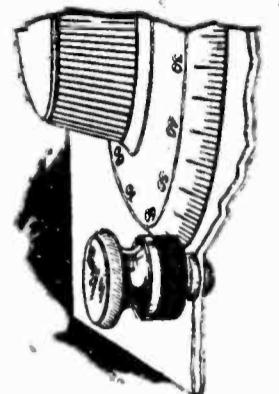

**Bradleyner**—Perfect Vernier Knob.



**Bradleyswitch**—Perfect Battery Switch.

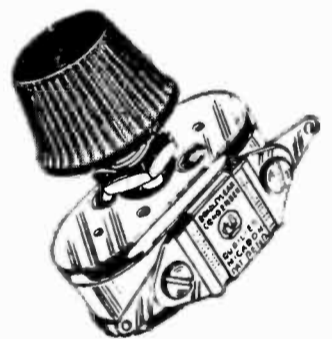

**Bradleyleak**—Perfect Grid Leak  $\frac{1}{4}$  to 10 Megohms.

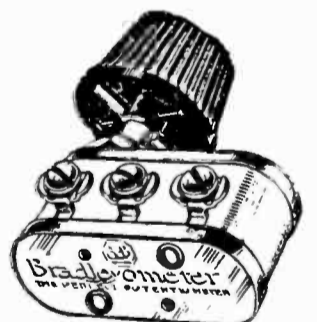

**Bradleyometer**—Perfect Potentiometer

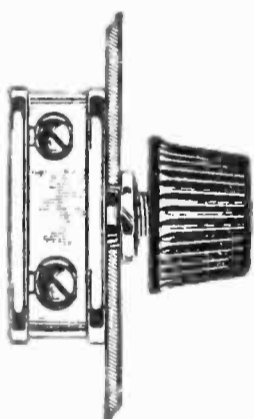

**Bradleystat**—Perfect Filament Control for All Tubes.



**Bradleyohm**—Perfect Adjustable Resistor.



**Bradleyunit**—Perfect Fixed Resistor.

**Allen-Bradley Co.**  
Electric Controlling Apparatus

278  
Greenfield  
Ave.



Milwaukee,  
Wisconsin

*Mfrs. of Graphite Disc Rheostats for  
Over 20 Years*

**ALLEN-BRADLEY CO.,**  
278 Greenfield Ave., Milwaukee, Wis.

Please send me your latest literature on the complete Allen Bradley line of Perfect Radio Devices.

Name .....

Address .....

★ Tested and approved by RADIO BROADCAST ★

ABSOLUTELY ESSENTIAL  
FOR SENSITIVE SETS

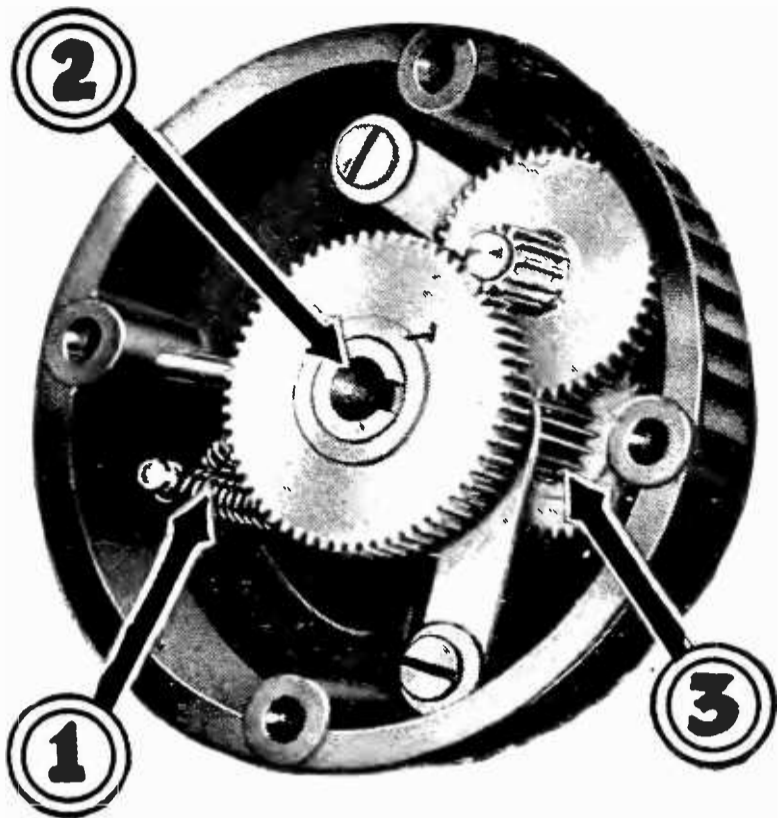

**NEW!**

## Accuratune Features



Canadian  
Representatives:  
RADIO, Ltd.  
Montreal, Canada

European Branch  
Office:  
Gaston E.  
Marbaix  
27 Anning St.,  
London, E. C. 2

1. **No Back Lash**—A new principle takes up all lost motion and back lash and produces a very smooth operating instrument.

2. **Long center bushing** eliminates all dial wobble and takes all standard condenser shafts. Permits dial mounting flush with panel. No cutting of condenser shafts.

3. **Gear mesh and alignment** perfected to the same degree of accuracy as the mechanism of a watch. Ratio 80-1.

**You can change** from ordinary dials to ACCURATUNE Micrometer Controls in an instant, no set alterations necessary. More efficient than built in verniers—a revelation in fine tuning.

Equip your set with ACCURATUNE dials and note the improvement.

*At your dealers, otherwise send price (\$3.50) and you will be supplied postpaid.*

Write for descriptive folder.

Mydar Radio Company, 9-D Campbell St., Newark, N. J.



★ Tested and approved by RADIO BROADCAST ★

# THE NEW CROSLLEY 51-SPECIAL

**\$23<sup>50</sup>**



*Of Course  
the Famous  
Crosley 51 Regular at  
**\$18<sup>50</sup>**  
Will be Continued*

Here is the popular Crosley 51 dressed up in new clothes. It is known as the Crosley 51-Special. This two tube, genuine Armstrong regenerative receiver is exactly the same as the nationally known Crosley 51, except it is installed in a larger cabinet in which there is room for dry cell batteries. Also there is the slanting panel, a feature that adds to the appearance of the set and makes operation more comfortable.

This radio is as artistic as it is efficient, appealing to the housewife who demands beautiful appearance and elimination of visible batteries. All Crosley radios are licensed under Armstrong Regenerative U. S. Pat. 1,113,149. Other models priced from one tube 50, at \$14.50 to the Trirdyn Special with sloping panel, at \$65. For sale by good dealers everywhere. Write for catalog.

*Prices quoted without accessories. West of Rockies add 10%.*

**THE CROSLLEY RADIO CORPORATION**

Powel Crosley, Jr., President

520 Sassafras St.

*Crosley owns and operates Broadcasting Station WLW.*



Cincinnati, Ohio

★ Tested and approved by RADIO BROADCAST ★

# Vigilance

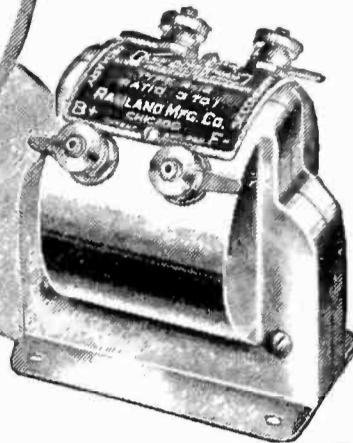
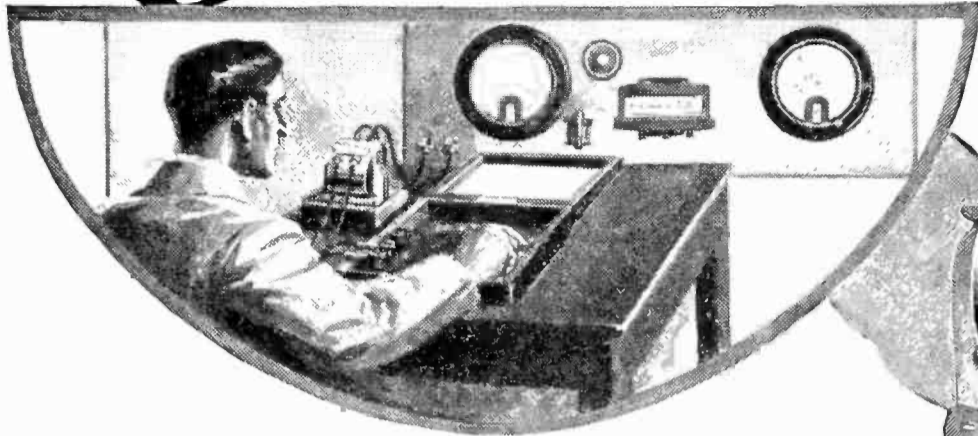

# Leadership



Every All-American transformer has stamped upon it a serial number which identifies the record of its individual test at the factory. The manufacturer stands behind it absolutely provided this serial number is not effaced. *Look for the number*, and for the famous red guarantee tag with the inspector's punch marks.

Of what importance is it to you as a *user* of radio transformers, to know that any particular brand, such as ALL-AMERICAN, has held continuously for a number of years the position of *proven leadership* in *quantity of sales*?

Simply this: that such an achievement is the best possible proof of *continued satisfaction* given to other ALL-AMERICAN

users. The average purchaser of a transformer chooses, above all, an instrument which has been *recommended* to him by a person whose judgment he respects.

Only by the most thorough accuracy and care in manufacturing, and unusual care in testing, is it possible for ALL-AMERICAN to maintain this position. Let it be your protection!

A new edition of the Radio Key Book, just off the press, illustrates an eight-tube set which is the sensation of the year. Send 10 cents for it now, coin or stamps.

ALL-AMERICAN RADIO CORPORATION 2652 Coyne St., Chicago  
E. N. Rauland, President

# ALL-AMERICAN

*Largest Selling Transformers in the World*

★ Tested and approved by RADIO BROADCAST ★

# What the Trirdyn gets where it's hotter than Summer!

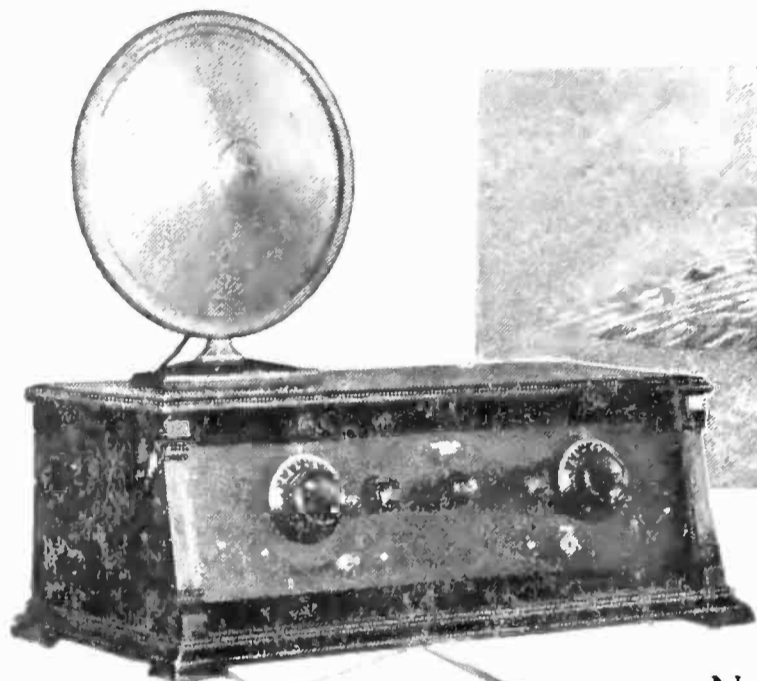

Crosley Trirdyn — on the Sahara Desert at mid-day—brings in Radio-Paris on the loud-speaker!

Not only at mid-day, but in February—in Northern Africa and far hotter than any American summer. The picture above, a post card snapshot sent from Tunis to Mr. Crosley, by D. F. Keith of Toronto, Ont., tells this story on the other side:—

Tunis, North Africa, March 3, 1925

Dear Mr. Crosley:

Fishing here is rotten but radio is fine. On the Sahara, using three tubes on the Trirdyn circuit, reception from Paris came through on the loud-speaker. Along the south coast of the Mediterranean, using this set, six or eight high power European stations came in with good volume by day-light and all of them after dark. Can usually get a few American after 1 a. m. Can you fish with us this year?

Cordially,  
(Signed) D. F. Keith

Further details on the margins of the picture:—

Sahara Desert, 250 miles south of Algiers, February, 1925. Receiving noonday concert from "Radio-Paris," Paris, using aerial and counterpoise.

Who said summer in America is a poor time for radio—if the receiver is a Crosley Trirdyn?

Every radio fan—actual and aspiring—is invited to think this over and then act.

*On the Trirdyn is the beautiful new Crosley Musicone, radio's most startling development. The Musicone's abilities and its beauty are so superior that we expect it to replace half a million loud-speakers this year. \$17.50.*

The Crosley Radio Corporation, 620 Sassafras St.  
Cincinnati  
Powel Crosley, Jr., President

# CROSLEY RADIO Better~Costs Less

**\$65.00**  
Accessories Extra

**Crosley Trirdyn Special**

Three tubes better the results of five or six

A highly efficient, non-radiating combination of tuned radio frequency, Armstrong regeneration and reflexed amplification.

New cabinet, sloping panel

Battery self-contained

Exclusive Crosley 3-tube circuit



★ Tested and approved by RADIO BROADCAST ★

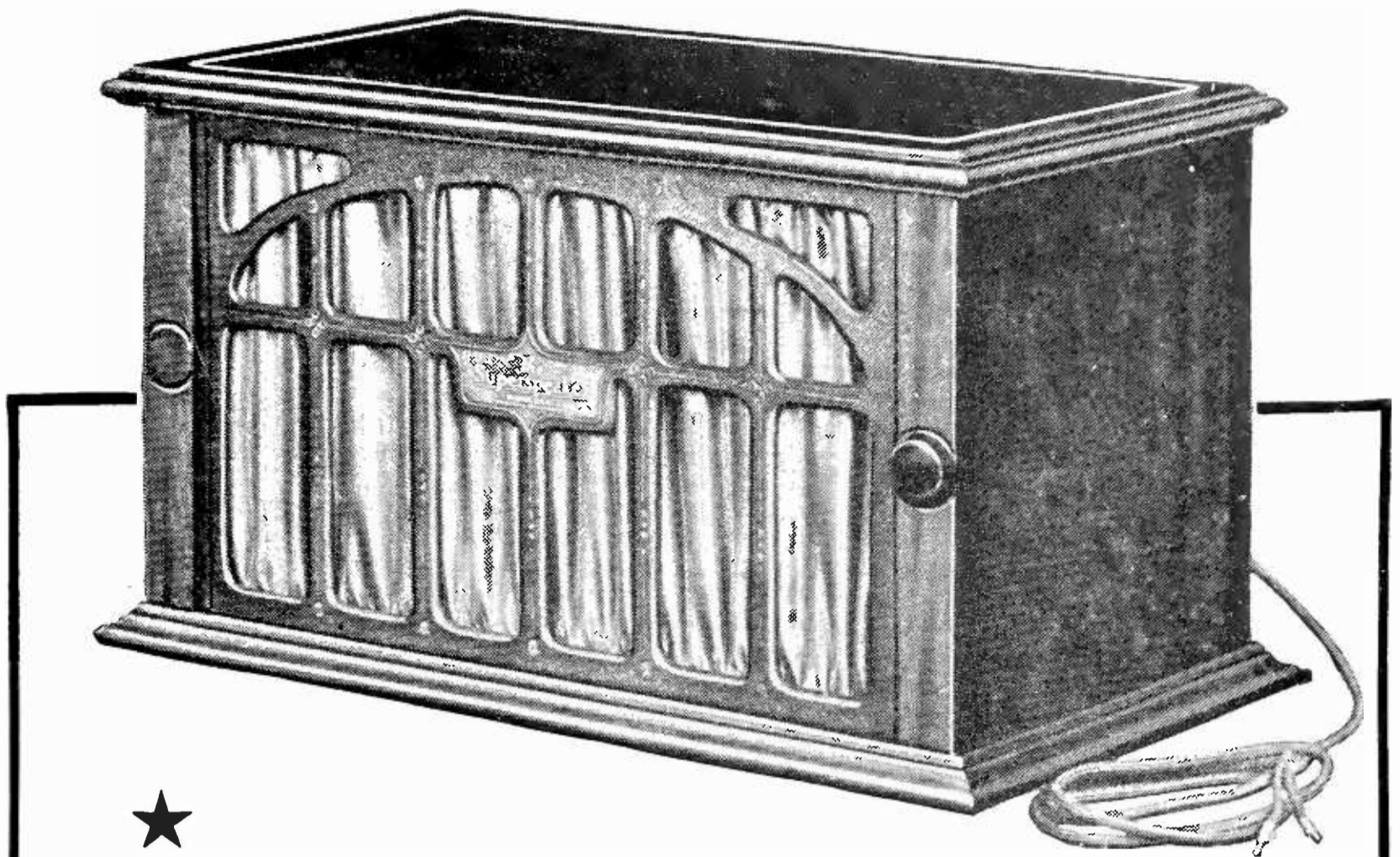

# And Now— The Superspeaker Console

In performance, it's a Superspeaker—enough said.

In Appearance, it's the finest piece of Radio cabinet work you have ever seen.

Just what you'd expect from two years' experiment and development by an organization with a record of leadership in the field of loudspeakers.

See it! Listen to it! Enjoy its ability to improve the appearance and performance of your set.

Of finest American Walnut or the new Clairemount Mahogany—Top inlaid with Arlington Ivory—Leather composition grill, richly draped with silk—Volume controlled by ebony knob—Superspeaker-Vemco Reproducing unit—Superspeaker-material concealed horn with full floating mounting. Overall size 10¼ x 17¾ inches, 10 inches high. Ask any Jewett dealer. Price \$40.00; west of the Rockies, \$42.50.

**JEWETT RADIO & PHONOGRAPH COMPANY**  
5672 TELEGRAPH ROAD PONTIAC, MICHIGAN

Factories: Allegan, Michigan—Detroit, Michigan—Pontiac, Michigan

Canadian Sales Offices:  
Walkerville, Ontario

Export Sales Offices:  
116 Broad St., New York City

*The Jewett Superspeaker—*  
All that the name implies.  
Recommended by experts  
everywhere. Price \$30.00.



*The Jewett Superspeaker Console—*  
A handsome cabinet with Superspeaker  
performance. Enough said. Price  
\$40.00. West of the Rockies, \$42.50.

*The Jewett Parkay Cabinet—*  
With parquetry top. Puts the  
amateur on a par with the most  
exclusive cabinet worker. All  
sizes, prices to correspond.

*The Jewett Micro-Dial—*  
Makes tuning 50 times as  
accurate. Fits any set.  
Needs only a screwdriver to  
install. Price \$3.50.

*The Jewett Vemco Unit—*  
Makes a loud speaker out of  
your phonograph. The Re-  
producer used in the Super-  
speaker. Price \$12.00.

*The Jewett Superspeaker  
Highboy—*Houses Radio set  
and all batteries. Superspeaker  
built in. Takes Radio into  
the realm of fine furniture.  
Price \$130.00.

# Jewett Quality Products

★ Tested and approved by RADIO BROADCAST ★

# Now Hear Radio Music Better Than Ever Before

By the end of this year, we expect to see the beautiful new Crosley Musicone replace at least half a million of the best of present-day radio reproducing devices.

For the Crosley Musicone, designed and built on entirely new principles, covered by *basic patents* issued and pending, reproduces music and the speaking voice *true to life* - -

Without distortion, extraneous overtones, resonance vibrations or other horn noises;

Over the *entire* musical scale, from lowest to highest notes, on *any* instrument;

Without overloading; and without chattering, because its diaphragm is a floating cone;

Without adjustments, or additional batteries;

Without directional properties or a horn;

And at a price that is revolutionary.

Ten thousand radio dealers are now displaying the beautiful Crosley Musicone. By all means hear it, and know for the first time what real radio music is.

*Crosley owns and operates station WLW, Cincinnati, the first remotely controlled super-power broadcasting station.*

## The Crosley Radio Corporation

720 Sassafras Street  
Cincinnati

Powel Crosley, Jr., President

### Guarantee

Dealers are authorized to sell the Crosley Musicone on five days' trial in your home. Satisfaction guaranteed or money refunded upon return.

Crosley manufactures receiving sets which are licensed under Armstrong U. S. Patent No. 1,113,149, and priced from \$14.50 to \$65, without accessories.

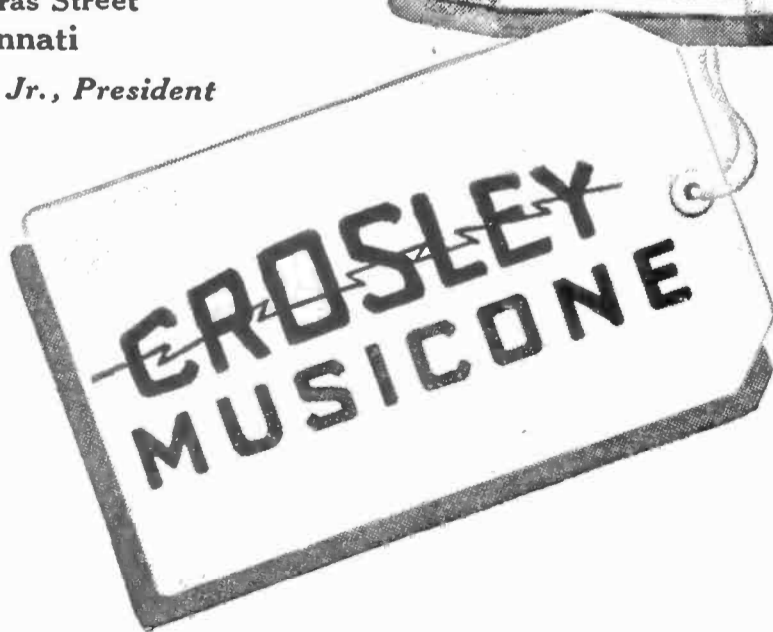

# 17<sup>50</sup>

Add 10% west of Rocky Mountains.

The Crosley Musicone is artistically beautiful—an ornament in any home. Write for complete description.

★ Tested and approved by RADIO BROADCAST ★

THE COUNTRY LIFE PRESS, GARDEN CITY, NEW YORK





# Ferguson

SIX

## *Astounding Results Make Ready and Satisfied Owners*

A gentle angel—or a mighty giant.

One of the most marvelous things about the FERGUSON SIX is a tone quality that carries true and sweet regardless of volume.

Only two dials are used for tuning—and even a child can do it; bringing in more stations in half the time than an expert using any other receiver.

The station selected, you can modulate your volume from the faintest whisper to concert hall capacity—and more remarkable still, there is no slurring or loss of quality on either high or low volume. Loud stations can be reduced at will to unobtrusiveness and yet perfect reproduction, and weak stations likewise brought up to the same volume as locals.

We accept the challenge of *any* one to compare this receiver on *any* desired quality with *any* other, regardless of *type*, number of *tubes* or *price*.

Many new dealers of the better class have applied for the increasingly valuable FERGUSON dealer franchise. There is some valuable territory still open. Dealers who cater to high class trade and want a radio line that sells and stays sold on its unusual merit are invited to write for details and demonstration.

*Illustrated catalog on request*

### *Be Convinced*

FERGUSON prices may go up—but never down. This receiver is a true investment because it is designed better, built better and performs better. Hear it at our nearest dealer—or dealers write us to show them what it will do.

## **J. B. FERGUSON, Inc.**

*Manufacturers of High Class Radio Receivers*

**Executive offices and showrooms:**

**41 East 42nd Street**

**New York**



**Ferguson Six—Console Model**

Complete with special built in loud speaker, with Amplion unit, compartments for "A" and "B" batteries and battery charger. Cabinet work the finest, genuine walnut, finished in latest high light styles. Plenty of room for books and radio literature. Top panel drops down when receiver is in operation, providing a handy desk arrangement.

Price, \$290

Batteries, tubes, and charger extra

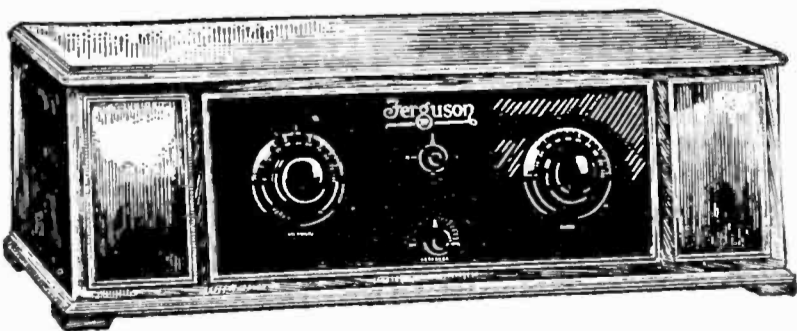

**Ferguson Six—Cabinet Model**

Employs two stages of balanced tuned radio frequency oscillating detector (equal to regeneration for added volume, but without radiation or effect on tuning); three stages of perfectly matched audio frequency. De Luxe high light walnut or mahogany cabinet with separate compartments for "B" batteries.

Price, \$180

Tubes and batteries extra

★ Tested and approved by RADIO BROADCAST ★

# The Wonder of Radio!



Crosley owns and operates station WLW, Cincinnati, the first remotely controlled super-power broadcasting station.

## CROSLLEY 50

### One tube set

**\$14<sup>50</sup>**

Add 10 per cent west of Rocky Mountains



51

**\$18<sup>50</sup>**

#### 2-Tube Crosley 51

Same as wonderful Crosley 50 with additional tube amplifier. Local and nearby stations on loud-speaker always and distance up to 1500 miles under average conditions. Much greater range with head phones.

#### Special Sloping Front

#### 2-Tube Crosley 51

Same as model 51, with cabinet holding all dry A and B batteries. \$23.50.

#### 2-Tube Crosley 51 Portable

The Crosley 51 in a black leatherette case, with nickel trimmings. Space for batteries. \$23.50.

#### Crosley Musicone

A marvelous new development of loud-speaking principles. Diffusion of sound creates perfect reproduction of all tones. \$17.50.

#### 3-Tube Crosley 52

A larger set for those who want greater reception range on the loud-speaker. Operates on three tubes, using wet or dry batteries. Consistent loud-speaker range 1500 miles or more.

#### Special Sloping Front

#### 3-Tube Crosley 52

Cabinet contains dry A and B batteries. Same efficient detection and reception as regular 52. \$35.

#### 3-Tube Crosley 52 Portable

Same as other 52 models, but in a black leatherette case. Easily carried. All batteries inside. \$35.

Prices quoted above do not include accessories. Add 10 per cent west of Rocky Mountains.

This is the latest refinement of the marvelous set that enabled Leonard Weeks of Minot, N. D. to catch the messages of MacMillan's North Pole expedition when sets costing ten times as much failed.

In this set Crosley has developed the famous Armstrong regenerative circuit. This circuit does with one tube what it takes three tubes to do in others.

This set will bring in stations from all over the country. It is simple and easy to operate. With accessories the total cost should be under \$25.00. Crosley keeps the cost down with his "radio-for-the millions" ideas in production.

Recent letters from enthused owners of the Crosley one-tube 50 report good reception at these distances:

Mrs. J. E. Martin at East Palestine, O. hears KGO at Oakland, Calif.

O. W. Bryant at Sunset, Texas gets WLW at Cincinnati, KDKA at Pittsburgh and Hollywood, Calif.

L. R. Pratt, Hammond, Ind. hears 5NO, New Castle, England.

Eugene Barnhouse at Brookfield, Mo. hears Montreal and Winnipeg, Canada.

Paul J. Hall at Osceola, Neb. hears 2LO at London, England.

Crosley manufactures receiving sets which are licensed under Armstrong U. S. Patent No. 1,113,149, and priced from \$14.50 to \$65, without accessories.

## The Crosley Radio Corporation

Powel Crosley, Jr., President

820 Sassafras Street, Cincinnati

★ Tested and approved by RADIO BROADCAST ★

# The MELODIES of MEMORY

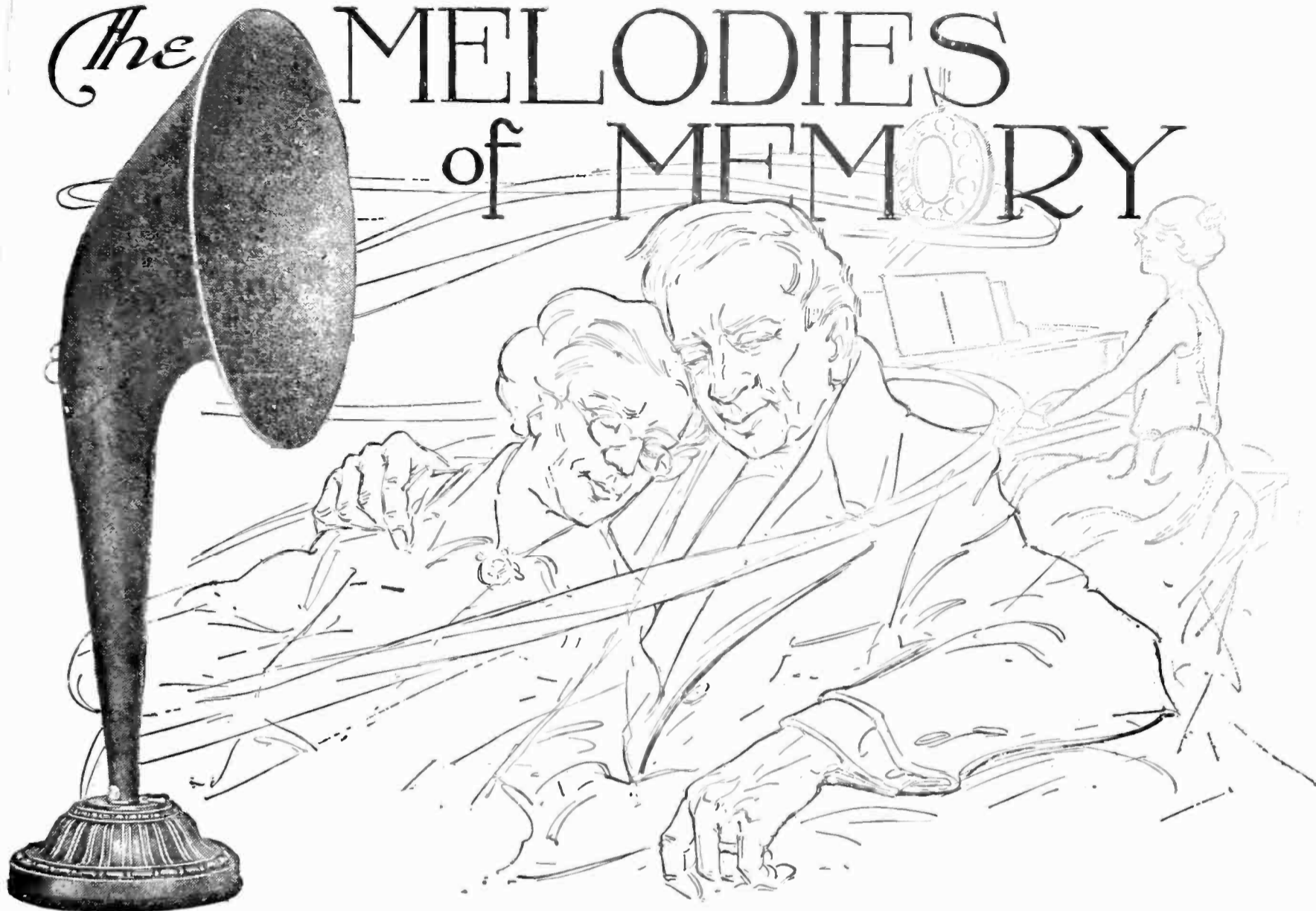

Model S Audio-  
phone \$25.00

Rubber horn 14½  
inches in diam-  
eter. Black mat  
finish with sil-  
vered base dec-  
oration.

#### The Cabinet Model

Model S and  
Model C, which  
is the cabinet  
design, are  
equipped with  
the new Super  
unit. This unit  
contains a spe-  
cially designed  
diaphragm of  
broad pitch  
range, reproduc-  
ing perfectly the  
high as well as  
the low notes.

**H**OLDING old friends and attracting new, the loved songs of yesterday live forever. Memory melodies of the air must not lose their romantic charm by any sort of distortion.

The full rich resonance of the singer's voice or the artist's instrument, is brought to the listener's ear by The Bristol Audiophone Loud Speaker.

Critical people now demand true quality of tone in reproduction. Volume of sound is no longer a distinguishing feature in radio reception. The Bristol Audiophone Loud Speaker reproduces with natural quality the most powerful tones and yet has an unsurpassed sensitiveness, due to its "Voice," which is not a mere phone unit, but a highly developed electromagnetic device.

*The Bristol Line includes four models priced from \$15.00 to \$30.00. If not at your dealer's, write for Bulletin AH-3025.*



The Bristol Company, Waterbury, Conn.

**BRISTOL** TRADE MARK **AUDIOPHONE** REG. U.S. PAT. OFFICE **Loud Speaker**



★ Tested and approved by RADIO BROADCAST ★

# What becomes of the bass notes in your radio set?



While the better transformers amplify quite evenly over the entire upper and middle registers of the musical scale, from about 60 cycles downward, there is a pronounced loss of amplification, as indicated above. Poorer transformers begin to drop off in amplification even higher on the scale with the result that lowest notes disappear entirely.

## The "Lost Octave"

*The deep low notes of the grand organ, bass viol, tuba, English horn and other instruments are practically "lost" in ordinary amplification.*

There is no variation in amplification over the entire range of musical frequencies with Thordarson **Autoformers**. No note is too low—no note is too high to be fully amplified by the Autoformer. In addition there are three other advantages.

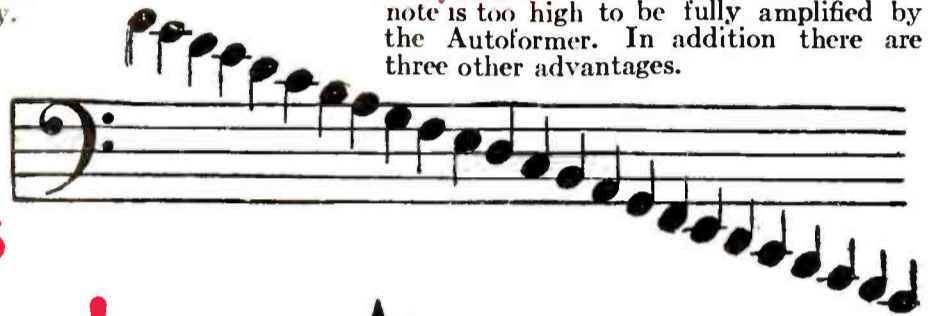

## Four great improvements in amplification!

Full amplification of those bass notes hitherto largely "lost!" Greater clarity on all signals! Improved reception of distant programs! Better volume control!

These are the four advantages achieved by this latest Thordarson development—the **Autoformer**.—Thordarson has succeeded in utilizing, for the benefit of your radio set, the same principle used in the line amplifiers adopted by the more recent high-powered broadcasting stations. The excellent quality of these stations (due to perfect amplification) offers conclusive proof of **Autoformer** effectiveness.

UNCONDITIONALLY GUARANTEED

# THORDARSON Autoformer

Trade-Mark Registered

## All Frequency Amplifier

**Autoformer** amplification is for those who seek the finest reproduction of programs to be had. It may be used with any set in place of the regular audio transformer hook-up. Full directions, with diagrams, for building a Thordarson **Autoformer** Amplifier are supplied with each instrument. Or

Write for the **Autoformer** Hook-up Bulletin---Just Out!

Thordarson Radio Transformers include: Audio Frequency (sub-panel or top mounting types) 2-1, \$5; 3½-1, \$4; 6-1, \$4.50. Interstage Power Amplifying, \$8 each. Power Amplifying, pair, \$13. **Autoformers**, \$5 each. All Thordarson Products are unconditionally guaranteed. Dealers everywhere. We ship direct upon receipt of price only if dealer cannot supply.

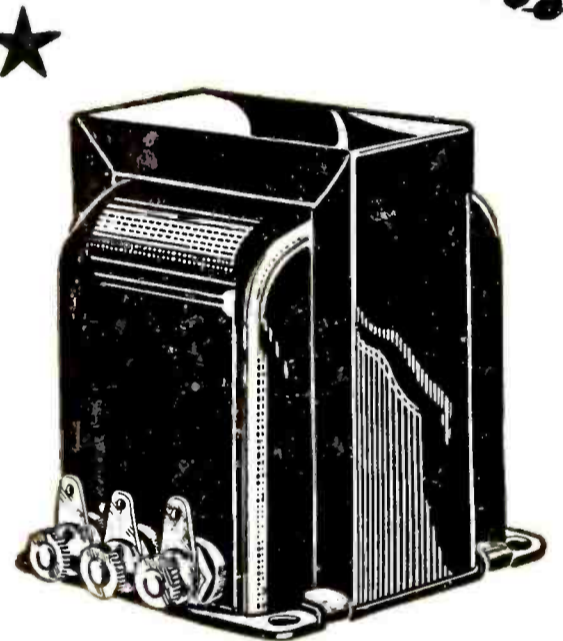

The Latest Thordarson Development

As the world's oldest and largest exclusive transformer makers, we have led for years in extending the amplifying range of transformers to lower and lower frequencies. In the **Autoformer**, we have finally perfected an instrument capable of bringing out the full depth of tone and full amplification of even the lowest notes played on any instrument. The **Autoformer** is an all frequency amplifier—which means it will amplify with even magnitude ALL notes within range of human ear. This has been accomplished by an ingenious adaption of capacities, impedances and resistances—developed and perfected by the Thordarson laboratories. *Only Thordarson builds the Autoformer.*

**THORDARSON ELECTRIC MANUFACTURING CO.**  
Transformer specialists since 1895  
WORLD'S OLDEST AND LARGEST EXCLUSIVE TRANSFORMER MAKERS  
Chicago, U.S.A.

★ Tested and approved by RADIO BROADCAST ★

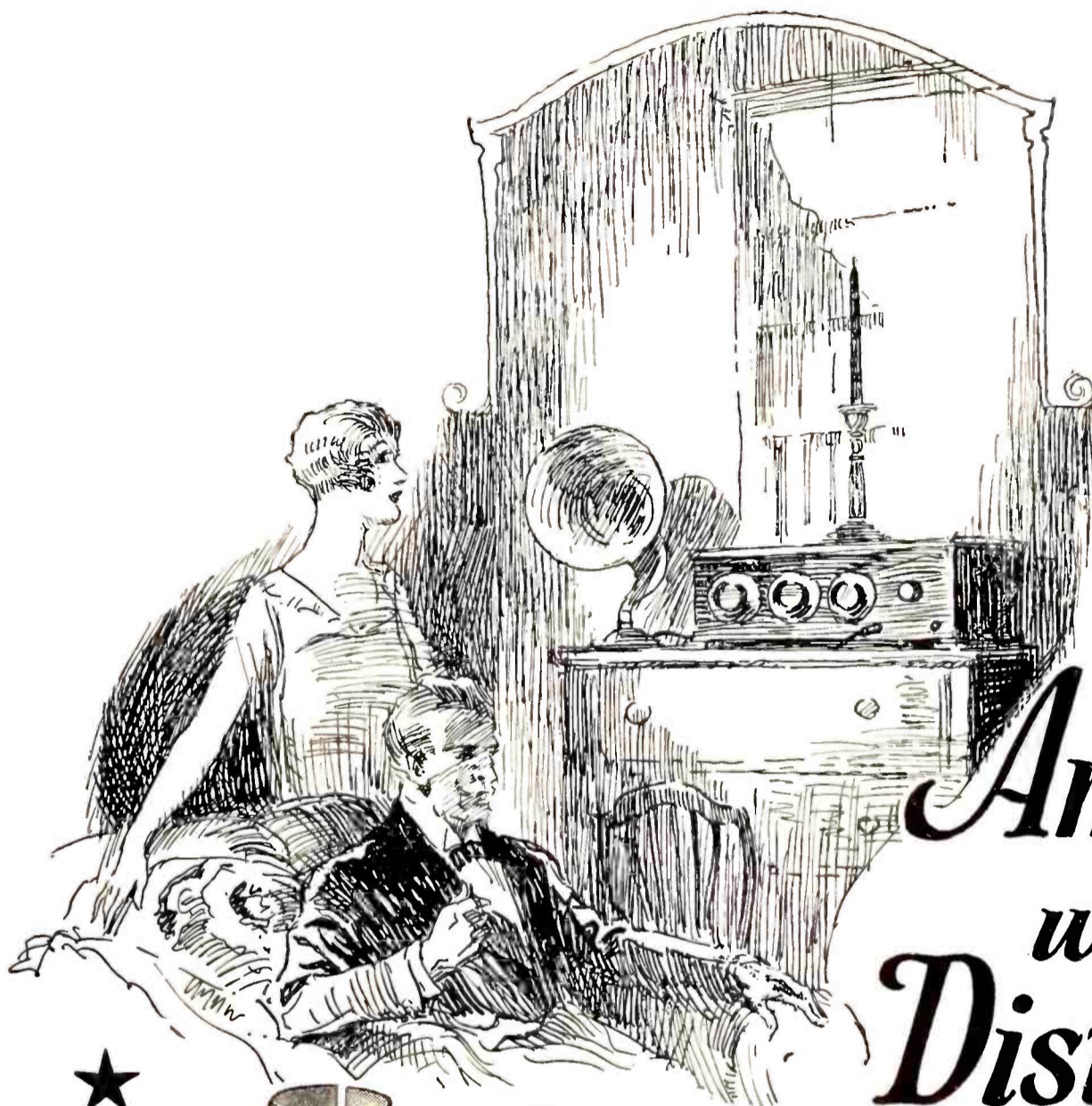

# Amplifies without Distortion

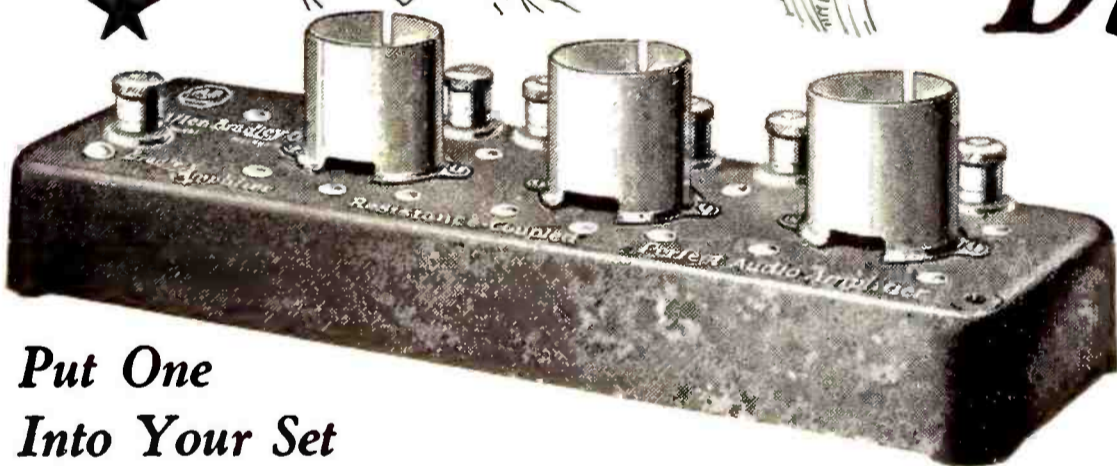

## Put One Into Your Set

**H**AVE you been troubled with distortion, due to faulty audio-frequency transformers? If so, slip a Bradley-Amplifier into your set and experience a new thrill in radio reproduction. No special wiring is necessary, because the Bradley-Amplifier is wired, ready for instant use. Send for new booklet "Amplifies without Distortion" today! It explains, fully, the principles of audio frequency amplification and how to improve tone quality.

ALLEN-BRADLEY CO., 278 Greenfield Ave., Milwaukee, Wis.

**T**HE latest Allen-Bradley contribution to better radio is the new Bradley-Amplifier, a marveously compact three-tube audio amplifier of the resistance coupled type.

Aside from its faultless tone quality and perfect reproduction, the Bradley-Amplifier is amazingly small in size. All circuits, resistors, and condensers are securely soldered within the base, leaving no exposed parts.

Another outstanding feature is the use of Bradleyunits (Molded Resistors) which do not deteriorate with age, nor are they affected by temperature and moisture. The Bradley-Amplifier requires no attention or adjustment.

# Bradley-Amplifier

## Resistance-Coupled

### PERFECT AUDIO AMPLIFIER

★ Tested and approved by RADIO BROADCAST ★



**Crosley  
2 Tube 51 S. D.**  
Mahogany finished cabinet holds all batteries  
..... \$23.50



**Crosley Pup**  
A genuine long range receiving set.....\$9.75

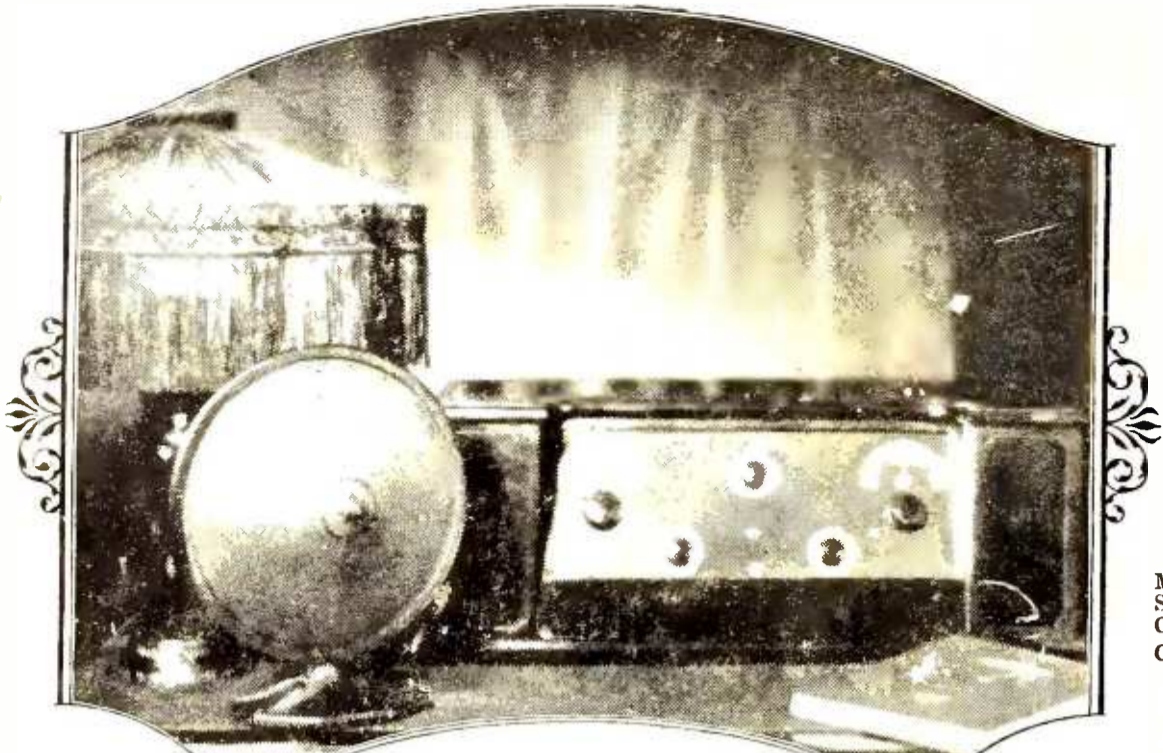

*Crosley Super-Trirdyn Special \$60<sup>00</sup>  
Crosley Musicone \$17<sup>50</sup>*



**Crosley De Luxe  
Combination**  
Musicone De Luxe... \$2  
Super-Trirdyn Special 6  
Console Table..... 2  
Complete .....\$11

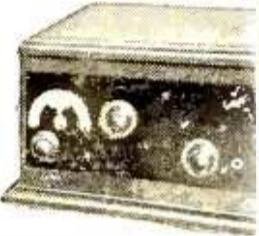

**Crosley  
8 Tube 52 S.D.**  
Highly selective;  
unusual range  
mahogany finished  
cabinet. ....\$32.50

## Better Results from 3 Tubes than from 5

Instead of passing the incoming signal once through each of 5 tubes, Crosley design, in the Super-Trirdyn, passes it through two of the three tubes several times, each time building up its strength and adding to its volume.

Even the technically uninitiated can see the advantages: simplicity instead of complexity; fewer dials to adjust; sharper accuracy in selecting stations; greater clarity; greater volume, greater ease in logging stations.

This simplicity of design combined with the economies of gigantic production makes possible a price of \$60.00 on the Super-Trirdyn Special, the most

efficient and beautiful of all Crosley receiving sets. For Crosley is the world's largest builder of radio sets—owning and operating parts factories, cabinet woodworking and assembly plants.

Listen to a Crosley Super-Trirdyn under the most exacting conditions and you will understand why it represents a genuine achievement in radio performance and value which all America was quick to recognize and reward with increasing sales.

Write for an illustrated catalogue of the complete Crosley line or see them at your Crosley dealer's. Authorized sales and service stations everywhere.

*Crosley manufactures receiving sets which are licensed under Armstrong U. S. patent No. 1,113,149 and priced from \$9.75 to \$60.00 without accessories. Add 10% to all prices West of Rocky Mountains. Crosley owns and operates WLW first remote control super-power broadcasting station.*



# CROSLEY RADIO

B E T T E R · C O S T S · L E S S

THE CROSLEY RADIO CORPORATION

CINCINNATI, OHIO

★ Tested and approved by RADIO BROADCAST ★

RB 0 '29

THE COUNTRY LIFE PRESS, GARDEN CITY, NEW YORK