

SEPT. 1925

RADIO

35 CENTS

BROADCAST



New Fields for the Home Constructor

A Universal Battery Charger

A Receiver for the Radio Beginner



*In the
ORANGE and
BLUE CARTON*

*Since 1915—
Standard
for all sets*

Types C-301A, C-299, C-300, C-11, C-12

Your Radio Set Can Be No Better Than Its Tubes

YOU may build an aerial that will overtop the Eiffel Tower, you may construct a set of materials that are worth their weight in gold, but—if you put a single inferior tube in any socket of your receiver—you will never know what it means to hear clear, pure, resonant tone.

Cunningham

RADIO TUBES



—dedicated to the task of intensifying the world's radio enjoyment
—will bring a magic symphony of radio delight into your home.

E. J. Cunningham Inc.

Home Office: 182 Second Street, San Francisco

Chicago

New York

Patent Notice: Cunningham Tubes are covered by patents dated 2-18-12, 12-30-13, 10-23-17, 10-23-17, and others issued and pending.

★ Tested and approved by RADIO BROADCAST ★

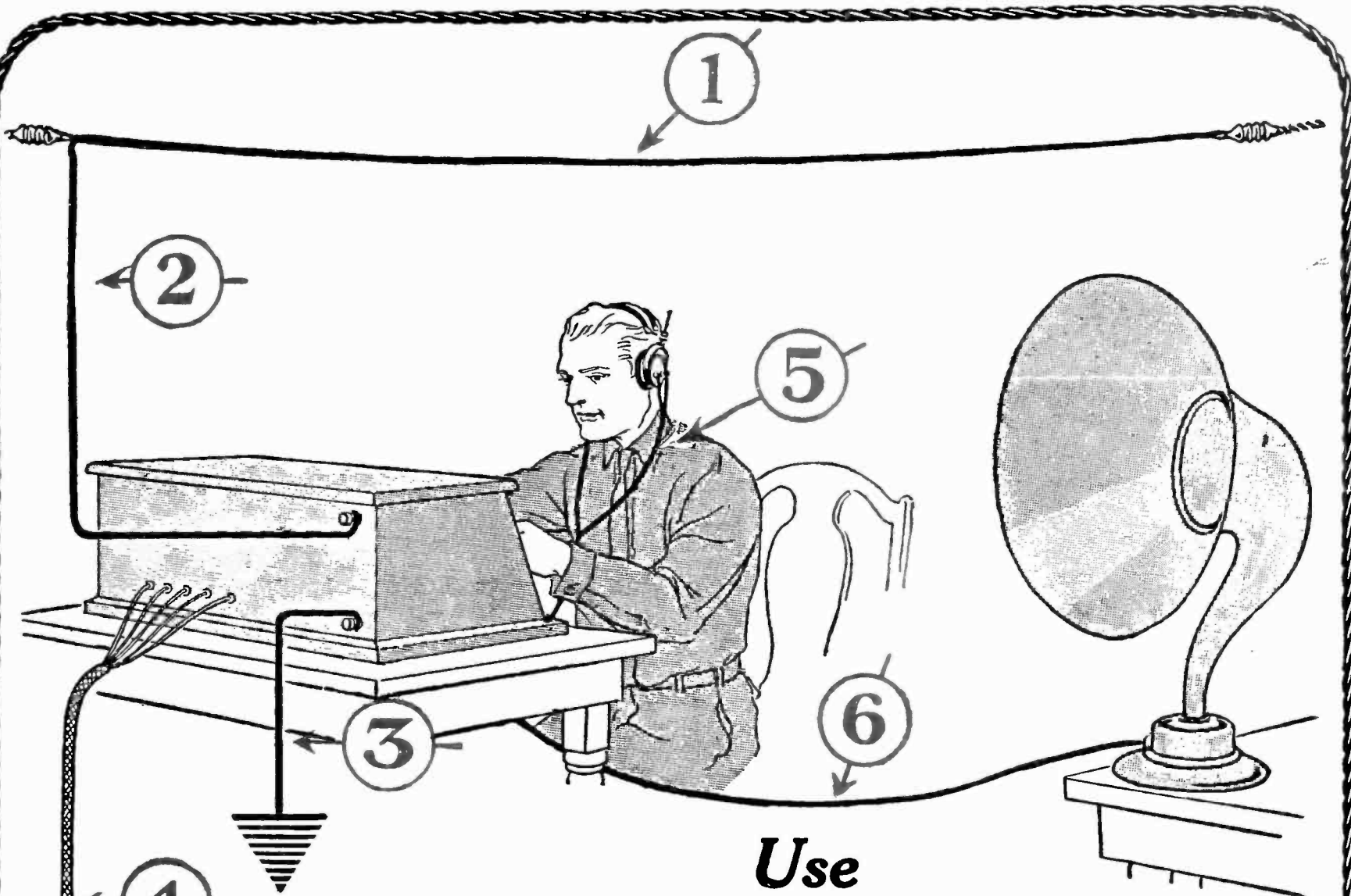

Use
Belden Radio Accessories

YOUR complete radio receiver is more than a cabinet containing coils, dials, and tubes. It includes the aerial, ground wire, battery cord, loudspeaker cord, and other important elements.

Every radio fan knows that Belden Radio Accessories insure maximum efficiency and range, because each item is made especially for one particular job, and it does that job well.

For instance, the Beldenam Aerial and Lead-In (Nos. 1 and 2) is the famous enameled copper aerial endorsed by leading radio authorities as the finest receiving aerial obtainable. The special Belden Ground Wire (No. 3) and Battery Cord (No. 4) make a neat, safe installation for every home.

Be sure to specify Belden Radio Accessories when you buy or build a receiving set. It pays!

Mail the Coupon
for
“Helpful Hints”
A Handy Booklet for Everyone

★

Belden Radio

Belden Manufacturing Co.
2312A S. Western Ave., Chicago

Please send me your booklet entitled
“Helpful Hints for Radio Fans.”

Name

Address

- 1** Beldenam Aerial Wire, made of 7 copper strands, each coated with baked enamel.
- 2** A continuation of No. 1 connecting aerial to set without joint.
- 3** Special Belden Ground Wire—Rubber covered.
- 4** The well-known 6-ft. Belden Battery Cord with five conductors enclosed in a brown braid.
- 5** Belden Headphone Cord.
- 6** Belden 20-ft. Radio Extension Cord.

Belden

★ Tested and approved by RADIO BROADCAST ★



★
MAKE
Your Phonograph
a Roberts Radio
Receiver
MORISON

Has Kits, with panels to Fit
Every Standard Phonograph

Morison service and advice together with the best known parts at right prices will help you to make a success of installing Radio Broadcast's wonderful new set in your phonograph. Be sure and state the style phonograph and size of panel.

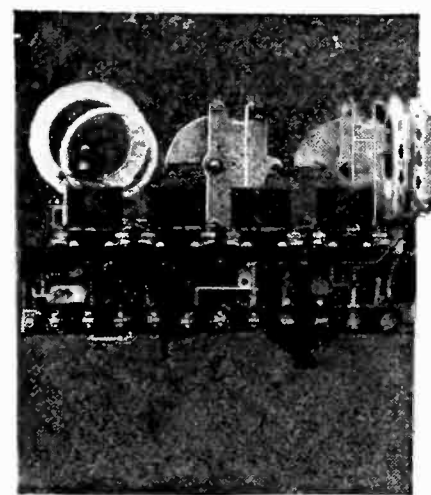

1 Set Sickles Coils	\$ 8.00
2 Benj. Sil. Plated St. Line Cond. .0005	
@ \$6.00 each	12.00
1 Pair Thordarson Push and Pull Trans.	13.00
4 Benj. Vibrationless Sockets @ \$1.00	4.00
1 Genl. Radio No. 285 Transformer	7.00
1 Carter Jack Switch	1.00
2 10 Ohm Genl. Radio Rheostate @ \$1.25 ...	2.50
1 Sterling Neutralizing Condenser	1.00
3 3 in. Eztoon Vernier Dials @ \$2.00	6.00
1 Pacent Single Circuit Jack50
1 Pacent Double Circuit Jack60
1 Amsco Ball Bearing Switch (7 pts. 2 stops)	.40
1 Dubilier 601 Fixed Grid Condenser with clips	
.0002545
1 Dubilier Fixed Grid Condenser .00240
1 Dubilier Fixed Grid Condenser .00560
1 Daven 2 Meg. Grid Leak50

\$55

1 Panel	3.50
1 Sub Panel	1.00
1 Binding Post Panel25
11 Engraved Eby. Binding Posts @ 15c	1.65
12 Lengths of Bus Bar @ 2c24
Screws, Lugs, and Spaghetti50

Build Your Super Autodyne
with Parts that Assure Success

(Published in July Radio Broadcast)

2 S-M 305 A S-L-W Condensers	\$ 5.00	2 .002 Condensers40
2 4 in. Moulded Dials	1.00	1 .0075 Condensers75
1 U. S. L. 6 Ohm Rheostat	1.00	2 .000025 Balancing Condensers	1.50
1 U. S. L. 240 Ohm Potentiometer	1.50	1 .25 Meg. Leak50
3 Eby. Binding Posts45	1 2 Meg. Leak50
1 Carter 101 Jack70	1 Carter No. 3 Switch	1.15
1 Carter 102A Jack80	1 Benjamin 8630 Switch30
1 S-M 211 Filter with Matched Tuning Capacity	8.00	1 Belden Color Cable75
2 S-M Chartered Intermediate Transformers ...	8.00	1 Pair Benjamin 8629 Shelf Brackets70
1 S-M 101 B Coupling Unit	2.50	1 Bakelite Panel, 7 in. x 18 in. x 3-16 in.	
1 S-M 6-Gang Socket Shelf		drilled, grained, and engraved	6.00
(536-201A, 537-UV199)	10.80	Spaghetti, Bus Bar, Screws, Lugs, Nuts, etc. ..	1.00
2 Thordarson 2 1/2—1 Transformers	4.00		

We are prepared to supply you with the make of phonograph attachment best suited to your machine. State make and model No. when writing.

MORISON
Electrical Supply Co. Inc

WHOLESALE RETAIL
 15 East 40th Street, New York City

WRITE TO-DAY
 C.O.D. MAIL
 ORDERS FILLED
 PROMPTLY

Ask us for any parts
 you can't get.

★ Tested and approved by RADIO BROADCAST ★

Sickles Diamond Weave Coils Were Used in the New Radio Broadcast Phonograph Receiver

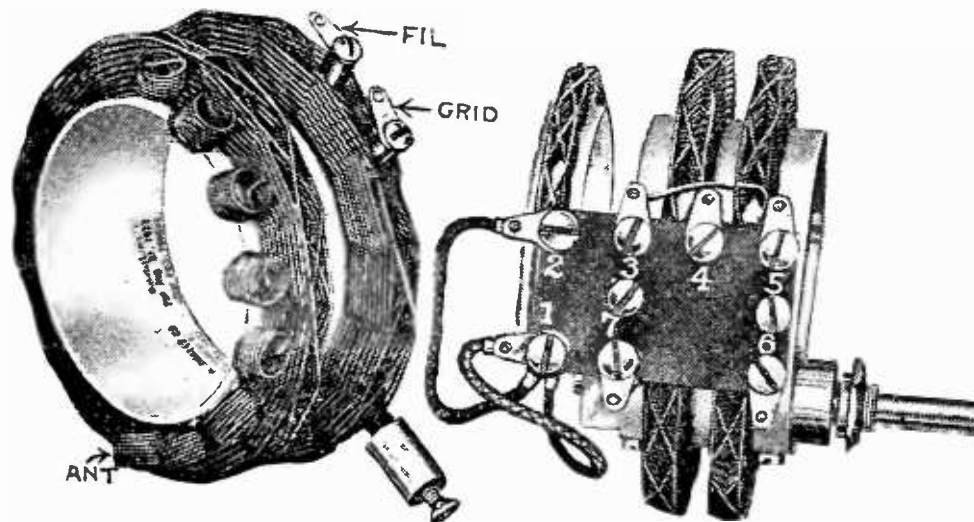

New No. 18A Coils for any Roberts Circuit

Price \$8.00

Patented August 21, 1923

Improved One Hole Panel Mounting Unit New N and P Coil

Designed in our laboratory and gives maximum amplification with perfect neutralization over both Low and High wave lengths, also added selectivity.

The new N and P Coil can be substituted for the present one in any No. 18 Sickles Diamond Weave Coil at a cost of \$1.50.



The F. W. Sickles Co.

335 Worthington St.

Springfield, Mass., U. S. A.

★ Tested and approved by RADIO BROADCAST ★

The New Transformer

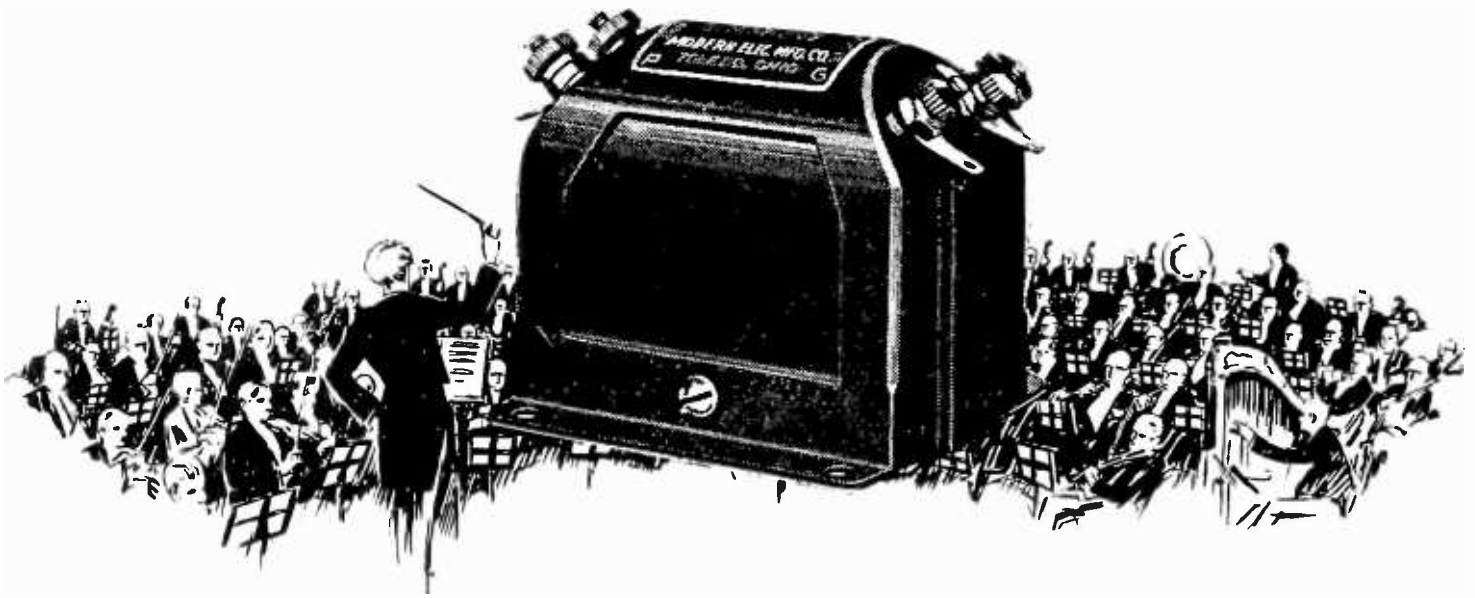

MODERN-SYMPHONY

Covers the Entire Range of Musical Frequencies

The new Modern-Symphony Transformer has been especially designed to reproduce and amplify the range of sound frequencies of any great orchestra. It will bring to you with equal faithfulness the basso profundo or the high treble.

The amplification characteristic curve covers a range of musical frequencies ranging from 60 to over 7000.

The new Modern-Symphony Transformer will delight you. Besides, it is built by a manufacturer of Standard Equipment.

MODERN ELECTRIC MFG. CO.
TOLEDO, OHIO

★ Tested and approved by RADIO BROADCAST ★

GENERAL RADIO

Rheostats and Sockets mean higher tube efficiency

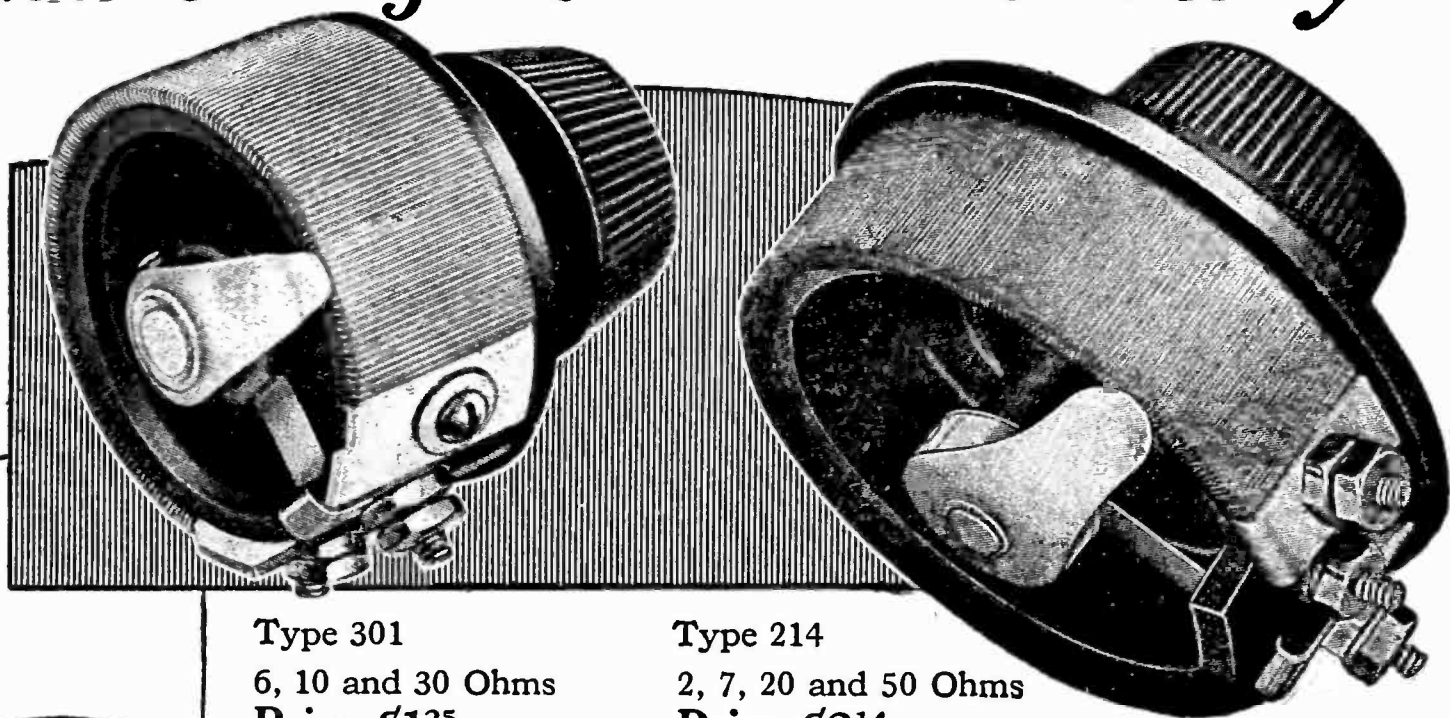

Type 301
6, 10 and 30 Ohms
Price \$1²⁵

Type 214
2, 7, 20 and 50 Ohms
Price \$2¹⁴

*General Radio Rheostats Are Smooth
Running and Uniform*

THERE is only one way to operate tubes at their peak of efficiency—*by the use of properly designed rheostats and sockets.* In building your set, remember that vacuum tubes are important factors in successful radio reception, and require rheostats which provide a gradual and uniform resistance control over the filament.

General Radio Rheostats are smooth running, uniform, and capable of very minute variations. Many of the well-known manufacturers of receiving sets have chosen General Radio Rheostats and Sockets as standard equipment because of their high efficiency in tube operation. Why not use them in the next set you build, and get more out of your tubes?

Sold at all good radio stores
Write for New Radio Catalog 920



The red cartons with the General Radio label are your unfailing assurance of satisfaction.

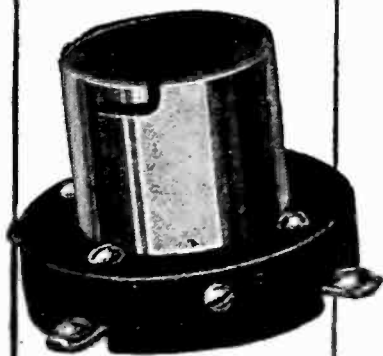

Type 156

For all standard base tubes. A positive wiping contact is made to the side of the tube prongs by double spring terminals. These terminals hold the tube firmly and prevent vibrations. Price \$1⁰⁰

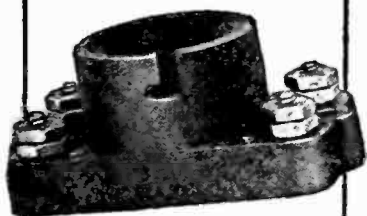

Type 299

For UV-199 Tubes. This socket is a particularly high-grade socket of moulded bakelite. Contact is made to tube prongs by phosphor bronze terminals with double leaf blades. Price 50c.

GENERAL RADIO Co
Cambridge, Mass.



★ Tested and approved by RADIO BROADCAST ★

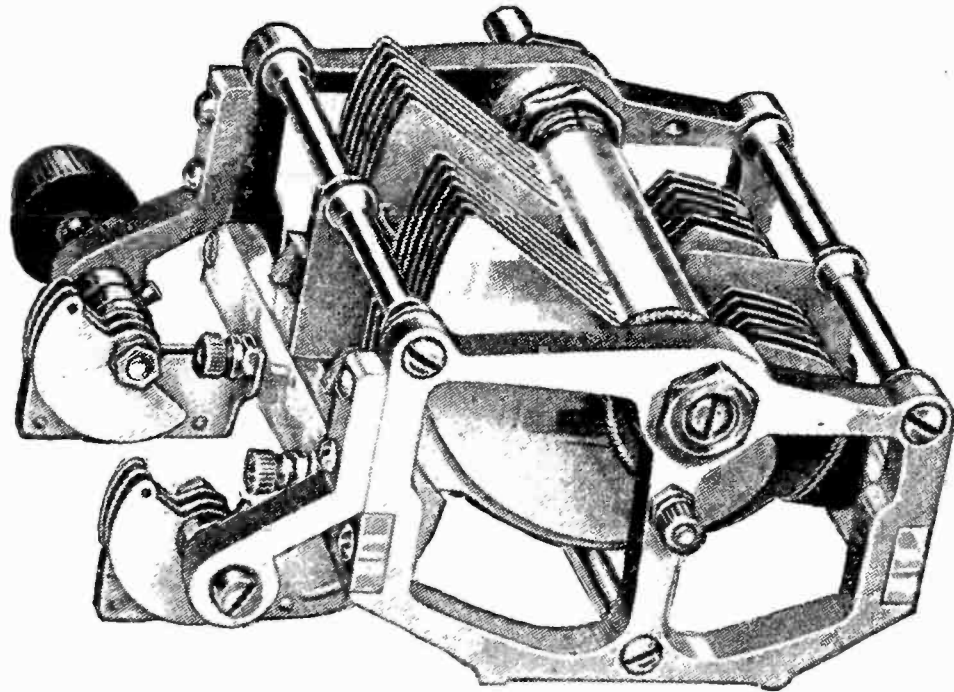

And Now—

The B-T Tandem Condenser

THE same high efficiency, and unequalled construction that put the B-T "Lifetime" Condenser in the front rank is also available in tandem form. More than just a "Double Condenser,"—two carefully balanced units in one frame, working from a single shaft. Independent auxiliary "Trimmers" provide the accurate balance vitally necessary in correct tandem design.

A product that really fulfills its purpose,—Simplified Control.

Complete information on request.

The B-T Torostyle Transformer

A "Toroid" that really works. Exhaustive research and years of experience in inductance pitfalls are behind this coil.

Arranged for short leads and easy wiring. Used in patented B-T Circuit.

Write for descriptive literature.

The B-T Tuning Control

Decorate your set, while making tuning easier with this "Control." Its smooth easy action is a delight.

Straight Line Frequency vs Straight Line Wave Length.

You've heard a lot about Station Separation on the lower waves. Is the answer in any condenser? We build both kinds,—and tell both sides,—in "Better Tuning," 8th Edition,—postpaid 10c.

BREMER-TULLY MFG. Co.

532 S. CANAL STREET

CHICAGO, ILL.

★ Tested and approved by RADIO BROADCAST ★

Still Another Tribute to NEW ENGLAND'S RADIO CRAFTSMEN

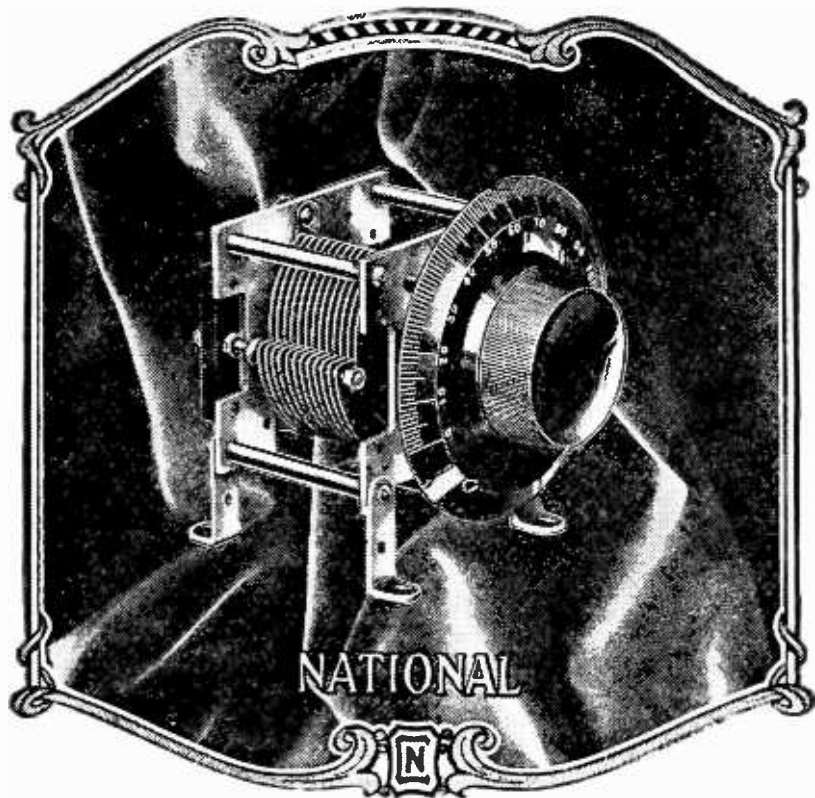

*The
product*
←
*The
tribute*
←

*Approved
For Control
of the
Ultra-Selective
Radio
Broadcast
Phonograph
Receivers*

Write for
Bulletin 106 R. B.

TELEPHONE JUNCTION 4888-W RADIO CALL 2843

Chas. A. Lowry,
Radio Specialist

RECEIVED SPECIAL EQUIPMENT TRANSMITTERS 30 NUMBER TRAIL

TORONTO, CAN. 1/24/25

The National Company,
Cambridge, Mass., U. S. A.

Gentlemen:

I have been using a pair of your National Vernier Dials on a super heterodyne receiver, and feel that you should know how well one user favors them.

I employ these dials on a very short wave super, where the tuning is needle sharp, and I must say they are a most delightful thing to handle. I tried several other dials before settling upon Nationals, but some were too fast, some altogether too slow in movement, while several well-known makes were absolutely worthless owing to the presence of "back-lash."

There are two beautiful things about the National besides its fine appearance. First, there is absolutely no back-lash, and second, the ratio is just right for easy handling -- not too fast; not too slow. I compliment you on the development of this splendid accessory.

Sincerely yours,
Chas. A. Lowry

★ **NATIONAL COMPANY**
110 BROOKLINE STREET CAMBRIDGE, MASS.

Sole Manufacturers of the Genuine and Justly Famous
BROWNING-DRAKE TRANSFORMER. PATENTS PENDING

★ Tested and approved by RADIO BROADCAST ★

It's mahogany to the eye— but in fact it's Bakelite

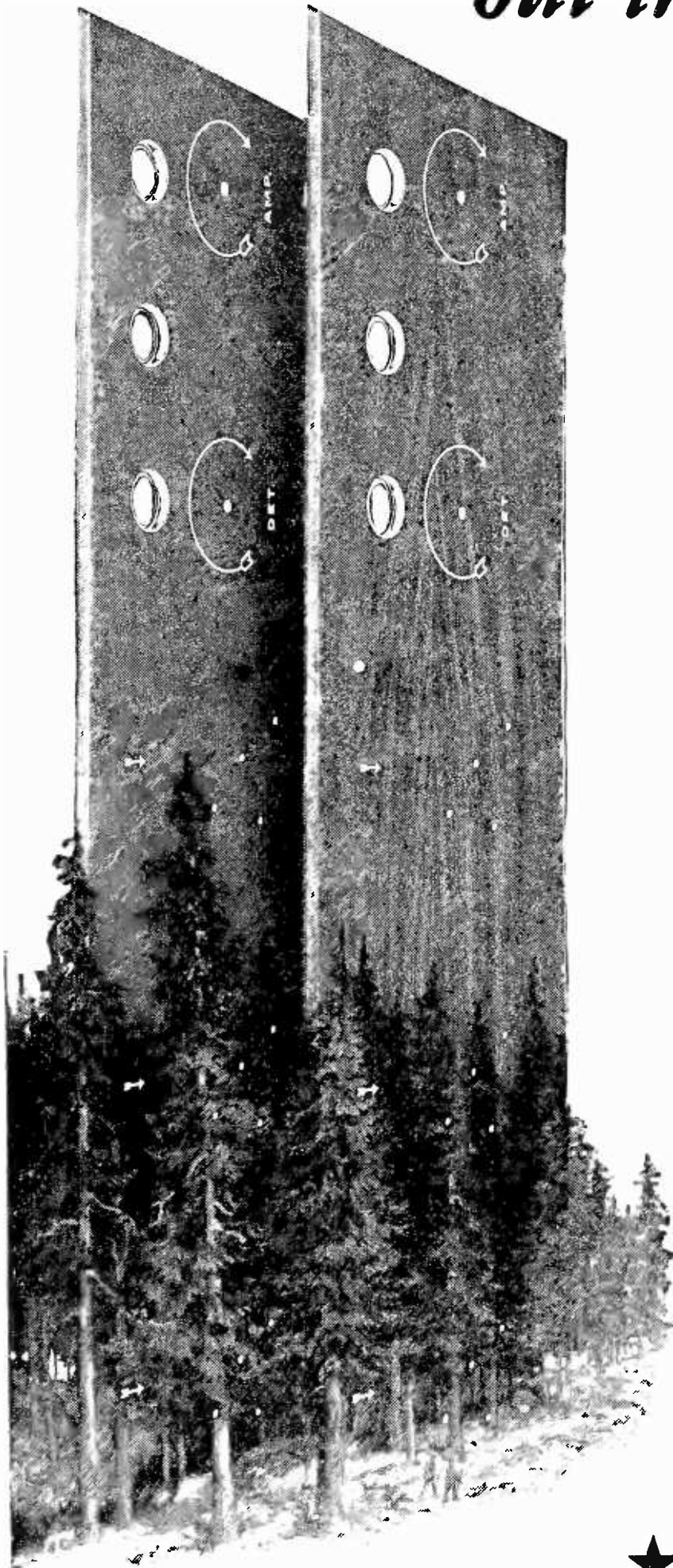

So perfectly is the grain and color of mahogany and walnut reproduced in these Bakelite Radio Panels, that the eye cannot distinguish them from the natural woods.

By using a Bakelite Panel that matches the wood in the cabinet, your finished set will be far more handsome than if a plain panel is used.

Rigid and strong, Bakelite Panels support the weight of heavy instruments without sagging. They will not compress, or cold-flow, under pressure of binding screws. Because of their resistance to extremes of heat, cold and moisture, they will not warp nor split. These properties and their insulation value, color and finish are permanent.

Be sure to ask your dealer to show you these wood finish Bakelite Panels—obtainable under any of the following trade names:

FORMICA
Trade Name Adhesive Laminating Sheets Tubes Rods

CELORON

Dilecto

Spaulding

Fibroc

Micarta

A Bakelite Panel on a set is an indication that the Manufacturer has used the best.

Write for Booklet 29

BAKELITE CORPORATION

247 Park Avenue, New York, N. Y.

Chicago Office: 636 West 22d Street



Bakelite is an exclusive trade mark and can be used only on products made from materials manufactured by the Bakelite Corporation. It is the only material which may bear this famous mark of excellence.

BAKELITE

REG. U.S. PAT. OFF.



BAKELITE is the registered trade mark for the phenol resin product manufactured under patents owned by the Bakelite Corporation.

THE MATERIAL OF A THOUSAND USES

★ Tested and approved by RADIO BROADCAST ★

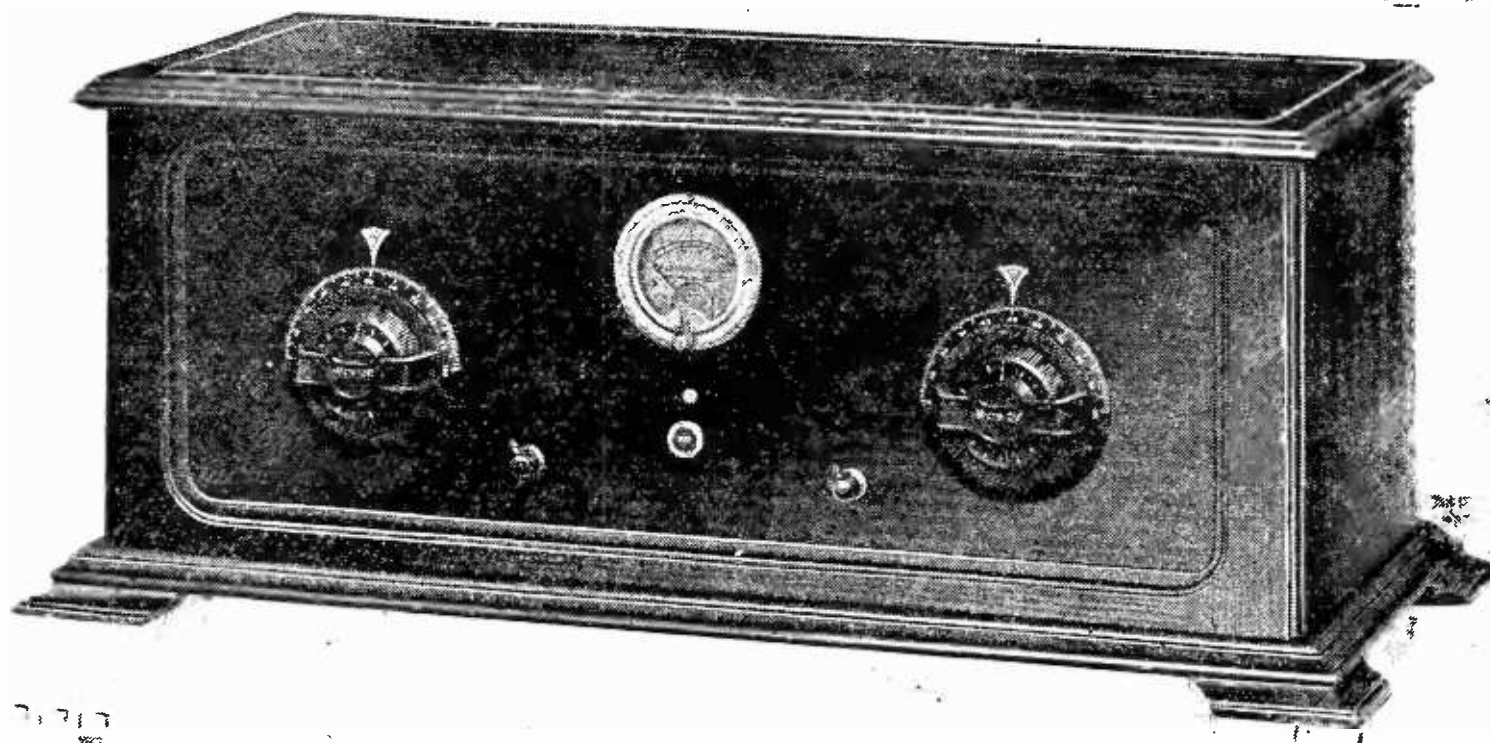

★

Now— The Jewett Receiver

Again Jewett leads the way to new and better radio reception.

First the Superspeaker—Now the Jewett Receiver.

Different—Yes, fundamentally so in design—Even more startlingly so in performance.

Distortion, squeals, whistles and other self-made noises—entirely eliminated—by a new and exclusive method of audio amplification. Top efficiency insured at all points on the dial from 150 to 600 meters.

Music as it is actually played—the human voice in its natural tones.

And with it all—the Jewett Receiver is beautiful—the richest, handsomest receiver you have ever seen.

The Receiver that meets and exceeds your fondest hopes for radio reception

JEWETT RADIO & PHONOGRAPH COMPANY
5672 TELEGRAPH ROAD PONTIAC, MICHIGAN

Factories: Allegan, Michigan / / Pontiac, Michigan

In Canada

Jewett Radio-Phonographs, Ltd., Walkerville, Ontario

Export Sales Office:

116 Broad Street, New York City

JEWETT

Startling! Revolutionary! These

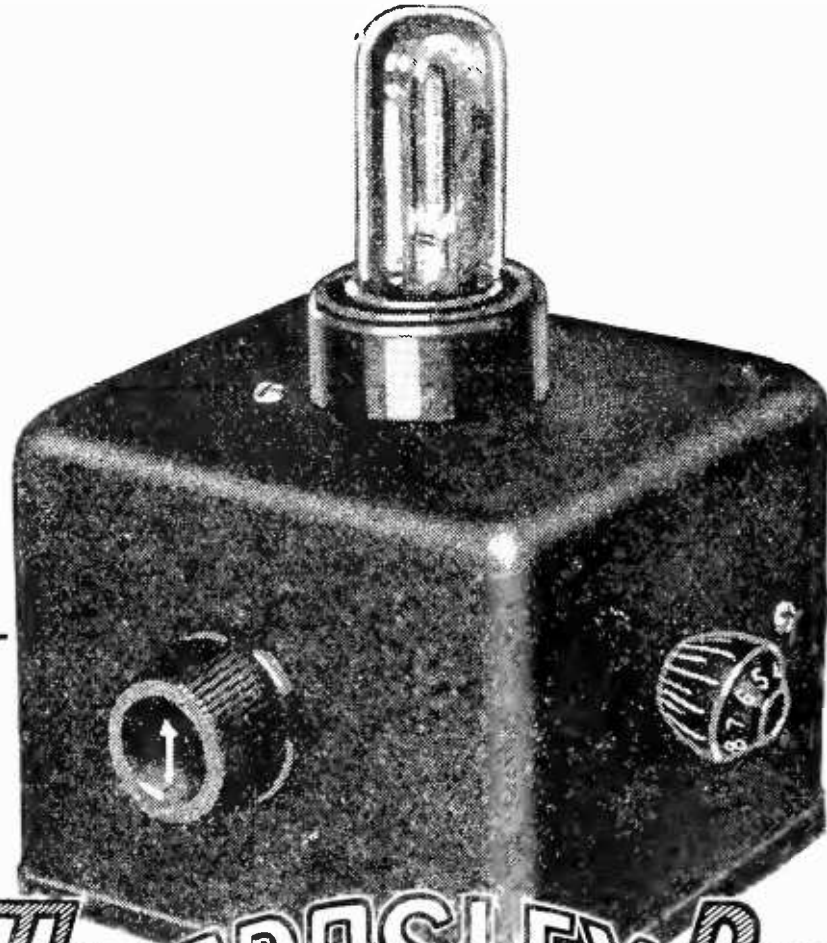

The CROSLLEY Pup

A genuine Armstrong Regenerative double circuit set

FIRST super-power broadcasting station remotely controlled—WLW, Cincinnati.

FIRST to develop an instrument reproducing in full tonal volume the entire range of music and the human voice—the Musicone.

FIRST to provide radio parts at prices that enabled millions to build their own sets.

FIRST to market a complete crystal set below \$25.

FIRST to develop a low priced single tube receiving set.

FIRST to sell sets using tuned radio frequency amplification.

FIRST to combine successfully tuned radio frequency amplification with regeneration and the reflex principle, making three tubes give the results of five or six.



Radio, with all its romance, knows no more magic name than Crosley.

From the time that Powel Crosley, Jr., first enabled millions to build their own sets by offering parts at a fraction of existing prices—down to the present day, radio progress and Crosley achievements have gone hand in hand. Now Crosley announces not only vital improvements in radio performance—but in the Crosley "PUP" offers this finer performance at the lowest price in radio history.

This compact, efficient receiver is a development of the famous Crosley one tube set, with which Leonard Weeks, of Minot, N. D., heard the

MacMillan Polar expedition while the rest of America listened in vain.

The employment of the double circuit not only reduces radiation to a minimum, but radically improves selectivity. It can be tuned through local stations more readily. Under average conditions, its radius, with head phones, is 1500 miles or more.

You can use the "PUP" to check the performance of your larger set; to entertain the youngster whose curious fingers cannot resist the lure of dials and switches; to install in the maid's room, or even in your office—for the air is full each day. You can take it on canoe trips, picnics, outings

and on your business journeys—for it's only half the size of a shoe box.

Engineered and built to the strictest standards of Crosley quality, this genuine long distance set can be offered at the phenomenal price of \$9.75 only because of its simplicity and Crosley's tremendous manufacturing facilities.

\$9.75
WITHOUT
ACCESSORIES

ADD 10% TO ALL PRICES WEST OF ROCKY MOUNTAINS

Crosley manufactures receiving sets which are licensed under Armstrong U. S. patent No. 1, 113, 149 and priced from \$9.75 to \$60.00 without accessories.



CROSLLEY

THE CROSLLEY RADIO CORPORATION
CINCINNATI

Crosley owns WLW, first remote control super-power broadcasting station.

★ Tested and approved by RADIO BROADCAST ★

www.americanradiohistory.com

New developments of Powel Crosley, Jr.

3 Tubes do the work of 6 in the new SUPER-TRIRDYNS!

You have not heard the perfection of radio reception until you have listened to these two new Super-Trirdyns. In them the need for more than three tubes is eliminated by the famous Trirdyn hook-up—which combines tuned radio frequency, Armstrong regeneration and reflex amplification. There is no radiation. Distant stations come in clear and sharp on the loud speaker and can be accurately tuned. Offered in solid mahogany cabinets, these new models are the aristocrats of radio reception at democratic prices.

DE LUXE COMBINATION

The extreme right sketched in outline is the new Super-Trirdyn Special De Luxe Combination on solid mahogany table, the Super-Trirdyn Special (batteries contained) and the Musicone De Luxe. Table \$25. Musicone \$27.50. Combination \$112.50.

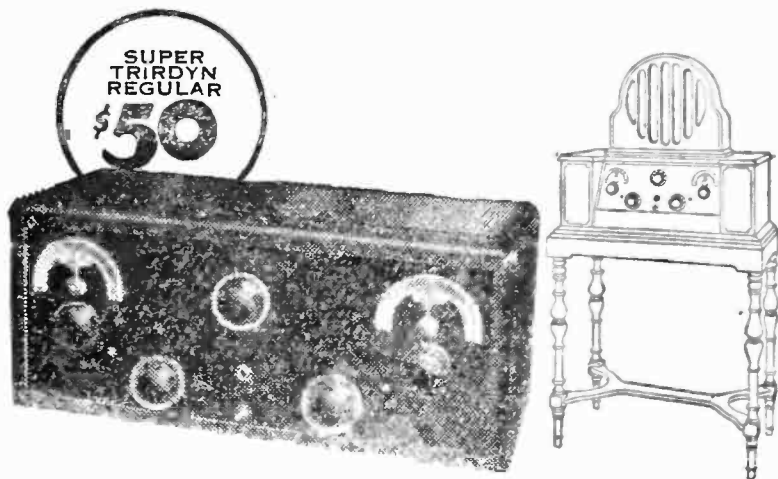

SUPER TRIRDYN REGULAR \$50

CROSLY RADIOS FIT EVERY PURSE

Two Tube Sets—the tremendous popularity of Crosley Models 50 and 50 Portable is proof of the efficiency of the Crosley Armstrong regenerative hook-up. Real long distance reception with dry batteries. Model 50, price without accessories \$16.50. Model 50 Portable, price without accessories \$16.00.

Three Tube Sets—Local and nearby stations on loud speaker always and distance to 1500 miles under average conditions. Much greater range with headphones. Model 51, price without accessories \$18.50. Model 51 Portable, price without accessories \$23.50.

Four Tube Sets—Distant stations come in on the Musicone with exceptional richness and volume. Model 52, price without accessories \$27.50. Model 52 Portable, price without accessories \$32.50.

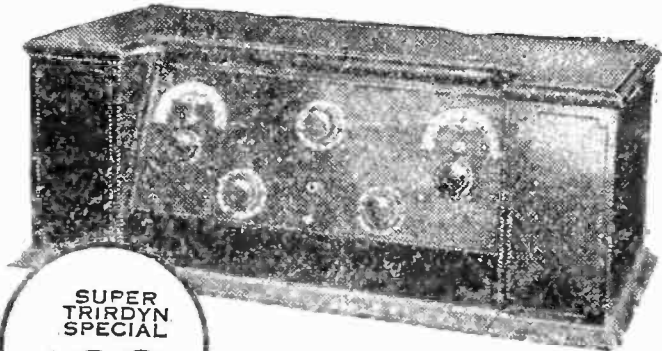

SUPER TRIRDYN SPECIAL \$60

RADICAL IMPROVEMENTS IN TWO POPULAR CROSLY RECEIVERS

2-Tube Special De Luxe 3-Tube Special De Luxe

Of interest to the millions who know Crosley's past achievements in the direction of a better and less expensive radio are these two new cabinet receivers. These low priced models represent radical improvements. More selective control and improved reception have been achieved by the use of the new worm type tickler, the new Crosley superior plate condenser and the double circuit. Radiation is reduced to a minimum. Both cabinets are attractive in design, with sloping panels and mahogany finished. Both have genuine Armstrong regenerative circuits, the 51 with one stage of audio frequency amplification; the 52 with two. Both are true long range receivers.

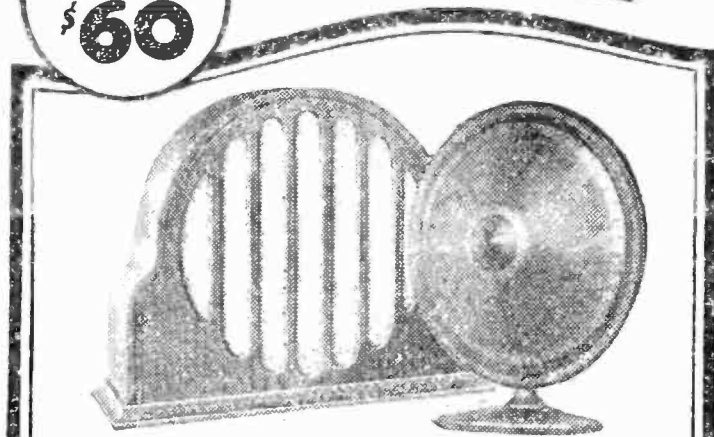

The MUSICONES

Rapidly replacing other types of loud speakers

It is expected that no less than 500,000 present day "loud speakers" will be replaced by the Musicone in this, its first year. Reproduces full tonal range of the human voice and music; requires no adjustments nor additional batteries. Patented actuating unit, covered by basic patents, is the secret of its faithful reproduction of all tones. Not the mere cone. Beware of imitation cone speakers. Price...

\$17.50

The Musicone De Luxe

The Musicone has been artistically combined with a clock case of beautiful mahogany with a grilled screen. Price of Musicone De Luxe.....

\$27.50

\$23.50

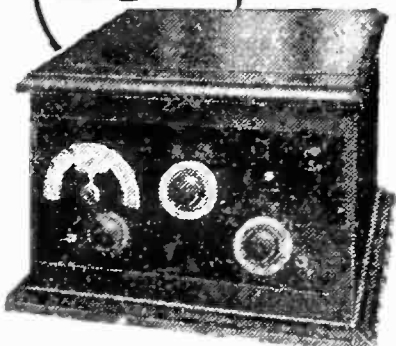

New 2-Tube 51 Special De Luxe

Mahogany cabinet with sloping panel, new style controls—enamel metal dials—cabinet will hold necessary dry batteries. Priced without accessories.

\$32.50

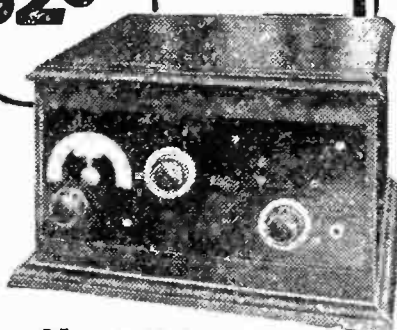

New 3-Tube 52 Special De Luxe

Mahogany cabinet of popular sloping panel, new style controls and art metal dials. Cabinet will hold necessary dry batteries. Priced without accessories.

RADIO



THE CROSLY RADIO CORPORATION
CINCINNATI

See the Crosley line at your dealers or write for full descriptive catalog.

★ Tested and approved by RADIO BROADCAST ★

THE BIG LITTLE



The biggest of all the little things—THE DAVEN GRID LEAK

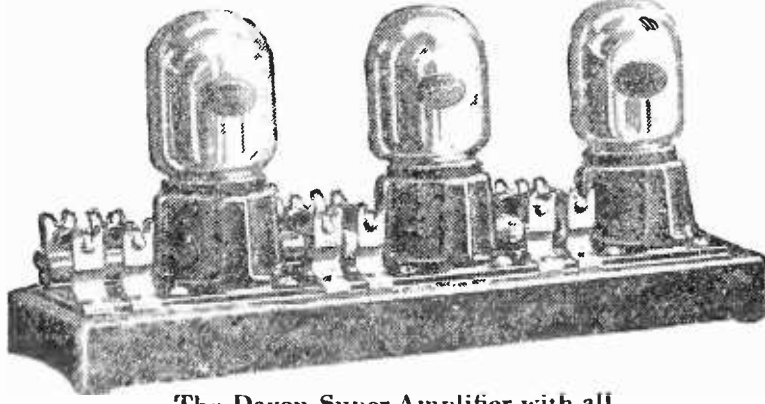

The Daven Super Amplifier with all labor of assembly eliminated \$15.00

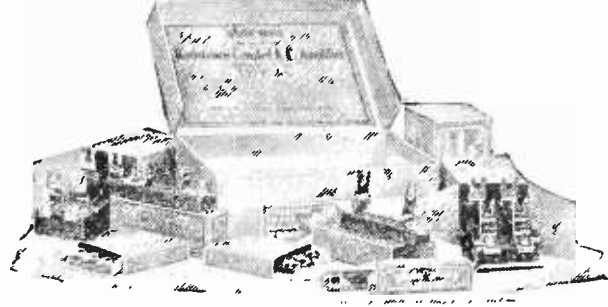

The Daven 3-Tube Amplifier Kit, complete except for sockets and tubes \$9.00



The Resistor Manual
A practical handbook on Resistance Coupled Amplification. At your dealer's 25c. By mail postpaid 35c.

THE discriminating owner of a radio set demands three things
 (1) Volume on the weakest signal
 (2) Tone quality that makes criticism impossible and excuses or qualifications unnecessary,
 (3) Both volume and freedom from distortion.

The last is today's problem. We can get volume. We can get quality. There is only one way to get both. Eliminate the distortion from which no circuit employing transformer coupled audio amplification is free. If a transformer will not amplify over-tones and under-tones alike at all frequencies, do away with the transformer. We must get rid of rushing, blowing, frying noises.

The Daven Radio Corporation have made this possible in their development of Resistance Coupled Amplifiers. If you will couple up Daven precision-built resistances and mountings under the direction of Daven engineers, you will know radio at its best.

DAVEN PRODUCTS ARE SOLD

USE THIS FREE COUPON
 DAVEN RADIO CORPORATION
 158-160 Summit Street, Newark, New Jersey

Please send me the following on Resistance Coupled Amplification: —

Check one.

- Resistor Manual. 25c is enclosed.
- Complete catalogue (free);

Name

Address

For dealers: Send your letterhead or card, or this coupon and we will have our nearest distributor communicate with you.



"The Sine"
DAVEN RADIO
Resistor

NEWARK

Reg. U. S.

THINGS OF RADIO



The DAVEN LEAKANDENSER—the combination grid leak and grid condenser

Daven bulletins are the A. B. C. of resistance coupled amplification. Write for bulletin on the Daven "big little thing" in which you are most interested, or get the Resistor Manual, a practical handbook for radio designers and builders.

Dealers who do not handle the Manual are invited to send for free sample.

WE are able to announce two new Daven products at this time. The Daven Leakandenser is a combination of a grid leak of Daven permanent constancy of value, and a grid condenser of fixed capacity, correct for all makes of detector tubes. It is mounted in a new snap fastener that does not permit it to shake out. Precision-built, simple, effective, sturdy and very handsome. Price \$1.00 each.

The new Daven High MU Tube increases the amplification of the Daven Super Amplifier to equal or exceed that obtainable with transformers. 6 volt, $\frac{1}{4}$ ampere—\$4.00 each.

The Daven Power Tube Type MU-6 for the last, or output stage—\$5.00 each.

ONLY BY GOOD DEALERS

of Merit
CORPORATION
Specialists
 Pat. Off.



NEW JERSEY



Clip Mounting No. 50—for single Resistor, Grid Leak or Ballast - - - \$.35 each

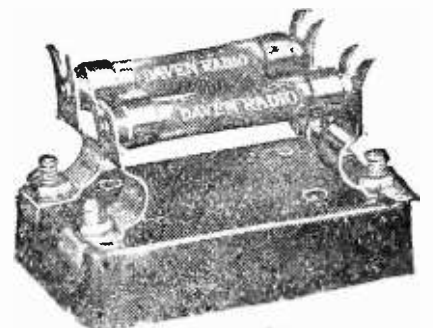

Resisto-Coupler No. 42—The first and most popular resistance coupling unit. With condenser - - \$1.50

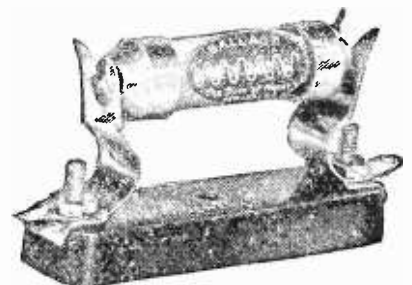

Daven Ballast Resistors for use with amplifying tubes in place of rheostats. Four types, without mounting. \$.75 each



The new Daven Tube MU 20 recommended for use with the Daven Super Amplifiers.



Nocturne

Miracle of science — this flight of music through the air! Into your home it comes, from hundreds of miles away. It speaks a universal language, straight to your heart. And not less a miracle is that magic building up of tonal power — still preserving every mood of the artist — until the room is filled. This is the supreme achievement of Rauland-Lyric.

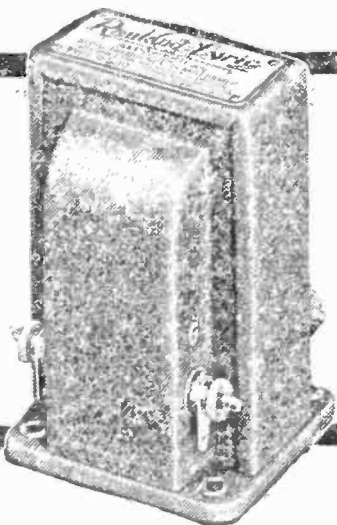

Rauland-Lyric is a laboratory-grade audio transformer designed especially for music lovers. The price is nine dollars. Descriptive circular with amplification curve will be mailed on request. All-American Radio Corporation, 4201 Belmont Ave., Chicago.

Rauland-Lyric
AN
ALL-AMERICAN
TRADE MARK
TRANSFORMER
The Choice of Noted Music Critics



ACME WIRE RADIO PRODUCTS

The New CELATSITE

Flexible stranded wire for "point to point" and sub-panel wiring—latest method of wiring sets. 5 colors, black, yellow, green, red and brown, one for each circuit.

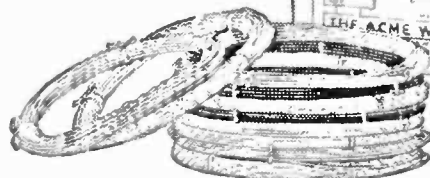

The Original Celatsite Wire

Celatsite is a tinned copper bus bar wire with a *non-inflammable* "spaghetti" insulation in five colors. Supplied in 30 inch lengths.

Flexible Varnished "Spaghetti"

A perfect insulation tube for all danger points in set wiring. Costs little more and is worth a lot more than the cheaper substitutes offered. Black, yellow, red, green, brown; for wires No. 10 to No. 18. 30 inch lengths.



Enameled Antenna Stranded



The best outdoor antenna you can put up. 7 strands of enameled copper wire; maximum surface for reception. Enameling prevents corrosion and consequent weak signals. 100, 150 or 200 foot coils, boxed.

Loop Antenna Wire

You can make a good loop with Acme wire made of 65 strands fine copper wire, green silk covered. Flexible; non-stretching, neat.

Celatsite Battery Cable

For connecting A and B Batteries (or current supply) to radio set. Silk braid covering 5 flexible Celatsite wires—5 feet long—a different color for each terminal. Prevents messy wiring and "blown" tubes.



Send for folder

THE ACME WIRE CO.

Dept. B

New Haven, Conn.

Also makers of fine enameled magnet wire and coil windings for Audio Transformers, Battery Chargers, "B" Battery Eliminators

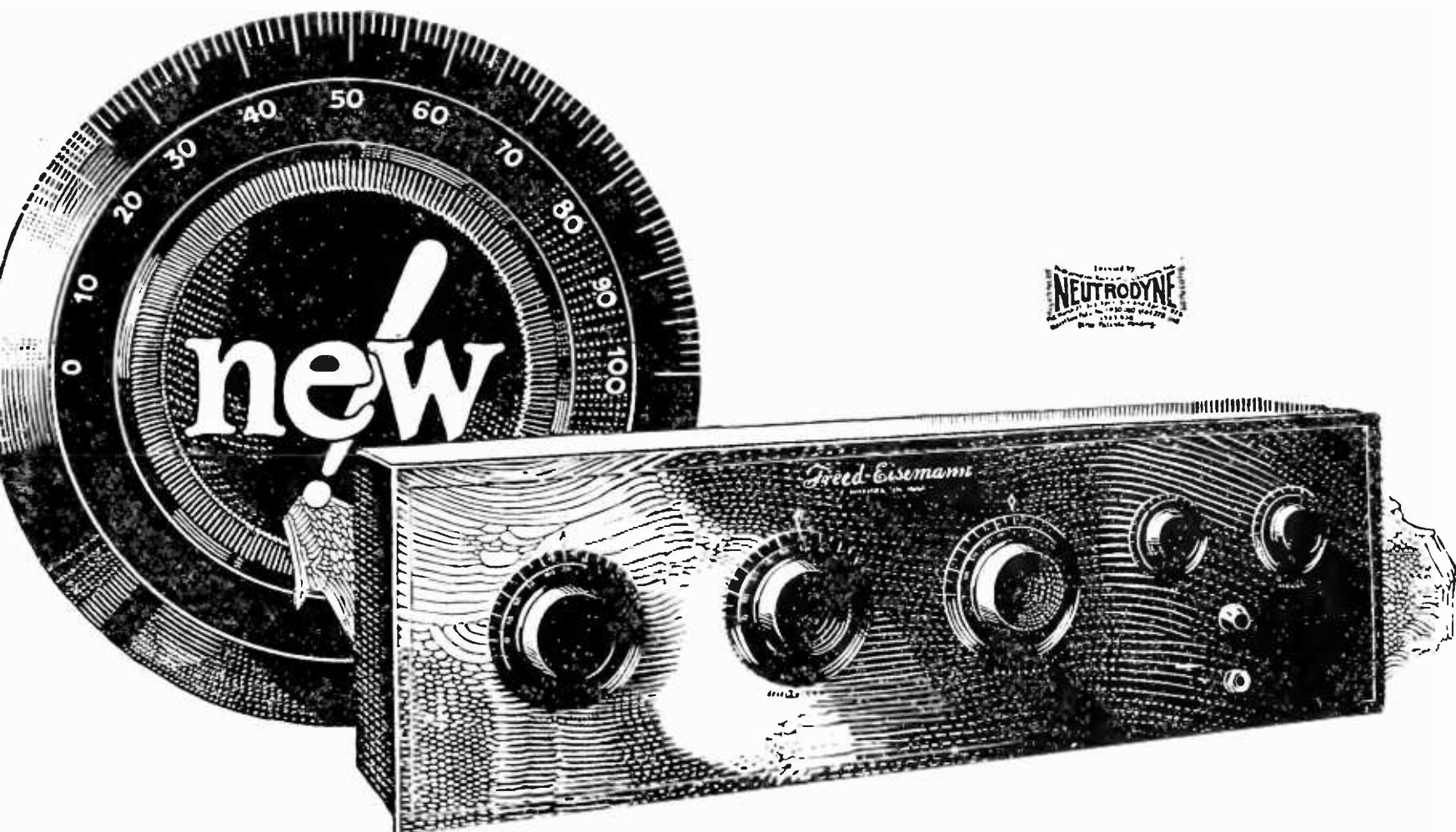

A real fan's set!

LAST YEAR the general public followed in the footsteps of the fans and gave Freed-Eisemann their preference—so overwhelmingly, in fact, that Freed-Eisemann became the largest and most successful Neutrodyne manufacturer in the world.

THIS YEAR the new Freed-Eisemann line reaches new heights in radio development. It is bound again to win the fans' enthusiastic approval.

Here, for instance, is one of the five new Freed-Eisemann models:

MODEL NR-7—A New 6-Tube Neutrodyne

FREED-EISEMANN engineers have done a real job on this receiver. In order to get absolutely true reproduction of received signals, the second audio stage uses two tubes connected in parallel with 135 volts in the plate circuit of these tubes. Greatly increased selectivity is

obtained by using a coupled primary coil in the antenna circuit. The detector socket is mounted on a shock proof support preventing all microphonic noises. Battery connections are made quickly and neatly with a cable furnished with the set.

Get this set, and be a jump ahead of the rest!



Freed-Eisemann

FREED-EISEMANN RADIO CORP., MANHATTAN BRIDGE PLAZA, BROOKLYN, N.Y.

★ Tested and approved by RADIO BROADCAST ★

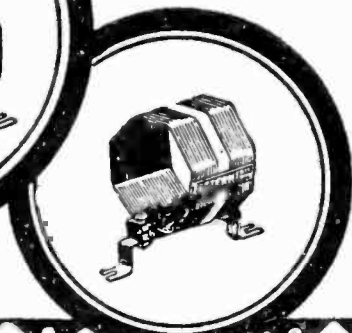
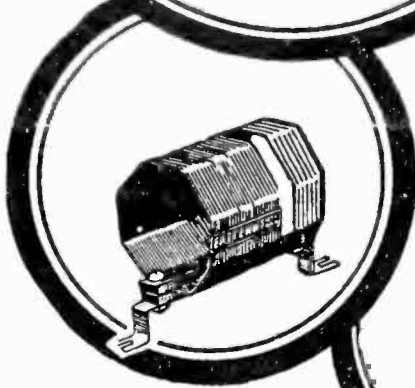
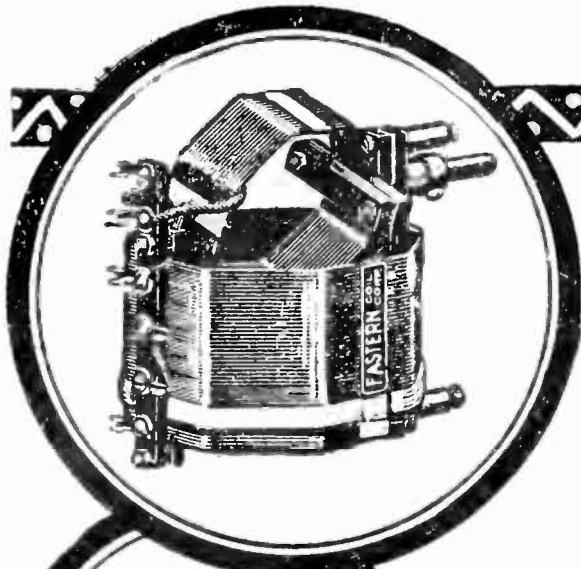

EASTERN

Make your set a Super-Het!

by adding the *new, revolutionary* O'Connor Frequency Changer as described in the June issue of Radio Broadcast. Only one extra tube is necessary. It's easy to build and the results obtained equal the best Super-Het.

Mr. A. O'Connor has *specified* the EASTERN PICKLE BOTTLE COUPLER (Type FC) for use in his remarkable Frequency Changer. Type FC Coupler \$6.00

EASTERN PICKLE BOTTLE COILS are also designed for perfect performance in the Roberts Circuit (\$8.50 per set), Browning Drake (\$8), DX Superdync, (\$8 per set), 3 Circuit (\$6) and for Tuned R. F. for .0005 or .00035 condensers (\$2 per coil).

At your dealers or direct, postpaid.

EASTERN COIL CORPORATION
22 Warren Street Dept. R. B. New York



pickle bottle COILS

EBY PATENTED BINDING POSTS

After you have put time, money and labor into the building of your set don't jeopardize its efficiency with doubtful binding posts.



Ensign Engraved

Ask your dealer to show you why EBY Quality Posts are the choice of over 150 radio manufacturers.

6 types—25 different markings—and the tops don't come off!

The H. H. EBY MFG. CO.
Philadelphia, Pa.



15c each

"THE TUBE WITH A PEDIGREE"



THERE is only one way to measure the value of a radio tube, regardless of who made it, and that is by the characteristic curve reading. In this way, and no other, can its value as a tube be determined in advance. All MUSSELMAN TUBES have a characteristic curve slip inclosed at the factory and certified when the readings are above the standard set by leading radio engineers as to what constitutes an unusually good tube.

Jobbers, manufacturers, and dealers are invited to write for details as to sales franchise.

Manufactured by
The Van Horne Co., Franklin, Ohio
SALES OFFICE
A. J. MUSSELMAN
602 Machinery Hall - Chicago

★ Tested and approved by RADIO BROADCAST ★

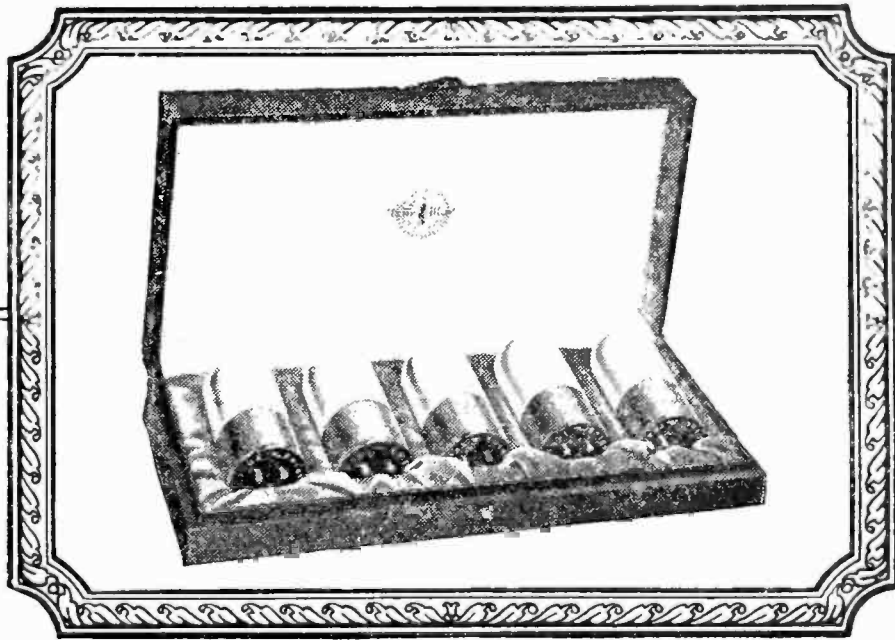

EFFICIENCY

On Long or Short Wave-lengths

FOR 2 to 60 meter receivers, such as are being built at the Brightson Laboratories to communicate with WNP, the McMillan expedition, the tubes must be dependable. They must be well matched, noiseless, and have a high amplification constant. Ordinary ununiform tubes cannot be expected to work efficiently on such short wave-lengths.

Brightson True Blue Tubes have been developed with characteristics making them more efficient on low wave-lengths than any other tube available to the amateur. Constant short-wave experimentation in the Brightson Laboratories, has shown the possibility of making a tube, which, while more efficient than ordinary tubes on broadcast wave-lengths is also more efficient on extremely low wave-lengths. A mutual conductance value, efficient on very low wave-lengths, will not function

properly on high-powered low frequency work. Brightson True Blue Radio Tubes have that happy medium which fits a tube for both types of reception.

10-Day Return Privilege

Unless True Blue Tubes prove interchangeably uniform, noiseless, crystal clear in tone and the handsomest, finest quality tubes you have ever used, you can return them in ten days for refund.

60-Day Guarantee

Whether you buy one True Blue Tube or a set of three, five, six, or eight in a safety case, each individual tube is covered by its own Brightson guarantee. If within 60 days a mechanical defect prevents any True Blue Tube from operating perfectly, you can return it for replacement.

If your dealer does not stock True Blue Tubes write us direct. Prices, 6 volt type "power Plus" for small sockets: "Standard" for large sockets, \$3.50 each.

BRIGHTSON LABORATORIES, INC.

Waldorf-Astoria Hotel

16 W. 34th Street, New York City

Philadelphia Office, 50 N. Eleventh St., Philadelphia, Pa.

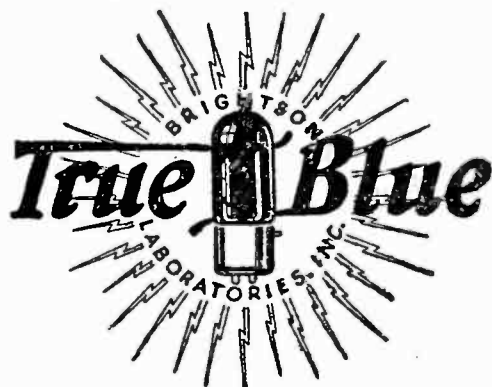

★ Tested and approved by RADIO BROADCAST ★

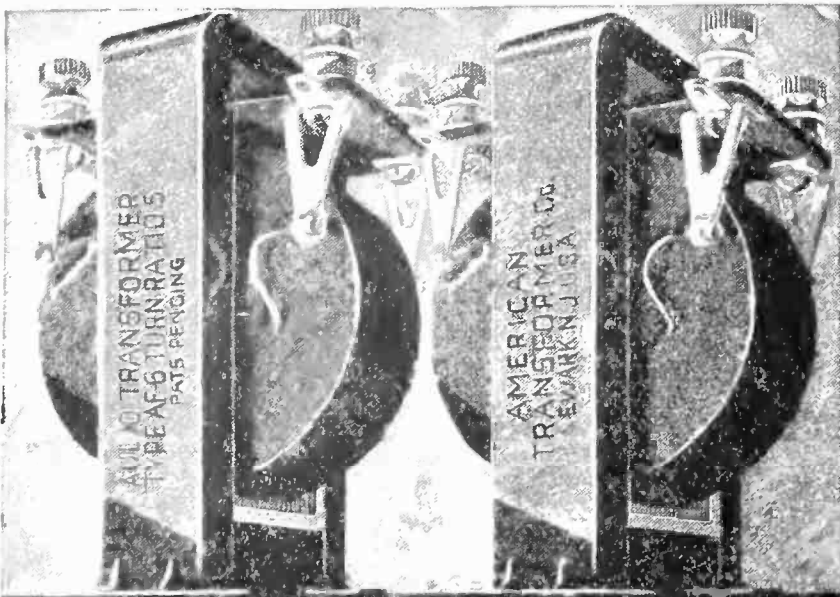

A PIONEER LEADER

AmerTrans continue from month to month as one of the *best* selling audio transformers.

There is ample volume, and the "tone-keen" characteristic of AmerTrans furnishes a pleasant, distinct reception value—most appreciated by the critical listener. In fact, there is no more efficient and permanent working part in any set than a pair of AmerTrans.

*Buy AmerTrans by the Pair
from an
Authorized AmerTran Dealer*

They are made in two types, one quality—A F 6, ratio 5:1, and A F 7, ratio 3½:1. Price either model, \$7.00. ★

AMERICAN TRANSFORMER
COMPANY

181 Emmet Street, Newark, N. J.

"Transformer builders for over 24 years"

AMERTRAN
TRADE MARK REG. U.S. PAT. OFF.

NEW — ★

A single control tuning element for two-control sets!

With a vernier that allows a variation between the two circuits of fifteen points on a 100 point dial!

Can be easily applied to
SUPERHETERODYNES
BROWNING-DRAKE
ROBERTS
HARKNESS

or any set employing two tuning controls.

Details on request

HANSCOM RADIO DEVICES
Woonsocket Rhode Island

Building Better Service into RADIO PARTS

Aside from recognized radio uses in which no other metals can be substituted, COPPER and its alloys help you to make good radio sets *better* sets.

For instance, binding posts are superior posts, and battery nuts give best service and satisfaction when made of dependable free-cutting BRASS rod. And—

★ their speedier production makes labor costs lower.

COPPER & BRASS
RESEARCH ASSOCIATION
25 Broadway, New York

This special insulation made to order for radio

—Now Built into a Line of Low Loss Parts

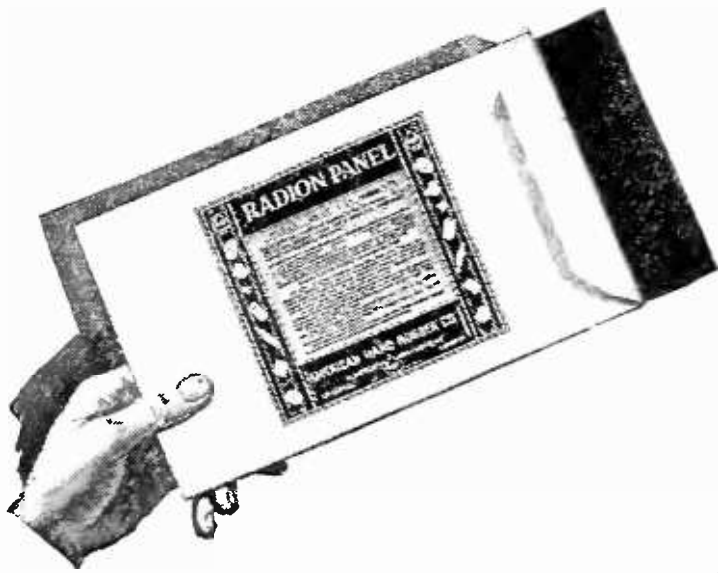

THE first choice of thousands of successful set builders is Radion Panels—made of *Radion*, the insulating material built to order by our engineers for radio exclusively.

Now we announce new developments in *radio parts* made of this perfect insulation that practically reduces losses in reception to a minimum.

These parts have the wonderful Radion finish, smooth and high-polished. This finish eliminates those losses caused by moisture gathering on the surface of ordinary insulation, causing leakage paths. The high-resistant characteristics found only in Radion Panels also mark these new parts.

You can now get Radion Sockets, Radion Dials, the new Radion Loud Speaker Horn, Radion Tubing, Radion Binding Post Strips, Insulators, etc. And, of course, Radion Panels (made in black and Mahogany) come cut in standard sizes for whatever set you wish to build.

Ask your dealer to show you these new Radion parts. Practically every radio store carries Radion Panels and will gladly get any of the new Radion parts if it hasn't them in stock.

*Send for Booklet,
"Building Your Own Set."*

MANY set builders have written us that our booklet, "Building Your Own Set," is the most practical and helpful they have seen. It gives wiring diagrams, front and rear views, shows new set with slanting panel, sets with the Radion Built-in Horn, list of parts and directions for building popular circuits. Mailed for 10c. Send the coupon to-day.

AMERICAN HARD RUBBER COMPANY
Dept. C9 11 Mercer St. New York City



The Radion Built-in Horn takes up small space in the cabinet and gives clear, rounded tones



The new No. 10 4-inch Radion Close-Tuning Dial, built to conform to the fingers. We believe it is the most beautiful dial yet designed.



RADION

The Supreme Insulation

Made to order for Radio purposes exclusively

AMERICAN HARD RUBBER COMPANY
Dept. C9, 11 Mercer Street, New York City
Please send me your booklet, "Building Your Own Set" for which I enclose 10 cents in stamps.

Name.....

Address.....

.....

★ Tested and approved by RADIO BROADCAST ★

A Revelation In Tone - - Volume - - Clarity

The Kellogg Symphony Reproducer brings the broadcasting studio into your very room, so realistic is its reproduction.

Piano music, the most difficult to reproduce, sounds so natural that you are completely carried away by its beauty.

Vocal selections retain all of the tone colorings of the artist.

Orchestra music is indeed a recreation, every instrument can be heard, clear and full.

Magnetic diaphragm control—used exclusively in the Kellogg unit—is the new principle that performs wonders in radio reproduction.

Nothing like it at twice the price—\$20.00 each.

At your dealers—hear one to-day

THE KELLOGG SWITCHBOARD & SUPPLY CO.
1066 W. Adams Street, Chicago, Ill.

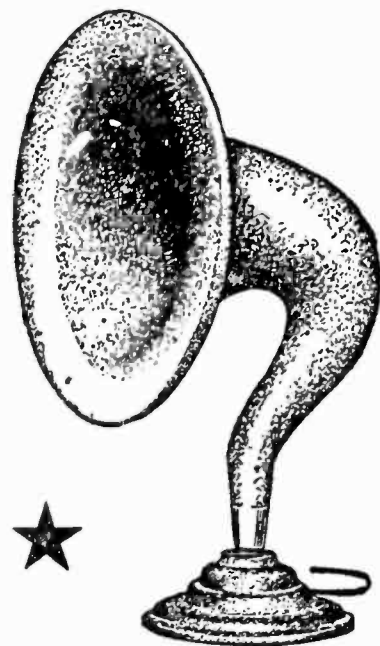

KELLOGG SYMPHONY REPRODUCER

**The Red Stripe
A Radio Guide Line**

For your protection, throughout the center of every Dilecto radio panel is a Red Stripe. You can see it along the edge of every panel.

If you buy or build a set look for the Red Stripe—and you'll be sure of the finest, strongest radio panel that can be made. Dilecto is a Phenolic condensation material.

THE CONTINENTAL FIBRE COMPANY
Factory: Newark, Delaware

Service on Dilecto, Conite, Context and Vulcanized Fibre from:
 New York, 250 Park Ave. Chicago, Wrigley Bldg.
 San Francisco, 75 Fremont St. Los Angeles, 307 S. Hill St.
 Seattle, 1041 Sixth Ave., South
 Pittsburgh, Farmers Bank Bldg.

Dilecto

BIG MONEY!

\$3,000 to \$10,000 a year

Want to make big, easy money? Learn how to install, operate, repair, construct and sell Radios. Write now for facts about the amazing opportunities for Radio experts, and our special offer of a **FREE** 1000-mile receiving set, and how you can quickly train at home by mail.

Be a Radio Expert

No previous experience necessary. Anyone with ordinary education can now learn Radio quickly under our simplified home-study plan. We need men right now to represent our Association. Be the Radio expert in your neighborhood. Get your share of the big profits. Hundreds about you want Radios and advice how to operate. You can earn enough money right from the start to pay for course. Nothing difficult about it. Low cost and easy terms.

FREE 1,000-MILE Receiving Set

Don't miss this big special offer to supply **FREE** all parts necessary to construct a high-grade 1000-mile receiving set. You can sell this set alone for practically the entire cost of the course. Send for the facts now. Find out all about this big-pay field. Address

Radio Association of America
4513 Ravenswood Ave., Dept. B-9, Chicago, Ill.

★ Tested and approved by RADIO BROADCAST ★

SELECTIVITY

THE OBEDIENT SLAVE TO YOUR DESIRES



Upon request, we will gladly mail you descriptive folder.

Just as the skillful fingers of a trained musician select and control the sensitive, vibrant strings of a harp—so, too, do you, who operate an APEX Radio Receiving Set, select and control the sound waves wafted through the air.

Stations thousands of miles away, or powerful near stations can be entirely and instantly isolated from interference.

This degree of finer selectivity is not the only triumph achieved by APEX scientific engineering principles. Full volume, wider range, greater clarity have been acquired and are enthroned in a setting of exquisite beauty of design and finish that place APEX Cabinets in the highest ranks of the finest furniture.

Only a dependable merchant is given the APEX dealer franchise. Your APEX dealer will gladly make a personal demonstration of APEX Quality Radio Apparatus.

APEX ELECTRIC MFG. CO.
1410 W. 59th St., Dept. 904
CHICAGO

Also makers of the famous APEX Vernier Dials and APEX Rheostats, which are sold by every good dealer in Radio.

Quality Radio Apparatus



Apex Baby Grand Console
Price \$225

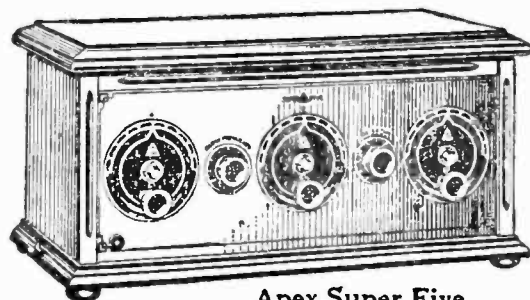

Apex Super Five
Price \$95
without accessories

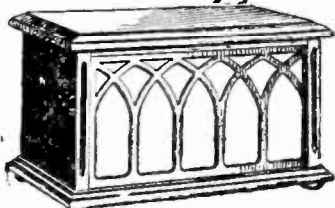

Apex Console Entertainer
Price \$27.50

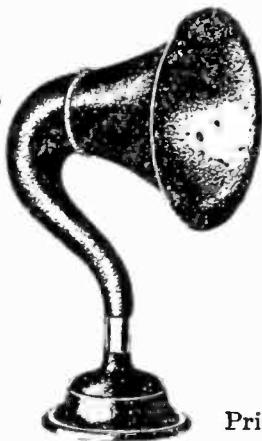

Apex Entertainer
Price \$22.50



Apex Utility Radio Table
Price \$75

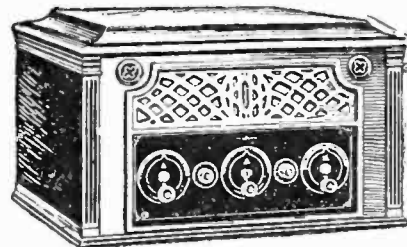

Apex DeLuxe
Price \$135

Prices West of Rockies slightly higher. Canadian prices approximately 40% higher

★ Tested and approved by RADIO BROADCAST ★

CONCERNING BURGESS BATTERIES

The unique position of esteem and confidence occupied by Burgess Radio Batteries is a natural development of the conservative policy which has characterized the manufacture, advertising and sale of Burgess products.

Of interest, perhaps, to the thinking battery buyer is the fact that no Burgess product is advertised or sold until its merit has been proven, not only by our own rigid tests, but also those of the foremost radio engineers, manufacturers and experimenters in the country.

Through friendly criticism and suggestions, together with extensive research and engineering by the C. F. Burgess Laboratories the efficiency of Burgess Batteries has increased to a degree which we believe is not equalled elsewhere.

Ask Any Radio Engineer

BURGESS BATTERY COMPANY

ENGINEERS - DRY BATTERIES - MANUFACTURERS
FLASHLIGHT - RADIO - IGNITION - TELEPHONE
GENERAL SALES OFFICE: HARRIS TRUST BLDG., CHICAGO
LABORATORIES AND WORKS: MADISON, WISCONSIN

BRANCHES

NEW YORK BOSTON KANSAS CITY MINNEAPOLIS
WASHINGTON PITTSBURGH ST. LOUIS

IN CANADA

PLANTS: NIAGARA FALLS AND WINNIPEG
BRANCHES: TORONTO • MONTREAL • ST. JOHN





★

Have you met

Major Tuner

REG. U.S. PAT. OFFICE

MAJOR TUNER will end those "interference blues." A set built with the MAJOR TUNER gets only one station at a time—the one you want to get and no other.

MAJOR TUNER is the most advanced form of three circuit Low-Loss tuner. It is packed with complete picture wiring diagrams and full instructions.

(If your dealer cannot supply you, write us)

BEL-TONE RADIO CO. \$4

161 Jamaica Ave., Brooklyn, N. Y.

For Quality

CORBETT'S

For Quality

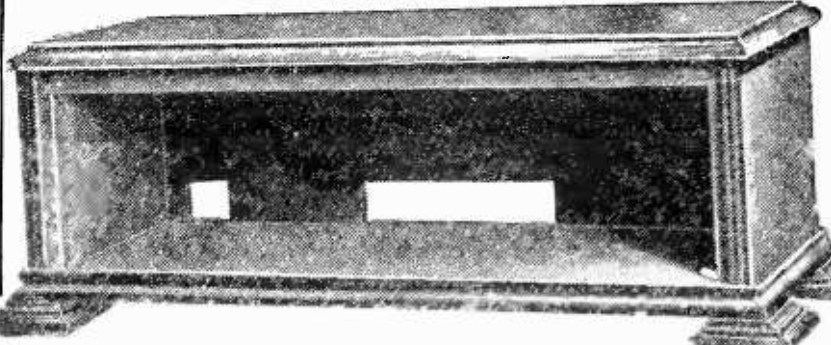

OUR NEW MODEL "B"

(Cu. illustrates "Cockaday" cabinet—rear slots are not included in other cabinets.)

Size	Mahog- any finish	Walnut or Mahog- any finish	Size	Mahog- any finish	Walnut or Mahog- any finish	Size	Mahog- any finish	Walnut or Mahog- any finish
7x10-8	\$5.40	\$7.00	7x26-8	\$8.25	\$10.85	8x30-8	\$10.85	\$14.25
7x12-8	5.70	7.40	7x28-8	9.00	11.90	7x18-10	8.35	10.90
7x14-8	6.00	7.80	7x30-8	9.85	12.85	7x21-10	9.15	12.20
7x18-8	6.70	8.75	7x27-9	9.25	12.20	7x24-10	10.00	13.15
7x21-8	7.30	9.50	8x24-8	8.50	11.20	7x26-10	10.85	14.25
7x24-8	7.80	10.30	8x26-8	9.25	12.20	7x30-10	11.65	15.15
COCKADAY CABINET for either set							10.50	13.60

Shipping Charges Prepaid

Our model "B" cabinet is neatly moulded, accurately made of best kiln dried lumber and well packed for shipment. Top hinged with nickle stop hinges. Carefully hand rubbed piano finish.

For full length piano hinge and lid stay instead of stop hinges add 4c per panel inch.

MOUNTING BOARDS—10 to 18 in., 40c; 21 to 26 in., 50c; 28 to 30 in., 60c each.

WRITE FOR BOOKLET offering best values in radio furniture. Inquiries solicited for special cabinets.

LIBERAL F.O.B. FACTORY DISCOUNTS to Dealers.

CORBETT CABINET MFG. COMPANY
St. Marys, Penna.



FERGUSON SIX
Console Model

"The Gold Standard of Radio Receivers" built into a graceful cabinet, finished in the choicest genuine walnut, with spacious compartments for batteries, charger, etc. The loudspeaker, of special design, employs the Amplion unit.

Price, \$290
(Accessories extra)



FERGUSON SIX
Cabinet Model

The Ferguson Six employs two stages of balanced tuned radio frequency, oscillating detector (non-radiating), and three stages of perfectly matched audio frequency. The De Luxe cabinet, with "B" battery compartments, may be had in either high-light walnut or mahogany.

Price, \$180
(Accessories extra)

The Gold Standard

EVERY INDUSTRY has its pioneers whose achievements blaze the trail and establish the standards. Ferguson, actuated by the desire to build fewer and better receivers, attained early distinction in the radio industry.

The high notes of a coloratura soprano; the rich, mellow tones of a bass horn reach your living room with crystal clearness and life-like tone fidelity through the Ferguson Six. To examine the graceful craftsmanship of this Receiver; to experience its easy, thoroughly dependable operation is to know why it has been called "The Gold Standard of Radio Receivers."

Have your Ferguson Dealer give you a comparative test, or write us.

J. B. FERGUSON, INC. ★
41 EAST 42ND ST. NEW YORK, N.Y.

Ferguson

J.B. INCORPORATED

The Gold Standard of Radio Receivers

Radio Broadcast

WILLIS K. WING
ASSOCIATE EDITOR

ARTHUR H. LYNCH
EDITOR

JOHN B. BRENNAN
TECHNICAL EDITOR

SEPTEMBER, 1925

COVER - - - - -	<i>From a Painting by Remington Schuyler</i>	
WHERE RADIO IS NOT SIMPLY "FURNITURE" - - - - -	<i>Frontispiece</i>	574
IS THE RADIO NEWSPAPER NEXT? - - - - -	<i>James C. Young</i>	575
AN ALL-WAVE TUNED RADIO FREQUENCY RECEIVER - - - - -	<i>Zeh Bouck</i>	581
WHEN BROADCAST STATIONS INTERFERE - - - - -	<i>C. B. Jolliffe</i>	586
CUTTING DOWN SPARK INTERFERENCE ON THE GREAT LAKES	<i>Corley W. Kirby</i>	590
THE MARCH OF RADIO - - - - -	<i>J. H. Morecroft</i>	593
WHAT IS TO BECOME OF THE HOME CONSTRUCTOR? - - - - -	<i>Keith Henney</i>	604
"AS THE BROADCASTER SEES IT" - - - - -	<i>Carl Dreher</i>	610
<i>Drawings by Franklyn F. Stratford</i>		
A SINGLE-CONTROL RECEIVER - - - - -	<i>C. L. Farrand</i>	620
FOR THE RADIO BEGINNER - - - - -	<i>Zeh Bouck</i>	623
How to Build the R. B. One-Tube Knockout Receiver		
The Vacuum Tube as an Amplifier		
Radio Terms Defined		
References to Good Radio Books		
THE LISTENERS' POINT OF VIEW - - - - -	<i>Kingsley Welles</i>	632
HOW TO MAKE A UNIVERSAL BATTERY CHARGER - - - - -	<i>Roland F. Beers</i>	640
SHALL I RUN MY SET FROM THE LAMP SOCKET? <i>By the Laboratory Staff</i>		651
"NOW, I HAVE FOUND . . ." - - - - -		658
A Short-Wave Low-Loss Receiver		
Two Shop Tricks		
An Automatic Potentiometer Cut-Out		
A Tool to Drill Holes in Glass		
Seven Construction Ideas		
Making a Neutralizing Condenser		
A Good Single Bearing for Rotor Coils		
A Handy Crystal Detector		
THE GRID - - - - -		664
How to Tell the Condition of Vacuum Tubes		
A Good Ground		
How to Compare Loud Speakers		
A Good Crystal Receiver		
A Three-Tube Double Reflexed Receiver		
Making Transformers for the Super-Het.		
Toroids for Neutrodynes		
On Matching and Unmatching Tubes		

Copyright, 1925, in the United States, Newfoundland, Great Britain, Canada, and other countries by Doubleday, Page & Co.
All rights reserved. TERMS: \$4.00 a year; single copies 35 cents.

F. N. DOUBLEDAY, *President*
ARTHUR W. PAGE, *Vice-President*

NELSON DOUBLEDAY, *Vice-President*
RUSSELL DOUBLEDAY, *Secretary*

S. A. EVERITT, *Treasurer*
JOHN J. HESSIAN, *Ass't. Treasurer*

Doubleday, Page & Co.
MAGAZINES

WORLD'S WORK
COUNTRY LIFE
GARDEN MAGAZINE & HOME BUILDER
RADIO BROADCAST
SHORT STORIES
EDUCATIONAL REVIEW
LE PETIT JOURNAL
EL ECO
THE FRONTIER

Doubleday, Page & Co.
BOOK SHOPS

NEW YORK: LORD & TAYLOR BOOK SHOP
PENNSYLVANIA TERMINAL (TWO SHOPS)
38 WALL ST.
GRAND CENTRAL TERMINAL
ST. LOUIS: 223 NORTH 8TH STREET
4914 MARYLAND AVENUE
KANSAS CITY: 920 GRAND AVENUE
206 WEST 47TH STREET
TOLEDO: LASALLE & KOCH
CLEVELAND: HIGBED CO.
SPRINGFIELD, MASS.: MEEKINS, PACKARD & WHEAT

Doubleday, Page & Co.
OFFICES

GARDEN CITY, NEW YORK
NEW YORK: 120 WEST 32ND STREET
BOSTON: PARK SQUARE BUILDING
CHICAGO: PEOPLES GAS BUILDING
SANTA BARBARA, CALIFORNIA
LONDON: WM. HEINEMANN, LTD.
TORONTO: OXFORD UNIVERSITY PRESS

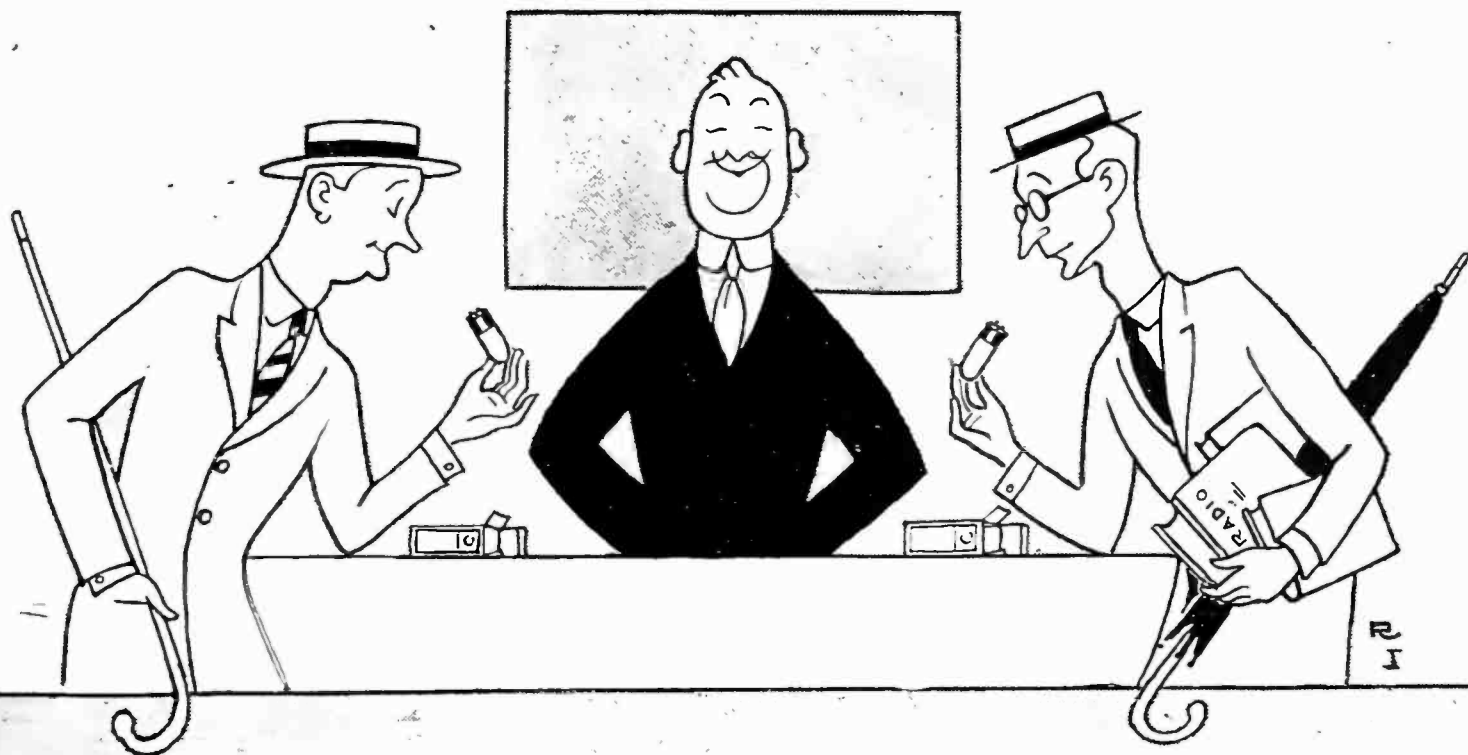

It isn't a
genuine
 UV-199
 unless
 it's a
Radiotron

The familiar names
 WD-11, WD-12,
 UV-199, UV-200
 and UV-201-A
 rightfully belong
 to *Radiotrons*
 only. To be sure of
 quality, it is im-
 portant to look care-
 fully at the base of
 every tube you buy
 to see that it carries
 the name *Radio-*
tron and the RCA
 mark as proof that
 it is a *genuine*
Radiotron.

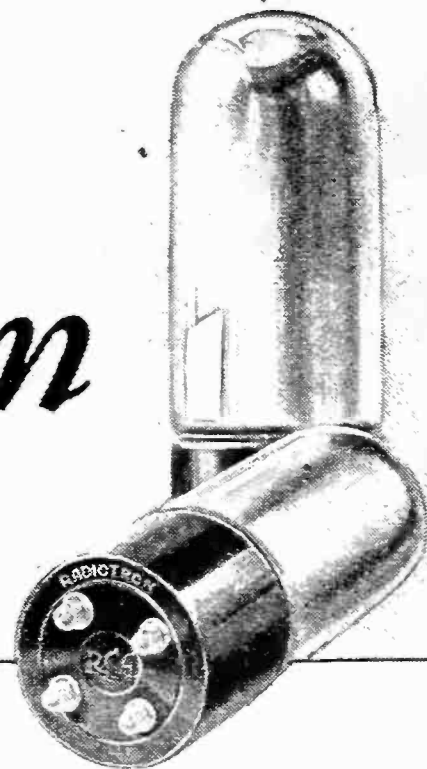

Radio Corporation of America

Chicago

New York

San Francisco



Radiotron

AN RCA PRODUCT

★ Tested and approved by RADIO BROADCAST ★



WHERE RADIO IS NOT SIMPLY "FURNITURE"

A farmer's home in central Iowa, where the radio receiver is a vital part of the home equipment. Farmers have found market reports a direct financial help to them during the daylight hours. In the evening the farmers are some of the most interested of broadcast listeners. Radio is helping to solve the problem of how to keep the farmers on the farm

RADIO BROADCAST

Vol. 7 No. 5



September, 1925

Is the Radio Newspaper Next?

Newspaper Organizations Have Been Quick to Seize the Opportunity of Radio—How the News is Sent Ashore and Afloat—The Possibilities of the Tabloid Radio Newspaper

BY JAMES C. YOUNG.

THE future of the press lies in the air. Radio represents the one channel of news expansion not already developed to the full. When Fort Sumter was fired on in 1861, the Pony Express rode full tilt for a whole week to carry the news to California. Even then the telegraph wire, linked from pole to pole between skirmishes with Indians, was advancing across the continent. This was the eighth wonder of the world, surpassing all other wonders in the descent of man—a tiny thread of copper carrying sound unmeasured distances.

Then came the telephone. Its appearance was coincidental with the girdling of the globe by cable lines. But the last and greatest age of communication did not begin until three decades later, when crude instruments first feebly recorded wireless waves. The last ten years have served to improve radio to such an extent that man can instantly transmit his thoughts around the sphere.

Meanwhile the newspaper has also developed until now it has become a permanent record of modern life. What is said and done the world over finds expression in this record. The total number of words sent daily by telephone, telegraph and cable, between newspapers everywhere, would test the average man's imagination. Radio, the newest agent

of the press, bears but a small part of this burden. On busy days, the word traffic between Europe and America will rise to 100,000 words. When business is dull this total falls off to 50,000 or even less.

But radio by no means is limited to the transmission of news between agents of the press. It is rapidly becoming a part of the press. We might call it an aërial edition and not be far in the wrong. More than fifty American newspapers send out bulletins at short intervals to the owners of radio sets both far and near, informing them of the latest decision of the British cabinet. That decision may not be half an hour old when some sheep herder in the backlands of Texas will learn that English labor has prevailed in its demands for better housing at state expense. Or the speeding waves of radio may convey word that Morocco is engaged in a new war. Even the gossip of Broadway and the last quotation on wheat are whisked around the world for all to hear.

This aërial edition of the press, usually issued every thirty minutes by the newspapers participating, offers possibilities which excel those of the established editions published daily by the great metropolitan plants. The instant communication of important matters to the whole body of mankind is now possible. Any great event that transpires to-day must



THE PONY EXPRESS

In the earlier days of national development was the chief means of communicating intelligence. The method was slow, not especially certain, and rather hard on the pony expressman. This old engraving shows an express relay station in the Rocky Mountains

be known within five minutes wherever men have ears.

THE INFLUENCE OF NEWS BROADCASTING ON THE PRESS

THIS new practice of instantaneous news broadcasting must essentially have a wide influence on the press. A dozen years ago the "extra edition" was the special marvel of the newspaper field. In some plants it was possible to produce such an edition within twenty minutes from the time of a world development. During the recent war these extra editions were almost an hourly event, particularly when the battle of the Marne hung in suspense and the Germans beat hard upon the door of Flanders.

Peace brought fewer editions and a steadier tone to the press. In the few years since 1918, radio broadcasting has developed so extensively and intensively that extra editions would lose much of their interest if the war were under way to-day. It might be argued that bulletins in front of newspaper offices whet the public appetite for news, instead of dulling its edge. But these bulletins are glimpsed by only a few thousands of people. And at best they are nothing more than skeletonized dispatches.

This is not the case with radio news broadcasting. When events justify, announcers inform a myriad listeners what has transpired. It is easy to read dispatches in full. Ordinarily news of the first rank arrives in short, preg-

nant messages. The man with a radio set may learn in the evening of some great event that his particular newspaper will not convey to him until the next morning. When an event of this kind is far distant—such as the Tokio earthquake—it frequently happens that a day or more will elapse before details begin to come through.

In view of all of these considerations, no one may doubt that radio is exerting a strong influence on the press, and the press certainly will have an equal bearing on radio. It would seem that the press has been somewhat backward in developing the possibilities of news transmission and broadcasting. Only a comparatively small group of American newspapers are using the international stations and there are but two press receiving stations in existence.

Publishers of small newspapers have found that radio broadcasting reduces interest in warmed over news. It is an old axiom of such newspapers that the scissors are mightier than the pen and seldom are the shears idle when a small paper is in the making. But the publication of matters already covered by some broadcasting station will not satisfy even country readers. The event may have been completed, perhaps wholly reversed, by the time that these papers appear.

Therefore small papers are beginning to suffer from radio competition. Even the papers in large cities will feel the stress of this competition as it expands. But we may be certain that the newspaper is a fixed institution. Although it may lose some of its claim to freshness, when news broadcasting becomes general, it will have wide opportunity to amplify and develop news. In a measure, the newspaper is likely to evolve along the lines of established magazine practice, departing somewhat from the breathless, last minute attitude that marks such a large section of the press. If that evolution ever comes about, it will bring a large measure of relief to an abused public. We may conceive of the day when no paper can print such headlines as this one—"Burglar Slays Widow; Flees With Jewels"—for the excellent reason that it will be "old stuff." When the next edition comes out the burglar may be in jail, by the help of radio.

THE EFFECT OF THE WAR

AFTER the Armistice, radio development received a new stimulus. But it also lost in momentum because of the lessening of concentrated attention by the world's best

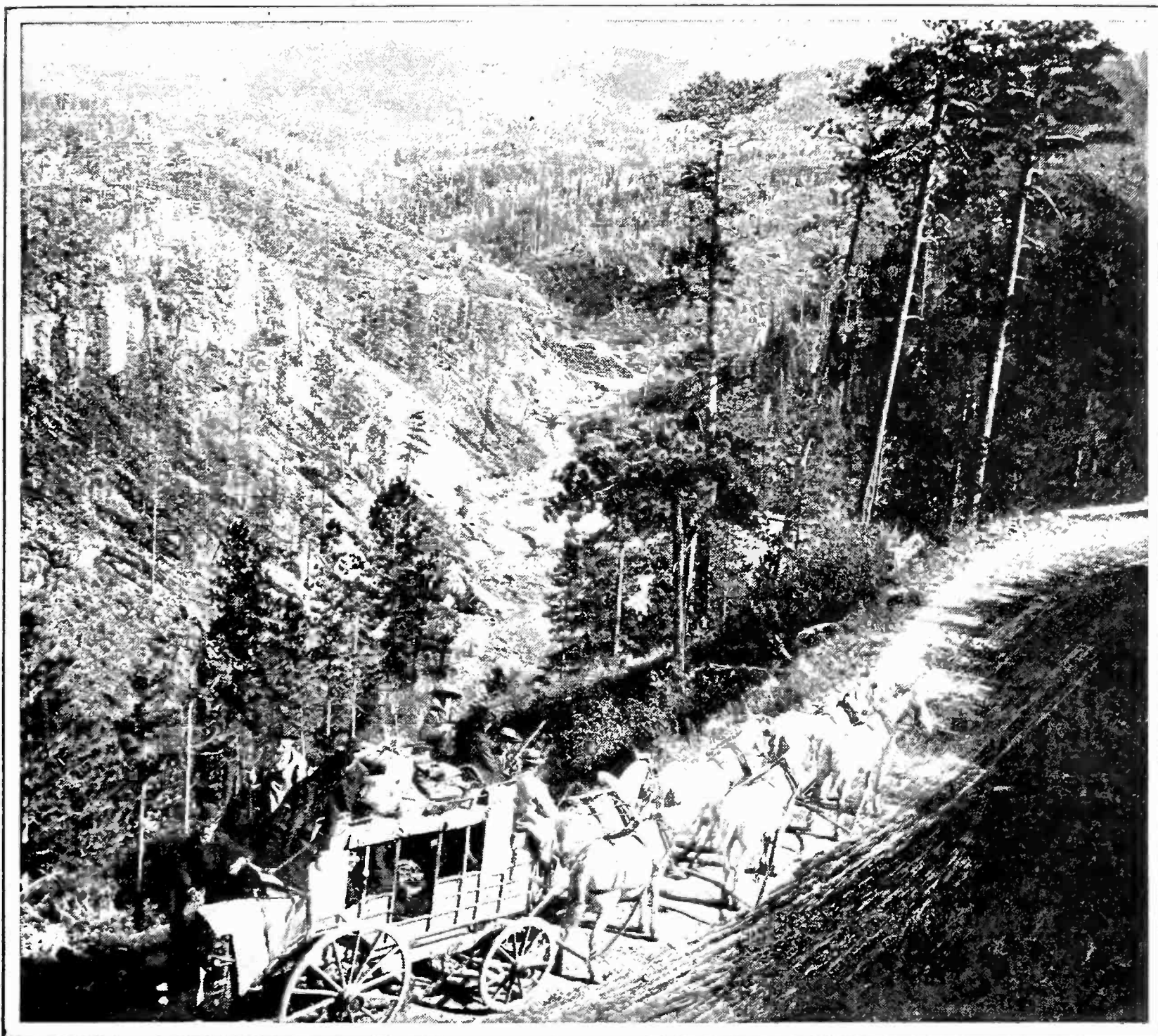

© Underwood & Underwood

A CALIFORNIA STAGE COACH

Navigating a mountain road. The article by Mr. Young draws an interesting parallel between the present almost instant methods of spreading news, seconds after it is news, and the infinitely slower methods available to our great-grandfathers

inventive brains. For a year or two the whole subject was vague and uncertain. Transatlantic service was bad. So the *New York Times*, always among the leaders in news enterprise, determined to install its own station. This station first went into use in 1920, becoming the example and cornerstone for all latter day developments. In the beginning it was largely an experiment, and the experimental spirit has continued to dominate its operation.

The *New York Times* has been called a war paper, because much of its prestige resulted from the thoroughness of its dispatches from 1914 to 1918. In the language of newspaper men, the *Times* "covered the war like it covered Harlem." The coming of peace left so many problems unsettled in Europe that prompt, dependable radio service was a necessity for the continuance of this policy.

The station has been equipped for the widest range of transmission. Its daily news report averages about 10,000 words, and these messages can be recorded from three stations simultaneously, on wavelengths of 50 to 25,000 meters. Some of these dispatches literally are sent around the world.

How such enterprise may be rewarded was indicated not long ago when the *Shenandoah*, the Navy's big dirigible, broke from her mooring mast at Lakehurst, New Jersey, and went careening away in a wild storm. The Navy already had lost two dirigibles, both by explosions, with heavy loss of life. Seemingly another tragedy impended. But word scarcely had been flashed from Lakehurst when the *Times* station picked up the *Shenandoah's* call and learned that all was well, the big ship plunging along in the gale, embarrassed but safe.

This event took place just about the hour that the *Times* was going to press. The news was duly printed on the first page, giving the paper a "beat" such as seldom falls to any publication in this day of news organization. The *Times* station also has been first with a number of sos messages and it figures daily in the dissemination of world news.

NEWSPAPERS INSTALL A JOINT STATION

PLAINLY the early success of the *Times* with radio dispatches was not to go unobserved. The American Newspaper Publishers Association, working through a special committee, determined to experiment with radio transmission. The *Times* and the *Chicago Tribune* have been prominent supporters of the plan, which resulted in the erection of a station at Dartmouth, Nova Scotia, for transatlantic work. This station is just across the bay from Halifax and affords the advantage of acknowledging radio dispatches by means of the imperial cable ending at Halifax.

In February of 1922, the station began operation and now is in direct communication daily with four of the big plants in Europe, those at Leafeld, and Northolt, England, Lyons, France, and Coltano, Italy. A new station is now under construction near by for the retransmission of dispatches which come

to Dartmouth. So far the traffic has been handled by telegraph and telephone wires, but it is planned to send the news direct to subscribers from the new plant.

This Dartmouth station and that of the *Times* work in close coöperation, one relieving the other when storms or other causes render reception difficult. The two of them would seem to have proved that radio transmission across the Atlantic is a thoroughly practical undertaking for private newspaper organizations. Such plants also afford some measure of protection in the despatch of news which may have great value. It is to be believed that the next year or two will witness further enterprise in this direction.

The New York *World*, also interested in the Nova Scotia plant, has conducted wide experiments in the transmission of photographs by radio. This subject has had attention from the *World* for several years and the photographs already received warrant belief that the *World* may install a station one of these days exclusively for the purpose of transmitting radio photographs.

Extensive experiments have been conducted by the International News Service, one of the Hearst organizations, for the purpose of automatic reception and elimination of static, doubtless with the view to installing a trans-

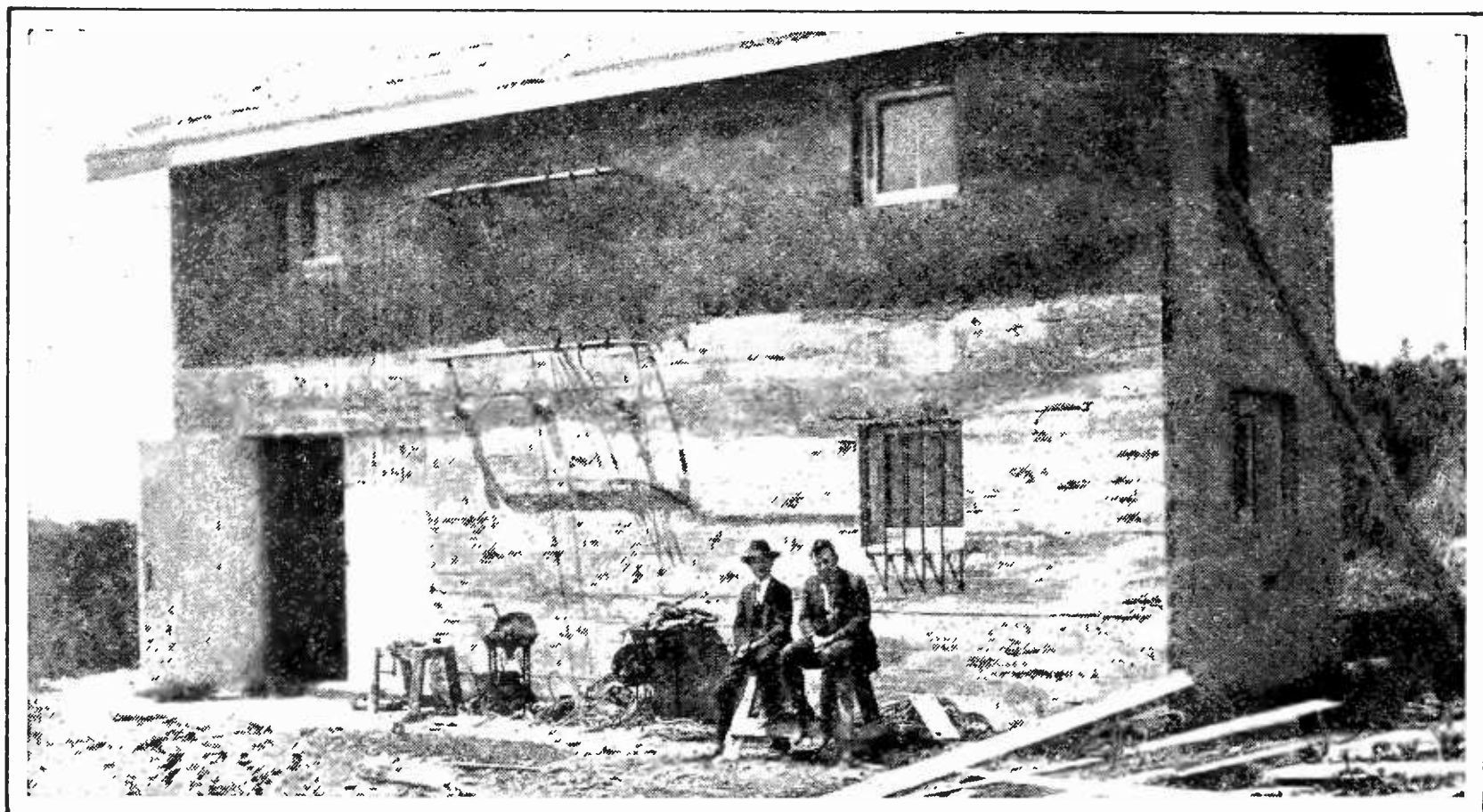

THE TRANSATLANTIC NEWSPAPER RADIO STATION

At Halifax, Nova Scotia, as it looked under construction in 1922. J. A. Burch, engineer, and F. E. Meinholtz, chief operator, New York *Times*, are seated, left to right. This station is maintained by a syndicate of about nine of the largest newspapers in the United States purely to receive press messages addressed to it from foreign countries. The messages are then forwarded to the supporting newspapers by the usual methods. Little transmitting is done from this site except to acknowledge messages and to get corrections. A power of about ten kw. is employed

atlantic station when conditions warrant it. These four news organizations have the radio field practically to themselves.

In the matter of broadcasting, first honors fall to the *Chicago Tribune*, which introduced the half hourly bulletin now sent out regularly from WGN in Chicago. The *Tribune* operated its own plant for a time but later determined to use one of the commercial stations. Its bulletins are well known to a large section of the American public, furnishing a brief survey in terse language of just what is going on in the world. The bulletins sent out by the Radio Corporation of America also are copied on ships in the seven seas. Some of the big passenger vessels, maintaining their own printing plants, reproduce these dispatches in the form of miniature newspapers which are distributed every day the traveler is aboard. On other ships, lacking this pretentious equipment, they still constitute a tie with the world of affairs which lies behind and before.

KYW, also in Chicago, broadcasts the bulletins of the local Hearst papers, which further inform the public of the activities of its neighbors whether they happen to live in the next county or on the next continent. Even secret treaties and whispered understandings have drifted into this great hopper of news. Radio now supplements the press in disseminating such information everywhere. The man who

runs need not pause to read. He can listen as he goes and take with him a concise, photographic mind picture of how the world is conducting itself.

MANY PAPERS BROADCAST NEWS

OTHER papers in many states are broadcasting news by radio, ranging from such diverse communities as Detroit to Fort Worth. It is an odd phase of New York journalism that none of the country's greatest papers so far have embarked in news broadcasting. But the practice is growing daily, notably in cities of the 200,000 class, where life is not quite so busy as in the big centers, and people presumably have more time to heed the world's gossip. It is even said that farmers' wives have quit listening on the party line when Mrs. Jones calls up the grocer, preferring to get the latest word from Paris about this season's dresses. Radio news is broadly diversified, as it should be. It is a noticeable reflection of the daily newspaper. First comes the "leader," the big story of the hour. Then the other news in a descending scale. Occasionally there is an editorial squib. The sports department, ordinarily the last in rank, frequently enjoys a larger number of minutes than all of the other departments joined together. The public may or may not care about the British cabinet decision and the new



THE RADIO ROOM OF THE NEW YORK "TIMES"

Here, operators are constantly on duty receiving press messages addressed to them from their correspondents abroad. A watch is also kept on the various commercial wavelengths. In that way, news is transmuted almost instantly from the air to the printed page. The *Times* has been able to score many news "beats" through the enterprise of their listening radio operators. F. E. Meinholtz, chief radio operator of the *Times* is standing, and R. J. Iveson is seated at the typewriter. The apparatus on the long table is devoted almost entirely to receiving from European stations on wavelengths of 10,000 meters and above

war in Morocco, but it always wants to know whether Babe Ruth has knocked another homer and if it really is true that poor old Ty Cobb has a "charlie horse" and must quit the game.

If the moralist wished to seek a lesson from the example the preponderance of sports news over other kinds, as broadcasted in the great radio press, he might find a number of interesting suggestions. For one thing, Americans are a vigorous people, with a strong leaning to the dramatic. Since Mr. Ruth and Mr. Cobb are the very essence of our national drama, the average radio user is deeply interested in their home runs and "charlie horses."

Another thing worth considering is the fact that sports news was the first of any kind to be sent out by radio. Baseball, football, and the prize ring lead where the serious figures of news and editorials are now beginning to follow.

It does not take much imagination to call up the day when we shall get a complete newspaper by radio read to us by a specially trained voice. Life is to be made a little simpler for the man who works all day and says he is "too tired to read the paper to-night." Before long he may have it read for him by a man who knows how, a man who will study his tastes and reactions with the skill of an actor.

Doubtless, our mentor not only will read us the news and the editorials and all about the baseball team, but maybe he will have a comic strip of his own, and we can imagine the funny little figures while he reads the captions. Then we also may expect a column of wit, written to order every day, never repeating a joke older than that one about the Irishman who carried bricks up the ladder while the man on top did the work.

Such is to be the radio newspaper of to-morrow, or something approximating this brief glimpse. Perhaps it will have a fashion column and the busy housewife can note down the sizes and descriptions of new dresses. Conceivably the cross word puzzle will be a feature if the fad lasts much longer. We could draw our own squares and spend the rest of the night happily, after the announcer gave us a few instructions. In fact, the radio newspaper may be made almost anything that the public wants. Whatever this evolution is destined to be, the radio newspaper has become an accomplished fact. And certainly there is the call now for the latest bit of news.

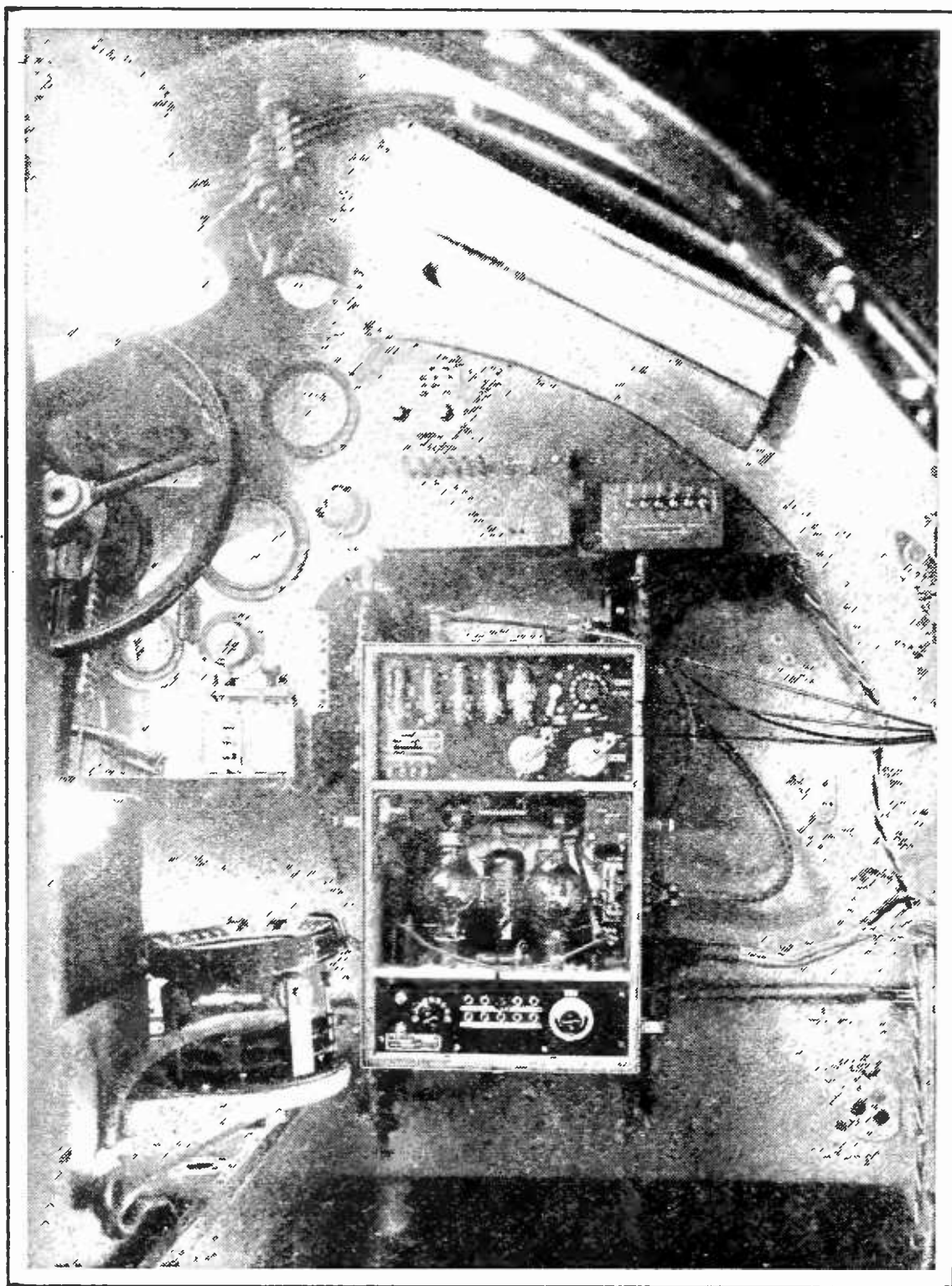

NEWS FROM AIRPLANES

Is being forwarded by radio. Both means have been most successful in impressing the present generation with the speed with which news is gathered and disseminated. The photograph shows a radio transmitter and receiver installed aboard one of the latest types of British airplanes belonging to the British Imperial Airways and used in cross-channel passenger and freight flights. This is the first photograph to reach this country of the interior of the control equipment of these planes, and is one of the few good photographs in existence of an airplane interior

An All-Wave Tuned Radio Frequency Receiver

How to Build an Efficient Receiver With High-Quality Audio Amplification, Designed to Cover the Frequency Band from 1500 to 116 Kilocycles (200 to 2600 Meters)

BY ZEH BOUCK

THIS receiver embodies no especially new circuit ideas, but it forms a very valuable acquisition to the receiving equipment of the experimenter who wishes to hear signals on other waves than those allotted to broadcasting in the United States and near-by countries. In France, England, Australia, and Germany there are broadcast stations transmitting way above the conventional wavelengths, and many American listeners have expressed a lively interest in hearing signals from those broadcasters. The use of resistance-coupled amplification insures excellent quality in the audio part of this circuit. And, too, for those broadcast listeners who are beginning to be curious about what is going on in radio telegraph channels; this set will give them a good frequency band from which to choose their signals. They can hear much traffic between ships at sea and shore stations and some amateur communication as well.—THE EDITOR

UNLIKE American stations, foreign broadcasters are not confined to the frequency band between 1500 and 520 kilocycles (200 to 575 meters). On the contrary, many foreign stations, particularly those of continental Europe, broadcast on frequencies below 500 kilocycles (above 600 meters), as well as upon the wavelengths with which our domestic amateurs are familiar. This elasticity of tuning somewhat complicates the situation of the foreign enthusiast, whose problems were recently brought home to the writer by the request of a Belgian friend for a receiver filling these particular requirements.

The set is to be operated at Turnhout, Belgium, some three hundred miles from SBR Brussels, the nearest broadcasting station, and about seventy-five miles from Antwerp. As the radio entertainment of my friend's family will be divided between England and the continent (and perhaps American stations), the receiver must respond with equal efficiency over a comparatively large frequency band—between 1500 and 116 kilocycles (200 to 2600 meters).

It is, of course, difficult to design an efficient receiver to cover this band employing one permanent set of inductances, i. e., using sufficiently large coils to attain the higher waves, and tapping for the lower waves. The losses and inefficiencies attending such ex-

tensive tapping would seriously impair the effectiveness of the receiver on the higher frequencies (lower waves).

Honeycomb coils suggest themselves in the usual three coil, primary, secondary, and tickler arrangement, as an obvious solution. Unfortunately, the wide separation of foreign stations implies the necessity of at least one stage of radio frequency amplification if consistent reception of four fifths of the stations is to be achieved. The efficiencies of the honeycomb coils in the conventional long wave circuits, however, are quite applicable to radio frequency amplification, and the ultimate receiver almost solves its own problems in the form of a "five honeycomb coil set."

With the growing stimulation of interest in international broadcasting and its reception, it is probable that many American enthusiasts will be interested in duplicating this receiver.

HONEYCOMB INDUCTANCES ARE USED

THE circuit is diagrammed in Fig. 1. The coils L are all honeycombs. L_1 is the antenna primary, and L_2 secondary inputting to the r. f. tube. L_3 functions as the primary of the radio-frequency transformer. L_4 is the r. f. secondary in the grid circuit of the detector tube, and L_5 is the tickler coil. It will be observed that the circuit is merely the conventional three-coil arrangement with the addition of a stage of tuned radio frequency

amplification. In changing wave bands, the coils in each of the five mounts are replaced by different sizes. By selecting the proper values, any frequencies used to-day for transmission of radio telephony or telegraphy can be received.

Returning to the circuit, switch S_x is the usual series-parallel switch which adds considerably to the tuning possibilities of the antenna tuning-condenser C_x . C_x is preferably a forty-three plate variable condenser. C_2 and C_3 are secondary tuning variable condensers each having a capacity of .0005 mfd. C_4 is a .006 mfd. Micadon by-pass condenser. C_5 is a .0025 mfd. bypass. C_6 is the usual .00025 mfd. grid condenser. C_7 , C_8 , and C_9 are the isolating-coupling condensers of the resistance-coupled amplifier, all being Micadons of .006 mfd. capacity. C_{10} is an output bypass condenser, capacity .006 mfd. which may or may not be necessary in individual receivers.

R_1 is a three hundred- to four hundred-ohm potentiometer which stabilizes the r. f. circuit. R_2 is the conventional 2-megohm grid leak across the grid condenser. R_3 is a General Radio ten-ohm rheostat. R_4 is a dismantled twenty-ohm rheostat placed in series with the small three-volt pilot lamp, PL. This lamp is located behind a colored glass jewel on the panel and is an effective and attractive signal that the tubes are burning. It is not, of course, essential to the operation of the receiver. R_5 throughout the resistance-coupled amplifier represents the coupling resistors of one hundred thousand ohms resistance. R_6 , R_7 , and R_8 are amplifier grid leaks, having respective values of 1 megohm, $\frac{1}{2}$ megohm, and $\frac{1}{4}$ megohm.

The coupling resistors, coupling condensers, and amplifying tube grid leaks are combined for efficient compactness into three Daven Resisto-Couplers. Daven resistors are used throughout the amplifier. The initials on the diagram represent the initialing on the couplers.

J_1 is a standard closed circuit jack, placed in the plate circuit of the first audio frequency tube. This is preferable to plugging-in on the detector. Jack J_2 is an open circuit jack with filament control. Switch S_2 turns on all filaments when the loud speaker plug is in jack J_2 , and the first three tubes with the plug is in jack J_1 .

The 4.5-volt C battery while not altogether necessary, is desirable. Particular note should be taken of the amplifier grid leak connections.

LIST OF PARTS

THE circuit diagram, Fig. 1, represents the following parts used in the construction of the receiver:

- One three coil Branston Mounting
- Two Cotocoil mounting brackets
- 5 Na-ald Sockets
- 2 .0005 mfd. variable condensers
- 1 .001 mfd. variable condenser
- 1 Midget vernier condenser (across C_3)
- 1 series parallel switch
- 1 Cutler-Hammer battery pull switch
- 1 General Radio ten-ohm rheostat
- 1 400-ohm General Radio potentiometer
- 1 .00025 mfd. Micadon
- 5 .006 mfd. Micadons
- 1 .0025 mfd. Micadon
- 4 Daven grid leak resistors, 2 meg., 1 meg., $\frac{1}{2}$ meg. and $\frac{1}{4}$ meg.
- 3 Daven 100,000-ohm coupling resistors,
- 1 7-inch x 21-inch bakelite panel
- 3 Daven Resisto-Couplers
- 8 Eby binding posts
- 1 Pacent closed circuit jack
- 1 Pacent open circuit, filament control jack

These parts represent an approximate cost of thirty-five dollars. To this price must be added the expense of whatever honeycomb coils are selected for reception of various frequencies.

CONSTRUCTION

THE constructional details of the all-wave receiver are clearly suggested in the panel layout, Fig. 3, and in the photographs of the completed receiver, Figs. 2, and 4.

Referring to the back of panel photograph, Fig. 2, the Cotocoil single honeycomb coil mountings are screwed to the baseboard near the right hand (rear view) end. Coils L_1 and L_2 are plugged into these receptacles. Partly hidden and to the right of the coils a resistance strip from a rheostat can be discerned, fastened to the baseboard. This is placed in series with the small three-volt pilot lamp as described in reference to the circuit diagram.

The pilot lamp itself is screwed into a small miniature socket from which the porcelain shell has been removed. It is placed beneath the antenna tuning condenser, and the glass jewel can be seen in the lower left of Fig. 4.

The large dial controls, in the panel photograph Fig. 4, are, left to right, tuning condensers, C_x , C_2 , and C_3 . The lower left is the series-parallel switch. The upper right hand knob is the midget vernier condenser across the tuning condenser C_3 . Below the vernier is the potentiometer.

In wiring the receiver, particular care should

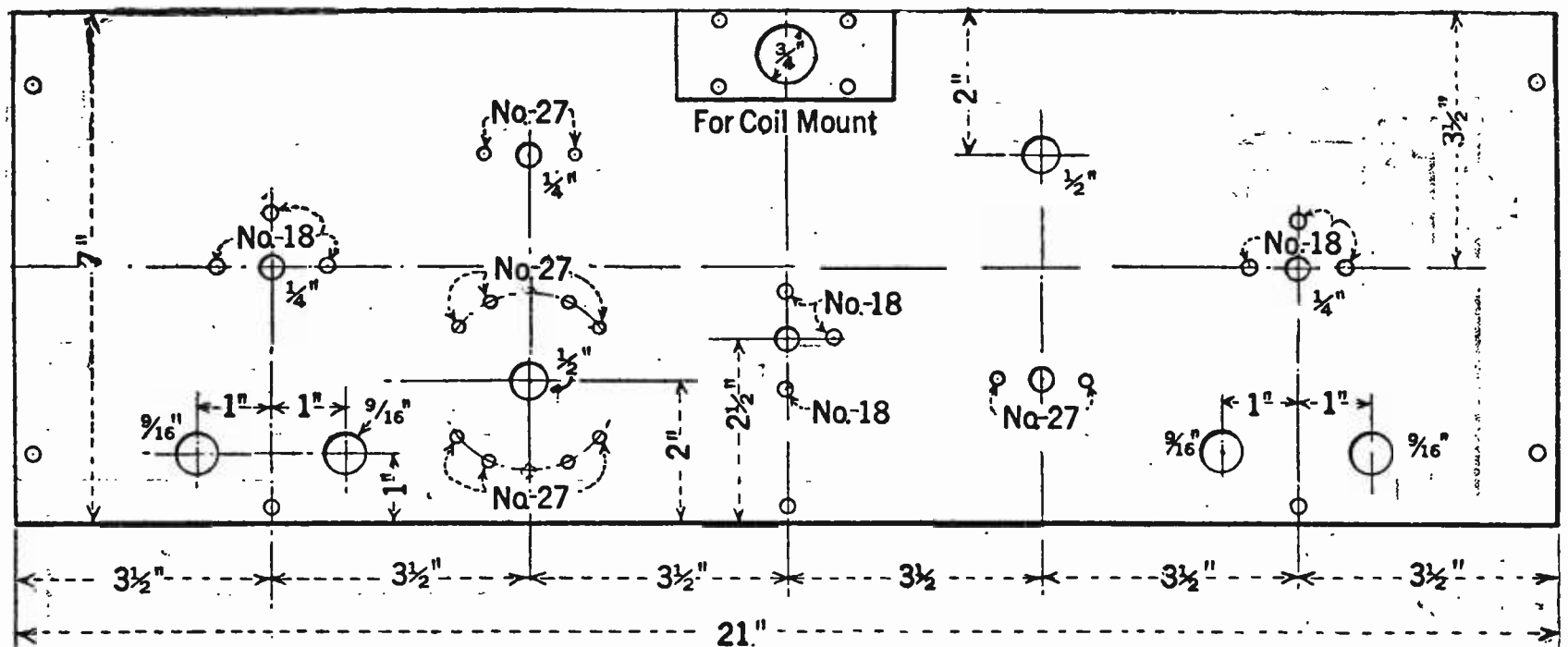

FIG. 3

The panel layout for the universal receiver. The numerals near the designated holes indicate the size drills to be used in drilling them

be observed in making connections between the A battery and the various tubes, resistances, and switches, being careful to follow every sequence on the diagram.

OPERATION

TUNING and operation of the receiver is quite the same as that of the conventional three honeycomb coil arrangement with the slight added complication of an extra control.

The following is a table of coil sizes for the various domestic and foreign broadcasting wavelengths:

1500 TO 600 KILOCYCLES (200-500 METERS)

L_1	L_2	L_3	L_4	L_5
35	50	35	50	75

665 TO 334 KC. (450 TO 900 METERS)

100	100	50	100	120
-----	-----	----	-----	-----

483 TO 272 KC. (620 TO 1100 METERS)

100	150	75	150	150
-----	-----	----	-----	-----

272 TO 115 KC. (1100 TO 2600 METERS)

150	250	150	250	200
-----	-----	-----	-----	-----

Unfortunately, the receiver I am describing was not in my hands sufficiently long to determine coil values for still higher waves. It is suggested that the experimenter guide himself by the sizes specified for the conventional three-coil long wave receiver.

There is also no reason why the all-wave receiver, efficiently constructed, should not be quite satisfactory on the extremely short waves—the region of megacycles. With Lorenz coils wound on a three-inch form, with fifteen spokes, the following sizes should cover from 40 to 70 meters. L_1 3 turns, L_2 6 turns, L_3 5 turns, L_4 6 turns and L_5 11 turns. On these extremely high frequencies, it is recommended that capacity neutralization be substituted for bias stabilization, with the potentiometer. A three-turn neutralizing coil should be wound simultaneously with L_3 , and connected as in the usual Roberts or Browning Drake arrangements. It is suggested that experimentation on wavelengths below two hundred meters be left to the more advanced and serious experimenter and amateur. The manipulation of the receiver on these frequencies requires more than ordinary skill, and even a comparatively non-radiating receiver, such as we have described is not innocuous under inexperienced operation.

In operating the all-wave receiver, the potentiometer should always be kept sufficiently far on the positive side to stabilize the r. f. tube.

Selectivity will be increased as coupling is loosened between L_3 and L_4 , as is usual with honeycomb receivers. Loosening this coupling will also increase the effectiveness of the r. f. controls. If situated within a mile or so of a high powered station, interfering oscillations may force themselves across the radio-frequency circuits. Breaking the connection close to the ground lead at X, Fig. 1 will eliminate such by-passed interference.

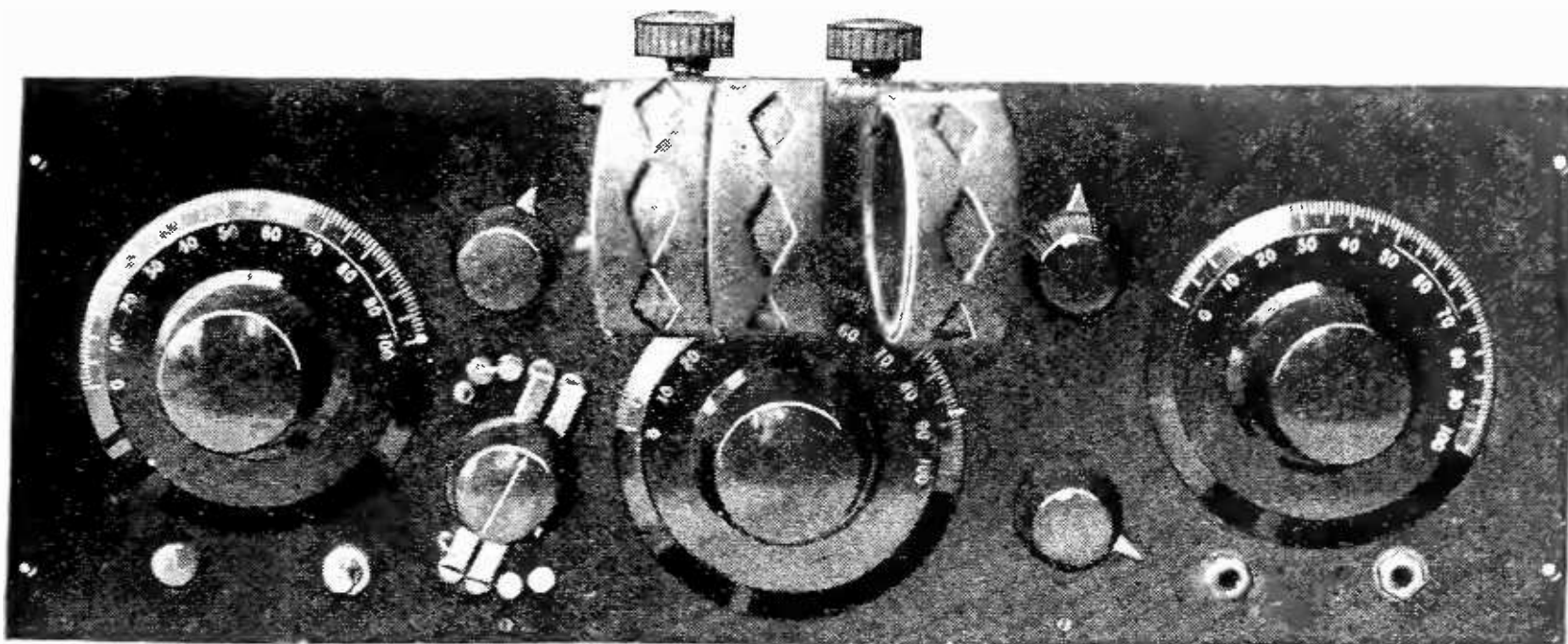

FIG. 4

Front view of the completed receiver. The two honeycomb coils to the left function as a tuned radio frequency transformer

HIGH-MU TUBES IN THE LAST AUDIO STAGE

IT IS recommended that five-volt vacuum tubes be used throughout the receiver. They will give excellent loud speaker results on distant stations with a good antenna. However, if high-mu tubes (there are several makes on the market) are available, they can be employed most effectively in the first and second stages of the resistance-coupled amplifier. A power tube (never a high-mu tube) in the

output socket will increase the possible volume without distortion. If the output is taken from jack J_1 , a standard tube should be used in the first resistance-coupled stage.

The tuning characteristics of the all-wave receiver are most satisfactory, providing selectivity and distance, while the resistance-coupled amplifier insures quality beyond reproach.

The following is a list of long wave broadcasting stations:

FOREIGN BROADCASTING STATIONS

AUSTRALIA:

2FC, 272 kc. (1100 meters)
2FL, 389 kc. (770 meters)
3LO, 174 kc. (1720 meters)
5MA, 352 kc. (850 meters)

AUSTRIA:

RH 500 kc. (600 meters)

BELGIUM:

BAV, 272 kc. (1100 meters)

CZECHO-SLOVAKIA:

OKP, 260 kc. (1150 meters)
Komarov 167 kc. (1800 meters)
Prague, PRG, 300 kc. (1000 meters)

DENMARK:

OXE, 130 kc. (2400 meters)

FRANCE:

FL, 115 kc. (2600 meters)

GERMANY:

LP, 440 kc. (680 meters)

HOLLAND:

PCGG, 280 kc. (1070 meters)
PA5 286 kc. (1050 meters)
PCFF 150 kc. (2000 meters)

HUNGARY, BUDA PESTH:

150 kc. (2000 meters)

SPAIN:

EBX, 250 kc. (1200 meters)

SWITZERLAND:

HBI, 272 kc. (1100 meters)

When Broadcast Stations Interfere

An Explanation of "Heterodyne" Interference Produced By Broadcast Stations—What the Department of Commerce Is Doing to Minimize the Difficulty—How the Listener Can Aid

By C. B. JOLLIFFE

Physicist, Bureau of Standards

FOR more than a year, RADIO BROADCAST has been printing informative articles about how various kinds of interference troublesome to the broadcast listener may be traced, reduced, or altogether conquered. Among the first of these was a series on "Man-Made Static" by A. F. Van Dyck, the first of which appeared in this magazine for April, 1924. In the July RADIO BROADCAST, there were two articles, one by John V. L. Hogan and the other by Dr. Alfred N. Goldsmith, which told how to use single-circuit receivers without annoyance to one's neighbors. This article, which is published by permission of the Director of the Bureau of Standards of the Department of Commerce, tells how the steady squeals produced by any two broadcast stations which are heterodyning each other occur, and the efforts being made by the Department of Commerce to lessen this rather unusual form of interference.—THE EDITOR

AT TIMES, when tuning-in a broadcasting station, there is heard in the receiving set a whistling sound whose pitch (frequency) cannot be changed no matter what is done to the controls of the set. As the tuning adjustments are changed, the whistle reaches greatest intensity at one point on the dials and dies away gradually as they are turned from this tuning point. The fact that the note remains the same pitch distinguishes it from the whistle of varying pitch ("birdies") produced by your own or some other person's generating (oscillating) receiving set.

If the tuning controls are turned slowly while one listens carefully it will usually be found that there are two stations which can be heard very close together when the whistle is at its maxi-

mum loudness. These two transmitting stations are "beating" and producing the whistle. Let us take, for example, two stations that are on frequencies of 800 and 801, kilocycles per second (wavelengths 375, and 374.5 meters). Signals from both of these stations enter the receiving set and in addition to giving up to the set the messages (music, etc.) which they carry, the radio-frequency currents produced by the carrier waves combine and produce a note which has a frequency

equal to the difference between the frequencies of the two received waves, in this case 1000 cycles per second. This is a high-pitched whistle. Any two stations that are closer together than 3000 cycles will give a whistle which can be heard, and which is very annoying. The frequency of the whistle

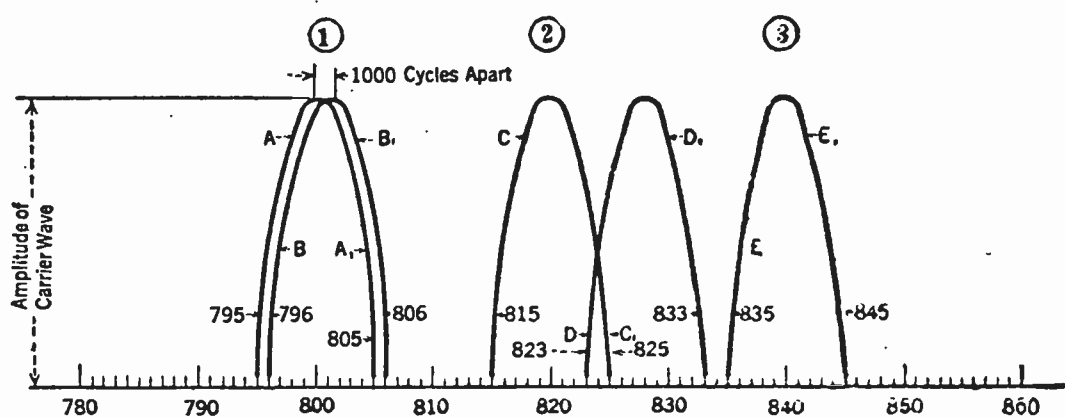

HOW BEAT NOTES ARE PRODUCED

In No. 1 the curve A-A¹ covers a range of from 795 to 805 kilocycles with its peak at 800 kc. Curve B-B¹ with its peak at 801 kc. covers a band of 796 to 806 kc. The beat is equal to the difference of the two—in this case 1,000 cycles. In No. 2 we have a less pronounced example. Here the peak of C-C¹ is at 820 kc. while that of D-D¹ is at 828. Since the transmitted wave is assumed to cover a band 10 kc. wide it is obvious that there will be an overlapping. The difference here is 8 kc. or 8000 cycles. Example No. 3 shows no overlapping and no beat is produced. It is possible in some instances where there is overlapping that the difference is so great as to produce a beat above the frequency range which the human ear can hear

is always the difference in the frequencies of the waves of the two beating stations.

The assignment of frequencies (wavelengths) which is made by the Department of Commerce to the transmitting stations is such that no two Class B stations operating simultaneously should be closer in frequency than 10,000 cycles. Two stations having a difference in their frequencies of 10,000 cycles produce a beat note which is too high to be readily audible. So if all Class B broadcasting stations maintain accurately the frequency which they are legally entitled to use they would produce no beat interference. These Class B stations are the ones to which the large majority of the people listen and are assigned frequencies between 550 and 1000 kilocycles (wavelengths 545 to 300 meters)

WHAT THE RADIO SUPERVISORS ARE DOING

THE radio supervisors are continually checking and adjusting the frequencies of the stations in their districts and making an effort to keep them exactly on their assigned frequencies. A transmitting station, however, requires constant inspection of its frequency for its operators to be sure that it remains constant. The supervisors are unable to give this much attention to a single station since there may be several hundred stations (broadcast, amateur, commercial, etc.) under the jurisdiction of one supervisor and his two or three assistants. It has been recommended that all broadcasting stations require and use an indicating instrument which tells them

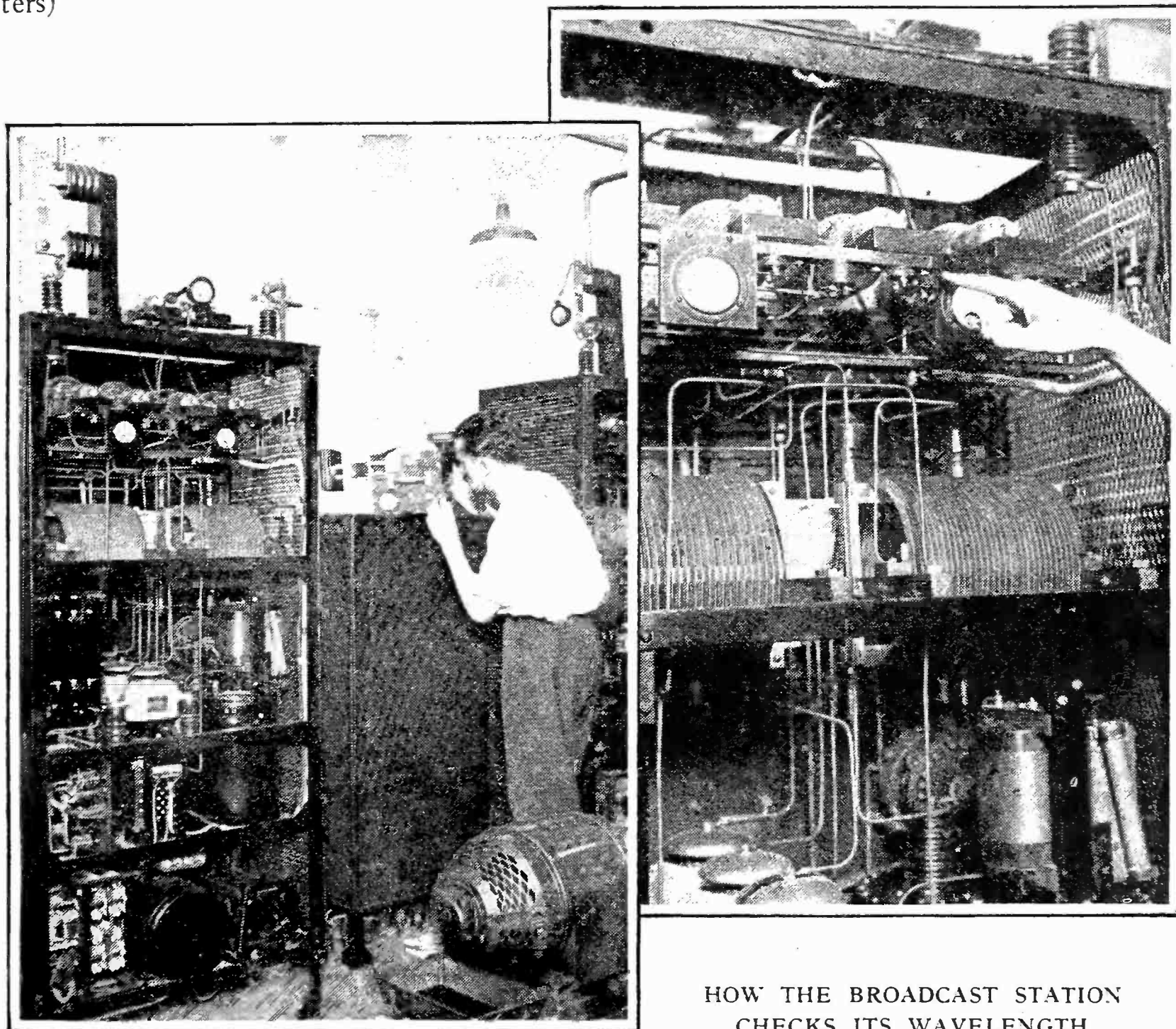

HOW THE BROADCAST STATION
CHECKS ITS WAVELENGTH

With the wavemeter, which the operator is adjusting here, it is possible to know whether the broadcasting station is complying with government regulations and transmitting on the wavelength assigned to it. In the photograph at the right, the hand is pointing to chokes in the radio frequency circuit. Sometimes in an oscillating circuit there are harmonic frequencies set up besides the fundamental frequency on which the station operates. To eliminate harmonic frequencies, choke coils resonant to these frequencies are employed to absorb them. Incidentally here is shown a very good example of the compact and rugged construction of the transmitter proper

when they are exactly on their assigned frequencies. Specifications for an instrument for this purpose have been prepared by the Bureau of Standards, and it has been put in use in several broadcasting stations after being set at the Bureau. This device has been found to be a valuable help in maintaining the stations on their proper frequencies.

During the past year, the Bureau of Standards has also been active in assisting the supervisors of radio in setting the broadcasting stations to their assigned frequencies and keeping them there. The Bureau of Standards has occasionally made simultaneous measurements with various supervisors on broadcasting stations to determine the frequency of the station or to check the setting made by the supervisors. This also serves as a check on the accuracy of the supervisor's wavemeter. Twice each month, standard frequency signals are sent out by the Bureau which can be used by the supervisors of radio as well as others to calibrate their wavemeters.

In addition to the measurements requested by the supervisors, the Bureau has made frequency measurements on many broadcasting stations. The results of these measurements are furnished to the supervisors and tell them what stations in their district are varying from their frequency and producing beats or likely to do so. Some of the supervisors of

radio are also equipped to make frequency measurements on distant broadcasting stations at their office. These measurements show that there are a few stations which have maintained their frequencies very accurately for nearly a year; in fact, so constant that they have been announced as standard frequency stations suitable for use for wavemeter calibration. These stations are announced each month in the Radio Service Bulletin, a publication of the Department of Commerce. The price is 25 cents a year and orders should be placed with the Superintendent of Documents, Government Printing Office, Washington, D. C. The constancy of these stations demonstrates that if special care is given by the operator, a transmitting set can be adjusted to its assigned frequency and be kept there over a long period of time.

HOW THE RADIO SERVICE HELPS ELIMINATE INTERFERENCE

THE work of the supervisors of radio, assisted by the Bureau of Standards, in setting and maintaining the frequencies of Class B broadcasting stations has been very successful. There are really very few whistles produced by transmitting stations. However, nearly constant supervision is necessary to keep the stations from changing. The station operators are cooperating in this work and

Station	Standard Frequency Stations		As- signed fre- quency (kilo- cycles)	Period covered by measure- ments (months)	Num- ber of times meas- ured	Deviations from assigned fre- quencies noted in measure- ments	
	Owner	Location				Aver- age	Great- est since Mar. 20, 1925
WQL	Radio Corporation of America.	Coram Hill, Long Is- land, N. Y.	17.13	4	31	<i>Per ct.</i> 0.1	<i>Per ct.</i> 0.2
NSS	United States Navy.....	Annapolis, Md.....	17.50	20	156	.2	.6
WCI	Radio Corporation of America.	Barnegat, N. J.....	17.95	2	13	.2	.3
WGGdo.....	Tuckerton No. 1, N. J.	18.86	20	159	.1	.4
WSOdo.....	Marion, Mass.....	25.80	20	122	.3	.2
WVA	United States Army.....	Annapolis, Md.....	100	1	20	.1	.4
WEAF	American Telegraph & Telephone Co.	New York, N. Y.....	610	4	45	.0	.0
WCAP	Chesapeake & Potomac Telephone Co	Washington, D. C.....	640	19	87	.1	.2
WRC	Radio Corporation of America.do.....	640	16	69	.1	.2
WSB	Atlanta Journal.....	Atlanta, Ga.....	700	19	78	.1	.4
WGY	General Electric Co.....	Schenectady, N. Y.....	790	22	124	.1	.2
WBZ	Westinghouse Electric & Manufacturing Co.	Springfield, Mass.....	900	12	35	.1	.4
KDKAdo.....	East Pittsburgh, Pa....	970	19	158	.1	.3

most of them are taking particular care to keep the frequency of their station where it should be.

You can assist in the elimination of beat notes produced by the interaction of the waves of two stations. Whenever you hear a whistle of constant pitch, that is, one which varies only in loudness as the controls of your receiving set are adjusted, it usually indicates that one or both of two transmitting stations are not adjusted to their assigned frequencies. If you can identify the two stations producing this whistle, notify the Supervisor of Radio in whose district the stations are located. A list of the radio districts is given at the end of this article. It is necessary that both stations which are producing the whistle be identified, for it is only necessary for one of them to be off its assigned frequency to produce a beat and without measuring instruments it is impossible to tell which one is wrong. There is also a possibility that one of the stations causing the "beating" is not a broadcasting station but an "oscillating" set of some kind whose frequency is being maintained constant. However, it is ex-

ceptional for a receiving set to be left adjusted in such a condition continuously, and whenever the frequency is changed the characteristic variable pitch whistle will be heard.

OSCILLATING RECEIVER INTERFERENCE MINIMIZED

IF THE broadcasting stations will maintain exactly their assigned frequencies it will not only eliminate the whistles caused by beats but will also help in the elimination of the other type of whistle caused by hunting for broadcasting stations while the receiving set is in an oscillating condition. When a transmitting station is located on the tuning dials, a record can be made of the dial setting. Then the next time it is desired to find out if that station is operating, all that is necessary is to set the controls at the point determined before. New stations can also be located with respect to the position of known stations.

The maintaining of the exact frequency of broadcasting stations therefore is of twofold importance: (1) the elimination of the whistles produced by the stations themselves, and (2)

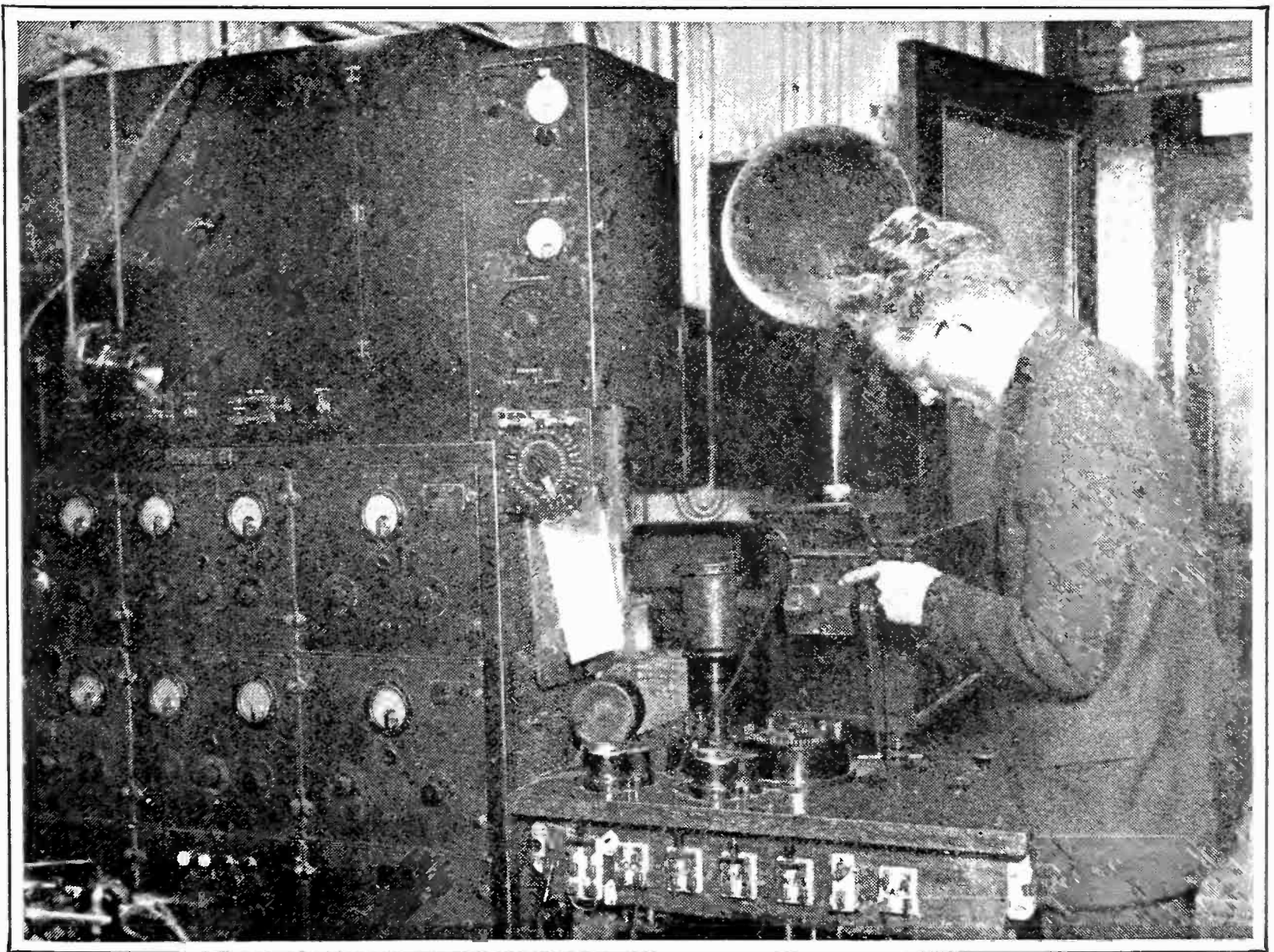

“SEEING” THE RADIO WAVE

At wjz, an oscillograph, or visual means for observing the character of the transmitted wave, is employed to check up on transmission. With this instrument the engineer may see whether his wave is within bounds, during all broadcast periods

increase in the ease of setting the dials to find stations and so eliminating some of the whistles produced by hunting for stations with a generating (oscillating) receiving set.

SUPERVISORS OF RADIO

- First District —Maine, New Hampshire, Vermont, Massachusetts, Rhode Island, Connecticut—U. S. Supervisor of Radio, Customhouse, Boston, Massachusetts.
- Second District —New York City and vicinity. Southeastern New York—U. S. Supervisor of Radio, Customhouse, New York, New York.
- Third District —Eastern Pennsylvania, Southern New Jersey, Delaware, Maryland, Virginia, D. C.—U. S. Supervisor of Radio, Customhouse, Baltimore, Maryland.
- Fourth District —North Carolina, South Carolina, Georgia, Florida,—U. S. Supervisor of Radio, Federal Building, Atlanta, Georgia.
- Fifth District —Tennessee, Alabama, Louisiana, Mississippi, Arkansas, Oklahoma, Texas, New Mexico—U. S. Supervisor of Radio, Customhouse, New Orleans, Louisiana.
- Sixth District —Arizona, Utah, Nevada, California—U. S. Supervisor of Radio, Customhouse, San Francisco, California.
- Seventh District—Washington, Oregon, Idaho, Montana, Wyoming—U. S. Supervisor of Radio, 2301 L. C. Smith Bldg., Seattle, Washington.
- Eighth District —New York (except second district), Western Pennsylvania, West Virginia, Ohio, Michigan—U. S. Supervisor of Radio, Federal Bldg., Detroit, Michigan.
- Ninth District —Indiana, Illinois, Kentucky, Wisconsin, Minnesota, Iowa, Missouri, North Dakota, South Dakota, Nebraska, Kansas, Colorado—U. S. Supervisor of Radio, Federal Bldg., Chicago, Illinois.

Cutting Down Spark Interference on the Great Lakes

Results of the Canadian-American Conference at Detroit Which Will Result in Better Receiving Conditions for Upper New York, Ohio, Michigan, Ontario, Illinois, Indiana, Wisconsin, and Minnesota

BY CORLEY W. KIRBY

INTERFERENCE from spark transmitting stations, which has regularly marred broadcast reception in every city along the Great Lakes, will be eliminated as a result of the conference held in Detroit May 4th and 5th by representatives of the United States Department of Commerce and the Canadian Department of Marine and Fisheries. In addition to representatives of the two governments, the conference was attended by representatives of the Canadian and American commercial radio companies, steamship companies and others who were directly interested.

The recommendations of the conference, which will undoubtedly be accepted by the respective governments, and which were agreed to by the commercial representatives attending, follow:

All Canadian and American coast and ship stations on the Great Lakes open for general public

service business must be equipped to work on a frequency of 420 kilocycles (a wavelength of 715 meters), which will be the normal frequency of the station. All Canadian and American stations must maintain a watch on this frequency.

The frequency of 342 kc. (875 meters) is authorized for the handling of general public service correspondence. The use of this wavelength by coastal stations is optional.

Communication between a coastal station and a station on shipboard or between ship stations shall be exchanged on the part of both by means of the same wavelength.

For general public service, communications between ship and shore and ship and ship when working with stations other than the nearest station must be on a wavelength of 875 meters or higher. Communication with a distant station will not be permitted if interference with the nearby station results.

All correspondence transmitted from a ship or shore station will be in regular message form and

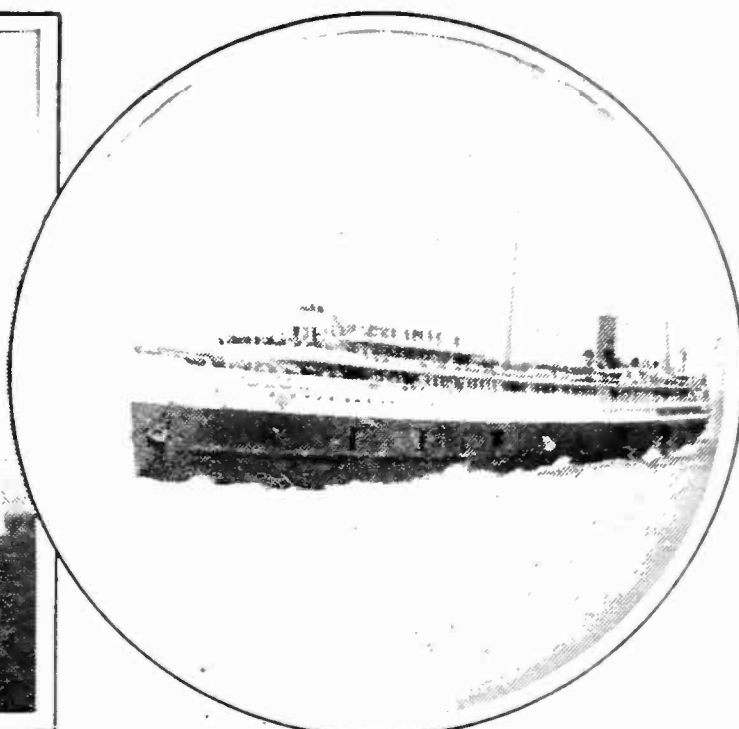
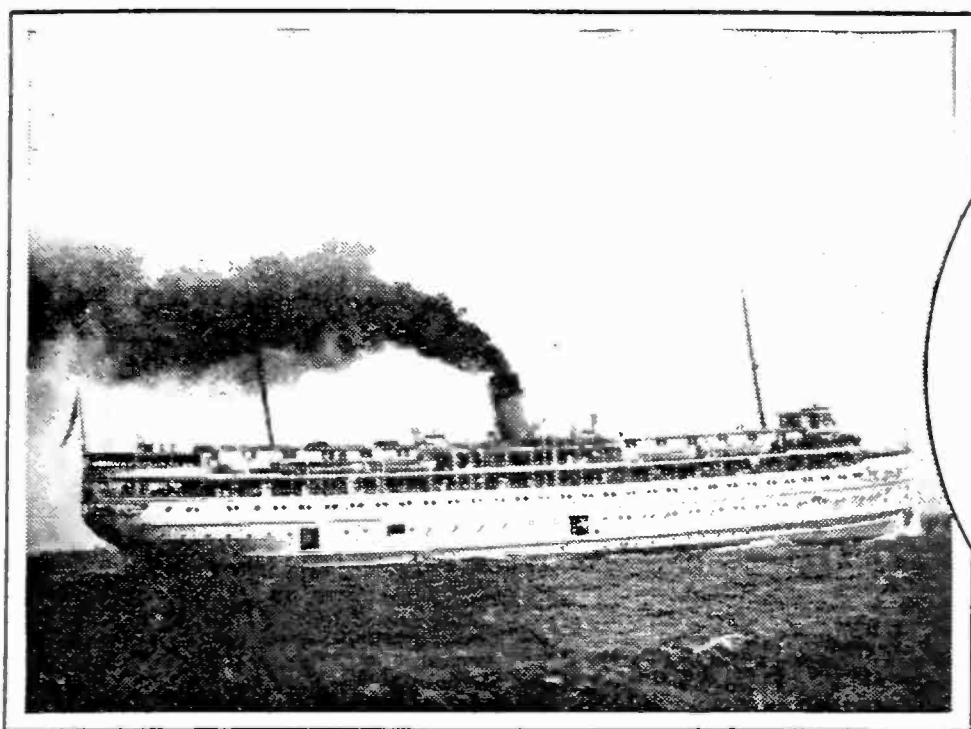

TWO LARGE GREAT LAKES PASSENGER SHIPS

The SS. *South American*, which runs between Chicago and Buffalo, and the SS. *Tionesta* which is one of two other passenger ships running between Buffalo and Duluth. There are many similar passenger ships and many more cargo vessels whose radio traffic, carried on with spark transmitters near the broadcast band has caused interference with broadcast receivers throughout much of the Middle West. The *North American* and *South American* and a number of cargo vessels have been equipped with continuous wave transmitters which does much to do away with broadcast interference. Vessels on the Pacific and Atlantic coasts are gradually being changed to continuous wave equipment also

copies of these communications must be placed on file.

The practice of transmitting notes under the prefix SVC or carrying on unofficial conversations must be discontinued.

The United States Government was represented by D. B. Carson, Commissioner of Navigation, and chairman of the conference;

W. D. Terrell, Chief Supervisor of Radio; Arthur Batcheller, Supervisor of Radio at New York; E. A. Beane, Supervisor of Radio at Chicago, and S. W. Edwards, Supervisor of Radio at Detroit.

The principal Canadian delegates were C. P. Edwards, Director of Radio Service for the Department of Marine and Fisheries;



CANADIAN AND AMERICAN RADIO OFFICIALS AT THE CONFERENCE

Held at Detroit, which arrived at the agreement to move the commercial radio communication channels above the broadcast range. At the head of the table is D. B. Carson, Commissioner of Navigation, Department of Commerce. Next on his left is E. A. Beane, Radio Supervisor at Chicago, C. P. Edwards, Director of the Radio Service of the Canadian Government, Department of Marine and Fisheries; next to Mr. Edwards is W. D. Terrell, Chief Supervisor of Radio, Department of Commerce, and next, Arthur Batcheller, New York Radio Supervisor. H. M. Short, Managing Director of the Canadian Marconi Company is at the left of Mr. Carson



THE HARBOR AT DULUTH, MINNESOTA

With Superior, Wisconsin, in the background. Duluth is the Northern terminus of Great Lakes steamship lines, and many cargo and passenger ships have carried on commercial radio traffic while in or near this area which has seriously interfered with broadcast reception. Radio listeners as far West as Minneapolis have been bothered by interference from ships on Lake Superior. The new agreement which goes into effect July 15th lifts the ship-to-shore bands above broadcast channels

W. A. Rush and S. J. Ellis, Supervisors of Radio in Canada, and H. M. Short, Managing Director of the Canadian Marconi Company.

The acceptance of the recommendations of the conference means the readjustment of the equipment of every ship and shore radio station on the Great Lakes. Due to the immense amount of work required to do this, the date when all of the changes must be completed has been set for midnight July 15. There are more than 300 ship and 50 shore stations which will go on wavelengths beyond the range of the broadcast receivers as a result of the conference.

Since the advent of radio broadcasting, the interference from the old type spark transmitters used in handling lake traffic has been most annoying during the summer months when navigation on the lakes was in full swing. This interference has been recognized by every one connected with radio as one of the greatest drawbacks to summer radio reception, but the expense which would be involved in changing all of them to non-interfering transmitters was considered too great for the commercial companies to bear.

THE CANADIAN GOVERNMENT CALLED THE CONFERENCE

THIS conference, which was called on the initiative of the Canadian government, reached an inexpensive and satisfactory solution of the problem with very little difficulty.

As a result of the accord arrived at, there will probably be annual conferences of a like nature to discuss problems which are of mutual concern to the two governments.

"We have recognized that the number of broadcast listeners is constantly increasing, and it was the result of a desire to bring them pleasure and enjoyment from summer radio that prompted the calling of this conference," said C. P. Edwards, Director of the Canadian Radio Service. "Our government this year is spending more than \$50,000 in changing the Sarnia, Toronto, Sault Sainte Marie, and Port Arthur shore stations from spark transmitters to continuous wave sets which cannot interfere with broadcast reception. These Canadian stations were equipped with $5\frac{1}{2}$ k. w. 240-cycle synchronous spark transmitters.

"An effort has been made to get all ships to cease using their radio transmitters while passing through the Detroit River and have them report to their respective companies by land lines; but this would cause expensive delays, and for the present all ships will continue to transmit necessary and important business while they are passing through the Detroit River. Finally, when all spark transmitters are outlawed by international agreement, all possibility of interference from commercial sources will be eliminated for the broadcast listener. I expect this agreement to be reached in March, 1926, at the scheduled International Conference at Washington."

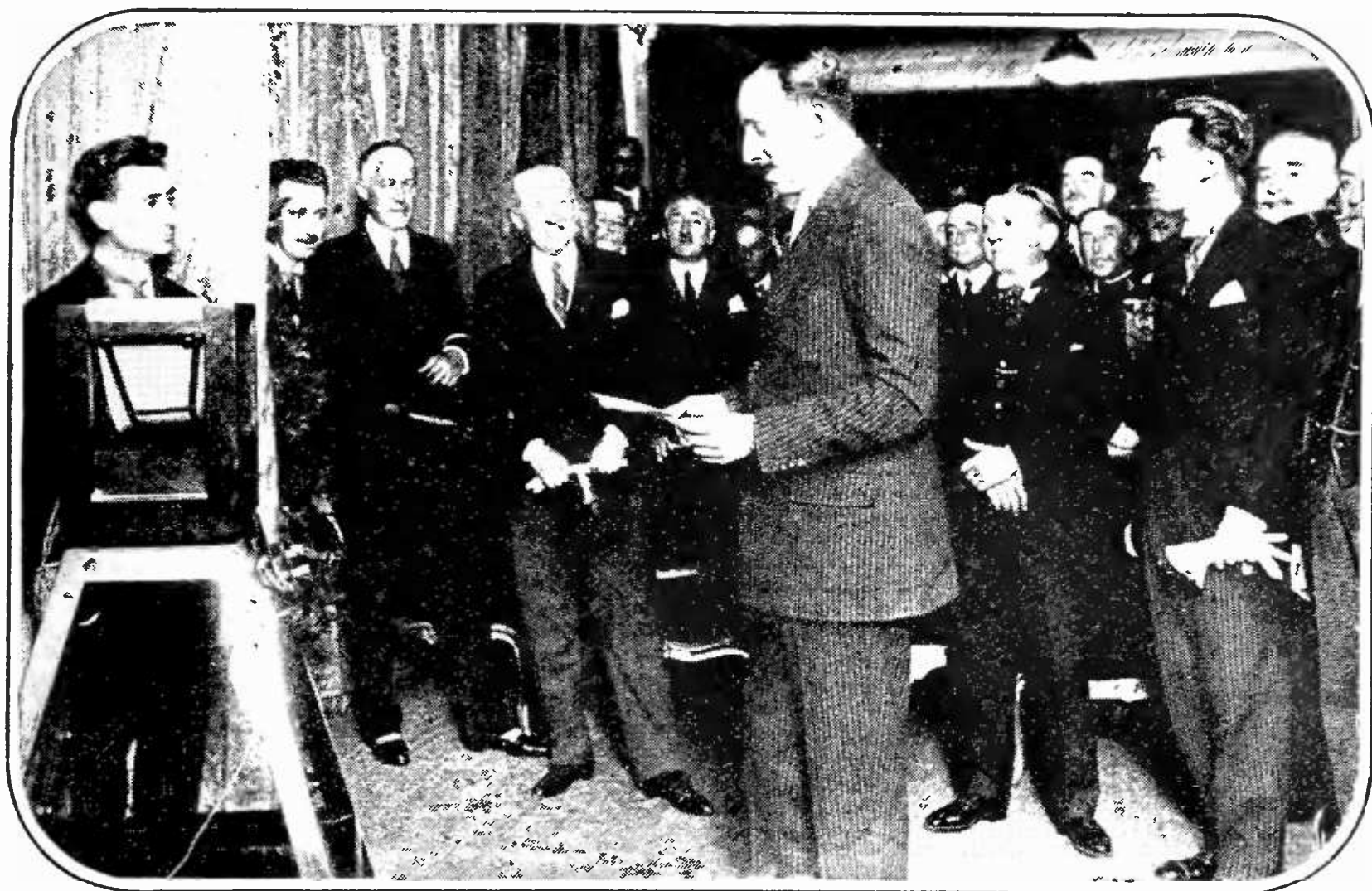

KING ALFONSO OF SPAIN

Before the microphone of the new Madrid broadcasting station. It is interesting to note the Marconi type microphone, suspended in a cradle of sponge rubber

THE MARCH OF RADIO

BY

J. J. Morecroft
Past President, Institute of Radio Engineers

The Increasing Use of Short Waves

IF ONE read the signs of the times aright, we shall all have to acquaint ourselves with sets designed for frequencies about ten times as high as those we use to-day. The ordinary frequency range to which we are accustomed extends from 545.1 to 1363 kilocycles (550 to 220 meters) and the recent accounts of the progress of radio indicate that we must soon be tuning our sets from one thousand to ten thousand kilocycles, (300 to 30 meters), ten times our present frequency.

We have often spoken of the necessity of extending our present broadcast band in order

to minimize interference among the ever increasing number of broadcasting stations. From the accounts of short wave work we continually see, it will not only be advisable; but necessary to go to these higher frequencies.

At three o'clock in the morning some British amateurs (what enthusiastic fellows they must be!), working with a portable field set, picked up American amateurs using only a few watts of very high frequency power. With a frequency of about fifteen thousand kilocycles, (20 meters), an English amateur has been able to communicate with a fellow Britisher in Australia. Our navy is carrying on extensive



© Barratt's

BRITISH AMATEURS ON A FIELD DAY

The radio societies of Golders Green, Hendon, Hounslow, and Inland Revenue held an outdoor meeting recently. Their short wave transmitter is shown in the photograph. Successful communication was obtained in daylight with American amateurs

tests with frequencies between five thousand and fifteen thousand kilocycles (60 to 20 meters), and is reporting unusual success with these waves and very small power. Argentina and South Africa have been able to carry reliable communications with small amounts of power at these high frequencies.

Sets designed for receiving these very short waves are very different from those to which we are accustomed. Condensers of two or three plates and small coils of from five to ten turns, depending upon their diameter, make up the tuning circuits; the antenna may be from ten to twenty feet long. There is almost as much difference in appearance between these sets and those we are using to-day as there is between our present ones and the receivers used for commercial transoceanic telegraphy.

Radio Comes to the Russian

ACCORDING to the Russian Information Bureau in Washington, even the lethargic Russian peasant is being rapidly converted to an appreciation of radio. Not only is the number of private receiving sets rapidly increasing, despite the poverty of

the average Russian to-day, but a more interesting development is taking place.

In the Moscow province alone, two hundred additional village reading rooms were equipped with receiving sets and loud speakers during the past season. Thus radio news becomes directly available to the peasant who could hardly afford a set of his own and also attracts him to a village center where other educating influences are at work.

The use of private receiving sets was prohibited by the Soviet Government up until last fall, when a licensing scheme went into effect. In Moscow alone it was estimated there were at least twenty thousand illegal sets in use before governmental permission for their maintenance was granted. Within two months after the licensing arrangement went into effect there were more than fifty thousand sets in use.

The State controls the radio industry in the same way that it controls all the others. Radio comes under the control of the Commissariat of Posts and Telegraphs. That bureau has forty-three transmitting stations and two hundred and eighty-two receiving stations, scattered throughout the territory of the Soviet union under its direction. The

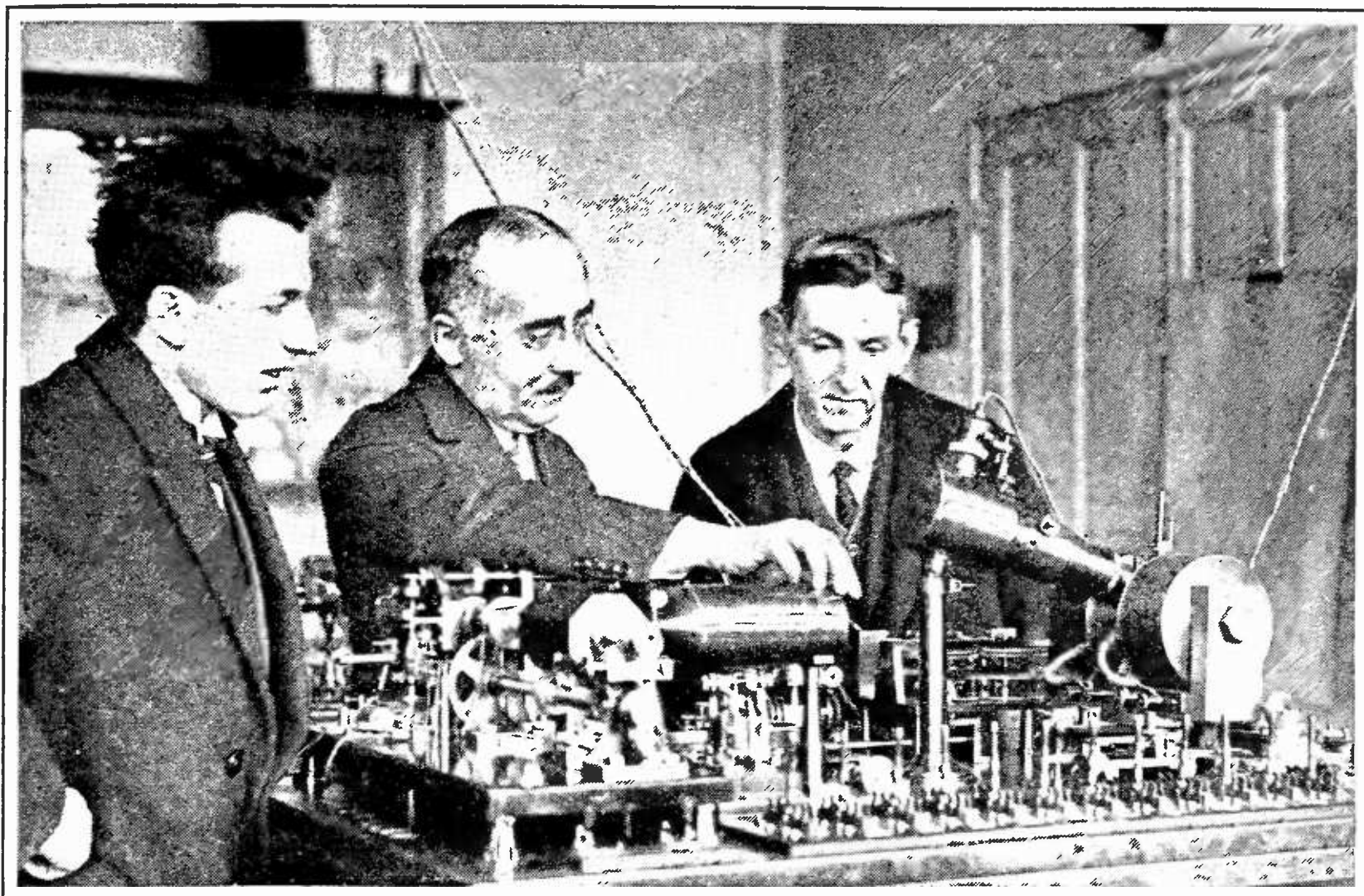

©Barratt's

M. EDOUARD BÉLIN

Explaining his system of transmission of photographs by wire. It is understood that little change in the equipment is necessary for application to radio circuits. For sending telegraphic messages, the exact original is duplicated at the receiving end. The Paris Post Office is using the system

manufacture of radio machinery, including receiving sets and parts, has been concentrated in a State manufacturing syndicate which operates three factories in Leningrad, one in Moscow, and one in Nijni-Novgorod. The Russian Information Service calls the Moscow factory one of the largest and most modern of those in Europe.

The Amateur Can Try Radio Pictures

EVER in the forefront of radio development, the amateur has now been invited by Mr. C. Francis Jenkins, well known for his radio picture development, to share his experiments. Mr. Jenkins has devised apparatus for radio picture transmission which has showed itself practicable to a certain extent and now apparently feels that the amateur can help to work the apparatus up into a form which may possibly be of more service than at present.

The Government will permit amateurs to carry on these experiments, provided they stay within their prescribed frequency limits, and Mr. Jenkins is ready to furnish apparatus which will start the keen amateur off on a new radio venture. Incidentally, if he takes up the

study of radio picture transmission seriously, the experiments will impart to the embryo radio engineer a good deal of modern science.

What Broadcast Wave Is Best?

MANY problems of radio, such as the amount of static or other interference present, prevalence of fading, etc., can be solved only by the statistical method. If an engineer wants to solve a technical problem he generally goes to his laboratory, sets up the proper apparatus and directly gets the necessary answer. If an insurance executive wants to know how long you or I will live, so he can offer fair insurance rates, he looks up vital statistics on perhaps one hundred thousand others about like us in age and occupation and so gets the answer for his problem by the so-called statistical method. It seems that many of radio's problems must be solved in this fashion.

WGXY is now sending out its programs simultaneously on four frequencies of approximately 180.6, 790, 1750, and 7890 kilocycles (1600, 379.5, 171.3, and 38 meters). The ordinary broadcast receiver will tune for only one of these, 790 kilocycles, but with a little work,

a short wave tuner can be built to receive the two higher ones, and the experiment is well worth trying. Schenectady is keeping a record of the amount of power they send out on the different antennas, and if listeners will send to the engineers a record as to how well the program was received on the different frequencies, whether static interfered more in one channel than in another, where fading was most noticeable, etc., a mass of data will be accumulated which will be useful in obtaining a statistical answer to the question as to what frequencies are best for broadcasting.

Receiving Is Good in California

THE California "booster" has still another catchy phrase with which to advertise his Heaven on Earth. "No Static" is the phrase which measurements recently made by the Bureau of Standards Transmission Laboratory permit the Californian to add to the present long list of that country's attractions.

The scientist talks about radio signals as so many "micro-volts per meter." A radio wave carries with it, or rather is, an electric field, whose intensity determines how loud the signal will be when properly received. An idea of the extremely weak electric field associated with signals from distant stations may be had from this comparison.

The ordinary dry cell develops an electromotive force of about 1.5 volts. In the air between the two terminals of a battery there is an electric field, rather weak to be sure, but still strong enough to be detected by a sensitive instrument. (The air will stand an electric field of about twenty thousand volts per inch before breaking down, permitting a spark to pass). If now we attach two metal plates to the terminals of the battery, hold them parallel to one another and about fifty inches apart, the electric field between these two plates will be about one volt per meter. As the plates are moved farther and farther apart, the electric field between them becomes correspondingly weaker, and if we were able to get the plates about one thousand miles apart, and still have them connected to the two terminals of the dry cell, the electric field would be about one micro-volt per meter. An electric field so weak is far past the comprehension, or even the imagination, of one who has not continually worked along scientific lines.

According to Dr. L. W. Austin, the man who has done more in this field than any other

American scientist, the signals from Europe in the Eastern United States, are from twenty to one hundred micro-volts per meter in strength. This is a good readable signal unless static is exceptionally bad. This same experimenter, working on the California coast, finds that the received signals from Java and the Philippines are only two to five micro-volts per meter and yet these weak signals are readable. That such weak electric fields are sufficient for successful communication speaks volumes for the absence of atmospheric disturbance on our West coast. A corresponding signal strength on the East coast of our country would be completely buried in the noise produced by atmospheric disturbances.

The Radio Situation in South America

THE president of the Radio Corporation has just returned from an extensive visit to South America. "In spite of foreign competition" he says, "American products and methods remain the most acceptable to South Americans." That must be good news for his company, which is actively striving to gain the South American market. There seems to be an increasing demand both for transmitting and receiving apparatus.

The installation of more transmitting stations seems to be the immediate need in South America. In our country one station serves, on the average, six thousand square miles of territory, General Harbord says, while in South America, one station serves three hundred thousand square miles. The General might also have added that in our country most of the stations try to serve the same six thousand square miles.

Commenting on the economic situation General Harbord remarks that the bill for broadcasting is in most cases paid for by radio advertisers and the trade, which cooperate with the stations to the extent of putting aside a percentage of their revenues from the sales of receiving sets to meet the broadcasting expense. Some stations accept advertisements from local merchants and these paid advertisements are sandwiched between the musical numbers which make up the program. The novelty of radio, and scarcity of diversified programs, make the listeners tolerate advertising for the present, but there is no indication, according to General Harbord's opinion, that this method of payment will be the final solution of the problem in South America.

Frauds in Manufacturing

THOSE acquainted with the development of commercial radio during the last two decades are well aware of its rather checkered career. Many a man has thought of radio as the happy hunting ground for stock promotion.

A radio fraud not so evident as these has recently come to light, and we are glad to say that the alleged swindler is speedily to be brought to trial. One of the well known resistor manufacturers, the Daven Radio Corporation, who, by care and engineering talent have built up a reputation for accurate resistors to be used as grid leaks etc., discovered that the product sold to the public under his trademark was by no means was dependable as the factory tests showed.

District Attorney Salomon was sufficiently impressed by the evidence of illegal traffic that he proceeded against the alleged head of this swindling ring, Moe Goldman. It appeared that the resistors Goldman was putting out were most unreliable. The reliable manufacturers in the radio field are not so numerous that we can afford to have our faith in any of them shaken by such methods as Goldman was apparently using.

Who Will Protect the Radio Listener?

PAUL B. KLUGH, Executive Chairman of the National Association of Broadcasters, recently commented on the present crowded condition of the ether, due to the limited frequency band available for class B stations and the ever increasing demand for room in this field by new stations.

Apparently having in mind some certain cantankerous manager, Mr. Klugh said:

Unless a certain broadcasting station, which is dissatisfied with its present wave allotment, recedes from the position it has taken, the matter will probably land in the courts. This

would be unfortunate because under the present law, Secretary Hoover is almost defenseless and is doing his best to preserve harmony. It is a hard thing to dissuade certain citizens, conversant with those phases of the Constitution which guarantee "equality," from demanding that which they believe to be their rights. The fact that the air is crowded to the limit doesn't interest them.

It is almost certain that the next Congress will pass some legislation giving to the Secretary of Commerce more legal hold on the broadcast situation. It is no secret that he

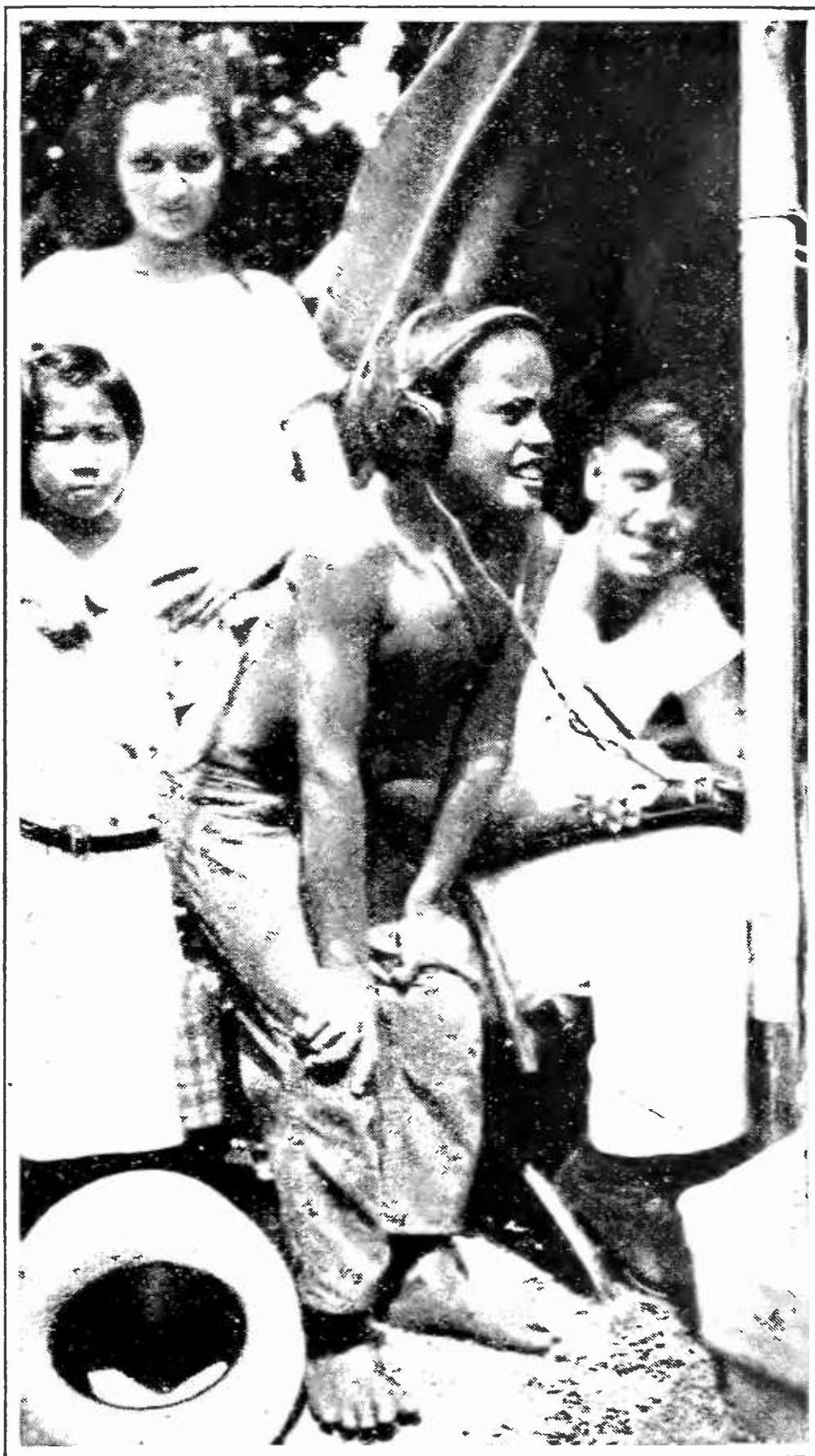

THE NAVY GIVES INSTRUCTION

To interested natives in Hawaii. Since the lessons are distinctly personal, it is evident that greater success can be had with headphones than the more public loud speaker



© Barratt's

ARTHUR BURROWS

The first manager of the new International Broadcast Bureau at Geneva. It is Mr. Burrows's work to attempt an amicable settlement of disputed points between the Continental broadcasters. There are said to be fifty-two stations there for forty-eight possible wave bands. Mr. Burrows was assistant controller and director of programs for the British Broadcasting Company

has practically none at present. It might be a very good thing to have a court fight on record so that our congressmen who have delayed action so long might be convinced that some action is an immediate necessity.

Mr. Klugh speaks for the broadcasters. But who speaks for the listeners? When one talks about equality in this broadcast tangle, the listener must come into the argument too. The broadcast channels must be assigned and used in such a manner that the most good and enjoyment comes to the millions of listeners. With this idea in mind, it is evident at once that the granting of a license to a new station should not rest at all on so-called constitutional rights. The desires of the listeners who will be benefited or be disturbed by the new broadcast channel should rule the granting of the license.

The Radio Service Needs Money

A WASHINGTON dispatch to the New York *Herald-Tribune* says that Secretary Hoover will ask Congress next winter for an appropriation for the support of more adequate radio inspection. There are entirely too few radio inspectors now in the Department of Commerce service. Their

number is small and their primary duty is to look out for marine radio. The radio inspection service was organized specifically to see that radio was installed and used at land stations and on shipboard so as to afford a maximum of protection.

When the problems of broadcasting descended on them, a tremendous increase of work has been loaded on the entirely inadequate inspection bureau. With the hundreds of broadcasting stations which have to be supervised by the few government men, and the hundreds of thousands of single-circuit regenerative receivers acting as transmitters, it is no wonder that thousands of complaints which pour into the radio bureau of the Department of Commerce receive such scant consideration. They simply cannot be handled.

The dispatch referred to above states that \$125,000 is to be requested for extra radio "cops," whose function it will be to keep their eyes on the broadcast channels, eliminating interference where possible and generally acting to keep the ether traffic moving in orderly manner. One hopes the Commerce Bureau will get this needed financial aid.

Supply and Demand in Radio

CERTAIN commodities enjoy a year round demand. We need telephone service, for example, just as much in the spring as in the fall, and just as many groceries in the summer as in the winter. Not so with radio apparatus, however; there is great decrease in the public demand for radio material as the summer months approach. In spite of many published opinions to the contrary, every sensible person knows that radio is not as much in demand in summer as in winter. Furthermore the outdoor attractions in summer call us away from the easy chair and the radio entertainment and probably it is best for us that such is the case.

Radio sales must be extremely seasonable. A radio manufacturer may look for a healthy demand for his products possibly eight months in the year and he must so organize his finances and production that the four comparatively "light" months do not force him into bankruptcy. This past season has caused many a downfall because these precautions were not taken. It is no secret that the great demand for sets last fall caused many an inexperienced manufacturer to overload himself with parts and complete sets, so that when the slump came he found himself with finished apparatus for

which there was no demand, an excessive inventory of parts, and a painfully strained credit.

A manufacturer in such a situation must sell his output no matter how great the sacrifice. It may bankrupt him to move out his goods at half their listed price but if they didn't move at all he surely would be ruined. This situation caused a tremendous dumping of sets on the market this spring and dozens of different sets could be bought for less than half their original selling price. In spite of this enforced movement of sacrificed sets, many smaller firms were forced to the wall. The industry probably benefited by the withdrawal of these poorly organized concerns. The public will be hesitant about purchasing sets in the fall at say a hundred dollars when past experience leads them to believe the same set can be purchased for forty-five dollars in the spring. This condition is unhealthy and is not conducive to a real March of Radio. Why is it not logical for the business man, launching out into the radio game, to emulate the iceman in a small town? Ice, coal, and wood, are his products, and fickle indeed must be the season when one or the other of his wares is not in demand. The radio business would be most economically carried on in conjunction with some other electrical enterprise (sufficiently like radio so that the same machinery and employees could be used) which would keep the factory busy at times when atmospherics and the open air turn our desires away from radio receivers.

"Ethics" In Radio

THERE are many of us who have sensed a very unsavory condition in certain commercial aspects of radio and certainly the recent proceedings between the Radio Corporation and the De Forest Company do nothing to weaken the impression that some of the commercial ethics of the radio are not of the highest type.

The first inkling the public had of the bad feeling between the two companies

referred to above was in newspaper reports to the effect that the Radio Corporation had planted spies throughout the plant of the De Forest Company. Further, it was said that these spies were delivering to the Radio Corporation all of the De Forest secrets which might be useful to a competitor — manufacturing processes and costs, sources of supplies, names of customers, quantities of apparatus sold and terms allowed to jobbers. The reports seemed to show that by this system of espionage the Radio Corporation was well on its way to ferret out every bit of information which might be of value in competitive warfare.

So serious were these charges that one was inclined to disbelieve them. An emphatic denial was awaited from the Radio Corporation officials. But the denial did not come; instead it was admitted that the Radio Corporation had actually established a system of spies in the De Forest plant and that these spies did bring their information to one of the Radio Corporation's trusted employes.

In the preliminary hearing, the Radio Corporation was enjoined from further spying on De Forest but was granted permission to use, for patent infringement purposes, whatever pertinent information its spy system had already brought forth.

Actions of this kind don't impress the radio public very favorably.

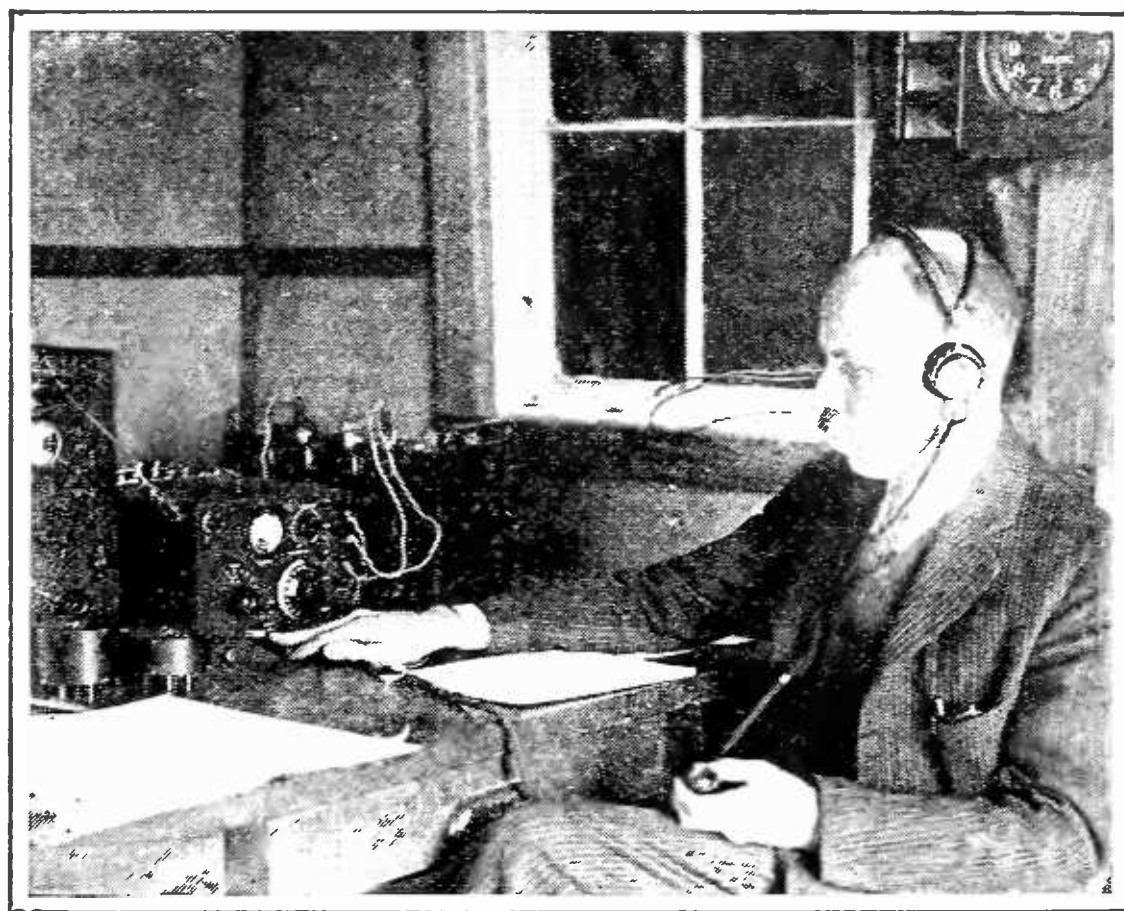

©Underwood&Underwood

COMMANDER A. HOYT TAYLOR

Of the Naval Research laboratory at the experimental short wave receiver. Using a 21-meter wave, operators at the laboratory recently communicated with Australia, a distance of more than 10,000 miles. A power of less than one kw. was used

The Month in Radio

THE Hazeltine Corporation reports that during 1923, the public bought 95,094 Neutrodyne sets, During 1924 a total of 279,780, and during the present year 129,630 such sets had been sold up to May first. These figures show that more than 500,000 neutrodyne sets have been manufactured and sold during the brief life of the patent.

IN THE annual summary of telegraph statistics, published by the Berne International Wireless Telegraph Bureau, it is shown that radio has had an ever increasing rôle in maintaining safety of life at sea. At the end of 1913, there were 3998 ship-to-shore stations in use, at the end of 1919, 6623 such stations, and at the end of 1924 there were 16,971 stations carrying messages from land to sea and vice versa.

GENERAL HARBORD'S report that foreigners like our radio apparatus is well borne out by the figures on exports for the present year. Last year the total radio exports were only slightly over \$6,000,000., but the present year makes a much better showing. Figures for corresponding months of last year and this year show the following values for radio exports.

	1924	1925
January.....	\$ 331,849.00	\$ 784,619.00
February.....	302,121.00	477,591.00
March.....	288,812.00	604,769.00
April.....	279,903.00	853,148.00
Total	\$1,222,685.00	\$2,720,127.00

These figures indicate a total export for this year of more than \$8,000,000.

IN SEPTEMBER, three Navy seaplanes will hop off from San Diego for Honolulu, thus furthering the prestige of an air force which already has the Newfoundland-Azores flight to its credit. The distance to be covered is much greater than the long flight of 1919, for twenty-eight hundred miles separate San Diego and Hawaii.

Careful preparations are being carried out to insure the safety of the venturesome pilots, and radio is expected to do its part. Unlike Amundsen, who kept us all on edge for many days wondering where he was and how he was

faring (he had no radio apparatus whatsoever), our flyers will carry the most modern radio outfits. The transmitters are of one hundred watts rating and should be good for transmitting at least five hundred miles.

It is interesting to note that the very short waves with which broadcast engineers are experimenting nowadays have been found unsuitable for airplanes. The ignition system of the engine is a prolific source of highly damped, high frequency currents which seriously interfere with the reception of signals in the region of ten thousand kilocycles (30 meters).

THE Music Master Corporation has just concluded a contract with the Ware Radio Corporation by which, hereafter, all the Ware products are to be marketed through the Music Master Company. The output of these combined companies will in the future carry the trade name "Music Master-Ware."

THE annual talk on the budget and taxes by President Coolidge and General Lord, was broadcast over a large part of our country a short time ago. These annual talks by those officials responsible for spending the money we pay as taxes seem an excellent illustration of the value of radio in government. If county and state officials likewise were made to account for their expenditures so that the taxpayers might see where their money was going, this good work of radio would be extended in the right direction and undoubtedly state and local taxes might be diminished the same as the federal taxes have been.

AT Bound Brook, New Jersey, the Radio Corporation's engineers are erecting what we had expected to pronounce the largest broadcast station in the world, but evidently the Germans are to outdo us. By next winter they expect to have on the air a station in Bavaria which will send out one hundred kilowatts of power. Some trouble may be experienced in the control of this amount of power by the human voice, but with their well known technical ability the German engineers will undoubtedly accomplish it. A frequency of three hundred kilocycles (1000 meters) is to be used at this new Bavarian station.

Another large German station of fifty kilowatts rating is being erected at Königs-wusterhausen. With these two large stations it is expected that all Germans, even if equipped with crystal sets only, will be able to pick up broadcast programs. It is not at all un-

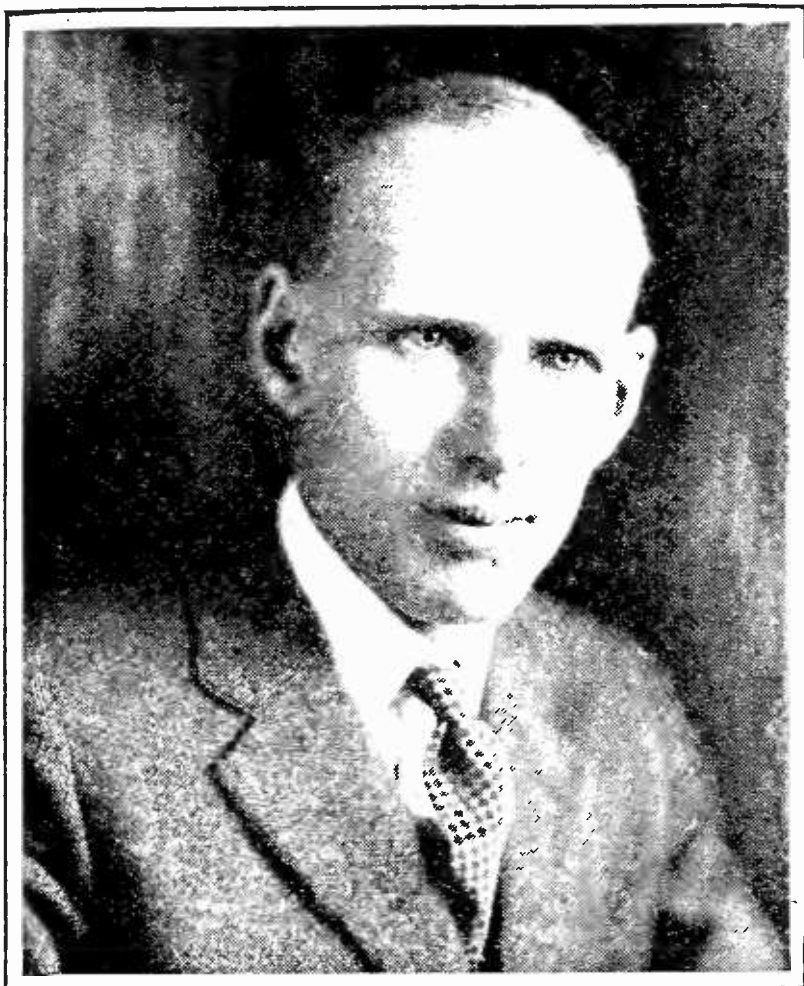

H. A. BELLOWS

Minneapolis; Director, Gold Medal
Station WCCO

"Any one who would now undertake to say what can be done through a great broadcasting station would be simply inviting trouble. An agency for the distribution of ideas, for education, service, and entertainment, has been created so suddenly that its possible scope is still impossible to define.

"The only real guide to the direction of a radio broadcasting station is public service. It is impossible to give everybody everything he wants. Just as a great newspaper combines its news, market, editorial, and sports features with its entertainment and educational features, so we are trying to make the service rendered to the public by our station so full that every listener, no matter who he is or where he may be, will feel that we have something of direct and personal value to him."

likely that many American listeners, at least in the winter time, will also hear these German stations.

AN INTERESTING example of how much unwise faith we place on our impressions was illustrated by the dispatch stating that 2LO, London, had recently changed its antenna arrangement and as a result many of the listeners had reported improvements in signal strength of twenty-five per cent. and some even as much as fifty per cent. It might interest these listeners to know that even if two signals are compared on the same night, one right after the other, not one of them could tell if one signal was twenty-five per cent.

louder than the other and if the signals were on successive nights, as theirs must have been, they couldn't possibly have told if one signal was one hundred per cent. louder. The ear is of little value as a measurer of sound intensity, probably because it has never been used in work of this kind. If two signals are compared on successive nights it would require a difference of several times rather than a few per cent. before the ear would give a reliable indication of change.

AFTER many tests to ascertain the utility of radio beacons on the coast of France, the Undersecretary of Merchant Marine, M. Danielou, has become convinced that his country would do well to help their navigators by putting in a quite extensive installation. A total of about thirty such radio searchlights are to be put in as soon as possible, some of them sufficiently powerful to be of use to vessels hundreds of miles at sea, some of them of low power for the guidance of ships in the larger harbors, while most of them will have a fifty-mile range.

AFEW months ago we heard a deal of talk about broadcast silent night, the idea being that one night of the week should be kept free by local broadcasters so that DX fans might have a chance to tune-in distant stations. Thus if New York stations all stopped broadcasting at 8 p. m., New Yorkers who so desired might listen to Philadelphia or Chicago, or other large cities. Similarly, the listeners in these cities could hear New York if their local stations kept off the air once every week. The idea doesn't seem to be "taking" at all. Chicago tried it, but new stations going on the air in that city do not anticipate falling in with this scheme.

It is quite evident to any one that listeners in New York City, for example, cannot hope to hear distant stations under ordinary conditions; with a dozen or more powerful local stations going, the station a thousand miles away has small chance of coming through on the average radio receiver. We can well see why New Yorkers don't take up the silent night idea but think it might be worth while for some of the other cities to do so. The best radio programs obtainable are sent out from New York, so what is the use of depriving the listeners of this entertainment that a few enthusiasts may tell their fellow workers on the morrow that they heard Cuba, or San Francisco. Silent night may be observed on Main Street, but it never will be on Broadway.



SIR JAMES A. M. ELDER

—New York; Commissioner for Australia
in the United States

"No element of world intercourse to-day is so pregnant with possibility or so potentially effective in the world's relationships as that modern miracle—the radio. While personal visitation and conversation must always remain preëminent in the world's activities and work, these are necessarily restricted to but a comparative few; radio reaches millions. Radio has brought America and Australia still closer together and is cementing the existing close friendship. The projection of the human voice across leagues of land and ocean opens up inestimable possibilities for the future.

"Some months ago, I had the unique privilege of speaking to Australia from Pittsburgh, a distance of ten thousand miles, an historic and epoch-making event. Radio is already in the possession of all Americans. It is a daily domestic necessity. In Australia, its use is rapidly extending; it is bringing the life of the great world into the homes and lives of sturdy pioneers in the far interior. Their isolation has disappeared, and their leisure hours are occupied to the full in these personal advantages which the radio provides. Radio is destined to be as popular in Australia as in America."

Why is the Radio Conference Postponed?

THE League of Nations has recommended that the coming international radio conference called by the United States to meet in Washington this fall be postponed until 1927. Government officials in Washington who have been interviewed were apparently inclined to believe that the League's recommendation would be followed.

It appears that, from the European point of view, postponement is advisable. A Paris radio conference is called for September of this year and the actions of this conference will of course affect the views of European delegates who attend the United States conference. There are various matters which the new agencies of Europe wish to bring up for action and it seems that the European conferees would do well to discuss their problems before bringing them to Washington. Our recent Pan-American conference is regarded as pointing the way for this preliminary European meeting.

Matters which the European contingent of the conference expect to bring up include the inviolability of messages, particularly copyrighted press matter, establishment of rules concerning multiple address messages delivered by the no-answer method, and censorship of radio telephone broadcasting. It seems that among other items which we might logically bring up for discussion is that of broadcast licenses. The idea of liberty has, it seems, gone to the limit in this field; month after month new licenses are issued and these certainly are not, in the main, for the benefit of the listening public. It certainly would do no harm to have a general open discussion on this question, and among those contributing to the discussion should be some capable representatives of the broadcast listeners.

We feel that there are too many matters of great importance now pending for this international conference to be postponed. It should be held not later than the Winter of 1925.

The Music Publishers Oppose Broadcasting

AT THEIR annual convention, the National Association of Sheet Music Dealers passed a resolution which expressed their idea of radio's help to sheet music sales. Radio may stimulate their sales for a short time, it was said, but in the long run the sales are decreased if the song is used in the radio channels. In the discussion, it was admitted that for music of a semi-classical nature the demand has increased after being broadcast by artists of ability. Some of the convention members pointed out that songs of a generation past, entirely forgotten, have been revived by using them in the radio programs.

Mr. Samuel Fox, one of the sheet music

publishers, however, favored the most stringent regulation of the broadcast performance of copyrighted music. He would have the publishers tell the broadcast program director just when and how he might use their songs.

Several dealers had expressed the idea that radio had increased their sheet music sales, but Mr. Fox requested that the minutes of the conference be changed so that this favorable comment regarding radio would be deleted.

Interesting Things Interestingly Said

E. H. ANDERSON (New York; Director of the New York Public Library): "Neither the movies, radio, or crossword puzzles have caused any decrease in the use of books, but whenever a decrease does occur in the use of books (in the New York Library) it is because of a shortage of books."

KENNETH B. WARNER (Hartford, Connecticut; Editor, *QST*, the official publication of the American Radio Relay League, writing about international amateur radio experiments on short waves): "To us the most fascinating angle to this international DX game is that it isn't a rich man's sport and it doesn't take an expert. It's wide open to everybody. The lowest-powered transmitters in the country are heard as far as the big watt-eaters, and the very simplest ham tuner pulls in the signals from the other side of the earth. We don't know to what it is leading, but it surely seems to be advancing that dream of ours of the day when large numbers of private citizens all over the world will sit down at their personally owned apparatus and converse with their friends in every clime. Amateur radio is performing a powerful service in the advancement of world-understanding."

MELVILLE E. STONE (New York; Counselor Associated Press): "I don't believe that radio can ever compete with the newspaper in supplying the public with news. There are fundamental difficulties in the collection and transmission of news by radio that could not meet the organized facilities of the coöperative associations of the newspapers for gathering and distributing news."

A CONVERSATION in the House of Commons quoted in the *New York Times* relating to unauthorized making of phonograph records from radio programs: Sir B. Chadwick, Parliamentary Secretary for the Board of Trade said: "There has been such a remarkable growth in radio that the law has not kept pace with it. There is reason to believe that the day is not far distant when an eager public may listen to the proceedings of Parliament.

One member: "God help us."

The Deputy Speaker: "I would point out that the bill refers to musical and dramatic performances."

COSMO HAMILTON: (New York; playwright and author): "Radio will profoundly affect writing in the next few years. Novelists will have to boil down their productions from the 100,000 words of the present to 5000 words, so that they may be read over the radio. In five years, reading will be superseded to a great extent. The public will listen to the author's stories over the radio and see its plays in the moving picture theaters."

COLONEL ALLEN S. PECK (Denver; District Forester in charge of government timber lands in Colorado, Wyoming, South Dakota, Nebraska, Michigan, and Minnesota): "A large number of the 200 rangers and twenty-six supervisors on duty in our six states are equipped with radio receiving sets. The fire warnings which are being broadcast over station KOA will therefore be of the greatest practical value. Radio will also be of the greatest value in reaching hundreds of coöperators and key-men in time of danger. Fire warnings will have the broadcast right-of-way at KOA."

CHAUNCEY M. DEPEW (New York; publicist; in an address opening WRNY, New York): "Many boys and girls listening to me this evening have made their own radio machines. The boys and girls of to-day have so many opportunities for their mental and spiritual advancement, which never existed before, that we older people wonder how we ever got on at all. . . . Much as we admire and wonder at these marvels, of which radio is one, which are the commonplace of our day, one may well wonder if they are necessary to greatness or great achievements. The greatest thinkers of antiquity, Plato, Socrates, and Aristotle, the guides of modern times, had none of these wonders. Washington, Lincoln, and the others accomplished their great and immortal deeds with only such opportunities as their times afforded."

THE Rev. Dr. James M. Ludlow (Pastor Emeritus, Munn Avenue Presbyterian Church, East Orange, New Jersey): "Radio is a scientific gain to humanity and a genuine pleasure to all mankind and will elevate the standards of sermons of ministers all over the country. Clergymen know that their church members would remain at home to hear a good sermon being broadcast rather than go to a church to hear the usual line which so often is given out from the pulpit on Sunday."

IN AN editorial in the *New York Times*: ". . . Yet there is no setting limits to the response of the American public to judicious stimulation. One may now go to London or Cherbourg for the price of a radio set."

H. R. KIBLER (Chicago; secretary, National Farm Radio Council): "Radio will assume a new significance to farmers and their families when it brings them, in addition to entertainment, information that can be supplied to their everyday problems. Radio must serve the farmer as a schoolhouse as well as a theatre."

What Is to Become of the Home Constructor?

Fascinating New Fields for the Enthusiastic Radio Constructor Who Wants to Go Further in Radio Than Set-Building—How to Build and Use Laboratory Apparatus Which Will Enable the Radio Student to Take a Real Share in Radio Testing and Design

BY KEITH HENNEY

THE veritable army of citizens who have become radio addicts since the coming of broadcasting have found that there are two distinct pleasures in radio. The first and foremost, and certainly the most lasting joy, comes from tapping the wealth of entertainment from the "infinite reaches of the air." The second, hardly less important, is derived from the home assembly of radio parts into a complete whole. There is the pride of mechanical accomplishment in that. But as Mr. Henney brings out in this excellent article, the home constructor who has passed through the various stages of construction, finally finds himself equipped with one or more receivers which satisfy him. What is he to do then? It is of course true that radio designers are constantly making this improvement and that, and are passing the information along to readers of their articles. No enthusiast who builds radio sets, trying first this one and that until he finds what to him is the ultimate, is wasting his time; we think that he could scarcely have spent his time in better fashion. But it is our purpose in the series of articles, of which this is the first, to carry these constructors on farther, and to show them experiments which will lead them in valuable and definite directions.—THE EDITOR

THE number of radio enthusiasts in this country who have learned the great amount they know about radio from building sets must be considerable. In addition to the amateurs, those tireless non-professional investigators of anything and everything radio, there is a new body of American citizens who have amassed a great deal of radio knowledge. They have built this receiver and that and they have found out by genuine practical experience many of the great electrical facts about radio—and found them out in a reasonably painless manner.

Let us take the case of the individual whom for want of a better name we shall call the "home constructor." He has found that some of the sets he has built do what was claimed for them, while others fall short. He is not sure whether the trouble lay in his own part of the work, or in the fundamental design. It is quite probable that in his variously apportioned radio reading, our constructor has acquired a pretty good working knowledge of radio theory. But after he has built his quota of receivers, what is left for him? Should he go on building more receivers? If he is an incurable constructor, he probably does. Somewhere in his array of sets he has found a number that satisfy him. His satisfactory

set gives him distance, selectivity and, best of all, quality. What then?

The editors of RADIO BROADCAST feel that there is more in radio than this type of experimenter has found. The constructor has built his receiving sets, and that is a necessary stage in his progress. He has had the real fun of making an intricate electrical unit that works; he has had a hand in harnessing those mysterious electrical forces with which so much is done and about which so little is generally known.

The home constructor is really a person with considerable mechanical and electrical talent and ingenuity, but in the last analysis he really assembles units which someone else has designed, someone better equipped technically than he.

He knows that experiments and measurements are constantly going on in well-equipped radio laboratories. New and more efficient coils must be made, the phenomena of audio frequency amplifiers and their associated apparatus is being investigated—much is yet to be learned about radio generally.

The value of the radio work of the Bureau of Standards is well known to our constructor and the bulletins describing this work may be had for the cost of printing them. Papers are read before the Institute of Radio En-

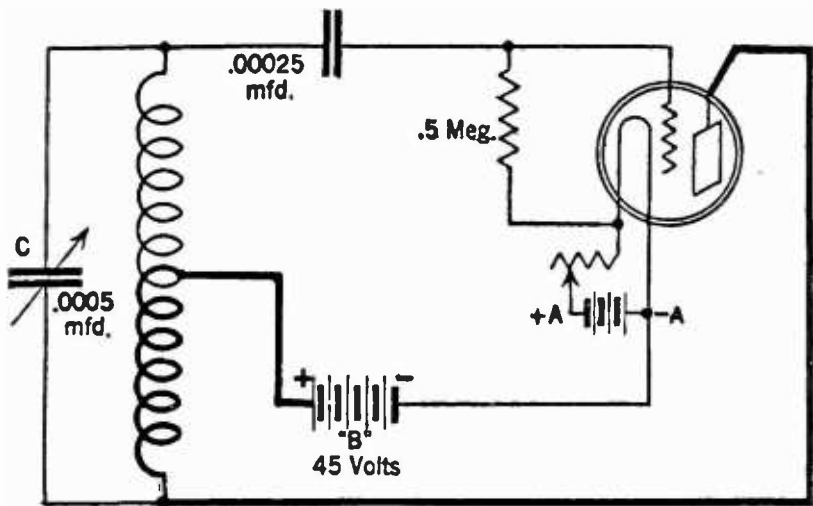

FIG. 1

The radio frequency circuit is schematically represented in this Figure. There is nothing tricky about it and the coils and condensers may be of any standard make provided their dimensions are such that they cover the range of wavelengths desired

gineers which circulate among a limited number. Probably an equal number have training to comprehend their contents.

NEW FIELDS FOR THE HOME CONSTRUCTOR

THERE is a big gap between the scientific papers and text books and the final synthesis of radio apparatus resulting from the technical discoveries which antedated them. These papers and books are either too technical, or at the other extreme, popular articles in many radio magazines are too simple. Many times the articles which attempt to popularize radio principles are incorrect or hazy, or both. Often they successfully leave the impression that the writer himself was not certain about what he wrote.

There is, unfortunately, no middle ground between the work of Government, university, and commercial laboratories and the home workshop of the constructor. It is to supply such a middle ground, that the staff of the Laboratory has been working for some months, and in future issues of RADIO BROADCAST they hope to present the result of their work. They hope to describe the building and use of simple and not too expensive apparatus which the constructor can assemble at home. With the aid of this equipment, the home constructor will find an entirely new outlet for his energies. He will no longer be forced to make new receivers, when he is on building bent, but he can turn his attention to the deeper and more lasting and equally interesting field of radio phenomena.

On the conviction that there were many of the radio fraternity who desire to know more about radio, RADIO BROADCAST was encouraged to publish in June, 1925, an article on the training required for a real radio en-

gineer, and the promise was made that future issues of this magazine would contain experiments that the home worker could perform, experiments that may prove to be much more interesting than the construction of apparatus that someone else has designed. The response to the article on radio training has made it evident that there were many of the home constructors who were suffering somewhat from ennui from the continuous round of one receiver after another, and gave the Editors the courage to go ahead with their endeavor to entice readers of RADIO BROADCAST into the fascinating field of radio experiment.

CONSTRUCTION ARTICLES OF PRACTICAL VALUE

THESE experiments will be tied up practically to radio equipment. The methods of design will be explained. And with this explanation, will be copious references to pamphlets and text books bearing on the subject under discussion. Where mathematics is involved, aid will be given in the use of the formulas, and it is hoped that it will be possible for the interested experimenter pleasantly to learn more about the use of simple radio mathematics. There are any number of people who are not content to be told that a thing is so, they want to know why it is so. If they can discover the whys themselves, and go further after that discovery, they have an absorbing future indeed before them. And who does not feel a peculiar psychological satisfaction at accomplishing some one definite object of value?

This series of articles will come close at times to the field of general physical and electrical science. The facts that are learned about radio, will often apply to similar phenomena in the realm of sound and light, and

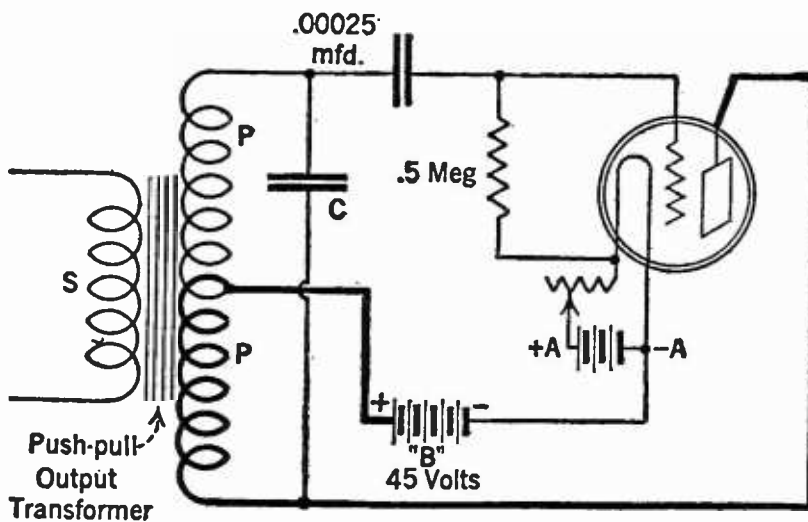

FIG. 2

The audio frequency part of the oscillator is, like the radio part, a simple Hartley circuit and a push-pull output transformer with a mid-tap may be tuned by a fixed condenser so that the tone emitted will be approximately 1000 cycles

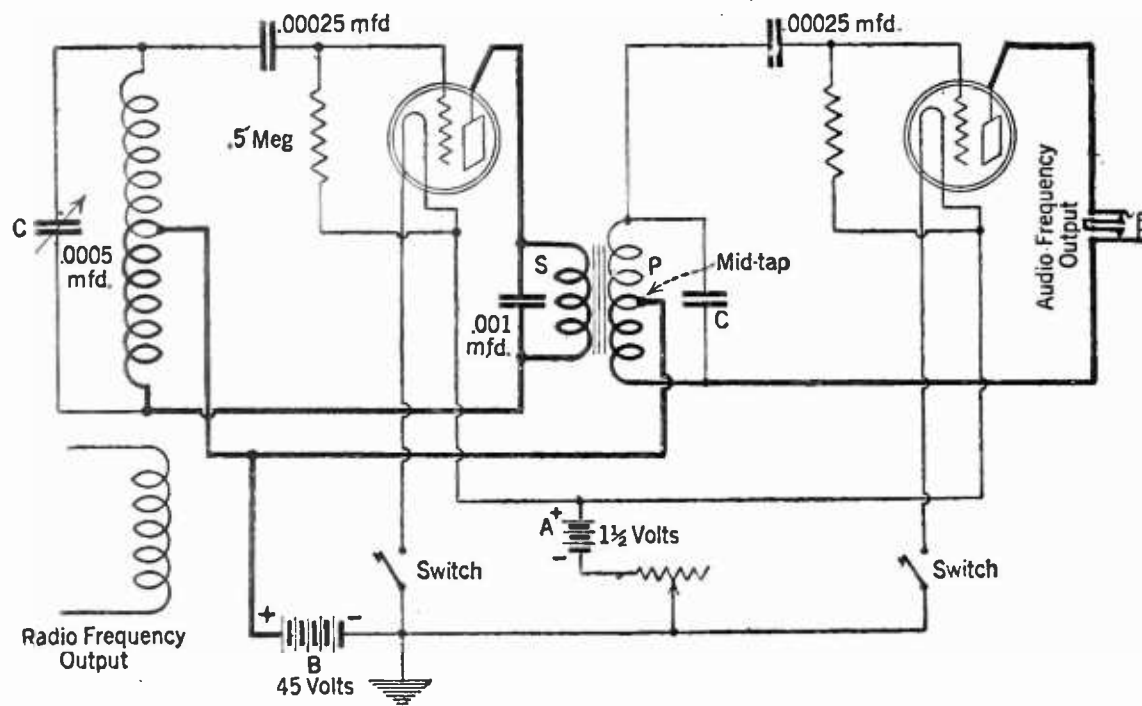

FIG. 3

This schematic diagrams represents the completed modulated oscillator with all of the accessory apparatus. Switches make it possible to operate either tube independently of the other, and in the audio-frequency oscillator is a jack so that the tone may be taken out for any of the uses described in the article

sometimes will have an important bearing on our appreciation of some of the fine arts.

It is tremendously difficult for the isolated experimenter to know all that is going on in this feverishly active field of radio. The experimenter is often at a loss to know what to read and what to do. It is distinctly possible to translate the highly interesting activities of the radio engineer into apparatus and into terms that the reasonably well-equipped experimenter can use and understand. It is just this task that the staff of RADIO BROADCAST Laboratory hopes to accomplish.

THE USEFUL MODULATED OSCILLATOR

THE first instrument that will be described has been called a "modulated oscillator," a name that perhaps sounds formidable. It is really one of the most useful, and, withal one of the most simple pieces of laboratory apparatus.

Briefly, it is a combination of a radio-frequency oscillator—a miniature transmitter—and an audio-frequency oscillator. The radio frequency part of the unit is so arranged that it will cover all frequencies from the lowest broadcasting frequency to the highest used by the transmitting amateur—from 6000 to 500 kilocycles (50 to 600 meters). The audio oscillator can be tuned to some definite tone, say 1000 cycles, and may be used to "modulate" the high frequency energy, or in the several ways mentioned below.

Either of the units comprising this apparatus may be used alone or both together, and if placed in a box including batteries, it is

a self-contained miniature broadcasting station. The laboratory instrument was designed with this object in view. The entire gear was placed in a box ($10\frac{1}{2} \times 7 \times 6$ inches), although it must be admitted that a larger cabinet would have made the assembly much simpler!

The radio frequency part of the circuit is shown in Fig. 1 which is a simple Hartley oscillator circuit. The condenser may be any good low loss instrument, preferably of the straight line frequency or straight line wavelength type. That used in the oscillator illustrated was the Lacault condenser with a straight line

wavelength curve. The coils may be of any variety, although those of the General Radio Company are very satisfactory as regards low loss and the simplicity with which the various wave bands may be covered.

DETAILS OF THE CIRCUIT

THE audio frequency part of the circuit is shown in Fig. 2 and is composed of the output coil of a push-pull amplifier. Instead of the primary leads going to the plates of two tubes, the two ends of the winding are connected to the grid and plate of one tube. The other winding is placed in the plate circuit of the radio oscillator, thereby introducing the audible tone into that circuit.

Fig. 3 is a schematic diagram of the combined unit utilizing common A and B batteries. In the Laboratory model illustrated in Fig. 4, two WD-12 tubes were used and two dry cells were placed within the cabinet. Two switches are included so that either tube may be operated independently of the other, and a closed circuit jack is placed in the audio oscillator so that the tone may be taken out for any of the purposes suggested below.

Although the grid condenser and leak values are designated on the diagrams, these values are not at all critical and may be varied within rather wide limits before the tubes refuse to function. The size of the condenser across the radio frequency coil determines, together with the inductance of the coil, the frequency to be generated. The General Radio coils are so designed that with a .0005 mfd. condenser, the 60-turn coil will cover the range

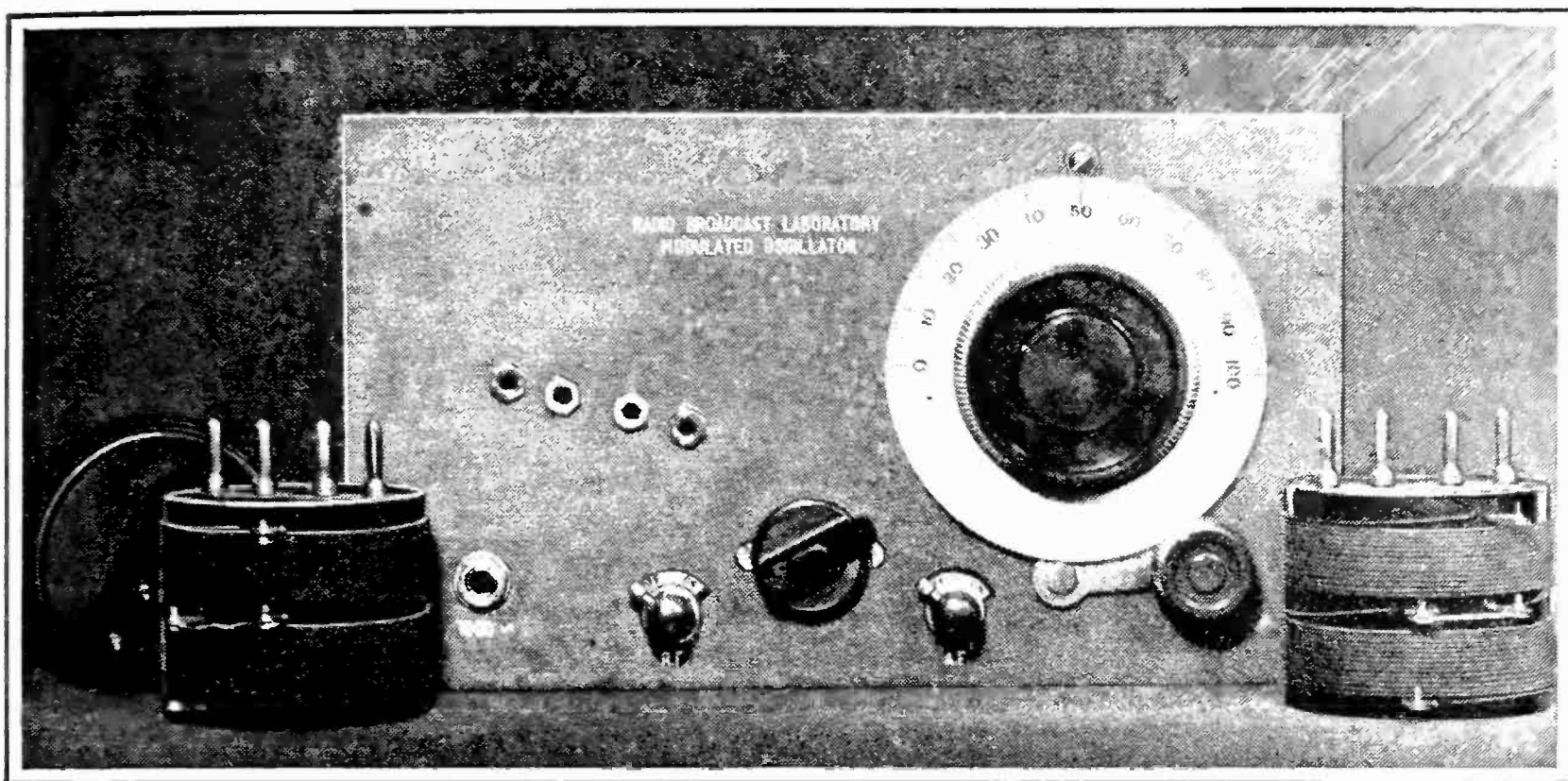

FIG. 4

This photograph shows clearly the panel layout of the modulated oscillator and it gives an idea of how the set of coils may be used to cover the entire band of wavelengths from 50 to 600 meters

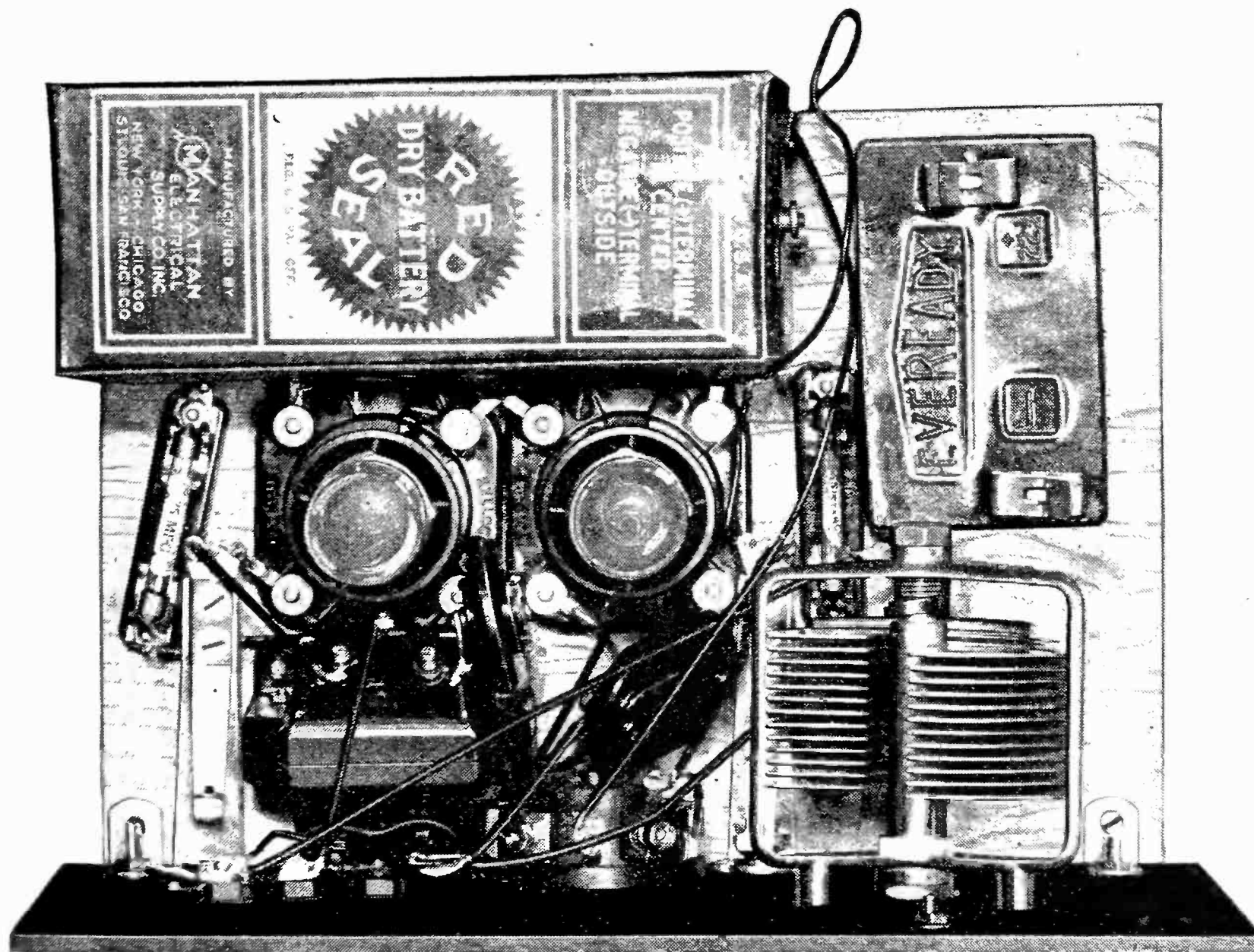

FIG. 5

The disposition of the various parts of the receiver may be seen from this photograph which looks down upon the completed oscillator. It must be admitted that less difficulty will be had in constructing the unit if more space is provided for the various parts

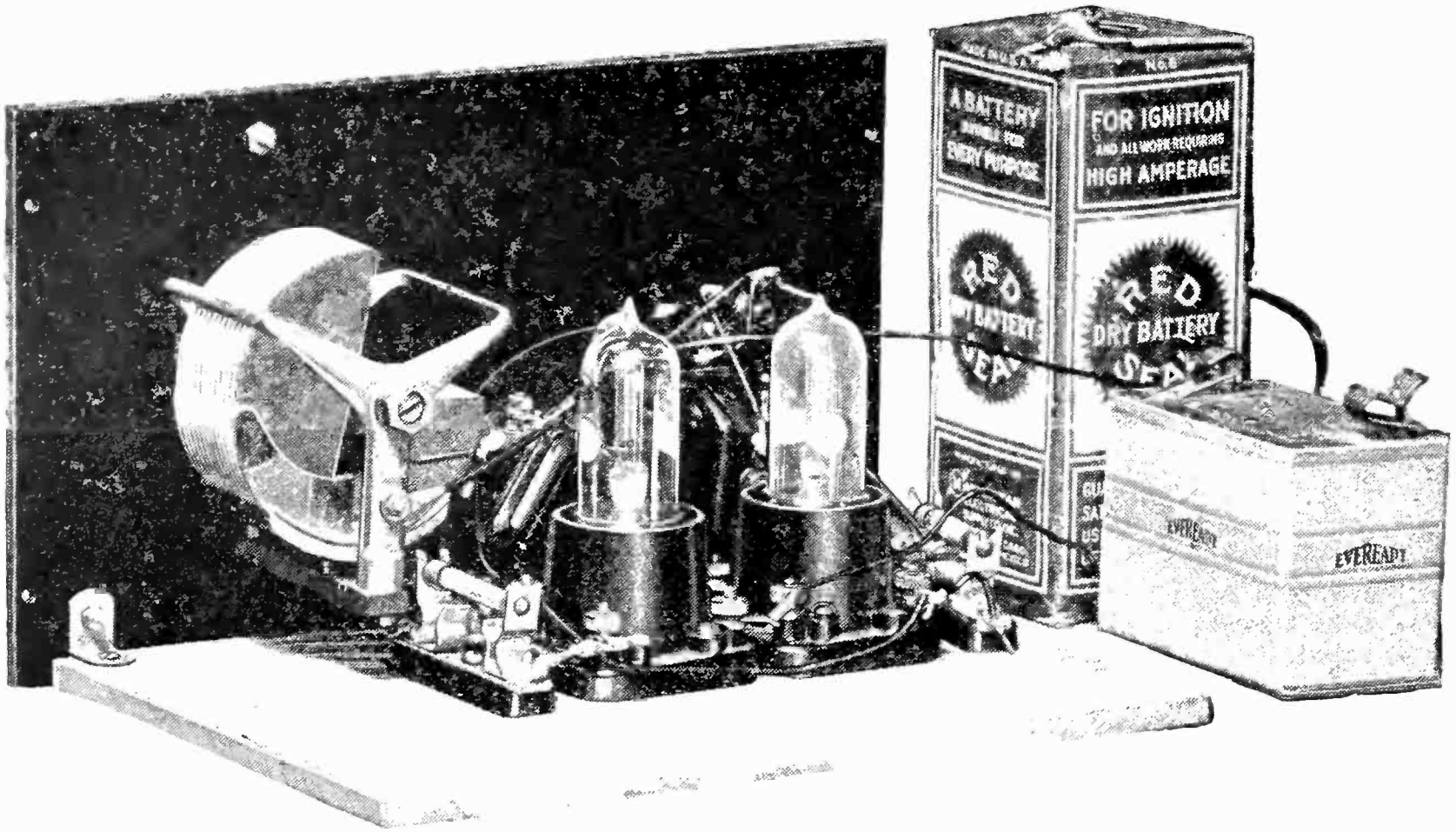

FIG. 6

A rear view of the oscillator gives a good idea of the small size of the one used in RADIO BROADCAST Laboratory. Both A and B batteries are contained in the cabinet so that it is a veritable portable broadcasting station

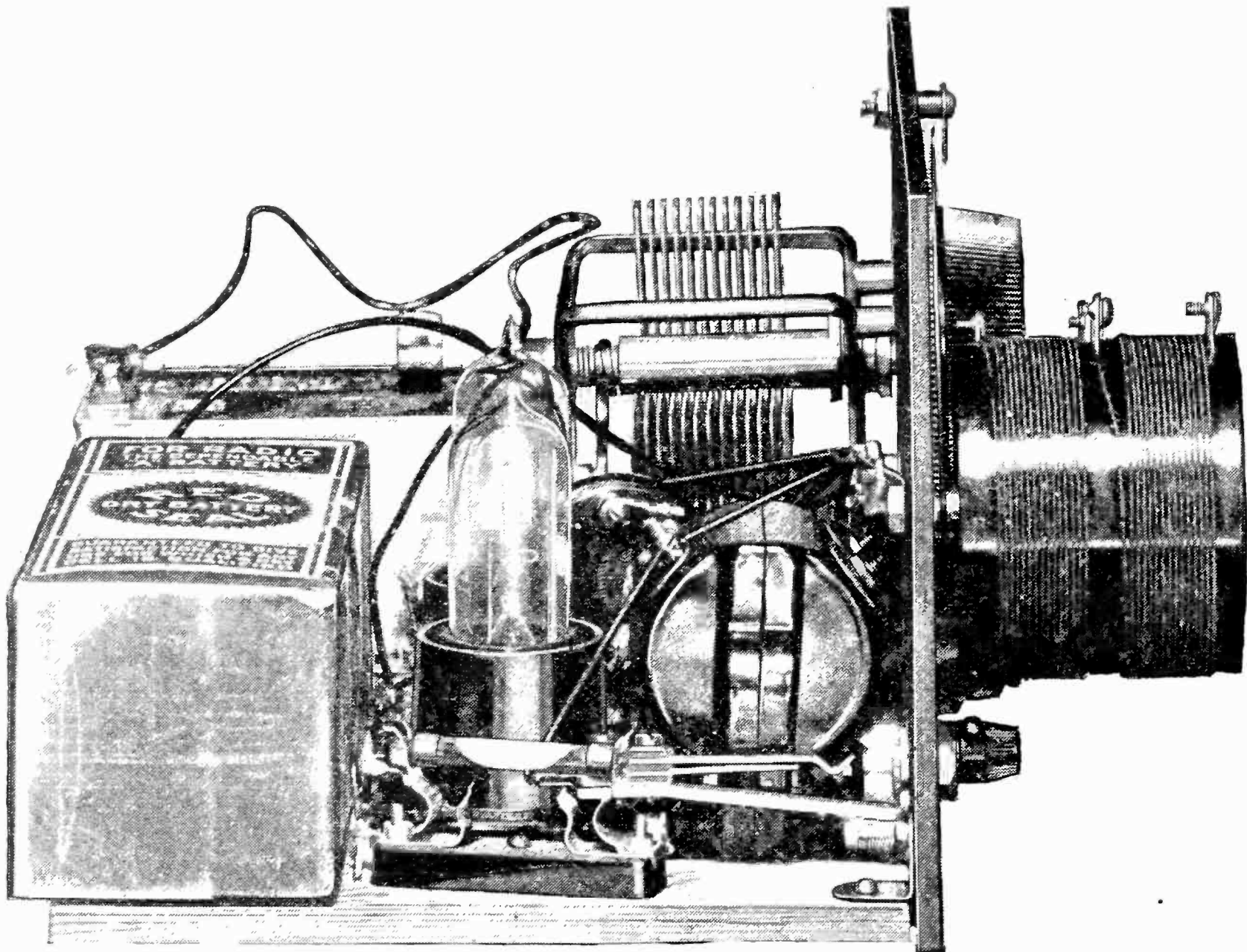

FIG. 7

An end view of the oscillator showing how the coil is placed with respect to the other equipment. This coil happens to be the one which will cover the 50 to 150 meter wavelengths

1500 to 500 kilocycles (200 to 600 meters) the 30 turn coil 3000 to 1000 kilocycles (100 to 300 meters) and the 15-turn coil, 6000 to 2000 kilocycles (50 to 150 meters).

BUILDING THE OSCILLATOR IS EASY

THE actual construction of the oscillator is not complicated. No one who has built a radio receiver should experience the slightest difficulty with this instrument. The photographs in this article show something of the layout used in the Laboratory, although more room is to be desired. The radio frequency leads between coil and condenser, and grid and plate of the associated tube should be short. Any tubes may be used; WD-12's were chosen in this case because it was possible to make the apparatus portable and self contained.

It would be well to build the low frequency part of the circuit first since only a pair of telephone receivers is necessary to ascertain whether the tube is oscillating or not. The coil used in the Laboratory's set-up was the All-American push-pull output coil, and tuned to about 1000 cycles with a condenser of .003 mfd. across the secondary. Placing the telephones across the secondary winding, or in series with the plate of the tubes will enable the constructor to tell at once what tone is being generated, and changing the tuning condenser will naturally change this tone. At about 1000 cycles, the receivers will work most efficiently, which can be told by the greater volume of sound emitted when the set-up approaches this frequency.

The actual frequency of the audio oscillator is not important, since all condenser and air-core coil measurements do not vary over the usual range of audio frequencies. The object of choosing approximately 1000 cycles is two-fold. First of all, the ear is most sensitive to frequencies in this neighborhood, and secondly, telephone receivers give the greatest response at about the same frequency.

After the audio end of the oscillator is functioning properly, the radio frequency circuit may be wired. It is only necessary to bring the oscillator near a receiving set to tell whether the combined units are operating properly.

HOW TO CALIBRATE THE OSCILLATOR

THE simplest method of calibrating the oscillator is to use it in connection with a receiver whose dials are already calibrated from the frequencies of known broadcasting stations. For instance, KYW or WEAf may

be tuned-in at the lower end of the broadcasting frequency band and then the modulated oscillator dial turned until the 1000-cycle note is heard in the receiver. At this point, the oscillator is sending out a signal on the frequency of the broadcasting station. If the radio-frequency condenser is a straight line wavelength affair, only two points are needed to make a wavelength curve of the oscillator, but it is safer to calibrate it by tuning-in several broadcasting stations. If the condenser is a straight line frequency instrument, a frequency curve may be made with two points. If the capacity of the condenser follows a straight line law, several points will be needed and neither the condenser degree-wavelength or frequency curve will be a straight line.

In future articles of this series will be described a new method for measuring the resistance of coils an extremely simple and accurate method that has not before been described in this country. A simple alternating current bridge developed in RADIO BROADCAST Laboratory will be described which will enable the home constructor to measure the inductance of coils, the capacity of condensers, and the resistance of various radio instruments. Other instruments and experiments will follow from time to time and whatever theory is necessary will be explained as fully as possible.

The uses to which the modulated oscillator may be put are listed below and specific directions for the use with special apparatus will follow in later articles.

USES OF THE MODULATED OSCILLATOR

1. AUDIO OSCILLATOR
 - A. Source of tone for testing open circuits.
 - B. Source of tone for measuring capacity, inductance, and resistance on an alternating current bridge.
 - C. Measuring audio frequency instruments, such as transformers, loud speakers, etc.
2. RADIO OSCILLATOR.
 - A. Source of radio frequency energy.
 - B. Separate heterodyne for super-heterodyne reception with any existing receiver.
 - C. For measuring losses in radio frequency circuits.
 - D. For measuring high frequency resistance of coils.
 - E. Heterodyne wavemeter.
3. MODULATED OSCILLATOR.
 - A. Source of modulated radio frequency energy —a miniature broadcasting station.
 - B. Calibrate receiving sets.
 - C. To measure frequency of incoming signals.

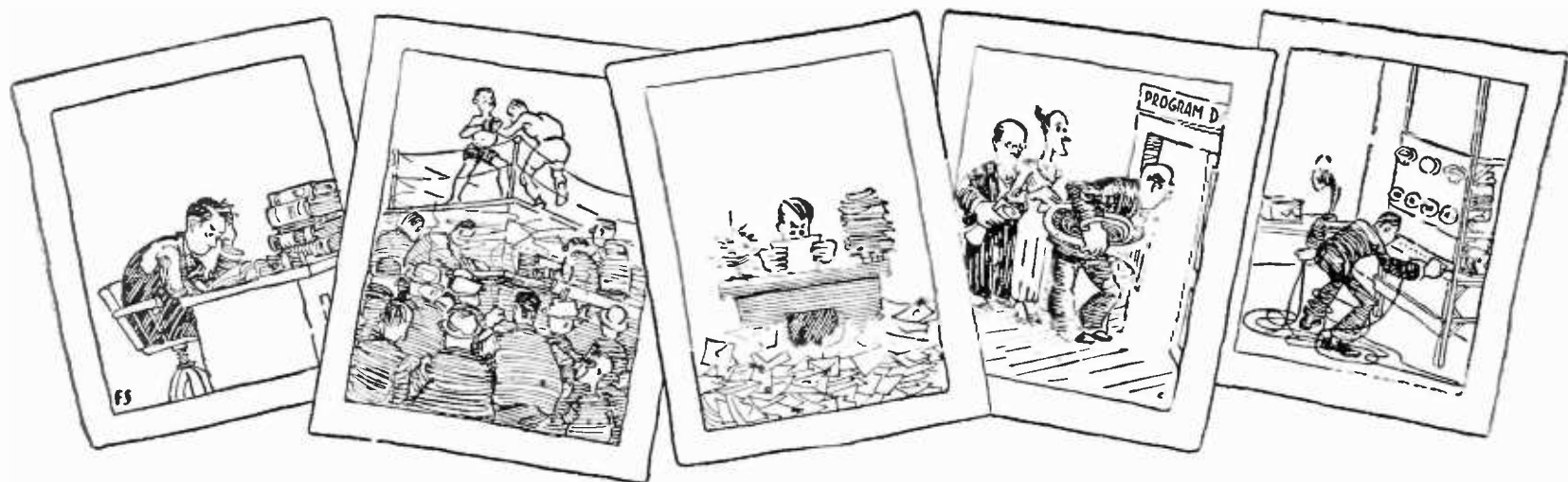

as the broadcaster sees it

by Carl Dreher

Drawings by Franklyn F. Stratford

How Broadcast Stations Function—From the Inside

ONE of the delicate points of broadcasting station organization lies in the relation between the operators and announcers, or, in a broader sense, between the program and operating staffs. It is absent only where the diverse functions of operation and announcing are united in one genius, who cajoles the artists, pours out his soul in expositions and introductions, and at the same time keeps a fearful eye on the antenna ammeter. Before these miracle-workers of the ten-watt class we can only bow in reverence, while wishing them, in the not inappropriate airplane pilots' phrase: "Soft landings, and the best of luck!" But in all the larger stations the announcing is done by one squad of men, and the operating by another, and as a rule the two groups differ widely in background, experience, training, outlook, objects, and traditions. Yet, if the program is to run smoothly, the announcers and program people on the one hand, the operators on the other, must work together at all times; the least failure in co-ordination may mean a break on the air. The necessary degree of coöperation can generally be secured only when each group, (1) knows its own business thoroughly, and (2) minds it, while (3) knowing enough of the problems of the other department to grease the machinery where required. In practice, this is not always as simple as it sounds in these general terms.

The trouble with the studio people is that

some of them expect miracles from the technicians. Or perhaps it would be more accurate to say that they act as if they expected miracles, while verbally disclaiming any such intention. They rarely have any engineering background, and from this it follows that they usually have a defective perception of technical requirements. They do not realize the sharp limitations of electrical equipment, and the fact that any technical enterprise is certain to fail unless the characteristics of the machinery are taken into account at every step. In engineering there are any number of ways of getting into trouble, and only a few ways—frequently only one—of doing the job right. This conclusion is beaten or burned into the hide of a technical man in his impressionable years. Any man who has suddenly found his face six inches above a 200-ampere arc when his screwdriver fell across the one-hundred-and-ten, or who has seen lightning come into an inadequately protected power plant and knock the switchboard into the next county, or viewed the remains of a \$75 thermo-couple meter after the leads got twisted, conceives a wholesome respect for inanimate nature. He realizes, not merely in words, but deep down in his liver, that one does not coerce nature; one can only take advantage of what she wants to do. This understanding does not make him an engineer, but it prepares him to be one. He realizes that he must play the game according to the rules of things as they are, if he wants to play

at all. His ingenuity, resourcefulness, and general wonder-working must all be erected on that foundation. Let him forget it, and immediately he comes to grief. Huxley said: "Nature's discipline is not even a word and a blow, and the blow first, but the blow without the word. It is left to you to find out why your ears are boxed." This is true just as much in the practical applications of science as in the biological situations to which Huxley had reference. Nature encompasses the carbon granules and the stretched steel diaphragm of a microphone just as much as the digestive processes of a lion in the African jungle; everything that happens anywhere, in the woods or in a broadcasting studio, is natural. The only difference between the technician and the layman is that the technician knows better in his special field what he can't get away with. He knows also that if one opening is left the thing will go wrong, just as when there is one hole in a kettle the soup will leak out, even if the rest is sound. Hence, in broadcasting, when, to the studio group, the men in charge of transmission seem most meticulous, dilatory, and over-cautious, the only trouble with them may be that they know their business.

There is no specific reason why announcers and operators, the principal representatives, in point of numbers, of the program and technical groups, should not get on well together. They are in the same boat. Both are in the show business, in which it is impossible to confine blunders and lapses to an inner circle. The operator lives in constant anxiety that something will happen to interfere with transmission. The announcer, likewise, is always handling dynamite. He must always be ready to reconcile diverse elements, to fill in awkward gaps, and to be interesting without offending anyone in his highly variegated audience. He certainly has no sinecure. As a rule, operators and announcers live together amicably enough. When any ill feeling arises between them, it is generally found to arise through the presence of inconsiderate and conceited individuals in one group or the other. An operator may be intolerant and arbitrary. When there is time, he should always explain why he wants something done

rather than take refuge behind the cloak of technical necessity, which covers a multitude of botched jobs. The mysteries of his craft are often susceptible of simple explanation to persons of average intelligence. It is not hard to explain to an announcer why he should keep his head turned toward the microphone, and he is more apt to keep it that way if he knows definitely what happens when he turns it to one side.

The announcer, on his part, just because he is a much photographed and advertised young man, should not get the idea that he is the whole works. The technical men behind the scenes are just as important as he is. It was the work of men of their class, after all, that made radio broadcasting, and got the announcers jobs in which they get more publicity per ounce of effort expended, than in any other vocation they could possibly enter. It is greatly to the credit of announcers as a class that they rarely let adulation turn their heads. Now and then the thing happens, manifesting itself in various annoying ways. I recollect one announcer, now happily departed from the pathways of the ether, who had the habit of using forms like, "I will now switch you over to the concert microphone. . . ." Actually the operators did the switching. It would have been better to say "we." A small matter? Yes, an exceedingly small matter. But, in this world of clashing egos, it happens to be one of those small matters which play an appreciable part in human

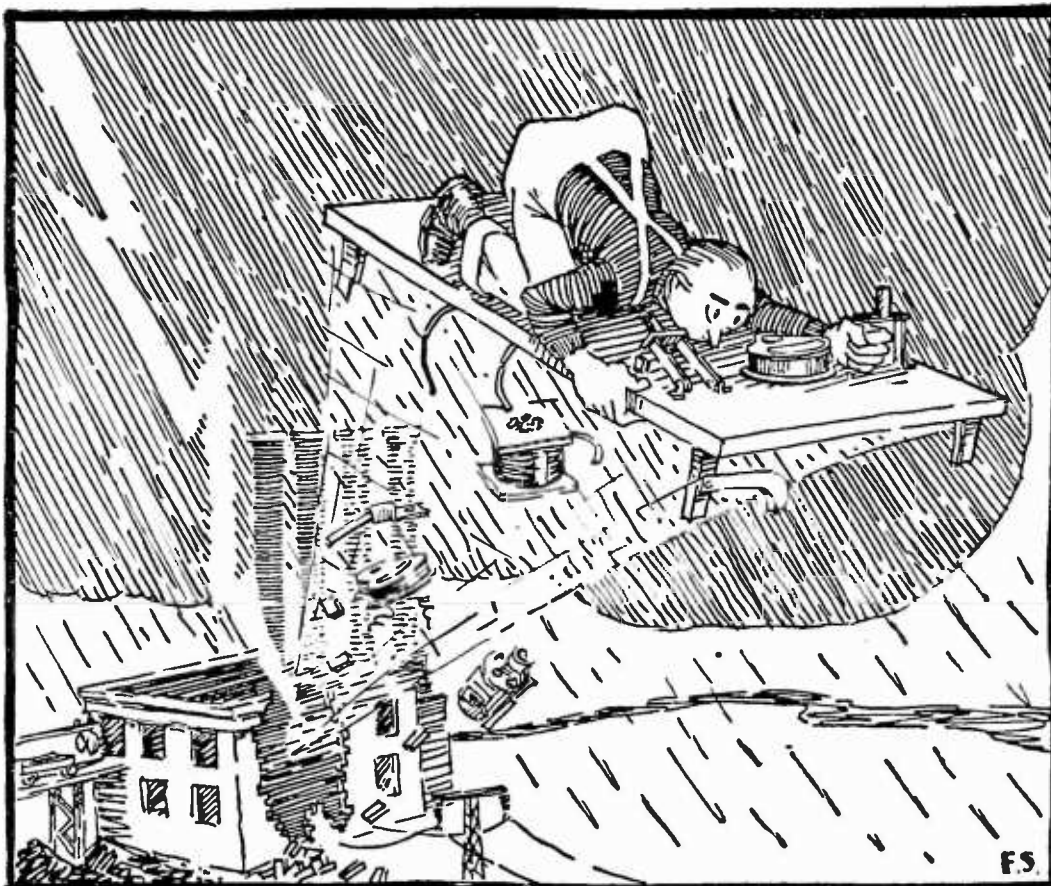

he conceives a respect for nature

relations, with power to influence enterprises for good or bad, according to the effect on the individuals who conduct them.

Divided responsibility has its disadvantages, but the larger broadcasting stations will probably continue to be run by two more or less independent departments, for the reason that it is rarely possible to get the required qualifications united in one individual, and because the advantages of specialization outweigh its disadvantages, on the whole and in the long run. When you listen to a broadcasting station whose program runs off smoothly, keeping up to schedule, without gaps on the air, snappy change-overs between the field and the studio, and the general impression of a systematized, properly thought-out organization, you may be sure that the technical and the studio staffs are working together, with each squad taking care of its assignment and making it as easy as possible for the others to cover theirs. When, on the contrary, you listen to false starts, wire talk going out on the air, orchestras starting while the announcer is still talking, and periods filled with nothing but the carrier hiss, the chances are that the studio and operating divisions are pulling in opposite directions. That may not be the only trouble, but it is probably one of them.

Microphone Placing in Studios

BEGINNING with this issue, it is our intention to publish each month at least one article on some technical aspect of the broadcaster's business. These articles will be on such subjects as microphone placing in studio and field work, effective broadcast station organization, maintenance problems, and various devices of practical aid in securing first-class transmission. In such a relatively new field as this, unanimity of opinion is neither to be desired nor expected, and the views of other operators of broadcasting stations will always be welcome.

One of the vital factors influencing the quality of a station's output is the placing of microphones in the studio. It is of about the same order of importance as the transmission characteristics of the audio amplifier and modulating system, which determine the treatment of the various frequencies of speech and music. If either the frequency characteristic or the microphone placing of the station should be very far off, good transmission is out of the question. By "good trans-

mission" we mean reasonably accurate reproduction in receiving sets of the performance in the studio.

The walls of studios are generally padded with felt, or covered with curtain material of the type known as Monk's Cloth, or otherwise deadened to reduce reverberation. The reason for this is that any echo or reverberation in the studio is exaggerated or added to by the reverberation in the room in which the performance is ultimately heard through the loud speaker. The proper "reverberation time"—the time required for a sound to die down to practical inaudibility—for good musical taste, is somewhat over one second. A good studio will in general have a reverberation time well below this value. The reverberation period of the room in which the receiver is placed will then make up the difference.

The most commonly used microphone is the double-button carbon type, because of its simplicity and low impedance. The latter characteristic permits the use of long leads, whose capacity, while much too large to be placed in parallel with a condenser transmitter, is negligible, when paralleled with an impedance of some 200 ohms, like that of a carbon microphone. Fig. 1 shows, schematically, how a double-button microphone is built and connected to the amplifier system of a broadcasting station. The microphone consists of a diaphragm, D, formerly made of steel, which in later models was changed to duralumin, an alloy of aluminum, in order to improve the sensitivity and the ratio of signal output to hiss. (Inasmuch as the operation of the device requires passing a direct current through the carbon, some hiss is always present, and this may become objectionable if the sounds being picked up are very faint.) This diaphragm, about two-thousandths of an inch thick, is stretched between clamping rings, and one side (the back) is about the same distance from a flat metal surface. The combination of mechanical tension and air damping gives the necessary characteristics of very high natural frequency and damping so that the device responds uniformly to sound frequencies between about 30 and 6500, or higher, depending to some extent on the freshness of the carbon. This quality of uniform response is of course essential for good quality. If a microphone has a natural period of 1000 cycles, say, it will respond violently to notes of this pitch, giving them undue prominence; some low grade transmitters actually show this fault. Again, the low or

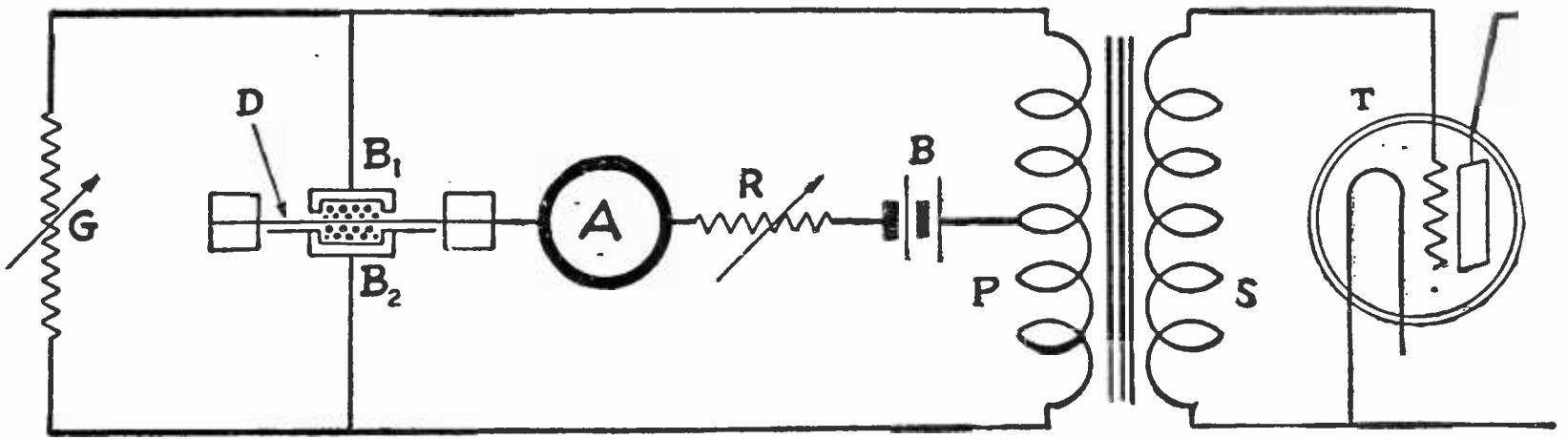

Fig. 1

high frequencies may be lost, resulting in "tinny" or "drummy" (muffled) output, respectively. It should be noted that the flat characteristic necessary for high quality reproduction is obtained only at the expense of sensitivity. The broadcasting microphone is about one one-thousandth as sensitive as the common telephone microphone, but the latter does not get much over 2000 cycles, and has

an 800-cycle resonance peak. That won't do for broadcasting in the 1925 style.

The stretched diaphragm, shown at D in Fig. 1, is free to vibrate between two cups or buttons, B₁ and B₂, filled with polished globular or egg-shaped carbon granules of a peculiarly rare and aristocratic variety, the output of which is largely produced by the concern which sends you your telephone bill

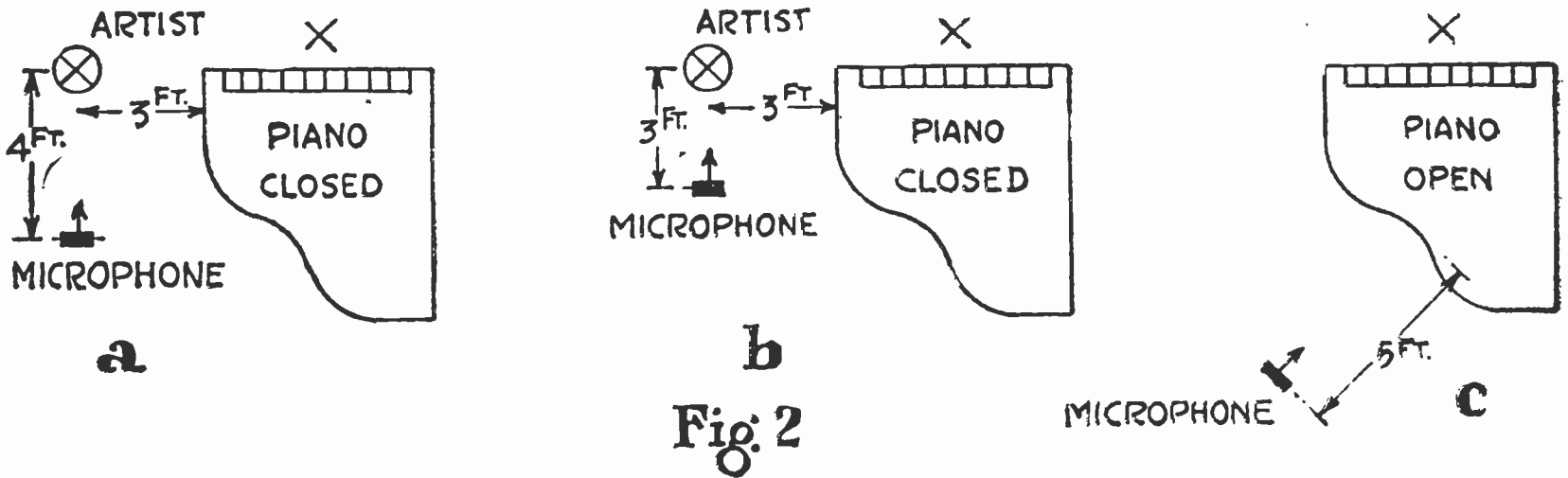

Fig. 2

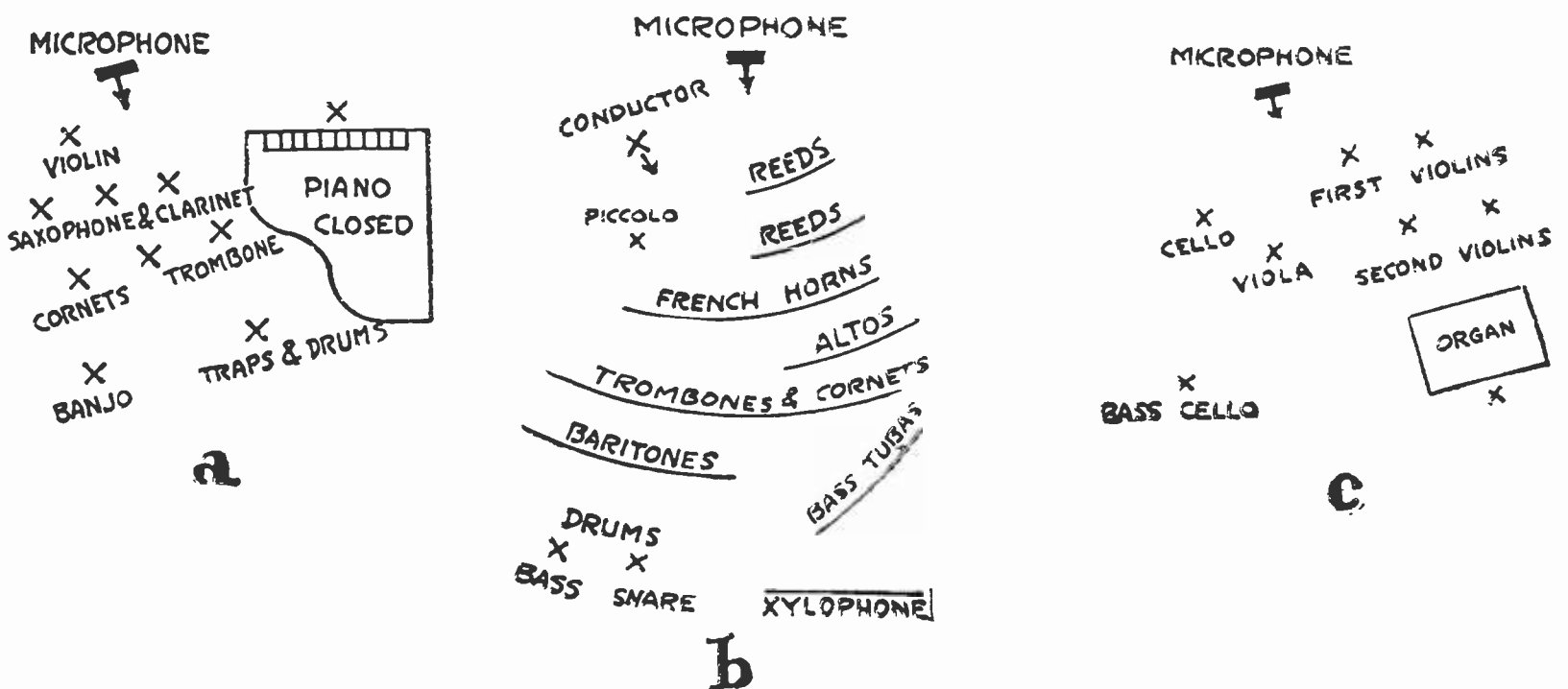

Fig. 3

each month. All is not carbon for broadcasting microphones which is black, just as all which glitters is not gold. The two buttons are connected to the primary or low impedance winding of a transformer, IT, the secondary of which feeds a tube, and so on up to the modulators. The vibration of the diaphragm, when sound waves impinge on the open side, varies the resistance of the two carbon paths according to the push-pull principle; at the same time direct current is fed to the buttons from a battery B, with its positive terminal connected to a midpoint tap on the transformer primary, while the negative pole goes to the diaphragm through a variable resistance R and milliammeter A. The direct current is adjusted to a value of 15–20 milliamperes per button, or about 40 mA. in all. Better still, a milliammeter may be connected in each leg rather than in the common lead; then any serious difference in resistance may be detected immediately. The buttons should not differ by more than 50 per cent.; a greater divergence indicates aging carbon or some other irregularity. It will be seen that with d. c. passing through the carbon, any variation in resistance supplies an alternating current to the input transformer. This current varies in accordance with the frequency and amplitude of the sound waves which reach the diaphragm. In other words, the device is a microphone, changing sound energy to proportionate electric currents. There is also a “gain” control, G, which varies the input to the first tube.

The carbon microphone is subject to a form of distortion called “blasting,” and that is one of the principal difficulties to be avoided in placing them. It is caused by excessive sound energy striking the diaphragm, and causing it to swing through such an amplitude that the carbon leaves the diaphragm momentarily, an effect which manifests itself both visually and audibly. The visual indication is on the microphone milliammeter, whose reading may drop from 40 mA. to perhaps 35 while the soprano holds a fortissimo note and takes a step forward impetuously at the same time. The audible indication is a harsh, throttling noise accompanying the music. Still another indication may be observed on the face of the control operator, who may also give expression to a blanket indictment of sopranos at such times.

The carbon in the microphone has a good deal to do with blasting. If the carbon is getting old, as indicated by rising resistance, it will blast more readily than when fresh.

And, of course, it must be the right sort of carbon. However, the best microphones will blast if the sound hits them hard enough. Some voices blast more readily than others, and some instruments more than others. A cornet or trombone, for example, blasts quite readily. The violin is less liable to this difficulty, but by no means immune. The saxophone is quite free from it. It would seem that preponderance of certain high frequencies, with a steep wave-form, is conducive to blasting. Soft instruments and voices do not blast. Moderate volume is also a protection, and that is why, for broadcasting purposes, very powerful voices are not at all desirable as a general thing.

In placing microphones, one tries to avoid blasting, in the first place, and to get the correct ratio of accompaniment to voice, or of one instrument to another, as a second and equally important consideration. In this process, something depends on the performers. For example, if one encounters a baritone who persists in singing with operatic volume in a small studio, he will probably cause microphone blasting. You try to reduce the blasting by moving the “mike” away from him, thereby cutting down the energy of the sound reaching the diaphragm. The result is that you run into a lot of reflection from the walls, the energy of which begins to be comparable with the sound reaching the transmitter directly from the performer, causing more or less distortion. At the same time, you lose the pianissimo portions, for it is a fact that people who try to broadcast with excessive volume usually sing very softly in the intervals between outbursts. The only solution is to arrange with the studio manager to avoid booking soloists of extreme volume range, and to blacklist them when they get by the audition.

Fig. 2 shows (a) a good general set-up for vocal solos with piano accompaniment; and (b) for violin solos. The arrangement will vary somewhat with different studios, but it is a good first approximation. Fig. 2c is a set-up for piano solo work.

It is always bad practice to let a singer use the accompanist’s notes. If the singer requires notes he should have his own music sheets. It is hardly possible to keep a balance if the soloist hovers around the keyboard of the piano.

Fig. 3 illustrates set-ups for (a) jazz orchestra; (b) brass band; and (c) string ensemble. In the case of the jazz orchestra, the violin is about three feet from the microphone,

and the farthest instruments some 14 feet. The violinist, if he is also the leader, may be angled off somewhat, so that he can direct the orchestra without being lost to the microphone. In the case of the brass band, the distance of the instruments varies from about four to thirty feet; if the studio is small, it may be necessary to obviate blasting by reversing the microphone, placing it back to the orchestra and with the bridge facing a dead surface. The string ensemble is shown with a parlor organ.

The height of the microphone is a factor which remains to be discussed. With vocal solists and violinists, it should normally be shoulder or head high. On piano solos, five feet remains about right, and this need not be changed for small ensembles. A brass band is sometimes better with microphone elevations of about seven feet. However, there are some curious nodes and anti-nodes set up in various studios which require experimentation with microphone elevations, as well as horizontal placing. The data given is only a first approximation in any case.

Radio Power and Noise Level

IN A recent talk before the Connecticut section of the A. I. E. E., Prof. W. J. Williams of Rensselaer Polytechnic Institute delivered himself of the opinion that power levels of broadcasting stations should remain just where they are. He is against any increase in power. The objection, to be sure, is a somewhat academic one, in view of the fact that almost everyone who can afford the money is getting a 5 kw. set to replace his 0.5 kw. outfit. Not everyone, alas, can undertake this expenditure. Among all the sounds heard in broadcasting studios, the jingling of the cash register is the least frequent.

A large station costs a pile of money, and all that one gets for the disbursement, besides the ability to address the populace, is the privilege of spending a lot more cash to keep the thing going. But it is not out of pity for the groaning broadcasters that Professor Williams rises in meeting. Were it so, we should wire him our congratulations and let it go at that. He speaks, ostensibly, for the listeners. We, also, are awash with altruism. Our heart goes out to the knob-turners of the land, as does the heart of the learned engineer from R. P. I., but our reasoning is at variance with his. So much so, that we must have at him, even if the magazine is barred from the newsstands

of Troy, and our name is hissed by all the listeners of WHAZ.

We shall be surprised, indeed, if the members of this WHAZ audience do not send us loads of poisoned cigars, live tarantulas, and infernal machines, for now, according to Professor Williams, they are a perfectly satisfied lot. "When we know," he says, "that this 500-watt station has been heard consistently in cool weather—about forty weeks a year for three years—across the continent in one direction and in Europe in the other, we can hardly be criticized for taking the stand that a power level of approximately this value is sufficiently high to meet the demands of the radio audience." What is *the* radio audience, and what are its demands? Possibly those members who are distance hunters pure and simple, who are satisfied to pick out the mystic letters W-H-A-Z while being batted in the ear by crashes of static, violet ray machines, electric bells, door-openers, and other miscellaneous natural and artificial noise makers—possibly this portion of the clientele is satisfied. In their interest, it might be a good thing to drop WHAZ's power to 50 watts or so. The station would be ten times as hard to hear, and the more rabid DX addicts would be proportionately happier. At the same time, Rensselaer's power bills would be somewhat reduced.

But what about the people who, while perhaps not disdaining to take a little DX flyer once in a while, want to get good music and decently intelligible speech out of their radio sets? They are getting it—from the locals,

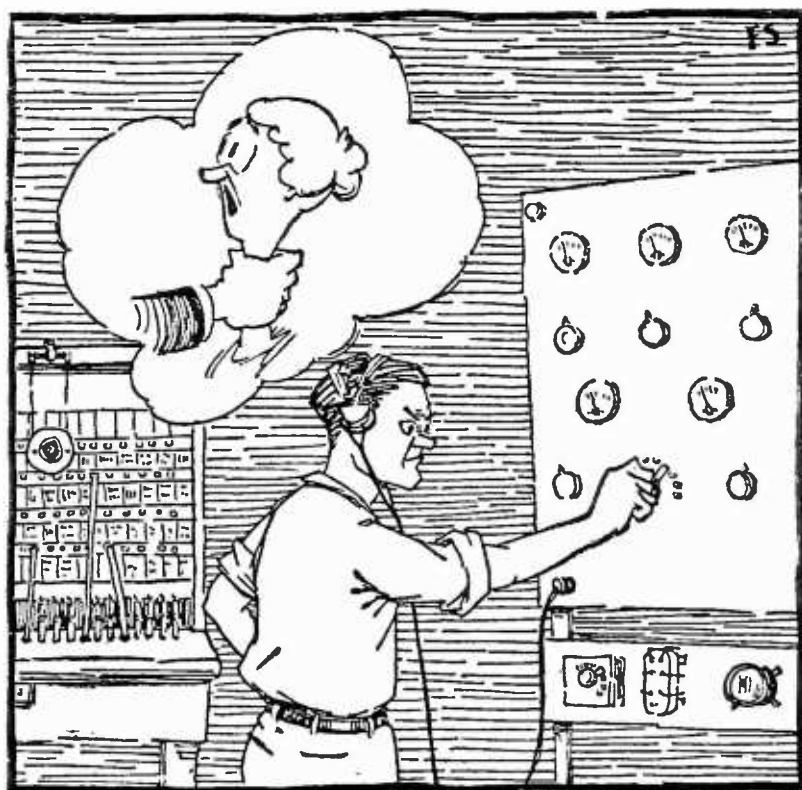

a blanket indictment of sopranos

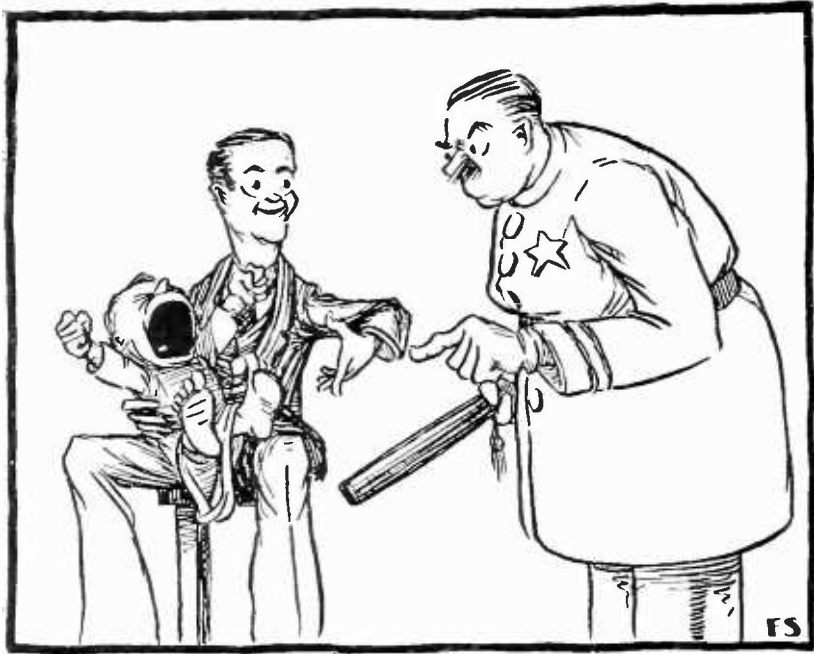

he expects it to be noisy

and, at greater distances, from those relatively few and enterprising stations which are in a position to pile on the kilowatts when they are needed. And what about the people whose nearest "locals" are several hundred miles away, and who want program service, not a guessing contest? Does anyone imagine that they are up in arms about so-and-so tripling the number of amperes in his antenna? Not at all, they think it is a very fine thing that they are able to get their market reports and jazz without samples of bedlam. They are in favor of an adequate signal for the farmers and ranchers, and they feel that they are entitled to it just as much as the city-dwellers. If you don't believe it, go out into the country and talk to them. Professor Williams, when he went to Hartford to deliver his paper, might have stopped off at the Berkshire village of Litchfield, 30 miles East, and inquired whether the Litchfielders get their program service from WHAZ, 73 miles to the Northwest, or WGY, 83 miles in the same direction. The answers would have given him a few foot-notes for his discourse.

Having expressed his undying trust in 500 watts, the Professor proceeds to discuss radio noise, which in part, he feels, shows a "healthy development condition," inasmuch as radio broadcasting is "the latest child of the physical sciences, and like every other child we should expect it to be noisy." This metaphor must be very comforting to discriminating listeners who want to hear the "Adagio Lamentoso" of the "Pathétique" with a quiet background. The amount of noise must be limited, we are told. By all means. Some good work is being done by public utility companies and other agencies in eliminating leaky insulators, radiating smoke precipita-

tors, and the like; at the same time a vigorous publicity campaign against squealing receivers has greatly reduced one source of disturbance. But when we get through, considerable noise will still remain for our "supers", with their amplification of 10,000-fold, to pick up. The only way to eliminate that would be to move to Samuel Butler's *Erewhon*, where no machinery was to be permitted, thereby eliminating radio noise, radio sets, and radio problems at a single stroke. This fact Professor Williams recognizes; he admits that it is "both theoretically and practically impossible to reduce the noise level to the vanishing point, as the cost to the public of such refinements would make the price of these utilities prohibitive." If this is true of artificial disturbances, is it not even more pertinent when it comes to the natural disturbance of static? As has been pointed out in a previous article in this department, no static reducing devices applicable to broadcast reception are available. The situation, as regards both natural and artificial static, may therefore be summed up as follows (calling A the signal strength and B the static): A should be greater than B . B is too large, and cannot be economically reduced to an inconsequential level. The obvious course is to increase A . To this measure Professor Williams objects, on the ground that it will increase interference. "It is necessary to establish a reasonably low power level limit," he maintains, "as the extreme sensitivity of the receiving set cannot be used without disagreeable interference."

Let us go to the bottom of this. Why are receiving sets made so sensitive? Because people want to hear distant stations, and because those stations provide only a very weak field at distant points, a lot of amplification is required to bring up the energy to audible level. If transmitter powers were increased, there would be no necessity for using the full sensitiveness of the set at any reasonable distances. Hence station interference would not be increased, except in the case of relatively primitive receivers located close to powerful stations. Nor is there any reason why sensitive receivers, equipped with a suitable volume control, should not be capable of distortionless reception from near-by powerful stations. At the same time, the ability of the signal to ride over disturbances would be increased. As we have pointed out before in discussions on this topic, radio transmission is really the sum of two kinds of amplification, carried out at the transmitter and receiver, respectively. The first is inherently

a selective and purposeful sort of amplification which brings up the desired signal only. The second is a generalized variety of amplification which brings up signal and noise indiscriminately. The latter has been pushed to a length which is not altogether healthy, and the next rational step is a boost in the centralized amplification of transmitters. A somewhat analogous situation is found in the electrification of railroads. The primary reason for electrification is that coal can be converted into power more economically at great centralized plants, and then transmitted to the individual electric locomotives, instead of burning it at relatively low efficiency in a large number of steam locomotives. In radio the problem is not merely efficiency in the sense of ratio of output to input, but a high ratio of signal output to undesired forms of energy, i. e., noise. In both fields, however, there is a trend toward centralization and higher power as the most effective means of gaining their respective objectives.

Quantitatively, in terms of amplification, just what does increase in power of broadcast transmitters amount to? Most people have a greatly exaggerated idea of what so-called "super-power" really means. They imagine receiving tubes within a hundred miles going blue, loud speakers dancing about on the table, ceilings tumbling down, and citizens frying eggs on electric ovens attached to their antennas. No such wonders, unfortunately, will come to pass. If we assume 50 kw. as the antenna power of a super-station, it will, under the same conditions, deliver a signal louder by one stage of transformer-coupled plus one stage of resistance-coupled audio amplification, than the signal of a 500-watt installation. The signal strength being proportional to the power, the 50 kw. transmitter will, at the same distance and with all other factors held constant, give a signal strength 100 times that of a 0.5 kw. set. A single stage of audio amplification, assuming a 5:1 ratio for the transformer and an amplification constant of 5. in the tube, which is about right for a UV-199 on 90 volts plate, is good for a current amplification of 25. Follow this with one stage of resistance—or impedance-coupled amplification, and the over-all magnification is already 125, a figure greater than the multiplying factor of the 50 kw. station over its 0.5 kw. rival. If two stages of transformer amplification, with ratios of 5:1 and 3:1 respectively, should be considered, the over-all amplification is 375, a figure much in excess of 100. What a "super" transmitter of this

order amounts to, therefore, is the presentation of a stage and a half of audio amplification to anyone who wants to listen to it. But amplification of the right kind, be it noted—*amplification of the signal only*. In other words, if you want to know what super-power to the extent of 50 kw. would sound like, tune-in a distant 500-watt station, and imagine its loudness increased by one and a half stages of audio amplification, without any increase in whatever interference accompanies the 500-watt signal. Or, better, assume the signal of the 500-watt station to remain constant; in that case the disturbances, for a 50 kw. outfit, will drop to one one-hundredth of the present level, or one and one half audio stages "down."

From the standpoint of the radio audience, would it not be better to have such stations, even at the expense of further loss in prestige by some of the midge broadcasters, instead of a crazy-quilt of 500-odd stations, many of which are worthless in quality of transmission and program, and serve no purpose except to caterwaul and heterodyne each other. If Mr. Williams wants to reduce station interference, he should advocate a reduction in the number of poor transmitters by enforcing decent standards of service, instead of opposing the sound engineering adjustments of organizations with the resources and determination to maintain the progress of the art. And, if he will ponder a little on the difference between the "I-think-I-heard-your-station-last-night" range and the effective service range of a station, he will perhaps reconsider an argument which is reminiscent of the early days of automobiling, when it was decreed that a flagman had to walk ahead of each automobile to prevent it from scaring horses.



the cash register seldom tinkles

The Memoirs of a Radio Engineer. IV

THE experiments of our small and youthful group of radio experimenters continued, during the summer of 1909, with the antenna lead-in swung to a small house in the backyard. This place was used for storage, and two buggy horses were also kept there, for the Bronx section of New York City was still semi-rural, and automobiles, while already common, had not yet driven out equine motive power to the present extent. This backyard was quite spacious, and not confined to the back; it also extended along the sides of the house, and contained four pear trees, two grapevines and summer-houses, and an unused well, covered with a great stone, harking back to the days when the borough had not attained the luxury of a municipal water supply. We had a miniature baseball diamond, about 20 feet square, in the yard, where we played ball during the day, and at night we foregathered, immediately after dinner, in the combined stable and storage house, to listen for wireless signals. Our set was the same: the four-wire flat top antenna, the detector of two needles with a length of pencil lead lying across them, the dry cell, and the 75-ohm watchcase telephone receiver. It was a simple set, if nothing else can be said for it. It could not squeal and disturb the neighbors, it had no knobs to turn, no tubes to burn out. We sat around it on the floor, taking turns in listening, but no sound was heard except the occasional stamp of a horse's hoof on the other side of the partition. We had a lantern, which we lit after dark, although, the set being one of zero adjustments, an expert could manage it just as well in the dark. But, light or dark, it brought in no signals. The only thing that had been changed was the ground. When the antenna came into the house the ground had been a water pipe; now it consisted of a length of gas pipe, driven into the ground between the planks of the floor. It did not get into the earth more than 18 inches, and electrically it was probably not a ground at all. We had some suspicion that it was the source of our difficulties, and we poured a few bucketsful of water on it, but without avail. Probably it would have had to go down eight or ten feet, in that dry soil, before we could have got any signals out of it. We didn't have that much pipe. Besides, we now got into trouble in another way.

In a house a few hundred feet distant, a

telephone went out of order. The trouble man came around and fixed it. A few days later it again developed a fault. It was repaired once more. In some way the subscriber got it into his head that the near-by "wireless" was interfering with the telephone service. He communicated this theory to the father of one of the boys in our crew, and in vain we pointed out that we had no transmitting set, and that it was impossible that our antenna could influence a wire line in any way. People are always suspicious of anything they do not understand. The whole neighborhood believed that some nefarious principle emanated from our outfit. It was not long before the owner of the barn on which one of our antenna supports rested requested that we hang our wires somewhere else. Anyway, we were not getting any signals. We could not hear the amateur up on Prospect Avenue, nor the Waldorf Astoria Hotel, on the roof of which a grand antenna had been erected. Public opinion was against us, and there was no friendly buzzing in the telephones to encourage us. It was September, school was starting again, and we were in a low frame of mind. We took the antenna down altogether, one afternoon, and the career of our first radio set was over.

There were better sets than ours, however. From the May, 1909, issue of the primordial radio magazine, *Modern Electrics*, the following description of one of them, owned by Mr. Ernest Carter of Abilene, Texas, is lifted:

Enclosed please find a picture of my wireless station. I am 15 years old and have been experimenting with wireless six months. On the right are the sending instruments. I use a one-inch induction coil, and run my coil from the 110 volts alternating current here. I use a water rheostat in connection with same; this gives very good results. You can see rheostat just back of coil.

I use two 3-quart Leyden jars for sending condenser, one on each side of spark gap. On this side of coil is my sending helix, which I made from 10 feet of No. 8 brass wire. The spark gap is on top of coil. I use an ordinary strap key for sending. With these instruments I can easily get a station 5 miles from here. For receiving I use 3 complete outfits, one is a 75-ohm relay with a coherer and decoherer, which signals me.

Another is a 1,000-ohm receiver which I made from a 75-ohm one, and an "auto" coherer with a rheostat regulator. The last one is a 1000-ohm receiver in connection with an electrolytic detector; tuning coil, condenser, and a potentiometer made of German silver wire. With the above instruments at night I can hear the Galveston and Dallas stations. I use the "auto" coherer to communicate with my friends that have stations here.

Just to the right above the coil is my d. p. d. t. switch, used to connect the sending and receiving with ground and aerial. My aerial is suspended from two 50-foot poles and is composed of 2 No. 14 B. S. copper wires 50 feet long and 2 feet apart.

Modern Electrics is a fine magazine, especially for wireless experimenters, and is a great help to me.

This was indeed a grand set, and it won the first prize of \$3 in the "Wireless Telegraph Contest." The 15-year-old experimenter already had the temerity to feed his spark coil from the 110-volt circuit, curbing it with a water rheostat; yet it was good for 5 miles. He was the possessor of "3 complete outfits," including the 1000-ohm receiver made out of a 75-ohm one—a characteristic touch! Finally, this Sybarite gloried in the possession of such astounding instruments as an electrolytic detector, a tuning coil, a condenser, and a potentiometer made of German silver wire. All I can say is that he would not have been safe in our neighborhood. Unfortunately the picture printed with the description does not lend itself to reproduction.

The runner-up in this "Wireless Telegraph Contest" was Mr. Bowden Washington, who has since become a prominent radio engineer, and a Fellow of the Institute. No doubt in other issues, numerous names appear which were obscure at that time, whose owners later played great rôles on the radio stage.

The contrast between the problems of the radio experimenter of sixteen years ago and those of to-day is rather striking. Broadly speaking, the problems of to-day are those of congestion, while those of 1909 were questions arising from the primitive state of the art and the limitations of both quantity and quality of personnel, equipment, and information. To-day our problem is not to hear stations, but, often, to shut them out, in order that we may listen to one desired signal. At the time of which I am writing, an experimenter often listened for hours without hearing a signal. There were not many stations, and with the rudimentary receiving equipment available only a few near-by transmitters could be heard at best. Picking up a signal was an

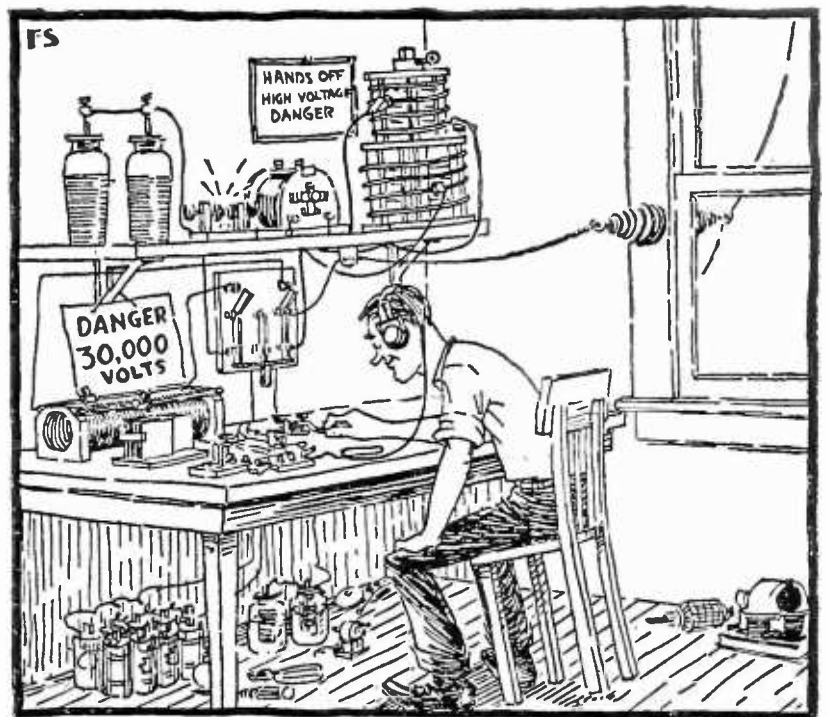

you could abuse him in morse.

event. "I heard a station last night," the proud operator would inform everyone he met the next morning. To-day there are not wavelengths enough to go around. Stations are crowded 10 kilocycles apart, and most of them have to divide time, or encounter interference, or feel some of the other effects of congestion. In 1909, compared to this, radio was an anarchist's paradise. If you wanted to put up a station and send, you asked no one's leave. You picked any wavelength you pleased, which was probably whatever wavelength your antenna happened to have, in its natural and innocent state. The Government took no notice of you. It did not assign you to 704.2 kilocycles, for no one knew what a kilocycle was. If anyone interfered with you, you could abuse him in Morse, and the police power would not interfere unless you followed it up with a personal assault. This procedure, incidentally, was quite *comme il faut*; many a pair of commercial operators met on West Street, New York, after a voyage, to have it out with their fists over an incident of "jamming" which had marred the serenity of the ether, as late as 1914. Good old days, bad old days, as you please; only one thing is sure:—we shall never see anything like them again.

The material appearing in this magazine is fully protected by copyright, and editors of periodicals are advised that unauthorized publication of circuit diagrams, technical descriptions, and parts or the whole of articles, without due permission and credit, is an infraction of the law. Those who wish to reprint material appearing in these pages are asked to communicate with the editor.



A Single-Control Receiver



Recent Developments in a Multi-Stage, Neutralized, Tuned Radio Frequency Receiver — Some Experiences and Data on Neutralizing Methods

By C. L. FARRAND

THIS paper is the second by Mr. Farrand giving the constants and data on his tuned radio frequency receiver known as the super-pliodyne. The first paper was printed in the July RADIO BROADCAST and dealt with the experiments and developmental work on the circuit. This paper describes further work on the neutralization methods used in the receiver. It is one of the Radio Club of America papers which appear exclusively in this magazine.—THE EDITOR

IN A paper read before the Radio Club of America on February 20, 1924, published in RADIO BROADCAST for July, 1925, a method of neutralizing feed-back in vacuum tubes, due to capacity coupling of the electrodes, was described. The purpose of the present paper is to describe a new method of neutralization which leads to greater selectivity and which may be combined with the former method to secure a desired selectivity and sensitivity.

The former method gave what in the present day would be considered minimum selectivity. The greatly increased number of broadcasting stations has, in turn, increased the demand for greater selectivity in sets. It was in attempting to satisfy this demand that the new method was derived. The selectivity of a multi-stage radio-frequency amplifier increases rapidly with the number of stages. The circuit design for each stage may be such that with a single stage, the selectivity may be entirely unsatisfactory; yet, with the chosen number of stages in circuit, the desired selectivity would be obtained. It is therefore necessary, dependant upon the number of stages to be used, to regulate the selectivity of each circuit to the desired value. In this, it is assumed that all the radio frequency circuits of the several stages are similar.

The circuit of each stage of, for example, a two-stage amplifier, must be extremely sharp. This same circuit used in a five-or-six-stage amplifier would have such selectivity that it would be practically impossible to tune the stations in. Amplifiers

have been constructed with a single control so selective that stations could only be tuned-in with extreme difficulty. Stations of substantial volume in that case were passed over without being noticed.

TUNING THIS SINGLE-CONTROL RECEIVER

IN THE manipulation of a single-control receiver of this type, the rotation of the control dial from 200 meters to 550 meters can be accomplished by a simple half revolution. The incoming signals of different wavelengths, as they are passed through rapidly, give rise only to a dull thud or click, sounding much the same as when the grid of an oscillating

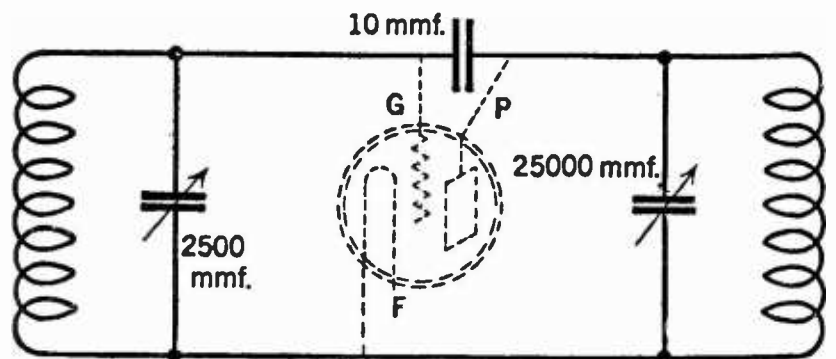

FIG. 2

receiver is touched, stopping the oscillations. At times, twenty or thirty such station clicks may be heard with one turn of the control dial. If the control is stopped at one of the clicking points, the modulation will come through.

It is, furthermore, necessary that the amplifier circuits be tuned in unison. It is obvious that the sharper the tuning of each circuit, the greater will be the difficulty experienced in maintaining tuning of each circuit. It is, however, practical in commercial production, to secure selectivity at least equal to that obtained by some super-heterodyne receivers, considering only one tuning position. The super-heterodyne, at the best, tunes at two points and, if not properly designed, at four and more tuning positions. The Super-Pliodyne receiver, using this system, tunes only at one point. The

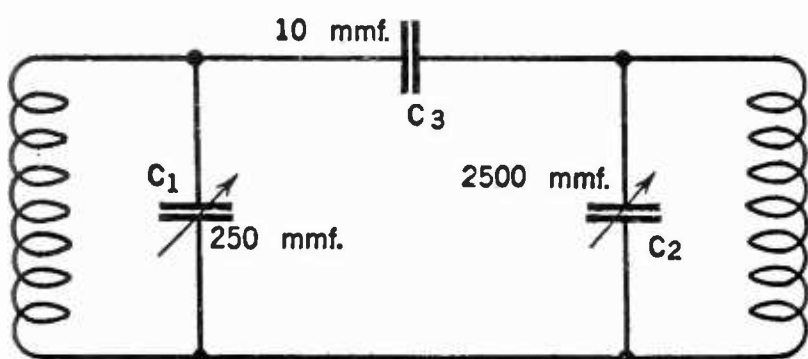

FIG. 1

necessity of matching individual circuits of the receiver has produced a uniformity of circuits from receiver to receiver within very accurate limits and, consequently, the entire receiver becomes practically a precision wavemeter; variation in calibration of the receiver varying about two meters.

COUPLING IN VACUUM TUBE CIRCUITS

IT IS obvious that the coupling of vacuum tubes and their associated circuits caused by the grid-to-plate capacity is dependent upon the proportion of the associated capacities due to the internal capacity of the tube. That is, if the circuit capacity is equal to the electrode, the capacity of tube coupling will be very great. If, however, the circuit capacity is very large in comparison to the electrode capacity, the coupling will be small.

The actual coupling, with a given coupling capacity and given input and output capacities, is independent of wavelength. In other words, the coupling is dependent upon the ratio of electrode capacity to input and output tuning capacity only, and not strictly speaking dependent upon wavelength. The coupling, K , is given by the equation

$$K = \frac{C_3}{\sqrt{(C_1 + C_3)(C_2 + C_3)}}$$

A circuit as shown in Fig. 1 would regenerate and oscillate vigorously when connected as vacuum tube input and output circuit. However, a circuit as

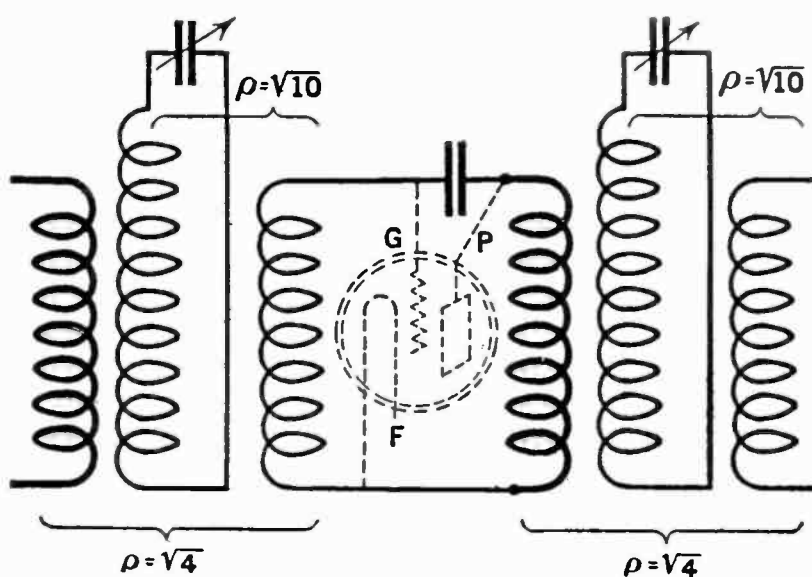
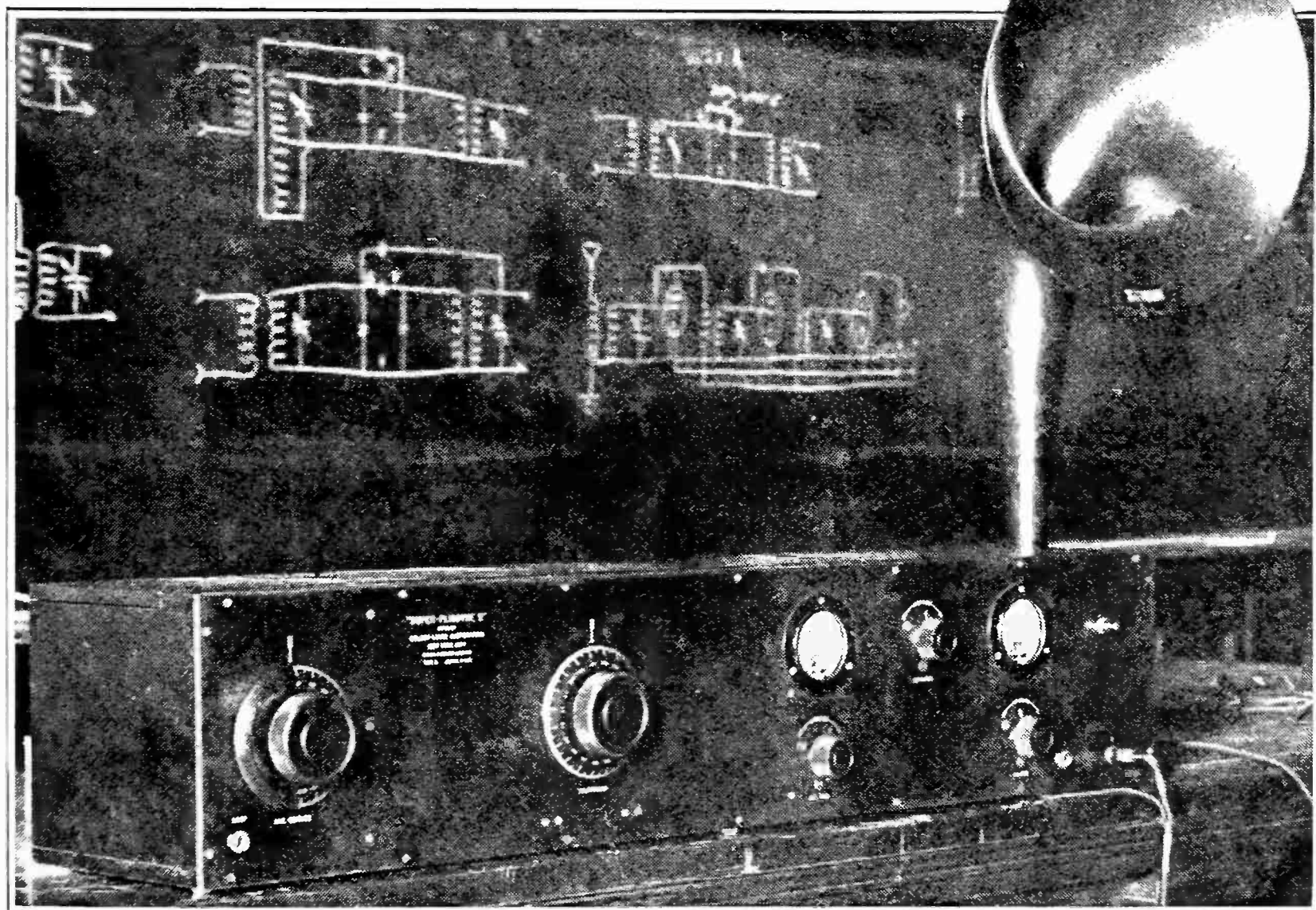

FIG. 3

shown in Fig. 2, with the input and output tuning capacities increased tenfold, would have a coupling coefficient of one tenth that of Fig. 1 and would be very stable.

In other words, a successful radio-frequency amplifier could be built which would have no tendency to regenerate, using a capacity of the order of .0025 mfd. tuning the input circuit, and .025 mfd. tuning the output circuit. It is, however, impracticable to build variable condensers of such capacity, particularly if it is desired to have them agree with each other within close limits.



A COMPLETED RECEIVER

Six stages of radio frequency amplification are used in this model. The set can be used with a very short antenna and in his demonstration before the Radio Club, Mr. Farrand used a 12-foot wire

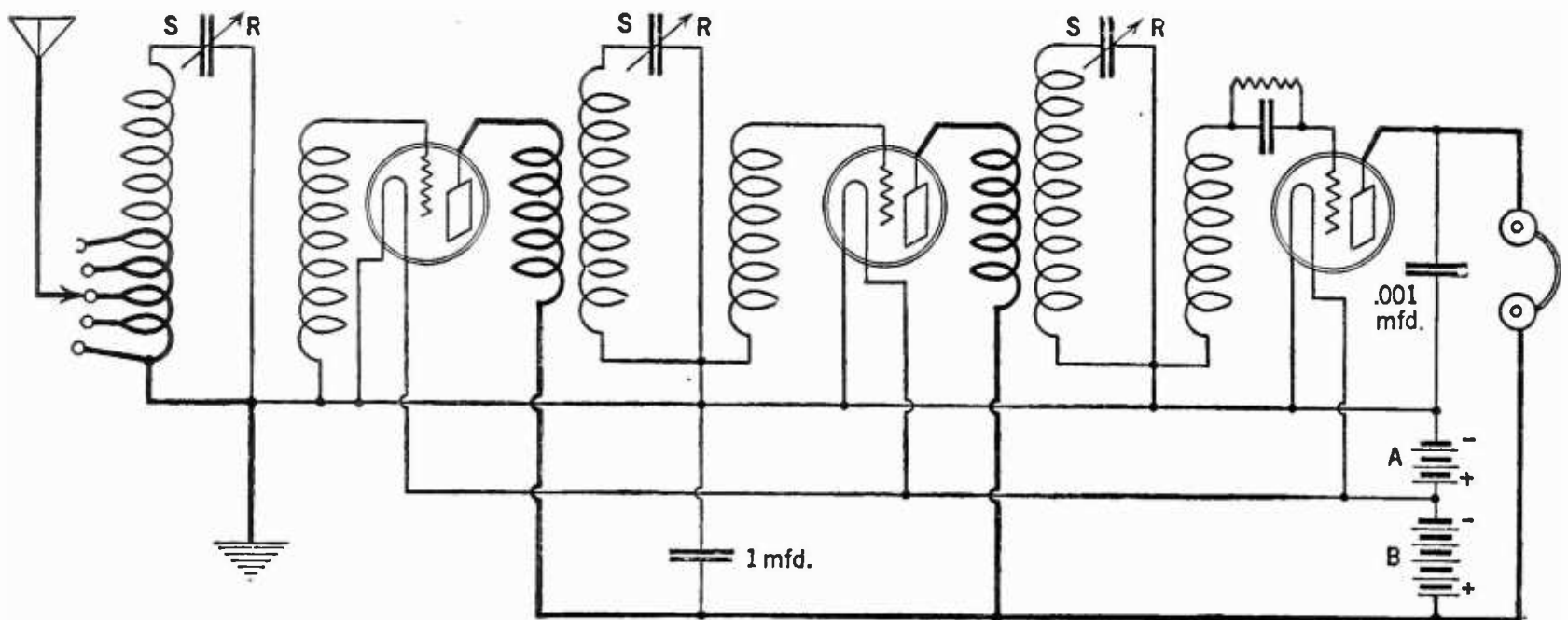

FIG. 4

The same result can be secured by resorting to a transformer. It is well known that a capacity connected to one winding of a transformer will be effective across the terminals of the other winding inversely as the square of the ratio of turns of the transformer, assuming the transformer has unity coupling. In practice it is difficult to approach unity coupling and the relations are slightly different, requiring, in general, an increase in turns of the untuned windings.

TUNING CIRCUITS OF THIS SET

THE present method involves connecting the tuning condenser of a chosen size which, from practical consideration, should be approximately 250 mmfd. across the terminals of a tuning winding. (See Fig. 3) Closely coupled to each other and to this winding are an input winding and an output winding. The input winding and output winding are chosen with a step-up ratio to satisfy the output and input impedances of a tube. This ratio should be between 3 and $4\frac{1}{2}$ to 1, depending upon the tubes used. In the Figure, a ratio of $\sqrt{10}$ or 3.16 is used. The ratio of turns of these two windings to the tuning winding is chosen so as to increase the effective tuning capacity of the grid circuit and, consequently, will increase the effective tuning capacity of the plate circuit. In practice, the ratio to be chosen depends upon the number of stages to be used, as it is necessary to use a more broadly tuned circuit with a greater number of stages.

For a two-stage amplifier, the ratio of tuning winding to grid winding should be about 2. For a five-stage amplifier, this ratio should be about three.

In view of the fact that the effective tuning capacity of the grid circuit has been increased, the resulting load of the input impedances of the tube upon the tuning circuit has been decreased. In this way, tuning is materially sharpened. In case the selectivity is too great, the compromise design may be made with the method described in the previous paper. The transformer may be designed so that

only a portion of the interstage coupling is neutralized by increasing of effective capacity, and the remainder of the capacity is neutralized by connection of resistance between the plate and grid electrode. (A condenser may be connected in series with a resistance to prevent a flow of direct current from the common plate battery.) In this way, the over-all selectivity of the amplifier may be regulated within very wide limits.

The effect of the input capacity of the vacuum tube upon the tuning is less. This is because the transformer makes the effective tuning capacity larger in proportion to the input capacity. This is advantageous as it is possible to increase the wavelength range within the scale of a condenser of given size. In practice, a range of 200 to 555 meters can be secured with a capacity of 250 mmfd.

The same effect may be produced by auto transformer construction but is less desirable on account of circuit difficulties.

It is desirable to destroy the natural period of the grid winding of the transformer by winding it with resistance wire. This has no effect upon the operation of the transformer.

It is also desirable to locate the transformer (input and output) winding at the low potential end of the tuning winding. This tends to prevent losses and permit a larger wavelength range.

Fig. 4 shows a two-stage radio-frequency amplifier circuit. The plate winding consists of 15 turns, wound left hand; the grid winding 47 turns of resistance wire wound right hand; the tuning winding 80 turns, wound right hand. The plate and grid windings are tightly coupled together, of equal length and about one third the length of the tuning winding, and are placed at the filament end. The plate winding is placed between the grid and tuning winding; the end of the plate winding opposite the filament ends of grid and tuning winding is connected to plate. The end of the plate winding opposite the grid end of grid winding, toward the stator end of the tuning winding, is connected to positive plate battery.

For the Radio Beginner

How to Build the R. B. One-Tube Knockout Receiver

Q THERE are so many beginners in radio who want to know how to build a good but inexpensive receiver that a series of articles, of which this is the third, have been prepared by Mr. Zeh Bouck, especially for the inexperienced builder. Most of the material for the first two receivers, described in the July and August numbers of this magazine, can be built from workable parts obtained at the five-and-ten cent stores. The simple crystal receiver, described in the July magazine can be built for about \$1.82, while the additional parts for the one-tube receiver outlined in the August number cost about \$6.12. The receiver described in this article is a revision of the One-tube Knockout receiver, made famous after its publication in this magazine in November, 1923.

The "Radio Lexicon" and "The Radio Primer" explain the theory involved in the receiver described and will be found very helpful to the newcomer in radio who not only wants to build a receiver that "works" but who also wants to know why it functions. Recommendation of collateral reading in the best text books is also given.—THE EDITOR

IN THE last two issues of RADIO BROADCAST we have described the construction of a crystal and bulb receiver. It is now quite logical that we combine these two receivers into a reflex set, the one-tube RADIO BROADCAST Knockout Set that will operate a loud speaker.

Though this receiver is necessarily more complicated than those we have so far described in The Beginners' Department, the inexperienced fan will not be over taxed in its design and construction. The photographs and drawings illustrate very clearly the manner in which the set is assembled, and we shall endeavor to make these points still more plain in our descriptions.

LIST OF MATERIALS

In Figure 1	Description
No. 1	2 Variable condensers, .0005 mfd. (Hammarlund, \$5.00 each)
No. 2	2 3-inch dials (5 and 10 cts store, at 10 cts., each)
No. 3	1 Crystal detector, preferably fixed (Pyra-tek with mounting, \$1.25)
No. 4	Rheostat, Amperite, or Daven Ballast for tube used (Daven Ballast with mounting \$1.00)
No. 5	$\frac{1}{4}$ pound of No. 22 s. c. c. or enameled wire (5 and 10 cts. store, 25 cts.)
No. 6	Socket for tube used (5 and 10 cts., store for UV199, 20cts.)
No. 7	Audio amplifying transformer, ratio about four to one, such as the Rauland-Lyric, Acme, General Radio, or AmerTran (AmerTran, \$7.00)
No. 8	5 Fahnestock clips or binding posts (5 and 10 cts. store clips, 10 cts.)

Cigar box, base-board, sheet of paste-board, a few feet of bus bar and No. 18 annunciator wire, screws.

Following the mention of the parts, the exact make and price used in the receiver we are describing is given in parenthesis. This represents a total expenditure of \$20.00 which can be considerably reduced, if desired, by the following substitutions purchased at the five-and-ten-cent stores: Variable condensers, 22 plates, at \$1.44 apiece; rheostat at \$.25, crystal detector, \$.20.

THE PANEL

ONCE again the cigar-box, the mechanical genius of the radio beginner, plays the combination part of panel and cabinet. A rather large box, about ten by six inches, should be secured. The hinged cover and paper are removed by soaking in water, and the wood is sandpapered to a clean, smooth finish. The bottom of the box is marked and drilled according to the panel layout in Fig. 2. (Detailed instructions on the preparation and working of cigar-box wood are given in The Radio Beginners' Department for July.) The writer found it more convenient to take the box apart and re-assemble it as the parts were mounted.

Due to the number and size of the parts represented by the one-tube reflex set, the depth of the cigar-box is rarely sufficient to contain them all. Therefore, a large base-board six inches wide, is substituted for one side of the cigar-box as suggested in the drawing, Fig. 3. After the panel is drilled, the

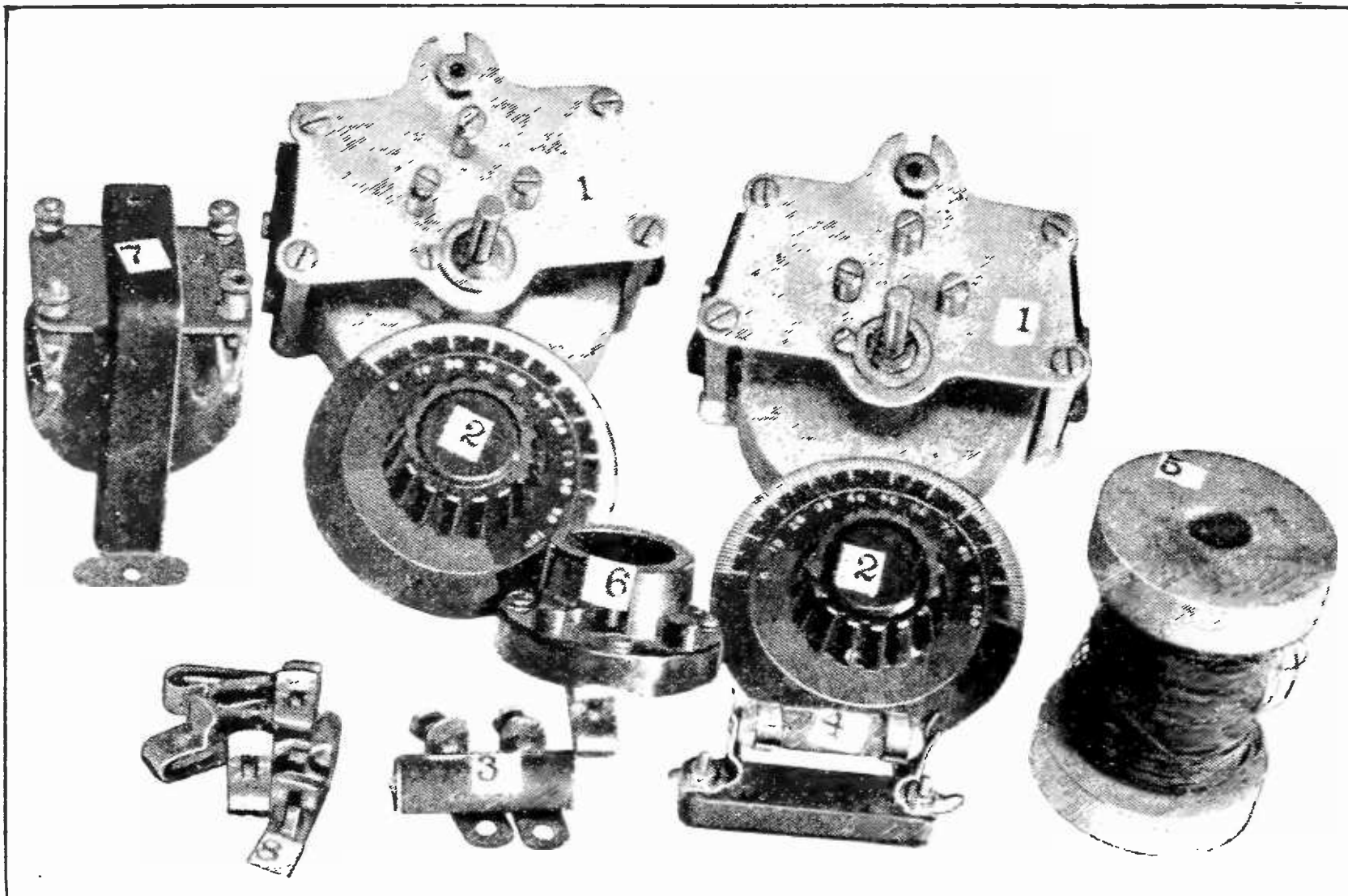

FIG. 1

The purchased parts that go into the construction of the Beginners' Model of RADIO BROADCAST'S Knockout One-tube receiver

cigar-box—or what is left of it—is built up around the baseboard, three inches or so of which will project out in back of the box. The top of the box (originally a side) is nailed in place last, after the socket is fastened to it, and the condensers and coils mounted respectively on the panel and sides.

A coating of green stain applied to this woodwork will add considerably to the appearance of the completed set.

THE COILS

SPIDERWEB coils offer a simple form of inductance to the inexperienced builder, and they were chosen in the construction of this receiver. The winding form, drawn to exact size, is shown in Fig. 4. This can be cut out and traced on pasteboard, from which material the forms are cut, or the dimensions can be noted and the figure re-drawn. Two combination coils, therefore two forms, are required, designated as T₁ and T₂ on the wiring diagram. Two windings are placed on each form, a primary and a secondary. A small hole is punched in the cardboard, the wire inserted, and then wound over and under the spokes. This first winding is the primary. The primary of T₁ has 15 turns of wire, and the

primary of T₂, 25 turns. At the finish of the primary winding, another hole is punched in the form and the free end of the wire slipped through. At the next spoke, just above the primary winding—a thirty-second of an inch or so—a third hole is punched, and the secondary winding begun. The secondary is wound the same way as the primary and fastened to a fourth hole at the final turn. The secondary of T₁ has 33 turns of wire and that of T₂, 30 turns.

Coil T₁ is mounted on the left hand side of the box (looking from the front) and T₂ on the right hand side. They are held in place by the wiring and by a tack, through one spoke on each coil, into their respective sides of the box.

If it is preferred, solenoid coils, such as those illustrated in Fig. 5, can be substituted for the spiderwebs. These are wound on two and a half-inch diameter winding forms. The secondaries are wound first and consist of sixty turns of wire for both T₁ and T₂. A layer of tape or empire cloth is placed over the secondaries, followed by the primary windings of fifteen turns on T₁ and 35 turns on T₂. (There are several commercial makes of transformers marketed for use with the so-called "Harkness Reflex" receiver, originally de-

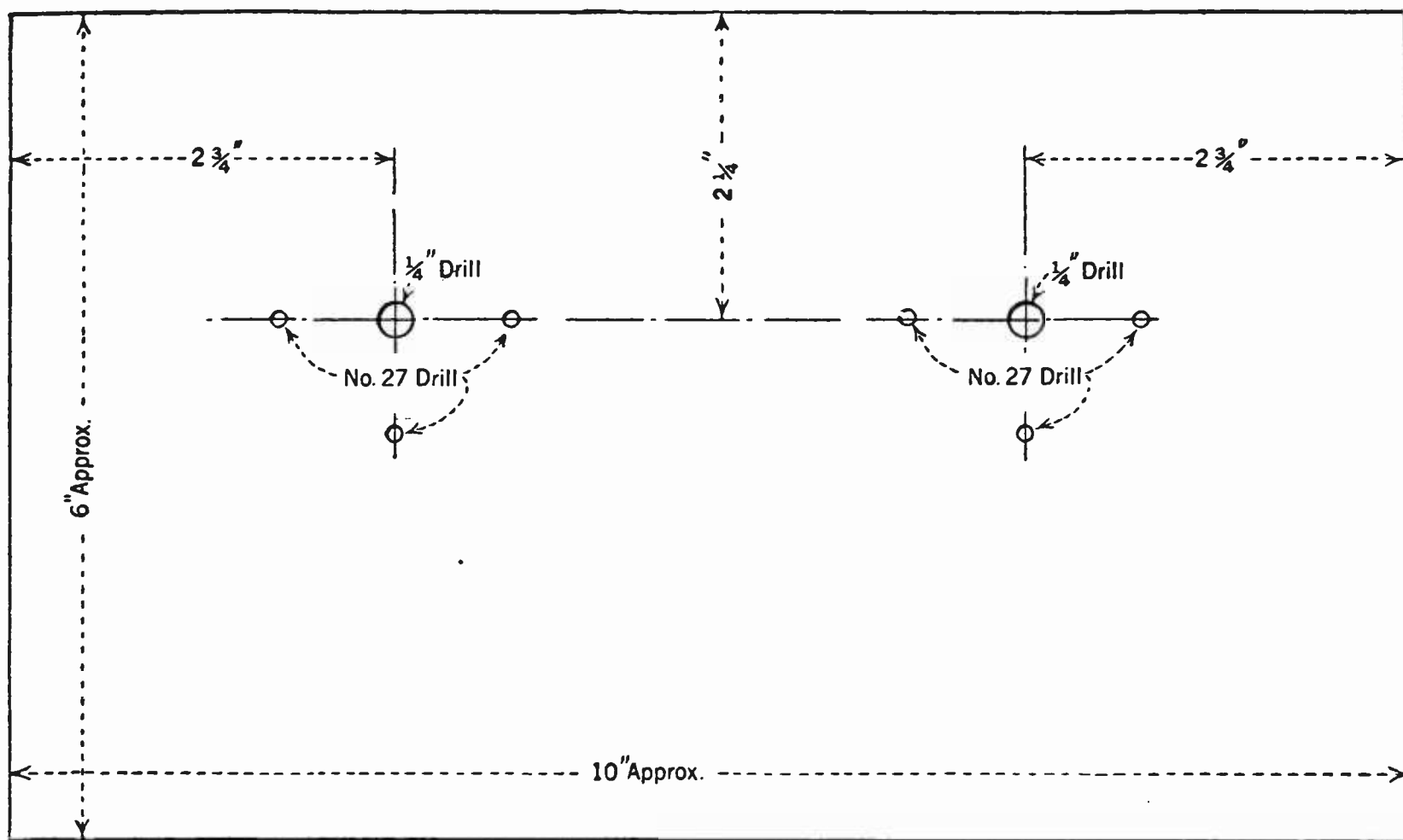

FIG. 2

The layout of the cigar box panel. The screw holes for the condensers are placed with the aid of the template furnished with the condenser

scribed in this magazine for November, 1923, which can be substituted for T₁ and T₂).

The socket is mounted on the top of the cabinet as suggested in Figs. 3, 6, 7, and 8. Four small holes are drilled beneath it through which wires pass, connecting to the socket terminals. No. 18 annunciator wire is used for this purpose, the remainder of the connections being made with the heavier bus bar.

All parts, excepting the transformer, can now be mounted. From left to right in Fig. 6, the following parts are seen: Coil T₂, variable condenser C₂, the fixed crystal detector, the amplifying transformer, variable condenser C₁, the Amperite or Daven Ballast resistance and coil T₁. The Fahnestock clips, from left to right are: 1, telephone receivers; 2, telephone receivers and plus B battery; 3, minus B battery and plus filament battery; 4, minus filament battery and ground; 5, antenna.

HOW TO DO THE WIRING

THE connections of the various parts are most conveniently made in the following order, with all parts, excepting the amplifying transformer T₃, permanently mounted:

Filament post on socket to binding post or Fahnestock clip number 3; remaining filament post to filament resistance (R in Fig. 9), and from the filament resistance to post number 4.

Outside secondary terminal of T₁ to grid of tube and stationary plates of the C₁; the inside (or beginning) secondary terminal to the rotating plates of C₁: The outside terminal of T₂ secondary connects to the stationary plates of C₂ and the inside terminal to the rotating plates.

The inside terminal of the T₁ primary connects to the antenna post of Fahnestock clip number 5; the outside or finish primary terminal leads to post number 4.

The plate of the vacuum tube is wired to the beginning of the T₂ primary and end of the primary to Fahnestock clip number 1.

The audio-frequency amplifying transformer, secondary to the right, is now mounted and the connections completed as follows:

The rotating plates of C₂ to one side of the crystal detector, DET; the other side of the crystal detector to the P post on the primary of the amplifying transformer; the plus primary post is wired to the stationary plates of C₂. The G post of the secondary runs to the rotating plates of C₁ and the F post to Fahnestock clip number 4.

All joints should be soldered cleanly, and the wires bent carefully into right angle bends. The inexperienced solderer is advised to read "How to Solder" by William Crosby in RADIO BROADCAST for May, 1925, before wiring the One-Tube Knockout receiver.

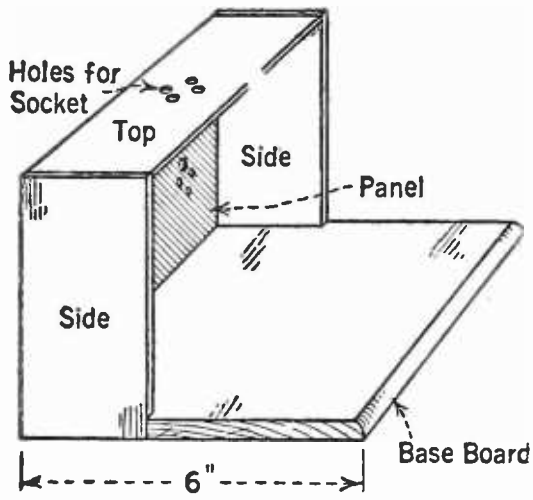
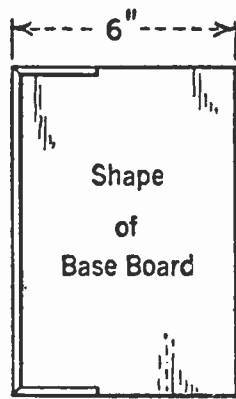

FIG. 3

Showing how the cigar box is built up about the baseboard.



TUBES AND BATTERIES

THE receiver described is designed for use with the UV-199 type tube and an A battery of three dry cells. It will function, however, equally well on five-volt tubes of the UV-201A type, with the proper A battery and filament resistance. Ninety volts on the plate will be correct for both tubes, though still higher voltages can be safely applied to the larger tube.

HOW TO INSTALL THE RECEIVER

A SUITABLE antenna, such as described in RADIO BROADCAST for July for use with the Beginners' crystal receiver, is connected to Fahnestock clip or binding post number 5. The ground lead is connected to post number 4, as well as the wire leading to the minus terminal of the A battery. The plus A battery and the minus lead of the B battery connect with post number 3. The

FIG. 4

Exact size of the winding form used in making the spiderweb coils T1 and T2

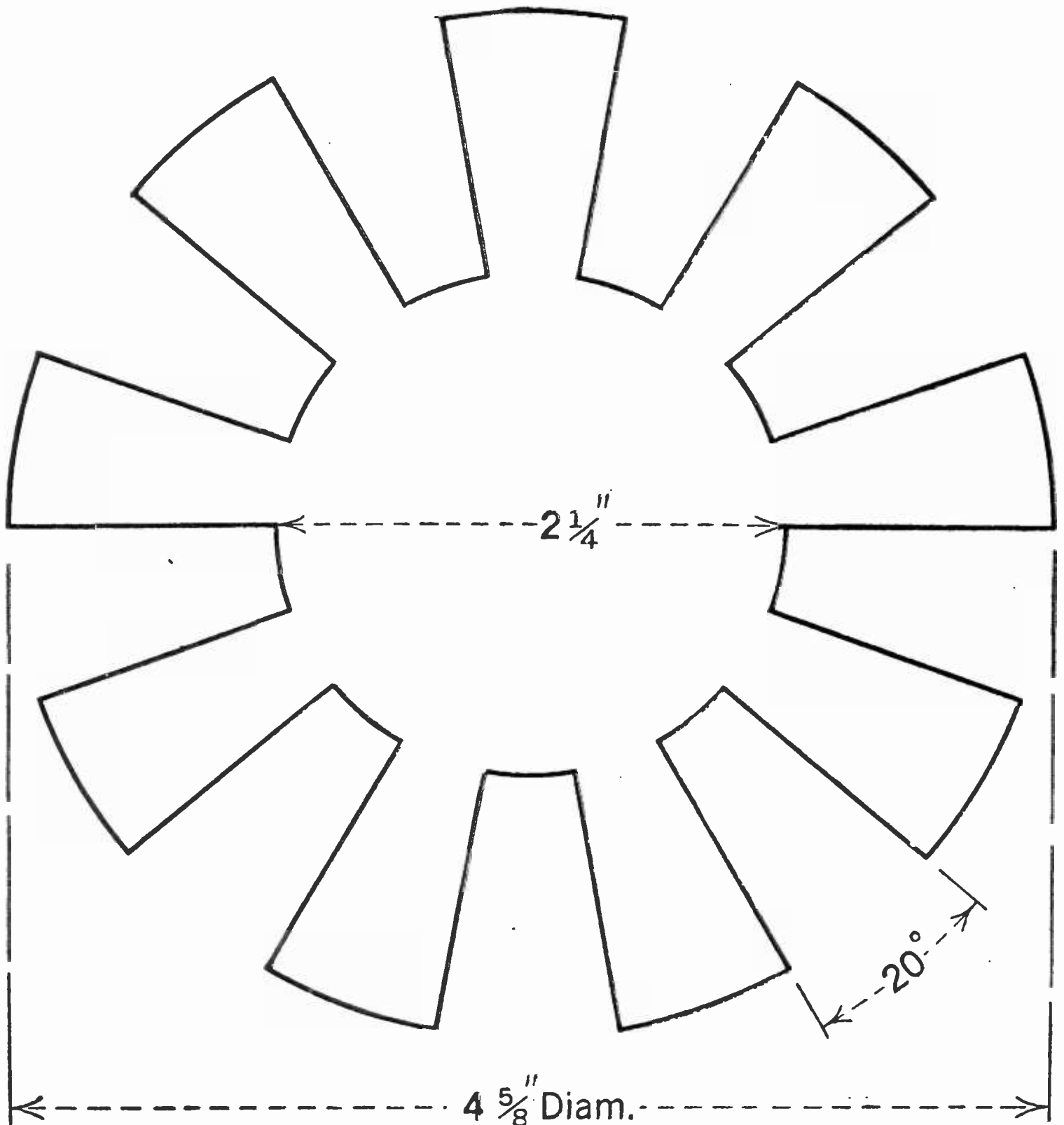

plus B battery terminal is wired to post number 2. The telephone receivers connect to posts 2 and 1. These connections are still further explained in the wiring diagram, Fig. 8.

OPERATING INSTRUCTIONS

THE tube is plugged into the socket and the rheostat turned on, or the Amperite or Daven Ballast clipped into the mounting. The dials should be set so that they read maximum when the rotary plates of their respective condensers are fully in between the stationary plates. The two dials are now moved simultaneously over the tuning range, keeping them at approximately the same settings. When a station is heard, the controls are carefully adjusted for maximum response. If the catwhisker type of crystal detector is used, it will require the usual adjustment. Reversing the connections to the crystal detector will often increase signal strength.

Properly constructed, this receiver should give loud speaker results on local stations.

CARE AND UPKEEP

THE filament and plate batteries should be kept at the proper voltage and B batteries which show

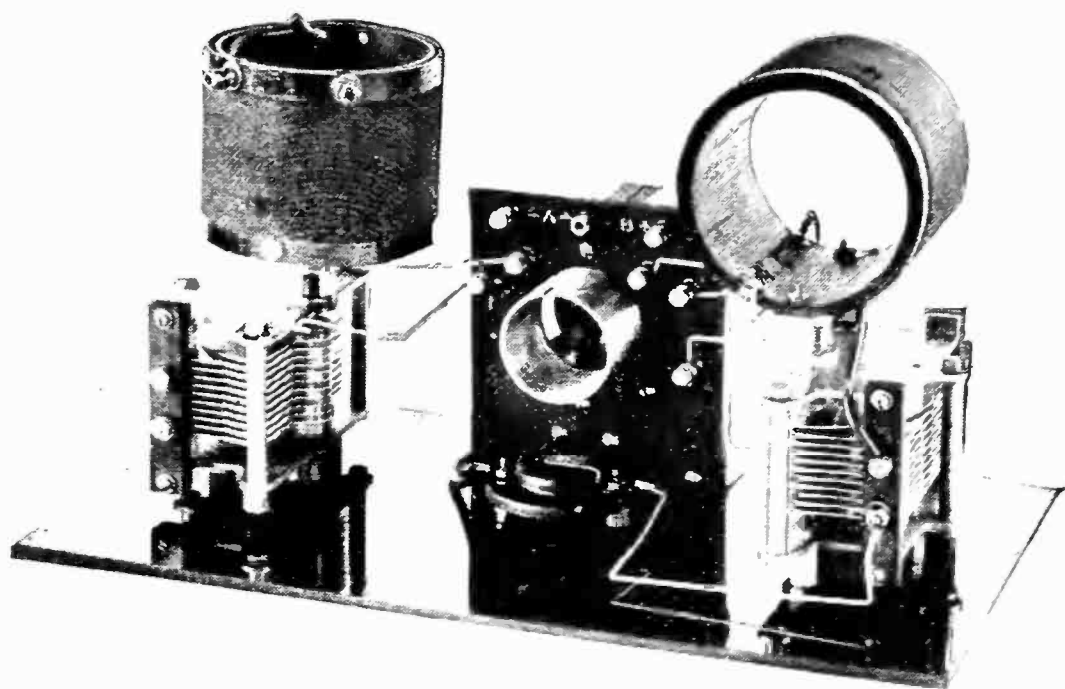

FIG. 5

The rear view of a more elaborate layout using solenoid coils. The more experienced builder will find herein plenty of play for his talent and ingenuity

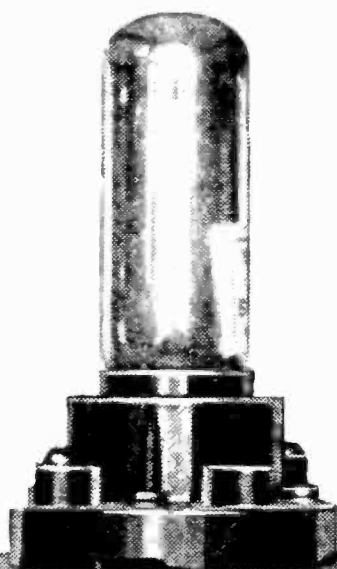
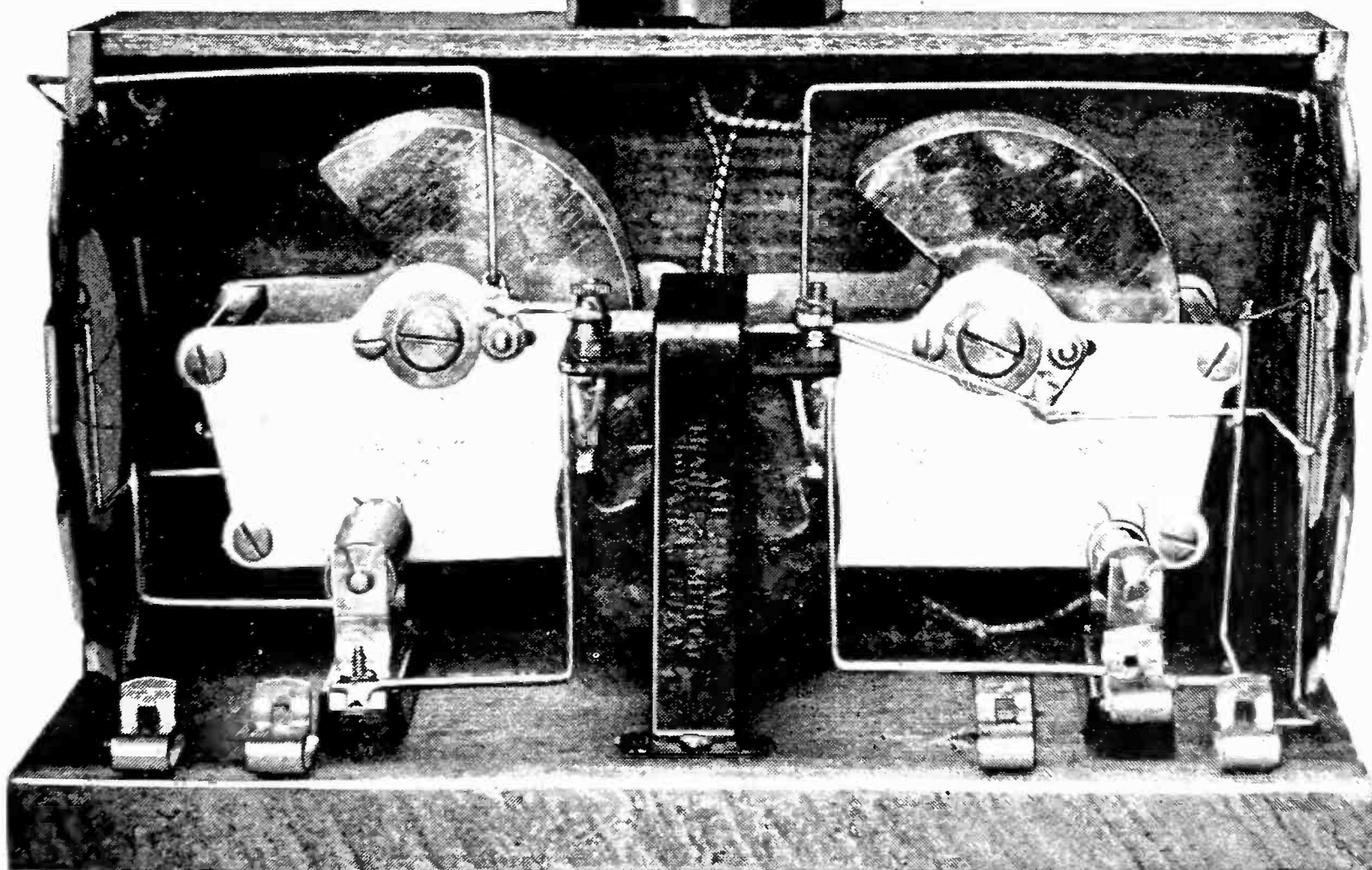

FIG. 6

The finished receiver from the rear. The transformer is mounted and wired last



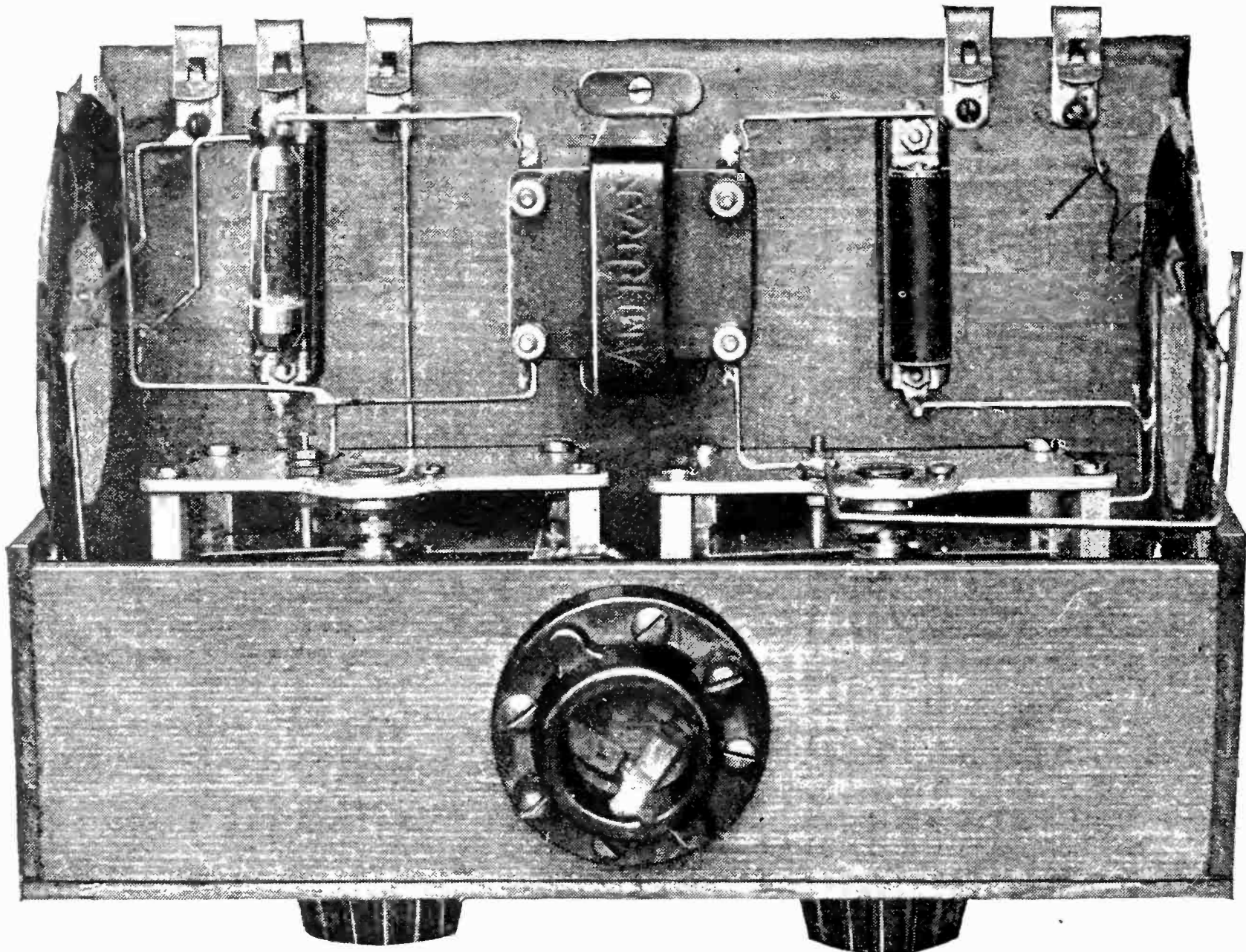

FIG. 7

Looking down on the completed set, showing the arrangement of the exposed parts

a drop of more than 25 per cent. should be discarded.

Inspect all connections occasionally and clean wiping contacts, such as in the vacuum tube socket, in order that there will be no loss due to contact resistance.

THE RADIO PRIMER

The Vacuum Tube as an Amplifier

AS USUAL in any discussion, exposition, or argument, we must have as a background a common fund of knowledge which contributes to the discussion but does not need to be explained itself. It is our starting point or premise—or perhaps the tools with which we are going to work. Most of our readers will understand these primary facts while those that do not are asked to accept them as truths, exactly as they do the assertion that the earth is round—without a personal demonstration of the undoubted fact.

WHAT WE KNOW

IN OUR explanation of how a bulb amplifier operates, we shall assume to know the following:

1. The grid of a vacuum tube is the screen-like element situated between the filament and plate.

2. Under normal operating conditions, a positive charge placed upon the grid will increase the plate current—the current supplied to the tube by the B battery. The plate current flows through the plate circuit which includes the space between plate and filament.

3. When a negative charge is placed upon the grid, the plate current is decreased.

4. An alternating current is a current that reverses its direction of flow periodically—usually many times per second. Another way of putting it is to state that any two points in an alternating current circuit reverse their polarities periodically.

5. A coil of wire passing a direct current that pulsates—grows weaker and stronger periodically—will induce in itself and in a

near-by circuit or coil, an alternating current.

6. In radio communication, we have mostly to deal with alternating currents—the high or radio frequency currents associated with the wave itself before detection (see *The Radio Primer* for August), and the audio frequency currents that follow detection.

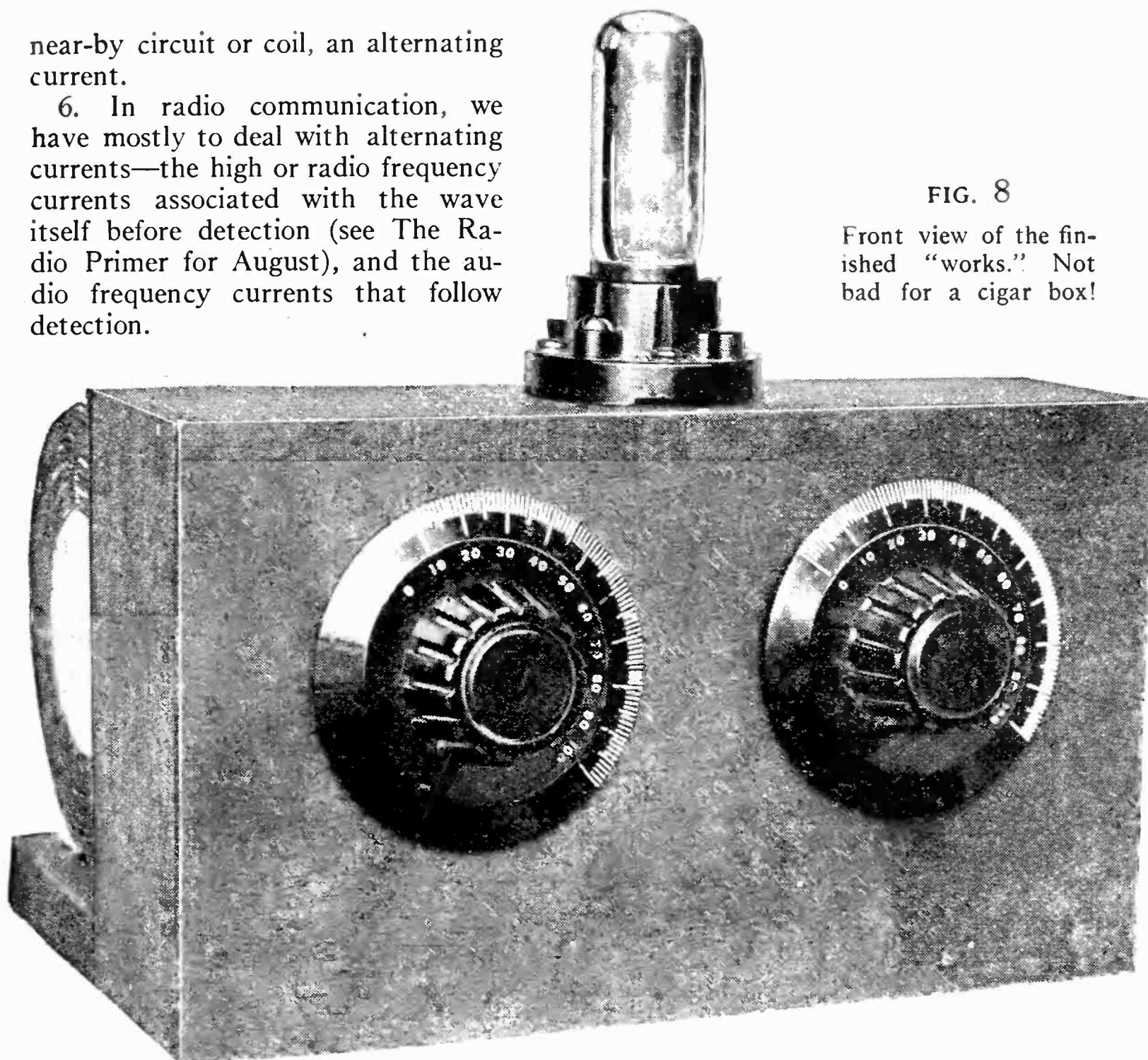

FIG. 8

Front view of the finished "works." Not bad for a cigar box!

OPERATION OF THE CIRCUIT SIMPLY EXPLAINED

IN ALL multi-tube receivers, and several single-tube arrangements such as that described in this department, all tubes exterior of the detecting circuit are amplifying tubes. The tubes that precede the detector (generally a crystal or a tube) are radio frequency tubes, and those that follow it are audio frequency tubes. In other words, the tubes before the detector amplify or make stronger the radio frequency currents picked up from the radio wave, while those after the detector intensify the sound frequencies. The difference between these two frequencies was explained in this department last month.

Both forms of amplification have their respective advantages and disadvantages. Radio frequency amplification, amplifying before detection, takes advantage of the multiplying action of the detector tube, and discriminates against stray sound frequencies. On the other hand it amplifies all r. f. (radio frequency) disturbances, such as static. Audio frequency

amplification provides the power required for the operation of loud speakers, but in addition to the desired signal it amplifies equally well parasitic tube noises and so forth. A judicious combination of the two systems is the closest approach to an ideal amplifying arrangement.

Both amplifying systems function in the same manner—i. e., through the repeating and amplifying action of the vacuum tube. Referring to diagram A in Fig. 10, let us assume that a radio frequency current is flowing in L1. This would be the case during reception if this coil were the secondary of a vario-coupler or a previous amplifying transformer. Thus the polarity at the terminals of the coil, X and Y, will change periodically, depending on the frequency of the station being received. For one fraction of a second X will be plus and Y negative, and in the next instant, Y will be plus or positive and X minus or negative.

Terminal X is connected directly to the grid of the amplifying tube, and therefore the polarity existing at X for any fraction of a

second, will be immediately applied to the grid. When X is positive the plate current through L₂ will increase. With the next alternation, and the reversal of polarity at X, the plate current will decrease.

Thus we have a rising and falling (or pulsating) direct current through a coil of wire, L₂. Therefore, according to our fifth premise, there will be induced in L₂ and in L₃, which is another coil placed close to L₂, an alternating current. This alternating current will be characterized by the same frequency as the original current flowing in L₁. However, due to the amplifying action of the vacuum tube, *the alternating current power in L₂ will be more powerful than the alternating current in L₁*. The action is analagous to the comparatively weak pressure of the finger on the trigger of a gun releasing, or controlling as it were, the much greater power expressed in the exploding cartridge. As little power will be lost in induction, the energy in L₃ will similarly be greater than that in L₁. This magnified signal is now applied to the next tube, either the detector or another amplifier, by connecting L₃ in the same manner that L₁ is connected to the

first tube. Thus amplification may be carried on through as many stages as is desired or expedient.

The coils L₂ and L₃ are combined into a single instrument or part that is designated as an amplifying transformer, of which L₂ is the primary winding and L₃ the secondary winding.

Transformer-coupled audio frequency amplification (amplification after the detector) is effected in the same manner, which is easily followed in diagram B of Fig. 10. Audio frequency alternating current is applied across the terminals X and Y of L₁ instead of high or radio frequency current, and a magnified duplicate is caused to flow in L₃. Audio frequency transformers, in order to meet the particular conditions under which they must operate, are wound on iron cores which are diagrammatically expressed by the lines between the primary and secondary coils.

AN EXPLANATION OF REFLEX CIRCUITS

IN REFLEX circuits, one or more tubes are made to amplify both radio and audio frequency currents. This combined operation

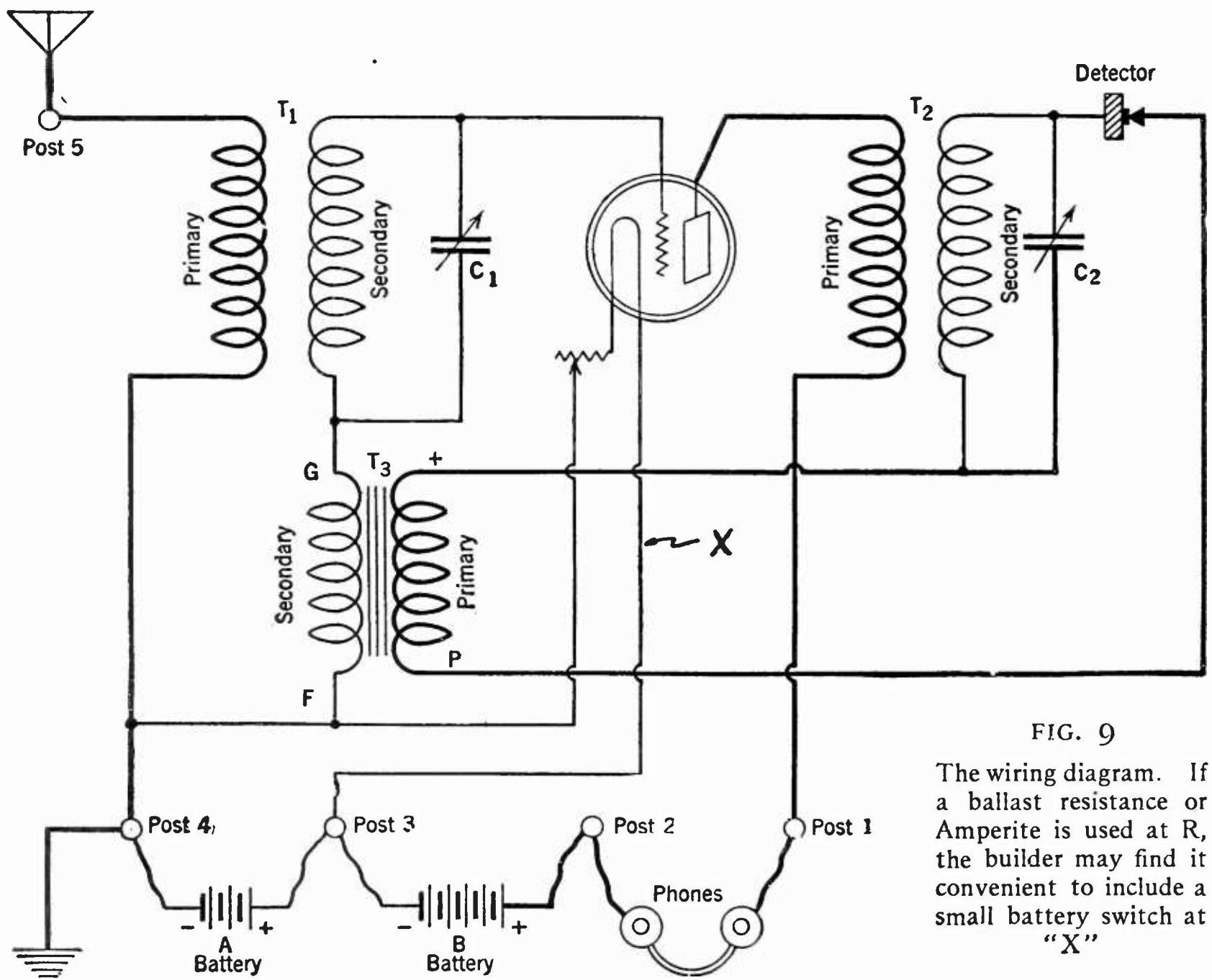

FIG. 9

The wiring diagram. If a ballast resistance or Amperite is used at R, the builder may find it convenient to include a small battery switch at "X"

will be made quite clear by tracing the operation of the one-tube Knockout receiver described for the radio beginner this month.

The radio frequency current is impressed upon the amplifying tube through the antenna coupler T₁. Here the radio frequency current is amplified and applied to the detecting circuit through the r. f. transformer T₂. It is detected as described in the Beginners' Department last month. The resulting audio frequency energy is now returned to the tube by the audio-frequency amplifying transformer T₃ where it is amplified, and finally outputted to the telephone receivers or loud speaker plugged into the jack.

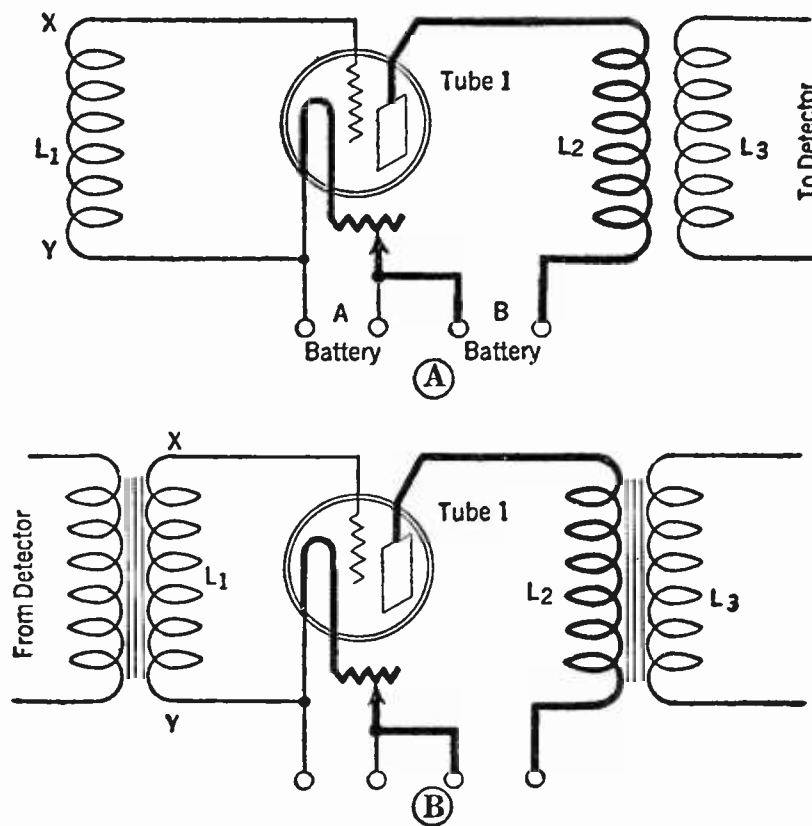

FIG. 10

Describing the action of an amplifier. The amplification is due to the relay action of the tube, the coils or transformers being merely used for the transference of energy from one circuit or tube to another

REFLEX: "Reflex" refers to imposing the double duty of a single vacuum tube of amplifying both radio and audio frequencies. The audio frequency output of the detector is reflexed (thrown back) on the r. f. tube or tubes.

THE RADIO LEXICON

PLATE CIRCUIT: The path of the current supplied by the plate or B battery, i. e., through the B battery, the filament of the tube, across the space within the tube to the plate, through whatever coils, such as loud speaker or telephone receiver windings, transformer primary or variometer, that may be included in the circuit and back to the B battery. The plate circuits in Fig. 10 have been drawn with heavy lines.

PLATE CURRENT: The current that flows through the plate circuit. It is sometimes referred to as "space current" due to the fact that it passes across the space between filament and plate of the vacuum tube.

PERIODIC: Recurring with equal intervals of time, such as the swing of a pendulum or the vibrations of a radio wave.

TRANSFORMER: An electrical instrument having two windings, a primary and secondary, generally placed close together, or otherwise maintained in inductive relation to each other. An alternating current of the proper frequency flowing in one winding will induce a similar current in the other.

AMPLIFYING TRANSFORMER: A transformer used for coupling the output of one amplifying tube to the input of the other. The primary of the transformer is connected in the plate circuit of the preceding tube and the secondary in the grid circuit of the succeeding tube. Special types of transformers are used in both radio and audio frequency amplification.

THE RADIO LIBRARY

THE action of the vacuum tube as an amplifier will be made more clear to the enthusiast and student by reference to the following works and pages:

The Outline of Radio by John V. L. Hogan, Chapter Nine. A non-technical and highly interesting account of amplification and vacuum tubes.

The I. C. S. Radio Handbook. Pages 237 to 239. A little more technical than Mr. Hogan's chapter, but still quite comprehensible to the layman.

Thermionic Vacuum Tube by Van Der Bijl. Chapter Seven. A highly technical treatise of the vacuum-tube amplifier. This is recommended to the student with a mathematical education as is:

Principles of Radio Communication, by J. H. Morecroft, Pages 570 to 571 and 824 to 830.



The Listeners' Point of View Conducted by Kingsley Welles

What Is Wrong With Sunday Radio Programs?

MOST radio programs that my set brings in on Sunday are pretty bad," remarked an acquaintance of ours the other day. "There are exceptions, I admit, but the Sunday radio menu seems to be religion, served up more or less tastefully with garnishing some times pleasant and more often not." He went on to explain that he was not an unreligious person, but that he did not care to have his loud speaker blare forth things religious all day.

Well, it takes all kinds of people to make a radio audience—to give a radio twist to the common platitude about the world—and there is no question that a standardized Sunday program would not please everyone. It is impossible for anyone, even a practised program director—who, by the way, is gradually becoming known as a radio impresario—to design a Sabbath program with, say, four parts "religion," three parts classical music, and one part dance music, shake it well before using and pour the result on the air, and know he is right.

Some stations have evaded the problem of

Sunday programs in the neatest possible manner by simply shutting up shop for the day. Others turn over their wavelength to a church and broadcast the entire service. Some of these add a musical program later on in the day. The truth is, of course, that most of the directors are groping, nothing less. Some of them go to absurdities, as witness WHT, the new Chicago broadcaster who announces with ill concealed pride that they broadcast special Sunday services, "The

National Radio Chapel" without stop for fourteen hours each Sunday. A non-stop religious service for fourteen hours automatically goes in the same class with six-day bicycle races, and endurance dancing contests.

And on Sunday afternoon, when we search the ether lanes, we find them singularly quiet. An indifferently capable soprano here, an installment of Sunday-school music there, or nothing. Later come vesper services and music. In the evening, the variety grows. The Capitol Theatre entertainment, devised by the popular "Roxy," reaches the Eastern and Middle United States



GOVERNOR ALFRED E. SMITH

Of New York, at his desk in Albany where he recently spoke through WGY and WJZ to the people of the State on the question of Long Island parks. Four times within the last year Governor Smith has resorted to radio to bring his ideas directly before the citizens

through WEAJ, WCAP, WJAR, WCTS, WEEL, WCAE, and WWJ. Aply staged, with artists of much more than ordinary ability, this program is to many the one glowing star in Sunday radio entertainment. The Goldman band concerts, reaching listeners through the same group of stations, are worth staying home for.

Dance music can be found on the air Sunday, too. However, most of the stations wait until eight or nine o'clock in the evening before their jazz musicians put lip to saxophone. Perhaps we are a bit new-fashioned, but we cannot quite agree with a correspondent who wrote us that "strains of jazz, breaking up Sunday peace and quiet, are little short of an outrage. I like radioed jazz but little at best; on week days I can stand it. On Sunday, however, I think station directors might give us one day of rest."

Dance music on Sunday via radio is not a whit more wrong than dance music on Sunday played on the phonograph or the piano. We will wager a shiny new B battery that there are few homes where a dance tune does not trickle from a phonograph or piano at least once on Sunday. It is not fundamentally wrong to play light music on Sunday. True enough, it is the Lord's Day, but aren't our ideas now of how it should be observed a bit different from those current in the Massachusetts Bay Colony in the early Eighteenth Century?

Program directors crowd their daily programs with every kind of talent known to radio, but have leaned over backwards when it comes to Sunday arrangements.

Why doesn't some enterprising broadcaster try the experiment of broadening out his Sunday offering? An instrumental concert from one to two in the afternoon would be very well received. The week day dinner concerts broadcast from a number of stations are deservedly popular. The domestic *lares* and *penates* are most apt to be guarded by the entire family on Sunday and programs aimed at the entire family would be most successful on that day.

Let us hear a traveller

who knows how to describe countries and people he knows. A speaker who can talk interestingly on books and plays should be well received. The Sunday papers have a following of readers who are popularly thought to find their varied contents pleasing Sabbath reading. If the broadcasters edit their programs with restraint along similar lines, we think they would strike a very popular note.

It is a mistake, by way of conclusion, to broadcast church services *in toto*. The church service is designed for the worshipper who participates by his presence. Pick-ups from churches are only moderately successful, because the highest skill of the broadcast engineer cannot overcome the reverberations always present in large church auditoriums. Result: the choir and the voice of the minister come through well, but the responsive reading and hymns sung by the congregation are fearfully muffled and usually sound like nothing human. The services run along at great length, without announcements—poor policy at best. The broadcaster discovered early that broadcasting a play direct from the stage was not satisfactory. Then came the so-called radio drama, given in the studio—a much more effective and desirable thing. For exactly the same reason, the especially prepared radio divine service is vastly more satisfactory.



BROADCASTING KITCHEN SECRETS

Mrs. Ida Bailey Allen at the microphone of WMCA, New York, telling the secret of a luscious fruit cocktail. Mrs. Allen is known throughout the country as the author of *Mrs. Allen on Cooking—Menus—Service*. Chef Louis Parquet of the Hotel McAlpin is preparing the dish and Arthur L. Lee, managing director of the hotel looks on

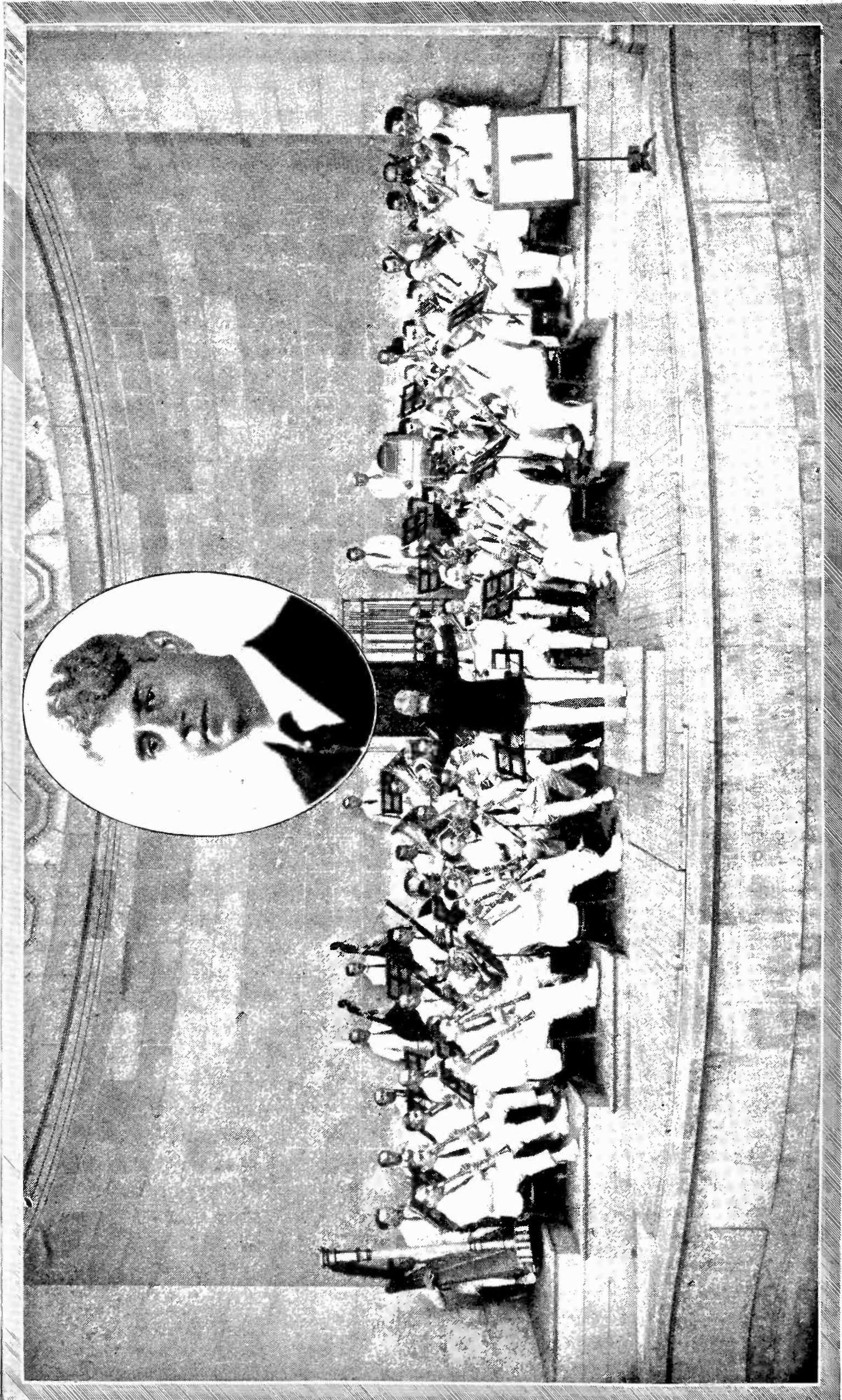

THE GOLDMAN BAND

Playing at the College of the City of New York. The insert (© Underwood and Underwood) shows Edwin Franko Goldman, the conductor of the Band. The concerts are broadcast on Sunday and Monday evenings throughout the summer and have proved their right to be counted among the most popular of broadcast features. They are heard through WEAF, WJAR, WEEI, WCAE, WCAP, WCTS, WCAE, and WWJ

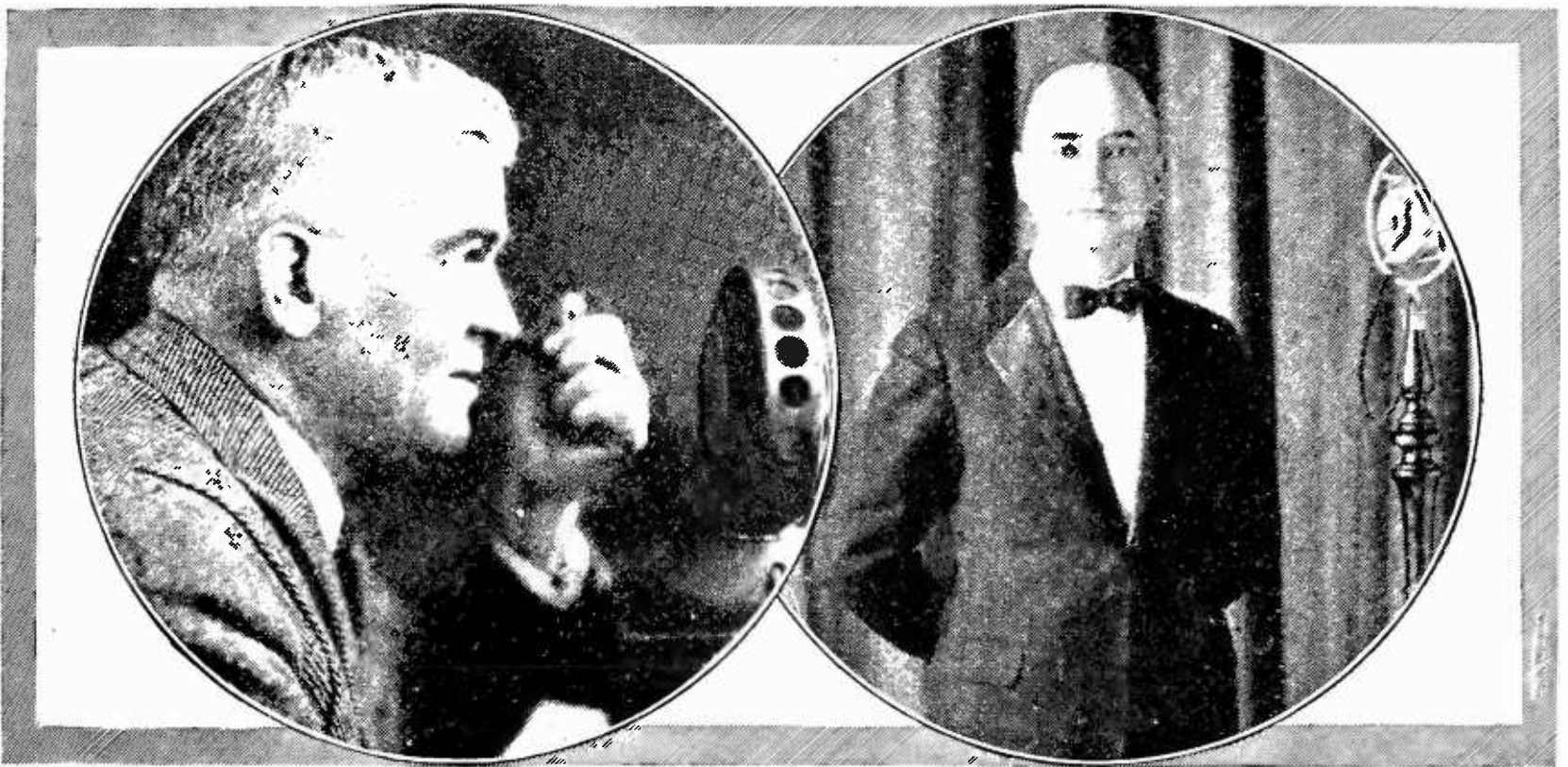

TWO PACIFIC COAST ANNOUNCERS

The "Town Crier," well known to the listeners of KNX at Hollywood, is represented in the photograph at the left, and "C. A.", Carl Anderson, one of the announcers of KGO at Oakland is the other

Quality, Quality, Who's Got the Quality?

IT IS not uncommon to hear an ardent broadcast listener say, during the reception of a program, "That sounds as if it had just gone through the wringer. Those fellows at xyz aren't putting out very good quality." The piano "sounds terrible," or "that violin squeaks like a wheezy wheezy Ford." So go the criticisms of these indoor amateur authorities. The truth is that the quality of musical sounds and speech from the majority of broadcasting stations is quite high. Good programs of good quality are the business of the broadcaster, and it is really no secret that he attends to it uniformly well.

It is the sad truth that radio receivers in many a home are quite incapable of perfect reproduction of sounds, music, and voice. As listeners, we have really been interested in how much volume our set would deliver, rather than in the quality which issues from our loud speaker. A change is coming in radio styles and the criterion is becoming not "how loud?" but "how good?"

A listener of our acquaintance went one evening to hear an orchestra which had always been a radio favorite of his. He admitted after the experience that the orchestra did not sound natural to him. His was a case of "loud speaker ear," although he was probably unaware of his malady. He had grown so used to hearing the orchestra whose tones and overtones were made unreal by his loud

speaker that when he heard the real tones they sounded entirely unnatural. His receiver and its appended loud speaker were simply unfaithful electrically. The biblical injunction to "first cast the mote out of thine own eye" applies only too well in radio. Before heaving coals of written or verbal criticism at the broadcaster, first see that there is no mote in your audio circuit.

And now that summer is here it is popular to rail at "static." It is foolish to minimize static. Every radio authority knows static exists and he knows that at times it is apt to be heavy in the summer, but being philosophical, he knows that it is temporary. Static in radio is really no more bothersome, taken by and large, than is coughing in a theatre, as some thoughtful soul once remarked. If static is bothersome during the summer, listeners may well be content with programs near by. Forcing a receiver on weak signals serves only to make the atmospherics boom in more strongly. And in passing, it is pertinent to remark that all that disturbs the listener is not static. Stray squeals and howls in a receiver are usually due not to the heavenly forces, but to some temporary indisposition of the receiver such as discharged B batteries, or to too much regeneration.

The radio listener these days no longer regards his set as an electro-mechanical wonder. He wants an instrument which he can install in his home without doing violence to his ideas of interior decoration and which he can compare with his phonograph in volume

and quality of voice and music. And now, Barkis willin', there is no reason why he shouldn't have it.

These U. S. As Others Hear 'Em

CAME, as the movie subtitles say, a letter into the office from Costa Rica the other day which phrased in interesting fashion, excellent suggestions for announcers, in which listeners not "amidst tropical heat and evergreen foliage" will heartily concur:

So far down as my country is from yours, between 1500 and 3100 miles of radius, south and amidst tropical heat and evergreen foliage, we can judge good music and good entertainment with full loud speaker. Some tiempo perhaps a sonata is on the air, an opera, a Novaes piano, a Burmerster violin, a Cincinnati bell song, or a beautiful negro glee club from Beaumont, Texas—is enjoyable, but the announcer fails to give us clearly the station or description, and that may be for the hesitation of speaking or from not toned voice, that although we can hear refined selections, we can not judge where they exactly come from.

It was suggested to Señor Amando Cespedes of Heredia, Costa Rica, the writer, that perhaps too frequent announcement of the station call would be boring to local listeners, and that the program was the thing.

"After all," Señor Cespedes wrote in answer, "are we not more interested in knowing with the beautiful program, the dear old spot on the map from which it comes? That is my reply. Radio to-day is not only yours. We down here have bought it from you, and we have a right to condense from the air the millions of frequencies that carry sweet chances, no matter if they are from jazz or from many a bad cowboy political talker."

"Sweet chances" from the air reach the ardent Costa Rican as well as the interested American. Señor Cespedes says that with his Roberts four-tube receiver he hears KSD, WGY, WSAI, WTAM, KFKX, KFDM, CYB, PWX, and KGO, who "are always very good on the air." "Davenport, woc, is also a life constructor," he continues. "But last night, I heard KFRU, from little Bristow of Oklahoma, doing an excellent, beautiful pass time that many a broadcaster should imitate. We all do not want jazz or string noise, and as we can easily tune-out, easily too can be done by the broadcasters to pick out with good intelligence their call letters."

Señor Cespedes hopes that his "tiny Costa Rica country" may some day reciprocate with

broadcasting. "Some day we will send our radio waves to you like Tuinicu, Porto Rico, or Europe are doing. Then you will hear music from the tropics, from the señoritas, from the monkies, or from our lovely bird singers; then you will feel my lovely country near you, feel our fresh air, our hurricane winds that do not harm any, you will hear our volcanos that stand proud near cities."

This "Super-Power" Nonsense

PERHAPS it is the publicity folk who are at it again, but it must be said that a lot of nonsense is being written—and worse, printed—about "super-power" broadcasting stations. When a 500-watt station increases its power to 5000 watts, the publicity men dash for their typewriters and tell the world that a new "super-power" station is now in existence, and intimate, if they do not actually say so, that forthwith any listener in Bangkok with a radio receiver assembled from a rubber boot and a tin can will be able to hear the emanations of their particular station.

"Super-power" is a term torn bodily from the electric power jargon. In that business the word means what it says. But in radio, five kilowatts is not much. Five hundred watts is about as much current as an ordinary domestic electric heater draws. It is equal to the current demanded by ten fifty-watt incandescent lamps.

When "super-power" was being debated at the last Hoover Radio Conference in Washington last October, Mr. David Sarnoff, vice-president of the Radio Corporation, very sensibly suggested that it would be more accurate to call stations operating on increased power "long range stations." And so it would. Local listeners will notice but little increase in intensity from a near-by five kilowatt broadcaster, particularly if the station be located some ten miles or more from the center of the city. At the time of writing, the Department of Commerce has allowed five broadcasters to use five kw. They are woc, Davenport, WLW, and WSAI, of Cincinnati, WCBD, Zion, Illinois, and wcco, Minneapolis-St. Paul. WEAJ, New York, is now using 3 kw. and WTAM, Cleveland, $2\frac{1}{2}$ kw, or 2,500 watts. This increase means better program service to more listeners, as Mr. Carl Dreher suggests on another page of this issue.

As many listeners know, wjz, New York, will soon move its transmitter to Bound Brook, New Jersey, where 40,000 watts will be avail-

able, although it is probable that when the new station goes on the air late in August, that only a fraction of that power will be used.

If rumored plans of the Radio Corporation go through, radio programs during the winter will have a strong international flavor. Says General J. G. Harbord, president of that Corporation

Within one year, American radio fans possessing the ordinary sets will be able to receive from Germany direct, through arrangements completed for broadcasting German programs through the plant of the Radio Corporation.

The foreign programs will be picked up by a sensitive receiver "somewhere in Maine," sent to Bound Brook by wire, and transferred there to the glowing wjz tubes. During the late fall of 1924, wjz rebroadcast some concerts from London, sent through the long range broadcasting station, 5xx, of the British Broadcasting Company at Chelmsford. These were only moderately successful, but there is every reason to believe that an exchange of good programs between the United States, England, and Germany will be an accomplished fact before the close of 1925. A Manila paper received here recently tells of the great interest in American programs. With high powered broadcasters looming on the electrical horizon, that should be possible in a year or so. So radio progresses.

Broadcast Miscellany

IT IS not unusual for radio programs from stations on the East and West Coasts to be suddenly interrupted—almost in the middle of a bar—without any warning or announcement. Results frantic testing of local tubes, batteries, and connections to determine some unsuspected flaw in the radio machine. The stoppage of the program is almost never due to faulty apparatus, for an sos from a ship a thousand miles away can cause an instant curtailment of every bit of radio traffic—broadcasting and ship-to-shore communication alike—with those dread code characters, . . . — — — . . . Broadcasting stations near the coast are required to listen-in for distress calls and stop their programs when an sos is heard.

BROADCASTING stations receive some curious letters, ranging from those which request aid in finding lost dogs to those pleading for another playing of whatever the current



BENNETT B. SCHNEIDER

At the microphone of wbz, at Springfield, delivering one of his Monday evening talks about books and their writers. Mr. Schneider, who is manager of the Doubleday, Page bookshop in Springfield, is presenting books in a pleasantly different fashion. Instead of critically discussing a book that many of his hearers have not read, Mr. Schneider attempts to give the facts about each book which are calculated to inspire interest in reading it. His talks are on alternate Monday nights at 10:40 Eastern Summer time

version of "Red Hot Mamma" happens to be. But the request which made the most serious problem to one broadcast station secretary was this: "I live on a farm a long distance from an electrical store. Will you please write me an address of a place which will sell me a cold storage battery?"

STATION wmcA, New York, every Tuesday evening puts on a program called the "Chiropractic Hour of Music." We confess that we were consumed by curiosity to know what chiropractic music was. Perhaps there would be a saxophone sextette in which the virtuosi could show their technical training by manipulating the spine of each silvered horn. Perhaps . . . but we heard their program before speculation could proceed further. Rather well played selections from well-known operas there were. Our main disappointment came with the conclusion of the "Hour" when they closed without the expected formality of a spinal "chord"!

WE OFFER our congratulations to our contemporary, *Radio News*, on the opening of its broadcast station WRNY, atop the Hotel Roosevelt in New York. Mr. Hugo Gerns-



FRED J. TURNER

Whose "Trips and Adventures" made him many friends through WEAf. Mr. Turner is now broadcasting his weekly feature through WJZ. In the course of his radio travels, Mr. Turner has "visited" industrial plants of all kinds and many places of public interest

back, editor of the magazine and supervisor of the station, has more than an ordinary problem on his hands, for having been assigned a frequency of 1160 kilocycles (258.5 meters), WRNY will probably find it very difficult to "get out." The short wavelength stations on Manhattan Island have always had trouble working north and south, although little in the matter of radiating west. And the station, representing a periodical dealing with radio subjects, will be looked up to by radio listeners everywhere to maintain a high standard of programs. A number of experiments are being tried at Mr. Gernsback's station, one of which is the broadcasting of hook-ups, in coöperation with the *New York Sun*. Another feature is a musical signal, dubbed the "staccatone"—a flute-like note emitted before the start of a program, during intermissions, and following the last number. The announced purpose of the signal is to make it more easy to recognize the station when the words of the announcer are indistinct.

INTERESTING material about books is as rare in broadcast programs as it is in the average daily newspaper. But there are two features on the air in the East which listeners have come to rate very highly. Mr. Oliver Saylor, an authority on the theatre and a decidedly interesting speaker about books and their makers, may be heard from WGBS, New York (948.8 kilocycles, 316 meters) every Thursday evening at 8:30, Eastern summer time, And from WBZ, Springfield, Mr.

Bennett Schneider, manager of the Doubleday, Page & Company bookshop in Springfield, broadcasts talks on books on alternate Monday evenings at 10:40, Eastern summer time. Reports from WBZ listeners say that Mr. Schneider's talks are received with great favor.

ANNOUNCERS have heard so much about clarity of speech and have had so many complaints about this and that and whatnot that many of them are leaning over backward in these matters, if, indeed, one can lean verbally backward. Any number of these gentry describing the evening musical progression of an orchestra stress their words, particularly "orchestra." It is almost invariably given as or-CHES-tra. Webster and other crystallizations of good verbal usage demand that the accent be placed on the first syllable. And some announcers of the Radio Corporation of America stations insist on calling their company the Radio Corporation of Amurrica—which is wholly out of place with the usually high quality of their announcing. And in passing, it should be noted that the deep-toned announcers of WGY have not yet discovered that the name of their company is the General *E*-lectric and not the General *A*-lectric Company. Small matters, these, perhaps, but mispronunciation and careless pronunciation can work wonders in spoiling an otherwise perfect program.

I'LL See You in My Dreams from wor" was the startling information trickling through our critical loud speaker the other evening. . . . and, again, WGBS was recently broadcasting a farewell concert from a White Star Line pier in New York. A sixty-piece orchestra made up of members of the Musician's Mutual Protective Association had gathered to wish musical godspeed to Mr. Samuel Untermyer, a New York lawyer who has done a great deal for their membership. As the time for sailing neared, the parting siren of the ship and the incidental noise of departure stopped further musical broadcasting. The announcer was stalling for time, so he resorted to *ex tempore* description. "As the last siren has blown, I see Mr. Untermyer leaning over the rail of this ship . . . and now . . . the last line which holds this magnificent liar . . . this magnificent liner, to the pier is parted." Mr. Untermyer, being a lawyer, probably has been called worse names in the heat of legal controversy, but the unintentional description of the bothered WGBS announcer caused many a local chuckle.

ON JULY 4th, at ten o'clock, Eastern summer time, the War Department arranged the second national program as a climax to Defense Test Day. The entire nation was hooked up to Washington by long distance telephone lines which supplied the program to twenty-eight broadcasting stations. This, as General Salzman, Chief Signal Officer of the Army, and Master of Ceremonies for the occasion, announced, was the largest number of broadcasting stations ever to radiate a single program. Seventy thousand miles of wire were involved in the long distance hook-up. The stations participating were WEAf, WCAp, WJAR, WCTS, WTIC, WGY, WGR, WFI, WCAE, WSB, WTAM, WSAI, WWJ, KYW, KSD, WDAF, WCCO, WOC, WFAA, WOAW, KOA, KSL, KFI, KPO, KGO, KGW, and KFOA. And many of us will not soon forget the address made by General Pershing and his stirring

appeal for adequate preparation for national emergencies. The program was by no means as impressive as that broadcast on September 12th last year because it was not as skillfully arranged. But even hardened radio men were impressed with the genuine drama of the affair. The success of this impressive hour must be laid directly at the door of the American Telephone and Telegraph Company, who donated their long distance wire network for the program. The technical excellence of their obscure engineers, quietly watching over the balance of those long lines, made it possible. And in time of national emergency, if ever again it comes, the President of the United States can address the entire country from his study in Washington. What would Wilson have given for such an opportunity when he made his immortal address to Congress in April, 1917!



PUTTING THE VILLAGE SMITHY ON THE AIR

Winger's Crescent Park Entertainers who are heard from WGR, Buffalo, on Friday evenings, shown playing in the village blacksmith shop at Ridgeway, Ontario, near Buffalo. In the photograph, left to right are Sam Anger, Mrs. Anger, Hugo Lautz, W. A. Winger, J. G. Willet, Ernie Clair, and Howard Brandel. The emery wheel, bellows, and forging hammer are not in use

How to Make a Universal Battery Charger

An Unusually Complete Description of a Two-Ampere Charger Consuming but 150 Watts Which Will Operate on Any Alternating Current Supply of from Twenty-Five to Seventy Cycles

By ROLAND F. BEERS

WITHIN the past year or so, radio constructors have shown a great interest in building battery chargers. An inexpensive chemical rectifier was described by James Millen in this magazine for June which has satisfied many readers who wished to construct a unit of the chemical type. The unit outlined in this article is slightly more difficult to construct, but the time and care taken in construction and assembly will be well repaid. The cost of parts, it will be noted, is only \$11. The wide range of commercial frequencies covered by this device will appeal to many radio listeners who have an alternating current supply other than 60 cycles. The current consumption of this charger is quite low—150 watts on full load—and that should appeal to the home builder very strongly.—THE EDITOR

BATTERY chargers may be classified into three general groups: electrolytic, thermionic, and vibrator types. When adapted to charging radio or automobile storage batteries, all three types possess similar operating characteristics. Their principal function is to convert the 110-volt alternating current obtained from a light socket to direct current at proper voltages to charge storage batteries.

The direct current output of battery chargers is not uniform in magnitude but is composed of a series of individual pulses, each a half cycle of rectified alternating current as shown in Fig. 1. With the advent of each half cycle or rectified wave, there occurs a change in current from the charger, increasing and decreasing rapidly as shown by the shape of the current curve at A. Here is shown the introduction of a positive half cycle or half wavelength, of duration denoted by $\frac{1}{2}T$, where T represents the period of an entire cycle or wavelength. During this first half period, energy is fairly shoved into the storage battery. The total amount of charging energy per cycle is represented by the area beneath the curve A times the average voltage for the same period. During the second half period, $\frac{1}{2}T$, we have a complete cutting off of the charging current, which is caused by the valve or rectifier action of the charger. If the charger is of the electrolytic or thermionic type, we may say in truth that a

valve is closed to the reversed current, as shown by the flat portion of the curve at B. In the vibrator charger, a switch automatically opens the battery circuit at the end of the first half cycle in order to prevent a reversal of current through the battery. At the end of this complete wave and at the beginning of a second, we repeat the action and charging of the battery is resumed.

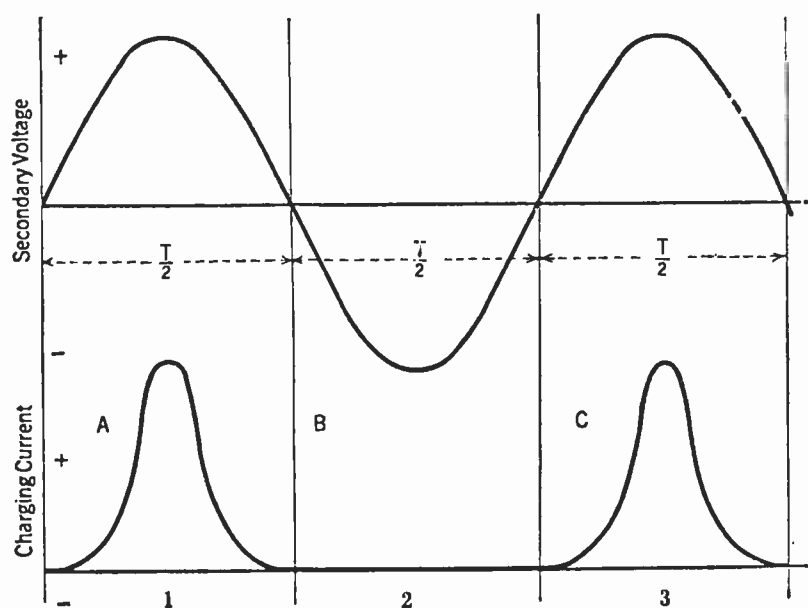

FIG. 1

A graphic representation of how a charger functions. The curve labeled "secondary voltage" shows the sine wave-form of the 60-cycle lighting circuit. That curve labeled "charging current" shows the portion of the alternating wave which is rejected in the rectifier allowing only the periodic pulsations of that portion of the curve where the current is "direct current" to enter the battery

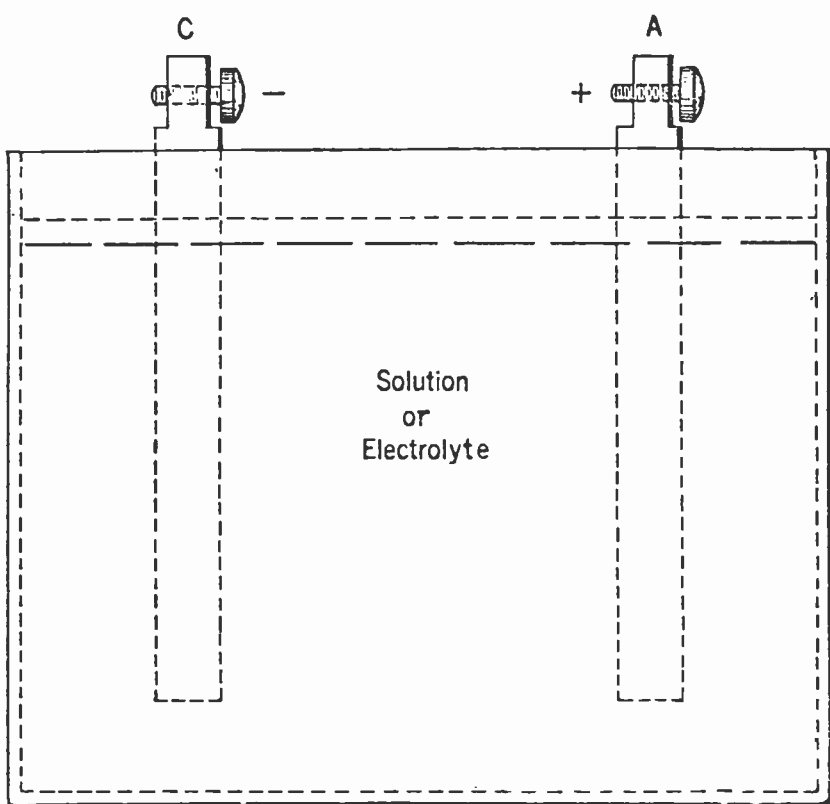

FIG. 2

A chemical rectifier in its simplest form. The positive terminal is the anode and the negative electrode is the cathode. Current may be passed from the cathode to the anode but not vice versa. Therefore, when the alternating current is on the positive half of the cycle, current flows through the rectifier into the battery but when the current is on the negative side of the cycle no current flows. This also produces a pulsating periodic flow of d.c.

NEVER CHARGE BATTERIES CONNECTED TO A RECEIVER

A BRIEF study of the character of the current supplied by battery chargers as outlined above will show why it is neither feasible nor advisable to charge storage batteries while they are connected to a radio receiver. The constantly changing battery current, when applied to the radio antenna and ground system, causes untold disturbance in the surrounding ether and may be interpreted as a form of malicious interference with radio reception. Fortunately, many charger manufacturers connect one side of the a. c. line to the output of the charger so that a house fuse is blown when the charger is operated as it is connected to a radio receiver.

Let us return to the consideration of charger design, in order to determine what are the elements with which we have to contend. The charger of lowest cost, from the point of view of home construction, could be made of the electrolytic type, provided pure metals could be procured for the rectifier electrodes. The rectifier cell illustrated in Fig. 2 consists of two electrodes, A and C, suitably suspended in a water solution in such a fashion that rectification occurs without excessive heating of

the rectifier cell. The combination usually employed in home-constructed chargers is a lead (negative) and an aluminum (positive) electrode dipping into a saturated solution of common borax. Other solutions which have been used successfully for charging B batteries are sodium phosphate, ammonium phosphate, and sodium acid tartrate. One form of this charger on the market consists of an iron cup which contains the solution, into which dips the aluminum rod. Another form of electrolytic rectifier on the market consists of a tantalum electrode dipping into a solution of sulphuric acid, whose specific gravity is 1.250. The area of the tantalum electrode is 15 sq. cms. and the volume of the electrolyte must be great enough to prevent excessive temperature rise.

A TWO-AMPERE "UNIVERSAL" CHARGER

FIGURE 3 is a schematic diagram which shows the electrical apparatus and connections necessary to assemble a battery charger. Details of construction are given below for a two-ampere charger which has universal frequency characteristics. That is to say, this charger, when built in accordance with the specifications, will operate satisfactorily on commercial frequencies ranging from 25 to 70 cycles, inclusive. The design disclosed below is not perhaps the most economically constructed for use on 60-cycle current, but its cost of operation is very small and should prove no objection to the experimenter who really wants to build his own charger. In addition, the improved efficiency of operation will be of considerable

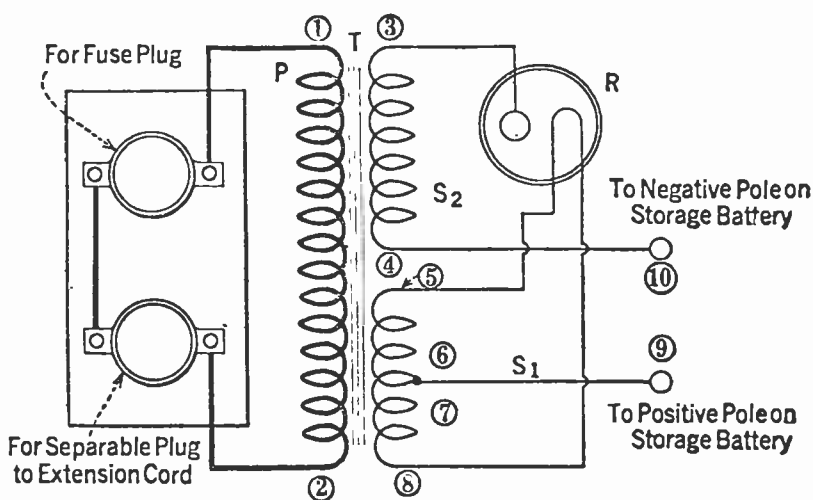

FIG. 3

The actual circuit diagram of the Beers tungar rectifier. This is different from that of the charger circuit in Fig. 10 in that a separate charging secondary is provided. Alternating current is induced into this secondary while the circuit in Fig. 10 is that of an auto-transformer employing the conductive system. There is no great difference between the two

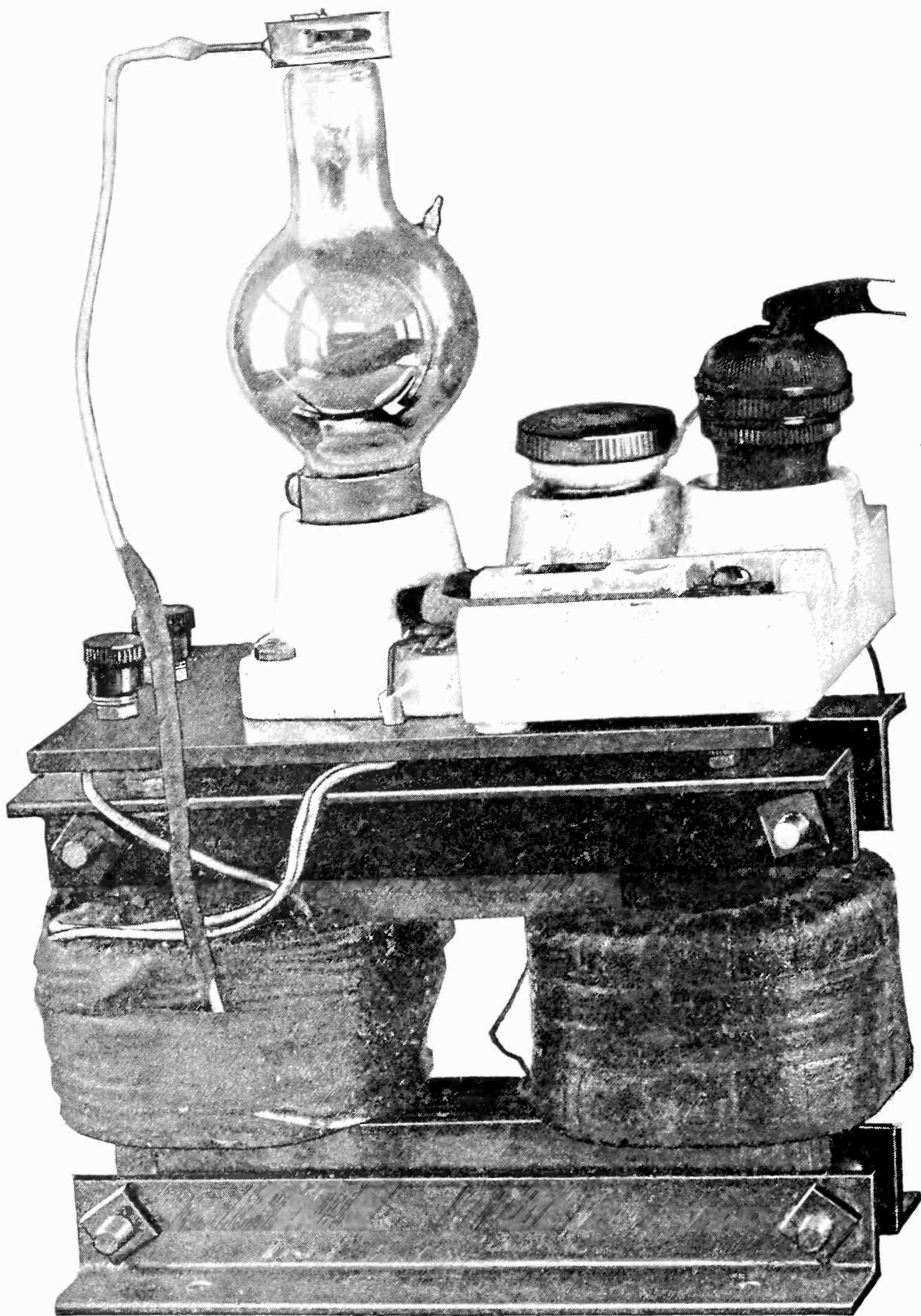
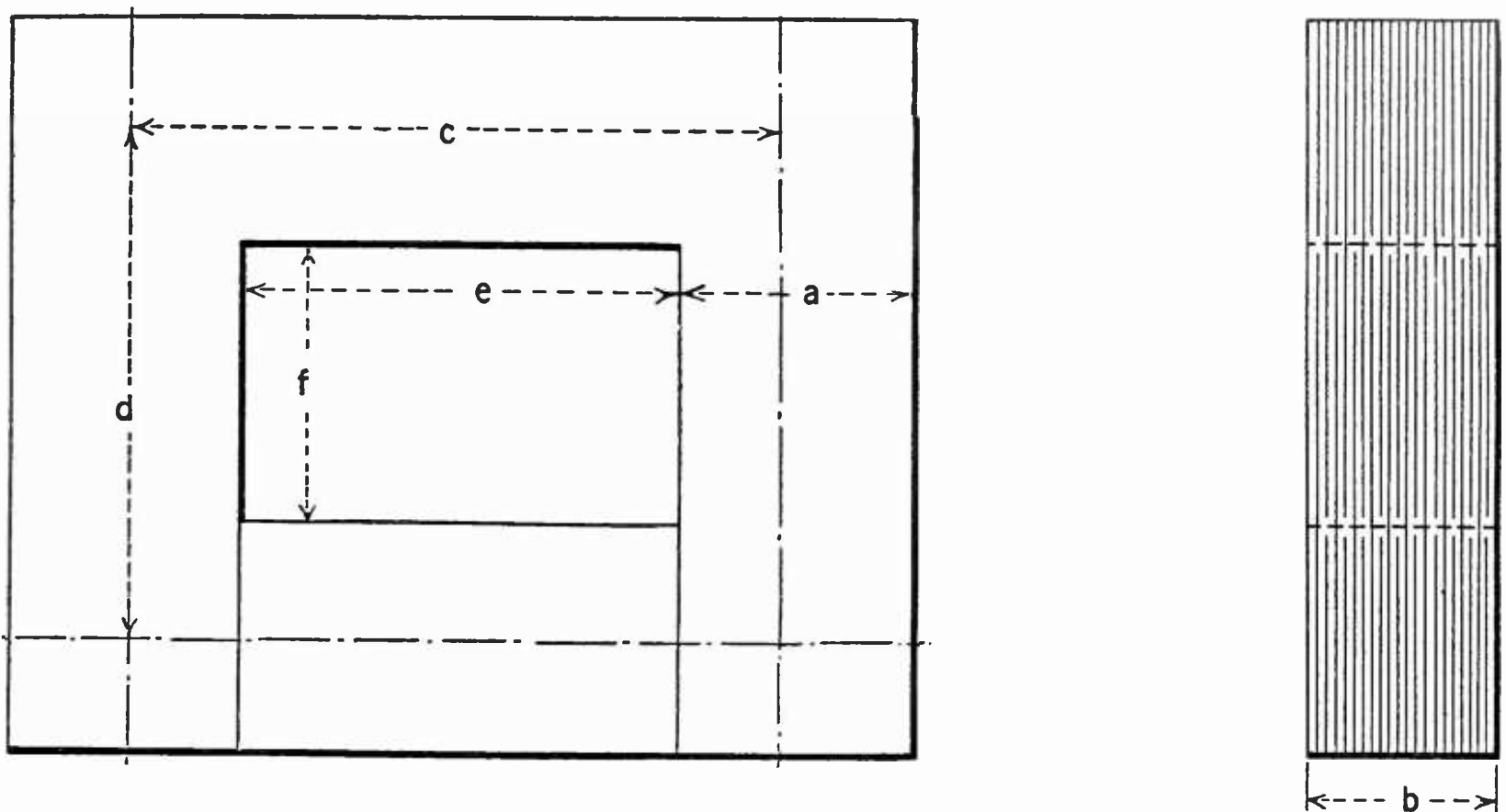

FIG. 4

How the made-up charger looks. A bakelite panel, situated above the transformer core, supports the output terminals, tungar tube and socket and input socket with fuse block



TRANSFORMER CORE

Symbols	Author's Design
Cross-Sectional Area = $a \times b$	2.0 Sq. Ins.
Outside Dimensions: Length = $a + c$	5.5 Ins.
Width = $a + d$	4.5 Ins.
Height = b	1.4 Ins.
Width of Steel Strips = a	1.4 Ins.
Thickness " " = t014 Ins.
Size of Window = $e \times f$	4.6 Sq. Ins.
Weight of Core = $(2c + 2d)(a \times b) \times .28$ Lbs.	8.0 Lbs.
Mean Length of Core = $2c + 2d$	14.4 Ins.

FIG. 5

The details and specifications for the construction of the core are outlined here. After the core-pieces are cut, it is absolutely essential that burrs be removed from the edges and that they be entirely flat. This is necessary to obtain the required number of pieces for the specified height of the core

advantage to the battery owner from the standpoint of power consumption. The no-load power of this charger on 60-cycle supply was measured and found to be less than 10 watts. The full load power consumption was found to be 150 watts.

Fig. 3 shows a transformer with three windings, which we will designate as P, S' and S''. P is the primary winding and is connected to the 110-volt alternating current light socket. S' is the filament secondary and supplies the power for heating the tungar bulb filament. This winding is provided with a center tap (6-7) which will be explained in detail later. Winding S'' is the charging winding and supplies the necessary potential to operate the tungar arc. Leads are taken out from points 9 and 10 which lead, respectively, to the positive and negative terminals of the storage battery.

HOW A THERMIONIC RECTIFIER OPERATES

THE operation of the tungar or other thermionic rectifier is fairly simple of explanation. It is well known that a heated filament *in vacuo* under the stress of potential will emit electrons which will flow in the direction of the applied potential. In other words, if the hot filament be made cathode and the cold plate the corresponding anode, a stream of electrons, hence electricity, will flow from cathode (-) to anode (+). However, no current will flow in the reverse direction, from plate to filament, and in this fact we obtain the valve or rectifier action of the tube. Now when we attempt to obtain heavy electronic emission *in vacuo* (i.e. of the order of 1 ampere) we are confronted with a secondary phenomenon. Very soon so many electrons fill the space between plate and filament that they neutralize the effect of the positive charge on the plate. The result is a slowing up of the electron stream, and a decrease in the current output of the rectifier. In order to offset the effect of the space charge, as it is called, the manufacturers

of the tungar tube introduce into the chamber a small amount of inert gas, called argon. This gas is unable to unite chemically with the metallic elements within the tube, but is capable of ionization through the bombardment of the electron stream. The constant impact of the billions of electrons passing to the anode soon detaches from the atoms of argon gas their positive nuclei and their charges. When these positive charges are liberated, their immediate action is to neutralize the space charge of the tube, as established by the excess electrons in the space between filament and plate. Every positive charge attaches itself to a negative electron and the result is a neutral atom. The process of breaking up and reconstruction continues until the tungar tube is shut off, and the total effect of the ionization is to produce a greater current-carrying capacity

It may be mentioned here that the tungar and similar types of thermionic tube do not perform well on voltages above 50 on account of the irregularity in the ionization process. If it were not for this fact, the tube might be used as the rectifier element in a form of B battery eliminator, as has been attempted by the author.

We will now proceed to the construction of a two-ampere charger, as illustrated in the photograph, Fig 4. The part of the unit most difficult to construct is the transformer, but if the following instructions are carefully studied, the author believes that the experimenter will have very little trouble in obtaining successful operation from his model.

THE PARTS AND MATERIALS REQUIRED

THE following table gives the exact amount of materials required. Deviations from the design given below may require somewhat greater amounts of copper and steel, which will have to be estimated by the builder.

MATERIALS REQUIRED

8 lbs. silicon steel, thickness .013" to .010"	\$ 1.60
1 lb. No. 20 d. c. c. wire	1.00
1 1/4 lb. No. 15 d. c. c. wire	1.25
1/2 lb. No. 14 d. c. c. wire50
1 porcelain Edison socket20
1, 2-plug porcelain fuse block35
2 separable plugs30
1 2-ampere plug fuse05
28 inches 1 inch x 1/8 inch angle iron25
4 2 x 1/4 inch stove bolts and nuts05
2 battery clips40
1 Fahnestock clip05
6 feet twisted lamp cord15
4 feet rubber covered No. 14 flexible cord25
1 2-ampere tungar rectifier tube, list	4.00
1 bakelite panel 4 x 7 inches25
	<u>\$10.65</u>

Prices given above are the highest retail prices

experienced by the author. Most builders have access to materials at lower cost.

In Fig. 5 are given the complete dimensions of the transformer core. In view of the difficulty with which the average amateur obtains silicon steel sheets such as are necessary to make this transformer, a few remarks may be of service in the process of construction.

The simplest way to obtain the steel laminations for the core is to go to your local electric light company office and ask for a junked pole transformer of from 1 to 5 k. v. a. capacity. Such transformers are often thrown away and are frequently sold for \$1 or less. If you are fortunate enough to obtain one of these burned out units, your problem of finding steel of the right quality is solved.

Another equally good source of silicon steel is from amateur supply houses who make a specialty of furnishing this material to transmitting amateurs. Advertisements of these firms are carried in current radio periodicals. The price is generally less than 20 cents per pound in 10-pound lots.

Assuming that you are still unable to obtain silicon steel of approximately .014 inch thickness (limits .010 inch to .018 inch), get in touch with transformer manufacturers or steel jobbers, from trade journals which are frequently on file in public libraries. Many times the author has received extreme courtesy from such firms who are willing to accommodate their inquirers with small quantities of scrap steel.

As a last resort for core material, go to your local tinsmith and get the best grade of soft sheet iron or steel he has. For the 60-cycle design outlined below, use exactly the amount of soft iron as is specified for the silicon sheet steel. For the lower frequency design, such as 25 cycles, use one half more cross-sectional area in the core. For example, using soft iron on 25-cycle chargers; we would build a core measuring in cross-section 1.8 inches x 1.8 inch or the equivalent, instead of the core as specified, which measures 1.4 inches x 1.4 inches. For frequencies intermediate between 25 and 60 use a direct proportion to obtain the proper amount of soft iron. However, the author strongly recommends the use of silicon sheet steel, if it can possibly be obtained.

MAKING THE CORE FROM POWER TRANSFORMER PARTS

IF YOU have obtained a junked transformer, place it near a hot stove or furnace for half a day in order to soften the filling compound.

Having removed the cover, attack the bolts which hold the core to the case. Remove these, together with as much of the black filling compound as possible and dump out the transformer on to a pile of old newspapers. If the core can now be taken out of doors and washed with kerosene, most of the black compound can be cleaned off. With a heavy block of wood or wooden mallet, drive out the core from the center of the windings. A convenient way to do this is to block up the windings on two 2 x 4-inch pieces while you are hammering on the core in the attempt to start it. Once loosened, the entire core can be pushed out when it will fall into bunches of steel laminations. These should be carefully separated and cleaned off with kerosene or carbon tetrachloride. Avoid bending or breaking any of the pieces, as you may need them all during the construction of the charger.

Most power transformers are made up of U-shaped pieces and straight pieces, as shown in Fig. 6. If you are fortunate enough to obtain such pieces as these, your core construction will be very simple. The dotted line shown at c—c, Fig. 6, shows how the steel laminations can be cut down to make the proper sized core. End pieces (shown at s) can be cut from the waste to make a closed rectangle. When cutting the steel for the core, extreme care should be taken in obtaining a perfectly tight fit, at g Fig. 6. If the cutting is done by hand, only very large shears should be used and each strip should be accurately measured and marked out before cutting. Carelessness in assembling this part of the charger may result in its failure to operate. The best way to cut the pieces for the core, regardless of their shape, is to take the entire lot of steel and your pattern to the local tinsmith's shop, where you will find squaring shears that may be used to great advantage in obtaining square edges. Often the tinsmith will let you do your own cutting, unless he is cautious in preventing accidents. In either event, the entire lot of steel can be cut out in this manner in less than an hour.

In case you have been unable to obtain the U-shaped pieces for the core, you may possibly get enough steel from the old transformer to make up the charger core in other ways. Fig. 7 shows the possibilities that may occur with commercial transformers, and the ingenuity of the experimenter will serve him in assembling the right amount of core material. Fig. 5 shows the dimensions recommended for an efficient two-ampere charger on all fre-

quencies. On account of the variations in the sizes of steel laminations available, it may be impossible to adhere to these dimensions exactly. For the benefit of those who do find these variations, the following limits will be helpful:

	min.	max.
1. Cross-sectional area of core— $a \times b$ may be, as shown, 1.4 ins. x 1.4 ins. or 1 in. x 2 ins. or 2 ins. x 1 in. etc.	2.0 sq. ins.	2.0 sq. ins.
2. Mean length of core — $2c + 2d$ where c and d are measured along center line of core	12.0 ins.	6.0 ins.
3. Area of window— $e \times f$ — $(c + a)(d + a)$	3.8 sq. ins.	4.6 sq. ins.

FIRST CORE ASSEMBLY

HAVING determined the size and shape of the core within the limits specified above, the pieces are temporarily assembled to determine if enough steel has been cut out. Piles of each leg or half core are stacked up and clamped up in a vise so that the actual core height (b) can be measured. When sufficient steel has been prepared, the outside measurements and cross-section are taken and noted for future reference.

We now proceed with the winding of the coils P, S' and S''. The first thing to do is to cut from a block of wood a piece shaped exactly like the section of the core which is to contain the windings (see Fig. 8). Dimensions shown are for the design recommended by the author. Whatever changes are necessitated by variation in steel sizes must be calculated by the builder. The winding block should be approximately 0.10 inch larger than the maximum width and height of the core in order to facilitate application of the completed windings. Slots 0.75 inch wide and 0.10 inch deep are cut longitudinally along each face of the block, in which strips of friction tape are laid before the winding is begun. A hole is drilled through the center of the block large enough to pass a 1/4-inch stove bolt for clamping the block in a chuck. Two pieces 3 inches x 3 inches are now cut from 1/4-inch stock to provide heads for holding the winding in place as it is wound. Quarter-inch holes are also centered in these pieces as shown in Fig. 8. The winding form and spool heads are now assembled upon the 1/4-inch bolt, and a nut

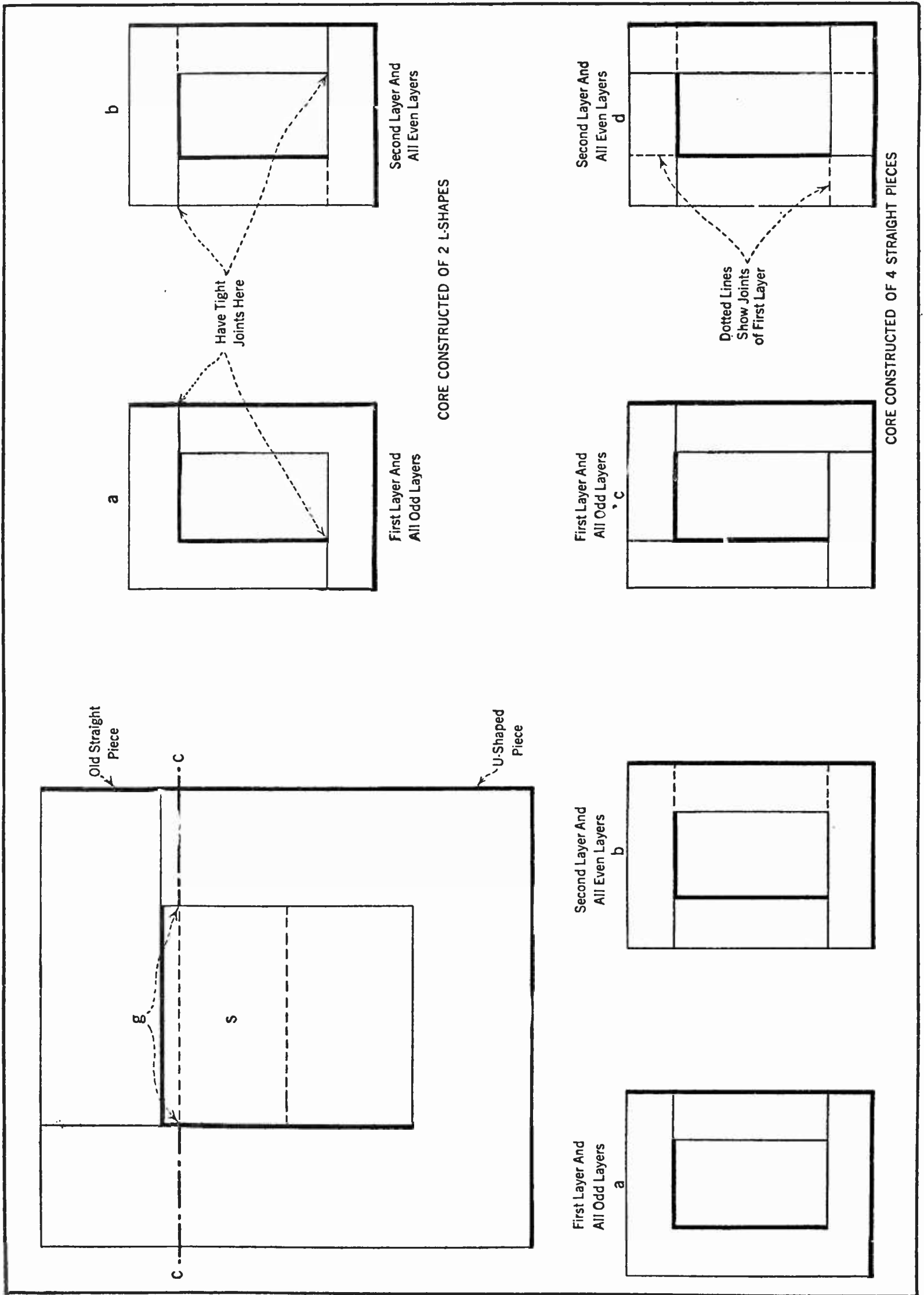

FIGS. 6 AND 7

Several types of transformer cores which may be employed in this construction. The sketches are self-explanatory

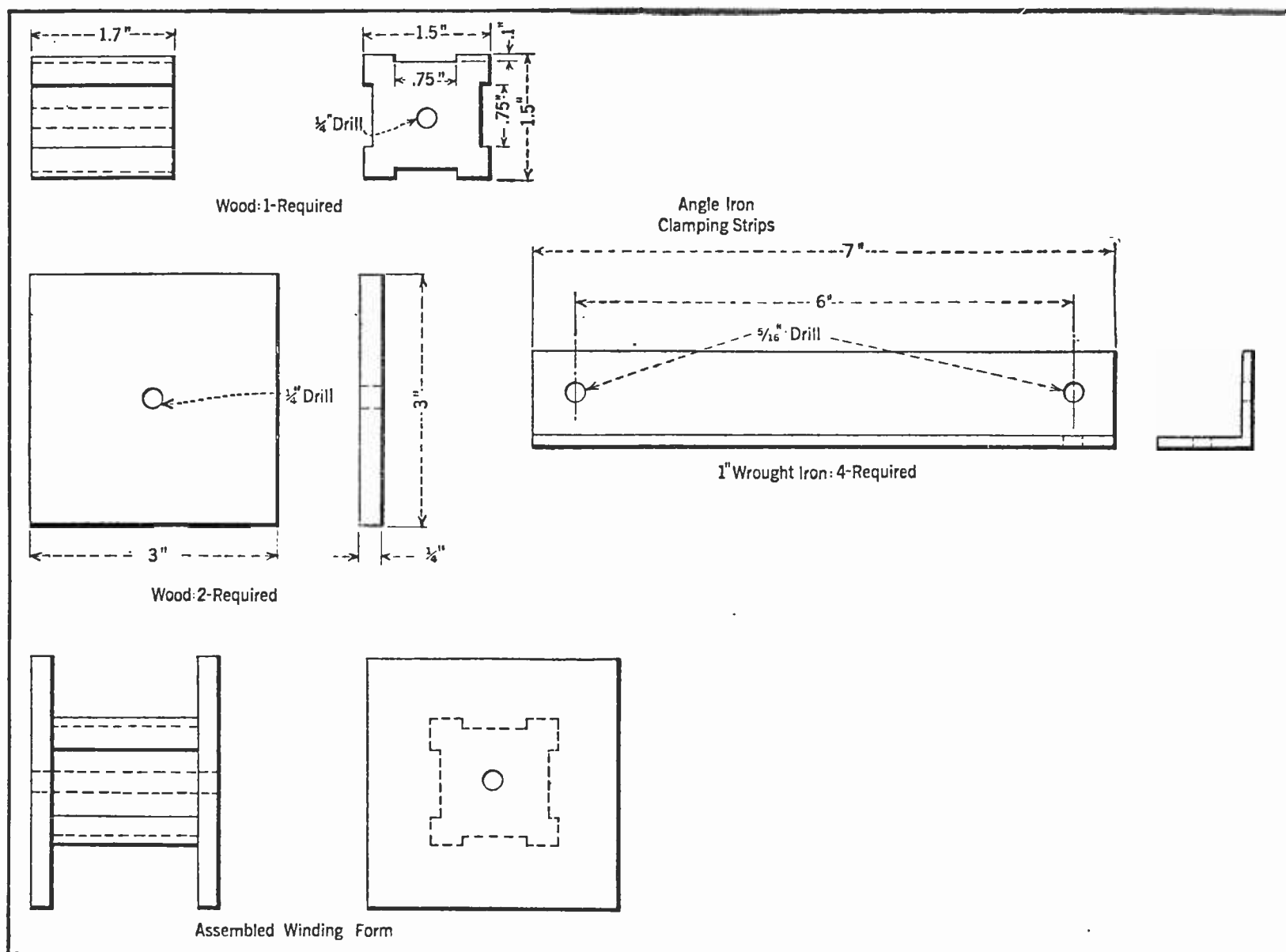

FIGS. 8 AND 9

Details of construction for the coil winding form and iron angle pieces. It is to be noted that many of the dimensions are indicated in decimals and it is urged that constructors adhere to these specifications

clamps the entire form together as shown in Fig. 8. The protruding end of the stove bolt is clamped in the chuck of a breast drill, hand drill, or carpenter's brace preparatory to winding the coils. Four pieces of $\frac{3}{4}$ -inch friction tape are cut approximately 6 inches long and laid squarely in the slots provided for them. The long ends of the tape are drawn up over the edge of the spool heads and stuck together in one spot near the center of the spool heads. A strip of heavy Manila wrapping paper is now cut four feet long and as wide as the distance between spool heads. Fig. 8 shows this strip, 1.7 inches wide. This strip of paper is tightly wrapped over the winding form after gluing the first end in place. If the builder sees fit, he may apply a thin layer of glue continuously over each layer of paper so that the paper shell when completed will serve as a firm support for the coils.

WINDING THE COILS

THE primary winding is wound first and consists of 570 turns of No. 20 d. c. c. wire, wound in smooth layers. The first end of the

primary winding is brought up the side of the spool and is later taped in place by means of one of the adjacent strips of tape. Approximately 24 turns per inch should be wound and pains should be taken to wind the wire as smoothly as possible, preventing overlapping of adjacent turns. When the winding is completed, the end of the wire is left about eight inches long as a terminal to connect to the flexible extension cord or terminal block as shown in the photograph. The long ends of tape which have hitherto been fastened to the spool ends are now drawn tightly over the winding and fastened in place. The spool heads are removed and the entire winding is now taped securely with one layer of friction tape, half lapped. The coil is now ready for assembly but before we can put the laminations in place, we must prepare the second coil which has two separate windings, S' and S'' .

Winding S'' consists of 150 turns of No. 15 d. c. c. wire wound in the same manner as P . Terminals are brought out each end of the coil, each consisting of about eight inches of the same wire used to wind the coils,

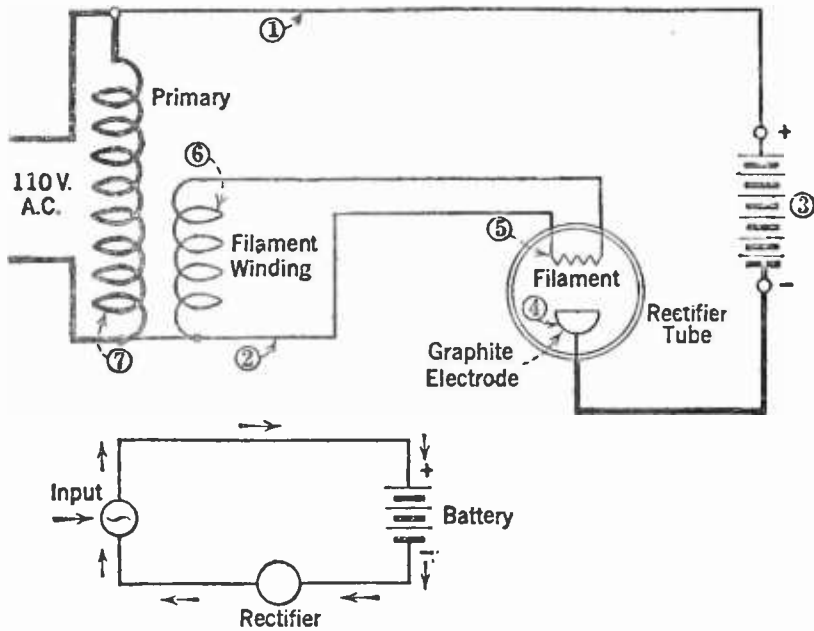

FIG. 10

How the tungar tube rectifies. The transformer primary (7) induces into the filament winding (6) a voltage for lighting the filament of the tube (5). When the battery (3) is in the circuit and current turned on, an arc is set up between the filament and the graphite electrode (4). When the line (1) is positive, current flows through it to the battery and through the electrode (4). Then through the arc to the filament and back to the other side of the line (2) completing the circuit. However, when the line (1) is negative, current tends to flow into the bulb from the filament to the graphite electrode, but as the resistance offered to the flow of current in this direction is very high no current will flow through it to the battery. Therefore, periodic pulsations of current in the right direction of flow is passed through the battery changing the chemical composition of its negative and positive plates thus restoring them to their original charged condition. This is a simple rectifier circuit of the standard manufactured type of tungar rectifier. Both this type and that described by Mr. Beers produce the same results

No. 15 d. c. c. One layer of friction tape is wrapped securely over S'' , and then winding S' is applied, which consists of 11 turns of two parallel No. 14 d. c. c. wires with a tap at the $5\frac{1}{2}$ turn. For convenience in winding this coil, the half pound of No. 14 d. c. c. which the builder has purchased is divided into two equal lengths which are wound together on one spool preparatory to winding the parallel strands. Then as the spool is unreel during the process of winding, it will be a simple matter to maintain the two wires parallel at all times, and to avoid their twisting or crossing each other. The tap brought out at the $5\frac{1}{2}$ turn should be a loop taken in the two wires at the same point, and should be in length about two inches. This tap is later cleaned thoroughly and a generous coating of solder is applied to form a lug of large current-carrying capacity. The end terminals of this winding (S') are treated in the same manner and are left of such a length that they can be carried directly to

the screws on the Edison socket without splicing. It is important that this circuit be of very low resistance (i. e. less than one ohm) so that it will carry the filament current of 4 amperes without heating. The finished coil, containing the windings S' and S'' is now removed from the winding form and taped with one half-lapped layer of friction tape.

HOW TO ASSEMBLE CORE AND WINDINGS

IN FIG. 4 may be seen the appearance of the finished coils as they are assembled on the core. When assembling the core, the steel strips or laminations should be inserted from first one side and then from the other so as to alternate the position of the air gap in the core at every layer. Figs. 6 and 7 show the position of the various types of laminations and the manner in which they should be arranged. Care should be taken when assembling the steel core that the insulation on the windings is not damaged to such an extent that turns of wire may become short-circuited to one another or to the core. When nearing the top of the core, place the partly assembled transformer in a vise, compressing the laminations as much as possible, and then squeeze in a few more pieces of steel. It may be necessary to hammer the last one or two pieces in place in order to obtain the necessary cross-sectional area of the core, but the operation should be attended with great care lest the coil windings become damaged.

The completed transformer is clamped together between four pieces of one inch angle iron or hard wood strips as shown in Fig. 9. One-quarter inch stove bolts, two inches long are needed for the transformer design shown in Fig. 5; others may be supplied by the builder to suit his individual requirements. The completed transformer should now be given a coat of black insulating paint in order to preserve the appearance and prevent rusting of the iron parts. It is advisable to paint the lead wires as well, in order to improve the effect of the insulation on them. For want of better insulating paint, the author used automobile enamel, which has withstood the heating effect of the charger remarkably well.

We are now ready to assemble the charger in whatever manner seems advisable to the builder. If he desires, he may cut a base-board of $\frac{1}{2}$ -inch hard wood, measuring 7 by 8 inches, and all parts may be assembled on this base in a compact manner. A more shipshape assembly, and one which leads to a

more commercial appearance, is illustrated in Fig. 4, where a terminal board of $\frac{1}{4}$ -inch bakelite 4 by 7 inches is mounted on the top of the transformer and contains the tungar tube socket, battery terminals and fuse block. The terminal board is set by brass bushings $\frac{1}{4}$ inch above the angle iron brackets and holes are drilled for mounting the various equipment and for passing the lead wires up to the proper terminals. This method of

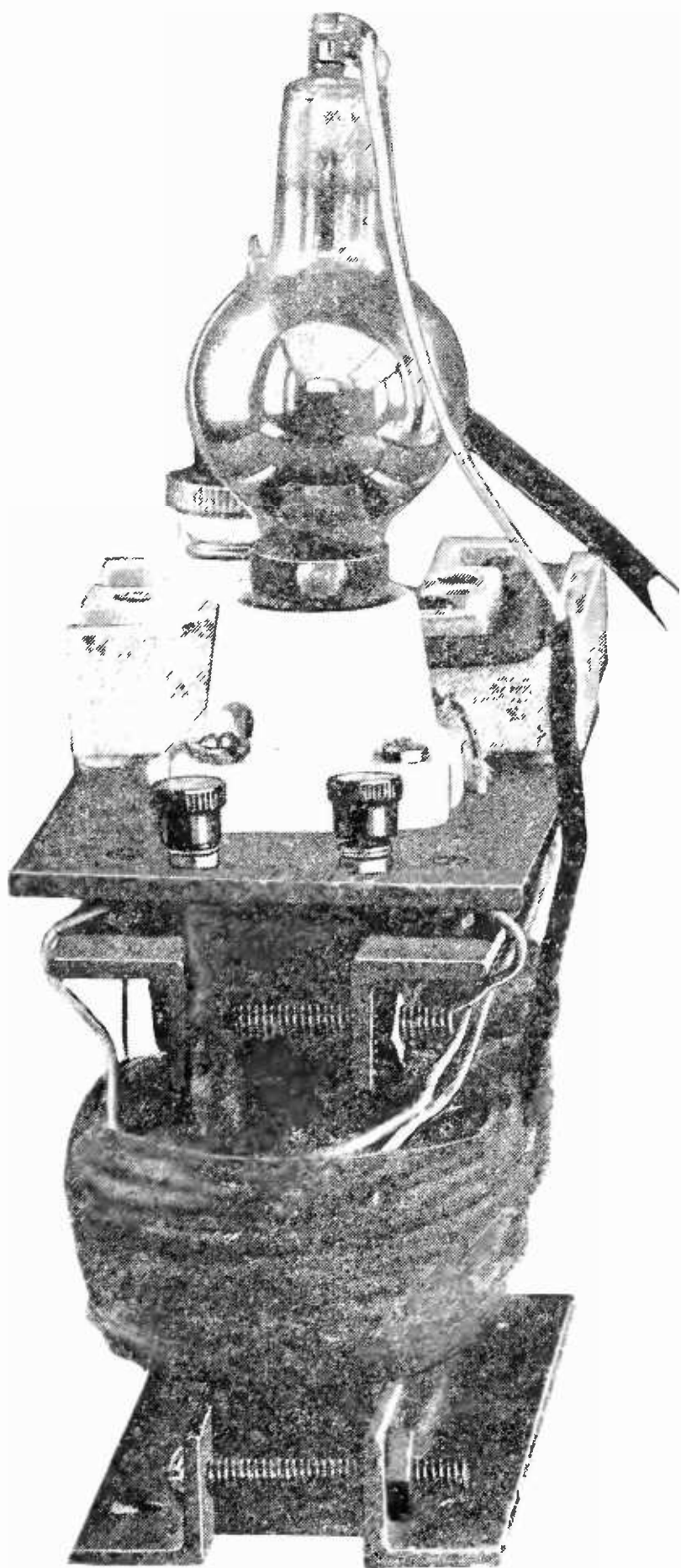
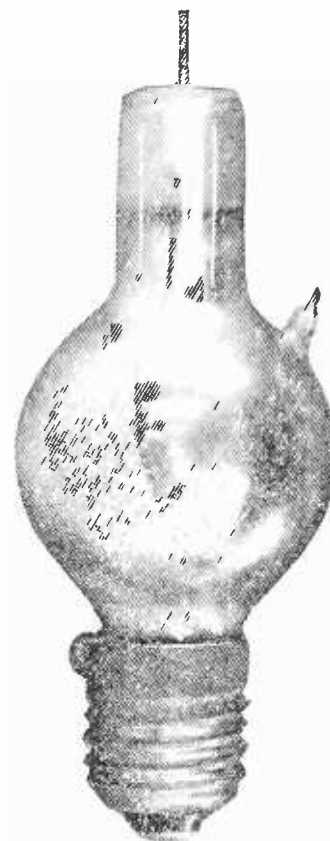

FIG. 11

Another view of the completed charger. This is an end-view picture and shows how the angle pieces are employed not only to hold the core together but as feet and supports for the bakelite shelf

FIG. 12

A typical rectifier tube. The screw-base allows it to be inserted in a standard lamp socket from which current is obtained for the filament. Connection is made to the graphite disc by means of a Fahnestock connector which clips on to the wire post projecting from the other end of the tube



assembly and wiring, suggested by H. F. Mason, is very compact and neat, as may be seen from the photograph, Fig. 4.

The porcelain fuse block serves two purposes: as a fuse holder for the two-ampere fuse and as a terminal block for the 110-volt extension cord. Wiring and connections are made in accordance with Fig. 3. Leads to the storage battery clips should be of No. 14 stranded rubber covered wire, and if a twin conductor cable is used, a polarity indicator should be provided. For want of a better indication, the terminal leading to the positive battery terminal may have a knot tied in it, or it may have a red string tied to it. The 110-volt extension cord may be of ordinary lamp cord.

FINAL INSTRUCTIONS

WHEN the charger has been assembled and connected to the battery for charging, inspection should be made to observe the initial performance. If possible, the charging rate should be measured, if only by means of a Ford dash ammeter or similar device. When charging a 6-volt storage battery, the rate should be 2 amperes; on a 12-volt battery the rate will be 1 ampere. If the charger delivers less current than the above amounts, and still gives some current greater than zero, turns should be added to winding S'' until the proper rate is attained. The percentage of turns it is necessary to add may be calculated from the percentage deviation from the normal charging rate. In case the charger fails entirely to operate, first look for loose wires or broken connections. Then try reversing the battery leads or clips and observe if charging ensues. Occasionally it will require the addition of several turns of wire to winding S'' in order to obtain satisfactory starting of the tungar arc, but this should be necessary only when the transformer has been assembled or wound care-

lessly. The extra turns are then necessary to offset the excess leakage flux from the transformer core.

When the charger has been adjusted so that it does charge at the proper rate, it should be left charging for at least two hours under inspection before it is pronounced satisfactory. During the inspection period, tests should be made of the core and coil temperatures. They will normally run at such a temperature that the hand can just

be held upon the hot parts without burning. Occasionally a charger will be found that will blister the hand if left on more than 15 seconds, but this charger is running at a high loss. If the temperature of any of the parts become as hot as this, look for short-circuited turns, low quality steel, or careless assembly of the core. Any of these three points will in itself be sufficient to warrant rebuilding the transformer.

*I*NTEREST among radio constructors is very strong in the problems offered in the design and construction of chemical plate supply units. James Millen, in the June RADIO BROADCAST, described an inexpensive chemical plate supply unit which has been built by a large number of experimenters. Another article by Mr. Millen will appear in an early number of the magazine. It will discuss the problems encountered in his and other chemical rectifiers, and answers to many queries about variation in the use and design of this unit.



The New Transmitting Station of "Radio Broadcast"

FOR the past three months, the Laboratory of RADIO BROADCAST has had a short wave transmitter in operation. The beginnings have been modest, for the antenna is supplied by a fifty-watt tube, operating on a plate voltage of 1100. A wavelength of 40 meters is now in use, although in the near future the station will also be operating on the lower waves at present permitted in the amateur communication band. Although various methods of plate supply have been tried, the transmitter is now operating from a bank of B batteries, and a good deal of experiment is in progress with the problems involved.

Since the call letters of the RADIO BROADCAST station, 2GY, were assigned, a large number of cards from amateurs who have heard our signals have been received. Since 2GY is listed in the current Government list of United States amateur call letters, practically all of the cards announcing the successful hearing of 2GY have been sent to Mr. F. X. Hayes, 162 East 82nd Street, New York, the former possessor of that call,

Amateurs who hear our station are asked to address their cards to the Director of the Laboratory, RADIO BROADCAST Magazine, Garden City, New York. We are very anxious to have complete reports from any listening amateur who will be good enough to send them to us. An acknowledgement will be sent in reply.

The transmitter in its present experimental stage, has a dependable daylight range of between eight hundred and a thousand miles. Communication has been established with many radio amateurs who are located within a thousand-mile radius of Garden City.

A number of interesting experiments in short wave transmission are in progress, and in later numbers of this magazine they will be described. It need not be thought by the broadcast listener that transmitting experiments of this sort are uninteresting to him. On the contrary, some of the most fascinating experiments being conducted in radio to-day lie in the field of short waves. Many of the problems to be solved in this work are very similar to those in the broadcast field.

Shall I Run My Set from the Lamp Socket?

RADIO BROADCAST Laboratory Analyzes Devices Commercially Available to Help Operate Receivers from Alternating Current — Helpful New Devices from the Manufacturers for the RADIO BROADCAST Phonograph Receiver

BY THE LABORATORY STAFF

J EACH month, the RADIO BROADCAST Laboratory will bring to its readers some of its findings in the field peopled by the manufacturers. The purchaser of radio equipment has little chance to find out what is wheat and what is chaff among the material that is for sale—that has become one of the tasks of the Laboratory. It is obviously impossible to test in the Laboratory, to illustrate, or even mention, all radio equipment which appears for sale. The apparatus mentioned in these pages is neither all that has been tested nor that which we believe to be the best on the market—it is merely representative equipment. Nothing in which the Laboratory does not believe will be described, nor will advertisements of poor apparatus coming from unreliable concerns be included in this magazine.—THE EDITOR

AT THE present time, there are two types of apparatus for sale to the radio public that operate from the light socket, battery chargers and battery eliminators. Of the chargers there are three kinds, depending upon the type of rectifying element that is used—whether vacuum tube, chemical, or mechanical. Of the eliminators, there are only two, since a mechanical rectifier has not, as yet, put in its appearance. These two types eliminate only the B battery, although manufacturers promise that the near future will see devices which will eliminate the A battery as well. It is only a question of time until it will be possible to get A, B, and C batteries from a light socket.

Tube battery-chargers consist essentially of a transformer to change the alternating voltage current to the proper value to operate the tube and deliver the charging current; a Tungar or Rectigon two-element tube, which is the rectifier element, changing alternating current to pulsating direct current; and certain resistances which are required to reduce the voltage to the proper value for charging A or B batteries.

The Acme charger, which is illustrated, was sent to the Laboratory for test and after performing well all winter still pushes two amperes into the Laboratory batteries. Similar chargers are made by others, and those sent to the Laboratory by the Westinghouse and General Electric companies are examples of a very high grade of electrical equipment.

Chemical chargers have a transformer and one or more jars of solution in which are two metallic elements. Current will pass through the affair in one direction but not in the other. The Balkite charger, now in the Laboratory, may be used when the receiving set is in operation—provided the battery is not too low in charge.

Mechanical chargers have vibrating contacts which permit current to flow into the battery in the proper direction at the proper time. They make a humming noise in operation, and like all other A battery chargers, their efficiency is about 25 per cent. when in actual use. In other words, 75 per cent. of the power put into the charger disappears there and only one fourth gets into the battery.

The Full-Wave Charger made by the Liberty Electric Corporation of New York City has been in use in the Laboratory and is a fast worker. The Ward-Leonard variable resistance in the photograph is used to lower the output voltage so that B batteries may be charged at various rates not to exceed one third of an ampere. A lamp may be used in place of the resistance, the size depending upon the voltage of the battery to be charged as well as the rate desired.

BATTERY ELIMINATORS

THERE is great interest in battery “eliminators” at the present time. The more important questions to be asked by a prospective purchaser are:

1. Is the eliminator effective?
2. Is it economical?
3. How long will it last?
4. Is it quiet in operation?

All eliminators consist of a transformer, a rectifying device, and a filter. The transformer boosts the 110 volts a. c. to whatever voltage is required so that the output is about 90 volts after accounting for the voltage drops in the rectifier and the filter.

Tube eliminators employ standard 5-volt, three-element receiving tubes, or special two-element rectifier tubes, and are high resistance devices. In other words, the more current that is drawn from

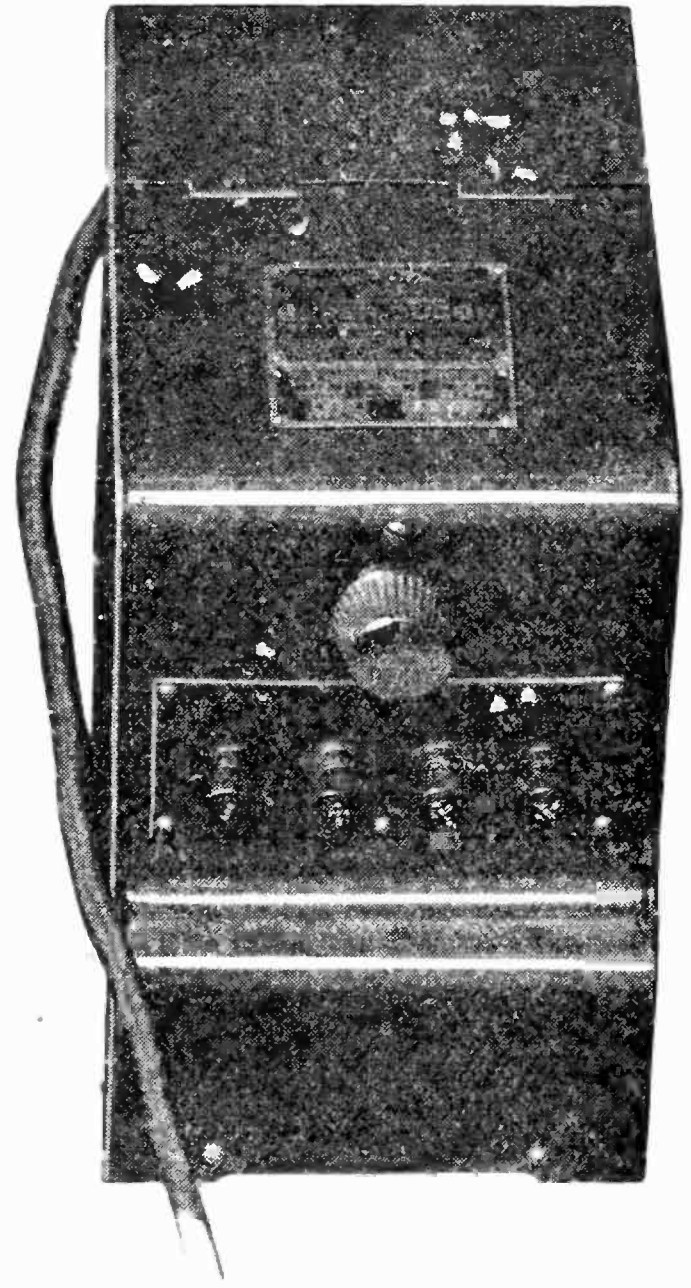

RADIO BROADCAST Photograph

Substitutes for B batteries are of two kinds, and here are examples of both of them. The Balkite device uses a chemical rectifier and is made by the Fansteel Products Co. The Super-Ducon uses a vacuum tube as the rectifier and is made by the Dubilier condenser people. The photo below shows the Acme charger with a Philco A battery. All have been in use in the Laboratory.

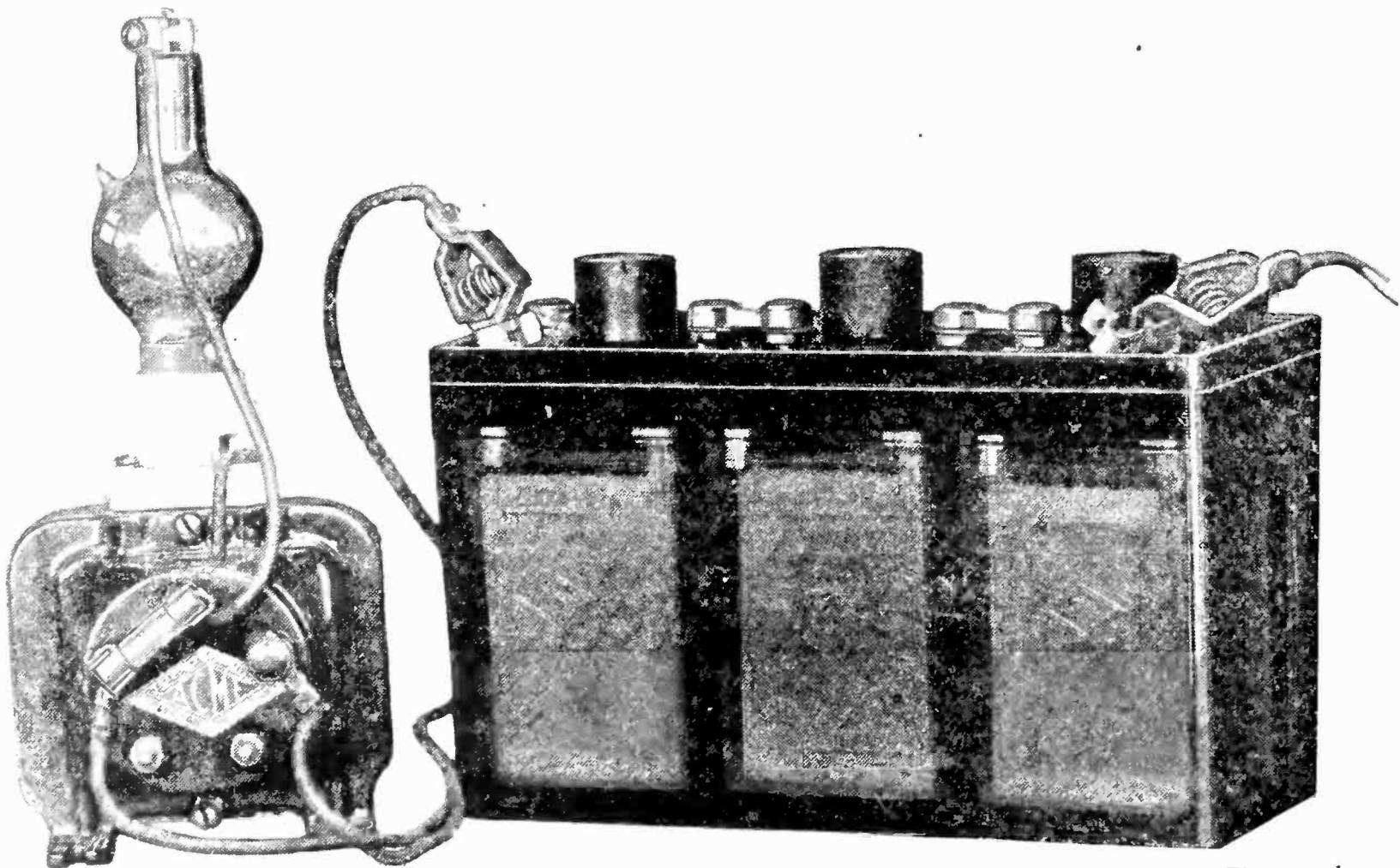

RADIO BROADCAST Photograph

The Apco B substitute using two rectifier tubes, and a convenient layout of accessory apparatus

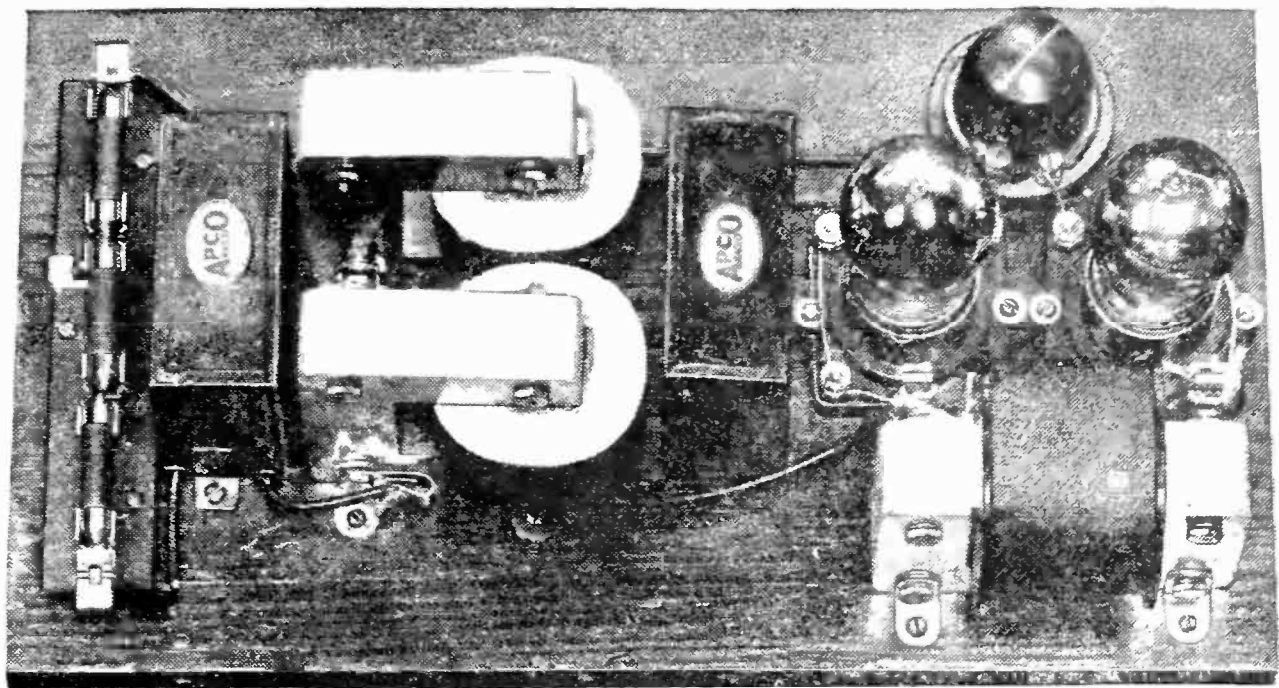

RADIO BROADCAST Photograph

The transformers below for transforming 110 volts a. c. to the voltage required for other purposes are made by the Dongan Electric Mfg. Co., and the Radio Foundation

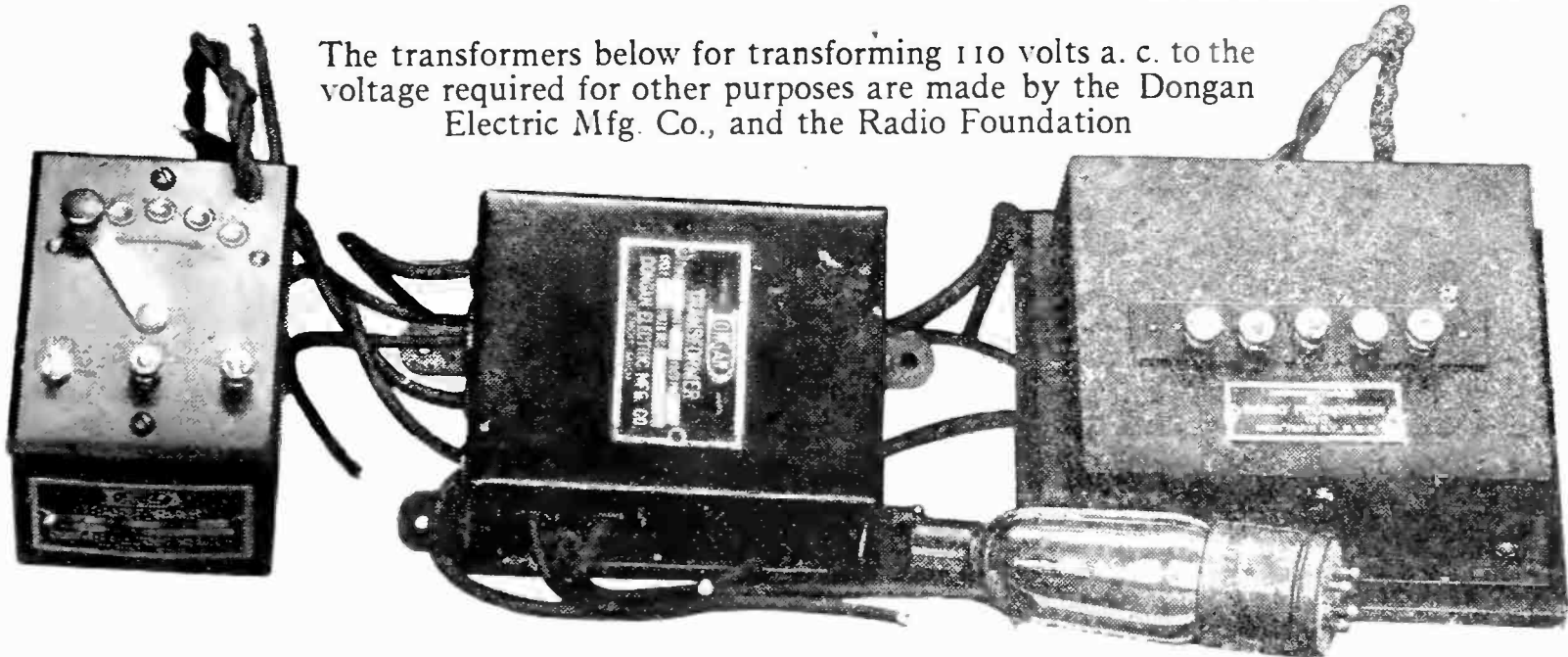

RADIO BROADCAST Photograph

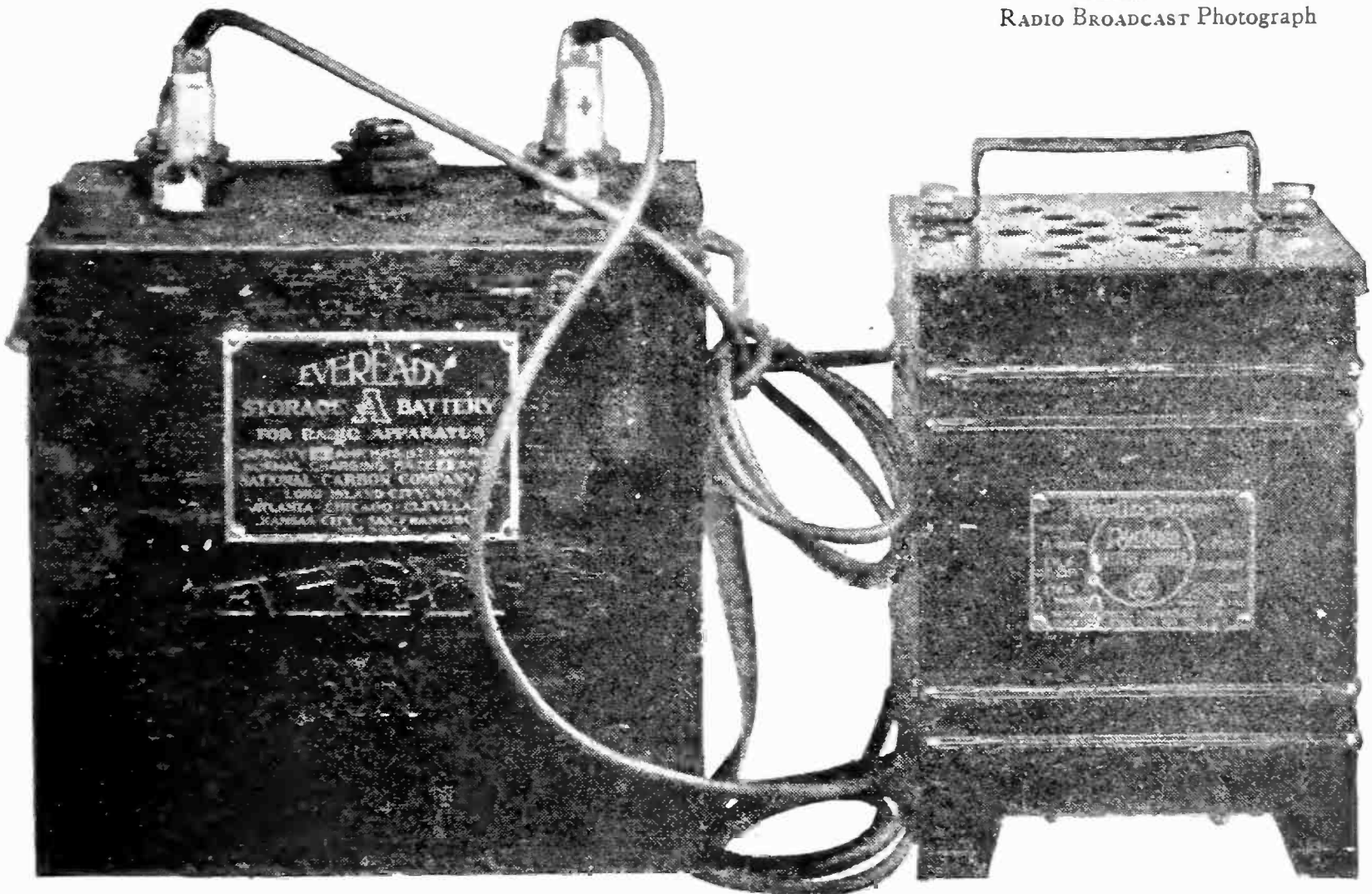

RADIO BROADCAST Photograph

Two electrical instruments from well known manufacturers. The Eveready A battery and the Westinghouse A battery charger — which will also charge B batteries

The A. C. tube together with several rectifier tubes which serve the various purposes outlined in the text

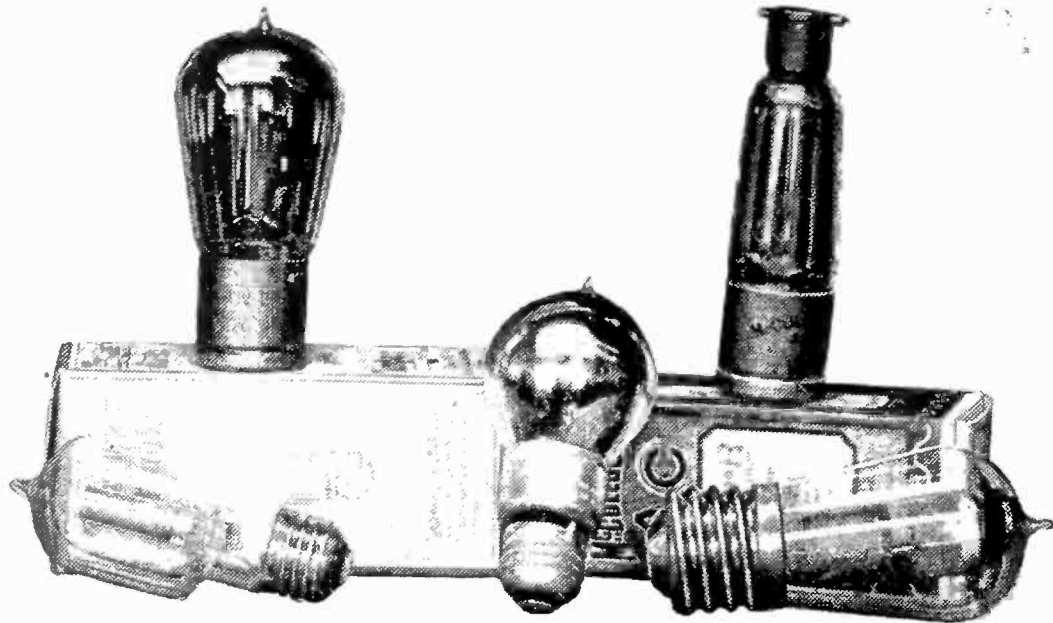

RADIO BROADCAST Photograph

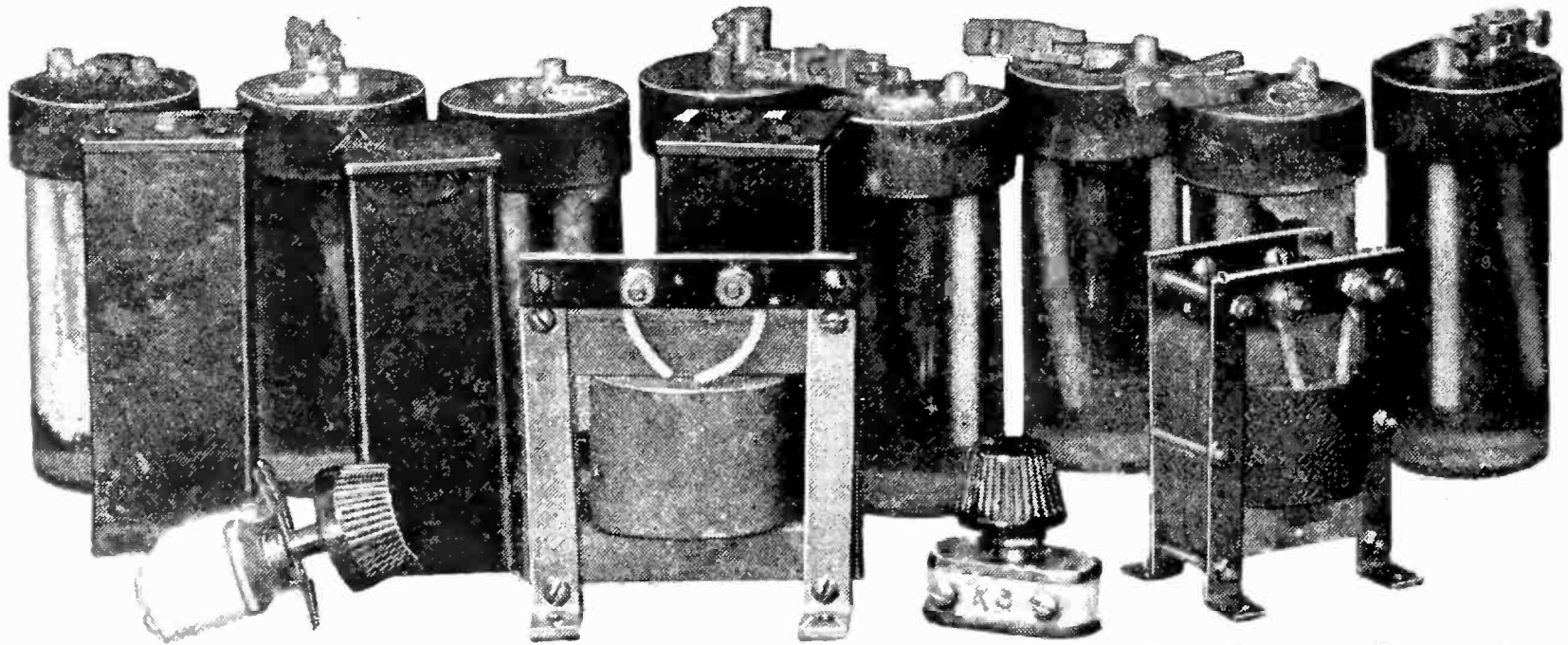

RADIO BROADCAST Photograph

A B battery substitute that anybody may build up from Molliformer parts. Here are chemical rectifier jars, filters and a transformer.

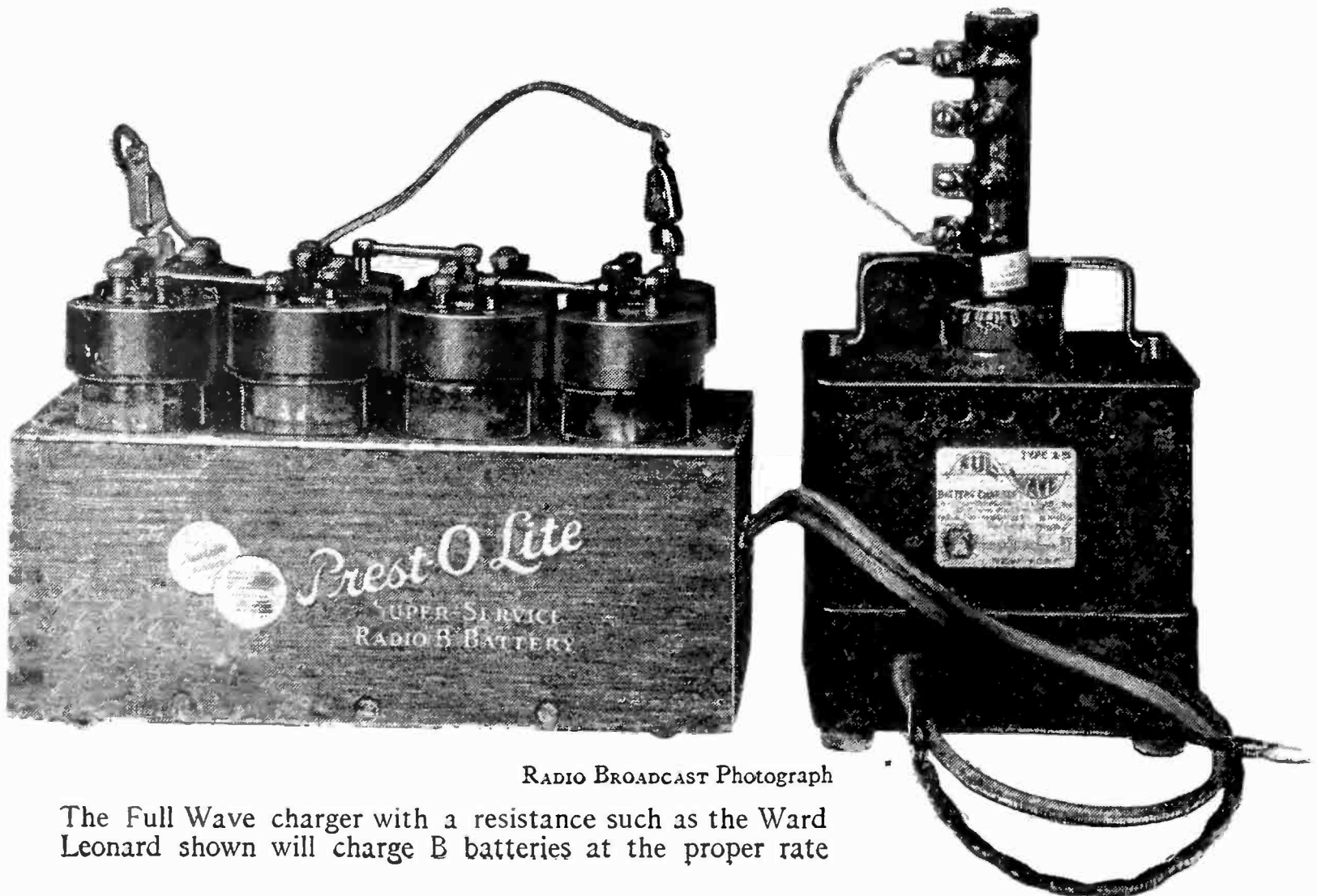

RADIO BROADCAST Photograph

The Full Wave charger with a resistance such as the Ward Leonard shown will charge B batteries at the proper rate

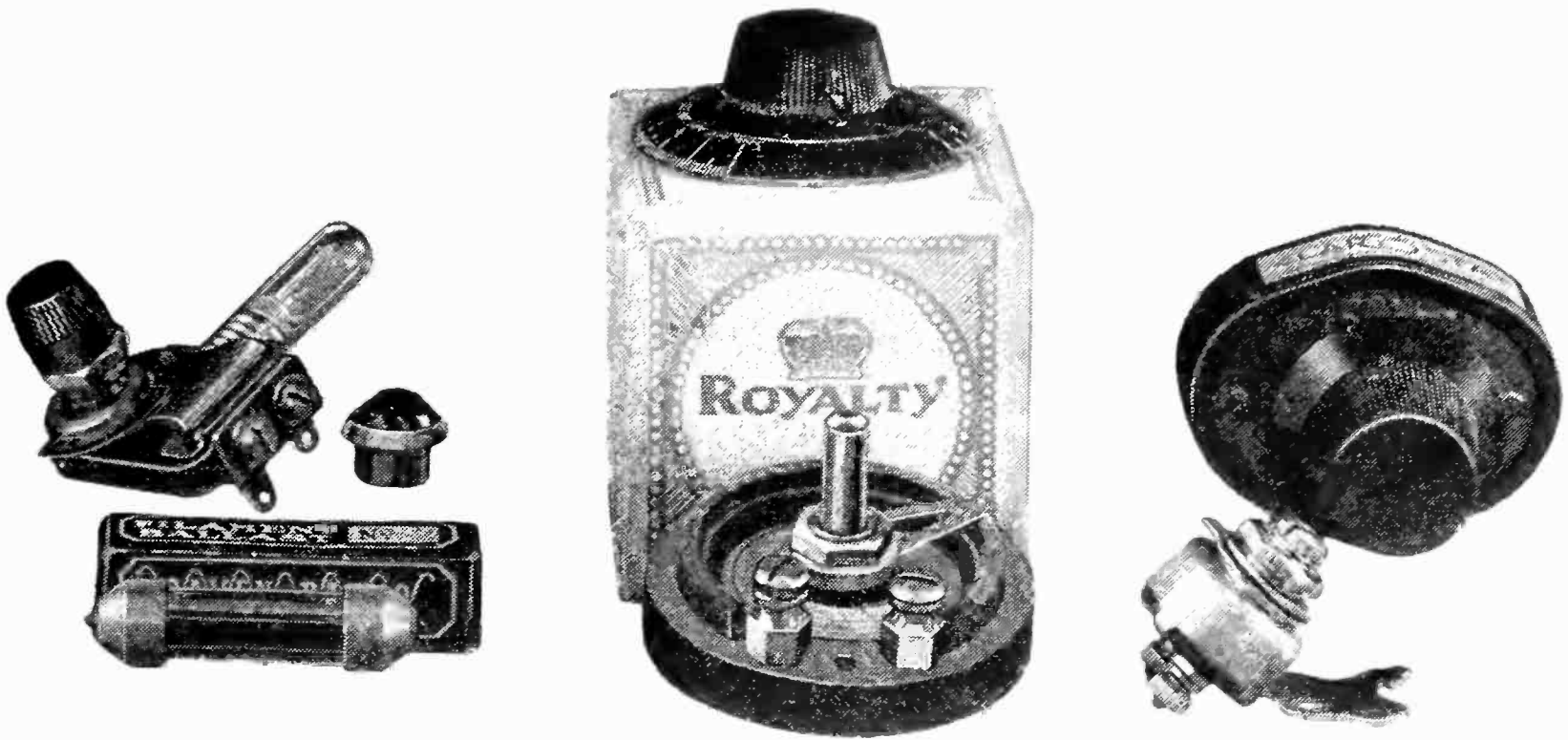

RADIO BROADCAST Photograph

Several interesting devices that have been sent to the Laboratory. They are variable high resistances, a pilot lamp, a lock filament switch and a ballast resistance designed to eliminate the need of rheostats

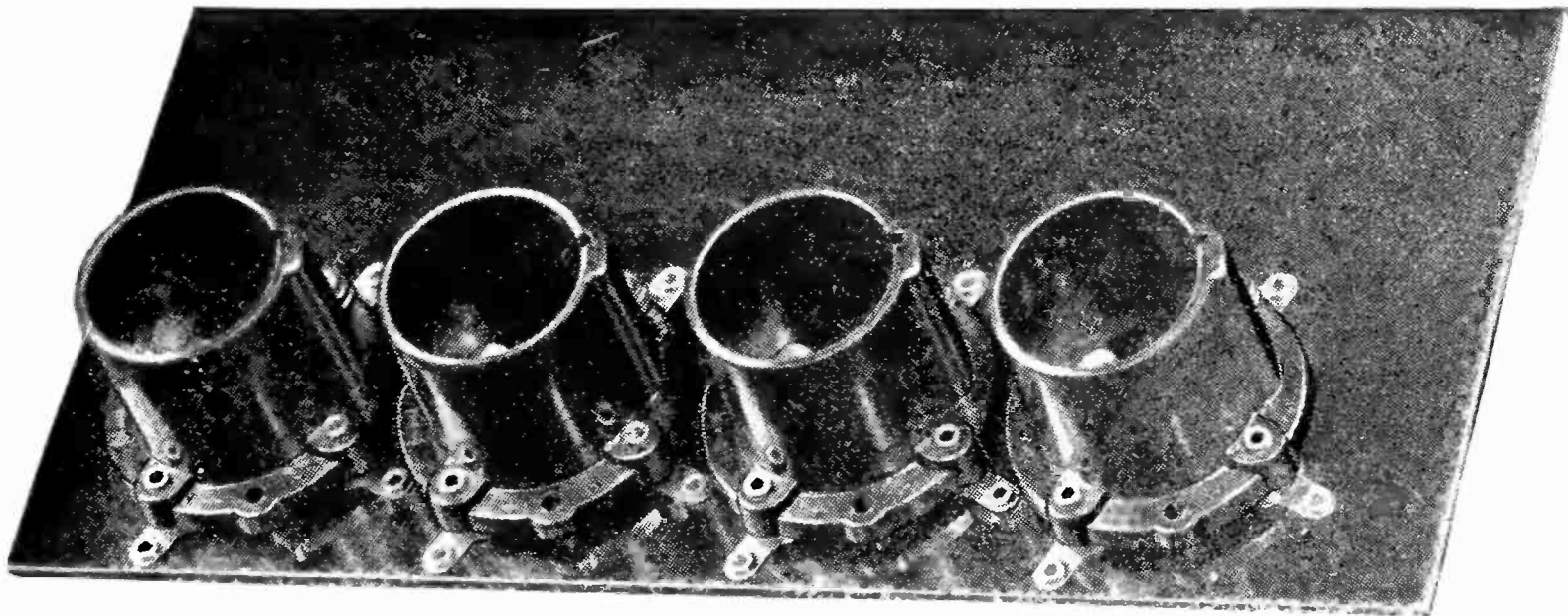

RADIO BROADCAST Photograph

Two views of a tube socket panel, the lower made by Burton & Rogers of Boston, the upper one by The Alden Mfg. Co., of Springfield, Mass. Both are designed for RADIO BROADCAST's Phonograph Receiver

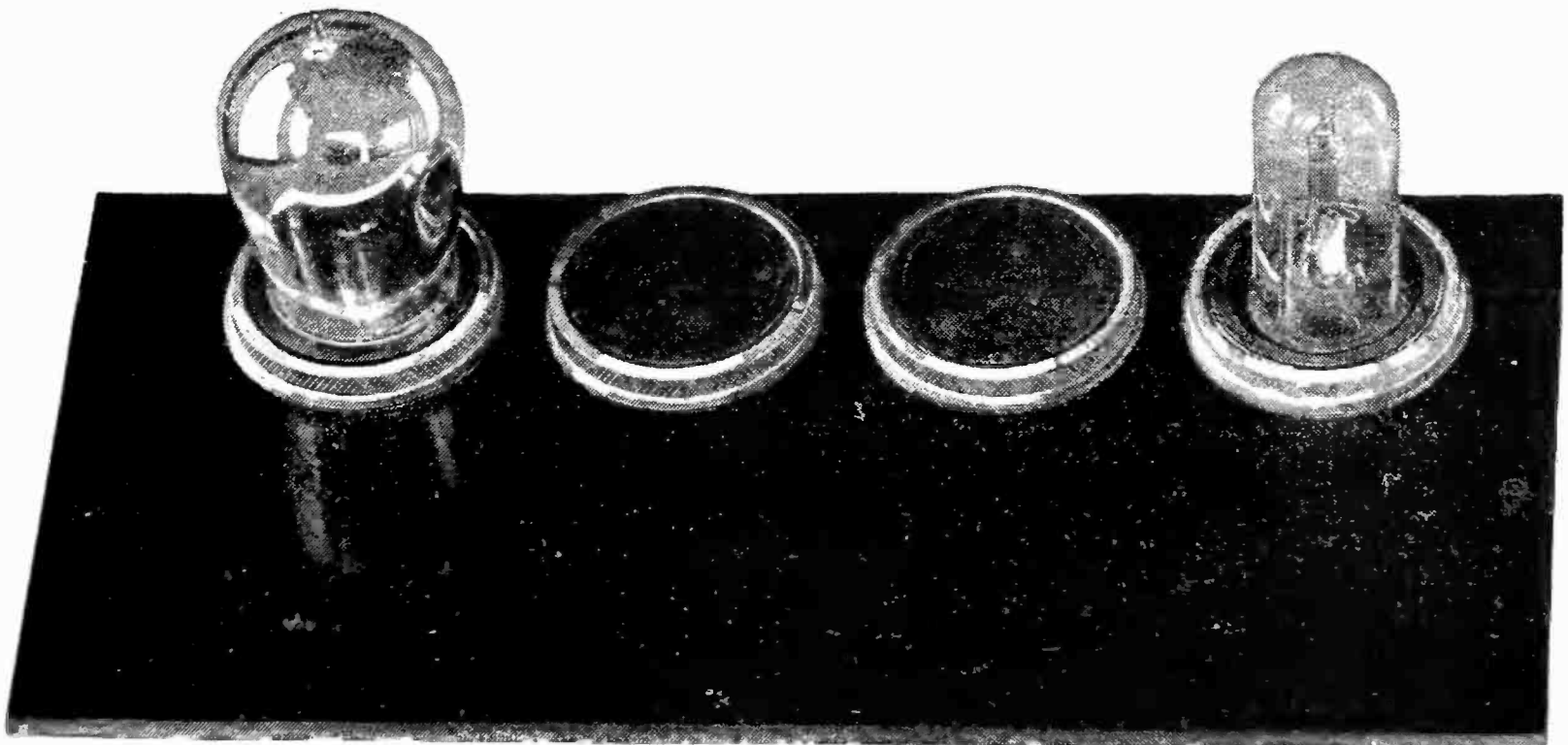

RADIO BROADCAST Photograph

them the lower will be the output voltage. That is a disadvantage and is due to the high resistance in the tube itself and in the filter. If a sufficiently high voltage is used at the start and if control resistances are included, this disadvantage may be partially overcome. There is one advantage in the high resistance feature since it is impossible to draw enough current from the device to blow up tubes, during accidental mix-ups in A and B battery leads.

Chemical B battery suppliers are generally low resistance affairs, and the output voltage is more independent of the output current load. The Balkite eliminator is an excellent example of this type of supply unit.

THE LIFE OF A TUBE TYPE ELIMINATOR

THE useful life of a tube operated eliminator depends entirely upon the life of the tube. In practice, the tube is used as a two-element rectifier and receiving tubes do not have sufficient electron emission to stand up under this kind of treatment. In the Laboratory, an average life of 200 hours has been obtained with receiving tubes with a five-tube set drawing about 25 mils. Some tubes lasted about 50 hours, others as long as 400 hours, but the average is too low. Special two-element tubes are now on the market for this service and samples have been sent to the Laboratory from Kellogg, Dubilier, Sea Gull, and Timmons. An average life of 600 hours may be expected from this newer type of tube.

Eliminators employing two tubes will last longer and deliver a better form of current—theoretically, at least. The component parts of such a set are well shown in the photograph of the Apco layout, and the “works” of a chemical supply unit may be seen in the Molliformer kit photograph.

Tube B battery substitutes have been sent to the Laboratory by the following manufacturers, Timmons, Kellogg, Mayo, Rhamstine, Dubilier, Apco, and Mu-Rad.

Several interesting tubes are shown in the accompanying photographs. They are the Rectron of Dubilier (used in the Super-Ducon) for B battery eliminator service, a Tungar for charging batteries, the McCullough tube whose filament runs from a. c., the S tube of the Amrad Corporation and the Neon Tube of the Neon Products Corporation. The latter two do not have filaments and operate upon the gaseous conduction principle. They may be used in either receiving or transmitting rectifiers, since 100 milliamperes may be taken from them safely.

The filters used in these various types of B battery suppliers are required to iron out the remaining hum which is due to the alternating current. If the filter has high enough inductance and enough condensers, the hum will not be noticeable on either loud speaker or head phones, and is a vital part of the instrument.

A step-down transformer is necessary for the McCullough tube, and two are illustrated in this article.

One is made by Dongan and the other by the Radio Foundation. A special transformer which supplies low voltage for amplifier filaments and 350 volts for power amplifier plate is also illustrated.

In deciding to purchase a battery eliminator, the prospective owner should discover whether it will cost him more to run than batteries, if it will be more convenient, and if more convenient and more expensive whether it is worth it. An average five-tube set worked three or four hours a day will cost about \$15 a year in B batteries, and an average B battery eliminator can be run ten hours for one cent, payable to the lighting company. Special tubes or the old type 201 tungsten filament tube should last at least 500 hours—and there you are.

PHONOGRAPH RECEIVER APPARATUS

A NUMBER of interesting gadgets have come to the Laboratory which have an application to the Phonograph Receiver. One of these is an A battery protector which automatically breaks that circuit when too much current is drawn. It is made by the Precise Corporation of Rochester who made circuit breakers for power companies before radio was literally on earth. It will protect a battery from accidental short circuit, or, when charging batteries from current surges.

Four-tube base panels are made by Benjamin Electric Company of Chicago, Alden of Springfield, and Burton & Rogers of Boston. The latter has the sockets set somewhat below the panel so that considerable space is saved. Views of these panels are shown.

Pilot lamps to tell one when tubes are lighted are made by Yaxley, and Carter of Chicago. These small lamps are set behind the panel with a glass window through which they may be seen. They take about .1 ampere at five volts, and make an attractive and useful addition to any receiver.

Ballast resistances which will take the place of rheostats in filament control have been sent to the Laboratory by Daven and Amperite.

A useful and interesting lock switch has recently come to the Laboratory from Carter. This switch turns on or off the filaments and requires a key similar to that used in automobile locks.

Two volume controls have presented themselves, one known as a Clarostat and the other a graphite resistance of several ranges sold by Electrad, Inc. Both of these may be used as volume controls—as may the Bradleyohm—by placing them across audio-frequency transformers; for B battery eliminators and for any other purpose where a high variable resistance is needed.

A very useful place for such variable resistance is across a fixed tickler, to control regeneration in a detector circuit as in the Roberts circuit. The ease of control appeals to the operator of the receiver, and the fact that amplifier plate voltages may be placed on the detector eliminates the business of tapping a B battery.

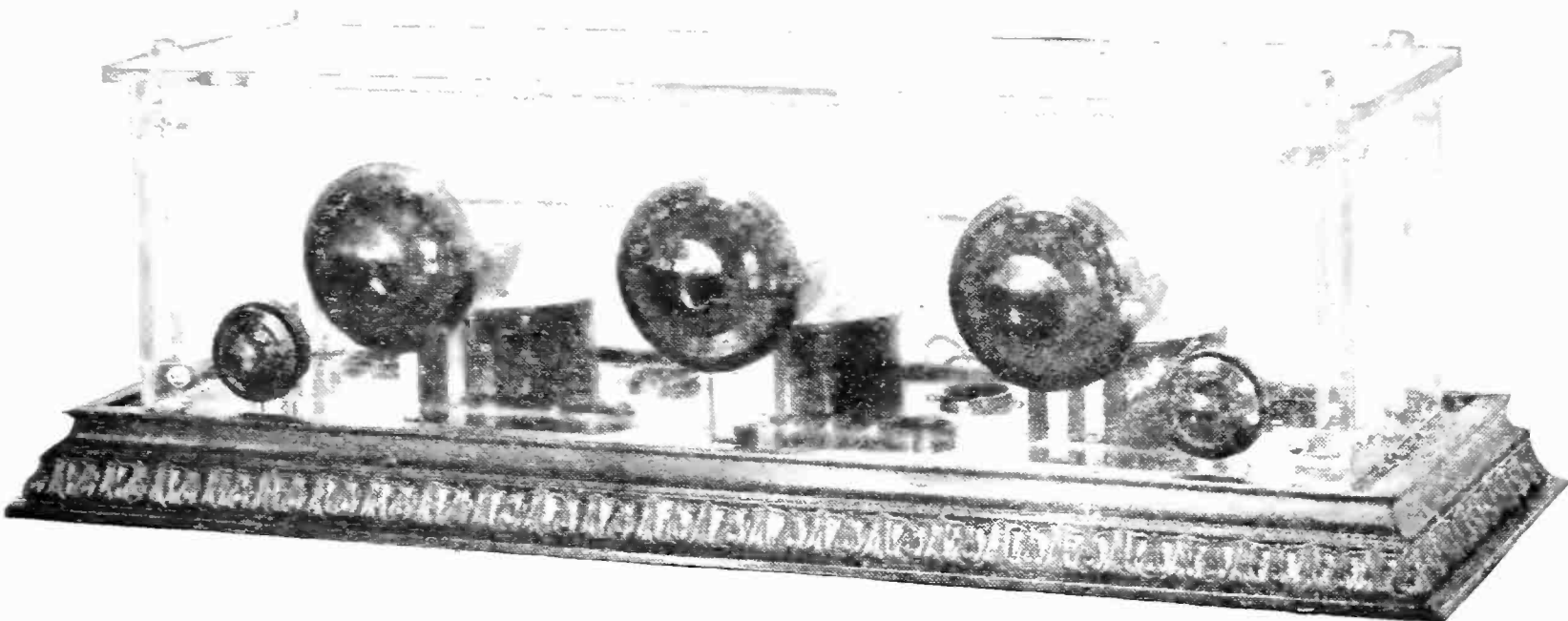

Two receivers and a loud speaker are illustrated in these photographs. The receivers are the Clearfield and the Richardson "5" They are both of the tuned radio frequency type. The Superspeaker Console speaker comes from the Jewett Radio and Phonograph Co.

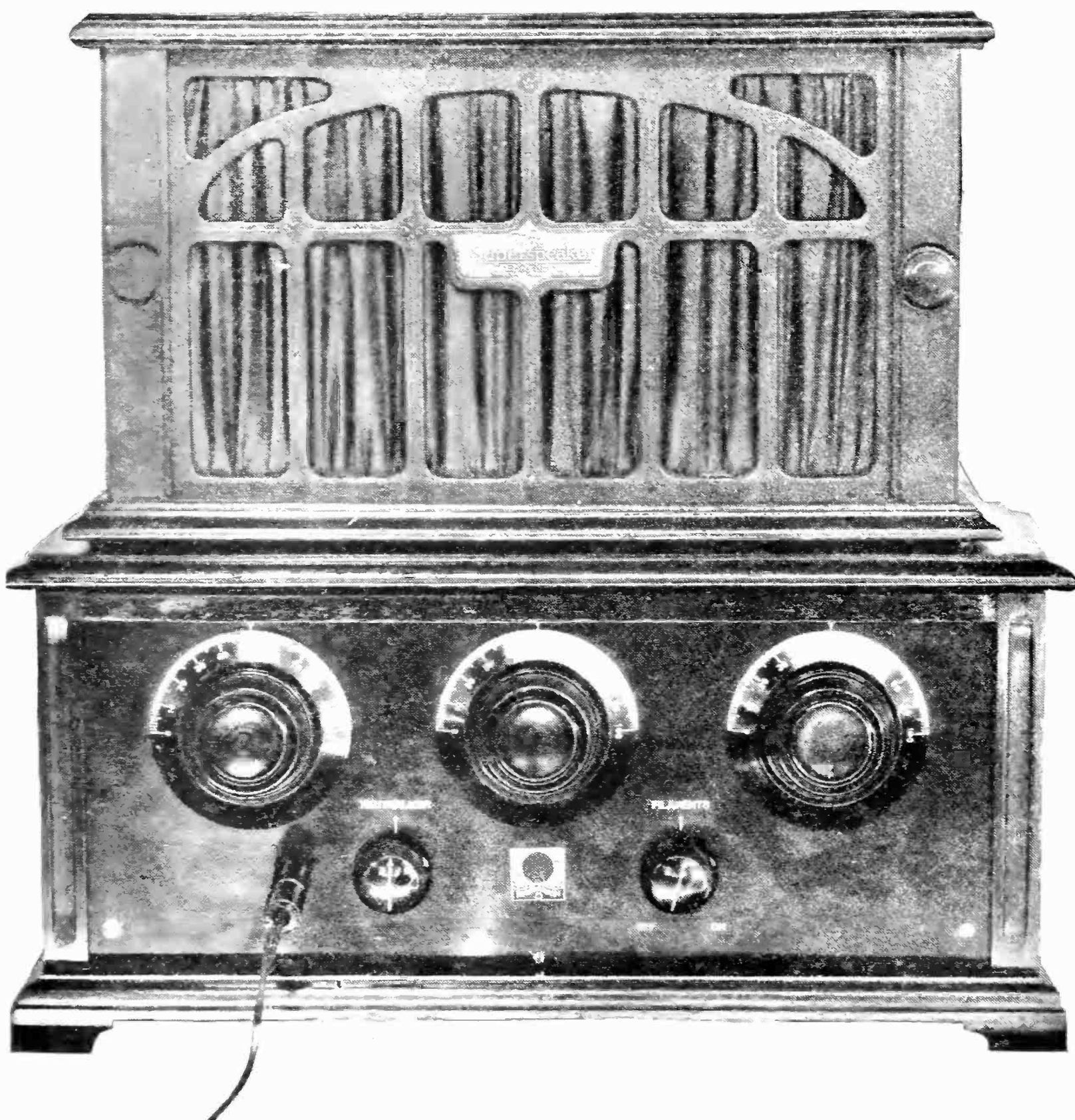

“NOW, I HAVE FOUND . . .”

A Department Where Readers Can Exchange Ideas
and Suggestions of Value to the Radio Constructor and Operator

A FIFTEEN DOLLAR CW “LOW LOSSER”

MANY fans wish to know something about the shorter wave work, which is both c. w. (continuous wave) and phone. It is very much worth while to build a “low loser” for such work because the results obtained are noticeably superior.

Low-loss, when stripped of all technicalities, simply means high efficiency. The big bugaboo of radio is resistance. So, any set which is built with the idea of reducing this will be a low-loss one and therefore of so much higher working efficiency. That being the case, make up your mind that the best is the cheapest in the long run and you will not spoil what otherwise is an excellent set. The total cost will not be over fifteen dollars, exclusive of tubes, batteries, and the head telephones.

The three circuits A, B, and C shown in Fig. 3, are all suitable for our purpose, but A has the disadvantage of being coupled too

closely to the antenna and we may therefore disregard it. B and C are not open to this objection, as the antenna circuit is coupled inductively to the secondary and entirely separate from the rest of the set. The choice between these two lies only in the method of securing the feedback control. In B it is secured by the tickler coil method so well known to the exponents of the so-called “three coil tuner.” In C it is obtained by a variable condenser. Take your choice.

Coil P need consist of but three turns of No. 18 “bell wire” $3\frac{1}{2}$ inches in diameter and bound or taped into circular form. Then mount it in any fashion so as to have it “stood up” a few inches from the grid lead of coil S. An easy way to do this is to support the free ends in two binding posts.

Coil S is constructed as follows: obtain two pieces of bakelite tubing each $3\frac{1}{2}$ inches in diameter and one half inch long. Obtain also six strips of bakelite each $\frac{1}{4}$ inch thick, $\frac{1}{4}$ inch wide and 3 inches long. Mark the

FIG. 1
Looking at the
receiver from
the rear

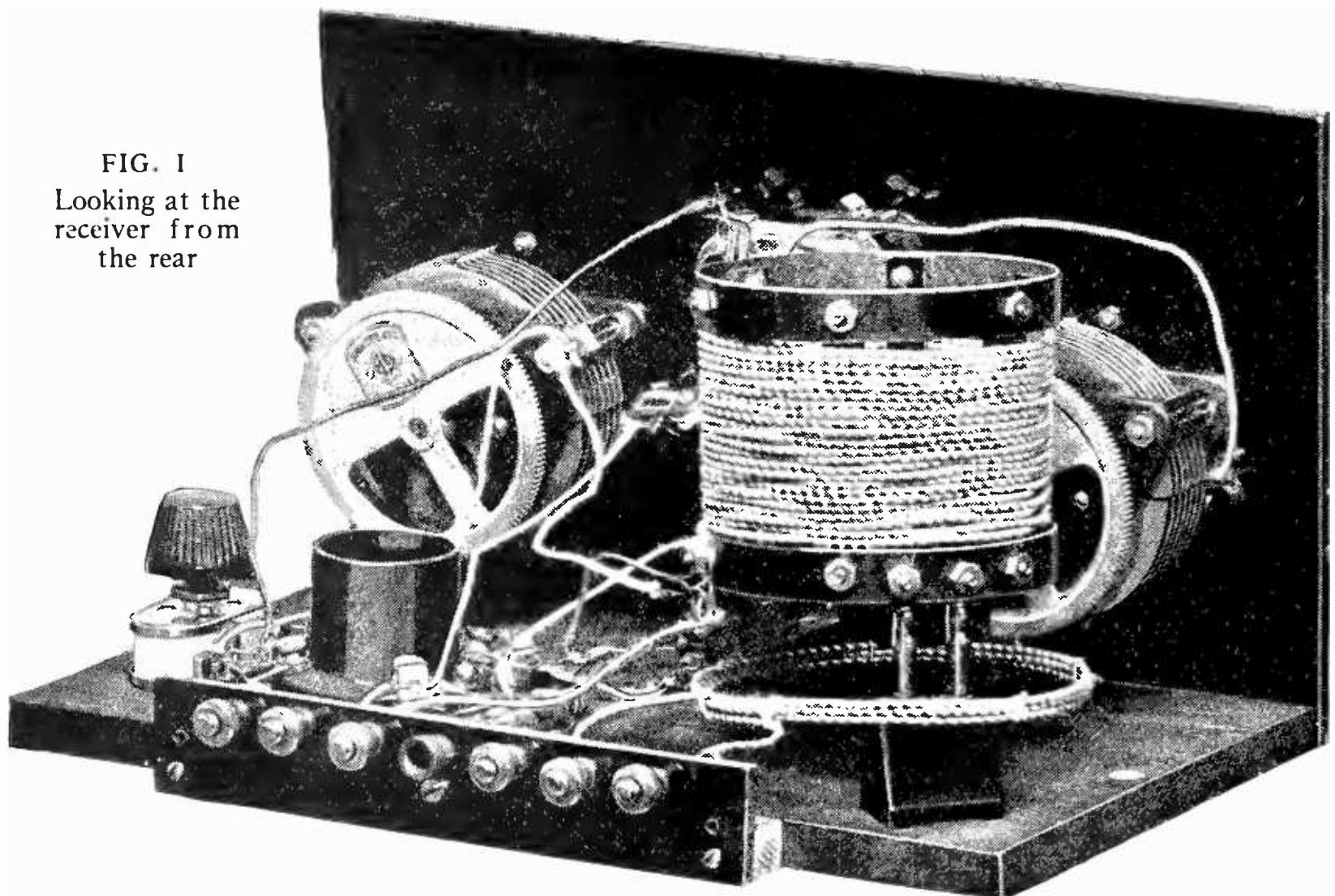

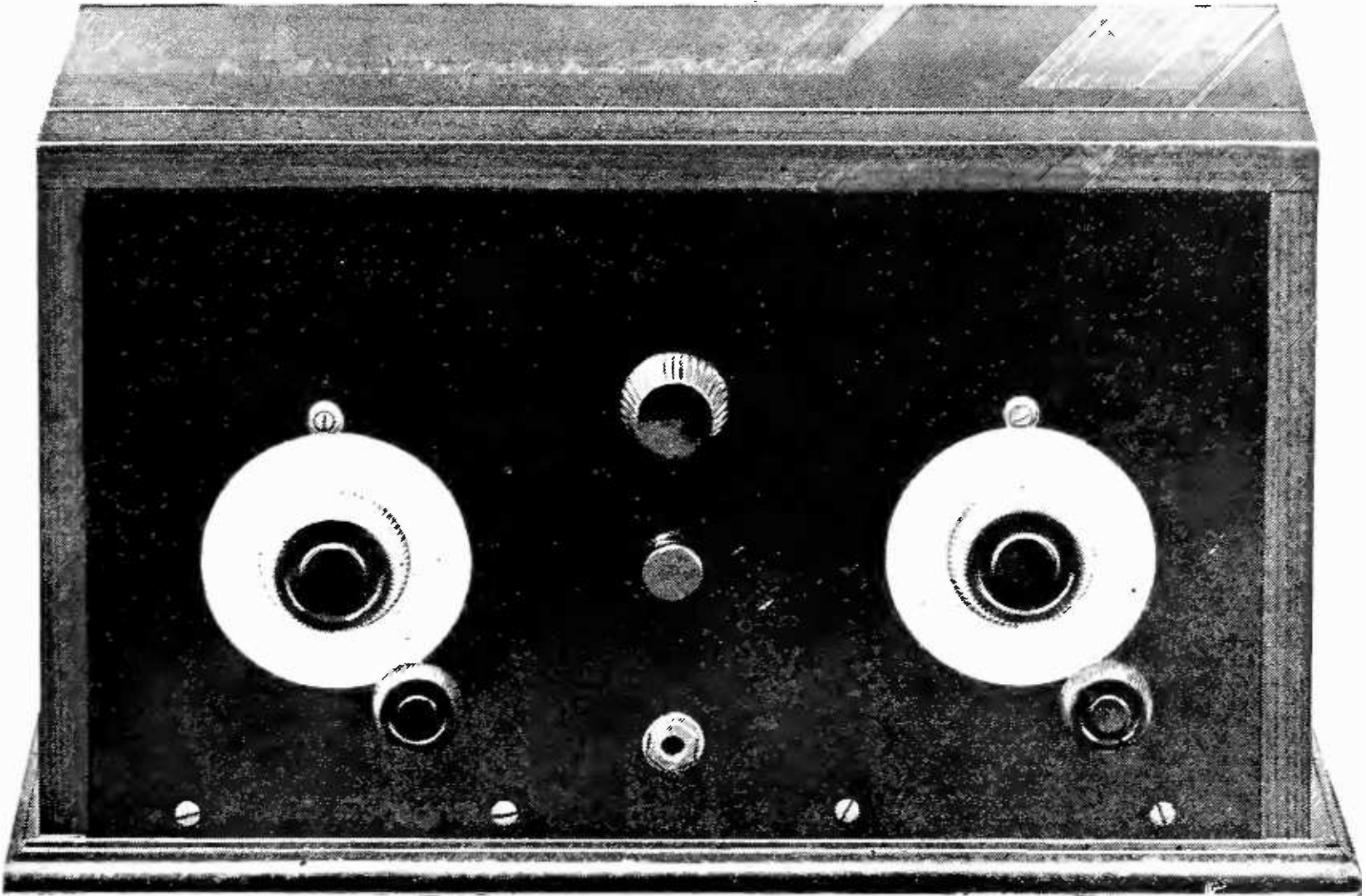

FIG. 2

A front, panel view of the receiver

periphery of each bakelite tube into six equally divided segments and drill a hole to take a 6-32 brass bolt at each point. Drill the ends of the strips with similar holes and you then have a nearly cylindrical form for winding, the ends of which are the two bakelite tube pieces and the sides of which are the strips. In case bakelite is not available dry wood may be used and the strips mounted with the aid of small wood screws. Be sure to have all wood thoroughly dry and to treat it with a light coat of melted paraffin to prevent moisture absorption.

Various methods of mounting this coil may be devised. The writer attached an old Paramount coil mount by means of two machine screws and used an ordinary Remler honeycomb coil mount as receiver for it. Two Remlers will do the same thing and such an idea enables coils to be easily shifted for different wavelength ranges. For the longer amateur waves, fifteen turns of No. 18 bell wire are used and ten turns for lower waves.

For the tickler coil "ball assemblies" may be made or purchased and first treated with a paraffin bath. Be sure to place your tickler at the filament lead of S to reduce its effect on tuning and remember to reverse its leads if regeneration is not first obtained. A small tickler of more turns has less disturbing effect

on tuning than a larger one of fewer turns. The number of turns varies in different sets, but ten turns may serve as a trial.

A small radio frequency choke may be needed at Ch in C.

In using condenser feedback, merely wind coil S and continue the winding, adding about ten turns to comprise the feedback winding, having provided a twist tap for filament. The feedback condenser, here, may be of .00025 mfd.

A well made variable condenser is a positive necessity. It should have a small amount of insulation present, it should be mechanically rigid, and good electrical connection must be had between members. The capacity should be .00025 mfd. maximum.

A good socket and variable grid leak are to be included. Finally, be sure you have a real antenna and ground. A single wire is sufficient. No panel layout is given here because so many experimenters will wish to work out their own.

In operating the set, note that the distance of the coil P may be varied from S as an advantageous feature because smooth tuning may not be had otherwise due to a resonance effect in the antenna, causing a "blank" in the tuning dial.

Several novel features to be noted in this set:

1. Ease of coil changes.
2. Filament connections by plug and jack, allowing ease of change to another set.
3. Use of Fahnestock clips as the set is primarily an experimental one and changes may be easily made.
4. A low-loss coil that is mechanically strong and electrically efficient.
5. A set which is simple, efficient, and easy to operate.
6. A set which is very low in cost.

—C. S. MUNDT, San Francisco, California.

TWO SHOP TRICKS

HERE'S an idea for a simple home made rig for cutting spiderweb coil forms, bezel holes in panels, or holes for the Ballantine vario-transformers. First drill a center hole with about a $\frac{3}{8}$ -inch twist drill in the panel, then drill a hole in a piece of hard wood about $\frac{3}{8} \times \frac{3}{4} \times 6$ inches long. Remove the drill from the brace or hand drill and leave the drill in the piece of wood. Next take a small file and grind the end down as shown in the sketch, Fig. 4, and clamp the file to the piece of wood with two five-and-ten-cent-store clamps. Fit the drill in the center hole in the panel and go round and round and back and forth, holding the drill in the left hand and the stick in the right. A stick 6 inches long will give you plenty of leverage. Cut from both sides and the result is a clean cut hole and, best of all, it is round. I can cut spiderweb forms with this which have one tooth longer than the others for support and all are the same size and look like factory goods.

This is a suggestion for a three-plate vernier condenser built for about twenty cents, and looks well from the front of the panel. First get a panel switch with bushing and about five cents worth of common sheet zinc (same as used for flashing). Cut out a piece the size shown and solder it to the end of the switch

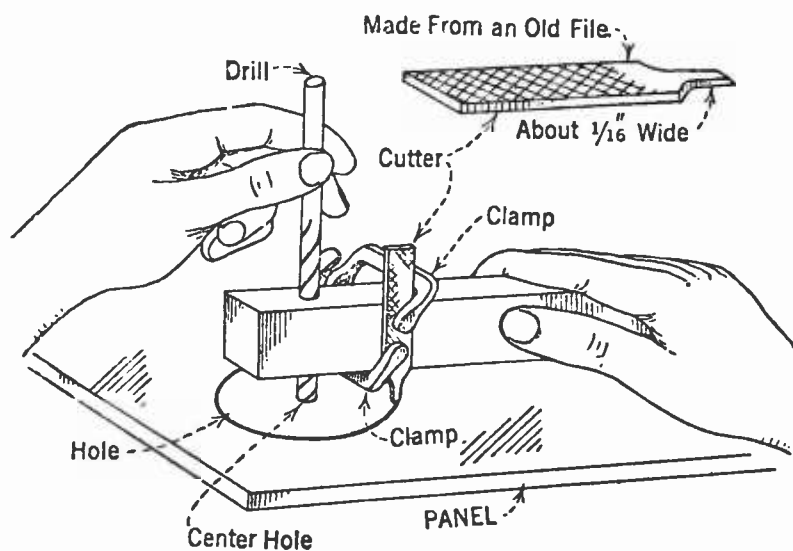

FIG. 4

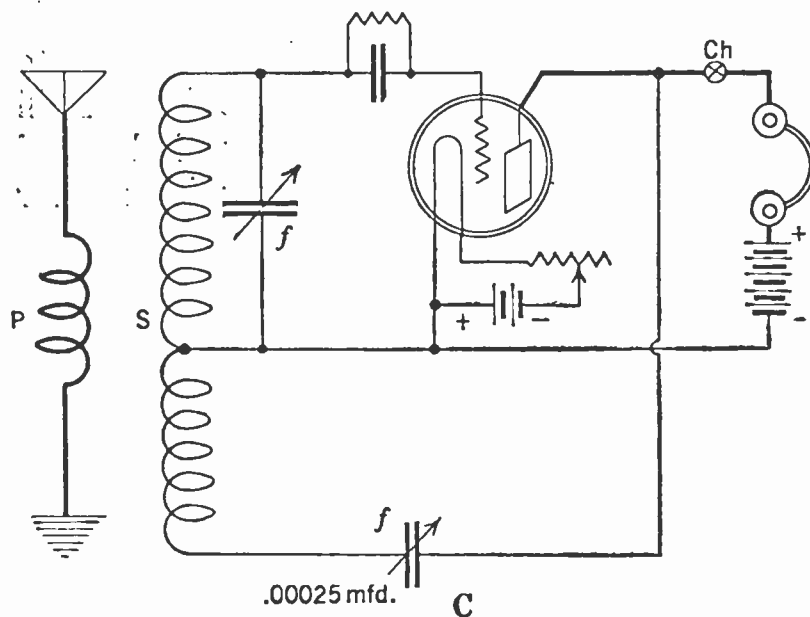
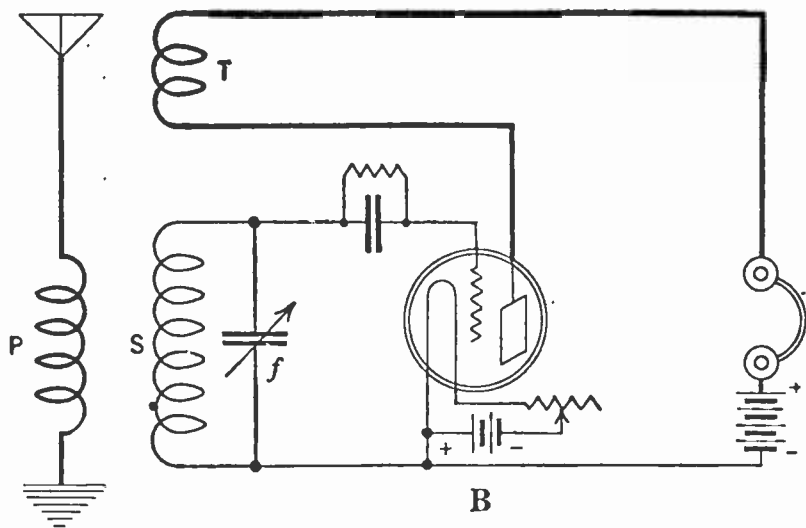
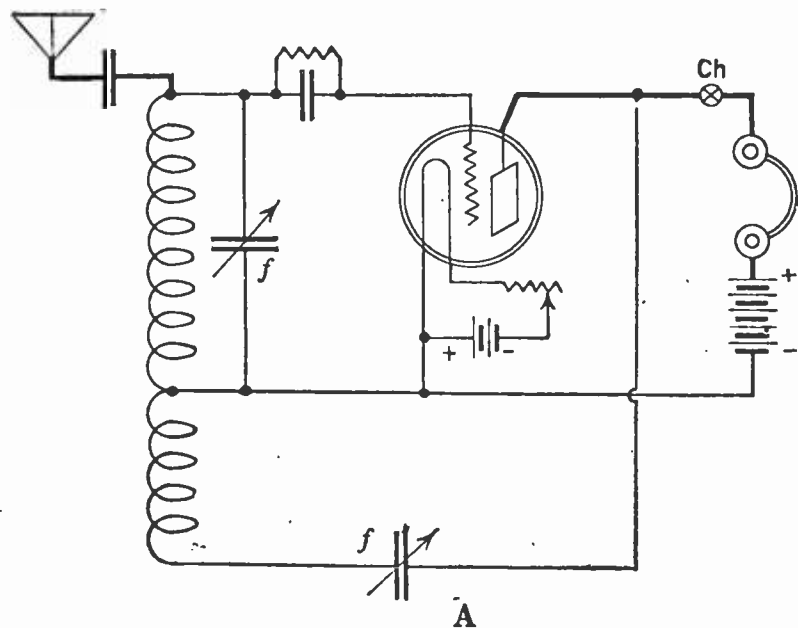

FIG. 3

shaft. After cutting out the other piece to the shape shown fasten it to the panel with screws and nuts or you can use switch points if you have them on hand. Connect this in parallel with the main variable condenser and you will get the surprise of your life. The rotor should be grounded. I made one of these the other day and found it better than the ordinary vernier condenser. See Fig. 5. Only the switch knob shows on the panel with the lever cut off.—WELSFORD A. WEST, Hopewell, Nova Scotia.

AN AUTOMATIC POTENTIOMETER CUT-OUT

NOW that multitube radio sets are being used so extensively we have frequent recourse to potentiometers to stabilize the radio frequency circuits. In the usual hook-up for a potentiometer, Fig. 6 it is hooked up directly across the A battery terminals. This, of course, slowly uses up current and as sets employing r. f. consume plenty of current without the help of a continual leak, we frequently resort to some form of cut-out switch.

The usual ratings of potentiometers are 200 and 400 ohms. The loss across a 200-ohm one amounts to about 0.03 amperes day and night or nearly one half the current consumption of a 6V-199 vacuum tube. The 400-ohm size has a current flow of 0.015 amperes, which in three or four weeks would run down a storage battery without the set being used at all.

The setting of a potentiometer does not affect this loss, as the entire resistance is connected across the battery and turning the dial to zero does not open the circuit, contrary to the belief of many people.

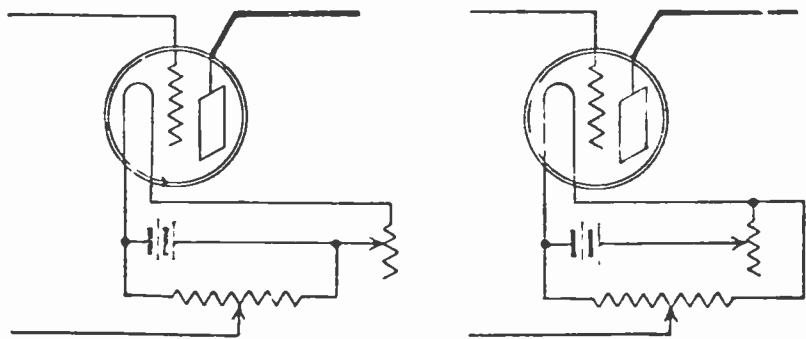

FIGS. 6 AND 7

Fig. 7 shows a hook-up that automatically cuts out the potentiometer when the filament rheostat of the first r. f. tube is turned off. The ohmage of the rheostat is added to that of the potentiometer, but that does not detract from its efficiency.—K. W. ROOT, Boston, Massachusetts.

A TOOL TO DRILL HOLES IN GLASS

TAKE an old three-cornered file and on an emery wheel, smooth down the face of all three sides, so that the edges are knife-like.

Then break off the point of the file, say about one inch from the bottom, and with the emery wheel bring all the sides to a point as in Fig. 8.

To drill holes in glass, mark your holes the same as on a bakelite panel but use a glass cutter to make the center mark. Make a

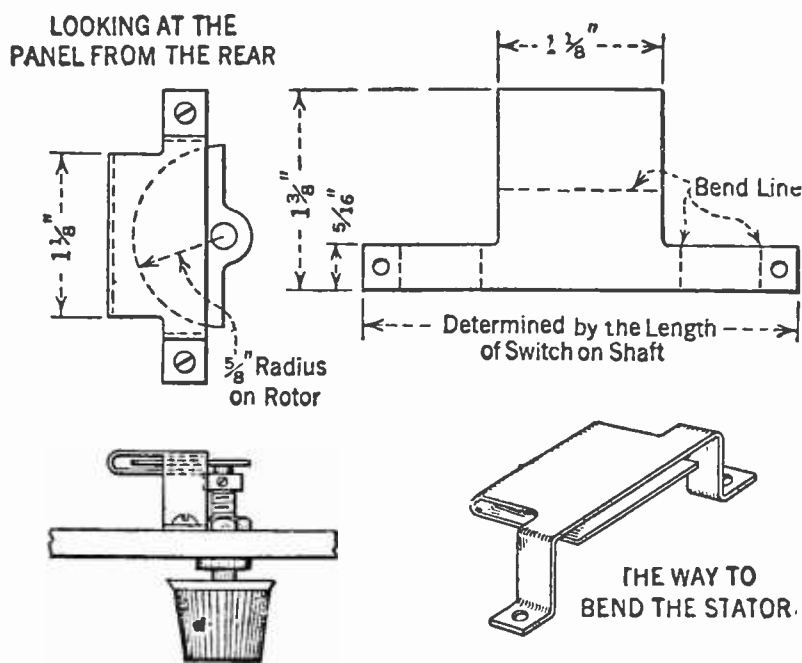

FIG. 5

small cross where you want the hole, then take the tool and put it in a brace. Put some turpentine in a small oil can and apply a little on the tool. Do not try to drill too fast as you are apt to break the glass, also do not press too hard on the drill. When almost through the glass, that is, when the point comes through the other side, turn the glass over and drill from that side. Do not cut too fast or chipping will occur.

Be sure to apply plenty of turpentine to the tool or it will not work satisfactorily. If it is desired to make the hole larger, use a file of greater size and ream out as with bakelite panels. Be sure the glass is on a level foundation.—C. J. EISEN, Watertown, South Dakota.

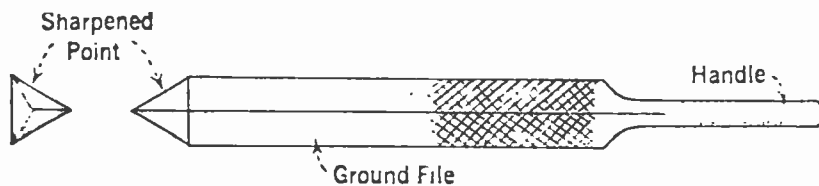

FIG. 8

SEVEN CONSTRUCTION IDEAS

TO START a screw in an inaccessible spot, an electrician sticks a bit of tape over the end of his screw driver, just thick enough to make a snug fit in the screw slot. In this way he can start the screw down a hole as deep as the screw driver itself.

The clock maker and watch maker use wooden screw drivers to handle their small screws. That is they sharpen a toothpick or wooden skewer to make a snug fit in the screw slot. You can start a nut in a hard place by lightly forcing it on the end of a hardwood stick, leaving one or two threads free.

Another trick is to wind a wire around the screw, to hold the screw where you want to

start it. The wooden-screw driver or the electrician's tape trick—paper will do in place of the tape—meet most emergencies, however.

Clockmakers, when they break off a steel screw in a brass plate, boil the plate in alum water. The alum attacks the steel, but not the brass.

Rubber panels, with all their advantages, have one defect which must be watched. Under constant pressure, rubber gives; and a nut, driven home tight, will gradually loosen. Go over your panel after a few weeks, and give all nuts an added turn with the socket wrench.

Wind the NP coil, of the Roberts set, on the same frame as its secondary, using No. 36, or finer, wire. Wind the NP on first, then the secondary on top of it. I think that the diamond-weave is best, giving a broader wave band and sharper tuning. Remove spokes of the winding form, and sew coil together with dental silk. Then a half-inch strip of bakelite, $\frac{1}{16}$ inch thick, slipped through the coil makes a firm support and provides space for terminals.

This use of fine wire primary is in line with recent developments, to cut down capacity between primary and secondary. Grebe used No. 40 wire in the Synchrophase; and Browning-Drake concentrates a fine winding in a narrow slot at one end of the secondary.

Wind a few turns too many on the secondary; then remove the excess, turn by turn, until the right hand dial tunes exactly like the left hand dial.

Space the tickler coil fully an inch from the face of the secondary. The better your set is designed, the fewer tickler turns will suffice. Start with 15, and remove them turn by turn, until it just spills over when fully advanced, on the high wave. In a lively set, with a detector tube that oscillates easily, 12 turns should be enough. Choose a good oscillator for your detector tube, and burn it as low as possible.

Why not adopt and familiarize the prefix "pico" for micromikes? Thus, instead of saying a "triple-O-five" condenser, for an instrument of 500 micro-micro-farads, let us say 500 picos, which is correct and simple, if we once get used to it. To be precise we should say pico-farads, but we could drop the farads, once we get used to the pico end of it. Thus our standard ratings would be in 1000, 500, 350, and 250 picos, for tuning condensers; and we would specify balancing condensers as from 5 to 10 to 50 picos. Also, to say a tuning condenser has a minimum of 15 picos would be much simpler to the average mind

than to follow the present practise of saying .000015 mfd.—F. I. ANDERSON, New York.

MAKING A NEUTRALIZING CONDENSER

A NEUTRALIZING condenser can be made at home very easily and at the same time very cheaply. Get a piece of good dielectric about 3 inches long and drill a hole about $\frac{1}{2}$ inch from each end. Bend two pieces of sheet copper or brass as shown in Fig. 9. Fasten them to the base by means of binding posts. Obtain a threaded brass rod $2\frac{1}{2}$ inches long that will fit a nut taken from a dry cell.

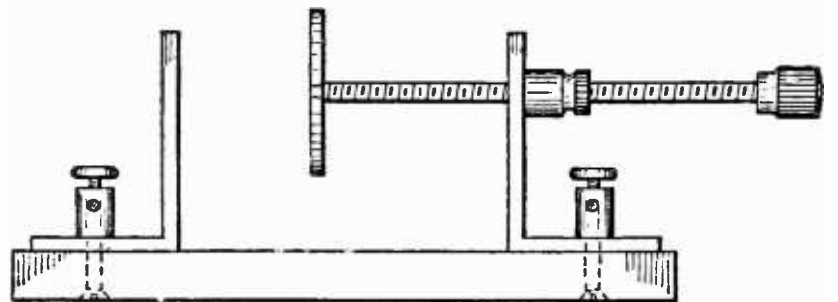

FIG. 9

Solder the nut to one of the bent pieces of copper or brass. Get a piece of copper about the size of a nickel and solder it to the brass rod, screw the rod into the nut and mount a small knob on the other end. You may neutralize your tubes by turning the knob back and forth, varying the space between the disc and the other copper angle.—CARL ROBERSON, Laurel, Montana.

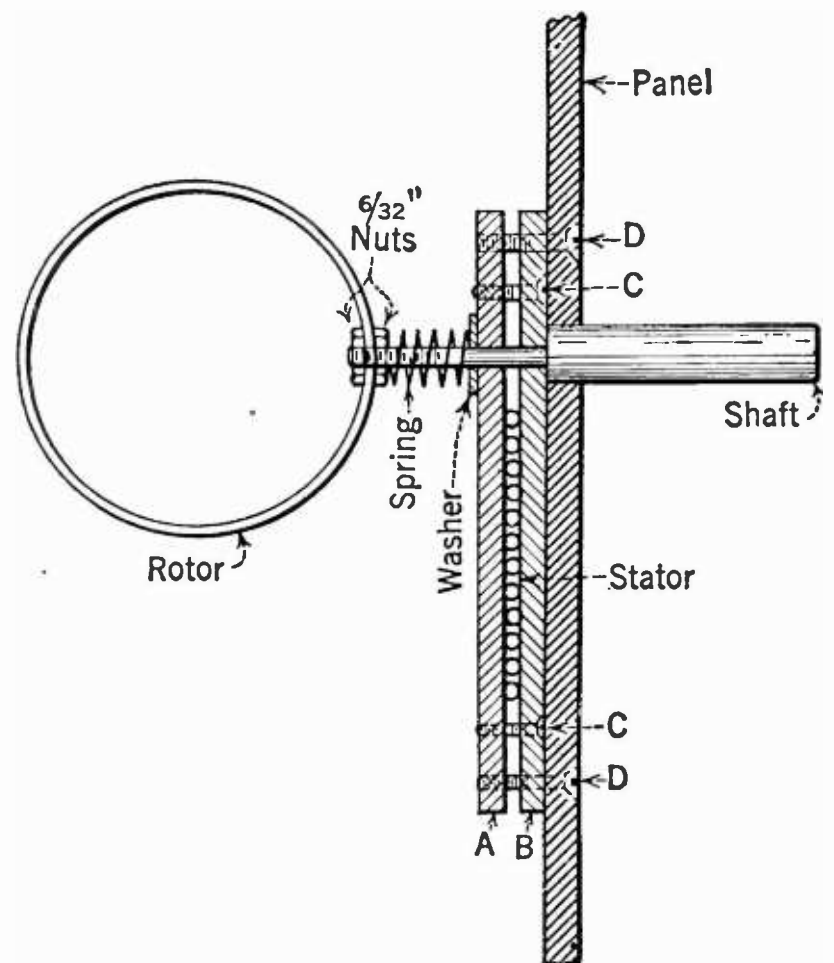

FIG. 10

A GOOD SINGLE BEARING FOR ROTOR COILS

THE bearing described here was first made for use with the self supporting low-loss coils recommended by Mr. Silver for his "Good Four-Tube Set."

The cross-section sketch, Fig. 10, shows pretty clearly just how the bearing mounts and works. A piece of regular $\frac{1}{4}$ -inch brass rod is turned down on one end and threaded to the size of a 6-32 machine screw. Usually this end will be about $\frac{3}{4}$ -inch long. The uncut end of the rod from the collar out is left standard length, about 1 inch long, to take a dial or pointer.

The two strips in the drawing are cut from some scrap 3-16 inch bakelite or similar material. The piece B may be about 3 by 4 inches instead of just a strip, as this will give the stator a more solid rest. It will also leave plenty of room for mounting binding posts where the various coil connections are made. The stator is firmly clamped between A and B by tapping holes and fastening with machine screws as shown at C-C, countersunk. This whole unit which now holds the stator coil is clamped to the back of the panel by the two machine screws at D-D.

Drill the panel to just clear the $\frac{1}{4}$ -inch shaft. The collar will rest against the strip B just behind the panel. Now drill the strips A and B to just clear the turned parts of the shaft, the 6-32 end.

Place a brass washer over the shaft and rest against inside face of A. A small spring is placed over the shaft and held against the washer by a 6-32 hexagon brass nut. Place the rotor on the shaft and clamp in place with the second nut.

Tension on the bearing is adjusted by tightening or loosening the two brass nuts. This should be just enough to allow your rotor to stay where last turned without any undue binding. I find this a real economical bearing which solves low loss coil mounting troubles and is easily made from parts in your "scrap box."—GERALD GRAY, West New York, New Jersey.

A HANDY CRYSTAL DETECTOR

A BURNED out tube can be used in making a crystal detector that is easily substituted for the detector tube in single or multiple tube sets.

An old tube is held in a gas flame until the cement holding it loosens sufficiently to allow

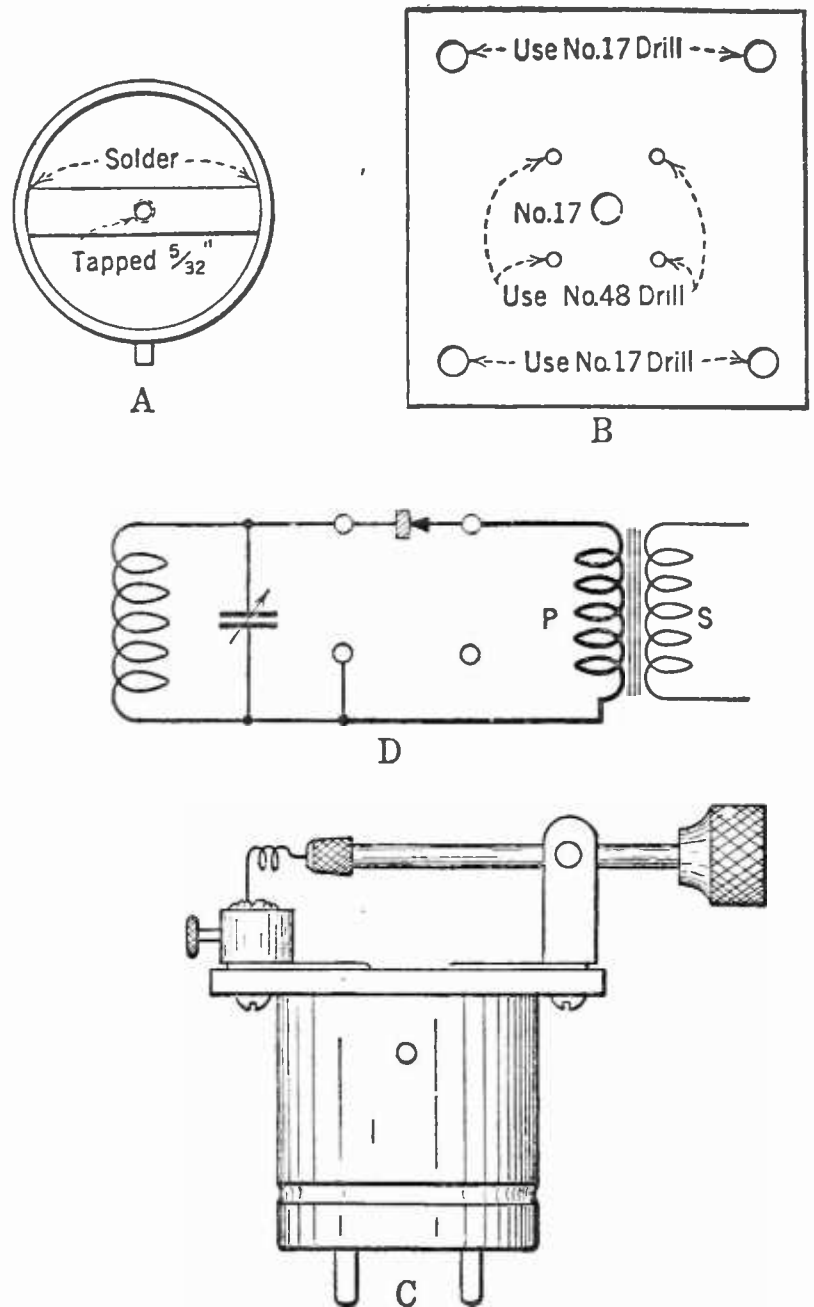

FIG. 11

the bulb to be drawn out of the base. A small piece of brass is soldered across the inside of the tube base, about 1-32 of an inch from the top. This is drilled and tapped for an 5-32 screw as in Fig. 11 A.

Cut a piece of bakelite or hard rubber about two inches square and drill as shown in B.

Solder four pieces of No. 18 bare copper wire 3 inches long in the prongs on the base, allowing them to project slightly. Slide the bakelite over the wires on top and put in the 5-32 screw in center. The wire is looped around machine screws in each corner. The crystal detector (which can, of course, be a fixed one) is connected from grid to plate, which is the same side as the pin is on. The other screws which connect to plus and minus filament have binding posts. See C in Fig. 11.

To use this device, remove the detector tube from its socket, short circuit the grid condenser, remove the detector plus B wire from the battery and connect it on the binding post of the crystal detector, but be sure to use the one which leads to your grid return as in D.—FRANK MEISTER, Jersey City, New Jersey.



QUERIES ANSWERED

MAY I HAVE A CIRCUIT AND EXPLANATION FOR THE TESTING OF VACUUM TUBES?

E. F. McC.—Chicago, Illinois.

HOW CAN I MAKE A TEST FOR A GOOD GROUND?

N. P. L.—Brooklyn, New York.

IS THERE SOME SIMPLE WAY FOR COMPARING LOUD SPEAKERS?

A. S.—Newark, New Jersey.

WILL YOU PUBLISH A CIRCUIT FOR A SIMPLE CRYSTAL RECEIVER?

M. O.—Patterson, New Jersey.

WHAT IS MEANT BY "MATCHING TUBES?"

S. T. A.—Montreal, Canada.

CAN THE ROBERTS RECEIVER BE USED WITH A LOOP?

L. A.—San Juan, Porto Rico.

WHAT COIL COMBINATION WILL REPLACE THE UV-1716 TRANSFORMER IN SUPER-HETERODYNES?

V. St. M.—Baltimore, Maryland.

HOW MANY TOROID COILS BE USED IN NEUTRO-DYNES?

R. M. T.—Detroit, Michigan.

HOW TO TELL THE CONDITION OF VACUUM TUBES

HOW efficient are your vacuum tubes? A vacuum tube, to be satisfactory must be able to operate over a long period of time at maximum efficiency.

Merely inserting a tube in a socket and noting whether it lights does not constitute a practical test of the tube's efficiency. Above it was said that a tube should be at its maximum point of efficiency for a long period of time to be satisfactory but this is the only figuratively speaking. Under actual operating conditions the efficiency of a tube will fall off as its hours of use increase.

To determine the condition of a tube it is necessary to know several things such as input voltage, its filament voltage and amperage, plate voltage, and the current in milliamperes which is being consumed in the plate circuit. To know these facts a test circuit having meters for testing the various voltages and currents must be employed. Such a circuit is shown in Fig. 1.

Storage battery tubes are usually operated at 5 volts and at this potential the current consumption should not be over $\frac{1}{4}$ of an ampere for the 201-A type. Dry cell tubes are either of 3-volt or $1\frac{1}{2}$ -volt operating potential and draw not over .06 amperes for the former and .25 ampere is for the latter.

When tubes are new, the

electronic emission which is indicated in plate milliamperes is naturally high when a normal plate voltage is applied, say 90 volts. As the tube grows older or if the filament is burned too brilliantly the plate mils decrease quite rapidly, materially affecting the property of the tube to function correctly and efficiently.

With the meter circuit described here it is possible to make graphs of the function of a tube at various grid or input voltages. By means of the variable resistance R_1 , the grid voltage may be varied from 10 volts negative to 10 volts positive.

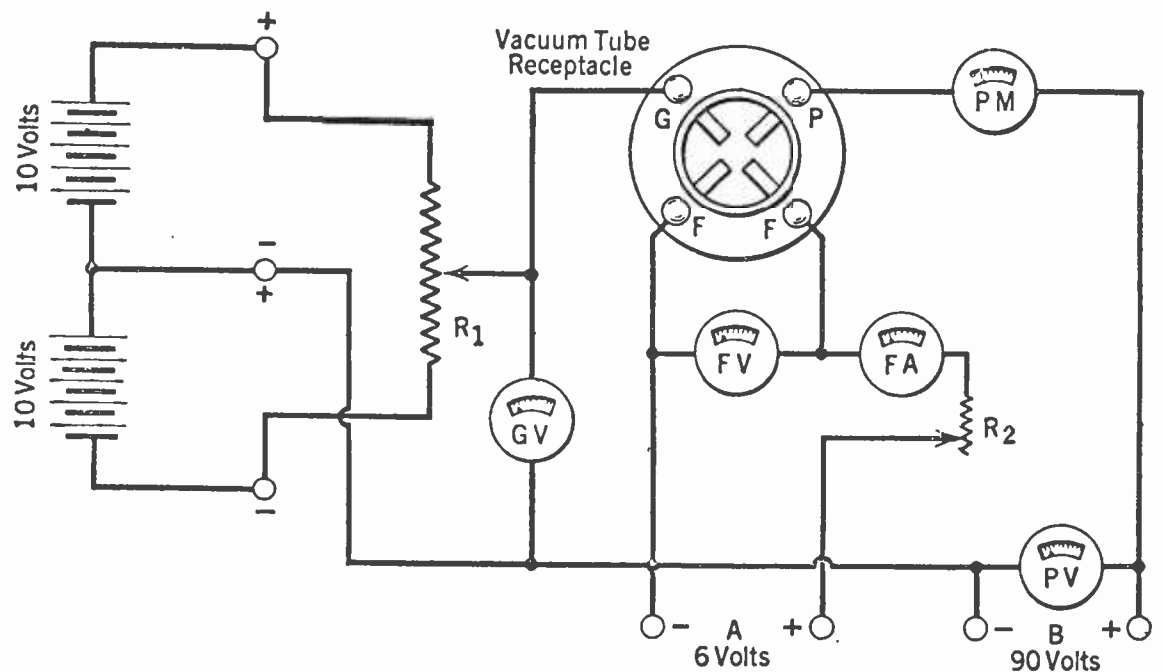

$R_1 = 400$ Ohms
 $R_2 = 60$ Ohms
 PM = Plate Milliammeter 0-10
 PV = Plate Voltmeter 0-120

FA = Filament Ammeter 0-15
 FV = Filament Voltmeter 0-6
 GV = Grid Voltmeter 10-0-10

FIG. 1

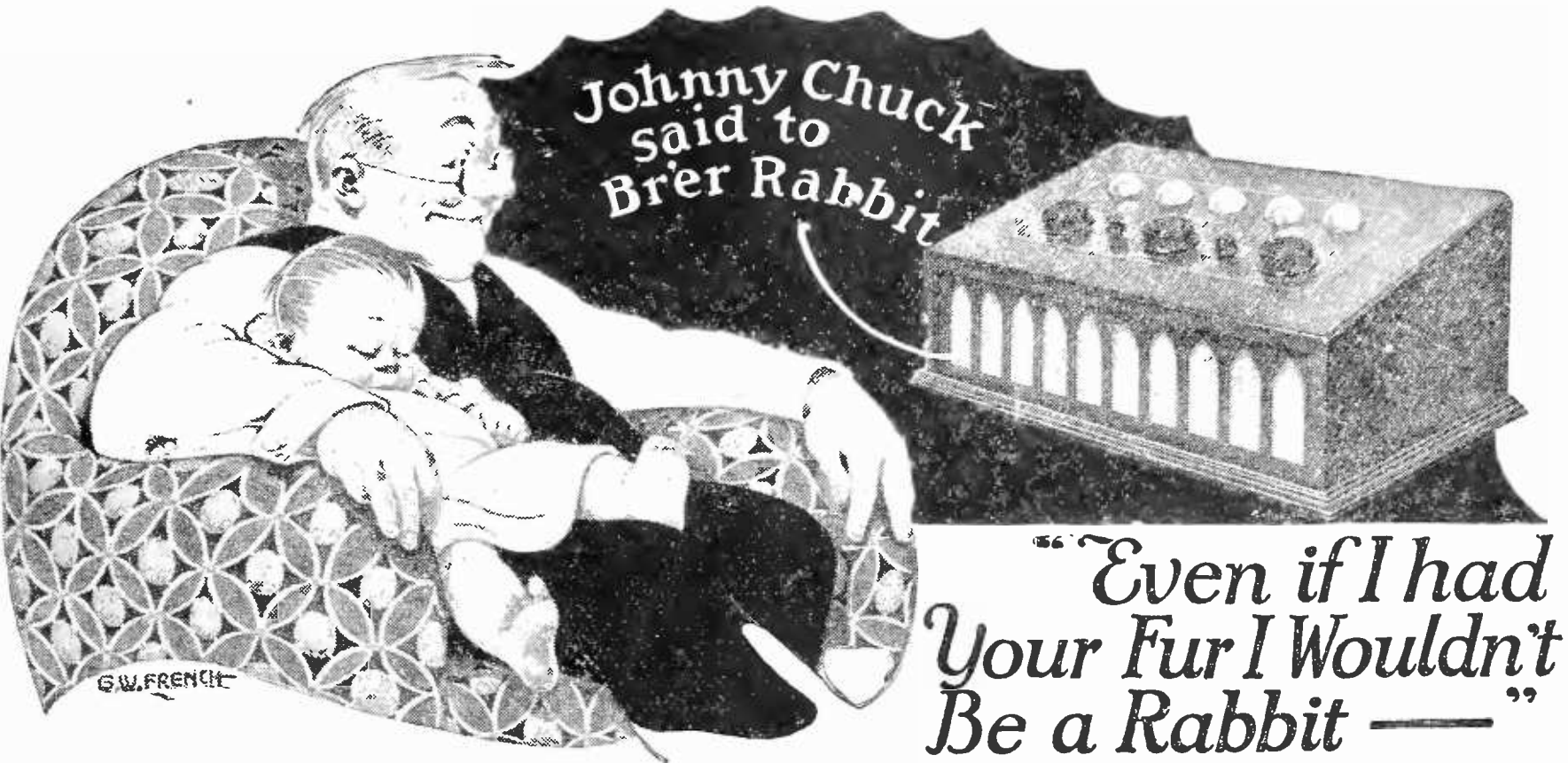

“Even if I had Your Fur I Wouldn't Be a Rabbit —”

AN attractive cabinet can never make an Ozarka out of any other radio. Far too many radio buyers pay more attention to the outer appearance and not enough to

the inside. The service behind the radio you buy is even more important than the inside or outside, your satisfaction depends on it. Let us see just what radio service is.

When your automobile runs as the manufacturer intended it should it is a real pleasure to drive it. But what do you do when something goes wrong? Do you immediately condemn the car?—no. Do you call in some handy man who can fix anything?—no.

You send for a service man who is trained in repairing your make of car. To correct the fault is easy for him because he knows. Some other mechanic might have to tear the car apart to locate the trouble.

The same is true of radio, no matter what price you pay—you will sometimes need the service of a service man. If he is factory trained and experienced he can and will deliver the kind of service you know you ought to have.

Ozarka instruments are only sold by direct factory representatives who are required to

take a complete course of instructions in Ozarka service directly under Ozarka engineers. By so doing we are assured that every purchaser of an Ozarka will have an experienced service man within reach at all times. 3100 such men today comprise the Ozarka service organization—more are being added daily. Ozarka service does not add a single cent to the price you pay for your radio—then why not benefit by it.

Ozarka instruments are sold only in competition side by side with others—do your own tuning and therefore decide for yourself just what Ozarka will do for selectivity, distance, volume and above all, tone.

Send for the book Ozarka Instruments No. 200; please give name of your county and we'll gladly have our Ozarka representative arrange a demonstration in your own home.

We Need a Few More OZARKA Representatives

RADIO offers a wonderful opportunity to men who wish to get into business for themselves. It is work that can be done, at the start, in the evenings and your spare time. You can hold your present position and learn radio under our plan. Ozarka instruments have been on the market for four years—they have successfully met all competition. Ozarka representatives have made good, not only because Ozarka Instruments are right but because our training in both selling and service is the most complete possible. All we ask is that you are willing to purchase your demonstrating instrument and willing to learn what we are willing to teach you. We have proven with 3100 men that with this training you can make good in radio. The Ozarka sales course consists of twelve lessons—a real course in salesmanship that costs you nothing—our training in service is so complete that you will know Ozarka Instruments in every detail.

Send Coupon for Free Book

To such a man, who will freely tell us something about himself we will gladly send a copy of the Ozarka Plan No. 100, a rather unusual book. You'll find it interesting because it proves why some men are millionaires and how others made them so—why some men get to the top while others don't—best of all it will show you how you can make more money and become really independent. Send for it today, but please mention the name of your county.

OZARKA

122 Austin Avenue B
Chicago, Illinois



INCORPORATED

122 Austin Avenue, B
Chicago, Illinois

Gentlemen: Without obligation send book "Ozarka Instruments No. 200" and name of Ozarka representative.

Name.....
Address.....City.....
County.....State.....

YOU'LL KNOW THE MAN BY THIS BUTTON!

Gentlemen: I am greatly interested in the FREE BOOK "The Ozarka Plan" whereby I can sell your instruments.

Name.....
Address.....City.....
County.....State.....

At each value of grid volts a reading of plate current (in milliamperes) is obtained. Only the grid volts reading is varied. The plate voltage is fixed at a definite setting such as 90 volts. The filament circuit is adjusted to the correct filament voltage and amperage. Thereafter it is not varied for that particular tube.

With cross-section paper it is possible to make a curve of the operating characteristics of the tube. Along the left hand vertical edge of the paper may be indicated the plate milliamperage readings, and the grid volts may be indicated along the bottom horizontal edge of the paper.

Starting at 10 volts negative grid, a reading of the plate current is taken and repeated for every two volts of grid input. This results in a series of points which gradually, then rapidly and then again gradually rise diagonally across the paper. After the readings are complete, the points may be joined together with a pencil or ink line producing a characteristic curve of the tube. See Fig. 2.

The more compact and vertical the curve is the better the tube functions as an amplifier. When the

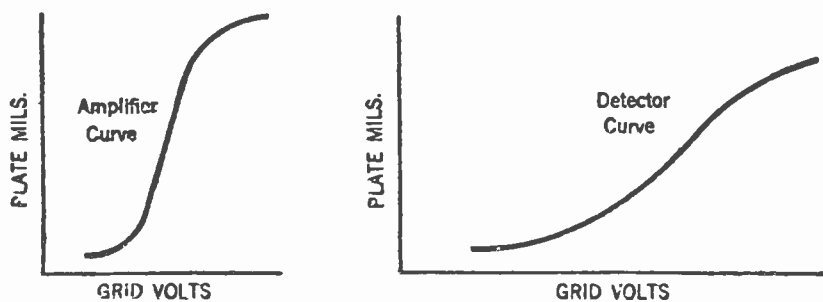

FIG. 2

lower or upper portion of the curve is spread out, the tube will operate very successfully as a detector. By means of this calibration method tubes may be compared and also selected for their various uses in a radio receiver.

A GOOD GROUND

THE problem of securing as near a perfect ground system for a receiver is one that should receive as much attention as the business of erecting a ship-shape antenna.

Cold water and radiator pipes are the usual grounding systems employed, but where the BX covering of light lines or in some instances the neutral line of a 3-wire light system is utilized it is well to make sure that they are actually grounded. To do this screw a 110-volt lamp into a socket to which has been attached two leads about two feet long. Use this arrangement as a test circuit by touching one of the leads on an object which previously has been quite definitely grounded. Now with the other free lead touch its end to first one side of the line, then the other and finally touch the middle line.

A circuit should occur on the two outside lines indicating that they are not grounded. However, for the middle line there will be no circuit inasmuch as it is the assumed grounded side of the 3-wire line. Under no circumstances should the lamp be shunted across both outside lines as the voltage there would be about 220 volts, blowing out the lamp.

Needless to say these tests should be made at the meter box where the 3-line system enters the house. Now while this test will indicate that the center line is not of a high potential in respect to the ground it is not a definite indication that it is

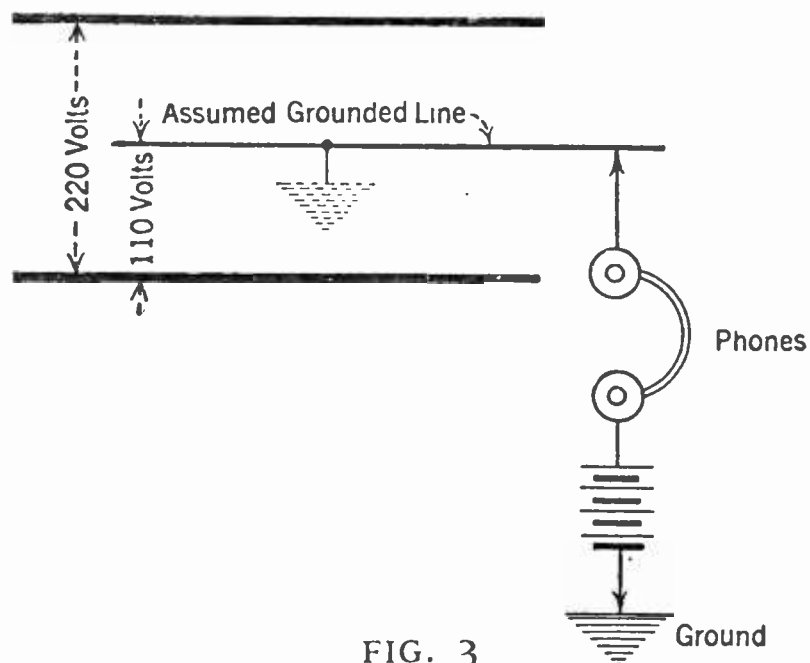

FIG. 3

grounded. Therefore, a circuit test should be made as shown in Fig. 3. A pair of phones and a B battery are all that is required. If a click occurs, the middle line is grounded.

HOW TO COMPARE LOUD SPEAKERS

RADIO dealers, experimenters and broadcast listeners are always interested to know whether or not their loud speaker is functioning satisfactorily.

Considering that a true test of a loud speaker would necessitate an elaborate outlay of precision test instruments it would seem that for those who wish to know how their own type of reproducer operates there is no suitable elementary method of attaining such ends. This is not entirely true where a comparison test will suffice.

Such a method is outlined and best understood by the circuit diagram in Fig. 4. A microphone button is attached to the pin lever of a phonograph tone arm. The primary of an audio frequency transformer is connected to the terminals of the button and the circuit is energized by a $4\frac{1}{2}$ -volt battery. By means of a two-point switch which is connected to the secondary circuit of the transformer as shown, it is possible, when loud speakers are attached to the binding posts, to flip over from one to the other making comparisons on volume output, the quality, resonance points, etc.

The music or other audio signal is obtained by having a record revolving on a phonograph turntable.

A good audio-frequency transformer is an absolute requisite in this construction. One having plenty of iron in its core (which is of large size), large windings and also important one of low ratio

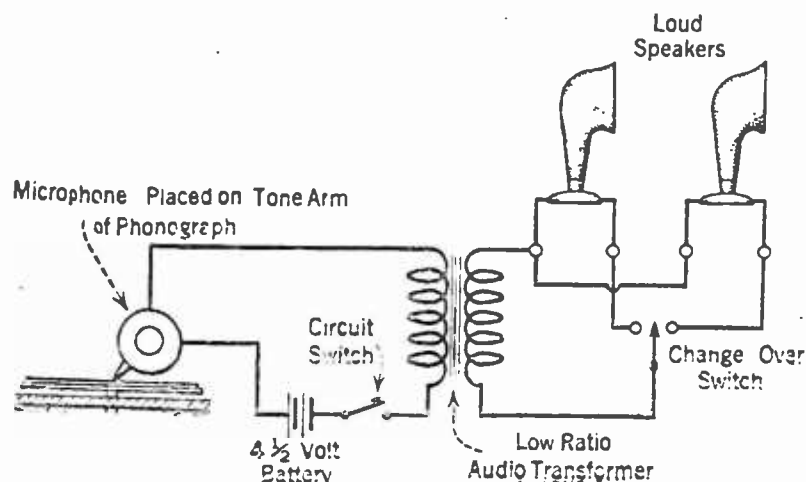
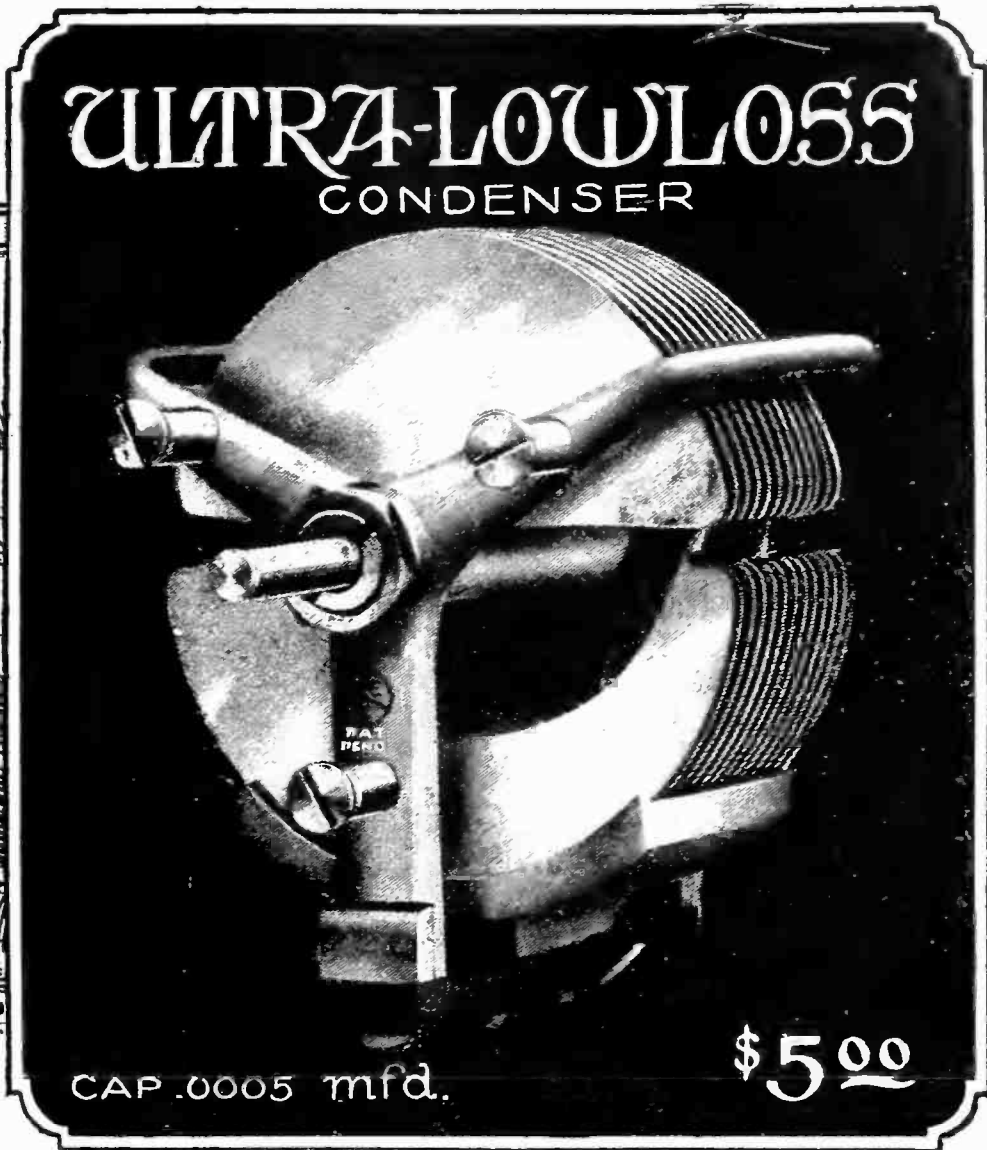
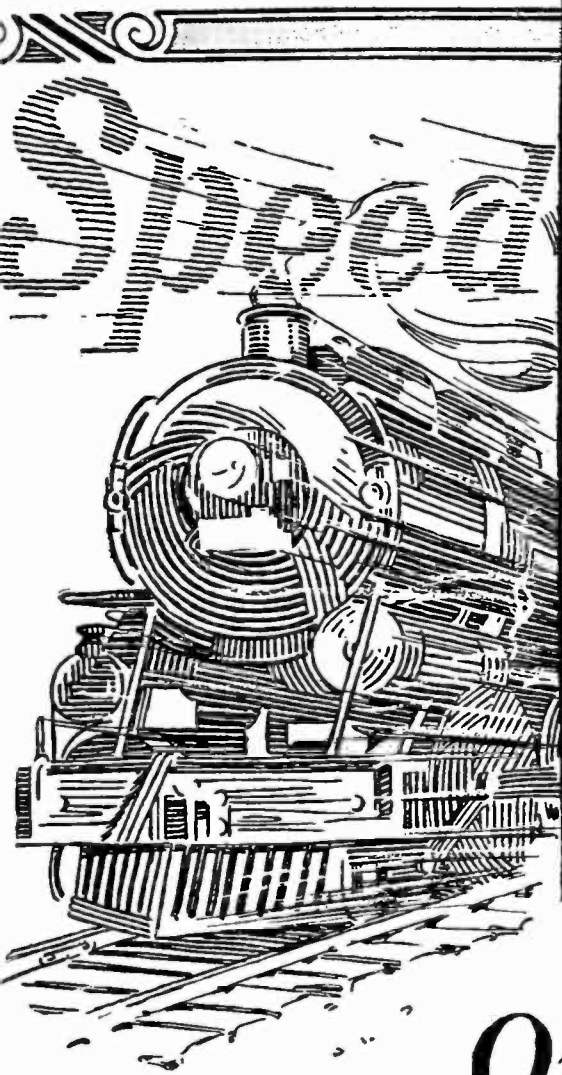

FIG. 4



CAP. 0005 mfd.

\$5.00

Quick, positive tuning

SPEED—ability to turn directly to any station, to tune-in instantly and get your station without interference from broadcasting on similar wavelengths—is the outstanding feature of the Ultra-Lowloss Condenser.

With one station of known wavelength located on the dial, all others can be found instantly. Special design of Cutlass stator plates distributes stations evenly over the dial—each degree on a 100 degree dial represents approximately $3\frac{1}{2}$ meters difference in wavelength.

In addition, losses common in other condensers are reduced in the Ultra-Lowloss to a minimum by use of only one small strip of insulation, by the small amount of high resistance metal in the field and frame, and by a special monoblock mounting of fixed and movable plates. Designed by R. E. Lacault, E.E., originator of the famous Ultradyne receiver and Ultra-Vernier tuning controls.

At your dealer's; otherwise send purchase price and you will be supplied postpaid

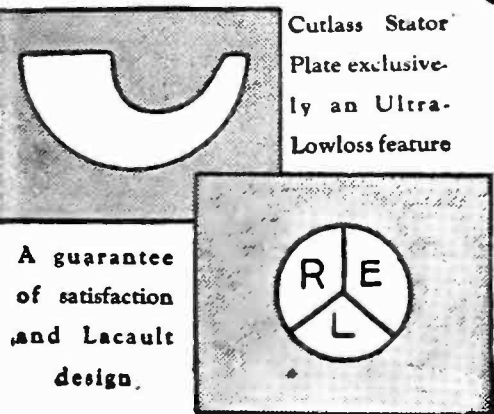

Cutlass Stator Plate exclusively an Ultra-Lowloss feature

A guarantee of satisfaction and Lacault design.

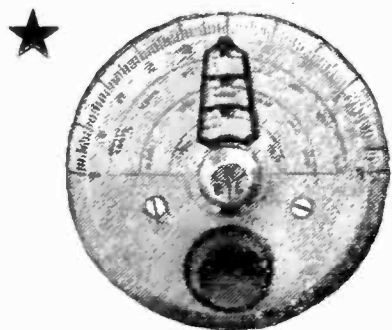

ULTRA-VERNIER TUNING CONTROL

Simplifies radio tuning. Pencil record a station on the dial—thereafter, simply turn the slider to your pencil mark and you get that station instantly. Easy—quick to mount. Eliminates fumbling, guessing. A single vernier control, gear ratio 20 to 1. Furnished clockwise or anti-clockwise in gold or silver finish.

Silver, \$2.50

Gold, \$3.50

ULTRA-LOWLOSS CONDENSER

PHENIX RADIO CORPORATION

116-C E. 25th St. New York

★ Tested and approved by RADIO BROADCAST ★

is desired. The Rauland-Lyric and the General Radio 285 and 285A transformers are satisfactory for such purposes.

Such an arrangement offers an exceptional field for test and experiment not only of loud speakers but of microphone buttons and audio transformers which may or may not be suitable for such work.

A GOOD CRYSTAL RECEIVER

FOR a good crystal receiver circuit we are pleased to offer that indicated in Fig. 5.

The arrangement is simplicity itself. The parts cost is very low and such items as the coil and detector may be home-made. Winding A consists of 45 turns of No. 22 d. c. c. wire wound on a 3½ inch cardboard or bakelite tube. The ends of this winding are connected to the variable condenser terminals. This part of the circuit acts as a selector trap.

The winding B is wound for 10 turns directly on top of winding A. It is insulated from winding A by a strip of paper or cambric cloth. For purposes of experiment it may be advisable to have winding B wound with 20 turns of wire tapped every 5 turns.

A THREE-TUBE DOUBLE REFLEXED RECEIVER

MANY inquirers want data and a circuit diagram for a Roberts receiver which could be used with a loop.

In RADIO BROADCAST'S Laboratory it has been found possible to operate an orthodox four-tube Roberts receiver on the antenna coil secondary without the aid of an antenna or ground. Naturally, too, a loop was successfully employed—but only for local stations. The first secondary coil was merely replaced by a loop as shown in Fig. 8.

If the reflex feature is taken out and a stage of straight audio substituted, much better quality of signals and sharpness of tuning will be observed.

For those experimentally inclined, the circuit diagram Fig. 6. should prove of unending interest. Here is shown a three-tube double reflexed receiver equal, in theory, to a standard five-tube set. Ex-

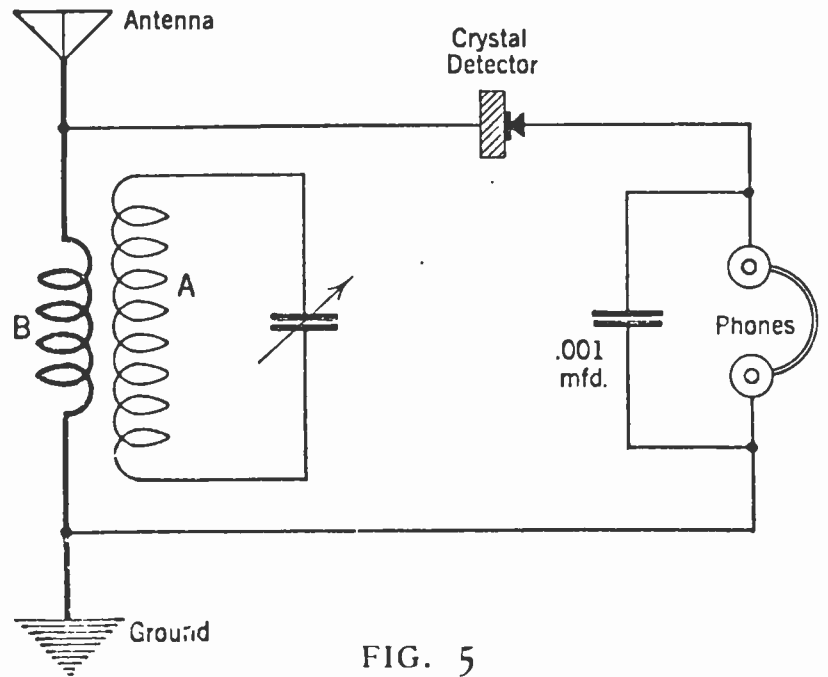

periments have been conducted at RADIO BROADCAST'S Laboratory and the set worked very well. But from a "how-to-make-it" standpoint it was felt to be of such little practical value that it was never especially described in the magazine.

Care should be taken in placing the coil units so that they are on the same plane and at right angles to each other. Bypass condensers are also important. For best results, the experimenter should try various values. Low ratio audio transformers have been found best for reflex work and especially so in all audio amplifiers where tone quality of the highest degree obtainable is desired. This data is advanced to our readers for what it's worth. It is not possible for us to furnish additional constructional notes for a completed layout. This data merely is to be regarded as of an experimental nature.

MAKING TRANSFORMERS FOR THE SUPER-HET

FOR about a year after the UV-1716 long wave radio-frequency transformers were put on the market, they acted as dust collectors and paper weights in many retail establishments throughout this country. Many of the radio jobbers found it difficult to explain to these dealers why

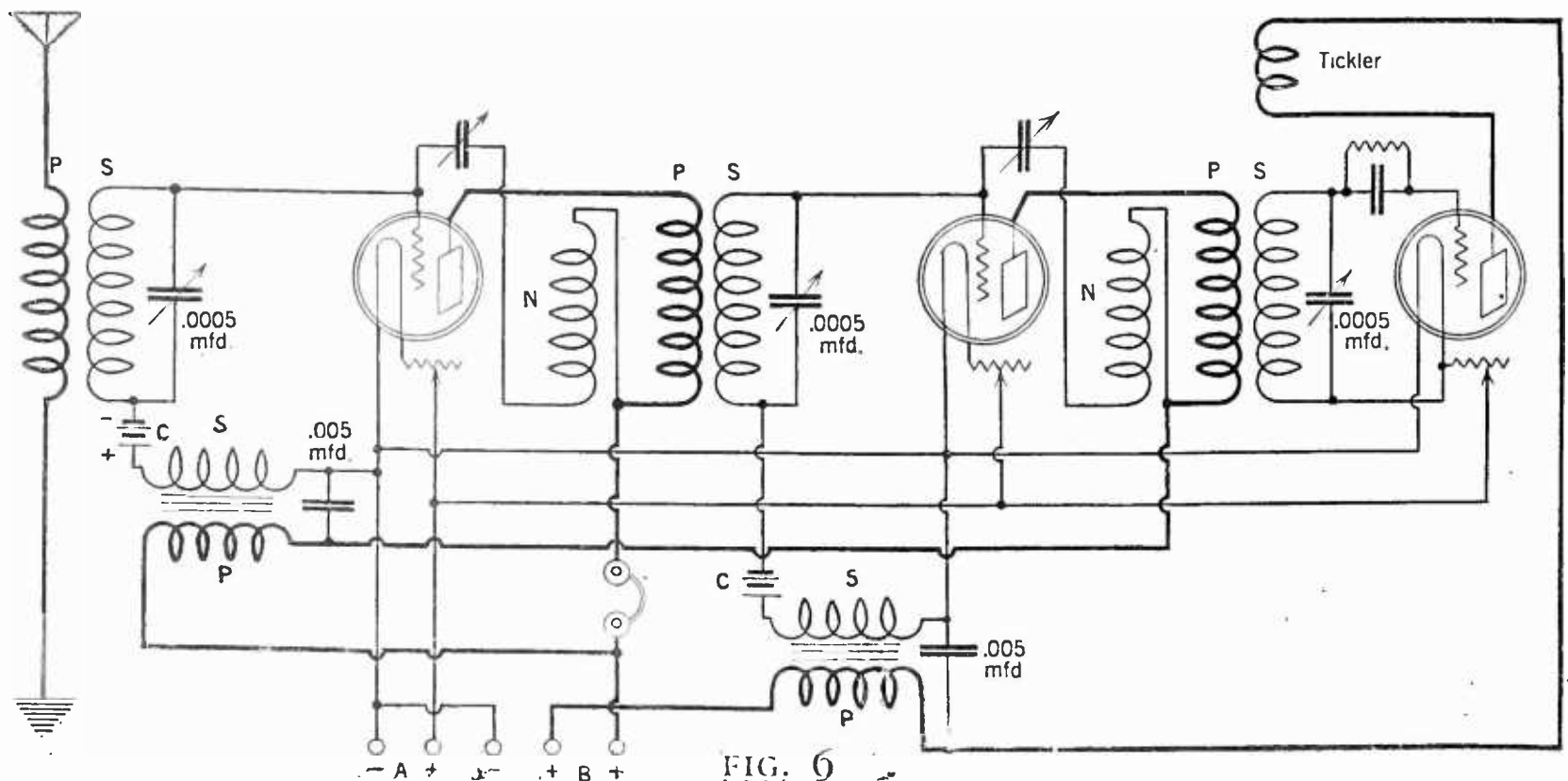

Only specialists can make *good* fixed condensers

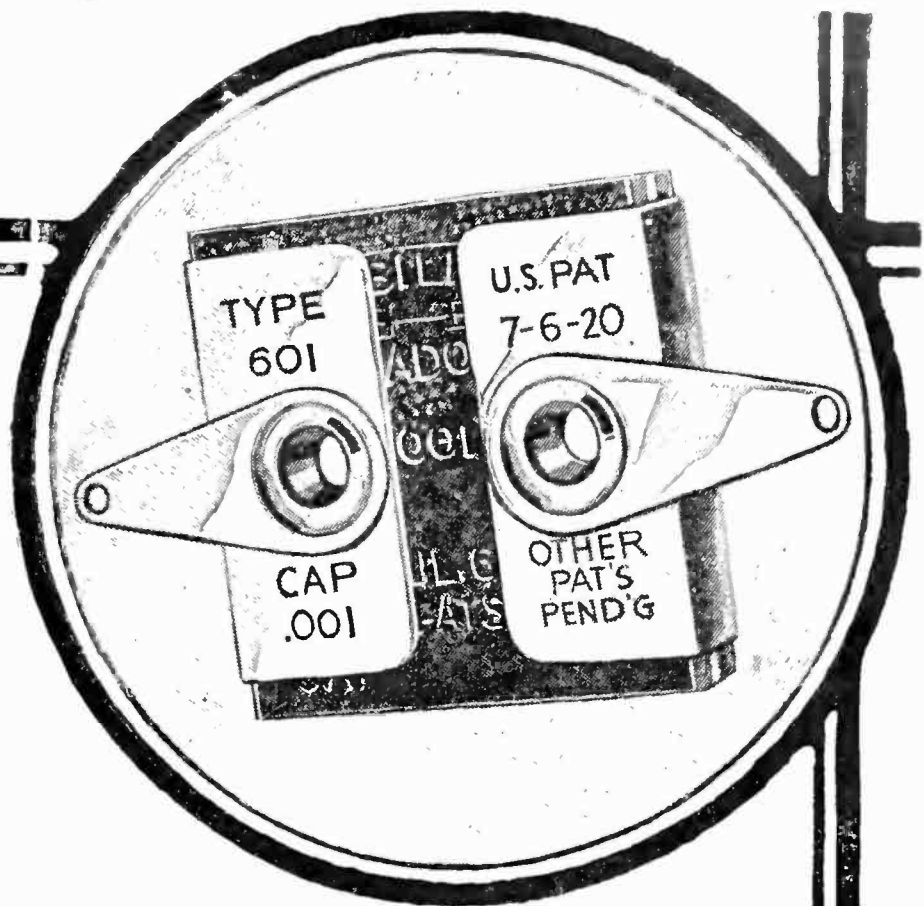

THE small fixed condensers in your radio set are there to help you get clear reception. If these little condensers are not made *most accurately* the quality of reception you get—even though your set may be excellent in all other respects—will be greatly impaired.

You will find that nearly all sets made—in fact over 90% of them—are equipped with Dubilier Micadons. This is the name by which all Dubilier fixed condensers are known.

Be sure your set—whether you buy it or build it—is equipped with Micadons. They are made by *specialists*.

Dubilier[★]

CONDENSER AND RADIO CORPORATION

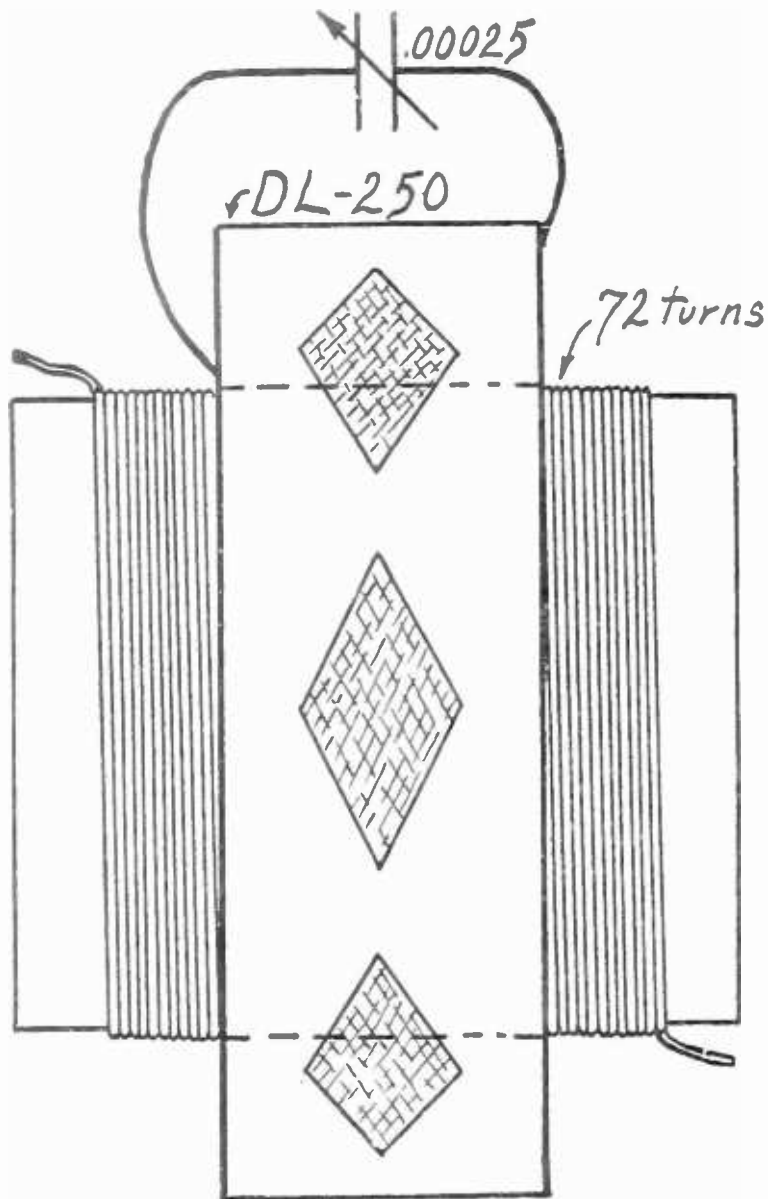

FIG. 7

so many of these transformers had been unloaded on them by glib salesmen. "Who," they would ask, "wants to use five thousand meter transformers when all the broadcasting is being done on less than six hundred meters?"

George J. Eltz, Jr., who is manager of the Radio Department for the Manhattan Electrical Supply Company, found this question extremely embarrassing. By developing a super-heterodyne in which these transformers would be used, he helped unload the shelves of every retail store in the country.

Today there are many types, shapes and sizes of intermediate transformers, but for those who wish to make their own, the data presented here will be of interest and value.

One of the simplest substitutes for this transformer, when used at its most efficient point—about 47,000 cycles—may be made as follows:

Procure a DL-250 coil and a piece of mailing tube just large enough to pass through it readily. On the mailing tube wind 72 turns of No. 32 double cotton-covered wire. These 72 turns form the primary. The DL-250 coil is shunted by a .00025 mfd.

variable condenser. See Fig. 7. The current in the primary from the plate should flow in the reverse of that entering the secondary from the grid.

In the development of the super-heterodyne, several designers deemed it expedient to get away from the long wave transformers designed to cover a wide band of frequencies in favor of another type for which certain advantages are claimed. This latter type requires no iron in its core nor does it require tuning. Its fundamental frequency is comparatively high, and it will not permit audio-frequency disturbances to pass through the radio stages.

A wooden spool $2\frac{1}{2}$ inches in diameter with two slots $3\text{-}16$ inch wide separated by $\frac{1}{8}$ inch and with a base diameter of $\frac{3}{4}$ inch is the winding form used for the windings. In the interstage transformers the primaries are wound with 800 turns of No. 32 d.s. c. wire, and the secondaries with 1000 turns of the same wire. The input transformer differs only in having its primary winding reduced to 300 turns so that with the .0005 mfd. condenser across this winding it resonates at approximately 99.9 k. c. (3000 meters).

The outside primary lead is run to the plate, the outside secondary to the grid. The inside primary goes to the B battery and the inside secondary to the stabilizer arm. The input transformer is used to feed from the first detector into the first r. f. tube.

TOROIDS FOR NEUTRODYNES

ONE of the latest improvements in radio apparatus, the low loss toroid coil, can be used in any of the neutrodyne and tuned radio frequency receivers to increase selectivity in tuning through local stations, and to stabilize the circuit. Its use in place of the customary aperiodic coupler used for tuning the first stage will improve the average receiver.

The interference, noise, and general tuning quali-

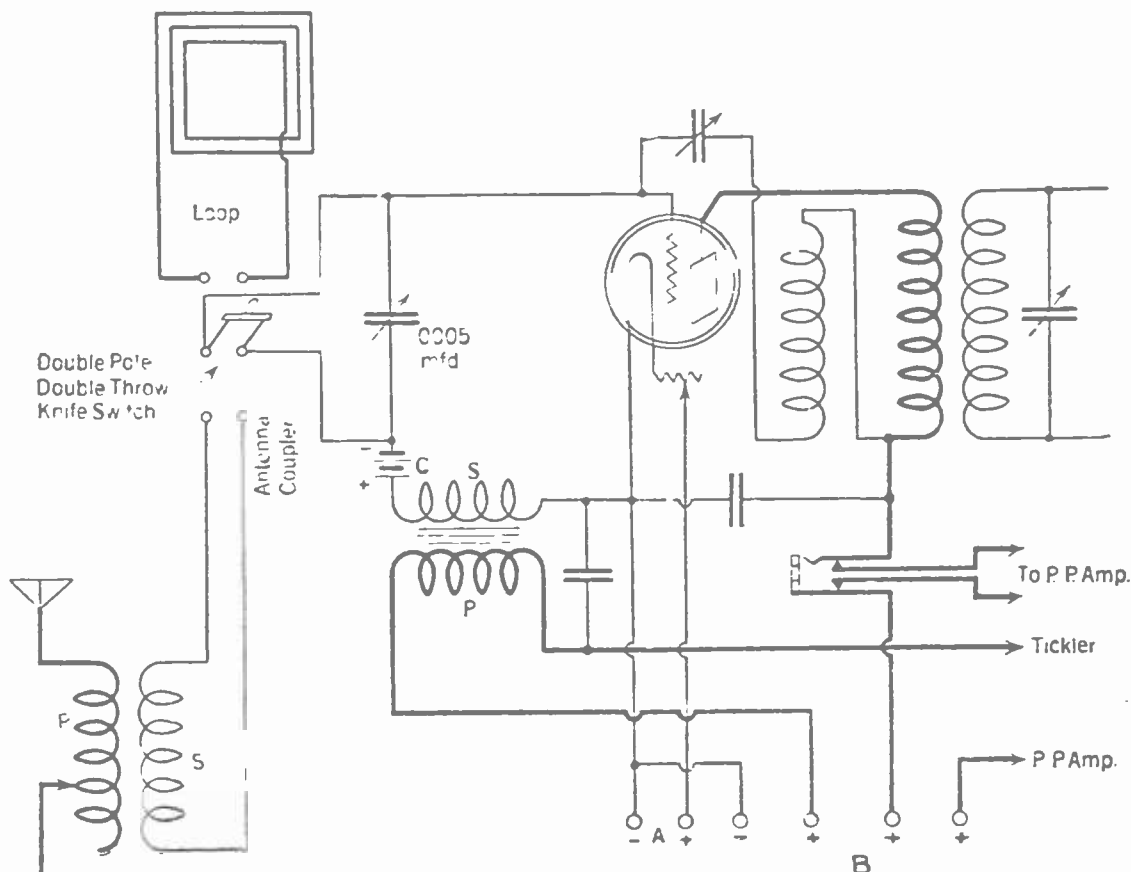
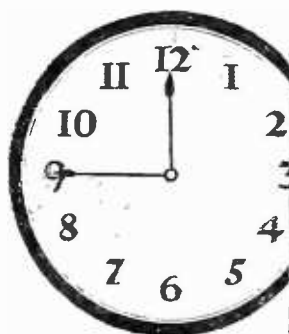

FIG. 8

Build this phenomenal new radio in 45 minutes



The revolutionary Erla Circloid-Five Factory-Bilt Kit—as you receive it.

Price \$49.50

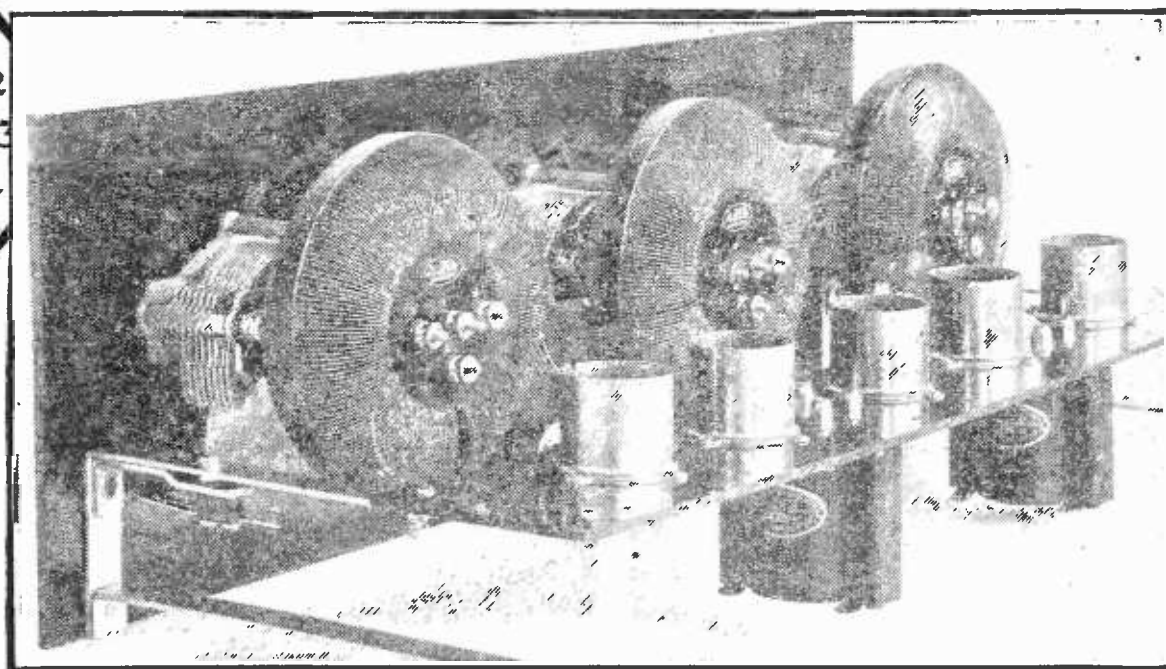

This new type kit is factory assembled. Ready cut, flexible, solderless leads make it ridiculously easy to wire. Amazing new inductance principle brings results hardly thought possible. Send for book, *Better Radio Reception*.

NOW anyone can build the finest of receivers in only a few minutes. No more wire bending or soldering. Merely attach a few ready cut, flexible eyeletted leads and the job is done. The finished set is unsurpassed even by the costliest factory-built receiver.

But most amazing is the new inductance principle incorporated in this last word in kits—called the Erla Circloid principle of amplification.

Four vital improvements result from this great discovery, which are not found in ordinary sets.

1. Greater Distance: Erla *Balloon *Circloids have no external field, consequently do not affect adjacent coils or wiring circuits. This enables concentration of proportionately higher amplification in each stage, with materially increased sensitivity and range.

2. More Volume: Increased radio frequency amplification made possible by Erla Balloon Circloids gives concert volume to distant signals inaudible with receivers of conventional type.

3. Increased Selectivity: Erla Balloon Circloids have no pick-up quality of their own. Hence only signals flowing in the antenna circuit are amplified. Static is greatly reduced for this reason.

4. Improved Tone Quality: The self-inclosed field of Erla Balloon Circloids eliminates stray feed-backs between coils and consequently does away with mashing of signals and distortion. Tone is crystal clear and perfectly lifelike.

Write for free information on kit—also book. See how 45 minutes of fun will give you the newest and most nearly perfected set known to radio science. Easy as A-B-C to finish. Examine it at any Erla dealers, or send the coupon for full information, illustrations and diagrams free. Also ask for remarkable new book, "Better Radio Reception," describing the sensational new Circloid principle. Enclose 10c for mailing and postage on book.

Electrical Research Laboratories

Dept. 109, 2500 Cottage Grove Ave., Chicago

*Trade Mark Registered.

ELECTRICAL RESEARCH LABORATORIES,
2500 Cottage Grove Avenue,
Dept. 109, Chicago, U. S. A.



Send me free information on kit. Enclose 10c for postage for book "Better Radio Reception."

This sign identifies authorized Erla distributors. All are equipped to give complete radio service.

Name.....

Address.....

City.....State.....

Dealers: Exclusive franchises are available to high class dealers in localities still open. Write or wire immediately.

★ Tested and approved by RADIO BROADCAST ★

ties of the first stage are amplified and eventually become the output of the receiver. If the first stage is broad in tuning, the receiver will very likely lack selectivity. The action of the first stage has a great deal to do with the ultimate performance of the receiver.

The usual type of transformer used has a single layer-wound coil on a tube, with a tap taken off for the antenna connection. The field of the magnetic lines of force around the ends of the coil, created by the flow of current through the wire, spreads out and sprays near-by pieces of apparatus, causing distortion and making the receiver unstable in operation.

The toroid type of coil, on the other hand, has an entirely self contained field that prevents magnetic spraying effects. The low loss feature of one of the manufactured type of coil now obtainable is due to the fact that the wires are indented at every other face around the coil, thereby lowering the distributed capacity and resistance losses below that of ordinary coils to a noticeable degree.

To incorporate the coil in a regular neutrodyne or tuned radio frequency receiver, all that is necessary is to remove the present coil used for tuning the antenna circuit and replace it with a toroid coupler. The same condenser can be used to tune the receiver providing it is of .0005 mfd. capacity.

To construct the complete receiver as shown in the diagram Fig. 9, the following list of apparatus will be needed:

- 1—toroid coupler.
- 2—radio frequency transformers, tuned type. (Radio Frequency transformers of the toroid type may be used here with excellent results).
- 3—.0005 mfd. variable condensers, preferably straight-line frequency low loss condensers so that the lower wavelength stations will be separated far apart enough to make tuning easy.
- 5—standard vacuum tube sockets and five rheo-

stats, 25-ohm for the 6-volt and 40-ohm for the 3-volt type tubes.

2—low ratio audio frequency transformers, 3 to 1 ratio.

1—.00025 mfd. fixed grid condenser; 2-megohm grid leak; single circuit phone jack, binding posts, wire, a 7 x 24 or 26-inch panel, and a 7 x 23-inch baseboard will complete the list of apparatus necessary.

Follow out the wiring diagram Fig. 9 in building the receiver, spacing the regular tuned radio frequency transformers at least six and one half inches apart. If toroid transformers are used, as well as the coupler, then the spacing can suit the arrangement of the rest of the apparatus in your set, without fear of interstage coupling.

ON MATCHING AND UNMATCHING TUBES

WITH the general consistency of the better vacuum tubes being sold to-day there is small necessity for "matching tubes." The fact is, for most purposes tubes are so similar in their characteristics that they may be considered as being matched. The notable exception is in the super-heterodyne, where juggling tubes around in the intermediate stages is usually necessary to secure satisfactory reception. But contrary to the general idea, this changing of tubes does not necessarily constitute matching. It is often a process of deliberate unmatching, which in many cases stabilizes the action of the amplifier.

Satisfactory reception on the "super" can seldom be achieved other than by use of the highest grade tubes. Some bulbs, which function in other receivers in this laboratory show up their defects in "super" operation. Howling, instability (uncontrollable oscillations with beat whistles) at normal plate voltages are evidence of poor or improperly balanced tubes in the intermediate amplifier.

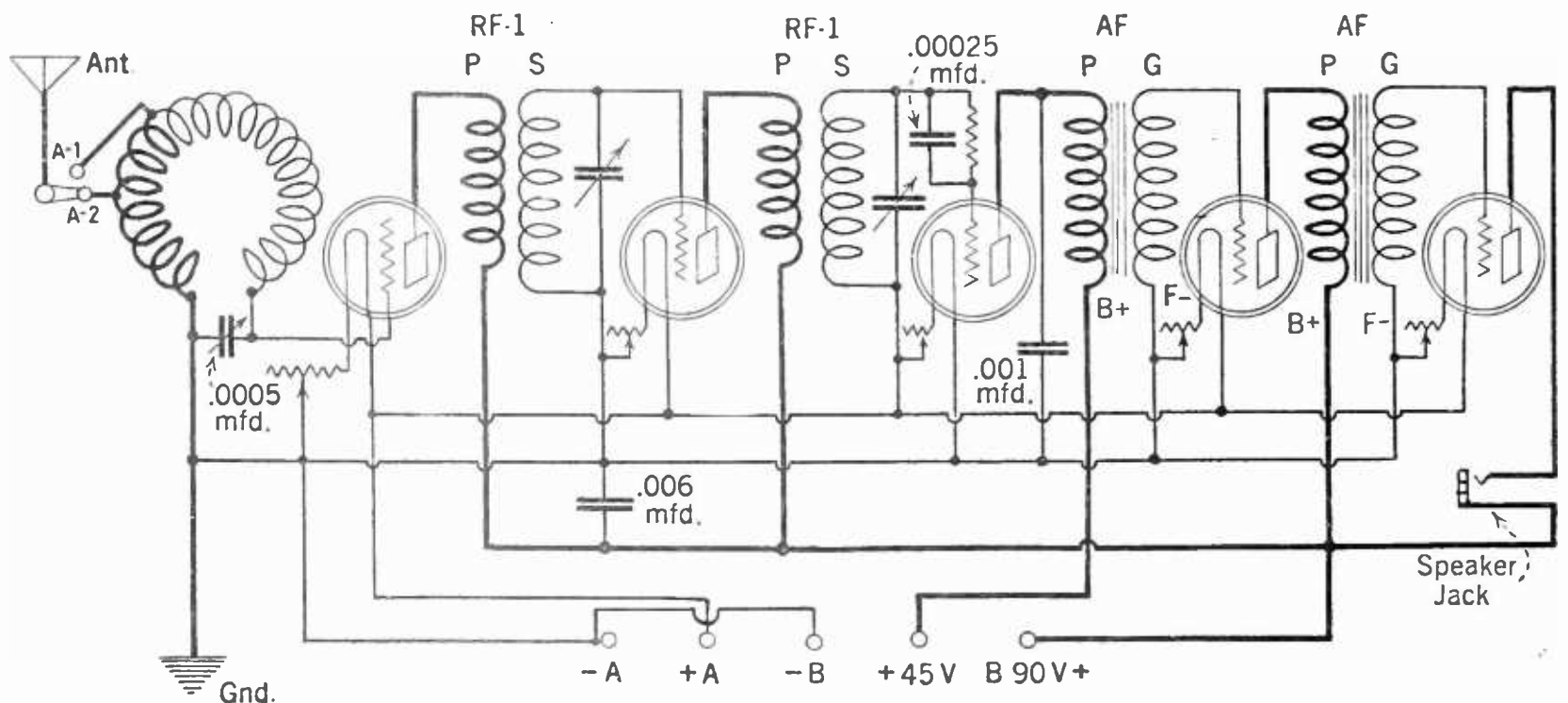

FIG. 9

Music Master Receiving Sets

A Logical Development

Music Master

*Resonant Wood
Insures Natural
Tone Quality*

TYPE 300

Five Tubes. New circuit. Connect with standard bell or cabinet type. MUSIC MASTER Reproducer or with specially designed art model reproducer illustrated. Great selectivity, extraordinary volume and wonderful tone quality. Solid mahogany cabinet, beautifully ornamented, brown mahogany art satin finish. **\$300**
Price

MUSIC MASTER Reproducer Model XII Drum Type. Specially designed art model illustrated. **\$35**
Price

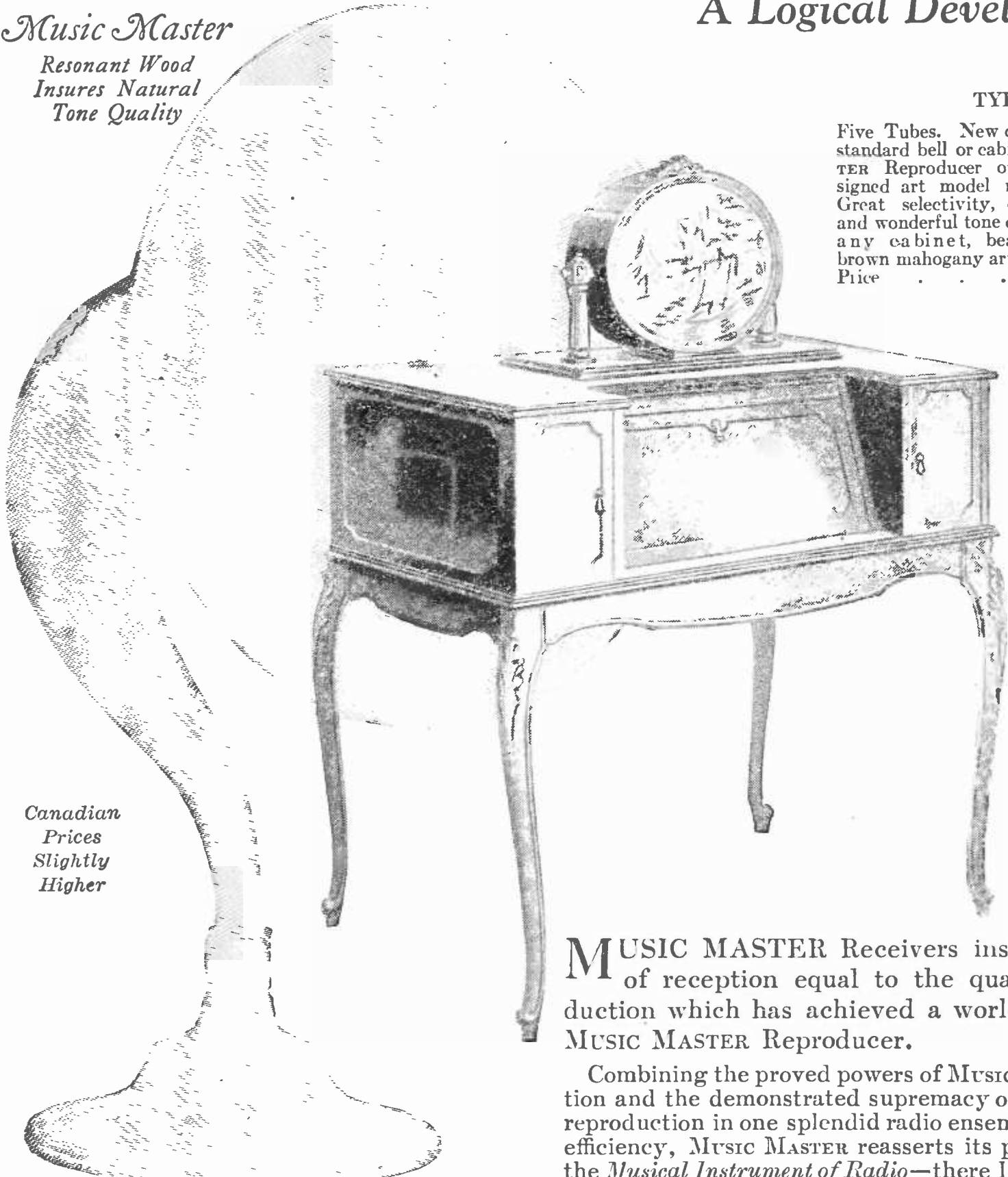

*Canadian
Prices
Slightly
Higher*

MUSIC MASTER Receivers insure efficiency of reception equal to the quality of reproduction which has achieved a world-standard in **MUSIC MASTER** Reproducer.

Combining the proved powers of **MUSIC MASTER** reception and the demonstrated supremacy of **MUSIC MASTER** reproduction in one splendid radio ensemble of supreme efficiency, **MUSIC MASTER** reasserts its pre-eminence as the *Musical Instrument of Radio*—there IS no substitute.

Authorized dealers everywhere are ready to demonstrate radio as you have always wanted to hear it. See Music Master—hear—compare—before you buy ANY radio set.

Music Master Corporation

Makers and Distributors of High-Grade Radio Apparatus

CHICAGO PHILADELPHIA, 128-130 N. Tenth St. MONTREAL
NEW YORK Canadian Factory: Kitchener, Ontario PITTSBURGH

*Ten Models \$50 to \$460
Guaranteed Unconditionally*

*Sold by Authorized Music Master
Dealers Everywhere*

MUSIC RADIO MASTER PRODUCTS

★ Tested and approved by RADIO BROADCAST ★

NEW!



No. 486 Eveready Layerbilt "B" Battery. 45 volts. Length, 8 3/16 inches. Width, 4 7/16 inches. Height, 7 3/16 inches. Weight, 14 1/4 pounds. Price, \$5.50.

The greatest improvement

ABSOLUTELY new in construction—perfected through years of research, the new Eveready Layerbilt "B" Battery is as superior to the old type as a tube set is to a crystal.

Heretofore, all dry "B" Batteries have been made up of cylindrical cells—no one knew how to make them any other way. The new Eveready Layerbilt is made of *flat* layers of current-producing elements compressed one against another, so that every cubic inch inside the battery case is completely filled with electricity-producing material. Layer-building heightens efficiency by increasing the area

of zinc plate and the quantity of active chemicals to which the plate is exposed.

After the most rigid laboratory tests, more than 30,000 of these new Eveready Layerbilt "B" Batteries were manufactured and tested by use under actual home receiving conditions. These tests proved that this new battery is far superior to the famous Eveready Heavy-duty Battery No. 770, which up to now we have ranked as the longest lived "B" Battery obtainable.

On 4-tube sets, 16 mil drain, it lasts 35% longer.

On 5-tube sets, 20 mil drain, it lasts 38% longer.

★ Tested and approved by RADIO BROADCAST ★

Radically different!

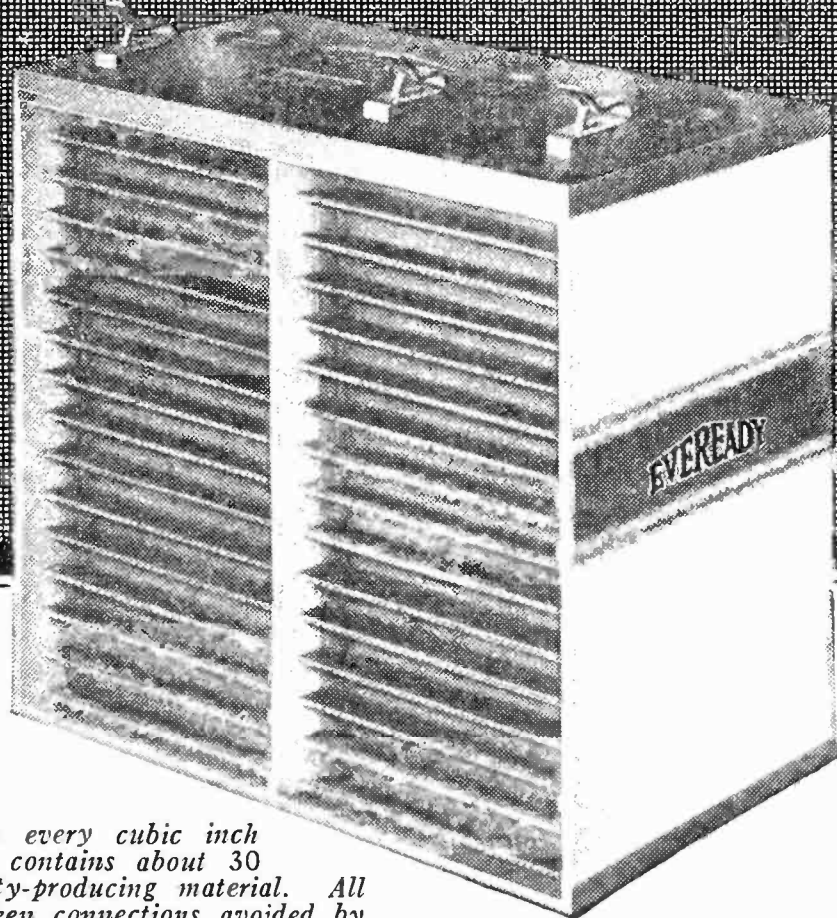

It's all battery. With every cubic inch packed to capacity, it contains about 30 per cent more electricity-producing material. All chance of loose or broken connections avoided by contact of full area of carbon plate against zinc plate. The scientifically correct construction.

ever made in "B" Batteries

On 6-tube sets, 24 mil drain, it lasts 41% longer.

On 8-tube sets, 30 mil drain, it lasts 52% longer.

The new Layerbilt principle is such an enormous stride forward in radio battery economy that we will bring out new sizes and numbers in this Layerbilt form as fast as new machinery is installed. For the present, only the extra-large 45-volt size will be available.

Buy this new Eveready Layerbilt No. 486 for heavy drain service. It far exceeds the performance for which Eveready Radio Batteries always have been famous and is, we be-

lieve, by far the most economical source of "B" current obtainable.

Manufactured and guaranteed by
NATIONAL CARBON Co., Inc.
 New York San Francisco
 Canadian National Carbon Co., Limited
 Toronto, Ontario

EVEREADY HOUR
EVERY TUESDAY at 8 P. M.
(Eastern Standard Time)
 Beginning September 29th, 9 P. M.
(Eastern Standard Time)
 For real radio enjoyment, tune in the "Eveready Group." Broadcast through stations—

WEAF New York	WSAI Cincinnati
WJAR Providence	WWJ Detroit
WEEI Boston	WCCO { Minneapolis
WFI Philadelphia	{ St. Paul
WGR Buffalo	WOC Davenport
WCAE Pittsburgh	

EVEREADY
Radio Batteries
- they last longer

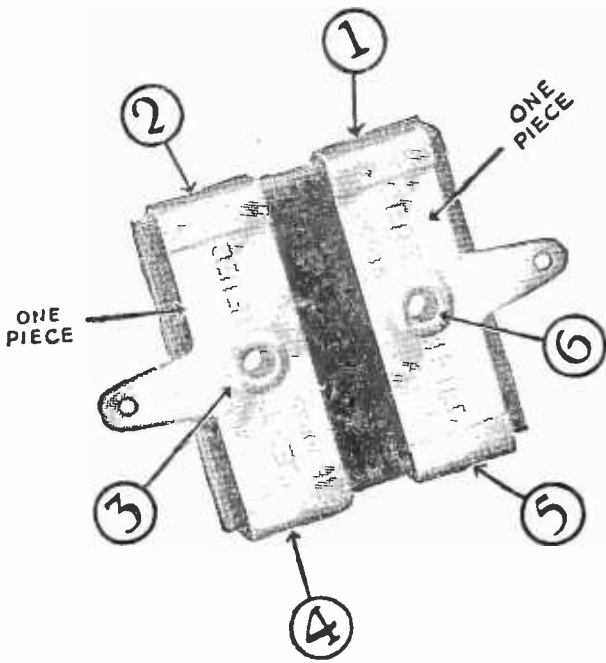

"The Six Point Pressure Condenser"



ELECTRAD INC.

428 Broadway

New York City

THE "Electrad" Certified Fixed Mica Condenser is a revelation in accuracy and design. Ingenious, rigid binding and firm riveting fastens parts securely at six different points insuring positive electrical contact. Value guaranteed to remain within 10% of calibration. Standard capacities, 3 types. Licensed under Patent No. 1,181,623, May 2, 1916, and applications pending. Price 30c to 75c in sealed dust and moisture proof packages.

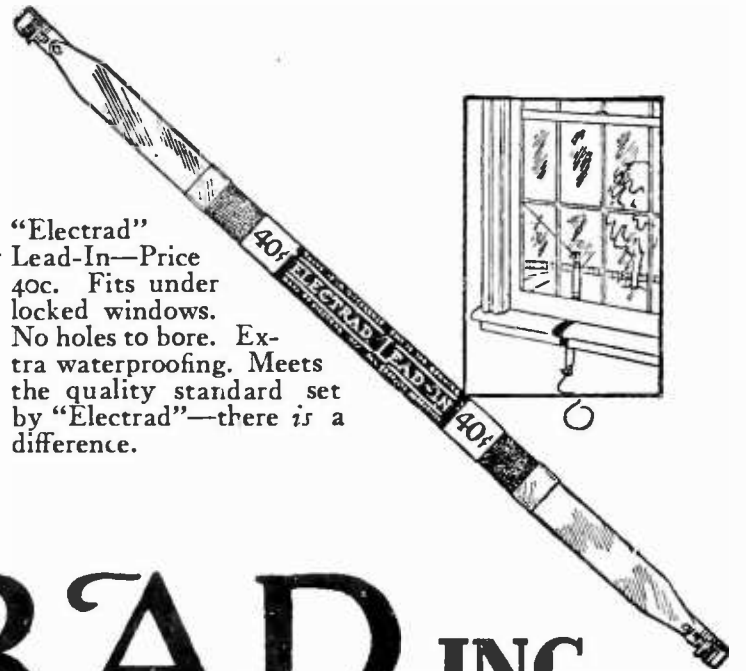

"Electrad" Lead-In—Price 40c. Fits under locked windows. No holes to bore. Extra waterproofing. Meets the quality standard set by "Electrad"—there is a difference.

ACH TUNING INSTRUMENT Using Expensive WORM GEAR

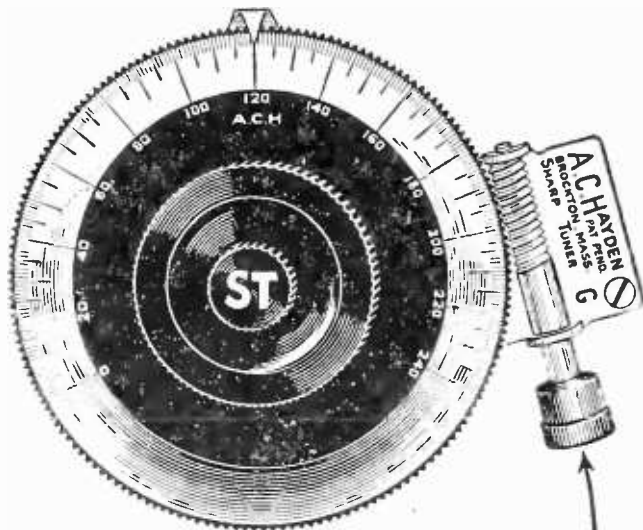

Why the A.C.H. is different

- 3 in. DIAL → ACH → 156-T0-1
- 4 in. DIAL → ACH → 215-T0-1

Price 3-inch size.....\$2.50 Price 4-inch size.....\$5.00
 Regular fitting 5/16 shaft. 1/4 and 3/16.....5c each extra

If not carried by your dealer, deduct 33 1/3%, his discount, and we will send you your required number of dials.

Add 19 cents each for postage and packing. Complete line of parts can be furnished on the same basis.

A. C. HAYDEN CO.
 BROCKTON - - - MASS., U. S. A.

INSURE YOUR TUBES

BY CONSISTENT USE OF

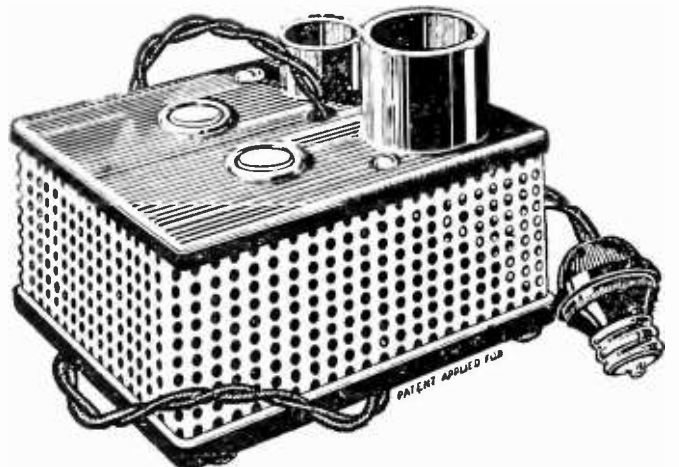

\$7.50 **BURTON & ROGERS**
TUBE
FLASHER

Brings Back Bad Tubes

Developed by an organization of long experience in the manufacture of electrical instruments.

Correct Engineering—Utmost Simplicity of Operation—One Model for D. C. or A. C.—Any Number of Cycles

Filament does not cool for an instant during flashing. Results will exceed your expectations. Cannot be burned out—Fully guaranteed. For tubes with thoriated filaments—type 201-A and 199 only.

Send for pamphlet "SAVE A LIFE"

BURTON & ROGERS MANUFACTURING CO.
 755 Boylston Street, Boston, Mass.

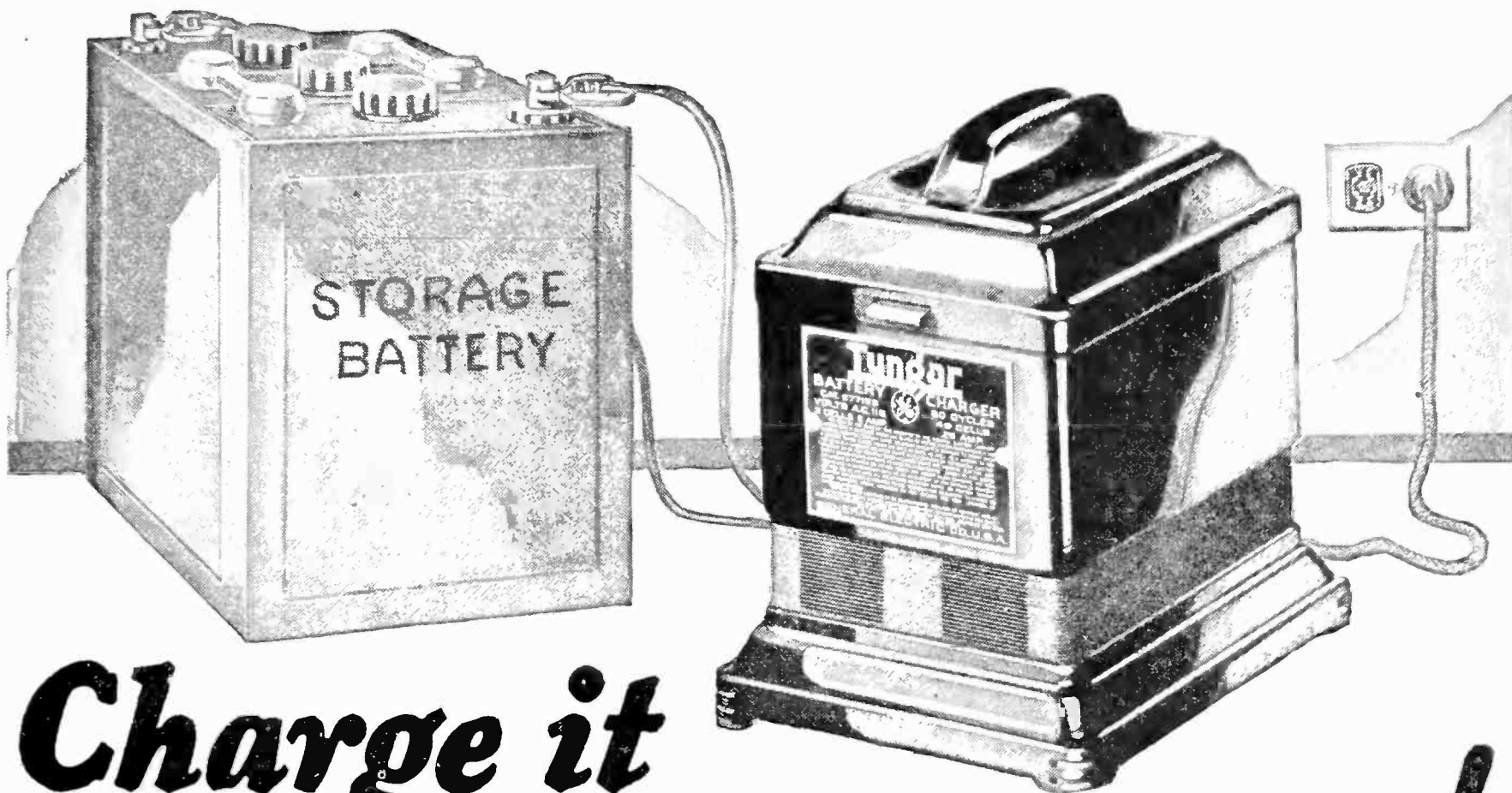

Charge it while you sleep!

Last thing at night—concert over—time to lock up. Radio battery low? Just clip on the Tungar, and plug it in. Or if you connect up the Tungar permanently, *just throw a switch*. Charge the battery while you sleep.

The Tungar is simple—makes no disturbing noise. And the low cost of Tungar recharging cuts battery upkeep to next to nothing. It means top notch performance—clear, full-volumed reception—*all the time!*



The Tungar is a G-E product developed in the great Research Laboratories of General Electric.

The new Tungar charges radio "A" and "B" batteries, and auto batteries.

Two ampere size (East of the Rockies) . . . \$18.00

60 cycles—110 volts

Tungar

REG. U.S. PAT. OFF.

BATTERY CHARGER

Tungar—a registered trademark—is found only on the genuine. Look for it on the name plate.

Merchandise Division
General Electric Company, Bridgeport, Conn.

GENERAL ELECTRIC

★ Tested and approved by RADIO BROADCAST ★

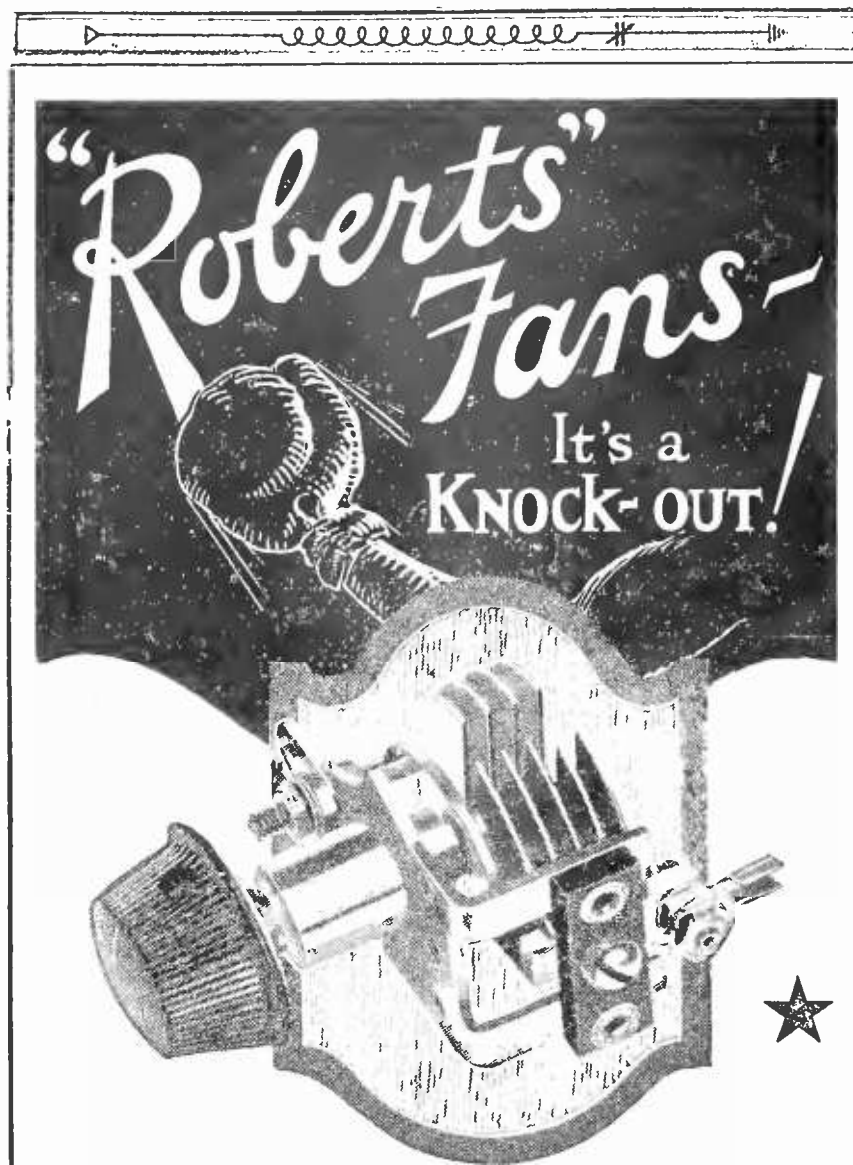

"Hammarlund, Jr."

A superior neutralizing condenser for your Roberts Receiver—or for any other receiver requiring a small variable capacity of absolute accuracy.

"Hammarlund, Jr." is the handsomest Midget you ever saw. It is a laboratory product, designed and built with the care and precision that have won world renown for Hammarlund workmanship. It has the unqualified endorsement of *Radio Broadcast*.

"Hammarlund, Jr." has a surprising number of uses other than neutralization. Diagrams will be sent on request.

Minimum Capacity .00004
Maximum Capacity .00032

Price \$1.80, including Bakelite Knob.
Standard $\frac{3}{16}$ in. shaft permits use of dial.

For Sale by the Better Radio Dealers

HAMMARLUND MANUFACTURING CO.
424-438 West 33rd Street, New York

For Better Radio
Hammarlund
PRECISION
CONDENSER

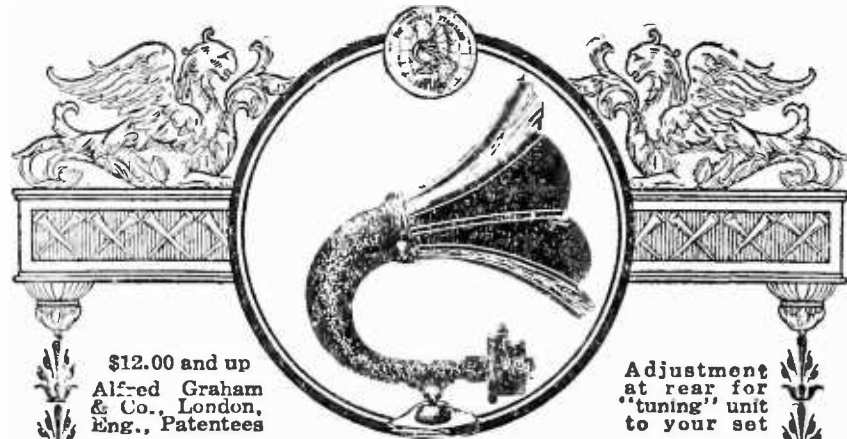

\$12.00 and up
Alfred Graham
& Co., London,
Eng., Patentees

Adjustment
at rear for
"tuning" unit
to your set

Test it for "Selectivity"

against any other loud speakers
Hear The Amplion *in comparison*; let your ears tell you why this creation of the actual originators and oldest makers of loud speakers leads in sales throughout the world. Not only is The Amplion supreme for clarity, realistic tone and *long distance* volume. It also has "*selectivity*"—the ability to *separate distinctly* the different instruments in an orchestra, or the various voices in a quartet, instead of jumbling them together. Interesting Amplion literature will explain why. Write for it and dealer's name.

AMPLION ★

The World's Standard Loud Speaker

THE AMPLION CORPORATION OF AMERICA

Executive Offices:

Suite, L. 280 Madison Ave., New York City

Canadian Distributors: Burndep of Canada, Ltd., Toronto



The TOWN CRIER

Radio's Most Beautiful Speaker

YOU will be delighted with the gorgeous colors . . . the stippled finish, and the novel design of the TOWN CRIER—the "SPEAKER WITH THE VOICE THAT THRILLS."

Ask your Dealer to show you a Town Crier Speaker. Write to-day for beautifully illustrated circular, describing the Golden Polychrome and Green Polychrome models.

LIST PRICE \$15.00 West of the Rockies \$18.50

GALE RADIO LABS.

2510 Irving Park Blvd.

Chicago, Ill.

The Radio Receiver Women Want

NO MATTER how much the radio experimenter's set pleases him, if it upsets the appearance and arrangement of the home it makes some woman unhappy.

While designed to meet the most exacting demands of those who know radio, The American Wireless Console Receiver is also designed to satisfy the woman of the home in beauty, size and proportion.



THE AMERICAN WIRELESS CONSOLE RECEIVER

Size 2 feet 4 inches wide, 3 feet 9 inches high,
1 foot 3 inches deep (closed),
richly paneled in two-tone walnut veneer.

Price including built-in loud speaker \$165.

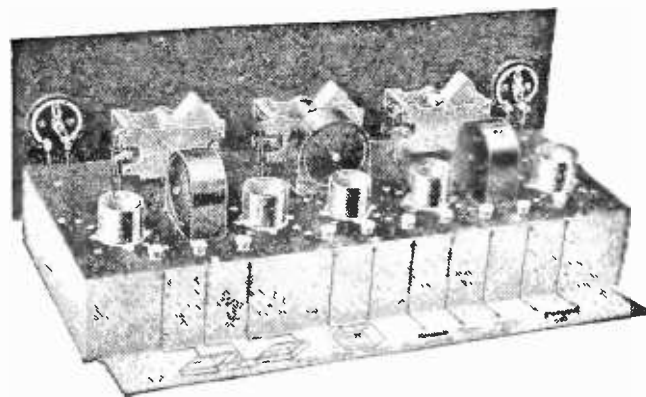

THE CIRCUIT

5-tube, concentrated tuned radio frequency, self neutralized, sub-panel cross wiring with 7 strand, tinned and cambric covered copper cable to avoid parallel leads and inter-capacity. Bakelite housed and shielded closed field coils. All batteries and storage A charger may be concealed in lower cabinet section as shown. Ask your dealer for a demonstration.

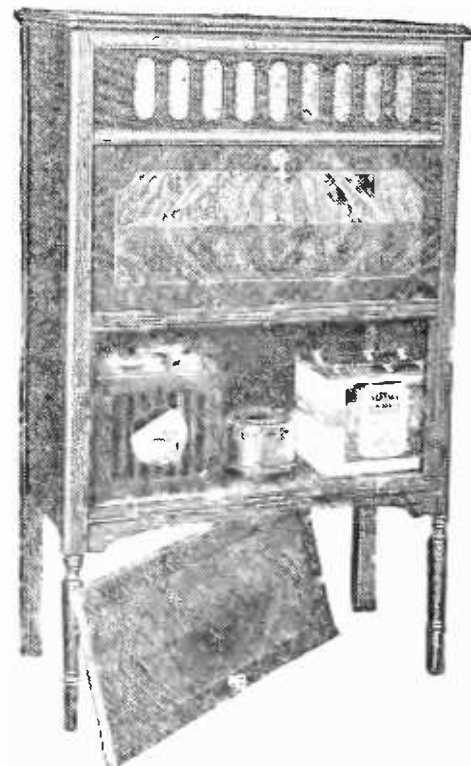

Radio Broadcast has tested the American Wireless Console and reports its selectivity, distance, ability and volume much above the average 5-tube, tuned radio frequency set. They particularly remark upon the excellent results obtained from the matching of loud speaker unit, horn and sound chamber. "It sounds like a fine cone type speaker rather than a horn."

American Wireless Corporation

NEW YORK CITY, N. Y.



Makers of

THE RADIO RECEIVER WOMEN WANT

★ Tested and approved by RADIO BROADCAST ★



TABLE NO. 31

Substantial table 15"x31"x29". Packed 1 each in carton, \$3.50.

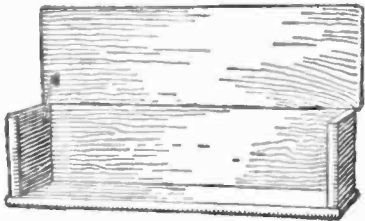

SPECIFICATIONS AND PRICES

Panel 7x9" 7" deep	\$1.80
Panel 7x12" 7" deep	2.00
Panel 7x14" 7" deep	2.25
Panel 7x16" 7" deep	2.30
Panel 7x18" 7" deep	2.40
Panel 7x21" 7" deep	2.50
Panel 7x24" 7" deep	2.60
Panel 7x26" 7" deep	2.70
Panel 7x28" 7" deep	2.80
Panel 7x30" 7" deep	3.25
Panel 7x36" 7" deep	4.75
Panel 7x40" 7" deep	5.25
Panel 8x40" 8" deep	5.75
8 or 9" deep add	30%
8 or 9" Panels add	30%

MBG

RADIO CABINETS

for your Radio Set

Get an MBG Cabinet for your set to-day. Any size you need at ridiculously low prices. All our cabinets are strongly made from beautifully grained Douglas Fir. Shipped in the natural wood with full instructions for staining at home to harmonize with 24 standard wood finishes. Make your radio set into an attractive piece of furniture at low cost.

**RADIO CABINET DEPARTMENT
EXPRESS BODY CORPORATION**

44 Lake Street

Crystal Lake, Ill.

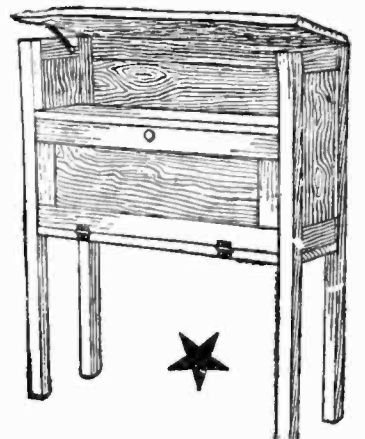

CONSOLE CABINET NO. 37

Panel	Bat. Comp.	
7x18", 9 1/2" deep	10"x11"x18"	\$10.50
7x24", 9 1/2" deep	10"x11"x24"	11.50
7x26", 9 1/2" deep	10"x11"x26"	11.50
7x28", 9 1/2" deep	10"x11"x28"	11.50

Additional door makes shelf in front of panel when open, extra, \$3.00

No. 37 Two-door console for 5-tube Atwater Kent set. Panel 8x30", 10 1/2" deep. Battery Comp. 10"x11"x30" \$17.50

To fit 6-tube Atwater Kent Panel 8x36", 10 1/2" deep. Battery Comp. 10"x11"x36" \$20.50

Mounting-boards, each, \$.50
Shipped set up complete, one to a carton.

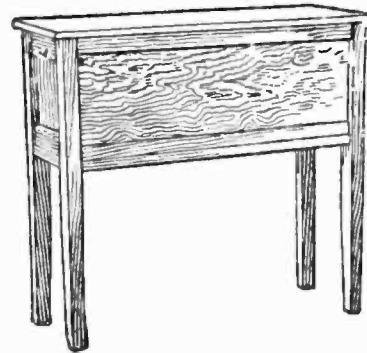

CABINET NO. 29

Battery compartment 10"x11"x29". Open back with shelf compartment for B battery. Paneled front to conceal batteries, over all measurements 11 1/2"x32"x29". Set up complete in carton, \$7.50, with panel door in rear, \$3.00 extra.

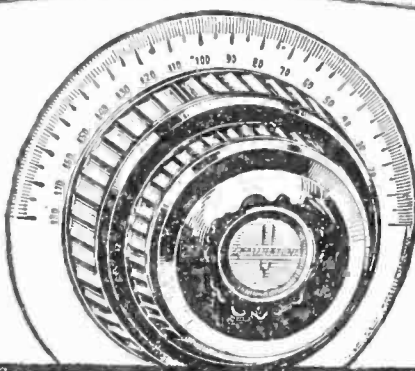

Patent April 21-25
Other Patents Pending

Geared 80 to 1

Adaptable to coarse or fine tuning, the infinite precision of the Accuratune brings in all stations within the scope of your set clearly, strongly, and with little effort on your part. Easily substituted in a few minutes for ordinary dials without alteration of your set. An essential accessory.

Write for descriptive folder

MYDAR RADIO CO.
3 CAMPBELL ST., NEWARK, N. J.

ACCURATUNE
REGISTERED GEARED 80 to 1 U.S. PAT. OFF.

Obsolete

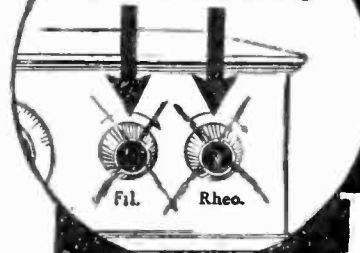

The HEART of the Circuit is

AMPERITE

The "Self-Adjusting" Rheostat

AMPERITE controls the flow of current through the tubes automatically just as the heart controls the flow of blood through the body. Does away with hand rheostats and filament meters. Eliminates guessing and all tube worry. Prolongs tube life. Lowers set cost. Proved and adopted by more than 50 set manufacturers. For perfect filament control you must use AMPERITE. \$1.10 everywhere.

RADIALL COMPANY

Dept. R.B.10, 50 Franklin Street, New York, N. Y.



Write for **FREE** Hook-ups

AMPERITE
REG. U.S. PAT. OFF.

The "SELF-ADJUSTING" Rheostat

★ Tested and approved by RADIO BROADCAST ★

NO-DIAL

(Patented)

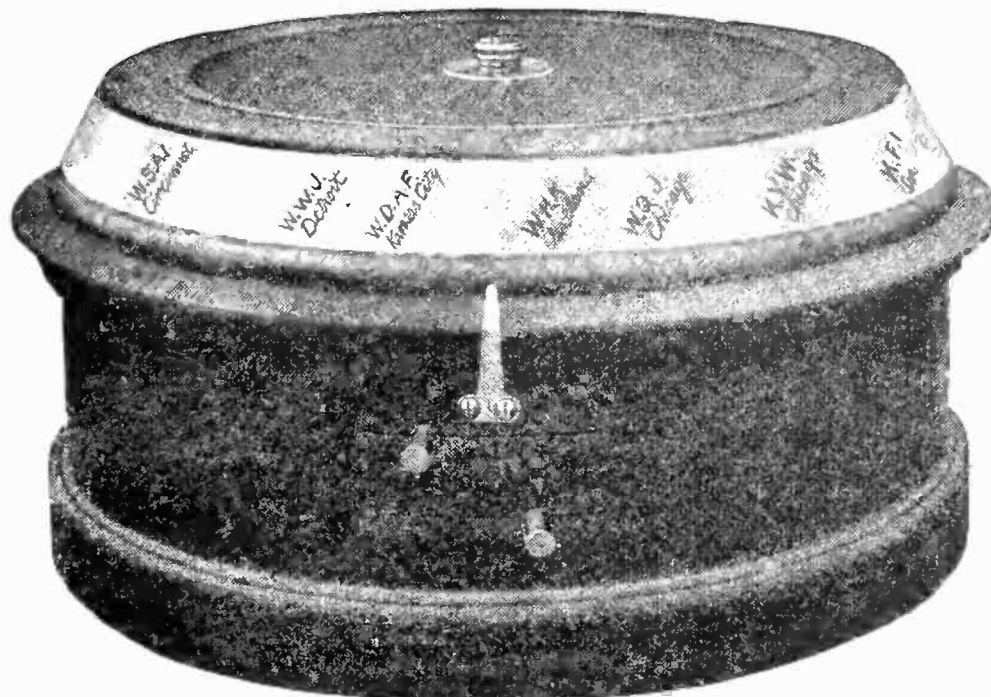

Licensed under Blackmore Patents and Patents Pending. Hogan Patents No. 1014002.

Revolutionizing Radio Operation

“NO-DIAL” so simple in operation, so positive in performance,
is just what you want!

Dials are old-fashioned—obsolete! Away with trouble, complicated tuning and puzzling operation! Scrap your log book! Forget your past disappointments. Radio is SIMPLICITY itself now! You, who have waited for the “grief-less” and “worry-less” radio receiver, can buy NO-DIAL safely.

VISIBLE STATION RECORD

The NO-DIAL brings in stations far and near by merely rotating the cover. Each station comes in at a certain point. As stations are received they are recorded right on the cover, and thereafter they will always come in at the same point. Thus you have a *permanent* and *visible* station record which is positive and un-failing.

IT'S BEAUTIFUL

The NO-DIAL represents a complete departure in radio set design. It is housed in a compact, circular case finished in popular brown crystalline, a perfect match for most high-grade loud speakers. Nothing to spot, scratch or mar. Easily cleaned with a damp cloth. Finally, it's trouble-proof and GUARANTEED.

See your dealer TO-DAY and ask for a demonstration. You'll be amazed!

LOUD AND CLEAR AS A BELL

The tonal qualities of the NO-DIAL will please everyone, due to the fact that they are directly caused by our latest combination in resistance coupled amplification. The tonal qualities are so sweet, so clear, so mellow! Harshness and interfering noises are absorbed and never reach the ear. Volume is regulated with a control lever. Far distant stations come in almost as distinctly as local. Results are positive and instantaneous.

Tube for tube, the NO-DIAL recognizes no superior, and on test it has out performed many higher priced receivers. The NO-DIAL will do everything any other single control set will do, and more, as regards fine volume, long range and clarity of tone.

The Ohio Stamping and Engineering Co. DAYTON, OHIO, U. S. A.

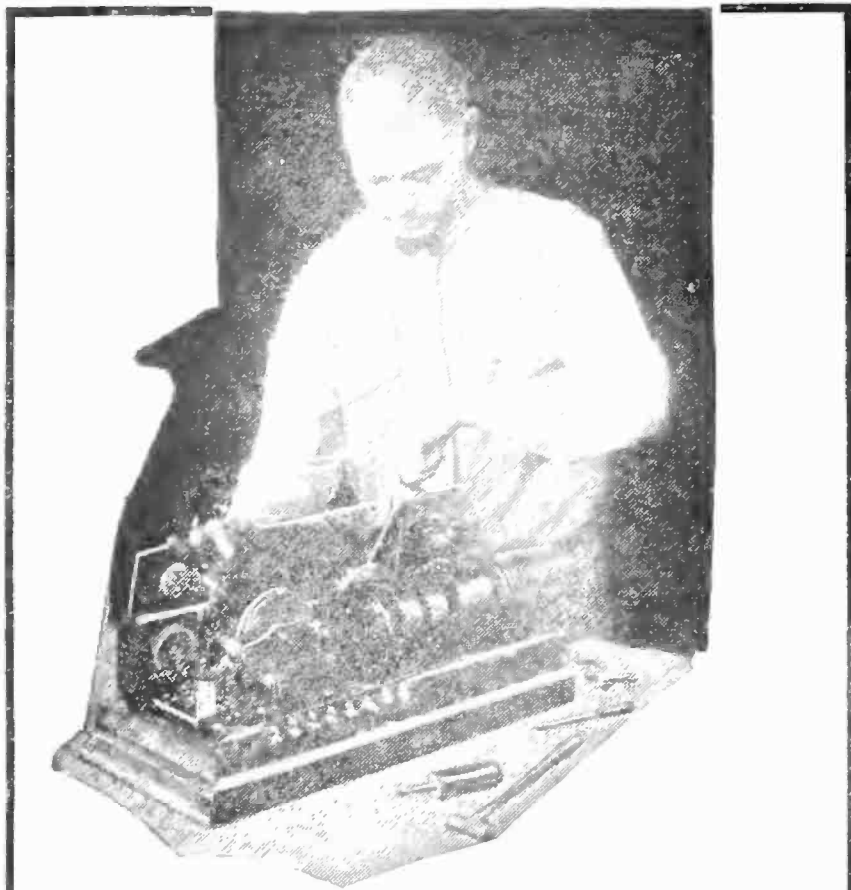

Earn \$50 to \$250 a week in RADIO

Men are needed NOW to build, sell and install Radio sets—to design, test, repair—as Radio Engineers and Executives—just a few of the big opportunities in this BIG PAY profession. No matter if you know nothing about Radio now, you can quickly become a Radio Expert by our marvelous new method of practical instruction. Easy to learn in your spare time at home—course includes all materials for building the latest up-to-date receiving sets. Hardly a week passes without our receiving urgent calls for our graduates. Scores of young men who have taken our course are already earning from \$75 to \$200 a week!

Send for FREE BOOK

Learn more about this tremendous new field and its remarkable opportunities. Send the coupon below—it is your Ticket to Success. Learn how you can quickly become a Radio Expert and make big money in Radio. For a short time we have a special offer for those who act promptly. Write TO-DAY.

NATIONAL RADIO INSTITUTE

Dept. 31-LB
Washington, D.C.

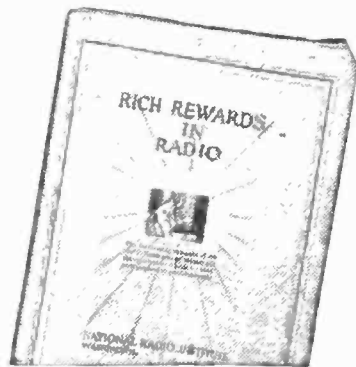

NATIONAL RADIO INSTITUTE
Dept. 31-LB, Washington, D. C.

Please send me without the slightest obligation your Free Book, "Rich Rewards in Radio." and full details of your special Free Employment Service. (Please write plainly.)

Name.....Age.....
Address.....
City.....State.....

**Make your set
a Super-Het**

The circuit described in Radio Broadcast for June and August will change any set into a super-heterodyne. It is particularly applicable to five tube neutrodyne and tuned RF sets. It changes these two circuits into super-heterodynes as good as most, and considerably better in some respects than any super-heterodyne circuit ever devised.

Stations come in at but one point on the oscillator dial. There is mathematically no possibility of harmonics. Full scale blue-prints with reprint of article \$1.00.

- Eastern Coil antenna coupler \$6.00
- O'Connor oscillator coupler . . . 6.00
- Special fixed condenser60
- Complete parts including panel drilled and engraved, special formica bushings, screws, and wire, blue prints and reprint 37.50



A. O'CONNOR & COMPANY
SUPER-HETERODYNE HEADQUARTERS SINCE 1923
9702 Euclid Avenue, Cleveland, Ohio

FAHNESTOCK CLIPS

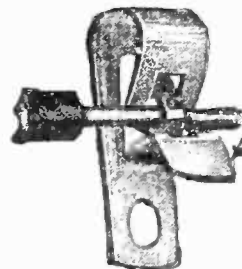

PRESS
DOWN
HERE



"Popular Wherever Radio is Used"

FAHNESTOCK Connectors are used by nearly every manufacturer of standard radio sets. On all batteries made by the National Carbon Co. FAHNESTOCK makes connectors for every RADIO PURPOSE.

"THE IDEAL CONNECTOR"

FAHNESTOCK ELECTRIC CO.
L. I. City New York

THE SILENT FRANCE MULTI-DUTY SUPER-CHARGER

Proven Superior!

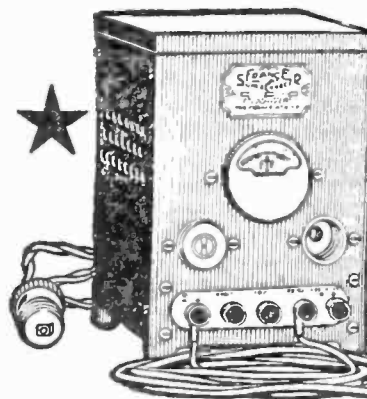

France Silent Super Charger charges 2, 4, 6 or 8 Volt storage battery at 5 to 7 Ampere Rate: charges 20 to 120 Volts of "B" Radio storage batteries IN SERIES at varying rates as desired.

Price \$22.00; West of Rockies \$23.00. Canadian prices upon request.

The France Mfg. Co.
10327 Berea Road
Cleveland Ohio

★ Tested and approved by RADIO BROADCAST ★

TORODYNE

Toroidal Receiver

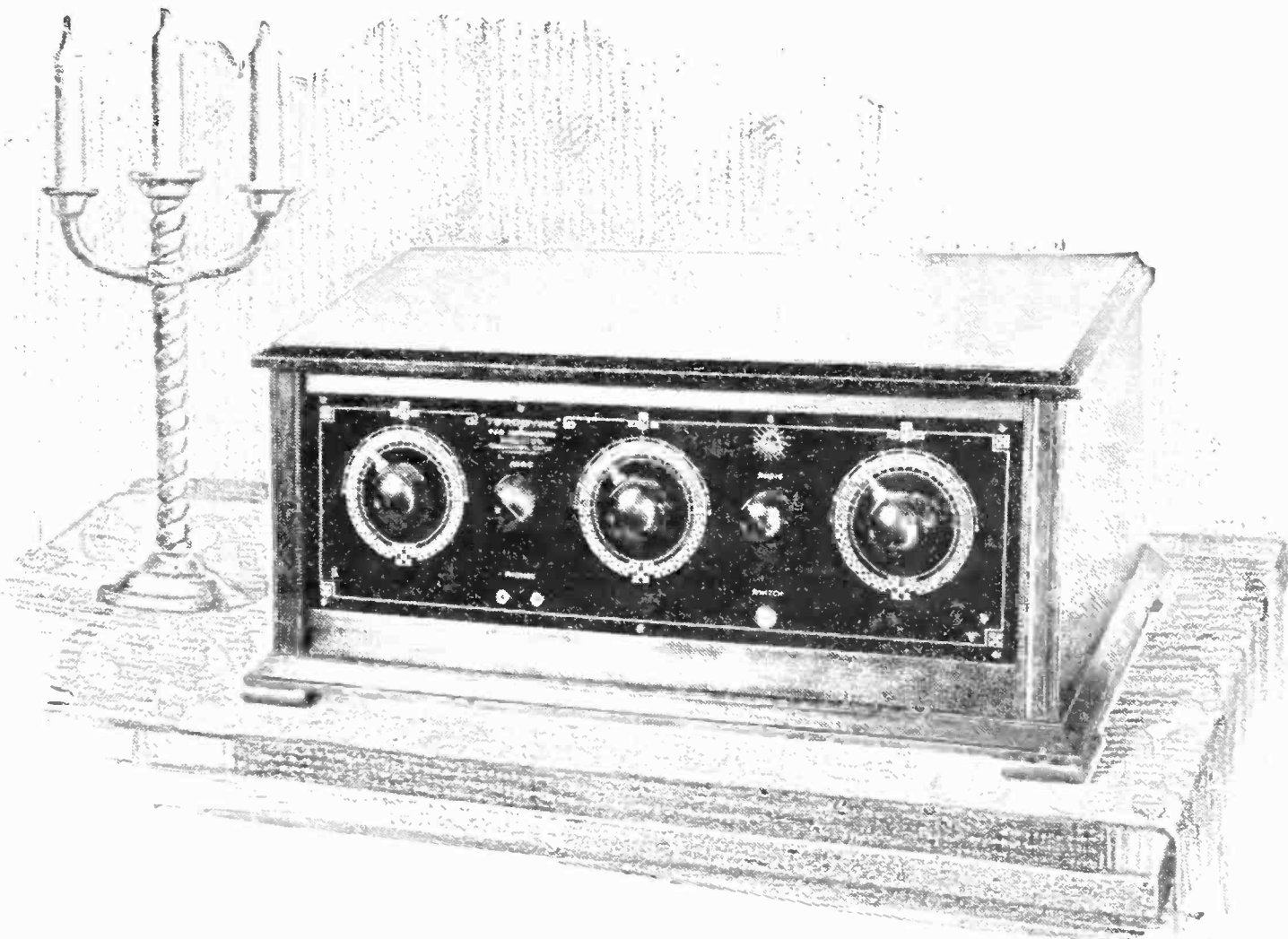

A New and Better Receiver

The TORODYNE is the newest AINSWORTH Receiver. It is one of the few really new developments of the season. Be sure to see it before placing your order.

What is the TORODYNE?

The TORODYNE is a five-tube, tuned radio frequency receiver employing Toroidal (doughnut-type) transformers. The entire arrangement is one of beauty, simplicity and refinement.

Why is it Better?

Largely through the use of Toroidal transformers which give it:

1. *Greater Selectivity* due to the fact that these coils do not pick up outside interference. Only the signal to which the set is tuned can be picked up.
2. *More Volume* by eliminating coupling. Greater amplification is thus secured without oscillations.
3. *Distance*. The greater amplification brings in distant stations with more volume, which naturally increases the range.
4. *Superior Tone Quality* is secured through the elimination of distortion and foreign noises by preventing stray feed-backs.

Appearance

The TORODYNE has a refined beauty that makes it very attractive. The panel is engraved in silver by a patented process. Pointers on Bakelite knobs, operate over a scale engraved on the panel. The cabinet is Adam brown mahogany.

Simplicity

Very easy to tune and logable. A silver engraved sub panel on the inside leaves only the three condensers and five tube sockets visible. All terminals are correctly marked to insure correct connections. Ample space is provided in the cabinet for the necessary "B" and "C" batteries. The TORODYNE will give greater satisfaction than any other set in its class. Ask your dealer for a demonstration. You will be sold on it immediately.

Price (without accessories) \$100.00

THE AINSWORTH RADIO COMPANY

304 Main Street

Cincinnati, Ohio

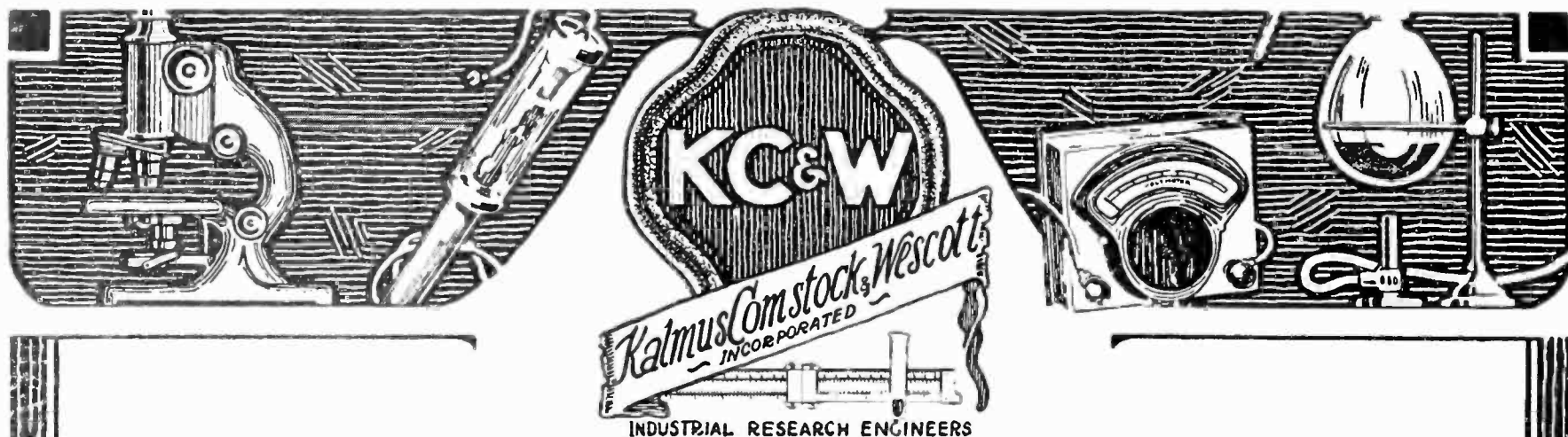

Scientific Research for Radio Manufacturers

Radio Manufacturers are constantly faced with scientific problems due to the discovery of new principles and the necessity for keeping their product in the front rank in Radio's rapid advance. Kalmus, Comstock & Wescott, Inc. offers to the Radio industry resources, equipment, and trained scientific skill necessary to solve these problems.

We maintain a staff of highly trained scientists and engineers with years of practical experience in the various fields of industrial research.

Our Laboratories, personnel and experience are available to Radio Manufacturers for a reasonable compensation. It will pay you to write for complete information.

KALMUS, COMSTOCK & WESCOTT Inc.
 110/114 BROOKLINE AVE. Industrial Research Engineers.. BOSTON, MASSACHUSETTS

here's sharp tuning for you!

THE NEW PACENT MICROVERN

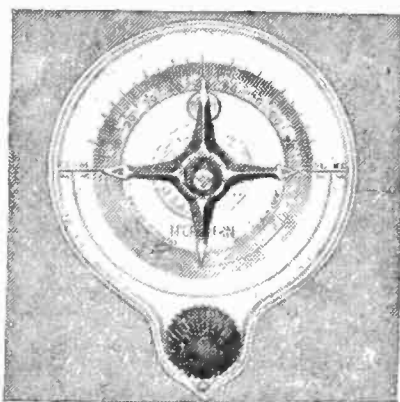

The Greatest of Vernier Dials

Improves tuning with any condenser—especially the Pacent Straight-Line Frequency. Note these special Microvern features:

- Most practical ratio—5 to 1.
- Proper size—4 1/4" diameter.
- Absolutely noiseless in operation.
- Positively no back-lash.

- Exclusive "Radiofile" feature simplifies logging.
- Direct reading in wave length and frequency.
- Provides an electro-static shield.

Write to-day for prices and full details

PACENT ELECTRIC COMPANY, INC.
 91 Seventh Avenue, New York City
 Washington Birmingham Detroit
 Chicago Jacksonville San Francisco
 Buffalo Boston St. Louis
 Minneapolis Philadelphia Pittsburgh
 Canadian Licensees: White Radio, Ltd., Hamilton, Ont.

DON'T IMPROVISE — PACENTIZE

A Laboratory Product



CRESCENT LAYITE RESISTANCES

for Distortionless Amplification

12,000, 48,000, 50,000, 100,000 Ohms. List \$1.50 each. Special Sizes to Order \$2.50 each. Dealers write for discounts. When Better Resistances are made they will be Crescents.

Crescent Radio Supply Co. 1-3 Liberty St., Jamaica, N. Y.

Increase Distance, Volume, Clarity

"Colytt" adjustable grid leak improves receiving. Gives proper value of leak in grid circuit, and holds it. Simple, compact, easy to install, only one hole in panel. Tunes any tube perfectly. Try the "Colytt" on Money-back guarantee. \$1.00 complete, with full directions. 3301

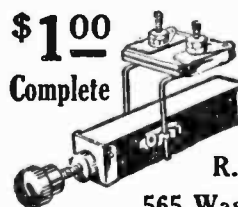

R. B. Colytt Laboratories
 565 Washington Blvd., Chicago



OUR BY PASS CONDENSERS WILL IMPROVE YOUR PRODUCT AND SAVE YOU MONEY

Capacities .006 to 5 MFD.

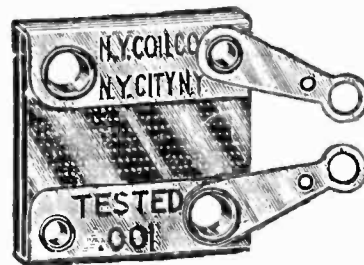

OUR MICA FIXED CONDENSERS NEED NO COMMENT—

for years their quality has been the standard of comparison. "Not to investigate is to lose money."

NEW YORK COIL COMPANY
 338 Pearl Street NEW YORK CITY
 Pacific Coast Representative:
 Marshank Sales Co., 926 Ins. Exch. Bldg., Los Angeles, Cal.



\$25

The **SAAL**
Soft **SPEAKER**

YOU need no longer object to loud speakers because of their harshness. Hear the Saal Soft Speaker at your dealer's.

The Saal has no blare, no blast, no metallic ring. It is not a trumpet. It is a faithful reproducer of radio programs. *It combines volume with a velvet tone.* It removes the objection to loud speakers.

The Saal is properly constructed for the accurate reproduction of sound. It is not straight-necked like a trumpet. The goose-neck is curved like a saxophone, the most melodious of all instruments. From the reproducing unit to the edge of the bell is one unbroken taper—one even,

unbroken enlargement of sound. The neck is of aluminum, a porous and non-vibrant metal with no tinny ring. The bell is of genuine Bakelite, the most perfect and resonant of all radio materials. There is no wood, no tin, no composition. It has nothing to warp, crack or deteriorate. It will last indefinitely.

The basis of Saal volume with tone quality is the reproducing unit described to the left. In appearance the Saal, with its large black bell, black stippled throat and graceful lines, is the aristocrat of horns. Also furnished with a brown bell and gold or silver stippled throat at \$5 extra.

SAAL Jr.

The same in every respect as the Saal Soft Speaker except it is smaller. Measures 18½ inches instead of 21½ inches in height.

\$20



The Saal Soft Speaker Unit is of the floating armature type exclusive with the most expensive reproducers. It automatically maintains its tone with any volume, and cannot be harmed by the loudest receiver. It will not break down with the longest or most constant use. All metal construction—no rubber gaskets. Used as standard equipment by many leading manufacturers of fine radio receivers in built-in reproducers.

SAAL *Soft* **SPEAKER**
★
VOLUME WITH TONE QUALITY

Manufactured and guaranteed by H. G. SAAL COMPANY, 1800 Montrose Ave., Chicago, Ill.



Trimm Chello Speaker selling at \$30 represents the ultimate in reproducing performance and design. Beautiful American Walnut Cabinet is pleasing in appearance. The Trimm Unit, reproducing all the tones found in radio with perfect fidelity, may be adjusted to give desired volume.

Volconite Tone chamber eliminates the noises and overtones which ruin broadcast reception. There is nothing superior in reproducers to the Chello, regardless of price.

TRIMM	
Superior Reproducers	
HEADSETS	
Professional - -	\$5.50
Dependable - - -	4.40
PHONODAPTERS	
Giant Unit - -	\$10.00
Little Wonder -	4.50
SPEAKERS	
Home Speaker -	\$10.00
Entertainer - -	17.50
Cabinette - - -	17.50
Concert - - -	25.00
Chello . . .	30.00

TRIMM
 RADIO MANUFACTURING
 COMPANY
 24 So. Clinton St.
 CHICAGO
 U.S.A.





Developed by
R. E. Lacault



no panel-no dials
6 tubes - \$135.00
Completely Wired
built-in loudspeaker
Write for Details
ULTRADYNE
 MODEL L-3
Out Sept. 10th
 PHENIX RADIO CORP. 116-C E.25 ST., N.Y.C.

Used
in
Finest
Sets



YAXLEY
No. 210

Neat
and
Compact

Pilot Light Switch

A combination of *Pilot Light* and *Midget Battery Switch*. Constantly indicates whether the radio set is "on" or "off." The pilot light bulb's eye is furnished in a choice of red, green or amber.

At the best radio dealers \$1.00—lamp extra.
 YAXLEY MFG. CO., Dept. B.
 217 N. Desplains St.
 Chicago, Ill.

YAXLEY

APPROVED RADIO PRODUCTS

★ Tested and approved by RADIO BROADCAST ★

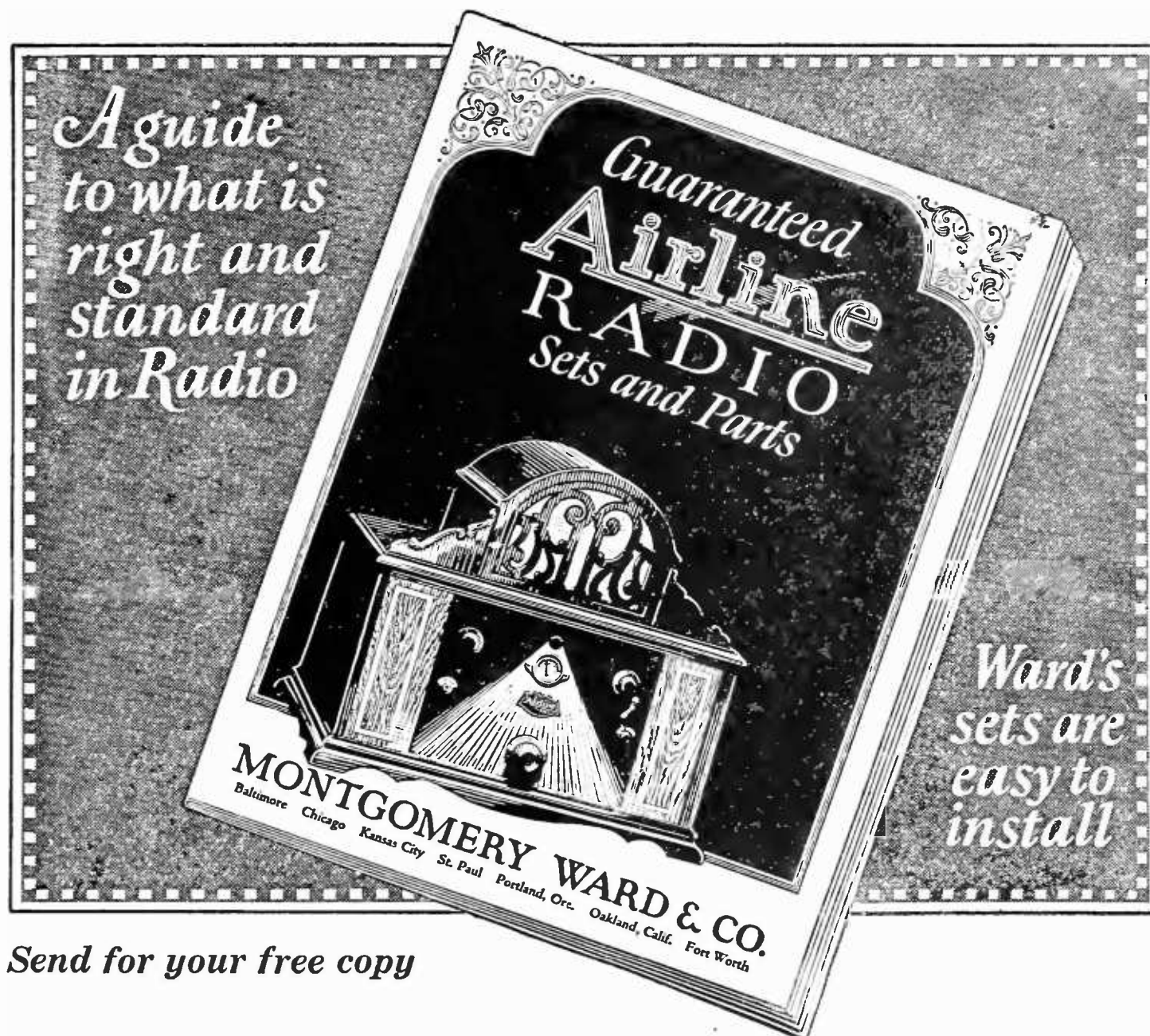

Send for your free copy

Ward's New Radio Catalogue

The best radio experts made this catalogue. It is one of the very best and most complete books on Radio ever published.

Its 52 fully illustrated pages are simply invaluable to everyone interested in radio. And one copy is to be yours Free—merely for the asking!

It shows guaranteed Radio sets, one tube sets that give remarkable results, and sets of every variety up to Ward's new five-tube one-dial control. Think of tuning in one station after another by turning a single dial!

It shows guaranteed, tested parts, batteries, cabinets, contains a list of stations,

a radio log for recording stations. It is a complete radio manual—sent entirely free!

Ward's is Headquarters for Radio

And best of all, the catalogue offers you everything new in Radio at a big saving in price.

At Ward's, everything for Radio is sold without the usual "Radio Profits." Thousands of pleased customers write us of their constant delight with Ward's Radio products.

Our 53 year old Policy

For 53 years we have sold only quality merchandise under a Golden Rule Policy. You can rely absolutely upon the quality of everything shown in this Radio Catalogue.

Be sure and ask for Radio Catalogue No. 27-R

ESTABLISHED 1872
Montgomery Ward & Co.

The Oldest Mail Order House is Today the Most Progressive

Baltimore Chicago Kansas City St. Paul Portland, Ore. Oakland, Calif. Ft. Worth

★ Tested and approved by RADIO BROADCAST ★



*A panel of
indescribable
Beauty*

Mahogany Finish

INSULINE ★

RICHER in color and more beautifully grained than mahogany itself! A panel that places your set on a high artistic plane, in harmony with the most elegant surroundings. Insuline is also furnished in Black and Frieze finishes.

We carry in stock all standard sizes in the three finishes above; also engraved panels in these finishes for all standard circuits. We cut, drill and engrave panels to order. Insuline is a perfect insulator; it does not crack, chip nor soften, and can be worked with ordinary tools.

Insist on "Insuline" from your dealer

RADIO PANEL AND PARTS CORP.

(INSULATING COMPANY OF AMERICA)

59 Warren Street Insuline Bldg. New York

What they have done for others they will do for you.

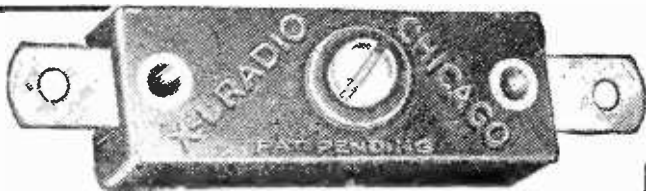

Improve Your Reception X-L VARIO DENSERS

MAKE POOR SETS GOOD—GOOD SETS BETTER

Endorsed and Used by the Foremost Radio Engineers of the Country

MODEL N—Capacity range 1.8 to 20 micro-micro-farads, as used in Radio Broadcast's Phonograph Receiver, for balance in Roberts two tube, Browning-Drake, McMurdo Silver's Knockout, Neutrodyne and tuned radio frequency circuits.

Price \$1.00

MODEL G—Two capacity ranges, .00016 to .00055 and .0003 to .001 Microfarads, for the Cockaday circuits, filter and intermediate frequency tuning in super-heterodyne and positive grid bias in all sets.

Price \$1.50

X-L RADIO LABORATORIES

2424 Lincoln Ave.

CHICAGO

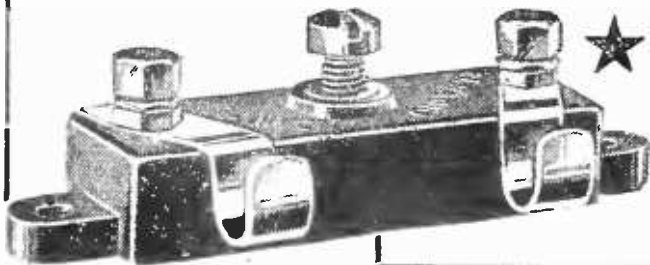

★ Necessary for the manufacture of high grade sets



\$3.50
24 Volts

RADIO Storage "B" Battery

12 Cells 24 Volts Lasts Indefinitely—Pays for Itself

Economy and performance unheard of before. Recharged at a negligible cost. Approved and listed as Standard by leading Radio Authorities, including Pop. Radio Laboratories, Pop. Sci. Inst. Standards, Radio News Lab., Lefax, Inc. and other important institutions. Equipped with Solid Rubber Case, an insurance against acid and leakage. Extra heavy glass jars. Heavy rugged plates. Order yours today!

SEND NO MONEY Just state number of batteries wanted and we will ship day order is received. Extra Offer: 4 batteries in series (96 volts), \$13. Pay expressman after examining batteries. 5 per cent discount for cash with order. Mail your order now!

WORLD BATTERY COMPANY

1219 So. Wabash Ave., Dept. 78, Chicago, Ill.
Makers of the Famous World Radio "A" Storage Battery
Prices: 6-volt, 100 Amp. \$12.50; 120 Amp. \$14.50; 140 Amp. \$16.00.
All equipped with Solid Rubber Base.

World FOR STORAGE BATTERIES RADIO

KDKA - WEAJ - WGN - WJS - KHJ - KGO - KFAJ - WJY - KOZ

LEARN THE CODE AT HOME with the OMNIGRAPH

"Just Listen—The Omnigraph will do the teaching"

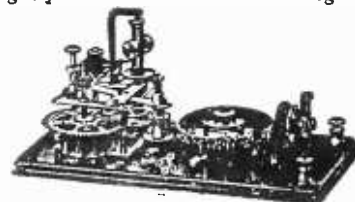

THE OMNIGRAPH Automatic Transmitter will teach you both the Wireless and Morse Codes—right in your own home—quickly, easily and inexpensively. Connected with Buzzer, Buzzer and Phone or to Sounder, it will send you unlimited messages, at any speed, from 5 to 50 words a minute.

THE OMNIGRAPH is not an experiment. For more than 15 years, it has been sold all over the world with a money back guarantee. The OMNIGRAPH is used by several Depts. of the U. S. Govt.—in fact, the Dept. of Commerce uses the OMNIGRAPH to test all applicants applying for a Radio license. The OMNIGRAPH has been successfully adopted by the leading Universities, Colleges and Radio Schools.

Send for FREE Catalogue describing three models. DO IT TO-DAY.

★ THE OMNIGRAPH MFG. CO., 13K Hudson St., New York City

If you own a Radio Phone set and don't know the code—you are missing most of the fun

★ Tested and approved by RADIO BROADCAST ★

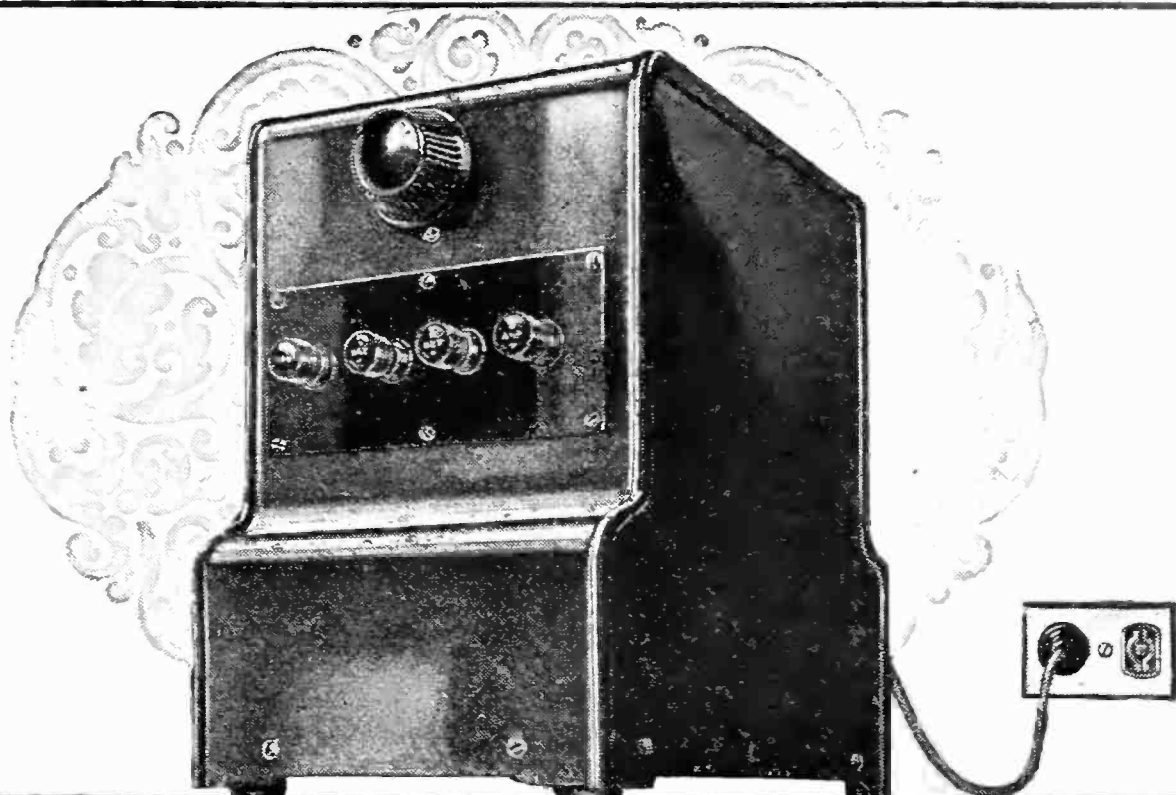

Super-Ducon

now has the *new* RCA
Tube—*specially designed*

Right in your electric light wires lies all the current you need to keep your radio set at the peak of efficiency.

A Super-Ducon, which now has the advantage of a specially designed RCA tube, Rectron UV-196, delivers a steady current of just the right voltage—always constant—always silent.

It takes the place of "B" batteries. Less trouble—lower up-keep—and better radio reception always—with a Dubilier Super-Ducon. Just plug it in on the house current.

Tested and listed by the National Board of Fire Underwriters.

Write for descriptive bulletin, 238th St. and Bronx Boulevard.

Dubilier

CONDENSER AND RADIO CORPORATION

★ Tested and approved by RADIO BROADCAST ★



Oh boy!

KESTER
Rosin Core
Radio SOLDER

Sure! is Safe and Simple

APPROVED BY
RADIO ENGINEERS
A GENUINE SOLDER

CHICAGO SOLDER COMPANY
4222 Wrightwood Ave., Chicago, U. S. A.

Originators and World's Largest Manufacturers of Self Fluxing Solder
YOUR DEALER CAN SUPPLY YOU

**Hoyt Meters Insure
Reliable Radio Reception**

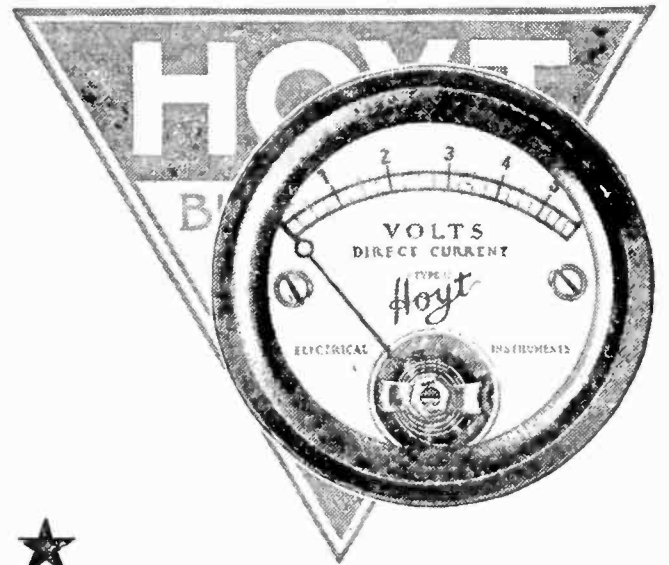

★
**Filament Voltmeter
Type 17—Moving Coil**

Keeps just the proper voltage on your tube filaments—a critical value in set operation Case 2" in diameter—Draws only 16 Milamps, and may be left in circuit continuously without affecting battery.

Hoyt builds a complete line of radio meters.

Send for our book HOYT METERS FOR RADIO

BURTON-ROGERS CO.

26 Brighton Avenue Boston, Mass.
National Distributors



WRITTEN 2-YEAR GUARANTEE

ARROW BATTERY

Battery Prices SMASHED!

To Consumers Only

Here is a real battery quality, guaranteed to you at prices that will astound the entire battery-buying public. Order Direct From Factory. Put the Dealer's Profit in your own pocket. You actually save much more than half, and so that you can be convinced of true quality and performance, we give a *Written 2-Year Guarantee*. Here is your protection! No need to take a chance. Our battery is right—and the price is lowest ever made. Convince yourself. Read the prices!

Auto Batteries	Radio Batteries
6 Volt, 11 Plate, \$9.50	6 Volt, 100 Amp. \$9.50
6 Volt, 13 Plate, 11.50	6 Volt, 120 Amp. 11.50
12 Volt, 7 Plate, 13.00	6 Volt, 140 Amp. 13.00

Buy Direct—Send No Money

We ask no deposit. Simply send name and address and style wanted. Battery will be shipped same day we receive your order Express C.O.D. subject to your examination on arrival. Our guarantee accompanies each battery. We allow 5% discount for cash in full with order. You cannot lose! Send your order today—NOW!

ARROW BATTERY CO.
Dept. 10, 1215 So. Wabash Ave., Chicago

Chart Your Radio Exploits!

GET this marvelous new help for radio explorers—a beautiful Air map, printed in three colors, with every station clearly marked and Time zones outlined! Size, 28 x 34 inches. There's no limit to the useful and amusing ways you can use

Collier's New Radio Map of the U. S. and Canada

With its help you can find out *instantly* how far any station is. If you use a directional aerial, you can point the loop exactly toward the station you want to get. The map also outlines the radio districts, and gives an alphabetical list of *all* stations and their operators.

Thousands have already been sold. Get yours *to-day!* At your news stand or radio dealer's, only 25 cents—or just mail a quarter to us.

P. F. COLLIER & SON COMPANY
244 Park Avenue New York City

★ Tested and approved by RADIO BROADCAST ★

1- Better color
- lasting luster



2- Lower free sulphur
- no discoloration

Triple your satisfaction by using Goodrich Radio Panels

3- Higher softening point
- no warping

LOW dielectric losses in the panel increase selectivity and range. Any good hard rubber panels are lower in dielectric losses than panels made from other materials.

We stake our reputation built up over a period of fifty-five years that Goodrich Hard Rubber Panels are absolutely satisfactory in every way and distinctly superior to other hard rubber panels in the three important respects listed above.

For maximum selectivity and widest range, use:

Goodrich Hard Rubber Radio Panels . . . Goodrich V. T. Sockets . . . Goodrich Variometers Unwound . . . Radiophone Ear Cushions Spaghetti Tubing Battery Mats

THE B. F. GOODRICH RUBBER COMPANY Established 1870 Akron, Ohio

Goodrich
RUBBER *Radio Products*

"Best in the Long Run"

★ Tested and approved by RADIO BROADCAST ★

The
Book-Cadillac

DETROIT'S FINEST HOTEL

1200 ROOMS WITH BATH, \$4 AND UP
WASHINGTON BLVD. AT MICHIGAN AVE.



All Guest Rooms Above Sixth Floor

Guest rooms of the Book-Cadillac begin on the seventh floor, thus obtaining unusual advantages in light, air and freedom from traffic noise.

All rooms have full outside exposure, giving magnificent views over the city and the Detroit River. Six express elevators afford rapid access to lobby and public rooms.

Your stay at Book-Cadillac is further made enjoyable by a wide variety of restaurants, serving substantial food at moderate prices.

*Special Luncheon, \$1.25 and Dinner De Luxe, \$2.00,
daily in Blue Room and English Grill
(Sundays excepted)*

*Club Breakfast, 55c and \$1.00
Cafeteria service in Coffee Shop.*

THE BOOK-CADILLAC
HOTEL COMPANY - DETROIT
ROY CARRUTHERS, *President*

PROFESSIONAL SET BUILDERS! *and* *dealers who build sets*

WE will shortly begin a series of newspaper advertisements featuring the work of individuals and dealers who build sets using Cardwell Condensers.

If you build to specification or from original design, it will be to your interest to communicate with us immediately.

Ask for details of plan. Be sure to give name of your jobber.

ALLEN D. CARDWELL
MANUFACTURING CORP.
81 Prospect Street, Brooklyn, N. Y.

INTERIOR DECORATION

by FRANK ALVAH PARSONS

Profusely Illustrated. Net \$4.00

At all booksellers DOUBLEDAY, PAGE & CO.

SELL to STORES CANDY, GUM AND MINTS!

**40%
to
160%
Profit**

I will put you in business as my DIRECT FACTORY AGENT AND JOBBER, to take orders for my full line of candies, chocolate bars, mints and chewing gum. Unlimited opportunities for hustlers. No experience needed. I furnish everything. Every store and everybody buys. Work spare time or fulltime. Write today for catalog, selling plan and FREE SAMPLES. Exclusive territory. ACT QUICK. MILTON GORDON, 808 Jackson St., Cincinnati, O.

Let the non-directional

Thor Speaker Lamp

[Patents Pending]

bring in your Radio programs and furnish light at the same time. Many models—many styles—parchment or any color silk shades.

Table lamp models \$35.

At your dealers—or delivered.

★ **THOR** Radio Division
of the Golden Gate Brass Manufacturing Co.
1239-1243 Sutter St., San Francisco, Cal. (125)

★ Tested and approved by RADIO BROADCAST ★

Back of Each Instrument

The assurance of reliable operation, which you have always felt when buying an ALL-AMERICAN Transformer, is now increased by a knowledge that it is the product of one of the largest and most completely equipped factories in America devoted exclusively to radio products.

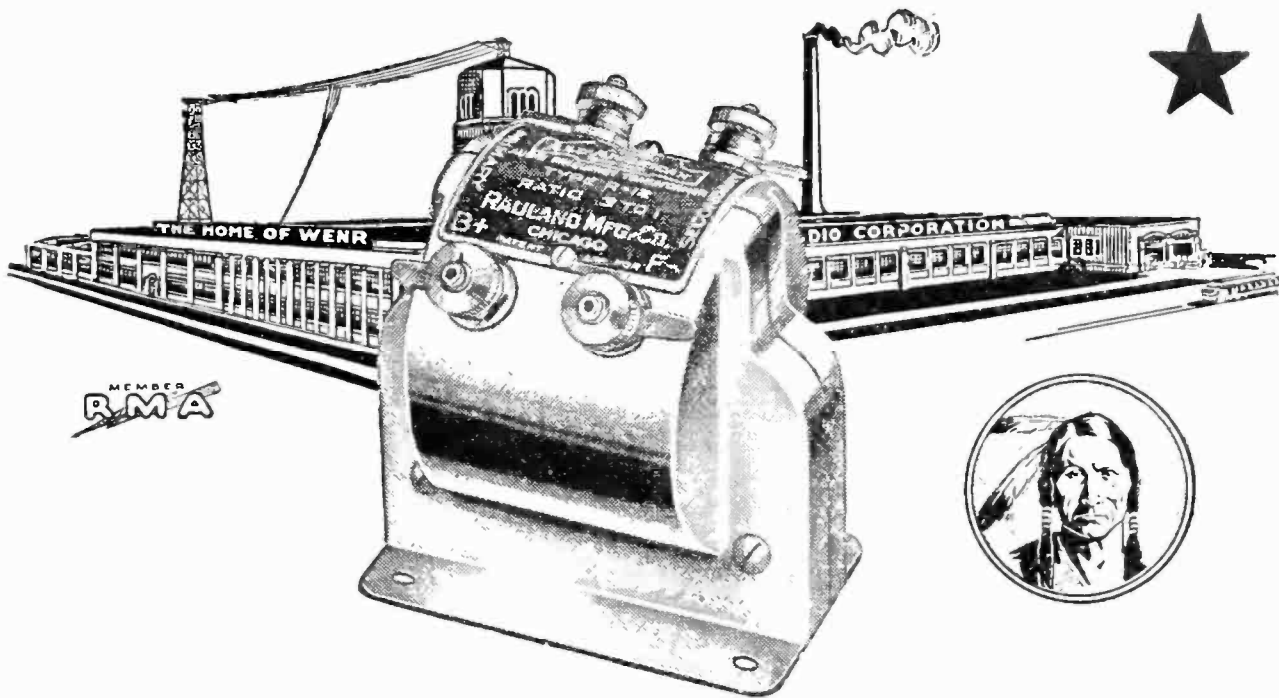

The RADIO KEY BOOK—new edition—is a practical handbook for all who wish to enjoy modern radio at its best. Send 10 cents—coin or stamps—for the KEY BOOK.

ALL-AMERICAN RADIO CORP., E.N. RAULAND, Pres., 4213 Belmont Ave., Chicago

ALL-AMERICAN

Largest Selling Transformers in the World

RATHBUN has a complete practical solution of the Straight Line Frequency Problem. No existing apparatus is similar to this invention in theory or universal application.

Watch for the announcement story in the next issue of this and other radio publications.

RATHBUN MANUFACTURING CO., Inc.
Jamestown New York



DUPLEX

DUPLEX STANDARD
"None better made"
Conform to Bureau of Standards specifications. Rugged construction assures permanent alignment.

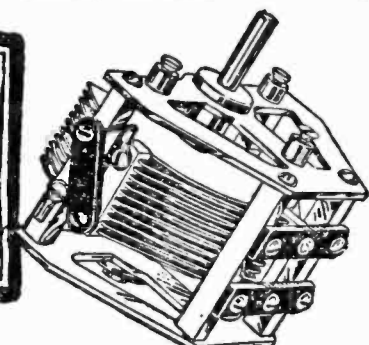

DUPLEX MATCHED CONDENSERS

ALWAYS READ ALIKE



ONLY ONE NUMBER TO LOG

Or eliminate logging—Dial by call letters or wave lengths. Specially tested and guaranteed. Matched, packed and sealed, to remain unopened until used. Literature on request.

DUPLEX CONDENSER & RADIO CORPORATION
46 Flatbush Ave. Extension, Brooklyn, N. Y.

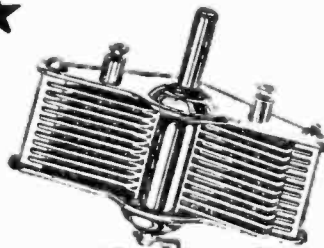

DUPLEX JUNIOR
"Best at the price"
A good, low-priced condenser. Die-cast rotor. Bakelite insulation. Many other features.

CONDENSERS

★ Tested and approved by RADIO BROADCAST ★

SM
SUPER PARTS



THE seven tube portable super-heterodyne receiver that won the grand sweep-stake prize in the recent Los Angeles Radio Show was built entirely of Silver-Marshall parts. The famous S-M 210 and 211 intermediate transformers used in the prize-winning set were largely responsible for the success attained and the remarkable results reported. The finest transformers you can buy. Supplied in sets of two 210's and one 211. Each, \$8.00.

See the New S-L-W Condensers!

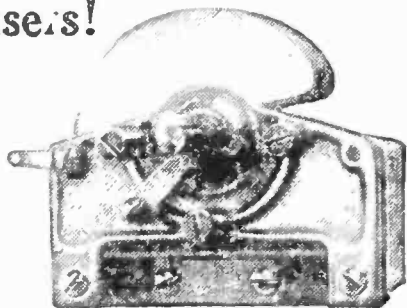

The new Silver-Marshall Straight-line-wavelength Condenser has been acclaimed by fans and authorities everywhere! Entirely silver-plated, with losses lower than laboratory standards. S-L-W plates assure *real* separation and selectivity. Used in the new Super-Autodyne receiver.

- No. 305 .0005.....\$6.00
- No. 306 .00035..... 5.75
- No. 307 .00025..... 5.50

Send 4c in stamps for Circulars of S-M Products, and reprints of article from Radio Broadcast, describing the remarkable new Super-Autodyne Receiver.

Silver-Marshall

103 S. Wabash Avenue
CHICAGO, ILL.

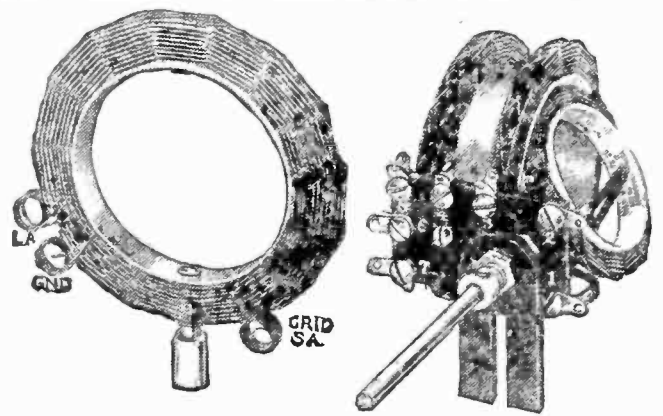

Coil Set No. 24 for Browning-Drake Circuit

★ **SICKLES**
DIAMOND-WEAVE COILS

(Patented Aug. 21, 1923)

For Browning-Drake, Craig, and Hoyt Circuits

Sickles Coils for the famous Browning-Drake Circuit are the latest Sickles achievement in efficient design for a particular use. They are priced at \$7.50 a set. When ordering specify set No. 24.

Coil set No. 20, at \$4.50, is for use specifically with the New Reflex Receiver designed by Albert G. Craig, using the Sodian detector.

Coils for the Hoyt Circuit at \$10.00 a set, for the Knock-out Reflex Circuit at \$4.00 a pair, the Tuned Radio Frequency coils at \$2.00 each and Coils for the Acme Reflex circuit at \$4.50 a-set are other standard Sickles Coils. We manufacture also for manufacturers' special requirements.

Send for descriptive catalog

The F. W. Sickles Co.
132 Worthington St., Springfield, Mass.



Burns

Loud Speaker

of Distinctive Beauty

Generous Proportions

NATURAL TONES WITH VOLUME

Handsome pyralin bell in several finishes. Aluminum sound column. Large size unit delivers remarkable tone and volume.

- No. 205B Polished Black Flare \$22.50
- No. 205D Mahogany Tinted Flare 25.00
- No. 205P Mother-of-pearl Flare 30.00

Manufactured by

★ **American Electric**
COMPANY

State and 64th Sts.

Chicago, U. S. A.

New Tubes from Old

Just think, now you can take your old, run-down tubes—tubes you formerly threw away—and give them the same snap and pep they originally had. That's what the Rhamstine* Tube BOOSTER will do for you, whether you use 201-A or 199 type tubes.

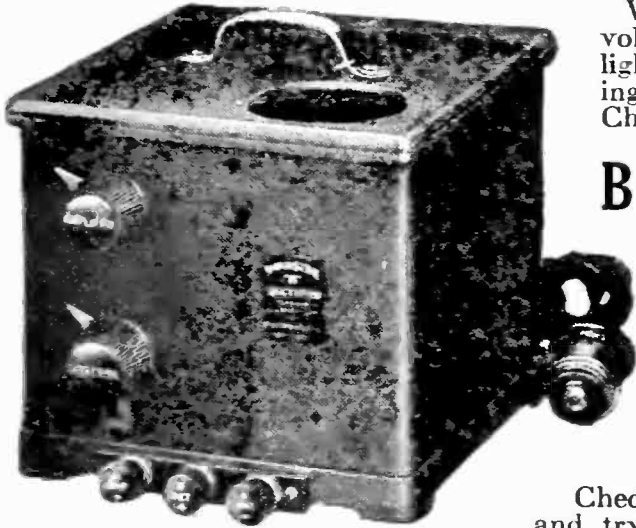

**Rhamstine★
"B" RECTIFIER**
Only \$25

J. THOS. RHAMSTINE★

506 E. Woodbridge St. Detroit, Mich.

Works on any alternating current 110 to 120 volts, 50 to 133 cycles—the ordinary electric light circuit. You can soon pay for it by boosting tubes for your friends and neighbors. Check the coupon below and pay on delivery.

Better than "B" Batteries

Silky smooth reception free from the annoyance of run-down batteries—that's what you'll get when you use the Rhamstine* "B" RECTIFIER for your source of B-power.

Operates on any electric light circuit of 110 volts AC. Detector voltage range from 0 to 50; amplifier 0 to 110. Use it on any tube set. Tube not included.

Check the coupon below, pay on delivery and try the "B" RECTIFIER for five days. If you are not entirely satisfied, return it and Rhamstine* will refund your money. Mail the coupon now—before you forget.

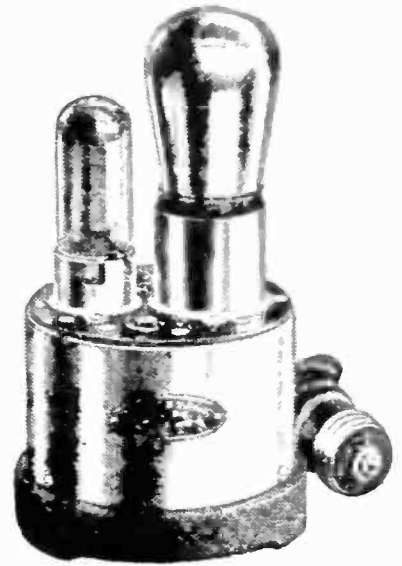

**Rhamstine★
Tube BOOSTER**
Only \$6

J. Thos. Rhamstine* (9)
506 E. Woodbridge, Detroit, Mich.

Please send me your () Tube BOOSTER at \$6; () "B" RECTIFIER at \$25, by express C. O. D. subject to inspection. If I am not entirely satisfied with the "B" RECTIFIER, I will return it to you in five days and receive a refund of the full purchase price.

Name.....

Address.....

The Sun
RADIO SECTION
NEW YORK, SATURDAY, JANUARY 24, 1925. 36 PAGES

The Three-Tube Rasla Receiver
How to Build This Remarkable Set, which Functions So Successfully That Many Distant Stations Become "Locals" Night After Night

Volume, Selectivity and DX
The Radio Sun sponsored the one tube Rasla and the two tube Rasla. The receiver was tested by the SUN staff. Tube for Tube this three bulb receiver surpasses any home built set, and tests showed the volume far too sufficient for the locations—fifty miles from the broadcasting station.
The Editors.

EDITORS are notoriously "hard-boiled." Before they go into ecstasies over a circuit, it must really be exceptional.

You can draw your own conclusions from the fact that the Rasla Reflex was editorially boosted by The N. Y. Sun and by many others.

Write at once for FREE picture diagram.
DAVIDSON RADIO CORP.
★ Dept. B, 222 Fulton St.
New York City

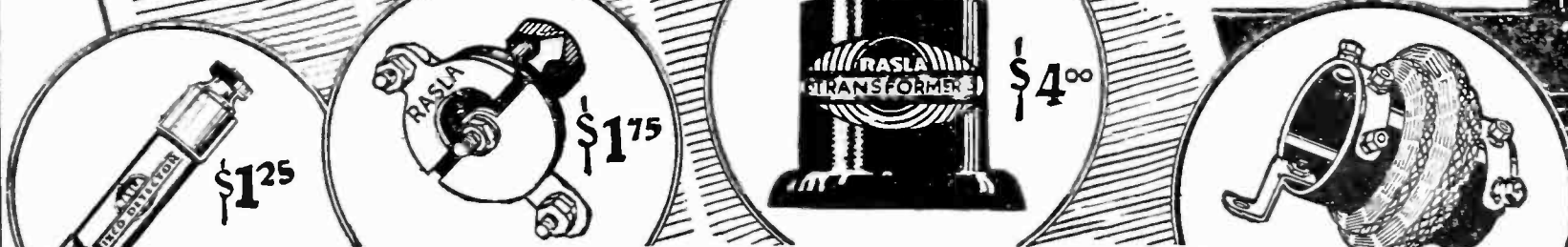

RASLA REFLEX

★ Tested and approved by RADIO BROADCAST ★



A Tube That
Out-Tests
and
Out-Performs
Your Best
Hopes
SEA GULL

Amplifying and Detector Tubes

Your test is best. You have to make them work—in your set—under conditions peculiar to your apparatus and your location. The achievements of others are only of passing interest and importance to you.

Sea Gull Tubes will adapt themselves to your set—your location—your problems.

We have limited our production so as to be able to scrutinize every step in each tube's making. The result is marvelous reception—quality of tone—economy of operation.

If your dealer can not supply you, we will send you as many Sea Gulls as you desire at \$3.00 per tube, C. O. D., plus the parcel postage.

Dealers and Jobbers write us for full information and discounts.

ABERDEEN SPECIALTY CO., Inc.
1641 N. Hutchinson St. Phila., Pa.

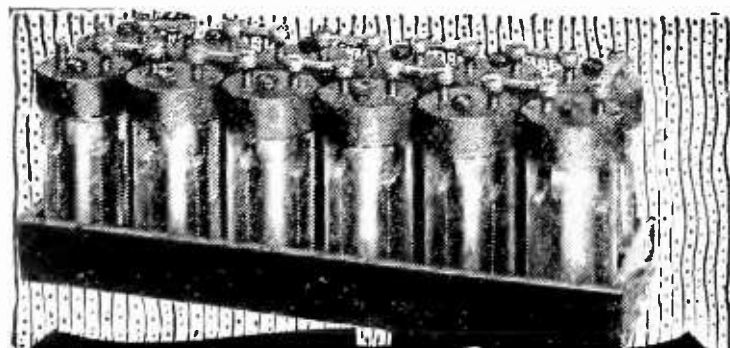

FREE!

To Each Purchaser of a **WORLD 6 V. Auto or Radio BATTERY**

12-Cell — 24-Volt Storage 'B' Battery

Positively given free with each purchase of a WORLD "A" Storage Battery. You must send this ad with your order. WORLD Batteries are famous for their guaranteed quality and service. Backed by years of successful manufacture and thousands of satisfied users. Equipped with *Solid Rubber Case*, an insurance against acid and leakage. You save 50 per cent and get a **2-Year Guarantee**



Bond in Writing **WORLD Battery owners** "tell their friends." That's our best proof of performance. Send your order in today. **Solid Rubber Case Radio Batteries**
6-Volt, 100-Amperes \$11.25
6-Volt, 120-Amperes 13.25
6-Volt, 140-Amperes 14.00

Approved and Listed as Standard by Leading Authorities including Radio News Laboratories, Popular Science Institute of Standards, Popular Radio Laboratories, Radio Broadcast Laboratories, Radio in the Home, and Lefax, Inc.

Solid Rubber Case Auto Batteries
6-Volt, 11-Plate \$11.25
6-Volt, 13-Plate 13.25
12-Volt, 7-Plate 16.00

Send No Money Just state battery wanted and we will ship day order is received, by Express C. O. D. subject to your examination on arrival. **FREE "B" Battery included.** Extra Offer: 5 per cent discount for cash in full with order. Buy now and get a guaranteed battery at 50 per cent saving to you.

WORLD BATTERY COMPANY
1219 So. Wabash Ave., Dept. 24 CHICAGO, ILL.

World For **AUTO and RADIO STORAGE BATTERIES**



KDKA - WEAJ - WGN - WJS - KHJ - KGO - KFAJ - WJY - KOP



WHOLESALE **LUDWIG HOMMEL & CO** EXCLUSIVELY
829 PENN AVENUE PITTSBURGH, PA.

FROST-RADIO

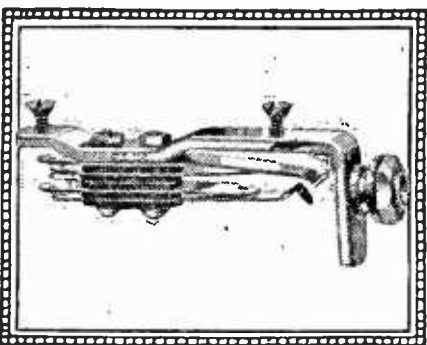

PAN-TAB JACKS
The newest and finest jacks made. For panel-hung or regular mounting. All types: 70c to \$1.00 list.



HERBERT H. FROST, Inc.
314-324 WEST SUPERIOR STREET, CHICAGO
NEW YORK CITY CLEVELAND KANSAS CITY LOS ANGELES

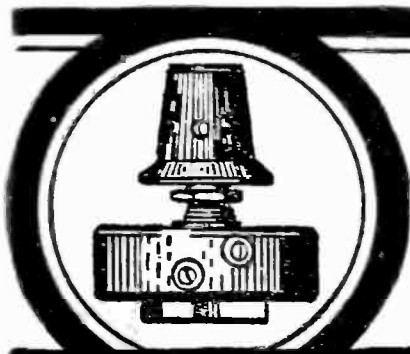

*This is the
Best Variable
Resistance With
Universal Range*

CLAROSTAT

CAN BE USED IN ANY CIRCUIT

The Clarostat connected across the secondary of the last transformer eliminates any possibility of distortion through uneven amplification of sound frequencies, as adjusting the Clarostat brings the amplifier circuit into a state where distortion caused by the transformers is eliminated entirely.

WHAT THEY THINK ABOUT CLAROSTAT:

I temporarily shunted the Clarostat across the secondary of that rusty old transformer—and let me tell you, I've tried every other distortion remover on that set, but *the Clarostat beats them all.*

Signed Harry A. Henhaw
206 West 14th St.
New York City

★ Price **\$2.25**

AMERICAN MECHANICAL
LABORATORIES, INC.
285-287 N. 6th St.
Dept. R. B., Brooklyn, N. Y.



22½ Volt

un-acid
everlasting
rechargeable

"B"

Storage Battery

\$2.95

including chemical



Does not lose charge standing idle. SPECIAL—2 22½ (45 volts) \$5.25; 90 volts \$10.00. Any special detector or amplifying voltage easily had. Very easily charged. Nearly 3 years sold on a non-red tape 30 day trial offer with complete refund if not thoroughly satisfied. Further guaranteed 2 years. Knock-down kits at still greater savings. Complete ready to run "B" battery charger \$2.75. Sample cell 35c. Order direct—send no money—simply pay expressman when delivered, or write for my free literature, testimonials, and guarantee. My large 36-page radio goods catalogue 10c. Same day shipments.

B. F. SMITH, 31 Washington Ave., Danbury, Conn.

FORMICA RADIO PANELS TUBES AND RODS

WRITE TO-DAY for your copy of our new catalog listing and pricing 3384 different sizes and kinds of Formica Radio Panels, 126 different sizes of Formica Tubes, and 21 different sizes of Formica Rods.

DRILLING—ENGRAVING

Lowest prices consistent with good work.

STARRETT MFG. CO.

521 S. Green St. - Chicago, Ill.

THE TUBE WITH A SENSIBLE GUARANTEE



All for You

SAY *Supertron* to your dealer and watch him smile—notice how different he will serve you. So confident. He will make sure that the number on the tube corresponds with the number on the guarantee certificate - - - Ah! If he does not smile—If he is not confident, or says "try this, it's just as good" then you must insist on *Supertron*—your dealer is obligated to you in consideration of your patronage.



U.S.A. \$2.00
Canada \$2.75

Genuine Supertrons are serial
numbered for your protection
AT ALL GOOD DEALERS

SUPERTRON MFG. CO.

222-228 Washington St.
Hoboken, N. J.

Export Div., 220 Bway., N. Y. City

Factory Offices Throughout the United States Distributors

- | | |
|--|--|
| Fireside Radio Set Co. - - - Chicago | Fort Wayne Iron Store - - - Ft. Wayne |
| Yahr & Lange Drug Co. - - - Milwaukee | Swanson Electric Co. - - - Evansville |
| The Roycraft Co. - - - Minneapolis | M. Baker & Son - - - Syracuse |
| Sorenson Lamp Co. - - - Des Moines | M. H. Johnson Electric Co. - - - Utica |
| Hippee-States Auto Sup. - - - Des Moines | Hinsdill Electric Co. - - - Troy |
| Orr Bros. - - - Cedar Rapids | American Phonograph Co. - - - Albany |
| Radio Dealers Sup. Co. - - - San Francisco | Rosen Talking Machine Co. - - - Boston |
| Western Light & Fix. Co. - - - Los Angeles | Balt. Hub Wheel & Mfg. Co. - - - Baltimore |
| Franklin Elec. Sup. Co. - - - Phila. | Cycle Auto Supply Co. - - - Buffalo |
| Keystone Radio Dist. Co. - - - Phila. | H. D. Taylor Co. - - - Buffalo |
| Allentown Radio Dist Co. - - - Allentown | Hamburg Bros. - - - Pittsburg |
| Goodlin Auto Sup. Co. - - - South Bend | Ed. J. Goetz Co. - - - Cincinnati |
| Reynolds Radio Co. - - - Denver | Elgin Radio Corp. - - - Elgin |
| Burr-Fowler - - - Syracuse | |

Exhibiting at National Radio Exposition
Grand Central Palace, Sept. 12-19



★ Tested and approved by RADIO BROADCAST ★

PYREX INSULATION

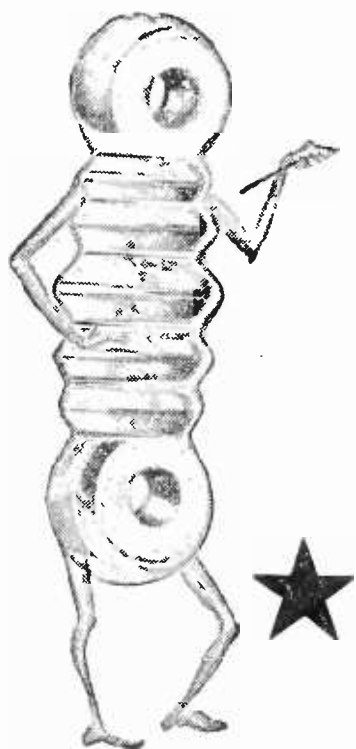

WHEN you overhaul your antenna for the approaching season of real reception consider the small cost of replacing your present insulators with PYREX Broadcast Insulators and forever forgetting insulator troubles and energy losses.

**A Pair of PYREX Insulators
(45c. each) is a Low Premium for
Insuring Reception**

PYREX Insulation is used on the antennae of the "Bowdoin," "Peary" and the planes of the Navy-MacMillan Arctic Expedition. PYREX is used on the ice patrol cutters of the Coast Guard Service. PYREX is used by the Navy, Lighthouse Service, Air Mail and Signal Corps. PYREX is used by many of the class "B" Broadcasting Stations.

PYREX is used by people who demand results.

**When You Buy PYREX Insulators, Look for the Trademark PYREX
All Good Dealers Sell PYREX**

CORNING GLASS WORKS
Industrial Division
CORNING **NEW YORK**

World's Largest Makers of Technical Glassware

★ Tested and approved by RADIO BROADCAST ★

Prest-O-Lite

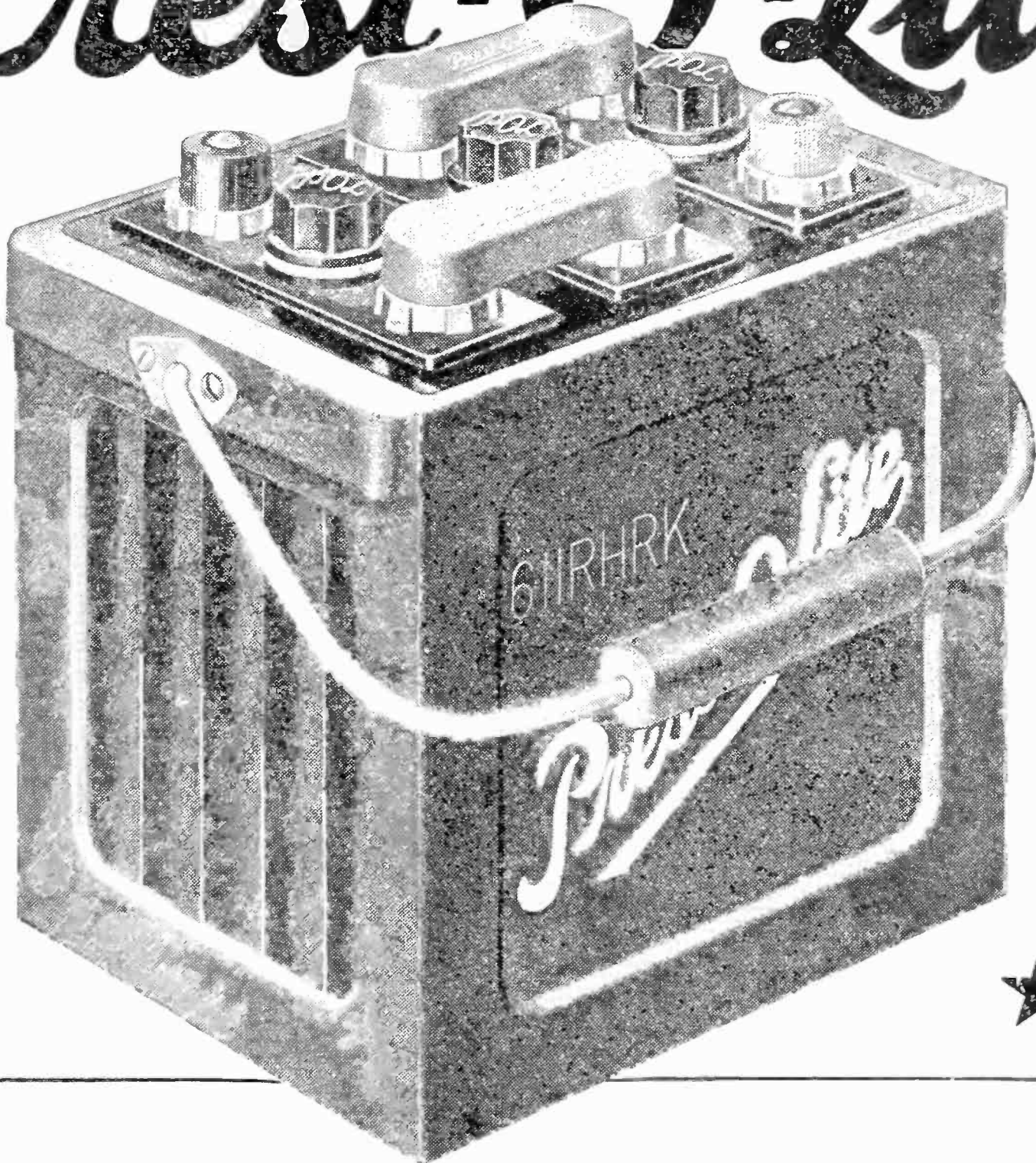

There are many improvements in the new Prest-O-Lite Battery

IN THIS new battery you'll find all the good points and high quality that have made Prest-O-Lite an unfailing aid to better radio. And in addition there are many important refinements and improvements that make it the most attractive, most convenient battery you can buy.

This new battery has a beautiful stippled finish hard rubber case that blends with any furnishings. The case is molded in one piece, giving sturdy, leak-proof strength.

To make the battery convenient to carry, the handle has been given a comfortable rubber grip.

The oversize terminal nuts on the binding posts are easy to turn and insure perfect contacts.

Novel rubber insulators completely cover the tops

and sides of the cell connectors, preserving the original fine finished appearance at all times and giving protection against accidental short circuits.

No effort has been spared to make this a battery you will be proud to own. Yet, like the rest of the Prest-O-Lite line, it is priced to offer you the biggest value of the day. Ask your dealer to show you this battery and the Prest-O-Lite Chart that helps you select the right battery for your set. Or write Indianapolis for a copy of our interesting handbook on radio storage batteries and how to charge them.

THE PREST-O-LITE CO., INC.
INDIANAPOLIS, IND.

New York San Francisco
In Canada: Prest-O-Lite Company of Canada, Ltd., Toronto, Ont.

★ Tested and approved by RADIO BROADCAST ★

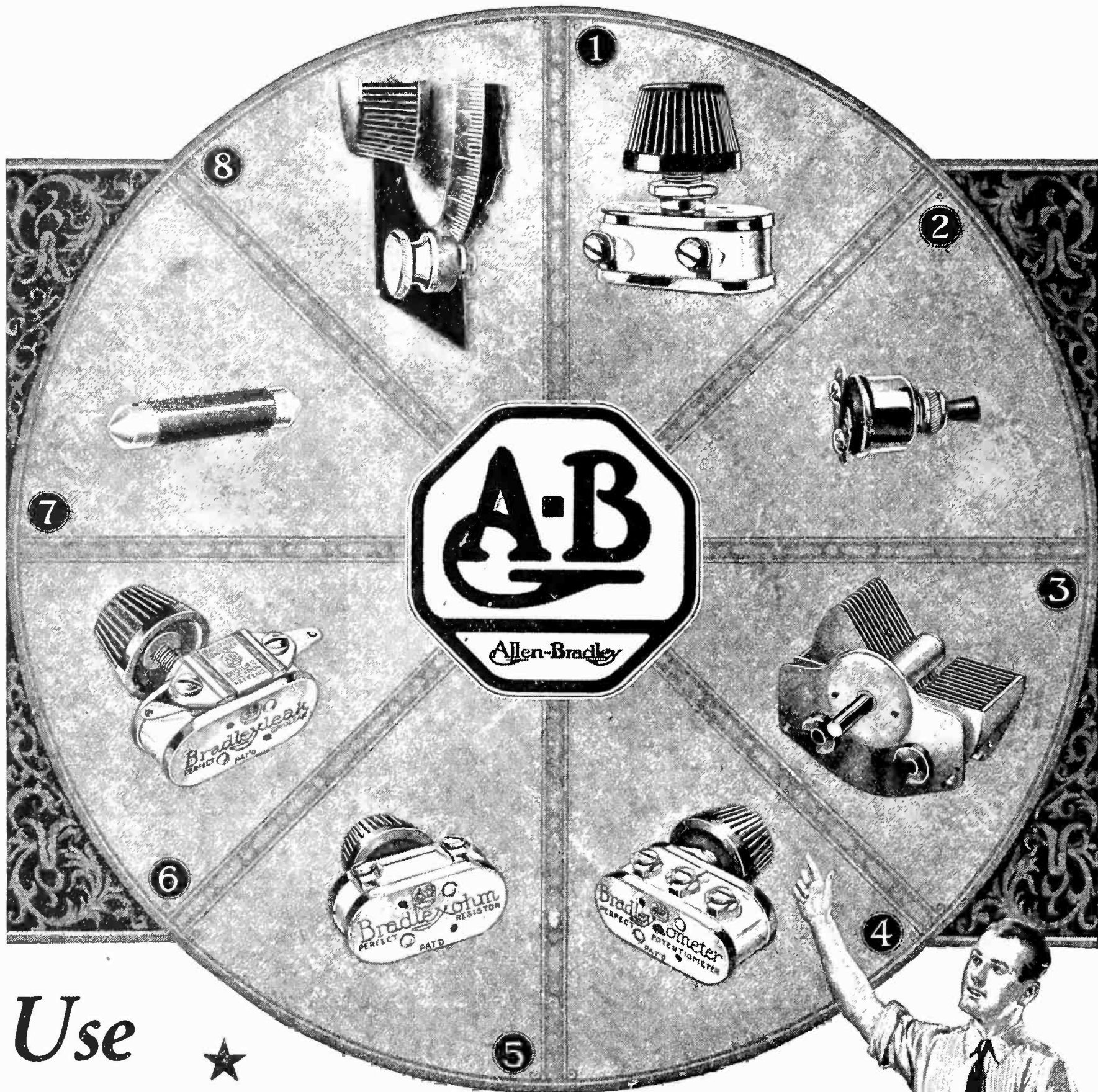

Use ★

Allen-Bradley Perfect Radio Devices for maximum selectivity and noiseless control

- 1 — **Bradleystat** — Noiseless Rheostat for ALL radio tubes.
- 2 — **Bradleyswitch** — Compact Switch for receiving sets.
- 3 — **Bradleydenser** — Low Loss Condenser for sharp tuning.
- 4 — **Bradleyometer** — Perfect Potentiometer for all circuits.
- 5 — **Bradleyohm** — Adjustable Resistor of every application.
- 6 — **Bradleyleak** — Adjustable Grid Leak for highest efficiency.
- 7 — **Bradleyunit** — Fixed Resistor for Resistance Amplifiers.
- 8 — **Bradleynier** — Vernier Knob, easily attached to any set.



ALLEN-BRADLEY CO., 278 Greenfield Ave., Milwaukee, Wis.
 Please send me your latest literature on the complete Allen-Bradley line of Radio Devices.

Name

Address

.....

★ Tested and approved by RADIO BROADCAST ★