

Eighteen Years of Amateur Radio

# RADIO BROADCAST

*V. 3 # 4*

In Touch with the World from the Arctic

August, 1923

*V. 3 # 4*

Porto Rico Fan Wins  
"How Far?" Contest

Sets for Summer

25 Cents

A Practical  
Super-  
Heterodyne  
with 199's



Published by

DOUBLEDAY, PAGE & CO.

Garden City, N. Y.

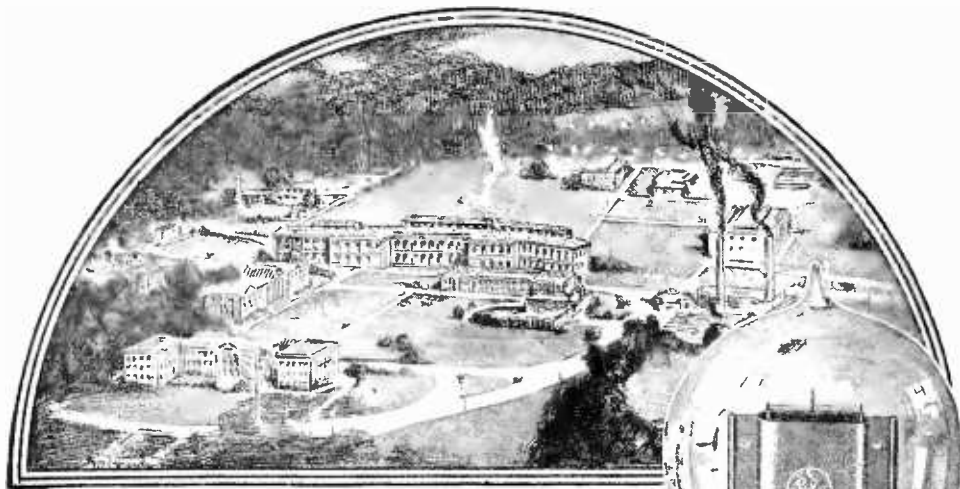

**One of the World's  
Largest Manufacturers  
with unlimited resources  
Builds Cunningham Tubes**

**F**ORTY-THREE years ago the carbon filament electric lamp, at that time considered the finest development in the electrical art, came into general use.

The important and ever-growing demand in the building and expansion of mighty factories, and the improvement of factory methods, until to-day the tungsten filament gas-filled lamp yields eight times the candle power for the same electric input.

In recent years these same highly skilled manufacturers have been devoting a part of their factories, and applying their engineering talent gained through years of experience, to the production of vacuum tubes.

The new Cunningham type C-301-A, Amplifier and Detector represents a combination of these years of manufacturing experience, and the engineering ability contributed by that great scientific organization, the Research Laboratory of the General Electric Company.

The low filament current of only one-fourth of an ampere and the extremely high mutual conductance of 700 micro-mhos, make the C-301-A the most efficient vacuum tube ever built for amateur and entertainment use in radio.

**Patent Notice:** *Cunningham tubes are covered by patents dated 11-7-05, 1-15-07, 2-18-08 and others issued and pending. Licensed for amateur, experimental and entertainment use in radio communication. Any other use will be an infringement.*



*A Specially  
Designed Tube  
For Every  
Radio Use*

*A. J. Cunningham Inc.*

**Home Offices:**  
248 First Street  
San Francisco, Calif.

**Eastern Representatives:**  
145 West Lake Street  
Chicago, Illinois

★ Tested and approved by RADIO BROADCAST ★



## Perfect Performance Guaranteed

Ace Type V, Armstrong Regenerative Receiver—\$20—Formerly known as Crosley Model V. For performance no receiver at its price can equal it.

A man writing from Evansville, Ind. says, "The other night I tuned in Kamach, Hawaii and held the concert for one hour. The music was clear and the speaking distinct." Quite a tribute.

Ace Receivers are licensed under Armstrong U. S. Patent 1,113,149. All Ace sets are equipped with the Crosley multistat, the universal filament control rheostat for all makes of tubes.

Wave length range 200 to 600 meters.

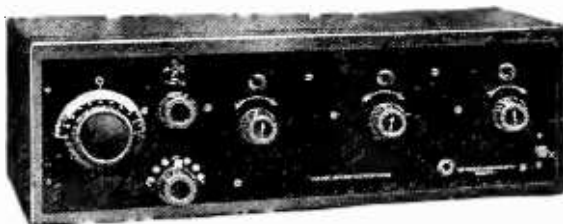

### Announcement

**ACE** TYPE 3 B  
\$50.

ets and new Crosley Condensers with molded plates. This is one of the latest and most efficient sets on the market for steady performance. Battery cabinet and bench can be furnished as extra equipment if desired. There is also a Model 3 B portable for camping trips and outings.

Live Jobbers and Dealers are taking advantage of the sales these instruments and other Precision instruments and parts are bringing them.

*Free Catalogue on Request*



## THE PRECISION EQUIPMENT COMPANY

POWEL CROSLY, Jr., *President*

820 Gilbert Ave.

Cincinnati, O.

★ Tested and approved by RADIO BROADCAST ★

# Radio Broadcast

ARTHUR H. LYNCH, EDITOR



## CONTENTS FOR AUGUST, 1923

|   |                           |
|---|---------------------------|
| <i>An Aid in the Fight Against Crime</i> - - - - -              | <i>Frontispiece</i>       |
| THE MARCH OF RADIO - - - - -                                    | J. H. M. 269              |
| IN TOUCH WITH THE WORLD FROM THE ARCTIC - - - - -               | BURNHAM McLEARY 282       |
| A DRY-CELL TUBE LOOP SET FOR LOCAL RECEPTION - - - - -          | ALEX. V. POLSON 288       |
| EIGHTEEN YEARS OF AMATEUR RADIO - - - - -                       | GEORGE E. BURGHARD 290    |
| "SELLING" THE PUBLIC ON BETTER CITY GOVERNMENT - - - - -        | J. L. SIMPSON 299         |
| ADVENTURES IN RADIO—When Messina was Destroyed - - - - -        | 303                       |
| PORTO RICO FAN WINS "HOW FAR?" CONTEST                          |                           |
| A Neighbor at Three Thousand Miles - - - - -                    | RICHARD BARTHOLOMEW 304   |
| UNLOADING THE MAIL FROM THE TRANSATLANTIC LINERS - - - - -      | M. G. CARTER 311          |
| THE GRIMES CIRCUIT WITH OUTDOOR ANTENNA AND COUNTERPOISE        |                           |
|   | HERBERT E. DILL 314       |
| RADIO ANGLING AND FISHERMAN'S LUCK - - - - -                    | THE REV. H. F. HUSE 316   |
| CRYSTAL RECEIVERS ARE WELL WORTH WHILE - - - - -                | ZEH BOUCK 319             |
| POWEL CROSLEY, JR. "THE HENRY FORD OF RADIO" - - - - -          | ALVIN RICHARD PLOUGH 323  |
| RECEPTION DE LUXE. - - - - -                                    | A. R. BOSCOV 325          |
| TEACHING SCHOOL FROM A BROADCASTING STATION - - - - -           | LLOYD JACQUET 331         |
| A TABLET DEDICATED TO THE RADIO CONGREGATION - - - - -          | 332                       |
| ALL BOY SCOUTS, ATTENTION! - - - - -                            | 335                       |
| SETS FOR THE GREAT OUTDOORS - - - - -                           | A. HENRY 336              |
| A PRACTICAL SUPER-HETERODYNE WITH 199'S - - - - -               | WALTER VAN B. ROBERTS 340 |
| A NEW REGENERATIVE RADIO-FREQUENCY COMBINATION - - - - -        | ROGER A. WEAVER 346       |
| THE GRID—QUESTIONS AND ANSWERS - - - - -                        | 350                       |
| ADDITIONAL BROADCASTING STATIONS IN THE UNITED STATES - - - - - | 352                       |
| NEW EQUIPMENT - - - - -   | 354                       |
| AMONG OUR AUTHORS - - - - -                                     | 356                       |

Copyright, 1923, by Doubleday, Page & Co. All rights reserved  
TERMS: \$3.00 a year; single copies 25 cents

F. N. DOUBLEDAY, Pres.

RUSSELL DOUBLEDAY, Sec'y.

ARTHUR W. PAGE, Vice-Pres.

S. A. EVERITT, Treas.

NELSON DOUBLEDAY, Vice-Pres.

JOHN J. HESSIAN, Asst. Treas.

DOUBLEDAY, PAGE & CO.

THE WORLD'S WORK  
CHICAGO: People's Gas Bldg.

COUNTRY LIFE

THE GARDEN MAGAZINE  
GARDEN CITY, N. Y.

SHORT STORIES

EDUCATIONAL REVIEW

BOSTON: Tremont Bldg.

LOS ANGELES: Van Nuys Bldg.

NEW YORK: 120 W. 32nd Street



# Radio "Blind-man's Buff"

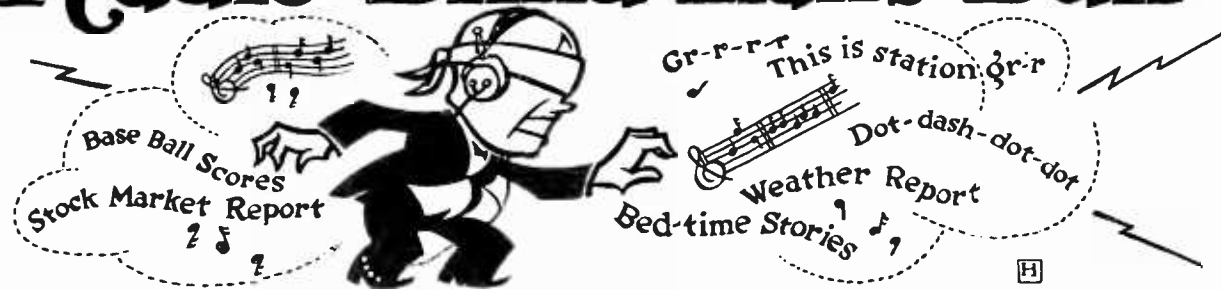

Picking your program with a single circuit receiver is a whole lot like playing blind-man's buff. You're not sure what you'll catch—nor how long you'll hold it.

In the midst of the entertainment you selected some other broadcasting station is quite likely to cut in and spoil the fun.

Selecting your radio equipment with your eyes open avoids this nuisance of jamming and scrambled messages.

Any radio-wise amateur will tell you that there's no comparison in genuine satisfaction between a single circuit instrument and the Paragon three-circuit receiver.

# PARAGON

Reg. U. S. Pat. Off.

## RADIO PRODUCTS ★

The amateur will tell you that the Paragon three-circuit receiver, because of its great superior selectivity and sensitivity, can pick and choose between broadcasting stations of about the same signal strength with less than one per cent differential.

This means that with a Paragon receiver you get what you want when you want it—complete messages and clear music from the station you tune in on, without interruption and jamming. Until you have listened in with a Paragon three-circuit receiver, you cannot guess the real pleasure and fascination of radio.

Long before broadcasting popularized radio with the general public, Paragon equipment was the choice of the experienced amateur. He will tell you today that if you want quality and satisfaction, Paragon Radio Products are the best and safest buy on the market.

*An illustrated Catalog of Paragon Radio Products Is Yours For the Asking*

DEALERS—The Adams-Morgan Company has an interesting proposition to make to reputable radio dealers who believe in quality merchandise. Details on request.

ADAMS-MORGAN COMPANY  
10 Alvin Ave., Upper Montclair, N. J.

Type RD-5 Regenerative Receiver and Detector—\$75.00  
Type A-2 Two-Stage Amplifier—\$50.00  
(Licensed under Armstrong Patents.)

Also Manufacturers of PARAGON  
Radio Telephone Amplifier  
Transmitters Transformers  
V. T. Control Units Control Dials  
Rheostats Amplifiers  
Potentiometers Receivers  
V. T. Sockets Switches  
Detectors Variometers

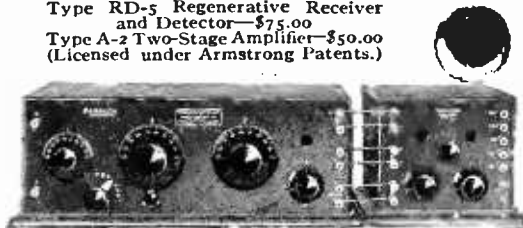

★ Tested and approved by RADIO BROADCAST ★



AN AID IN THE FIGHT AGAINST CRIME

The New York Police Department has installed receiving apparatus on some of its automobiles and motorcycles, making it possible to receive orders sent from the powerful broadcasting station at Police Headquarters

# RADIO BROADCAST

Vol. 3 No. 4



August, 1923

## The March of Radio

### BUYING SETS ON THE INSTALLMENT PLAN

**T**HERE are undoubtedly many homes where a good receiving set would be welcome, which have up to now missed the evening's radio entertainment because of the rather high cost of a good radio outfit. To get the sort of apparatus which will operate a loud speaker satisfactorily requires in the neighborhood of \$200, including a good loud speaker. For the set alone it will be necessary to give, perhaps, \$125, if stations a thousand miles distant are to be picked up with any degree of ease and certainty.

Now such an expenditure is often impossible in the form of a cash payment and one wide-awake company—The American Radio and Research Corporation—has realized this and by associating itself with a reputable credit house, has arranged to sell its sets so that they are available to the public on the partial payment plan. A 10 per cent. deposit for the set, and time payments extending over a year, will enable the family to enjoy radio while they are paying for the set. Of course many people feel that if they cannot afford to pay cash for an article, they cannot afford it at all; to these, the scheme offers nothing. But there are thousands of families willing to go into a contract to pay for some luxury, who would have to do without it if the contract plan were not in existence. This fact is evidenced by the tremendous popularity of the partial payment plan in the automobile industry; probably

more than half the cars purchased to-day are obtained in this manner. And, we may ask, how many of us pay cash for our homes?

Those who depend upon the small boy of the family to buy the parts and assemble the set are probably fairly well "sold" by this time; but a purchasing public, numbering millions, is still to be equipped with radio. With new stations going up, and the programs of the older ones continually increasing in excellence, this part of the public is waiting to purchase radio sets which require no tinkering nor complicated adjustments before they are ready to provide entertainment. These sets will, for some time to come, probably be sufficiently expensive to warrant the use of the policy of delivering the goods to the customer for a very small payment and relying on the pleasure which is had by the purchaser, to keep further payments coming in on time.

Incidentally, this will do much to help kill off the poor trash on the market, because if such apparatus is bought on the installment plan, the family will sacrifice the first payment and give back the set rather than continue to pay for something which is not what it is represented to be.



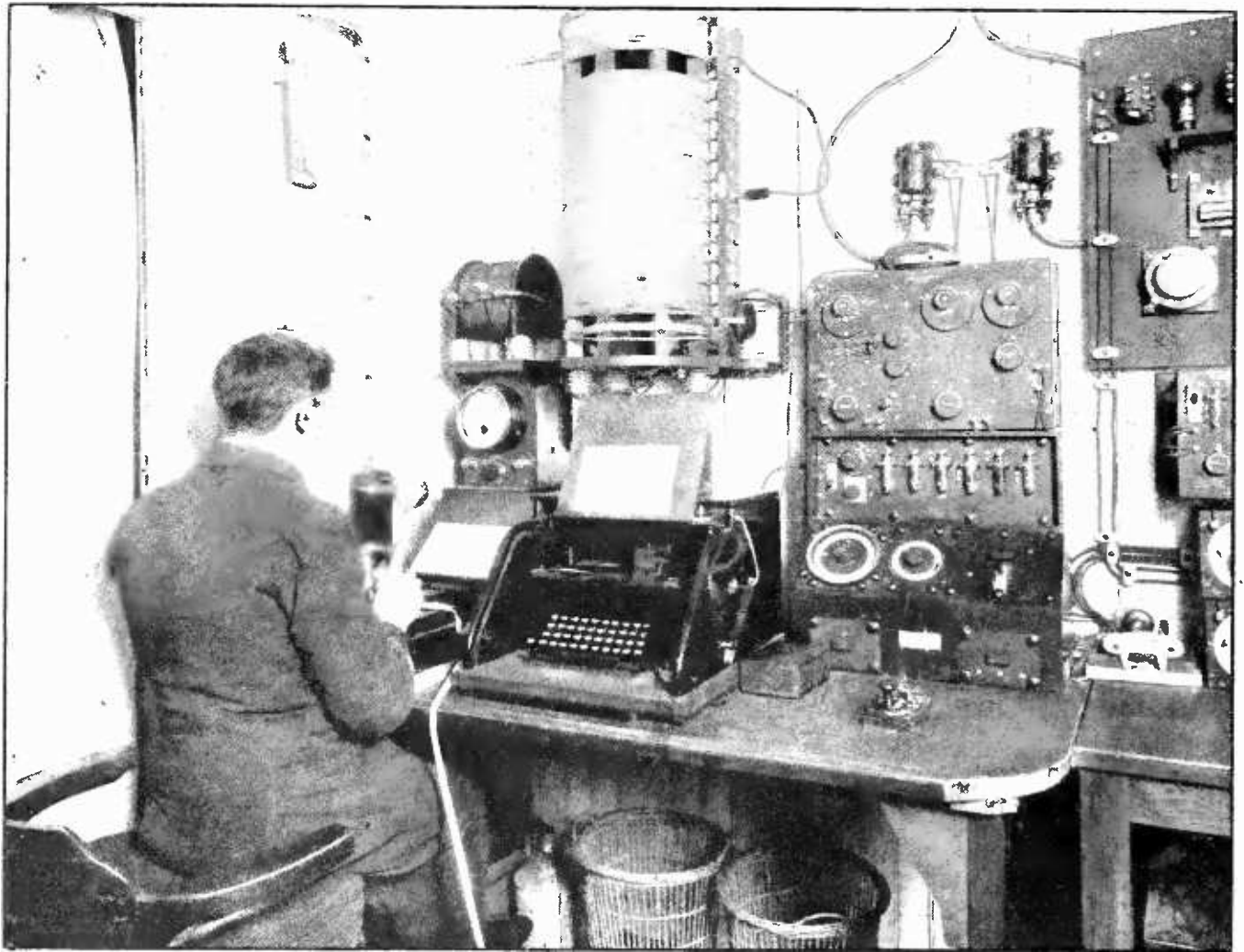

PREPARING MESSAGES TO BE SENT AT 80 WORDS A MINUTE

This operator, on the S. S. *Majestic*, is using a perforating machine to make records of radio messages on a tape. The work is done at a time when traffic is slack. When the ship nears port and a great deal of business has to be rushed through, the tape is fed into an automatic transmitting apparatus and buzzed off in short order

### Music Publishers With Vision

WE HAVE several times had occasion to express our disapprobation of the action of the popular music writers in prohibiting the broadcasting of any of their compositions without the payment of rather large license fees. The recent action of the Radio Corporation in cutting out from their programs all compositions controlled by the Society, evidently verified our guess that this grasping after revenues, where none was in sight, would react to the detriment of these composers and publishers. It is with real pleasure that we now record the action of another group of music composers and publishers; producers of the so-called "standard" music, as contrasted to the "popular" variety.

In a report on the subject of broadcasting, a

committee of the Music Publishers' Association of the United States says: "Our committee has been carefully investigating the broadcasting of copyrighted music since last November. In our report, just adopted by the Association, we point out that music publishers are vitally interested in radio broadcasting as a great future user of music and that our rights in the use of copyrighted music in public performances must be protected. However, we appreciate the fact that radio broadcasting is still in a chaotic and experimental state, and that while ultimately it will have to be placed on a commercial basis if it is to develop its potentialities, nevertheless the commercial side of the broadcasting problem has not yet been solved.

"In view of these facts, *and also because we desire to coöperate in developing the music possibilities of radio*, we believe that we should allow the use of our copyrighted compositions



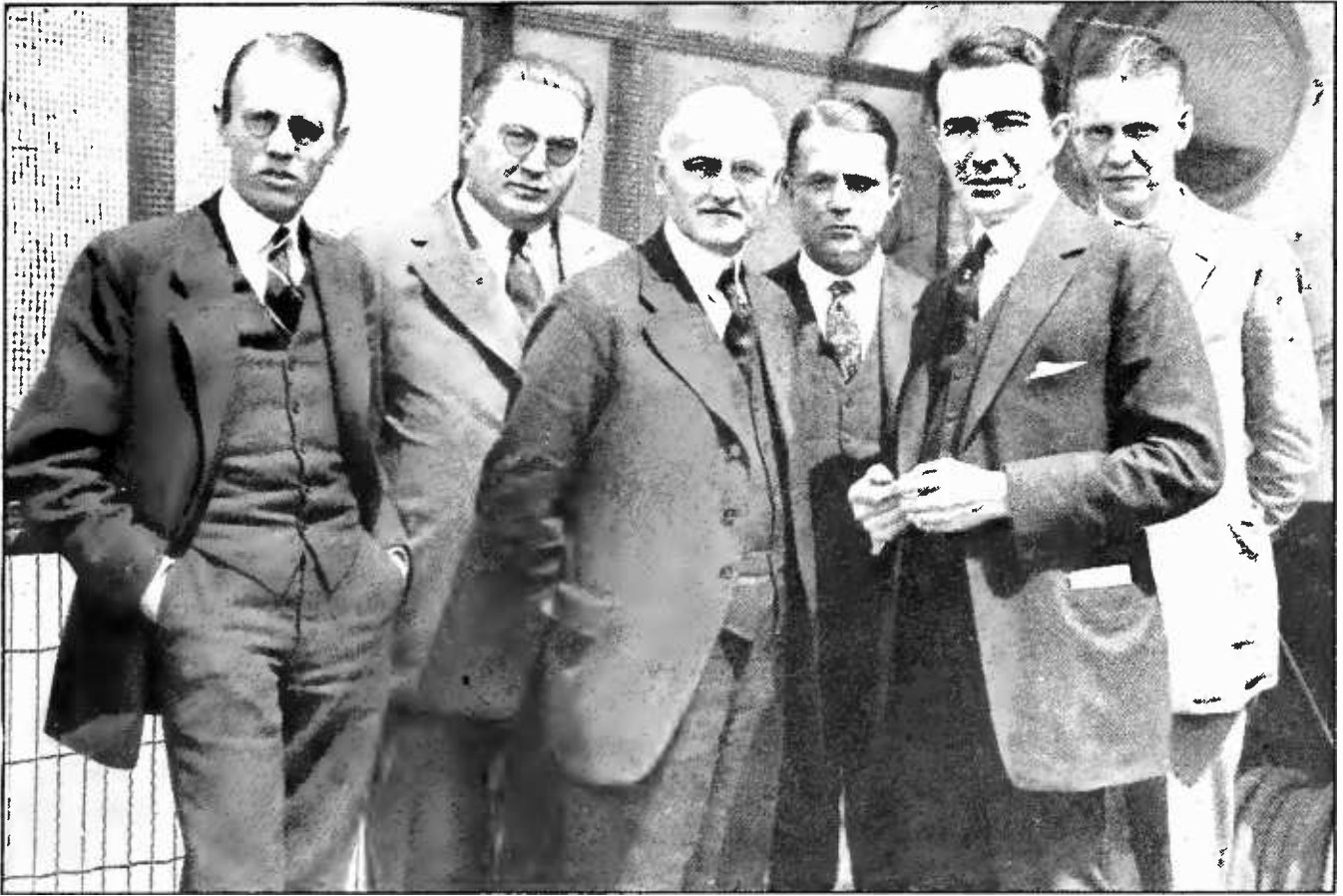

SOME OF THOSE RESPONSIBLE FOR THE NATIONAL ASSOCIATION OF BROADCASTERS

Left to right: J. E. Jenkins, of WDAP, Drake Hotel, Chicago; Frank J. Elliot, WOC, Davenport, Iowa; Henry Ramsey, Chicago Board of Trade; Thorne Donnelly, WDAP; E. F. McDonald, Jr., WJAZ, Edgewater Beach Hotel, Chicago; and W. Johnson, WFV

for broadcasting without charge for the present and without prejudice in our rights."

In another part of the report the musical possibilities of radio are hinted at and present defects mentioned; altogether the report shows keen analysis and liberal judgment of the members of this organization, and we heartily recommend its perusal (especially the italicized part) by the more short-sighted members of the American Society of Composers, Authors, and Publishers.

#### Will the Composer Pay for Broadcasting?

**M**ANY and varied have been the suggestions volunteered to solve the question—who is going to pay for broadcasting? This was the subject of our first editorial in the very first number of our magazine; it seemed at that time the one important question involved in the future development of radio, to which no satisfactory workable answer had been given. To-day, more than ever, this question is uppermost in the

minds of those concerned with the future of broadcasting.

There are two large organizations interested in the question which can get along indefinitely with conditions as they are: undoubtedly the Radio Corporation has a large income from the sales of tubes and sets, and the American Telephone and Telegraph Company can charge up its broadcasting expense to development without seriously reducing its dividend. But there are scores, or even hundreds, of broadcasting stations which cannot continue in this fashion. Their future is not promising unless some source of revenue is found and found soon. This is especially true since the popular music writers have begun to insist on their royalty rights and want to collect money where there is none.

Now, the American Society of Composers, Authors, and Publishers undoubtedly numbers among its members many of the better writers and composers of popular music, but we have wondered of late if it were not possibly adopting tactics like those of some labor unions, suppressing potential talent so that those in the

Society might better control the dividend sources. Although we have never tried the experiment (not having sufficient gift along musical lines) we imagine that a new song and score writer, not in the Society, and not wanted in it, might have quite a difficult time getting his wares on the market. If this is so, the scheme outlined in the pamphlet before us may succeed very well, and in succeeding, indicate at least one way in which broadcasting may be made self-supporting.

A group of broadcast managers have combined to form the nucleus of the National Association of Broadcasters. The proposed constitution and by-laws are well drawn up and show the executive ability of the organizers. Membership in the Association is suitably divided into classes, and other formalities are taken care of properly, such as membership fees, schedules for broadcasting, and care of

*surplus funds.* The mention of this last item started us thinking. Surplus funds from the operation of a broadcasting station!

Well, here's the idea. Musical genius is to turn over its compositions, properly copyrighted, to the Association—for nothing. The Association will, through its members, put the composition "on the air" and so bring it at once to the public's attention and if the listeners think the stuff is good the composer's product is "sold." The composer begins to reap his royalties from the publication and sale of his music, and the Association, as its reward for putting the music before the public, is to get the mechanical royalties—those reaped from phonograph records and roll music. When the composer turns his work over to the Association to broadcast, these mechanical royalties are conveyed to it in the contract.

This looks like a very good scheme, and we

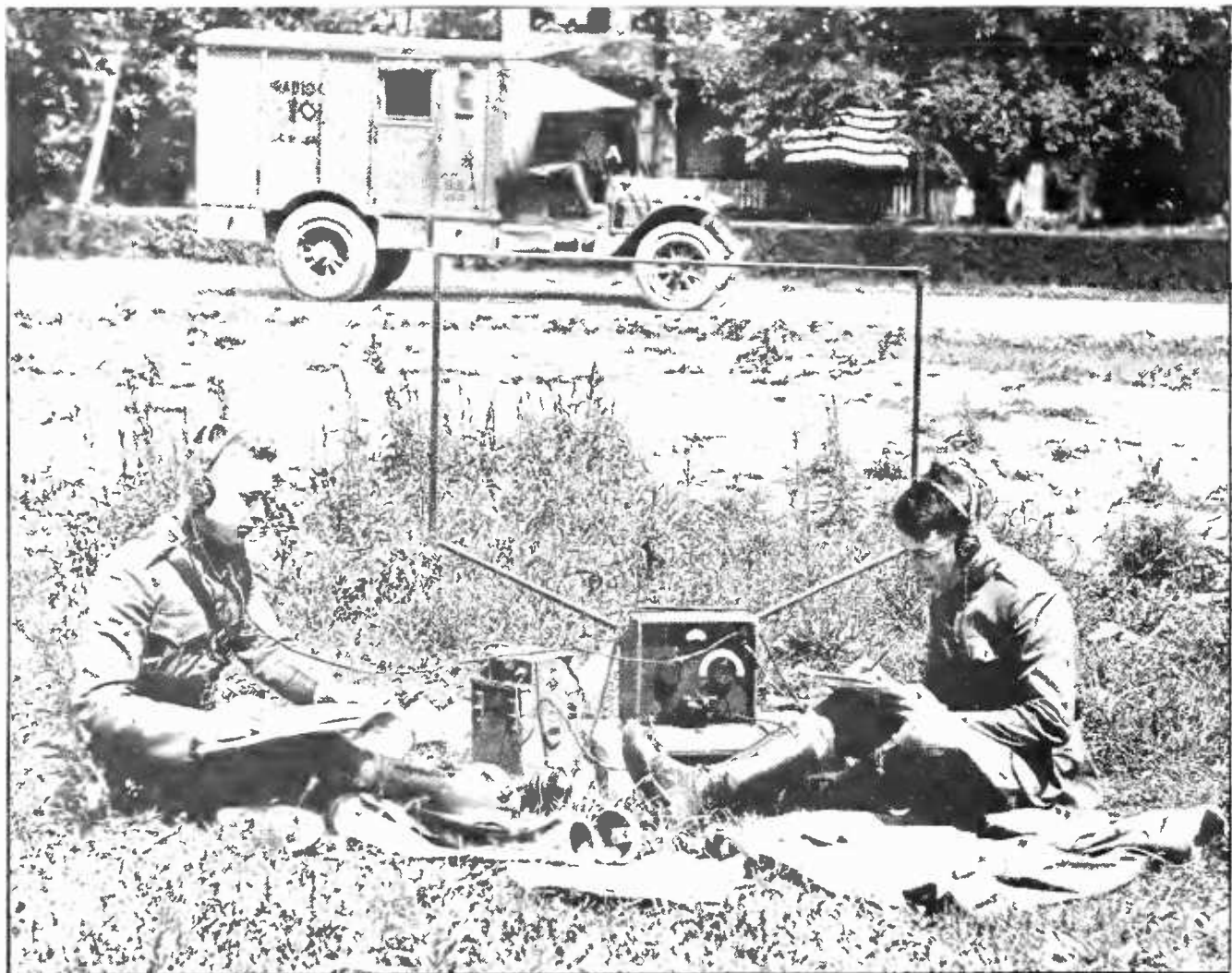

RESERVE OFFICERS AT CAMP VAIL, NEW JERSEY

Using an outfit with a collapsible loop. With this little machine it is possible to send and receive, even though located deep in a dug-out. This set was developed by William Preiss during the War

shall watch its development with interest. All stations represented in the Association will send out the compositions contracted for by the society, on a schedule arranged by the Board of Directors, so that a definite, known advertising campaign is assured to the composer. It is for the best interests of both parties to the contract that the new piece be "put over", because both benefit from large sales. As far as we can see, composers and broadcasters alike have everything to gain and nothing to lose in trying out the scheme. If it works, as we hope it will, societies like the A. S. C. A. P., which have been so insistent on radio royalties, will have to look elsewhere for funds to pay their eminent counsel.

In outlining the need for this society, one of its organizers informed us of the following incident, which, he maintains, is but one of a number:

An author sold one of his compositions to a Chicago music house. It remained dormant for a long time. Later, arrangements were made with a broadcasting station to have the author sing his own song. It made quite a hit and has enjoyed a good sale. Radio has actually brought this author out of obscurity. Then, because the author had made an arrangement with the A. S. C. A. P., he was prevented from singing his own song at all radio stations that failed to pay royalties to his society.

The new Association is made up of some of the leading broadcasters in the country and they have very good ground for the belief that they are in a position to popularize their own songs. Powel Crosley, Jr., a member of the Association, has already started a music publishing company and the first song to be popularized by radio is now being put on the air. Is this the handwriting on the wall?

### The Effect of Broadcasting on the Churches

**O**N TWO recent occasions we have commented on the effect of broadcasting upon church attendance. It is evident that effects of considerable importance may be looked for. We had ventured the guess that the smaller churches would probably lose in attendance as the worshippers at these small country churches, with their itinerant pastors, came more directly in contact with services at the larger metropolitan church with their wonderful music and inspiring



THE HONORABLE ERNEST LAPOINTE

Canadian Minister for Radio. He is to supervise the activities of the twenty-odd broadcasting stations and arrange for the collection of the \$1.00 tax levied on every broadcast receiver. It is estimated that there are more than 150,000 receiving sets in use in Canada at the present time

preachers. It seemed to us, also, that an argument might be found on the other side of the question: the country pastor, ordinarily having but little contact with the larger churches, administered by the more capable preachers of his denomination, might himself install a receiving set, and so gain ideas and inspiration for his own services. Ordinarily, he is dependent upon the printed word for his sermons, but by radio he is put directly into the audience of the best thinkers and speakers of his church. In this way, we believed, he must improve himself, and this improvement might result in the increased interest of his own little band of worshippers.

These were only guesses, as most of the opinions on the effect of radio broadcasting must be for some time; but that the guesses come somewhere near the mark would appear from a recent letter in which an Episcopal bishop voices his ideas on radio. The letter is from Bishop Stearly, and reads as follows:

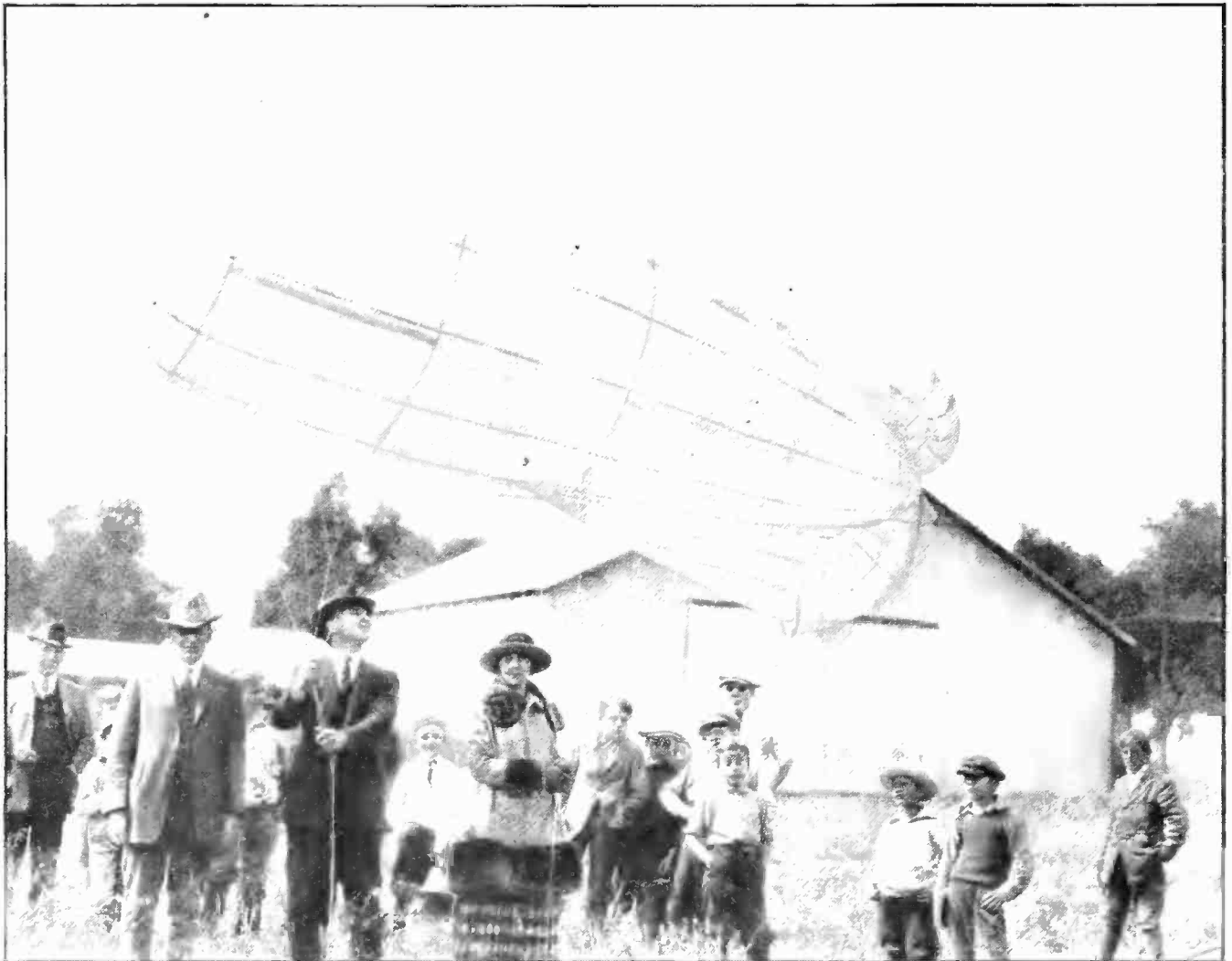

USING A YOUNG BLIMP TO SUSPEND THE ANTENNA

Mr. Roy Knabenshue, of Burbank, Calif., a pioneer aeronaut, constructed this 14-foot balloon, filled it with hydrogen, and sent it up with 200 feet of antenna wire attached. Using a commercial two-stage receiver, he claims to have received various broadcasting programs with greater clearness than when using a horizontal antenna suspended in the ordinary way. Mrs. Knabenshue and Mr. R. W. Coburn (on either side of Mr. Knabenshue) assisted in the experiments

The wide-spread use in private homes of the wireless apparatus lays a fresh responsibility upon the clergy and laity in regard to services of the church. It is debatable whether the broadcasting of sermons of popular preachers and of entire church services will act as a stimulant or a deterrent to church-going.

Why go to your parish church when you can sit at ease in your parlor and hear the heavenly music of a capable choir and be charmed by the fervid eloquence of a magnetic preacher?

There seems to have entered into our crowded and throbbing life another ally of those forces which make difficult the assembling of the faithful for praise and prayer. The habit of church-going has a hard time in the face of Sunday excursions, movies, sacred concerts, automobiling, and broadcasting.

What this means to us, I suspect, is, at the bottom, a challenge to our ingenuity, wisdom, and devotion. None of these things, nor all of them together, can fill the deepest need of the spirit in man,

and in the church, in its worship and teaching and work and fellowship, are the potencies capable of bring to men the highest satisfaction, the deepest and most abiding joys.

Now it becomes necessary for the clergy to make the church more attractive than the world's entertainments, to discover to men the possibilities within it for strength and refreshment, and the gifts of grace in its bestowing, more precious than earthly things.

#### Broadcast Central, Comprising WJZ and WJY

**T**HE past month saw the opening of probably the best equipped radio broadcasting station in America, the Radio Broadcast Central of the Radio Corporation of America. It is located on the top of Aeolian Hall, one of New York's tall buildings in the



centre of the city. Trouble from power absorption in the neighboring buildings, and poor radiation, might have been anticipated, but from results so far reported the station seems to function excellently.

The Radio Corporation's previous broadcasting station, WJZ, located in Newark, a dozen miles from New York, was extremely inaccessible to lecturers and performers. This drawback was partially remedied by fitting up a studio in New York City, and sending the voice currents by wire to the radio station. But this scheme gave much trouble; the wires used were leased from the Western Union Telegraph Company, and in spite of assurances that they were "as quiet as it was possible to make them," noises of all sorts were picked up by them between the studio and the transmitting station. In fact, on the night when they were first put in commission, while the

Western Union official was telling us—via radio—how quiet his wires were, they were picking up so much extraneous noise, unknown to him, that his words were scarcely intelligible.

A studio and radio transmitter should be as close together as it is possible to make them, because wire connections between them even under the best conditions *will* pick up *some* disturbing "electrical noises." Broadcast Central's studios (there are two of them) are directly under the antenna, so that trouble from this source has been eliminated.

Two antennas, suspended from the same masts, lead to two entirely separate transmitting sets, each of which has its own control equipment. Each studio controls one of the antennas, and as these and their respective transmitters are tuned for different wavelengths, both studios and antennas may operate simultaneously without interference. This

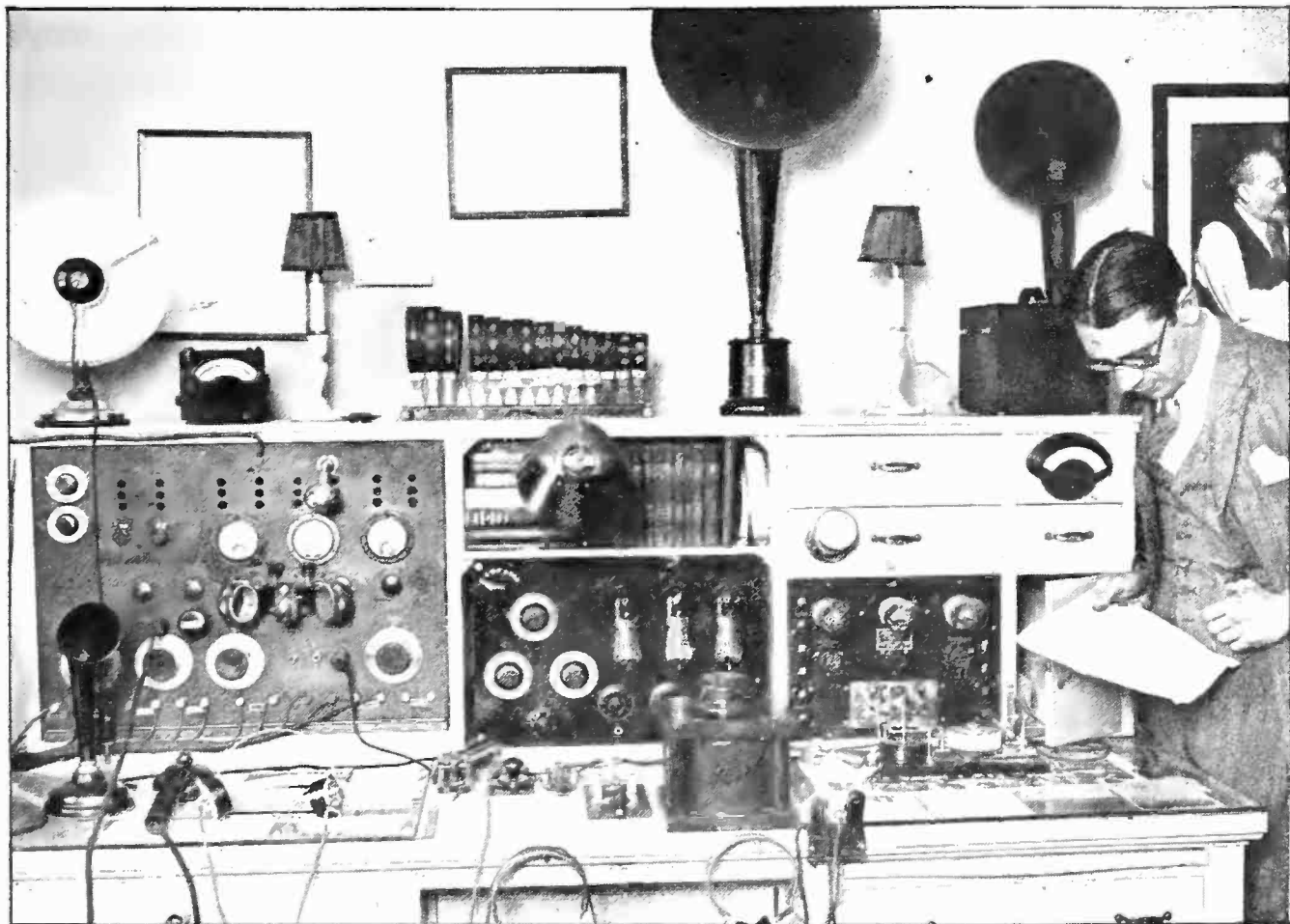

#### A PLACE FOR EVERYTHING AND EVERYTHING IN ITS PLACE

Amateur station 2ABT, owned by Mr. George Freisinger of New York. It is one of the most elaborate in the East, and its performance is in keeping with its appearance, as Mr. Freisinger (at right of picture) has heard stations in Europe as well as all over America. The 300-watt transmitter is not shown, but the combination transmitter and receiver of the navy type, using 20-watt Singer tubes for transmitting, and a standard honeycomb regenerative hook-up with two stages of amplification for receiving, is mounted on the desk at the left. In the centre is a special type amateur receiving unit with two stages of A. F. amplification. At the right, is a three-stage power amplifier

is the first time such a system has been introduced into the broadcasting game.

These paragraphs do not pretend to give a technical description of WJY and WJZ, but one very ingenious scheme of control does warrant mention here; the visual control of the amount of modulation of the antenna current. The high-frequency antenna current is rectified by a tube outfit and thrown on to an oscillograph screen, and a wavy line of light shows the operator exactly how much the antenna current is being varied by the singer's voice. Moreover, this operator has at his immediate command the control of the amount of modulation sent to the antenna—if a singer puts too much fortissimo into her voice so that the antenna current would be modulated too much to sound well, the effect of the voice on the antenna current can be at once (and unknown to the singer) cut down, thus tem-

pering the singer's effect on the transmitter. The idea is very much like having an orchestra perform in a room enclosed by shutters which could be opened or closed by a listener outside; if the performers put too much intensity into their playing the outside listener could close the shutters when they played too loudly and open them when the softer passages were being executed.

Some such control over radio modulation is absolutely essential if the quality of the received signal is to be good. While one performer will sing with tremendous volume, and stand close to the microphone, the next, standing farther from the microphone and singing with less force, may scarcely affect the antenna current. The engineers of the Radio Corporation are to be congratulated on the method which they have developed to solve this problem.



#### THE FIRST DEMONSTRATION OF THE RADIO TAIL-E-PHONE

The scene is laid in Leadville, Colorado, in 1905, when Mr. C. B. Cooper (sitting on the apparatus) was Superintendent of Construction for the United Wireless Company. Mr. Cooper is now a member of the Hoover Conference Committee, the Board of Governors of the National Radio Chamber of Commerce, and Chairman of its Broadcasting and Finance Committees, and Treasurer of the Radio Broadcasting Society of America. In 1917, he left construction work to organize the Ship Owners' Radio Service, in Seattle. Recently he started the C. B. Cooper Company, Factory Representatives. His company acts as New York representative for the Crosley Manufacturing Company



LISTENING TO WJAZ FROM JUST OUTSIDE THE STUDIO

Guests at the Edgewater Beach Hotel, Chicago, can see the broadcasters through the windows at the left and the control room operators through the windows at the centre. At the same time, they can listen to the program by means of a receiver and loud speaker

### Secretary Hoover Acts

WE BEMOANED the failure of Congress to act on the White bill, by which the broadcast situation was to be remedied; but before the echo of our moans had died away we found the situation suddenly remedied without the White bill! Apparently feeling that it already had sufficient authority, and that the situation was bad enough to warrant immediate action, the Department of Commerce, acting in accord with the opinion of the radio experts and authorities of the country, has reassigned frequencies to practically all the broadcasting stations in the country and has done it so well that we no longer have any cause for complaint. Instead of the bedlam of noise to which we had become almost accustomed, there is practically no interference at all. With a good receiving set, one can go through the range of wavelengths assigned to broadcasting and pick up perhaps twenty stations with no appreciable interference.

To be sure, it was possible for the expert, even under previous conditions, to get rid of much of the interference, because no two stations sent on exactly the same wavelength, and by using two- and three-circuit tuners with just the right amount of regeneration, he was able to cut out many of the disturbing stations. Most of us, however, were not sufficiently expert, and didn't have sufficiently complicated sets (and didn't want them, either) to do such fine tuning. But now no such skill is required. Even the novice can eliminate practically all interference; and the concerts, ever improving in quality, are really worth while staying at home to hear. The finer passages are not spoiled by the whining beat note of a competing station, as they formerly were.

With this re-assignment of wavelengths, a big step has been taken in forwarding the interests of radio broadcasting; considering the apparent ease with which it was accomplished we wonder more than ever why the Department of Commerce delayed its good work so long.



THE BOOM IS ON IN ENGLAND

And manufacturers are hard-put to supply the increasing demand for broadcast receivers. These women are doing light assembly work at the Marconi Works in Chelmsford

### The Interdepartmental Radio Advisory Committee

FROM the Department of Commerce we have received a bulletin describing the successful functioning of the committee of representatives from all governmental departments having a serious interest in radio communication. For some time past various departments have been doing more or less broadcasting, and as it seemed only consistent with the Federal Government's activities in other branches of coordinating the work of various government sub-divisions to cut down expense and interference, Secretary Hoover brought about in April, 1922, the formation of the Interdepartmental Radio Advisory Committee, which we discussed in these columns about a year ago. The scope of the Committee's activities was widened in January of this year to include not only questions of methods of, and material for, broadcasting, but all other radio matters in which the several departments may be interested.

The Chairman of the Committee is Acting Assistant Secretary S. B. Davis of the Department of Commerce, and he has with him repre-

sentatives of the Departments of Agriculture, Interior, Justice, Labor, State, Treasury, War, and Navy, Bureau of the Budget, Interstate Commerce Commission, Post Office, and the Shipping Board. Whereas the power of this committee is purely advisory, its members have cooperated so harmoniously that no matter has yet been brought up for consideration which has not been amicably solved. As its fundamental principle in controlling the extension of governmental radio activities, the committee has wisely concluded "that radio broadcasting should not be used where wire telegraphy or telephony or printed publication would be as satisfactory."

In the words of the bulletin, "the several departments feel that the committee has been a satisfactory clearing house for government radio matters. While the experimental broadcasting system has operated satisfactorily to date, the experience which has been had with it should be used as a basis of a rational plan for a government broadcasting system. The question is, of course, intimately related with the existing and prospective privately owned broadcasting stations throughout the country. If radio is to become of maximum benefit to



the people, the Government must continue to study the question of properly organized broadcasting and other services. There are constant occasions for the curtailment or expansion of the Government's radio plant and the committee's effort is to coordinate these needs and fulfill them with maximum economy."

### Radio Repays its Genius

**T**O THOSE who have followed, even superficially, the development of radio in America, the name of Alexanderson is well known. The contributions which have come from him and his co-workers are many and varied; his work is not apparent in the receiving sets with which most of us are familiar but deals rather with the engineering features of radio. The reduction of losses in the huge insulators used in suspending the large antennas of the Radio Corporation's transmitting stations, the ingenious scheme for reducing earth losses of an antenna by his "multiple tuning" method, the magnetic behavior of iron at the excessively high frequencies used in radio, and the design and construction of the immense high-frequency alternators which bear his name, serve to illustrate the type of work which this engineer is contributing to the advancement of this branch of electrical engineering.

He now undoubtedly feels repaid a thousand-fold for the energy he has devoted to radio research, as will be evident from the following narrative from the News Bureau of the General Electric Company:

Monday, April 30, Verner, six-year-old son of Dr. Alexanderson, was lured from his home by the promise of a gift of rabbits, and kidnapped. The police had practically no clue to work on; in spite of the active work and close cooperation of the newspapers, police, and radio broadcasting stations, the case appeared to be at a standstill and the whereabouts of the boy remained a mystery for three days.

Bert Jarvis, of Theresa, Jefferson County, N. Y., a village of a thousand inhabitants, listening-in Monday night on his home-made radio set, heard WGY, the Schenectady broadcasting station of the General Electric Company, announce the kidnapping of Verner Alexanderson. Jarvis rents boats to fishermen and acts as caretaker for numerous summer cottages in the vicinity of Theresa. A few days before the kidnapping, he had rented an



DR. ALEXANDERSON AND HIS SON

isolated cottage to a man who was bringing his family up from the city for the season.

After hearing the radio description of the missing boy and the kidnapper, Jarvis's suspicions were aroused. Tuesday he met the owner of the cottage and asked him who had taken possession. The owner explained that it was only an old woman, a little boy, and one man.

It so happened that the man when renting the cottage had said that he was going to bring his daughter. Jarvis's suspicions grew and Wednesday he decided to ride out to the vicinity of the cottage in his motor boat. He stopped at the cottage and asked the old woman who came to the door for a glass of water. He entered the house and saw a child on the bed. Jarvis returned to the cottage later and asked for candle wicking for his motor. On this visit he waved to the boy and the boy waved at him.

Thursday morning, Jarvis saw a photograph of the kidnapped boy in the *Syracuse Post Standard* and this picture tallied with the boy in the cottage. Now sure of his ground, Jarvis reported to the Deputy Sheriff and a few hours



HOMeward BOUND WITH THE CAVE-MAN SET HE MADE AT SCHOOL

This English youngster is eager to see what's on the air down in London. The apparatus looks a bit primitive but it's easy to "get at," at least

later Verner talked over the long distance telephone to his father and mother.

The successful use of radio in the Alexander-son case has convincingly proved the value of broadcasting as a publicity factor when far-reaching results are desired in a short time. WGY announced the kidnapping within two hours after it had been reported to the police. Other broadcasting stations joined their voices to the voice of WGY, and the story, with a description of the missing boy, went over the entire country. Radio fans were everywhere enlisted in the search. The newspapers kept them posted on the progress of the case and also furnished them with pictures of the boy. Through Hudson Maxim, the members of the Amateur Relay League took up the case and hundreds of spark sets flashed the story through the air.

Dr. Alexanderson made a personal appeal from the Schenectady broadcasting station. After the boy had been found he again addressed the radio audience thanking everyone for his interest, sympathy, and assistance. He placed special emphasis on the coöperation of the press and police.

## West Coast to Have a New Station

THE General Electric Co. has started work on a new broadcasting station to be located in Oakland, Cal. Most of the broadcasting stations to date have been fitted up in more or less makeshift quarters in buildings already erected, but this new Western station is to be built for radio from the ground up.

Research is being carried on to determine how reverberatory an ideal studio should be; a room having no echoes at all gives the transmission a peculiar empty quality, whereas too much echo from walls and ceiling makes the speech unintelligible and accentuates severely certain musical notes.

A small power house for the radio apparatus will be built below the antenna, which will be of the multiple tuned type. An interesting feature of the new station is the use of water-cooled triodes for the oscillator and modulator; although the normal antenna power from these tubes will be only 1000 watts, the possible output, to be used for test purposes, will be many times as much.

It is expected that the programs will be broadcasted not only from artists in the station studios, but that also, by suitable wire connections provided by the Pacific Telegraph and Telephone Company, any of the interesting events taking place in San Francisco, the West's metropolis, will be put on the air!

## The U. S. Health Service Functioning by Radio

THAT radio is surely becoming one of the very necessary factors in our every-day life is evidenced by the following recent note from the U. S. Public Health Service:

The steamship *West Cabons*, lying at anchor in Baltimore harbor, about nine miles from the city, needed medical help at about 3 a. m. recently and needed it quickly. A member of the crew had fallen into the hold and injured himself seriously. So the captain of the ship sent a wireless broadcast asking help.

The call was picked up, not in Baltimore, nine miles away, but at Cape May, about 100 miles due east of Baltimore. As Cape May was separated from the *West Cabons* by parts of New Jersey and Delaware and by the eastern shore of Maryland, not to mention Delaware and Chesapeake bays, no direct help from it was possible.

But the operator was on the job. Promptly he consulted the long distance list in the Baltimore telephone directory and called up the residence of

the Public Health Service, Surgeon-in-Charge of the Marine Hospital in Baltimore—100 miles to the west. The surgeon, roused from sleep to receive the message, asked him to radio certain emergency treatment to the *West Cabous* and to direct the captain to send a boat to a certain pier in Baltimore, where he would find a surgeon waiting to go to the ship with him. And so, in the middle of the night, in less than an hour from the time the call for help was sent, a sea-going ambulance carrying a Public Health Service officer reached the side of the injured sailor.

### Good News For Our Readers

EVERY one really interested in the development of radio realizes that to understand its problems a knowledge of its more technical features is most desirable. Of course, we cannot all expect to be radio experts, but we can learn to read, intelligently and with reasonable comprehension, papers dealing with the technical progress on radio.

Those of you who look at radio in this light will appreciate our good fortune in having been chosen by the executive committee of the

Radio Club of America as the magazine to publish the papers presented at its meetings.

In the membership of this club are included nearly all the best-known amateurs in the vicinity of New York. Not only do the members themselves contribute interesting and valuable papers on the various phases of radio, but well known workers in the field from the research laboratories of the large manufacturing companies have always appreciated the honor of being invited to speak before the members, and have gladly done so. We have frequently attended the meetings of the Club and have always come away with added knowledge and renewed enthusiasm for the radio game.

RADIO BROADCAST is to be congratulated on having been selected by the Radio Club of America for the publication of its papers. We believe that the class of readers to whom RADIO BROADCAST appeals is such that the Radio Club may feel sure that its papers are reaching an intelligent and appreciative audience. —J. H. M.

### AT CAMP—FOR THE TIME BETWEEN SUPPER AND SLEEP

The large home set can be taken over the hills and far away, when the family chariot does the toting





DR. MACMILLAN AT THE NEWLY INSTALLED SET ON THE "BOWDOIN"



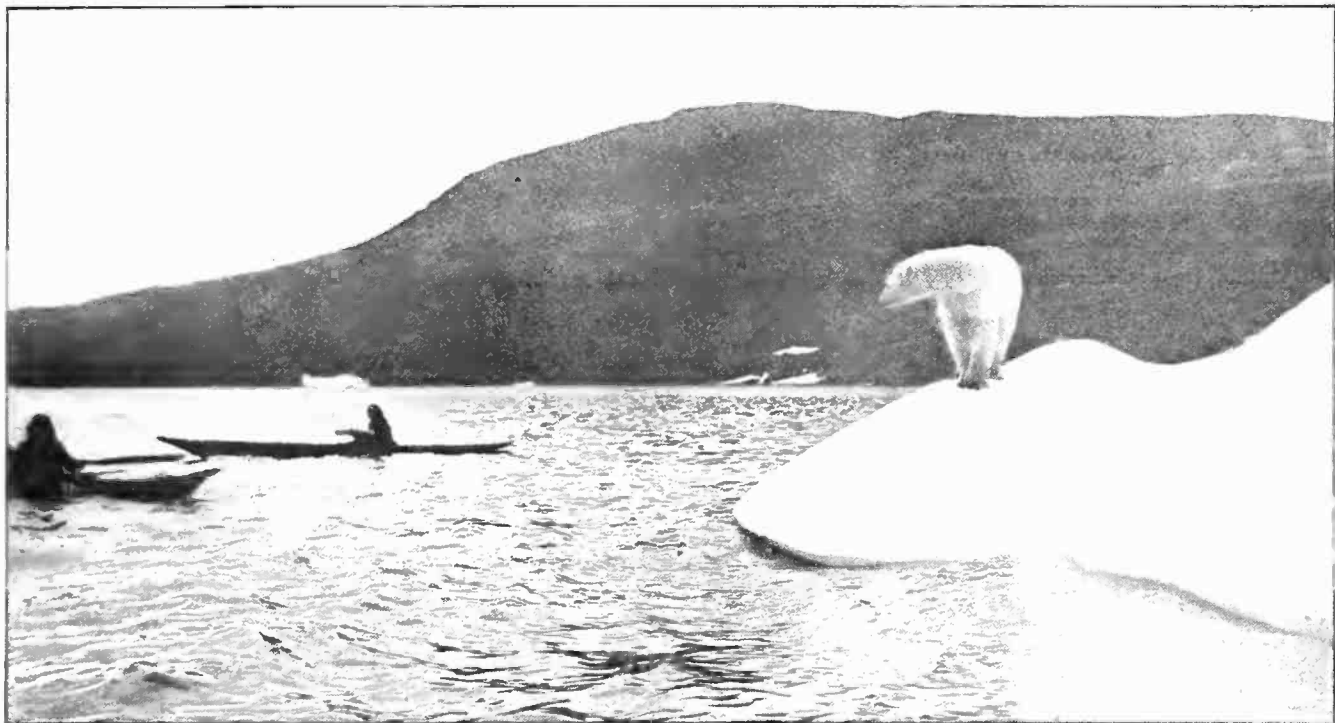

THE "MONARCH OF ALL HE SURVEYS," IN ETAH, NORTH GREENLAND

## In Touch with the World from the Arctic

How Dr. Mac Millan Came to Take Radio with Him to the Far North. The Question of Communication Through the "Auroral Band." How Broadcasts from Civilization will Relieve the Greatest Hardship of the Expedition, and How the Explorers will Flash Back Weekly Code Messages to Civilization

By BURNHAM McLEARY

WHILE you lounge in your easy chair this winter, listening to violins in some distant city, give a thought to the brave ship *Bowdoin*, captained by Donald B. MacMillan, the Arctic explorer; for he and his seven ship-mates will likely enough be listening to that same orchestra and perhaps be dancing to its music on the sparkling ice-fields of the Frozen North.

For radio is on its way to meet the Eskimo.

About a month ago it set out from Wiscasset, Maine, ensconced in the forward end of Captain MacMillan's 89-foot schooner and bound for the northernmost limits of Eskimo Land, hardly three hundred miles from the Pole itself.

And while you are picturing the pleasures which radio will bring to these Arctic explorers,

stand by and listen for the signals of their far-off station. For under the ice-battened hatches of the *Bowdoin*, there is a wireless operator, Donald H. Mix by name, who hails from Bristol, Connecticut; and his hand on the key will be flashing each week a five-hundred word story of adventure (in a special code prepared for the purpose by the Government) to seventy of the leading newspapers and magazines of America. He will transmit, also, coded diagrams of all new lands and harbors found and charted by the expedition. Each message will be signed with the letters WNP. The full name of the sending station, happily christened by the Government, is Wireless North Pole.

It's a great thing for radio, this adventuring into the land of perpetual stillness, undoubtedly the greatest from the standpoint of



DONALD H. MIX, RADIO OPERATOR ON THE  
PRESENT EXPEDITION

He was selected from a group of many applicants to take charge of the *Bowdoin's* communication with the outside world. He is 21 years old, a graduate of the Bristol High School, Bristol, Conn., and an amateur operator of six years' standing

popular appeal that has yet taken place; and the story of how it all came about adds an interesting chapter to radio history.

On March 21, 1923, Captain Donald B. MacMillan, F.R.G.S., was guest of honor at a dinner given by U. J. ("Sport") Herrmann at the Hotel Sherman, Chicago, and attended by prominent officers of the Naval Reserve. At this dinner Captain MacMillan told of the true hardships of the Arctic—not the cold, not the lack of food, but the awful solitude, so terrible indeed that men go mad because of it. He recalled one expedition in particular when this tragic fate befell a number of the crew and the only way the remainder of the party could get back to safety was to shoot them.

Seated next to Captain MacMillan was E. F. MacDonald, Jr., radio fan and owner of the powerful Edgewater Beach Broadcasting Station.

"Why in the world don't you take along a radio receiving set?" was MacDonald's immediate question.

"Haven't room," replied MacMillan.

"Great goodness, man," said MacDonald, "do you realize how little space a radio set would take up—and don't you see what it would do? I don't mean a radio equipped with ear-phones, but a set with a big loud-speaker that could be heard in all parts of the ship. Why, at a single stroke you would eliminate, by your own testimony, the most terrible hardship of your entire voyage. Your men could listen to the same concerts, the same orchestras, which they would be hearing if they were at home, could get all the news of the day, could even receive direct messages from their families back in civilization. Give me space no bigger than that"—MacDonald measured the limits with his two hands—"and I'll not only furnish the radio that will do all this but have it installed and let you try it out."

"All the space I've got left," said MacMillan, "is four cubic feet. If you can do it in that, go ahead."

This conversation took place in March. Two months later the idea of radio communication had made such appeal to the explorer that he had arranged to take with him not only a standard Zenith receiving set but also a 500-watt Zenith transmitter, and had told the carpenter to rip out four bunks in the forward end of the forecabin to make room for it.

The set selected was located in the laboratory on the second floor of the Zenith plant on the outskirts of Chicago. The motor generator was placed on skids approximately eight feet from the transmitting unit. Leads were run across the floor in a temporary manner and the set was then ready for test. The aerial consisted of 4, wires No. 22, 7 strand, 52 feet long, an exact duplicate of the antenna which was subsequently used on the ship. One porcelain insulator was used at the opposite end. The lead-in was composed of two wires connected to the outside wires and came down over the side of the building spaced five feet away, and in through the top of a window through a formica tube, to the set, the total length of the lead-in being approximately thirty-eight feet. The free end of the aerial was supported on top of an electric sign approximately twenty-five feet above the roof of the building. The opposite end was supported by a long wire attached to the flagstaff which is located in the center of the front of the building and was approximately fourteen feet above the roof. All rheostats and controls for the motor generator were temporarily bolted

to the floor in order to save time in the installation for trial purposes.

When the test was started at 10:30 P.M., the operators immediately started to get in touch with amateur station 1AW. However, 1AW did not find the wavelength until 1:30 in the morning when communication was established through the means of a relayed message from 3JJ. Immediately afterward, Hartford switched their wavelength and caught the testing station and worked for approximately 1½ hours with the ease of being in the same town. At the time the lower wavelength (220 meters) was used, the radiation was 3½ amperes, and on 310 meters 5 amperes. Under full load, the machine delivered 5½ amperes into the antenna on 220 meters, and 6½ amperes on 310 meters.

The  $\frac{6}{10}$  K. W. motor generator was driven by storage batteries of 32 volts, each an exact duplicate of conditions on board the *Bowdoin*. Two 50-watt power tubes were used. During the test the following stations were worked: 1AW, Hartford, Conn.; 8Q, Freeport, Pa.; 3JJ, Washington, D. C.; 6KA, Los Angeles, Calif.; 9BXA, Denver, Colo.; 8AWT, Syracuse, N. Y.; 9ZT, Minneapolis, Minn. (daylight); 9CWB, Columbia, Mo.

Meanwhile, the adventure had so appealed to MacDonald that the explorer invited him to go part way with him and the invitation was accepted; so that even while you read this article, MacMillan and MacDonald are headed toward the North Pole. The latter, however, plans to end his northward journey at the Eskimo village of Hopedale, Labrador, the farthest point from which he can get a mailboat back before ice closes navigation for the winter.

Incidentally, Mr. MacDonald will return to the United States with information of real importance to the success of the expedition, for his personal contact with the crew will have shown him exactly what kind of radio program most appeals to the men and will enable him to put on just such a program once a week at the Edgewater Beach Broadcasting Station in Chicago.

The selection of the operator to accompany radio on its first adventure in the Arctic, forms a story in itself. Strangely enough, it is not physique and ability that are the most important qualifications for success in the Arctic, but personality—the faculty for making oneself congenial in the close quarters of an ice-bound ship. In the search for the right man,



THE CREW OF THE "BOWDOIN" ON HER 1921-22 CRUISE

Hiram Percy Maxim, President of the American Radio Relay League, was appealed to, and his aid was readily enlisted. Mr. Maxim sent out a call for volunteers. Hundreds responded. From this group, five were picked as candidates, the final choice being made by Captain MacMillan.

#### WILL RADIO PENETRATE THE AURORAL BAND?

WITH a single powerful radio station sending messages from Farthest North, opportunity will be afforded for studying certain phases of radio transmission in a way that has never before been possible. For example, there is a period of 141 days during which a message sent at midnight must traverse hundreds of miles of sunlight before it reaches darkness. How will this unusual condition affect the reception of the message?

Again, a request will be issued to all members of the American Radio Relay League to stand by on a certain evening of each week and tune in for Station WNP. What portions of the American continent will receive these messages? Where will they come through clearest? If a line be drawn on the map through the stations that succeed in picking them up, what sort of an arc—if it be an arc—will that line describe? Of especial significance is this latter question, for the reason that never before has

a scientific attempt been made to transmit wireless messages through the "auroral band" which encircles the North Pole, and which, it is believed, will act as a powerful deterrent. In this connection it is hoped that these experiments will shed new light of a purely scientific nature upon that great mystery of the heavens, the Aurora Borealis.

Of the nature of the news that will be flashed to us from out the Arctic, we may gain some inkling from the talks which Captain MacMillan has given in recent months. He tells, for example, of the marvelous Arctic summer, when the weather is mild and emerald fields are agleam with myriads of little twinkling flowers. He tells, also of vast mineral deposits—a twenty-foot vein of coal, for instance, utterly exposed and waiting only for the great airships of the future. Doubtless, too, he will have interesting reports to make of the glaciers of the Far North, now known to be advancing rather than receding, and believed by many to foreshadow for this thriving continent of ours, a return engagement for the Age of Ice.

#### AN APPRECIATION OF THE ESKIMO

MOST interesting of all, however, will be his studies of the Eskimo—in many ways the only remaining specimen to whom humanity can point with pride! Devoted to his wife or wives, kind to his children, reverent always toward his elders, ready always to bring up the orphan as his own, the Eskimo is so free from guile that he may well thank his lucky stars that he has no money, for the white man would surely go after it.

Very naïve is the Eskimo. Shown a telephone set by Captain MacMillan, one of them jabbered into one end of it, just as he had seen the white man do and then ran as fast as he could to the other end, to see if he could hear his own voice coming through. Failing in that, he cut the wire, puzzled over it for a while, and then averred that the whole business was impossible as the wire had no hole in it!

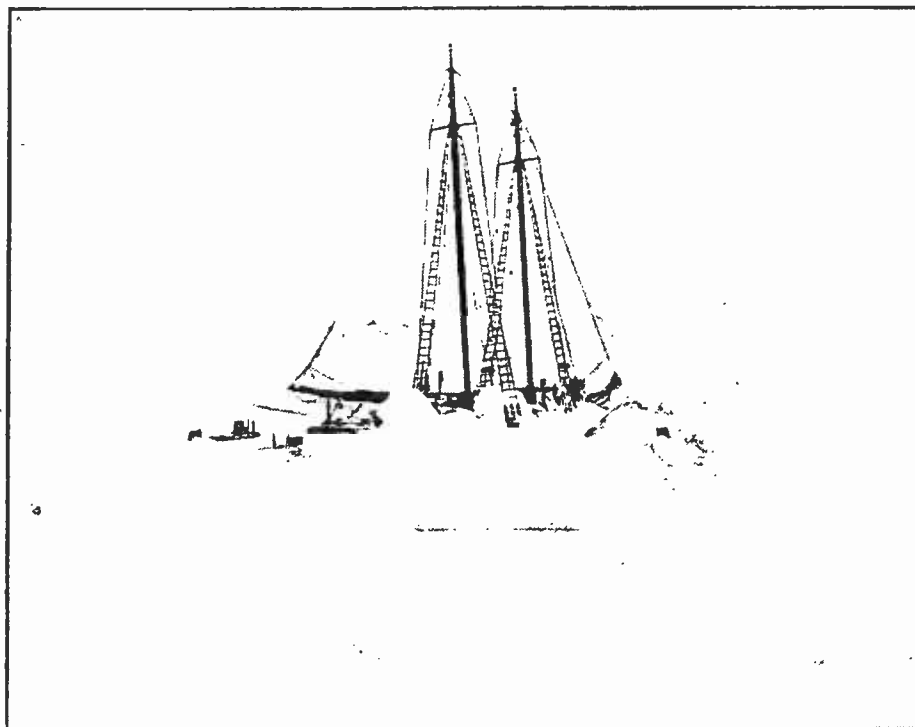

THE "BOWDOIN" FROZEN IN FOR THE WINTER  
Note the snow igloos built on the deck of the ship, covering the hatches to retain the warmth



Shown, in motion pictures, the traffic on Fifth Avenue, he exclaimed, "Oh, see the dog sleds that move without dogs."

Naïve, indeed, the Eskimo, but a rather good sort, for all that—and he doesn't have such a bad time of it, either, according to MacMillan.

If an Eskimo baby lives five days, it is almost certain to be good for sixty years—unless it falls through the ice, or gets killed by a bear or a walrus. Except for heart disease and rheumatism, sickness in the Arctic is practically unknown. No good Eskimo would ever think of having such a thing as a "cold."

Time, too, is practically unknown to the Eskimo. He keeps no calendar, has no weeks or months or years. No Eskimo woman knows her age.

Although the Eskimo is deeply religious, he would never think of praying to God for help, because he holds that it is not necessary; God is his friend. His only prayers are to evil spirits, begging them to let him alone. He is sure of a future life; to his mind no one with any sense would question it. Some day he will go to heaven, a place where it's warmer, and the hunting's good.

What will the Eskimo say when he listens to the radio? Something about spirits, you can be mighty sure; for the Eskimo's explanation of motion pictures, which Captain MacMillan introduced him to last year, was, in effect, that the white man had cleverly conjured up the spirits of people in distant lands and put them through their tricks! Doubtless he will say now that the white man has found out a way to make those "spirits" talk and sing!

#### FOURTEEN MONTHS—OR FOUR YEARS?

**H**OW many months shall we be privileged to entertain our guests in the Arctic and how long will they be able to send us instalments of life in the great white solitudes?

Fourteen months, if all goes well—but one never knows.

In the year 1913, for instance, Captain MacMillan headed an expedition to "Crocker Land," which Peary reported having seen on his successful dash to the Pole in 1908. Incidentally, Captain MacMillan, who up to that time had been a professor at Bowdoin College, his Alma Mater, accompanied Peary on his earlier expedition, being third in relief when the final dash was made. On this "Crocker Land" Expedition MacMillan journeyed 300



HAPPY LAUGHING AL-NING-WA OF THE SMITH SOUND TRIBE

Eskimos do not keep a calendar, and no Eskimo woman knows her age. But that is the least of Al-ning-wa's worries

miles across a field of solid ice to a point 100 miles beyond the supposed location of "Crocker Land." It was nowhere to be seen. He then turned back and ascended the exact elevation from which Commander Peary had sighted "Crocker Land," and there, at a distance of 100 miles, he beheld this imaginary country—*rugged hills and wooded stretches, a perpetual and permanent mirage!*

In 1913, as I said, Captain MacMillan set out on this expedition to be gone only fourteen months. Four years later the ice of the Arctic gave up a ship, and a band of weary explorers made their way back to "civilization," there to learn for the first time that practically the entire world was at war!

Great changes have come about since then. Radio may not have made the whole world kin—but at least it has placed its people all on speaking terms.

War smolders, and at present writing, the only terrible thing that impends is another presidential contest. This time, however, the men of the *Bowdoin*—happily enough—will not



IF AN ESKIMO BABY LIVES FIVE DAYS, HE IS GENERALLY GOOD FOR SIXTY YEARS

This most northern Eskimo boy in the world is taking a sun bath twelve degrees from the North Pole on the northern shores of Greenland

be kept in darkness. For better or worse, they shall have the news—and no man quicker than they! Thus, betwixt wars and rumors of wars, these men up North shall have full opportunity to size this old world up—and who shall say

that they may not indeed *prefer* to stay four years and perchance find out the answer to that question the Eskimo is always asking: "*Why do you and all the other white people like it better to live so far from our home?*"

## A Dry-Cell Tube Loop Set for Local Reception

By ALEX V. POLSON, E. E.

**T**HE receiving set here described is one which was built after a few weeks' experimenting with loop aerial sets, and it is primarily designed for reception from broadcasting stations that are not over a hundred miles away.

This set has operated satisfactorily, signals being clear and loud, while it was being carried around the house. As the detector tube used is a  $1\frac{1}{2}$ -volt tube, the set may be made very compact and may therefore be used as a portable outfit which will prove convenient where a ground connection cannot easily be made.

A feature of this set that is a little unusual is the *double loop aerial*, one loop being used as a regular loop aerial and the other being used as a tickler coil. The diagonals for the frame consist of two pieces of dry wood  $2\frac{1}{2} \times \frac{1}{2} \times 18$  inches, mortised at the centre and mounted as shown in the accompanying diagram (Fig. 1). Two sets of binding posts are mounted on the face of the frame as shown. The loop aerial proper consists of 15 turns of No. 20 D. C. C. magnet wire spaced one eighth of an inch apart and held in place by saw cuts made in the ends of the diagonals. The ends of the wire should

be connected to two of the binding posts. The tickler loop consists of 14 turns of No. 20 D. C. C. magnet wire spaced one quarter of an inch apart and held in place on the face of the frame by small brads. The ends of this coil are connected to the other two binding posts.

The inductance coil shown consists of 60 turns of No. 24 D. C. C. magnet wire wound on a cardboard tube 4 inches in diameter and 3½ inches long. Taps are taken off at every tenth turn. The variable condenser is an 11-or 23-plate one, with a vernier for best results. In mounting the condenser and inductance it was found that considerable space could be saved by putting the condenser inside the inductance tube. The rheostat should preferably be one with a vernier, as very close regulation of the filament temperature is advisable with the peanut or other 1½-volt tubes. The grid condenser may be of either .0005 or .00025 mfd. and should be used in conjunction with a variable grid leak. The phone condenser may have a capacity of .001 or .002 mfd. The panel used by the writer is of mahogany, one quarter of an inch thick, but any one of the several radio panel materials may be used satisfactorily. Tin foil was stuck on the rear of the

panel and connected to the negative side of the B battery to cut out body capacity effects. Care should be taken that the tin foil does not touch any of the metallic parts such as binding posts or contact points as

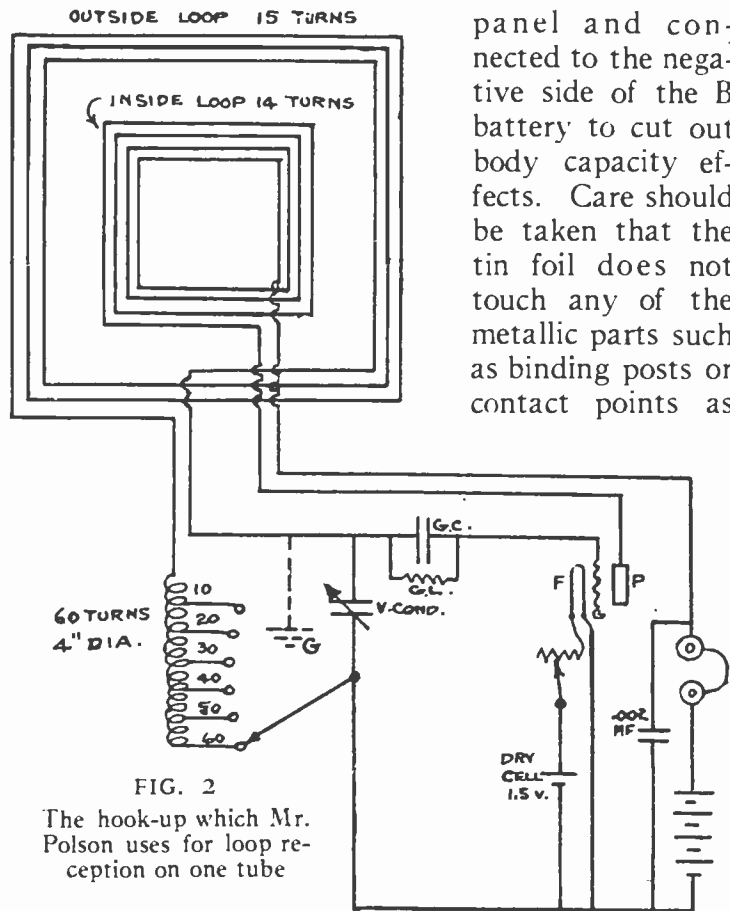

FIG. 2  
The hook-up which Mr. Polson uses for loop reception on one tube

this may short circuit some of the apparatus. About eighteen or twenty will probably be the best B battery voltage to use.

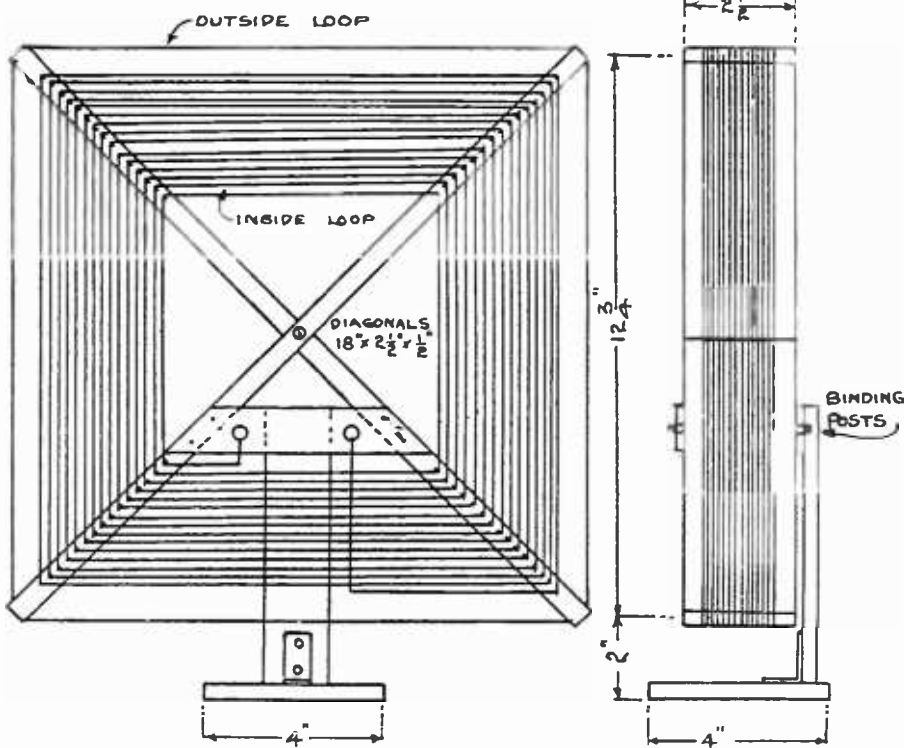
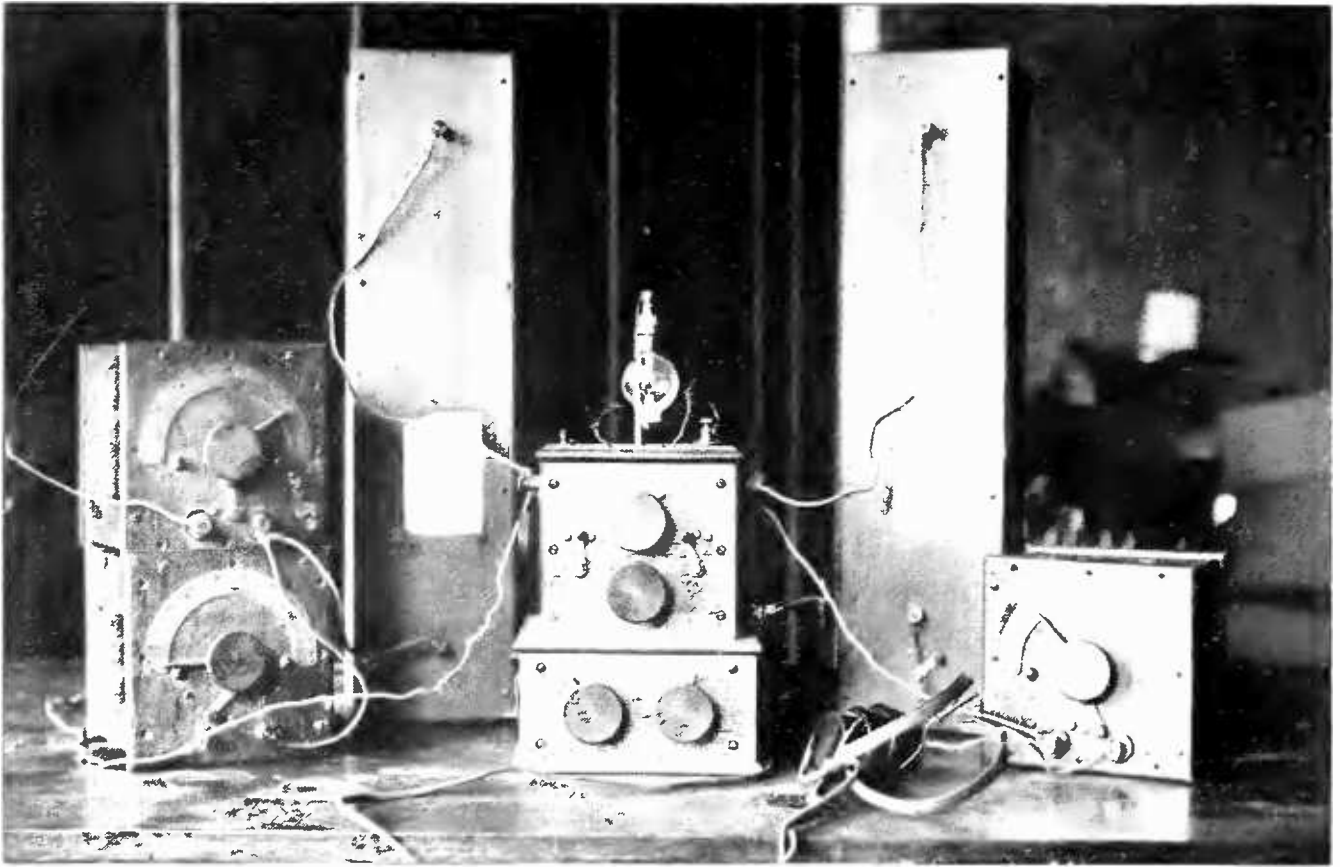

FIG. 1

To operate the set, it is only necessary to point the loop so that its edge points toward the broadcasting station, turn on the filament, set the inductance switch to about 50 turns and vary the condenser until signals or a whistling sound is heard. Further adjustment of the rheostat and vernier condenser will then clear up and bring the signals in at their best. If it is impossible to get signals at all, the tickler should be reversed at the binding posts, as the tickler must be connected in the proper direction. If the ground connection shown by the dotted lines (Fig. 2.) is used in addition to the loop, signals will be much improved in intensity.



### JUNK WORTH A MILLION!

With this very equipment, Edwin H. Armstrong discovered regeneration—the receiving system that revolutionized radio reception and made the inventor famous



# Eighteen Years of Amateur Radio



The Days When Hams Could Send on Any Wave. The “Junior Wireless Club Limited,” Which, in 1911, Became the “Radio Club of America.” Pioneer Experiments and Inventions. Early Measures to Reduce Interference. Recent Activities Sponsored by the Radio Club

By **GEORGE E. BURGHARD**

President of the Radio Club of America

It is with pleasure that we present this paper on amateur radio, prepared by one of the foremost American amateurs. This paper has just been read before the Radio Club of America at the close of a successful season of lectures.

We feel sure that the readers of **RADIO BROADCAST** will be glad to learn that the Radio Club of America has chosen our magazine for the exclusive publication of its papers, and we wish to express our appreciation of the compliment paid us.

Such solons as Professor M. I. Pupin, Professor L. A. Hazeltine, Professor J. H. Morecroft, E. H. Armstrong, W. C. White and many others, present to this Club papers of importance, in which we feel sure that you will find great interest.

The second of these papers, which will appear in our September issue, deals with the latest of all the vacuum tubes—those employing thoriated filaments—and is the work of Mr. W. C. White, of the General Electric Company, who helped develop the tubes.—**THE EDITOR.**

**I**N AN attempt to create a precedent which it is earnestly hoped will be followed as long as the Radio Club of America exists, this paper is presented as the first of a series of papers by the Chief Executive, describing the activities of the organization and its members during the last twelve months. As this is the first of the series, however, it may be well to review the achievements of the Club from the time of its inception, and even the work of its members before the idea of organization had materialized. In this way it is possible to gain a good idea of the beginnings of amateur radio as well as the early strivings of the art in general, since the Club numbers among its members many of the radio pioneers.

It is the earnest hope of the writer that the aforementioned precedent will be followed closely and that each succeeding President of the Club will prepare and read a paper covering its accomplishments during his period of office. Thus, an accurate record of Radio Progress can be maintained and should prove of considerable interest and value both to the present and future radio generations.

The early days of radio were indeed days of darkness and pioneering—days when traffic had to be handled with a coherer and a straight gap spark transmitter. This meant that the personnel was really the most important factor, and operators were developed who could copy coherent messages under conditions when the average mortal could distinguish nothing but crashes and noises. These men, who learned their lessons in a very hard school, learned them well and are in many cases the prime factors in radio to-day.

At the same time that the commercial companies were making their initial stand, the fascination of sending messages through space without wires began to take hold of the younger generation, and we have the beginning of amateur radio, about 1905. Of course, there had been private experimenters prior to this, but the real radio amateur had his beginning in the end of 1904 to 1905. Small boys began to inveigle their parents into giving them money with which to buy wire and other material to build their own sets in imitation of those used by the commercial companies. Their efforts were gallant indeed, for there were no books

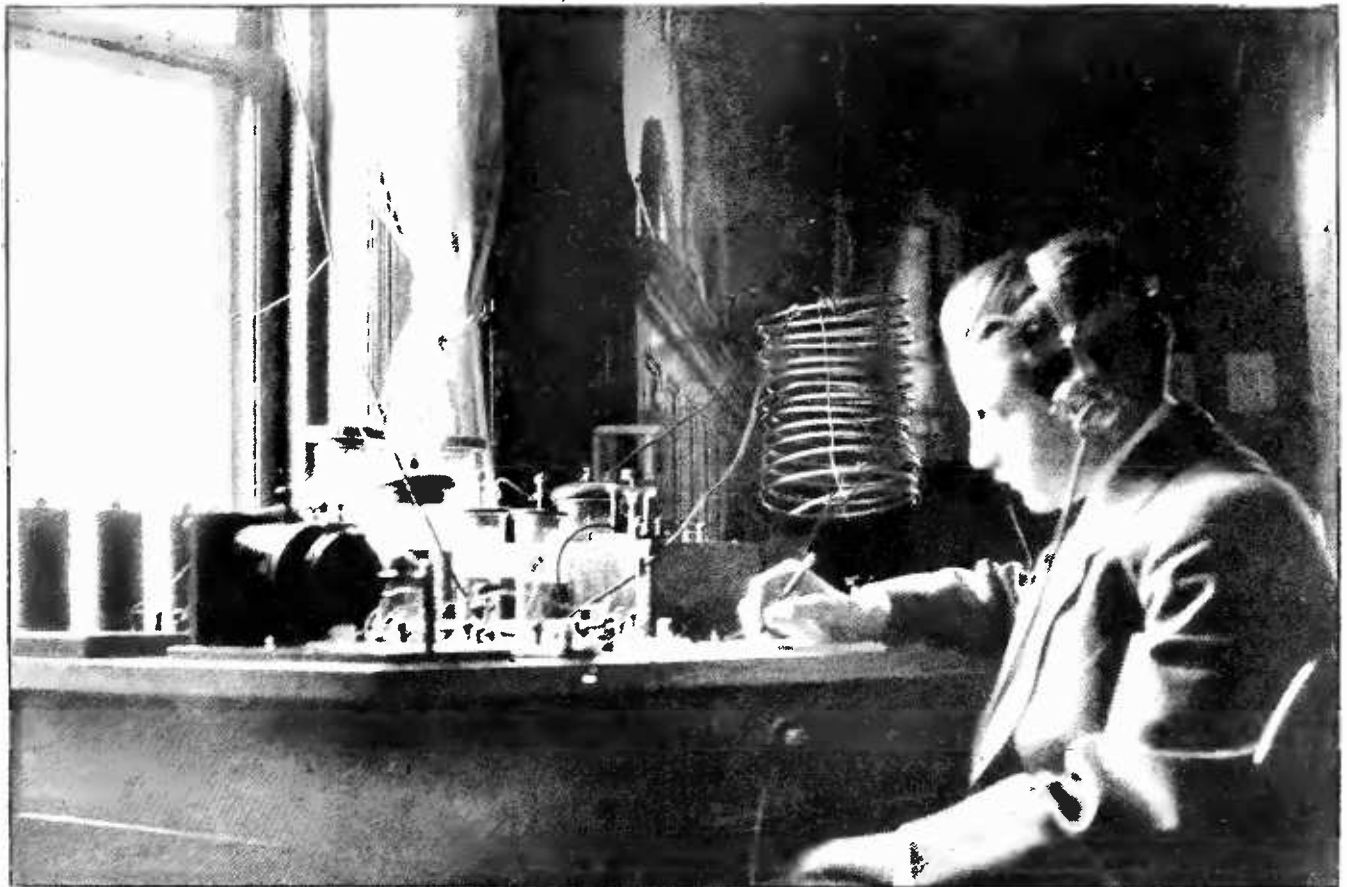

BACK IN 1910, WHEN THE WRITER WAS AN ARDENT FAN  
George Burghard operating one of his first transmitters, located at 1 East 93rd Street, New York City



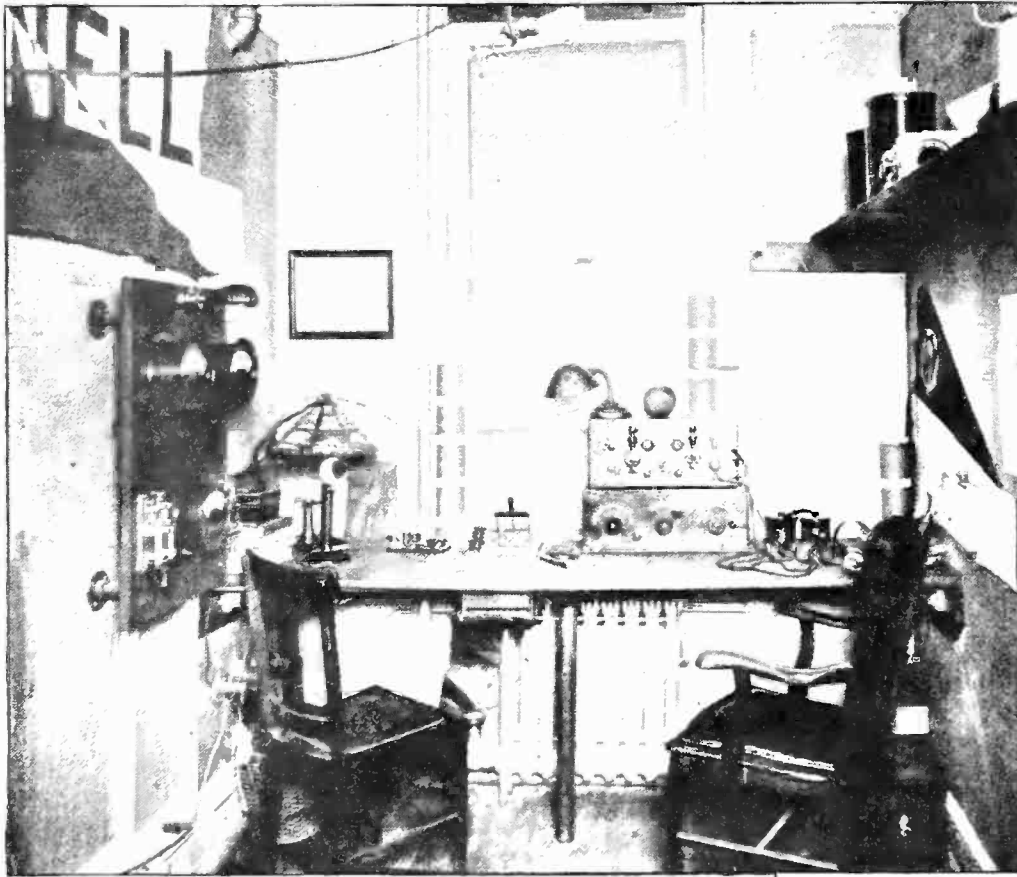

## THE RECEIVER

AT 2 PM

Not the time of day but the call letters of the station owned by John Grinan and Adolph Faraon. Amplifiers were almost unknown when this station, in New York, heard the "Coast," and the two tubes were both used as detectors, with individual controls

to guide them. But the results proved successful in some cases, where the frequency of the transmitter happened by chance to be within the range of the receiver, or someone had gained expert knowledge from the operators at Manhattan Beach or the Waldorf Astoria where the main commercial land stations were located. With the crude apparatus and the embryo knowledge available, it was really remarkable that those boys could communicate at all, but almost any night one could hear messages being exchanged between stations in New York City covering distances of approximately a mile or two.

At that time there were perhaps a handful of these amateurs in New York City, but they grew rapidly in numbers and by 1909 they had already organized into the "Junior Wireless Club Limited." This organization, which was really the first of its kind, held regular monthly meetings at the Hotel Ansonia where the President, W. E. D. Stokes, Jr., was living at that time. The original membership consisted of eleven men who, it may be said, were the founders and charter members of the Radio Club of America: W. E. D. Stokes, Jr., George Eltz, Jr., Faitoute Munn, Ernest Amy, Frank King, Graham Lowe, Frank Whitehouse, Lyman Butler, and George E. Burghard. These young boys were the leaders of amateur radio at that time and soon drew all the live operators into their organization.

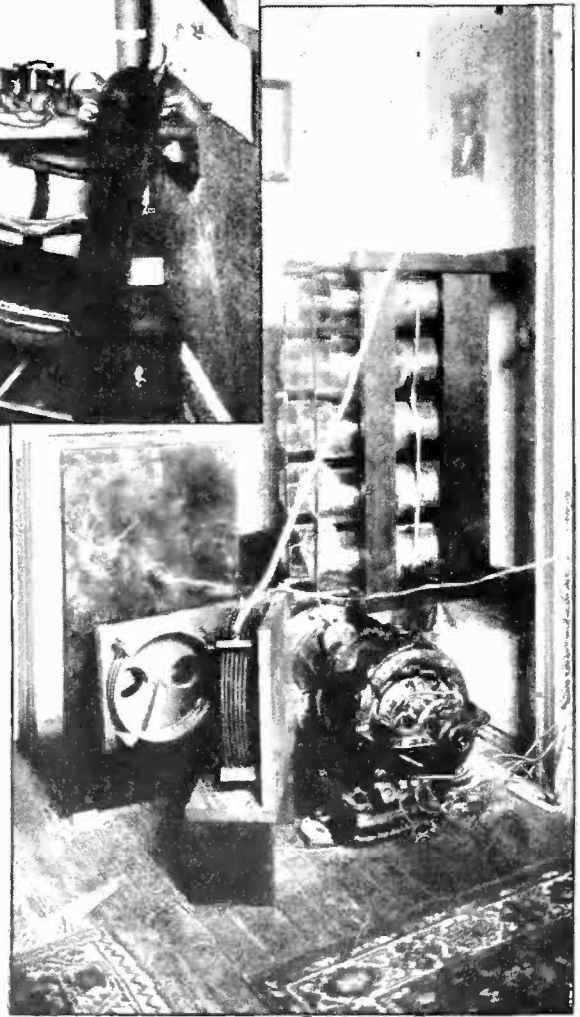

## 2 PM'S TRANSMITTER

This was the first amateur station to transmit across the continent

In 1910, under the auspices of the Radio Club, the father of all radio call-books was born. It consisted of a single mimeographed sheet with some thirty-odd names. Later this was increased to two sheets, then four blue printed sheets, and so on until the task became too ponderous and had to be undertaken by real publishers.

The following list is copied from the original typewritten sheet. (The question marks indicate names or addresses that could not be made out):

BB Max Bamberger, 16 W. 70th St.  
 GX Harlow Hardinge, 331 W. 101st St.  
 9 ? Melly, 328 W. 96th St.  
 HB Doctor Besser, SE Cor. Bdwy & 144th St.  
 DR Dr. W. G. Hudson, 312 W. 109th St.  
 VD Randolph Runyon, Yonkers, N. Y.  
 C George Cannon, Mount Vernon  
 SK G. Skinner, Mount Vernon  
 GE George Eltz, ? W. 47th St.  
 WR W. Russell, 242 W. 104th St.  
 VN Irving Vermilya, Mount Vernon  
 BB Louis Schulman, ? W. 106th St.  
 K9 Francis C. Knochel, ? W. 159th St.  
 YN G. Popper, 763 Beck St., Bronx  
 PC Percy Corwing, 5 West 107th St.  
 DG Harry Johnson, Patterson, N. J.  
 IY Fred Tracy, 4 W. 129th St.  
 BF Brace Fidler, ? W. 129th St.  
 RG Alfred Roebing, Far Rockaway  
 UH Ernest Hubner, 1657 First Ave.  
 WL Walter Lemon, 94th St. & Bdwy.  
 GW G. Bartlett, 8 W. 108th St.  
 EA Ernest Amy, 48 W. 70th St.  
 DX Elmer Avers, 235 W. 103rd St.  
 SG Vincent Lamarche, 70 W. 46th St.  
 CH John Myers, 315 W. 40th St.  
 GH Doctor Goldhorn, Mount Vernon  
 KH K. Harries (2)  
 QW C. D. Winslow, 1985 Amsterdam Ave.  
 PX P. H. Boucheron, 303 E. 48th St.  
 JB Louis Bahr, 1929 Amsterdam Ave.  
 JF John Farrington, 467 W. 159th St.  
 TR George Post, 292 Riverside Drive  
 CP Clarence Pfeiffer, Ridgewood, N. J.  
 AH Arthur Herbert, 138 W. 123rd St.  
 CS Charles Schaffer, 459 E. 147th St.  
 YP Fred Parsons, 764 Beck St., Bronx  
 BO Massey Wireless Co., 170th St. & Jerome Ave.  
 FK Frank King, 326 West 107th St.

In 1911 the membership had increased considerably, and the name was changed to The Radio Club of America, which is the name it bears to-day. By this time books and other literature on various radio topics began to appear, so that the knowledge of the Club members was greatly increased and papers were delivered at their monthly meetings, which were held at the home of Frank King, who was elected first President of the new organization. The first papers consisted of short talks describing the various stations operated by the members, and various they were indeed. It is almost useless to attempt descriptions, but perhaps the accompanying photographs will serve to give an idea of the types of apparatus used and the great handicap under which communication was maintained in those days when it was considered a great event to work Yonkers from New York City direct. But still, even this was a great advance over the old coherer days. Now there were

crystal detectors, microphone detectors, and even electrolytic detectors. Boys were busily engaged in breaking up chunks of rock in an attempt to find a good piece of carborundum, copper pyrites, or zincite, or groveling on hands and knees diligently searching the floor for the missing piece of Wollaston wire which was always diminutive and hard to find. These new detectors together with the advance in knowledge enabled the amateur operator to establish quite reliable communication within the city limits and occasionally a superhuman feat such as working Yonkers, a distance of about fifteen miles was accomplished, but for some unknown reason it was impossible to get any signal across to Brooklyn.

And yet the strivings of this handful of boys led to great things and great things were discussed at the meetings. No one thought of the far-reaching possibilities of the Hudson coated filament at the time when Dr. Hudson delivered his paper describing this very useful invention over the pool table at Frank King's house in 1913, nor were the stupendous results of the regenerative circuit in any way apparent at the time E. H. Armstrong told us all about it at one of the meetings in 1915. Who could have dreamed of the extent to which radio telephony would grow when, in 1911, George Eltz and Frank King constructed and operated an arc telephone transmitter at 107th Street and actually played music for the benefit of the fleet in the Hudson River when the alcohol didn't explode in the arc chamber and cause a violent break-down without any time for an apologetic "one moment, please." This may be said to constitute the first real broadcasting station ever operated with any degree of success.

By this time the three-electrode vacuum tube had appeared on the scene. Audions they were called, and cost \$5.00 a piece, but every amateur had to have one. So down to the Metropolitan Tower he would go, up to the DeForest Radio Company's laboratory, leave his five and go home with his most precious possession. Of course the number of identical new circuits and inventions developed by these boys was great, but nevertheless communication was greatly benefited and messages could be sent and received over distances of approximately 50 miles, quite regularly. This marked a great advance in amateur radio.

During these early days, the activities of these amateur experimenters aroused con-

siderable interest, and it was not long before the Government began wondering what it could do to control these newcomers. The idea of restricting the free air had never occurred to any one before. The result was a bill introduced by Senator Depew in 1910, prohibiting amateur radio communication. The then members of the Junior Wireless Club quickly rallied, and a committee was sent to Washington to plead the cause of the amateur before Congress. The plan was successful and the bill was lost. In 1912 the Alexander Wireless Bill was introduced, which purported to do all that the Depew Bill had failed to accomplish and even more. The Club also took action on this bill, killed it in Committee, and later, through the concerted action of its members in the service after the Armistice, definitely settled the matter.

In 1912, one of the most illustrious members of the Radio Club, E. H. Armstrong, developed the feed-back circuit which has made possible the broadcasting of to-day. This, of course, did wonders for the amateur. All kinds of tuning coils and couplers were put into use, and sets were operated to the Nth degree of regeneration until finally real communication with the Western amateur stations was established and amateur radio came into its own.

This also opened another field to the amateur, namely transatlantic reception. Perhaps the first attempts at hearing the stations of Europe were made by Paul Godley, Harry Sadenwater, and Louis Pacent, who in 1914 strung an antenna from the Palisades on the Hudson River and with a specially constructed receiver listened patiently for what they had never heard before. Little did Godley think at that time that some years later he would be listening just as attentively, under different conditions, in a tent in Scotland, for the signals of his brother amateurs in America.

In those days, of course, there were no licenses and no regulations for amateurs. Everyone used whatever wavelength he happened to hit upon, and the great difficulty of getting a wave meter left that unknown in most cases. The only way to find out whether the set was in tune was by inserting a carbon filament lamp in series with the antenna and adjusting the helix [antenna tuning inductance] for maximum brilliancy. Some stations had aerials of as many as eight or ten wires, one to two

hundred feet long, and sparks gaps directly coupled. This, of course, could not continue, so the Radio Club welcomed the new license regulations and did a great deal toward assisting Radio Inspector Marriott and later Harry Sadenwater in clearing up the mess. In fact, the relationship of the Club with the Department of Commerce has always been most friendly. On one occasion the two organizations combined to track down an amateur station in Brooklyn with a loop mounted on an automobile. The boy had for no apparent reason been sending out distress calls, and after a whole night's searching the station was finally located and the culprit called to account.

This was going a long way toward the right system of coöperation, especially in those days when the notion of free air still prevailed and

it was actually necessary for the operators of one commercial station to invite certain amateurs to go swimming at Coney Island so that the relief operators could handle their traffic without interference!

The Club soon outgrew its quarters at Frank King's home in 107th Street and it was not long before the attendance at meetings grew so large that it became necessary to use the large lecture halls of Columbia University for the monthly gatherings. As the art grew and radio knowledge was more readily obtainable, the character of the papers also changed. The small body of amateur operators gradually changed to a large scientific organization of recognized standing, before which the leading lights in the radio world were glad to deliver papers on their newest discoveries. But in spite of these changes the club idea and spirit of comradeship was never lost, and even to-day the Radio Club of America is as proud of its congenial club spirit as it is of its scientific standing.

In 1915 the Club installed and operated a transmitting and receiving station in the Hotel Ansonia where Admiral Fletcher had made his headquarters. The station operated by the Club members handled all of the Admiral's traffic with the fleet in the Hudson River. Several hundred messages were handled, and President Wilson himself sent a message from the *Mayflower* commending the good work. The Navy League also presented the Club with a banner in recognition of its services.





PROFESSOR PUPIN AND THE DELEGATION THAT VISITED 1BCG AT GREENWICH, CONN.

The trip was made with a view to using this station for transatlantic work on short waves. Professor Pupin is seated in the centre of the group, with George Burghard at his right, and E. H. Armstrong at Burghard's right

A year later, amateur station 2PM which has gone down in history as one of the most famous of all amateur stations, owned and operated by John Grinan and Adolph Faraon, succeeded in breaking all records by sending the first transcontinental relay message from New York to California. This affair was not prearranged but was accomplished during the ordinary transmission periods and the answer was received back in New York in one hour and forty minutes from the time of transmission. Several weeks later the same station and the same operators succeeded in getting signals to California, a distance of some 2,500 miles overland, a feat which had heretofore been deemed impossible with an input of one kilowatt on amateur wavelengths.

Activities had to be suspended for the next few years, due to the fact that all the members of age enlisted in one branch of the service or another. The war records, which have been chronicled elsewhere, make too lengthy a

proposition for this paper. It suffices to say that practically all were officers in radio capacities and in charge of important operations, such as radio aircraft, radio schools, laboratories, field service, etc. Notably, E. H. Armstrong, with the armies in France, invented the super-heterodyne receiver which aided greatly in establishing successful radio communication at the front.

After the Armistice was signed and things began to assume a normal appearance, Club activities were resumed and the first event was a get-together dinner, held at the Hotel Ansonia, in honor of E. H. Armstrong upon his return from France. Many prominent men were among those present and due homage was paid him for his great work with the Expeditionary Forces.

In 1919, a successful flight was made by the Navy Department from Halifax to the Azores, in which radio played an important part. Three planes were used and

of course radio was a very important part of the equipment and the operators had to be of sterling worth. Lieutenant Harry Sadenwater, a Radio Club member, was chosen to operate the set on the NC 1. Unfortunately, this ship was forced to the water within twenty miles of the Azores and it was due to the valiant efforts of Lieutenant Sadenwater that the storm-tossed crew were finally rescued by a destroyer which responded to his calls after some fifteen hours of gruelling work.

When, in 1921, the American Radio Relay League instituted its amateur transatlantic tests, the Radio Club of America built a special continuous-wave transmitting station at Greenwich, Conn. and succeeded in winning the prize offered by Mr. Burnham, of England, for the best station in the test. This station not only succeeded in transmitting audible signals to Paul Godley, also a member of this club, in Scotland, but was heard in Germany, Italy, and France. It also broke all records by sending a complete 12-word message to Scotland and later sent three complete messages direct to Avalon, Catalina Islands, off the coast of

California. These feats aroused such interest in view of the low power and short wavelength used (i. e., 1 K. W., 215 meters), that such prominent men as Professor M. I. Pupin of Columbia University and David Sarnoff, General Manager of the Radio Corporation, went to Greenwich to visit the station.

By this time the number of amateur stations had increased to a tremendous extent, and with broadcasting just about beginning, communication was becoming almost impossible. The Radio Club investigated the situation and found that most of the interference was caused by spark and interrupted continuous wave transmitters. It therefore undertook a vigorous campaign of advice and suggestion, through papers presented before the membership, to educate the amateur in the whys and wherefores of pure continuous-wave transmission and its many advantages over the older forms. The campaign proved successful and is still in progress.

It was at one of these meetings in 1922 that E. H. Armstrong startled the radio fraternity by producing a sufficient volume of music

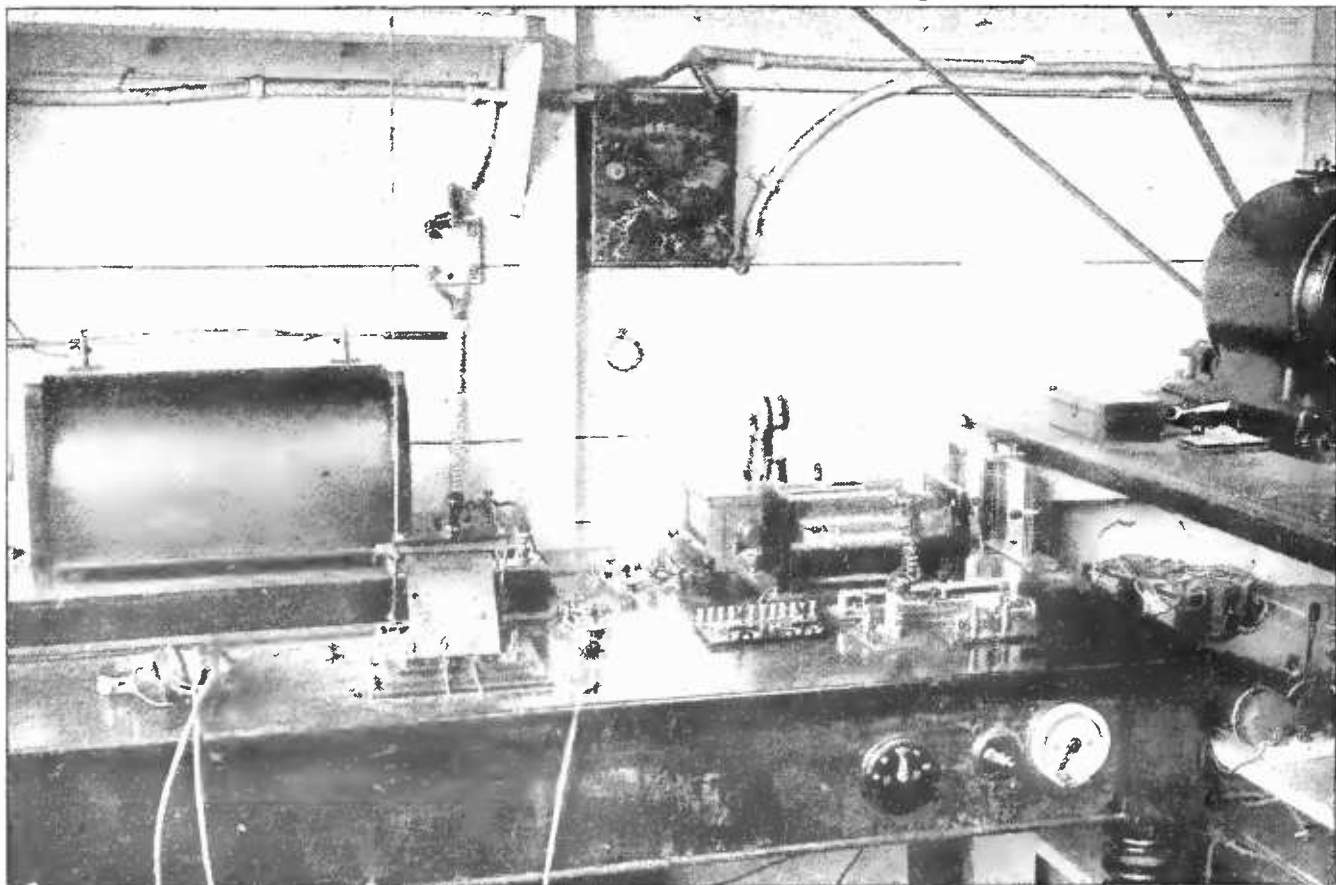

THIS IS FRANK KING'S STATION, FK, NOW NOTHING BUT A MEMORY OF PAST GLORY

Old-timers will recognize several antiques, including a variable condenser, loose coupler, crystal and electrolytic detectors, and that king of QRM—the 10-inch spark coil



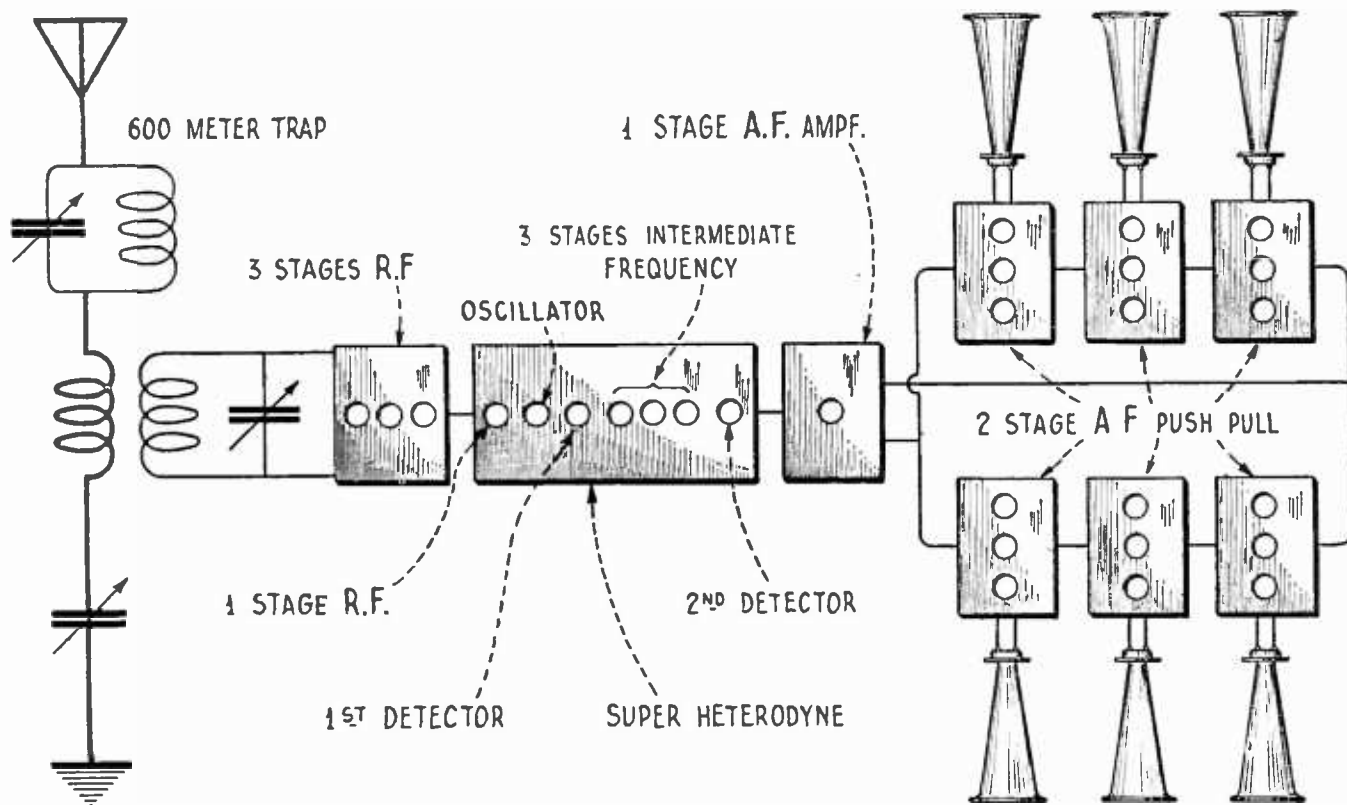

SCHEMATIC DIAGRAM OF THE LOUD SPEAKER SYSTEM USED AT GRAND CENTRAL PALACE

to fill the large lecture hall, using his newly invented super-regenerative circuit, a loop aerial and only one Western Electric J Tube. This performance, of course, had never been equalled, and when it is considered that the signals were coming from station WJZ, at Newark, N. J., and that the receiving set was located in a steel building with a copper roof at Columbia University, it was certainly an epoch-making event.

In December 1922, The Radio Exposition Company held a large Radio Show at the Grand Central Palace, New York. As everyone knows, if all the exhibitors at a Radio Show are permitted to receive broadcast programs at the same time, chaos would result due to heterodyning between the receivers themselves. In order to avoid this difficulty, the exposition directors decided to permit only one concern to do all the receiving. This, of course, was an unhappy thought since there was no way of deciding which company this should be, without causing vigorous protest from the other exhibitors. Finally it was decided to choose a non-commercial organization. The lot fell to the Radio Club of America. A special committee was appointed and the work begun. Tests were made a week prior to the opening of the

show with various types of antennas and finally it was found that even a loop would pick up too much of the noises resulting from commutator sparking, circuit breakers, and electric locomotive shoes, from the power houses in the vicinity and the New York Central tracks directly beneath, so that a single wire about fifteen feet in length had to be used. The problem proved to be twofold and a great deal more ponderous than was at first anticipated. First there was the matter of doing away with extraneous noises so as to deliver pure radio signals to the power amplifiers and secondly a physical problem of placing the loud-speaking horns so that there would be no re-echoes or dead spots. The first was solved after much experimentation by the small antenna, a 600-meter frequency trap, and a super-heterodyne receiver. The acoustic problem, however, offered stubborn resistance. Six loud speaker units with four-foot straight horns were obtained, and the question was how to place them so that the sound would fill the entire Grand Central Palace exhibition hall. At first, they were hung radially in a cluster from the ceiling in the centre of the floor space. This proved unsuccessful since many re-echoes were produced from the side walls and dead spots resulted from large columns. Finally,

after trying several other positions, it was decided to place the horns on the balcony directly in front of the specially constructed booth which housed the receiving and amplifying apparatus. It is interesting to note that all the horns had to be placed together because any separation by placing horns at various points about the hall produced out of phase relationship and distortion. As it was, only five horns could be used, since the sixth faced a wall and produced a decided re-echo which interfered with the speech to a marked degree.

The receiving and amplifying apparatus used, consisted of the small antenna described before, a frequency trap consisting of a coil and variable condenser, a tuned circuit, three stages of radio-frequency amplification, a super-heterodyne receiver with one initial stage of radio-frequency amplification, and three stages of intermediate-frequency amplification, and the usual oscillator and two detector tubes; one stage of audio-frequency amplification and then six two-stage audio-frequency amplifiers of the push-pull type, connected in series parallel, each amplifier feeding one horn, the sixth horn being in the booth and acting as a pilot for the operators. Some twenty-nine tubes were used in all and each horn may be said to have had fourteen tubes connected to it. Of course, the drain on the batteries was great, but four 250-ampere-hour 6-volt storage batteries supplied the filaments without much trouble, while 95 dry cells connected in series successfully handled the plate supply. The diagram on page 297 gives an idea of the general layout and circuits.

This system proved very successful and in spite of many sceptical opinions at the outset, sufficient volume was produced to fill the hall amply, and on the last night, the signals from WEAJ were reproduced with such intensity that several of the audience on the main floor were seen to hold their hats in humorous indication of their approval.

In 1922, when Secretary Hoover found it necessary to call a meeting of the radio interests before a special committee of his choosing, the Radio Club was represented on the Committee by E. H. Armstrong. Thus the Club again as of old took an active part in the regulation of radio by Congress. This special committee reported direct to Congress

on its findings, and did much to help frame the present regulations.

This brings the tale of the activities of the Radio Club up to the present day. It is hoped that they may continue along the same lines for many years to come and that those policies which have been followed in the past and the ideals for which the Club stands will never be forgotten. The Radio Club of America was organized to propagate the art of radio telegraphy and telephony in all its branches, and



true to this ideal it has always lent its aid to the best of its ability to all phases of the art. It originated as an amateur organization with a scientific purpose. It fought for the continued existence of the amateur and helped to educate him. It lent a helping hand to commercial radio, by

research and coöperation wherever it could. It gave all it had to the Government when it was in dire need of radio personnel, and, finally, when that new element in radio cropped up—the broadcast listener—it gave him much needed assistance. This organization belongs to no one branch of the radio art but to all branches and therefore its duty at present must necessarily be one of education. Through the medium of its papers and discussions as well as the individual efforts of its members, it must endeavor to terminate the disastrous conflict which has sprung up between the original radio amateur or traffic amateur and the broadcast listener. Both classes must be trained and assisted to become mutually beneficial to one another. The traffic man must be shown how to construct his transmitter so as to create minimum interference, and the broadcast listener how to operate his receiver at the point of maximum selectivity. Neither one nor the other can or should be permitted to die out, for each has his own particular value. The broadcast listener class is composed of the general public whose pleasure and comfort must not be interfered with at any cost, while the splendid services of the traffic amateurs in the World War will never be forgotten and surely entitle them to an everlasting right of existence. But, unless these two warring factions, can be educated to coöperate and aid one another, one of the two is doomed; and this task of education for the good of the radio art must now be the important work of the Radio Club of America as well as all other radio clubs throughout the United States.

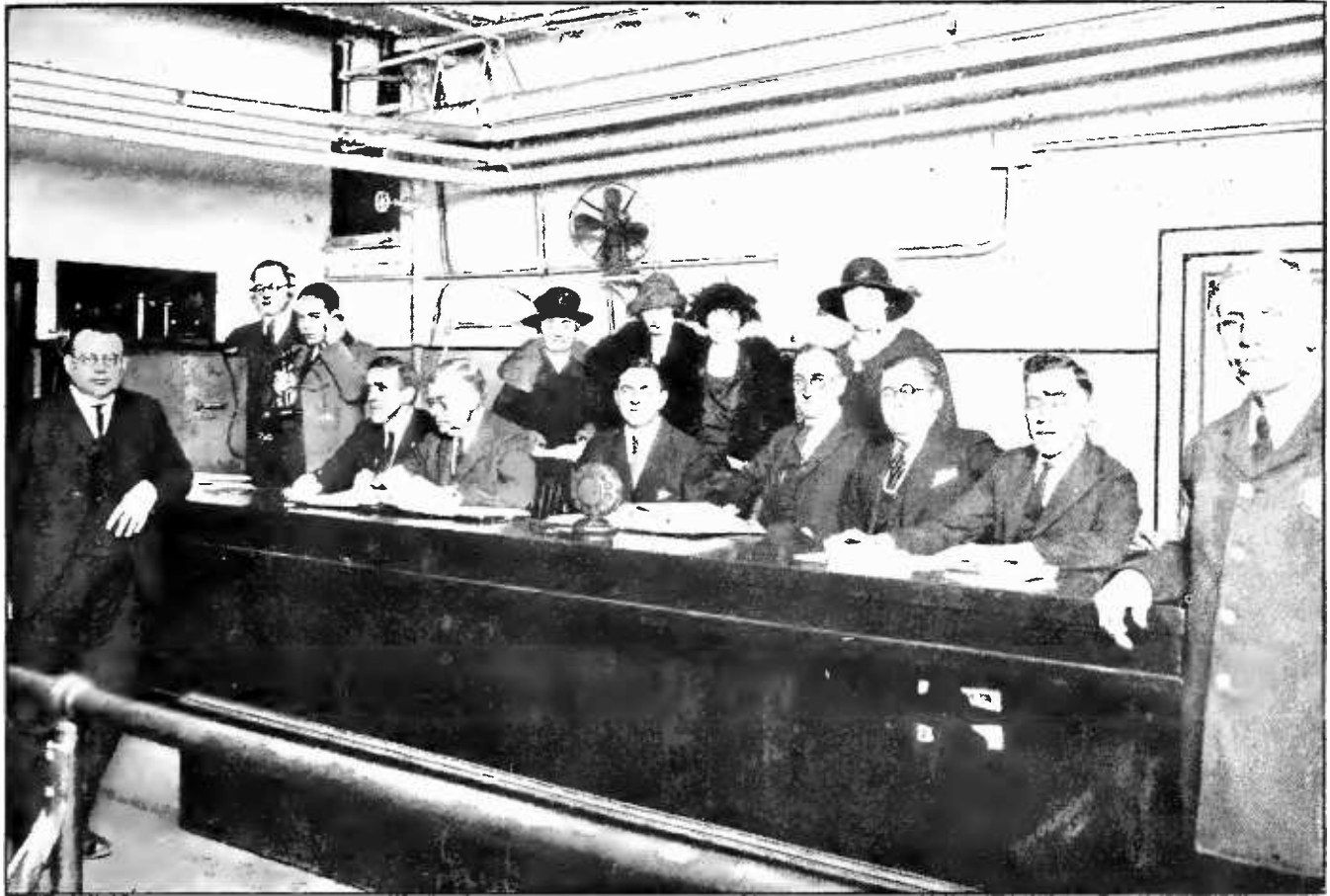

BROADCASTING A NIGHT SESSION OF A KANSAS CITY COURT

A part of one of Mayor Cromwell's "civic radio nights." Judge Michael J. Kilroy of the North Side Court is at the right of the microphone

## "Selling" the Public on Better City Government

How Mayor Cromwell's Civic Radio Night Programs Bring Sessions of the Municipal Court Into the Homes of Kansas City Residents

By J. L. SIMPSON

**C**OULD the average business or professional man of Kansas City, or any other full-grown city in the United States, if suddenly called upon, take over the job of mayor of the city? Even the business man who regards his job as tedious or difficult might be pardoned for regarding such a step as jumping from the frying pan into the fire, especially with the horde of voters who "put him over" sitting back in an attitude of critical observation, waiting for the first sign that the new

chief executive of such city may fail to turn out a full day's work, with each and every twenty-four hours.

Frank H. Cromwell, who was overwhelmingly elected to preside over the "Heart of America" at the last municipal election, recently found himself in this precise predicament, and didn't exactly enjoy this sensation. He had specialized in the butter and egg business until his election about one year ago, and discovered very shortly that he knew much more about the intricacies of dealing in those commodities

than he might reasonably expect to know about his new job for some time to come. Commenting upon this startling discovery, he said:

"I wasn't Mayor long when I found out I'd have to learn a lot of things about the machinery of city government I'd never dreamed of. I was up against the proposition of learning a new business—for the operation of a city government is a business of the most intricate sort."

The first morning Mayor Cromwell sat in his new office, he made the discovery that he was boss of twenty-three city departments, each separate and distinct from the others, just as in any great corporation.

Each department, he found, had a certain duty to perform in giving service to the public, and must give satisfactory service to its "customers" very much in the same manner as a street car company, a water and light company, or the grocer or baker around the corner. And at the head of each of these departments he found a board, or an individual, in control.

To this successful butter and egg merchant—the new mayor of a city of 350,000 people—the job of rightly comprehending, to say nothing of intelligently directing this great municipal corporation, looked like a mighty big task. True, he was very familiar with the process of turning butter and eggs into dollars and cents—but this was different! However, like a true business man, he set about to learn this new executive job—city government. He made up his mind to discover "what made the watch tick" in the city hall, and especially to ascertain the source of the "wherewithal," and the close connection between the taxpayers' "outs" and Kansas City's "ins."

Then followed tedious hours, days, and weeks, while the Mayor, surrounded by instructors, departmental heads and the like, bent over wide tables and delved into great books—amazing arrays of tabulated reports and totals—striving to gather something beyond a mere superficial knowledge of how and where the city

obtained the funds which are the lubricant of city government, and, more important, how to direct the distribution of these millions of dollars.

After weeks of study along this line, bringing gradual enlightenment, he came to realize that his own ignorance of the functioning of the municipal government was as nothing compared with what the average voter knew of the conduct of his city's business.

Here was a real problem—and one of universal application. The merchant, to exist, reasoned the mayor, must sell his wares, and to sell

his wares he must advertise. The city, with a great stock of wares to sell, also should advertise. The voter—the ultimate consumer at the city store—must know what is on the counters and shelves. He must be informed of the "service" offered by his city.

The mayor pondered over this problem. How was he to "take the city government to the voter?" How was the voter "to be sold" on the proposition of operating his city government?

After compressing the problem into this understandable form, Mayor Cromwell compiled a list of prospective advertising mediums, jotting them down on a slip of paper.

"Printed publicity is good," he said "providing that a sufficient number of people will read it.

"Public meetings will draw only a negligible per cent. of the population. We might write letters, but that would entail great expense, and perhaps only a few persons would pay any attention to them."

On Mayor Cromwell's desk, as he thus pondered this question, lay a magazine. The cover design caught his attention. It was of a woman singing before a microphone, her voice being broadcasted by radio to thousands of listeners-in.

Suddenly Mayor Cromwell saw a "great light." "That's it!" he shouted. "I'll broadcast my lessons in city government to the voter. We'll *say it with ether waves.*"

Mayor Cromwell likes to make his dreams

Said Mayor Frank H. Cromwell: "A year as Mayor of Kansas City has revealed to me that an astoundingly large number of our citizens are ignorant of the functions of the various city departments. Only a few persons find time to attend public meetings. I believe that radio offers a medium through which citizens of a municipality who have little or no opportunity to learn the details of municipal government, can inform themselves of the work of the various departments."

come true. Perhaps that is one reason why he made a success in the butter and egg business; or why he managed to win the race for mayor of Kansas City, while every newspaper in town was plugging for his opponent.

There followed immediately a conference with Emory J. Sweeney, president of the Sweeney Automotive and Electrical school, and owner of one of the most up-to-date broadcasting stations in the United States.

"We could broadcast civic radio night programs from your station," explained Mayor Cromwell to Mr. Sweeney, "and our big difficulty—that of finding a medium of maximum expression—would be solved."

Mr. Sweeney was interested in the mayor's plan. So a date was set for the first civic radio night. It was announced as "Hospital and Health Board Night," with Dr. E. H. Bullock, Kansas City health director, as principal speaker, and Mayor Cromwell as master of ceremonies.

Thousands of radio set owners, not only residents of Kansas City, but of surrounding communities, were surprised and pleased by the new type of program. Letters of commendation and telephone calls poured into the mayor's office, calling for "more along the same lines."

The feature of the second civic radio night was an address by John Pew, City Counselor. His address was aimed directly at voters and taxpayers, and he explained to them exactly "where the money goes" in keeping the wheels of the city government revolving at the necessary speed.

The third city official whose voice was broadcasted from station WHB was Charles Tucker, President of the Board of Public Welfare; he explained the operation of men's and women's reformatories, the municipal farm, and the scores of similar activities connected with his department.

Fred E. Turner, President of the Fire and Water Board, was the next speaker. He described the romance—and service—rendered

by the fire department, to each home in the city, and the courage and loyalty of the grizzled firemen, on a par with that of the soldier upon the battlefield.

Chas. S. Foreman, Assistant Engineer for the Water Department, told citizens and voters of the work in connection with furnishing a constant supply of fresh water for the city, while Ernest Tucker, Secretary of the City Plan Commission, outlined some of the commission's plans for the future betterment and growth of Kansas City.

But the big sensation and dramatic *coup* of Mayor Cromwell's civic radio night programs was entirely different from any of these, and one which almost took away the breath of a public accustomed to thrills of many kinds.

"We'll introduce something lively now," said the mayor to his assistants. "Why not permit the voters to listen-in on a session of one of our municipal courts—allow them to learn of the functioning of this department of our city government?"

Thus it happened, one night in March, radio fans in Kansas City and the Middle West were startled by this announcement:

"This is station WHB, broadcasting a session of the North Side Court, Michael J. Kilroy, presiding judge, as one of Mayor Cromwell's civic radio night programs. Just a minute, please."

A whirring drone followed—a minute of suspense, then—

"The next case," said the voice of the bailiff, "John Strong vs. the City; charged with drunkenness."

The arresting officer was called. John Strong could be heard walking up to the bench.

"John Strong, you are charged with drunkenness," came the voice of Judge Kilroy over the air. "Guilty or not guilty?"

"Guilty, your honor," replied the prisoner. "I'm always drunk—when I can get it!"

"One hundred dollars!" came the judge's reply.

And down through a regular docket of the



MAYOR FRANK CROMWELL  
Who is letting Kansas City listeners-  
in know how their city is run



court was broadcasted a slice of the comedy and tragedy found daily in the courts of Kansas City, yet beyond the imagination of many of the old-time residents of the town. It was a civic program with an appeal which was new to thousands of people wearing headsets that night in March.

Mayor Cromwell, to date, had played his trump card in educating the voter along the lines of better city government; had, in fact, taken the mysteries and practical workings of the various departments, and, more startling still, the courts themselves, right into the homes of tax-payers and voters, and had shown them the cost of operation and the results.

But what has been done is just a beginning. The mayor is convinced that this innovation is proving a valuable medicine in curing some of the city's chronic ills.

"We plan to broadcast a program each month," declared Mayor Cromwell, "and, to the best of my knowledge, this stunt is the first of its kind in the United States. I believe it is educational and will go a long way toward bringing the city government closer to

the people who pay to maintain it, and I believe further, judging from the interest and favorable comment, that the programs are appreciated."

Let those who doubt the tangible results achieved read some of the letters received relative to the civic radio night programs. Here is an excerpt from a letter written by one of the city's most successful insurance men:

I had the good fortune to listen in on the civic program broadcast by the Sweeney radio station last night and feel impelled to write and say that I appreciated it. It is of the greatest importance that our citizens, who are all stockholders in this, our great Kansas City corporation, should be informed fully as to all our civic affairs. . . . The program you have outlined will accomplish this most satisfactorily, in my opinion.

One could spend a whole day reading letters of this sort—sufficient proof that American people are willing to devote their time to a study of municipal government, especially, when it is brought to them in as novel and appealing a manner as that conceived and executed by Mayor Cromwell.



**BILLIE ORR, OF YOAKUM, TEXAS, REACHES OUT MORE THAN 1000 MILES WITH THIS SET**  
He saved up for a few simple parts, wound his inductance on a salt-box, salvaged some old telegraph wire for an aerial, used his dad's auto storage battery as the "A Batt.," and pulled in Detroit, Denver, and Atlanta. He has left plenty of room for the stage or so of amplification which he hopes to add

# Adventures in Radio

Perhaps no other branch of science enjoys the romance and the spirit of adventure ever present in radio. It matters not whether it is the radio telegraph or the radio telephone; both have equal advantages in this respect. Of course, radio telegraphy is the older of the two, and its exploits are more numerous; up to now, it has covered a wider field of endeavor, both on land and on sea.

Aside from its everyday uses, radio figures in a great many strange happenings which few devotees of broadcasting know about. Many of these are unique, not always possible or practicable to duplicate; some are accidents, others mere incidents, still others great adventures—adventures never to be forgotten and which stand out as red-letter days for the individuals concerned.

By adventures in radio we mean that which deviates radically from the commonplace. Radio has been responsible for many innovations. Some of them stand out as monuments of scientific achievement; others are ignominious exploits to which this high art has been subjected. All, nevertheless, are intensely interesting, breathing the very spirit of adventure and romance.

It will be the purpose of this department to report, from time to time, such radio adventures as have actually taken place, with real human beings as principals. The series will range over the entire world, including incidents in Sweden, Patagonia, and far-off Japan as well as in the United States.

We shall be glad to receive accounts of radio adventures from readers of the magazine, either their own experiences or authentic experiences of others.—THE EDITOR.

## When Messina was Destroyed

THE following paragraphs are from a letter received by RADIO BROADCAST from Mr. Stuart Lupton, now American Consul at Chefoo, China:

In the latter part of 1908 I was appointed Vice Consul at Messina, Italy, arriving at my post on December 22nd. At 5:20 A.M., December 28th, the city was almost totally destroyed by a disastrous earthquake. Owing to my having changed my lodgings on the 26th, I was fortunate enough to escape injury. As soon as I could I made my way to the Consulate, becoming more and more aware of the tremendous damage done as I walked along in rather a dazed condition. On my arrival, I found the place a heap of ruins which I had great difficulty in distinguishing. I realized that there was no chance of the Consul or his wife having escaped, and also that matters looked black for me. I knew very few people in the city, was practically penniless as I had not drawn any money after my arrival, and my knowledge of Italian consisted of less than a dozen words. I found all public services had stopped, cables were broken, land lines down and altogether things looked hopeless. That night I was a refugee on board a merchant vessel in the harbor. Seventy-eight people were packed in a small saloon, two or three cabins, and connecting passageways, with the rain coming down in sheets. The next morning we all had to go ashore again, as the steamer was to sail for Constantinople. Shortly afterward the British cruiser *Sutlej* came into port, stopped for about four hours, and left again with 1,100 wounded on board.

As the last boat was leaving for the ship, I had an inspiration. Seeing a piece of brown paper lying on the ground I picked up the cleanest portion and scribbled a message to the Captain of the *Sutlej*, asking if he would wireless a message to our Consul at Malta, to be relayed to the Department of State. A sailor said he would give it to the Captain, but did not know whether it could be sent or not. On the following Saturday, I found that the message had been sent, and that it was the first authentic news of the disaster received in the United States.

About this time I went on board the British Cruiser *Muierva* to call on the Captain, and while on board was told the following story. Captain Cagni, one of the best known and bravest officers of the Italian Navy at the time, had arrived in Messina in command of the battleship *Napoli*. On arrival, he paid several visits of ceremony, one of them being to Captain Wake, of the *Muierva*. He told Captain Wake that he had started from Naples to Gibraltar a day or two before the earthquake, and when nearing the latter port his wireless operator had intercepted a fragment of a message. All that was received was, "Messina destroyed." At that time there was a great deal of friction between Italy and Austria, so Cagni jumped to the conclusion that war had been declared and that an Austrian squadron had bombarded the city. Hence he turned and went full steam for Messina with the full intention of engaging any Austrian man of war he might meet. Fortunately, none was encountered, or the World War would have started ahead of time.



THE PRIZE-WINNING CONTRIBUTIONS ARE IN THIS LITTLE PILE  
Photo taken after the five-day blizzard which effectively tied up traffic on the Editor's desk

## Porto Rico Fan Wins "How Far?" Contest

Richard Bartholomew of Garrochales, P. R., Captures First Prize—a De Forest D-7 Reflex Loop Receiver—with Home-Made Three-Circuit Regenerative Receiver of Unique Design. Hears Many West Coast Stations Regularly. His Story

Before Mr. Bartholomew tells you about his very remarkable reception and his more remarkable receiver, there are a few words we want to say about our "How Far?" Contest.

As you may remember, our first contest—"How Far Have You Heard on a Single Tube?"—was a great success, so great, in fact, that we felt sure that one allowing any number of tubes and any kind of a receiver would be of even more interest to you. Accordingly, we announced the second contest, figuring that it would be successful from the firing of the first gun.

After three months of waiting for a publishable article for this contest, we decided that one of two things had occurred: either the interest in DX work had taken a sudden and universal slump or you were all sitting tight, figuring on coming up strong on the last lap and crossing the finish line a winner. If you could see our desk for an instant you would appreciate that the first of our suspicions was groundless.

We are snowed under. To be frank about it, we were entirely unprepared to handle the reams of material that arrived in time to be included in the contest. For the next week or so we are going to be up to our ears and no mistake, but it is going to be great fun, and we are sure that many of the articles will be suitable for publication.

And the articles themselves are not all that we have; one of the fellows went as far as making dictaphone records of the stations he heard. Unfortunately these records failed to stand the trip and arrived in a more or less pulverized condition. But with photos and diagrams and broadcasting maps and lists of stations and distances heard and descriptions of receivers and two or three sample home-made coils (all "world-beaters"), as well as a tremendous amount of "dope" on many "best" circuits—we have something to do.

As you may remember, in the rules for our contest the following paragraph appeared:

"In judging contributions, the quality and interest of photographs, text, and drawings, and the originality and general effectiveness of the apparatus described will have greater weight than the list of stations heard, although a long list of distant stations will distinctly help."

The contestant whose material measured up best has been chosen; but the short time remaining before we go to press, and the fact there are several contestants well toward the lead whose work is so nearly equal that a hasty decision might be an unjust one, make it impossible for us to announce the remaining three prize winners. They will therefore be announced in the next issue and several other articles deserving honorable mention will also be published if space permits.—THE EDITOR.

# A Neighbor at Three Thousand Miles

By RICHARD BARTHOLOMEW

(FIRST PRIZE)

**N**ATURALLY it has been of much interest to me to sit here in Porto Rico and listen to all parts of the United States,\* and up into Canada, and over to Cuba; but what appealed to me still more was to sit here in my shirt sleeves, with all doors and windows open, and listen to reports of five, six, or seven inches of snow and the thermometer ranging from freezing down to fifteen below zero. Then was when I could sit back and (if mean enough) give you the laugh; but if I listened in long enough I would again get back to a warm climate—California—although there the time was four hours later than in Garrochales.

My set is of the regenerative type, but due to the hook-up I use and a special method of shielding, there is *absolutely no body capacity* noticed, even while working on stations 3,525 miles away. In one instance, I adjusted the receiver to bring in KFI, Los

\*Mr. Bartholomew sent with his manuscript and photos a whole sheaf of letters which he had received from far-away broadcasting stations, verifying his records and commenting on his remarkable work. Here are excerpts from three of these letters:

"I wonder if you have received a notification that you are the winner of the Western Electric ear phones awarded to the person who heard the concert on October 28th, the farthest distance from Minneapolis? The announcement created a tremendous amount of interest in this city. On that evening we were heard by forty-six states in the Union, four provinces in Canada, in addition to you.

Program Director, WLAG."

"We received your card reporting hearing our Radiophone and wish to thank you very much for same. We believe this reception to be a record for a 50-watt transmitter.

WKY RADIO SHOP,  
Oklahoma City, Okla."

"You *are* our neighbor . . . you are certainly doing some good reception.

HALE BROS., INC.,  
Radiophone Broadcasting Station KPO,  
San Francisco."

This last station is 3,500 miles from Porto Rico!

Angeles, and without changing the dials I heard about 20 different selections. This was on their opening night. I have heard them many times since.

The adjusting of this set is more than simple, for often I have tuned in eight stations only by turning the grid dial. At one time I had to be away from home a while, and so showed my

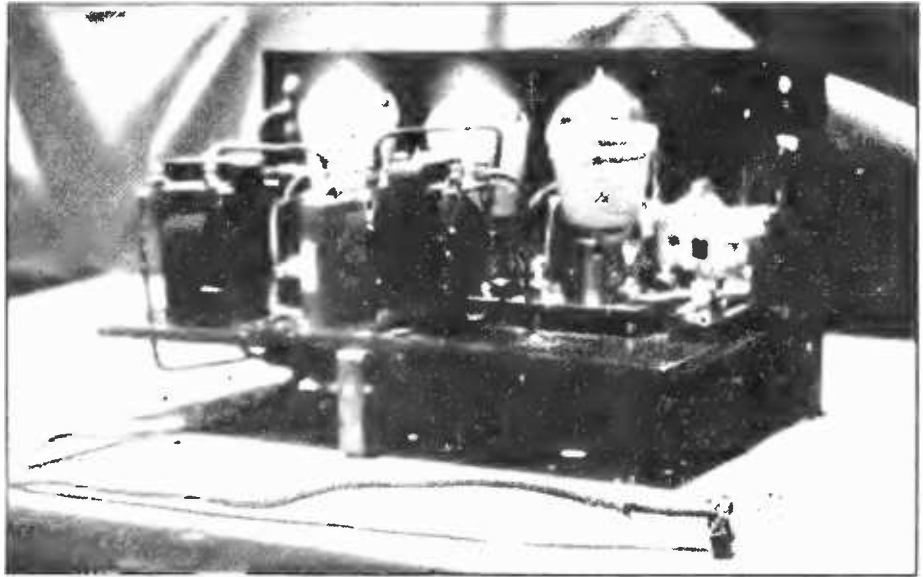

THE DETECTING AND AMPLIFYING UNIT SHOWING SHIELDED TUBES

wife how to connect the batteries, as she wanted to try the set. Upon returning, I found that she had had music every night, and the first night received eighteen selections, with names of pieces and artists, from WGY, 1,600 miles away.

Now we might as well roll up our sleeves and get right to the principal business of the day, which is, how you can make a receiver such as mine and how you can use it to best advantage.

## MATERIALS NEEDED FOR CONSTRUCTION

- 15 binding posts
- 18 switch points
- 3 switch levers
- 2 two-circuit jacks
- 1 single-circuit jack
- 1 Bradleystat
- 2 wire-bound rheostats (or Bradleystats)
- 1 potentiometer
- 1 grid leak (1 megohm)
- 1 grid condenser (.00025 mfd.)  
(1 double mounting if Radio Corp. materials are used)
- 3 tube sockets

- 2 transformers audio. (Amertran or UV-712)
  - 1 .001 mica phone condenser
  - 1 panel, 7" x 18" for receiver (bakelite)
  - 1 panel, 7" x 12" for detector and amplifier (bakelite)
  - 1 piece of bakelite, rubber or wood, 7 x 11, for mounting transformers and sockets in detector unit
  - 2 vernier controls for variometers, friction type
  - 12 pieces of buss wire or No. 18 wire with spaghetti
  - 2 variometers having 66 turns on the rotor and 60 on the stator. Those wound with large wire and not using shafts for contacts are preferred
  - 1 variocoupler, same type as variometers, but with 30 turns on the rotor and about 48 on the stator, tapped so that it can be adjusted to every, or every other, turn
  - 1 piece of tubing of non-conductive material, dia. 4", length 1½"
  - ¼ lb. of No. 20 D. C. C. wire
  - 3 dials. One for each variometer and one for coupler
  - 1 4-volt flashlight battery
  - 1 piece of copper foil. 7" x 18" (shield)
- A few odd screws, brads and stove bolts  
 Enough ¼" lumber to make the two cabinets, one 7" x 8" x 18" and the other 7" x 8" x 12". Stain for same  
 Small bottle of shellac for painting loading coil
- 4 brass hinges (small) with screws
- Regular equipment:
- 1 6-volt A Battery (storage)
  - 2 22½ or 24 volt B battery either dry or storage
  - 1 pair of good phones
  - 1 detector tube, UV-200
  - 2 amplifying tubes, UV-201 or UV-201-A
- Antenna and ground equipment.

#### CONSTRUCTION OF THE RECEIVER

ON the piece of tubing listed just above, make two small holes  $\frac{1}{8}$  in. from the edge and  $\frac{1}{4}$  in. apart. Through these two holes fasten the end of the No. 20 wire and make thirty turns, using the system of bank winding illustrated in Fig. 1. Make the first turn  $\frac{1}{8}$  in. from the edge and wind the wire in the same direction as the windings of the stator of the plate variometer. At thirty turns take off a

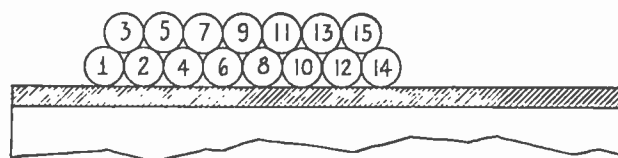

FIG. 1

Showing how the turns are made in bank-winding

tap, then wind thirty more and fasten the end as before. This makes a coil of 60 turns with a tap at 30. Now fasten this coil on the left hand side of the plate variometer, as shown in Fig. 2. (The coil is shown at the right of the variometer in Fig. 2, but this is because the view is from the rear). The writer did this with shellac, but any method will do. Place the taps so that they will be toward the panel.

Paste over the face of the panel a piece of white paper and on this draw out to size the dials, binding posts, switches, switch points, and verniers, always leaving enough space for the sides of the cabinet. Put on this drawing all holes to be made, to size, their centres, and whether to be counter-sunk or not.

Now try placing all the parts on the panel as indicated by the drawing you have made, including variometers and coupler, and see that they do not interfere one with the other. (The writer found that he could best place the variometers 13 inches apart, centre to centre, with the shaft  $3\frac{1}{2}$  inches from the top of the panel. The coupler shaft went half way between those of the variometers and 1 inch above them.) But as all variometers, etc., are different, you will have to experiment a bit to determine how to place and fasten them on the panel.

Using a centre punch, punch each hole and bore it. Glue the copper foil to the back of the panel and cut away around the holes for the shafts, all switches, switch points, and all binding posts *except the ground and filament posts*. Be sure that the foil is not closer than  $\frac{1}{16}$  inch to any of the parts other than the two binding posts mentioned. Solder the shield to these two posts.

Now you are ready to mount all the parts. Do so and wire them according to

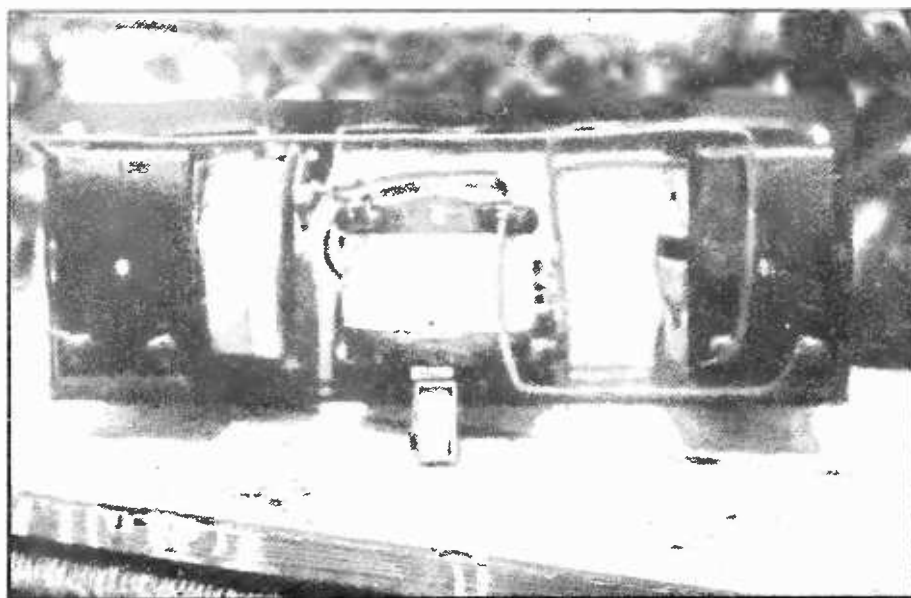

REAR VIEW OF THE RECEIVING UNIT



the diagrams (Figs. 3, 4, and 5). Solder all contacts and run wires in straight lines making turns at right angles. Neat, painstaking work at this point will amply repay you for the longer time it takes.

#### CONSTRUCTION OF THE DETECTOR AND AMPLIFIER

THE panel of the amplifier unit is laid out and handled in the same way as that of the receiver, except that there is no need of a shield. Keep in mind that the binding posts have to correspond with those in the receiver, so should be placed at the same distances from the top of the panel.

The base supporting the sockets, transformers, etc. rests upon the jacks and is bolted to them. This means that one small hole has to be made in the detector and second-stage jacks, through which the base is made fast with two small bolts.

The Bradleystat is placed on the left hand side of the panel. Then comes the two wire-wound rheostats and last the potentiometer. These are evenly spaced across the panel and are on the middle or central line. The jacks are placed halfway between these about  $1\frac{1}{4}$  in. from the bottom of the panel. The five holes

made for each light are placed directly above the jacks; the top hole is 1 inch from the top of the panel.

The parts are now mounted on the panel and the base (of bakelite or wood) is put in place after cutting out a section to allow for the potentiometer and B battery leads. Now set the sockets, C battery, transformers, and grid (leak and condenser) mounting in the best possible positions. Try to keep the grid leads

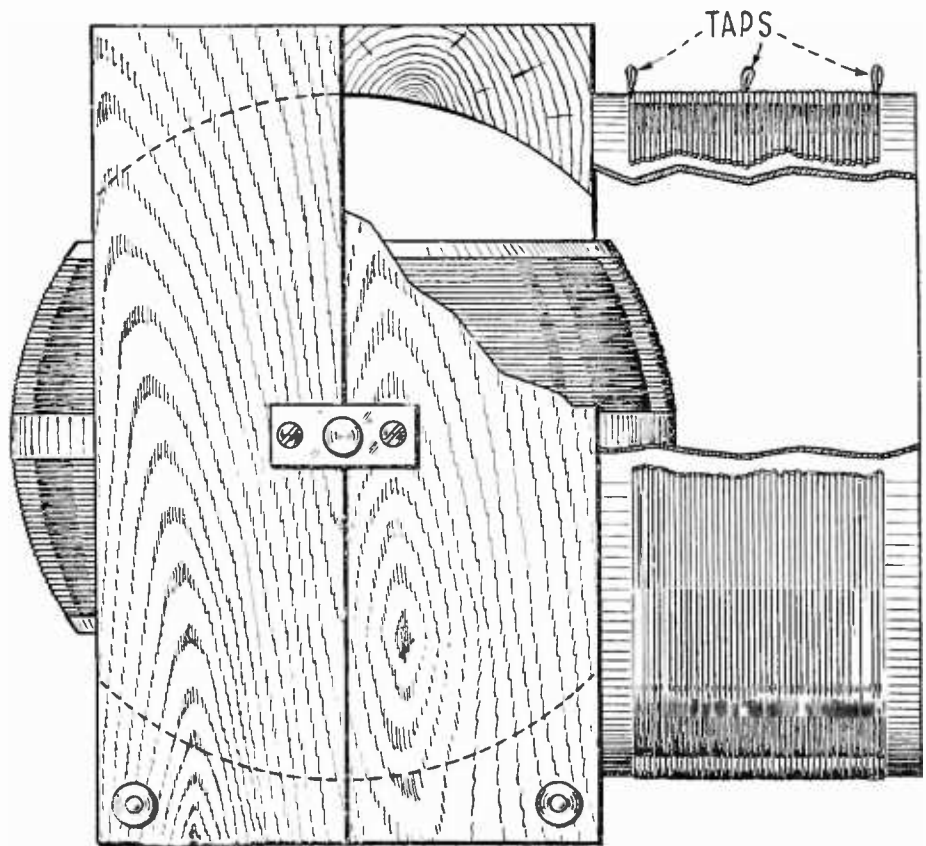

FIG. 2

Plate variometer and coil, rear view

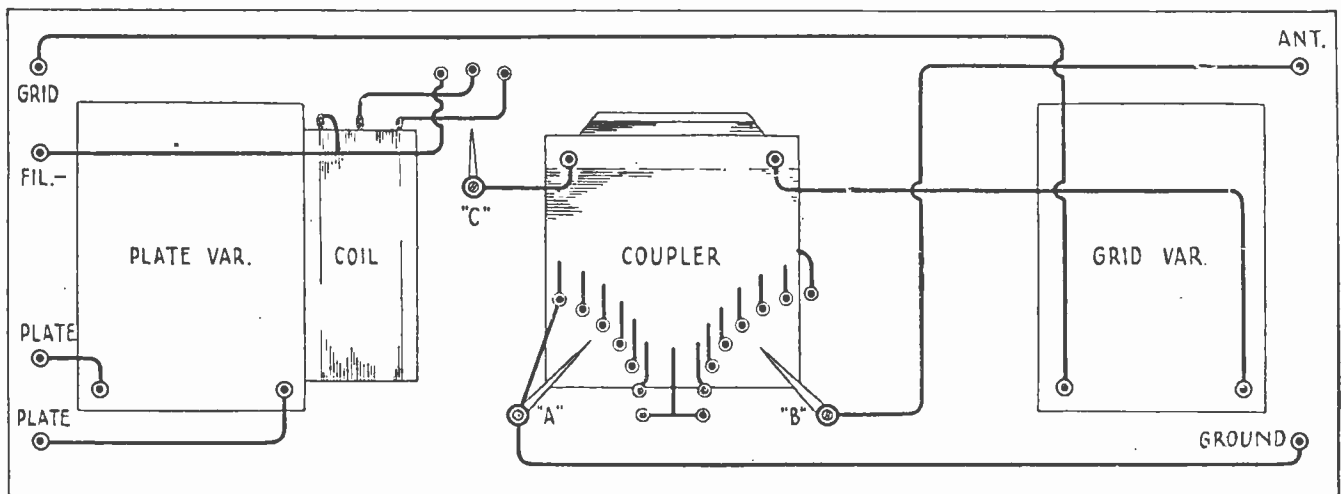

FIG. 3

Schematic wiring diagram of the receiver unit, rear view

as short as possible, the cores of the transformers at right angles to one another, and the lights directly back of the holes in the panels. When well placed, mark the position of each piece on the base, also mark holes for running the wires to the primaries of the transformers, plates of the tubes, and condenser shunted across from the plate to the filament (phone condenser, .001). Remove the base, bore all holes, mount the parts, and replace for wiring.

Don't overlook the negative binding post for the B battery, as this is placed on the back side of this base. A hole is made through the rear of the cabinet to admit the lead.

#### WIRING THE RECEIVER

**M**AKE all leads as short as you can, running them horizontally or vertically, with the turns forming sharp right angles.

Solder all connections possible, and be sure that all unions are good and clean.

The diagram, Fig. 3, is that of the rear view of the receiver. Note posts "Fil-" and "Ground"; they are the ones that should be soldered to the shield. The ground wire goes to the fine taps at switch marked A, and the switch and end of coil are connected as in the circuit diagram (Fig. 5). The aerial goes to

the coarse taps or switch B (Fig. 3). Switch C is use for the loading coil.

The taps at A are taken every turn.

The taps at B are taken every six turns.

#### WIRING THE DETECTOR AND AMPLIFIER

**M**AKE all the leads as short as possible, especially the grid leads; also be careful that the grid and plate leads do not run parallel for any great distance.

The binding post for the negative of the B battery is placed on the base supporting the sockets, etc., and a hole is made in the cabinet back to admit the lead.

All tubes are wound with No. 20 wire. This can be done in any way as long as the wire makes a perfect shield as high up on the tube as possible, leaving the end of the tube uncovered (see photo showing tubes wound with wire). The writer fastened the wire in place with small pieces of tape. Both ends of the wire are fastened together and grounded to the negative of the filament, or negative of the A battery.

Solder all connections, and when everything is ready try lighting the tubes before you connect up the B battery. It may save blowing out a tube.

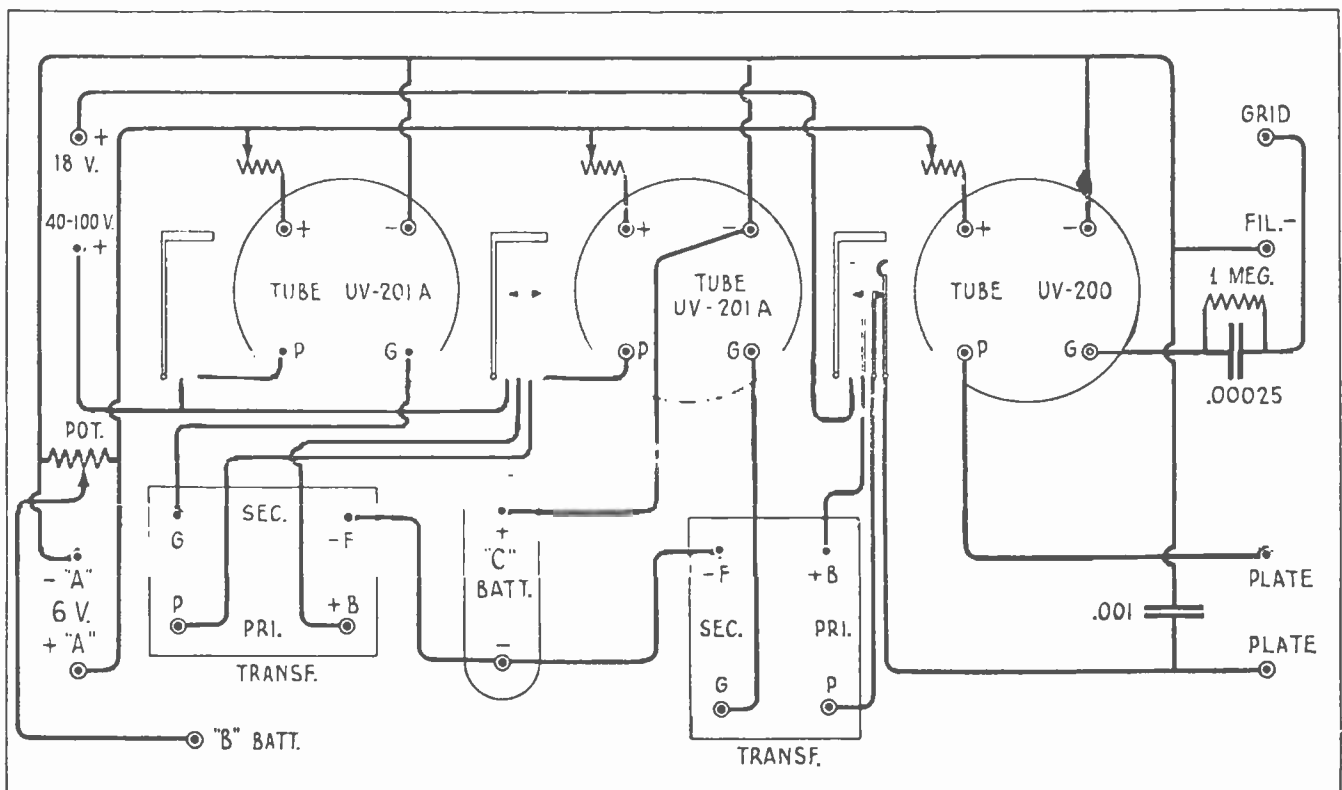

FIG. 4

Schematic wiring diagram of detector and amplifier unit, rear view

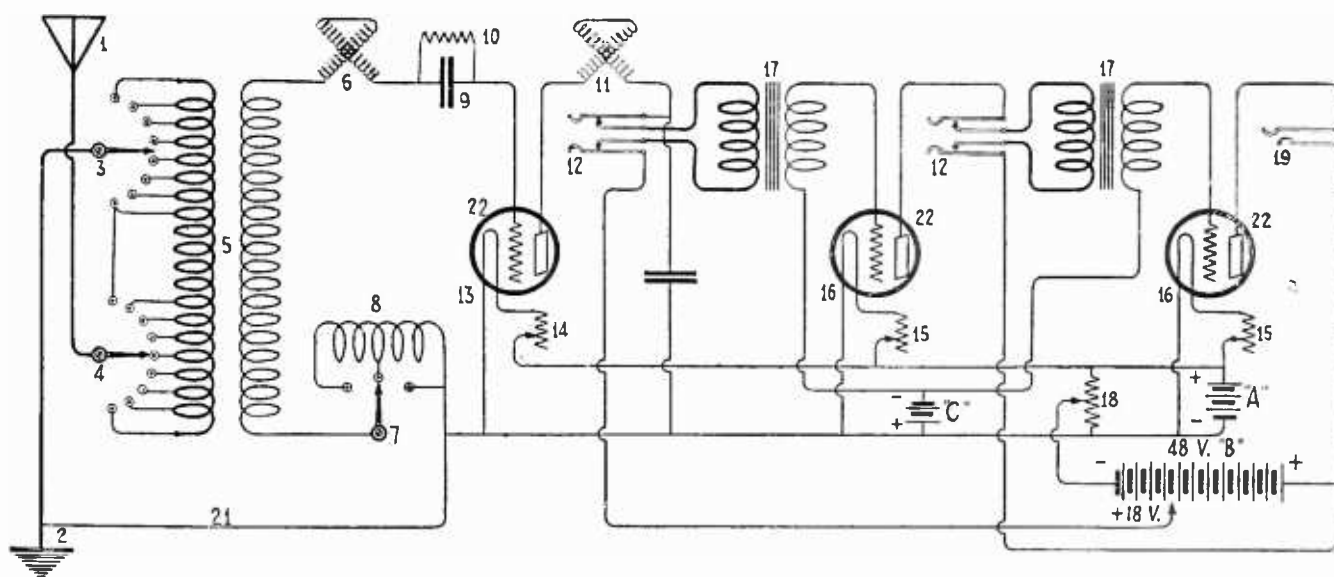

FIG. 5. CIRCUIT DIAGRAM FOR MR. BARTHOLOMEW'S COMPLETE RECEIVER

1—Antenna; 2—Ground; 3—Switch for fine taps on coupler; 4—Switch for coarse (six turns) taps on coupler; 5—Variocoupler; 6—Grid variometer; 7—Switch for loading coil; 8—60-turn coil on 4" tube; 9—Grid condenser, .00025; 10—Grid leak, 1 megohm; 11—Plate variometer; 12—Two-circuit jack; 13—UV-200 tube; 14—Bradleystat; 15—Bradleystats or other rheostats; 16—UV-201 or UV-201-A; 17—Audio transformers; 18—Potentiometer, 200 ohms; 19—Single-circuit jack; 20—Phone condenser, .001; 21—This line represents the copper shielding; 22—No. 20 wire is wound around the tubes as shields, connected to the negative of the A battery or filament (connection not shown here); A—6-volt storage battery; B—Two 24-volt storage batteries for plate circuit (dry-cell B batteries will do); C—4-volt flashlight battery

#### GETTING THE MACHINE READY TO USE

**B**E VERY careful that all leads to and from each piece of apparatus are correct.

Put the machine in a place or on a table wide enough so that you can rest your arms while making adjustments. This is necessary in picking up DX stations as the slightest turn may make the difference between failure and success.

Place the batteries as close to the machine as possible (see to it that they are well charged and kept so, for although you may be able to pick up a close station on weak batteries, you will never hear a distant one).

Keep a piece of emery paper near the machine if you are using sockets whose contacts are of the spring type that only touch the tip of the tube. It will be necessary to clean these tips every few days.

#### TUNING

**S**ET the grid and plate variometer dials so that the rotors are at right angles to the windings of the stators.

Set the coupler dial so that the windings of stator and rotor are nearly parallel. Leave it in this position until the last when a slight change may increase the signals.

Set the coupler taps switch so that there will be about 24 turns used. This applies to

a single-wire aerial about 160 feet long from the receiver to the furthest point. For shorter aeriels you will need more turns.

Set the loading coil switch so that the loading coil is cut out of the circuit. Do not bother with this coil until you have learned to operate the machine without it.

Place the phone plug in the first-stage jack and turn on the amplifying tube, slightly for a UV-201-A and almost full for a UV-201. Now light the detector tube which is controlled with the Bradleystat. This should be turned on until you hear a hissing in the phones. Then turn it back a slight fraction of a turn.

The potentiometer is turned to approximately the middle point if using about 18 volts on the plate of the detector.

Now rotate the grid variometer toward the left, *slowly*, and listen for the whistling that indicates a broadcasting station. If you have to move it a great distance then a slight adjustment of the plate variometer may be necessary to keep the tube near the hiss.

When a signal is heard, readjust the filaments of the amplifier and detector tubes until the signal is strongest, using the least current necessary. Now readjust the variometers using the verniers and always keeping the station within hearing. Usually this will mean turning first one and then the other dial toward the left. At some point you will

find that the station will drop in clearly or drop out. If it comes in clearly, O.K., but if it drops out, you have turned too far, either with one or both variometers. Take it *slowly* at first. If you get the station, but the signals are not clear, try adjusting the Bradleystat and potentiometer. These last two adjustments are very necessary on distant stations.

It might be well to add here that if any capacity effect is noticed on either variometer, try reversing the two leads and see if that does not do away with it.

If, after trying all this, you do not pick up any signals, change your switch on the coupler primary and try again. The longer the aerial, the fewer turns you need on the primary. The shorter the aerial and longer the wavelength of the station, the more turns you need. Now, if you don't hear anything, check over the wiring again.

The loading coil in the secondary can be used for all broadcasting stations, but it is most helpful on the class B stations or those having a wavelength of 400 meters and over. In this case use the middle tap (30 turns) and for 500 to 600 meters use the full coil (or 60 turns). It will be found with this coil in the circuit that more attention has to be paid to the adjustment of the plate variometer, and the writer believes that it makes his machine much more selective. For, while using this coil, he can separate stations that could not be separated without it. It will also be found that where a station comes in clearly with the grid variometer the set at 110 (on a 180° dial), and the plate variometer at 90° (without the coil), you will now have to turn the grid variometer to about 100° and the plate variometer will have to be set around 110°. But with practice this coil will prove very efficient. The writer has heard three stations in California six nights in succession, a distance of more than 3,350 miles, and they always came in at the same setting of the dials.



Mr. Bartholomew's station list is so remarkable, especially when it is appreciated that he is located about 500 miles south and 900 miles east of the lower end of Florida, that we are printing it in full.\* You will note that all the stations heard are more than 1,000 miles from Garrochales, and that six are more than 3,300 miles away.

| CALL LETTERS               | LOCATION               | MILEAGE |
|----------------------------|------------------------|---------|
| KDKA                       | East Pittsburg, Penn.  | 1,650   |
| KFI                        | Los Angeles, Calif.    | 3,350   |
| KHJ                        | Los Angeles, Calif.    | 3,350   |
| KOP                        | State College, N. Mex. | 2,675   |
| KOP                        | Detroit, Mich.         | 1,850   |
| KPO                        | San Francisco, Calif.  | 3,525   |
| KSD                        | St. Louis, Mo.         | 1,950   |
| KUO                        | San Francisco, Calif.  | 3,525   |
| <i>Examiner and Herald</i> |                        |         |
| KYW                        | Los Angeles, Calif.    | 3,350   |
| WAAK                       | Chicago, Ill.          | 2,000   |
| WAAM                       | Milwaukee, Wis.        | 2,050   |
| WAAP                       | Newark, N. J.          | 1,550   |
| WAAW                       | Wichita, Kan.          | 2,250   |
| WBAK                       | Omaha, Neb.            | 2,300   |
| WBAP                       | Harrisburg, Penn.      | 1,575   |
| WBAV                       | Fort Worth, Texas      | 2,150   |
| WBL                        | Columbus, Ohio         | 1,725   |
| WBT                        | Anthony, Kansas        | 2,275   |
| WBZ                        | Charlotte, N. C.       | 1,400   |
| WCAL                       | Springfield, Mass.     | 1,600   |
| WCX                        | Northfield, Minn.      | 2,300   |
| WDAE                       | Detroit, Mich.         | 1,850   |
| WDAF                       | Tampa, Fla.            | 1,225   |
| WDAJ                       | Kansas City, Mo.       | 2,150   |
| WDAL                       | College Park, Ga.      | 1,400   |
| WDAR                       | Jacksonville, Fla.     | 1,250   |
| WEAF                       | Philadelphia, Penn.    | 1,500   |
| WEAO                       | New York, N. Y.        | 1,500   |
| WEAY                       | Columbus, Ohio         | 1,725   |
| WFAA                       | Houston, Tex.          | 2,000   |
| WFAT                       | Dallas, Tex.           | 2,100   |
| WQAM                       | Sioux Falls, S. D.     | 2,400   |
| WFI                        | Miami, Fla.            | 1,050   |
| WGI                        | Philadelphia, Penn.    | 1,500   |
| WGM                        | Medford Hills, Mass.   | 1,600   |
| WGR                        | Atlanta, Ga.           | 1,500   |
| WGY                        | Buffalo, N. Y.         | 1,775   |
| WHA                        | Schenectady, N. Y.     | 1,675   |
| WHAF                       | Madison, Wis.          | 2,100   |
| WHAM                       | Pittsburg, Penn.       | 1,650   |
| WHAO                       | Rochester, N. Y.       | 1,775   |
| WHAS                       | Savannah, Ga.          | 1,250   |
| WHAZ                       | Louisville, Ky.        | 1,725   |
| WHB                        | Troy, N. Y.            | 1,675   |
| WIP                        | Kansas City, Mo.       | 2,150   |
| WJAN                       | Philadelphia, Penn.    | 1,500   |
| WJAX                       | Peoria, Ill.           | 2,000   |
| WKY                        | Cleveland, Ohio        | 1,750   |
| WJZ                        | Oklahoma City, Okla.   | 2,200   |
| WLK                        | Newark, N. J.          | 1,550   |
| WLW                        | Indianapolis, Ind.     | 1,825   |
| WLAG                       | Cincinnati, Ohio       | 1,725   |
| WLAL                       | Minneapolis, Minn.     | 2,325   |
| WLAK                       | Tulsa, Okla.           | 2,125   |
| WLAT                       | Bellow Falls, Vt.      | 1,700   |
| WMAB                       | Burlington, Iowa       | 2,100   |
| WDAP                       | Oklahoma City, Okla.   | 2,200   |
| WMAQ                       | Chicago, Ill.          | 2,000   |
| WNAC                       | Chicago, Ill.          | 2,000   |
| WMAF                       | Boston, Mass.          | 1,600   |
| WMAJ                       | Round Hills, Mass.     | 1,600   |
|                            | Kansas City, Mo.       | 2,150   |

\*Regarding this list, Mr. Bartholomew writes:

"Have also picked up many other stations including Denver, Colo., and parts of telephone conversations between Avalon, Calif. and Catalina Island; but have not included them in this list as I have not heard call letters and location together.

"All of the above stations were heard on *one step of amplification only*. On two steps I use a home-made loud speaker (Baldwin unit and horn), and with it I have heard California 30 feet from the horn."

| CALL LETTERS | LOCATION            | MILEAGE | CALL LETTERS                       | LOCATION               | MILEAGE |
|--------------|---------------------|---------|------------------------------------|------------------------|---------|
| WMAK         | Lockport, N. Y.     | 1,775   | WWI                                | Dearborn, Mich.        | 1,850   |
| WMAT         | Deluth, Minn.       | 2,350   | WWJ                                | Detroit, Mich.         | 1,850   |
| WMAZ         | Macon, Ga.          | 1,400   | CANADA                             |                        |         |
| WMC          | Memphis, Tenn.      | 1,800   | CHYC                               | Montreal, Quebec, Can. | 1,850   |
| WOAI         | San Antonio, Texas  | 2,175   | CFAC                               | Calgary, Alberta, Can. | 3,500   |
| WOAN         | Lawrenceburg, Tenn. | 1,700   | CUBA                               |                        |         |
| WOAW         | Omaha, Neb.         | 2,300   | PWX                                | Habana, Cuba           | 1,000   |
| WOC          | Davenport, Iowa     | 2,100   | F. H. Jones                        | Tuinucu, Cuba          | 900     |
| WOI          | Ames, Iowa          | 2,225   | AMATEURS AND EXPERIMENTAL STATIONS |                        |         |
| WOO          | Philadelphia, Penn. | 1,500   | 2EL (on phone)                     | Freeport, N. Y.        | 1,500   |
| WOR          | Newark, N. J.       | 1,550   | 1XAE (on phone)                    | Springfield, Mass.     | 1,600   |
| WOS          | Jefferson City, Mo. | 2,050   | 2XI (on phone)                     | Schenectady, N. Y.     | 1,675   |
| WPA          | Forth Worth, Texas  | 2,150   | TOTAL MILEAGE, AIR LINE . . . . .  |                        |         |
| WPAC         | Okmulgee, Okla.     | 2,100   | 172,075                            |                        |         |
| WPAL         | Columbus, Ohio      | 1,725   | BROADCAST STATIONS HEARD . . . . . |                        |         |
| WQAO         | Parksburg, Penn.    | 1,525   | 90                                 |                        |         |
| WRP          | Camden, N. J.       | 1,550   | AVERAGE MILEAGE . . . . .          |                        |         |
| WSB          | Atlanta, Ga.        | 1,500   | 1,911                              |                        |         |
| WSY          | Birmingham, Ala.    | 1,600   |                                    |                        |         |

MR. BARTHOLOMEW'S OUTFIT COMPLETE

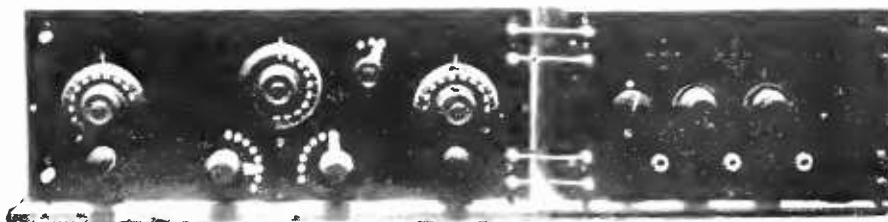

# Unloading the Mail from the Transatlantic Liners

By M. G. CARTER

**I**N ACCORDANCE with certain existing laws, the contracts with the various steamship companies provide that all foreign mail brought in on their ships shall be delivered to the receiving Post Office at the expense of the steamship companies. The New York Harbor Mailboat Service is maintained to facilitate the rapid handling of incoming foreign mail by utilizing the time spent by the ships in passing public health inspection at quarantine.

There are times when the mail-carrying ships from South America, the West Indies and abroad arrive too late to pass the doctor at quarantine which sometimes means a delay of twelve hours. However the mail is not delayed, but is taken aboard the mailboats and brought to Pier 72, North River, New York, and thence by trucks or train to the distributing Post Offices. This relieves the steamship companies of the considerable expense of trucking the mail to the Post Office, and min-

imizes congestion on the piers after the ships have docked.

The Harbor Mailboat S.S. *President* (radio call letters, NURL) is the flagship of a fleet which includes two and sometimes three steam lighters each capable of carrying from two to three thousand bags of mail, while the *President* has a capacity of approximately five thousand sacks.

A twenty-four hour watch is maintained every day of the year in all kinds of weather, by three crews both on the dock and on the mailboat. This is necessary because the ships arrive at all times of the day and night. It is the radio operator's job to receive notification of the approach of mail-carrying vessels as far in advance of their arrival in quarantine as is possible; to ascertain the amount of mail on board, where it is stored, whether separated or not, and the approximate time of the vessel's arrival in quarantine, so that those in charge can prepare various organizations to handle the mail.



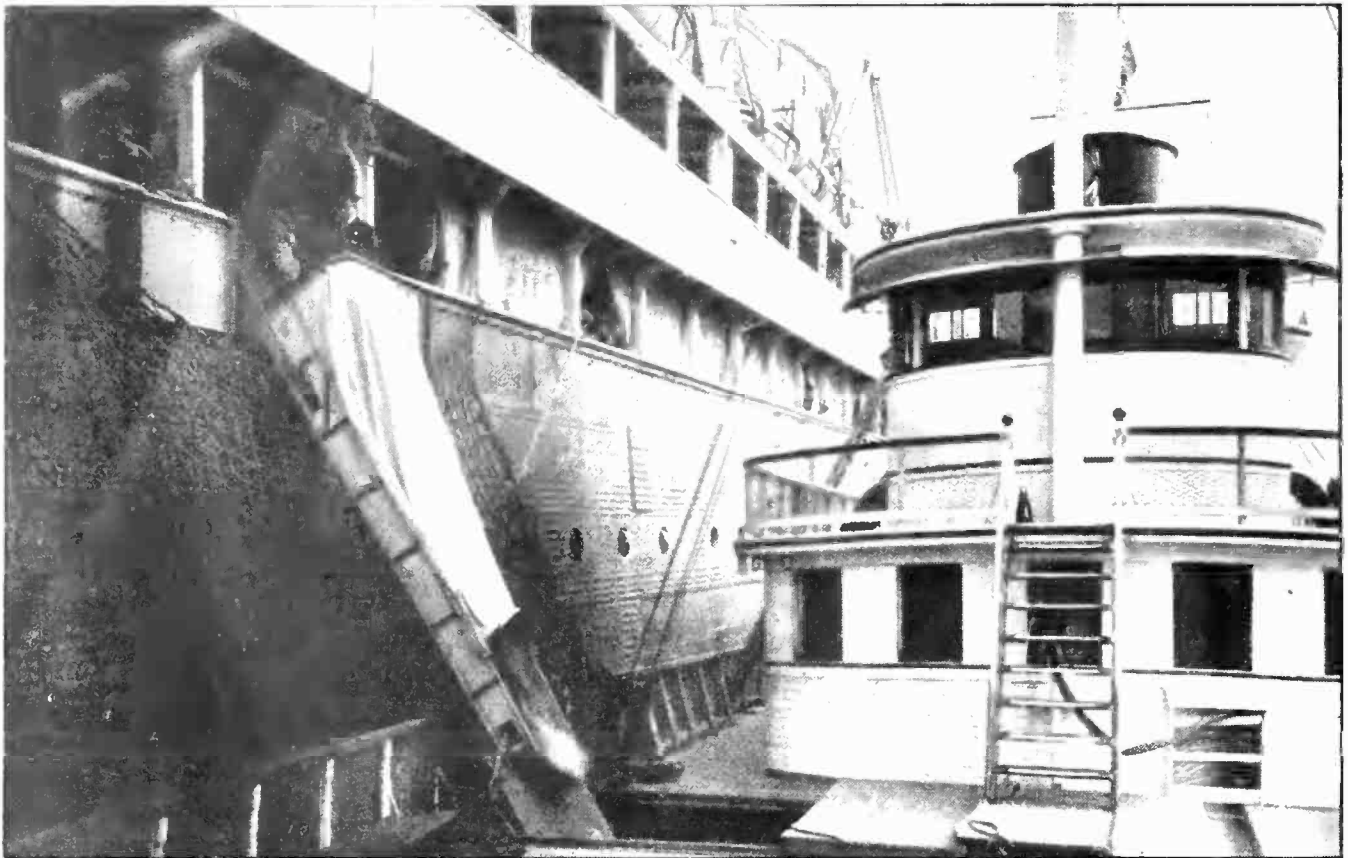

#### FROM SAILOR TO "PRESIDENT"—IN FIVE SECONDS

The Harbor Mailboat *President* is shown in action alongside the *Mauretania*. Fifty sailors on each side of the liner drop the mail down the chutes as fast as possible. The day this picture was taken, 7,500 bags—approximately 60 carloads of mail—were transferred to the mail boats in an hour and twenty-eight minutes.

By the receipt of such information the extra men are not ordered on duty until necessary. This saves the Post Office Department money on each ship met, amounting to a considerable sum at the end of the year. Some of the ships carry from four thousand to twelve thousand bags of mail, and for these, special schedules are made for boats, trains and auto trucks, and extra men must be secured to perform the service expeditiously.

It is interesting to note that during the past year 1470 ships were met and approximately 750,000 bags of foreign mail handled. December was the heaviest month, with a record of 95,801 bags taken from the ships at quarantine.

The Post Office Department publishes a list of mail-carrying ships and their expected time of arrival in New York. The radio operators keep close watch on these ships for any irregularities in their time of arrival and amount of mail carried. For example, let us say that the *Mauretania* or the *Majestic* or the French Liner *Paris* is listed to arrive on a certain day with ten thousand sacks of mail. The radio opera-

tors watch for her and when within range send a message to the commander of the vessel, somewhat as follows: Commander, *Majestic*. Please advise number sacks mail how much on deck whether separated and time you expect reach quarantine. The reply soon comes back: Mailboat *President* 5165 bags New York City starboard 4061 bags Railroad port 893 bags Parcel Post hold number three expect reach quarantine 315 P.M. Commander, *Majestic*. From such information the clerks in charge are enabled to procure enough men and to dispatch such boats as are necessary to handle that particular situation.

On the other hand, suppose that a thick fog prevents the boat from coming up the channel to quarantine and she anchors off Ambrose Channel Light-vessel. It becomes necessary to keep posted by radio as to the exact movements of the vessel so that no mailboats will be dispatched aimlessly. If conditions permit, the mailboat often goes to Gravesend Bay, or even to Ambrose in fog, gets the mail, and returns to her pier; and the mail is delivered in Philadelphia, Pittsburg, and Boston before

the ship docks! Then again, suppose that a ship approaches that ordinarily carries mail, but this particular trip has none. It is by radio that such information is obtained, and a trip to quarantine is made unnecessary. As another example, a boat may be listed as carrying five hundred sacks of mail, but stops at another port en route to New York and picks up perhaps fifteen hundred sacks. If it were not for the radio reports, a small crew would be dispatched which could not handle such an amount of mail while in quarantine.

The radio equipment on the Mailboat *President* comprises a U. S. Navy 1-KW 500-cycle spark transmitter which has a daylight range of two hundred miles. The receiver consists of a U. S. Navy short-wave receiver with detector and a U. S. Army low-frequency amplifier type SCR-72. With this receiver, ships are picked up two thousand miles east of New York. All communications between the boat and the pier are made through the New York Navy Radio Station, NAH.

The important fact regarding the radio service is that the operators who maintain the watches are men of experience. Four men make up the radio personnel: J. Maresca, H. L. Swart, O. N. Johnson and M. G. Carter

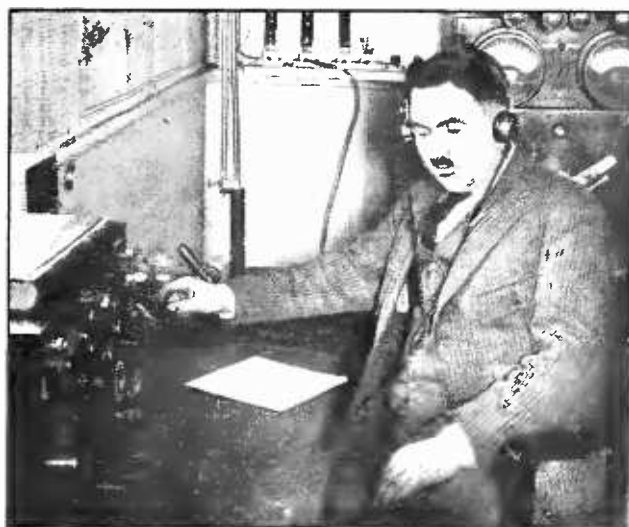

CHIEF OPERATOR M. G. CARTER AT THE KEY  
In the radio room of the Harbor Mailboat *President*

(operator in charge). All of these men have had at least ten years', and some fifteen years', experience in such organizations as the Radio Corporation of America, International Radio Telegraph Company, Signal Corps, Navy, and the Air Mail Radio Service. Consequently, the work is handled with uniform efficiency, in spite of the fact that in the vicinity of New York the radio traffic is very heavy.

#### MAIL FROM THE OLD COUNTRY AND POINTS EAST

Before the *Manchuria* arrives in New York Harbor, the sacks are brought up on deck ready to be tumbled down the chutes when the mailboats come alongside. Boat No. 28 is shown receiving the mail, with No. 14 and No. 6, near by, about to steam off to take mail from the *Mauretania*

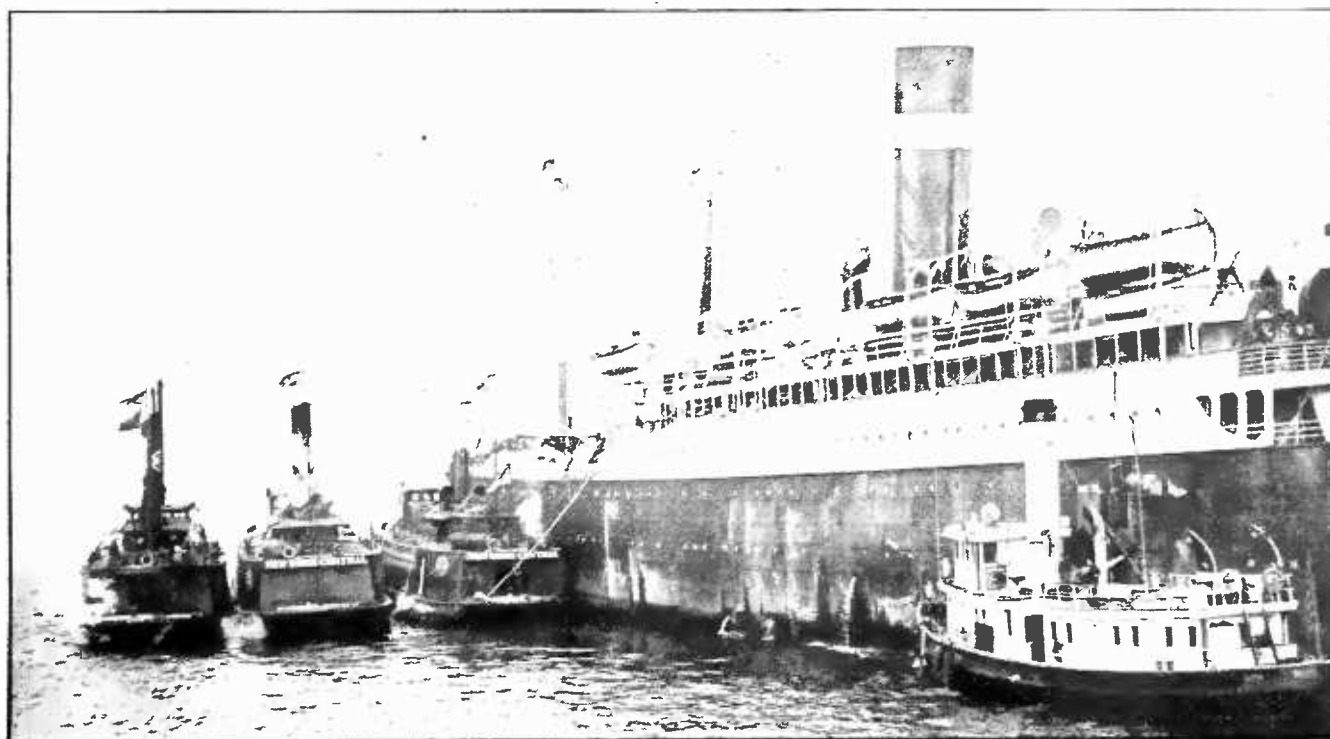

# The Grimes Circuit with Outdoor Antenna and Counterpoise

An Adapted "Inverse Duplex" that has Brought in California from Boston, Massachusetts

By HERBERT E. DILL

I AM using apparatus built in accordance with several published descriptions of the David Grimes "Inverse Duplex" three-tube set, with an outdoor antenna and a counterpoise, tuning by means of a standard Remler variocoupler and 43-plate and 23-plate condensers.

To enumerate the stations listened to each night and frequently well into the morning, would be literally to copy the lists of prominent broadcasting stations one finds in the radio column of the daily press. I am not missing anything. Having completed this Grimes circuit to my entire satisfaction, I have gladdened the hearts of a score of amateurs in my community by turning them loose without restriction upon my junk-pile of coils, con-

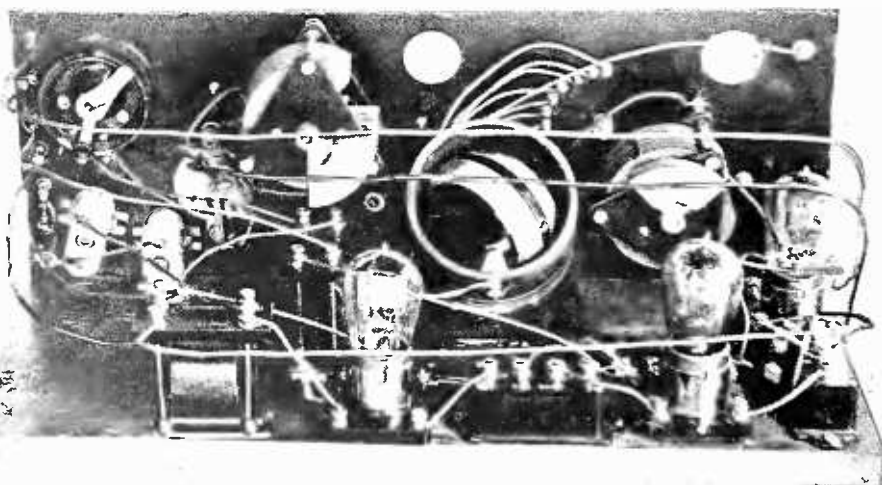

THE INVERSE DUPLEX SET MADE BY THE AUTHOR

densers, variometers, tuners and the like with which my den and attic and cellar have been littered for two years. It is such a pleasure to have *just one outfit* in the corner of my den and to feel satisfied with the results it gives me.

My circuit diagram is like the one published in RADIO BROADCAST for April, except that the loop is replaced by the apparatus indicated in (Fig. 1). Cunningham tubes, type 300 and 301 are used; Acme R2 and R3 and Chelsea transformers; General Radio variable condensers and potentiometer; Micadon fixed condensers; and Eveready large size block B batteries. The storage battery is of 100-ampere-hour capacity, kept well charged by means of a Tungar rectifier.

Difficulty has been experienced in selecting rheostats for this circuit because very careful adjustment of filaments seems necessary. Excellent results were obtained experimentally with separate

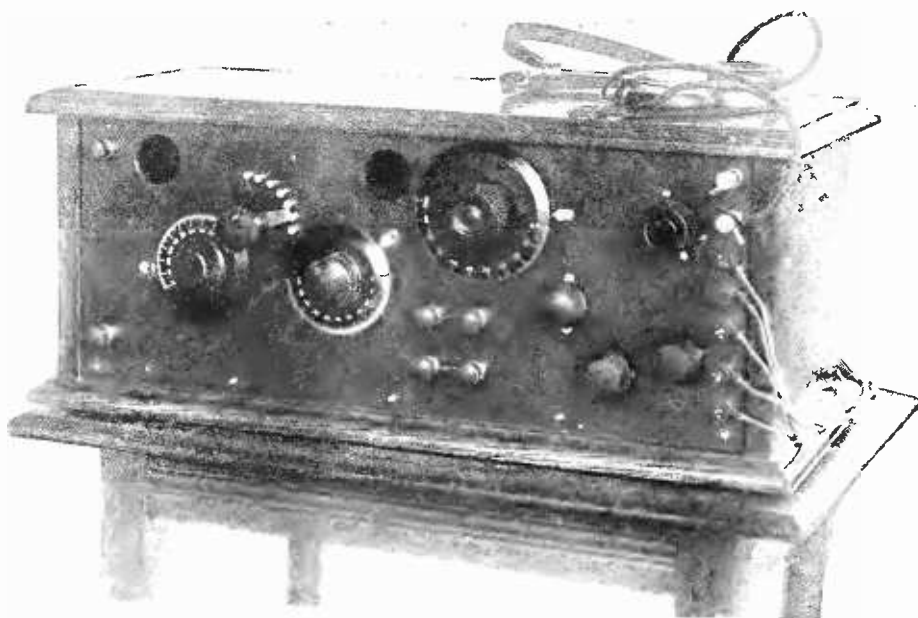

A NEAT JOB

After he had successfully made and operated this set, Mr. Dill gave away all the radio "junk" he had accumulated in the past two years



MR. DILL AT HIS "JUST ONE OUTFIT"

FIG. 1  
The secondary terminals replace the terminals of the loop (Fig. 2)

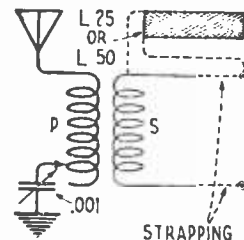

controls improvised of resistance wire with sliding contacts, but these are hardly suitable for neat panel mounting.

A Remler variocoupler is employed to permit experiments with various types of antenna ground and counterpoise, but by removing the strapping connecting two pairs of binding posts on the front panel, the Remler tuner is disconnected and any type of loop may be wired directly to the set.

The specifications of the original Grimes set that appeared in the April issue of RADIO BROADCAST have been carefully followed, with the exception of the addition of this variocoupler for tuning, and the installation of the separate filament controls. Extraordinary success with this Grimes circuit is due principally to my excellent location, the use of an outdoor antenna, and a counterpoise calculated to work perfectly with the set.

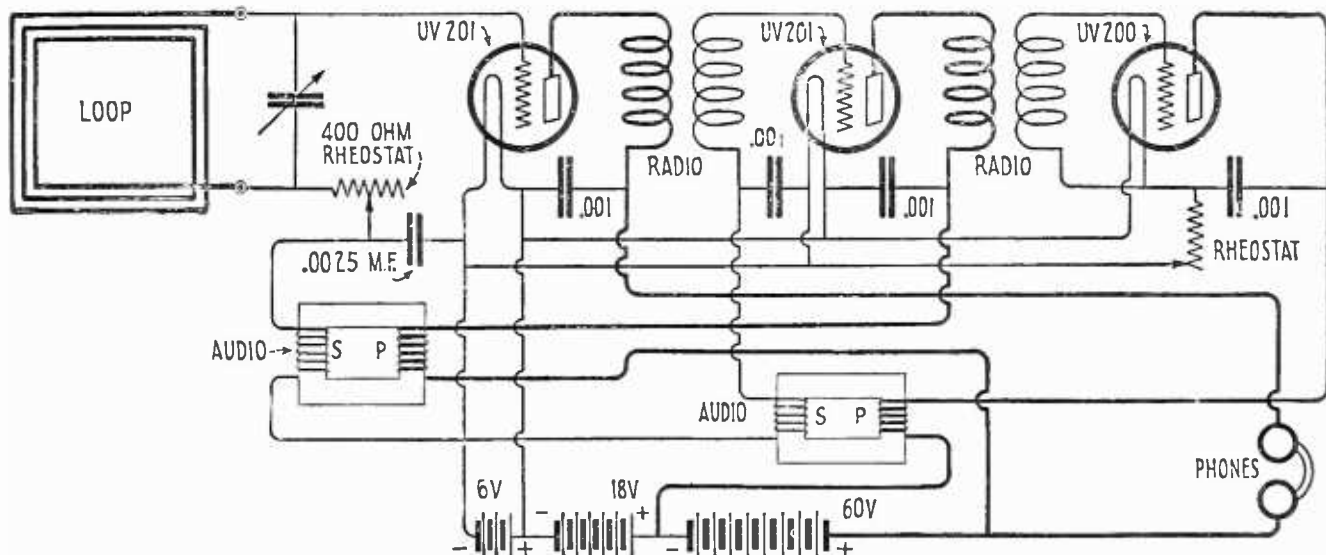

FIG. 2

The regular hook-up of the Grimes "Inverse Duplex." The only changes made by Mr. Dill in constructing his own set are the use of separate filament controls and the antenna and counterpoise arrangement shown in Fig. 1. A double-pole, double-throw switch, cutting in a loop, might be employed to advantage—especially when it is desired to receive from local stations

# Radio Angling and Fisherman's Luck

The Thrill that You Get When the Game Takes the Fly, and the Way that You Feel When It Doesn't. The Inspiration and Power for Good of Broadcasting, as Seen by One Clergyman

By REV. H. F. HUSE

In an editorial published in a previous issue, we expressed the belief that radio would prove a valuable asset to the preacher in the small town, in broadening his vision and educating him in a manner otherwise impossible. The Rev. H. F. Huse, Pastor of the United Baptist Church in Dover-Foxcroft, Maine says, in telling of the single-tube receiving set built by his fifteen-year-old son:

"One night, just before starting for a church service I heard a beautiful voice at WSB, Atlanta, Georgia, singing 'The Heart that was Broken for Me.' It tuned my soul at once for the service I was to lead." And again, "I shall never forget Miss Bennett's voice and the words as they went out from WOR, Newark, N. J. in the transoceanic broadcasting concert of February 24th . . . her wonderful voice came with a clearness that was startling. It made one think of the shepherds long ago, startled, as they were, in their midnight vigils by voices out of the air. I listened with rapt interest to the greetings she spoke at the end of the concert: 'I wish to express the great privilege I feel has been mine in singing to the people, not only of my own country, but also to the people of France, Italy, Belgium, Switzerland, and other countries of Europe. I send my most cordial greetings to all. . . .' Such, I thought, is the spirit of America, the spirit of Christianity, the spirit of good will the world needs. Moreover, broadcasting is glorified as it scatters this cordial good feeling to the ends of the earth."

THE pleasures of radio are many and varied. There is first of all the satisfaction which comes in acquiring the information that accompanies all this new knowledge, the energies, the subtleties, the mysteries of radio. There is the wonder of this new thing, this agency that makes it physically possible for us to hear instantaneously out of the air the voice of man from the ends of the earth.

There is the joy of a new and wholesome interest in life. There is the delight in the friendship and fellowship of those whose voices we hear over the air, and whose wonderful talent we so much enjoy. There is the delight of the family circle gathered about the radio set in the home. And not least among the pleasures of radio is the angling for stations!

More than once this winter as I have sat at the receiving set, and twisted the dials first one way and then another, in trying to pick up a station, I have thought of the similarities and the contrasts between casting upon the radio

waves for a station strike, and whipping the surfaces of pond and stream for the sudden flash of yellow and gold, the strike that means the battle royal with the red-spots, and at last the pleasure of leading Mr. Trout by the nose or walking him upon his tail into a fish basket for my lady's dinner the next day.

I taught my boy to fish before he was in his teens. Now that he is in his teens he has come

back and taught me radio. And what a time we have had together, with phone on ear, angling for the stations, and what a thrill as we have landed them, the little ones and the big ones, all the way from Dover-Foxcroft, in the heart of Maine, to Tuinucu, Cuba in the South, and to Kansas City, the home of the Night Hawks, in the West.

In angling for stations as in angling for trout, sometimes the game takes hold and sometimes it doesn't. When the stations do bite, it gives you a thrill of pleasure; and when they don't, it sometimes tries your patience; but a true sport in radio, as



I TAUGHT HIM TO FISH



in fishing, takes things as they come without too many complaints.

I once took a friend fishing to a fine brook where I had always had good success. I wished very much for this friend to see some of the beauties that I knew were in its sequestered pools and swift currents. But that day they just would not bite. And this friend of mine stood on the bank and "joshed" me for fair:

"Trout! This brook never saw a trout! Let's go up in the woods and fish, we will get just as many as we get here, and then we won't get our feet wet!" Well, I've talked the wonders of radio to friends. I have told them the fine speeches and splendid music we hear, and how at times the box just bursts with sound! And then I have invited them in for an evening. I have seated them at my side and adjusted the phones and then begun angling. I have angled and angled. But it has been an off night. Nothing doing. A few ripples in the radio waves, but nothing worth while coming in. I have felt that their thought of radio was

like that of the friend on the bank when the trout would not come to the hook.

Last night I invited in a friend. It was Sunday night and I wished very much to pick up a good church service. Like children whom we wish to speak their pieces before company, and sometimes fail us, so at times it is with radio. Nothing took hold very well until after this friend had gone and then with another twist of the dial I picked up WBZ, Springfield and heard a fine address by the pastor of the Methodist Church of that city!

I taught my boy fishing and he has taught me radio. When the fifteen-year-old came home and said: "Dad, we are behind the times. We have got to have a radio set," then it was time for the boy's best chum to sit up and take notice. I made the agreement that if he would find out how to construct a set, and convince me that he could do it, I would dig down and see if I could find the wherewithal

to pay the bill. "Say, Dad, you're the real article! The set is ours. I have the parts we need all down on paper, their prices, and the hook-up." The eighth wonder of the world is the way a boy in his teens learns these new things—and so quickly! We looked over the list of parts and prices. The total cost was \$40.92.

In due season, the box was made, the parts that we sent for came, and the set was constructed. The antenna was hung from the parsonage to the church vestry, and I was thankful indeed when this job was ended, without broken legs or pneumonia from climbing and scrambling over snow-covered roofs with the wind blowing a gale and the mercury down below zero.

In radio as in fly fishing the "hook-ups" are as varied as the fifty-seven orders of pickles. Speaking of flies, Henry Van Dyke says: "The blasé trout demands something new, something modern. It is for this reason that an altogether original fly, unheard of, startling, will often do great execution in an over-fished pool." So it is with radio sets and hook-ups. Every now and then it's the new hook-up that seems to gather in the stations.

#### THE HOOK-UP AND THE CABINET

WATCH the fisherman," says Henry Van Dyke again. "When he comes home with a full basket of trout on his shoulder, or a quartet of silver salmon covered with green branches in the bottom of the canoe. His face is broader than it was when he went out, and there is a spark of triumph in his eye." Who is there who has not seen the radio smile on the face of another, or felt the thrill in his own soul the morning after a successful catch? What fisherman returning home at night from an all-day outing to brook or pond has not been greeted with the question: "What luck?"

Our radio record began Sunday night, February 11, 1923. Up to the date of this writing our parsonage radio creel has to its credit the



HE TAUGHT ME RADIO



SOMETHING DOING IN THE AIR

following stations a thousand or more miles distant: KSD, PWX, WDAF, WDAJ, WFAW, WLAG, WMC, WOAW, WOC, WOS, WSB, SKW (Tuinucu, Cuba), and WKAQ. Considering our location in the heart of Maine and upon the outer circle of the area that includes the broadcasting stations, our catch is "not too bad."

Reflecting upon what has come out of the air to the listeners, one cannot fail to be impressed by the wonderful talent that everywhere in America seems to be the same—talent of speech and song, orchestra and band, solo and chorus. Parenthetically, as a preacher, may I say that the way in which the broadcasting stations have so generously lent themselves to the service of the churches is one of the finest instances of religious coöperation in a big way that the Christian world has ever seen.

Would that there were time and space to tell something about certain speeches and sermons and music that I have heard. It is said that Daniel Webster put together his famous reply to Haynes as he fished along the waters of a New England trout stream. Be this as it may, the radio listener finds not only mental change and rest in what comes to him out of the air, but

he finds inspiration to better things and nobler effort.

There have been such fine things from all the stations that it does not seem fair to mention one without mentioning all. But the "big fish" that I have missed someone else catches! There stands out in my memory the "New York City Symphony" from WEAJ, the "Albany Chorus" from WGY, the exquisite music from the "Waldorf Astoria" through WJZ, and the selections by the Little Symphony Orchestra via KDKA. One night just before starting for a church service I heard a beautiful voice at WSB, Atlanta, Georgia, singing "The Heart That Was Broken for Me." It tuned my soul at once for the service I was to lead.

I shall never forget Miss Bennett's voice and words as they went out from WOR, Newark, N. J. in the transoceanic broadcasting concert of February 24th. It was midnight. The transmission conditions were perfect, and her wonderful voice came in with a clearness that was startling. It made one think of the shepherds long ago, startled, as they were, in their midnight vigil by voices out of the air. I listened with rapt interest to the greetings she spoke at the end of the concert. "I wish to express the great privilege I feel has been mine in singing to the people not only of my own country but also to the people of France, Italy, Belgium, Switzerland, and the other countries of Europe. I send my most cordial greetings to all, and, to the people of Concord, N. H., my love."

Such, I thought, is the spirit of America, the spirit of Christianity, the spirit and goodwill the world needs. Moreover, broadcasting is glorified as it scatters this cordial good feeling to the ends of the earth.

#### THE RADIO ANGLER'S ROD AND REEL

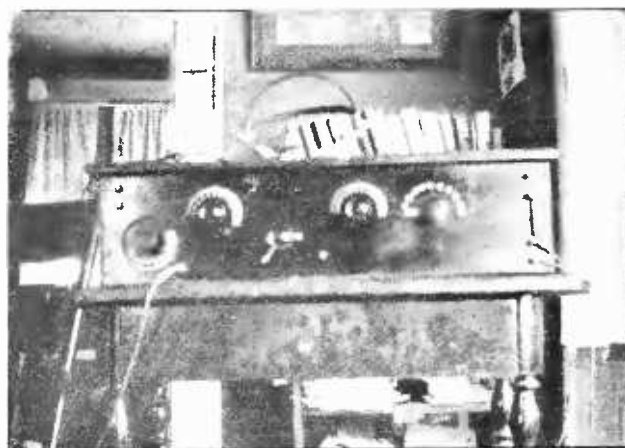

# Crystal Receivers are Well Worth While

Some Types that are Simple to Put Together, Cheap, and of Value Both to Beginner and Confirmed Enthusiast

By ZEH BOUCK

Are you: interested in radio but without any experience in it; eager to enjoy the programs that fill the air, and to have the fun of building or operating your own receiver; broke—or at least unwilling to pay “beaucoup francs” for apparatus which you think you cannot operate, to hear programs which you think you may not care for? If so, get yourself a crystal set and have a taste of radio reception before tackling vacuum-tube apparatus.

Or, if already of the radio fraternity, are you building and rebuilding, soldering and unsoldering apparatus that passes in a single week through the throes of super-regeneration and inverse duplex? If so, build yourself a crystal receiver as a standby to tide you over whenever your tube set is *hors de combat*, so to speak. —THE EDITOR.

THE advent of the dry-cell tube, and the general drop in the price of vacuum-tube apparatus has by no means sounded the knell of crystal receivers. The advancement in bulb apparatus has been accompanied by similar strides in crystal equipment, notably in the development of synthetic crystals which make possible fairly consistent reception over moderately long distances. Experienced operators still recommend the purchase or construction of crystal receivers by beginners, as the least expensive way of mastering the fundamentals of tuning, and by the possessors of bulb apparatus as a standby when tubes burn out and batteries run down. When bulbs have suddenly ceased to function, many an interesting program has been “saved” by requisitioning a discarded crystal set. Also, a familiarity with the theoretical and practical aspects of crystal reception is of value in the operation and design of many reflex sets, in which a crystal is used as the detector.

The crystal provides the simplest means of detecting radio signals, and reception is effected by imposing the incoming radio-frequency energy on the circuit containing the detector, where it is “rectified.” The radio current, as the reader is probably aware, is an alternating current and of so high a frequency that, due to a phenomenon known as reactance, it cannot pass through the windings of the telephone receivers. However, by means of rectification, which the crystal accomplishes

through its property of passing electricity in only one direction, half the alternating current is suppressed, leaving only that part traveling in one direction (a direct current), which passes quite readily through the receivers.

There are several ways in which the radio wave may be delivered to the crystal, but as the sound from an unamplified crystal set is actually furnished directly by the power of the received wave, which is necessarily weak, only two methods, those making the most of the weak radio impulses, will be considered. The fact of direct power transformation, from energy of radio frequency to energy of audio frequency, should be constantly borne in mind when building crystal apparatus, to emphasize the necessity of painstaking construction tending to eliminate all possible losses. A carelessly made tube set may work, its imperfections probably being manifest in un-

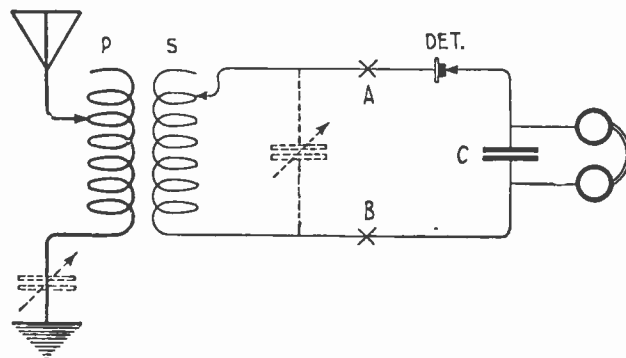

FIG. 1

The preferred crystal circuit, which, with the addition of the indicated condensers, makes an excellent set

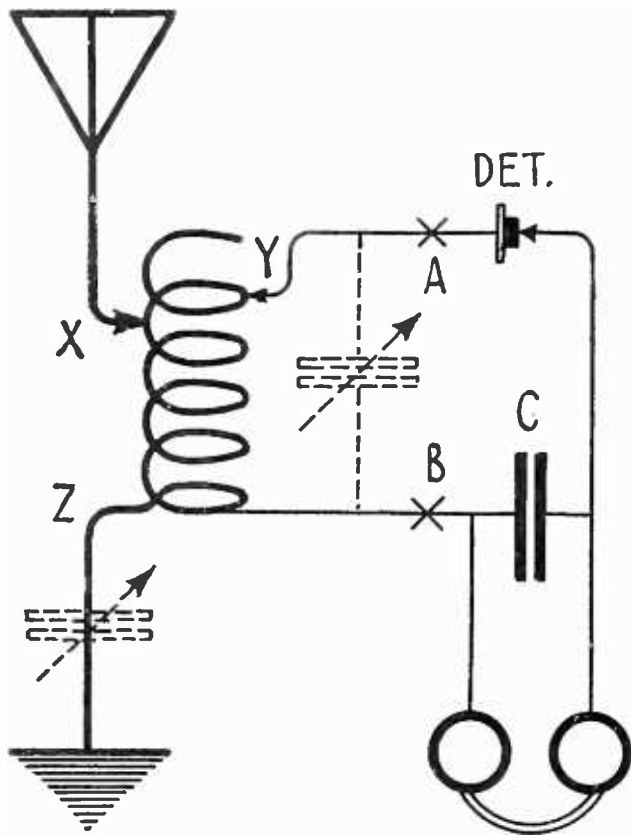

FIG. 2  
An efficient and simpler circuit

desirable sounds and lack of selectivity; but a poorly constructed crystal receiver, incapable of compensating for inefficiencies by local batteries, will function far below its ability.

The most efficient system of crystal reception employs a loose- or variocoupler in the tuning circuit. Fig. 1 indicates the manner in which it is connected to the detector and phones. The coupler, P S may be of the type designated commercially as the "universal" or "all-wave" coupler, or it may be a standard short-wave variocoupler with the secondary coil rewound (if necessary) with smaller wire. Good variocouplers can be had from reliable dealers for from \$2.75 to \$6; for the person who does not care to make his own apparatus and yet would be glad to save money by assembling bought parts himself, the purchase of a variocoupler is recommended. Many complete crystal receivers, of course, are also on the market. They cost comparatively little to buy, and nothing at all to operate, since they require no bulbs or batteries. However, a home-made coupler is well within the ability of many experimenters, and the primary coil should be wound with 60 turns of any convenient wire on a three-and-a-half-inch tube, tapped every sixth turn. The secondary may be

wound with 72 turns on a three-inch tube, tapping every twelfth turn.

If the fan already possesses a short-wave variocoupler, but does not care to rewind and tap the secondary, a variometer may be added to the circuit at point A, figure 1, and tuning accomplished by means of it.

The loose-coupler circuits are very selective, and close tuning is possible through variation of the coupling.

A single coil of wire combining the functions of both primary and secondary, is, perhaps, the more usual form of inductance for crystal reception, but while quite efficient, it necessarily lacks the advantages gained by variable coupling. This circuit, Fig. 2, is theoretically identical with that just discussed, the turns of wire between X and Z acting as the primary, and those between Y and Z as the secondary coil. (It might be well to note here that the functioning of many electrical circuits, particularly those associated with wireless, depends upon one coil acting in the capacity of two or more.)

The inductance coil in Fig. 2 may be wound with 120 turns of No. 20 to No. 28 magnet wire, and tapped every tenth turn. Fig. 3 shows the method of doubling up on the taps, permitting the two switch levers to cut in individual amounts of wire from the same taps.

The fixed condenser, shown across the telephone receivers, should be of about .0015 microfarad capacity.

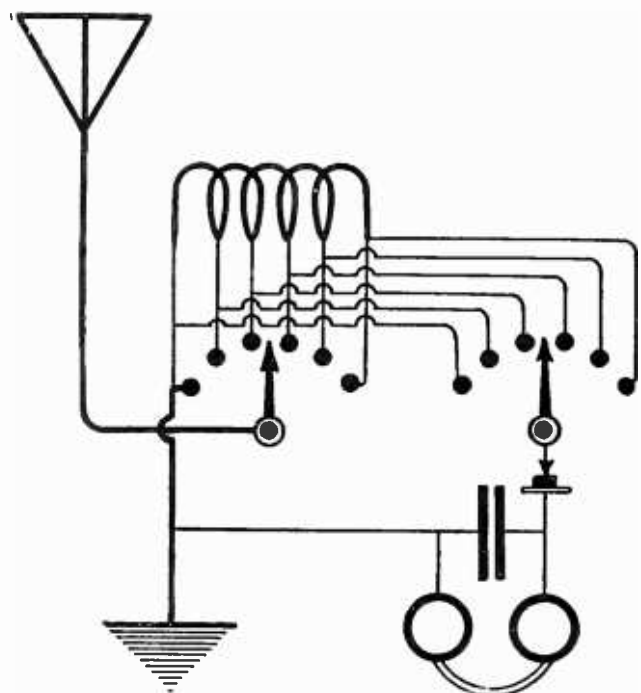

FIG. 3

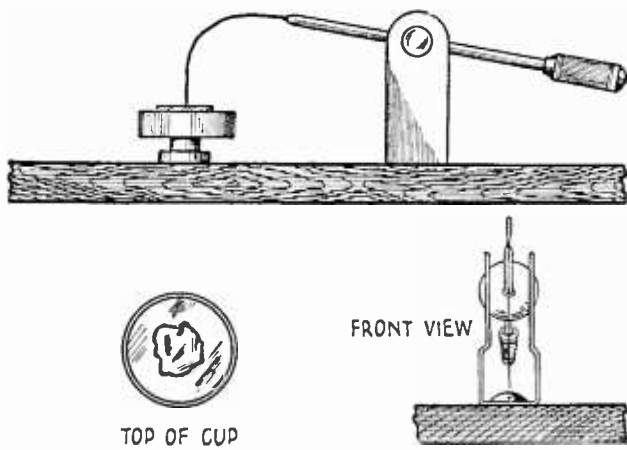

FIG. 4

A simple form of crystal detector for home construction

The crystal sets just described are well adapted to the refinements associated with audion equipment, and the addition of variable condensers in the primary and secondary circuits will add to the selectivity, and to the ease with which the apparatus may be tuned. Such condensers are indicated by dotted lines in Fig. 1 and are preferably of the 43-plate (.001 mfd.) size, though the 23-plate condensers will be found useful. If only one condenser is available, it can probably be used to greater advantage across the secondary coil, in the loose-coupler circuit, and in the ground-lead when the tuning coil is used. Whether or not condensers are employed, apparatus constructed in conformity with the directions given, will respond to all the broadcast wavelengths.

The detector itself may be any one of the popular types on the market, from the simple moving-bar design to the more elaborate

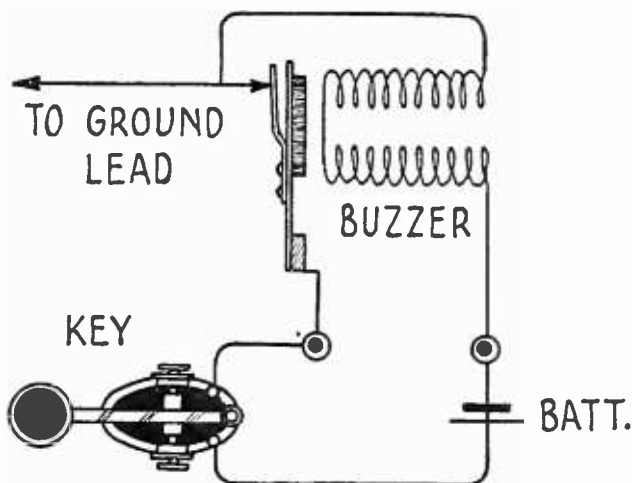

FIG. 5

Test buzzer connections

glass-enclosed instruments. The majority of crystal detectors are of the cat-whisker type in which contact with the crystal is effected by means of a fine, springy wire such as phosphor-bronze. Such a detector is easily built by the experimenter. A simple design is shown in Fig. 4. The support is a "U" shaped strip of brass or other convenient metal. The ball and the brass rod which is passed through it after drilling, may be made from the end of a curtain rod. The cat-whisker (a short, single strand from a flexible lighting cord, will do for this) is soldered to one end of the rod, while an insulating handle is attached to the other. The crystal may be purchased mounted in a revolving cup.

Another popular detector design which is particularly adapted to mounting on a vertical

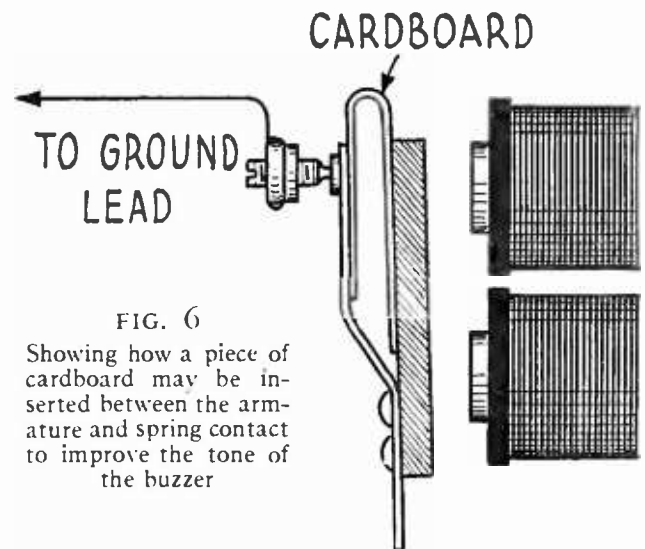

FIG. 6

Showing how a piece of cardboard may be inserted between the armature and spring contact to improve the tone of the buzzer

panel is that of the rotating type made in the form of a hard-rubber wheel. It contains a sensitive crystal with which contact of the required delicacy is obtained through gold or other metallic dust. Adjustment is effected by turning and tapping the wheel.

The crystal itself may be galena, a natural crystal, or a synthetic product, which is sometimes more sensitive than the average natural mineral. Galena is a double sulphide of lead and silver along with many unrectifying impurities—all in varying proportions. It is not difficult to imitate the natural process of galena crystallization, and the majority of manufactured crystals are merely an artificial galena built up in the most efficient proportions (from a rectifying standpoint) with the useless and perhaps undesirable impurities eliminated.

A crystal set is most easily adjusted for the



highest sensitivity by means of artificial signals from a test buzzer. The buzzer, though preferably of the high-frequency type, may be of the ordinary door-bell design, the note of which can often be improved by inserting a pasteboard slip between the armature and the spring contact (Fig. 6). The sole connection between the buzzer and receiver (and no connection at all is required when the detector is correctly adjusted) is a single wire running from the stationary contact to the ground-lead (Fig. 4). The detector should be adjusted while the key or push-button is down, and the note of the buzzer will be plainly audible in the receivers when a sensitive adjustment is secured.

The apparatus is preferably mounted on a panel after the fashion of bulb sets, with the detector placed on the front in such a manner as to permit easy adjustment. A push-button may be set flush in the panel for operating the buzzer test, but many enthusiasts prefer a telegraph key on the operating table, making the buzzer additionally useful for code practice. Care should be taken in the construction and mounting of the instruments, in order that the crystal receiver may be given the finish and appearance which it merits.

#### ADDING AN AUDION TO THE CRYSTAL RECEIVER

THE crystal sets which have been described employ a tuning system that is readily adaptable to bulb reception, it being merely necessary to build up the bulb equipment as an auxiliary unit. The additional parts which will be required are: the bulb, A and B batteries, socket, rheostat, grid condenser and grid leak, and the plate variometer. The extra equipment should be connected as shown in Fig. 7, and is hooked up to the crystal receiver by connecting wires A' and B' to wires A and B respectively in Figs. 1 or 2 after eliminating the detector and receivers (the phones of course being transferred to the bulb circuit).

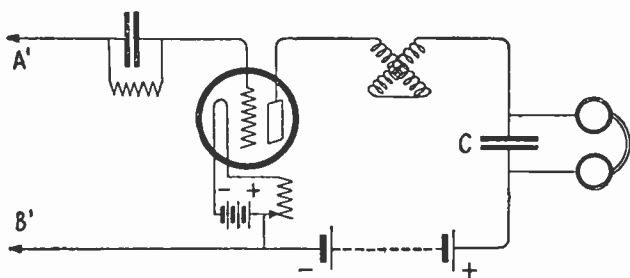

FIG. 7

The bulb unit for connection to Figure 1 and 2. This will make the crystal set into a regenerative receiver

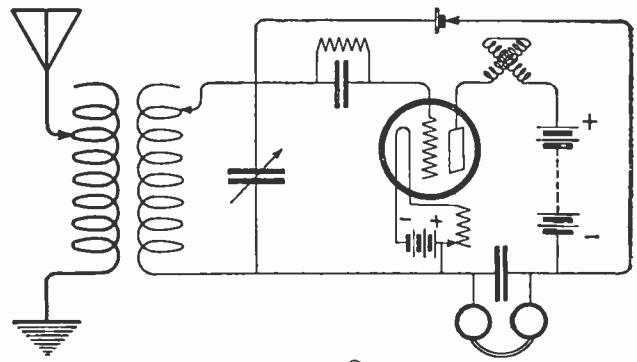

FIG. 8

A combination audion-crystal set, permitting instant change to either form of detection

The result will be an efficient regenerative receiver, which, if desired, may as easily be changed back to a crystal set.

Fig. 8 shows a combination crystal-tube set in which either form of detection is immediately available. When tube reception is desired and the tube is lighted, it is merely necessary to remove the cat-whisker from its position on the crystal. When crystal reception is preferred, the current that lights the bulb is turned off and the cat-whisker is adjusted to rest lightly on the crystal. No switches are required unless it is desired to keep the detector permanently adjusted, in which case a single-pole single-throw switch may be placed between the crystal detector and the phones, thus obviating the necessity of removing the cat-whisker. The principle is quite clearly indicated in Fig. 8, and it may be applied with equal simplicity to almost any crystal or bulb circuit which you may at present possess.

The crystal receiver is capable of remarkable results when constructed and operated with some degree of "finesse"—which, alas, is often as totally lacking in radio as in bridge. The close of the war found crystal receivers covering fifty to a hundred miles, *on amateur power and wavelengths*; and until much more recently they were used almost exclusively for commercial work (due to patent complications on bulb apparatus), traffic being handled in many instances over distances of a thousand miles! Of course, you cannot expect to hear broadcasting stations a thousand miles away with a crystal set, and even fifty-mile reception may be considered exceptional; but if you live within about twenty-five miles of a broadcasting station, you should be able to hear it consistently and plainly; and the music will come in without the distortion so common with sets employing vacuum tubes.

# Powel Crosley, Jr.—“The Henry Ford of Radio”

By ALVIN RICHARD PLOUGH

**T**HE other day I visited two large radio plants where several hundred people are daily engaged in turning out radio apparatus to meet the tremendous demand for such products. When I was ushered into the office of the president of this enterprise, I found that he was a much younger man than I had expected; in fact he confessed to being thirty-six. His youth impressed me and I marveled at his ability to grasp big problems and make quick decisions. What ability he has along this line, he says, has been developed through the many and varied things he has done during his business career.

Those who knew Powel Crosley, Jr., President of the Crosley Mfg. Co., as a very young man, refer to him as a “rolling stone” type of boy; but now they are glad to “hand it to him” as a sound business man. Such has been the change in sentiment about the man who operates the radio plants I visited in Cincinnati, and who has been referred to as “the Henry Ford of radio,” because he builds such large quantities of good and comparatively inexpensive radio apparatus.

Mr. Crosley told me that it was in 1921 that he first became interested in the radio business. He considers that he owes a great deal to his young son for the position that his company holds in the radio industry. It was on Washington's Birthday, just two years ago, that his boy, who was then nine years old, wanted a

radio set. He took the boy to the factory of the Precision Equipment Company, which was manufacturing receiving sets and is one of the original licensees under the Armstrong patent. It was Mr. Crosley's intention to buy an expensive set as a toy for Powel, 3rd, but he

found that the least expensive one cost about \$130, which appeared to him to be too much of an investment for a small boy's toy. The insistence of the boy was followed by the purchase of parts to assemble a set and notwithstanding the limited amount of broadcasting two years ago, Mr. Crosley and his son became ardent radio enthusiasts.

Less than two years after his first visit to The Precision Equipment Company's factory, he purchased a controlling interest in that corporation, which is now being operated as a separate organization, so that he is now at the head of two radio manufacturing companies!

The early career of Powel Crosley is very interesting. Before going to work, his academic education consisted of public school and military preparatory school, one year of engineering work in college and two years at law school.

His first job was rebuilding some old telephones during a summer vacation while in the public schools. This was followed by work in various phases of the automobile business during summer vacations from college. During his last year in law school he was employed by a large bill-posting company to acquire leases



HE FIRST BECAME INTERESTED IN RADIO TWO AND A HALF YEARS AGO

Now he is head of two radio manufacturing companies



MR. CROSLY BROADCASTING AT WLW, CINCINNATI

on locations for their signs. Before completing his course in the law school, he decided that there were opportunities for quicker financial returns than in law, so he did not complete his course but obtained a position with a Cincinnati concern selling municipal bonds. This was followed by the organization of a small company, of which he was president, to manufacture a low-priced, six-cylinder car. This was in the days when there were not more than two or three six-cylinder cars on the market. Although the first car was built and operated successfully, others were never put into production because of a lack of sufficient capital.

A few years later, he took up advertising and sales work, which was followed by the organization of another automobile manufacturing company to build a very light six-cylinder car, and later, another company to build a light four-cylinder car. Neither of these companies went into production due to the lack of sufficient capital.

It was then, Mr. Crosley says, that he determined never again to attempt to operate on other people's money. He had experienced

several disappointments and now started over again, with the intention of making advertising his life work. He associated himself with an advertising agency on a drawing account of only \$20 a week in 1914, and later changed his connection to another agency. By 1916 he had built up a fairly large and profitable clientele. Through the service rendered to one of his clients, he was induced to become interested in the organization of a company to sell one and later several automobile specialties. This company he purchased outright in the spring of 1917, and it has grown to be one of the largest concerns of its kind in this country.

From all this it will be seen that Mr. Crosley has exceptional ability in business organization. But it was his realization of the difficulty of obtaining an efficient and inexpensive receiving set in 1921—and due also to the fact that he wanted something to manufacture which would keep his wood-working plant in full operation—that he plunged into the radio business and turned out simplified apparatus which could be manufactured in large quantities and sold at low prices.

# Reception de Luxe

By A. R. BOSCOW

**T**HE receiving set described in this article is of a type created to satisfy the ideals of the most lavish experimenter and amateur who wants a highly sensitive instrument, responsive to the 100-600 meter wave band, embodying as simple a system of control as is consistent with efficient operation. While there are no radical departures from standard radio circuits, the auxiliary circuits possess some novel features.

Before the final assembly of this set, practically every known receiving circuit had been tried during the previous twelve years that the writer had been experimenting with radio. This set, then, expresses what he believes to be the ultimate in receivers at the present time on the lower band of wavelengths and for actual performance and ease of control exceeds the seven-tube super-heterodyne operated at this station last year.

Practically all the stations heard have come in clearly on the loud speaker, which consists of a Vocarola attachment on a large horn, and most of the stations were heard with considerable volume on one step of audio amplification and quite a number on the detector alone. While the above remarks refer particularly to broadcast reception, it must not be inferred that this is the set's only feature, for amateur CW stations have been copied in every district.

The set employs six tubes—three radio-frequency stages, a detector, and two audio-frequency stages. The tuning circuits are arranged for either loop or antenna reception. When used with an antenna, the tuning elements consist of a primary condenser, a variocoupler and secondary condensers. When used with a loop, plugging in on the loop jack disconnects the primary circuit and variocoupler, leaving the secondary condensers in parallel with the loop for tuning. The primary

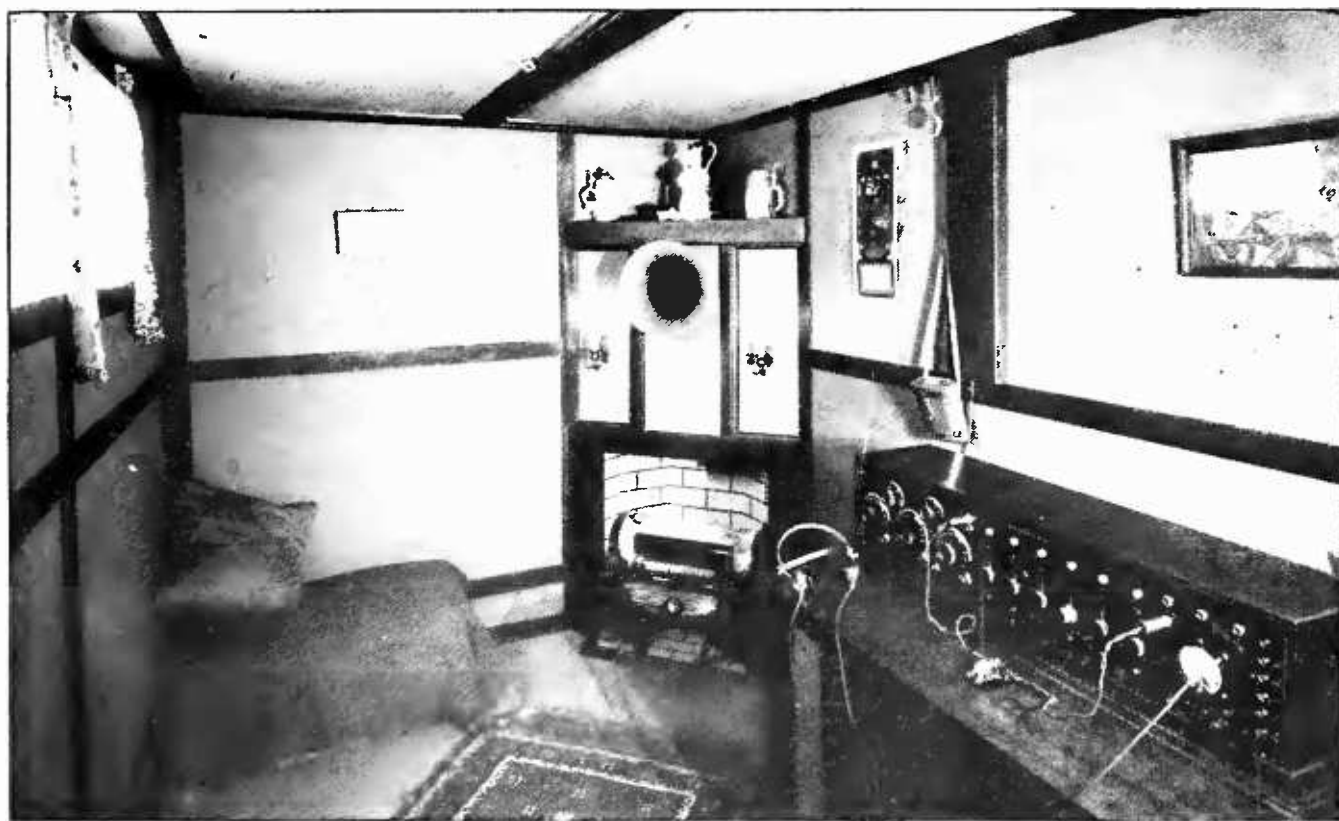

THE COMFORTABLE RETREAT WHICH MR. BOSCOW BUILT IN THE BASEMENT OF HIS HOUSE

The fireplace is electric and thermostatically controlled—no getting up from the set to put logs or coal on during the winter evening!

inductance is variable by means of a tap switch mounted on the back panel, while the secondary circuit is tuned by three condensers (two variable and one fixed). The shaft of the variocoupler was lengthened to include the shaft of the three-plate vernier condenser which is thus made to rotate with the coupling coil in such a manner that as the coupling is increased, the vernier condenser capacity is decreased, thus tending to stabilize the resonant point of the primary and secondary circuits and helping to prevent detuning when the coupling is changed. In parallel with this condenser is the main secondary condenser of thirteen plates which is in turn shunted by two .00015 mfd. condensers in series. When the main secondary condenser is set at 0, the secondary wavelength is approximately 180 meters and increases to 420 meters at full scale. If now one of the small mica condensers is cut out by the switch provided, the secondary wavelength becomes 400 meters at 0 and increases to about 600 meters at full scale. This arrangement gives a full vernier effect with a small variable condenser and still provides a large range of wavelengths.

In case it is desired to use the tuning elements without the radio-frequency bank, a

jack has been provided which enables a crystal or other detector to be plugged in. The tuning is accomplished in the usual manner.

In addition to the usual jack arrangement which enables the signals to be received on either the detector or the first or second audio amplifiers, an additional jack has been provided so that an external detector can be plugged in on the audio-frequency bank. This jack in connection with the one associated with the loop jack enables crystal reception, utilizing the tuning elements with or without audio-frequency amplification and makes an ideal arrangement for local reception.

A rather extensive system of voltage control has been provided and has proved to be an absolute necessity. A 0-10 D. C. voltmeter is connected through a two-pole, triple-throw, cam-key switch to three separate circuits, one of which follows along on a buss under the filament rheostats, to which is connected six double-pole single-throw push-button switches which are in turn connected, one to each of the tube socket terminals. With the key in the proper position, pressing any one of the push-button switches shows the voltage on the terminals of its associated tube. A second circuit from the key switch goes to the A battery terminals

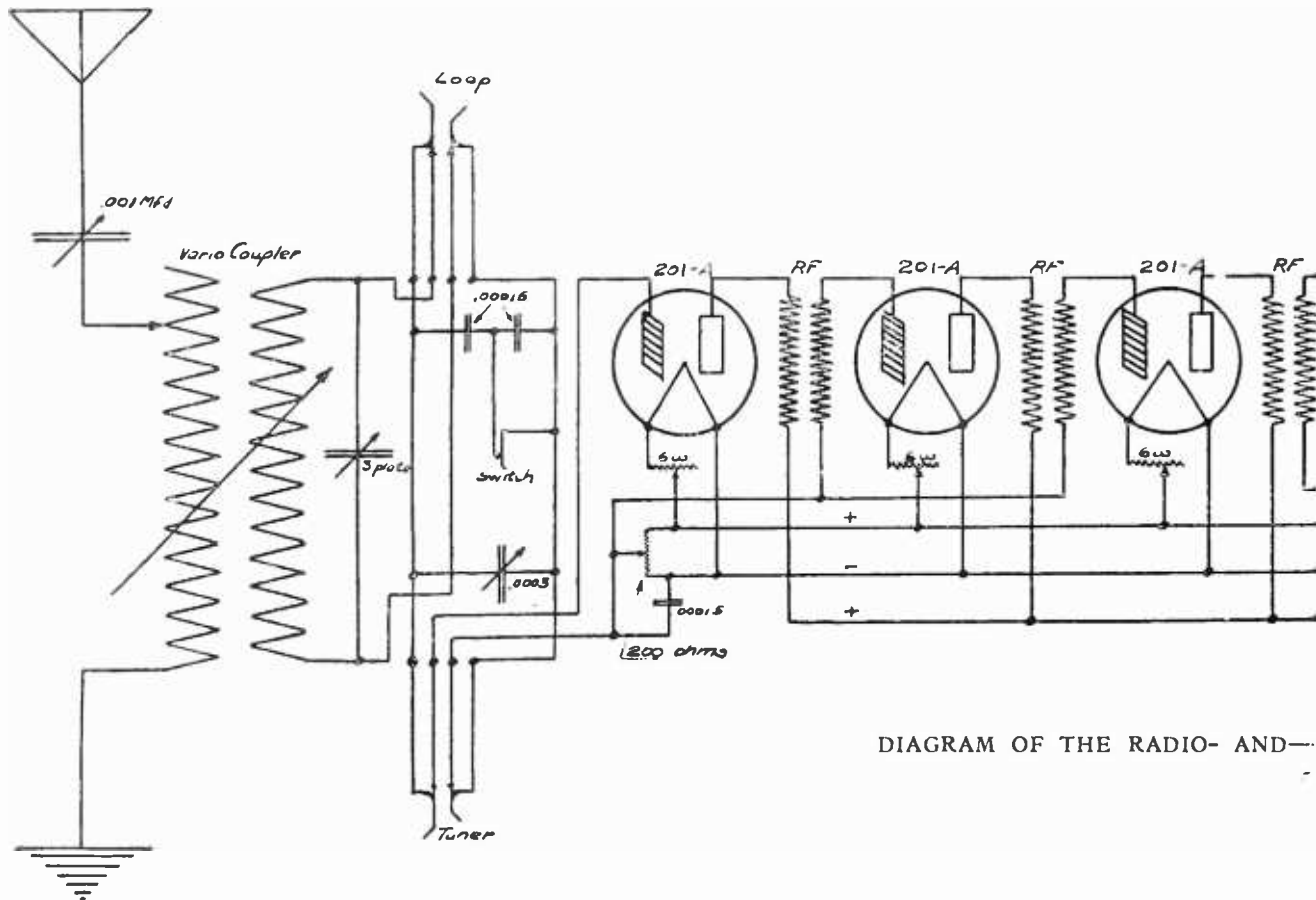



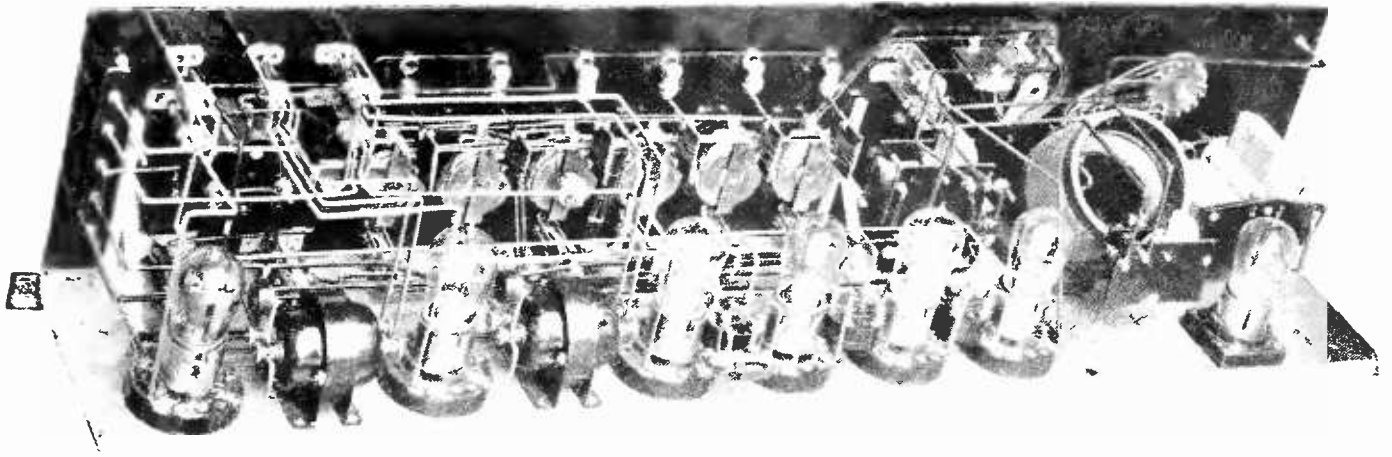

IT IS A PLEASURE TO SEE A HOME-MADE SET AS NEATLY BUILT AS THIS

so that the condition of the storage battery may be determined at will. The third circuit goes through a high resistance to the B battery terminals and enables a reading of the plate voltage. The amount of this resistance varies with different makes of voltmeters but should be of such a value that a scale multiplier of 10 may be used. That is to say that when the key switch is thrown to the B battery position it is only necessary to make a mental calculation to get B battery voltage by multiplying the scale reading by 10. Such an arrangement

permits readings up to 100 volts on a 10-volt meter.

Because of the amount of equipment in the set, it was not possible to have the tubes so located that their filaments could be observed through windows or holes, and an auxiliary indicating system was provided. Above each rheostat control knob has been placed a small bulls-eye, similar to those used in the older types of telephone switchboards. Behind each bulls-eye a 2-volt 1-candle-power light has been placed and connected through a suitable re-

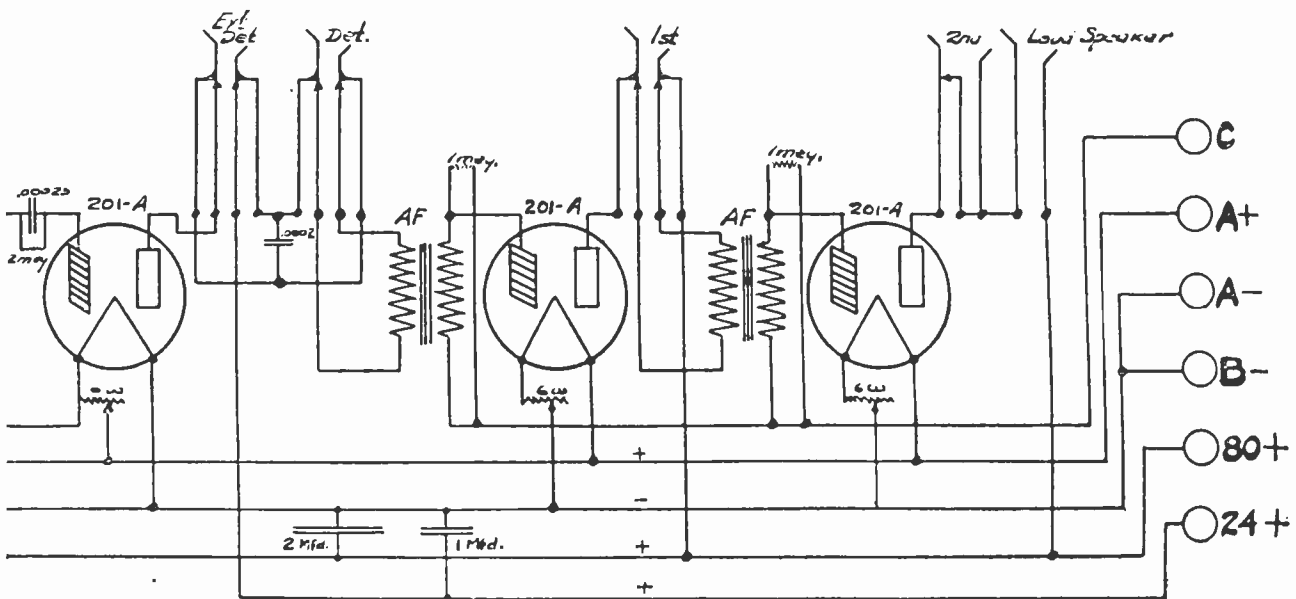

—AUDIO-FREQUENCY CIRCUITS

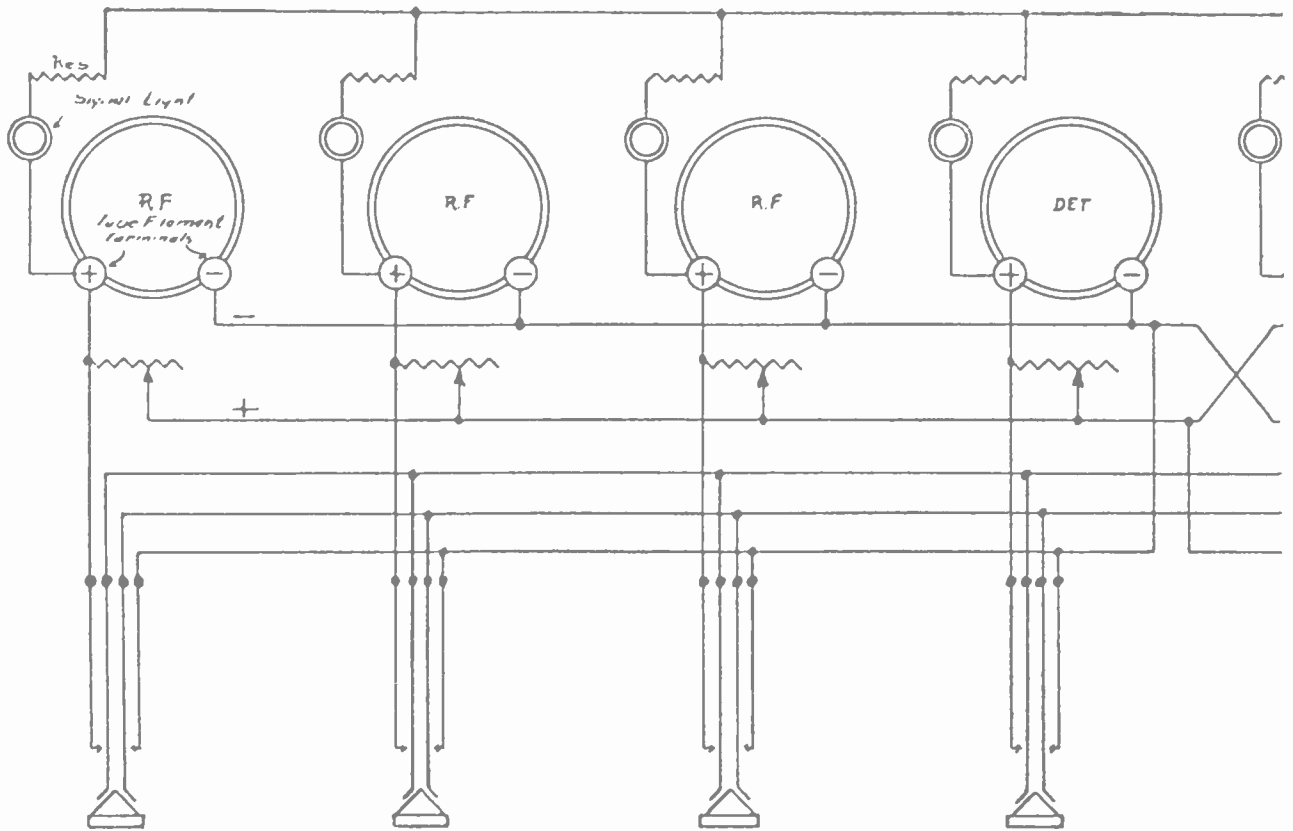

THIS DIAGRAM SHOWS THE VOLTAGE-CONTROL AND INDICATING-LIGHT—

sistance, wound on flat bakelite strips, to the tube side of the filament rheostat. As the filament of each tube is turned on the indicating lamp also lights, giving an attractive as well as an effective indication of the tubes in use.

The common returns from these indicating lamps are connected to a second key switch which is in series with the main filament leads from the A battery which provides three switching combinations:

- 1.— All A battery current off.
2. A battery on tube filament buss.

- 3.—A battery on tube filament buss and indicating lamp circuits.

These combinations make it possible to operate the set with or without the indicating lamps being lighted.

Binding posts are provided for the following terminals; antenna, ground, A battery leads, B battery leads and audio amplifier grid bias, the first two being located at the left end of the panel, while the others are at the right end. The panel is of bakelite  $\frac{3}{16}$ " x 8" x 38" and is screwed to the wooden base along the bottom

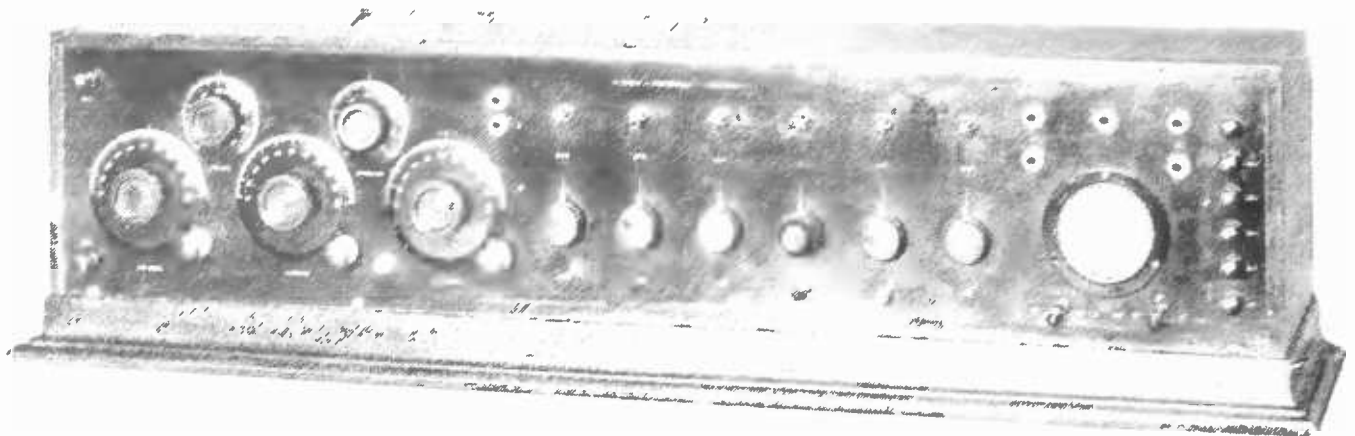

DE LUXE IS THE WORD FOR IT

Note the small pilot lights above the six rheostats, indicating whether the vacuum tubes are lit or not

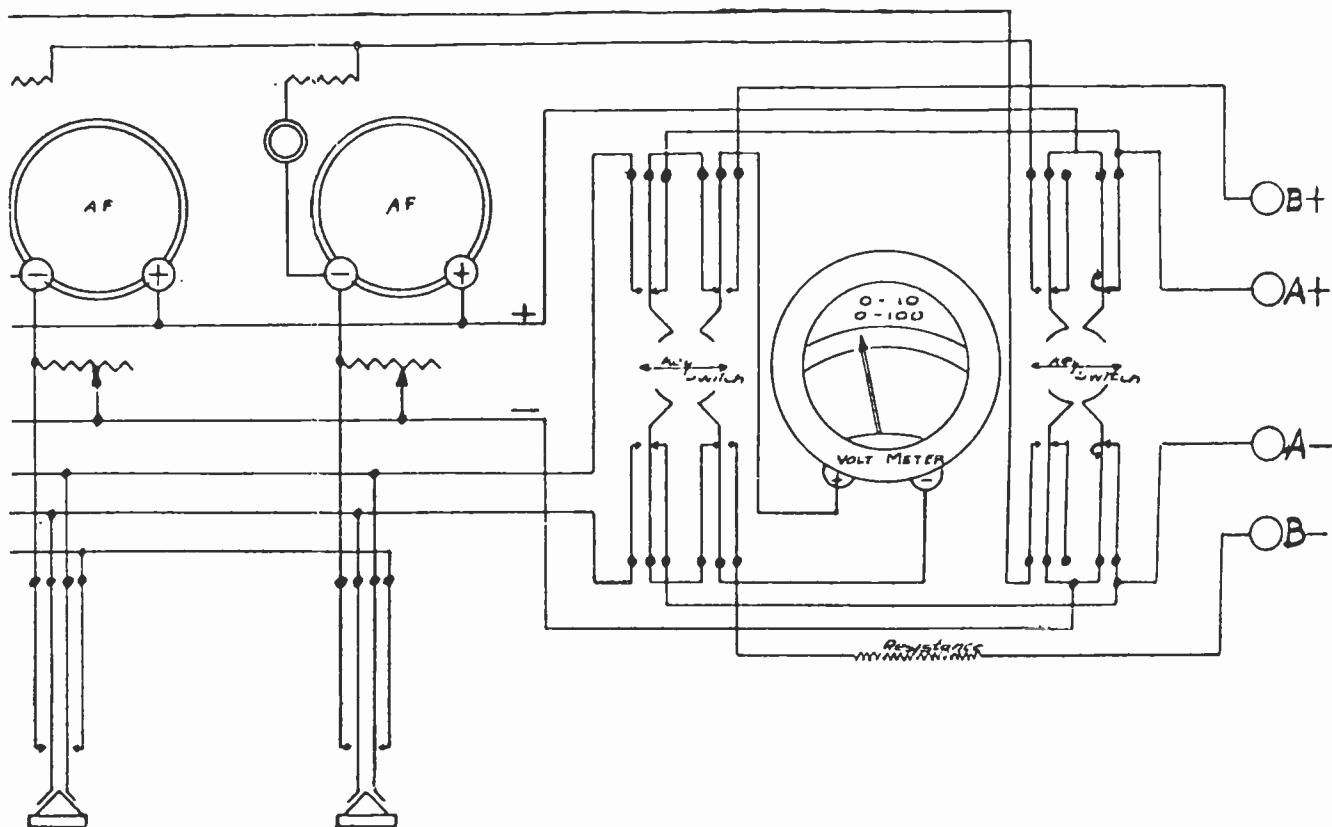

—CIRCUITS AS USED BY MR. BOSCOW IN HIS ELABORATE RECEIVER

of the panel and is maintained in an upright position by cast aluminum brackets. This panel and base are arranged so that they will slide in and out of the mahogany case. Rubber-rimmed vernier controls make for easy manipulation.

With the exception of some of the voltmeter leads the set is wired throughout with No. 14 copper wire covered with "spaghetti". Red colored covering is used for the primary circuits, green for the secondary circuits (the same as the wire covering on the variocoupler), and yellow for the balance of the radio and audio frequency wires. Black covering is used for the battery and other circuits.

The following standard parts were used in the construction of the set:

|                         |               |
|-------------------------|---------------|
| Binding Posts           | EBY           |
| Dials                   | Chelsea       |
| Rheostats               | Cutler-Hammer |
| Jacks                   | Pacent        |
| Variable Condensers     | Wireless Shop |
| Fixed Condensers        | Micadons      |
| Vario-Coupler           | Remlar        |
| R. F. Transformers      | Murad         |
| A. F. Transformers      | Radio Corp.   |
| Tubes                   | " " 201-A     |
| Sockets                 | " "           |
| Potentiometer           | " "           |
| Grid leak and Condenser | Dubilier      |
| Voltmeter               | Jewell        |
| Vernier knobs           | Arkay         |

#### THE ANTENNA

THE antenna is of cage construction 24 inches in diameter at the outer end, tapering to two inches at the lower end, with a 1 inch, three-wire cage lead-in. The flat top has 4 wires (No. 14 hard-drawn copper wire) and is 40 feet high at one end and 30 feet high at the other. This construction amounts practically to a one-wire antenna, but with the wire in cage style built on small brass rings of increasing diameter. The reason for this kind of antenna was an attempt to reduce the high-frequency resistance.

#### HOW THE SET IS OPERATED

THE A battery switch being closed, the successive filaments are adjusted so that the proper voltage is impressed on each tube. This procedure is made easy by the conveniently placed voltmeter push button located under its corresponding rheostat. This method of always burning the filaments at constant potential insures consistent duplication of long-distance reception as well as conserving the operating life of the tubes. The detector tube filament temperature is somewhat governed by its plate voltage as well as by the position of the stabilizer, so that it often

happens that its filament is operated above or below normal temperature. This adjustment can only be determined by experiment and varies from time to time. As both the radio and audio amplifier banks are connected to one plate voltage buss, their plate potential is the same and appears to be best at about 75 volts. The detector plate voltage is a variable factor, but gives best results at about 24 volts, when amplifier tubes are used throughout. A grid bias of from  $1\frac{1}{2}$  to 3 volts on the audio-frequency tubes prevents distortion at that point as do also the 1-megohm grid leaks connected across the output of the audio-amplifying transformers. As it is essential for best telephone reception to operate the receiver without local oscillation, the stabilizer is adjusted until this condition is obtained. The tuning now becomes nothing more than a rough adjustment of the antenna circuit by means of the primary inductance tap switch in conjunction with the primary condenser, a variation of coupling until a signal is heard, then an adjustment of the secondary condenser until maximum signal is obtained. A reduction of coupling is then advisable and slight readjustments of the condensers until you have the signal as you want it. With a minimum of coupling, the receiver is most selective, and by rotating the secondary condenser it is possible to go rapidly from one station to another without interference between them although they may be on only slightly different wavelengths. In this respect the set is so selective that it is possible to tune out a local 500-watt station on 402 meters and bring in a 360 meter station 1,100 miles away. Due to the radio-frequency amplification there is but little loss in signal strength when used with a minimum of coupling.

Some of the distant broadcasting stations

heard by the writer in Portland, Oregon include:

| STATION | LOCATION                | AIR LINE MILES |
|---------|-------------------------|----------------|
| KLZ     | Denver, Colo.           | 1035           |
| KSD     | St. Louis, Mo.          | 1810           |
| KFAF    | Denver, Colo.           | 1035           |
| WDAP    | Chicago, Ill.           | 1860           |
| WCX     | Detroit, Mich.          | 2100           |
| WOC     | Davenport, Ia.          | 1710           |
| WSB     | Atlanta, Ga.            | 2270           |
| WBAP    | Fort Worth, Tex.        | 1680           |
| WDAF    | Kansas City, Mo.        | 1575           |
| WHAZ    | Rensselaer, Troy, N. Y. | 2550           |
| CHCF    | Winnipeg                | 1315           |

#### USING A LOOP

IF IT is desired to use a loop, the tuning operation consists simply of varying the secondary condenser and the direction of the loop until the signal is at a maximum, always keeping the stabilizer down just below the oscillating. Frequent voltage tests of both the A and B batteries, as well as of the filament potentials, are essential to consistent and successful operation.

The "De Luxe" part of this radio reception would not be possible in a cold garage or among a crowd of visitors in the living room, for instance, so I have given my set an attractive and comfortable place to live in by building a small room in the basement with a painted linoleum floor and paneled walls and ceilings of plaster board. Comfort is assured by an electric fireplace (thermostatically controlled) in one corner of the room, from the top of which appears the horn of the loud speaker. Reception of a sort is possible with almost any kind of apparatus, but not the least enjoyable feature of it consists in being able to sit in your own cozy room, listening to St. Louis, Los Angeles, or Calgary, as the notion happens to strike you, and knowing that you will not be troubled with interference of any kind.

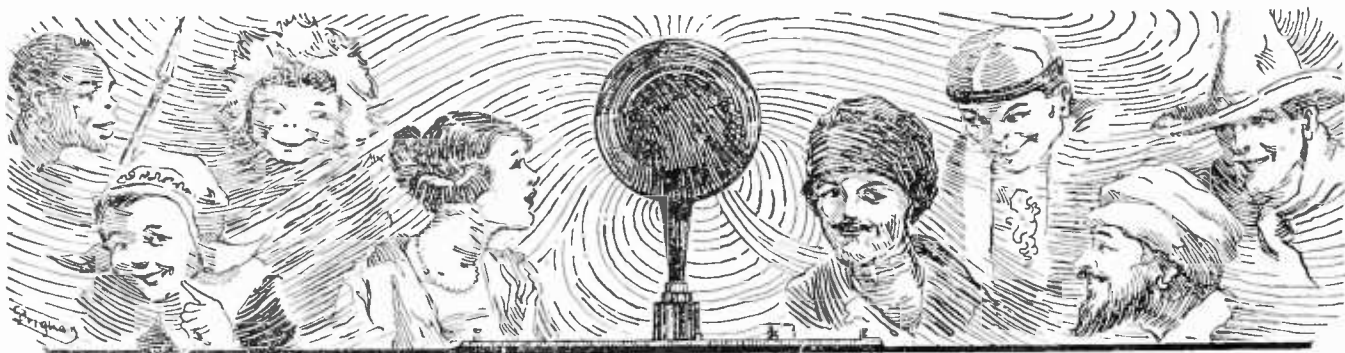

# Teaching School from a Broadcasting Station

A Successful Test by WJZ and the New York Board of Education

By LLOYD JACQUET

**T**O BE the first group of students instructed by radio, is something of a distinction, and it seems to belong to the class in accounting of the Haaren High School, in New York City.

At a recent meeting of educators, attended by officials of the Board of Education and members of the faculty, it was decided that the experiment should first be carried out at the Haaren High School under the direction of Mr. R. Wesley Burnham, the principal, and Mr. Fred Siegel of the faculty. This was to be the

first experiment made to determine the feasibility of conducting a course of instruction by radio in an educational institution in New York or elsewhere.

Accordingly, WJZ, the Westinghouse broadcasting station, was chosen as the station through which to conduct the experiment. Sensitive receiving sets were installed in the school room and at headquarters in the Board of Education Building, through the courtesy of the Radio Corporation.

Voice amplifiers were attached to the receive-

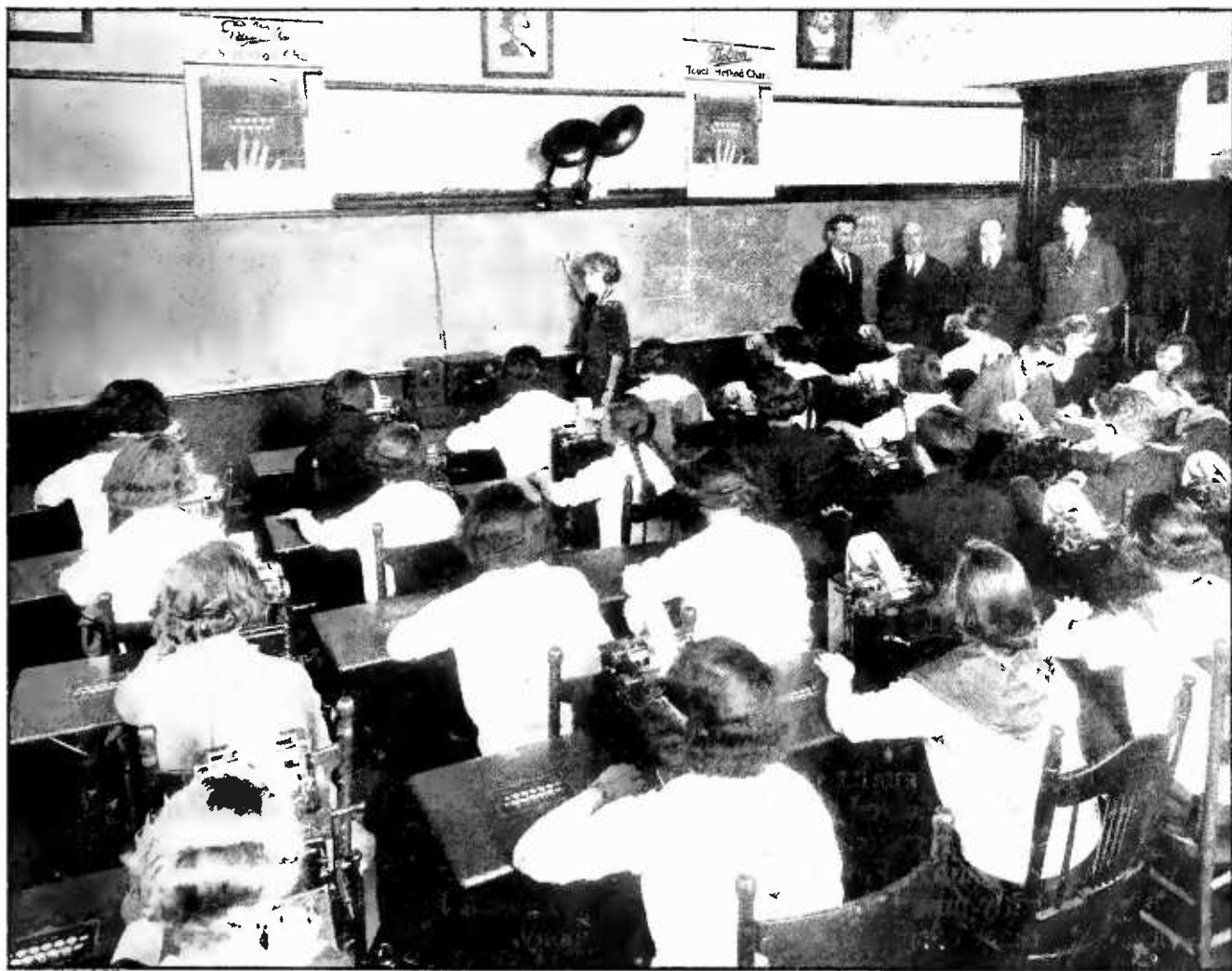

A CLASS IN ACCOUNTING AT THE HAAREN HIGH SCHOOL CONDUCTED BY RADIO

ing sets, so that a large audience could hear the broadcast simultaneously.

Promptly at 1:15 P. M. on a particular afternoon, the announcer's voice came through loud and clear. At the Haaren High School, 11 Hubert Street, New York, the buzz of conversation stopped abruptly.

Dr. Gustave Straubenmuller, Associate Superintendent of the Board of Education, was the first speaker.

"Thirty pupils of the Haaren High School sitting in a classroom in their school building will be instructed by their teacher from the WJZ studio. This is the first time that pupils are being instructed this way."

He was followed by Mr. Burnham, Principal of the High School. He told, briefly, of the part-time and cooperative plan of education.

All the speeches were taken down in shorthand by students in the class room.

A few seconds later, Mr. H. W. Leyenburger, head of the Business Practice Department, addressed his class in accounting, and began the lesson.

"I am glad to greet my class in Machine Calculation in this way," said Mr. Leyenburger. "In the classroom about thirty girls are assembled for regular work in Machine Accounting. To-day the class room is equipped with a loud speaker. Miss Ella Hastings, the class teacher, is in immediate charge of the work.

"The problems that will be given involve the four fundamental processes: Addition, Subtraction, Multiplication, and Division. Now, if you are ready, I will give the first problem—

"Question No. 1. Find Trial balance," said Mr. Leyenberger, whose voice was per-

fectly registered in the classroom. "4832.60; 5392.75; 3570.00—Answer!"

In the classroom, the adding machines were going full speed. One question followed another at a brief interval, until the six problems, involving addition, percentage, cost plus, division, pro rata, etc., were all given.

A few minutes after the lecture was completed, the correct answers to the problems were sent out and received at the Board of Education headquarters, where they were checked up against the results arrived at by the students. The overwhelming correctness of the pupils' work testifies to the faultless manner in which radio waves carried the many details of the complicated problems, every one of which had to be received perfectly to permit of a correct solution.

Principals of more than twenty-five city high schools were interested listeners-in at headquarters. Far away classes in business schools were interested audiences also.

Haaren High School was not the only one to receive this instruction. Other high schools, radio equipped and operated by the pupils, also listened-in, and the telephone brought to waiting officials reports of successful reception from schools scattered all over the city. This was proof conclusive that hundreds, even thousands of pupils in many widely separated locations can listen to leading instructors and educators with whom they otherwise would never come in contact.

Officials of the Board of Education were warm in their praise of radio as a factor in school education, and are already discussing methods for the immediate broadening of the service.

The advent of the "University of the Air" may be at hand.

## A Tablet Dedicated to the Radio Congregation

**A** BRONZE memorial tablet, donated by and dedicated to the invisible radio congregation of Calvary Episcopal Church, Pittsburgh, Pa., was recently unveiled during the church services of that congregation. The Rev. Edwin J. van Etten, pastor of the church and the first minister to have his services broad-

casted; Bishop Alexander Mann, of the Pittsburgh Episcopal diocese; H. P. Davis, representing Station KDKA, which station first broadcasted the church services; and other prominent Pittsburghers took part in the ceremony.

More than 4,700 people, representing 40 states of the Union, five provinces of Canada,



Cuba, Bermuda, London, and ships sailing the Atlantic Ocean contributed to the purchase of the tablet. The contributions came in every form of legal tender—silver dimes, stamps, nickles, pennies, and checks. There was a surprising number of Canadian dimes. A worker in a Southern cotton mill sent Dr. van Etten two cotton socks with a nickel in each toe. A sailor sent 120 pennies he had won playing penny ante.

These contributions came as a result of Dr. van Etten's idea that the radio congregation to which he had been preaching since January 2, 1921, might like to contribute to some sort of memorial. Accordingly, during the reading of his regular church announcements, Dr. van Etten told his unseen hearers of a plan to have small contributions from such of them as might like to participate, the sum obtained to be used for a memorial.

Response to this idea was almost instantaneous. An hour after the announcement was broadcasted contributions were received from people living in Pittsburgh. People in the vicinity even walked to the minister's home a few minutes after they had heard his voice by radio and left their contributions.

The first announcement was sent out into the ether one Sunday last February, and contributions have been coming into Calvary Church ever since. The amount obtained, all of it in small contributions, has been used to purchase a beautiful bronze memorial tablet.

The tablet is 30 x 26 inches in size. On it is a bas relief map of the territory where Calvary's church services have been heard. The map is crossed with jagged lines, indicative of radio waves emanating from the radio station at East Pittsburgh.

On the tablet is the following inscription

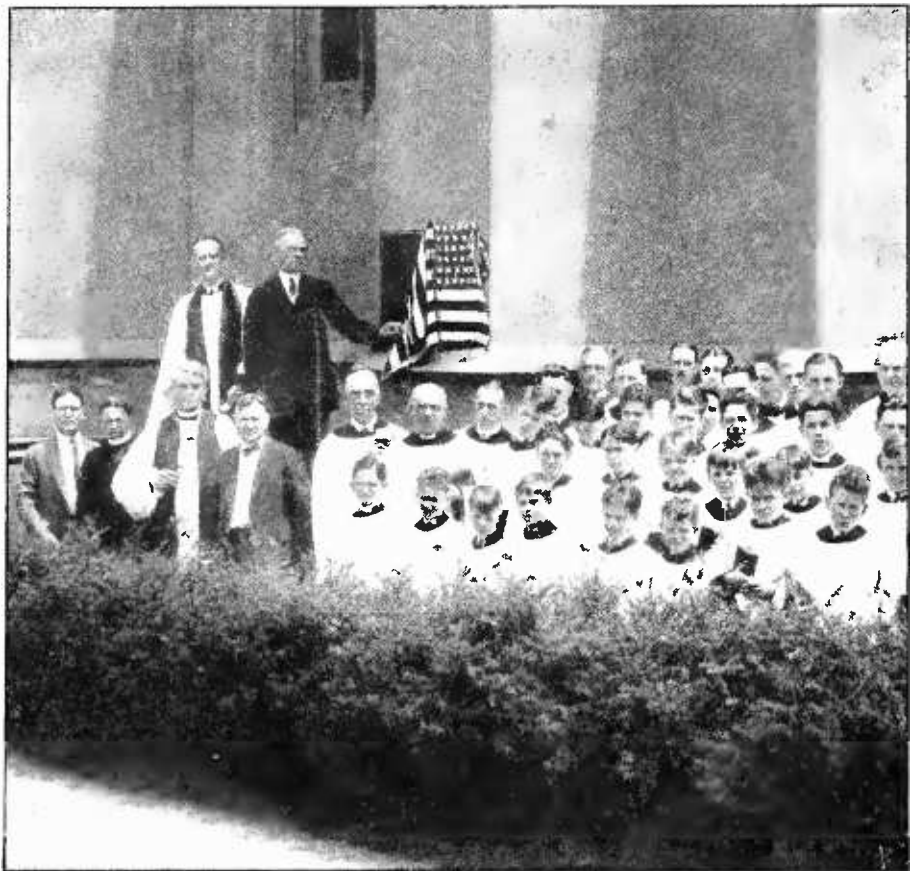

#### THE DEDICATION OF THE RADIO TABLET

Mr. H. P. Davis, Vice-President of the Westinghouse Electric & Manufacturing Company, is standing nearest the tablet. On his right is the Rev. Edwin J. van Etten, pastor of the church, and believed to be the first minister in the world to broadcast a sermon. In front of Dr. van Etten is Bishop Alexander Mann, of the Episcopal Diocese of Pittsburgh, and at Bishop Mann's left is Mr. John Frazier who installs the Westinghouse Company's direct telephone connections for broadcasting outside events

which will undoubtedly be read with great interest in the years to come: "January 2, 1921, from Calvary Church for the first time in history a church service was broadcasted by radio wireless by the Westinghouse Electric & Manufacturing Company. This tablet was placed (1923) by the Unseen Congregation."

The words of H. P. Davis, Vice-President of the Westinghouse Company, made a deep impression on the visible audience, as no doubt they did on the unseen listeners miles away.

"Other cities have memorials, but Pittsburgh is proud to be the first to broadcast by radio to the world her own religious worship," declared Mr. Davis, "Pittsburgh is further proud to have as a citizen Rev. E. J. van Etten, rector of Calvary, the first minister in the world to catch the vision of sending his message out into the highways and byways by radio.

"It is impossible for me to express in words the great good he has done for thousands of people by recognizing and using radio for such



TABLET AT CALVARY CHURCH, PITTSBURGH

More than 4,700 people, scattered all over North America, contributed small amounts toward this memorial

a noble purpose. It has enabled him to reach and to console the sick and the shut-ins all over this continent, without detracting one iota from the excellent work he is doing in his own parish. Mr. van Etten has reached suffering people who have been cut off from church services for years and who never expected to hear church services again. His initiative has made possible this splendid memorial gift from which I have just lifted the American flag, which Calvary always will point to with pride.

"I see in the future constant pilgrimages making way to this spot where we stand to view this tablet and to read these words. You who gather about this church to-night are the first to make that pilgrimage.

"Pittsburgh is proud to be the home of Calvary Church, the first church in the world to extend by radio its services beyond its own parish, into every corner in the country, to an

audience which in numbers, in denominations, and in location never before has been comprehended.

"This testimonial of appreciation has come back to Calvary from the unseen congregation. The bronze tablet, for which contributions have come from more than 40 different states, from five Canadian provinces, from ships at sea, from England, Mexico, Honduras, and Cuba, is placed to commemorate in a prominent and permanent way the pioneering done by Calvary Church of Pittsburgh and Station KDKA in the broadcasting of church services."

Mr. Davis's talk and the singing of one verse of "America" by the surpliced choir and the audience, and Dr. van Etten's brief benediction all were broadcasted via the microphone which stood on a tripod near the speakers. Even the noise of the passing street cars and whirring auto engines could be heard by the radio listeners hundreds of miles away.

Dr. van Etten, who has preached nearly every Sunday to his radio congregation since his first sermon in 1921, declares the radio possibilities for the clergy to do good work are boundless.

"Mission churches without a parson may have the best religious services," he said. "Hospital wards have been equipped. Our parish is doing organized work by wireless. We have several receiving sets. The church home hears our services through one of the sets. The invalids of the parish are enjoying the use of two others. Outside our own parish family, groups all over the country gather at the library table for a wireless Sunday night worship. Thousands can have services who never had the chance before. I feel radio is a wonderful boon to the church."



# All Boy Scouts, Attention!

*RADIO BROADCAST* is holding a contest, ending July 31, 1923, to determine *WHAT BOY SCOUT TROOP HAS DONE OR IS DOING THE MOST WITH RADIO.*

## Prizes for Winning Articles

**FIRST PRIZE: CROSLY MODEL X 4-TUBE RECEIVER.**

*This receiver, which may be used with dry-cell tubes if desired, consists of detector, one stage of tuned radio-frequency and two stages of audio-frequency amplification. (Advertised in RADIO BROADCAST).*

**SECOND PRIZE: MUSIC MASTER LOUD SPEAKER.**

*This is the new loud speaker made by the General Radio Corporation. (A picture and description of it appear in the advertising pages of*

*RADIO BROADCAST).*

**THIRD PRIZE: THREE**

*The WD-11 is the well-known dry-cell tube manufactured for the Radio Corporation. (Filament voltage 1.5, of the third prize may have UV-199's*

*WD-11 VACUUM TUBES.*

*cell tube manufactured for the Radio plate voltage 22½—45). The winner or UV-201-A's if he prefers.*

*A YEAR'S SUBSCRIPTION TO given as prizes for the ten next best*

*These prizes will be awarded to troop may delegate one of its members to*



*"RADIO BROADCAST" will be contributions in this contest.*

*troops, not to individuals, although any prepare the story.*

## Rules of the Contest

1. *Articles must be true accounts of radio with relation to your particular troop: what you have done, or are doing, or both.*
2. *Every article must be written by a Scout or by more than one Scout belonging to one troop.*
3. *Articles should be between 500 and 1000 words long.*
4. *Good photographs to illustrate the article will count 50% in judging contributions.*
5. *Typewritten manuscript, double-spaced, is desired, though not required.*
6. *Address contributions to Scout Contest, Radio Broadcast, Doubleday, Page & Company, Garden City, N. Y.*

*Scouts have done splendid work in maintaining communication by radio in time of floods and disaster, in copying and spreading the market reports transmitted by the government Farm Bureaus, in training themselves along mechanical and electrical lines, and, in short, in using radio as a part of scout work in a way consistent with the best traditions of scouting. What have you to tell of your troop's past or present activities? Get your scribes and photographers under way with that story which will put in a strong bid for first prize. How would a receiver with three stages of amplification go in your troop?*

*The winners will be announced in the September number, and at least one of the three best articles will appear in that issue.*

# Sets for the Great Outdoors

By A. HENRY

This article, prepared for RADIO BROADCAST by a radio man of wide experience should be interesting and helpful to all of you who are contemplating trips into the country this summer or autumn. Mr. Henry has used radio receivers in automobiles and small boats for several years, and his remarks on various types of bought receiving sets and their use may assist you in choosing a good outfit for yourself. A receiver on your vacation will be a source of great pleasure if it is kept in working order, but it will only be an extra package to lug around if it "goes bad."

The author has just returned from a thousand-mile automobile trip and some of the difficulties encountered are still fresh in his mind. He has prepared what we think is a very practical and helpful article.—  
THE EDITOR.

**Y**OUR vacation this year, and your shorter trips into the country, may be made much more enjoyable if you arrange to take a good receiving set with you. Receivers for any kind of use and suited to almost any pocket-book are now available, so that there is no reason why—even though you be in the woods of Maine or the mountains of California—the World Series baseball scores, music, and other entertainment should not come to you in the evening.

With most of us, the cost of a radio receiver is a rather important item, and for this reason it may be well to consider several types, ranging in price from a few dollars to two hundred or more.

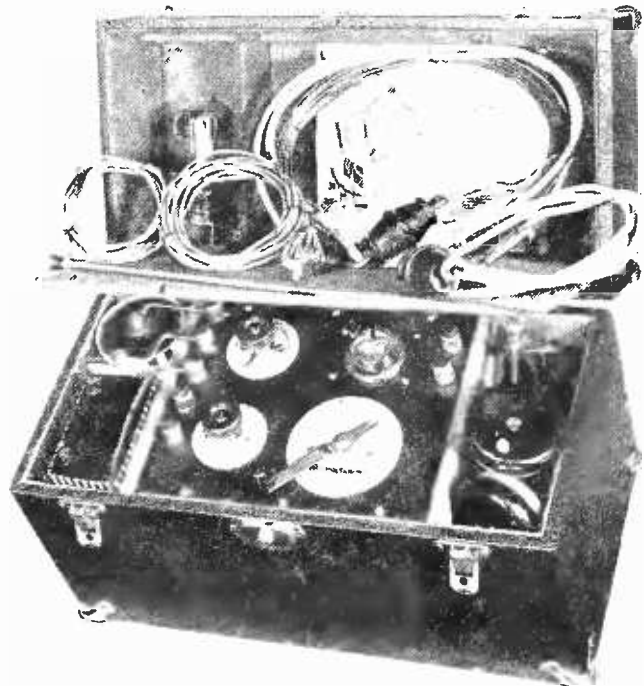

A PLACE FOR EVERYTHING  
Is found in this neat carrying case.  
Interior view of the set shown above



A PORTABLE RECEIVER

That includes everything from the antenna to a spare tube. It was developed by Lyon and Healy, the Chicago music company

The single-tube receivers that have furnished so much enjoyment in your homes during the last few months will serve equally well on a camping or boat trip, provided, of course, there is room enough to erect a single-wire antenna. Where a single tube is used there are only two circuits that will prove satisfactory over any distance. They are the single- or double-circuit regenerative outfits and the single-tube reflex with a crystal detector. There is little need in dwelling upon the use of the home-made receiver, for any one who is ingenious enough to have made and operated one, will have little difficulty in shifting it from the house to the automobile or boat.

Realizing the great demand there would be for portable receivers this summer, some of the commercial companies have developed compact

machines that will work very satisfactorily over comparatively long distances. One receiver of this nature is the "Aeriola Sr.," which is made up with a tube that operates from a single dry cell and one small "B" battery. This receiver, along with a complete antenna equipment, tube, and batteries may be had for \$75. It is quite small and may be tucked away almost any place in the camping outfit and may be set up in a few minutes. A single-wire aerial stretched from a tree to your automobile from 50 to 75 feet and a few feet above the ground should receive at night over distances of five hundred miles.

Another and equally satisfactory portable receiver is the new outfit made by the Colin B. Kennedy Company. Where this outfit is used with dry-cell tubes, it is entirely self-contained with the exception of the antenna. It comes in a cabinet 15" x 7½" x 7" and weighs seventeen pounds. It sells for \$75 with tube, dry batteries, phones, and carrying case.

Another very compact portable receiver designed for use with two tubes, having the A and B batteries right in the carrying case, is known as the Radiola 11. It is manufactured by the General Electric Company and sells without antenna equipment for \$97.50. With this outfit, it is necessary to put up the antenna and make some sort of a ground connection. The necessary equipment for this may be procured for a dollar or so. All the other wiring has been taken care of by the manufacturers.

A fourth outfit, and one which we believe will be found popular during the summer, has been made up by the firm of Lyon & Healy in Chicago. It incorporates a single tube regenerative receiver with the necessary batteries for operating it, a spare vacuum tube, and a complete antenna equip-

ment provided with shackles and ropes which make it possible to erect the antenna in a jiffy. All the equipment is placed in a well made containing case. This outfit sells for the reasonable price of \$100.

Where the antenna and ground connections would be inconvenient, it is possible to use some form of loop receiver. We have secured some very satisfactory results in operating a three-tube De Forest reflex outfit, using telephone receivers. This outfit may be had complete with UV-199 tubes, the necessary adapters, "A" and "B" batteries, and a pair of telephones, for approximately \$162. Where a loud speaker is desired, it is possible to use this De Forest outfit with an antenna from 25 to 50 feet long. No ground connection is necessary. In this



ON TOP OF THE WORLD IN THE CUMBERLAND MOUNTAINS

Louis G. Pacent, the radio manufacturer, C. F. Goudy, Instructor of Mechanical Engineering, Pratt Institute, and the author entertained a few Shriners on their way to the Washington gathering

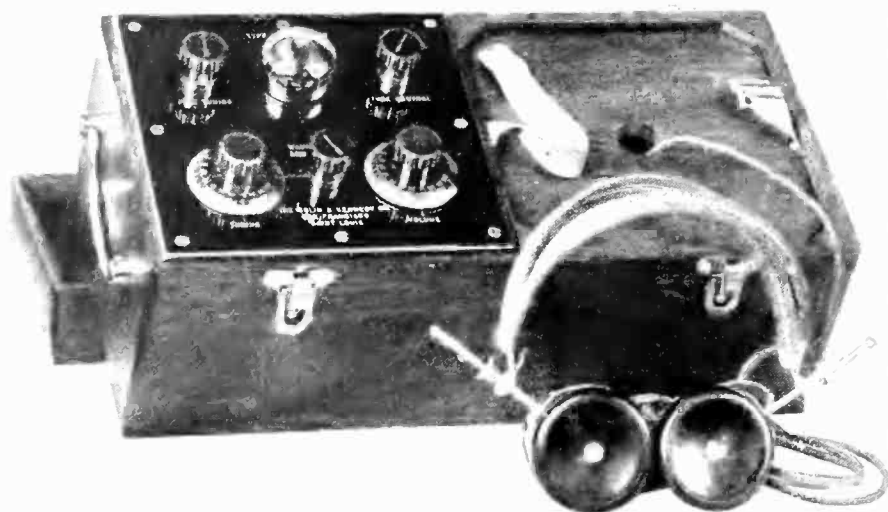

THE COLIN B. KENNEDY PORTABLE

case, however, instead of using UV-199 tubes, the 201-A's are found more satisfactory and may be operated from the automobile or boat storage battery as described a little farther on.

The De Forest four-tube receiver, called the D-10, may be used to operate a loud speaker with UV-199 tubes over comparatively long distances without an antenna, and inasmuch as the A and B batteries may be carried in the lower part of the receiver cabinet, this outfit is very practical for traveling. The necessary equipment, including the loud speaker, a good pair of telephones, and a carrying strap may be had for approximately \$225.

Where it is desired to operate without antenna, ground, or loop, the new four-tube Grebe receiver may be used. In this case, a single wire some twenty feet long, thrown over the top of the car or across the roof of the deckhouse on a boat, will work very satisfactorily and collect energy enough for the operation of a loud speaker over comparatively long distances. Where the auto or boat battery is used, it is already grounded to some part of the motor and the single wire is all that is necessary. It may be run around an auto top or up the mast on a boat.

#### ENTERTAINING A CROWD

**L**OUd speaker operation, as we have considered it so far, is not of the character that will entertain a whole community or supply music with volume enough for dancing in the open. This may be accomplished, however, if any good power amplifier is used. The Western Electric or Magnavox three-tube amplifier, for example, used with UV-201-A tubes operated from a storage battery and one

105-volt B battery and a  $22\frac{1}{2}$ -volt B battery in series will be enough to supply music for the entertainment of rather large audiences.

It is quite likely that most vacationists will find that receivers operated from dry cells will suit their purpose best and there is little use in discussing receivers of this character, for those of standard make are supplied with complete instructions.

But where the automobile or boat storage battery is to be used to light the filaments, a certain amount of care must be

exercised to prevent the filaments being burned out, especially while you are in some place where new vacuum tubes cannot be obtained. In an automobile, plugging in on the storage battery is a simple matter. Most machines are provided with a dash light and the wiring system is made to accommodate either single- or double-contact bayonet-based lamps. By taking the lamp out of your dash socket you can determine the character of wiring in your machine. Having found this out, it is but necessary for you to call upon an automobile accessory store and procure an attachment plug from which a pair of wires may be led to supply the current for operating your filaments. In connecting these attachment plugs, care should be taken to have all the contacts firm. A loose contact will cause a great deal of noise. Before placing the wire in the attachment plug, it is a good plan to solder the end of each wire so as to make it a solid mass rather than a number of strands. By so doing the contact screw in the attachment plug will not cut through the thin wires and there is very much less possibility of a short circuit. The most suitable wire for work of this sort is called

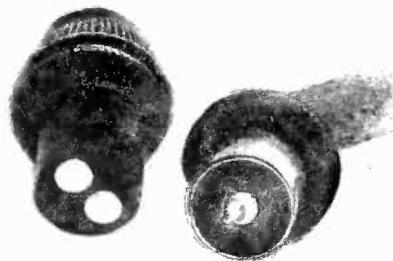

SINGLE OR DOUBLE CONTACT

That's the question when you wish to use your auto storage battery to light your filaments. With one of these little adaptors plugged in your dash socket you can get "juice" in a jiffy



double-conductor Rome super-service cord. Number 16 will be found satisfactory. The wire in this case is entirely rubber-covered and it will stand a great deal of abuse and twisting without breaking. For its entire length throughout the cord, one wire is covered with a cotton material of a different color from the other, making it an easy matter to connect the positive side of the battery where it should be connected.

Another method of using the automobile battery—although not quite so convenient as the plug cord attachment—is using two large clips fastened to the end of the battery leads, which in turn are snapped on to the terminals of the battery. This arrangement, however, makes it necessary to lift the floor boards every time a connection is desired and on the road frequently results in the dirtying of clothes and the possibility of ruining them with the acid deposit found on an automobile battery. Great care should be taken to prevent any possible short circuits. The free ends of the leads from the storage battery should be kept well separated while the attachment plug is in the socket, unless they are connected to binding posts on the receiver.

In the event that ordinary lamp cord is used instead of this cord, the matter of determining the polarity of the storage battery is a com-

paratively simple matter. It is but necessary to stick the leads into a raw potato and it will be found that a greenish deposit will soon appear around the positive lead.

#### DON'T BURN OUT YOUR TUBES

A SAFE method of preserving the filaments is to connect an ordinary 25-watt 110-volt lamp in series with them. Where this is done and the B battery leads happen to touch the A battery terminals, the filaments will not be burned out. This precaution is especially recommended where an attempt is made to operate the receiver from the automobile or boat battery while in motion. As a matter of fact, the use of the set under these circumstances is not recommended.

Some of the little stunts that will be found invaluable on the camping trip are shown in the accompanying illustration. Others will suggest themselves to you as you prepare for your trip. There is one word of caution that I would have you remember, for I believe it will offset the possibility of carrying a receiver that will be out of business when you want most to use it: *be sure that the receiver is packed well.* Do not leave it out until the last minute and then stick it wherever it will go, because the vibration is hard on soldered connections and they are likely to part. The safest place to carry vacuum tubes is in their sockets, but where the receiver is of the cabinet variety some soft paper or cloth should be put in on top of them. This should be removed when the set is in operation.

If you are not the owner of a set at present, in deciding upon the receiver to take with you it is well to remember that when your vacation is over you will want a good receiver in your home and it is well to consider, in purchasing the receiver, the amount of home use you are likely to require from it.

Another thing that will add to the pleasure of your trip is a camera. Photographs of your party entertaining people where radio was previously unknown, for instance, will be a source of pleasure to you, not only now but in the years to come.

#### IT IS WELL TO SOLDER THE ENDS

When flexible cable is used, to prevent the binding screws in the plug from cutting the individual strands



### A CALL BOOK FOR THE AMATEUR

All the active amateur and broadcasting stations in the U. S. and Canada are contained in the fourth edition of the Amateur Radio Call Book, published by the Radio Directory & Publishing Co., 45 Vesey St., New York. A large two-color map, suitable for mounting on cardboard, is an added feature.

# A Practical Super-Heterodyne with 199's

By WALTER VAN B. ROBERTS

Princeton University

**R**ADIO fans all over the country are constantly experimenting with "new hook-ups," and the papers and magazines are full of circuit diagrams. One might think that there were a vast number of really different methods of radio reception. Actually however, there are only a few fundamentally different schemes in use, and all circuits are based on these. For example, out of the fundamental idea of regeneration, there have sprung hundreds of apparently different regenerative receiving circuits. These may differ in ease of adjustment, but, *with the same tube and antenna, any type of regenerative receiver, if properly built, will be exactly as sensitive as any other type.* Hence, if you have a good regenerative receiver and are not satisfied with its sensitivity, there is no use wasting time and money trying other regenerative circuits. Rather, improve the one you have.

Nearly all circuits in use at present are based upon the following fundamentally different schemes for increasing the strength of the signals:

- (1) Regeneration
  - (2) Super-regeneration
  - (3) Radio frequency amplification
  - (4) Super-heterodyne
- } (a) untuned  
} (b) tuned

Without discussing these methods at length, their limitations and drawbacks may be pointed out briefly:

(1) Regenerative circuits, when allowed to oscillate, annoy the neighbors, and the sensitivity obtainable without loss of quality is not great enough for the satisfactory use of a loop antenna.

(2) Super-regenerative circuits are not very selective, and are noisy if the signals are weak.

(3) Untuned radio-frequency amplification

with the present type of tubes is not entirely satisfactory (in the writer's opinion) due principally to unavoidable transformer losses.

Tuned radio-frequency amplification, with regeneration prevented by the "neutrodyne" principle, seems very satisfactory, except that for great sensitivity tuning becomes difficult on account of the large number of circuits that have to be tuned.

(4) The super-heterodyne method seems to have no inherent drawbacks or limitations. To justify

this rather sweeping statement, let us consider briefly the three most important features in any receiving set.

First, sensitivity: here nature, in the form of "static," spark sets and other interfering radio transmitters, imposes a limit to the useful sensitivity of any receiving set. For if the static and other interference coming in on the same wavelengths as the signal are stronger than the signal itself, then no amount of sensitivity will be of any use, for the undesired noises will always be louder than the signals. Thus, there is no sense in possessing a radio receiver that is any more sensitive than enough

## THE ULTIMATE RECEIVER

In this comprehensive article, Mr. Roberts discloses the advantages of the super-heterodyne in which the intermediate-frequency circuit may be either of the untuned- or tuned-transformer variety and in which neutrodyning and reflexing may be employed to advantage.

This is not the receiver for the novice to attempt building, because a certain amount of familiarity with radio-frequency circuits is necessary.

During our recent visit to Princeton University, we inspected and operated, with Mr. Roberts, the completed receiver. To say that it tunes sharply would be putting it mildly, while its ease of operation is remarkable. There is a growing respect for the super-heterodyne, and we shall welcome information from those who experiment with the intermediate-frequency transformers along the lines outlined in this article.—THE EDITOR.

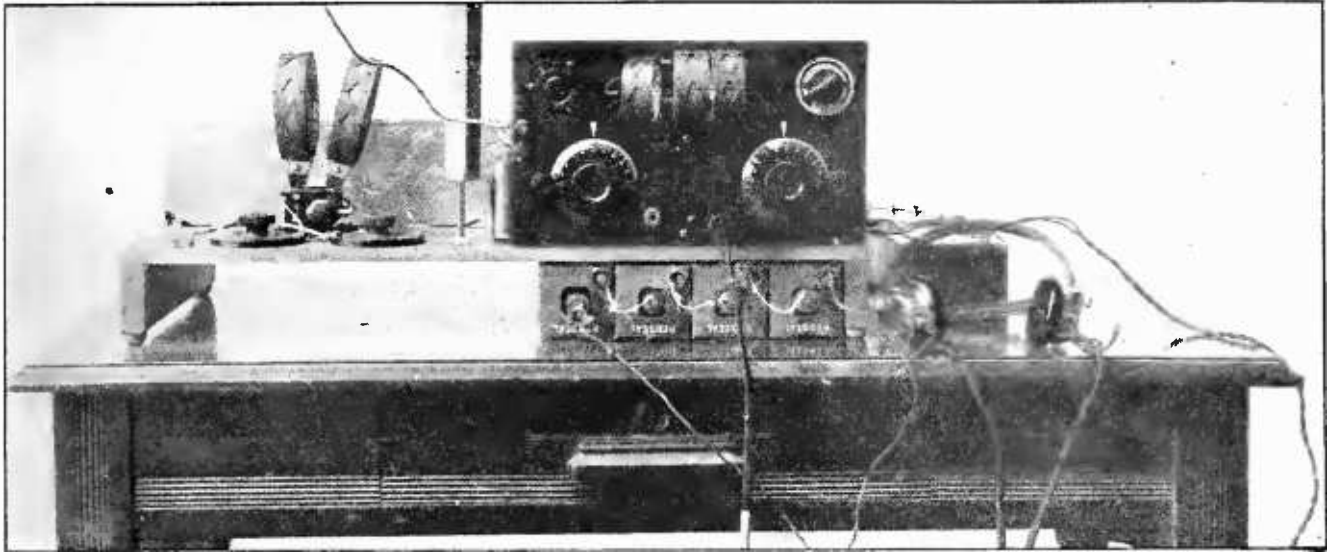

FRONT VIEW OF SUCCESSFUL SIX-TUBE SUPER-HETERODYNE BUILT BY MR. ROBERTS

The set uses two stages of intermediate-frequency amplification coupled by R. C. A. long-wave transformers, and one stage of A. F. amplification. The rheostat in upper left-hand corner of panel controls the volume, the left-hand condenser tunes the loop, and the right-hand condenser tunes the heterodyne

to bring in static and other noises with annoying loudness on the days when the interference is minimum. Any further increase in range will have to be obtained by the use of more power on the part of the transmitting stations.

Second, selectivity: here we have a very much more definite limit. To transmit music of high quality requires not a single frequency or wavelength, but a band of frequencies about 10,000 cycles wide. Thus, a station that advertises a concert "on 600 meters" will really be using all the wavelengths between about 594 and 606 metres, while a station transmitting on 300 metres will use all wavelengths between  $298\frac{1}{2}$  and  $301\frac{1}{2}$ . Hence the receiving set must receive these *bands* of wavelengths. If it is so selective as to receive only a narrower band, the quality of the received music suffers. On the other hand, if it is too "unselective" to eliminate signals on wavelengths outside of the necessary band, then there is just so much more opportunity for interference to get in. The ideal selectivity would be realized, of course, only when all wavelengths lying in the necessary band are received *equally* well and wavelengths outside the band are not received at all.

Third, ease of operation: only two controls should be necessary, one to select the station it is desired to hear, and the other to regulate the volume.

The super-heterodyne system can be made to meet all these requirements. There is very little trouble in getting all the sensitivity that is

desirable for working with a loop antenna. The selectivity can easily be made sufficiently close to the ideal, and by using what are called "band pass filters"<sup>1</sup> it could be made ideal; but this refinement hardly seems worth while. The controls are simple—one knob to control volume and two condensers to tune with. Here again, the ideal could be attained (if thought worth the trouble) by gearing or shafting the two condensers together so that turning a single knob would operate both condensers, the plates being cut to such shape that the relative values of the capacities would always be exactly correct. Or, almost as good, a single knob could turn two ordinary condensers so that they are approximately correct, and a small vernier condenser in parallel with one of them could be used to make the tuning exact after the station is picked up.

Having pointed out that the super-heterodyne method meets the most important requirements of a radio set better than any other

<sup>1</sup>A band-pass filter is an arrangement of capacities and inductances that allows almost uniformly free passage of all frequencies lying in a specified band, but almost completely prevents the passage of currents of any frequency lying outside this band. Band pass filters can be made successfully to pass a band of medium frequencies, but cannot be made to pass a narrow band of very high frequencies such as used in broadcasting. Hence they could not be employed directly in an ordinary receiving set, but if the super-heterodyne method is used, the intermediate-frequency amplification can be made to take place at a frequency sufficiently low so that a band pass filter could be constructed that would make the amplifier satisfy approximately the condition previously mentioned for ideal selectivity.

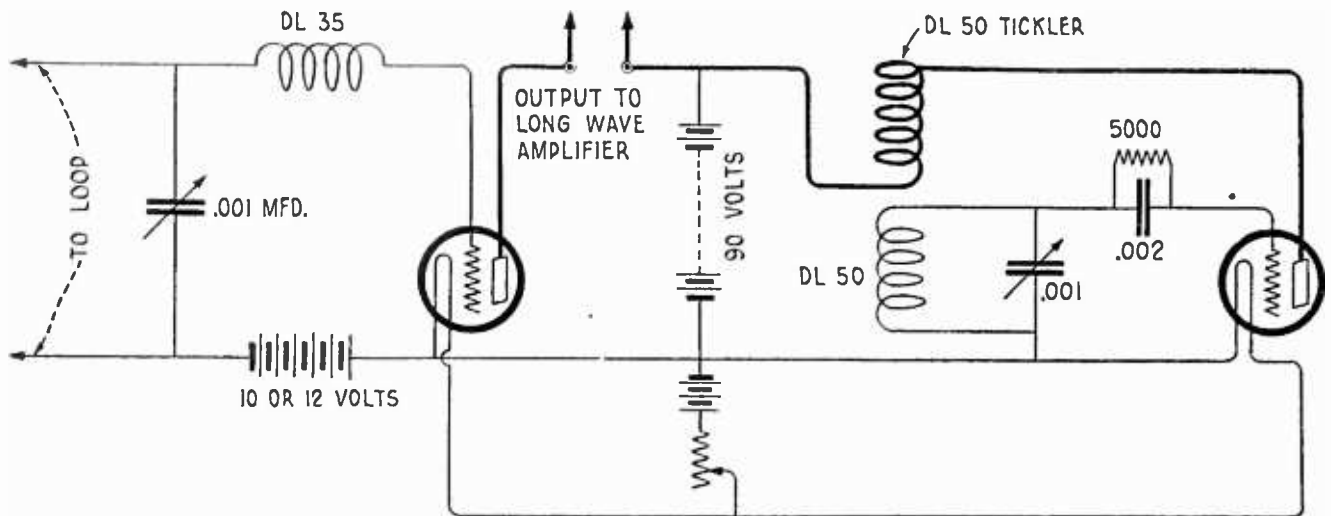

FIG. 1

The frequency changer is used to alter the incoming signals so that they may be put through a radio-frequency amplifier which operates on comparatively long waves

method in use at present, it will be well to describe this method briefly before going on to consider the actual circuits. The fundamental idea is supposed to have resulted from the following train of reasoning: a radio-frequency amplifier is comparatively easy to build for long wavelengths, but extremely difficult to make operate on short waves. But the signals to be received are on short waves. Then why not change the short-wave signals into long-wave signals? If this were done, long-wave radio frequency amplifiers could be used to receive them. Thus a super-heterodyne receiver really consists of two units, a frequency-changer and a long-wave receiving set. These two units are as distinct from one another as an ordinary radio set and the audio-frequency amplifier that is used with it. If you have a satisfactory frequency-changing unit, you can connect it up to any kind of long-wave amplifier and detector, or vice versa. It is to be hoped that in the future, radio apparatus makers will put out a first class long-wave amplifier-detector unit built to receive a fixed band of frequencies about 10,000 cycles wide. The amateur can then buy one of these and make his own frequency-changer to feed it, just as he may now buy a Western Electric 7A audio amplifier and builds his own radio receiver to feed it.

In the meantime, the amateur will have to experiment with his own make of long-wave amplifier, and it is the construction of this that presents the only difficult problem in making a super-heterodyne.

Returning to the frequency changer, its oper-

ation is as follows: if two voltages of different frequencies are simultaneously applied to the grid of a detector tube, then in the plate circuit of the tube will be found a number of currents of different frequencies, among these being a current whose frequency is equal to the *difference* between the two frequencies supplied to the grid.<sup>2</sup> Our frequency changer, then, is a detector tube having two frequencies supplied to it: first, the signal, which is picked up by a loop antenna, and second, a frequency supplied by a separate vacuum-tube oscillator, the "heterodyne," which feeds the detector tube by means of any suitable type of coupling. In the output of the frequency changer there will then be found a frequency which is equal to the difference between the signal frequency and the frequency of the heterodyne oscillator. By adjusting the heterodyne frequency, this difference may be made anything we please. The operation may be illustrated as follows: suppose we have a long-wave amplifier-detector unit that receives only waves of about 3,000 metres,

<sup>2</sup>Assuming that the plate-circuit current of the frequency-changer tube varies as  $(K + \text{grid potential})^2$ , where  $K$  = the "B" battery voltage - the "C" battery voltage times the amplification constant of the tube, then if the incoming radio waves produce a voltage  $i_s \sin st$  upon the grid and the heterodyne oscillator impresses  $i_h \sin ht$  upon the grid at the same time, the plate current will be  $(k + i_s \sin st + i_h \sin ht)^2 = k^2 + i_s^2 \sin^2 st + i_h^2 \sin^2 ht + 2k i_s \sin st + 2k i_h \sin ht - \frac{1}{2} i_s i_h \cos(s+h)t + \frac{1}{2} i_s i_h \cos(s-h)t$ , by expanding and using a simple trigonometric reduction. It is the last term only that we are interested in, for it represents the current having a frequency equal to the difference between the signal and heterodyne frequencies. The coefficient  $\frac{1}{2} i_s i_h$  shows that the strength of this current is directly proportional to the strength of the voltage introduced by the heterodyne oscillator, hence the advantage of making this as great as possible.

which is a frequency of 100 kilocycles. Now suppose a signal is coming in at a wavelength of 400 metres, which is a frequency of 750 kilocycles. If we adjust the heterodyne tube to oscillate at a frequency of 850 kilocycles, then the difference between the heterodyne frequency and the signal frequency is 100 kilocycles, and this is just right to be fed to the long-wave amplifier. On the other hand, if the heterodyne oscillated at 650 cycles, the difference would again be 100 kilocycles. Thus there are always two possible settings for the condenser that adjusts the frequency of the heterodyne oscillator, either of which will bring in the same station. Sometimes it will be found better to use one than the other, but usually it makes no difference.

In building a frequency-changing unit, the chief points are: use as high a "B" battery voltage as available on both the frequency changing tube and the heterodyne; in the grid circuit of the heterodyne oscillator put a grid condenser and leak that will allow the tube to oscillate most strongly (say .002 mfd. or more and 5000-ohm leak); in the grid circuit of the frequency-changing tube put an amount of "C" battery that can best be determined by experiment (if 90 volts of "B" battery are used, 10 or 12 volts of "C" battery will be about right); and, finally, adjust the coupling between the heterodyne oscillator and the frequency-changing tube so as to get plenty of the heterodyne frequency supplied to the frequency-changing tube. Up to a certain point, the more the better, because the output of the frequency-changer tube is proportional to the *product* of the signal and the heterodyne voltages.

Any sort of heterodyne oscillator circuit can

be used, and coupled, in any fashion. One convenient arrangement is the use of a three-coil honeycomb mounting which allows trying different coils and a great range of wavelengths to be received. These three coils are connected as shown in the circuit diagram, Fig. 1. The D. L. 35 and the tickler coils should be the movable ones.

As the only two adjustments in tuning are the two variable condensers here shown, it is well worth while to get the very best condensers for the purpose. The receiver tunes very sharply, and a list of stations with the exact settings of the condensers cannot be kept unless the construction is so rigid that a certain setting always gives the same capacity. For this reason it is inconvenient to use condensers with separate verniers. The General Radio condenser, with a small knob turning the condenser through a reduction gear, is completely satisfactory.

There should be no difficulty in building a good frequency-changing unit, and once made, it can be used without change in connection with any new or improved long-wave amplifier that may later be put on the market or described. The scheme, mentioned earlier in this article, of gearing the two condensers together so as to have only one knob to turn, is not recommended to the average constructor. Nature has given us two hands, and after a little practice it is not difficult to turn the two condensers simultaneously, keeping their relative values about right.

We now come to the more difficult unit to build, the long-wave amplifier. Before taking up the question of the *best* type, a very easy type to make will be described. The reason it

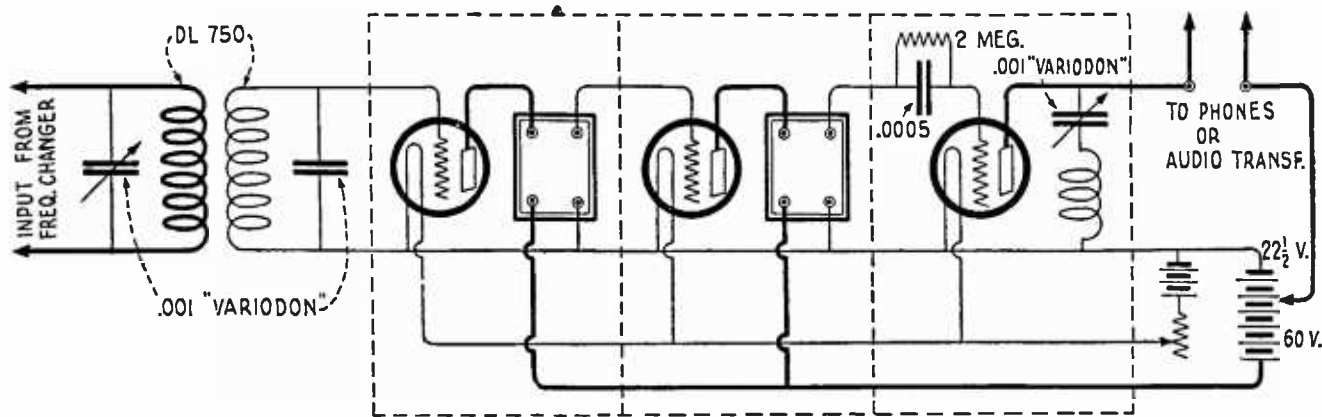
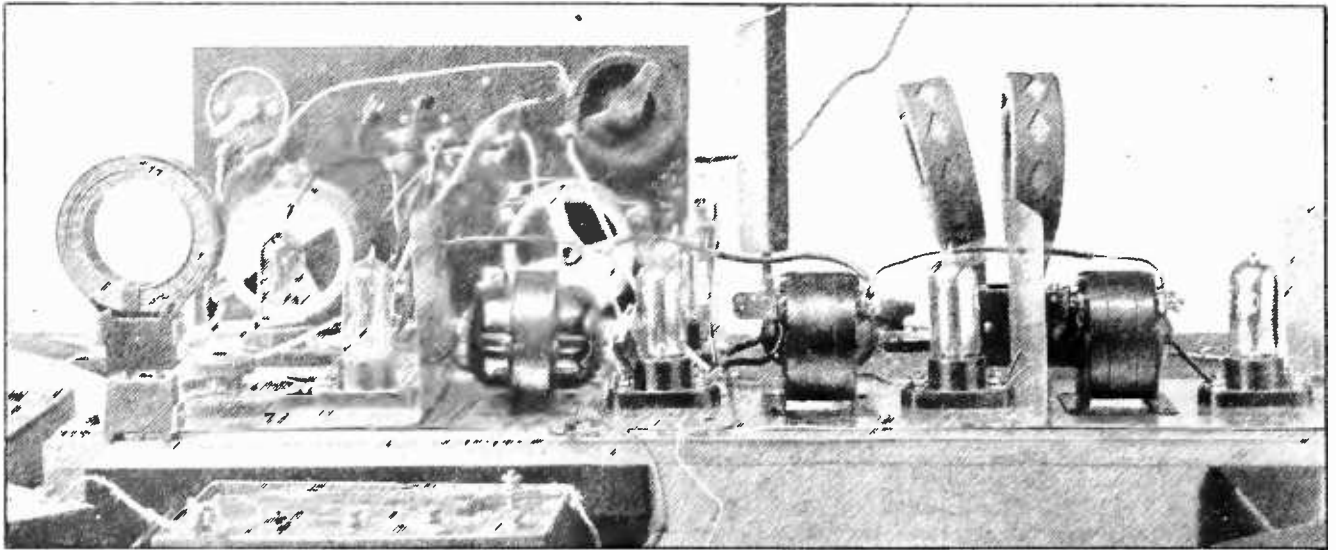

FIG. 2

The intermediate-frequency amplifier is coupled to the frequency changer by two DL750 coils shunted by .001 variable condensers. The amplifier itself is made with UV-1716 transformers and each stage is thoroughly shielded as shown by the dotted lines



REAR VIEW OF THE EXPERIMENTAL SUPER-HETERODYNE SET

The covers that complete the shielding are removed. At the extreme left is the inductance coil for the tuned shunt that by-passes the intermediate-frequency current around the phones. This set runs on four new dry cells and 60 volts B battery, and operates a 10-D loud speaker very nicely for powerful stations up to about fifty miles away

is easy is because the transformers used are the Radio Corporation long-wave transformers and do not require tuning. The only precaution is to put some shielding between stages, preferably having each stage in a metal compartment (which however needs no top on it). In the circuit diagram, Fig. 2, the metal is indicated by the dotted lines and it will be noticed that the grid lead to each tube is as short as possible.

The loose coupling between the D. L. 750 coils gives the selectivity. Once the best tuning and coupling are found, this is never changed. The variable condenser and inductance in the compartment with the detector tube play a very important part in preventing the amplifier from howling. In most receiving sets there is a "by-pass" condenser to shunt the radio-frequency currents around the phones, but unless this capacity is very large, only a portion of the current is shunted. In the case of an amplifier working on a fixed frequency, however, this shunt circuit can be tuned so as to by-pass *all* the radio frequency, so that none of it gets outside the metal compartment and thus cannot get back to the input of the amplifier and cause howling. This device is especially necessary if any reflexing is to be done. An .001 "Variadon" condenser and a D. L. 750 coil will obviously tune to the right frequency, for this is the combination used to tune the input to the amplifier, but it would be better to use the smallest coil that can be tuned by the .001 condenser to the frequency used.

If the amplifier still howls in spite of this

tuned shunt, try reversing the connections to the primary of one of the radio-frequency transformers. Also try tuning the "Variodons" in the input to various frequencies. A setting can usually be found where the oscillations of the amplifier will stop. If not, something is wrong with the wiring, or a bad "B" battery is being used, or the leads to the "B" battery are too long.

#### RESULTS WITH 201-A'S

USING a frequency changer and long-wave receiver having the constants shown, and one stage of audio amplification with 6 volts of "C" battery on the grid of the audio amplifier tube and 90 on the plate, all six tubes being UV-201-A's, very good loud speaker results were obtained. Stations up to 100 miles away were received loudly enough in day time to be heard all over a fair-sized room, using a Western Electric 10-D loud speaker. At night the sensitivity was good enough to allow stations as far west as KHJ and KF1 in California to be heard on the loud speaker (from Princeton, N. J.), and others not so far but of lower power and hence even more difficult to pick up. As a result of the work with this amplifier, it was concluded that with UV-201-A tubes, if everything is made to work its best, two stages of intermediate-frequency amplification is all there is any practical use for. Another stage could, of course, have been put in and the amplification cut down to the desired amount by a device such as will be described later.



## THE UV-199 TUBE

THE receiver just described is well within the ability of the average constructor to duplicate and perhaps improve upon. More experienced radio fans may, however, like to tackle the proposition of making a set to run on dry cells. Assuming that six Radiotron UV-199's are used, they can be arranged in three groups, each group having the filaments in series. Thus only 180 milliamperes will be required and can be supplied by 5 dry cells in series, with a 10-ohm rheostat that can be cut out as the dry cells run down. The heterodyne tube and the frequency-changing tube can have their filaments in series, and the final detector and the first intermediate-frequency tube are also in series. Three stages of radio-frequency amplification are required because the output of the frequency changer as well as the amplification per stage will be less when using 199's than with 201-A's. To get the most out of the tubes, a stage of audio can be added by reflexing back to one of the radio-frequency amplifier tubes. To get the most out of each stage of radio-frequency amplifier tubes, transformers should be used that match the impedance of the 199 tube, and at the same time supply the necessary selectivity. Four tuned transformers will give too great an overall selectivity for good quality if very long waves are used, so that it is better to use a fairly high intermediate frequency, and this in turn will probably render necessary the use of the "neutrodyne" system for the prevention of regeneration due to the internal capacity of the tubes. This is in addition to shielding each stage as well as possible by putting each in a separate metal compart-

ment. Finally, the loudness of the signals can be controlled by a rheostat of about 50 ohms in series with the filaments of either pair of tubes in the intermediate-frequency unit. If the audio current is reflexed back to the first tube in this unit, then the above mentioned rheostat should control the filament currents in the second and third tubes, while if the audio is reflexed back through the second or third tubes, the rheostat should control the filament current through the first tube and detector. Thus the tube doing the audio-frequency amplifying will always have its filament current up to normal, and the quality will not be affected by cutting in the control resistance. The advantage of reflexing back to the first tube is that it is the one least "loaded" by the high frequency, while the disadvantage is that any feed-back is more likely to make the amplifier regenerate or oscillate. It is of course possible to obtain two stages of audio amplification by the "inverse duplex" arrangement, but even if the difficulty of keeping the amplifier stable is overcome, the quality is likely to suffer, and one stage is sufficient when working with the head set.

A receiver built upon the foregoing plan (see Fig. 3 and photos) was built by the author at Princeton and has been used for a week or so with very good results. Although June is not a very good month for long-distance work, Chicago stations are heard regularly at night, and several other fairly distant ones have been heard, notably 6KW in Cuba, a low-powered set. The operation of the set is a pleasure. The two condensers have to be set just right, and if both of them are moved even a degree or so, loud local stations drop out of hearing

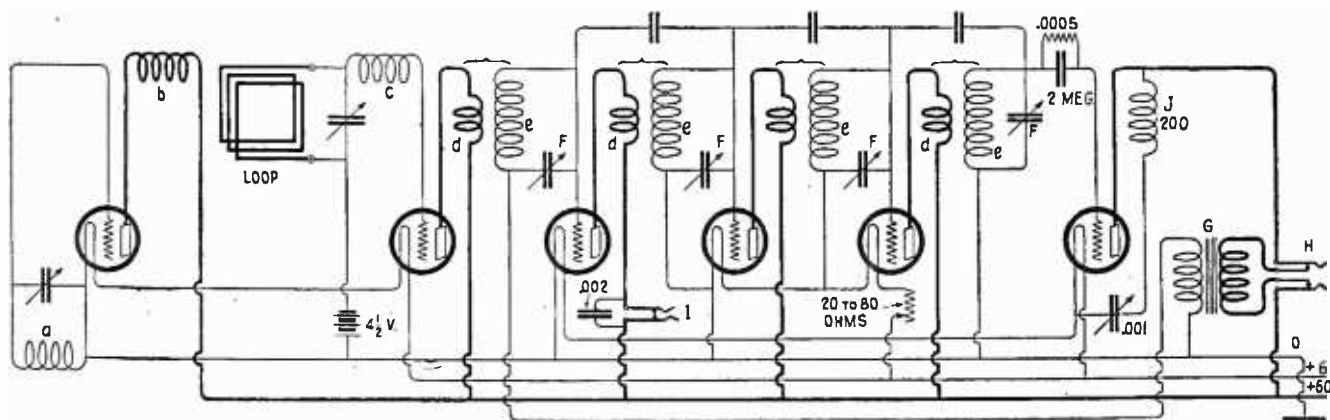

FIG. 3

The circuit diagram for the complete receiver built and used by Mr. Roberts. a and b = DL50 coils; c = DL35; d = 70-turn coil of 32 D.C.C. wire on the tube inside e; e = DL250; F = Variodons; G = audio transformer; H = closed-circuit jack; I = open-circuit jack; J = DL200

completely. The amplifier is very stable, whether one is listening in on the detector or with the stage of audio amplification, and the 80-ohm rheostat controls the volume perfectly. However, the sensitivity can probably be much improved by perfecting the design of the R. F. transformers. The ones in use at present have a secondary consisting of a 250 D. L. coil tuned by an .0004 Variadon. The primary is about 70 turns of 32 D. C. C. wire wound on a cardboard mailing tube of such size that the primary fits snugly inside the D. L. 250 coil. The connections are such that current entering the primary from the plate circulates in a direction opposite to that of current entering the secondary from the grid. This is necessary to "neutrodyne." This design was the only one tried, and probably can be considerably improved. In putting the set in operation, the steps are as follows: start with all the neutrodyne capacities obviously too great—using, say, pennies about  $\frac{1}{4}$  inch apart. Set all the secondary condensers to the same values. Listen in on the detector and pick up some loud local station. Then leaving the two condensers in the frequency changer, alone, go over all the condensers in the intermediate-frequency amplifier and get the best setting for each. Then reduce the neutrodyne

capacities to a point just above regeneration (with 190 tubes no neutrodyne capacity at all is absolutely necessary for the lower frequencies). Finally, plug into the audio-amplifier output and adjust the tuning of the shunt between the detector plate and filament so that there is no tendency for the set to oscillate. The set should now be working satisfactorily. After using it a few days so as to know about how sensitive it is, try using a different intermediate frequency by changing all the condensers across the transformer secondaries in that circuit and going through the same process. In this fashion the best frequency to work at will be found. There will probably not be a great deal of difference.

The foregoing hints have been given in a rather sketchy fashion because it is assumed that any one competent to improve upon the transformers will not require a more detailed description. After further experiments which he intends to make, if the writer hits upon a transformer design that completely satisfies him, an exact description of it will be given; so that any one with good mechanical ability will be able to build himself this six-tube dry-cell receiver that has all the advantages of the super-heterodyne control, the neutrodyne type amplifier, and the "reflex" system, rolled into one.

## A New Regenerative Radio-Frequency Combination

By ROGER A. WEAVER

**W**HILE experimenting with regenerative receivers for operation on ground circuits, a broadcast fan developed a circuit with remarkable possibilities. One of the original models of the apparatus was made in the office of the editor of RADIO BROADCAST, and in initial tests, signals were received from Calgary, Alberta, without any antenna and using a steam pipe ground system for intercepting the ether waves.

During the remainder of the summer, Mr. Wagner and Mr. Lynch carried on extensive experimental work, constructing various models of receivers. In the fall of 1922, Mr. A. H. Grebe became interested in these experiments

and shortly after that time Mr. Wagner joined the engineering staff of A. H. Grebe & Co., Inc., for the purpose of developing the new receiver.

After some months of experimenting, a receiver was built fulfilling every requirement for long range, adaptability, and simplicity of operation.

As may be seen from the accompanying illustrations, the receiver is entirely self-contained, except for the loud speaker, and a 20-ft length of silk-covered wire which is used for the aerial. This wire may be concealed beneath the carpet or run along the picture molding. There are separate rheostat controls for each tube, and switches are provided for



## When you build your own

**H**ALF the fun of radio is in building your own set, as every amateur who has made one knows. And when you buy a panel, of course you want the best. You can construct a neat, attractive set that looks like a professional job when you use Celoron Radio Panels.

Celoron panels are handsomely finished, are easy to machine, and will engrave evenly without feathering. The high dielectric strength, uniformity, and superior insulating qualities of Celoron make it the ideal material for radio panels.

### *Buy them ready-cut*

Celoron Radio Panels come ready-cut in standard sizes. Each panel is wrapped separately in glassine paper.

Ask your radio dealer for one of the following standard sizes:

- |                           |                            |
|---------------------------|----------------------------|
| 1.—6 x 7 x $\frac{1}{8}$  | 4.—7 x 18 x $\frac{3}{8}$  |
| 2.—7 x 9 x $\frac{1}{8}$  | 5.—9 x 14 x $\frac{3}{8}$  |
| 3.—7 x 12 x $\frac{1}{8}$ | 6.—7 x 21 x $\frac{3}{8}$  |
|                           | 7.—12 x 14 x $\frac{3}{8}$ |

If your dealer has not yet stocked these panels, get him to order for you; or write direct to us, designating by number the size you want. Celoron is also made in full-size sheets, and we can furnish panels in any sizes desired.

### *This booklet free*

Our booklet, "Tuning in on a New World," contains a list of the leading broadcasting stations in the United States and Canada, several efficient hook-ups, and an explanation of the symbols used in radio diagrams. This booklet will be sent free on request. Just drop us a line.

## Diamond State Fibre Company

BRIDGEPORT

(near Philadelphia)

PENNSYLVANIA

Offices in Principal Cities

In Canada: Diamond State Fibre Co. of Canada, Limited, 245 Carlaw Ave., Toronto

**To radio dealers:**

Celoron Radio Panels cut in standard sizes offer an exceptional opportunity for quick sales and substantial profit. Write for special dealer price list showing standard assortments.

★ CONDENSITE  
**CELORON**  
 STANDARD RADIO PANEL

★ Tested and approved by RADIO BROADCAST ★



changing the rheostat range from either 0-5 or 0-50 ohms. This permits the use of any desired combination of tubes, from UV-199, which consumes but 60 milliamperes to the 201's which may draw as high as one ampere. Of course, it is expected that the receiver will be used with dry-battery tubes, and compartments have been provided for both filament and plate batteries.

An operating switch located on the lower right corner of the panel controls the filament and output circuits in such a manner that when this switch is pulled all the way out, all four tubes are lighted, and when the switch is pulled but half way out only three tubes are lighted. With the switch in the latter condition, the set may be used with head telephones for dis-

tant reception, or with a loud speaker for local reception. An "Aerial Switch," located at the extreme left of the panel, controls a set of small mica condensers which are necessary to provide for the variation in wavelength range incident to the use of the set in various locations. Under all circumstances, it is possible by means of this switch to tune in the complete wavelength range of 200 to 600 meters. For the direct control of wavelength, two dials with the usual Grebe tangent wheel verniers are used. One of these, the "Secondary Wavelength Dial," is calibrated directly in wavelengths, thus facilitating speed and accuracy in tuning to distant stations of known wavelength but low audibility. Tuning of the primary circuit is ac-

complished with a similar dial, while the control of regeneration is effected through the movement of the small tangent wheel centrally located between the wavelength dials.

A feature well worthy of mention is the manner in which two or more of these receivers operate in close proximity of one another. Three of these receivers were installed in one room, and operated simultaneously without any material effect of reradiation being noticeable. For example, it was possible to tune in one set to WEA, and then proceed to tune the second and third sets to the same wavelength without causing a disturbance,

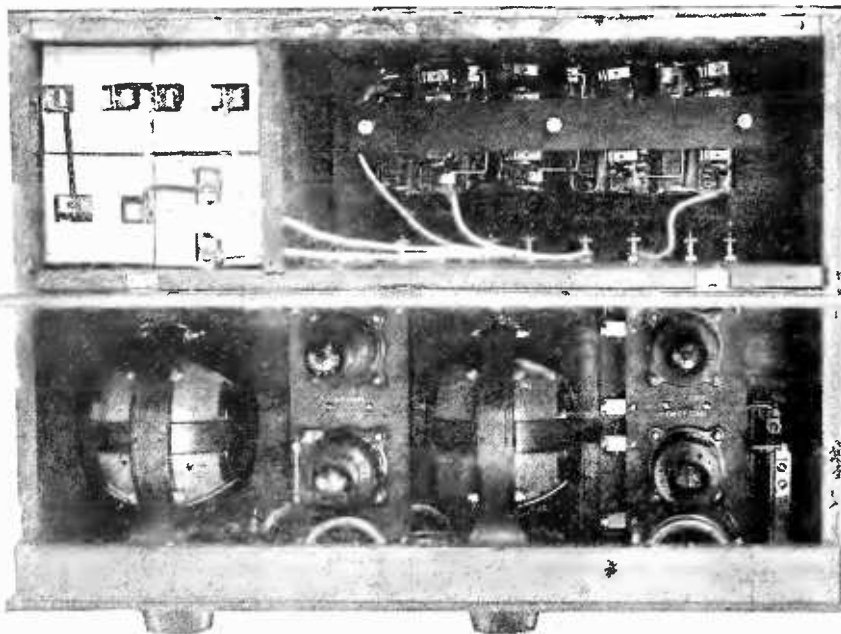



THE man who purchases a Magnavox for its *clearness* of reproduction, finds additional advantages in its use which contribute greatly to his enjoyment of Radio.

For instance, due to its extreme sensitivity, the Magnavox can reproduce distant signals which to ordinary reproducers would be indistinguishable. Ask your dealer for a demonstration.

Magnavox R2 Reproducer and 2 stage Power Amplifier (as illustrated) \$115.00

R2 Magnavox Reproducer with 18-inch horn: the utmost in amplifying power; requires only .6 of an ampere for the field . . . . . \$60.00

R3 Magnavox Reproducer with 14-inch curvex horn: ideal for homes, offices, etc. . . . . \$35.00

Model C Magnavox Power Amplifier insures getting the largest possible power input for your Magnavox Reproducer  
2 stage \$55.00  
3 stage 75.00

*Magnavox Products can be had from good dealers everywhere. Write for new booklet.*

**THE MAGNAVOX COMPANY**  
Oakland, California  
New York Office: 370 Seventh Avenue

# MAGNAVOX PRODUCTS

No Radio Receiving Set is complete without them



8-R

★ Tested and approved by RADIO BROADCAST ★





# Out of Door's with a Portable Radiola

## RADIOLA II

Take it along—up to the mountains—out to the beach. On every auto trip and every camping trip.

Throw an insulated wire over a tree. That's all the antenna you need. Attach a ground wire to a bit of pipe in the earth, or a house pipe indoors. That's all the installation you need.

When it's home, the portable Radiola is a fine piece of furniture, of rich mahogany finish. When it's out-o'-doors, it's an easy-to-carry set, with a handle to carry it by, and all its batteries tucked away inside it. Two tubes give it power to hear over long distances—or to operate on a loud speaker over short distances.



**RADIOLA II** with two Radiotrons UV-199, all batteries and pair of head phones: \$97.50.

*This symbol of quality is your protection*



*"There's a Radiola for every purse"*

At the nearest Radio or Electrical Store

**Radio Corporation of America**



*Sales Department*  
233 Broadway, New York  
*District Sales Offices*  
10 So. LaSalle St., Chicago, Ill.  
433 California St., San Francisco, Cal.

# Radiola

REG. U. S. PAT. OFF.



Radio Corporation of America  
Dept. 2066 (address nearest office listed)

Please send me your free Radio Booklet describing sets from \$25 to \$350.

Name

Street Address

City  R. F. D.

State

★ Tested and approved by RADIO BROADCAST ★

## Radio Broadcast

station and they tune in, it causes a lot of noise and lessens the strength of my signals. Our aerials are about twenty feet apart. Theirs is a two-wire antenna, 125 feet long, while mine is a single-strand, 160 feet long, strung about five feet lower than theirs.

*Is there any way of overcoming this interference?*

K. B. WILKES-BARRE, PA.

JUDGING from the results, the probability is that the two stations in question are using single-circuit regenerative sets, and the above is a fair example of the difficulties to which the too general adoption of apparatus of this type has given rise. Though the antennas in this case are unusually close together, the same condition is found in many congested radio districts.

The noise is doubtless a heterodyne caused by the interaction of the individual oscillations set up in each antenna during the process of tuning, or the conjunction of one or both with the broadcasting wave.

The undesirable effects can doubtless be greatly reduced by running the two aerials at right angles to each other. However, as it is almost impossible to tune a single-circuit receiver without throwing it into an oscillating state, the disturbances can be totally eliminated only by a complete change in equipment at both stations. RADIO BROADCAST recommends a receiver of the primary, secondary, and tickler type operated with loose coupling, or a variocoupler and twin-variometer regenerator. These receivers radiate comparatively weak oscillations, and are more selective than the single-circuit sets.

## Supplemental List of Broadcasting Stations in the United States

LICENSED FROM MAY 18 TO JUNE 15 INCLUSIVE

| CALL SIGNAL | STATION   | FREQUENCY<br>(Kilocycles) | WAVE-LENGTH |
|-------------|---|---------------------------|-------------|
| KFHP        | Radio-Bug Products Co., Kearney, Nebr.                | 1220                      | 246         |
| KFHQ        | Curtis Bros. Hardware Store, Los Gatos, Calif.        | 1240                      | 242         |
| KFHS        | Dow, Clifford J., Lihue, Hawaii                       | 1090                      | 275         |
| KFIJ        | Sidney I. Thorean, Platte, S. Dak.                    | 1270                      | 236         |
| KFIK        | Gladbrook Electrical Co., Gladbrook, Iowa             | 1280                      | 234         |
| KFIL        | Windisch Elect. Farm Equipt. Co., Louisburg, Kansas   | 1280                      | 234         |
| KFIO        | North Central High School, Spokane, Wash.             | 1190                      | 252         |
| KFJA        | Central Power Co., Grand Island, Neb.                 | 1230                      | 244         |
| KFJB        | Marshall Elect. Co., Marshalltown, Iowa               | 1210                      | 248         |
| KFJD        | Weld County Printing & Publishing Co., Greeley, Colo. | 1270                      | 236         |
| KFKA        | Colorado State Teachers College, Greeley, Colo.       | 1210                      | 248         |
| KFKH        | Denver Park & Amusement Co., Lakeside, Colo.          | 1330                      | 226         |
| KFLE        | National Educational Service, Denver, Colo.           | 1120                      | 268         |
| WABI        | Bangor Railway & Electric Co., Bangor Me.             | 1250                      | 240         |
| WABJ        | The Radio Laboratories, South Bend, Ind.              | 1250                      | 240         |
| WABK        | First Baptist Church, Worcester, Mass.                | 1190                      | 252         |
| WABL        | Connecticut Agri. College, Storrs, Conn.              | 1060                      | 283         |
| WABM        | Doherty, F. E., Saginaw, Mich.                        | 1180                      | 254         |
| WABO        | Grover, Waldo C., La Crosse, Wis.                     | 1280                      | 234         |
| WABW        | Lake Avenue Baptist Church, Rochester, N. Y.          | 1190                      | 252         |
| WCBA        | Charles W. Heimbach, Allentown, Pa.                   | 1070                      | 280         |
| WBBD        | Barbey Battery Service, Reading, Pa.                  | 1280                      | 234         |
| WCBD        | Voliva, Wilber Glenn, Zion, Ill.                      | 870                       | 345         |
| WDBC        | Kirk Johnson & Co., Inc., Lancaster, Pa.              | 1160                      | 258         |
| WDBF        | Phillips, Robert G., Youngstown, Ohio                 | 1150                      | 261         |
| WJY         | Radio Corporation of America, New York, N. Y.         | 740                       | 405         |
| WJZ         | Radio Corporation of America, New York, N. Y.         | 660                       | 455         |
| WRAW        | Good, Horace D., Reading, Pa.                         | 1260                      | 238         |
| WRAX        | Flexon's Garage, Gloucester City, N. J.               | 1120                      | 268         |
| WSAD        | J. A. Foster Co., Providence, R. I.                   | 1150                      | 261         |
| WTAG        | Kern Music Co., Providence, R. I.                     | 1160                      | 258         |
| WTAK        | Swan-Bower Co., The, Steubenville, Ohio.              | 1130                      | 266         |

### DELETIONS FROM MAY 1 TO MAY 30

|      |                       |      |                      |
|------|-----------------------|------|----------------------|
| KDN  | San Francisco, Calif. | WAAQ | Greenwich, Conn.     |
| KDZH | Fresno, Calif.        | WAAS | Decatur, Ga.         |
| KFAZ | Reedley, Calif.       | WDAC | Springfield, Ill.    |
| KFCQ | Casper, Wyo.          | WEAT | Tampa, Fla.          |
| KFGF | Mount Vernon, Wash.   | WFAU | Boston, Mass.        |
| KFGM | Abilene, Tex.         | WGAD | Ensenada, P. R.      |
| KFHC | Norman, Okla.         | WGAH | New Haven, Conn.     |
| KFV  | Yakima, Wash.         | WGAJ | Shenandoah, Iowa     |
| KLB  | Pasadena, Calif.      | WHAR | Atlantic City, N. J. |
| KQY  | Portland, Oreg.       | WJZ  | Newark, N. J.        |
| KYI  | Bakersfield, Calif.   | WPA  | Fort Worth, Tex.     |
| KYJ  | Los Angeles, Calif.   | WPM  | Washington, D. C.    |
| WAAJ | Boston, Mass.         | WWAJ | Columbus, Ohio.      |