

Popular Radio

Edited by **KENDALL BANNING**



* **JANUARY**
1925

In this Issue —
**How to Build an 8-Tube
Super-Heterodyne-Reflex
Receiver**



Radiotron
WD-11.
The ideal dry
cell tube.



Radiotron
WD-12.
The standard
base dry cell
tube.



Get a good detector

Radiotrons WD-11 and WD-12 are the same tube but with different bases.

Radiotron WD-12 has a standard navy-type base. With it, you can change your set to dry battery operation. Ask your dealer today.



This symbol of
quality is your
protection

What will Radiotron WD-11 and WD-12 do as detectors? First—they are sensitive to weak signals—superlatively sensitive, as remarkable distance performances show in thousands of one-tube sets. Second, they are good “oscillators”—and that is important in regenerative circuits. And third, they are quiet in operation—add no electrical noises to the music, or speech. Radiotrons WD-11 and WD-12 are famous as audio and radio frequency amplifiers—too—and have made possible the hundreds of thousands of dry battery receivers that are in use today. They mean clear, true reception—over big distances—with dry batteries! Be sure to get a genuine Radiotron.

Radio Corporation of America

Sales Offices: Suite No. 41

233 Broadway, New York

10 So. La Salle St., Chicago, Ill.

28 Geary St., San Francisco, Cal.

Radiotron

REG. U. S. PAT. OFF.



Oh Boy—what fun! Big fights, sports, real music, talks crammed full of interest. All yours by radio —with a *Matched Tone* Headset!

The *Matched Tone* makes both ears hear the same sound at the same instant. It gives you every syllable—clear, lifelike, vividly real. Get the world's fun —and get it all—with a Brandes.

Brandes



Superior Matched Tone Headset \$6
\$7 in Canada



Table-Talker \$10.
50¢ extra west of the Rockies
In Canada \$12.00



Navy Type Matched Tone Headset \$8
\$9 in Canada

The name to know in Radio

Copyrighted by O. Brandes Inc., 1925

All apparatus advertised in this magazine has been tested and approved by POPULAR RADIO LABORATORY

POPULAR RADIO

EDITED by KENDALL BANNING



CONTENTS for JANUARY, 1925

(Cover design by Frank B. Masters)

VOLUME VII

NUMBER 1

Carrier Rays that Kill	FRONTISPIECE
Religion's Raid on Radio	<i>Armstrong Perry</i> Page 3
1,000 Printed Words a Minute by Radio	<i>Charles A. Herndon</i> 11
Electrons in the Stars	<i>E. E. Free</i> 16
How to Improve Broadcast Reception	<i>John V. L. Hogan</i> 23
IV: Noises that Come in With the Waves	
Simple "How-to-Build" Articles for Beginners	<i>Laurence M. Cockaday</i> 31
No. 5: How to Build a Single-tube Tuned-plate Receiver	
The Men Who Made Radio	34
Second Installment	
How to Build an 8-tube Superheterodyne Reflex Receiver	<i>Laurence M. Cockaday</i> 36
How to Get Started in Radio	<i>Alfred P. Lane</i> 51
The Proper Rating for Inductive Instruments	<i>Oliver Lodge</i> 56
Article No. 11	
A Measurement Chart for the Simple Calculation of Combined Resistance	<i>Raoul J. Hoffman</i> 58
Inductance Coils	<i>E. L. Hall</i> 60
A College Certificate by Radio	<i>Sam Pickard</i> 67
"By Their Fists Ye Shall Know Them"	<i>Earl Dana</i> 71
DEPARTMENTS	
What Readers Ask	<i>Laurence M. Cockaday</i> 74
In the World's Laboratories	<i>E. E. Free</i> 80
What's New in Radio Apparatus	<i>Technical Editor</i> 88
"Trouble Shooting"	<i>S. Gordon Taylor</i> 92
Broadcasts	<i>David Lay</i> 95
Listening In	<i>Kendall Banning</i> 99
Hints for Amateurs	<i>Albert G. Craig</i> 103
Facts You Hunt For	<i>Richard Lord</i> 105

VOLUME VII

JANUARY, 1925

NUMBER 1

Published monthly by Popular Radio, Inc., 627 West 43rd St., New York, N. Y., telephone number Chickering 1906; E. R. Crowe, President; Kendall Banning, Vice-President; H. C. Bodman, Secretary; Douglas H. Cooke, Treasurer; Joseph T. Cooney, Asst. Treasurer. Price 25 cents a copy; subscription \$3.00 a year in the U. S., Canada and all countries within the domestic postal zone; elsewhere \$3.50 a year, payable in advance. The International News Company, Ltd., No. 5 Bream's Bldg., London, E. C. 4, sole distributors in England. Entered as second class matter April 7, 1922, at the Post Office at New York, N. Y., under the act of March 3, 1879. Copyright, 1925, and title registered as a trade-mark by Popular Radio, Inc. Copyright in Great Britain by Popular Radio, Inc., 6 Henrietta St., Covent Garden, W. C., London, England.

Printed in U. S. A.
LAURENCE M. COCKADAY, Technical Editor

E. E. FREE, Ph.D., Contributing Editor

JOHN V. L. HOGAN, Contributing Editor

For advertising rates address

E. R. CROWE & COMPANY, INC.

New York: 25 Vanderbilt Avenue

Chicago: 225 North Michigan Avenue

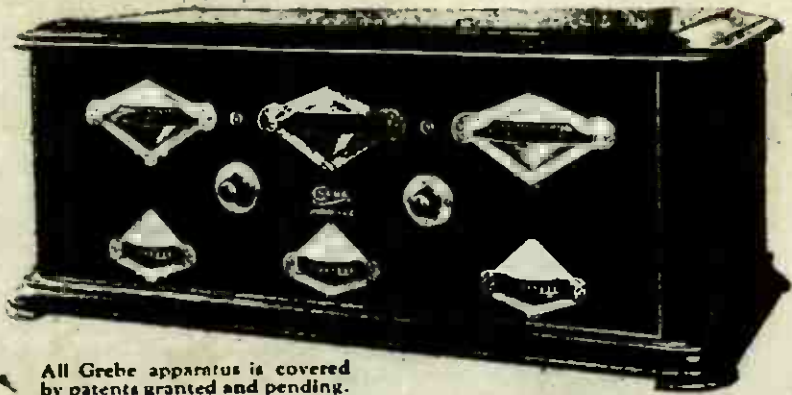

All Grebe apparatus is covered by patents granted and pending.

The GREBE

"By many words wit is exhausted."

— Lao Tzu

The Synchronphase needs no extravagant claims.

Doctor Tzu

SYNCHROPHASE

TRADE MARK

A BROADCAST Receiver that marks a step forward in radio design which will stand as a challenge to the industry for a long time to come. Its surpassing craftsmanship is equalled only by its easy, dependable operation.

Greater sensitivity has been gained through two stages of *Balanced* tuned radio frequency—the result of many months of intensive research by the Grebe engineering staff. Extreme selectivity has been obtained by the use of *Binocular* coils.

The settings for the various broadcast stations are equally spaced over the dials. This is accomplished by S-L-F (straight line frequency) condensers.

A new type of volume control gives an unbroken range of six variations of audio amplification.

Write for literature

A. H. GREBE & COMPANY, INC.

Van Wyck Blvd., Richmond Hill, N.Y.

Western Branch: 443 So. San Pedro St., Los Angeles, Cal.

This Company owns and operates Station WAHQ.

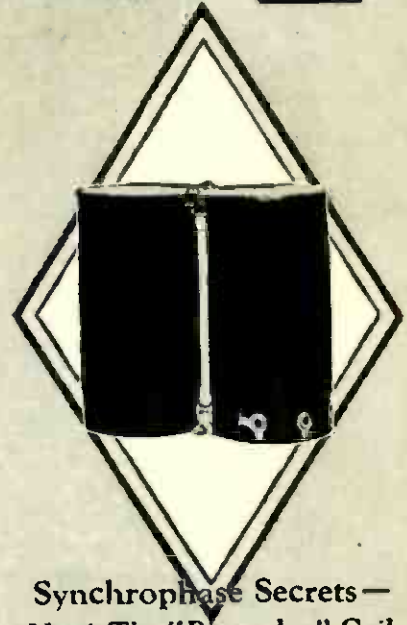

Synchronphase Secrets —
No. 1 The "Binocular" Coil

A truly fieldless coil with which the detector and radio stages are tuned. Unaffected by impulses from undesired local stations, its use is a tremendous factor in the success of the Synchronphase.



TRADE MARK
REG. U. S. PAT. OFF.

PAGES WITH THE EDITOR

THE difficulty in getting reliable vacuum tubes confronts practically all broadcast listeners; for that reason the following letter from Mr. H. M. Noyes of West Orange, N. J., is not only pertinent but of widespread interest. He writes:

* * *

"WHY not give a little publicity to the tube situation? Even if the purchaser asks for a 'genuine R. C. A. Radiotron,' as suggested in advertisements, the results obtained in too large a percentage of cases are far from 100 percent perfect. It appears to be only a matter of luck whether the purchaser gets a good tube. The so-called testing apparatus in use at most retail stores, with which the sellers are fortifying themselves against complaint, furnishes (according to my experience) a very incomplete test, if it can be truthfully claimed that it is really a test of operating efficiency at all.

* * *

"It seems to me no more than fair that the purchaser of a tube should be guaranteed that it will give perfect results in a set, and that he should not be asked to be satisfied with anything less. No set is any better than its tubes. A great many tubes sold today as perfect would give even the finest superheterodyne a black eye."

* * *

MR. NOYES hits upon a live subject—the substitution of imitation products for the genuine. This practice is the source of endless trouble to everyone concerned.

* * *

It is characteristic of the so-called "bootleg" tubes that picked specimens perform very well for a few days. But the average tube is poor and all of them lose their sensitiveness after a few hours of use.

* * *

"I HAVE never yet found an imitation of a standard vacuum tube that would stand up," one of the foremost radio experts tells the Editor, "and unless you are pretty sure of the product, I do not think that radio fans should purchase these. And the product of the 'exchanges' that profess to repair tubes is, so far as my experience goes, as bad or worse."

* * *

THE immediate solution of the difficulty lies in not merely demanding but getting the genuine, specified article in every case—a policy which POPULAR RADIO has consistently and persistently maintained from its first issue.

* * *

THE vacuum tubes advertised in POPULAR RADIO are tested in the POPULAR RADIO LABORATORY. And only those that function satisfactorily are permitted access to our columns.

* * *

ON page 436 of POPULAR RADIO for November appeared a picture of Wilbur Glenn Voliva of Zion City, Illinois, broadcasting from sta-

tion WCBD. The religious sect which Mr. Voliva heads and which owns that station was erroneously referred to as the "Latter Day Saints," whereas (as a reader kindly points out) it should have been referred to as the "Christian Catholic Apostolic Church." The "Reorganized Church of Jesus Christ of Latter Day Saints" owns and controls station KFIX at Independence, Mo.

* * *

"THE Mormons of Utah, who erroneously call themselves 'Latter Day Saints' have a station also," reports the Editor's correspondent, Mrs. M. D. Graham of Burlington, N. D.

* * *

AMONG the letters that reach the Editor are many that contain appeals for advice about investments in radio enterprises of various kinds. All such inquiries are referred to experienced brokers—preferably to experienced and conservative brokers whose business it is to know the real values behind stock certificates.

* * *

To Elbert H. Gary, the head of the U. S. Steel Corporation, is credited the most apt reply to a question of stock values.

"Do you think steel stocks will go up or down?" a woman once asked him.

"Yes," was the answer, "I think they will. They rarely stand still and they *can't* go sideways!"

* * *

"I DON'T suppose that you get many letters from this side of the water," writes Mr. H. Auger of London, "so here goes. POPULAR RADIO makes its appearance every month on the larger bookstalls* and ultimately finds its way onto my shelves. The Four-circuit Tuner described in the January issue was the first set completed from instructions, and despite the substitution of other parts it has worked magnificently. Although I am within three miles of our local station 2LO, this station is entirely eliminated on 365 meters and Manchester (2ZY) is tuned in strongly. I use a two-step audio-frequency amplifier, although I caught most DX stations on the detector.

* * *

"THANK God your magazine makes radio *human*, which it is," writes W. C. Holman, of New York. "Who cares, among the general public, for the technique alone? It's the romance of radio—the humanness of it—you get into your magazine. I read the blamed thing in spite of myself. You make the headlines so interesting they lead me into buying copies."

* * *

"PERMIT me to thank you for your contribution to the radio art. You have given us in the Cockaday Four-circuit Tuner, a circuit that will work rings around the best of them."

—RICHARD A. BLAIR, Buffalo, N. Y.

* English for "newsstand."

(Continued on page 6)

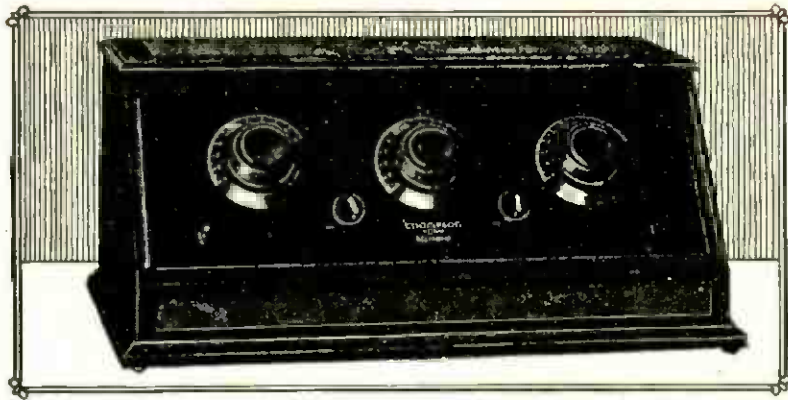

"Experience is the Vital Factor in Excellence"

THOMPSON RADIO

THE THOMPSON COMPANY is the only organization that has been manufacturing radio apparatus exclusively for fifteen years. During this time its research laboratories have perfected developments which have contributed largely to the advancement of the radio industry.

This wide experience, now available in the Thompson apparatus, means Receiving sets and Speakers that embody the latest and best practice in Radio Engineering.

A critical investigation of each model will disclose outstanding features of genuine effect, in artistic appearance, naturalness of tone, simplicity of operation.

Radio in the home broadens the scope of human happiness. Every day the broadcast program carries something for every member of the family.



The 5-tube GRANDETTE is \$125. The 5-tube PARLOR GRAND, (shown above) is \$145. The 6-tube CONCERT GRAND is \$180. Prices are without tubes or batteries. The Thompson Speaker, with conical diaphragm and other special features, is now \$28.

Write for attractive literature and name of Thompson dealer near you.

R. E. THOMPSON MANUFACTURING CO.
FACTORY: JERSEY CITY, N. J. 30 CHURCH STREET
NEW YORK, N. Y.



CONCERT GRAND

THOMPSON
SPEAKER

GRANDETTE

PAGES WITH THE EDITOR
(Continued from page 4)



"What does the editor of POPULAR RADIO look like?" inquires a reader, Edward W. Stone, of Springfield, Mo. In answer, Lieut. James W. Cottrell submits the above snapshot which he made recently at the Reserve Officers training camp, at Sea Girt, N. J. The commanding officer at the left is Col. Edward A. Shuttleworth, U. S. A.; at the right is Lieut. Col. Kendall Banning, Signal Corps, O. R. C.—who left POPULAR RADIO in the hands of its competent staff long enough to get in a few days of military instruction.

THE little item that appeared in this department in which Mr. Turton of Guatemala told of how he obtained a copy of the October, 1923, issue of POPULAR RADIO in that remote country and of the difficulties which he had to overcome in getting parts with which to build a receiver that was described in that number, has called forth an interesting reply from another South American reader, Amando Cespedes Marin of Heredia, Costa Rica.

"We have radio on almost every farm," he reports. But apparently the life of the radio fan is somewhat more turbulent in Costa Rica than in our own country. Two months before, the land was shaken by earthquakes, and it was in a letter from Mr. Marin that station PWX of Havana received and first broadcast the news of that, "many a town of ours had been destroyed by furious quakes," including Mr. Marin's own home!

But a little detail like that does not discourage a real dyed-in-the-wool fan. "My loudspeaker was smashed," Mr. Marin admits, "but I pulled my Cockaday set from the ruins, raised my antenna again and amidst the trembling of the earth I picked up Lincoln, Ne-

braska, Pittsburgh, Los Angeles and some Texas stations!"

If Mr. Marin hasn't the indomitable spirit of the true radio fan we don't know who has!

HERE is the kind of "kick" that the Editor likes to get: "I have been reading with a great deal of interest the comments made about your improved four-circuit tuner under the department, *Stations I Have Heard*. I have refrained from writing you before as I was waiting to see if I could not find some fault with my own set, which I built from your description. But up to date the only fault I have found with it is that the volume is so great that it will rattle the loudspeaker unless the resistance units are switched in! I have received a total of 72 stations on the loudspeaker; unless I get them on the loudspeaker I don't even count them! Situated here in the central part of Ohio I get everything from ocean to ocean. 100-watt stations in Oklahoma are received, and WGY is picked up during the day as well as at night. And I received the English stations during the transatlantic tests."

—J. C. LUVISI, Marion, Ohio.

THE little article by H. W. Sinclair, "A Compact Radio Kit for a Spring Hike," that appeared in a recent number, is still bringing in a quite unexpected number of letters from readers who built it and whose reports border on the enthusiastic: "I am more than surprised at the results obtained from this hook-up," writes Wm. C. Brown of Detroit. "Although I somewhat changed the type of the parts described, the concerts come in great. At the present time I am using a UV-200 6V Radiotron tube; a 43-plate V-C. 22½-volt B battery and a 75-turn honeycomb coil. After the parts were assembled I had no trouble in picking up WBZ in Springfield, Mass.; WOS of Jefferson City, Mo.; WDAP of Chicago, Ill. and WCBF in Zion, Ill. All of which I credit to H. W. Sinclair and POPULAR RADIO!"

"I MAY say that I have constructed over 30 sets, and am an electrical engineer surveyor for our largest insurance company, so I know something about radio. But must also say that the finest set I have ever handled is the one described in your June, 1924, issue, pages 567-576. It is in my opinion easily the best this side of the Atlantic and I have recommended it to many of my friends, telling them about POPULAR RADIO at the same time."

—A. A. MOODIE, Walkerville, Newcastle-on-Tyne, England

Kendall Banning
Editor, POPULAR RADIO



Hear Him
by **RADIO**
in your home

Funny? He's a Riot, a Laugh
Factory, A Fifth Alarm!!! The
whole nation knows his name and
fame.

But how few can actually see
him in person!!!

Radio leaps the Barriers of Time
and Distance. Listen-in when
next he's on the air. Cun-
ningham Radio Tubes make
Clear Reception a Certainty.
Why Gamble on sub-standard
equipment for the nerve-center
of your set?

More than ever—
Quality Counts.



Since 1915
Standard for all sets

Types C-301A, C-299, C-300, C-11, C-12
In the Orange and Blue Carton
Price \$4.00 each

PATENT NOTICE: Cunningham tubes are covered by patents dated 2-26-09, 2-18-12, 12-30-13, 10-25-17, 10-23-17, and others issued and pending. Cunningham 40-page Data Book fully explaining care and operation of Radio Tubes now available by sending 10c in stamps to San Francisco Office.

Cunningham
RADIO TUBES

E. J. Cunningham Inc.

Branch
CHICAGO

HOME OFFICE
182 Second Street
SAN FRANCISCO

Branch
NEW YORK



J. MATHESON BELL
President, Ozarka, Inc.

I have trained 2274 men to make big money in radio

I can do the same for you

WHO were these men? They came from all walks of life. I have just looked up ten of them. One school teacher, one railroad man, one drug clerk, one die-maker, one electrician, one insurance man, one farmer's son, one traveling salesman.

How much are they making? \$50 to \$500 a week. The \$50 men are mostly those who give me their spare time. A great many of my representatives start that way.

How much did they know about radio at the start? Very little, in many cases nothing. Lack of radio knowledge is not a handicap. In fact, I rather prefer the man who hasn't delved too deeply into radio theory. We have our own methods—they are successful—and the man with nothing to unlearn makes the biggest success of our plan.

Sales experience naturally would be of some value, but it is not absolutely necessary. Unlike other articles, a radio instrument does its own talking. The best time for your demonstrations is evenings, which is possibly your spare time. You

can safely put Ozarka in competition with any instrument on the market today, regardless of its price.

The man I want is known in his community as upright and reliable. He may not have any considerable amount of money, but he has a little; in fact, in many cases the man who is particularly interested in my plan is the man who is having rather a hard time making ends meet. He is, however, the type of man who would not handle anything unless he was thoroughly convinced of its merit. If you are this kind of a man and are really sincere in wanting to improve your financial conditions, I'll be very glad to tell you of the Ozarka Plan. I can train you to make considerable more money than you are now making. I have done this with 2274 men in the past two years, and I will do it for you if you will do your part.



This button identifies Ozarka representative in your city—is your assurance of complete radio satisfaction.

This Large Book tells how to make \$100 per week under Ozarka Plan

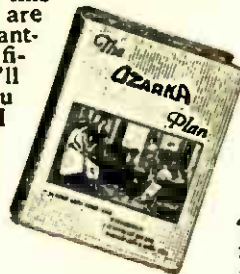

The Ozarka Plan is fully described in a large illustrated book. I will send a copy to men who are willing to tell me fully about themselves. The Ozarka book is a true

Ozarka four tube radio for operation with loud speaker as low as

\$39.50

OZARKA, INC.

806 Washington Blvd., Chicago

story of life, of men, of why they fail, and how they succeed. It tells how men are carving out futures for themselves in this fascinating business of radio.

In territory not now covered, I want the right man. If you feel qualified and are willing to put forth the necessary effort to obtain a splendid, profitable business of your own, write me and say "Send your Ozarka Plan Book No. 100." It may be the turning point in your life. Don't fail to mention the name of your county.

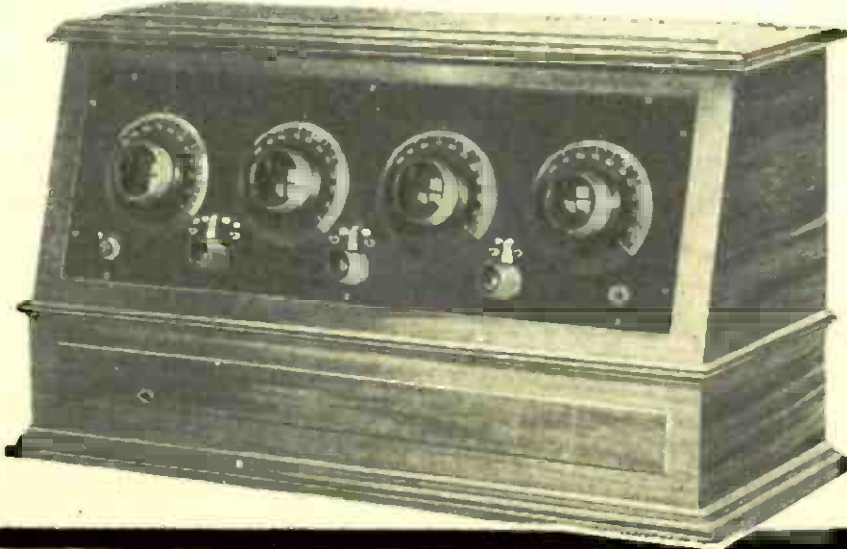



"POPULAR RADIO, from its inception, has shown merit of the sort greatly needed in spurring the radio industry to bigger, cleaner, more lasting efforts, and in educating the public to an appreciation of those efforts. I know of no agency that can point to greater success along these lines than yours. Your sort of work will always make itself felt in a very decided fashion."

—PAUL F. GODLEY



Underwood & Underwood

Carrier Rays That Kill

A spectacular night-demonstration of the "death ray" apparatus of H. Grindell-Matthews (described in detail by the inventor for the first time in POPULAR RADIO) was recently held on the Island of Flat-holme in England. The inventor states that this machine is now capable of projecting its death-dealing powers more than 3,000 feet.

Popular Radio

VOLUME VII

JANUARY, 1925

NUMBER 1



Religion's Raid on Radio

- ¶ *One out of every fourteen broadcasting stations in the United States is today owned by a church and operated by a church—or under a church's direction.*
- ¶ *These stations are used, directly and indirectly, for propaganda by the various religious sects.*
- ¶ *Scores of other "special" broadcasting stations are owned and operated by institutions under the control of religious bodies.*
- ¶ *In the protection of broadcast listeners generally—as well as of the church as an institution—these propagandists must be held in check.*

By ARMSTRONG PERRY*

WE used to expect the churches to be at least fifty years behind the times—but times have changed. They are speeding up.

It was only ten or fifteen years after motion pictures had taken their place with the foremost amusements that the churches began using them with religious motive. Sometimes a censor stood in front of the machine and held a newspaper over the lens when the film became too interesting from a worldly point of view, but there is less today that the religious leaders expurgate.

Everything that attracts people to the vaudeville show is being tried in church—even dancing girls at the regular serv-

ices. So it is not altogether a surprise that the churches, at the beginning of the

* Armstrong Perry, who wrote this article, has been a church member since he was eleven years of age. He has been a member of the Young Men's Christian Association for twenty-eight years and was a secretary in that organization for fifteen years. Since the beginning of the Boy Scout movement in this country he has been a Scout official, and the twelfth Scout law is this: "A Scout is Reverent." He was, perhaps, the first layman invited to occupy a church pulpit and talk on Radio. His pastor is a radio enthusiast and builds receiving sets for parishioners who live so far from his church that they cannot always attend its services. This should make it clear that Mr. Perry has no prejudice against any means, radio least of all, for promoting interest in religion. But he has decisive objections to the plans of preachers who want to make it impossible for listeners to hear anyone but themselves.



The encroachment of religious discussions upon popular radio programs is already beginning to arouse the protests of the broadcast listeners.

radio era, are among the first to try to grab the air.

A prominent divine in New York has announced plans for opening a station that will blanket the metropolitan district and a good deal of other territory. "Listen to me or to nothing!" seems to be his slogan. Voliva, leader of the Dowieites, puts on a show at his station—WCBD—as good as any, and slips in his religious theories at psychological moments. One of his big ideas is that the world is flat, and that of course eliminates from radio the need for discussing the Heaviside theory and others advanced to explain why ether waves follow the curve of the earth.

In the latest list of broadcasting stations, thirty-six—about seven percent—are owned and operated by churches. A number of others, connected with colleges and other institutions, are also under the control of religious leaders. Among the sects represented are Presbyterian, Catholic, Baptist, Methodist, Latter Day Saints, Christian, Christian Scientist,

Zionist, Congregational, Methodist Church (South), Lutheran and Seventh Day Adventist. Some have low-power sets and transmit only their Sunday services. Others are using all the power the law will allow and operating all day long and into the night.

Complaints from listeners on Staten Island have been published in the newspapers and are to the effect that WBBR, operated by the People's Pulpit Association, transmits daily and blankets the whole island. The Association is composed of the followers of Pastor Russell, who during his lifetime was content to hire the largest auditoriums available and lecture free of charge to those who came to hear him. Los Angeles fans complain of religious propaganda that crowds out programs they would rather hear. Around Zion City, Illinois, there have been complaints that are but feeble forerunners of the storm that may arise when Voliva opens up with his new five-kilowatt transmitter, one of the most powerful in the world used for broadcasting.



If the broadcasting stations are reduced in number and the religious interests control them, we may at times be forced to listen-in on church propaganda or nothing.

The air is filling up with propaganders. This is viewed with alarm by radio folks with other interests. Those who have been putting on Plug Tobacco Quartettes, Safety Razor Minstrels, and entertainers who have joked and jazzed all manner of trade names into the subconsciousness of ultimate consumers, are beginning to demand what right religion has to interfere with the business of advertising. Will the increase of propaganders scare away the propageese who swallow their offerings?

The answer to the complex situation, if there is one, goes down to the root of things. Religious leaders claim—and no one will deny it—that religion has as good a right to the ether as education or business. Educational broadcasts are not objected to because educators usually are modest and unobtrusive. Seekers after truth find it, and it makes them humble. Business is business. It does not hesitate to spread its propaganda by any and all methods available. But usually it has the common sense to avoid trying to force

itself upon an unwilling public. It is more often adroit in its methods and it appreciates the value of good-will. The religious leader, viewed in the light of history, is sometimes the least wise, the least tolerant, the most bigoted of all. There are those who follow closely the teachings and practice of Jesus and try to win men by serving them; but too often the religionist stands on the platform that one man and God constitute a majority, and the majority rules. The Word of God is interpreted in as many different ways as there are bigots, and each knows he is right.

Some persons who have the best interests of radio at heart see in the present situation a menace. It is an open secret that the larger corporations concerned with radio development are looking forward definitely to a sweeping reduction in the number of broadcasting stations. It is predicted that in a few years there will be but six or eight super-stations, whose programs will be relayed, perhaps, to stations having only a local range.

<i>Call Signal</i>	<i>Location of Station</i>	<i>Operated and Controlled by—</i>	<i>Wave-length</i>	<i>Power (watts)</i>	<i>Denomination</i>
KFBG	Tacoma, Wash.	First Presbyterian Church	360	50	Presbyterian
KFBU	Laramie, Wyo.	The Cathedral	283	50	Catholic
KFDD	Boise, Idaho	St. Michaels Cathedral	252	10	Catholic
KFDX	Shreveport, La.	First Baptist Church	360	100	Baptist
KFGX	Orange, Tex.	First Presbyterian Church	250	500	Presbyterian
KFGZ	Berrien Springs, Mich.	Emmanuel Missionary College	268	250	Seventh Day Adventists
KHFF	Shreveport, La.	Central Christian Church	266	150	(Not Stated)
KFIX	Independence, Mo.	Reorganized Church of Jesus Christ of Latter Day Saints	240	250	Christian Catholic Apostolic Church
KFMB	Little Rock, Ark.	Christian Churches of Little Rock	254	...	(Not Stated)
KFOC	Whittier, Cal.	First Christian Church	236	100	(Not Stated)
KFRP	Redlands, Cal.	Trinity Church	211	10	Episcopal
KFSG	Los Angeles, Cal.	Echo Park Evangelistic Assn.	278	500	Evangelical
KJS	Los Angeles, Cal.	Bible Institute of Los Angeles	360	750	Interdenominational
KTW	Seattle, Wash.	First Presbyterian Church	360	750	Presbyterian
WABE	Washington, D. C.	Y. M. C. A.	283	100	Evangelical
WABK	Worcester, Mass.	First Baptist Church	252	10	Baptist
WABO	Rochester, N. Y.	Lake Ave. Baptist	252	10	Baptist
WABZ	New Orleans, La.	Coliseum Place Baptist Church	263	50	Baptist
WBBL	Richmond, Va.	Grace Covenant Church	283	50	(Not Stated)
WBBR	Rossville, N. Y.	Peoples Pulpit Assn.	244	500	(Not Stated)
WBBS	New Orleans, La.	First Baptist Church	250	100	Baptist
WCAJ	University Pl., Neb.	Nebraska Wesleyan University	360	500	Methodist
WCAL	Northfield, Minn.	St. Olaf College	360	500	Norwegian Lutheran
WCAM	Villanova Pa.	Villanova College	360	150	Catholic
WCBD	Zion, Ill.	Wilbur G. Voliva	345	500	Christian Catholic Apostolic Church of Zion
WDAH	El Paso, Tex.	Trinity Methodist Church (South)	268	50	Methodist
WDM	Washington, D. C.	Church of the Covenant	234	50	Presbyterian
WEW	St. Louis, Mo.	St. Louis University	261	100	Catholic
WFAQ	Cameron, Mo.	Missouri Wesleyan College	360	10	Methodist
WJD	Granville, Ohio	Denison University	229	50	Baptist
WMAN	Columbus, Ohio	First Baptist Church	286	10	Baptist
WMAY	St. Louis, Mo.	Kingshighway Presbyterian Church	280	100	Presbyterian
WOQ	Kansas City, Mo.	Unity School of Christianity	275	500	(Not Stated)
WPAT	El Paso, Tex.	St. Patricks Cathedral	360	20	Catholic
WPAU	Moorhead, Minn.	Concordia College	360	20	Norwegian Lutheran
WQAO	New York, N. Y.	Calvary Baptist Church	360	100	Baptist
WQAW	Washington, D. C.	Catholic University	236	5	Catholic
WWL	New Orleans, La.	Loyola University	280	100	Catholic

SOME OF THE BROADCASTING STATIONS OWNED AND CONTROLLED BY CHURCH BODIES

These 38 stations are listed in the Government's official record of stations. Information concerning the denomination of each was obtained by direct communication and from published statistics.

What if this happens, and the religious interests come to control the big stations? Will we have to listen to religious propaganda or nothing?

Probably no such fear is justified. Those who look forward to a system in which less than a dozen stations will provide programs for the whole country are kidding themselves, unless they have the power to kill an interest in local programs by local people, which exceeds the interest in big programs and big stars by a ratio of three and one-half to one, according to a recent investigation. The fact remains, however, that religious prejudice, religious zeal, religious jealousy, grow faster and die harder than any other sentiment of the human race. It will be easier to start right than to readjust after serious mistakes will have been made.

It is bad enough to have different religious denominations preaching against each other and working against each other, all in the name of the same God, within the walls of their own meeting houses. In that case we do not have to listen to them unless we choose to. But if they get to competing in the air, we broadcast listeners will be out of luck. Already the Fundamentalists and their opponents have had their fling in the ether and a large part of listening America had a bad attack of spiritual nausea. So long as power is limited so that a propagandizing station can be tuned out, the situation is tolerable. The radio manufacturer and dealer especially are not averse to a condition that requires a high degree of selectivity in receiving sets. But when a broadcaster acquires a right to radiate an amount of power that will force oscillations in all receivers within five, ten or fifty miles, for any number of hours he may choose to monopolize the ether, he will have reached the ideal of the religious fanatic and the point where the average listener will junk his receiving equipment.

The desire to limit religious broadcasters so that they cannot disturb the peace



Kadel & Herbert

AN AGGRESSIVE BROADCASTER OF THE DOCTRINES OF THE FUNDAMENTALISTS

For weeks the ether about the eastern section of the United States was filled with the debates about church creeds; chief among the debaters was Rev. John Roach Straton, of Calvary Baptist Church, New York.

of an entire community is not an evidence of antagonism toward religion. Religion is a fundamental instinct. No man can escape it, even if he wants to. Few attack the churches which represent the beliefs of their respective members. The rank and file of Americans are willing to let the other fellow express his religious views and feelings as he pleases, so long as he does not interfere with the rights of others.

But ministers there are who are not satisfied to let folks choose for themselves. They consider themselves divinely called to impose on others their own ideas and call them the Mind of God.

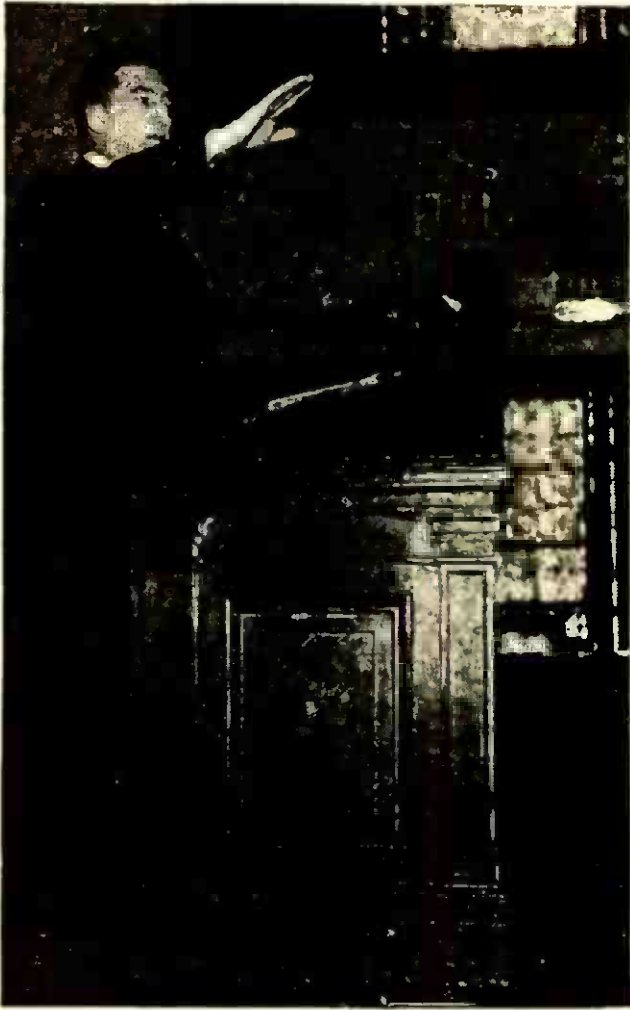

Kadel & Herbert

HOW A SERMON IS BROADCAST

Standing in his accustomed place in the pulpit, Rev. Lewis K. Dixon of the City Temple, New York, faces not only his parishioners but a microphone by means of which he broadcasts his sermon over several states.

Not long ago I attended the commencement exercises of a class of theological students, graduating from one of the oldest and most dignified theological seminaries in the world. The impression was forced upon me that not one of them was a normal human being. Every one of them looked as if his only refuge from the bug-house was to get bolstered up by divine authority before the alienist spotted him. One of them had robbed houses and forged checks. The facts were known by authorities in his church. These men were being commissioned as ambassadors of God to American communities. Ministers must be judged by the same standards as other folks, except that in assuming religious leadership they

place upon themselves an additional responsibility. They are not different from other men. Some of them lie, steal, commit murder; others rise to supreme heights of heroism.

The average minister is sane, is helpful and needs no restraint. It is the selfish, egotistic, erratic, possibly brilliant religionist who needs curbing. The same types of men come into prominence in religious bodies as in politics. There is no politics keener or more bitter than church politics. Some seats in the House of Representatives and in the House of Bishops are won by the same methods. We do not hesitate to deprive the politician of his power when he turns it against the rights of the common people. No more should we hesitate to fight the preacher when in the name of God he oversteps the bounds of decency and forces an obnoxious presence upon unwilling millions. In doing so we will have the approval and support of the majority of the clergy, as well as of all other right-thinking people.

No new machinery is needed for the regulation of propagandists, religious or otherwise. We have no adequate radio laws, but we have a Secretary of Commerce who is better than most of our laws. The best law can be evaded and nullified more easily than a public official with common sense, an honest purpose and the nerve to do his duty. He has shown a disposition to listen to all points of view and to make regulations to safeguard the rights of all radio users. There is no doubt that religious leaders and societies, especially those of irrational, freakish tendencies, will bring to bear all possible pressure to enable them to monopolize the ether. They can be held in check by the expression of public opinion. To suggest that they should be limited is not inimical even to their own interests. They may not realize it, but nothing does so much to harm their own cause as trying to force it upon the public. The sane, constructive religious leadership of the country should be up-



The remote control apparatus used in St. Thomas Church, New York, for broadcasting services from WJZ.

SOME OF THE SPECIAL STATIONS OWNED BY INSTITUTIONS UNDER CHURCH INFLUENCES

Call Signal	Location of Station	Operated and Controlled by—	Wave-length	Denomination
1XK	Newton, Mass.	Boston College	(Not given)	Catholic
1XN	Middletown, Conn.	Wesleyan University		Methodist
2XZ	New York, N. Y.	Forham University		Catholic
2YA	Camp Dix, N. J.	Knights of Columbus		Catholic
3XI	Washington, D. C.	Catholic University of America		Catholic
3XJ	Philadelphia, Pa.	St. Josephs College		Catholic
3XM	Princeton, N. J.	Princeton University		Presbyterian
3YO	Easton, Pa.	Lafayette College		Presbyterian
3YI	Washington, D. C.	Knights of Columbus		Catholic
5XBG	Waco, Tex.	Baylor University		Baptist
5XZ	Grand Coteau, La.	St. Charles College		Catholic
5YR	New Orleans, La.	Loyola University		Catholic
5YV	Fort Worth, Tex.	Knights of Columbus		Catholic
7YC	Seattle, Wash.	Y. M. C. A.		Evangelical
7YD	Seattle, Wash.	Knights of Columbus		Catholic
7YG	Portland, Ore.	Y. M. C. A.		Evangelical
7YS	Lacy, Wash.	St. Martins College		Catholic
8XAK	Springfield, Ohio	Wittenberg College		Lutheran
8YAC	Cincinnati, Ohio	Xavier College		Catholic
8YAJ	Cleveland, Ohio	Y.M.C.A.		Evangelical
8YM	Granville, Ohio	Denison University		Baptist
8YU	Dayton, Ohio	Y. M. C. A.		Evangelical
8YYK	Delaware, Ohio	Ohio Wesleyan		Methodist
9XT	Collegeville, Minn.	St. Johns University		Catholic
9YAP	Davenport, Iowa	St. Ambrose College		Catholic

held by an immediate and vigorous expression of public opinion concerning the proper regulation of religious broadcasting stations; otherwise it may be deprived of its share of the ether by the wrongdoing of those what want it all.

What happens when religious zealots gain control was illustrated when an intolerant priesthood forced the Reformation and split Christendom; when a political church drove the Pilgrims to seek freedom of worship in the wilderness of America; when they in turn drove out men like Roger Williams, founder of Rhode Island, who died regretting that there was no church which his conscience would permit him to join. The strong religious organization could monopolize its field in those crude days, but can any, or all of them together, deprive our coun-

try today of the privilege of hearing what it has a right to hear?

Possibly the preachers who covet their neighbors' air see in that no violation of the Ten Commandments. Perhaps they have twisted a well-known saying of Jesus into this form: "It is more blessed to transmit than to receive."

A wise announcer, when a radio speaker wanders into direct advertising or other forbidden fields, quietly throws a switch and lets him talk on and on into the microphone, blissfully unconscious of the fact that his hot air goes so far and no further. Perhaps similar courtesies can be extended to the religious crank. Then radio listeners can tune in what they want to hear instead of leaving their receivers, disgusted by asinine attempts to cram "religion" down their throats.



Pacific & Atlantic

"THE EARTH IS STATIONARY" IS THE STRANGE DOCTRINE PREACHED BY THE CHRISTIAN CATHOLIC APOSTOLIC CHURCH

Out in Zion City, Illinois, is located one of the largest and most active of the church radio stations, WCBD, whose odd beliefs are exploited through the ether. Its overseer, William Glenn Voliva, recently exhibited a map of the globe upon which he had penciled the route of the world-fliers; he said that it showed the aviators merely flew in a circle over the flat surface of the earth.

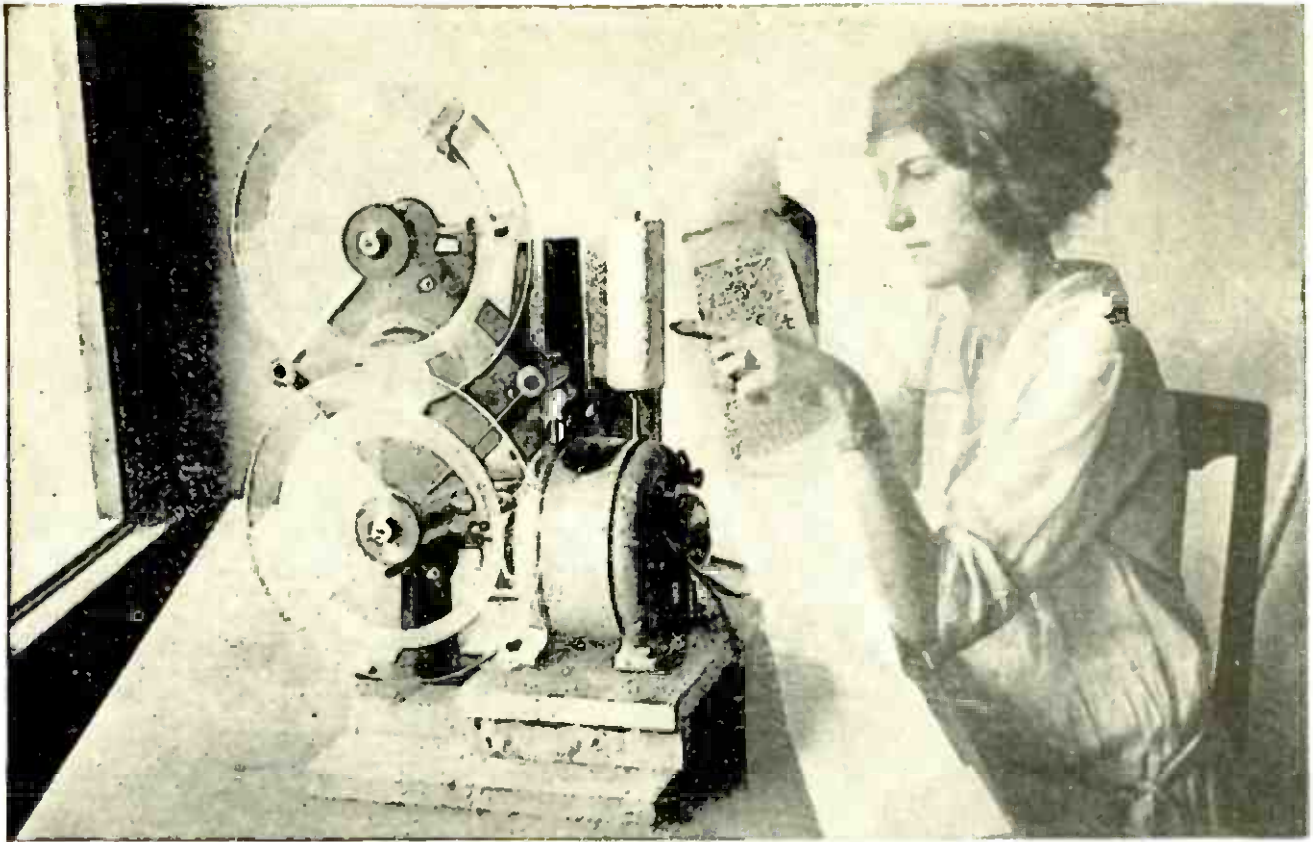

From a photograph made for POPULAR RADIO

A MAIL BOX OF THE FUTURE?

This is the apparatus that feeds into the transmitter the long rolls of typewritten correspondence that is to be sent by radio.

1,000 Printed Words a Minute by Radio

By means of this new invention—(which is here described for the first time)—the contents of an entire newspaper page can be transmitted in less than ten minutes. What will this development mean to commerce in general—and to journalism in particular?

By CHARLES ALLAN HERNDON

“**W**HAT will radio do to the newspapers?”

This question was asked in newspaper offices when radio broadcasting first burst into popular use. The new means of communication contained tremendous potentialities. Enthusiasts promptly predicted that radio would cripple if it did not entirely displace the daily printed pages. Publishers hastily issued statements denying that such would be the case. They gave reasons—but behind the reasons doubts could be detected. There

was a vague feeling that this new thing held a menace for the newspaper.

Now, C. Francis Jenkins, consulting engineer and inventor of Washington, D. C., has an answer to this query.

Instead of being an enemy or destructive competitor of newspapers, radio can be made their greatest ally in bringing greater speed and accuracy to the gathering and assembling of news. But this is not to be done by radio as we ordinarily think of it. The radio messages will be for the eye, not the ear. Mr. Jenkins has

devised a machine by which news copy can be sent by radio direct from a typewritten sheet in one newspaper office and automatically reproduced in exact facsimile on a photographic paper strip in any number of other newspaper offices.

Mr. Jenkins is daily sending radio photo messages of any length desired at a speed of one hundred words a minute. This rate is much faster than similar messages can be sent by telegraph. Mr. Jenkins claims that one thousand words are easily within the bounds of possibility by this method.

From the insertion of the typewritten copy in the sending machine to its exact reproduction at the other end, the whole process will be automatic. Light and radio waves, speediest messengers of the universe, will deliver the news as written without the errors which now frequently

arise in the handling of copy between distant points.

This same system may also be used to carry business letters. By this means, Mr. Jenkins says, they can now be sent more quickly and cheaper than they can be carried by the government's mail planes. Beside speed, the auto-radio-graph has the advantage over telegraph and cable messages, in that it retains the authentic character of the autograph letter. It is not merely the same words that are transmitted, but the writing of the original is faithfully reproduced in all its details—including the exact signature.

In order to understand the new method, we should recall that there are certain substances such as selenium and thalium, that are less resistant to electric current in the light than they are in the dark. In other words, when such sensi-

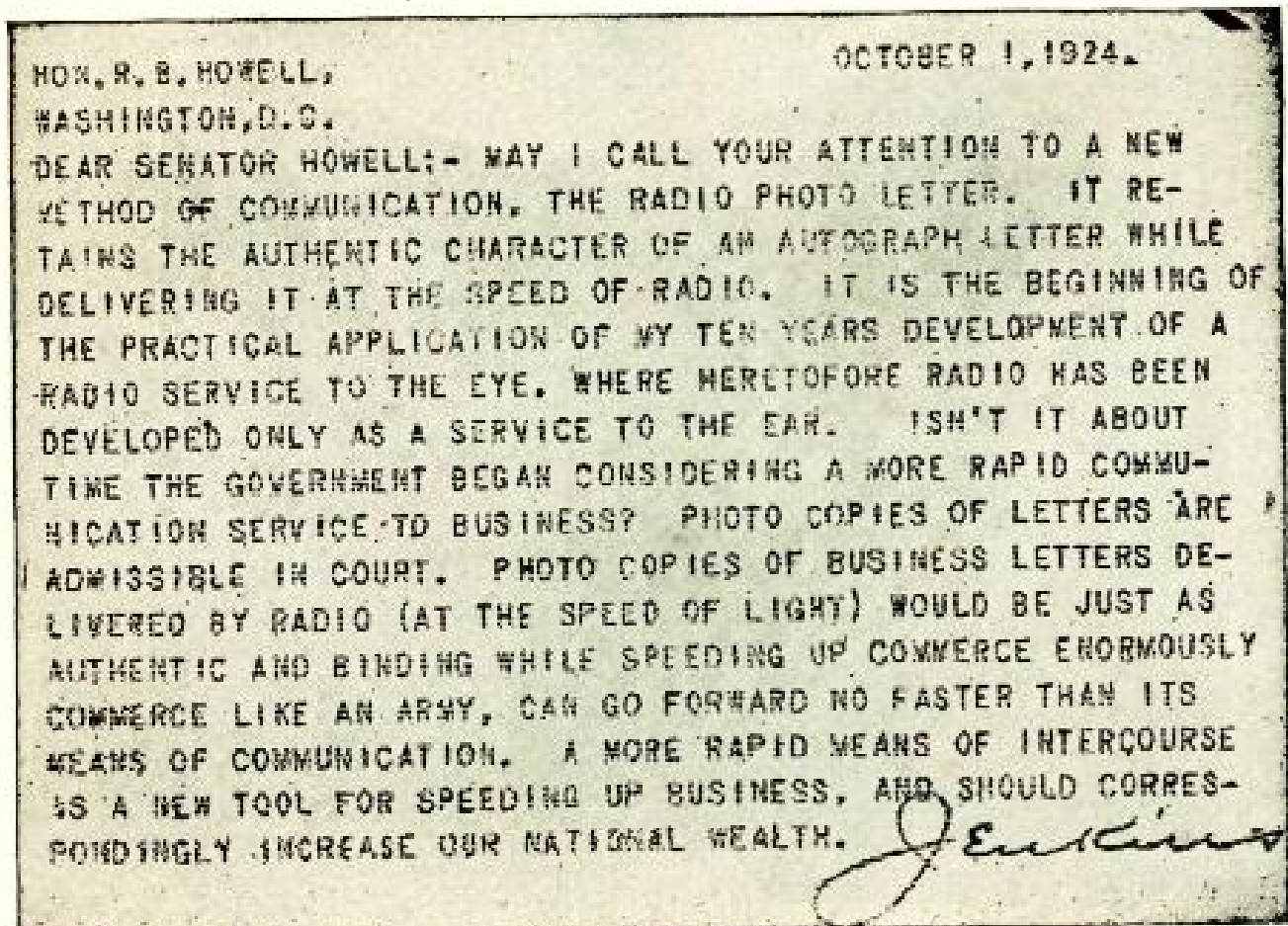

From a photograph made for POPULAR RADIO

A PERSONAL LETTER SENT BY RADIO

A letter as it actually appears when received. Less than a minute was required to send this permanent message. The inventor says that it will be cheaper and quicker to send letters like the above than to dispatch them by airplanes. And it is even more authentic than a carbon copy of a typewritten letter.

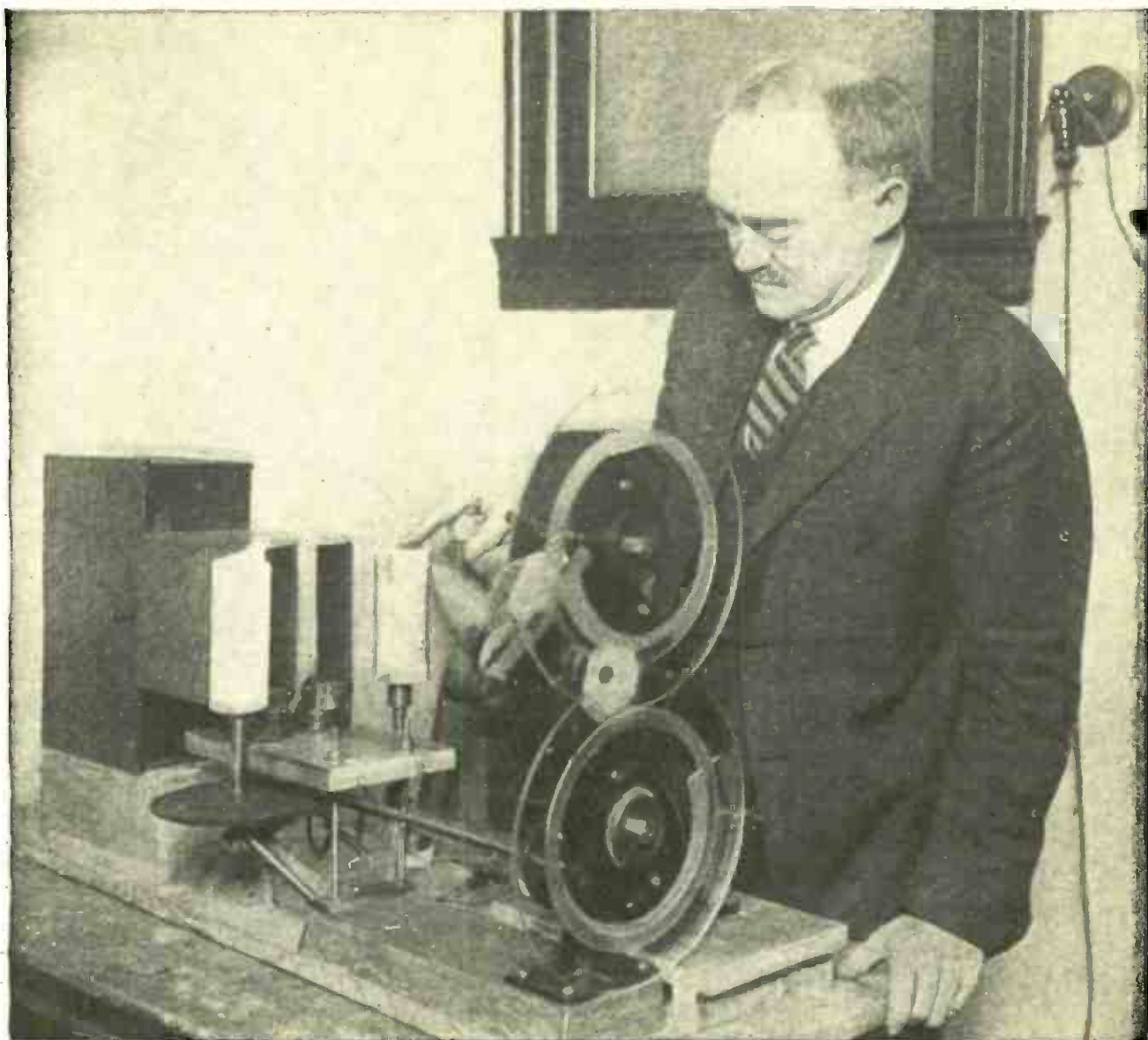

Harris & Ewing

THE COMPLETE SENDING APPARATUS

The glass disks of the sending apparatus shift the image of a letter like a typewriter carriage shifts a sheet of paper. The typewritten copy moves from the roll (at which Mr. C. Francis Jenkins, the inventor, points) past the electric light.

tive substances are illuminated an electric current can be passed through them more easily than when no light strikes them. This peculiar property of these elements is the keystone of the new radio device.

The legibility of the letters and words on this page is due to the contrast made by the black ink on the white paper. In sending such matter by radio, the problem is to convert that black and white into terms of light and darkness which in turn will impede or promote the current flowing through the light-sensitive cell. These variations of current go to the broadcasting apparatus where they are

sent out just as similar variations of current produced by variation in sound waves are sent.

Here is the way this is done in the Jenkins apparatus. The letter or other typewritten matter is placed on spools and threaded through the slot of a magic lantern or stereopticon machine. When the lantern is turned on an image of one line of the typewritten matter is projected across the room just as the image on a stereopticon slide would be. Instead of a screen to receive the projected image, however, there is a box containing one small hole facing the projecting machine. In this box is the light-sensitive cell that

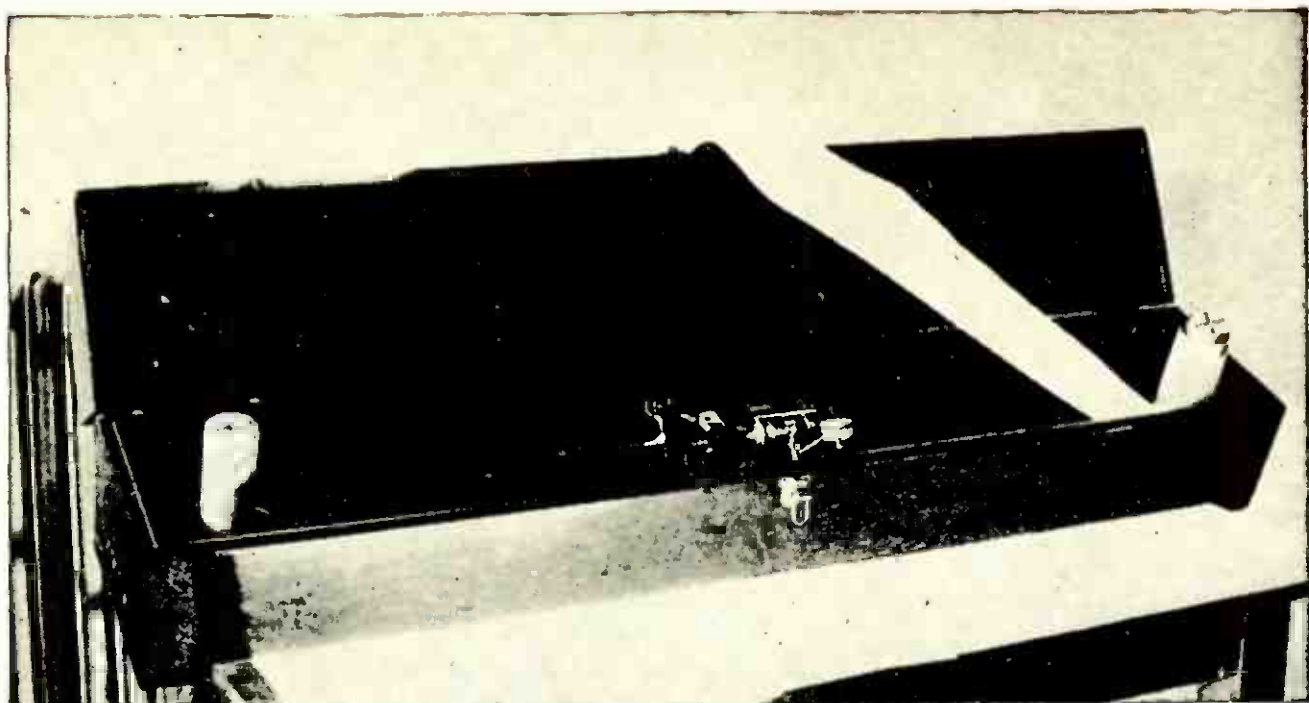

From a photograph made for POPULAR RADIO

THE RECEIVING APPARATUS WORKS ON THE SAME PRINCIPLE AS THE CAMERA

The unexposed film moves as rapidly past the enclosed electric light as the typewritten message at the transmitting end travels. Much difference in speed would blur the message.

controls the current and which is connected with the broadcast apparatus.

Only one fine pencil of light can enter the hole and reach the light sensitive substance, and so affect the current at one time. When the image of one of the lines typed across the paper is projected toward the box, there is just one small part of that image which is projected into the tiny hole in the box. If that small part is a portion of the image of a letter, the current flowing through the cell is broken. If that small part is part of a space between letters, the light is permitted to fall on the cell and the current flows freely. Obviously, in order to send the entire typed line, every fraction of its image must be passed in front of the tiny hole in the box. In typing words, we write one letter at a time until we have spelled out the word. In sending by radio, however, only one fractional part of the space or letter is transmitted at a time; just one small part of the letter T or half of a period, for instance.

The Jenkins radio machine uses two devices to move the image so that each

part of it is successively brought over the hole opening onto the light-sensitive cell. The spools which hold the original typed or other material are slowly turned, slowly carrying the typed lines past the slit through which the lantern's light comes.

In front of the projection lantern, however, is a still more ingenious device. While the slowly winding spools carry the paper from the top to the bottom of the typed matter much as the line spacer on a typewriter does, this other apparatus tends to the movement across the paper from one side to the other as the letter spacer on a typewriter does.

Instead of shifting the paper itself, however, this latter apparatus shifts the image projected toward the hole in the box. It consists of two glass disks or wheels, the edges of which overlap. The edges of these glass wheels are shaped so that they act as a series of prisms. The prism, it will be recalled, bends a ray of light from its direct path. The different parts of the edges of these disks have different angles so that the bending is greater in one part than in another. The

net result is that the image passing through these moving prisms is shifted up and down in front of the hole in the box across the room.

In short, light from behind the original typed or other matter projects an image of that writing across the room where by means of this shifting apparatus the entire image is part by part allowed to fall on the hole leading to the light sensitive cell. The dark parts produce corresponding breaks in the current while the light parts of the image produce corresponding pulsations of electric current. The radio apparatus connected with the photographic machine responds to the variations, reproducing them in varying pulsations which are transmitted.

The lead-in wire from the receiving antennas is connected with an electric lamp which lights up as the current comes through and goes out when the current is broken. This lamp is enclosed in a metal cylinder in which there is just one tiny hole opposite the film.

This photographic film moves at the same rate at which the original typed copy is moving at the sending station. The cylinder in which the lamp is enclosed moves at the same rate that the image is shifted by the prismatic disks in

the sending station. The result is that the alternate flashing and extinguishing of the light builds up bit by bit an exact reproduction of the original manuscript.*

A new means of communication more rapid and more accurate than those now in use has been devised with still greater speed not only possible, but probable in the near future. How far the development may be carried no one can say. When we let our minds run back to the feeble beginnings of other great inventions and their astonishing developments, we realize that the wonders of radio service to the eye may reach proportions staggering to the imagination.

* Readers of POPULAR RADIO will recall that Mr. Jenkins used similar apparatus and the same method in sending and receiving his photo-portraits by radio. (See POPULAR RADIO for December, 1923.) However, the quality of that work required a somewhat more complicated series of prismatic disks and a more delicately adjusted receiving apparatus. Sending half-tone portraits with their different shadings also required more sensitive light cells at the broadcast station. It was necessary to obtain quality to sacrifice speed.

The radio photo-letter, on the other hand, is a comparatively simple proposition. It is merely a question of contrast of light and dark. Of course, the greater the contrast between the words and their background the clearer will be the reproduction. While Mr. Jenkins has demonstrated that it is entirely practical to send from the ordinary typed copy paper, he has found that the best results are obtained by the use of stencil sheets. Black sheets in which the letters are stenciled are better than the typed sheet, for where the letters are cut out there is nothing to interfere with the full strength of the projecting light passing through, while the black background furnishes the greatest contrast.

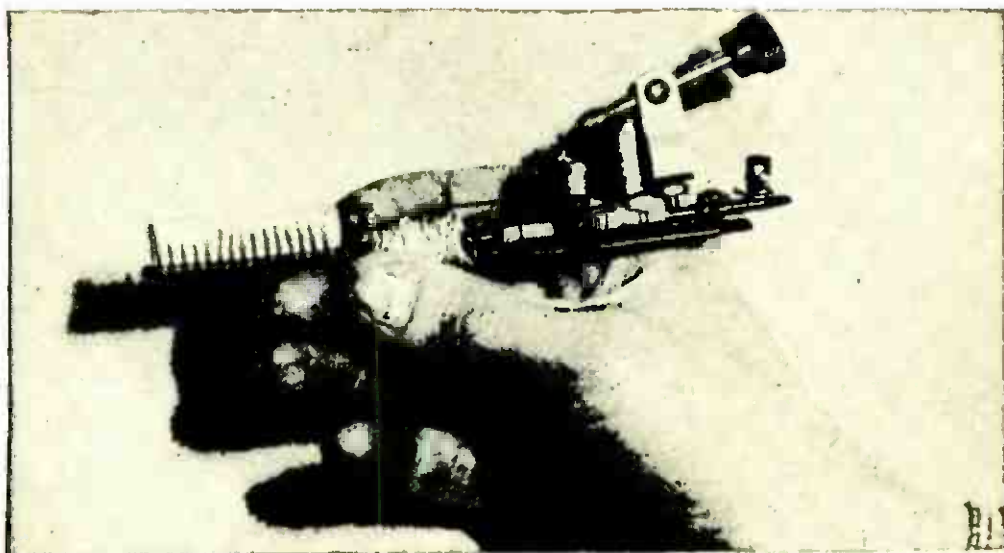

Pacific & Atlantic

A SET BUILT ON A TOOTH BRUSH

This miniature receiver exhibited recently in New York was built by William L. Wray, who claims that it works. It contains a crystal detector, an inductance and a fixed condenser.

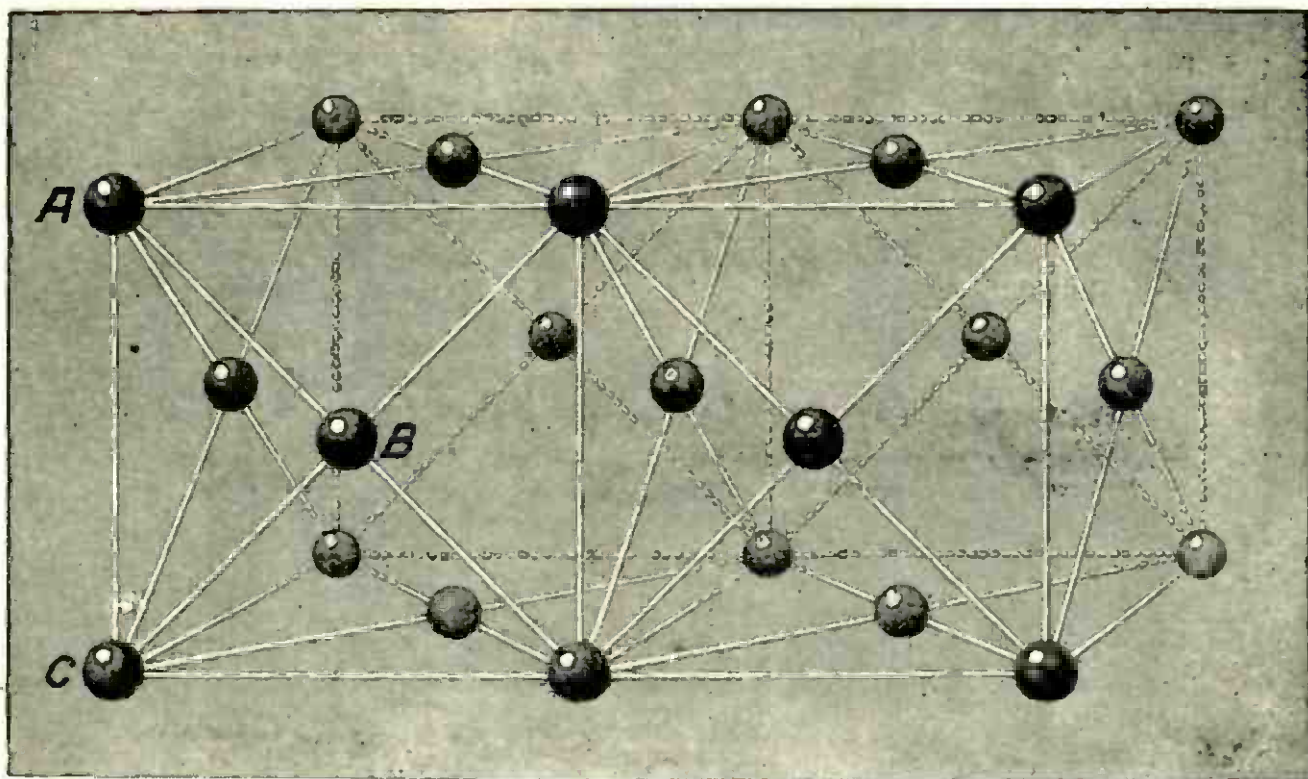

From a drawing by Arthur Merrick

This drawing shows how loose and open is the structure of all terrestrial matter. The spheres represent the central nuclei of the atoms in a piece of copper. In this drawing they are greatly exaggerated in diameter, in proportion to their distance apart.

Electrons in the Stars

To operate a radio set on a distant star would be very different from operating one on earth. The universe is composed of atoms, electrons and ether waves—but they are not always put together in the same patterns as those with which we are familiar. The stars are “vast bubbles of electricity” emitting radio and other etheric waves. One star has been found, for example, which is composed of gaseous matter but which is, nevertheless, thousands of times heavier than the heaviest terrestrial metal!

By E. E. FREE, Ph.D.

THE fundamentals of the universe seem to be everywhere the same. Matter on earth is made up of the two kinds of particles of electricity; the electron and the positive nucleus or proton. In addition to these we have the ether waves of light, of X rays, of radio and the rest. All these things the physicists have studied in our earthly laboratories.

And off in the depths of space we find exactly these same things. There are protons and electrons in the sun. The ether waves that reach us from there—whether waves of light or heat—are essentially the same waves that we can pro-

duce and study here on earth. Even in those other suns which dot the vaster reaches of the visible universe and which we call the stars there exist, we believe, exactly these same fundamental things. The matter of these stars is made up of protons and electrons just as matter is on earth. The ether waves of these stars are the same light rays, and presumably the same X rays and gamma rays and radio waves, with which we are already familiar.

Just as the chemist can pick out of a pile of coal one small spoonful that is a fair sample of the whole mass of the ma-

terial, so we can take the composition of this little earth of ours to be a fair sample—so far as its fundamentals are concerned—of the entire vast universe. That we can see.

But the local arrangements of things in the stars are very different from what they are on earth. Here on earth the electrons and the protons stay together fairly well in the form of our familiar and useful atoms. Only when we manhandle it pretty severely in the laboratory can we induce an atom to let go of any of its electrons and to take part in what we call a "chemical change." When we do get a lot of electrons loose from atoms we are apt to be disconcerted.

For example, a lightning flash is a lot

of loose electrons. Billions of billions of them have been detached from the atoms to which they properly belong and are ranging around on their own. They are not too pleasant to have about. From the human point of view it is far more comfortable not to have a crowd of loose electrons—or of protons—for close neighbors.

But the stars are different. It is probable, the astronomers have come to believe, that some of the stars consist largely of loose electrons and either of loose protons or of atomic nuclei that carry many fewer electrons than is normal on earth. These nuclei resemble the entirely free protons in possessing powerful charges of positive electricity. The elec-

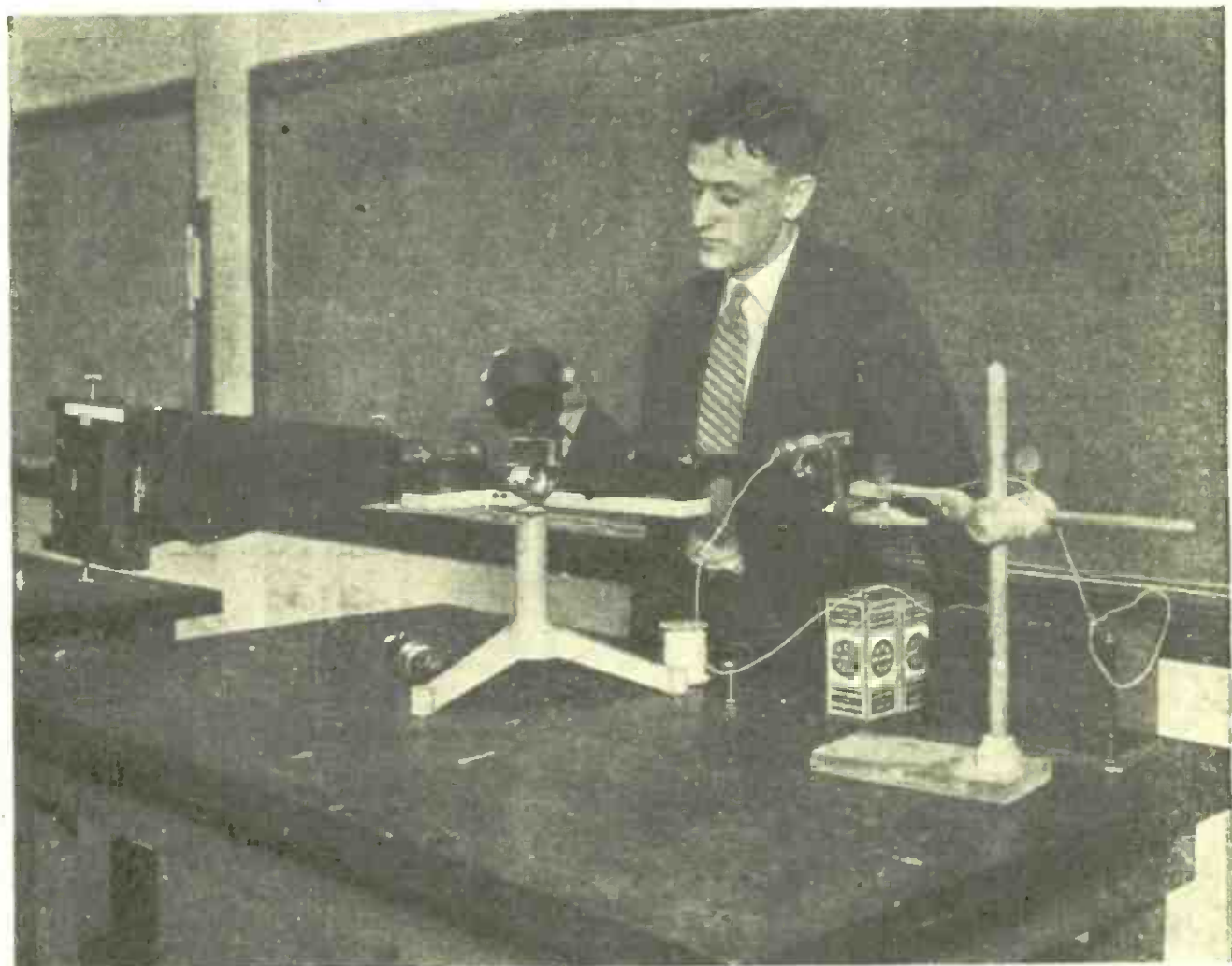

From a photograph made for POPULAR RADIO

HOW ATOMIC SPECTRA ARE STUDIED IN THE LABORATORY

Professor H. H. Sheldon of New York University is shown with a spectrometer adapted for photographing and measuring the spectrum of a gas sample. The spectrum produced in the electric discharge tube on the right is photographed in the camera attached at the left.

trons, you remember, are negative electricity. And so, when a star consists mainly of loose electrons plus a number of protons or of loose atomic nuclei it is no longer composed of "matter" in our earthly sense of that word. It is really a vast bubble of electricity.

What would happen to you at the center and focus of a lightning flash is literally nothing in comparison with what would happen to you at the center of such a stellar bubble of electricity. The voltages there must be measurable, we imagine, in billions or even trillions of volts. The temperatures probably exceed a million degrees. The intensities of light and of X rays and of other forms of ether waves are so strong as to be quite incomprehensible to us.

The rays of our sun, concentrated by a burning glass only a foot in diameter, will instantly shrivel up your finger tip as though you had stuck it into the hottest furnace. This is less than one square-foot of ether-wave energy at a distance of some 90,000,000 miles. Imagine what the ether waves of light and of heat would be like at the sun's surface. Then imagine, what we believe to be quite true, that the intensity of the ether waves inside some of the stars is possibly a billion times larger than their intensity on the surface of the sun!

The inside of a star bears about the same relation to anything that we can produce on earth as the fiery throat of the world's greatest volcano bears to the flame of a match.

Let us consider, for example, a remarkable star that Professor Eddington discussed recently in his address before the British Association for the Advancement of Science at Toronto. This star is the so-called "companion" of the dog star, Sirius.

The astronomers have known for a long time that the dog star is really double. Instead of being a single star like our sun, it consists of two bodies, each of them a vast stellar globe. They revolve around their common center of

gravity like a dumb-bell turning end over end.

From observations of the variation in the light of Sirius and of its distance from the earth and from various other data the astronomers have been able to calculate the approximate mass and size and brightness of these two companion stars. For the smaller of them the calculations indicated a size about three times that of the earth but a mass nearly as large as that of the sun. Figured out as density, this disclosed a star more than 50,000 times heavier than the same volume of water.

The sun is only about one-third heavier than water; the earth is about five and one-half times heavier; the heaviest substance that we know—the metal named osmium—is only twenty-two and a half times heavier. What wonder, then, that the astronomers believed this figure of 50,000 times the density of water to be absurd? They assumed that their calculations were wrong somewhere and thought no more about it.

But it appears from Professor Eddington's work that this is not absurd at all. This remarkable star probably really is as heavy as this, so heavy that a quarter-inch buckshot made of its substance would weigh (on earth) nearly four pounds. What a material to use for bullets!

How this can possibly be true brings us back to the structure of the atom. In the previous articles on atoms and electrons in POPULAR RADIO we have seen that the common model of an atom is that familiar to us in the solar system.* At the center of each atom there is a nucleus which corresponds to the sun. Around this nucleus revolve a number of electrons that correspond to the planets. Not all these electrons are in or near the same plane, as our astronomic planets are. On the contrary they revolve around the atomic "sun" in an extremely compli-

* See, for example, "700,000,000,000,000,000,000 Electrons for a Cent," POPULAR RADIO for January, 1924, pages 41-48, and "Bohr's New Theory of Atoms," POPULAR RADIO for April, 1924, pages 319-327.

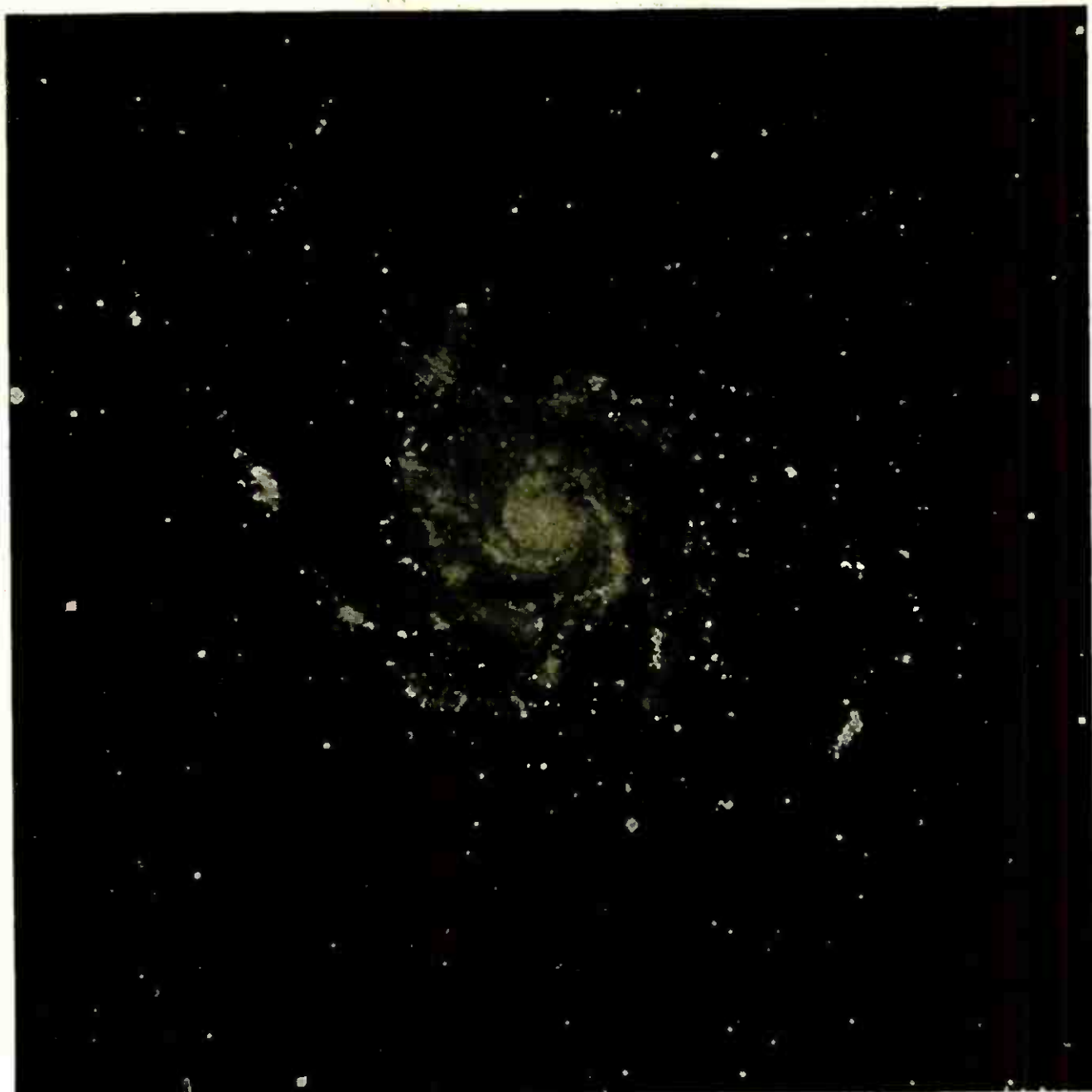

Brown Brothers

WHAT ARE THE ATOMS LIKE IN THESE GIANT WHIRLS?

Astronomers have discovered many hundreds of these giant nebula scattered through the depths of space. They spread across distances thousands of times the entire span of the solar system, yet they appear to be composed mainly of thin gas or of fine dust. Gradually the ether waves of light that they send us are enabling scientists to unravel the secrets of their nature.

cated network of orbits, a network about which we still know very little, except in the case of a very few kinds of atoms that happen to be simple and easy to investigate.

It is apparent that this makes the atom a very open kind of structure. In our solar system there is ample space between the sun and the various planets. An airship capable of traversing space might

wander around a long time inside the solar system and never come near any planet at all. Inside the atom matter is still scarcer and space is still more plentiful. It is possible to calculate that inside what seems to be the substance of a copper wire there is actually only .000,000,000,2 percent of anything solid. All the rest of the "wire" is really empty space.

Nevertheless the atoms in that copper

wire are what we call "in contact." This means that the outermost electron planets of two adjacent copper atoms come close to each other as they fly around in their respective orbits. The atomic centers cannot come any nearer. If they did their outermost electron planets would collide and something would happen to the system. That is why you cannot squeeze the copper atoms closer together and make the copper denser than it is.

But there is one thing that might happen to copper and that would permit it to get much denser. It is the thing that has happened, Professor Eddington believes, in the very dense companion star of Sirius. This is the removal of some of the outer electrons from the atoms.

We know from experiments on earth that this can really happen. In POPULAR RADIO for August, 1924, Dr. Robert A. Millikan described the remarkable experiments of himself and Dr. Bowen with what he calls "stripped atoms," that is, with atoms from which one or more of the outermost electron planets have been removed.* As many as six such electrons can be stripped away from certain kinds of atoms, leaving a residue which is still recognizable as an atom of that particular kind but which has, of course, somewhat different properties from the ordinary un-stripped atom with its full complement of electron planets.

Even before this work of Dr. Millikan, a distinguished physicist of India, Dr. M. N. Saha, had suggested that this stripping off of the electrons from an atom might actually be occurring in stars and in the sun and might be the explanation of certain peculiarities of the light sent to us by atoms of some of the chemical elements, especially calcium, from the upper layers of the sun's surface.

This suggestion has been confirmed. We know that stripped atoms actually do occur in the sun as well as in Dr. Millikan's laboratory. In the stars still hotter than the sun the stripped atoms are prob-

ably still more numerous and their electrons are presumably stripped away still more completely. It may be, even, that *all* the electron planets are stripped away, leaving only the naked nucleus of the atom, as though our sun should lose all its planets and go off by itself through space.

You see immediately how this would permit a much greater density of matter than we could ever obtain on earth. If the copper atom had no planetary electrons, so that the central suns of all the atoms could lie close together, metallic copper might have a density not merely 50,000 times as great as water but *over ten billion times as great as water*. An inch of ordinary copper wire, condensed to this degree, would weigh over two hundred tons!

It is apparent, then, that the density which the astronomers found for this companion star of Sirius is not absurd at all. Great as it is, it still permits a very loose arrangement of the atoms in it. All that is necessary is that a few of the outermost electrons of most of the atoms shall have been stripped away. This, Professor Eddington believes, is just what has really happened.

The force that has done this stripping away of the electrons may be heat, but it is much more likely to be ether waves. The intensity of such waves inside a star is tremendous. On earth the inside of most things is dark. Ordinary matter does not send out light or any other kind of ether waves. But inside a star all the matter is shining with light or possibly with heat rays or with X rays. It is like being at the very center of the glowing arc of a great searchlight.

So important is this intensity of the internal light inside a star that it is believed to be responsible for the great size of some of the stars. For example, the star named Betelgeuse, the great red star at the shoulder of the constellation of Orion, has been measured by an attachment fitted to the telescope at the Mount Wilson Observatory. It is found to have the

*"Do Electrons Play or Loaf," by Robert A. Millikan, POPULAR RADIO for August, 1924, pages 109-116.

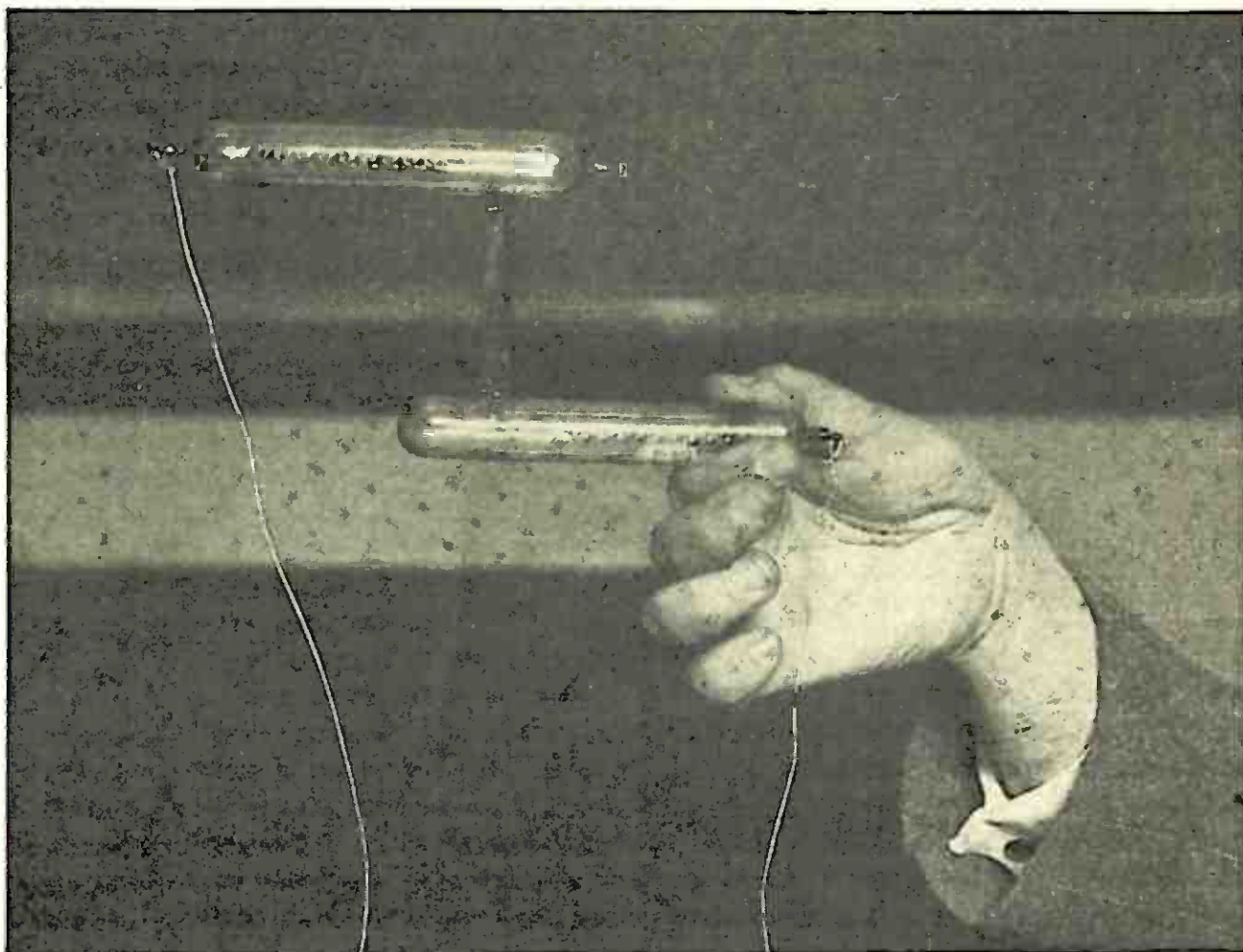

From a photograph made for POPULAR RADIO

HOW A HYDROGEN SPECTRUM IS PRODUCED

This is a close-up view of the same spectrum tube shown attached to the spectrometer reproduced on page 17. The tube is filled with hydrogen and an electric discharge is sent between the platinum terminals sealed into the upper and lower legs of the tube. This causes the hydrogen atoms in the tube to lose and regain their electrons so that they send out light pulses and produce the spectral lines.

tremendous diameter of approximately 215,000,000 miles, larger than the entire orbit of the earth.

Nevertheless, we believe that this star does not contain much more actual matter than does our sun. Its density, then, must be extremely low. Astronomers believe, in fact, that Betelgeuse and some other stars like it are nothing but bubbles of the thinnest imaginable gas. If we landed inside the mass of Betelgeuse we would think ourselves in a perfect vacuum, so thin and tenuous is the matter of the star.

This constitutes, you observe, the opposite extreme from that of the companion star of Sirius. The Sirius star is far denser than any kind of matter that we can produce on earth; Betelgeuse is far

less dense than any vacuum that we have been able to attain. The stellar laboratories transcend ours in both directions.

In the case of Betelgeuse the agency that has blown out the star to this astonishing thinness is believed to be light. Light possesses, you remember, a pressure. That is why the tails of comets are usually directed away from the sun; they are blown backward by the pressure of the sunlight. And this light pressure, acting on the fine particles of matter that compose the mass of Betelgeuse, are believed to have dispersed these particles—atoms or whatever they may be—through all this vast sphere of space that our telescopes show us to be occupied by the star.

In the giant stars like Betelgeuse the

effect of the ether waves of light on the star is to distend the star like a swollen bubble. In the case of the small "dwarf" stars like the companion of Sirius the effect of the ether waves is to strip off the electrons from some (or all) of the atoms of matter, thus permitting the star to grow many times more dense.

Why do ether waves act in these opposite ways in the two stars? We do not know. It must depend, of course, on some difference of conditions in the two bodies. Possibly it is an initial difference in mass. This is what Professor Eddington is inclined to believe. Possibly it is merely a difference in age. Betelgeuse may be a young star; the companion of Sirius an older one. Or maybe it is the other way around; the Sirius star being an early stage of stellar life and Betelgeuse a later stage. All these questions we must leave for future research to answer.

There is, however, another aspect of these matters that is of especial interest to radio engineers. It is the question of what becomes of the electrons.

If, in stars like the companion of Sirius, most of the atoms have lost a number of their electrons, these stars must operate as great factories for loose electrons. Do these electrons remain inside

the stars or do they drift off into space?

It is probable that in the main they stay within the stars. They become loose electrons drifting around inside the mass of the star just as loose electrons occur in a lightning flash. The inside of such a star might be described, indeed, as a concentrated ball of lightning.

But some of the electrons probably escape. There is a growing mass of evidence to indicate that space itself is not really empty but that it contains a vast number of electrons and perhaps even some atoms; drifting around singly in the void between the stars. In space itself, then, there may be a kind of "space charge," not so very unlike the space charge inside a vacuum tube.

We are not sure about this yet. No scientist will set his name to it. But it *may* be true. Presently the advances of astronomy and of physics will prove it for us, one way or the other. And if there are really great numbers of escaped electrons and other electric charges occupying the interstellar space that we have been thinking of as empty, it can hardly be that these charges will prove without their influences on such terrestrial matters as atmospheric electricity, on the earth's magnetic field or on radio communication.

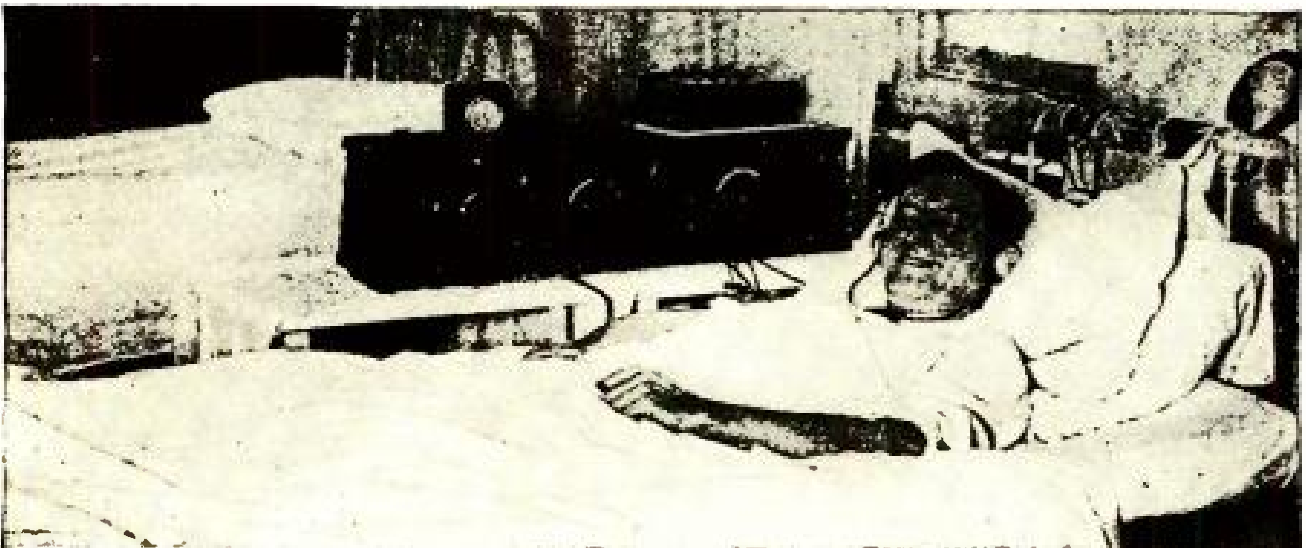

World Wide

OLD DR. RADIO IN THE WALTER REED HOSPITAL AT WASHINGTON

The curative effect of broadcast entertainment upon invalids is becoming so generally recognized that many hospitals are extensively equipped with receiving sets.

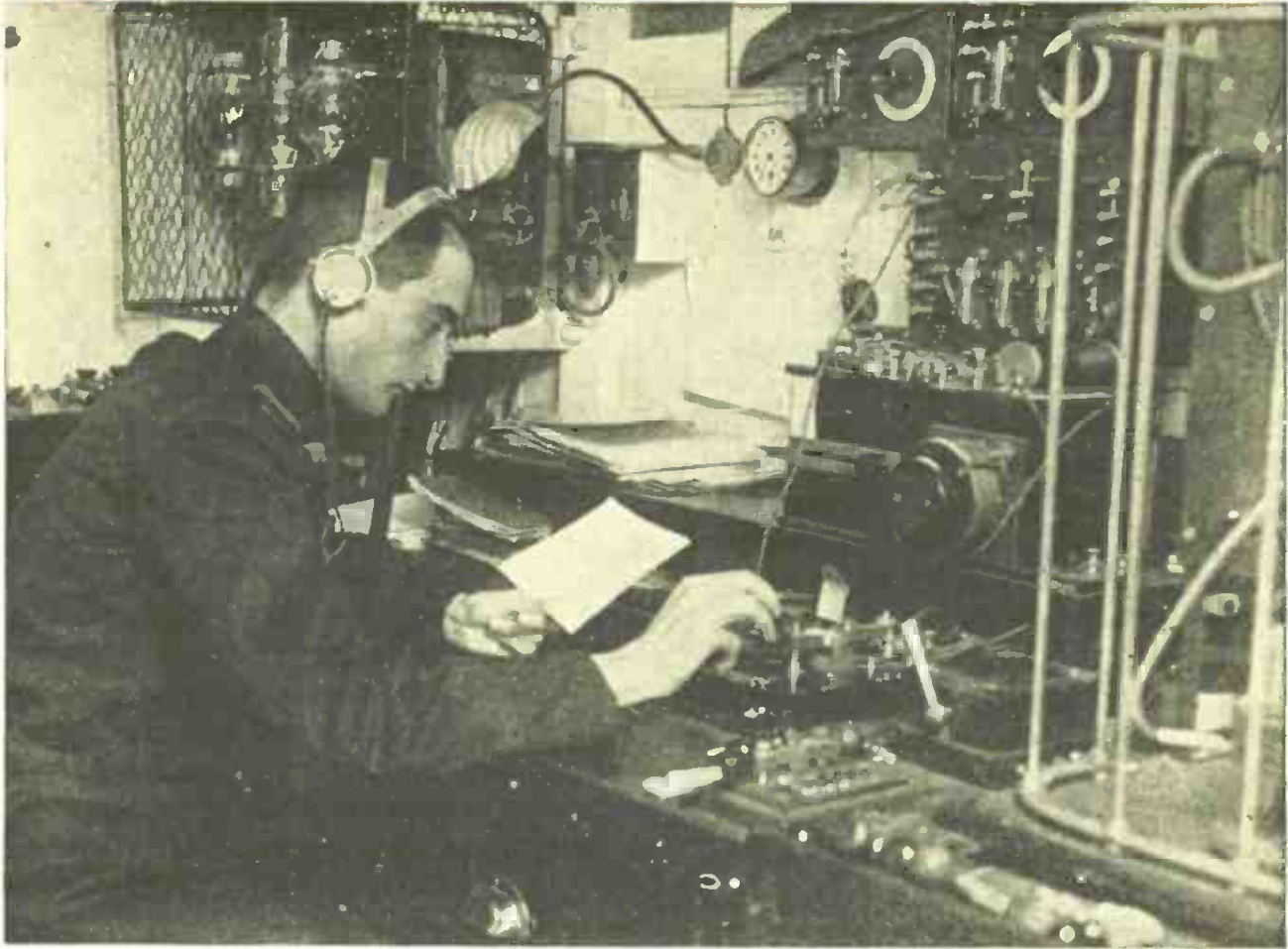

Kadel & Herbert

THIS TYPE OF SHIP STATION DOES NOT "BUTT-IN" ON BROADCAST LISTENERS

The latest type of CW radio-telegraph sets installed on ships are large factors in improved broadcast reception. The oscillations from this tube transmitter stay where they are put and do not spread out over numerous wavelengths.

HOW TO IMPROVE Broadcast Reception

IV: *Noises That Come in With the Waves*

Most of the interfering noises that are likely to arise within a receiving set, and some of those that come in from outside the receiving station, have been discussed in POPULAR RADIO for August, September and October, 1924. Now we come to a consideration of the remaining kinds of disturbing sounds—that originate at points away from the receiver.

By JOHN V. L. HOGAN

GENERALLY speaking, there are four kinds of interfering noises that may come in with the radio waves you desire to receive.

The *first* of these is caused by variations in the carrier wave from the station to which you are listening, and we have

already looked into the matter of frequency and intensity variations in these carrier waves.

The *second* kind of interfering noise is that caused by radio waves other than the one to which you are listening; interference of this kind may produce several

quite different effects in your receiver.

The *third* kind of interference is that arising from natural or atmospheric electrical discharges, and is what we ordinarily call "static" or "strays."

The *fourth* type of noise is produced by electric power or signalling lines or the apparatus connected to them, and is usually called induction.

Let us go back for a moment to the first type of interference.

Noises caused by frequency fluctuations in the carrier wave being received have been fairly well covered in the previous articles. We have also studied the matter of intensity variations to some extent, and in the August article it was pointed out that an uneven power supply at the transmitting station, or the use of bad modulating apparatus, would cause a noisy carrier wave. Before leaving the topic of "noisy carriers," as they are often called, it will be worth while to consider in a little more detail several of the ways in which they are set up. The ideal carrier wave for any radio telephone station would of course be absolutely uniform as to frequency and intensity. When no voice or musical signal is being sent out, the wave should not vary in any way. Such a uniform carrier wave, when received upon a non-oscillating receiving set, would produce no sound whatever in the telephones or loud-speaker. Consequently, when either music or speech was impressed upon this silent carrier wave it would be conveyed to the receiving station and there reproduced without any disturbing sound caused by wave fluctuations.

Now let us suppose that the transmitter which we are considering has a perfect carrier wave, within practical limits. That is to say, let us imagine that when we tune to the wave from this station we hear nothing except the telephonic voice or music. This will imply that the transmitter has a well-designed power source, so that no noises will arise from its irregularities. It also means that the modulating apparatus introduces no undesira-

ble interference. If the modulator, in addition to quiet operation, has the ability to impress upon the carrier wave faithfully-copied variations corresponding almost exactly with the sound variations that strike the pick-up microphone, we have every reason to expect high grade transmission from the station.

Why Carrier Waves Are Sometimes Noisy

But it often happens that a broadcasting transmitter has a carrier wave that is normally silent and free from frequency changes, together with a modulating system that is capable of high-quality tone production, yet that when we listen on some particular occasions the signals are accompanied by noises and are not clearly reproduced by our receivers.

When this happens, many listeners are apt to say that the trouble is caused by "bad modulation."

As a matter of fact, the modulating operation of the radio transmitter may be perfect and the troubles may occur far away from the modulation apparatus of the broadcasting station. It is much more common, in well-planned broadcasting stations, for noises and distortion of this kind to develop in the pick-up microphone (and its amplifier and connecting line systems) than in the modulating apparatus itself.

If you know what to look for, it is not hard for you to pick out cases where noisy carrier waves are produced by the effects of the pick-up line that connects the microphone with the radio generating portion of the broadcast transmitter. Usually the short pick-up line that runs from oscillation generator and modulator equipment to a nearby studio is quite free from such influences, and thus when the station is broadcasting events from its studio there may be none of the interfering noise heard by radio listeners.

On the other hand, it is quite common for the longer pick-up lines that are used

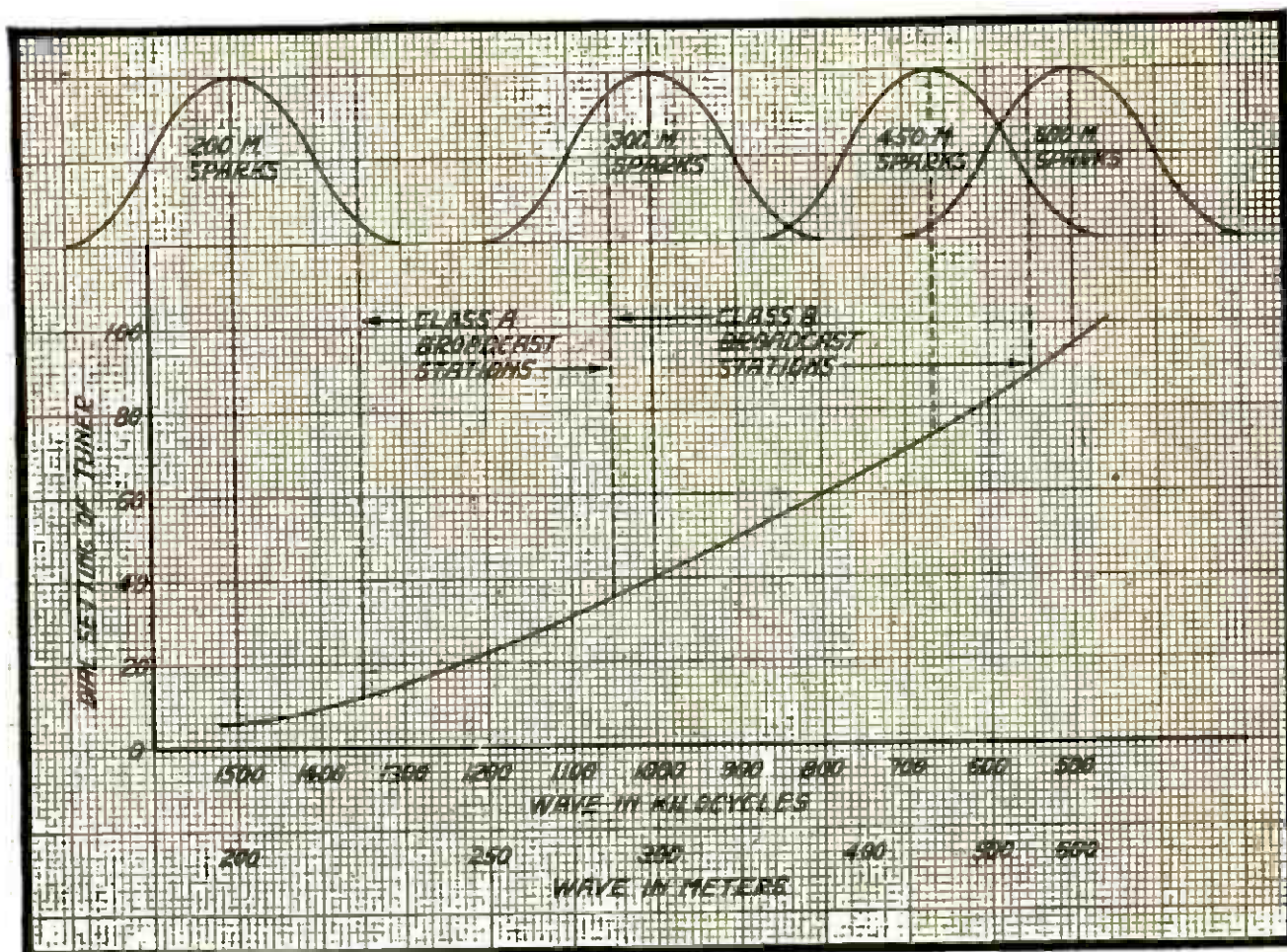

HOW THE SPARK SETS MAKE TROUBLE

The curves at the top of the figure show how signals from spark transmitters of commercial radio-telegraph stations spread out over the broadcast wavebands. The reason for changing the spark-set wavebands is apparent from this illustration.

in transmitting "out-of-studio" programs (such as park concerts, sports, and so forth) to bring various kinds of noises into the radio sending apparatus. If the carrier wave, as heard between the announcements or the numbers of the program, is silent when transmission from the studio is going on, but noisy when outside events are being broadcast, you may be sure that the noise is a wave-intensity variation introduced by disturbances affecting the long pick-up lines.

Sometimes the sources of these noises may be identified by listening closely; electric motors, stock tickers and telephone ringers all have characteristic sounds. Any of them may induce disturbing currents (in a microphone pick-up line) which, when conveyed to the modulating apparatus, will be impressed upon the outgoing radio waves and thus carried to your loudspeaker.

The Causes of Poor Quality

In the same way you may note variations in the quality of reproduction when listening to different program items that are broadcast from some particular station. If the speech is clear and distinct when the speaker is at the studio, but muffled and hard to understand when he is talking over a long pick-up line, you may be sure that the faulty transmission is not caused by "poor modulation" but by poor transmission to the modulating apparatus. The defects introduced by poor pick-up lines, which often will convey telephone currents of some frequencies far better or far worse than a good average value, are particularly noticeable in musical transmission. Often a poorly adjusted pick-up line so distorts the currents that the tones of individual musical instruments cannot be identified with certainty.

¶ When you notice noisy carrier waves or distorted transmissions of the kinds I have just described, you will be doing a great favor to broadcast listeners generally if you will write to the management of the offending broadcasting station and tell them what you have observed.

But when you write, don't say that the trouble is caused by "bad modulation" if in fact the modulator is doing its best and the noise is introduced by the pick-up lines!

How to Reduce Radio Frequency Interference

Next let us take up the second general type of interfering noises that come in with the waves.

This second type is radio wave interference. To make improvements in your reception when it is disturbed by radio interference is not, as a rule, a matter of writing letters to the interfering stations. In the vast majority of cases the trouble can be completely remedied, or at any rate greatly reduced, by modification or careful adjustment of your receiver.

Radio wave interference is probably the greatest single cause of imperfect broadcast reception. It is of course true that there are many defective radio receivers in use, and that these sets reproduce noisily or with distortion, but so far as I can determine the great majority of receiving sets function correctly within the limits set by their design. In two of the earlier articles of this series I took up some of the more usual sources of trouble within the receivers themselves, and indicated how these troubles could be done away with. We must now assume that your receiver is working as well as it can, and, in treating "outside" causes of receiving difficulties, limit ourselves to effects that occur in spite of a more or less approximate perfection in the individual parts and the assembly of the receiving set. If your set is not working well, and if you can locate the trouble

within its circuits (as outlined in the October number, for instance), you should repair it before giving any time to the matter of outside interference.

There are three main varieties of radio wave interference, and these have come to be known as "sparks," "whistles" and "cross-talk."

The division called "spark interference" should really include all types of telegraphic code disturbance, even though the interfering radio-telegraphic station is not of the spark type. Practically all interference of the code classification, however, comes from the old-fashioned spark transmitters that are still in use in so many radio-telegraph stations, and so all of it is generally blamed on sparks.

In the survey of interference that I made by tabulating the letters received after my tenth talk on the subject, broadcast through WEAJ last winter, I found that out of over 5,000 interference complaints the greatest number emphasized spark disturbances as being most prominent.

Of course, conditions vary both with the type of receiving set in use and with the location of the receiver; some people who wrote me experienced absolutely no trouble from spark interference, but they were in general situated away from the coast lines and therefore away from the places where telegraphic signals from ships at sea are received most loudly. Interference from code transmitters is growing less as time goes on, because more and more spark sending stations are being re-equipped with modern transmitters that cause less disturbance. Further, there is in formulation a plan to reduce the trouble from the spark transmitters still remaining in service, by transferring their operations to wave-frequencies farther removed from the broadcasting range. Assistance along these lines will assuredly be welcomed by broadcast listeners everywhere, but as great progress in either direction will necessarily take some time it seems well worth while to see what can be done to



Keystone

AN OLD SPARK SET THAT MAKES THE ETHER WAVES WILD

This type of radio-telegraph transmitter is fast disappearing; the Government is replacing them in its stations with CW sets that will cut out the old "busting-in" that used to be such a nuisance. The assignment of new wavebands for them will also help solve the problem.

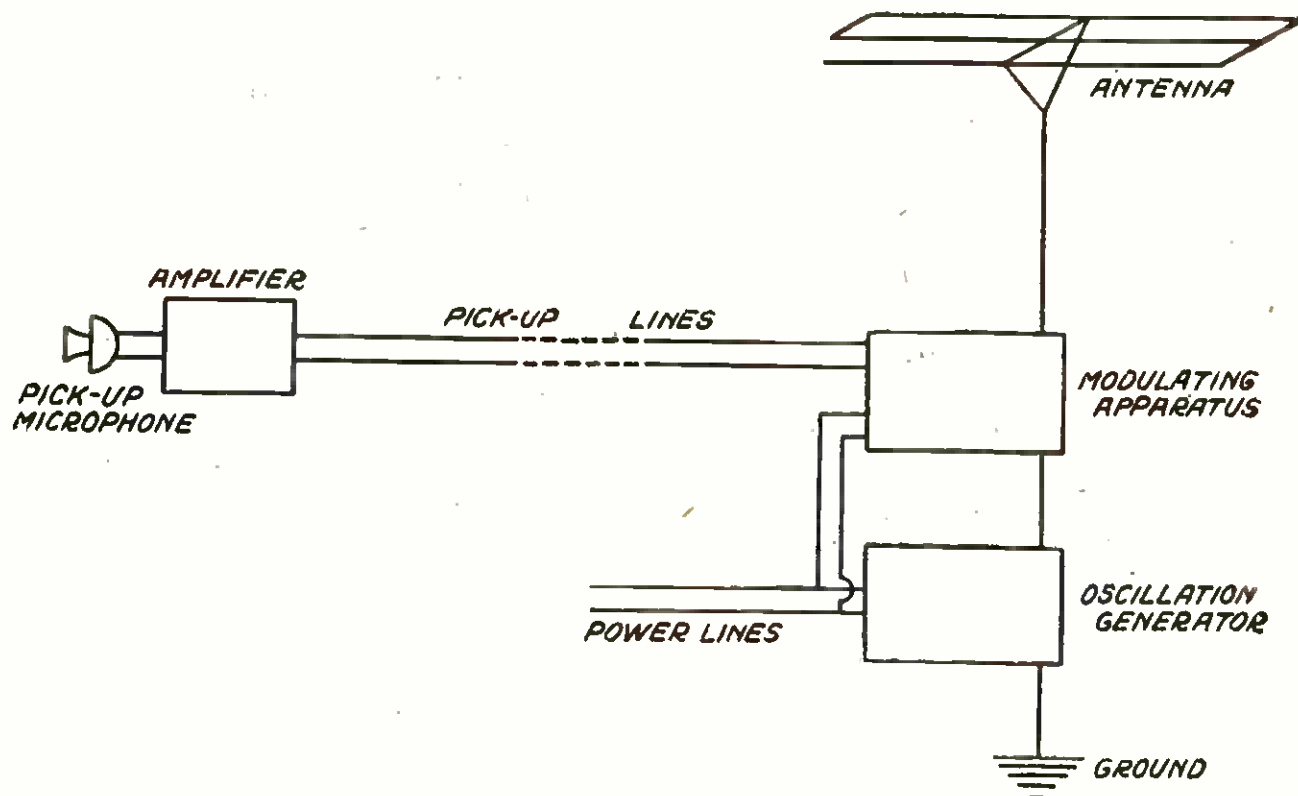

THE MODULATOR IS BLAMED FOR MOST FUZZY NOISES

In reality the pick-up microphone, the amplifier and the pick-up lines shown in the diagram above are the sources from which many stray noises come to your loud-speaker.

make receiving sets themselves less susceptible to spark interference.

How to Meet the "Spark" Problem

Let us see, then, just what the spark interference problem amounts to.

Suppose that you are listening to a broadcasting station of which the wave frequency is 610,000 cycles a second, corresponding to a wavelength of 492 meters.

Your receiver may be sufficiently well tuned to prevent your hearing any other broadcasting stations, but still the broadcast program may suddenly be interrupted by loud dots and dashes that come in from some unknown radio telegraph transmitter. Whether or not you are disturbed by such code interference will depend mainly upon four factors. The first of these is the difference between the frequencies of the desired wave and the interfering wave. The second is the width of wave-frequency band occupied by the interfering wave. The third is the excluding power (or sharpness of tuning) of your receiver; and the fourth

is the intensity of the interfering signal compared to the broadcast signal you desire to receive.

We should examine these four factors separately if we are to understand the situation, and if we do not understand the problem we are trying to solve there will be only an exceedingly remote chance of our making any progress. From some viewpoints it is one of the misfortunes of present-day radio that the practical development of broadcasting has come so rapidly, for the demand for apparatus and services of all kinds has been too great and too sudden to permit sound engineering to be the rule rather than the exception.

Considering, then, the effect of frequency difference upon interference, it is not hard to see that with other conditions remaining unchanged we will have least trouble from interfering waves that are widely different in frequency from the wave we desire to receive. This is simply because any receiving set that has any pretensions to selective ability, or the

power to respond well to signals of some particular (tuned) frequency while excluding signals of other (untuned) frequencies, will discriminate to the greatest extent between waves of widely different frequency values.

What differences in wave frequency may we expect under today's conditions of broadcasting and marine radio-telegraph signalling?

The best and most concise answer to that question may be had from a tabulation of the various values of wave frequency in use, as shown below:

It is quite evident that amateur spark transmitters that use waves at or near the frequency of 1,500 kilocycles (1,500 thousand cycles or 1,500,000 cycles) will be likely to interfere with reception from broadcast stations that use the higher frequencies in class A, and that marine spark transmitters will often cause trouble in receiving from class B stations near the frequencies of 1,000 kc, 666 kc and 500 kc. There is little message traffic handled by ships at the high-frequency wave of 1,000 kc, and the Department of Commerce has assigned no broadcasting wave nearer to it than that of WSAI (Cincinnati) at 970 kc; consequently the 1,000 kc ship wave does not greatly trouble

broadcast listeners. The 666 kc wave has been extremely bothersome, as it comes right in the middle of the broadcasting range:

- 640 kc KFI, WCAP and WRC (Los Angeles and Washington)
- 650 WCAE (Pittsburgh)
- 660 KDZE and WJZ (Seattle and New York)
- 666 *Ship Interference*
- 670 WMAQ (Chicago)
- 680 WOS (Jefferson City)
- 690 NAA (Radio, Va.)

Regulations have been put into effect by the Department of Commerce, however, which have had the effect of greatly reducing the marine traffic transmitted at 666 kc, and this has been of great help to broadcasting. The most important marine traffic wave, of 500 kc, is still largely used by spark transmitters and still causes much interference for listeners who are receiving from KSD (St. Louis, 550 kc), KYW (Chicago, 560 kc), WNYC and WOAW (New York and Omaha, 570 kc), and some others which use the lower-frequency waves.

When you experience spark interference with your broadcasting reception, it is a good plan to tune your receiver to the interfering station for a moment. If your set is of one of the types in which

<i>Frequency</i>	<i>Wavelength</i>	<i>Service</i>
1,500,000 cycles	200 meters	Amateur Radio-telegraph Transmitters
1,350,000	222	Class A Broadcasting Stations
to 1,050,000	to 286	
1,040,000	288	Class B Broadcasting Stations
to 1,000,000	to 300	
1,000,000	300	Marine Radio-telegraph Transmitters
1,000,000	300	Class B Broadcasting Stations
to 670,000	to 448	
666,000	450	Marine Radio-telegraph Transmitters
660,000	455	Class B Broadcasting Stations
to 550,000	to 546	
500,000	600	Marine Radio-telegraph Transmitters

the scale readings are more or less proportionate to the wavelength to which it is tuned, you can get a very fair idea of the wave frequency of the station causing the trouble. For instance, if WNYC comes in at 80 on your tuning dial and the code interference becomes louder as the dial reading is increased to 95, for example, it is evident that the interfering wave is in the neighborhood of 500 kc. If the interference is loudest near the tuning point for WJZ or WCAE, the bothersome station is probably using the

666 kc wave. If the interference is far down the scale it may come from 1,000 kc ships or 1,500 kc amateur transmitters. The radio-telegraph transmitters occasionally send out incorrectly adjusted waves (and both commercial and amateur stations sometimes offend in this respect); a little experience in observing interference as suggested above will aid you to determine this fact, and you may be able to do some good by reporting your test to the Radio Supervisor in your particular district.

Q *The next article will tell more about this spark interference problem and will point out some of the things the listener can do to reduce its harmful effects.*

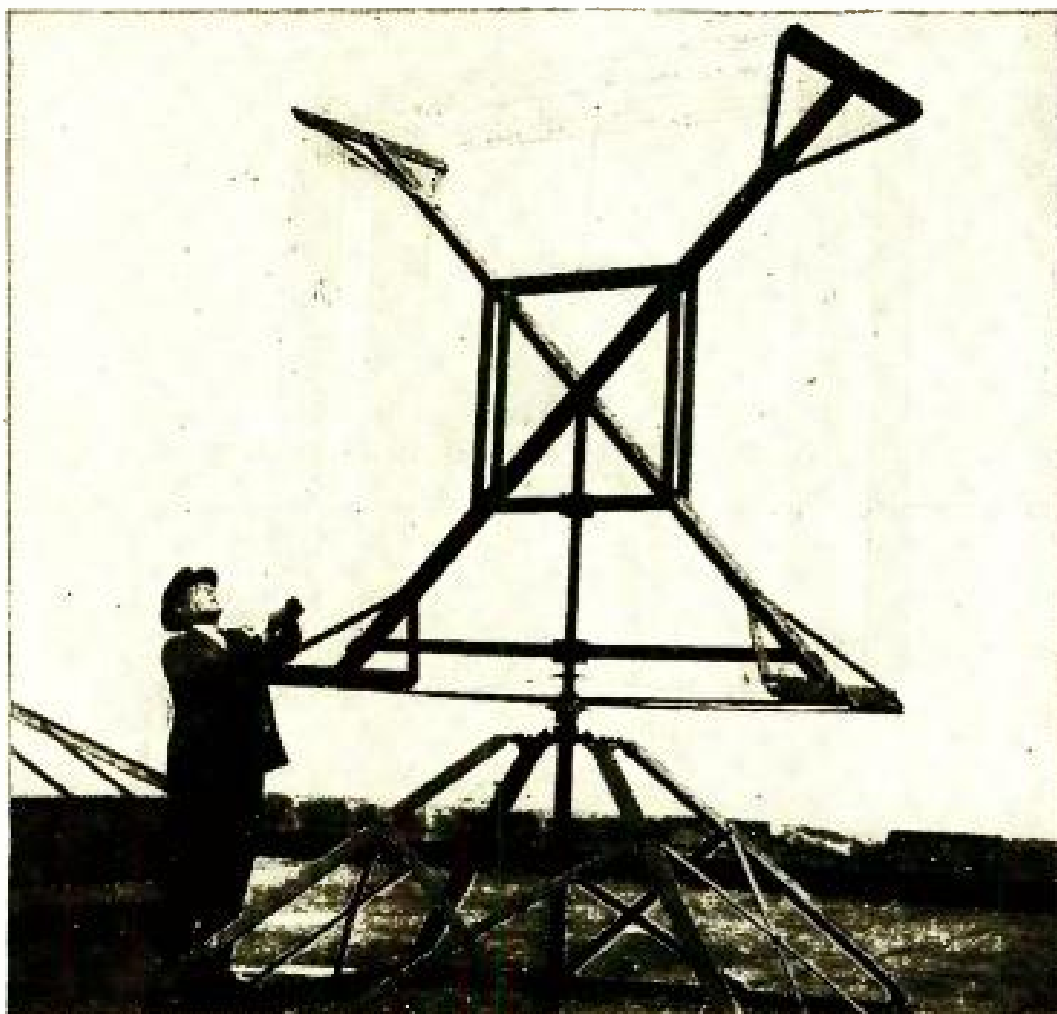

Photopress

ONE OF THE LARGEST COMMERCIAL LOOPS IN THE WORLD
It receives from a distance of 8,000 miles; and it is eight feet square. The United States Shipping Board uses it in London to conduct its daily business with the American headquarters in New York.

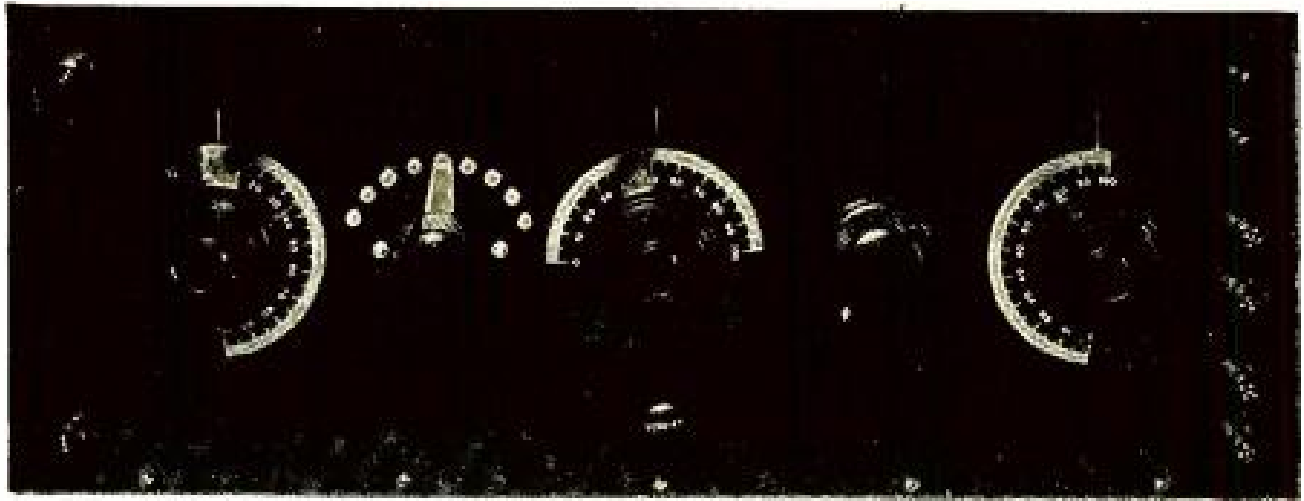

THE FRONT VIEW OF THE PANEL

The dial at the left controls the coupling between the primary and the secondary circuits, the taps control the antenna wavelength, the middle dial controls the secondary wavelength and the dial at the right controls regeneration. The small knob between the latter two dials is for the filament current control.

Simple "How-to-Build" Articles for Beginners No. 5

How to build a single-tube tuned-plate receiver

By LAURENCE M. COCKADAY

COST OF PARTS: *Not more than \$25.00*

APPROXIMATE RANGE: *500 miles.*

HERE ARE THE ITEMS YOU WILL NEED—

- | | |
|---|--|
| A—R. P. C. variocoupler; | F—Electrad combination variable grid-leak and condenser; |
| B—New York Coil Co. vernier variable condenser, .0005 mfd.; | G—Amsco switch lever; |
| C—Coto compact variometer; | H—composition panel, 7 by 18 inches; |
| D—Goodrich vacuum tube socket; | I—baseboard, 7 by 17 inches; |
| E—CRL filament rheostat, 6 ohms; | and eight binding posts. |

THE fifth receiver of this series is a vacuum-tube regenerator that employs a variocoupler and a variable condenser for tuning the antenna and secondary circuits, respectively, and a variometer for tuning the plate circuit and thus controlling regeneration.

This receiver was built in POPULAR RADIO LABORATORY with the express purpose of submitting to the beginner a set that will teach him the principles of regeneration and allow for good head-phone reception from local and distant stations.

The set is simple to construct and op-

erate, as are all of the other sets described in this series.

Take these pages to a radio dealer and ask him to supply you with the parts listed above. Then carry the parts you have obtained to your home and to your kitchen work table and set them up on the panel and the baseboard as shown in the picture diagram and in the two photographs accompanying this article.

Next wire up the instruments as indicated in the picture diagram. If you follow the circuits as given there, you cannot make a mistake, since all the connections are clearly shown and the in-

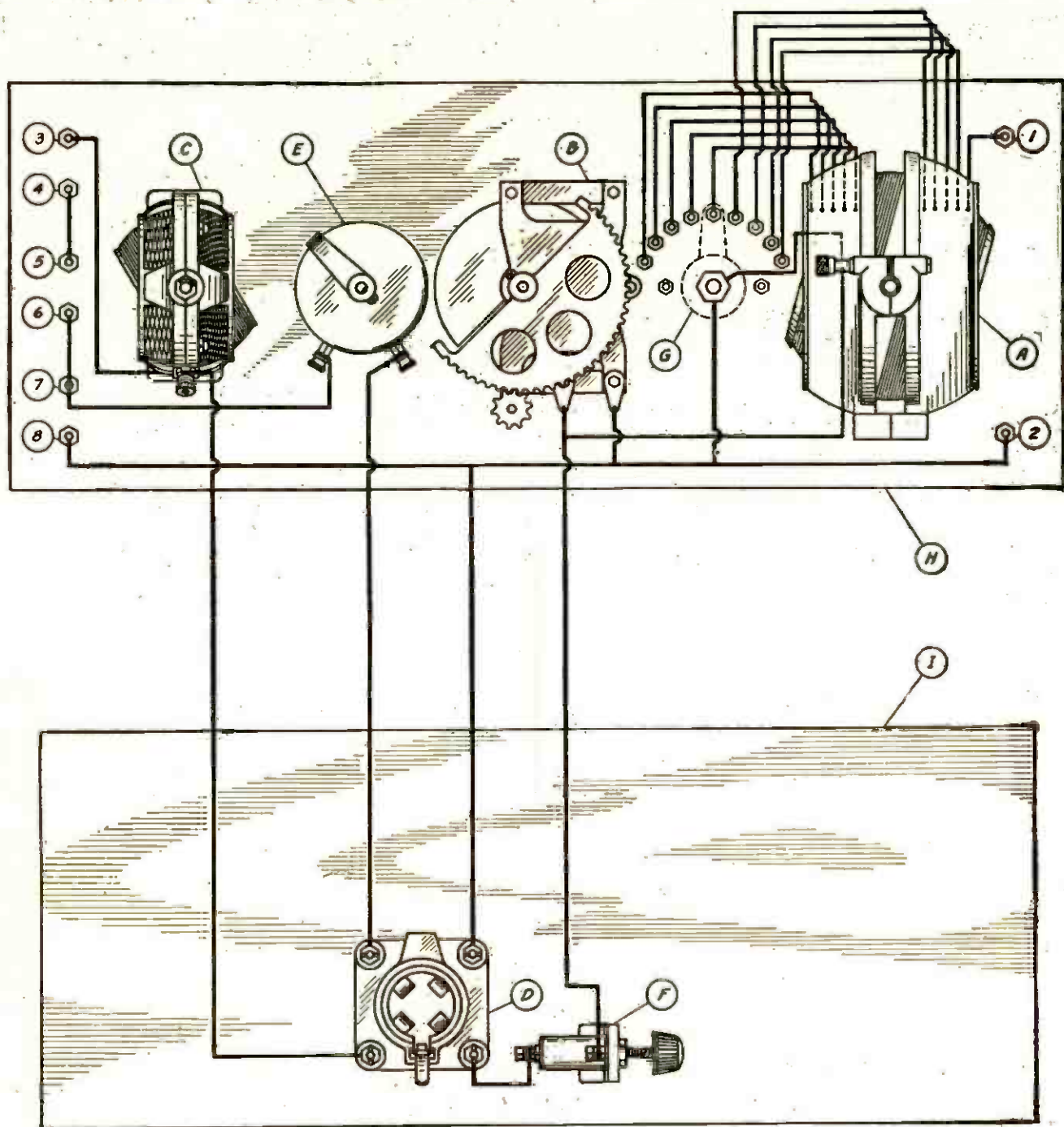

THE "PICTURE DIAGRAM" OF THE HOOK-UP

This illustration shows the exact manner that the instruments should go in the set. The upper rectangle shows the back of the panel, and the lower shows the baseboard. All parts are lettered to correspond with the designations in the text.

THE PREVIOUS ARTICLES OF THIS SERIES

- No. 1: How to Build a Single, Dry-cell Tube, Four-circuit Tuner; August, 1924.
- No. 2: How to Build a Single, Dry-cell Tube, Reflex Receiver; September, 1924.
- No. 3: How to Build an Efficient Crystal Receiver; November, 1924.
- No. 4: How to Build a Single-tube, Reinartz-circuit Receiver; December, 1924.

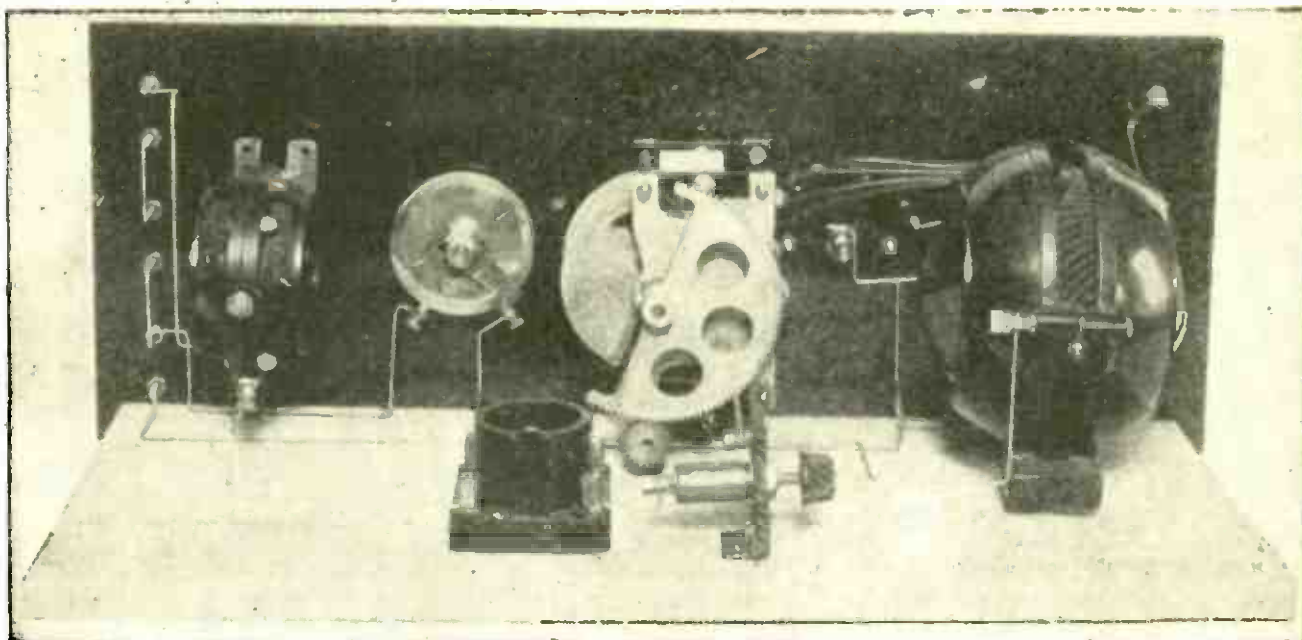

VIEW OF THE SET FROM THE REAR

Compare this photograph with the picture diagram when you are mounting the parts or wiring up the set. The wiring is extremely simple and can be done in less than one-half hour.

struments are all marked with designating letters that re-appear in the list of parts and in the text.

When you have finished wiring up, all you have to do is to connect the headphones, the antenna, ground, and the batteries to the set.

The antenna and ground connections should be attached to the binding posts marked No. 1 and No. 2. The telephones should be connected to the posts No. 3 and No. 4. Connect a six-volt storage battery across the posts No. 7 and No. 8, with the positive terminal connected to post No. 7. Connect a 22½-volt "B" battery across the posts No. 5 and No. 6, with the positive terminal connected to the post No. 5. A 100 to 150-foot single wire antenna will be suitable.

To tune the set, place the switch lever G on the middle tap, for a starter, and with the dials A and C at zero, rotate the dial of the condenser B until you pick up a signal. Then make the final adjustments for G, C, and A. Next set the grid-leak F to the loudest signal strength. The rheostat E should be set just below the point where a hissing sound is heard in the phones.

You will find that you will get sharper tuning when the coupling between the coils of the coupler A, is lessened. In other words the tuning will be sharper when these two coils are placed almost at right angles.

Do not allow the set to squeal or you will disturb your neighbor's reception. Make this your first and final rule, and you will not cause trouble!

How to Build a Simple Set That Runs on Dry-cell Batteries

IN POPULAR RADIO for next month—February—will appear another "how-to-build" article that will tell the beginner by means of a picture-diagram, photographs and text, the construction of a single-stage of audio-frequency amplification of the transformer-coupled type, that can be run on dry-cell batteries. This amplifier may be hooked to any of the single-tube receivers that have been described in this series.



Courtesy of Tufts College Library

The MEN WHO

2nd Installment

THE FIRST TO PATENT A METHOD OF RADIO COMMUNICATION

AMOS E. DOLBEAR, a professor of physics at Tufts College, and an inventor of numerous electrical devices, patented a wireless communication method in 1886. His transmitter was an elevated wire with an induction coil but no spark gap; his receptor was a telephone receiver. Considerable uncertainty surrounds the practical value of his experiments.



From a photograph made for POPULAR RADIO

THE FIRST INVENTOR TO RULE THE ELECTRIC WAVES

ELIHU THOMSON, an American inventor, performed experiments with high-frequency currents with the aim of developing a practical method of electric welding. His work, however, resulted (about 1876) in the theory of alternating currents that has been expanded into the theory of radio waves. He produced a 64-inch spark, but made no attempt to signal with it. Thomson did not consider the behavior of his high-frequency currents as anything but simple inductive action. In reality he was creating and controlling damped electric oscillations capable of producing the first type of waves used in radio.

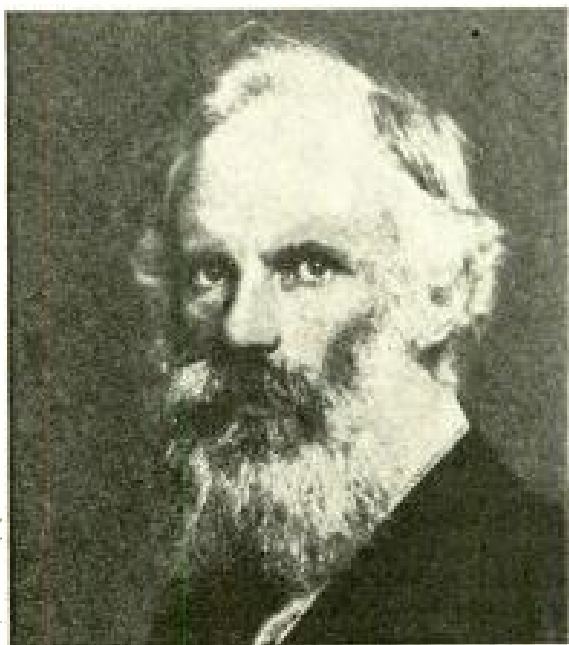

THE FIRST TO EXPOUND A RADIO SIGNALLING THEORY

As a student of Maxwell, it was to be expected that GEORGE F. FITZGERALD of Dublin would follow up the electric wave theory of his tutor. He sought a confirmation of Maxwell's theory, and although he was never able to arrive at proof, he pointed out in 1883 that the discharge of a condenser could be used to signal through space. He believed it would be possible to produce a manageable wave. In 1887 Hertz experiments verified the calculations and predictions of Fitzgerald in most phases.

MADE RADIO

THE GERMAN WHO PROVED THE THEORIES OF RADIO WAVES

HEINRICH HERTZ, a German scientist, in 1887 experimentally proved Maxwell's theory of the similarity of light and electric waves. He created sparks and used a circuit of wire, "the Hertz resonator," as a spark detector. He measured the length and velocity of the electro-magnetic waves he produced. He discovered besides that these electric waves are sent out at regular intervals; and that they are susceptible to refraction and polarization. His work was the first solid foundation for future radio experiments.



THE DISCOVERER OF "THE EDISON EFFECT"

By observing the emission of electricity from hot carbon filaments of his electric incandescent lamp, THOMAS A. EDISON in 1883 paved the way to the development of the vacuum tube. By sealing a plate within an incandescent bulb he was able to establish a circuit through the heated gas and carbon particles. In 1885 Edison signalled from a moving train, employing the inductive effect that occurs in telephone circuits. He patented his invention; and showed in his patent application the need of an elevated antenna to overcome the curvature of the earth. He pointed out besides the possibility of signalling from ships to shore and VICE-VERSA.



THE PROPHET OF RADIO COMMUNICATION

SIR WILLIAM CROOKES is best known as a chemico-physicist and for his discoveries about electrical discharges IN VACUO. In 1892 he startled the imagination of the world when he outlined theoretically the principles of modern radio communication. On the basis of the work of Hertz, he prophesied a simple method of generating electric waves; a method of tuning, and finally a directional means of transmission. His proposal was based on the use of the Morse code between two stations properly attuned. He foresaw the use of numerous wavelengths to overcome interference.



Elliott & Fry

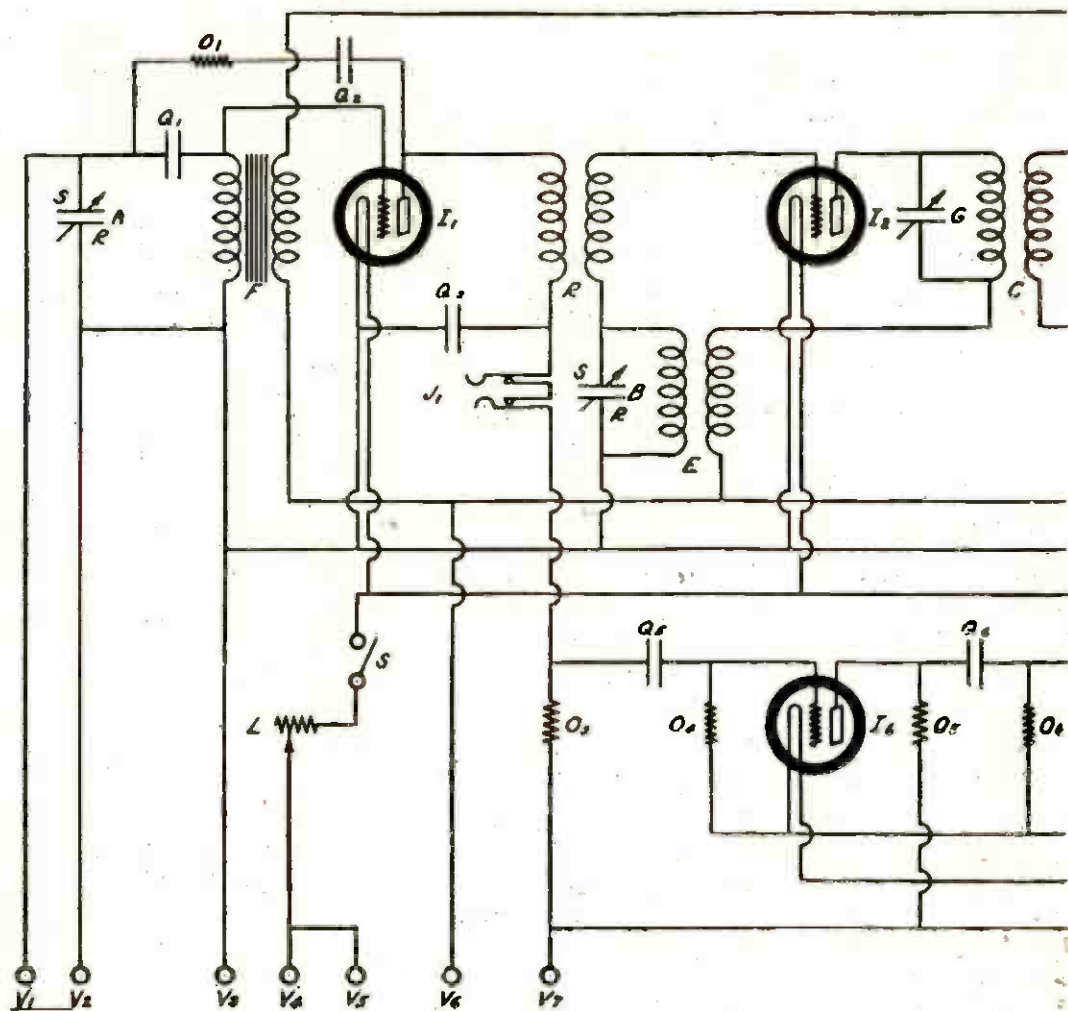

HOW TO BUILD AN 8-TUBE SUPERHETERODYNE REFLEX RECEIVER

Here is a new loop receiver that embodies the latest and most advanced principles that are known for radio reception. In it there are used in combination, a new method of reflexing, the superheterodyne principle of radio-frequency amplification, the second-harmonic autodyne oscillator, the phidyne method for preventing feed-back and radiation, and resistance-coupled audio-frequency amplification. Although this may appear to be complicated, the set is not difficult to make. It tunes simply, and brings in the local and distant programs on a loop with startling strength and clarity, and without interference.

—EDITOR

By LAURENCE M. COCKADAY, R.E.

COST OF PARTS: *Not more than \$80.00*

RECEIVING RANGE: *Up to 3,500 miles*

HERE ARE THE ITEMS YOU WILL NEED—

- A—General Instrument "Low-loss" condenser, Isolantite insulation, .0005 mfd.;
- B—General Instrument "Low-loss" condenser, Isolantite insulation, .001 mfd.;
- C—Haynes-Griffin "Input transformer," (new type);

- D1, D2, D3 Haynes-Griffin Intermediate Transformers (new type);
- E—Precision autodyne coupler;
- F—Karas Harmonic audio-frequency transformer;
- G—Amplex grid-denser, .0005 mfd.;

Attention is called to the fact that this article is protected under the provisions of Section 3 of the Copyright Law of the United States.

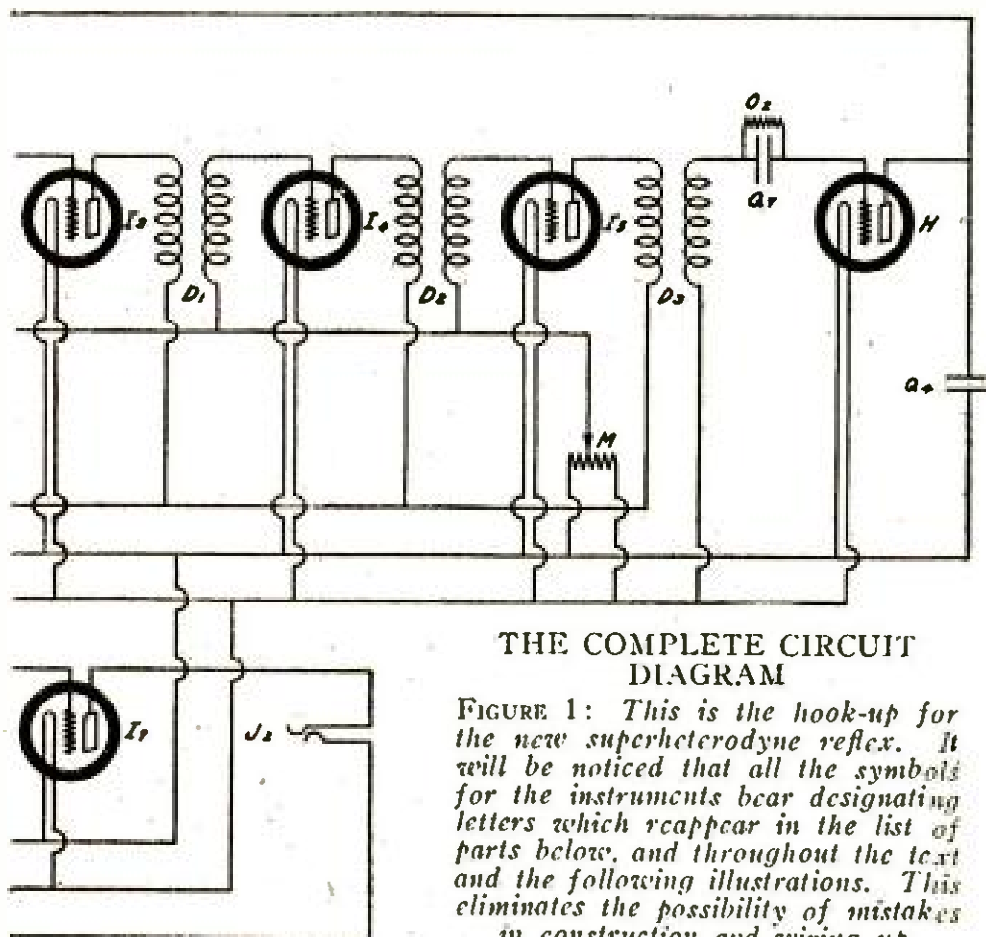

H—Benjamin Cle-ra-tone socket;
 I1, I2, I3, I4, I5, I6, I7—Federal sockets No. 16;
 J1 and J2—Pacent jacks, double circuit and single circuit, respectively;
 K1 and K2—Naald 4-inch dials;
 L—Amsco rheostat, 2 ohms;
 M—Amsco potentiometer, 400 ohms;
 N1 and N2—Daven Resisto-coupler mountings;
 N3—Daven grid-leak mounting;
 O1—Daven resistor, .5 megohm;
 O2—Daven resistor, 5. megohms;
 O3—Daven resistor, .005 megohm;
 O4—Daven resistor, .5 megohm;
 O5 and O6—Daven resistor, .25 megohm;
 P—panel, 7 by 24 inches;

Q1 and Q2—New York coil mica condensers, .0001 mfd.;
 Q3, Q4, Q5, Q6—New York coil mica condensers, .006 mfd.;
 Q7—New York coil mica condensers, .00025 mfd., with grid-leak mounting;
 R—Duratran radio-frequency transformer;
 S—Walbert "A" battery switch;
 T—baseboard 9 $\frac{3}{8}$ inches by 22 $\frac{3}{4}$ inches by $\frac{1}{2}$ inch;
 U—Connection block 1 inch by 9 inches by $\frac{3}{8}$ inch;
 V1, V2, V3, V4, V5, V6 and V7—Eby binding posts;
 W—brass brackets;
 X—Cabinet for 7 by 24-inch panel, (9 $\frac{1}{2}$ inches deep inside measurement).

THERE are many good places where the owner or prospective owner of a receiving set cannot put up an outdoor antenna and many accessible places where the outdoor antenna would not be efficient. This article is written for those who are concerned about the selection of an outdoor antenna location.

The superheterodyne receiver described here operates from a loop antenna and is easy to tune. It has only two tuning dials located centrally on the

front panel. All the tubes are controlled by a single rheostat, and regeneration in the intermediate amplifier is controlled by a single potentiometer. These two latter controls need to be set only once; and the rest of the tuning is done entirely with the two larger dials K1 and K2 shown in Figure 4.

The set is comprised of the following theoretical components:

1. A loop tuning circuit connected to a single stage of radio-frequency amplifica-

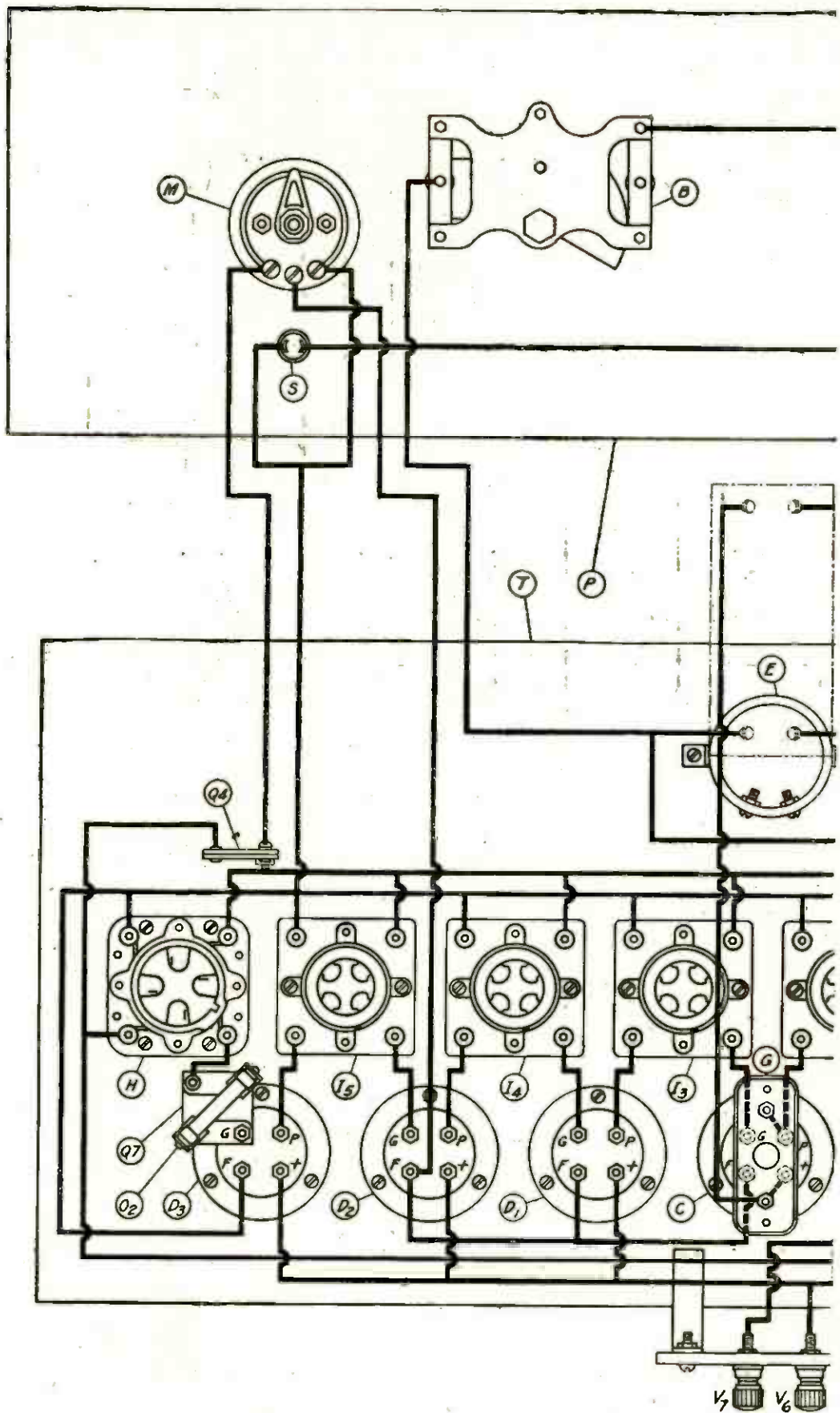

THE WORKING PLAN FOR CONNECTING UP THE VARIOUS

FIGURE 2: The upper rectangle represents the panel and on it the instruments are drawn just as they appear. The lower rectangle represents the baseboard and the instruments are drawn in about their relative positions.

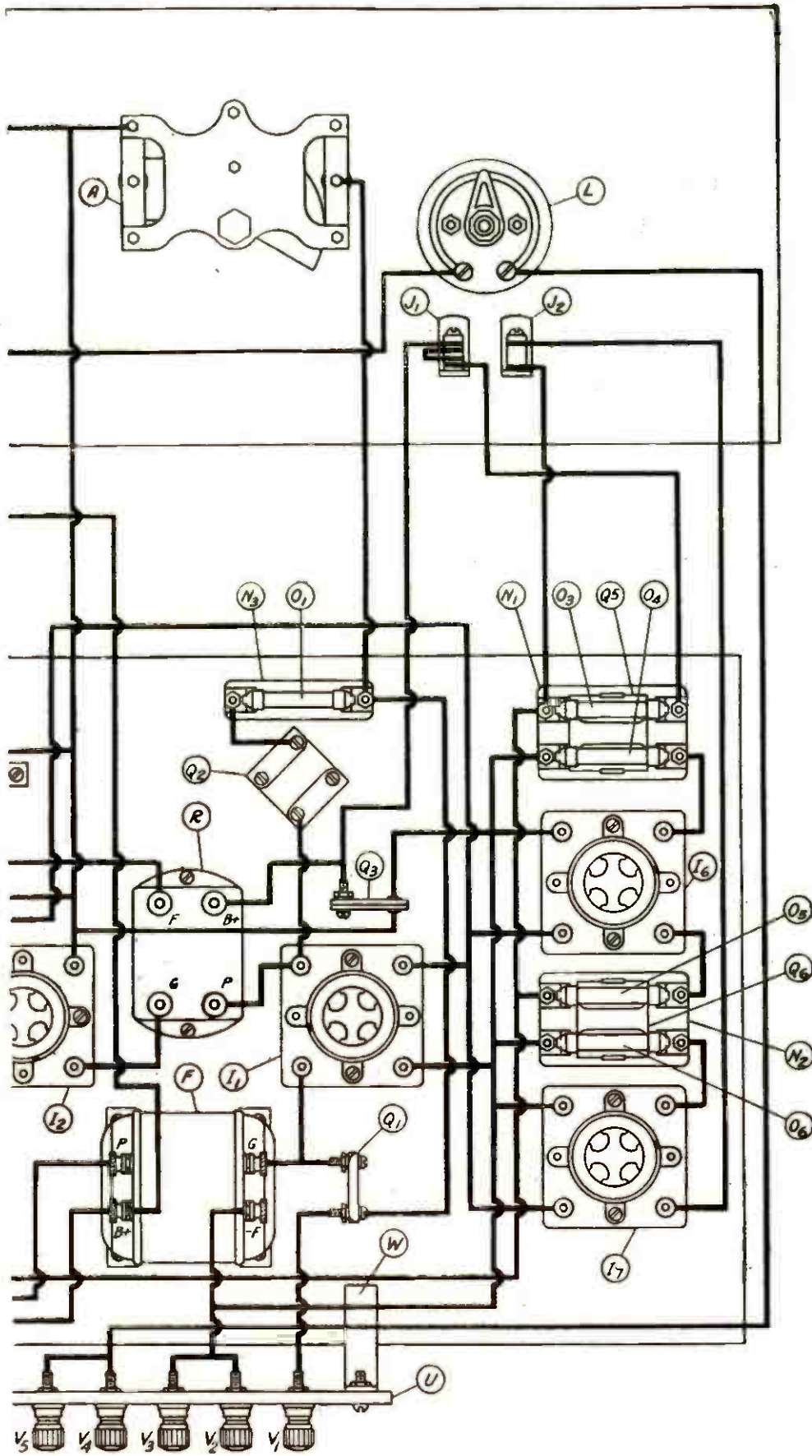

INSTRUMENTS TO MAKE UP THE COMPLETE CIRCUIT

The wires drawn in in heavy black lines show the exact way to run the wires to connect the instruments and parts after you have mounted them according to the instructions given.



THE PANEL VIEW OF THE RECEIVER

FIGURE 4: This gives an idea of how the set looks from the front and as the dials and knobs are marked with letters which correspond to the instruments to which they are attached, the prospective operator will have no trouble in locating the various tuning controls as they are explained in the instructions for tuning.

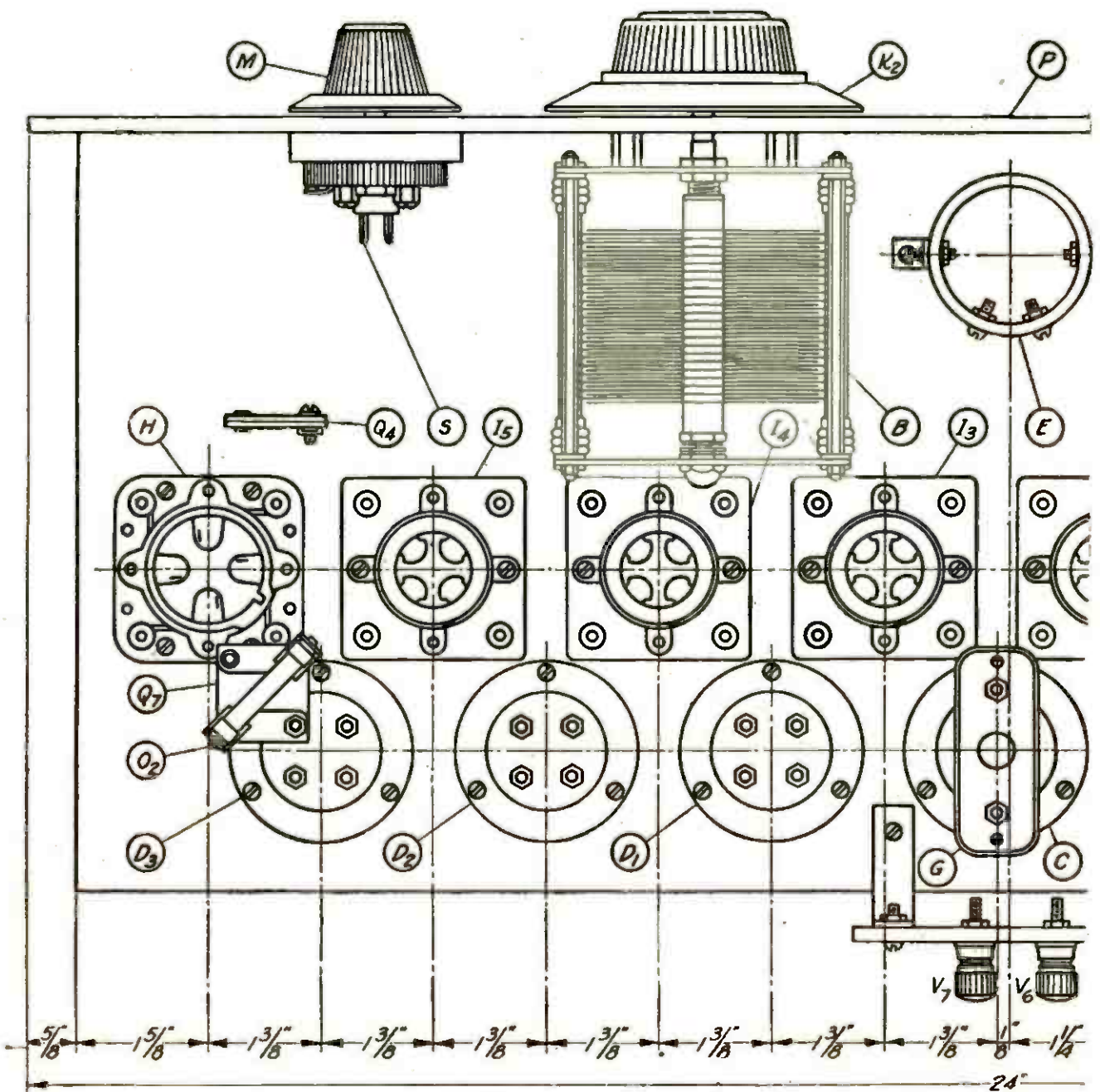
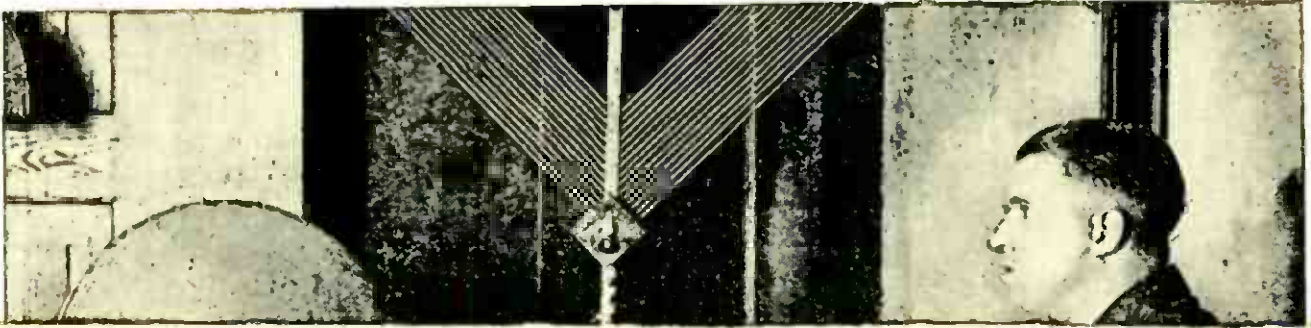

THE WORKING DRAWING FOR CONSTRUCTION

FIGURE 5: Here are shown the correct positions for the instruments which are mounted on the baseboard. The positions are given, center to center, for all instruments.

receiver is exceptional. Distortion is eliminated and the original quality of the music and speech is retained.

The theoretical wiring diagram of the new receiver is given in Figure 1. Figure 2 contains the picture diagram of the receiver in which the instruments are shown as they actually appear with the wiring indicated by heavy black lines and connected to the terminals of the instruments.

If the chart directions are followed religiously, the builder cannot go wrong in wiring up the set.

The Parts Used in Building the Set

In all the diagrams in this article each part bears a designating letter. In this way the prospective builder of the set may easily determine how to mount the instruments in the correct places and connect them properly in the electric circuit. The same designating letters are used in the text and in the list of parts at the beginning of the article.

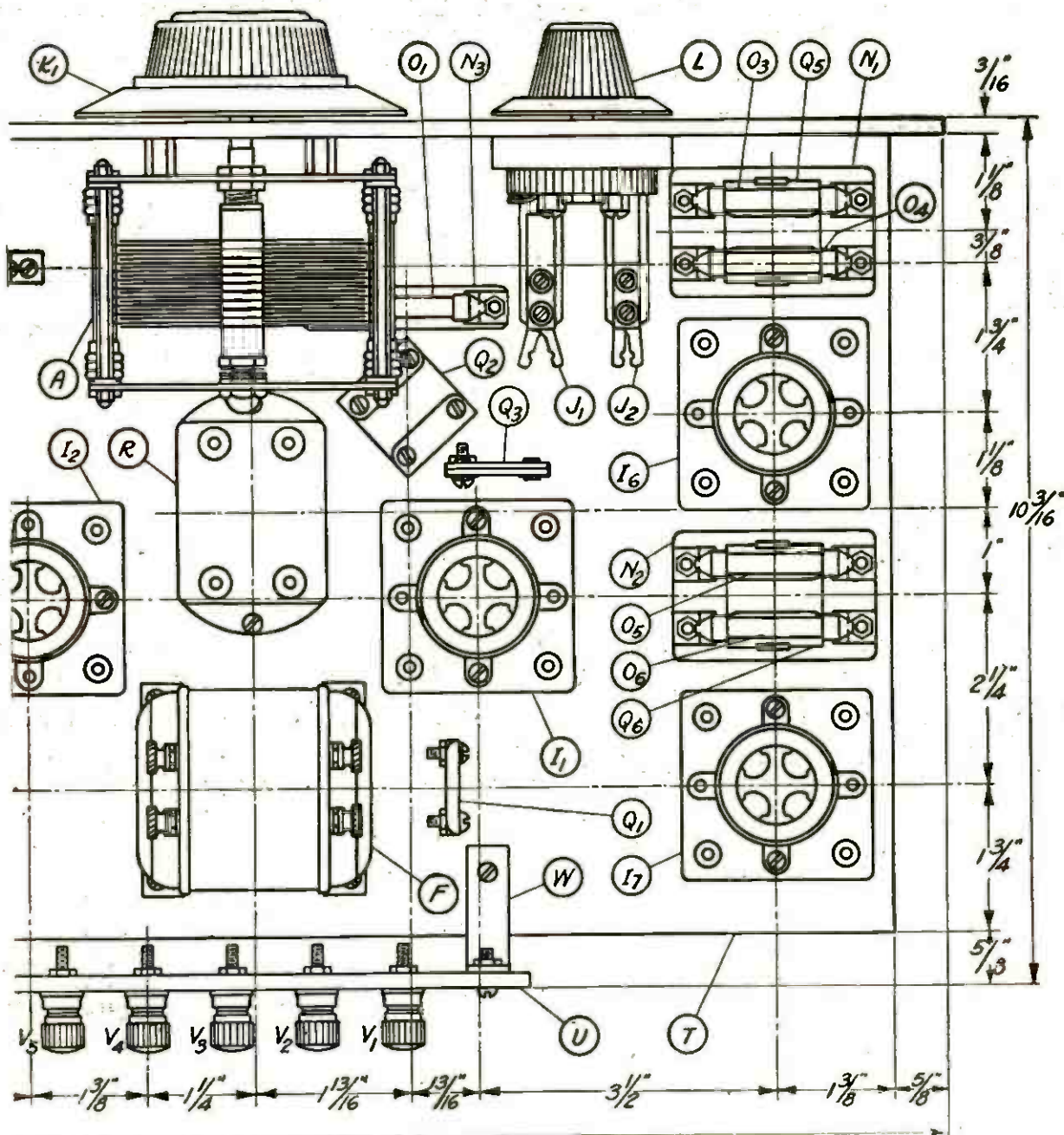

Q The list of parts there given includes the exact instruments used in the set from which these specifications were made up; but the experienced amateur will be able to pick out other reliable makes of instruments which may be used in the set with equally good results. For exact duplication of results, however, we recommend the parts specified to the novice.

If instruments other than the ones listed are used it will necessitate only the use of different spacing of the holes drilled in the panel for mounting them.

How to Construct the Set

After procuring all the instruments and materials for building the set, the amateur should prepare the panel P. (Shown in Figures 3, 4, 5, 6, 7 and 8.)

First of all, cut the panel to the correct size, 7 by 24 inches.

Then square up the edges smoothly with a file. The centers for boring the holes (which are necessary for mounting the instruments) should be laid out on the panel as shown in Figure 8. A convenient method of doing this is to lay out all center holes on a piece of paper the same size as the panel; then the piece of paper should be pasted on the panel and the centers marked directly on the panel by punching through the paper.

If all the holes to be drilled are first started with a small drill, one-sixteenth inch in diameter or less, they will be more nearly centered.

The holes outlined with a double circle should be countersunk, so that the flat-head machine screws used for fastening the instruments will be flush with the panel. All the rest of the holes in the panel are straight drill holes. Sizes for the diameter of these holes have not been given, but the builder will read-

ily decide what size hole is necessary by measuring the size of the screws and shafts of instruments that must go through the holes.

When the panel is drilled, it may be given a dull finish by rubbing lengthwise with fine sandpaper until the surface is smooth; then the same process should be repeated, except that light machine oil should be applied during the rubbing. The panel should then be rubbed dry with a piece of cheese-cloth; a dull permanent finish will be the result. Or, the panel may be left with its original shiny-black finish, if care is exercised, so that it is not scratched during the drilling.

After the panel has been prepared you are now ready to mount the instruments on it. First fasten on the two variable condensers, A and B, with three screws to each instrument, and then attach the two knobs and dials K1 and K2. These fasten to the condensers by means of set-screws. The condenser plates should be all in mesh when the dial settings read 100.

Next attach the rheostat L and the potentiometer M, by means of two screws to each instrument and attach the two small dials that come with them. See Figures 3, 4, 5, 6 and 7 for mounting the condensers, the rheostats and the potentiometer. Next mount the two jacks J1 and J2 in the proper places, see Figures 4, 5 and 6.

When this is done mount the filament battery switch S by unscrewing the large nut on the front of the switch and refastening it after the switch has been inserted through the

panel. This switch has a removable element which can be taken out when the set is not in operation, making it impossible to operate the set in the owner's absence. This finishes the mounting work on the panel and it can be set aside for the time being.

Now prepare the baseboard. It should be cut from $\frac{1}{2}$ inch hard wood such as oak to the size shown in Figure 5. Be sure that it is squared up properly and then you are ready to mount the instruments that go upon it.

First mount the eight sockets H and I1, I2, I3, I4, I5, I6, and I7 as shown in Figures 3, 5, 6, and 7. These are fastened to the baseboard by means of wood screws.

Be sure that the slots in the sockets are turned in the correct position as shown in Figure 5. Next mount the two resistor-couplers N1 and N2, as shown in Figures 3, 5, and 6. Use small wood screws.

Now fasten down the grid-leak mounting N3 as shown in Figure 5. Next screw down the transformer F and the radio-frequency transformer R in their respective places as indicated in Figures 3 and 5. Then mount the autodyne coil E with two small brass wood screws fastened through the two brass brackets as shown in Figure 5. Be sure that you mount it with the terminals turned away from the direction of the panel when it is attached.

After these parts are placed, fasten down the input transformer C (it has a "C" marked on the top) in the correct place, see Figures 3 and 5.

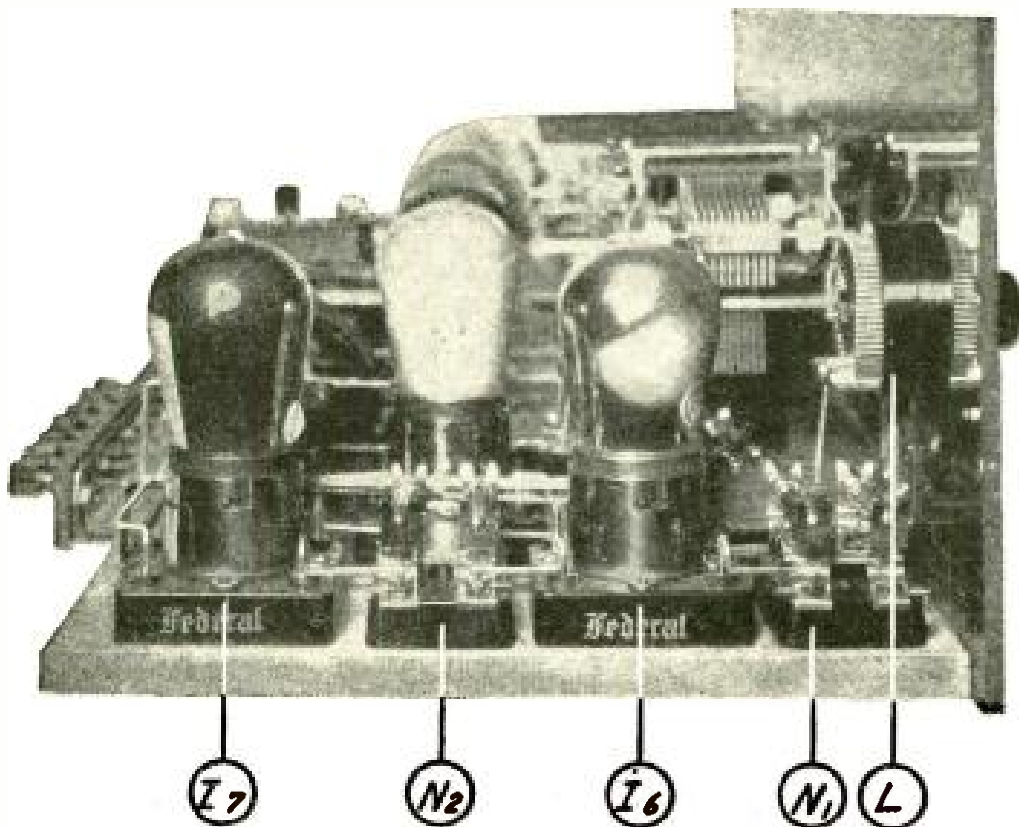

VIEW OF THE SET AS SEEN FROM THE LEFT

FIGURE 6: This illustration shows the general manner of mounting the sockets, the resistor-coupled units and the condenser and rheostat.

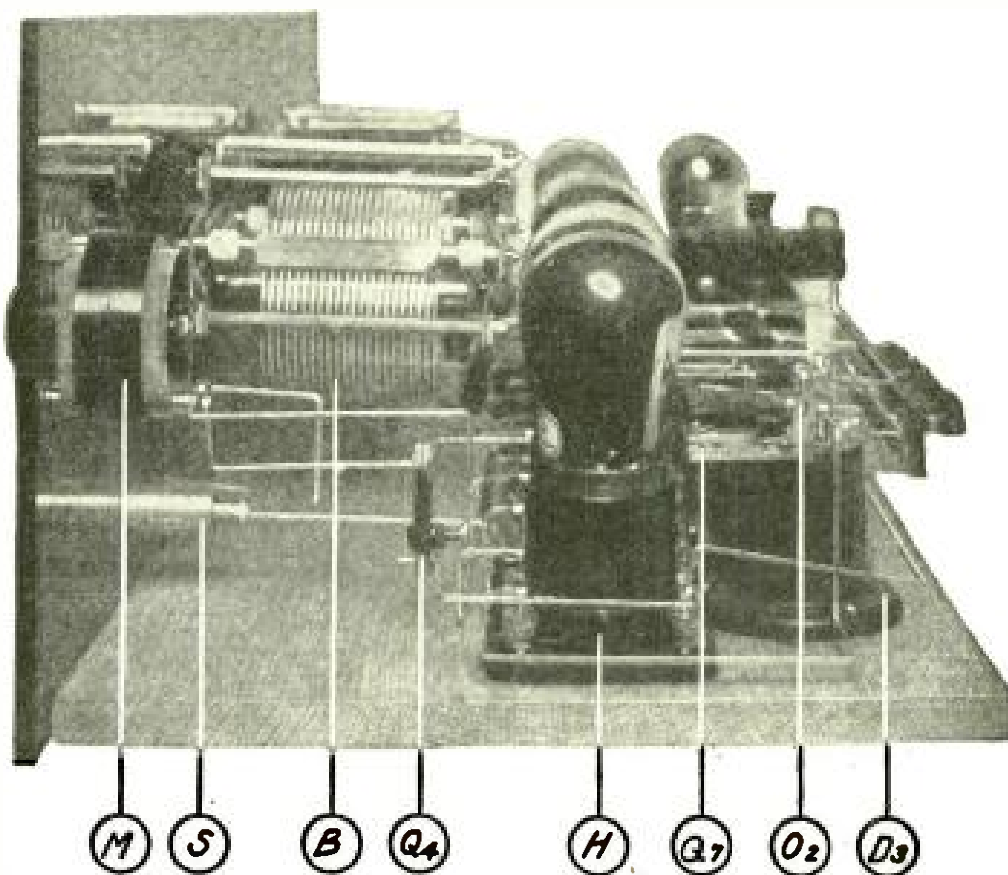

VIEW OF THE SET AS SEEN FROM THE RIGHT

FIGURE 7: This end view gives the manner in which the transformers, condensers, the potentiometer and filament switch are mounted.

Now attach the three intermediate transformers D1, D2, and D3 in a similar manner, see Figures 3 and 5. Be sure that the terminals marked + and F are turned toward the rear of the set in all of these four latter instruments.

The next job is to prepare the connection block U and the brass brackets W shown in Figure 10 and to mount on them the binding posts V1, V2, V3, V4, V5, V6, and V7. Then mount the whole connection block unit in the proper position on the base T as shown in the working diagram Figure 5.

Next insert the two condensers Q5 and Q6 in the resisto-couplers N1 and N2. The two center clips on the couplers are for the condensers. See Figures 3, 5, and 6.

Then insert the resistor O3, and the resistor O4 in the coupler N1 in the order shown in Figure 5. Next do the same with resistors O5 and O6 in the coupler N2.

Now you can insert the resistor O1 in the grid-leak mounting N3. The remaining resistor and fixed condensers will be mounted when the wiring is being done. This completes the construction work. You are now ready to begin the wiring of the set.

How to Wire the Set

The design of this set is such that the grid-circuit wiring of each of the five tubes may be made extremely short and isolated from the other circuits. In fact, all the tuning circuits and leads are so arranged that short connec-

tions may be used. As this is the case, the set may be wired with bus-bar with little loss in efficiency.

A tinned-copper, round bus-wire is recommended. All connections should be first shaped so that they will fit and then soldered carefully in place. Refer to the wiring diagram in Figure 1 and more specifically to the picture diagram in Figure 2, for the exact way to run the wires.

Start wiring up the parts mounted on the baseboard T before you fasten the panel to it. Begin with the binding post V3 and run a wire to post V2 and along to the terminal F — on the transformer F. From here continue the wire over to terminal F on the socket I1, and from here continue to terminal F on socket I7 and thence to terminal F on the coupler N2. From here carry the remainder of the same wire to similar marked posts on the socket I6 and the remaining coupler N1. Then carry a joint from this wire past the radio-frequency transformer R, and secure to terminal F on socket I2 and carry an extension to the same marked terminals on the sockets I3, I4, and I5 and continue on to the terminal marked (—) on socket H. Next solder a wire from the bottom right-hand terminal of the autodyne coupler E (looking from the rear) and fasten it at a convenient spot along the other series of wire connections you have just completed. This series may be considered as the negative filament bus.

Next start a wire at the terminal marked

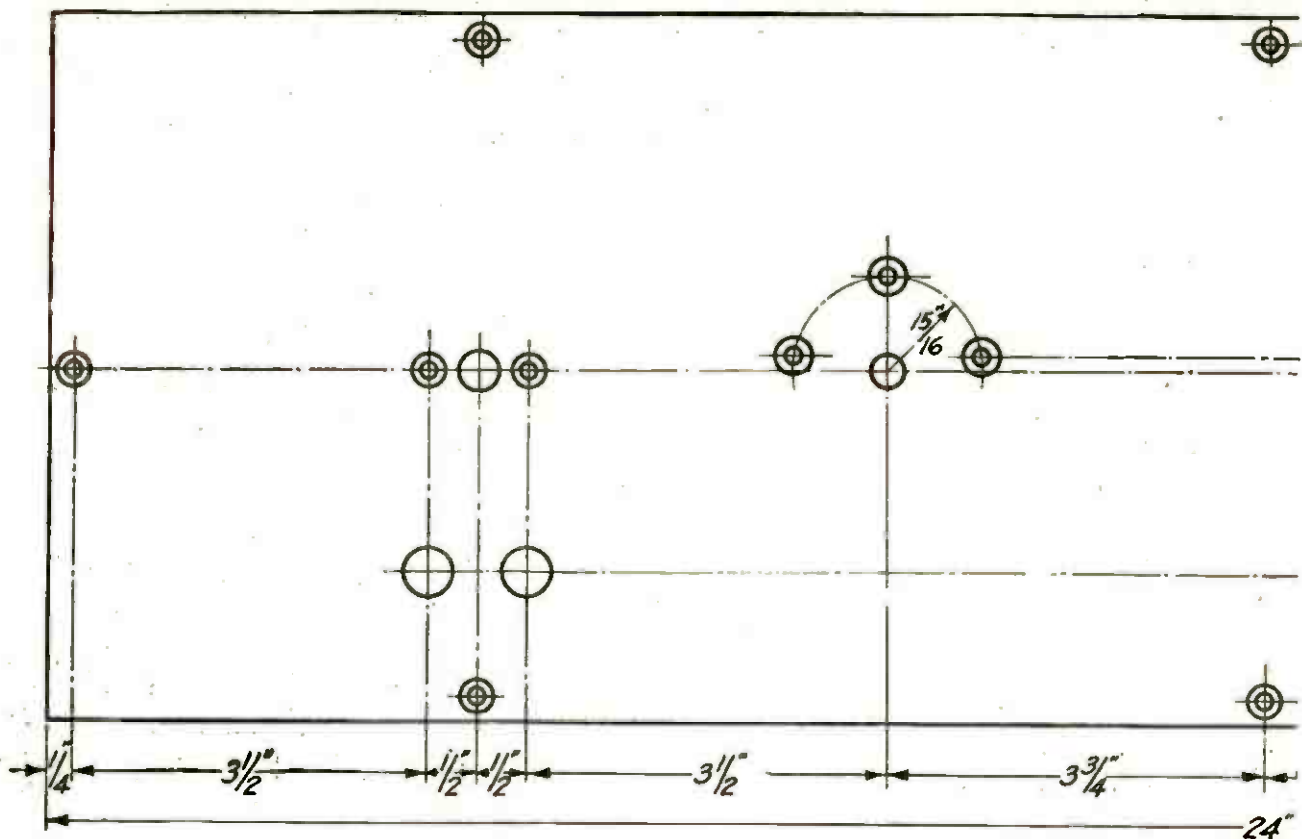

THE DRILLING PLAN FOR THE PANEL

FIGURE 8: This drawing shows where to drill the holes for mounting the instruments. The correct spacings are given for the holes. The holes outlined with a double circle should be countersunk. Always start drilling holes in the panel with a small drill—one-sixteenth is a desirable size. Never attempt the drilling without using a sheet of paper with the holes properly marked on it and then pasted on the panel.

F+ on socket I7, thence to the same terminal on socket I1, then on to the same terminals on sockets I2, I3, I4, I5 and I6, and then to terminal marked (+) on socket H. From this point continue the same wire around socket H and terminate it at the terminal marked F on the transformer D3. This series is the main part of the positive filament bus.

Then join terminal G on the socket I7 with the terminal G on the coupler N2. Do the same with the two corresponding terminals on the socket I6 and the coupler N1.

Now join terminal P on socket I6 with the terminal P on the coupler N2. Then join terminal G on the transformer F with the terminal G on the socket I1. Then join terminal P on the radio-frequency transformer R with the terminal P on the socket I1.

Next join terminal G on the radio-frequency transformer R with the terminal G on the socket I2.

Next join terminal P on the socket I2, with terminal P on the input transformer C. Then do the same with the same marked terminals of the sockets I3, I4 and I5 and the same marked terminals of the intermediate transformers D1, D2 and D3, respectively.

Then join terminal G on the transformer C with terminal G on the socket I3. Do the same procedure with transformers D1 and D2 and sockets I4 and I5, respectively.

Following these operations fasten one side of condenser Q7 to the terminal G of transformer D3 and connect the other side of the condenser to the terminal marked G on socket H. When this is done place the resistor O2 in the clips on condenser Q7 that you have just mounted.

Now connect the three (+) terminals on transformers D1, D2 and D3 with a wire and run an extension of it over to binding post V6 and continue on with a wire running first to the terminal marked B+ on the transformer F and then on and over to the upper right-hand (looking from the rear of the baseboard) terminal of the autodyne coil E.

Next run a wire connecting the three terminals marked F on the transformers C, D1 and D2; and then connect one side of the condenser Q2 with the terminal P on socket I1. Connect the other side of this condenser with the left-hand terminal of the grid-leak mounting N3 (looking from the rear). This leaves the condenser Q2 suspended and supported entirely by the bus-bar wiring.

Next run a wire from the terminal marked + on the transformer C over to the upper left-hand terminal of the autodyne coil E (looking from the rear). Now run a wire from the terminal marked P on the transformer F, alone in back of the transformers C, D1, D2, and D3 and fasten it to the ter-

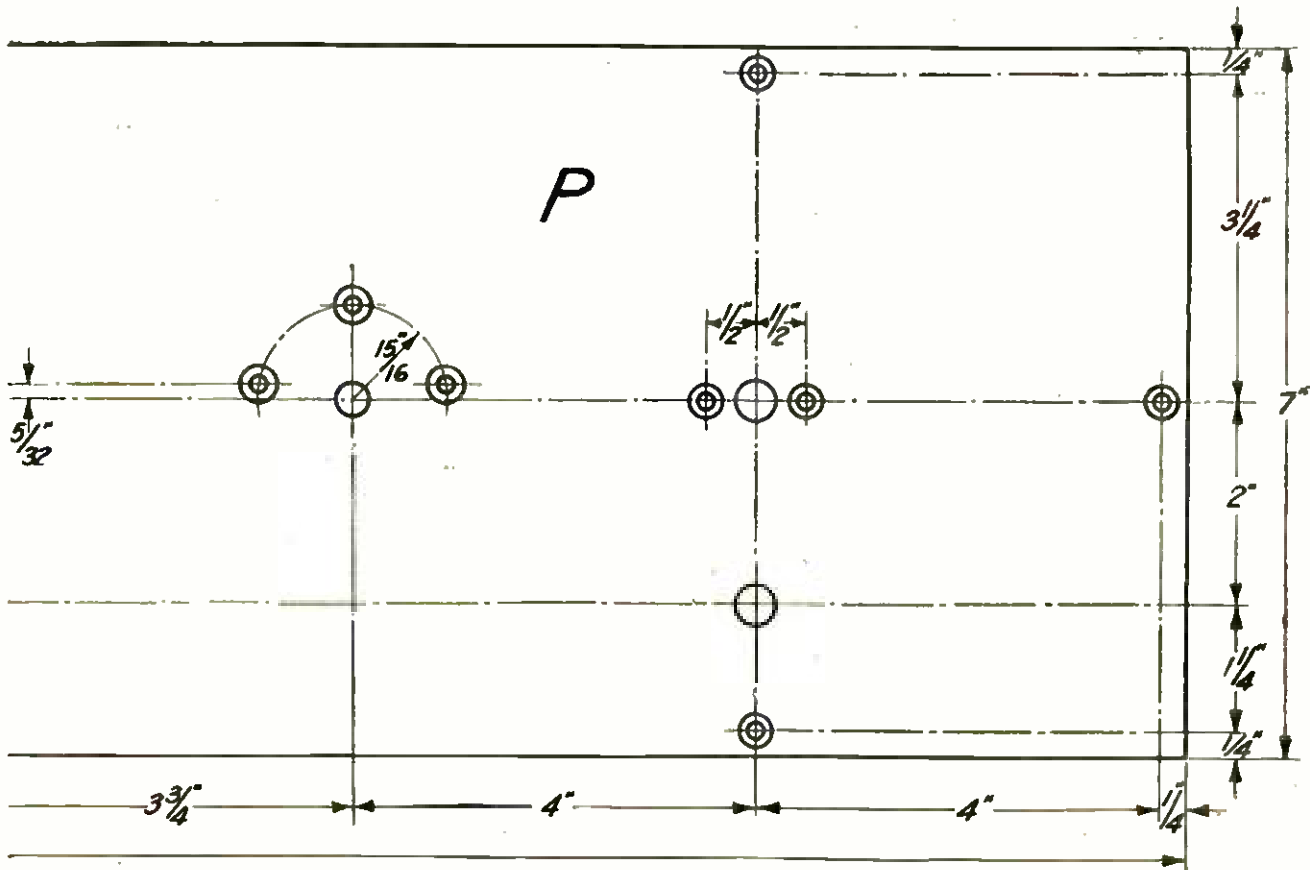

terminal P on the socket H. This is as far as the wiring can progress on the baseboard before the panel is attached.

But, before attaching the panel P to the baseboard there is one connection that should be made on the instruments mounted on the panel itself. Run a wire from the right-hand terminal (looking at the back of the panel) of the filament switch S, over and close to the panel and terminate it at the left-hand terminal of the rheostat L (also looking from the rear).

Next fasten the panel P securely to the baseboard T by means of three brass wood screws inserted through the three special holes in the panel and into the edge of the wood of the base. You are now ready to complete the wiring.

First run a wire from terminal P on coupler N1 to the bottom terminal of the jack J1. Then connect the two middle terminals of this jack together with a short bit of wire. Next connect the top terminal of the same jack with the terminal marked B+ on the transformer R.

Now run a wire from terminal B+ on coupler N1 to the bottom terminal of the jack J2, and continue on to the B+ terminal on coupler N2 and still continue on from here with varnished-cambric tubing covering on the bus wire until it terminates at the binding post V7. This is the only part of the wiring where it is advisable to use insulated covering on the wiring. It is necessary in this case because the wire is a positive 135-volt "B" battery lead that is close to the other wires.

Next run a wire from the top terminal of the jack J2, straight back and around the edge of the socket I7 and attach it to the terminal P of that socket. Now connect the right-hand

terminal (looking from the rear) of the grid-leak mounting N3 with a wire running to the lug on the stator plates of the condenser A. Then run a branch of this wire straight back between socket I1 and transformer F and drop it down and connect to binding post V1.

Next connect binding posts V4 and V5 with a wire and run an extension of it over to the right and straight forward and connect it to the right-hand terminal (looking from the rear) of the rheostat L.

Now run a wire between the two lugs on the rotor plates of the two condensers A and B, and run an extension of this wire down and attach it to the wire that runs to the lower right-hand terminal (looking from the rear) of the autodyne coil E.

Then run a wire from the lug on the stator plates of the condenser B, down to the lower left-hand terminal of the autodyne coil E and run an extension of this wire over and attach to the terminal marked F on the radio-frequency transformer R.

Next connect terminal marked F+ on socket I5 across to the left-hand terminal (looking from the rear) of the filament battery switch S and run an extension of this wire to the right-hand terminal (also looking from the rear) of the potentiometer M.

Now start a wire from the center post on the potentiometer M and pass it through toward the back of the set between the sockets I4 and I5 and connect it to the wire running to the terminal F on transformer D2.

Next run a wire from the left-hand terminal (looking from the rear) of the potentiometer M and connect it to the wire joining the terminal marked (-) on the socket I1. Connect one side of the condenser Q4 to this

point and run another wire from the other side of the same condenser around the socket H to the terminal marked P.

Connect one side of condenser Q1 to the wire that runs to binding post V1, and connect the other side of the same condenser to the wire that leads to the terminal G on the transformer F. This leaves the condenser suspended and supported by the bus-bar wiring. The next job will be to fasten one side of the condenser Q3 by a wire connected with the wire running to the top terminal of the jack J1. The other side of the condenser should be connected to the wire that runs between terminal F on socket I6 and terminal F on socket I2. This condenser is also supported by the wiring.

The last connections will be to fasten one side of the grid-denser G to the wire running to the terminal P on the transformer C, and to connect the other side of the same condenser to the wire running to the terminal marked + on the same transformer.

This completes the wiring. Be sure that while you are following this text matter in hooking up the instruments, you are also following and checking off your work on the diagram in Figure 2. At the same time it would be well to look through all the photographs to get a fuller check-up on the actual positions of the wires themselves. When you have finished the job, it is advisable to re-check from your diagram with the assistance of a friend.

This concludes the wiring. The set can now be fastened in the cabinet with the connection block flush with the rear of the cabinet. You are now ready to install the set and put it into operation.

How to Install the Set.

Place the set on the table or desk where it is to be used. Set the loop antenna at the left of the set, or on top of the left end of the cabinet. The loop that was used to make the calibration chart shown in Figure 12 is the large tapped Korach loop.

Connect the bottom binding post of the loop to binding post No. V1 on the set. The middle binding post of the loop should be connected to the binding post V2. If it is convenient a ground wire may be attached to the post V2 also, although this is not absolutely necessary. *No outdoor antenna is required.*

Connect the 6-volt storage "A" battery and the 135-volt (three 45-volt sections of "B" battery connected in series) "B" battery to the other binding posts on the set as shown in Figure 11.

Push the button of the "A" battery switch S in for the "off" position. Then insert eight UV-201-a tubes or eight C-301-a tubes in the sockets.

Next set the grid-denser G about three-quarters of the way turned down (clockwise). The set is now ready for operation.

How to Operate the Set.

First push the loudspeaker plug into jack J2. Jack J1 is used for the headphones or where less volume on the loudspeaker is required. Then turn the rheostat L to the "off" position. Pull out the "A" battery switch S on the "on" position and adjust rheostat L to between 50 and 70 on the small dial. Examine the tubes to see if they light properly. Set the potentiometer M at about 25 on the dial.

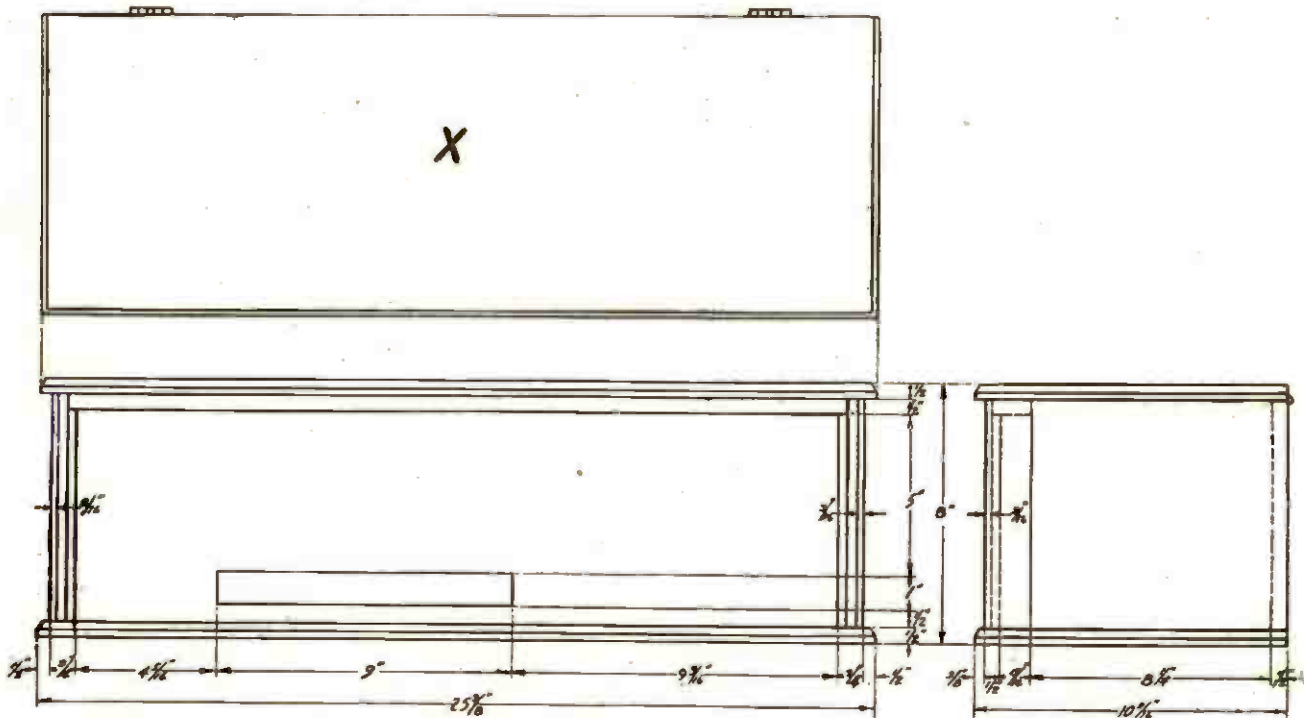

THE DIMENSIONS FOR THE CABINET

FIGURE 9: This diagram (which contains the top, front, and side measurements for the walnut cabinet) may be turned over for construction to a competent cabinet maker who can build it from these directions exactly the right size for the panel.

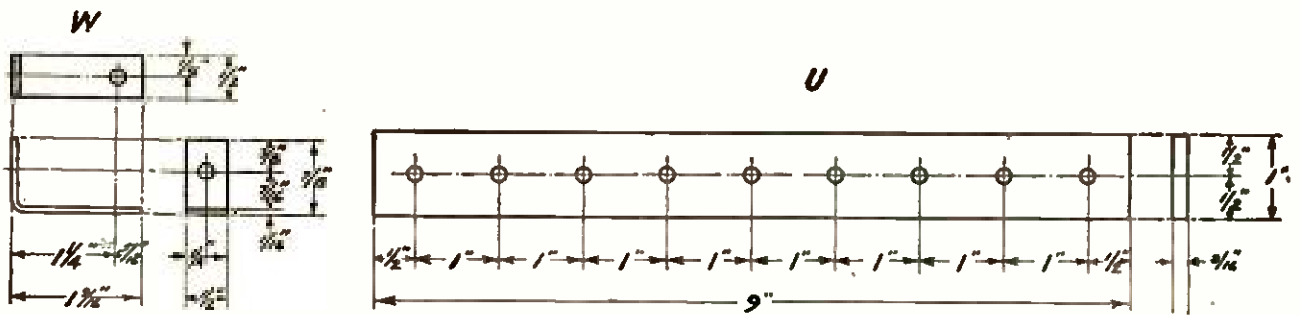

DETAILS OF THE CONNECTION BLOCK AND THE SMALL BRASS BRACKETS

FIGURE 10: This drawing gives the necessary data for making the insulated block or strip on which the binding posts are to be mounted. It also gives the dimensions for the small brass brackets that are used to fasten the block to the baseboard.

The loop tuning is controlled by the knob K1 which is attached to the condenser A. Now refer to the tuning chart in Figure 12.

Look at the program list in one of the daily papers and pick out a powerful local station that is broadcasting. Find out its wavelength and then find out the proper setting for the knob K1. This is given by the curve K1 on the chart. The figures at the bottom of the chart give the wavelength and the figures at the left of the chart give the desired settings of the dials. Set knob K1 according to the proper reading and then refer to the chart for the setting of knob K2 which controls the autodyne-oscillator frequency and which is attached to condenser B. When you have determined this setting set the knob K2 accordingly. If the loop is turned in approximately the right direction you should immediately hear the station you want to pick up.

Next re-adjust the two dials K1 and K2, one at a time for the best signal strength. Volume after this can be adjusted by means of the potentiometer M. Increasing the setting of the potentiometer increases the signal strength and decreasing the setting decreases the signal strength. Then re-adjust the grid-condenser G for maximum strength and leave it set.

The left edge of the loop should be pointed in the direction of the station that you want to get. This will always be true if you have connected it in accordance with the instructions given. Always leave the switch on the loop set on the middle tap. Otherwise the tuning chart will not hold true for the knob K1.

Next, due to variations in the tubes, start changing the tubes around in the various sockets until you find the best combination. This may take you as long as fifteen minutes, but it is worth while and you will find that distance will be brought in sometimes 200 or 300 percent better by merely changing one tube.

For distance reception the potentiometer M should be adjusted nearer toward the point where the loudspeaker squeals. This is the point of greatest amplification.

Don't worry about disturbing your neighbors with squeals; they can't hear you if you try, because it is impossible to make the set radiate!

When you have made all these initial adjustments the only other adjustments you will need are the pointing of the loop, the setting of the two dials K1 and K2, and the adjustment of the potentiometer for proper volume.

If a Western Electric cone-type loudspeaker No. 540-AW is used with the set, you will be

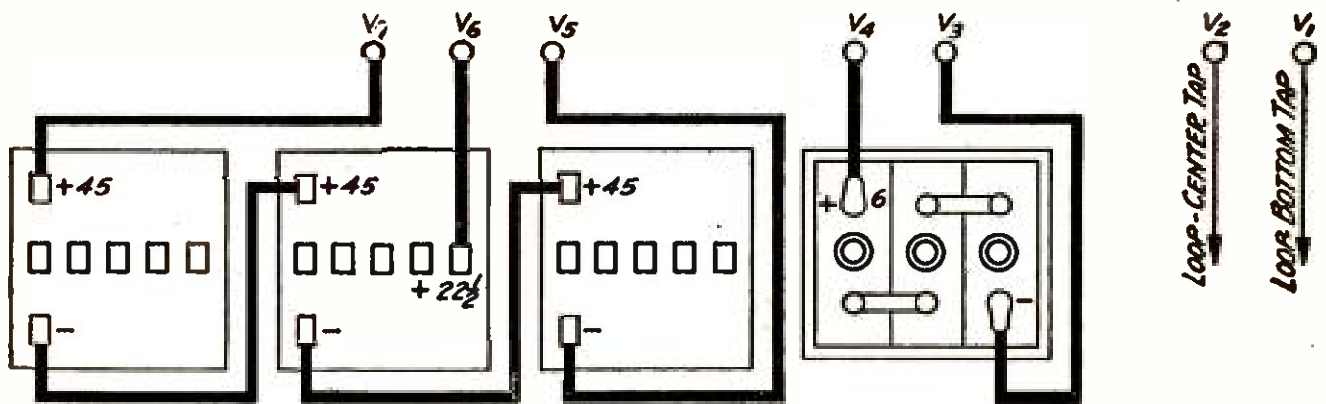

HOW TO HOOK UP THE BATTERIES

FIGURE 11: This drawing prevents you from making mistakes in connecting the batteries to the terminals. If you follow these instructions the set will be hooked up correctly because the terminals shown in the wiring diagrams are marked with designations that correspond with the numbers given here.

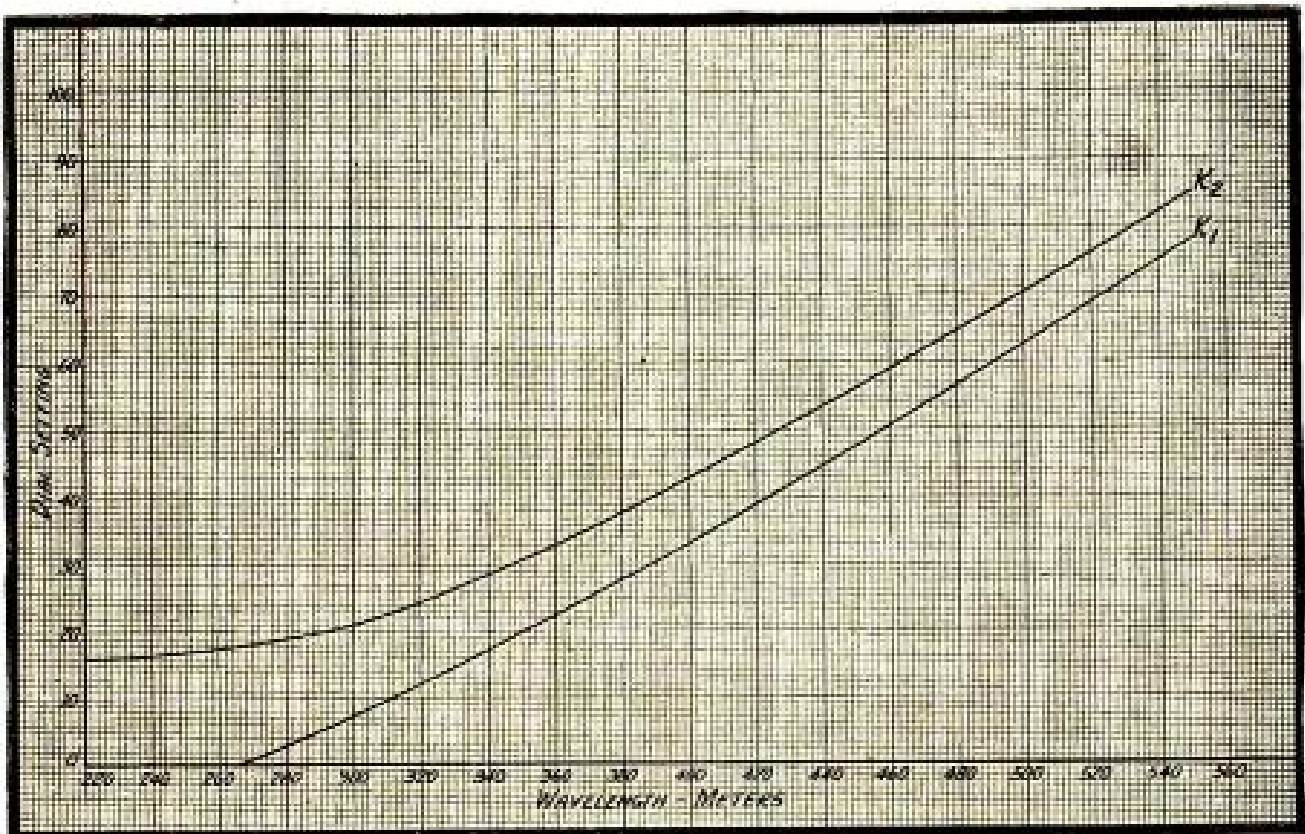

THIS TUNING CHART TELLS YOU HOW TO SET THE DIALS

FIGURE 12: Cut out this diagram and paste it securely in the lid of the cabinet. To find any wavelength, and therefore, any station of which you know the wavelength, all you need do is to pick out the perpendicular line that cuts through the wavelength you want; follow the line up to the curved line K1 and then follow the horizontal line, which also runs through the same spot on this curved line, until you end up at the left-hand scale setting which gives the proper setting for the dial marked K1. Then go through the same process with curve K2 to find the proper setting for dial K2. This is all you need to do to tune the new set.

surprised with the lifelike quality of the music and speech you will pick up. You should be able to pick up almost any station listed

in the broadcast programs at any time they are "on the air" without interference, provided the static conditions are not too severe.

Working Blueprints of This Receiver

IN order to accommodate readers who may desire actual-size diagrams of this 8-Tube Superheterodyne Reflex Receiver, a set of three blueprints has been prepared, consisting of—

- One panel pattern (actual size);
- One instrument layout;
- One picture diagram of all parts, showing the wiring.

This set of three prints will be forwarded, postage prepaid, upon receipt of \$1.10.

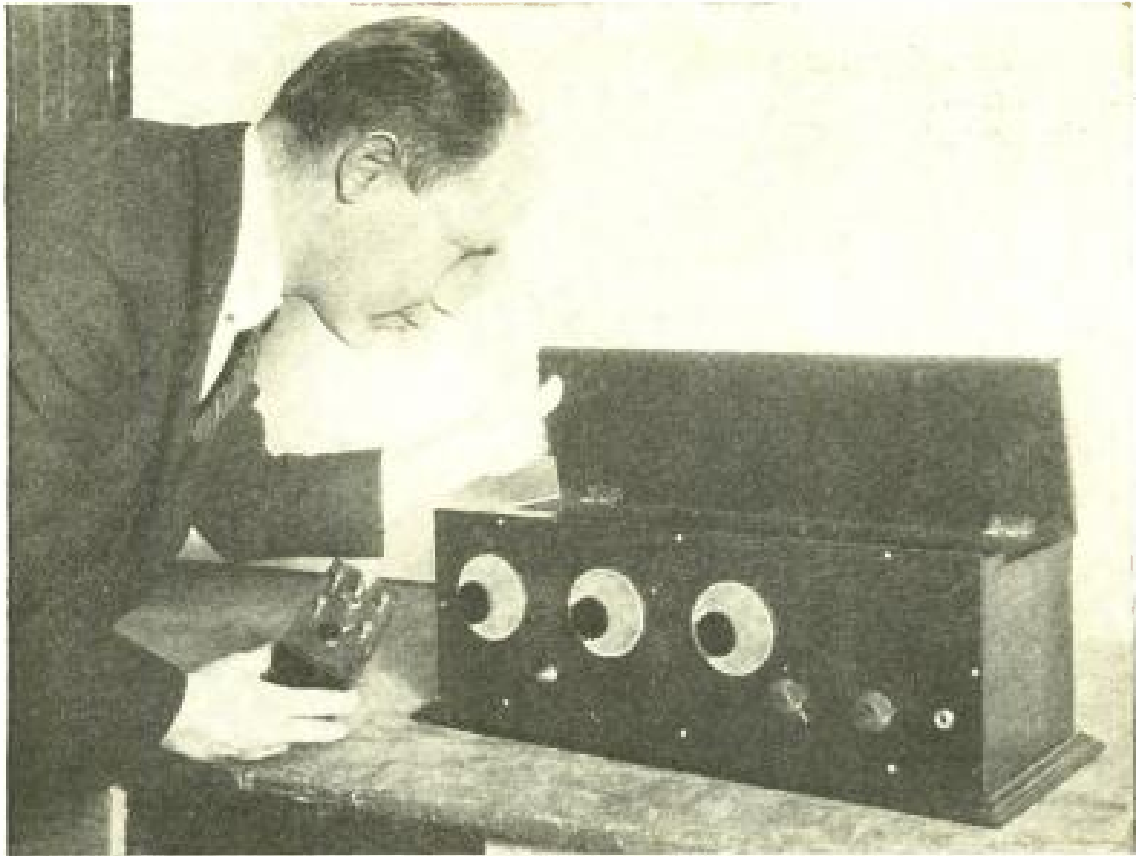

From a photograph made for POPULAR RADIO

BIG SETS FROM LITTLE CRYSTALS GROW

The simple little crystal set at the left, that may cost from \$5.00 to \$10.00, starts many a fan upon the path to the vacuum tube set at the right.

How to Get Started in Radio

Practical pointers for the novice who is thinking about buying his first receiving set

By ALFRED P. LANE

UNLESS a man has had some training along electrical lines, radio is a complicated and mysterious force that is beyond his understanding.

The very names, "condenser," "tuning inductance," "frequency" and the other technical phrases which have been brought into our vocabulary by radio convey no meaning to him. So he usually concludes that he must either trust blindly to the dealer to sell him a complete radio outfit that will be suitable for his use or he must be content to go without it altogether.

Obviously, the simplest way to get

started in radio is to go to a reliable dealer and tell him what you want in the way of results.

If your requirements are within the bounds of radio possibilities, the dealer will quote you a price on a complete outfit. But there are thousands of men who cannot afford to drop into a dealer's store and order a complete receiving outfit. A large number of such men are not mechanically inclined; and the prospect of building a radio receiver frightens them from undertaking it.

Broadly speaking, there are three distinct classes of radio receiving sets. Each

class is excellent for the purpose for which it is intended.

First, the crystal set. This is low in cost and easy of construction. It is the simplest type of radio receiver, as it utilizes a crystal to rectify the radio signals so that they can be heard by means of telephone receivers. If you are satisfied to receive the programs from only the local broadcasting stations that are within a few miles of your home and if you are willing to wear a pair of headphones, the crystal receiver will bring to your ears music and speech with a quality that cannot be excelled by even the most expensive set made. The upkeep cost of a crystal receiver, too, is practically nothing. It has no batteries, and the only expense is the price of a new crystal every six months or so—and the best crystals do not cost over twenty-five cents.

Second: The vacuum-tube set that uses only one vacuum tube. This type constitutes the next broad division in radio receivers. Such a receiver gives louder signals from the local stations than can be obtained from a crystal receiver; and when conditions are favorable, stations hundreds of miles away may sometimes be heard with sufficient volume. An ad-

ditional advantage of the tube receiver is that it may be made much more selective than the crystal set so that one may choose between the programs that are being offered by the local stations. A tube set is a power-operated device, however. It consumes electric energy, and the chief expense for maintenance is, therefore, the cost of the current that it uses. There are tubes now on the market that can be operated by the current supplied by dry batteries. These tubes give excellent results. They do not, however, produce as strong signals as the tubes that consume more current and which are consequently more economically operated by a storage battery. On the average, a receiver that uses one dry-battery-operated tube will cost about \$8.00 a year to maintain. This figure includes the cost of the dry batteries and the normal depreciation of the tube.

Third: The multi-tube set. This class of radio receivers includes all outfits that use more than one vacuum tube. It is small wonder that the average man is bewildered by the conflicting claims of the enthusiastic advocates of the various types of sets that fall within this third class. Essentially, the object of using

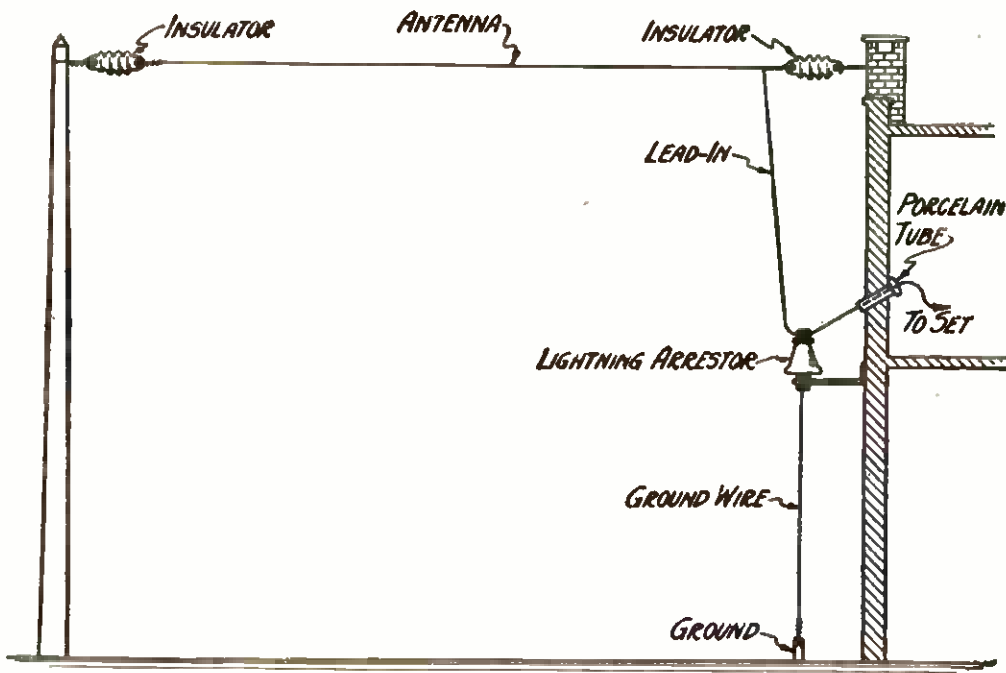

THE SIMPLEST WAY TO RIG UP YOUR ANTENNA

FIGURE 1: This shows how to connect your set to the antenna and how to hook up the lightning arrester to the ground and antenna lead-in.

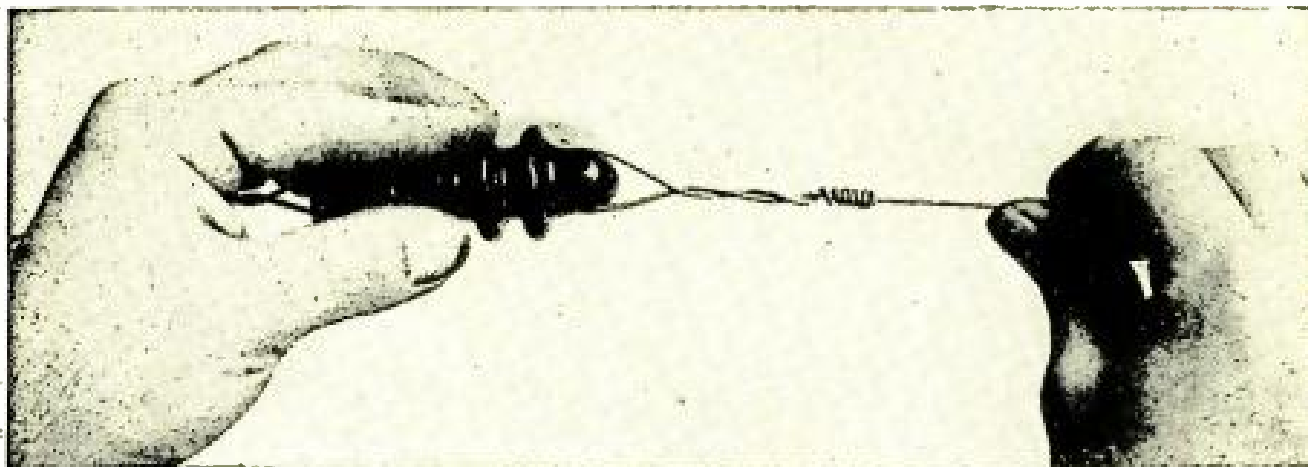

From a photograph made for POPULAR RADIO

PROPERLY TWISTED JOINTS ARE HIGHLY IMPORTANT

FIGURE 2: *Be sure to twist tightly the wire that holds your antenna insulators to their supports, as shown above.*

more than one tube is to increase the strength of the electrical impulses that are set in motion by the arriving signal so that a loudspeaker can be operated, or to increase the distance over which reliable reception can be maintained. These results are attained by amplification—either at radio or audio frequencies, but it is not necessary for anyone to understand just what these terms mean in order to build a satisfactory radio receiver.

Multi-tube receivers can be operated by the current from dry batteries, but usually the batteries would be used up rapidly, so that a storage battery is more economical in the long run. The cost of maintaining such a set depends on the number of tubes, the type of batteries used and, of course, the average number of hours a day during which the set is to be in operation.

There is one point that the novice should keep clearly in mind:

The number of tubes in a set has nothing whatever to do with the quality of music or speech that may be heard with it.

The multi-tube set has three distinct advantages over the single tube or crystal outfit. In the first place, the big set will operate a loudspeaker; secondly, it will receive signals from distant stations with considerable volume; and, thirdly, it will often bring in all the local stations without any outdoor antenna (the wire that is strung up outside the house to bring

the radio energy into the receiving set).

For purposes of illustration, let us assume, for instance, that you are located within fifteen miles of at least one reasonably powerful broadcasting station; that you are in a position where you can put up an antenna; that you want to enjoy radio broadcasting, but that you know nothing of radio and you are not particularly handy with tools.

Naturally you do not want to invest any more money than you can help—at least not until you are a little more decided as to just what you are going to require.

To begin with, you will want to put up an antenna. It will be useful no matter what kind of a radio receiver you buy or build; and the fact remains that any given degree of radio reception can always be obtained with a simpler and less expensive receiving set when you use an outdoor antenna than if you try to get the same results on a loop or an indoor antenna.

Erecting an antenna is really simple. There are just two factors to keep in mind. One is to get the wire as high and as far from the building as possible, and the other is to make sure that nothing except the insulators touches the wire until it reaches the binding post that you will provide to connect it to your receiving set.

Study Figure 1 carefully and you will

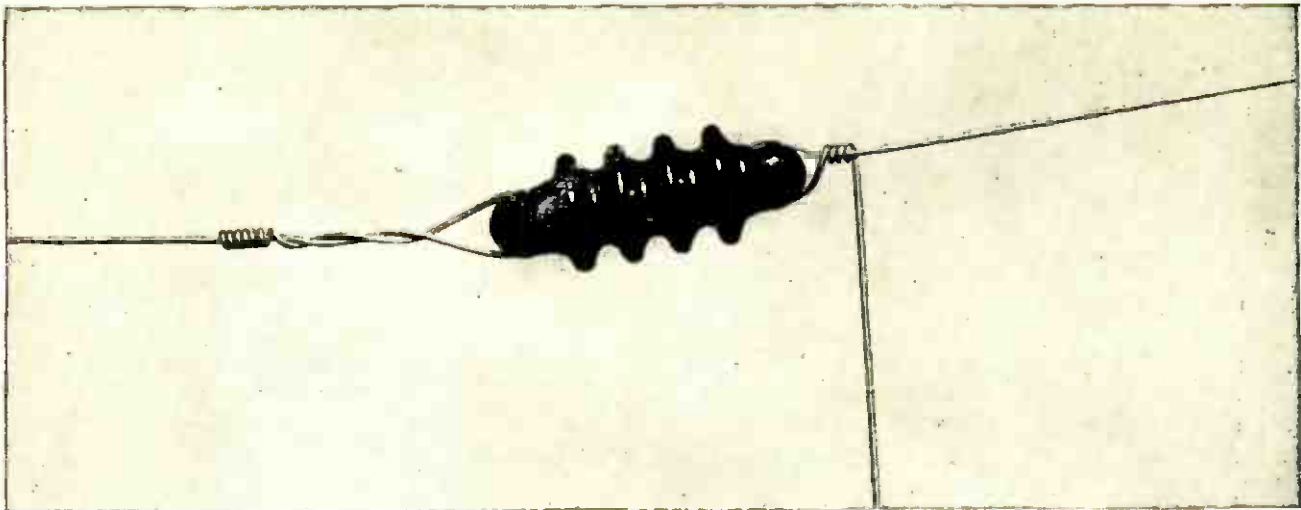

From a photograph made for POPULAR RADIO

HOW TO AVOID CUTTING AND JOINING THE LEAD-IN

FIGURE 3: Here is shown how the antenna wire in one piece can usually be dropped from the insulator directly to your window, thus avoiding joints that reduce signal strength.

see that you will need some wire, two insulators that have a hole for fastening in each end, and a porcelain tube through which to run the wire into the house. The length of wire you will need depends on how long you can make your antenna—try to get it at least 100 feet long. A length of over 150 feet is not advisable and a length of 80 feet is about as short as will give you satisfactory results. The only tool you will need is a pair of pliers with which you can cut and bend the wire.

In erecting your own antenna you may have to substitute a chimney, a corner of your neighbor's house or some other handy projection for the pole shown in Figure 1.

The first step is to cut off a piece of the wire and fasten one end of it around the pole or chimney that you have selected; then fasten the other end of the short piece through the hole in one end of the insulator. A few inches of wire will do to fasten this insulator unless you make it fast to a tree, in which case it is desirable to cut a piece long enough so that the insulator will clear the foliage of the tree. Be sure to twist the ends of the wire securely as shown in Figure 2.

Now fasten the end of the second insulator in the same way at the point where you want the other end of the antenna.

If you do not feel that you are capable

of boring a hole for the porcelain tube, or you have no augur bit of the right size, you can have the carpenter or some friend do this for you. Another solution is to buy a patented "lead-in" instead of the porcelain tube. These lead-ins are so constructed that you can shut the window right down on them and no special holes are necessary. (It might be well to talk this matter over with your dealer when you buy the wire for the antenna.)

Nothing remains now but to fasten one end of the antenna wire through the hole in the farthest insulator, thread the end of the wire through the hole in the nearest insulator, twisting it as shown in Figure 3, and then through the porcelain tube or connect it to the binding post on the special lead-in.

The lightning arrestor you should use really has nothing to do with the reception of radio signals. Its function is to drain off the electrical charges that collect on the antenna during an electrical storm. The connection of this important accessory is simple. Clamp one binding post to the antenna and run a wire from the other binding post to a length of iron pipe driven several feet into moist soil. If the ground is rocky, you can run the wire in the cellar window and connect it by means of a ground clamp to the cold water pipe at any convenient point. Your

dealer can supply you with a ground clamp and he will gladly show you how to fasten it.

No man likes to spend money for radio parts and then find that he must buy a whole new set of parts when he begins to build a more elaborate set. At the same time it is advisable for you to build,

first, a crystal receiver because it is the simplest of all radio receivers to build and the parts can be obtained without a great outlay of money. A solution of the problem of discarded parts is to design the crystal set to be made with parts that can be used later for more elaborate tube receivers.

Q *The next article of this series will describe a simple crystal receiving set and a following article will tell how to build a vacuum tube set which will include in its make-up every single part that was used in the crystal set except the crystal and its mounting.*

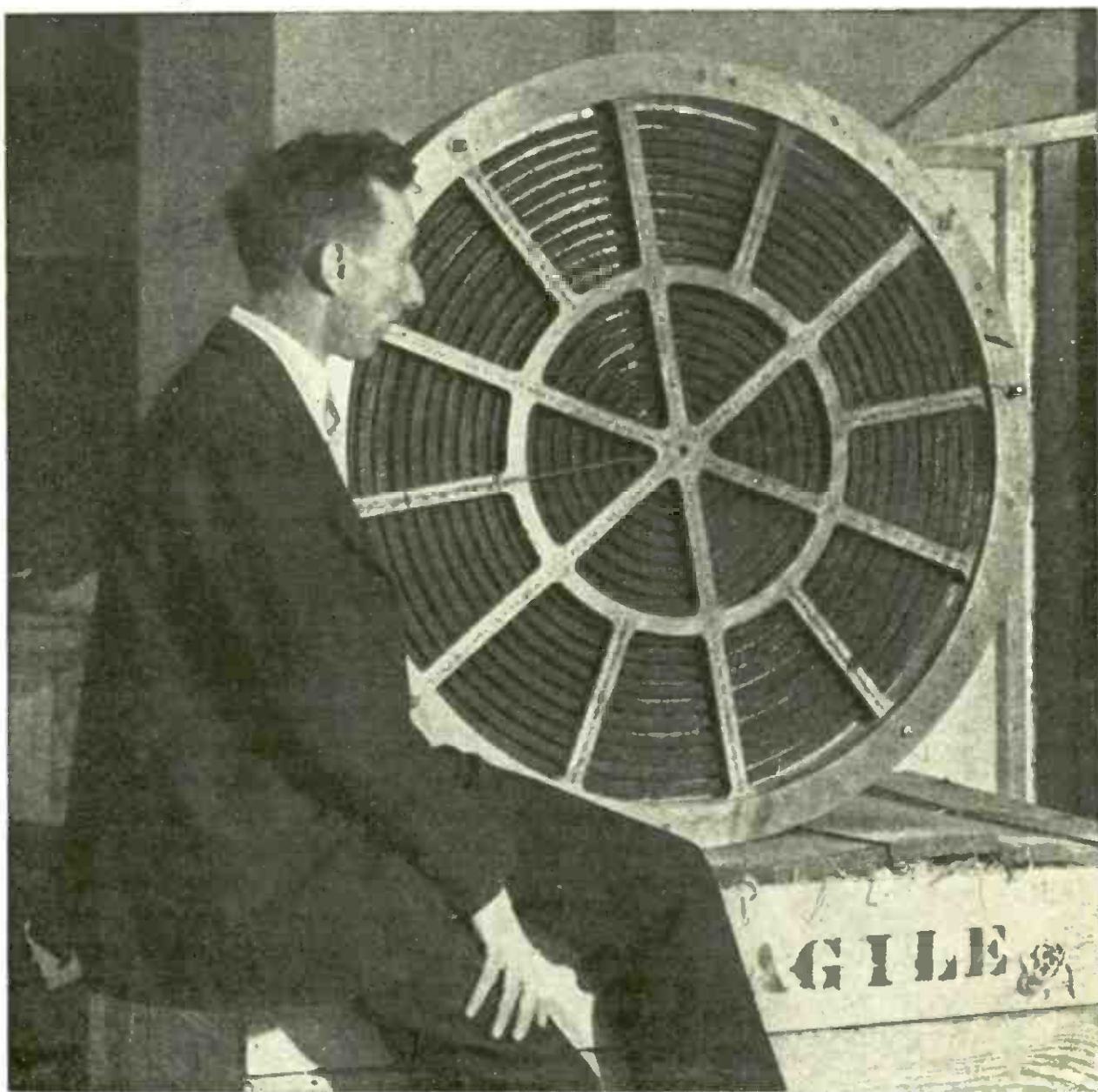

THE WORLD'S "LOUDEST LOUDSPEAKER"

A human voice can be heard over a distance of five miles with the aid of this remarkable apparatus, according to the claim of its inventor, Mr. C. W. Hewlett, who is pictured above.

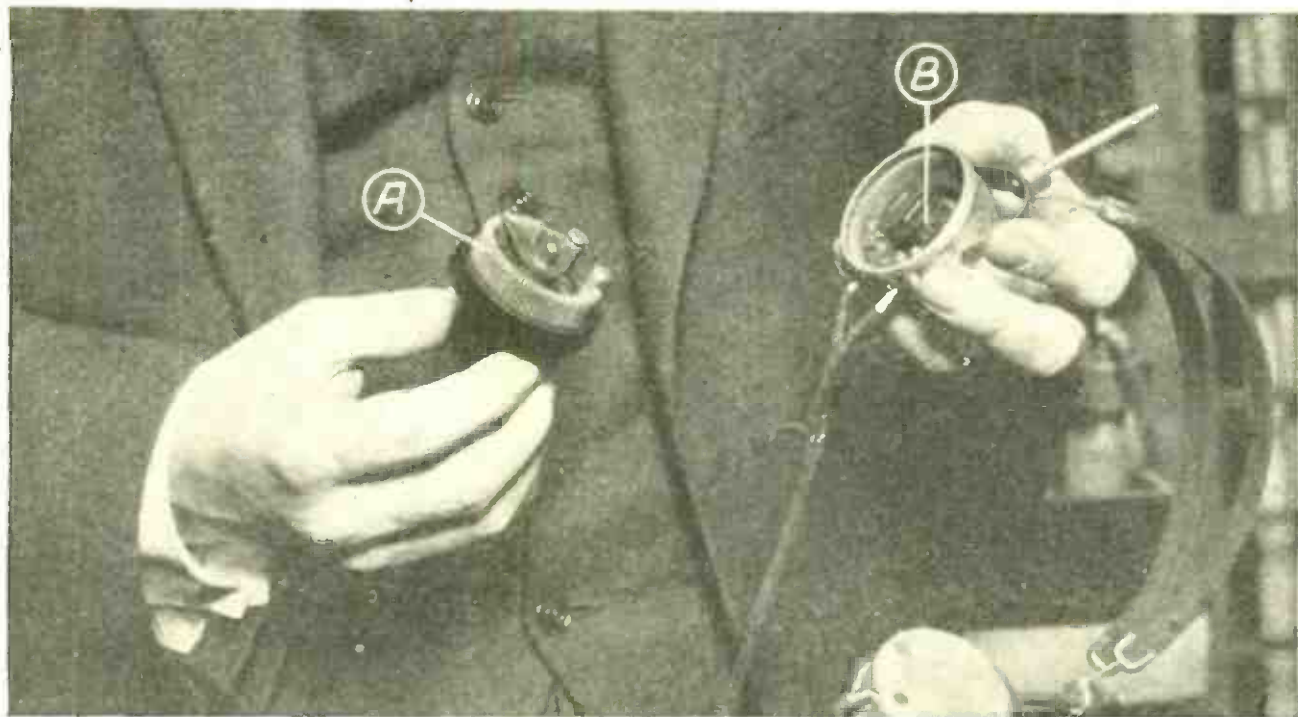

From a photograph made for POPULAR RADIO

WHERE RESISTANCE COUNTS AND WHERE IT DOES NOT

The rheostat A (shown above) is rated in ohms, whereas the headphone magnet coil B, when rated according to resistance specifications, has no significance to the user.

The Proper Rating for Inductive Instruments

Article No. 11

When you buy radio apparatus—headphones, couplers and loudspeakers, for example—do not select them on the basis of resistance of the windings (which means nothing) but by *specifications in terms of inductance, advises—*

SIR OLIVER LODGE, F.R.S., D.S.C., LL.D.

IT appears to be customary for makers of radio apparatus to rate their headphones, loudspeakers and transformers by the resistance of the windings. That is probably because the resistance is so easily ascertained and verified. But it is not a good mode of specification, and may lead to misunderstanding. What we want to know especially about a transformer is the number of turns of wire in both the primary and the secondary, so as to give the transformer ratio, and so as to enable us to calculate the inductance of each coil, and the mutual induction between them. These, of

course, can be ascertained by experiment, even when the transformer contains iron. But some estimate could be made of them, if the number of turns and the other dimensions were known. *Resistance gives no information at all.*

The situation is much the same in the case of other electrical instruments. Galvanometers, for instance, are usually specified by resistance. And there must be a temptation to wind them with badly conducting wire, in order to get the high resistance more easily. It ought, therefore, to be widely known that high resistance in an inductive winding is no

famous "vortex atom" theory of Lord Kelvin as well as of the still earlier "tubes of force" idea of the great Faraday. Nevertheless the idea of Mr. Gore is undeniably interesting. It was inevitable that we would have, before long, attempts to carry the atomization of the universe down below the electron and the proton and to visualize the nature of the "particles" of which these two might be thought of as composed. It is a bit surprising to find the ether itself caught in this fashionable tendency to atomize everything, to see it, too, split up into its "ultimatoms."

But, after all, this is no more wonderful than atoms and electrons were when we first heard about them. Speculations like those of Mr. Gore not only keep us occupied in the salutary business of guessing, they frequently have the still more useful rôle of stimulating somebody to do a little experimentation.

Does Radio Cause Explosions?

GENERAL NEGREI of the Roumanian Army has been studying the probable cause of the explosion of munitions which occurred some months ago on the outskirts of the city of

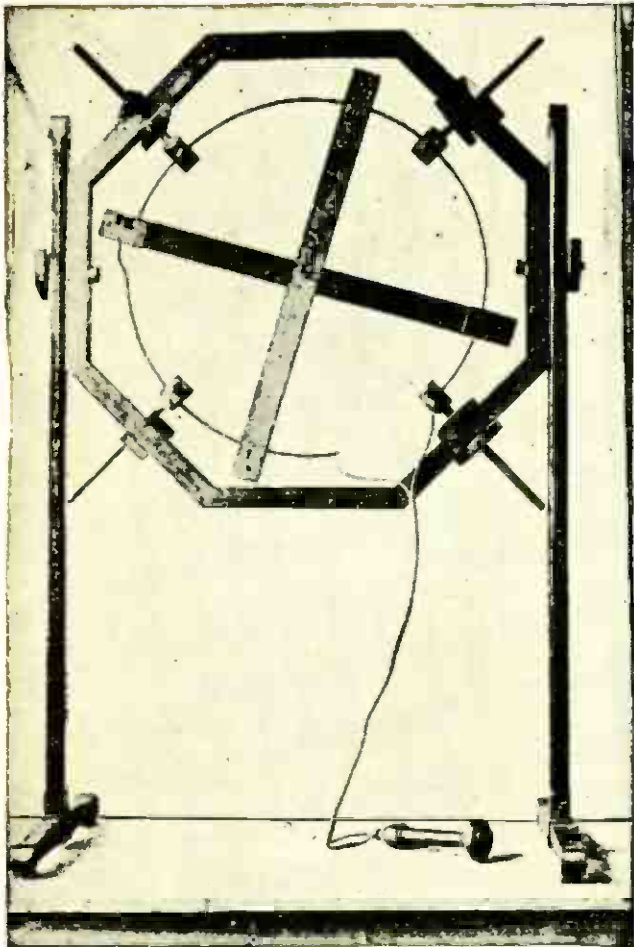

THE FIRST RECEIVING LOOP

In 1894 a Frenchman, Turpain, used this loop to receive Hertzian waves over short distances. Other loops at that time received small visible sparks, a circumstance now recalled by General Negrei to explain mysterious explosions.

Bucharest, with serious damage not only to the military magazine itself but to the surrounding countryside as well. The General has fixed the guilt, in his own mind at least, on an interference of radio waves.*

He does not imagine that the radio waves themselves ignited the explosives. It is more probable, he believes, that the waves generated small potentials in iron rings or other metal articles, that these potentials produced small sparks and that some one of these sparks was responsible for the fatal touch that set off the magazine.

There is no denying that this is possible in theory. If one has a metal ring containing a small spark gap, like an old-fashioned Hertzian loop; and if one places this ring in the proper relation to a powerful radio-frequency field, sparks will be produced in the gap in the ring. That was the original form of Hertzian detector. The Editor of this Department built one of them more than twenty years ago.

But, granting this, it is extremely unlikely that the energy of a radio station from ten to a thousand miles away would produce any sparks like this in the Bucharest magazine. The energy would be too feeble. Furthermore, General Negrei neglects the fact that induction from nearby electric machinery, of which there is doubtless plenty in Bucharest, would be incomparably more powerful as a spark-producing agency than any radio station as yet erected in that or any other country.

It is possible that electromagnetic (or electrostatic) induction *might* produce sparks inside a powder magazine and might touch off an explosion. For this reason it is wise that all metal parts in such magazines be securely grounded, as is usually done. But there is no reason why radio must accept the general's indictment as the culprit of Bucharest.

* The General's opinions are described in a special interview granted to the Bucharest correspondent of "The Radio Week in Europe," a radio news service by Mr. F. M. Delano, Paris representative of POPULAR RADIO. This interview was quoted in numerous American newspapers, for example, by Captain R. S. Wood in the Radio Section of the *New York Evening World* for September 13, 1924.

An Electric-wave Generator Constructed in 1898

THERE has recently been deposited in the United States National Museum, at Washington, what is probably the first vacuum-tube generator ever built—a tube constructed by Mr. D. MacFarlan Moore, in 1898.

It is not built, of course, on the principle of the audion. On the contrary, it is really no more than a rotating generator for high-frequency current constructed inside a glass bulb, so that it could be operated in a vacuum. It was put together originally as a source of high-frequency current for the operation of gas-filled glow lamps, with which devices Mr. Moore was then working. It was used, however, as a generator of electric waves as well, and for a month in 1898 waves produced by this tube were used to ignite a bomb at the

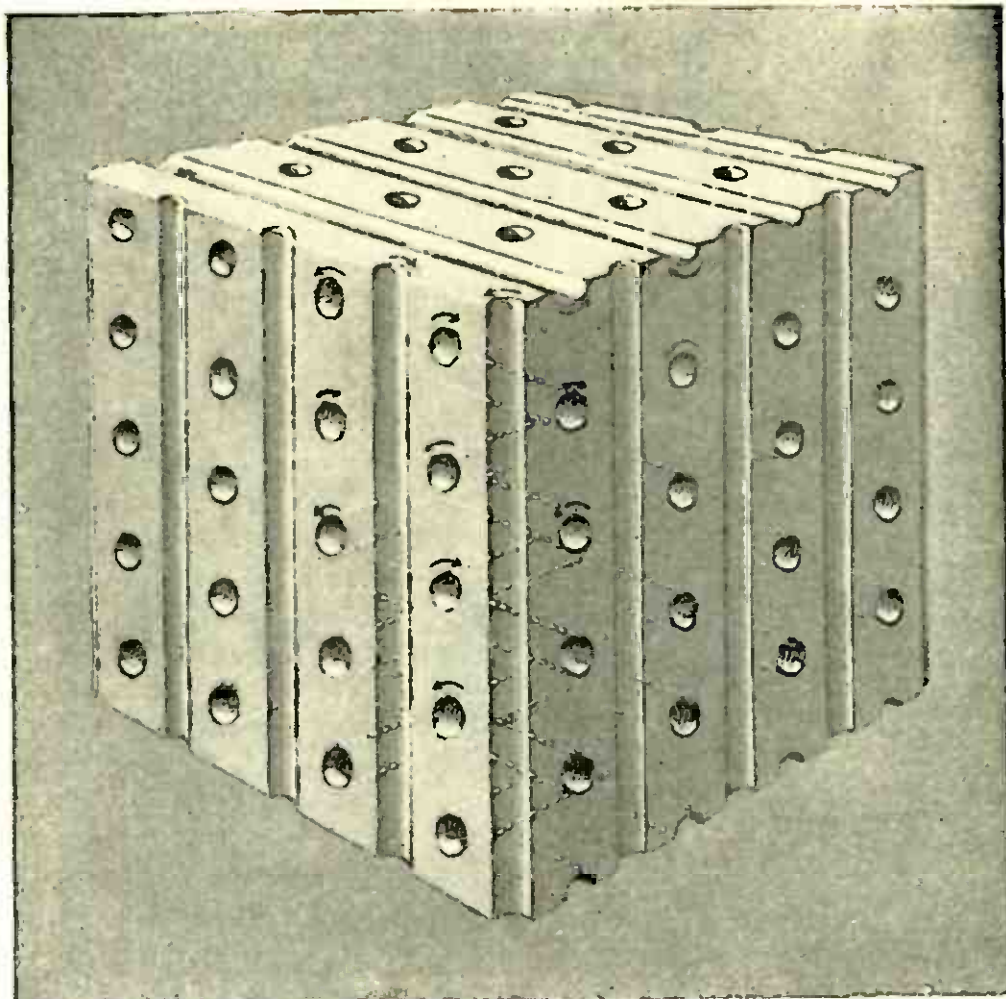

Redrawn by Arthur Merrick from a diagram in Mr. Gore's paper

A NEW IDEA OF THE STRUCTURE OF THE ETHER

Mr. William Gore believes that the ether is a mass of rotating tubes, some of which, arranged in three directions only, are shown in this drawing. Adjacent tubes are supposed to rotate in opposite directions. Light waves and radio waves are supposed to travel along the inner surfaces of the tubes.

ether of space is full of holes and these holes give the explanation of universal gravitation and radiation.**

The ether is supposed by Mr. Gore to consist of some variety of extremely small units, conceived as particles and called "ultimatoms." The nature of these is not specified further. The ether, composed of a mass of these particles, is compressible, just as is a gas composed of an assemblage of ordinary atoms. Running through the ether in every direction are a vast number of long, narrow whirls or "vortices." These are of exceedingly minute diameter, far smaller than anything with which we are now familiar. They are very long; possibly infinite in length. They might be thought of (although Mr. Gore does not use this analogy) as a vast interlacing network of long and narrow waterspouts, like the waterspouts that are occasionally produced by the down-reaching whirl of a tornado.

As the ether particles of these whirling tubes are revolving around the axis of the tube, they

are subject to centrifugal force. This drives them outward from the center. The whirl becomes hollow; that is what makes it into a tube.

Radiation is supposed to be a wave traveling along the inner surface of one of these tubes, much as a wave would travel on the surface of water. Whenever an electron hits one of the tubes such a wave is set up in it. That means a pulse of light.

The electron itself, as well as the proton and all atoms of matter built out of these two particles, does not belong, Mr. Gore thinks, to the system of ether tubes. These particles (and therefore all matter) are probably composed of some other kind of whirl or vortex among the tiny ether-particles or "ultimatoms." Possibly the material particles are ring-whirls instead of long tube-whirls.

The presence of the electrons distorts the ether tubes. The tubes must pass around an electron as the hose lines in a fire must pass around an intervening building. This distortion of the tubes causes pressures and drags. These constitute gravitation.

Experienced physicists will see in this new theory more than one reminiscence of the once-

* "A New Theory of Gravitation and Radiation," by William Gore. *The Journal of the Royal Astronomical Society of Canada* (Toronto), vol. 18, pages 345-366 (October, 1924).

The Electrons Inside Crystals

Bit by bit the physicists of the world are accumulating the information that will enable us, presently, to solve the mysterious relations of crystalline substances to electrons and to electric currents, relations which find, perhaps, their most mysterious manifestation of all in the familiar yet incomprehensible behavior of the galena and the catwhisker in a crystal detector.

The latest bit of information about crystals is some work on large, single, metal crystals reported by Professor P. W. Bridgman of Harvard University.* Ordinary metals consist of a vast number of very small crystals all jumbled together. In some metals, as, for example, in cast iron, you can see the shining points of the tiny crystals on a freshly broken piece of the metal. In other metals the crystalline structure is apparent only under a microscope.

* "Some properties of Single Metal Crystals," by P. W. Bridgman. *Proceedings of the National Academy of Sciences* (Easton, Pa.), vol. 10, pages 411-415 (October, 1924).



General Electric

THE LARGEST COPPER CRYSTALS EVER MADE

These pointed rods of copper are really single crystals produced according to a new method of heat treatment devised by engineers of the General Electric Company. The multitude of small crystals in ordinary copper are induced to rearrange themselves so that one large crystal is formed.

Recently the metallurgists have developed methods of making larger single crystals of some of the metals, crystals which attain, in some instances, dimensions of an inch or more across. The availability of these large crystals induced Professor Bridgman to measure some of their physical properties. Tests were made on crystals of tin, zinc, bismuth, cadmium, antimony and tellurium. They included measurements of the elastic constants, the compressibility, the expansion with rise of temperature and the electrical resistance.

The most interesting feature of the results from the viewpoint of radio is the relation of the electrical resistance to the direction of the axes of the crystal. Nearly all crystals have one or more directions in which they break most easily, the so-called "planes of cleavage." With the exception of antimony, Professor Bridgman finds that the electrical resistance is greater across these cleavage planes than in other directions. It is supposed that the atoms of the crystal are separated by greater distances in the direction perpendicular to these planes and, if so, the new data indicate that the electrons move less readily across this place where the atoms are farther apart.

Professor Bridgman's results also indicate that when the crystals are strongly compressed in the direction perpendicular to the cleavage planes, so that (presumably) the atoms are driven closer together, the electrical resistance in this direction decreases, indicating that the electrons now find it easier to pass across the narrowed "gap" that constitutes the cleavage plane. However, the increase of the conductivity across the compressed plane is not exactly proportional to the compression of the crystal, so mere nearness of the atoms is not a full explanation of the ease of electron passage. As Professor Bridgman concludes, "without doubt the details of atomic structure are involved," and these details of atomic structure, as we are learning to be all too sure, are matters of the most extreme complexity and difficulty.

Is the Ether Full of Holes?

It has been some time since we have had a new mechanical suggestion about the nature of the ether. Most of the modern theorists have preferred either to leave the ether altogether out of account, as Dr. Steinmetz urged in his now-famous POPULAR RADIO article on "There Are No Ether Waves," or else to trust themselves to the intangible symbolism of mathematics and avoid any ideas that had to be expressed by diagrams or models.

But at the last meeting of the Royal Astronomical Society of Canada Mr. William Gore took his courage in both hands and stepped forth with a new mechanical ether-model. More than that, he suggested that his model might explain the great mysteries of radiation and of gravitation, as well as providing some clues to the underlying truths hidden in the theory of relativity, the Bohr theories of the atom and the quantum theory. As he himself expresses his idea it is "that the

The two condensers, one for the tuner and one for the oscillator, are geared together so that both have the same capacity, these capacities altering alike as the dial of one of the condensers is turned. This dial constitutes the single tuning control. In the superheterodyne it is necessary, you remember, that the two circuits, the tuner and the oscillator, maintain not a constant *ratio* of frequencies but a constant *difference* of frequencies. In order to accomplish this the constants of the two circuits are so designed that an even variation of the two condensers has just this effect over the range of wavelengths between about 250 meters and

600 meters. Constants for these circuits are given in the article cited.

The set requires, also, a single filament resistance which controls all the tubes, and a potentiometer for the grids of the amplifying tubes. Neither of these is critical. The first detector tube is operated without "B" battery. Plate voltage is supplied by the "A" battery.

The filament resistance and the potentiometer having been adjusted, once for all, at approximately the correct points, all stations within the wavelength range can be tuned in, one by one, by turning the single dial that controls the two condensers.

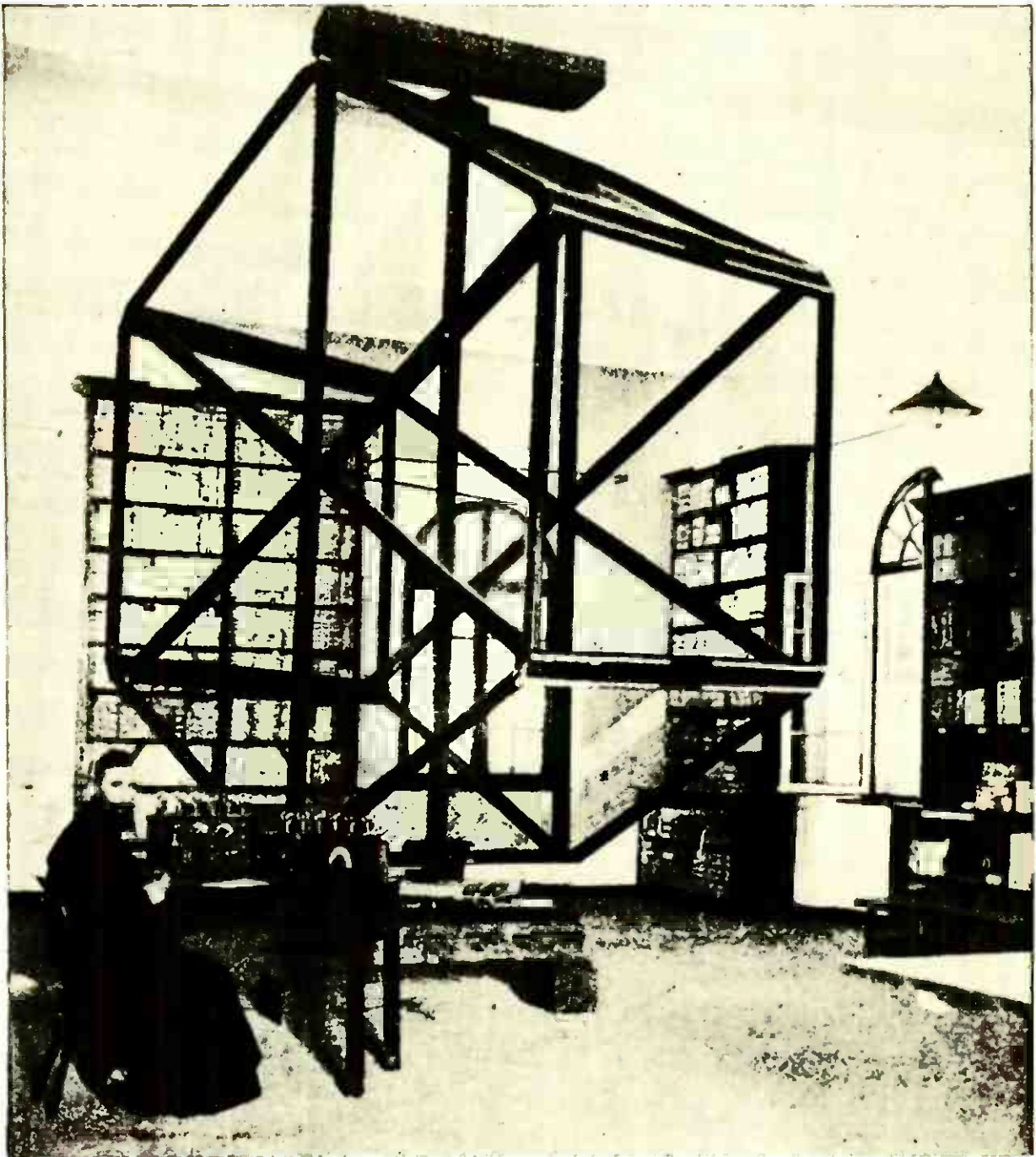

F. M. Delano

A CHINESE STATION IN THE PROPOSED LONGITUDE SURVEY

This great loop receiver at the Observatory of Zi-ka-wei, China, is one of those that General Ferrié proposes to use in his plan to check by radio the exact values of the longitude of places on the various continents.



IN THE WORLD'S LABORATORIES

CONDUCTED BY DR. E. E. FREE

The Earth's Exact Shape To Be Determined by Radio

THERE is considerable uncertainty about the shape of the earth and about the exact position of the continents on it. Not that the accepted figures are wrong by any number of hundreds of miles. But it is quite possible that they are wrong by as much as some hundreds of feet, and that is an error (or possible error) far too large to allow the accurate-minded scientists to sleep peacefully of nights.

This possible error arose through an uncertainty in the determination of longitudes; the longitude of a place being its distance east or west of a selected meridian, usually the meridian that passes through the town of Greenwich in England or the other meridian that passes through Washington, D. C. These distances cannot be measured directly. Even if one chose to face the labor of dragging a tapeline over the width of the United States the accuracy attained would be small. There would be too many inequalities of the ground to go over or around and the accumulated errors of the tapeline itself would be too large.

The only practical way to measure longitude, which means the only practical way to measure the east-and-west distance that separates two places on the earth's surface, is by means of the stars. If an astronomer at one place observes the exact instant at which a selected star passes the center wire of a telescope directed exactly upward, and if then another astronomer at the other place makes the same observation of the same star, the difference in time between these two instants gives you, by a simple calculation, the distance that the two places are apart in longitude.

This requires, you observe, that the two astronomers should know the time with extreme exactness. They cannot use the same clock. So what they do do is to compare their clocks very accurately. They used to do this by carrying a very precise chronometer from one observatory to the other one. Nowadays they do it by means of the radio time signals.

The use of radio time in this way has been going on for several years between certain of the larger observatories. Now it is to be extended, says the French radio expert, General Gustav Ferrié, to the measurement of a general control net for longitudes all over the earth.*

There have been, it seems, some more or less frequent differences in the stellar time as observed at different stations. This may be due to some inaccuracy of the astronomic or chronologic instruments. Or it may be due to some error of longitude or even to a slipping of part of the earth's crust or of the whole continent.

There is good evidence that the coast of California actually has slipped northward by a number of feet and is moving still. A distinguished German geologist, Professor Wegener, believes that all the continents are movable and really drift about, very slowly, over the surface of the earth. General Ferrié and the co-operating scientists, including Professor William Bowie of the United States Coast and Geodetic Survey, propose to find out, by careful time comparisons by radio among the different stations, whether or not these remarkable ideas have any basis of truth.

* According to a special interview with General Ferrié released in the United States by "The radio week in Europe," a radio news service by Frederic M. Delano, issue number 30, released October 28, 1924.

A Superheterodyne With One Control

THE latest step in the simplification of radio is taken in a new superheterodyne described by Mr. James L. McLaughlin of the Precise Manufacturing Corporation and in which the essential operation of tuning is accomplished by turning a single dial.* The secret lies in a combination of geared condensers and especially designed inductances and capacities in the tuner and oscillator circuits.

* "The One-control Superheterodyne," by James L. McLaughlin. *OST* (Hartford, Conn.), vol. 8, number 4, pages 9-14 (November, 1924).

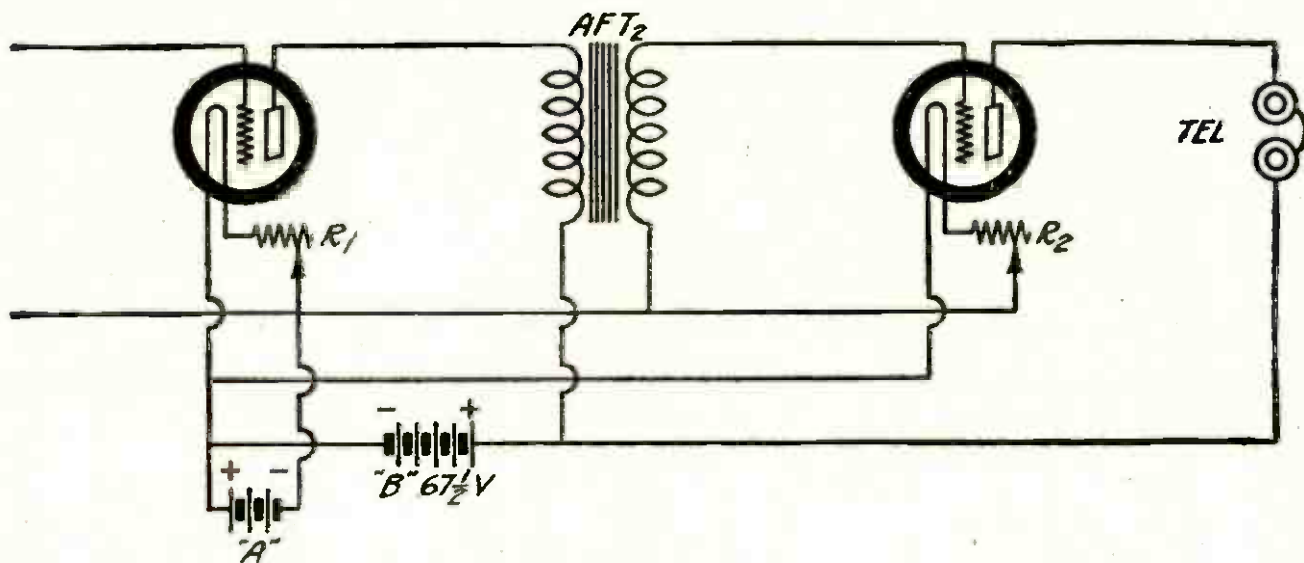

Voltage of the "B" Battery for a Soft Tube

QUESTION: I have a four-circuit tuner with resistance-coupled amplifier and I find that I get better distance and better local reception when I use only 16½ volts on the plate of my C-300 detector tube. I thought that these tubes were better when used on 22½ volts of "B" battery potential. Is it a peculiarity of the tube I am using?

W. C. HARRIS

ANSWER: No. You will get better results when using either the 16½-volt tap or the 18-volt tap on the "B" battery, because this circuit includes a plate control potentiometer. When you turn the potentiometer you add part of the "A" battery potential to the potential of the "B" battery, so that you may actually have 22½ volts on the plate of the tube even though you are using the 16½-volt tap. The extra potential supplied to the plate circuit is established by potentiometer adjustment.

"B" Battery Economy on Resistance-coupled Audio-frequency Amplification

QUESTION: Which is the most economical on "B" battery current, the resistance-coupled amplifier or the transformer-coupled amplifier for audio-frequency work? I have been told that the "resistance-coupled" affords good clear reproduction but that it consumes

great amounts of current from the "B" batteries.

THOMPSON AIRLEN

ANSWER: The mean or average current drawn by a resistance-coupled audio-frequency amplifier properly hooked up is much less than the mean current drawn by a transformer-coupled amplifier. Then, the fact that the resistance-coupled amplifier modulates downward, while the transformer-coupled amplifier modulates upward gives the final decision to the resistance-coupled method for "B" battery economy.

Correcting Misinformation About the Four-circuit Tuner

QUESTION: I have written to the *Radio Digest* in regard to information on the four-circuit tuner. Here are some extracts from the letter I got in return:

"We are advising in your inquiry that we have not given much space to the Cockaday circuit. While it is a selective type, it has a very decided limitation when it comes to volume. . . . Some degree of favor has attended construction of the circuit but generally speaking, we have found the reverse."

C. G. SCHLEGEL

ANSWER: Neither of the above statements is correct. The four-circuit tuner is noted for the volume it produces. Also, there are probably more four-circuit tuners built or in construction than any other type of home-made receiver, and the overwhelming majority of users are perfectly satisfied with their results.

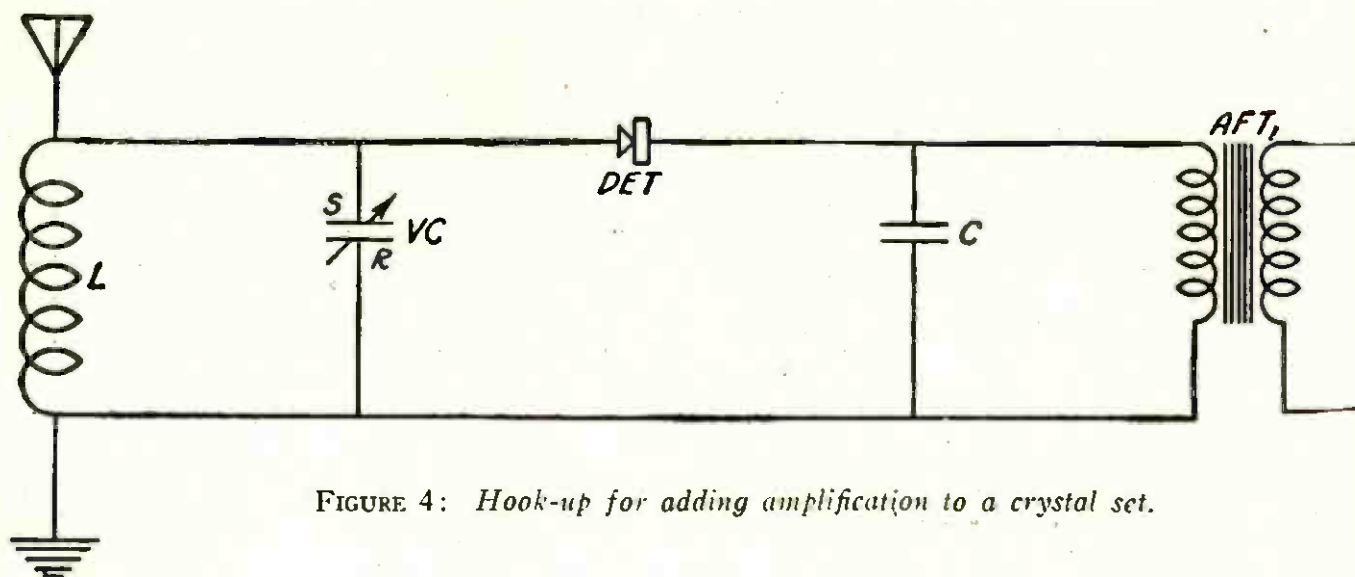

FIGURE 4: Hook-up for adding amplification to a crystal set.

Two Stages of Audio-frequency Amplification Added to a Conductively-coupled Crystal Receiver

QUESTION: Can you help me in adding an audio-frequency amplifier to a regular crystal set? I want to retain the clarity that I get at present with my crystal receiver but I want to add the amplifier to use with a loudspeaker, if possible.

S. D. ANDERSON

ANSWER: You will find the complete circuit in Figure 4. The parts for this are the following:

- L—honeycomb coil, size L-35;
- VC—variable condenser, .0005 mfd.;
- DET—crystal detector;
- C—mica fixed condenser, .0005 mfd.;
- AFT1 and AFT2—audio-frequency amplifying transformers;
- R1 and R2—filament rheostats, 30 ohms;
- TEL—telephones.

Use hard tubes for the amplifiers. These tubes may be either dry-cell tubes or storage battery tubes may be used.

A Set Entirely Mounted on a Panel

QUESTION: I want to build a three-circuit set for use in a phonograph and would like to know if you think it would be possible to mount all the instruments directly on a square panel that I could put in the top of my phonograph cabinet. I already have a three-circuit regenerative receiver that I built from plans published in POPULAR RADIO, and

am so pleased with it that I would like to rebuild it into the phonograph.

How could I mount the sockets?

H. GORDON YOUNG

ANSWER: This plan would be entirely feasible. You could use panel-mount sockets if the panel is to be set vertically, or you could use ordinary sockets mounted on top of the panel if the panel is to be set horizontally. If you do not wish to have the tubes visible, they may be fastened on the lower side of the panel so that they will hang down when in use. This position will in no way interfere with their functioning. You can place any of the instruments in any position and they will work satisfactorily as long as the leads are kept short and the audio-frequency apparatus is kept separated a proper distance from the radio-frequency apparatus.

Craig Circuit With Sodion Tube

QUESTION: Can the sodion tube be used in the Craig circuit? I would like to try this if you think it would be advisable. I have a small set that uses a sodion tube and the reception is extremely clear with it. I also have a Craig four-tube set and would like to use the above-mentioned type of tube instead of the ordinary soft detector tube.

ALEXANDER CROSBY

ANSWER: In the coming February issue of POPULAR RADIO you will find another article by Mr. Craig, who will tell you how to build another of his famous receivers with a sodion tube as a detector. This will give you the information you require and also help you to improve the set you have already built.

FIGURE 3: Diagram of connections for adding a Cockaday resistance amplifier to a Haynes detector unit.

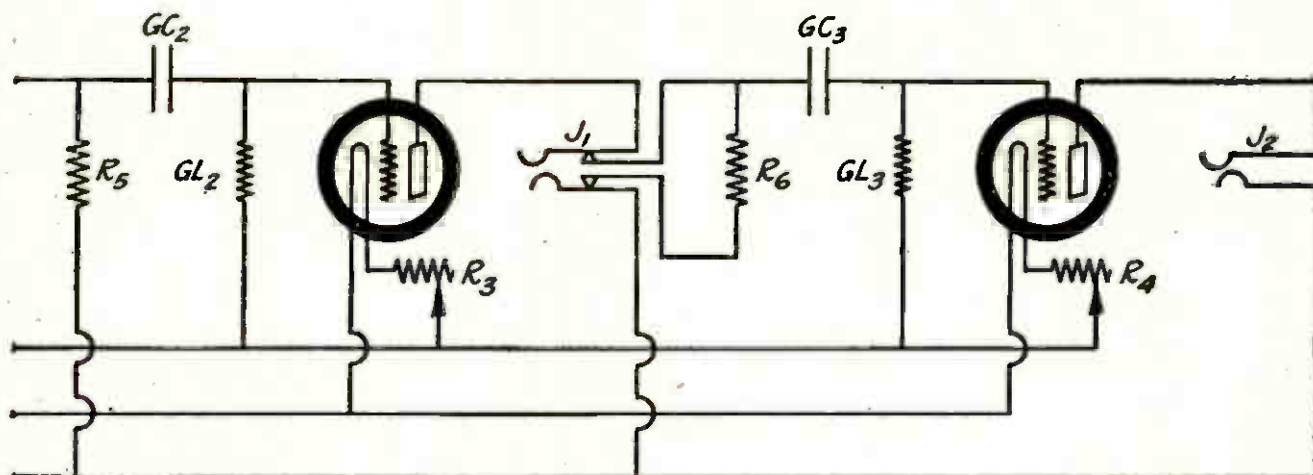

Value of Pigtails on Variable Condensers

QUESTION: I notice that several manufacturers equip their condensers with pigtail connections. They emphasize this point in their advertising as a valuable addition to a condenser. Another group of manufacturers makes a point of the fact that *their* condenser is *not* equipped with pigtail connections and *they* use it as a sales argument. I want to buy a variable condenser and am at a loss to know what to select.

SAMUEL V. LANDES

ANSWER: There is little to choose between a condenser with a well-made, tight-fitting bearing that runs true, and a condenser with both a good bearing and a pigtail. If the bearing is a snug-fit a good connection to the rotor plates is assured. If the bearing is imperfect, a pigtail will eliminate a poor connection. If the manufacturer turns out a good bearing by exact work, the pigtail is unnecessary. However, some manufacturers may want to make doubly sure by supplying both. The variation in inductance resulting from rotation and the change of position of the pigtail is a negligible factor with the present frequencies used in broadcasting.

Wooden Baseboards

QUESTION: Why is it that you specify composition panels for radio sets in place of wood, whereas you specify wood for the baseboard and mount instruments

directly upon the wood? It seems to me that this is misleading. If wood will do for the base, why will it not do for the panel? And conversely, if composition panels should be used, why should not composition baseboards be used?

ARTHUR HOPKINS

ANSWER: Instruments designed for mounting directly on the panel usually have the live parts of the circuit in direct contact with the material of the panel itself. This is the reason why the panel must be of efficient insulating material. Instruments for base-mounting, however, always have an insulated base which serves as an insulated panel. The baseboard for use with these instruments, then, does not have to be of insulating material at all. Wood is used because it furnishes an easy material for fastening the screws that mount the instruments.

Filament Connections for the UV-199 Dry-cell Tube

QUESTION: How many dry-cells should be used with the 199 tube? I have forgotten and don't want to take a chance of burning out the three tubes of my set. I have a three-tube set. G. P. A.

ANSWER: Three ordinary dry batteries such as used for the bell circuit in your house will suffice. Connect them in series, that is, connect the positive of one battery to the negative of the next and so on, and then connect the two remaining terminals to the tubes through the proper rheostat. These tubes work on a potential of 4.5 volts of "A" battery.

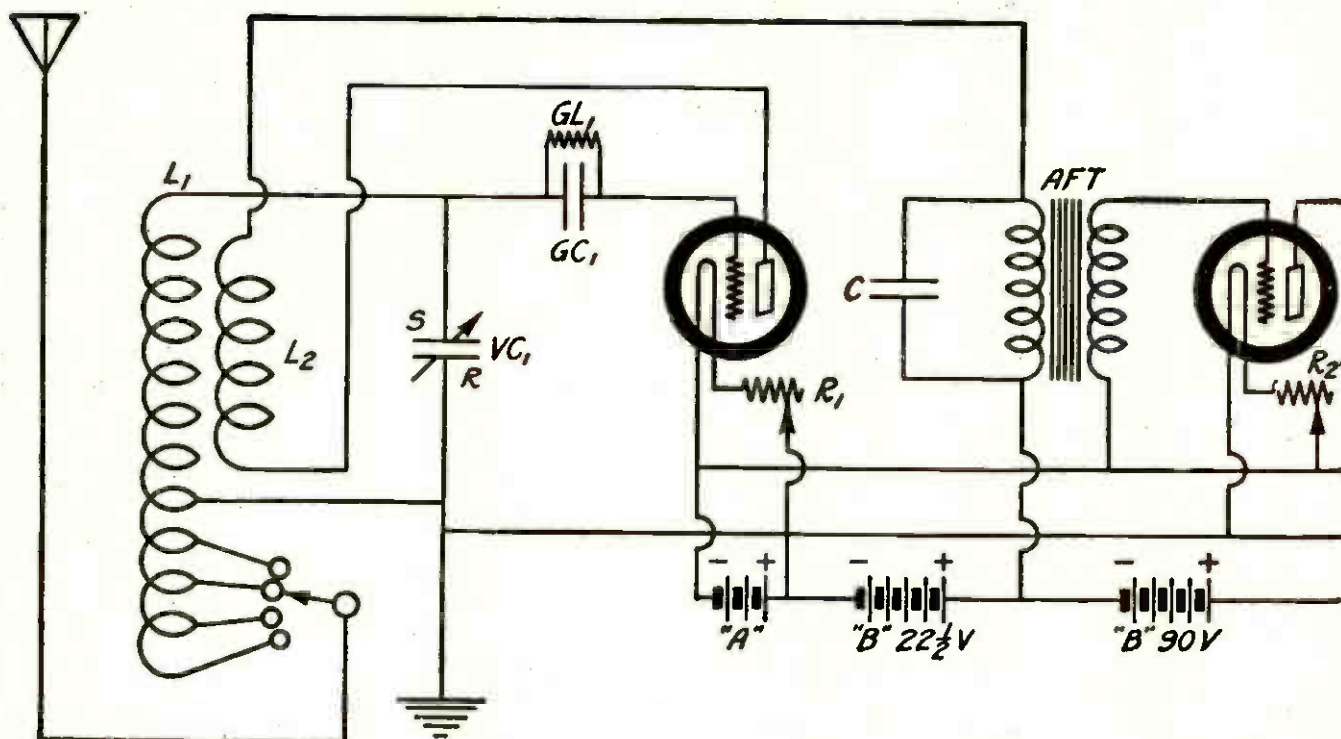

The Haynes Tuner With the New Cockaday Resistance Amplifier

QUESTION: I have a Haynes circuit which uses three tubes. One is used as the detector, in a separate cabinet with the tuning apparatus, and the other two tubes are in another cabinet with the audio amplifying transformers.

I get good distance with this set, even on the loudspeaker, but I would like to improve the quality.

Would it be possible for me to add the amplifying system that Mr. Cockaday described in his latest article on the four-circuit tuner with the resistance-coupled amplifier? If so, please let me have the complete diagram of the whole set for four tubes.

ROGER BURKE

ANSWER: Yes, this would be possible and will improve the tone quality of the received signals greatly.

The diagram for this change is shown in Figure 3.

The parts that will be needed, together with their constants, are given in the following list:

L1 and L2—Haynes coupler;
VC1—variable condenser, .00025 mfd.;
C—mica fixed condenser, .0005 mfd.;
GC2 and GC3—mica fixed condensers, .006 mfd.;
GC1—mica fixed condensers, .00025 mfd.;
GL1—variable grid leak;

GL2 and GL3—grid leaks, $\frac{1}{2}$ megohm;
R1—filament rheostat, 6 ohms;
R2, R3 and R4—filament rheostats, 30 ohms;
R5 and R6—plate resistances, 250,000 ohms;
AFT—audio-frequency amplifying transformer;

J1 and J2—double-circuit and single-circuit jacks, respectively.

Use a soft tube such as the UV-200 or the C-300 for the first tube, which is the detector, and use hard tubes such as the UV-201-a or the C-301-a or the DV-3 for the three other tubes, which are amplifiers.

The Mounting of Audio-frequency Transformers

QUESTION: I am designing a small 4-tube radio-frequency and audio-frequency set that employs the reflex principle. Does it make any difference how close to the radio-frequency transformers the audio-frequency transformers are mounted? Will you please tell me just how close the iron part of the audio-transformers can be placed to the radio-frequency parts without impairing the over-all efficiency of the set?

DONALD RADMERE BROOKS

ANSWER: It is a good precaution to mount any audio-frequency instruments at a distance of not less than two inches from radio-frequency coils. The iron in these instruments will cause losses in the coils which have the effect of increasing the resistance of the radio-frequency circuits of which the coils are a part.

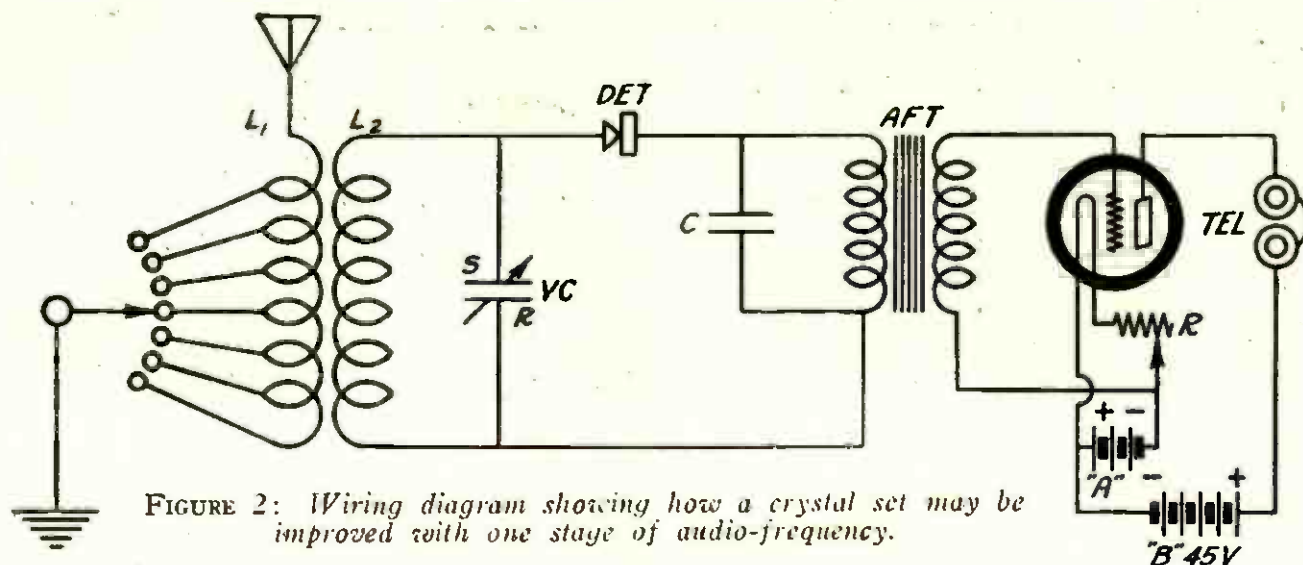

FIGURE 2: Wiring diagram showing how a crystal set may be improved with one stage of audio-frequency.

Adding One Stage of Audio-frequency to a Crystal Set

QUESTION: Please show by diagram how I can add a single stage of audio amplification to my crystal receiver which uses a vario-coupler, a variable condenser and a crystal detector.

Also please show me where to connect the batteries.

H. ROBINSON

ANSWER: The circuit you require is shown in Figure 2.

The parts that you will need are the following:

L1 and L2—primary and secondary coils of variocoupler;

VC—variable condenser, .0005 mfd.;

C—mica fixed condenser, .0005 mfd.;

DET—crystal detector;

AFT—audio-frequency amplifying transformer;

R—filament rheostat, 30 ohms;

TEL—telephones.

Use either C-299 or UV-199 tubes for the amplifier if you wish to use $4\frac{1}{2}$ volts of dry-cells.

Use a WD-12 if you intend to use a $1\frac{1}{2}$ volt dry cell.

If you intend to use a storage battery use either a UV-201-a tube or a C-301-a tube.

A Potentiometer or a Resistance in a Radio-frequency Circuit

QUESTION: Which would you advise using of the two methods for controlling regeneration in a simple radio-frequency amplifier circuit? The two methods I refer to are (1) the use of a potentiometer, and (2), the use of a

resistance in series with the input tuning.

HAROLD G. BRENT

ANSWER: We recommend that you use the potentiometer with the resistance of this instrument connected across the "A" battery and the pointer-lever connected to the grid return of the input circuit. In this case as the lever is advanced toward the negative side of the winding, the regeneration in the circuit will be increased. A similar movement in the opposite direction will decrease regeneration.

Connecting the Potentiometer-rheostat in the Four-circuit Tuner with the Resistance-coupled Amplifier

QUESTION: When I turn the potentiometer knob on my new four-circuit tuner all around to the positive side I find that it begins to smoke. Is there something wrong with the instrument? Or have I connected it the wrong way?

H. N.

ANSWER: This instrument has been changed since the article on the four-circuit tuner was written, and the connections on two of the posts have been reversed. Looking at the set from the rear, the first post on the left should be No. 1. The second post will be No. 2. The third post is No. 4, and the small connection strip that protrudes downward is No. 3.

There is a packing slip that comes with the new instrument that shows these changes and indicates the proper manner of connection. However, if you follow the diagram as printed in the magazine, with the numerals as given above, you will have the connection made correctly and the trouble will be eliminated. This will also increase the selectivity of your set considerably.

WHAT READERS ASK



CONDUCTED BY LAURENCE M. COCKADAY

In justice to our regular subscribers a nominal fee of fifty cents per question is charged to non-subscribers to cover the cost of this service, and this sum must be inclosed with the letter of inquiry. Subscribers' inquiries should be limited to one question or one subject.

A Single-tube Reflex

QUESTION: Will you kindly let me have the circuit for a reflex receiver using one tube, a crystal detector and an audio-frequency transformer. I have no radio-frequency transformer.

JOHN S. HANTE

ANSWER: A circuit that should fill your requirements is shown in the diagram in Figure 1. You will need the following parts to build the set:

L1 and L2—primary and secondary coils of variocoupler;

L3—rotor or tickler coil of coupler;
VC1 and VC2—variable condensers, .0005 mfd.;

R—filament rheostat, 30 ohms;

P—potentiometer, 400 ohms;

C1—mica fixed condenser, .001 mfd.;

C2—mica fixed condenser, .0005 mfd.;

C3—mica fixed condenser, .0005 mfd.;

AFT—audio-frequency amplifying transformer;

TEL—telephones;

DET—crystal detector.

A hard tube such as the DV-3, the C-301-a or the UV-201-a is recommended for use with this circuit.

A single-wire antenna of about 100-foot length will be sufficient.

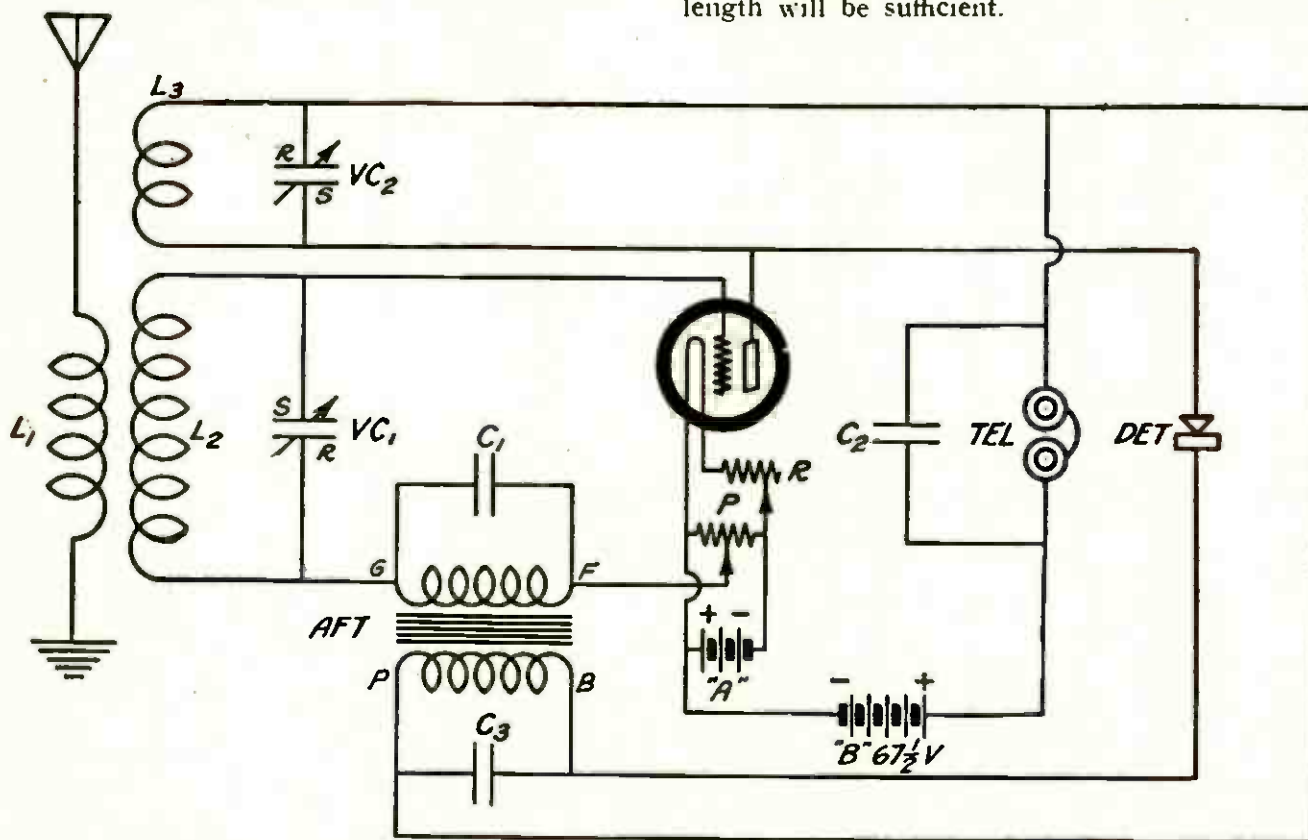

FIGURE 1: Hook-up for a one-tube, reflex receiver.

than one who is not. And the subtleties of rhythm in code transmission are a permanent source of interest to the operator. It is for this reason, perhaps only unconsciously recognized, that many operators have expressed their disapproval of mechanical transmitters. A mechanical transmitter is a source of uneasiness and of fatigue to the receiving operator.

Foolish and absurd as it may seem, I have remained continuously for six hours in my radio room aboard ship and listened with intense concentration to everything transmitted on 600 meters without undue fatigue. I have also, under similar conditions, been completely tired out after copying an hour's worth of press sent by tape. Such mechanical transmission, which lacks the intimacy of man

to man intercourse, is quite uninspiring.

Every experienced ship operator can look back with a great deal of pleasure to the old days when he could recognize many of his friends at sea by their "swing," without having heard the call letters of their ships. Furthermore, practically no two stations sounded exactly alike, and it was possible for an experienced operator to discover the identity of every land station and many ships by listening to just a few letters in the middle of the message. A few words midway in a text that was being sent from old WST (Miami, Fla.) or WHA (Cape Hatteras, Va.) caught on the wave many thousand miles away, gave an operator a thrill and made him glow with pleasure for the rest of the day.

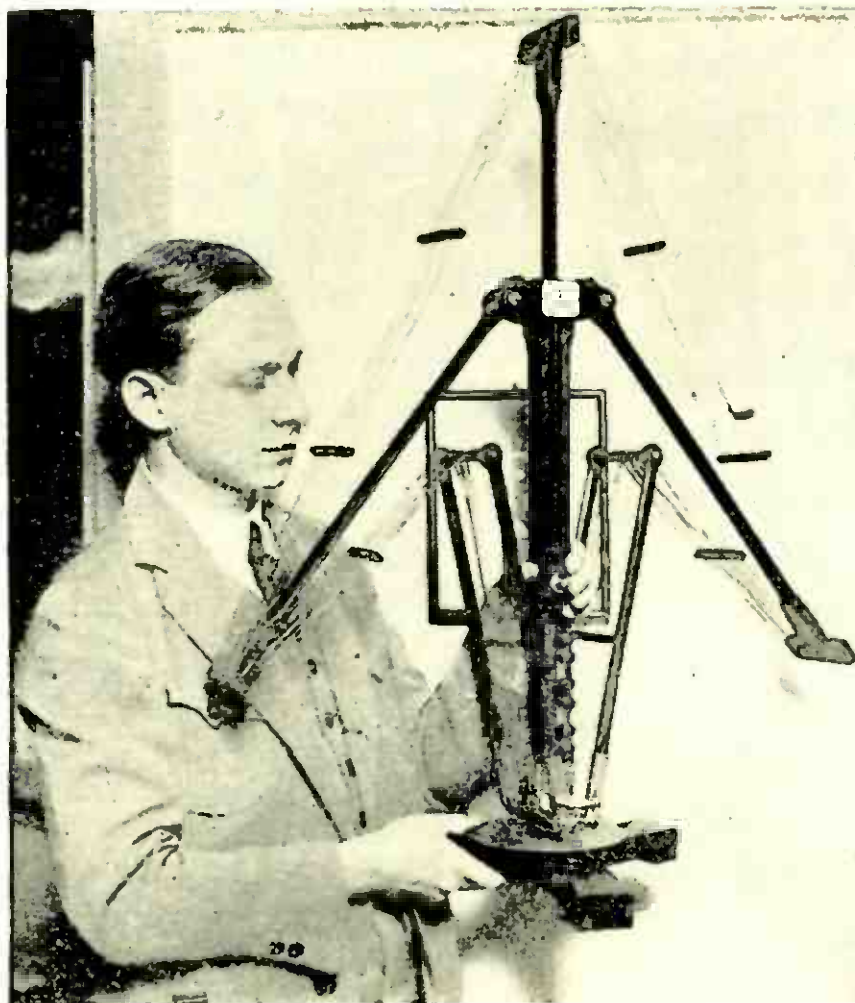

Kadel & Herbert

AN ANTENNA WITH WHICH YOU CAN TUNE

Here is a new type of German loop which not only folds up, but which changes the degrees of receptivity besides by varying the relation of the wires. It is wound with German Litz wire, which cuts down the high frequency resistance.



From a photograph made for POPULAR RADIO

THERE IS AN AESTHETIC THRILL IN THE "MUSICAL ELEMENT OF TRANSMISSION"

"I have been as much thrilled by listening to the work of a good operator," states the writer, "as I have by a good musician." The above picture shows Donald C. Wallace (9-ZT), an amateur of Minneapolis.

exactly the same manner; there are as many variants of a specific message as of a Chopin *Étude*. As an operator gains experience, the subtleties of transmitting rhythm become apparent to him and the pleasure in listening to code work becomes akin to that of listening to music. I have myself at times been as much thrilled by a good operator as I have been by a good musician.

At the base of this there is the instinctive feeling for rhythm that is possessed by all human beings. At certain stages of civilization this feeling manifests itself by a passion for dancing; in the most cultured circles this rhythmic desire is satisfied by listening to the higher types of music. In this sophisticated class a greater subtlety, a greater elegance and refinement of rhythm are demanded. So it is among operators.

Some time after his initiation into the brotherhood, every radio operator has his

dancing period—a period when he does tricks with his key which bring down upon him the curses of many busy operators. It is usually after the first two or three years, during which the operator is perfecting his technique of reception and transmission, that he becomes aware of a distinctly pleasurable sensation while he listens to the transmission of good operators. When this sensation is analyzed it is discovered to be an æsthetic thrill induced by the musical element of transmission.

As experience in receiving is accumulated and as the purely mechanical elements of translation from dots and dashes mastered, so that they are no longer an impediment to prompt comprehension, the musical element asserts itself, becoming a source of pleasure to the operator.

This fact has also its practical value.

An operator who is thoroughly interested in his work is vastly more efficient

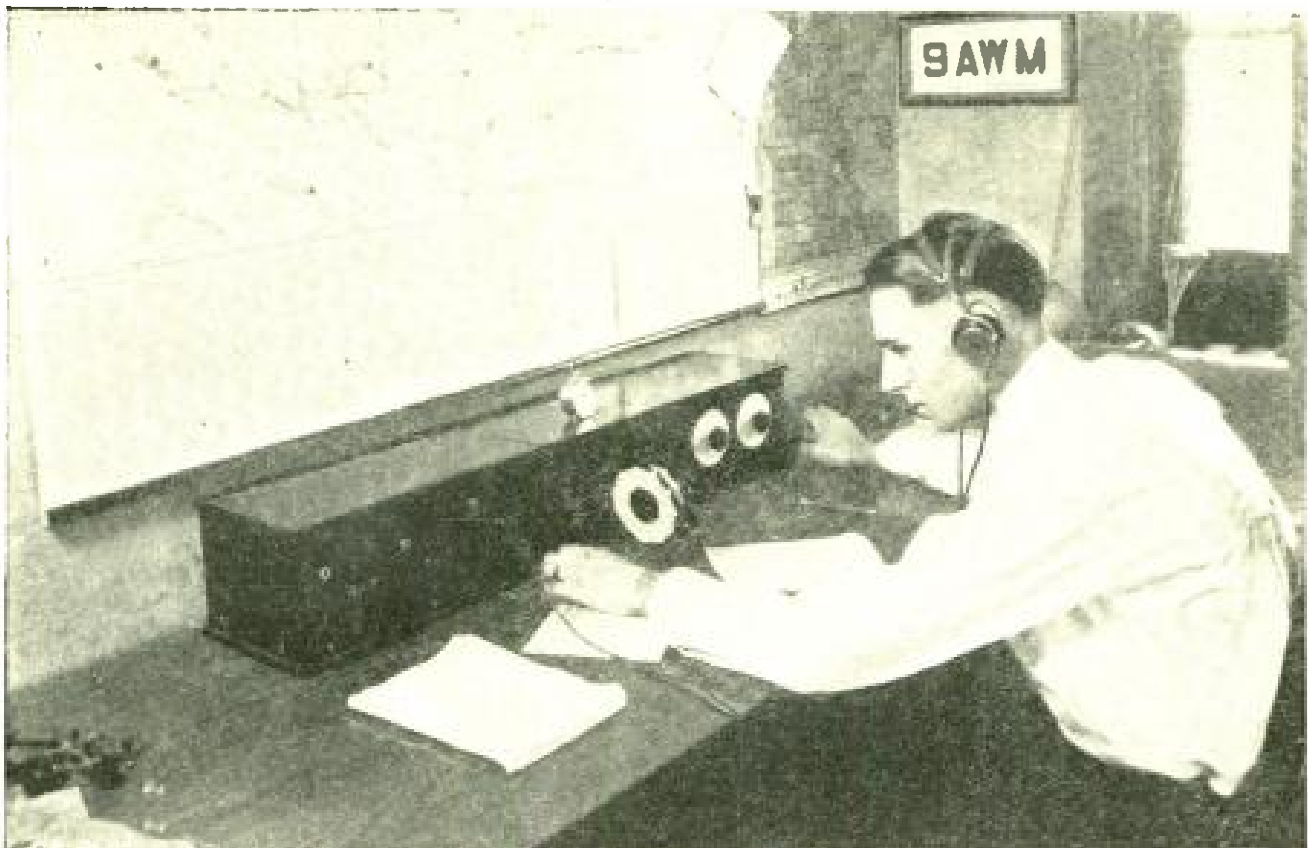

From a photograph made for POPULAR RADIO

A MECHANICAL TRANSMITTER IS A SOURCE OF FATIGUE TO A RECEIVING OPERATOR

Not only does it lack the intimacy of man-to-man intercourse, but it also lacks the characteristic rhythm that each transmitting operator acquires unconsciously. This picture shows Lloyd V. Berkner, an amateur of Sleepy Eye, Minn. (9AWM).

“By Their Fists Ye Shall Know Them”

Do you think that code transmission is a purely mechanical operation? “There are as many variants of a specific message as of a Chopin *Étude*,” states an old-time amateur—

EARL DANA

EVERY broadcast listener has, on occasion, tuned in the wavelengths near 600 meters and listened to the transmission of messages by the system of dot and dash signals known as the International Morse, or Continental Code. You have done so yourself.

Perhaps you were intrigued by the rhythm and pitch of these signals. Perhaps you even took the trouble to look carefully at a code chart; perhaps you actually analyzed these dot and dash combinations and discovered for yourself that the shortest combinations represent the

letters that are most frequently used and the longer combinations represent the less common letters.

And perhaps you got the impression that code transmission by radio is a purely mechanical operation.

But anyone who believes that radio operating is a purely mechanical function is decidedly mistaken.

A good operator is an artist. To an experienced radioman there is a distinctly æsthetic thrill in listening to the sending of a good operator.

No two operators interpret the code in

subjects, should have many opportunities to give thanks to science and the man who strived to bring resultant wealth of information to their ears.

In the immediate air above the farmstead is just the information that will help the farmer solve his most difficult problems. It takes no flight of fancy to picture the evening radio class lending attentive ears to the oracular voice conveyed across the continent.

Since announcement of a regular "College of the Air," applications for enrollment have come from practically all states of the Union. "Hard times" on the farm, it seems, have aroused the interest of the country population in better farming methods. Extensive investigations and the resultant valuable findings of agricultural colleges and the Department of Agriculture have shown the way to a more profitable agriculture. The problem has been that of introducing these improved practices more universally—and that is precisely what radio is now doing.

A large part of the 39,000,000 potential students on farms in the United States will have an opportunity to learn

by radio the findings of agricultural science and apply them to their farm business. At present only 150,000 students attend the agricultural colleges of the country. It is estimated that every tenth farm in Kansas is now equipped with receiving sets. A recent radio census shows that there are 25,000 sets on farms in Missouri. There are approximately ten times that number of radio outfits on farms over the United States.

What are the possibilities?

Who dares say? One Kansas farmer already has made the statement that radio market reports saved him \$400 on one shipment of cattle. It takes a trained horticulturist to determine just when to put on certain sprays; the Kansas State Agricultural College announces these dates. Ravages of hog cholera and other animal diseases can be checked by using preventative measures—and these measures are broadcast at the right time.

"The College of the Air" is carrying the practical, helpful knowledge into the home—to those who can make immediate, practical use of it.

Kansas State Agricultural College		
<i>Extension Division</i>		
ENROLLMENT CARD		
Radio Course in Agriculture and Home Economics		
Name	Age	Date
P. O. R. F. D. or St.		
State Business ..		
Time 7:00 to 8:00 P. M.		
Enrolling in course in		
1. Poultry (Monday)	<input type="checkbox"/>	4. Ag. Economics (Thursday) <input type="checkbox"/>
2. Livestock (Tuesday)	<input type="checkbox"/>	and Engineering
3. Crops, Trucks, Soils (Wednesday)	<input type="checkbox"/>	5. Home Economics (Friday) <input type="checkbox"/>
Kindly check above subjects which you expect to study X.		
Do you expect to ask for an examination when the course or courses is completed?		
.....
Station Call K F K B	No Fees Nor Tuition	Meter Length 286

THE ADMISSION TICKET TO THE COURSES BY RADIO

Without having to venture from their homes men and women may now go back to school by filling out these enrollment blanks and installing radio sets.

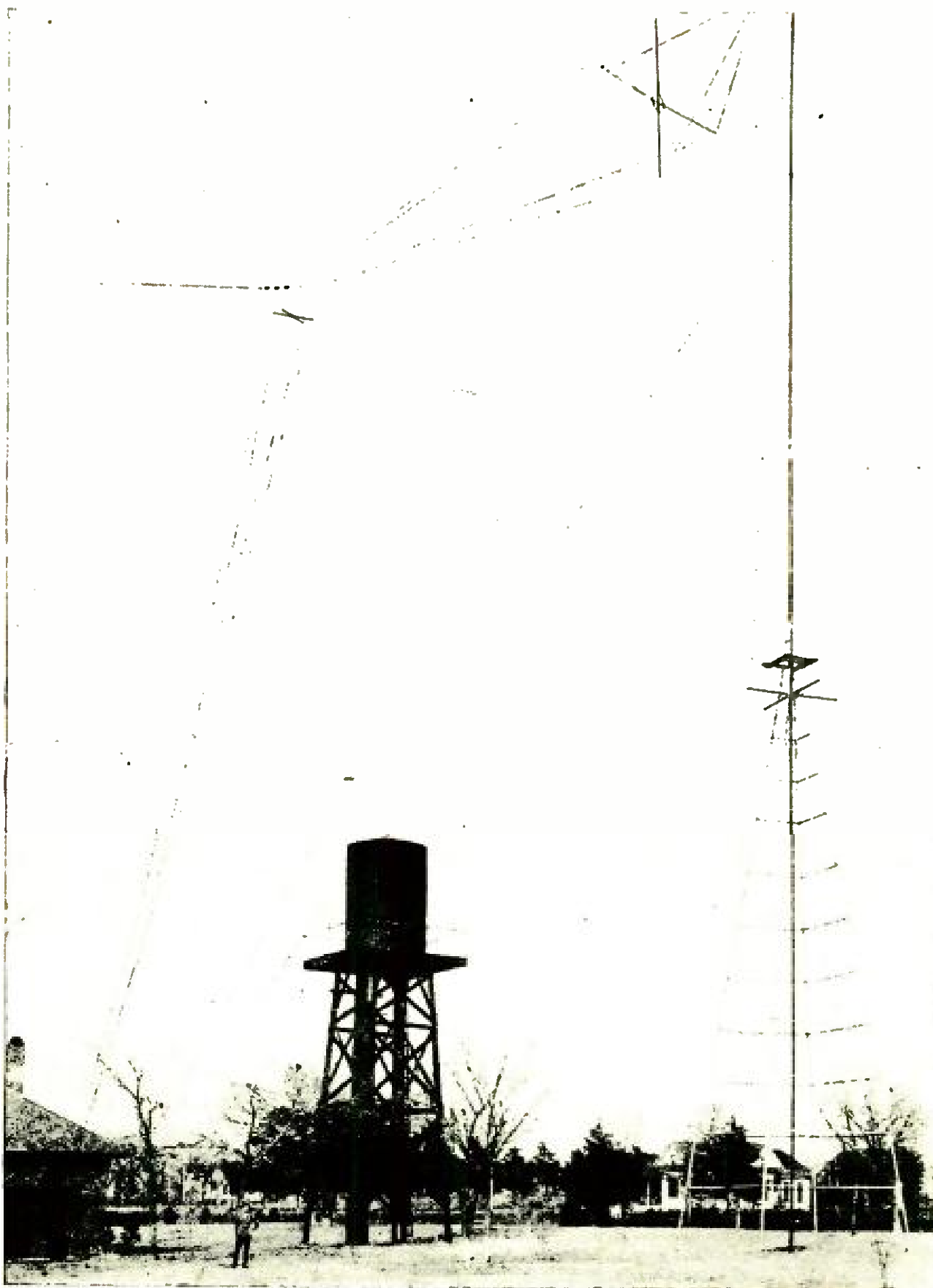

THE RADIO ROSTRUM OF A MODERN COLLEGE

This is station KFKB, the mouthpiece of the college that is educating the Kansas farmers. The eight-months courses are broadcast by remote control from the transmitter that is 25 miles from the college. As part of a comprehensive plan for extending the broadcast curriculum over the entire Middle West, the college is building its own 500-watt station on the college campus.

Since the courses by radio were begun over a thousand students have enrolled. Last winter half of the students took examinations. However, there are hundreds of others who don't bother to enroll, but, who, nevertheless listen in. The college is therefore bringing information and entertainment to a far greater number than the enrolled.

Forty Courses by Radio

Forty radio courses, embodying the essentials of that number of college subjects of especial interest to farmers, will be broadcast this winter from KSAC, the new 500-watt station that operates on 341 meters. Each week day evening at seven o'clock the classes assemble throughout the state.

"The only regular college course in the world which is given by radio—enroll in it."

That was the cry that went out last year when the college started its radio courses. And the cry is still more lusty this winter.

Interesting information on subjects ranging from law to the beef-cattle industry, from the feeding of babies to the writing of business letters are broadcast throughout the school year. Lectures are given Monday, Tuesday, Wednesday, Thursday, and Friday evenings for four semesters of eight weeks each during the school year.

Monday and Tuesday evenings are devoted to lectures on agriculture.

On Wednesday evenings the engineer has his innings. How to build the house and landscape the grounds; a discussion of auto, truck and tractor troubles and a dozen other subjects are listed.

How to keep the baby from crying, how to keep your husband from growling, how to save your money, your strength, how to make dresses and hats look like Paris models,—all these are taught to any aspiring woman who tunes in on Thursday evening.

On Friday evening the division of General Science presents lectures on

public speaking, business English, law, sociology, music, chemistry, zoölogy, and botany.

Kansas is 400 miles long, 200 miles wide, 5,000 miles deep and "as high as the heavens." Her agricultural college announces the weekly program. Tonight, for example, the Male Quartet and the Girls' Glee Club will entertain you a few minutes with selections portraying college life. These numbers will give you a breath of campus atmosphere; the head of the Poultry Department, will interrupt the melodies long enough to give some new facts which the experiment station has learned about profitable poultry production; his suggestions on management of breeding stock, selection of hatching eggs and artificial incubation and brooding are practical and timely. Each Monday night some specialist in poultry work will discuss feeding, care and management of baby chicks. Parasites and natural enemies of the farm flock which often spell ruin to this important side line to the business of farming will be subjects of discussion later.

And thus the nation has become the new campus of the Kansas State Agricultural College.

Radio's Contribution to Civilization

President Jardine believes that radio's greatest contribution to civilization may lie in its influence upon the life and action of the farm population. It is to become a vital necessity for their economic, spiritual and intellectual life, he predicts, by delivering the farmer and his family from the sense of isolation, by coping with class and sectional differences, by keeping boys and girls on the farm, and by making possible a system of agricultural education through the radio extension courses of the agricultural colleges.

The plastic minds of the young folks who may now receive inspiration and wisdom from college professors, well-informed in all the special agricultural



OVER 1,000 STUDENTS HAVE ENROLLED FOR THIS "RADIO COURSE"
And about 500 of these took the examinations that entitled the successful students to this "Radio Course Certificate" as evidence that they had listened in and profited by the lectures that were broadcast.

A College Certificate by Radio

How one progressive college in the West is extending its sphere of influence by instituting "the first regular college course to be given by radio"

By SAM PICKARD

OUT in Kansas the farmers are hanging a new kind of certificate upon the walls of their homes. It certifies that the recipient "has satisfactorily completed the work and passed the required examinations in the first regular college course to be given by radio" by the Kansas State Agricultural College.

A miniature reproduction of this novel college certificate is shown at the top of this page.

Anyone who has a radio set is eligible to take the course. Pa and the hired man have enrolled in the dairy course. Ma is particularly pleased, because the master of the house attends his classes

in their own living room. Ma sews while the lectures come in on the family tube set. On other evenings the hired man discusses with Pa the printed lectures of the course, which they receive free of charge from the state college.

"The College of the Air" (as they call it in Kansas) was inaugurated more than a year ago to bring helpful information and entertainment to rural communities. Anyone in the United States and Canada may enroll. Upon the completion of the course and the passing of an examination, he receives a certificate signed by the college president.

layers, and wound on a tube about $6\frac{1}{2}$ inches in diameter. The apparent inductance of this coil varied from 1,660 to 1,415 microhenries over the range from 820 to 2,330 meters. Its pure inductance or low-frequency inductance was about 1,390 microhenries and its distributed capacity about 20 micromicrofarads. All of these values may be changed by the *method of mounting the coil*, the *presence of metal objects* in the immediate vicinity of the coil and the *absorption of moisture* by the form upon which the coil is wound. The consideration of these factors in coil construction is often overlooked.

All of the above remarks have been made concerning fixed inductors or coils. There are on the market continuously variable inductors often incorrectly called variometers. This is a misnomer because a meter usually is used to measure something, while in these instruments the inductance is simply changed and no measuring is done. Any of the above characteristics could be obtained upon a variable inductor

in much the same manner as explained above. Measurements of the inductance of such apparatus are often made at an audio frequency such as 1,000 cycles a second. Such results are absolutely useless for work at radio frequencies, as the apparatus behaves entirely different at audio frequencies. In many of the variable inductors where a large amount of insulating material is in the field of the coil, the distributed capacity becomes very large. Because of the large distributed capacity, the apparent inductance for any setting of the variable inductor will vary with frequency or wavelength. The apparent inductance for a given setting will be larger for the higher frequencies or lower wavelengths than for the lower frequencies or higher wavelengths. As the wavelength is increased the values will come closer and closer to the values obtained at audio frequencies, but it is obvious that measurements must be made at high frequencies if the results are to be employed for operation at these higher frequencies.

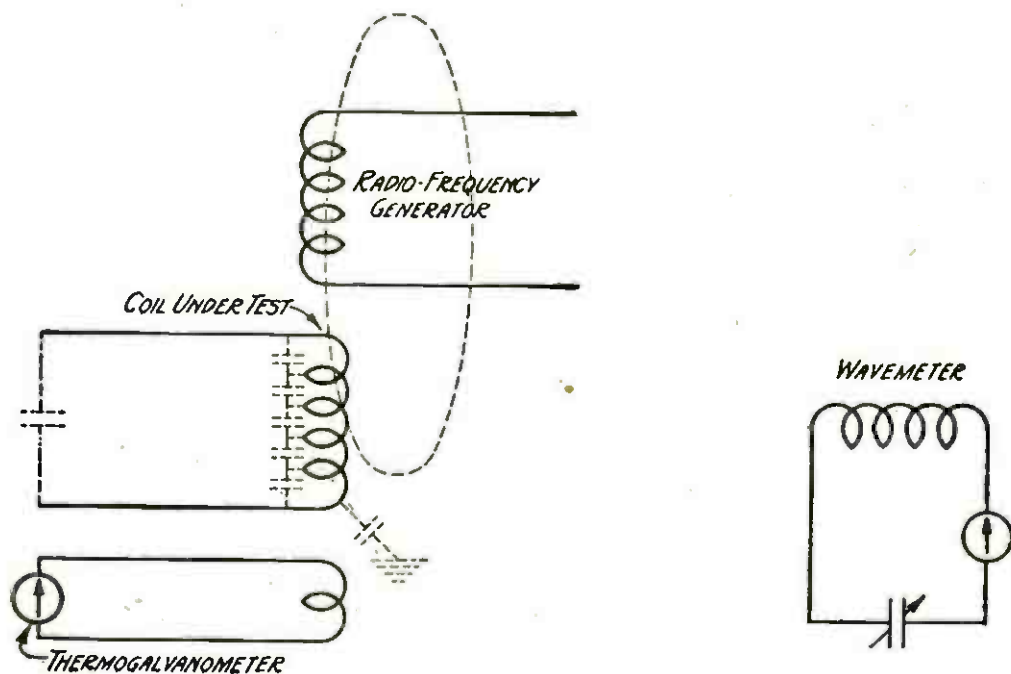

CIRCUIT DIAGRAM OF THE MEANS OF FINDING THE NATURAL FREQUENCY OF COILS

FIGURE 6: With the coil under test left open, the wavelength of the circuit can be determined as in Figure 3; (using the electron tube radio-frequency generator as a driver with a thermogalvanometer) and the capacity corresponding to this wavelength is the distributed capacity of the coil.

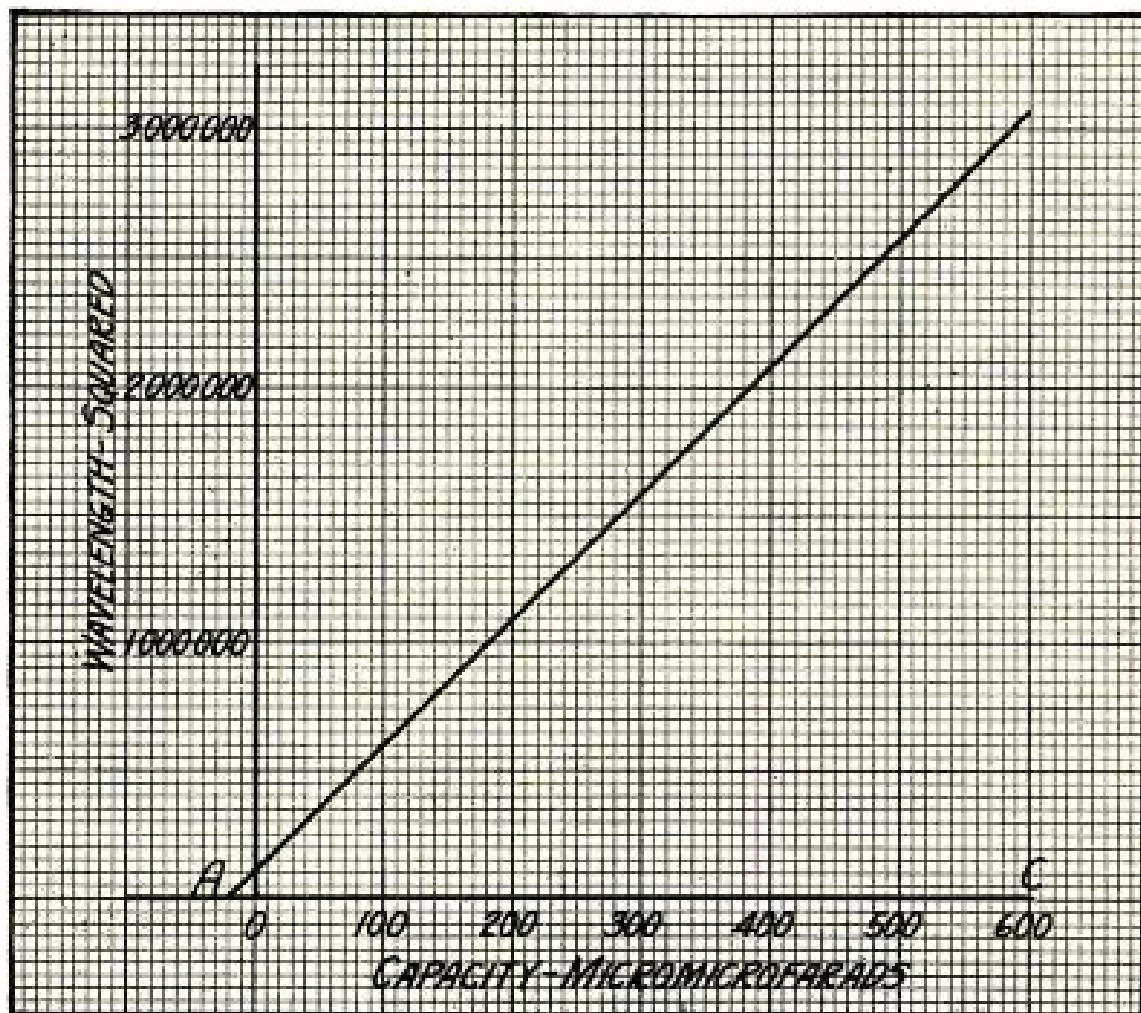

CHART OF THE SQUARE OF THE WAVELENGTH PLOTTED AGAINST CAPACITY

FIGURE 5: If a coil had no distributed capacity, the straight-line curve shown above would pass through the origin 0. The distance 0-A represents the distributed capacity of the coil under test.

lengths to which it would respond or go into resonance. That is the case and one or more frequencies can usually be found at which the coil will be in resonance when the two ends of its winding are not connected to anything. To determine one or more of these frequencies the coil is placed near a radio-frequency electron tube generator and a resonance indicator consisting of a thermogalvanometer and a turn of wire are coupled to the coil. The frequency of the generator is varied until a resonance indication is observed, when the frequency or wavelength of the generator is measured with a wavemeter.

Figure 6 shows the connections.

The frequency giving the greatest indication in the thermogalvanometer will be the natural frequency of the coil and

will be the shortest wavelength at which resonance may be found. The natural period is usually much higher than the frequency to which the coil would be in resonance if the circuit contained any capacity of such values as are ordinarily employed.

Measurements upon some coils will show little, if any, change of apparent inductance with frequency or wavelength and the distributed capacity will be found to be very small also. Measurements upon two spider-web coils gave such results, also the measurements upon a cylindrical spaced single layer coil. Coils of these two types give sharp tuning in radio circuits and are well-suited for use in some radio receiving sets. The data given in the table is for a coil of 70 turns bank wound in four

the apparent inductance. We will determine the capacity of the condenser and the wavelength of the generator for these points. After squaring the values of wavelength, plot these values as ordinates against the corresponding values of capacity in micromicrofarads. (See Figure 5.)

If the measurements have been carefully made, these points will lie on a straight line which may be drawn through these points and extended to the abscissa axis, as in Figure 5.

It is seen that this line cuts the ordinate axis some distance from the origin and continues to the left of this axis. The distance OA, measured by the same scale as OC, is the value of the distributed capacity for the coil, and in this case is about 20 micromicrofarads.

One perhaps wonders how this small value of capacity, the distributed capacity, enters into the fundamental equation for the wavelength of a circuit made up of an inductance coil and a condenser in series, which may be written

$$\lambda = K\sqrt{LC},$$

λ being in meters, K a constant. L the inductance in the circuit and C the capacity in the circuit. The quantity C in this equation is made up of the capacity in the condenser and the distributed capacity of the coil.

The pure inductance of the coil may be calculated from the equation:

$$L_p = \frac{0.2818\lambda^2}{(C+C_o)}$$

Where

L_p = pure inductance in microhenries,

λ = wavelength in meters,

and

C = capacity of condenser in micromicrofarads.

C_o = distributed capacity of coil in micromicrofarads.

It was stated above that the distributed capacity of an inductor may be made up of innumerable small capacities between the various turns of wire in the coil. If this is true it would seem that a given inductance coil might have one or more frequencies or wave-

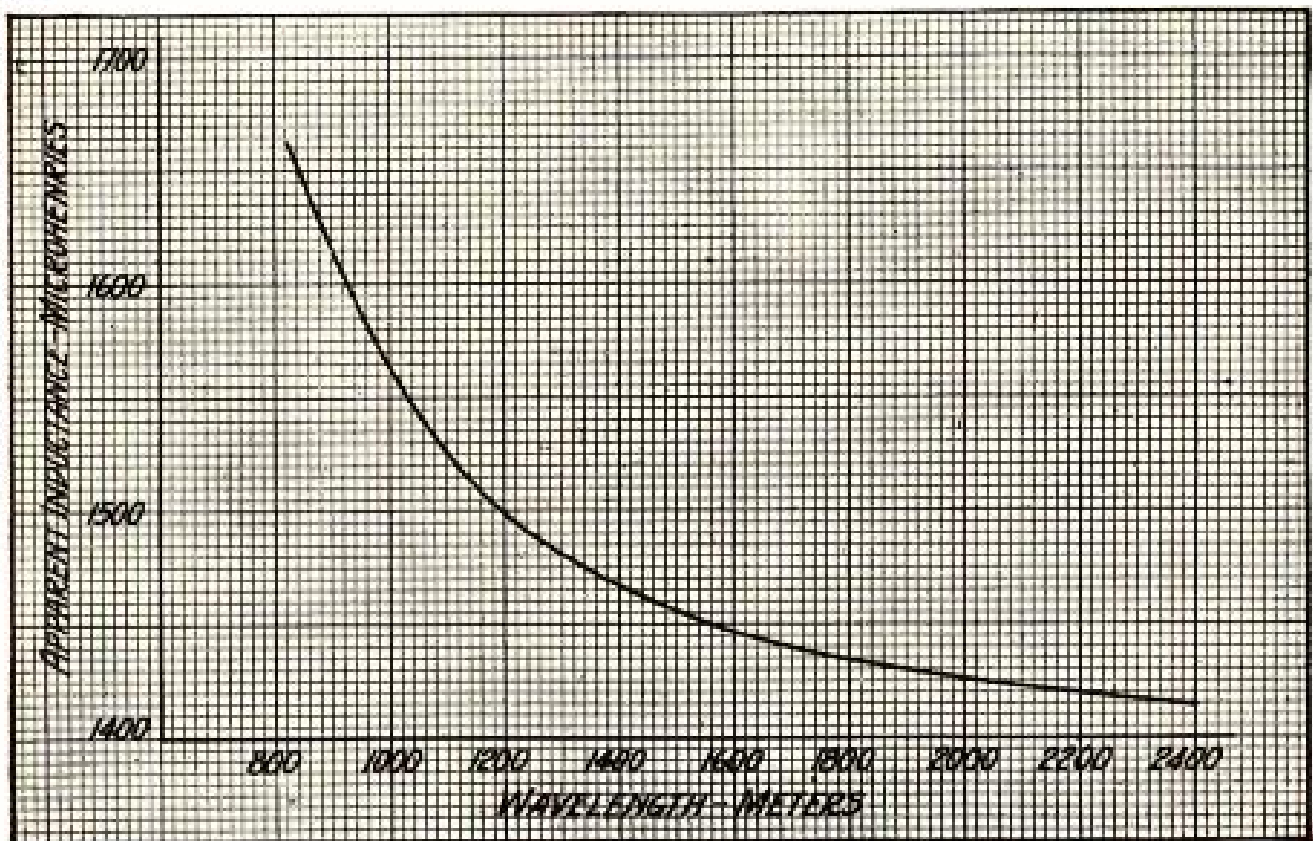

CURVE OF THE CHANGES OF APPARENT INDUCTANCE WITH WAVELENGTH

FIGURE 4: This graph shows that the apparent inductance of a coil increases much more rapidly at the lower wavelengths or higher frequencies.

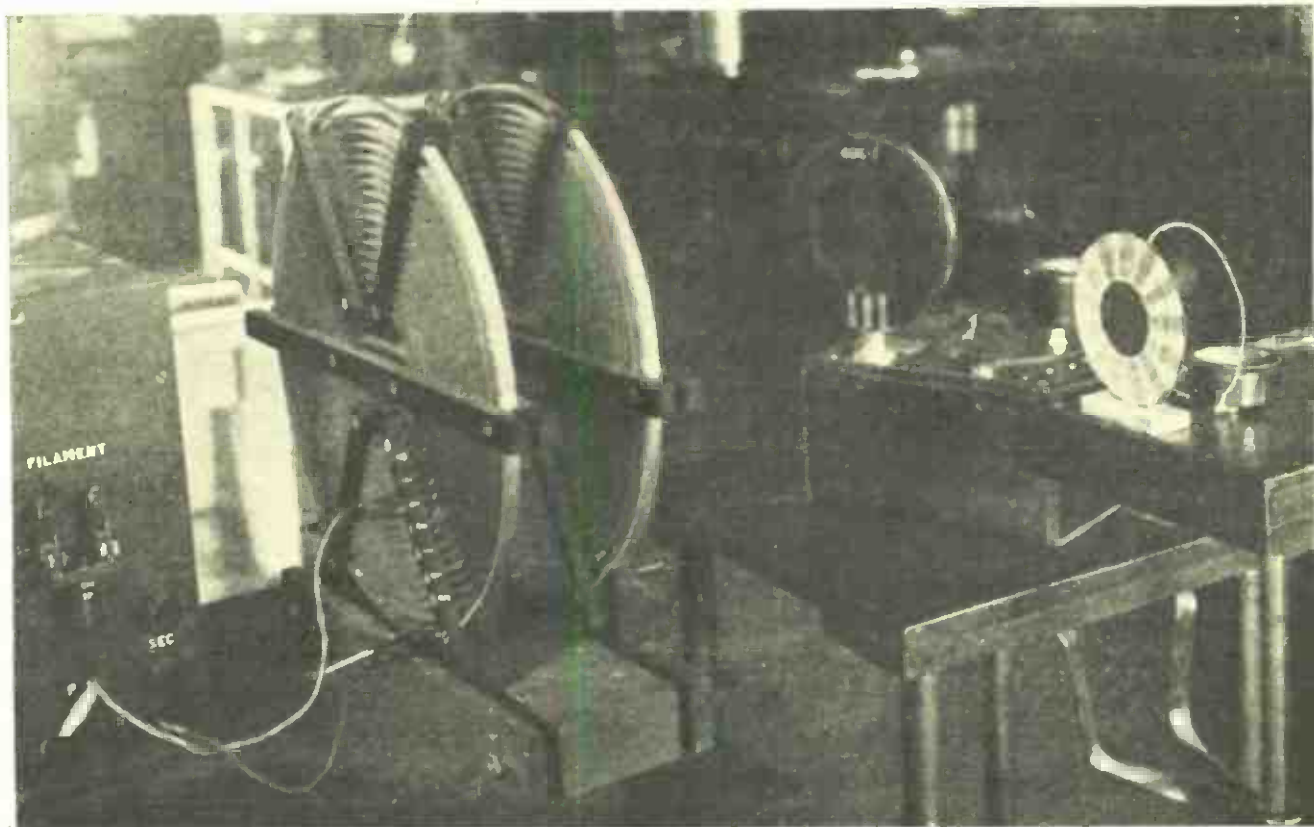

Harris & Ewing

THE EQUIPMENT FOR DETERMINING THE NATURAL FREQUENCY OF INDUCTORS

The apparatus (from left to right) is a radio-frequency electron-tube generating set with pancake coils, a wavemeter, a spider-web coil under test and a loop of wire connected to a thermogalvanometer.

The connections are indicated in Figure 3.

The procedure is similar to that given above in that the radio-frequency generator is started and the condenser in the circuit of the coil under test is varied until a maximum deflection is obtained in the circuit consisting of the thermogalvanometer and single turn of wire. The single turn of wire may be from four to six inches in diameter and is placed two or three inches from the coil under test so as to have its axis parallel to the axis of the larger coil. The coupling between the coil and generator should be kept as loose as possible and yet have a deflection in the thermogalvanometer which is readily seen. Having determined the resonance point, the setting of the condenser *S* is read and the wavelength of the generator is determined with the wavemeter. Several points may be obtained and a curve may be drawn showing the change in

apparent inductance with frequency or wavelength. Figure 4 shows the values of inductance and wavelength in Table I in plotted form.

If we should make measurements of the inductance of this same coil, using direct current or alternating current at 1,000 cycles a second (for instance), we might find that the values we obtained that way would be somewhat less than the values we have just obtained at radio frequencies. This is because in the equation used above for calculating the apparent inductance it has been assumed that the only capacity present was in the variable condenser.

We stated at the beginning that the coil itself had some capacity in itself which we call distributed capacity.

We will now make a few calculations to determine the value of the distributed capacity of the coil. We may select three or more sets of observations from the data already taken in determining

variable condenser in the test circuit is then varied until the buzzer note is heard in the telephone receivers.

The coupling between the two circuits may now be loosened so that the buzzer note is heard only at a very definite setting of the condenser *S*, which setting is recorded and also the setting of the wavemeter. If the condenser of the wavemeter is changed to another setting a different frequency or wavelength will be set up and another point on condenser *C* may be found. As many points as desired may be taken in this way.

Upon completion of these tests we will have two columns of data from which to make our calculations of apparent inductance, one column of condenser settings for which we know the corresponding capacity values, and a second column of condenser settings for which we know the corresponding frequency or wavelength values. These values might appear as shown in the first and third column of Table 1.

TABLE NO. 1

- Determination of apparent inductance of coil

Condenser Setting <i>S</i>	Capacity, Micromicrofarads	Wavemeter Setting and Coil	Wave Length, Meters	Apparent Inductance, Microhenries
10.1	114.5	179.4 B3	822	1660
30.1	247.2	94.5 A4	1150	1506
50.2	375.8	4.5 B4	1400	1467
80.1	565	96.4 B4	1700	1440
139.9	951	36.8 C4	2188	1422
170.0	1144	81.2 C4	2400	1416

The apparent inductance in Table 1 was calculated from the following formula:

$$L_a = \frac{0.2818\lambda^2}{C}$$

Where

L_a = the apparent inductance in microhenries,
 λ = the wavelength in meters,

and

C = the capacity in micromicrofarads of the known condenser.

The same measurement may be made with greater ease and accuracy by using an electron tube radio-frequency generator as the driver, a wavemeter to determine its frequency and a thermogalvanometer and single turn of wire to determine the resonance point.

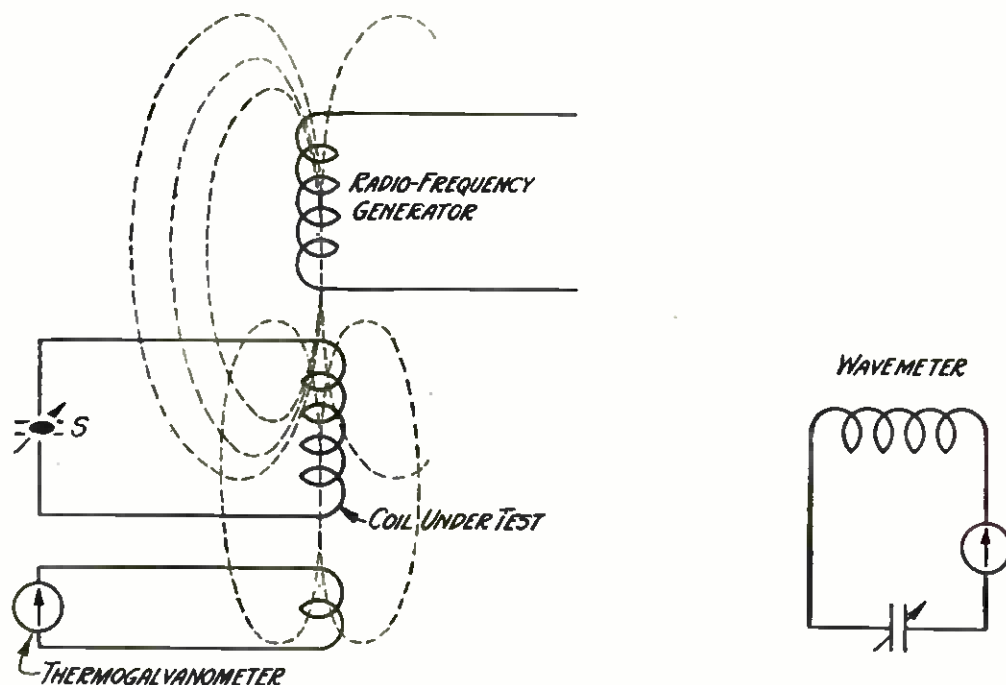

HOOK-UP OF THE SIMPLER AND MORE ACCURATE METHOD OF MEASURING FREQUENCIES

FIGURE 3: This diagram indicates the mode of frequency determination that employs an electron tube radio-frequency generator as a driver, a wavemeter and a thermogalvanometer for indicating the resonance of the circuit under test.

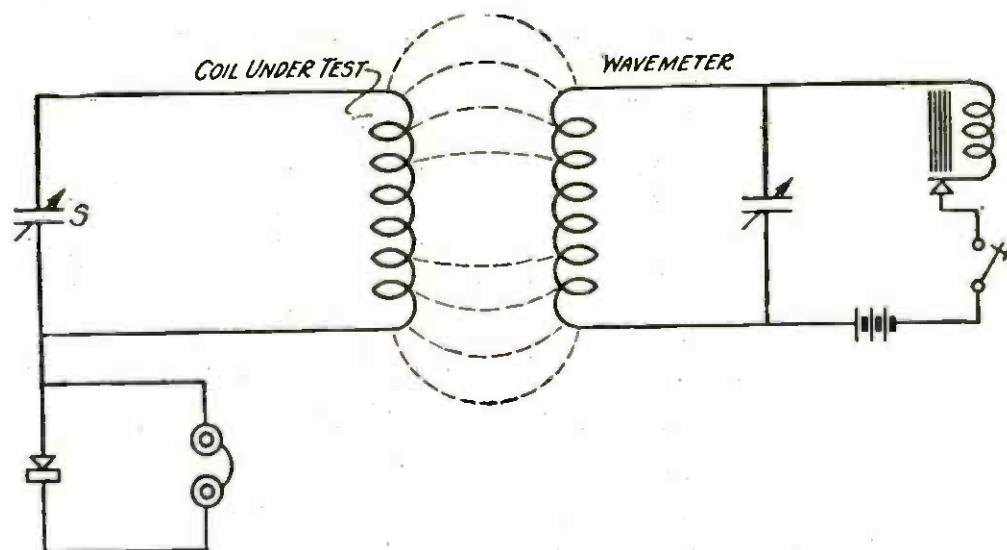

CIRCUIT DIAGRAM OF THE AUDIBLE MEASUREMENT METHOD

FIGURE 2: This shows the hook-up that employs a buzzer-driven wavemeter to excite the circuit under test. A crystal detector and phones are connected to this circuit to determine its resonance point.

capacity," as it is made up of innumerable small capacities between the various turns of wire in the coil and between the coil and surrounding objects.

Figure 1 (a) represents the usual method of denoting an inductor in a circuit. If we take account of the distributed capacity, we might think of it as in Figure 1 (b) where all the innumerable small capacities enter in.

The characteristics of an inductor which we will consider at radio frequencies will be the apparent inductance, the pure inductance, the distributed capacity and the natural frequency.

In measuring these characteristics, in addition to the inductor to be measured, it will be necessary to have one or more calibrated variable condensers of different values sufficient to cover the desired range of frequencies or wavelengths, a calibrated wavemeter which may or may not be equipped with a buzzer, a pair of telephone receivers and a crystal detector.

First, we will determine the apparent inductance of a coil using the buzzer driven wavemeter as a driver and repeat the measurements using the radio-frequency generator as the driver. First connect the terminals of the inductor to the terminals of the calibrated variable

condenser and connect the crystal detector and telephone receivers at one point of this circuit as shown in Figure 2. The connections between the inductor and condenser should be as short as possible. The buzzer on the wavemeter is started and the wavemeter coil is brought near the coil under test so that the coupling between the coils is rather close. The setting of the

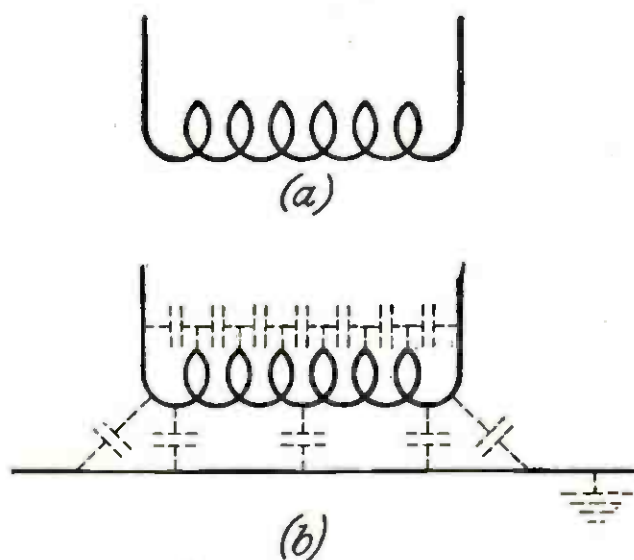

TWO VISUALIZATIONS OF INDUCTORS

FIGURE 1: The upper diagram (a) is the conventional inductance symbol. The lower diagram (b) indicates the existence of the distributed capacities of an inductive circuit that are never graphically represented.

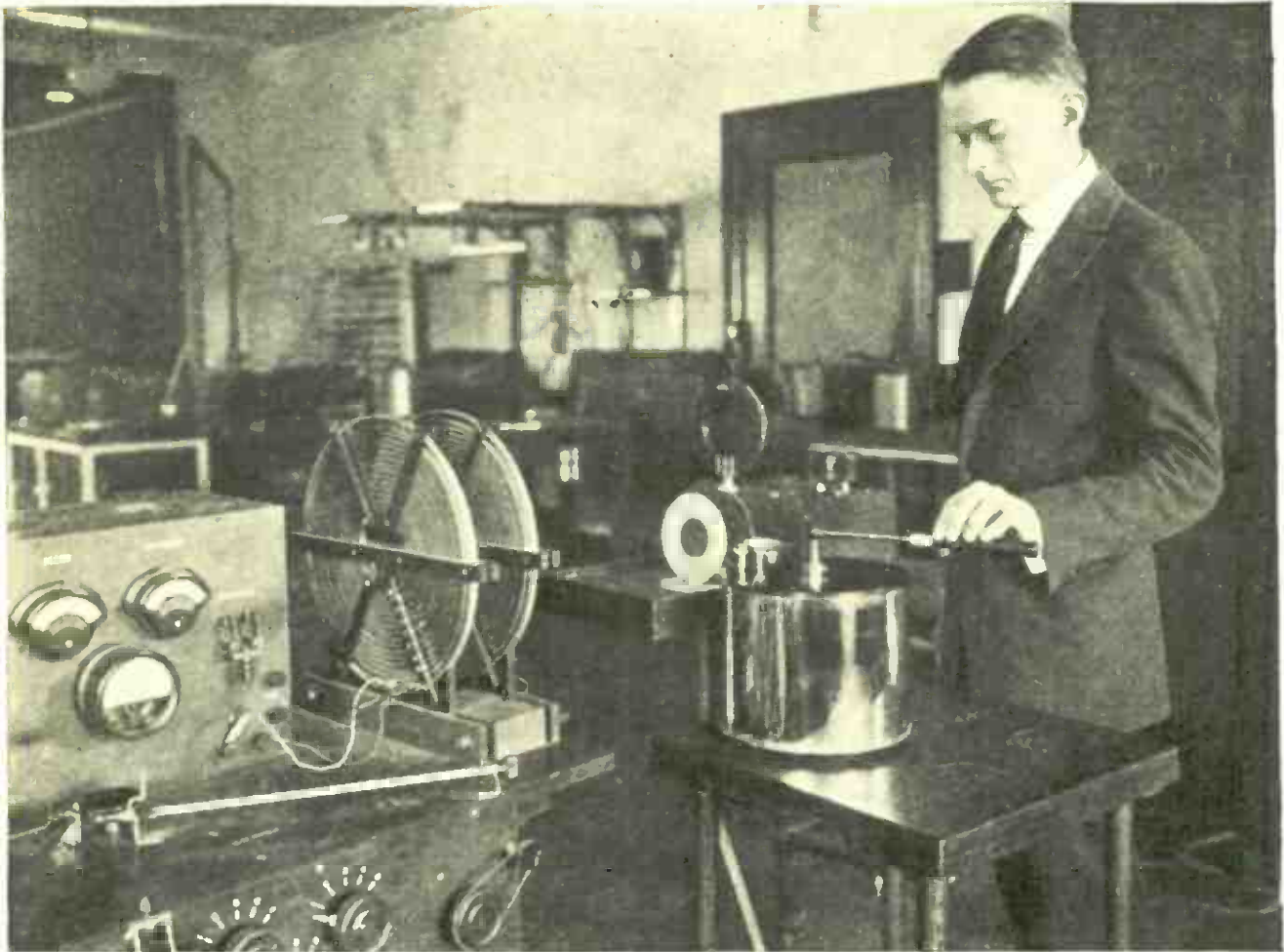

Harris & Ewing

THE NECESSARY APPARATUS FOR DETERMINING THE CONSTANTS
OF COILS USED IN RECEIVERS

The small spiderweb coil under test is shown connected to a laboratory standard variable condenser with the oscillator at the left and the wavemeter in the background.

INDUCTANCE COILS

How Their Characteristics Are Measured*

This article tells how the Bureau of Standards determines the general behavior of inductors, with particular reference to radio circuits. This information will assist those who are sometimes puzzled by peculiarities of their hook-ups.

By E. L. HALL

AN inductance coil or inductor is sometimes improperly called an "inductance." An inductance coil or inductor possesses an electrical property called inductance, but it also possesses electrical resistance and a certain amount of capacity when used in circuits at radio frequencies. The latter property

is usually spoken of as "distributed ca-

*In this article no attempt is made to give specifications as to type, dimensions, size of wire or method of supporting the wire for inductance coils for any specific purpose. The methods of determining certain important characteristics of several types of inductance coils used in radio work are given and some experimental data from which certain conclusions may be reached as to some factors in the design of such coils.

Published with the permission of the Director of the Bureau of Standards, Department of Commerce.

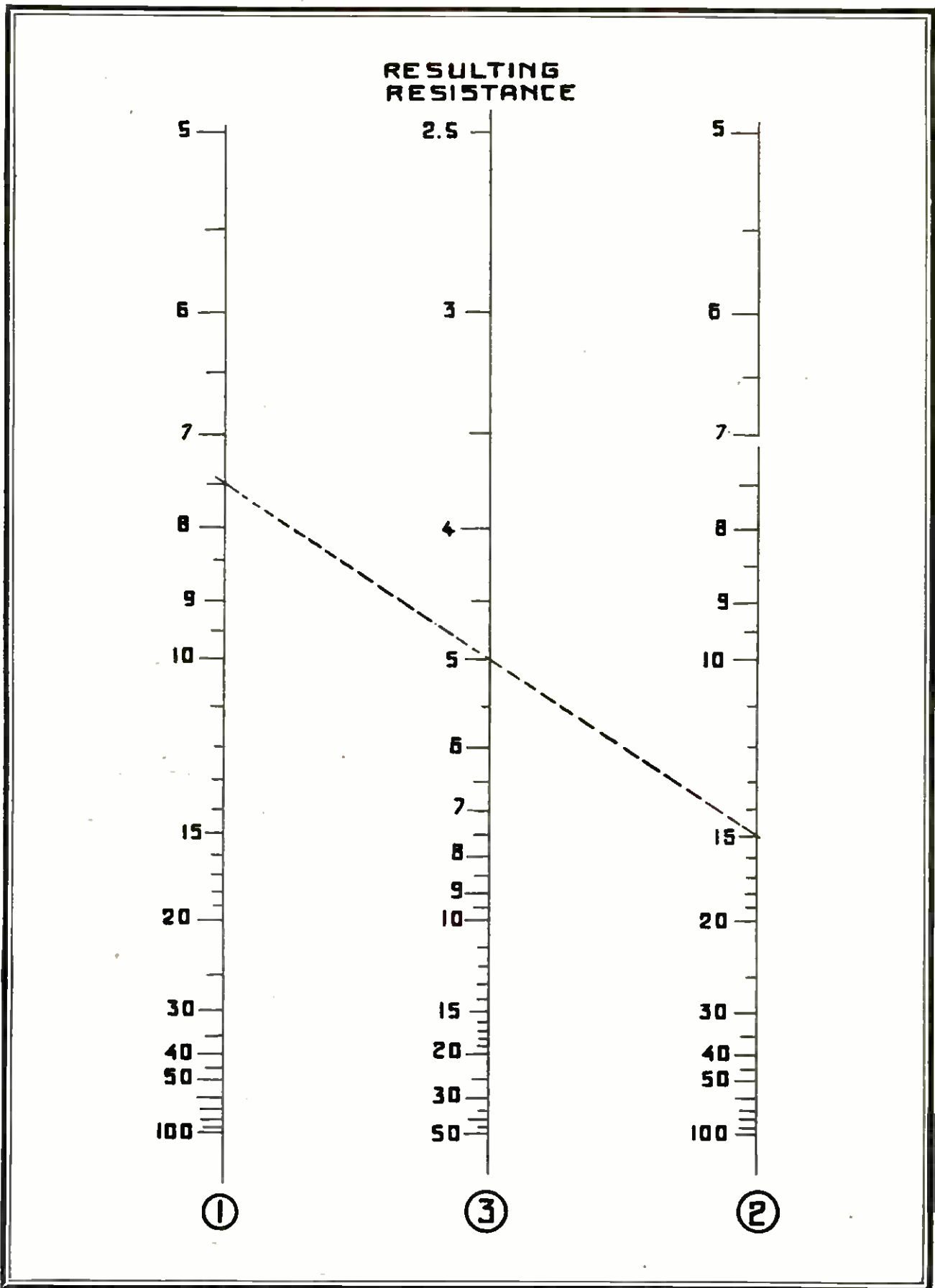

**HOW TO USE THIS CHART FOR FIGURING YOUR RESISTANCES
AT A GLANCE**

Put your ruler on line 1 at the number of ohms of one rheostat connected in parallel and join it with the number of ohms of the other rheostat on line 2; then read the effective resistance on line 3. The dotted line shows how it is done.

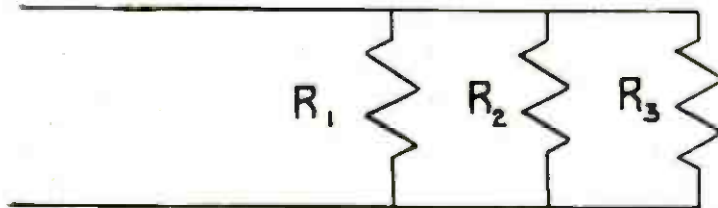

TWO WAYS OF CONNECTING UP RESISTANCES

The figure at the top shows resistances in series; the figure at the bottom shows them in parallel—which are often confused in calculating resistances.

A MEASUREMENT CHART

FOR SIMPLE CALCULATION OF COMBINED RESISTANCES

ARTICLE NO. 11

By RAOUL J. HOFFMAN, A.M.E.

THE amount of current which will flow in any given electrical circuit can be calculated by the use of Ohm's law, which has been dealt with in a previous article.* The equation for this law takes into consideration a single resistance or several resistances connected either in series or in parallel.

The combined resistance of a number of units which are connected in series as shown in Figure 1, is the sum of the separate values according to the equation:

$$R = R_1 + R_2 +$$

The effective resistance of a number of units connected in parallel as shown in Figure 2, can be calculated by the equation:

$$1/R = 1/R_1 + 1/R_2 + 1/R_3 +$$

If you use the accompanying chart the equation for resistances in parallel may be solved graphically. You need only to draw a straight line from one known resistance picked out on No. 1 scale to the value of the second resist-

ance on No. 2 scale and the resulting resistance value can be read off at the point where the line you have drawn intersects scale No. 3.

For example: Assume that we have two rheostats connected in parallel and the individual resistances of the rheostats are $7\frac{1}{2}$ ohms and 15 ohms respectively. To find the effective resistance of the circuit we connect $7\frac{1}{2}$ on scale No. 1 with 15 on scale No. 2 and we find the effective resistance to be 5 ohms which is the point at which the line will intersect scale No. 3. If these same two rheostats were connected in series the resulting resistance would be $22\frac{1}{2}$ ohms.

To obtain the resistance of a number of units some of which are connected in series and others in parallel in the same circuit, the effective resistance of the parallel portions of the circuit are obtained separately by the use of the chart and then these figures are added directly to the values of the resistance units which are connected in the circuit in series.

* See POPULAR RADIO for September, 1924.

advantage at all. So far as it goes, it is a defect. Resistance is unavoidable in a coil wound with a great length of fine wire. But nobody wants resistance for its own sake. Resistance is only of value when heat is desired, as in a heating coil or a lamp filament, and when it is deliberately put into a circuit to limit the flow of current. For all ordinary instruments the less the resistance the better. High resistance in a coil should only mean that a great number of turns of wire have been crowded into a compact space, and the tacit assumption is that the highest conductivity wire has been used. If not, then a specification in terms of resistance is misleading. The number of turns of wire ought to be recorded on any instrument, because that cannot subsequently be ascertained. Anyone can ascertain the resistance, without trouble, by means of a Wheatstone bridge.

Either the diameter of the wire, or the total length of wire used, should also be recorded. Either of these quantities involves the other, if the number of turns and the mean radius of the coil are known.

To give the resistance is only an easy short-hand way to tell one coil from another, if they have all been made in the best possible way; but without this

guarantee an instrument's "resistance" may be misleading, and might lead a manufacturer to imagine that high resistance was a desideratum to be obtained in any manner he chose, instead of an unavoidable condition inseparable from the other data and the properties of matter.

I believe that wire as thin as No. 45 gauge can be coated with enamel as an initial insulator. If so, such wire or something rather less fragile ought to be serviceable. And whether that wire should be wound compactly, or how far the turns should be separated from each other is a question of compromise which can be best ascertained by practical experience. Basket or open winding is found to be good for radio purposes, though if the shortest length of wire is employed and wound in the shape to give maximum inductance, I doubt if it is necessary to separate the turns much. For although compact winding will give more capacity, as well as more inductance, the reduction in the length of wire, due to the adoption of the best shape, will give a decrease of capacity—nearly as much diminution as separation of the turns would give, since such separation would necessarily involve the employment of a greater length of wire in order to give the required inductance.

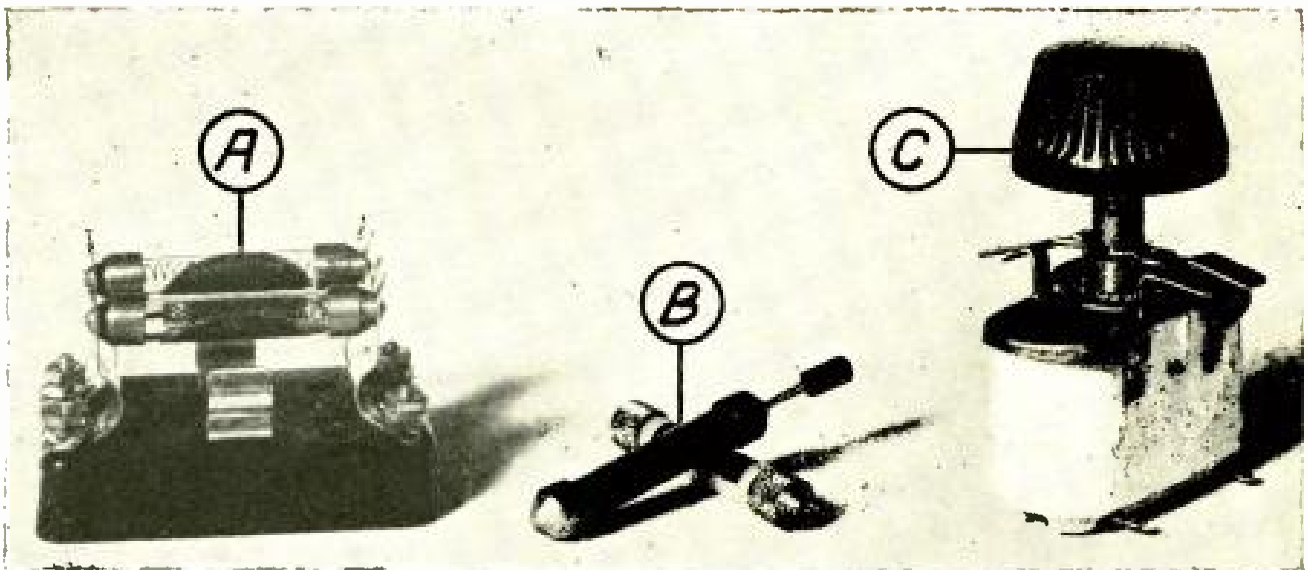

From a photograph made for POPULAR RADIO

RESISTANCE IS ESSENTIAL IN THESE THREE TYPES OF GRID LEAKS

A is an ordinary grid leak; B a variable grid leak, and C a carbon pile grid leak, the resistance of which varies with pressure.



Harris & Ewing

THE RADIO GENERATOR THAT BLEW UP BOMBS IN 1898

Mr. Carl W. Mitman, of the United States National Museum, is shown with the vacuum-mounted, rotating generator used in demonstrations of radio bomb ignition in Madison Square Garden more than a quarter of a century ago. The tube is now in the National Museum.

opposite end of Madison Square Garden in New York, resulting in an exhibition explosion of a model of the battleship *Maine*.

The glass part of the tube is two and one-half inches in diameter and eleven inches long. Inside it is a metal shaft about one-eighth inch in diameter and which fits into bearings at the ends of the tube. The upper end of this shaft carries a heavy flywheel, while the lower end of it carries the commutator. The commutator has nine segments and four metal brushes bear against it, each of which is connected to a wire sealed into the glass of the tube.*

* Facts supplied by Mr. C. W. Mitman, Curator of Engineering, United States National Museum.

'A Radio Amplifier Is Added to the Geophone

THE geophone is the special sound detector developed, mainly by the United States Bureau of Mines, for hearing sounds conducted through the rock in mines or other underground passages. In case of an accident in which some of the miners are entombed it is possible to hold a geophone against the rock and to hear taps or other signals made by the imprisoned miners. It is even possible to communicate messages in this way, using a code

of taps or scratches, or even (in some cases) by speech conducted through the rock.

The original geophones consisted simply of a diaphragm pressed against the rock, usually by the aid of a lead weight. Above this diaphragm was an air space, communicating by rubber tubes with a nipple inserted in the ear. The arrangement was essentially the same as in the familiar physicians' stethoscope. Carbon microphones, constructed on the principle of the telephone transmitter, have also been tried.

Now two students at the University of Pittsburg, working out a thesis for their University degree and co-operating with the officials of the United States Bureau of Mines, have developed a geophone that employs a pick-up telephone, arranged on the electromagnetic principle, to which is attached a three-stage audio-frequency amplifier.* The amplifier is transformer-coupled and involves no unusual features of design. Tests with the improved geophone underground indicated that the distance at which rock-conducted sounds can be heard by its aid is about twice as great as with the simple, non-electric geophone.

* "Improvement of the Geophone by the Use of Electrical Sound Amplifiers," by Walter T. Ackley, Jr., and Clifton M. Ralph. *Reports of Investigations, United States Bureau of Mines* (Washington, D. C.), serial number 2639, 5 pages (September, 1924), mimeographed.

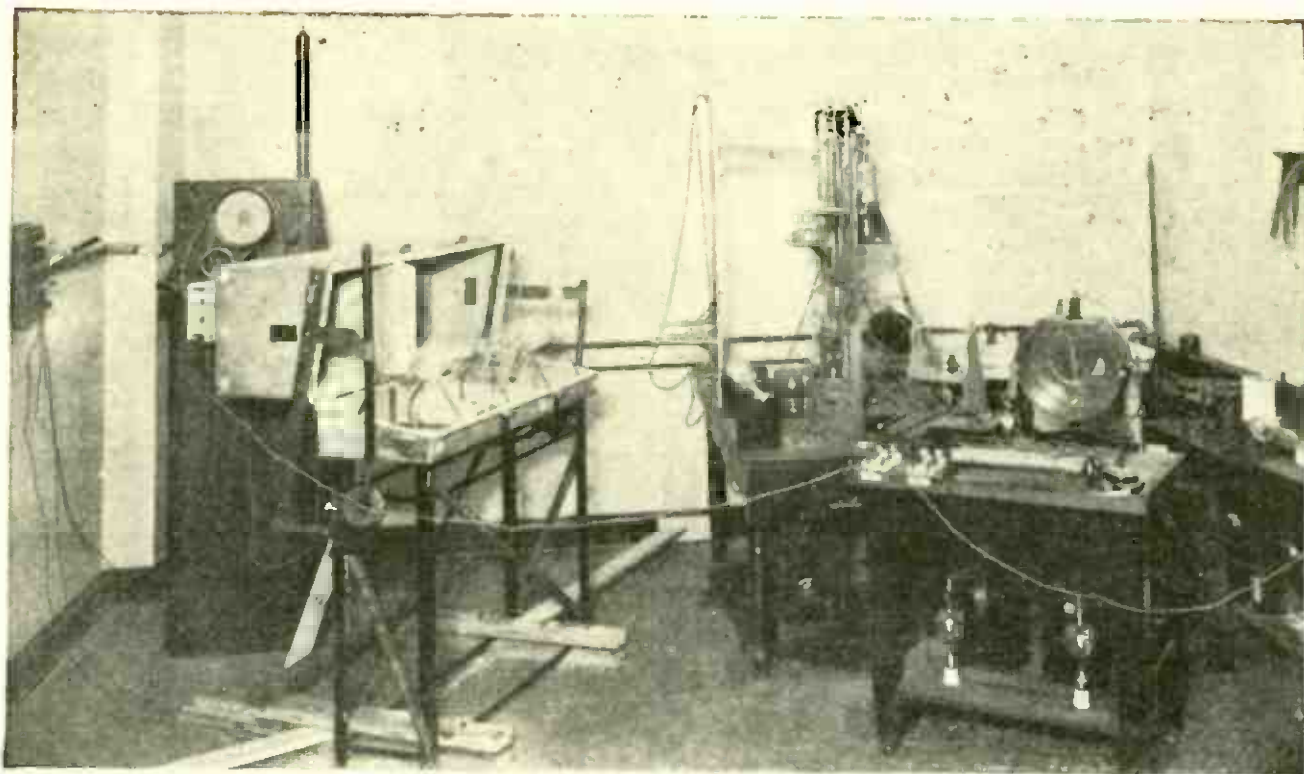

U. S. Bureau of Standards

HOW THE BUREAU OF STANDARDS MAKES OSCILLOGRAPH TUBES

In the furnace at the left of the picture the tubes intended for use as cathode-ray oscillographs are baked while they are being exhausted. In this way all possible traces of gas are cooked off from the glass walls and are removed by the vacuum pump. The vacuum pump itself is shown at the right.

Cathode-ray Oscillograph Is Used for High Frequencies

READERS of POPULAR RADIO are already familiar with the operation of this remarkable instrument on frequencies within the usual radio range, where it has many times proved its extraordinary value in disclosing just what is happening in an oscillating circuit.* Recently, however, Dr. A. Dufour of Paris has been able to apply the instrument to the measurement of frequencies far above the usual range.†

The waves studied include some as short as 30 centimeters (approximately one foot). The oscillograph was applied successfully in the range between this length and a wavelength of 3 meters; a frequency range, that is, between 100,000 and 1,000,000 kilocycles. The waves longer than 2.79 meters were produced by vacuum-tube oscillators. Those shorter than this length were produced by spark discharges of condensers in essentially the manner originally employed by Hertz.

The research as a whole is another important step toward the control and practical utilization of the very high-frequency waves, corresponding to wavelengths of less than 10 meters.

* See "An Electron Pencil for Studying Radio Circuits," by Paul Findley, POPULAR RADIO, vol. 5, pages 328-334 (April, 1924).

† "On the Registration of Electromagnetic Oscillations of Great Frequency," by A. Dufour, *Comptes Rendus de la Academie des Sciences* (Paris), vol. 178, pages 1478-1480 (April 28, 1924).

Are Radio Waves Slower Than Light Waves?

CAPTAIN T. J. J. SEE of the Mare Island Navy Yard, who has been so vigorous though ineffectual an opponent of the Einstein Theory, has found something else to attack. He announces that radio waves are not like light because, as he thinks, they move more slowly. The announcement has had considerable newspaper publicity and it may be well to point out that it has no basis in fact.

Captain See cites two supposed determinations of the speed of radio waves, neither of which was made by himself. He averages these two arithmetically and comes out with the figure of 165,000 miles a second. This is slower than the speed of 186,000 miles a second, well established as the speed of light. That is all that there is to the See case.

The joker in this argument is that neither of the supposed determinations cited by the captain was intended as an exact determination of radio's speed. Nor did the engineers who made these two determinations so regard them. Accordingly, the only contribution that Captain See has made to the matter is to compute the average of two figures, neither of which pretended to be exact.

The speed of radio waves has never been determined with any great exactness. There are strong theoretical reasons for believing that it is very close to the speed of light, if not exactly the same. And what experimental evidence there is, is in accord with this view.

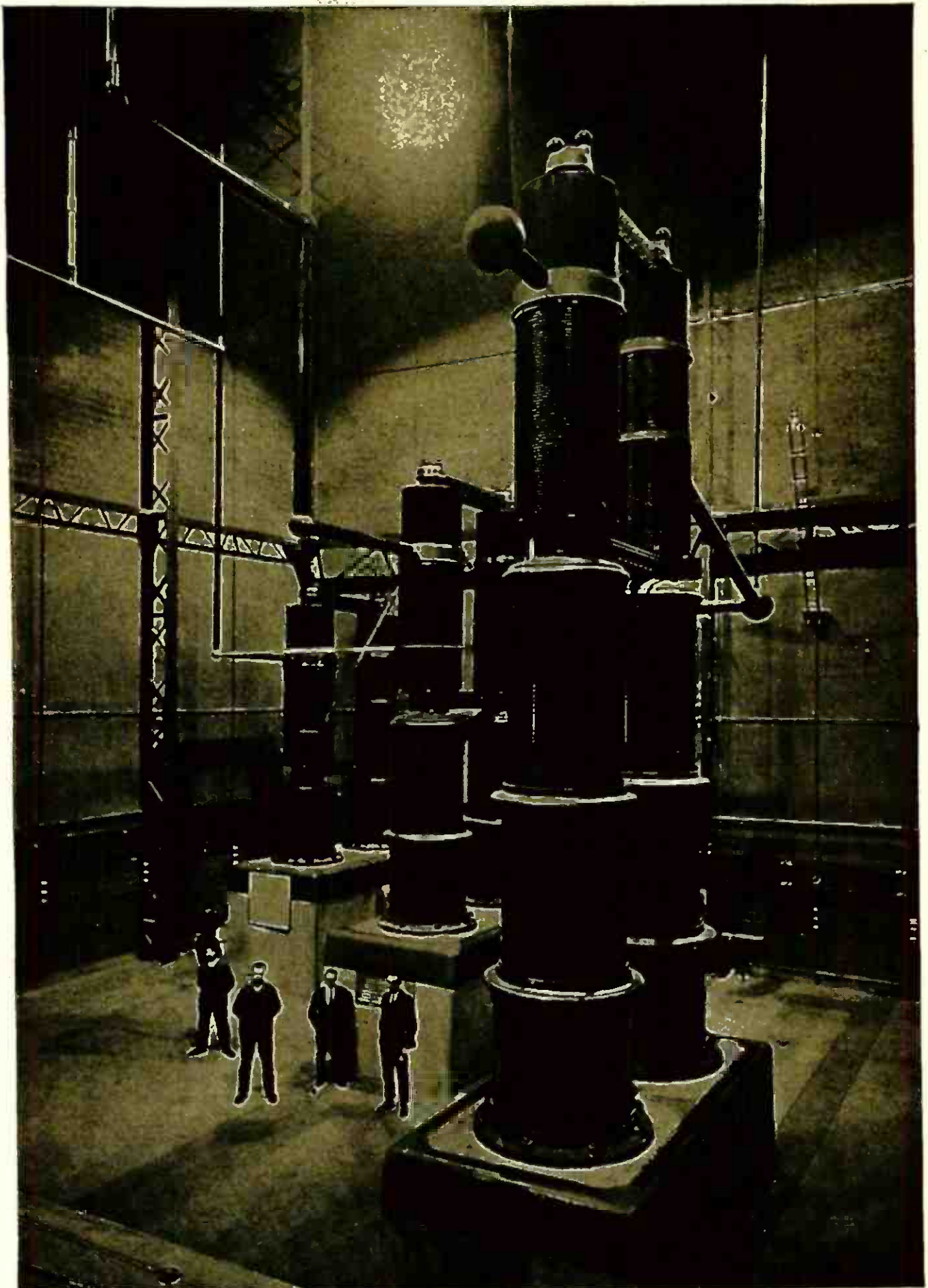

F. M. Delano

TRANSFORMERS THAT PRODUCE 1,400,000 VOLTS
A view in the high-voltage test room of the Laboratoire Ampere, near Paris.



This department is conducted by POPULAR RADIO LABORATORY for the purpose of keeping the radio experimenter and the broadcast listener informed concerning the newest inventions and the approved developments in radio equipment. Only such apparatus as has been tested and endorsed by the Laboratory is noted in these columns.

TUNING INDUCTANCE UNITS

Duo Lateral coils; Pacent Electric Co.
 Phusiformer; Pathé Phonograph and Radio Corp.
 Pearleo variocoupler; Pearl Radio Corp.
 Pearleo variometer; Pearl Radio Corp.
 Tuning unit; Pfanstiehl Radio Service Co.
 Variometer; Pfanstiehl Radio Service Co.
 Inductance for Reinartz Circuit; Pfanstiehl Radio Service Co.
 Pink-A-Tone oscillator coupler; Pinkerton Radio Corp.
 Variometer; Pioneer Radio Corp.
 Variocoupler; Pioneer Radio Corp.
 Precision Cockaday coils; Precision Coil Co., Inc.
 R. P. C. variometer; Radio Products Co.
 R. P. C. variocoupler; Radio Products Co.
 Receptrad oscillo-coupler; Radio Receptor Co.
 Receptrad filter coupler; Radio Receptor Co.
 Cockaday coils; Radio Surplus Stores.
 Variometer; Raven Radio, Inc.
 Variocoupler; Raven Radio, Inc.
 RBC-KM Filter, oscillator-coupler and transformer; Rieger-Bailey Co. of America, Inc.
 Variometer; Ritter Radio Corp.
 Ray coils; R. C. Schoonhoven.
 Variocoupler; Shamrock Mfg. Co.
 Shepco all-wave coupler; Shepard-Potter Co., Inc.
 Diamond-weave inductance coils; F. W. Sickles Co.
 Variometer; F. W. Sickles Co.
 Variocoupler; F. W. Sickles Co.
 Tuned transformer coil; F. W. Sickles Co.
 Knockout coil; F. W. Sickles Co.
 Silver oscillator coupled; Silver-Marshall, Inc.
 Vario-Coupler; Simplex Radio Co.
 DX tuner; Simplex Radio Co.
 Kelcoil; Syco Radio Products Corp.

Oscillator coil; Sypher Mfg. Co.
 Tuning coil; Sypher Mfg. Co.

VARIABLE CONDENSERS

Variable condenser; Pacent Electric Co.
 Balcon; Pacent Electric Co.
 Variable vernier condenser; Pearl Radio Corp.
 Crofoot variable condenser; Premier Electric Co.
 Rico condenser; Radio Industries Corp.
 R. P. C. variable condenser; Radio Products Co.
 Microdenser; Radio Shop.
 Straightline condenser; Radio Stores Corp.
 Variable condenser; Rathbun Mfg. Co., Inc.
 Micro air condenser; Reliable Parts Mfg. Co.
 Neutralizing condenser; Reliable Parts Mfg. Co.
 Microdenser; Sterling Mfg. Co.
 Silver, low-loss condenser; Silver-Marshall, Inc.

RHEOSTATS

Rheostat; Pacent Electric Co.
 Vernier rheostat; Precise Mfg. Corp.
 Microstat; Premier Electric Co.
 Duostat; Premier Electric Co.
 Amperite; Radiall Company.
 Rheostat; Raven Radio, Inc.

TUBES

O-T silver-tone tubes; O and T Electric Corp.
 Atlas tube; R-S-K Company.
 Radiotron tubes; Radio Corporation of America.
 Vacuum tube; Ravac Company, Inc.
 Vacuum tube; Schlickerling Products Mfg. Co.

SOCKETS AND ADAPTERS

Sockets and adapters; Pacent Electric Co.
 Bakelite socket; Pioneer Radio Corp.
 Silver 5-gang No. 199 socket; Silver-Marshall, Inc.

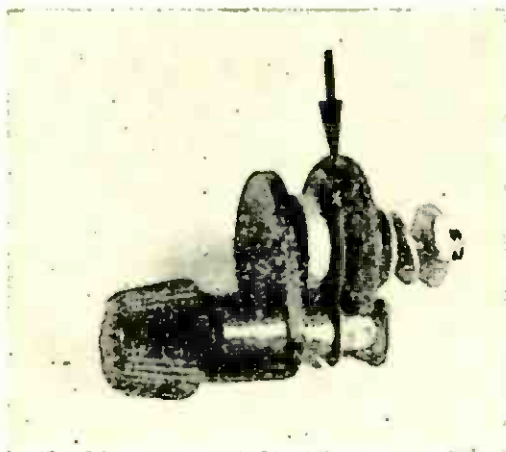

A NOVEL VERNIER

Name of instrument: Mechanical vernier.
Description: A neat attachment that can be fastened against the regular knob of a condenser or variometer. It contains a small knob which, when turned, rotates a rubber rimmed wheel which in turn engages with the outer periphery of the dial and produces a slow vernier rotation of the instrument to be controlled.
Usage: As a fine adjustment and rotation control for a tuning instrument.
Outstanding features: Can be attached directly to the panel of a set without altering the instrument it controls.
Maker: Radio Units, Inc.

SELF-SUPPORTING COILS

Name of instrument: Three-circuit coupler.

Description: An inductive coupling device consisting of three form-wound coils of the proper value of inductance for the broadcasting wavelength range. The coils are prevented from spreading by a paper tape binder with a cohesive binder. The wiring is not filled.

Usage: As an inductive tuning device in a regenerative circuit.

Outstanding features: Self-supporting coils constructed without a shellac or varnish filler to hold the wires in position.

Maker: Eastern Coil Co.

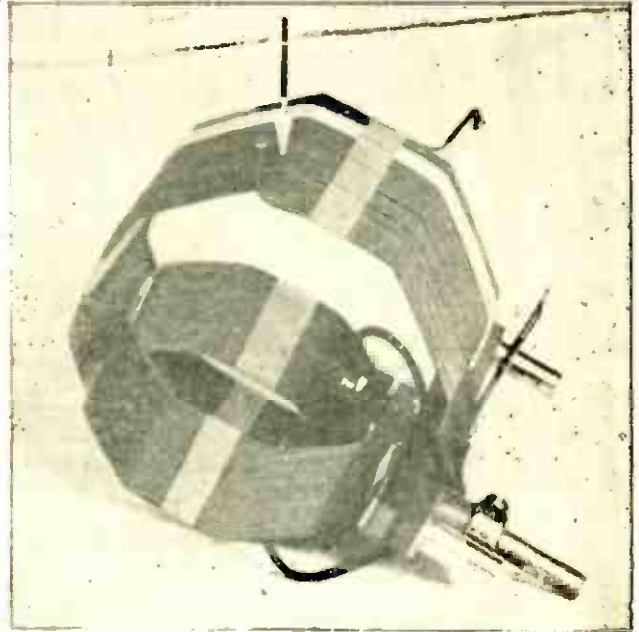

Self-supporting windings; no shellac.

SWITCHES

Saturn battery switch; Saturn Mfg. and Sales Co., Inc.

RECEIVING SETS

Portable receiver; Operadio Corp.

Low wave receiving set; Ott Radio, Inc.

Receivers; Ozarka, Inc.

"Minute Man" receiver; Pathé Phonograph and Radio Corp.

"Penn C" selectedyne receiver; Pennsylvania Wireless Mfg. Co.

"Ultradyn" receiver; Phenix Radio Corp.

S-P-2 receiver; Pittsburgh Radio Supply House.

"Acc" receiver; Precision Equipment Co.

"Radiola" receivers; Radio Corporation of America.

R-212 receiver; Radio Service Laboratories.

Echophone receivers; The Radio Shop.

Tone-A-Dyne receiver; Resas, Inc.

Crystal receiver; Ritter Radio Corp.

Receivers; Service Radio Co.

Thermodyne receiver; Shepard-Potter Co., Inc.

Shepeo All-Purpose receiver; Shepard-Potter Co., Inc.

Receiver; Silverset Radio Co.

Giblin Radiocar receiver; Standard Radio and Electric Co.

7-tube Superheterodyne receiver; Stanwood Electric Specialty Co., Inc.

PHONOGRAPH ATTACHMENTS

Phonograph attachment; Perfectone Radio Corp.

Rico loudspeaker unit; Radio Industries Corp.

Thorola phonograph attachment; Reichmann Co.

Victophone; J. Thos. Rhamstine.

Needlephone; J. Thos. Rhamstine.

Royalflame unit; Royal Electrical Laboratories.

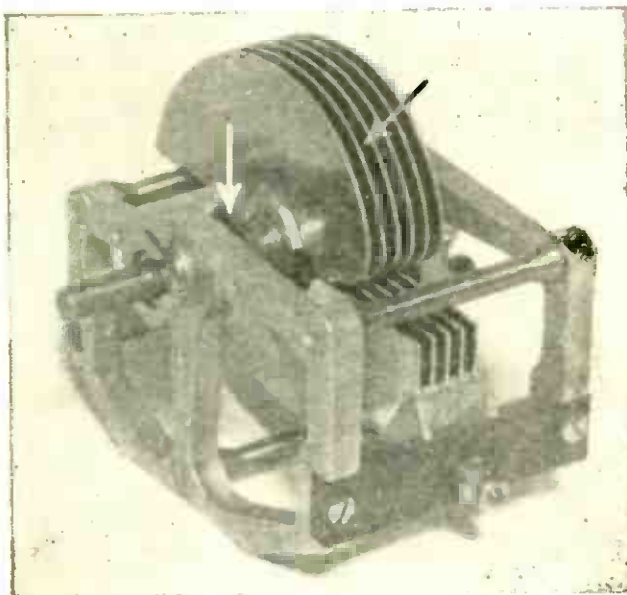

Novel bearing and cut-away rotor plates.

RADIO CABINETS

Campbell radio cabinets; Perkins-Campbell Co.

Radio desk; Peters Electric Cabinet Co.

Radio desk; Robbins Woodworking Co.

Radio tables; Salisbury Bros. Furniture Co.

Radio cabinets and furniture; Southern Toy Co.

Glass cabinets; Steffen Glass Cabinet Co.

POWER AMPLIFIERS

Radiola balanced amplifier (push-pull); Radio Corp. of America.

POTENTIOMETERS

Potentiometer; Pacent Electric Co.

Potentiometer; Premier Electric Co.

RADIO-FREQUENCY TRANSFORMERS

Ultraformer; Phenix Radio Corp.

Pink-A-Tone Transformer; Pinkerton Radio Corp.

Super-multiformer; Precise Mfg. Co.

R. F. transformer; Rubicon Co.

Silver R. F. transformer unit; Silver Marshall, Inc.

Giblin R. F. transformer; Standard Radio and Electric Co.

Matched superheterodyne transformers; Sypher Mfg. Co.

Ultradyn transformer; Sypher Mfg. Co.

A WELL-MADE VARIABLE CONDENSER

Name of instrument: Variable condenser.

Description: The plates of the rotor are cut away to give a straight wavelength curve when shunted across a tuning coil. The frame is of cast aluminum and finished off neatly. Clear bakelite is used for insulation and it is placed so that dielectric losses are reduced to negligible quantities. The bearings are of novel construction and should eliminate any end play of the shaft.

Usage: In any radio-frequency circuit for tuning.

Outstanding features: Low losses. Straight-line wavelength curve. Rigid construction. Well insulated.

Maker: Bremer-Tully Mfg. Co.



Single-piece, spring connectors and lugs.

LOOPS

Loop; Pacent Electric Co.
 Curtantenna; Pathé Phonograph and Radio Corp.
 Loop; Pollard Bros. Mfg. Co.
 Collapsible loop aerial; Radio Association of America.
 Duo-Spiral folding loop; Radio Units, Inc.
 Loop aerial; Ritter Radio Corp.
 Silver collapsible center-tapped loop; Silver-Marshall, Inc.
 "Key to the air" cage antenna; Stafford Radio Co.

HEADPHONES

Everytone headsets; Pacent Electric Co.
 Headphones; Perfectone Radio Corp.
 "Special" headphones; Randolph Radio Corp.
 Royalphone headset; Royal Electrical Laboratories.
 Decca Gold Seal headset; Stanley and Patterson.

PHONE PLUGS

Plugs; Pacent Electric Co.
 Poly plug; Polymet Mfg. Corp.
 Automatic plug; Saturn Mfg. and Sales Co., Inc.

PANELS

Panels; Panelyte Board Co.
 Insuline radio panels; Radio Panel and Parts Corp.
 Bakelite-Duresto; Spaulding Fibre Co., Inc.

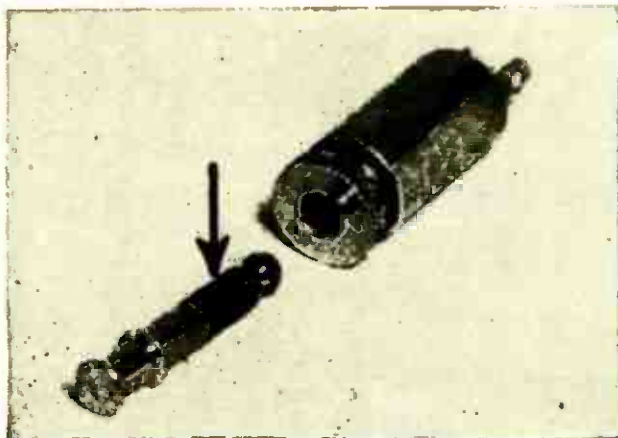

Removable locking element.

A NEW SOCKET

Name of instrument: Vacuum-tube socket.

Description: A socket for standard tubes which contains connection springs which grip the tube prongs and eliminate the necessity of turning the tube when putting it into the socket. The soldering terminal is one piece with the connection spring.

Usage: For mounting standard makes of vacuum tubes.

Outstanding features: Good contact. No possibility of loose connection. Neat appearance.

Maker: Cutler Hammer Manufacturing Co.

MISCELLANEOUS ACCESSORIES

Radio wall map; Ozarka, Inc.
 Radio tool set; Perry-Fay Co.
 Metalelectric soldering iron; Post Electric Co.
 Radio frames; Quimby Radio Frame Corp.
 "Run-a-Radio"; Radio Appliance Co., Inc.
 Amateur radio call book; Radio Directory and Pub. Co.
 "Radeco" safety fuses; Radio Equipment Co.
 Anchor lightning arrester; Radio Receptor Co.
 Tiny-Turn vernier control; Radio Units, Inc.
 Rajah snap terminals; Rajah Auto Supply Co.
 Battery tester; Reliable Parts Mfg. Co.
 Filler and battery carrier; Reliable Parts Mfg. Co.
 Electric solder set; J. Thomas Rhamstine.
 Braided ribbon antenna wire; Ross Antenna Co.
 Round antenna wire; Ross Antenna Co.
 Loop wires, Litz wires and cotton covered wire; Ross Antenna Co.
 Safe-guard insulation; Safe-Guard Insulation Co.
 Lightning arrester; Simplex Radio Co.
 Terminal tags; Somerville Radio Stores.
 Stranded braided antenna wire; Springfield Wire and Tinsel Co.
 Panel type and pocket type meters; Sterling Mfg. Co.
 Filament meter; Sterling Mfg. Co.
 Spintite wrenches; Stevens and Co.
 Speed-up tools; Stevens and Co.
 Panel cutter and bezel beader; Stevens and Co.
 Combined drill and countersink; Stevens and Co.
 Super-antenna; Super-Antenna Co.

LOUDSPEAKERS

Loudspeaker; Pathé Phonograph and Radio Corp.
 Loudspeaker; Perfectone Radio Corp.
 Loudspeaker; Radio Corporation of America.
 Loudspeaker; Radiolamp Company.
 American Bell loudspeaker; Randolph Radio Corp.
 Thorola loudspeaker; Reichmann Co.
 Thorophone loudspeaker; Reichmann Co.
 Royalphone loudspeaker; Royal Electrical Laboratories.
 Loudspeaker; Shelton Co.

A FILAMENT BATTERY LOCK-SWITCH

Name of instrument: "A"-battery switch.

Description: A small battery switch which is to be fastened to a radio panel. It contains a removable plug element which may be hidden while the set is not being used. This prevents anyone but an authorized person from using the set. It should be especially applicable to a set used by a family with children.

Usage: For turning on and off the battery that lights the filaments of vacuum tubes.

Outstanding features: A battery switch that locks in the "off" position.

Maker: Walbert Manufacturing Corp.

A WELL-INSULATED JACK

Name of instrument: Bakelite jack.

Description: A jack which is mounted upon a bakelite shell which serves as the insulation. The contact springs are strong and should serve as a positive connection at all times. The connections are brought out to binding posts at the rear.

Usage: In a receiving set for making connection to the headphones or the loud-speaker.

Outstanding features: Insulated frame. Positive connections. When properly installed they are dustproof.

Maker: Consolidated Instrument Co. of America, Inc.

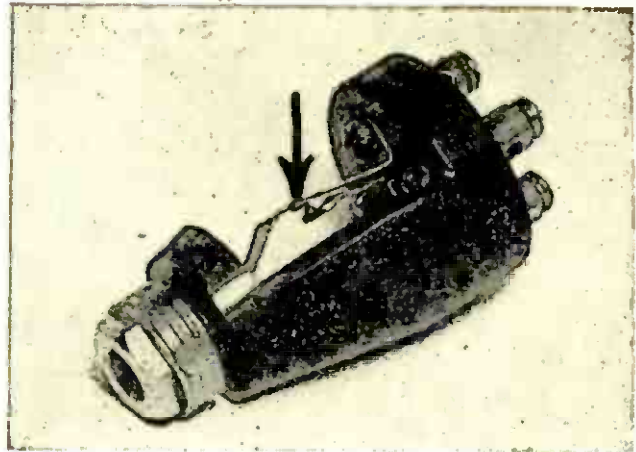

Improved contacts.

SETS IN KIT FORM

Ultradyne kit; Phenix Radio Corp.
Pink-A-Tone Superheterodyne kit; Pinkerton Radio Corp.

Superheterodyne kit; Raven Radio, Inc.
De Luxe Neutrodyne kit; Harold M. Schwab, Inc.

Tuned radio-frequency kit; Shamrock Mfg. Co.
Silver superheterodyne kit; Silver-Marshall, Inc.
Ultradyne kit; Sypher Mfg. Co.

CRYSTAL DETECTORS

Detector stand; Pacent Electric Co.
De-Tec-Tone crystal detector; Pyramid Products Co.

Semi-fixed detector; R-U-F Products Co.
Rough wonder crystal; R-U-F Products Co.

Roll-o crystal; Roll-o Radio Corp.
Fixed detector; Rusonite Products Corp.
Sensitive cartridge detector; Stafford Radio Co.

AUDIO-FREQUENCY TRANSFORMERS

Audioformers; Pacent Electric Co.
Audio-frequency transformer; Precise Mfg. Corp.
Push-pull transformer; Precise Mfg. Corp.
"Hegchog" audio-frequency transformers; Premier Electric Co.

Receptrad audio-frequency transformer; Radio Receptor Co.

All-American audio-frequency transformer; Rauland Mfg. Co.

Audio-frequency transformer; Reliable Parts Mfg. Co.

Audio-frequency transformer; J. Thomas Rhainstone.

Duplex transformer (push-pull); Rubicon Co.

Audio-frequency transformer; Rubicon Co.

Giblin audio-frequency transformer; Standard Radio and Electric Co.

Audio-frequency transformer; Superior Products Mfg. Corp.

A GOOD INTERMEDIATE-FREQUENCY TRANSFORMER

Name of instrument: Radio-frequency amplifying transformer.

Description: A transformer designed for medium high wave radio frequency amplification. It works out very satisfactorily for the intermediate amplifier in a superheterodyne. The coils themselves are contained in a neat bakelite cover and base, which also carry the terminals. These terminals are brought out to soldering lugs.

Usage: In any high wave amplifier at a radio-frequency. The specified frequency should be obtained.

Outstanding features: Coils entirely enclosed. Equipped with soldering lugs. Good amplification constant.

Maker: Sampson Electric Co.

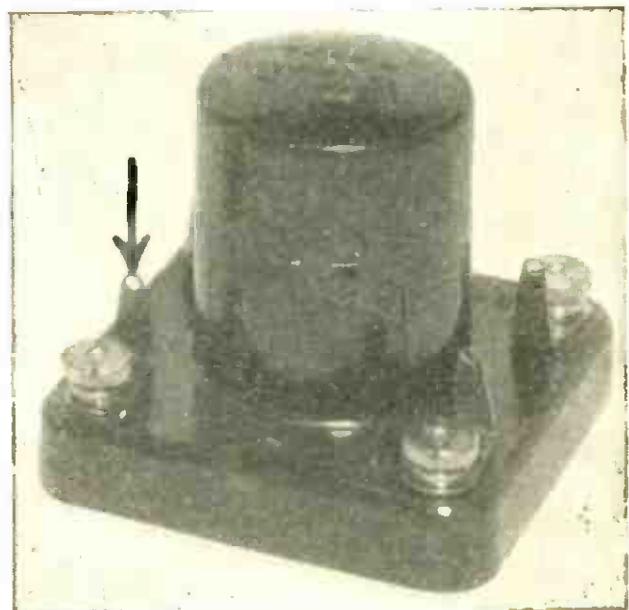

Equipped with soldering lugs.

Q This list of apparatus approved by the POPULAR RADIO LABORATORY will be continued as a part of the WHAT'S NEW IN RADIO APPARATUS department until all instruments, parts and complete sets have been included. The listing is alphabetical by manufacturer's name and the installment in this issue goes only to the end of letter S.



“TROUBLE SHOOTING”

CONDUCTED BY S. GORDON TAYLOR

EVERY radio receiver requires a careful balancing of all of its parts if the best results are to be obtained. Two receivers made from exactly the same design may give widely different results, owing to variations in the parts used, the skill of the experimenters and the locations of the receiver. This department is conducted for the special benefit of readers who have built the radio receivers described in POPULAR RADIO and who want to profit from the experience of others in operating them—to learn the little kinks that get the maximum results.

How to Improve the Real “DX” Regenerative Receiver

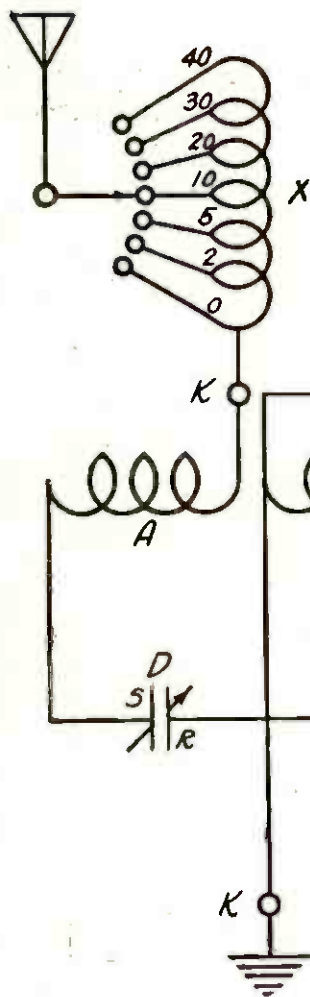

(This set was described in POPULAR RADIO for January, 1923, and further data on coils appeared in the December, 1923 number, pages 516-517.)

THE original receiver was designed to cover a lower wave band than now used for broadcasting. The maximum wavelength was limited to 500 meters or less.

The additional data in the December num-

FIGURE 1: This diagram shows how to connect the coil X for changing the wavelength of the regenerative set to meet higher wave band conditions.

ber showed how to rewind the coils to cover the higher wavelengths. To help those who do not wish to remove and rewind the coil the following suggestion is offered: On a 3½-inch tube wind 40 turns of No. 18 DC copper wire tapped at the first, second, fifth, tenth, twentieth, thirtieth and last turns. Connect this coil in the antenna circuit, as shown in Figure 1. The coil itself need not be placed in the receiver cabinet and in any case should be kept at right angles to the primary and the secondary coils so that it will not be in inductive relation with them.

How to Increase the Selectivity

ON the higher wavelengths interference is sometimes caused by high-powered stations located close to the receiver. Where such trouble is experienced it may be remedied by removing a few turns from the end of the primary winding (the end next to the secondary winding). If necessary, all but five turns may be removed from this primary winding. This increases the distance between primary and secondary and therefore provides looser coupling. To prevent a loss in volume due to this lesser coupling the tuned loading coil described

in the foregoing can be used to advantage.

Greater Volume without Distortion

WHILE the "B" battery voltage specified for the amplifier of this receiver was 90-135, the higher voltages cannot usually be used to give greater volume without losing some of the fine tonal qualities of the receiver. However, the use of a "C" battery connected in the grid return of the last two tubes, as shown in the diagram in Figure 1, will eliminate this trouble. The exact voltage for the "C" battery can best be determined by experiment. Usually, a 4½-volt battery is sufficient for "B" battery voltages between 90 and 112½. Over 135 volts should not be applied to the plates of UV-201-a tubes. Where a voltage as high as this is used, about 9 volts of "C" battery will probably be necessary.

When dry-cell tubes are used a "C" battery can be used to advantage even if the plate voltage is only 90 volts. A "C" battery is quite essential with voltages over this figure. It is not worth while to use higher than 90 volts on the plates of dry-cell tubes as the increase in volume is by no means proportionate to the increase in voltage.

Tuning the Four-circuit Receiver

WHILE the tuning of the Four-circuit Receiver is so simple that detailed explanation seems unnecessary, there have been a number of inquiries for additional data. The following is therefore published.

For the first step turn the knob of the Gridenser, which is connected across the primary of the first audio transformer, in an anti-clockwise direction as far as it will go. Then adjust the Bradely-leak so that the plunger barely makes contact with the internal elements. Slight pressure is felt at this point as

the knob is turned, or, if the tubes are turned on, there will be a rattling sound when the plunger comes in contact with the disks inside. The proper setting is usually about a quarter turn, clockwise, from this point.

Setting the two instruments in this manner will give maximum regeneration and selectivity. If there is too much regeneration at these settings, either or both of the knobs may be turned a little further in a clockwise direction, but only after making sure that the over-regeneration is not due to wrong adjustment

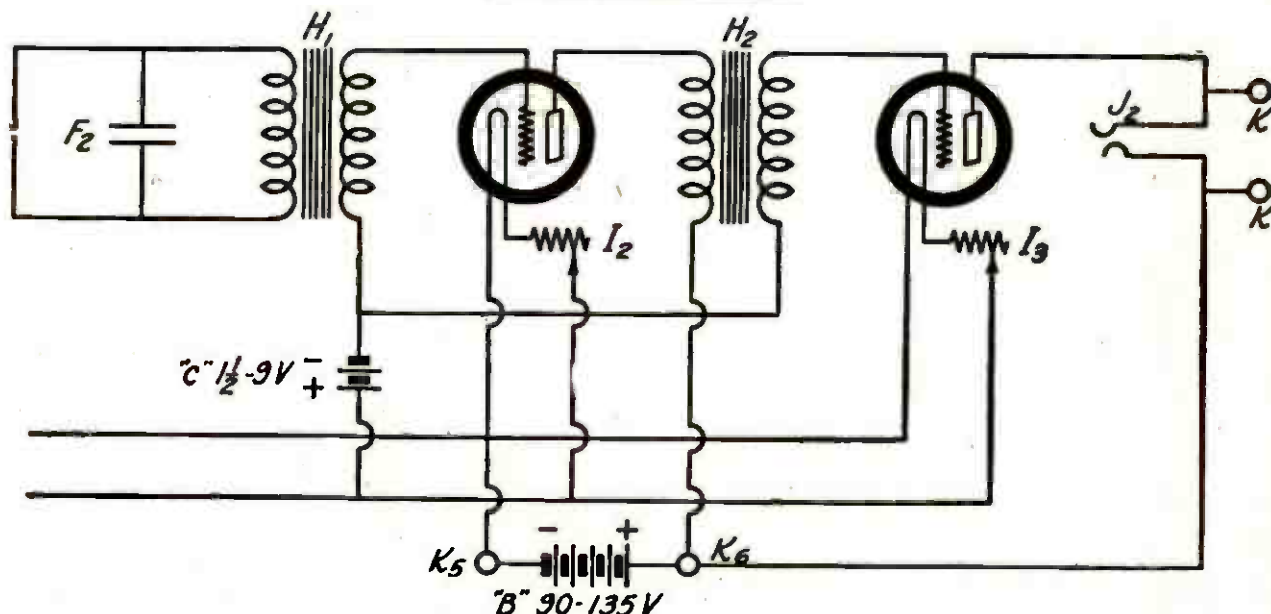

of the rheostat or potentiometer in the detector circuit.

With the two instruments adjusted as described, turn up the detector rheostat until the detector filament is quite bright. At a certain point, usually about three-quarters of the way around on the rheostat, there will be a rushing sound in the phones or loudspeaker. The filament rheostat is properly adjusted just before this sound occurs.

In the beginning the potentiometer should be set with the sliding contact near the center of the winding, but should be readjusted when a station is tuned in. The proper setting is determined by the incoming signal sounds. Where the signals have the greatest volume without being "mushy" or distorted the potentiometer is properly set.

With the inductance switch set on the fifth point from the left you are prepared to tune in stations. Specific suggestions for settings of this switch cannot well be given as this depends on the particular antenna in use in each individual case. With a large antenna the first three or four switch points from the left will be used mostly, while with a shorter antenna there will be little use of points one, two and three. An average antenna of 150 feet in length will usually require the use of points 4, 5 and 6 almost exclusively; a comparatively small antenna, points 5, 6 and 7; a longer antenna, points 1 to 5. In any case the lower points of those required by any particular antenna will bring in the low-wave broadcasters, while the points to the right are best for the higher-wave stations.

Rotate the Dials Together

With the switch set on point 5 for a starter, turn the two dials slowly until a station is heard. It is understood that in tuning both dials should be rotated together. This is not absolutely essential. In fact the first dial from the left may be set at one position; say 50, and left there for all stations. However, the circuit is so balanced that best results are obtained by turning the dials together.

Then, with the vernier knob of the second condenser from the left, which tunes the secondary circuit, tune the station in as loud as possible. Try other switchpoints too, until the one is found for the station you want. Next readjust the filament rheostat and potentiometer to determine best point.

The fact that this receiver does not squeal when tuning in a station, if the receiver is properly adjusted, is often confusing to operators who are used to tuning single-circuit receivers or most other forms of regenerative receivers; or receivers which make use of radio frequency amplification other than the neutrodyne. If the receiver has a tendency to squeal it is due either to wrong setting of the leak or Gridenser, too high detector filament current (rheostat adjustment), or by having

the inductance switch set on too low a point.

There is no need for further instruction regarding the adjustment of the amplifier. In the new resistance-coupled amplifier, the only adjustments are the Bradley-ohms and these should be screwed up to the point of maximum volume and clearest tone. Their setting is by no means critical. In the 5 tube Four-circuit Receiver described in the January, 1924, issue, which made use of push-pull amplification, the amplifier tube rheostats must be adjusted, of course. They should be set at the lowest point which will give the required volume and clarity. Also the switch lever controlling the resistances should be adjusted according to the volume desired.

Adjustment for Unusual Selectivity

In cases where the new resistance-coupled Four-circuit Receiver is operated extremely close to a broadcasting station it may be found that greater selectivity is desired. This can be obtained by moving the single-turn coil of bus-wire (coil A) further to the left. This coil serves to provide the coupling between the antenna and secondary circuits. By moving it to the left it is spaced further from the secondary coil (coil B) thus providing looser coupling and greater selectivity. It may be found that this move results in slightly reduced volume but where one is so unfortunate as to be located close to powerful broadcasting stations this is a sacrifice that is worth while, especially as this receiver has volume to spare.

While the connections at the ends of the coil windings may be tight after making, later the heat of the soldering iron used near the coil may cause them to loosen up thus resulting in loose contacts; or perhaps allowing soldering flux to get in between the ends of the windings, the binding post and the soldering lug. This may result in limited wavelength range of the receiver, poor selectivity, or general inefficiency. Several cases have appeared lately where such troubles were directly traced to this cause.

Limited Wavelength Range

Occasionally we receive a report that a four-circuit receiver will not bring in distant stations operating on the higher wavelengths. The cause has not yet been ascertained. It has not been true of any of the receivers tested in the POPULAR RADIO laboratory, except those with loose coil connections. However, the difficulty can be remedied by connecting a small fixed condenser from the antenna to the ground binding posts. The size of this condenser will vary in different cases but it is usually between .0001 and .0005 mfd. Where this practice is resorted to the condenser should be disconnected when not actually needed, or in other words, should be used only when tuning to the higher wavelengths.

Q The hook-up and operation of a one-tube Four-circuit Tuner in combination with a distortionless amplifier will be described in the "Trouble Shooting" Department in the next issue.



BROADCASTS

CONDUCTED BY DAVID LAY

ITEMS of general interest that you ought to know; bits of useful information that every radio fan ought to know.

Concerts May Be Broadcast Without Royalty Fee

AMATEURS benefit by a recent decision in the Federal courts which holds that the transmission of music played from a copyrighted musical score is not a violation of the copyright law. When an authorized performer plays before a loudspeaker, Judge Knox, of the United States District Court holds that the musician is merely enlarging his audience. "The performance is one and the same whether the 'listener in' be at the elbow of the leader of the orchestra playing the selection, or at a distance of a thousand miles," the judge ruled.

* * *

Radio Catches Viennese Speeders

To overcome the speed mania of Viennese motorists, the Vienna police department has installed transmitting and receiving sets in police automobiles. With these few speedy police cars, it has proved easy to trap motorists even when they escape to the outskirts of the city.

* * *

21 Stations in One

THE German giant radio station at Koenigs-wusterhausen has become 21 stations in one. Recently a 50 K.W. Poulsen arc transmitter was installed there which now provides this station with 21 independent transmission units. What success has been attained with several of them operating at one time on different wavelengths, of course, has not been made public.

* * *

Defies the "Censor" for Her Candidate

AN attempt to use station WNYC, the municipal broadcasting station in New York, for political propaganda succeeded when a young woman singer ended her concert with "three little words." As is the custom for many broadcasters, the young woman concluded her concert with "Now good night and

don't forget to—" but instead of inviting her audience to listen for her next concert, she said "vote for Davis." Almost needless to add she has been stricken from the list of entertainers at the station.

* * *

American Captures DX Prize

THE world's record for amateur radio long distance two-way communication was captured from a South American operator when W. B. Magner of San Pedro, Calif., made contact with Frank D. Bell of Waihemo, New Zealand, a total distance of 6,900 air miles. The previous world's record established by Carlos Braggio of Bernal, Argentina, was 6,400 miles. Mr. Magner wins the Australian boomerang offered to the first radio amateur of North America to establish communication with Australasia. K. L. Riedman of Long Beach, N. Y., operating station 6CGW, wins a pair of green suspenders as a consolation prize. Mr. Riedman exchanged messages with the New Zealand operator about half an hour after Mr. Magner made the contact that broke the record. All communication was accomplished between 12.20 and 2.20 A. M.

* * *

The Government Amateur List Is Published

FANS who want to know who the new and the old amateurs are may obtain the new amateur list issued by the Department of Commerce by sending 25 cents in currency to the Superintendent of Documents, Government Printing Office, Washington, D. C.

* * *

The Radio Industry Grows Up

RECENT reports of the Department of Commerce show that the infant industry of manufacturing radio apparatus has grown into a \$48,000,000 baby. These figures for the year 1923 show that \$500,000 was spent for headphones, \$5,000,000 for loudspeakers, \$12,000,000 for tube receiving sets and \$500,000 for crystal sets.

2,500 Tons of Copper Used in Radio

THE Copper and Brass Research Association has made a study of the amount of copper absorbed, so far, in the making of radio sets and radio apparatus. They estimate the total as about 5,000,000 pounds. It is expected that an amount of copper equal to this will be used each year for the next five years at least, possibly longer. The probable total number of radio sets in the country when radio reaches its maximum is estimated as 15,000,000, which seems likely to be too low an estimate rather than an excessive one.

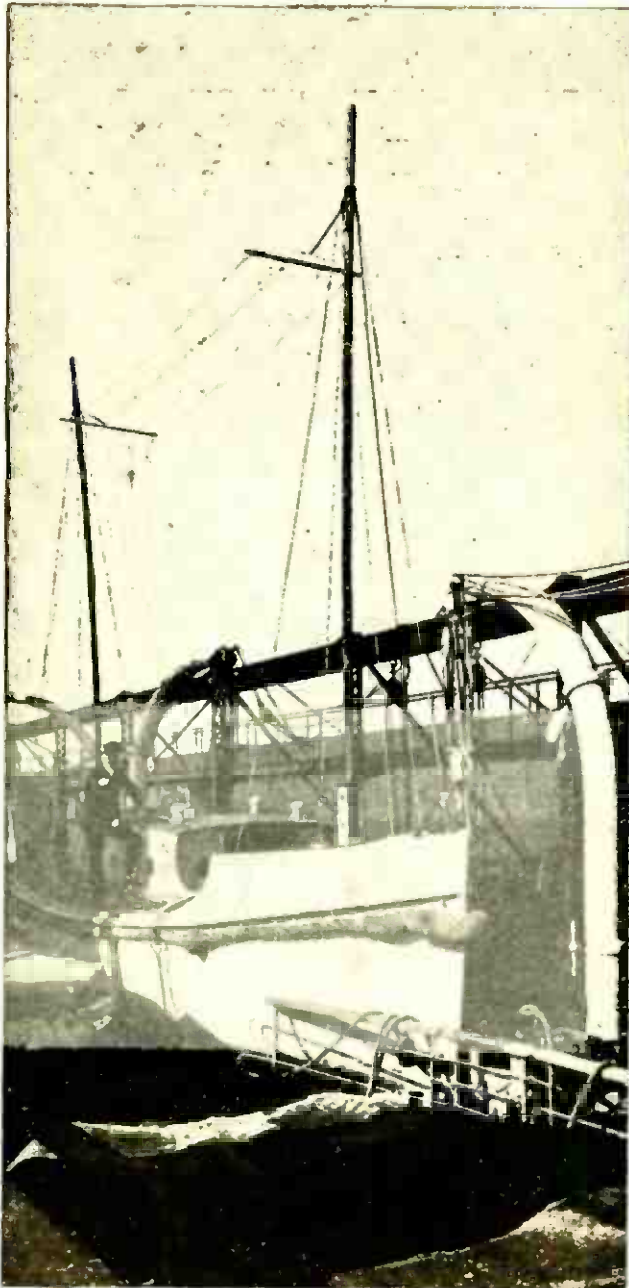

Edwin Levick's

NOVEL RADIO INSTALLATION ON LIFEBOATS

In order to enable the survivors of shipwrecks to establish communication with rescuers, ocean liners are now equipping lifeboats with transmitting sets. This picture was made on the AQUITANIA.

Mercury-arc Tube Used as Amplifier

A NEW type of amplifier for radio use has been reported to the French Academy of Science in Paris. It consists of a vacuum tube in which there is maintained a mercury arc like that of the familiar mercury-arc rectifier for alternating current. Around a part of this arc there is a metal sheath that is connected to the signal to be amplified. This sheath serves as the control electrode, analogous to the grid of an ordinary tube. Alterations of the electric charge on this sheath-electrode affect the current passing in the mercury arc. It is said that an amplification of more than a billion times can be obtained by this tube, but the apparatus has not yet been applied to telephony and it is not certain that it can be.

* * *

Convicts Use Radio to Smuggle Dope

RADIO receiving sets have been banished from the Eastern State Penitentiary in Pennsylvania, as it was found that the convicts were utilizing them to receive dot-and-dash messages that told how narcotics were to be smuggled into the prison. A visitor who knew the radio code was asked by one of the convicts to adjust his set; when he had the apparatus working, he was surprised to hear a message stating that a rubber ball filled with dope would be tossed over the wall that day. The guards were notified—and the order that abolished radio sets followed when the ball that came over the wall that afternoon was found to contain dope.

* * *

Do Radio Waves Affect Pigeons' Flight?

A SPANISH experimenter, the chief of the radio station at Paterna, reports some curious observations he has made of the apparent effect of radio on the sense of direction of carrier pigeons. During a transmission, he released several of his pigeons and they rose and circled over the station. Each time that they passed directly over the antenna they were observed to falter in their flight. As soon as they had passed over the antenna, they resumed their steady flight to the pigeon house. This manifestation took place, states the experimenter, no matter what wavelength was used, but when the radiation was under one hundred watts the effect on the pigeons was scarcely noticeable.

* * *

Murderer Trapped by Radio

A MAN in Liverpool, England, murdered his mother-in-law and then succeeded in putting to sea aboard an oil-tanker. A radio message to the ship caused the captain to arrest the man, who was turned over to the police immediately upon landing.



Gilliams

SPORT NEWS BY RADIO

In Berlin, radio receivers have become a part of the equipment of every well-appointed club; in the afternoon the members gather to hear the latest racing results and other sport items, and in the evening to hear other entertainment.

Scientists Hear That Radio Will Find Mines

THAT radio methods will come into greater use in prospecting for unknown beds of minerals was the prediction made to the British Association for the Advancement of Science by Professor Sherwin F. Kelly of the University of Toronto. After reviewing the numerous electrical methods that have been employed, more or less successfully, in geological work, Professor Kelly described in detail the processes in which an audio-frequency current is introduced into the outcrop of a mineral-bearing vein or rock formation, the mineral body being then traced underground by means of the strength of the audio-frequency field on the surface of the ground. The current tends to follow the more highly conducting layers of rock.

Texas Prison Farms to Have Radio Sets

CONVICTS at various prison farms in Texas shortly will be given a radio treat if plans under advisement by welfare and prison-reform workers are carried out. Radio sets will be installed at each of the prison farms and nightly concerts will be furnished to the convicts. A public subscription is being taken up and funds raised in this manner will be used

to install the equipment. There are a dozen or more prison farms in eastern Texas and the several hundred convicts spend their nights in so-called "bunk houses," where the radio sets will be installed.

A Beetle's Love Song Is Broadcast

A FEATURE on the program sent out by a London broadcasting station recently was the "love song" that a beetle makes when he is singing to his mate. At the appropriate moment in a lecture on natural history the beetle was permitted to broadcast through a special microphone. Just what stimulus was applied to the beetle to make him perform at the right moment is not stated in the report.

Prizes for Efficiency to Radiomen

RADIOMEN in the Argentine navy are stimulated by the award of prizes to operators who qualify in copying code messages of fifty words at the rate of 22, 24 and 26 words a minute. These prizes, however, are withheld for bad conduct and also if the contestant is not in good physical condition. Athletic training is required in all radio stations both afloat and ashore wherever there is more than one operator.

Help Check Up Mars!

How many fans heard "spooky" noises between July 24 and September 24?

An attempt is being made to get data about Mars that was begun more than 2,000 years ago when Aristotle made his first observations of the "ruddy" planet. The Chairman of the Mars Check-up Committee at 280 Madison Avenue, New York, is receiving information from amateurs who kept audibility records between the dates referred to.

The Aerial League of America that initiated this plan believes that information from "hams" may aid in determining the causes of the electromagnetic phenomena that was registered when Mars was close to the earth recently.

* * *

Accident Victims Identified by Radio

Two persons killed in an automobile accident in Texas were identified through the medium of station WFAA at Dallas. The police authorities enlisted the aid of the station which broadcast information about the victims. A casual remark of an amateur to an acquaintance about such a use of a broadcasting station led to an identification of the two persons killed.

Radio Helps Turn Off the Gas

A WOMAN of Cleveland went for a moonlight ride on a Lake Erie steamer recently and just after the boat pulled out from the dock she remembered that she had left the gas burning under the hot water tank in the cellar. She sent a radiogram to the Cleveland Fire Department and ten minutes later two firemen went to the Chandler home and turned off the gas.

* * *

Broadcasting Begins in Portugal

PORTUGAL is now on the broadcasting map of Europe through the enterprise of one of her amateurs, Senior E. Mussche of Lisbon. With the permission of the aero service of the army, Senior Mussche has set up a four-tube transmitting set which can be heard about 125 miles away. He expects to increase his power to attain a range of 300 miles.

* * *

Shenandoah's Radio Compass Proves Useful

DURING the recent flight of the naval air cruiser *Shenandoah*, the first use of radio compass bearings by an airship was made. While near New York, the airship encountered heavy fog, and asked the New York harbor radio compass stations for her bearings. These bearings proved sufficiently accurate.



Photopress

BRINGING THE EAGLE'S SCREAM INTO THE HOME

The British station 2LO recently broadcast the language of the wild residents of the London Zoölogical Gardens; this picture shows how the notes of birds in an aviary were picked up for transmission with a portable microphone.



CONDUCTED BY KENDALL BANNING

WHAT little kink have YOU discovered for increasing the efficiency of your set? What helpful bits of radio information have you picked up that will be of use to the other fellow? POPULAR RADIO will pay one cent a word for items for this department, and a monthly prize of \$10.00 in addition for the best contribution. Send your items to *Listening In* Editor, POPULAR RADIO, 627 West 43rd Street, New York City.

Transmits Seven Hundred Miles with Amplifier Tube

AMATEURS with transmitting sets located in less favorable territory for radio will read with envy this letter from an amateur in Rockford, Iowa. Think of transmitting 700 miles with an ordinary amplifier tube and 16 volts on the plate! It would be unbelievable if there had never been anything of the kind done before—but read Mr. Mitchell's letter:

"Last March I built a transmitting set, according to the instructions given in Mr. Cockaday's article, 'How to Build an Amateur Transmitter.' I did not follow his instructions very closely, however, for I only built a one-tube outfit. I wound my coil with bell wire, using no taps of any kind, and I used a low-frequency call buzzer, such as those used in school ringing systems. I used a wall board panel, no radiation meter and no shellac or varnish. Using one C-301 amplifier tube, and 16 volts of "B" battery, I was reported loud by 9DJR, seven hundred miles away. In closing, I wish to thank Mr. Cockaday, and those who helped, for the work that they have done to aid us hams."

A. T. MITCHELL (9DCK)

Lightning Plays Queer Trick with Radio Antenna

SO many tales have been told about the peculiar effects that lightning can produce that new reports are likely to be greeted with suspicion. But a

reader located in Fayetteville, New York, sends along the actual, physical evidence to support a story that is certainly freakish enough to suit anybody. The piece of wire mentioned in his letter is now resting on the Editor's desk, and the technical staff states that it knows of no mechanical process that will split a stranded antenna wire exactly in half and produce the peculiarly patterned flat surface that appeared on the sample. One side of the stranded wire appears as if it had been subjected to pressure under a stamping machine, so perfect is the design Nature has executed. He writes:

"I note in the *What Readers Ask* department of POPULAR RADIO for July that only three instances are known in which lightning has struck an antenna. I have had an antenna up most of the time since 1912, but I have just had my first experience with lightning. The flash struck it directly on the lead-in. The antenna was of the L type and was fastened to a tree by means of No. 12 galvanized wire with two six-inch insulators. The lead-in itself consisted of two seven-strand wires with an old-fashioned, 600-volt ground switch and a water-pipe ground. The charge leaked over the insulators enough to melt the galvanized wire. The antenna proper was not harmed but the lead-in was torn up into small pieces and strewn all over the ground. My set is inductively coupled, but enough current got through somehow to burn out my detector tube. The amplifier was not connected up at the time. The piece of the lead-in which I enclose shows it as it looked the whole length."

A. L. WING

Who Will Pay the Broadcasters' Bills?

THE old question "Who Will Pay for Broadcasting" is evidently destined to be a subject for argument until it is answered—and answered satisfactorily. It seems to be agreed that the problem will have to be settled on a sound economic basis; that is why the following opinion from Hiram L. Jome of the Department of Economics of Denison University of Granville, Ohio, is of special interest.

The writer has noted with much interest the article entitled *Broadcasting on the "Pay as You Enter Plan"* appearing in the August number of POPULAR RADIO. In this article

Gen. Squier proposes in brief that residents in apartment houses and guests in hotels should defray the cost of broadcasting. We are all interested in some practicable way of meeting this problem; General Squier is an authority in the field of technical wireless, and, therefore, his scheme deserves careful consideration.

But General Squier's proposal seems to the writer to be weak in the following respects:

I. It is not compulsory. He provides that the guests may pay or not as they see fit. "There will be no compulsion."

This would be no improvement over the present system. Listeners are now perfectly at liberty to contribute to the broadcasting stations if they wish. But, out of 150 broadcasting stations which the writer has, and is studying, *only two* report such contributions. In one case public-spirited men have made donations. Several colleges report aid from graduating classes. A considerable number of the broadcasting stations report a lack of interest



Frederic W. DeLano.

WHEN THE WORLD COMES TO YOUR DOOR

The athletic young chap in the center is the famous Criqui, the French boxing champion who was recently scheduled to broadcast a talk from a station in Paris. But his trainers would not permit him to leave his quarters—so the broadcasting station considerably sent the microphone to him!



From a photograph made for POPULAR RADIO

THE POPULAR RADIO PORTABLE RECEIVER ON TOUR

One of the features of this set (described in POPULAR RADIO for July, 1924) is its peculiar efficiency when in operation in motor cars. The ignition system of the car has practically no effect on it and the cushioned sockets make it immune to the jars and bumps that put less well designed and well built receivers out of commission.

by their audiences, as manifested by the number of applause cards and telephone messages received. Now, what guarantee have we that the audiences would exhibit a greater liberality and a sustained "cash down" altruism under the proposed plan?

II. The suggestion is founded, in the writer's opinion, on the wrong theoretical principle. Although ability to pay is the proper and predominant principle which should be followed in the determination of the amount of assessments, nevertheless, the theory of benefits received should be invoked in justifying any attempt at raising money, whether compulsory or voluntary. I do not believe it to be a sound principle to exact money from the rich and not from the poor; but I do think that the wealthy should bear the greater portion of the burden. Why should the farmer, who may be poor (and occasionally well-to-do) be exempted from the payment of his share for the maintenance of broadcasting stations? Why should the city dweller in

residence houses (who may be poor and sometimes rich) not pay his share? Why ask only dwellers in hotels and apartments (and not all these are wealthy: the writer knows of apartment dwellers who are paying from one-half to three-fourths of their income for rent) to pay for the privilege of being a part of the vast unknown and unseen audience that listens in on the broadcast programs?

III. Who gets the benefit from radio? Not only the hotel guest. He has ample opportunity to attend lectures and places of entertainment. He may not feel inclined to spend the evening in his room or apartment. He wants to get out and see the town. Not only the resident in apartments. His place of abode is usually conveniently located. But also the much more numerous city and country people often remotely and inconveniently located who occupy the great American Home.

Let every one contribute, each according to his ability.

—HIRAM L. JOME

Radio Sets That Earn Money

THOSE of us who have come to regard radio merely as a source of entertainment sometimes disregard the essentially practical features of it—features, indeed, that can be converted into dollars and cents. Just what these practical features mean to the farmer (as well as to the country merchant who deals in radio) is pointed out in this communication from Roxbury, Ohio:

Down in Athens County, Ohio, I recently found a dealer who successfully sells radio sets to farmers by showing them how to get something out of the air besides concerts.

This dealer serves a community where radio sets were formerly looked upon as instruments of doubtful value. To change this opinion was not easy—but this dealer knew farmers. He knew they enjoyed music, lectures, and other material which was being broadcast; he also knew that before investing hard-earned cash, the farmer must be shown a method whereby he could profit in dollars and cents from his investment. So he began to teach his patrons the practical side.

To accomplish this, he first staged a series of "radio parties." But, soon finding that he was not reaching the right audience, he put a little advertisement in the county newspaper

at a cost of \$1.86, and worded his copy thusly:

YOU ARE INVITED

*to Whitman's store
every night this week
between the hours of
eight and ten.*

AND ON SATURDAY NIGHT

*if you were not benefited
by what you heard—call at
the door, and receive 30 cents for
every hour you spent there.*

"After the first evening," the dealer stated, "I saw that I had taken a step in the right direction. A short time later, a farmer declared that a market tip had netted him \$16.00 on a livestock deal. Another had widened his butter and egg market through the list of quotations given out by my radio set, and several were getting good results from the lectures and farm hints which came in from the big stations. To each patron I explained how this information could be had at any time merely by installing a receiving set in his home and how it could be systematized to suit any farm requirements. Before the month was gone I had made sales to thirty percent of my audience.

"My service plan didn't stop there," the dealer continued. "I taught my patrons how to use their sets in getting farm information. I furnished a list of stations that send out agricultural news and explained how they might keep charts of quotations, thereby having a marketing service equal to the large newspapers.

—F. R. COZZENS



AN OLD-TIMER SELLS RADIO ON TRIAL

A. H. Cain of Roodhouse, Illinois, installs radio receiving sets on trial in his neighbor's homes and finds there is usually a check waiting on his next visit. Cain is examining his remote controlled amateur spark transmitter.

HINTS FOR

AMATEURS

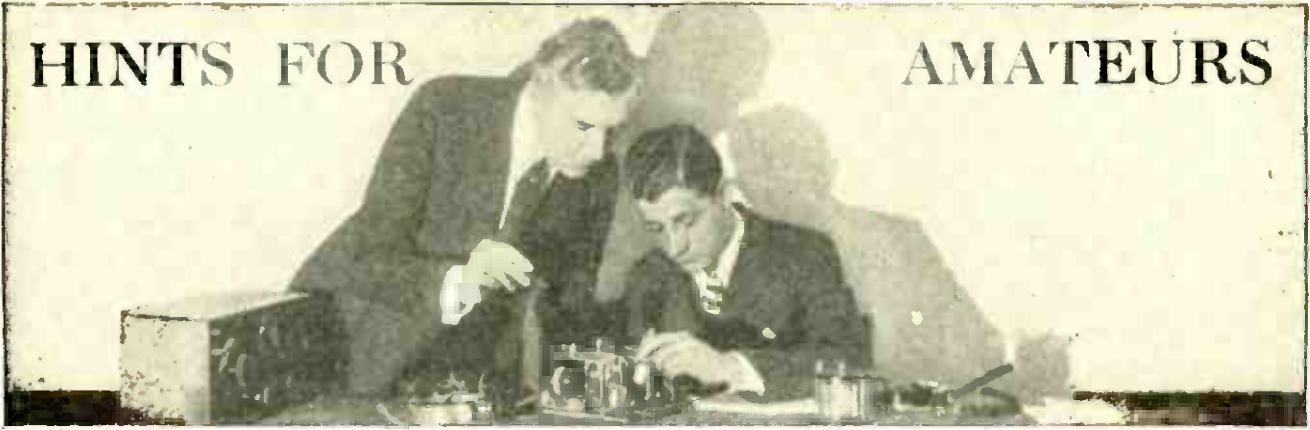

CONDUCTED BY ALBERT G. CRAIG

Watch Out for Poor Socket Contacts

INTERMITTENT sizzling and crackling noises in a loudspeaker, which often sound like static, are frequently due to poor contact between the prongs on the bottom of the tube and the springs in the socket. A remedy for this condition is to remove the tube and clean the ends of the prongs with sandpaper or a very fine file. This trouble is more often found with one-ampere detector tubes than with the amplifier tubes that consume but one-quarter of an ampere mainly because the effect of a slight increase in the resistance of the circuit is more pronounced with a large flow of current.

Gassing May Not Mean Full Charge

THE only really reliable way to tell when a storage battery is fully charged is to test the specific gravity with an instrument known as a hydrometer. It is true that a battery gives off gas when it is fully charged, but unless the charging rate is quite low, the gassing starts considerably before the battery has reached its full capacity.

Keep the "B" Battery Clean

OFTEN "B" batteries are placed in a corner without covering of any kind. Dust settles on them—and when the weather is damp the dust soaks up mois-

ture and current leaks slowly across the damp dust from terminal to terminal. It is desirable to keep batteries in a dust-proof place. If this is not possible, the next best thing is to keep the tops of the batteries clean.

Electric Lines May Be Dangerous

NEVER erect an antenna so that it crosses over or under a power line. Either the antenna may fall or the power line may fall and cause danger to the operator of the set that is connected to the antenna.

Keep the antenna as far away as possible from any other wires. The results will be better anyway. Power lines in close proximity to an antenna cause a shadowing effect or an absorption effect and sometimes both.

Corroded Antenna Wire Causes Weak Signals

IF your antenna has been up for a year or more the chances are that the surface of the antenna wire has become corroded due to the action of the weather. Radio frequency currents travel on the surface of the wire and often the weakening signals carried by them is due to this corrosion. This trouble is particularly prevalent in large cities where the atmosphere is contaminated with sulphur fumes and other chemicals from manufacturing plants.

Enameled wire is excellent for antennas as the enamel protects the surface of the copper from the gases and other corrosive elements in the atmosphere.

Low-loss Coils Should Be Placed Correctly

THE object of winding coils in the basket or open form is to reduce the high-frequency losses. But all the advantages that may be gained by this kind of winding are nullified if the coil is placed in the receiver close to the plates of the condenser or other metal object. The losses in the coil under such conditions may be far greater than would occur in an ordinary coil that was properly placed.

Make the Antenna and Lead-in of One Piece

It is often difficult to solder the end of the lead-in wire to the antenna; and a poor joint at this point means weak signals. When a new antenna wire and the lead-in are first twisted together, the contact will undoubtedly be good, but exposure to the weather will soon corrode the joint. If you find it inconvenient to make a properly soldered joint at this point it is desirable to make the antenna and lead-in one piece.

The Receiver May Not Be to Blame

BROAD tuning is not always the fault of the receiving set. An antenna that is too long will cause almost any set to tune broadly, except the four-circuit tuner, which works best with a long antenna. It is often possible to tune distant stations clearly when the locals are transmitting, by the use of a short antenna. A long antenna usually brings in local stations so broadly that distant stations cannot be heard.

Where High Resistance Is Unimportant

RADIO fans often hesitate about running a wire from their receiving set to a loudspeaker in another part of a house, because they fear that the extra resistance of the wire cuts down the strength of the signals. Actually, however, there is already so much resistance in the loudspeaker circuit that even several hundred ohms of added resistance will have little effect on reproduction.

Smooth Turning Dials Aid Close Tuning

NOTHING is more aggravating, when you are tuning in a distant station, than dials which stick and turn in jumps. This difficulty may be due to the construction of the condenser itself, but often the cause may be found in a shaft that is binding on the edge of the hole in the panel. If this is the trouble, it can be remedied by taking the condenser off the panel and filling out the hole slightly.

When the "C" Battery Is Not Needed

If your "B" battery voltage does not exceed $67\frac{1}{2}$ volts, the use of a "C" battery does not add to the volume or clearness of the loudspeaker provided the filament connection of the secondary circuit of your amplifying transformers is made to the proper point in the circuit. The rheostats should be in the negative leads to the tubes and the transformer connected between the negative pole of the "A" battery and the rheostat.

Use the Best Quality of Solder

Good solder is made of equal parts of tin and lead. As lead is much cheaper than tin, there is solder on the market that contains very little tin. Poor quality solder is difficult to work with. For instance, it will not flow readily into joints.

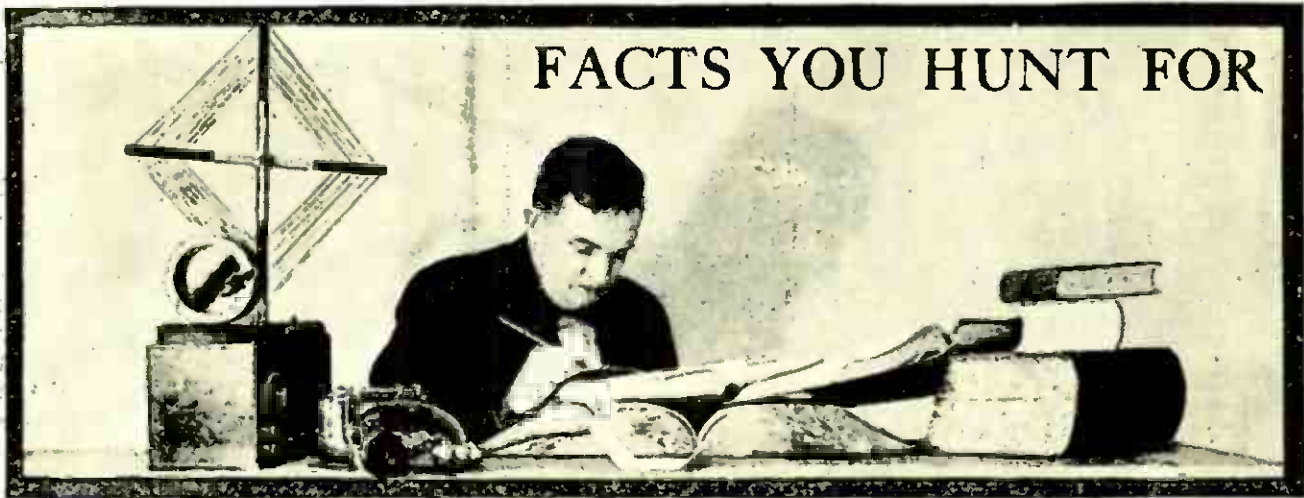

FACTS YOU HUNT FOR

CONDUCTED BY RICHARD LORD

A limited number of questions of general scientific interest will be answered each month in this department. Readers are invited to send in questions that have puzzled them—but the selection of questions for answer cannot be guaranteed nor can questions outside the radio field be answered by mail.

Is it any easier to send radio waves between two stations in one direction than it is in the reverse direction?

THERE is no evidence indicating any difference so far as the path through the ether is concerned. The ether is not believed to offer any resistance to the waves or to discriminate in any way between waves going in different directions.

What is the principle of the electrostatic telephone receiver?

IN the ordinary telephone receiver the forces that cause the diaphragm to vibrate are magnetic. They come from the magnets in the telephone, these magnets being affected by the currents that flow through the windings that surround the magnet poles. The electrostatic telephone substitutes electrostatic forces for these magnetic ones. The diaphragm is one plate of a condenser. When the charge on this condenser is increased (in correspondence with electric impulses that come in over the wires) the two condenser plates attract each other. This bends the diaphragm inward. When the charge is decreased again the diaphragm springs back. This produces the vibration that makes the sound.

What is the piezo-electric effect?

THIS is the name given by scientists to the property of some crystals by which they develop an electric charge if they are twisted or squeezed. "Piezo" means to press. The famous "talking crystals" of Rochelle salt described in POPULAR RADIO for September, 1922, work on this principle. So does the pressure

gauge used to measure the pressures in the explosion chambers of big guns. Although the piezo-electric effect has been known to scientists for over 40 years, no satisfactory theory for it has ever been formulated.

Where can I find data about the different sizes of wire that are safe for different amounts of electric current?

THE following table is that given in the National Electric Code for rubber-covered insulated wire. Bare wire will carry still more current than this without damage, although the wire may get hot. But if you stick to this table you will be safe under all ordinary conditions.

Number	6	wire	50	amperes
"	8	"	35	"
"	10	"	25	"
"	12	"	20	"
"	14	"	15	"
"	16	"	6	"
"	18	"	3	"

Wire smaller than number 18 should not be used where there is any possibility of its carrying more than a fraction of an ampere of current.

Why is a soldering flux or acid necessary when soldering two wires together?

THE flux or acid merely cleans off the two wires so that there is an absolutely clean surface for the solder to stick to. All metal wires, even if they seem to be quite clean and bright, really are covered with a thin film of tarnish derived from the chemical action of the air. The flux removes this.

Is there such a thing as an inaudible sound?

Yes. Ordinary sounds differ from each other in pitch, which means frequency. A shrill sound, like that made by a piccolo or a cricket has a very high frequency. A low, deep sound, like that of a fog horn, has a low frequency. Vibrations can be produced which have so high a frequency or so low a frequency that they cannot be heard at all by the human ear. See the article on wavelengths and kilocycles in POPULAR RADIO for November, 1923.

The books say that you can cut a sheet of glass with shears if you hold it under water, but I have not been able to do it. What is wrong?

We fear it is the books that are wrong, not you. We, too, have tried to follow this familiar direction many times, always with disastrous results. The only way to cut glass successfully, so far as we know, is with a glass cutter or a diamond.

What is the difference between an ammeter and a galvanometer?

THERE really is no difference. Both of them measure current and while there are several different varieties of each they all work on the same set of scientific principles. Usually, the name galvanometer is applied only to instruments that measure small currents and the name ammeter mainly to ones that measure relatively large currents, but this distinction is frequently disregarded.

What is the kinetic theory of gases so much referred to in the theory of vacuum tubes?

A GAS is supposed to be composed, really, of a vast number of separate particles, the molecules, which fill the space occupied by the gas. These particles are supposed to be flying about violently all the time like the bees in a flying swarm. They continually hit against each other and against the walls of a bulb or anything else that contains the gas. This hitting of the particles against the wall is what produces gas pressures. The laws that govern the behavior of a cloud of gas particles moving about among each other in this way have been worked out mathematically and these laws are what constitute the theory about which you inquire. "Kinetic" means simply "moving." The theory is really "the theory of moving gas particles." It is useful in the theory of vacuum tubes because all such tubes, even the most perfectly evacuated ones, contain a few gas particles and these move about in accordance with the kinetic theory.

How can one tell the difference between the primary and the secondary of a transformer?

If the transformer is a "step-up" one, that is, one used for increasing the voltage, the primary is the coil with the fewer turns of wire, the secondary, has the more turns. For a step-down transformer this rule is reversed. Most transformers can be used, of course, either way. If you put current into the few-turn coil you get out a higher voltage from the other coil. If the current enters the many-turn coil you get a lower voltage from the few-turn one.

Do the luminous paint compositions, some of which have the word "radio" as an element of their names, operate by means of radio waves?

No. The better varieties of these paints contain a little radium, which is where the "radio" comes from in their names.

Why are bakelite, hard rubber and such materials better for radio panels than plain wood?

THE main reason is that most kinds of wood, unless they have been very carefully treated with chemicals, will always take up a little water from the air. This water makes the wood to some extent a conductor of electricity and causes some loss of the very feeble high-frequency currents upon which the proper operation of the radio set depends.

How can I make hard rubber out of ordinary soft rubber?

You cannot, at least as a practical matter. The natural rubber, as it is obtained from the sap of the rubber tree, is a gummy, sticky substance of no use whatsoever. The various kinds of commercial rubber are made from it by complicated processes which can be carried out only by experts in a well-equipped factory. Two things are involved: the change of the internal physical structure of the rubber itself, and the addition to it of varying amounts of sulphur. This is what is called "vulcanization." Unless you are a rubber expert you had better buy the kind of rubber you want and not try to make it for yourself.

What is a cadmium cell?

THIS is a special kind of electric battery, the active element of which is a piece of metallic cadmium, which is one of the chemical elements and much resembles zinc in its general properties. An electric battery made with a cadmium pole happens to have a very constant voltage and it is used, therefore, as a convenient standard of electromotive force for laboratory measurements.



CELORON

BAKELITE RADIO PANEL

Size 7 x 12

MANUFACTURED BY
DIAMOND STATE FIBRE COMPANY
 BRIDGEPORT (Near Philadelphia) PENNSYLVANIA, U. S. A.

MAKERS OF
CELORON-Diamond-Fibre-VULCAWOOD

Offices in Principal Cities
 IN CANADA: DIAMOND STATE FIBRE COMPANY, OF CANADA, LTD., TORONTO, CAN.
Made and Patented in U. S. A.

How to Work and Finish Celoron Bakelite Panels

DRAW full size layout of the holes to be drilled on a sheet of heavy paper, cut to exact size of panel. Transfer centers of holes through the paper to the Celoron panel with a pointed instrument.

The drilling can be done with a carpenter's brace or a brass drill, but metal-cutting twist drills should be used, not ordinary wood bits. Begin to drill from the front side of the panel. To avoid chipping on back, clamp panel to a board or work bench. Counter-sink holes with a larger size drill. Holes can be threaded with standard machine taps.

If a dull or mat finish is desired rub down the panel with No. 00 sandpaper. The sandpaper should be wrapped around a wooden block and the rubbing all done in one direction, not with a circular motion.

Wipe off the panel with an oiled cloth.

As popular as radio itself

AS more and more radio novices become seasoned fans, the popularity of Celoron Panels multiplies.

Today Celoron is the accepted standard for radio panels. Sets of many foremost makes are equipped with Celoron bakelite panels and parts.

Celoron does no chip or crack. It does not soften, warp or buckle. It is infusible and will stand up under atmospheric changes.

Look for Celoron Panels where you buy your radio supplies. Insist on Celoron insulation in the parts you buy.

Celoron is also made into tubing which has all of the insulating qualities of sheet Celoron. It is used extensively by manufacturers of the best radio instruments. It is made in all sizes.



Give this Celoron sales-starter a chance on your counter and watch your panel sales mount.

Wherever chimneys smoke and wheels turn, there are countless electrical and mechanical uses for Celoron and Diamond Fibre.

DIAMOND STATE FIBRE COMPANY

Bridgeport, Pa., and Chicago, Ill.

The oldest and largest manufacturer of vulcanized hard fibre and laminated bakelite materials in the world.

Which would

This →

"WITHOUT ACCESSORIES"

Radio instrument	Loud speaker	Ground clamp
Antenna wire	Window lead in	Antenna spring
Connection wires	Mechanic's labor	Hammer
Clips	Storage battery	Nails
Lightning arrester	"B" batteries	Screws
Insulators	Tubes	Staples

Separate price for each of these items, plus your time.

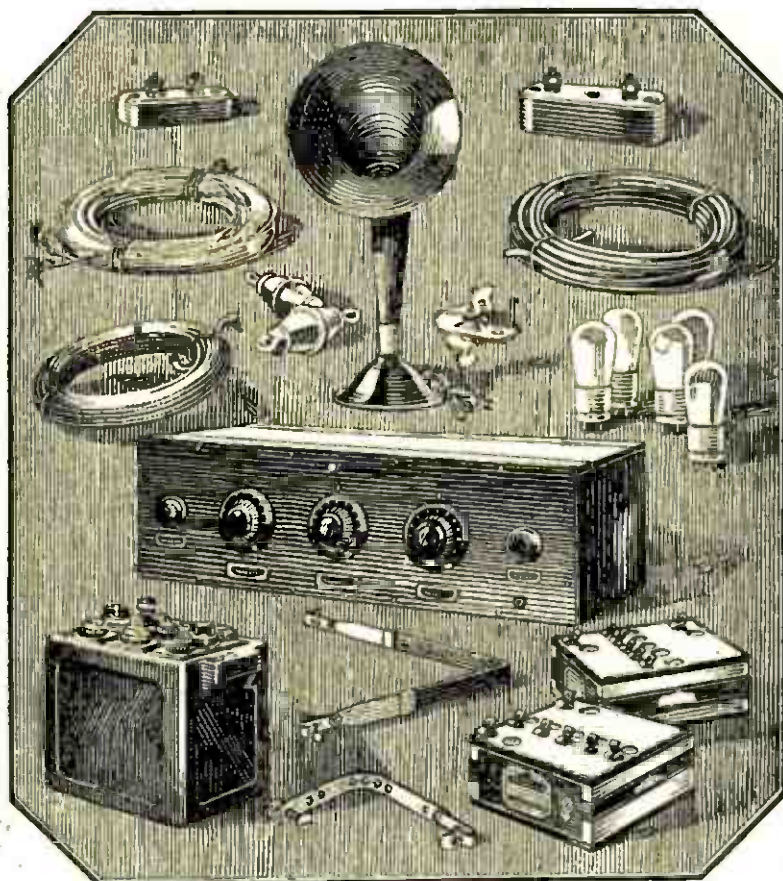

What "complete self-contained"

IT is the best of fun, we admit, to hook up a radio set, to string your antenna from tree to house, to connect your ground wire—at least it is fun if you are mechanically minded.

If, however, you want principally to use a radio set, there are two things of primary importance—first, that its tone and quality shall be absolutely pure, non-metallic and accurate; secondly, that it shall be as little

fuss and bother to you as is humanly possible. This means De Forest D-12 Radiophone—the leader in the field—bearing the imprint of Dr. Lee De Forest, the man whose great invention paved the way to radio broadcasting.

As to tone—it is impossible to describe the clean and natural quality which this instrument gives. You simply must hear it

DE FOREST RADIOPHONE

REG. U. S. PAT. OFF.

REG. U. S. PAT. OFF.

All apparatus advertised in this magazine has been tested and approved by POPULAR RADIO LABORATORY

you choose?

DE FOREST D-12 RADIOPHONE

Complete in one unit, with everything necessary to use it immediately — all at the one initial cost.

Prices according to cabinet finish and batteries.

With dry batteries

In Fabrikoid cabinet	\$161.20
In Mahogany cabinet	176.20

With storage batteries

In Fabrikoid cabinet	\$180.00
In Mahogany cabinet	195.00

← or this

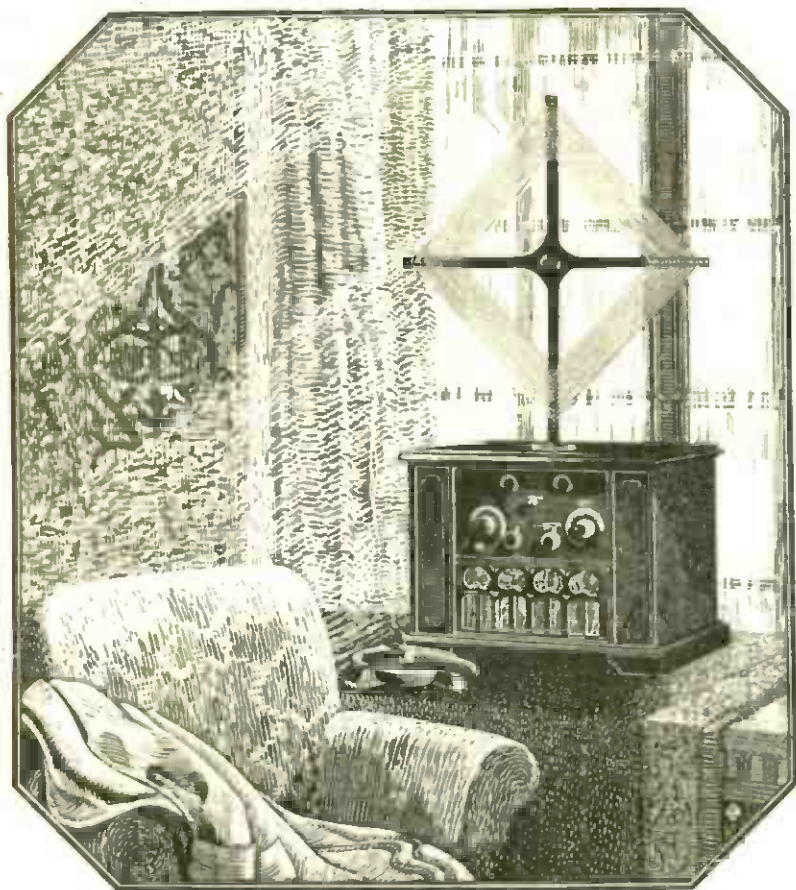

means as in De Forest

and judge for yourself. And as for convenience, remember these important things: it is self-contained and complete in one unit—usable within five minutes after it enters your home—easily movable from room to room because it does not need to be attached to either antenna or ground.

When you find the De Forest agent in your vicinity you find a man who knows

radio—a man who has given us his word that he will see that every instrument he sells is thoroughly inspected and properly serviced after the sale.

Avail yourself of his help. He desires, as we do, that you should get the fullest enjoyment and satisfaction from your instrument.

DE FOREST RADIO COMPANY, JERSEY CITY, N. J.
Also makers of De Forest Tubes, The "Magic Lamp" of Radio

DE FOREST RADIOPHONE

REG. U. S. PAT. OFF.

REG. U. S. PAT. OFF.

All apparatus advertised in this magazine has been tested and approved by POPULAR RADIO LABORATORY

Haynes-Griffin

RADIO SERVICE, Inc.

41 West 43rd St., N. Y. City

250 W. 49th St.,
New York

MAIL ORDER DEPARTMENT

111 So. Clark St.,
Chicago



A. J. HAYNES

Associate, Institute of Radio Engineers, designer of Haynes-Griffin Intermediate Wave Transformers and other special parts for the super-heterodyne

Use Haynes-Griffin MATCHED TRANSFORMERS in your new "Super"

The Haynes-Griffin Method of Laboratory Testing and Matching transformers assures you of "super" results right from the start. It does away completely with the most common and bothersome source of trouble in the super-heterodyne—unmatched or improperly matched transformers.

Every Haynes-Griffin Transformer is tested after manufacture and its peak of resonant frequency ascertained. Then the transformers are matched in sets of four which show identical characteristics. There's no guess or doubt about it—actual laboratory tests with accurate meters is positive proof that every set of Haynes-Griffin Transformers will work at maximum efficiency. The Haynes Laboratory test insures the highest degree of amplification, selectivity, sensitivity, and tone quality.

Plenty of the Following New and "Hard-to-get" Apparatus in Stock for Immediate Delivery

- | | |
|--|--------|
| General Instrument .001 Isolantite Condenser..... | \$6.00 |
| General Instrument .0005 Isolantite Condenser..... | 5.50 |
| Precision Autodyne Coupler Daven .25 Resistance..... | 3.50 |
| .005 Daven Resistance..... | .50 |
| .5 Daven Resistance..... | .50 |
| 5 meg Daven Resistance..... | .50 |
| .006 N. Y. Coil Condenser..... | .75 |
| .0005 G. N. Y. Coil Condenser | .45 |
| .0001 N. Y. Coil Condenser... | .35 |
| Federal No. 16 Socket..... | 1.20 |
| Benjamin Standard Socket... | 1.00 |
| Set of 4 Matched Haynes-Griffin Intermediate Transformers..... | 20.00 |
| Amplex .0005 Gridenser..... | 1.25 |
| Pyrex Insulator..... | .45 |
| Amsco 400 ohm potentiometer... | 1.50 |
| Amsco 2 ohm Rheostat..... | 1.35 |
| Electric Soldering Iron..... | 1.25 |
| Pacent D. C. Jack..... | .60 |
| Pacent S. C. Jack..... | .50 |
| Walbert Filament Switch..... | .50 |
| Voltmeter 0-50..... | .90 |
| Dubilier Duratran..... | 4.00 |
| Karas Audio Transformer..... | 7.00 |
| Pyrex Socket..... | 1.50 |
| Daven Resistance Coupler..... | 1.25 |
| Daven Single Mount..... | .40 |
| Cutler-Hammer Socket..... | .90 |
| Naald 4 in. dial..... | .75 |
| Hard Rubber Strip 1 x 10 in. (Drilled)..... | .25 |
| Special 7 x 24 cabinet..... | 10.00 |
| Korach Tuned Loop..... | 16.50 |

Every Transformer Is Individually Tested



Haynes-Griffin Transformers are meter-tested and matched under the supervision of A. J. Haynes.

MATCHED!



After being tested, every set of Haynes-Griffin Intermediate Wave Transformers is packed in a sealed carton containing the Haynes-Griffin Guarantee that each transformer has been tested, found electrically and mechanically perfect and carefully matched with the other three. Set consists of one Input and three Inter-Stage Transformers. Price, set of four \$20.

Dealers: For information on Haynes-Griffin Products and name of distributor nearest you write to Tested Radio Products, Inc., 244 W. 60th St., New York City.

HAYNES-GRIFFIN RADIO SERVICE, Inc.
250 W. 49th St., New York City
111 So. Clark St., Chicago

Haynes-Griffin

RADIO SERVICE, Inc.

41 West 43rd St., N. Y. City

250 W. 49th St.,
New York

MAIL ORDER DEPARTMENT

111 So. Clark St.,
Chicago

Special Service to Builders of Cockaday Circuits

Within three days after the announcement of a new Cockaday Circuit Haynes-Griffin has a complete stock of the exact parts specified by Mr. Cockaday. The instant a new Cockaday Receiver is made public our buyers in Chicago and New York secure large supplies of apparatus so that our customers can secure the first of the new and "hard-to-get" parts.

Haynes-Griffin will not make any substitutions. You will receive exactly the identical material specified by Mr. Cockaday for the circuit you wish to build. Inferior apparatus invariably results in loss of efficiency and often in hours of fruitless trouble shooting.

PARTS FOR THE COCKADAY 4-CIRCUIT TUNER With Resistance Coupled Amplifier

1 "Precision" Cockaday Coil.....	\$5.50	1 Improved Single Circuit Jack.....	.70
1 "Cardwell" Variable Condenser (.0005 mfd.).....	5.00	1 Improved Filament battery switch.....	1.00
1 "Cardwell" Variable Condenser (.00035 mfd.).....	4.75	1 "Precise" Audio Frequency Transformer No. 285-A.....	5.00
2 "Accuratune" Micrometer control dials..... each	3.50	3 "Electrad" Certified Grid-Leaks 1/2 megohm..... each	.50
1 "New York" Mica Fixed Condenser (.00025 mfd.).....	.35	3 "Electrad" Certified Grid-Leak mountings..... each	.25
9 "New York" Mica Fixed Condensers (.005 mfd.).....	.60	9 Switch Points..... each	.01
each.....		2 Stops..... each	.01
1 "Amplex" Grid-denser.....	1.25	1 Switch Lever "Amsco".....	.25
1 "Bradleyleak".....	1.85	1 7 x 24 x 3/16" Grade "A" Hard Rubber Panel (Drilled).....	4.00
3 "Bradleyohms" No. 25..... each	2.00	Sub-Base 9 3/8 x 22 3/4.....	1.00
5 "Benjamin" Cle-ra-tone Sockets for U. V. 201-A tubes..... each	1.00	7 x 24 Solid Mahogany Cabinets.....	10.00
1 "Amsco" Dubl-wundr Combination potentiometer-rheostat.....	2.00	1 Binding Post Strip 7 x 1 x 1 3/4 x 1.....	.20
4 "Amperites" No. 1-A with mountings..... each	1.10	8 Binding Posts..... each	.20
3 Improved Double Circuit Jacks..... each	1.00	Bus Bar, lugs, solder and screws.....	1.00

A genuine complete set of official blue prints with full construction and operating descriptions, as published by Popular Radio, sent post-paid upon receipt of \$1.10.

FREE! Each Month. Live News of All The Latest Radio Developments

Here's What Appeared in the November Issue

- A New Three-Stage Power Amplifier
- How to Build Your Own B Battery Eliminator
- A Frank Discussion of the Newest Development in Loud Speakers
- A New Tube Matching Device, Designed by Mr. Haynes
- A Super-Heterodyne That Any Radio Fan Can Build
- Detailed Description of New Parts and Accessories
- A One-Stage Resistance Coupled Amplifier
- And Many Other Features

"Radio Dispatch" gives you just the information you have been looking for. Where to buy the products you see advertised—how much they cost—and how to get them as quickly as if you lived next door to a big radio store. PR.1

"Radio Dispatch" is edited personally by A. J. Haynes to keep you informed of every new radio development. It is his personal message to his friends who depend upon him to tell them "What's New in Radio?"

"Radio Dispatch" is sent absolutely free to anyone interested in radio. No subscription, no obligation of any kind. Mail the coupon to our nearest store.

HAYNES-
GRIFFIN
RADIO
SERVICE, Inc.
250 W. 49th St.
New York City
111 South Clark St.
Chicago, Ill.

Please put me on your mailing list for "Radio Dispatch."

HAYNES-GRIFFIN RADIO SERVICE, Inc.

250 West 49th St., New York

111 So. Clark St., Chicago

Name.....

Address.....

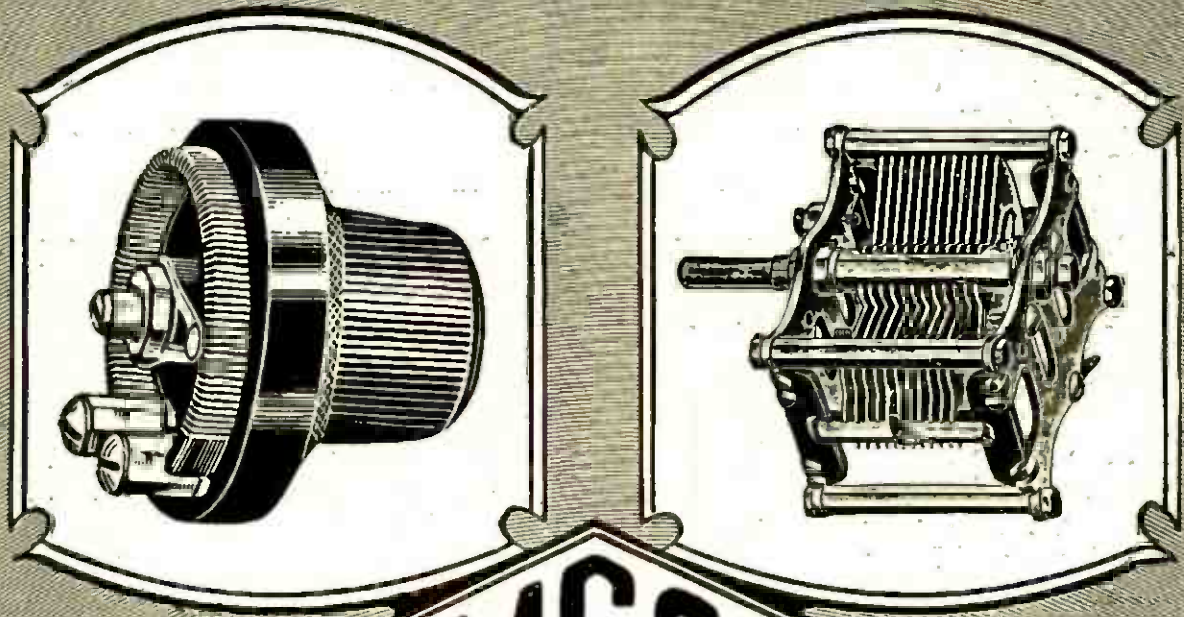

AMSCO

RHEOSTATS POTENTIOMETERS *and* LOW LOSS CONDENSERS

Amsco quality radio parts—the standard of excellence, by which all other parts are judged. Used by many of the leading set manufacturers.

AMSCO RHEOSTATS: Assure perfect filament control thereby assuring longer tube life.

AMSCO POTENTIOMETERS: For plate voltage control on receiving tubes. Essential when sensitive tuning is required.

Genuine Bakelite Bases and Dials used exclusively on Rheostats and Potentiometers

AMSCO LOW LOSS CONDENSERS: Laboratory instruments designed for perfection in set building. Really low loss.

Ask your dealer or write for interesting literature



AMSCO PRODUCTS INC. BROOME & LAFAYETTE STREETS, N.Y.

All apparatus advertised in this magazine has been tested and approved by POPULAR RADIO LABORATORY

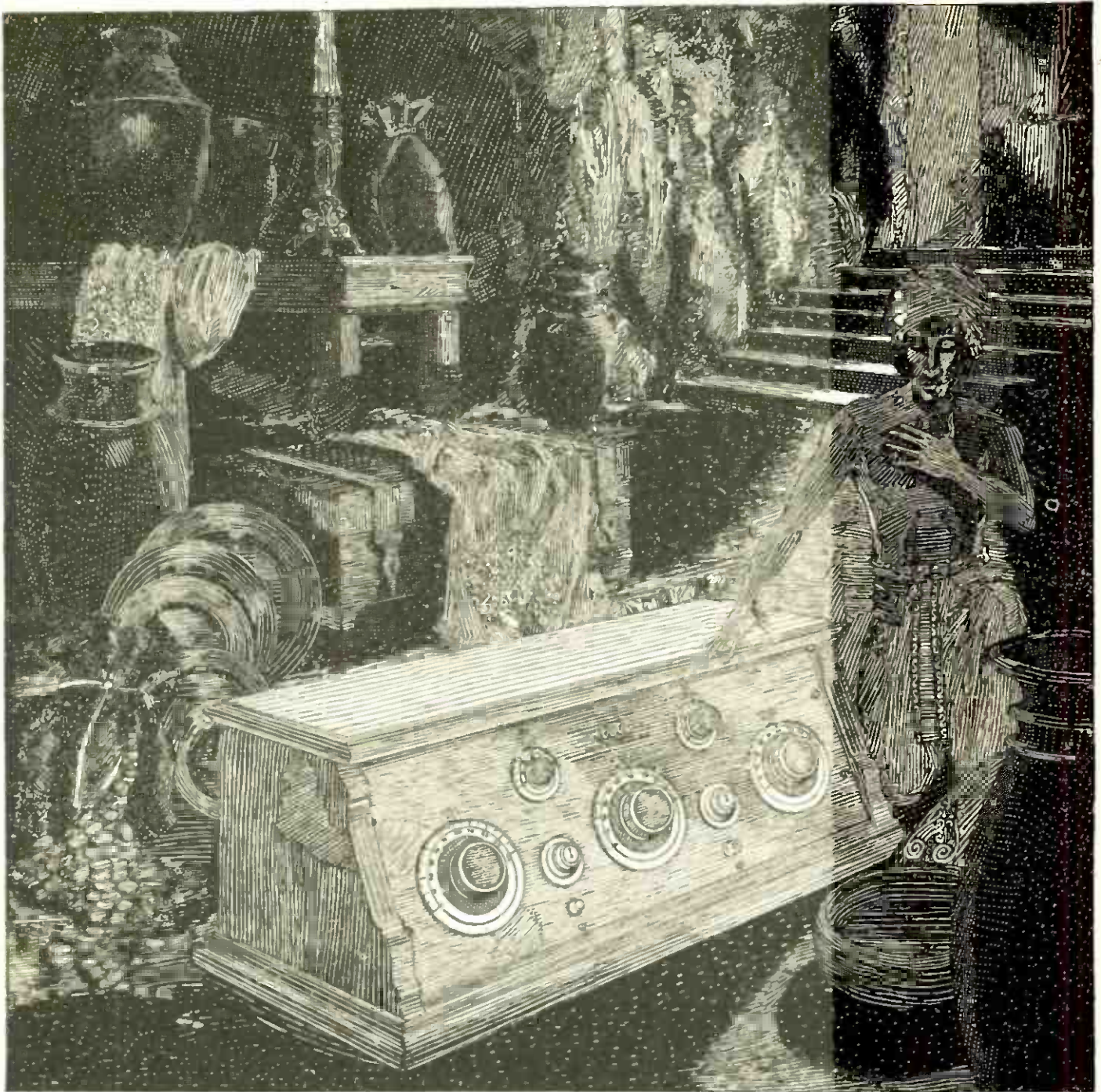

MELCO SUPREME—the “Open Sesame” that reveals the priceless treasures of the air! Melco reception is to the ear, like a great masterly-cut gem to the eye. Clear, Flawless, Supreme.

Ready for Distribution January 1st, 1925

MELCO SUPREME RECEIVER TUNED RADIO FREQUENCY

Write for interesting literature



AMSCO PRODUCTS INC. BROOME & LAFAYETTE STREETS, N.Y.

All apparatus advertised in this magazine has been tested and approved by POPULAR RADIO LABORATORY

CONTRACTOR TO BRITISH, FRENCH AND ITALIAN GOVERNMENTS

C. F. Elwell.

MEM. INST. ELCO. ENGINEERS.
 FELL. INST. RADIO ENGINEERS.
 MEM. AM. INST. ELCO. ENGINEERS.
 MEM. ASS. ELET. ITALIANA.
RADIO ENGINEER.

DESIGNER & MANUFACTURER
 OF ALL KINDS OF
 WIRELESS PLANT
 AND CONTRACTOR FOR
 COMPLETE INSTALLATIONS

SPECIALIST IN ALL SIZES OF
 POUlsen ARC GENERATORS
 UP TO 1000 K.W.

LONDON & PARIS.

TELEGRAMS: "ELRADIOENG, WESTCENT, LONDON"
 CABLES: "ELRADIOENG, LONDON"
 WESTERN UNION CODE.
 TELEPHONE: REGENT 1607.

Craven House,
 Kingsway,
 London, W.C. 2.

October 20th, 1924.

General Instrument Corp.
 425 Broome Street,
 New York, New York. U. S. A.

Dear Sirs:

By first post, and without delay, please ship me six (6) Variable Air Condensers type 56D 500 μmfd s maximum capacity, insulated with Isolantite and by the same post six (6) Variable Air Condensers type 51D 500 μmfd s maximum capacity, insulated with Pyrex.

It may be of interest to you to know that we have no condenser on this side to equal yours in the matter of phase angle difference. As a matter of fact, in all my many years of radio experience, I have never had an opportunity before to experiment with a Variable Condenser having a phase angle difference of a little over three (3) seconds.

I am using your condensers in a very small set, and can hear your American Stations nightly very clearly and without difficulty.

Yours sincerely,

CFE/GG

C. F. Elwell.

From Oversea

NOLOSS
TRADE MARK
TYPE 51
PYREX INSULATION

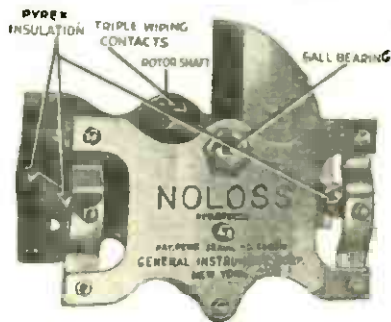

NOLOSS
TRADE MARK
TYPE 56
ISOLANTITE INSULATION

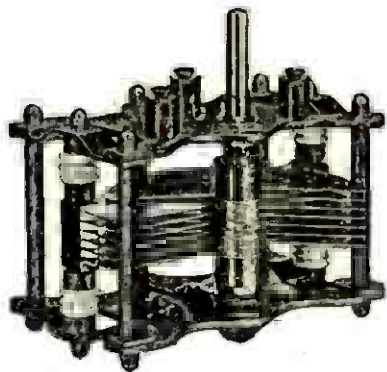

THE unapproached quality of General Instrument NOLOSS, Pyrex and Isolantite Condensers, is acknowledged.

The phase angle difference (measured at 1500 kilocycles) of 3.6 and the power factor of .00175 percent is the result of engineering skill that commands recognition.

NOLOSS Condensers have proved their electrical supremacy, their mechanical superiority. They are ruggedly built with jealous watchfulness to permanently withstand wear and tear—a vital condition in obtaining oversea results.

General Instrument Corporation

Manufacturers of Laboratory Equipment

423 BROOME STREET
NEW YORK, U.S.A.

The By-Pass Condenser

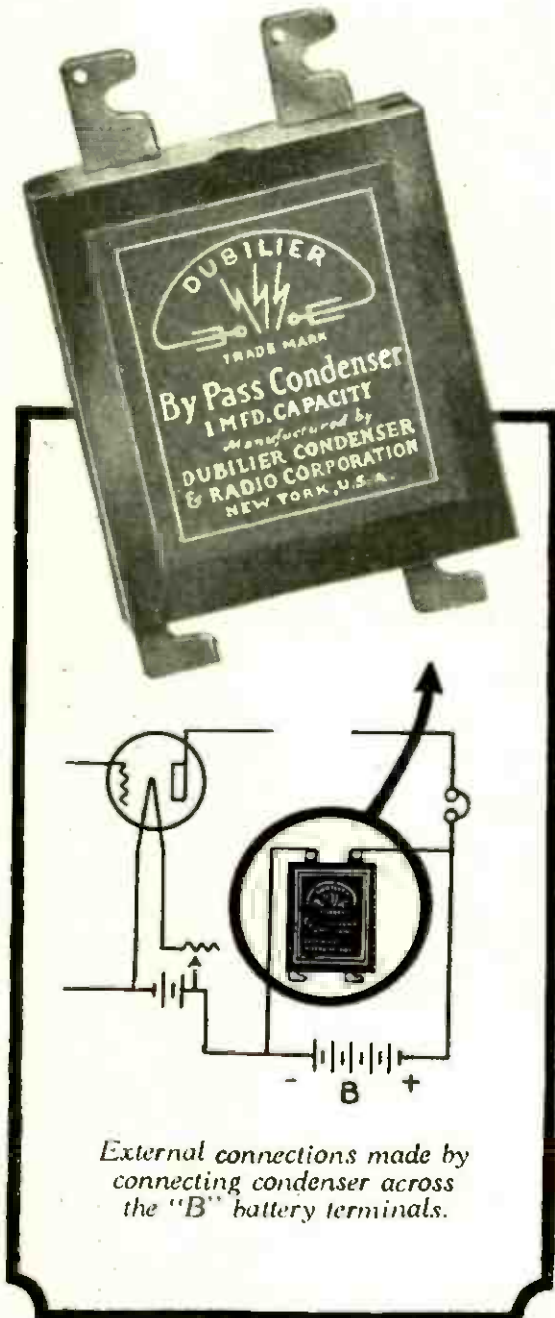

YOU will get the program clearer if you install a Dubilier large capacity By-Pass Condenser in your radio set. Just locate it as the diagram indicates. The result is that the minute fluctuations of the "B" battery are smoothed out into a steady, even flow of current, devoid of all noises.

The result is astonishing! Signal strength is increased—tones purer—volume smoother. The whole program comes in far truer and pleasanter than ever before.

This By-Pass Condenser in quality of material and workmanship measures up to that high standard for which all Dubilier radio devices are famous.

Dubilier

CONDENSER AND RADIO CORPORATION

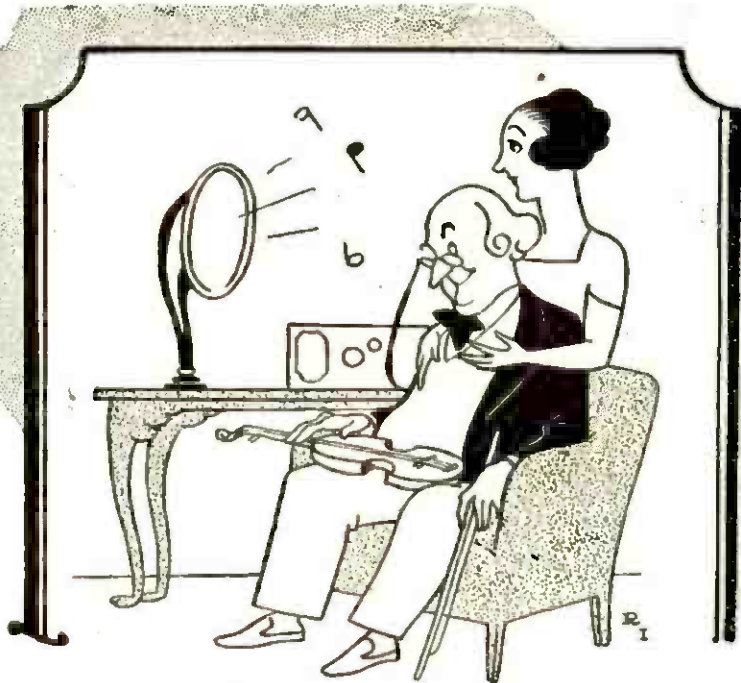

Radiola Loudspeaker
 Type UZ-1325
 Now \$25.00

Music for the critical

Time was when people were so impressed with the wonder of radio, and so entertained by the fun that came over, that they actually didn't mind the bluster of a noisy horn. But most of us aren't like that now. We want music that is music—we want speech that is really human speech—unclouded by horn sounds. And we can have it now—with a Radiola Loudspeaker.

You cannot blame every extraneous sound on the loudspeaker. But if your set is working perfectly, all it needs, to give you clear, faithful, undistorted reproduction, is a Radiola Loudspeaker. Hear one today, and if you really want to judge the difference, ask to hear it in competition with others.

Radiola

REG. U. S. PAT. OFF.

LOUDSPEAKER



This symbol of quality  is your protection

RADIO CORPORATION OF AMERICA

Sales Offices:
 233 Broadway, New York
 10 So. La Salle St., Chicago, Ill.
 28 Geary St., San Francisco, Cal.

ATWATER KENT LOUD SPEAKERS

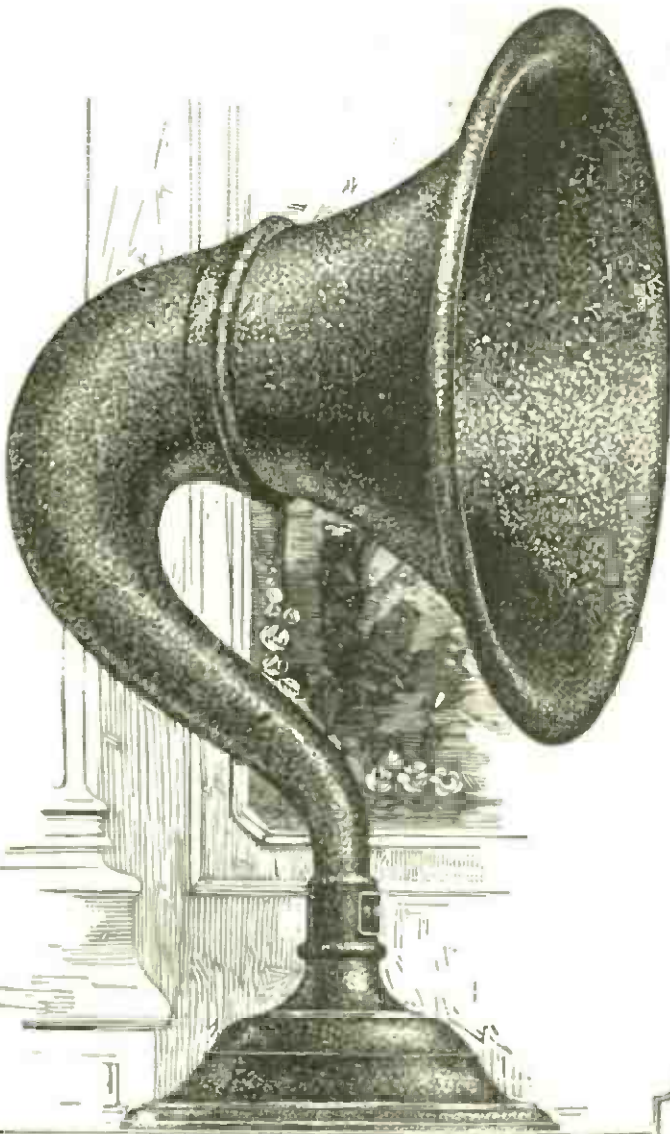

Complete Radio Enjoyment

THERE is a delightful surprise in store for you—an added fascination in radio—when you take home an ATWATER KENT Loud Speaker.

Your radio receiver provides a new and always interesting form of entertainment—but you will find that the last full measure of radio enjoyment comes with the use of an ATWATER KENT Loud Speaker. It re-creates each broadcast into rich and natural tones and in ample volume thus making your radio the generous family entertainer you want it to be.

Pure in tone, the ATWATER KENT Loud Speaker has no peer in the reproduction of broadcasts. Its design, correct in every detail, is the result of skilled engineering research. Its quality, characteristic of all ATWATER KENT products, is the reward of work well done plus the finest materials that money can buy. Your dealer has three models. Take one home today.

ATWATER KENT MANUFACTURING COMPANY
4712 Wissahickon Ave., Philadelphia, Pa.

Bring Out the Best
from Any Set



Pacific Coast prices
slightly higher

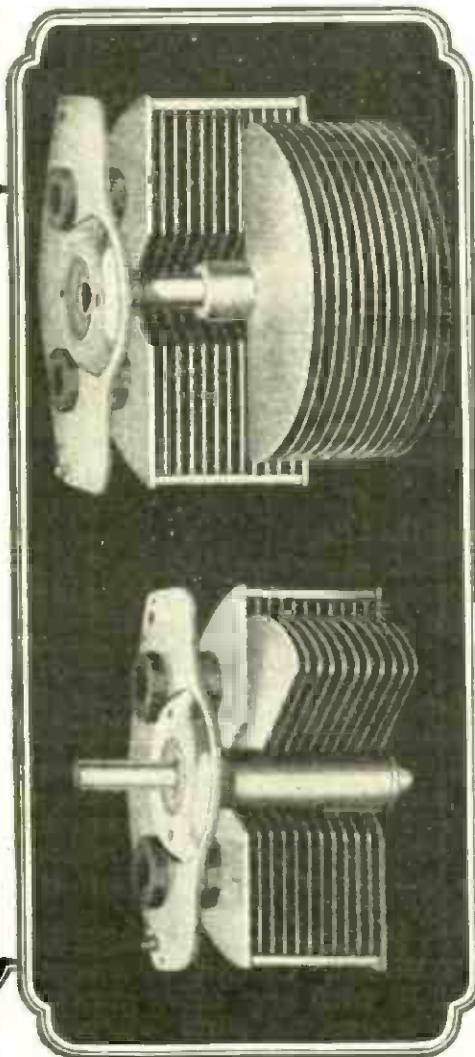
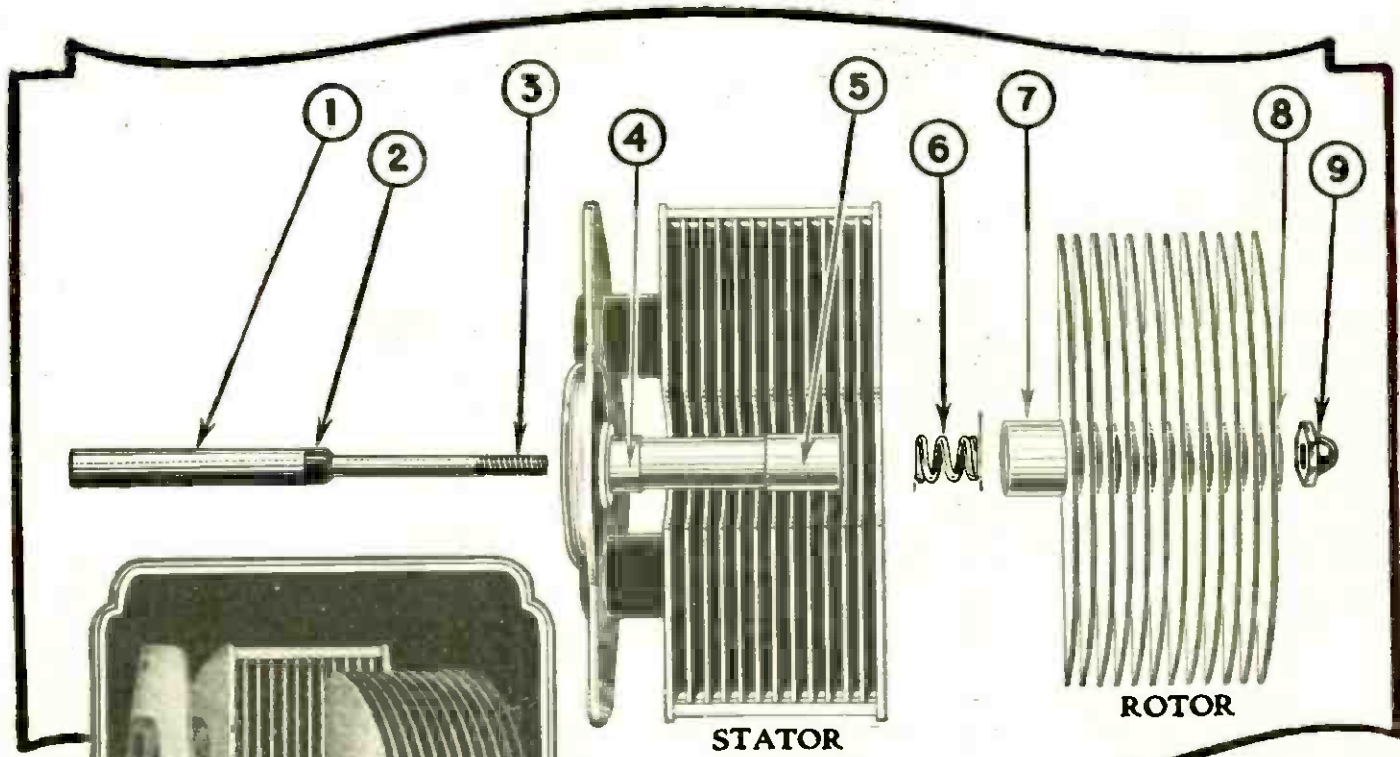

The Condenser with the "full floating axle"

The striking feature of the Bradleydenser is the rigid double bearing, based on the principle of the "full-floating" automobile axle, that eliminates the usual outer pivot-bearing for the rotor shaft, and still provides a non-sagging support that insures perfect alignment of the rotor plates.

The rotor plates, soldered on a long, hollow tube extending from [7] to [8], revolve on a hollow steel stem provided with two bearings [4] and [5]. The alignment and support of the rotor is independent of the condenser shaft [1], as shown by the first photograph at the left. The shaft [1] merely turns the rotor. It slips through the hollow steel stem and its threaded end [3] is secured to the rotor at [8] with the nut [9] as shown in the second photograph. The spring [6] prevents end-play.

This design, combined with the use of soldered brass plates, results in a rugged, long-life condenser of extremely high efficiency. For superior service, use the Bradleydenser.

Allen-Bradley Co.
Electric Controlling Apparatus.

General Office and Factory: 276 Greenfield Ave., Milwaukee, Wis.

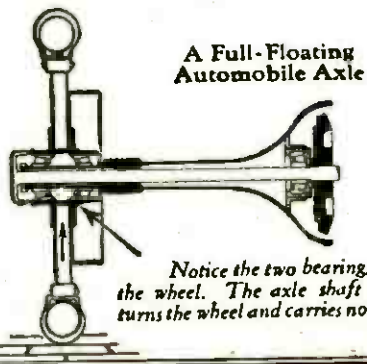

A Full-Floating Automobile Axle
Notice the two bearings for the wheel. The axle shaft only turns the wheel and carries no load.

Bradleydenser

PERFECT VARIABLE CONDENSER

Are You Fooled by "Low Loss" BUNK!



A RATHBUN Condenser is *Honest!*

WHY?

Because no claims are made for it that cannot be substantiated. It is not only *Low-Loss*, but *Highly Efficient* (see Lefax report). *Low-Loss*, a questionable phrase usually adds \$2 or \$3 to the price of a condenser. Metal End Plates Do Not Necessarily Mean Low-Losses. *Eddy-currents* must be

taken into account. These do not exist in *Bakelite* End Plates. They are often more serious than dielectric losses at radio frequencies.

Experts Say

"Replacing the dielectric material in a condenser by metallic materials for the purpose of lowering its resistance may not always bring the results that are desired. What is gained in the way of reducing dielectric absorption may be more than over-balanced by what can be lost in the way of eddy-currents, etc. This, in fact, may be very pronounced as we go toward the ultra-short wave lengths, for it must be remembered that eddy-current losses and skin-effect go up rapidly with the frequency while dielectric absorption goes down."

SYLVAN HARRIS.

"Losses due to eddy-currents in metal end plates of condensers are more serious at radio frequencies than in condensers using a good dielectric material, such as Bakelite."

H. F. HARMON, *Engineer*,
Formerly of Bureau of Standards.

Statements that Say:

- "Our Condenser has *No-Loss*"
- "Our Condenser has *Lowest Loss*"
- "Losses Cannot Be Measured"

ARE BUNK

"Rathbun" tells the truth. Write for information and learn the TRUTH.

NOTE THESE POINTS: Low prices, single-hole mounting, overall plate protection, correct alignment, rigid, simple, light, compact and durable. Nothing to get out of adjustment. Will stand a lifetime of service. Low loss and high efficiency.

GUARANTEE: If you can get **LONGER** distance, **SHARPER TUNING**, **CLEARER** reception or **MORE VOLUME** with any other condenser on the market today, return ours, your money will be refunded.

DEALERS: If your jobber does not carry Rathbun Condensers, order direct.

RATHBUN MANUFACTURING COMPANY,
Dept. PR. 2, Jamestown, N. Y.



Molded on every original single-hole-mounting low-loss unconditionally guaranteed Condenser.

RATHBUN
SINGLE-HOLE MOUNTING
SUPERIOR CONDENSERS

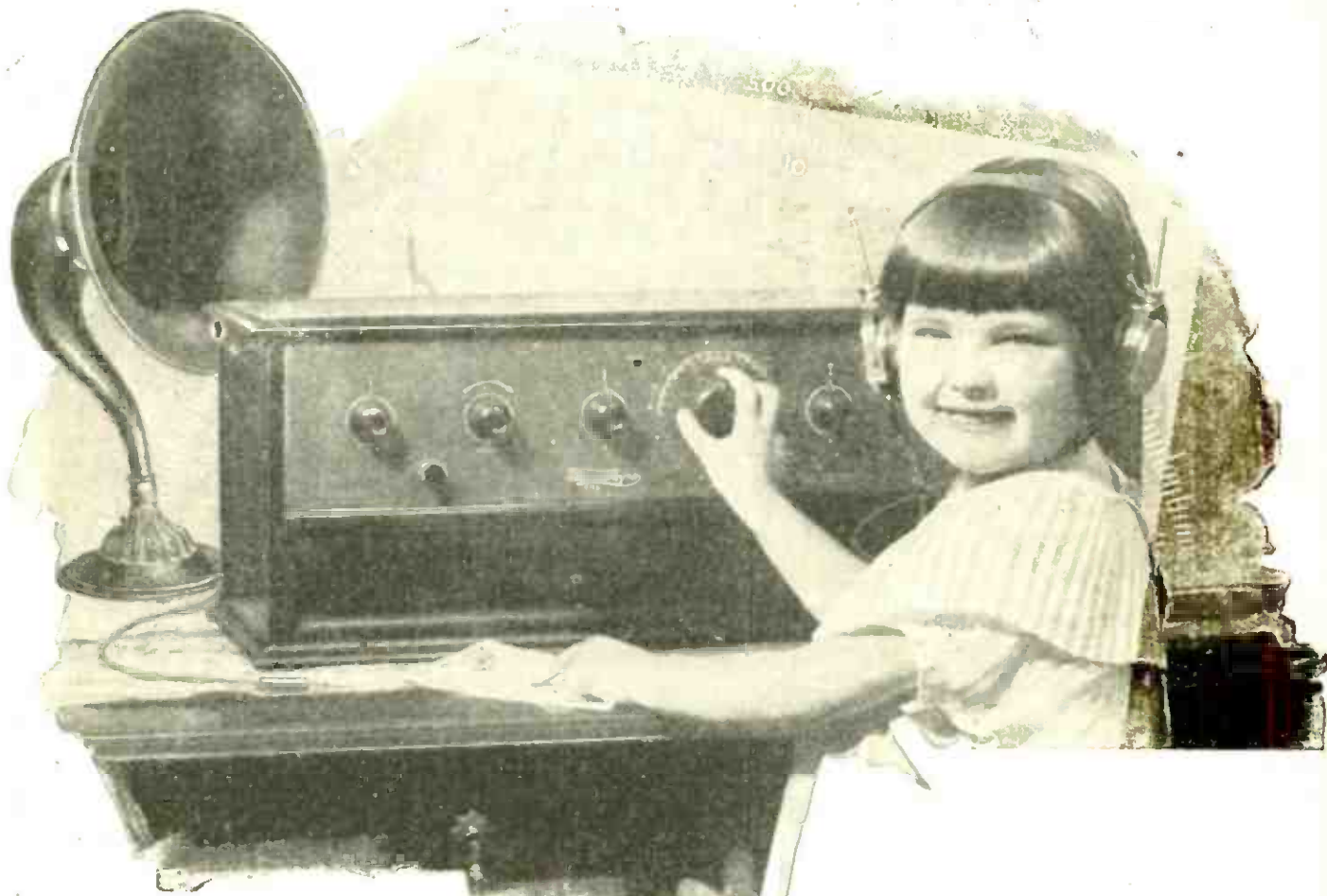

6 tubes with one control

HERE'S the outstanding accomplishment of recent reception development—6 tubes, 3 stages of thermionic frequency, detector and 2 stages audio frequency—all with *one control!* Stations always come in at same point with the single control—selections are made according to the wave-lengths as published in newspapers. If it's in the air Thermiodyne will get it regardless of distance. Thermiodyne calibrations are in wavelengths instead of meaningless degrees, thus afford-

ing practically instantaneous reception. Tuning in six to ten different stations in a minute's time is no task, even for a child. In Thermiodyne, which is the first six-tube set to successfully tune three stages of amplification before the detector, the evils of static are minimized or eliminated entirely. There is lots to be said about the achievements of the newly improved Thermiodyne. Here we can but hint at them. Your dealer can show these new details; or, write today for our descriptive folder containing the whole Thermiodyne story.

◆ THERMIODYNE RADIO CORPORATION ◆

◆ PLATTSBURGH, N. Y. ◆

Price \$140
without accessories

Thermiodyne

Reg. U. S. Pat. Off.

[Ther · m̄ · odyne]

TF6

All apparatus advertised in this magazine has been tested and approved by POPULAR RADIO LABORATORY



GILFILLAN NEUTRODYNE



*"What a lovely tone
this set has"*

THE clear true tone of the Gilfillan Neutrodyne brings out the finer shadings of musical reproduction. With the aid of the finding chart anyone can tune in quickly without howls or squeals. Distant and difficult stations are easily brought in even while locals are playing.

The Gilfillan Neutrodyne is extraordinarily sensitive to faint signals and has an almost uncanny power of selectivity. This is especially desirable where many stations are broadcasting and the interference is great. The volume, clarity and ease of operation of these sets is a revelation.

We invite a comparison of the workmanship and performance of these sets with any others. The excellence is due to the years of experience in the manufacture of radio equipment.

STYLE GN-1 In a handsome two-tone American Walnut cabinet harmonizing with any interior. Price without accessories, **\$175**

STYLE GN-2 has the same Neutrodyne construction and features in a smaller cabinet. Price without accessories **\$140**

These sets are manufactured at three factories conveniently located to the jobber and dealer.

Send for Literature to Nearest Office

2525 W. Penn Way
KANSAS CITY

GILFILLAN BROS. INC.
1815 W. 16th St., LOS ANGELES

225 W. 57th Street
NEW YORK CITY



Radio Apparatus that Brings in the Stations Say the Radio Bugs!

February 14, 1924

KELLOGG SWITCHBOARD & SUPPLY CO., Chicago, Ill.

Gentlemen:

My antenna is fifty feet high, and slants towards the lead-in. I have a three-circuit set, completely equipped with Kellogg parts. In the list which I am enclosing, those stations marked with an asterisk were received in one night [five hours]. The complete list numbers 154 stations, all received over a period of 115 days.

WOS*	WMC*	WEAF*	WPA	KJR	KPAF*	KNJ*
WOC*	WJY	PWX	WAAW	9CGU	WJAK	WJAD*
WHB*	WNAV*	8XG	WCK*	CKAC	CFGX*	ICU
WLAG*	WGR*	CKCK*	WEAH	WBL	KFKX	WJAL*
WJAN	WSAI	KSD*	KLZ	WOAI	WLAT	WXV*
WHAZ	9XN	WII	KWH	3KY	WHQ	6KW*
WJAX	WCX*	WBAH	KFCA	WOAT	WGAH*	WEAD*
WHAS*	WTAS	KFKB*	WRM	(3NO)	WLAO	5RK*
WGY*	WPAD	WTAM	WSY*	CHCE	WHAA	CFCD*
KYW*	9DYY	WOO*	KFBV	5CA	WDAV	KDZE*
WOAE	WWJ*	WAAZ	WFI	(2LO)	WKY	WKAQ
WJAZ*	WEB	WJAG	WOI	9CFO	WHN	WWAC
WOAW*	WOQ*	WBAV	WIP*	9DXL	WBAY	WPE
WFAA*	WEAS*	WRC*	KFDY	WIAS	CYL	CJCI
WDAF*	WDAR*	WHA	KON	WSAB	KFED	CFCN
WSB*	KFEB	KOI	WMAJ	WBZ	KFMX	WDAN
KDKA	WBAP*	WBAK	WEV	WEAN	WCAN	9BD
WMAQ*	KPO*	NAA*	WMAK	WNAC	KFFQ	9CDK
KFI*	WCAE*	WOR	KLX	WJAR*	WIAO	9CDU
KHJ*	WJZ	WPAH	KGW*	WNAD*	WPB	KOE
WLW	WHAN	WJAO	WGAM	WPAM	KFEL	9DCK
WCBD	CFAC	WHAM	KGN*	WMAB	5CU	WDAP*

Thirty-four of these stations are over a thousand miles, and the whole list includes over thirty-five states, all but one of the Canadian Provinces, Cuba, England, Porto Rico, Mexico, Honolulu and Alaska.

Let's give nine hurrahs for Kellogg parts, the best in the world.

Yours very truly, H. C. BROWN, Peoria, Ill.

Every piece of Kellogg radio is guaranteed—your protection of absolute satisfaction. Get the most out of your favorite circuit by using Kellogg parts. USE—is the Test

Kellogg Switchboard & Supply Co.

1066 W. Adams St., Chicago, Ill.

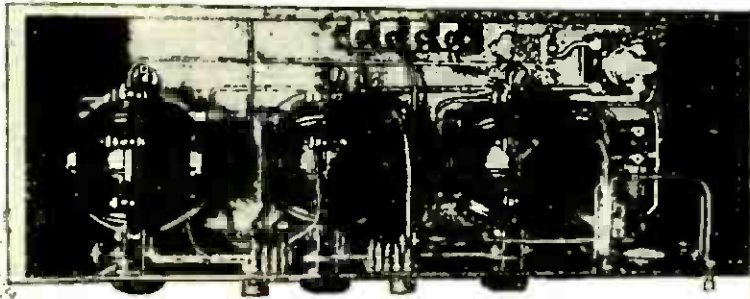

Modulation plus Regeneration

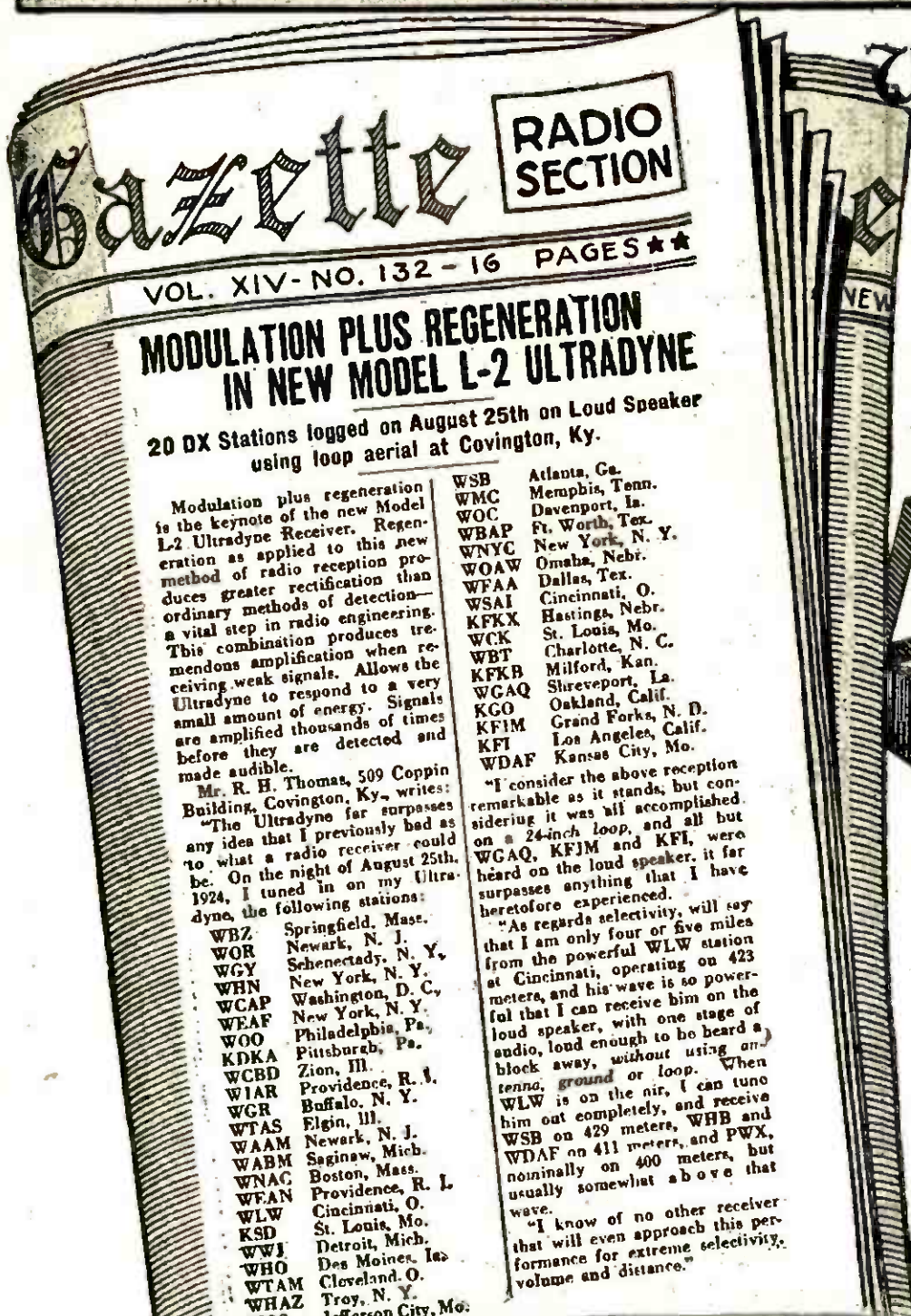

ULTRADYNE MODEL L-2

This application of regeneration is the most recent development of R. E. Lacault, E.E., A.M.I. R.E., since his perfection of the "Modulation System" used exclusively in the Ultradyne and which has so revolutionized all conception of selectivity, sensitivity, volume and range.

This Model L-2 Ultradyne, without a doubt, represents the peak of present day super-radio engineering skill.

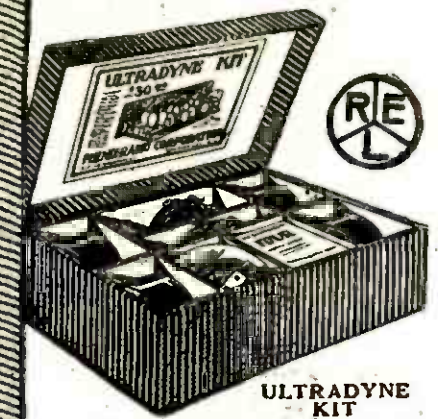

ULTRADYNE KIT

Consists of one low loss Tuning Coil, one low loss Oscillator Coil, one special low loss Coupler, one type "A" Ultraformer, three type "B" Ultraformers, four matched grid condensers. The Ultraformers are new improved longwave radiofrequency transformers, especially designed by R. E. Lacault, Consulting Engineer of this Company and inventor of the Ultradyne. To protect the public, Mr. Lacault's personal monogram seal (R.E.L.) is placed on all genuine Ultraformers. Ultraformers are guaranteed so long as this seal remains unbroken.

\$30.00

Send for the 32 page illustrated book giving latest authentic information on drilling, wiring, assembling and tuning the Model L-2 Ultradyne Receiver. **50c**

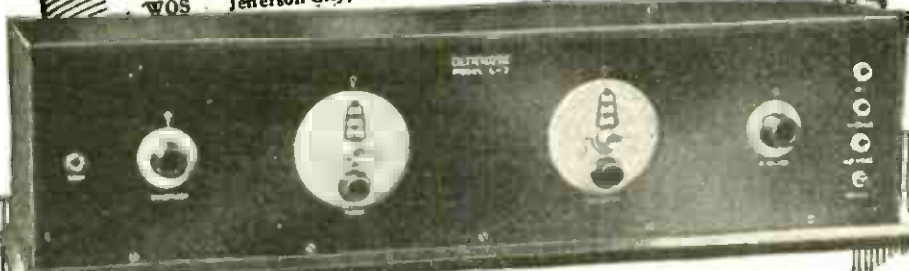

PHENIX RADIO CORPORATION
7-9 Beekman Street, New York City

Low Losses and Amplification *go hand in hand*

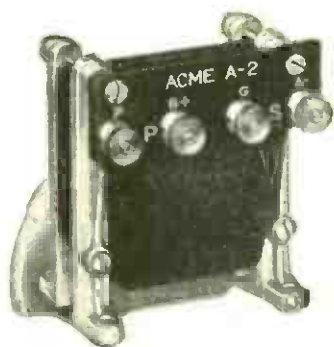

ACME A-2
Audio Frequency
Transformer



ACME R-2, 3, 4
Radio Frequency
Transformer

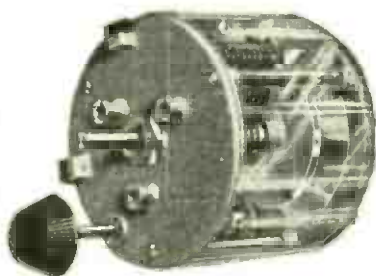

ACME .0005 M.F.
Low Loss Condenser

THE energy that your antenna or loop receives is at best only a little. Every bit of this energy you can save is the same as amplification. No matter what the circuit, you must have both low losses and amplification so that your loud-speaker can reproduce the distant stations loud and clear.

Acme Apparatus insures low losses, and amplification without distortion, for any circuit.

To get low losses, just replace your present condenser with a new Acme "lowest loss" condenser, and to get amplification without distortion, use Acme Transformers. Then you will get ten times the fun tuning in distant stations. You will get everything on a loud-speaker so that a whole roomful of people can hear and you will be able to enjoy all year 'round radio.

Send 10 cents for 36-page book, "Amplification without Distortion," containing many diagrams and helpful hints on how to get the most out of Radio.

ACME APPARATUS COMPANY
Dept. 96 Cambridge, Mass.

ACME ~for amplification



Atlas

TRADE MARK

RADIO REPRODUCTION Speaker

ATLAS floods the room with the best that's in your set. Write for the interesting booklet you ought to read before buying any speaker.

Multiple Electric Products Co., Inc., 365 Ogden Street, Newark, N. J., Dept. W. New York, Boston, Philadelphia, Baltimore, Pittsburgh, Detroit, Chicago, St. Louis, Rialto Building, San Francisco.

Marconi Wireless Telegraph Co. of Canada, Ltd. Sole Canadian Distributors

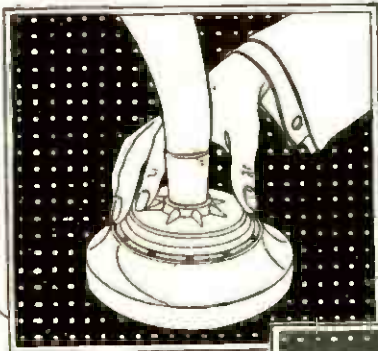
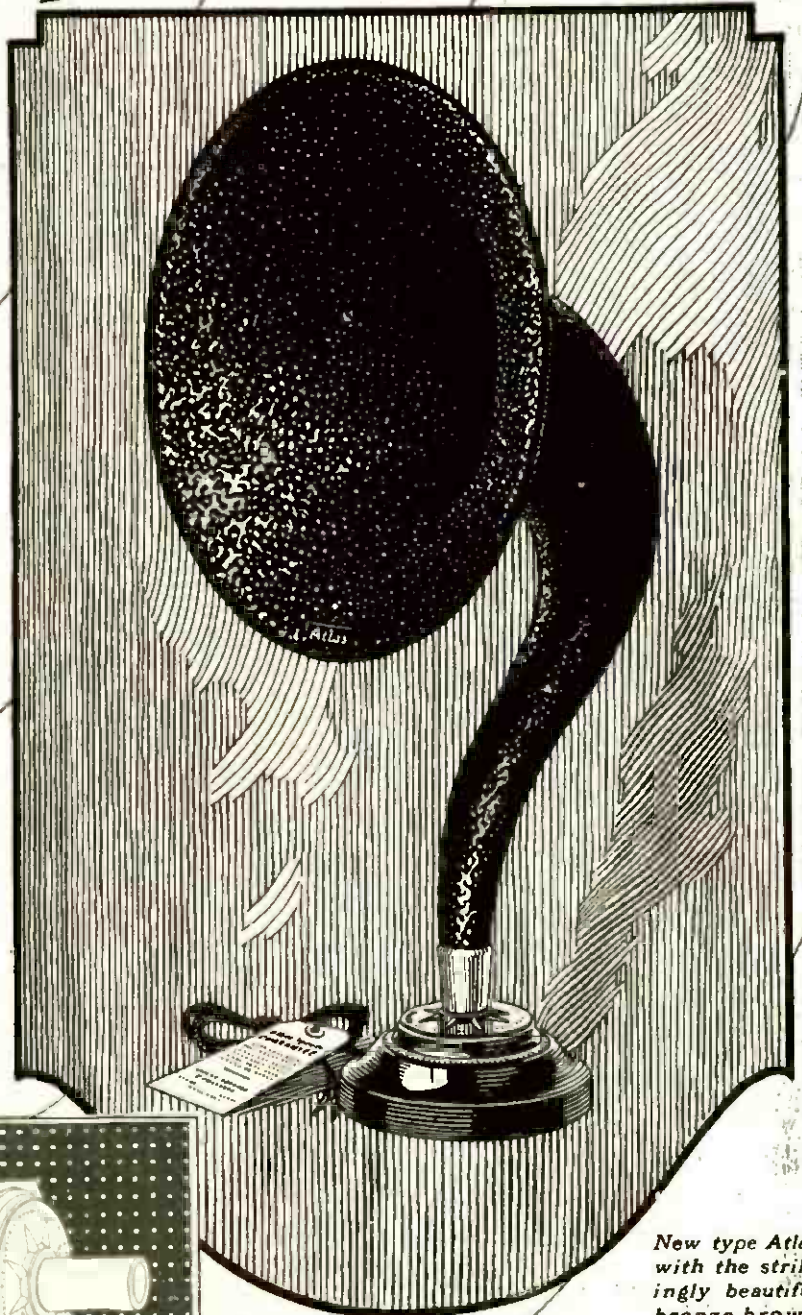

A slight turn of the exclusive Atlas harmonizer (Pat. applied for) — and your speaker is harmonized with the broadcast you are hearing and the set you are using. It gives you radio—as you ought to hear it.

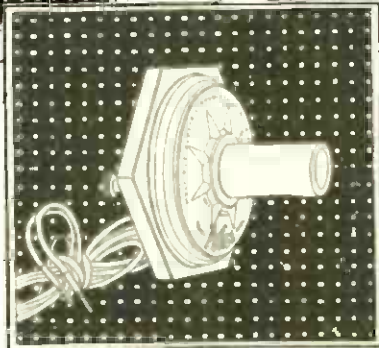

Atlas unit, with attachment couplings to fit all standard phonographs.

New type Atlas with the strikingly beautiful bronze-brown ripple-finish gooseneck horn.

All apparatus advertised in this magazine has been tested and approved by POPULAR RADIO LABORATORY

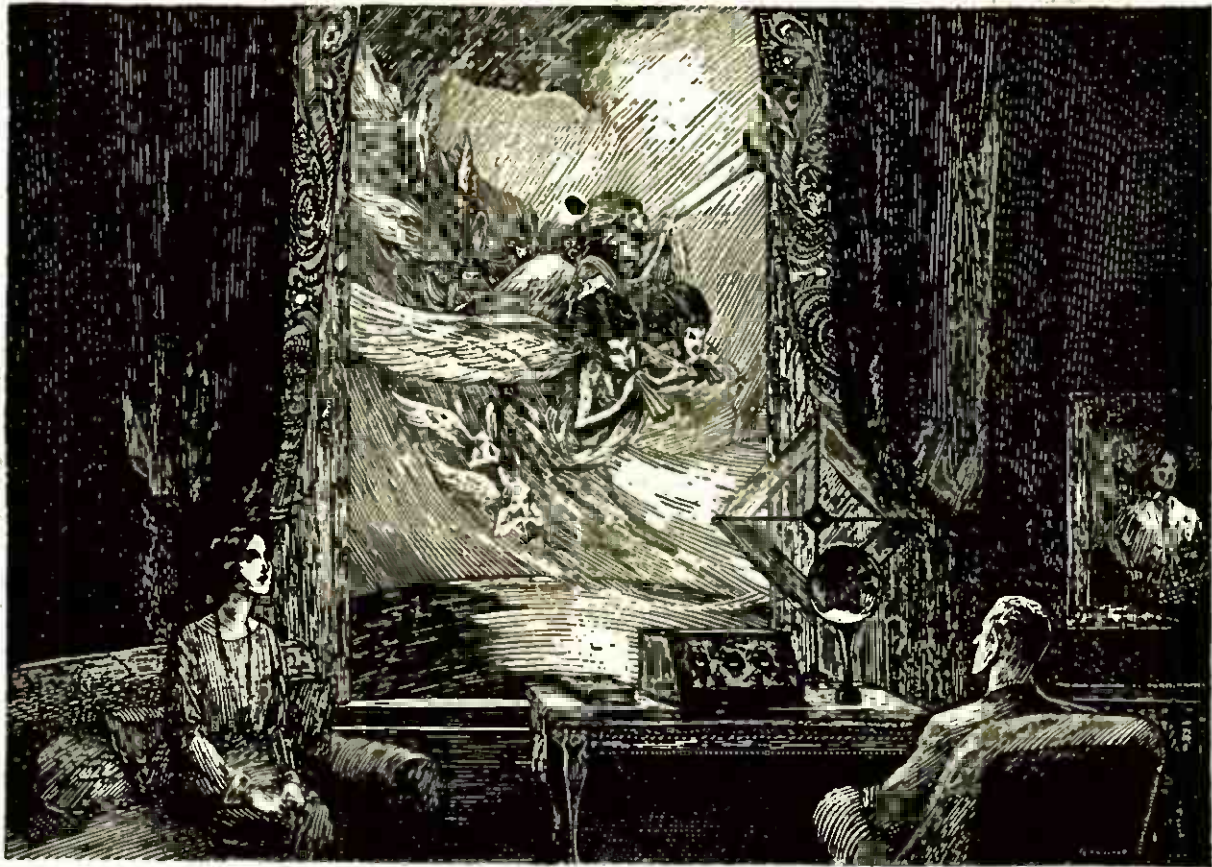

The Finest Entertainment Whispers at Your Window

THE *Mercury* Receiver was born at the very moment when its qualities were beginning to be demanded by the public. It is the *perfect* reflex receiver.

Absolute faithfulness of reproduction; all the distance two stages of perfectly engineered tuned radio frequency can provide; simple exactness of tuning which admits but one signal at a time—these are a few of the features which contribute to *Mercury* greatness.

We respectfully suggest critical side-by-side comparison between the *Mercury* and any other set made.

MERCURY RADIO PRODUCTS CO. • 50 CHURCH ST., NEW YORK CITY

Visit your dealer or write direct for De Luxe Catalog

TECHNICAL

Highest existing development of Grimes Inverse Duplex System. Four tubes reflexed and equal to six straight (two tuned radio frequency, tube detector and three stabilized audio frequency). Operates from loop (furnished) also indoor or outside antenna *without change in set*. "Last word" low-loss engineering at every point.

MERCURY BROADCAST RECEIVER

Licensed under Grimes Patents—issued and pending
"The STRADIVARIUS of RADIO"



APPEARANCE

Solid American Walnut Cabinet. Hand rubbed genuine piano finish. Inclined panel of heavy-gauge, etched ordnance bronze. Set rests on felt protecting buttons. Balanced panel arrangement of controls. All "A" and "B" dry batteries self-contained. Price, with loop; but *without* tubes and batteries, \$165 list.

INVERSE DUPLEX SYSTEM • INSURES NATURAL TONE QUALITY



The men who know say "Use Formica"

ONE hundred and twenty-five of the leading radio manufacturers of America by their example tell you to use Formica as the panel and tube material in the set you are building. They use it themselves—because they know it to be the most uniform, best looking, most satisfactory form of Bakelite.

The bigger the panel you use and the more apparatus you mount on it the more important it is to use Formica. For Formica will not sag, warp or get out of shape—it has the strength to give you years of perfect service.

This year, scores of manufacturers will use Formica base panels, and Formica terminal strips. They stop electrical losses and greatly increase the efficiency of a set.

There is no question as to which is the best radio insulating material—and you want the best. Four beautiful finishes: Gloss black, flat black, mahogany and walnut.

Dealers: For the big Neutrodyne and super-hetrodyne panels, Formica is practically a necessity. Formica will sell stronger than ever this year.

THE FORMICA INSULATION COMPANY
4641 Spring Grove Avenue, Cincinnati, Ohio

FORMICA

Made from Anhydrous Bakelite Resins
SHEETS TUBES RODS

All apparatus advertised in this magazine has been tested and approved by POPULAR RADIO LABORATORY

Murdock Five Tube Neutrodyne!

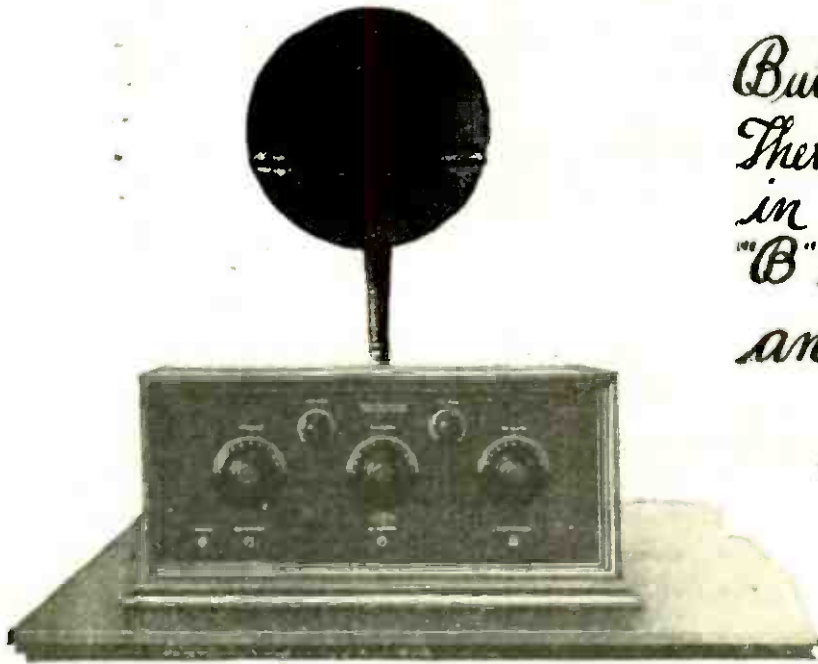

Built in Loudspeaker.
There's a compartment
in the cabinet for
"B" batteries.

and the price is

\$100.⁰⁰

We have been making high quality radio apparatus since 1904—20 years of successful experience and this is our newest achievement, a Murdock Five Tube Neutrodyne with built in loudspeaker to sell for \$100.⁰⁰. When you have heard the clear reproduction of distant and local stations and when you have seen the beautiful mahogany cabinet design you will agree with us that it is the best radio set value

WM. J. MURDOCK CO.

500 Washington Ave., Chelsea, Mass.

Branch Offices:

New York Los Angeles
Chicago Seattle
San Francisco

MURDOCK RADIO PRODUCTS

Standard since 1904

Send for
this free
hooklet—
paste this
coupon on
a post card
and mail



WM. J. MURDOCK CO.,
500 Washington Ave., Chelsea, Mass.

Gentlemen:—Please send me, with-
out obligation, your free booklet de-
scribing the Murdock Neutrodyne
Receiver.

Name
Street
City State

Write today for your free copy of

Ward's New Radio Catalogue



WARD'S Radio Catalogue is a big 68-page book—a real reference volume on quality Radio Equipment. In addition to descriptions of sets, parts and hook-ups, much matter of general interest to every radio fan is included. The book will prove fascinating to the confirmed radio enthusiast as well as the beginner.

Tested and guaranteed
Radio equipment sold without the usual Radio profits

WARD'S Radio Department is headed by experts who know and test everything new. Who know by experience what is best—what gives the best service.

Our catalogue is prepared under their supervision. It shows all the best hook-ups, everything in parts and complete sets—so simple that you yourself can install them in a short time.

Headquarters for Radio

Today Ward's is serving thousands upon thousands of Radio fans who have written for our catalogue, who have been surprised to see how low in price the standard Radio equipment can be sold without the usual "Radio Profits."

You, too, can profit by writing for a free copy of Ward's Radio Catalogue. If interested at all in Radio, you should write for this book. See for yourself the savings.

Our 52-Year Old Policy

For 52 years we have sold quality merchandise. We never sacrifice quality to make a low price. In buying Radio Equipment at Ward's, you are buying from a house of proven dependability. Address our house nearest you: Dept. 38-R

ESTABLISHED 1872
Montgomery Ward & Co.

The Oldest Mail Order House is Today the Most Progressive

Chicago Kansas City St. Paul Portland, Ore. Oakland, Calif. Ft. Worth

Tower

**When
Knighthood
was in Flower**



**TOWER
Scientific**

\$2.95

Plus a few cents postage

**A STANDARD
OF QUALITY**

Knights of Old once fought to maintain a standard of honor, often battling against great odds to protect and uphold their ideals. Today that same unwavering spirit of honor and superiority predominates in the production of Tower's Scientific Headsets.

**WORLD'S GREATEST
HEADSET VALUE**

Only Government Licensed Radio Operators are allowed to test and approve Tower's Scientific Headsets, thus guaranteeing uniform tone quality.

If your dealer cannot supply you, order direct by post card, and we will ship immediately parcel post, C. O. D.
Address Dept. J for quick service

The Tower Mfg Corp.
98 Brookline Ave., Boston, Mass.

Scientific

At Last

An Audio Transformer that Meets the Exacting Requirements of Reflex and Superheterodyne Circuits

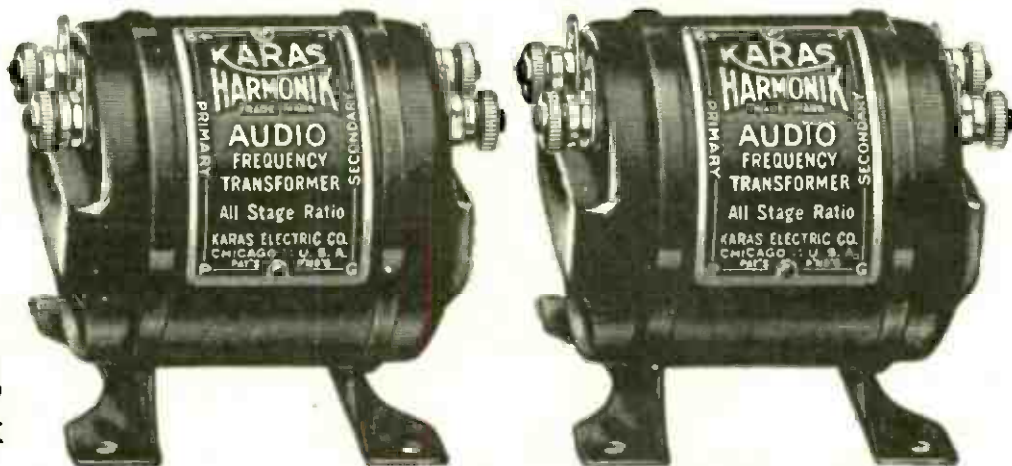

KARAS Harmonik

\$7⁰⁰

THE Success of your Reflex or "Super" depends as much on your Audio Transformers as on any part of your equipment. In fact, your audio transformers are among the most vital parts of your set. What good is selectivity—or distance—or any other quality, unless you have plenty of volume of clear, undistorted musical reception?

The time has come when the musical quality of radio reception is the first thing by which a set is judged.

The demands of a reflex circuit on its audio transformers are very, very exacting. Ordinary transformers will not do. Karas Harmoniks are recommended by those who know, as the one and only transformer that will enable a reflex circuit to perform at its best.

When it comes to superheterodynes, again you meet *extremely* particular requirements. It takes an extraordinary transformer to handle the big volume detector output of a "super" through two stages of audio amplification without distortion or howling.

Fortunately for radio a new transformer capable of meeting these exacting requirements has at last been developed.

Our New Karas Harmonik Audio Frequency Amplifying Transformer has taken the entire country by storm. Everybody is talking of the wonderful things it does.

True Musical Reception

Music that is absolutely true and natural. Clear, round, full, mellow tones. Piano music that could never be mistaken for a harp or a banjo. Speech so natural that you would instantly recognize the voice if you knew the speaker. Orchestral music poured out of the loud speaker with all the tones of each one of the instruments so accurately amplified that you feel as though you were sitting in the concert hall. This is what you hear when you listen to radio reception amplified through Karas Harmonik Transformers.

An Engineering Triumph

Karas engineers, with the experience gained in building hundreds of thousands of audio transformers, worked more than a year and spent many thousands of dollars to achieve this result. Distortion—that bursaboo of radio—is entirely eliminated. Low tones and very high tones are amplified equally with the middle tones. The many vital harmonics and rich overtones—that quality that distinguishes music from noise—are brought out in their full beauty.

Many important electrical engineering problems had to be solved to accomplish this uniform amplification—and to deliver a high amplification factor absolutely free from the disagreeable distortion characteristic of all ordinary transformers.

Distributed capacity between turns—hysteresis and eddy current losses—and reluctance to the path of magnetic flux, all were reduced to a point never before achieved in transformer design. In every detail of construction, from the windings of the coils to the outer shielding, electrical and magnetic factors have been so co-ordinated as to produce that much talked of—but never-before-realized result—great volume without any distortion whatever.

An Exceptional Money-Back Guarantee

The remarkable performance of Karas Harmoniks justifies an unusual guarantee. Instead of the usual meaningless guarantee of "material and workmanship" we give you a straight-from-the-shoulder, money-back guarantee of *Satisfaction*. Put a pair of Karas Harmonik Transformers in your set. Use them for 30 days. If you do not feel that they are giving you truly marvelous reception—a tremendously more pleasing reception than you have ever heard before, send them back to us and we will immediately refund your money without question or quibble. No strings to this offer! No reservations! No chance to lose a single penny by accepting it.

Buy from Your Dealer or Direct from Us

Your dealer is authorized to make you this guarantee if he has our goods in stock. We are supplying dealers as fast as the output of our factory permits. If your dealer is not yet supplied send the coupon below and we will send you a pair of transformers direct.

Of course, you will use a pair of Karas Harmoniks in the next new set you build. Remember, their quality and volume performance is equally superior in any circuit from the most simple to the most complex. But you don't need to build a new set in order to enjoy the beautiful distortionless music that Karas Harmoniks have made possible. Put a

pair in your old set. It's easy to make the change.

Ask your dealer today if he has secured in stock of Karas Harmoniks. If not, sit right down and mail the coupon at once.

To Jobbers and Dealers

Distribution of Karas Harmonik Transformers through regular jobber and dealer channels is being carried out as rapidly as the output of our factory permits. In the meantime mail applications will be taken care of in the order they are received, on an allotment basis. Write us for test records, discounts, etc.

To Set Manufacturers

We positively prove that Karas Harmonik Audio Frequency Transformers will vastly improve the musical quality of your set by any form of test you wish to impose. When you are convinced of this you will naturally want to use them. Write or wire us and arrangements for tests will be made promptly.

Send No Money with the Coupon!

Karas Electric Co.
4040 N. Rockwell St.
Dept. 5831, Chicago

Please send me pair of Karas Harmonik All Stage Radio Audio Frequency Transformers. I will pay postman \$7 apiece, plus postage on delivery. It is understood that I am privileged to return the transformers any time within 30 days if they do not prove entirely satisfactory to me, and my money will be refunded at once.

Name.....
Address.....
City.....
Dealer's Name.....
Dealer's Address.....

If you send cash with order we'll send transformers postpaid.

KARAS ELECTRIC CO.
4040 North Rockwell St., Dept. 58-31, Chicago, Ills.

FREED- EISEMANN



Can you do it?

There are fourteen "locals" in New York City. Can you hear them — one at a time in full volume—without overlap?

Then—can you tune them out and get distance without interference? Can you pick up your DX station by the log, without fishing for the squeal?

All this is the every-day performance of the FREED-EISEMANN Radio Receiver. Installed in the same building with a broadcasting station, it has tuned out the station and brought

in other programs from distant cities.

The secret is *finesse*. Each FREED-EISEMANN Receiver is custom-built by trained experts, not mere assemblers. The condensers are specifically designed, as are the matched radio frequency coils. Seventeen separate tests insure the perfection of each FREED-EISEMANN Receiver.

Four-tube and five-tube models. Price \$100 up, slightly higher in Canada and west of the Rockies. Booklet "Buying a Radio" free on request.

Freed-Eisemann Radio Corporation
MANHATTAN BRIDGE PLAZA, BROOKLYN, NEW YORK



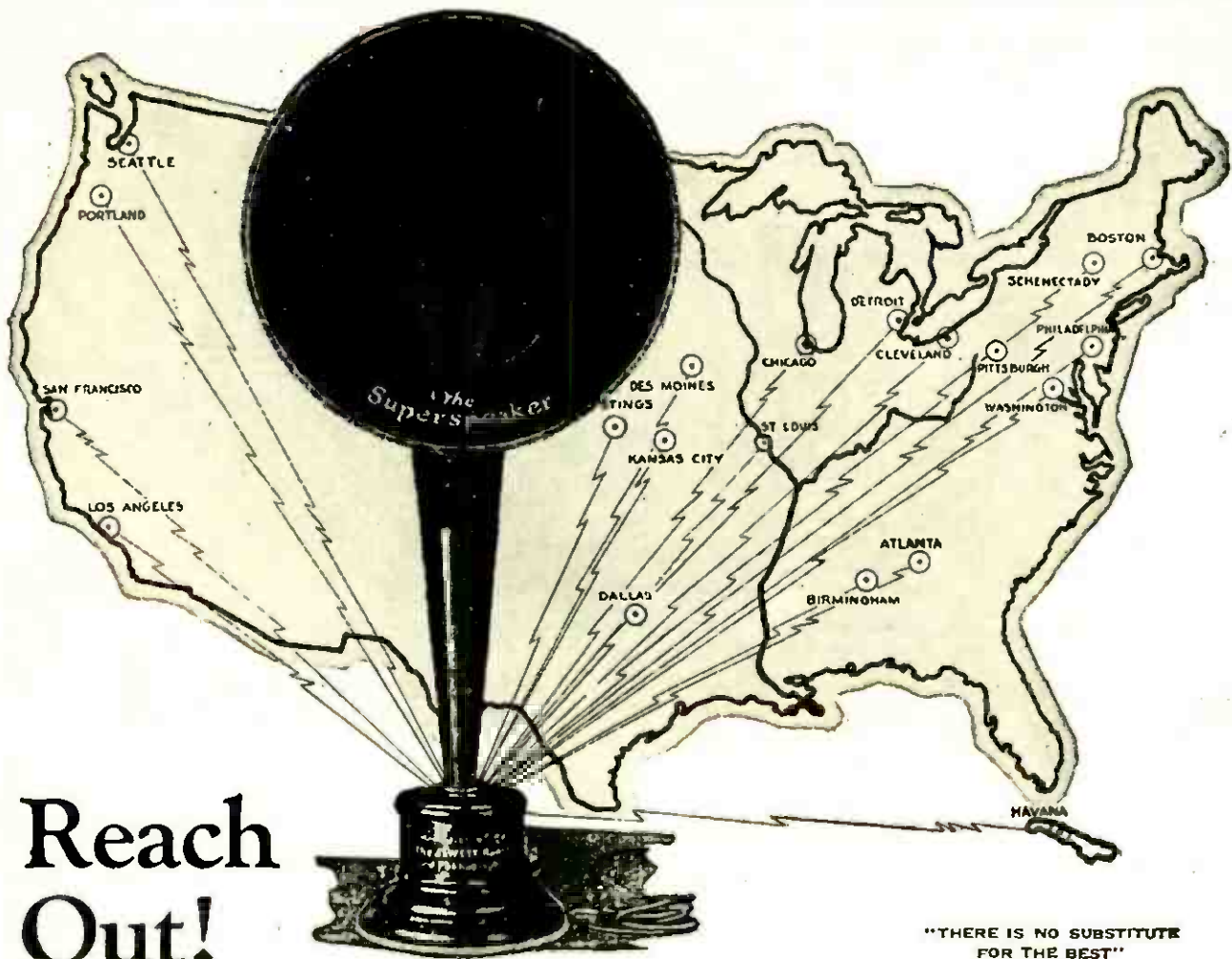

"THERE IS NO SUBSTITUTE
FOR THE BEST"

Loud-Speaker reception from nearby stations will be only a small part of your enjoyment of a Superspeaker and a modern Radio Set. The air is full of music and voice from far and near. Nearly 100 high powered stations are begging admission to your home theater. Tune your set to the entertainment that suits you best. Through the graceful throat of the Superspeaker, reception will come in naturally, clearly, and with amazing volume.

For The Superspeaker is a true musical instrument. It is the work of experienced musical instrument builders. In design, materials, workmanship and performance, it differs notably from all other devices of its kind.

Regardless of the size or power of your set—regardless too, of your prior experience in amplified reception—Superspeaker performance will surprise and delight you. Just ask any of the thousands of Superspeaker users from coast to coast.

Enjoy your home theater to the full limit of its possibilities.

Install a Superspeaker and sweep the ether.

A big, substantial instrument. 26 inches high, with 14-inch bell, and weighing over 5 pounds—Handsome finished in ebony gloss—Needs no extra batteries or coils—Adjustable for volume—Wears forever—Built complete in our own plants at Detroit and Allegan, and backed by the guarantee of a million-dollar corporation. List price \$30. (West of Rockies, \$32.50). Ask your dealer.

JEWETT RADIO & PHONOGRAPH CO.
5668 TWELFTH STREET, DETROIT, MICHIGAN

The Superspeaker

Trademark
Registered



THE SUPERSPEAKER
For Homes or Public Reception.

THE SUPERSPEAKER UNIT

Makes a Loud Speaker out of Your Phonograph.

THE JEWETT PARKAY CABINET

With Parquetry Top—All Standard Panel Sizes.

THE JEWETT ADAPTO CABINET

Houses Any Set and Equipment—Superspeaker built-in.

THE JEWETT MICRO DIAL

Makes Tuning 50 Times as Accurate.



Make dumb Loud Speakers talk!

Don't blame the circuit or yourself if only noise comes from your loud speaker. Hilco apparatus makes the dumbest loud speaker talk.

The Hilco Laboratories contain special equipment of marvelous accuracy for determining whether new circuits and apparatus developed by Hilco research engineers will give maximum satisfaction.

Ever striving for perfection, Hilco developed a new type of Fixed Condenser guaranteed accurate within 5% of rating; the famous 7-tube Super Hilco-Dyne Kit enabling anyone to construct at a moderate cost, radio's most superb receiver; the Hilco Lo-Loss Tuned Radio Frequency Kit and the Hilcoflex Kit, containing essential parts for building really efficient 5 and 3 tube sets at

little cost; the Hilco Multiformer perfecting the Reflex and Neutrodyne when used as replacement coils.

When you buy Hilco apparatus for improving your present receiver or the construction of a new one you are getting the latest in scientific radio apparatus that is distinctively different and superior in efficiency and appearance.

Literature describing Hilco products free—Blue Prints of circuits sent at actual mailing cost of 10c.

Please address Dept. 11,

A.E. HILL MFG. CO.
Atlanta Georgia



Ask Your Dealer

about Hilco Products, especially

- Super Hilco-Dyne Kit \$30.00
- Lo-Loss T.R.F. Hilco Kit 17.50
- Hilcoflex Kit 8.50
- Hilco Multiformer 2.25
- Hilco Fixed Condensers.
- Hilco Super Het replacement parts for perfecting Super Hets.

WRITE FOR DESCRIPTIVE MATTER

THAT SILVER SUPER

in DELHI, N. Y.

is rolling up some record.

Last Month

Mr. George C. Cannon wrote. . . . Silver Super adjusted . . . fine test run . . . all reasonable stations received on loud speaker. . . . Brought in KGO with loud speaker volume on an 18" Loop four consecutive nights. . . .

NOW Mr. Cannon reports . . . have received KGO (Oakland) on Silver Super, in Delhi, N. Y., every night that they have transmitted for the past two weeks. . . . Wonderful reception . . . loud speaker volume on an 18" Loop. . . .

And that Silver Super in Delhi is only one of hundreds that are amazing their listeners. . . .

SILVER SUPERS

all over the country are rolling up similar records in routine performance . . . records not matched by any other receiver. . . . Silver Supers do out-perform the best of them—regardless of make and price . . . they are 7-Tube Wonders and you can build them yourself with pliers, screw driver and a soldering iron.

Parts

- Portable Model \$57.65
- Laboratory Model 63.60

Mail your order today. Shipments prepaid East of the Rockies.

Get the "WHY"

of Silver Supers—The book of facts that every Radio Fan should have—Send for it today. It's Free!

Announcement

Watch for the 4-Tube Silver Knockout—the set that equals the Silver Super, on a 70 foot antenna.

Circulars on SILVER SPECIALS upon request.

Dealers: Write for our attractive Merchandising Plan.

Eastern Distributor: 20th Century Radio Corp., 102 Flatbush Ave., Brooklyn, N. Y.

The BOOK

The Portable Silver Super-Heterodyne—the real dope on the supers how to build them on your kitchen table. Price 50c.

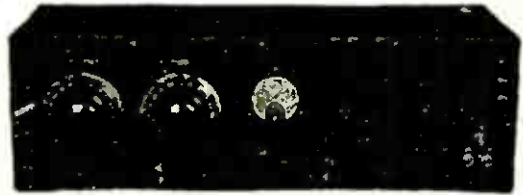

LABORATORY MODEL



Type 101

Silver Coupling Unit Small, Compact, Ultra-Efficient, \$2.50

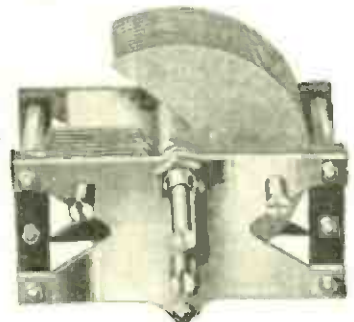

Type 301

Silver Low Loss Condenser. Loss Immeasurable; Ideal for any circuit. \$4.50



Type 401

Silver 50 KC Transformer Unit. The Original Employs 2 Interstage and a filter transformer. 1 1/2 to 3 times the efficiency of anything on the market. \$14.00

- 30 KC RF Tuned Output Transformer No. 201. . . \$3.50
- 50 KC RF TRANSFORMER Unit No. 401. \$14.00
- 5 Gang-199 Socket No. 501. \$3.00
- Collapsible Center-Tapped Loop No. 601. \$6.50

Silver-Marshall, inc.

105 SOUTH WABASH AVE.

DEPT. E

CHICAGO

AMERICAN BRAND CONDENSER

\$ **5**⁰⁰
IN CANADA
\$7.00

100 to 1

With the
**Worm
Drive
Vernier**

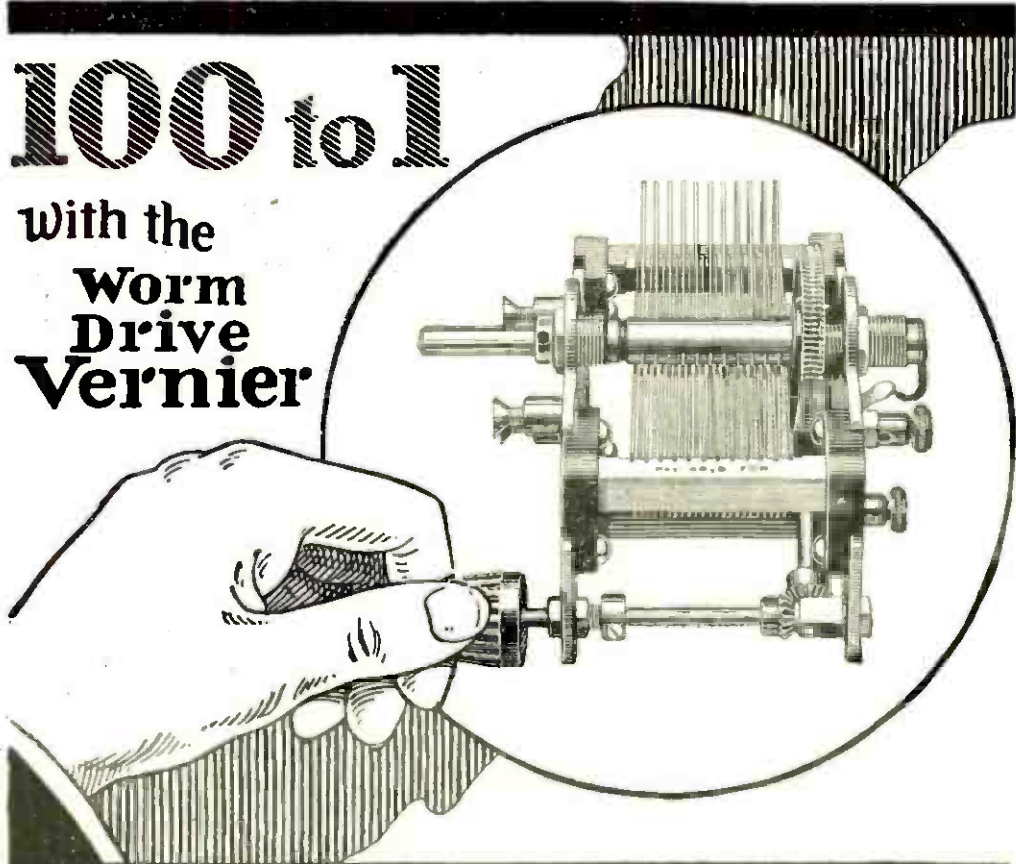

One of the biggest contributing factors to the growing popularity of Radio reception is this fine tuning condenser.

Made with a geared vernier having a ratio of 100 to 1, American Brand Condensers assure the successful operation of any set—especially when there is more than one broadcasting station in the air. For DX reception, American Brand Condensers can't be surpassed.

American Brand Condensers need only to be seen to prove their superior qualities. Ask your dealer to show it to you and to give you a descriptive folder.

Wholesale Distributors everywhere throughout the country are prepared to fill dealer's orders.

Note to Dealers: If your jobber is out of stock, please write us.

AMERICAN BRAND CORPORATION

8 WEST PARK STREET

NEWARK, N. J.

Announcing B O S C H



Absolutely
Reliable

Backed by
the Bosch
Guarantee

Delivers "B" current from
the electric light socket

the new

NOBATTERY

The Bosch Nobattery is a device which enables anyone to obtain from an electric light-socket perfect and ample plate voltage for radio vacuum tubes. It takes the place of all "B" batteries and is decidedly more efficient, reliable, convenient and economical.

The Bosch Nobattery is a development of the American Bosch Magneto Corporation, which holds a supreme position in the production of fine electrical apparatus. Its great New England manufacturing plants, and its enviable reputation as a producer of high quality precision apparatus should establish immediate confidence in this latest development for the improvement of radio reception.

Do not confuse the Bosch Nobattery with other devices made for eliminating "B" batteries. It is radically different in design and construction, delivering an abundance of current at 15 to 150 volts.

Here's a new radio device you can buy with absolute confidence. It is of the same high quality as all Bosch electrical units, and is backed by the famous Bosch Guarantee of "satisfaction or your money back."

Write for illustrated literature giving full particulars.

DEALERS—Don't delay—the demand is sure to be enormous. Wire today for sales proposition and discounts. State whether you are a dealer or jobber, and give references to aid us in quick allocation of territories.

PRICES

Type BAN for Alternating Current \$49.50
Type BDN for Direct Current 30.00

AMERICAN BOSCH MAGNETO CORP.

Main Office and Works: Springfield, Mass.



Chief Points of Superiority

1. Suitable for any receiving set, using 1 to 14 tubes—will also take care of power amplifier.
2. Unlimited current supply.
3. Requires no attention—does not run down or wear out.
4. Cannot burn out radio tubes even if wrongly connected.
5. Uses no tubes—there's nothing to repair or replace.
6. Costs only a fraction of a cent to operate.
7. Detector voltage adjustable—from 15 to 50 volts.
8. Amplifier voltage adjustable, too—from 90 to 150 volts.
9. Constant voltage—plenty of pep.
10. Gives clear tone, greater volume, and more distance.
11. It is NOISELESS—there's absolutely no hum or distortion.
12. Will operate low power transmitting sets.

Built by the makers of the world famous Bosch Magneto

The Importance of Good Radio Panels

An inferior panel will reduce the efficiency of your reception through surface leakage. You can avoid this by building your set with

ELECTRASOTE TRADE MARK PANELS



These beautifully finished panels will neither warp nor change color. They are scientifically constructed to reduce surface leakage to a minimum, hence assure increased efficiency of the set.

One of the famous "sote" products introduced by The Pantasote Company, Inc., Electrosote Radio Panels are sold strictly on their merits—yet are

Lower Priced
than other standard panels

Make your Set an "Electrasote Panel Set"—and get results!

On sale at good Radio Dealers

M. M. FLERON & SON, Inc.
Sole Sales Agents
Trenton, New Jersey

The Authorized Cockaday Coil

\$5.50

Specified in
October
POPULAR
RADIO
as

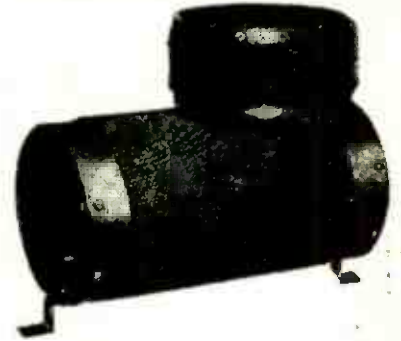

Cockaday Precision Coil

The only coil specified by Mr. Cockaday in his New Four Circuit Tuner, with resistance coupled amplification because it meets all his specifications.

The only authorized Cockaday Coil, made in strict accordance with specifications of Laurence M. Cockaday, inventor of the famous Cockaday Four Circuit Tuner. Wound on hard rubber tubing, 1/4 inch wall, with No. 18 D. S. C. copper wire which insures selectivity, greater volume, sharp tuning and maximum sensitivity. Guaranteed.

Gets distant stations easily and clearly. Hundreds have substituted this quality coil for those of inferior make and are amazed at the improved reception, selectivity and general D-X results.

At your dealers, otherwise send purchase price and you will be supplied postpaid
In Canada \$7.75. Canadian Distributor, Perkins, Ltd. Montreal.

PRECISION COIL CO., Inc.
209-B Centre St., New York

"Be Sure It's a Hammarlund"

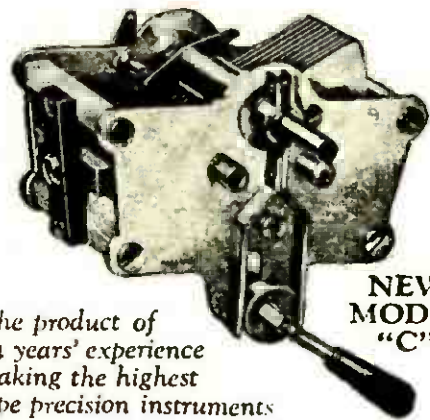

The product of
14 years' experience
making the highest
type precision instruments

NEW
MODEL
"C"

U. S. &
Foreign
Patents

HAMMARLUND VERNIER and PLAIN CONDENSERS

For Greater Distance, Less Interference and
BETTER TONAL QUALITY

Buy A Hammarlund At Your Dealer's

WRITE FOR DESCRIPTIVE FOLDER

HAMMARLUND MFG. CO.,
424-438 W. 33rd Street, New York

Canadian Representative:
RADIO, LIMITED, Montreal

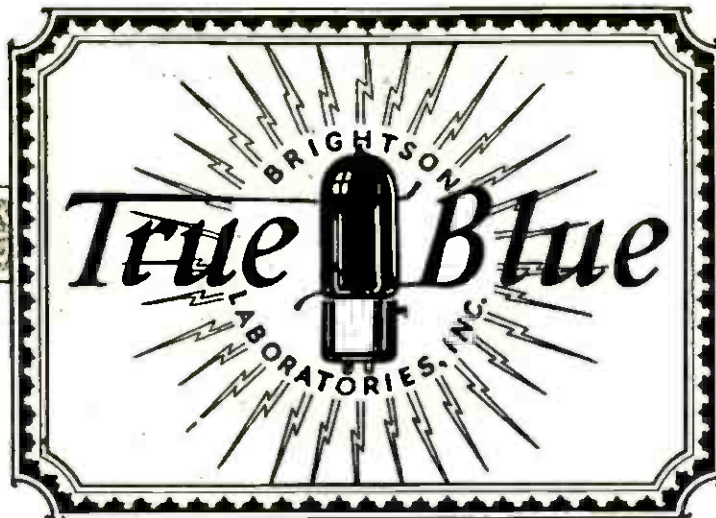

The Finest Radio Tube in the World!

Absolutely Uniform

Interchangeable

VASTLY SUPERIOR To Any Tube Heretofore Made

The new TRUE BLUE filament assures two to three times longer average filament life. The plate voltage is: Detector 20-40, Amplifier 40-150, yet the filament consumption is only $\frac{1}{4}$ ampere. TRUE BLUE reproduces all tone frequencies with but three volts. For VOLUME, voltage can be varied to six volts. Standard base. TRUE BLUE contact points are sterling silver, which means that there are no resistance losses from

corroded tube prongs. The genuine Bakelite base ends capacity losses and the special TRUE BLUE construction eliminates microphonic noises as well as sponge rubber mountings.

ONE, THREE, OR FIVE IN A CASE

Retail price \$6 each, whether sold singly or in cased sets for Neutrodyne, Super Heterodyne or other types of radio apparatus.

At all reliable radio dealers. If your dealer is temporarily out of stock, TRUE BLUE tubes will be sent anywhere prepaid, upon receipt of retail price

BRIGHTSON LABORATORIES, Inc., 67-73 Winthrop St., Newark, N. J.

Some desirable
Jobber Territory
is still
available if re-
sponse is
prompt.



**TRUE BLUE
tubes are
FULLY
GUARAN-
TEED**



No. 23—About 1/4 actual size

No drain in a Nagel Voltmeter

Test your "B" battery with an ordinary voltmeter of low resistance and you will drain it.

Test it with a Nagel High Resistance Voltmeter and you need have no fear of ruining it.

Nagel Voltmeters are standard—60 ohms per volt—strictly quality products from the same factory that has for years made measuring instruments for over 6,000,000 automobiles.

When you buy your voltmeter demand "Nagel—60 ohms per volt." Don't take any less. If you can't get it, write direct, giving your dealer's name.

THE W. G. NAGEL ELECTRIC CO.
TOLEDO, OHIO

NAGEL

Manufacturers of
**DRY CELL TESTERS · AMMETERS
 HIGH-RESISTANCE VOLTMETERS
 and VOLTAMMETERS · BAKELITE
 HOT MOULDED INSULATIONS**



Murdock Phones

are backed by 20 years of successful experience. There are over 1,000,000 in use today. Murdock's are famous for distinct reproduction and for their light weight. With the Murdock Multiple Plug you can use from one to four phones at the same time.

WM. J. MURDOCK CO.
502 Washington Ave. Chelsea, Mass.

Free Booklet

Write for our free booklet "The Ears of Radio." It contains important data on headphones.

MURDOCK RADIO PHONES

Standard since 1904

Establishing a New Standard!

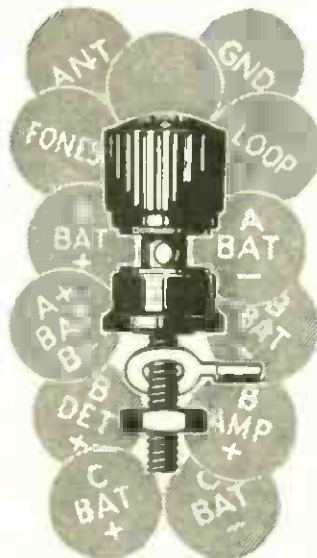

The New and Improved

"READ'EM" BINDING POSTS

"The Knobs Can't Come Off"

NEW MARKINGS FULFILL EVERY DEMAND

The Utmost in Quality and Appearance at the Lowest Price

15c.

At Your Dealers or sent Postpaid.

THE MARSHALL-GERKEN CO.

Toledo, Ohio

SWEET THE AIR With Air-Way

No matter how modest the ideas of the radio beginner, he soon begins to search for distant stations.

Then is when he appreciates an AIR-WAY Receiver.

All distant signals come to any set, but they will not fight their way in through unnecessary losses and high resistances.

AIR-WAY Receivers are the last word in LOW LOSS construction and tuned radio frequency amplification and build up the weakest signals to pleasing audibility.

Oscillation is perfectly controlled and all extraneous noises eliminated without neutralizers or complicated adjustments.



AIR-WAY No. 41, 4-Tube

We claim without reservation that AIR-WAY Model 41 is superior in every quality of radio reception to any other four-tube set ever built, and unequaled by any set at less than nearly twice the price.

The selective qualities are unexcelled in any set, operating on an outside aerial.

The dignified design of the solid walnut case and the workmanship and finish of the panel equipment give it an outward appearance

in keeping with the operative quality.

A set that meets all market conditions and all individual requirements; one that the Dealer may sell to the inexperienced user or the most discriminating expert and be sure that either will attain results satisfactory in every way. Price \$65.00.

AIR-WAY No. 51

The latest development in tuned radio frequency with two stages of radio frequency amplification, detector and two stages transformer coupled audio frequency amplification.

Offered without reservation as a set that will give general satisfaction to all broadcast listeners regardless of previous radio experience.

Price, as illustrated, \$125.00.

Also furnished in handsome Console type cabinet of solid walnut. Price, \$375.00.

AIR-WAY Apparatus is the result of several years' study and development by skilled radio engineers, and is strictly up to the minute in radio design.

Operation is simplified to the limits of the radio novice, and quality throughout is developed to meet the demands of the most discriminating of radio experts.

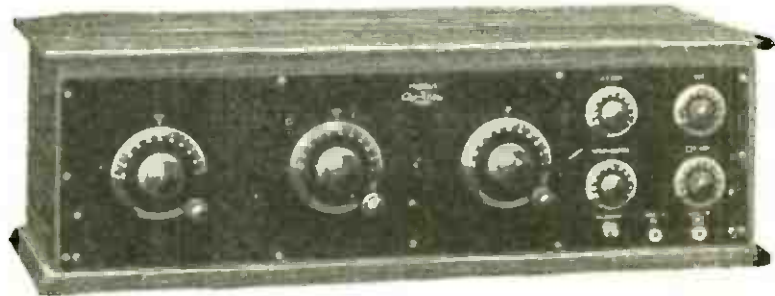

AIR-WAY Apparatus is distributed through established Jobbers and Dealers only. Write our Sales Department for Catalog of the complete line.

AIR-WAY ELECTRIC APPLIANCE CORP.
TOLEDO, OHIO

Sales Department
The Zinke Company
1323 S. Michigan Blvd.
Chicago, Ill.

Export Department
220 Broadway, St. Paul Bldg.
New York, N. Y.
Cable Address, Airwayvac New York



Look
for this
Trade Mark

Don't Guess— Buy B-H Radio Tubing

When you buy Radio Tubing (Spaghetti) ask for B-H Brand—it is your guarantee. Packed in our trade-marked carton.

It is better because it is—
Made of special woven cambric, has six coatings of varnish, is proof against water, oil and acid, is extremely flexible and is *guaranteed* not to crack.

You will find longer life and greater durability in B-H Radio Tubing.

Your satisfaction is our aim—our trade mark is your protection. Ask for it by name.

If your dealer cannot supply you, order direct from us.

Also Manufacturers of High Grade Optical Tubing and Magneto Tubing of High Dielectric Strength.

Dept. 5

**Bentley-Harris Mfg.
Company**
Conshohocken, Penna.

Electric Soldering Irons



For continuous work, Solderette Senior is recommended. Most simple construction of all large irons. Heating element of Nichrome wire, easily renewable. Made with a grip that a real mechanic demands. Solderette Senior comes packed single iron in carton, with cord and plug complete as illustrated.

List Price \$3.00

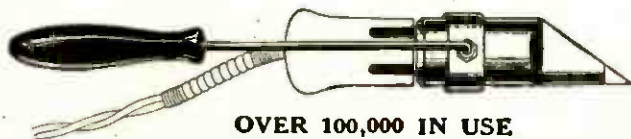

OVER 100,000 IN USE

It's what the whole radio world has been looking for and wanting—a real, practical electric soldering iron at a reasonable price.

List Price \$1.50

Dealers Write

THE BEEHLER CO.
1443 North 13th St., St Louis, Mo.

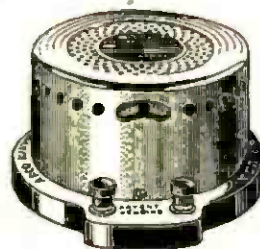

Don't Blame Your Set!

If the batteries run down, you're lucky to get anything but "sounds."

APCO Battery Charger keeps radio batteries *alive*.

Works noiselessly, efficiently, surely, full'y charging any radio battery overnight for a few cents. $7\frac{1}{2}$ ampere capacity. Pays for itself in six months. Guaranteed one year.

Write for circular and dealer's name.

APCO MFG. CO.
SPICER ST. PROVIDENCE, R. I.

APCO BATTERY CHARGERS

for "A" and "B" Batteries

THE LARGEST RADIO STORES IN AMERICA

Hookups!

All the latest and best "Kits" in our new

RADIO CATALOG



FREE

NO other Radio Catalog includes such a complete assortment of the best and latest Knock-Down Kits, Parts, and Accessories. You need this book—write for your **FREE** copy today!

An Unequaled "Kit" Service

All parts for each "KIT" have been carefully selected and tested by our staff of graduate Radio Engineers—satisfactory results are guaranteed.

Completely drilled and engraved panel included with each "KIT." Makes set building easy and sure. No other concern gives this **FREE** service.

Easy to understand **Instruction Book** and **Blue-Prints** included with each Outfit. No technical knowledge required to build your radio set.

Save Money On **GUARANTEED APPARATUS**

Our business is to buy up manufacturers' and government surplus stocks, jobber and dealer bankrupt stocks—but only brand-new, fully guaranteed, nationally advertised apparatus. Our enormous buying power permits us to pay spot cash and get rock-bottom prices—even way below manufacturer's costs. That's why our catalog is crammed with thousands of wonderful Radio Bargains.

**Dealers!
Jobbers!
Manufacturers!**

ATTENTION!

We will pay you spot cash for your surplus stocks—brand-new apparatus only! Write and tell us what you have.

CHICAGO SALVAGE STOCK STORES

509 S. State Street, Dept. P. R. 6, Chicago

Write for your **FREE** copy of our new catalog today—just your name and address on a post-card will do. Please add the names of any of your friends interested in Radio.

Remember our motto: **Salvage means—SAVE, SERVICE, SATISFACTION**

MAXUM TWINS

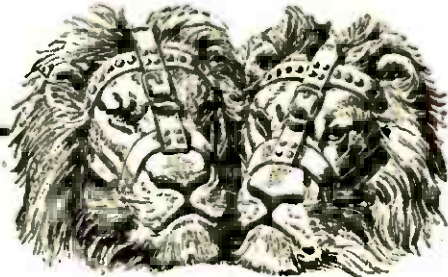

Radio

Audio



"MAXUM" Audio Frequency TRANSFORMERS
PRICE \$5.00

"MAXUM"
TRANSFORMERS

Insure the volume, tonal quality, and smooth operation of any circuit by installing these tried and proven TRANSFORMERS—the product of a PIONEER in the Radio Field.

Made in all ratios to meet the particular requirements of any "hook-ups".

Bulletins and circuit diagrams will be mailed on request.

THE MAXUM RADIO & ELECTRIC CO.
P. O. Box 5445, Philadelphia, Penna.

Successors to the Radio Div. of the Fairmount Elec. & Mfg. Co.

CARDWELL
THE ORIGINAL LOW LOSS
ROTOR-GROUNDED
CONDENSER

The CARDWELL is the original low loss rotor grounded condenser, and to this day it is without a peer. The leading radio engineers and technical editors still recognize the CARDWELL as the ONE BEST. Scientifically designed in the beginning, it has not been necessary to change the CARDWELL in any material way to maintain its



undisputed superiority.

Play safe—say Cardwell

See the CARDWELL at all dealers

A post card to us will bring you an education on condensers

ALLEN D. CARDWELL MFG. CORP.
81 PROSPECT ST., BROOKLYN, N. Y.



The **"SELF ADJUSTING"**
Rheostat

\$1.10

Everywhere

Write for
FREE
Hook-ups

No rheostat knobs on panels to turn—no meters needed—no tube worry. One amperite, used in series with each tube, inside the set, automatically supplies just the right current for each individual tube's greatest efficiency. Works on thermo-electric principle. Simplifies wiring. Reduces set cost. Proven in use. Adopted by more than 50 set manufacturers. No set is up-to-the-minute in design without it.

RADIALL COMPANY
Dept. P. R. 4 50 Franklin St., New York

AMPERITE
"means right amperes"

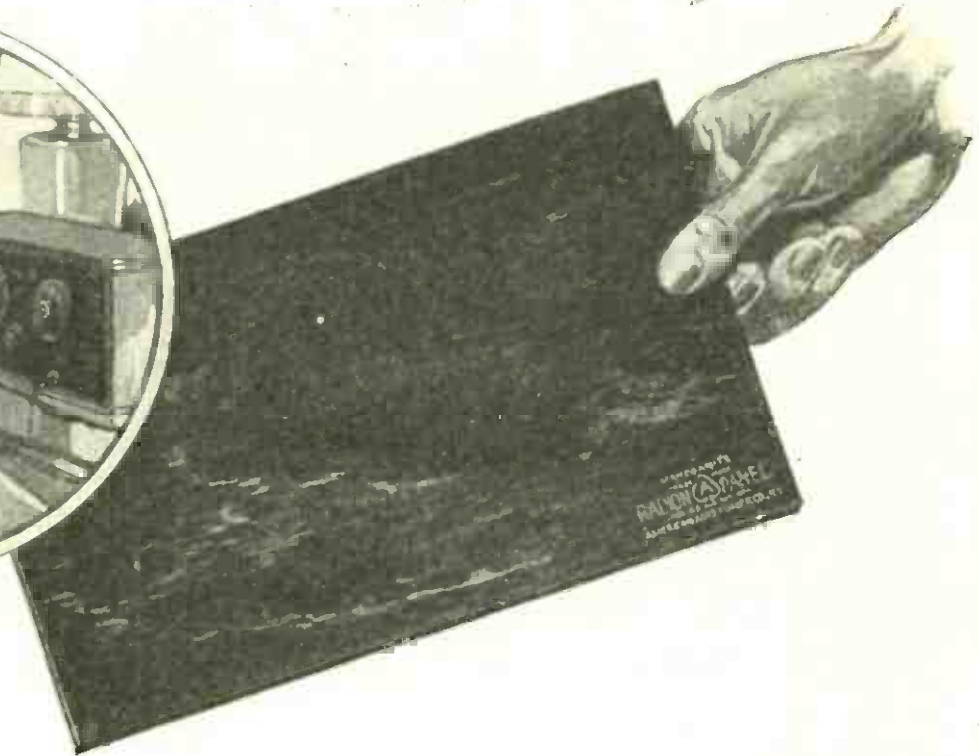

SEND for booklet "Some Insulation Stickers Explained." Use the coupon below.

Surface leakage exceptionally low with this panel —built to order for radio

THE needs of radio are *special*. Better results have invariably followed the use of apparatus and materials designed for its own unique demands.

Radion is a special material, developed to order by our engineers to meet the needs of radio. For radio-frequency insulation its characteristics are highest as proved conclusively by authoritative laboratory tests. Surface leakage and dielectric absorption are shown to be exceptionally low.

You can see the difference by the finish. You can see that Radion is different if you look at the finish. That high-polished,

satin-like surface is not only good-looking but useful as well. Moisture and dirt cannot gather to form leakage paths and cause leakage noise.

Radion is mechanically right, too. It resists warping. No special tools are needed to make a clean-out workmanlike job. Everybody knows that it is the easiest material to cut, saw or drill. Comes in eighteen stock sizes, two kinds, Black and Mahoganite.

Other Radion Products

The same qualities of low-loss insulation and attractive appearance characterize Radion dials (to match panel), binding post panels, insulators, knobs, etc.—also the new Radion built-in horn.

Better performance will make it worth your while to ask for Radion by name, and to look for the name on the envelope and the stamp on the panel. Radio dealers have the exact size you want for your set.

AMERICAN HARD RUBBER COMPANY, Dept. PR-1, 11 Mercer St., New York City

Chicago Office: Conway Building

Pacific Coast Agent: Goodyear Rubber Co., San Francisco—Portland

RADION

The Supreme Insulation

PANELS

Dials, Sockets, Binding Post Panels, etc.

AMERICAN HARD RUBBER COMPANY, 11 Mercer St., New York City.

Please send me your booklet "Some Insulation Stickers Explained," and your complete instructions for building a 2-tube DX Loud-Speaker set.

Name.....
Address.....
City..... State.....

All apparatus advertised in this magazine has been tested and approved by POPULAR RADIO LABORATORY



try
VirBren
you'll buy again

THE KIT
\$29.65

The Kit Includes:
—3 Transformers DX-2H
—1 Transformer DX-Input
—1 Oscillator Coil
—1 Blue Print
—and complete information

Type	Peak Wave-length	Price
DX-2H	5,000 Meters	\$6.60
DX-Input	5,000 Meters	\$6.60
Oscillator Coil		\$3.00
Antennae Coil		\$3.00
DX-18	220-550 Meters	\$6.40
DX-19	220-550 Meters	\$6.40
Standard Mounting		.90

Points of Efficiency of VirBren DX-2H Transformer

- 1—Patented construction which eliminates capacity losses, resulting in highest possible amplification.
- 2—Smooth Oscillation control at peak wavelength.
- 3—Quiet operation.
- 4—The peak wavelength placed at a point where highest amplification is obtained with minimum of interference.
- 5—Sharply tuned input transformer provides great selectivity.

BUILD BY THE VIRBREN PLAN — loud speaker volume on 16-inch loop from Coast to Coast

A Letter from Satisfied User:

"On November 19th I tuned in K G O, Oakland, Cal., using a 16-inch loop. Loud speaker volume from Coast to Coast is assured when you use VirBren apparatus."

VirBren apparatus was developed by three Radio Engineers having 18 years' experience with the U. S. Bureau of Standards.

FREE COUPON

Radio Instrument Co., Dept. 939 D. St., N. W., Washington, D. C.
Gentlemen: Please mail me free information regarding your products, or send me by return mail.

You will find enclosed \$.....

Name.....
Address.....
City.....

You'll hear the duplicate of this loud speaker when Gabriel blows!!



Exceptional volume—tone value and clarity all in perfect quality

A really wonderful recreator for your Radio set. You must hear it and you'll be convinced. We guarantee this.

We also make the "Remola Recreator", a cabinet type of fine mahogany with an exquisite tone. Price \$25.00.

At all dealers or sent on receipt of price

THE REMO CORP., Meriden, Conn.

Loud Clear RUBICON DUPLEX

Pure tones and full-voiced volume can be had only with Push-Pull amplification. A good speaker operated from a pair of RUBICON Duplex transformers leaves nothing to be desired. It's the Duplex winding!

Free folder tells why

Your copy of "The Inside Story" ready to mail. Just send name and address on a postal.

Send for "The Inside Story" today

RUBICON COMPANY
918 Victory Bldg.
Philadelphia

SUCCESS depends on—

How well your set is made.
Not how many tubes you use.

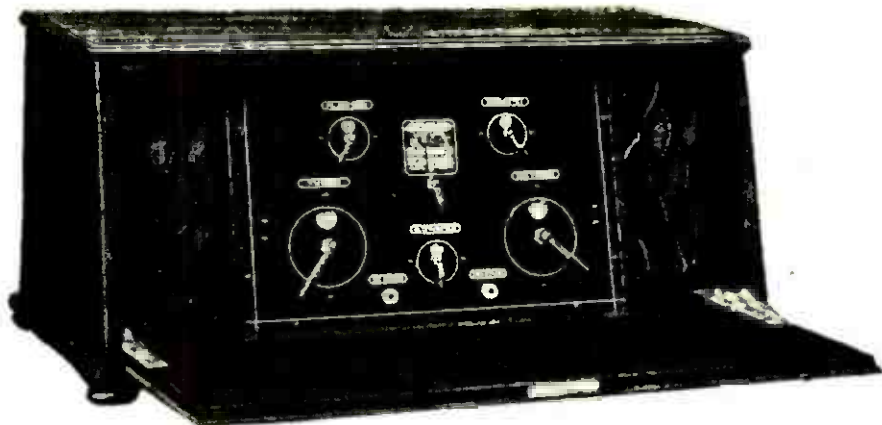

MRC-4, \$150.00

Michigan MRC-4 is America's most beautiful set. Not only is it the best of the cabinet maker's art, but electrically it has no equal.

One stage of radio frequency, a detector and two stages of audio frequency give you

Distance
Selectivity
Volume

with a tone arm that eliminates all harsh or mechanical notes. You have perfect reproduction.

The Set is equipped with a self-contained Loud Speaker unit and horn. The unit is adjustable. Ample room is provided for "A" and "B" Batteries, etc.

Other Michigan Models from the MRC-2, two tubes, to MRC-4, four tubes, priced from \$37.50 and up.

There is a Michigan for every requirement. Go to your dealer and ask for demonstration.

We will be glad to send you illustrated folder of all models. Write us.

Licensed under Armstrong U. S. Pat., 1,113,149-letters pending 807,388

MICHIGAN RADIO CORPORATION

33 Pearl Street

Grand Rapids, Michigan



Laboratory Apparatus—What It Means

Among the scores of Super-Heterodyne parts and circuits, which are the best? Severe impartial laboratory tests alone can give you the answer. Only after a model has proved itself in that way do we endorse it. Super-Heterodyne distance, volume, tone purity—that is what Norden, Hauck laboratory apparatus means to you.

Super-Heterodyne

C-7

A Long Distance Concert Receiver

Will Be Your Eventual Receiver

The famous Experimenters Information Service C-7 Design—laboratory apparatus—naval standards. A regenerative super-heterodyne employing a local oscillator. None of the so-called new “circuits” or modification of standards approaches it in efficiency.

All material we furnish is endorsed and recommended by the designer.

Send For Price List—Saves You Money

FREE INFORMATION—Write for descriptive matter and price list on this remarkable unit.

Full Stock On Hand—Norden, Hauck & Co. carry complete stock of parts for immediate shipment.

NORDEN, HAUCK & CO.

Offices and Engineering Laboratories
1617 Chestnut Street, Philadelphia, Pa.

AMPLEX

GRID-DENSER

YOU won't believe what an Amplex GRID-DENSER can do for your set until you actually try one.

Any circuit—Super-Heterodyne, Four Circuit Tuner, Neutrodyne—GRID-DENSER will improve it.

Follow the lead of radio men like Cockaday, Haynes, Sleeper and many others. Replace all your fixed condensers with GRID-DENSERS and get greater distance, louder and clearer signals.

In either the .0005 with or without gridleak clips or .001 type or type N (neutralizing) **\$1.25**

FREE: ask your dealer for the FREE Hook-up Booklet.

AMPLEX INSTRUMENT LABS.
88 W. Broadway, Dept. P 1, N. Y. C.

“Better than a Fixed Condenser”

MODERN

“PUSH-PULL” Transformers

Not only was the MODERN “Push-Pull” the first transformer of this type to be offered the radio public but it is also first in the matter of Quality Amplification.

MODERN Super-Six “Reflex”

This Circuit Is Easy to Build
Full-size wiring diagram and complete constructional bulletin of above circuit mailed on receipt of 4c. in stamps. Write for it today.
Modern Transformers make any set better. Insist on genuine Modern Transformers.

THE MODERN ELECTRIC MFG. CO.
World's Largest Manufacturers of Radio Transformers Exclusively
Toledo, Ohio



I am the Voice

I am a violin. I am tom toms. I am grand opera and vaudeville.

I enchant youth like the Pied Piper. I am a teacher. I am town crier.

Verily, I shrink the world . . . But never am I my own master . . .

For Thorola Loud Speaker can sing and play and speak only what goes into the radiocasting microphone—nothing is lost—nothing is added but volume. Extreme volume is suggested by the very size of the Thorola reproducer—so large as to permit scientific accuracy which is impossible in miniature!

But the greater the volume, the purer the tone must be to satisfy the musical ear. So it was absolutely necessary for Thorola to introduce features associated

only with finest musical instruments. The exclusive Thorola Controlled Mica Diaphragm was created, bringing highest musical art to radio. And for the first time the overtones—which *make* true music or natural voice—are preserved in all delicacy by the Thorola Separix found in no other loud speaker.

For the beautiful Thorola horn, Thorite was evolved, a laboratory compound, acoustically perfect beyond natural materials. For harmonizing *each* Thorola with the characteristics of *each* radio receiver, the Synchronizer is provided, putting Thorola always at its best on every set, ready to bring the radio of a continent in the very finest music-room style. Let Thorola betterments bring the culture of music to your set.

Under the remarkable 10-day Refund Warranty, Thorola must fulfill every claim—must improve reception, power, range. **TONE QUALITY.**
 Thorola 4, \$25 Thorola 9 (Cabinet) \$40
 Thorola 6 (Phonograph Attachment) \$15
 Thorola models require no battery
 Thorophone (Power Type Speaker) \$45

REICHMANN COMPANY
 1725-39 West 74th St., CHICAGO

Thorola

THE SPEAKING LIKENESS

All apparatus advertised in this magazine has been tested and approved by POPULAR RADIO LABORATORY

Prevents tubes burning out

Safeguard your tubes against "B" battery wires being connected to the filament or "A" battery circuit binding posts through error; against "B" battery wires coming in contact with the filament wires while making adjustments inside the set; or against short circuits caused by tools dropped across the wiring by installing the

"GEM" Radio Fuse

Is it worth risking the loss of tubes that cost \$20.00 or more when you can positively protect them from burn-outs due to short circuits for a few cents with a "Gem" Fuse?

With this fuse in your set, you simply blow the fuse when there's a "short" and don't injure your tubes. A new fuse can be slipped into the socket in a second and costs but 35c.

"Gem" Fuses are *guaranteed*. If not at your dealer's, sent postpaid, with fuse block for attaching to your set, for 60c. Write for interesting booklet.

Chicago Fuse Mfg. Co.

Manufacturers of
Electrical Protecting Materials
and Conduit Fittings

1507 West 15th St.

Chicago, Ill.

Dealers: Write for our attractive proposition

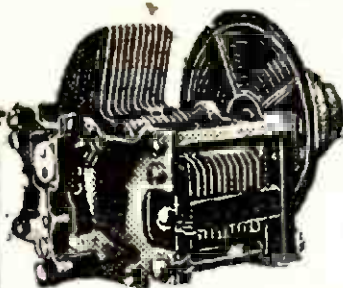
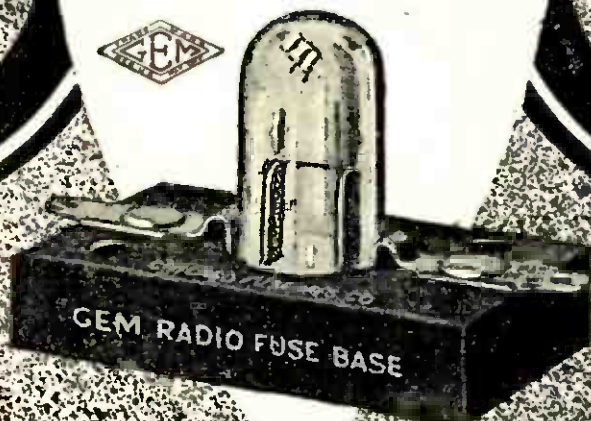

DUAL RATIO

GROUNDING ROTOR

LOW-LOSS CONDENSER

PLAIN & VERNIER TYPE

PRECISION MOVEMENT, ABSENCE OF GEARS OR COMPLICATED PARTS



Improved Type RHEOSTATS and POTENTIOMETERS All Sizes

GENUINE BAKELITE

SUPERIOR CONSTRUCTION



United Scientific Laboratories, Inc.
92-94 E. 10TH ST. NEW YORK CITY



DeJUR ONE HOLE RHEOSTAT

Insures perfect contact and minute regulation of the filament voltage, giving uninterrupted reception and clear and pure reproduction of programs.

GUARANTEED

Any part replaced at any time. Consider these exclusive DeJur features: Non corrosive, heat resisting, interchangeable resistance element, contact slider and shaft made in one piece and permanently set at the factory—all these exclusive DeJur features at no additional cost.

At dealers everywhere. Jobbers and dealers write for discounts.

DeJUR PRODUCTS Co.
Lafayette & Broome Sts., New York

FOR BEST RESULTS—USE PRECISE

Power Amplifying Transformers in your Push-Pull Audio Circuit



LABORATORY INSTRUMENTS AT COMMERCIAL PRICES

ONLY \$11⁰⁰ PER PAIR

THE success of the "Push-Pull" circuit is absolutely dependent upon critically balanced transformers for the attainment of volume reception without distortion. The amazing results secured by PRECISE "Push-Pull" Transformers offer still more evidence of PRECISE superiority. Try them once and you will understand why thousands of radio experts are installing them every week—literally making the PRECISE line the most popular everywhere. Sold by the better dealers.

Get our new booklet of full Superheterodyne information and constructional data, \$1.00

Precise Manufacturing Corporation, Rochester, New York

BRANCHES

53 W. Jackson Blvd., Chicago 821 Market St., San Francisco

Eastern Sales Office—Niagara Sales Corp., 3-5 Waverly Place, New York City

Southern Representatives—Saal Products Sales, Inc., 35 Warren Street, New York City

CANADIAN DISTRIBUTORS

Perkins Electric, Ltd., Toronto, Montreal, Winnipeg

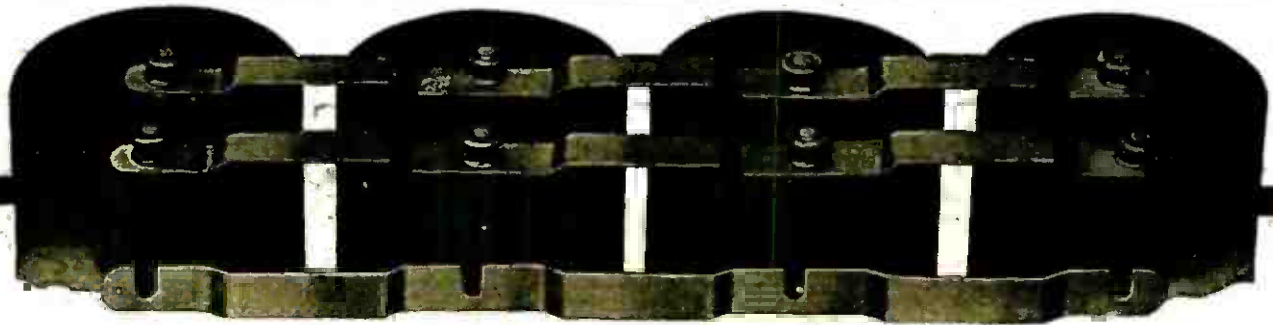

Mitchell Battery Connectors

will hook up your dry cells in a jiffy. No fumbling with wires. No danger of blowing your tubes through incorrect connections. If you follow the picture, you can't possibly go wrong. One of the greatest little time savers in Radio.

WD11, WD12 Tube Chart	
No. of Tubes	No. of Cells
1	2
2	3
3	4
4	5
5	6

To hook up dry cells in parallel, for operating WD 11 and WD 12 tubes, slip the slots of two Mitchell Connectors over the binding posts, and tighten nuts as shown in picture. For less than four cells, cut off connectors. For more than four cells, use two or more pairs of con-

nectors. Follow the cell chart at the left. To hook up dry cells in series, cut a pair of connectors into four two-cell strips. Use these strips to connect the positive pole of one cell to the negative of the next. One pair of connectors will thus care for five cells.

Price, 25 cents per pair

R. MITCHELL CO. [Instrument Makers for 47 Years] 257 ATLANTIC AVE. BOSTON, MASS.

POLYPLUG

Positive Contact Always Maintained

Simply slip the Polyplug into the loud speaker or head phone socket and a positive contact is maintained regardless of pulls, jerks and jars on the phone cords. The tension slot, an exclusive feature, makes the Polyplug the most convenient and efficient plug made.

It's genuine Bakelite, too.

At all reputable dealers

POLYMET MFG. CORP.

70 Lafayette St. New York

75¢ WORTH IT

Duo-Spiral Folding Loop

Price \$8.50

Reduces Static

Increases Selectivity

Easily Portable

Patents Pending

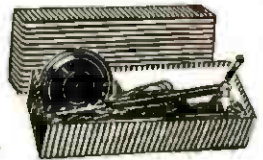
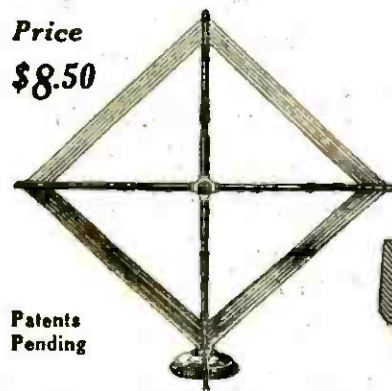

The highest development in a portable aerial. Compact, convenient and self-contained. Rotates on base, which is provided with silvered dial graduated for calibration. Handle permits adjustment without body capacity effects. Handsomely finished in silver and mahogany. Can be used anywhere.

TINY-TURN

A superior vernier control which makes perfect tuning easy. Has a gear ratio of 30 to 1. Rotates in same direction as dial. Easy to install. Fits any standard panel. Handsome nickel and ebony black finish. Price 75c. If you cannot secure DUO-SPIRAL, and TINY-TURN at your dealers, write us direct.

Radio Units Inc.

1301 First Avenue Maywood, Ill.

Perkins Electric Ltd., Montreal

No. 772
45-volt
large
vertical
Price
\$3.75



NO. 772
EVEREADY
RADIO BATTERY
45 VOLTS
30 CELLS
This Eveready "T" battery contains thirty parallel cells, each specially designed to give long and dependable service.
This battery occupies much less table space than the horizontal type "T" battery of the same size and volume.
NATIONAL CARBON CO. INC.
Manufactured in New York, California and Canada
1935



No. 766
22½-volt
large
horizontal
Price
\$2.00

Dry "B" Batteries are more economical and more dependable than any other source of plate current!

Cut your operating cost

THIRTY years' experience in the manufacture of dry batteries has enabled us within the past two years to steadily and greatly improve "B" Battery quality. Eveready "B" Batteries are now from two to three times better than ever before.

Eveready "B" Batteries will long outlast any others, and are the most economical and dependable source of plate current. These are strong statements, but they have been proved by tests in our own and in independent laboratories. Check them for yourself on your own radio set. Get Eveready "B" Batteries.

There is an Eveready Radio Battery for every radio use.

Manufactured and guaranteed by
NATIONAL CARBON COMPANY, INC.
Headquarters for Radio Battery Information
New York San Francisco
Canadian National Carbon Co., Ltd., Toronto, Ont.

EVEREADY
Radio Batteries
-they last longer

DXL

TRADE

MARK

Variable Condenser



LOW LOSS
(Practically No Loss)
—A Fact

New distances—new thrills are yours with D. X. L. Straight-line Low Loss Condensers. For Low Loss is a definite fact.

Your set will give its absolute maximum. D. X. L. Condensers are manufactured with infinite precision upon the exclusive D. X. L. design.

With the D. X. L. Condenser, radio reception approaches perfection. Designed for all super-sensitive sets. Fully guaranteed. Buy from your dealer or from factory direct.

LIST PRICES

- 11 Plate.....\$4.00
- 17 Plate..... 4.25
- 23 Plate..... 4.50
- 43 Plate..... 5.00

Set Manufacturers

Our special manufacturers' proposition will interest you. D. X. L. Condensers will increase the merit of your product.

Distributor

Sales agencies wanted to develop distribution in certain territories. D. X. L. offers an unusual merchandising proposition. Write or wire.

Interesting description sent on request

D. X. L. RADIO CORPORATION
5767 Stanton Ave.
DETROIT, MICH.

TRADE

DXL

MARK

BLUE BIRD

Radio Tubes
DISTINCTLY NEW
AND EFFICIENT



satisfying every radio fan's wish in performance and price. Our direct sales plan enables us to sell at this low figure. "Bluebird" assures increased range and undistorted volume.

- TYPE-400
5 Volts, 1 Ampere Detector Tube
 - TYPE-401A
5 Volts, .25 Ampere Amplifier and Detector
 - TYPE-498
¾ Volts, .06 Ampere Amplifier and Detector
 - TYPE-499-A
¾ Volts, .06 Ampere with Standard Base Amplifier and Detector
 - TYPE-412
1½ Volts, .25 Ampere Platinum Filament Amplifier and Detector
- ALL STANDARD TYPES..... \$2.50**

Type-02 5-Watt Transmitters \$3.00

EVERY TUBE GUARANTEED

to work in Radio Frequency. Especially adapted for Neutrodyne, Reflex and Super-Hetrodyne Sets.

Shipped Parcel Post C. O. D.

WHEN ORDERING MENTION TYPE

BLUEBIRD TUBE CO.
200 Broadway New York City

CRESCENT LAVITE RESISTANCES

- 12,000
- 48,000
- 50,000
- 100,000



LIST
\$1.50

Special Sizes to Order

Approved by Popular Radio Laboratory

When better resistances are made they will bear the Crescent label.

Special and standard size bakelite panels and tubes cut to order.

We promise highest grade material, prompt service, and lowest prices.

Let us quote you on your needs

CRESCENT RADIO SUPPLY CO.
1-3-5 LIBERTY ST. JAMAICA, N. Y.
Cable Address "Cresrade"

Wire Your Set With
CELATSITE

You can't beat it for a neat job. It's No. 14 tinned copper wire with varnished insulation. Highly dielectric; moisture proof. Bends without cracking. Strips like the bark on a whistle! Looks like spaghetti, but smaller. 5 beautiful colors. Send for Free Folder, "How to Solder"; also describes "Celatsite" and other Acme products.

THE ACME WIRE COMPANY
Dept. P New Haven, Conn.

ACME RADIO WIRE NEEDS

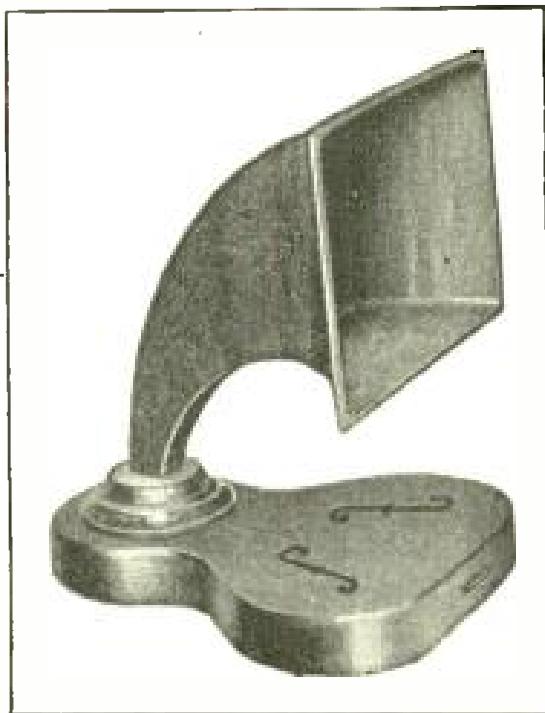

Wonders Never Cease!

WHEN TIMBRETONE was first offered to the Radio Public a year ago, it met with instant success. It is different, both in construction and tone quality. With the Violin principle and all wood construction, it could not be otherwise.

Small, light in weight and beautifully finished in mahogany, it harmonizes with the furnishings of the room.

Six months ago, the Laboratory gave us a new diaphragm and without telling our customers, we experimented by shipping speakers equipped with it, among our regular speakers. **ACTION STARTED RIGHT THEN!**

NOW IT CAN BE TOLD!

The new TimbreTone has a special Baldwin unit with TimbreTone diaphragm—a synthetic plate. It is non-metallic and gives a still wider tone range with clarity and sweetness, already a marked attribute of TimbreTone speakers. The volume is increased without distortion.

It is now the much-to-be-desired addition to a good set and satisfies the "Hard-to-please" where "Quality" counts more than "Quantity".

Ask your dealer or jobber to order one for you to try and read the refund agreement.



Made in Hoosick Falls, N. Y.

by the

TIMBRETONE MFG. CO.

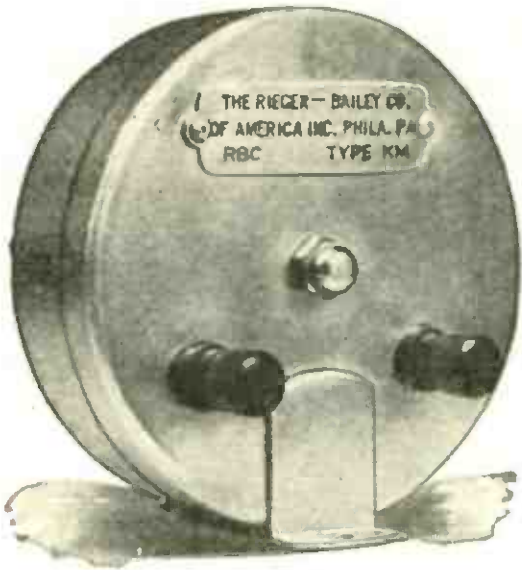

RESULTS!

From the *First Laboratory Superheterodyne* available for assembly by the inexperienced builder.

When you assemble a receiving set you expect—

- Clarity
- Volume
- Distance
- Selectivity
- Freedom from distortion

R. B. C. Superheterodyne units guarantee these results when installed according to simple instructions—results previously conceded possible only under laboratory conditions.

This is because each one is:—

- A Laboratory product
- Matched to a predetermined standard
- Built with air core, insuring selectivity and clarity
- Cased in nickled brass, eliminating inter-tube and transformer coupling, and atmospheric disturbances

The design of these units eliminates a potentiometer, permitting low "B" battery consumption of 6-10 miliamperes on 8 tubes.

These and many other features are found in

THE R. B. C.—TYPE KM OSCILLATING COUPLER, FILTER AND TRANSFORMER

With Blueprints—\$42
Order direct from us

The Rieger-Bailey Co. of America, Inc.
815 Real Estate Trust Bldg., Philadelphia, Penna.



Your Set Is Worthless

With a Run-Down Battery

The only way you can accurately gauge the strength of your battery is with the

Perfection HYDROMETER

(Scientifically Perfect)

It's in the float. If the name **PERFECTION** is not on the float it is not a genuine **PERFECTION**.

Depended upon for years by automobilists for instant, accurate, battery testing. Expertly made. Heavy one-piece hydrometer barrel—soft acid proof rubber connections—heavy ribbed bulb—designed to prevent leakage.



\$1.00 at all radio stores

Bemco Manufacturing Company
243 W. 55th St.
N. Y. City

Big Dealer-discounts

Send for our new catalog

It lists and illustrates absolutely dependable, guaranteed sets and parts. Give your customers what they want—when they want it; but buy it so that you can make a good profit. We're supplying hundreds of radio dealers satisfactorily every day. Write for catalog and discounts sheet. You'll be astonished at the prices quoted.

Ask for catalog No. 9

W.E. Fuetterer Radio Supply Co.
2123-25 Locust St. Louis, Mo.

W.E. Fuetterer Radio Supply Co.

Send for our latest catalog

New York Coil Company's Radio Products

ANY CONDENSER CAN BE CALLED LOW LOSS. BUT ONLY ITS PERFORMANCE QUALIFIES THE NAME. In THE NEW YORK GROUNDED ROTOR scientific designing, together with the highest grade of materials and instrument workmanship combine to produce a condenser that is in a class by itself—no other condenser manufactured incorporates so many *actual improvements*.

.0005 (23 plate) without Vernier, \$4.50. Geared Vernier attachment complete \$1.50

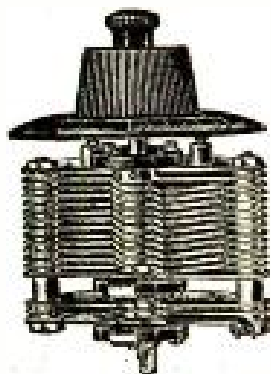
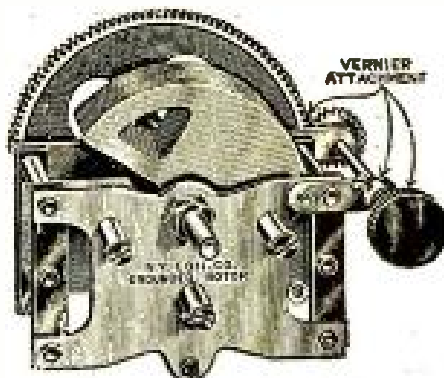

OUR STANDARD NON-GROUNDED CONDENSERS made in four sizes, with or without vernier, are universally recognized for their efficiency, workmanship and low price—made possible by large production.

Price with Vernier Knob and Dial 23 Plate \$3.50. Without Vernier 17 Plate \$1.80. 23 Plate \$2.00. 43 Plate \$3.00



Type A—No Clips

NEW YORK PRECISION MICA FIXED CONDENSERS add the *real* undistorted tone quality to your receiver—and play a most important part in selectivity, volume and distant reception. In fact no

item used in a Radio Receiver requires more precision and makes use of such exacting measurements as our Mica Condensers. They are universally endorsed by the leading Radio engineers and most discriminating manufacturers—yet they cost you no more than the ordinary product.

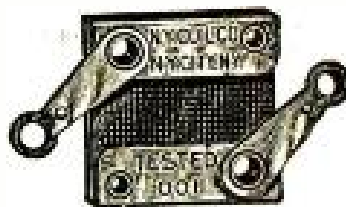

Type B

NEW YORK COIL COMPANY

338 Pearl Street, New York City, N. Y.

Pacific Coast—MARSHANK SALES CO., 1240 S. Main St., Los Angeles, Calif.

RAVEN *Superheterodyne* KIT



Takes the Guess
Out of "Superhet"

Comprises

1 Two Coil Filter Circuit
3 R. F. Transformers
3 Sockets
Binding Posts
with Oscillator and
Full Size Blue Print

THE heart of the Superheterodyne—a complete compact monobloc radio frequency long wave length unit—perfectly matched, assembled and wax-sealed in one piece genuine Bakelite casing. Factory wired, synchronized and tested. No soldering needed. Assures the perfect balance of parts essential to Superheterodyne performance.

At All Reliable Dealers **\$25**

RAVEN RADIO, INC.

8 Learned Street

Albany, N. Y.

"Good Parts Make a Good Set"

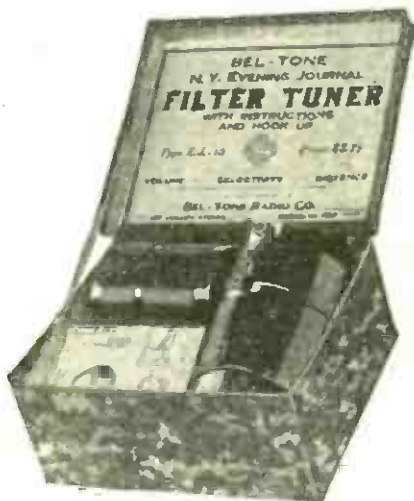

The Filter Tuner

The BEL-TONE Low-Loss Filter Tuner takes all the guesswork out of building a Filter Tuner Set. This unit has been built to the exact specifications laid down by McGinnis and Maher of the N. Y. Journal. It bears their signature of approval.

The BEL-TONE Filter Tuner is made with bakelite tubes and green silk wire. It is packed in a neat box with complete instructions. **\$3⁷⁵**

BEL-TONE RADIO CO.

161-167 Jamaica Ave. Brooklyn, N. Y.

Other BEL-TONE Good Parts are: Bel-Tone Kit Type AC-30, Bel-Tone Variometer, Bel-Tone Variocoupler, Bel-Tone Mounted Binding Posts.

REDUCE STATIC

Pat.
Pending
690459



\$10.00

Prepaid in U. S.

by using our super-sensitive
Omni-Directional Aerial

*Collapsible, Ornamental,
Mechanically Perfect*

Can be used either as a loop or antennae inside or outside. A wonderful value featured at a price within the range of all.

Ask your dealer or send order direct

The Portable Globe Aerial Co.
1602 Locust Dept. 34 St. Louis

BRAIDED COPPER RIBBON



CLEARER SIGNALS

INCREASED RANGE

TAKES LESS BATTERY CURRENT

Our newest and best
radio antenna wire

Braided Flat Ribbon

Contains over one-half mile of wire strands. For out door or indoor use. In Copper—Tinned Copper—Enameled Copper. We also make round antenna wires in all types and metals. Loop wires, Litz wires, Cotton covered wires.

Poss Antenna Co.

9 Charles St., Providence, R. I.

KING QUALITY NEUTRODYNE RECEIVER

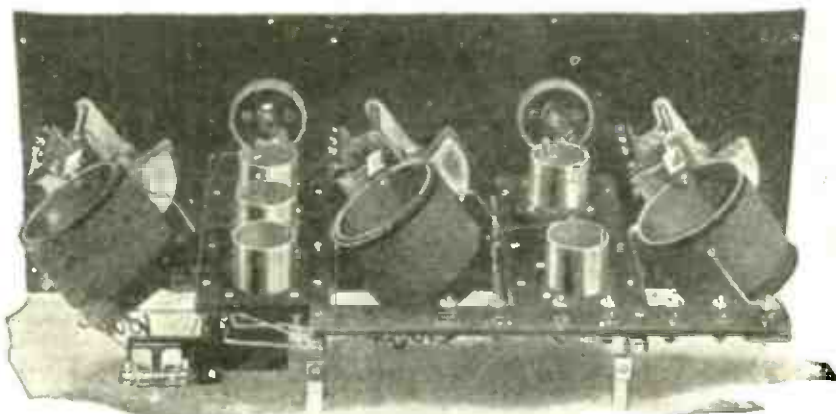

THE King Quality Neutrodyne is a receiver in which the most recent advances in radio engineering and craftsmanship have been incorporated. The wave amplifiers not only produce enormous amplification but are extremely selective—a combination which has been the goal of radio engineers for many years.

No effort or expense has been spared in making the King Quality Neutrodyne the best receiver for home entertainment which has yet been produced.

Write for King Quality Neutrodyne Set Catalog

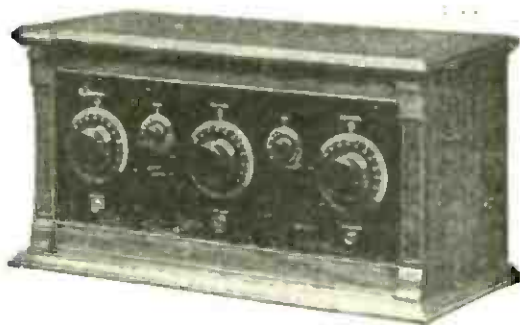

**KING QUALITY PRODUCTS, INC.
BUFFALO, N. Y.**

In Canada: King Quality Products, Ltd., Bridgeburg, Ont.





LOW LOSS PRODUCTS

RADJO products are efficient anti-capacity parts that stand the acid test of comparison.

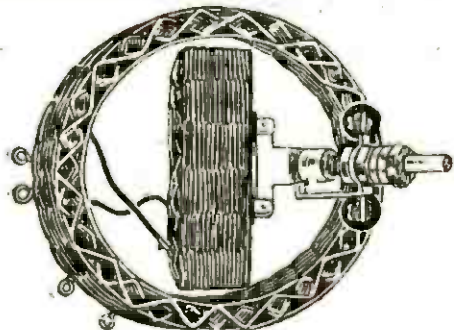

"Radjo" 180° Low-Loss Tuner

It can be mounted in any position necessary to meet the wiring requirements of your present circuit and it can be substituted for any coupler you are now using. Lorenz system basket weave, the most efficient yet devised. Radjo Low-Loss Tuners are made in two models.

The three circuit tuner with a 180 degree movement of the rotor.

The single or double circuit tuner has the primary with eight taps as the stationary coil, with a 180 degree movement of the rotor.

Price, Either Type..... \$5.50

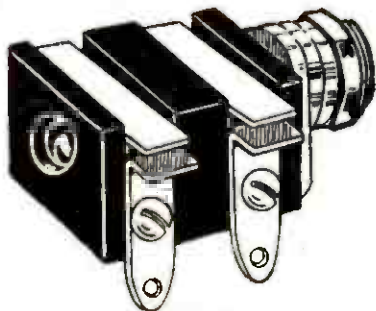

Patents Pending

"Radjo" Anti-Capacity Jacks and Switches

A new departure in radio apparatus. Designed for radio circuits exclusively with advantageous features possessed by no other jack on the market. Their infinite low capacity merits their use. Wiping contact is of extremely large area under a maximum tension. Radjo jacks are small and compact, requiring very little space.

The Line Consists of Five Jacks and Three Switches

Write today for interesting literature giving complete information regarding Radjo Low-Loss Products.

JOBBERS—DISTRIBUTORS
Write for Our Proposition

THE SHARP SPARK PLUG CO.
WELLINGTON OHIO

"Sharp" Products—Licensed M'n'frs

PRECISION AUTODYNE COUPLER



\$3.50

MANUFACTURED BY
PRECISION COIL CO.
209 CENTRE ST. NEW YORK



Tapped Loop \$8.00
Untapped Loop \$6.50

If your dealer cannot supply you, order direct giving your dealer's name



Collapsible Loop Aerials Built by Radio Engineers

Quality reception . . . greater selectivity . . . no static. A convenient, efficient, fully guaranteed loop. Thousands in use everywhere. Built by Radio engineers. Wave length range with 23 plate condenser is 180 to 600 meters. H. F. resistance at 400 meters, only 7 ohms. Wire is stranded, of great tensile strength and high conductivity. Inductance .2 millihenry. The 4-point tapped loop will improve your super-heterodyne. Sold by leading dealers.

Write for Catalog

Send your name and your dealer's name for the Lincoln Catalog. Describes Lincoln Loops, Lincoln Low-Loss Condenser, Lincoln "Long 45" Tuner, Lincoln Kit, and Lincoln Oscilloscope. Shows 6 interesting hook-ups.

Lincoln Radio Corporation - 224 North Wells St., Chicago



Anti-capacity JACKS



Anti-capacity SWITCHES



Lower-Loss Vernier VARIABLE CONDENSERS



Lower-Loss PHONE PLUGS



Lower-Loss RHEOSTATS



Lower-Loss SOCKETS

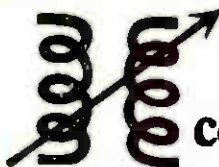

Lower-Loss VARIO-COUPPLERS



Lower-Loss GRID LEAKS



Lower-Loss INDUCTANCE SWITCHES



Lower-Loss POTENTIOMETERS

NO SOLDERING : LESS DRILLING : SCIENTIFICALLY BUILT

DX—but not only DX— Volume and Tone!

All Jos. W. Jones radio parts are *low loss*. So a set built with these parts brings in longer DX with greater clarity, selectivity, and more natural tone.

Jos. W. Jones parts make set-building easier, too, for they require *less drilling* and *no soldering*.

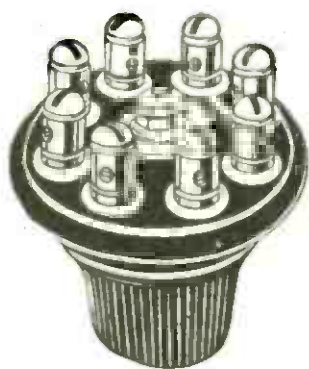

JOS. W. JONES

Low Loss

INDUCTANCE SWITCH



Variable GRID LEAK

Jos. W. Jones Jacks and Switches are anti-capacity. Made for radio use only. No long parallel leads; which means no capacity effects. Always ask for the switches with the little red button.

For Best Results Build With JOS. W. JONES

Jacks	Switches	Variable Condensers	Phone Plugs
Vario-Couplers	Rheostats	Potentiometers	Grid Leaks
	Inductance Switches	Sockets	

JOS. W. JONES

TRADE MARK

"IMPROVED"

radio parts

JOS. W. JONES RADIO MFG. CO., Inc. 40-42-44-46 W. 25th St., New York
(Formerly Radio Improvement Co.)

Headed by Jos. W. Jones—for 28 years a successful engineer and builder of precision instruments

Branch Offices

Philadelphia: 1011 Chestnut Street Boston: 99 Bedford Street
Chicago: 53 West Jackson Blvd.



"SUPERTRAN"
Reg. U. S. Pat. Off.

RATIOS
3½ to 1
5 to 1

\$6.00

SUPERTRAN

Audio Transformer

It's up to the audio transformer to amplify without distorting — to increase the volume without affecting exactness in reproduction. That's just what Supertran Audio Transformers do. They are "certified" by scientific tests to be unequalled for volume, clarity, purity and quality of tone.

An exclusive feature of the Supertran is its shield, insuring absolute protection against damage to the coil while mounting. With any amplifying tube Supertran gives excellent results.

*At good dealers everywhere
Write for Interesting Literature*

Distributed by

Wetmore-Savage Co., Boston
The Beckley-Ralston Co., Chicago
Coast Radio Supply Co., San Francisco
Excel-All Radio Co., Bloomfield, N. J.
Radio, Limited, Montreal, Canada

FORD MICA CO., Inc.
33 East 8th Street
New York

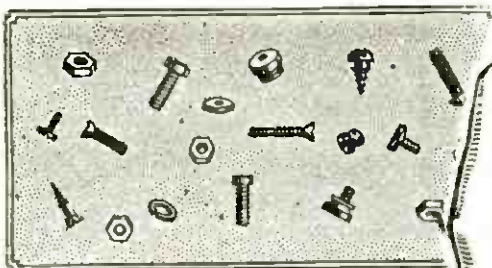

ONE C & C "REACHIT" WRENCH

TAKES THEM ALL

No necessity to pick over a half dozen wrenches to fit one nut when you use a REACHIT wrench. It not only fits all sizes, but automatically

HOLDS THEM ALL

firmly (with adjustable jaws) while getting into the intricate positions. **NO OTHER TOOL CAN DO THIS.** It assures a tight connection in the hard-to-get-at places.

**A Real Tool for Mechanic, Electrician
and Radio Builder**

Nickel finish, hardened jaws and fully guaranteed

Price \$1.50

If your dealer cannot supply you, will be sent post paid on receipt of above amount and your dealer's name.

CAUFMAN & CLOUGH CO.
WILMINGTON, DEL.

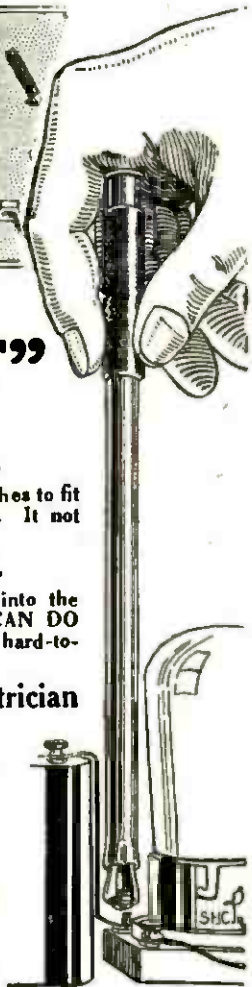

40 Ft.

"HERCULES" Aerial Mast \$25

FREIGHT PREPAID

20 Ft. Mast \$10 or 60 Ft. Mast \$45. All steel construction. Each Mast complete with guy wires and masthead pulley. Write for literature and **FREE BLUEPRINT.**

S. W. HULL & CO. Dept. B-2
2048 E. 79th St. Cleveland, O.



The Easiest Way to Do Hard Jobs

"Buzz Boice" will take the hard work out of hundreds of jobs with the



BOICE-CRANE JUNIOR SAW

Does your ripping, mitering, tenoning, sanding, grinding. Special blades cut bakelite. Extension guide accommodates panels 24" wide. Saws 1½" stock. Driven by motor attached to any light socket.

SOLD ON MONEY BACK GUARANTEE

W. & J. BOICE

1730 Norwood Ave. Dept. 901 A Toledo, O.

"Largest makers of small bench machines in the world"



Write for Catalogue—Saws, Joiners, Band Saws

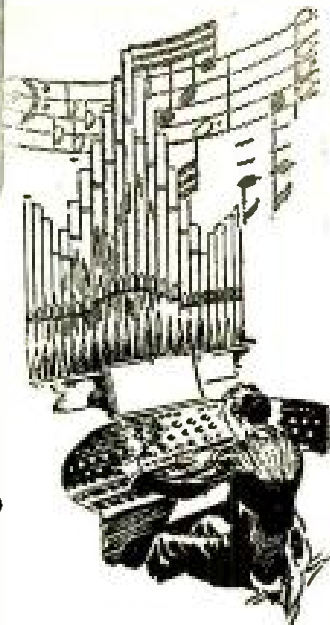
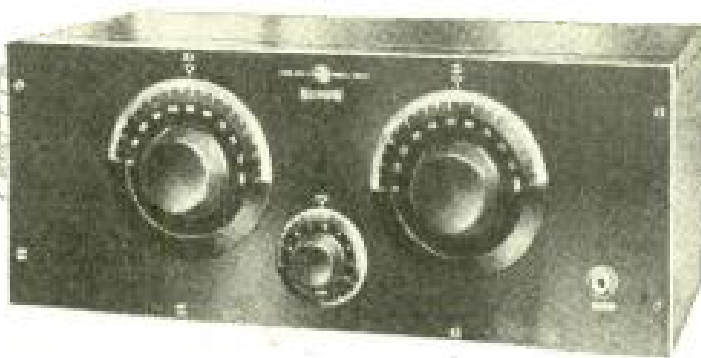

The FADA Neutro-Junior

—a wonderful performer

MANY people prefer a Neutrodyne radio receiver but have deferred buying because they do not want a set that requires more than three tubes.

The FADA Neutro-Junior is a three-tube Neutrodyne. It is far superior to ordinary three-tube sets, for it possesses many of the desirable qualities of the larger Neutrodyne receivers. In volume, in selectivity, in ability to get distant stations and in tone quality the Neutro-Junior is an amazing performer. Enclosed in a solid mahogany cabinet it is a remarkable value at \$75, enabling almost anyone to own a handsome, efficient radio receiver at a price they can afford to pay.

The Neutro-Junior has only two control dials, both of which read practically the same at all times. This ease of control simplifies your tuning.

The FADA full line of Neutrodyne receivers includes six models—three, four and five-tube sets in plain as well as in art-craft cabinets at a price range of \$75 for the three-tube set to \$295 for the five-tube Neutrola Grand.

Your dealer will be glad to demonstrate the Neutro-Junior or any of the other FADA models. Ask him.

F. A. D. ANDREA, INC., 1581 JEROME AVE, NEW YORK

FADA

Radio

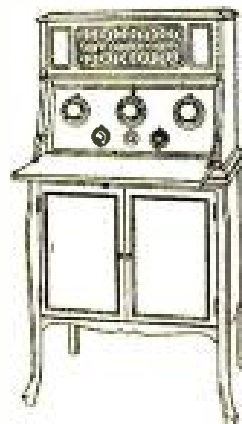

FADA Neutrola Grand

No. 185/90-A. The five-tube Neutrola 185-A mounted on FADA Cabinet Table No. 190-A. Price (less tubes, batteries, etc.) \$295.



FADA Neutroreceiver No. 175-A

Mahogany cabinet. Inclined panel and roomy battery shelf. 5 tubes. Price (less tubes, batteries, etc.) \$160.



GEN-WIN gets DX

37 West 125th Street,
New York City.
Oct. 20th, 1924.

Radio Section,
S. Y. Evening Mail and Telegram,
New York City.

Dear Sirs:

Several months ago you published a diagram and article on the "GEN-WIN" Low Loss Tuner. This looked very good to me and I tried it. My first set worked perfectly. On the lead speaker, in fact I brought in such stations as WJL Dallas, WJL St. Louis, WJL St. Louis, and a number of others, and with an aerial or ground I heard Pittsburgh with good volume on the lead speaker.

My second set using the same tuner beats the first. So fast I am doubtful if the average constructor or buyer will bring in the DX as it does so loudly and so clearly. In spite of the fact that I am using 2 DR100 tubes (Detector and 2nd aml) and a 30 foot copper ribbon aerial and a 30 foot ground wire to the water pipe. The first time I got it on at 10:30 P.M. the interferences from local and distant sets on base that I could not hold it but a few minutes. The second time, Saturday evening, or I should say Sunday morning at 1:30 P.M., S. Y. I tuned them in on the lead speaker. While from the St. Francis Hotel in San Francisco was being broadcast, then a "Piano Solo" which was followed by a few Popular numbers and the program ended with some music from the Garden Room of the St. Francis Hotel, with some music from the Garden Room of the St. Francis Hotel, with some music from the Garden Room of the St. Francis Hotel.

This, in my estimation is a pretty good record for a 2 tube set, using no Radio Frequency but just Triodes. Good luck nevertheless. What do you think of it.

Very truly yours,
J. H. H. H. H.

P.S. At times, the volume from WJL could be heard thru' out a three room apartment district. An enclosed stamped, addressed envelope for your reply.

With the Silver Plated Primary

REG. APP. U.S. PAT. OFFICE.

U. S. Bureau of Standards Bulletin proves that silver has lower series resistance than any other metal. Another known fact is that radio frequency currents travel on the surface of wire. Therefore, if surface conductivity is increased, the set employing the wire will be made more efficient.

GEN-WIN Low Loss Tuner employs an aperiodic primary of special silver plated copper wire. Condenser tuned secondary and self supporting spiderweb tickler are also of latest low loss design. A



\$7.00

Pat. App. For At Your Dealer or Sent Postpaid

GEN-WIN Low Loss Tuner will enable you to build the most efficient regenerative set ever designed, both for DX and local reception. They are unconditionally guaranteed.

With each tuner you get a complete set of detailed blue prints (full size panel pattern, instrument layout and picture wiring diagram) for latest Gen-Win Low Loss Set. Separately 50c. Write for descriptive circular, Dept. P.R. 125.

GENERAL RADIO WINDING CO
214 Fulton St New York

Facts Count!

We can prove the efficiency and superiority of **DUPLEX CONDENSERS**. This proof is set forth in two interesting folders entitled "Cons" and "Facts." **WRITE FOR THEM TODAY**

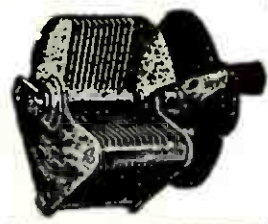
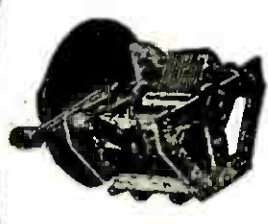

"FR" Series

"DR" Series

The highest quality low loss condenser made. Used by foremost set manufacturers.

A low loss precision condenser of high value and unusually low price.

See Duplex Condensers at your Dealers. Also ask to see the "RK" Supplementary Kit for building "Super-Het" and other long wave circuits.

THE DUPLEX ENGINE GOVERNOR CO., INC.
50 Flatbush Av. Ext. Brooklyn, N. Y.

RAJAH SNAP TERMINALS

SOLDERLESS

For Panel, Base and Battery Connections
Approved by Popular Radio Laboratory and L. M. Cockaday



Patented Sept. 23rd, 1924.

Eliminate the noise due to poor connections and save the time and trouble of screws—or the common spring clip terminal. Just snap on or off. The Phosphor Bronze spring clip insures a positive contact. Connection attached to or removed from cable in half a minute, giving an absolutely tight and secure connection without the use of solder. Not only a convenience but a necessity for Satisfactory Radio Operation. Price, complete, as illustrated, each 20 cents. Base studs, which fit all screw battery posts, each, 6 cents.

RAJAH SNAP TERMINAL

For Radiator Ground Connections

Just remove the center screw that holds the valve handle in place; slip the screw thru the hole in the special Rajah base designed for this purpose and replace the screw.

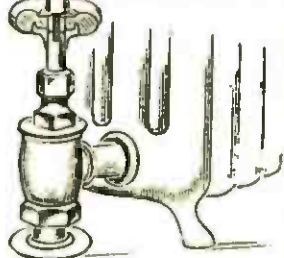

You have an absolutely positive ground connection in half a minute, and ground wire may be instantly attached or replaced at will. Price, same as regular Rajah terminals. Base only, which fits any Rajah Connector, 6 cents.

Special Introductory Offer:
1 dozen terminals and studs, by mail prepaid, \$2.00
In ordering, specify whether regular or ground bases are desired.

RAJAH AUTO SUPPLY COMPANY
BLOOMFIELD, NEW JERSEY, U. S. A

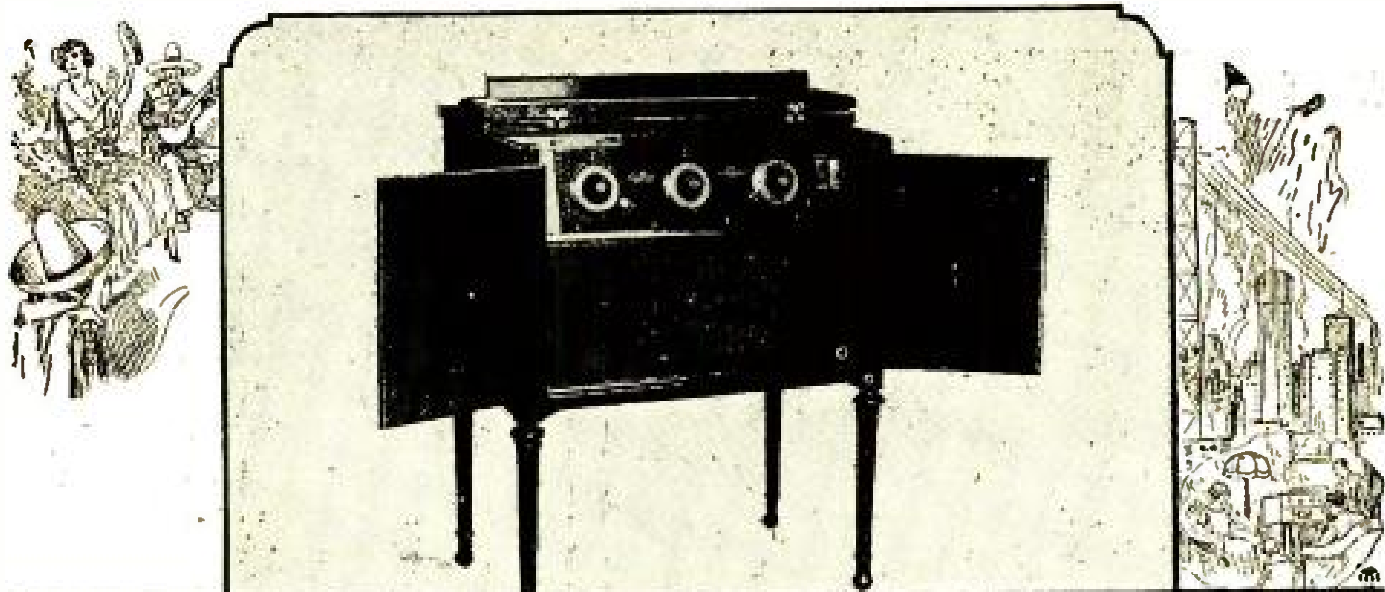

SELECTIVITY

WITH A Radiodyne you can choose from any of the programs on the air. Nearby broadcasting cannot prevent you from getting distant stations. The Radiodyne will bring in the program you select clear and distinct no matter where broadcasted or where you live.

If you can get it with any set you can get it better with the

Some
RADIODYNE

Type WC-12

Features

- Has an Amazing Degree of Selectivity
- Uses 6 Dry Cell Tubes
- Receives from Great Distances
- Has Wonderful Volume
- Exceptional Clarity
- Self Enclosed in Beautiful Two-Tone Mahogany Cabinet
- All Models are Comparatively Low Priced

Write for Our Free Booklet

WESTERN COIL & ELECTRICAL CO.
 308 Fifth Street
 Racine, Wisconsin

Radiodyne

All apparatus advertised in this magazine has been tested and approved by POPULAR RADIO LABORATORY.



Knockout Reflex Coil No. 8
Price \$4.00 a Pair



Tuned Transformer Coil No. 14
Price \$2.00

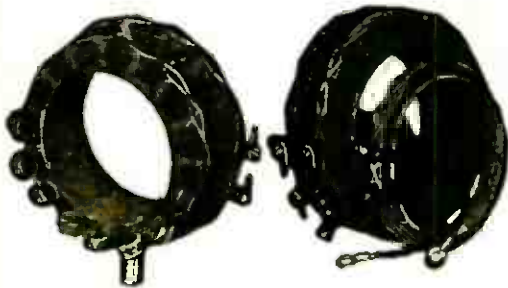

Coils for Roberts Circuit, No. 18
Price \$8.00 a Set

SICKLES

DIAMOND-WEAVE COILS

Patented Aug. 21, 1923

For the Roberts Circuit

Two units of remarkable efficiency, built specifically for the immensely popular Roberts Circuit. Primary and secondary coils in unit No. 1 are mounted on an insulating sleeve, with the primary coil left free to allow for adjustment in coupling.

Unit No. 2 contains primary, secondary, neutralizing coil, and tickler. The tickler is provided with 180 degree dial control. The tickler is also provided with an additional adjustment of coupling to conform to different characteristics of tubes or variations in plate voltage.

Among other popular Sickles products are the Tuned Radio Frequency Coil for self-neutralizing Tuned Radio Frequency Circuits, and the Knockout Reflex Coils. We manufacture coils for all popular Circuits and for special requirements.

Send for descriptive catalog

The F. W. Sickles Co.

339 Worthington Street
SPRINGFIELD, MASS.

for
Faint-
Hearted
Sets!



Vt-25 Variotransformer

After you check your batteries, tubes, transformers and fixed condensers, and spot all doubtful connections, and still the music sounds like it came from Mars, pounce on your tuner. It may look innocent yet be as leaky as some people's idea of secrecy!

The L + K Variotransformer should solve your problem. It gives you the DX amplification of two fixed R. F. Transformers, makes one tube do the work of two without reflexing, and eliminates the variable condensers usually placed across tuned R. F. Transformers, along with its losses.

It works alone in any standard hook-up, and is very effective with the L + K Variable Clarifying Selector in the aerial circuit for fine tuning. The Variotransformer is \$8.50; the Selector is \$7.00. Send for

FREE BOOK

showing complete L + K line, Greene Concert Selector hook-up, and other effective circuits. (Jobbers, Dealers—write.)

Dept. P. 654 Grand Ave. New Haven, Conn.

LANGBEIN + KAUFMAN **L+K**
High Grade "Low Loss" Tuning Devices A Guide to TECHNICAL ACCURACY

Radio  Plate

"B" BATTERIES

Can you think of a more practical Christmas gift?
And your friends will appreciate your thoughtfulness.

**DIAMOND ELECTRIC
SPECIALTIES CORP.**

102 SO. ORANGE AVE., NEWARK, N. J.
Dealers—Jobbers, Write for Proposition

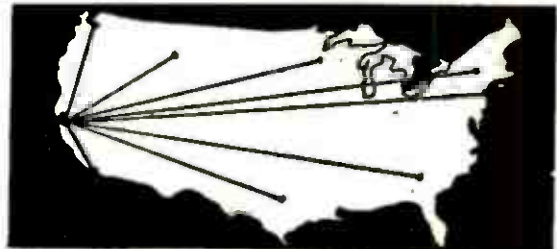

ON ONE TUBE

BIG FREE BOOKLET tells the story. California users of CROSS COUNTRY CIRCUIT hear Atlantic Coast, Canada, Cuba, Mexico and Hawaii. Atlantic Coast users hear England to California. Our new plan makes this set easiest and cheapest to build. One hour puts in operation. One tuning control. No soldering. Any Novice can do it. BIG BOOKLET FREE or complete instructions for 25c stamps or coin.

VESCO RADIO CO.

Box PR-117

Oakland, Cal.



Samson Super-Kit

Another Radio Achievement

KIT INCLUDES

- 3** Samson Long Wave Transformers
5000 meter wave length
- 1** Samson Filter Transformer
for this wave length
- 1** Samson Oscillator Coupler

*Also full information on how to
Build This Set*



All Samson Transformers are made with the
FAMOUS HELICAL WINDINGS

Remember that "Samson" stands for 42 years
of leadership in the manufacturing of electrical
specialties. Other Samson Radio products:

SAMSON AUDIO TRANSFORMERS

SAMSON PUSH-PULL TRANSFORMERS

Write for Proof of Samson Superiority

SAMSON ELECTRIC CO. :: Canton, Mass.

Sales Representatives in Larger Cities

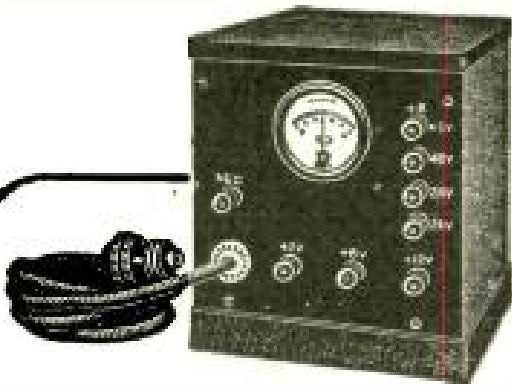

HANDY CHARGER

Charge your radio batteries while you sleep, with the Ultra Handy Battery Charger. It needs no watching. It cannot overcharge your battery. Even if left for several days no harm can be done.

The Ultra Handy Charger is very simple to operate. Merely connect the plug on the charger to any lamp socket and the charger to the battery by the two battery clips and turn on the current as you would light the electric light.

Charges Them All

Handy Charger Features

- | | |
|-----------------------|--------------------------|
| No bulbs to break | No auxiliaries necessary |
| No acids to spill | No sticking contacts |
| No fast-wearing parts | No wood used—fireproof |

The thousands of Handy Chargers in use today are the finest testimony of their popularity. Our users are our greatest boosters. Send the coupon today and learn more about this great convenience and money saver.

Ultra Charger F. O. B. St. Louis
\$ 18.00

INTERSTATE ELECTRIC Co.

4339 Duncan Ave. St. Louis, Mo.

I am interested in the Ultra Handy Battery Charger. Please send me literature and name of dealer who will gladly demonstrate.

Name

Address

City State

FREE Greatest Catalog of Radio Bargains



Send for It Today

It contains a thousand bargains of everything in radio: parts, supplies, complete parts for sets, complete sets, etc., also a mine of very latest information on all different circuits, complete list of broadcasting stations and other valuable data. Send your name and address and we'll send FREE Catalog.



American Bell Loud Speaker

\$3.95
 without unit
 \$4.95
 with unit

With American Adjustable Unit. Wonderful volume, clear reception. Speaks for itself without coaxing. 10-inch bell—made of non-vibrating material.



HEADPHONES "Randolph Special"

2200 Ohm moulded headset, properly designed to give strong and clear reception. Biggest headphone value ever offered.

Hundreds of Other Bargains

Our catalog is filled with bargains like these. Order direct from this ad. We prepay charges. Don't buy anything in radio before you see our catalog. FREE Service Dept.

RANDOLPH RADIO CORP.
 159 N. UNION AV. DEPT 278 CHICAGO, ILL.

E B Y

BINDING POSTS

Twenty-five They Don't
 Different Lose
 Engraved Tops Their Heads



H. H. EBY MFG. CO.
 Philadelphia



CARTER "ONE-WAY" Plug



Look this plug over. Compare it with all others, then you will know why set and loud speaker manufacturers have adopted it as standard equipment. There is nothing to equal it for quality, workmanship, design and service. Don't waste time and money experimenting, buy the best—buy Carter.

Any dealer can supply. Write us for Catalog. In Canada—Carter Radio Co., Limited—Toronto.

Carter Radio Co.
 1807 REPUBLIC BUILDING
 CHICAGO

The Culmination of Radio

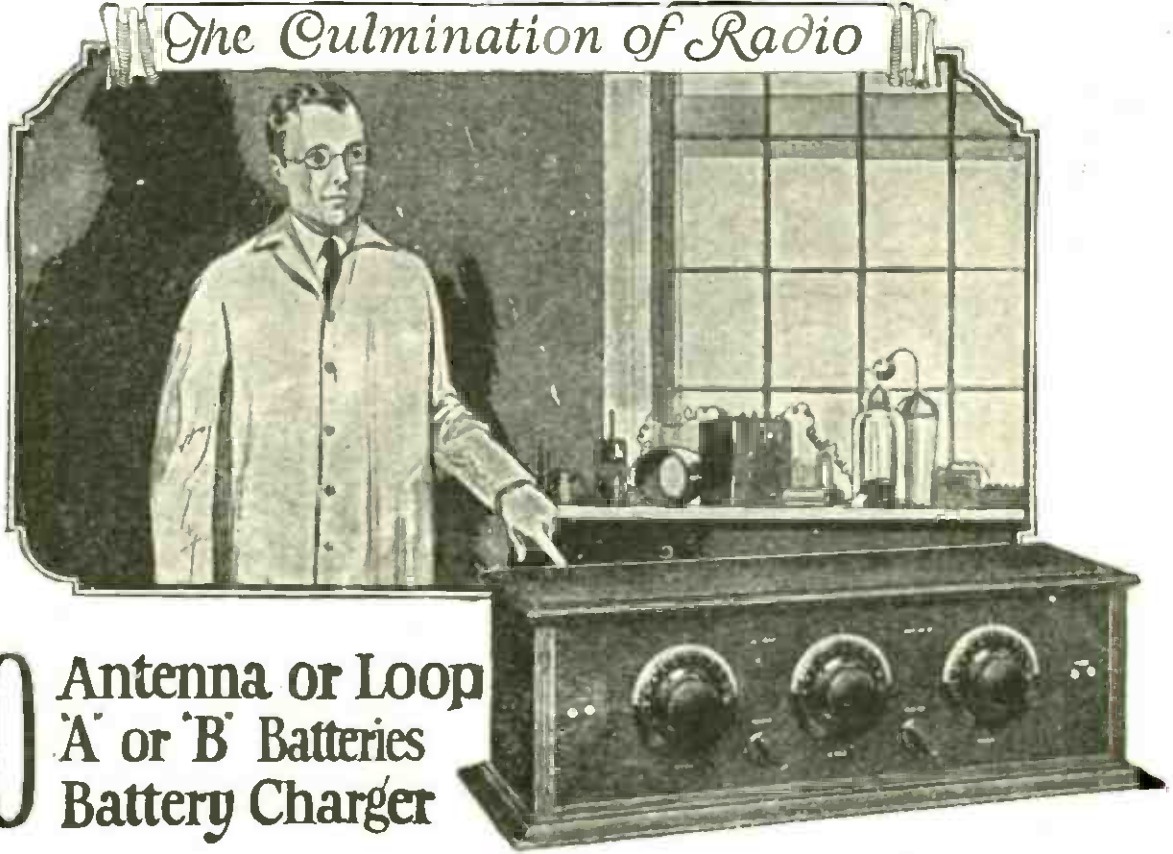

NO Antenna or Loop
A or B Batteries
Battery Charger



No Outside Aerial

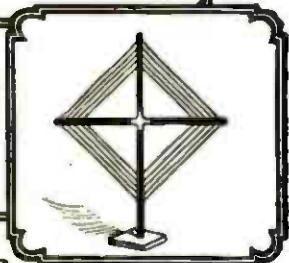

No Loop

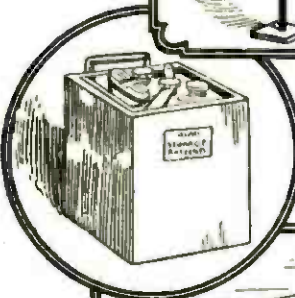

No Storage Battery

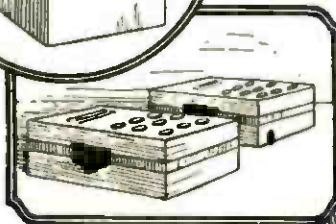

No "B" Batteries
No Battery Charger

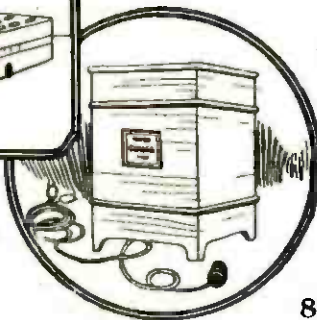

JUST plug into the nearest electric light socket, and the *Mu-Rad MA-20* will entertain you without any further attention.

The New
MU-RAD RECEIVER
MA-20

The Last Word in Radio

Cumbersome aerials and loops, mussy storage batteries, troublesome "B" batteries, and the battery chargers—all the former expensive and complicated accessories of radio—made obsolete by this "culmination of radio."

Write for Illustrated Literature and the name of the nearest store where you can see *Mu-Rad Receivers*.

MU-RAD LABORATORIES, INC.

809 FIFTH AVE ASBURY PARK, NEW JERSEY



FOR TONE AND DISTANCE

USE INSULINE PANELS!



INSULINE is a panel that is praised enthusiastically by manufacturer, dealer and amateur. It is easily engraved and machined, never warps or sags, and holds all

mounted parts like a vise.

INSULINE comes in three beautiful colors—black, black anti-capacity, mahogany—and the new frieze finish. In standard and special sizes.

INSULINE being a poor conductor of electricity, doesn't dissipate the electrical energy needed to operate your set. It gives you a silvery, mellow tone, with big volume and great distance.

For panels, dials, tubing, sockets and mounting strips—Insist that your dealer give you INSULINE

RADIO PANEL AND PARTS CORP.

59 Warren St.

(Insulating Co. of America)

New York

Western Branch: INSULATING CO. OF AMERICA, Madison, Wis.

Manufacturers, Jobbers and Dealers Write Our Nearest Branch for Booklet and Prices

Get Those Tantalizing Stations

With **E-Z-TOON** (EASY TUNE) Radio Dials

Stations close together and hard to get are brought in easily with E-Z-TOON Radio Dials. The larger dial is for coarse tuning (finding the stations) and the smaller dial is for fine tuning (tuning stations clear). The ratio of the larger dial to the smaller dial is 50 to 1. E-Z-TOON dials give that fine vernier adjustment that "Radio fans" have been longing for. Zero on either right or left.

There are no cogs, gears, backlash or lost motion. E-Z-TOON Dials require only a screw-driver to install. Take off old dials—slip on E-Z-TOON and tighten set screw. We also furnish small dials to match for Rheostats, Switches, etc.

3" Dials \$2.00
4" Dials \$2.25
2" Rheostat Dials 40c

Order from your Dealer. If he can't supply you, write

E-Z-TOON RADIO CO.
3236 W. Washington St., Indianapolis



SAFE-GUARD INSULATION

KEEP
A CAN
HANDY

MEETS every condition of the new Lo-Loss idea in radio set construction. It should be used as an insulating enamel or cement on all form wound coils, bare wires, and soldered joints. Also used to replace Spaghetti.

Safe Guard Insulation increases energy and clearness to your set by reducing current leakage.

Clear and semi-transparent colors.

Accept no Substitute

Safe Guard Insulation Co.

Landsdale

Penna.

All Radion Products MAHOGANITE and BLACK RADION PANELS

All Stock Sizes and "That Special Size for Your Phonograph, Portable, Super or Odd Size Cabinet"

WHOLESALE

RETAIL

Send for Price List

NEW YORK HARD RUBBER TURNING CO.
212 Centre Street

New York City

MAGNATRONS

large
base



TYPE
DC
199

A Better Tube

MAGNATRONS today are better tubes than they ever were before—and that is saying a great deal. MAGNATRONS occupy a front rank position among vacuum tubes; they know no superiors and very, very few equals.

MAGNATRONS have been changed both internally and externally. All types are now manufactured in the tipless form. This is an important feature; it greatly reduces the chances of accidental breakage. The bases, too, have been improved. Pure bakelite is used, thereby cutting down leakage and capacity.

The internal changes in MAGNATRONS make these tubes more fitted than ever for efficient radio frequency amplification and powerful audio frequency amplification.

MAGNATRONS are made in three types—the DC-201A, the DC-199 with the miniature base, and the DC-199 with the large standard base. The list price of all types is \$4. Your dealer will be glad to show MAGNATRONS to you.



TYPE
DC
201A

miniature
base



TYPE
DC
199

CONNVEY ELECTRIC LABORATORIES
309 Fifth Avenue NEW YORK CITY

How FIL-KO-LEAK Improves Reception

Here's a typical "grid log" which shows the need of a variable grid leak. A Fil-Ko-Leak was substituted for 1 meg. fixed leak. It was adjusted for each station until volume was greatest and distortion eliminated.

Note: only four of thirty-one stations came in with the Fil-Ko-Leak set at 1 megohm, the value of the leak it replaced.

Station	Megohms
WFAA, Dallas, Texas	5
WMH, Cincinnati, Ohio	2 1/2
WSB, Atlanta, Ga.	5
WSH, Chicago, Ill.	2
WGN, Chicago, Ill.	2
WVAI, Cincinnati, Ohio	1
WHG, Kansas City, Mo.	1 1/2
WLV, Cincinnati, Ohio	4 1/2
KSD, St. Louis, Mo.	4 1/2
WCBD, Zion City, Mo.	3 1/2
W-FAS, Elgin, Ill.	5
WOC, Davenport, Iowa	5
KGO, Oakland, Cal.	2 1/2
KFI, Los Angeles, Cal.	1 1/2
WDAR, Philadelphia, Pa.	4 1/2
WMAT, Dartmouth, Mass.	1
WBZ, Springfield, Mass.	1
WEAF, New York	3
WOO, Philadelphia, Pa.	3 1/2
WOR, Newark, N. J.	4
WVJ, Detroit, Mich.	1
WTAM, Cleveland, Ohio	2
WOS, Jefferson City, Mo.	1/2
WTAK, Oak Park, Ill.	1/2
KDKA, Pittsburgh, Pa.	3 1/2
KYW, Chicago, Ill.	3 1/2
WDBH, Worcester, Mass.	4 1/2
KFNF, Shenandoah, Iowa	5
WQJ, Chicago, Ill.	3 1/2
WDAF, Kansas City, Mo.	1
WHK, Cleveland, Ohio	1 1/2



Improved Reception with FIL-KO-LEAK

YOU can "log" your FIL-KO-LEAK just as you do your other tuning units. You will get stations you never heard before. You will clear up distortion on nearby broadcasters and increase volume of weak, distant stations and get them with crystal clarity. You read FIL-KO-LEAK resistance in exact terms of the megohm through a peep-hole in the panel. (It's also equipped for baseboard mounting.) Resistance element is constant and accurate, and is not affected by atmospheric conditions, wear or jarring. Every FIL-KO-LEAK is guaranteed to be perfect electrically and mechanically, and to be accurately calibrated over the operating range for all tubes (1/4 to 5 megohms). This calibration is doubly checked. Send 2c stamp to Dept. P. R. 125 for literature on improved reception.

FIL-KO-LEAK \$2
SCIENTIFICALLY CORRECT VARIABLE GRID LEAK
Individually Calibrated In Canada \$2.90

If your dealer has none, send his name with remittance direct to
DX INSTRUMENT CO.
Harrisburg Pa.

Tuning Feature Directional Can Be Logged Collapsible



Patent Applied For

KORACH TUNED LOOP

Positively the last word in loop construction. Gives remarkable results because it may be tuned and logged. Exclusive features give you Selectivity and Distance unheard of before with loop aerials. We want you to see for yourself. So send at once for our

GUARANTEED TRIAL OFFER

We will send this loop on ten days' trial. You are the judge. Simply send \$2.00 as a good faith deposit with your order. Deposit balance (\$14.50) with Postman when loop arrives. Try it for ten days. If not perfectly satisfied in every way, return and you get the \$16.50 back WITH NO QUESTIONS ASKED. You take no risk! Our offer is guaranteed, so send now.

HERMANSON-KORACH MFG. CO.
309 So. LaSalle St. Dept. 8 Chicago, Ill.

Full Particulars on Request

Dealers and Jobbers who are rated: We will ship sample on memo. invoice for inspection and test. Write today.

VOLT-X VARIABLE GRID LEAK

Give Your Tubes a Chance

The Grid Leak determines the efficiency of your set. The proper Grid resistance varies for each tube, and the conditions under which it operates.

VOLT-X GRID LEAKS are positive and smooth in action with an accurate range of from 1/4 to 15 megohms. They fit any standard leak mounting, and get the absolute maximum from your tubes.

Grid Leak \$1.00
Grid Leak Mounting .30



BURTON & ROGERS MFG. CO.
755 BOYLSTON ST. BOSTON MASS.

ATWATER KENT R A D I O

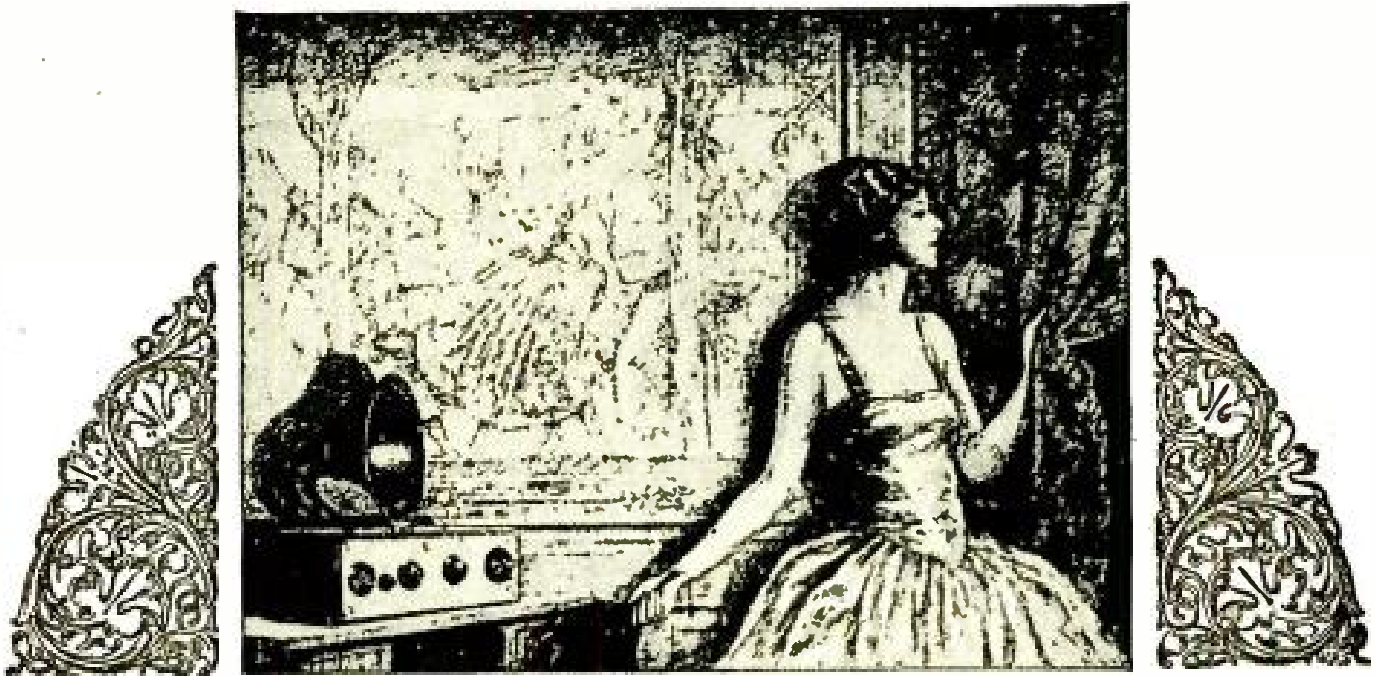

FOR the owner of Radio there is more and better broadcasting than ever before. Concerts, operas, lectures, sermons, educational courses, market, weather and special reports, and always the thrill of unexpected announcements of important happenings.

ATWATER KENT Radio in your home will assure you countless evenings filled with joy.

You will find ATWATER KENT Receiving Sets and Loud Speakers well within your means. To fully appreciate their many advantages, see the new Models at any radio dealer's.

Note the materials used in their construction;

the best that money can buy. Feel how smoothly the dials turn; that's but one example of their master workmanship. And then listen to the remarkable reception. Note the ease with which you can bring in stations, with ample volume, even from a distance.

For selectivity, distance, volume, clear reception, simplicity of operation and beauty of design, ATWATER KENT Radio is unexcelled.

These qualities your radio must have to give you perfect satisfaction. Be sure of getting them all by buying ATWATER KENT.

Instructive literature on request

ATWATER KENT MANUFACTURING CO., 4712 Wissahickon Ave., PHILADELPHIA, PA.

THINK OF WHAT IS BACK OF IT

Pacific Coast prices slightly higher

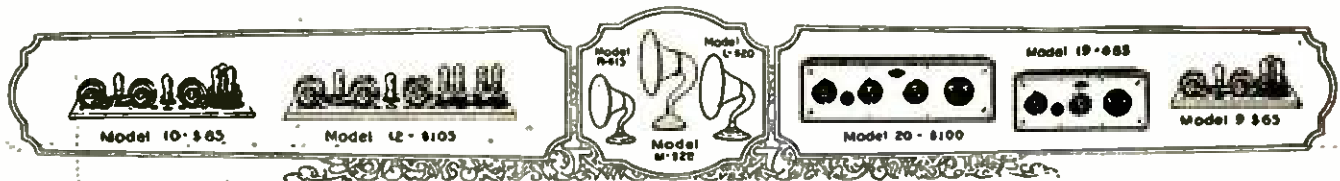

All apparatus advertised in this magazine has been tested and approved by POPULAR RADIO LABORATORY

Junk Your "B" Batteries

Use the

MU-RAD B Radiator

End of "B" battery troubles—noises, "fading" and frequent replacement. "B" battery current steady, uniform ALL THE TIME. A practical instrument—not an experiment. Supplies current enough for sets using as many as 8 tubes. No generator hum. Absolutely harmless, does not interfere with lighting current: protected against damage to itself. See the B-Radiator at work in your Dealer's Store.

Write for Literature and the
Name of the Nearest Mu-Rad Dealer

MU-RAD LABORATORIES, INC.
809 FIFTH AVE ASBURY PARK, NEW JERSEY



WHAT IT IS

Primarily the Mu-Rad B-Radiator is an instrument for transforming ordinary house-lighting current (110 Volt, 60 cycle alternating current) into the same sort of current as was formerly obtained from B batteries. Not in the least complicated to use—the plug on the end of the cord attached to the B-Radiator is screwed into any lamp socket just as you attach a vacuum cleaner, electric heater or iron. The wires which formerly lead to the "B" batteries are connected to the binding posts on one end of the B-Radiator. Takes up little more room than one 45-Volt B Battery—the metal box is 6" wide x 4 1/2" deep x 10" long. Uses ordinary UV-201-A or C-301-A vacuum tubes.

Astonishing Loop Results On Super-Het Circuits

The many advantages of loop reception have now been increased by the remarkable new Bodine Low-Loss Folding Loop. The stranded wire used is bank-wound on the basket-weave principle. With circuits sufficiently sensitive for loop operation, especially the Super-Heterodyne, the Bodine makes the set more selective, increases DX range, cuts down static and interference, and through lowered resistance and distributed capacity materially increases volume and clarity. You must SEE the Bodine to fully realize its big advance over the old-style loop.

If your radio dealer cannot supply you, you may send order direct to us. Shipped post-paid on receipt of \$8.50 and your dealer's name. Special Tapped Loop for Inverse-Duplex. \$10. Be sure to give make or type of circuit used.

BODINE
BASKET-WEAVE
LOOP AERIAL

BODINE ELECTRIC CO.
2256 W. Ohio Street
Chicago, Ill.

The
Low-Loss
Loop
Aerial

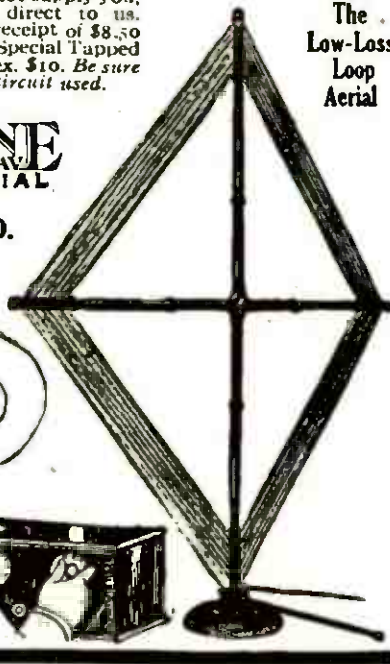

GREWOL

The

PERMANENT DETECTOR

\$1.50

Patented May 15, 1923
Serial No. 1464997
Infringement subject to
prosecution

Reflex Crystal

Insures greater distance, selectivity, sensitivity. Replace your present crystal with the Grewol Fixed Detector. All you need to improve your set.

2 IN 1 CRYSTAL
Two surfaces instead of only one. Double life, double value. 50c

At your dealer's, or direct.
Mention dealer's name.

2 IN 1

GUARANTEED BY

GREWOL MFG. CO.

NEWARK, N.J.

HEATH RADIANT

Non-Dielectric Condensers



Marconiphone

Used by

MARCONI

Grounded Metal End Plates

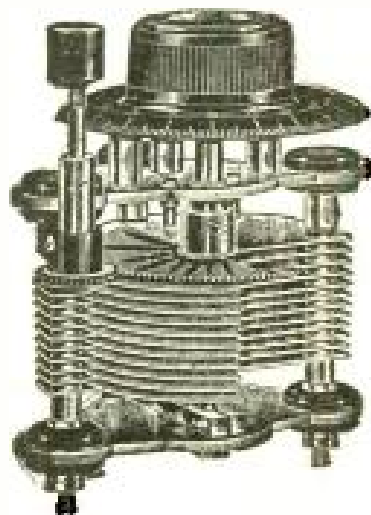

Permanently Flat Plates

Stamped under huge presses to absolute flatness, tempered to prevent warping.

Micrometer Geared Vernier

Ordinary adjustments reduced by separate geared adjustment to hairbreadth distinction. We guarantee the Heath Vernier Condenser to be more highly selective than any condenser employing a vernier which actuates ALL of the plates.

IN designing a receiver to bear the magic name of "Marconi" only the most *dependable* instruments were safe even to consider. The eventual selection—after exhaustive research and tests—of HEATH CONDENSERS for this famous receiver, tells a convincing story of *lasting dependability*—the hidden extra value that you get with every Heath Condenser.

PRICES FOR VERNIER CONDENSERS

		With Dial	Without Dial
No. 12AV	12 Plate.....	\$5.00	\$4.35
No. 24AV	24 Plate.....	5.50	4.85
No. 44AV	44 Plate.....	6.50	5.85

Non-Vernier types in all capacities.

Heath Sockets with the Exclusive Shock Absorber Feature, Price 75c. Heath Genuine Bakelite Dials in 3 diameters

See these Heath Products at your dealer's

Write for Literature

**HEATH
Electric**

204 First
Street

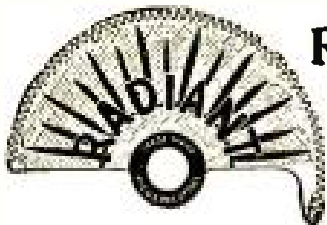

**RADIO &
Mfg. Co.**

Newark,
N. J.

Canadian Distributors: Marconi Wireless Telegraph Co. of Canada, Ltd., Montreal, St. Johns, Vancouver, Winnipeg, Halifax and Toronto.



BAKELITE

Trade Mark Reg. U. S. Pat. Off.

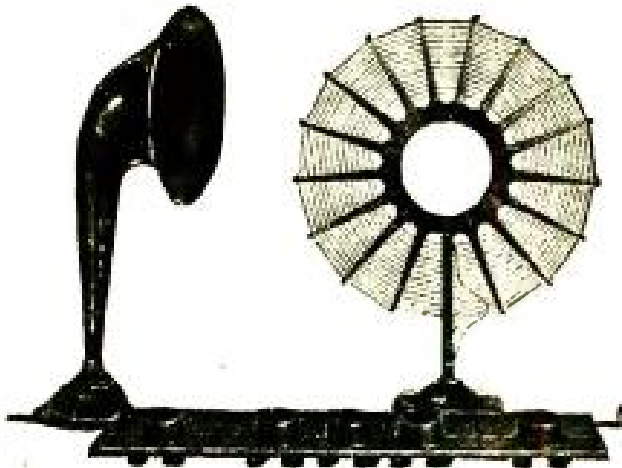

A constant factor in radio development

Radio design progresses rapidly—but radio's standard insulation continues to be Bakelite.

For the further refinement of radio sets and parts, radio engineers rely upon Bakelite. Typical of many new Bakelite applications are the Musette Loud Speaker, the Paramount Loop and the Amsco Tube Mounting Panel.

Of all insulating materials Bakelite alone combines the many characteristics vital to efficient radio reception.

Write for booklet "K"

BAKELITE CORPORATION

247 Park Avenue, New York, N. Y.
Chicago Office: 636 West 22d Street



Send for our *Radio Map*

The Bakelite Radio Map lists the call letters, wave length and location of every broadcasting station in the world. Enclose 10 cents to cover the cost and we will send you this map. Address Map Department.

THE MATERIAL OF A THOUSAND USES

"NOL-LOS" Variable Condenser \$4.00

- 1—Sharp Tuning
- 2—Perfect Shielding
- 3—No Body Capacity
- 4—Mechanically Rugged
- 5—Easy to Install
- 6—Built to All Capacities
- 7—Losses so Low that they are negligible

The Perfect Condenser for Any Circuit

"Nol-Los" the Perfect Condenser appeals strongly to every Radio Fan and Scientific Experimenter. Built of aluminum, it is mechanically rugged and easily mounted in any position requiring only one hole in panel.

Its superiority over any other Condenser produced is universally acknowledged.

It has withstood the severest laboratory tests.

When buying a Condenser, ask for "Nol-Los"

Dealers and Jobbers write for terms.

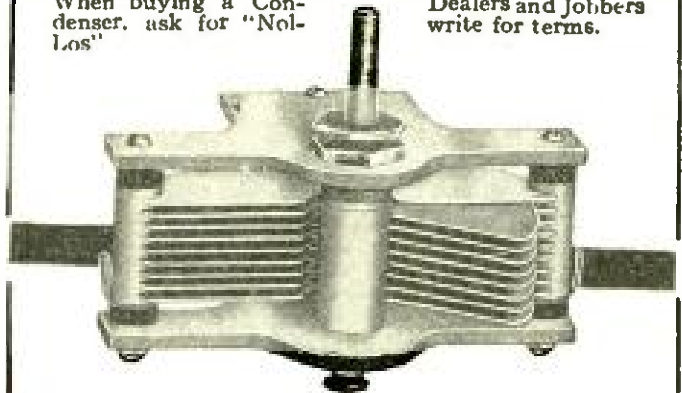

B. Crosser Sons Co., Inc.
55B Sudbury Street, Boston, Mass.



12 Cells
24 Volts
Solid Rubber Case

\$3.50 SPECIAL INTRODUCTORY PRICE

For a limited time *only*, and to introduce this new and superior Storage "B" Radio Battery to the Public, we are selling it for \$3.50. Regular Retail Price is \$5.50. You save \$2.00 by ordering NOW. A finer battery cannot be built than the

World Storage "B" Battery (12 CELLS—24 VOLTS)

To ten million homes with Radio Sets—and to countless millions of prospective buyers—this World Storage "B" Battery brings a new conception of battery economy and performance. Here is a battery that pays for itself in a few weeks—will last for years and can be recharged at a negligible cost. And you save \$2.00 by ordering now.

A Superior Battery Equipped With Solid Rubber Case

Has heavy duty 2 1/8 in. x 1 in. x 1-4 in. plates and plenty of acid circulation. Extra heavy glass jars allow ready observation of charge and prevent leakage and seepage of current. Recharging charge, while idle, at constant voltage. You will find this battery a boon to long distance reception. It does away with a great many noises so often blamed on "static." Mail your order today.

SEND NO MONEY

Just state number of batteries wanted and we will ship day order is received. **EXTRA OFFER:** 4 batteries in series (96 volts) \$13.00. Pay Expressman after examining batteries; 5 per cent discount for cash in full with order. Send your order NOW and save \$2.00.

WORLD BATTERY COMPANY
Makers of the famous World Radio "A" Storage Battery
1219 S. Wabash Ave., Dept. 77 Chicago, Ill.

SAVE \$2.00 BY ORDERING NOW!

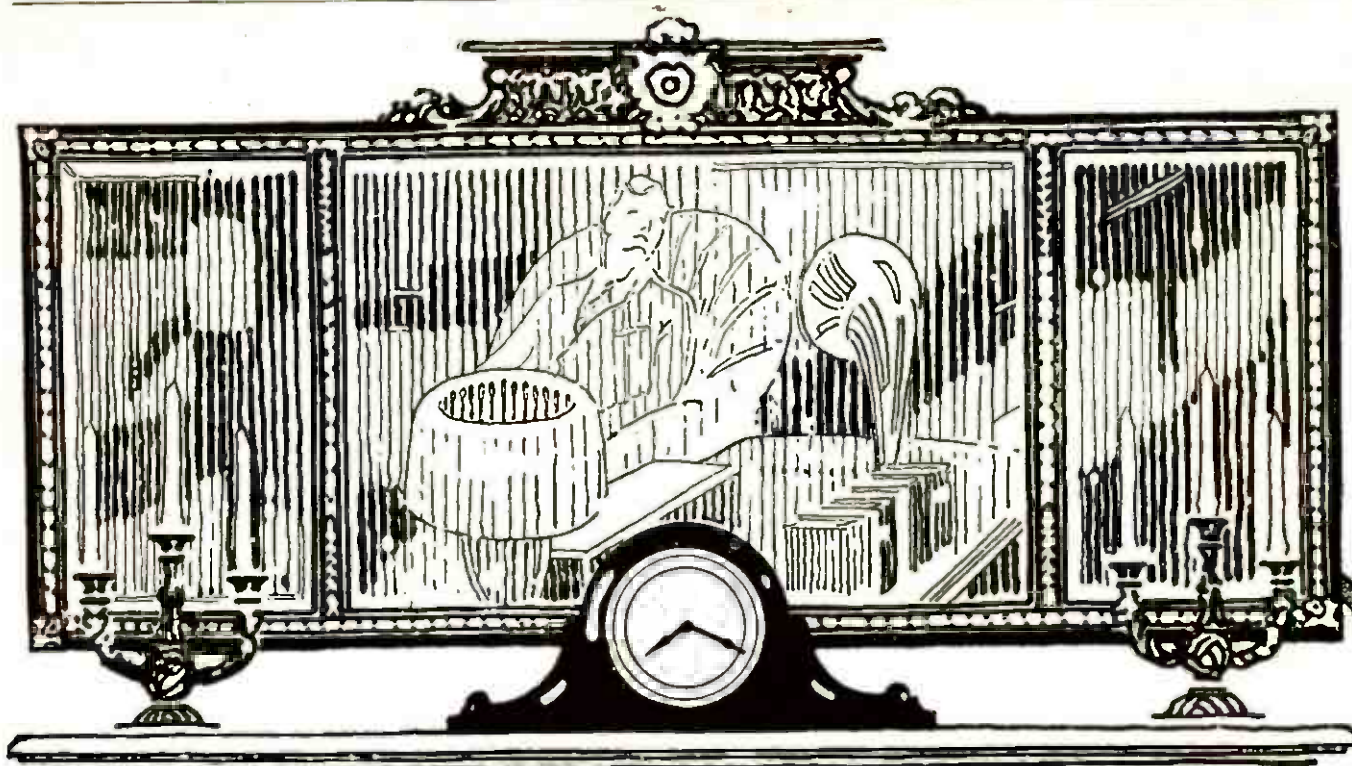

!! Perfect Reception - Indoors - Anywhere !!

THERE are so many places to use TALKING TAPE—indoors. It adapts itself anywhere.

TALKING TAPE is flexible—yet strong—and is easily handled without kinking or curling. Its twelve parallel strands of flat metal, woven with the fabric, provide maximum receptive surface with minimum bulk, and bring in distance with surprising quality and volume. Wonderfully selective, too.

TALKING TAPE works perfectly with all types of receivers—tube or crystal. Buy two or three boxes from your dealer today—and use it indoors in different rooms in different ways. Various suggestions for use are given with each box.



Manufactured by
HOPE WEBBING COMPANY

For Forty Years
The World's Largest Manufacturers of Electric Tapes
PROVIDENCE, R. I.

TALKING TAPE

**The Perfect
Radio Aerial**

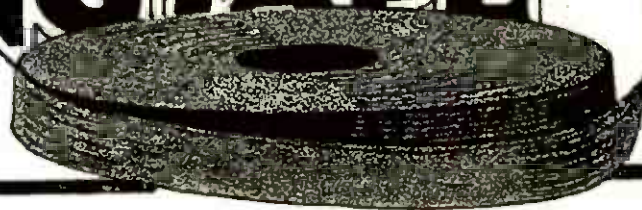

All apparatus advertised in this magazine has been tested and approved by POPULAR RADIO LABORATORY



A sensation among radio fans!

Like countless others, you too will welcome the results given by Airtron Tubes. Due to their improved, scientific construction, every syllable and note comes in on an Airtron flawlessly clear, round, full and natural in tone. And they're guaranteed for *stamina*—good, long, active service. Used and endorsed by radio authorities.

Type 200, 6 Volt, 1 Amp. Det.

List Price Type 12, 1½ Volt, .25 Amp. Det. and Ampl.

Type 201A, 5 Volt, .25 Amp. Det. and Ampl.

\$4.00 Type 199, ¾ Volt, .06 Amp. Det. and Ampl.

Sold by all dealers, or shipped C. O. D. direct by parcel post. Mention type when ordering.

H. & H. RADIO CO. Dept. 102. 514 Clinton Avenue, Newark, N. J.

DEALERS—Write for discounts

AIRTRON

RADIO TUBES



THE LOST CHORD

is not lost when you stop the leakage of antenna energy with PYREX insulators.

PYREX, the all-weather insulating material, delivers all the energy to your set.

At the Better Dealers
PRICE 45c EACH

CORNING GLASS WORKS

Industrial Division

CORNING

NEW YORK

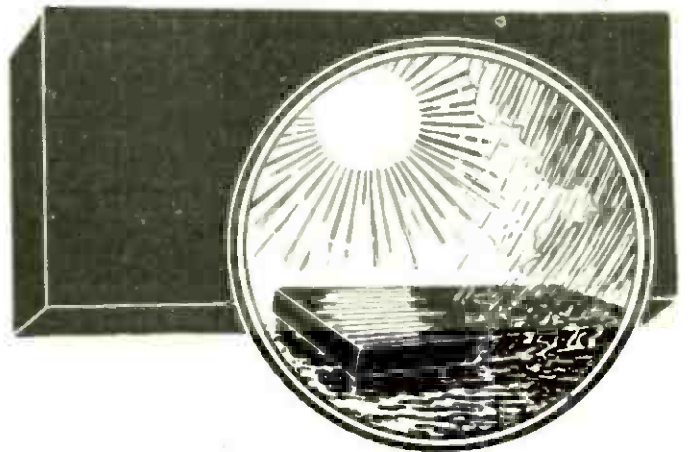

won't warp or swell?

Heat won't warp a Bakelite-Dilecto panel and water won't make it swell. No weather element can change its form or sleek finish.

bakelite-dilecto

(Distinguished by its Red Stripe)

Makers of finest radio sets use Bakelite-Dilecto for panels. Amateurs who make their own outfits know it to be the most satisfactory material known. Used ten years in the U. S. Navy and Signal Corps.

THE CONTINENTAL FIBRE CO.
Factory: Newark, Delaware

Service from:

New York, Woolworth Bldg.
Chicago, Wrigley Bldg.
Pittsburgh, 301 Fifth Av.

San Francisco, 75 Fremont St.
Los Angeles, 307 S. Hill St.
Seattle, 1041 Sixth Av., So.

All apparatus advertised in this magazine has been tested and approved by POPULAR RADIO LABORATORY

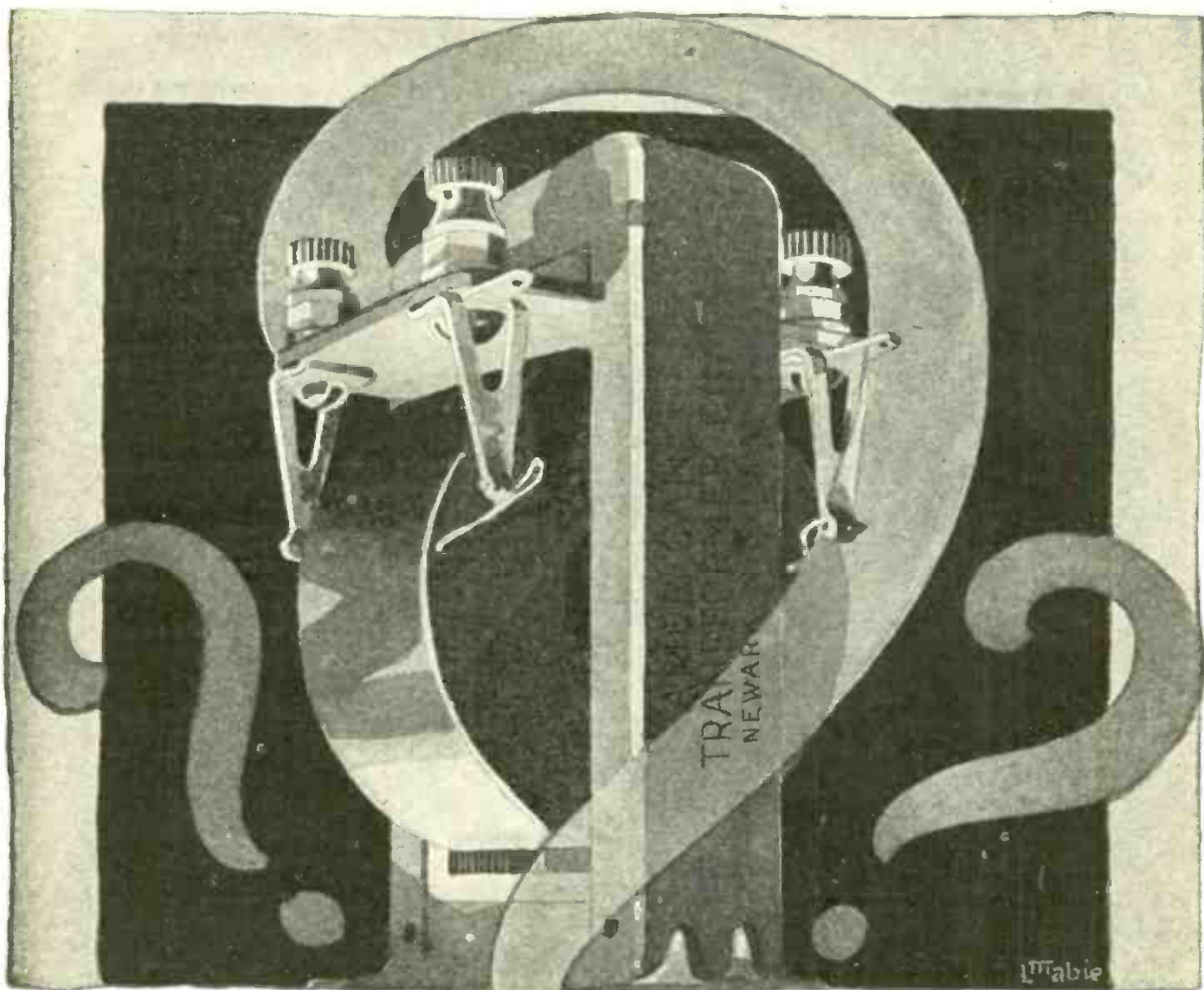

Is AmerTran the best

AmerTran is recommended to you as the "best" audio frequency transformer because:

AmerTran gives the *most* uniform amplification. All tones are amplified nearly alike.

AmerTran insures amplification of the *highest* order with minimum distortion.

AmerTran makes tubes deliver the *utmost* in volume, clarity and tone quality.

Use a pair of AmerTrans and you have *the* combination to get *all* two stages can possibly deliver.

AmerTran is made in two types, one quality — A F 6— Ratio 5:1 and A F 7—Ratio 3½:1. Buy them by the pair!

AMERICAN TRANSFORMER COMPANY

181 EMMET STREET, NEWARK, N. J.

"Transformer builders for over twenty-three years"

Price either model \$7.00 at your dealer's.

AMERTRAN
TRADE MARK REG. U.S. PAT.

Send for leaflet giving useful amplifier information.

All apparatus advertised in this magazine has been tested and approved by POPULAR RADIO LABORATORY

More Adventures of **BURGESS** RADIO BATTERIES

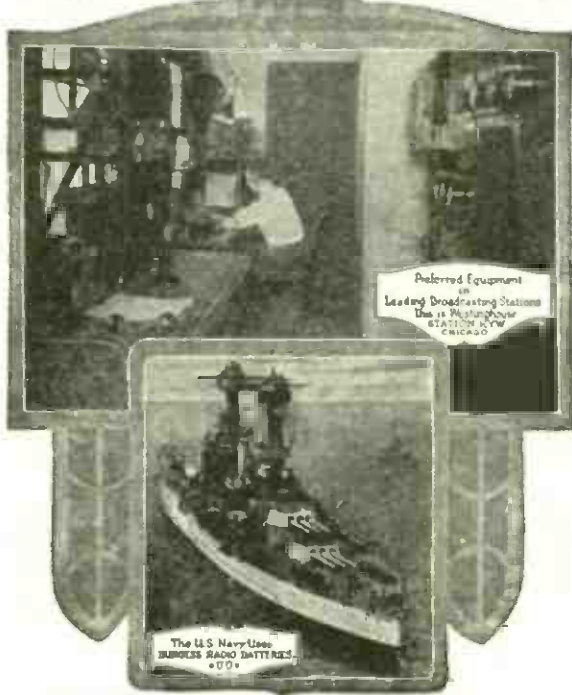

U. & U. Photo

The same Burgess Radio 'A', 'B' and 'C' Batteries which are today faithfully serving the nation's armed forces on land and sea and in the air, and used by leading radio broadcasting stations, experienced radio engineers and amateurs, are sold in your own community by your own dealer for your own receiving set.

When you replace your old batteries, ask your dealer for Burgess. Insist upon this brand of laboratory products—you will receive the same measure of satisfactory service that has won the confidence of the radio public.

"Ask Any Radio Engineer"

BURGESS BATTERY COMPANY

Engineers DRY BATTERIES Manufacturers
Flashlight Radio Ignition Telephone

General Sales Office: Harris Trust Building, Chicago 11

Laboratories and Works:
Madison, Wisc.

In Canada:
Niagara Falls and Winnipeg

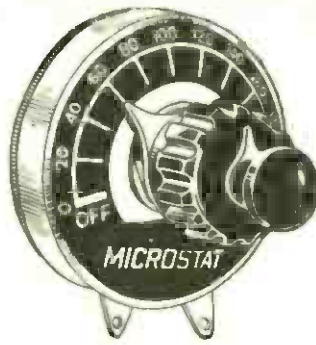

Premier Microstat The Sliding Scale Vernier Rheostat Fine Tuning Made Easy

Premier "MICROSTAT" is a wonder for tuning in the distant stations. Stands alone in its fineness of adjustment and minute control. Two resistor units—one six ohms and one forty ohms—connected in parallel. Vernier adjustment on high resistor. Noiseless in operation. Insures perfect freedom from sputtering and scratching.

Premier "DUOSTAT" combines two rheostats in one. Provides all necessary control of two tubes with one panel mounting.

Premier Double Disconnect Potentiometer is the last word in plate current control. Its special feature, a double break switch, automatically disconnects "A" and "B" batteries when lever is off. Absolutely prevents battery waste and tube burn out danger.

All three above instruments are typical in design. Each requires only one hole in panel. Bakelite moulded. Silver etched dials. Many other superior features. All one price—\$2.50 each.

Write for Free Bulletin No. 94 showing complete line of Premier Quality Radio Parts. Ask your dealer if he has Premier free hook ups. If not, send his name and receive a set free.

Premier Electric Company

3807 RAVENSWOOD AVE., CHICAGO

PREMIER Quality Radio Parts



Accurate Capacity Instantly

Reads directly in microfarads from .000005 to .021 in successive steps of .000005 mfd.

Manufacturers, Jobbers and Dealers write for details and prices. You will find this instrument indispensable in accurately classifying, testing and matching the capacity of fixed and variable condensers.

Originally designed and used to commercially test Ben Franklin Micadensers, the all metal and mica fixed condenser.

Most popular Micadenser Capacities priced as follows:

.0001 to .0005 - 35c. .0006 to .0025 - 45c.
.005 - 60c. .006 - 75c. .015 - \$1.75
.00025 with Bracket for Grid Leaks - 45c.

Micadensers in Matched Pairs (warranted exactly same capacity) at 25c a pair additional.

We will furnish any exact capacity value in Micadensers at 10c. above regular price.

At all good Jobbers and Dealers. If dealers can't supply, Ben Franklin Micadensers will be sent prepaid, on receipt of remittance with order.

THE BEN FRANKLIN RADIO MANUFACTURING COMPANY
2650 Superior Avenue
Cleveland, Ohio

All apparatus advertised in this magazine has been tested and approved by POPULAR RADIO LABORATORY

AMPLION

The World's Standard Loud Speaker

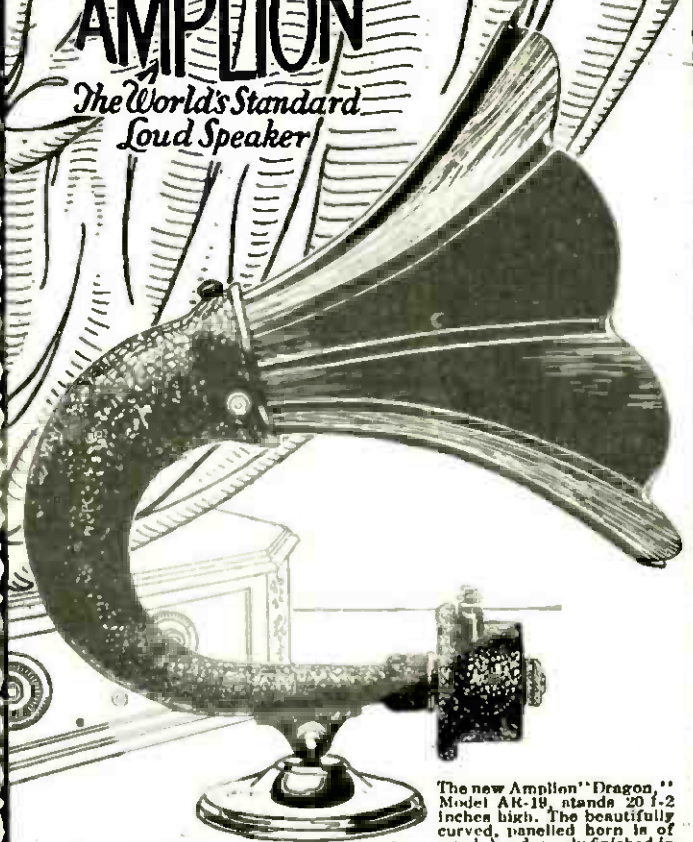

The new Amplion "Dragon" Model AR-18, stands 20 1/2 inches high. The beautifully curved, panelled horn is of wood, handsomely finished in mahogany. The acoustically correct, exclusive "dragon shape" of the sound conduit provides—in compact space—exceptionally long tone travel with gradual amplification. Also, this conduit is non-resonating, being rubber insulated at both ends. Crystalline enamel on both sound conduit and unit adds further beauty to appearance. The weighted nickel-plated base is hinged to permit tilting the horn to any angle. The Amplion "Floating Diaphragm" unit may be removed and with proper adaptor attached to a phonograph whenever desired. No battery or power amplifier required. Price \$42.50.

mahogany. The acoustically correct, exclusive "dragon shape" of the sound conduit provides—in compact space—exceptionally long tone travel with gradual amplification. Also, this conduit is non-resonating, being rubber insulated at both ends. Crystalline enamel on both sound conduit and unit adds further beauty to appearance. The weighted nickel-plated base is hinged to permit tilting the horn to any angle. The Amplion "Floating Diaphragm" unit may be removed and with proper adaptor attached to a phonograph whenever desired. No battery or power amplifier required. Price \$42.50.

Pedigree of the AMPLION

- In 1887—Mr. Alfred Graham demonstrated the first practical loud speaker which the world had ever heard.
- In 1893—Graham Loud Speakers commercially produced.
- In 1894—Graham Loud Speakers first used in the British Navy. Graham transmitters applied to phonographs for loud speaking reproduction.
- In 1896—Graham loud speaking naval telephones adopted by the British Admiralty.
- In 1898—Graham Watertight Loud Speakers patented. Placed on many warships and mercantile vessels throughout world.
- In 1902—Complete Graham Loud Speaker installations, on central battery plan, erected on warships as the sole means of communication aboard ship.
- In 1906—The most extensive loud speaker naval installation to date, made by Gramams, including a Graham exchange system fitted to British warship "Dreadnought".
- Onwards—Graham Loud Speakers applied to all sorts and conditions of service in many countries and on many seas.
- By 1919—No less than 12,000 Graham loud speaking installations in operation on ships alone.
- In 1920—(Long before other loud speakers were thought of!) "AMPLION" Loud Speakers produced for wireless by Alfred Graham & Co. "AMPLION" trade mark registered.
- In 1922—AMPLIONS adopted as standard equipment by leading makers of radio sets abroad.
- In 1923—AMPLIONS introduced into the United States, Canada and remaining portions of the world.
- In 1924—Impossibility of importing AMPLIONS fast enough to supply demand made it necessary to form The Amplion Corporation of America to market and manufacture AMPLIONS on this side.

favorite of the world's music lovers!



Amplion "Junior Deluxe" AR-114, \$27.00



Amplion "Junior" AR-111, \$24.00



Amplion Phonograph Units, \$19.50



Amplion "Dragonfly" AR-102, \$13.60*

*Price slightly higher in the far west.

SHOULD NOT the world's oldest makers of loud speakers rightly be expected to create the world's finest loud speakers?

The Amplion is their development.* You have only to see it, to hear it in comparison, to understand why it has become the largest selling loud speaker—the favorite of music lovers in all quarters of the globe.

For sensitivity, clarity and natural tone throughout the entire musical range—for volume without distortion—the Amplion is supreme. As your ears will testify. You will never know the true merit of your set until you hear it over an Amplion. A treat awaits you. Visit your dealer's store for a comparison. Literature on request.

THE AMPLION CORPORATION OF AMERICA
 Executive Offices: 280 Madison Avenue, New York City
 Canadian Distributors: Harrold of Canada, Ltd., 175 King St. West, Toronto
 * Alfred Graham & Co., London, England, patentees

**RADIOLA III—FREE
with course**

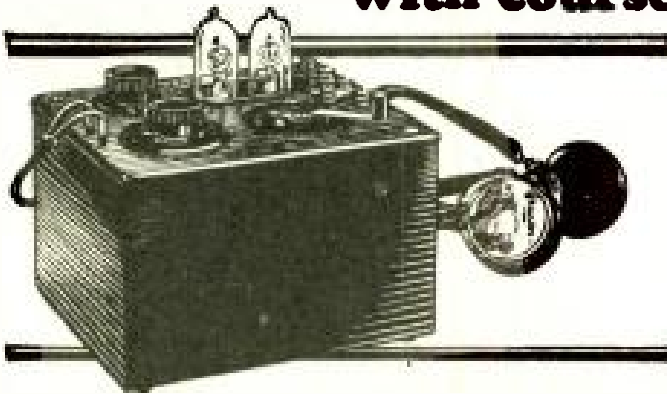

**A Life Career
for YOU in RADIO**

Thousands have won success in radio. Right now our graduates are voyaging to foreign ports as radio operators—ships' officers—with good pay—and no expense for rations and quarters. And hundreds of them are holding high salaried positions on land.

You, too, can earn big pay—and visit strange lands—or win success in radio right in this country! A few months of interesting study at home on the special Home Study Course of the Radio Institute of America and you can secure your Government Commercial Radio License—and your first radio job.

**RADIOLA III—FREE
with course**

The course is a new one, completely revised. New text-books. Radiola III with two tubes and Brandes headset and other exceptionally high grade apparatus free with course. Experts correct and grade your papers and answer all your questions. The most comprehensive and up-to-date radio instruction obtainable anywhere.

Don't delay. Fill out the coupon and send it today for our new booklet.

Radio Institute of America
(Formerly Marconi Institute)
Established in 1909
322A Broadway, New York City

RADIO INSTITUTE OF AMERICA
322A Broadway, New York City

Please send me full information about your Home Study Course of radio instruction.

- I am interested in the complete course including code instruction.
- I am interested in the technical course without code instruction.

Name.....

Address.....

FORE'S MASTER FORE BATTERY CHARGER



Charges Radio A-6 Volt and 48 Volt B Battery in Series or 2-48 Volt B Batteries in Multiple Any Charging Rate.

Charges 6-Volt Automobile Batteries. The Fore Battery Charger will make anyone proud of his radio set.

Call at your jobber or dealer for them or write either address below for advice as to where they can be obtained.

Manufactured by
Fore Electrical Mfg. Co.
5255 N. Market Street
St. Louis, Missouri

Sales Department
The Zinke Company
1323 S. Michigan Blvd.
Chicago, Illinois

The Morrison TONER

**SMOOTH
CLEAR
ELIMINATES ALL
HARSHNESS**



Just another step forward in reproducing radio's real tone values—that's what the Toner does. Leading engineers say this. Fans who want the best can have the pure tones, exactly as they are broadcasted, free of all the peculiar noises of radio, free of the harshness common in long distance work.

Anyone can attach a Toner to his set in a moment's time. From then on he can't hear a radio program with enjoyment without a Toner. Adaptable for all sets using one or more stages of audio frequency.

You can add another tube for 3 steps of audio frequency by using the Toner.

A handsome, nickel plated instrument. Sold on Morrison money-back guarantee.

2-Color Radio Book Free

MORRISON LABORATORIES, INC.
345 East Jefferson Ave. Detroit Mich.
Manufacturers of the famous Morrison Loud Speaker

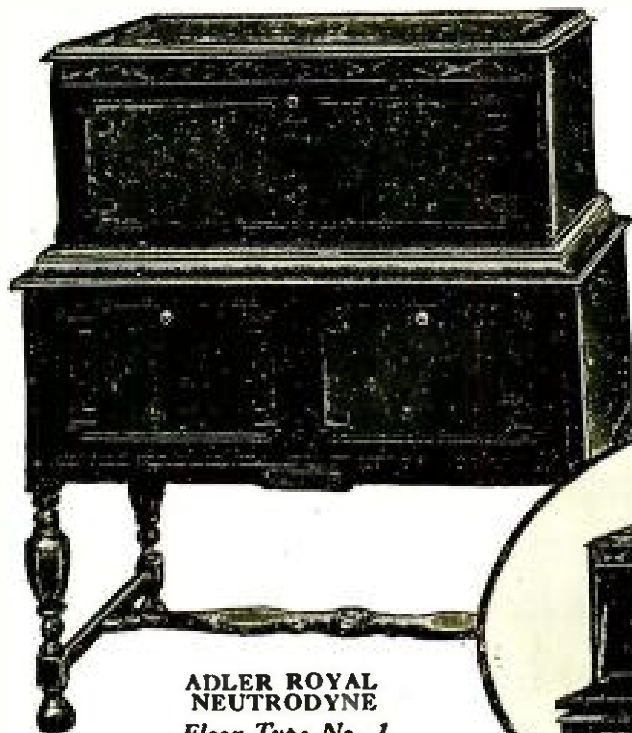

**ADLER ROYAL
NEUTRODYNE
Floor Type No. 1
ELIZABETHAN**

\$350.00; loud speaker built in, without tubes or batteries; other styles \$160.00 and upwards.

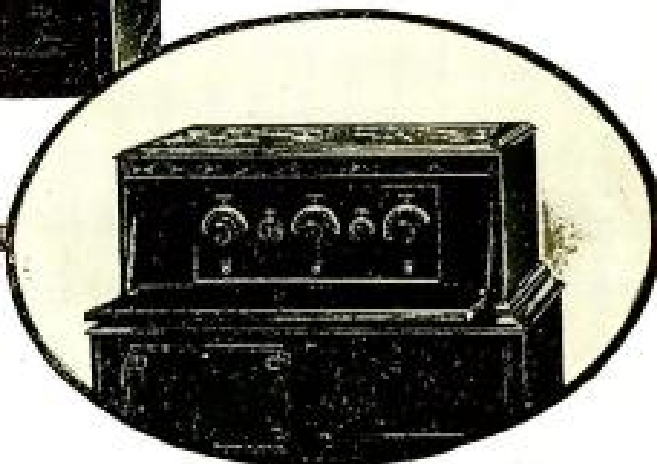

**Every Radio Owner Will Want
This Free Log Book**

SEND the coupon below to-day for your copy of a fascinating booklet describing the complete Royal line of radio sets, phonographs and combinations, with prices, together with a log book of principal sending stations to make your own records of dial readings.

Adler-Royal 5 Tube Neutrodyne

*Set 199 designed and built for dry cells
Set 201-A designed and built for storage batteries*

ADLER-ROYAL Neutrodyne incorporates the most recent advances in Radio engineering. You have your choice of two different styles. Set 201A operates on the usual "A" storage battery. Set 199 is designed and built to operate on dry cells. Wave amplifiers not only produce exceedingly high wave reinforcement but at the same time they are extremely selective.



Adler-Royal Neutrodyne 201A

Control for audio frequency and radio frequency is separated. In simplified language this means that when a station is amplified, the de-

sired tone volume is obtained without distortion.

Remarkable selectivity

EVEN in the hands of a beginner, it has been possible to tune in on twenty-five stations the first night. The Adler-Royal Neutrodyne not only meets the needs of those who are simply interested in broadcasting reception, but for the radio expert, it will more than satisfy. Wired like the finest telephone switchboard and with power to amplify that is remarkable, it may be truthfully said that "the air holds no secrets from an Adler-Royal Neutrodyne."

Adler-Royal is on exhibit only at the higher class stores whose reputation is an additional guarantee of the quality of the Royal line.

ADLER MANUFACTURING COMPANY, INC.
General Sales Office: 881 Broadway, New York City
Factories: Louisville, Ky.

Adler-Royal NEUTRODYNE



The Adler-Royal Neutrodyne is licensed under the Hazeltine Neutrodyne Patents and manufactured for us by King-Hinners Radio Co.

ADLER MANUFACTURING CO.
881 Broadway, New York City. PR-1
Please send me the Adler-Royal illustrated Booklet and Log.

Name.....

Address.....

All apparatus advertised in this magazine has been tested and approved by POPULAR RADIO LABORATORY

BARKELEW

Porcelain Pedestals

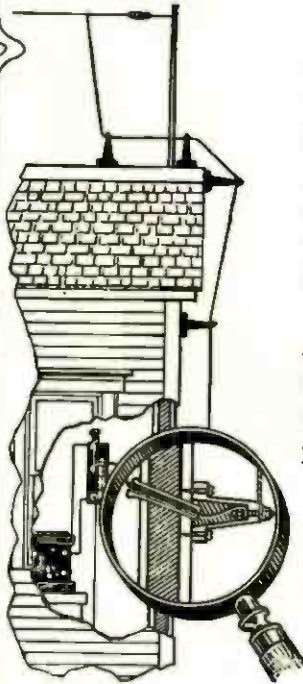

AN insulator with a rigid clamp for the lead-in wire.

A pedestal mounting for Ground Switches, Lightning Arrester Switches or Lightning Arresters.

An insulating spacer for mounting free of table or wall, any other piece of apparatus.

In all cases it spaces the apparatus 5" clear of the mounting surface.

This brown glazed Porcelain Pedestal has so many different applications that it at once becomes a fast moving stock article.

Two wood screws 2" long are furnished with each pedestal.

For full description see our Radio Catalog No. 32 at your dealer. If he hasn't his copy, we have one for him.

The Barkelew Electric Mfg. Co.
Middletown, Ohio, U. S. A.



BROWN GLAZE
No. 611 Price \$.40 ea.



CHICAGO, 15 Clinton St.
DETROIT, McKerchey Bldg.
DENVER, Denham Bldg.

NEW YORK, 157 Chambers St.
WASHINGTON, D. C., Mills Bldg.
MINNEAPOLIS, 1017 Lumber Exch.

SAN FRANCISCO, 75 Fremont St.
LOS ANGELES, 443 S. San Pedro St.
SEATTLE, 1041 Sixth Ave., S.

WHERE RADIO FANS BUY PARTS OF RECOGNIZED MERIT COCKADAY KITS

3 Bradleyohns No. 25.....	2.00 ea.	6.00
9 New York Mica Fixed Condenser (.0005 mfd.).....	.60 ea.	5.40
1 New York Mica Fixed Condenser (.00025 mfd.).....		.35
1 Precise Audio-Frequency Transformer No. 285-A.....		5.00
1 Ampertone No. 1-A with mounting.....	1.10 ea.	4.40
1 Cardwell Variable Condenser (.0005 mfd.).....		5.00
1 Cardwell Variable Condenser (.00035 mfd.).....		4.75
6 Benjamin Cle-ra-tone Sockets for UV-201A Tubes.....	1.00 ea.	5.00
8 Improved Double Circuit Jacks.....	1.00 ea.	8.00
1 Improved Single Circuit Jack.....		.70
2 Accurate Micrometer Control Dials.....	3.50 ea.	7.00
1 Ameco Dubl-Wandr Combination Potentiometer and Rheostat.....		2.00
1 Amplex Grid-denser.....		1.25
	Complete	\$44.35
Precision Cockaday coil Set.....		5.50
1 Set "Precision" Cockaday Coils sent free with order for complete set of above parts.		
CAPT. PAUL S. EDWARDS' NON-RADIATING SEVEN TUBE SUPERHETERODYNE RECEIVER		
1 Sangamo Oscillator Coil Unit - 2 Sangamo Type AT-60 Intermediate-Frequency Transformers, Air core.....		22.50
2 Sangamo Type IF-50 Intermediate-Frequency Transformers.....		22.50
Complete set of Above Parts Carefully Matched.....		22.50
1 Cardwell Right-Hand Vernier Condenser (.0005 mfd.) with 3 in. Dial.....		6.85
1 Cardwell Left-Hand Vernier Condenser (.0005 mfd.) with 3 in. Dial.....		6.85
1 Cardwell Split Stator Balancing Condenser.....		4.00
2 Dubilier Mica Fixed Condensers (.00015 mfd.) with Grid Leak Clips.....	.45 ea.	.90
1 Dubilier Mica Fixed Condenser (.005 mfd.).....		.60
1 Dubilier By-Pass Condenser (.5 mfd.).....		.90
1 Daven 1/2 megohm Grid Leak.....		.50
1 Daven 2 megohm Grid Leak.....		.50
2 General Radio 30 Ohm Type 801 Rheostats, 1.25 each.....		2.50
2 Stromberg-Carlson Audio-Frequency Transformer, 4.50 each.....		9.00
1 Benjamin No. 8627 Seven Socket Shelf with sockets and binding posts.....		12.00
1 Saturn Single Circuit Jack.....		.50
1 Saturn Double Circuit Jack.....		.70
1 Carter Jack Switch.....		1.00
1 Benjamin Battery Switch No. 8640.....		.30
1 Pr. Benjamin Shelf Brackets No. 8629.....		.70
1 Benjamin Bakelite Panel for Grid Condenser No. 8632.....		.15
1 Composition Radion Panel 7 in. x 18 in.....		2.25
		72.70
1 Portenna Loop.....		7.00
The Portenna Loop sent free with order for complete set of above parts.		

Try us on any radio parts you have been unable to secure.

MORISON
Electrical Supply Co. Inc.
C.O.D. Mail orders will be shipped promptly Retail

15 EAST 40th STREET NEW YORK CITY

DX "mushy"?

FREE BOOKLET

TUBE CONTROL
UNITY

On "Tube Control" tells how to bring in distant stations clear and loud. Just drop a post card to

UNITY MFG. CO.
226 North Halsted Street
CHICAGO, U. S. A.

RADIO TAUGHT AT HOME

New Easy Method by Penna. State College

No more tiresome stumbling thru complicated blue-prints and pictured hook-ups — no more costly guessing or aimless experimenting — a sound working knowledge of fundamental practise and theory leading to proficiency is readily acquired thru the easily mastered correspondence courses in Radio Transmission and Reception — one elementary, one advanced — offered by the Pennsylvania State College. As this is a State Institution we can offer these very helpful courses at cost. For full information write Division A, Dept. of Engineering Extension,

PENNSYLVANIA STATE COLLEGE
State College - - - Pennsylvania

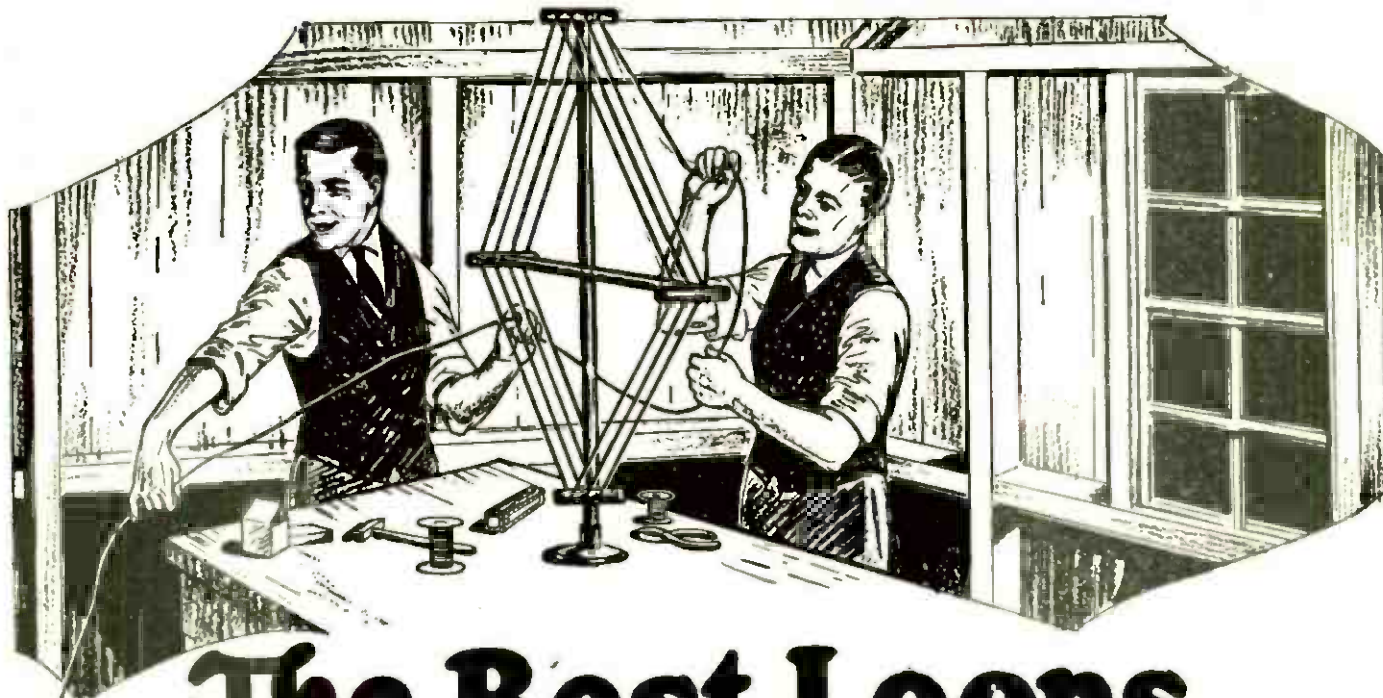

The Best Loops are wound with *Special* wire

A good loop antenna must fulfill two requirements; it must be electrically efficient, and it must be mechanically satisfactory. To combine both requirements is difficult unless a special wire, made especially for loops, is used.

Belden Loop Wire is made of sixty exceedingly fine strands of copper wire twisted with five strands of phosphor bronze wire, enclosed in an insulating covering. The sixty copper strands afford a low resistance circuit for the radio-frequency oscillations of the loop; the

phosphor bronze strands provide the tensile strength that makes Belden Loop Wire non-stretching and non-sagging. Ideal for collapsible loops.

When you build a loop, make one that will give maximum signal strength and still keep snug and tight, after long usage. For special work, use Belden Litz Wire. Our new booklet, "Helpful Hints for Radio Fans," has a lot of good ideas that will help you. Send for it. It's free. Use the handy coupon.

OTHER BELDEN RADIO PRODUCTS

Ask your dealer to show you Belden hook-up wire, enameled aerial wire, terminals, battery cords, and a dozen other Belden items, sold in distinctive Belden cartons. Build Belden Quality into your radio set.

Free Booklet!



Belden

Manufacturing Company

2316 S. Western Avenue
Chicago, Illinois

Belden Manufacturing Company
2316 S. Western Ave., Chicago, Ill.

I would like to know more about good loops. Send me your latest booklet—Helpful Hints for Radio Fans. Be sure to explain Litz Wire, too.

Name _____

Address _____

DEALERS! Attach the coupon to your business letterhead for complete dealer information on the Belden Line of Radio Products.

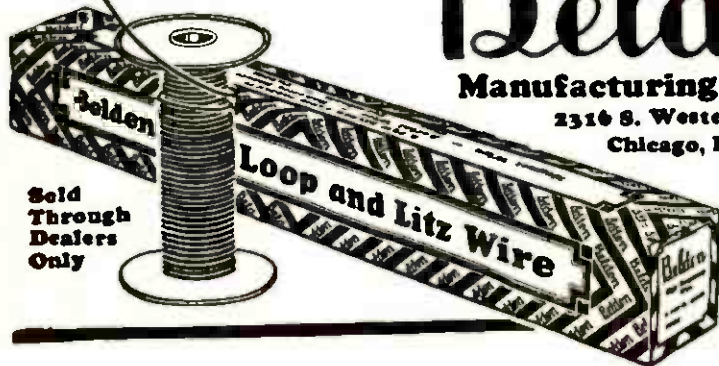

Sold Through Dealers Only

Why it is Better

THE picture tells the story—seven practical, sensible reasons why Federal sockets should be in your “pet” hook up.

Federal sockets are but another evidence of the care and engineering skill used in designing and making Federal Standard Radio Parts.

There are over 130 standard parts bearing the Federal iron-clad performance guarantee — their use means—“Balanced Circuits” with better performance.

FEDERAL TELEPHONE AND TELEGRAPH CO.
Buffalo, N. Y.

Boston New York Philadelphia
Chicago Pittsburgh
San Francisco Bridgeburg, Can.



Federal

Standard RADIO Products

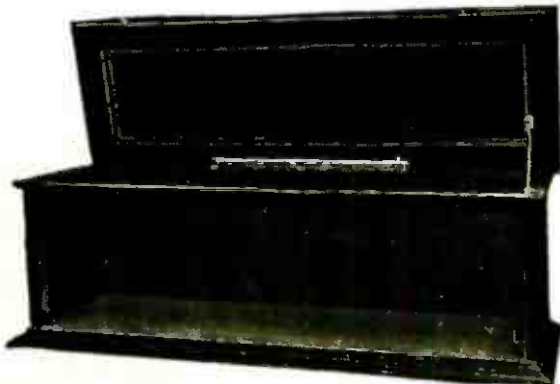
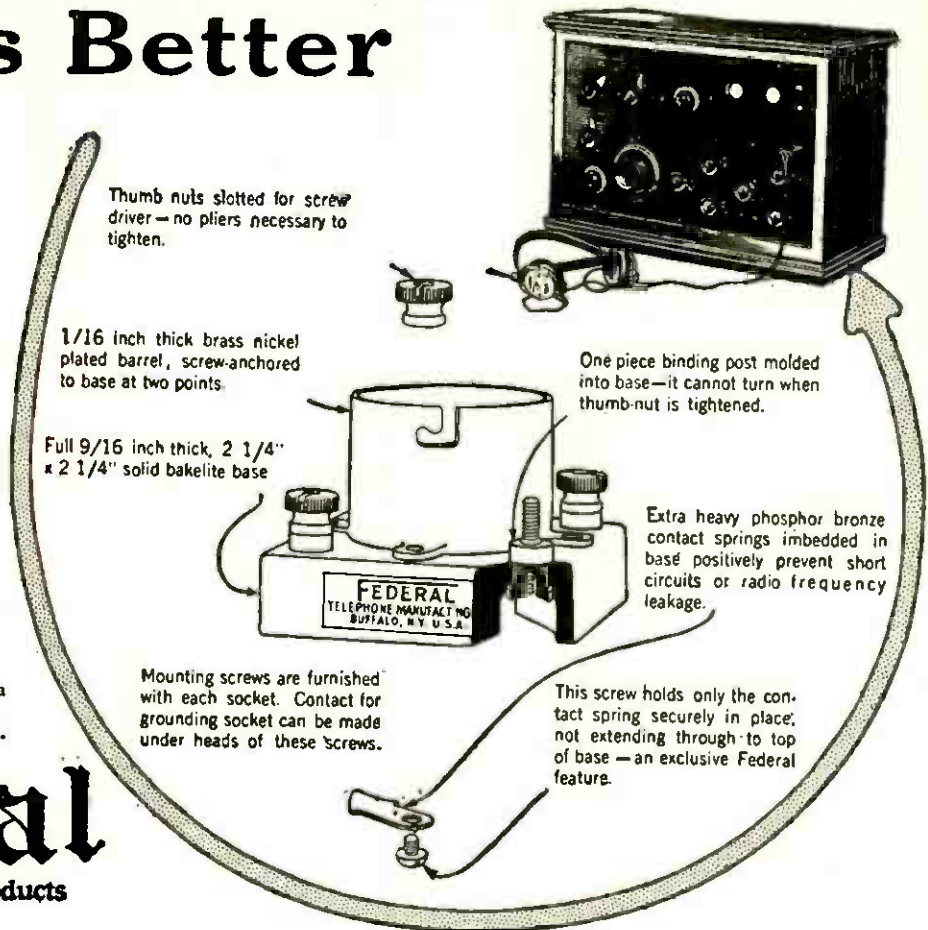

It's a Beauty!

—Priced Exceptionally Low
Because We Sell Direct to You

If you want an attractive, high-grade, carefully built cabinet—one you'll be proud to own—our style "C" model, pictured above, will more than meet your requirements. And, buying right from the maker, you save amazingly on every size.

Note the paneled construction of sides and top of this cabinet. Made of Genuine Cuban Mahogany, beautifully finished. Front rabbeted to fit panel. Nickel plated piano hinge and lid support.

Size	Unfinished	Finished
7 x 12 x 7	\$ 4.95	\$ 5.70
7 x 14 x 7	5.75	7.50
7 x 18 x 7	6.60	8.35
7 x 21 x 7	7.50	9.25
7 x 24 x 7	8.25	10.00
7 x 26 x 7	9.25	11.00
7 x 30 x 7	10.00	12.50

By "finished" is meant a waxed, rubbed finish. Cabinets shipped promptly on receipt of purchase price. Bulletin showing our complete line of cabinets sent on request.

A. HALL BERRY
71 Murray Street New York

ARROW BATTERY SLASHES Prices

Prices Smashed!
Quality Not Sacrificed
TO CONSUMERS
ONLY

Here is real battery quality, guaranteed to you, at prices that will astound the entire battery-buying public. Order direct from factory. Put the Dealer's Profit in your own pocket. You actually save much more than half, and so that you can be convinced of true quality and performance, we give a **Written Two-Year Guarantee**

Here is your protection! No need to take a chance. Our battery is right—and the price is the lowest ever made. Convince yourself. Read the prices!
Special 2-Volt Radio Storage Battery, \$3.75
Special 4-Volt Radio Storage Battery, 6.00
6-Volt, 60 Amp. Radio Storage Battery, 7.00
6-Volt, 80 Amp. Radio Storage Battery, 8.00
6-Volt, 100 Amp. Radio Storage Battery, 9.50
6-Volt, 120 Amp. Radio Storage Battery, 11.50
6-Volt, 140 Amp. Radio Storage Battery, 13.00

We ask for no deposit. Simply send name and address and style wanted. Battery will be shipped the day we receive your order Express C. O. D., subject to your examination on arrival. Our guarantee accompanies each battery. We allow 5% discount for cash in full with order. You cannot lose! Act quick. Send your order today—NOW.

Arrow Battery Co.
1215 South Wabash Ave.
Dept. 7 Chicago, Ill.



Herald MODEL B



\$12



The Big, Clear Voice of Radio!

TUNE in on Christmas! Hear the Holiday programs and big special events through a Herald Loud Speaker. The ideal gift for your home or any home with a radio. The gift that will bring you enjoyment every day in the new year. Hear it at your dealer's.

The Herald Model B.—Height 25 inches. Bell 12 inches. Fibre horn and art metal base. No batteries required. No adjustment necessary.

HERALD ELECTRIC CO., Inc., 113 Fourth Avenue, New York

All apparatus advertised in this magazine has been tested and approved by POPULAR RADIO LABORATORY



Cannon-Ball Headset \$3.50

Cannon and Miller have put into Camco Headsets and Loud Speakers the best that hands, modern machinery, and specialized experience can produce for the price. Probably one of your neighbors is a Camco enthusiast. Ask him, your dealer or write for folder



"Radio as you like it"

Camco Cannon-Ball Headset, \$3.50; Camco Grand Headset, \$4.75; Camco Loud Speaker, complete with permanent adjustment Loud Speaker unit, \$9.50. West of Rockies, \$10.50.

CAMCO GUARANTEE

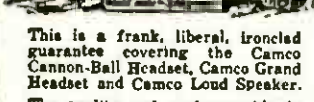

This is a frank, liberal, ironclad guarantee covering the Camco Cannon-Ball Headset, Camco Grand Headset and Camco Loud Speaker.

The quality and craftsmanship in a Camco product proves itself when it goes through the test of actual service. The Camco product that you buy must satisfy you.

Every Camco dealer is authorized to cheerfully refund the full purchase price to any purchaser upon the return of a Camco product if it fails to give absolute satisfaction within a period of ten days from date of purchase.

Cannon & Miller Co., Inc.
C. Cannon
President

Dealers: Ask your jobber about Camco products or write for complete details.
CANNON & MILLER CO., Inc.
SPRINGWATER, N. Y.

LOMBARDI GROUNDED ROTOR LOW LOSS CONDENSER

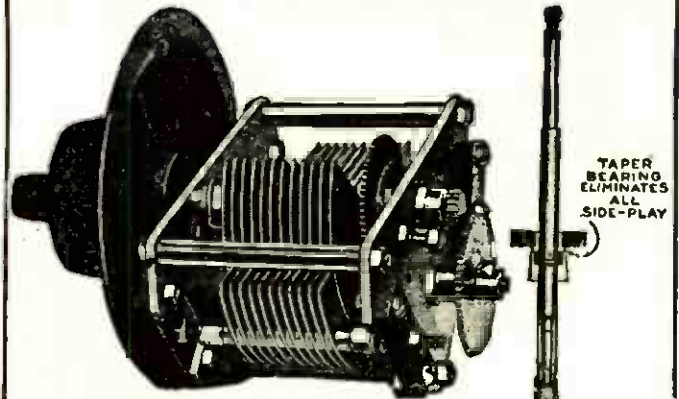

An ACCURATE, ATTRACTIVE CONDENSER of moderate dimensions with the following special features:
LOWEST DIELECTRIC LOSSES.
PIGTAIL CONNECTION and STOP.
GEARED VERNIER SHAFT runs thru ROTOR SHAFT making it UNNECESSARY to DRILL an EXTRA HOLE in PANEL for VERNIER and it WILL TAKE ANY SIZE DIAL.
45 DEGREE TAPERED BEARING and BALL and THRUST TYPE with adjustable spring tension (PAT'D).
ALUMINUM END BRACKETS and PLATES and ACCURATE SPACING.
 TESTED by YALE LABORATORY to be one of the BEST.
 Actual test sent on request.
 Condensers furnished plain or geared Vernier or with Vernier dial.

Literature sent on request

THE LOMBARDI RADIO MFG. CO.
71 MINERVA ST., DERBY, CONN.

FAHNESTOCK CLIPS



the Perfect Radio Connectors—are used by Manufacturers of Standard Sets and Parts—and Makers of Wet Batteries and exclusive on Eveready Dry Batteries. Their Sure Patented Grip is Recognized Universally by Enthusiastic Users.

FAHNESTOCK ELECTRIC CO., - L. I. CITY

VACUUM TUBES REPAIRED

WD-11, WD-12, \$2.00
UV-201A, UV-199,
And others for

Quick service. All tubes repaired by us guaranteed to work as good as new. Send your dead tubes. All you pay is \$2.00 plus Postage to Postman.

THOMAS BROWN CO.
511-519 Orange St., Newark, N. J.

The GREATER Neutrodyne EAGLE Balanced Receiver

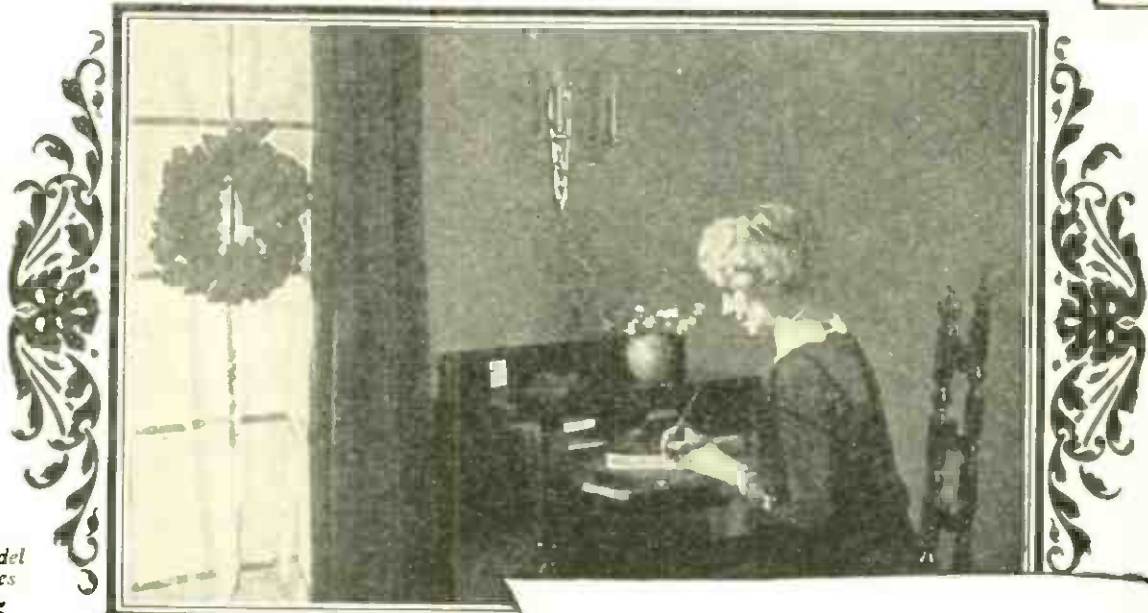

New Model
B 5 Tubes
\$175

A Happier New Year

Reasons for Buying the New Model B Eagle

GUARANTEE — The warrantee that accompanies every Eagle Receiver fully protects you.

Exclusive Eagle Instruments
Multiple (filament control) switch, ball-bearing, die-cast condensers, revolving resistor element rheostat — new refinements of the neutrodyne receiver.

BALANCE

The perfect balance of tube capacities, which is the secret of neutrodyne efficiency.

Write for Literature

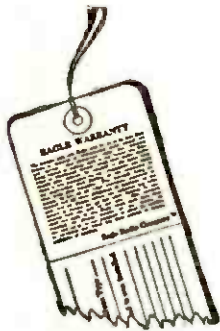

EAGLE
18 Boyden Pl.



RADIO CO.
Newark, N. J.

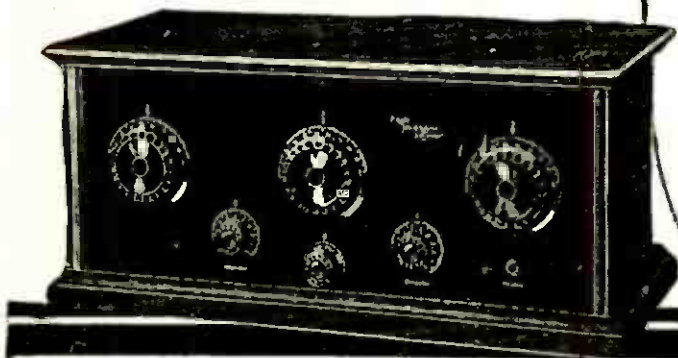

My dear Boy:

Only your wonderful thoughtful
ness could have found just the very
gift I wanted — the New Eagle
Receiver. When folks asked me this
year "Was Santa Claus good to you?"
I told them I had someone who
was better to me than even Santa Claus.

I was a little afraid that
radio might prove too complicated
for me but the Eagle is so easy
to operate as my phonograph. John
made up a log for me and now all
I do is decide on the program I want
to hear and turn the dials to the
numbers for that station. No more
loneliness, long evenings, dull times.

My Eagle keeps me entertained.
John says it's the best radio set
money could buy to which I replied,
"Of course, didn't Bob select it for me?"
Now John is going to get a new Model
B Eagle. Says it's just the set he's
been waiting for.

I appreciate this wonderful gift
more than I can tell you.
Your affectionate
Mother

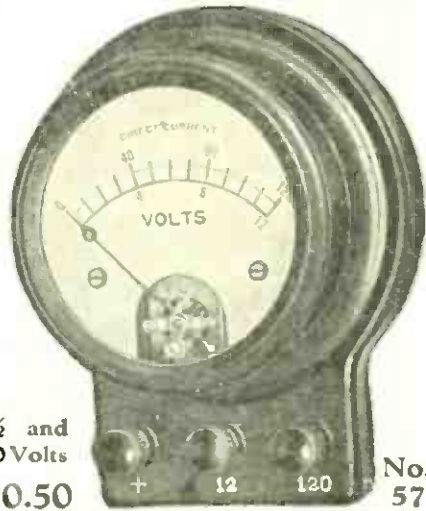

7½ and
150 Volts
\$10.50

No.
57

Test Your Batteries Often!

☐ The Jewell No. 57 is the instrument that dealers use in testing "A", "B" and "C" Batteries as they sell them.

☐ Set owners who demand the best from their outfits should have one for battery tests—also grid and filament voltages.

15-A RADIO CATALOG

☐ This instrument, in several ranges, is fully described in our 15-A catalog where we illustrate the most complete line of Radio instruments manufactured.

Order from Dealer

Jewell Electrical Instrument Co.

1650 Walnut St. - Chicago

"25 Years Making Good Instruments"

Coto

"Built First to Last"

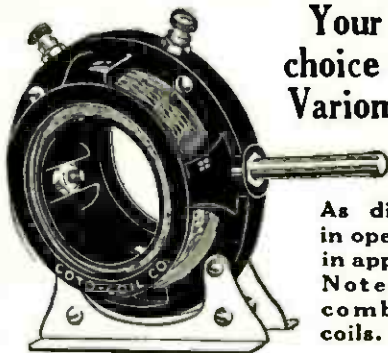

Your Best
choice among
Variometers!

As distinctive
in operation as
in appearance.
Note honey-
comb stator
coils.

A gem of radio designing. In moulded bakelite. Range is 200 to 600 meters. Positively quiet and conforming to very highest standards of variometer operation.

\$5

If your dealer fails you, write us for immediate delivery

COTO-COIL CO. 87 Willard Ave., Providence, R. I.

New York, Rm. 961, 50 Church St.; Chicago, Rm. 280, 508 So. Dearborn St.; Philadelphia, Rm. 623, Victory Bldg.; Los Angeles, 1113 Wall St.; Export Dept., Rm. 2316, Woolworth Bldg.; New York; Pittsburgh, Rm. 705 Granite Bldg.



New Hexagon Shaft

Insures Condenser
Perfection

To eliminate fanning, the rotor blades are stamped with a hexagon hole and held rigidly on hexagon shaft. Found in types 3 (plain) and 4 (all-vernier), **CELORON END PLATES**; types 5 (plain) and 6 (all-vernier), **METAL END PLATES**.

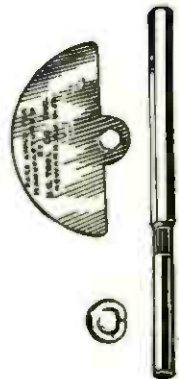

100% GUARANTEED

Write for Folder

U. S. TOOL COMPANY, INC.
116 Mechanic St., Newark, N. J.

Mfrs. of special tools, dies, jigs
automatic machinery and sub presses.

MICRO-SELECTIVE TUNING CONTROL

PRIZE WINNERS

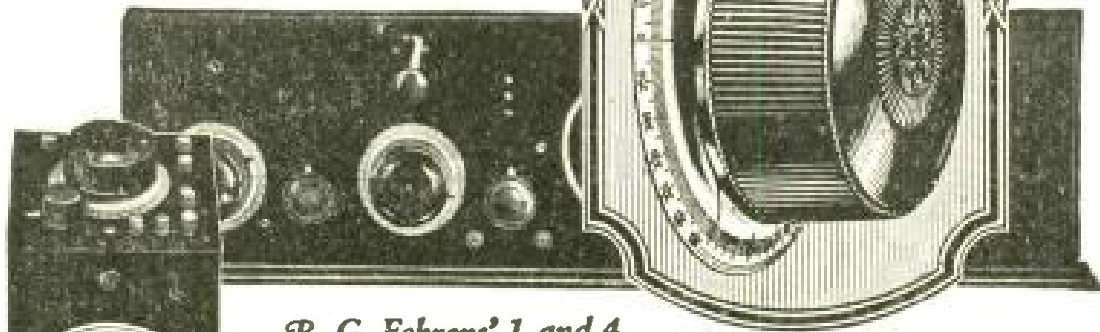

Members of
R.M.A. and
N.R.T.A.

R. G. Fehrens' 1 and 4
tube sets equipped with

WALBERT UNIVERNIER

Win two prizes (1st and 6th)
at New York Radio Show

Certainly am enthused about UNIVERNIER. Took two prizes in New York Radio Show with two sets, both equipped with UNIVERNIERS. Owe a great deal to their appearance and ease in tuning-in distant stations on that account. A plate vernier is passe and other geared verniers mean separate control—there's nothing like a UNIVERNIER.

Yours truly,

R. G. Fehrens

WHY not make your set a winner, too? Be able to tune-in those hard-to-get distant stations quickly, easily, clear and loud. Simply replace each of your dials with a UNIVERNIER, the original geared tuning dial. You'll never realize how many good stations you've been missing until you equip your set with Walbert UNIVERNIERS.

7 Features of the Improved UNIVERNIER

- 1—12-to-1 ratio—proven the right ratio.
- 2—Entire range of set under continuous vernier control. (That's why the UNIVERNIER is a record breaker—it gets the stations that are missed if "searching" has to be done by coarse adjustment.)
- 3—Positive smooth action—no slipping or jerking.
- 4—Sturdier mechanism.
- 5—New attractive "dished" dial.
- 6—Cannot destroy the accuracy of low-loss condenser bearings.
- 7—Costs no more than a good dial.

Mahogany Knob and Gold-plated dial
\$1.50

Black Knob and Silver-plated dial
\$1.25

At your dealer or sent postpaid on receipt of purchase price.
(Please mention dealer's name.)

Jobbers and Dealers: Write for Discounts.

The WALBERT MANUFACTURING CO.
933 Wrightwood Avenue Chicago, Illinois



The Walbert Safety Rim Socket is guaranteed not to break at the slot. Our scientific bakelite design decreases inter-element capacity thereby utilizing all available grid voltage for producing signals. (New tubes have bakelite bases for same reason.) Soldering lug and double-spring contact integral. The most attractive socket on the market.



Don't worry any more about someone meddling with your radio set while you are away. Simply remove key from Walbert Filament Lock Switch and take it with you just as you take the ignition key from an auto. Sturdy, compact, efficient. Shell and key handle insulated from circuit. No finer switch made, and none made with unique lock feature.

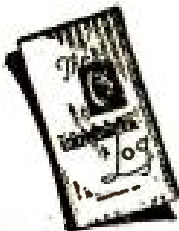

WALBERT
Parts with a Purpose

ALL WALBERT PARTS PROTECTED BY PATS. OR PATS. PEND., U. S. AND FOREIGN

FREE!
Send 2c stamp for
FREE copy of
UNIVERNIER
LOG BOOK

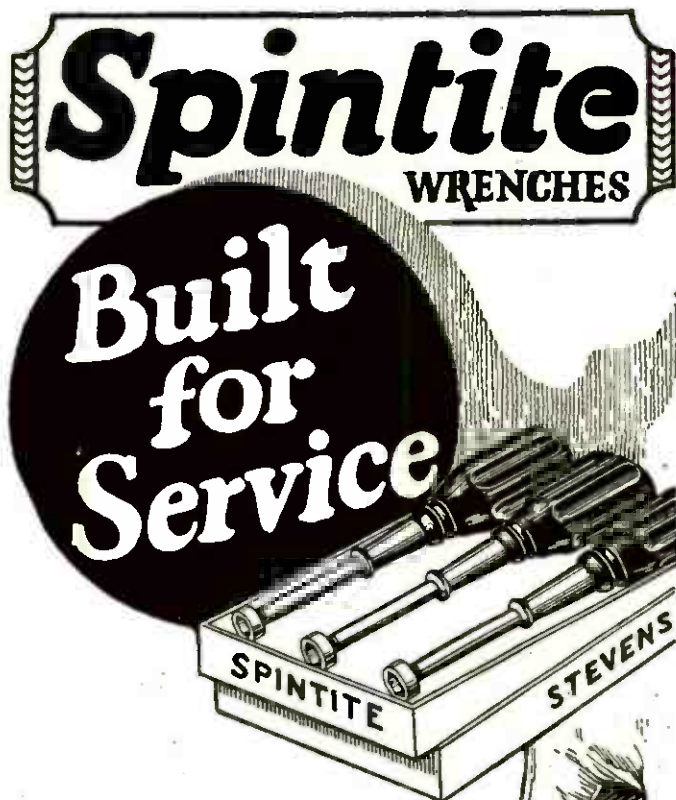

When you buy a set of Spintites you buy *real tools*, built for *lasting service*.

Shank and head of tough drop-forged steel that stands the gaff of long wear; convenient one-piece construction, giving greater strength and durability; no separate parts to weaken with use or get lost.

Quality tools through and through. Heads accurately machined to size. Handle of hard-wood, rubberoid finish—not painted; deeply fluted to form a sure and comfortable grip. Substantial *steel* ferrule. Shank firmly anchored to prevent "turning" in handle under heavy stress.

You'll be proud to own a set of these convenient Spintites, which enable you to get into the cramped corners with ease, making joints that are *as tight as if soldered!*

SPINTITES MAKE ACCEPTABLE HOLIDAY GIFTS

Set of 3 most popular sizes for Round or Hex nuts, as desired, in box \$1.00.

Set of 7 Hex sizes in handsomely finished metal base \$3.50.

If your dealer can't supply Spintites order direct from us. Write today for Booklet 21, describing all the "Speed-Up" Tools for radio.

Stevens & Co.
Toolsmiths since 1899
375 Broadway, New York

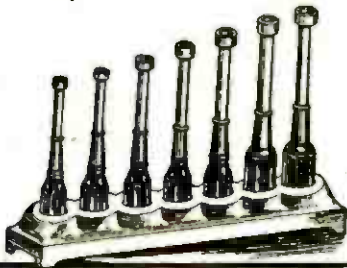

NODUST Will Keep Your Radio Set CLEAN

Everyone who builds a radio set needs a NODUST! You cannot get the most out of your set unless it is kept clean *inside*. Each stroke of a NODUST produces a powerful blast of compressed air that removes every particle of dust and dirt from places that cannot be reached with a cloth or brush.

NODUST

Made to last a lifetime; light, strong and simple to operate. Wood mountings that cannot short circuit. If your dealer cannot supply you, send us \$1.00, and you will receive your NODUST by return mail.

PEIFFER & COMPANY
82 Liberty Street
Newark, New Jersey



Hundreds of miles with Roll-O Crystals!

Get Results you never before believed possible by equipping your crystal or reflex set with the famous Roll-O Tested Long Distance Crystals. Consistent reception of DX stations—Read the proof:

H. J. Hallam, 5 Koenig Ave., Cincinnati, Ohio, got 11 stations the first night he used them.

J. E. White, Milwaukee, Wis., writes that Roll-O Crystals improved his receiving range 100% over any other crystal on the market.

James Bridge, Okotoks, Canada, writes he heard Omaha, Nebr., 1120 miles away, loud and clear with his universally sensitive Roll-O Crystal.

Send your dollar today for TWO ROLL-O TESTED LONG DISTANCE CRYSTALS. Special Catwhiskers and complete instructions, all for \$1.00 postpaid. All covered by our money back guarantee of satisfaction.

5 in 1 Fixed Crystal Detector

A new invention in Radio. Gives you your choice of the most sensitive parts of the crystal at all times. Wonderful for either crystal or reflex sets. Complete with Roll-O Crystal—\$2.00 postpaid

ROLL-O Superset

The best on the market. Combines the 5-in-1 Detector, Primary and Secondary Tuning, attachments for as many as six pairs of phones. \$6.00 postpaid.

Dealers, Jobbers and Manufacturers' Agents—Write

THE ROLL-O RADIO CORPORATION
Dept. 50 Cincinnati, Ohio





Adapto

RADIO CABINET



Beautiful Furniture Piece To Enclose Your Radio Set

Where room charm is indispensable as radio there is a decorative problem which a mahogany or walnut Adapto Radio Cabinet delightfully solves.

This charming cabinet holds everything "radio"—out of sight. Insert your own set—if small, adapt it with special adaptor frames at either end. Slip battery and other essentials in a drawer. Inbuilt at top is a horn—needing only your loud speaker unit. Small drawer for tools—spacious shelf for B batteries—other conveniences too numerous for mention here!

Send today for circular.

DEPT. A

L. R. Donehue Lumber Company
PERTH AMBOY, N. J.

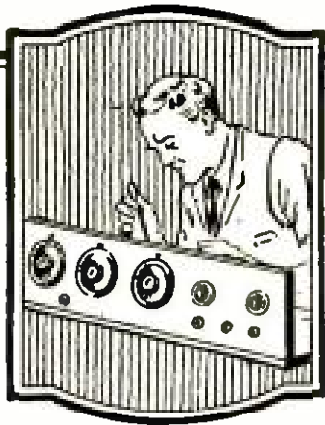

When it's "Pacentized" you are sure of results

SELECTIVITY—distance—volume—these results are dependent on the parts you use. It's poor economy to slight such vital parts as jacks, rheostats, condensers, etc., when Pacent Radio Essentials, built by the pioneer radio parts manufacturer, cost no more than inferior parts.

18 years of radio experience are back of every Pacent part. Over 30 of the leading makes of receiving sets are Pacent equipped. This is convincing proof that the Pacent trade mark stands for leadership. Let the judgment of those makers be your guide in buying parts. Send for our complete catalog.

THE PACENT ELECTRIC COMPANY, Inc.
91 Seventh Avenue, New York City

Washington Minneapolis Boston San Francisco Jacksonville
Chicago Birmingham Philadelphia St. Louis Buffalo

Pacent RADIO ESSENTIALS

**PACENT
Radio Essentials**

- Adapters
- Improved Audiometer
- Autoplug
- Balcon
- Coil Plug
- Coil Plug Receptacle
- Condensers, Low Loss
- Detector Stand
- Diode
- Diode Plug
- Diode-Lateral Coils
- Headsets, Everytone
- Jacks
- Jack Set
- Radiolamp
- Loop Plug
- Loop Jack
- Multijack
- Plugs
- Potentiometers
- Rheostats
- Resistors, Laboratory
- Sockets
- Transformer, etc., etc.

TRADE MARK

"DON'T IMPROVISE - PACENTIZE"



3/4 of a million in service

TINNED "COPPERWELD" WIRE

THE IDEAL RADIO ANTENNA
IN CARTONS

with antenna construction directions printed on the reverse side.

BUY IT IN CARTONS FROM YOUR DEALER
COPPERWELD STEEL COMPANY

New York San Francisco Chicago
Braddock P. O., Rankin, Pa.

Self Balanced T.R.F. Transformers

Zig Zag Pat. Aug. 21, '23

Silk wire interlaced. No compounds or pins.



Set of 3 with mountings and instructions postpaid

\$4.50

Type F23 Journal Filter Tuner Coils per set... \$2.50
Type F25 Journal One Knob set Coil... 1.25
Type F22 Wave Trap Filter Coil... 1.25

NOLTE MFG. CO., Dept. B.
61 Gautier Avenue Jersey City, N. J.

RADIO TUBE EXCHANGE

We Repair All Standard Makes of Tubes, Including

W.D. 11 or 12
U.V. 199 or C. 299 \$2.00
C. 11 or 12
U.V. 201A or C. 301A
D.V. 1 or D.V. 2
U.V. 200 or 201
C. 300 or 301



U.V. 202 Repaired, \$3.00

All tubes guaranteed to do the work.

RADIO TUBE EXCHANGE
200 BROADWAY, NEW YORK

All Mail Orders Given Prompt Attention. Orders Sent Parcel Post C. O. D.

FRESHMAN MASTERPIECE

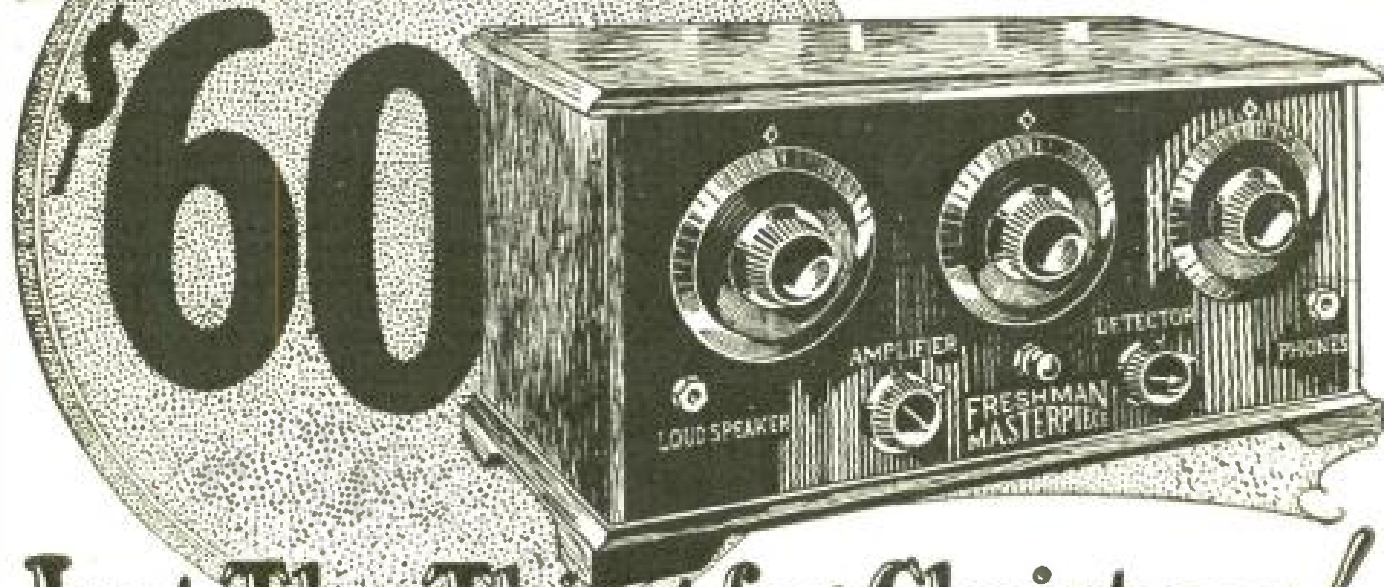

Just The Thing for Christmas!

A 5 Tube Tuned Radio Frequency Receiver

made of the finest low loss materials and in a beautiful genuine solid mahogany cabinet, that is attractive enough for the most pretentious room, and at sixty dollars, economical enough for the most modest. It is without a doubt

*The Greatest Value Ever Offered
in a Radio Receiving Set*

Combines all points essential to the perfect receiver. Real distance reception without that squealing and howling. So selective that once a station is picked up—it can be brought in again on the same points on the dials, whenever you want it. And what's more,

It's the easiest set in the world to operate

All genuine Freshman Masterpiece Sets have a serial number and trade-mark riveted on the sub-panel. The Receiver is not guaranteed if number has been removed or tampered with.

Chas. Freshman Co. Inc.
Radio & Condenser Products

Ask your dealer to install one in your home
Beware of Imitations and Counterfeits.

Freshman Building

240-248 West 40th Street, New York

Biggest dollar's worth in RADIO



100,000 SOLD

Compiled by
HARRY F. DART, E.E.
Formerly with the Western Electric Co., and U. S. Army Instructor of Radio.
Technically edited by
F. H. DOANE

THE greatest book on Radio ever written. Price only \$1. Filled with sound, practical, tested information for every radio fan, from beginner to hard-boiled owl. Written, compiled and edited by radio ex-

perts of national reputation.

You may dip into this I. C. S. Radio Handbook at random, or hunt up special information you want, or read it right through. Starts with simple explanations of Radio phenomena and leads you along gently until you can understand the most technical diagram. Hundreds of suggestions for getting more pleasure out of Radio. Will save you from wasting money on things that won't work.

New—Authoritative—Complete

514 PAGES

150 ILLUSTRATIONS

Every page tells you something useful. And there are 514 pages! More than 150 illustrations and diagrams! Note this partial list of contents:

Electrical terms and circuits, antennas, batteries, generators and motors, electron (vacuum) tubes, every receiving hook-up, radio and audio frequency amplification, broadcast and commercial transmitters and receivers, wave meters, super-regeneration, codes, license rules. Many other features.

Money back if not satisfied

Send \$1 today and get this 514-page I. C. S. Radio Handbook before you spend another cent on parts. Money back if not satisfied.

MAIL THE COUPON TODAY!

International Correspondence Schools
Box 8254-D, Scranton, Penna.

I enclose One Dollar. Please send me—post-paid—the 514-page I. C. S. Radio Handbook. It is understood that if I am not entirely satisfied I may return this book within five days and you will refund my money.

Name.....

Address.....

Check here and enclose \$1.50 if you wish the do luxe edition, bound in Leatheroid.

FREE To Each Purchaser of a World Battery



A 24-Volt "B" Storage Battery positively given FREE with each purchase of a WORLD "A" Storage Battery. The WORLD Battery is famous for its guaranteed quality and service. Backed by years of Successful Manufacture and Thousands of Satisfied Users. You save 50%.

Prices That Save and Satisfy

Auto Batteries	Radio Batteries
6-Volt, 11 Plate \$12.25	6-Volt, 100 Amps. 12.50
6-Volt, 13 Plate 14.25	6-Volt, 120 Amps. 14.50
12-Volt, 7 Plate 17.00	6-Volt, 140 Amps. 16.00

Shipment Express C. O. D. subject to examination. 5 per cent discount for cash in full with order.

2-Yr. Guarantee Bond In Writing With Each World Storage Battery

proves satisfactory World performance. Mail this ad with your name and address—we will ship battery day order is received; and give you your choice of "B" Storage Battery or a handsome nickel finish Auto Spotlite, FREE. Write TODAY.

WORLD BATTERY COMPANY

1219 So. Wabash Ave. Dept. 3 CHICAGO, ILL.

This FREE "B" Storage Battery takes the place of dry cell "B" batteries. Can be recharged and will last indefinitely. To be sold retail for \$6.00. It is the only battery of its kind equipped with solid rubber case—and insurance against acid and leakage. Take advantage of this remarkable introductory offer NOW. (To those who prefer it, we will send FREE a handsome nickel finish Auto Spotlite, instead of the "B" battery. Be sure to specify which is wanted.)

GIVEN FREE
To introduce this new and superior World "B" Storage Battery to the Public



S. HAMMER RADIO CO.
305 Atkins Ave. Brooklyn, New York

Special!!

5 TUBE NEW COCKADAY 4 CIRCUIT TUNER WITH Resistance Coupled Amplifier KIT

FREE GENUINE BAKELITE PANEL Drilled and engraved, worth \$8.00, with all orders for this Kit received up to February First.

PARTS In this Kit are exactly as specified and recommended by Mr. Cockaday in the October issue of Popular Radio, also featured in our new catalog

WIRED This set wired complete in genuine mahogany cabinet **\$85.00**

We Specialize in Cockaday Kits



Our Sets and Kits
Approved by Popular Radio Laboratories

WRITE FOR OUR NEW CATALOG

containing 28 pages, unexcelled bargains in standard nationally advertised radio accessories parts sets-kits.

Orders over \$5.00 Shipped Prepaid, Money Orders or C.O.D. One-third must accompany all C.O.D. orders. Not insured unless insurance charges included.

I Can Qualify You as a Radio Expert in a Few Months!

Learn at Home

Earn \$2500 to \$10,000 a Year

Merle Wetzel, one of my students, reports that he is now making three times what he did before becoming a radio expert. Emmett Welch writes that after finishing my training he made \$300 a month and all expenses. George Jones says, "To your course I credit my present position as manager of this Radio Department." Another graduate is now an operator of a broadcasting station, PWX of Havana, Cuba, and earns \$250 a month. Still another graduate, only 16 years old, is averaging \$70 a week in a radio store. Hundreds of other former students enthusiastically tell of their successes as radio experts! The field of Radio to-day is a real treasure house of wonderful opportunities. It offers rewards beyond your fondest dreams! Mail coupon to-day for my Free Book just out—which explains in detail the amazing opportunities in this World's Fastest Growing Industry.



E. R. HAAS
Director, National
Radio Institute.

Hundreds of Big Paying Positions Waiting

Do you want to earn far more money than you ever dreamed possible? Do you want to be your own boss—to have a profitable business of your own? Do you want to travel the whole world over—and make big money while doing so?

Radio offers you all of these opportunities—and more! Radio, the new infant industry; Radio, growing with leaps and bounds; Radio, the field of endeavor with the most promising future of all!

Hardly a week goes by without our receiving calls

for our graduates. "We need the services of a competent Radio Engineer"—"We want men with executive ability in addition to radio knowledge to become our local managers"—"We require the services of several resident demonstrators"—these are just a few small indications of the great variety of opportunities open to our graduates.

Our course is an absolutely complete one which qualifies for a government first class commercial license. It gets you the bigger paying jobs in Radio.



Pay Increases Over \$100 a Month

I am averaging anywhere from \$75 to \$150 a month more than I was making before enrolling with you. I would not consider \$10,000 too much for the course.

(signed) A. N. Long,
120 N. Main St.,
Greensburg, Pa.

Doubles Salary

I can very easily make double the amount of money now than before I enrolled with you. Your course has benefited me approximately \$3,000 over and above what I would have earned had I not taken it.

T. Winder,
731 Belford Ave.,
Grand Junction, Colo.



From \$15 to \$80 a Week

Before I enrolled with you I was making \$15 a week on a farm. Now, I earn from \$2,080 to \$4,420 a year, and the work is a hundred times easier than before. Since graduating a little over a year ago, I have earned almost \$4,000 and I believe the course will be worth at least \$100,000 to me.

(signed) Geo. A. Adams,
Route 1, Box 10, Tamaqua, Pa.



This Wonderful FREE BOOK Has Shown Thousands The Way To Bigger Money

This Free Book has opened the eyes of thousands to the glorious opportunities in Radio. Never in all history has an industry jumped into prominence so rapidly. Millions of dollars now spent yearly on Radio. Hundreds of big money positions have been created almost overnight. Thousands of men trained in Radio are needed. If you are ambitious—if you are looking for a field which offers big money, fascinating work, advancement and a real future, send for this Free Book. It costs you nothing. You obligate yourself in no way. Yet this book can easily mean all the difference between the work you are doing now and wonderful success!

For a short time we are offering a reduced rate to those who enroll now. Act promptly and save money.

Before you forget—mail the coupon NOW!

NATIONAL RADIO INSTITUTE
Dept. 32CB, Washington, D. C.



E. R. HAAS
NATIONAL RADIO INSTITUTE
Dept. 32CB, Washington, D. C.

Without obligation on my part, please send me the free book, "Rich Rewards in Radio," with full details as to how I can quickly train for a high-salaried position in my spare hours at home. Also tell me about your free Employment Service, and about your special short time offer. Please write plainly.

Name Age

Street

City State

THE ULTIMATE IN RADIO RECEIVERS

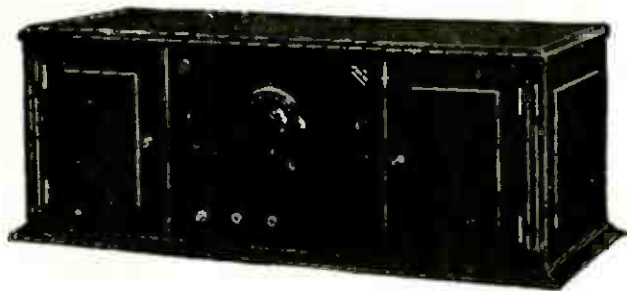

One Dial — Six Tubes

Distance is no barrier to reception with this set —it is very selective and has wonderful volume. Resistance Coupling is used for its amplification making the tone quality perfect. Cabinet in American Walnut or Mahogany.

List Price \$125
 West of Rockies 135
 Canada 165



Sold
 Everywhere

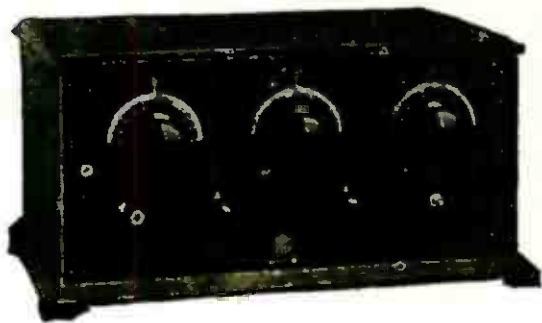

A Five-Tube Set

Here is a tuned Radio Frequency set that is especially designed to meet the demand for a high grade receiving set at a medium price. It is very selective, having extraordinary distance range and great volume. Cabinet of genuine American Walnut.

List Price \$85
 West of Rockies 90
 Canada 115

The Brandola

THE J. F. BRANDEIS CORP. :: :: 39 Oxford Street, Newark, N. J.

Ware

NEUTRODYNE

Receiver Type T is a remarkable instrument. Three tubes with one reflexed accomplishes four tube results. Distant stations secured with ease. No squeals or howls. Clear tones. Only two tuning dials. Dry cell tubes and batteries enclosed in handsome Mahogany cabinet.



14 inches wide, 10 3-4 inches high, 13 1-2 inches deep
 Ware Neutrodyne, Type T \$65.00
 With all accessories, including loud speaker... 98.00

No other set will give you more dependable service and real value.

"Crosley" one tube model No. 50 14.50
 With tube and Crosley phones 22.25
 "Crosley" two tube model No. 51 18.50
 With tubes and Crosley phones 30.25
 "Crosley" three tube model No. 52 30.00
 With tubes and Crosley phones 45.75
 Also headquarters for "Cockaday," "Radiola," "Atwater-Kent," "DeForest" and other popular receivers. Full line of separate parts.

Everything that is Reliable in Radio. Our Service Bureau will gladly help you solve your problems.

Nine years of prompt, fair and courteous dealing

Hartt & Lane, Inc.

Wholesale and Retail
 780 6th Ave., near 44th St., New York City

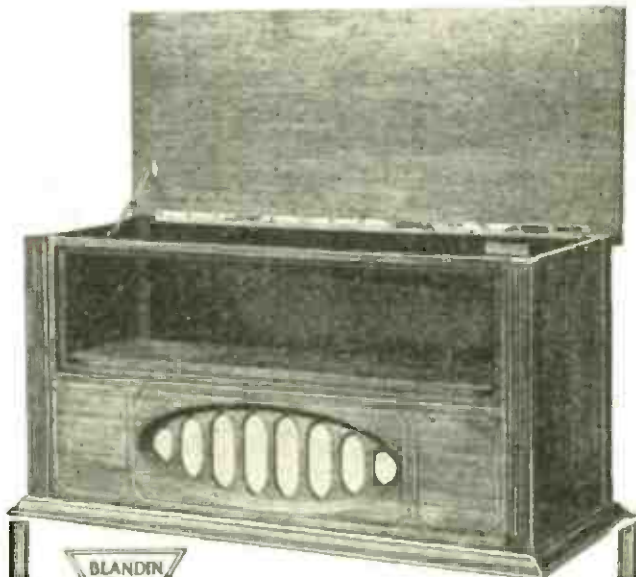

The New "35-D" Super Radio Cabinet

Panel at top 7 x 26-10 1/2". Deep enough for 8 tubes. Built-in spruce horn. Two dry cell compartments. Door in back. Built of mahogany—piano finish. Same quality and equipment as

Blandin Triple "A" De Luxe Series

Also new De Luxe sizes. 7 x 18-7"; 7 x 24-7"; 7 x 26-7 1/2"; 7 x 30-8"; 8 x 36-8" and 8 x 40 x 8". Write for illustrated price list.

Jobbers and dealers, write for discounts

BLANDIN PHONOGRAPH COMPANY, INC.
 1500 16th St. :: :: RACINE, WIS.



An easy way to get distant stations more clearly

IF YOU want clear radio reception—with more freedom from those disturbing noises—you must have clean, perfect contact between tubes and sockets. It's the contact that counts.

Perfect Contact assured with Na-Ald De Luxe Sockets. Broad wiping surface of four special dipped phosphor bronze socket clips press both on sides and ends of tube terminals making constant clean, bright contacts.

Clean Easy Feature. The two to eight tubes do not have to be removed and sandpaper used to scrape the socket contacts, within the awkward depths of your set. Duo-contacts are easily cleaned and film of oxide between tube and socket, better known as corrosion, which can ruin contact, is quickly

removed by rotating each tube three or four times. This feature of Na-Ald Sockets saves trouble and time.

Highest Insulating Qualities. Lowest loss and highest insulating qualities are insured in Alden Sockets by using Alden Processed genuine Bakelite.

You can obtain Na-Ald Sockets at radio, electrical and hardware stores. Use them not only in the set you build but also install them in the set you buy, if not already adopted by the manufacturer. Sockets for all tubes. De Luxe 75c; others 35c, 50c, 75c.

Send for free copy of radio booklet—"What to Build."

ALDEN MANUFACTURING COMPANY

Also makers of the famous Na-Ald Dials
Springfield, Mass.

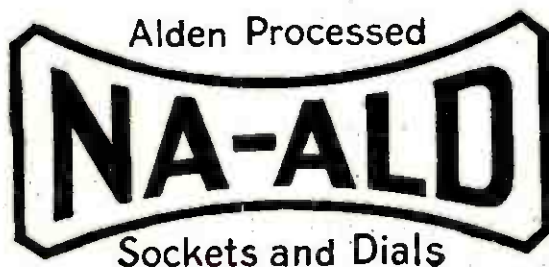

ALDEN MANUFACTURING COMPANY,
Dept. C-2, Willow Street, Springfield, Mass.

Please send free copy of booklet "What to Build," showing tested and selected circuits.

Name

Address

City.....State.....

"ROYALFONE" KING OF ALL

The Loud Speaker

Unit With the Acoustic Control

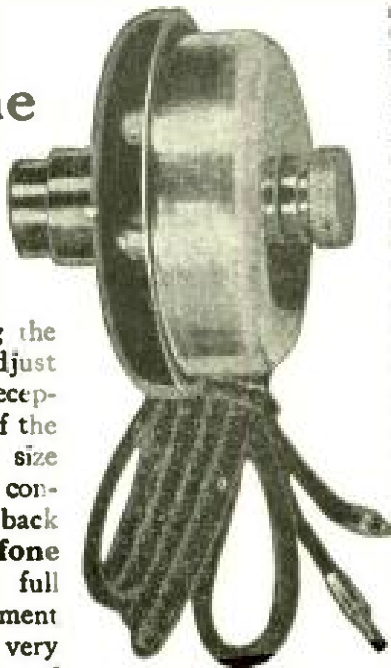

Without touching the dials, you can adjust the volume of reception to the taste of the listeners and the size of the room. The control knob on the back of the **Royalfone Unit** permits a full range of adjustment from very soft to very loud without a trace of muffling, blare or any distortion. Makes a high class loud speaker out of any phonograph or horn, at a minimum cost.

Complete with Heavy nickel-plated nozzle and ample connecting cord.
\$5.00

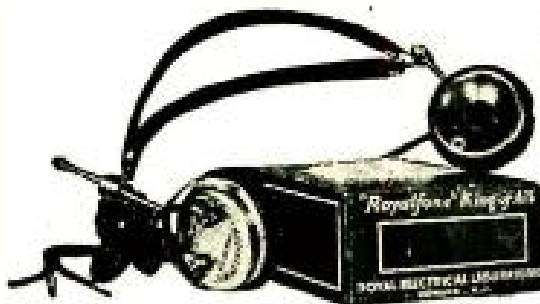

"ROYALFONE" KING OF ALL HEADSET

Greater distance by using the **Royalfone Headset** because it reproduces the faintest signals your set can detect. Try a pair at your dealer's.

PRICE \$4.50

Write for Literature

**ROYAL ELECTRICAL
LABORATORIES**

Newark Dept. P. R. N. J.

Good tools build good receivers



The Westwyre soldering iron is a good tool and should be in every household. Detachable tip, renewable heat unit, 6 ft. asbestos covered cord, two piece plug, non-heating handle rubberoid finish, tube gun metal finish, heat chamber polished brass.

- Westwyre Model.....\$2.50
- Westwyre Junior.....\$1.50
- Variable Condensers.....\$3.00 to \$4.25
- Elf Crystal Receivers.....\$1.50

By manufacturers of

Westwyre Variable Condensers



At your dealers, or send direct

THE WESTWYRE COMPANY
Westfield, Mass.

This new Speaker banishes old speaker faults



DOESN'T growl, doesn't shriek, doesn't blare, doesn't screech. Instead, it brings in all the soft high tones of the music and the delicate low ones with a beautiful, natural clearness new to loudspeakers. This speaker is new in principle, new in shape, new in material, the most interesting development in the speaker field. Write for "The Loudspeaker You Have Waited For," giving full information.

TH. GOLDSCHMIDT CORP., Dept. P1
15 WILLIAM STREET New York

Imported
NeK LOUDSPEAKER

W*HEN* "The King of the Ivories" is tickling the keys at WOS.
W*HEN* WOR comes rolling in from the East and KFI, in its time and turn brings greetings from the Pacific coast.
W*HEN* your Saturday evening dance from WTAM is making just the biggest kind of a hit—*remember that*

WILLARD RADIO BATTERIES

are contributing to your enjoyment, for at these and at 175 other leading Broadcast Stations Willard Batteries are used to furnish the steady current that is required for perfect amplification of voice and music.

Write to **WTAM** for this booklet
 (The Voice of the Storage Battery)

Every owner of a receiving set should have these booklets. They tell how to get greater distance, more volume and better tone quality; and they show why Willard Batteries are the most economical and most satisfactory form of power you can use.

WTAM is the Radio Research Laboratory and Broadcast Station of the Willard Storage Battery Company, Cleveland, Ohio. The wave length is 361 meters—on the air for your enjoyment every Monday, Wednesday and Saturday evening.



Tear me off the page and mail me to WTAM. I'll bring you "Better Results" and "Proper Use and Care."

Name.....
 City and State.....
 Address.....
 P.R. 6

You'll Think You're in the Same Room with the Broadcaster!

This New Creation in Audio Transformers Assures Perfect Reproduction of Sound

Melodies, rhapsodies, jazz, addresses, announcements—taken out of the air, amplified and faithfully reproduced, are heard as distinctly in the home as in the broadcasting room, for you get the pure tone and full pleasing volume which the Sterling "Full Range" Transformer was especially designed to give. It amplifies sounds of low frequency as well as those of high frequency. Of course you want the full range.

The "Full Range" not only marks a great advance in transformer design and efficiency, but its fine appearance adds greatly to the dignity and beauty of the set. Unsightly wiring is eliminated and the making of connections simplified by locating the terminals on the sides near the base.



Price
\$6.00

Sterling

FULL RANGE
AUDIO FREQUENCY TRANSFORMER

together with Sterling Radio Frequency and Intermediate Frequency Transformers make a trio that will surely defeat distortion and amplify perfectly

Mfd. by

THE STERLING MFG. CO.
CLEVELAND Dept. G OHIO

FREAS Battery Testers

It's Your Battery That Talks!

THOSE harsh noises that mar reception are due to poor battery action. To keep the current smooth and uniform, frequent and accurate hydrometer tests are positively essential. Read the pulse of your radio battery with a Freas Battery Tester.

Simple. Reliable. Scientifically adjusted to U. S. Bureau of Standards requirements. Built for long service. Acid-proof container prevents electrolyte from injuring clothes or rugs.

FREE BOOKLET By the well-known radio engineer, Major J. S. Hatcher, U. S. A. Tells you how to secure best reception results. Send four cents for mailing cost.

FRANCIS L. FREAS GLASS WORKS

America's Largest Hydrometer Manufacturers

CONSHOHOCKEN, PENNSYLVANIA

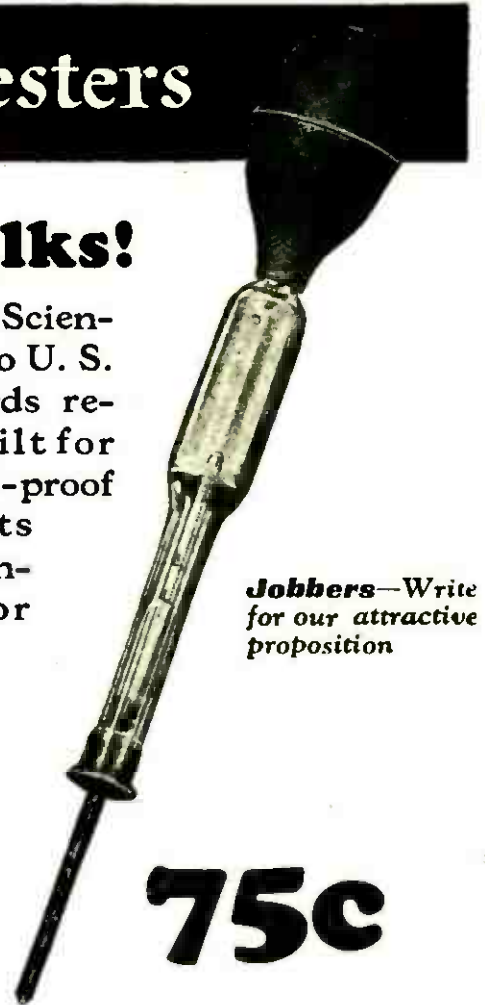

Jobbers—Write for our attractive proposition

75c



B-METAL

U.S. TRADE MARK Registered

LOUD-TALKING CRYSTAL

*Concert Tested
and Guaranteed*

This Name on Package Insures Genuineness

*B-Metal Refining Co.,
Detroit, Michigan.*

Seventh Floor
525 Woodward Ave.

Ask Your
Dealer First

Andy Gibson

AMPL-TONE

GUARANTEED



Radio Headsets

Price \$5.00

For three years these headsets have been tried, tested and proven their value. There are thousands in use today and are still giving perfect satisfaction. Ask your friends. They know. They are unexcelled for crystal sets and capable of great distance reception with tube sets.

Buy one pair and you will immediately order more. We can't make all the phones used so we make the best. Write us for phones or circulars, if your dealer fails you.

Dealers: Quick turnover is our motto.
Write us.

The Union Fabric Co.
Derby, Conn.

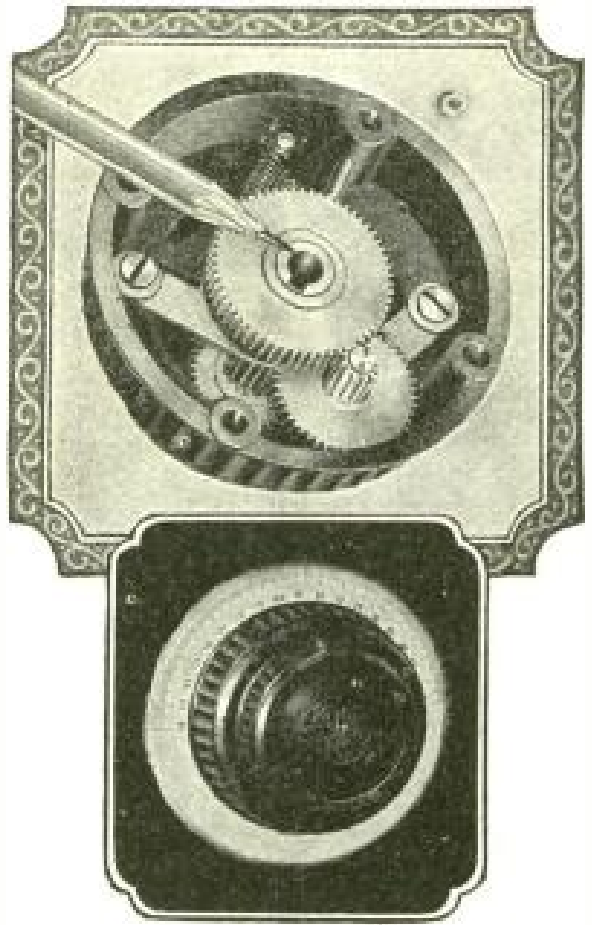

All Wobble Eliminated By Long Center Bushing

Look at that long center bushing! Watch the new model Accuratune when you tune in—how smooth it operates—how precise its movements without the slightest indication of wobble.

Few vernier dials, built as they must be to take all standard condenser shafts, are designed as the Accuratune to positively eliminate this universal objection—dial wobble.

And just this one point of refinement characterizes the complete make-up of the Accuratune Micrometer Control—features that assure most unusual tuning efficiency.

Micrometer Controls easily replace ordinary dials without any set alterations. Just tighten the set screw on the large knob.

New Accuratune Features

Geared 80-1 ratio.

No back lash.

No cutting of condenser shafts.
Flush panel mounting.

At your dealers, otherwise send purchase price and you will be supplied postpaid. Price \$3.50.

ACCURATUNE

80-1

MICROMETER CONTROLS

Mydar Radio Co., 9-B Campbell St., Newark, N. J.

Canadian Representative: Radio Ltd., Montreal

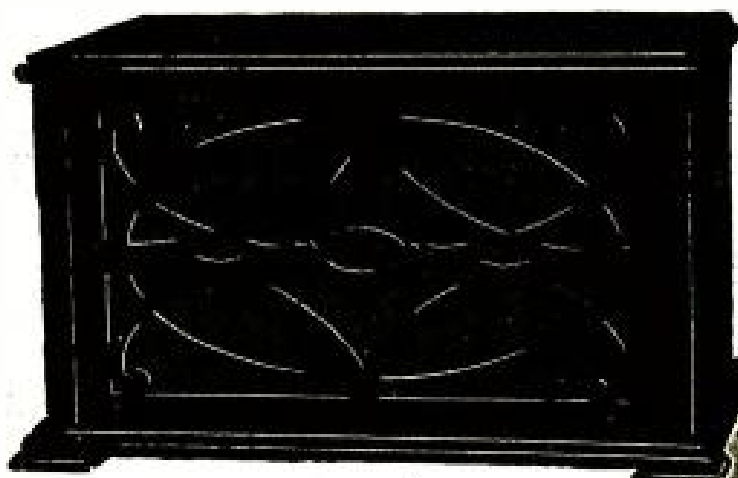

Model "C"
Cabinet Type
\$30.

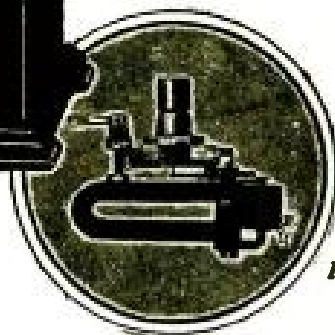

Pat'd.

The New Cabinet Model

FOR those who admire the full, round, musical voice of the Audiophone, but prefer a cabinet design, we have brought out this splendid model.

The case is of real mahogany, of a character to give it equal fellowship with your grand piano. The design goes nicely with the most tasteful furnishings. The size, 17 x 10 x 10 $\frac{1}{4}$, is just right for the top of your phonograph or your receiving set.

It has the sound mechanism of our Model "S," but its square design gives it a sweetness of its own.

Not a "Phone Unit"

The voice of the Audiophone is not a "phone unit." It is a highly developed, electro-magnetic tone reproducer. This results in an instrument which reproduces with natural quality in most powerful tones, yet has a sensitiveness equal to any loud speaker developed.

The Bristol line includes five Audiophones priced from \$12.50 to \$30.00. If not at your dealer's write for Bulletin No. 3022-L.

THE BRISTOL COMPANY
Waterbury, Conn.

The Voice of the Audiophone



Model "S"
Audiophone
\$25.00

Rubber horn
14 $\frac{1}{2}$ inch di-
ameter. Velvet
mat finish of
mottled bronze
and gold; clas-
sic base.

Bristol **AUDIOPHONE** LOUD SPEAKER

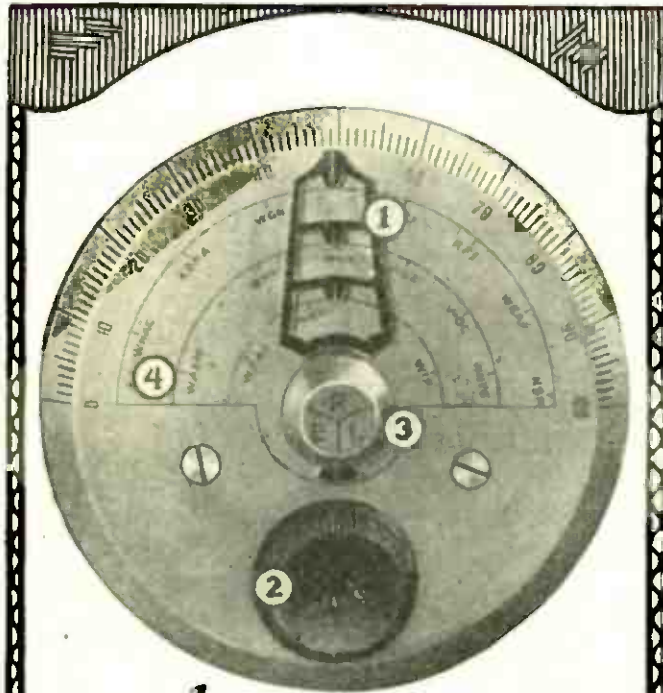

and now - Forget Wavelengths

IN the Arabian Nights story, the words "Open Sesame" magically—instantly—opened the door. The ULTRA-VERNIER Tuning Control is the "Open Sesame" to any station once difficult to find, or stumble upon.

Simply pencil-mark any station on this cleverly contrived beautifully silvered dial. Then forget its wavelength—turn the finder to your mark, and, without awaiting the announcer, know you hear this pet station.

Moreover, the ULTRA-VERNIER is a single vernier tuning control. Replace your old dials with ULTRA-VERNIER Tuning Controls—today!

1. This alignment is the gauge for penciled station records.
2. Operates vernier for hair-splitting adjustment.
3. Takes standard condenser shaft lengths—easy to mount.
4. Penciled station records easily erased from silvered dial.



Designed by R. E. Lacault, E.E., A.M.I.R.E., inventor of the famous Ultradyne circuit. This monogram seal (R. E. L.) is your assurance of Lacault design.

Made by the Hammarlund Mfg. Co., your assurance of quality and dependability—produced solely for the Phenix Radio Corporation. At your dealer; otherwise send purchase price and you will be supplied postpaid.

\$2.50

Write for descriptive circular.

ULTRA-VERNIER
TUNING CONTROL
Phenix Radio Corporation
7-9 Beekman Street
New York City

This Big Book FREE

A Handsome 100 Page Volume
In Substantial Cloth Binding

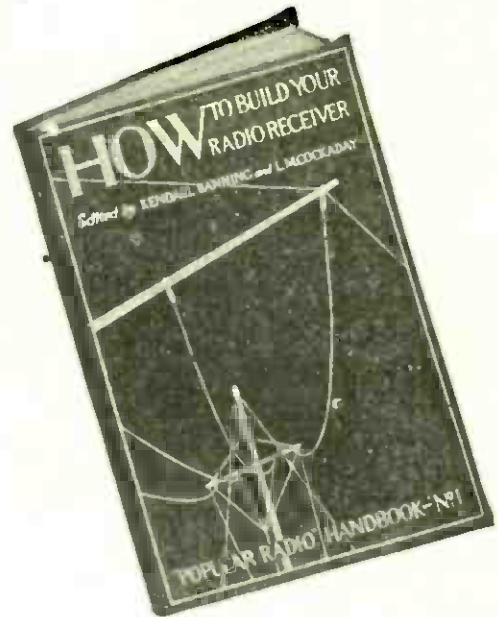

Takes the Mystery Out of Radio

THE purpose of the editors in compiling "How to Build Your Radio Receiver" was to provide a dependable working guide for the construction and operation of receiving sets that would enable beginner and expert alike to build a set that would best suit his individual requirements. To offer the widest possible choice they selected seven representative circuits that in laboratory tests had proved most nearly ideal from the viewpoint of selectivity, tone, volume, distance, simplicity of construction, ease in tuning, reliability and general all-around satisfaction. These seven sets include the simplest crystal set; one tube; three tube; five tube; and even a six or eight tube regenerative super-heterodyne!

It's Cheaper to Build Than to Buy

The actual building of any of these sets can be accomplished by following the instructions given. With the descriptive matter are accurate diagrams and illustrations that show exactly how to assemble, mount, wire and operate each set. The list of parts needed specifies by manufacturer's name those actually incorporated in the demonstration set built in our own laboratories.

Aside from the actual constructional data, this book is in every sense a Ready Reference Guide on Radio. It contains picture diagrams of the forty-four symbols used in radio; suggestions about aeriads; how to select your parts; tips on tuning and other valuable suggestions.

An Attractive Combination Offer

For the next thirty days we will give you a copy of "How to Build Your Radio Receiver" FREE and enroll you for all privileges of the Technical Service Bureau, under the personal direction of L. M. Cockaday, at no further expense, on receipt of your remittance of \$4.00 in payment for a 16 months' subscription for POPULAR RADIO—the outstanding monthly in the radio field—the magazine that keeps you in touch with the latest radio developments—shows you how to improve your broadcast reception. Send no money now unless you prefer—pay the postman on delivery of the book—and in any event understand that you run no risk, for your money will be refunded without question if you will notify us within ten days that you are not more than satisfied.

POPULAR RADIO

627 West 43d St. New York City

Popular Radio, Dept. 15
627 West 43d St., New York City Date.....
Enclosed remittance of \$4.00 is payment in full for a 16 months' subscription for POPULAR RADIO and copy of "How to Build Your Radio Receiver" FREE.

Name.....

Address.....

City..... State.....

Check here and remit \$2.00 if you prefer POPULAR RADIO for 7 months only in combination with "How to Build Your Radio Receiver."

Offer Expires January 20, 1925.

Unsurpassed selectivity, sensitivity, range, volume and tone combined

Looks like—and performs like—a \$200 radio set



BUILT TO GIVE LOUD SPEAKER ENTERTAINMENT FROM STATIONS THOUSANDS OF MILES DISTANT WHILE LOCAL STATIONS ARE BROADCASTING

Can be used as a 2-tube, 3-tube, 4-tube or 5-tube set!

"Coast to Coast" reception verified by Miraco Users

Every Miraco user is an enthusiastic booster—these letters are typical of the many we receive.
Miraco "Shows" Missouri
 I bought one of your radios last summer and like it fine. Have picked up stations from Coast to Coast and from Canada to Cuba. My motto with the Miraco is: "What's the use to pay more when the Miraco will reach as far as you can understand the language?"
 —George V. Scott, Moberly, Mo.

N. Y. Hears England & Brazil
 Am very glad I bought a Miraco as it works the best of any I have heard. All the people who come to listen say that when they buy a set it will be a Miraco. Have heard London, England, and Rio de Janeiro, Brazil, with my Miraco. It sure works fine. It is the best set on the market for the price.—Leo Link, Marcy, N. Y.

Pennsylvania Hears Calif.
 The Miraco is a real "Coast to Coast" set. Last night I tuned in on KGO, Oakland, Cal., WFAA, Dallas, Texas, KFKX, Hastings, Neb., besides fifteen other stations. Have received 55 in all. It is a wonderful set for the price.—Earl C. Way, Coleman, Pa.

Iowa Hears N. Y. to Calif.
 Have heard from New York to California on my Miraco. All who have heard it think it fine.
 —Chauncey Bailey, Stockport, Iowa.

Beats Some \$300 Sets
 The Miraco that I bought last fall is giving better satisfaction than some \$300 sets others have here.—Otis Morris, Warren, Idaho.

Nebraska Hears Cuba
 Miraco sure is a go getter. I get better reception than anyone in this neighborhood. Had WSAI, Cincinnati, on loud speaker in July—pretty good for warm weather. I tuned in KGO, Oakland, Cal., and WBZ, Springfield, Mass., and have heard PWX, Havana, Cuba, a number of times.—Verne J. Gustason, Blair, Nebr.

"Hears the Scotch"
 I am proud of my Miraco. Have had Cuba, Canada, Glasgow, Scotland—of which any one should be proud—with nearly every station in the U. S.—Parke A. Neet, Catlin, Ind.

The Marvelous MIRACO Ultra 5

- costs only \$ **75**

Send for free bulletins and **SPECIAL OFFER today!**

[FIVE TUBE OUTFIT IN BEAUTIFUL SOLID MAHOGANY CASE]

Completely built, thoroughly tested and factory guaranteed by one of America's oldest and most reliable manufacturers of quality sets! Years of experience and quantity production explain its almost incredible price. Users say that friends who see and hear it are amazed that it sells for less than \$150 or \$200. Radio experts, who know good construction and quality parts, are equally astonished. You, too, will be delighted, thrilled, amazed with your big five-tube Miraco Ultra 5 in its beautiful hand-rubbed solid mahogany cabinet!

Imagine getting all this for \$75—a beautiful sweet toned "coast to coast

loud speaker" set, composed of finest parts, equipped with the latest improvements, refinements and features found on costliest sets. An instrument approved by radio's highest authorities! A set anyone can connect and operate. Even beginners learn quickly to cut through the "locals," get distant stations loud and clear, log stations and return to them at will. (Full directions with each set.) It is non-radiating, non-distorting, non-howling. Has cut-out switch—and a first stage phone jack for tuning—on Bakelite panel. All wiring concealed under Bakelite sub-base. Works on storage battery or dry cells. Literature describes other newest features.

Other Miraco Long Distance Sets \$14³⁵/_{up}



Miraco Model R justly deserves its title, "Radio's finest low priced quality receiver." One tube acts as a tuned radio frequency amplifier and detector combined. A great distance getter. Easy to

operate and log. Covers all wave lengths 150 to 625 meters. Like all Miraco sets, it operates on a storage battery or dry cells. Never such value before at only \$14.35. Send coupon today!



This wonderful new Miraco Model R-3 is the three-tube, long distance, loud speaker set that has created such a sensation. Easy to tune and log. Covers wave lengths

150 to 625 meters. Detector acts also as a tuned radio frequency amplifier. 2 stages audio frequency amplification. Has no equal for simplicity, volume, range or clearness at anywhere near its price of \$29.50. Use coupon!

All the Proof you want is waiting for You!

Reports from the many users in every state prove Miraco Tuned Radio Frequency Receivers—at rock bottom prices—have efficiency of sets costing up to three times as much. Remember that Miraco Sets are the product of a long established, reputable manufacturer—pioneer builders of sets. Send for further evidence that they are Radio's finest moderately priced receivers. All Miraco sets bear the endorsement of radio's highest authorities. Mail coupon now for latest bulletins, SPECIAL OFFER and plenty of additional testimony from users leaving no doubt that "Miraco Radio Gets 'em Coast to Coast."

Dealers! Jobbers! Agents!
 Write for the new Miraco proposition.

The wonderful tone, volume and distance-getting ability of Miraco Sets makes them easy to sell. Send coupon for proposition; good territory open.

Send coupon for free bulletins or order direct from this ad

MIDWEST RADIO CORPORATION
 Pioneer Builders of Sets, 479 - K E. Eighth St., Cincinnati, O.
 Send free literature, SPECIAL OFFER and all particulars regarding Miraco Sets. () Jobber () Dealer () Agent () User

NAME.....
 ADDRESS.....



Daytonia \$ 285 00

Amazing Simplicity

THEY said it couldn't be done—but we've done it. Every DAY-FAN set comes to you already logged.

ALL DIAL SETTINGS ARE THE SAME FOR EVERY SET—EVERYWHERE—ON EVERY ANTENNA



OEM-7 Four Tubes, \$98
OEM-11 Three Tubes, \$90

A complete list of broadcasting stations with corresponding dial settings comes with each set. This new and exclusive DAY-FAN feature makes it the last word in simplicity—the easiest to tune—the surest to get pleasing results.

Selectivity? The stations you want are brought in clearly and distinctly with just one adjustment.

Clarity? The Duo-plex circuit, developed in our own laboratories, banishes common distortion difficulties.



Dayola . . \$125

Distance? Under favorable conditions a DAY-FAN set will easily span the continent for you. The DAY-FAN line comprises models priced from \$90.00 to \$285.00. Every one a beauty and everyone a remarkable value.

Write for Literature.

The DAYTON FAN & MOTOR CO.
Manufacturers of High-Grade Electrical Apparatus for more than 35 Years
DAYTON, OHIO.

Day-Fan

RADIO

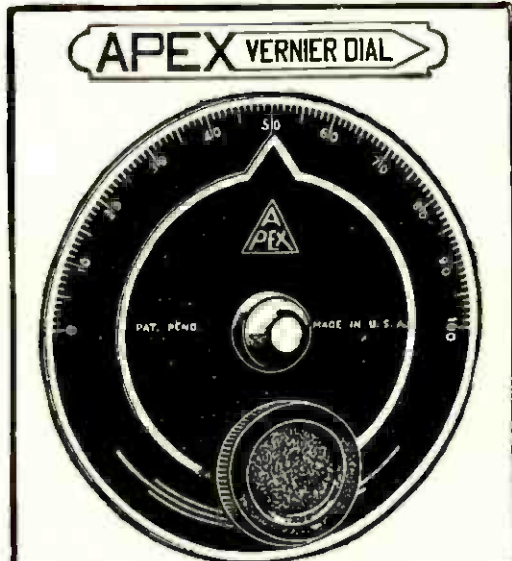

It Brings 'Em In!

Get more stations—greater range—bigger volume—finer selectivity—less interference. Lasts forever. The one big advance yet made in tuning. Ratio 12 to 1. Quickly applied to any shaft. For sale by all good Radio Dealers. If unable to obtain from dealer, enclose \$2.50 for nickel-silver finish, or \$3.50 for De Luxe satin finished gold.

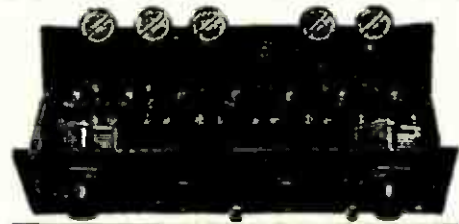

7-Tube Super-Heterodyne for \$97.50

Receive the parts complete to assemble your own set. Coast to coast on an 18-inch Loop. Assemble this 7-tube Heterodyne Super-heterodyne on a 7x18 in. panel in three hours. Parts complete, including drilled and engraved panels, condensers, sockets, transformers, dials, connecting plugs, cables, etc., with drawings, diagrams and instructions. Price of cabinet—to fit—on application. If your radio dealer cannot supply parts for complete Heterodyne Radio Set, send check or money order for \$97.50 and name of your dealer.
APEX ELECTRIC MFG. CO., Dept. 102
1410 W. 59th Street, CHICAGO

Globe LOW-LOSS TUNERS

Loses Nothing
Tunes every radio
impulse the aerial
receives

No Metal
No Eddy Current Losses

Little Insulation
Low Distributed Capacity

Large Wire
Self Supporting

Anti-Capacity Windings
Low R. F. Resistance

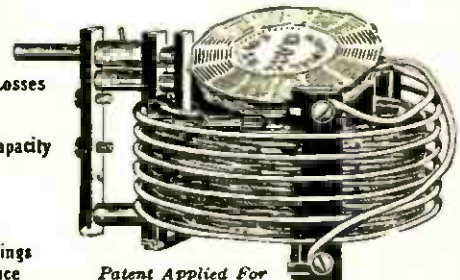

Patent Applied For

GET ORIGINAL GLOBE COILS

Standard Tuner (Broadcast Range).....\$7.00
Short Wave (35-135 Meters).....\$7.00
For Superdyne Circuit.....\$8.50
R. F. Transformer.....\$6.00

Circular on Request. Dealers and Jobbers Write.

SEND ORDERS DIRECT TO

Globe Radio Equipment Co.

217 WEST 125th ST., N. Y. C.

* Imitation is Deceit. * Legal Action Pending.

Telos Radio

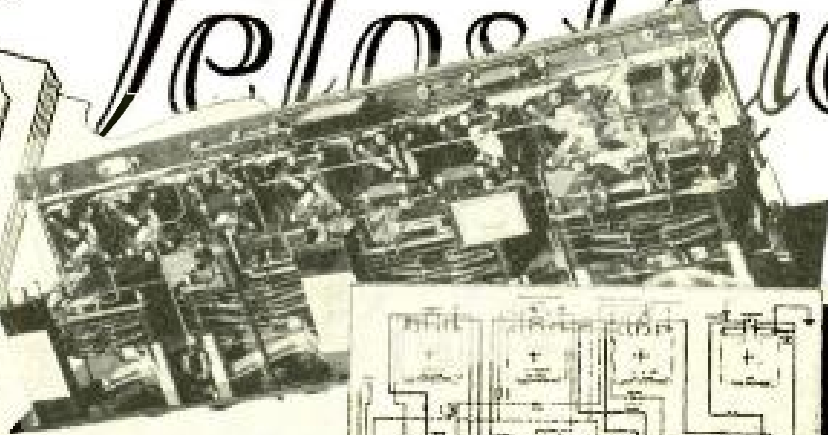

Interior wiring of a typical Telos Set. Every step is clearly explained in the instruction book and diagram.

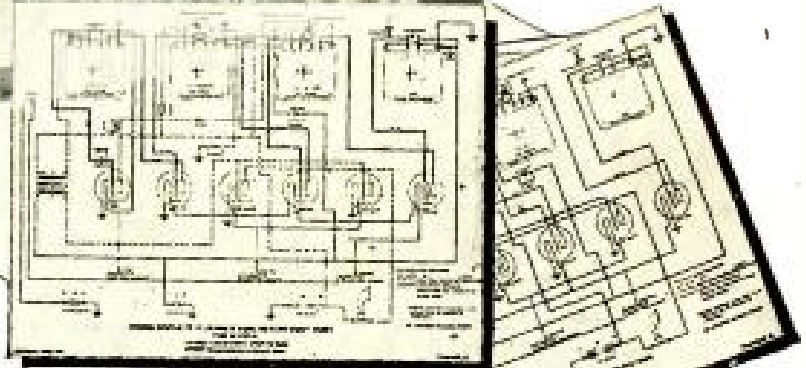

The KIT of a Thousand Possibilities

WHEN, up to now, have you heard of *three* stages of tuned R.F.—perfectly and automatically stabilized! When, up to now, have you heard of 2, or even 3, stages of resistance-coupled A.F. — superimposed (reflexed) on the radio frequency tubes? Yet you won't have the slightest difficulty in accomplishing this with the equipment in the Telos Kit.

And you can do it with dry cell tubes—U.V. 199's or D.V. 3's throughout.

But you're not limited to that combination either. Truly, Telos is the KIT of a thousand possibilities! You can introduce a crystal detector if desired. You can use one, two or three stages of transformer A.F.; you can use W.D. 12 tubes for the R.F.,

with filaments connected in series, and 201 A's for the Detector and A. F.

These and countless other combinations you'll want to try, are fully covered in the handsome instruction book and detailed blue-prints that come with every KIT.

You'll also be interested in "Unicontrol", the clever device whereby all dials turn together for rough tuning, then separately for the finer adjustment. It's in the KIT, too!

But get the full story! Use the coupon now! Every real fan will want a copy of the new Telos booklet!

DANZIGER-JONES, Inc.
Dept. A
25 Waverly Place
New York N. Y.

DANZIGER-JONES, Inc.
Dept. A, 25 Waverly Place
New York, N. Y.

Send me at once your booklet "The KIT of a Thousand Possibilities".

Name.....

Address.....



THE SENSATION OF EVERY RADIO SHOW

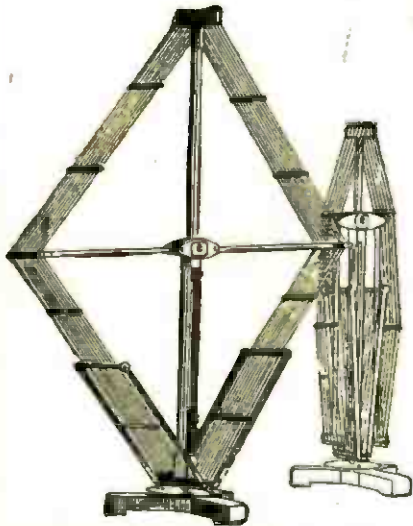

Height 42 inches. Width 40 inches

NOW \$25.00
Formerly \$35.00

**THE BIG FEATURE AT THE RECENT SHOWS
NEW YORK, BALTIMORE, BOSTON AND CHICAGO**

The 1925 D. T. W. Imported German Loop

Electrically and mechanically this loop has no equal. USE it—Compare it—if you do not find this to be true—Return it to your dealer, who is authorized to refund your money.

THIS amounts to a FREE trial.

Why the loop is a better loop:

1. Plan of construction.
2. Superior quality of materials used.
3. Original 60 strand German Litz.
4. Careful attention given to details of construction.
5. Method of cutting the inductance, allowing use as two or three tap loop. No dead end losses.

Distributor Zones now being allotted for loop and other D. T. W. Products. Progressive and responsible dealers solicited.

Manufactured by the Deutsche Telephonwerke und Kabelindustrie of Berlin, Germany
The telephone company of Germany

If your dealer cannot supply you, **\$25.00** Shipped in a permanent cylindrical container. Money back Parcel Post C. O. D. Formerly \$35.00 guarantee.

\$1.50 extra west of Chicago
Usual Discount to Radio Dealers

TOBE C. DEUTSCHMANN, American Representative and Distributor
46 A. Cornhill, Boston, Mass.
Reference: First National Bank, Boston, Mass.



WHOLESALE RADIO SERVICE COMPANY

9 Church St. N.Y.C.
DEPT. P

Our WRS Cockaday kit is a complete kit. Every part is exactly as Mr. Cockaday himself built it. Everything from the authorized condenser right down to the last screw. The construction work on this kit has been carried to the point where all you have to do is fasten the parts in place, cut and fit the wires, solder them in place, and you have a very handsome and reliable long distance receiver.

No Chance of Going Wrong When You Buy Our Kit

NEW COCKADAY FOUR CIRCUIT TUNER WITH RESISTANCE-COUPLED AMPLIFIER

ALL PARTS EXACTLY AS SPECIFIED BY MR. COCKADAY

OUR KIT IS ABSOLUTELY COMPLETE TO LAST SCREW

List of Parts:			
1 Cockaday Precision or Gen-Win coll.	\$5.50	1 Amsco switch lever	\$.25
1 Cardwell 21 pl. .0005 mfd. condenser	5.00	9 Switch points and 2 stops	.20
1 Cardwell 17 pl. .00035 mfd. condenser	4.75	1 Improved filament battery switch	1.01
2 Accurate micrometer control dials	7.00	1 7 x 24 panel, drilled and engraved	3.50
1 N. Y. mica fixed condenser .00025	.35	3 Electrad certified grid leaks 1/2 meg.	1.50
1 Amplex Gridenser	1.25	3 Electrad grid leak holders	.75
6 Benjamin clearstone sockets	5.00	3 Bradleyohms	6.00
1 Amsco Dubl-Wunder comb. pot-rheo.	2.00	1 Bradleyleak	1.85
4 Amperites No. 1-a	4.40	3 Sub panels	.50
3 Improved double circuit jacks	3.00	1 Base board	.75
1 Improved single circuit jack	.70	8 Rajah Terminals	1.60
1 Precise audio frequency transformer	5.00	20 ft. bus wire	.20
9 N. Y. mica fixed condensers .005	6.40	1 box assorted Dixie screws, nuts, etc.	.50
		Total	\$67.95

As an appreciation of the tremendous volume of business that our customers have given us during the past year, we offer

FREE

FOUR GENUINE UV 201-A RCA TUBES WITH EVERY KIT ORDERED.

Our New Free Catalog is Now Ready It contains everything new in Radio; standard merchandise and the prices are surprisingly low. Just send us your name and address. everything illustrated is guaranteed.

The secret of easy charging



MAYBE you think the storage battery a difficult proposition. Charging is what used to cause trouble—until we developed

The New Silent GOLD SEAL HOMCHARGER

Now charging is as simple as ABC. Here's the HOMCHARGER way: Slip two spring clips over the battery terminals, and screw a plug into any lamp socket. That's all. Go right on using your set, if you want. You can even sleep in the same room with the HOMCHARGER, it's so quiet.

So get a good storage battery, the new silent GOLD SEAL HOMCHARGER, and enjoy radio at its best.

Handsome: Finished in mahogany-red and gold. Non-scratching rubber feet. Absolutely safe, absolutely certain, care-free. Unqualifiedly guaranteed.

THE AUTOMATIC ELECTRICAL DEVICES CO.

Largest manufacturers of Vibrating Rectifiers in the World
132 West Third Street, Cincinnati, Ohio
Under the same management as the Kodak Manufacturing Co.

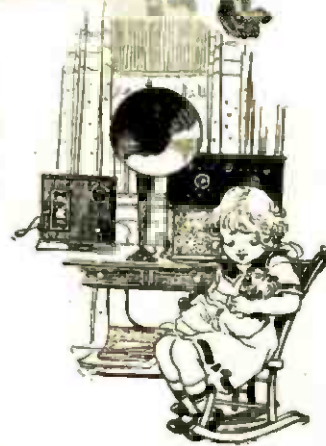

FREE!

Ask your dealer or send direct for a copy of the booklet, "The Secret of Distance and Volume in Radio," containing valuable information as well as complete details of the new silent

GOLD SEAL
HOMCHARGER

14 GOLD SEAL HOMCHARGER features

- | | | |
|---|--|---|
| <p>1—Simple; needs no care.</p> <p>2—Efficient; costs about 5c to charge the average battery, much less than bulb or liquid types of charger.</p> <p>3—Quick; brings battery up to full charge overnight.</p> <p>4—Tapers charge; cannot injure the battery.</p> <p>5—Clean; no bulbs to break, no liquids to spill or produce fumes.</p> <p>6—Dependable; adjusted and sealed at factory.</p> <p>7—Lasts forever; only one</p> | <p>moving part, the Tungsten contact, which can be replaced at \$1 after many thousands of hours of use.</p> <p>8—Fool-proof; charges automatically, no matter which clip is attached to which battery terminal.</p> <p>9—Safe; approved by Fire Insurance Underwriters. No danger of shock or fire.</p> <p>10—Beautiful, sturdy metal case finished in mahogany-red and gold.</p> | <p>11—Universal; made in types for all voltages of alternating and direct current. Charges all radio "A" and "B" batteries and automobile batteries.</p> <p>12—Quiet; its faint hum cannot be heard in next room.</p> <p>13—Unqualifiedly guaranteed.</p> <p>14—Popular price; sold everywhere for \$18.50; in Canada \$26. Complete, no extras to buy.</p> |
|---|--|---|

A VERY POPULAR STYLE OF RADIO TABLE

No. 30-R

Plenty of leg room.

Weight crated 85 pounds.

Send for free catalogue of Radio Furniture

Specifications—Hardwood, rubbed mahogany or golden oak finish; height over all, 31 inches; size top 24x34 inches; drawer, with lock, size 4x10x13³/₄ inches; battery cabinet, size 17x14¹/₄x16 inches.

Prices—No. 30-R—Freight paid East of the Mississippi River, Cash With Order.....\$18.00
 Rocky Mountain States.....\$20.00
 Pacific States.....\$22.50



NOTE: Cut shows battery cabinet on left, but these tables are all made with cabinet on right.

IMMEDIATE SHIPMENT

OUR LATEST STYLE

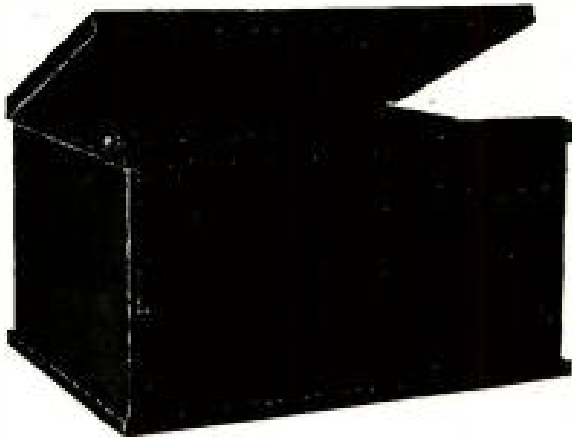

Radio Cabinets Strong and Rigid. Remember That We Pay Mail and Express Charges. It Makes Quite a Difference When Comparing Prices.

Specifications—Hardwood, rubbed mahogany finish. Top hinged, ends of top splined to prevent warping.

Panel Size	Depth	Price	Panel Size	Depth	Price
7 x 14.....	10.....	\$3.00	7 x 26.....	10.....	\$4.50
7 x 18.....	10.....	3.25	7 x 27.....	9.....	5.00
7 x 21.....	10.....	3.50	7 x 28.....	10.....	6.00
7 x 24.....	10.....	3.75			

Mail and express prepaid east of Mississippi River
 To Rocky Mountain States add 50 cents each
 To Pacific States add 75 cents each

THE SOUTHERN TOY COMPANY

Dept. P.

Hickory, N. C.

A new **FOUR WAY** Product



(Patent Applied For)

Loud Speaker Extension Unit

COMPLETE

THIS COMPLETE UNIT enables those who want to use the Loud Speaker in other parts of the house to do so without removing set. Insert plug from loud speaker into jack; place plug on end of cord into set. This can be done readily and saves the trouble of using tools or soldering iron.

PRICES, including Jack, Plug and Cord

10 foot cord.....	\$2.25	40 foot cord.....	\$3.00
20 foot cord.....	2.50	50 foot cord.....	3.50
30 foot cord.....	2.75	100 foot cord.....	5.75

Manufactured by

Four Way Co. :: Myrick Bldg. :: Springfield, Mass.



It's true! Battery Crystal It's new

1000 Miles on Reflex Sets

A. H. Miller, originator of B-Metal and Miller B-Metal now gives to Radio a startling invention - the Battery Crystal. This marvelous crystal keeps permanently electrified to the highest degree and brings stations heretofore out of reach into easy range on 1 Tube Reflex sets. 1000 miles away comes in as clearly as you now get local stations with ordinary crystals.

DEALERS Operates Loud Speaker on local station. You can expect 4 times the volume as from ordinary crystals. One Miller Battery Crystal is good for 10,000 hours. Order direct if your dealer cannot supply you. Complete details in free booklet—ask for one.

A. H. MILLER RADIO CO.
 1259 W. Grand Boulevard Detroit, Michigan

Genuine
Miller-B-Metal

EISEMANN

ELECTRICAL EQUIPMENT

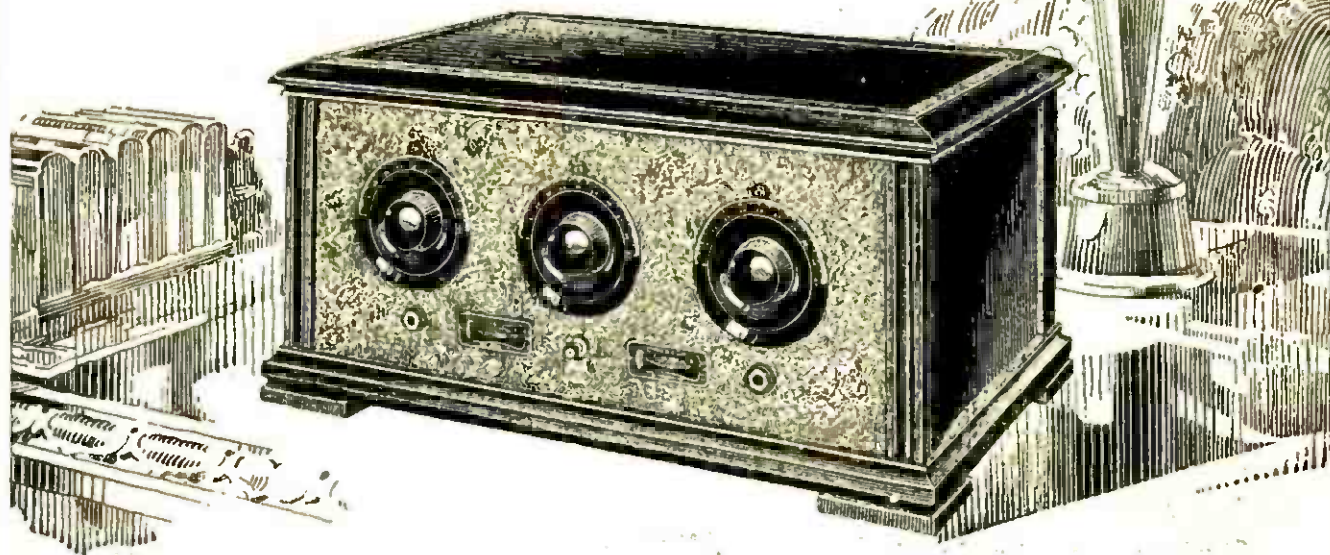

Type 6-D Broadcast Receiver

Non-oscillating ~ Non-radiating

SPECIFICATIONS

Circuit: Two stages of tuned radio frequency amplification, detector and two stages of audio frequency amplification. Non-oscillating. Non-radiating. Astatic transformers used to minimize mutual induction.

Tubes: Five in all. Jacks provided for either five or four tube operation.

Batteries: Either storage or dry cells.

Cables: Complete set supplied for "A" and "B" batteries.

Wave lengths: 200 to 600 meters, with uniform efficiency of reception.

Aerial: 75 to 125 feet, single wire.

Panel: Aluminum, with attractive crystal black finish. A perfect body capacity shield.

Dials: Sunken design. Shaped to fit the hand and permit a natural position in tuning.

Resistors: Adequate resistance for all standard base commercial tubes.

Condensers: Single bearing, low leakage losses.

Sockets: Suspended on cushion springs which absorb vibrations.

Cabinet: Mahogany, with distinctive lines and high finish. Ample space provided for "B" batteries.

THE real, intrinsic value of the 6-D Receiver can be fully appreciated only by making direct, side-by-side tests with other makes.

Such comparisons need not be confined to sets in the same price-class. The 6-D is the equal, in every detail, of many receivers priced \$25, \$50 and even \$75 higher.

Performance of the highest order, strikingly attractive appearance and moderate price—all these elements of true worth are found in the 6-D.

You will note its clarity and the full, generous volume. You will also observe the unusual sharpness of tuning. And the finely carved, high finish mahogany cabinet will make a strong appeal.

Price \$125.00 without accessories. For sale by reliable dealers.

EISEMANN MAGNETO CORPORATION

General Offices: 165 Broadway, New York

DETROIT

SAN FRANCISCO

CHICAGO



All apparatus advertised in this magazine has been tested and approved by POPULAR RADIO LABORATORY

BENJAMIN CLE-RA-TONE SOCKET CLEARER RADIO TONE

Spring Suspended—Shock Absorbing
Prevents unnecessary mechanical noises. The tube holding element "floats" on perfectly balanced springs. Vibration is thus counteracted and so-called "tube noises" done away with.

Spring supports are not affected by stiff bus wiring. Molded parts are genuine Bakelite.

8645 For Standard Base V. T. . . \$1
8646 For UV-199, etc., Tubes . . . 1

Cle-Ra-Tone Gang Socket



Simplifies construction of receiving sets. Cle-Ra-Tone Gang Socket may be used with almost any of the popular forms of circuit. Consists of Cle-Ra-Tone Sockets attached to Bakelite shelf and set of binding posts.

Standard or VT Sockets	UV-199, etc. Sockets	Dimensions of Shelf	No. of Sockets	
8613	8603	7 7/8" x 4 1/8" x 1/4"	3	\$5.50
8615	8605	17 1/4" x 4 1/8" x 1/4"	5	10.50
8626	8606	17 1/4" x 4 1/8" x 1/4"	6	11.25
8627	8607	17 1/4" x 4 1/8" x 1/4"	7	12.00



Radio Battery Switch

Lightest and neatest switch made. Mounts in single 1/4 inch panel hole. No spacer washers required. Push-Pull single contact features give positive contact. When it's in it's off, avoiding accidental cutting in of battery.



No. 8640, \$0.30

No. 8629 Brackets, extra, the pair, \$0.70

No. 8632 Grid Leak Panel, extra . . .15

Your local dealer will supply you, or address

Benjamin Electric Mfg. Co.

120-128 S. Sangamon St., Chicago

247 West 17th Street, New York

448 Bryant Street, San Francisco

NAA

Get 'Em

The only scientifically selected detector minerals on the market today are the genuine N.A.A.

60¢

METER TESTED M RADIO CRYSTALS D

Full, clear rectification insured by newly developed visible laboratory meter-testing. Perfect for reflex. Price 60c at your dealer or direct. Recommended by Radio News, Popular Radio, Acme Apparatus Company, etc.

The Newman-Stern Co.

1740 East Twelfth Street
Cleveland, Ohio

Pioneers in Tested Crystals

Nuggets of Sensitiveness

METER TESTED
NEWMAN-STERN

Best for Reflex

and Crystal Sets

FRESHMAN

Double Adjustable
Crystal Detector

No more searching for the sensitive spot. —Merely turn the knob as you would a dial.

For base or panel mounting, complete with Freshman Super - Crystal

\$1.50

At your dealer's, otherwise send purchase price and you will be supplied postpaid.

CHAS. FRESHMAN CO., Inc.
240-248 W. 40th St., N. Y.

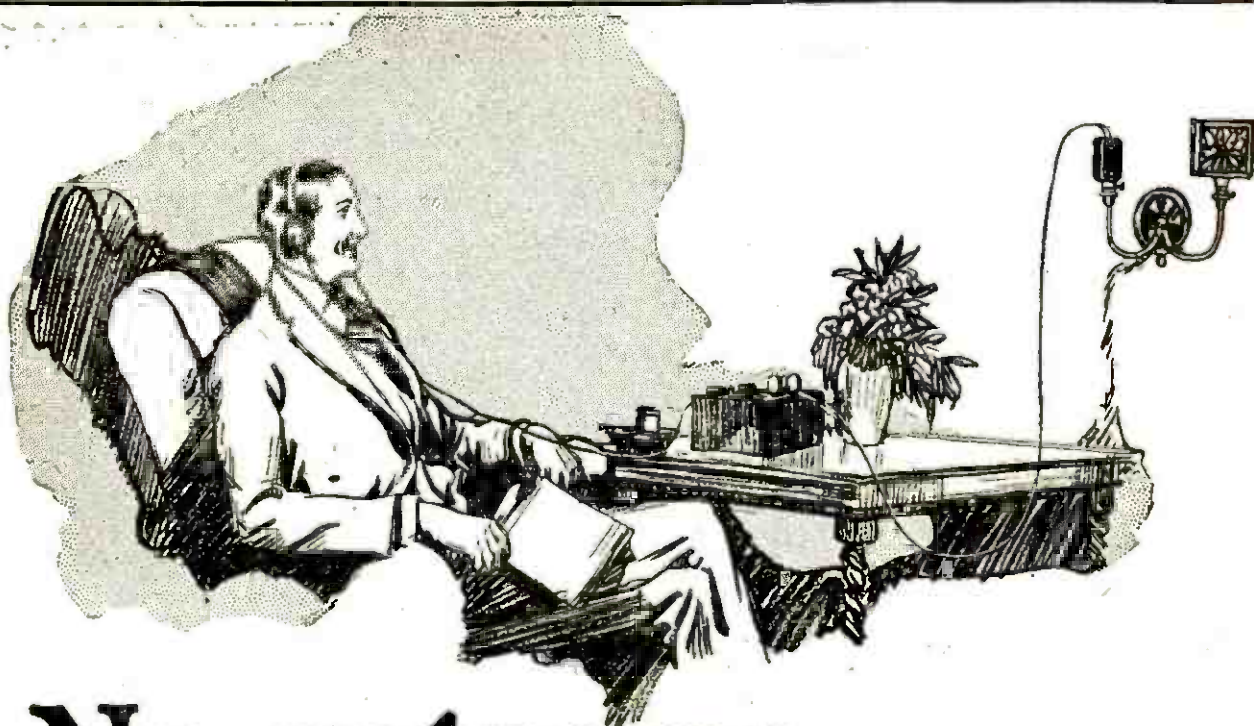

No antenna —Just the Ducon



The Ducon sells for \$1.50
in all reliable stores

No more need to labor and toil over erecting an aerial. No more need to worry about the appearance of a bulky indoor loop in your home. The Ducon saves your time—and solves your problems.

Screw the Ducon into any accessible electric light socket and when you want to hear a program just tune in.

The Ducon brings in the stations clearly. The fact that over 400,000 fans use it is convincing proof.

Try it. You can purchase a Ducon on a five-day trial basis from your radio dealer.

Dubilier

CONDENSER AND RADIO CORPORATION

Fleron RADIO SPECIALTIES

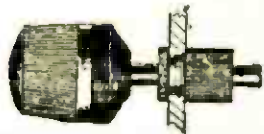

VERNIER ADJUSTER

The best adjuster on the market. Spring holds head away from dial when not in use. With slight adjustment spring can be made to hold head against dial if desired. Patented. 65c.



LEAD-IN BUSHING

This device makes a workmanlike finish at a point in aerial installation that has been a source of power loss. Adjustable to most every normal thickness. Black Body Porcelain. Black Glaze. \$1.10 each.

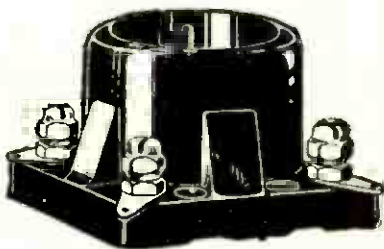

PORCELAIN SOCKETS

Lowest losses of any socket. Very carefully made. Black Body, Black Glaze. Side and bottom contact springs of reinforced phosphor bronze. Solder Tabs. Cap Nut for screw-driver or Spintite Wrench. All parts nickel plated. 65c. each.



PORCELAIN INSULATORS

Lowest power losses in the antenna Dielectric absorption reduced to minimum because of very low phase difference of Fleron Porcelain. Very tough body. Solid Black Glaze. Seven sizes, 20c. to \$1.00. Each insulator in a separate carton.

For Sale by all Good Jobbers and Dealers

M.M. FLERON & SON, Inc.
TRENTON, N. J.

PERSIL RADIO SERVICE

2114 Mapes Ave.

New York

IN DEMAND NOW!!

Hard to Get Parts

Cardwell Condensers, Precise Audio-Frequency Transformers.

General Instrument Variable Condensers, .0005 and .001 Haynes-Griffin Transformers, Input and Intermediate Precision Autodyne Coupler. Benjamin Sockets. Federal Sockets. Amplex Grid-denser, Bradley Leak, Karas Harmonik Audio-Frequency Transformer. Amoco Rheostat, 2 Ohms. Amoco Potentiometer 400 Ohms. Walbert Filament Lock Switch. Bradley Ohms.

We Specialize in Cockaday Kits

Special!

5-Tube Cockaday, 4-Circuit Tuner

KIT Resistance Coupled; Parts exactly as Specified, Blue Prints. BusWire, etc. **\$64.00**

Free! A Rubbed and Finished Mahogany or Walnut Cabinet With Above Kit

WIRED In Genuine Walnut or Mahogany Cabinet **\$85.00**

Delivered Free Anywhere. Canada. Add 5% to Order. One-third Must Accompany All Orders. Insured if you wish.

Shoot your questions and troubles to us. No charge for advice. Our radio experts are at your service.

KEYSTONE RADIO LIGHTNING ARRESTERS

YOU are assured maximum signal strength when you use a LOW LOSS KEYSTONE Radio Lightning Arrester. The Keystone Arrester is made from genuine Bakelite, thus providing perfect insulation between antenna and ground. It is water, dust and damp proof and has heavy high speed discharge electrodes. Install a Keystone NOW! Approved by Underwriters E1835.

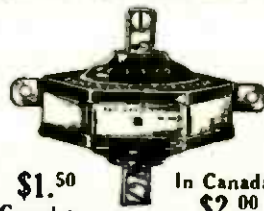

\$1.50 Complete

In Canada \$2.00

ELECTRIC SERVICE SUPPLIES CO.

Philadelphia
New York
Chicago

SIMPLEX DX TUNER

180°

\$3.50

Spiral Wound Moulded Rotor

A high quality tuner specially designed for the Three-Circuit Untuned Primary Circuit. Unexcelled for long distance and extremely selective. Good volume. No soldering required.

At Reliable Radio Stores

SIMPLEX RADIO CO. (Mfrs.) PHILADELPHIA, PA.

They say~

- 1** **THEY SAY OF THE NEW SUPER-ZENITH:**
 "Greater clarity and volume. Amplification is always at a maximum in each stage for any wave-length. Three stages audio frequency amplification."
Zenith amplifies with Thordarsons!

- 2** **THEY SAY OF THE KENNEDY:**
 "The Kennedy tone quality is superb; full-rounded, musically pure reproduction of any program within a good long range. No hollow tones or distortion. For the Kennedy is a *musical instrument*. A musician will enjoy its purity of tone."
Kennedy amplifies with Thordarsons!

- 3** **THEY SAY OF THE MURDOCK NEUTRODYNE:**
 "To hear the real voice of the nation full and clear—you want volume. . . . Volume that floods your room. . . . Distant stations can be tuned in with remarkable clearness and volume."
Murdock amplifies with Thordarsons!

- 4** **THEY SAY OF THE ANDREWS DERESNADYNE:**
 "It secures the finest tone and high selectivity with increased volume and distance. It brings to the home . . . a reproduction of music really comparable to the original. In volume the Deresnadyne will give anything from a mute tone to a volume that fills a large hall."
Deresnadyne amplifies with Thordarsons!

ZENITH
KENNEDY
Radiodyne
Pathe
ULTRADYNE
MURDOCK
MICHIGAN
Howard
DZARKA
MUSIO
PFNSTIEHL
PHOENIX
ANDREWS
MALONE LEMON
AUDIOLA
GATES
GLOBE
HARMONY
ODELL FERRY
PEERLESS
DUCKS DELUXE
SAAL
AND MANY
OTHERS USE
THORDARSONS

NOTE!
 that Thordarson makes a 2:1 audio—also an Interstage Power Amplifying Transformer. Prices below.



Superiority Proved!

Note the emphasis placed upon *tone quality* in the advertising of the finest sets—the sets that have Thordarson amplification. People want radios that are *musical instruments*. Leading makers are responding with sets embodying the best audio amplification. That is why *more* Thordarsons than all competitive transformers combined are now used in high-grade radios.

Is your present set disappointing? Buy a Thordarson—equipped set—or replace your audio frequency transformers with a pair of Thordarsons—or follow the lead of the leaders and build with Thordarsons. You will be delighted with the *even* volume they deliver over the *entire* musical range. All stores can now supply Thordarsons. If your dealer is sold out, you may order from us by mentioning his name. Interesting bulletins sent free. Write.

THORDARSON ELECTRIC MANUFACTURING CO.
Transformer Specialists Since 1899
WORLD'S OLDEST AND LARGEST EXCLUSIVE TRANSFORMER MAKERS
Chicago, U.S.A.

UNCONDITIONALLY GUARANTEED

THORDARSON
Super
AMPLIFYING TRANSFORMERS
Standard on the majority of quality sets!

TYPES AND PRICES: Thordarson "Super" Audio Frequency Transformers are now to be had in three ratios: 2-1, \$5; 3½-1, \$4; 6-1, \$4.50. Thordarson Power Amplifying Transformers are \$13 the pair. Thordarson Interstage Power Amplifying Transformer, \$8. Write for latest hook-up bulletins—free.

All apparatus advertised in this magazine has been tested and approved by POPULAR RADIO LABORATORY



The Red Seal feels "light as a feather" on your head ~ ~

Two o'clock in the morning—and still fishing for DX stations! But your Red Seal Headset is so comfortable you can't realize you've had it on for hours.

The headband of the Red Seal is covered with soft rubber and is held in shape by flexible wires which exert just enough pressure to keep the 'phones comfortably against your ears.

No protuberances to catch in the hair or to scratch furniture; no distortion; will not "chatter" with strong signals; full rich tone; high impedance; genuine Bakelite case.

Made by
MANHATTAN
 ELECTRICAL SUPPLY CO., INC.
 NEW YORK CHICAGO
 ST. LOUIS SAN FRANCISCO

MAKERS OF FAMOUS RED SEAL DRY BATTERIES



Old Man Ohm Says:

"Here is the Ideal Rheostat for all Tubes



Exact size cut of the Marshall-stat

\$1.75



—and he ought to know. He is the fellow who measures resistance. He finds that the Marshall-stat varies resistance not step by step, but smoothly, continuously and uninterruptedly from zero to maximum.

He also finds—and you will too—that the Marshall-stat: Is compact.

Requires only one hole in panel.

Is vernier all the way but requires only one adjustment.

Can be used with any tube or combination of tubes.

Has only two terminals and cannot be connected incorrectly.

MARSHALL ELECTRIC CO.
 3237 Locust Blvd. St. Louis, Mo.

Old Man Ohm has an interesting folder on the Marshall-stat. Send for it.

Noiseless Grid Leak

40c
 each in any value from 1/4 to 10

FRESHMAN SUPERIOR

You can depend upon them to remain accurate at all times

Made of high resistance material impregnated throughout (not coated paper). Unaffected by climatic conditions. Will not deteriorate. Clamped between solid knurled ferrules assuring rigid construction and firm contact at all times.

At your dealer's, otherwise send purchase price and you will be supplied postpaid.

Chas. Freshman Co., Inc., 240-248 W. 40 St., N. Y.



Boys are the Backbone of the Radio Business

The President speaks, and all over the country millions of radio sets are tuning in to catch his words. Five years ago a favored few, living near by, might have listened in. Now the whole country listens. Radio has captured the home, and the conquest was only made possible by the tremendous energy, ingenuity and curiosity of boys.

Boys' imaginations were caught by the lure of radio. They pioneered with their home-made sets. They spent their hard-saved nickels for parts. They enlisted the interest and roused the enthusiasm of their parents. They opened the family coffers. Dad went out to get his son the best he could afford, with son acting as advisor, buyer and constructor-in-chief. And to-day, the

vast majority of radio sales are made to boys, or to parents buying for boys or with the boys' advice.

THE AMERICAN BOY goes right to the heart of the boy market. It is the favored magazine of 500,000 radio-inoculated boys averaging 15½ to 16 years old—sons of well-to-do parents. Its stories and articles deal with radio authoritatively. All its contents hold their interest and confidence.

Always striving to improve their sets, indefatigable in insistent wanting, commanding their parents' enthusiastic co-operation in their radio activities—these youths are the backbone of the radio business; the radio manufacturer's greatest market.

Copy reaching us by January 10th will catch the March

The **American Boy**
The Biggest, Brightest, Best Magazine for Boys in All the World

Michigan issue.

*Wonderful!
startling!*



**The NEW
UNCLE SAM
MASTER COIL
TUNING COIL**

THE COIL WITHOUT LOSSES

- 1—U. S. Bureau of Standards forms of latticed hard rubber.
- 2—Perfect spacing of each turn because of new type American Ambassador Litz.
- 3—Eliminates adhesives.
- 4—Increases volume 50 to 180 per cent over old type coils. Also improves selectivity.
- 5—Laboratory tests prove conclusively that it is the only coil worthy of the name low loss.
- 6—**WARNING**—Use Ambassador Condensers and Transformers designed and manufactured by Ambassador Engineers, for best results with the Ambassador Coil.

FREE! Ask your dealer or send self-addressed stamped envelope for wiring diagrams of circuits in which this remarkable coil can be used.

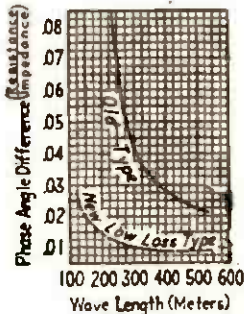

UNCLE SAM ELECTRIC CO.
215 E. Sixth St. Plainfield, N. J.

DONGAN

**Perfect
Balance
This is the
Audio
Frequency
Transformer**

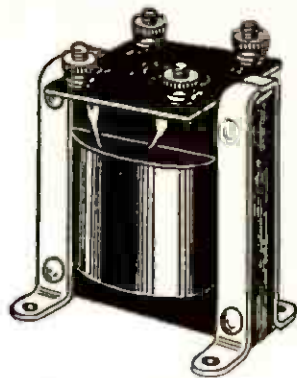

Type C—\$3.00 list

Selected by Popular Radio—

to use in building the "Low Loss Short Wave" Receiver described in the November issue.

Dongan Type C. Audio Frequency Transformer possesses that happy transformer combination—the quality of maximum amplification with minimum distortion. Built for all tubes and hook-ups—Ratios 3½ to 1 and 6 to 1.

VOLTMETER

Positively accurate and reliable—saves its price in short while. Ask about Dongan Double Duty High Resistance Voltmeter.

A Really Beautiful Instrument

Details and Discounts on Request

Dongan Electric Manufacturing Co.
2983 Franklin St. Detroit, Mich.

Transformers of Merit for 15 years

KESTER Radio SOLDER
(Rosin-Core)

*If your dealer cannot supply you
send us 25c in postage*

CHICAGO SOLDER COMPANY
CHICAGO, U. S. A.

KESTER Radio SOLDER
(Rosin-Core)

*If your dealer cannot supply you
send us 25c in postage*

CHICAGO SOLDER COMPANY
CHICAGO, U. S. A.

**Use
RESISTANCE!**

DURHAM



Grid Leaks

75¢

Variable:—
No. 101—1.10 to 5 meg. —soft tubes.
No. 201A—2 to 10 meg. —hard tubes.
No. 100—1000 to 100,000 ohms by part.
Metalized Fixed:—
Over ¼ meg. 50c; under, 75c.
DURHAM & CO., INC., 1936 Market Street, Philadelphia

at dealers
or postpaid

Cockaday specifics

RESULTS that far surpass the average Super-Heterodyne are yours with this New Cockaday Four Circuit Tuner. Add to that the economy of using five tubes instead of eight and you'll surely decide on this AMPLEX KIT.

Never before has set building been made so easy and results so certain. Everything for the New Cockaday Four Circuit Tuner, from coils to condensers and from dials to brackets is included in this AMPLEX KIT. The panel is completely drilled and engraved. The baseboard is just the right size. All the parts are ready, even the busbar wire. The authentic POPULAR RADIO Blueprint shows how to make all connections.

There is no possible way of going wrong when you build this New Cockaday Four Circuit Tuner the AMPLEX KIT Way. Before the evening is over you will be ready to tune for DX stations up to 3,500 miles away.

This AMPLEX KIT contains all the parts originally specified by Cockaday. It is the product of co-operation between the AMPLEX engineers and POPULAR RADIO. If your dealer cannot supply you send us your remittance at once!

1 "Precision" Cockaday Coil Set	\$5.50	\$5.50	1 "Improved" SC Jack	\$.70	\$.70
1 "Cardwell" Vari. Cond. .0005	5.00	5.00	1 "Improved" Battery Switch	1.00	1.00
1 "Cardwell" Vari. Cond. .00035	4.75	4.75	1 "Precise" Transformer	5.00	5.00
2 "Accuratune" Dials	3.50	7.00	3 "Electrad" 1/2 meg. Leaks	.50	1.50
1 "Amplex" GRID-DENSER	1.25	1.25	3 "Electrad" Mountings	.35	1.05
1 "N. Y." Fixed Cond. .00025	.35	.35	8 Binding Posts	.10	.80
9 "N. Y." Fixed Cond. .005	.60	5.40	4 Y Brass Brackets	.05	.20
5 "Benjamin Cle-ra-tone" Sockets	1.00	5.00	7 Switch points and 2 stops		.14
1 "Bradley" leak	1.85	1.85	X1, X2, X3 Panels—3 for		.75
3 "Bradleyohms" No. 25	2.00	6.00	Bus Bar		.25
1 "Amsco Dubl-Wundr"	2.00	2.00	Baseboard		1.00
1 Switch Lever	.30	.30	Set of POPULAR RADIO Blueprints and Instructions		1.10
4 "Amperites" No. 1-A with mountings	1.10	4.40			
3 "Improved" DC Jacks	1.00	3.00			
			Official Total List Price..	\$64.99	

FREE—A completely drilled and engraved genuine bakelite panel free with every kit

AMPLEX INSTRUMENT LABS.
88 West Broadway Dept. P. 1A N. Y. C.

The *NEW*
Cockaday Set

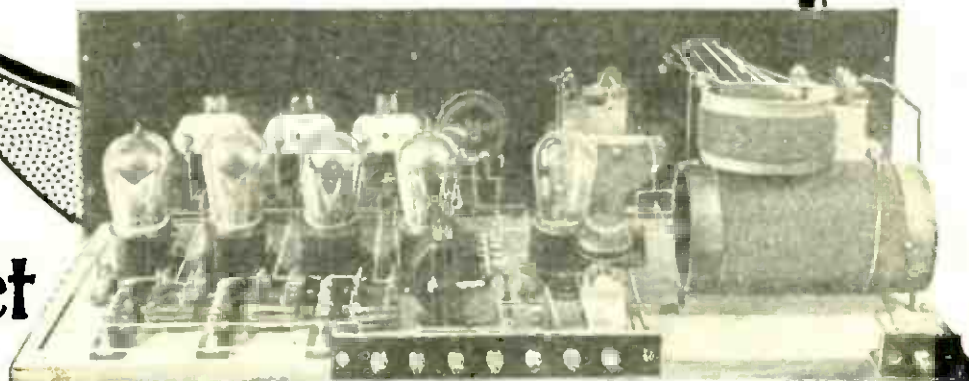

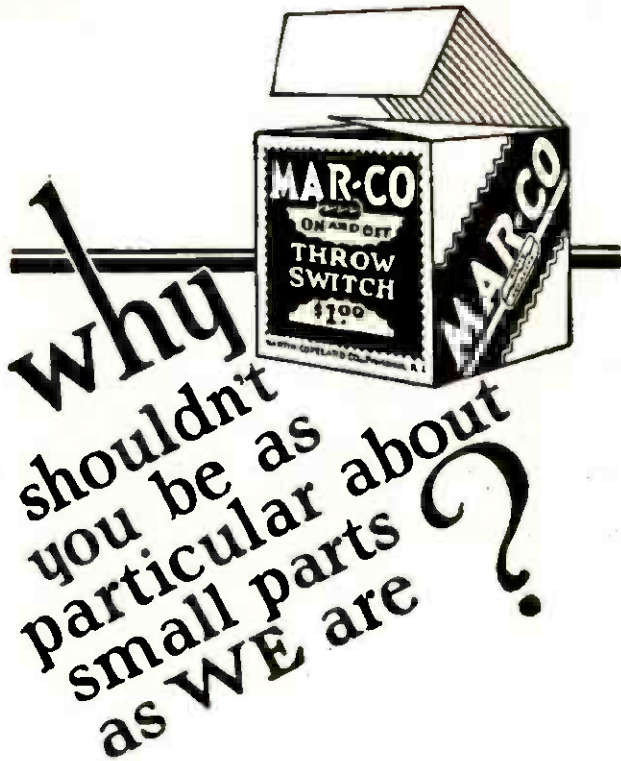

Why shouldn't you be as particular about small parts as WE are?

YOU USE THEM.

YOU DEPEND on them to help your larger instruments.

YOU EXPECT small parts to preserve the energy that reaches your set.

So why shouldn't YOU be as particular about their quality as WE are?

WE think no accessory too unimportant to build as carefully as we make fine optical instruments. All the craftsmanship we have developed in 44 years of precision work, we put into every MAR-CO small radio part.

Then we put them into the unmistakable MAR-CO packages, so that if you are as particular as we are, you can easily get the "leak-proof" service we build into them.

Simply say "MAR-CO" . . . and insist on seeing the MAR-CO package . . . when you want plugs, jacks, switches, grid-leaks, vernier condensers and other small parts.



For Quality **CORBETT'S CABINETS** For Quality

NEW COCKADAY

Built to Specifications in October Issue
(Rear slots not included in other cabinets.)

Size	Mahogany finish	Walnut or Mahogany	Size	Mahogany finish	Walnut or Mahogany	Size	Mahogany finish	Walnut or Mahogany
7x10-8	\$3.60	\$4.50	7x24-8	\$5.40	\$6.75	7x40-8	\$9.00	\$11.25
7x12-8	3.80	4.75	7x26-8	5.75	7.20	7x27-8	6.45	8.00
7x14-8	4.00	5.00	7x28-8	6.30	7.90	8x36-8	8.90	11.10
7x18-8	4.65	5.70	7x30-8	6.90	8.60	8x40-8	10.50	13.25
7x21-8	5.00	6.25	7x36-8	8.00	10.00	8x26-8	6.45	8.00
Cockaday illustrated.....				6.90	8.60			

Nickel piano hinge 6c per inch. Mounting boards 35c. above 30 in. panel 50c. Nicely moulded top and base, nickel stop hinges. Adam Brown Mahogany finished with DuPont varnishes carefully hand rubbed eggshell. Accurately made of heat kiln dried lumber and well packed. Charges prepaid to Mississippi River.

And now "Corbett's Panels"

For you we have perfected a new panel that matches your cabinet. Made of laminated wood finished with moisture and mar proof DuPont's DUCO lacquer. Modern radio has eliminated switch taps, body capacity, etc., and manufacturers are using our panels to enhance the beauty of their sets. They sell at a fraction of the cost of other panels and are guaranteed to please in every way. Fitted free to Corbett's Cabinets.

1/2 in. thick, mahogany finish, mahogany or walnut. Any size 1c per square inch, add 10c for postage.

WRITE FOR BOOKLET offering best values in radio furniture. TERMS: PANELS, CASH WITH ORDER. CABINETS, CASH or C. O. D.

CORBETT CABINET MFG. COMPANY
1415 East St., Pittsburgh, Pa. 5323 N. Carlisle St., Philadelphia, Pa.

RayCoils Span the Atlantic and Half of America



During the European tests Major Schoonhoven heard 2LO and 22Y in England. RayCoils "A" for Reinartz, RayCoils "B" for RCS and Ultra Audion Circuits, RayCoils "C" for RCS, Ultra Audion and Tuned Radio Frequency Circuits, RayCoils "D" for Tuned Radio Frequency and Neutralizing Circuits of 4, 5 and 6 Tubes. RayCoils "E" for Reflex Circuits.

- A = \$2.50
- B = 2.00
- C = 2.00
- D = 2.00
- E = 2.00

Use the RCS Circuit with or without Radio Frequency for Simplicity in operation and results. Not equalled by any set for volume and distance.

Coils in Separate Box With Wiring Diagram

Working Blue Prints of four sheets 12x18 of all standard circuits, as Variometer Hookup, Reinartz one and three tube, R.C.S. three and four tube and R.C.S. five tube Tuned Radio Frequency, 50 cents a set.

We also carry a complete line of Carter, Howard, Kellogg, Modern, All-American and Trimm parts. If your dealer cannot supply you, we will mail direct.

R. C. SCHOONHOVEN
Major Q. M. R. C.

310 SENECA ST. ELGIN, ILL.

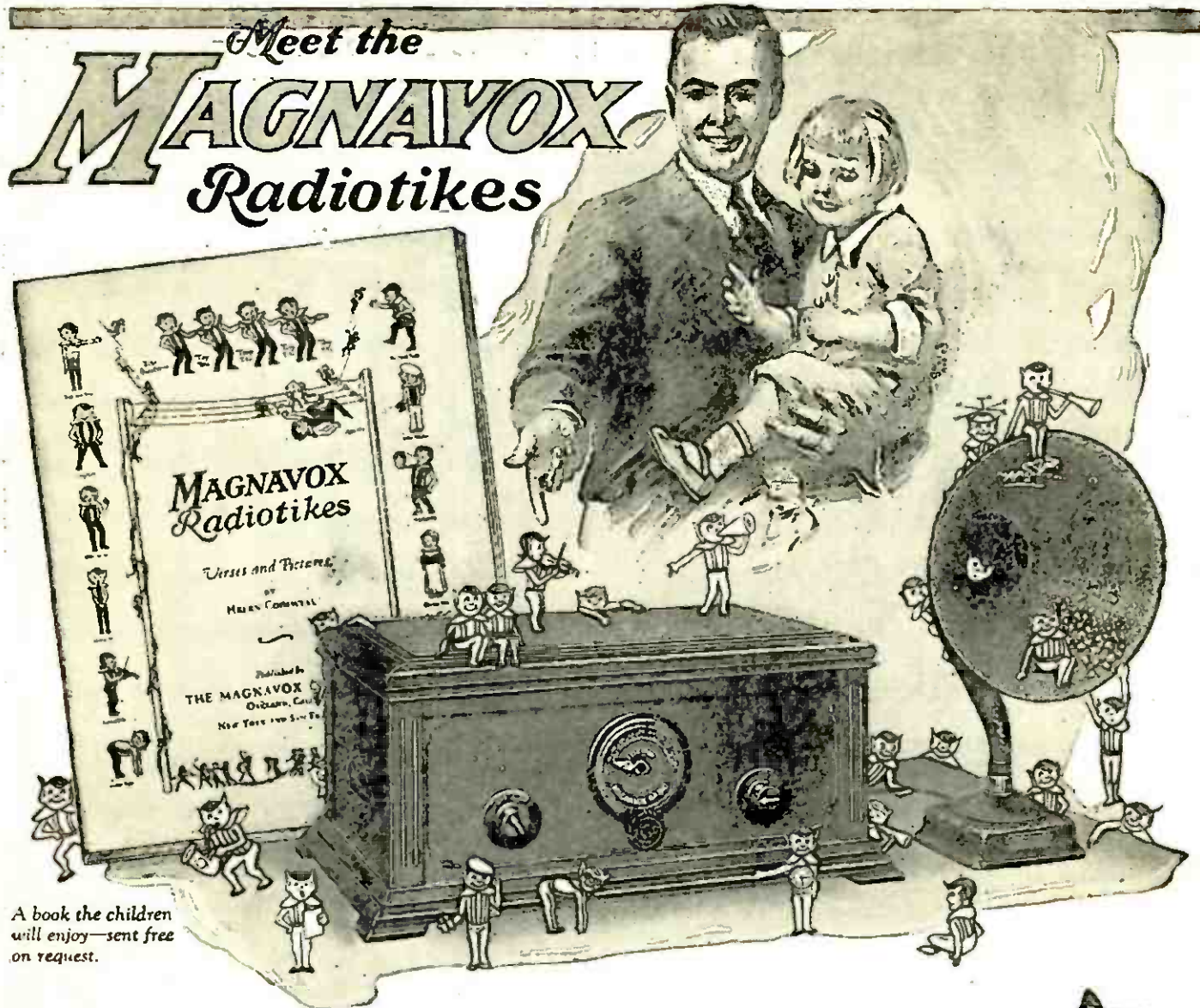

THE new Magnavox Receiver (with or without built-in Magnavox Reproducer) is an entirely new development of tuned radio frequency.

The ease of selecting the desired station directly with *one dial* is only equalled by the quality of Magnavox reception—the highest musical standard yet achieved in radio.

Magnavox Radio products are sold by reliable dealers everywhere. Interesting literature sent free on request.



TRF-5
RECEIVING SET
A 5-tube circuit in carved mahogany cabinet complete with a Magnavox Reproducer
\$125

TRF-50
RECEIVING SET
with doors and built-in Reproducer
\$150

THE MAGNAVOX COMPANY
OAKLAND, CALIFORNIA

New York: 350 West 31st St.
Chicago: 162 N. State St.
San Francisco: 274 Brannan St.

Canadian Distributors: Perkins Electric Limited, Toronto, Montreal, Winnipeg

1R

Send me a complimentary copy of Radiotikes.

Name

Address

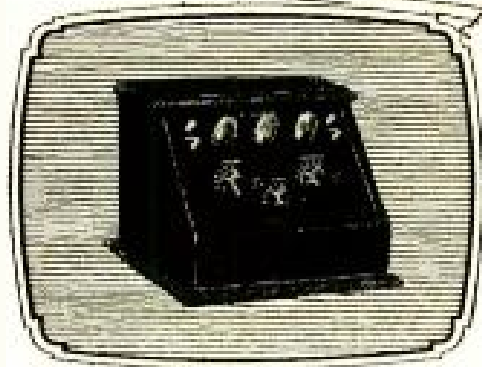
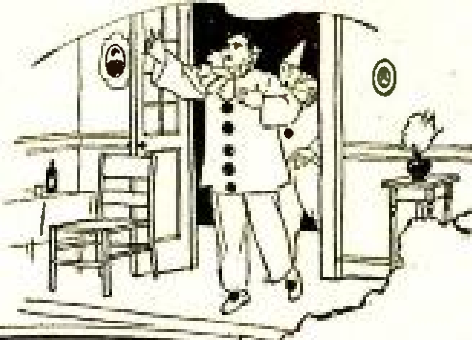

Echoes of Opera Through the ECHOPHONE

Echophone "V-3"

Licensed under
Armstrong
Patent No.
1,113,149
Without Tubes
and Batteries

\$50



Echophone "F-5"

Without Tubes
and Batteries

\$110⁰⁰

The Echophone "V-3" singles out the stations radio-casting the entertainment you want to hear—lets you in on the thrills of grand opera—the jokes and merriment of musical comedies.

Its range covers all the better known stations in the country. Gives loud speaker volume on stations 1500 and 2000 miles distant. Voice modulations high and low notes are reproduced in clear, undistorted tones.

Simple to operate (only two tuning controls)—and economical to maintain—(use dry cell batteries) this beautiful 3 tube regenerative receiver with its self-contained mahogany finished cabinet is for \$50.00 the outstanding value in moderately priced sets.

For those who want longer range and still greater volume there is the Echophone "F-5" a 5 tube combined radio and audio-frequency receiver that operates from either indoor or outdoor aerial.

Ask your dealer about these sets today. In the meantime drop us a postal for our descriptive folder. Address

The Armac Radio Co., Agents
1120 N. Ashland Ave., Chicago, Ill.

Manufactured by The Radio Shop
1120 N. Ashland Ave., - Chicago, Ill.
Long Beach, Cal. - Sunnyvale, Cal.

ECHOPHONE

Storage Battery Results at Dry Cell Cost

"Take No Chances—Use Como" COMO DUPLEX

The World's Standard Push Pull Transformer



PRICE \$12.50 per pair
For maximum volume without distortion

What Prominent Writers on Radio Subjects say About Como.

Lewis B. Hagerman, Technical Editor, *Chicago Post*: "Actual Tests show this transformer to be far superior to any others of similar makes."

R. J. Robbins, *New York Sun*: "After consideration of several well-known makes of push pull transformers which are available 'COMO DUPLEX' was selected as most satisfactory."

C. White, *Radio World*: "'COMO DUPLEX' is infinitely superior—most other push pull transformers seem to be ordinary transformers with a center tap brought out as a makeshift."

E. P. Gordon, *Open Road*: "A system of audio-amplification which is becoming increasingly popular. Its use . . . will give surprising results in both quality and volume, and is thoroughly recommended by this department."

NEED WE SAY MORE?

COMO APPARATUS COMPANY

446 Tremont St.

Boston, Mass.

For Sale at Leading Dealers

Gold Plated Aerial Works Wonders

Amazing new antenna The Goldenrod works wonders with any set. Clearer reception; more stations; greater volume; no "fading"; won't corrode, lasts lifetime. Used by Government, Ocean Liners, Broadcasting Stations.

Now Everyone Can Have It

Solid Phosphor Bronze Wire, heavily plated with 18 kt. gold. Gold antenna long known to be best, but too costly. Now thru Goldenrod methods of manufacture, every set user can have one.

USE GOLD PLATED BUS WIRE. No resistance—makes the ideal wiring for your set. Genuine 18 kt. gold plated wire at very low prices. Write for prices and sample.

FREE illustrated folder giving complete details and proof of wonderful results from Goldenrod Aerial—"Best Because It's Gold Plated." Write quick and soon get new joys in radio reception!

IMP RADIO CORPORATION

Dept. 101

6 East Lake Street

CHICAGO

Radio Dealers HEADQUARTERS

The House of a thousand values

Eight Big
Warehouses

Write for
Catalog C1003

WAKEM & McLAUGHLIN
225 E. ILLINOIS ST. — CHICAGO



A New Standard

of Quality



National \$12.

Ben Franklin proved one idea to be correct. When you listen to a Radio program through Holtzer-Cabot instruments, all doubt will be eliminated as to the make you will buy.

Price, quality and thirty-five years' of experience are the reasons.

Ask your dealer to make a comparison demonstration.

Loud Speaker Attachment



\$10.00

Holtzer-Cabot Loud Speaker
Loud Speaker Phonograph Attachment
No. 2 Universal Head Phones
No. 4 National Head Phones

WRITE FOR BOOKLET

Department PR

THE HOLTZER-CABOT ELECTRIC CO.
125 Amory Street BOSTON, 6161-65 South State St. CHICAGO

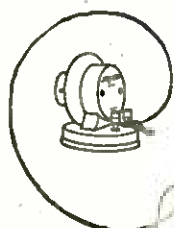

AUDIO FREQUENCY



RADIO IN A NUTSHELL

**GET THE DISTANCE
—HEAR IT CLEARLY**

How to obtain this result for the least expense? — the answer is in the transformer.

LIBERTY LOW LOSS TRANSFORMER

(at a popular price) makes any good set better or your money back.

Buy from your dealer or postpaid from factory by remitting price

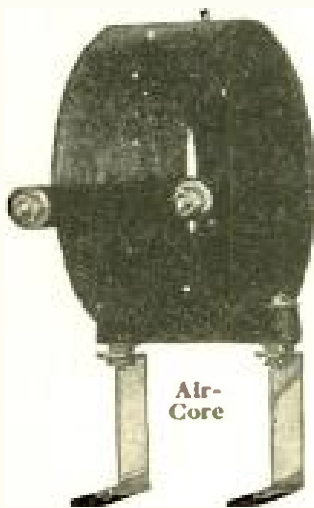

Radio Frequency

Audio Freq. Trans. Base Mounting Type

Ratio	Price
3 to 1	\$4.50
5 to 1	4.75
9 to 1	4.75
Panel Mounting Type same price	
Radio Freq. Trans.	\$1.50
Terminal lugs, per dozen	.10
per thousand	4.00

Write for special folder describing **LIBERTY Sealed Five tuned Radio Frequency Receiver** \$100.00



Liberty Terminal

Dealers Write
Liberty Transformer Co., Inc.
555 N. Parkside Ave., Chicago

INSTANT HIT!



The "Ideal" Loud Speaker Console

In Walnut or Mahogany

AT \$47.50

Sent freight paid to any point east of Missouri river—cash with order.

Ideal Radio Cabinet Co.

Blue Island, Ill.

CATALOGUE ON REQUEST

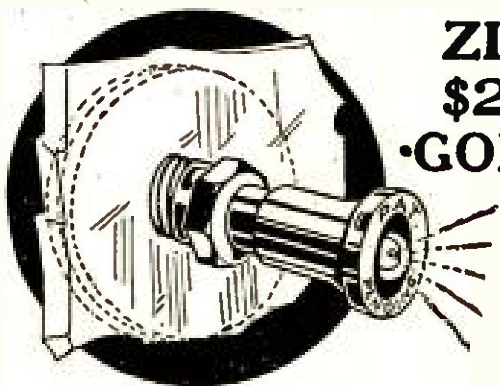

**ZIP!
\$20
GONE!**

"Every Tube Blown Out Again" —EVER HAPPEN TO YOU?

YOU can't foresee when it will occur—loose connection, bit of solder, slipping screwdriver—and there's all five tubes gone in a flash! Not only money loss but the evening spoiled.

These Costly Accidents Can Be Prevented

A KANT-BLO on your set gives absolute permanent protection for any number of tubes. Just install it and forget it.

Not Additional Apparatus

KANT-BLO simply takes the place of a binding post battery switch. Only one needed for any set and then you are protected indefinitely. Not only prevents blow outs but warns you that there is something wrong. If your dealer is out of stock, send us \$2 for a KANT-BLO Binding Post Style, or \$3 for the Switch Style and we will ship direct to you charges prepaid.

Kant-Blo

SIGNAL



"Lights on any Short Circuit"

Manufactured by **GANIO-KRAMER CO. Inc.**, NEW YORK

Sole Distributors **APEX RADIO CO. Inc.**

503 FIFTH AVE., NEW YORK

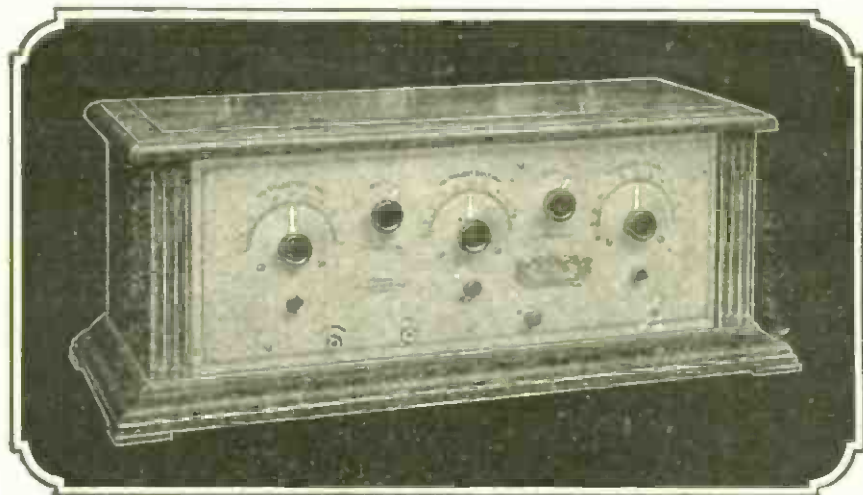

Five Tube Tuned Radio Frequency Set \$120.00

The Powerful, Coast to Coast SUPER CLEAR-O-DYNE

L OUD speaker signals that will fill your house over distances of 3,000 miles in good radio weather! The greatest selectivity that is possible in any set. Stations always come in at the same settings—a child can get distance!

Solid mahogany cabinets and gold finished panels—a set that harmonizes with the richest furnishings.

You can't buy more in any radio set! At the astonishingly low price of \$120.00 this is the greatest purchase in radio today!



The Super Clear-O-Dyne in a console cabinet, \$190.00

Clear-O-Dyne is a sensation. It is going big. Quick deliveries on your orders.

- | | |
|---------------------------------|---------------------------------|
| Clear-O-Dyne Model 70.. \$75.00 | Clear-O-Dyne Model 80. \$120.00 |
| Clear-O-Dyne Model 71.. 90.00 | Clear-O-Dyne Model 82 |
| Clear-O-Dyne Model 72 | Console..... 190.00 |
| Console.....135.00 | Other Sets from \$60.00 up. |



THE CLEAR-TONE RADIO COMPANY • CINCINNATI, OHIO

All apparatus advertised in this magazine has been tested and approved by POPULAR RADIO LABORATORY

An Advertisement by a Radio Fan

The advertisement below was written by a Radio Fan. It expresses our ideas so well that we are glad to sign it

You will find that the correct design and superior construction of

YAXLEY

Approved Radio Products

improve your receiving.

Each device shows the careful planning of a skilled radio engineer. Your convenience in mounting the device in your set and operating it are taken care of in the design as well as the electrical and mechanical requirements of the device.

There is no stinting in the selection and use of high quality materials. Pure silver, phosphor bronze, brass and other materials are used as occasion demands. Then the workmanship is of the best. Terminals are tinned for soldering.

The result is a superior product both for service and appearance and yet the price is right.

Yaxley Jacks



Take Yaxley Jacks as an example. They have one nut mounting. Drill one hole and mount on any standard thickness panel without the use of spacer washers. Springs are genuine phosphor bronze. Pure silver self-cleaning contact rivets. Frames of brass. Positive contact always assured.

Code No. 4, Interstage, Illustrated \$1

Other popular types are:

- Code No. 1—Open Circuit..... \$.70
- Code No. 3—Single Filament Control. .90
- Code No. 4A—Two-circuit Filament Control..... 1.00

There are other styles to meet your particular requirements

Ask your dealer or send his name with your order to

YAXLEY MFG. CO.
Dept. P, 217 N. Desplaines St., Chicago

The "LITTLE JOE" Lightning Arrester

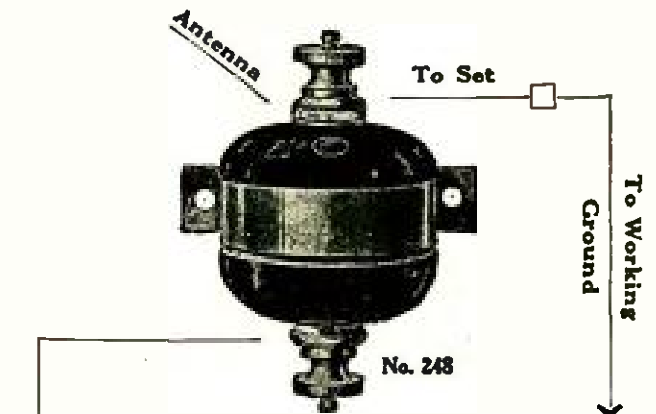

Card No. E-5841

Jan. 5, 1923, Underwriters Approval

Especially designed for Radio Work

Made of Porcelain, small, neat, rugged and serviceable. Can be suspended on antenna or fastened to wall.

Ask your dealer or write for further information

E. H. FREEMAN ELECTRIC CO.
TRENTON, NEW JERSEY

STORAD

Storage "B" Batteries

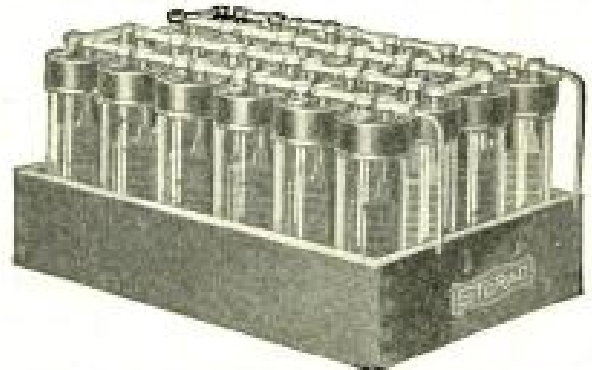

THE BATTERY THE MODERN RECEIVING SET REQUIRES

Satisfactory results with the new receiving sets, especially Super Heterodyne, can be obtained only with the use of large capacity, heavy duty storage B Batteries — batteries that are built special for this purpose in order to stand up under the severest service requirements. At the same time compactness is necessary.

The vital element, STORAD plates, are especially designed for this purpose and are 5/16" thick. These are separated by combination wood and rubber separators inclosed in specially molded glass jars and sealed with patented acid proof rubber caps.

- 4500 M. A. H.—24 volt No. 4524
- 4500 M. A. H.—48 volt No. 4548

Ask your dealer. Literature on request

Desirable distributors' territory still available

The Cleveland Engineering Lab. Co.
2141 Superior Viaduct, N.W. Cleveland, O.

Now... all you need is the Charger



With your big new Christmas set working new radio wonders, making new records for DX and bringing in stations on the speaker....

All you need is a charger to keep your batteries fit.

You don't want to bother with *sending out* a run down battery. Charge it at home yourself with a Unitron.

Unitron Chargers for radio batteries are simple, quiet and safe. No moving parts to get out of order. No watering, oiling, adjusting or repairing ever necessary.

Unitrons are made in two sizes. Model 0 and Model 00. Each of these current rectifiers is efficient. Both are *low-loss* chargers which perform their work without waste of current. This assures economy of operation.

The Unitron is self-regulating. Charging rate decreases as the battery is refilled with new charge.

Send for the Interesting Book
"A Little Less Noise....Please"
It Will Help With Your New Set

Model 00 \$18
Charges any
type of
A battery

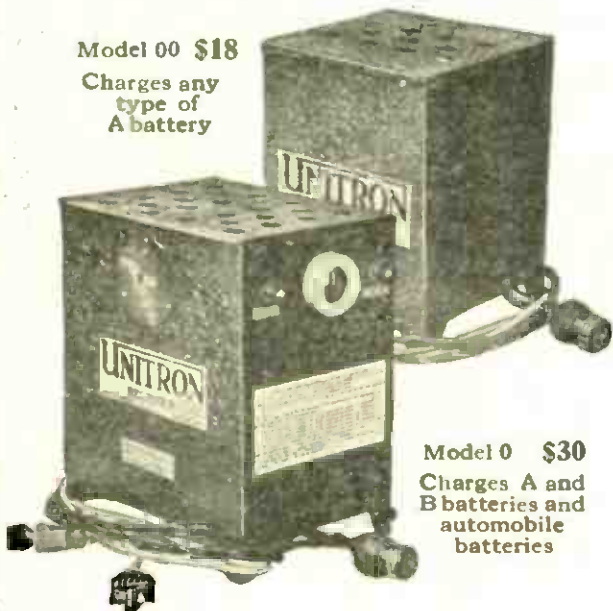

Model 0 \$30
Charges A and
B batteries and
automobile
batteries

FOREST ELECTRIC COMPANY

Pioneer Manufacturers of Industrial Current Rectifiers

New and Wilsey Streets

Newark, New Jersey

Advertising by PICARD-SOHN, INC. N.Y.



DeRoy Phusiformer

Manufactured under license agreement

Simplicity Wins!

ELIMINATE the complicated assemblies of condensers, variometers, couplers and frequency transformers! Forget the worries of balancing and neutralizing this maze of instruments.

The DeRoy Phusiformer takes their place and does their work more efficiently. Build any number of different circuits with the same DeRoy Phusiformers without discarding one single part. Increase your range and volume from one to six tubes as you wish simply by adding DeRoy Phusiformers. No complicated wiring, no muss, no fuss! Sets built this way do NOT howl, whistle, squeal or distort the programs in the slightest—absolutely tone-pure reception!

Price With Dial **\$9.00**
Each

If your dealer does not as yet handle DeRoy Phusiformer, send money order for the required amount of units.

DeROY RADIO CORP.
285 Plane Street, Newark, N. J.

Model A
2400 Ohms
\$4.00 List

Model B
3000 Ohms
\$5.00 List



Repeater Phones
"Single Pole"

guarantees
MATCHLESS REPRODUCTION

From all parts of critical America, from wireless workers, amateurs, and from those who just insist upon the best, comes enthusiastic indorsement for Repeater Phones. Distance is annihilated, obstacles vanquished by Repeater.

This matchless tone quality is due chiefly to the "Single Pole" feature, exclusive with Repeater. All the power of the air unleashed flows evenly, smoothly through Repeater's "Single Pole"—you are certain of exact, faithful reproduction.

ASK FOR our illustrated booklet containing complete details. **DEALERS**—In Repeaters you will find a popular appeal. Our discounts will interest you. Write for Merchandising Plan.

The New Improved "Repeater"

MOSS-SCHURY MFG. CO., INC.
Radio Division
2013 Franklin Street - - Detroit, U. S. A.



NEAT and simple to install, the Jones Multi-Plug affords a plug-in connection between set and batteries, antenna, and ground. The seven contacts take care of all input connections, two A Battery and three B Battery leads in cable and antenna and ground which are separate leads. The 8' cable not only affords a neat wiring arrangement but permits placing batteries in basement or other convenient place.

Jones
MULTI-PLUG

THE STANDARD SET CONNECTOR

Used by Leading Set Manufacturers Including

Howard-Workrite-Zenith-Mu-Rad

Write for illustrated folder of
Panel Mounting and Binding
Post types

HOWARD B. JONES
618 S. Canal St.

Chicago

The Difference They Make In Reception Is Amazing

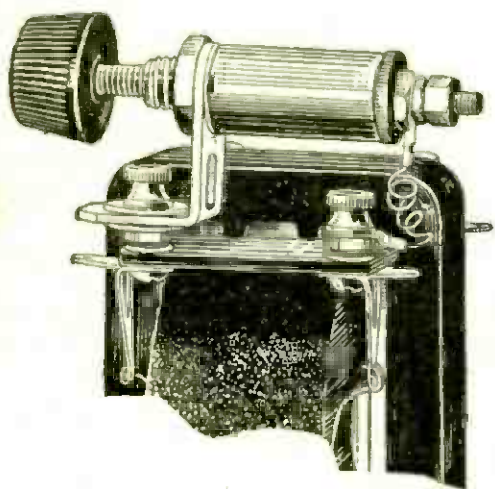

Electrad Audiohm Eliminates Distortion

Also whistles, squeals and howls. Assures clear-cut, smooth reception of all notes of music and voice—bringing out the true actual values of each tone. Reproduces all notes without blur or falsetto exaggeration.

You mount the Audiohm across the secondary of your audio transformer. Can be attached in a minute, and without solder. Easy to operate as setting your watch. Fits any transformer—and lasts for years.

Buy an Audiohm today and get perfect reception. We guarantee results. Price only \$1.50.

A Perfect Variable Grid Leak

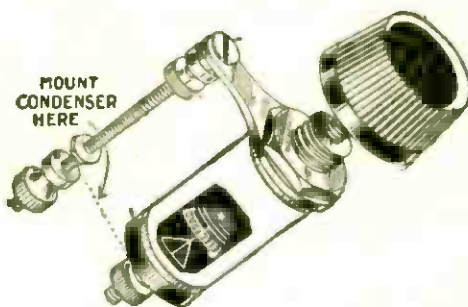

Electrad Variohm Gives that Last Hair's- breadth Tuning

Permits you to get stations you never heard before. Clears up those stations you have heard only indistinctly. Affords that super-fine tuning which every discriminating fan has long been seeking.

The Variohm is a wonderful variable grid leak that works with exquisite precision. Allows infinitely fine variations of adjustment from $\frac{1}{4}$ to 10 megohms, and coarser adjustment from 10 to 30 megohms.

Install a Variohm in your set today—and get the fullest power, clarity and distance from it. Guaranteed. Price \$1.25 unmounted, \$1.50 mounted.

*Electrad Audiohms and Variohms are on sale at most good radio stores
If your dealer doesn't carry them, order direct, and give his name*

ELECTRAD Inc.

428 Broadway, New York City

Satisfaction plus better reception
 A FEATURE IN
The Brunswick de Luxe Ambassador
 with **VISIDIALS**

A slight turn of the *visidial*, then . . . well, you will be surprised at the improved reception made possible by the use of *visidials*. A thousand times you will marvel at the possibilities of the Brunswick De Luxe Ambassador. It has been tested and proved the most phenomenal buy on the radio market today.

Dealers write for attractive discounts

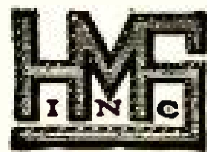

Price \$60.00

HAROLD M. SCHWAB, Inc.

Manufacturers and Distributors

55 VESEY STREET

Dept. PRJ

NEW YORK CITY

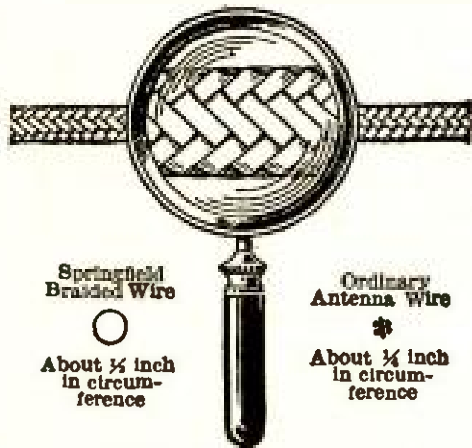

Springfield Braided Wire

About 1/2 inch in circumference

Ordinary Antenna Wire

About 1/8 inch in circumference

Increase your Range

From 15 to 100 per cent

You can, with your present equipment, by using **SPRINGFIELD 16-STRAND BRAIDED ANTENNA**. Most wonderful wire for indoor loops. Its extra large surface twice that of ordinary wire—enables you to get greater distance and clearness. 125 feet in your attic, in strands 3 feet apart, gives better results than 150 feet of ordinary wire outdoors. Write for free booklet. At dealers—or send us \$2.50 for 100 feet. Dealers and Jobbers—write for prices and terms.

SPRINGFIELD WIRE & TINSEL CO.

67B Taylor St.

Springfield, Mass.

New York Office: 51 E. 42nd Street

Tel. Vanderbilt 5090

Springfield 16 Strand Braided Antenna

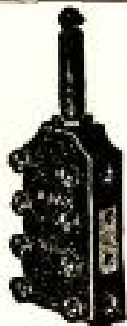

AJAX
ST. LOUIS

Multi Radio Plugs

No. 18—For Jacks

No. 18A—For Binding Posts

Connect One, Two, Three or Four Receivers or Loud Speaker—Always in Series. Giving equal amount current to all. Multiple connections will give good results only to one of least resistance.

AJAX ALWAYS IN SERIES WITH POSITIVE CONTACTS

Price \$1.00 Each

For Distinctive values in Radio parts demand AJAX-St. Louis

AJAX ELECT. SPEC. CO.

1928 Chestnut, St. Louis

Write for complete Radio Price Sheet.



MAILED ABSOLUTELY GUARANTEED



D-201 A., D-200, D-199, D-12, in standard sizes to fit any socket. The internationally famous

DUTCH RADIO VALVE

will be \$2.25 plus postage

Three sent for \$6.50 plus postage (any type).

Approved by Popular Radio Laboratories.

Order from nearest point.

St. Louis Radio Tube Laboratory
 3572 Olive Street St. Louis, Mo.
 D. R. V. IMPORTING CO.
 515 Orange St. Newark, N. J.

FOR ANY CIRCUIT IN ANY SET "YOU CAN'T BEAT THE DUTCH"



Applause from everywhere!

OUR own rigid tests of KIC-O "B" Storage Batteries and Rechargers are amply confirmed by the comments we receive from all over the United States and Canada. Thousands of unsolicited letters have told us that KIC-O Equipment does what we have designed it to do—insure.

Better reception—lower cost

It is not only that KIC-O "B" Storage Batteries give greater range and clearer reception because of their slow even discharge, but also that they have longer life and are trouble proof. Not harmed by idleness, overcharging or other acts of neglect which damage ordinary batteries. All new materials used in its construction. Recharged easily and economically from ordinary alternating circuit lighting line, by means of KIC-O Single or Double cell chargers.

ASK YOUR DEALER OR WRITE

KIMLEY ELECTRIC COMPANY, Inc.
2667 Main Street Buffalo, N. Y.

MANUFACTURERS OF



STORAGE "B" BATTERIES AND CHARGERS

PZ indicates panel type with switches. CZ is plain type without switches.

Voltage	M. A. H.	Type P Z.	Type C. Z.
130	2500	\$36.00	\$33.00
100	"	27.50	24.50
70	"	21.50	18.50
45	"	16.00	14.50
22½	"	7.50

KIC-O CHARGERS

KIC-O Special Charger Chemicals.....	\$0.75
Type K-1 Single unmounted.....	1.50
Type K-2 Single mounted.....	3.50
Type K-3 Multi-polar mounted.....	5.00

GUARANTEE

Your money back on any KIC-O Battery if not satisfied within 30 days' trial. Write for full information on "B" Batteries.

ORDER COUPON
 Kimley Electric Company, Inc.
 2667 Main St., Buffalo, N. Y.
 Gentlemen: Please ship C.O.D. the following KIC-O Equipment under your satisfaction guarantee.

Type Price

Battery Voltage

Charger as follows:

Signed.....

FREE PARTS!

Introduce POPULAR RADIO to a few of your friends and take your pick of radio parts

HERE is an opportunity for you to secure all or any of the parts needed to build complete either of two very popular receivers or an amplifier—and at no expense. You, surely, are well acquainted with the features of POPULAR RADIO that have given it more subscribers than any other radio publication. Won't it be easy to use your enthusiasm in inducing your friends and their friends to subscribe too?

To make it possible for you to secure an order from everyone we will permit you to make the following offers:

POPULAR RADIO			
24 Months for \$5.00 counts 75 credits			
12	"	"	3.00
8	"	"	2.00
6	"	"	1.50
4	"	"	1.00

You remit the full amount collected with names and

addresses of subscribers and ask for the parts that your total CREDITS entitle you to; or, if you prefer, let us credit them to you and when you have a substantial total, order the parts you want and we will charge against your CREDIT account.

As a further concession, suppose you have sent us 5 annual subscriptions for POPULAR RADIO, and in addition to a set of Approved Cockaday Coils want a 6-ohm Amsco Rheostat. The Coils are 220 CREDITS and the Rheostat, 50 CREDITS. The subscriptions total only 250 CREDITS and you need 20 CREDITS more. We will permit you to buy the additional CREDITS at 3c. apiece—so for 5 annual subscriptions and 60c. in cash we will ship the two parts you want.

NO CREDITS allowed on your own subscription and subscriptions sent us on this offer do not include premiums to the subscriber too, as we want you to have the full CREDIT value.

CREDITS Needed for Parts Required for the Tuned Radio-Frequency Reflex Receiver

(Described and illustrated in POPULAR RADIO for August, 1924)

Quantity	Item	Credits
1	—Hammariund .0005 mfd. (21-plate) condenser	240
1	—Hammariund .001 mfd. (41-plate) condenser	280
1	—U. S. Tool 3-plate condenser	60
1	—R. U. F. semi-fixed crystal detector	50
1	—Amsco 30-ohm rheostat	50
1	—Carter double-circuit jack	40
1	—Carter single-circuit jack	36
1	—Federal No. 65 audio-frequency transformer	280
1	—Amer. ran Type A-F7 (ratio 3 1/2 to 1) audio-frequency transformer	280
2	—N. Y. Co. mica fixed condensers .001 mfd. (with soldering lugs) @ 16	32
	Amsco switch lever with switch points and stops	19
	Materials for the construction of the special fixed coupler and the radio-frequency transformer	85
2	—Federal sockets for 199 tubes @ 40	80
1	—Composition panel (Radion 7" x 18")	90
1	—Cabinet (Shecco 18")	190
8	—Eby Binding Posts @ 8	64
2	—UV-199 or C-299 vacuum tubes @ 200	400
		2276

CREDITS Needed for Parts Required for the NEW Cockaday 4-Circuit Tuner with Resistance-Coupled Amplifier

(Described and illustrated in POPULAR RADIO for October, 1924)

Quantity	Item	Credits
1 set	—"Precision" Cockaday Coils	220
1	—"Cardwell" variable condenser (.0005 mfd.)	200
1	—"Cardwell" variable condenser (.00035 mfd.)	190
2	—"Accuratune" micrometer control dials @ 140	280
1	—"New York" mica fixed condenser (.00025 mfd.)	14
9	—"New York" mica fixed condensers (.005 mfd) @ 24	216
1	—"Amplex" grid-denser	50
1	—"Bradley" leak	74
3	—"Bradleyohms" No. 25	240
5	—"Benjamin" Cle-ra-tone sockets for UV201a tubes	200
1	—"Amsco Dubl-Wundr" combination potentiometer-rheostat	80
1	—"Amsco" switch lever	12
4	—"Amperites" No. 1-A with mountings	176
3	—"Improved" double-circuit jacks	120
1	—"Improved" single-circuit jack	23
1	—"Improved" filament battery switch	40
1	—"Precise" audio-frequency transformer No. 285-A	200
3	—"Electrad" Certified gridleaks 1/2 megohm @ 20	60
2	—"Electrad" Certified grid leak mountings @ 14	42
7	—Switch points @ 1	6
2	—Stops @ 1	2
1	—Composition panel 7" x 24" x 3/16"	120
8	—"Ra,ah" snap terminals @ 8	64
		2634

CREDITS Needed for Parts Required for the 7-Tube Non-Radiating Super-heterodyne Receiver

(Described and illustrated in POPULAR RADIO for December, 1924)

Quantity	Item	Credits
1	—"Sangamo" Oscillator Coil Unit	900
2	—"Sangamo," type AT-60, intermediate-frequency transformers (air core)	
2	—"Sangamo," type IF-60, intermediate-frequency transformers (iron core)	290
1	—"Cardwell" condenser, No. 123-BVL, with 3-inch "Aristocrat" dial	
1	—"Cardwell" condenser No. 123-BVL, with 3-inch "Aristocrat" dial	290
1	—"Cardwell" condenser, No. 155-B	160
2	—"Dubilier" mica fixed condensers .00015 mfd. with clips for grid leak @ 18	36
1	—"Dubilier" mica fixed condenser .005 mfd.	24
1	—"Dubilier" by-pass condenser .5 mfd.	36
1	—"Daven" 2 megohm grid leak	20
1	—"Daven" 1/2 megohm grid leak	20
2	—"General Radio" 30 ohm, type 301, rheostats @ 50	100
2	—"Stromberg-Carlson" audio-frequency transformers No. 3-A @ 180	360
1	—"Benjamin" seven socket shelf No. 8627 (Complete with seven sockets and 11 binding posts)	480
1	—"Benjamin" battery switch, No. 8640	12
1	—Pair of "Benjamin" shelf brackets No. 8629, for socket shelf	28
1	—"Benjamin" bakelite panel for grid condenser, No. 8632	8
1	—"Saturn" single-circuit jack	20
1	—"Saturn" double-circuit jack	28
1	—"Carter" jack switch No. 3	48
1	—Composition panel, 7x18 inches	90
1	—"Portenna" Loop	280
		3226

The specifications in all three sets name the parts used in building the original laboratory sets. We know that these parts if used will insure satisfactory results. But it does not prevent you from using other brands which will prove equally satisfactory. In fact, if you prefer some other brand or any parts not listed on this page, tell us what you want and we will tell you the number of credits required. We are prepared to supply any radio material you may require.

We also want to call your attention to the famous POPULAR RADIO Simplified Blueprints described on page 140. Any of these sets will be supplied for only 44 Credits.

Or for 60 Credits you may have a copy of "How to Build Your Radio Receiver" described on page 110.

POPULAR RADIO

Department 11

627 West 43d Street, New York City

SPAULDING-BAKELITE

Endorsed by

- Andrews Radio Co.
- C. D. Tuska Co.
- Chelsea Radio Co.
- Coto Coil Co.
- Rawson Elec'l Instr. Co.
- The Framingham Co.
- Elec'l Products Mfg. Co.
- Forest Electric Co.
- American Mechanical
- F. A. D. Andrea, Inc.
- Resas, Inc.
- Magnus Electric Co.
- R. E. Thompson Mfg. Co.
- Dynomotive Radio Corp.
- Ware Radio Corp.
- Phenix Radio Corp.
- Chicago Radio Laboratories
- Operadio Corporation
- Howard Radio Co.
- H. G. Saal Co.
- Krasco Mfg. Co.
- Wells Mfg. Co.
- Ferro Mfg. Co.
- Joy Kelsey Corp.
- Clapp Eastham Co.
- De Witt LaFrance Co.
- Cutler Hammer Mfg. Co.
- Shepard-Pötter Co.
- and others

Specially Processed for RADIO

WHEN you consider its source, you can readily understand why SPAULDING-BAKELITE is demanded by discriminative radio fans and leading manufacturers.

Made in the Spaulding plant, famous for over fifty years of specially processed fibre — accorded the Spaulding limitless facilities for uncommon manufacturing — this bakelite for radio panels and tubes is likewise specially processed and especially dependable.

Beautiful black, everlasting, high gloss finish. Drills, saws and engraves safely; will not shrink or split. Highest in dielectric strength. Supplied in standard sizes, individually packed in envelope containers — special sizes to order.

Write nearest office for descriptive circular

Spaulding -BAKELITE

Spaulding Fibre Company, Inc.

- Factory: Tonawanda, N. Y.
- Sales Offices—Warehouses*
- 484 Broome St., N. Y. C.
- 141 N. 4th St., Phila.
- 659 W. Lake St., Chicago
- 15 Elkins St., Boston
- 310 E. 4th St., Los Angeles
- 171 2nd St., San Francisco
- 509 First National Bank Building, Milwaukee

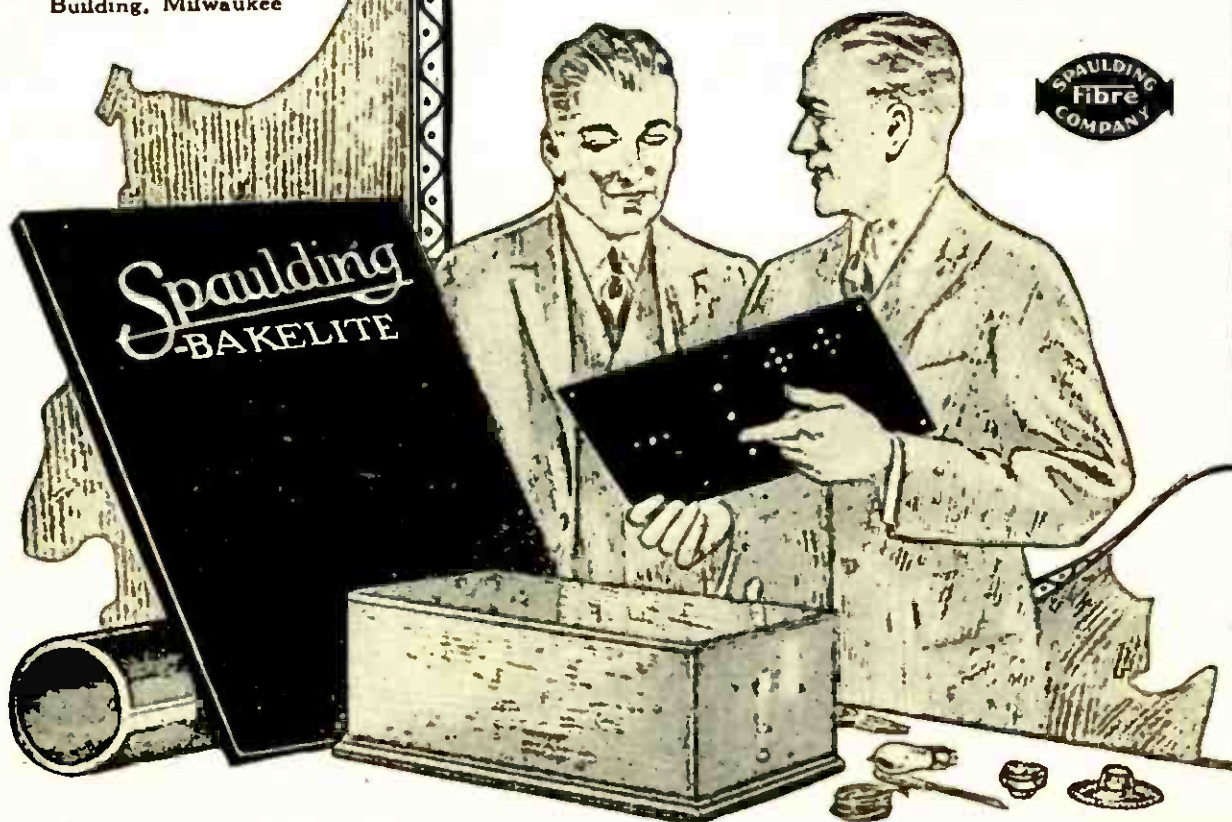

Simplified Blueprints

for the Cockaday 8-Tube Reflex Super-Heterodyne described on page 36 of this issue

EACH set consists of three prints; (A) Panel Pattern; (B) Instrument Layout; (C) Wiring Diagram.

Panel Pattern.

This blueprint is the exact size of the actual set. So accurate that you need merely lay it on your panel and drill as indicated. You can readily appreciate the convenience of this Blueprint. No scaling to do, no danger of ruining the panel through faulty calculation.

Instrument Layout.

Again you have an actual size print of each instrument and binding post and its exact location both on the panel and within the cabinet. Even the cabinet structure is clearly shown.

Wiring Diagram.

The unusual feature of this Blueprint is that it is a **full size picture diagram** of the finished set. Each instrument or other part appears exact size and the wires are so clearly traced from one contact to another that you can connect all terminals accurately without even knowing how to read a hook-up diagram.

Blueprints Ready.

At the present time four sets of Blueprints are available and have been priced at the very low figure of \$1.10 per set, postpaid. Each set consists of three Blueprints and we cannot break a set to supply single prints.

Your Choice of Blueprints for the Cockaday 8-Tube Reflex Super-Heterodyne or any of the following at \$1.10 for each set

The 7-Tube Non-radiating Super-heterodyne was described in detail in the December issue. It has only two dials and many features not found in any previously designed receiver of this size. Cost of parts about \$80.00.

NEW Cockaday 4-Circuit Tuner with Resistance Coupled Amplifier. This five tube set, described in the October issue of POPULAR RADIO, is the sensation of the year. It is remarkably easy to build; cost, about \$65.00, does not exceed that of the ordinary three tube set; has only two tuning controls and one vacuum tube control; is absolutely distortionless and is unsurpassed in loud speaker volume and distance range. If you are going to build one of these new sets or are planning to rebuild your old three tube Cockaday Set you should secure a set of Simplified Blueprints to insure absolutely accurate results.

Non-Regenerative (Simplified Neutrodyne) Tuned-Radio-Frequency Receiver, described in the April, 1924, issue of POPULAR RADIO. Cost of parts about \$44.00.

Audio-Frequency Amplifier, absolutely distortionless, described in the May, 1924, issue of POPULAR RADIO. Cost of parts about \$41.00.

Any of the above sets of Blueprints will be mailed postpaid on receipt of \$1.10

POPULAR RADIO, INC.

627 West 43rd Street

Dept. 14

New York City

POPULAR RADIO, Inc., Dept. 14
627 West 43rd St., New York City Date.....

Enclosed is my remittance of \$....., for which kindly send me Blueprint Set (s) consisting of Panel Pattern, Instrument Layout and Wiring Diagram as checked below:

8-Tube Cockaday Reflex Super-Heterodyne.
 7-Tube Non-radiating Super-Heterodyne Receiver.
 NEW Cockaday 4-Circuit Tuner with Resistance-Coupled Amplifier.
 Non-Regenerative Tuned-Radio-Frequency Receiver.
 Audio-Frequency Amplifier.

Name.....
 Address.....
 City..... State.....

Any one set of three Blueprints for \$1.10; any two sets for \$2.20; any three sets for \$3.30; any four sets for \$4.40; all five for \$5.50

NOTE:

Dealers write for terms

All apparatus advertised in this magazine has been tested and approved by POPULAR RADIO LABORATORY

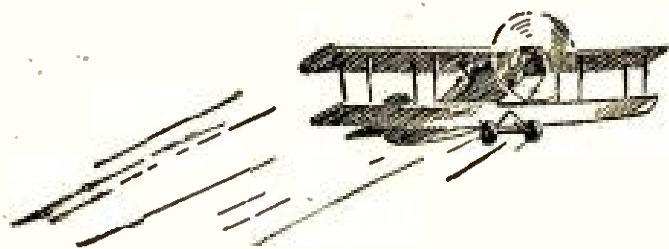

Bringing to earth the airplane type receiver

RADIO frequency transformers as designed by Jackson H. Pressley, Chief Engineer, Radio Laboratories, U. S. Signal Corps, Camp Vail, New Jersey, and manufactured by the Sangamo Electric Company, assure you of precision instruments.



The essential needs for airplane use are:

First—Extreme compactness with maximum amplification per transformer stage;

Second—A transformer so designed that there is negligible coupling between stages no matter how they are spaced;

Third—Stability without the aid of manual controls.

It was only after months of experimenting that Mr. Pressley was able to attain these results, and the adoption of his transformers as standard for airplane use speaks for itself.

A set of these radio frequency transformers and coupler coil will be delivered anywhere in the United States for \$22.50.

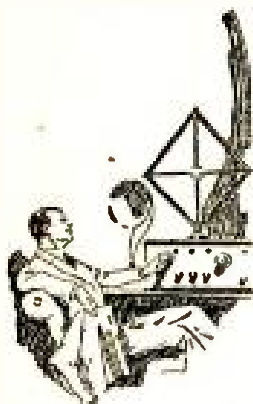
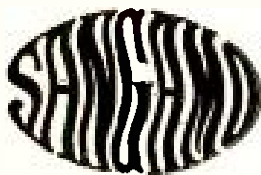

ASSOCIATED SANGAMO ELECTRIC COMPANIES

CAPACITY 3500 METERS PER DAY

SANGAMO ELECTRIC COMPANY
Springfield, Illinois

BRITISH SANGAMO COMPANY LIMITED
Pondersend, Middlesex, England

SANGAMO ELECTRIC COMPANY
OF CANADA LIMITED Toronto, Ontario

ASHIDA ENGINEERING COMPANY
Osaka, Japan

8820-2

Domestic Offices—New York, Chicago, Birmingham, San Francisco, Los Angeles. Radio Division—50 Church Street, New York

All apparatus advertised in this magazine has been tested and approved by POPULAR RADIO LABORATORY

RADIO FOR EVERY PURPOSE
AND ANY PURSE—\$5 TO \$32.50



Model C-18 Three-tube Receiver. Gives five-tube volume with only three tubes, due to reflex amplification. Finished in black leatherette.

\$28⁰⁰

Start the year RIGHT
—with KODEL

KODEL means the best that radio can give you, at amazingly low prices. One dial brings in all the stations anybody wants—everything that's hearable. Two dials in the 3 and 4 tube sets only. Nothing over \$32.50!

There's a KODEL receiver for everyone—crystal, portable, one, two, three and four tubes.

All KODEL sets embody the unique KODEL circuit, discovered by an independent experimenter. Either dry or storage batteries may be used at will. KODEL operates without an antenna, if necessary. The receiver that is making radio history.

See the KODEL line at your dealer's. If he does not carry these marvelous sets, send us his name and address and we will send you the interesting KODEL catalog, from which you can order direct. Money returned if any KODEL set does not more than satisfy you.

DEALERS: The KODEL is a sensation wherever introduced. Write for terms.

KODEL MANUFACTURING CO.

Under the same management that made the HOMCHARGER famous.

132 West Third Street Cincinnati, Ohio

FREE! Write for instructive KODEL catalog, entitled "Radio for Every Purpose and Any Purse." **FREE!**

Centralab
Radio Products

are used by

- Mu-rad Radio Laboratories**
- A-C Electrical Mfg. Company**
- Federal Telegraph Company**
- Andrews Radio Company**
- National Airphone Corp.**
- The Haldorson Company**
- The Lyradion Mfg. Company**
- Globe Electric Company**
- Zenith Radio Corporation**

Centralab
RHEOSTAT

has immovable coils, eliminating noise and dead spots.

- No. 206—6 ohms . . . **\$1.25**
- No. 230—30 ohms . . . **1.25**

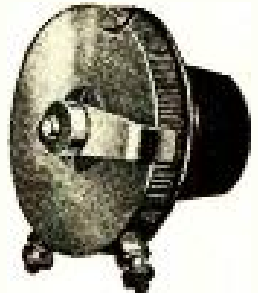

Centralab
NON-INDUCTIVE POTENTIOMETER

has no sliding contacts or wire-wound resistor, and assures noiseless tuning.

- No. 110—400 ohms . . . **\$1.50**
- No. 111—2000 ohms . . . **1.75**

Centralab
ADJUSTABLE GRID LEAK

gives smooth even regulation from 1/4 to 8 megohms.

- No. 106 . . . **\$1.25**
- No. 107—(with .00025 condenser) . . . **1.00**

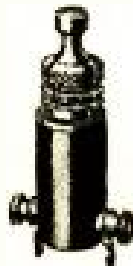
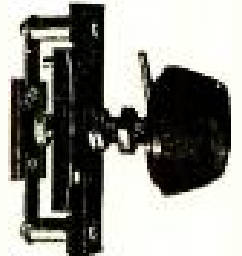

Centralab
BATTERY SWITCH

is compact and small, with firm positive contacts enclosed for protection from dust and injury.

- No. 300 **500**

Sold by leading radio dealers everywhere

Centralab

CENTRAL RADIO LABORATORIES
305 Sixteenth St. MILWAUKEE, WIS.

What Dealers say about the CUSTOMERS we referred to them

- Walter Battery & Ignition Co., Zanesville, Ohio. "We have sold some supplies from these inquiries."
- National Electric Service Co., Morgantown, W. Va. "We have had several good leads."
- Blakeslee Elec. Supply Co., Du Bois, Pa. "We have been very successful in following such leads."
- Mouthrop Bros., Du Bois, Pa. "They have helped me very much in interesting prospects."
- O. D. Mott & Co., New Castle, Pa. "It has helped us quite a lot and has given us a chance to sell radio to people we would not have had any other way."
- Geo. Meyers Hardware Co., Altoona, Pa. "Very good. Please send some more."
- Geo. Meyers Hardware Co., Altoona, Pa. "It helps us to sell more radio supplies."
- Gilligan Elec. Co., New Castle, Pa. "Very useful."
- Utility Electric Co., Indiana, Pa. "We secured over 50% of them."
- Gardner Bros., Elwood City, Pa. "Very good; keep it up."
- W. F. Frederick Piano Co., Uniontown, Pa. "Fine."
- Altoona Elec. Supply Co., Altoona, Pa. "They have brought in new customers and consequently more sales."
- Mellich-Keyes Co., Steubenville, Ohio. "They have usually made new customers."
- Saltz Battery & Elec. Co., East Liverpool, Ohio. "They have sold some of prospects mailed us."
- W. Va. Radio Sales Corp., Charleston, W. Va. "We have used them and received results."
- Peterson Elec. Co., Wheeling, W. Va. "Have sent some business to us."
- Virginia Novelty Co., Martinsburg, W. Va. "Helps our sales and advertises us."
- Holt-Rowe Novelty Co., Fairmont, W. Va. "I have had very good success."
- The Salzer Elec. Company, Cleveland, Ohio. "This method is ideal."
- Austin-Hindes Elec. Co., Conneville, Pa. "We have made several sales by them."
- W. Va. Radio Sales Corp., Charleston, W. Va. "Have proven very useful."
- Scottsdale Battery Service, Scottsdale, Pa. "Have given your Company credit for your interest taken this way and appreciate same."
- Kerber Elec. Co., Cleveland, Ohio. "They have brought us in contact with people we would not have met otherwise."

Hommel's policy of referring customers to their local dealers means additional sales and real money profit to them.

We make the co-operation between our dealers and ourselves as close and as tangible as is possible.

Your name could just as well be on our dealer list, and you could profit just as these dealers are profiting.

Our illustrated Encyclopedia of Radio Apparatus 266-P is free to dealers. Ask for it.

WHOLESALE

EXCLUSIVELY

LUDWIG HOMMEL & CO

929 PENN AVENUE



PITTSBURGH, PA.

All apparatus advertised in this magazine has been tested and approved by POPULAR RADIO LABORATORY



DEPENDABLE HEADSET

Absolutely the best metal case headset on the market. Selling at a moderate price, it gives you more than your money's worth. Bi-polar type, with forged magnets of highest grade tungsten steel, wound to full 2400 ohms.

TRIMM

Superior Reproducers

HEADSETS

Professional - - **\$7.50**
 Dependable - - **\$5.00**

SPEAKERS

Concert Model - **\$25.00**
 Home Speaker - **\$10.00**

PHONODAPTER

GIANT Unit - **\$10.00**
 Little Wonder - - **\$4.50**



Member Radio Manufacturers' Association

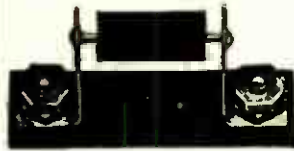

Permanent Cartridge Detector
 Guaranteed for reflex and all R. F. circuits.
PRICE \$1.00

INDOOR CAGE ANTENNA

A highly efficient Antenna System sold on a guarantee of *Reliable Reception.*

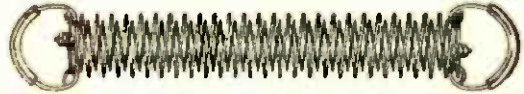

Patented. The Genuine bears the trade mark "Key to the Air".

\$2 At your dealer's—or direct by mail on receipt of price.

STAFFORD RADIO CO.

Medford Hillside - - - Massachusetts
 Send for circuit diagrams of Single Tube Receiver



The Ideal NEUTRODYNE

Licensed under Hazeltine Patents No. 1,450,080 and No. 1,489,228 and other Patents Pending

BLUEPRINTS FREE

Any set of famous Popular Radio Simplified Blueprints described on page 140 will be sent you absolutely free.

You know how helpful, interesting and practical POPULAR RADIO is. You fully appreciate that at \$3.00 a year it is a real bargain. Consequently you should find it easy to convince one, two or more of your friends, who are not now subscribers, of the unusual value when any one of these four sets of Simplified Blueprints (described on page 140) is offered free with their twelve months' subscription for POPULAR RADIO at the regular price of \$3.00.

In addition to the Blueprints given to your friends we will allow you one set free for each *new* subscription you send us with a \$3.00 remittance. For five *new* subscriptions and remittance of \$15.00 you would be entitled to all five sets free.

Only one set of Blue prints free with a renewal subscription whether your own or a friend's.

POPULAR RADIO, INC., Dept. 13,
 627 West 43d Street, New York City

Enclosed is my remittance of \$ covering annual subscription for POPULAR RADIO (additional names on sheet attached).

- 8-Tube Cockaday Reflex Super-heterodyne Receiver.
- 7-Tube Non-radiating Super-heterodyne Receiver.
- NEW Cockaday 4-Circuit Tuner, with Resistance Coupled Amplifier.
- Non-regenerative Tuned-radio-frequency (Neutrodyne) Receiver.
- Audio-frequency Amplifier.

Name.....

Address.....

Foreign postage 50c. extra. No extra for Canada.



THREE B BATTERIES

Another example of the Westinghouse policy of meeting the customer more than half way is illustrated by the three types of B Batteries which are offered for his choice.

On the left is the 22-MG-2, a 22½ volt, glass-cased battery of 1200 milliamper hours capacity. In the center is the 24-RG-2, also glass-cased but larger in capacity; 3500 milliamper hours, 24 volts. On the right is the 22-LG-2, our largest B Battery, 22½ volts, 6000 milliamper hours capacity.

No matter what your set, you can find a Westinghouse B Battery to fit it; all rechargeable and all in glass cases. Sturdy, durable and good looking, they are as good as they look.

A Batteries in glass cases in 2, 4 and 6 volt units, and three capacities of 6 volt units in one-piece composition cases. A 6 volt C Battery in a glass case completes the Westinghouse Radio line.

WESTINGHOUSE UNION BATTERY COMPANY
SWISSVALE, PA.

Distributor for South America, Mexico and Cuba
THE WESTINGHOUSE ELECTRIC INTERNATIONAL COMPANY
Mexico City, Buenos Aires and Havana

Distributor for Canada
CANADIAN WESTINGHOUSE CO., LTD.
Offices in all principal Canadian Cities

WESTINGHOUSE
RADIO
"A," "B" and "C"
BATTERIES

All apparatus advertised in this magazine has been tested and approved by POPULAR RADIO LABORATORY

Good Batteries Give Music — Poor Ones Give Noise



USL Radio "A" Battery in one piece hard rubber container.

Thousands of enthusiastic USL users endorse USL radio batteries. There is a reason for it. USL has built properly designed quality batteries for 25 years.

USL radio batteries cost no more. In fact, USL low prices will surprise you. Ask your local USL dealer for prices. Have him tell you why USL batteries are better.

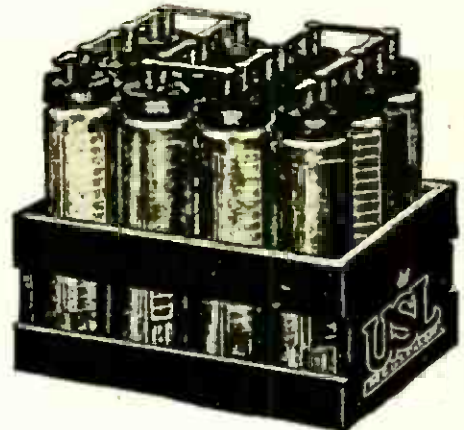

USL Radio "B" Battery Made in 24, 48 and 96 volt sizes.

For Every

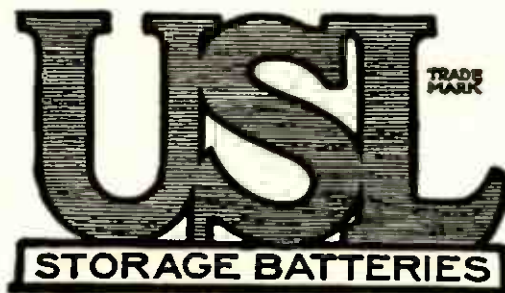

Radio Need

U. S. LIGHT & HEAT CORPORATION., Niagara Falls, N. Y.

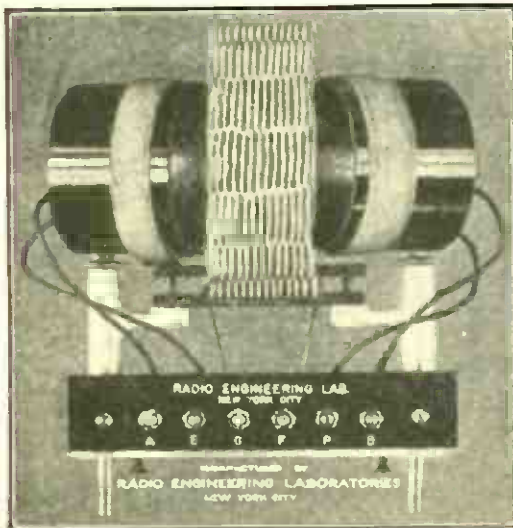

The LOPEZ Low Loss Tuner

Endorsed by R. A. BRADLEY, Technical Editor of **WIRELESS AGE**

as "the best low loss tuner for maximum selectivity and great reception range. In congested metropolitan areas the results obtained with the LOPEZ LOW LOSS TUNER far surpass any other make. It is also superior in sensitivity on distant stations.

All coils are set back sufficient distance from panel to prevent any possible hand capacity effects and dielectric losses in panel. Regeneration at all wave lengths, tunes easily and its secondary can be calibrated. Variable Antenna Coupling adapts tuner to any antenna length."

Broadcast Type 200 to 600 meters

Regular Amateur 40 to 205 meters

Circuit diagrams, panel drilling template and instructions with each tuner

PRICE

\$10.00
EACH

At your dealer's or sent direct postpaid

A. C. LOPEZ & CO.
344 Fifth Avenue, New York City

DeForest License



Honeycomb Coils

Back and Front Panel Mountings
Plain or Gearing—
Genuine Bakelite

The Universal all-wave inductance—accepted as standard in regard to superior construction and electrical units of measurement. Ask Your "Old Timer" radio friend why sets using honeycomb coils are better; they give closer tuning, greater selectivity and range. No dead end losses, easy to operate, 16 sizes, mounted, and unmounted. Interchangeable with all mountings. Be sure the set you buy or build has them.

Send 25c. for Super Heterodyne, Radio Frequency and Honeycomb Coil Circuits and Complete Catalog

CHAS. A. BRANSTON, Inc.
Dept. 2, 815 Main St. Buffalo, N. Y.
In Canada—CHAS. A. BRANSTON, Ltd., Toronto

The Famous BEL-CANTO LOUD SPEAKERS NOW at your DEALER

10" Bell—22" High—\$10
15" Bell—29" High—15

(Goose Neck)

If Your Dealer Cannot Supply You. Write Us and We Will Advise Where to Purchase One.

BEL-CANTO RADIO & TEL. EQUIP. CO., Inc.
872 B'way, N. Y. C. Tel. Stuy. 1921

Radio Without the Horn!

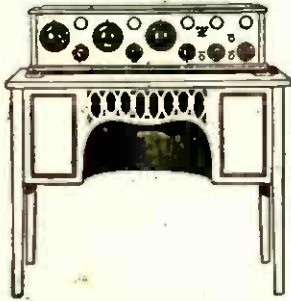

Goodbye to the Old-Fashioned Horn Speaker!

A Vastly Better Reproduction With this New Radio Console!



"Our old horn speaker never gave tones like this! An artistic addition to the living room—everything in its place—it's a joy!"

New Console Has Its Own Perfect Loudspeaker!

Ample Space for All the Rest of Your Outfit!

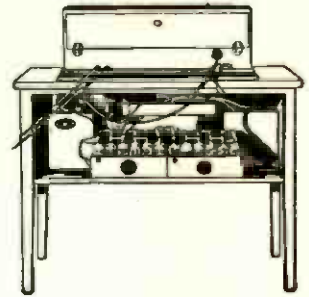

HERE is something that enables you to enjoy radio in the home without the clutter of unsightly apparatus that plays havoc in the decorative scheme of your living room! The horn speaker is out of date and out of place in radio for the home. This console with its in-built loudspeaker is scientific and sightly.

A Truly Wonderful Tone

It does a better job of reproducing, for it has the best unit of all that have been tried and its sound-box is of resonant wood instead of metal, fibre, or composition.

The appearance of a Windsor loudspeaker console is a delight. Its convenience is a joy. A piece of real living room furniture of pleasing lines and finish—and it accommodates all the miscellany of equipment which hitherto had no place except on table tops, shelves or floor. Ample space on top for any set, with plenty of elbow room in front. Nothing in sight but the dials. Everything else goes inside—from behind—in spaces cleverly designed to hold the largest batteries and outfit—besides the self-contained loudspeaker—all unseen and protected from dust or disturbance.

You Need This Console Whatever Your Present Outfit Is

It makes no difference what kind of radio outfit you have—this console was designed for your use. The graceful exterior of this console gives no hint of its inner utility, for it is a simple and effective piece of furniture in every line. But a glance at the interior reveals a most ingenious arrangement of the in-built loudspeaker with space either side and in front. These spaces are ample for the largest A battery, and the largest

wet B batteries and the largest charging outfit. It is 38 in. long, 18 in. deep, and 29 in. high. Notice the artistic grill that conceals soundbox, and the provision of "knee room" beneath. Made in mahogany or walnut finish, and the price is only \$40! (West of the Rockies, \$42.50.)

Dealers!

The sale of these consoles has already reached extraordinary figures. They are selling in surprising quantities in even smallest stores where there is one in the window or on the floor. It is a convenience and a value not to be duplicated.

Write us for discounts and particulars of big newspaper advertising campaign.

INVESTIGATE!

Dealers everywhere are now showing the Windsor loudspeaker console, and have them for immediate delivery to your home. If you haven't already seen this remarkable contribution to radio

enjoyment and convenience, write us now for the name of a nearby store where you may view it. We will also send you complete information. Remember, this console gives you not alone a marvelously faithful reproducing unit and sound box, but an altogether new beauty and utility in the provision for your entire radio outfit. Mail coupon or postal.

WINDSOR FURNITURE COMPANY (9)
1422 Carroll Ave., Chicago

Please furnish pictures and full details, also name of nearest dealer who has the new Windsor loudspeaker console.

Name.....
Address.....



Pat. Nov. 18, 1924

\$40

Loudspeaker Included
West of the Rockies, \$42.50

Windsor Loudspeaker Console

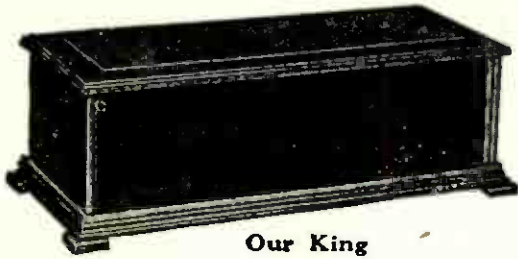

Our King

Utility cabinets are all made of carefully selected lumber. They are beautifully finished and hand rubbed. The workmanship is of as high grade as in the best furniture.

By ordering direct from us you obtain factory to consumer prices and save jobber and dealer profits. If not entirely satisfied with the cabinets received, money will be refunded without question.



Our Monarch

DOES YOUR SET LOOK AS WELL AS IT WORKS?

Your set performs well but does it look well in your home? You owe it to your home and to your set to use a good looking cabinet. Utility cabinets will look well in the best surroundings, and are worthy of the highest grade sets.

Our King type of black walnut (illustrated above) is the best we make and as good a cabinet as is made. Our King is also made in birch.

Our Monarch (illustrated below) is made of walnut also. It differs from Our King chiefly in that it has a split top—a type preferred by some.

Our DeLuxe is of the same general type as our Monarch, but is built of thinner lumber and consequently is cheaper.

For Panel	Deep	Birch No Base	DeLuxe Black Walnut	Monarch Black Walnut	King Black Walnut	King Birch
6 x 7	7"	\$1.75	\$3.75	\$4.40		
6 x 10 1/2	7"	2.25	4.65	5.35	\$5.35	\$3.35
6 x 14	7"	2.75	5.45	6.20	6.20	3.85
6 x 21	7"	3.25	5.90	6.80	6.80	4.60
7 x 12	7"	2.80	5.50	6.50	6.50	4.00
7 x 14	7"	3.00	5.80	6.70	6.70	4.20
7 x 18	7"	3.25	6.00	6.80	6.80	4.35
7 x 21	7"	3.60	6.50	7.40	7.40	4.90
7 x 24	7"	4.10	7.25	8.00	8.00	5.35
7 x 26	7"	4.75	7.80	8.50	8.50	5.80
7 x 27	7"	5.00	8.50	9.00	9.00	6.25
7 x 28	7"	5.25	9.50	10.00	10.00	6.80
7 x 30	7"	6.00	10.00	11.00	11.00	7.00
7 x 24	10"	5.60	9.25	10.00	10.00	6.70
7 x 26	10"	6.25	9.80	10.50	10.50	7.25
7 x 27	10"	6.50	10.75	11.50	11.50	7.70
7 x 28	10"	6.75	11.50	12.00	12.00	8.00
7 x 30	10"	7.00	12.00	12.50	12.50	8.20
8 x 36	8"				12.00	8.75
8 x 40	8"	6.00	11.50	12.50	12.50	9.25
9 x 14	10"	3.95	6.40	7.00	7.00	5.25
9 x 21	10"	5.00	7.70	9.25	9.25	7.50
9 x 24	10"	6.00	9.50	10.50	10.50	8.50
12 x 14	10"	4.25	7.00	8.00	8.00	5.50
12 x 21	10"	4.75	9.50	10.50	10.50	7.25

Order Direct From

UTILITY CABINET COMPANY

439-443 27th Street,

MILWAUKEE, WIS.



OUR TYPE 499
Detector and Amplifier

The HIGH QUALITY — LOW PRICE CLARITRON TUBE \$2.30 BY MAIL

YOU OWE IT TO YOURSELF TO USE CLARITRON TUBES

You cannot get a better tube at any price—and why pay more? Our Price is low because we sell direct and are content with a fair profit.

We guarantee that CLARITRON TUBES measure up to the highest standards. The well known New York Testing Laboratories declared CLARITRON to be better than standard tubes selling for \$4.00.

We make all kinds of tubes including:

Our No. 501A—for same use as 201A
Our No. 112—for same use as WD12

Our No. 499—for same use as 199
\$2.30 for any type

We ship all orders as soon as received. Shipments made by Parcel Post, C. O. D., or Pre-paid on Receipt of Express or Postal Money Order.

SUPERIOR RADIO COMPANY, Dept. 201

176 Shephard Ave.

Newark, N. J.



OUR TYPE 501A
Detector and Amplifier

RADIO

Large and most complete stock of Quality Radio merchandise at standard prices. Complete sets and standard parts of reliable makes. There's sixty-five years of uninterrupted service back of the "House that Satisfies." Reliable Radio merchandise is the only kind that's worth while. You can be certain of reliable, complete satisfaction and prompt delivery if it comes from Andrae.

Send for catalog

JULIUS ANDRAE & SONS CO.
127 Michigan St. Milwaukee, Wis.

ANDRAE In Business Since 1860



TRADE MARK
RADIO

Exclusive choice of Dr. MacMillan for his North Pole Expedition

Seven Models from \$95 to \$550

They Cost More—but They DO More

Zenith Radio Corporation 328 So. Michigan Avenue CHICAGO, ILL.

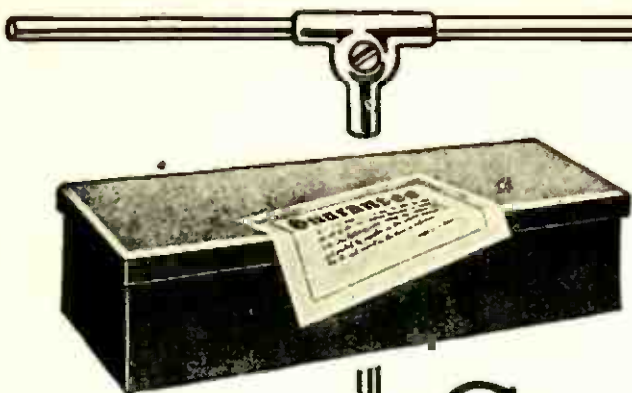

CIR-KIT makes the Greatest Circuits Easiest to Own



Secondary output windings of high impedance make Erla Push-Pull Transformers, exclusive in design, best suited to high resistance loud speakers. \$10 per pair.



Only the special spring arm, the perfected bearing and winding of Erla Precision Rheostats permit such supersensitiveness. Single-hole mounting preserves factory adjustment. \$1.10.



Neatest, most convenient in form. Erla Autogrip 2-Way Phone Plugs assure smoothest connection of tips and most positive contact, with no manipulation. A typical Erla improvement. 75c.

In a motor car—the engine. In a skyscraper—the substructure. In a radio receiver—the circuit. The circuit, Erla knew, must be the foundation of finest possible radio. So Erla first evolved those particular circuits which have ever since been rated most powerful, tube for tube, a result inherent only in Erla principles. And today the trend in radio clearly indicates that Erla Supereflex circuits may be selected in full confidence of continued pre-eminence.

That these fundamentally superior circuits are at the same time also easiest to construct, with utmost economy, is another epochal Erla attainment, made possible by the Erla *CIR-KIT*. With *CIR-KIT* you yourself can construct Erla Supereflex circuits from genuine Erla Precision Radio Apparatus, specially designed to assure the most efficient functioning of Erla Supereflex principles.

Erla *CIR-KIT* supplies everything needed, in a factory-sealed carton, sold under warranty. Erla Synchronizing Transformers, Erla Miniloss Condensers, Erla Precision Rheostats, Erla Cushion Spring Sockets, Erla Tested Crystals, and all the other matchless Erla units are provided. You can assemble them with perfect results virtually guaranteed by full-sized blueprints, drilled and lettered panel, stenciled baseboard, precisely locating every unit and connection. There is no soldering, thanks to Erla Solderless Connectors. Pliers and screwdriver alone are needed to bring you the de luxe radio of Erla Supereflex circuits, at lowest possible cost.

ELECTRICAL RESEARCH LABORATORIES
Department R, 2500 Cottage Grove Avenue, CHICAGO

ERLA

How To Neutralize Easily and Quickly

THE RELIABLE MICRO AIR CONDENSER

Does In a Few Seconds What You Couldn't Do Before in Hours

Have you ever been driven to the point of distraction trying to neutralize precisely? One minute you think you have it and the next you haven't. Finally you give up and let it go at that. Now anyone can neutralize if they use the Reliable Micro Air Condenser. Simply follow the instructions shown in the illustration. Note that this device locks the neutralized position into place, as securely as the lock on a safe. Then you sit back and listen to radio entertainment in comfort. No interruptions for adjustments. No annoying disturbances. If you want this extra refinement in your set ask your dealer for the Reliable Condenser. Or write direct to us if he cannot supply you. This condenser, mounted on base, formerly cost \$1.00. Now reduced to **60c**



The Reliable Parts Mfg. Co.
2819 Prospect Ave. Cleveland, O.

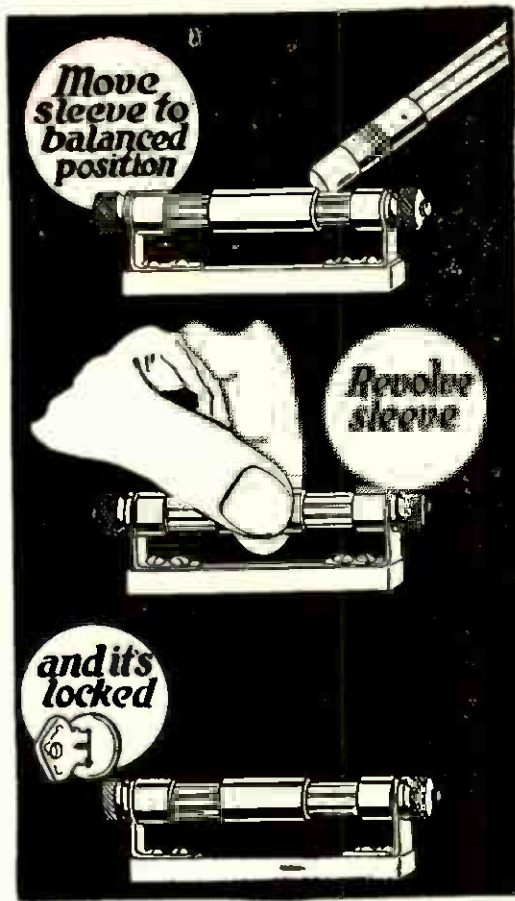

The Premier 20 Ft. Extension Cord Complete With Plug \$1.75

Haven't you often wanted to use your loudspeaker or phones in other parts of the house? You can easily do this by attaching The Premier Extension Cord. If your dealer cannot supply you, write direct to us.

Mfg. By Crescent Braid Co., Inc. Providence, R.I.

Campbell

RADIO CABINETS

"From the Lumber to You"

Special Sizes to Order



Mounting Boards
50c each

WILL NOT WARP OR CRACK

Made of No. 1 wood finished in either Mahogany or Walnut, bright or rubbed finish to match the finest of furniture.

PRICES

Cash with order, prepaid east of Missouri River; west, add 15 cents to quoted price. Send Post Office or Express Money Order.

Manufacturers' and Dealers' Liberal Discounts Sent Upon Request
THE PERKINS-CAMPBELL CO. (Established 1879)

410-440 New St., Cincinnati, O.

Panel Sizes	"From the Lumber to You"	
	Imitation Mahogany	Genuine Walnut or Mahogany
7 x 10 x 7	\$3.00	\$4.75
7 x 14 x 7	3.30	5.50
7 x 18 x 7	3.82	6.75
7 x 24 x 7	5.25	9.00
7 x 26 x 7	6.05	10.00
7 x 28 x 8	7.25	11.50
7 x 27 x 9	7.25	12.50
7 x 40 x 10	11.25	18.00

(References: Dun or Bradstreet's)

The DAVEN SUPER AMPLIFIER



The Super-Amplifier



Condenser Mounting



Grid Leak Mounting

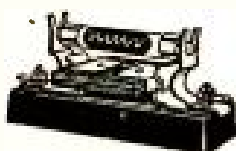

Combination Mounting No. 51

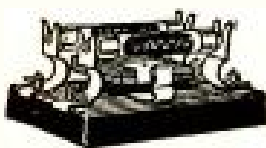

The Resisto Coupler

Read the "RESISTOR MANUAL." A thirty-two page hand-book on Resistance Coupled Amplification with interesting data and hook-ups.

Price 25 cents
At Your Dealers

DAVEN RADIO

Today, more than ever, the discriminating radio fan is insisting on quality reception—the blatant reception of the past will no longer satisfy. Resistance Coupling is the ultimate method of audio amplification because of its perfect reproduction.

The Daven Super-Amplifier is the aristocrat of all amplification devices—it comes ready to install in any set, condensers and resistors included and the complete unit laboratory tested and ready to give an immediate and superior service. It reproduces with fidelity the voice or musical instruments, as if the radio were not, and that the artists themselves were performing in your own home.

Sold at all good Radio Stores

DAVEN AMPLIFIER KITS (without sockets and condensers) for those who build their own:

3-STAGES	\$8.00
4-STAGES	10.50

Manufacturers of the Daven Grid Leaks
Resistors and Mountings

DAVEN RADIO CORP.

"Resistor Specialists"

Newark

New Jersey

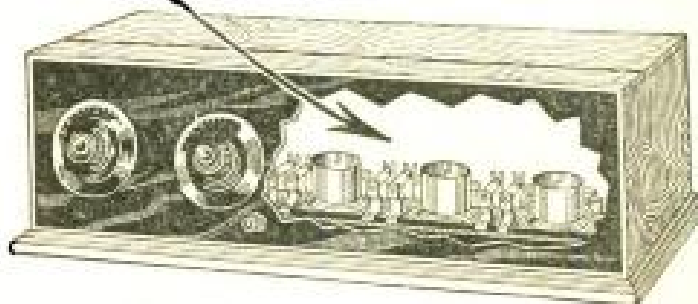

All apparatus advertised in this magazine has been tested and approved by POPULAR RADIO LABORATORY

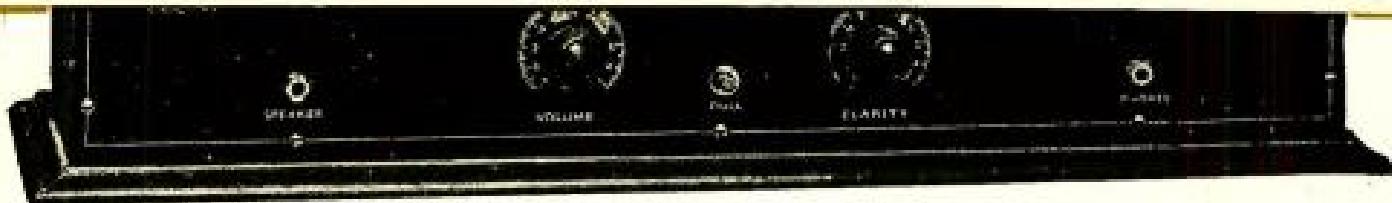

All apparatus advertised in this magazine has been tested and approved by POPULAR RADIO LABORATORY

EARN

SOS HYDROMETER

Best by Test for Radio and Automobile Batteries
Simple - Durable - Accurate

RATES REDUCED

Your choice of the best magazines at less than publisher's regular prices

POPULAR RADIO Two annual subscriptions \$5.00 Additional one year gift subscriptions only \$2.50		
*Judge *Popular Radio \$8.00 Reg. For \$5.50	*Cosmopolitan *Good Housekeeping Popular Radio \$9.00 Reg. For \$7.75	Film Fun *Judge *Popular Radio \$10.00 Reg. For \$7.35
Pictorial Review Modern Priscilla Popular Radio \$6.50 Reg. For \$5.25	McCall's Popular Radio \$4.00 Reg. For \$3.50	Live Stories Snappy Stories Popular Radio \$9.00 Reg. For \$7.85
Today's Housewife McCall's Popular Radio \$5.00 Reg. For \$4.00	*American Magazine *Woman's Home Companion Popular Radio \$7.00 Reg. For \$5.75	Success Popular Radio \$5.50 Reg. For \$4.25

* Combinations starred (*) must go to one address.

MAKE any selection you wish from the following list, to be sent to different addresses if desired. Remit only the amount shown in the right-hand column, if more than one magazine is ordered. All quotations cover twelve issues to the year unless otherwise specified.

American Magazine.....	\$2.50 reg. for	\$2.50
Atlantic Monthly.....	4.00	4.00
Baseball Magazine.....	2.00	1.75
Century Magazine.....	5.00	4.00
Christian Herald (52 issues)...	2.00	1.85
Collier's Weekly (52 issues)...	2.00	1.75
Cosmopolitan Magazine.....	3.00	3.00
Delineator.....	2.00	1.50
Designer.....	1.50	1.10
Etude (Music Magazine).....	2.00	1.75
Excelsa.....	2.50	2.00
Field and Stream.....	2.50	2.25
Film Fun.....	2.00	1.85
Forbes Magazine (24 issues)...	5.00	4.50
Good Housekeeping.....	3.00	3.00
Harper's Bazar.....	4.00	4.00
Harper's Magazine.....	4.00	3.50
Hearst's International.....	3.00	3.00
House and Garden.....	3.50	3.25
House Beautiful.....	3.00	2.75
Judge (52 issues).....	5.00	4.50
*Ladies' Home Journal.....	1.00	1.00
Live Stories.....	2.00	1.85
McCall's Magazine.....	1.00	1.00
Modern Priscilla.....	2.00	1.60
Outlook (52 issues).....	5.00	4.50
People's Home Journal.....	1.00	.90
Pictorial Review.....	1.50	1.50
Popular Radio.....	3.00	2.50
Popular Science Monthly.....	2.50	2.50
Q. S. T.....	2.00	1.85
Radio.....	2.50	2.00
Radio Broadcast.....	4.00	3.50
Radio Digest (52 issues).....	5.00	4.50
Radio News.....	2.50	2.25
Review of Reviews.....	4.00	3.00
*Saturday Evening Post.....	2.00	2.00
Science and Invention.....	2.50	2.25
Snappy Stories (24 issues).....	4.00	3.50
Sunset Magazine.....	2.50	2.00
Theatre Magazine.....	4.00	3.75
Today's Housewife.....	1.00	.75
Vogue (24 issues).....	5.00	4.50
Wireless Age.....	2.50	2.25
Woman's Home Companion ..	1.50	1.50
World's Work.....	4.00	3.50

For Boys and Girls

American Boy.....	\$2.00 reg. for	\$2.00
American Girl.....	1.50	1.40
Boys' Life.....	2.00	1.75
Boys' Magazine.....	1.00	.85
Child Life.....	3.00	2.50
Every Child's Magazine.....	1.50	1.25
Every Girl's (10 issues).....	1.00	.95
Everyland (10 issues).....	1.50	1.40
John Martin's Book.....	4.00	3.50
Junior Home Magazine.....	2.50	2.25
Kindergarten-Primary (5 issues).....	.75	.70
Little Folks.....	2.00	1.75
St. Nicholas.....	4.00	3.25
Youth's Companion (52 issues).....	2.50	2.50

*These magazines do not club but may be added to any combination at the price shown.

THIS page represents an opportunity for you to secure your entire season's reading at a substantial cash saving over regular rates. The special combinations above and the representative list at the side should cover all the magazines you are accustomed to read. But if any of your favorites are missing, let us quote prices. You will find our rates as low or lower than you can get anywhere else.

As most of these combinations can be sent to different addresses, you will find that your friends and neighbors will be glad to have you forward their order with your own that they may take advantage of these very low prices.

If your subscriptions for any of these magazines have not yet expired, your present order will be entered as an extension.

So fill out the coupon below and mail it promptly. Magazine prices change so rapidly that these rates cannot be guaranteed for more than thirty days.

POPULAR RADIO

627 West 43rd Street, New York City, N. Y.

Date.....192 .

POPULAR RADIO, Dept. 12,
627 West 43d Street,
New York City, N. Y.
Enclosed remittance of \$..... is payment in full for the
magazines ordered on the attached list.

Name.....

Street and Number.....

City..... State.....

(If not a NEW subscription, please mark R after
the name of the magazine, to indicate RENEWAL.)

Prices for Canada and foreign countries will be quoted on request.

 TESTED AND LISTED AS STANDARD BY UNDERWRITERS' LABORATORIES



Balkite—the noiseless battery charger

can be used while the set is in operation

The Balkite Battery Charger is entirely noiseless. It can be used while the radio set is in use. It does not create disturbances in either your set or your neighbor's. It has no moving parts, vibrators or bulbs, and has nothing to break, adjust or get out of order. It is simple and unfailing in operation. Besides charging "A" batteries it will also charge "B" batteries of the lead type in multiples of 6 cells. Sold by leading radio dealers everywhere.

FANSTEEL

Balkite Battery Charger

Price \$19⁵⁰

West of the Rockies \$20 • In Canada \$27⁵⁰

Manufactured by FANSTEEL PRODUCTS CO., Inc., North Chicago, Ill.

All apparatus advertised in this magazine has been tested and approved by POPULAR RADIO LABORATORY

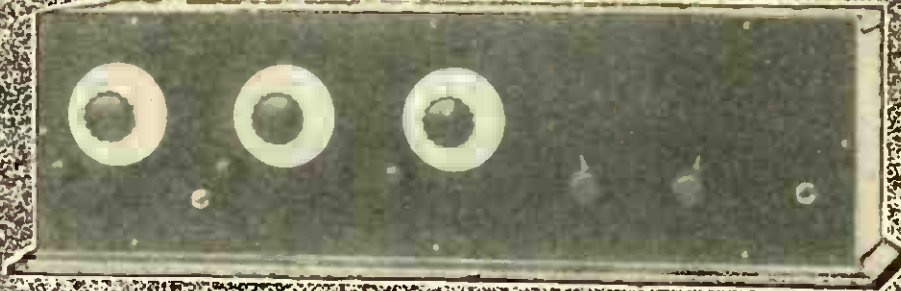

WHAT OTHERS SAY

The five tube Biltmore is absolutely the best receiver which can be had at any price.

Kenneth B. Hutchinson,
Fennville, Mich.

I have had quite a few sets, but I have never had any which has had anywhere near the clear reception that the Biltmore has.

C. E. Lundgren,
Wausa, Neb.

I am enclosing a list of 78 stations which I have received to date on the loud-speaker (I do not use phones) with the Biltmore 4 tube set. I have received a number of stations not on the list, as I was uncertain as to their call letters. (This includes 7 eastern stations—clear across the continent, from coast to coast.)

W. A. Hooker,
Medford, Oregon.

Write for literature

Biltmore Master Reflex

4 tube \$100

5 tube \$125

Biltmore Radio Co. Boston 30, Mass. (TR)

Dulce-Tone
Radio Talking Machine Speaker

Clear Up Your
Radio's Voice



Two models to fit all talking machines except "hill-and-dale" reproducers. Retail price complete with 6-foot phone cord, \$10.

Link your radio to your talking machine with a Dulce-Tone. Have radio reception as clear and distinct as the vocal and instrumental reproduction obtained when playing a record!

Dulce-Tone eliminates all the hoarse wheezes and blares developed by your loud speaker. Sounds are sharp,

clear-cut, precise — because Dulce-Tone uses the complete, "balanced" reproducing unit of your talking machine.

Ask your radio or music dealer to let you hear the finer, better reproduction which you can obtain with a Dulce-Tone. If possible choose a quiet hour when you can listen undisturbed.

If your radio or music dealer has not Dulce-Tone in stock write us direct. There is no other instrument with Dulce-Tone's features

THE TEAGLE COMPANY, 1125 Oregon Avenue, Cleveland, Ohio

NEW GENERAL RADIO PRODUCTS

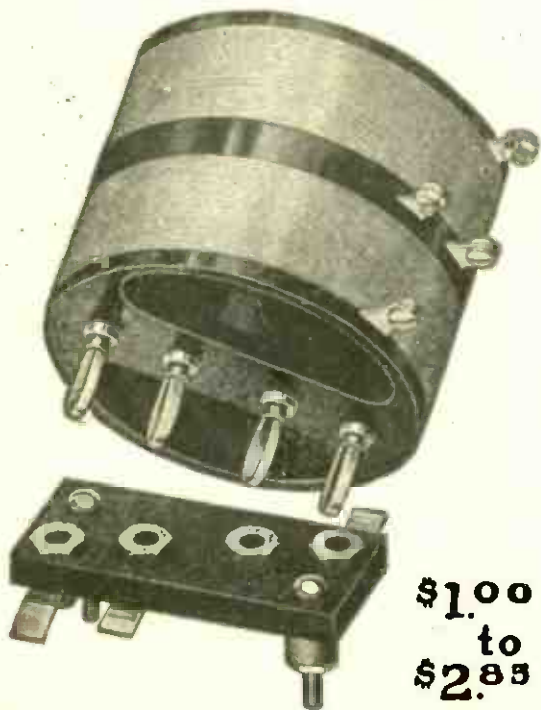

\$1.00
to
\$2.85

New Low Loss Coils



\$5.00

A New Variometer

Radio Builders and Experimenters—here are the newest additions to the well known *General Radio* line of Quality Parts!

A *Variometer* unusually compact in size and efficient in operation.

Low Loss Coils that mount as easily as a vacuum tube—ideal for oscillator and antenna coupling coils for superheterodyne circuits.

The New Geared Vernier Dial—an improvement in the appearance and operation of any well planned set.

They are all popular instruments selling at popular prices.

See them at your dealer's or write for our new radio catalog 919-U.

GENERAL RADIO CO.
Cambridge, Mass.

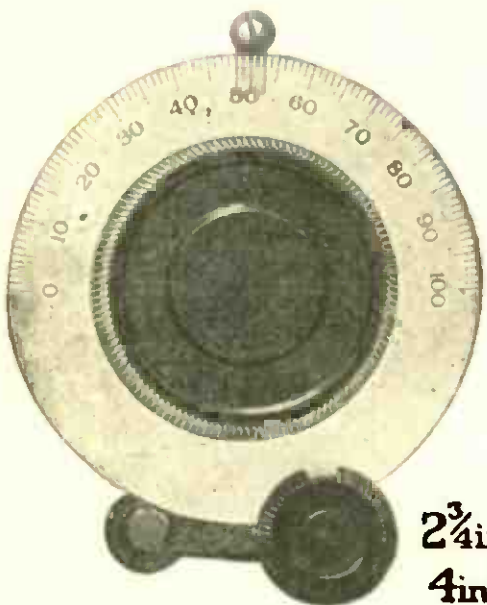

2 3/4 in. \$1.50
4 in. \$2.50

New Geared Vernier Dials

Before You Build Your Radio Set

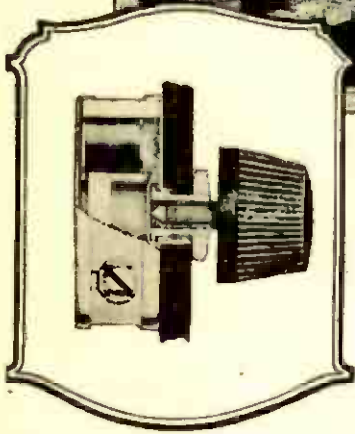

See the New Allen-Bradley Line

Radio amateurs are building better receiving sets, today! They want greater distance, better selectivity, and clearer reception.

The new Bradleystat, Bradleyleak, Bradleyohm, Bradleyometer and Bradleyswitch have met with instant favor, everywhere. In a super-class, by themselves, they are the exclusive choice of the discriminating amateur who has learned from experience that noiseless, stepless control is essential for perfect radio reception. Your set will work better with Allen-Bradley Radio Devices. For sale by leading dealers.

Distinctive Features

- 1—Extremely compact without loss of control.
- 2—One-hole mounting for panels. Table mounting if desired.
- 3—Noiseless, stepless control, due to graphite discs.
- 4—Guaranteed against defects in material and workmanship.
- 5—Sold in distinctive checkered cartons by leading radio dealers.

Allen-Bradley Co.
Electric Controlling Apparatus

General Office and Factory: 276 Greenfield Avenue Milwaukee, Wisconsin

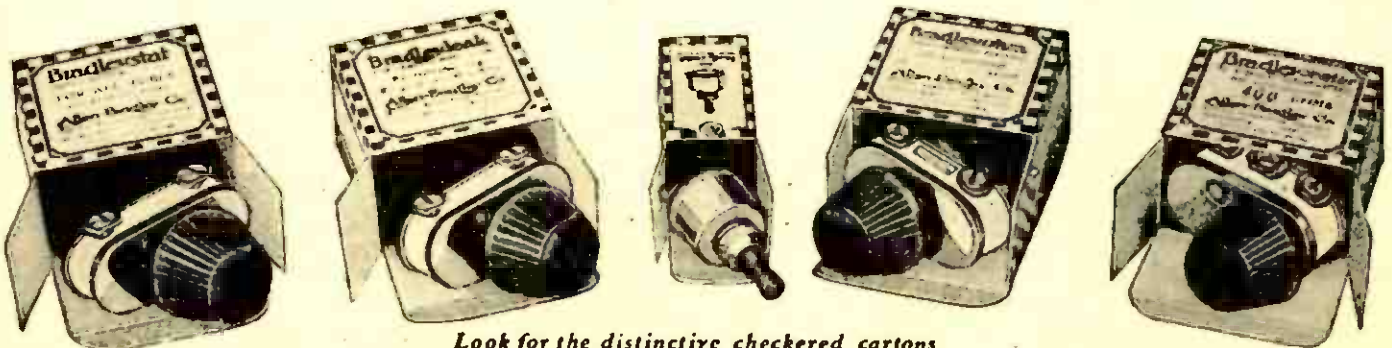

Look for the distinctive checkered cartons which identify all Allen-Bradley Radio Devices.

All apparatus advertised in this magazine has been tested and approved by POPULAR RADIO LABORATORY

WLW



Abroad at Home with a CROSLLEY MODEL X-J

PRICE \$65

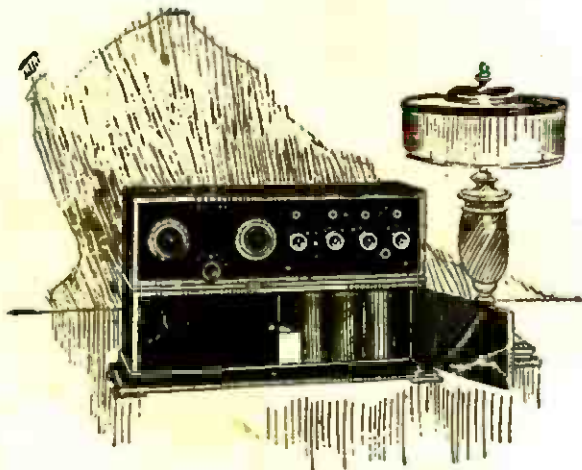

CROSLLEY MODEL X-J

A 4 tube radio frequency set, incorporating one stage of Tuned Radio Frequency Amplification. Detector and two stages of Audio Frequency Amplification, with jack to plug in on three tubes for head phones; new Crosley multistats, universal rheostats for all makes of tubes; new condenser with molded plates; filament switch and other refinements of details. A mahogany-battery cabinet which makes the set completely self containing may also be had to fit the Model X-J at a cost of only \$16. See illustration above. See this beautiful receiver at your dealers.

"List prices on our equipment West of the Rockies 10% higher. In Canada add duty."

Wonderful opera from New York, love songs from the tropics, dance music from Chicago; stock quotations, stirring speeches, amusing stories from where you will—all these pleasures and utilities are brought truly, clearly, right to your fireside, if you own a Crosley Model X-J Radio Receiver.

This beautiful new Crosley 4 tube Model contains the same units as the famous Crosley Model X, with added refinements of detail which make it even better. At bringing in distant stations, the Model X established many records during the past year. Sebring, Fla., continually heard Honolulu. A man writes from Nassau, British West Indies, "First of all on Friday night, June 29, 1923, I heard Honolulu." He goes on to relate that practically all stations in the United States were brought in clear as a bell.

With the Crosley Model X-J even better receptions are assured. We unhesitatingly claim that it is the best radio receiver ever offered, regardless of price.

For Sale by Good Dealers Everywhere

Write for free catalog which shows the complete Crosley line of instruments and parts. In it you will find just the receiver to suit your needs and pocketbook. Crosley Receivers without batteries, tubes and head phones range in price from the efficient 2 tube Model VI at \$28 to the beautiful Console Model at \$150.

CROSLLEY MANUFACTURING CO.

1116 Alfred Street

Cincinnati, O.

New York Office. C. B. Cooper, 1803 Tribune Building, 154 Nassau Street, Beekman 2061.

Boston Office. B. H. Smith, 755 Boylston Street, Room 316.

Chicago Office, 1311 Steger Building, 28 E. Jackson Blvd., R. A. Stemm, Mgr.

Philadelphia Office, J. H. Lyte, 65 North 63rd Street.

St. Louis Office. Robert W. Bennett Co., 1326 Syndicate Trust Building.

CROSLLEY

Better - Cost Less
Radio Products

The New C & W Console Receiver



*Completely Self Contained
with Loud Speaker*

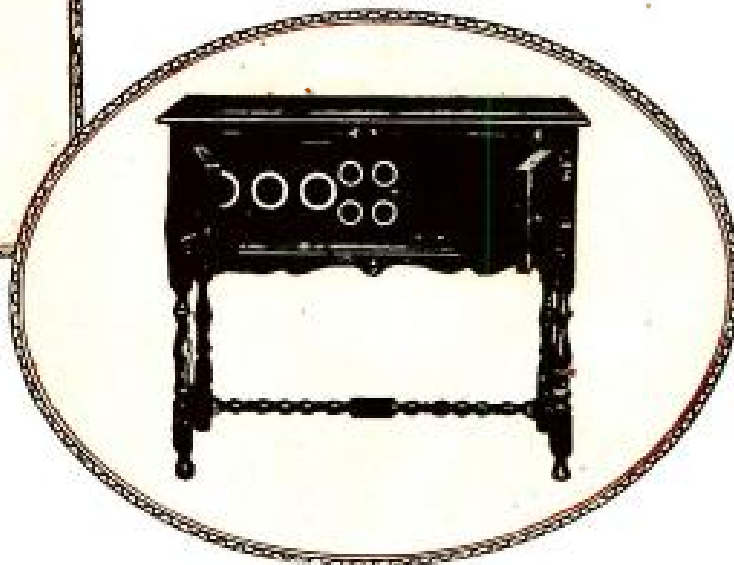

*A Moderate Priced Set that
will make Radio Entertainment
Permanent in Thou-
sands of Homes.*

Higher selectivity than any other instrument in its class—clearer signals by actual test—this three tube, double circuit Receiver is the last word in radio for the home.

Set is complete with 3UV 199 tubes; 3 large A Batteries; 3 B Batteries and Loud Speaker—ready for antennae and ground connections. Ask your Cutting and Washington dealer or write for illustrated catalog.



Cutting and Washington Receiver 11A—similar in mechanical design to console model, but of regular cabinet type. This C & W Model has enthusiastic users all over the United States. Write for illustrated catalog.



Cutting and Washington Receiver 12A—"Town and Country" model (portable type). A turn of a switch changes it from single circuit set for outing use, to a double circuit set for use in the home with permanent antennae. Ideal all purpose set.

Dealers: Write for full details of C & W Line and Dealer Plan, and copy of interesting book, "The Future of Radio Retailing." No obligation.

Cutting & Washington Radio Corp.
Kasota Building
Minneapolis **Minn.**

Cutting and Washington

Standard of Excellence in Radio Since 1914