

# Popular Radio

**JUNE  
1923**

**20¢**



**How to Use Your Set  
on Your Vacation**

# to give you greater faith in the business of RADIO

*An announcement of great importance to Dealer and User alike*

## Cutting and Washington

America's oldest manufacturers of commercial radio equipment

*Announce a sales policy that assures a permanent profit to dealers—permanent service to users—*

*Announce the new 11A receiver—leader in the C & W lines—admittedly one of the highest developments in radio science.*

1. Dealers are chosen to assure high class representation and able service.
2. Discounts enable dealers to actively sell and *service* instruments.
3. National advertising to demonstrate the excellent quality of Cutting & Washington sets.
4. Complete line of Sets of scientific design, correct engineering and highest quality materials.
5. Co-operative local advertising plan to cut costs of selling.
6. Complete merchandising plan covering every phase of a profitable business in radio.

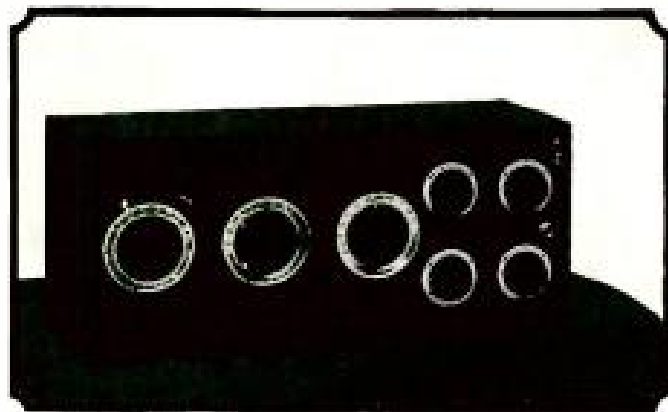

### Years Ahead in Radio

1. Designed by Dr. Fulton Cutting and Mr. Bowden Washington, whose apparatus is used on United States Ships, Areoplanes, and shore Stations.
2. Manufactured by one of the world's largest manufacturers of automatic electric equipment.
3. Licensed under the famous Armstrong Patents—admittedly the best circuit for radiophone reception.
4. Exclusive features that make for extraordinary simplicity and effectiveness.
5. An inbuilt quality that insures continued operation eliminating need of troublesome service.

**Dealers:** Write at once for complete details of this real opportunity in radio.  
**Distributors:**

**Cutting & Washington Radio Corp., Minneapolis, Minn.**

Please mention POPULAR RADIO when answering advertisements.



# Brandes

It is a fifteen year old tradition of the Brandes factory that the saving of lives at sea may depend upon the precision of our work. And while that will always be our thought, it means maximum clarity, maximum strength of reception, maximum pleasure and entertainment to over 500,000 users of Brandes *Matched Tone* Radio Headsets.

*Send ten cents in stamps for the "Beginner's Book of Radio." It explains radio in terms that anyone can understand.*

*Made in Canada and England by*  
**Canadian Brandes Limited, Toronto and London**  
*Distributed in Canada by Perkins Electric Limited*  
**Toronto — MONTREAL — Winnipeg**

**C. BRANDES, Inc., 237 Lafayette St., N. Y.**

## *Matched Tone*

TRADE MARK REG. U.S. PAT. OFF.

## Radio Headsets

# POPULAR RADIO

EDITED by KENDALL BANNING



## CONTENTS for JUNE, 1923

(Cover design by Frank B. Masters)

VOLUME III

NUMBER 6

How Radio Will Bring Education to the Masses... <i>Jno. J. Tigert</i> .....	Page 405
The Most Sensitive Machine in the World for Recording Currents.....	406
How to Use Your Radio Set on Your Vacation.... <i>William F. Crosby</i> .....	407
The First of a Series of Articles on Practical Summer Radio	
The Radio Bug on the Sky-Scraper..... <i>Homer Croy</i> .....	420
How the Microphone Transmitter Works..... <i>Laurence M. Cockaday</i> .....	424
Simple "How" Articles for the Beginners—No. 10	
How to Build a Good Single-Tube Receiver..... <i>A. H. Rice, Jr.</i> .....	429
The New Method for Extracting Electrons..... <i>Irving Langmuir</i> .....	434
How to Make a Crystal Detector Stand..... <i>A. Hyatt Verrill</i> .....	439
Machines That Record the Voltages of Peas..... <i>Waldemar Kaempffert</i> .....	445
How to Determine the Constants of Your Antenna <i>Morris S. Strock</i> .....	448
The Truth About the Heising Scheme for Modu- lation—As I See It..... <i>Robert C. Benchley</i> .....	454
One of the Coming Functions of American Uni- versities..... <i>R. H. Goddard</i> .....	457
The Coming Use of Frequencies That We Can Hear <i>Oscar C. Roos</i> .....	459
Wagner by Wireless..... <i>William H. Easton</i> .....	462

### DEPARTMENTS

What Readers Ask.....	466
Listening In.....	472
Hints for Amateurs.....	478
"Stations I Have Heard".....	481
Broadcasts.....	483

VOLUME III

JUNE, 1923

NUMBER 6

Published monthly by Popular Radio, Inc., 9 East 40th Street, New York, N. Y., telephone number Vanderbilt 9985; H. B. Emerson, President; E. R. Crowe, Vice-President; Harvey Fisk, Treasurer. Price, 20 cents a copy; subscription \$2.00 a year in the U. S., Canada and all countries within the domestic postal zone; elsewhere \$2.25 a year, payable in advance. The International News Company, Ltd., No. 5 Bream's Bldg., London, E. C. 4, sole distributors in England. Entered as second-class matter April 7, 1922, at the Post Office at New York, N. Y., under the act of March 3, 1879. Copyright, 1923, and title registered as a trade-mark by Popular Radio, Inc. Printed in U. S. A.

E. E. FREE, Ph.D., *Contributing Editor* LAURENCE M. COCKADAY, R.E., *Technical Editor*

Please mention POPULAR RADIO when answering advertisements.



"He who lightly promises,  
is sure to keep but little  
faith" - Lao Tzu

Wink knowingly  
at him who would sell you  
something "just as good" as a  
**Grebe Receiver**

*Doctor Mu.*

A. H. GREBE & CO., Inc.  
Richmond Hill, N. Y.

Western Branch  
451 East 3rd Street, Los Angeles, Cal.

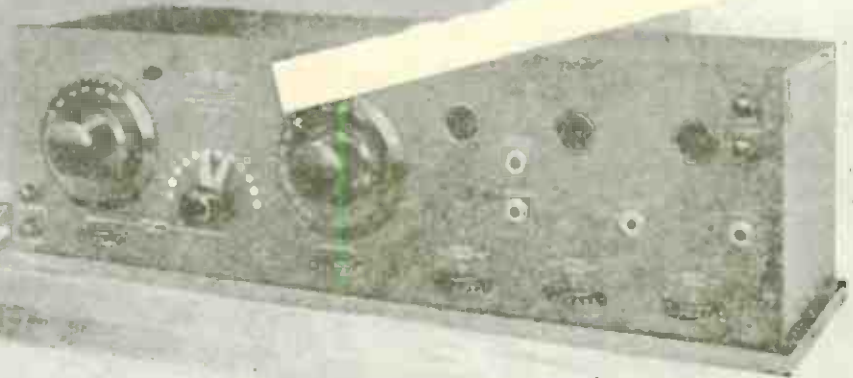

Write for  
"Musings of  
Dr. Mu."

Licensed under Armstrong  
U. S. Pat. No. 1113149

# A PAGE WITH THE EDITOR

JUST what features of POPULAR RADIO are of the greatest interest and value to our readers? What kinds of articles do they prefer? Which of our departments are "getting over" most effectively?

To enable the Editor to meet the desires of our readers to best advantage, to make it possible for him to know their wants, a questionnaire has recently been sent out to a selected list of 3,500 subscribers. The replies are pouring in as this number goes to press.

\* \* \*

WHEN these replies have been classified and studied, the Editor will have a word or two to say to our readers—to their advantage.

\* \* \*

GENERAL Squier's call upon the readers of POPULAR RADIO—in our April number—for a suitable word or term that might be applied to that particular type of broadcasting which he discovered and which is based on wired wireless principles, has brought interesting responses from all over this country and Canada. One of the most original comes from MacArthur Morgan of St. John, P. Q., who proposed the apt term *Squiercasting*.

Well, why not? Were not the names of Henry and Watt and Ohm and Ampere and countless other inventors and discoverers perpetuated in the same way by being incorporated in the language of science?

\* \* \*

"As the wireless wave is led along the leads of a transmission system," suggests Henry N. Potter, of Glendale, California, "why not term the system *leadcasting*?"

\* \* \*

"WHY not call it *directcasting*?" proposes E. W. Moreau, of Detroit. *Radiowire* is the term coined by B. Loudon, of Washington, D. C. Among other words submitted are *relay-casting*, *linecasting* and *recasting*.

\* \* \*

WHO says that the Middle West is not alive to its opportunities? From Flint, Michigan, came in the first nine-year-in-advance subscription to POPULAR RADIO—accompanied by a check from Mr. F. Pruchnicki. If the magazine increases in size during that period proportionately as it has during the past year, by 1932 it will consist of 35,840 pages!

\* \* \*

HERE'S a pertinent word of warning from A. D. Twinbull of Sidney, N. S.; "Even we Canadians," he writes, "have to be at the bookstalls early to get POPULAR RADIO; it sells out quickly up here."

(For the benefit of our Yankee readers, we may explain that the English word *bookstall* translated into American is *newsstand*.)

\* \* \*

BUT the dangers of being left out in the cold without a copy of POPULAR RADIO are not con-

finied to our neighbors up north. Right here in little old New York an insistent radio fan applied at eleven large newsstands on April 10 for a copy of our April number, and every stand was *completely sold out*. Yet, inquiry showed that these eleven newsstands had been furnished with 530 copies of our April issue!

\* \* \*

THE only way to be *sure* of your copy every month is to subscribe!

\* \* \*

THOSE of our readers who have been brought up in a doctor's family are familiar with the practice of "G. P's" (Grateful Patients) of making gifts to the man who cured them of their ills. Happily for our Technical Editor, this custom is extending among the radio fans whose troubles he is similarly dissipating. To date the Technical Editor has received two crates of oranges, one box of grapefruit, one side of lamb, four automobile tires and so many cigars that he generously shares them with the Editor!

\* \* \*

FEW compliments have pleased us more than this one that comes from John Leuthold of Colorado; he writes:

"Always I am impressed with the dignity of the magazine—that something which takes radio science out of the realm of mere pastimes and fads and places it in the forefront of civilizing and world-advancing science."

\* \* \*

WITH the single exception of Laurence M. Cockaday's article in our September issue on "How to Build the New Armstrong-Circuit Receiving Set," none of our "how to build" series has brought into the Editor's office the flood of letters as the same author's article in our January issue "How to Build a Real DX Regenerative Receiver." If anyone doubts the efficiency of this set—and occasionally a reader has had difficulty in getting it to operate—refer him to Byron L. Smith, of Spring Valley, N. Y., who writes:

"I have constructed the DX receiver according to instructions in POPULAR RADIO. The results I obtain from it are truly marvelous. . . . It is truly the set for the novice and for the DX bug alike."

\* \* \*

If you see it in POPULAR RADIO it's so!

  
Editor, POPULAR RADIO

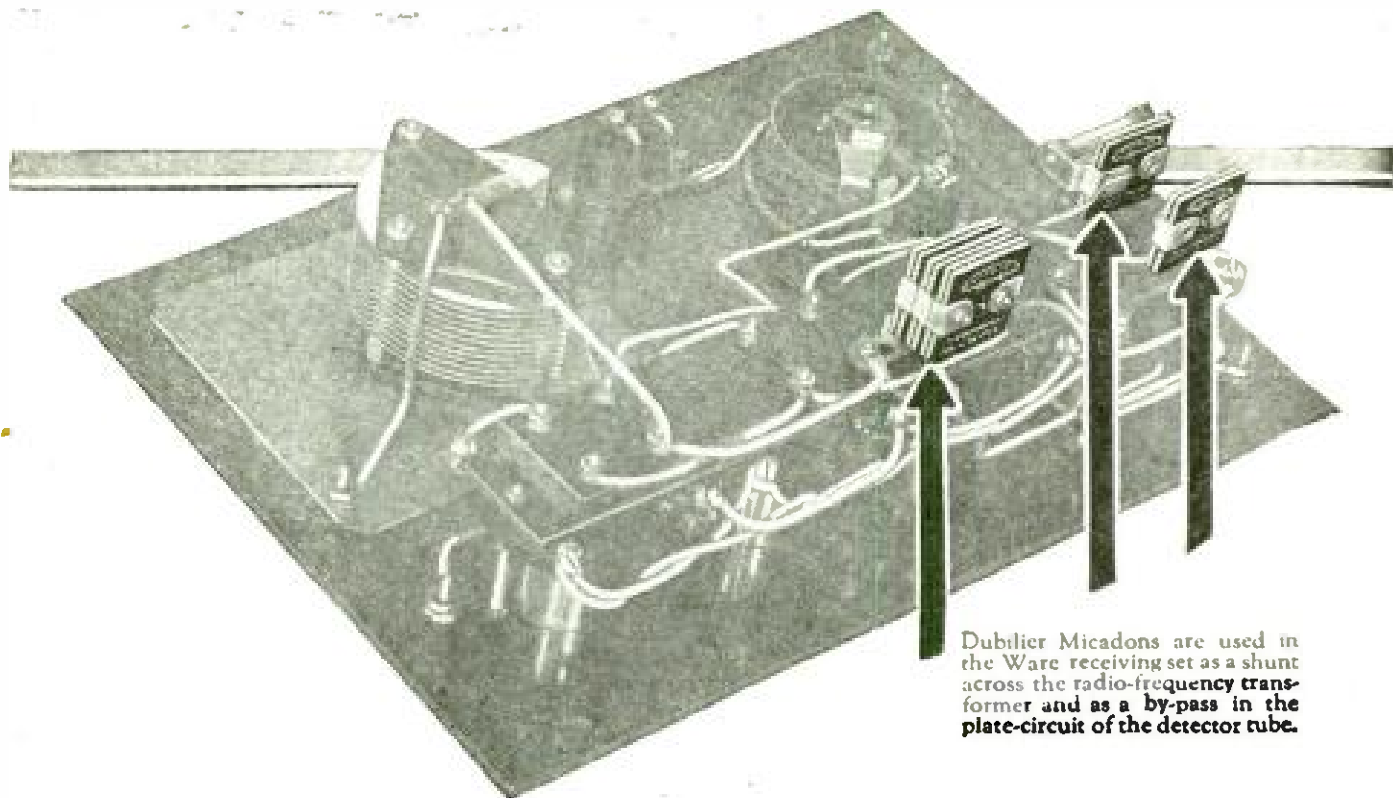

Dubilier Micadons are used in the Ware receiving set as a shunt across the radio-frequency transformer and as a by-pass in the plate-circuit of the detector tube.

## —and in Ware Receiving Sets

**O**NLY an infinitesimal amount of energy is received by any set. Losses must be avoided in amplifying it before detection. Hence the condensers in the circuit must be permanent in capacity. They must deliver all the energy stored up.

Because Dubilier Micadons alone meet this requirement they are exclusively used in the well-

known efficient Ware radio sets and in other sets made by reputable manufacturers.

Unless a set is equipped with Dubilier Micadons you are not receiving the broadcasting station at its best.

Price 35 cents to \$1.50 each, depending on the capacity.

Ask your dealer to tell you more about Dubilier Micadons.

### DUBILIER CONDENSER AND RADIO CORP.

48-50 West Fourth St., New York

#### Branch Offices in the Following Cities

Los Angeles, Cal.  
St. Louis, Mo.

Atlanta, Ga.  
Huntington, W. Va.  
Washington, D. C.

Chicago, Ill.  
Pittsburgh, Pa.

Distributed in Canada by Canadian General Electric Company, Ltd., Toronto







Harris & Ewing

## How Radio Will Bring Education to the Masses

*"THE general public has grown so vast, the need of continuous education so great, and the necessity for sending out information so pressing as to make highly desirable some means of popular information in addition to the sometimes long-delayed government bulletin. Radio furnishes the means of reaching this audience quickly and regularly."*

JNO. J. TIGERT  
UNITED STATES COMMISSIONER OF EDUCATION

be misled into believing that everything that is high-priced is therefore good.

The best plan is to get acquainted with some radio man who has been in the game for a number of years, and get from him an authoritative list of materials needed, and the names of the various makes. This list may serve as the basis of the vacation set.

Do not be deceived by outward appearances of radio apparatus. "All that glitters is not gold"; sometimes the flashy piece of apparatus and the most highly polished set will prove to be far from satisfactory. Before you buy it, investigate carefully and find out if the set really works.

Last summer many camps were equipped with radio sets of all sorts and descriptions. Needless to say, the majority of them were simple crystal sets;

consequently, the results, in a great many cases, were far from satisfactory. However, there are occasions when a crystal set can meet the campers' needs. This article describes both a set that makes use of a dry-cell and vacuum tube, and also one that uses a crystal detector. The circuits are almost identical. Excellent results should be obtained with the tube set, and good results from the crystal set, *provided* that a good piece of crystal is obtained. Success with a set of this kind depends upon the crystal; unless a good one is used, the set may just as well be left at home.

The circuit illustrated in Figure 1A shows an unusually simple crystal detector receiver.

Figure 3A shows the same tuning circuit connected up with a vacuum tube detector. With the latter, it is recom-

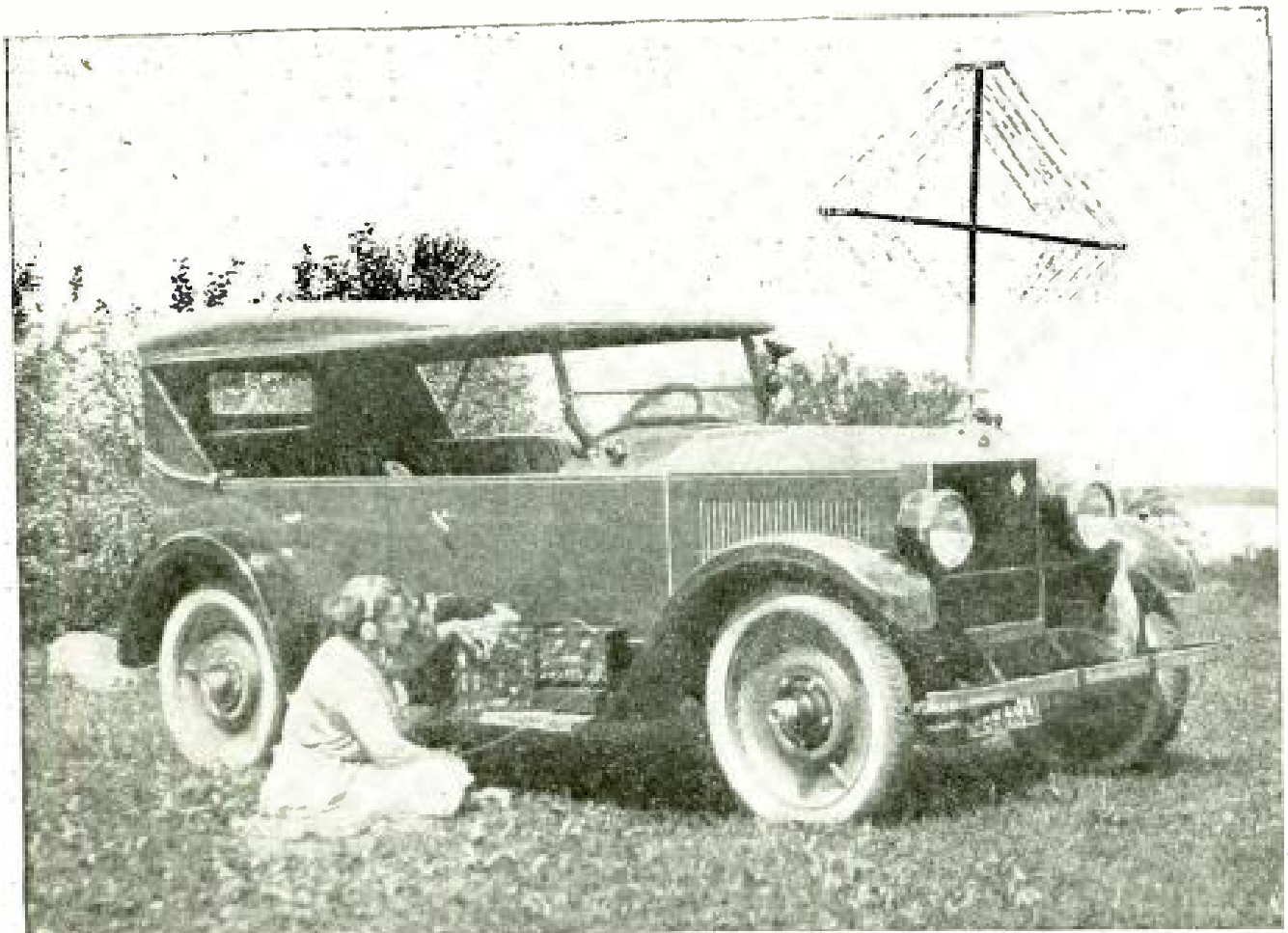

Kadel & Herbert

#### RADIO BY THE ROADSIDE

*Here is a radio frequency set installed on a pleasure car, with a loop antenna attached to the hood. This gives good results if it is carefully adjusted—but it is not as simple or easy to operate as the installation described elsewhere in this article.*



Harris & Ewing

## How Radio Will Bring Education to the Masses

*"THE general public has grown so vast, the need of continuous education so great, and the necessity for sending out information so pressing as to make highly desirable some means of popular information in addition to the sometimes long-delayed government bulletin. Radio furnishes the means of reaching this audience quickly and regularly."*

JNO. J. TIGERT

UNITED STATES COMMISSIONER OF EDUCATION

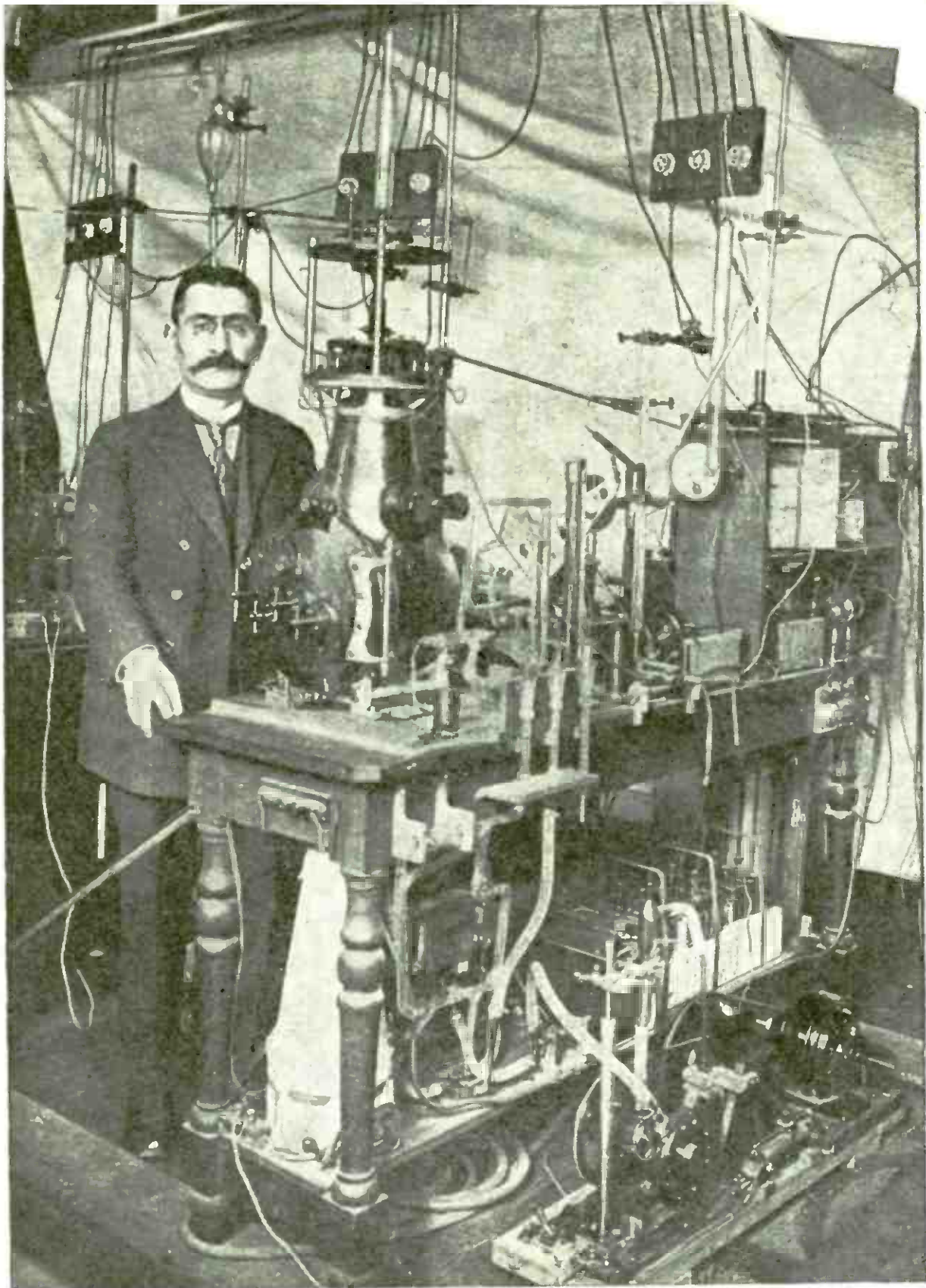

Dorien Leigh, London

### The Most Sensitive Machine in the World for Recording High Frequency Currents

*This complex device is the "cathode oscillograph," invented by the French scientist, M. Dufour. It is delicate enough and its action is speedy enough to picturize currents which oscillate at the rate of 1,000,000 vibrations a second. M. Dufour is professor of physics at the Faculty of Sciences in Paris. The machine will probably be used for receiving high-speed radio messages without the services of operators.*

# Popular Radio

VOLUME III

JUNE, 1923

NUMBER 6



## HOW TO USE YOUR RADIO SET ON YOUR VACATION

*Don't Be Scared by the "Static" Bugaboo!*

Much erroneous information has been circulated among novices in regard to that mysterious "static" that supposedly renders radio helpless in the summer months. The fact is that static is seldom strong enough seriously to interfere with the reception of radio signals even during the warm season; the only time that static really grows to a volume enough to curtail reception is when an electrical storm is passing through the immediate neighborhood. A great deal of enjoyment may be gotten out of a summer radio installation in the camp, on the automobile, on the farm, at the seaside or at any isolated place. The author has used radio in this way for summer after summer; from his practical experience this article has been written.—EDITOR.

By WILLIAM F. CROSBY

**T**HIS is the time of year when the prudent radio man is making his plans for using his set on his vacation outings.

While there are many ways in which a radio receiving set may be used in the summer, the automobile trip or camping trip probably afford the best opportunities for getting practical service from it.

For this purpose the now familiar dry-cell tube comes to the rescue, by doing away altogether with the heavy and cumbersome storage battery. It is no longer much of a task to construct a set that may be easily transported by a vacation hiker in his blanket roll. In the past, a vacuum tube set has been quite out of the question; now, however, a small set

may be made up that will weigh only a few pounds and that can be arranged in such a way as to be entirely self-contained, with all the apparatus and batteries within the cabinet.

When you plan to assemble your vacation set, don't make the mistake of buying low grade or cheap materials.

The average radio fan apparently does not notice the difference between the various makes of radio apparatus. If a dealer displays an article that is called by a familiar name but that costs less than the standard product, the chances are that the inexperienced fan will purchase the cheaper article. Here is often where his first mistake lies.

On the other hand the fan should not

be misled into believing that everything that is high-priced is therefore good.

The best plan is to get acquainted with some radio man who has been in the game for a number of years, and get from him an authoritative list of materials needed, and the names of the various makes. This list may serve as the basis of the vacation set.

Do not be deceived by outward appearances of radio apparatus. "All that glitters is not gold"; sometimes the flashy piece of apparatus and the most highly polished set will prove to be far from satisfactory. Before you buy it, investigate carefully and find out if the set really works.

Last summer many camps were equipped with radio sets of all sorts and descriptions. Needless to say, the majority of them were simple crystal sets;

consequently, the results, in a great many cases, were far from satisfactory. However, there are occasions when a crystal set can meet the campers' needs. This article describes both a set that makes use of a dry-cell and vacuum tube, and also one that uses a crystal detector. The circuits are almost identical. Excellent results should be obtained with the tube set, and good results from the crystal set, *provided* that a good piece of crystal is obtained. Success with a set of this kind depends upon the crystal; unless a good one is used, the set may just as well be left at home.

The circuit illustrated in Figure 1A shows an unusually simple crystal detector receiver.

Figure 3A shows the same tuning circuit connected up with a vacuum tube detector. With the latter, it is recom-

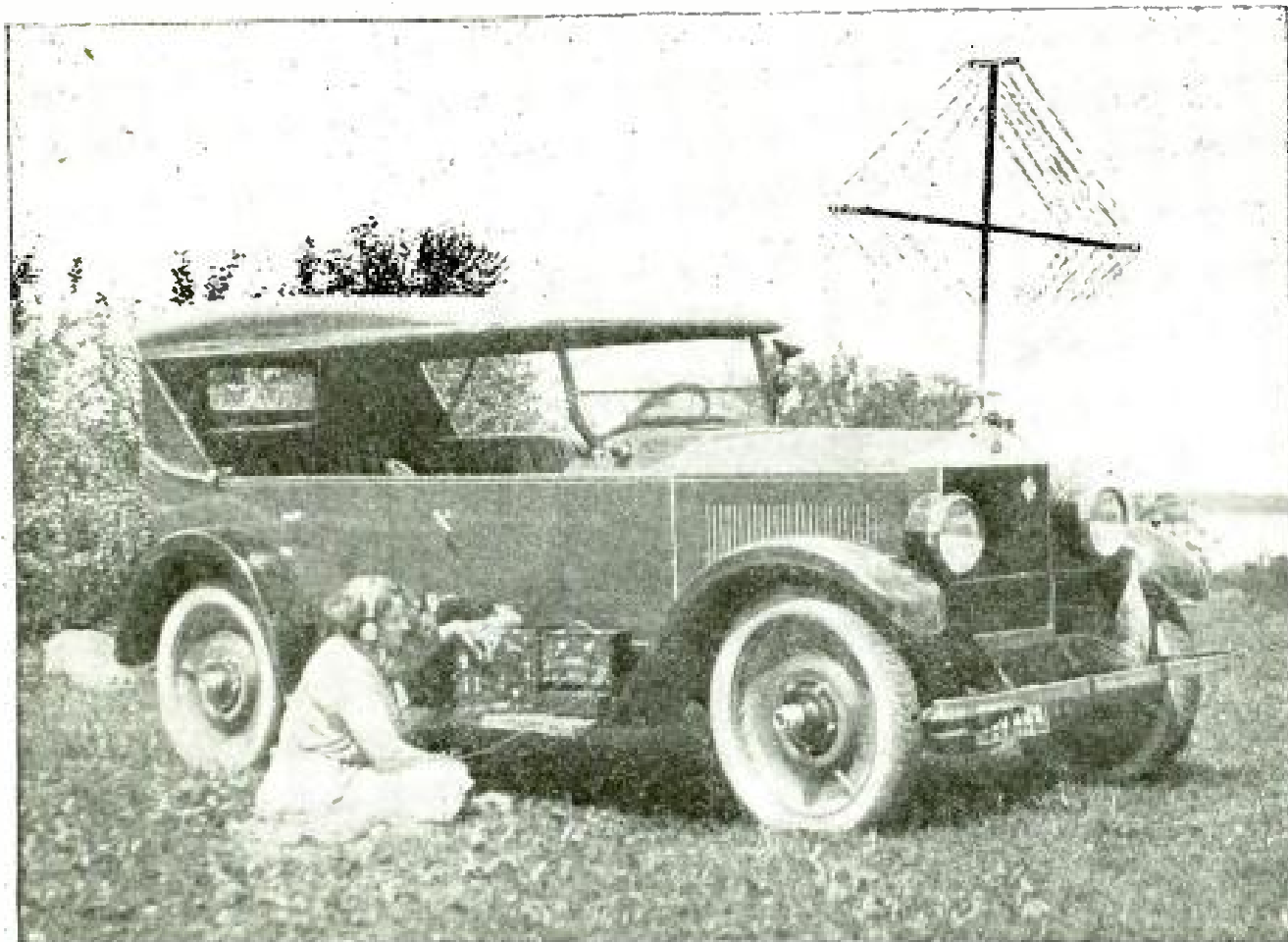

Kadel & Herbert

#### RADIO BY THE ROADSIDE

*Here is a radio frequency set installed on a pleasure car, with a loop antenna attached to the hood. This gives good results if it is carefully adjusted—but it is not as simple or easy to operate as the installation described elsewhere in this article.*

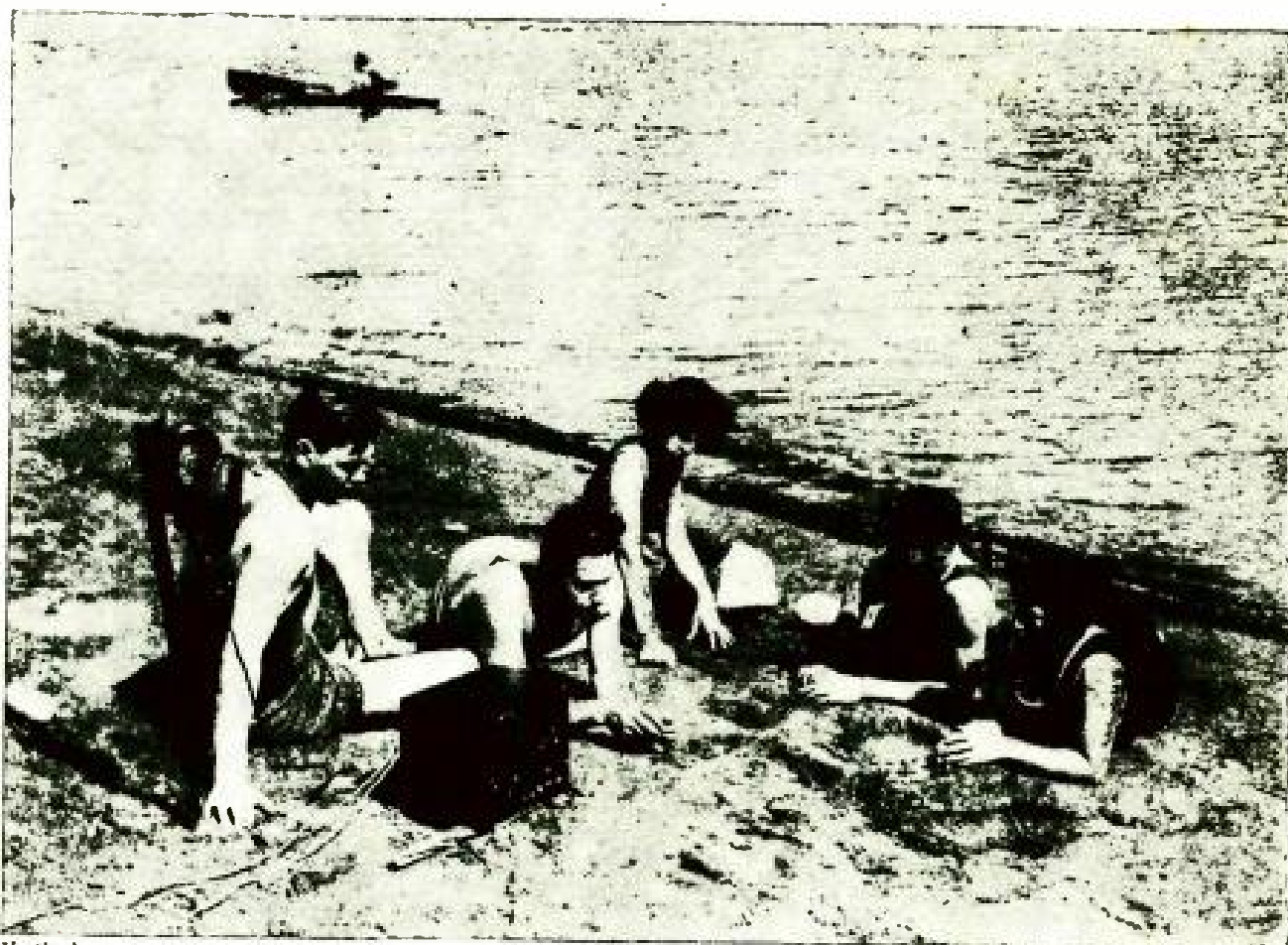

Westinghouse

### A CHURCH SERVICE ON THE BEACH

*A couple of insulated wires thrown over the sands in place of an antenna and a ground, a portable set and a loudspeaker, furnishes a happy solution to the vacationist who wants to miss neither his Sunday devotions nor his morning dip.*

mended that one of the dry-cell tubes be used, thereby eliminating the storage battery. If one of the regular six-volt tubes is used, no change will be required in the circuit, but a different type of socket will be necessary and, of course, the "A" battery will have to be of six volts, instead of one-and-one-half volts.

In Figure 1A, A represents an ordinary wooden variometer, B the crystal detector, C the head set, D the phone condenser and E a fixed condenser of about .0005 mfd. capacity.

Figure 1 gives a perspective view of the set as it should look when completed. The instruments should be mounted on a panel set into the front top of the cabinet, and a recess should be provided at the rear, so that the phones may be placed out of the way when the set is being carried or when it is not in use. Some hooks should

be provided on the sides so that the cover of the set may be drawn down securely in order to make the box watertight against rainstorms; a strip of soft felt pasted on the edge of the lower lid will help to this end. Then by closing down the top tightly, the felt strip will be compressed and most of the dampness will be kept out.

There are many other little refinements that may be worked out. It may be possible, for example, to arrange the aerial and the ground wires on reels, such as are used for deep-sea fishing, and to have these reels screwed fast on the back of the box. Another item that should be included with the set is a good heavy strap for carrying it about. This may be arranged in such a way that it may be unstrapped and laid aside when the set is in actual operation; this strap should be made long enough so that the box may

be slung over the back or carried from the shoulder.

In the vacuum tube set, designed for use when camping, the circuit will remain identical, with the exception that a tube will be used in place of the crystal detector.

In Figure 3A it will be noticed that the letter A stands for the variometer; B, in this case, represents a small mica grid condenser and leak. The elements of the tube are shown by 1, 2 and 3; 1 being the grid, 2 the plate and the two figures 3 representing the two filament leads. The letter C refers to the head phones. D is the rheostat and E is the small .0005 mfd. fixed condenser. "A" is a dry-cell and "B" is a 22½-volt small-size battery.

Now for the arrangement of the set:

The over-all length will be governed entirely by the size of the variometer and the rheostat. This will also apply to the width. In order to keep the size as small as possible, the best arrangement will be

to have the vacuum tube socket placed on top of the insulating panel that is used to mount the instruments upon. Figure 3 also gives an idea of just how the completed set should look.

By placing the vacuum tube on the top of the panel, it will be necessary to remove the tube itself every time the set is to be closed; for this purpose an opening should be left (at the back of the cabinet) large enough to take both the tube and the receivers. It will be advisable to keep the tube in the box in which it originally comes, as this is packed well; if the tube is placed inside as suggested, it will stand a lot of knocking around without becoming broken. In this case, however, in order to keep the phones from knocking about too much, a strap should be fastened inside of the box to hold them fixed in one position. It would be a good plan to do this in the case of the crystal detector set also.

Before you buy or make the box, it

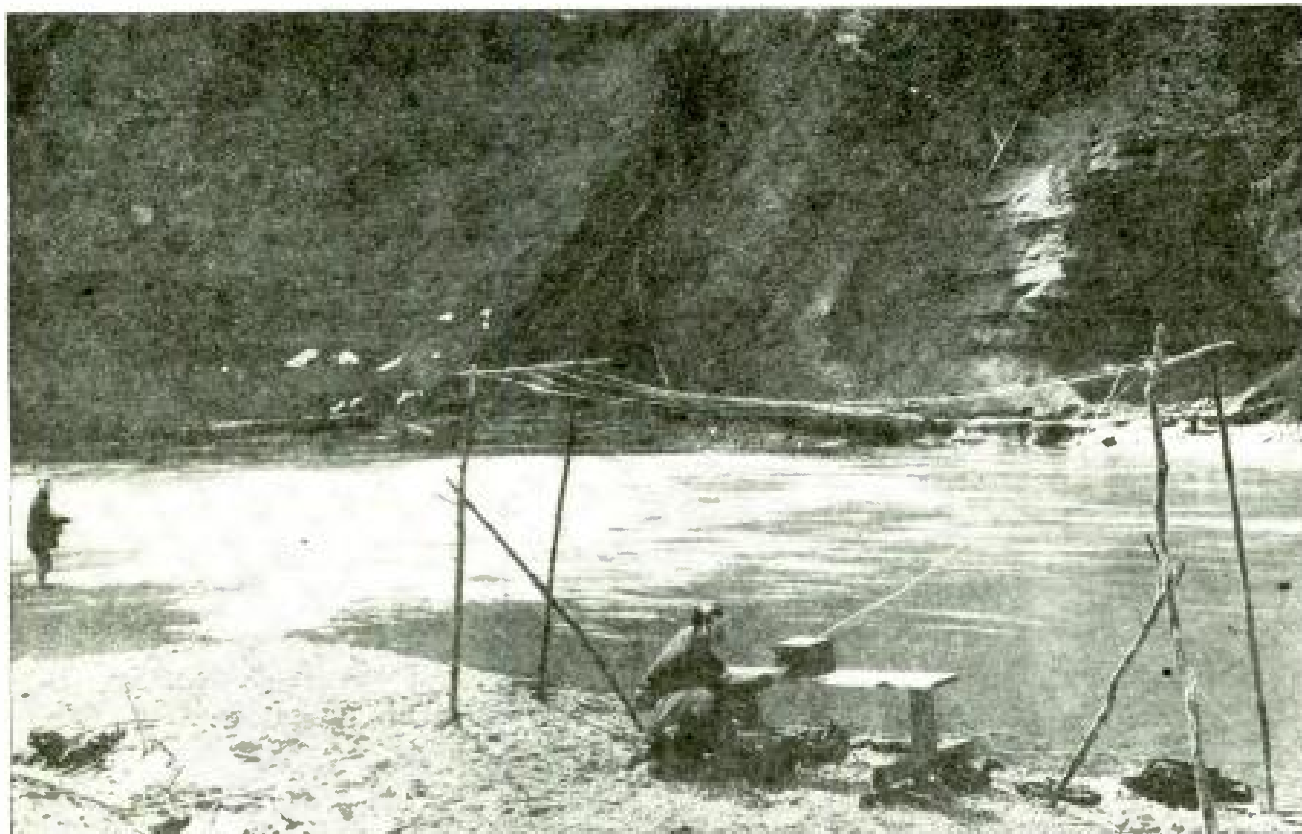

International

#### A RUSTIC ANTENNA ON A SALMON STREAM

*On the banks of the Green River in Washington these anglers installed a receiving set that added immeasurably to their enjoyment of the evenings far up in the mountain country of the northwest.*



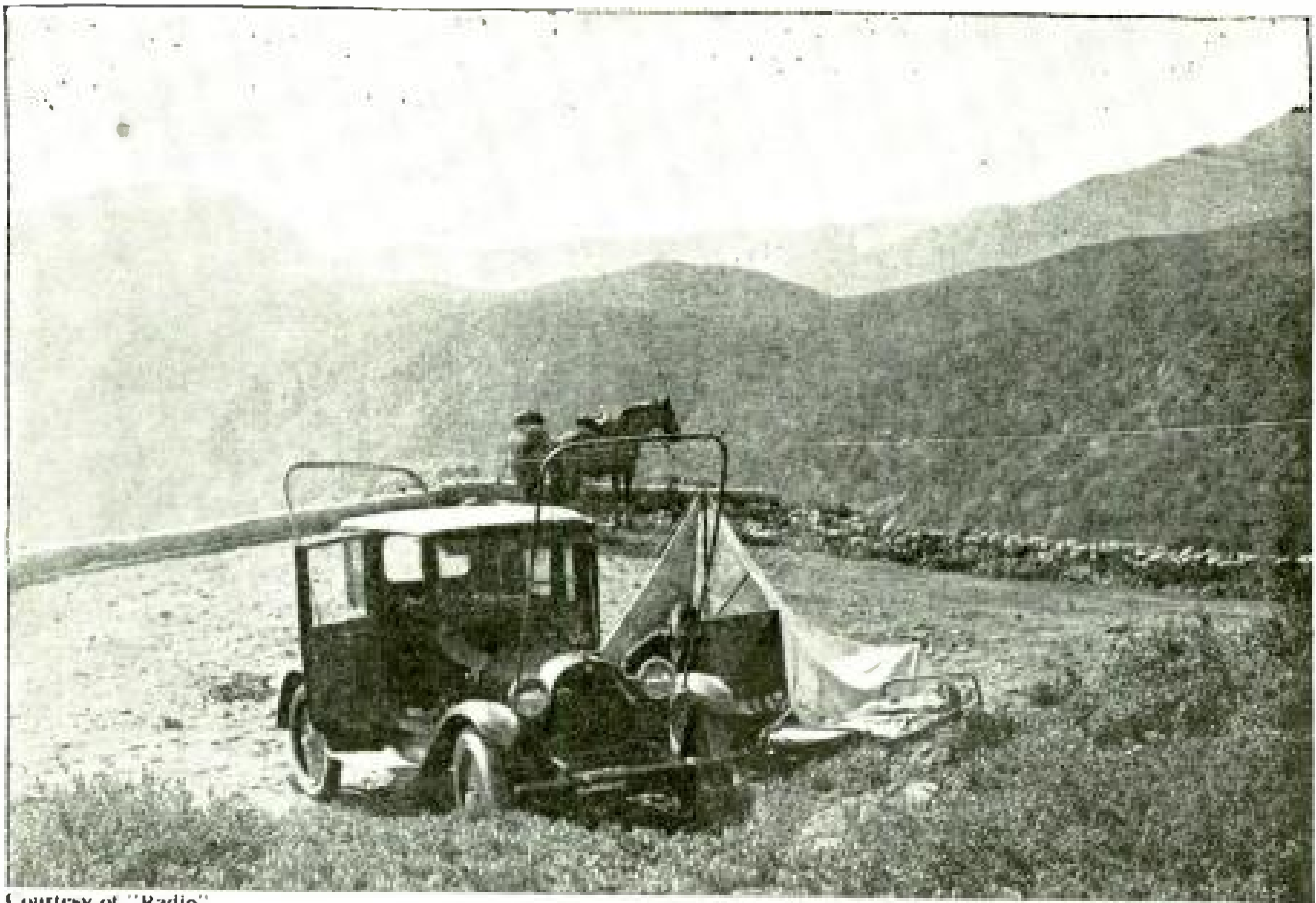

Courtesy of "Radio"

### TAPPING THE MOUNTAIN AIR FOR MUSIC

*By means of a single-wire antenna attached to a nearby tree, these motorists are enabled to establish their camp as a receiving station within a few minutes, and where could a grander setting be found for the world's greatest symphonies than on the high spots of the world?*

would be wise to obtain a dry battery, the "B" battery, the phones, and the case in which the vacuum tube comes, in order to design the set correctly and to provide room for every item. The batteries, both "A" and "B" may be arranged so that they lie in the bottom of the cabinet, one at each end. Of course, one of the small-sized "B" batteries should be used, in order to save as much space as possible.

The carrying strap and the felt waterproofing strip will also have to be taken care of in much the same manner as in the other set.

With a receiver of this kind, surprising results may be obtained if the set is properly made and properly operated. The operation is so exceptionally simple that there should be little trouble on that score, but the making of the set requires real care and thought.

Use insulated wire and be sure to solder all connections.

Remember that when a piece of metal (such as a binding post or switch arm) is left out in the open, as often happens with a set of this kind, it will corrode or become oxidized. When that happens the operator soon realizes that the signals have faded out, and for no apparent reason. It might be well therefore, to use a plug and jack system for the telephones on the vacuum set particularly.

At this point it would be well to point out that the dry-cell tube is just as good as any other when it is used as a detector; it is also good as an amplifier. If it is used in this latter capacity, it will be necessary to have it suspended on springs, on account of microphonic noises in the tube itself. This is accomplished by mounting the sockets on a

piece of wood or other material, and then by putting a small brass spring at each corner of the wooden strip. The springs, in turn, should be fastened in such a manner that they will keep the wood piece suspended about one quarter of an inch clear of everything else in the set.

It is possible to work out for this set a two-stage amplifier that will fit into the opening where the receivers and the tubes are normally stowed; in such a case there will be no place for the other parts unless a separate box is made. A two-stage amplifier of this sort was made



Keystone View Co.

**BE SURE THAT THE CONNECTIONS  
ARE FASTENED TIGHT!**

*And be sure to remove the tubes from the sockets while the car is traveling, in order to avoid breakage.*

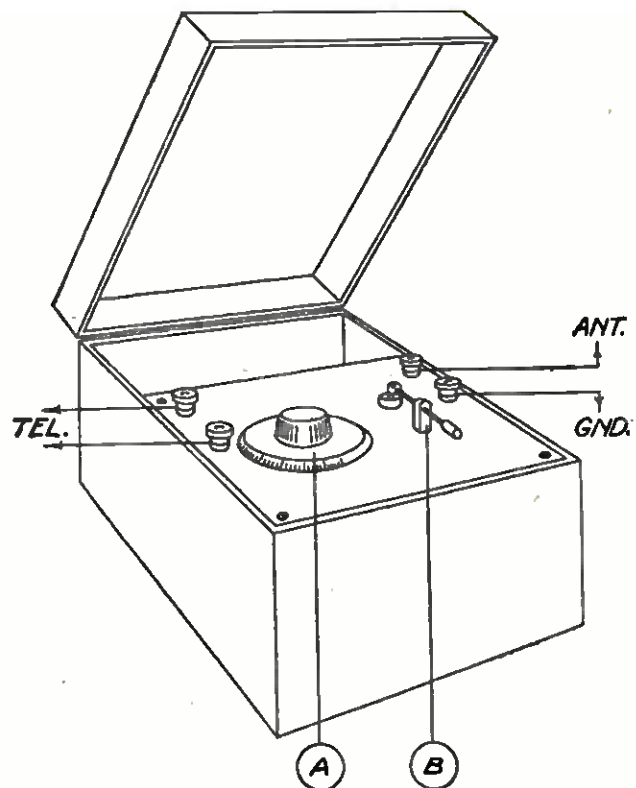

FIGURE 1

recently that took up a space of only four inches by eight inches. The tubes were mounted on the top and the transformers on the bottom, while the single rheostat that controlled both of the tubes was placed in such a way that it came directly between the two sockets. Jacks were arranged across the end of the panel to take care of the detector, the first stage and finally both stages and the detector.

A simple radio set to be used in an automobile presents problems that are not so easy to solve. In the first place it is hardly worth while to build a set that will operate while the auto is in motion. If this is done radio frequency amplifiers will be needed, and the cost will mount into considerable money; besides, there will also be the added drain on the storage battery and the large size of the set itself.

On the other hand a small, compact set may be built that will work well from the storage battery of the car, and it may be used whenever the car is standing still—such as at the bathing beach or on a camping trip.

The circuit chosen is one of the

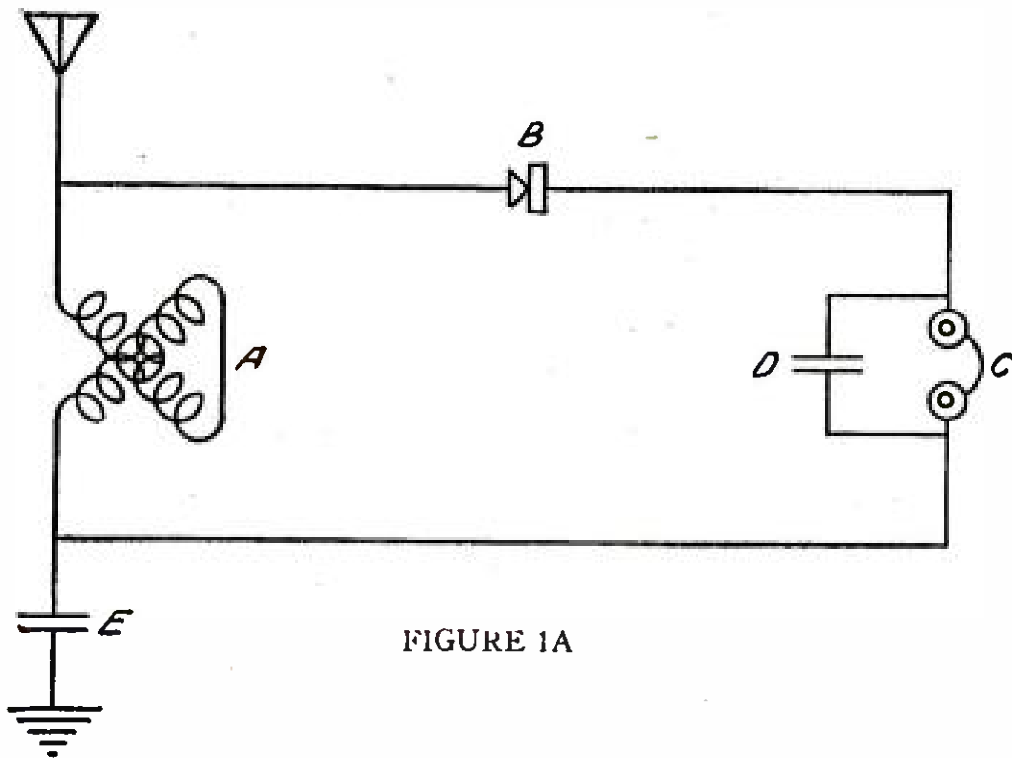

FIGURE 1A

#### A PRACTICAL RECEIVER AND HOOK-UP FOR A MOTOR CAR

FIGURE 1 (at the left) shows the outside of the crystal set, and FIGURE 1A (above) shows how to connect A, the variometer; B, the crystal detector; C, the telephones; D, the telephone fixed condenser and E, the fixed condenser in the ground lead.

simplest for the purpose and if operated correctly, all sorts of long-distance stations should be received in good style.

The circuit shown in Figure 4A is the so-called "single-circuit set" which is not recommended for crowded areas on account of the fact that it will also act as a transmitter.

The circuit for the car is a little more expensive to make than the others that are here described, but the results compensate for the added cost.

Figure 4A shows the actual wiring diagram of this type of receiver. A is the stator of the variocoupler; B is the rotor of the same instrument; the grid leak and the condenser are shown at C, and D is the vacuum tube; E is the headphones; F is a 43-plate variable condenser.

Note that in both Figures 3A and 4A, as in nearly all vacuum tube circuits, there is a common terminal on one leg of the "A" battery and one leg of the "B" battery. This connection is run across from the negative lead of the "A" battery to the negative side of the

"B" battery. Care must be exercised to see that the "A" and "B" batteries do not become connected in the wrong places, because if the "B" battery current happens to get into the filament circuit, the builder of the set will have to make a trip to the nearest radio store to purchase a new vacuum tube. The filament will burn out almost instantly.

Notice that the diagram provides for a cabinet or box similar to the one used in the other sets. An opening is left in one end so that the tubes and the headphones may be easily transported without risk of breakage. It is not well to leave the tubes in the sockets, as the vibration of the automobile is liable gradually to work them loose, in which case they may become broken.

Figure 4 also gives a good idea of what the completed set should look like. The coupler is placed on the left-hand side of the cabinet, with the switch lever and switch points above it and the variable condenser on the right at the bottom. Directly above the variable condenser the rheostat knob will show and the tube and

socket will be placed behind this instrument. The cabinet is a little different from the others suggested, in that it has a front that drops down to form a sort of desk for the operator. There should also be a small hinged door at the top so that the tube may easily be removed from its socket. The "B" battery may be

secured in place inside of the cabinet in back of the variable condenser or the coupler. The panel itself will have to be recessed back a little from the front of the cabinet so that the front may be closed up without interfering with the protruding knobs.

A set of this kind, if it uses a six-volt tube, may be connected directly to the storage battery of the car. It is suggested that the radio man have a mechanic install on the dash two binding posts that are at all times connected to the six-volt car battery circuit. This will make it a very simple matter simply to clip the battery leads on these binding posts at any time to connect up the set for use.

If required, a two-stage amplifier may also be added to the set. If this is done, the size will increase considerably and likewise the drain on the storage battery.

The two-stage amplifier hook-up is also shown, so that the set may be complete in every way. It is also possible to make use of some sort of a horn with an outfit of this kind. Such a horn may be built right into the cabinet with only the opening showing. In order to have the horn as long as possible, arrange it in such a way that it lies lengthwise in the cabinet, as shown in Figure 5. This is a general plan view of the two-stage amplifier, showing the horn in place. By following this plan it will be possible to have the receiver on the outside of the

#### HOW TO PUT UP YOUR ANTENNA WIRE IN THE WOODS

*Merely attach a weight to the end of a fishline, throw it over the limb of a tree, and pull up the wire attached to the other end of it. To take it down, detach the weight and the wire may be pulled back and wound up again.*

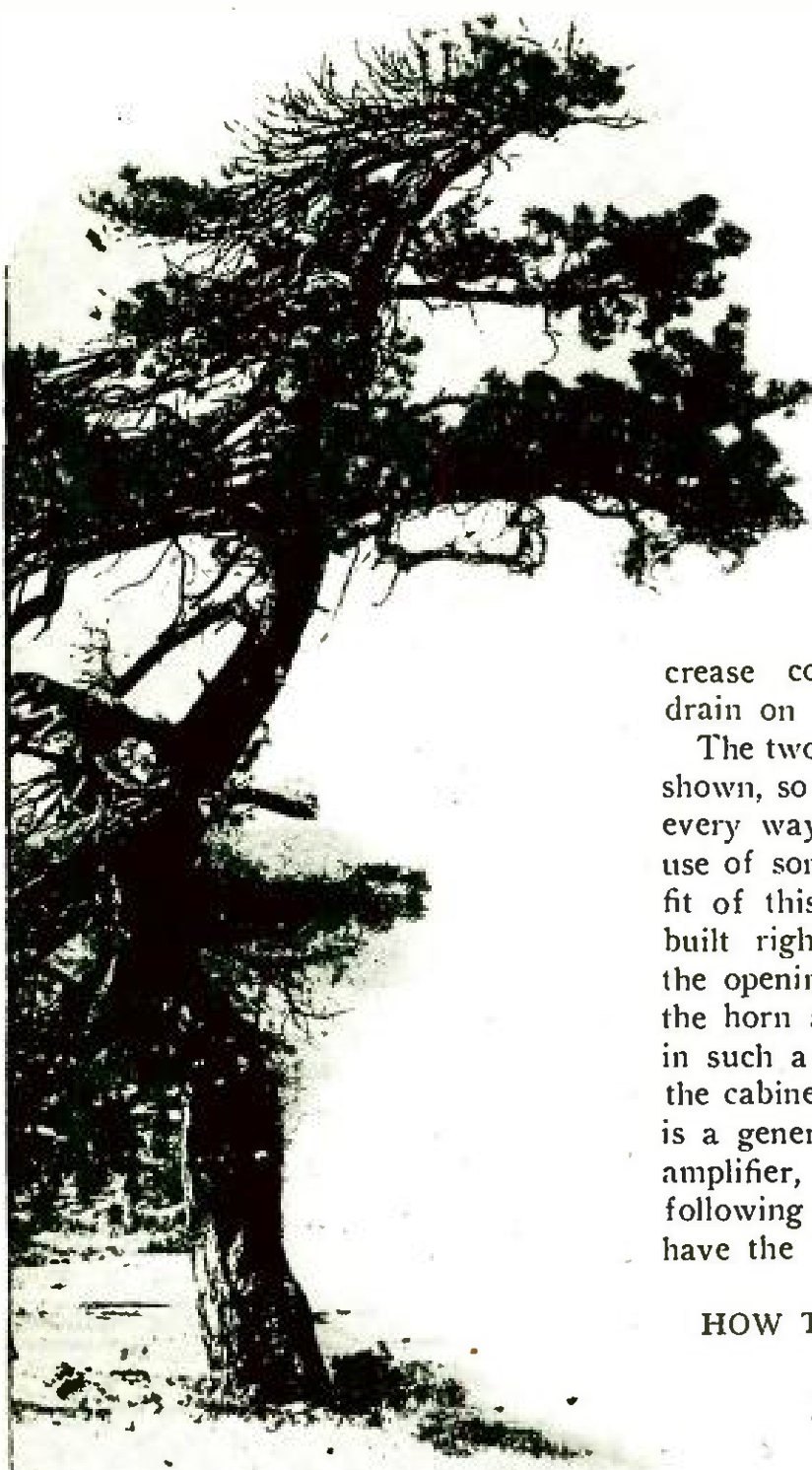
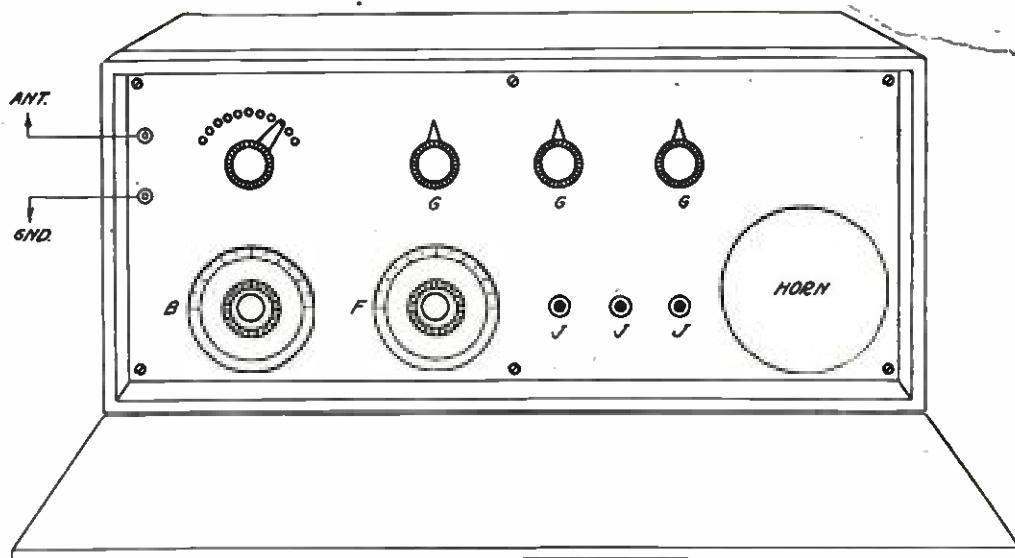

FIGURE 2

The makeup for a complete set with two stages of amplification and a loudspeaker, all in one cabinet. The component parts of this set are the same as shown in Figures 4, 4A, 5, and 5A.



cabinet where it is easily accessible; the adjustment of the pressure on the receiver is sometimes necessary in order to get the best tone and the clearest music. A half turn one way or the other on the set-screw may make a great deal of difference in the quality of the received signals.

Needless to say, the two-stage amplifier (as shown in Figures 5 and 5A)

may be run from the same car storage battery.

If the best results are expected of this amplifier, be sure to solder all connections. Do a neat wiring job and keep the wires separated a respectable distance away from each other.

Be sure to turn the two transformers at right angles to each other so that there will be no chance for howling.

Connect the terminal marked S-1 (or sometimes marked G) to the grid of the tube, and remember that this is the most important lead in the whole set. Keep it as short as possible and be sure it is well soldered.

Figure 2 is a view of a completed set with two-stage amplifier and loud speaker built all in one.

The aerial is an important part of the outfit, but it is easy to erect. No elaborate system is needed; a single wire from fifty to one hundred feet in length will be sufficient for all receiving work.

In order to place the aerial at a suitable height, it should be strung up to some nearby tree or fence. Care should be used that there are no power wires along one side of the road, at least, and it will be well to give them a wide berth, as sometimes they carry rather high voltages.

Keep the aerial away from power lines and thus avoid serious accidents.

Here is a simple scheme for raising





Kadel &amp; Herbert

## A COMPACT SET FOR THE CAMPER

*The radio frequency loop set as shown on page 408 is equally serviceable in the woods. In case an ordinary antenna is used (as shown on page 410) a large stone attached to a ground wire and dropped into the water furnishes excellent grounding.*

an aerial well off the ground without the necessity of climbing up a tree or pole; select a good length of fairly heavy fish-line, with a sinker on one end of it. Pick out some tall object, such as a tree, and fling the weight with the fishline attached to it over one end of the branches. To the other end of the fishline attach a small porcelain insulator, and to this connect one end of the wire.

Haul up on the other end of the fish-line and pull the aerial well up into the tree. The lower end of the aerial should be connected direct to the binding post on the receiving set, but some sort of a strain insulator of light weight should be attached to the car so that there is no pull exerted directly on the set.

To take the aerial down, merely untie the sinker; the fishline will then run freely through the branches of the tree and may be wound up, together with the wire from the aerial.

This arrangement may be used with any of the sets described in this article; in the last named set (if the two stage

amplifier is used) signals may be heard by simply erecting a small aerial to run over the top of the car and down to the radiator cap. The results will not be as

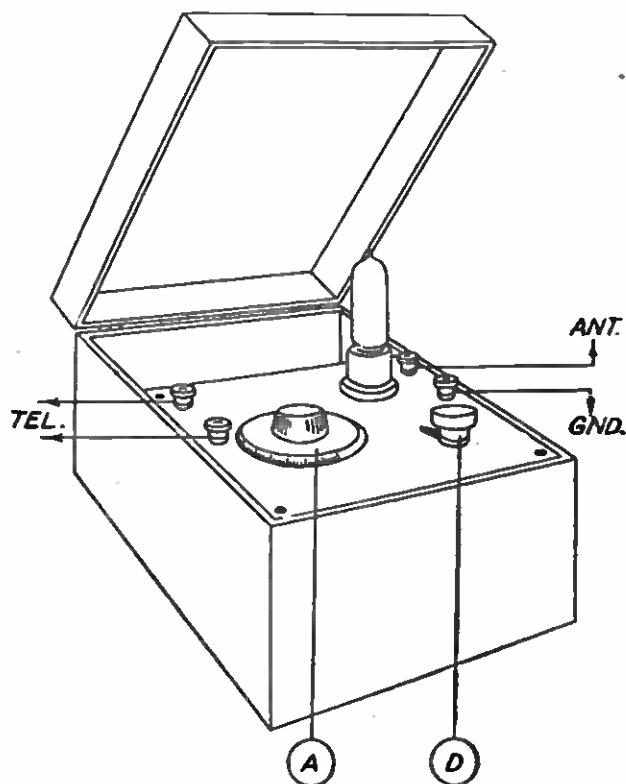

FIGURE 3

good, however, and the other type of aerial is recommended.

If there are no trees at hand (such as at a beach) a wire suspended a few feet above the sand may give fairly good results. If the wire is strung at the same height as the top of the car it will clear the head of anyone who may walk under it. Usually there is a piece of driftwood handy; this may be stuck in the sand and made to serve as a support. But almost any wooden object will serve, so long as the wire is kept insulated from the ground itself.

For the ground connection it is possible to use the metal frame of the car as a "counterpoise" ground. This, however, is not always satisfactory, and it is wiser to provide a sharply-pointed iron

or brass rod, that may be driven into nearby moist ground. The deeper the rod goes into the moisture the better will be the ground; a piece eighteen inches long should be sufficient. An ordinary ground clamp or a binding post may be affixed to the upper end of it, and the ground wire from the set may be connected to this.

Do not let the bugbear of "summer radio" idleness stand in your way. Take a set with you to the beaches, to the mountains or wherever you intend to spend your vacation. A small portable set may even be made to take away on week-end trips. The pleasure of a picnic supper in the mountains to the strain of the latest music from the city will be a pleasure not soon forgotten.

*A later article will describe in detail how to install a radio set in the cabin or on the deck of your motor boat or cruiser or in your canoe, and how to make general use of it during the summer months; it will show how to install the aerial and ground systems and also point out the best types of sets to use and tell why.*

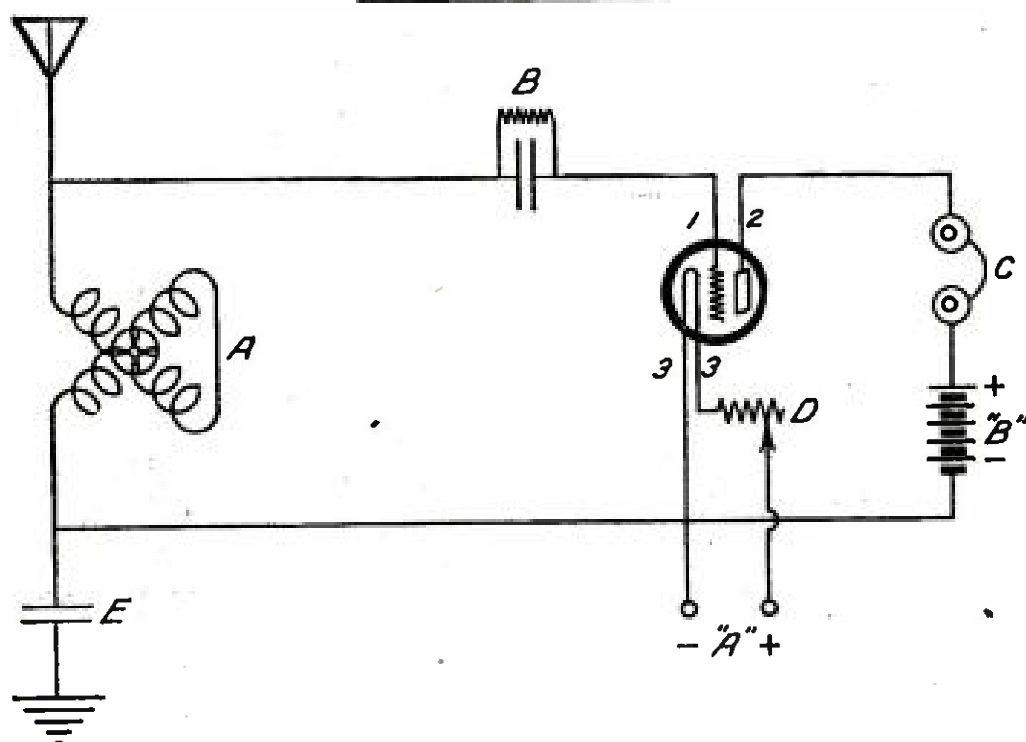

THE CABINET AND HOOK-UP FOR THE PORTABLE TUBE RECEIVER  
 FIGURE 3 (at the left) shows the outward appearance of the set, and FIGURE 3A (above) shows the electrical connections for: A, the variometer; B, the condenser; and grid leak; C, the telephones; D, the rheostat, and E, the ground fixed condenser. "A" is a  $1\frac{1}{2}$ -volt dry-cell and "B" is a small size  $22\frac{1}{2}$ -volt battery. The numerals 1 and 2, refer to the grid and plate of the tube respectively, and the two "3's" are the filament wires.

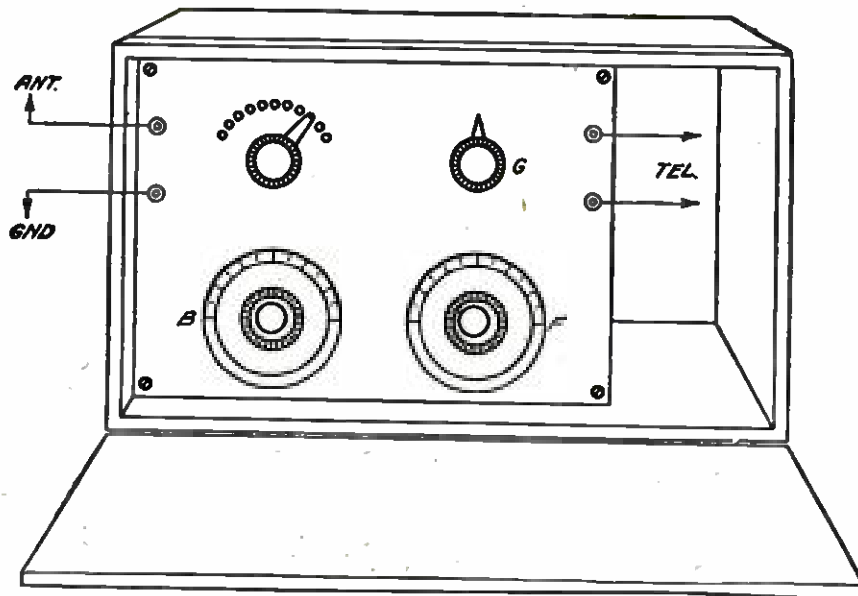

### THE CABINET FOR THE AUTOMOBILE RECEIVING SET

FIGURE 4. This set is larger and also more efficient than the set shown in Figures 3 and 3A. It would be rather bulky to carry around on a hiker's trip, but is well adapted for installation on a motor car.

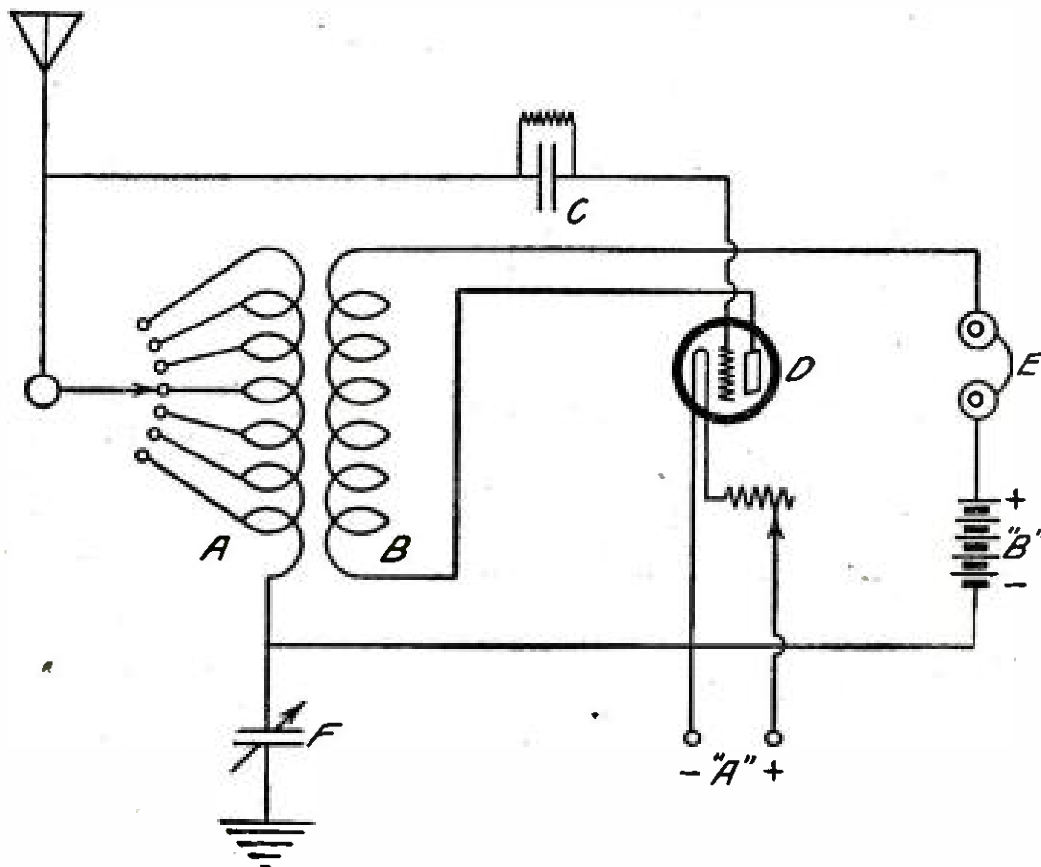

### THE HOOK-UP FOR THE AUTOMOBILE SET

FIGURE 4A. The parts are: A, the primary of the variocoupler; B, the secondary; C, the condenser and grid leak; D, the vacuum tube; E, the telephones and F, the variable condenser. "A" may be the storage battery of the car and "B" is a 22½-volt battery.



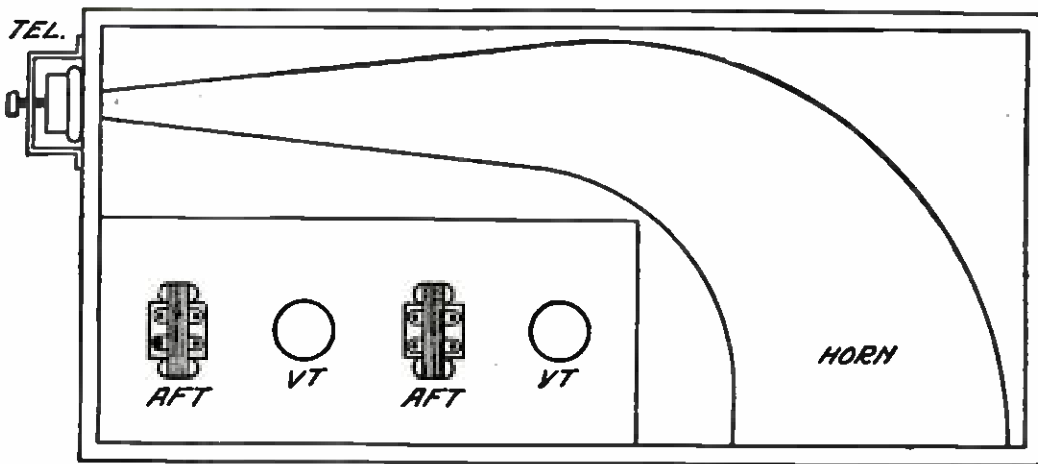

THE TWO-STAGE AMPLIFIER FOR USE WITH THE AUTOMOBILE SET

FIGURE 5: This diagram is a plan view of a two-stage amplifier that may be made to use with the set shown in Figure 4, or it may be incorporated with the other set into a single set, as shown in Figure 2. The horn is built right into the cabinet.

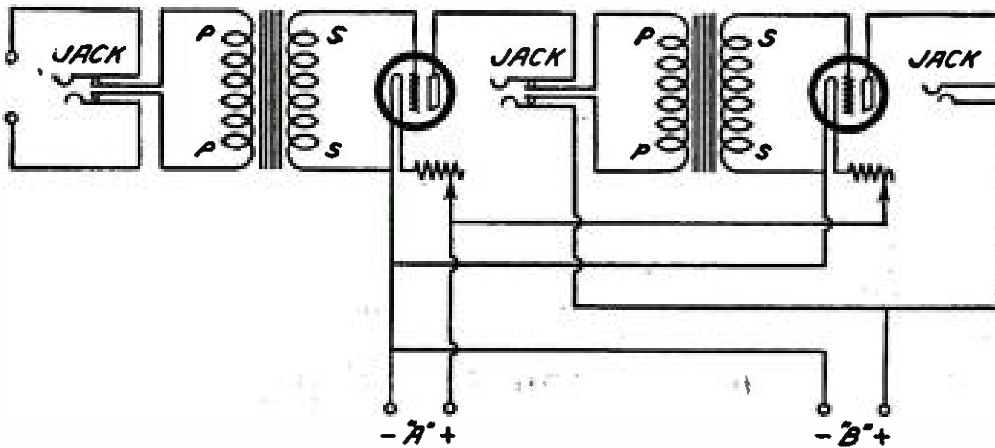

THE CIRCUIT DIAGRAM OF THE AMPLIFIER

FIGURE 5A. Showing connections for the jacks, the tubes, the transformers and the rheostats.



Westinghouse

In the next issue of POPULAR RADIO the author will tell how to install a receiving set on your canoe, rowboat, launch or yacht.

# The Radio Bug on the Sky-Scraper

By HOMER CROY

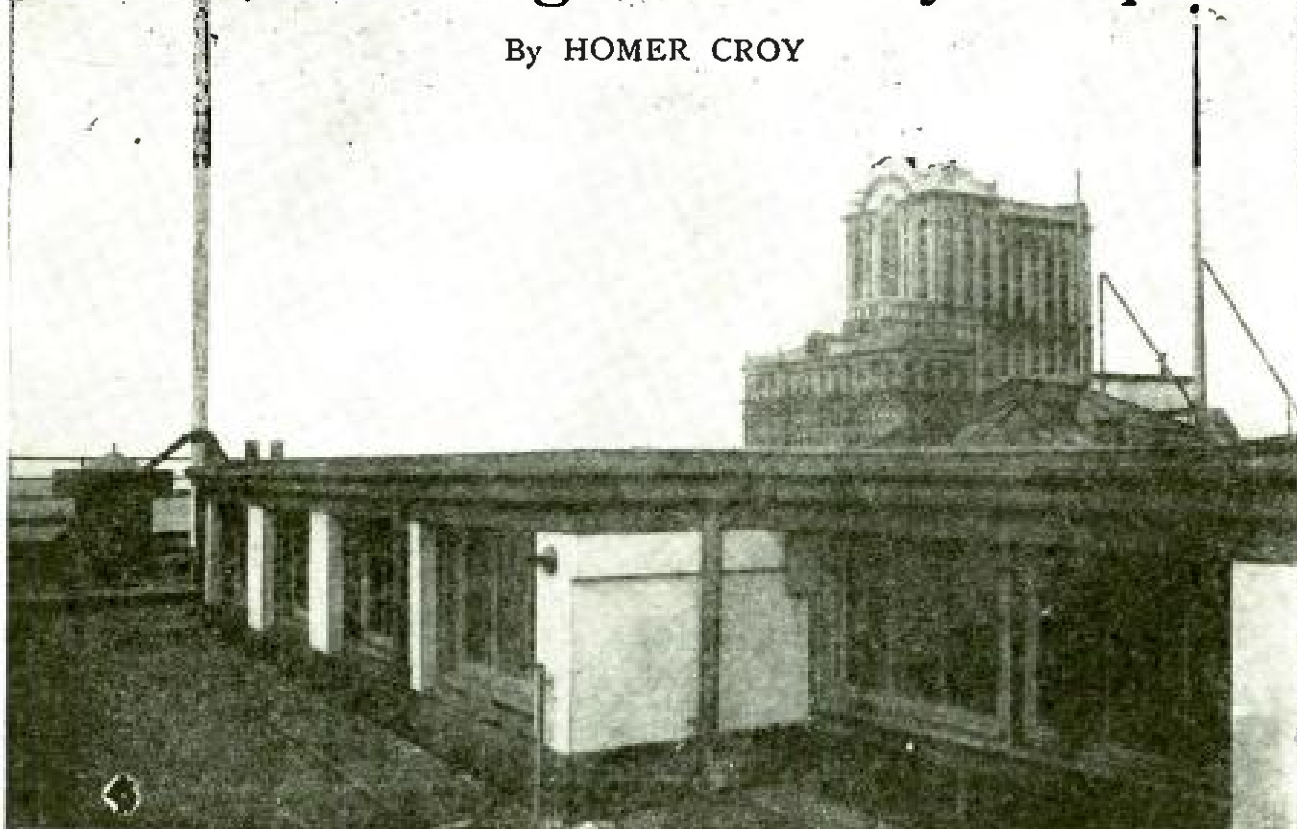

From a photograph made for POPULAR RADIO

## **Q** *The True Story of a Big Business Man Who Is Making Come True a Modern Arabian Nights Dream of His Boyhood*

**A**T 24 State Street, New York, is a skyscraper, and on top of the skyscraper is a radio bug. He is a very unusual and a very different bug.

The story began a number of years ago in Columbus, Ohio, where a poor boy was selling newspapers. The boy had to hump himself from early morning until time to fall into bed. This is not so wonderful in itself, as thousands of poor boys have gone into the world with a bundle of papers under their arms. It was the recognized way to get to the top. In fact, if a person rose to prominence without having sold papers in his early days he was ashamed of it. He was afraid people would think that he didn't amount to much. But this boy, whooping it up on a corner, was unusual; he loved music.

The boy became a man, the man be-

came a financier and the financier became busier than ever. The passion for music still slumbered in his soul, but there was no time to satisfy it. Instead he became busier and busier, for now the ex-newsboy was operating in Wall Street and was a Power—none other than Henry L. Doherty of business fame.

In many cities of the United States every wheel that turned, every light that burned, paid its tribute to his genius. He was banker, oil operator, engineer, inventor and so on down the list—and all the time the germ of his love for music was softly swishing around in the depths of his subconsciousness. He had made his pile and yet he hadn't been able to appease his passion. Something was still gnawing. gnawing. . . .

He became busier and busier, and Big Business became a millstone around his

neck. He dared not go off and leave it; if he did a power plant was certain to break down and two hundred thousand people with candles would be going around cursing in the dark. He could not leave business to go into the country to build himself a home, so he bought the roof of a skyscraper and there built himself a "bungalow." (That is what he called it, but to a humble writer it looked like a mansion.) There it was up among the flagstaffs, overlooking New York harbor, with something like a dozen rooms. And a bachelor! A colored maid met me at the door and led me down a long hall lined with old and rare prints of early New York and deposited me in the reception room; in a moment a colored man, looking like a Pullman porter, appeared with something to smoke. I began to nose around.

Rooms. All kinds of rooms. A gymnasium; a squash court, a handball court, billiard room, chemistry laboratory, and a solarium, as well as plain, everyday, ordinary rooms; a whole string of them. The fire laws were such that a wooden structure could not be used and as a result it was made out of steel and stucco. The "bungalow" was only a few blocks from his office at 60 Wall Street so that he could dodge back and forth without loss of time—as quickly as the average man could get to the subway.

At last Henry L. Doherty could have whatever he wanted. He could build his dream house. Expense was to be spared in no way. What did he get? The germ of his youth had been gnawing—and the first thing he put in was an aerial. It was installed long before the radio craze swept the country. Why did he

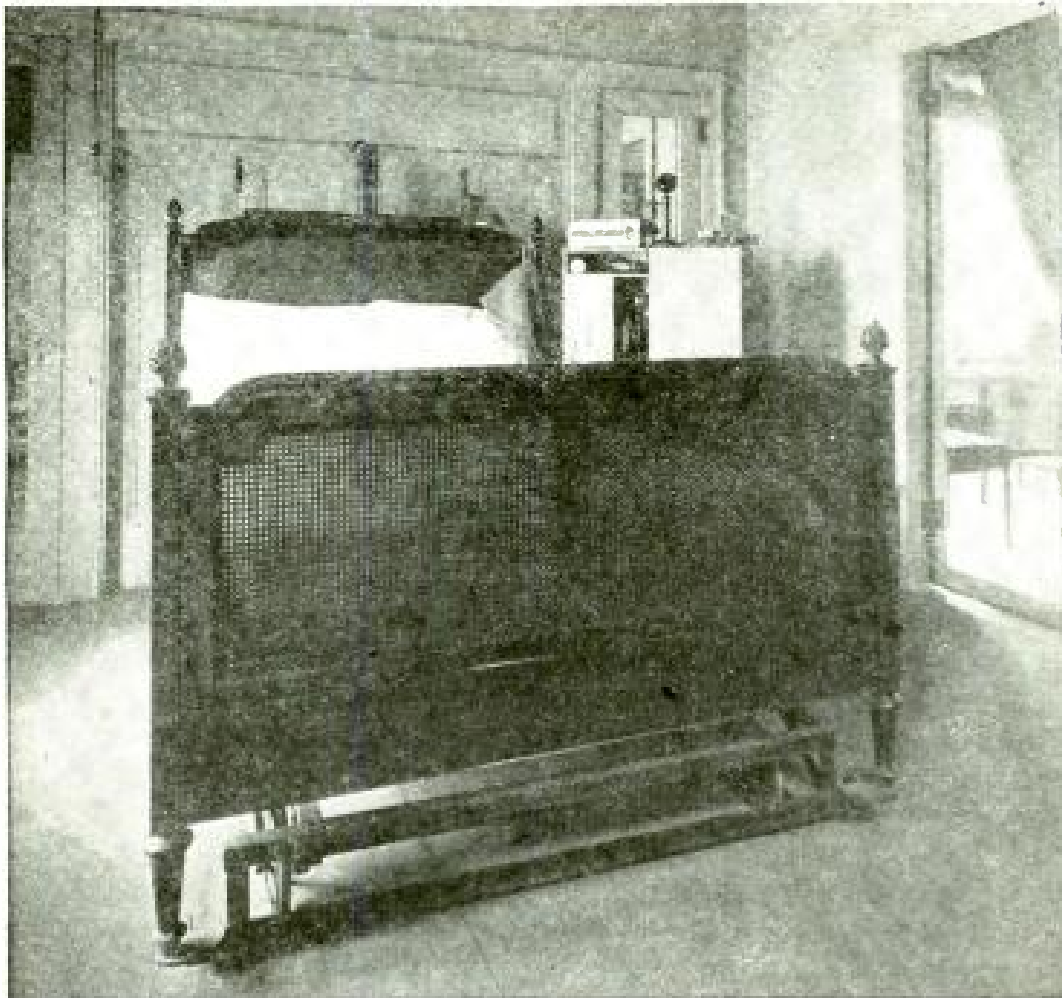

From a photograph made for POPULAR RADIO

#### THE MAGIC BED WITH ITS RADIO ATTACHMENT

*By merely pressing a button electrically-operated doors open and the bed with its occupant rolls out under the stars and listens in upon the world of the ether.*

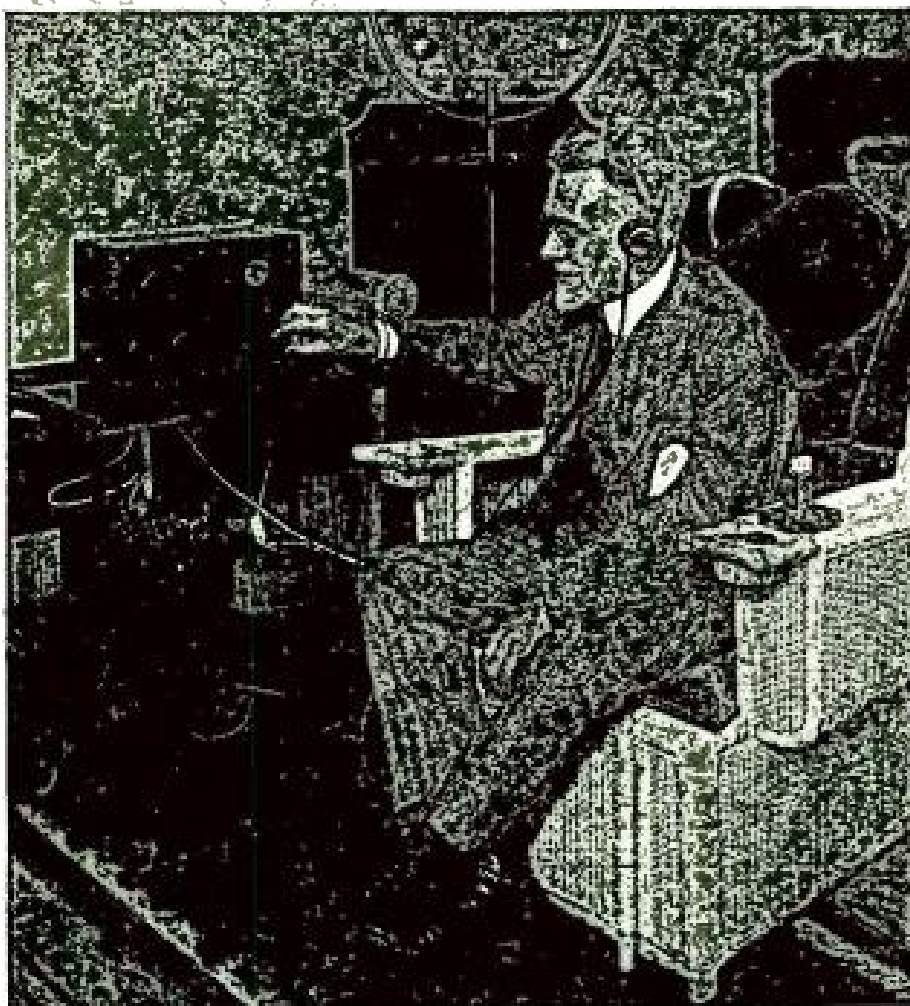

From a photograph made for POPULAR RADIO

#### A SYMPHONY CONCERT SERVED ON A BREAKFAST WAGON

*Unable to shake off the business cares of Wall Street early enough to enable him to attend musical entertainments, Mahomet Henry L. Doherty summons mountain music to him.*

want it? Not for weather reports, not for lectures on how to brush your teeth without any of the bristles coming out; the Man in the Moon did not interest him. He wanted music. He could have had a dozen seats at the Symphony if he had wanted them, but he was too tired; any minute something might go wrong with one of his companies, and he must be on the job. So he went to radio. Lead-in wires he had all over the place. When he was resting in the solarium he did not want to trot into the sitting-room to find out what the ether had to offer. He could plug in almost any place and hear what was going on. His receiving set was mounted on a breakfast-wagon and softly it moved on wheels of rubber. In whatever part of the house he was, he simply touched a button and his man in the

white coat came trundling in the mobile receiving set; and then in his sun parlor, or on his open air balcony, up among the stars, he leaned back in comfort and hitched onto the ether. There among the clouds the ambitions of his boyhood were realized.

A singer who was a great favorite of his was Frances Paperte. She was the wife of one of his office managers. Long had he been trying to get to the opera to hear her, but always was Business about his neck. And then one evening Frances Paperte was asked to go to one of the sending stations to entertain and at that hour Henry L. Doherty put everything else aside and for the first time in months was able to hear her sing.

His enthusiasm did not stop here. He had a most amazing bedroom, a bedroom which would make the Begum of Bhopal

stare and stutter. It was an electric bedroom. In fact, there were three rooms lined up in a row and a most marvelous contraption they were. One was a dressing room and there in the warmth he climbed into his pajamas and piled into bed. He pushed a button and electric doors opened; he pushed another button and lo! the bed began to move. It was mounted on a track and out of the room it shot. In the next room, which was a sleeping porch, it stopped and waited to see what he wanted. If it was a clear night and the stars were overhead, he touched another button; more electric doors opened and out he shot under the Pleiades. His portable receiving set was beside him and there lying in bed on the roof of a skyscraper the dream of his boyhood was realized. A big mahogany cabinet was fastened to the sides of his bed by a swinging arm. Here were telephones, call buttons, buzzers and a writing desk so that if at any time during the night he woke up with an idea he could slap it down on paper. When the radio concert was over, he took the receivers off his ears, turned over—and another day was done. The dream of his boyhood was realized.

On the wall of the reception room was something that struck me. It seemed almost prophetic—so closely did it seem to link the past with the present. It was a framed photo of Longfellow, for Henry L. Doherty was a great lover of poetry. Set in the frame was an autographed letter by Longfellow, and underneath it, all in the same frame, were Mr. Doherty's two favorite stanzas. The picture had been his many years and was just as he had moved it to his new home. The second stanza was:

And the night shall be filled with music  
And the cares that infest the day  
Shall fold their tents, like the Arabs,  
And as silently steal away.

Thus when the day was done, and the darkness fell from the wings of night, up there among the clouds, the night for

Henry L. Doherty was filled with music. The thing which he had admired from youth and which he had carried with him for years, was now a reality. The music which he could not afford to go to now came to him.

But to Henry L. Doherty music, entertainment, was not radio's all.

"What," I asked him, "do you think of radio?"

"We are just entering the door," he said. "I see such a wonderful era ahead for it that we are going to employ it commercially. We spend \$13,000 a month on telegraph bills. That is too much. We are going to change all that and use radio. But with us that is only the beginning. Through the central part of Ohio we run all the traction lines, light the cities and furnish the power for the machinery in the manufacturing plants—such cities as Warren, Lorain, Ashland, Mansfield, Masillon, and Alliance. At any moment something may go wrong with one of our power plants. Practically every wheel in these cities would stop. We have been depending on the telephone lines for communication, but at the very moment that we need the lines most they are out of commission—possibly from a heavy sleet storm. Our power lines are up on high steel cables and underneath are the telephone lines, spanning miles and miles. If one of the big power wires breaks it paralyzes the telephone. We are now drawing up plans to use our big power wires to talk over—line radio, you know, wired wireless. In a few months we expect to be running interurban cars, power machinery, electric lights and at the same time be talking over the same wires. Then if in a sleet storm one of the power wires breaks down, radio will leap the gap in the wire and go on—communication will be kept open. That is how much I think of radio."

It makes one gasp. Truly enough, we are just at the door. The Radio Age is upon us.



WHAT HAPPENS WHEN WE SPEAK  
 FIGURE 1: A diagram that shows how sound waves spread.

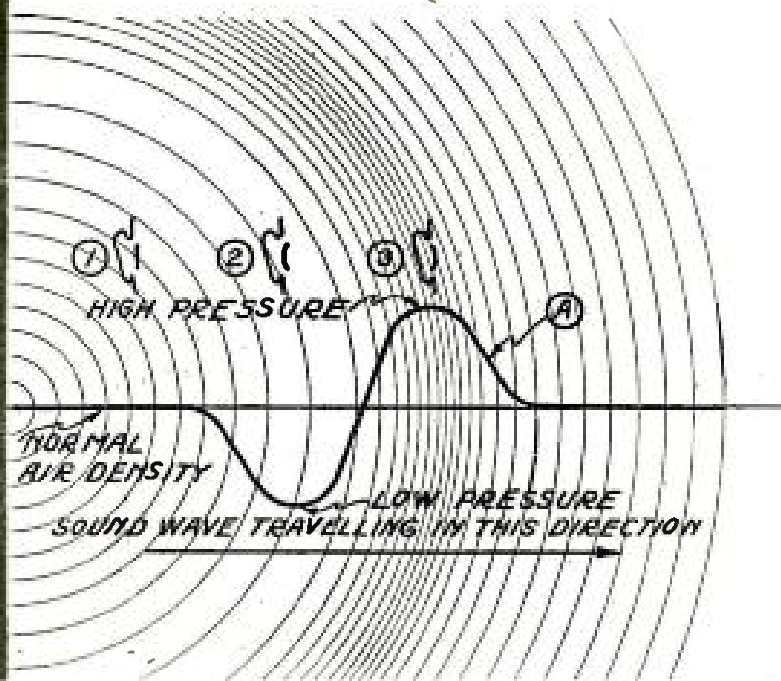

# How the Microphone Transmitter Works

SIMPLE "HOW" ARTICLES FOR THE BEGINNER—NO. 10

*"Do you know what sound is?"  
 "Do you know how and why you hear sounds?"  
 "Do you know how the microphone changes sound waves into electric currents?"  
 Until you can answer all of these questions you cannot have a clear understanding of radio telephony. This article answers them.*

By LAURENCE M. COCKADAY, R.E.

"SOUND" exists only in our brains. We ordinarily say that sound "travels." It does not. Indeed, it does not exist at all outside of our brain, for sound is merely a record on our brain produced by a sound "wave."

If there were no human beings on earth, there would be no sounds on the earth—for there would be no brains upon which the sound waves could make a record. Sound waves might be created, but no sounds would be recorded.

What, then, is a sound wave?

First of all, we are sure that a sound wave is not a wave of sound, inasmuch

as sound does not exist outside of the living body. From its very name we learn that it is a wave—a wave that makes a record on our brain. But what kind of a wave? A wave in what? Here we have a clue.

Sound waves are waves in air. We are sure of this because sound waves will not pass through a vacuum. They must have some sort of a gas (such as air) through which to travel.

The earth is covered with a blanket of air which at any certain point has a fairly constant density; the molecules of air are fairly evenly spaced, in other words.

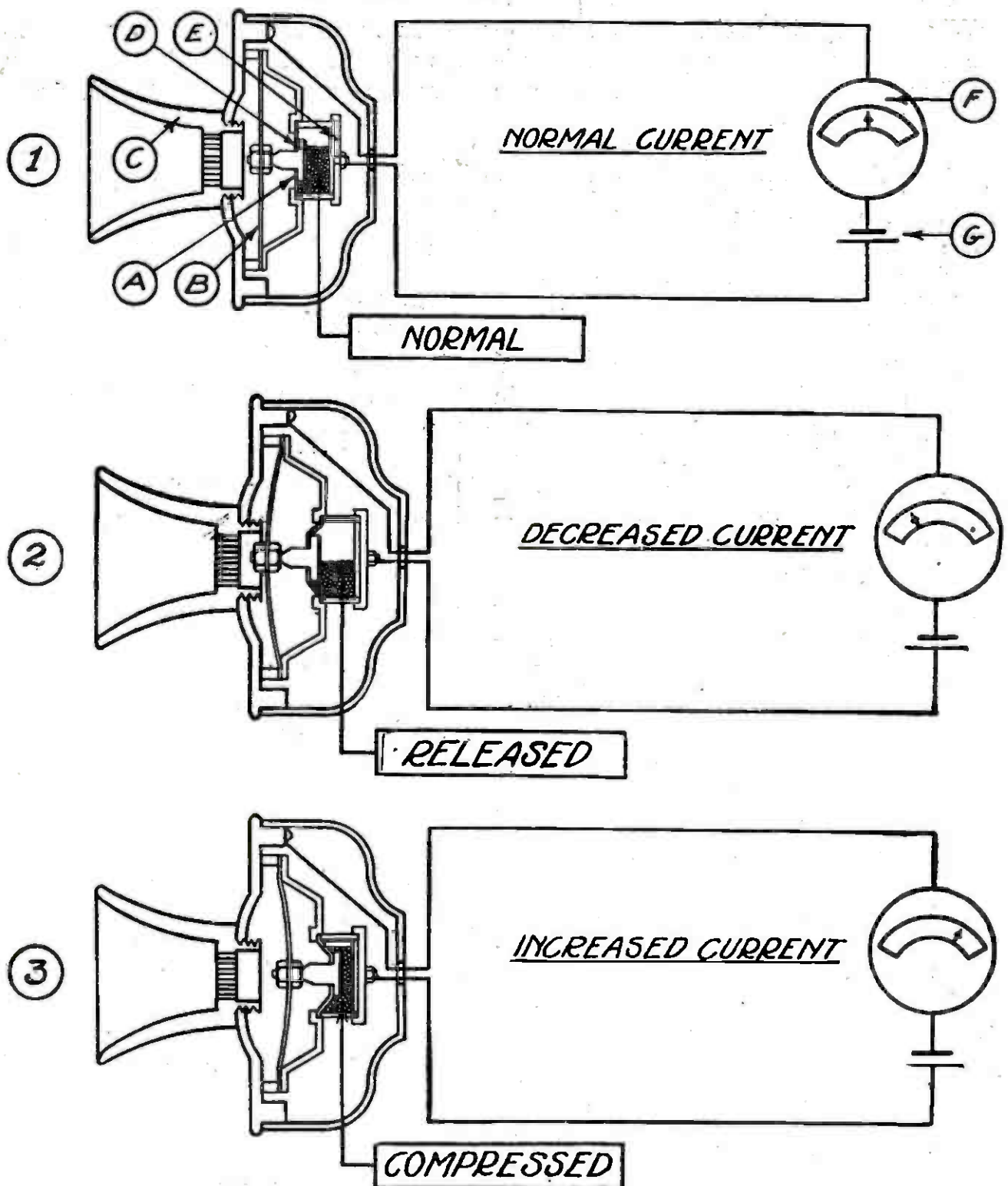

**HOW THE ELECTRIC CURRENT THAT FLOWS THROUGH A MICROPHONE VARIES WITH THE SOUND WAVES IMPRESSED ON THE DIAPHRAGM**

FIGURE 2: A microphone consists of a collector horn (C) and a diaphragm (B), to which is attached a plunger contact (D); this passes through a flexible insulating disc (A), which forms one end of a cylinder (E), which contains the carbon grains—all of which are shown in (1), above. A current from a battery (G) passes through the circuit, which includes the carbon grains; this current is registered on a meter (F). When the diaphragm is vibrated, first on one side and then on the other, by sound waves [as shown in (2) and (3)], the carbon grains are released and compressed, respectively, and a smaller or greater amount of current flows through the microphone. This variation of the strength of the current that flows through the microphone is directly in proportion to the strength of the sound waves which come from the voice or the musical instrument, and which are impinged against the diaphragm.

When Milady sits at the opera on a warm evening, she languidly passes a beautifully feathered fan before her face. Little thought she gives to the fact that she is producing a "wave in the air," or in other words, an "air wave." But she is. In one sweep of the fan the molecules of air are crowded together in front of the fan and spread far apart in the region in back of the fan. A wave is produced; it strikes her face; she feels it.

This wave is exactly like a sound wave, except that it is produced about once in every one or two seconds, whereas a sound wave is produced at the rate of from 16 to 20,000 times a second. Air waves which are produced at these frequencies (16 to 20,000 waves a second) then, are called "sound waves." We call them sound waves because the human ear responds only to air waves of these frequencies. We say we cannot hear some sounds because they are too low or too high in pitch.

A sound wave, therefore, is an air wave of a frequency that can be picked up by the ear and that will produce sound records on the brain.

How do we hear sounds?

Science tells us, in the study of anatomy and physiology, that the ear consists of an outer sounding-board, or reflector, which concentrates the sound waves and leads them into a tubular passageway to a thin stretched diaphragm called the ear-drum. This ear-drum vibrates in time with the sound wave impressed upon it and produces a nerve impulse (something like an electric current) which travels along the "hearing" nerves up to the brain, where it is recorded directly on the brain. This brain record is sound. It will be seen that the sound wave does not travel to the brain, but it is converted into an impulse by the ear, which *does* travel to the brain.

If we study the diagram in Figure 1 we will understand how the ear vibrates in time with the sound waves which pass by it.

Here we have a picture of a man with his mouth open and producing one single air wave or sound wave. Before the man spoke the air density in his vicinity was even; the air molecules were undisturbed. This could be illustrated by drawing lines in front of him with equal spacing, showing an equal spacing of the air molecules. However, when he speaks and a sound wave issues from his mouth in ever-widening circles, the air molecules are displaced.

If we could automatically stop a sound wave and make it visible so that we could examine it, it would look something like that shown in the diagram. A human ear in the portion of the wave shown at 1, would be in a region of normal air density as shown by the curve A drawn on the diagram and therefore the ear-drum would be in a normal position, as shown, giving a normal impulse to the brain. In this position of the ear-drum we hear nothing, as the brain records only *variations* of the strength of nerve impulses.

If the ear were in the position 2 (in relation to this stationary wave), it would be in a region of low air density or low pressure (see the curve A at this point), and the ear-drum would curve outward on account of the partial vacuum outside of the ear. This would produce a lesser nerve impulse to be transmitted to the brain.

If the ear were in the position 3, it would be in a region of high air density or high pressure (see curve A at this point) and the ear-drum would curve inward on account of the pressure outside of the ear, and a greater nerve impulse would be transmitted to the brain. Thus "sounds" or records of sound waves are produced in the brain which have the same frequency as the original air waves that pass the ear.

The ear, then, changes sound waves into nerve impulses which have the same time and energy characteristics as the sound waves themselves.



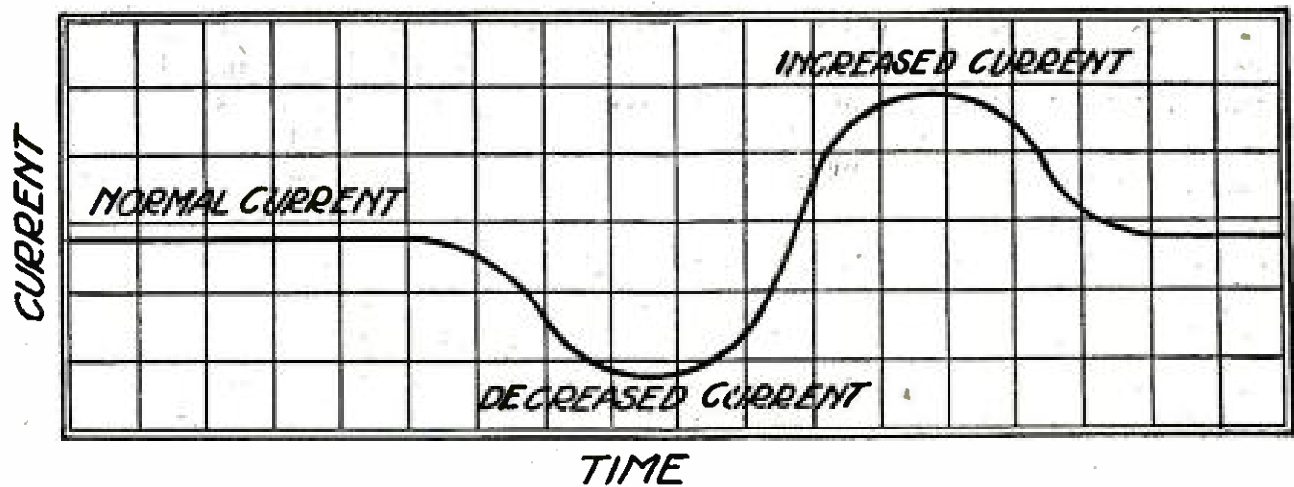

FIGURE 3: This diagram shows how the electric current that flows through a microphone varies with the strength of the sound waves. The currents for the three positions of the diaphragm shown in Figures 1 and 3 are indicated.

Someone may say: "If science understands what the ear is, and how it works, why is it that it cannot devise an artificial ear that can record sound waves?"

That is just what science has done. It has developed a device that changes sound waves into impulses in exactly the same general way as the ear does, except that the impulses are of an electrical quality and travel over wires instead of being nerve impulses which travel over organic wires called "nerves."

This brings us to our last question:

How does this instrument, the microphone, change sound waves into electric currents?

This is really very simple, as we shall see. First of all, this artificial ear (the microphone) consists of an outer sounding board C (shown at 1, Figure 2), which gathers up the sound waves and impresses them on the diaphragm B. On the back of this diaphragm, fastened to it and free to move with it, is a sort of plunger contact D. This plunger contact passes through a flexible insulator disc A, which forms one wall of a cylindrical box E, which is filled with carbon

grains. The cylinder is connected in an electrical circuit in such a way that the electric current from a battery G has to pass through the carbon grains in its path around the circuit. The only way it can pass through the carbon grains is to pass from one grain to another as they make contact with one another. If they are pressed tightly together a large current will flow through them, and if they touch each other only lightly, a small current will flow through them. If, for experimental purposes, we connect a measuring meter F in series with the circuit, we will be able to read the value of current flowing. If no current flows through the meter, the pointer will be at zero at the left of the scale, and as the current increases the pointer will travel over the scale to the right, recording an increase of current in accordance with its deflection.

Now if we place a microphone in position 1 (in Figure 1), in place of the human ear, the diaphragm will be in a normal position and the pressure exerted on the carbon grains contained by the cylinder E will be normal, and therefore a normal current will be measured by the

meter F, flowing through the electrical circuit.

The diagram in Figure 3 further illustrates the normal value of the current that flows through the microphone, by the straight line just above the outline of the microphone with the diaphragm in position 1.

Now imagine the wave (Figure 1) to be passing by the microphone until the microphone is in position 2. The diaphragm will now be curved outward. Referring again to Figure 2, at 2, we see that when the diaphragm is curved outward it draws the plunger contact with it, and this lessens the pressure on the carbon grains. They are released and touch each other lightly and the current flowing through them is decreased. See how the current value falls off, for this condition, during the time when the diaphragm is in this position (2), Figure 3.

When the wave has advanced so that the microphone finds itself in the position 3 in Figure 1, the surface of the

diaphragm will be curved inward.

Referring, once more, to the diagram (at 3) Figure 2, we see that the diaphragm pushes the plunger contact into the cylinder, compressing the carbon grains tightly together so that the resistance is decreased and a large current flows through them, as indicated by the meter F. Now see how the current gains in strength during the time when the diaphragm is in this position (3) in Figure 3.

If you compare the shape of the curve of the sound wave, in Figure 1, which is a measure of the air density, you will see that it corresponds exactly with the shape of the electric current wave in Figure 3, which is a measure of the current density.

Now ask yourself the three questions at the beginning of this article, and see if you can answer them in the affirmative!

*In the next article we will consider how the telephone "receiver" converts electrical currents back into sound waves.*

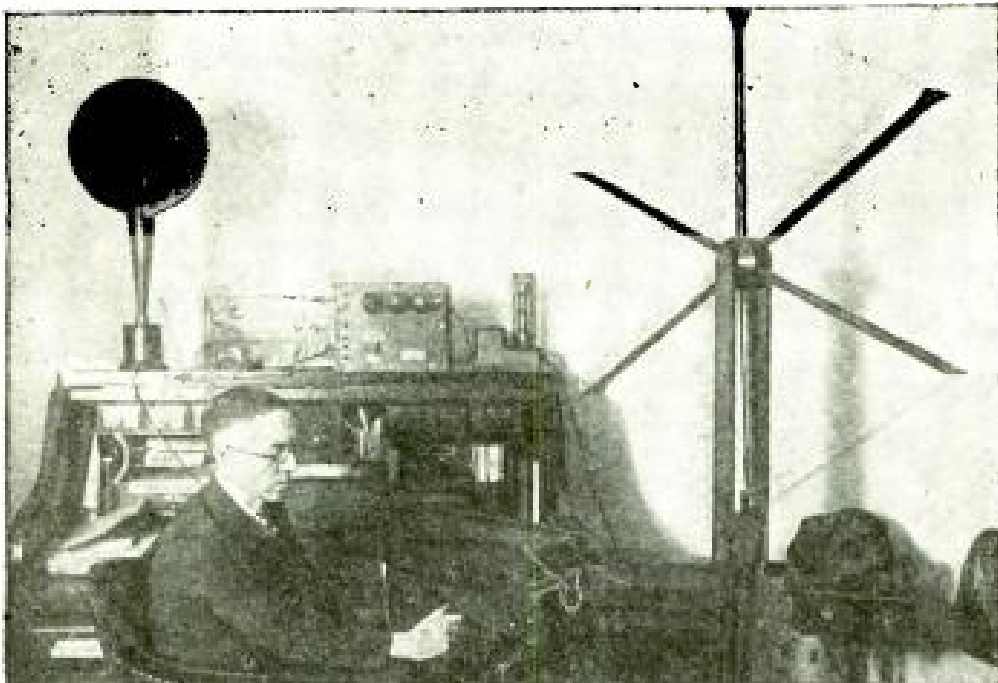

International

#### EXTENDING CONGRESS'S "GALLERIES" TO INCLUDE THE WHOLE NATION

*Representative Vincent M. Brennan of Michigan recently introduced a resolution which provides that all the proceedings and debates of Congress be broadcast by the Navy's radio station at Arlington, Virginia. Representative Brennan is here shown at his own receiving set which he has installed in his office in the House Building in Washington.*



From a photograph made for POPULAR RADIO

#### THE INVENTOR GIVES A DEMONSTRATION.

*Here is the "Greene receiver" in operation. It gets its name from Lloyd C. Greene who is not only a successful experimenter but also the radio editor of the Boston "Globe."*

## HOW TO BUILD A GOOD Single-Tube Receiver

Radio fans in New England have met with such success in building and operating this simple but remarkably efficient set that a detailed description of it is here published for the benefit of readers everywhere. The tuning is simple, the range is exceptionally wide—and the parts can be bought for less than \$33.00.

By A. H. RICE, JR.

**T**O meet with favor among the vast majority of radio fans to-day, a receiver should be simple to construct, efficient, inexpensive and, what is perhaps of even greater importance, easy to operate.

The receiver described has a wavelength range of 175 to 600 meters, and is provided with vernier controls on the filament rheostat and antenna tuning condenser—the advantages of which are immediately appreciated when tuning in long-distance stations.

A potentiometer is employed across the "A" battery, thus providing a vernier adjustment of the potential impressed across the plate and filament.

Regeneration is obtained by means of a variometer in the plate circuit, for it has been found that the tuned plate method of securing regeneration in the circuits is superior to either external capacity coupling between the plate and grid circuits or the present popular method of electromagnetic coupling between these circuits.

With the controls above noted, the circuits may be brought very close to the point of oscillation, which is a desirable feature, as it is possible to approach gradually a peak value of regeneration on a given wavelength without forcing the circuits into oscillation, as is the case with other types of regenerative receivers. By this means of control the novice is better equipped to pick up distant stations, because of the amplification obtained as this peak value of regeneration is approached.

In addition the receiver is more selective in tuning than those of similar design because of the fact that it is possible to approach a higher peak value of regeneration without causing the circuits to oscillate; as it is a generally accepted fact that tuning becomes sharper as regeneration is increased, it will be readily understood why this feature is so desirable.

It is not essential that the constructor and operator of this set have an ex-

pert knowledge to operate it with a reasonable amount of success on phone reception. Nor does its construction require tools other than those usually available in the average household. A pair of pliers, a screw-driver and a soldering kit are the most useful tools to have at hand. However, if the panel work is to be done by the experimenter, additional tools will be needed. This work, however, can be done at any small shop at slight cost and those who are not equipped to do it themselves need not feel that the construction of a neat set is beyond them.

It should be borne in mind that the receiver contains no parts unnecessary to its successful operation; therefore it is necessary to follow instructions carefully and to subject the instrument to a thorough test before attempting to modify or improve upon it.

#### How to Build the Set

The standard size of panel used (8 inches by 12 inches by  $\frac{1}{8}$  inch) was chosen because

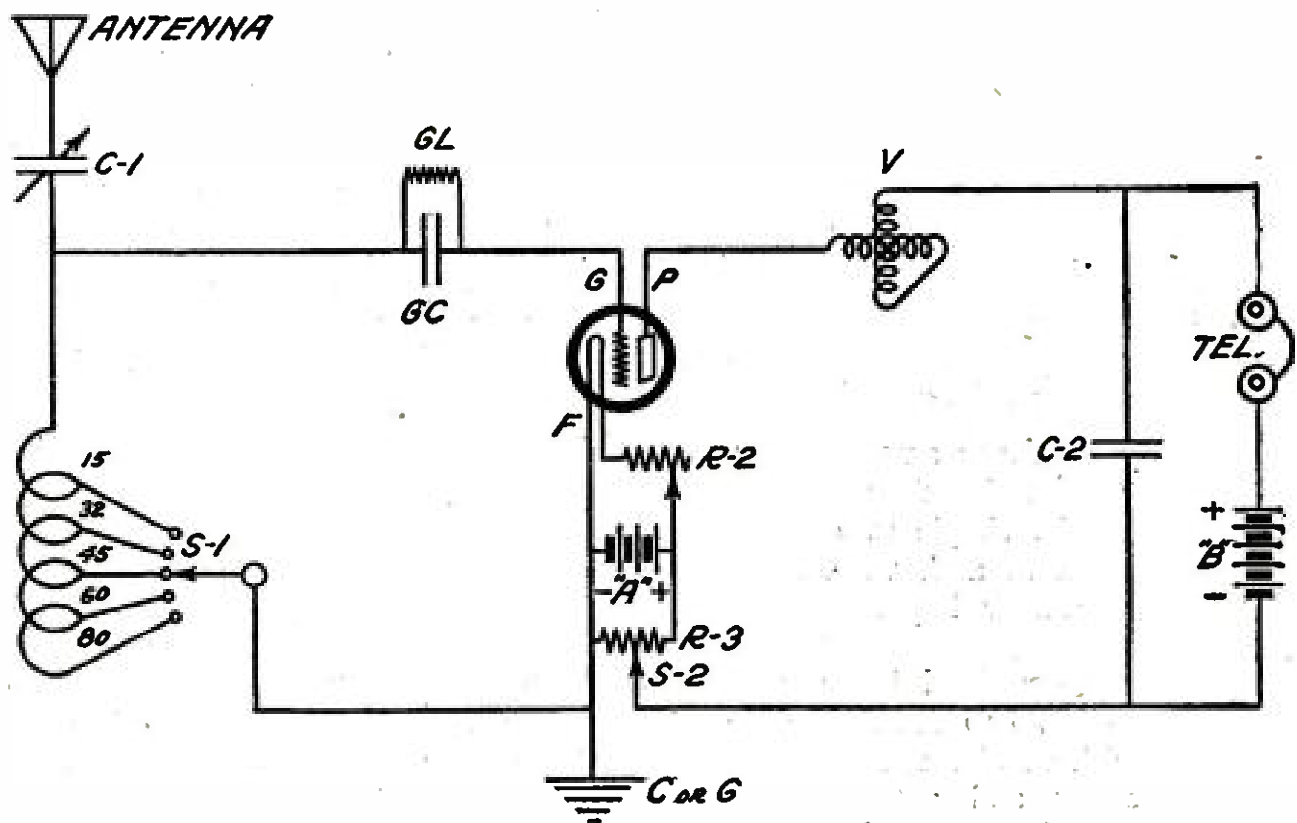

THE WIRING PLAN FOR THE RECEIVER

FIGURE 1: The instruments should be connected exactly as shown in the diagram in order to get best results. The designations are the same as used in the text and the builder should, therefore, have no difficulty in putting the set together and operating it.

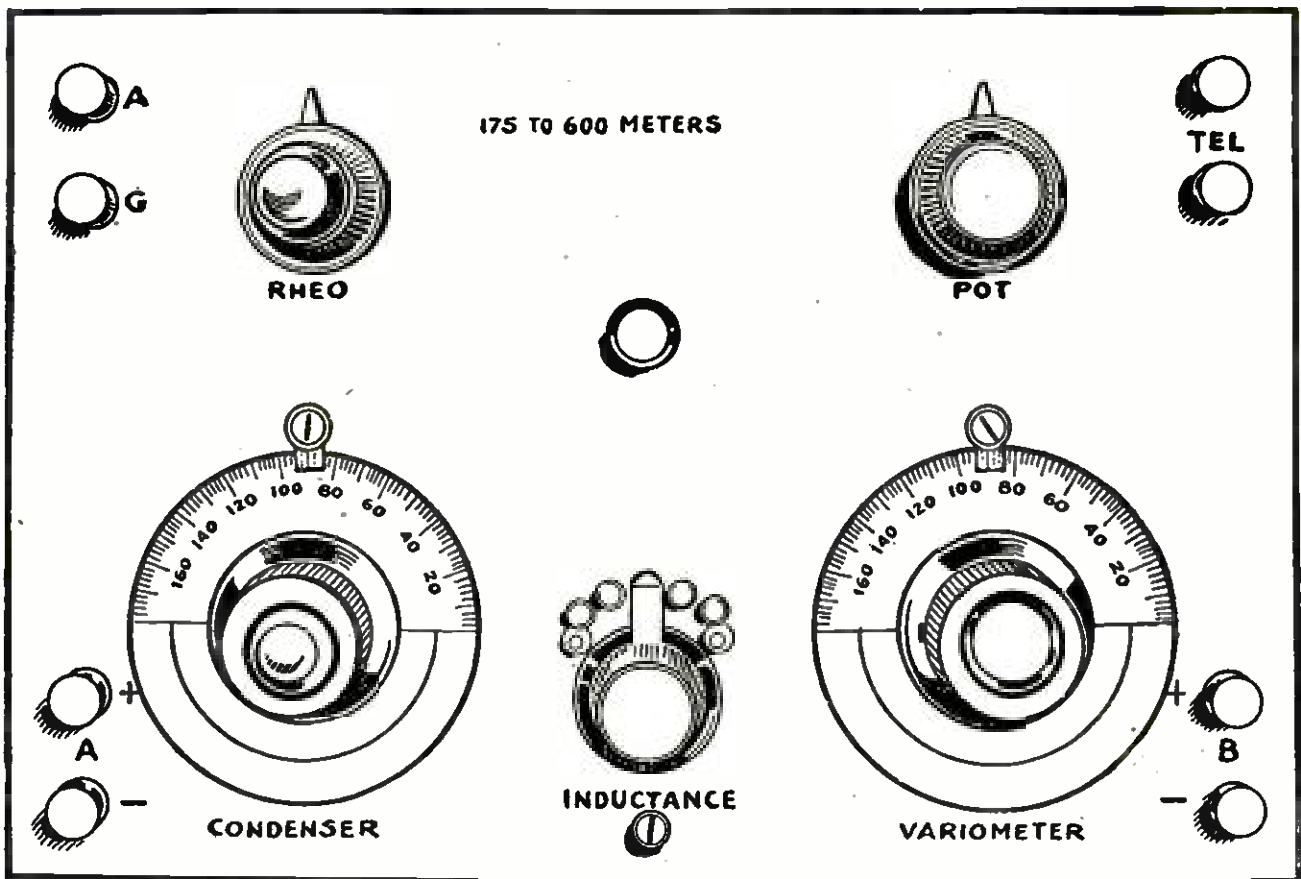

### THE FRONT OF THE SET

*How the front of the panel appears after the dials and binding posts are attached. The terminals are plainly marked for the batteries and the telephones, and for the antenna and the ground.*

it accommodated the various parts and accessories without undue crowding.

A suggestion is offered here to those who may desire to follow the panel layout of the model shown in the drawings: A pencil line is drawn lengthwise along the panel  $2\frac{1}{8}$  inches from the bottom; a pencil line is next drawn from the top of the panel to the bottom  $2\frac{3}{8}$  inches from the left side or edge, and another an equal distance from the right-hand edge. The intersections of the horizontal line and the two vertical lines comprise the centers of the two  $3\frac{1}{4}$ -inch dials shown in the model. By using these dimensions it was found that the variometer could be utilized to support the panel upon which the other apparatus is mounted.

It will be noted here that a Remler variometer is used, although variometers of other reliable makes may be used.

Now draw a line lengthwise along the panel and parallel to the base,  $1\frac{1}{4}$  inches from the top edge. The intersections of the two vertical lines and this horizontal line at the top of the panel indicate the positions of the potentiometer and rheostat knobs.

The location of the switch, binding posts and circular window for viewing the vacuum tube may be made according to the taste of the individual in balancing up the panel design. If it is desired to have the panel engraved, indicating the various controls, information may be obtained at any radio supply

house regarding concerns equipped to do this work.

A copper shield should be used on the back of the panel as shown in the diagram. By its use body capacity effects are reduced when tuning and the wiring of the receiver may be greatly simplified by utilizing the shield as a return from different parts of the circuit which need to be connected to the "A" battery and ground.

When the set is properly wired, the inductance switch arm, negative side of the potentiometer, negative "A" battery terminal, negative filament lead from the vacuum tube, and the ground binding posts are all connected to the copper shield.

To apply the copper shield to the back of the panel proceed as follows:

Procure a piece of copper foil .001 inch thick. Cut this to a 6-inch by 9-inch sheet; apply a thin coat of shellac to that part of the back of the panel upon which the copper foil is to be fastened. Before placing the foil upon the panel, touch a lighted match to the back of the panel and allow the alcohol to burn off. The surface will then become sticky and when the copper foil is applied the shellac will dry quickly, making a smooth and neat job. When this is dry (which should not require more than five minutes), with a sharp pointed knife cut away the copper foil in all places where parts of the apparatus or wires, which should not be connected to the shield, might touch.

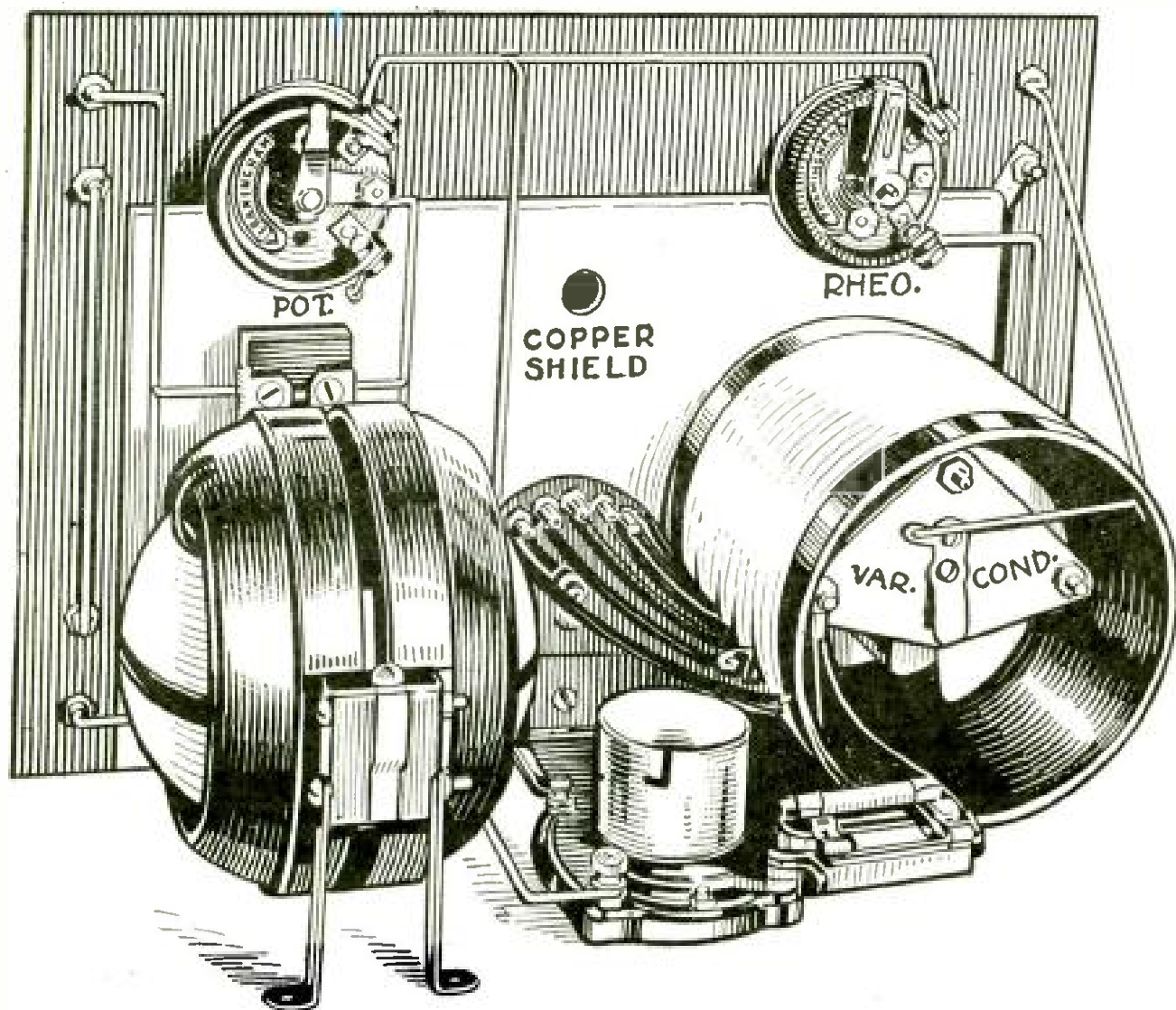

#### A REAR VIEW OF THE SET

*Showing in detail the arrangement of the parts and the method of applying the copper shield.*

Connect to the shield only those parts that are specified.

If the potentiometer is wired to the rheostat as shown in the rear view of the set, it will be in circuit only when the vacuum tube is lighted. This method of wiring eliminates the use of a separate "A" battery switch to open this circuit through the potentiometer when the receiver is not in use.

Now refer to the circuit diagram (Figure 1).

The symbols shown represent the following: The triangle in the upper left hand corner indicates the antenna, which may consist of one or two wires 100 to 120 feet long, supported at an average height of 30 feet; C-1 is a vernier variable tuning condenser with a capacity of .0005 mfd.; GL is a grid leak of  $\frac{1}{2}$  megohm resistance; GC is a grid condenser having a capacity of .00025 mfd.; (if a WD-11 tube, operating on one dry cell, is used, a 1-megohm grid leak and .00015 mfd. grid condenser should be employed).

G is the grid, F the filament, and P the plate of the vacuum tube; V the variometer; "TEL" the head telephones.

C-2 is a by-pass condenser with a capacity of .0005 mfd.

"B" is a 22½-volt "B" battery (note how the *plus* terminal of this battery is connected to the telephones).

L is a coil wound with No. 22 wire, either single or double cotton covered, on a bakelite tube 4 inches in diameter and 3½ inches long with taps taken off at the 15th, 32nd, 45th, 60th and 80th turns and brought to switch points, represented by the small circles in the diagram. S-1 is a switch lever for varying the wavelength.

"A" is a 6-volt storage battery, preferably of 80 ampere-hour capacity, (if a WD-11 tube is used, a 1½-volt dry battery is all that is required to light the filament).

Note that the *plus* terminal is connected to the rheostat which controls the current flowing through the filament by regulating the amount of resistance of R-2 in the filament circuit.

S-2 and R-3, "A" battery potentiometer, are connected as shown; C, at the bottom of the drawing represents the ground connection, or

## WHAT THE PARTS COST

C-1—U. S. Tool variable condenser, .0005 mfd.....	\$6.00	V—Reimler or Atwater-Kent variometer	\$9.00
L—Tapped coil, wound with No. 22 S. C. C. copper wire.....	2.00	Vacuum tube socket.....	.75
GL and GC—Dubilier combination grid leak, ½ megohm and grid condenser, .00025 mfd.....	1.50	Vacuum tube.....	6.50
C-2—Micadon fixed condenser, .0005 mfd	.35	8 binding posts.....	.40
R-2—Framingham rheostat.....	1.25	Copper sheet.....	.30
R-3—Framingham potentiometer.....	2.00	Panel .....	1.00
		S-1—Switch and taps.....	.50
		Connecting wire.....	.20
		<i>Total cost (approximately).....</i>	<i>\$31.75</i>

better, the connection for the counterpoise.

If a counterpoise is used, the same precautions should be taken with it regarding lightning hazard, as are observed in the antenna installation. It should be equipped with an approved type of arrester, and to make doubly sure it should be grounded, when not in use, with a standard lightning switch. No one should entertain any misgiving regarding lightning, as it is a well established fact that a properly installed antenna system is the best kind of protection.

The receiver, when properly constructed, and connected to a single wire antenna 120 feet long, will enable one to hear amateur stations on 200 meters, radiophone broadcasting stations on 360 and 400 meters, and also commercial stations on 600 meters.

#### *How to Operate the Set*

To operate the receiver, connect antenna, ground (or counterpoise), "A" and "B" batteries, and telephones to the proper binding posts. Before inserting the vacuum tube in its socket make sure that all connections are correct and that the filament rheostat is in the "off" position. The rheostat is "off" when turned in an anti-clockwise direction as far as it will go.

When the vacuum tube is lighted by turning the rheostat knob in a clockwise direction, care should be taken not to burn the filament any brighter than is necessary to hear signals. When the WD-11 tube is used it burns so dimly at normal filament temperature that it is difficult to observe any glow at all.

Now let us suppose that the rheostat is turned half way on.

Set the inductance switch on the fourth switch point counting from the left. If no broadcasting is heard, turn the variable condenser, first in one direction and then in the reverse. Turn it *carefully*—do not spin it. If nothing is heard, try the third tap on the switch, varying the condenser as before.

When a signal is picked up, try increasing the inductance and at the same time decreasing the antenna tuning condenser. If the sta-

tion can be picked up by using more turns on the coil and less capacity the sharpness of tuning at that particular wavelength setting will be increased.

When the signal has been tuned to give the loudest response in the telephone receivers, try rotating the variometer rotor in a clockwise direction and then in the reverse. If the filament temperature of the tube is too low, no increase in signal strength will result. Slowly increase the filament temperature of the vacuum tube until the desired effect is obtained when the variometer is rotated.

If a squeal is heard in the telephones as the point of loudest signal is approached in the variometer adjustment, turn it in the reverse direction slightly and resort to the potentiometer adjustment as a final means of obtaining the loudest signal without squealing being produced.

When properly operated the receiver is never allowed to go into oscillation—it is not necessary. If any squeals are heard when the set is not oscillating the causes are: either two broadcasting stations are heterodyning, or an oscillating receiver and a broadcasting station are heterodyning or two oscillating receivers in the immediate vicinity are heterodyning.

The circuit is equally efficient when a WD-11 vacuum tube is used, the only changes required being in the value of the grid leak and grid condenser and the addition of an "adaptor" which fits into the standard tube socket. This results in a considerable saving, as a 1½-volt dry cell may be used in place of the conventional storage battery. It then becomes an ideal set for portable work.

Numerous letters have been received from amateurs who have built the set, who have reported hearing stations between 1,000 and 2,000 miles distant more consistently and with much better audibility than they had been able to obtain before with a single tube.

## A Combination Long and Short Wave Receiver

*In a near issue of POPULAR RADIO Lester A. Twigg will tell how to make a set for receiving long waves and short waves, that will enable you to pick up either the code or the broadcasting.*

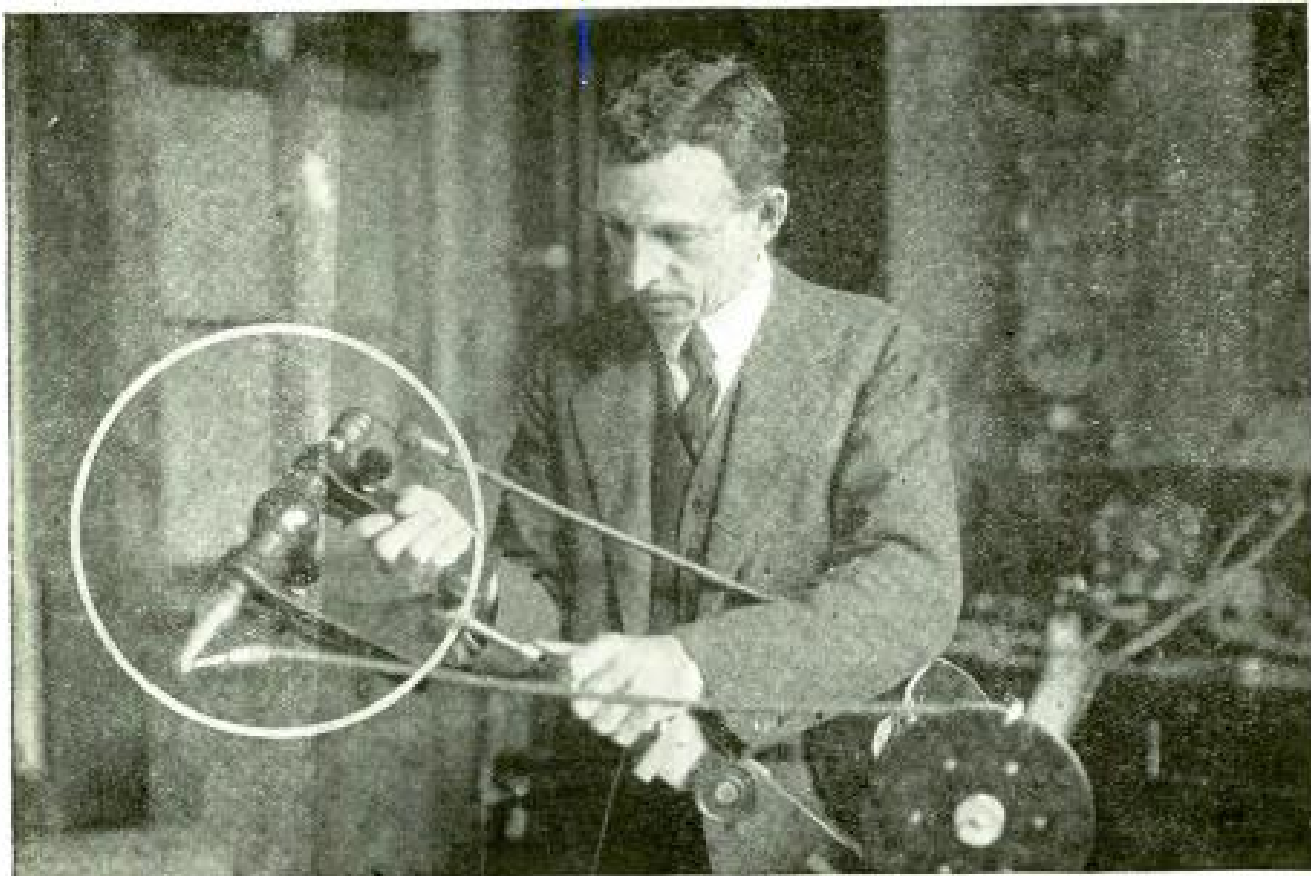

General Electric

DR. COOLIDGE DEMONSTRATES HIS INVENTION, THE  
"COOLIDGE TUBE"

*This is generally known as the hard X-ray tube—an electron discharge device that constitutes one of the most important of the applications of this phenomena to every-day uses.*

## THE NEWEST METHOD FOR EXTRACTING ELECTRONS

*How the use of thorium is getting higher filament emission at a low temperature in the new vacuum tubes*

So important to the radio amateur does POPULAR RADIO consider the work on electron emission, conducted by the assistant head of the great electrical research laboratories in Schenectady, that the following summary has been prepared of the various reports on the subject as given by him at the Carnegie Institute of Technology in Pittsburgh and before the members of the American Physical Society at Boston and representatives of the American Institute of Electrical Engineers.

By IRVING LANGMUIR, PH.D., D.Sc.

WHEN metals are heated in high vacuum, electrons, or minute particles of negative electricity, evaporate from their surface. If there is another electrode in the evacuated space which is given a positive charge the electrons drift over to this electrode plate or anode so that a current flows between

the two electrodes. Dushman has recently derived an equation which should supersede the well-known Richardson equation, giving the relation between the electron current and the temperature of the filament (cathode). The advantage of this new equation is that there is only one constant which we need



to know for each different filament material, instead of two constants which were necessary for the Richardson equation.

The electron emission from a large number of different materials has recently been measured. The thoriated tungsten filament gives a current at a temperature of 1,500° Centigrade absolute, which is about 130,000 times greater than that from ordinary tungsten. Measurements have also been made of filament materials that have even greater emissions.

In order to make use of the total electron emission that a filament is capable of giving, it is necessary to apply to the plate of the tube a high enough voltage to overcome what is known as the "space charge" effect. When small amounts of gases are present in the partial vacuum, positive ions are formed in the space between the filament and plate, and these tend to neutralize the negative space charge and allow the current from the filament to pass across the space at much lower plate voltages. In other words, the effect of gases is to increase the current-carrying capacity of the tube.

Such an effect is used in the tungar rectifier. Care must be taken as to just what gas is used for the purpose, for many gases have the effect of poisoning the filament, and cutting down its emis-

sion of electrons to a small value.

If very high voltages are used on the plate, so as to produce intense electric fields, it is possible to *pull* electrons out of the filament. In fact, it is possible to pull electrons even out of cold filaments, that is, filaments at ordinary temperatures. The currents obtained this way from the filament come from very minute areas, but in these areas the current density amounts to more than one hundred million amperes to the square inch.

The thoriated tungsten filament is a tungsten filament containing one or two percent of thorium, usually in the form of oxide. When such a filament is heated to about 2,500° Centigrade, a little of the thorium oxide is changed into metallic thorium. In the meantime, however, any thorium on the surface of the filament evaporates off, leaving only pure tungsten. If the filament temperature is then lowered to about 1,800° Centigrade, the thorium gradually wanders or diffuses through the filament, and when it reaches the surface (provided that the vacuum is almost perfect) remains there and gradually forms a layer of thorium atoms which never exceeds a single atom in thickness. The thickness of this film is therefore about .00000001 inch, yet this film increases the electron emission of the filament more than one hundred thousand fold.

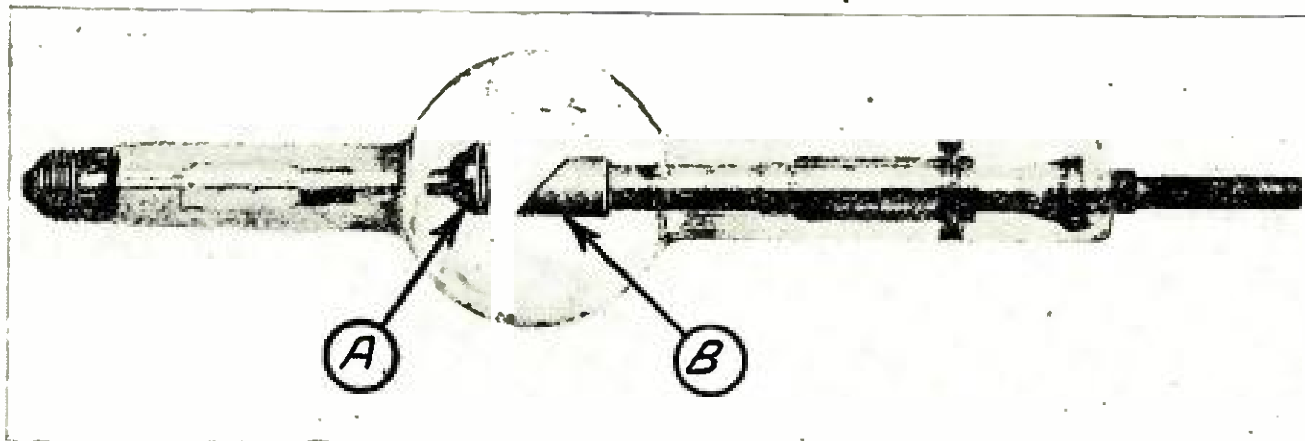

THE FAMOUS X-RAY TUBE THAT ENABLES SCIENCE TO APPLY ELECTRONS TO RELIEVE HUMAN ILLS

*It consists of two important elements; A is the cathode, from which the electron stream swarms across to the target B, around which the X-rays are propagated.*

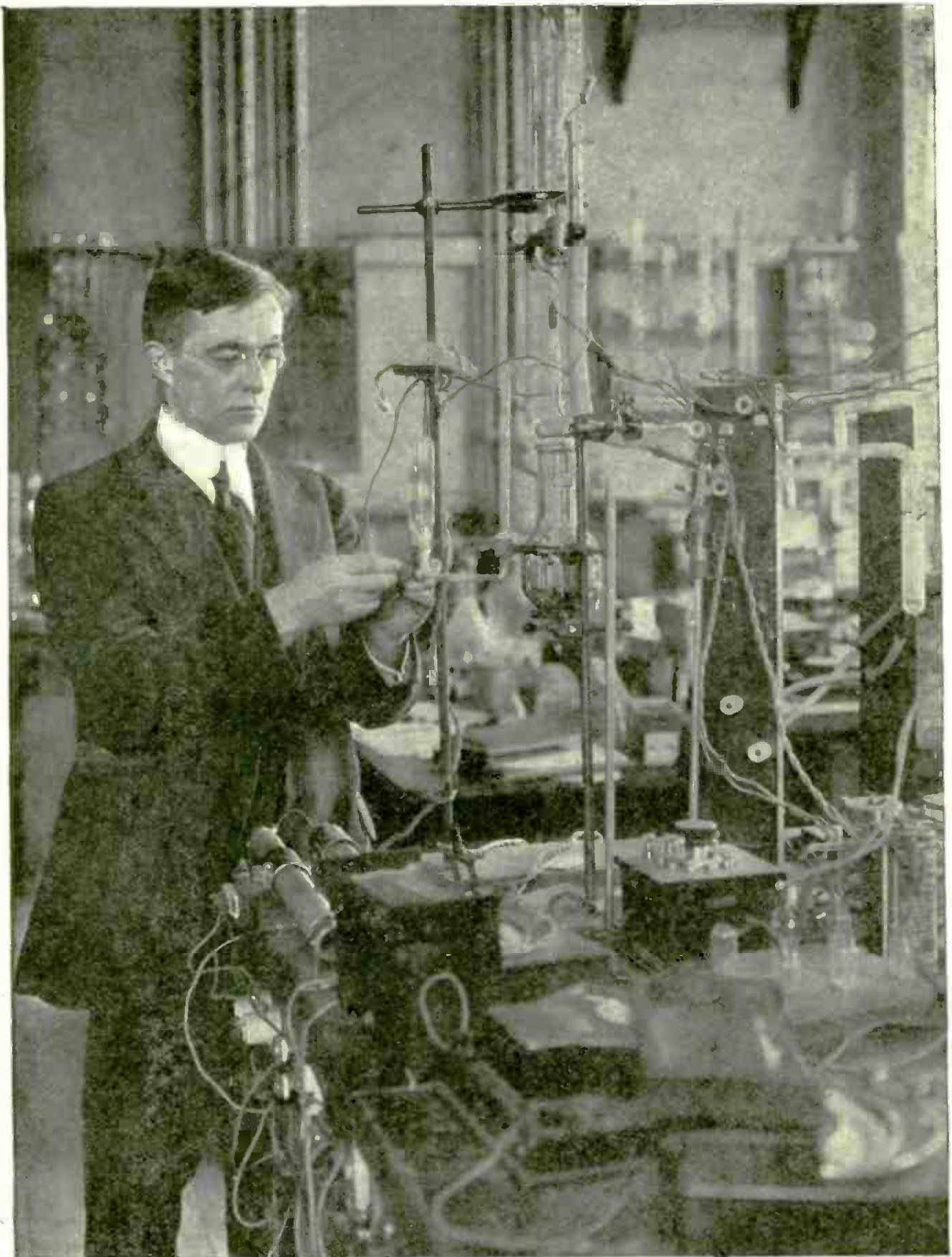

General Electric

**ONE OF THE FOREMOST RESEARCH PHYSICISTS  
IN THE WORLD**

*Perhaps more than any scientist in the world, Dr. Irving Langmuir, of the General Electric Company laboratories, has contributed to the knowledge of electron-discharge apparatus—with which this article deals. Among his numerous honors in science are included such coveted awards as the Nichols, Rumford and Hughes medals.*

Two of the latest radio tubes which have recently made their appearance and are known as radiotrons UV-201A and UV-199 embody the new principle of the thoriated filament.

Of course this useful film is very sensitive and needs some protection to keep it in good condition. Very slight traces of water vapor or other gases would oxidize this film and destroy it.

This may be avoided by putting in the bulb some substance that combines with the water before it has a chance to attack the thorium film. One such a substance is metallic magnesium.

Furthermore, it is necessary to avoid heating the filament to too high a temperature, or the film might evaporate off. It is therefore best to operate such a filament within a rather narrow range of temperature close to 1,700° Centigrade, where the ratio of evaporation is small, and where the temperature is high enough for the thorium gradually to diffuse to the surface and continually repair any damage done by the effect of slight traces of residual gases.

The thoriated tungsten filament opens up many new fields of scientific investigation. By measuring the electron currents, it is possible to determine accurately

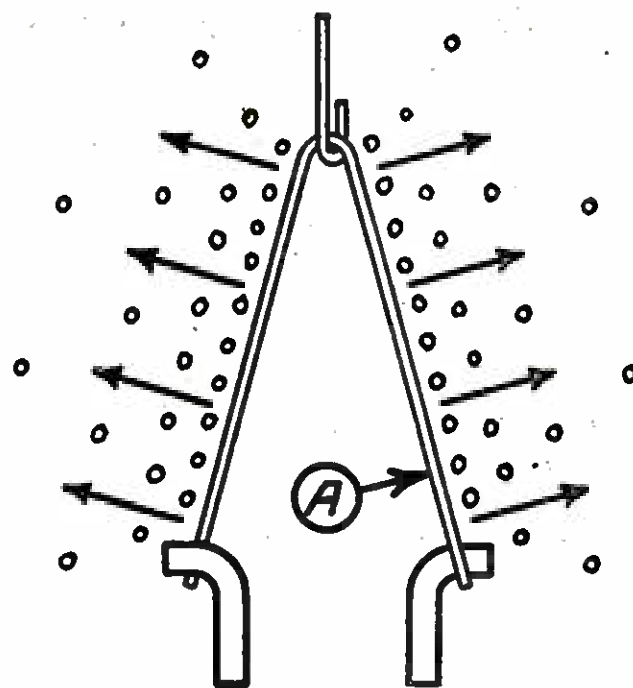

#### THE ELECTRON DISCHARGE FROM THE ORDINARY FILAMENT

*The arrows on this much-simplified drawing shows the direction taken by the electrons that are emitted from the heated tungsten filament, A.*

ately exactly how much thorium is present on the surface. An amount of thorium corresponding to only one one-thousandth of the surface covered with a layer one atom deep is easily measurable in this way. It is possible to knock off a thorium film by bombarding it with positive ions, moving at high velocities, and in this way the true nature of the bombardment can also be determined.

Most of the applications of high vacuum tubes have depended upon the control of electron currents—as, for example, by the grid in the three electrode tube.

The action of the grid is due to the charge on the grid that modifies the space charge effect. This is the action that is employed in practically all tubes used to-day for radio transmission and receiving.

There are many other methods, however, of controlling electron currents. An important method is that used in the magnetron, where there are only two electrodes in the evacuated space and the control is obtained by means of a

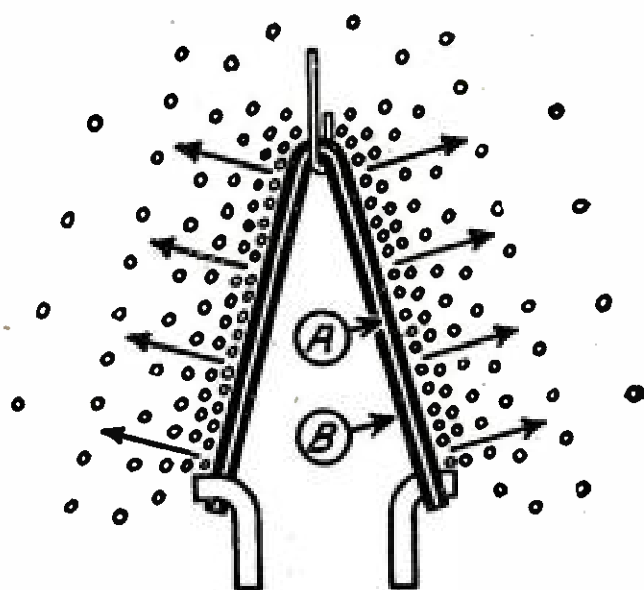

#### THE ELECTRON DISCHARGE FROM THE THORIATED FILAMENT

*Note the greatly increased emission of electrons from the tungsten filament, A, which has been coated with a minute layer of thorium, B.*

magnetic field generated by an external coil of wire. A still simpler form of magnetron suitable particularly to very large power tubes, consists of a very large straight filament in the axis of a cylindrical plate. The magnetic field produced by the current flowing through the filament is enough to prevent electrons flowing between cathode and anode. By heating the filament with alternating current which periodically falls to a low value, a large electron current can be made to flow from the filament to the plate also periodically. This gives a pulsating or oscillating current, which can be used for radio transmission. A 1,000-kilowatt tube of this kind is in process of development; preliminary tests have been in every way satisfactory.

Another form of tube by which electron currents can be controlled is the dynatron. This depends upon subjecting one of the three electrodes in the tube to electron bombardment in such a way as to cause electrons to be splashed out of it, just as water can be splashed out of a cup by attempting to fill it too

rapidly from a faucet. A tube of this kind acts like a real negative resistance, and may be used for producing electrical oscillations with considerable efficiency.

One of the most important of every day applications of electron discharges from hot cathodes is in the Coolidge X-ray tube, which is now almost universally used as a source of X-rays. These tubes were first made about 1913 and are gradually being improved in many respects. The latest type of tube, suitable for use by dentists, is a small tube weighing only a few ounces, and only about three inches long. Because of the special features of this tube, the entire X-ray outfit, including the transformer, lead screen and regulating apparatus, weighs only a few pounds and takes up a space of only a small fraction of a cubic foot.

One great advantage of this new form of tube, besides its convenience, is its absolute safety, even in the hands of inexperienced operators, for there are no high voltages in any part of the apparatus which is accessible.

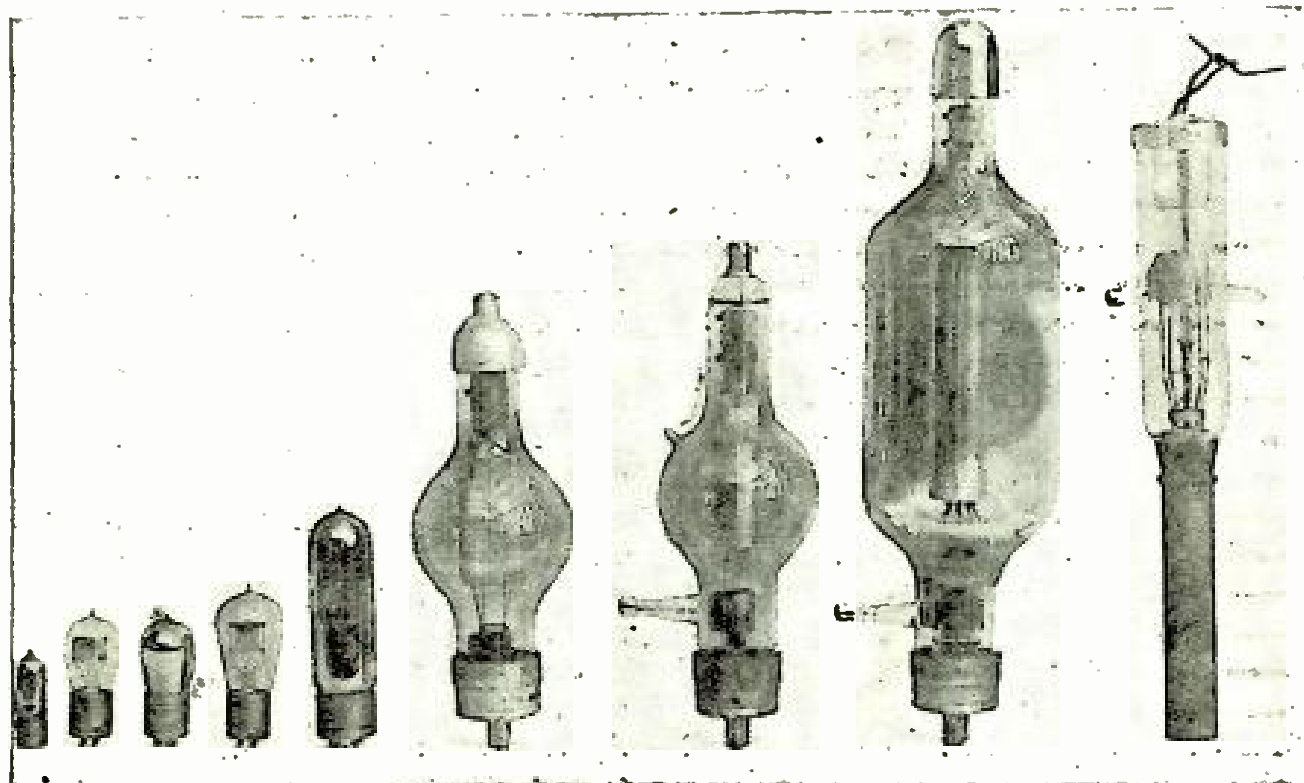

General Electric

*The three tubes at the left are for receiving; two of them have the new thoriated filament. The other six are for transmitting; they range from 5 to 20,000 watts output.*

# How to Make a Crystal Detector Stand

By A. HYATT VERRILL

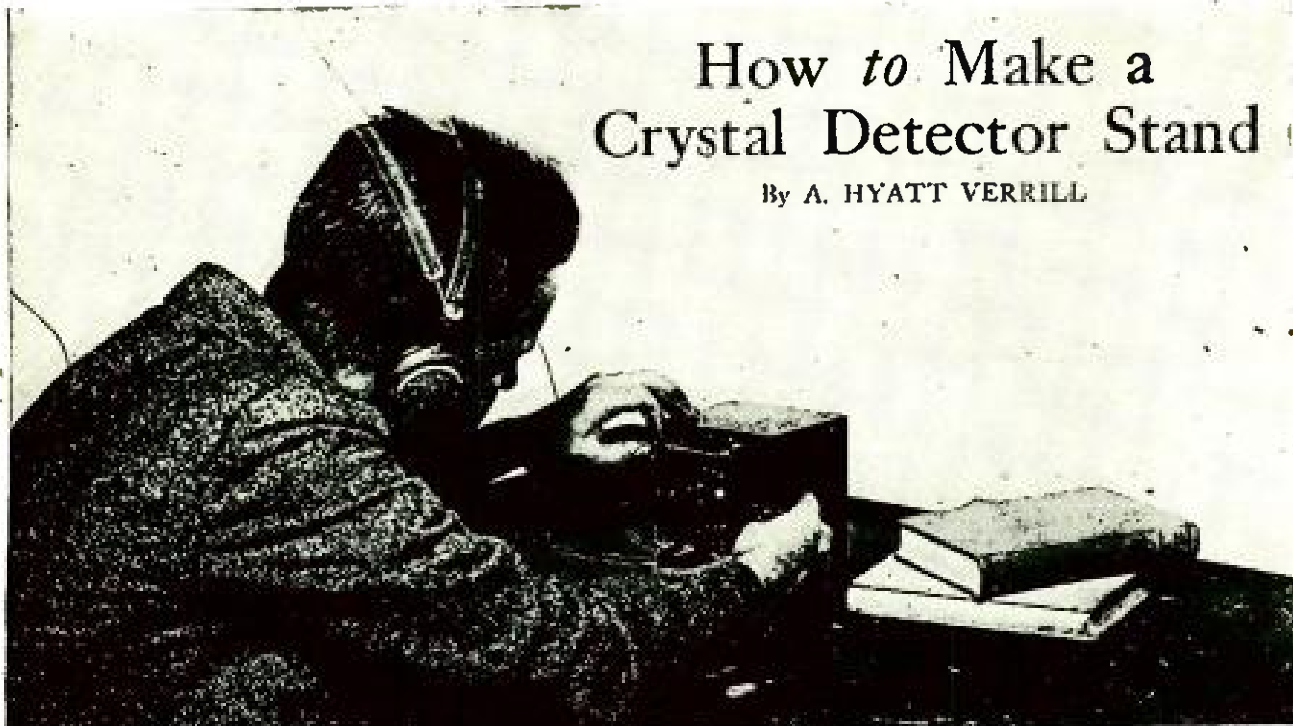

From a photograph made for POPULAR RADIO

## FINDING THE SENSITIVE SPOT

*The value of a crystal set depends upon the rectifying qualities of the crystals. It is important, therefore, that the stand which holds the crystals should facilitate the finding of the sensitive spot. This article tells how to build one for 75 cents.*

**A**LTHOUGH a crystal detector is a simple instrument, and while almost any home-made set will work after a fashion, nevertheless a great deal of its success depends upon the efficiency of the apparatus itself. A really good detector must possess several important features which are often lacking in cheap, ready-made instruments and are always absent in roughly made "cat whisker" affairs such as the average novice devises.

Not only must a detector have perfect contacts and connections throughout but it must be capable of adjustment in various directions and must be rigid—for in order to obtain good results the most sensitive spot on the galena crystal must be found. This can only be done by "feeling" over the crystal with the fine wire or "cat whisker" contact. If the latter is fixed, or if it is merely provided with a coil or spring on itself, it is practically impossible to "feel" unless the crystal is moved about, which is a clumsy and unsatisfactory method. Furthermore, even when the most sensitive spot is found

and the contact is established, a slight jar or vibration may throw it off again, and a new adjustment must be made. Of course anyone who is accustomed to the use of machine tools and who owns a set of screw-taps and dies can make a good detector, but those amateurs and beginners who are not familiar with metal working and who do not own taps and dies naturally do not care to purchase them merely for the purpose of making parts of their sets.

The detector shown in the accompanying diagrams has been designed especially for those who wish to construct their own instruments but who are not skilled in the use of metal-working tools or have none. If the detector is made neatly and according to the following directions it will be found fully equal to any of the ready-made instruments—indeed, better than the majority. Moreover, it may be made at a total cost of less than 75 cents.

The only tools needed are a small iron vise, a screwdriver, a pair of flat-nosed pliers, a soldering iron, a jackknife, a

small hammer, a file, a hack-saw and a few drills. A breast drill or an ordinary bit-brace with some bit-shanked twist drills will answer all purposes. Even if you have to purchase the drills to fit your bit-brace the cost of the detector should not be over \$1.25 or \$1.50; such drills are almost a necessity if you intend to install or make a radio set.

The materials required are some sheet brass of about  $1/32$  inch and  $1/8$  inch thickness, a brass rod  $5/16$  inch or  $3/8$  inch in diameter, a short length of fine phosphor-bronze, brass or platinum wire, a few  $5/32$ -inch or  $1/4$ -inch brass screw-headed bolts with nuts, a few brass lock-washers or spring washers of the same size as the bolts, two binding-posts and some knurled thumb-nuts to fit the bolts or some binding screws and nuts from old dry batteries, a piece of wood or fiber about  $1/2$  to  $3/4$  inch thick and 4 inches square, and a piece of brass tubing with an inside diameter which will slip easily over the brass bolts.

This may appear to be a formidable list, but as the pieces are all small it really amounts to very little. If you have a pair of tinner's shears (which may be purchased for 50 cents) you can easily cut the thinner brass yourself; otherwise, you can get the nearest tinsmith to cut it for you, or can manage with a hack-saw and file.

The first thing to make is the rod that carries the contact wire or "cat whisker." This is a  $5/16$ -inch or  $3/8$ -inch brass rod  $2\frac{1}{4}$  inches long as shown in Figure 1. In one end of this rod drill a small hole, and insert the fine wire, which should be bent as shown and should project from the rod about  $1/2$  inch. Solder this wire in position and turn to the next part. This is the holder for the rod and consists of a strip of brass about 5 inches long,  $1/2$  inch wide and from  $1/32$  inch to  $3/64$  inch thick. Bend this back upon itself at the center, as shown in Figure 2; this is best done by holding the strip in the vise and bending it sharply over (tapping with a hammer along the fold until

a right angle is formed), and then bending the sides down close together by hammering along the bend.

Next, grip the folded strip in the vise with  $1/2$  inch of the folded end projecting, and bend it over at right angles, as shown in Figure 2A. Place the strip in the vise, with the free ends projecting, and with the top of the vise jaws  $3/4$  inch from the right angle bend. Spread the free ends apart and force a brass or iron rod or bolt  $1/4$  inch in diameter between them, as shown in Figure 2B. By gently tapping with the hammer and bending back the ends with pliers, form the two sides of the strip as in Figure 2C. The strip, when removed from the vise, should now appear as in Figure 2D.

Round and smooth off the sharp corners and edges, as shown, by means of a file. Bore holes the size of your brass screw-headed bolts (or of the terminal screws from the old dry battery) through both sides of the brass, as shown. When you bore the hole through the free ends, secure the ends in the vise or you will have trouble. Also, make this hole a trifle larger than the screw. Insert the brass screws or bolts through these holes and solder the heads firmly to the brass strip as indicated in Figure 2E.

Now take a strip of  $1/8$ -inch brass, 3 inches long and about  $3/4$  inch wide and make a good sharp right angle at  $3/4$  inch from one end as shown in Figure 3. In this bore four holes the size of the brass screws or bolts—three holes in the short leg of the angle, as shown, and one near the upper end—about  $3/8$  inch from the end, as shown in Figure 3A. Round and smooth the sharp corners and edges and attach the strip to a neatly-made and finished panel or base of wood, fiber or Bakelite as indicated in Figure 4. Use two round-headed wood screws to secure the brass strip to the base and in the third hole on the short angle place a binding post or terminal screw, as illustrated in the diagram.

Assemble the contact rod and holder as shown in Figure 4 and 4A, attaching

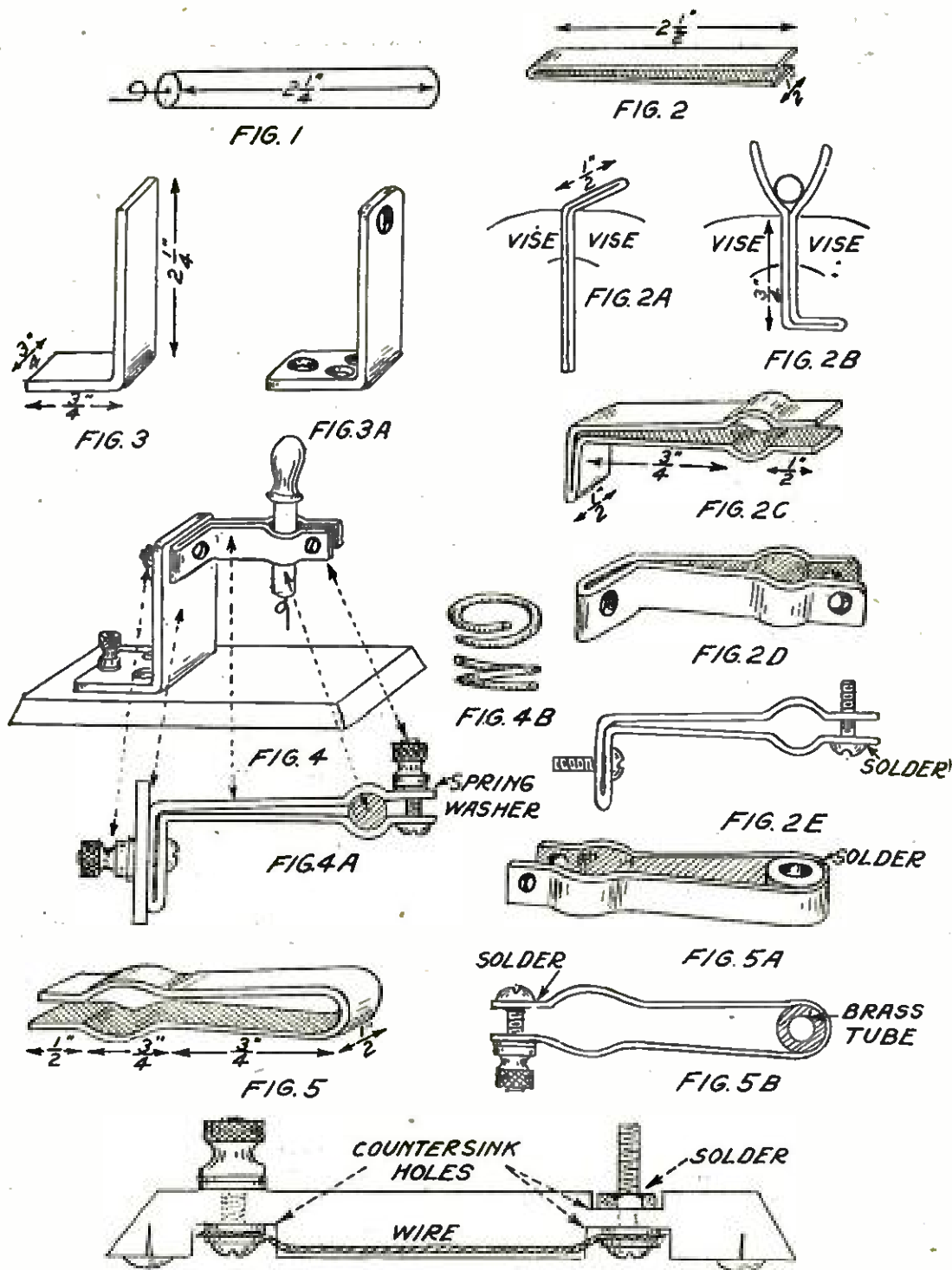

FIG. 6  
THE PARTS FOR THE CRYSTAL STAND

This diagram gives the detail of the small metal parts which go to make up the stand, and indicates the proper methods for assembly. Figure 1 shows the detail of the rod and "cat whisker." Figures 2 to 3A show details of construction for the rod support. Figures 4 and 4A show how they are mounted on the base. Figures 5 to 5B show the details for the crystal holder. Figure 6 is a side view of the base, showing how the screw, which holds the binding post, is connected to the crystal holder by a wire run underneath the base.

the holder to the upright by the screw and using a spring washer and knurled washers you can readily make excellent ones by cutting sections from a brass spiral spring, as shown at Figure 4B. Now slip the rod, Figure 1, through the holder and slip the rubber bulb of an ordinary medicine dropper over the end,

washers you can readily make excellent ones by cutting sections from a brass spiral spring, as shown at Figure 4B.

Now slip the rod, Figure 1, through the holder and slip the rubber bulb of an ordinary medicine dropper over the end,

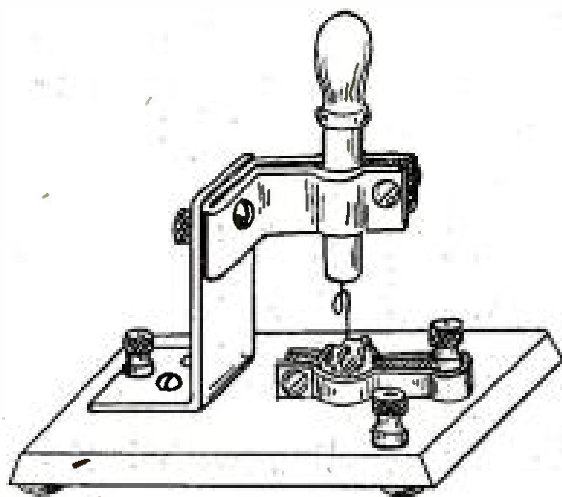

FIG. 7

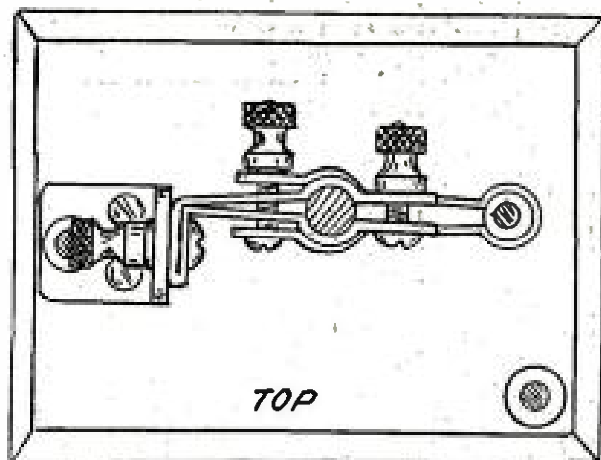

FIG. 8

## THE COMPLETE ASSEMBLY

Here are shown a side view (Figure 7) and a view from above (Figure 8) of the detector stand as it is finally put together for use.

as shown in Figure 4, 7 and 8, or fit a hard rubber knob to it. By tightening on the thumb nut at the free ends of the holder the rod will be held firmly, and by loosening it, it may be turned or moved up and down as desired. The spring washer and nut which secure the holder to the upright may be adjusted so that the holder is immovable, swings freely or binds at any intermediate point.

Next make the crystal holder by bending a strip of the 1/32-inch brass, 1/2 inch wide, in the form shown in Figure 5. Make the semicircular bend or fold at the center around a 1/4-inch or 3/8-inch rod, and in the bend solder a short section of brass tubing with an inside diameter that fits snugly over one of your brass bolts, but that does not bind, as shown in Figure 5A. If the hole in the tube is too small it may easily be enlarged by running a drill through it; if it is too large it cannot be made smaller. Accordingly if you cannot secure just the right size get a tube a trifle too small and bore out the hole to suit. Bore a hole to take one of the screws through the free ends as shown, making the hole on one side slightly larger than the screw to allow some play, and solder the head to the other side as you did with the rod holder. Fit a washer and thumb-nut on the screw as in Figure 5B.

Now place the crystal holder upon the stand or panel, as shown in Figures 7 and 8, with the crystal grip under the end of the contact rod when the latter is in the position shown in the cut, Figure 7, and in line with the upright. When in the proper position, mark where the hole in the brass tube comes, and after removing the holder bore a hole through the base to take one of the brass bolts, countersinking a space to take the nut on the upper surface of the panel as in Figure 6. Bore a similar hole at the other side of the panel and countersink both holes on the under side to accommodate washers and screw-heads, shown in Figure 6. Insert a long screw in the hole to secure the crystal holder, placing two washers between the head and the lower surface of the panel, with a wire between them as illustrated. Screw the upper nut down tightly, by holding it with the pliers and turning the screw-headed bolt with a screwdriver, and solder the nut firmly to the bolt.

In the other hole, place a binding-screw as shown in Figure 6 and connect the wire as indicated, cutting a groove in the bottom of the panel for the wire so that all will be flush on the bottom. It is a good plan, however, to place a leather-headed upholsterer's tack at each corner, as this will give a firm bearing and will



prevent the panel from slipping when in use. If you have any trouble in working at these things with the upright and contact-rod in place, you should remove them as soon as the position for the crystal holder is marked.

Finally, assemble the crystal-holder as shown in Figures 7 and 8, place the crystal in it and clamp it tightly; the de-

tor is then ready to connect and use.

By keeping a slight tension on the spring washers under the thumb-nuts, the parts may be moved for "feeling" and yet will not be jarred out of position. By tightening the nuts the parts may be securely locked in any position desired. The whole affair is very compact, as the base is but four inches square.

### What Radio Is Doing for the Farmer

**I**n none of the many fields into which radio has entered does it promise to render more essentially practical and valuable service to so many people as in the field of agriculture. How the government authorities are broadcasting specific information concerning the planting, raising, packing, shipping and marketing of farm products will be told in a near issue of POPULAR RADIO.



General Photographic Service

#### A RADIO STATION WITH SIX CYLINDERS

*When Mr. and Mrs. J. C. Davenport of Indianapolis, Indiana, set out in their radio-equipped automobile on a 40,000-mile state to state pilgrimage, it was both to enjoy a vacation and to demonstrate the usefulness of radio on tour. How they succeeded may be judged from the crowds that gathered to hear the radio entertainment they furnished whenever they stopped.*

He is a storm center of scientific controversy. His revolutionary theories on the nature of plant life and of the ways in which plants respond, by microscopic movements, to injuries and to disturbances of their surroundings; his almost mystical interpretation of some of his delicate physical experiments, have brought down upon him some criticism from many of the more material-minded students of plant physiology. But all of Dr. Bose's critics credit him with being an extraordinary successful designer and manipulator of physical instruments. His apparatus for detecting minute movements and electrical changes in plants is, admittedly, the most delicate that has ever been built. The radio world, which was, as Mr. Kaempffert points out, one of the first fields of Dr. Bose's work, suffered a serious loss when his inventive genius was turned away from it into the investigation of the properties of living matter.—EDITOR

By WALDEMAR KAEMPFERT

**S**IR JAGADIS CHUNDER BOSE (pronounced Bo-zay) is an extraordinary figure. He is the first oriental who has won for himself a commanding place in modern physics.

Here is a devout, intensely religious Bengalese of the purest blood who has perfected the most delicate instruments for accurately measuring the reaction of plants and so-called "dead" metals to alcohol, ether, heat, light, and forces of every imaginable kind, and who has laid bare the molecular mechanism of living and "dead" matter's reaction to a hun-

dred different stimulants and thus upset our time-honored notion that orientals in general and East Indians in particular are much too metaphysically inclined to conduct research in the modern scientific spirit.

Not only has Bose opened up an entirely new realm in physics but he even regards his startling discoveries as a scientific confirmation of the traditional doctrines of his people. His work is of such importance that it has been at last adequately recognized by the leading scientific societies of Europe and America



—among them the famous Royal Institution of London.

Bose's announcements that metals wince under blows, that they become torpid when frozen, that they can be narcotized like a living animal, and that they become weary from mechanical abuse were so astounding that they were long unappreciated at their true scientific value.

Similarly, his investigations of plants (conducted purely from a physicist's point of view) which revealed the whole mechanism of plant responses to heat, electric currents, ether, and mechanical shock were long incomprehensible to biologists familiar only with the microscopic method of studying living tissues. His instruments are of marvelous delicacy. With their aid he reveals the death-throes of a carrot, measures the voltage of a single pea, makes a cabbage leaf visibly shudder with pain and causes a geranium literally to start when a door is slammed.

Bose first drew attention to himself soon after Hertz had experimentally

proved the existence of the waves which are now practically applied in radio communication. Those were the days when the coherer was the most efficient detector known.

Bose succeeded in producing waves of a length so short that he bridged the gap between the heat waves of the spectrum and Hertz radiations. He devised a detector far more sensitive than the familiar Branly coherer—a detector which depended not upon metal filings or powder but upon fine wire springs, adjusted with a thousand regular contacts and under the control of a screw. This detector proved to be far more sensitive than Branly's coherer.

He made one of the most exhaustive studies on record of the optical properties of the Hertzian waves—work which was commented upon with admiration in this country by Dr. Kunz of the University of Illinois.

During the course of these experiments Bose conceived the idea of constructing an artificial sense-organ which would have a range of sensitivity far wider than that of any known eye, photographic plate or radio detector—something which not only would see visible rays but the invisible rays with which we deal in radio.

So he devised such an artificial sense-organ.

When he placed before it a glass of water—the equivalent of the eye's aqueous humor—all electric and heat rays and some ultra-violet rays were absorbed, as they are by the human eye.

The brain of this eye was a galvanometer. When he removed the glass of water the "eye" became exceedingly sensitive to radio and heat waves. Instead of marveling at his own ingenuity Bose simply remarked:

"Perhaps we do not sufficiently appreciate, especially in these days of space-signaling by Hertzian waves, the importance of that protective substance which veils our sense against insufferable radiance."



THE EFFECT OF ETHER ON A GERANIUM

*A graphic record, as made by the crescograph, of the reactions of a live plant which had been "put to sleep" by ether and then awakened.*

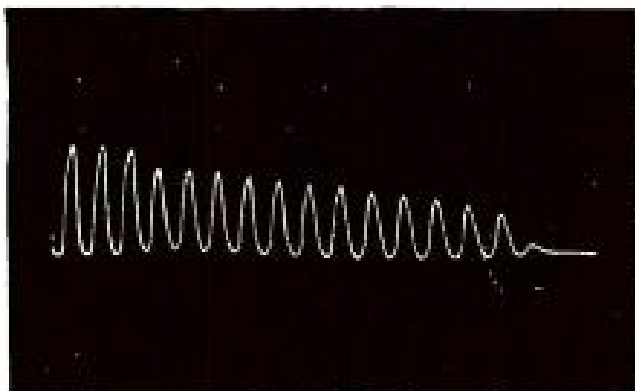

HOW POISON AFFECTED A VEGETABLE

*In this instance the vegetable was put to death. Note the effects of the drug, as shown by the gradually lessening response of the reactions.*

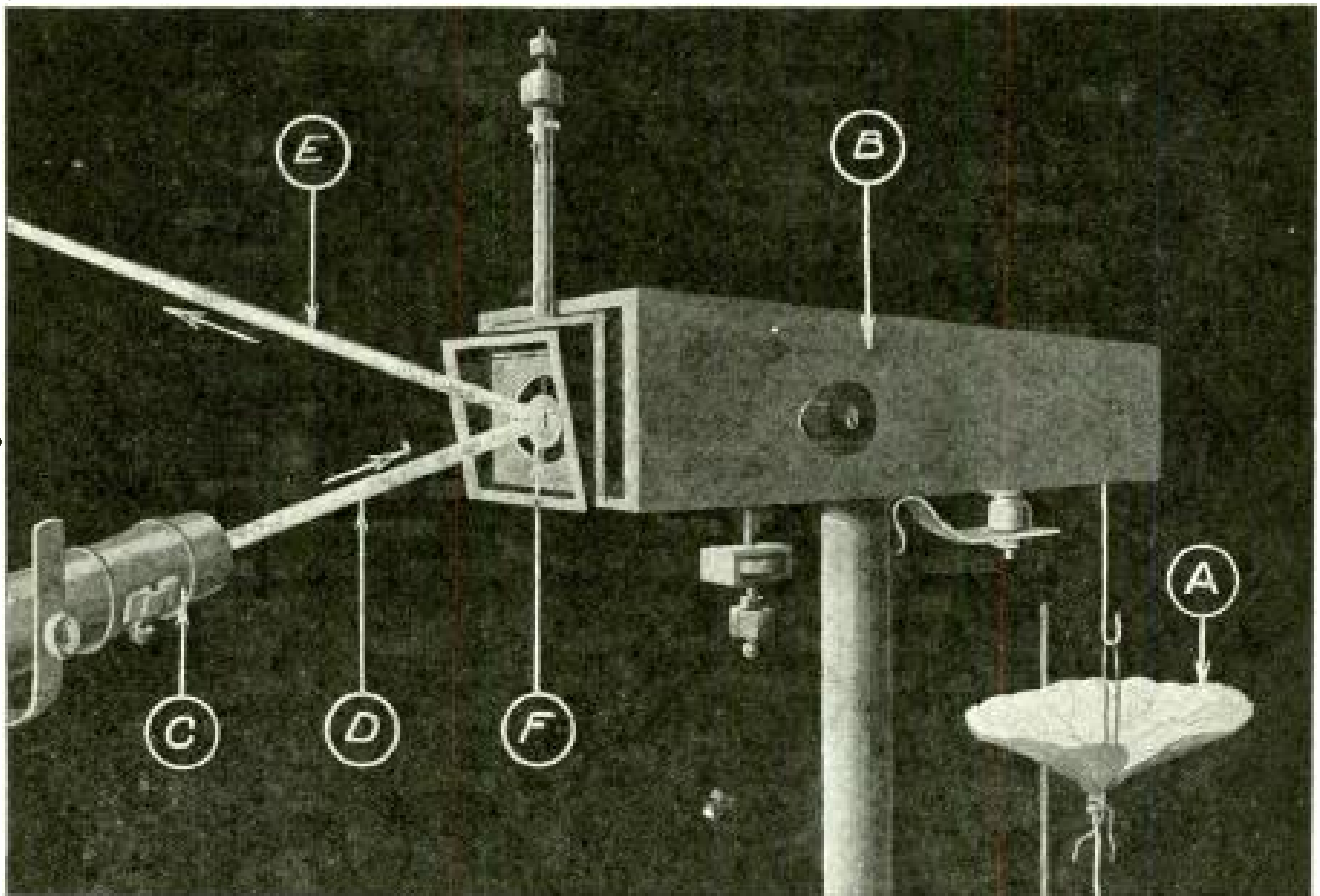

From a drawing by Henry M. Picken

#### HOW THE REACTIONS OF PLANTS ARE RECORDED

*A is the plant under observation which is held taut by a thread and lever fastened to the recording apparatus. B is the crescograph proper which contains a sensitive balanced magnet, which transfers the reactions of the plant to the small vibrating mirror F, so that a beam of light D projected from a lamp C is reflected along a path E to a sensitized screen which makes a permanent record like those shown on preceding pages of this article.*

Dissect this artificial eye and what do we see?

Merely two tiny crystals of galena, adjusted to contact-sensitiveness. These experiments, made about 1900, probably revealed for the first time the possibilities of the crystal detector. Bose may, therefore, be regarded as the pioneer of crystal detection.

Most astonishing of all is Bose's discovery that plants respond to radio stim-

ulation. He showed that very short electric waves retard growth. He proved with his magnetic crescograph, which magnifies plant reactions ten million times, that the perceptive range of a plant is inconceivably greater than ours. It may be that all the waves sent out by ships, great transatlantic stations, and by hundreds of broadcasting stations have an effect on vegetation which we may some day be able to understand.

### How to Make a Good Tube Receiving Set for Less Than \$16.00

*In the next issue of POPULAR RADIO—July—will appear a complete and detailed description of a remarkably simple but efficient long-distance receiver that any amateur of ordinary proficiency with tools may build at home. Ask your newsdealer TODAY to reserve a July copy for you!*

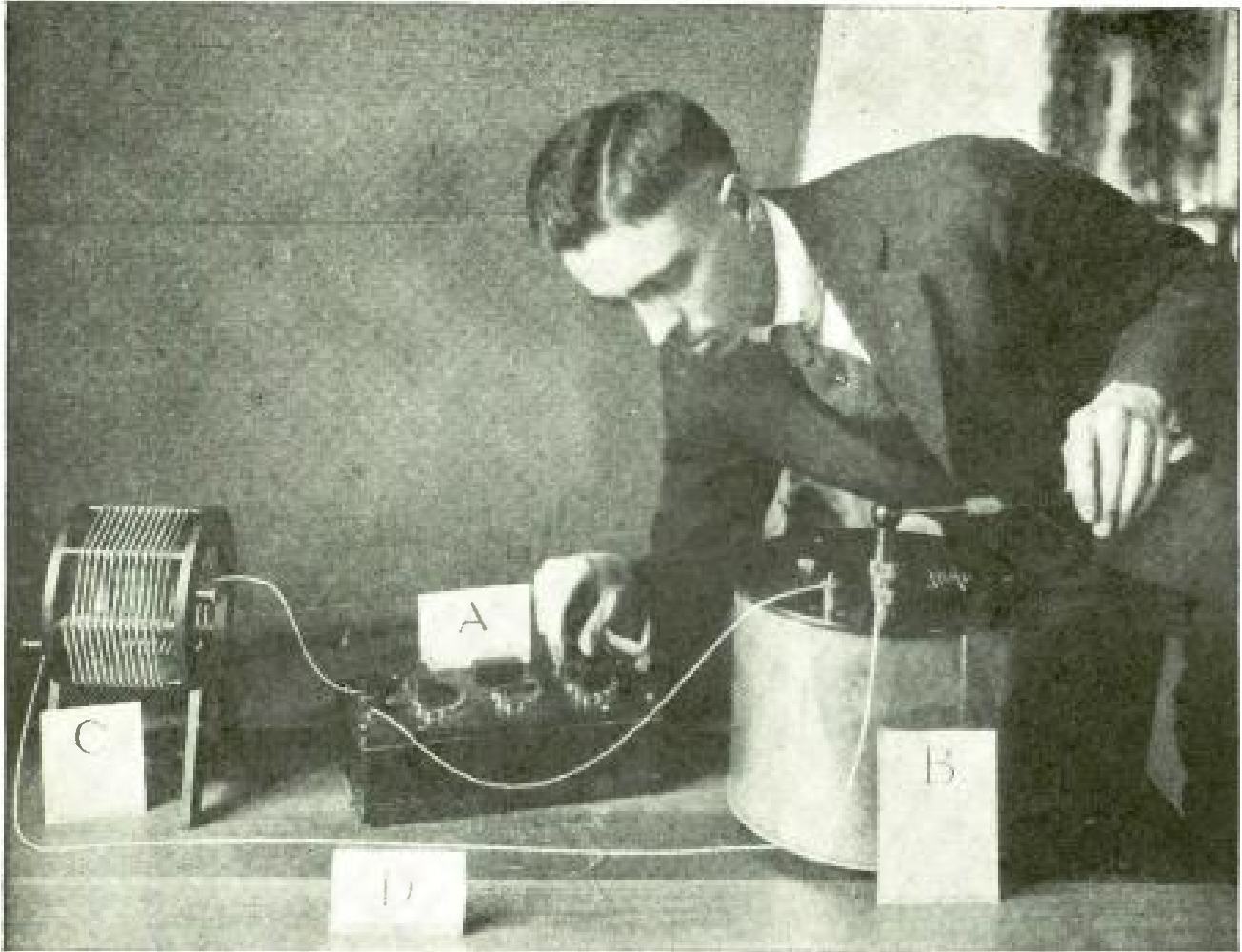

From a photograph made for POPULAR RADIO

#### THE "PHANTOM ANTENNA" USED FOR LABORATORY TESTS

*The author demonstrates the resistance box, A, which can be set at any value of resistance to be substituted for the resistance of the antenna; B, the variable condenser, which substitutes the capacity; D, the wire substituted for the ground, and C, the coil which furnishes the inductance which would be found in the real antenna. Mr. Strock is connected with the Bureau of Standards, and the following article was prepared by permission of the Director.*

## HOW TO DETERMINE THE Constants of Your Antenna

*Do you know the capacity of your aerial? Do you know its resistance? Do you know its inductance? If not, you do not know whether or not you are getting maximum results from it. This article tells you how to find out.*

By MORRIS S. STROCK

**W**HETHER an antenna is a poor or a good receiver of radio waves depends to a great extent upon its constants (electrical properties which can be determined by measurements or sometimes estimated or computed) and by another property of the antenna, "effective height."

The term "constant" is somewhat misleading because some of these electrical properties of an antenna vary greatly with the length of radio waves to which the antenna is tuned. But at a particular wavelength the constants of an antenna when used with a ground do remain much the same for a considerable period.

What are the constants of an antenna?

- (1) Resistance;
- (2) Capacity;
- (3) Fundamental wavelength, and,
- (4) Inductance.

The resistance of an antenna is the opposition which it offers to the flow of the high-frequency (rapidly reversing) currents induced in it by the radio wave. High-frequency or radio frequency currents flow only on the surface of a conductor. Therefore if the surface area is increased the resistance will be reduced. Antenna resistance is a complex quantity, but it may easily be expressed in ohms.

The capacity of an antenna is a property which enables it to hold a certain electrical charge, and then to discharge this in the form of electrical energy through the receiving set to earth. Capacity is expressed in microfarads.

The fundamental wavelength of an antenna is the length of the wave to which it will respond when it is connected directly to earth. Thus if an antenna has a fundamental wavelength of 290 meters, electrical vibrations or oscillations will be set up in the receiving antenna by a transmitting station that is sending out signals of this wavelength.

The inductance of an antenna is a sort of electrical inertia which retards the changes in the rapidly reversing current induced in the antenna by the incoming radio wave.

On page 448 is shown an artificial antenna in which the required value of resistance is obtained by adjusting the box A and the required value of capacity by adjusting the condenser B; while a fixed value of inductance is obtained in the coil C. The wire D represents the conducting earth under the antenna. The condenser B consists of two sets of overlapping plates which are at all times insulated from each other.

The interior of the condenser is shown in Figure 1. An antenna is a condenser in which the wires and the earth take the place of the two sets of overlapping plates. The coil C has about the same

inductance as the average simple receiving antenna. If the wire in the coil is unwound and pulled out straight, its inductance is much less. This explains why the long wire in an antenna has so small an inductance value. In practice no attempt is made to secure a certain value of antenna inductance. The constants in the artificial antenna are "lumped"; in a real antenna they are "distributed."

If the inductance and capacity of an antenna (artificial or real) are increased, its fundamental wavelength is increased. (The capacity is more easily changed than the inductance.) The resistance has no effect on the fundamental wavelength, but if the resistance is increased the current induced by the radio wave is decreased.

Imagine that the inductance of the artificial antenna is "distributed," and that the coil C is the tuning coil of the receiving set. Then we may connect a variable condenser across the terminals of the coil, and thereby increase the wavelength to which the complete antenna system will respond. To decrease the wavelength of the system, we may insert the condenser in the wire leading from the right-hand terminal of the coil to the box A.

The artificial antenna on page 448 is a poor receiver of radio waves because its dimensions are so small that it cannot pick up much energy.

In Figure 2 is shown an antenna (erected on the roof of the Radio Building at the Bureau of Standards) which is used for receiving from radio telephone broadcasting stations. The antenna is 115 feet long and 18 feet above the roof. The lead-in wire (shown at the right end) is 45 feet long and passes down the far side of the building, and then through a window. The resistance of this antenna was measured first with a ground connection made to a gas pipe (inside ground), and then with a ground connection made to a pipe driven into the ground (outside ground) directly below

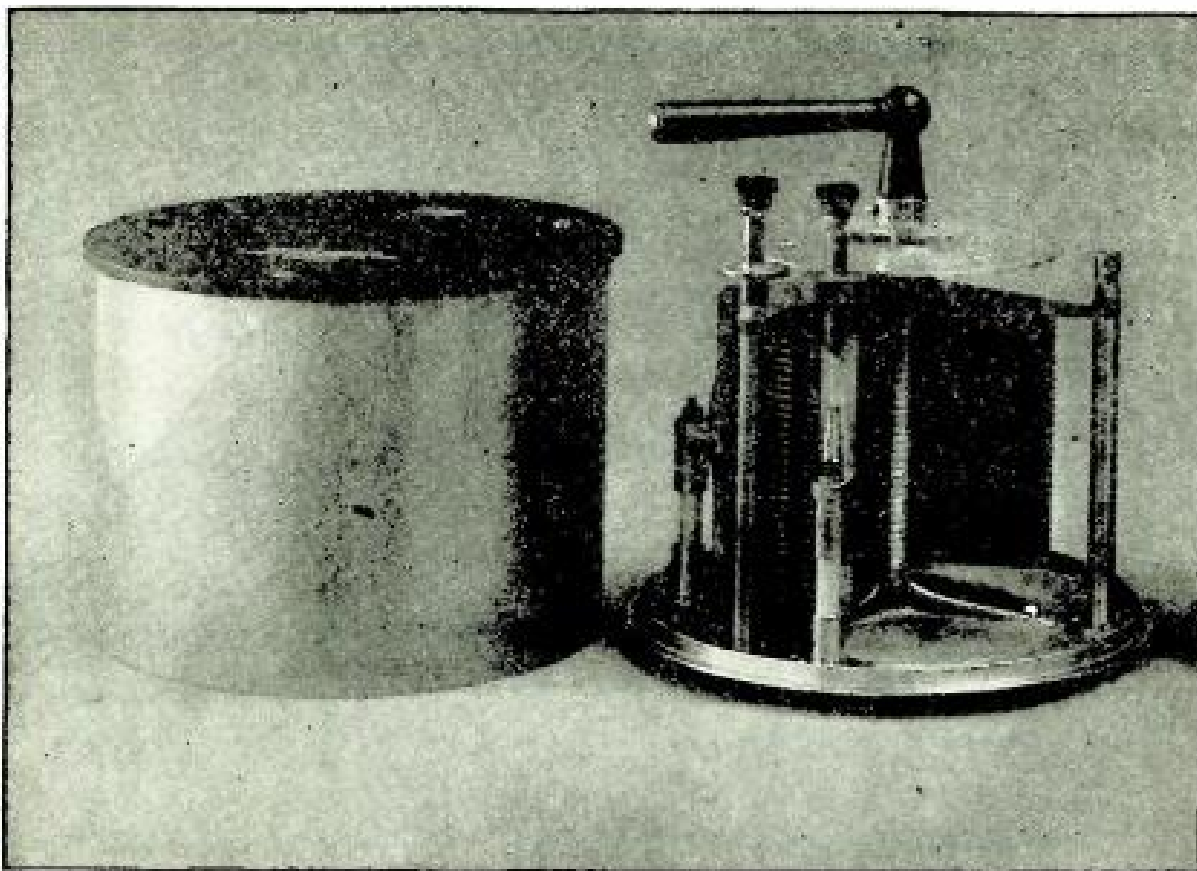

#### A DELICATELY CALIBRATED VARIABLE CONDENSER

FIGURE 1: Here is shown a standard variable condenser which has been taken out of its protective casing. By rotating the black lever the rotary plates telescope inside of the stationary plates and the capacity of this instrument is varied. This instrument is used in the phantom antenna which is shown at B in Figure 1.

the lead-in wire. The measurements were repeated with a single wire in the horizontal part of the antenna. The other constants were measured with the inside ground only as the particular kind of ground connection would make little difference. The results of these measurements are given below:

##### RESISTANCE WITH INSIDE GROUND

*At 1,110 Meters*

- 14 ohms (two-wire antenna)
- 6 ohms (single-wire antenna)

*At 400 Meters*

- 34 ohms (two-wire antenna)
- 43 ohms (single-wire antenna)

*At 360 Meters*

- 45 ohms (two-wire antenna)
- 37 ohms (single-wire antenna)

##### RESISTANCE WITH OUTSIDE GROUND

*At 1,110 Meters*

- (Not measured for two-wire antenna)
- 16 ohms (single-wire antenna)

*At 400 Meters*

- 22 ohms (two-wire antenna)
- 23 ohms (single-wire antenna)

*At 360 Meters*

- 23 ohms (two-wire antenna)
- 17 ohms (single-wire antenna)

##### CAPACITY WITH INSIDE GROUND

- 0.00053 microfarad (two-wire antenna)
- 0.00038 microfarad (single-wire antenna)

##### FUNDAMENTAL WAVELENGTH

- 230 meters (two-wire antenna)
- 190 meters (single-wire antenna)

##### INDUCTANCE

- 25 microhenries (two-wire antenna)
- 22 microhenries (single-wire antenna)

These results show that the resistance of an antenna varies with wavelength, and that at the shorter wavelengths it was reduced by using a single-wire antenna with an outside ground connection. Antenna capacity decreases as the wavelength increases, and then becomes approximately constant. The higher fundamental wavelength of the two-wire antenna is due to higher capacity and inductance as compared with a single wire.

How may one determine the constants of an antenna?

Resistance can only be measured with special apparatus which is elaborate and expensive. It can *not* be computed. The

other constants can be measured with less elaborate and, consequently, less expensive apparatus. It is also possible for one who owns a receiving set to measure these other constants with fair accuracy by adding a few simple pieces of apparatus. This method can not be described here, owing to lack of space.

Capacity can be computed, although in many cases it is necessary to make allowances for intervening objects, and other factors. On some antennas the computed capacity will check closely with that measured. In other cases the accuracy is not so good. In the formula

$$C = \frac{12.2 h \sqrt{A} + 2.7 A}{1,000,000 \times h} \dots (1)$$

- C = capacity in microfarads
- h = height of antenna above ground in feet
- A = area of horizontal portion of antenna in square feet

To apply this formula to a single-wire antenna, A is obtained by multiplying the length of the nearly horizontal portion of the antenna by 2.5. The result obtained for C must be multiplied by a factor as follows:

LENGTH OF ANTENNA (IN FEET)	FACTOR
30	1.12
40	1.16
50	1.2
60	1.24
70	1.28
80	1.32
90	1.36
100	1.4

Owing to conditions about the average receiving antenna, this result should now be increased by about 20 percent. The factor is not used when the antenna has more than one wire and in addition has a length less than eight times its width.

Fundamental wavelength in meters may often be accurately computed for a single-wire antenna by multiplying the total length of wire in feet by 1.37. Practical allowances can be made for an antenna of several wires close to obstructions, although the result will not be so reliable.

The inductance (L) of an antenna can not be accurately computed by a theoretical formula. It can be computed after one knows the fundamental wavelength ( $\lambda_0$ ) and capacity (C), from the formula

$$L = \frac{\lambda_0^2 \dots \dots \dots (2)}{3,550,000 \times C}$$

If the reader has not the facilities for measuring antenna constants, he may determine them by applying the formulas just given.

To illustrate the method some typical antennas will be considered. The preceding formulas and the following examples apply to "L" antennas—the type used in the majority of cases. If the lead-in is taken from the center, the capacity remains about the same, but the fundamental wavelength is decreased.

*Example 1:*

A single wire 80 feet long and 40 feet high; lead-in wire is brought down vertically from one end. The antenna and lead-in are clear of obstructions. If the ground connection is good, the resistance of this antenna at 360 meters should not be more than 15 ohms.

To compute the capacity use formula (1) and let  $h = 40$  and  $A = 80 \times 2.5 = 200$ . Substituting these values in formula (1)

$$C = \frac{12.2 \times 40 \sqrt{200} + 2.7 \times 200}{1,000,000 \times 40} = 0.000186$$

This value is multiplied by the factor 1.32 giving

$$C = 0.000245$$

increasing the value 20 percent gives.  
 $C = 0.000294$  microfarads

If the antenna is close to trees or obstructions, or if the lead-in is closer than one foot from the building, the capacity will be increased still more.

The total length of wire (vertical and horizontal) in this antenna is 120 feet. Multiplying this by 1.37 gives 165 meters as the fundamental wavelength. Add 10

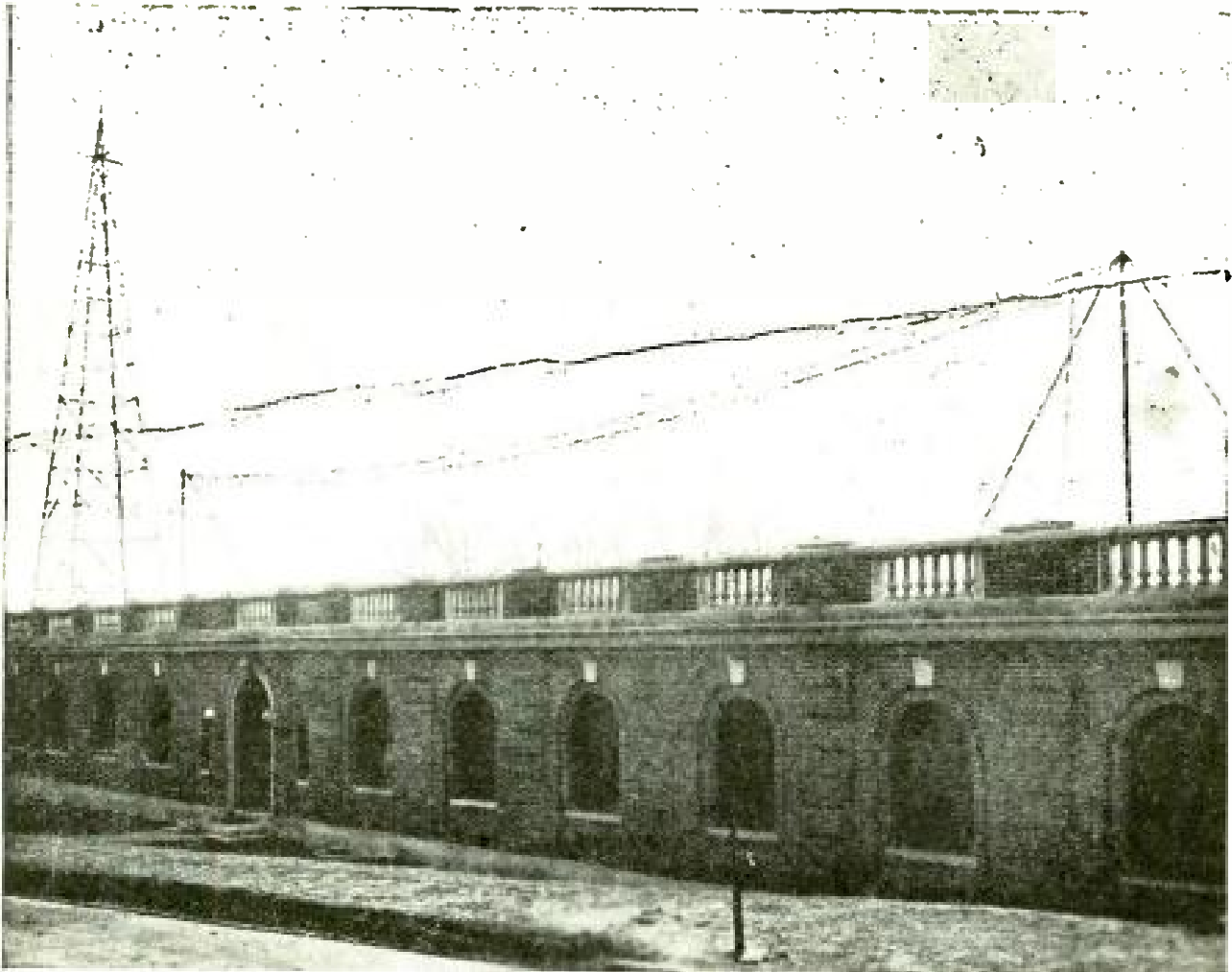

#### WHERE UNCLE SAM TESTS AMATEUR AERIALS

FIGURE 2: A special two-wire testing antenna used by the Bureau of Standards in Washington. This is of the inverted L type, and was used for making the determinations explained in this article.

percent to this value if the antenna or lead-in is close to obstructions.

Inductance is computed from formula (2) and is:

$$L = \frac{(165)^2}{3,550,000 \times 0.000294}$$

$$= 26 \text{ microhenries}$$

The same method of computation may be applied to single-wire antennas of various heights and lengths.

#### Example 2:

A two-wire antenna 40 feet long and 50 feet high with the wires three feet apart; the lead-in wire is brought down vertically from one end. With a good ground connection the resistance of this antenna, if it hangs clear in space, should not be more than 10 ohms at 360 meters. Because of its comparatively short length

this type of antenna is likely to be erected in a restricted space. In this case its resistance may be increased two or three times. The capacity is computed as before, using  $A = 40 \times 3$ , and is found to be 0.000192 microfarads. (If the wires are closer than 3 feet, the value of  $A$  is the same). Although the antenna has more than one wire, its length is greater than eight times its width; a factor of 1.16 is therefore used in obtaining the result. As before, buildings or obstructions which are very close will increase this capacity.

Multiplying the total length of wire (90 feet) by 1.37 gives 125 meters as the fundamental wavelength. This antenna has a capacity somewhat higher than if a single wire were used. The fundamental wavelength is thereby increased. To allow for this, increase 125 by 15 percent. This gives 145 meters



for the fundamental wavelength. Again increase this value by 10 percent if obstructions are near. Inductance, computed as before, is 23 microhenries.

What is the best receiving antenna?

This is not an easy question to answer; in fact it can not be answered at all unless one knows the location of the antenna and the type of receiving set.

If you have a receiving set with a regenerative tuner or one that employs some kind of radio frequency amplification it is not necessary to have a very high antenna; in some cases a high antenna may be a disadvantage. If you live in a part of the country where static is bad, a high vertical antenna (especially one of several wires) is undesirable. Instead, a single horizontal wire should be used. But if you have a receiving set with a simple (non-regenerative) detector and not more than one step of radio frequency amplification, it is well to have the antenna as high as possible, and also to keep it away from all obstructions. A receiving set connected in the ground lead close to the ground increases the effective height of the antenna and improves reception.

The following points apply irrespective of the kind of receiving set:

(1) Unless you are using an antenna near its fundamental wavelength or one which is exceptionally long compared to its height its directional effect will be slight and not worth considering.

(2) The antenna and lead-in should be kept as free as possible from swaying. The lead-in should be kept as far from obstructions as possible. The vertical part of an antenna is as important as the horizontal part. After the wire has entered the building, it must not be tacked to the wall.

(3) No. 14 copper wire is large enough for any ordinary receiving antenna and ground connection. Larger wire or stranded wire is better because it is mechanically stronger. Of course the greater the surface area, the lower the resistance, but in practice there are

so many other features of resistance involved that a larger conductor than No. 14 is not necessary. It makes no difference whether the wire is bare or insulated.

(4) All connections, especially those made outdoors should be soldered; this insures permanently low resistance. Ground connections to a pipe can best be made with a clamp; a clean surface for contact should be secured. It sometimes happens that a receiving station is situated where the soil is dry and where there is no natural ground connection; in this case a counterpoise (which is nothing but another antenna suspended near the surface of the ground, under the regular antenna) should be substituted. The counterpoise should consist of several parallel wires.

(5) Unless a high antenna is used, natural supports can usually be found. The ropes that support the antenna should have insulators inserted in them. Glazed porcelain is best, but oak blocks boiled in paraffin can be used.

(6) If the fundamental wavelength of the antenna is above 250 meters, a condenser connected in series with the wire leading to the receiving set should be used. If a fixed condenser is used its capacity should be about 0.0003 microfarad. To allow tuning to a wider range of wavelengths a special switch may be used in such a way that a variable condenser may be connected in series with the coil or shunted across the terminals.

(7) It is a good plan to take the lead-in from the center of the antenna instead of the end, when by so doing extra bends can be eliminated.

(8) A water pipe is a better ground connection than a radiator or gas pipe. An iron pipe driven several feet in *moist* earth may be used.

(9) A single wire will usually give as good results as several wires in the horizontal portion of an antenna. If space is limited, two or more wires may be used.

This article concerns antennas most effective in the reception of wavelengths between 200 to 450 meters.



From a photograph made for POPULAR RADIO

**"FRANKLY, I CANNOT FOLLOW PROF. MORECROFT'S  
LINE OF REASONING"**

*In certain essential particulars, Mr. Benchley's conceptions of radio phenomena differ radically from Prof. Morecroft's. "At least," he states, "I am bound by no traditions or preconceived notions."*

## THE TRUTH ABOUT The Heising Scheme for Modulation

—As I See It

A REMARKABLE COMMENTARY ON A REMARKABLE BOOK

By ROBERT C. BENCHLEY

**D**IRECTLY at the start of his "Principles of Radio Communication" (John Wiley & Sons) Prof. J. H. Morecroft falls into a regrettable error. "Everyone is more or less familiar," he says in his opening sentence, "with elementary experiments having to do with electrically charged bodies."

This is obviously an overstatement.

I, for one, am not familiar to any degree at all with electrical experiments. I have never rubbed fur on a dry day, neither have I polished a glass rod with a cloth to induce it to attract bits of paper. I have had other things to do. Furthermore, I am quite sure, if one day I *did*

have the leisure and the roving inclination to rub a glass rod with a cloth, that it would turn out to be the first glass rod in the history of electrical experiments which would *not* attract bits of paper. Rather than face this humiliation, I expect never to try.

Thus we see at the very beginning that Prof. Morecroft has generalized too freely. In this large manner he continues:

"It has been firmly established that every atom of matter is charged with minute particles of negative electricity, so-called *electrons*."

All right, Prof. Morecroft, supposing

that I, as a doubter bound by no traditions, should say flatly that this is not so?

Suppose that I were to deny that every atom of matter is charged with minute particles of negative electricity and assert that, on the contrary, every atom of matter contains minute particles of fresh figs? What would you do about it? Bring a representative selection of atoms to my office on any day that you may choose and we will go over them, one by one, together!

Perhaps this is quibbling. I really don't know. However, I will string along with Prof. Morecroft from this point through his remarks on "Mutual Induction and Magnetic Coupling" (I thought there might be something spicy in that one, but there wasn't), "Decrement from Form of Resonance Curve" and "React-

ance and Resistance of Parallel Circuits," and all without a protest. Not one word of it meant anything to me, so I see no use in protesting, even though I am quite certain that most of it is entirely wrong. It simply sounds wrong to me, that's all. I can't help how I feel, can I?

It is not until page 665, on which begins an analysis of the Heising Scheme for Modulation, that my blood boils and I am unable to control myself any longer. In the first place, I have no patience with all these new-fangled schemes for modulation. Why can't they let well-enough alone? As a matter of fact, this whole radio business, from start to finish, seems quite unnecessary. I was getting along all right before it was invented and I still manage to scrape along without knowing any more about it than I can help. If

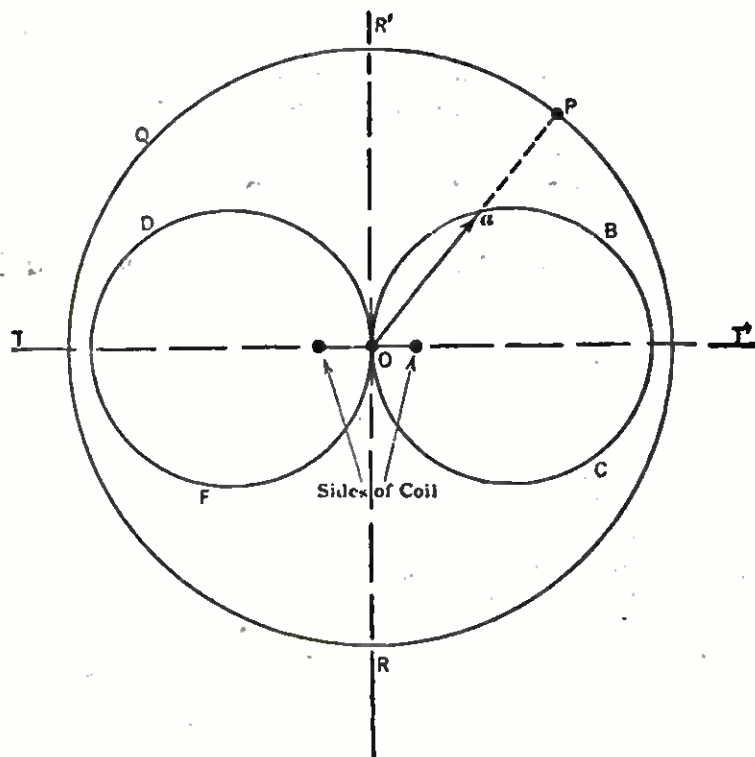

FIGURE 1

The above cut is taken from page 710 of Prof. Morecroft's book. For lack of a better caption we will call it "Full-face personality photograph of Common or Typhoid-Bearing House-Fly (magnified 1,000 times and even then it wasn't satisfied)." The reader will note, by following carefully the line T-T that not only has the static been done away with but that the fly can see just as well as it ever could, in fact, probably better. The food, entering at R, is carried by a special series of coils to F and C, where it waits twenty minutes for a connection with the train from South Framingham. Where Prof. Morecroft falls down is in supposing that the rim of the circle is going to run through P necessarily. According to the old plans, it would run eight miles to the north, which would make the Professor's chart look pretty silly. An odd thing about this figure is that, no matter in what part of the room you stand, the fly always seems to be looking at you and following you with his eyes. Try it and see.

I had my way, the whole thing would be stopped by law before someone gets hurt.

But this Heising modulation scheme strikes me as particularly pernicious. In order to understand it you have to refer to a picture on the opposite page which shows the number of yards gained in rushing by Yale in the first half and the number of yards gained by Harvard's punting in the second. Then there is, in the same picture, a good idea of what the dining-room groundplan will look like, with the stairs leading up out of it into the second floor. Also a cross section of the first bicycle blue-prints.

Working with this picture as a base, you assume (just for fun) that the microphone is actuated by a sine wave of

sound, and *furthermore* (get this, now) that the sine wave of sound gives a sine wave of e.m.f. across the secondary terminals of the transformer S.

All right. That is assumed.

*Note.* In order that the possible variation in the impedance impedance of the grid-filament circuit of the modulating tube may not produce distortion of the terminal voltage of the transformer secondary, a high resistance R of constant value is permanently connected across the secondary to give the load circuit of the transformer an essentially constant impedance. That is, of course, provided that there are no other bookings for the hall on that night.

You can't make me believe, however,

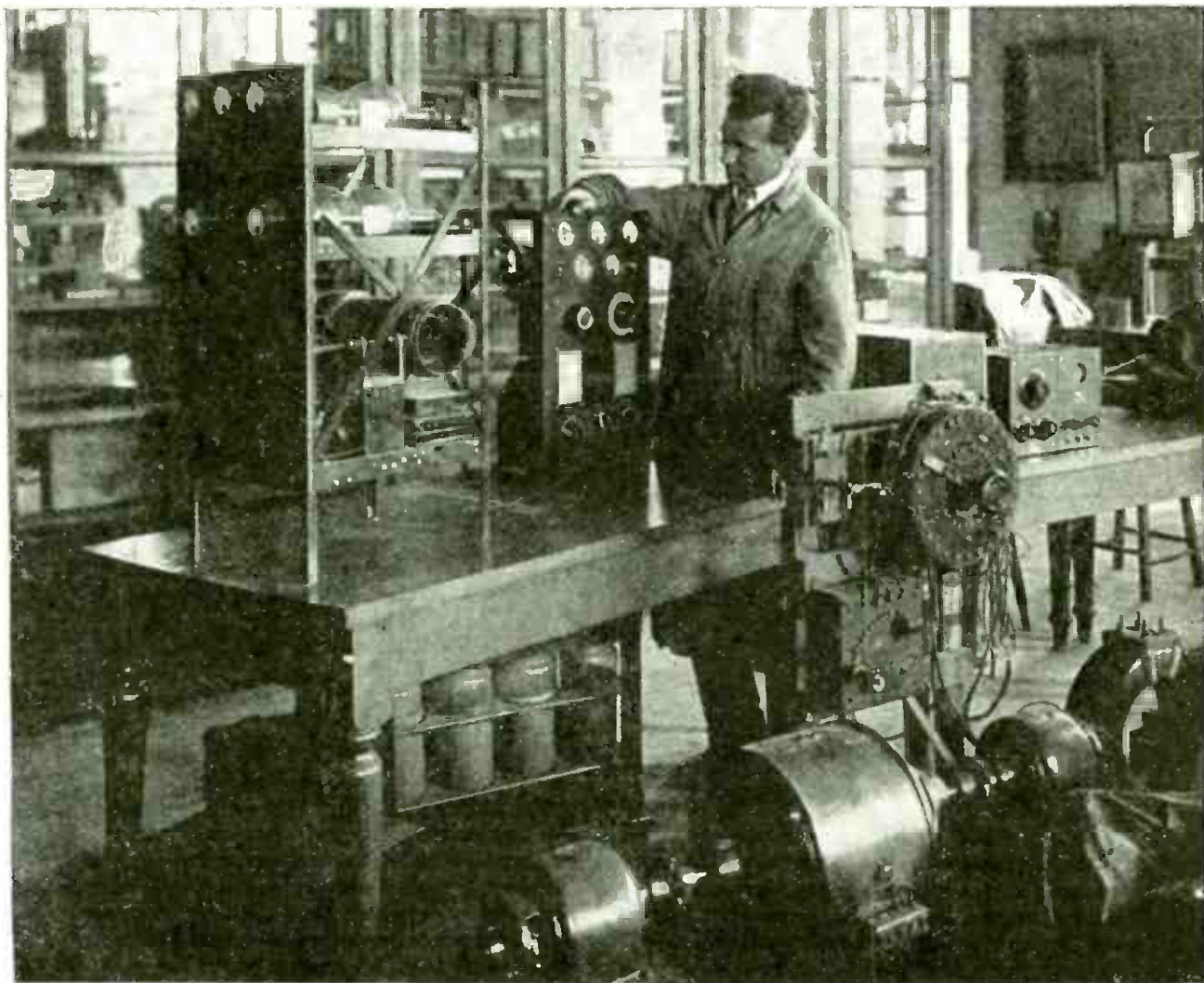

From a photograph made for POPULAR RADIO

### ONE OF AMERICA'S FOREMOST AUTHORITIES ON RADIO PHENOMENA

*Prof. J. H. Morecroft of Columbia University, engaged in experimental work on vacuum tubes in his laboratory. He is the author of a book which is the subject of comment in the accompanying text.*

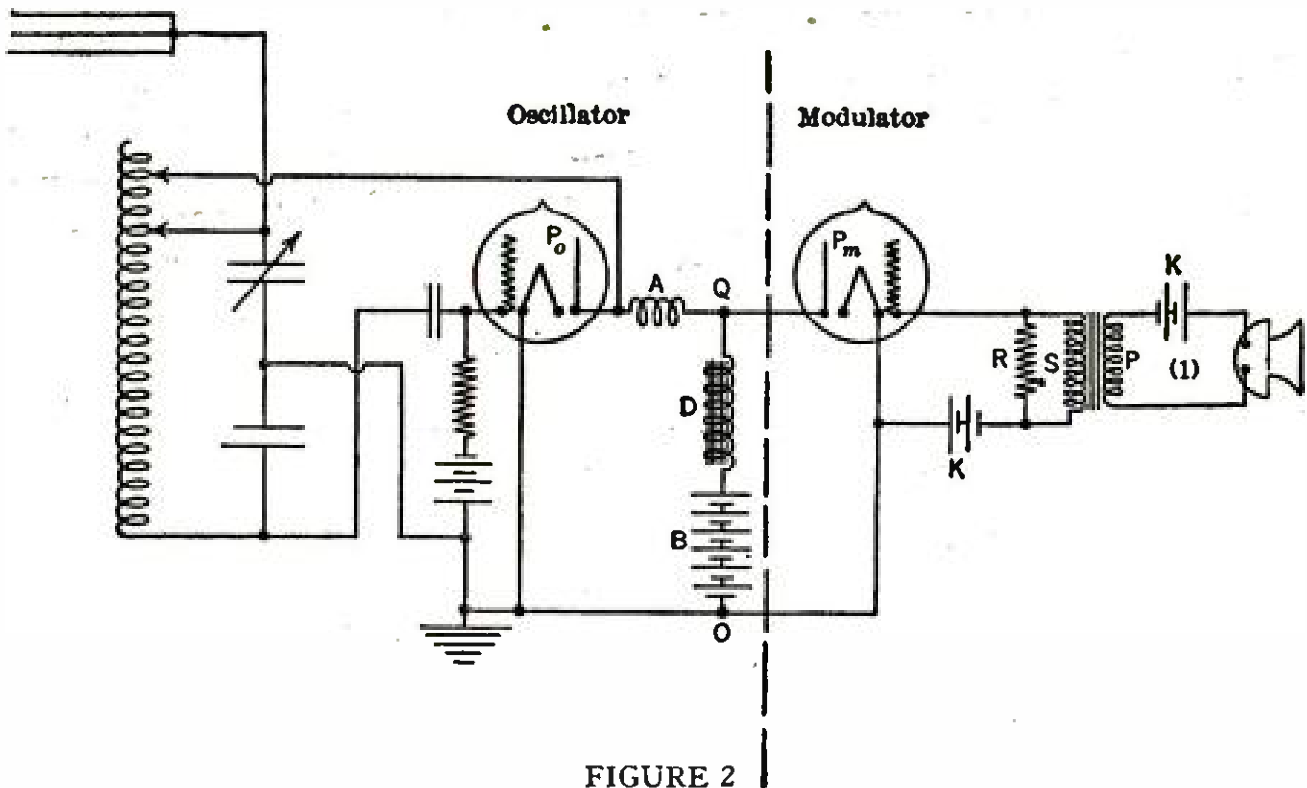

FIGURE 2

*This graphic representation of the Heising scheme shows at a glance not only the number of yards gained by Harvard's punting in the second half of the football game, but also how the dining-room floor plan will look with the stairway and a cross section of the first bicycle blue-prints.*

that it is as simple as all that. There is a catch in it somewhere. And here it is. Below we find:

Average value of  $I=0.08$  ampere  
Inductance of coil  $D=2$  henries.

Now, of course, the ampere part is clear enough. And so is the "2 henries," for that matter, but it does seem as if Prof. Morecroft had picked a peculiarly unhappy place for kidding. Probably he would have liked to have gone on in the same vein:

Inductance of antenna= $6$  ralphs  
e.m.f. vector= $3$  theodores  
decrement of wave-meter= $14$  georges.

In a way, this flippancy is characteristic of the chief trouble with Prof. Morecroft's book. It is just kid, kid, kid, all the way through. Of course, we all realize that every subject, even radio, has its lighter side, but it does seem as if a professor in Columbia University might by this time be able to deal seriously and soberly for at least ten successive pages without recourse to gags and sure-fire laughs.

If you have a spare evening and want a good book to pick up and throw down, "Principles of Radio Communication" will suffice, but for solid instruction it is much too light.



#### ONE OF THE COMING FUNCTIONS OF AMERICAN UNIVERSITIES

*"I am personally interested in the market of radio extension education, as I believe it to be one of the coming functions of American universities.*

R. H. GODDARD  
Clark University

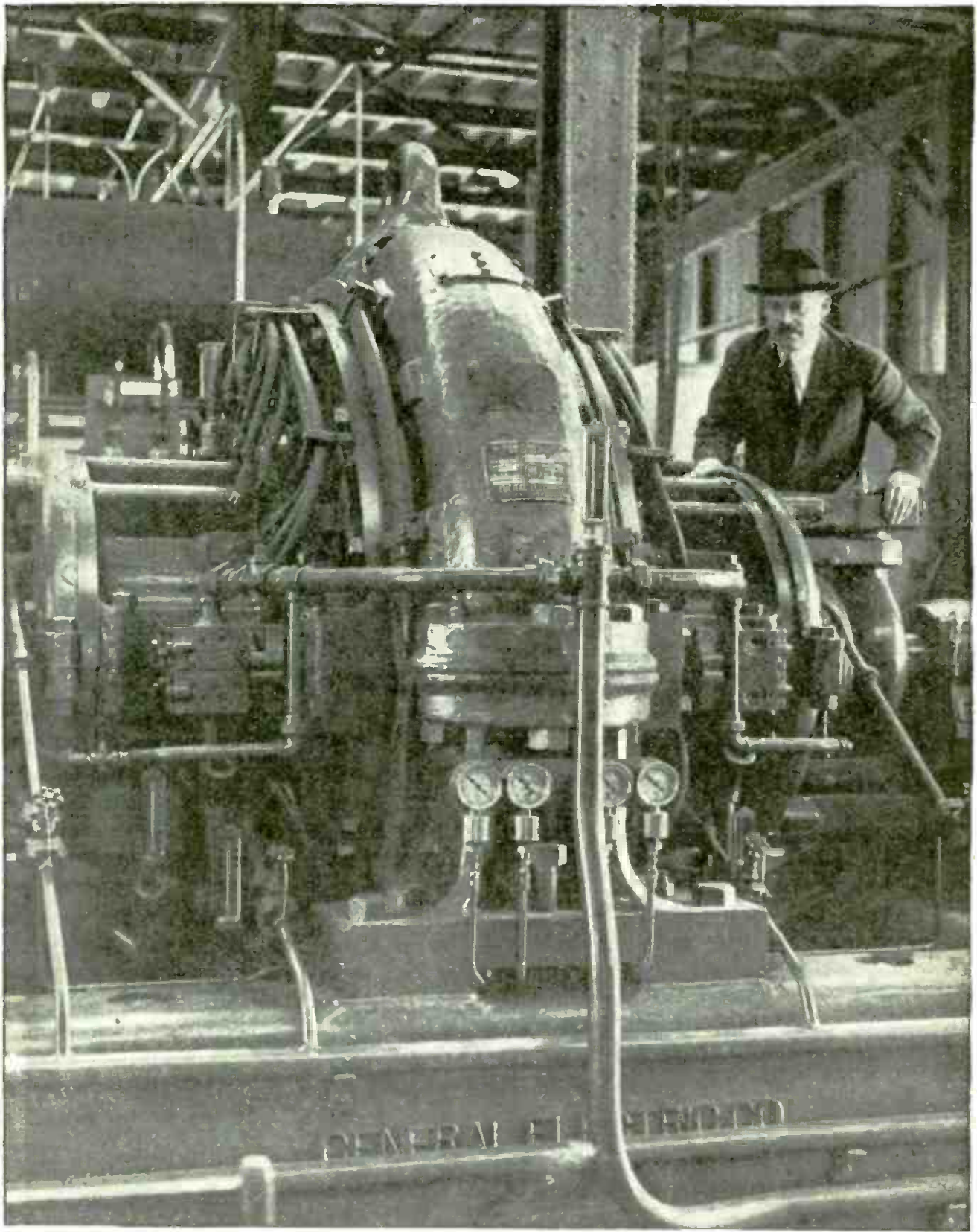

General Electric

### This Mechanical Monster Produces a 30,000-Meter Wave

*The higher wavelengths used in transatlantic radio communication, ranging from 10,000 to 30,000 meters, are made possible by the power generated by this Alexander-son type of high-frequency alternator. Several of these whirling giants are used for energizing the antennas of the transmitting stations at Radio Central on Long Island, New York. Its inventor, Dr. E. F. W. Alexanderson, is here shown viewing his remarkable brain-child.*

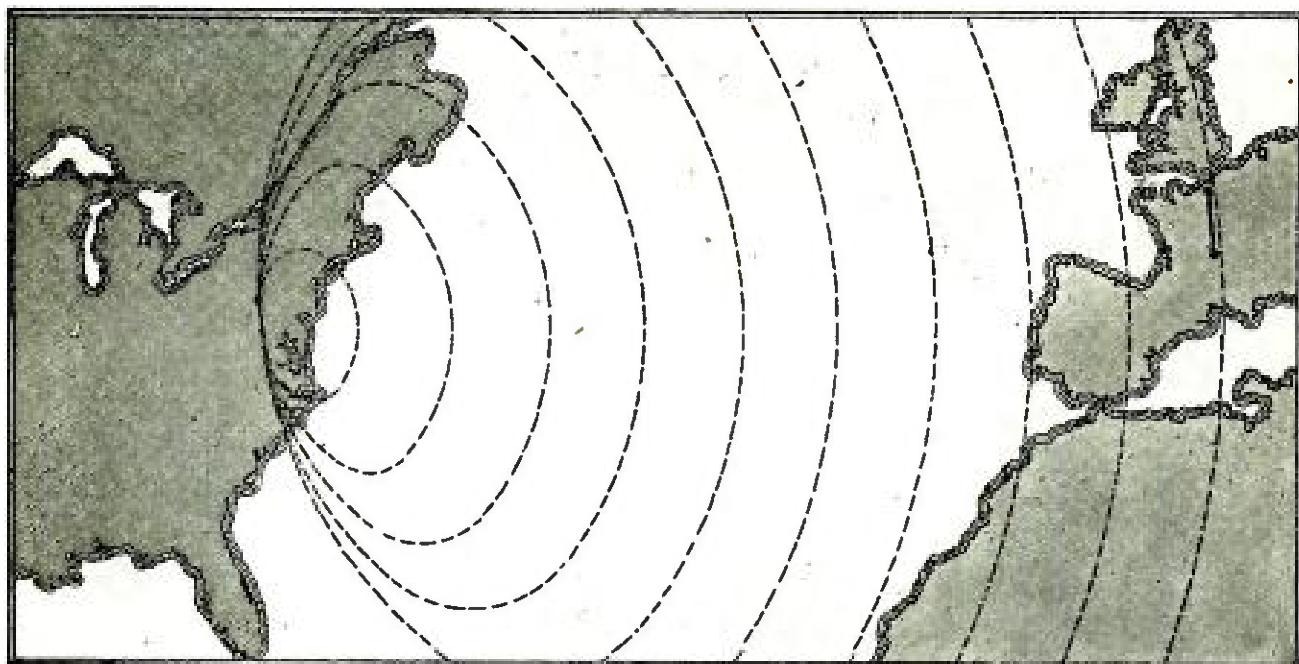

#### A PLAN FOR SPANNING THE ATLANTIC ON LOW POWER

*At present transatlantic communication is carried on with high power on wavelengths up to 30,000 meters—waves which are inaudible. By using base-line antennas about 220 miles long this communication may be carried on at still longer wavelengths with waves that are audible.*

## THE COMING USE OF Frequencies That We Can Hear

*Experiments with audio frequency shows that its possibilities in "earth telegraphy" have scarcely been realized. Its application to the longer wavelengths is here pointed out.*

By OSCAR C. ROOS

THE temptation at the present moment is to ignore the field which modern high-power transmitting stations are approaching—the 30,000 meter wave and over; radio experimenters and the electrical world in general are directing their attention at present to very short waves. For that matter very short waves have been neglected for years; they have been used only occasionally as scientific tools in the laboratory, although Stone, Ladd and Marconi have used the shortest wavelengths—going down to two meters.

But the long wavelength—a wave, for instance, nineteen miles long which does not radiate until about five miles away from the station—is sure to be of interest.

The great drawback at present to the use of such waves is the fact that the radiant point, or rather cylinder, around a station allows less and less energy to flow out in the form of waves as the field gets weaker. The balance goes back to the antenna as the energy of a stationary wave, giving effects of distributed self inductance and capacity. This is the reason why power wires radiate very little energy at 60 cycles a second. The radiant cylinder for a vertical power wire under these conditions in New York would pass close to Atlanta, Nashville and Chicago—about 775 miles away. With such a weak field the radiation is immeasurably small.

It is worth while to dwell on the real meaning of the radiant cylinder. It is

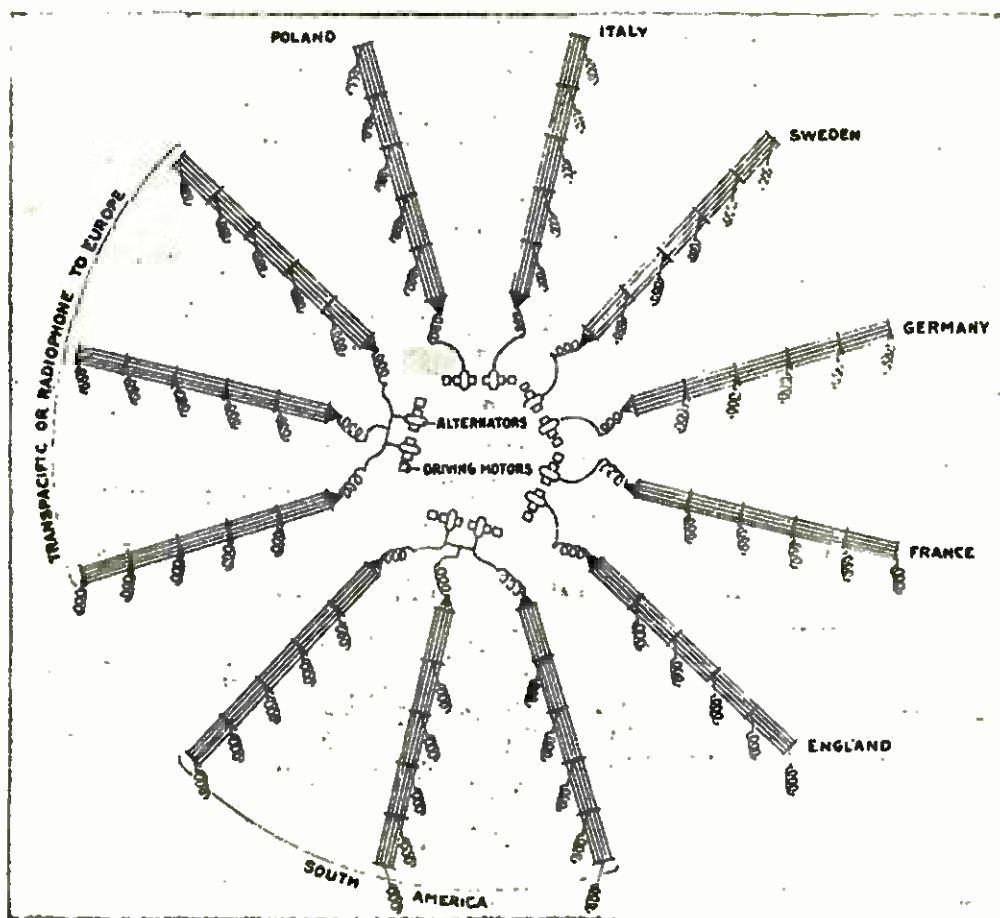

Radio Corporation of America

#### A LONG WAVE ANTENNA SYSTEM

*How the powerful high frequency alternators are connected to the multiple-tuned antennas at Radio Central. Most of the antenna systems are pointed in the opposite direction from the country with which they communicate.*

a cylinder rather than a sphere, as relatively little energy is radiated vertically; and in any case the comparison is only intended to indicate that the greater part of the energy is traveling in a direction parallel to the imaginary plane touching the earth at the station. The use of the long wave creates problems of ground and dielectric losses which increase with the wavelength and are produced through direct induction by the stationary waves set up in the antenna system and in surrounding metallic systems, especially if there are any short waves produced in the form of harmonics.

It is more than probable that circuits in which the natural wavelength is many times as long as the greatest mechanical dimension, will be used in handling long waves; this has been done by Alexanderson and others with the multiple-tuned antenna. Most linear objects when oscillating have a wavelength be-

tween 2.1 and 2.5 times their dimensions; thus the difference in behavior of these two classes of circuits, used with proper amplifiers for receiving, opens a large field for experimentation.

It has been maintained by French engineers that the possibilities of audio frequency have not yet been realized in connection with "T. P. S.," or what is known as earth telegraphy. Judging from their work in the World War, an antenna ten miles long would give reliable communication under average conditions with another parallel to it—300 miles away overland.

Reasoning along these lines and bearing in mind the much less favorable conditions of transoceanic work, they believe that a ground antenna of about 220 miles in length, situated on the French coast, would provide excellent communication with a similar antenna in the United States.



Such a system is illustrated on page 459. In this system the transmitting and receiving wires should be near the shore and arranged so as to be parallel, with the ends grounded. They would have the same natural frequency as the wave to be transmitted, and undamped waves would be used which could be heard without a detector to rectify them. The ratio of antenna length to range is now more than 50 on land, but would be less over the sea.

It has often been suggested that audio frequency waves be used commercially in "T. P. S." For the average person this would mean a wavelength greater than 30,000 meters, although many engineers can hear LY (the Lafayette station at Bordeaux) on a 6-stage radio frequency amplifier without a heterodyne. The ordinary telephone diaphragm can be made to vibrate at these high rates if the frequency coincides with the natural overtones of the diaphragm.

If audio frequency waves were used the detector tubes themselves might give out a note; the Lafayette station, at 22,100 meters, gives out a frequency of

13,630 cycles or about two octaves above the top note of the piano. The wavelength of this sound in air is about one inch, and one engineer in a testing station at Rockland, Maine, where signals were being measured, could hear these acoustic waves in a room twenty feet from the set.

The advantages of doing away with detectors and audio amplifiers are obvious. If the telephone for transforming sound to electric currents and *vice versa* could be replaced by a device which would have little or no mechanical inertia, the problem of reducing static by acoustic means to a negligible amount would be permanently solved and long distance radio communication at the longer wavelengths would be assured.

The use of such waves would call for the introduction of reliable mechanical relays, and if real rectifiers were combined with them and the heterodyne principle used to produce pulses at 10 to 100 a second, we could actually use tuned relays for recording the messages. This would minimize both static and interference to a large extent.

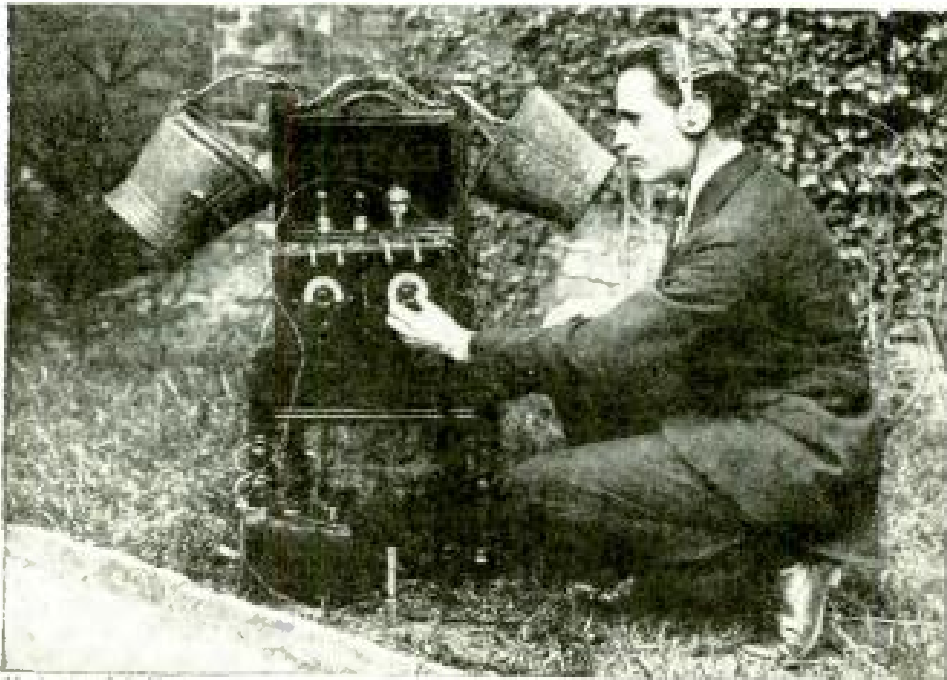

Underwood & Underwood

**BAILING MUSIC FROM THE ETHER WITH A PAIR OF PAILS**  
*A radio fan in Sheffield, England, has found that it is unnecessary to purchase a loop antenna as long as his garden is furnished with two ordinary tin pails. Using them as a literally "home-made" loop, he has had no trouble in picking up music broadcast from Manchester and London.*

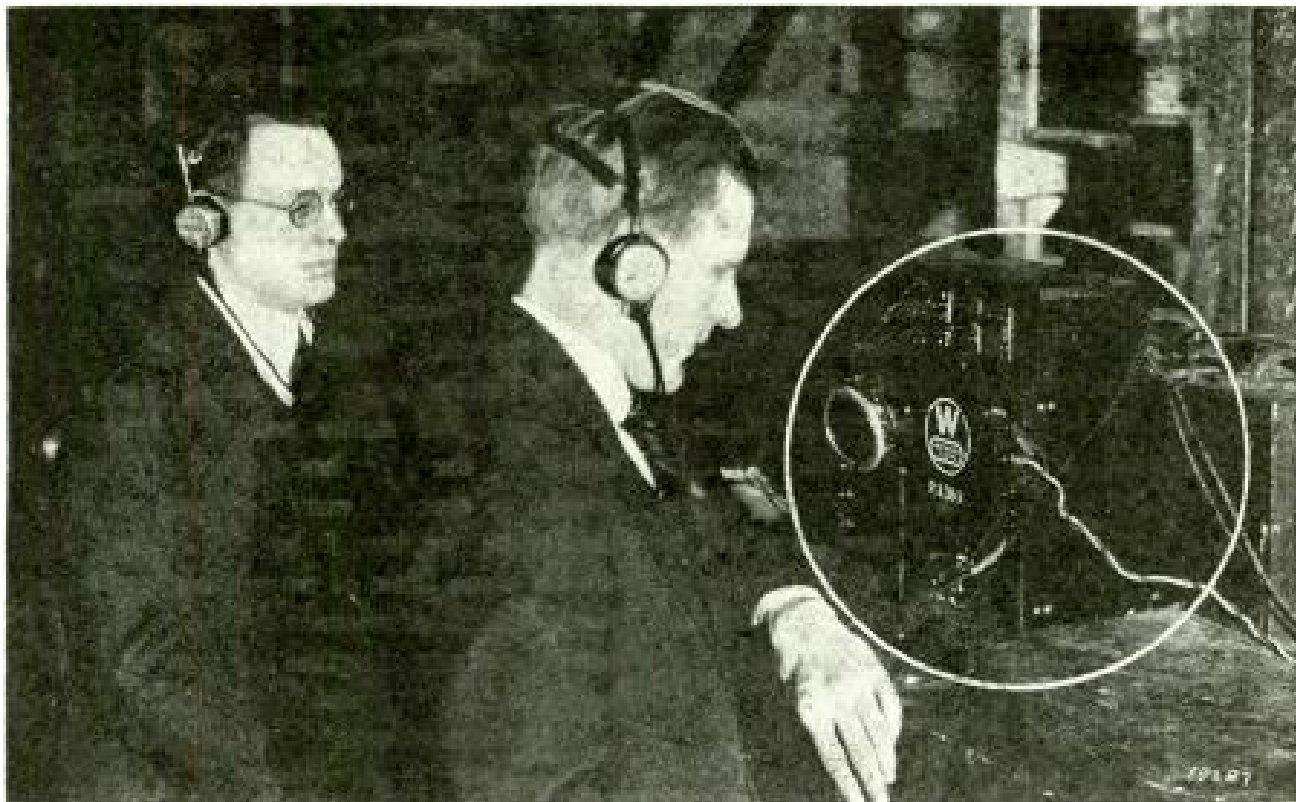

From a photograph made for POPULAR RADIO

#### THE "OFF STAGE" MEMBER OF THE CAST

*In the wings—just out of sight of the audience—the announcer and listener carefully regulate the volume of the production as picked up by the microphones. In the circle is shown the pick-up speech amplifier box with the microphone switch box on top of it.*

## Wagner by Wireless

The broadcasting of grand opera by transferring the sounds direct from the stage to the transmitting station is developing into a real art. Practically all of the world's greatest opera companies are now broadcasting their performances—with the single exception of the Metropolitan Opera in New York. How it is being done and the effect that it is having on the attendance is here told.

By WILLIAM H. EASTON, PH.D.

THE opening performances of the heralded "Wagnerian Opera Festival," held at the Manhattan Opera House, New York, this spring, were poorly attended. Of course every Wagnerian devotee who could raise the price was there. But as the empty seats testified, the general public simply was not interested.

The management of the Festival was worried; financial disaster stared them in the face.

Then a sudden and remarkable change occurred.

On Monday morning of the second week, there was a riot around the box office. Thousands of people crowded in to buy seats. The management, entirely unprepared for such a state of affairs, had to summon the police to keep order. From then on, "standing room only" signs were hung out for each performance. The season which was originally planned to cover only three weeks was extended to seven weeks. A large proportion of the audiences consisted of those who were not familiar with Wagner, as was shown by their ques-

tions at the box office; while mail orders for seats poured in from points at long distances from New York.

What caused the change?

Simply this. On Saturday night of the first week, broadcasting station WJZ of Newark broadcast the performance by means of telegraph wire between the auditorium and the station\* and continued to do so once a week thereafter as long as the season lasted. No better proof of the cultural value of broadcasting is possible. People not only enjoyed this superlatively good music as they heard it by radio, but they spent their money to hear more of it.

Those of the radio audience who

\*How the technical difficulties of doing this were met was described in the article "Symphonies by Telegraph" in POPULAR RADIO of February, 1923.

could attend the operas in person did so; those who could not wrote to WJZ. Though the daily mail of this station is always large, it doubled and trebled during the opera season. The most interesting of the letters came from the Wagnerites who lived in remote places and had picked up the operas unexpectedly. Such an event to these people was a far more joyful surprise than the ploughing up of a pot of gold would be.

"As I was idly playing with my receiver last night," wrote a Canadian, "I tuned in a very fine soprano voice singing Elsa's Dream from *Lohengrin*. 'Good!' I thought. 'I wish they would give us more of that kind of music.' Suddenly something happened that made me jump to my feet. I heard trumpets

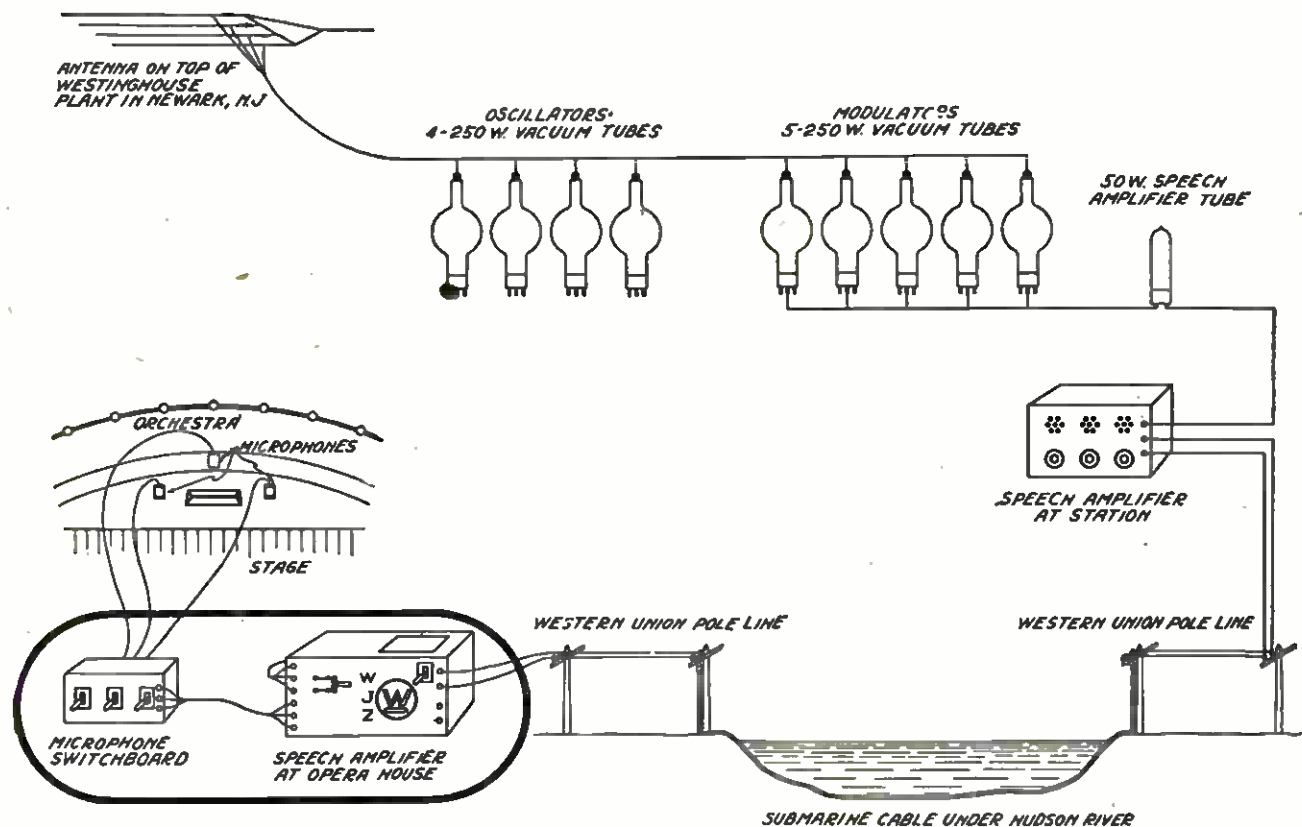

#### HOW THE MICROPHONE SWITCHBOARD AND AMPLIFIER ARE CONNECTED

The switchboard can pick out one particular microphone which is nearest the singer on the stage by merely "flipping a lever." The sounds picked up and converted into electric currents by the microphones are amplified to the correct volume by the apparatus in the speech amplifier box, and the amplified currents are sent over wires through the city, under the river on a submarine cable, up on the pole lines again and out to the station in Newark, where they are re-amplified a number of times and are used to control 5 quarter-kilowatt modulator vacuum tubes, which in turn control 4 quarter-kilowatt oscillator vacuum tubes, which furnish the radio frequency energy to the antenna system.



Underwood &amp; Underwood

#### A PICK-UP AMPLIFIER BELOW THE STAGE

*Here the operator and announcer listens in on a pair of receivers and controls the volume of pick-up, so that it is brought to the cars of the listening audience with the proper tonal values.*

in the accompaniment! Was it possible that I was listening in to an actual performance of the opera? I held my breath in expectation until the chorus that follows the solo confirmed my hopes. I called my wife. She listened for a moment and then phoned excitedly to two musical friends. For the rest of the evening we four sat drinking in the superb music we had all heard so often years ago but hardly expected ever to hear again. Yet it came to us in these Canadian wilds, every note and every word of it. And the announcer tells us we are to hear more! How Wagner lovers all over the country must be thanking you!"

But many who had never heard Wagner before were hardly less enthusiastic. "I am an opera goer," wrote one, "but

I have always intentionally dodged Wagner. Too highbrow for me! But from now on, it's Wagner for me!"

The average listener will, however, undoubtedly be at loss to understand this feeling. Wagner is more or less of an acquired taste, and his music-dramas rarely appeal to those who do not understand the dramatic action or the meaning of the music. But radio provides an ideal method of learning just these things. The next time a Wagnerian opera is broadcast, read in advance a Wagnerian handbook (which may be obtained from any public library or music house). This will give you the story of the opera you are to hear, and explain the themes which run through the music. These themes, each of which has a meaning, are for the

most part simple melodies which can be played on the piano with one finger, but they are used by the composer to produce the most marvelous effects. Provide yourself also with a libretto of the opera (which can be obtained from music houses for twenty-five cents) or better yet, a piano score, which can be found in almost every public library. Thus equipped, you will be able to follow both the action and the music.

Technically, the broadcasting of the operas proved to be difficult. A perfect balance must be kept at all times between the orchestra and the voices, as they are equally important. But the powerful *fortissimos* of the full orchestra tended to drown out the singers; while the immense lung-power possessed by all Wagnerian singers tended equally to drown out the beautiful *pianissimo*

passages of the orchestra accompaniment.

To add to this complication, the acoustics of almost all theaters are unsuitable for broadcasting; and unless special preventive measures are taken, there is invariably a blurring of the sounds due to echoes. Circumstances over which the broadcasting station had no control prevented preliminary experimentation, and its engineers had to trust to their best judgment in placing the microphones. In consequence, the broadcasting of the first operas was not all that could be desired, but the imperfections were carefully studied and steps were taken to eliminate them. By the time the fourth opera was sent out, however, everything was working smoothly, and in the judgment of competent critics the performances thereafter were remarkable achievements.

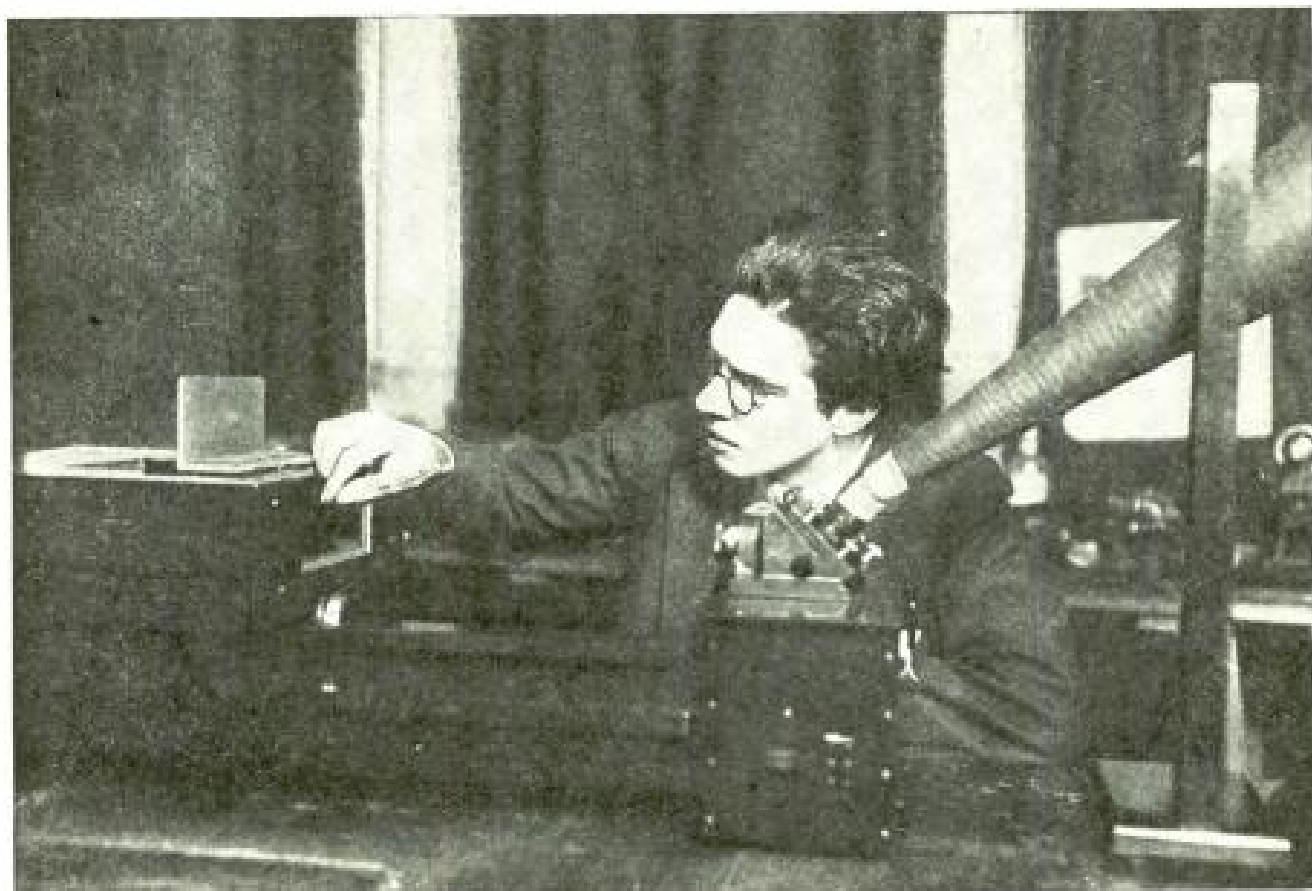

Dorien Leigh, London

**AN INSTRUMENT THAT RECORDS AND ANALYZES SOUND WAVES**  
*This apparatus, the invention of Prof. A. M. Low, of England, readily distinguishes sounds which are so much alike that the human ear cannot perceive their differences—one more instance where science has produced a machine more sensitive than the human organs of perception.*

## WHAT READERS ASK



*THIS department is conducted for the benefit of our readers who want expert help in unravelling the innumerable kinks that puzzle the amateur who installs and operates his own radio apparatus. If the mechanism of your equipment bothers you—if you believe that you are not getting the best results from it—ask THE TECHNICAL EDITOR.*

**T**HE flood of inquiries that has poured in upon the Technical Editor has not only furnished evidence of the need of this department, it has also necessitated a system of handling the correspondence that will insure the selection of and answer to only those questions that are of the widest application and that are, consequently, of the greatest value to the greatest number of our readers. Our correspondents are, accordingly, asked to co-oper-

ate with us by observing the following requests:

1. Confine each letter of inquiry to one specific subject.
2. Enclose a stamped and self-addressed envelope with your inquiry.
3. Do not ask how far your radio set should receive. To answer this inquiry properly involves a far more intimate knowledge of conditions than it is possible to incorporate in your letter.

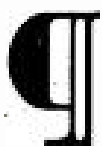

*In justice to our regular subscribers, the Technical Editor is compelled to restrict this special service to those whose names appear on our subscription list. A nominal fee of 50 cents is charged to non-subscribers to cover the costs of this service and this sum must be enclosed with the letter of inquiry.*

**QUESTION:** What does the grid leak do in a vacuum tube receiver? I have never seen any explanation of what this instrument is for, but I notice that all sets seem to be provided with it.

ALBERT THOMAS

**ANSWER:** We take it for granted that you understand that it is the alternating negative and positive charges on the grid of the detector tube that cause the fluctuations of plate current that actuate the telephones. Briefly, when the grid is charged at a negative potential by an incoming impulse, this charge on the grid repels the negative electrons trying to cross from the filament to the plate; this causes a reduction in plate current. When the grid is charged with a positive charge the electrons from the filament are attracted strongly toward the grid and plate; this causes a great increase in plate current. When no signals are being received, the electron flow from the filament is continuously causing the grid to be charged negatively, and if this condition were to continue the plate current would eventually cease. To prevent this the grid

leak is placed so that the negative charge on the grid may leak off when it becomes excessive. The resistance of the grid leak determines the maximum negative charge that can accumulate on the grid; when a charge tends to increase above the maximum value for the resistance that is used, the grid leak allows the excess to leak off. This keeps the free negative grid potential at the correct value for best operation as a detector.

\* \* \*

**QUESTION:** I have a regenerative receiving set with which I have been able to pick up long distance stations from time to time. My worst trouble seems to be that my set oscillates too much. How can I cut this down?

J. B.

**ANSWER:** You may reduce the strong oscillation in your set by one of three methods: by not turning up the detector filament rheostat quite so high; by using a lower plate voltage on the detector tube; or by using a grid condenser of a lower capacity.

—among them the famous Royal Institution of London.

Bose's announcements that metals wince under blows, that they become torpid when frozen, that they can be narcotized like a living animal, and that they become weary from mechanical abuse were so astounding that they were long unappreciated at their true scientific value.

Similarly, his investigations of plants (conducted purely from a physicist's point of view) which revealed the whole mechanism of plant responses to heat, electric currents, ether, and mechanical shock were long incomprehensible to biologists familiar only with the microscopic method of studying living tissues. His instruments are of marvelous delicacy. With their aid he reveals the death-throes of a carrot, measures the voltage of a single pea, makes a cabbage leaf visibly shudder with pain and causes a geranium literally to start when a door is slammed.

Bose first drew attention to himself soon after Hertz had experimentally

proved the existence of the waves which are now practically applied in radio communication. Those were the days when the coherer was the most efficient detector known.

Bose succeeded in producing waves of a length so short that he bridged the gap between the heat waves of the spectrum and Hertz radiations. He devised a detector far more sensitive than the familiar Branly coherer—a detector which depended not upon metal filings or powder but upon fine wire springs, adjusted with a thousand regular contacts and under the control of a screw. This detector proved to be far more sensitive than Branly's coherer.

He made one of the most exhaustive studies on record of the optical properties of the Hertzian waves—work which was commented upon with admiration in this country by Dr. Kunz of the University of Illinois.

During the course of these experiments Bose conceived the idea of constructing an artificial sense-organ which would have a range of sensitivity far wider than that of any known eye, photographic plate or radio detector—something which not only would see visible rays but the invisible rays with which we deal in radio.

So he devised such an artificial sense-organ.

When he placed before it a glass of water—the equivalent of the eye's *aqueous humor*—all electric and heat rays and some ultra-violet rays were absorbed, as they are by the human eye.

The brain of this eye was a galvanometer. When he removed the glass of water the "eye" became exceedingly sensitive to radio and heat waves. Instead of marveling at his own ingenuity Bose simply remarked:

"Perhaps we do not sufficiently appreciate, especially in these days of space-signaling by Hertzian waves, the importance of that protective substance which veils our sense against insufferable radiance."



THE EFFECT OF ETHER ON A GERANIUM

*A graphic record, as made by the crescograph, of the reactions of a live plant which had been "put to sleep" by ether and then awakened.*

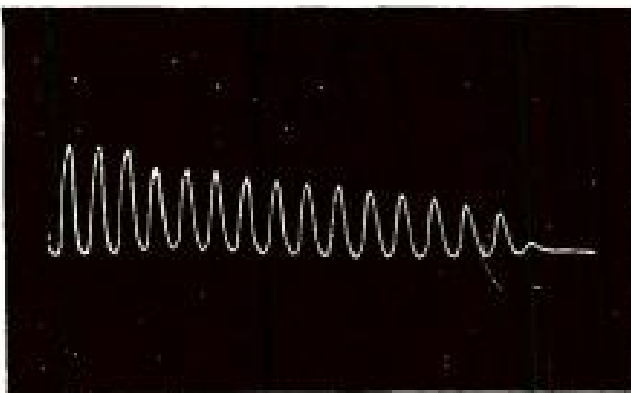

HOW POISON AFFECTED A VEGETABLE

*In this instance the vegetable was put to death. Note the effects of the drug, as shown by the gradually lessening response of the reactions.*

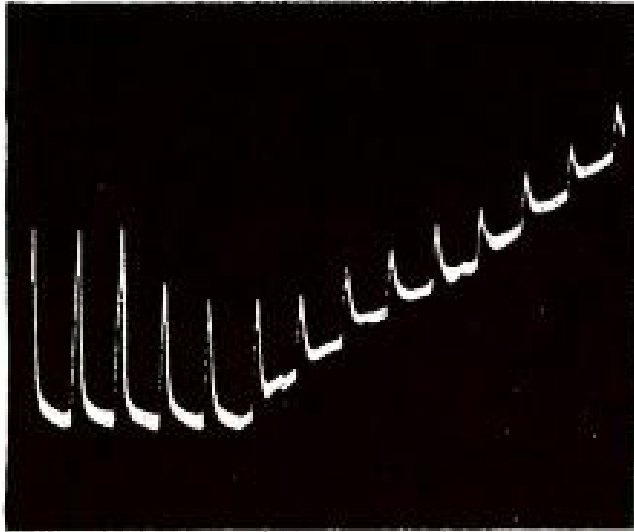

### THE DEATH-THROES OF A CARROT

*This oscillogram shows the crescograph response of a carrot before and during a period that it is subjected to chloroform. At the left is shown the normal response and to the right is shown the response growing weaker and weaker as the plant expires.*

## MACHINES THAT RECORD The Voltages of Peas

THE subject of the following article, Dr. J. C. Bose, has been all his life a storm center of scientific controversy. His revolutionary ideas of the nature of plant life and of the ways in which plants respond, by microscopic movements, to injuries and to disturbances of their surroundings; his almost mystical interpretation of some of his delicate physical experiments, have brought down upon him some criticism from many of the more material-minded students of plant physiology. But all of Dr. Bose's critics credit him with being an extraordinary successful designer and manipulator of physical instruments. His apparatus for detecting minute movements and electrical changes in plants is, admittedly, the most delicate that has ever been built. The radio world, which was, as Mr. Kaempffert points out, one of the first fields of Dr. Bose's work, suffered a serious loss when his inventive genius was turned away from it into the investigation of the properties of living matter.—EDITOR

By WALDEMAR KAEMPFERT

**S**IR JAGADIS CHUNDER BOSE (pronounced Bo-zay) is an extraordinary figure. He is the first oriental who has won for himself a commanding place in modern physics.

Here is a devout, intensely religious Bengalese of the purest blood who has perfected the most delicate instruments for accurately measuring the reaction of plants and so-called "dead" metals to alcohol, ether, heat, light, and forces of every imaginable kind, and who has laid bare the molecular mechanism of living and "dead" matter's reaction to a hun-

dred different stimulants and thus upset our time-honored notion that orientals in general and East Indians in particular are much too metaphysically inclined to conduct research in the modern scientific spirit.

Not only has Bose opened up an entirely new realm in physics but he even regards his startling discoveries as a scientific confirmation of the traditional doctrines of his people. His work is of such importance that it has been at last adequately recognized by the leading scientific societies of Europe and America



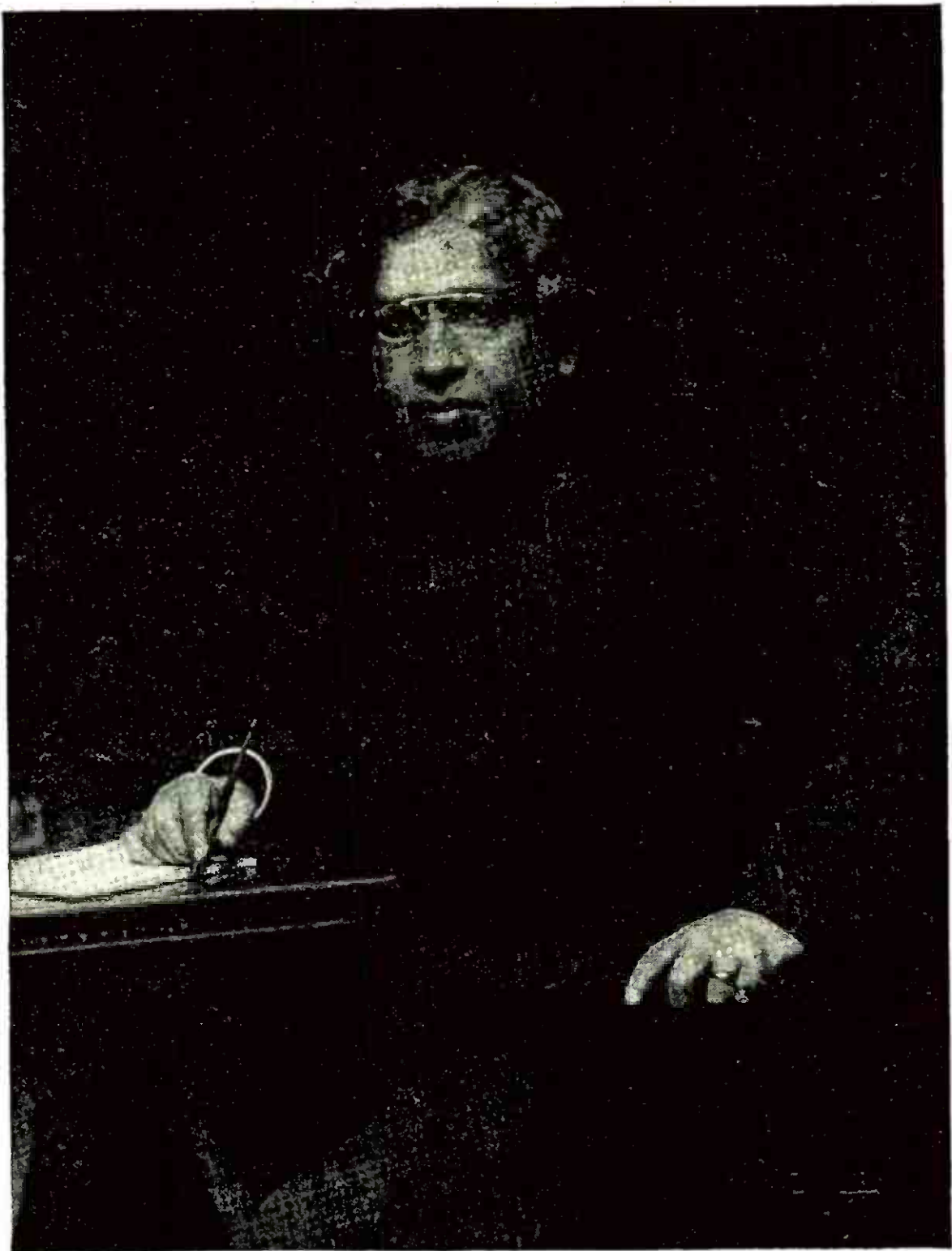

Hollinger, N. Y.

### *The Man With a Radio Eye*

*Of all the experimental work done by the East Indian scientist, Sir Jagadis Chunder Bose, none has been more remarkable than his creation of what is, in effect, an artificial sense-organ that is infinitely more responsive to the certain rays with which we deal than is the ordinary photographic plate or the human eye.*

---

prevent the panel from slipping when in use. If you have any trouble in working at these things with the upright and contact-rod in place, you should remove them as soon as the position for the crystal holder is marked.

Finally, assemble the crystal-holder as shown in Figures 7 and 8, place the crystal in it and clamp it tightly; the de-

tector is then ready to connect and use.

By keeping a slight tension on the spring washers under the thumb-nuts, the parts may be moved for "feeling" and yet will not be jarred out of position. By tightening the nuts the parts may be securely locked in any position desired. The whole affair is very compact, as the base is but four inches square.

### What Radio Is Doing for the Farmer

**I**n none of the many fields into which radio has entered does it promise to render more essentially practical and valuable service to so many people as in the field of agriculture. How the government authorities are broadcasting specific information concerning the planting, raising, packing, shipping and marketing of farm products will be told in a near issue of POPULAR RADIO.



General Photographic Service

#### A RADIO STATION WITH SIX CYLINDERS

*When Mr. and Mrs. J. C. Davenport of Indianapolis, Indiana, set out in their radio-equipped automobile on a 40,000-mile state to state pilgrimage, it was both to enjoy a vacation and to demonstrate the usefulness of radio on tour. How they succeeded may be judged from the crowds that gathered to hear the radio entertainment they furnished whenever they stopped.*

QUESTION: What is the proper resistance for a potentiometer used with the radio frequency amplifier to stabilize the grid circuits?

F. B. LOZIER

ANSWER: A potentiometer of 200 to 300 ohms resistance will be best. This high resistance will allow only a small flow of current from the "A" battery and will not run it down perceptibly.

\* \* \*

QUESTION: What is the correct voltage for a "B" battery to be used on the plate of the detector tube for long distance reception?

L. JOHNSON

ANSWER: This depends upon the type of tube you are using. With a soft detector tube, 16½ to 22½ volts on the plate will give the best results. In that case, use a tapped "B" battery and test out the set on distant signals with different voltages between these two values until the best is found. For extremely loud signals from local stations it is best to use a hard tube, with about 90 volts on the plate. This will give a great deal of strength. It is not good for weak signals, however, as the tube is too unstable and will burst into oscillation. When a hard tube is used for distance, it is best to use 22½ to 45 volts on the plate.

\* \* \*

QUESTION: Please give me a diagram of a simple reflex circuit for one tube and a crystal detector. Let me know also what instruments I will have to obtain to construct the set.

C. G. ROOS

ANSWER: A circuit is shown in Figure 1 which will be suitable for you to use. The parts used in the set are as follows:

- L1 and L2—primary and secondary windings of a variocoupler;
- VC—variable condenser, .0005 mfd.;
- AFT—audio frequency amplifying transformer;
- RFT—radio frequency amplifying transformer;
- R—rheostat, 5 ohms;
- Det—crystal detector;
- C1—fixed condenser, .0005 mfd.;
- C2—fixed condenser, .0005 mfd.;
- Tel—head telephones, 3,000 ohms.

The set is tuned in the ordinary manner and the crystal adjusted to the most sensitive spot.

\* \* \*

QUESTION: Are 201-A vacuum tubes suitable for use in my super-regenerative set that I built according to the specifications in the November issue of POPULAR RADIO? At present I am using Western Electric tubes, but they are getting old and I want to be prepared to replace them.

LEROY HETZEL

ANSWER: The new 201-A vacuum tubes which take but a quarter of an ampere of current for the filament are exceptionally well suited for this use; they will give just as good results as the tubes you now use.

\* \* \*

QUESTION: I have a small set. Would it be best to use a pair of telephones attached to a horn or a regular loudspeaker?

J. A.

ANSWER: A loudspeaker would be best.

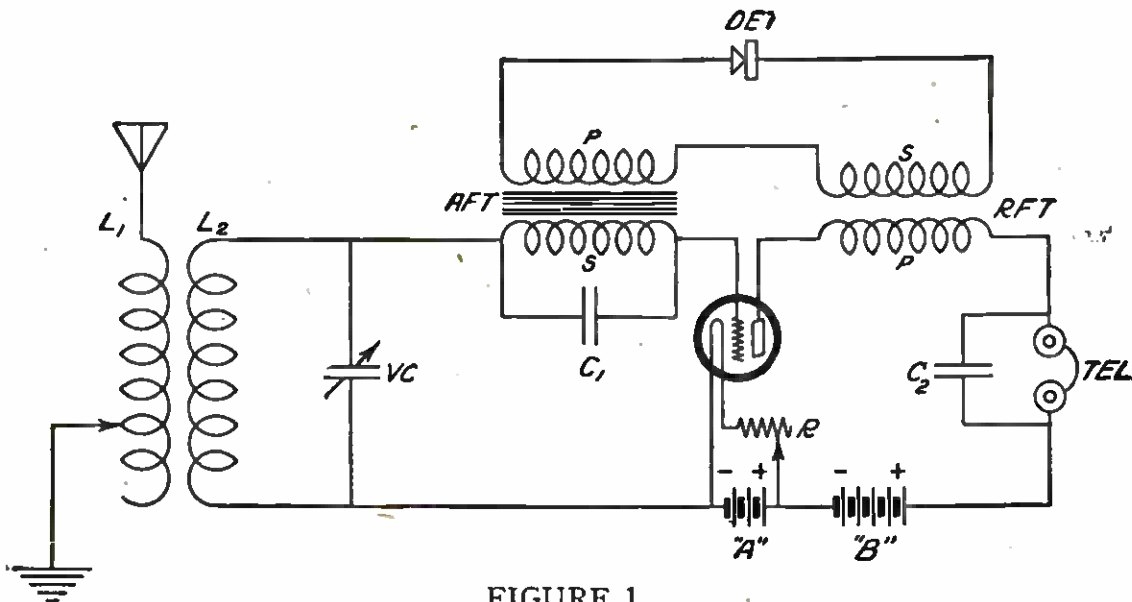
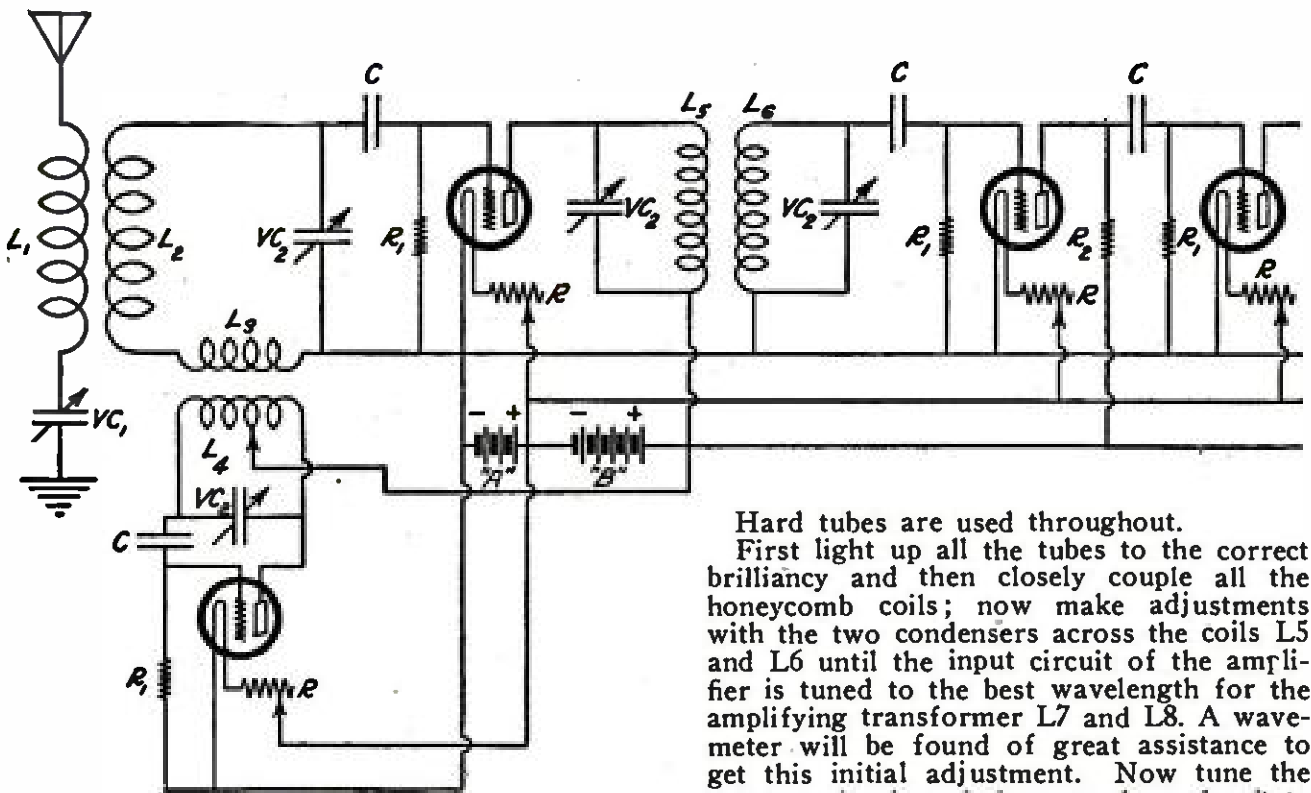

FIGURE 1

A simple reflex set with one tube and a crystal detector.



**QUESTION:** Please show me a hook-up of an Armstrong super-heterodyne receiver that uses three stages of resistance-coupled radio frequency amplification and two stages of audio frequency amplification. I would like also a list of the special parts needed to build such a set and any other information that will help me. I have built quite a few sets which embody numerous hook-ups and have had good results on the whole, but I have heard that this is the best and most selective circuit there is.

LEE BARTINDALE

**ANSWER:** An eight-tube super-heterodyne circuit is shown in Figure 2. The designations on the diagram refer to these parts:

- L1—honeycomb coil, L-35;
- L2—honeycomb coil, L-50;
- L3—honeycomb coil, L-25;
- L4—honeycomb coil, L-50;
- L5 and L6—honeycomb coils, L-300;
- L7 and L8—primary and secondary coils of radio frequency transformer that have 3,000 to 5,000 meters range;
- VC1—variable condenser, .001 mfd.;
- VC2—variable condenser, .0005 mfd.;
- C—mica fixed condenser, .0005 mfd.;
- C1—mica fixed condenser, .001 mfd.;
- R—rheostats, 5 ohms;
- R1—grid leak, 2 megohms;
- R2—resistance unit, 100,000 ohms;
- AFT—audio frequency transformers.

Hard tubes are used throughout.

First light up all the tubes to the correct brilliancy and then closely couple all the honeycomb coils; now make adjustments with the two condensers across the coils L5 and L6 until the input circuit of the amplifier is tuned to the best wavelength for the amplifying transformer L7 and L8. A wavemeter will be found of great assistance to get this initial adjustment. Now tune the antenna circuit and the secondary circuit to the correct wavelength by means of the condensers VC1 and VC2, and rotate the condenser VC2, which is connected across the coil L4. At two adjustments of this condenser, the static and signals will come in loudly. Finally loosen the coupling between L5 and L6 and re-tune with the two variable condensers of that circuit until the signals are strengthened and clarified. Adjustment of the filament currents may now be made, and for changes in wavelength the only other variables will be the primary and secondary condenser and the heterodyne condenser.

If a loop is to be used with this circuit it may be connected in place of the coil L2. In this case the outdoor antenna, the coil L1, and the antenna tuning condenser VC1 will be eliminated.

\* \* \*

**QUESTION:** Is there any type of loudspeaker that does not use a horn? If so, how does it work?

C. H. G.

**ANSWER:** There is one manufacturer who makes a loudspeaker that propagates sound waves in free air directly, without the use of a megaphone, horn, or other acoustic amplifier. This is made possible by the use of a large flexible diaphragm, conical in form and made of paper, which produces sound waves that correspond substantially in relative amplitude as well as in pitch to the original sound waves. It is claimed that the distortion which is usually found in a horn, where violent air disturbances are generated in a confined space, is eliminated with this instrument.

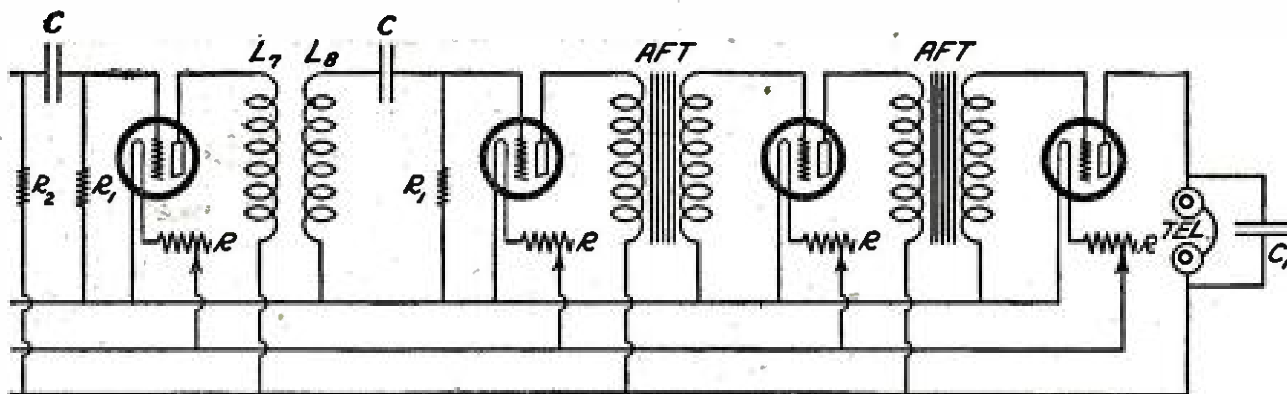

FIGURE 2

The famous Armstrong super-heterodyne receiver; it uses two detector tubes, one oscillator tube, three radio frequency and two audio frequency amplifier tubes.

QUESTION: What is the correct capacity for a variable condenser in series with the primary coil of my variocoupler and for a variable condenser across the secondary coil of my variocoupler? I want to have a tuning range of from 200 to 500 meters so that I will be able to tune in both amateur and broadcasting stations.

CHARLES STEWARD

ANSWER: The variable condenser in the primary circuit should have a capacity of .001 mfd.; the variable condenser shunted across the secondary should have a capacity of .0005 mfd. and should have a vernier attachment for fine tuning.

\* \* \*

QUESTION: What kind of wire should I use in my receiving antenna?

J. J. AMES

ANSWER: Seven-strand No. 14 copper wire is best. Solid wire of the same size may be used, but the greater surface of stranded wire makes it give better results.

\* \* \*

QUESTION: Please send me a diagram of a regenerative single-tube circuit that will not be seriously affected by body capacity while it is being tuned.

A. CROMWELL

ANSWER: The circuit is shown in Figure 3. The antenna circuit is tuned by the tapped coil L, and the variable condenser VC1 which has a capacity of .001 mfd. The secondary circuit is tuned by the variable condenser VC2, .0005 mfd. and the variometer Var1, and the regeneration is controlled by the variometer Var2. The rotary plates of the condenser VC1 should be attached to the ground wire. GL is a grid leak of 2 megohms, and GC is a mica fixed condenser of .00025 mfd. capacity. The bypass condenser C should be of approximately .001 mfd. capacity.

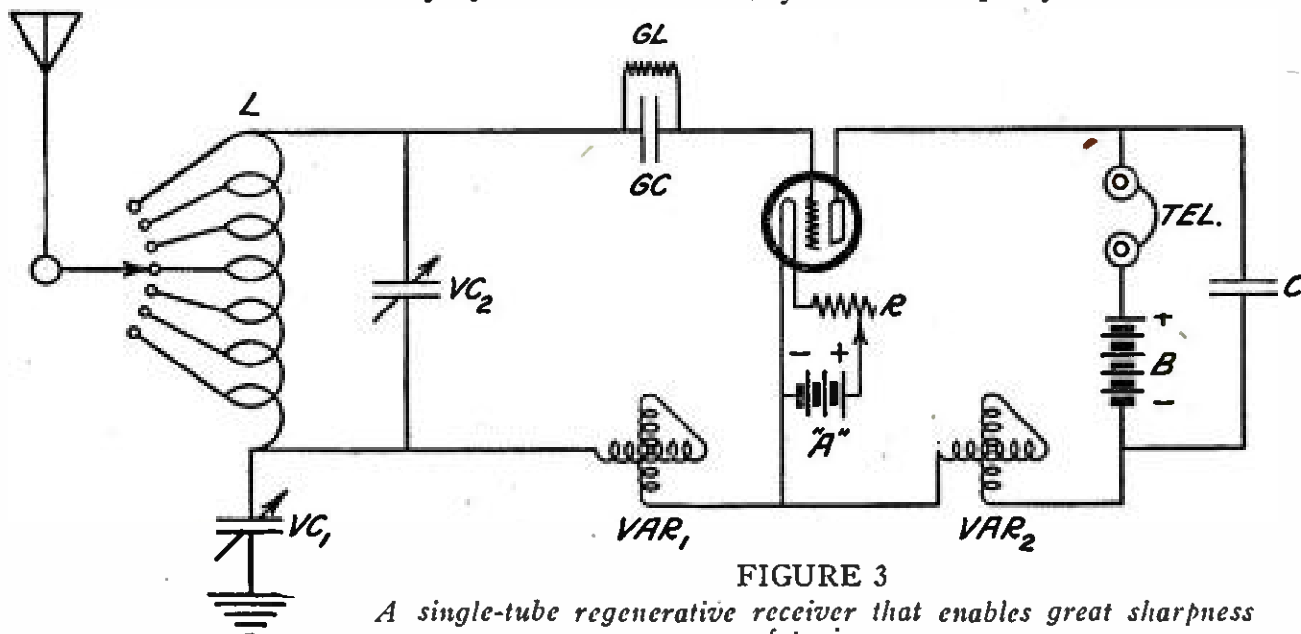
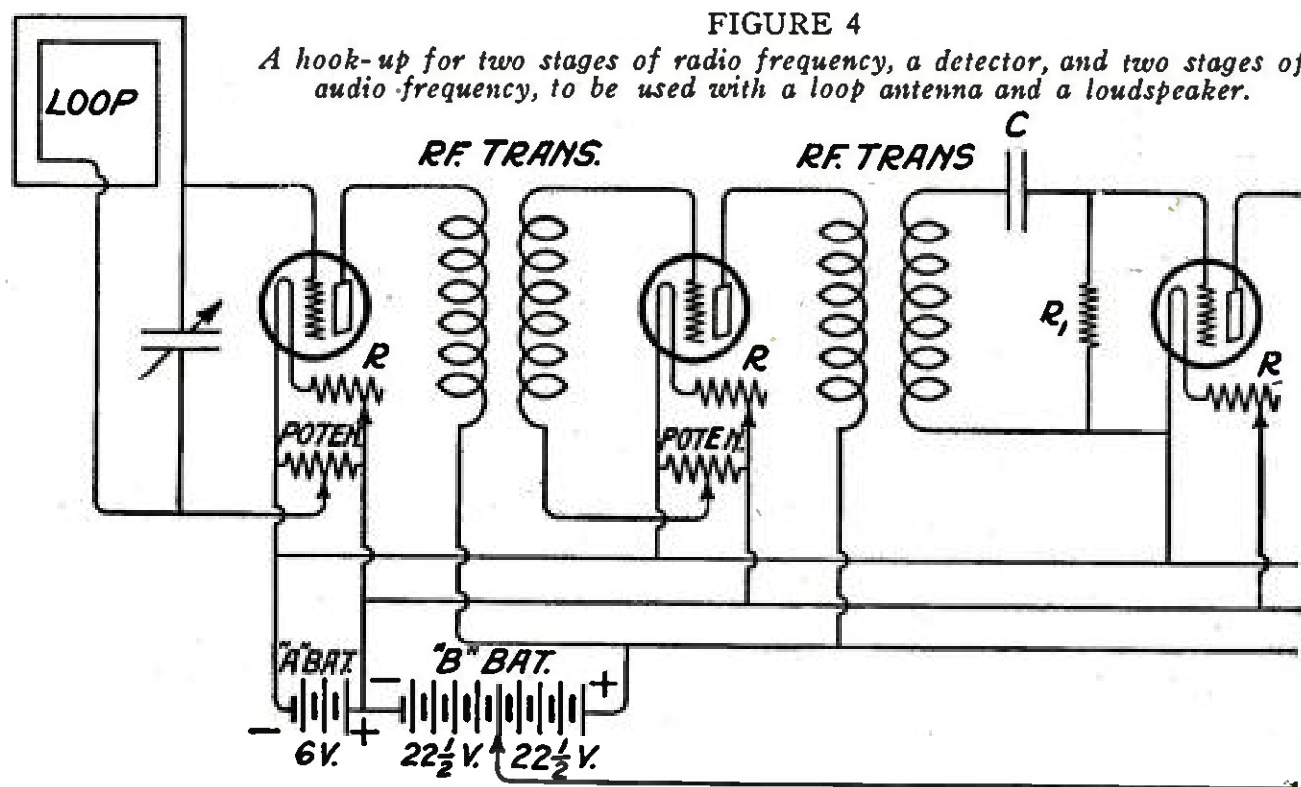

FIGURE 3

A single-tube regenerative receiver that enables great sharpness of tuning.



**QUESTION:** Please draw a diagram that shows how to connect the following instruments so as to have two stages of radio frequency amplification and two stages of audio frequency amplification with a vacuum tube detector:

- 1 loop antenna;
- 4 amplifying tubes;
- 1 detector tube;
- 5 rheostats;
- 2 potentiometers;
- "A" and "B" batteries;
- 1 grid condenser, .0005 mfd.;
- 1 grid leak, 2 megohms;
- 1 Western Electric loudspeaker, type 10-D;
- 2 G. E. radio frequency transformers;
- 2 All American audio frequency transformers;
- 1 Federal jack;
- 1 variable condenser, .0005 mfd.

Please show clearly what to do with the potentiometers.

ROBERT DENTON

**ANSWER:** In Figure 4 you will find the proper circuit for connecting these instruments. The potentiometers are used to keep the grid at a correct negative potential that will permit the greatest amplification possible without oscillation in your tubes. We have

shown a tap on the "B" battery; this will allow you to use a soft tube for the detector if you so desire. You did not state what size loop you intended to use; we advise a loop three feet square wound with 12 turns of wire spaced  $\frac{3}{4}$ -inch.

\* \* \*

**QUESTION:** Can I mount one stage of audio frequency amplification on the left-hand side of my receiving set and the other stage on the right-hand side? This will give my set a balanced appearance and will improve its looks greatly.

A. F. CLARK

**ANSWER:** This would not be advisable. The audio frequency apparatus should be grouped together and the radio frequency apparatus should be grouped together. A good arrangement is to place the tuning instruments at the left of the panel, the detector in the center, and the audio frequency apparatus at the right. Never place the amplifying transformers near the tuning apparatus; the iron cores will be certain to cause loss of tuning efficiency.

\* \* \*

**QUESTION:** I want to add radio frequency amplification to my set for "DX" reception. I have a loop antenna. What is the least number of stages I should use?

HARRY KANE

**ANSWER:** Use at least two stages. This will bring in local stations with good volume and clarity; at the same time it will amplify the "DX" enough.

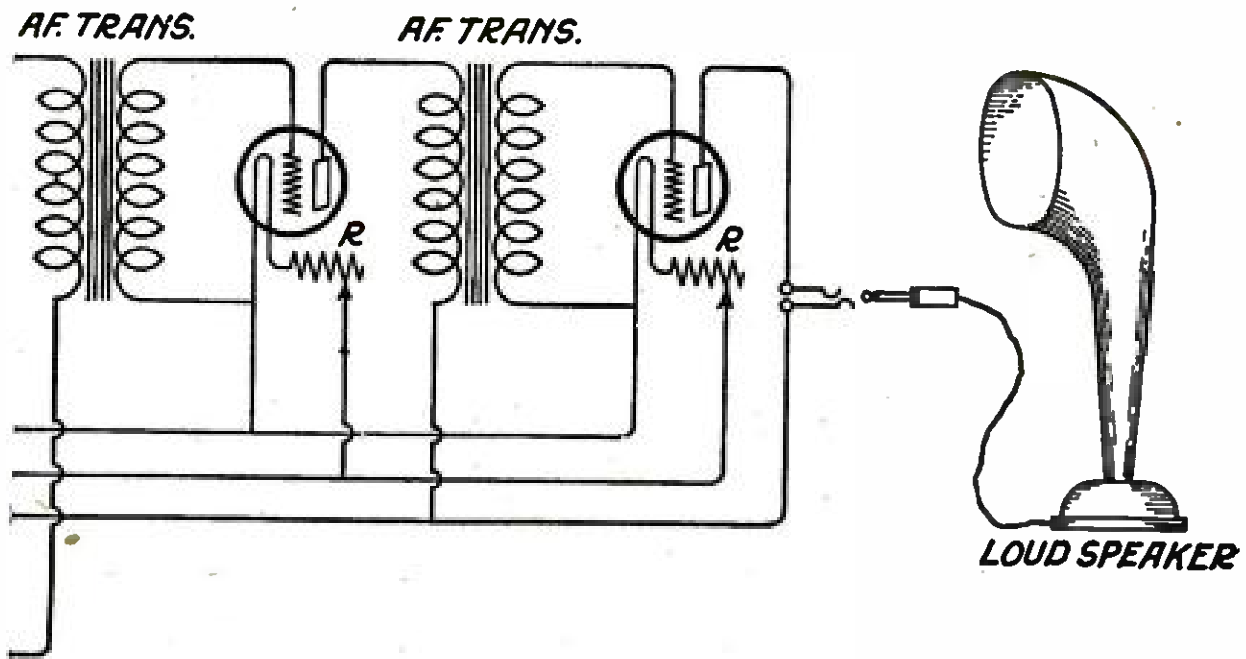

QUESTION: Please give me a hook-up showing how to add one stage of radio frequency amplification to the circuit shown in Figure 4, on page 212 of the November issue of POPULAR RADIO.

AUSTIN FARMER

ANSWER: The diagram in Figure 5 gives you the information you require. The extra

parts needed for this hook-up are as follows:

- R1—filament rheostat;
- 1—hard vacuum tube;
- P—potentiometer, 200 to 300 ohms;
- RFT—radio frequency amplifying transformer;
- 2—"B" batteries, 22½ volts each;
- C—fixed telephone condenser.

The tuning of the set will be by the same procedure as before the amplification was added.

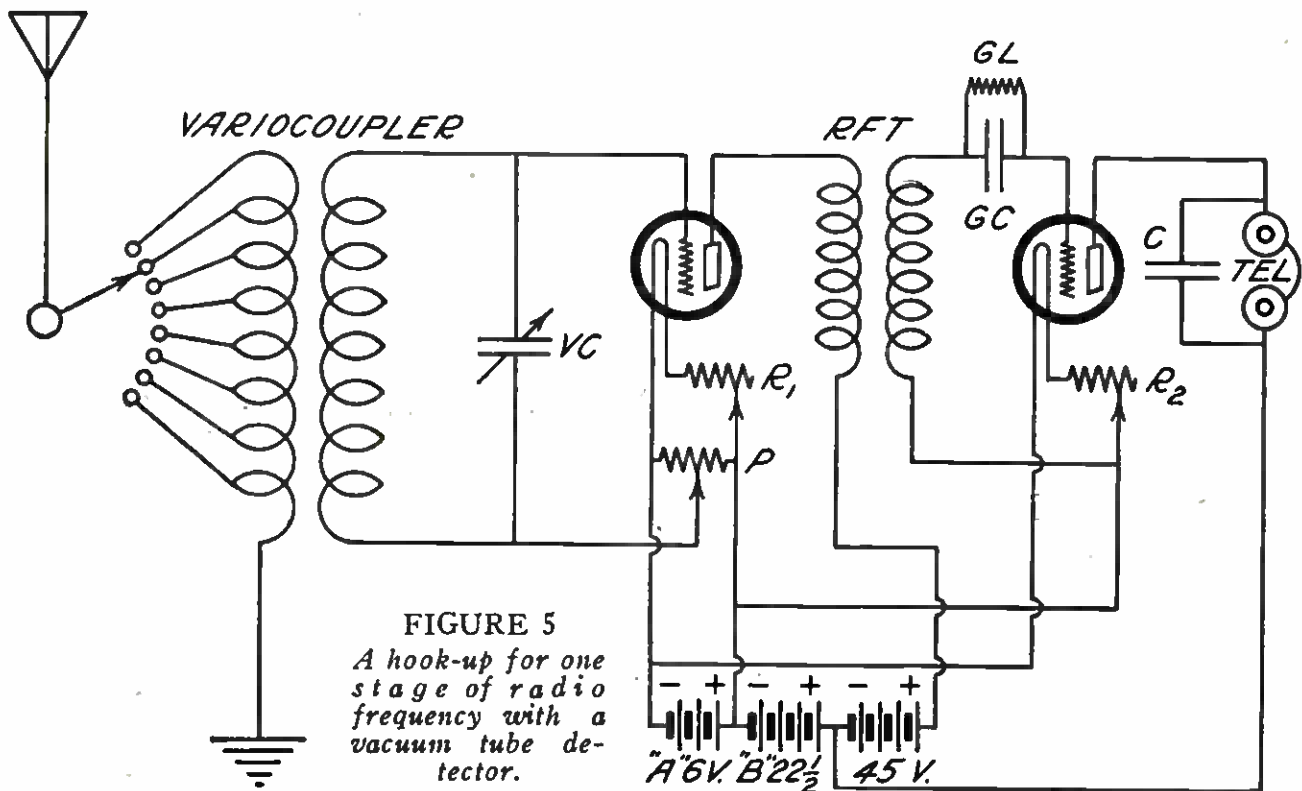

FIGURE 5

A hook-up for one stage of radio frequency with a vacuum tube detector.



HELP your neighbor. If you have discovered any little Kink that helps to eliminate trouble in your radio apparatus, or if while experimenting with the connections of your set you should run across some interesting phenomenon, or if you should discover some new hook-up that gives better results—send it to the "Listening In" page.

## The New Broadcasting Schedule

**T**O divide the entire United States into fifty districts and to give each a first-class broadcasting station with sufficient power to completely cover that district:

To assign a band of wavelengths all the way from 220 meters to 545 meters for broadcasting purposes to be distributed among the stations:

That, in brief, is the major benefit resulting from the Conference of the National Radio Committee in Washington which ended on the 24th of March.

Previously, most of the 500 broadcasting stations in the United States were concentrated around the three wavelengths 360, 400 and 485 meters. As a result of the most recent recommendations it will now be possible to assign to the majority of stations individual wavelengths and to divide the stations into two classes.

The most powerful stations will be in Class "B" and will embrace stations formerly in Class "A" and Class "B."

The new Class "A" stations will have an output up to 500 watts in the antenna and will use wavelengths between 222 and 286 meters.

The new Class "B" stations will have

an output between 500 and 1,000<sup>w</sup> watts in the antenna and will use wavelengths between 300 and 545 meters. These stations are subjected to special regulations to insure the quality and continuity of their program.

Class "C" stations will be stations who wish to continue on 360 meters. No new Class "C" licenses will be issued.

By "staggering" stations over the country, it will be easily possible to continue broadcasting without the discouraging interference now experienced.

During the recent hearing, the writer brought out the fact that 90 percent of telegraphic interference which broadcast listeners experience results from American-owned or controlled ship stations, on wavelengths around 450 meters. In line with this observation the use of the 450 meter wavelength by ship stations is to be abolished between 7.00 and 11.00 P. M., local standard time. At the same time every effort is to be used to get the companies concerned to alter the adjustment of their equipment in order that the traffic which is now handled on 450 meters may be shifted to wavelengths between 700 and 800 meters, a band of wavelengths having been secured in this zone through relinquishment of seldom used wavelengths previously reserved



for the use of government stations.

Provision is also made for a new field of radio telephone service—ship to shore service—which would enable persons on shore to talk to those aboard ships. This correspondence will take place between 800 and 952 meters and between 1,053 and 1,277 meters.

It has also been decided that the reading of telegrams or letters by broadcasting stations should be permitted, providing the text matter is of general interest, and so long as the signer of the letter or telegram is not addressed in person. Also that the re-broadcasting of a program from distant stations is to be permitted as a service only on a broadcasting wavelength and with the authorization of both the original broadcaster and the Department of Commerce.

The present scheme differs in many respects from that one outlined by the

Radio Committee a year ago, in that no provision for broadcasting on wavelengths above 600 meters is made. As is quite generally known, the absorption, reflection, and refraction of radio waves of the higher frequencies (600 meters and below) is very marked. The effects are generally termed as due to "freaks" or to "fading." There are many less thickly populated sections of the country which might perhaps be better served if the broadcasting were done on wavelengths above 1,000 meters due to the comparative absence of the transient phenomena mentioned above. But, it must be said that considering the extreme complexity of the problems to be solved, the Radio Conference has accomplished some very important results and all who are interested should feel no hesitancy in giving credit where credit is due.

PAUL F. GODLEY



Pacific and Atlantic

#### THE EXPERTS WHO RE-ARRANGED THE WAVEBANDS FOR BROADCASTING

*In order to meet the emergency created by the failure of Congress to pass the White Radio Bill, and to establish temporary measures that may bring order out of the confusion caused by 580 broadcasting stations, Secretary Hoover called upon these men for advice. Here are some of the advisors (left to right): C. Francis Jenkins, Paul F. Godley, Hiram Percy Maxim, F. H. Schnell and Major General George O. Squier—all contributors to POPULAR RADIO.*

Cities Get Special Wavelengths

ONE of the immediate results of the recent conference of radio experts in Washington was the allocation of special wavelengths to broadcasting stations of the Class B group by cities—a system that promises to establish the whole broadcasting situation on a basis that will be greatly to the advantage of all concerned. The real significance of this step will be described in POPULAR RADIO by John V. L. Hogan, in a following issue.

ZONE 1	
City	Wavelength in Meters
Springfield, Mass. } Wellesley Hills, Mass. }	337
Schenectady, N. Y. } Troy, N. Y. }	380
New York City and Newark, N. J. ....	{ 405 455 492
Philadelphia, Pa. ....	{ 509 395
Washington, D. C. ....	435
<i>Reserved: 303, 319, 469, (357), (288).</i>	

ZONE 2	
Pittsburgh, Pa. ....	326
Chicago, Ill. ....	448
Davenport, Iowa } Des Moines, Iowa }	484
Detroit, Mich. } Dearborn, Mich. }	517
Cleveland, O. } Toledo, O. }	390
Cincinnati, O. ....	309
Madison, Wis. } Minneapolis, Minn. }	417
<i>Reserved: (294), 345, (366).</i>	
ZONE 3	
Atlanta, Ga. ....	429
Louisville, Ky. ....	400
Memphis, Tenn. ....	500
St. Louis, Mo. ....	546
<i>Reserved: 300, 316, (353), 375, 462, 333.</i>	
ZONE 4	
Lincoln, Neb. ....	341
Kansas City, Mo. ....	411
Jefferson City, Mo. ....	441
Dallas, Tex. } Fort Worth, Tex. }	476
San Antonio, Tex. ....	385
Denver, Colo. ( <i>Reserved</i> ) ....	323
Omaha, Neb. ....	527
<i>Reserved: (361), (291); 306.</i>	
ZONE 5	
Seattle, Wash. ....	492
Portland, Ore. ....	455
Salt Lake City, Utah. ....	312
San Francisco, Cal. ....	{ 509 423 395
Los Angeles, Cal. ....	469
San Diego, Cal. ....	536
<i>Reserved: (297), 330, (349), (370).</i>	

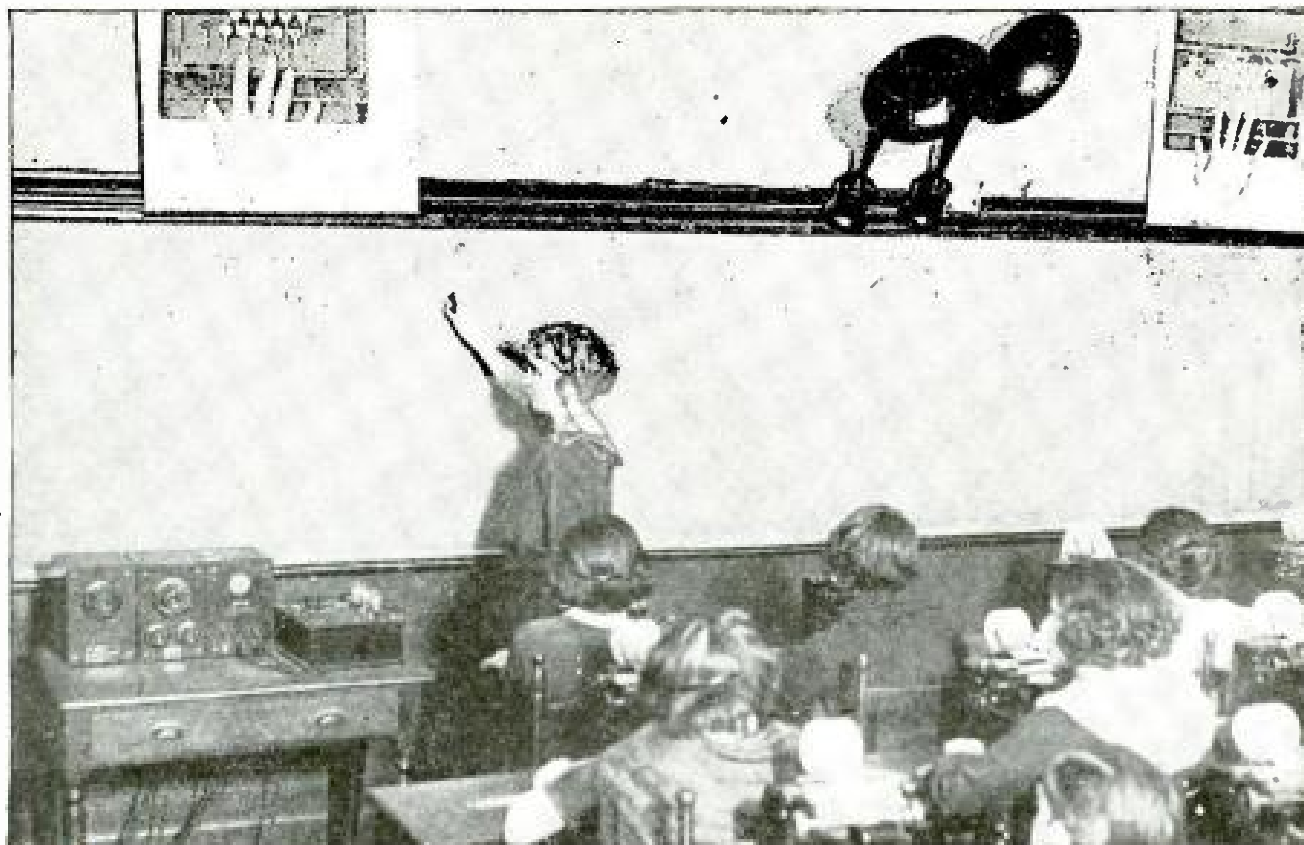

Fotograms

LESSONS FROM A LOUDSPEAKER

*Just to show that classes in school may be conducted by radio—perhaps in many schools simultaneously—the Haaren High School in New York recently staged a demonstration during which problems were transmitted from WJZ, and the answers were given after a proper interval, so that the pupils could check up their work.*

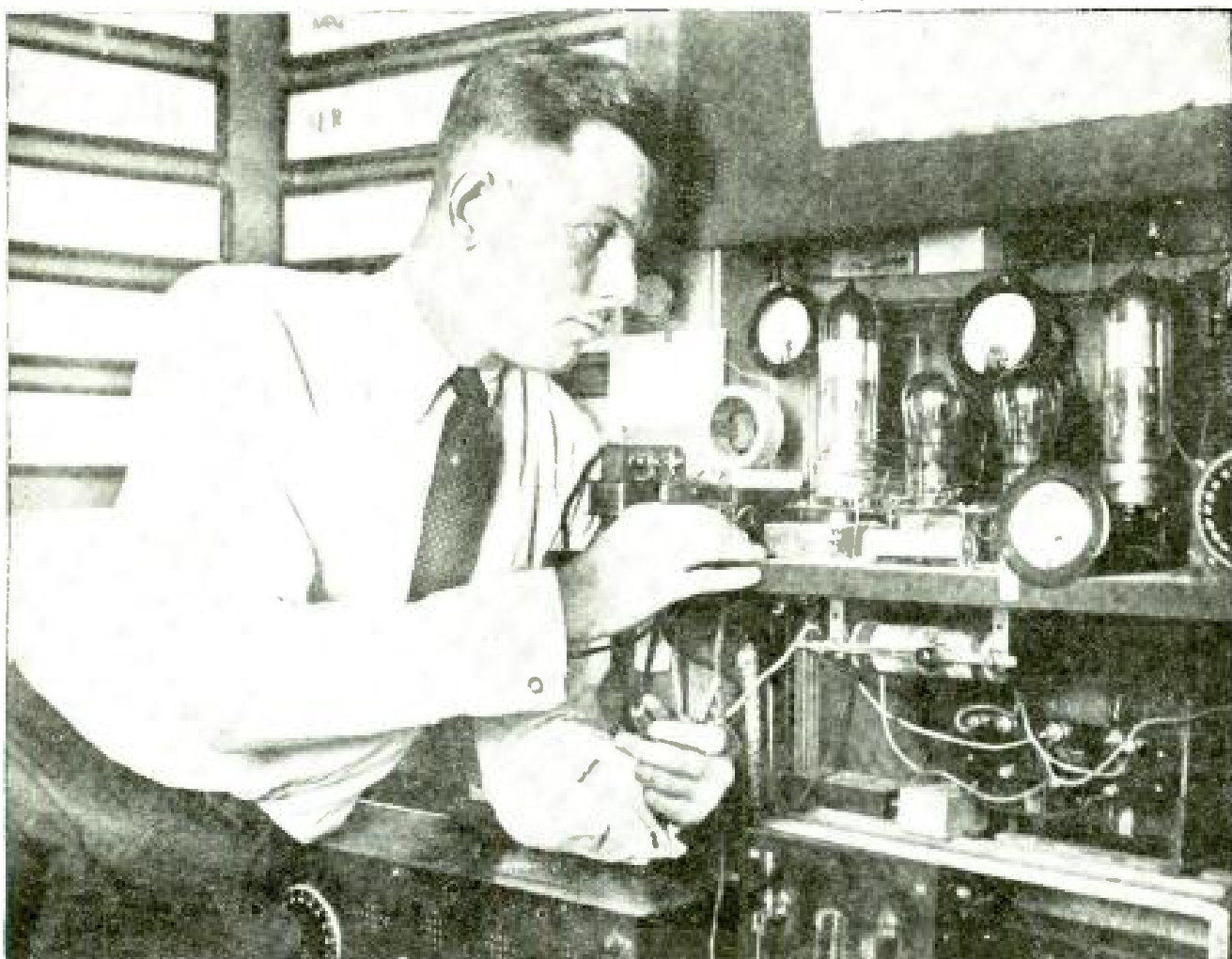

Kadel &amp; Herbert

### THE BEST AMATEUR SENDING AND RECEIVING SET IN THE COUNTRY

*Once a year the Hoover cup is awarded by the Department of Commerce to the radio amateur who owns the best apparatus for both transmission and reception and the major portion of which is home-made. The award for 1922 has just been given to Frederic R. Ostman of Ridgewood, N. J., whose call letters 2OM will be recognized by the amateurs throughout the country.*

### How Broadcasting Is Getting Started in England

**A** QUARTER of a century and more ago, when "wireless" was a term that was known to only a small group of experimenters, Mr. A. Frederick Collins was demonstrating successfully his first radio apparatus. It is of particular interest, therefore, to learn from such an experienced old timer of the present beginnings of the popular interest in broadcasting in England. Mr. Collins writes from the Authors' Club of London:

Broadcasting has been in the melting pot for the past year but it has now been poured out into a bright, concrete ingot. This long-desired and highly satisfactory result is due, primarily, to the efforts of the amateurs who

were members of the Wireless Society of London, but whose scope has recently been extended to include all of the other amateur wireless organizations of Great Britain and which are now included under the name of the Radio Society of Great Britain.

The Wireless Society of London was organized ten years ago at the home of a well-known amateur, René H. Klein, of West Hempstead, who originated the idea of it. He had the foresight to realize that there was bound to develop more or less friction between the amateurs and the Post Office\* authorities, unless some sort of co-operation could be established between them.

A few months later the society was expanded to include all the other local wireless clubs which were then springing up all over the country. A number of workers who stood high in the art of wireless were chosen Vice-Presidents and from these a President was elected—Mr. A. A. Campbell Swinton,

\*The Post Office controls all forms of communication in Great Britain.

F. R. S., who held the office for a period of seven years, although for four of these the society was in a state of suspended animation due to the war.

But between the time of its organization and Great Britain's entry into the war, a large number of the best type of wireless amateurs had enrolled as members of the society. In those early days apparatus for sending or receiving was not so easily made or procured here as it is now. Few amateurs owned their own sets; instead, a number of them would club together, hire a room, install the apparatus and own and operate it jointly. In this way the members of the Wireless Society of London raised a fund, bought a wireless set and installed it in a clubroom that was open to members. At the beginning of the war the aerial had to be taken down and the apparatus was officially sealed, but classes in the Morse code were held and expert advice was given to all members who wanted it.

Curiously enough when the war was over the Post Office authorities were reluctant to grant permission to the society to resume its active pre-war operations, and it was not until 1919 that a committee was appointed to formulate a plan so that the station could again be re-opened; this was accordingly done and the desired permission was obtained.

During the war, however, amateur wireless societies sprang up like mushrooms and the

Wireless Society of London got busy in the effort to bring them all into one fold.

At the present time there are about one hundred and twenty-five societies affiliated with this parent organization.

The first broadcasting to be done in Great Britain was done by the amateurs themselves. In the London district nearly every evening in the week during the past two years there has been broadcast entertainment of some kind; indeed, so prevalent had amateur broadcasting become in 1921 that the society had to call together all of those who held transmitting licenses in and around London in order to regulate their programs so that the interference of the sending stations would be reduced to a minimum.

In the same year another conference of the society was held. The new president, Dr. J. Erskine-Murray, at that time asked the Postmaster-General to give the Marconi Company—who stood ready and willing to do it—permission to broadcast a weekly program. After some six months elapsed this request was refused. Here, then, was a test for the strength of the affiliated wireless societies. The secretary of the Wireless Society of London sent out a petition to the various societies throughout Great Britain which asked the Postmaster-General to grant permission to the Marconi Company to broadcast a weekly program. This petition was signed by the presidents of

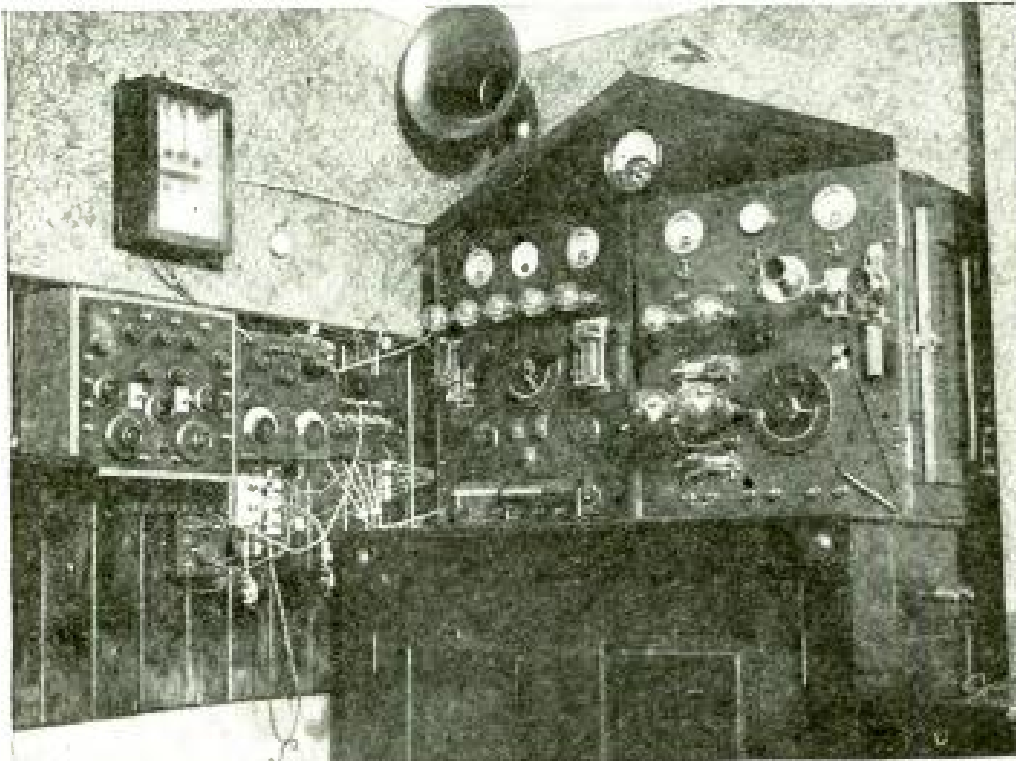

© Dorien Leigh, London

#### A RADIO SET WITH AN ENGLISH ACCENT

*The distinctly foreign appearance of this apparatus is apparent at a glance to the American amateur. Note the receiving equipment (on the left) for reception on high and low wavelengths, and the "thermionic tubes," for transmitting, on the large gabled cabinet at the right. Both receiving and sending stations in England require government licenses, which are issued only to stations that use British-made parts.*

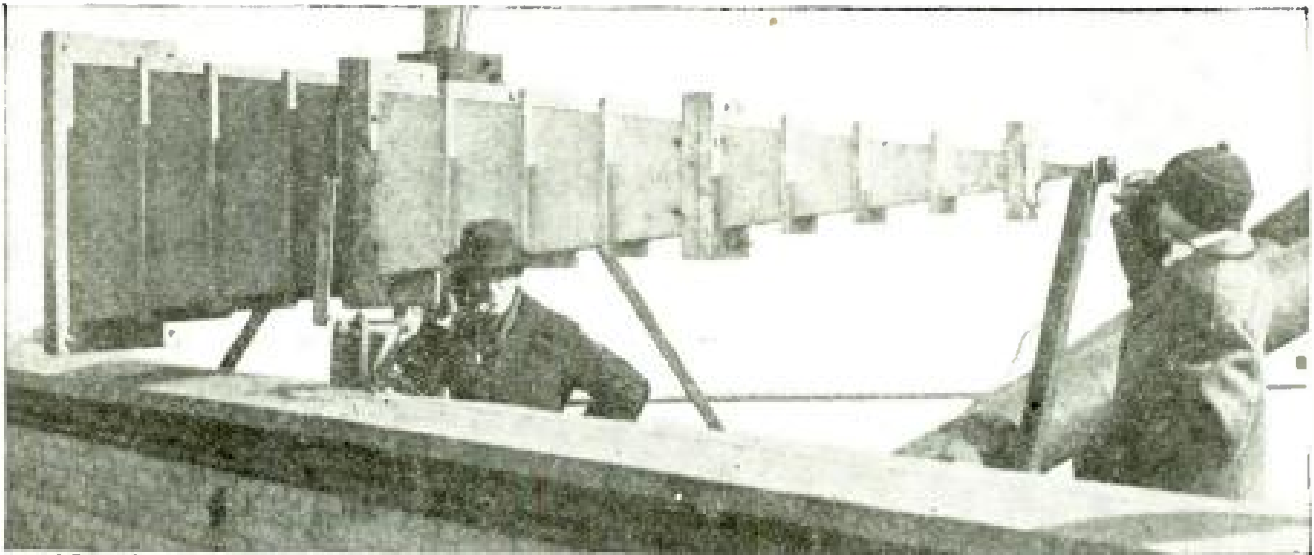

Kadel &amp; Herbert

### A LOUDSPEAKER THAT WAS HEARD FOR MILES

*When the president of a large manufacturing company recently sailed from New York, he was bidden farewell by his employees by means of this gigantic instrument that bellowed messages and songs to him from the roof of the office building. Radio fans who use amplifiers will recognize how the stunt was done.*

sixty-three societies. Before a fortnight had elapsed the desired permission was granted.

Within another fortnight the Marconi Company began to broadcast a musical program every Tuesday night. Immediately there was a great demand for wireless receiving apparatus. It was a good rule for it worked both ways in that as the number of users of these sets increased the greater the necessity grew for more broadcasting stations; further, and even more important, the wireless enthusiasts who lived beyond the range of the London broadcasting station wanted cities nearer to them to have similar stations.

Now there are six large British electrical companies who had the financial backing, the engineering brains and the electrical equipment to operate broadcasting stations if they chose to do so. If all of them had entered the field independently chaos would have certainly followed. These six big companies are the Marconi Wireless Telegraph Company, the British Thompson-Houston Company, the Metropolitan-Vickers Electrical Company, the General Electric Company and the Western Electric Company.

To prevent the confusion that necessarily would have resulted had each of these companies operated its own broadcasting station the heads of them decided to organize a company which would be devoted solely to broadcasting; thus it was that the British Broadcasting Company, Ltd., was organized. Of this Lord Garrisford was made the chairman.

This new company has just acquired the license for the erection and operation within Great Britain and Ireland of stations as a public service for broadcasting by means of wireless telegraphy and telephony. News, information, concerts, lectures, speeches, weather reports, theatrical entertainments and other matter of interest will make up the programs which are to be given every evening.

As the British Broadcasting Company operates under the license of the Post Office, the Postmaster-General will only issue the licenses for receiving sets to those who buy their wireless sets of members of the company. That is, every British manufacturer of wireless apparatus must become a member of the Broadcasting Company before he can sell receiving sets of any kind and each set must be approved by the Post Office authorities, which mark it with a seal.

No foreign-made sets of any kind can be used for receiving broadcasting programs and this ruling of the Postmaster-General will remain in force for the next two years. Moreover, no one can get a license for, or use a receiving set until it is marked with the official seal.

Prior to the organization of the Broadcasting Company, which has just been effected, only a British subject could get a license to use a receiving set, but this restriction has now been removed.

The purpose of having all of the makers of apparatus join the Broadcasting Company is to provide the latter with funds to carry on the broadcasting stations and to standardize all the receiving sets to the end that they will not re-radiate. Further, the Post Office charges the amateur 10 shillings (about \$2.25) for a license to receive; half of this sum will be handed over to the Broadcasting Company to help defray expenses.

There are now broadcasting stations located at London, Manchester, Birmingham and Newcastle; others are being fitted up at Plymouth, Cardiff, Glasgow and Aberdeen. Those who own vacuum tube receiving sets can easily get one or all of these stations, but for the benefit of those who own crystal receiving sets other stations are being planned.

British radio enthusiasm is really under way.

A. FREDERICK COLLINS

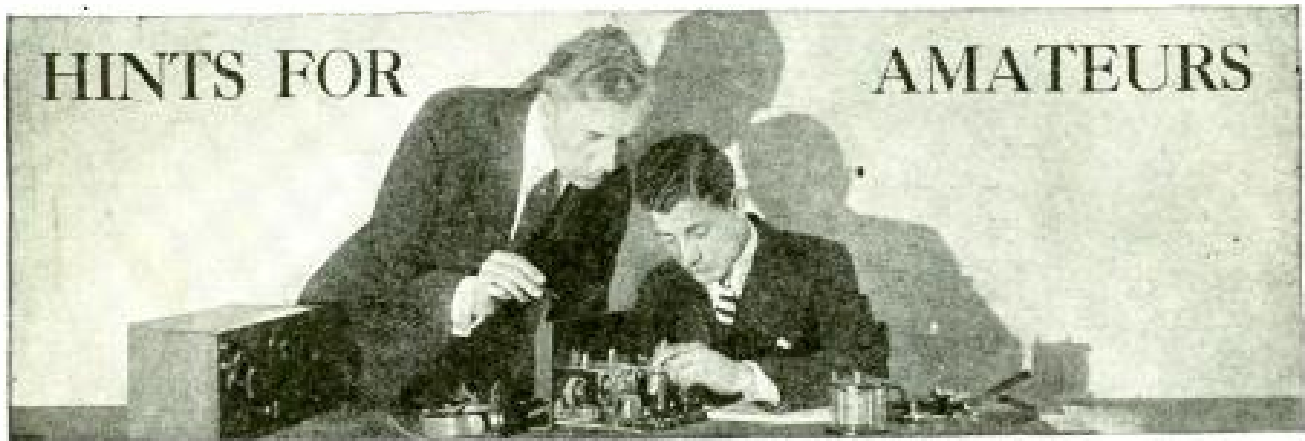

WHEN you connect up a set from a diagram, you will find it helpful to observe the following procedure:

Start at the antenna binding post and connect it to the instrument as shown in the diagram you are following. When this connection has been completed, draw over that connection on the diagram with a colored pencil. You will then know that that connection is complete. Then from the other terminal of the same instrument connect a wire to the next instrument as shown on the diagram. Cover this connection on the diagram with a colored pencil line and do the same thing with every line on the diagram.

When all the connections are redrawn in colored pencil you will know that you have completed hooking up your set and that it has been done correctly. This will eliminate mistakes and make the job simple.

\* \* \*

OSCILLATIONS are induced in an antenna by passing radio waves only when the antenna circuit is tuned to the frequency of the oscillations which caused the waves to be radiated from the distant transmitting antenna. You have to tune in the signals that you desire to hear by adjusting the knobs that control the capacity or inductance in the antenna circuit of your receiver, before the passing waves will cause currents to flow through your receiving instruments, thus supplying the necessary electrical energy to cause the telephones to function and reproduce the transmitted signals.

BAKELITE or formica panels for radio sets, if left with the natural highly polished finish, soon become scratched and ragged. A durable satin finish may be imparted to the panel by rubbing it with sandpaper of medium coarseness—rubbing in one direction until the surface is perfectly smooth and all irregularities have disappeared. A smooth grade of sandpaper should then be used until a dull finish is obtained. This will leave the panel with a gray-green tint, but upon applying some furniture oil to the surface and rubbing dry with a soft cloth, a beautiful black color will appear which will be permanent. Rub the panel in one direction only, with a long straight stroke.

\* \* \*

WHEN you solder connecting wires to the terminals of jacks for making connections to the telephones, it is important to keep soldering flux from running down onto the insulating segments which separate the different spring contacts.

If the flux runs down into the insulating segments it causes leakage and it is to this that many experimenters owe the trouble they have with their homemade sets.

Use only enough flux for the solder to take hold; a thin film is enough.

Another point to remember: be sure that the contacts make and break properly when you have completed the wiring of the set. Sometimes they get bent out of position slightly and do not touch properly; you may never discover it, and never get the new set to work right.

It may interest the novice to know that the ordinary vacuum tube used for receiving is rated at a power of approximately one watt, or about one-fiftieth of the power that is used to light the ordinary electric-light bulb.

\* \* \*

MANY amateurs who build their first vacuum tube transmitting set, can get it to oscillate properly only on wavelengths that are in excess of what is allowed them by the law. When they find that it is impossible to make it function properly on a lower wavelength, it is natural for them to get reckless and "take a chance." They adjust it for the lowest wave on which they can radiate and let it go at that. Eventually the radio inspector pays them a visit and their license is suspended.

They could avoid all this trouble if they understood the difficulties involved and knew that a counterpoise would solve them.

When a set refuses to work on a low wavelength, the cause is usually one of the following two points: the antenna resistance is too high, or the antenna capacity is too high. In the first case, the antenna oscillating circuit has such a large value of resistance that it can not be induced to sustain oscillations; they are damped out. In the second case the capacity is too high and the antenna really acts as a short circuit to the vacuum tube oscillator circuits.

A counterpoise will remedy this trouble, as it will reduce both antenna resistance and capacity. At the same time it will be the equivalent of a perfect ground and it will enable you to have almost double the radiating surface that is presented by an ordinary antenna and ground system.

For best results a counterpoise should be stretched underneath the antenna, near the ground, but not touching it; its area should be equal to or more than the area of the antenna itself. Good results, however, may be obtained with a counterpoise consisting of another antenna just

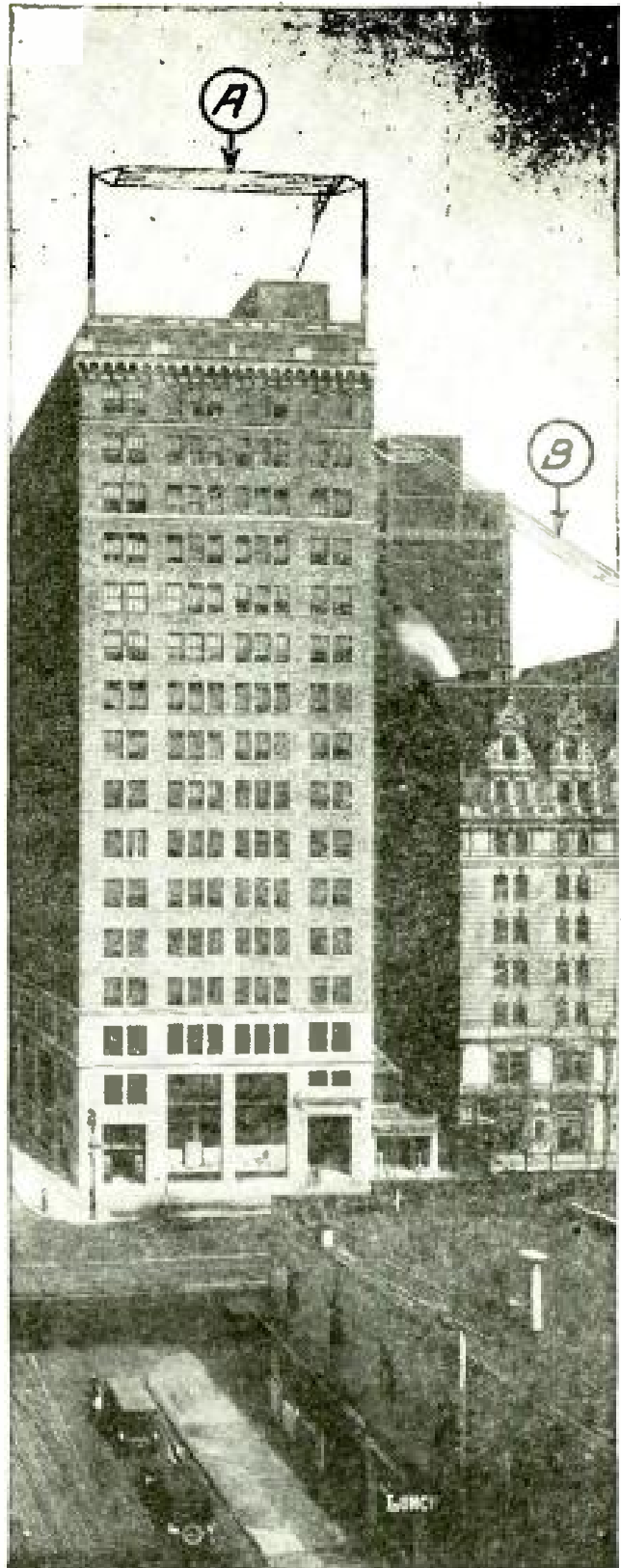

Brown Bros.

#### HOW A COUNTERPOISE IS INSTALLED IN THE CITY

FIGURE 1: When the available space is limited the counterpoise may be practically a second antenna which runs off in another direction from the main antenna; indeed, this is often the only arrangement that is possible in the city where ground space on which to set up a counterpoise in the usual way is conspicuous by its absence. In this picture A is the regular antenna and B is the counterpoise.

like the main antenna that runs off in some other direction and is used instead of a ground.

A counterpoise will sharpen up the tuning both for receiving and transmitting, and will, on that account, cut out a great deal of interference. When a good ground cannot be obtained, a counterpoise offers the only solution. Two methods of arranging a counterpoise are shown in Figures 1 and 2.

\* \* \*

If a potentiometer is used across the "A" battery for maintaining the grid of the radio frequency amplifier tube at the correct free grid potential, the best results will be obtained. If the potentiometer is advanced too far in one direction, however, the tube will begin to oscillate and the telephone signals will

disappear. The amplifier can be used for picking up C. W. signals when the tubes are oscillating by slightly detuning the circuits from the wavelength of the transmitting signal; then the signals will sound like a whistle following the dots and dashes of the code.

\* \* \*

A SHARP wave means that the transmitting station radiates a large proportion of energy in the form of Hertzian waves of uniform length, and only a small proportion of energy in the form of wavelengths which vary from this.

\* \* \*

Do not "test" any kind of a battery by "shorting" it with a pair of pliers or a wire, as this injures it. The best way is to use a voltmeter across the battery while it is discharging at its normal rate.

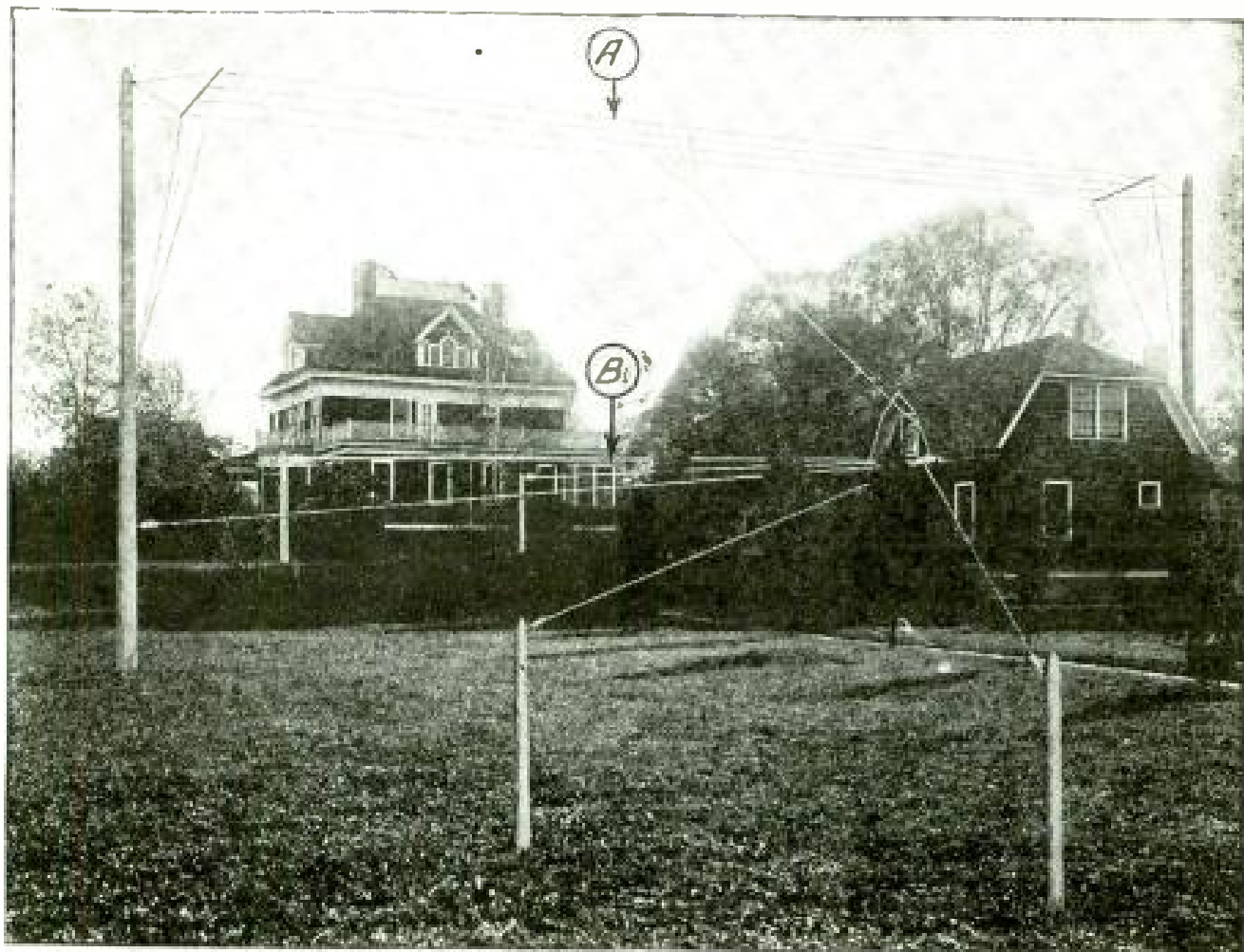

Brown Bros.

#### A PRACTICAL SUBSTITUTE FOR YOUR GROUND

FIGURE 2: To be most effective the counterpoise B should be placed directly under the antenna A; it should be fan-shaped and should be suspended high enough above the ground to be well clear of the head of any passerby.



## "STATIONS I HAVE HEARD"



If you are getting good results with your receiving set, tell your fellow-readers of POPULAR RADIO how you get them. Give the call letters of the stations you hear, the locations of them, the type of apparatus that you are using and **HOW YOU ARE USING IT.**

### WHAT THREE SPIDER-WEB COILS CAN DO

USING three spider-web coils, Kenneth Ogden of New Haven, Conn., makes his single tube cover a distance of 900 miles. His record reception is from WOC, Davenport, Ia. He also hears WDAJ of College Park, Ga., and 21 others.

The coils are home-made, he says, and are used with a 43-plate condenser in the antenna circuit and a 23-plate condenser across the secondary coil. His antenna is made of two wires, spaced three feet apart, 120 feet long, suspended 35 feet above the ground.

\* \* \*

### LIKES REINARTZ HOOK-UP

IN case it means anything to anybody, Earl Lampman wants to mention that by using one tube in a Reinartz circuit, he has heard KHJ and KFI of Los Angeles, Calif., approximately 1,850 miles away.

\* \* \*

### HE HEARS ACROSS THE ATLANTIC

ANOTHER to join the distinguished ranks of plain ordinary laymen who are picking up American concerts in Europe is Joseph P. Price, who writes from Sussex, England, that he hears WEAJ of New York with five tubes in a radio frequency hook-up.

\* \* \*

### CRYSTAL SET SPANS DISTANCE OF 750 MILES

H. P. JOHNSON of Victoria, B. C., is surprising himself by receiving broadcast programs 750 miles away on his crystal receiver. His outfit consists of a home-made variocoupler, tapped at every turn for seven turns and then at every tenth turn for seventy more turns, making a total of eighty turns. He uses 2,000-ohm phones and a piece of galena for a detector. His antenna is made of two stranded wires

75 feet long suspended 35 feet above the ground. He writes:

"On the evening of January 27 my son received a program from KPO, San Francisco, Calif., and heard the announcer distinctly. We believed this to be some queer freak of radio until we picked up the same station a number of times later, and under various weather conditions.

"We have also heard talking and singing on this same simple set from Portland, Ore., and from another station in San Francisco which we are as yet unable to identify. The music from KPO came in quite clear and distinct and the whole orchestra was plainly heard as well as piano and violin solos and a number of vocal selections."

\* \* \*

### 5,000 MILES IN TWO HOURS IN AN ARMCHAIR

"SPEAKING of records for speed," writes E. R. Hammond of Newark, N. J., "I have just figured the mileage my armchair has made during the past two hours. I have traveled over 5,000 miles, with the aid of my three tubes and my standard hook-up of two variometers and a variocoupler.

"I listened to a popular song being played in about seven kinds of syncopation at once by WWJ in Detroit, Mich, and by a slight movement of the dials which did not even disturb the ashes on my cigar, I heard a lady finish up with the chorus of the same song at WSB, Atlanta, Ga. Others on my calling list were WHB, Kansas City; WIP, Philadelphia, Pa.; WGY, Schenectady, N. Y.; and WDAP, Chicago."

\* \* \*

### REACHES 23 STATES WITH THREE TUBES

A TOTAL of 58 stations, located in 23 states, were heard by John S. Frampton in Spangler, Pa., during a period of 17 days, he says. He

made the DX receiver described in the January number of POPULAR RADIO, using an aerial only 15 feet above the ground.

The greatest distance over which he received is 2,250 miles. The station is KOG of Los Angeles, Calif. Other records are PWX of Havana, Cuba, 1,260 miles; WBAP, Fort Worth, Tex., 1,170 miles; WLAL Tulsa, Okla., 1,000 miles, and five others more than 1,000 miles away. The total distances of all stations heard amounts to 31,994 miles. He has heard as many as 27 stations during one evening.

"Using either the ground connection or the antenna alone, I can hear Chicago and Atlanta, Ga., with fair volume," Frampton says, "and when in Brooklyn, I can pick up WEAJ of New York without either."

The aerial, 15 feet high, is made of one strand, No. 16 rubber covered wire, 120 feet long.

\* \* \*

#### ONE TUBE COVERS 1,000 MILES

WHILE it is not unusual for one tube to cover a distance of 1,000 miles with proper tuning devices and a good antenna, the set which will do it consistently in several different directions is good enough to make listeners in wonder how it is done.

Raymond H. Carlson of Wheeling, W. Va., does it with a single-circuit tuner. He tunes his aerial by using various lengths of wire, and has decided that 50 feet is the best length for his particular type of set, and that added length weakens his signals.

His best records are PWX, Havana, Cuba; KDZU, Denver Colo.; DN4, Denver, Colo.; WDAO, Dallas, Tex., and CJCG, Winnipeg, Canada, all more than 1,000 miles away. He has heard from 22 states.

\* \* \*

#### GIVES COUNTERPOISE CREDIT FOR LONG-DISTANCE RECEPTION

FOR covering a distance of 1,500 miles with one tube, the counterpoise of M. S. Levert of Boston, Mass., is given chief credit. Before he erected the counterpoise he could not receive as far as 1,000 miles, he says.

His tube works on a storage battery, and his set is tuned with two condensers, a variocoupler and a variometer. The aerial consists of four strands of wire spaced two feet apart, 100 feet long and 45 feet high. The counterpoise, used instead of a ground connection, has similar dimensions and is hung nine feet above the ground.

\* \* \*

#### A FAN WHO HAS PICKED UP EVERY STATION IN THE COUNTRY

SIGHING with the shade of Alexander, Arthur F. Glover of Kansas City, Mo., regrets that "there are no more worlds to conquer." He hears everything in the United States, and after he has finished with the other continents, there will be nothing new to hear unless it be from the other planets which to all appearances are behind the times.

As he is located in the center of the United States, his greatest records, with his six tubes, are KHJ of Los Angeles, Calif., and WKAQ

of San Juan, Porto Rico. He hears 87 others, knows most of the popular songs by heart and says that he is studying Spanish by the ether method.

\* \* \*

#### HOW HIS SMALL SET GREW

WITH practically no tools at all, Hilliard Hamblin of Warsaw, Canada, made a crystal set, using what he happened to find about the house. It has now grown into a single tube set and in this second venture he has heard 50 stations, the total of their distances amounting to 25,155 miles.

"My aerial is only 25 feet high and 100 feet long," he writes, "made from copper ribbon taken from a Ford magneto. I use a well for my ground."

His set has three home-made honeycomb coils, 50 turns in the primary, 100 turns in the secondary and 100 turns in the tickler. He uses 43-plate primary and secondary condensers, a variable grid condenser but no grid leak.

Using 2,000-ohm phones he sometimes covers a distance of 1,500 miles. Some of the distant stations he has received from are WDAP, Chicago, Ill.; WBZ, Springfield, Mass.; KSD, St. Louis, Mo.; WSB, Atlanta, Ga.; WHAS, Louisville, Ky.; WLW, Cincinnati, O.; WAAM, Newark, N. J.; WOC, Davenport, Ia., and WGF, Des Moines, Ia.

\* \* \*

#### A 53,217-MILE JOURNEY ON ONE TUBE

ALTHOUGH his tube has no mileage guarantee, G. E. Tallman of Seneca Falls, N. Y., writes that it has gone 53,217 miles and has not begun to show signs of wear. He arrives at the mileage by adding the distances of 85 stations he has heard with his single-circuit regenerative receiver. His aerial is a single solid wire 165 feet long with a 35-foot lead-in.

His record includes KHJ, Los Angeles, Calif.; 2,300 miles; CJCE, Vancouver, B. C., 2,230 miles; PWX, Havana, Cuba, 1,475 miles; WGAB, Houston, Tex., 1,400 miles; WCAJ, University Place, Nebr. and WNAX, Norman, Okla.

\* \* \*

#### HOW A \$14 RECEIVER DOES IT

"My friends do not understand how I do it," says D. Cromar of Windsor, Canada, who covers more than 800 miles on his crystal set, and goes on to remark that it is a simple matter. He uses a loose coupler, home-made, a 23-plate variable condenser, a phone condenser and a piece of galena. These instruments, together with his phones, cost \$14.00.

The aerial used is made of two wires 50 feet long and 30 feet high. The lead-in is 50 feet long, and he uses the water pipe for a ground connection. During a period of seven hours, from seven in the evening until two in the morning, he has heard KDKA, Pittsburg, Pa.; KDQA, Chicago Ill.; WCI, Barnegat, N. J.; WSA, East Hampton, N. Y.; WSB, Atlanta, Ga.; WDAC, Springfield, Ill.; WHAZ, Troy, N. Y.; WIAP, Springfield, Mass.; WCV, Cape May, N. J.; WSV, Little Rock, Ark.



ITEMS of general interest that you ought to know; bits of useful information that every radio fan ought to know.

#### *Ether Waves in an Igloo*

WHAT is probably radio's "farthest north" is reported by Mr. J. P. Henderson, of a Dominion Government exploration party; at Fort MacPherson, well within the Arctic Circle, music broadcast by CFCN at Calgary, 2,000 miles away, came in loud enough—when a loudspeaker was used—to fill a large igloo. The Esquimaux held a weird impromptu dance to this music and bestowed on W. W. Grant, the announcer at CFCN, an unpronounceable name that means "the voice from the box."

\* \* \*

#### *The Most Powerful Radio Station Afloat*

WHEN the U. S. S. *Leviathan* is put into operation by the United States Shipping Board this June it will not only be the largest vessel to fly the Yankee flag but it will carry the most powerful and the most complete radio outfit ever placed on a ship. In addition to its regular radio telegraph apparatus consisting of a vacuum tube set capable of delivering six times as much power to the antenna as the usual ship outfit and able to maintain communication at a distance of 3,000 miles, it will be equipped with radio telephone and with two emergency sets.

\* \* \*

#### *South Americans Listen in on a New York Fight*

NEW YORK was joined to Argentina by radio for the first time in history when round-by-round ringside reports of the Firpo-Brennan prize fight were transmitted from the high-power radio station at Rocky Point, L. I., and were picked up in Argentina. The reports were sent out on a long wavelength; for the benefit of local fans, after they were received they were immediately sent out again on a short wavelength by an Argentine broadcasting station.

\* \* \*

#### *Radio Saves a Life at Sea*

JOHN H. STEEL of the U. S. Lighthouse Service owes his life to radio. He was on duty on the Fenwick Island light-ship, thirty miles southeast of Cape May, when he was taken suddenly with an acute attack of appendicitis;

immediately a radio call for help was sent out, and a Coast Guard cutter, in spite of a storm that was raging, made its way out to the light-ship. He was transferred to the cutter, and rushed ashore in time for an operation that saved his life.

\* \* \*

#### *Radio in the Home of the Buccaneers*

ONE of the last parts of the world to remain in primitive isolation will be connected to civilization when a radio station is set up which will enable the Turks and Caicos Isles, chiefly known as the ancient haunts of the pirates, to communicate with the other islands of the West Indies.



International

#### TALKING THROUGH HIS HAT

With an umbrella for an antenna and a receiving set in a straw hat, Miss Helen Flaishman, of Philadelphia, has devised this stunt set. It was made by her fifteen-year-old brother Nathan.

### *A Transmitting Machine That Sends 80 Words a Minute*

IN tests recently conducted between the *Majestic* and a shore station a speed of 80 words a minute was attained by the use of sending and receiving machines, and was shown to be practicable for commercial use. Some idea of what this means may be gained from the fact that it is virtually impossible to



Underwood & Underwood

#### WHO OWNS THE ETHER?

*The first radio lawsuit to involve this question is being tried in Illinois with Herbert Hoover and Hiram Maxim among the distinguished witnesses. Wylie Bergman, the eighteen-year-old owner of a \$1,000 transmitting station (the antenna tower of which is shown above) is being sued by Edward McWilliams, a banker, on the ground that he interferes with McWilliams' reception of the broadcasting.*

maintain a speed higher than 25 words a minute when messages are transmitted and received by hand.

\* \* \*

#### *Lighthouses to Flash Radio Beams*

A NEW phase in the history of radio as a means of insuring a greater safety to ships at sea will open with the installation on all lighthouses and lighthouses during the next three months of radio "beacons" for the purpose of sending directional signals which will enable mariners to establish their exact location. These "beacons" will be of enormous value in foggy weather when a lighthouse is virtually out of commission; even in clear weather they will carry farther than the ordinary light.

\* \* \*

#### *Another High Award in Science Goes to an Inventor of Radio Apparatus*

THE Franklin Institute of Philadelphia has awarded the Elliott Cresson Medal to Dr. Lee De Forest for his invention of the audion or three electrode vacuum tube. The committee report on which the award was based characterized the invention of the audion tube as "one of the most important ever made in the field of the electrical transmission of intelligence."

\* \* \*

#### *French Fans Are Beginning to Listen In*

THERE are now about 50,000 privately-owned radio receiving sets in France—as compared to an estimated 2,000,000 in the United States.

\* \* \*

#### *Radio Fans to Have a Church of Their Own*

To bring the church direct to the people by radio is the plan proposed by the Radio Church of America, which was incorporated recently in Sacramento, California, under the laws of the State of California. It purports to be non-sectarian and non-denominational. Headquarters of the church will be in San Francisco. Branches will be established wherever a broadcasting station is available.

\* \* \*

#### *6,000 New Fans a Month in England*

IN spite of the relative difficulty in amateur operation owing to a government control that requires a license for every receiving station and prohibits the use of home-made apparatus, the wave of radio enthusiasm that has just begun to hit England seems likely to become at least comparable to what it was here. One month's application for licenses was 6,000—and that was before the "boom" had really started.

\* \* \*

#### *Do Insects Communicate by Radio?*

DR. E. PORTER FELT, the state entomologist of New York, points out that there is a marked resemblance between the antennas of insects and the solenoid or loop antenna used with radio. He has received successfully using an antenna patterned carefully after that of the gall midge. While it is probable that these antennas are designed for the reception of sounds too minute to be audible to the human ear, it is within the bounds of possibility that insects actually do communicate by radio.

Please mention POPULAR RADIO when answering advertisements.

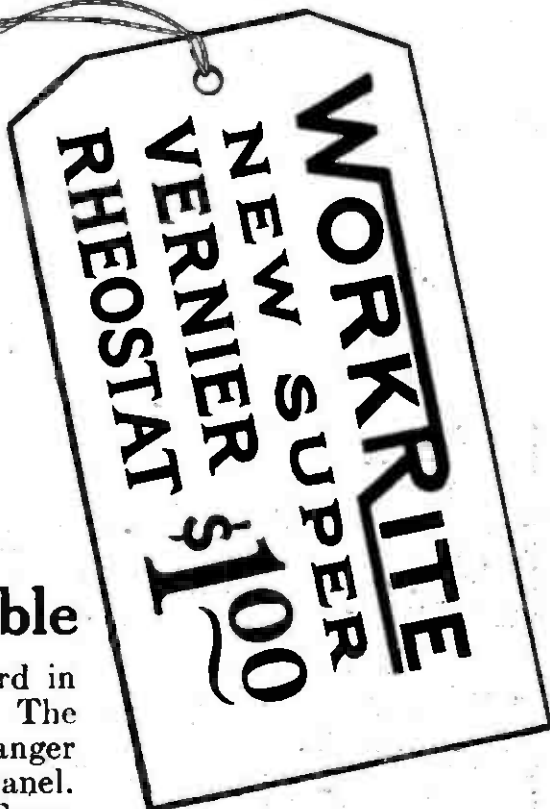
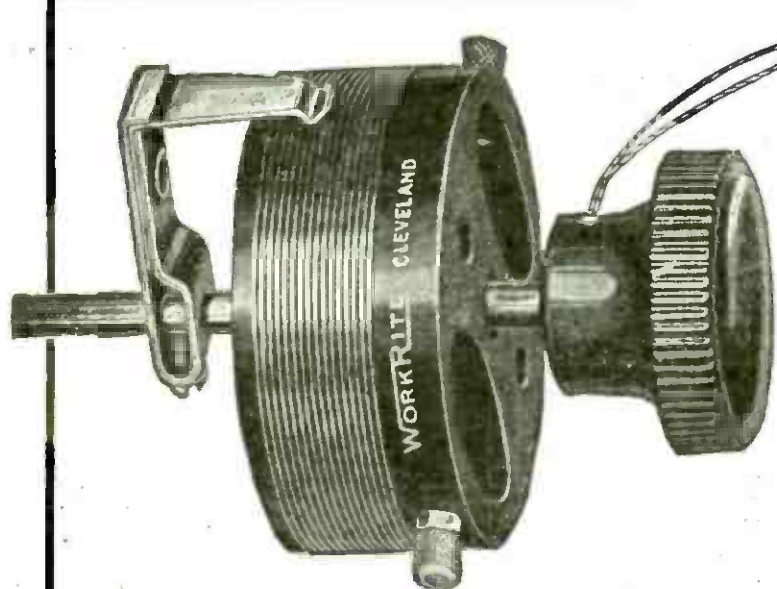

## 50,000 Adjustments Possible

Here is an instrument that is the last word in Rheostats. 50,000 adjustments for \$1.00. The drum is moulded and can not shrink. No danger of the wires loosening. Easy to mount on panel. Pushing the knob way in turns off filament. Turning the knob gives the very finest adjustment. Often a turn of 1/32 inch will clear up a station or separate two stations.

The regular Rheostat has 6 ohms resistance. For the 201A and 301A tubes 6 to 12 ohms resistance is necessary for the best results. For the new UV199 tubes, you need 30 ohms.

A WorkRite Super Vernier Rheostat on your Detector Tube will double the efficiency of your set. Try it and see. Put a WorkRite Rheostat on each of your tubes and get perfect adjustments.

### WorkRite New Super Vernier Rheostat \$1.00

(With 15 ohms resistance \$1.10 With 30 ohms resistance \$1.25)

**LET US HELP YOU BUILD YOUR RADIO SET**

*Read What One WorkRite Radio Fan Writes*

Dayton, Ohio, March 30, 1923.

Last August I assembled a radio set using your WorkRite Parts, employing your hook-up. With this outfit I have heard voices from every State in the Union with the exception of Nevada and Mississippi, from each border province in Canada, from Cuba, from Porto Rico, and upon three occasions from Hawaii. Pacific Coast stations come in nightly: I have heard 31 of them, etc.

Ralph C. McSherry, 114 N. Western Ave.

### OTHER WORKRITE RADIO PRODUCTS

WorkRite Super Variometer . . . . .	\$ 3.50	WorkRite 180° Super Vario Coupler . . . . .	\$3.50
WorkRite E-Z-Tune Dial . . . . .	.75	WorkRite Concert Headset . . . . .	6.00
WorkRite Concertola, Jr. . . . .	12.00	WorkRite Switch Set . . . . .	.50
WorkRite Concertola, Sr. . . . .	24.00	WorkRite Hydrometers . . . . .	.75
WorkRite 25 ohm Resistance Cartridge 40 cents			

*"WorkRite Radio Parts WorkRite"*

**THE WORKRITE MANUFACTURING CO.**

**5512 EUCLID AVE., CLEVELAND, OHIO**

*(Branch Office, 536 Lake Shore Drive, Chicago)*

# BUILD YOUR OWN RADIO OUTFIT

## HIGH QUALITY GOODS AT LOW PRICES

### FAST SERVICE—THE PRICES QUOTED DELIVER THE GOODS TO YOUR DOOR

#### BARAWIK SPECIAL PANEL MOUNTING VARIABLE CONDENSERS

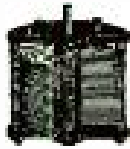

- J812—43 plate .001 Mfd. . . . . \$1.73
- J813—21 plate .0005 Mfd. . . . . 1.43
- J814—11 plate .00025 Mfd. . . . . 1.32
- J815—3 plate Vernier 98c

These are especially high grade condensers and we guarantee them to be mechanically and electrically perfect. Genuine bakelite end plates of high dielectric and great mechanical strength. Sturdy aluminum alloy plates perfectly spaced to insure smooth, even reliable capacity. Our low prices save you money. These condensers are of the very best make and are not to be compared with any inferior cheap condensers offered. We guarantee them to please you or your money back.

#### COMBINATION VERNIER VARIABLE CONDENSERS

- J824—23 plate .0005 Mfd. Price . . . . . \$2.89
- J826—43 plate .001 Mfd. Price . . . . . 3.45



The latest improvement in condensers consists of regular variable condenser controlled by large knob and dial. Separate small knob mounted above dial controls a three-plate vernier condenser. This arrangement permits of very fine tunings. High-grade design and construction. Finely finished. Suitable for panel mounting.

#### INDUCTANCE "HONEY COMB" COILS



Carefully made — fine looking coils. Highest efficiency. Low distributed capacity effect, low resistance—high self inductance. Very firm enamel impregnation. Range given in meters when varied with .001 variable condenser. Mounted coils have standard plug mountings.

Turns	Meters	Art. No.	Not Mntd.	Art. No.	Price
25	120-250	J301	\$0.39	J320	\$0.89
35	175-450	J302	.42	J322	.96
50	240-720	J303	.49	J323	1.04
75	390-910	J304	.54	J324	1.08
100	500-1450	J305	.58	J325	1.13
150	600-2000	J306	.63	J326	1.17
200	900-2500	J307	.72	J327	1.26
250	1200-3500	J308	.78	J328	1.35
300	1500-4500	J309	.82	J329	1.36
400	2000-5000	J310	.97	J330	1.57
500	2800-6100	J311	1.12	J331	1.63
600	4000-10000	J312	1.27	J332	1.78
750	5000-12000	J313	1.43	J333	1.93
1000	7900-15000	J314	1.70	J334	2.28
1250	9750-19500	J315	1.92	J335	2.49
1600	14500-26500	J316	2.18	J336	2.65

#### COIL MOUNTINGS



- J340—Three coil mounting. . . . . \$3.95
  - J341—Two coil mounting. . . . . 2.95
- High grade fine looking mounting. Polished black composition. Center receptacle stationary, two outer ones adjusted by knobs. Takes any standard mounted coil.

#### GALENA DETECTOR

Easy fine adjustment. Crystal mounted in cup. Moulded base and Knob. Brass parts polished nickel finish. J732—Each . . . . . 59c



**This Guarantee Protects You.** Examine the goods we ship you. They must suit you in every respect. If you are not satisfied with your purchase return the goods at once and we will refund the price you paid.

- #### VACUUM TUBES
- Standard Brands—Cunningham Radiotron. Every one guaranteed new and perfect. We will ship brand in stock unless you specify otherwise.
- J105—Detector UV200 or C300 . . . . . \$4.38
  - J112—Amplifier UV201A or C301A. Each . . . . . \$5.95
  - J115—5 Watt Transmitter. . . . . 7.70
  - J107—WD11 1½ volt. . . . . 5.95
  - J109—WD11 adapter. Each . . . . . 43c

- #### VACUUM TUBE SOCKETS
- Our Special Socket. A wonderful value. Moulded entirely of bakelite. Four binding post connections. Right angled contact springs.
- J140—For Standard Base Tubes. Each . . . . . 39c
  - J108—For WD11 Tubes. Each . . . . . 49c

- #### PORCELAIN BASE AND TUBE
- J144—Crosley for either panel or table mounting for Standard Base. . . . . 36c

- #### GRID CONDENSER
- High Grade combination type for panel or table mounting Metal tube. Highly insulated base. For Standard Base Tubes.
- J146—Each . . . . . 45c

- #### VARIABLE GRID LEAK
- Pencil mark type. Resistance may be varied exactly as needed.
- J100—Each . . . . . 19c

- #### VARIOMETER
- J410—Completely assembled, price \$2.69 Perfect in design and construction. Accurate wood forms. Correct inductive ratios. Solid baked windings, positive contacts. Highest efficiency.
- J411—Not assembled but all parts complete, except wire. Including winding form. . . . . \$1.48

- #### VARIO-COUPLER
- With this loose coupler and two variometers, together with the necessary other parts, a highly efficient tuning set can be made. Easily mounted on panel. Primary winding on formica tube.
- Inductively coupled for 180 to 600 meters. Multiple taps permit fine tuning.
- J415—Price, completely assembled. \$2.45
  - J416—Not assembled, but all parts complete. Price, except wire. . . . . 1.18
  - J417—Rotor ball only. Each . . . . . 29c
  - J408—Bakelite Stator tube only. Ea. . . . . 35c

#### RADIO FREQUENCY AMPLIFYING TRANSFORMER

J995—Each . . . . . \$3.95  
This transformer will get the long distance stations loud and clear. Permits of easy sharp tuning. Helps cut out static and interference. Makes your set sensitive enough to use a loop aerial. Enclosed in metal case affording perfect shielding. Suitable for panel or base mounting. Because of its special design can be mounted in any V. T. socket. Works with any make of tube. Wave ranges 150 to 550 meters. Wiring diagrams included.



#### OUR SPECIAL AUDIO FREQUENCY AMPLIFYING TRANSFORMERS

- As high as three stages can be used without howling, due to proper impedance ratio, minimum distributed capacity, low core losses and proper insulation. Mounted style has bakelite panel with binding post connections. Unmounted has core and coils assembled with two holes in core for fastening to apparatus.
- J234—10 to 1 Mounted. Each . . . . . \$3.48
  - J235—10 to 1 Unmounted. Each . . . . . 2.95
  - J236—3 to 1 Mounted. Each . . . . . 3.40
  - J237—3 to 1 Unmounted. Each . . . . . 2.85

#### FILAMENT CONTROL RHEOSTATS

- Crosley—Wound on vulcanized fiber. Adjustable to any panel. Complete with knob.
- J130—Each . . . . . 45c
- Best grade. High heat resisting base. Diam. 2¼ in. cap. 1½ amp. Resistance 6 ohms. 1¼ in. Knob with pointer.
- J132—Each . . . . . 45c

#### POTENTIOMETER

Same style as above rheostat. Gives fine "B" battery adjustment. Resistance 140 ohms.

- J133—Each . . . . . 98c

#### VERNIER RHEOSTAT

Gives exceedingly fine control of a battery current. A necessity for best receiving results.

- J135—Each . . . . . 78c

#### PLATE CIRCUIT "B" BATTERIES

You can make real savings on these batteries. Don't pay more. We guarantee them to equal any on the market regardless of price. Absolutely uniform. Extra long life.

- J180—Signal Corps type, small size, 15 cells. 22½ volts. Each . . . . . 95c
- J184—Variable Large Navy size, 5 taps, giving range from 16½ to 22½ volts in 1½ volt steps. Each . . . . . \$1.80
- J188—Combination Tapped 45 volts, 30 cells, 6¼x4x6 battery. Tapped to give 45, 22½, 21, 19½, 18, and 16½ volts. Handles both detector and amplifier tubes. Ea. \$3.55

#### DETECTOR CRYSTALS CAREFULLY TESTED

- J736 Galena, Arlington tested, per piece 19c
- J738 Silicon, Arlington tested, per piece 19c
- J735 Tested, Galena, per piece . . . . . 9c
- J737 Tested, Silicon, per piece . . . . . 9c

# THE BARAWIK CO. 102 S. CANAL STREET CHICAGO, ILL.

# USE BARAWIK STANDARD PARTS

**YOU SAVE MONEY WHEN YOU BUY FROM US**  
**FAST SERVICE—THE PRICES QUOTED DELIVER THE GOODS TO YOUR DOOR**

## SOLID BARE COPPER WIRE

Solid bare copper wire for aeriads, leads or wiring instruments.

- Solid Bare Copper Wire, size 14  
 J240—100 ft. coil 49c  
 J242—500 ft. coil \$2.35
- Solid Bare Copper Wire, size 12  
 J244—100 ft. coil 67c  
 J245—500 ft. coil \$3.05

## STRANDED ANTENNA WIRE

Cabled of fine copper strands. Very flexible. High tensile strength. Best for antennas.

- J248—100 ft. coil 72c  
 J249—500 ft. coil \$3.20

## ANTENNA INSULATORS

- J260—Size 1x3 1/4. Two for... 17c  
 J262—Size 2 1/2 x 3 1/4. Two for... 55c  
 J264—Size 1 1/2 x 4. Two for... 69c  
 J266—Size 1 1/2 x 10 1/2. Two for \$1.29

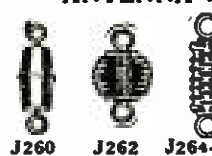

## OUTDOOR LIGHTNING ARRESTER

J980—Price... \$1.58  
 Protect your instruments with this lightning arrester. You cannot afford not to. Weather-proof porcelain case. Air gap type. Permanent. Durable. The most practical quality arrester obtainable. Underwriters approved.



## PORCELAIN BASE SWITCHES

Fine white porcelain bases. Copper contacts and blades. Can be used as antenna switches.

- J385 Single Pole Single Throw. Each 20c  
 J383 Single Pole Double Throw. Each 32c  
 J384 Double Pole Double Throw. Each 50c



## SWITCH LEVERS

Moulded composition knob. Exposed metal parts polished, nickel finish. Fitted with panel bushing, spring and two set nuts. A high grade switch.

- J380—1" Radius } Each  
 J381—1 1/4" Radius } 19c  
 J382—1 1/2" Radius }



## SWITCH LEVER STOP

Brass, polished nickel finish.  
 J386—Dozen 18c. Hundred \$1.05.

## ONE-PIECE DIAL AND KNOB

Moulded of highly polished black composition with clean plain engraved scale and numerals in contrasting white enamel. Ribbed knob to fit the hand. An attractive neat pattern.

- J900—2 1/4" Diam. for 3-16" shaft. Ea. 19c  
 J901—2 1/4" Diam. for 1/4" shaft. Ea. 19c  
 J904—3" Diam. for 3-18" shaft. Ea. 25c  
 J905—3" Diam. for 1/4" shaft. Ea. 25c  
 J906—3 1/2" Diam. for 3-16" shaft. Ea. 35c  
 J907—3 1/2" Diam. for 1/4" shaft. Ea. 35c



## GUARANTEED QUALITY GOODS

at money saving prices. You can build the parts purchased from us into your set and feel confident of the best results. If what you want is not shown here write us for prices—we have every part for your set ready for quick shipment and the prices are right.

## RADIO JACKS AND PLUGS

Finest grade jacks. improved design. Best materials. Phosphor bronze springs. Silver contact points. Nickel finish. Mount on panels 1/4 to 1/2 in. thick.

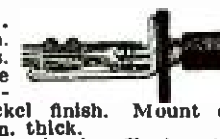

- J390—Open circuit. Each... 43c  
 J391—Closed circuit. Each... 49c  
 J392—Two circuit. Each... 60c  
 J393—Single cir. fila. control... 69c  
 J394—Two cir. fila. control... 85c  
 J395—Plug. Large space with set screws for attaching cord. Each... 49c

**COMPETITOR JACK AND PLUG**  
 Well made, durable, smooth working. Interchangeable with any standard jacks and plugs. Solder connections. Nickel finished metal parts.

- J387—Open Circuit Jack. Each... 27c  
 J388—Two Circuit Jack. Each... 35c  
 J389—Standard Plug. Each... 35c

## BINDING POSTS

Brass, polished nickel finish. Washer and 6-32" screw extending 1/4".  
 J370—Large size—barrel and knob 1/4" long, dozen... 85c  
 J372—Smaller size—barrel and knob 9-16" long, dozen... 70c  
 J370-2 dozen... 70c  
 J374—Large size with composition knob, dozen... 50c  
 J376—Large size with hole for phone tip or wire, dozen... 80c  
 J378—Small size with hole for phone tip or wire, dozen... 35c



## STORAGE BATTERY

A very high grade battery made especially for radio service. Guaranteed. Properly cared for will give years of service for filament lighting.  
 J194 6-v., 40 amp. size. Each... \$10.00  
 J196 6-v., 80 amp. size. Each... 12.50  
 Price does not include transportation.

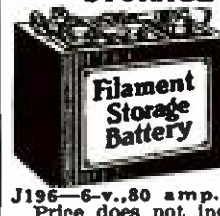

## CABINETS

Fine-looking cabinets solidly built. Made of genuine solid mahogany in elegant hand rubbed finish. You will be proud of your set mounted in one of these cabinets. Hinged tops. Front rabbeted to take panels. Panels not included. Prices are transportation paid.



Panel Size	Inside High	Dimensions Wide	Art. No.	Price Each
6x7"	5 1/2"	6 1/2"	J420	\$2.48
6x10 1/2"	5 1/2"	10"	J422	2.75
6x14"	5 1/2"	13 1/2"	J424	3.30
7x14"	6 1/2"	13 1/2"	J423	3.60
7x18"	6 1/2"	17 1/2"	J426	3.90
7x21"	5 1/2"	20 1/2"	J425	4.20
9x14"	8 1/2"	13 1/2"	J428	3.70
12x14"	11 1/2"	13 1/2"	J430	4.40
12x21"	11 1/2"	20 1/2"	J432	5.25

## SOLID GENUINE CONDENSITE CELERON PANELS

Notice our very low prices in this fine quality grade 10 genuine solid sheet Condensite Celeron (a product with mechanical, chemical and electrical properties like formica and bakelite). Machines well without chipping. Won't warp. Waterproof. Highest mechanical and dielectric strength. Attractive natural polished. Black finish which can be sanded and oiled for extra fine work.

Panel Size	Art. No.	Price	Art. No.	Price	Art. No.	Price
6x7"	J450	\$0.50	J460	\$0.75	J470	\$0.98
6x10 1/2"	J451	.75	J461	1.18	J471	1.47
6x14"	J452	1.05	J462	1.55	J472	2.05
7x14"	J458	1.20	J468	2.60	J478	2.40
7x18"	J453	1.55	J463	2.30	J473	3.10
7x21"	J457	1.78	J467	2.65	J477	3.60
9x14"	J454	1.60	J464	2.30	J474	3.10
12x14"	J455	2.10	J465	3.10	J475	4.15
12x21"	J456	3.15	J466	4.65	J476	6.20

## HOME CHARGER BATTERY CHARGING RECTIFIER

Charge your battery at home over night for a few cents. Simply connect to any 110 volt 60 cycle light socket. turn on current and rectifier does the rest automatically. Will work for years without attention. Simple connections. Gives a tapering charge which batteries should have. You can make it pay a profit charging your friends' auto batteries. Long connecting cords with pair of battery clips. Prices are Transportation Paid.  
 J201—For 6 volt battery... \$13.95

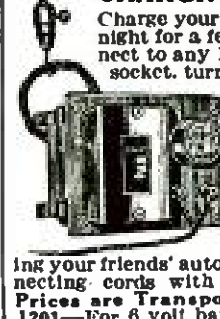

## BARAWIK QUALITY HEADSETS

These headsets have proven on rigid tests to be one of the very best on the market. The tone quality is excellent with an unusual volume. Skilled workmen make them from only the best selected materials. The receiver cases are brass in fine polished nickel finish. Polished black ear pieces. Fabric covered head band comfortably and quickly fitted to the head. Supplied with 5-foot cord. These sets were designed to sell for much higher prices, and at our price are a wonderful bargain. We guarantee that you will be pleased with them and agree that they are the best value by far yet offered. If they don't suit you we will cheerfully return your money.



- J770—2000 ohm... \$3.75

## OTHER STANDARD BRAND HEADSETS

- J751—Murdock 56, 2000 ohm... \$4.20  
 J752—Murdock 56, 3000 ohm... 4.95  
 J764—Frost, 2000 ohm... 4.20  
 J766—Frost, 3000 ohm... 4.85  
 J756—Red Head, 3000 ohm... 5.85
- J758—Western Electric, 2200 ohm... \$9.50  
 J754—Baldwin Type C with universal jack plug... 12.00  
 J755—Baldwin Type C unit... 5.50  
 J768—Brandes, 2000 ohm... 6.95

**THE BARAWIK CO. 102 S. CANAL STREET CHICAGO, ILL.**

Please mention POPULAR RADIO when answering advertisements.

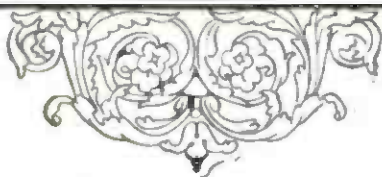
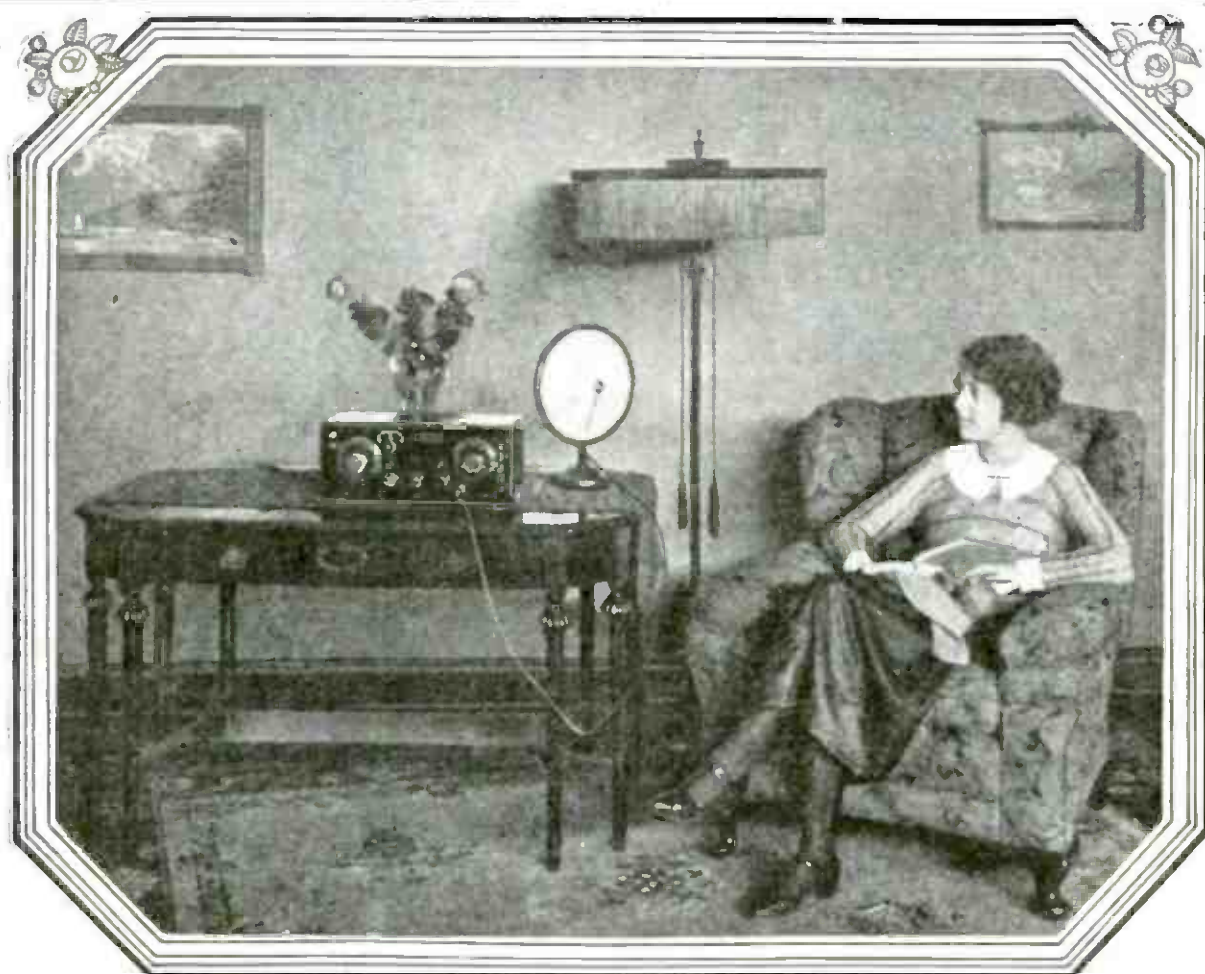

## The SP2 Receiver Has "That Something"—

A Receiver that can be demonstrated with a world of satisfaction and sold with remarkable ease.

The SP2 is everything the radio-receiver purchaser anticipates in the ideal set of his fancy.

It brings in the local stations in all the fullness and clearness of the actual performance of the sender. Stations, broadcasting simultaneously, are tuned in and cut out at pleasure, readily and surely.

Noise and disturbance are practically eliminated. The SP2 is listened to with genuine delight. It gives a **QUALITY** performance; the entertainment as afforded by broadcasting stations **EVERYWHERE**—and at its best.

Long distance stations come in on the SP2 **clearly and distinctly** even to the "faintest" signals that mark the range of a highly efficient receiving set.

The SP2 Receiver has an unlimited range and is nationally known for its compactness of size, elegance of appearance, superiority of quality and scientific perfection.

**Retails at \$100**

**CATALOG 101A**—A complete catalog of radio equipment and valuable radio information, will be mailed on receipt of 10c in stamps

**Distributors For**  
The SP2 Receiver—  
Pathe Loud Speaker—  
Amrad—  
Cunningham—  
Atwater Kent—  
Sleeper—  
Reflex Speaker—  
Callophone—  
Homcharger—  
Autostat—  
Radiall—  
Frost—  
Baldwin—  
Pacent—  
Jansen—  
Dubilier—  
E. M. P.—  
A. B. C.—  
Keystone—  
Hafner—  
and other reputable manufacturers.

**PITTSBURGH RADIO SUPPLY HOUSE**

963 Liberty Avenue

Pittsburgh, Pa.



## WASTED EFFORT

The building of a radio set is absorbingly interesting.

The prime motive actuating men and boys of all ages in assembling their own receivers is the realization that only by so doing can a practical knowledge of radio telephony be acquired.

Thus, the different circuits and functions of the various parts are better understood.

Heretofore, much tedious labor has been involved in the undertaking. Laying out the panel and the drilling of from forty to eighty holes, as well as the mounting of tap-switches and soldering of primary leads, have all contributed to making the job a laborious one.

Eisemann units and panels eliminate more than half the labor ordinarily required.

All units are simply attached to aluminum panels with screws and nuts. All panels are completely drilled. Several sizes of panels are offered, with openings provided for any number of units that may be desired. The panel, itself, acts as a perfect body capacity shield. The variocoupler is complete—a tap-switch being carried inside the rotor.

Before starting to build a Receiving Set, it will be found worth while to examine Eisemann radio products.

*Descriptive literature on request.*

### EISEMANN MAGNETO CORPORATION

William N. Shaw, *President*

BROOKLYN, N. Y.

DETROIT

CHICAGO

SAN FRANCISCO



# THE STANDARD OF CONDENSER VALUE

HAS BEEN SET BY

## Vernitrol Condensers

BALANCED VERNIER TYPE

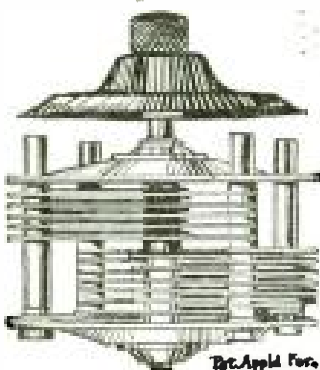

*Pat. Appl. For.*

Independent Vernier Plate. Rigid Metal End Shields. Micrometer Spacing. Internally Balanced. Heavy Bearings. Low Losses.

Supplied in the Following Sizes:

	(4-Inch Dial)	
.00025 MF. . . . .		\$5.50
.0005 MF. . . . .		6.50
.001 MF. . . . .		7.50

## RHEOSTATS AND POTENTIOMETERS

Of Rugged Construction yet giving that Smooth Control so necessary for Fine Adjustment

### Duotrol

(Vernier Type with Dial)  
\$2.00

### Amplifier

(Plain Type with Dial)  
\$1.50

### Potentiometers

(300 Ohms with Dial)  
\$2.50

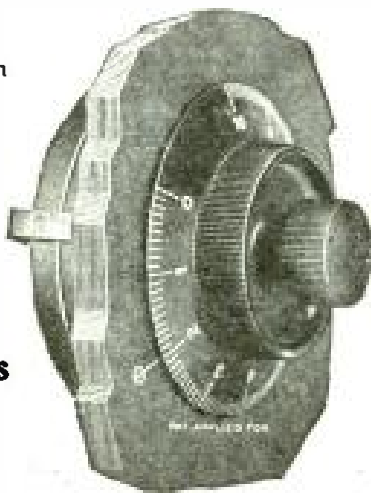

Complete with dials to repeat settings. Rheostats furnished in the proper resistances for both old and new tubes. Type A-12 ohms. Type A99-30 ohms.

# MALONE-LEMMON LABORATORIES

342 Madison Avenue  
New York City

## CHARGE YOUR RADIO BATTERY at HOME for a NICKEL



**PATENTED ARMATURE**  
The HOMCHARGER'S only moving and wearing part, replaceable after thousands of hours' use for \$1.00. Tungsten contacts now used exclusively. Will not stick, corrode or wear excessively.

Enjoyable concerts and maximum receiving range are obtained only when your battery is fully charged.

## THE HOMCHARGER

charges your "A" or "B" battery OVER NIGHT for a nickel without removing it from your living room. Operates silently—charging rate governed automatically. No fuss—no trouble—no dirt—requires no watching.

The HOMCHARGER is the ONLY battery charger combining all of these necessary features. SELF-POLARIZING—FIVE to EIGHT-AMPERE charging rate—UNDERWRITERS' APPROVAL—beautifully finished in mahogany and old gold—UNQUALIFIEDLY GUARANTEED. Over 100,000 now in use.

The minute you buy a radio set you need a Homcharger—get it then. All good radio and electrical dealers sell it complete with ammeter, etc., for \$18.50. \$25.00 in Canada.

Write for FREE circular showing why the HOMCHARGER is the BEST battery charger at any price.

MOTORISTS — THE HOMCHARGER will also charge your AUTO Battery.

THE AUTOMATIC ELECTRICAL DEVICES CO.  
132 WEST THIRD ST.  
CINCINNATI, OHIO

Largest Manufacturers of Vibrating Rectifiers in the World

# truth about filament controls

Electronic flow in the vacuum tube depends upon the heat of the filament. This heat varies as the square of the current. Therefore, it is easily seen that the most infinitesimal variation of filament heat has a tremendous effect on the electronic flow and upon reception. A wire wound rheostat cannot provide the fine adjustments necessary to filament control. It was not designed to do so. Inferior filament controls are scarcely better. The Fil-Ko-Stat is distinctly designed to utilize the great tuning possibilities of the vacuum tube. It gives absolute control of the electronic flow, permits the finest tuning possible and assures longer life to the tube. Fine adjustment of fractional currents makes it ideal for dry cell tubes and infinitesimal control of the electronic flow gives that fine adjustment so very essential in D. X. tuning. It is non-microphonic, operates absolutely silent. Fine adjustment starts where tube begins to function. At full on, resistance is practically zero—definite off indicates complete A Battery disconnection.

Graphic proof of Fil-Ko-Stat superiority as shown here, can be had in any well equipped laboratory. This comparison of fine adjustment control range of Fil-Ko-Stat with rheostat and other filament controls clearly indicates Fil-Ko-Stat superiority.



## Proof!

**NO DISCS TO BREAK OR CHIP**

Resistance element so finely divided, further division impossible. Fil-Ko-Stat, compact in size, takes little space on panel, replaces other controls without re-drilling.

**GUARANTEED**

The Fil-Ko-Stat is to all purposes "fool proof." Each instrument is packed with the maker's guarantee that it will be replaced if broken within one year.

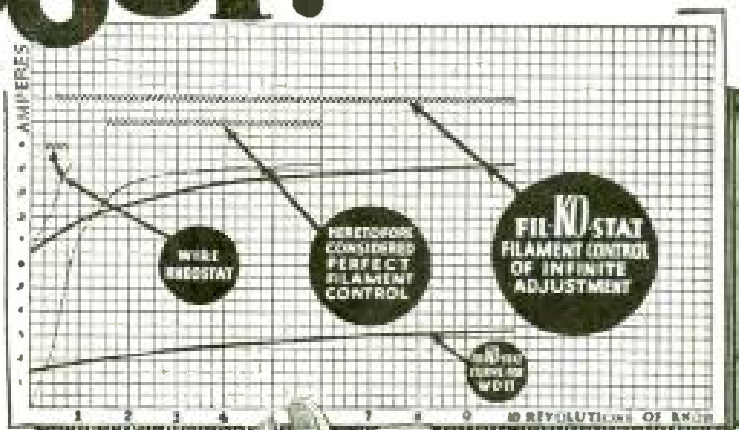

Fitted with Fahnestock Clips

**\$2**

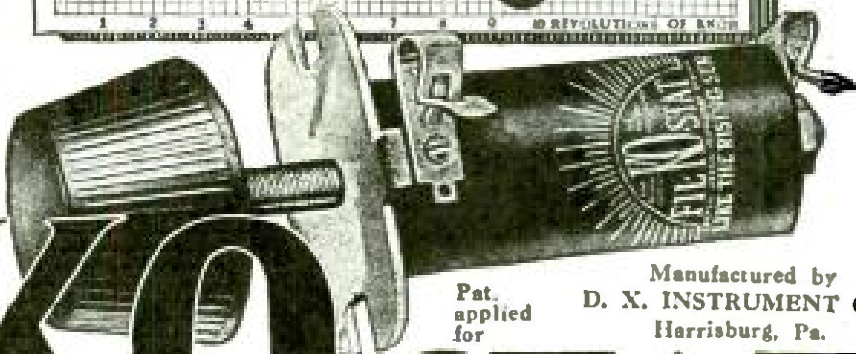

Pat. applied for

Manufactured by  
**D. X. INSTRUMENT CO.**  
Harrisburg, Pa.

# FIL-KO-STAT

Wire orders filled to jobbers and dealers.

Say "Fil-Ko-Stat" to your dealer today. If he has none in stock send his name with your remittance direct to

**RADIO STORES CORPORATION**

Sole International Distributors.

Department P. R. 6, 218-222 W. 34th St.

Please mention POPULAR RADIO when answering advertisements.

PACIFIC COAST BRANCH  
329 Union League Bldg.  
Los Angeles



### The Superlative Inductance

Four years of careful attention to the details of manufacture of this type of inductance unit has yielded a product of unquestioned superiority. And with increased efficiency in manufacturing methods, moderate prices prevail for all sizes

Ask Your Dealer

**Cotoco**

"Built First to Last"

**COTO-COIL CO. PROVIDENCE**

## WHY METRO HEADPHONES ARE SUPERIOR

TRADE MARK  
**METRO**

### ACTUATING COILS

METRO HEADPHONES are supremely sensitive, matched in tone and uniformly efficient, largely because of the precise winding of the actuating coils which energize the magnets. Each coil wound with one unbroken length of thin-as-hair wire. Specially designed, extremely accurate winding machine insures uniform tension of wire, entirely eliminating the possibility of short-circuited turns. Only highest grade of pure, enameled copper wire used. Insist on Metro Headphones and be sure of quality.

\$6.00

**Little Giant Receiving Set**  
A surprisingly compact set, Simplest tuning device. Complete with Metro Headphones \$14.00

**Metro Wave Selector**  
Makes any set highly selective. Completely separates 360 from 400 meters \$7.50

**METRO ELECTRICAL CO., Inc.**  
Manufacturers of Metropolitan Radio Products  
69 Goble Street Newark, New Jersey

Please mention POPULAR RADIO when answering advertisements.

**CROSLEY**  
BETTER COST LESS  
**RADIO**  
PRODUCTS

"WLW BROADCASTING STATION  
**CROSLEY**  
MFG., CO.,  
CINCINNATI, O.



**THE HEIGHT OF EFFICIENCY**  
Crosley Model X, Price \$55

Clearly, distinctly, as though given in the same room, messages from W.L.W. Broadcasting Station, Crosley Mfg. Co., Cincinnati, are heard in all parts of America if a Crosley Model X—a four tube radio frequency set—is used. This remarkable instrument, very easy to tune, simple and beautiful in construction, has repeatedly brought in messages over 4,900 miles away.

Other Crosley Models, like the Model VIII, three tube set—price \$48, and the Model VI, two tube set—price \$28, have given exceptional results to thousands of satisfied users everywhere.

Write for Catalog Showing Complete Crosley Line. For Sale By Best Dealers Everywhere.

Besides a complete assortment of receivers, Crosley manufactures parts for replacement or home construction.



Jobbers and Dealers Will Be Interested in the Crosley Proposition.

New York Office, C. B. Cooper, 1803 Tribune Bldg., 154 Nassau St.  
Boston Office, B. H. Smith, 929 Blue Hill Ave., Dorchester  
Chicago Office, 1311 Steger Bldg., 28 E. Jackson Blvd.,  
R. A. Stamm, Mgr.

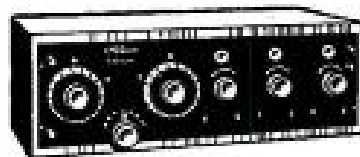

**CROSLEY MANUFACTURING COMPANY**  
616 ALFRED ST. CINCINNATI, OHIO

**Remarkable  
Regenerative  
Receivers**

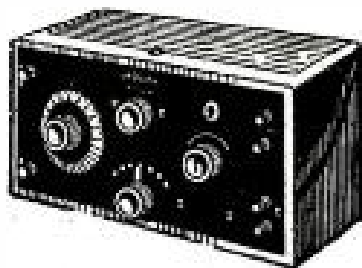

**Ace Model V  
\$20**

Formerly known as Crosley  
Model Vc

This one tube receiver is astounding the radio world with its wonderful achievements. Stations more than 1,000 miles away are being regularly copied on this set. In comparison to its price, there is no receiver on the market today to equal it in performance.

Because of its size and price the Ace Model V is a great summer seller.

Licensed under Armstrong U. S. Patent No. 1,113,149.

Live Jobbers and Dealers are eagerly taking advantage of the sales this instrument and the rest of the Precision instruments and parts bring them.

Free Catalog on Request.

**THE PRECISION EQUIPMENT CO.**  
*Powel Crosley Jr. President*

616 GILBERT AVE.

CINCINNATI, OHIO

# Large Map 2 colors-2x3ft. with

4<sup>th</sup>  
Edition  
\$1.00

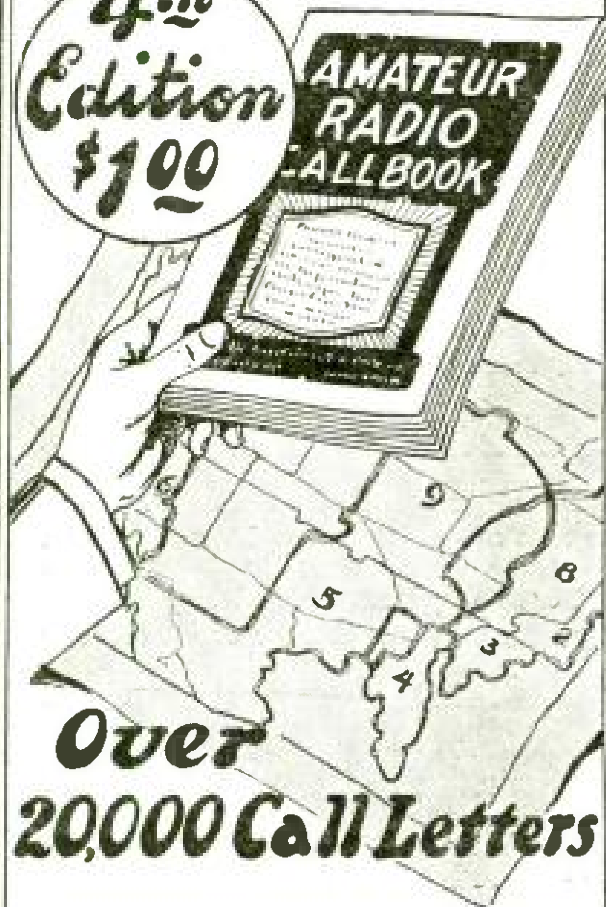

Over  
20,000 Call Letters

Indispensable to every radio owner. Contains up-to-date list of over 20,000 Amateur, Commercial, Army, Navy, Transoceanic High Powered, and Broadcasting Stations in the United States and Canada; International Morse Code and Convention Signals; the construction and operation of the Reinartz Tuner, Detector, and one-stage Amplifier; also an abundance of other useful information.

Included with the book is a splendid two-color map of the United States and Canada, 2x3 ft., showing radio district boundaries, standard time lines, geographical location of broadcasting stations, etc.

### Buy the Book with the Blue Cover

The greatest dollar value on the radio market. At your dealers or direct by mail. Use check or money order. Do not send stamps.

Dealers: write for proposition

Radio Directory and Publishing Co.  
45-J Vesey Street New York City



## More Money For You in RADIO

**T**HE amazing expansion of Radio has opened up thousands of wonderful new positions on land and sea. Big salaries, fascinating, easy work, short hours, and a wonderful future are offered to ambitious men who get into Radio now.

Take advantage of these wonderful opportunities to step into a big paying position in this great new field. Radio offers you an opportunity to travel and see the world, with all expenses paid, and a fine salary besides. Or you can stay at home and work up to a position paying up to \$10,000 a year.

### Easy to Learn Radio at Home

Hundreds of men are already earning handsome incomes in this wonder science. If you want to get into a profession where opportunities are unlimited make Radio your career—become a Certified Radio-trician.

Thousands of Certified Radio-tricians are wanted to design Radio sets; to make new Radio improvements; to manufacture Radio equipment and to install it; to maintain and operate great Broadcasting stations and home Radio sets; to repair and sell Radio apparatus; to go into business for themselves; to operate aboard ship and at land stations.

You can easily and quickly qualify in your spare time at home through the help of the National Radio Institute. Prominent Radio experts will help you. Four wonderful instruments are loaned to students making the work thoroughly practical. The same plan that has already helped hundreds of our graduates to real success and real money in Radio is open to you.

### Send for Big Book

No other field today offers such great opportunities as Radio. Take your choice of the many wonderful openings everywhere. Prepare now to step into the most interesting and best paid profession today. Read about the opportunities open now—the different kinds of work—the salaries paid. Write today for the 44 page book that tells how America's first and biggest Radio school can make you a Certified Radio-trician in your spare time. Mail the coupon or write a letter NOW. National Radio Institute Dept., 32-F, 1345 Pennsylvania, Ave., N. W., Washington, D. C.

**NOTE:** These opportunities are open only to men and boys eighteen and over. High School boys and others under Eighteen years of age interested in radio can make big money in spare time after school hours through our special spare time course. If you want information simply sign the coupon and send it to us.

National Radio Institute, Dept. 32-F  
1345 Pennsylvania Ave., N. W., Washington, D. C.

Without obligation send me your book "How to Learn Radio at Home" which tells all about the opportunities in Radio, how spare time study at home will qualify me quickly as a Certified Radio-trician so I can get one of the splendid positions, and how your Employment Service helps me to secure the job I want.

Name ..... Age.....  
Street.....  
City ..... State.....



# CROSLEY

## Uses Formica for Panels and Insulation

**C**ROSLEY radio sets are universally known and used. They are produced in a factory that is famous for its well developed production methods and factory systems.

Radio engineers for the Crosley Manufacturing Company, like those of nearly every other well known independent radio manufacturer, appreciate the superior qualities of Formica insulation for radio.

They use it in panels and for many other purposes in connection with their radio product, because it is good looking, because it works well with ordinary tools and because it has high di-electric strength and maintains it indefinitely, improving with age.

The Crosley Company is a large distributor of Formica panels and of radio parts of its manufacture in which Formica is used for insulation purposes.

*Formica dealers can supply you promptly with panels in all standard sizes.  
They can also supply special sizes when you want them.*

## The Formica Insulation Company

4641 Spring Grove Avenue  
Cincinnati, Ohio

### SALES OFFICES

50 Church St., New York, N. Y.  
422 First Ave., Pittsburgh, Pa.  
1042 Granite Bldg., Rochester, N. Y.  
415 Ohio Bldg., Toledo, Ohio

1210 Arch St., Philadelphia, Pa.  
1819 Lyndale Ave., S. Minneapolis, Minn.  
Sheldon Bldg., San Francisco, Cal.  
Whitney Central Bldg., New Orleans, La.

414 Finance Bldg., Cleveland, Ohio  
9 S. Clinton St., Chicago, Ill.  
313 Title Bldg., Baltimore, Md.  
47 King St., Toronto, Ontario

---

# FORMICA

Made from Anhydrous Redmanol Resins  
**SHEETS TUBES RODS**

---

RADIO  
**PEARLCO**  **PRODUCTS**

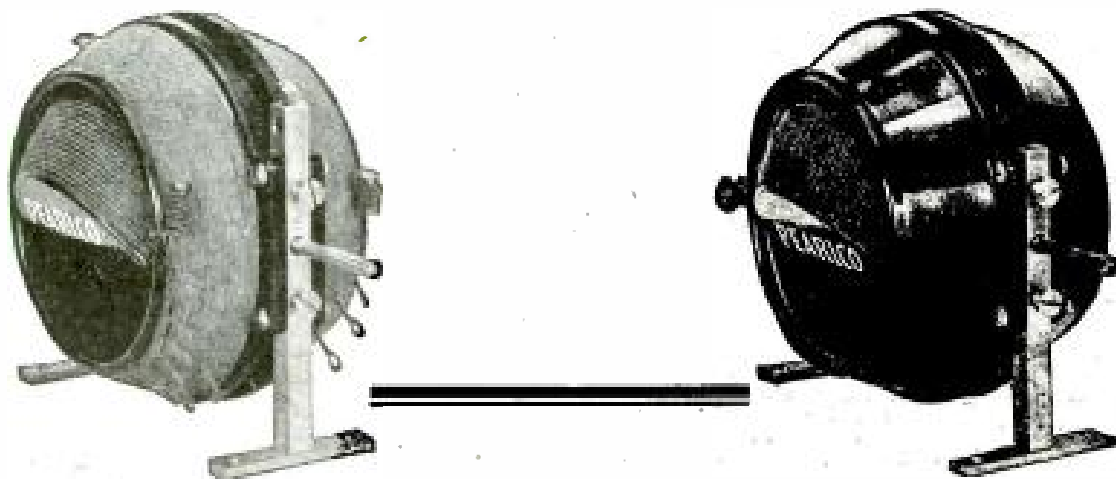

PEARLCO RADIO PRODUCTS, of which the variocoupler and variometer, molded in Bake-Lite, here shown are specimens, are now being successfully introduced to Radio Owners.

Made under the supervision of a noted radio engineer of 18 years' experience, these products are guaranteed the best of their kind on the market.

Please ask any dealer about Pearlco Products or write us.

**PEARL RADIO CORPORATION**  
1033-35 Race Street Philadelphia, Pa.



**BOTH HEAR ALIKE**

*Thousands of Satisfied Users Know—*

Clarion "Uniform Quality" Headsets are built from the best of materials and with careful attention to the fine manufacturing details necessary for the production of delicate and uniform receiving apparatus.

Clarion "Uniform Quality" Headsets do not add a tone of their own to the broadcast, varying with each headset, but reproduce voice and music as transmitted.

Clarion "Uniform Quality" Headsets are ideal for outdoor reception. They are ruggedly built, light in weight, neat in appearance and low in price. Every set is sold with a real, money-back guarantee. The purchaser must be satisfied.

If your dealer cannot supply you, order direct enclosing money order and address.

*Attractive proposition to the trade.*

**RADIO SUPPLY COMPANY**  
HORNELL, NEW YORK

**CLARION**  
*"Uniform Quality"*  
**Headsets**  
**\$5.00**





**\$25**

**Insist Upon the Atlas Amplitone**

Only the Atlas Amplitone can Re-PRODUCE. If your dealer has none, ask him to order for you.

*Natural*  
**Re-PRODUCTION**

The artist's presence can almost be felt in the startlingly natural Re-PRODUCTIONS by the *Atlas Amplitone*. Not a sign of blast or distortion, for the Amplitone, itself, is a fine musical instrument.

Designed by musicians, acoustic experts and radio engineers in response to the demand for an improved loud speaker. Many important refinements that increase the pleasures of radio without adding to its cost. A fine musical instrument applied to radio reception. Acknowledged supreme by highest musical and radio authorities.

*Atlas*  
**AMPLITONE**  
**LOUD SPEAKER**

Complete with connecting cord and full instructions for connecting and adjusting.



**Atlas Amplitone Unit**

You can make your own loud speaker with this part of the *Atlas Amplitone* (without horn or base) and a horn of any phonograph, except the Brunswick. With phonograph attachment **\$13.50** and instructions

Unit without Attachment, \$12.50

*WRITE for Illustrated Booklet*

**Multiple Electric Products Co., Inc.**

Radio Division

**7 Orange Street**

**Newark, N. J.**

# This is the New DICTOGRAPH RADIO Loud Speaker

with The Adjustable  
Air Gap That Tunes  
Out All Harshness

Invite your friends tonight. Surprise them with a real concert or dance.

The wonderful new Dictogrand will create the illusion that the artists are in the very room with you. Just go to your dealer's and hear this remarkable, clear-toned instrument. Take it home and plug in for the finest entertainment you've ever known. You don't need extra batteries.

Like all the other famous Dictograph Products, the Dictogrand is guaranteed for one year.

If your dealer hasn't the DICTOGRAND in stock, write to us direct.

## DICTOGRAND

Mahogany Finish

\$28.50

DICTOGRAPH  
PRODUCTS  
CORPORATION  
220 W. 42nd St., N.Y.C.

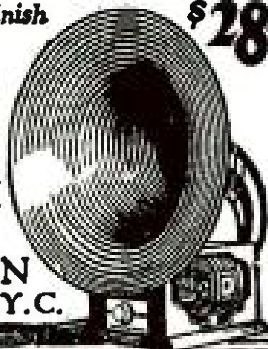

## RITTER LOOP AERIAL \$1.00

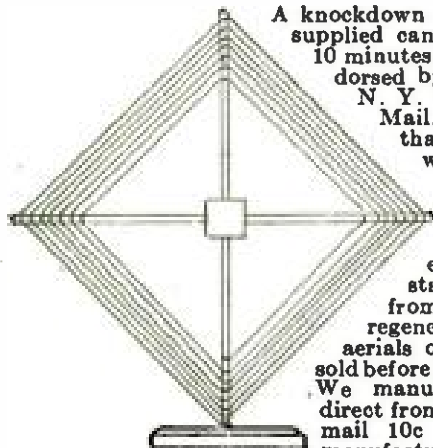

A knockdown aerial. All parts supplied can be assembled in 10 minutes. Tested and endorsed by Popular Radio, N. Y. Globe and N. Y. Mail. We guarantee that the Ritter Loop will eliminate lightning and landlord trouble, reduce static, interference from sending stations and noises from your neighbors' regenerative sets. Loop aerials of this kind never sold before for less than \$5.00. We manufacture and sell direct from our factory. By mail 10c extra. We also manufacture the now famous

Ritter Grand Crystal Set which will tune up to 800 meters. Price \$3.50. Dealers write for our proposition.

RITTER RADIO CORPORATION  
232 Canal Street New York City

# Wave Trap

TRADE MARK  
PATENT APPLIED FOR

The Missing  
Link  
in RADIO



## Stops Interference!

The "WAVE TRAP" will eliminate interfering broadcasting stations and enable you to listen to your favorite station.

It will work on any set, greatly increase its selectivity and clearness, and eliminate code and spark stations.

It is mounted on a Formica panel in a handsome mahogany finished cabinet 6x5x6. It is a high grade instrument throughout and a valuable addition to the operation and appearance of any set. It comes to you complete and there are no extras to buy. It is installed in a minute by changing only one outside connection.

Use the "WAVE TRAP" for real results.

850  
CHARGES  
PREPAID

Herbend Electric Co.

21 E. SOUTH WATER ST.

CHICAGO

Circular on request

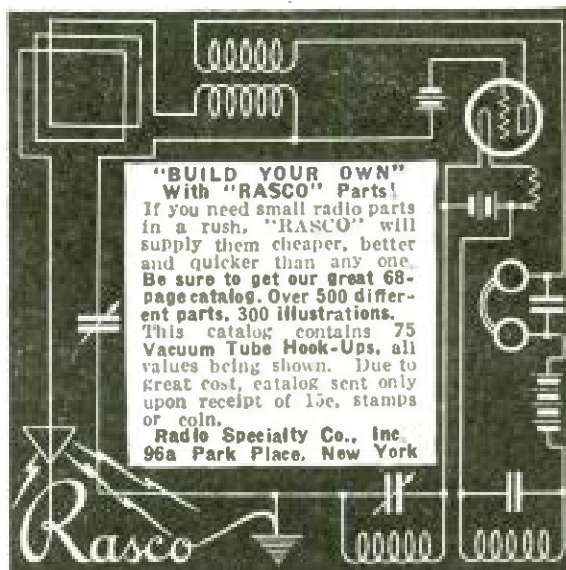

# ACME

for amplification



## The City's Music In Vacation Times

Thousands of summer resorts are going to keep in touch with the world by radio. Thousands more wish that they had thought of it.

The Jones *Symphony* Receiver, detector and three stage, is particularly fitted for this service.

Because: **FIRST**, it is positively in a class by itself in the durability of its construction and assembly.

**SECOND**, its simplicity of operation.

**THIRD**, its-reliability.

We sell with the Jones *Symphony* Receiver, for this purpose, a stout traveling case. All you need to do is to disconnect your leads, put the *Symphony* in the case, turn the lock, put the case in your car with a couple of "B" batteries and you are all fixed. Use your automobile battery. If that isn't convenient, use "peanut tubes" with adapters. If you want the best, we suggest using regular tubes with a six-volt battery. You can rent one at any town.

But in any case include a Jones Receiver in your summer outing plans. The *Symphony* will repay you many, many times over.

Summer radio has been handicapped by absurd stories of noises. The quality of our *Symphony* receiver, and more efficient broadcasting stations have eliminated many defects heretofore assumed to be caused by static. On most summer nights, especially in dry weather, the receiving is as good as at any other time in the year.

The use of the *Symphony* under many and varied conditions proves it to be one of the most efficient long distance receivers on the market. Every part of the *Symphony* is built and inspected by the Kellogg Switchboard & Supply Company, for twenty-five years manufacturers of highest grade telephone equipment.

Ask your dealer — If he has not a *Symphony* in stock, or complete information, wire us immediately. Get your order in at once to avoid delay.

**JONES RADIO COMPANY**

LYTTON BUILDING. CHICAGO

The *Symphony* is manufactured under U. S. Patent No. 1113149. Armstrong Regenerative Circuit

# FLEWELLING-KAUFMAN-REFLEX ULTRA REINARTZ-NEUTRODYNE

and other circuits are greatly improved by using  
**“MICON”** TESTED MICA CONDENSERS

Endorsed not only by experts, but  
by dealers, amateurs—in fact,  
every one interested in radio.



**Because** The design of “Micons” is such that constant equal pressure is exerted on the condenser plates over the entire area. “Micons” assure absolute noiselessness, clarity of tone, accuracy, constant fixed capacity. “Micons” are invaluable as a protection against damage to the filament and their consequential short life.

.006 Micon.....\$1.00  
.005 Micon......75  
.001 Micon......40

Other “Micon” Sizes					
.00005.....	30c	.0015.....	40c	.01.....	60c
.00025.....	35c	.002.....	40c	.015.....	2.00
.00035.....	35c	.0025.....	50c	.02.....	2.50
.0005.....	35c	.003.....	\$1.50	.025.....	3.00

AT YOUR DEALERS—otherwise  
send purchase price and you  
will be supplied postpaid.

Ask for  
**FREE**  
Diagram of  
KAUFMAN  
CIRCUIT

**Chas. Freshman Co. Inc.**  
*Radio Condenser Products*  
106 Seventh Ave. New York  
*Home of Freshman Variable Resistance Leaks*

Ask for  
**FREE**  
Diagram of  
FLEWELLING  
CIRCUIT

## The Best Headset



HIGHEST AUDIBILITY  
PERFECT MATCHING  
GREATEST VOLUME

### Why Strain Your Ears?

T. B. H. Headsets reproduce  
clearly and naturally. No “Fuzz” or  
“Tinny” tone. Extremely sensitive.

Aluminum cases—6 Foot cord—Weight 12 oz.  
Type 6-A 17500 Turns (2200 ohms) Hard Rubber caps \$7.00  
Junior 16000 Turns (2000 ohms) Composition caps \$5.00

*If your dealer does not carry them he will order them for you  
Dealers and Jobbers write for discounts*

**THE T. B. H. CORPORATION**  
DANSVILLE, NEW YORK, U. S. A.



## A Loud Speaker and Reproducer in One **BRISTOL**

TRADE MARK  
**AUDIOPHONE**  
REG. U. S. PAT. OFFICE

**MORE THAN A LOUD SPEAKER** the **AUDIOPHONE** is a real reproducer of the original broadcasting. It is easy to listen to the Audiophone reproductions because they are so perfect. The speech, songs and instrumental music are not blurred or disguised by mechanical distortion. You get all the fine shadings and every inflection. In fact, the very personality of the artist seems to be present as you listen.

**DEVELOPED** in the laboratories of an engineering firm known the world over for recording instruments of precision.

**COMPLETE** in every way and ready to connect to the receiving set.

**NO AUXILIARY BATTERIES** are required for magnetizing.

**ADAPTED FOR** use on all types of two or three stage power amplifiers.

### MADE IN TWO MODELS—

**BRISTOL AUDIOPHONE SR.** Loud Speaker, Size of Horn  
15 inches Diameter. Price.....\$32.50

**BRISTOL AUDIOPHONE JR.** Loud Speaker, Size of Horn  
11 inches Diameter. Price.....\$22.50

**THE BRISTOL SINGLE STAGE POWER AMPLIFIER** for use with the usual two stage amplifier can be furnished, which will greatly increase the range of the Audiophone where desirable. Price.....\$25.00

Write for Bulletin—3006-L

**THE BRISTOL COMPANY**

**WATERBURY, CONN.**

Boston New York Philadelphia Pittsburgh Detroit Chicago St. Louis San Francisco



*Here it is—the Perfect "Fishing" Record*

**E**XPERIENCED radio operators have found a big advantage in keeping permanent records of their "catches."

**White & Wyckoff's Handy Radio Record is the ideal record form.**

It tells at a glance the code, location, ownership, wave length, date of every find. The sheets are perforated and can be taken from any part of the pad without disturbing the others.

Get this Handy Radio Record and keep a convenient and systematic record of your radio results. At your dealers or send us \$1.00 for 5 pads of 50 sheets each, size 6"x9". Sent postpaid anywhere on receipt of price. Remit by check, cash or money order to

**WHITE & WYCKOFF MFG. CO.**  
Makers of the famous Autocrat Stationery  
100 Water Street  
Holyoke, Massachusetts

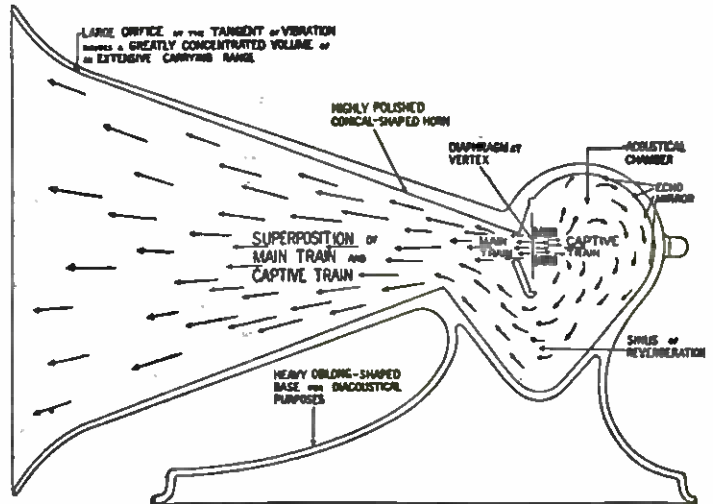

**ECHO-JONE**  
GIVES FINE NEEDLE TONE TO THE RADIO PHONE

**A REAL PORTABLE LOUDSPEAKER**

Unaffected by Climatic Conditions

NO PART TO BREAK OR JAR OFF

IDEAL FOR

*Vacation, Outing or Travel*

NO PULP to Crumble

NO WOOD to Warp

NO TIN to Bend

But

**CASTED ALUMINUM for DURABILITY**

Now Equipped With  
A TONE REGULATOR

**Retail Price \$35.00**

**WILLIAMS RADIO COMPANY**

Radio Tone Specialists

1438 Washington Blvd., Detroit, Mich.

*Your Radio Set on a*

**ROBBINS  
RADIO DESK**

Presents an attractive appearance. All wires, batteries and other accessories are entirely concealed. Various finishes to harmonize with your furniture.

*For sale by first-class radio and furniture dealers or write*

**Robbins Woodworking Co.**

Dept. B

Libertyville, Illinois

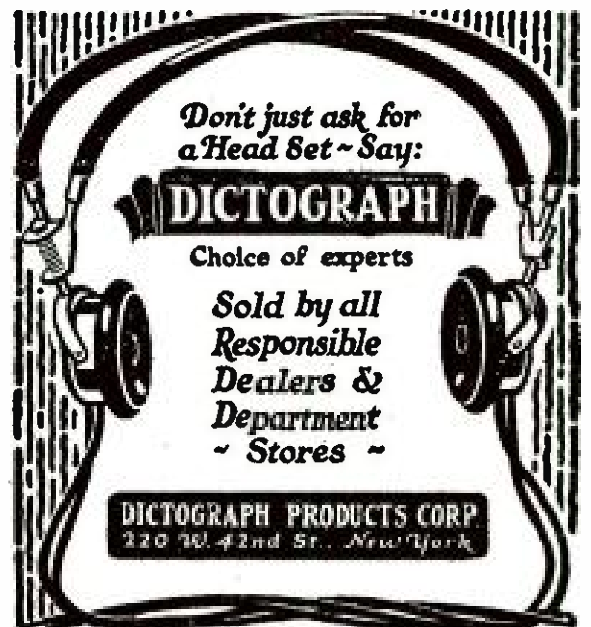

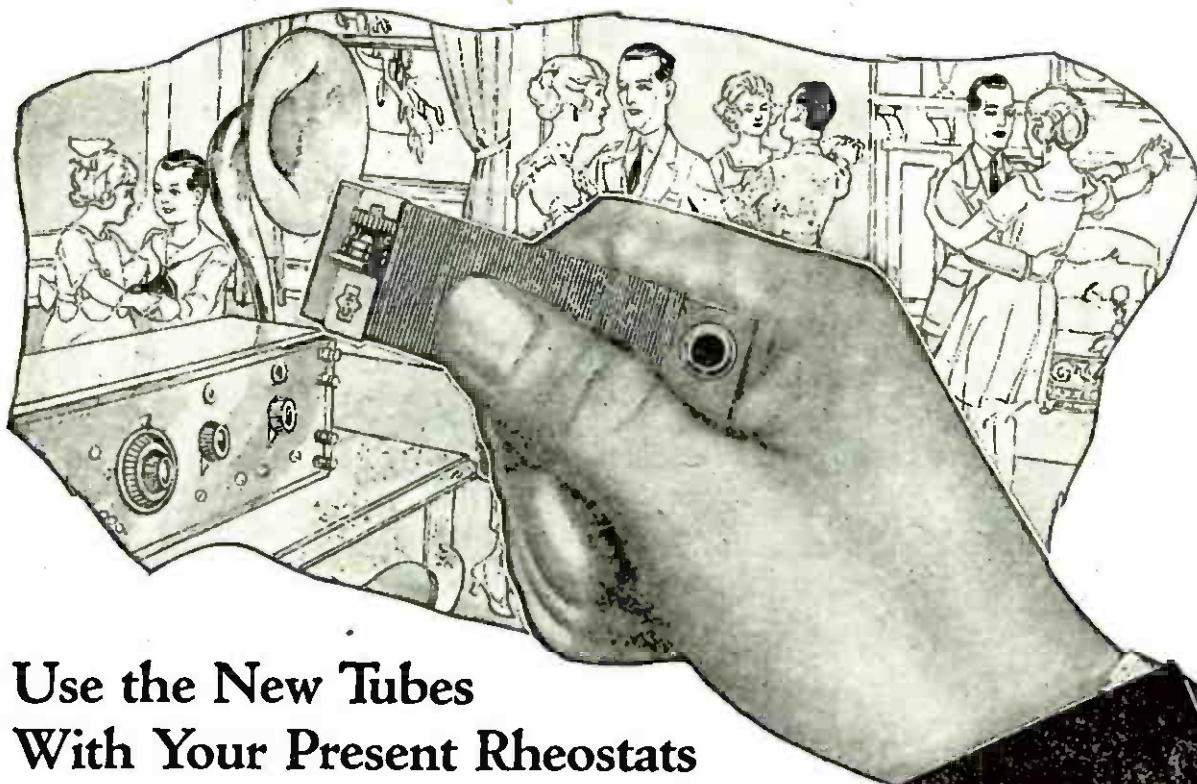

## Use the New Tubes With Your Present Rheostats

The resistance of each of your present rheostats (4 to 6 ohms) is too low to control the new quarter ampere tubes (UV201A and C301A).

Cutler-Hammer engineers, however, have come to the assistance of the radio man once more and offer a small adjustable 25 ohm unit that can be attached to one of the posts of your present rheostat and with very little if any, wiring, and no loss of time, make it possible to use these new and better tubes for maximum results. It makes "junking" of your present rheostats unnecessary and saves the trouble and expense of redrilling your panel for new ones.

The C-H Radio Resistance Unit is arranged for use with all makes of rheostats and for panel mounting. This new unit increases the range of your 0-5 ohm rheostat to 0-30 ohms, the slider being adjustable over the entire range to care for changes in battery potential. After once set, this adjustment requires practically no attention and regulation of the tube is obtained entirely by turning the rheostat knob.

### THE CUTLER-HAMMER MFG. CO.

Member Radio Section,  
Associated Manufacturers of Electrical Supplies  
MILWAUKEE, WISCONSIN

Carried by dealers everywhere. If yours has not been supplied, send 25c direct plus 10c for mailing

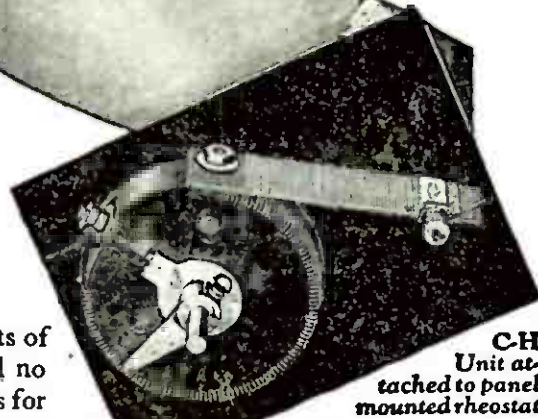

C-H Unit attached to panel mounted rheostat

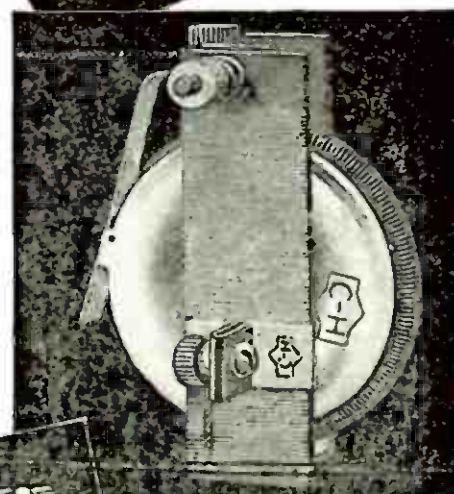

C-H Unit attached to standard C-H Rheostat



C-H Unit mounted on post fastened to panel; then wired in series with rheostat. Easy, neat, effective mounting



# RESISTANCE UNIT

FOR RADIO RHEOSTATS

# "AMSCO FOR BETTER RADIO"

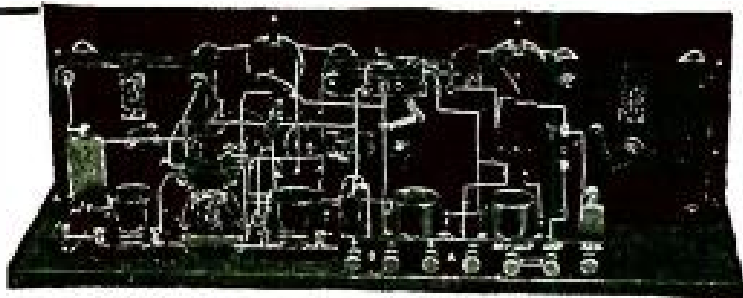

"Melco-Supreme" Radio-Frequency Receiver



Audio-Frequency Transformer

FROM the Melco Supreme Radio Frequency Receiver, down to the smallest Inductance Switch or Binding Post, Amsco Products are known the world over for their scientific correctness, mechanical perfection and ruggedness of construction. You'll buy Amsco Products on their appearance, but keep them because of their durability and dependability.



Honeycomb Coil and Plug

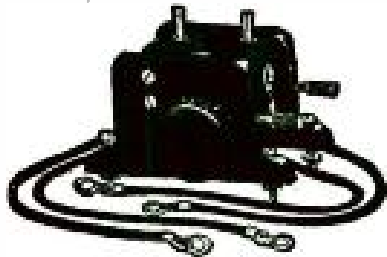

Honeycomb Coil Mounting

Write for our Booklets Nos. 1001 and 1002 illustrating and describing our entire line of quality apparatus.

## AMSCO PRODUCTS, Inc.

Fairbanks Building  
Broome and Lafayette Sts., New York City

Successors to Mortimer Radio Corporation  
Advance Metal Stamping Company



Audio-Frequency Amplifying Variometer



OPEN

# RADIO CABINET

WILL FIT ALL RECEIVING SETS  
MAHOGANY PIANO FINISH  
PRICE \$60.00

DEALERS AND JOBBERS

Write for Our Proposition

PETERS ELECTRIC CABINET CO.  
HORNELL, N. Y.



CLOSED

# F-F BATTERY CHARGER

All TYPES But "B"  
Charge AUTO  
Batteries  
Overnight  
Right in  
Your CAR

\$15



CHARGE  
RADIO & AUTO BATTERIES.

CHARGES RADIO "A" & "B" & AUTO STORAGE BATTERIES at HOME Overnight, for a Few Cents From Any 100 to 130 Volt 60 Cycle A. C. Lamp Socket. Eventually You Will Buy An F-F CHARGER & The Sooner You Buy One; The More You Save. A-B Charges All 6 Volt & up to 120 Volts Of "B" & Loud Speaker Storage Batteries in Series Inductively At Home Overnight. Disconnecting & Multiple Connections Unnecessary. Charging Circuits Separate. No Chance For Grounds, or Short Circuits. Nothing To Slop Over, Be Filled, Burn Out, Need Attention Or Cause Trouble. Infusible Rectifying Brushes Maintain Constant Efficiency Uninterruptedly. COMPLETE PORTABLE AUTOMATIC. No Skill Required. AMMETER eliminates Guess Work. Nothing Like It Made. Lasts A Lifetime. Screw Plug In Lamp Socket; Snap CLIPS on Battery Terminals; Turn Switch & Battery is Charged in Morning. Charged Batteries Mean Fewer Expensive Replacements. It Costs Less To Buy An F-F CHARGER Than To Be Without One. INSIST on The F-F CHARGER. Built By A Master Of The Art in 7 TYPES. Thousands Sold Make Possible These POPULAR PRICES

Type 6 charges 6 Volt Battery At 6 amperes \$15	Type 12 charges 12 Volt Battery At 5 amperes \$15
Type 8 charges Radio "B" Batteries Upto 120 Volts \$15	Type A-B is Combination Of 6 & 8 \$20
Type 16 charges 6 Volt Battery At 12 amperes \$20	Type 16 12 charges 12 Volt At 7 amps \$20
Type 16 26 is a Combination Of Types 166 & 1612 and Charges Both 6 & 12 Volt Batteries \$28	

Types B & A-B are Radio Specials. Types 166, 1612 & 1626 are For Heavy & Rapid Charging. SHIPPING WEIGHTS Complete with AMMETER & BATTERY CLIPS 11 to 15 lbs. PURCHASE from DEALER; Mail Check, or WRITE us to SHIP TYPE desired C. O. D. ORDER Now, or WRITE immediately for Free Descriptive CHARGER Bulletins 44 & 44A.

FRANCE MFG. CO., Cleveland, Ohio.



Please mention POPULAR RADIO when answering advertisements.

# IMPROVED

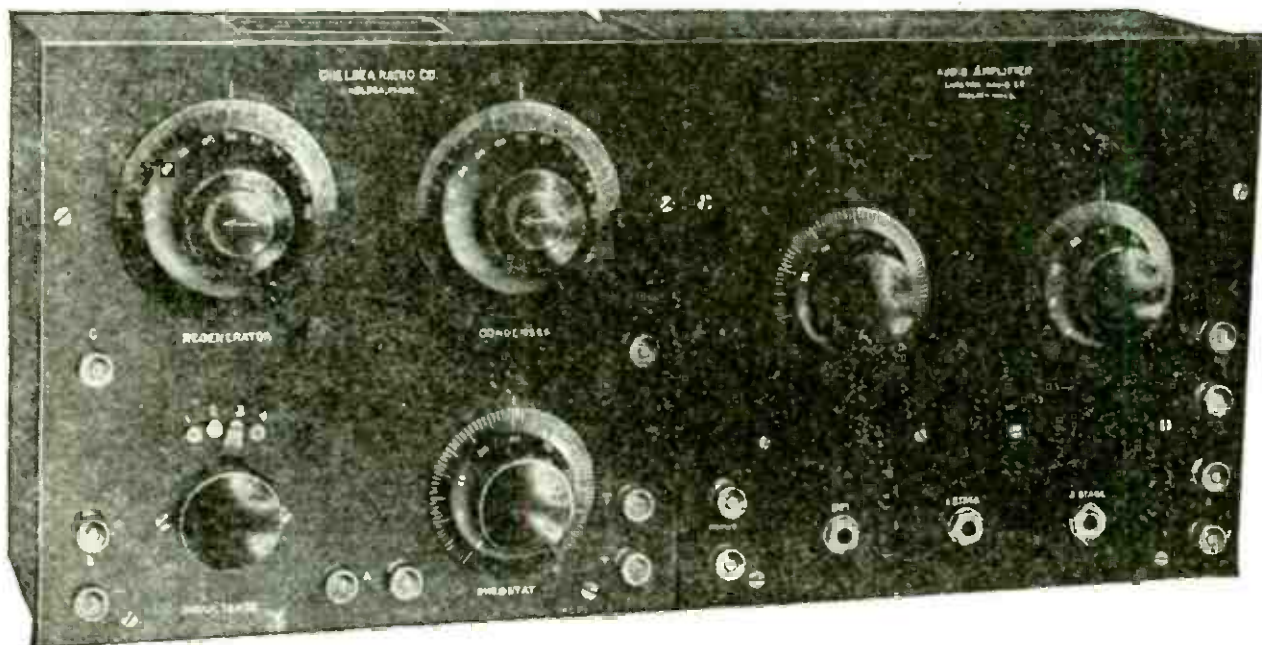

## REGENERATIVE RECEIVER

Licensed under U. S. Patent No. 1113149 for Amateur Use Only

Range 150 to 750 Meters

Vernier Controls

Receiver \$45.00

Amplifier \$35.00

*Dealers:---Write for Our New Proposition*



No. 8 \$6.50

### Vernier Condensers

12 Models  
\$2.50 to \$6.75

Write for Bulletin No. 7



No. 7 \$6.75

## CHELSEA RADIO CO.

177 Spruce Street

Chelsea, Mass.

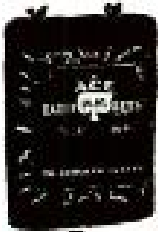

# ACE

## THE FINEST IN BATTERY PRODUCTION

THE best does not always mean the most expensive, for Ace Batteries sell at a price that meets with instant favor, yet the quality far surpasses anything on the market.

Ace Batteries are different. They have higher voltage to carry them thru conditions of greatest current drain.

### Radio "A" Batteries

made in several types of 1 to 4 cellpower, 1½ volts and 6 cellpower, 4½ volts for W-D 11 tubes.

### Radio "B" Batteries

made in several types for every existing condition.

Dealers: We have a wonderful proposition for you. Write

## The Carbon Products Co.

Lancaster, Ohio

Manufacturers all kinds of Dry Batteries, Carbon Brushes, Welding Carbons, etc.

### DISTRICT OFFICES:

105 W. Monroe St. Chicago, Ill. 708 S. Second St. Philadelphia, Pa.  
11-12 Moore St. New York, N. Y. Plymouth Bldg. Minneapolis, Minn.  
1001 Main St. Dallas, Texas

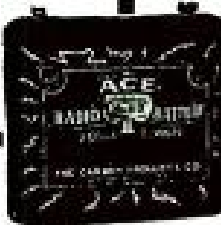

## "VB" RADIO CRYSTAL SET

An inexpensive, efficient radio receiving set. Has surprisingly loud, clear tones. Is extremely simple to operate. Receives up to 550 Meters within a radius of 25 Miles.

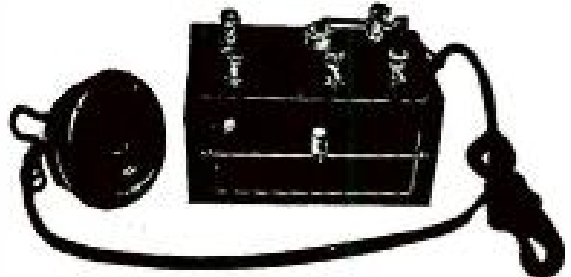

Without phone or antenna . . . \$1.50

With single phone (1400 ohms) receiver and cord . . . \$3.50

With double headset (2800 ohms) \$5.75

Antenna Equipment for the above set 50c extra.

Satisfaction Guaranteed or Money Refunded

Sent prepaid to any address upon receipt of money order or will send C. O. D. parcel post.

Dealers write for proposition.

Manufactured by

## B. W. WHITEHURST

250 South Street

Newark, N. J.



Na-ald Special Socket No. 499

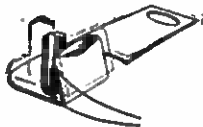

Na-ald De Luxe No. 400

## It's the contact that counts

The dual-wipe contact strips of the Na-ald De Luxe socket avoid the trouble experienced with the socket of conventional design. Because of thorough cure and high dielectric properties this socket keeps plate to grit losses at a minimum (of particular importance in Flewelling Circuit or in Radio Frequency).

Price 75 cents

The Na-ald Special Socket No. 499 is a sturdy little socket for the G. E. No. 199 dry-cell tube. It has special slot construction, and is moulded of genuine Bakelite. The heat from soldering connections will not affect these sockets.

Price 50 cents

Booklet with wiring design and instructions for Hazeltine's Neutrodyne circuit, together with other selected circuits, packed with each Na-ald product or sent in exchange for cover taken from any Na-ald carton.

Alden Manufacturing Co.

formerly

Alden-Napier Co.

Dept. C 52 Willow St. Springfield, Mass.



## Your Dealer Probably Has "All-American" Amplifying Transformers

(RADIO and AUDIO Frequency)

If he has thus far missed these highly important aids to clear strong radio reception, tell him you'll buy "All American" or nothing.

They cost no more; and your set is entitled to the best the art has produced. Our Radio Frequency Transformers should be used to amplify radio frequency impulses before they reach the detector tube and the Audio Frequency Transformers to strengthen the detected signals. The combination of the two forms the ideal long-distance radio reception hookup for either headphone or loudspeaker reproduction.

Ask your dealers first before you write. If none of them can supply you, send orders to us with name and address of Dealer you wish to favor, and transformers will be sent you postpaid at the prices named. FREE Hand Book of Radio Hookups—25 up-to-date diagrams of Successful Circuits. Send 2c stamp to cover postage.



RADIO FREQUENCY R-10 (150-550 meters) \$4.50



AUDIO FREQUENCY R-12 (Ratio 3 to 1) \$4.50  
R-13 (Ratio 10 to 1) 4.75  
R-21 (Ratio 5 to 1) 4.75

## RAULAND MFG. CO.

200 No. Jefferson St., Chicago, Ill.

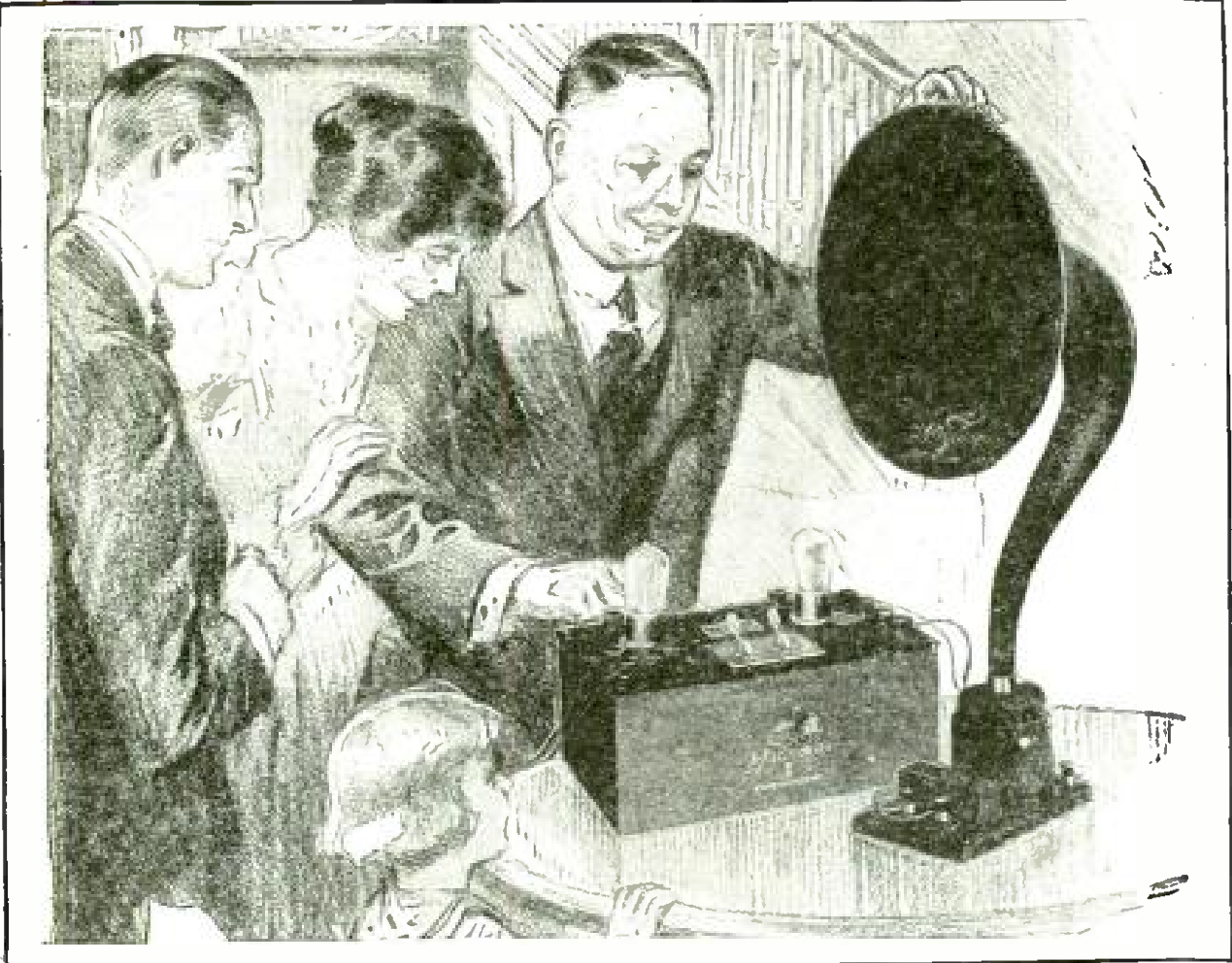

*These two devices have revolutionized Radio:*

## The Magnavox Reproducer and the Magnavox Power Amplifier

THE efficiency of Magnavox Radio apparatus is best realized by comparison with other instruments constructed on less modern scientific principles. When operated in accordance with instructions, satisfactory results are assured.

Magnavox R3 Reproducer and 2 stage Power Amplifier (as illustrated) \$90.00

R2 Magnavox Reproducer with 18-inch horn: the utmost in amplifying power; requires only .6 of an ampere for the field . . . . . \$60.00

R3 Magnavox Reproducer with 14-inch curvex horn: ideal for homes, offices, etc. . . . . \$35.00

Model C Magnavox Power Amplifier insures getting the largest possible power input for your Magnavox Reproducer  
2 stage \$55.00  
3 stage 75.00

Magnavox Products can be had from good dealers everywhere. Write for new booklet.

**THE MAGNAVOX COMPANY**  
Oakland, California  
New York Office: 370 Seventh Avenue

# MAGNAVOX PRODUCTS

*No Radio Receiving Set is complete without them*

6-T

**\$ 10**



**Your phone plus  
FIBERTONE  
equals a clear  
LOUD SPEAKER**

Now is the time to prepare your radio equipment for use during the vacation months. Enjoy your summer with radio, and those screechy, vibrative sounds so common to metal horns, and amplify every word or note into clear, bell-like tones with a Fibertone horn plus one of your phones. Besides perfect action, Fibertone horns are beautiful, their surface being finished in a black crystalline.

If your dealer can't supply you, write direct to

**FIBER PRODUCTS CO.**  
240-C North 10th Street  
Newark, N. J.

*Distributors and Jobbers: Write for terms*

**CORYPHONE**

**"RADIO" HEADSETS  
AND  
LOUD  
SPEAKERS**



Coryphone "Radio" Double Receiver Headsets  
3200 OHMS, \$9.50  
2000 OHMS, \$8.00

Single Receiver Types  
1600 OHMS, \$5.00  
1000 OHMS, \$4.25

Coryphone "Loud Speaker" with Adjustable Feature, \$40

Coryphone "Master Tone" The Loud Speaker Jr., \$22

The world's finest reproducers. Coryphones have many exclusive features and are best by comparison. Ask your dealer to demonstrate these remarkable values.

*Sold by*  
**ESTABLISHED DEALERS EVERYWHERE**  
If your local dealer cannot supply you order through him or send order and remittance direct to us,

**CHAS. CORY & SON, Inc.**  
183-7 Varick Street, New York  
PHILADELPHIA BOSTON SAN FRANCISCO  
The Bourse 88 Broad St. 11 Mission St.

*Illustrated Literature on Request*

**a Chi-Rad  
Special!**



**for W.D. 11 tubes -**

Standard, threaded rubber, Willard's, specially adapted for use with W. D. 11 tubes. Supply current at 2 volts to one W.D. 11 tube for 210 hours on a single charge. Rechargeable. Brand new, size 4x5½x7 inches—Chi-Rad guaranteed.

This is a time and quantity limited offer—orders will be filled, first come, first served. Get yours first by ordering now!

2-Volt Willard Charged . . . \$7.50  
2-Volt Willard Dry . . . . . 6.50

**Chicago Radio Apparatus Co.**  
415 S. Dearborn St. Chicago, Ill.

**Radio PATHFINDER & Wall Map**

**EDUCATIONAL**



**"Pathfinder Gauge is all the Rage"**  
How far will your set reach?

Air-Line "DISTANCE" in Meters and Miles from your HOME anywhere to all Broadcasting stations in the U. S. The PATHFINDER GAUGE does it. Use the GAUGE and "Tune in" the Station. Gauge complete with Wall Map 36"x 24" showing location, call letters and wave length of Broadcasting Stations, Standard Time Zones, radio districts, and other valuable information. No set complete without this outfit. Mailed prepaid, rolled in tube with full instructions.

Heavy paper \$1.00  
Cloth Mounted \$2.00  
(DO NOT SEND STAMPS)

**RADIO MEASUROGRAPH**  
231 Tribune Annex  
Dept. R. MINNEAPOLIS • MINN.

### General Radio Type 300 Amplifier Unit—

Works equally well with crystal or tube detectors. Is a compact unit, wired ready for external connections. Two or more units may be used together to obtain multi-stage amplification.

#### Prices

Type 300-A Amplifier Unit for WD-11 Tubes, complete except for tube and batteries, \$7.50

Type 300-B Amplifier Unit, for standard 6 Volt Tubes, \$8.00

### Type 231-A Transformer

—Gives the maximum amplification possible without distortion. Like all Amplifying Transformers manufactured by The General Radio Company, the Type 231-A is guaranteed.

Price \$5.00

### General Radio Type 214 Rheostat—

A convenient, practical instrument, equally well adapted for experimental service or permanent installations. You'll never cause unpleasant noises in the phones when you rotate the contact arm of a Type 214 Rheostat.

#### Price

For the new UV201-A Tubes, 20 Ohms.

For the newer UV199 Tubes, 20 Ohms.

For the Standard Tube, 7 Ohms.

\$2.25

### Type 214 Potentiometer—

To get your gas detector on that sensitive kink by fine adjustment of the plate potential, use this General Radio 400 Ohm Potentiometer. It will control regeneration in your radio frequency amplifier by a positive grid bias.

Price \$3.00

### Amateurs—

Bring your problems to us. Our Engineering Staff is always at your disposal.



For more than eight years, among men who know and use Radio Apparatus of the better sort, the name—General Radio Company—has been accepted as a guarantee of all that goes to make up satisfaction and as synonymous with the advances in theory and practice which accompany all true Radio progress.

As an example—for the amateur who wants real Radio efficiency—there is no single piece of apparatus which more completely fills its niche than the General Radio Type 300-A Amplifying Unit—the Amplifying Unit which requires no storage battery.

If you are interested in Radio Apparatus in which price is subordinated to satisfaction, send for Bulletin 914 U. It is an educational pamphlet for the amateur who wants better equipment.

## GENERAL RADIO CO.

*Manufacturers of*

Radio and Electrical Laboratory Apparatus  
Massachusetts Avenue and Windsor Street  
Cambridge, Mass.

5169

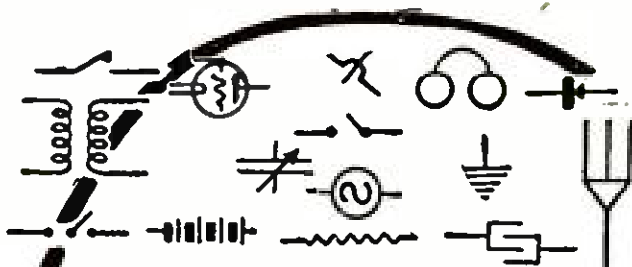

## hitch 'em to B-D-X-X

Radio units work best on Bakelite-Dilecto (xx grade) panels and bases. This wonder-material gives absolute insulation and has tremendous mechanical strength.

# bakelite-dilecto!!

(A Laminated Phenolic Condensation Product.)

Highest in dielectric strength. Tough, durable, yet readily machined. Keeps its shape, color and glossy finish always. Resists heat, water, steam, fumes and solvents. Used in the U. S. Navy and Signal Corps nearly NINE YEARS!

Don't rush ahead with "just anything" for a panel. Get real Bakelite-Dilecto (xx grade) and you'll get best results.

**THE CONTINENTAL FIBRE CO.**  
Factory: NEWARK, DELAWARE

Dealer Service from:

New York, 233 Broadway  
Pittsburgh, 301 Fifth Ave.  
Chicago, 332 S. Michigan Ave.  
San Francisco, 75 Fremont St.  
Los Angeles, 411 S. Main St.  
Seattle, 95 Connecticut St.

## Regal No. 140 Filament Rheostat

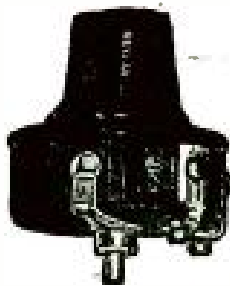

Has full exposed resistance wire, giving critical adjustment so necessary to the efficient operation of a vacuum tube. Fine, smooth working control. Handsome knob, heat resistance base and highly nickel-plated parts. 6 ohms resistance—2.2 amperes. . . . \$1.00

## The Big "Regal" Line

Power Rheostats, Potentiometers, Inductance Switch, Variocoupler, Tube Sockets, Jacks, Condensers, Knobs, Dials, etc. Send for Catalog No. 27.

(If your dealer does not handle Regal Products—write us direct)

## "Regal" Inductance Switch

A 15-point switch complete in one unit. Requires but one hole to mount on panel. Smooth wiping contact over heads machined to same height on one piece contacts. Complete soldered assembly attached, or removed from panels by means of one threaded shaft bushing. Gives inductance regulation by \$2.00 dial contact. . . . .



**The American Specialty Co.**  
Bridgeport, Conn.

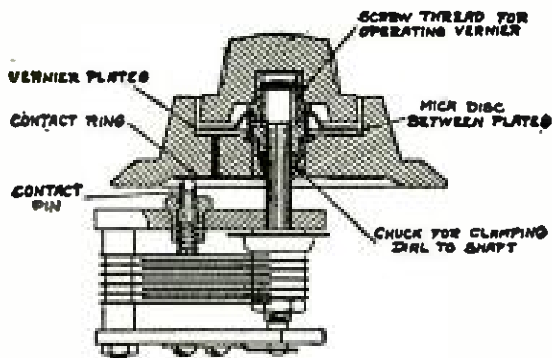

## NEW "UNITED" VERNIER Dial Assembly

More Power, and Far Greater Selectivity

Large capacity, due to the large area of the mica-insulated copper vernier plates.

Great fineness of tuning, due to the delicate screw thread adjustment of Vernier.

Short-circuiting rendered practically impossible. Note that the opposing circuits are located in the knob and Dial—a new and better way.

This new United Vernier Dial Assembly can be attached to any plate condenser, it being necessary to drill only one hole. Price, Postpaid. . . . . \$2.50

### UNITED VARIABLE CONDENSERS

WITH NEW TYPE VERNIER DIAL ASSEMBLY

43 plate. . . . . \$6.50	5 plate. . . . . \$5.00
23 plate. . . . . 6.00	3 plate. . . . . 4.75
11 plate. . . . . 5.50	

"UNITED" AMPLIFYING TRANSFORMER. Audio Frequency magnetically shielded. Fine piece of precision workmanship. Ratio 5 to 1. Each, \$4.50.

All United Products are sold under a positive money-back guarantee. When you remit or write for circular, give us the name and address of your favorite Radio dealer.

**UNITED MFG. & DISTRIBUTING CO.**  
536 Lake Shore Drive, Chicago, Ill.

New York Office - - - 50 Church St., New York, N. Y.  
San Francisco Office - 709 Mission St., San Francisco, Cal.

## AMPL-TONE PHONES

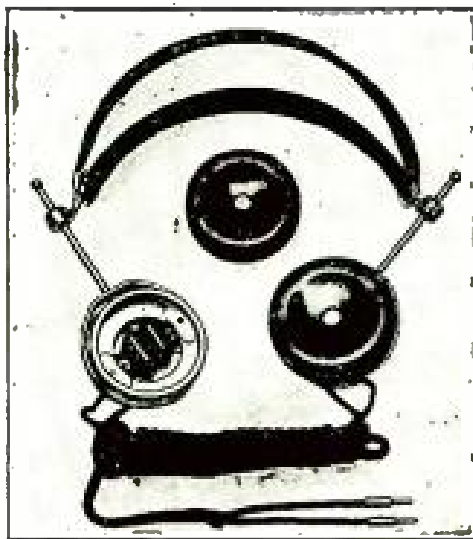

2200 Ohms—\$6.00

AT LAST, the public may have these EXCELLENT equal of the expensive phones, for beauty, comfort, tone and durability.

Money back guarantee protects you. "Wonderful value," "Equal to \$12.00 phones," and other testimonials on file.

Write for special prices for a limited period

DEALERS: Get in on our special advertising and extreme discounts. One sample for \$3.00 cash.

**C. M. FRENCH MFG. CO.**  
SEYMOUR, CONN.

Please mention POPULAR RADIO when answering advertisements.

# MU-RAD RECEIVERS SUPREME



*Two thousand, three thousand, four thousand miles and more away—stations in every direction contribute to the daily pleasure of MU-RAD owners. The extraordinary sensitivity of these receivers, using only a two-foot, indoor loop aerial, provides continually new thrills and surprises. Remarkable clarity. Selects with astonishing distinctness. Easiest imaginable to operate. Nominal guarantee of 1000 miles reception.*

*Write for literature*

*The New  
Star in  
the Radio  
World*



## **MU-RAD LABORATORIES, INC.**

**809 FIFTH AVE. ASBURY PARK, NEW JERSEY**

Please mention POPULAR RADIO when answering advertisements.

## DELICATE SOLDERING in RADIO

Both the manufacturers' and amateurs' problem on all fine work is readily solved by the instrument constructed for this particular purpose.

### THE POST SOLDERING IRON

Platinum Heating Unit—Interchangeable Tips—Universal Current

(Large and Small)

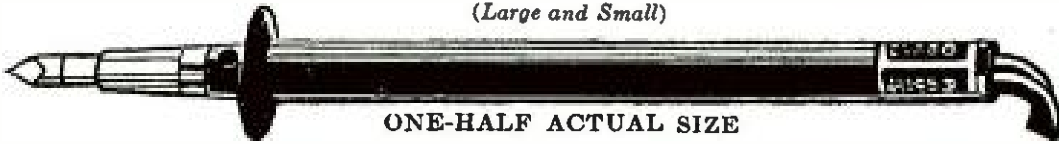

ONE-HALF ACTUAL SIZE

**\$6.00**

Awarded Certificate of Excellency, N. Y. Evening Mail Radio Institute

From your Dealer, or write

POST ELECTRIC COMPANY (Instruments Division), 30 E. 42nd St., New York

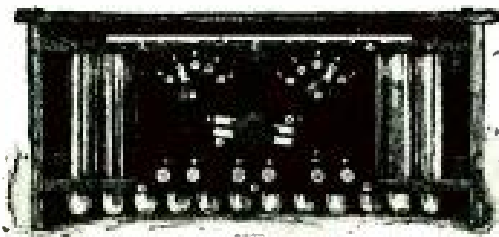

## KICO Storage "B" Batteries give long service at low cost

Alkaline type, will not sulphate or buckle. Not harmed by short-circuiting, overcharging, or standing idle. Panel switches afford single cell variations. Easily re-charged from any 110-volt A.C. line by means of small home rectifier. One charge lasts three to six months in detector plate circuit.

Prices without rectifier:	Plain	(With Panels)
16 cell 22 volt.....	\$5.50	
24 cell 32 volt.....	\$7.25	\$11.75
36 cell 48 volt.....	\$9.50	\$14.00
50 cell 68 volt.....	\$12.50	\$17.00
78 cell 100 volt.....	\$17.50	\$22.50
108 cell 145 volt.....	\$23.50	\$28.50
Unmounted rectifier....	\$1.00	
Mounted rectifier.....	\$2.50	

### SATISFACTION GUARANTEED

Money is refunded if user is not satisfied after 30 day trial. Write for full information on "A" and "B" Batteries.

**KIMLEY ELECTRIC COMPANY, Inc.**  
1357 FILLMORE AVENUE BUFFALO, N. Y.

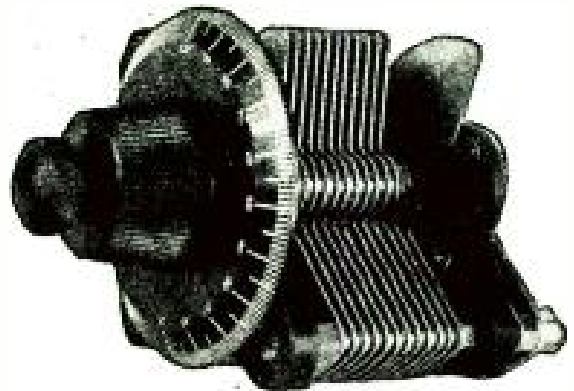

## GRIN VARIABLE CONDENSERS

Standard Constructions, Aluminum Plates, Moulded Ends, Accurate Spacing. Plain or Vernier.

LIST PRICES

11 Plate, Plain.....	\$3.00
23 Plate, Plain \$4.00 Vernier.....	6.50
43 Plate, Plain 4.50 Vernier.....	7.00
Vernier Only.....	1.75

Manufactured by

**VIZZO PRODUCTS COMPANY,**  
Shelton, Conn.

Distributors for N. Y. City and the following states: Penn., W. Va., Va., Md., Del., D. C., N. C., S. C., Ga., and La.

**THE EASTERN SPECIALTY COMPANY,**  
3551 No. 5th St., Philadelphia, Pa.

Distributors for Ohio and States west.

**VIZZO PRODUCTS COMPANY,**  
5238 Ludlow St., Phila., Pa.

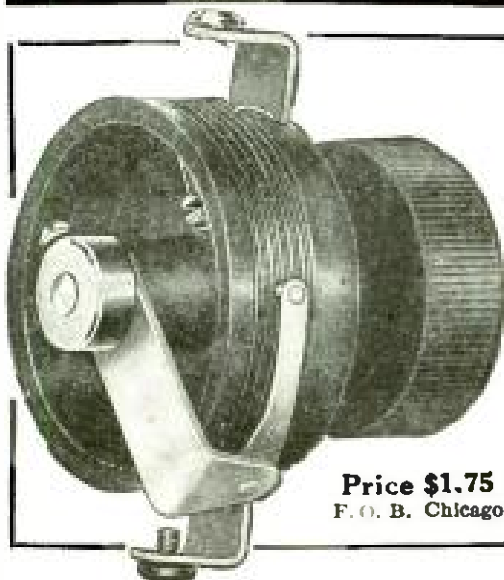

Price \$1.75  
F. O. B. Chicago

## THE UNITY VERNIER RHEOSTAT

An Improvement on the Jenkins Rheostat

A Single Wire in a Groove, followed by a point constantly in contact, gives noiseless adjustment, and permits of infinitesimal refinement in tuning.

A Cut-Out Switch operates with no change in adjustment, permitting a set to be turned on and off by the Rheostat with absolutely no change in tuning.

Manufactured in any resistance. 6 ohm and 25 ohm carried in stock. Guaranteed for one year.

**THE UNITY MFG. CO.,** 224 No. Halsted St., Chicago, Ill.

"Hear a set that uses one"



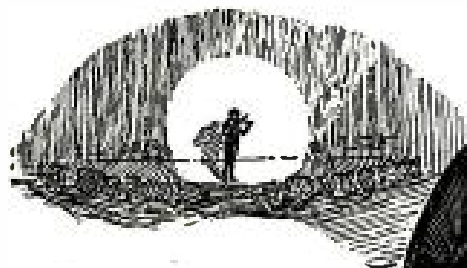

14-inch Home Model, \$30  
21-inch Concert Model, \$35

In your home, you hear the same sweet tones of the same violin, played on the stage or broadcasting room at the same instant.

ONE OF THE  
**GERACO**  
PHONOGRAPH ATTACHMENTS



# Music Master

RADIO AMPLIFIER

## The Instrument of Radio Realism



### Geraco Phonograph Attachment

Converts your Victrola or Columbia into an efficient loud-speaker. Complete, \$10. For sale through jobbers and dealers everywhere.

JOBBERS  
DEALERS

A MUSIC MASTER will be sent you with full privilege of return. Write for full description of the GERACO Line and prices.

The horn of MUSIC MASTER is *wood*, for the same reason a violin is wood. MUSIC MASTER gives more than a reproduction; more than a re-creation; it IS the artist himself, in the pure, mellow-sweet tones of ACTUALITY!

Not a mechanical device, but a musical INSTRUMENT. It does not squawk, vibrate or twist tone. Experts on acoustics, in long study, have eliminated reproducer-faults and the result is the *perfect* MUSIC MASTER.

Comes complete, ready to attach in place of headphones. No extras to buy. Hear MUSIC MASTER at the home of a radio-friend or at your dealer's. Let it talk for itself!

**GENERAL RADIO CORPORATION**  
Makers and Distributors of High-Grade Radio Apparatus  
PHILADELPHIA  
CHICAGO S. W. Cor. 10th & Cherry Streets PITTSBURGH



**HARTMAN VARIOCOUPLER**  
WITH  
**SPIDER WEB ROTOR**  
PROVIDES  
REMARKABLE SELECTIVITY IN TUNING  
*Designed for us by Alfred A. Crossley*  
**Price \$6.50**  
*Write for bulletins on Hartman Radio Products*  
**THE HARTMAN ELECTRICAL MFG. CO.**  
MANSFIELD, OHIO

# Getting DX

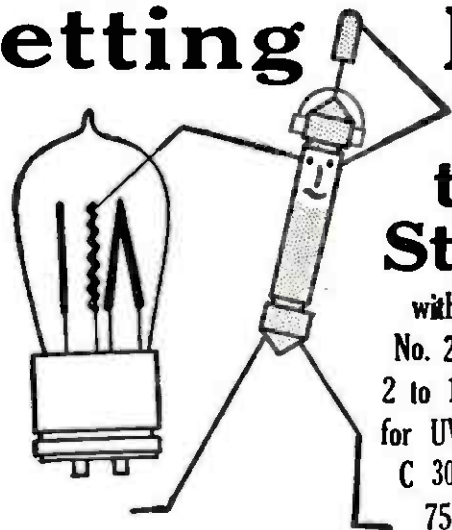

## thru Static

with the new  
No. 201A Special  
2 to 10 megohms  
for UV 201A and  
C 301A Tubes  
75c each

Tuning for DX—distance stations—is greatly helped by keeping the tubes as quiet as possible. This means variable resistance in the grid circuits—DURHAM Variables, with the plunger adjustment. Try them and get rid of a lot of trouble from static.

DURHAM & CO., 1936 Market St., Philadelphia

## Durham Variables High Resistance

McNEARY  
**RADIO SCALOMETER**  
Radio Map and Broadcasting Directory

**EVERY RADIO FAN NEEDS IT**

You have just tuned-in a distant station. Of course you want to know how far it is. With the Scalometer mounted on the accompanying map you have the answer at a glance—instantly and correctly.



**A Scalometer tells**

<b>RANGE OF YOUR SET</b>	<b>DISTANCE OF ALL D-X CALLS</b>
--------------------------	----------------------------------

*If your dealer can't supply you, send one dollar to*

**EMBLEM MFG. CORP.**  
251 Middle City Bldg.  
Philadelphia

**SCALOMETER**  
An instrument of precision in a beautifully finished aluminum case.

**RADIO MAP**  
Authoritative, up-to-the-minute, showing broadcasting stations, time zones, radio districts, cities and towns in U. S. and Canada.

**BROADCASTING DIRECTORY**  
In handy booklet form with broadcasting stations alphabetically arranged by call letters.

**ALL THREE \$1.00**



# Thrills!!!

Thrills never end when you have a Tuska Popular—the regenerative receiving set that experts recommend. Signals clear and sharp come in night after night from faraway stations. And for nearby programs, plenty of volume without distortion. Every part Tuska-made; known for 12 years as fine radio instruments.

The C. D. TUSKA CO., Hartford, Conn.

**TUSKA POPULAR No. 225**  
Regenerative Receiving Set, Tuska receiver, detector and 2-stage amplifier, licensed under Armstrong U. S. Patent No. 1,113,149. Catalog No. 15-A, showing Popular and other sets, on request.



# TUSKA RADIO

# All-Ways Better



# MAR-CO

## Mar-co Inductance Switch

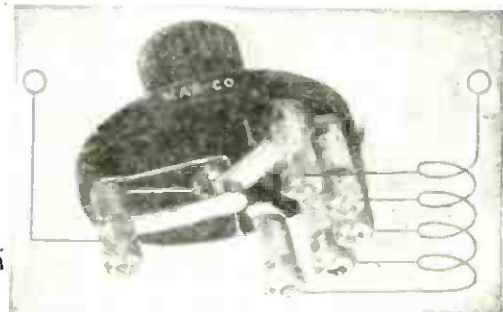

**MAR-CO INDUCTANCE SWITCH.** The finest on the market. Small. Finely made. Exclusive features. No loose connections. Perfect contact at every tap. Only one hole in panel necessary for rigid, secure mounting. No special tools necessary for trouble-proof connections—just ordinary pliers. The only inductance switch with *separate positive locking arrangement* for seating switch arm in proper place on contact. This locking action is felt upon turning knob. Prices, including attractive dials and Bakelite Knob with imbedded brass bushing—5 points, \$1.00; 7 and 9 points, \$1.25; 11 points, \$1.50; 13 points, \$1.75.



**MAR-CO VERNIER RHEOSTAT** will bring the most critical tube to the highest point of efficiency by means of an extremely delicate adjustment. 6 ohms resistance—2 amperes capacity. Calido-nickel-chromium Resistance Unit, and Bakelite Base and Knob. Price, \$1.50.



**MAR-CO FILAMENT SWITCH.** Type 400-A. Insures maximum efficiency from batteries by disconnecting them from set when not in use. Mounts through one drilled hole and presents a fine appearance. Price, \$0.90.

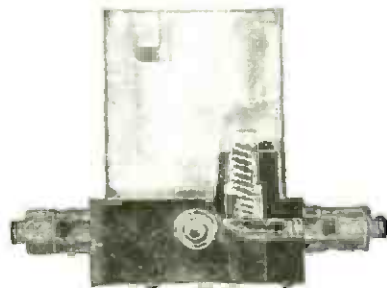

Our new UV199 cushion socket provides the resilient non-microphonic mounting necessary to protect the delicate, fragile filament of the new UV199 tube. Unexcelled for neatness, small size, positive electrical contact and mechanical perfection. Hard Rubber Insulation. Price, \$0.75.



**MAR-CO JACKS.** Short circuit impossible. Highly nickeled. Formica insulation. Sterling silver contacts. Extra washers allow wide range of panel adjustment. Price,

No. 3 Single Open Circuit.....	\$0.65
No. 4 Single Closed Circuit.....	.75
No. 1 Double Circuit.....	.90
No. 5 Single Filament Control.....	1.00
No. 6 Double Filament Control.....	1.10

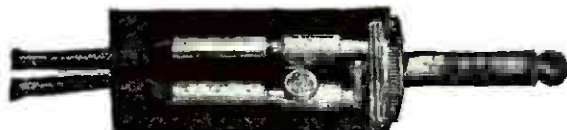

**STA-PUT PLUG.** Fits any tip. No tools necessary to fasten. Instant connection or disconnection. Mechanically correct. Finely made and finished. Price each, \$0.60.

## Martin-Copeland Company

Providence, R. I.



## 1200 MILES with a Crystal Set Using



A Needles, California, radio fan writes:

"Using M. P. M. Crystal, I picked up Los Angeles, San Francisco, Salt Lake, Denver and St. Louis. It is far superior to any crystal I have ever used."

Before discarding your Crystal Set for an expensive Tube outfit, give M. P. M. Crystal a trial!

**Beware of imitations!** The genuine Million Point Mineral is sold only in separate crystals packed by our company in boxes bearing the trade-mark "M. P. M."

Send 25c and name of your Radio Dealer for a sample M. P. M. Crystal—concert-tested and guaranteed. 35c for mounted Crystal.

**M. P. M. SALES COMPANY**

Department PR

247 So. Central Ave. Los Angeles, Cal.



Warren Radio Loop,  
cut away to show  
construction



## Make Your Set Portable for Camping and Vacation

CONTINUE to enjoy the radio programs on your camping trip or wherever you spend your vacation. A Warren Radio Loop allows you to take your set anywhere. Sizes as small as 6 inches square, that can be fitted inside your cabinet. Send a postal for our Bulletin I-102, containing hookups.

A Type for Every Set at the Best Dealers

Type A-737 (300-700 meters) 6 inches square—non-directional.....	\$10
Type A-7236 (175-1000 meters) 6 inches square—non-directional.....	\$12
Type B-2537 (300-700 meters) 18 inches square—directional.....	\$20
Type BL-2520 (150-18,000 meters) with honeycomb coil 18 inches square—directional.....	\$25

Send for Bulletin I-102

V-DE-CO RADIO MFG. CO., Dept. F, Asbury Park, N. J.

## It's a Winner!

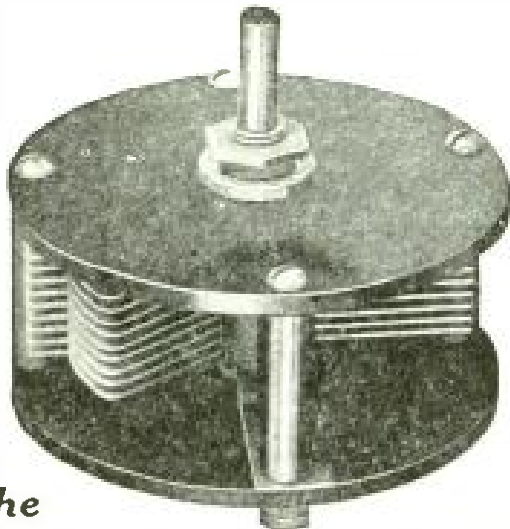

### The RATHBUN SINGLE HOLE MOUNTING CONDENSER

This Variable has won the heart of Radio Fans everywhere—Why? Because it is different and better. Its construction is perfect throughout.

- (1) Only 1 hole to drill for mounting.
- (2) Plates die-cast in milled brass tubes.
- (3) Formica ends for plate protection.

Variter, 11 plate, 23 plate and 43 plate  
at your dealers or direct from

Rathbun Mfg. Co., Jamestown, N. Y.

Listen in with a

## Dodge TONE AMPLIFIER

A scientifically perfect instrument, with wood pulp sound chamber, designed by one of the foremost acoustical specialists. This Perfect Tone

### RADIO LOUD SPEAKER

insures the most delicate reproduction of voice or music and positively eliminates distortion and metallic sound.

The Dodge Tone Amplifier is enclosed in a handsome mahogany cabinet, with front panel and sound chamber finished in black. Size of complete outfit: 12 in. high, 9¾ wide, 8¼ in. deep.

The Dodge Tone Amplifier is made especially for home use, with any set of three tubes or more. No batteries necessary. No adjustments. Complete, ready for immediate use. Merely hook up and \$25.00 listen. Price.....



Liberal Discounts to Jobbers and Dealers

Model No. 10

ACKERMAN BROTHERS COMPANY, Inc.  
Dept. "PR," 301 W. 4th Street, New York, N. Y.

Please mention POPULAR RADIO when answering advertisements.

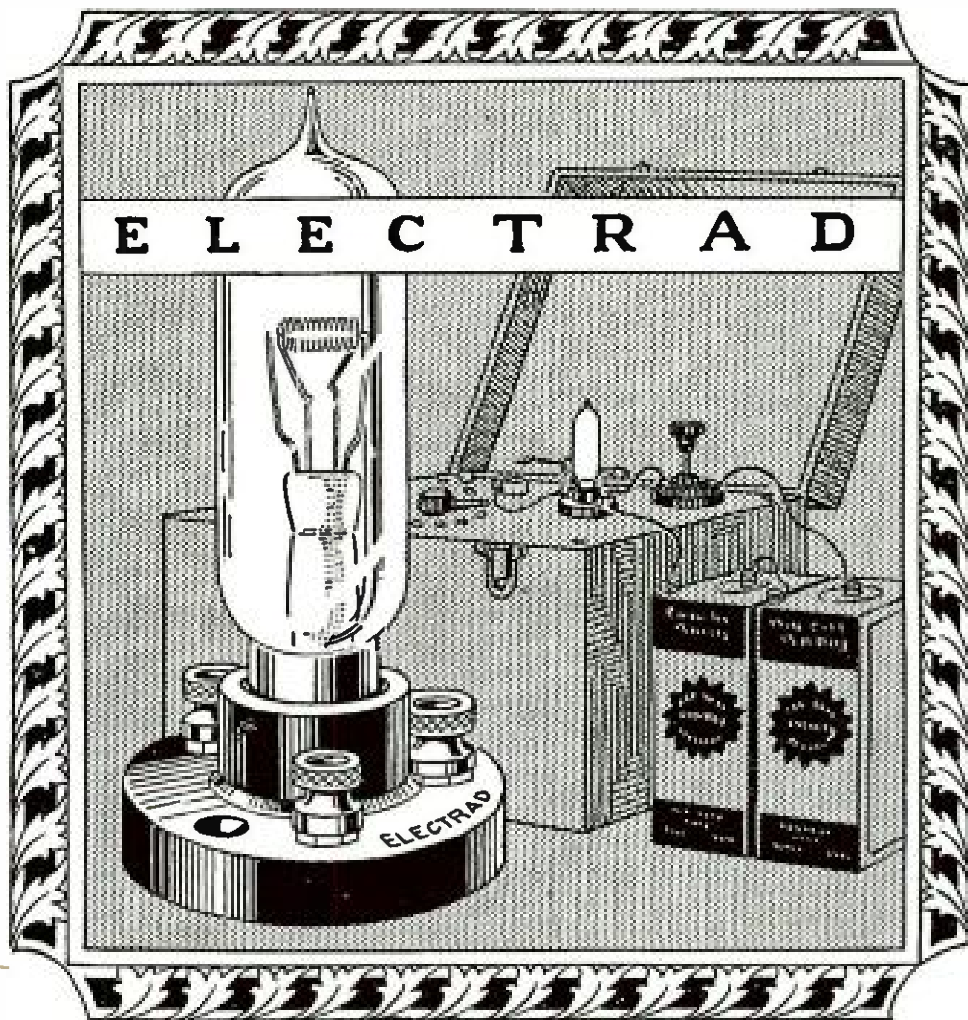

# Diode

## A DRY CELL TUBE FOR \$2



Variable high resistance unit,  
1/10 to 5 megohms. Does the  
work of a thousand grid leaks.  
Contains standard mica con-  
denser of proper capacity.  
Bakelite. Price complete \$2.00.

Something new in radio. Diode! A two element vacuum tube that is more sensitive than a crystal. Diode does the work of a high priced instrument and eliminates the use of storage and "B" batteries. Its reception of word and note is absolutely without howl. The low cost of Diode and its economical operation turns radio into an inexpensive luxury.

Tube with socket \$2.50. Ask your dealer or write direct, sending dealer's name and 10c. postage.

#### Branch Offices

C. H. Wallis & Co., 1409 Syndicate Trust Bldg., St. Louis, Mo.  
802 Forsyth Bldg., Atlanta, Ga.  
703 Granite Bldg., Pittsburgh, Pa.  
1028 Fourth Ave., Huntington, W. Va.  
709 Mission St., San Francisco, Cal.  
337 S. Western Ave., Los Angeles, Cal.

Munsey Bldg., Washington, D. C.  
1121 Pine St., Seattle, Wash.  
53 W. Jackson Blvd., Chicago, Ill.  
1403 Monadnock Block, Chicago, Ill.  
636 Victory Bldg., Philadelphia, Pa.  
1011 Chestnut St., Philadelphia, Pa.

**ELECTRAD CORPORATION OF AMERICA**  
428 Broadway, New York

## FIL-FONE CONTROL SWITCH

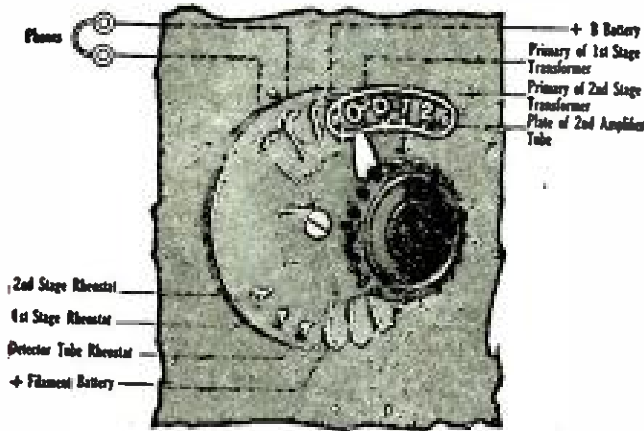

**Price \$3.00**

Protected by Patents Pending

Dispenses with jacks and plugs. Saves money in building sets. Positive and progressive control of filaments.

Send for circular F. F. S., No. 2 for complete description

**DISCOUNTS ON APPLICATION**

(Complete Radio Catalog sent on receipt of 6c for mailing)

**The A-C ELECTRICAL MFG. CO.**  
Dayton, Ohio

## U. S. Bureau of Lighthouses Indorses SPIDER WEB COILS

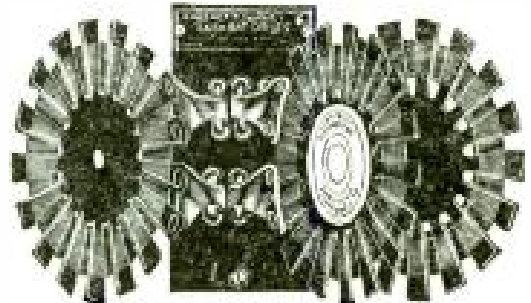

Turney's Spider Web Plex Coils are taking first place in the Radio Field, eliminating the variocoupler as a tuning unit and making child's play of station finding.

Wave length range—960 meters with condenser in shunt. No body capacity.

Eugene T. Turney's patent on Spider Web Winding is the only one granted by the Government. They are wound on automatic machines—also patented, making absolute uniformity certain.

See your dealer, or mailed direct on receipt of \$4.50, cash or money order (no stamps or checks). Hookups for tube and crystal sets included.

**TRISTAN SALES CORPORATION**  
Sole National Distributors  
1 Union Square New York

INSTRUMENT MAKERS

DEPENDABLE PRODUCTS

SINCE 1909

PRECISION HIGH EFFICIENCY  
**CRYSTAL SETS**

Guaranteed to receive local broadcasts with volume and clarity equal to any sets manufactured

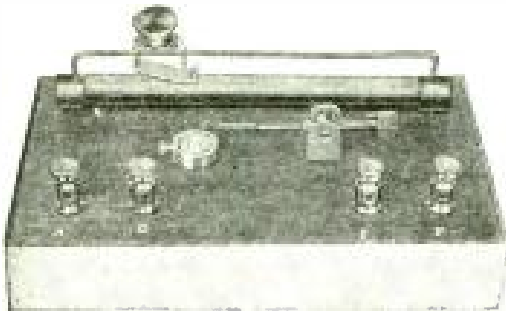

Without Phones or Aerial

**TYPE "A"** (Shown in cut) - - \$1.25  
**TYPE "B" De Luxe** - - \$5.00  
Type A (complete), \$6.00 Type B (complete), \$11.00

Sent prepaid upon receipt of express or postal money orders.

Money refunded if not absolutely satisfactory. Dealers and Jobbers write for discounts.

**BOYS:** You can make good money selling these sets. Write for terms.

**THE EASTERN SPECIALTY CO.**  
3552 N. Fifth Street, PHILADELPHIA, PA.

## Radio Dealers!

**DO** you sell copies of POPULAR RADIO in your store? One dealer sold 150 copies of the May issue in just *two days!* If you are not cashing in on the demand for single copy sales, by all means get in touch with the nearest branch of the American News Company and have them supply you on a *fully returnable* basis.

If you wish further information, write to POPULAR RADIO, Dept. 63, 9 East 40th Street, New York. We'll also tell you how you can make good money taking *subscriptions* to this livest and most practical radio magazine.



# The Family Circle Gives You What You Pay For

But the close-up view of an orchestra seat is much better—so it costs more. It is precisely the same with Radio Equipment. *You get what you pay for.*

You can buy a single-circuit receiving set at a much lower cost than you will have to pay for a Paragon three-circuit receiver—but at what a sacrifice of pleasure and satisfaction! Night after night of splendid entertainment simply ruined by mixed messages and general jamming from the hundreds of broadcasting stations.

With a Paragon three-circuit receiver, you can select the radio programme of your choice from the various programmes being broadcasted on any night, get it promptly and hold it from start to finish if you desire. Ask any experienced amateur what he thinks about

# PARAGON

Reg. U. S. Pat. Off.

## RADIO PRODUCTS

The amateur will tell you that the Paragon three-circuit receiver, because of its great superior selectivity and sensitivity, can pick and choose between broadcasting stations of about the same signal strength with less than one per cent differential.

This means that with a Paragon receiver you get what you want when you want it—complete messages and clear music from the station you tune in on, without interruption and jamming. Until you have listened in with a Paragon three-circuit receiver, you cannot guess the real pleasure and fascination of radio.

Long before broadcasting popularized radio with the general public, Paragon equipment was the choice of the experienced amateur. He will tell you today that if you want quality and satisfaction, Paragon Radio Products are the best and safest buy on the market.

*An illustrated Catalog of Paragon Radio Products Is Yours For the Asking*

**DEALERS**—The Adams-Morgan Company has an interesting proposition to make to reputable radio dealers who believe in quality merchandise. Details on request.

**ADAMS-MORGAN COMPANY**  
20 Alvin Ave., Upper Montclair, N. J.

Type RD-5 Regenerative Receiver  
and Detector—\$75.00  
Type A-2 Two-Stage Amplifier—\$50.00  
(Licensed under Armstrong Patents.)

<b>Also Manufacturers of PARAGON</b>	
Radio Telephone	Amplifier
Transmitters	Transformers
V. T. Control Units	Control Dials
Rheostats	Amplifiers
Potentiometers	Receivers
V. T. Sockets	Switches
Detectors	Variometers



# ATWATER KENT

RECEIVING SETS AND PARTS



If you are now working with a one-tube set, the 2-stage amplifier shown here will give you the necessary volume of sound to make a

loud speaker possible.

It is a compact unit — transformers are sealed in the base so that no dampness can affect the working quality of the instrument. To demonstrate the damp-proof qualities, one of these instruments was soaked in a tub of water for several hours, then put into a circuit and tested for reception with perfect results.

Send for an illustrated folder showing all parts and complete sets.

ATWATER KENT MFG. COMPANY  
4933 Stenton Ave., Philadelphia

## In Any or All Stages of audio frequency amplification

### The AMERTRAN



Price \$7

Ask your electrical dealer, or sent carriage charges collect. (Wt. 1 lb.)

can and should be used.

It is made in only one type and one ratio. Its flat-top amplification curve precludes the possibility of distortion on the part of the transformer when used in any or all stages.

It will give the same clear-toned distortionless amplification with all tubes which are approximately alike in A. C. Impedance and Amplification Factor, such as

WD-11, UV-201-A,  
UV-199, C-301-A,  
C-301, UV-201.

Its amplification in one stage  
is 38.6; two stages 1490

American Transformer Company

Designers and builders of radio  
transformers for over 20 years

175 Emmet St., Newark, N. J.

# Sidbenel

## "B" BATTERY

### LASTS 5 YEARS

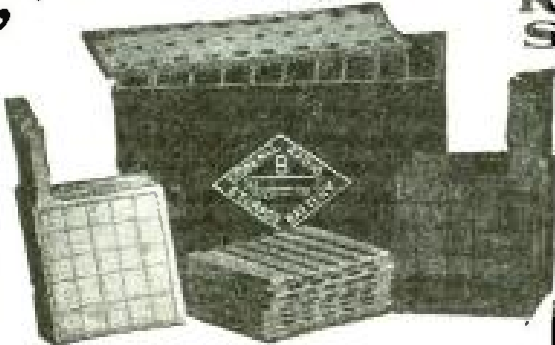

Exceptionally powerful. Makes weak signals strong. A single charge will last six months, recharged (for less than 1/2c) from any lamp socket or farm lighting generator. Patented high ampere plates charged and formed before leaving the factory.

Positively eliminates battery noises often blamed on static.

Container will not leak and is made of genuine hard rubber. Size 2 1/2" x 3" x 4 1/2".

You assemble the battery easily and pleasurably in less than ten minutes. Complete illustrated directions with each battery.

Large illustrated circular on request.

Price, 22 1/2 volt, unassembled, type S200..... \$4.25  
assembled, type S200..... 4.65  
New type S201-sealed with lugs..... 7.50  
Rectifier for A.C..... .35

Dealers and Jobbers write for proposition  
Dept. PR

Sidbenel Radio Equipment Mfg. Co., Inc.  
25 W. Mt. Eden Avenue, New York City

STATEMENT OF THE OWNERSHIP, MANAGEMENT, CIRCULATION, ETC., REQUIRED BY THE ACT OF CONGRESS OF AUGUST 24, 1912, OF POPULAR RADIO  
Published monthly at New York, N. Y., for April 1, 1923.

STATE OF NEW YORK }  
COUNTY OF NEW YORK } ss.

Before me, a Notary Public in and for the State and county aforesaid, personally appeared Kendall Banning, who, having been duly sworn according to law, deposes and says that he is the Editor of POPULAR RADIO, and that the following is, to the best of his knowledge and belief, a true statement of the ownership, management, etc., of the aforesaid publication for the date shown in the above caption, required by the Act of August 24, 1912, embodied in section 443, Postal Laws and Regulations, to wit: 1. That the names and addresses of the publisher, editor, managing editor, and business managers are: Publisher, POPULAR RADIO, Inc., 9 East 40th St., New York City; Editor, Kendall Banning, 9 East 40th St., New York City; Managing Editor, None; Business Managers, POPULAR RADIO, Inc., 9 East 40th St., New York City. 2. That the owner is: New Fiction Publishing Corporation, 9 East 40th St., New York City, whose stockholders are: Abel I. Smith, 120 Broadway, New York City; Marjorie L. Sargent, Premium Point, New Rochelle, N. Y.; H. B. Emerson, 9 East 40th St., New York City; Metropolitan Finance Corporation, 9 East 40th St., New York City, whose stockholder is Harvey Flsk & Sons, Inc., 34 Pine St., New York, whose stockholders are: Frank B. Ansted, Connersville, Ind.; William G. Audenried, Jr., 34 Pine St., New York City; Harvey Flsk, 34 Pine St., New York City; Pliny Flsk, 34 Pine St., New York City; Lorin L. Homer, 34 Pine St., New York City; Henry K. Hooker, 40 State St., Boston, Mass.; Wilfred Jessup, 34 Pine St., New York City; James Magill, Land Title Bldg., Philadelphia, Pa.; F. O. March, 52 Wall St., New York City; Joseph R. Paul, Westinghouse Bldg., Pittsburgh, Pa.; Carlton W. Rich, 60 State St., Boston, Mass.; Richard U. Sherman, 246 Genesee St., Utica, N. Y. 3. That the known bondholders, mortgagees, and other security holders owning or holding 1 per cent. or more of total amount of bonds, mortgages, or other securities are: None. 4. That the two paragraphs next above, giving the names of the owners, stockholders, and security holders, if any, contain not only the list of stockholders and security holders as they appear upon the books of the company but also, in cases where the stockholder or security holder appears upon the books of the company as trustee or in any other fiduciary relation, the name of the person or corporation for whom such trustee is acting, is given; also that the said two paragraphs contain statements embracing affiant's full knowledge and belief as to the circumstances and conditions under which stockholders and security holders who do not appear upon the books of the company as trustees, hold stock and securities in a capacity other than that of a bona fide owner; and this affiant has no reason to believe that any other person, association, or corporation has any interest direct or indirect in the said stock, bonds, or other securities than as so stated by him.

(Signed) KENDALL BANNING, Editor.

Sworn to and subscribed before me this 31st day of March, 1923.  
[SEAL] EUGENE S. BIBB, Notary Public.



# FADA RHEOSTATS AND POTENTIOMETERS

are practically standard with the whole radio industry. It was FADA rheostats in 1921 that were in greatest demand and today FADA rheostats and potentiometers are sold in most every store. Despite imitations, and bootleg radio traffic the FADA trade-mark on rheostats still sets the standard of quality and service.

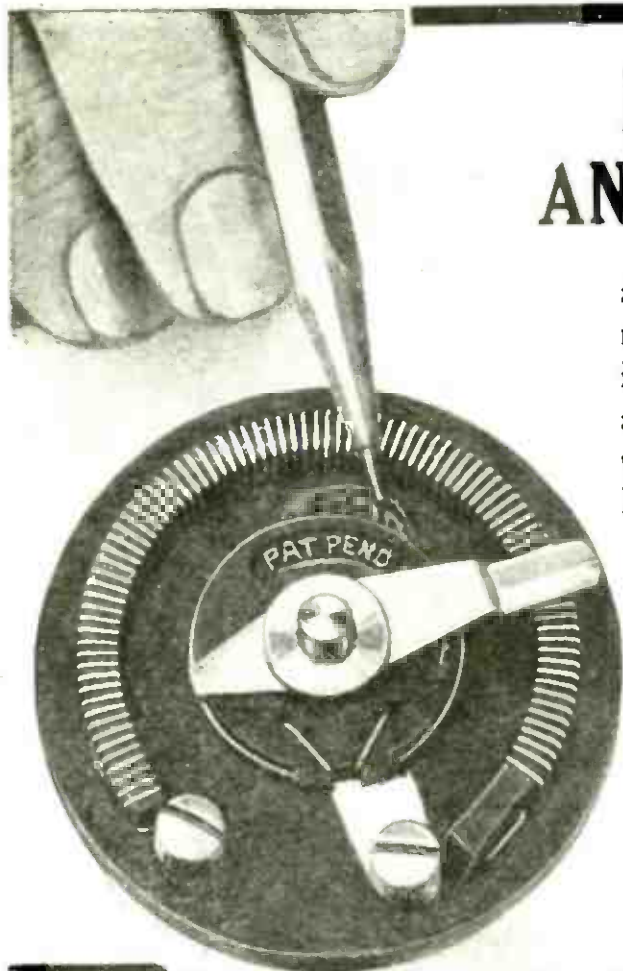

- 120-A 5 ohm plain rheostat for all 6 volt tubes . . . . . \$0.75
- 121-A Power Rheostat for three or four tubes in parallel. 1.20
- 150-A 5 ohm vernier Rheostat for best control of 6 volt detector tubes . . . . . 1.25

- 151-A Vernier attachment. Instantly converts almost any 3-16" shaft rheostat into vernier type. . . . . .50
- 152-A Potentiometer, 200 ohm, for Kaufman, Flewelling, and many other radio frequency amplifier circuits. . . . . 1.00
- 153-A 8 ohm rheostat—used for low filament current tubes. Can be converted to vernier type by using the 151-A attachment. . . . . 1.00
- 154-A 400 ohm Potentiometer. Has many uses in radio frequency amplifier circuits. . . . . 1.00
- 155-A 8 ohm vernier Rheostat—same as No. 153-A but with vernier. . . . . 1.50
- 156-A 60 ohm Rheostat for one to four UV-199 or other low filament tubes on either 4 or 6 volt battery. . . . . \$1.25

FADA products include nearly everything that the radio experimenter needs to construct his own receiving equipment.

The FADA Handbook of Radio Facts and a bulletin describing the new FADA "ONE-SIXTY" receiver with the neutrodyne circuit will be sent for 10c.

**F. A. D. ANDREA, INC.**  
1581-D JEROME AVE. N. Y. C.



Please mention POPULAR RADIO when answering advertisements.

# 32,069 Graves!

Somewhere in Europe there are to-day 32,069 graves of American Soldiers.

Each year since the World War it has been found necessary to raise money to decorate these graves on Memorial Day.

In order to obviate similar annual calls in the future, an Endowment Fund is being created which will insure an annual tribute of flowers on Memorial Day for all time.

Approximately \$300,000 is needed. \$100,000 has already been raised. The American Legion has pledged itself to raise the remaining \$200,000 before May 30th of this year.

Every American should have an interest in this fund and a distinct pride in its purpose. Every donation, no matter how small, will be appreciated.

Our slogan is: "At Least a DIME From Everybody." Make your check payable to

**"Graves Endowment Fund"**

and mail to

**FRANK B. GUEST, 85 West 103d Street, New York City**

# SPECIAL OFFER

Two new yearly subscriptions to POPULAR RADIO for only . . . . \$3.



Rope this Special Offer! Any radio enthusiast can do it. You and a friend of yours may have POPULAR RADIO for a whole year, provided you are both NEW subscribers. You only have to throw a check for \$3 around the double coupon and MAIL IT TO-DAY.

*(Coupon good until June 20th, 1923)*

POPULAR RADIO, Dept. 62,  
9 East 40th Street, New York City  
Please send POPULAR RADIO for one year to:

NAME.....

ADDRESS.....

CITY..... STATE.....

And also to this other new subscriber. Here's my cash remittance—(or a check or money order for \$3).

NAME.....

ADDRESS.....

CITY..... STATE.....

*(No extra for Canada. Foreign countries 25 cents extra per subscription.)*

[Please mention POPULAR RADIO when answering advertisements.]

Used and  
Recommended  
by  
**Reinartz**

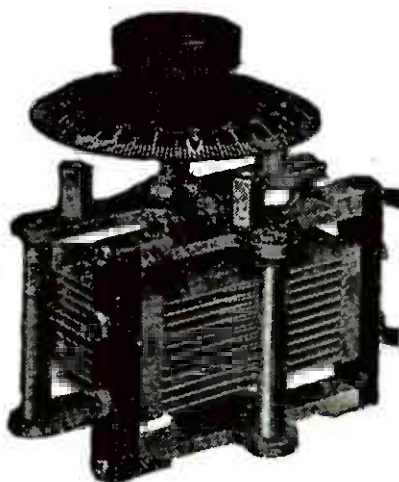

**TYPE 123-A**  
.0005 MF (Max)  
**\$4.75**  
(WITHOUT KNOB  
AND DIAL)

**T**hrow away your  
old condensers!  
When you build the  
new Cockaday 'Four-  
Circuit Tuner' you'll  
need

**CARDWELL**

**"Four-Zero" Variables**

Zero "Body Capacity" Effects  
Zero Radio Frequency Losses  
Zero Leakage  
Zero Maintenance Trouble

**A POSTCARD BRINGS YOU AN  
EDUCATION ON CONDENSERS**

ASK FOR BOOKLET D

**The Allen D. Cardwell Mfg. Corp'n**

85 PROSPECT ST.

BROOKLYN, N. Y.

*Designers of Standard Radio Instruments*  
**CARDWELL Products are used All Over the World**

## THE NEW RT-8

Radio Frequency Transformers are specially designed by the Radio Service LABORATORIES for maximum efficiency when used with any low current consumption tubes on the market.



For Audio Frequency, the new RT-A2 will give you 100% Tone Quality and High Amplification without distortion. For best results on both tone and distance, use Radio Frequency RT-8 (for all stages) in the black case, retail price \$6.00, and Audio Frequency RT-A2 in brown case, retail price \$6.50. For sale at all reliable electrical or Radio Stores. If your dealer cannot supply you, order direct. Order

by type number, accept no substitute, and remember that all Radio Service Laboratories' Transformers are individually triple tested and unconditionally guaranteed.

Send ten cents for booklet on Radio Frequency with schematic diagrams—a most valuable and helpful publication for the radio amateur and expert.

**RASLA SALES CORPORATION**

National Distributors  
DEPT. P, 10 E. 43rd ST. NEW YORK CITY

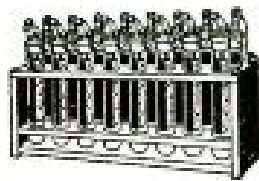

\$4.00, complete, 22½ Volts

Renewal \$2.50

Cheaper than a "B" storage battery and requires no attention

No corrosive or dangerous liquids

## The Carbon Giant "B" Battery

Guaranteed for One Year  
Each Renewal Guaranteed for One Year

This battery is similar in principle and voltage to the ordinary dry "B" battery. It contains enough water, however, to complete the chemical reactions involved and therefore it is far more efficient and will give longer life in proportion to its size than batteries of the dry type.

Best for high voltage loudspeaker installations. Best for ordinary broadcast reception. Best for DX.

Remittances should include parcel post charges on 7 pounds. Circular on request. Dealers and agents, please write.

The Copper Giant Battery Co., Lansdowne, Pa.

## RADIO FREQUENCY AMPLIFICATION

Get the best results with radiophone reception. Long distance reception, purity and volume of tone reproduction, static reduction, and selectivity. We have working plans, blue prints, with exact specifications of parts to assemble to construct a three tube set. Gives marvelous results. Save worry and experimentation in building one of these sets. Any amateur can build. Guaranteed results. Sent for \$1.00 postpaid.

RESEARCH LABORATORIES  
Carthage, Mo.

## W.T. 501 Detector Tube

\$2

For tube sets or to convert crystal sets into tube sets at small cost. Special socket 40c extra. Special Adaptor 75c extra.

RADIO RESEARCH GUILD  
40 Clinton Street NEWARK, N. J.

## RUSONITE

CRYSTAL RECTIFIER

MULTIPOINT

A Synthetic CRYSTAL DETECTOR sensitive over its entire surface Eliminates all detector troubles. Extraordinary clearness and volume. Endorsed by radio experts and press. Sold in sealed packages only. Join the ever-increasing Rusonite fans.

Price, mounted..... 50c

Sensitiveness guaranteed RUSONITE CATWHISKER 14-Karat Gold Multiple contact. 25c

Supersensitive..... Order from your dealer or direct from us.

Rusonite Products Corp., Dept. "P," 15 Park Row, N. Y.

## LEARN RADIO

Here's your opportunity. Radio needs you. Win success in this fascinating field. Trained men in demand at highest salaries. Learn at home, in your spare time.

## Be a Radio Expert

I will train you, quickly and easily, to design, construct, install, operate, repair, maintain, and sell all forms of Radio apparatus. My new methods are the most successful in existence. Learn to earn

\$1,800 to \$10,000 a Year

FREE Wonderful, home-construction, tube receiving set, of latest design. Write for "Radio Facts" free. Engineer Mohaupt. American Electrical Association Dept. 66 4513 Ravenswood Ave., Chicago

## Get Our New Loose-Leaf Catalog

Just off the press. Lists all the latest sets and parts. The best stock in Chicago. Catalog also tells how to build a Reflex Set to take on your vacation trip.

Send 10c for your copy today

LYNN RADIO CO.

Sixth Floor Consumers Bldg.

220 So. State St.

Chicago, Ill.

## SPECIAL BARGAIN

WONDERFUL TUBE SET 1000 MILE RANGE 18.00

Newark Can Get Davenport, Iowa

Free—one pair \$8.00 Everett Phones with each set purchased

Descriptive Circular on Request

## VARIABLE CONDENSERS

Bakelite End Plates Standard Construction

3 Plate.....\$1.25	21 Plate.....\$1.75
11 ".....1.50	43 ".....2.25

Enclose Money Order and Goods will be Shipped immediately by Parcel Post, Postage C.O.D.

AERO MFG. CO., 142 Market St., Newark, N. J.

# RADIO this SUMMER

*Will be Good*

It entirely depends on yourself whether you continue your enjoyment of radio this summer. Here are four very good reasons why you should get maximum enjoyment from the air at all times.

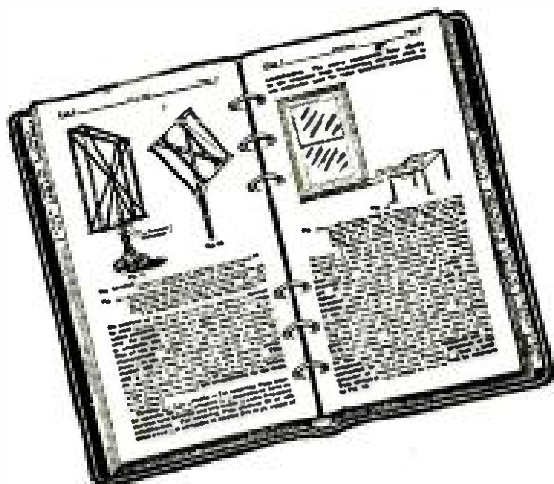
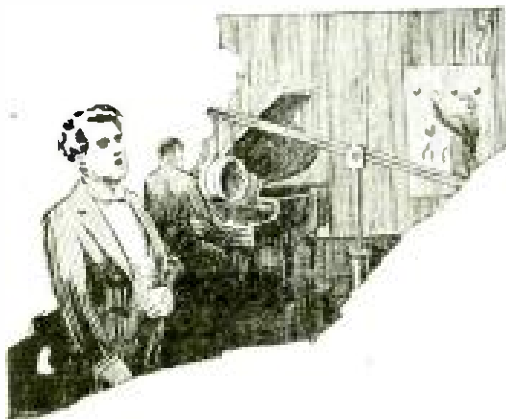
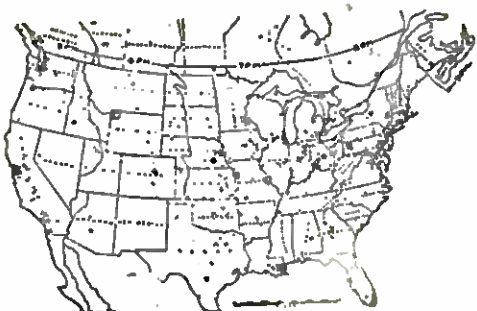

**1** Perfection of portable receiving sets now makes possible their use outdoors. You can dance, "spoon" and listen to good radio music, on your camping trip, boating cruise, or automobile tour.

**2** There are plenty of good broadcasting stations now all over the country. No place in the United States is farther than 150 miles from a good broadcasting station, and at that distance "static" cannot interfere with good reception.

New wave-lengths being assigned also make it possible to "tune to" twice as many local stations as heretofore.

**3** Improvements in transmission equipment and methods of sending, together with better quality and more frequent broadcasting, insures better reception and a more enjoyable program at all times.

**4** Here is the foundation on which to build your radio enjoyment. The Lefax Radio Handbook will start you right and keep you that way. It is written by the two chiefs of the Radio Department, U. S. Bureau of Standards. It is a loose leaf pocket-size book, bound in beautiful imitation black morocco leather. Lefax Radio Handbook never grows old. A monthly service called "Radiofax" keeps perpetually up to date. Lefax Radio Handbooks are sold by leading radio dealers and stationers. Price \$3.50 including Radiofax for one year.

**LEFAX, INC.**

902 S. 9th Street  
Phila., Pa.



## World Radio Batteries SAVE YOU 50%

WRITTEN 2 YR. GUARANTEE

In buying a WORLD, the highest quality battery built, direct from the manufacturer, you gain two profits. First: you get a battery free from extravagant selling expense. Second: you get the profit charged by the middle-man. You take no risk. We ship express C. O. D. subject to your inspection, or will allow five per cent for cash with order. Mail your order today!

**COMPARE THESE PRICES**

RADIO PRICES:	
6 Volt. 60 Amps.	\$10.00
6 Volt. 80 Amps.	12.50
6 Volt. 100 Amps.	14.50
6 Volt. 120 Amps.	16.00

No other manufacturer offers such a high quality battery at such a low price. Save 50 per cent on your next battery and get better and longer service—buy a World Storage Radio Battery. Write today.

World Battery Co., 1219 S. Wabash Ave., Dept. 3, Chicago

# NOVO "B" BATTERIES



NOTE THE INSULATED BINDING POSTS AND 7/16" WIRE CONNECTOR

**NOVO M'FG CO.**  
 524 W. 33rd ST. NEW YORK  
 531 S. DEARBORN ST. CHICAGO

## RADIO BLUEPRINTS

Blue Print Design of Radio Receiver, guaranteed range 1,000, 3,000 miles, using dry cells. . . . . 10c  
 Blue Print Two Stage Amplifier for above outfit. . . . . 10c  
 Blue Print of Radio Frequency Amplifier for above. . . . . 10c  
 Guaranteed 1000 Ohm Phone Receiver Post-paid. . . . . \$2.00  
 Guaranteed Bakelite Couplers, Green Silk Post-paid. . . . . \$3.00

*We sell Guaranteed Apparatus.*

Send 10c for Our Complete Catalog!  
 Agents Wanted—Liberal Commissions  
 Badger Radio Co., 493 E. Water St., Milwaukee, Wis.

## FREE Radio Catalog



Our big stocks of standard makes of radio sets, parts and supplies enable us to make prompt shipment from stock. Play safe—buy standard equipment from a reliable house. No cut price material.

Send \$5.00 for Murdock Complete Loud Speaker, 70c for "A" Battery Switch, 80c for pair Rubber Ear Muffs.

**JULIUS ANDRAE & SONS CO.**  
*In Business since 1860*  
 127 Michigan Street Milwaukee, Wis.

### Super-Sensitiveness!

THE crystal is the "bull's-eye" of your crystal receiving set. Unless it is super-sensitive you are wasting time and entertainment and cannot "hit" the combination for best results. Insist upon the genuine original Arlington Tested "NAA" Detector Minerals. They are carefully selected from bulk stock, individually tested and guaranteed super-sensitive.

Galena, Silicon or Goldite price per crystal, 25c. Same mounted in brass cup, 40c. Obtainable at your dealer's or sent direct (post-paid) on receipt of price.

**The Newman-Stern Co.**  
 Newman-Stern Building Cleveland

## A NATIONAL RADIO TUBE SERVICE

Send us your burned out or broken Detectors or Amplifiers and receive maximum allowance on the purchase of NEW TUBES. UNLIMITED QUANTITY ALWAYS ON HAND FOR IMMEDIATE SHIPMENT.

We allow you Seventy-five Cents on an old UV200 in the purchase of a new one and One Dollar on WD11 and 12 when buying new Tubes, corresponding allowances on all makes.

### Radio Tubes Repaired in One Week

Customers who purchase new tubes from us are entitled to a special discount on repair work. In other words we sell you new tubes and then keep them in shape for you.

We also usually have on hand a quantity of uncalled-for refilled, licensed tubes at very moderate prices, all guaranteed.

**OUR REPAIRED TUBES SPEAK FOR THEMSELVES.**  
 Write to-day for Circular P7 which will explain all the details. SHIPMENTS PROMPTLY MADE C. O. D. TO ALL POINTS IN THE U. S. A.

**RADIO TUBE LABORATORIES**  
*Vacuum Tube Specialists*  
 776 Broad Street Newark, N. J., U. S. A.

## CHARGE YOUR BATTERY

(RADIO OR AUTO) at HOME for a NICKEL



**The HOMCHARGER**  
 POPULARLY PRICED—PAYS FOR ITSELF  
 SEND FOR THE AUTOMATIC ELECTRICAL DEVICES CO. FREE BOOK 132 W. THIRD ST. CLEVELAND, OHIO

## 24 HOUR SERVICE

LARGEST COMPLETE STOCK  
 of Standard Supplies in Middle West—Write for 64-Page Catalog No. D-10

DEALERS  
 Greater Discounts Better Profits

**AMERICAN RADIO MFG. CO.**  
 107 E. 13th St. Dept. P KANSAS CITY, MO.

## RADIO-PATENTS

Procured. Send sketch or model today for examination, prompt report and advice. No charge for preliminary advice. Write for free booklet and blank form on which to disclose your idea. Highest references. Promptness assured.

**CLARENCE A. O'BRIEN**  
 Registered Patent Lawyer, 1036 Southern Building, Washington, D. C.



**THE MOON RADIO CORPORATION**  
*Manufacturers of*  
**Ultra-fine Receiving Sets**  
 12 Diagonal Street  
 Long Island City, N. Y.

# Every Radio "Bug" OK's the Kellogg Variometer

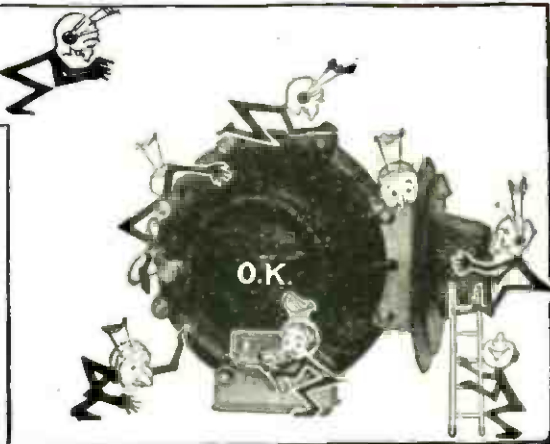

A product that stands up under the test of service of the widest range. The stator and rotor shells are of molded Bakelite, of extra strong rib design. A handsome brown in color.

The windings are of the highest grade insulated wire, terminating on binding posts securely molded in the Bakelite shell. The flexible wires used to bring the rotor leads to the outside of the variometer are of special construction with a heavy insulation.

Ample size bearings assure smooth, even movement with long life, a spring of proper tension takes up all play and prevents back lash. There are no sliding contacts, nothing to wear, nothing to "short," or produce noises.

High inductance and low distributed capacity.

Have your dealer show you other Kellogg radio parts—each in a class by itself. Get the most out of radio. Build it with Kellogg time-tested equipment. Use the following KELLOGG radio equipment for better results:

Variometers, \$8.00; Variocouplers, \$9.00; Tuner Coils, \$3.00; Head Sets, \$10.00; Microphones, \$8.90; Tube Sockets, \$.75; Plugs, \$1.00; Four Conductor Jacks, \$1.10; Two Conductor Jacks, \$.75; Six Conductor Jacks, \$1.25; Four Inch Dials, \$1.25; Forty Three Plate Variable Condenser with Five Plate Vernier-Four Inch Dials and Knobs, \$8.75; Twenty Three Plate Variable Condensers with Five Plate Vernier-Four Inch Dial and Knob, \$7.75; Eleven Plate Variable Condensers with Five Plate Vernier-Four Inch Dial and Knob, \$6.75; Miniature Condensers, \$.75; Rheostats, \$2.00; Air Choke Coils, \$1.00; Iron Core Choke Coils, \$1.35.

Kellogg Radio Apparatus proves the least expensive in the long run. Why experiment. Buy the best.

*All Kellogg Radio Parts are manufactured and guaranteed by*

## Kellogg Switchboard & Supply Company

CHICAGO, ILLINOIS

Columbus, Ohio

Kansas City, Mo.

San Francisco, Cal.

Portland, Ore.

*Kellogg Apparatus exclusively is used in building the Symphony Receiver*



# “How I Located My Trouble”

A Massachusetts radio enthusiast tells of a happy discovery that finally solved his difficulties.

‘I COULDN’T figure out what was wrong with my radio set,’ states a Fitchburg business man whose experience is interesting because it shows how one simple little adjustment will sometimes make such an amazing improvement in results.

“I had erected my antenna in just the right way, had connected up my different instruments with the greatest care, had added improvements that were designed to bring my apparatus to the highest possible perfection,” he continues.

“I spent a good many hours talking over my problems with dealers and experts. I followed one suggestion after another. But still the same old trouble!”

### Do You Have This Trouble?

“In spite of all my efforts, when I wanted to hear some particularly interesting broadcasting program, other stations kept breaking in; I found difficulty in getting long distance points; and intermittent squeals, whistles and howls would persist, no matter how I tuned or adjusted my dials.

“I was pretty nearly convinced I’d have to get some high-priced installation man to come out to

my home and set me right, when purely by chance I happened to pick up a copy of POPULAR RADIO—and thumbing through its pages I found the very answer to my problems!

“There in black and white, diagrammed and explained, was a simple, practical suggestion that turned the trick for me.”

### The One Best Way to Get Results

Many other radio enthusiasts, too, who want to get the most out of their sets have found in POPULAR RADIO many an idea and practical suggestion that has made a world of difference in their enjoyment of this fascinating pastime, and saved them hours of experiment and costly error.

If you don’t already *subscribe* to POPULAR RADIO, don’t miss this opportunity of getting the magazine regularly at your permanent address.

A year’s subscription will **save you money** over what you would pay on the newsstands, and will bring you the magazine every month, rain or shine.

### Your Questions Answered **FREE!**

Then, too, as a regular subscriber, any questions you wish to ask of the Technical Editor will be answered **free of charge**. This is one of the most valuable features of POPULAR RADIO’s service, and is the same service for which non-subscribers pay 50 cents for each question asked, and they say it’s worth many times what they pay. *Yet you can get this same added service absolutely free.*

### The Coupon Entitles You to This Service

Simply fill out and mail the attached coupon today and your subscription will start with the very next issue. If you have some problem to put up to our Technical Editor now, send in your question with the coupon and he will be glad to straighten you out. This is a privilege to which all subscribers are entitled, and we want you to take full advantage of it.

But do not delay sending in your subscription. Get POPULAR RADIO regularly each month and don’t risk missing any of its scores of helpful and practical suggestions.

POPULAR RADIO, Dept. 60,

9 East 40th Street, New York City

Please put me down for a year’s subscription to POPULAR RADIO, beginning with the July issue. I am enclosing \$2 in full payment which also entitles me to free use of your Question and Answer Department.

Name .....

Address .....

RA (No extra for Canada. Foreign countries 25 cents postage extra.)



Please mention POPULAR RADIO when answering advertisements.



No. 185 VARIABLE CONDENSER . . . \$4.25  
CAP. .00035 M. F. 17 PLATES

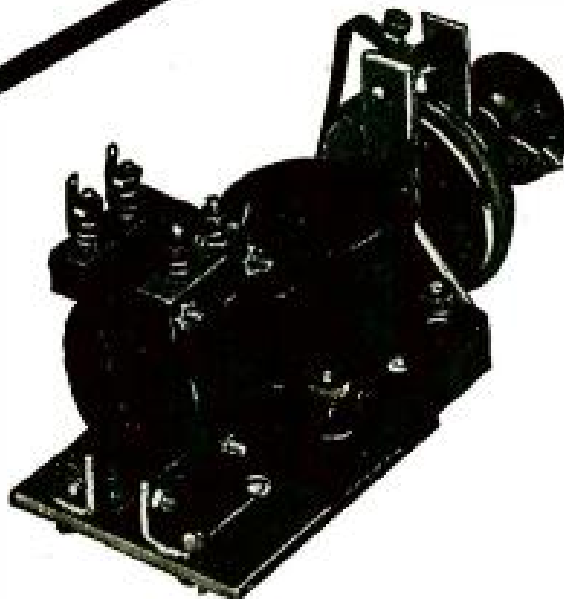

No. 198 AMPLIFYING UNIT . . . \$7.50  
ACME TRANS.

No. 211 DETECTOR UNIT . . . \$2.40



No. 167 COUPLER . . . \$5.50



No. 164 KNOB AND DIAL . . . \$0.75  
MOLDED BAKELITE

### R. MITCHELL & CO.

255 Atlantic Ave.

Boston, Mass.

*For 47 years Manufacturers of Scientific and other equipment  
Look for trade mark on every piece*

Jobbers and Dealers write for discounts

# You Can't Beat This Big Offer!

MONEY saved is money earned. Radio enthusiasts want the most for their money. Here is an opportunity for you to get unusual value for your subscription dollars.

"POPULAR RADIO" and "RADIO" (San Francisco) known the nation over for the wealth of practical information they contain, in addition to a mass of most timely radio news, valuable constructional data for those who "roll their own," feature articles by the leaders of the industry, the latest radio developments and discussions on everything worth-while

talking about, have joined forces in a great money-saving clubbing offer in order to give *you* these leading two radio publications at a cost very little more than the subscription price of either magazine alone. Just imagine—you can subscribe to *both* "POPULAR RADIO" and "RADIO" for a full year for only \$3.00—a saving to you of \$1.50 over what you would pay for them separately.

If you are already a subscriber to either magazine—or both—you can extend your subscription for another year at this unusually low rate.

*This is undoubtedly one of the most liberal subscription offers yet made*

**"POPULAR RADIO" and "RADIO"**  
—one full year for only \$3.00  
—a saving of \$1.50

POPULAR RADIO, Dept. 61,  
9 East 40th St., New York City, N. Y.

Send me "POPULAR RADIO" and "RADIO" for one full year. I enclose \$3.00.

Name.....

Address.....

Here's the little coupon that will save you big money if you mail it before June 20th.

Don't turn this page until you have clipped the coupon and started it on the way to "POPULAR RADIO."

# RHAMSTINE\*

## Victophone

### A NEW LOUD-SPEAKER.

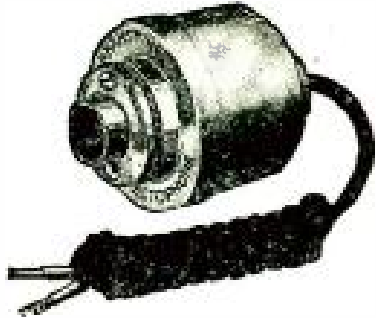

Price \$7.50 complete with cord

No batteries are required to operate it.

Adjustable poles.

A venturi opening in the cap correctly designed to increase volume.

Rubber gasket between the tone-arm flange and the cap to reduce metallic vibration.

The *Victophone* is a correctly designed loud-speaking receiver. It can be used with any type of horn but it is especially designed to be attached to the tone-arm of various phonographs.

Remove the reproducer from your Victrola and put on the Rhamstine\* *Victophone*, adjust the pole regulator until the tone and volume are just right—and see if it does not fully meet your needs for a perfect loud-speaker.

The *Victophone* is nickel-plated and highly polished. It bears the name Rhamstine,\* assuring you of satisfaction in your purchase.

Order yours today Dealers write for discount.

Manufactured by

**J. THOS. RHAMSTINE\***

2162 E. Larned St.

Detroit, Mich.

\*Maker of Radio Products

# Good bye Aerials! So-Long Static!

## SHORT CUT ANTENNA

Replaces aerials, loops, electric light plugs, etc. Eliminates lightning dangers. Reduces static and other interference. Gives clearer signals and tone. Works on all standard vacuum tube sets. Makes your set portable. Size only 6¾x2½ ins.

Postpaid anywhere \$5.00

Satisfaction guaranteed or money refunded

**Short Cut Radio Corporation**

241 W. 54th Street  
NEW YORK

DEALERS:  
Write for Our Proposition



Size, 6¾ ins. by 2½ ins.

SHORT CUT RADIO CORPORATION  
241 W. 54th St., New York

Send me one SHORT CUT ANTENNA  
(a) for which I will pay \$5.00 C.O.D.  
(b) for which I enclose ..... for \$5.00

I have a .....

Name .....

Street .....

City .....

State .....

Dealer's name and address .....



# PACENT JACKS

## Standard With Leading Set Manufacturers

The sets shown are just a few of those whose makers standardize on PACENT Jacks. The set maker's reputation rests as much on what he buys as on what he builds. Therefore he buys jacks with a reputation for honest quality and satisfactory performance—PACENT Jacks. Present price revisions mean increased VALUE

### PACENT JACK PRICES

No. 61	Open Circuit Jack.....	\$ .60
No. 62	Closed Circuit Jack.....	.75
No. 63	Double Circuit Jack.....	.85
No. 65	3 Spring Automatic Jack..	.90
No. 66	5 Spring Automatic Jack..	1.00
*No. 67	7 Spring Automatic Jack..	1.00

*\*(Necessary in Hazeltine as well as many other Circuits)*

PACENT Jacks are just one item in the line of PACENT Radio Essentials, every one of which is designed to efficiently fill a definite radio need.

Write for Descriptive Bulletin P6

PACENT ELECTRIC CO., Inc.

22 Park Place, New York, N. Y.

Sales Offices: Chicago, Philadelphia, St. Louis, Minneapolis,  
Washington, D. C., San Francisco, Jacksonville

Canadian and British Licensees: Colonial Radio, Ltd., Hamilton, Can.



**DON'T IMPROVISE—"PACENTIZE"**  
**Pacents**  
**RADIO ESSENTIALS**

# Teleradio

(TRADE-MARK)



## SUPER SENSITIVE PHONE

USED IN EVERY STATE IN THE UNION

are the result of years of experience in the construction of delicate electrical apparatus.

They are designed and built on sound engineering principles. They are famous for their super sensitiveness, superior quality of tone, volume, and clearness—accurately reproducing either vocal or musical sounds with wonderful tonal qualities. *Equally satisfactory for local or long distance work.*

Growing popularity — INCREASING SALES prove it is the PERFORMANCE and SATISFACTION of TELERADIO *correctly balanced* Phones that really count.

**TRY THEM AND BE CONVINCED**

Type C, 2000 ohms, \$6.50; Type B, 2200 ohms, \$7.50; Type A, 3000 ohms, \$9.00.



### TELERADIO FILAMENT RHEOSTAT

Can be mounted on panel or table

Will carry 1½ amps without overheating and is wound to 6 ohms resistance

Price, \$1.00

### TELERADIO LIGHTNING ARRESTER

Electrical No. 5837

Approved by the National Board of Fire Underwriters

Price, \$1.00

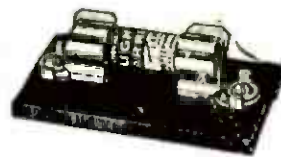

### TELERADIO FILAMENT PROTECTOR

For detector and amplifying tubes

Complete, 60c

Extra fuses, 10c each



### OTHER TELERADIO "HIGH QUALITY" PRODUCTS

Variable Condensers, 3-11-23 and 43 plates, \$1.50, \$2.50, \$3.00 and \$4.00, respectively. Tube Sockets, 60c; Fixed Phone and Grid Condensers, 35c each; Grid Leak Condensers, 50c each.

*Jobbers and Dealers write for our attractive proposition*

## TELERADIO ENGINEERING CORPORATION

484-490 BROOME STREET, NEW YORK CITY

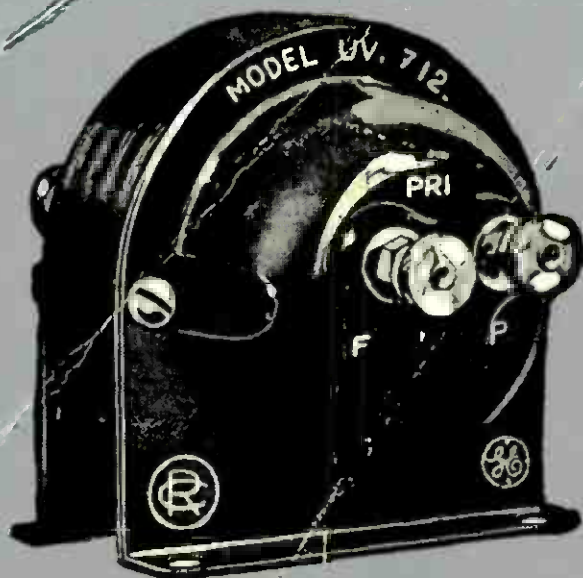

Transformer  
UV-712  
\$6.50

# Volume — undistorted!

*With Audio-Frequency Transformer UV-712*

- Complete shielding to prevent interaction between fields.
- Sturdy build to withstand rough use and much handling.
- Exact construction to eliminate distortion in each stage of amplification.
- Special care to minimize transformer losses, thus giving unequalled volume.



*This symbol of quality  
is your protection*

*Particularly Designed for Use With RCA Radiotrons*

**Radio Corporation**  
of America  
*WORLDWIDE SERVICE*

*Sales Dept. Suite 6067  
233 Broadway  
New York*

*District Sales Offices  
10 So. LaSalle Street  
Chicago, Illinois*

*433 California Street  
San Francisco, California*