

# RADIO

FOR BETTER RESULTS USE

# EVEREADY

"A" and "B" BATTERIES  
WITH YOUR RADIO SET

### EVEREADY "A" BATTERIES

- No. 6810 50 Amp. Hrs. \$15.00
- No. 6860 90 Amp. Hrs. 18.00
- No. 6880 110 Amp. Hrs. 20.00

- Hardwood Box, Mahogany Finish
- Convenient Handle, Nickel Plated
- Rubber Feet, Protect the Table

No Accidental Short-Circuits

All Eveready "A" batteries are equipped with a 4 volt as well as a 6 volt terminal, making it possible to use either 6 volt or 4 volt vacuum tubes in your set

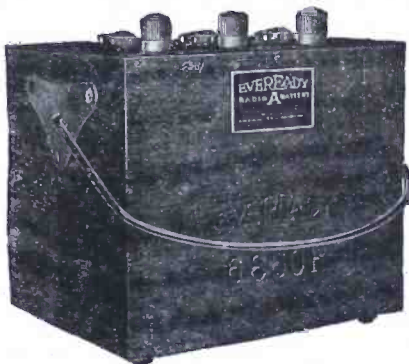

### EVEREADY "B" BATTERIES



- No. 766—15 Cells—16½ to 22½ Volts (1½ Volt Steps) \$3.00
- No. 763—15 Cells—16½ to 22½ Volts (1½ Volt Steps) \$1.75
- because of limited capacity, due to small cells, No. 763 is recommended only where light weight and small space are essential
- No. 767—30 Cells—16½ to 22½ Volts (1½ Volt Steps) with a 45 Volt Tap for the Amplifier Tubes . . . \$5.50
- No. 746—72 Cells—16½ to 22½ Volts (1½ Volt Steps) with a 45 Volt Tap and a 108 Volt Tap . . . \$15.00

Guaranteed to be Absolutely Noiseless

Columbia Ignitor Six-Inch Dry Cells Equipped with Fahnestock Connectors

Columbia Dry Cells are suitable for the filament or "A" circuit of Westinghouse WD-11 Vacuum Tubes, which require one six-inch dry cell per tube

Visit our Exhibit, RADIO SHOW Space 56, Grand Central Palace, New York

NATIONAL CARBON COMPANY, Inc.  
Long Island City, N. Y.

Atlanta      Chicago      Cleveland      Kansas City

# POPULAR RADIO

EDITED by KENDALL BANNING



## CONTENTS for DECEMBER, 1922

(Cover design by Gerald Leake)

VOLUME II

NUMBER 4

Radio for Schools and Colleges.....	John J. Tigert.....	Page 229
The Advance Agent of the New Era.....		230
Is the "Heavside Layer" Theory Valid?.....	Elihu Thomson.....	231
Who Will Pay for Broadcasting?.....	Waldemar Kaempffert.....	236
Broadcasting as an Educational Force.....	Clarence H. Mackay.....	237
Radio on Your Motor Car.....	Frederick Siemens.....	246
Radio Opens a New Era.....	Lec De Forest.....	253
6000 Miles on 20 Watts.....	Richard Lord.....	254
Radio as a Power for Educating the People.....	Ernest M. Hopkins.....	259
How to Select the Best Coil for Your Set.....	J. H. Morecroft.....	260
Radio's Chance to Render a Public Service.....	Adolph Lewisohn.....	267
How to Make and Use a Loading Coil.....	A. Hyatt Verrill.....	268
The Seventh of a Series of "How to Make" Articles		
The Best Antenna for Transmitting.....	David Lay.....	272
The Cage Type—No. 3		
The Public Benefit of Good Broadcasting.....	Edward R. Hewitt.....	274
A Loud Speaker from a Conch Shell.....		275
How the Vacuum Tube Detects.....	Laurence M. Cockaday.....	276
Simple "How" Articles for the Beginner—No. 7		
A Receiving Set That Takes Down Notes.....		281
How to Make a Series-Antenna Condenser.....	Watson Davis.....	282

### DEPARTMENTS

Listening In.....		286
How to Combine Your Crystal and Vacuum Tube.....		
The High Cost of Radio in Germany.....		
Blocking Bandits with Radio.....		
A Static-Proof Radio Set.....		
Radio on Life-Boats.....		
Side-Line Reports by Radio.....		
What Readers Ask.....		289
Broadcasts.....		293
Adventure in the Air.....		295
I Pick Up a Warning from an Unknown Hero.....		
I Deliver a Death Message via the Purser.....		
A Radio Message Penetrates Prison Walls.....		
Broadcasting Should Benefit the Community.....	Harry Pratt Judson.....	296

VOLUME II

DECEMBER, 1922

NUMBER 4

Published monthly by Popular Radio, Inc., 9 East 40th Street, New York, N. Y., telephone number Vanderbilt 9985; H. B. Emerson, President; E. R. Crowe, Vice-President; P. O. Batch, Treasurer. Price, 15 cents a copy; subscription \$1.50 a year in the U. S., \$1.75 in Canada; elsewhere \$2.00 a year, payable in advance. The International News Company, Ltd., No. 5 Bream's Bldg., London, E. C. 4, sole distributors in England. Entered as second-class matter April 7, 1922, at the Post Office at New York, N. Y., under the act of March 3, 1879. Copyright, 1922, and title registered as a trade-mark by Popular Radio, Inc. Printed in U. S. A.

E. E. FREE, Ph.D., Contributing Editor LAURENCE M. COCKADAY, R.E., Technical Editor

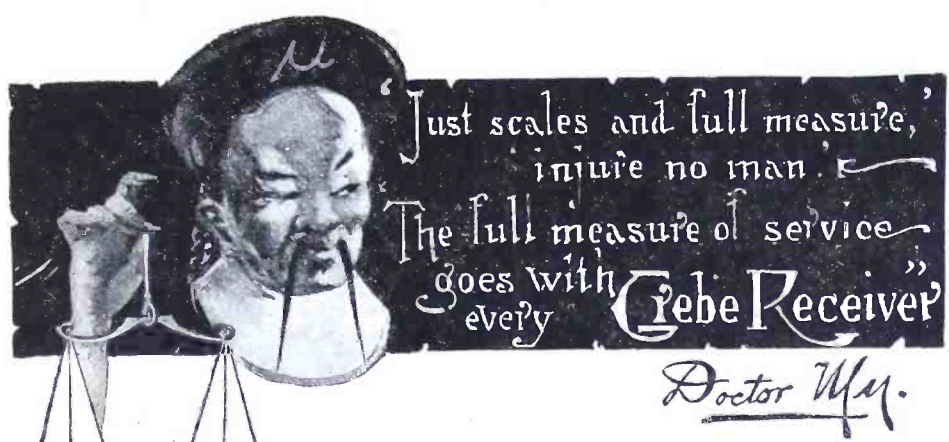

**A**NYONE who knows a radio will tell you how well the Grebe CR-5 performs on the daily concerts, lectures, etc., in the air.

Two simple tuning adjustments are used. Tiresome adjustments, unpleasant interruptions are unnecessary with the Grebe CR-5. Its

range, 150—3000 metres.

Ten years experience in satisfying a critical radio public has taught us how to build it for your year-round enjoyment.

If your Dealer does not sell Grebe Radio Apparatus, send us his name and receive interesting circular.

**A. H. GREBE & CO., Inc.**

Van Wyck Blvd., Richmond Hill, N. Y.  
General Offices and Factory  
Western Branch—451 East 4rd St., Los Angeles, Cal.

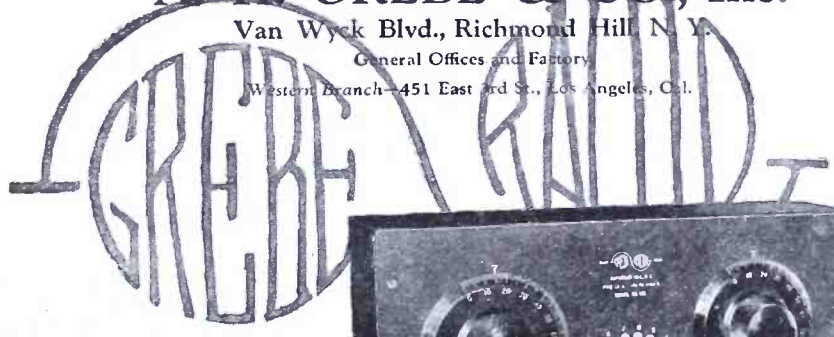

Licensed under  
Armstrong U. S. Patent,  
No. 1113149.



# A PAGE WITH THE EDITOR

EVERY radio fan knows—or *ought* to know—what the “Heaviseide Layer” theory is and how it affects radio waves. If he doesn’t, he may turn to page 231 and find out. Dr. Elihu Thomson there states that the theory is invalid, and gives his reasons. In the January issue Sir Oliver Lodge states that the theory is perfectly good, and also gives his reasons.

\* \* \*

THUS another international argument is precipitated!

\* \* \*

THE broadcasting of the side-line reports of the World-Series baseball games at the Polo Grounds in New York—thanks to the timely cooperation of the Western Union Telegraph Company—was not only a treat to hundreds of thousands of radio fans, but also a stimulant to the radio industry as a whole. As this issue of POPULAR RADIO goes to press negotiations are pending for broadcasting side-line reports of the big football games of the East. Only failure to obtain the necessary wires from the athletic fields to the broadcasting stations will prevent the plan from being carried into effect.

\* \* \*

“I AM a crippled soldier and have been in the hospital since December, 1919,” writes Cyril A. Newman (Serial No. C—613,886) from the Mercer Hospital at Trenton, N. J. “I won’t be able to leave the Government’s care for some years. Can you help me get a radio outfit to help pass the time? I haven’t any money with which to buy one—but I’m radio crazy.”

\* \* \*

THROUGH the generosity of a POPULAR RADIO reader, veteran Newman’s request has been granted. But his plea has given the Editor an idea. Why not send discarded radio sets to other invalids in other hospitals?

\* \* \*

RADIO sets forwarded to the office of POPULAR RADIO will be distributed among disabled veterans without charge—and after investigation of each case.

Where could a radio set be located to better advantage than at a cripple’s bedside?

\* \* \* \*

“WE have been advertising in six of the leading radio papers, and have had our advertisements keyed,” writes H. M. Linter of the Teleradio Corporation of New York. “We find that we get two replies from POPULAR RADIO to only one from *all the other five publications combined.*”

\* \* \*

THOSE are strong words, Brother Linter! But you are not alone in your experience with

POPULAR RADIO’s advertising pages. Here, for example, is what S. J. GROSSMAN, of the Man-Day Radio Corporation, writes:

“Dollar for dollar, your magazine has brought in returns far better than any other publication—and we advertise only in the best magazines.”

\* \* \*

THE letters quoted above are but typical of dozens. They are of peculiar interest to the Editor because they indicate that POPULAR RADIO is actually reaching the class of reader at which it is aiming—the radio novice and the radio amateur.

\* \* \*

EVER since the successful broadcasting of the New York Philharmonic concerts last summer, POPULAR RADIO has been making efforts to arrange for the broadcasting of additional concerts this winter by the same great orchestra. As this number goes to press it appears that this project will be accomplished. Important as this undertaking is in itself, it is but part of a great nation-wide program which this magazine is working—and working hard—to build up for the benefit of radio fans and of the radio industry.

\* \* \*

“YOUR November number,” writes Dr. William H. Easton of New York, “contains two remarkable features. One is the first intelligible description of the Relativity Theory, in Sir Oliver Lodge’s contribution; the other is the first simple, clear-cut description of the action of a regenerative receiver in John V. Hogan’s article.”

Our own ideas exactly!

\* \* \*

“I COULD go on for page after page of tribute to POPULAR RADIO and still not say enough,” writes Frank Feigle of New Kensington, Pa., at the conclusion of a letter. “We radio old-timers need your magazine as letters need stamps.”

The Editor can add only the hope that they will be as inseparable.

\* \* \*

WITH this issue POPULAR RADIO introduces to its readers a new member of the editorial staff—George B. Chadwick, captain of the famous 1903 Yale football team, editor, officer in the World War and for the past three years Director of Publications of the American Red Cross, National Headquarters, Washington, D. C. Mr. Chadwick is taking over the duties of Managing Editor.

  
Editor POPULAR RADIO



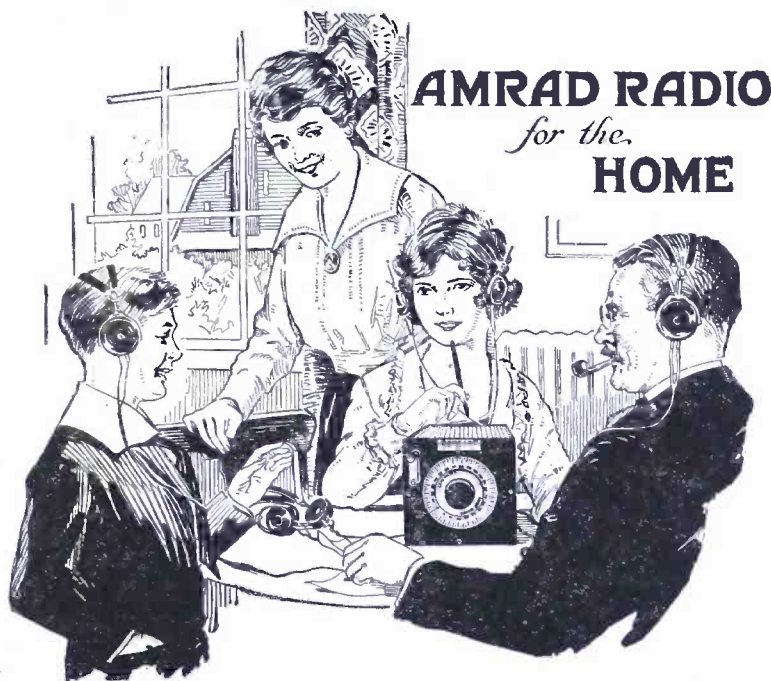

## AMRAD RADIO *for the.* HOME

### *Make this a Radio Christmas— But satisfy with AMRAD*

Unless you have heard the AMRAD, you haven't heard Radio. AMRAD Receiving Sets—large or small—incorporate the latest, TESTED refinements only possible after many years of deliberate research and actual Radio engineering and manufacturing experience.

Superior performance, reasonable cost, lasting satisfaction—if your Radio is AMRAD.

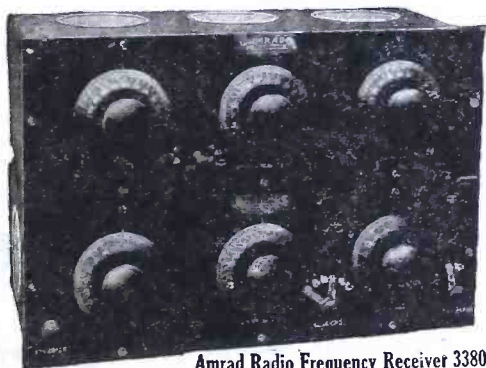

**Amrad Radio Frequency Receiver 3380**

Latest Amrad Quality Receiver, furnished completely assembled in Solid Mahogany Cabinets. Price, less tubes, \$125.00

### **Go to Your Dealer**

Ask him to show you the latest AMRAD Receiving Sets, from \$21.50 to \$300.00. If your dealer is not supplied, place your order, and he will fill it quickly. Look for the green and yellow AMRAD labels in the best stores, and insist on seeing the AMRAD *before* you purchase.

*Complete new catalogue describing over 80 Radio Specialties, 10c. in stamps*

**AMERICAN RADIO AND RESEARCH CORPORATION**  
217 College Ave., Medford Hillside, Mass.  
(4 Miles North of Boston)

New York City  
17 Park Row

Chicago  
220 So. State St.



Tuner, Detector and Two-Stage Amplifier  
Type 115



RHEOSTAT  
Type 103

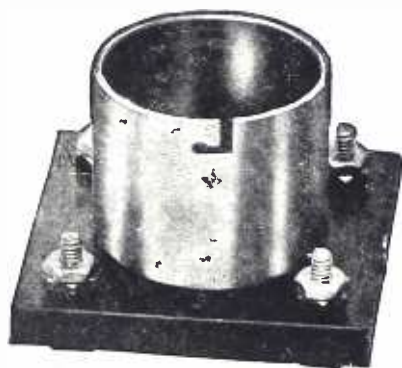

SOCKET  
Type 109

**D**OES years of experience in manufacturing Radio Transmitting and receiving Apparatus for **THE UNITED STATES GOVERNMENT** mean anything to you?

**VICTOR** engineers and workmen have had this experience and are capable of producing highly satisfactory Radio Apparatus.

*Our line includes :*

Complete Receiving Sets  
Tuners  
Tuners and Detectors  
Tuner, Detector and Two-Stage Amplifiers  
Tuner, Detector and Three-Stage Amplifiers  
Detector Units  
Detector and Two-Stage Amplifiers  
Single-Stage Amplifiers  
Two-Stage Amplifiers  
Variometers  
Variocouplers  
V. T. Sockets  
Rheostats  
Grid Condensers  
Plate Condensers  
Variable Condensers  
Knobs, Dials, Binding Posts, etc.



## VICTOR RADIO CORPORATION

799 East 135th Street, New York City

*Manufacturers of Complete Radio Sets and Parts*

CATALOGUE ISSUED ON REQUEST



From a photograph made for POPULAR RADIO

## Radio for Schools and Colleges

TO THE EDITOR OF POPULAR RADIO:

*"I am greatly interested in the use of the radio for educational and cultural purposes. . . . I am hoping that we may be able to do some work of this description shortly."*

*Jno. J. Tager*

COMMISSIONER OF EDUCATION  
OF THE UNITED STATES

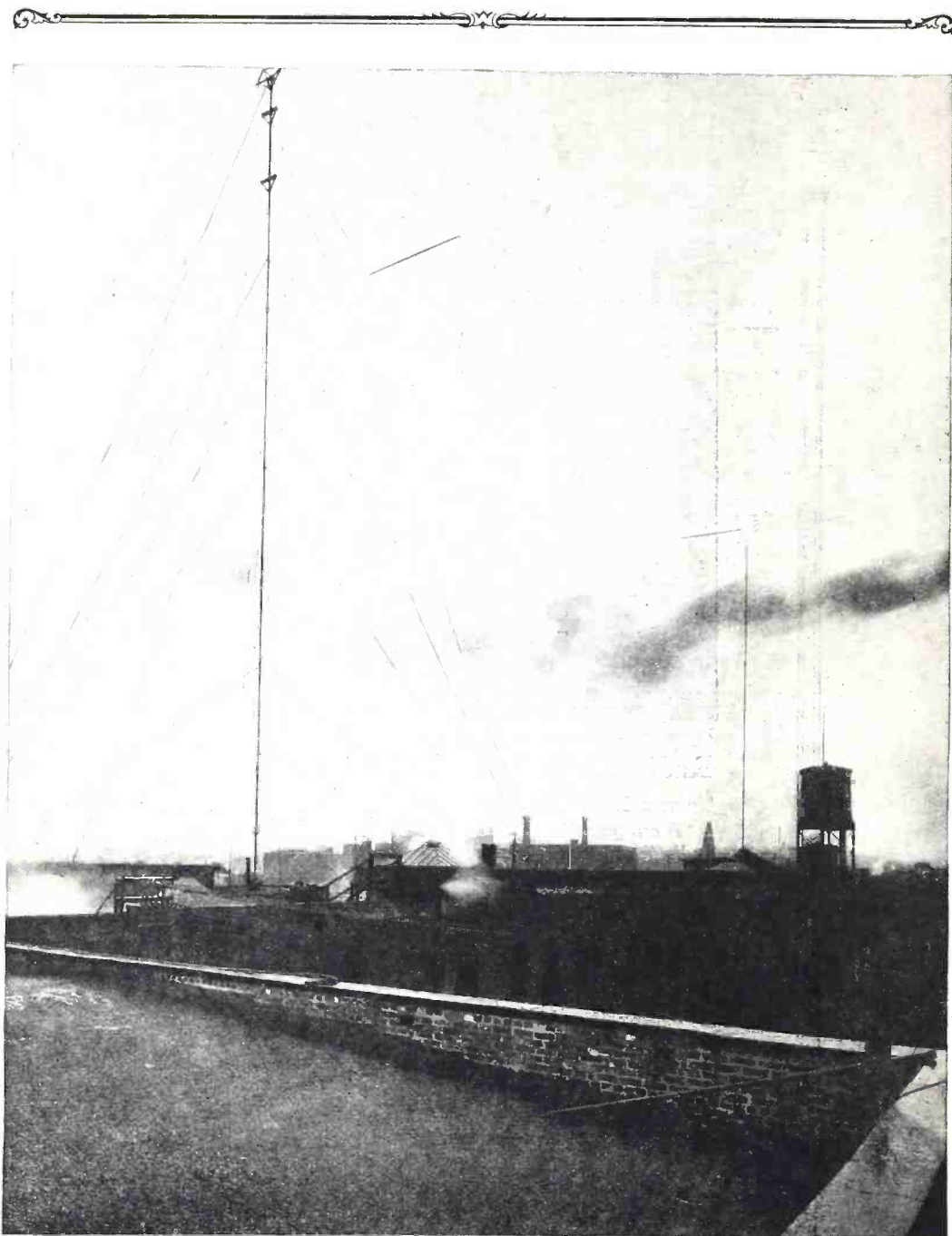

From a photograph of WJZ Station made for POPULAR RADIO by Westinghouse

## The Advance Agent of the New Era

**Q** "We have as yet but caught a glance of the social destiny that radio will fulfil. . . . It will achieve the task of making us think together, feel together, act together, not merely as a nation but as a world!"

—SEE PAGE 236



# Popular Radio

VOLUME II

DECEMBER, 1922

NUMBER 4



## Is the "Heaviside Theory" Valid?

*The Answer in the Negative*, by DR. ELIHU THOMSON

*The Answer in the Affirmative*, by SIR OLIVER LODGE

### FOREWORD

WHEN Marconi's historic feat of transmitting signals across the Atlantic by means of "wireless" was established as a fact, a group of eminent scientists cast about for a theory that would explain how the radio waves were sent around the curvature of the earth. According to notions conceived up to that time, light waves and radio waves traveled only in straight lines. To explain this new phenomenon, therefore, a theory known as the "Heaviside layer theory" was evolved. This theory presupposes a spherical layer of ionized gas or minute conducting particles of matter, suspended about fifty miles above the surface of the earth; this layer is presumed to serve as a reflector and to bend or deflect the radio waves and thus send them around the earth in a circular path. Another group of no less famous scientists, however, emphatically deny the validity of this theory. They explain the phenomena by means of the "gliding wave theory," according to which the waves are led around the curvature of the earth by ground conduction. This latter theory is upheld by the distinguished American scientist, Dr. Elihu Thomson, who was one of the first great experimenters in this field. The other side of this discussion will appear in this magazine for January—written by the eminent English scientist, Sir Oliver Lodge.—EDITOR

BY ELIHU THOMSON, PH.D., SC.D.

WHEN Marconi brought out his system of wireless telegraphy about 1896, it was at first thought by most scientists or physicists of the time that it was a plain case of the sending out of waves of the Hertzian type, which Dr. Heinrich Hertz had so ably investigated ten years before. If such were the case, the transmission was necessarily in straight lines from the oscillator; necessarily, also, such waves could not follow the curvature of the earth's surface, but they must leave the earth as if they were light beams—another case of electromagnetic waves moving in a straight course.

There were some of us, however, who, taking into account the grounding at the base of the antenna, recognized the fact that the Marconi transmission was not made by real Hertzian waves, but on account of the grounding, by half-Hertzian waves only, and that the Marconi oscillator or antenna system was a half-oscillator only. From this it followed that the waves were in reality attached to and guided by the earth's surface, and particularly by the sea surface, more conductive than the land.

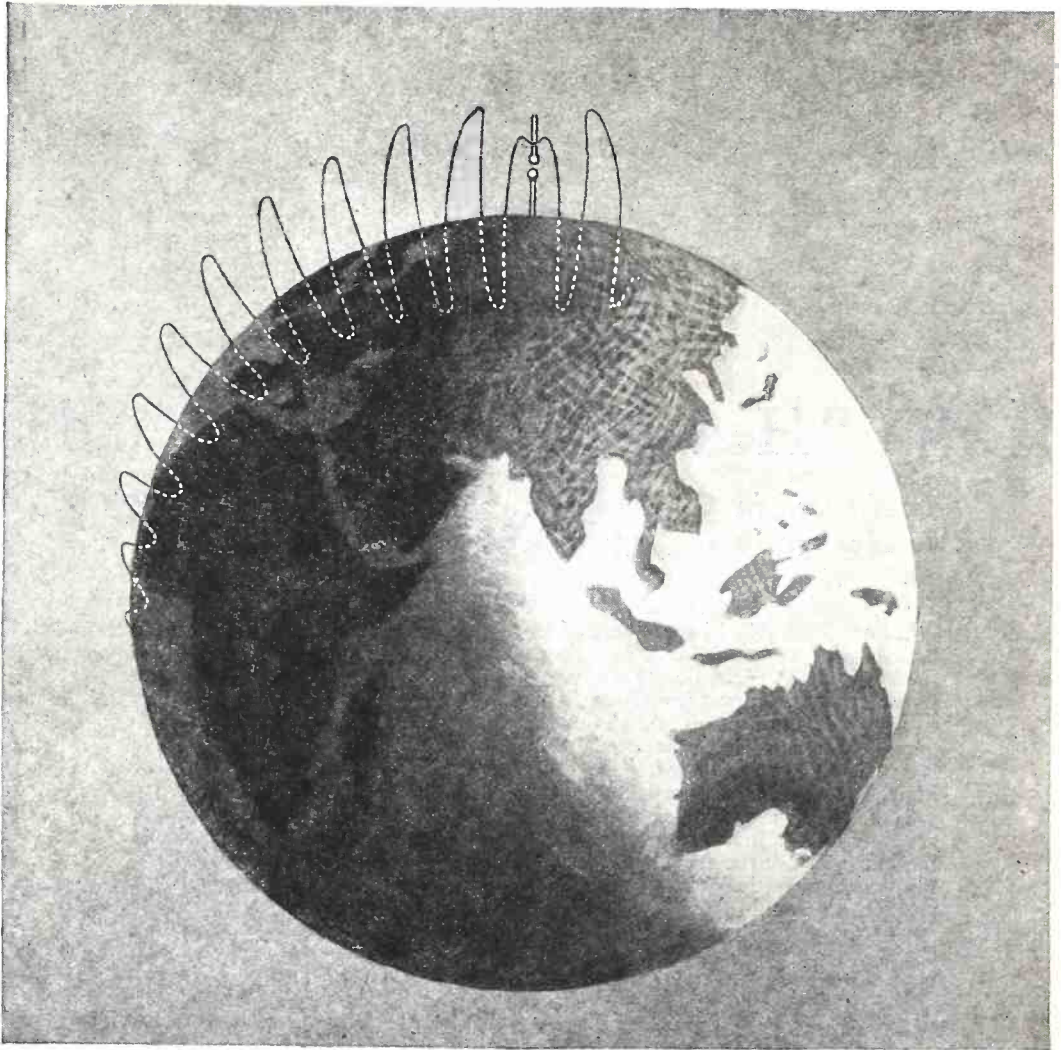

THE "GLIDING WAVE" THEORY—WHICH DR. THOMSON ACCEPTS

*"The radio waves are in reality attached to and guided by the earth's surface, and particularly by the sea surface which is more conductive than the land," states the American scientist. According to this theory, the half-Hertzian waves propagated from a grounded system would follow the curvature of the earth and would be accompanied by electric currents in the earth and sea surface, and by magnetic and electrostatic fields in the space above the earth's surface.*

It followed that there would be electric currents in the sea and earth-surface accompanying these half-Hertzian waves, and magnetic fields overlying the currents in the space above the earth's surface.

When it was announced by Marconi a few years later that he had received signals across the Atlantic ocean by flying a kite, the cord of which constituted an antenna with the usual ground, many re-

garded him as something of a faker. At least, they believed that he was mistaken in his observations. Among these doubters were not a few of the leading scientific men and engineers of the day. It followed that if the waves were of true Hertzian type and were propagated in straight lines, they could not by any possibility curve around and over a mountain of water nearly two hundred miles high, as they would have had to do if they

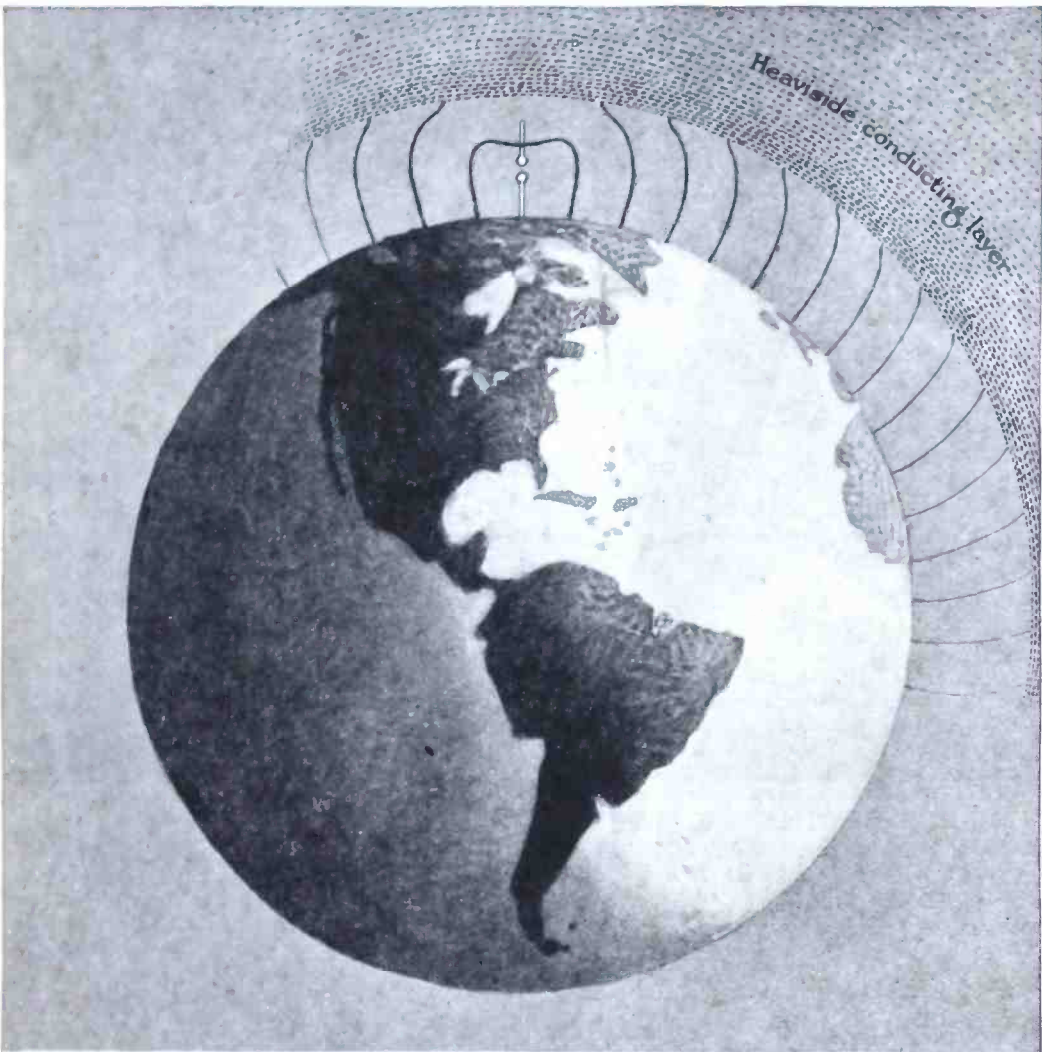

#### THE "HEAVISIDE LAYER" THEORY—WHICH SIR OLIVER LODGE DEFENDS

*The "conducting layer" theory, which is proving a bone of contention among scientists, assumes that this hypothetical Heaviside layer (which would have to present a smooth surface fairly impenetrable to the radio waves) bends these radio waves by successive reflections, without diffusing or mixing them up, around the surface of the earth. "This assumption," according to Dr. Elihu Thomson, "strains the imagination too far, and plainly will not work."*

crossed the Atlantic close enough to the earth's surface to be detected.

As it was soon demonstrated that Marconi was right and that the signals *did* come around the curve of the earth's surface, those scientists who failed to recognize (and some of them even yet seem so to fail) that there was a fundamental difference between the waves in their propagation and in their generation as regards true Hertzian waves,

had been mistaken—and not Marconi.

Then a singular thing happened.

When confronted with the facts, this assumption pure and simple was made, which unfortunately lives and has character even today: that there was an electric mirror of ionized gas, or conducting gas, say fifty or sixty miles up in our atmosphere, the under surface of which was so definite as to reflect the waves without diffusing or mixing them up, and





From a photograph made for POPULAR RADIO by General Electric

#### HE BELIEVES THAT THE "CONDUCTING LAYER" THEORY IS A FALLACY

*No one can question Dr. Elihu Thomson's standing as an authority on electrical phenomena. In addition to degrees from several universities, membership in many learned societies and decorations from foreign governments, he holds the Rumford, Fritz and Edison medals in science. He is the head of the Thomson Laboratories of the General Electric Company.*

so send them around the earth by successive reflections from above.

I think that anyone who reflects for a moment on the requirements in such a case must predict that such an assumption is not only unnecessary, but that it strains the imagination too far, and plainly will not work. In order to work, it would have to be something like a metal surface, confined to a certain smooth regularity and of such a nature that the wave fronts could not penetrate it to any considerable depth without being turned back. It must be without swellings or wavy contour, and it must reflect the waves in such a way as not to interfere with those that are more directly transmitted, and so keep the waves in phase. It would have to be, as it were, Nature's gigantic whispering gallery for electric

waves. The assumption itself (if it could be shown to be probably true, with the required limitations) might have justified the extended and complicated mathematical treatment it has received at the hands of some able men. But an assumption, if not needed or not true, is not helped by such treatment. The mathematics may be valid enough, but they do not make the assumption itself valid. Reasoning on false premises, whether mathematically or otherwise, does not make the conclusions valid.

According to what has for many years been known as the "gliding wave" theory, there never was and never could have been any doubt of the waves used by Marconi (the half-Hertzian) following the rotundity of the earth's surface.



Experience shows that transmission over the sea is far better than over the land. Direction finding discloses that the direction of transmission favors the sea.

Experience shows that when the land surface between two stations has been wetted by rains, great improvement in the transmission follows, to be again lost when the land surface is once more dried by evaporation. A good ground for the transmitting system or an ample condenser counterpoise is shown to favor greatly the launching of the waves. That the waves above the earth's surface tend to follow closely that surface, or may even be said to cling thereto, accords with the results obtained from aerial antennæ, ground antennæ and loops or coils used as antennæ.

There never has been any occasion for the existence of the assumption of an upper conducting layer of such a nature as to reflect the waves without confusing them or diffusing them, and it is regrettable that such an assumption, having once received the sanction of great names, thereby continues to have a support and recognition which should never have been given and was never needed.

The views presented by me in 1913\* have been more and more confirmed by practice in the years since elapsed. They represented the views of the group, by whom the assumption of an upper reflecting layer was recognized from the start as a fallacy.

\*See "Wireless Transmission of Energy," published in the Report of the Smithsonian Institution for the year 1913, pages 243 to 260, inclusive.

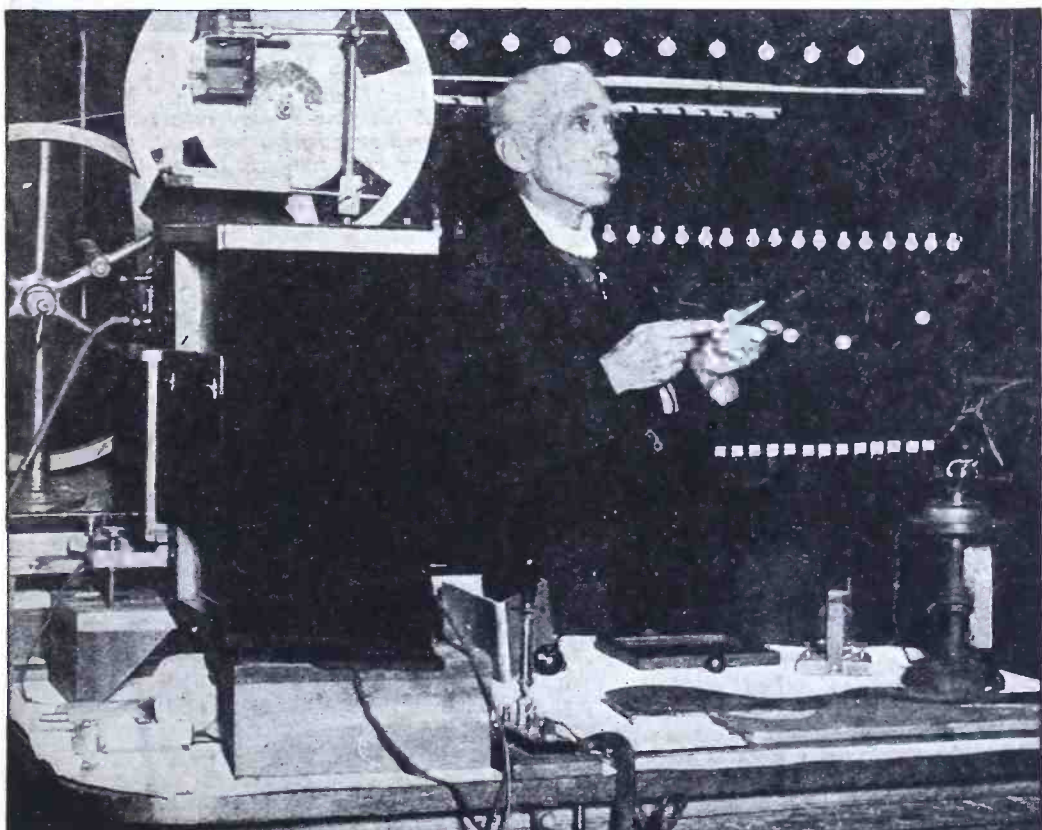

Kadel & Herbert

#### ONE OF THE EARLIEST BELIEVERS IN THE HEAVISIDE THEORY

*An apostle of the Heaviside theory, Dr. J. A. Fleming, F.R.S., a scientist and physicist of the highest type who has contributed many valuable books on scientific subjects and has made exhaustive researches in radio and the characteristics of dielectrics. He is the inventor of the Fleming valve, the first vacuum tube used in radio.*

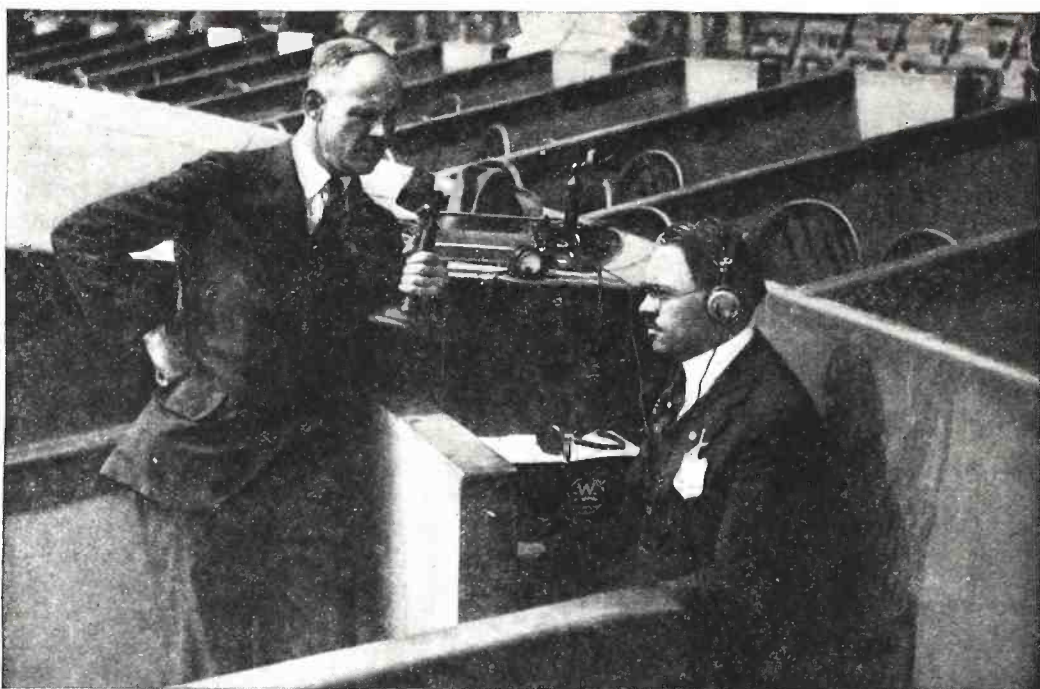

Kadel & Herbert

#### 4,000,000 BASEBALL FANS HEARD HIS VOICE

*When Grantland Rice, the popular sport editor of the "New York Tribune," broadcast from the New York Polo Grounds via WJZ his play-by-play report of the world-series baseball games, his audience was scattered over half a continent. Grand opera, symphony concerts, lectures and speeches have been similarly transmitted by wire to broadcast stations. The immediate problem before the broadcasting stations today is to obtain the wire service.*

## WHO WILL PAY FOR BROADCASTING?

*A Frank and Searching Outline of Radio's Most Pressing Problem and the Possible Ways of Solving It*

By WALDEMAR KAEMPFERT

#### *The Broadcasting Crisis in a Nutshell:*

Upon the nature of the broadcast programs the public interest in radio—and consequently the immediate future of the radio industry—is hanging.

When radio first seized upon the public fancy, interest was centered on the radio apparatus itself—the mechanical medium by which the broadcast programs were received. The novelty of the instrument must inevitably pass. The public's interest is properly becoming centered on the programs themselves.

Radio is unquestionably destined to play a vital part in the affairs of men, perhaps a more vital part than has ever been played by a single invention or discovery. It is vastly more than

a mere instrument for receiving jazz, bed-time stories and similar light entertainment. It has already demonstrated its significance as a great educational and cultural force. The foremost educators and publicists of the country are beginning to realize its possibilities. Radio is beginning to take its place as an instrument for rendering a world-wide public service of inestimable value.

The day when eminent musicians, lecturers and others can be induced to visit remote broadcasting stations and entertain free of charge is passing.

To meet this situation POPULAR RADIO has proposed a nation-wide broadcasting project that offers a practical solution that *can be put*

into immediate effect. It aims to raise the broadcast programs to the highest possible level, to the end that they may be coordinated and made to serve a great public service.

Briefly, the plan provides:

1. For the installation of permanent wiring to the more important auditoriums where musical programs, lectures by eminent scientists and publicists, and other important features are given.

2. For the transmission by wire, to a small but highly select group of powerful and adequately equipped radio stations, such programs as may be selected for broadcasting.

3. For the coordination of these important features as elements of an organized program, developed on a nation-wide scale, under the direction of properly constituted authorities that may include the country's foremost educators, scientists and patrons of the fine arts.

In other words, the plan provides for reaching out and tapping those auditoriums, lecture-rooms, opera houses, concert halls, athletic

fields—possibly even the halls of Congress—to the end that the world's greatest music and the world's greatest scientists and publicists may be figuratively brought into the home of every radio fan—and eventually into every school and college.

That the project is eminently practical from a technical standpoint has been repeatedly demonstrated, notably by the broadcasting of the Philharmonic Orchestra concerts from the City College Stadium in New York last summer—an enterprise initiated by this magazine.

The project has been outlined to some of the leading educators, scientists and patrons of the fine arts in the country, who are not merely giving it their endorsement but in many cases are giving it their active cooperation.

To carry this project (or any similar project) into effect requires wires. Without wires the programs cannot be conveyed to the broadcasting stations.

The immediate problem is: How may the necessary wires be obtained?—EDITOR

DR. FOSTER of Newark felt constrained to open a broadcast sermon with the words: "I cannot address you as citizens of Newark because my voice is being heard beyond the limits of the city. I cannot address you as fellow Americans because my voice is being heard perhaps in Cuba, in Canada, and in Central America. I cannot address you as brethren of my faith, because only a very insignificant part of the great number who are listening to me are of my own faith. And, therefore, I must address you as fellow human beings."

Here we catch a glimpse of the social

destiny that radio will fulfil. The United States shrinks into a pocket handkerchief, the world into a little ball that can be held in the hand. We boast of the magnificent distances that make these United States what they are; yet, because they are magnificent, these distances estrange us. To most of us Oakland, Seattle, St. Louis are mere places on the map. An idea holds us together—the idea that we of St. Louis, Chicago, and New York are all citizens of the same commonwealth. Radio will achieve the task of giving a reality to this idea.

Henceforth the actual voices of Presi-

## Broadcasting as an Educational Force

TO THE EDITOR OF POPULAR RADIO:

*"I fully appreciate the very great educational possibilities of broadcasting, and let me also say that I am in every way sympathetic with the movement which will bring to the great masses of the people the opportunity to hear by broadcasting the exceptional concerts which are given by such organizations as the Philharmonic, as well as to hear our great singers and lecturers."*

*Loorene H. Murphy*

President, the New York Philharmonic Society



Brown Bros.



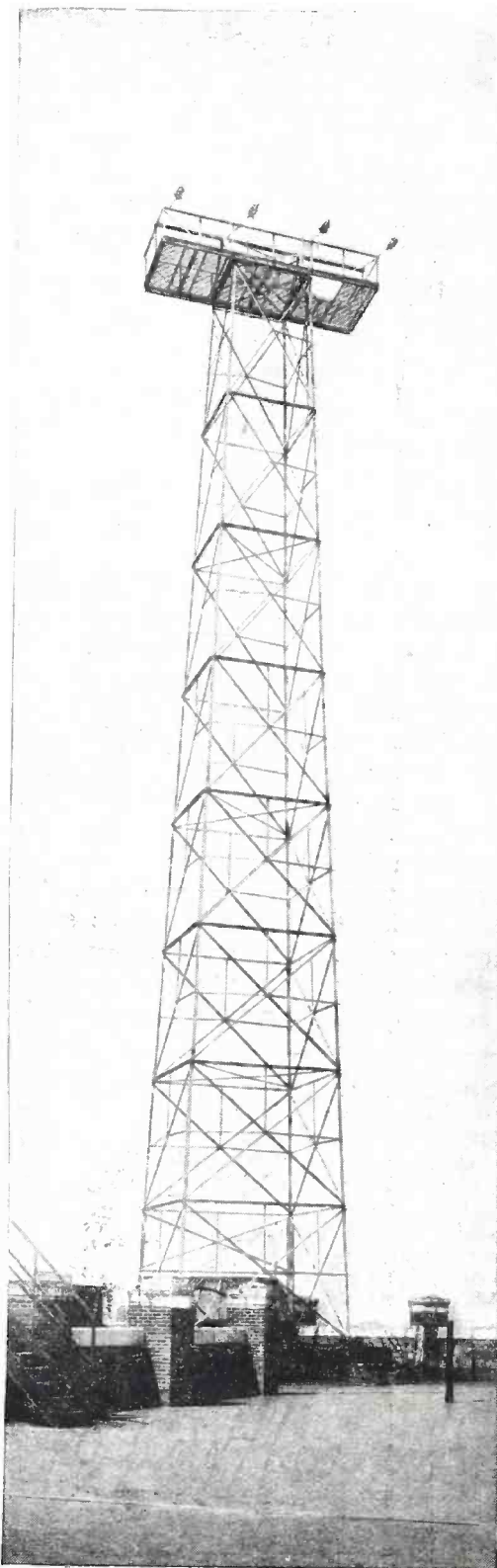

dents and Governors will be heard by the people. No longer will we be content with the cold, impersonal type by which official proclamations and messages now reach us. The President of the United States will be a real personality—something more than an abstraction. He will literally enter every home when the occasion justifies his addressing the people of the United States in person. Solemn as was Woodrow Wilson's declaration of war on the memorable day when he called upon Congress to break with Germany, a thousand times more solemn would have been the accents of his living voice than were the scareheads by which his declaration was announced by the newspapers.

The phonograph has brought the interpretations of great musicians into the homes of lonely farmers and ranchmen. But radio will carry to the great open spaces the plays, the lectures, the operas that make city life what it is. It will link Fifth Avenue millionaires with Wyoming cow-punchers, sailors on lonely seas with Massachusetts mechanics. The lumberman of the north woods, the sugar-planter of the south, the California fruit grower and the Virginia tobacco planter will become next door neighbors of the ether. Radio is destined to transform the United States, the whole continent, into a huge auditorium.

¶ *But before anything remotely resembling this radio millennium can come to pass, broadcasting must be organized as a business.*

Present-day broadcasting is an astounding anomaly. Probably the manufacturers of radio sets who first timidly began to entertain the multitude and who were amazed at the overwhelming, enthusiastic response of that same multitude never realized that, like nobility, broadcasting imposes obligations.

#### THE MOST SIGNIFICANT STATION IN AMERICA?

*Despite the fact that WBAY has met with unexpected technical difficulties and is still inoperative pending "experimental work," it may yet prove to be the storm center—or the solution—of the whole broadcasting problem.*



Like the lawyers when they cross-examine an expert, let us ask a hypothetical question or two.

Assuming that within the range of WPQ, the manufacturer who pays the expense of maintaining the station has sold all the sets that the territory will absorb, will he continue to pay from \$2,000 to \$10,000 a month to instruct and amuse his one-time customers, as well as the customers of his competitors?

Or, will he pocket his profits and stop broadcasting then and there?

We have but to ask these questions to expose the inmost nature of the broadcasting station's true function. *Broadcasting is essentially a public utility.*

The department stores and newspapers may have the right to close their stations, but the manufacturer of radio sets who has taken it upon himself to radiate music and lectures into space, primarily in the interest of those who have purchased his apparatus—dare he stop? Will

he be permitted to stop? Is not his reputation for honest dealing at stake?

Clearly, there is a radio burden as well as a White Man's burden.

The time is rapidly approaching when the novelty of singing for nothing into a transmitter will wear off, when artists, actors, and professional lecturers will ask: "What is there in it for me?"

Professional entertainers do not live by publicity alone. Broadcasting is bound to become more and more expensive as the public demand for better and better programs becomes more and more insistent. The electric light company that supplies current, the city street railway system that provides cheap transportation, the water company upon which thousands are dependent, the public utility company that renders any service whatever cannot afford to ignore the rights of those that it undertakes to serve. And broadcasting is already a public utility. Some way must be found of making it profitable.

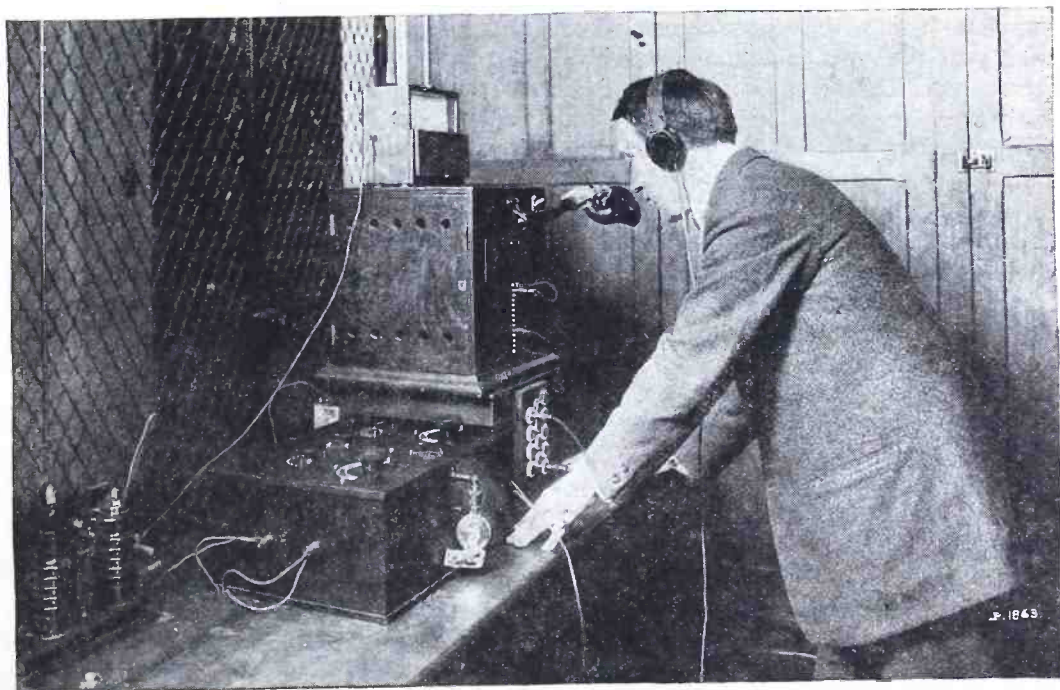

#### RADIO SERVICE TO MOVING TRAINS

*As long ago as 1915 the Lackawanna Railroad experimented successfully with radio communication between its headquarters and its trains en route. Last August the concerts of the New York Philharmonic Orchestra were heard on Lackawanna trains in Pennsylvania.*

Someone has cried: "Let the Government levy a tax on radio receivers and contribute the proceeds to the support of broadcasting stations."

In Europe, familiar as it is with operas and theaters supported by the state and the city, it is conceivable that money might thus be raised. But a radio subsidy in America—never. We haven't even a national theater or a national opera.

Radio blazed into being, so far as the general public is concerned, simply because the broadcasting station flashed song and speech into space. Broadcasting stations must be maintained, and expensively maintained, if this marvelous interest is not to languish and die overnight. And that it will be maintained there can be no doubt. To keep the public interest alive some means must be devised of collecting revenue from the public. But how?

The Radio Apparatus Section of the Associated Manufacturers of Electrical Supplies, comprising at present about twenty of the more enlightened and progressive makers of radio apparatus, has expressed its willingness to share the financial burden imposed by broadcasting. The business of broadcasting is to become co-operative, and the self-imposed taxes will, of course, be passed on to the public after the manner of all taxes. Upon the apparatus of the contributing manufacturers the insignia of the Association is to be placed—a symbol signifying that they have recognized their obligation and have met it by the payment of a fair levy. No doubt a few "get-rich-quick" manufacturers will refuse to pay the slight, just tribute demanded, but the conspicuous absence of the Association's insignia from their sets will proclaim these Wallingfords of the industry for what they are. Whether or not the public will be moved by its sense of fair play to refrain from buying instruments that are not thus identified by the Association's seal, remains to be seen.

If co-operative broadcasting is thus undertaken by most of the manufacturers, one station will take the place of many stations. The interference that now marks attempts to receive on wavelengths that differ from one another by only a few meters will disappear. Moreover, not one company but many companies will dictate the character of programs, and broadcasting will more accurately reflect the public taste.

One unique plan is that devised by the American Telegraph and Telephone Company as the result of an "insistent demand" for broadcasting facilities. The company's manufacturing subsidiary received numerous orders for private broadcasting instruments, which, had they been made and sold, would have increased the difficulty now experienced in avoiding interference. Moreover, there were many small firms that could not afford to install their own transmitting stations and that wanted to make the most of radio's possibilities. *Broadcast for hire* was the solution. So, the American Telegraph and Telephone Company has built an experimental station (WBAY, located in New York City), which may be rented for a definite time at a fixed price by anyone who has a message to convey or a song to sing.

Assume that you are a manufacturer of pianos. You wish to impress a vast radio audience with the tone quality of your instrument. You hire the station for an hour a day, three days in the week, for two months. The announcer introduces himself and his subject, "Signor Pablo Portadino, the well-known baritone of the Metropolitan Opera House, will sing the Prologue from *I Pagliacci*, accompanied by Giuseppe Martucci on the Benson concert-grand piano." Giuseppe strikes the opening chords and Portadino proceeds to explain in rich Italian tones that the players on the stage are only human. The tone quality of the piano must make some impression.

Or, you are a manufacturer of vacuum cleaners and you wish to instill in your





Photo by Post-Dispatch, St. Louis

#### A PILLAR ON WHICH THE RADIO INDUSTRY RESTS

*Such broadcasting stations as this one (KSD in St. Louis) keep alive the public's interest in radio. It may soon become part of a great radio net for relaying the world's best music and the voices of the world's foremost scientists, educators and publicists into every home and school, as part of a nation-wide educational program.*

unnumbered audience a holy fear of dust. You describe alarmingly what work a broom does in casting up disease germs. Then you contrast these unhygienic, preposterous proceedings with the modern sanitary method of vacuum-cleaning. "To anyone who brings us orders for five Supreme vacuum cleaners," your hired tempter concludes, "the Supreme Vacuum Cleaner Company will give a crystal-detector radio set."

Or, you are running for Mayor of New York and you are opposed by too many influential newspapers. To reach the voters you plead with them for half an hour each night over a period of two weeks preceding election.

The plan has possibilities. To be sure, the advertiser, the political candidate, the social reformer, the religious fanatic will be the first to avail himself of the golden radio opportunity presented. How will

the public respond? It is impossible to foretell. If the lecture is dull, if the musical bait offered by the piano manufacturer is not appetizing enough to be swallowed, it is assumed that the radio audience will voice its disapproval by letter to the firm or orator responsible for a dull radio time.

In the evening, the station will broadcast sheer entertainment—music, talks on interesting subjects, stories. The morning and other hours of the day will be reserved for the advertiser and the propagandist. No matter what price he may be willing to pay he must not trespass on the evening, unless he is ingenious enough to devise a feature that will harmonize with a concert program. When the government finally allocates wavelengths the station will modify this policy. Instead of limiting the advertiser and the man with an axe to grind to a specific time of day, the station will assign him to a wavelength on which he may expound to his heart's content at any hour that happens to be available.

The government has already indicated that it will not permit a wholesale abuse of radio by the advertiser.

On the other hand, advertising on some wavelengths will be permitted. If advertising proves to be the American Telegraph and Telephone Company's chief source of revenue, it will have to be of a new, almost hypnotic variety. It must hold the interest as if it were a play or a comic opera. Lecturers must be found as winning and convincing as the serpent in the garden of Eden. If the hired stentor contents himself with: "Ladies and Gentlemen, the Morpheus mattress, which is made by the well-known Rosenberg Company of Kalamazoo, has the softness of a downy cloud and the durability of battleship armor," his audience will yawn and glide to a wavelength on which Al Jolson is singing "April Showers," or a popular jazz orchestra is playing the latest fox trot.

But the American Telegraph and Telephone Company is not concerned

with these aspects of radio propaganda. Its sole business is to operate a station for hire; it leaves possible patrons to their own devices. It will certainly be cheaper for newspapers and department stores to hire such a public service station by the hour than to conduct stations of their own. From these sources alone revenue enough may be earned to pay all broadcasting costs.

But what of opera, what of artistic song recitals, what of lectures by distinguished university professors—lectures purely educational in character?

The company will do much to use radio for this purpose at first during the evening hours and later on special wavelengths. Perhaps a Carnegie, ashamed to die rich, will hire the WBAY station and pay theatrical managers for the privilege of brightening thousands of homes. It is music and lectures, sent through space, without thought of any direct personal advantage to the broadcaster, that have made radio what it has become. If the American Telegraph and Telephone Company has actually conceived the most practical plan of placing radio broadcasting on a sound business footing, possibly municipalities may pay the royalty that will unquestionably be demanded by the producers of operas and plays. And why not? Every self-respecting community now taxes itself for parks and the bands that play in them.

If the American Telegraph and Telephone Company's experiment proves successful we shall undoubtedly witness the establishment of broadcasting stations that can be hired by the hour, day or week, all over the country—stations interconnected by special wires so that the radio address delivered in New York may be simultaneously broadcasted from Maine to California. Other engaging possibilities suggest themselves. A public utility broadcasting service, such as this, nation-wide in its scope, may well claim from the Government the right to radiate on a dozen different wavelengths, so that



concerts may reach us on one, the news of the day on another, educational discourses on a third, artful propaganda on a fourth.

Certainly one broadcasting station, subject only to such control as the Government may impose, is more likely to serve the public better than a number of stations in the same community. Indeed, as time passes and radio develops, a few broadcasting stations, erected at strategic points, will probably take the place of hundreds that are bound to be established within the next year or two. There will be less interference, and the tuning will be sharper and more selective.

Broadcasting stations are now far too eclectic. They give us weather reports, stock market quotations, orchestral music, bedtime stories for children, lectures, and Arlington time. The Government regulations, being what they are, we must accept what reaches us on the prescribed wavelength whether we like it or not. There is little opportunity of "tuning in" to receive what another station has to offer, if the closing prices on

the stock exchange do not interest us, simply because near-by stations all transmit on the same wavelength and must so time their programs that there will be no interference. Mr. Hoover's commission has allocated wavelengths, and if its

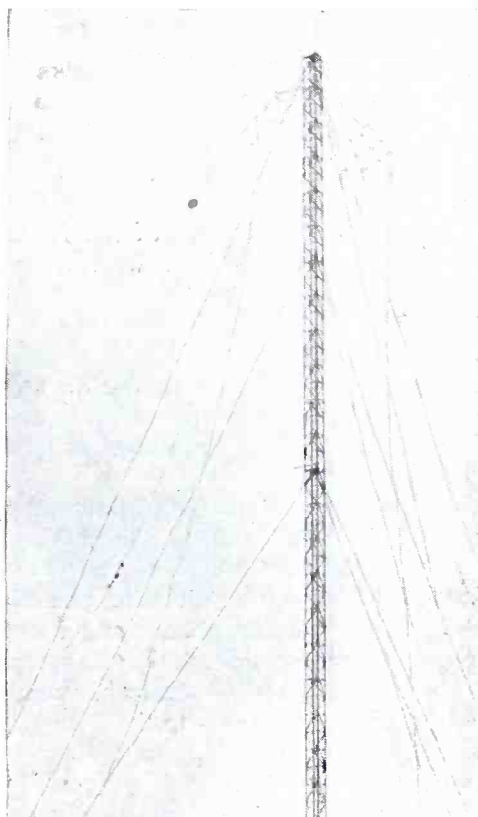

#### WHO PAYS FOR SUCH STATIONS, AND WHY?

*Properly enough, Boston's foremost broadcasting station, WGI, is located within the grounds of Tufts College. Who will eventually pay for maintaining broadcast programs?*



### WILL RADIO PUT THE SMALL CHURCH INTO THE DISCARD?

*This particular community service in Pennsylvania was broadcast from KDKA. Services in the country's foremost churches may be similarly broadcast—with the aid of wires to the radio stations.*

recommendations become Governmental regulations, radio entertainment and instruction will reduce itself to a matter of wavelengths rather than of stations. In other words, sporting news, symphonic music, song and instrumental recitals, dance music, stories, and lectures will each be radiated on its own wavelength.

Hence, the receiving set of the future may possibly be provided with tuning dials bearing such legends as "Jazz," "Opera," "News," "Market Reports," "Musical Comedy," and "Symphony Orchestra." We shall turn the dials of our sets to the proper legend and listen to that which happens to interest us most at the moment.

Whatever may be thought of the practicability of the significant experiment of the American Telegraph and Telephone Company, the ultimate possible linking of our wire-telephone system with a score of broadcasting stations that can be hired, as one hires a taxicab, reveals the true relation of radio to the wire system of communication, although the company intends to connect stations by special wires. Only a fantastically optimistic radio enthusiast cherishes the illusion that radio will completely supplant wires—that all the miles of wire, all the complex, ingenious switchboards in central stations, all the expensive conduits that encase cables will be scrapped. The truth is that radio will prove to be a valuable extension of the network of wires that enmeshes the country and the continent. In the future drama, music, entertainment will be picked up wherever it is available at its best and carried by wire directly to the broadcasting station.

"We shall have the pleasure of listening to Madame Rubin, late of the Warsaw Opera, in a rendition of the Mad Scene from *La Gioconda*," announces the



Westinghouse

voice at the broadcasting station. In these paleozoic days of radio, Madame has obligingly motored, trolleyed, or otherwise transported herself to the broadcasting station, there to plant herself in front of the transmitter and give her full-throated best. In the near future, Madame will exercise her prima donna's right of displaying her temperament and of singing, when, where and how she pleases. Instead of transporting her heaving bosom to the broadcasting station, she will sit at home, sing into a transmitter, and her voice will be carried by wire to the broadcasting transmitter by which it will be prodigally radiated into space. At present, the sheer novelty of singing from a broadcasting station, of momentarily converting herself into a vocal sun that shines into thousands of homes is enough to induce her to present herself in person at the station. If



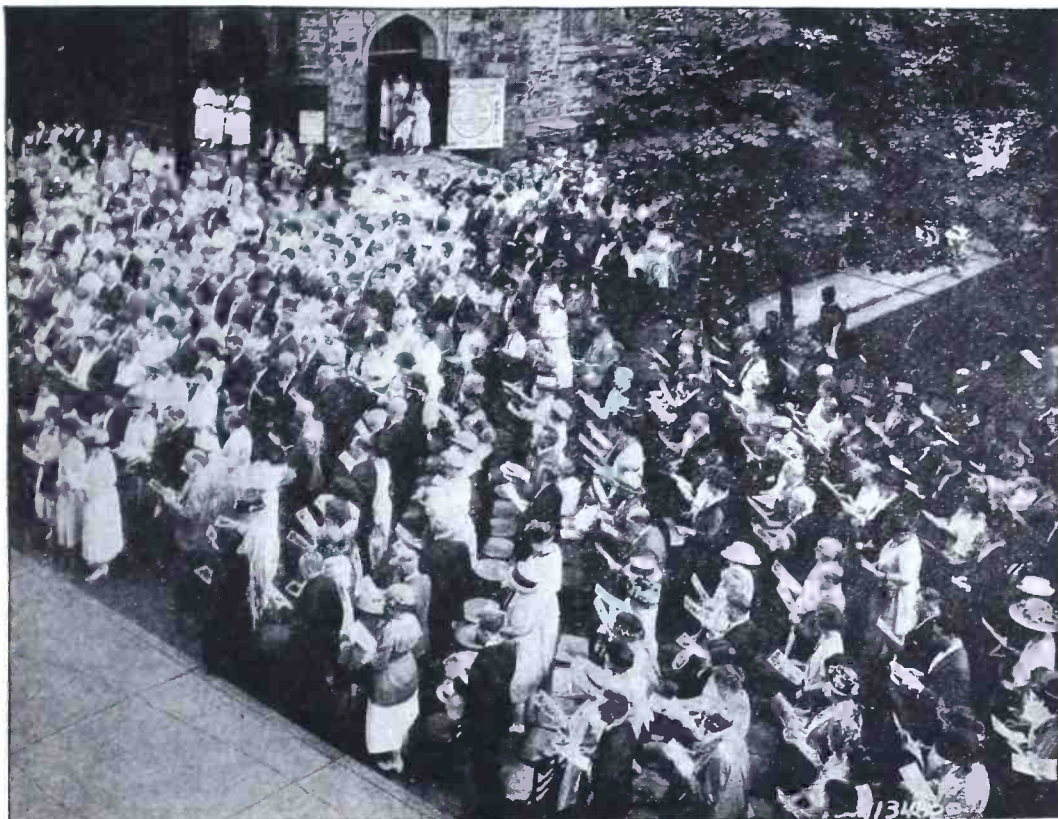

Westinghouse

Madame only knew that even now she might sing to millions in her boudoir, clad in a comfortable kimono!

"Listeners-in" there will always be in the great cities, but it is in enlivening the dull small town and the lonely farmhouse, in robbing the great open spaces of their loneliness and monotony, that radio will probably play its most important part. Hence, we may find broadcasting stations serving both the country and the city by radio and telephone.

The use of city telephone wires to bring to apartment-house dwellers the strains sung into the transmitter of a distant broad-casting station suggests an extension by the carrier-wave system of what may be called "narrow-casting." The system has been so frequently discussed, particularly in the pages of this magazine, that the principle upon which its operation is based need not be elaborated here. It is enough to recall that high-frequency currents can be transmitted over telephone

or power line without interfering with one another or with the currents for conducting which the lines are built. There would be no difficulty about collecting revenue. The telephone company would rent an extra telephone receiver, even a loud-speaker, to each subscriber. "Plug in" and you hear the music transmitted from the central station.

Similarly, the electric light companies could narrowcast over their own lines. They have but to install the necessary high-frequency transmitting apparatus and to supply proper receiving instruments.

When telephone or power lines are thus used for wire narrowcasting there will be none of the interference that now marks radio broadcasting. Gone will be the dots and dashes of the telegraphic spark-set, and gone the grinding of static. Gone, too, will be the possibility of getting something for nothing by "listening in" with a home-made receiver.





© Underwood & Underwood

#### PRACTICAL—BUT INCONVENIENT

*If this motorist really wants to receive broadcast programs, this installation may be commended on grounds of efficiency. But it is a bit spectacular for the average fan.*

## Radio on Your Motor Car

*Eight Ideas for Installing a Receiving Set  
That Will Really Work*

By FREDERICK SIEMENS

**T**O install a radio receiving set on your automobile is a thoroughly practical undertaking—provided, of course, that you observe the approved scientific methods of installation and disregard the fantastic conceptions of inexperienced novices or publicity seekers, who rig up “stunt” sets that are designed rather to attract attention than to receive radio signals. There are few outdoor uses of radio that have excited more popular interest than its application to the pleasure

car; yet the number of fake installations that do not work has tended to discredit such attempts on the part of the amateur.

There is no reason, however, why such installations should not be widely popular; indeed, the rapidly growing number of them would indicate that they are opening up new possibilities for enjoyment, particularly during the fall and spring months when the weather conditions are propitious for outdoor sports and when the static is not a serious

factor In some cases the success of such radio-equipped motor cars has been so marked that sets supplemented by loudspeakers have blocked the traffic and called for police interference.

The most important point to be considered in such an installation is the type of energy collector or antenna which is to be used.

First of all there is the vertical loop antenna. This type of antenna gives good results; but to attain the maximum efficiency it must be pointed directly at the transmitting station, and this is not always possible on account of the ungainliness of the apparatus. Who, for example, would care to have a loop such as is shown at the head of this article, permanently installed on his car?

Of course, a miniature vertical loop can be installed somewhere out of the way on the car, as is shown in one of the other pictures, but even in such a case the whole car must be pointed at the transmitting station in order to get loudest results.

One interesting application of the loop type of antenna to automobile uses is that used by E. B. Myers in the set he designed for Miss Corinne Griffith, the film actress. This apparatus is in effect a portable radio set with radio frequency amplifiers and a vertical loop antenna fashioned into the cover of the valise-like carrier. When the set is in use the lid is opened and the whole set is turned until the received signals are heard most clearly. This set can be placed on the seat of any motor car, as it takes up scarcely any more room than a person, even with its equipment of batteries. With such an outfit it is reported that broadcasting programs can be heard a distance of fifty miles or more. Six tubes are used for this purpose, including three stages of radio and two stages of audio frequency amplification, and a detector.

Another form of loop antenna which can be used successfully is known as the "horizontal loop." This type of antenna is particularly adaptable to installation

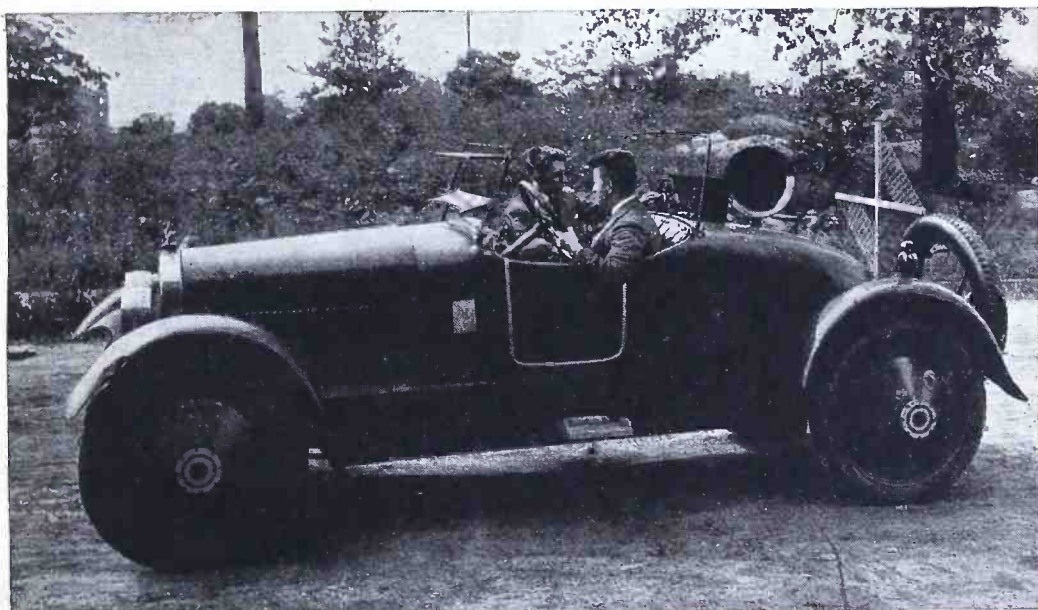

From a photograph made for POPULAR RADIO

#### THE ARMSTRONG SUPER-REGENERATIVE SET ON AN AUTOMOBILE

*The vertical loop, located at the rear of the car, in combination with a loudspeaker, creates such a volume of sound that the owner was warned by a traffic policeman in New York against collecting a crowd that obstructed traffic.*



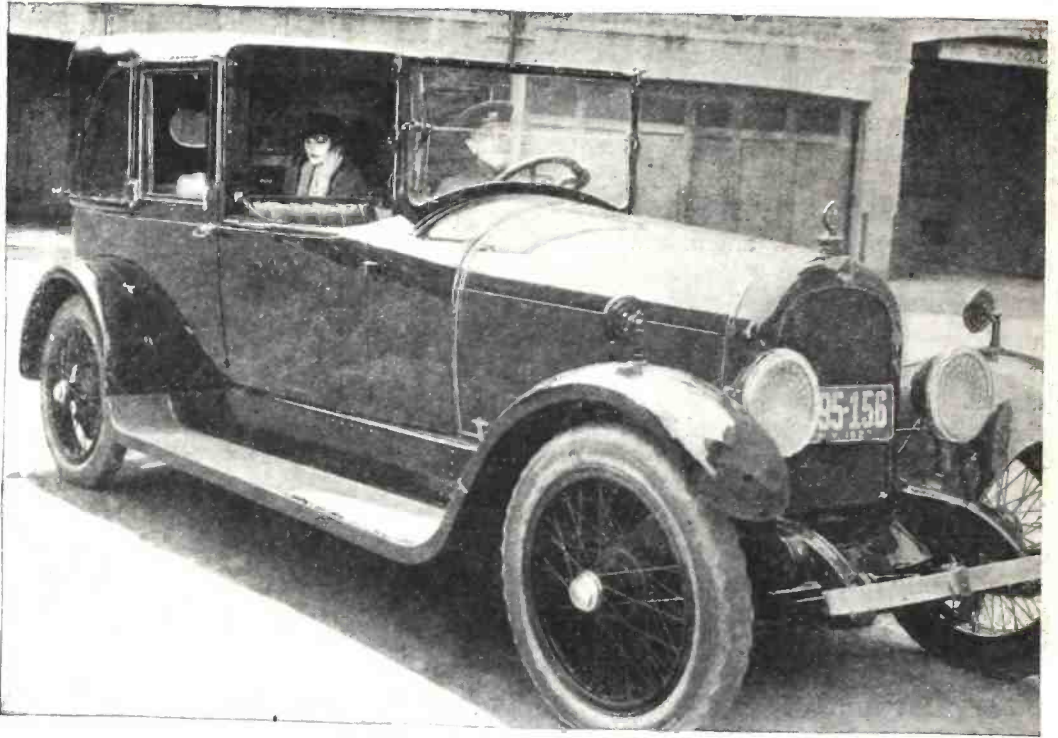

#### A PORTABLE SET DE LUXE

*The loop antenna, the property of Miss Corinne Griffith, the film star, is coiled in the leather case of the portable receiving set, which may be carried about and used with no more inconvenience than a traveling bag.*

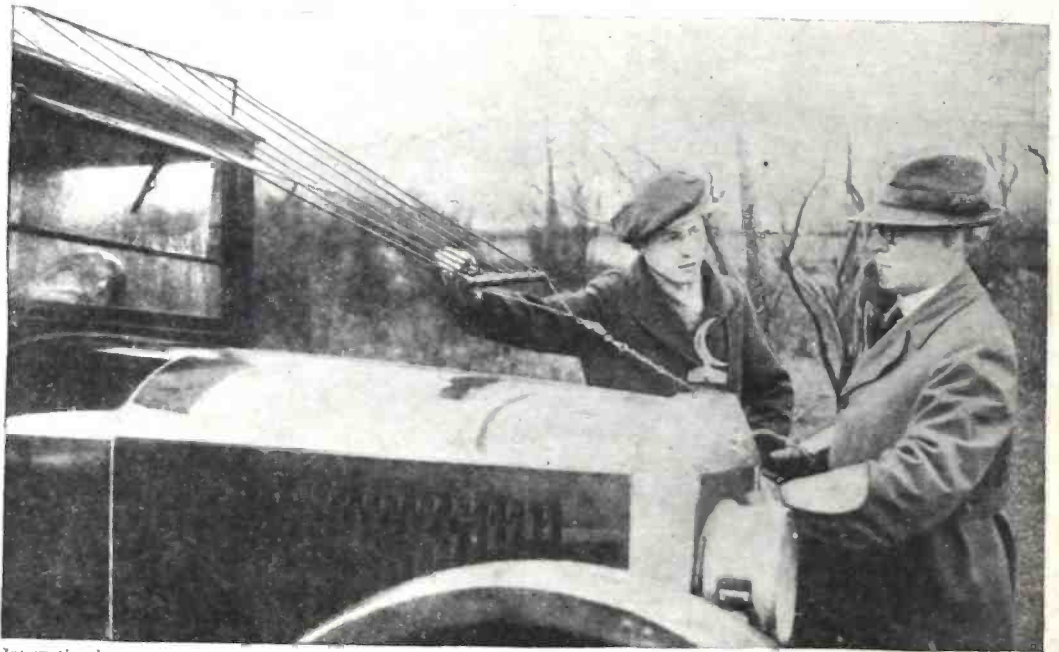

International

#### THIS ANTENNA IS DRAPED OVER THE TOP OF THE CAR

*A Chicago physician, Dr. David Cottrell, uses the radiator cap as one support of his antenna and the rear tire rack for the other.*





© Underwood & Underwood

**A HORIZONTAL LOOP ANTENNA ON THE ROOF OF A LIMOUSINE**  
*This installation may be made a permanent fixture on the car, and has the advantage of being out of the way. This set, owned by a Cincinnati fan, cost \$50.*

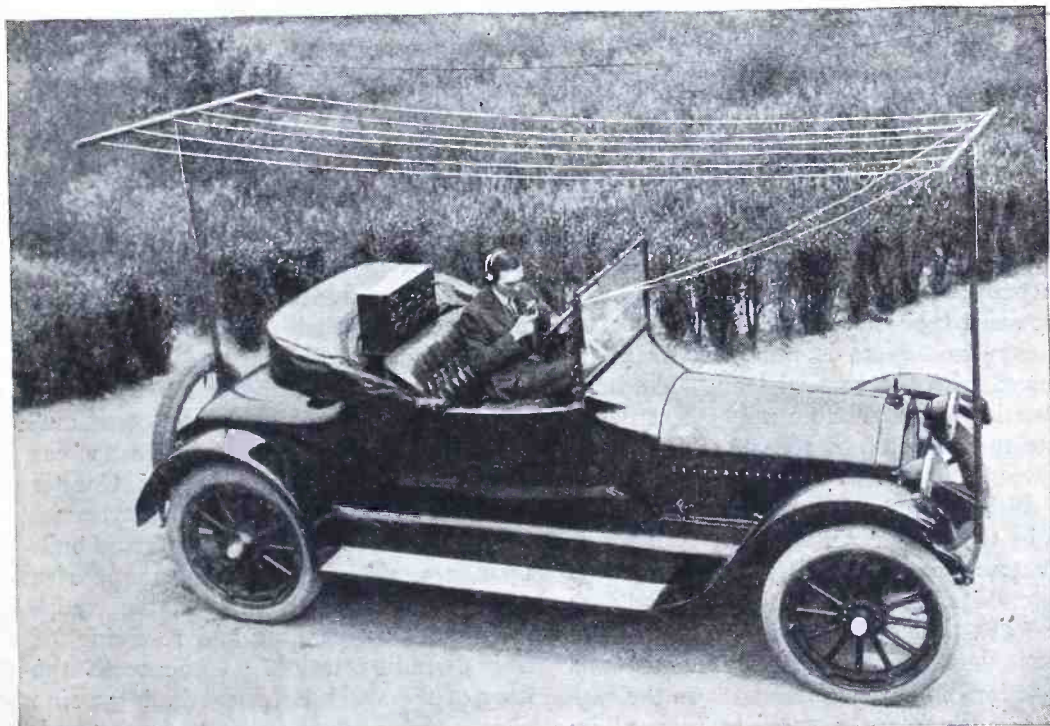

Pacific and Atlantic

**CUMBERSOME—BUT ESSENTIALLY PRACTICAL**  
*Here is a real antenna, easily dismantled, that A. H. Grebe, of New York, uses both for receiving and transmitting.*

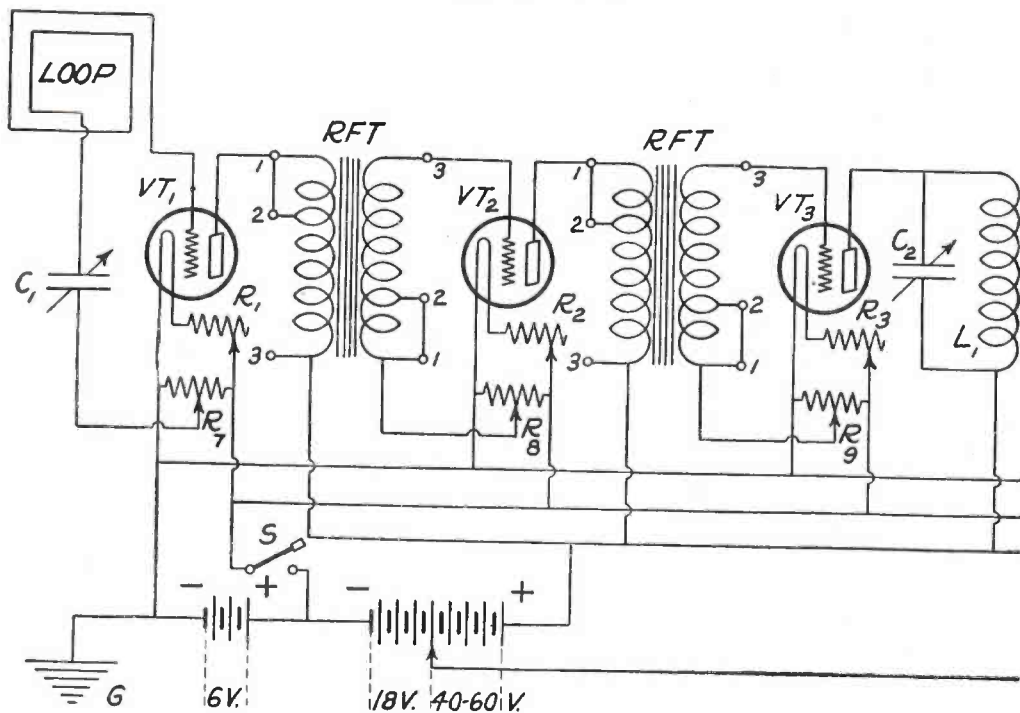

on the top of a closed car, such as shown in the illustration on page 249; note that the wires run in a horizontal plane, instead of vertically. This fixed arrangement makes the horizontal form of loop non-directional, or in other words, the antenna receives equally well from any direction. One obvious advantage of this feature is that it does not necessitate turning either the car or the loop for the best results. In order to get loud signals, the same type of receiver with radio frequency amplifiers is necessary as is required with the vertical loop. The horizontal type of antenna might be stitched into the cloth top of the car; in that case it would be invisible and out of the way.

A third type of antenna which seems to be the most popular of all with which amateurs experiment is the small flat-top antenna supported on short masts fore and aft. Such an outfit is illustrated in the illustration on page 249. This antenna functions in the same manner as the regular outdoor antenna generally used by amateurs, although on account of its abbreviated size it does not pick up as much energy as its larger cousin. With

this antenna system it is necessary to use a ground; the latter is usually made by attaching the wires to the metal chassis of the car. Some of the large busses operated by a transit company in Oakland, California, have had this type of antenna installed; on account of the long bodies of the busses, it was necessary to use only a two-step amplifier set in order to produce good signals. In a short time all of the eighty-five busses of this service will be equipped with radio for the entertainment of the passengers.

A radio equipped motor car that is so elaborate and complete as to come outside of the classification of pleasure car has recently been built by the Chester County Radio Club in Pennsylvania. They purchased a five-ton truck and built upon it a special body in the shape of a regular radio shack, with all the equipment, both for sending and receiving, of a real radio station. Underneath the floor of the shack is fastened a large zinc plate which is used instead of a ground. The plate forms an effective counterpoise. This portable radio station (for it is really that rather than a touring car)

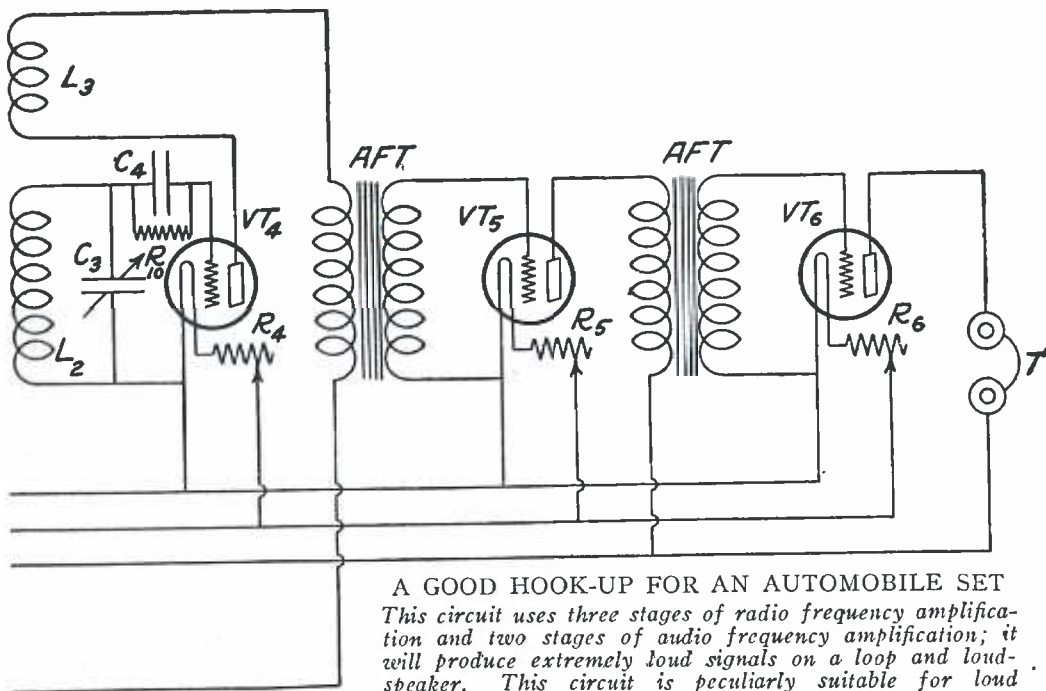

#### A GOOD HOOK-UP FOR AN AUTOMOBILE SET

*This circuit uses three stages of radio frequency amplification and two stages of audio frequency amplification; it will produce extremely loud signals on a loop and loud-speaker. This circuit is peculiarly suitable for loud reception on an auto.*

has a government license, and 3OI has been assigned as its official call number. The transmitting equipment consists of a 10-watt radiophone, the receiving set being of the two-step regenerative type. The receiving set of this remarkable machine has copied signals as far away as Indiana, Maine and Georgia.

A Chicago physician has installed a radio receiving set on his car, however, and adopted the same type of antenna. But his antenna is not fastened on masts, running over the top of his coupé instead on special insulating brackets, with the ends fastened on the radiator cap and the tire rack respectively. (See illustration on page 248.) The ground is made on the frame of the car.

One of the first men to do really constructive work in the installation of radio sets on pleasure cars is Al Grebe of Richmond Hill, Long Island. He installed a remarkably efficient antenna of this type, and then proceeded to include on board a transmitting set as well as a receiving set. Both the transmitting and the receiving experiments were very satisfactory. All of the electrical energy

for the sets was furnished by the power plant of the car.

A fifth installation which is, in effect, a cross between the last two types of antennæ mentioned, is that employed by M. Phanto. With the use of multi-stage amplification this set can reproduce the broadcasting programs by means of a loudspeaker with such strength that the signals are audible more than a block away from the car. Even racing cars have been equipped with receiving sets to enable the driver to obtain information or instruction while on his dash around the track.

There is no doubt that radio on moving vehicles will be further developed to the point where it will not only be a novelty, but a convenience to the public, as well as a means of direct communication commercially from a company's office to its delivery wagons or trucks. Already radio installations are not unknown on government vehicles; the Army, the fire departments, the forestry service and the police departments are at the present time using radio successfully on their trucks and airplanes. In England the fire



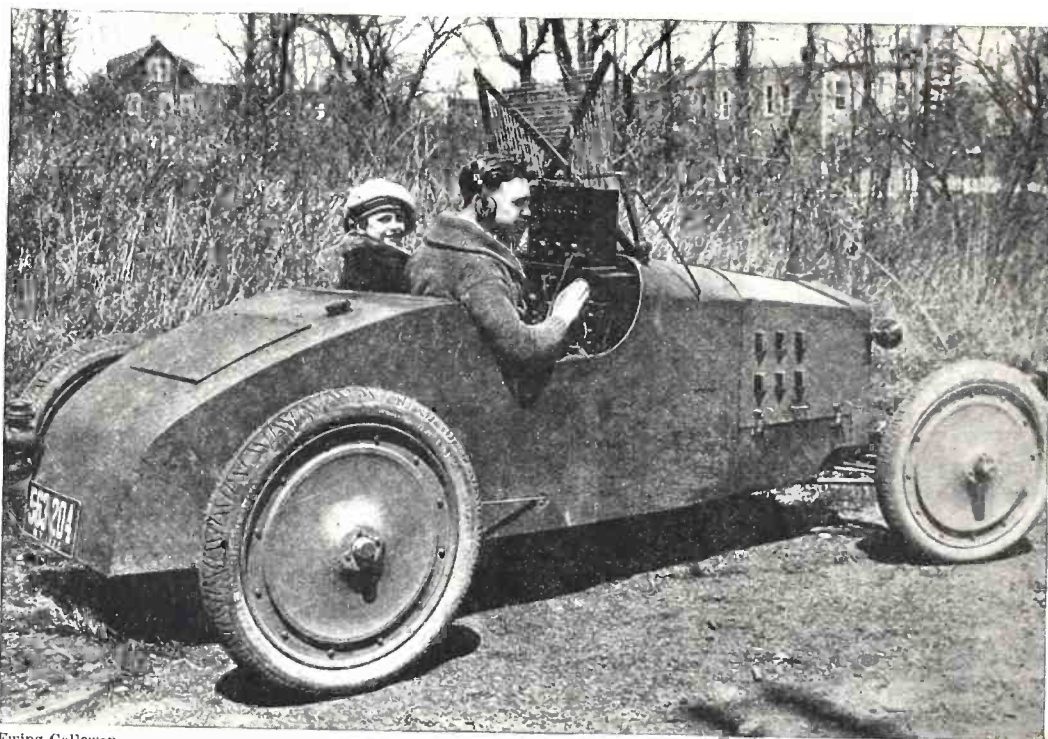

Ewing Galloway

#### A BIG RECEIVER ON A LITTLE RUNABOUT

*This fan, R. E. Leppert, Jr., of Harrison, New York, has shown ingenuity not only in installing a practical set on his car, but also in camouflaging his Ford!*

departments of some of the cities have been carrying on experiments to determine the value and usefulness of radio communication. Radio telephone transmitters and receivers have been installed on the trucks of a number of its fire brigades, and have proved effective in keeping the home station and the trucks in touch with each other in a way that has been impossible heretofore. The antenna system employed on the cars consists of a wire strung from a pole at the rear of the truck to any support that happens to be in the vicinity. Grounding of the apparatus is accomplished by means of throwing out two large wire-mesh mats which are attached to the set by means of insulated wires. Of course this system can be used only when the truck is motionless, but the increased length of the antenna adds so greatly to the range of the set that this disadvantage is said to be more than offset. The use of radio on commercial trucks is anticipated by a

large baking company in Philadelphia, which has installed sets on its delivery trucks; among the purposes one is to direct the out-of-town delivery service.

The police are also using radio motor vans to deal with emergencies that arise in the handling of crowds during public demonstrations.

The motorized radio played quite a part in successfully dealing with the massed crowds during the last May Day demonstrations in Paris. Two large vans equipped with powerful transmitting and sensitive receiving sets were employed for this purpose; one was stationed at Choix Le Rois and the other in the yard of the prefecture, kept there for an emergency call. Both of these vans were in constant communication with each other; and a plane, also equipped with radio, reported any gathering of large crowds to the vans, who in turn issued instructions to the police of that district. The radio in this instance was a powerful

instrument in the hands of the law, as it kept all districts under supervision of the prefecture in a way that would not have been considered possible a few years ago. The type of antenna used was a vertical two-wire affair, supported on a collapsible pole raised through the roof of the van.

Another novel use for radio on a touring car was developed in San Francisco a short time ago by the American Bible Society in "selling Bibles by radio." An auto which was equipped with a radio receiving set carried the voice of A. Wesley Mell, secretary of the Pacific agency, to the crowds that gathered around the car on its passage through the streets.

There is no doubt of the success of motorized radio. The uses to which this form can be put are increasing in number

daily. On pleasure cars, however, the most convenient and probably the most efficient type of installation consists of a horizontal loop antenna stitched into the top of the car, with a receiver that uses radio frequency amplification and audio frequency amplification combined. Either the new Armstrong circuit or the circuit shown in Figure 1 would be suitable. The lighting batteries of the car may be used for heating the filaments; the only other batteries required are the "B" batteries. The set can be installed under the dash in front of the seat next to the driver, where it will be out of the way but accessible for adjustment. Such a set would hardly be noticeable in the car; yet its efficiency would enable very loud signals to be received by the use of the loudspeaker.



Paul Thompson

## Radio Opens a New Era

TO THE EDITOR OF POPULAR RADIO:

*"It is very gratifying to see someone taking the initiative in a broad-spirited public movement to enlarge the present scope of radio broadcasting. Certainly at the present stage of radio development there is a decided lack of public spirit manifested by those who should be the very ones to take the lead in this matter.*

*"The possibilities of radio broadcasting, long predicted, are now realized by all who are in any way associated with the engineering side of this new art; all that remains is the application, so that the present generation may enjoy the truly remarkable advantages heretofore retained by the few, but now to be had by the great mass of our population.*

*"All true lovers of music, all those who desire to extend educational opportunities to the many, government officials who are interested in helping to enrich the lives of many millions—one and all, I believe, owe it not only to themselves but to humanity in general to see that the best in art, education, literature and music is put at the disposal of all those who make up the major part of our nation.*

*"As one who has long had in view the application of the radio art to the definite field of music, education, art and literature, I am frankly glad to see you enter the lists on behalf of the public."*

*Lee de Forest*

Inventor and Scientist



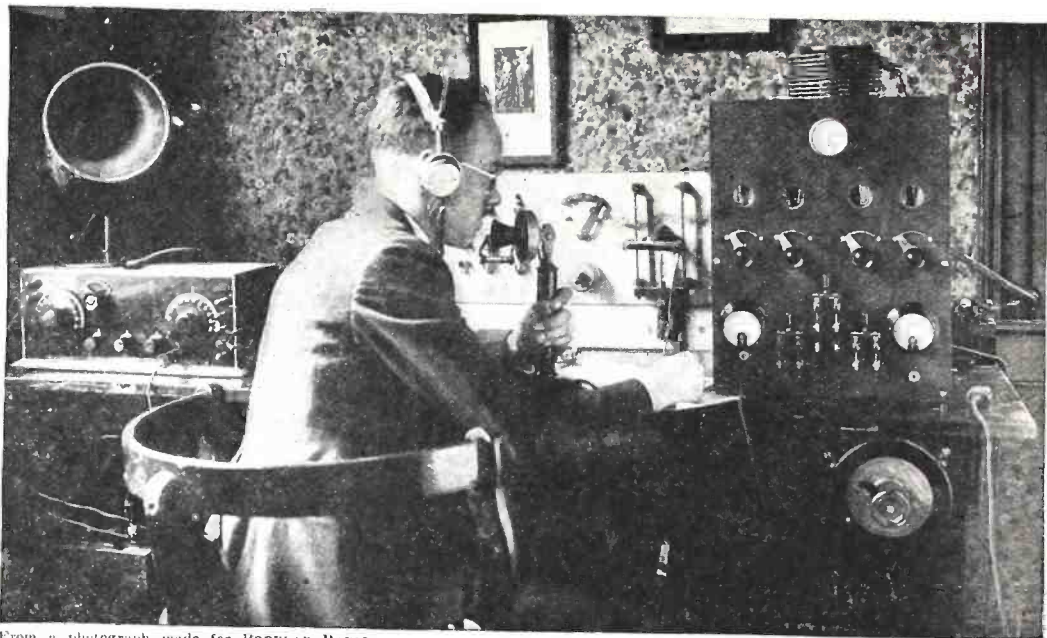

From a photograph made for POPULAR RADIO

#### THE AMATEUR WHO DID IT

*This is W. K. Thomas. At his right is the transmitter, with the receiver at his left. An ordinary desk telephone microphone is used to talk into, and it is attached to the transmitter, while the telephones on the operator's head are attached to the receiver. The large switch near the operator's hand is used to change from sending to receiving. The completeness of this station typifies the advance of the amateur in radio.*

## 6,000 Miles on 20 Watts

*The Remarkable Radio Apparatus Operated  
by 8LF that Has Made Possible Some of His  
Notable Achievements*

By RICHARD LORD

ON the night of November 6, 1921, radio operator Farmer, on board the steamship *West Prospect*, 2,750 miles west of San Francisco, picked up continuous wave signals from a radio amateur who signed off "8LF." Investigation revealed the amazing fact that in real life 8LF is W. K. Thomas, who lives in Pittsburgh—6,000 miles distant from the remote spot in the Pacific where his signals were recorded on that notable evening.

This achievement is made hardly less remarkable by the knowledge that Mr. Thomas employed a telegraph-telephone transmitter of only 20-watts power. For

the benefit of the lay reader, it may be explained that 20 watts represents only about 40 per cent. of the electric power required to operate the ordinary incandescent lamp.

Despite its modest power, however, the Thomas set has proved of remarkable efficiency in long distance transmission. On the night of April 19, 1921, it carried on communication with the Catalina Islands, California, a distance of about 3,000 miles. Nightly communication has been carried on over distances ranging between 300 and 1,200 miles. The voice (antenna current 1 ampere), with two oscillators and two modulators, has been



heard as far south as Orlando, Florida, as far east as Philadelphia, as far north as Michigan and as far west as Kearney, Nebraska. A few years ago 8LF was using a 1 K.W. spark transmitter with an input to the antenna of 246 watts; on the C.W. set (the same set as is described here), the total input is 46.8 watts. Six times the distance has been covered with 200 watts less input. Efficiency on the spark transmitter was about 12 percent and on C.W. nearly 60 percent.

A detailed description of this set is of more than casual interest to the amateur.

The antenna system is composed of six parallel wires spaced 3 feet apart and 65 feet long, suspended at the far end on a ship mast affair on top of a telegraph pole, planted in the rear of the residence. The other end is supported by a mast on top of the house, both 45 feet

above the ground. This antenna system has a low natural period and also low resistance, operating most efficiently at approximately 200 meters.

All panels are made of  $\frac{1}{4}$ -inch bakelite. The front panel is 14 inches by 18 inches, the main shelf 10 inches by 14 inches and the sub-shelf is 4 inches by 14 inches. Mounted on the main panel is an antenna meter in the center (at the top). Holes  $1\frac{1}{2}$  inches in diameter are drilled for peep holes for each tube, and as the shelf is mounted on micarta uprights 10 inches from the top of the main panel, the alignment of the holes should be such as to permit a proper vision of the active elements of the tubes, plate, grid, and filament. The rheostats for the filaments are mounted under each peep hole.

The general position of all knife switches is shown in Figure A. Two

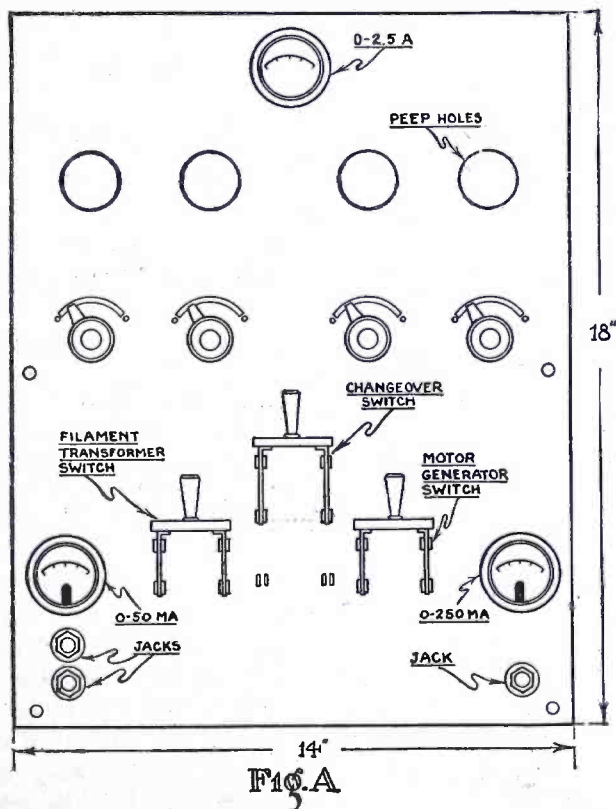

*This diagram shows the layout for the front panel of the transmitting apparatus illustrated on the opposite page.*

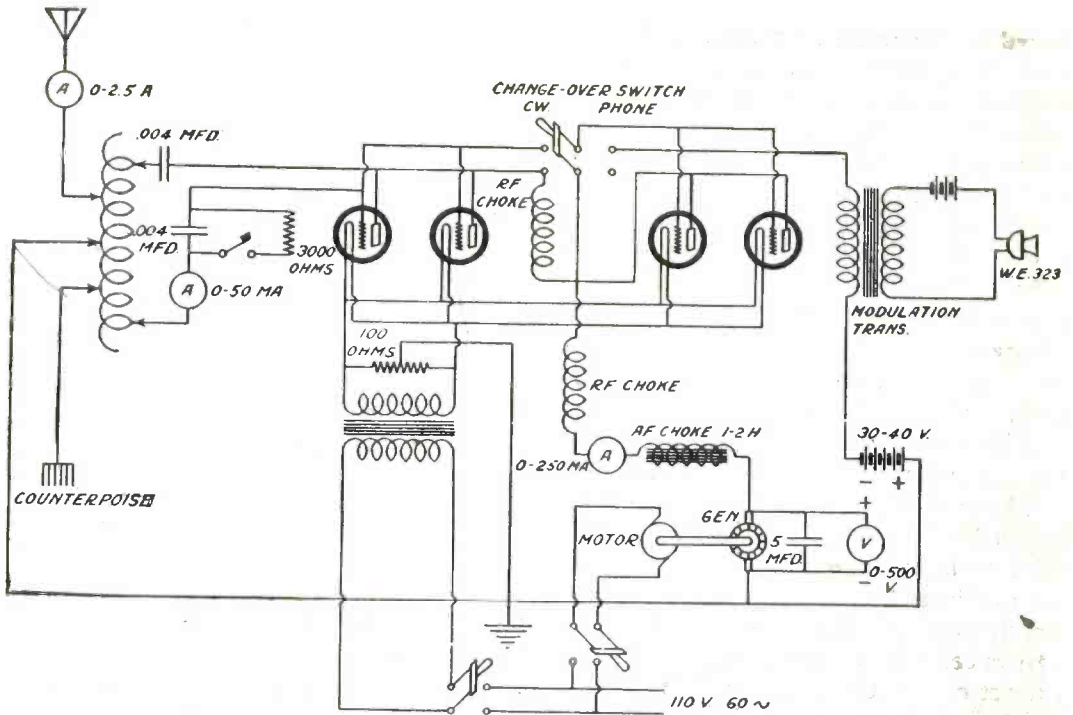

#### THE WIRING DIAGRAM OF THE THOMAS SET

Circuit diagram for 4-5 watt tubes, using Heising modulation for voice. The tube filaments are heated by a step-down transformer operated off the 110-volt A.C. lines. The motor-generator, which supplies the high-voltage direct current for the plate circuit of the tubes, is also operated from the same power source. A switch is provided for using all four tubes as oscillators, for C.W. telegraphy—in which case the telegraph key in the grid circuit is used in forming the code characters.

milliammeters should be incorporated in the set—one to register the grid current (full scale deflection 50 milliamperes) and another to register the total plate current (full scale deflection 250 milliamperes). Three jacks and two plugs are used. With this arrangement the use of but one telegraph key is necessary. One of the plugs is connected to the key, which, when plugged into the upper jack on the lower left-hand side of the panel, will make and break the 6-volt circuit to the buzzer and when plugged into the right-hand jack on the panel will make and break the grid leak circuit for continuous wave transmission. The other jack is connected to the modulation transformer. The microphone is connected to another plug which should be inserted in the lower left-hand jack.

On the main shelf are mounted four sockets and the inductance coil and the

buzzer. The inductance is 7 inches in diameter and  $9\frac{1}{2}$  inches high; it is wound with No. 10 bare copper wire, 35 turns  $\frac{1}{4}$  inch apart. The wire is wound into grooves cut in the bakelite uprights and fastened securely at both ends. The builder can readily devise some sort of suitable connection clip for No. 10 wire.

On the small sub-panel placed under and parallel with the main panel and mounted on another set of brackets are the modulation transformer, grid condenser, grid leak, plate condenser, audio frequency choke coil and two radio frequency choke coils. The grid condenser is made up of seven pieces of copper foil .002 inches by  $1\frac{1}{2}$  inches by  $2\frac{1}{2}$  inches, as conductors, with thin strips of mica as dielectric, pressed and immersed in boiling paraffine. For the grid leak a Ward-Leonard resistance tube of from 3000 to 5000 ohms resistance is used. The plate

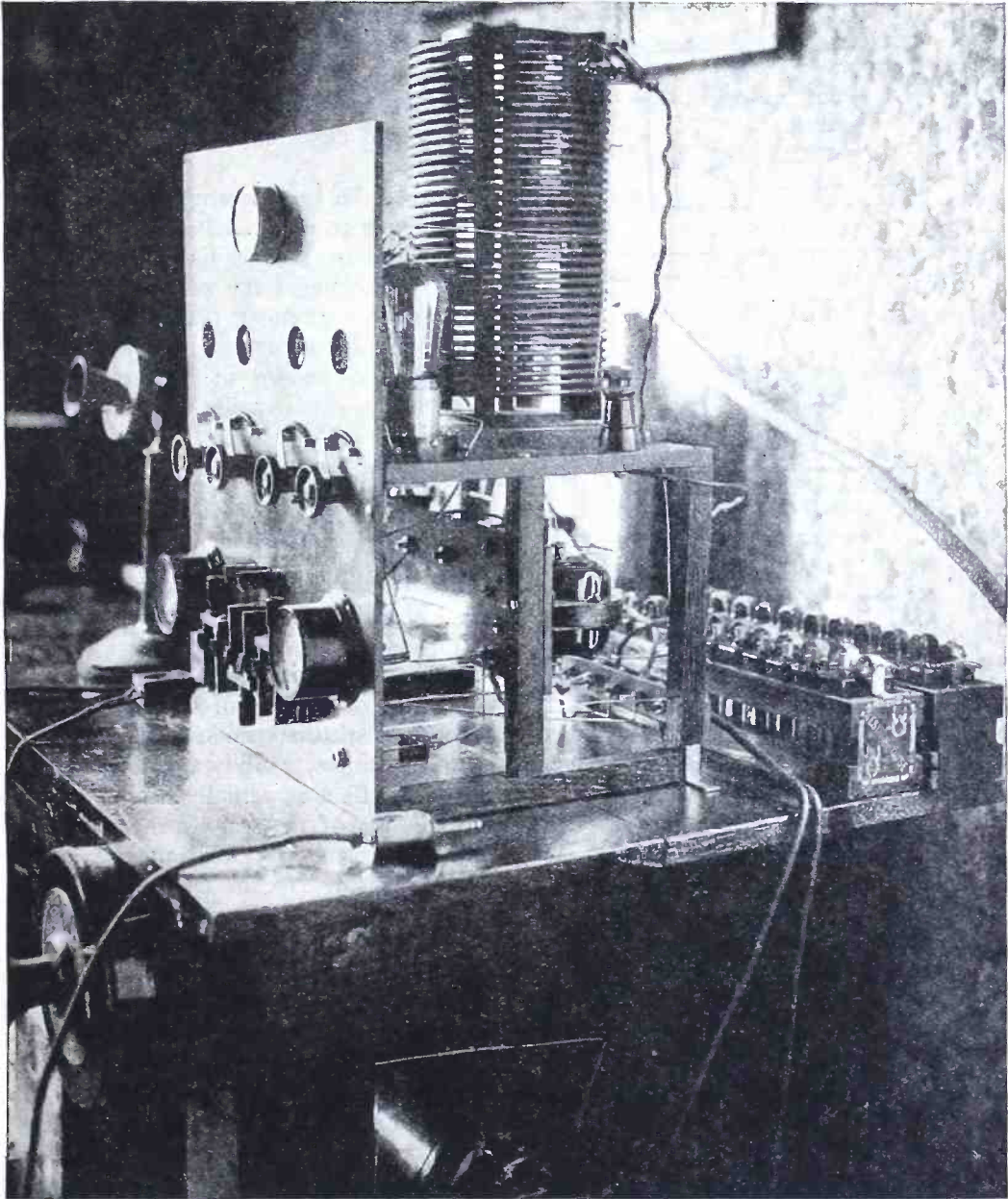

From a photograph made for POPULAR RADIO

#### A CLOSE-UP OF THE THOMAS TRANSMITTER

*This is the apparatus on which 8LF has communicated from his home in Pittsburgh to stations as far west as 2,750 miles off the Pacific Coast. This view of the set gives a comprehensive idea of the general assembly of the panels and the bracket supports. The oscillation transformer and tubes are mounted on the shelf, and the modulation transformer and choke coils are fastened to the back panel. The binding post strip is also shown attached to the two rear wooden supports.*

condenser is a .25 mfd. condenser, but any condenser that will stand the plate voltage is suitable; in fact, a duplicate

of the grid condenser will be entirely satisfactory. This condenser prevents a short on the generator in case the antenna



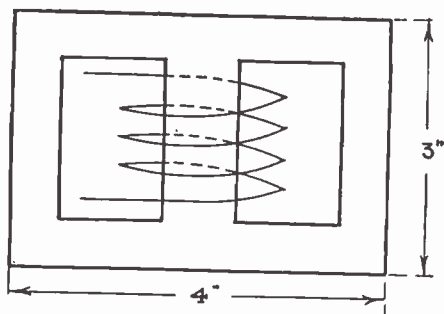

FIG. B

The dimensions for the iron core of the audio frequency choke coil.

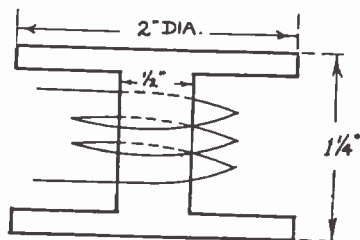

FIG. C

Dimensions for the wooden spools upon which the radio frequency choke coils are wound.

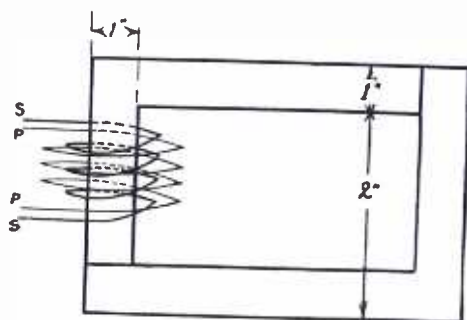

FIG. E

Dimensions of the iron core for the filament lighting transformer.

should accidentally become grounded.

The audio frequency choke coil is made up of approximately 3,000 turns of No. 30 DSC wire wound on a micarta square tube that fits snugly over the center leg of iron punchings, the dimensions of which are shown in Figure B. Both of the radio frequency choke coils are wound on micarta spools, the dimensions

of which are shown in Figure C; they should be wound full with No. 30 DSC. These spools do not necessarily have to be made of micarta, but may be constructed of cigar box wood treated with paraffine.

Across the back micarta uprights that help support the shelves is bolted a micarta strip 1 inch by 14 inches, on which is arranged the necessary binding posts for the filament, plate, grid, buzzer, and microphone current supply; they are arranged as shown in Figure D. All condensers, choke coils, filament heating transformers and other parts are available on the market.

Experiments have been made with various sources of plate supply; the most satisfactory is the motor-generator, which is a direct-coupled affair, delivering 150 watts at 400 volts. The filament supply is obtained by stepping down the 110-volt, 60-cycle current to 7 to 8 volts by means of a transformer. Across the secondary of this transformer is a 100 ohm resistance, center-tapped to obtain the same effect as actually center-tapping the winding of the transformer. A suitable transformer for this purpose can be made by using No. 10 DCC wire as the secondary with 32 turns and No. 22 DCC as the primary with 400 to 440 turns, tapped for variation of voltage. The secondary winding is placed nearest the core, being wound on a square tube, 2 1/2 inches long, and the primary winding is placed directly over this winding, the core being assembled in a square "O" shape. There are so many suitable transformers on the market for this purpose that anyone who is unable to obtain satisfactory punchings for the core would hardly be justified in attempting to construct it; however, Figure 3 shows a transformer that is suitable for supplying one to five tubes with current for operation. A 1,000-volt, 5 mfd. condenser should be placed across the generator or plate supply and one audio-frequency choke coil connected in series with the generator. This forms an effi-

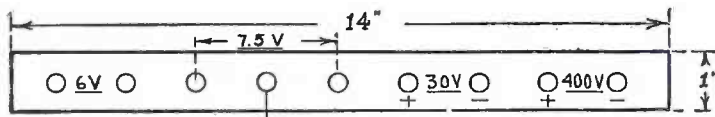

FIG. D

Diagram of the strip of micarta upon which the binding posts for the battery connections are mounted.

cient filter for doing away with the commutator ripple.

The entire set is wired with No. 14 solid bare copper wire in accordance with the diagram shown in Figure F; with proper care in wiring, and assuming that the antenna system is suitable, the antenna current should be approximately 2.5 amperes, using four tubes as oscillators on 200 meters. For transmitting

the voice, two tubes should be used as oscillators and two tubes as modulators; the antenna current should be 1 ampere or more.

Any amateur who builds a set from this description will presumably attain results similar to Mr. Thomas'—providing, of course, that his antenna system is adequate and that the local conditions are favorable.

**Q** How many radio fans know just what is the difference between a "hard" tube and a "soft" tube? How many know the specific uses for which each is designed? In the next issue of this magazine—JANUARY—Prof. William C. Ballard, Jr., of Cornell University, will answer these questions; incidentally he will give the amateur other information of practical helpfulness.

## Radio as a Power for Educating the People

TO THE EDITOR OF POPULAR RADIO:

*"It seems to me that there are undreamed-of possibilities for the utilization of radio broadcasting in the interest of educating the public. I think the mistake is too frequently made of thinking that education can be secured only through formal institutions of learning. Of course, the fact is that any open-minded individual is becoming more educated all the time simply by the use which he makes of the accessible opportunities of life; and many a man of acquisitive mind acquires a better education by himself than many another does, even with the assistance of one of our foremost colleges or universities. If a broadcasting program could be devised and made available under the guidance and direction of a group of men free from any suspicion of pleading for special causes, it would be a tremendously valuable contribution to raising the general level of intelligence and culture."*

*Ernest M. Stephens*

President of Dartmouth College



# HOW TO SELECT *The Best Coil for Your Set*

By PROF. J. H. MORECROFT

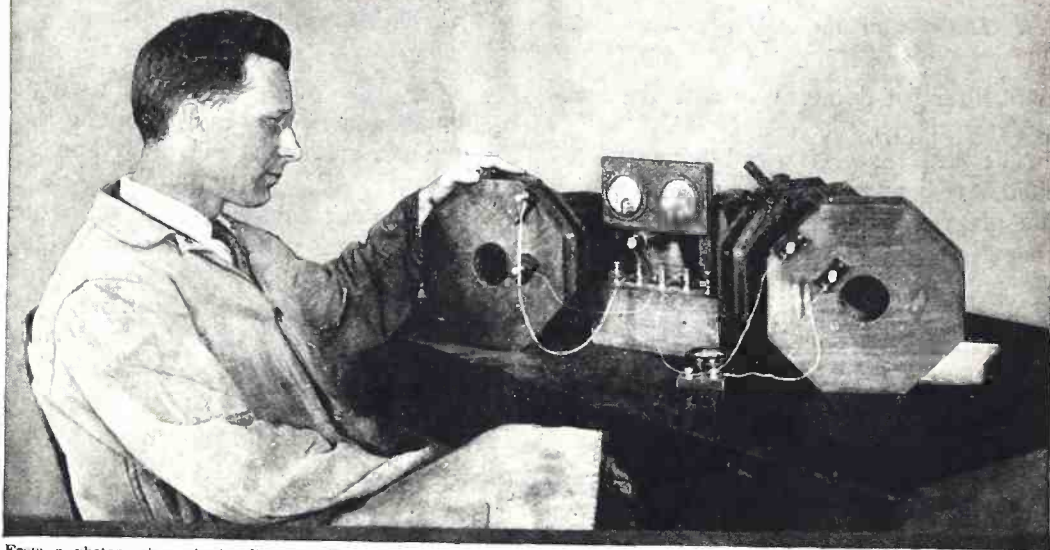

From a photograph made for POPULAR RADIO

*In this article the author, who is one of the foremost radio experts in the country and a member of the faculty of Columbia University, tells the radio amateur what his coil really does and points out how he may determine the particular kind that will best serve his particular purpose.*

IT would seem that such a simple thing as a coil could require but little analysis; that anyone could build a coil which would prove satisfactory when used in a radio circuit. Of course anyone *can* build a coil which will operate in a radio circuit; the question is—how good is the coil and how well will it operate compared with the best coil which can be built for the purpose?

It is the purpose of this article to point out some of the factors which determine just how good a coil is and how well it should function.

There are three so-called electrical constants which enter into all of our calculations in radio work; not only enter into our calculations but which also determine completely how well a set may operate. They are:

- The inductance;
- The capacity;
- The resistance.

Resonance is, of course, the key-note of operation of all radio circuits; the product of the inductance and capacitance used in the circuit determine at what frequency resonance is obtained. The sharpness of this resonance (that is, the relative ease with which it lets through the desired frequency as compared with others of different frequencies not desired) is determined by the ratio of the resistance of the circuit to its inductance.

It is evident that the characteristics of a coil, simple thing as it is, are well worth while studying; this study soon shows that resistance and inductance at radio frequencies are not the simple



things taught in elementary physics, but are rather complicated—so much so that theory alone cannot predict what the constants of a coil will be at high frequencies, so that recourse must be had to experimental determination.

The student of electricity learns that if the voltage (in volts) of a continuous current circuit is divided by the current (in amperes) which flows through a circuit, the quotient will be the resistance of the circuit (in ohms), and that this resistance is constant unless the temperature changes. In an alternating current circuit the same quotient yields the impedance of the circuit, the impedance being made up of two components, resistance and reactance. If the current lags

behind the voltage, in phase, the reactance is inductive; if the current leads, it is capacitive. The resistance of the circuit is not the same value at all as would be determined by continuous current test, using Ohm's law for its calculation; in fact, a circuit which shows millions of ohms resistance to continuous current flow may have only a fraction of one ohm for a high frequency alternating current.

As Ohm's law does not suffice to determine resistance in an alternating current circuit we must get a new definition which does meet the situation. This definition, which is applicable to all circuits for continuous as well as for alternating current (that is, it includes Ohm's

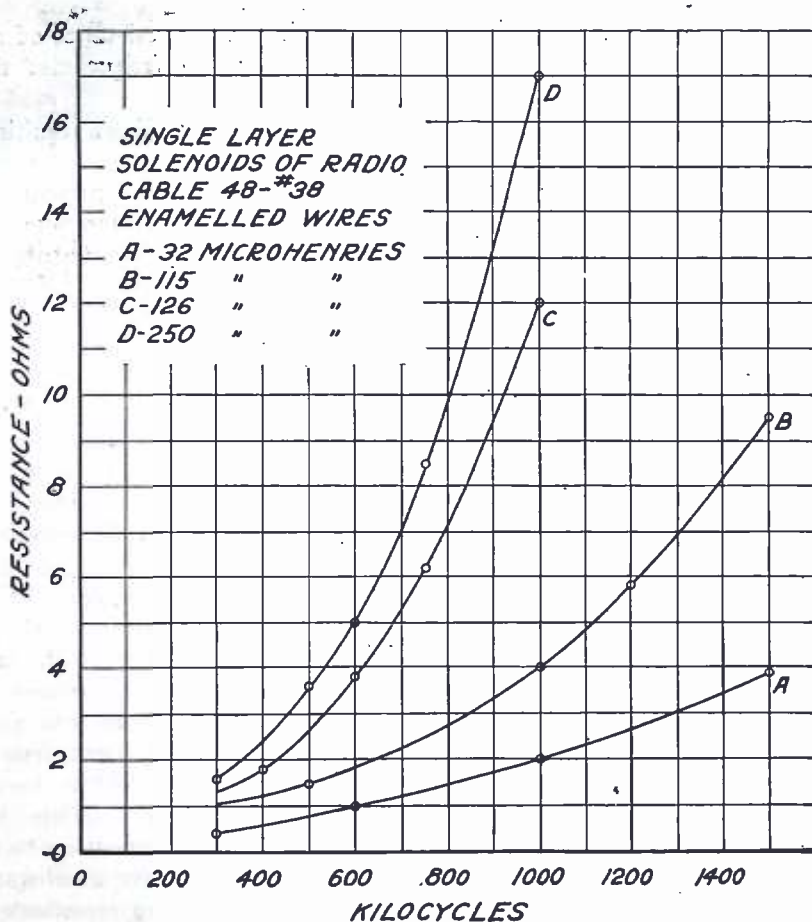

FIGURE 1

A resistance-frequency chart of single layer solenoids of different values of inductance.

law as a special case) is

$$\text{Resistance} = \frac{\text{Power used in the circuit}}{(\text{current flowing in the circuit})^2}$$

If the power is given in watts, and the current in amperes, the resistance will come out in ohms.

It might be questioned how this definition can be used in radio circuits—can we use a watt-meter to read the power used? The answer is “no”; the procedure indicated by the definition does determine the resistance but is not generally followed. We could put the circuit in a calorimeter, measuring the rate at which heat is developed, divide the amount of this heat by the square of the measured value of the current flowing, and so determine the resistance; but such a method is not suitable for rapid and accurate determinations.

It is possible to so adjust the circuit that its reactance is zero, in which case the resistance is given by Ohm's law.

$$R = E/I$$

In another method the alternating current Wheatstone bridge is used, by which the resistance and reactance of the coil are both determined at once when the bridge is balanced. The bridge is probably not accurate however at more than a few hundred thousand cycles a second so that the resonance method (making the reactance equal to zero) is the only one available.

If the frequency of the power supply is known (as it will be by wavemeter determination) and the capacity used in the circuit to establish resonance is accurately known, the inductance of the coil, as well as its resistance, is determined by the resonance test. So with a good wavemeter, and a well built and carefully calibrated condenser, with suitable thermocouples for current measurement, resistance and inductance measurements may be made with a fair degree of accuracy for frequencies as high as ten million or more.

This article gives the results of a few

measurements made by the writer in such a fashion; from these results certain conclusions may be drawn which are interesting to the radio enthusiast. By the radio enthusiast is meant the one who is interested in knowing *why* certain things are as they are, not the one who merely boasts that he furnishes the neighborhood with so much noise from his set that the police department have to censor him, or the one who hears so many distant stations that actually do not exist. Recently the writer received two letters from the enthusiastic West giving in detail conversations which some amateur had heard over his phone set; these conversations took place when the transmitting station was closed tight under lock and key.

Why should the resistance of a coil be different at radio frequencies than for continuous current?

There are many things resulting in an increase in resistance for the high frequency alternating current which do not exist at all for continuous current or very low frequency alternating current. For continuous current all of the cross-sectional area of the conductor is useful in carrying current, whereas for high frequency, due to what is called the skin effect, but a small part of the copper may be useful in carrying current. The losses in bits of metal used in the construction of the coil (for terminals, for example) change the effective resistance of the coil, always making it greater than it is for continuous current. The material on which the coil is wound is in a high frequency electric field, and even though it be a perfect insulator, permitting no current at all to leak from one turn of the coil to the next, it is subject to losses called “dielectric losses,” or “dielectric hysteresis.” This loss increases directly in proportion to the frequency and so may give a substantial increase in the effective resistance of the coil at the high frequencies used in radio.

It might be thought that this change in effective resistance with increase of

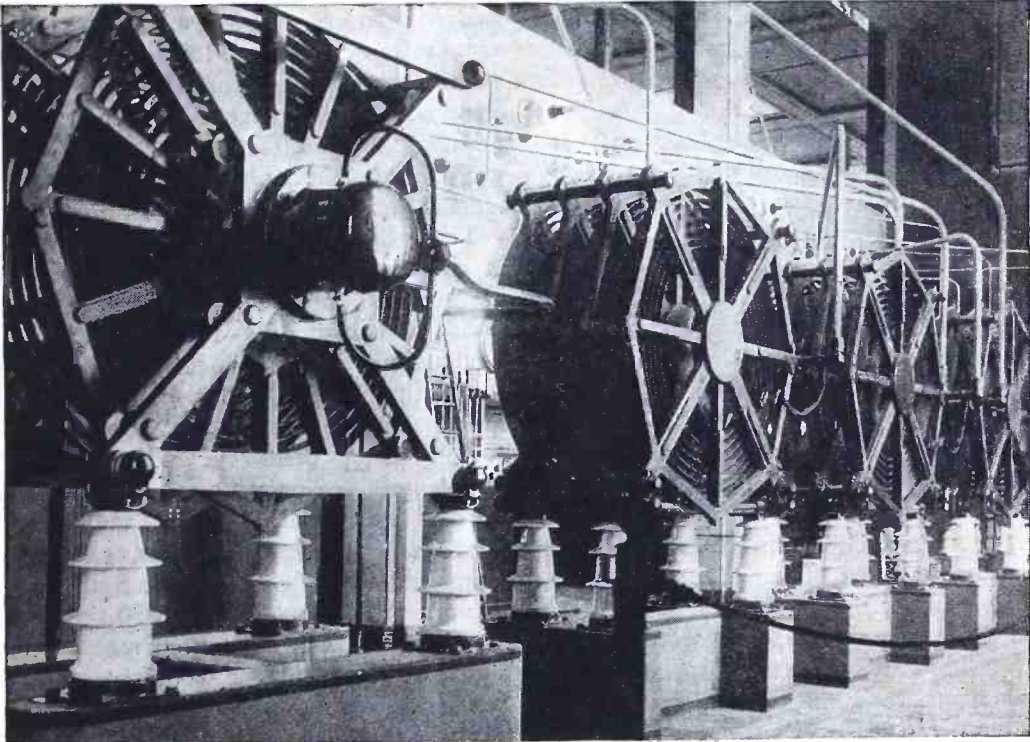

International

### GIANT LOADING COILS IN THE RADIO STATION AT NAUEN, GERMANY

*The amateur, who deals with electrical powers which are infinitesimal in comparison to those used for trans-oceanic telegraphy, should be careful to use coils that will squeeze out into the antenna even that last little fraction of a watt that is trying to find a small hole to sneak into and peacefully sleep, instead of being shot out into cold space*

frequency is not worth bothering about—perhaps a few per cent. But such is not the case; the resistance for high frequency alternating current may be many times as much as it is for continuous current. Thus one coil such as might be used in an ordinary receiving set had a continuous current resistance of 0.45 ohms; at 500 meters wavelength it had 3.5 ohms, and at 200 meters it had 18 ohms. In other words, the coil had forty times as much resistance as the wire table for resistance of copper wires would predict. This was not a defective coil, but a good single layer solenoid of No. 20 solid copper wire.

To show how the resistance of coils varies with frequency the curves of Figure 1 are given; they are experimentally determined curves for ordinary solenoids such as are used in receiving sets

of the better class. The wire of which the coils were made was of radio cable, made of 48 strands of No. 38 enameled copper wires properly bunched together. Up to frequencies above one million cycles a second the cable shows itself superior to solid wire, as the solid wire has not the same cross section as the cable but is of such a size that it winds the same number of turns to the inch. The continuous current resistance of the solid wire was only about one-half as much as that of the cable, showing there was more copper in it than there was in the cable. Above one million cycles, however, the solid wire actually becomes better than the much more expensive cable, or "litzendraht," as it is sometimes called.

The superiority of the solid wire is well shown in Figure 2, which gives the



resistance of solid wire and cable coils of the proper number of turns to make them suitable for short wave sets. It will be seen that at the higher frequencies the solid wire has less resistance than the cable, although at the frequency used in broadcasting (about 833,000 cycles) the cable is considerably the better of the two. As to just where the solid wire becomes better than the cable will depend somewhat upon the form of coil; the conclusions reached from these curves holds only for coils of similar shape and method of winding. It is comforting for the amateur who "builds his own" to know that the cable, costing about twenty times as much as the solid wire, and which is also troublesome to tap, is but little better than the cheap, easily worked solid wire.

For a given type coil, wound of a given kind of wire, at a specified frequency, there is one coil which gives a better performance than one with either more or less turns; that coil having the greatest ratio of reactance to resistance will tune best, be most selective; to get this highest ratio a coil with the proper number of turns must be used.

Using two and three layer banked winding solenoids, made of radio cable (48-38's), the ratio of reactance to resistance was found for various coils as given in Figure 3. The coils were all of the same diameter (about 4 inches), and the length varied with the number of turns used. These curves indicate that to get the best tuning (greatest selectivity) a proper coil should be used for a certain wavelength. Thus, for tuning to 500 meters we should use coil A in preference to any of the others, but for 800 meters practically all of the coils are equally good. It must be borne in mind that the conclusions drawn from these curves, while in general correct for any form or type of coil, hold specifically true only for coils of this size and wound with the kind of wire used here; also that the losses in the condenser used in conjunction with the coil for tuning must be con-

sidered. In general if two coils have the same ratio of reactance to resistance, that with the smaller inductance is preferable, as it will require a greater capacity for tuning and the effective resistance of a variable condenser always decreases with increase of capacity.

The resistance of the loading coils used in transmitting sets is an extremely important factor in the efficiency of the station. Unfortunately the requirements for tuning, as at present carried out, practically require that a coil of heavy copper strip be used so that clips can be moved along them for adjusting the wavelength. The resistance of these coils is excessively high at radio frequencies. In one coil of heavy copper strip measured by the writer the resistance at 3000 meters was 350 times as much as its continuous current resistance; at 200 meters it would have been thousands of times as great as one would think, looking at the amount of copper used. In a certain one-kilowatt transmitting station the loading coil got so hot that it was uncomfortable to touch; it seems likely that two or three hundred watts were being used up in this coil, an amount of power which required an investment of perhaps \$200 in tubes to generate. It seems advisable to build the loading coil of heavy radio cable, of the proper number of turns to tune the antenna to a slightly lower wavelength than it is desired to radiate, and bring the circuit up to the desired wavelength by putting a good variable condenser in parallel with the antenna. If the loading coil of your transmitter gets appreciably hot it is a safe guess that the coil has a very high resistance and is inefficient.

The coefficient of self-induction of a coil may be easily calculated when the dimensions of the coil and number of turns are given. If the coil is measured at, say, 1000 cycles the calculated value of  $L$  will be found the same as the measured value, generally closer than 1 per cent. If, however, the coil is measured at radio frequency the inductance may be

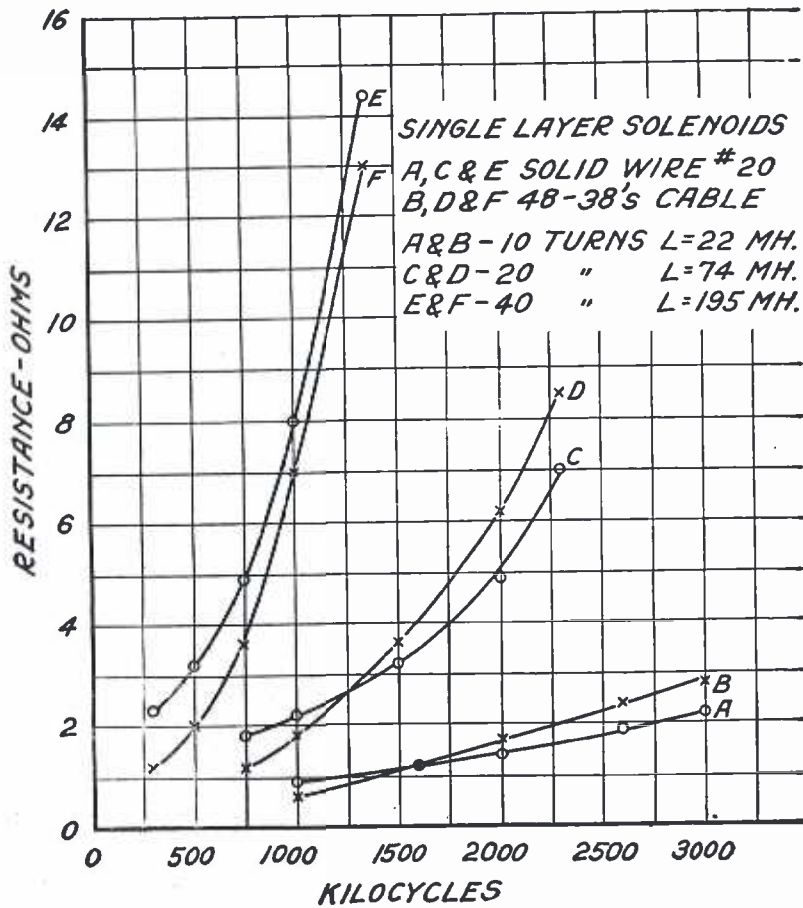

FIGURE 2

Another resistance-frequency curve for coils wound with No. 20 wire.

found either slightly less or considerably more than the measured value. And in the extreme case what is evidently a coil measures up as a condenser!

The reason that the measured value of  $L$  may come out smaller than the calculated value is because of the shift of the current from a more or less uniform distribution throughout the cross-section of the wire at the low frequency, to a crowding to that side of the wire which is closer to the axis of the coil at radio frequencies. As this shift in the current is equivalent to a decrease in the radius of the coil, of course the measured value of  $L$  is smaller than the calculated one, as the formula assumes a uniform distribution of current. If radio cable is used in constructing the coil this effect cannot

occur, so the value of  $L$  does not show a decrease as the frequency is raised; the effect occurs to the greatest extent in the strip coils used for transmitting loading coils.

The apparent increase in inductance with increase in frequency exists in all coils, no matter how they may be built, and does result in an increase in the measured value of  $L$  at the higher frequencies, no matter with what kind of wire the coil is wound. In the solid wire, or copper strip coil, therefore, we may expect the inductance to decrease slightly at first as the frequency is raised and then to increase, whereas with cable wound coils the measured value of  $L$  will show a continual increase in  $L$  as the frequency is raised. This increase

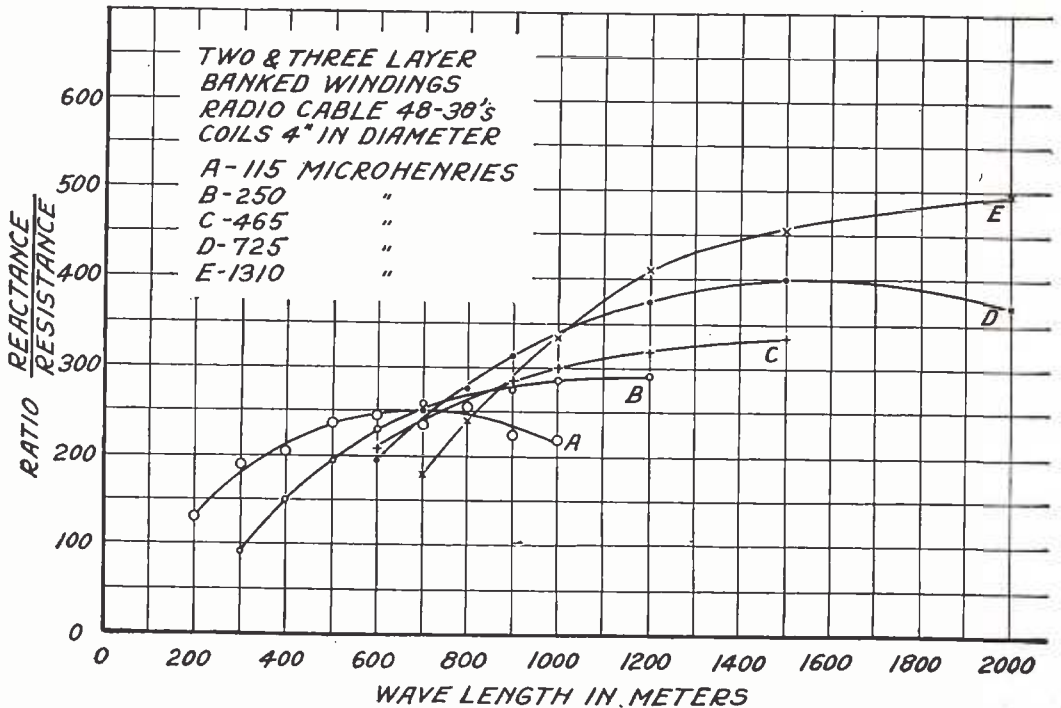

FIGURE 3

This chart shows the ratio of reactance to resistance for two and three layer bank-wound coils at different wavelengths.

is due to the distributed capacity of the coil itself. Each part of the coil acts with every other part to form a kind of complicated condenser, so that the coil really should be represented as a coil in parallel with a fixed condenser, the capacity of this condenser being equal to the distributed capacity of the coil. This representation is not complete because actually the capacity of the coil changes with frequency, an effect which is generally neglected in treating the theory of coils.

The effect of this distributed capacity is, in general, not detrimental, but may be so if the capacity is comparable to that used with the coil for tuning purposes. In this case, as the capacity of the external condenser is only a part of the total effective capacity in the circuit, variation of its value does not accomplish tuning as sharply as if there were no capacity of the coil affecting the circuit.

It might seem that distributed capacity

in a coil is not objectionable, as we have to have a condenser connected to the coil anyway—for tuning purposes. But such is not the case. It is best to keep this capacity as small as possible because the dielectric used in that capacity is poor compared to the dielectric used in the external condenser. The distributed capacity of the coil has cotton, paper, shellac, or enamel, for its dielectric, whereas the regulation tuning condenser is a very well built air condenser, and air is far superior to any other substance as a dielectric; it has no losses at all.

The various turns and layers of a coil should be kept reasonably far apart if the distributed capacity is to be kept low, and the dielectric between layers and turns should be air, if possible. Several years ago the writer showed how such a construction could be carried out without too much difficulty. Using air for the dielectric between layers has the double advantage of low specific inductive capacity and also prevents leakage of cur-



rent in passing from one layer of the coil to another.

Many times a solenoid is furnished with many taps and a multipoint switch for tuning purposes; although this is a convenience it does not give as good results as a single coil of the proper number of turns. This is especially true if but a small fraction of the coil is to be used, say a quarter or less. In such cases the coil acts as an auto-transformer, the unused portion having comparatively high voltages induced in it and thus producing large unnecessary copper and dielectric losses in the unused portions. Also it is evident that the switch points mounted in the panel of bakelite or similar material constitute a condenser in parallel with the tuning condenser; in this connection it should be borne in mind that losses in the bakelite, or leakage across from one point to another, is, of course, just as detrimental as leakage in the coil itself.

To prevent the losses in the unused

portion of the coil it is best to build the coil in sections, an inch or more apart; many times it will be found advantageous to short-circuit that part of the coil which is not being used. This is especially true when but a small part of the coil is being used. Although there will be eddy current losses in the short-circuited part of the coil these losses may be less than if the coil were not shorted. There will be practically no dielectric losses in the unused parts of the coil, because the voltage in these parts will be low; and furthermore it is quite possible that there will be less current in the unused part than if it were not shorted, strange as this may sound. If there are several sections in the unused portion of the coil it will not be necessary to short all of the unused part; shorting the section directly next to that part of the coil which is being used is, in practically all cases, almost as satisfactory and as a matter of fact it is in general easier to accomplish.



George Grantham Bain

### Radio's Chance to Render a Distinguished Public Service

TO THE EDITOR OF POPULAR RADIO:

*"I entirely approve of your plan of extending the radio broadcasting program for educational and cultural purposes. It is a forward step in our civilization and the commencement of a very important movement to give the world at large a chance to participate in entertainments, instruction, musical programs and lectures, which heretofore could only be given to a comparatively small number, being limited to the space which could be given the audience in a building. By now being broadcasted they are opened up to a large public all over the world; in fact, to whoever wants to take advantage of the opportunity offered."*

*Adolph Lewisohn*

Donor of the Stadium of the College of the City of New York



From a photograph made for POPULAR RADIO

### THIS HOME-MADE SLIDING COIL COST 50 CENTS

*A loading coil may be made either with a sliding contact for adjustment or the coil may be tapped. The coil described in this article is of the latter type.*

## How to Make and Use A LOADING COIL

*The Seventh of the Popular Series of "How to Make"  
Articles for the Radio Novice*

By A. HYATT VERRILL

**F**EW of the more simple devices used in radio telephony are less understood and less appreciated by the average novice or beginner than the loading coils. In the columns of questions and answers in the radio periodicals a large proportion of the queries seek information about the distance at which a set can receive and the use of loading coils to bring in signals.

The idea that the use of a loading coil will increase the distance at which a set can bring in signals appears firmly fixed in the minds of many radio fans who apparently do not understand that wavelength and distance have very little to do with each other. The wavelength is

merely the length of the radio wave, and the shortest wave may travel completely around the earth, although it might not be possible to detect it with the instruments we now have. On the other hand, the best of sets might not pick up an extremely long wave message, even though the set were within a couple of miles of the sending station; whether or not a wave of a certain length is received depends as much upon the wavelength range of the set as upon its distance from a sending station.

Also, if the set can be tuned or adjusted to the desired wavelength the distance at which it can bring them in depends entirely upon its sensitiveness

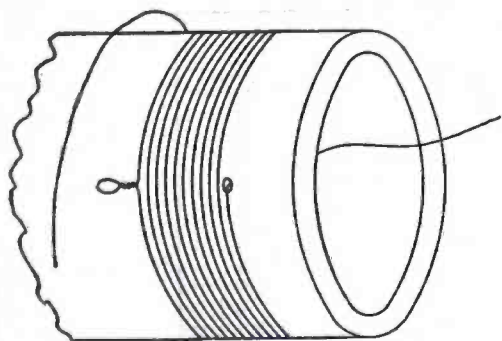

FIGURE 1

*This diagram shows how a tap is made.*

and has nothing to do with the wavelength.

Hence the novice should remember that when he adds a loading coil to his set it merely increases the wavelength or the size of waves which can be received and does not increase the distance at which a signal may be received. It must also be borne in mind that different types or forms of loading coils must be employed with different types of sets. If you are using a set with a single circuit and a simple inductance, a single primary coil loading coil may be used. If you are using a double circuit set with a primary and secondary or coupled inductance then to obtain the best results the loading coil must also be a double or coupled coil.

A loading coil in effect is simply an extension of the aerial circuit; by adding it to your set you merely increase the

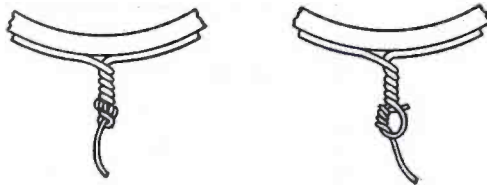

FIGURE 2

*How a connecting wire is joined to a tap. The wire is twisted around one side of the loop and then the whole is twisted together.*

wavelength of your aerial circuit by adding to the inductance already in the set. Loading coils also are made in various forms. Some of them are of large diameter and narrow surface; others are long and cylindrical. The latter form is the simpler to make.

Also, the longer the loading coil and the more turns of wire upon it the greater the wavelengths which may be brought in. As few amateurs wish to pick up the very longest waves, however, a coil which will bring in waves up to 5,000 meters is amply sufficient.

To make such loading coil—to be used with a single circuit set—is a simple matter; an excellent coil may be constructed at a cost of far less than you would pay for a ready-made coil. No special tools are required and the materials needed are few and inexpensive.

For a coil to load up to about 4,000 meters you will need a tube of formica or some similar composition, about one foot in length and four inches in diame-

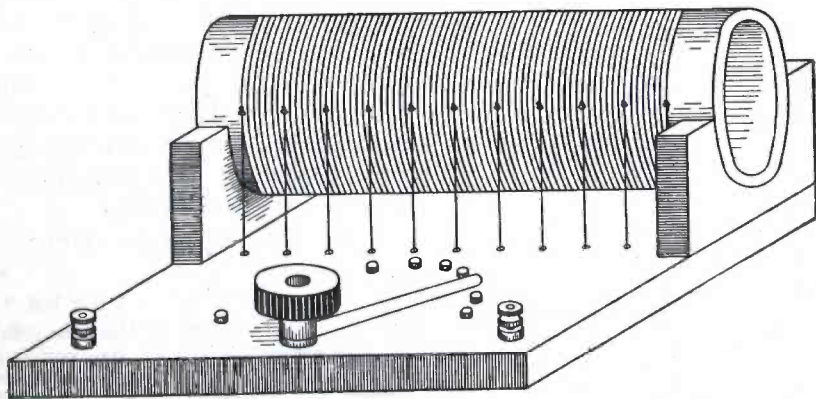

FIGURE 3

*This is how the completed coil looks when it is mounted on a base-board.*



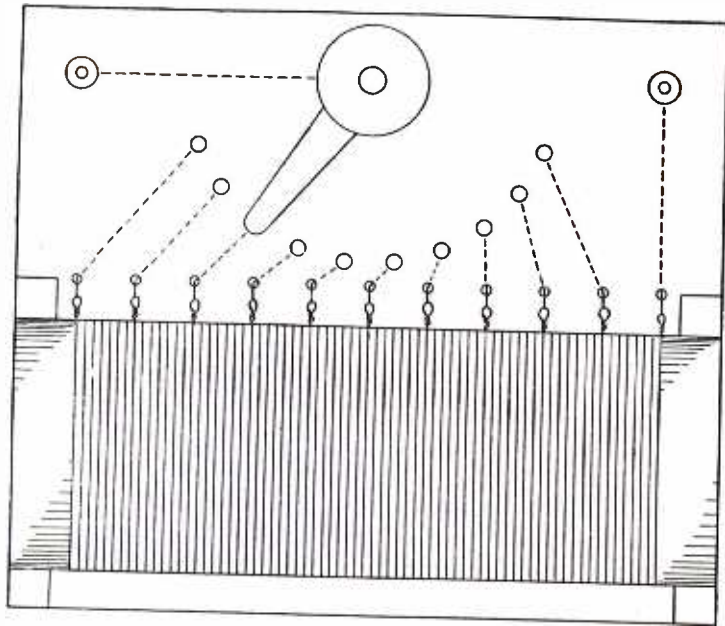

FIGURE 4

*A plan view of the coil, showing how the switch joints, switch blade and binding posts are wired beneath the base-board.*

ter, a ten point multiple switch; binding posts; some cotton or silk insulated No. 20 or 22 copper wire and a base or panel of wood or bakelite on which to mount the coil.

If the coil tube is one foot in length it will take practically 250 turns of wire, leaving half an inch bare at each end for attaching or mounting the coil.

Begin by making a small hole half an inch from one end of the coil. Run an end of the wire through this hole with six or seven inches projecting and fasten it to the inside of the tube by means of sealing wax. Then wind on the wire smoothly and evenly, keeping the turns close together until you have wound on twenty-five turns. Make a loop or tap in the wire (see Figure 1) and continue winding for another twenty-five turns. Here another tap should be taken and the winding should proceed, taking a tap at each twenty-five turns until the wire has covered the coil to within half an inch of the other end, when it should be passed through a small hole as in starting and secured in the same manner. This will give you nine taps and the loose ends.

The next step is to scrape carefully

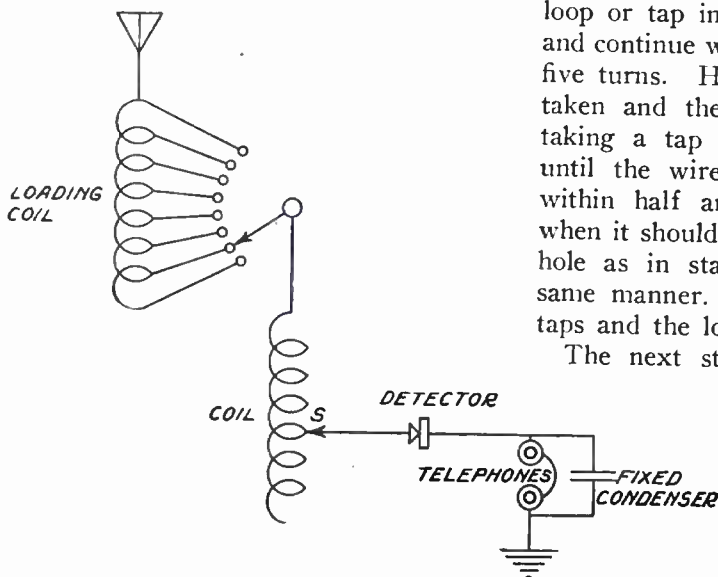

FIGURE 5  
*How the loading coil is connected in a single circuit receiver.*

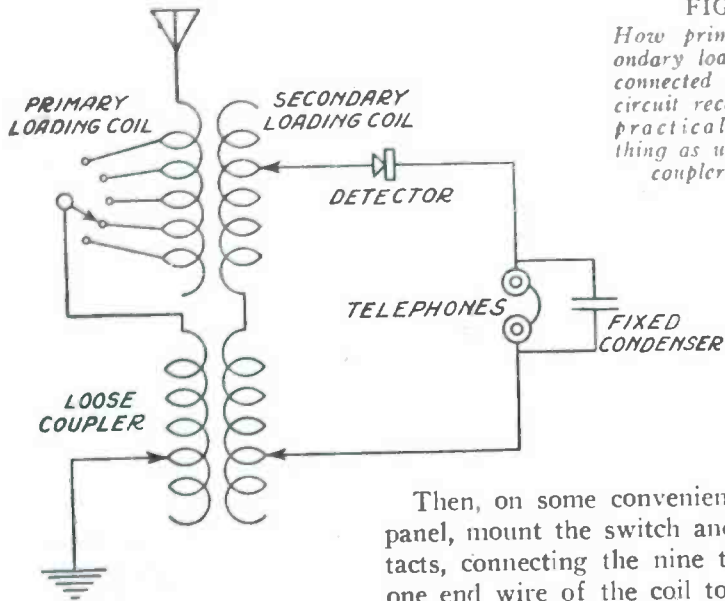

FIGURE 6  
How primary and secondary loading coils are connected in a double circuit receiver. This is practically the same thing as using two loose couplers in series.

the insulation from the tap loops, clean the exposed wire and twist in a six or eight-inch length of wire in each loop. By twisting the wire around one side of the loop and then twisting the whole together (see Figure 2), a good connection may be made, but as soon as all have been thus twisted in you should go over them and solder the wires. Then slip a section of varnished cambric tubing over each tap and wire so as to completely cover the exposed copper.

The coil should then be mounted on a base or panel by using two uprights or supports, each with a half circular opening cut in them, as shown in Figure 3. The bare ends of the coil should rest in these and should be secured by means of small brass screws through the coil from the inside. Place these screws as close to the ends of the coil as possible and use as few and as small screws as will secure the coil firmly.

Then, on some convenient part of the panel, mount the switch and switch contacts, connecting the nine tap wires and one end wire of the coil to the ten contact points. Then connect the switch arm post to a binding post and lead the other end wire of the coil to a second binding post as shown in Figure 4. The coil is then ready to use; this is done by running your lead-in to one binding post and connecting the aerial terminal of your set to the other binding post as shown in Figure 5.

In tuning for the longest waves place the switch "S" at the loading coil end. Then move the loading coil switch to the proper point and do your finer tuning with the regular coil.

If your set uses a coupled coil the loading coil is a trifle more difficult to make, for it must consist of two inductances, one a trifle smaller than the other and placed within the other, each tapped and arranged to connect in series with the corresponding inductances on your set. (See Figure 6.) The same methods are followed in making these inductances.

TO THE EDITOR OF POPULAR RADIO:

"I should think that a project such as yours for improving the quality of the radio programs ought to have the heartiest support. . . . It would certainly be worth while for the college to install a complete receiving and amplifying set in one or more of the college auditoriums, if such programs as are suggested could be received."

GEORGE H. NETTLETON  
Acting President of Vassar College

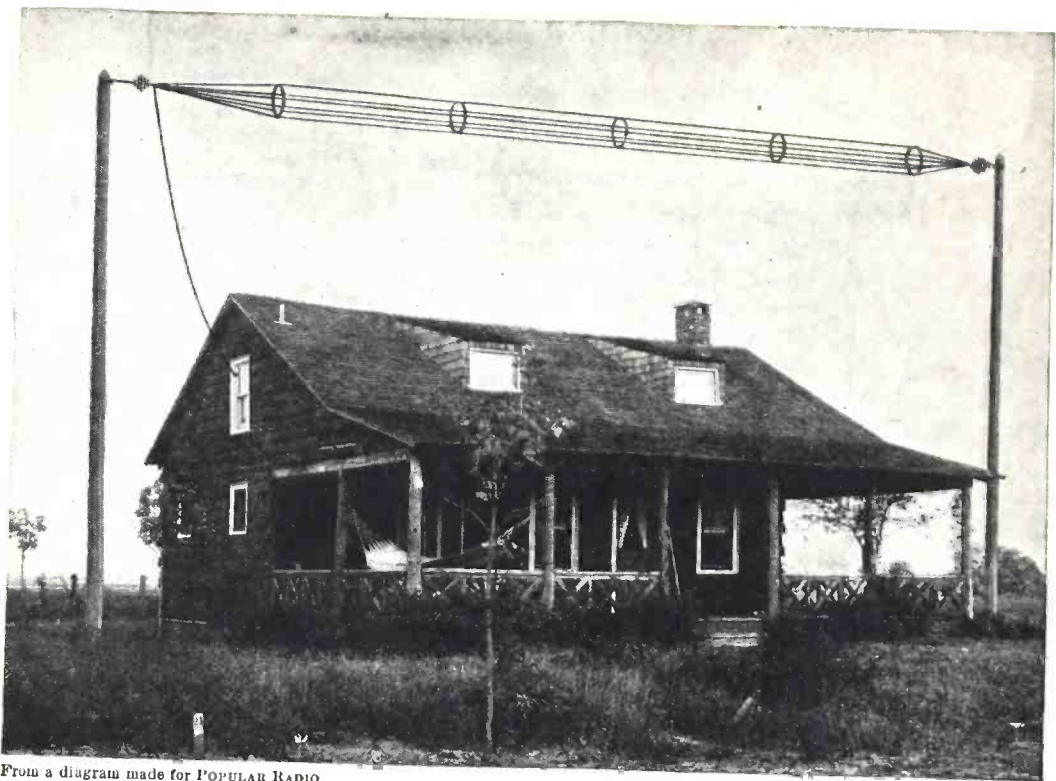

From a diagram made for POPULAR RADIO

AMATEURS HAVE SENT AND RECEIVED TRANSATLANTIC  
MESSAGES WITH THIS TYPE OF ANTENNA

*As the amateur is limited to transmission or low wavelengths a highly efficient antenna is a prime necessity. This is the best for his purpose.*

## The Best Antenna for Transmitting

THE CAGE TYPE

*The Third of a Series of Short Articles on the  
Antennae Best Adapted for the Amateur's Uses*

By DAVID LAY

THE cage type of antenna is meeting with increasing popularity among the advanced amateurs, especially with those amateurs who are trying to establish new records for transmitting. In view of the fact that the amateur is limited to small power for transmitting purposes, any increased efficiency that can possibly be obtained in the apparatus that he uses is of the utmost importance.

The ordinary flat-topped antenna uses four wires, the outside wires carrying more current than the inner wires; or in other words, the outside wires are worked

at a higher efficiency than the inner wires. That this is so is shown by the comparison of electrostatic fields around the different wires of such an antenna. A cross-sectional view of these fields is shown in Figure 1. It will be noticed that the two outside wires 1 and 4 have more lines of force connecting them to the ground than the two inner wires 2 and 3. This of course indicates that there is more current flowing in the outer wires than in the inner ones, and this difference in current can be determined by actual test.

In the cage type of antenna the wires



are not spaced in a plane or flat top but are arranged in a circle, as shown in the diagram in the photograph. In an antenna of this design the currents flowing in the antenna wires are more evenly distributed; even the top wire has the same current as the lower ones.

In Figure 2 is shown a diagram of the electrostatic field that surrounds a cross-section of a cage type of antenna. Notice that all the wires have approximately the

same number of lines of force attached to them. In this type of antenna all the wires are worked at the same efficiency.

This type of antenna also gets its increased efficiency because of its tubular shape, for it is well known that the metallic tube is the most efficient conductor of high frequency currents.

In building such an antenna it is advisable to cut the wires the correct length and lay them on the ground. If a six-

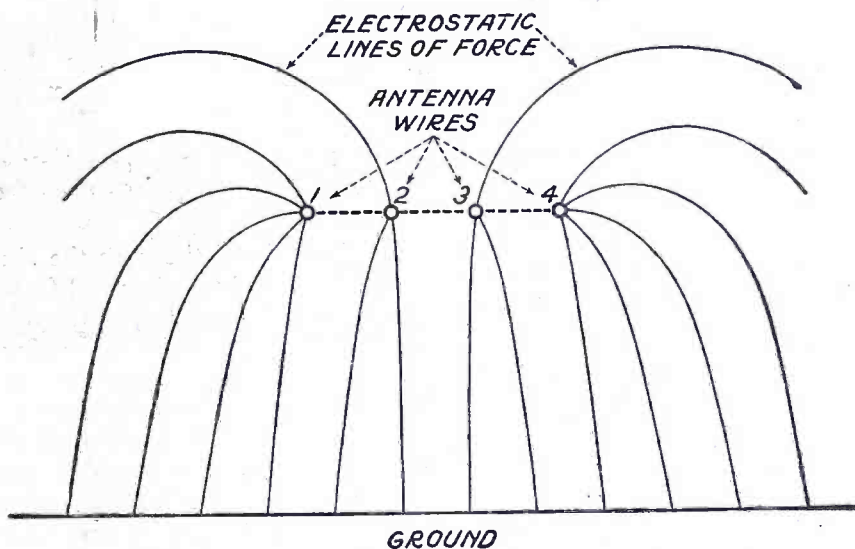

FIGURE 1

*The potential gradient around the end wires 1 and 4 in a flat-top antenna is much greater than the middle wires 2 and 3. This is evidenced by the crowding of the electrostatic lines of force around the outer wires. In other words, the two outside wires do most of the work and the top side of the antenna does hardly any work at all.*

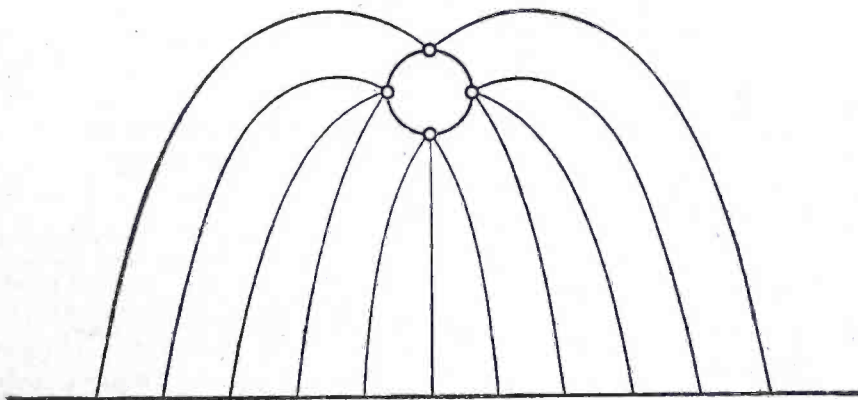

FIGURE 2

*In the cage type of antenna, however, all the wires have practically an even chance, and each of them presents a much greater effective radiating surface than in the arrangement shown in the upper diagram.*

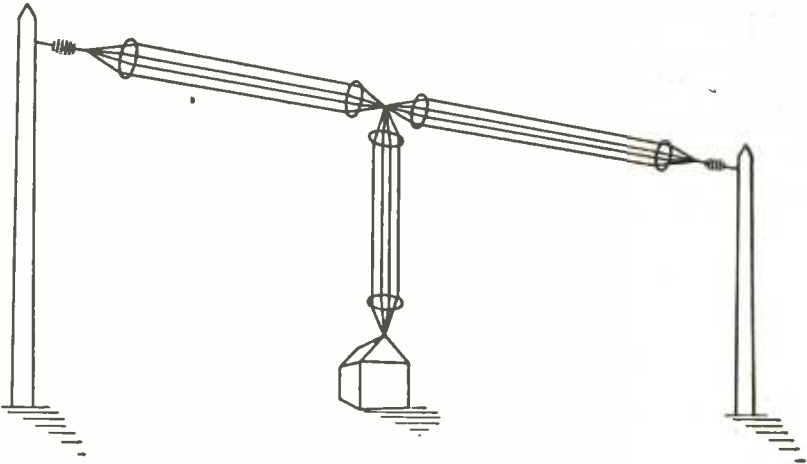

FIGURE 3

The cage antenna may be used as a T-type by building three small cages, using two of them as the horizontal part, with the third cage fastened between them and serving as the lead-in.

wire cage is to be built, six lengths are cut and stretched out along a flat piece of ground and one by one they are fastened and soldered to the supporting loops. These loops can be made of No. 00 hard copper wire bent into a circle one foot in diameter and soldered. There should be a loop at every 15-foot distance along the antenna. Thus for a 75-foot antenna, six loops will be required, including the additional loop at the end. Each loop should be marked with a file into six sections so that the wires can be attached and soldered in such a way that the position of each wire will be exact when the cage is hoisted into place

At the ends of the cage the six wires should be joined together and fastened to a long 22-inch insulator, to the other end of which is attached the supporting cable.

The cage antenna can be used as an inverted L type of antenna (see diagram on photograph), or as a T-type antenna. In the case of the inverted L-type, the lead-in is connected to the end of the cage; in the case of the T-type two smaller cages are used with the lead-in fastened between them as shown in Figure 3.

The lead-in may also be constructed in the form of a cage. The loops for the lead-in should be 8 inches in diameter, instead of one foot.



### The Public Benefit of Good Broadcasting

TO THE EDITOR OF POPULAR RADIO:

"I heartily approve of your proposed plan to broadcast good music and valuable information from the great centers of New York and the country. I see no reason why this should not be done, especially as the expense of doing it is now relatively small and the public able to benefit by it is large."

*Edward R. Hewitt*

Treasurer, Cooper Union

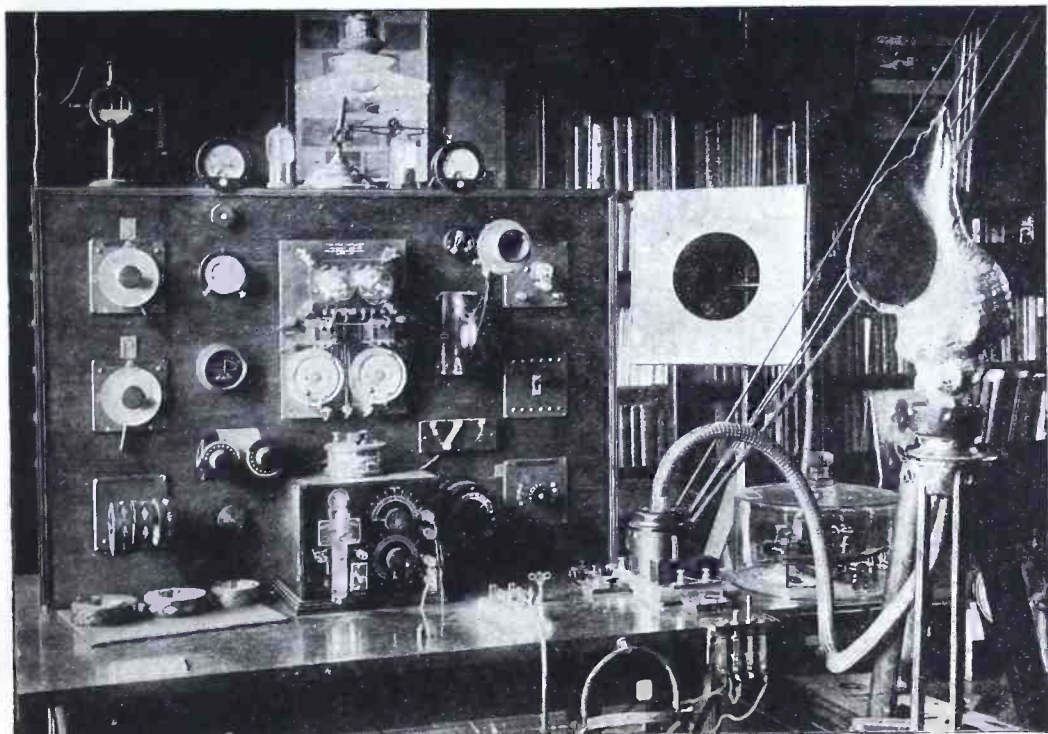

From a photograph by Ewing Galloway

## A "Loud Speaker" *from* a Conch Shell

**A** LOUD speaker made from a sea shell is a new and easily constructed device that amplifies the smallest details of broadcast music with a minimum of the echoes and harsh distortions made by metal amplifying horns.

The compartment of the human ear known as "the winding staircase" suggested the sea shell to the inventor, Father Frederick L. Odenbach. After experimenting he found that a triton or conch shell served the purpose best. So he sawed off the tip of the shell making a cross section of about an inch and a half in diameter. The opening in the sawed end of the shell was then widened out and the winding chamber inside was enlarged so that it was about the size of a finger. The shell was mounted on a block of wood to hold it solid, and a piece of ordinary garden hose was attached. The hose was extended to a sensitive telephone receiver or to one of the many commercial sound-amplifying devices

which use a horn for a resonator.

The sea shell amplifier is reported to work well in a parlor, but for concert halls the inventor has perfected a pyramid horn of thin wood. The wooden horn is not quite as clear as the shell amplifier but it is more powerful. The pyramid horn was made two inches square at the small end and a foot square at the large end. Thin shellacked wood was used for all four sides, two opposite sides of pine and two of maple. The opposite sides were connected by thin splinters of wood, fitted into the interior of the horn.

Over the large end was placed a thin piece of wood with a round hole in the center, six inches in diameter. This was the ordinary wood used on the backs of framed pictures. The wooden pyramid was connected to some kind of electromagnetic amplifier, in the same manner as the sea shell was connected, with a length of rubber hose.



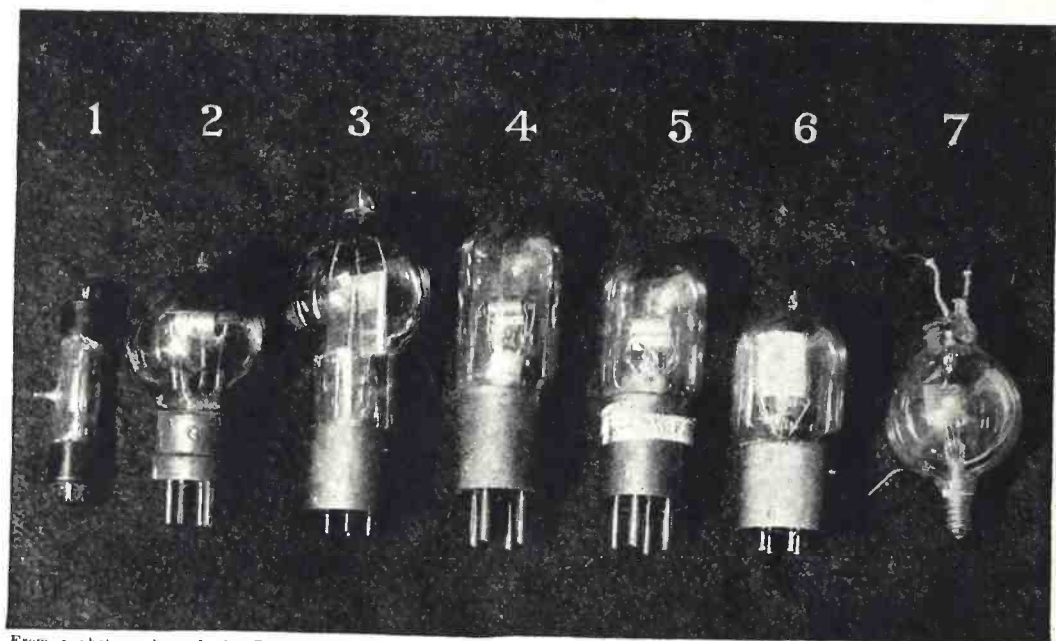

From a photograph made for POPULAR RADIO

### AN UNUSUAL COLLECTION OF AMERICAN AND FOREIGN TUBES—

*The various forms of vacuum tubes shown above may be identified as follows: 1, the Myers audion (American); 2, amplifier tube used by the French; 3, the De Forest rectifier tube (American); 4 and 5, German tubes made during the war (on account of the scarcity of brass in that country at the time, the bases of these tubes were made of iron); 6, the well-known Moorhead Electron-relay (American); 7, the original De Forest "Audion" (American).*

## How *the* Vacuum Tube Detects

SIMPLE "HOW" ARTICLES FOR THE BEGINNER—NO. 7

By LAURENCE M. COCKADAY, R.E.

**I**N the preceding article on the crystal detector we learned that radio frequency currents must be "rectified" or reduced to a pulsating direct current before they can be used to produce sound waves in the telephones. The crystal detector does this on account of its inherent "unidirectional conductivity." By unidirectional conductivity is meant the ability of the crystal to pass currents through itself in one direction, while preventing currents from flowing through itself from the opposite direction.

Thus, if a crystal be connected in an alternating current circuit, only half the impulses will flow through it and the

other half of the impulses (trying to flow in the other direction) will be resisted, or held back. A crystal, then, conducts currents much better in one direction than in the other, and the current that actuates the telephones in a crystal set is that current (which happens to be flowing in the right direction) which the crystal lets through. It will readily be seen that this actuating current is but a part of the received energy, and if all the incoming current could be put to work in some way or other, much louder signals would be produced in the telephones.

We shall now see how the vacuum tube uses all of these received impulses, both positive and negative, and uses them so as to act as a trigger acts in a gun. It

\*See "How the Crystal Detector Detects," in POPULAR RADIO for October, 1922.

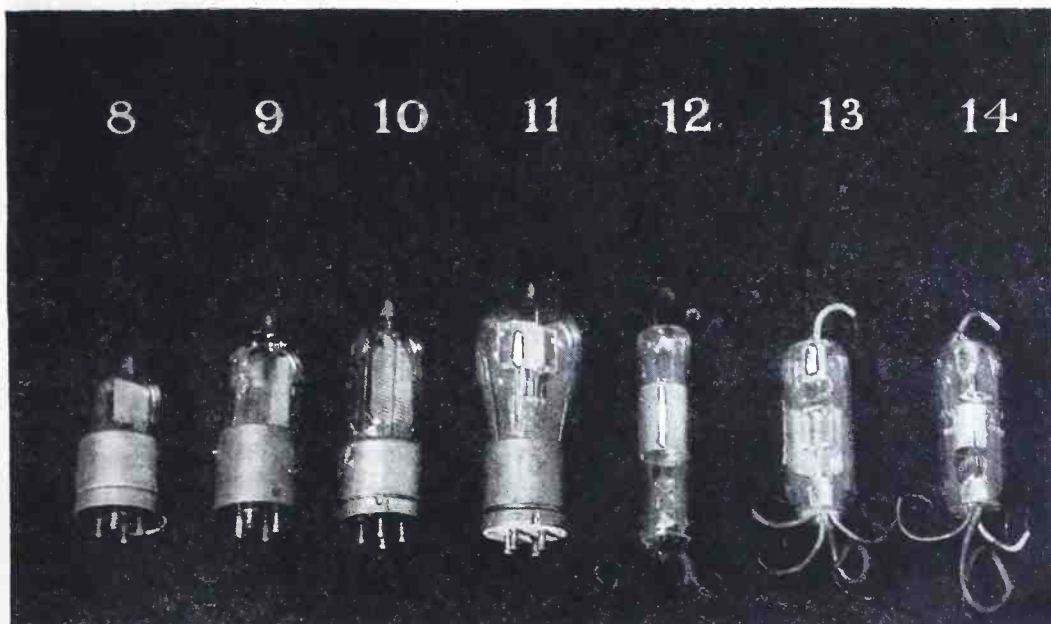

—INCLUDING SOME OF THE EARLY MODELS USED BY AMATEURS  
 8 is the De Forest VT-21, a wartime tube (American); 9, the Moorhead amplifier tube (American); 10, the Western Electric VT-1, used by the U. S. Navy and the U. S. Signal Corps during the war (American); 11, the Radiotron, now in common use for detection and amplification (American); 12, the tubular "Audiotron," at one time the amateur's favorite detector (American); 13, an amplifier tube with a second spiral grid that serves as a plate (Japanese); 14, a detector tube, evidently copied after the "Audiotron" (Japanese).

takes but a small effort to pull the trigger, although the resultant explosion is many times more powerful than the trigger effort. So the vacuum tube uses the feeble received currents to "trigger off" larger currents supplied by the "B" battery and in this way at the same time amplifying or strengthening the signals. In this case the "B" battery may be likened to the powder in the gun, and the feeble incoming impulses may be likened to the pressure upon the trigger. An incoming impulse pulls the trigger of the vacuum tube, so to speak, and the "B" battery connected in the plate circuit of the tube immediately "shoots" the energy to reproduce the trigger impulse in much amplified fashion. This is made possible by the rectifying and amplifying qualities of the vacuum tube itself, giving receiving results far superior to those of the crystal detector which possesses only the quality of rectifying.

Edison, while studying the effects of

heated filaments of carbon in the old-fashioned electric incandescent lamp, found out that the filament got thinner and thinner as the lamp burned, and that the glass bulb began to get darker and darker at the same time. The filament seemed to be disintegrating, and giving off particles which shot across the evacuated space and stuck to the glass. He conceived the idea of placing another electrode or wire in the lamp that would collect these little particles which constantly were being driven away from the filament. Later he found that the extra wire became charged slightly negative every time the lamp was turned on, and finally a battery was connected across between the wire and the filament, with the positive terminal of the battery connected to the wire. Immediately a current was detected flowing in this circuit, and when the lamp was turned off, the current promptly stopped. This action was called the "Edison effect," and we know

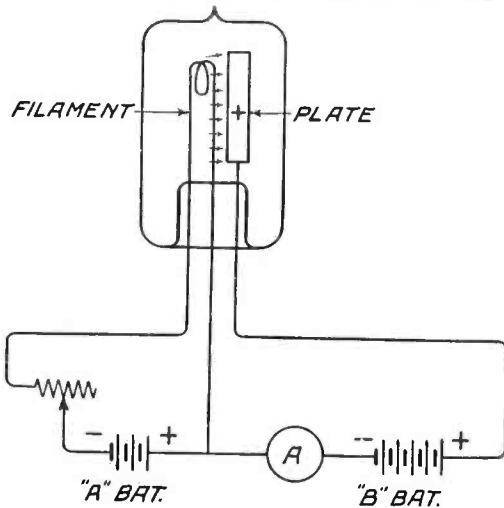
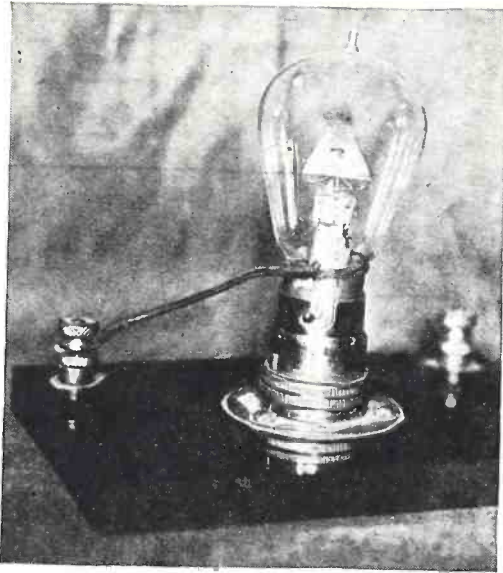

FIGURE 1

*A model of the first vacuum tube, made by J. A. Fleming in England; it contains only the filament and the plate. The diagram illustrates its unilateral conductivity.*

now that all filaments when heated in a vacuum give off electrons which fly off and away from the filament.

Fleming made use of the Edison effect when he designed his valve which consisted of a filament and a metal plate in a vacuum tube. In Figure 1 is shown a diagram of a Fleming valve connected to an "A" battery for heating the filament and a "B" battery for keeping the plate positive to help attract the negative elec-

trons. When the tube is connected up (as shown in the diagram) with a current-measuring device, A, connected in series with the "B" battery, and the "A" battery current is turned on (thus heating the filament), a current is immediately indicated by A, flowing in the plate circuit. If the "B" battery is reversed so that the plate is negative, no current is measured by A, showing that the tube will pass current from the plate to the filament, but not from the filament to the plate. This of course is true only while the filament is heated and giving off electrons—the electrons really constituting the plate current, although we consider the current as flowing in the opposite direction to the electrons.

Before we go any further, there are three points to remember which are important if we are to understand the action taking place in the vacuum tube:

*First:* a vacuum tube will pass current only from the plate to the filament.

*Second:* the strength of this current is dependent upon the density of the stream of electrons passing from the filament to the plate.

*Third:* the density of the stream of electrons is dependent upon the temperature of the filament, the kind of material the filament is made of, the distance between the filament and the plate, and the amount of "B" battery potential applied to the plate.

While experimenting with electron streams in flames and hot gases, De Forest found that he could control the strength or density of the stream of electrons by placing a charged wire mesh in the path of the stream. That this is a fact will at once be evident to anyone who knows that "like charges repel, and unlike charges attract." The electrons are negative, and when the mesh is charged negatively the electrons in the stream which are trying to pass through the holes in the mesh are repelled and the stream is reduced and stops, and when the mesh is charged positively, the electrons are strongly attracted and the stream is increased and strengthened.



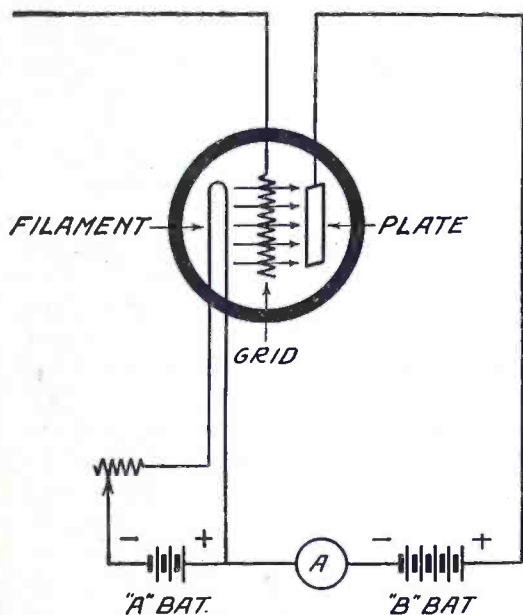

FIGURE 2

Diagram of the insulated grid in the vacuum tube.

De Forest then applied this principle to the vacuum valve and interposed his famous "grid" in between the filament and the plate. (See Figure 2.) In this diagram the grid is shown disconnected and has no externally applied charge on it. In this state the tube would act about the same as the Fleming valve; that is, there would be a flow of electrons across from the filament to the plate if the filament is heated. This is the same as stating that a current would flow from the plate to the filament (refer to the three points to be remembered, mentioned above). The electrons would pass through the spaces in the grid.

Now suppose we should connect a small battery "C" across from the filament to the grid with the negative terminal connected to the grid and the positive terminal connected to the filament, as shown in Figure 3. This would make the grid negative with respect to the filament, or in other words a negative charge of 2 volts will be placed on the grid. Let us study the effect of this charge on the grid in the diagram. The electrons trying to leave the filament, represented by the arrows,

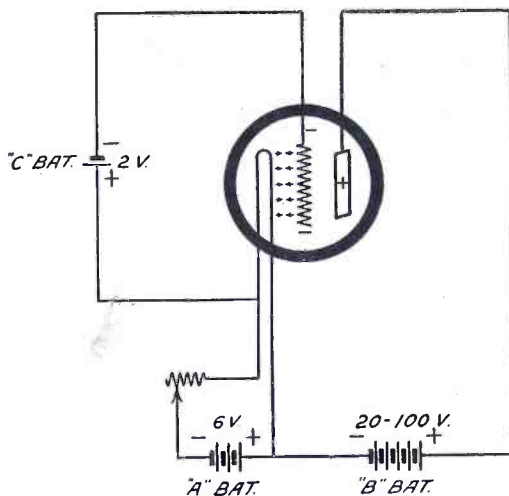

FIGURE 3

This diagram illustrates the action of the negative charge on the grid.

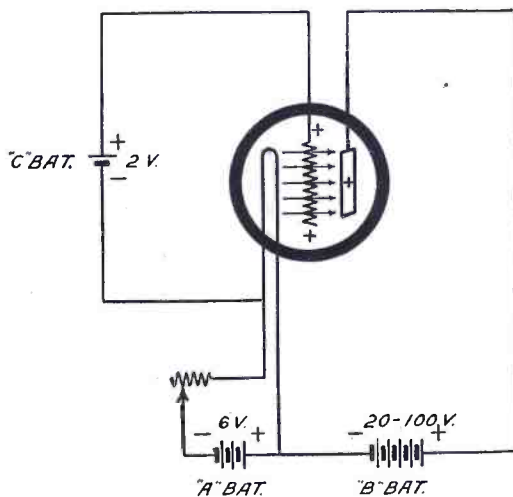

FIGURE 4

The action of the positive charge on the grid. Compare this with the diagrams above.

are negative. The grid is charged negatively, by the "C" battery. Remembering the fact that "like charges repel and unlike charges attract," we readily see that the electrons are repelled and forced back to the filament; a small number, or none, ever get across to the plate. Hence, in this condition the tube lets little or no current across from the plate to the filament.

What would happen if we suddenly were to reverse the terminals of the "C" battery which is charging the grid? Let

us investigate in Figure 4. In this case the grid would have a positive charge of 2 volts, and the negative electrons would be strongly attracted across from the filament to the grid. When they get this far on their journey they begin to feel the greater attraction of the higher positive voltage charge on the plate and they pass through the spaces in the grid in a flying effort to get to the plate, which receives them "with open arms," so to speak. The attraction of the positive charge on the grid draws many times more electrons from the filament than would ordinarily leave it, and thus the density of the stream is increased many times. Another reference to our famous three points will prove that there is at this time a much stronger current flowing from the plate to the filament. The current flowing across from the plate to the filament of course is a direct current, and is known as the "plate current" of the tube. To sum up the action of the tube in a few words, we might say that "the plate current (explosion) of the vacuum tube can be controlled by the voltages (trigger) applied to the grid."

Now we can see the likeness between the action of the vacuum tube and the action taking place in firing a gun.

It takes a very small change in grid

voltage to effect large changes in the values of plate current, and it is this plate current that is used to actuate the telephones in a vacuum tube receiving circuit. The feeble received impulses are used to "trigger off" much larger currents supplied by the "B" battery, in this way at the same time amplifying and strengthening the incoming signals. This is the reason why the vacuum tube gives so much stronger signals than the crystal detector, which only rectifies the weak incoming impulses.

In Figure 5 is shown a conventional circuit with a vacuum tube used as a detector. The loose coupler is used to tune in to the desired wavelength, so that the radiated energy may be received and applied to the grid in the form of high frequency impulses. These impulses vary the amount of the direct plate current of the tube so that the same voice waves as spoken into a distant telephone transmitter are reproduced and amplified in series with the plate and "B" batteries. A grid condenser is used to supply the incoming charges to the grid of the tube. The grid leak resistance is used to prevent the negative charges accumulating on the grid in such large quantities that the tube becomes inoperable.

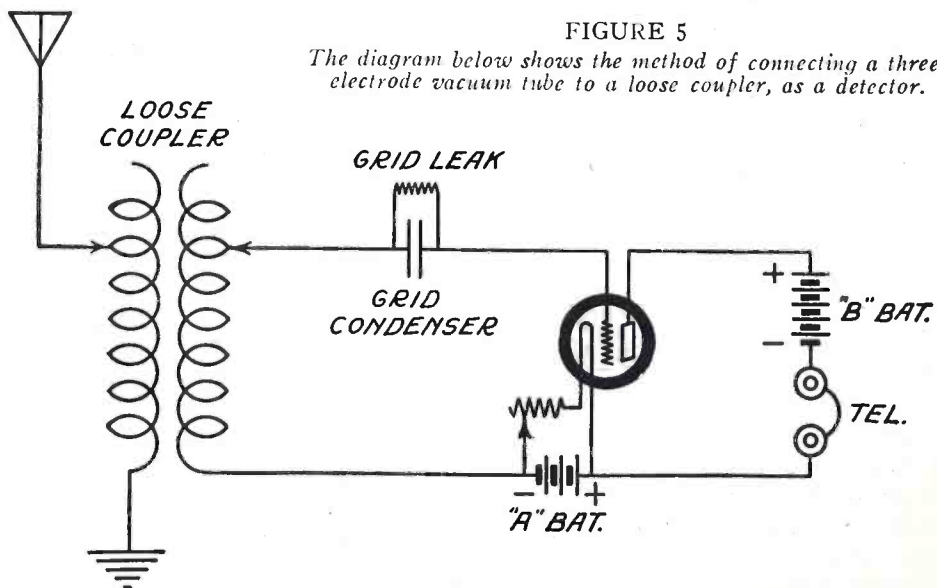

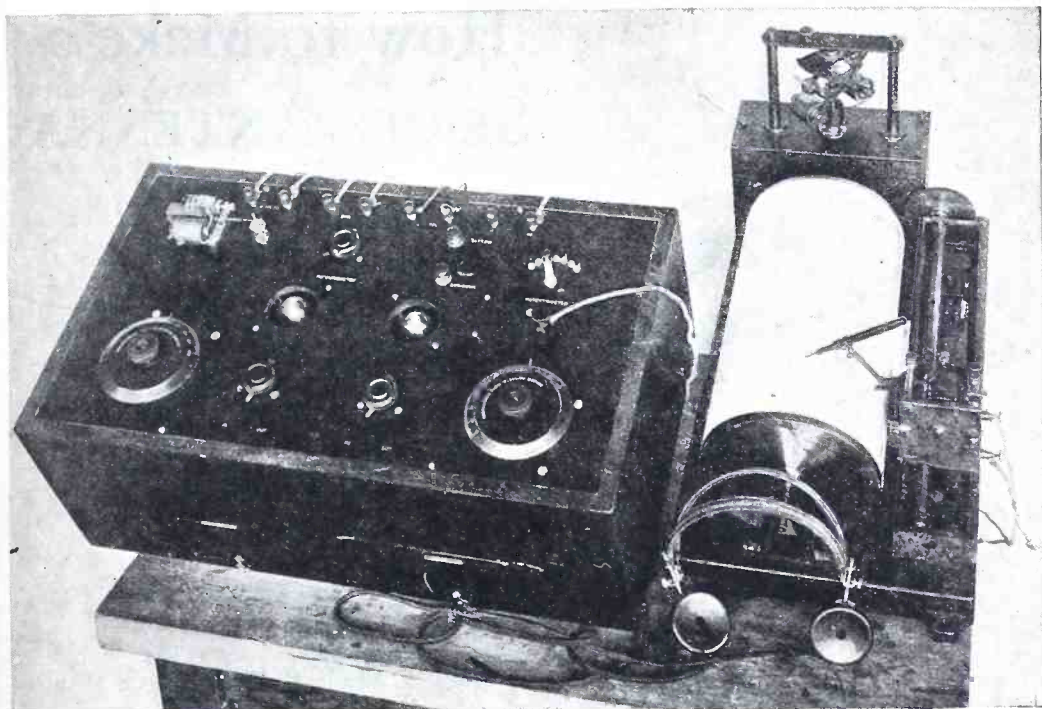

Bureau of Standards

*With the aid of an ordinary fountain pen, this novel radio set makes a written record of code signals that come in during the operator's absence.*

## A Receiving Set that Takes Down Notes

**I**F you are an operator, amateur or professional, who fears that some message of value may come in by radio while you are away from your receiving set, you need carry your anxiety no longer. You may merely employ a mechanical understudy that will automatically take down the signals—and take them down in writing—while you are absent.

This novel device has been built by Dr. E. A. Eckhardt and Dr. J. C. Karcher of the Bureau of Standards in Washington. It copies down the dots and dashes sent from a distant transmitting station without any supervision whatever from a radio operator, and the permanent record made by this machine may be deciphered at leisure by anybody who possesses a copy of the code chart. The dots and dashes are recorded as short and long humps along a continuous spiral inked line made by an ordinary fountain pen around a slowly revolving cylinder—

shown on the right of the illustration.

A feature of the device is the fact that it functions without the use of amplifiers, yet at the same time it is possessed of great sensitivity, copying messages from as far away as Lyons, France—a distance of 3,800 miles.

The actuating mechanism for moving the pen back and forth and sidewise while the cylinder revolves (thus recording the received impulses), consists of an extremely sensitive electromagnet.

The device was built for the specific use of the Coast and Geodetic Survey of the United States Department of Commerce, and at present is being used for recording time signals on surveying expeditions in remote sections of the country.

It is conceivable that from this device may be developed a machine for long-distance writing by radio—even to the signing of checks.



# How to Make a SERIES-ANTENNA CONDENSER

Do you want to increase the flexibility of tuning in your set—especially on the lower wavelength ranges? This article tells how to make the necessary condenser for 50 cents.

BY WATSON DAVIS

THOSE readers of POPULAR RADIO who have built the radio receiving sets that have been developed by the Bureau of Standards in Washington and described in specific detail in this magazine\* may now improve their apparatus by adding a condenser in the antenna circuit. The fact that this addition may be made at home for the modest sum of about half a dollar commends it to the radio fan to whom the cost is a factor as well as to the fan who finds delight in building his equipment with his own hands.

The effect of the series-antenna condenser in a receiving set is to enable the receiving equipment to give signals of somewhat greater intensity when tuned to wavelengths of 300 meters or less. It will thus be seen that the effect of this condenser is just the opposite of the effect obtained by a greater number of turns of wire on a tuning coil, which, it will be remembered, permits the receiving equipment to respond to longer wavelengths.

The series-antenna condenser described here has a rated capacity of about 0.0003

\*See "How to Make and Install Your Own Receiving Set" in May, 1922; "How to Make and Operate a Two-Circuit Receiving Set" in July, 1922, and "How to Add a Vacuum Tube to Your Crystal Receiving Set" in November, 1922.

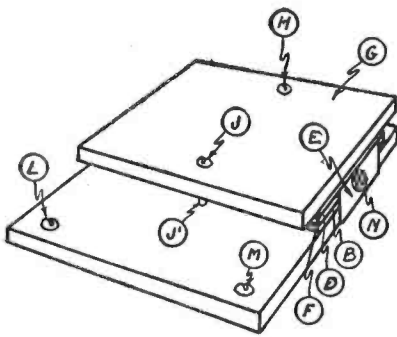

FIGURE 1A

This drawing shows the condenser completely assembled. The parts designated by letters are described in the accompanying text.

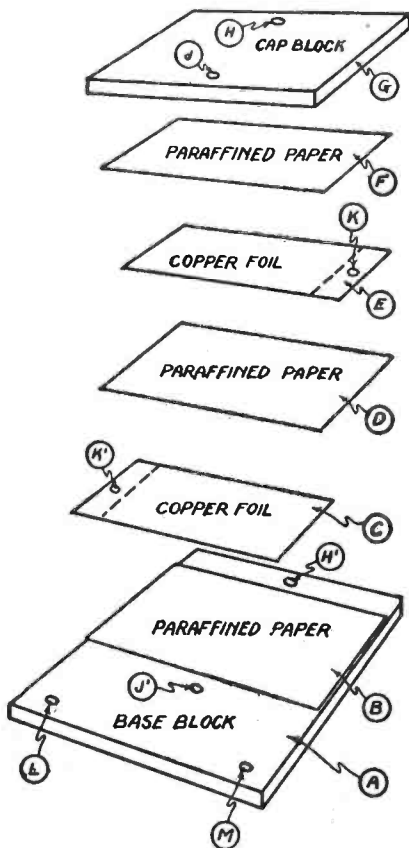

FIGURE 1B

This diagram shows the component parts of the condenser in the correct order of assembly reading from the bottom upward. The different parts are prepared as indicated in this article.

microfarad (300 micromicrofarads). This is how to build it:

#### How to Make the Condenser

The condenser is shown in detail in Figures 1A and 1B. Two thin strips of metal, C and E, 1 inch wide and 3 inches long, are used with three sheets of insulating material, B, D and F, 1½ inches wide by 3 inches long. The metal strips may be thin copper, brass or aluminum. Each of the three sheets of insulating material is made up of two pieces of heavy white writing paper which are separately dipped in clean, melted paraffin. Each pair of sheets is then pressed together by means of a warm iron; when cold the strip is cut out to the required size. A sheet of clear mica, of about the same thickness as the two sheets of writing paper mentioned above may also be used for the insulating material. Two blocks, of hard wood (G is 2½ by 3½ inches, A is 3 by 3½ by ½ inches) are cut out. Two screws pass through holes H and J in the upper block G, which is placed over the block A, so that the edges of the two blocks are even on three sides. (See Figure 1A.) The holes for the screws H and J are ¾ inch from the sides of the block G and equally distant from the ends.

Having located the correct position of the block G, the screws in holes H and J are loosened and the block is removed from A, leaving two small holes H' and J' to locate the proper position of the blocks when the condenser is finally assembled. The two

screws L and M are located just far enough in from the front edge (see A Figures 1A and 1B) so that the block A may be screwed to the left end of the baseboard of the receiving set. (See Figures 2 and 3).

The wooden blocks are of dry wood smoothed up with sandpaper and given a coat or two of varnish which will not absorb moisture, or treated with paraffin.

A sheet of the paraffined paper (or mica) B is placed on the block A between the holes H' and J' so that its ends are even with ends of the block. A thin metal strip, C, is placed in position so that it lies in the center of B and has its right end ½ inch in from the edge of the base block and its left end projecting ½ inch over the opposite edge of the base block. (See Figure 1B.)

Another sheet of paraffined paper D is placed on C directly above B. The second piece of thin metal E is placed on D and above C, except that one end of the metal strip E extends ½ inch over the right edge of block A instead of the left, as did C. The third sheet of paraffined paper F is placed on E directly above D and B.

The alternate sheets of paraffined paper and thin metal are held carefully in position, and the block G is placed over them and screwed in position. The right end of the thin metal strip E is bent down, and a round-head brass screw N is passed through a hole K punched or drilled in the end of the metal strip. The projecting end of the strip C is not visible in the Figure 1A, but it is bent and fastened

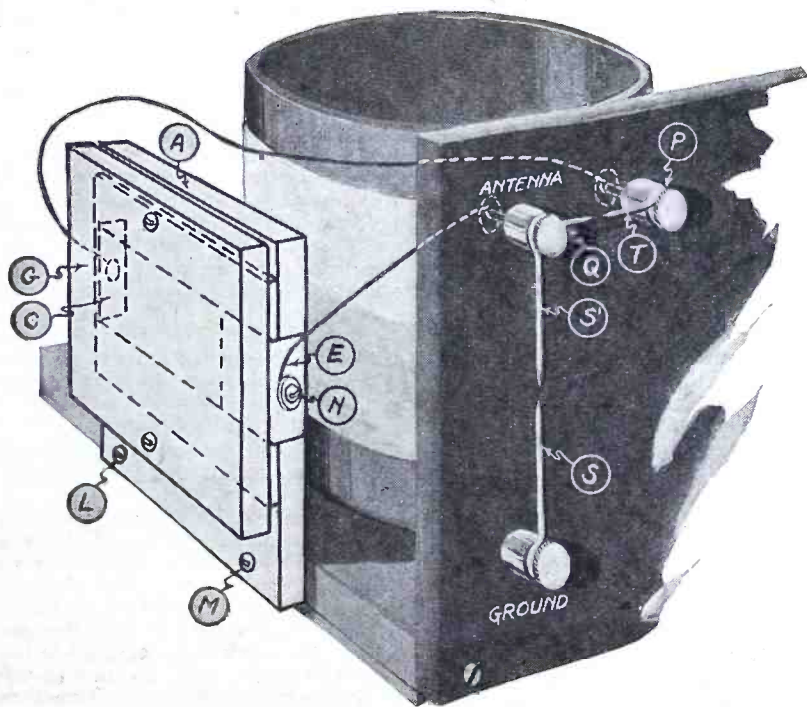

FIGURE 2

How the condenser is used in combination with the single circuit receiver.

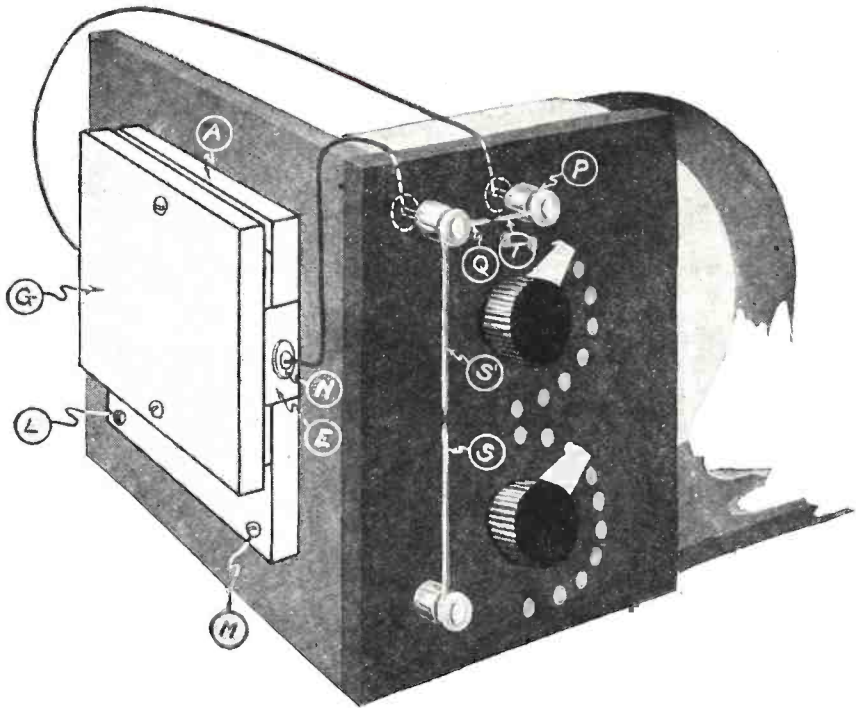

FIGURE 3

*This drawing shows how the antenna condenser should be connected to the double circuit receiver.*

in the same manner as E. The completed condenser resembles the sketch shown in Figure 1A.

#### *How to Mount and Wire the Condenser*

The condenser is mounted on either the single-circuit receiving set described in the May issue of *Popular Radio* or the two-circuit receiving set described in the July issue. Figure 2 shows the method of mounting the condenser on the single-circuit receiving set. The condenser is fastened to the end of the baseboard by means of the screws L and M. A binding-post P is added to the panel of the receiving set about 1 inch from the binding-post marked "Antenna," as shown in Figure 2. A wire is clamped under the condenser screw N which passes through the metal strip E, forming one terminal of the condenser. This wire is led to and connected to the back of the binding-post marked "Antenna" without disturbing any of the other wires which are already connected to this binding-post. Another wire is connected to the terminal of the metal sheet C and led to the back of the binding-post P.

In the diagram in the May issue a short stiff wire is shown attached to the "Antenna" binding post and extending toward a similar wire attached to the "Ground" binding-post. The wire on the "Antenna" binding-post is removed and a longer one substituted so as to form parts Q and S; Figure 2. A similar short piece of stiff copper wire T is attached

between the first and second nuts of binding-post P. There is a very short gap between wires Q and T and between S' and S. These gaps are for protective purposes when one forgets to throw the lightning switch to the grounded side. Another method of protection would be to install a lightning arrester in the antenna system. The arrester may be installed just outside or just inside of the building, preferably the former. This serves as an extra precaution when one forgets to throw the lightning switch to the ground terminal when the receiving set is not being used.

If the condenser is mounted on the receiving set described in the July issue, it may be placed as shown in Figure 3. In other words, it is mounted upon the vertical board which supports the primary coil tube previously described. The connections from the condenser to the binding post on the front panel of the two-circuit set are made as described above.

If the connections to the receiving set have been made as described, the antenna lead-in wire is removed from the binding-post marked "Antenna" and connected to the new binding-post which has been added to the front panel of the receiving set. (See P, Figures 2 and 3). The condenser is now included in the electrical circuit together with the tuning coil, between the antenna and ground. This connection to the binding-post is used when it is desired to receive wavelengths of 300 meters or below. To receive wavelengths of 300 meters or more,



the antenna lead-in will ordinarily be connected to the binding-post marked "Antenna" and the operation of the receiving set is then as described in the previous articles. The switches are set so as to include more turns of wire on the tuning coil (or the primary coil of the two-circuit receiving set) with the antenna lead-in connected to F than when it is connected to the binding-post marked "Antenna," when tuning to a given wave frequency.

This will provide greater coupling, resulting in greater energy transfer from the primary to the secondary, and hence louder signals.

#### What It Will Cost

The material required and the costs of the various items are listed as follows:

2 metal strips (copper, brass or..... aluminum).....	\$0.10
3 sheets of mica (if used).....	.20
1 binding-post (any type).....	.10
6 wood-screws.....	.10
2 small wooden blocks.....	
Paraffin .....	
Paper .....	
Total cost.....	\$0.50

### Photographing Our Emotions—by Radio!

**Q** How highly sensitive radio apparatus is now being used in the realms of medicine for recording the physical and nervous conditions of patients; how this same apparatus is even making graphic records of the reactions of our thoughts—will be told in the January issue of POPULAR RADIO by Dr. Henry Smith Williams.

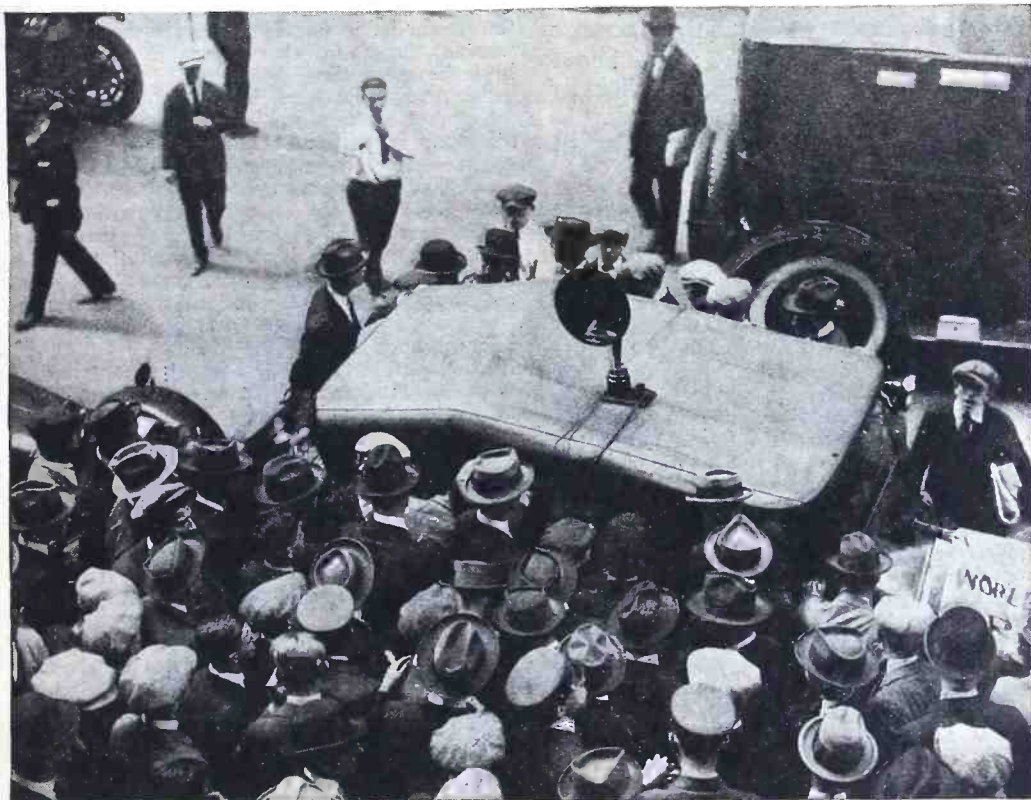

International

#### RADIO BRINGS BASEBALL TO THE CURB

*Some intimation of the possibilities of radio for adding to the sum of human happiness was demonstrated over a wide area during the World-Series baseball games in New York, when sideline reports of each play were broadcast from WJZ—thanks to the timely cooperation of the Western Union in furnishing wires. One enterprising radio amateur installed a receiver on his motor car and demoralized the financial center of the world for a few hours when he established himself on Wall Street and permitted millionaires and office boys to follow the score.*



## LISTENING IN

HELP your neighbor. If you have discovered any little Kink that helps to eliminate trouble in your radio apparatus, or if while experimenting with the connections of your set you should run across some interesting phenomenon, or if you should discover some new hook-up that gives better results—send it to the "Listening In" page.

### How to Combine Your Crystal and Your Vacuum Tube

ONE reader finds that he can use a crystal and vacuum tube at the same time with a saving of life of both the tube and batteries and at the same time increase the strength of signals over and above the strength that a crystal will ordinarily produce. He uses a circuit similar to that on page 222 of the July issue of POPULAR RADIO. He writes:

I have my crystal detector connected across my vacuum tube circuit; that is, from the top side of my loose coupler to the negative terminal of my "B" battery. This enables me to hear signals through my crystal detector. Then I turn on the tube, with the crystal still connected, and find that the signals increase in sound to a point nearly equal to that of the tube when it is used by itself with about half the current it takes to bring in the signals on the tube. I have the wire connecting the crystal to the negative "B" battery loosely connected and by lifting it away and thus disconnecting the crystal, the signals disappear. This proves that by the use of both detectors the signals can be increased with half the power from the battery, which saves the charge in the battery and at the same time lengthens the life of the tube, as it does not have to burn so brightly. Test this out to your own satisfaction and see what you think about it.

W. J. THOMPSON

\* \* \*

### The High Cost of Radio in Germany

THE radio fan abroad is not blessed with the advantages of his Yankee *confrère*. The handicaps under which Hans struggles in Germany, for instance,

is briefly outlined by Vice-Consul Nathaniel B. Davis in Berlin:

German manufacturers of radio apparatus and equipment are not in a position to make extensive deliveries of their product. This is due to the fact that up to the present time the demand has not been sufficiently great to warrant the manufacture of radio instruments in large quantities.

Amateur radio work is not popular in Germany and stations are not numerous. Radio telephony in particular is almost an unknown science except to engineers, professional operators, and experimenters. The principal reasons given for the lack of interest in radio on the part of the general public are that amateur stations are a luxury beyond the means of the average German, under present economic conditions, and official restrictions on their use.

All radio communication in Germany is under the control of the Federal Post Office Department, which operates the commercial stations. Private installations must ordinarily be made by the Department; in exceptional cases private companies or individuals may be authorized to erect their own plants, but they must first obtain a license from the Post Office Department. The fee for such a license varies according to the size of the plant, with a maximum of 2,000 marks a year.

At present only one station in Berlin is licensed to broadcast. This station broadcasts market and exchange quotations. Subscribers to its service are permitted to install receiving stations upon payment of the license fee and the monthly subscription rates, which vary at present from 1,000 marks to 7,500 marks, according to the class of subscription. Subscribers may rent receiving sets from the Post Office Department for 2,500 marks a month if they do not desire to build their own.

In spite of the lack of demand for short-wave amateur apparatus there are a number of firms in and about Berlin which manufacture either complete receiving sets or parts. Vacuum tubes are almost unavailable, and practically all receiving sets manufactured in the Berlin district operate with crystal detectors.

## Blocking Bandits with Radio

**T**HE use of radio for running down law-breakers is not new. But a novel and dramatic use of it is being found, for it is thwarting the bandits of Mexico; here is a description from a former official of the American Chamber of Commerce in Tampico:

It took robbery and violent death at last to bring radio into the Tampico oil fields as the new hope of the oil companies, and the *rurales* who are supposed to preserve law and order. The recent killing of one American, the wounding of two others and the taking of 42,000 pesos from a paymaster for the *Companias del Agwi* finally decided that organization to apply to the Mexican Government for a permit to install radio receiving and sending apparatus, for connecting its headquarters in Tampico with its sea loading stations and camps in the lower field, in the State of Vera Cruz.

Robberies have been of almost weekly occurrence in the great Tampico field, which takes in hundreds of square miles of jungle in which, heretofore, the bandits have found it easy to outwit the *rurales*. A gang of bandits that was recently broken up was armed with portable telephones and had been listening in on the private lines of companies; there is little doubt that the

arrangements for the transportation of the payroll stolen from the *Agwi* company were discovered by the bandits in that manner. The company had arranged to send the money over the most dangerous part of the trip by airplane, believing it could evade bandits in that way, but the bandits evidently had learned all the details of the plan, and held up the paymaster before he reached the place where he was to have taken the airplane.

The Mexican Government has a monopoly on all telegraph and telephone communications, however, and it is only by special permit that any private company can transmit or receive messages. The great oil companies have such permits and all the principal companies have private telephone lines—the only long-distance telephone lines in Mexico. All radio outfits which cross the border, therefore, must be reported to the Mexican Government, and it is believed that the government can easily keep tab on all such equipment in territory under its control, so that it will be virtually impossible for bandits to listen in on the oil companies by radio. At present, the bandits know nothing of radio.

The experiment the *Companias del Agwi* is about to make will be watched with great interest by about thirty other oil companies, and it is probable that soon radio will have secured a start in Mexico from which there will spread rapidly, enlightenment and progress throughout the entire Republic.

LEE SHIPPEY

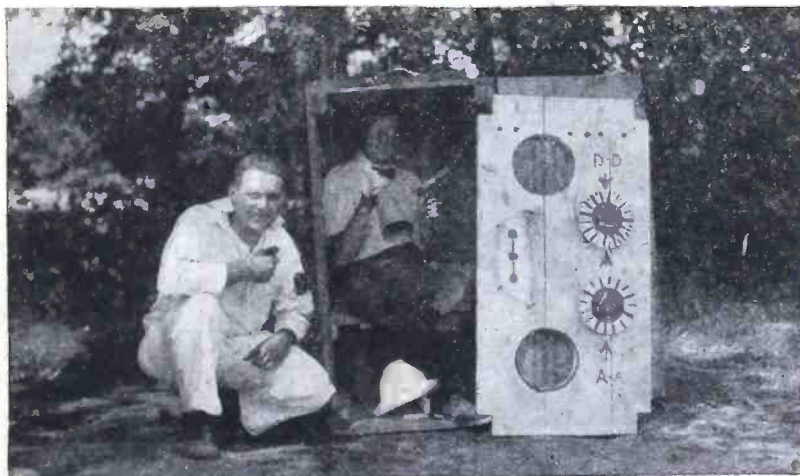

### A STATIC-PROOF RADIO SET

*When two hundred members of the American Canoe Association recently gathered at Sugar Island, near Ganagoque, Canada, for an evening's entertainment, they were treated to a truly remarkable exhibition of the possibilities of radio. A huge (and obviously home-made) receiving set was carried out before the audience, an aerial was solemnly run up on a flag-pole and a serious radio lecture was delivered by the "operator," Oscar S. Tyson. Inside of the set was concealed George P. Douglas, who with the help of a phonograph for music, a megaphone for speaking, two flash-lights for tubes and several "rattlers" and "squeakers" for static gave a very creditable bit of broadcasting which entirely fooled the audience—until the front plate of the set was removed at the end of the entertainment.*



### Radio on Life-Boats

**E**VEN the life-saving boats of the romantic Coast Guard service are becoming modernized—by the installation of radio sending and receiving apparatus. (Glance at the cover design on this magazine.) Some months ago the Bureau of Standards conducted some tests of this equipment off Atlantic City; new experiments are now being carried on at the Curtis Bay Station, south of Baltimore. Only the expense of the apparatus has prevented earlier installations. How the problem is being worked out is told by an expert as follows:

The one great hindrance to the work of life-saving corps has been in maintaining communication. In pre-radio days the only methods of communication between a foundering ship and vessels were the use of rockets and the shooting off of bombs, and even these were of limited value as they served only as a means for determining the approximate posi-

tion of the vessel in distress, and could give no details of the trouble.

Radio, as supplied to the vessels themselves, has offered a partial solution to this problem; the application of radio to the life-boat itself has been a more difficult problem to solve, largely because an antenna mast and antenna on a life-boat, even though of the sturdiest construction, could last only a few moments in a heavy sea. Further, when a life-boat approaches a ship's side, the aerials would undoubtedly be carried away when the boat rolled over against the vessel. To overcome this difficulty a new type of antenna has been developed which does not require masts; it is virtually a loop antenna, and is the outcome of a considerable amount of experimental work in connection with the installation of radio on submarines.

A heavily insulated wire is run from the bow of the life-boat down along one side of the keel, extending back to the stern, up the stern, and then back to the bow on the same side of the boat along the scuppers. The same wire is then led in the same path, fore and aft, on the other side of the boat, so that it forms a two-turn loop. The two terminals are led to the radio telephone installation, which is located under the canvas spray-hood. This form of antenna can be used for both transmitting and reception over the normal cruising range encountered. The equipment used is of the Western Electric type that was employed during the war on submarines and sub-chasers. The transmitting and receiving apparatus used at the Coast Guard land station is also of the Western Electric type.

By the use of this new equipment, the life-saving boat may be at all times in two-way communication, not only with the land base, but with the vessel in danger, and with other ships standing by.

D. C. SANDERS



#### THE MODERN SUCCESSOR TO THE ROCKET

*Conversation by radio between shipwrecked mariners and their rescuers may lack the dramatic touch furnished by fireworks-signals. But it will save more lives.*

### Side-line Reports by Radio

**O**NLY the inability of the broadcasting stations to obtain the necessary telephone wires for transmitting side-line reports of the big football games this fall prevented the radio fans from listening in on any considerable number of these picturesque events. One university is apparently going to do its own broadcasting in its own way, as this note from New Haven will attest:

The authorities at Yale University announce that in the future athletic events will be broadcast by radio to the surrounding cities. This means that anyone within a distance of about fifty miles of New Haven will be able to receive by radio play-by-play reports of the football, hockey, lacrosse and other games.

## WHAT READERS ASK



THIS department is conducted for the benefit of our readers who want expert help in unravelling the innumerable kinks that puzzle the amateur who installs and operates his own radio apparatus. If the mechanism of your equipment bothers you—if you believe that you are not getting the best results from it—ask THE TECHNICAL EDITOR.

THE flood of inquiries that has poured in upon the Technical Editor has not only furnished evidence of the need of this department: it has also necessitated a system of handling the correspondence that will insure the selection of and answer to only those questions that are of the widest application and that are, consequently, of the greatest value to the greatest number of our readers. Our correspondents are, accordingly, asked to cooperate with us by observing the following requests:

1. Confine each letter of inquiry to one specific subject.
2. Enclose a stamped and self-addressed envelope with your inquiry.
3. Do not ask how far your radio set should receive. To answer this inquiry properly involves a far more intimate knowledge of conditions than it is possible to incorporate in your letter.

The questions that are not of sufficient general interest to warrant publication in this department will be answered personally. Many

of these questions are being answered by referring the correspondents to items that have already been printed in these pages. To get the full benefit of this service, therefore, save your copies of POPULAR RADIO.

QUESTION: Please give me a hook-up for a tuning coil, a crystal detector, a variable condenser and a honeycomb coil.

T. P. D.

ANSWER: A circuit that uses the instruments you have on hand is illustrated in Figure 1. You will not need the honeycomb coil, but you will get better results if you obtain a fixed telephone condenser and hook it across the telephones as shown in the diagram. This condenser will serve to shunt the radio frequency currents around the telephone, allowing only the audio frequency currents to pass through them.

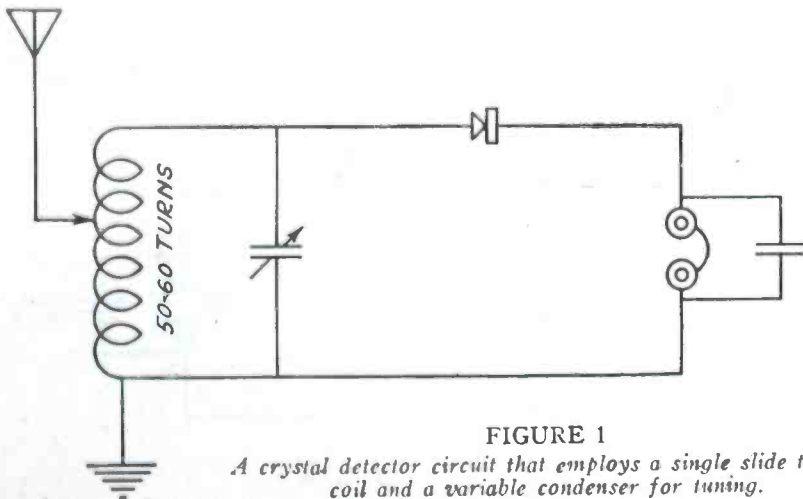

FIGURE 1

A crystal detector circuit that employs a single slide tuning coil and a variable condenser for tuning.

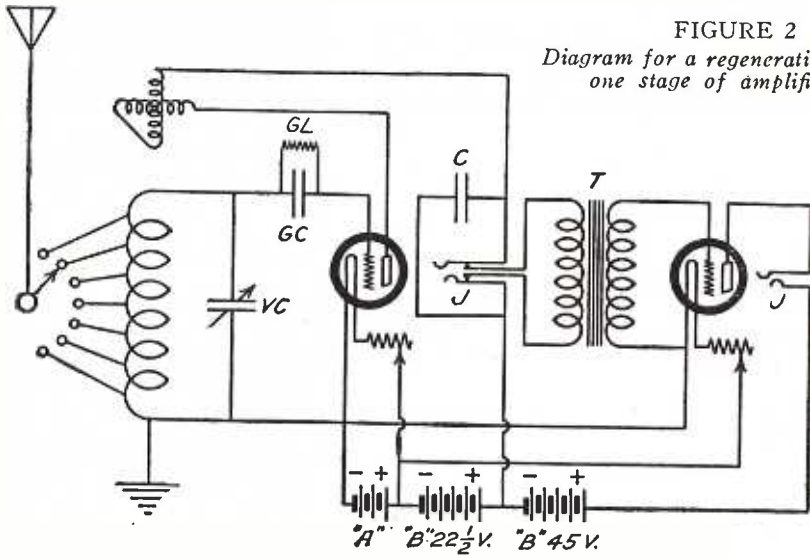

FIGURE 2  
Diagram for a regenerative set with one stage of amplification.

QUESTION: Please give me a hook-up for this set: a 43-plate variable condenser, an inductance coil (10 taps), a variometer, an Acme amplifying transformer, two rheostats, two sockets, a Cunningham detector tube, a Radiotron amplifier tube, three "B" batteries, a grid leak and condenser, and an "A" battery.

WILLIAM ENGLE

ANSWER: See the diagram in Figure 2. The antenna tuning is accomplished by means of the taps, the secondary circuit is tuned by the variable condenser VC, and the plate circuit is tuned with the variometer. The first jack is a double circuit jack and the second is a single circuit jack. This circuit will be found to be selective and easy to tune.

QUESTION: Will you give me a hook-up using the two-slide loose coupler, as described in the July issue of POPULAR RADIO? This circuit should also include one fixed condenser, one variable condenser, crystal detector and phones.

RAYMOND LANGLEY

ANSWER: This is shown in Figure 3.

\* \* \*

QUESTION: How can I cut out static on a regenerative set?

JAMES GOOCH

ANSWER: We know of no method of cutting out static entirely. It may be materially reduced by the addition of a single stage of radio frequency amplification to be attached immediately before your present regenerative circuit.

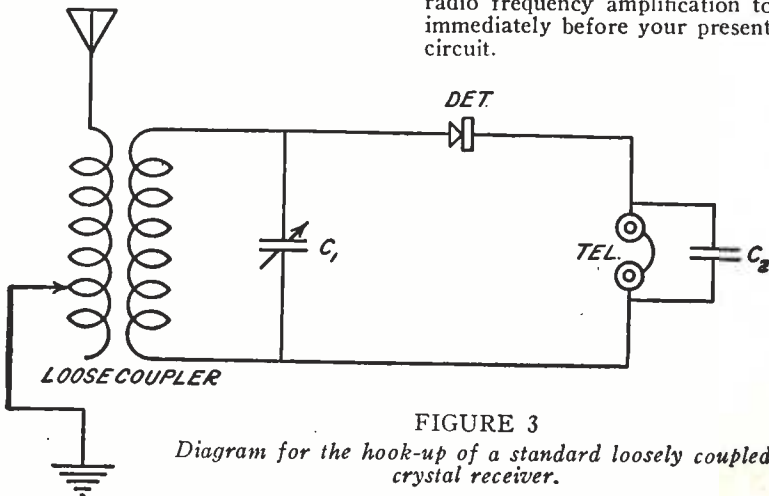

FIGURE 3  
Diagram for the hook-up of a standard loosely coupled crystal receiver.



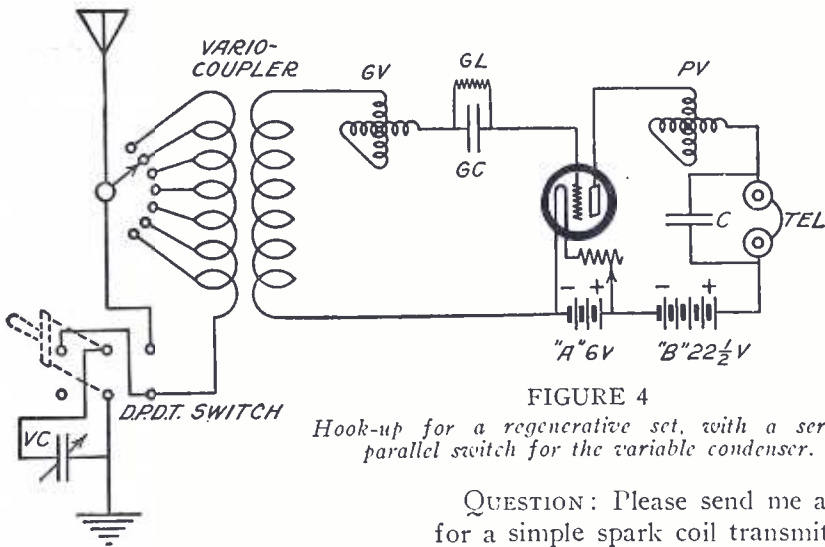

FIGURE 4

Hook-up for a regenerative set, with a series-parallel switch for the variable condenser.

QUESTION: Kindly send me a hook-up for the following: variocoupler, two variometers, variable condenser; also a circuit that shows the connections for a series-parallel switch.

J. A. BEATTY

ANSWER: The hook-up is shown in Figure 4. The variometers are designated as GV and PV, and the grid leak and condenser are marked GL and GC. C is a fixed telephone condenser. The antenna circuit is tuned by the taps on the primary and by the condenser VC. The secondary circuit is tuned by the grid variometer GV, and the plate circuit is tuned by means of the plate variometer PV. The series-parallel switch will be found very effective for changing the wavelength range.

QUESTION: Please send me a hook-up for a simple spark coil transmitter.

R. HARRIS

ANSWER: This set may be made of a Ford coil, and will operate on a few dry batteries. The wavelengths of the transmitted signals are controlled by the two clips on the oscillation transformer. See Figure 5.

\* \* \*

QUESTION: Please give me, by diagram, the best hook-up for a plate and grid variometer, variocoupler, a series-parallel switch for a condenser in the primary of the variocoupler, and a vacuum tube detector. What "ohmage" phones would you recommend?

IVAR SWANSON

ANSWER: Consult the answer to J. A. Beatty and the diagram in Figure 4. Telephones of 3,000 ohms are recommended. This circuit should be very efficient if the instruments you intend using are of a reliable make, and if the set is assembled in a careful and workmanlike manner.

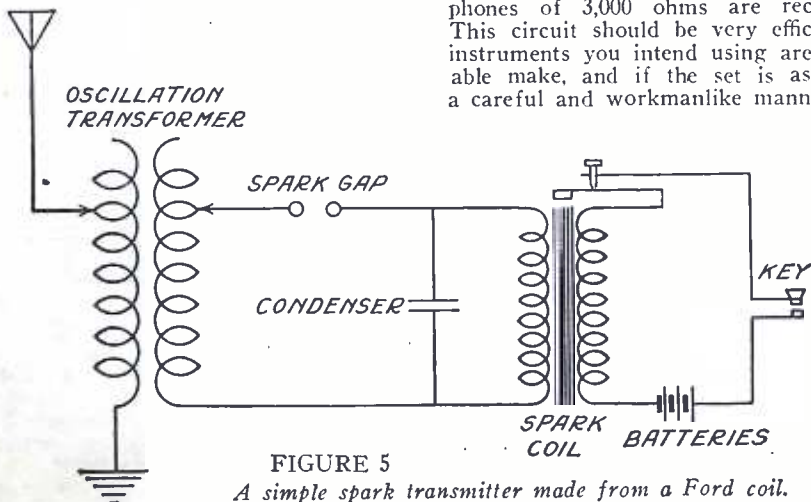

FIGURE 5

A simple spark transmitter made from a Ford coil.

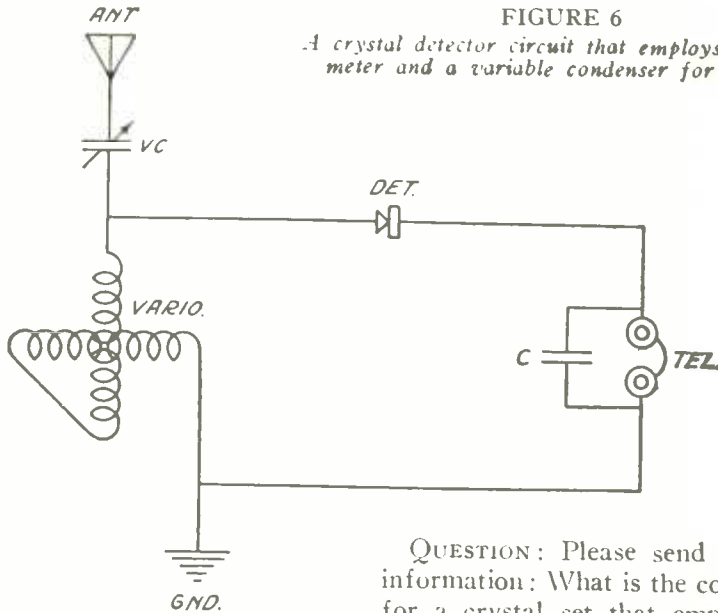

FIGURE 6

A crystal detector circuit that employs a variometer and a variable condenser for tuning.

QUESTION: Please give me a hook-up for a crystal receiving set that uses a variometer and a variable condenser.

WALTER STRANG

ANSWER: Figure 6 gives you the hook-up you require. The secondary circuit is tuned by the variometer, and the antenna circuit is tuned by the variometer and variometer in combination. A fixed condenser C is connected across the telephones. The variometer and the variable condenser both vary the wavelength of the circuit continuously, so that very minute changes in wavelength are possible and interference is reduced to a minimum.

QUESTION: Please send the following information: What is the correct hook-up for a crystal set that employs a variometer, a variocoupler, a fixed condenser, a crystal detector and phones? Would a crystal set that contains these items be helped by the addition of two coils? One coil has 16 taps, (8 turns to a tap), and the other has 11 taps, ranging from 20 turns to 5 turns to a tap.

JACK CLOVER

ANSWER: You may use the hook-up shown in Figure 7. The two coils you speak of would not help you much, but you could improve the set by the addition of a variable condenser connected across the secondary of the variocoupler. This set could be easily changed to a regenerative vacuum tube receiver.

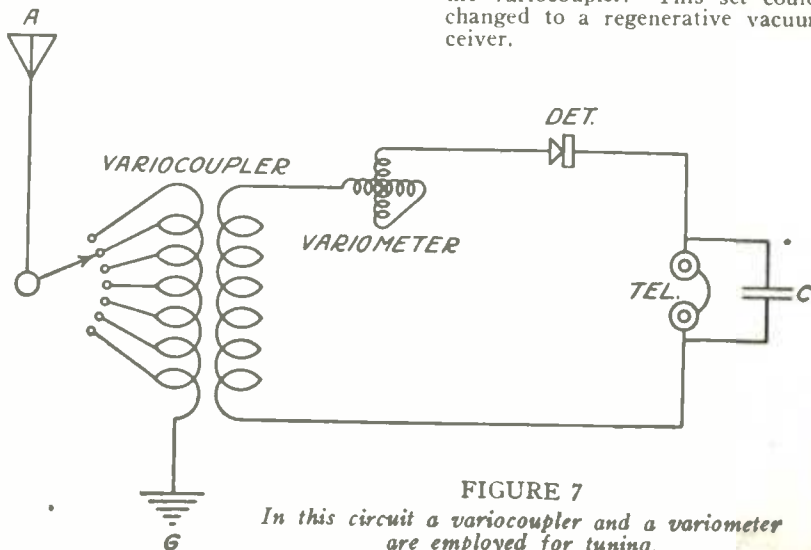

FIGURE 7

In this circuit a variocoupler and a variometer are employed for tuning.



## BROADCASTS

ITEMS of general interest that you ought to know; bits of useful information that every radio fan ought to know.

### *A Radio Message Averts a Battle*

JUST as the British forces were on the point of opening fire on the advancing cavalry of the Turkish Nationalists (which had just occupied Kum Kalesi in the neutral zone), and thus precipitated what in all probability would have been another war, Col. Shuttleworth, of the British forces in Chanak received a radio message from General Harington in Constantinople that gave orders to suspend the attack. Under a flag of truce the representatives of the two conflicting forces parleyed—and the impending battle was avoided.

\* \* \*

### *A New Radio Set Sells an Old House*

UNABLE to dispose of an old house in Dallas, Texas, an enterprising real estate operator installed the very latest radio receiving set in it, and so advertised in the leading paper. From the dozens of offers that poured in he selected one that enabled him to dispose of the property at a good price.

\* \* \*

### *General Pershing Listens In*

THE recent mysterious appearance of an antenna running around the top of one of the big army limousines used by General Pershing gave rise to rumors that the former chief of the A. E. F. had become a radio fan. The installation was made by the general's son, Warren, in collaboration with an obliging army sergeant.

\* \* \*

### *Connecticut Amateurs Signal to Porto Rico*

FOR the first time in the history of radio communication has been established between amateurs in Porto Rico and this country. Messages have been exchanged between the Porto Rico Radio Club and the American Radio Relay League headquarters in Hartford. The first message from the island to the mainland was relayed from San Juan, Porto Rico, to 4FT Atlanta, Ga., thence to 4BX at Wilmington, N. C., and finally to 1QP, J. L. Reinartz, South Manchester, Conn. A

return message was transmitted from Hartford to San Juan in the record time of one hour and 27 minutes.

\* \* \*

### *Radiograms by Wire*

THE next time you want to send a message by radio merely drop into (or telephone to) the nearest Postal Telegraph office and enter your order. Arrangements have been completed with the Radio Corporation of America for co-operating in the handling of this traffic.

\* \* \*

### *The Radio Bug Bites Royalty*

NOW that the Prince of Wales has joined the ranks of the radio fans and has had a set installed at Windsor Castle, high society in England may no longer hesitate to accept the new art as *de rigueur*. It is even rumored that the Prince has so interested the King and Queen in radio that receiving apparatus may be installed at Buckingham Palace.

\* \* \*

### *Miniature Radio Sets for Children*

THE radio station located in the Eiffel Tower is affecting the toy industry of France, according to M. Lepine, former Prefect of Paris. Little Pierre has lost interest in his tin soldiers and even in his scooter, and is now saving his centimes for a miniature radio set.

\* \* \*

### *The Human Voice Spans the Atlantic*

WHAT is said to be the first authentic record of the human voice being carried across the Atlantic by radio on low wavelengths was made October 6th, when Sir Thomas Lipton spoke from WOR station in Newark and was heard in London by Gordon Selfridge.

\* \* \*

### *A Radiogram Saves 217 Lives*

ANOTHER stirring chapter was written in the romance of radio at sea when the steamship *City of Honolulu* burst into flames while 670 miles off the California coast on October 12th.



Not only did radio keep the world informed of the progress of the fire, but brought help in time to save all of the passengers and crew. Before the days of wireless such a conflagration would have meant suffering and death.

\* \* \*

#### *Grand Opera in an Airplane*

THE commercial passenger airplane that flies between Geneva to Paris installed a receiving set this fall and entertained its fourteen passengers with concerts broadcast from Lausanne. It is not inconceivable that members of Parliament, the French Senate and other legislative bodies will soon be enabled to attend the deliberations of their respective organizations, while they are in the air—they referring to the members only.

\* \* \*

#### *A Radio Set Squelches a Native Uprising*

THE natives of Nyassaland, Central Africa, got their first introduction to radio when the British forces penetrated that territory recently with motor lorries fitted with wireless installations. So terrified were the superstitious blacks with the "machine that could speak without



International

#### A CORKING IDEA

*When a press agent tells us that a small wire attached to corkscrew inserted in a flask acts conveniently as a new kind of radio receiver, of course we believe it—not! What the press agent really had in mind was to arouse public curiosity in the exhibits promised for a coming radio show.*

mouth and hear without ears" that they promptly assumed that the god of the ether could listen in even upon their secret whisperings. So they promptly behaved themselves accordingly.

\* \* \*

#### *Fighting Floods by Radio*

To broadcast warnings of flood, not only for the purpose of summoning aid but also to warn distant residents of impending danger, a radio sending station has been installed near the source of the Verde River in Arizona—the water supply base of a 200,000-acre irrigation project. Radio offers the only means of communication between Phoenix and the upper reaches of the river, where storms often cause enormous damage to the country below.

\* \* \*

#### *Hypnotized through the Earphones*

CAN a sane, normal human being be hypnotized by radio? Evidence in the affirmative is offered by Miss Beatrice Kyle, who donned the earphones and permitted herself to be put into a trance for a period of several hours and exhibited on a cot in a store window in Birmingham, Ala. The hypnotist was located at a radio transmitting station several blocks away.

\* \* \*

#### *Radio Substitutes for the School Ma'am*

THE project for employing radio for educational purposes is apparently nearer fulfillment in Hawaii than in this country. The superintendent of public instruction in Honolulu has just announced plans for installing radiophones in the rural schools; eventually programs of an educational nature will be broadcast from the headquarters of public instruction. Slowly but inevitably radio is destined to bring the world's greatest educators to the Little Red Schoolhouse.

\* \* \*

#### *A Power Plant in a Suit Case*

TESTS recently conducted at the Rocky Point Station of the Radio Corporation of America, prove that the new high-power vacuum tubes are superior to the cumbersome and expensive high-frequency alternators now in use for transoceanic radio communication. A special test set that employed six of the new General Electric Company 20 K.W. tubes, was recently put into transatlantic service, without notifying either the sending operators or the receiving operators on the other side of the world. Neither the foreign operators nor the Americans noticed any difference in the signals, so it is assumed that the signal strength was comparable with the alternator signal, although the antenna current with the tubes was only a little over half that produced by the alternators.

This is a remarkable achievement, particularly when it is borne in mind that the alternators take up almost the center floor space of the huge Rocky Point plant, whereas the tubes which accomplished the same results could almost be put in an ordinary suitcase.

## ADVENTURE IN THE AIR

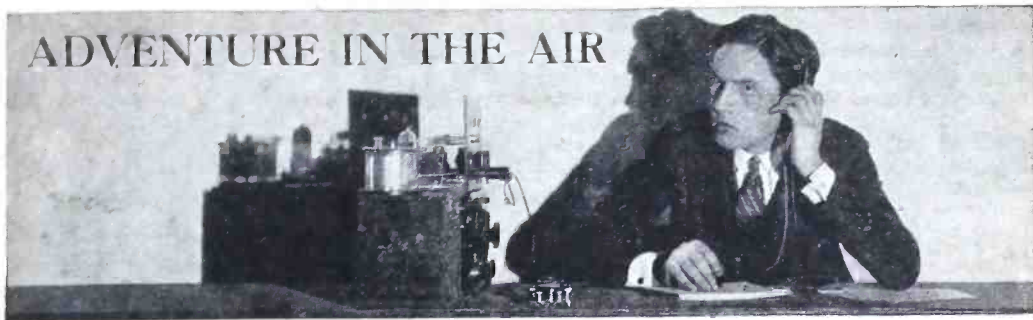

WHAT is the biggest thrill YOU ever got over the radio? Have you ever picked up a call for help? Or located a lost friend—or helped to run down a fugitive, or listened in on a conversation of peculiar personal interest to yourself? For every anecdote, humorous or grave, ranging from 50 to 300 words in length, the Editor will pay upon acceptance. Address contributions to the Editor, ADVENTURE IN THE AIR DEPARTMENT, 9 East 40th Street, New York City.

### I Pick Up a Warning From An Unknown Hero

TALES of the exploits of un-named heroes stir the blood and establish one's faith in the innate great-heartedness of the well-known but often maligned Human Race. Here, for example, is a true tale from the sea that comes from an experienced ship's radio operator:

We were steaming ahead through a hurricane such as is only known in the Caribbean Sea and the Gulf of Mexico. The *Grayson*, a typical tramp steamer of small tonnage, was laboring heavily in the fearful weather. Her skipper was a worried man. Shortly after dark he came into the wireless room to ask me if I had received the regular weather forecast from the radio station at Jamaica. I had not heard a thing from that station or any other for over twelve hours, and told him so. He expressed his opinion of me and of wireless operators in general.

"I've got to call at Kingston and it's a tricky harbor," he growled. "I want to know how the wind is going to set me when I make it, and it's up to you to get the reports. The last man always gave them to me and I want you to give them to me."

He slammed the door as he made his exit.

Patiently I tried to pick up some signals which would at least give me an indication that my set was working. I had been thus busying myself for over an hour when suddenly I heard "CQ, CQ," which is the signal for all stations to copy. It sounded like a ship station calling.

"CQ," he continued, "Jamaica is being shaken by terrific earthquake. Huge tidal wave sweeping Kingston harbor and vicinity."

Then followed a series of unreadable dots and dashes which dwindled into a profound silence. Not another signal, no call letters, no signature was sent.

Breathlessly I carried this missive to the skipper. He read its contents, grunted his surprise and asked, "Where did this come from?"

After I had told him I did not know where it had come from or who had sent it, he again expressed his opinion of wireless operators in general and of me in particular.

I returned to my post in the wireless cabin to listen in for more news, but a silence broken only by bursts of static had again fallen over the Caribbean.

Along toward midnight, the skipper came stamping into the cabin. He had lost some of his gruffness.

"Sparks," he said—and I knew when he addressed me as Sparks that we were on better terms—"are you sure you got this message over the wireless and didn't dream it?"

I assured him.

"Well," he mused, "there is something funny; we should have picked up the light at Kingston over an hour ago, and we can't see it yet."

"Maybe the lighthouse has toppled over," I suggested.

"Maybe," he agreed. "I'm going to haul around and steam offshore, anyway."

At eight bells, we had swung around and were putting out to sea again, and I turned in. The following morning, after breakfast, I got in touch with a British cruiser. He confirmed the dispatch I had received the previous night, and added that the radio station at Kingston had been demolished by the earthquake at noon the previous day. That eliminated the possibility of Kingston having sent that mysterious message.

Where the warning came from and who sent it is still an unsolved problem. Possibly some vessel in the vicinity, equipped

with radio, had undertaken to warn off other ships, even though caught in the tidal wave herself. Several vessels were wrecked there at the time. Perhaps some gallant operator stuck to his post in the face of death and sent the warning which saved the *Grayson* and our whole company. But the brave chap evidently never lived to tell the tale or to know of our gratitude.

E. JAY QUINBY

## I Deliver a Death Message *via* the Purser

**E**VERY radio operator who has either received or sent a notice of death can appreciate the feelings of Mr. Hecht—both before and after the fateful message was delivered to the addressee:

While sailing on the Great Lakes as radio operator on the S.S. *Missouri* I received a message from WGO, Chicago. The message was then two days late, and it was the kind that an operator hates to either send or receive. It was worded somewhat like this:

JOHN RYAN SS, MISSOURI  
YOUR FATHER IS DEAD COME HOME  
AT ONCE  
SISTER

Instead of giving the message to a cabin boy for delivery in the usual way, I took it to the Purser and explained its contents. He said that he would deliver it in a way that would make it easier than as if Mr. Ryan received it without warning of its contents.

The Purser found Mr. Ryan in his cabin. "The operator just received a message for you; it contains some bad news from your home. Your father is dead."

Mr. Ryan dazedly repeated the Purser's words:

"My father is dead? Why, sure he's dead.

He ought to be dead; he died thirty years ago!"

What the Purser said to me will have to go unprinted, and the Chicago radio station received a pointed service message.

R. H. HECHT

## A Radio Message Penetrates Prison Walls

**T**O pick up a bit of news by radio that may save you from an otherwise sure death must give a man convicted of murder an honest-to-God thrill—particularly if that bit of news comes to him in a prison cell, literally within the shadow of the electric chair. This adventure comes from Boston:

When George Rollins, convicted of murder, was listening in on his little radio set on the evening of August 10th, he picked up a piece of information which may bring about his pardon. Rollins was in his cell, listening to the regular late news broadcast from WGI at Medford Hillside, near Boston. Suddenly announcement was made that Governor Sproul of Pennsylvania was to release Frank Smith, alias Jesse Murphy, who had confessed some months before to one of the two murders of which Rollins was convicted. The two killings occurred in February, 1917; no one had yet paid the penalty for them. Rollins and his brother Charles were both implicated and convicted; while George was awaiting sentence, Murphy confessed to one of the murders. While he did not confess to the killing, he positively stated that Rollins did not do it.

Naturally, George Rollins secured a new lease on life when he heard the news by radio that Murphy was about to be released from the Philadelphia Penitentiary and would be brought to justice in Boston.

H. M. TAYLOR



International

## Broadcasting Should Benefit the Whole Community

TO THE EDITOR OF POPULAR RADIO:

"The plan you suggest seems to me an excellent one, and I hope will result in distinct benefit to the whole community."

*Felix Frankfurter*

President, University of Chicago



# THE IDEAL CHRISTMAS GIFT A WORKRITE CONCERTOLA FOR THE WHOLE FAMILY

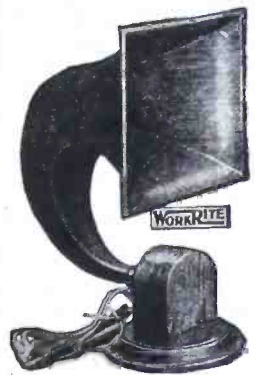

CONCERTOLA JR.

One of these Loud Speakers is just the thing to make Christmas a merry time for the family. "Workrite" quality means that it will Workrite. Winter evenings will be short and lively with a Workrite Concertola on your set.

Except for the phone units, THERE IS NOT THE SLIGHTEST METAL in either the Workrite Concertola Senior or Junior. The sound chambers of the Concertolas are made from our specially developed material, which reproduces voice or music in a clear, loud tone without the slightest distortion. Just right for the home. Why listen to music through a "tin-panny" metal horn that loses all the beautiful tones of the artists, when you can get a Workrite Concertola that will give you perfect reproduction of concerts?

**IMPORTANT!** A special phone unit has been developed for use in the Workrite Concertolas. The combination is unequalled. This phone unit will not be sold separate from the Concertolas.

The Workrite Concertola Senior is built from numerous plies of the finest mahogany, oil rubbed and finished exactly like your piano. It is 10" square by 15" high. Place it on your library table and run wires to your set in any other part of the house.

Test the Workrite Concertolas side by side with ANY other loud speaker on the market—then you can readily see the superiority of "Workrites."

**Workrite Concertola Jr. with Cord and Phone Unit, \$12.00**  
**Workrite Concertola Sr. with Cord and Phone Unit, \$24.00**

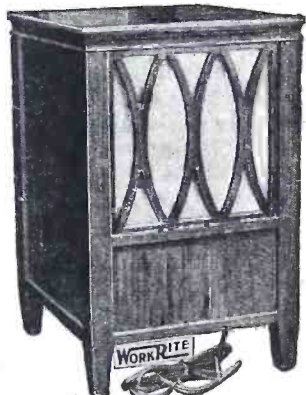

CONCERTOLA SR.

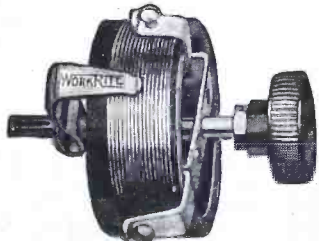

PATENT APPLIED FOR

## THE EXACT ADJUSTMENT WITH THE WORKRITE SUPER VERNIER RHEOSTAT

Here is a Real Rheostat—something entirely new and very much needed. Indispensable on the detector tube when tuning in long-distance concerts or code. Pushing in knob turns off bulb. Quick adjustment anywhere between 6½ ohms and zero. Turn the knob and get 50,000 DIFFERENT ADJUSTMENTS. All metal fittings made from brass and nickelled. Positively Never Gets Hot. The Workrite Super Vernier Rheostat is really remarkable in its performance and will double the audibility of distant concerts. Price..... **\$1.50**

## WORKRITE CONCERT HEADPHONE

We make no big claims for this headphone. All we ask is: TRY THE WORKRITE CONCERT PHONES SIDE BY SIDE WITH ANY ONE ON THE MARKET, even those costing twice as much. Then you will know which is best. Our new sanitary headband is covered with strong celluloid which is easily cleaned. Phone cases made from aluminum. Magnets made and arranged for 100% efficiency. Extremely sensitive and free from distortion. Weight complete with cords only 12 ounces. Try a set and see what a REAL phone is like. PRICE COMPLETE **\$8.50** WITH CORD.....



SEND FOR OUR FREE CATALOGUE

**THE WORKRITE MFG. CO.,** 5540 EUCLID AVENUE  
CLEVELAND, OHIO  
(Branch Office: 2205 MICHIGAN AVE., CHICAGO)

# EISEMANN

**T**HE advanced design of Eisemann radio units has met with instant favor wherever shown. The concave dial gives a mounting flush with panel. In appearance it is in marked contrast to the usual protruding knobs and dials. Another distinctive feature is the complete self-insulation of each part, making possible the use of a panel of wood, metal, or any other material.

## Variometer

Both Rotor and Stator forms moulded of Bakelite. Extremely light in weight. Electrical losses reduced to a minimum.

Price each \$8.75



## Variocoupler

The primary Tap Switch for tuning the antenna circuit is an integral part of the Variocoupler. No external switch, shielding, dial, or knob necessary.

Price each \$10.50

In addition to the units illustrated, other Eisemann products are Head phones, Vacuum Tube Sockets and Audio Frequency Transformers — all made to the highest electrical and mechanical standards.

## Variable Condenser

### Balanced type

Rigidly constructed. Metal bearings front and rear. Rotary plates balanced, assuring constancy of setting. Vernier equipped.

Capacity .001 mfd.  
Price each \$7.50

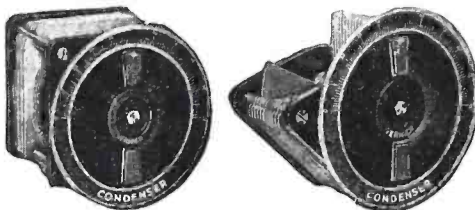

## Variable Condenser

### Unbalanced type

Aluminum plates accurately spaced eliminating any possibility of "shorts" between plates and assuring a more constant air gap. Vernier equipped.

Capacity .001 mfd.  
Price each \$7.00  
Capacity .0005 mfd.  
Price each \$6.50

A combined Filament Rheostat and Potentiometer, with concave dial which conforms to the design of the parts illustrated, is now in course of preparation.

Write for Descriptive Folders.

## EISEMANN MAGNETO CORPORATION

William N. Shaw, President

DETROIT

BROOKLYN, N. Y.

CHICAGO

# Bel-Canto

## The Superlative Loud Speaker



### To the Radio Public

The Bel-Canto is entirely different from any other loud speaker on the market—in a class by itself. See it and hear it and know for yourself why hundreds of orders for this remarkable instrument are pouring into our factory.

The Bel-Canto is built on a new and patented principle of radio acoustics. The sound is amplified *without any distortion* and the tone is of such clarity and mellowness as to surpass any other amplifying device that we know of—even those selling at \$100 or more. Yet the price of the complete Bel-Canto is only \$30.

If your dealer has not yet stocked the Bel-Canto, order direct from the factory. We will send postpaid on receipt of price or by C.O.D. the complete instrument—including special amplifying phone, hard rubber plug and ample cord.

**BEL-CANTO CORPORATION**  
417 E. 34th Street  
New York

*Marvelous in Performance*

### To Jobbers and Dealers

To give you a free opportunity to demonstrate the Bel-Canto to your customers and to prove *by actual performance* in comparison to any other loud speaker on the market that the Bel-Canto is a far superior instrument, we make the following special offer to the trade only.

Fill out and mail the coupon. We will ship the complete Bel-Canto to you C.O.D.—deducting the maximum discount. Try out this remarkable loud speaker. If at the end of 10 days you are not more than satisfied with its performance, you may return it to us and we will unconditionally refund your money.

This special offer is to the trade only and is limited to *one* complete Bel-Canto.

Bel-Canto Corp., 417 E. 34th St., New York  
Gentlemen: Please send me C. O. D. one complete Bel-Canto Loud Speaker. You are to refund my money at the end of 10 days if I am not entirely satisfied.

Name .....  
Address .....  
City .....

*Beautiful in Appearance*

Patents applied for



# BUILD YOUR OWN RADIO OUTFIT

## HIGH QUALITY GOODS AT LOW PRICES

FAST SERVICE—THE PRICES QUOTED DELIVER THE GOODS TO YOUR DOOR

### BARAWIK SPECIAL PANEL MOUNTING VARIABLE CONDENSERS



- L812—43 plate .001 Mfd. . . . . \$2.35
- L813—21 plate .0005 Mfd. . . . . 1.90
- L814—11 plate .00025 Mfd. . . . . 1.40
- L815—3 plate Vernier 1.05

These are especially high grade condensers and we guarantee them to be mechanically and electrically perfect. Genuine bakelite and plates of high dielectric and great mechanical strength. Sturdy aluminum alloy plates perfectly spaced to insure smooth, even reliable capacity. Our low prices save you money. These condensers are of the very best make and are not to be compared with many inferior cheap condensers offered. We guarantee them to please you or your money back.

### COMBINATION VERNIER VARIABLE CONDENSERS

- L824—23 plate .0005 Mfd. Price . . . . . \$3.79
- L826—43 plate .001 Mfd. Price . . . . . \$4.48



The latest improvement in condensers consists of regular variable condenser controlled by large knob and dial. Separate small knob mounted above dial controls a three-plate vernier condenser. This arrangement permits of very fine tuning. High-grade design and construction. Finely finished. Suitable for panel mounting.

### INDUCTANCE "HONEY COMB" COILS



Carefully made—fine looking coils. Highest efficiency. Low distributed capacity effect, low resistance—high self inductance. Very firm enamel impregnation. Range given in meters when varied with .001 variable condenser. Mounted coils have standard plug mountings.

Turns	Range	Art. No.	Not Mtd.	Art. Price
25	120-250	L301	\$0.39	L320 \$0.97
35	175-450	L302	.42	L322 1.07
50	240-720	L303	.49	L323 1.00
75	300-910	L304	.54	L324 1.12
100	500-1450	L305	.58	L325 1.16
150	600-2000	L306	.63	L326 1.21
200	900-2500	L307	.72	L327 1.30
250	1200-3500	L308	.78	L328 1.36
300	1500-4500	L309	.82	L329 1.40
400	2000-5000	L310	.97	L330 1.55
500	2800-6100	L311	1.12	L331 1.70
600	4000-10000	L312	1.27	L332 1.85
750	5000-12000	L313	1.43	L333 2.00
1000	7900-15000	L314	1.70	L334 2.38
1250	9750-19500	L315	1.92	L335 2.60
1500	14500-26500	L316	2.18	L336 2.76

### COIL MOUNTINGS

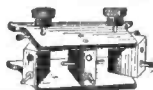

L340 Three coil mounting . . . \$3.95  
High grade fine looking mountings. Polished black composition. Center receptacle stationary, two outer ones adjusted by knobs. Takes any standard mounted coil.

### GALENA DETECTOR

Easy fine adjustment. Crystal mounted in cup. Moulded base and Knob. Brass parts polished nickel finish. L732 Each . . . . . 86c



**This Guarantee Protects You**  
Examine the goods we ship you. They must suit you in every respect. If you are not satisfied with your purchase return the goods at once and we will refund the price you paid.



### VACUUM TUBES

Standard Brands—Cunningham Radiotron. Every one guaranteed new and perfect. We will ship brand in stock unless you specify otherwise.  
L105 Detector. Each. . . \$4.45  
L110 Amplifier. Each. . . 5.95  
L115 5 Watt Transmitter 7.70

### MYERS TUBES

L113 High-Mu Audion. Has 5 times amplification of ordinary tubes. Oscillates anywhere from 2 to 300 volts on plate. Each . . . . . \$5.00  
L116 Receptacle for above. Each. . . 4.00  
L117 Adapter to adapt Myers tubes for use in any standard socket. Each. . . \$1.05

### MYERS CHOKE COIL

L119 Each . . . . . \$3.50

### VACUUM TUBE SOCKETS

Our Special Socket. A wonderful value. Moulded entirely of bakelite. Four binding post connections. Right angled contact springs. L140 Each. . . . . 39c

### PORCELAIN BASE AND TUBE

L144 Crosley for either panel or table mounting . . . . . 42c

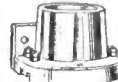

High Grade combination type for panel or table mounting. Metal tube. Highly insulated base. L146 Each . . . . . 45c

### GRID CONDENSER

L162 Mounting holes spaced to fit lugs of above leak. Cap. .00025 MF. . . . . 17c  
L163 Same as 162 but higher grade. Enclosed in metal case . . . 39c



### VARIABLE GRID LEAK

Pencil mark type. Resistance may be varied exactly as needed. L160 Each. . . . . 21c

### VARIOMETER

L410—Completely assembled, price \$2.89.  
L411—Not assembled but all parts complete, including winding form, \$1.90.  
Perfect in design and construction. Accurate wood forms. Correct inductive ratios. Solid baked windings. Positive contacts. Highest efficiency.

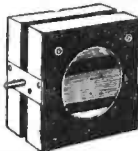

### VARIO-COUPLER

With this loose coupler and two variometers, together with the necessary other parts, a highly efficient tuning set can be made. Easily mounted on panel. Primary winding on formica tube. Inductively coupled for 180 to 600 meters. Multiple taps permit fine tuning.  
L415 Price, completely assembled \$2.40  
L416 Not assembled, but all parts complete. Price . . . . . \$1.35  
L417 Rotor ball only. Each . . . . . 29c



### RADIO FREQUENCY AMPLIFYING TRANSFORMER

L995 Each. . . . . \$3.50  
This transformer will get the long distance stations loud and clear. Permits of easy sharp tuning. Helps cut out static and interference. Makes your set sensitive enough to use a loop aerial. Enclosed in metal case affording perfect shielding. Suitable for panel or base mounting. Because of its special design can be mounted in any V. T. socket. Works with any make of tube. Wave ranges 150 to 550 meters. Wiring diagrams included.



### OUR SPECIAL AUDIO FREQUENCY AMPLIFYING TRANSFORMERS

As high as three stages can be used without howling, due to proper impedance ratio, minimum distributed capacity, low core losses and proper insulation. Mounted style has bakelite panel with binding post connections. Unmounted has core and coils assembled with two holes in core for fastening to apparatus.  
L234 10 to 1 Mounted. Each. . . \$3.69  
L235 10 to 1 Unmounted. Each. . . 2.95  
L236 3 to 1 Mounted. Each. . . 3.59  
L237 3 to 1 Unmounted. Each. . . 2.85



### FILAMENT CONTROL RHEOSTATS

Crosley—Wound on vulcanized fiber. Adjustable to any panel. Complete with knob. L180 Each . . . . . \$4.00



Best grade. High heat resisting base. Diam. 2 1/2 in. cap. 1 1/2 amp. Resist. 6 ohms. 1 3/4 in. Knob with pointer. L132 Each. . . . . 48c

### POTENTIOMETER

Same style as above rheostat. Gives fine "B" battery adjustment. Resistance 140 ohms. L133 Each. . . . . \$1.05

### VERNIER RHEO-STAT

Gives exceedingly fine control of a battery current. A necessity for best receiving results. L135 Each. . . . . \$1.19

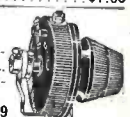

### PLATE CIRCUIT "B" BATTERIES

You can make real savings on these batteries. Don't pay more. We guarantee them to equal any on the market regardless of price. Absolutely uniform. Extra long life.

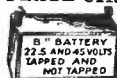

L180 Signal Corps type, small size, 15 cells, 22 1/2 volts. Each. 95c.  
L182 Large Navy size, 6 1/2 x 4 x 3, 15 cells, 22 1/2 volts. Each. . . . . \$1.75  
L184 Variable Large Navy size, 5 tans, giving range from 16 1/2 to 22 1/2 volts in 1 1/2 volts steps. Each. . . . . \$1.80  
L186 Double Navy size 6 1/2 x 4 x 6, 30 cells, 45 volts. Suitable for amplifier circuits and power tube use. Two or more of these units in series may be used in C. W. and radiophone circuits. Each. \$3.40  
L188 Combination Tapped 45 volts, 30 cells, 6 1/2 x 4 x 6 battery. Tapped to give 45, 22 1/2, 21, 19 1/2, 18, and 16 1/2 volts. Handles both detector and amplifier tubes. Each . . . . . \$3.55

THE BARAWIK CO. 102 S. CANAL STREET CHICAGO, ILL.

# USE BARAWIK STANDARD PARTS

**YOU SAVE MONEY WHEN YOU BUY FROM US**  
**FAST SERVICE—THE PRICES QUOTED DELIVER THE GOODS TO YOUR DOOR**

### SOLID BARE COPPER WIRE

Solid bare copper wire for aeriels, leads or wiring instruments.  
 Solid Bare Copper Wire, size 14  
 L240—100 ft. coil 45c  
 L242—500 ft. coil \$2.16  
 Solid Bare Copper Wire, size 12  
 L244—100 ft. coil 61c  
 L245—500 ft. coil \$2.75

### STRANDED ANTENNA WIRE

Cabled of fine copper strands. Very flexible. High tensile strength. Best for antennas.  
 L248—100 ft. coil 65c  
 L249—500 ft. coil \$2.95

### ANTENNA INSULATORS

L260 Size 1x3 1/4. Two for.....19c  
 L262 Size 2 1/2 x 3 1/4. Two for.....58c  
 L264 Size 1 1/2 x 4. Two for.....80c  
 L266 Size 1 1/2 x 4. Two for.....80c  
 L260 L264-610 1/2. Two for \$1.35

### OUTDOOR LIGHTNING ARRESTER

1980 Price.....\$1.68  
 Protect your instruments with this lightning arrester. You cannot afford not to. Weather-proof porcelain case. Air gap type. Permanent. Durable. The most practical quality arrester obtainable. Underwriters approved.

### PORCELAIN BASE SWITCHES

Fine white porcelain bases. Copper contacts and blades. Can be used as antenna switches.  
 L385 Single Pole Single Throw. Each 20c  
 L387 Single Pole Double Throw. Each 32c  
 L384 Double Pole Double Throw. Each 50c

### SWITCH LEVERS

Moulded composition knob. Exposed metal parts polished, nickel finish. Fitted with panel bushing, spring and two set nuts. A high grade switch.  
 L380—1" Radius } Each  
 L381—1 1/4" Radius } 22c  
 L382—1 1/2" Radius }  
**SWITCH LEVER STOP**  
 Brass, polished nickel finish.  
 L386—Dozen 20c. Hundred \$1.40

### ONE PIECE DIAL AND KNOB

A fine looking knob and dial moulded in one piece. Neat clean cut design. Polished black finish. Clear plain engraved scale with numbers and lines in contrasting white enamel. Ribbed knob that fits the hand. The three sizes used on the same panel can be arranged to produce a very attractive effect.  
 Three and four inch sizes are marked 0 to 100 and 180° of the scale. 2 1/4 inch size is marked 0 to 9 over 270° of scale.  
 L900—2 1/4 inch Diameter for 3-16 inch shaft. Each.....39c  
 L901—2 1/4 inch Diameter for 1/4 inch shaft. Each.....39c  
 L904—3 inch Diameter for 3-16 inch shaft. Each.....49c  
 L905—3 inch Diameter for 1/4 inch shaft. Each.....49c  
 L906—4 inch Diameter for 3-16 inch shaft. Each.....59c  
 L907—4 inch Diameter for 1/4 inch shaft. Each.....59c

### GUARANTEED QUALITY GOODS

at money saving prices. You can build the parts purchased from us into your set and feel confident of the best results. If what you want is not shown here write us for prices—we have every part for your set ready for quick shipment and the prices are right.

### RADIO JACKS AND PLUGS

Finest grade jacks. Improved design. Best materials. Phosphor bronze springs. Silver contact points. Nickel finish. Mount on panels 1/2 to 3/4 in. thick.  
 L390 Open circuit. Each.....45c  
 L391 Closed circuit. Each.....52c  
 L392 Two circuit. Each.....63c  
 L393 Single-cir. fila. control. 70c  
 L394 Two cir. fila. control.....88c  
 L395 Plug. Large space with set screws for attaching cord. Each.....54c

### COMPETITOR JACK AND PLUG

Well made, durable, smooth working. Interchangeable with any standard jacks and plugs. Solder connections. Nickel finished metal parts. Fiber barrel on plug.  
 L388 Two Circuit Jack. Each.....35c  
 L389 Standard Plug. Each.....35c

### BINDING POSTS

Brass, polished nickel finish. Washer and 6-32" screw extending 3/4".  
 L370 Large size—barrel and knob 3/4" long. dozen.....85c  
 L372 Smaller size—barrel and knob 9-16" long. dozen.....70c  
 L374 Large size with composition knob, dozen.....60c  
 L376 Large size with hole for phone tip or wire, dozen.....80c  
 L378 Small size with hole for phone tip or wire, dozen.....38c

### STORAGE BATTERY

A very high grade battery made especially for radio service. Guaranteed. Properly cared for will give years of service for filament lighting.  
 L194 6-v., 40 amp. size. Each. \$10.00  
 L196 6-v., 80 amp. size. Each. \$12.50  
 Prices are Transportation Paid

### BARAWIK QUALITY HEADSETS

These headsets have proven on rigid tests to be one of the very best on the market. The tone quality is excellent with an unusual volume. Skilled workmen make them from only the best selected materials. The receiver cases are brass in fine polished nickel finish. Polished black ear pieces. Fabric covered head band comfortably and quickly fitted to the head. Supplied with 5-foot cord. These sets were designed to sell for much higher prices, and at our price are a wonderful bargain. We guarantee that you will be pleased with them and agree that they are the best value by far yet offered. If they don't suit you we will cheerfully return your money.  
 L770—2000 ohm.....\$4.00

### OTHER STANDARD BRAND HEADSETS

L751 Murdock 56, 2000 ohm.....\$4.45  
 L752 Murdock 56, 3000 ohm.....4.95  
 L764 Frost, 200 ohm.....4.45  
 L766 Frost, 3000 ohm.....5.40  
 L756 Red Head, 3000 ohm.....5.85  
 L758 Western Electric, 2200 ohm.. 9.50

### CABINETS

Fine looking cabinets solidly built. Made of genuine solid mahogany in elegant hand rubbed finish. You will be proud of your set mounted in one of these cabinets. Hinged tops. Front rabbeted to take panels. Panels not included. Prices are transportation paid.



Panel Size	Inside High	Inside Wide	Inside Deep	Art. No.	Price Each
6x7"	5 1/2"	6 1/2"	7"	L420	\$2.48
6x10 1/2"	5 1/2"	10"	7"	L422	2.75
6x14"	5 1/2"	13 1/2"	7"	L424	3.30
7x18"	6 1/2"	17 1/2"	7"	L426	3.90
6x21"	5 1/2"	20 1/2"	7"	L425	3.90
9x14"	8 1/2"	13 1/2"	10"	L428	3.70
12x14"	11 1/2"	13 1/2"	10"	L430	4.40
12x21"	11 1/2"	20 1/2"	10"	L432	5.25

### SOLID GENUINE CONDENSITE CELORON PANELS

Notice our very low prices on this fine quality grade 10 genuina solid sheet Condensite Celoron (a product with mechanical, chemical and electrical properties like formica and bakelite). Machines well with any chipping. Won't warp. Waterproof. Highest mechanical and dielectric strength. Attractive natural polished. Black finish which can be sanded and oiled for extra fine work.

Panel Size	Art. No.	Price	Art. No.	Price	Art. No.	Price
6x7"	L450	\$0.50	L460	\$0.75	L470	\$0.98
6x10 1/2"	L451	.75	L461	1.18	L470	1.47
6x14"	L452	1.05	L462	1.55	L472	2.09
7x18"	L458	1.20	L468	2.60	L478	2.40
7x21"	L453	1.55	L463	2.30	L473	3.10
9x14"	L457	1.78	L467	2.65	L477	3.60
9x14"	L454	1.60	L464	2.30	L474	3.10
12x14"	L455	2.10	L465	3.10	L475	4.15
12x21"	L456	3.15	L466	4.65	L476	6.20

### BATTERY CHARGING RECTIFIER

Charge your battery at home overnight for a few cents. Simply connect to any 110 volt 60 cycle light socket, turn on current and rectifier does the rest automatically. Will work for years without attention. Simple connections. Gives a tapering charge which batteries should have. You can make it pay a profit charging your friends' auto batteries. Long connecting cords with pair of battery clips. Prices are Transportation Paid.  
 L201 For 6 volt battery.....\$13.98



# THE BARAWIK CO. 102 S. CANAL STREET CHICAGO, ILL.



# Wisconsin "Listens to the world" with MR-6



FROM Wisconsin alone during one month come reports of De Forest MR-6 Receiving Sets getting California, Colorado, Kansas, Texas, Tennessee, Georgia, Kentucky, Pennsylvania, and New York—distances up to 1500 miles. One man listened across the entire continent, getting Santa Cruz, California and Atlanta, Georgia, the same evening. The unsolicited testimonials as to the way this efficient but inexpensive set "listens to the world" are on file in our office and copies will be sent to anyone interested in writing direct to the owner.

Multiply such experiences as these by the thousands of MR-6 sets in use all over the nation—to say nothing of the De Forest Everyman and Radio-home sets—and you get an idea of the way De Forest is serving the nation with the joys of radio.

De Forest manufactures receiving sets all the way from the least expensive to the most elaborate, and laboratory tested high quality parts for those who "build their own." If it's De Forest, it's built in a way worthy to sustain the reputation of that great name.

If you want the best radio has to offer—the songs, the stories, the news of the world—more clearly than you have believed possible and from farther away—you can't go wrong on De Forest!

De Forest Radio Tel. & Tel. Co.  
Jersey City, N. J.



## Up-to-Date Radio Books

JUST OFF THE PRESS

### THE RADIO EXPERIMENTER'S HANDBOOK

By M. B. SLEEPER

Gives wiring diagrams and hookups, explains the theory and operation of damped and undamped transmitting sets, and receiving equipment. The book is profusely illustrated. Tells you the things you want to know about wireless in simple, untechnical language. In this respect, it differs from most radio books in that it tells you what you want to know, and not what the author thinks you ought to know. 16 chapters. Fully illustrated. Price \$1.00.

### Other Popular Radio Books

- Radio Hook-Ups**, by M. B. Sleeper . . . \$ .75  
Indispensable to the radio amateur who designs or builds his own receiving apparatus.
- Radio Design Data**, by M. B. Sleeper .75  
Gives tables and data for designing, receiving and transmitting apparatus.
- Construction of New Types Trans-Atlantic Receiving Set**, by M. B. Sleeper . . . . .75  
Tells how to listen to the high-power telegraph stations of foreign countries.
- Construction of Radiophone and Telegraph Receivers for Beginners**, by M. B. Sleeper . . . . .75  
Tells in detail the building of radio apparatus.
- How to Make Commercial Type Radio Apparatus**, by M. B. Sleeper .75  
Describes in detail many commercial types of transmitting spark and vacuum tube sets, both telephone and telegraph and receiving equipment of all kinds.
- A B C of Vacuum Tubes Used in Radio Reception**, by E. H. Lewis . . 1.00  
A book explaining in detail all about vacuum tubes.
- Experimental Wireless Stations**, by P. E. Edelman . . . . . 3.00  
A book describing all modern improvements.
- Wireless Telegraphy and Telephony Simply Explained**, by A. P. Morgan 1.50  
A book the radio experimenter cannot afford to be without.
- FREE! Catalogue of Radio, Automobile and Other Books Sent Free on Request.*

Radio Dealers and Electric Supply Houses supplied at special discounts. Write for quotations.

The Norman W. Henley Publishing Co.  
2 West 45th Street, New York



*Multiplies  
Radio's  
Marvels!*

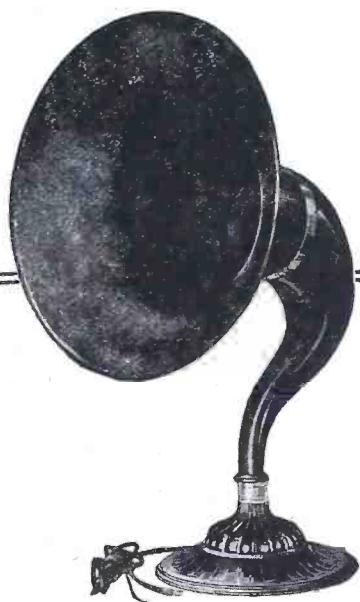

TRUE TONE  
AT LAST!!

MUSIC MASTER HORN  
CONQUERS "SCREECH" AND  
"SNARL" AND "HOWL"

AND MAKES LISTENING A JOY!

**A**NY up-to-the-minute Radio Dealer will demonstrate this wonderful Horn on **YOUR OWN SET**. Tune in to your limit and judge the Music Master by what it delivers to your own ears.

Fits any set. No extra batteries, no extra current needed. Makes head sets obsolete. A roomful—a theatre-full!—can listen to any program and hear every cadence, every shading of music or speech, through the Music Master.

Fourteen inch aperture (Home Model) \$30  
Twenty-one inch (Concert, dancing, etc.) \$35

Tell us your dealer's name before you request this free test. Then we can make sure he has Music Master to show you.

**JOBBER S —  
DEALERS**

Sample Music Master Horn shipped to responsible members of the Radio or Phonograph trade with **FULL PRIVILEGE OF RETURN**. Write for list-prices and full details.

**"GERACO" LINE**

Everything worth selling in Radio Apparatus of **TESTED** merit. Ask for price lists. See the Geraco Phonograph Attachment. Makes any Victor or Columbia a **LOUD SPEAKER** for Radio receiving. Use it as sound-box. Only \$10.

**THE GENERAL RADIO CORPORATION**

*Makers and Distributors of High-Grade Radio Apparatus*

624-28 Market Street, Philadelphia

806 Penn Avenue, Pittsburgh

**GERACO**  
PROVEN RADIO PRODUCTS

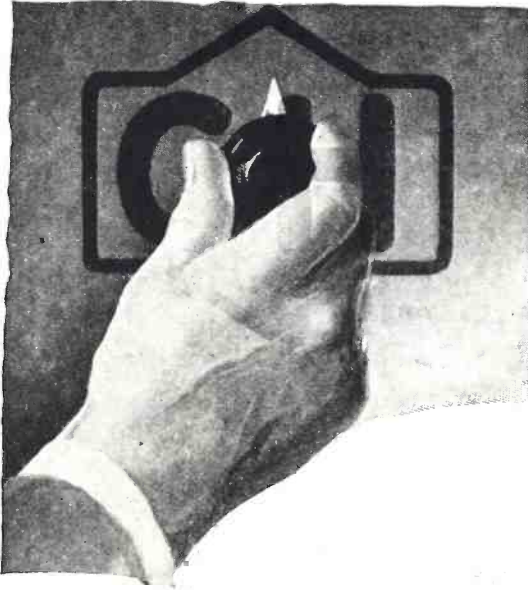

## Radio Rheostats of Reputation

Protecting every C-H Radio Rheostat stands a guarantee stronger than human hands can write. The decades of persistent and successful development of rheostatic control by the engineers of CUTLER-HAMMER have inspired a faith in their trade-mark that is far too worthy to forfeit.

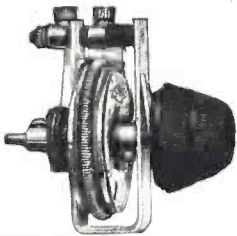

C-H Radio Rheostats are built in two styles, Type 11601-H1 with vernier adjustment for detector tube control and Type 11601-H2 is furnished without vernier for amplifier tube control. Both rheostats have a range of four ohms with one ampere current capacity.

Type 11601-H1 \$1.50 with vernier...  
Type 11601-H2 \$1.00 without vernier

rheostat—a device in which precision and reliability are essential.

THE CUTLER-HAMMER MFG. CO.  
Milwaukee, Wisconsin

**CH** RADIO RHEOSTATS  
\*BUILT BY RHEOSTAT BUILDERS\*

*Like the  
romance of  
radio itself*

is the story of the phenomenal growth of the company whose name has been linked with radio from the earliest days. Twelve years is a long time in radio—yet over twelve years ago—in 1909, to be exact—William B. Duck began his pioneer work in radio equipment.

Way back in those early days Mr. Duck foresaw with an almost perfect vision the ultimate growth of radio. He was the first and only one to put a "human touch" in a catalog embracing a scientific subject; he realized how largely educational such a catalog must be to accomplish its ultimate purpose—and today, with radio on every tongue, there is in Duck's "Wonder Catalog" an even larger wealth of practical radio information and diagrams than will be found in any of the earlier editions—and in language easy for the layman to understand. It is little wonder that Duck's catalog is universally known as "The Radio Amateur's Bible."



At All Worth-While Radio Stores  
Enquire for Duck Products at Your Dealer's  
Embraces 62 instruments—58 parts—the largest and most comprehensive line produced by any radio manufacturer. They should be had at all worthwhile retail stores throughout the United States and Canada. In selecting your radio equipment at your dealer's, insist on seeing Duck's products—products that have stood the test of time.

### DEALERS

We offer very attractive discounts on our radio instruments. Dealers who carry "Duck" products add prestige to their radio department and create satisfied customers.

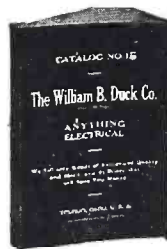

## DUCK'S

Big 256-Page  
Combined Radio  
Text-Book and

## CATALOG

as well as all former editions is now, as in the past, all radio catalogs in one. No other other half so large. It displays not only Duck goods but the products of practically all worth-while manufacturers and contains more up-to-date and practical radio information than will be found in any text-books. Send 25c in coin for this wonderful book—a retainer that hardly pays the cost of printing.

The WILLIAM B. DUCK CO.  
227-229 Superior St., Toledo, Ohio  
Established 1909

# TREMENDOUS DEALER ENTHUSIASM OVER REMARKABLE S-P-2 RECEIVER!

Demonstrated superiority against regenerative receivers, with list price of just \$85. Popularity with public, growing in leaps and bounds, makes it the greatest seller on market.

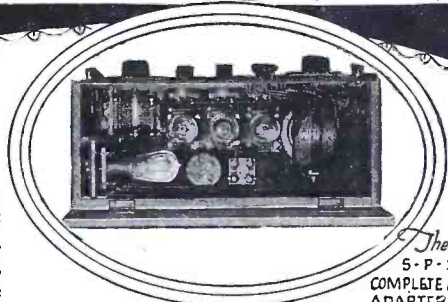
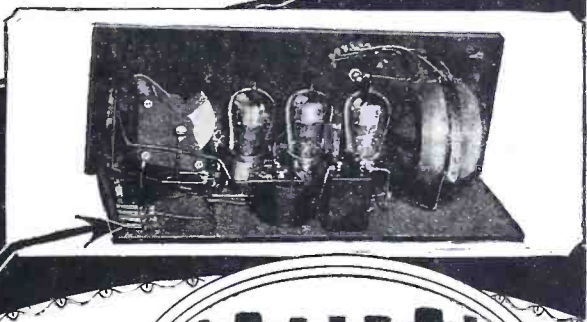
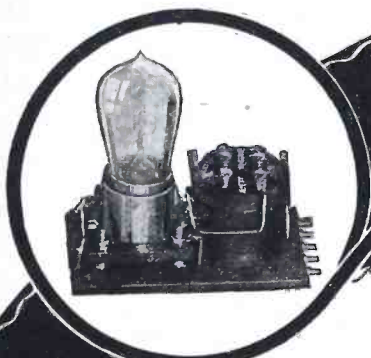

The  
S-P-2  
COMPLETE with  
ADAPTER.

The S-P-2 RECEIVER, now in vast production and under the severe test of hundreds of dealers everywhere, has thoroughly established its claim of ACTUAL SUPERIORITY as against any regenerative receiver now offered costing \$125 to \$180, based on actual comparisons. THE LIST PRICE OF THE S-P-2 IS BUT \$85, WITH AN ADDITIONAL CHARGE OF \$15 FOR THE ADAPTER.

The S-P-2 is a complete Receiver of radio-telephone and radio-telegraph signals over a wavelength range of from 180 to 650 meters, using three tubes, viz.: detector, one stage of radio frequency amplification and one stage of audio frequency amplification.

An Adapter representing an additional stage of audio frequency amplification, added to the S-P-2 Receiver AS SIMPLY AS INSERTING A TUBE INTO A SOCKET. Without necessitating the change of a single binding post, wire or batteries or headphones! The S-P-2 Adapter is a basic patent and is thoroughly covered.



## Distributors for

Lyradion Sales & Eng. Co.  
Sleeper Radio Corp.  
Jewett Mfg. Corp.  
A. B. C.  
Pacent Elec. Co.  
Schieber & Jensen  
Elec. Prod. Mfg.  
Penn Radio  
Atwater Kent  
Homecharger  
Radisco  
Electrose  
Mitchell-Rand  
Callophone  
Amer. Radio & Research Corp.  
Baldwin Radio  
Dubilier

**WHOLESALE ONLY**

**DEALERS:**  
Write for Catalogue 101A

# PITTSBURGH RADIO SUPPLY HOUSE

963 Liberty Ave. Pittsburgh, Pa.

BELL TELEPHONE  
GRANT 3632



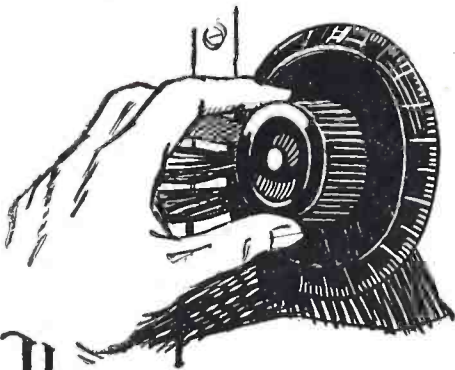

## How to stop noises when you touch dials

Have you ever noticed in tuning a radio receiving set that when you touch dials, knobs or switches it causes a humming or whistling noise? It is annoying, isn't it? These distracting sounds will disappear if you install dials, knobs and other parts made of

# RADION

Tests by disinterested laboratories have shown conclusively that RADION is without exception the best material for radio parts and panels because it comes closest to being the perfect insulation.

Have you tried RADION? If not, secure a dial or other part from your dealer today. Take it home and experiment—that's the best way to become convinced of its unusual qualities.

And while at your dealer's, ask him to show you a RADION Mahoganite panel. Its beautiful mahogany grain will please you. It won't warp and is easy to work. If your dealer cannot serve you, write us direct for all information giving us his name.

*Dealers Are Invited to Write for Lists*

**American Hard Rubber Company**  
 11 Mercer Street New York

# REAL RADIO VALUES

*Order Direct and Save Money*

Look Over These Holiday Specials

	Regular Price	Our Price
Unit Audion Control Panels (Detector) .....	\$ 6.50	\$ 5.00
Unit Audion Control Panels (Amplifier) .....	13.50	10.00
Glass-enclosed Crystal Detectors—less crystal .....	2.00	1.50
23-Plate Universal Condenser, bakelite ends, .0005 Mfd.....	4.00	2.50
43-Plate Universal Condenser, bakelite ends, .001 Mfd.....	5.00	3.00
3-Plate Universal Vernier Condenser, .000246 Mfd.....	1.50	75c
Keystone Variometers, 150-580 meters .....	5.00	4.00
6 V., 60-80 Amp. Storage Batteries .....	16.00	12.00
Open Circuit Jack .....	.60	.33
Single Circuit Jack .....	.75	.40
Double Circuit Jack .....	.90	.48
Double Circuit Jack Filament Control .....	1.00	.55
Single Circuit Jack Filament Control .....	1.20	.63
Saturn Automatic Grip Telephone Plug .....	1.50	.98
Ajax Socket Rheostat .....	2.00	1.40
Dictograph Headsets, 3,000 ohms .....	8.00	8.00
Dictograph Loudspeakers .....	20.00	20.00
Bestone Filament Rheostat .....	1.00	.60
Bestone Variocoupler, 3-inch dial, 150-600 meters .....	8.00	5.75
Bestone Variocoupler, 3-inch dial, 150-580 meters .....	7.00	4.75
Bestone Socket, metal shell, bakelite base .....	1.00	.75
Federal, Jr. Receiving Sets, Dictograph Headset .....	25.00	15.00

Everything sent F. O. B. Jersey City the same day we receive your order. Send Money by Registered Mail, Post Office or Express Money Order.

*All Goods Guaranteed  
 the Best There Is*

**HOLMES RADIO PRODUCTS**  
 999-P Bergen Avenue, Jersey City, N. J.

# This is station K.S.&S.Co.

## Broadcasting Better Radio Equipment

### *First—A Short Talk on Kellogg Head Set Superiority*

Kellogg head sets are the lightest on the market which is a prime requisite for comfort in any Radio receiving. They are built of highest quality material and their design is based on 25 years engineering experience in telephone receiver construction. Kellogg head sets are supplied under the following codes and resistances: No. 69A, 2400 ohms, including head band and six foot cord; No. 69C, 2000 ohms, including head band and five foot cord; No. 74A, 1000 ohms single receiver with head band and five foot cord. Kellogg head sets are adapted for use by campers with portable receivers.

### *Second—A Brief Description of Kellogg Jacks and Plugs*

Kellogg Radio jacks likewise are a standard product, once installed in your set, will give service and last indefinitely. Hundreds of thousands of Kellogg jacks and plugs in telephone work are in service the world over. They are designed for all standard Radio practice with the following codes: No. 501 is a four-conductor two break type, No. 502 is a two-conductor open circuit type, No. 503 is a three-conductor, single break type, No. 504 is a four-conductor, single make contact type, No. 505 is a six conductor, one make, two break type.

### *Third—Why You Should use Kellogg Grid Leaks and Condensers*

Because, first of all, they are accurate—no variation, regardless of atmospheric conditions, insuring uniform receiving.

### *Fourth—The Reliability of Kellogg Transmitters*

Kellogg Company transmitter or microphone is proving exceptionally reliable in Radio work. Today there are over three million Kellogg telephone transmitters in service, and their record is unsurpassed.

### *Fifth—Kellogg Tube Sockets Are Built of Kellogg Bakelite and a Standard Product Easily Installed, and Reliable*

Write us today for our Kellogg Radio bulletin, completely listing our supplies which include insulators, batteries, arresters, etc.; and investigate the latest Kellogg Radio products, every one of which is designed and built on the basis that—Use, is the Test.

## Kellogg Switchboard & Supply Co., Chicago

*"Signing Off" until Next Issue*

*"and wishing you a Merry Christmas."*



For 25 Years Manufacturers of High Grade Standard Telephone Equipment



## What matched tone means

COUNTERFEITS strive to duplicate only the best. That is why many headsets are sold with the claim that they are "as good as Brandes."

But to be "as good as Brandes," the phones must be *matched in tone*. Otherwise the listener concentrates on one and the advantage of having two is lost.

Brandes headsets are *Matched Tone* headsets. Hence the faintest sound is heard distinctly by *both ears*.

Reginald Fessenden, the father of the radio telephone, designed the first Brandes headset fourteen years ago. Ever since that time, Brandes *Matched Tone* headsets have been the standard.

Send ten cents in stamps for the "Beginner's Book of Radio." It explains radio in terms that anyone can understand.

### Distributors and District Offices:

Munsey Bldg., Washington, D. C.; 709 Mission St., San Francisco, Cal.; 33 South Clinton St., Chicago, Ill.; 76 Pearl Street, Boston, Mass.; 1220 Nicollet Ave., Minneapolis, Minn.; International Electric Company, Wellington, N. Z.

## C. Brandes, Inc.

*Matched Tone* Headsets

237 Lafayette St., New York

Dept. P. R.

Made in Canada by Canadian Brandes, Ltd., Toronto and distributed by Perkins Electric, Ltd., Montreal

Result of 14 Years' Experience

## Compare These Prices

Why Pay More When You Can Get Rock Bottom Prices From Us

## \$ Save \$ Save \$ Save

Just glance over our list and send us your money order. Twenty-four hours after receiving your order, it is on its way to you.

List Price	Our Price
\$5.00 Radiotrons UV-200 .....	\$4.24
6.50 Radiotrons UV-201 .....	5.75
16.00 Baldwins Phones Type C .....	13.98
7.75 Baldwin Unit Loud Speakers .....	6.75
45.00 Magnavox .....	38.00
6.00 Murdock 3,000 ohm Phones .....	5.00
5.00 Murdock 2,000 ohm Phones .....	4.25
8.00 Federal 2,200 ohm Phones .....	6.00
8.00 Brandes Superior Phones .....	7.00
5.00 Acme Transformers .....	4.25
1.00 Double Jacks .....	.60
.70 Single Jacks .....	.50
2.50 Bull-Dog Plugs .....	1.25
1.50 100 ft. stranded Aerial Wire .....	.50
.50 Aerial Insulators .....	.20
1.00 100 ft. stranded Aerial Wire .....	.40
75.00 Paragon RA-10 .....	68.00
25.00 90 Ampere guaranteed storage Battery .....	18.00
8.00 Westinghouse W.D. 11 Tubes 1 1/2 Volt operated on 1 Dry Cell. Can be used as Detector or Amplifier..	7.25
1.50 Sockets for W.D. 11 Tubes .....	1.00
1.00 Rheostats .....	.75
1.00 Fada Rheostats .....	.65
1.00 Vacuum Tube Socket .....	.50
18.50 Homchargers .....	15.50
3.50 B Batteries Volt Meters 0-50 V .....	2.75
4.50 Murdock Enclosed 43 plate Variable Condensers .....	4.00
4.00 Murdock Enclosed 23 plate Variable Condensers .....	3.75
3.25 Murdock Panel Mounting 23 plate Variable Condensers .....	3.00
4.00 Murdock Panel Mounting 43 plate Variable Condensers .....	3.60
3.75 23 plate Variable Condensers .....	2.25
4.75 43 plate Panel Mounting Variable Condensers .....	2.50
12.00 Western Electric VT-1 .....	7.50
13.00 Western Electric VT-2 .....	8.25
8.00 Atwater-Kent Variometers .....	7.00
8.00 Atwater-Kent Variocouplers .....	7.00
4.50 Thordarson Audio Transformers .....	3.75
1.00 Fixed Condenser .....	.50
1.50 Crystal Detectors .....	.75
8.00 3000 Meter Loose Couplers .....	4.75
4.00 Tuning Coils .....	2.00
Contact Points (per doz.) .....	.15
Switch Levers 1 1/2 in. Radius .....	.25
Honeycomb Coils, All Sizes, 20% Discount	

Space being limited we are obliged to omit many items.

Write for our quotations.

## Cut Rate Radio Co.

DEPT. A.

P. O. Box 472 Newark, N. J.





Make it  
the **GREATER** Radio  
Christmas

THE gift of all gifts is Magnavox Radio, the Reproducer Supreme: the gift that will mean most to every member of the family, young and old. Based upon the electro-dynamic principle, Magnavox Radio has no comparison with "loud speakers" which merely combine a megaphone with the ordinary telephone receiver.

R-2 Magnavox Radio with 18 inch horn . . .	\$85.00
R-3 Magnavox Radio with 14 inch horn . . .	45.00
Model C Magnavox Power Amplifier 2 stage,	80.00
3 stage,	110.00

Magnavox Products can be had from good dealers everywhere. Our interesting new booklet (illustrated in three colors) will be sent on request.

The Magnavox Co., Oakland, California  
New York: 370 Seventh Avenue

**MAGNAVOX RADIO**  
The Reproducer Supreme



# HOMCHARGE

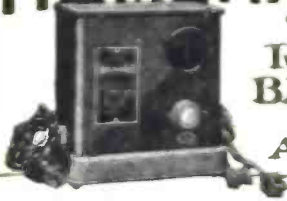

Your  
**RADIO  
BATTERY**  
for  
**A NICKEL**

Enjoyable Radio Concerts and maximum receiving range are obtained only when your battery is fully charged.

Don't be bothered with the inconvenience and expense of taking your battery to a service station every few days for recharging. The

**RADIO  
HOMCHARGER  
DE LUXE**

has been designed especially for this purpose. It charges your "A" or "B" battery overnight without removing from the living room—gives taper charge—cannot harm your battery in any way. Simplicity itself. Only two wearing parts, replaceable after several thousand hours' use for One Dollar.

## AN ORNAMENT FOR YOUR LIVING ROOM

Beauty has been combined with utility in the NEW RADIO HOMCHARGER DE LUXE. The body is beautifully finished in rich Antique Mahogany—the base and fittings in a handsome dull gold. Equipped with rubber feet, it cannot mar polished surfaces. It harmonizes with the finest living room.

## OVER 50,000 HOMCHARGERS IN USE

50,000 users have heartily endorsed the HOMCHARGER. Beware of imitations when buying and insist on obtaining the genuine which bears our registered trade name, HOMCHARGER.

Furnished complete. No extras to buy. Price \$18.50 (25.00 in Canada) at all good dealers, or shipped prepaid upon receipt of purchase price.

Booklet illustrating the NEW RADIO HOMCHARGER DE LUXE in actual colors is FREE for the asking. Send for your copy today.

DEALERS—JOBBER: Over 150,000 HOMCHARGERS will be sold this fall and winter. Send for your copy of "HOMCHARGER Business Builders" and see how you can get your share of this business.

## CAUTION

When buying a Rectifier insist upon the following:

- 1—SELF-POLARIZING FEATURE, otherwise your battery may be ruined through reverse charging.
  - 2—AT LEAST FIVE AMPERE CHARGING RATE, otherwise it will require several days to fully charge your battery.
  - 3—UNDERWRITERS' APPROVAL, otherwise in case of fire your insurance may be void.
- The HOMCHARGER is the only Rectifier at any price which combines the above three NECESSARY HOMCHARGING features.

## The Automatic Electrical Devices Company

132 West Third St., CINCINNATI, O.

Largest  
Manufacturers  
of  
Vibrating  
Rectifiers  
on the World



BRANCH OFFICES:  
New York Chicago  
Philadelphia Detroit  
Los Angeles Dallas  
Pittsburgh Baltimore  
Minneapolis Atlanta  
St. Louis New Orleans

TYPE A FOR SMALL INDUSTRIES

OVER 24,000 IN USE

## PLAY SAFE! INSIST ON GETTING "UNITED" RADIO PRODUCTS

Follow the example of the Radio-wise experts who buy each part with an exact knowledge of its true value.

**United Transformers** amplify weak sounds; bring in distant stations; with clear, pleasing distinctness.

A beautiful piece of workmanship with sturdy steel shell, furnished in black enamel with buffed nickel strip. \$4.50



## United Variable Condensers

Correct in design, high grade in workmanship. Plates are held positively, so that short-circuiting is practically impossible.

### LIST PRICES

43 plate . . . \$4.50 8 plate . . . \$2.75  
23 plate . . . 4.00 3 plate . . . 2.25  
11 plate . . . 3.50 without dial or knob.

**United Variable Condensers, with Variable Attachment Dial and Knob.**

46 plate \$6.50 26 plate \$5.50

United Transformers and Condensers have been adopted as standard equipment by leading makers of radio receiving sets. Their judgment is a safe guide for you.

Tell your dealer you want "United" or nothing. Circulars free.



**UNITED MFG. & DISTRIBUTING CO.**  
536 LAKE SHORE DRIVE-CHICAGO

## STATEMENT OF THE OWNERSHIP, MANAGEMENT, CIRCULATION, ETC., REQUIRED BY THE ACT OF CONGRESS OF AUGUST 24, 1912, OF POPULAR RADIO

Published monthly at New York, N. Y., for October 1, 1922.

STATE OF NEW YORK } ss.  
COUNTY OF NEW YORK }

Before me, a Notary Public in and for the State and county aforesaid, personally appeared Kendall Banning, who, having been duly sworn according to law, deposes and says that he is the Editor of Popular Radio, and that the following is, to the best of his knowledge and belief, a true statement of the ownership, management, etc., of the aforesaid publication for the date shown in the above caption, required by the Act of August 24, 1912, embodied in section 443, Postal Laws and Regulations, to wit: 1. That the names and addresses of the publisher, editor, managing editor, and business managers are: Publisher, Popular Radio, Inc., 9 East 40th St., New York City; Editor, Kendall Banning, 9 East 40th St., New York City; Managing Editor, None; Business Managers, Popular Radio, Inc., 9 East 40th St., New York City. 2. That the owners are: New Fiction Publishing Corporation, 9 East 40th St., New York City; Metropolitan Finance Corporation, 9 East 40th St., New York City; Medbury Blanchard, 509 Fifth Ave., New York City; Le Roy Bargest, (only stockholder owning 1% or more of stock of Metropolitan Finance Corp.), 9 East 40th St., New York City. 3. That the known bondholders, mortgagees, and other security holders owning or holding 1 per cent or more of total amount of bonds, mortgages, or other securities are: None. 4. That the two paragraphs next above, giving the names of the owners, stockholders, and security holders, if any, contain not only the list of stockholders and security holders as they appear upon the books of the company but also, in cases where the stockholder or security holder appears upon the books of the company as trustee or in any other fiduciary relation, the name of the person or corporation for whom such trustee is acting, is given; also that the said two paragraphs contain statements embracing affiant's full knowledge and belief as to the circumstances and conditions under which stockholders and security holders who do not appear upon the books of the company as trustees, hold stock and securities in a capacity other than that of a bona fide owner; and this affiant has no reason to believe that any other persons, association, or corporation has any interest direct or indirect in the said stock, bonds, or other securities than as so stated by him.

(Signed) KENDALL BANNING, Editor.

Sworn to and subscribed before me this 18th day of September, 1922.  
[SEAL] EUGENE S. HUBB, Notary Public.





*Claude  
Yates*

## The SANDMAN'S STORY



*Catalog Number Four  
contains Marvellous  
article on tuning  
Receiving Sets.  
10 cents  
brings it  
to you*

On a Tuska Radio Receiver, every evening you can hear "The Sandman's Story". This delights the children. Later comes entertaining Radio Broadcasting for grown-ups.

Tuska Radio will bring dependable broadcasting into your home. A Tuska Radio Receiver makes a wonderful Christmas Present.

Tuska Radio is substantial, reliable, dependable and recognized. Inspect today at your dealer's.

### THE C. D. TUSKA COMPANY

Bartholomew Ave. Hartford, Conn.  
Pacific Coast Office, 711 Mission Street, San Francisco, Calif.

# TUSKA RADIO

*Established 1911*



# "Chi-Rad" Storage "B" Battery—



built for service. Absolutely unequaled in quality and price—half the cost of the cheapest well-made storage "B" battery. Better and cheaper than dry cell "B" batteries because rechargeable.

Will operate a tube approximately 1,000 hours on a single charge. Recharged overnight with "Chi-Rad" Storage "B" Battery Charger at a cost of about 5c.

No noises or leakage losses with "Chi-Rad" Storage "B" Batteries. Guaranteed for service, or to be returned at our expense. Order your battery *now*.

- No. 102 "Chi-Rad" Storage "B" Battery
  - 22½ volt section (mounted) . . . \$6.00
  - 2¼ volt section (single cell) . . . .50
  - No. 102a "Chi-Rad" Storage "B" Battery
  - Charger . . . . . 1.90
- (ORDER BY NUMBER)

Write for your free copy of our new catalog.

Dealers—Write for territory on "Chi-Rad" Radio parts and sets.

**Chicago Radio Apparatus Co.**  
415 South Dearborn Street :: Chicago



## The Only Knob and Dial Without a Set-screw



The unsightly and troublesome SET-SCREW is at last eliminated. No more splitting the head of the set-screw or stripping of threads, perhaps ruining the dial.

To mount the TAIT-KNOB-AND-DIAL simply hold the dial with one hand and screw on the knob with the other; a few seconds does it. No tools are necessary. When fastened it is self centering and self aligning.

This beautiful patterned KNOB-AND-DIAL is made of the best grade of BAKELITE.

To those building their own sets—Don't fail to use this dial, it is REVOLUTIONARY in its field and is the PEER of all KNOBS-AND-DIALS. If your dealer has none, write us and we will refer you to one who has.

Dealers—If your Jobber is not stocked up, write us and we will refer you likewise.

List price—4" model \$1.50; 3" model \$1.00

We Sell Strictly to Manufacturers and Jobbers—whom we invite to write us for samples and discounts.

**TAIT KNOB & DIAL COMPANY, Inc.**  
11 East 42nd Street Dept. P. New York

Patented June 20, 1922.

# START RIGHT AND CARRY ON

With James R. Cameron's

## "TEXT BOOK ON RADIO"

**HOW** to build your own set, from crystal to Super-regenerative.

**WHAT** to use.

Profusely illustrated.

The finest coat pocket, flexible bound "TEXT BOOK ON RADIO," with a complete List of "Radio Terms" and Classified Index.

CLOTH BOUND : : \$2.50  
 FLEXO-LEATHO : : \$3.00

ALSO

### "RADIO'S THREE BEST SELLERS"

*Radio for Beginners* . . \$1.00  
*Radio Dictionary* . . . .50  
*How to Build Your Own Set* .25

CUT HERE

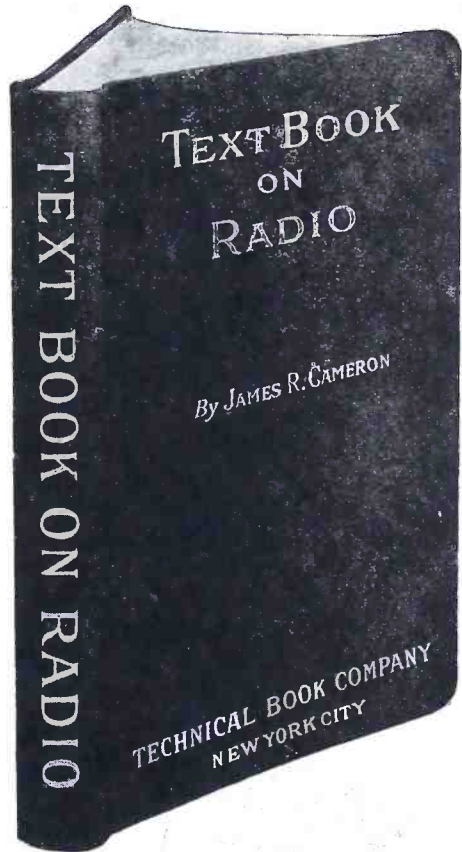

GENTLEMEN—Kindly enter my order for the following:

.....  
 .....  
 .....

Name.....

Street.....

City and State.....

**TECHNICAL BOOK CO.**  
 130 West 42d Street Dept. P New York

# THESE RADIO SUPPLIES ARE YOURS THEY COST YOU NOTHING!

We will give you cost-free any of the radio supplies listed on this page without its costing you a single penny. You have only to show your December copy of POPULAR RADIO to a few friends. Tell them this number is only one of twelve corking good issues, the best Dollar-And-A-Half buy in the market. They'll subscribe!

You may have any number of articles provided you have the necessary subscription credits. Here's an idea that will help you get them: A subscription to POPULAR RADIO makes an ideal Xmas gift both on account of its *suitability*

and its extremely low price. It's the one gift that lasts for a whole year.

## FILAMENT CONTROL RHEOSTAT

It is used for controlling the brilliancy of a vacuum tube so that the utmost efficiency may be obtained from your receiving set.

Send two (2) yearly subs at \$1.50 each.

## VACUUM TUBE SOCKET

A vacuum tube socket of this sort is very necessary in all receiving sets that employ tubes. Have you one?

Send two (2) yearly subs at \$1.50 each.

## MICA GRID CONDENSER

You may have either a mica grid condenser or else a phone condenser. Either makes a thoroughly efficient device needed in receiving circuits.

Send two (2) yearly subs at \$1.50 each.

## A RADIO READING COURSE

This course comprises five illustrated lecture books, approved and edited by Prof. J. M. Morecroft of Columbia University—an elementary study of radio.

Send three (3) yearly subs at \$1.50 each.

## TWO INDUCTANCE COILS

Inductances for use in the new Armstrong super-regenerative circuit. They consist of two Duo-Lateral or Honey-Comb coils, Nos. L-1250, and L-1500.

Send eight (8) yearly subs at \$1.50 each.

## VACUUM TUBE U-V-201

The vacuum tube U-V-201 can be used in a receiving set for rectifying or amplifying. It is more efficient than the crystal detector.

Send ten (10) yearly subs at \$1.50 each.

**IMPORTANT:** Full remittance must accompany each order. An additional charge of \$.25 postage for Canada and \$.50 for each foreign subscription is necessary. Please specify what you want when you send your order. This offer is not good after January 15, 1923.

# POPULAR RADIO, Inc.

9 East 40th Street

New York City



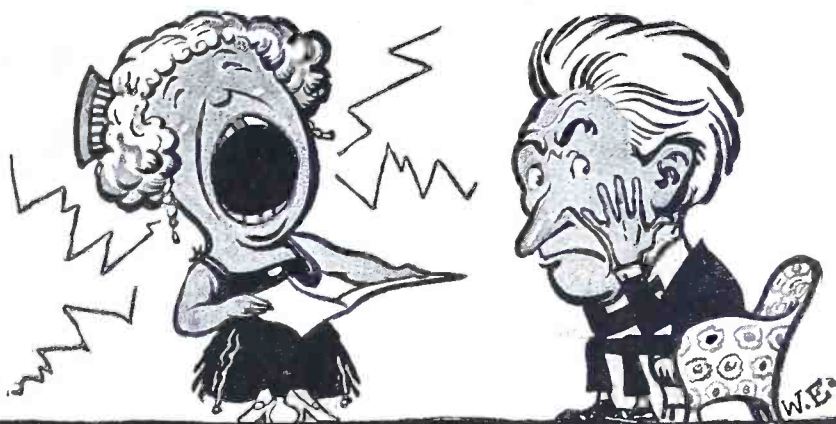

## “Can those shrieks”

**H**OW often have you sat helpless while some amateur Farrar has tried to hit “High C.” But when your radio set starts in to show off its shrieking talent you need not go through another ordeal. Just drop in at your nearest radio store and order an Acme *Audio Frequency Amplifying Transformer*. Hook it up to your detector set and sit back easy. You’ll be surprised how clearly and distinctly incoming sounds may be heard. Then, too, the tones are natural. Something usually so lacking in the ordinary set.

You will also want the Acme *Radio Frequency Amplifying Transformer* because this will greatly increase the range of your set whether it be vacuum tube or crystal detector. Both Acme *Audio* and Acme *Radio Frequency Amplifying*

*Transformers* sell for only five dollars. Your set is not complete without them.

The Acme Apparatus Company (pioneer transformer and radio engineers and manufacturers) are also manufacturers of one and two stage amplifying units, detector units, detector and two stage amplifying units, the Acme Clear Speaker, the Acme-fone. Acme C. W. and spark transmitting apparatus offer the amateur an opportunity to not only receive but send his own messages. For sale at radio and electrical stores or write direct to the Acme Apparatus Company, Cambridge, Mass., U. S. A., or New York Sales Office, 1270 Broadway. Ask also for instructive free booklet on the operation of amplifying transformers, both audio and radio frequency types. You need it.

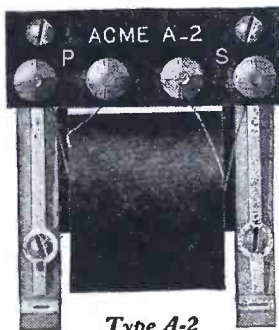

*Type A-2*  
*Acme Amplifying Transformer*  
Price \$5 (East of Rocky Mts.)

# ACME

*for amplification*



TYPE 247 CONDENSER

# DESIGNED NOT MADE

Would you buy diamonds at a corner grocery store? Of course not; you do not expect the grocer to be a diamond expert! Then why buy condensers that are simply made instead of being designed?

For many years the GENERAL RADIO COMPANY has been supplying the research and educational institution laboratories throughout the country with radio apparatus of the highest quality. The Bureau of Standards and other government laboratories are extensive users of our equipment. The experience obtained in this line has enabled us to design instruments for the citizen radio field that represent the latest developments in engineering and mechanical skill.

For seven years we have been supplying radio condensers that have been a standard for low losses and excellence in construction. Our latest addition to this line of condensers is the type 247. Send for **Free Radio Bulletin 911-U** and learn why these condensers are so popular.

MODERATELY PRICED AS FOLLOWS:

- Type 247A— .001 M. F. Mounted, Shielded.....Price, \$6.00
- Type 247B— .001 M. F. Unmounted, with Counterweight.....Price, 3.75
- Type 247E—.0005 M. F. Mounted, Shielded.....Price, 5.56
- Type 247F—.0005 M. F. Unmounted, with counterweight.....Price, 3.25

This condenser is but an example. We manufacture a complete line of the finest radio instruments and parts.

## GENERAL RADIO COMPANY

Massachusetts Avenue and Windsor Street,

CAMBRIDGE, 39, MASSACHUSETTS

*Standardize on General Radio Company Equipment Throughout.*

Do not confuse the products of the GENERAL RADIO CO. with those of the other concerns using the words "General Radio." The General Radio Co. has been manufacturing radio and scientific instruments for many years. It has no affiliations with any other company.

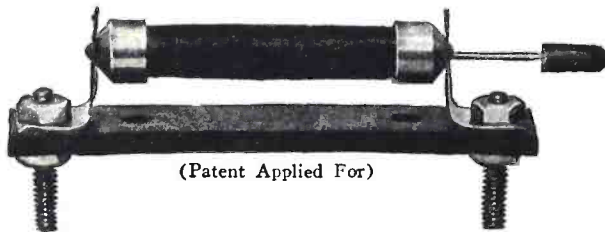

(Patent Applied For)

## THE ONLY ONE IN AMERICA

With the usual type of "Grid Leak," which is of fixed value, it is necessary to try a number of them to determine the one best suited.

### The Durham Variable High Resistance (Adjustable Grid Leak)

is the only one of its kind now on the market, because it is *adjustable* over a wide range and will maintain its value permanently after initial setting—It is non-inductive and has negligible capacity.

Made in two sizes:      No. 100—1,000 to 100,000 ohm range  
    No. 101—100,000 to 5,000,000 ohm range

*Wire or write for samples and prices to*

## DURHAM & COMPANY

1936 Market Street

Radio Engineers

Philadelphia, Pa.

# That Satisfying Pride in Your Radio Set

You know how it is when you own anything that is really fine. You're proud of it and jealous for it and want others to appreciate it as you do. You'll feel in full measure that satisfying thrill of pride in your radio set when you own Kennedy equipment. Even such friends of yours as are not radio "fans" will admire the handsome appearance and perfect finish of your Kennedy installation. And those who are radio experts will be even more enthusiastic over its splendid performance.

## KENNEDY EQUIPMENT

The Beautifully Finished and  
Wonderfully Efficient

# KENNEDY

*Short-wave Regenerative Receiver Type 281*

An ideal set for general use. Highly sensitive, selective and efficient—easy to operate—finely made in every detail. Meets the requirements of keen radio students who recognize and demand the best. Yet it is so simple to use that perfect results can readily be obtained by novices. Ask your dealer to show you the Kennedy Type 281 Regenerative Receiver, and *write* our nearest office for latest Kennedy Bulletin C-3.

All Kennedy Regenerative Receivers are licensed under  
Armstrong United States Patent No. 1,113,149

## THE COLIN B. KENNEDY COMPANY

INCORPORATED

SAN FRANCISCO

U. S. A.

SAINT LOUIS

KENNEDY  
EQUIPMENT



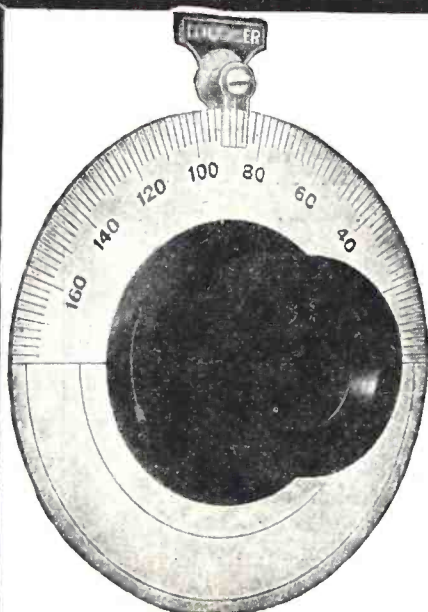

### PRICES

4-in. Dia. Dials... \$1.50  
 3 1/4-in. Dia. Dials. 1.00  
 1 3/4-in. Dia. Dials. .60  
 Specify 1/4-in. or 3/8-in. Shaft  
 Hole.

# SOMERVILLE

STANDS FOR  
 DISTINCTIVE APPEARANCE AND OPERATING CONVENIENCE

The THREE-IN-ONE DIAL places it beyond competition. The price is based on huge production.

**FIRST** Silver lacquered brass dial contrasts with Black Panel. The knob fits the fingers without fatigue.

**SECOND** Lower half of scale may be calibrated in meters or station call letters with pencil.

**THIRD** The tail of dial tag makes contact with back of dial and connects with ground, removing hand capacity.

### SOMERVILLE DIAL TAGS 5c.

Completing the line of terminal  
 and Jack tags

Makes your metal dial a shield and tells you what's what; with the celluloid pointer at 10c adds the finishing touch to your set.

ALL READINGS AVAILABLE

## SOMERVILLE RADIO

LABORATORY EST. 1917

43 CORNHILL, BOSTON

NEW CATALOG NOW READY-WRITE

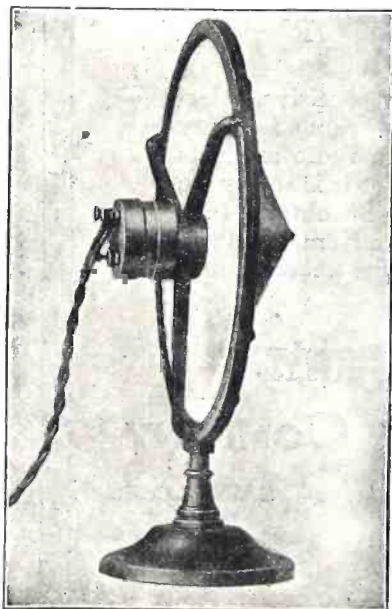

## THE PATHÉ LOUD SPEAKER

Has No Superior

It reproduces exactly the sound sent out and has none of the "tinny" noise that must come from a metal horn. It operates with any two stage amplifying set. Insist on hearing a Pathé operate before you buy.

Price, \$24

THE SOUND WAVE CORPORATION

30 Grand Avenue, Brooklyn, New York

Makers of Quality Dials, Variometers, Variocouplers, and Loud Speakers

# DICTOGRAPH Radio HEAD SET

Was ~~\$12.00~~ Now

Why This Sensational  
Reduction in Price?

A SWEEPING cut of \$4.00 in the price of the Dictograph Radio Head Set! The tremendous endorsement of radio enthusiasts has made possible this sensational reduction. To meet the demand, production has been planned on a new, gigantic scale. Great manufacturing economies establish the new price—only \$8.00 complete with 5 ft. cord.

A wonderful bargain! And, above all, a wonderful head-set—the world's standard of supreme quality for super-sensitive and accurate sound-transmission.

The same quality, the same guarantee, the same supreme Dictograph head-set in every respect but the price. Type R-1, 3,000 ohms, for all types of receiving sets.

*The Standard of the World*

## DICTOGRAPH Radio LOUD SPEAKER

The Perfect Loud Speaker  
for the Home

Public demand has made possible the Dictograph Loud Speaker at the low price of only \$20.00, complete with 5 ft. flexible cord. A handsome instrument that reproduces every sound in crystal-clear, natural tones, full volume, and free from distortion or noise. Ask for demonstration at reliable radio dealers. Get world-famous DICTOGRAPH quality and still save money.

Dealers: Order through your jobber or write direct for names of authorized distributors.

**DICTOGRAPH PRODUCTS CORPORATION**  
220 West 42d Street (Branches in all Principal Cities) New York, N. Y.



Note: Plans are now under way for the production of the new 4,000 ohms Dictograph SUPER-TONE Head Set, the most perfect radio head set that can be made. For the most delicate work, the most exacting requirements. A new standard of super-sensitiveness! List Price, \$12.00.

\$20





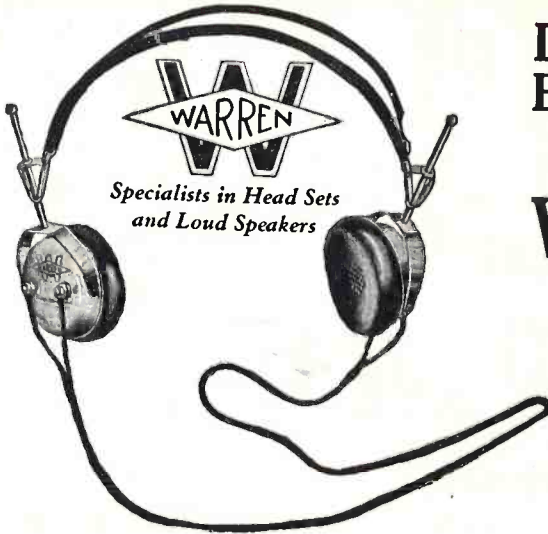

## Delight of Perfect Broadcast Reception

*is Found in the*

## Warren Phones

THE WARREN is indeed a Head Set which, at anything like equal price, cannot be equaled for sensitiveness, articulation and clearness, or in all around excellence of design and construction.

2000 Ohms \$7.00

3000 Ohms \$9.00

ASK YOUR JOBBERS—OR WRITE US

*Attractive Discount to Jobbers and Dealers*

**WARREN RADIO PHONE MFG. CO., Inc.**  
Warren, Rhode Island, U. S. A.

## Is It Hard to Choose a Christmas Present for the Boy?



ACE RADIO BROADCAST RECEIVER

Licensed under  
Armstrong U. S. Patent  
No. 1,113,149

IF he has real red blood in his system, he will want a radio broadcast receiver, or the parts with which to make his own.

Start him right in this fascinating new field—give him an ACE Radio Concert Receptor or ACE

Radio parts. Incidentally you will enjoy Radio as well as your boy.

*Let us send you our descriptive booklet, "Radio In Your Home."*

**THE PRECISION EQUIPMENT COMPANY**  
2437-2439 Gilbert Avenue Dept. XM Cincinnati, Ohio





## —And a Flock of Radio “Bugs” Step Up to Broadcast Their Christmas Orders!

Three million eager American boys know that this year Santa won't have any excuse for mistaking their orders on account of poor writing. Billie, last year got a Doll and he wrote for a Ball! Santa's Frost-Fones are a guarantee of clear accurate Radio reception. They will bring satisfaction to thousands of homes through their dependable service.



### Something New—A Plug for 60c

No. 139  
All Terminal Plug  
60c



Showing screw binding post terminals with phone cord tips inserted

#### Frost-Radio Leaders

Frost-Radio Protector—Frost-Radio Tuning Coil  
Frost-Radio Extension Cord and Plug  
Frost-Radio Improved Jacks and Plugs  
Frost-Radio Receiving Transformers  
Frost-Fones—Cunningham Tubes  
Remler Radio Apparatus

Your local dealer can supply you



# HERBERT H. FROST

NATIONAL FACTORY DISTRIBUTORS  
TO THE ELECTRICAL-RADIO JOBBER

154 W. LAKE ST. CHICAGO, ILL.

## Dubilier Micadons reduce tube noises

Tubes howl partly because condensers fluctuate in capacity. Dubilier Micadons are mica condensers which are *permanent in capacity*. Hence they reduce tube noises and greatly improve reception. Dubilier Micadons are made in several types to meet every radio need. The price varies from 35c to \$1.00 each, depending on the type and the capacity.



Micadon type 600. Molded case. With and without grid-leak mounting. Prices range from 75 cents to \$1.00 each, depending on capacity.



Micadon type 601. Connect by eyelet terminals to build up desired capacity. Price 35 cents and 40 cents each, depending on capacity.

**BRANCH OFFICES:**

- San Francisco..... 709 Mission St., Suite 701-704
- St. Louis, Mo..... Syndicate Trust Bldg., Suite 1409
- Washington, D. C..... Munsey Bldg.
- Chicago, Ill..... 33 S. Clinton St.
- Atlanta, Ga..... 802-3 Forsyth Bldg.

# DUBILIER

Condenser & Radio Corp.  
48-50 West 4<sup>th</sup> St. N.Y.

Canadian Distributors: Canadian General Electric Co., Toronto, Can.

# NOVO "B" BATTERIES FOR RADIO

22½-45 & 105 VOLTS

**NOISELESS  
DEPENDABLE  
GUARANTEED**

**ASK YOUR DEALER**

**NOVO MANUFACTURING CO.**  
424-438 W. 33<sup>rd</sup> ST.  
NEW YORK

531 SO. DEARBORN ST., CHICAGO.

Give him a  
**PACENT MULTI JACK**  
**\$1.50**

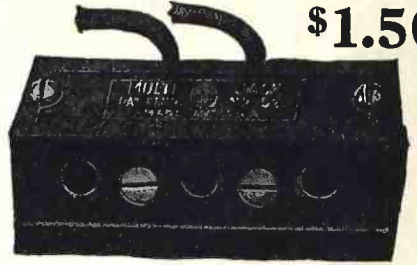

Your radio friend or relative will appreciate a gift of one or more PACENT MULTI JACKS (three independent jacks in a single base). Then three can listen in. Ask your dealer to show you PACENT products and look for the PACENT trade mark.

Send for descriptive bulletins, PR106

**PACENT ELECTRIC COMPANY**  
INCORPORATED  
Executive Offices: 22 Park Place, New York, N.Y.  
BRANCH OFFICES

Philadelphia  
Chicago



Washington, D. C.  
San Francisco

"This is a RADIO Christmas"

## CHELSEA CONDENSERS



**NO. 1  
PRICES**

No. 1	Table .001	\$5.00
No. 2	Table .0005	4.50
No. 3	Panel .001	4.75
No. 3a	Panel without dial	4.35
No. 4	Panel .0005	4.25
No. 4a	Panel without dial	3.85
No. 5	Panel .00025	3.75
No. 5a	Panel without dial	3.35
No. 6	Panel vernier	2.90
No. 6a	Panel without dial	2.50
No. 7	Panel with vernier	6.50
No. 8	Table with vernier	6.75

**GENUINE BAKELITE CONSTRUCTION**  
The best and most complete line of condensers in existence.

Write for our catalogue No. 7.

**CHELSEA RADIO COMPANY**  
177 SPRUCE STREET  
CHELSEA, MASS.



**E**XTEND Christmas cheer throughout the year by topping the gift list with a

**FADA RECEIVER-AMPLIFIER**

Every member of the household can easily operate and enjoy this master instrument, commanding, as it does, entertainment from various broadcasting stations, bringing it, in true clearness of tone, to your own fireside. Although a very simple instrument, the Fada receiver-amplifier embodies those true refinements typical of all Fada equipments and parts.

The Fada Handbook will be sent you upon receipt of 5c to cover postage. It's plumb full of things about radio you ought to know. Please mention name and address of your nearest radio or electrical dealer.

F. A. D. ANDREA

1581-D JEROME AVE., NEW YORK CITY





# RHAMSTINE\* RADIO FREQUENCY TRANSFORMER

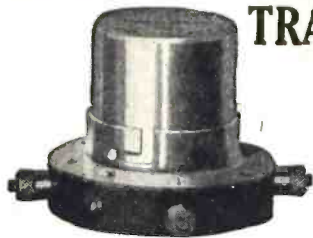

**\$4.50**

*Complete with  
mounting*

Rhamstine\* has produced in this transformer every quality which you would naturally look for. In efficiency it is comparable with others costing much more and in design and finish it is doubtful if you can find its equal. Each transformer is equipped with a base mounting and sold at a price exceptionally low as compared with the high value of the unit.

Type 1, 200-500 meters, especially efficient for the present broadcasting services.

Immediate deliveries.

Manufactured by

**J. THOS. RHAMSTINE\***

2152 E. Larned St.

Detroit, Mich.

**\*Maker of Radio Products**

## FREE Radio Catalog

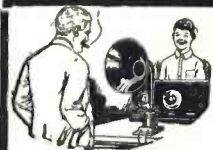

Describes and illustrates our large complete stock of Radio Equipment of all kinds. We can make immediate shipments of proven, reliable equipment. Protect yourself against disappointment by taking advantage of our experience and reliability.

Send \$5.00 for Genuine Cunningham or Radiotron Detector Tube

Free catalog sent on request

**JULIUS ANDRAE & SONS CO.**

*In Business since 1860*

127 Michigan Street

Milwaukee, Wis.

## Na-ald

Special

### Socket W. D. 11

Designed especially for the new tube of the Radio Corporation which is operated by a single dry cell. Special clips of phosphor bronze with side wipe and strong gripping action on contact pins. Nickel plated binding screws. Highest quality throughout. Moulded from Condensite.

**ALDEN-NAPIER CO.**

Dept. C

52 Willow St. Springfield, Mass.



**STORAGE BATTERY COSTS  
ARE ELIMINATED BY USING**

# SUNECO TUBE ADAPTER

Which enables you to use the famous dry cell vacuum tube in any radio set socket. Directions:—Insert tube in Adapter, insert Adapter in socket. Tube circuit is automatically adapted to conform to your set. Save time money, and rewiring changes by using this Adapter.

Price \$1.50 each

Send money order or cash if your dealer cannot supply you. Dealers write for proposition.

**Sun Equipment Co.**  
Dept. R  
67 Exchange Place  
New York



## \$1 Loud Speaker \$1

Adapter

Hear all broad-casting through phonograph. Make your own horn. Attach B-R Phonadapter to YOUR phonograph. All can hear. Entire family, neighbors, guests can hear operas, lectures, latest news, with this adapter. Stretches over receiver of Baldwin or Brandes type head-set and attaches to tone-arm of ANY phonograph. Made of soft, pure gum rubber. Quickly attached and removed. Thousands in use. Absolutely no voice distortion. For single receiver.....**.75**

For pair of receivers (more than twice the volume) **\$1**

## Amplitone Loud Speaker

An inexpensive, loud speaking horn especially adapted for home use. Ample volume. Quality tones. Throat of horn consists of successive sound expansion chambers. Each chamber amplifies previous one. Furnished either with single or double B-R Phonadapter. Price **\$8** only.....

## Bell Horn

A Bell Horn with ball swivel. Turns up, down, to side—any angle desired. Automatic adjustment. Very simple. No screws, thumb nuts, etc. Black finish. Complete, with phone, ready to attach to two stage amplifier.....**\$15**

**The Beckley-Ralston Co.**  
1825 So. Michigan Ave.  
Chicago, Ill.

Go to your dealer. If he cannot supply you send money order, check or currency at our risk. Prompt delivery — postpaid. Also send us name of favorite dealer.





## Your Christmas will be more enjoyable~ *With a Crosley Radio Receiving Set*

Let the children hear Santa on Christmas Eve. The entire family will enjoy the Christmas Carols and the appropriate Concerts and Dance Music during the Happy Holidays.

Listen in for Crosley Broadcasting. Our new station, WLW, is one of the largest and best in the country, and can be heard in any part of the United States and Canada, east of the Rockies, with a Crosley Model X. This instrument as in all of our larger units incorporates one stage of Tuned Radio Frequency Amplification. We were the first to bring this feature on the market, and have developed it to its highest degree. This simplifies tuning, increases the range and clarity and eliminates interference. Crosley instruments are popular wherever they are tried.

With a Crosley Outfit, you are assured of an enjoyable time every evening in the week. A single wire from your house to a nearby tree or building, is all that is necessary. Connect this to your set and you are ready to tune in any number of stations and hear a wide variety of selections. Easy to install and easy, even for a novice, to operate, a Crosley Receiving Set will solve your entertainment problem.

We make any size instrument from \$25 up, and all parts necessary to build your own set.

Your jobber or dealer should be able to furnish you with Crosley Apparatus. If not, send us his name and order direct.

WRITE FOR CATALOG

**CROSLEY**  
BETTER-COST LESS  
**RADIO**

**CROSLEY MANUFACTURING CO.**

Department PR4  
Cincinnati-Ohio

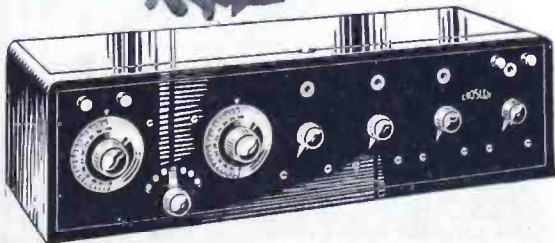

**CROSLEY RECEIVER MODEL X.** A four-tube outfit the same as shown in the above scene. It consists of Tuner, one stage of Tuned Radio Frequency Amplification (the feature that has made our instruments so popular), Detector and Two Stages of Audio Frequency Amplification in a beautiful mahogany finished cabinet. It will bring in distant stations loud and clear. Price without phones, batteries or tubes, \$55.00.



# DIALS



2 in. 20c.      3 in. 27c.      2 3/4 in. 25c.

With Brass Insert and Set Screw  
Specify whether 3-16 in. or 1/4 in. Insert



\$1.75  
"SESCO" Variocoupler  
600 Meters

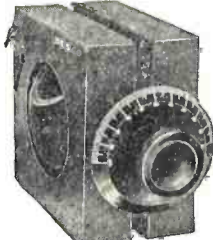

\$2.50  
"SESCO" Variometer

Standard Mod. 8 Phones, 2500 Ohms, \$5.75

Half with order, balance C. O. D.

**STANDARD ELECTRIC SALES CO.**  
843 Broad Street      Newark, N. J.

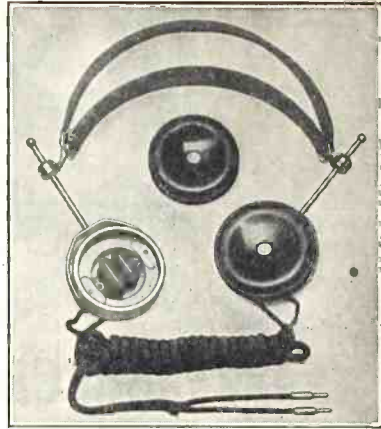

**\$8 LIST PRICE \$8**

**2,200 OHMS      LOUD AND  
LIGHT WEIGHT      CLEAR**

*Dealers May Send  
\$3.20 for Sample*

**FRENCH MFG. CO., Seymour, Conn.**

## Speed Up Your Production

by sawing bakelite, formica, brass, copper, carbon, or wood on a

### Junior Bench Saw

A precision machine especially adapted to the rapid and accurate production of small duplicate parts. All metal construction. Top 10" x 13", elevates for grooving, tilts, 10 degrees for beveling. Saws 1 1/2" stock. Easily driven by 1/4 hp. or 1/2 hp. motor. Attachments for grinding and sanding. Special saws for bakelite, brass, etc. furnished from stock. **\$28.75**

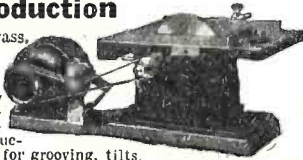

Junior Bench Saw with guides and one 6" wood saw \$60.00  
Motor Driven Unit as shown, mounted on iron base with 1/4 hp. ball-bearing motor, belt tightener, belt, cord, plug, and switch, \$60.00. Write for fully illustrated circular.

Manufacturers and amateurs will be interested in our Handlathe, Junior Bench Drill, Handisaw and Ball-Bearing Motors.  
**W. & J. BOICE, Dept. 612, 114-23rd ST., TOLEDO, OHIO**

BUILD YOUR OWN RECEIVING SET WITH

## "Scientifically Superior" Radio Supplies

Receiving Combination CR-1 Complete \$12.00

100 ft. copperclad aerial wire .....	\$1.00
50 ft. insulated ground wire .....	.75
2 Midget aerial insulators, each 25c. ....	.50
1 Ground Clamp .....	.12
1 Inductance coil (150-600 meters) .....	1.00
1 Crystal detector .....	1.50
1 Tuning condenser (General Radio) .....	3.25
1 Pair Murdock head phones (2,000) .....	5.00
4 Binding posts, each 5c. ....	.20
1 Composition panel 6 by 9 .....	1.00

Total \$14.32

Expert radio advice free to our customers.

**SCIENTIFIC RADIO CO., 112 W. 16TH ST., NEW YORK, N. Y.**

## HEAR RADIO RIGHT!

Starnes Superadio Specials, same as used in the Harry T. Starnes lecture-demonstrations throughout United States and Canada, in piano finish mahogany cabinets.

Detector, and One Stage Audio Frequency Amplifier ..... \$40.00

Detector, and Two Stage Audio Frequency Amplifier ..... \$50.00

With Automatic Filament Control... \$60.00

Two Stage Radio Frequency Amplifier, the best ..... \$75.00

Also High Quality Three Stage Radio, and Audio Amplifiers.

### WRITE FOR PRICES

Special 2500-mile Receiver, which caused so much comment on Chautauqua and Lyceum Tours recently..... \$200.00

Also Clapp-Eastham, Westinghouse, Radio Corporation and other high-grade products, at interesting prices.

**STARNES SUPERADIO SERVICE      Covington, Indiana**



**NA-ALD**

De Luxe  
**V. T. Socket**

Contact strips of laminated Phosphor bronze press firmly against contact pins, regardless of variation in length. No open current trouble possible. Socket moulded from genuine Condensite. Practically unbreakable. Special protected slot, with exterior reinforcement. Unaffected by heat or bulbs or soldering iron. All excess metal eliminated, aiding reception. May be used for 5 Watt power tube. Highest quality throughout. Price, 75c.

Special proposition to dealers and jobbers.

**ALDEN - NAPIER CO.**

52 Willow St.      Dept. C      Springfield, Mass.



# The Tower of Babel will be Sending this Winter

Forty powerful broadcasting stations, all operating on one narrow wave band—that's the situation confronting the radio fan this winter. With the ordinary single circuit it will be like listening in on the Tower of Babel.

The PARAGON three circuit receiver, because of its greatly superior selectivity and sensitivity, can pick and choose between broadcasting stations of about the same signal strength with less than one per cent differential.

PARAGON three circuit receivers are always more satisfactory to operate. This winter any other kind of a receiver is obsolete and practically useless. When you pay out your good money, get a modern receiver—the PARAGON.

ADAMS-MORGAN COMPANY

20 Alvin Avenue

Upper Montclair, N. J.

Also Manufacturers  
of  
PARAGON  
Radio Telephone  
Transmitters  
V. T. Control Units  
Rheostats  
Potentiometers  
V. T. Sockets  
Amplifier  
Transformers  
Detectors  
Control Dials  
Amplifiers  
Receivers  
Switches  
Variometers



Type RD-5 Regenerative Receiver (Including Detector)

Type A-2 Two-Stage Amplifier

(Licensed Under Armstrong Patents)

# PARAGON

Reg. U. S. Pat. Off.

## RADIO PRODUCTS

# MICON

Tested Mica Condensers



Assure: Absolute noiselessness, Clarity of tone, Accuracy, Constant fixed capacity

Size	Price	
.00025	\$0.35	Complete diagram of the Armstrong Super-Regenerative Circuit FREE with every purchase of MICONs.
.0005	.35	
.001	.40	
.002	.40	
.0025	.50	
.005	.75	
.01	1.50	

Sizes .0025 and .005 are especially adapted for the new Armstrong Super-Regenerative Circuit. Micon can be had in all capacities from .000025 to .01.

At your dealer's—otherwise send purchase price and the desired Micon will be sent without further charge.

**CHAS. FRESHMAN COMPANY, Inc.**  
290 HUDSON STREET NEW YORK CITY

**3000 Ohm Sets \$3.98**  
PLUS 20 CTS. POSTAGE AND PACKING  
Satisfaction Guaranteed or Money Back



We mail phones the day your order arrives. Every pair tested, matched and guaranteed as sensitive as \$8 to \$10 Sets. Circular Free.

**TOWER MFG. COMPANY**  
114 STATION STREET, BROOKLINE, MASS.

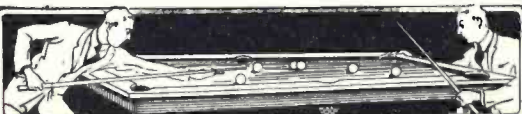

## BURROWES

### Home Billiard & Pool Tables

Magnificently made in all sizes, at all prices. Game exactly same as standard table. Become expert at home. Use in any room, on any house table or on its own folding stand. Quickly leveled. Put up or down in a minute. Small amount down, easy payments. Ask your dealer or WRITE TODAY for Catalog.  
**E. T. BURROWES CO., 150 Free St., Portland, Maine**

## RADIO & AUTO STORAGE BATTERIES CHARGED FROM A LAMP SOCKET AT HOME At a Cost of a Few Cents With An



## \$15 F-F BOOSTER

Full Wave Automotive Magnetio Charging Rectifier for 105-125 Volt, 60 Cycle, A. C., Type A-B Charges, 6 Volt, "A" and Auto and up to 120 Volts, of "B" and Loud Speaker Storage Batteries, in Series Inductively at home overnight. Disconnecting and Multiple Connections Unnecessary. Charging Circuits Separate. No Grounds. No Danger. No Skill Required. AM-METER eliminates Guesswork. Infusible Electrodes Rectify Current. Will Charge a Dead Battery.

Charges AUTO & RADIO Batteries. Leave Battery Connected. Screw Plug In Lamp Socket, Snap Rectifier Clips on Battery Terminals. Turn Switch and Battery is Charged in Morning. Nothing like it made. Is it not gratifying to feel your Radio Batteries are ready for all Radiophone Music and News? Never having to be careful of, or tell friends your Batteries are Dead? Fully charged Batteries by starting car quick, require fewer expensive replacements. Do not think your Battery is Dead and Worth Out because it will not start your car. Buy a Booster which fills it with life, saves more than its cost and lasts a lifetime. 7 types built by Master of the Art and POPULARLY PRICED.

Type 6 Charges Radio "A" & Auto 6 V. Batteries at 6 Amp. \$15  
Type B Charges Radio "B" Batteries up to 120 V. in Series \$15  
Type A-B Charges "A" & "B" Radio & Auto Batteries in Series \$20  
Type 12 Charges 12 Volt Batteries at 5 Amperes \$15  
Type 166 Charges 6 Volt Batteries at 12 Amperes \$20  
Type 1612 Charges 12 Volt Batteries at 7 Amperes \$20  
Type 1626 is Combination of 166 & 1612 Charging 6 & 12 V. \$28  
The Larger Types are for heavy Batteries, or where time is limited. Shipping Weights, 11 to 15 Pounds. Purchase from Your Dealer, or Send Check for Prompt Express Shipment. If via Parcel Post have remittance Include Postage & Insurance charges. Or have us ship You Type desired C. O. D. Other F-F BATTERY BOOSTERS Charge Batteries from Farm Lighting Plants and D. C. Circuits. For GROUP CHARGING use our 100-Volt Automatic ROTARY RECTIFIER, 12 Battery, 8 Ampere Size, \$135. ORDER Now or WRITE Immediately for FREE BOOSTER BULLETIN 44 and ROTARY 44A.

**THE FRANCE MFG. CO., OFFICES & WORKS: CLEVELAND, OHIO, U. S. A.**  
Canadian Rep: Battery Service & Sales Co., Hamilton, Ontario, Canada



## Agents

LARGE MANUFACTURER OF SHIRTS  
wants Agents to sell complete line of shirts direct to wearer. Exclusive patterns. Big values. No capital or experience required. Write for free samples.

MADISON SHIRT MILLS  
507 Broadway, New York, N. Y.

## RADIO Complete set \$15

Send for circular describing the SENSITONE Long Distance Armstrong Regenerative Radio Receiving Set, which we sell, complete with batteries, tubes, head set and aerial—all ready to listen to concerts—on easy payments. Enjoy the pleasure of radio while paying for a Sensitone.  
Halold R. Wakem & Co. 851 Washington Blvd., Chicago

Down \$10 per Month

35c EACH 3 FOR \$1.00



## NA-ALO

genuine CONDENSITE DIAL  
The dial that runs true

Numerals engraved on bevel and knob so shaped that fingers do not hide them. Thin edge with clear graduation to make accurate reading easy. Concealed set screw in metal insert. Will not warp or chip. Finish and enamel permanent.

2" dial for rheostat potentiometer use, 35c.  
3 7/8" dial, 75c.

Send stamps for complete literature.

**ALDEN-NAPIER CO.**  
52 Willow St. Dept. C Springfield, Mass.



# BRILLIANTONE RADIO PRODUCTS

Dept. C—874 Columbus Avenue, New York

**\$1.00** Brings any one of these Combinations quickly to you



No. 1

- 100 Feet No. 14 hard-drawn antenna wire.
- 4 Porcelain insulators.
- 1 Solid copper approved ground clamp.
- 1 Single-pole, double-throw approved lightning switch.
- 20 Feet No. 14 weatherproof insulated lead-in wire.



No. 2

- 1 Wound Enameled wire coil, 8 inches long, 3 1/2" Diam.
- 2 Brass rods, 9 inches long, with evenly drilled holes.
- 2 Brass sliders to fit the above rods.
- 4 Nickel-plated brass binding posts.



No. 3

- 2 60-cent switches (1 1/2-inch lever).
- 20 Nickel-plated brass contact points with nuts.
- 4 Nickel-plated brass stops with nuts.
- 4 Nickel-plated brass binding posts.
- 1 Detector stand unmounted includes: Adjustable cup, adjustable eat-whisker (any position), 2 extra binding posts, 2 connections from cup and detector to binding posts.
- 1 Drilled fiber base for mounting same.



No. 4

- 1 Nest of 4 radio tubes, 8 inches long by 3, 3 1/4, 4, 4 1/4 inches in diameter.
- 1 Spool No. 24 cotton covered wire, 375 feet.
- 1 Hardwood Rotor.

All the above merchandise guaranteed or money refunded.

CUT HERE—

PLEASE CHECK BEFORE ITEMS DESIRED—FILL IN COUPON AND MAIL  
A FEW OF OUR SPECIALS

### B. R. P. PRODUCTS

- B.R.P. Rheostats, fibre base (Tapered Type).....\$ .50
- B.R.P. Rheostats, porcelain base..... .75
- B.R.P. Potentiometer (200 ohms)..... 1.00
- B.R.P. Moulded Sockets (unbreakable)..... 1.00
- B.R.P. Audio Frequency Transformers (11 to 1)..... 4.00
- B.R.P. Radio Frequency Transformers (150 to 500 M.)..... 3.00
- B.P.R. Variometer (to 800 meters)..... 3.00
- B.R.P. Variocouplers (Panel and Laboratory Type in one)..... 3.50

### B. R. P. Variable Condensers Guaranteed Capacity Tested by the Rubican Laboratories, Phila., Pa.

- TYPE "A"—MOULDED ENDS**
- 3 Plate, capacity .00005.....\$1.50
  - 7 Plate, capacity .0001..... 2.00
  - 11 Plate, capacity .0003..... 2.50
  - 23 Plate, capacity .0005..... 3.00
  - 43 Plate, capacity .001..... 3.50
- TYPE "B"—ALUMINUM ENDS**
- 3 Plate, capacity .00005.....\$1.00
  - 7 Plate, capacity .0001..... 1.25
  - 11 Plate, capacity .0003..... 1.50
  - 23 Plate, capacity .0005..... 1.75
  - 43 Plate, capacity .001..... 2.25

### STANDARD MERCHANDISE AT REDUCED PRICES

- \$4.50 Thordarson Amp. Transformers (Audio).....\$3.00
- \$7.00 UV712 Audio Frequency Transformers (Radio Corp.)..... 6.00
- \$6.50 UV1714 Radio Frequency Transformers (Radio Corp.)..... 5.50
- ZETA Radio Frequency Transformer..... 3.50
- Brandes "Superior" (2200 ohms)..... 6.75
- Murdock (3000 ohms)..... 5.00
- Federal (2200 ohms)..... 6.50
- Klosner Vernier Rheostat..... 1.00
- Bradleystat (Best Vernier)..... 1.65
- Jacks, single, open or closed (Firth)..... .35
- Jacks, double, closed (Firth)..... .50
- Plugs, bulldog grip (Firth)..... 1.00
- .002 and .005 Mica-Bakelite Condensers..... .25
- .0005 and .00025 Condensers with Var. Leak..... .25
- .0005 and .001 Fixed Mica-Bakelite Condensers..... .20
- Two-Slider Tuning Coil (mounted)..... 1.50

BRILLIANTONE RADIO PRODUCTS  
Dept. C, 874 Columbus Avenue, New York

Enclosed find money order for articles ordered. I agree to pay parcel post charges when delivered.

Name .....

Address .....

City .....

**BRILLIANTONE RADIO PRODUCTS**  
Dept. C, 874 Columbus Avenue, New York



# Just What You Want



**W**HETHER you require two binding posts, a simple crystal set, or one of the standard tube sets with amplifier and loud speaker, you may obtain it *at the right price* at any radio shop displaying the Sorsinc sign. There is a skilled radio man on hand to advise you, too.

**"It Pays to Buy at the Sorsinc Store"**

*Mr. Dealer:—If you are a progressive merchant you may display the Sorsinc sign. Let us tell you how.*

**SHIP OWNERS RADIO SERVICE, Inc.**  
80 Washington Street New York

*Wholesale Distributors*

**SORSINC Branches:**

Boston, 46 Cornhill St.	San Francisco, 591 Mission St.
Baltimore, 11 N. Eutaw St.	Chicago, 538 So. Dearborn St.
New Orleans, 740 Union St.	Seattle, 67 Columbia St.

# Antenella

(No Antenna or Aerial Needed)



Does away entirely with antenna and all outside wiring, lightning arresters, switches and all other inconveniences.

**ANTENELLA** enables you to enjoy Radio pleasures in any room in your house. Place your receiving set anywhere and merely attach Antenella to any electric light socket. No current consumed.

**At your dealer's—\$2.00**

If he can't supply you send purchase price and you will be supplied promptly without further charge.

**CHAS. FRESHMAN COMPANY, Inc.**  
290 Hudson Street New York City



## NA-ALD

Small Space  
**V. T. Socket**

35c. each      3 for \$1.00

Moulded genuine condensite. Requires but small space for mounting. Readily accessible binding posts. No excess metal to interfere with efficiency. Unaffected by heat of bulbs or soldering iron. Phosphor bronze contacts. Nickel plated brass binding screws. Slash cut slot. Price possible because of large production.

*Special proposition for dealers and jobbers.*

**Alden-Napier Co.**

Dept. C 52 Willow St., Springfield, Mass.

# RUSONITE

CRYSTAL RECTIFIER

**MULTIPOINT**  
(Patent Pending)

**A synthetic CRYSTAL DETECTOR sensitive over its entire surface**

Eliminates all detector troubles. 50% increase in clearness and volume. Endorsed by Radio experts and press. Awarded certificates of excellence. Sets a new standard of efficiency.

Price postpaid, mounted  
Sensitiveness guaranteed **50c**

*Dealers and Distributors Quoted Attractive Discounts*

**RUSONITE PRODUCTS CORPORATION**  
Dept. P 15 Park Row, New York

**RADIO** Easily Learned

Be a Radio Expert. Make big money. Win success in this new, uncrowded field. Trained men needed.

**\$1,800 to \$6,000**  
a year easily earned. I will train you quickly, at home, in your spare time, to construct, install, operate, repair, maintain and sell radio outfits. Short course, low cost, easy terms, money back guarantee. Write for "Radio Facts" FREE.

Engineer Mohaupt, American Electrical Association  
Dept. 512 4513 Ravenswood Ave., Chicago

# Springfield Antenna

*16 Strand Braided*  
**INCREASE YOUR RANGE—**

with your present equipment. Most important invention. If your dealer hasn't it, send us \$2.50 for 100 ft. Jobbers write us.

**SPRINGFIELD WIRE & TINSEL CO.**  
387 B Main Street Springfield, Mass.

## MINIATURE STORAGE BATTERY PLATES FOR SALE

Size, 5/8x2 1/2 inches. Suitable for "test tube B batteries" and experimental work. These plates have cast alloy grids and are made in the best possible manner.

**"B" STORAGE BATTERIES**  
24, 50 and 100 volts; or any voltage made to order. Oil sealed. Write for illustrations.  
**J. A. RITTER**      LANSLOWNE, PA.

**JOY-KELSEY CORPORATION**  
Manufacturers  
**RADIO EQUIPMENT**  
4021 West Kinzie St. Chicago Ill.

*Nuggets of  
Sensitiveness!*



## The "Bull's Eye" of the Crystal Receiving Set

Good results depend upon your hitting the super-sensitive spot of a sensitive crystal. There's only one way to be sure of good results, and that's to be sure you're using the right crystals.

It's mighty annoying to waste time (and entertainment!) because of worthless crystals.

Hit the bull's eye the first time and every time. Play safe, take no chances—use the original, proven crystals—the "NAA" Arlington Tested brand. Each "NAA" is selected from *sensitive bulk stock*, and is *individually tested* and guaranteed super-sensitive.

"NAA" Galena, Silicon or Goldite: Price per crystal, individually packed—\$.25.

Mounted crystals, set in Wood's metal in brass cup, \$.40. At your dealer's, or direct postpaid.



# The Newman-Stern Co

The Newman-Stern Bldg., Cleveland, O.

Also producers of the famous "Red-Head" Radio Receivers and the Teagle line of *Better* Radio Equipment.

# Don't Wear a Truss

## BE COMFORTABLE—

Wear the Brooks Appliance, the modern scientific invention which gives rupture sufferers immediate relief. It has no obnoxious springs or pads. Automatic Air Cushions bind and draw together the broken parts. No salves or plasters. Durable. Cheap. Sent on trial to prove its worth. Never on sale in stores as every Appliance is made to order, the proper size and shape of Air Cushion depending on the nature of each case. Beware of imitations. Look for trademark bearing portrait and signature of C. E. Brooks which appears on every Appliance. None other genuine. Full information and booklet sent free in plain, sealed envelope.



MR. C. E. BROOKS

**BROOKS APPLIANCE CO., 199 C State Street, Marshall, Mich.**



**NA-ALD**

**COGSWELL**

## Variable Condenser

Most advanced design, with highest quality material and workmanship thruout.

Duraluminum end plates; pig tail connection. Accurate plate alignment, convenient binding posts and genuine Condensite Na-aid Dial. Bent or shorted plates unknown in this condenser.

Prices range from \$2.50 for 3 plate Verrier with dial to \$4.70 for 43 plate Precision.

Send stamps for complete catalog.

**ALDEN-NAPIER CO.**

52 Willow St. Dept. C Springfield, Mass.

DOUBLE HEAD PHONES



## BOYS! A REAL RADIO SET ABSOLUTELY FREE

RUSH your name and address and we will tell you HOW you can get this RADIO SET ABSOLUTELY FREE. RADIO SET comes to you complete, with single slide tuning coil, crystal detector and phone condenser, AND DOUBLE HEAD PHONES. No batteries required; no experience. Write Today for Free Radio Plan.

**HOME SUPPLY CO.,**  
131 Duane St.,  
Dept. 108  
New York City

# AGENTS \$6 A DAY

taking orders for Non-Alcoholic Food Flavors. Every variety. Put up in collapsible tubes. Always fresh. Three times the strength of bottled flavors. Not sold in stores. Fast repeaters. Big income every day.

### Men and Women

devoting full time can make \$6 to \$9 a day. Big money for spare time. Largest concern of its kind in the world. Over two million dollars' worth of orders taken last year by our Representatives for Zanol Pure Food Products, Toilet Preparations, Soaps, Laundry and Cleaning Specialties and Household Supplies. Every article guaranteed. Write for Sample Outfit and Money Making Proposition.



**American Products Co.**

7300 American Building, Cincinnati, Ohio

# SPECIAL XMAS OFFER

For a six weeks' period beginning November 15th, we will accept NEW subscriptions to POPULAR RADIO at the special trial rate—two NEW yearly subscriptions for two dollars (\$2.00). To get the full benefit of the Special Xmas Offer, bear in mind that both subscriptions must be NEW. An extra charge of \$.25 is necessary to cover the postage cost on each Canadian subscription and \$.50 for foreign countries. All subscriptions will be entered for one year beginning with the current issue. A Six Weeks' Offer. Better act right away! Use the double coupon.



(Coupon good until January 1, 1923)

**POPULAR RADIO**  
9 East 40th Street, New York City

Please send POPULAR RADIO for one year to:

NAME .....

ADDRESS .....

CITY..... STATE.....

And also to this other new subscriber. Here is a two-dollar bill—or a check for two dollars).

NAME .....

ADDRESS .....

CITY..... STATE.....



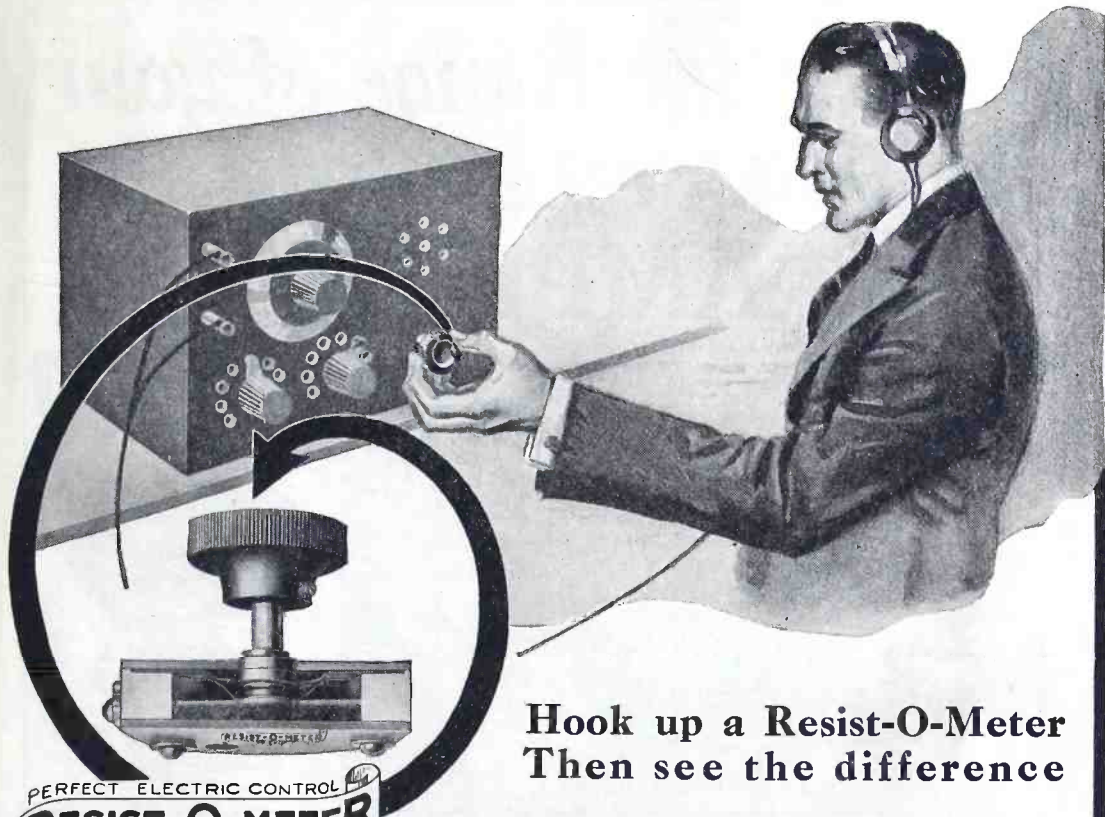

## Hook up a Resist-O-Meter Then see the difference

PERFECT ELECTRIC CONTROL  
**RESIST-O-METER**  
TRADE MARK

The Resist-O-Meter illustrated is Type A Filament.  
Price, \$1.80

**We manufacture  
the products listed below:  
Resist-O-Meters**

Type A—Filament  
“ B—“B” Battery  
“ C—Potentiometer  
“ D—Variable Grid Leak

**Test-Rite Condensers  
in following capacities:**

Phone .001 mfd.  
Grid .00025 “  
Grid .0005 “  
Grid Leak .0005 “ 1-meg.

V. T. Sockets  
Engraved Binding Posts  
Accessories

Patent Attorneys  
Pennie, Davis, Marvin,  
Edmonds

**A** VARIABLE resistance that is variable, not by a series of steps or by a sliding contact, but continuously between the extreme ranges of its terminals without a break, micrometer controlled for accurate adjustment of proper current values of the “A” and “B” batteries.

*This ideal has been developed—The Scholes Resist-O-Meter.*

This Scholes Resist-O-Meter possesses the following additional and essential advantages:

1. It is non-microphonic.
2. It possesses the lowest resistance at full compression (almost zero).
3. It is made in models giving various ranges of control previously not attained (covering every requirement for radio use).
4. It is made in compact and conventional form requiring minimum room for mounting.

The Scholes “Resist-O-Meter,” in principle, has been used for more than seven years in electro-chemical processes in which exceedingly accurate and constant current control is required.

This apparatus, simple in the extreme, has been refined and perfected to adapt it to the minute currents and sensitiveness of control needed for radio work.

The Scholes Radio and Manufacturing Corporation hold the sole license to manufacture this type of radio rheostat. It is sold only under the name “Resist-O-Meter,” and fully protected by patent and trade mark rights. Your dealer will supply it. Ask for the Scholes Resist-O-Meter.

Write Mr. C. W. Preston

**SCHOLES RADIO & MANUFACTURING CORP.**  
32-36 West 18th Street, New York City

# Increase the Range of your AERIOLA SR. with the new AC AMPLIFIER

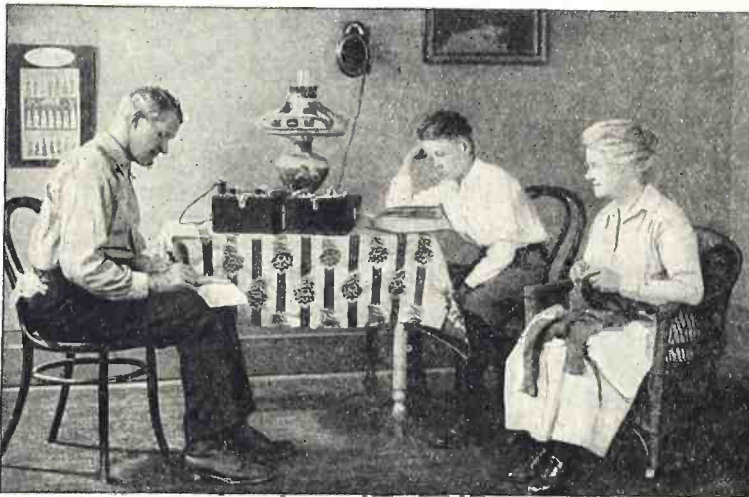

**T**HE new A C Amplifier, to a considerable extent, increases the reception possibilities of the Aeriola Sr. With head telephones and the A C Amplifier reception ranges of one hundred to three hundred miles become possible for the owner of an Aeriola Sr., depending on local conditions. Used with the Vocarola loud-speaker, the Aeriola Sr. and A C Amplifier fill a whole room with music and speech received over distances of ten to thirty miles.

Anybody can make the simple connections required, including mother and the girls.

*See this New Amplifier at Your Dealer's*

**Radio**  **Corporation**  
*of America*

Sales Dept. Suite 2067  
233 Broadway  
New York City

District Office  
10 South La Salle St.  
Chicago, Ill.



## AERIOLA AMPLIFIER

Model AC  
Complete with 2WD-11A  
vacuum tubes  
(without batteries)

**\$68.00**

⌘ ⌘ ⌘

## VOCAROLA LOUD-SPEAKER

Model LV  
**\$30.00**



*This symbol of quality  
is your protection*

*Before buying radio  
apparatus, always  
consult the book  
"Radio Enters the  
Home." Price 35  
cents by mail or at  
your dealer's.*

# Teleradio

## Products Give Satisfaction

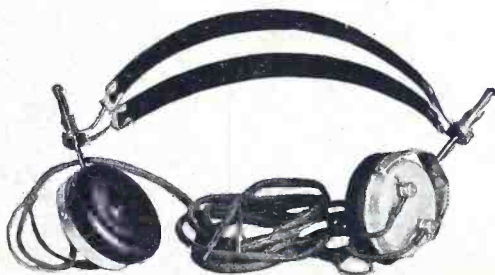

**TELERADIO SUPERSENSITIVE PHONES TYPE C, \$6.50.** The performance of a pair of phones is what really counts. Write for our trial offer. Type B, \$7.50—Type A, \$9.00.

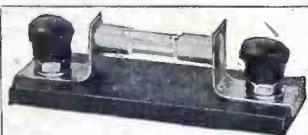

### TELERADIO FILAMENT PROTECTOR

Here is the cheapest vacuum tube insurance you can buy.

The Teleradio Tube Protector complete sells for 60c and extra fuses for 10c apiece. Not much to pay when you figure that each time you blow out a 10c fuse you save the price of a \$5 or \$6 tube.

List

Price.60

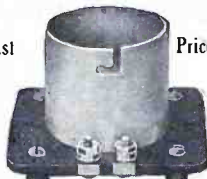

### TUBE SOCKET

A well-constructed, durable socket. Shell made of drawn aluminum. Hygrade insulated base. Legs not current carrying. Contacts made of phosphor bronze. All parts nickel-plated.



### TELERADIO LIGHTNING ARRESTORS

Approved by National Board of Fire Underwriters.

Electrical No. 5837  
The only approved arrester that retails at \$1.

## OTHER TELERADIO PRODUCTS

Rheostats, \$1.00. Variable Condensers—3, 11, 23 and 43 Plates, \$1.50, \$2.50, \$3.00 and \$4.00, respectively. Fixed Phone and Grid Condensers and Grid Leak Condensers.

*If your dealer has not yet stocked Teleradio Products, order direct and mention your dealer's name. Dealers: Ask us about our "Dealer's Stock Order" proposition.*

**TELERADIO ENGINEERING CORPORATION**  
484-490 BROOME STREET, NEW YORK



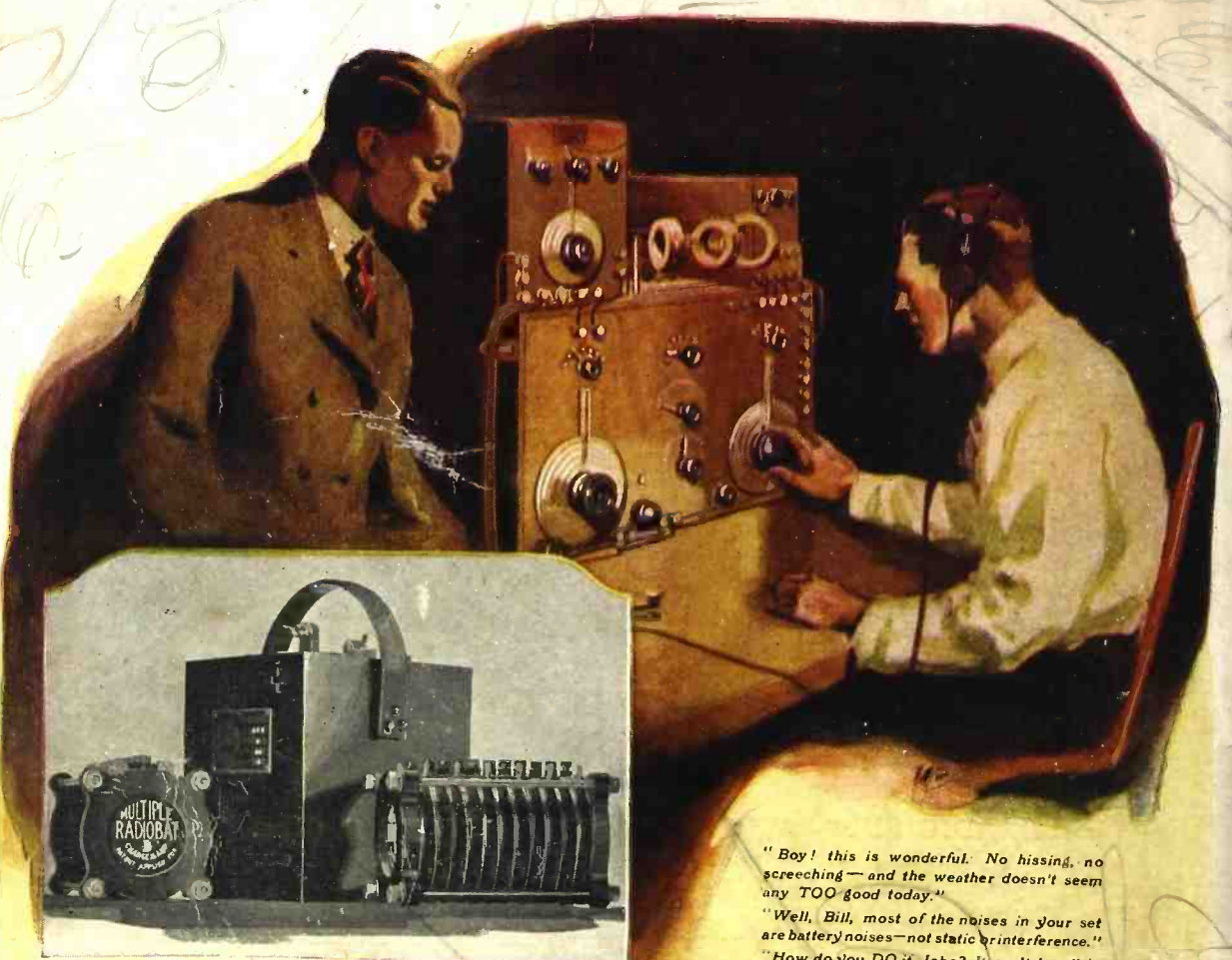

"Boy! this is wonderful. No hissing, no screeching—and the weather doesn't seem any TOO good today."

"Well, Bill, most of the noises in your set are battery noises—not static or interference."

"How do you DO it, John? It can't be all in the tuning."

"It isn't in the tuning at all. It's Radiobats "A" and "B". Try 'em and HEAR!"

—and now  
 harmony replaces discord!

**M**USIC—clear as a bell; speech—every word is marvelously distinct; jazz—uninterrupted syncopation; opera—with full-toned quality and beauty in strong relief.

Clear radio reception is a matter of batteries. Elimination of most noises is a matter of batteries, rather than static or other interference.

Irregular voltage output, natural in ordinary "B" batteries, causes noises. Unvarying current output stops these noises—and this marvelously clear and life-like reception results.

Because RADIOBATS "A" and "B" are the only batteries able to act correctly, we urge you to

listen to a demonstration at your dealer's. There is no way to hear such reception till these new-principle batteries are hooked in.

RADIOBATS "B"—as well as "A"—are leak-proof because they have the only solid electrolyte; and are more economical, because, like "A" Batteries, they are indefinitely rechargeable at home.

Send your dealer's name and address that we may arrange an immediate demonstration.

Multiple Storage Battery Corporation  
 350-B Madison Avenue, New York



Send for this intensely informative book. It is absolutely FREE.

Equip your set with "A" and "B"

# RADIOBATS

The Permanent Radio Power-UNIT