

# POPULAR COMMUNICATIONS

MAY 1984 \$1.95

## Unlicensed Radio Networks Rule The Seas

- TV DX—It's Back
- The Violent World Of Shortwave
- We Review The Sony ICF-2002
- Mystery Transmissions: An Analysis
- Radio In The Gas Bag Fleet
- Britain's Black Radio
- Hear The Army's Mini-Broadcast Station

0-860

MAKO



Actual slow motion frames from Ham MasterTapes



1. Larry, N2NY, Lee, KA2RNV



2. Lee discharges cap



3. In slow motion it's dazzling



4. Wow. Can we see it again?

**You've never seen this, like this,  
before this!**

**And you can see it—in color—again and again  
when you own the N2NY Ham MasterTapes.**



Ever see a cap discharge in slow motion? You will on Ham MasterTapes. Ham MasterTapes can perform the dozens of complicated demonstrations necessary for a beginner's understanding of Ham Radio Theory.

Finally, a step-by-step course in Ham Radio Theory is available on color videotape. The Larry Horne N2NY Ham MasterTapes video course is a unique, effective teaching technique expertly produced by New York's leading professionals in studio and field videotape.

- Video Graphics highlight important details.
- Carefully worked-out demonstrations on video avoid the problem of getting complex gadgets to work on command in front of a class.
- Working examples of every ham radio component, device, or system covered in the FCC guide can be clearly understood.

The N2NY Ham MasterTapes give you a basic grasp of concepts that build theory background—not only for passing the FCC tests, but for understanding electronics.

The hobby has long needed better, clearer, high-tech teaching aids to help newcomers into our wonderful world of Ham Radio.

These six-hour tapes cover completely all the material needed to understand Novice and Tech/General Theory and operations, and include the new 200-question FCC syllabus used beginning September 1983.

Only \$199.95. Order direct and specify Beta or VHS format. Call or write: Larry Horne, N2NY at

**Ham MasterTapes™**

THE N2NY HAM RADIO COURSE ON VIDEOTAPE

Ham MasterTapes  
136 East 31st Street  
New York, N.Y. 10016 212-673-0680.

© 1983 N2NY Productions, Inc.  
CIRCLE 31 ON READER SERVICE CARD

# AEA Brings You The RTTY Breakthrough

## NEW MBATEXT™ \$109.95 VIC-20 MBATEXT or C-64 MBATEXT



**MBATEXT™** is the most advanced MBA (Morse, Baudot, ASCII) software plug-in cartridge available for the VIC-20 or Commodore 64 computer. Compare our outstanding features and price to the competition.

- KEYBOARD OVERLAY instructions to avoid constant referral to the manual
- RTTY and ASCII SPEED ESTIMATE MODE
- BREAK-IN CW MODE
- QSO BUFFER RECORD TOGGLE
- WORD PROCESSOR style insertion, deletion, and correction in TEXT EDIT MODE
- CW AUTO SPEED TRACKING plus SPEED LOCK
- BREAK-IN BUFFER that is easy to use
- Low speed FARNSWORTH CW TRANSMISSION (between 5 and 14 WPM)
- RE-TRANSMIT

RECEIVED TEXT DIRECTLY without need of disk or cassette • DISK, CASSETTE, OR PRINTER storage of message and QSO buffers • RECEIVE AND TRANSMIT 5-99 WPM MORSE • 10 SOFT-PARTITIONED™ MESSAGE (OR TEST) BUFFERS • WORD WRAP • TIME OF DAY CLOCK • PRECOMPOSE SPLIT SCREEN OPERATION • STATUS INDICATORS on screen • EASY START-UP by simply typing SYS 44444 or SYS 33333 • DEDICATED FUNCTION KEYS for quick operation • Ability to IMBED CONTROL FUNCTIONS in type-ahead buffer • WORD OR CHARACTER mode • SELECTABLE BAUDOT UNSHIFT ON SPACE (USOS) • SEND/RECEIVE 60, 67, 75, 100, 132 WPM BAUDOT PLUS 100, 300 BAUD ASCII • RTTY BLANK-FILL and MORSE BT option for idle transmit periods • AUTOMATIC PTT • computer control of TONE REVERSE • MASTER MENU, COMMAND MENU, and OPTIONS MENU makes MBATEXT™ easy to use with no prior experience • INCLUDES CABLE TO INTERFACE WITH AEA model CP-1 COMPUTER PATCH™ • POWERED BY HOST COMPUTER.

## NEW MICROPATCH™



**MICROPATCH™** IS A NEW LOW-COST, HIGH-PERFORMANCE Morse, Baudot and ASCII SOFTWARE/HARDWARE computer interface package. The MICROPATCH™ model MP-20 or MP-64 incorporates the complete MBATEXT software ROM (described above) for either the VIC-20 or Commodore 64 computers. All circuitry and software is incorporated on a single, plug-in cartridge module featuring the following:

- TRUE DUAL CHANNEL MARK AND SPACE MULTI-STAGE 4 POLE, CHEBYSHEV ACTIVE FILTERS
- AUTOMATIC THRESHOLD CORRECTION for good copy when one tone is obliterated by QRM or SELECTIVE FADING
- EASY, POSITIVE TUNING with TRIPLE LED INDICATOR
- NOT a low-cost, low-performance phase-locked loop detector!!!
- SWITCH SELECTED 170 Hz or WIDE SHIFT on receive
- 800 Hz multi-stage active CW FILTER
- AUTOMATIC PTT
- RTTY ANTI-SPACE
- demodulator circuitry powered by external 12VDC (not supplied) to AVOID OVERLOADING HOST COMPUTER and for maximum EMI ISOLATION
- EXAR 2206 SINE GENERATOR for AFSK output
- SHIELDED TRANSCIVER AFSK/PTT INTERFACE CABLE PROVIDED
- PLUS or MINUS CW KEYED OUTPUT
- FSK keyed output.

and for maximum EMI ISOLATION • EXAR 2206 SINE GENERATOR for AFSK output • SHIELDED TRANSCIVER AFSK/PTT INTERFACE CABLE PROVIDED • PLUS or MINUS CW KEYED OUTPUT • FSK keyed output.

The Micropatch is structured for easy upgrading to the AEA Computer Patch™ advanced interface unit without having to buy a different software package! Simply unplug the external computer interface cable (supplied with the Micropatch) from the Micropatch and plug it into the Computer Patch.

**\$149.95 MP-20 or MP-64**

RECEIVE ONLY VERSIONS **\$129.95 MPR-64 or MPR-20**

## COMPUTER PATCH™



**COMPUTER PATCH™** is the name of our most advanced computer interface equipment for Morse, Baudot, ASCII, or AMTOR operation. The CP-1 will allow you to patch most of the popular personal computers to your transceiver when used with the appropriate AEASOFT™ TU software such as AEA MBATEXT, AMTOR TEXT™, or the MBATEXT RESIDENT ON THE MICROPATCH units. AEA also offers a full feature software package for the Apple II, II plus and IIE; TRS-80 Models I, III and IV; and the IBM-PC. The CP-1 will also work with certain other computers using commonly available software packages.

The CP-1 offers the following advanced and high quality features:

- HANDSOME ALL METAL ENCLOSURE FOR MAXIMUM RF IMMUNITY
- DUAL CHANNEL, MULTI-STAGE ACTIVE MARK AND SPACE FILTERS
- AUTOMATIC THRESHOLD CORRECTION
- RECEIVE 170 HZ FIXED OR 100-1000 HZ VARIABLE SHIFT
- 800 HZ multi-stage CW FILTER
- PRE-LIMITER AND POST-LIMITER FILTERS
- SERIAL RS-232 FIELD INSTALLABLE OPTION
- 117 VAC WALL ADAPTOR SUPPLIED
- PLUS (+) and MINUS (-) CW OUTPUT JACKS
- MAGIC EYE STYLE BAR GRAPH TUNING INDICATOR
- SCOPE OUTPUT JACKS
- NORMAL/REVERSE front panel switch
- MANUAL (override) PTT switch
- VARIABLE THRESHOLD for CW
- ANTI-SPACE RTTY
- KEY INPUT JACK for narrow shift CW ID on RTTY, CW practice, or keyboard bypass.

The CP-1 is made in the U.S. with high quality components including double-sided glass epoxy through-hole plated boards, complete with solder mask and silk screened parts designators.

**\$239.95 CP-1**

## PACKAGE SPECIALS

**\$274.95**

Combine the VIC-20 or COMM-64 MBATEXT™ software with the CP-1 at time of purchase and you receive a SPECIAL PACKAGE PRICE. NOW the best RTTY COMPUTER INTERFACE SYSTEM is available at prices comparable only to vastly inferior systems.

CP-1/20 (CP-1 with VIC 20 MBATEXT) CP-1/64 (CP-1 with C-64 MBATEXT)

## Advanced Electronic Applications, Inc.

P.O. BOX C-2160 • LYNNWOOD, WA 98036 • (206) 775-7373 • TELEX: 152579 AEA INTL

10/20/83

Please send all reader inquiries directly.

# NEW!



## Scanners

**Communications Electronics™**, the world's largest distributor of radio scanners, introduces new models with special savings on all radio scanners. Chances are the police, fire and weather emergencies you'll read about in tomorrow's paper are coming through on a scanner today.

We give you excellent service because CE distributes more scanners worldwide than *anyone* else. Our warehouse facilities are equipped to process thousands of scanner orders every week. We also export scanners to over 300 countries and military installations. Almost all items are in stock for quick shipment, so if you're a person who prefers fact to fantasy and who needs to know what's really happening around you, order your radio today from CE.

### NEW! Regency® MX5000

List price \$599.95/CE price \$379.00  
**Multi-Band, 20 Channel • No-crystal scanner**  
**Search • Lockout • Priority • AC/DC**  
**Selectable AM-FM modes • LCD display**  
*World's first continuous coverage scanner*  
 Frequency range: 25-550 MHz, continuous coverage. Never before have so many features come in such a small package. The Regency MX5000 mobile or home scanner has continuous coverage from 25 to 550 MHz. That means you can hear CB, Television audio, FM broadcast stations, all aircraft bands including military and the normal scanner bands, all on your choice of 20 programmable channels.

### NEW! Regency® MX3000

List price \$299.95/CE price \$181.00  
**6-Band, 30 Channel • No-crystal scanner**  
**Search • Lockout • Priority • AC/DC**  
 Bands: 30-50, 144-174, 440-512 MHz.  
 The Regency Touch MX3000 provides the ease of computer controlled, touch-entry programming in a compact-sized scanner for use at home or on the road. Enter your favorite public service frequencies by simply touching the numbered pressure pads. You'll even hear a "beep" tone that lets you know you've made contact.

In addition to scanning the programmed channels, the MX3000 has the ability to search through as much as an entire band for an active frequency. The MX3000 includes channel 1 priority, dual scan speeds, scan or search delay and a brightness switch for day or night operation.

### NEW! Regency® Z30

List price \$269.95/CE price \$179.00  
**6-Band, 30 Channel • No-crystal scanner**  
 Bands: 30-50, 144-174, 440-512 MHz.  
 Cover your choice of over 15,000 frequencies on 30 channels at the touch of your finger.

### NEW! JIL SX-200

CE price \$264.00/NEW LOW PRICE  
**8-Band, 16 Channel • No-crystal scanner**  
**Quartz Clock • AM/FM • AC/DC**  
 Bands: 26-88, 108-180, 380-514 MHz.  
 Tune Military, F.B.I., Space Satellites, Police & Fire, D.E.A., Defense Department, Aeronautical AM band, Aero Navigation Band, Fish & Game, Immigration, Paramedics, Amateur Radio, Justice Department, State Department, plus thousands of other restricted radio frequencies no other scanner is programmed to pick up.

### Regency® HX1000

Allow 60-120 days for delivery after receipt of order due to the high demand for this product.  
 List price \$329.95/CE price \$209.00  
**6-Band, 20 Channel • No Crystal scanner**  
**Search • Lockout • Priority • Scan delay**  
**Sidelit liquid crystal display**  
 Frequency range: 30-50, 144-174, 440-512 MHz.  
 The new handheld Regency HX1000 scanner is fully keyboard programmable for the ultimate in versatility. You can scan up to 20 channels at the same time. When you activate the priority control, you automatically override all other calls to listen to your favorite frequency. The LCD display is even sidelit for night use. A die-cast aluminum chassis makes this the most rugged and durable hand-held scanner available. There is even a backup lithium battery to maintain memory for two years. Includes wall charger, carrying case, belt clip, flexible antenna and nicad battery. Reserve your Regency HX1000 now.

### Regency® R106

List price \$149.95/CE price \$92.00  
**5-Band, 10 Channel • Crystal scanner • AC/DC**  
 Frequency range: 30-50, 146-174, 450-512 MHz.  
 A versatile scanner, The Regency R-106 is built to provide maximum reception at home or on the road. Rugged cabinet protects the advanced design circuitry allowing you years of dependable listening.

### NEW! Regency® D810

List price \$399.95/CE price \$244.00  
**8-Band, 50 Channel • Crystalline • AC only**  
 Bands: 30-50, 88-108, 118-136, 144-174, 440-512 MHz.  
 This scanner offers Public service bands, plus Aircraft and FM broadcast stations. You can listen to Bach or a Boeing 747, the Rolling Stones or the riot squad, or any of 50 channels. Plus special direct access keys let you listen to police, fire, emergency, or any of your favorite channels just by pushing a button.

### Regency® R1040

List price \$199.95/CE price \$124.00  
**6-Band, 10 Channel • Crystalline • AC only**  
 Frequency range: 30-50, 144-174, 440-512 MHz.  
 Now you can enjoy computerized scanner versatility at a price that's less than some crystal units. The Regency R1040 lets you in on all the action of police, fire, weather, and emergency calls. You'll even hear mobile telephones.  
 Programming the R1040 is easy. Merely touch the keyboard and enter any of over 15,000 frequencies on your choice of 10 channels.

### NEW! Regency® HX650

List price \$119.95/CE price \$79.00  
**5-Band, 6 Channel • Handheld crystal scanner**  
 Bands: 30-50, 146-174, 450-512 MHz.  
 Now you can tune in any emergency around town, from wherever you are, the second it happens. Advanced circuitry gives you the world's smallest scanner. Our low CE price includes battery charger/A.C. adapter.

### QUANTITY DISCOUNTS AVAILABLE

Order two scanners at the same time and deduct 1%, for three scanners deduct 2%, four scanners deduct 3%, five scanners deduct 4% and six or more scanners purchased at the same time earns you a 5% discount off our super low single unit price.

### OTHER RADIOS & ACCESSORIES

Regency® 403 Scanner	\$59.00
Regency® Z10 Scanner	\$149.00
Panasonic RF-9 Shortwave receiver	\$84.00
Panasonic RF-B50 Shortwave receiver	\$129.00
Panasonic RF-799 Shortwave receiver	\$219.00
Panasonic RF-2600 Shortwave receiver	\$199.00
Panasonic RF-2900 Shortwave receiver	\$249.00
Panasonic RF-3100 Shortwave receiver	\$279.00
Panasonic RF-B300 Shortwave receiver	\$195.00
Panasonic RF-B600 Shortwave receiver	\$429.00
Panasonic RF-6300 Shortwave receiver	\$539.00
Bearcat† 350 Scanner	\$399.00
Bearcat® 300 Scanner	\$349.00
Bearcat® 260 Scanner	\$259.00
Bearcat® 250 Scanner	\$279.00
Bearcat® 200 Scanner	\$189.00
Bearcat® 210XL Scanner	\$229.00
Bearcat® 20/20 Scanner	\$289.00
Bearcat® 151 Scanner	\$169.00
Bearcat® 100 Scanner	\$289.00
Bearcat® Five-Six Scanner	\$129.00
Bearcat® DX1000 Shortwave Receiver	\$489.00
Bearcat® Weather Alert	\$49.00
Freedom Phone® 4000 Cordless telephone	\$239.00
Fanon FCT-2000 Cordless telephone	\$139.00
SP55 Carrying case for Bearcat Five-Six	\$15.00
MA-506 Carrying case for Regency HX650	\$15.00
FB-E Frequency Directory for Eastern U.S.A.	\$12.00
FB-W Frequency Directory for Western U.S.A.	\$12.00
TSG "Top Secret" Registry of U.S. Government Freq.	\$15.00
RRF Railroad Frequency Directory	\$10.00
ESD Energy Services Directory	\$10.00
ASD Frequency Directory for Aircraft Band	\$10.00
SRF Survival Radio Frequency Directory	\$10.00
TIC Technique® for Intercepting Comm. Manual	\$12.00
CIE Covert Intelligence, Elect. Eavesdropping Man.	\$12.00
B-4 1.2 V AAA Ni-Cad batteries (set of four)	\$9.00
B-6 1.2 V AA Ni-Cad batteries (set of four)	\$12.00
A-135c Crystal certificate	\$3.00
A60 Magnet mount mobile antenna	\$35.00
A70 Base station antenna	\$35.00
Add \$3.00 shipping for all accessories ordered at the same time.	
Add \$12.00 per shortwave receiver for U.P.S. shipping.	
Add \$3.00 shipping per scanner antenna.	

### BUY WITH CONFIDENCE

To get the fastest delivery from CE of any scanner, send or phone your order directly to our Scanner Distribution Center™. Be sure to calculate your price using the CE prices in this ad. Michigan residents please add 4% sales tax or supply your tax I.D. number. Written purchase orders are accepted from approved government agencies and most well rated firms at a 30% surcharge for net 30 billing. All sales are subject to availability, acceptance and verification. All sales on accessories are final. Prices, terms and specifications are subject to change without notice. All prices are in U.S. dollars. Out of stock items will be placed on back-order automatically unless CE is instructed differently. A \$5.00 additional handling fee will be charged for all prepaid orders under \$50.00 or purchase orders under \$200.00. Shipments are F.O.B. Ann Arbor, Michigan. No COD's. Most products that we sell have a manufacturer's warranty. Free copies of warranties on these products are available prior to purchase by writing to CE. International orders are invited with a \$20.00 surcharge for special handling in addition to shipping charges. All shipments are F.O.B. Ann Arbor, Michigan. No COD's please. Non-COD and foreign checks require bank clearance.

**Mail orders to:** Communications Electronics,™ Box 1002, Ann Arbor, Michigan 48106 U.S.A. Add \$7.00 per scanner for U.P.S. ground shipping and handling in the continental U.S.A. For Canada, Puerto Rico, Hawaii, Alaska, or APO/FPO delivery, shipping charges are three times continental U.S. rates. If you have a Visa or Master Card, you may call and place a credit card order. Order toll-free in the U.S. Dial 800-521-4414. In Canada, order toll-free by calling 800-265-4828. Telex CE anytime, dial 810-223-2422. If you are outside the U.S. or in Michigan dial 313-973-8888. Order today.

Scanner Distribution Center™ and CE logos are trademarks of Communications Electronics.

† Bearcat is a federally registered trademark of Electra Company, a Division of Masco Corporation of Indiana.  
 ‡ Regency is a federally registered trademark of Regency Electronics Inc. AD #031584A

Copyright ©1984 Communications Electronics

Order Toll Free ... call  
**1-800-521-4414**



**Consumer Products Division**

818 Phoenix □ Box 1002 □ Ann Arbor, Michigan 48106 U.S.A.  
 Call TOLL-FREE 800-521-4414 or outside U.S.A. 313-973-8888

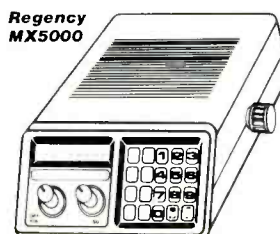
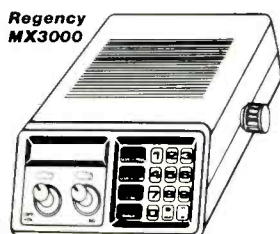

CIRCLE 63 ON READER SERVICE CARD

## EDITORIAL STAFF

Tom Kneitel, K2AES  
Editor

Anita Hipius  
Associate Editor

## CONTRIBUTING EDITORS

Gerry L. Dexter  
Shortwave Broadcast

Joseph E. Jesson  
RTTY Monitoring

R.L. Slattery  
Survivalist Communications

Harry L. Helms, KR2H  
Utility Communications

Darren Leno, WD0EWJ  
Alternative Radio

Harold A. Ort, Jr.  
Military Consultant

Janice Lee  
Radar Detectors

Chuck Gysi, N2DUP  
Scanners

Jeffrey Keating, WB4KDH  
Satellite TV

Gordon West, WB6NOA  
Telephone Accessories

## BUSINESS STAFF

Richard A. Ross, K2MGA  
Publisher

James Reilly  
Associate Publisher

Herb Pressman, KA2UGV  
Advertising Manager

Arnold Spasato, KA2TYA  
Advertising Representative

Dorothy Kehrwierder  
General Manager

Arlene Caggiano  
Accounting

Cheryl Chomicki  
Subscriber Services

## PRODUCTION STAFF

Elizabeth Ryan  
Art Director

Dorothy Kehrwierder  
Production Manager

Gail M. Schieber  
Production Assistant

Pat Le Blanc  
Phototypographer

Hal Keith  
Technical Illustrator

Offices: 76 North Broadway, Hicksville, NY 11801. Telephone 516 681-2922. Popular Communications (ISSN 0733-3315) is published monthly by Popular Communications, Inc. Corporate officers: Richard A. Ross, Pres.; Thomas S. Kneitel, Vice Pres.; Alan M. Dorhoff, Secretary. Second class postage paid at Hicksville, NY and additional offices. Subscription prices: Domestic—one year \$14.00, two years \$25.00, three years \$36.00. Canada/Mexico—one year \$16.00, two years \$29.00, three years \$42.00. Foreign—one year \$18.00, two years \$33.00, three years \$48.00. Foreign Air Mail—one year \$71.00, two years \$139.00, three years \$207.00. Entire contents copyright ©1984 by Popular Communications, Inc. Popular Communications assumes no responsibility for unsolicited manuscripts, photographs, or drawings. Allow six weeks for change of address or delivery of first issue. Printed in the United States of America.

Postmaster: Please send change of address to Popular Communications, 76 North Broadway, Hicksville, NY 11801.

# POPULAR COMMUNICATIONS

MAY 1984

VOL. 2, NO.9



8

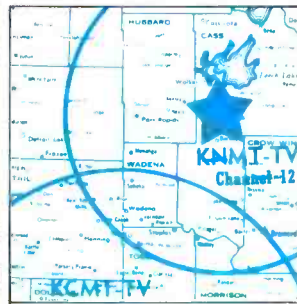

12



38

## FEATURES

### Worldwide Bootleg Radio Networks

8

Listen in on pirate networks!

by Gordon West, WB6NOA

### TV DX – It's Back (Again)!

12

Here's how to tune in on this season's TV DX.

by Darren Leno, WD0EWJ

### The Violent World of Shortwave

14

All the excitement in the world, and it's right at your fingertips.

by Gerry L. Dexter

### Here's Station WFG

18

The U.S. Army's own mini-broadcast station.

by Staff Sgt. John Eroh & Spec. 4 Michael Foley

### QSL's – What?

20

Ten good reasons why you didn't get that special QSL card.

by Tom Kneitel, K2AES, Editor

### Equipment Review: The Sony ICF-2002 Receiver

24

The ICF-2002 is a handy portable receiver that allows for excellent reception of desired broadcasts with a minimum of hassle for the non-technical listener.

by Ken Wickliffe

### Numbers Transmissions

26

We beam in on the elusive mystery with a serious analysis.

by Robert M. Dyquetta

### Radio In The Gas Bag Fleet

32

The U.S. Navy's airships have slowly drifted into history but not yet out of the memory of those who monitored them.

by Tom Kneitel, K2AES, Editor

### DX Ahoy!

38

Maritime communications continue to show up on frequencies you never thought of.

by Rick Maslau, KNY2GL

### Tom Delmer And Britain's "Black" Radio

42

A crafty use of two-way radio as a propaganda and psychological warfare tool.

by Don Jensen

This month's cover: Unlicensed radio networks rule the seas. Photo by Larry Mulvehill, WB2ZPI.

## DEPARTMENTS

Beaming In	4	Scanner Scene	58
Mailbag	6	Communications Confidential	60
POP'COMM Products	37	Pirates Den	66
Satellite View	46	Survival	68
Listening Post	50	Washington Pulse	70
RTTY Monitoring	54	Communications Shop	75
On The Line	56		

## RECEIVE RTTY/ASCII/CW on your Personal Computer



**RTTY/ASCII/CW  
SWL COMPUTER  
INTERFACE** MFJ-1225  
\$ **69.95**

Receives commercial, military, and amateur RTTY/ASCII/CW using your personal computer.

The MFJ-1225 Computer Interface plugs between your receiver and VIC-20, Apple, TRS-80C, Atari, TI-99, Commodore 64 and most other personal computers. Requires appropriate software.

Copies all shifts (850, 425, 170 Hz shift and all others) and all speeds. Automatic noise limiter suppresses static crashes for better copy. 2 LED tuning indicator makes tuning fast, easy, positive. 4½ x 1¼ x 4¼ in. 12-15 VDC or 110 VAC with optional adapter, MFJ-1312, \$9.95.

**MFJ-1250 Software Cartridge** for VIC-20 or MFJ-1251 for Commodore 64, \$49.95 each. Receive: CW5-99 WPM; RTTY 60, 67, 75, 100 WPM; ASCII 110, 300 baud plus more features.

### INDOOR TUNED ACTIVE ANTENNA

MFJ-1020  
\$ **79.95**



**MFJ-1020 New Indoor Active Antenna** sits on your desk ready to listen to the world. Rivals, often exceeds, reception of outside long wire. Unique Tuned Active Antenna minimizes intermode, provides RF selectivity, reduces noise outside tuned band. Also use as preselector for external antenna. Covers 300 KHz to 30 MHz in 5 bands. Adjustable telescoping antenna. Controls: Tune, Band Selector, Gain: ON-Off/Bypass. LED. FET, bipolar circuitry. Phono jack for external ant. 6x2x6 in. 9-18 VDC or 9V battery. 110 VAC with adapter, MFJ-1312, \$9.95.

### REMOTE ACTIVE ANTENNA

54 inch remote active antenna mounts outdoor away from electrical noise for maximum signal and minimum noise pickup. Often outperforms longwire hundreds of feet long. Mount anywhere - atop houses, buildings, balconies, apartments, mobile homes, on board ship.

Use with any radio to receive strong clear signals from all over the world. 50 KHz to 30 MHz.

High dynamic range eliminates intermodulation. Inside control unit has 20 dB attenuator, gain control. Switch 2 receivers and auxiliary or active antenna. "On" LED. 6x2x5 in. 50 ft. coax. 12 VDC or 110 VAC with MFJ-1312, \$9.95.



MFJ-1024  
\$ **129.95**

Order from MFJ and try it. If not delighted, return within 30 days for refund (less shipping).

One year unconditional guarantee.

Order yours today. Call toll free 800-647-1800.

Charge VISA, MC. Or mail check, money order. Add \$4.00 each for shipping and handling.

**CALL TOLL FREE ... 800-647-1800**

Call 601-323-5869 in Miss., outside continental USA, tech/order/repair info. TELEX 53-4590

**MFJ ENTERPRISES,  
INCORPORATED**

Box 494, Mississippi State, MS 39762

CIRCLE 76 ON READER SERVICE CARD

# BEAMING IN

BY TOM KNEITEL, K2AES

## AN EDITORIAL

### International Broadcasting Follow-Up

Little did I know when I sat down at the magic keyboard to tap out my January editorial that I would strike a resonant note which would cause so many readers to offer their comments. Apparently the topic of international broadcasts beamed to North America is volatile and I wasn't alone in wondering why these broadcasts didn't have larger audiences hereabouts.

Reader Dave Larson of Harlingen, Texas didn't think too much of my thoughts that rock music played by local groups in various nations would appeal to North American audiences. He felt that there is already too much of this loud and generally unappealing stuff on American stations. Dave commented that there is already plenty of good alternative music available on the international shortwave bands—the kind of entertainment that one cannot easily hear on American stations—jazz, flamenco, etc. Also, there's a lot of interesting news that doesn't get picked up by American news services but which is highly relevant to Americans. For example, Dave points out that during the anti-nuclear demonstrations in England (prior to the deployment of the Cruise missiles), a group of local residents filed a suit in Federal District Court to block the deployment of the missiles. This was reported on BBC and Deutsche Welle, but our own ABC news was the *only* domestic service to carry the story when they mentioned it several days later. Being a professional newsman, Dave says that such leads are invaluable to him, as they should be to all persons who are interested in what's happening around the world.

Stephen Keithley, WD9FJL, of Alexis, Illinois generally agreed with my editorial and most especially with the idea that there is a vast information gap when it comes to encouraging the general public about international broadcasts. Steve said that if everybody read *POP'COMM* there would be no problem since the magazine is stimulating and interesting enough to fire the imagination of even those folks with only the most passing or casual interest. Unfortunately, everybody in North America doesn't read *POP'COMM*. He suggests that manufacturers of clock radios, stereos, CB's, and other electronics equipment might be convinced to pack in with their equipment special information kits advising the public about shortwave and what it holds. The same literature might also be distributed to schools and libraries. He'd like to see *POP'COMM* prepare this material and get the ball rolling with its distribution.

From Minneapolis came a letter from Arnold Timm offering several ideas covering a

varied range of approaches in order to get the work out to the public about listening to shortwave broadcasts. One concept which seemed to me to be especially clever was for broadcasters to prepare travel or tourism videotapes about their respective cities or nations during which information about their station (including frequencies and schedules) might be presented, or at least an address to write for a program schedule. These videotapes could be provided for showing on North American TV stations and cable systems. A similar project might be undertaken with audiotapes and North American AM/FM broadcasters.

Andrew Cornwall, Dartmouth, Nova Scotia agreed that the political rhetoric sent out over many international broadcast stations is quite boring, but that swapping the polemics for music isn't going to be a substantial improvement because interference and fading makes music sound pretty rotten on shortwave. For his own tastes and listening interests he'd like to hear more broadcasts about the various nations—their customs, cultures, sciences, weather, languages, industries, and people. He'd even like to hear their domestic news as well as their views on international events (but not if it is going to be given the heavy-handed political propaganda twist they seem to be so happy to offer). Basically, he holds up the Canadian Broadcasting Corp. (CBC) as a good example of well-oriented and structured programming and thinks that overseas listeners to Radio Canada International (RCI) are pretty lucky. I think he feels that listeners in North America would probably like to have similarly oriented and structured programs in English beamed in this direction from Europe, South America, Asia, and the Middle East.

Jack Fowler of San Diego, California noted that the national media seems generally reluctant to feed the general public enough information on shortwave to be of any use in tuning in on anything. He mentions that when the Space Shuttle Columbia was launched last December with ham W5LFL aboard, many newspapers and radio/TV stations noted that W5LFL had a small transmitter aboard which could be directly monitored by Americans. "Nowhere did I ever find the actual frequencies given—except when I listened to Radio Netherlands," observed Fowler! In the San Diego area a rebroadcast of the ground/space communications was aired over a repeater link from the Jet Propulsion Laboratories (JPL); a local

(Continued on page 74)

# J.I.L. INTRODUCES PROFESSIONAL ULTRA-SUPER MULTIBAND RADIO/COMPUTERIZED PROGRAMMABLE SCANNER

UNINTERRUPTED FREQUENCY COVERAGE  
150 KHz—3.7 GHz WITH RF CONVERTER

# SX-400

SERIES

SCANNING MONITOR RECEIVER



**New JIL SX-400 synthesized scanner designed expressly for commercial/professional monitor users that demand features not found in ordinary equipment...**

## OPTIONALLY EQUIPPED RF CONVERTER/COVERAGE 150 KHz-26 MHz AND 520 MHz—3.7 GHz

- CHANNEL SPACE SELECT SWITCHES (12 SWs. 26 MHz—520 MHz)
- MOMENTARY RECALL OF ANY MEMORY CHANNEL, CONVENIENT 2-WAY SCANNING
- QUICK SEARCH WITH PRIORITY CHANNEL
- CONTINUOUS 26—520 MHz GENERAL-COVERAGE, WIDER COVERAGE (150 KHz—3.7 GHz) WITH RF CONVERTER (OPTIONAL)
- WITH DATA INTERFACE (OPTIONAL), COMPUTER CONTROLLED • MEMORY CHANNEL EXPANSION, • 20 CH HIGH-SPEED REPROGRAMMING • RECORDING OF FREQUENCY, VOICE AND TIME • AND ALL FUNCTIONS REMOTE CONTROLLABLE
- BUILT-IN ANL (AUTOMATIC NOISE LIMITER) EFFECTIVELY SUPPRESSES AM-PULSE-TYPE NOISE
- HI-FI RECEPTION OF FM/TV BROADCASTS BY NARROW/WIDE SWITCHING OF FM IF FILTER BANDWIDTH
- CONTINUOUS SEEKING WITHOUT INTERRUPTIONS BY BIRDIES
- STOP MODE CHANGE SWITCH ENABLES SCANNING AND SEEKING FOR MODULATED SIGNALS
- AC ADAPTOR (OPTIONAL)

## SPECIFICATIONS (SX-400)

- **Frequency Range:** 26-520 MHz
- **Channel Space:** VHF 5 KHz or 6.25 KHz, UHF 10 KHz or 12.5 KHz
- **Sensitivity:** VHF FM 0.5 μV 12 dB S/N, AM 1.0 μV 10 dB S/N, UHF FM 0.5 μV 12 dB S/N, AM 2.0 μV 10 dB S/N
- **Selectivity:** FM 60 dB at ±15 KHz, AM 60 dB at ±10 KHz
- **Memory Channels:** 20 channels
- **Dimensions:** 300(W)×90(H)×210(D)mm
- **Weight:** 3.5 Kgs.

**J.I.L.**

J.I.L. - L.A. CORPORATION 17120 Edwards Rd., Cerritos, Ca. 90701, USA

Tel: (213) 926-6727

Telex: 067209

CIRCLE 35 ON READER SERVICE CARD

The most interesting questions we receive will be answered here in each issue. Address your questions to: Tom Kneitel, Editor, Popular Communications magazine, 76 North Broadway, Hicksville, NY 11801.

### Yeas And A Nay

Bravo! The story on paramilitary radio in February was just what I was looking for. Hidden away at Pontiac MO in the Ozarks is an isolated survival community known as CSA Zarepath Horeb. It's a heavily guarded place and everybody wears military camouflage uniforms—even the kids. The place has a complex communications center and a large radio tower. After several frustrating years of trying to get enough information to monitor CSA-ZH, your February story helped me to tune in. They're waiting for the world to end!

B. J. Whelan, KMOØDW  
(near) Ocie, MO

I don't argue with the accuracy of the information POP'COMM offers on pirate radio and things such as smugglers and paramilitary users. I do argue with the need for your readers to be provided with this information. Personally, I find it frightening.

Roger Levesque  
Burlington, VT

My file of POP'COMM issues comprises the most extensive reference file one could ever hope to assemble on what's really taking place in the world of communications and broadcasting. I especially like the information on clandestine broadcasters, military, and spy stations. Keep it coming.

Harry Marton  
Phoenix, AZ

### Recalling "WGM"

This is in reference to the "Outlaw Callbook" which ran in the February issue. Thanks to this story I learned something more about the history of the town I've lived in for the past 19 years! Your story listed station WGM, which was shut down as a pirate in 1932. This station was located at what is called Goble's Nob, which is about 1/4-mile from where I live. My mom says she remembers WGM from when she was a little girl. It was a great story except that you spelled the name of my town incorrectly. You spelled it "Jeanette," but we spell it "Jeannette." I really enjoy POP'COMM.

Greg Lazar  
Jeannette, PA

### Memories Of Walt Kinney

In regard to the late Walt Kinney (W4GJ), formerly Chief Engineer of "1-lung" station WTTT/WBAY (April POP'COMM "Beam-

ing In" column), sometime after Walt gave up WTTT I hired him as a field technician. At the time I was Asst. Director of Communications for Eastern Air Lines. We were in an expansion program and knowing Walt was on the loose we were happy to get him. Sometime while he was with EAL the company experienced a strike and suspended operation and he was caught in Dothan, Alabama. I got a message from him requesting authority for transportation to Miami on Delta Airlines. I realized that I had to get him back home but air authorization was out so I sent him a simple message reading "THE BUSES ARE STILL RUNNING." You can imagine his negative reaction. For months he refused to talk to me. Finally we made peace but for years after that, whenever he called me on the phone the first thing he would say would be, "The buses are still running." Walt's pride and joy was the Quarter Century Wireless Assn. (QCWA) and I believe he was the founder of the Southeast Chapter, the oldest chapter in Florida. I sure miss the old codger!

Vance Murr, W4FWI  
Miami Springs, FL

### Low Down

How low in frequency can radio signals be generated? Are there practical uses for radio signals at the bottom of the spectrum?

E. Lewis  
Gastonia, NC

*Experiments are currently being conducted with frequencies as low as 70 and 45 Hz (that's Hz, not kHz). The antenna coils carry several hundred amperes and the antennas themselves are about 110 miles in length. Only very slow speed CW can be sent on such frequencies (one single letter taking about eight minutes to send), however using a transmitter putting out only 1 watt of RF, signals might be sent around the world 24-hours per day and can be received by submarines located as much as 35 feet below the surface. Because of their unique propagation characteristics, such frequencies are generally considered to have an enormous military communications potential. There is some controversy regarding possible negative effects these signals might have on the environment. — Editor*

### Terrorist Radio

Do the various Arab terrorist organizations use shortwave to communicate with one another? If so, how do I go ahead obtaining the frequency?

Salim Arzan  
Ankara, Turkey

*Although nothing much has been mentioned about such communications of late, these groups have been noted in the past using frequencies around 14338 to 14348 kHz, also 14128 kHz. The Black September organization seemed to prefer 14290 kHz a*

*while back. Several languages were used and ID's were made up from several digits. I don't know the present status of any of these transmissions. Rotsa ruck! — Editor*

### Low Band Skip DX

I have logged very weak signals consisting of two-way weather communications between aircraft and ground stations. Although all communications are in English, locations mentioned include Seoul and the Sea of Japan. The frequency for these transmissions is 37.30 MHz. Has anybody else reported these transmissions, and how can I find out what they are?

Maurie Wellington, KCA6TJ  
Redwood, CA

*There's a good possibility that you're hearing one or more of three U.S. military facilities in South Korea which operate ground/air weather stations on 37.30 MHz. These military facilities are known as A-511 (Pyongtoek), H-201 (Yongsan), and H-220 (Tong du Chon). If this is what you're hearing, it's a nice catch and congratulations are definitely in order. Other monitoring enthusiasts please note! There's plenty of DX on the low band if you just take the time to listen carefully for those weak signals. — Editor*

### A Timely Inquiry

I was starting to wonder why my reception reports to hams and shortwave broadcasters were not bringing in as many QSL cards as I thought they might, even though the reports were highly detailed. When I heard a station at, say, 9 p.m. Central Standard Time on January 17th, the report I'd send out would specify 0300 GMT January 17th. What occurred to me was that when dealing with GMT (UTC), the date changes at 0000 GMT and my reports should have actually read 0300 January 18th. As soon as I corrected this in my reception reports I noticed a marked increase in the percentage of QSL's I received. I wonder how many other newcomers make this error. Please mention this in POP'COMM so that anyone else doing this can take it into account.

Charles Huntington  
DeSoto, IL

*Not at all an uncommon error made by many folks getting started in the DX hobby, Charles. Using GMT takes a little break-in period for just about everybody and when you finally get the hang of it, you look back on the errors you made and wonder why they weren't obvious right from the start! There are some international broadcasters who are sharp enough to match a detailed reception report against their program log and realize that there is a one day offset error in the date because the listener didn't realize it should have been changed at 0000 GMT—and they'll QSL anyway. Those QSL cards you received before you caught the error are from such stations. — Editor*



# SWL HEADQUARTERS

NATIONS LEADING SHORTWAVE EQUIPMENT SUPPLIER

## ICOM R71

THE ULTIMATE RECEIVER



Designed for Serious DXing

**NEW**

### ICOM DID IT AGAIN

- 100 KHz-30MHz
- Keyboard entry
- 32 memories
- Remote control (optional)
- Scanning
- Pass band & notch tuning
- Memory back-up
- Wide dynamic range
- Voice synthesizer (optional)
- See ICOM's ad in this issue for more details.

#### EEB Options Installed

1. Mechanical filter (Replaces SSB ceramic filter) ..... \$95.00
2. FL44A 8 pole crystal filter replaces SSB ceramic filter \$159. Installed ..... \$179
3. FM (Detection) 10 meter band \$39.50. Installed ..... \$49.50
4. 12V DC Kit \$9.95. Installed ..... \$15.00

Suggested Manufacturers Retail Price \$799  
Call for your special EEB discount price today.

### KENWOOD R-2000



- 100 KHz to 30 MHz
- All mode AM-CW-SSB-FM
- 10 memories (memorizes mode)
- Memory backup
- Memory scan
- Programmable band scan
- 24-hour clock-timer
- VC-10 VHF converter 118-174 MHz \$139

R-2000 \$599.95 ..... SALE \$499  
R-1000 \$499.95 ..... SALE \$429  
R-600 \$399.95 ..... SALE \$329  
ADD \$6.50 UPS

### SONY ICF-2002



Introductory  
Special  
**\$229**  
List \$249.95

Features: Ten memory channels • 12/24 hour quartz clock/PLL tuning for drift-free performance • Dual conversion Super-heterodyne for high sensitivity • SSB/CW

ICR-4800 \$99.95 ..... SALE \$69.95  
ICF-6500W \$199.95 ..... SALE \$99.95  
ICF-6800W \$699.95 ..... SALE \$549  
ICF-7600A \$169.95 ..... SALE \$139  
AN-1 \$79.95 (AC Adapt \$9.95)  
ADD \$4.00 UPS

### RTTY-CW-ASCII

Now enjoy the rest of the bands! A stable receiver, home computer and interface unit allows you to copy many of those "coded" signals.

AEA Micropatch MPR-64 or MPR-20 ..... SALE \$119.95

HAL CRI-100 or CRI-200 ..... SALE \$229 or \$279  
Software available \$44.95 to \$89.95

KANTRONICS RADIOTAP ..... SALE \$179.95  
Complete. All you need for interfacing

MFI 1228 Complete with software.  
Nothing else to buy ..... ONLY \$99.95

SEE MANUFACTURERS ADS THIS ISSUE  
FOR MORE DETAILED INFORMATION

### YAESU FRG-7700

Sale \$399



- 150 KHz-30MHz
- All mode AM-CW-SSB-FM
- Digital frequency and clock

#### Options:

- FRA-7700 active antenna ..... \$59
- MU-7700 12 channel memory ..... \$135
- FRT-7700 antenna tuner ..... \$59
- FF-5 VLF low pass filter ..... \$20
- DC-7700 12 VDC kit ..... \$8
- FRV-7700 VHF converter ..... \$135
- ADD \$6.50 UPS

SPECIAL  
PACKAGE DEAL  
7700-MU7700  
FRA-7700  
499<sup>95</sup>

### PANASONIC RF-B600

Sale

\$429  
List \$595  
(\$6.00 UPS)



- 1.6 to 30 MHz, FM/LW/MW/SW
- Micro computer multi-tuning system
- 9 memory stations, scan
- Slow/Fast rotary tuning
- 10 key direct access tuning
- Universal voltage

RF-9 \$99.95 ..... SALE \$89.00  
RF-B50 159.95 ..... SALE \$129.00  
RF-085 ..... CLOSE OUT \$49.95  
RF-B300 \$249.95 ..... SALE \$209  
RF-3100 \$379 ..... SALE \$279  
ADD \$4.00 UPS

### 1984 WORLD RADIO TV HANDBOOK



Sale  
\$17.50

- The shortwave listeners' Bible
- A reference guide for the beginner and serious DXer
- 145 pages devoted entirely to listings of SW, MW, LW, and TV stations around the world
- Listings of English SW broadcasts
- An annual review of shortwave receivers
- \$17.50 post paid USA book rate (add \$4 Air)

### SHARP

**NEW!**



- Portable 10 band receiver
- LCD frequency display/clock
- Program timer/sleep/alarm
- LW/MW/7SW/FM stereo
- FV-610GV \$169.95 ..... SALE \$139.95
- FV-310GB \$119.95 ..... SALE \$99.95  
(Same as 610GV less LCD readout/clock/FM stereo)
- ADD \$4.00 UPS

### G.E. WORLD MONITOR

Sale

\$169  
List \$229.95  
(\$4.00 UPS)



Digital readout, wide and narrow selectivity BFO for SSB & CW.

- 3.5 - 31 MHz SW/MW/FM
- 120V/220V or battery



- We ship world-wide
- SASE for FREE Catalog
- Foreign 3IRC's Air Mail
- Shipping charges not included
- Prices & specifications subject to change without notice



10 Miles West of Washington, D.C.  
Sorry—No COD's  
10-5 Tues., Wed., Fri.  
10-9 Thursday  
10-4 Saturday  
Closed Sunday and Monday

Electronic Equipment Bank  
516 Mill Street, N.E.  
Vienna, Virginia 22180  
Order Toll Free 800-368-3270  
Virginia 703-938-3350



CIRCLE 56 ON READER SERVICE CARD

# Worldwide Bootleg Radio Networks

## Listen In On Pirate Networks!

BY GORDON WEST, WB6NOA

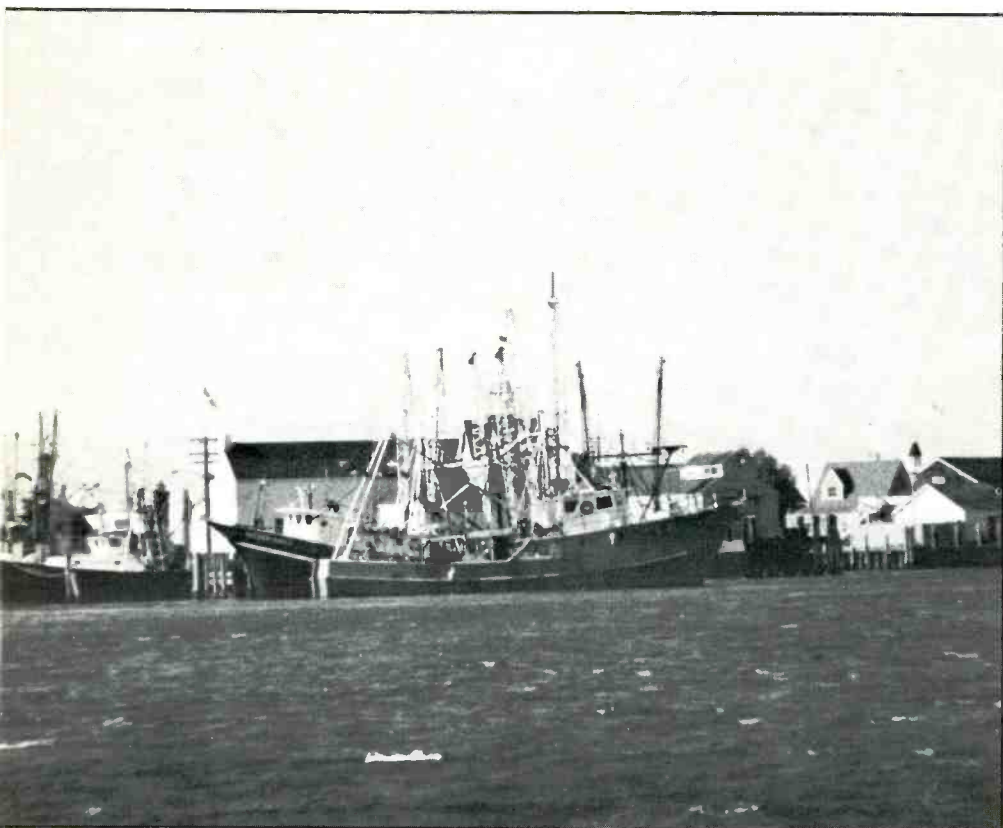

Commercial fishing boats have been known to stray into frequencies outside the authorized bands in order to insure privacy.



A temporary pirate base for HF operations.



Loran positions are accurate to within 50 feet.



A pirate station which was in use on a drug running boat.

“Roger Four Six, we will meet you at Loran waypoint three,” crackles a quick message on 14395 kHz. No callsign, no other identification. The message is just short enough to foil any type of direction finding.

Welcome to the world of two-way radio pirates. Seems that some folks have discovered that for less than \$1,000 anyone can set up a station with worldwide coverage which is 100% legal on the ham bands but also 100% illegal if operated outside of the normal ham band limits.

Radio pirates aren't anything new. Their operation is generally confined to frequencies just outside the edges of band limits. For instance, by changing the LO or by repro-

gramming the PLL system of a standard CB transceiver, it isn't at all difficult to force the set to operate above or below the authorized CB band (26.965 to 27.405 MHz). Therefore, the frequencies above and below the authorized band are rich with unauthorized activities. The majority of those monitored on such frequencies appear to be frustrated hi-tech CB operators who don't want or can't seem to get into the ham fraternity. Some say that they resent the ham community forcing them to learn CW to qualify for a license. These folks rag chew for hours, exchange QSL cards, see how many countries they can work—and they don't seem to have any special fears that they will be

tracked down by the FCC. Yes, they are well aware of FCC monitoring and enforcement cutbacks and they seem to have convinced themselves that they'll never get caught. The majority of their communications are strictly hobby type chatter and they really aren't using their equipment to coordinate activities that are connected with criminal activities. Some have even branched out onto other bands and one ex-patriate CB pirate net has shown up from time to time on 6660 kHz!

These stations weren't the case with that first call we received on our communications receiver. The Loran coordinates and a waypoint designator possibly indicated a mid-

channel rendezvous for an exchange of drugs or other contraband. High-seas radio pirates find that illegal activities can be coordinated by using the plentiful array of HF ham radio equipment now available throughout the world.

The use of VHF and HF radio systems for all sorts of tacky activities, such as smuggling, is at an all-time high. Rarely is there a drug seizure at sea without a lot of sophisticated radio and navigational equipment involved. High frequency radios that span between 3 and 30 MHz allow these pirates to chat over thousands of miles. The lower frequencies (below 5 MHz) allow the seaborne pirates to maintain communications up to 500 miles away for contacts with nearby vessels. VHF marine and VHF/UHF ham gear can be pressed into service when the vessels are closer than 50 miles. Switching to 1 watt power allows the operators to stay in touch with one another, but limits their transmission coverage to short distances.

Not all of this activity is connected with smuggling. Another popular use of unauthorized frequencies/transmissions is by certain commercial fishermen. Commercial fishermen guard their fishing zones vehemently. Their locations, they feel, must be kept secret to prevent rival commercial fishermen from zeroing in on them and thinning out their catch. In order to keep communications private with their own home base, some fishermen have begun to feel that shifting to illegal frequencies is perhaps the best way to insure secrecy and privacy.

"It ain't no secret—all of us are using those illegal radios to keep our communications private. We got fish-spotter airplanes and helicopters we need to contact. When they sight a hot spot, they let us know the Loran coordinates so we can get over to it. Anybody listening in on that conversation might steal the information from us. Sure, we use ham sets, sometimes ham frequencies, but we are more than 50 miles offshore so we don't bother nobody," comments a veteran commercial fisherman who normally operates off the coast of southern California. The inside of his cockpit looks something like the interior of a Boeing 747! His boat has the latest in aeronautical and marine radio gear, ham equipment, and even scramblers to mask some of the transmissions (just in case some of their transmissions are monitored by outsiders).

## Frequencies?

"If it's close in, we use the 6-meter ham band. Every day we shift frequencies, and on certain days we flop sidebands. If we want to yak with our home base, we then switch over to an HF rig," added our radio pirate.

It's fascinating to see how they figure out the range and bands for using the HF radios. "If we're 200 miles out, we use something near 2 MHz. If we're 300 miles out, we go up to frequencies near 3 MHz. Five hundred miles out, 5 MHz. One thousand miles out, we use spots at 10 MHz." In a strange way, it makes sense—the higher the frequency, the



Many ham stations are set up to chase boot leggers out of the ham bands.

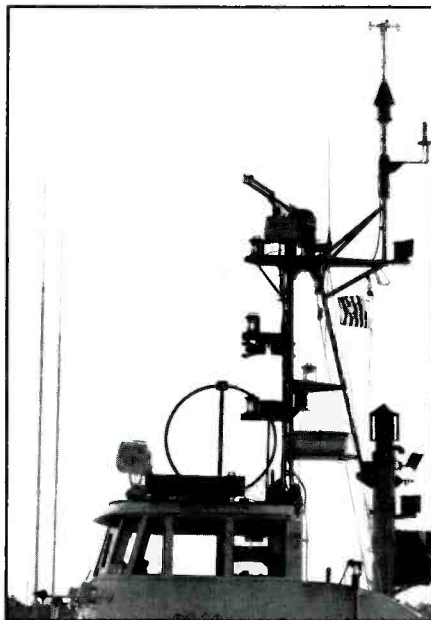

The Coast Guard uses marine direction finders to thwart drug pushers.

longer the range. This is obviously an unorthodox and non-technical way of selecting frequencies—not by the textbooks, but they tell me that it seems to work out well for their operation.

There is also a well-known community of ham radio pirates who use the ham bands for communications in the South Seas. Most of these operators are accomplished mariners who have never bothered to get a ham ticket—feeling that they legally don't need an FCC license since they are thousands of miles away from the United States and in international waters. However, in truth, the FCC regulations regarding the use of ham radio and ham callsigns aboard American registered vessels tells a different story.

"On vessels registered in the United States, including pleasure boats, regardless of whether the vessel is in U.S. or international waters, the Amateur Radio Operator must have an FCC authorization. In addition, a U.S. licensee is expected to comply with the pertinent statutes, rules, and regulations of the relevant foreign radio authority when operating within the territorial jurisdiction of that country," comments James C. McKinney, who, until recently, was the Chief, Private Radio Bureau, Federal Communications Commission.

## They Don't Care

Nonetheless, thousands of illegal but realistic appearing Amateur Radio callsigns are routinely heard on the 15- and 20-meter ham bands (21 and 14 MHz). Mariners using their unlicensed sets simply invent counterfeit callsigns similar to whichever foreign country they happen to be near, or whichever nation happens to strike their fancy. Vessels operating in the Caribbean area seem to prefer to pirate with VP2-prefixed counterfeit callsigns. A host of Japanese-type callsigns are appropriated for use by mariners in the Pacific, although without any authorization.

## Favorite Radios

Before the advent of all-band ham HF transceivers, all of these people were relegated to using stock sets which were unable to tune outside of the ham bands. The licensed Amateur Radio operators could quickly spot interlopers on their frequencies and take steps to evict them.

Crystal sets were then used, but such transceivers would keep the radio pirate rock-bound on a specific frequency. Multi-channel military equipment was usually too expensive for the average bootlegger.

Then enters the all-band, all-frequency transceiver. These sets can receive on any



Commercial fishing boats don't like to let competitors know where the fishing is good, so some of them have moved on to offbeat frequencies.

frequency between 300 kHz and 30 MHz, but are factory set to transmit only on authorized frequencies. It was quickly discovered, however, that it takes perhaps 60 seconds to include transmitting capabilities on any frequency covered by the receiver. The yanking out of a jumper wire, the clipping of a diode, or the addition of a single wire may be all that is necessary to make the changeover to all-frequency transmitter.

The bootleggers don't have to present any type of license to obtain transceivers. Most don't even have to take the sets to technicians to have them modified, so simple is the task!

### Bootleggers' Antennas

Radio pirates were also fast to discover that it takes a special antenna cut to the desired frequency in order to get any reasonable power output from these new-generation solid-state rigs. One solution is to use a longwire and an antenna tuner. This (along with a decent ground plane) works quite well. The antenna tuner can match the load to any frequency selected by the operator. Some antenna tuners will resonate any wire longer than 30 feet on any frequency between 30 kHz and 70 MHz!

### VHF

Amateur radio frequency-synthesized transceivers are the sets of preference by radio pirates, and the bands in use are 50 to 54 MHz, 144 to 148 MHz, 220 to 225 MHz, and 430 to 450 MHz. A separate set is required for operation on each of these bands. The more astute pirates avoid the 144 to 148 MHz band because it is so heavily used by legitimate operators. The 50 to 54 MHz band is preferred by fishermen because of the good propagation capabilities over sea water. The 220 to 225 MHz band is a favorite because few hams use "220" and also because scanners don't normally pick up this band. Inexpensive hand-held transceivers work wonders on the 220 MHz band. The 430 to 450 MHz band is used only for extremely short-range communications.

### Cautions

Those who illegally operate within the confines of authorized ham bands are soon discovered by hams. Ham operators pride themselves in direction-finding and can usually locate a bad apple within their barrel in short order and there are many hams organized into groups which devote a lot of time to seeking out intruders. Hams have been known to track down illegal radios on fishing boats using VHF by searching for them with their own private aircraft. These people love the adventure of tracking down bootleggers—it's a challenge! They've become so good at it that even the FCC is now using hams to seek out violators.

Operating outside of the ham bands is also rather tricky and dangerous. If the pirate should happen to pick a military frequency, the military (who also have direction finders) will rapidly swoop down on such stations and remove them from the air.

The FCC pays special monitoring attention to all frequencies used for the safety of life and property such as 2182 and 8364 kHz, and 121.5 or 156.80 MHz. The agency takes immediate action against those who misuse such frequencies.

The longer a radio communications pirate operates, the more assured of "getting away with it" he becomes. That causes the pirate to take more chances, make longer transmissions, and generally get careless and sloppy. This often leads to the detection and closing down of the station.

The penalties for operating radio transmitting equipment in an unauthorized manner are stiff and can include fines and even prison terms. If such activities are used to support illegal activities, the penalties are compounded. Therefore, even though the equipment and the desire to operate unauthorized may be present, there are far too many risks involved to make such activity appealing to any persons other than those who enjoy taking lots of chances.

The radio bands are full of pirates. Obviously there are many folks who like to take chances. Eventually, and sooner or later, most of them do get caught.

## Operators Pay Forfeiture For Out Of Band Operation

Two licensed amateur radio operators paid forfeitures for violations of FCC Rules. The forfeitures are a result of an investigation by several FCC Field facilities into an unauthorized use of a shortwave frequency.

Ronald F. Arsenault, KA2QMX, of Clifton Park, NY, and Dave L. Goodfellow, KA2GWV, of Hampton, VA, were fined following a joint investigation involving the Commission's New York and Norfolk field offices, and long-range direction finding by various FCC Monitoring stations. Arsenault was fined \$1,100 for willful out of band operation, transmission of false call signs, and refusing to allow inspection of his amateur station. Goodfellow was fined \$600 for willful out of band operation and transmission of false call signs. Both Arsenault and Goodfellow hold Technician class licenses.

Both operators were part of a small group of amateur operators who regularly operated on a frequency several hundred kilohertz outside the allocated 40 meter amateur band.

The amateurs were issued Notices of Apparent Liability to Monetary Forfeiture in September, and paid the forfeitures imposed against them.



## Government Takes Action Against Dealer Of Illegal Marine Radios

On October 19, 1983, United States Marshals from the Mobile, Alabama Office, in conjunction with Engineers from the Atlanta District Office of the Federal Communications Commission, seized approximately 53 radio transmitters at S.E.E., Inc., a marine radio dealer in Bayou La Batre, Alabama. In addition, an allegedly illegal radio transmitter was seized at a nearby residence which was being used as an unauthorized marine radio station.

A spokesperson for the FCC stated that this effort is part of an ongoing crackdown on illegal ship radio usage in the coastal areas of the Gulf of Mexico including Florida, Alabama, Mississippi, Louisiana, and Texas. This unlawful activity consists in part of operation of marine radio transmitters on frequencies that are set aside for use by mobile telephones, Police Departments, Fire Departments, and other radio services essential to the protection of lives and property. Numerous urgent complaints have been received from Police Departments and other authorized users for assistance in removing these unauthorized stations because of the danger of interference to emergency communications.

S.E.E., Inc. is suspected of being a major supplier of the radios used for this illegal operation.

The search warrants were issued by Federal Magistrate David Bagwell upon evidence developed in a joint effort by the FCC's Atlanta and Kansas City Regions and presented to Assistant U.S. Attorney Ruddy Farve, for the U.S. Attorney, Jeff Sessions, III, the Southern District of Alabama.

The value of the seized property was estimated at \$39,000.

# Bring Your Listening Into Focus!

FREQUENCY LISTS  
SCANNING  
SHORTWAVE LISTENING  
UTILITIES DX'ING  
SATELLITE RECEPTION  
STOCK EXCHANGE  
EXPERIMENTER'S WORKSHOP

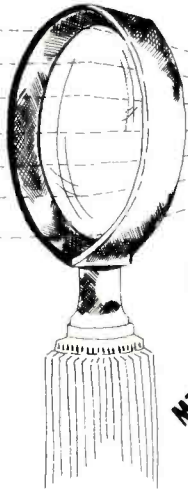

# MONITORING TIMES

130 DOG BRANCH ROAD, BRASSTOWN, NC 28902 704-837-2216

## MAKES HEADLINES

*Monitoring The AWACS Net*  
*Tracking The Great Storms*  
*Special Report: Space Shuttle Panorama*  
*Monitoring Nuclear Shipments*  
*Spy Numbers Transmitter Located*

\$10.50-1 year • \$20.2 years • \$30.3 years  
Canadians please add \$9.50 per year.  
Foreign subscribers please add \$9.50 per year for surface mail or \$28.00 per year for air mail.

**Finally** - a monthly tabloid newspaper written for you, the listener. 32 fact-filled pages on how to improve your listening post, where to hear those intriguing frequencies, home brew projects to save you \$\$\$ AND MORE!

Here's a sample of subscriber's feelings about MONITORING TIMES:  
"I felt it necessary to praise you on your informative, unique paper. I subscribe to many different magazines on shortwave communications and scanning, but your publication is the one that I enjoy most of all." —Bob Blackburn, Highland, MI.  
"I've found MT contains far more useful information than other magazines." —Charles Dean, Andover, KS.  
"MT is a unique publication that offers something for every type of reader that is unavailable from any other hobby publication." —Nicholas Berkholtz, Minneapolis, MN.

**JOIN BOB, CHRIS, NICHOLAS AND THE THOUSANDS OF OTHER ENTHUSIASTIC SUBSCRIBERS TODAY!**

CALL NOW TOLL FREE 1-800-438-8155 (cont. US except NC) to place your subscription for 2 or 3 years on Mastercard or Visa. Or for a one year subscription mail your check to Grove Enterprises, Inc., 140 Dog Branch Road, Dept. P, Brasstown, NC, 28902. Office phone 704-837-9200.

**FREE SAMPLE AVAILABLE UPON REQUEST**

CIRCLE 59 ON READER SERVICE CARD

## NEW LISTENING ADVENTURES



### HEAR MORE THAN EVER BEFORE WITH THE NEW M-600A MULTI-MODE DECODER

Simple connections to your shortwave receiver and video monitor or printer will let you monitor thousands of Morse and Radioteletype signals in Marine, Commercial, Government, Military and Press Services. Converts standard CW and RTTY plus low and high speed ASCII, non-standard shift RTTY, Bit-Inverted RTTY and TOR (Telex Over Radio -FEC & ARQ). Isolated loop MIL-188 or RS232 provided; optional parallel printer port available.

### CONTACT US FOR DETAILED INFORMATION

Phone: 614 866-4267  
MC & VISA Accepted

Special Price  
**\$689.95**

(Ohio residents add 5.5% sales tax)

### UNIVERSAL SHORTWAVE RADIO

1280 Aida Drive, Reynoldsburg, Ohio 43068

Please send all reader inquiries directly.

## DOUBLE YOUR RANGE

### Metz Tuned Base-Loaded Whips

Two Models Are Available: One For Scanners And One For Shortwave Receivers. Simply Replace Your Telescopic Whip With The Metz System. Metz Whips Plug Into Your External Antenna Connector.

- Two Models: Scan 1 covers 30 MHz to 512 MHz  
SW 1 covers 50 kHz to 54 MHz
- All stainless steel—won't corrode
- Tuned coils offer 3 dB gain over telescopic whips
- Plug included to match your receiver
- Every coil tested and serialized
- No external power required
- Whip only 54" tall
- Whip may be remounted mobile with accessory \$25.00 magnetic mount
- Whip may be remounted on your roof with accessory \$5.00 angle bracket.
- Lifetime guarantee

Metz stainless steel antennas are used worldwide by Mariners, Police, Business, and Commercial Radio users. It was the Ham Radio operators who discovered the phenomenal range increase when used on Ham worldwide and VHF equipment. Well-known radio expert Gordon West, WB6NOA, gives the Metz whips his highest rating: "They equal the range of active antenna systems at one-third cost, and when you replace your telescopic whip with the Metz, you'll really hear the difference!" \$59.95 from Metz Communication Corp. corner Rt. 11 & 11C, Laconia, NH 03246 Phone Orders: 800-258-4680 (Visa/MasterCard/C.O.D.) Technical Info: 603-528-2590



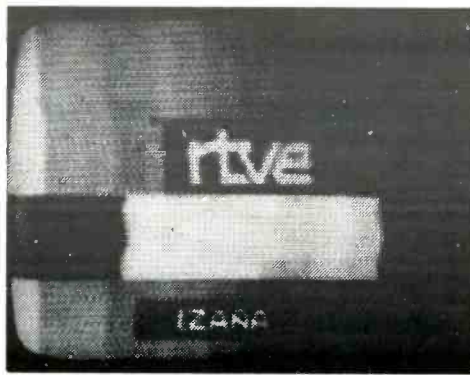
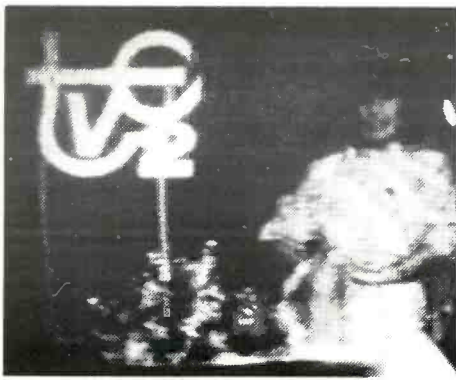

# TV DX – It's Back (Again)!

## Here's How To Tune In On This Season's TV DX

BY DARREN LENO, WDØEWJ

If you have a TV set and a TV antenna, you have the bare essentials to participate in the challenging field of TV DXing! With a little patience and persistence, you will be able to receive distant TV stations, enhance your viewing pleasure, and obtain several new additions to your ever-growing collection of QSL cards.

Let's define a "distant" TV station as one that is some distance from your house and that you are not normally able to receive; but, by some "miraculous" atmospheric phenomenon (which we will not explore in depth in this article) called tropospheric propagation and temperature inversion, you are able to receive over great distances—several hundred miles, or even further. In fact, one of my best catches was over 1500 miles away! However, personal experience has shown me that the stations you'll receive most often will be within 400 miles of your location.

The atmospheric phenomena reach their peak during the spring and summer months, and often continue into the fall. Although this type of propagation is most prevalent on the VHF channels, UHF stations also have the potential to be seen and heard over great distances. The best time to do your TV DXing is usually in the evening, as well as in the morning hours before noon. Although TV propagation sometimes continues throughout the day, this does not happen as often as one would like. One of my favorite times to

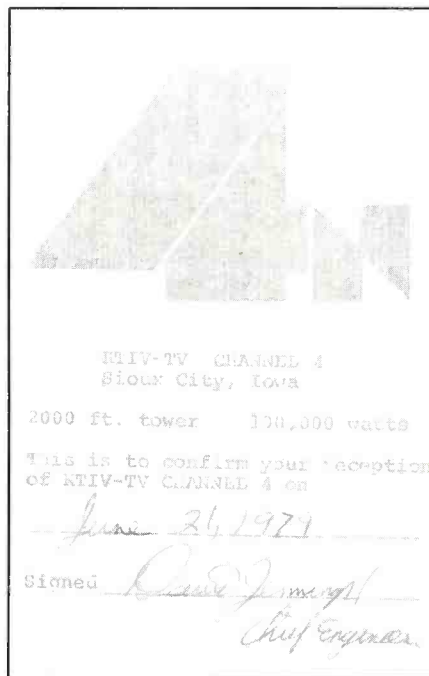

DX TV stations is early in the morning, around 5:30 a.m., just as they sign on the air for the day.

### What Do I Need?

You may already own the basic equipment needed to begin DXing TV stations. Obviously, the first thing you're going to

need is a black-and-white or color television.

A high quality directional TV antenna with a rotor is also a plus and will definitely increase your chances of pulling in the "weak ones" by allowing you to pinpoint your target, as well as reject competing TV stations on the same channel, thus minimizing interference. It will also enable you to reject a competing TV signal on the same channel that is coming from a different direction. Your antenna should be mounted above obstructions (trees, electrical wires, etc.) for maximum efficiency, and it should be properly guyed. High quality coaxial cable with low line loss never hurts, and neither does a television signal amplifier.

A video cassette recorder (VCR) is to TV DXers what a cassette tape recorder is to an SWL. You'll be able to record and collect portions of the TV stations you hear—especially station ID's. Most of these items are available at your local electronic stores. A must item for any TV DXer to own is some kind of guide that lists TV stations. I've found *White's Radio Log* to be a big help. It's available through CRB Research, P.O. Box 56, Commack, NY 11725, for \$4.95 plus \$1 postage.

You may also consider joining a club that caters to TV DXing. The World Wide TV-FM DX Association, a member of ANARC, may be of interest to you. Send an SASE to WTFDA, PO Box 514, Buffalo, NY 14205, for more information.



July 28, 1978

Mr. Darren S. Leno  
1904 South 16th Avenue  
Moorhead, MN 56560

Dear Darren:

Thank you very much for your recent letter. We that you were able to receive KCMT TV, Channel 7 at July 24th. This letter hereby confirms the program at that time as you have it outlined in your letter stations that we refer to are microwave relay stations our signal from Alexandria to a sister station, KN Walker, Minnesota. I am enclosing a coverage map which you may find of interest.

Coincidentally, my brother, Harold E. Flint North Dakota, told me that he also received Channel night as your report so apparently, the weather evening were such that the signal was getting on

Thanks again for writing.

Sincerely yours,

*Glenn W. Flint*  
Glenn W. Flint  
Vice Pres./Gen.

GWF:ml  
Encl.

CENTRAL MINNESOTA TELEVISION COMPANY - KC

GLENN W. FLINT  
Gen. Mgr.



### COVERAGE MAP

KNMT-TV  
Channel 12  
Tower Height:  
999 Feet  
Power:  
30,000 Watts

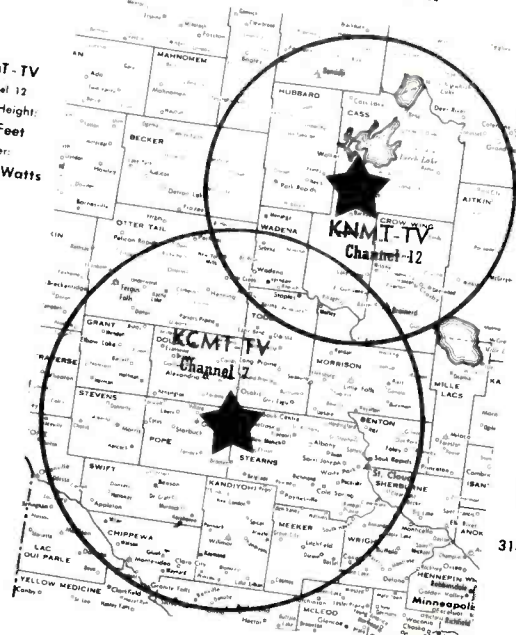

KCMT-TV  
Channel 7  
Tower Height:  
1135 Feet  
Power:  
316,000 Watts

### Central Minnesota Television Company

KCMT-TV  
Alexandria, Minn.

KNMT-TV  
Walker, Minn.

KCMT-FM  
Alexandria, Minn.

## Verifying TV Stations

After spending a lot of time, energy, and money just to tune in distant TV stations, you finally pick up one! If you're like any normal DXer (AM, FM, or SW) you're probably going to want some kind of tangible proof—something you can hold in your hand to prove that you, Joe Dee-xer in Tuttle, North Dakota, actually picked up KUID in Moscow, Idaho.

Most TV stations will happily send you any kind of verification they can. Since I am under the impression that most of them are not bombarded with reception reports, a simple letter to the Station Manager or Chief Engineer explaining what you are after will usually bring satisfactory results. Although most TV stations will send you a verification letter, some of them have QSL cards.

The first rule when asking for a QSL from any kind of broadcast station is to substantiate your claim. In other words, send along a brief description of what you saw or heard,

especially commercial messages. Second, be sure to include as graphic a description of the quality of the station's signal as you possibly can. Third, explain that you watch distant TV stations as a hobby, and that you would very much appreciate a card or letter stating that it was indeed their station you were receiving.

So far, my QSL percentage on TV stations is 100%! Quite often, letters I've received from TV stations come with key chains, matchbooks, coverage maps, a station history, bumper stickers, or any number of collectable promotion materials. Once I even received a letter from the president of a small TV network in central Minnesota who invited me to visit him if I was ever in the neighborhood.

Many libraries carry a collection of phone books for various metropolitan centers in the United States. This is an easy way to look up the address of a TV station when writing for a QSL.

If you try really hard, but just can't seem to locate an address for a TV station, there is a sneaky way to get your letter through that usually works, especially in the smaller towns. For example, if you can't find KUID's address, but you know they are located in Moscow, Idaho, address your envelope to: KUID-TV, Moscow, ID. Since the post office is going to hate me for telling you this, I may as well start making amends now by asking you to *at least* look up the city's zip code at your local postal station.

DXing TV stations can be a very interesting, fun, and challenging hobby. Now that the season is upon us, why not unscrew the cable TV connector in the back of the TV set, hook up the old antenna that's rusting away on the roof, and see what you can see. One word of caution—don't spend too much time staring into the screen of your TV set at close range; it may be a strain on your eyes. Good luck with your viewing!

# The Violent World Of Shortwave

BY GERRY L. DEXTER



Radio Free Kabul's headquarters near the Afghanistan border.

**B**eing a shortwave broadcaster can be dangerous to your health. In fact, if you're not careful, it can kill you.

While broadcasting in the United States can be a pretty tame affair, in other countries things are a lot different.

People in the USA often don't realize that in most other countries, radio is often *the* communications medium. While the broadcast industry in some small third world country may be only a minute fraction of the size of this country, it often has an importance that is out of proportion. Radio stations are always among the targets of any well-planned coup. Governments often do not allow broadcasters the freedom to speak out, and those that do must take their chances with possible consequences.

In short, broadcasting can often be a highly dangerous business. Station owners, pirate broadcasters competing for a commercial audience, defectors working at stations, announcers who speak out against real or imagined wrongs often take their lives into their hands. Hazards of clandestine broadcasting from within the target area can lead to capture, torture, and death.

There have been incidents over the years when owners, managers, or announcers found themselves in jail for their efforts and, at worst, found themselves dead.

Engineers at the various transmitting points for the Radio Free Kabul network in Afghanistan have been killed or wounded in skirmishes with the Soviet occupation forces (see the feature on Radio Free Kabul in the September, 1983 *POP'COMM*). At least three persons have been killed as the Russians relentlessly attempt to track down the various sites from which this network operates inside occupied Afghanistan.

Radio Venceremos, the anti-El Salvador clandestine station has had personnel lost in similar encounters. The El Salvador clandestine stations, including Radio Farabundo Marti and Radio Guazapa, keep their own news reports out in the field with the guerrillas and are thus exposed to life-threatening situations on a regular basis.

Broadcast personnel in Ghana were recently ordered to take a three week course in military training. The purpose? To give them some background and ability to help them defend "Broadcasting House" against any armed takeover or attempted coup which might occur in the future. As we noted, radio stations are prime targets for coup-planners.

## Murder In The Mountains

La Voz de Atitlan was a friendly little radio station located on the southern shore of the

famous Lake Atitlan, a volcano lake bordered on three sides by towering mountains in Solola Department, Guatemala.

La Voz de Atitlan operated as a radio school, broadcasting courses in reading and writing to the local Indian population from a 500 watt (and later 1 kilowatt) transmitter. Studio and transmitter were located in a school at Santiago de Atitlan.

One day in late 1980 the station's director, Casper Calar, was taken by the Guatemalan army or by right wing elements, and shot and killed. The president of the station, Juan Ajtzip Alvarado, who also served as an announcer, may have been killed at this time or in a separate incident.

The work of the station was apparently not approved of by one or more factions controlling the guns. La Voz de Atitlan is no longer even on the air.

## Mayday, Mayday!

"This is Radio Northsea. We are on fire! A bomb hit us!"

Such was the distress call sent out over the regular broadcast channel of the Dutch pirate ship Radio Northsea International in May of 1971.

Frogmen had planted a bomb near the ship's engine room late that night. The entire ship's crew save the captain and chief engineer were ordered into the lifeboats.

Fortunately, Dutch Naval and firefighting vessels from a nearby port managed to put out the fire before extensive damage was done and Radio Northsea was able to return to the air early in the morning.

The incident was brought on by disagreements with another Dutch pirate station, Radio Veronica, which had been in operation since 1960. Radio Northsea brought competition to Veronica when it came on in 1970.

An agreement was worked out between the two whereby Veronica paid Northsea over \$250,000 not to broadcast in Dutch, the language Veronica was using exclusively. In turn, Radio Northsea gave Veronica the bill of sale for the Northsea Ship, the *Mebo II*, and allowed itself to be staffed by Veronica-approved Dutch personnel.

But later, Radio Northsea's owners had a change of heart about the language agreement and tried to repay the loan. Veronica refused. Radio Northsea's people, whom the agreement had forced off the ship, then returned in a tugboat in an attempt to forcibly seize the *Mebo II*. After several attempts, they were successful, the Dutch crew was sent back to shore.

The bomb attack by Radio Veronica's agents was an attempt to regain control of the ship again.

As far as we know, there were no deaths or injuries in this mini-war. Those involved were lucky.

## Death Of A Pirate

Reginald Calvert was the head of the pirate station Radio City which operated from an old World War II gunnery platform in the Thames Estuary.

On June 19, 1966 Radio City was the tar-



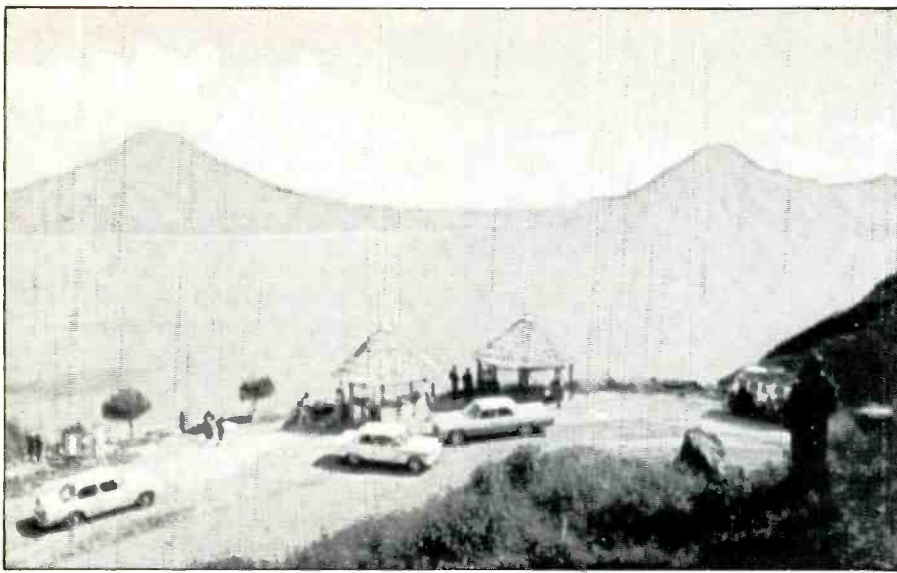

Lake Atitlan, Guatemala, home of La Voz de Atitlan.

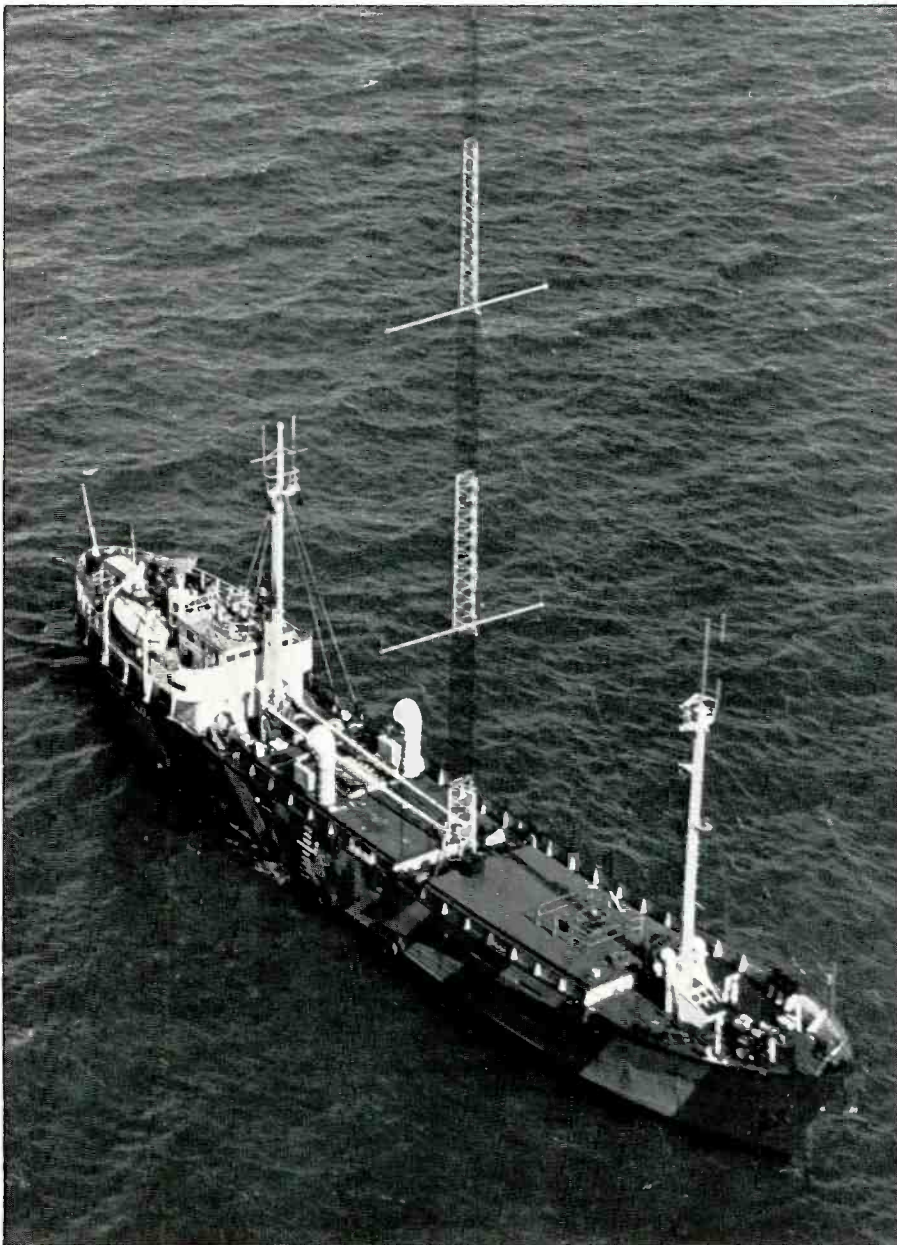

Radio Northsea International, victim of a bomb attack by the competition.

get of a raid by a party of 11 persons, including one woman. The group boarded the fort, held the station's staff of seven at gunpoint and stole the crystals from the transmitter before leaving.

Calvert, on hearing news of the raid, went immediately to the police. Since the legality of the pirate operation in England generally was up in the air at the time, the police did little about the complaint.

That same evening, Calvert paid a visit to a man named Major Oliver Smedley, director of a number of commercial concerns and very active in Labour party politics.

Calvert, by this time in a seething rage, forced his way into the house and fought with Smedley in an upstairs bedroom. A few minutes later neighbors heard a gunshot and shortly thereafter, Smedley appeared at a nearby house asking to use the phone in order to call the police. Smedley had shot and killed Calvert.

As the details became known it turned out that Smedley had connections with various British pirate broadcasters and actually owned the transmitter used by Radio City.

Calvert had been negotiating with other groups seeking financial support and Smedley became concerned over the fate of his transmitter for which he had not yet received payment.

It was Smedley who sent out the boarding party and Calvert must have suspected that Smedley was behind the raid.

Calvert confronted Smedley and a fight broke out ending in Calvert's death by shotgun blast. Smedley was found not guilty of manslaughter, the jury ruling he had acted in self defense.

### Who Killed Georgi Markov?

The above was the title of a Public Broadcasting System television special a couple of years ago.

Markov was a former Bulgarian writer and TV commentator who defected in 1969. He moved to London and worked for the British Broadcasting Corporation's Bulgarian Service. He also did pieces for Radio Free Europe.

On his way to work at the BBC's Bush House external service headquarters one day in September, 1978, he paused at a crowded bus stop near Waterloo bridge. Suddenly he felt a sharp jab, turned around to look and a man behind him apologized for bumping him with his umbrella. The man got into a taxi and disappeared.

That evening, Markov developed a fever. He told friends he believed he had been the victim of an umbrella attack but no one believed him. Four days later he was dead.

Markov had achieved national acclaim in Bulgaria when he was still a citizen there. He was on a first name basis with the head of state. He probably knew enough about Bulgarian secret police practices to accurately judge who had been responsible for the attack on him and how it had been done.

How had it been done? The umbrella had a trigger on the staff, just below the curve of



Two Bulgarian defectors working at the BBC's Bush House External Service headquarters were murdered.

the handle. When pulled, the trigger releases a spring-drive piston device which drove a CO<sub>2</sub> cartridge, in turn forcing a poison pellet through the length of the umbrella, out the hollow tip and into the victim's body at high speed. The pellet, about 1/16" in diameter, had two very small holes in it which allowed a slow-acting poison to seep out. The murderer has never been found.

Three weeks before the attack on Markov another Bulgarian defector, Vladimir Kostov, was the target of an umbrella attack in Paris. Kostov was a good friend of Markov's. He became ill but survived. Doctors found a poisoned pellet in his back. Kostov, before his defection, had worked for Bulgarian radio and television. It's nearly certain that Markov had heard of the attack on his friend, adding to his own certainty about what had happened to him.

Still another Bulgarian defector, Vladimir

Simeonov, age 30, was found dead at the bottom of the stairs in his apartment building in London some three weeks after the killing of Markov. There was no sign of foul play. A post mortem showed death by asphyxiation. Simeonov may have been the victim of a gas gun pen. Undoubtedly he, too, was killed by the Bulgarian secret police. Simeonov had been a disc jockey and news reader for the BBC's Bulgarian service.

Some of the hard-hitting broadcasts aired by these men are thought to have caused the retribution.

### Death Of A Diplomat

Not very many years ago, the government of Equatorial Guinea was run by a murderous clique headed by Federico Macias Nguema. Virtually all contact with the outside world was cut off. The govern-

ment stations, formerly friendly and responsive to DXers reception reports, went "black."

A determined DXer, seeking a QSL, contacted a United Nations representative of Equatorial Guinea. The diplomat said he would be going home soon and would see what he could do for the DXer.

The diplomat was murdered by government forces on his return. While the diplomat's shortwave connections were tenuous at best and while shortwave connections were undoubtedly not the cause of his demise, still, one can't help but wonder.

### The Government Steps In

The case of Victor Danchev, the Radio Moscow announcer who doctored his newscasts in reporting on Afghanistan, made newspapers everywhere.

Danchev, a newscaster for Radio Moscow's World Service in English, re-wrote some of the stories he was supposed to read. In the Danchev versions, Soviet troops in Afghanistan were called invaders, occupiers. Danchev, on another occasion, changed a story about nuclear forces to indicate that the Soviet Union was determined to have a greater supply of missiles than the NATO forces.

The people at Radio Moscow didn't catch the first such rearranged story. Nor the second. But after the third, Danchev was released.

He remained in Moscow for a brief period while the higher-ups decided what to do about him.

Eventually, he was sent back to his home in Tashkent in the Uzbekistan. Reports now indicate that he has been committed to a mental hospital. Most people are aware of the connotation "mental hospital" has and the uses to which such places are put in the Soviet Union.

The director of Polish Radio and TV got himself into trouble through black market dealing and high living, reportedly driving a big car and owning a fabulous home in which ostentatious parties were given where a certain degree of sexual activity was not uncommon.

He has plenty of time to reflect on the good old days now, as he is serving a long jail sentence.

The manager of a radio station in Chile was arrested recently for allowing anti-government commentaries to be aired on his station.

In Chile, in Peru, in Guatemala—employees of radio stations never know when they'll find themselves looking down the barrel of a machine gun. Dissident elements can break into a station at any time with the intent of airing their revolutionary message.

There are probably many other stories and events of this type that we simply don't hear about.

It's safe to say that all the chapters in this book haven't yet been written and that having connections to a radio station will continue to be a somewhat dangerous business throughout the years ahead.

#### SUBSCRIBER SERVICE

### CHANGE OF ADDRESS

Planning to move? Please let us know six weeks in advance so you won't miss a single issue of POPULAR COMMUNICATIONS

Attach old label and print new address in space provided. Also include your mailing label whenever you write concerning your subscription to insure prompt service on your inquiry

POPULAR COMMUNICATIONS  
76 N. Broadway,  
Hicksville, NY 11801

ATTACH LABEL HERE

NEW ADDRESS HERE

PLEASE PRINT

NAME \_\_\_\_\_

ADDRESS \_\_\_\_\_

CITY \_\_\_\_\_ STATE \_\_\_\_\_

DATE \_\_\_\_\_ ZIP \_\_\_\_\_

# Viking International

The Source! Compare prices!

## NEW! MICROMINIATURE LONG PLAY CASSETTERECORDER

with built-in very sensitive voice activation

**AUTOREVERSE!**  
(no flipping of cassette)



Dimensions: 4 1/4 x 3 3/4 x 1 1/4"  
Plays 4 hours on C180  
3 hours on C120

**\$145**

## NEW! ULTRAminiature microphone with BUILT-IN linedriver.

To send microphone signals over long lengths of UNSHIELDED cable or wire. VERY sensitive. System consists of mike/driver and recorder interface/power supply. Can also be used with an amplifier.



**\$290**

## TELEPHONE VOICE CHANGER

This one WORKS!

Slips over telephone handset. Voice characteristics are continuously variable. Uses custom LSI circuitry. Call for over the phone demo.



Now only **\$389**

## SECURE TELEPHONE X2

YOU HAVE SEEN THIS PHONE BEFORE (AT \$2090!!!)



**NOW** only **\$1290**

**FACTORY DIRECT**  
(NO MORE MIDDLEMEN)

## L-O-N-G DISTANCE MICROPHONE SYSTEM

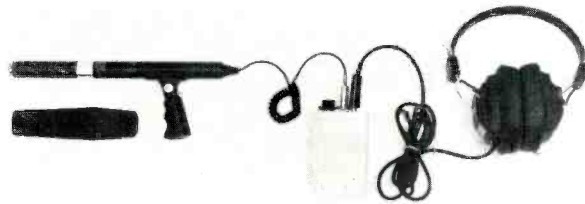

**NEW!**

Send for 2 page brochure

**\$159**

## PORTABLE TELEPHONE SCRAMBLER



WHY PAY \$990 a pair?  
OUR price is **\$840** a pair.

## VIBRATING POCKET TRANSMITTER DETECTOR



only **\$290!**

Dimensions: 2 1/4" x 7/8" x 3 1/2"

## TEN HOUR CASSETTE RECORDER

NEW FLAT MODEL



**BEST** sounding 10 hour recorder!

- AC/DC operation
- Digital tape counter
- Records 5 hours per side (10 hours total)
- Complete with cassette

**SENSATIONAL NEW LOW PRICE!**

**\$93**

With voice activation **built-in** (nothing dangling outboard) — **\$119**

## TAPE RECORDER AND TRANSMITTER DETECTOR



**COMPARE PRICES!** **\$635**

## TELEPHONE AUTOSTART

- start/stop recorder automatically
- uses no batteries
- does not load line
- best since 1969
- Special TA210X model turns our 10 or 14 hour recorders completely on/off, saving batteries
- Beware of primitive imitations!

Made in USA



only **\$25.95**

← ← ← works with TA210X

**BEWARE** of look-alike imitations!



CA. residents add 6 1/2% tax.

**VIKING INTERNATIONAL**  
P.O. Box 632, Newhall, CA 91322  
Phone (805) 252-1820  
Telex 182836

**BIG NEW 52-PAGE CATALOG**  
\$5.00 (U.S. and Canada, first class mail)  
\$7.00 (all other countries, air mail)

**DEALER PRICES? OF COURSE!**

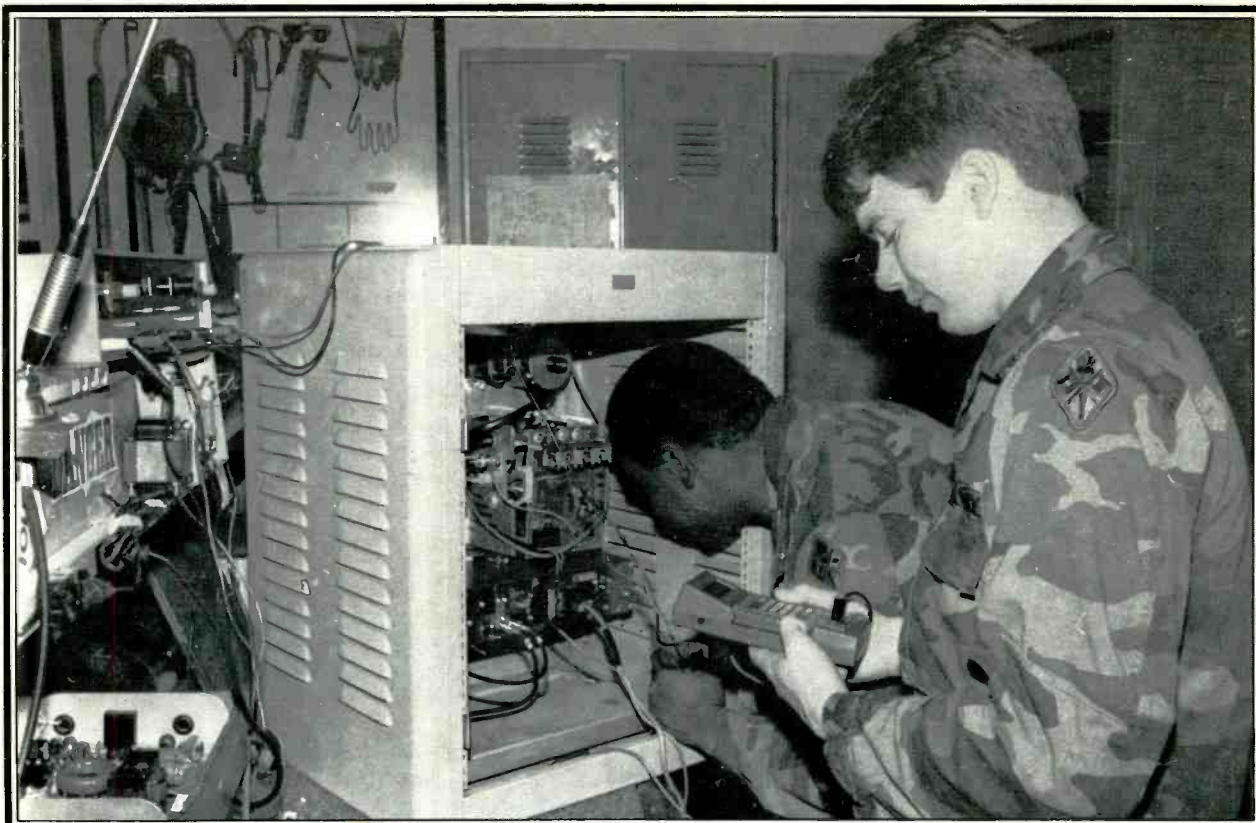

WFG engineers, *Pvt. 2 Frank Mulkey* (fore ground) and *Pvt. 2 Brian Gordon*, run an electrical test on a reel-to-reel tape deck. (All photos on these pages by *Pfc. Sheralyn Bundy*, Fort Gordon Public Affairs Office)



*Pfc. Pat Knapick* broadcasts in the on-the-air studio.



*Spec. 4 Eric Reeder* searches for material in the record library.

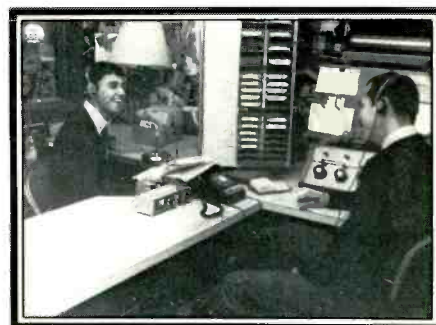

*Pfc. Paul Ramirez* and *Pfc. Pat Knapick* are "live" on WFG.

# Here's Station WFG

## The U.S. Army's Own Mini-Broadcast Station!

BY STAFF SGT. JOHN EROH & SPEC. 4 MICHAEL FOLEY

Wherever U.S. troops are stationed around the world, there is usually a military radio or television station providing entertainment, news, sports, and command information. The vast majority of these media are operated overseas by the Armed Forces Radio and Television Service to give our service members a taste of America.

However, at Fort Gordon, GA, "Home of the Signal Corps," soldiers can tune in to one of the few stateside, military-operated

radio stations that provides 24-hour programming.

WFG Radio broadcasts on 640 kHz using low-power, carrier-current transmitters that are placed around Fort Gordon in compliance with part 15.7 of FCC Rules and Regulations. This regulation requires that WFG's signal not interfere with licensed broadcasts and that the signal remain within certain strength limits. The audio is also carried on Channel 13 of Gordon Cablevision, which

covers the post housing areas and the adjacent towns of Grovetown and Harlem, GA. When not airing training films or other command programs, the post-wide Educational TV System also carries WFG broadcasting into classrooms and training areas.

WFG broadcasts are mostly powered by Low Power Broadcasting, Inc. (LPB) 25C, 20-watt tube transmitters and LPB 4C, 5-watt linear amplifiers. The transmitters and amplifiers are hooked up to power lines

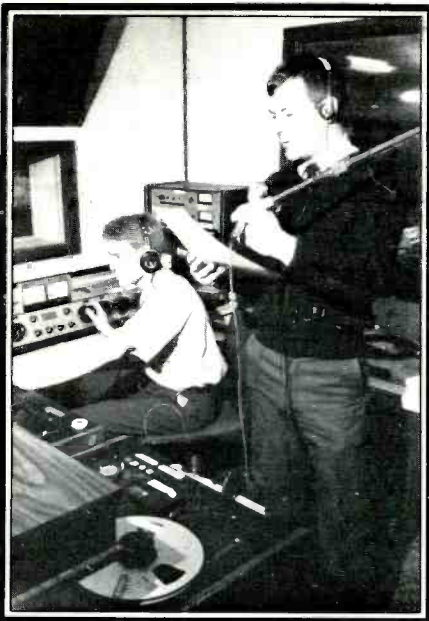

Spec. 4 Michael Cowles (left) and Spec. 4 Eric Reeder record a public service announcement in the production studio.



Spec. 4 Michael Cowles at work in the production studio.



Pfc. Paul Ramirez prepares WFG's automation system.



Pfc. Pat Knapick cues another record in the on-air studio.

which act as antennas via LPBT1A coupling units. A few of the newer LPB TX2-20, 20-watt transistorized transmitters and TCU-30 coupling units have replaced the 25C transmitters in problem areas. Most of the equipment is installed in boiler rooms to limit unauthorized access.

WFG Radio has two studios: one for on-the-air use and one for production. The production studio can be converted to on-air use by making a change in the main patch panel. Both studios are equipped with a Gates Broadcast Console, two Gates 1201 turntables, an ITC 3D broadcast cartridge machine, and two ITC 770 reel-to-reel tape decks.

The on-air studio has a cassette recorder that is automatically activated when the disc jockey's microphone is turned on. This device allows the radio station supervisor to make air checks and monitor professional progress. In order to provide up-to-date weather information, the on-air studio is also equipped with a Heath computer weather station, a Heath automatic rain gauge and a Bearcat Weather-Alert receiver that monitors the National Weather Service broadcasts from Bush Field airport in Augusta, GA. Additionally, there is a Heathkit phone patch in both studios to facilitate call-in, on-the-air news reports and actualities.

During weekdays, WFG broadcasts live from 6 a.m. to 6 p.m. Programming consists of a variety of music, command information, public service announcements (many of which are produced by the radio staff), locally-produced feature programs, and AP news audio. When not live, programming consists of prerecorded programs furnished by the Army Information Radio Service (AIRS) in Washington, D.C. AIRS programming, mostly music interspersed with command information, is played on an outdated Schaffer automation system which controls five ITC 770 tape decks and one Ampex 350 tape deck.

The most popular service that WFG offers is the unit or "Block Party" music promotion. Station engineers have converted an 8' x 12' travel trailer to a portable on-air studio. The trailer is equipped with a Gates control console, two Gates 1201 turntables, and a Gates cartridge machine.

The trailer is also equipped with several different microphones to facilitate ease of operation. The disc jockey has a microphone inside the trailer that allows him to work undisturbed, and there is a Master of

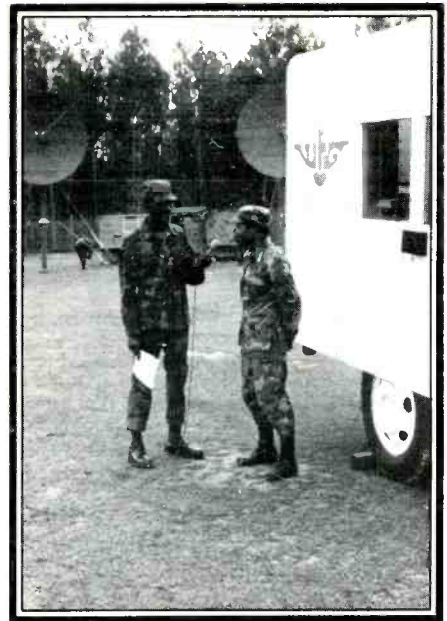

Some of the programming at WFG consists of interviews with military personnel stationed at Fort Gordon.

Ceremonies microphone plugged into a connector on the side of the trailer. Two wireless microphones have also been installed and future plans call for an RF amplifier and splitter to enhance wireless reception.

The public address system consists of a Peavy 300-watt amplifier and four Peavy 100-watt speakers. To reduce set-up time, engineers have installed a wiring harness at two pavilions where we frequently provide entertainment.

For indoor parties, WFG has a portable cabinet with two turntables and a built-in control console. Wires are run from the control console to the Peavy amplifier in the trailer, and then the signal is sent back inside to the Peavy speakers.

Because of the size of Fort Gordon's broadcast area (approximately 8,000 acres), WFG has found it expensive and troublesome to maintain a carrier-current system. Some of the problems encountered include intermodulation between adjacent transmitters (requiring some transmitters to be operated at 630 and 650 kHz), interference from power transformers, lack of above-ground power lines in some areas, and the unavailability of telephone lines to carry the signal.

To solve some of these problems, WFG has obtained the services of a military consulting engineer who, in his spare time, has conducted many of the required studies. WFG is also applying for permission to install and operate an educational FM stereo radio station. The application is under review at the Department of the Army.

Being the "Home of the Signal Corps," it's fitting that WFG and Fort Gordon should be the trend-setter in the field of military broadcasting.

QSL's will be sent to anyone who sends a correct reception report to: WFG Radio, Public Affairs Office, Fort Gordon, GA 30905.



Major international broadcasters all have QSL cards that they offer to listeners.



Most hams have QSL cards and these can often verify countries which could not otherwise be QSL'd. The problem is that many hams won't QSL reception reports.

# QSL's – What?

## Ten Good Reasons Why You Didn't Get That Special QSL Card!

BY TOM KNEITEL, K2AES, EDITOR

Are you getting a respectable return of QSLs from your reception reports? What do you consider respectable—40%, 50%, 75%, or 100%? Many times I find that conversations with DX listeners reveal complaints about the results they've gotten from sending out reception reports and hoping to get a verification (QSL) card or letter in return. It's a touchy subject and I've heard some very long and sad tales of woe—the one that got away and that sort of thing. Some DX fans easily hit the boiling point when it comes to QSLs, either bemoaning the ones they should have gotten but didn't, or the ones received by other listeners which they couldn't themselves snag. As one who has had a couple of decades worth of QSL fortunes and misfortunes, I suppose my opinions are as good or as bad as anybody else's.

The art and science of QSLing goes back to the very earliest days of radio. When the first ham operators and broadcasters were taking to the airwaves and the first listeners were seated at home with their cat's whisker receivers, it was as big a deal to hear a distant (DX) station as it was to be the operator of a transmitter which was "getting out" for a few

hundred or a thousand miles. At some point, an unknown hero thought up the idea of the parties involved exchanging postal cards to commemorate the accomplishments of both the receiving and the transmitting stations. People could then prove to others that their (usually homebrewed) equipment was capable of contacting or hearing stations across the continent or the county, or even overseas. These postal cards came to be known as QSLs and they invariably adorned the walls of the stations involved in the pioneer communications.

As time marched on, QSLs seemed to become a regular part of the radio scene, and collecting them from all stations worked or heard became quite important. Long after the pioneer days when the cards were used to celebrate the fact that both parties were awestruck that their signals were heard over a particular distance, they had evolved into something more than that. Yes, they still (in some cases) were proof of some unique or rare DX achievement, but more than that, they were exchanged as a courtesy or souvenir between stations in contact or as a result of reports from listeners. Indeed, CB operators even like to swap them by mail and in

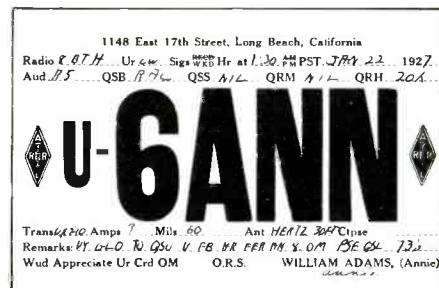

QSLing goes back to the early days of radio when operators seemed amazed that they were actually "getting out."

person at their get-togethers.

Insofar as they are used within the monitoring hobby today, they are sought after by listeners to acknowledge their reception of signals from various stations. These stations can include shortwave broadcasters AM/FM/TV broadcasters, hams, and all sorts of other stations. The QSLs (which can be in card or letter form) are sought after in response to a reception report. All of this is not without its definite problems, hence the complaints and squawks from within the ranks of hobbyists.

### Ideally Speaking

Ideally, a proper reception report to a broadcaster should contain the date and time of the reception, the frequency monitored, a complete and highly detailed description of the programming monitored for a 15 to 30 minute period, and full information about the strength and quality of the signals (including information on any signal fading noted). Program information should include names of songs and advertisers, news topics discussed, etc. In all cases, a summary of the receiving equipment you are using should be provided. It's question-

able as to how much practical value (if any) this will have to a station that receives the report, but nonetheless it has become the basic formula for a proper reception report intended to solicit a QSL card from a broadcaster.

Where the problems come in is that some stations simply never send back a QSL after you've gone through all of the trouble of listening to them, writing out a report, and spending the postage to mail it to them. What nerve! This can be frustrating to many listeners who had high hopes of verifying the reception of a special station, either for their own personal satisfaction, for bragging to other DX fans, for using in a competition, or for qualifying for DX accomplishment awards offered by various radio clubs or publications.

Between the dream of sending off a report and the stark reality and realization that no valued QSL is forthcoming in response is a world filled with traps, dead ends, disappointments, and glitches. Permit me to enumerate ten common problems of some of the pitfalls I've noted. You can then better assess your chances of surviving the QSL wars without grief and hassle.

### What's Working Against You?

1. Some stations simply don't verify reception reports as a matter of policy and there may be a dozen reasons behind that policy. Broadcasters, for instance, are not primarily operating for the purpose of verifying reception reports. Those who do verify reports perform the service as a gesture of goodwill, for public relations purposes, or as a reason to add the listener's name to their mailing list. In any event, it's all secondary to their primary mission of broadcasting. A good way to find out if a particular broadcaster will verify reception reports is to look it up in the *World Radio TV Handbook (WRTVH)* since that book often tells the policies of the stations listed. If it is silent on a station's policy, or if it says that QSLs are not issued, then it is a waste of time to bother seeking one. Many listeners nevertheless think that surely the station will make one exception and so they send a report anyway. If you're a gambler then be my guest, but don't get into a snit if they shun your request. On the other hand, there are those rare listeners who have actually succeeded in lucking out with a few of these stations over the years. I have not been one of those people the few times I tried.

2. Even stations that normally do QSL may temporarily suspend issuing QSLs because of financial or staff problems, or because a shift has taken place in the political structure of the country. If you've sent a report to a station that normally QSLs and have gotten no results for your trouble, try again in a few months. Keep in mind that the mail service in some nations is not especially dependable and your original reception report may never even have reached its destination. But also don't write a station off the books because you haven't heard from them



Pirate broadcasters may QSL but some who say they will don't have a good track record.

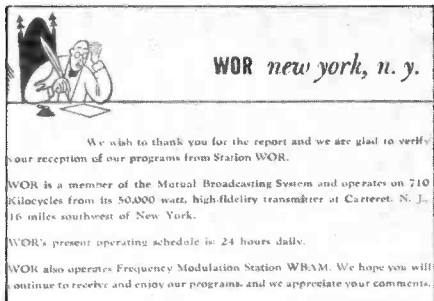

Broadcast band stations sometimes have actual QSL cards, but most seem to send a QSL letter.

within a week or two. I've had QSLs arrive as much as a year or two after the original report was sent. Allow at least 8 to 12 weeks before expecting a reply to a reception report; 5 to 6 months before you start thinking that you've been stiffed.

3. At least 25% to 30% of the reception reports received by major international broadcasters are unworthy of receiving a QSL. They contain no specific program data or else what is presented is so vague or ambiguous that it can't be matched up with the station log. Some DX stations get a larger percentage of crummy reports, plus many reports which are outright, blatant, and deliberate phonies. There are stations that will send out QSL cards or letters in response to any report (even phonies) sent to them; they do it to keep the goodwill of the person who sent in the report, to hopefully cultivate a liking for some political point of view they're promoting, and/or because it really makes no difference to them at all if the report is accurate, inaccurate, falsified, vague, or for some other station entirely that has been put in a wrong envelope by mistake. Indeed, I once received a QSL from Cuba in response to a report which I made out to The Voice of Israel and incorrectly addressed to Radio Havana! There are some self-respecting stations which either ignore a vague, incorrect, or deliberately falsified report or will send back a letter refusing to verify. In my own case, Radio Havana, which received the report I had intended for the Voice of Israel, politely returned the material I had sent them in error and pointed out my goof.

4. The actual value of reception reports sent to many broadcasters is minimal except if they are using new equipment, or a new antenna, or are on a new frequency or schedule. Radio Moscow already knows that its North American service is usually

### DX ANTENNA TUNER KIT

(Similar to unit described in July issue)



All parts needed to build kit **\$14.95**

### VHF CONVERTER KIT

Receive any 4 Mhz segment between 60-230 Mhz

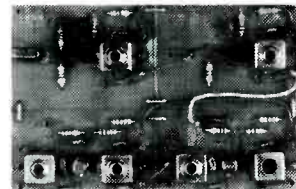

TUNE IN AIRCRAFT, VHF HAMS AND PUBLIC SERVICE ON YOUR SHORT WAVE SET

Complete kit with instructions less crystal **\$25.95**

BUILD RECEIVERS, TRANSMITTERS, TRANSCEIVERS, VOICE DESCRAMBLERS

Send For Hobby Kit Brochure

**MORNING DISTRIBUTING CO.**

P.O. Box 717 Hialeah, Fla. 33011

CIRCLE 23 ON READER SERVICE CARD

## MARTIN TOWERS

See the difference - the way it looks

- Glistens in Sun - shines in moonlight
- Exceptionable beauty and durability; enhances one's home or business
- Thoughtful engineering - all bolted - no welds to break - strongest aluminum tower made
- Easy to transport, export, store, install, repair
- Hazer accessory raises and lowers equipment and brings things down to ground level

Others will see the difference in your Martin Tower and envy the investment value. By adding the Hazer, tower climbing is needless. The HAZER brings equipment down to ground level keeping it in upright position for maintenance, tuning, calibration. Flexible use with wide variety of antennas, lighting, meteorologic or other scientific packages. Find out why the biggest difference in Martin Towers is the way it looks.

Send self-addressed stamped envelope today for information.

**Glen Martin Engineering, Inc.**

Box P253, Boonville, Mo. 65233  
816-882-2734

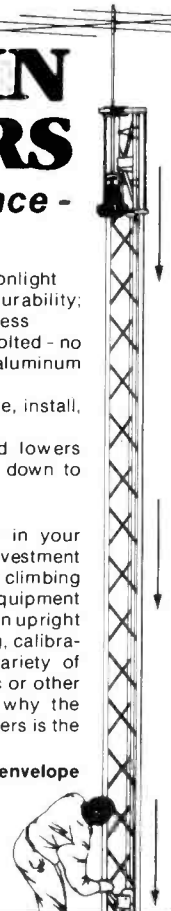

CIRCLE 66 ON READER SERVICE CARD



Commercial communications stations heard on the international bands seldom QSL unless they are furnished with a prepared card to sign and return.

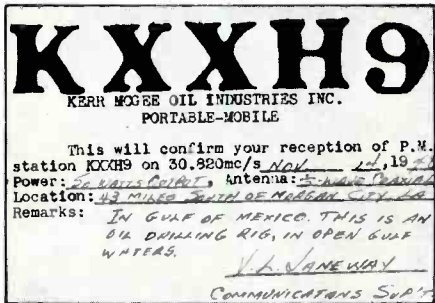

Industrial communications stations used to be much more liberal about QSLing than they have become in recent years. In any event, they would require a prepared card.

heard fairly well hereabouts. The Voice of America is also reasonably well assured that their transmitters in the United States can be heard here and since they don't present programming directed to American listeners, they frankly don't much care that listeners in this country can hear them. A 250 watt AM broadcaster 2,000 miles from your location is indifferent to the fact that they can be heard outside of their own county even though the listener who picked up the station at a great distance may be foaming at the mouth in ecstasy at his accomplishment. Likewise, 50,000 watt clear channel AM broadcasters such as WLW, WWVA, or WOAI have had reception reports from Albania to Zaire; it's no big news to them to know that you heard them in Wisconsin or Louisiana. Again, you're banking on the station's desire to cultivate your good thoughts about them or else their interest in seeing you achieve success and satisfaction with your hobby. If they are neither interested in your goodwill nor your QSL collection, then you've got problems. It happens. Most clear channel AM broadcasters will gladly QSL reception reports even though they tell the station nothing they did not already know. Smaller privately owned shortwave broadcasters, however, do generally appreciate reception reports and find them useful. Their major complaint is that some listeners tend to attempt to flatter them by falsely reporting their signals to be far better than the stations know they are. An honest report of a poor signal is of far more value to such a station in evaluating its coverage than a phony baloney "pinning the needle" or "20 over S9" report which they know is illogical and impossible.

TERRITOIRE DU CAMEROUN

POSTES  
ET  
TELÉCOMMUNICATIONS

N° 070/TR-V

RÉPUBLIQUE FRANÇAISE

Liberté - Egalité - Fraternité

Douala, le 19 JAN. 1957.

Monsieur,

J'ai l'honneur d'accuser réception de votre rapport de réception de la station radioélectrique de Douala (Cameroun), et vous en remercie.

Veuillez trouver ci-joint, en retour, votre carte QSL.

Croyez, Monsieur, en mes sentiments très distingués./-

P. LE DIRECTEUR  
L'INGENIEUR EN CHEF, DELEGUE

*[Signature]*  
M. MERCIER

Monsieur TOM KNEITEL  
97-10 62 ND Drive Rego Park 74 NEW-YORK (United States of America)

Many smaller nations don't necessarily relate to English language reports.

5. Furnishing return postage for getting a QSL from a government-owned broadcaster is seldom necessary. Many small, privately-owned stations, however, are willing and able to supply a QSL only upon the condition that the listener furnish some form of return postage. This can either be in the form of uncanceled stamps from the nation in which the station is located or else it can be in the form of an International Reply Coupon (IRC) which can be purchased at most post offices. Even though some stations actually request that return postage be supplied, they get a surprising number of QSL requests from listeners who don't send the postage. This is either because they did not know the station's policy or because the listener figured that he or she would omit the postage and hopefully the station would send the QSL anyway for the sake of goodwill. There are also listeners who send uncanceled stamps from their own nation under the mistaken impression that they can be used to mail out a QSL card or letter to the nation where the stamps are from. It doesn't

work that way. A letter being sent from, say, Bolivia, to the United States or Canada cannot use American or Canadian postage stamps. Such stamps are worthless for this purpose. One way or the other, many listeners have their otherwise worthwhile reception reports ignored because they should have sent return postage but didn't. The WRTVH sometimes advises if return postage is required. If it doesn't specify one way or the other, my policy is to include an IRC to any station that is not operated by a government agency. Undoubtedly I've wasted IRC's being sent to stations that didn't require them, but I balance that against the QSLs I've obtained and I think I've come out ahead in the long run.

6. Stations that are neither broadcasters nor hams are usually classified as "utility" or "ute" stations. This would include stations heard on a scanner, or CW, SSB, RTTY stations, or ships, aircraft, military, commercial point-to-point, and stations that communicate with ships and aircraft. While it is possi-



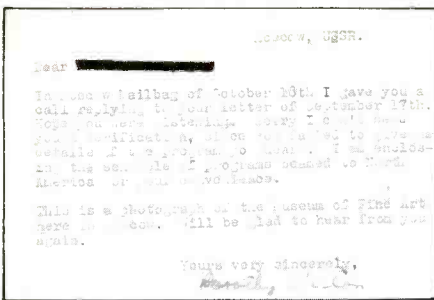

Sometimes a QSL is refused because the listener made an honest error in station identification and reported to the wrong broadcaster. Other times, as shown in this postcard, a QSL is refused because the reception report is too vague.

ble to obtain verifications from such stations, it isn't easy—in fact, it's a whole new ball game. Yet many who have decided to embark upon the QSL route blissfully send off reports to such stations as if they were broadcasters and then squawk when they get no response. Few of the ute stations will respond to a reception report that does not contain a prepared QSL card enclosed by the listener that the station can sign and return (postpaid). Ute stations don't usually have QSL cards, nor are they particularly interested in being monitored or hearing from people who monitor their signals. Reports to utes have nevertheless brought verifications from some fascinating stations. Your chances of getting a response are substantially increased when you include a reply card, furnish the postage, and *don't* include in your monitoring data the exact detailed contents of the transmissions you monitored. Just list the callsigns of the stations called or worked by the station you heard. Any other course of action will probably produce no results at all.

7. While many ham operators are very cooperative and obliging in responding to reports from listeners, probably far more fall into two other categories. Category 1: Those who may respond to certain reports from listeners (perhaps listeners in other nations). Category 2: Those who consider all listener reports to be a nuisance and who aren't inclined to reply to any of them. In just about all cases, those who do respond to listener reports (SWL reports) do so out of the goodness of their hearts and not because the reception reports serve them any useful purpose. Moreover, rare DX stations are inundated with reports from listeners and would soon run out of QSL cards and postage money if they attempted to acknowledge those reports. Again, however, sometimes a ham station in a particular location may well be the only way of verifying a nation you need for an award—or, you may just be into monitoring the ham bands for the enjoyment those frequencies have to offer. Your success will be increased if you send your report to the ham by means of an "SWL card" rather than a letter and also include return postage. Most QSL card printers offer SWL cards—check their ads in ham publications such as *CQ* magazine.

8. It sometimes seems inconceivable to

Americans that not everybody in the world can read and write English. While reception reports in English are readily understood by a great many shortwave broadcasters, there are plenty of stations that are unable to make heads or tails out of an English language reception report and therefore ignore all such reports. This seems to be especially true with smaller privately owned broadcasters located in Central and South America. While a report sent to them in Spanish may well bring a beautiful and colorful QSL, an English language reception report is often a total waste of time and postage.

9. Notwithstanding any of these factors, there are stations that actively solicit reception reports and announce an address where to write for a QSL. Despite this they somehow don't send back the QSL when a report is provided. Perhaps this is because of oversight, neglect, laziness, or because of outright deceit. It's an old story. American pirate broadcasters receive more complaints directed at their QSLing policies than any other category of stations, although one cannot condemn them *en masse* since some have been quite attentive to QSLing. The American shortwave pirate known as The Voice of Democracy (7418 kHz) is typical of the stations that announce a QSL address over the air but don't seem to have any intention of responding with a QSL. There is really nothing you can do about such a situation except take your chances and hope that the station will have some integrity.

10. Many reception reports to stations that might otherwise look kindly towards QSLing don't succeed because the report never got there due to an incomplete or incorrect address on the envelope. Addresses of ham stations are provided in the *Radio Amateur Callbook's* two volumes, one for the U.S. and the other for stations outside the U.S. Shortwave station addresses can be obtained from the *WRTVH* and also from books published by Gilfer Shortwave (P.O. Box 239, Park Ridge, NJ 07636). Also, check out *POP'COMM* and various radio club publications such as those issued by *FRENDX*, *ASWLC*, *SPEEDX*, and *ACE*.

If you keep these things in mind you'll quickly see that QSLing is dependent upon many variable factors and there are no guarantees. The best you can do is hope to tilt the scales of fate in your direction. Never forget that because of some of the factors I've enumerated here, a QSL card does not offer 100% proof that its owner actually heard a particular station, just as the lack of a QSL card is not necessarily a way of proving that a station was not monitored. In any event, QSLing is merely an adjunct to the hobby of listening or monitoring and it certainly doesn't pay to get hot under the collar about such matters. Listening should be enjoyable for its own sake; when and if you get to the point where you're chafing and steaming because you didn't get a QSL that you wanted, then maybe it's time to re-examine your perspectives and decide if this hobby is bringing you the enjoyment and relaxation you had originally hoped it might.

## "INSIDER'S INFORMATION"

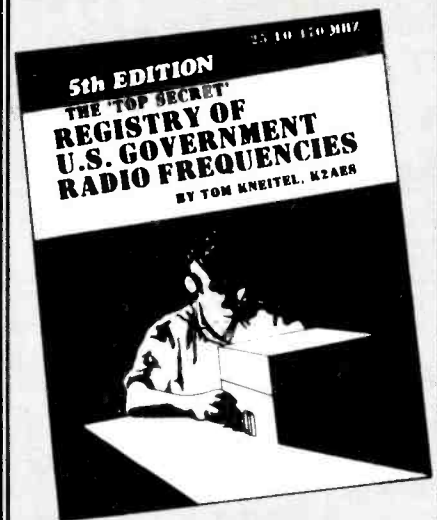

Since 1967, CRB Research has been the world's leading publisher and supplier of unique hobby and professional books and information including:

- Scanner Frequency Guides
- Shortwave Frequency Guides
- Military/Federal Communications
- Broadcast Station Registries
- Undercover Communications
- Survival Communications
- Covert Operations
- Electronic Espionage
- Surveillance
- Monitoring
- Cryptography & Codes
- Bugging
- Wiretapping
- Communications Antennas
- Electronics & Projects
- Authentic Combat Communications Cassettes
- & Other Related Topics!

New titles are constantly being added to our exciting catalog. If it's interesting and unusual, we've got it. You'll see! Ask for our latest FREE catalog!

**CRB RESEARCH**  
P.O. Box 56 Commack, NY 11725

# EQUIPMENT REVIEW:

## The Sony ICF-2002 Receiver

Sony's new ICF-2002 is not likely to induce masses of shortwave listeners to trade in their Yaesu or ICOM receivers, but it definitely fills a gap in the radio marketplace. It is not used for base station DXing of a serious nature, but it is an extremely portable radio that can bring the world of shortwave to places far removed from the traditional listening shack. And it is likely to make shortwave radio more accessible to the mass of potential listeners intimidated by the bulk and complexity of most shortwave rigs.

Because of its model number, the ICF-2002 is often compared by potential buyers to the earlier ICF-2001. This is unfortunate because the two are very different radios that have different capabilities and markets. While the 2001 was sold as a general purpose receiver in competition with such models as Panasonic's RF-2900 and RF-3100, the 2002 is aimed at the traveler or the non-technical person interested in the content of international broadcasts rather than the ability to pick up many obscure signals.

When looking at the 2002, its most obvious feature is its size, which is 18x11x3 cm., or 7"x4½"x1¼". These dimensions place it squarely in the realm of the pocket portable, even though only the largest pocket will accommodate it. In spite of the 2002's small size, the controls have been well-designed to facilitate easy use. The buttons on the keyboard are amply large, and many controls have been placed on the sides to make room for the very readable frequency display and clock.

The 2002's orientation toward the less-technical listener becomes evident when the tuning sections are analyzed. Though the receiver incorporates full coverage from 153 to 29995 kHz, plus the 76 to 108 MHz Japanese FM band, not all frequencies in these ranges can be tuned. For instance, longwave is accessible only in 3 kHz steps (153, 156, 159, etc.). If you enter a frequency that is not a multiple of three, such as 158 kHz, the receiver simply rounds it down to the next-lowest "allowed" frequency, which in this case is 156 kHz. Similarly, medium wave can be tuned in either 9 or 10 kilohertz steps (switchable), and shortwave tunes in increments of 5 kilohertz.

It is important to note, however, that a fine tuning control is included, which permits reception of all frequencies the digital system skips. But there is no frequency

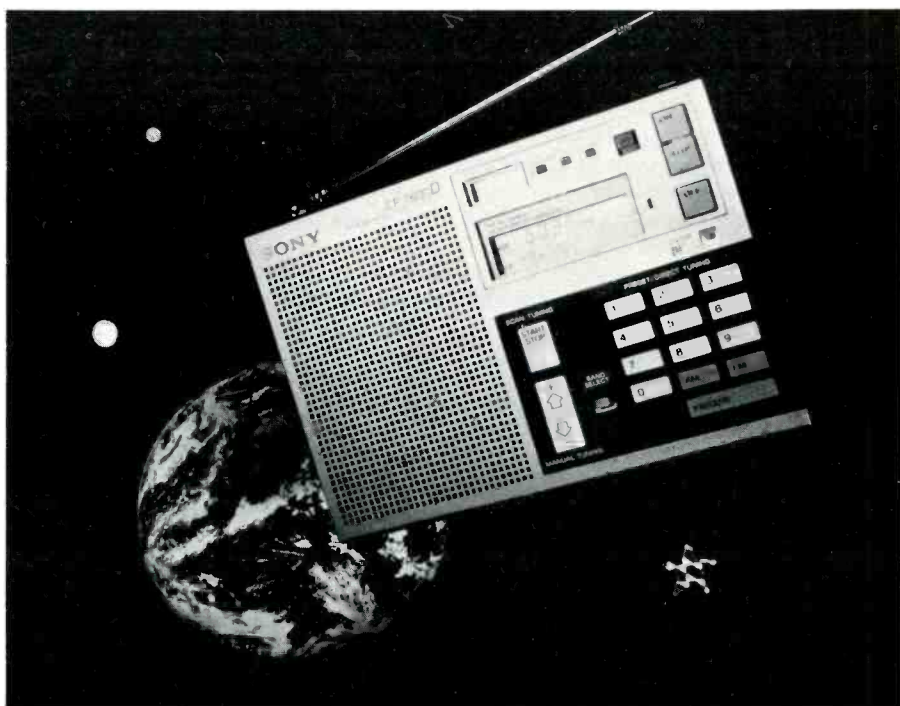

*Sony ICF-2002 is a welcomed new addition.*

readout of where the fine tuner has moved you. For international broadcasts, this tuning system is fine because most of these stations fall on the frequencies directly tuned by the radio. But for ham, RTTY, or other non-broadcast communications, it is not accurate enough.

Aside from the direct-entry tuning, the 2002 also permits manual and automatic scanning, plus memory presets. With auto-scan, you just push a button and the receiver searches for signals, waiting for 1.5 seconds at each one to give you a chance to hit the stop button if you like what you hear. Auto-scan tends to stop only at the strongest signals, though, and can also be stopped by strong interference, rendering it less-than-perfect. The manual scan simply lets you scan up or down the frequencies by pressing a switch on the front of the radio. If you hear something interesting, just release the switch and the radio stops scanning. Finally, the memory presets let you store ten frequencies for recall at the touch of one button.

Regardless of the tuning system, shortwave listeners will be most interested in the radio's performance as a receiver. This can be difficult to judge objectively, in view of

differing reception conditions and possible irregularities of interference from one test to the next. To try to eliminate these variables, I compared the 2002 side-by-side with some receivers selling for comparable prices: a Panasonic RF-2200 and RF-2900, and a Radio Shack DX-400.

In the initial test, the 2002 consistently returned a slightly weaker signal than any of the other receivers. This turned out to be due to its whip antenna, which is considerably shorter than that of its competitors. When all four receivers were connected to the same longwire antenna, their reception was approximately equal. The 2002 even exhibited superior reception at times on the 16 and 13 meter bands. A longwire antenna, however, is rather inconsistent with the 2002's usefulness as a portable. So I searched for more practical ways to improve reception.

The best improvement measure turned out to be the use of the AC adapter or the battery pack. Apparently, the 2002 uses the wires leading from these accessories as additional antennas, improving signal capture. Incidentally, the battery pack, which uses 4 cells, is included with the radio, while the

AC adapter is an extra-cost option.

Using the adapter or battery pack, the 2002's performance moved into the same league as its competitors, which is to say very respectable. With the 2002 and its battery pack, I was able to achieve regular reception of Radio Korea (South), Radio Norway, and Voice of Turkey, all of which presented some problems for me in the past. Naturally, reception of all the international big-time broadcasts (BBC, VOA, Radio Moscow, Deutsche Welle, etc.) is very clean and interference-free.

The shortwave section is also quite selective and stable. On all but the strongest signals, there is no adjacent channel interference. This makes it possible to scan through, say, the 19 meter band, and hear station after station. And stability, crucial for intelligible reception of single-sideband, is very good. Once an SSB signal is tuned, it rarely has to be adjusted. Stability, in fact, was much better than on the two Panasonic radios, and equal to the Radio Shack model, which is another direct-entry receiver.

Good selectivity and stability also carry over to medium wave (520-1616 kHz), but sensitivity on this band could stand improvement. The other three receivers, especially the Panasonic RF-2200 with its rotatable medium wave antenna, produced cleaner, stronger signals on this band. Medium wave performance is fine for normal use as a radio receiver, but DXers of this band might look elsewhere.

Similar comments apply to FM. Reception here is pretty good, but it's not the best available, either. FM performance improved significantly, though, when I connected the receiver to an external FM antenna. The length of the built-in whip again proved to be a handicap to optimum reception. The 76-108 MHz Japanese FM band is a convenience for travelers to the Orient, but it's not of much use in North America.

So the ICF-2002 fares very well as a receiver, even when compared with models that are much bigger and less convenient to use. The shortwave section performs admirably, and medium wave and FM are nothing to be ashamed of. Longwave (153-519 kHz, on the 2002) is also included, but I had little opportunity to test it since no signals were present. Other longwave receivers used at my location have performed similarly, though, so the lack of reception is no indictment of the 2002.

In terms of general convenience and ease of use, the 2002 shines above the pack of shortwave radios in general. The 12/24 hour clock is a thoughtful addition, since it can be set for UTC time to simplify finding the right programs at the right times. The clock also incorporates a standby function, allowing you to use the 2002 as a clock-radio—either to wake you up or turn on when a desired program comes on the air. Additionally, the radio has a sleep mode which provides automatic shutoff after 65 minutes of operation.

While the radio is powered by 4 batteries, the clock and station memories are sepa-

rately operated by two more cells of the same size. Because the clock and memory batteries are likely to last much longer than those powering the radio, the need to often reset the clock and reprogram the memories is eliminated.

Also on the topic of batteries, Sony seems to have solved the battery consumption problems of the 2001 in the 2002. While the 2001 virtually ate batteries, the 2002 is much more reasonable in its battery consumption. Sony estimates the battery life at 12 hours, assuming 4 hours per day of use. By listening less than this, the life can be, of course, extended. The batteries have been in my set for about 20 hours, and I've experienced no significant performance decline. My internal batteries are only used about 20 minutes per day, though.

Audio quality is fairly good for a receiver of the 2002's size, and the 400 milliwatt power output is sufficiently loud for most uses. Insufficient volume may be a problem, however, if the radio is used in noisy locations or where it must be heard from a considerable distance. The tone is controllable only by a high/low (music/news) switch, and the sound is delivered through a speaker of just under 8 cm., or slightly over 3 inches, in diameter.

Some of Sony's small radios have a stand built-in to the back, allowing the receiver to be leaned back at an angle for more stability and easier use of the controls. This would be

a welcome addition to the 2002. As it is now, the radio tips very easily when in the upright position, and must be supported from behind if the controls are to be used. Leaning the antenna to one side makes the radio even more unstable, upsetting at even the slightest nudge. Though tipping is usually not a serious problem, listeners should take care not to place the radio anywhere tipping could result in a fall from a table or other high place.

Sony's ICF-2002 carries a suggested retail price tag of \$249.95. The price includes the receiver, a battery pack, a cloth carrying case, instruction manual, and a shortwave book. Some U.S. dealers also sell the ICF-7600D, which is simply a 2002 intended to be sold in Europe. There are no technical differences between the 2002 and the 7600D, so all comments about one apply equally to the other.

The ICF-2002 is a very good receiver, even when its size is not considered and it is compared directly with larger radios. When its size is figured into the equation, it quickly becomes excellent. For the non-technical listener, it allows reception of desired broadcasts with a minimum of hassle. For the seasoned shortwave listener, it mobilizes the previously-homebound hobby. It is an excellent buy and a valuable contribution to the shortwave scene.

**Review by Ken Wickliffe**

## POPULAR COMMUNICATIONS

### Back Copies

*At present we have copies of all of our back issues available, commencing with the first issue (September '82). These can be ordered by mail at \$1.75 each from Popular Communications, 76 North Broadway, Hicksville, NY 11801. Be sure to specify which issues you want to order.*

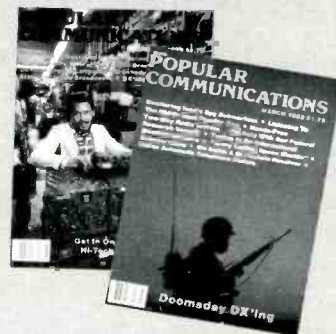

## You're Invited . . .

The Southern California Area DXers, American Shortwave Listeners Club, and Association of North American Radio Clubs will be joining forces to promote the DXing/Shortwave Radio Listening Hobby to the general public. Titled "SCADS Goes To College," this special one day event will take place on Saturday, May 12, 1984 from 9 a.m. to 4 p.m. at Golden West College, Golden West at Edinger, Huntington Beach, California as part of the GWC Community Festival '84. There will be a shortwave receivers display to hear broadcasts from around the world, radio club and equipment/receiver information, and plenty of helpful folks on hand to answer questions about the hobby. The Festival also offers free parking, free admission, an arts & crafts area, an international foods section, and entertainment throughout the day. DXers and SWLs are invited to bring family and friends to attend this once a year extravaganza. See you there!

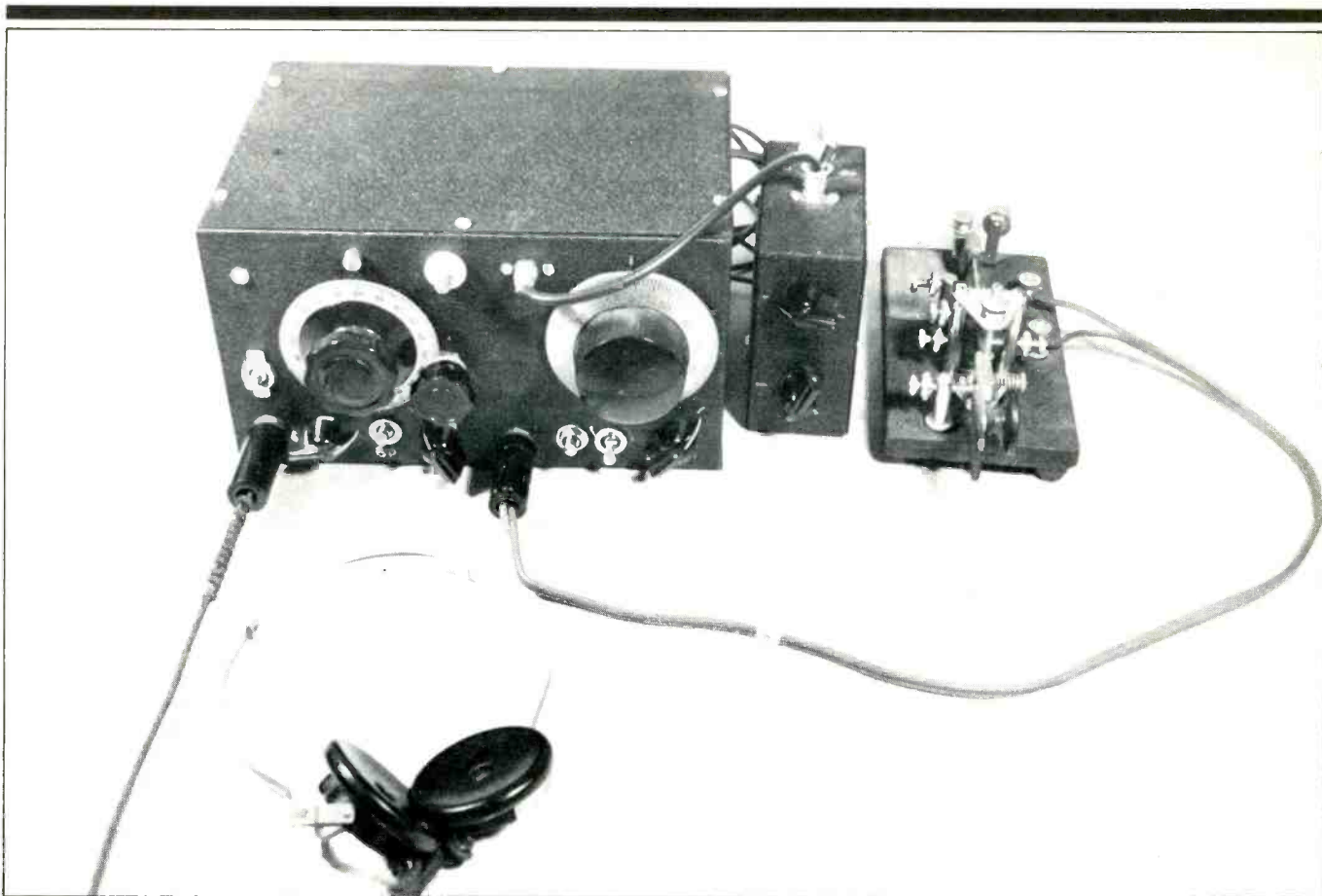

***We Beam In On The Elusive Mystery With  
A Serious Analysis***

# NUMBER TRANSMISSIONS

BY ROBERT M. DYQUETTA

**M**onitoring and investigating the Number Transmissions can be a fascinating, time consuming, and frustrating endeavor. Where do they come from, what do they mean, who is behind them??? Answers to these and other questions have been the cause behind the quest of number investigators since the mid 1960's.

Exactly when the number transmissions began is not at all certain. This uncertainty is due, in part, to their similarity to a World War II weather reporting system. During the war, the U.S. military established a weather observation network that was scattered throughout the Caribbean and Central and South America. Weather data was transmitted by radio, and in order to prevent its usage by the enemy, the data was encoded. This simple substitution system was composed of 5-digit groups. Each group depicted conditions for one specific site, and they were transmitted in a 3 and 2-digit fashion.

Today, the 5-digit format is the standard worldwide meteorological reporting system known as 5-figure metro.

After WWII, the metro system was regularly heard in voice, Morse code, and radioteletype modes. Military forces likewise used coded message groups. Combined, few utility monitors paid but scant attention to these types of coded broadcasts.

The turning point came shortly after Fidel Castro ascended to power in Cuba (1959) and the tragically botched 1961 CIA/Anti-Castro operation known as the Bay of Pigs invasion. By the mid-1960's, utility monitors were encountering several distinctive types of coded group transmissions whose format and frequency usage denoted something other than metro broadcasts and encoded military traffic. The efforts of the early pioneering monitors laid the foundation for the unique and specialized group of devotees, known today as the number monitors.

Number transmissions come in several formats, making them readily distinguishable from one type to the other. Language, gender, transmission mode, and element grouping are the most easily recognized attributes, with s/on ident or pre-message sequence being the other trademark. For some of the very active monitors, merely hearing the vocal characteristics is (for them) enough to identify the number type. All it requires is a familiarization of the distinguishable transmission traits peculiar to each class of number type. I might add that although voice mode is the most readily monitored, there is, likewise, a healthy Morse code family of number type transmissions. These CW transmissions have only recently attracted the attention that they deserve.

The widespread interest in the number transmissions is largely the result of media type exposure. Without this coverage, the number transmissions would be a very ob-

scure part of utility monitoring. Fortunately there are several excellent sources of information; articles, reader comments, and regular columns can be found in the mass media publications, such as *Popular Communications*, SWL club bulletins including *ACE*, *ASWLC*, and *SPEEDX*, with number loggings included in their respective utility columns. These are invaluable sources for the dedicated number buff, and they provide a variety of data and speculative material to aid in the buff's own probings. It is through these combined efforts that the answers will someday surface. In the meantime, we continue to acquire data, analyzing and hypothesizing in an effort to fit pieces together in this very mysterious radio jigsaw puzzle.

The prevalent theory among number buffs is that these transmissions are part of intelligence operations—messages or instructions to agents in the field—or to put it simply, “Spy” transmissions.

### **Spy Transmissions?**

The cloak and dagger assumption has much going for it. None of the frequencies in use are identifiable in government or ITU registry listings. No government, nor agency of, has admitted their involvement. In fact, inquiries usually produce replies which are vague and often contradictory. The seemingly haphazard arrangement of numbers, letters, or alpha-numerical groupings all denote encoded messages. The lack of internationally recognized call letters or voice idents likewise denotes a clandestine mystique. All in all, the evidence seemingly points to well organized, highly secret clandestine type operations.

One dedicated number investigator (along with his group) did, as a *Monitoring Times* article related, actually RDF German language number transmissions to Nauen, East Germany. This though has not fully answered the question. QSA/QSB analysis of the GG/YL transmissions has shown that a percentage are definitely coming from within the western hemisphere. To complicate matters, the EE/YL (English/Female) number transmissions have so many similar characteristics as the GG/YL type that they are believed to be the same operation. By contrast, the very popular SS/YL types (Spanish/Female) exhibit QSA/QSB characteristics that place the majority to be transmitted from within the United States. But as these investigations tend to geographically isolate many of the number types, their other obvious transmission parameters defy the rationale of their being intelligence/spy related.

All number types have a very common characteristic . . . they all adhere to a very rigid, day-time-frequency schedule. This DTF pattern is blatantly obvious, so much so that if you had the time, you could monitor and establish a day by day, 24-hour transmission schedule for any of the number types. This rigid DTF patterning seems very incongruous with intelligence criterias.

From a time line aspect, most number transmissions start their initial transmission

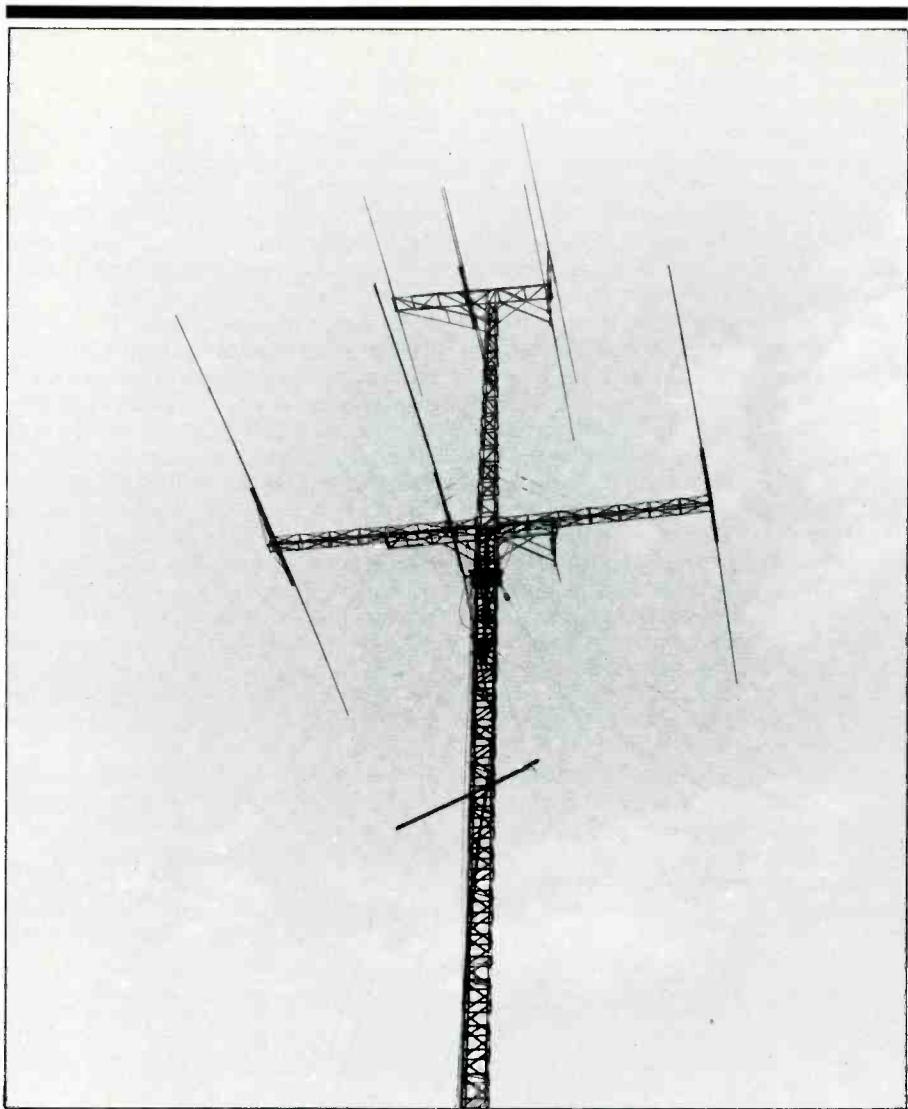

*Numbers transmissions are beamed to someone somewhere. But who and where and where do they really come from?*

sequence on the hour, or at a specific time within the hour. All have an s/on sequence that is repeated at a two, five or even ten minute duration prior to the coded text transmission. The predominant use of the on-the-hour start is mildly absurd from an intelligence standpoint. Predictability in cloak and dagger operations is never the norm, yet more than 75% of all number types start like clockwork on the hour. It is as if the number transmissions ascribe to the precepts of a radio version of *TV Guide*.

All number transmissions repeat the initial message; it is very logical in case part or all of the first transmission was missed. This is either accomplished as an immediate rebroadcast of the text (same frequency), at a later time and frequency, or during a different DTF period. What is most illogical is to repeat the exact same message over and over again. In the mid-1970's, one “number” investigator found a 5-digit SS/YL transmission being repeated exactly digit for digit, 7 days a week, same time and frequency, for almost 180 consecutive days. More

recent transmissions show similar repetitive patterning, with some utilizing the same weekday DTF for 12 consecutive weeks. The 5-digit SS/YL transmissions appear to be the rerun queen of the number transmissions. Then too, an actual message would be considered to have a relevant and short time line usefulness. To illustrate: “meet agent Z at point X, 0300 hours Thursday” . . . This message's value ceases at 0300 hours on Thursday, and any further transmission of it is a waste of time. Of the repetitive multi-month rebroadcasts of the 5-digit SS/YL transmissions, the assumption must be made that many of its messages have no time line limitations to them at all. To put it more simply, the bulk of these transmissions are relaying nothing of immediate usefulness, nor in the long run are they saying anything of value. Even if the same message required extended rebroadcasting, isn't it more rational to reconfigure the plain text so as to hide that fact when its encrypted text is transmitted?

The 5-digit SS/YL transmissions have

another remarkable feature. As of this writing, these are the only type of transmissions that run upwards of four different transmissions all during the same hourly period, starting on the hour. The 5-digit setup transmits on one frequency, then several minutes later, or at plus 30 minutes, it repeats the entire sequence on a different frequency.

By contract, the 4-digit SS/YL setup utilizes two frequencies (similkey) and then immediately rebroadcasts the coded text on the very same similkey pair. One to six days later, the transmission is again repeated. Initial start is on the hour. Voice is not the same as the 5-digit female.

The 3-digit SS/YL uses the same voice as the 4-digit SS/YL. Frequency usage is also similkey. It has a 5 minute s/on sequence that consists of one-second interval time tones. At plus 30 minutes, an average of three to six 3-digit groups are repeated over and over until plus 40 minutes. Unlike most other voice transmissions there is no s/off. This type of number transmission only operates at widely spaced hourly periods throughout the 24 hours. When it is active during this time frame, it repeats the same message for each broadcast.

A Morse code transmission on 6840 kHz (0325 GMT start) is likewise odd. It has the same 5 minutes of time tones, then into very slow CW repeats of 4 element, alphanumeric groups (usually four groups). This CW transmission uses only a total of ten letters and numbers—A,B,D,E,N,T,U,V,4,6—

and runs until plus 40 minutes. It too has no s/off. No similkey frequency has yet been found, although the same transmission occurs at 1725 GMT on 18737 kHz.

The 5-digit GG/YL transmissions start on the hour with phonetic letter repeats. Each of its 5-digit groups are repeated twice in a row. Transmission is similkey. Formats vary, and some number types more than others appear to be what one would expect of an intelligence type operation.

Another very obvious facet of the number transmissions is the use of AM, A3H, USB, or standard type CW modes. Anyone with minimal utility experience and a simple SW receiver can monitor these transmissions. It is almost as if the number transmissions are deliberately designed to be heard by anyone. The transmitter carrier often comes up on frequency well before the start of the transmission—in some cases, as much as 60 minutes prior. Some are just of an open carrier variety. Others have distinctive electronic tone sequences, while a few even dry run several seconds of their number transmission at random intervals. Is this what one would consider to be a proper intelligence procedure?

Modern radio technology readily makes available a multitude of esoteric transmission modes ranging from frequency hopping, burst, to split frequency message segmenting. Even if the receptor of these transmissions has only a basic SW receiver, there are simple methods to secrete the transmis-

sion. For example: "at 0417, bring up the carrier; 0418, send a brief s/on ident sequence; at 0419 transmit the message. Immediately after transmission is completed, shut down the carrier." This DTF would not be used again in the same specific arrangement. The next hour, the sequence could be time lined: 0539, 0540, 0541, on a different frequency. Standard voice or CW can be used, but there would be no scheduled type of DTF pattern. The hallmark of a true "spy" type transmission is no discernible transmission pattern. But what *all* the number types are doing is just the opposite.

Granted, one can defend this illogical procedure. If the cipher is of a secure type, then even if the transmission is monitored, cracking the cipher would be only a very remote possibility. If you use different cipher tables for each transmission, the overall result is a relatively secure system. But why advertise your operation by adhering to a rigid DTF schedule and employing straightforward transmission modes?

Another common element with the voice mode transmissions is the splicing technique, known as electronic insertion. All voice mode number types employ a pre-recorded message format. Number transmissions, tape recorded years apart, are identical in their vocalization, as is each same element to one another. For example, the 5-digit SS/YL numeric "ocho" has the same time line duration and oscilloscope pitch/frequency pattern, no matter which ocho

# NRD-515 COMMUNICATIONS RECEIVER

## GENERAL COVERAGE 100 KHz. to 30.0 MHz.

**NOW THE ULTIMATE IS AFFORDABLE**

**PRICE BREAKTHROUGH !!!**

**NRD-515 Receiver .1-30 MHz  
\$949.00**

**NDH-518 96 Channel Memory  
\$235.00**

**NCM-515 Keypad Controller  
\$175.00**

**NVA-515 External Speaker  
\$45.00**



For more information on this or other SWL products write to:

**UNIVERSAL SHORTWAVE RADIO**

1280 Aida Drive  
Reynoldsburg, Ohio 43068  
Phone: 614-866-4267

The NRD-515 offers more features and performance than any other receiver in its class. Exceptional selectivity and stability make this an excellent radio for RTTY and FAX reception. Designed for the serious DXer who demands the best!

Please send all reader inquiries directly.

you scrutinize. This would be impossible if each message was actually spoken, recorded, and then transmitted over the air. What is being done is that the vocalizations are taken from a master source by which each element is electronically inserted onto the program tape to form a cohesively spoken message. This technique is quite apparent when you listen to many transmissions made by the same number type. The voice sounds mechanical, lacking any inflections of vocal variety. During some high QSA level transmissions, faint clicks can be discerned between spoken elements. Those clicks are the switching signature of electronic insertion techniques.

Most voice mode transmissions employ a female voice. The reason for this is quite logical. The female voice has a higher frequency pitch than the male, and the human ear can more readily detect higher pitch variances than lower pitch. This makes the female vocalizations easier to understand, especially if the transmission is weak, slightly distorted, or otherwise experiencing some outside interference. A more subtle reason is psychological. Men tend to pay more attention to a female voice.

The 5-digit SS/YL type is the undisciplined brat of the numbers world. Transmitter carrier overpowering the voice, poor modulation, on the air tape rewinds, start of one tape, stop, then start up of a different tape, plus other flubs. All tend to suggest that this type lacks operational discipline. In contrast, the 4-digit SS/YL type is a smooth, tight, professionally transmitted operation.

## A Common Thread

This brings us to the most subtle common thread that sews all the number types together.

*Question:* If various intelligence agencies (either within the same government or of different nations) decided to conduct a radio operation, what are the chances that *all* would adopt very similar basic transmission parameters? The answer—virtually none. Each would tailor its operation to the specific requirements dictated by said operation. Some investigators suggest that one is a deliberate mimicking of the other in order to confuse the situation. But would all choose to mimic the basic format of the other? The chances seem quite remote, and the only people fooled would be the uninformed, casual monitor.

So isn't it a most curious fact that all number types, regardless of specific language, gender, group arrangements, s/on sequences, and so on, all appear to be the same basic system? Think about this for a moment, especially those of you who are very active in number monitoring. Isn't there a gut feeling that what you are monitoring are just aspects of a single operation????

For years, dedicated number buffs have monitored, recorded, and examined one number type after another. Some have exclusively worked on just one type. To modify an old cliché, we've been so involved in

# SONY®

**ICF-6500W  
AM/FM WORLD BAND RADIO**

- 3 SW/MW/FM high performance, easy to use, world band receiver.
- LCD frequency readout for all bands.
- Dual conversion circuitry for increased sensitivity and reduced interference on SW.
- BFO for SSB/CW reception.
- Slow/fast tuning dial for quick tuning.

**EEB SCOOPS THE MARKET—**

**50% OFF**  
LIST \$199.95

**ONLY \$99.95**

**LIMITED TIME OFFER**





**Electronic Equipment Bank**  
5126 Mill Street, N.E.  
Vienna, VA 22180  
703-938-3550  
HOURS: 10-5 Tues, Wed, Fri, 10-9 Thurs,  
10-4 Sat, Closed Sunday and Monday

**800-368-3270**

Add \$3 for UPS

CIRCLE 26 ON READER SERVICE CARD

examining one or a few trees that we have failed to realize that it is part of the same forest.

I can offer no black and white proof to support this theory. There are indications that many number types are related. Some have very similar transmission specifics that suggest a common origin. By evaluating the total spectrum of similarities, intuition whispers that they are all part of, and interrelating within, a single operation. Exactly what this operation is, is currently unknown.

Some basic conclusions regarding number transmissions in general can be made. The secrecy surrounding these transmissions is very, very good. This tight and total security can only be accomplished via government involvement, because if it were of a commercial aspect, some civilian would have exposed the operation a long time ago. Only government agencies have the leverage to enforce secrecy on current and former personnel. Therefore, the number transmissions have something to do with national security. This though, does not mean that they are of an intelligence nature. There are aspects of business and commerce that are part of the national interest.

Another obvious fact is that some of the number types have been on the air anywhere from 15 to 20 years. This translates into a long term effort supported by a stable financial base, with a single minded determination to carry out operations, day after day, year after year, including holidays.

The number transmissions beg to be intensively investigated. Every angle of probing must be explored, be this via monitoring or through other non-monitoring aspects. It is not to say that the number buffs want to deliberately destroy (by exposing) these operations. The number transmissions themselves have compromised their very existence with their distinctive, scheduled transmissions. It is no secret which frequencies they employ, and coded messages can be recorded by anyone. Their transmissions are an open secret, available to anyone who takes the time and effort to seek them out.

What the number buffs seek is only the ba-

sic answers—Where do they come from? Who is responsible for them? What is the basic idea of what the operation is all about? In the scheme of things, we have the right to know some aspects, but not necessarily the need to know certain specifics. We are not naive children. If these transmissions are related to our national security interests, then we would be the last to wish to see the hampered or stopped. But there is a vacuum of knowledge, and until the truth displaces this void, number buffs have no choice but to continue to seek the answers.

Therefore I now make a direct appeal to those who run the number transmissions. Interest in these transmissions will always have its adherents. It is specifically because the basic facts are unknown that interest in them will continue to exist. You can be assured that the number buffs will persist in investigating, for time is on their side. As for the number buffs themselves, they encompass the full spectrum of society—students to retirees, doctors to teachers, clergy to police. Their political views vary, but their numbers interest is a common one. You, by your cloak of secrecy and disinformation, have bred and nurtured the very force that is now chipping away at your door. Don't blame us. Blame the rubber stamp bureaucracy to which we are all slaves.

The most logical course of action is for you to come forward with the basic facts. After all, there is no lasting security in silence, nor are noble motivations upheld by lies and deceptions. The answers will come, but by bit, regardless of the web of secrecy you have enveloped around your operation. In the long run, it would be far better to hear the answers from you rather than for the number buffs to confront you with them. Revealing these basic answers will not impede or destroy your operation. If anything, they will serve to legitimize them.

Once this is accomplished, the mystery will be no more, and the challenge it fomented will dissolve. Then you can continue to go about your own business, and the number buffs will shed their affiliation and move on to another mystery.



# Radio In The Gas Bag Fleet

***The U.S. Navy's Airships Have Slowly Drifted Into History But Not Yet Out Of The Memory Of Those Who Monitored Them***

BY TOM KNEITEL, K2AES, EDITOR

**B**limps, these days, are those things that fly over sporting events and beaches to remind us of the Goodyear Tire and Rubber Company. And Zeppelin is a recently disbanded rock group more formally known as Led Zeppelin. But at one point in time, these words meant quite a bit more, especially to those who haunt the federal and military communications frequencies. For many years blimps and zeppelins were prized catches on the frequencies used by the U.S. Navy, and between 1917 and 1960 there were approximately 250 in service by the Navy. It was during World War II that the so-called "gas bag fleet" came into its own—reached its peak size. Unfortunately, in the spectacular development of aviation during the war years, public attention was focused on the huge bombers and wasp-like fighter and interceptor aircraft. Little was (and has been) said about the lighter-than-air craft, yet they were most definitely instruments of battle and their movements were accompanied by considerable drama.

It should be pointed out that when we speak of blimps and zeppelins, we are discussing different but related types of airships. Actually, there are three types of lighter-than-air ships—rigid, semirigid, and nonrigid. Rigid ships are the dirigibles (also known as zeppelins), such as the USS *Macon*, USS *Los Angeles*, and others. In these airships, the bag filled with helium gas is built around a metallic framework.

Semirigid ships are those which have a certain amount of framework within the bag. The only USN airships which approached this type were the USN's old O-1 and the latter ZMC-2.

Nonrigid airships (or blimps) have no internal structure at all. The shape of their bags is maintained by gas pressure. These were the most numerous of the USN airships.

Because of the airships ability to travel twice as fast as a surface vessel or hover motionless over one spot, they were particularly important for use in submarine search and depth-bomb attack. Men in an airship could see farther and more clearly than men on a surface vessel. From an airship, a submerged submarine could be spotted more quickly than from a surface craft. A periscope in a moderate or heavy sea was extremely difficult to spot from the surface, but from an airship it could be seen without much difficulty and its location could be radioed from the airship to a destroyer—or the airship could, itself, drop depth charges. Airships were also used for escorting convoys, locating floating mines, and for photographic surveillance.

Smaller airships had a cruising range of 1,000 miles, while the dirigibles could cruise over a 4,000 mile range. Dirigibles did not have a record of being especially durable, most having fallen victim to accidents. On the other hand, blimps were not nearly so vulnerable as most people believed and while they could be brought down with cannon fire, they could withstand a .30 caliber machine gun attack. However, the airships



... from the publishers of **CQ**

# You be the judge...

Here's what you've been looking for — an all new hard-hitting monthly magazine which gives a unique insider's view of what's really going on in the world of communications. POP' COMM is your primary source of information — bigger and better than any communications magazine, with exciting coverage of scanners, shortwave broadcast & utility stations, spy stations, pirate and clandestine broadcasters, RTTY monitoring, survivalist communications systems, FCC news, wiretapping and bugging, voice scrambling/unscrambling, surveillance/undercover communications, satellite & cable TV, sophisticated telephones, & more. What you've been looking for all along! Take advantage of substantial savings over the newsstand price by subscribing now. Don't miss out on even one single issue of POPULAR COMMUNICATIONS — order your subscription now.



## Twelve Issues \$14.00

# SUBSCRIBE NOW & SAVE!

### POPULAR COMMUNICATIONS 76 N. Broadway, Hicksville, NY 11801

Yes! The NEW POPULAR COMMUNICATIONS is just the magazine I've been looking for. Start sending it to me now! I understand that I may cancel at any time for any reason, and receive a full refund on my unused subscription.

Paid by:  Check  Money Order  MasterCard  Visa  
My account number is:

--	--	--	--

Name \_\_\_\_\_  
Street \_\_\_\_\_  
City \_\_\_\_\_ State \_\_\_\_\_ Zip \_\_\_\_\_

- 1 Year (12 issues) \$14.00  
Newsstand price \$23.40
- 2 Years (24 issues) \$25.00  
Newsstand price \$46.80
- 3 Years (36 issues) 36.00  
Newsstand price \$70.20

Canada/Mexico — one year \$16.00, two years \$29.00, three years \$42.00; Foreign — one year \$18.00, two years \$33.00, three years \$48.00; Foreign Air Mail — one year \$71.00, two years \$139.00, three years \$207.00.

Please allow 8 weeks for delivery.

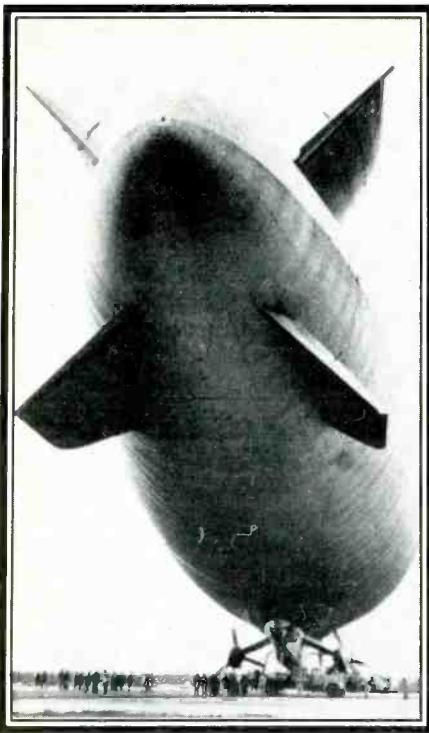

The U.S. Navy ZPG-3W was first flown in July, 1958. It was destroyed when wind drove it against a hangar in February, 1960.

were not used on a fighting line; they were normally deployed on scouting and recon missions and their only combat action was in regard to submarines. The K-74, in fact, was lost after a battle with a U-boat.

### Radio Operations

Since a primary function of airships on patrol was to radio submarine sightings to other Naval units, airships were equipped with extensive radio installations. Since crew size was usually limited because of space limitations in the gondola, the radio operator (or *sparks*, as he was known on all Naval craft) might be required to fill several jobs in addition to manning the radio shack. For instance, he might do double duty as the airship's cook, monitoring for incoming signals while he cooked up a pot of beans in the airship's electric galley.

Airships also carried a supply of at least six 500-mile range homing pigeons, not only to be used in case of radio failure but for use when the airship was operating under conditions of radio silence. The pigeons were fitted with different colored capsules attached to leg bands—white capsules for routine or practice messages and red capsules for emergency messages. These pigeons were trained to fly back to the airship's base—such as Moffett Field (California) or Lakehurst Naval Air Station (New Jersey). During the war, bases were also established in other areas along our coasts, plus the islands of the Caribbean and Atlantic, and, later, in Africa and Europe.

Very early airships were assigned 3 and 4-letter callsigns commencing with the letter "N," as used by all USN vessels. As time went on, the Navy began allocating airships

The U.S.S. MACON (ZRS-5) had the radio callsign NZRLC.

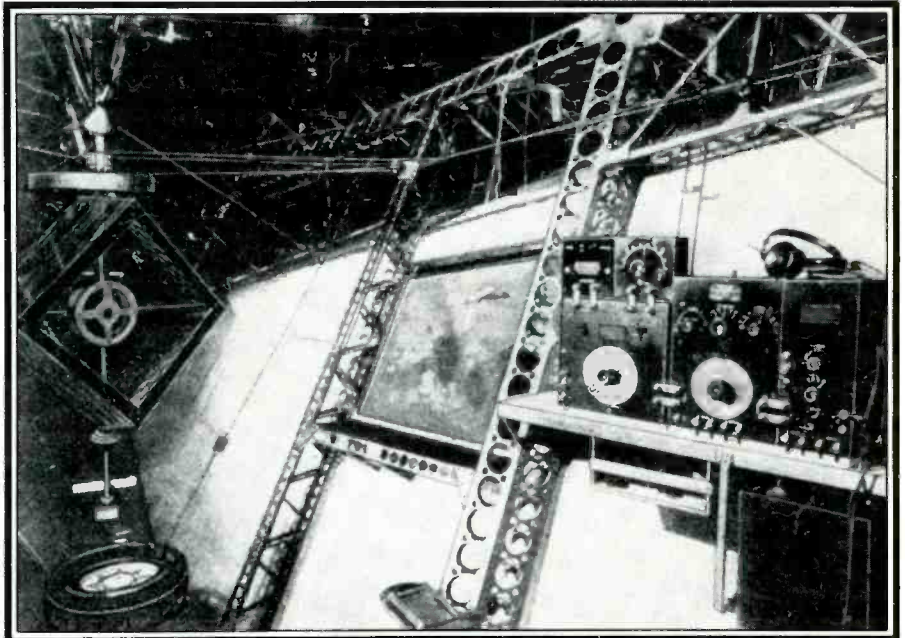
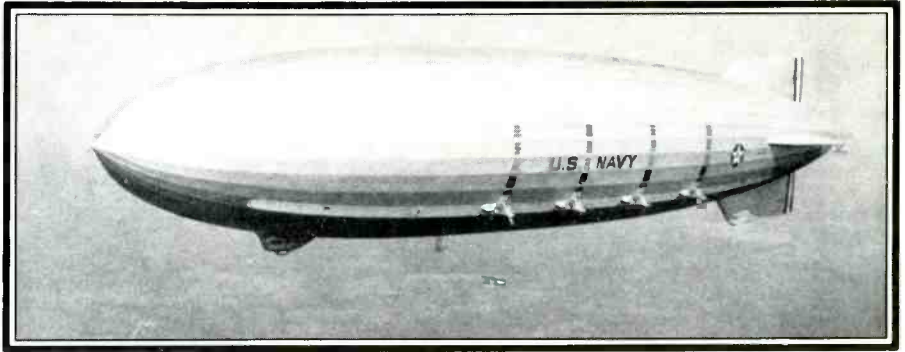

The U.S.S. LOS ANGELES, known on the air as NERM and NZRLA.

5-letter "N" callsigns. An interesting bit of trivia is connected with airship callsigns. Normally, the Navy freely recycles its callsigns; as a vessel is removed from the Navy's roster of commissioned vessels, the callsign is given to a newly added vessel. Indeed, some USN "N" callsigns have, over a period of about 70 or more years since the Navy began using such callsigns, been assigned to six or more different vessels. The callsign NERK was first assigned to the USS LAKE TULARE, a World War I vessel. In 1923, when the giant 680 ft. dirigible USS SHENANDOAH was commissioned, that callsign was available for reassignment and it was given to the airship. Her maiden flight on 4 September 1923 was given enormous media coverage. That flight was followed by a number of other voyages, including a 9,000 mile transcontinental trip. On 3 September 1925, after only two years in service, the USS SHENANDOAH broke into three parts in a line storm over Ohio, killing 14 members of her crew of 43. The callsign given to the airship was retired from active assignment and was from that time on (through present day) used to signify a general call to "any or all U.S. Navy ships." Most

Naval communications personnel today seem to be totally unaware of the historic and sentimental origins of NERK; it stands as a memorial to this popular airship and those who perished aboard her.

By the time the United States entered World War II, all of the Navy's dirigibles were gone from service and the blimps were exclusively used, escorting some 90,000 surface vessels without a single vessel lost by submarine attack. After the war, interest in lighter-than-air ships generally diminished, although several new airships were put into service to explore the possibilities of finding a peacetime role for them. By 1961, the U.S. Navy ended its lighter-than-air programs and retired all of its remaining airships from active duty.

In 1950, I managed to hear two K-class airships operating on 6595 kHz, one of the international air-route frequencies used at that time. These were operating out of the Weeksville Naval Air Facility in Elizabeth City, North Carolina. I was lucky enough to get both of these airships QSL'd. Although I never heard another USN airship on the air, I have spoken to monitors who were listening during the war years and they tell me that

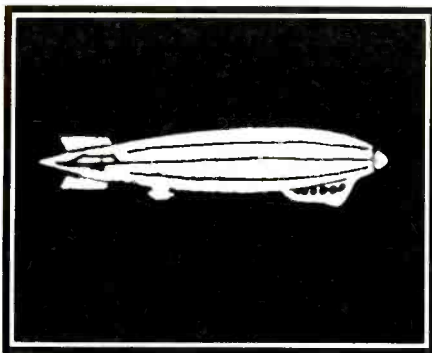

The USN at one time awarded this "Rigid Airship" specialist's rating.

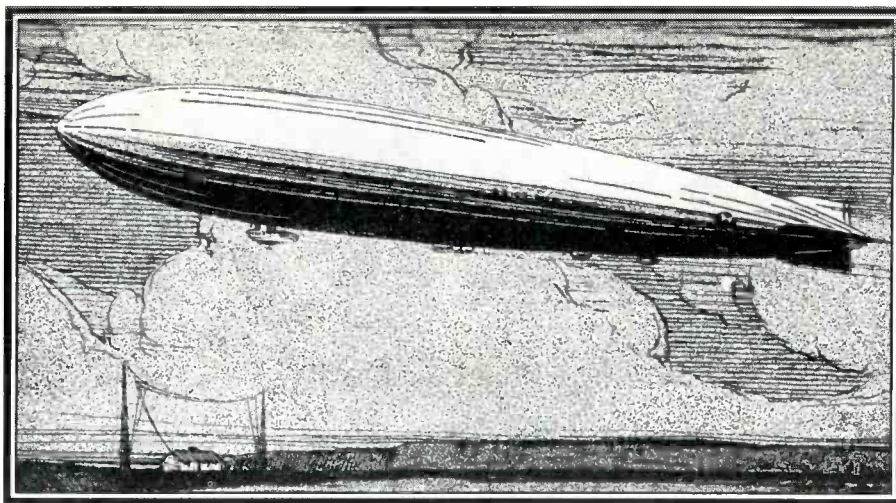

The ill-fated U.S.S. SHENANDOAH. Its old radio callsign still lives on to this day.

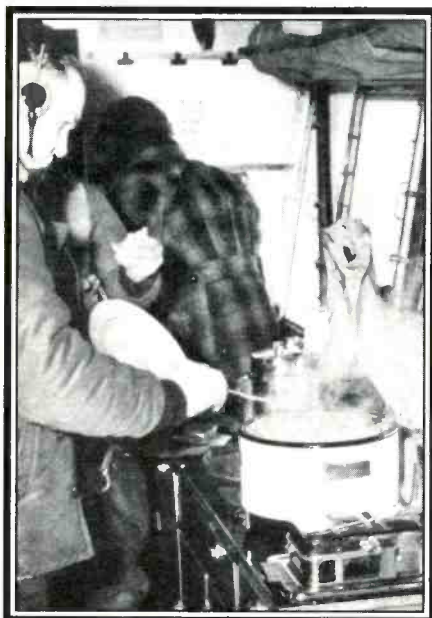

"Sparks" stirs the meal on an electric stove while keeping ears alert for signals. Beans were a winter ration. Note heavy garments.

they made for exciting listening, although there was no possibility of QSLing them during that period.

Today, the only airships you're likely to hear are those operated by Goodyear. They can be monitored on 132.0 MHz by listeners in the areas where these airships operate.

I've included here a listing of the various airships operated by the USN over the years with supplemental information (as available) on the callsigns of these airships.

## A Current Role?

After 1961, the military forces have speculated and made some tentative plans for how airships might be utilized in the future, but only the U.S. Air Force is presently using anything even remotely akin to an airship. These are two airship-like balloons (175 ft. long and holding 250,000 cu. ft. of gas) which are unmanned radar platforms that hover at an altitude between 10,000 and 12,000 feet. They are equipped with AN/DPS-5 radar equipment, the data from which is fed to the Tactical Air Command's Region Operation Control Center at Tyndall Air Force Base (FL). These were developed under Project SEEK SKYHOOK by the Air

Force Electronic Systems Division to spot ship and aircraft traffic, and the USAF uses these systems to assist the U.S. Customs Service in the detection of drug smuggling craft. These radar units are stationed where they can conduct surveillance on heavily travelled smuggling routes.

One unit is deployed at Cape Canaveral Air Force Station and the other is at Cudjoe Key, Florida. Neither is flown as if it were a true airship; instead, each is connected to the ground by a tether and remains in a more-or-less stationary position.

Next month we'll take a rare look at the communications "shack" aboard the most famous rigid airship ever flown, *The Hindenberg*. Never-before-published photos and descriptions of the unusual electronics aboard *The Hindenberg* will be revealed for the first time, and you'll get a look at one of the very few QSLs issued by this airship—which became the focal point of the world's most talked-about and most mysterious air disaster.

## For More Information

*The Complete Book of Airships, Dirigibles, Blimps & Hot Air Balloons*, by Don Dwiggin, 352 pages, 234 illustrations, is a comprehensive history of airships. This soft-cover book is available at \$9.95 (plus \$1.85 for shipping/handling) from CRB Research, P.O. Box 56, Commack, NY 11725.

## USN Airship Types

**"A" Class:** This was a non-rigid type built in 1917. Only one ship of this design was produced, the DN-1, later called the A-1. It was 175 ft. long and contained 114,800 cu. ft. of gas. It leaked and was abandoned after three flights.

**"B" Class:** A non-rigid type produced in 1918. These airships had from 77,000 to 84,000 cu. ft. of gas. Fifteen were built, numbered B-1 to B-15.

**"C" Class:** A non-rigid type built in 1918. These carried 182,000 cu. ft. of gas. They were numbered C-1 to C-30. The C-5 was lost when winds tore it away from its mooring mast in Newfoundland in May of 1919; no lives lost.

**"D" Class:** A non-rigid type made in 1918.

They carried 189,000 cu. ft. of gas. They were numbered D-1 to D-6.

**"E" Class:** A small single engine non-rigid type made in 1918 and numbered E-1.

**"F" Class:** A small single engine non-rigid type made in 1919 and numbered F-1.

**"G-1" Class:** The G-1 was acquired by the USN in 1935. It was formerly the 183,000 cu. ft. Goodyear "Defender" (NC-12A, callsign KHIDW).

**"G" Class:** Seven non-rigid training blimps, numbered G-2 to G-8, were produced in 1943. These were 192 ft. in length, 53 ft. wide, 62 ft. high, and carried between 183,000 and 196,000 cu. ft. of gas. They could fly at 65 knots.

**"H" Class:** Only one was built, the H-1. It carried 43,000 cu. ft. of gas, had a single engine, and could be towed or used as a kite or balloon.

**"J" Class:** The first of these non-rigid ships was completed in 1922. An unknown number were built. These carried 210,000 cu. ft. of gas. J-3 was assigned the USN callsign NZNJT; J-4 had the callsign NZNJF.

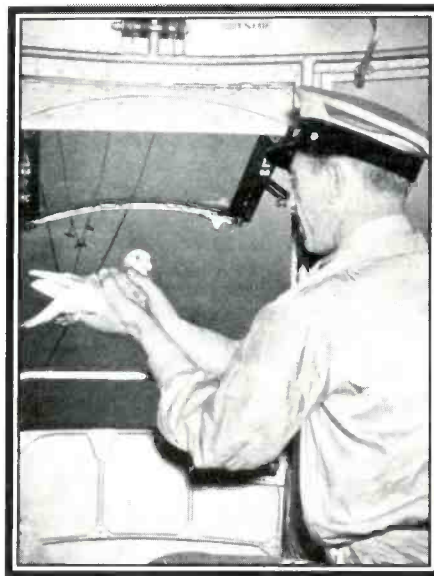

Each patrol airship took along a crate of six birds—four carry routine messages to the loft, two are reserved for emergencies. Should ship and radio be disabled, they might direct rescue.

**"K-1" Class:** Built in 1931 and scrapped in 1941, this non-rigid type consisted of one airship called the K-1. It had 320,000 cu. ft. of gas.

**"K-2" Class:** Non-rigid type holding 404,000 cu. ft. of gas, 250 ft. long. Known to be in use in 1941. Unknown as to how many were built but possibly twelve, which may have been numbered K-2 to K-13.

**"K" Class:** Similar to the K-2 type and numbered K-14 to K-135. Built 1938 to 1941, these patrol non-rigid airships were 252 ft. in length, 62 ft. wide, 79 ft. high, and could travel at 67 knots. The USN callsigns ran consecutively from NVPTA through NVPVO for K-14 to K-79; from NAABA through NAACZ for K-80 to K-131. Other callsigns unknown for K-132 to K-135.

**"L" Class:** Numbered L-4 through L-22, these were training airships of the non-rigid type built from 1938 to 1942. They were 148 ft. in length, 47 ft. wide, 54 ft. high, and could travel at 53 knots. They held 123,000 cu. ft. of gas.

**"M" Class:** Non-rigid patrol types numbered M-1 to M-4 were built 1943-44. They were 294 ft. in length, 71 ft. wide, 89 ft. high and could do 89 knots. They carried at least 647,500 cu. ft. of gas, and some records say 735,000 cu. ft.

**"N" Class:** An unknown number of 403 ft. non-rigid types of this class were built between 1958 and 1960. They could travel at 90 mph and carried 1,516,000 cu. ft. of gas.

**"O" Class:** This was a semi-rigid type purchased from Italy in 1919. Only one was obtained, the O-1, and it saw service for three months.

**"TC" Class:** Two non-rigid airships, the TC-13 and TC-14, were obtained from the Army prior to WWII. These were built in 1930 and were dismantled in 1943. They were 240 ft. in length and carried 384,000 cu. ft. of gas.

**"XM" Class:** The former M-1 was modified after WWII and renamed the XM-1. The XM-1 held 725,000 cu. ft. of gas and in November of 1946 it established a 170 hr. 17 min. world's endurance record for continuous unrefueled flight.

**ZMC-2:** This was built in 1929 and scrapped in 1941. It was a single, all-metal-class semi-rigid airship 150 ft. in length which carried 202,000 cu. ft. of gas. Only one was built and its callsign was NZMCT.

**ZPG2W:** (and its prototype predecessor, the ZPG-2) was built in 1955. These were 1,000,000 cu. ft. non-rigids and could travel at 70 knots. One set a 300 hour continuous flight record.

**"ZPG-3W" Class:** Four giant non-rigid types built in 1958 for the Navy. These held 1,500,000 cu. ft. of gas and were 403 ft. in length. They were deployed with sophisticated electronic early-warning electronics and would report aircraft movements to the Continental Air Defense Command. They normally patrolled the U.S. coast off New England. One was destroyed in February of 1960 when a gust of wind blew it into a hangar at South Weymouth, MA.

**ZR-1:** The ZR-1, or *USS SHENANDOAH*, was built in 1923 and was the first helium filled rigid airship. It was 680 ft. in length, 79 ft. wide, and carried 2,115,174 cu. ft. of gas. Its callsign was NERK. It was destroyed in a storm over Ohio in 1925; 14 crew members lost their lives. The airship was a copy of the German L-49 design.

**ZR-2:** The former British rigid airship R-38 was obtained by the Navy in 1920. It carried 2,700,000 cu. ft. of gas. During its fourth trial flight in England, on 24 August 1921, it broke in two and 16 officers and crew members lost their lives.

**ZR-3:** The ZR-3, or *USS LOS ANGELES*, was the former German LZ-126 built in 1924. This was a 658 ft. rigid airship which weighed 46 tons and could carry 46 tons of cargo and 20 passengers. It was filled with 2,470,000 cu. ft. of gas,



Looking like an airship, this is actually a U.S. Air Force balloon-borne radar platform used to spot drug smugglers. (Photo courtesy U.S. Air Force)



The Goodyear blimps are the most visible reminder of the great airships.

and during its long career it flew more than 5,300 hours. It was decommissioned in 1932, then later recommissioned and it served on active duty until 1939. The callsign was NERM, later changed to NZRLA.

**ZRS-4:** The *USS AKRON* (ZRS-4) was built in 1931. It was 785 ft. in length and was filled with 6,500,000 cu. ft. of gas. It carried a ton of bombs and also five F9C-2 fighter aircraft which could be launched and recovered while the airship was in flight. It had a crew of 83. After 1,000 hours of service, it was destroyed in a storm off New Jersey on 4 April 1933 and 73 officers and crew perished. The airship's callsign was NZRLB. The fighter aircraft associated with the *USS AKRON* were assigned the callsign NVMDA. The *AKRON* also carried radiofacsimile (FAX) equipment for copying weather maps, also a radio direction finder, plus three communications receivers covering LF, MF, and HF. A loop antenna was used for radio direction finding.

**ZRS-5:** The *USS MACON* (ZRS-5) was the sister ship of the *AKRON* and was identical in design. It was placed in service at about the same time as the *AKRON* but was stationed in Sunnyvale, California (the *AKRON* was stationed in

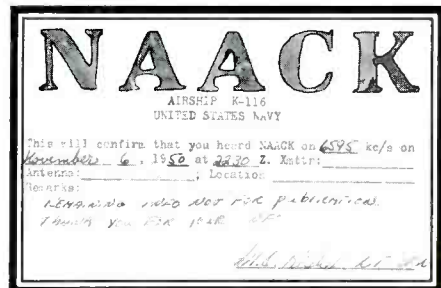
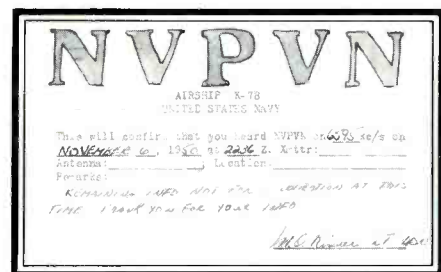

These two QSL cards were received by the author from "K" Class airships.

New Jersey). On 12 February 1935, the upper fin structure of the tail assembly failed and resulted in loss of control of the airship. Soon after, there was severe gas leakage followed by collapse of the airship's internal structure. The *MACON* then fell into the Pacific and slowly sank—two lives were lost. The *USS MACON*'s callsign was NZRLC. The callsign of the aircraft she carried is not known.

**ZS2G:** Built for the Navy in 1954, it was a successor to the WWII K-Class airships. It carried 650,000 cu. ft. of gas.

**ZSG-4:** Built for the Navy in the early 1950's, this small non-rigid airship carried 527,000 cu. ft. of gas.

(This listing does not cover unmanned barrage balloons nor free flight balloons which were used for training purposes.)

# PRODUCTS

## REVIEW OF NEW AND INTERESTING PRODUCTS

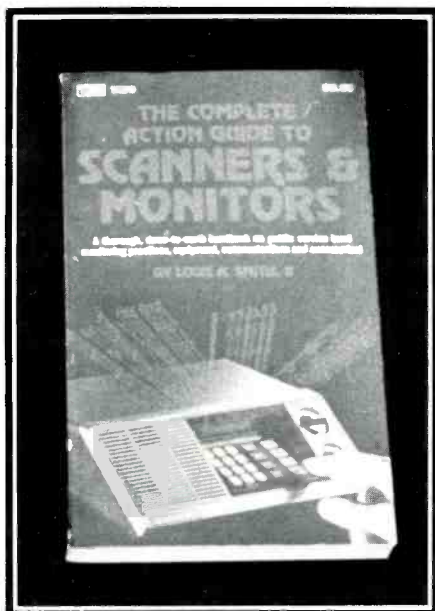

### Complete Action Guide To Scanners

Louis Smith crammed a very large helping of useful scanner information into his book *The Complete Guide To Scanners & Monitors*. This fat 256 page fully illustrated book is put together in a manner so straightforward that even a beginner can grasp it, while experienced scanner users will find it equally useful and valuable. Smith tells how to savvy scanner specs, how to locate frequencies in many radio services operating between 30 and 512 MHz, discusses scramblers and the common (and uncommon) codes and terms used over the air for speed and privacy.

Smith describes scanners themselves, as well as antennas and all kinds of accessories to insure maximum reception. He provides data on state/local ordinances relating to mobile scanner usage. In all, it's a goldmine of information, helpful data, and just plain good advice from an author who really knows his topic well and can convey his thoughts in an easy-to-read manner. It's a book that has managed to cover all of the bases on every conceivable aspect of scanner usage, explaining the unique aspects of police, fire, medical, business, industrial, maritime, mobile telephone, and various other two-way services. Plenty of good advice here on setting up your scanner installation too. You name it, and if it relates to scanners, Smith has covered it with depth and insight in his most comprehensive handbook.

*The Complete Guide To Scanners & Monitors* is available from CRB Research, P.O. Box 56, Commack, NY 11725. The book is \$9.95 plus \$1 for mailing by 4th Class to USA/Canada/APO/FPO.

### Palm Sized System That Tells When Someone Is Lying

CCS has released an exciting new product, a palm sized lie detection system.

The MINI VSA incorporates the same state-of-the-art technology that has been used by law enforcement and lie detection professionals for many years. Now in its compact new form the MINI VSA has a multitude of applications: To find out if employees are stealing; to know if business associates are cheating; to be sure that your friends are really your friends.

For the first time ever, lie detection can be used by businessmen and laymen in virtually limitless capacities.

The new MINI VSA can actually be carried in a purse, briefcase, or coat pocket. It has a silent digital readout that tells you in unmistakable numerical terms if the speaker is lying.

CCS has been a leader in the field of high technology lie detection for more than ten years. The original VSA Mark IX-P is currently used by law enforcement, police departments, and in the legal and medical fields. Recent advances in micro-chip technology have led to the development of this electronic marvel as well as other sophisticated systems. In addition, CCS manufactures electronic bug detectors, wiretap defeat systems, bullet proof apparel and vehicles, infrared surveillance systems, and bomb detection.

For more information, contact CCS Communication Control Inc., 633 Third Avenue, New York, NY 10017 or circle 110 on the readers service card.

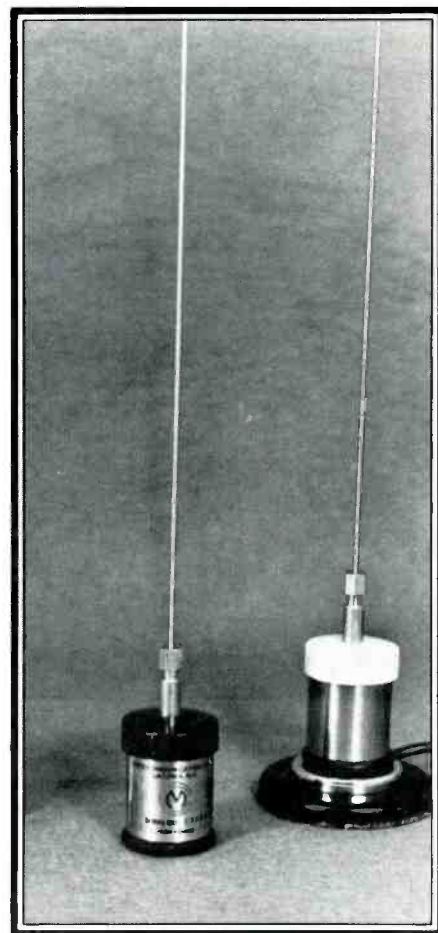

### Stainless Steel Antennas

Metz Communication Corporation announced a complete line of VHF and UHF stainless steel antennas, hardware, and low loss RG-8/X coaxial cable. Stainless steel coils are designed for each group of amateur radio frequencies from the 28 MHz band through 450 MHz. This also includes the elusive 220 MHz band. Each stainless steel coil is pretested, identified with a serial number, and specially coded for the band of operation.

All antennas mate with any 5/8" x 24" threaded connector with SO-239 configuration. Magnetic mounts, through-vehicle mounts, and many other types of mounts are available from Metz.

All Metz coils are capable of handling 250 watts over extended periods of time. The distinctive stainless steel coil is not only impressive looking, but impressive performing.

For more information about the complete line of Metz stainless steel antennas for amateur radio use, land mobile radio use, aviation radio, and monitoring, contact Metz Communication Corporation, Corner Route 11 and 11C, Laconia, New Hampshire 03246, or circle number 107 on the reader service card.



Many large ships are permitted to use special frequencies in the business bands at times when loading or unloading cargo or oil.

# DX Ahoy!

## Maritime Communications Continue To Show Up On Frequencies You Never Thought Of!

BY RICK MASLAU, KNY2GL

People who like to tune in on maritime communications know that the best places to hear these communications are either between 2 and 22 MHz or the 156 MHz VHF marine band. Yes, there are some boats that operate on CB frequencies, and some that are prone to bootlegging on assorted out-of-the-way frequencies; this then summarizes your basic haunts of ship and shore stations, right? Well, not quite!

If you stop and think about it, police and fire boats turn up on police and fire frequencies in addition to the VHF marine band.

They have more than one communications system aboard and can operate in the Police or Fire Radio Service under separate licenses than those used for regular VHF marine communications. Similar arrangements are made by vessels operated under the auspices of port and harbor authorities and environmental agencies. They are operating on Public Safety Radio Service frequencies as well as Marine Radio Service frequencies. Get the picture?

Let's extend this idea. What about U.S. Navy ships and U.S. Coast Guard cutters?

True, they can operate on regular maritime frequencies, but they can also be monitored on their own reserved frequencies. Then we'll also have to include other federal operations which have vessels connected with their activities—U.S. Customs, Department of Commerce, TVA, Department of the Interior, NASA, and others. As you can see, there's a vast sea of communications activity out there, all of which is happening far afield from the places you'd usually expect to listen for this activity. Many people who like to eavesdrop on maritime communications

**Table 1**

Columbia River Bar Pilots, Astoria OR	KON734	151.685 MHz
	WRF621	151.685 MHz
Lake George Steamboat Lines, Lake George, NY	KTX405	154.54 MHz
Knutson Towboat Co., Coos Bay OR	KOL493	43.00, 48.68, 49.26 MHz
Parker Boat Lines, Put-in-Bay OH	KQI747	151.685 MHz
Port Clinton OH	WRS665	151.685 MHz
Riverview Boat Line, Wisc. Dells WI	KLM910	151.745 MHz
Treasure Isle Cruises, St. Croix VI	KEZ250	157.625 MHz
	WCH353	150.905
Winnepesaukee Steamship Co, The Weirs NH	KDA290	35.14 MHz
Woods Hole Oceanographic Institute, Woods Hole MA	KRJ946	151.685 MHz

*This is a random sampling of just a few of the many maritime operations that can be monitored on industrial radio service frequencies.*

*Offshore oil rigs communicate with each other with supply vessels and shore stations on industrial frequencies.*

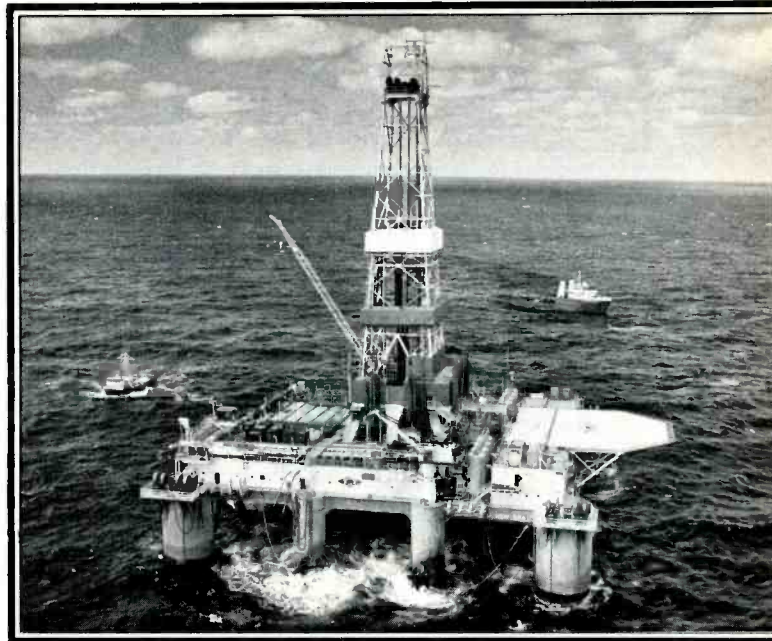

have already figured this out and have commenced to shake from their heads the notion that maritime two-way can be monitored only in the most obvious places. But, even in addition to these extra bonus frequencies I've just listed, there's still more—other frequencies which a few of the specialists haven't yet discovered!

### Least Explored

One of the least explored possibilities for tuning in on maritime communications is looking for them on the frequencies used by stations in the Business and Special Industrial Radio Services. True! It simply doesn't occur to many listeners, even experienced ones, that these frequencies are used aboard all sorts of vessels and are fully licensed in addition to any regular marine radio capabilities of the vessel. But when you realize that many who own and operate vessels of all sizes can easily qualify for FCC licenses in these radio services, then you can see the potentials for such operations for those who have a requirement to discuss their business operations away from the marine frequencies. This could offer privacy advantages or greater range, less channel crowding, or any of a dozen other benefits.

Some of those who are licensed on industrial channels include marine research facilities, fishing fleets, ferries, yacht clubs and marinas, tugboat companies, marine terminals, dredging companies, steamship lines, sightseeing and tourist lines, oil drilling and exploration companies, harbor and river pilots. It may well be that some of these companies are far more active on industrial frequencies than they are on the regular maritime frequencies. Note also that there are several UHF business band channels that are specifically reserved for maritime, low-power operation for "communications concerned with cargo handling from a dock, or cargo handling facility, to a vessel alongside." These frequencies include: 457.525, 457.55, 457.575, and 457.60 MHz.

**Table 2****Ships On 31.48 MHz**

Name	Reg. Callsign	Length (ft.)	Type
GULF ACE II	WYT9447	123	Tug
GULF BARON		89	Tug
GULF CHALLENGER	WYZ5243	121	Oil Exploitation
GULF DUKE		133	Tug
GULF EXPLORER	WK5255	117	Tug
GULF FALCON		107	Tug
GULF FLEET #4	WZH9521	167	Oil Exploitation
GULF FLEET #8	WYT8709	165	Oil Exploitation
GULF FLEET #10		166	Oil Exploitation
GULF FLEET #12	WYN6094	168	Tug
GULF FLEET #14		170	Tug
GULF FLEET #15		168	Tug
GULF FLEET #18		171	Oil Exploitation
GULF FLEET #20		166	Oil Exploitation
GULF FLEET #21		166	Tug
GULF FLEET #22		170	Oil Exploitation
GULF FLEET #23	WYB6797	170	Oil Exploitation
GULF FLEET #24		167	Oil Exploitation
GULF FLEET #25		167	Oil Exploitation
GULF FLEET #26		170	Oil Exploitation
GULF FLEET #27		167	Oil Exploitation
GULF FLEET #28		156	Oil Exploitation
GULF FLEET #29		166	Oil Exploitation
GULF FLEET #30	WYT8527	165	Oil Exploitation
GULF FLEET #31	WYB6662	166	Oil Exploitation
GULF FLEET #208		208	Freight Barge
GULF FLEET #260		260	Freight Barge
GULF FLEET #261		260	Freight Barge
GULF FLEET #262		260	Freight Barge
GULF FLEET #290		290	Freight Barge
GULF FLEET #291		290	Freight Barge
GULF HAWK		106	Tug
GULF KING	WX9725	121	Tug
GULF KNIGHT	WV9736	99	Tug
GULF MISS	WZJ8031	111	Tug
GULF PACER	WYH7675	89	Tug
GULF PRIDE	WZG9583	96	Tug
GULF PRINCE II		100	Tug
GULF QUEEN II	WZG9584	96	Tug
GULF RAMBLER	WYT8732	136	Tug
GULF SEAS	WYR2513	91	Tug
GULF STAR	WYR2512	86	Tug
GULF STORM	WYZ6535	99	Tug
GULF TITAN		100	Tug
GULF VIKING	WX7860	95	Tug
GULF WIND	WYZ6536	91	Tug
MARY DE FELICE		86	Tug

# The Nation's SWL/HAM Headquarters!

**ege, inc.**

13646 Jefferson Davis Highway  
Woodbridge, Virginia 22191  
Just 25 minutes south of Washington, D.C.  
Store Hours: MWF 12 noon—8 p.m.; TThS 10 a.m.—4 p.m.

Wash., D.C. area 643-1063  
In Virginia 800-572-4201

## PANASONIC

Now in Stock  
RF 2200, RF 3100, RF 799, RF 9  
—Call for Introductory Prices—



## ICOM R71 OUR #1 SELLER

A Commercial-Grade Receiver  
at a Not-So-Commercial Price  
—Call for Your Best Price—

## Interested in RTTY/CW Reception with Your Computer for Under \$100?

Call Us About  
the New MFJ RTTY/CW Reader

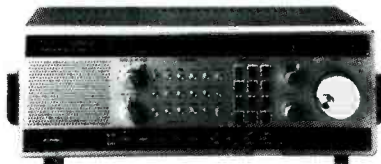

## BEARCAT DX1000 LISTEN TO AM/USB/LSB/CW/FM BEARCAT SCANNERS IN STOCK

## SONY

SWL Receivers in Stock  
Models 2002, 4800, 6500, 7600A  
—Call for a Good Deal—

## REGENCY

Full line of Scanners  
Handhelds, Mobiles, Base Stations  
—Call for Our Low Prices—

## BOOKS, ANTENNAS & ACCESSORIES

—In Stock—

Send 60¢ in Stamps for Catalog  
Dealer Inquiries Invited

For Orders and Quotes—Call

# 800-336-4799

CIRCLE 24 ON READER SERVICE CARD

## THE SHORTWAVE PROPAGATION HANDBOOK Second Edition

The all new revised 2nd edition of *The Shortwave Propagation Handbook* is here. Authors W3ASK and N4XX explore the whys and wherefores of how radio signals between 3 and 300 MHz travel over long distances under the influence of sunspots, the ionosphere, meteor trails, auroral ionization, sporadic-E, scatter phenomena, and other factors. Through fascinating text, amply supplemented by many charts, photos, and illustrations, you find out how to predict and use to your communications advantage the various types of skip openings—whether you're using a scanner to monitor the low or high VHF bands, an HF communications receiver or transceiver to pinpoint that hard-to-hear station, or are a 27 MHz operator or an Amateur operator looking for that rare country—the information in this book will tell you what you need to know so that you can take the fullest advantage of your communications facilities.

The all new 2nd edition of *The Shortwave Propagation Handbook* is only \$8.95, postpaid (sent by Book Rate Mail—allow time for delivery). Order now.

Popular Communications  
76 N. Broadway, Hicksville, NY 11801

Please rush me my copy of the 2nd Edition of *The Shortwave Propagation Handbook*:

\$8.95 for the book plus \$2 for shipping & handling.

Name

Address

City  State  Zip

Mastercard  VISA

My account number is:

--	--	--	--	--	--

A random sampling of a few Business Radio Service maritime users is shown in Table 1. Actually there are hundreds of licenses that could have been given, but this is to give you some general idea of the types of companies involved.

One of the things that brought all of this to mind is that POP'COMM has received dozens of inquiries asking if we could help in identifying the seemingly unusual appearance of numerous ships in contact with one another and with shore stations on 31.48 MHz whenever skip propagation conditions permit distant reception on the VHF "low band." Since these inquiries have appeared from areas throughout the U.S. and Canada, it does seem that the "strange" network is enjoying a large audience, and also that the use of a Special Industrial Radio Service frequency has thrown a lot of folks into a quandry. Some have asked if these stations are legit or if they come from within the ranks of the maritime bootleggers who have been on the airwaves. Maritime communications, the writers say, aren't supposed to be taking place on 31 MHz. Here's the story on the 31.48 MHz maritime transmissions.

The base stations that communicate with the vessels are licensed to the Gulf Fleet Marine Corp., 225 Naronne Street (Suite 600), New Orleans, LA 70112. This company's three base (shore) stations are:

KQZ242 Leeville LA  
KXF841 Harvey LA  
WZU846 Sabine Pass TX

The ships with which these stations communicate are owned under several corporate names, but are all located at the same address as Gulf Fleet Marine Corp., and (with one exception) have names which commence with the word "Gulf." These are all large vessels, mostly well over 100 feet in length, and they appear to be engaged in the offshore oil operations which take place throughout the Gulf of Mexico. Some of these vessels have regular maritime radio callsigns, but when they operate on 31.48 MHz, their operation is one common FCC callsign assigned to Gulf Fleet Marine—KT7813. A listing of the various Gulf Fleet Marine vessels thought to be active on 31.48 MHz is shown in Table 2.

It should be remembered that 31.48 MHz is authorized by the FCC for a great many stations that have no connection with the communications described here, so you may well hear others on the frequency when the band is ripe for distant reception. My own listening efforts there, however, do indicate that Gulf Fleet Marine's network is regularly heard with good quality signals.

Monitoring maritime communications has always been interesting and exciting, and if you've never spent any time on the regular frequencies, you ought to give it a try. But don't stop there. I've given you some insights towards expanding your horizons and helping you to realize that these transmissions can be anywhere and everywhere. They're there—go get 'em!



# Clean up the computer clutter.

**For less than \$250  
you can make your  
investment in yourself  
pay off!**

Chances are you have spent a couple thousand dollars on setting up a computer system that gets a lot of your work done. But sometimes it gets to be work to work at it.

I know that when I have to move two program manuals and a pencil holder to boot up the disk drive, it is work. When there is an unlabeled floppy (that I am going to identify some day) on top of the monitor and the business check-book is on top of the printer . . . and I will remember (I hope) before the next "report" comes through . . . that is work.

I found the annoyance of my own "computer clutter" was even worse than the extra work the disorder created. And that is when I started looking for some practical furniture for my computer set up. Since I had already spent a lot of money on the system itself, I was really dismayed when I found out how much it would cost to get a decent-looking desk or even a data table for my equipment. \$400 . . . \$500 . . . even more for a sleazy unit that looked like junk! In fact, it was junk! And it took a long time for me to find something that was really worth the money . . . and more.

A lot of my working day is spent with my computer, and I will bet a lot of your time is too. So I figure a "home" for my system—a housing that is good looking as well as efficient to work at—will pay off two ways:

1. Less work: an efficient and orderly layout will save me time and energy.
2. Personal satisfaction: good quality furnishings look better; they just plain feel better to work at too.

So imagine how good I felt to find the "Micro-Office" Work Center! These are fine pieces of computer system furniture that make my office-at-home as pleasant a place to work as it ought to be. And the

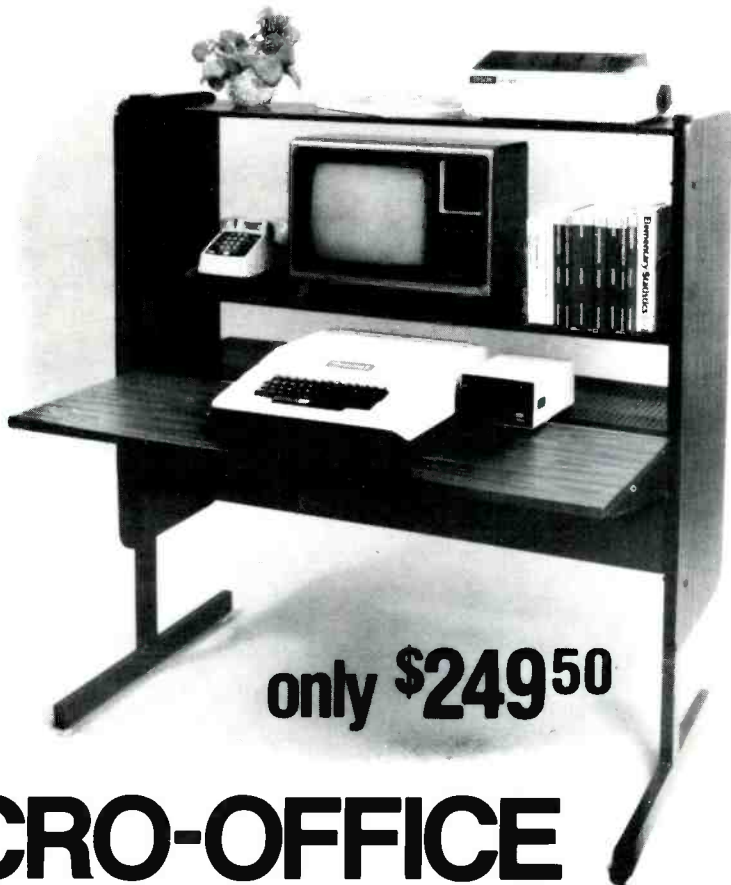

## MICRO-OFFICE WORK CENTER

biggest and best surprise is the low, low price for such good quality.

Here is what you get—all for only \$249.50 plus shipping.

- Mar-resistant work surface. Your choice of oak or walnut grained. Work surface height is adjustable to your keyboard, your chair, your height.

- Two shelves plus work surface extender. Both shelves tilt to lock in position so that monitor faces you—in a position that does away with screen glare squinting and neck craning forever. Retainer bar keeps equipment from sliding off shelf. Snap-in bookends hold reference manuals and programs.

- Strong, sturdy and steady. All-steel welded frame construction is concealed by top-quality wood grain surfaces with finished trim. Adjustable floor levelers included. The work center is really a piece of fine furniture.

- There is no risk in buying from us either. We will make a full refund of purchase

price plus shipping charges if you return the workcenter within 30 days for any reason whatsoever. In addition, the product is warranted for any defects in materials or construction for a full year from date of purchase. This is a no-risk investment in your own productivity and work efficiency that will pay off for years to come—even if you do not yet have a microcomputer of your own.

- Take your choice for your own work center decor:

Order 48-inch unit in walnut, #2KPO-945, or in oak, #2KPO-947. Only \$249.50 for each unit plus \$20.00 shipping charge. On orders for two or more units at the same time, shipping charge applies to only the first unit ordered. Shipment made UPS, so we cannot ship to post office box. Illinois residents please add \$15 per unit sales tax. Please allow 10 extra days for personal checks to clear. Sorry—at these special offer prices we cannot ship c.o.d. or bill direct.

**CALL TOLL FREE TODAY WHILE SUPPLIES LAST: 1-800/323-8064.**

**In Illinois call 1-312/251-5699. Or mail check with order to:**

## Micro-Mart Distributors

**Dept. PC05 • 1131 Central Street • Wilmette, IL 60091**

## A Crafty Use Of Two-Way Radio As A Propaganda And Psychological Warfare Tool

# Tom Delmer And Britain's "Black" Radio



Sefton "Tom" Delmer at the microphone, circa WWII. (Picture from dust jacket of his book, *Black Boomerang*, by Viking Books, 1962. Photo courtesy Radio Times Hulton Picture Library)

BY DON JENSEN

**E**infühlungsvermögen.

The Germans had a word for it, but Sefton "Tom" Delmer, the crafty head of Britain's WWII "black" broadcasting, called it empathy.

For a "black" station—a clandestine radio whose audience credibility comes from its guise as a patriotic but disaffected voice from the targeted country—it's the difference between success and failure.

A "black" broadcaster, Delmer insisted, needs an intimate knowledge not only of the language of the country against which he proposes to operate, but of its domestic conditions and ideology as well.

That description fits Delmer to a tee. Born in Berlin in 1904, the son of an Australian university lecturer, he lived the first 13 years of his life in Germany. After his graduation from Oxford, he returned to Berlin as an English teacher and, later, a foreign correspondent for London newspapers. As a member of the foreign press, he had access to the future leaders of Nazi Germany—Goring, Goebbels, Himmler and, especially, Adolf Hitler.

It was the perfect background for a "black" propagandist, and helps to explain why a trio of Delmer's secret wartime stations—Gustav Siegfried Eins, Duetscher

Kurzwellensender Atlantik, and Soldatensender Calais—were so astonishingly successful.

Today, some 40 years later, Delmer's clandestine stations remain the classic textbook examples for psychological warfare operations.

Both sides, the Axis and Allies, operated clandestine radios early in the war. The story of the Nazis' secret broadcasting agency, Buro Concordia, was told in a recent *POP! COMM* feature.

By early 1940, Britain's psywar efforts were centered in a secret governmental branch called Special Operations 1 (SO1). It

had two Reseach Units—as the clandestine stations were dubbed for cover purposes—on the air.

The first, The German Freedom Station, was a right-wing operation headed by an elderly former Reichstag legislator of the German Centre Party.

It broadcast on 9,710 kHz, shortwave, and its transmission began in typical “black” propaganda style.

“Achtung! Achtung! Here is Germany calling! Germans, look for the truth. Listen to our broadcasts. You must realize that he who condemns that Nazis is not an enemy of Germany, and he who is a friend of the Nazis can never be a true friend of Germany!”

Its favorite trick was to broadcast “Advanced Lessons in Sabotage through the Radio Waves.”

“Pretend you are sick,” the station urged German workers. “Faint near your machine. Hold your breath and smoke a cigarette immediately afterward. This will make you feel rotten! Forget to oil your machines; throw file dust into the works. Find any excuse to work not at all or as little and ineffectively as possible!”

But the Freedom Station folded when its exiled chief fell ill.

The second SO1 station called Sender der Europäischen Revolution, the Radio of the European Revolution, was run by Neubeginn, a group of exiled German Marxists.

The left-leaning station broadcast 12 hours a day, from 7 a.m. to 7 p.m., on 9,615 kHz. It appealed to workers to shake off the fascist yoke and preached a doctrine of European community, peace and goodwill—and Marxism.

The RUs were loosely controlled by the SO1’s Richard Crossman, but in point of fact, the exile groups were largely left to their own devices.

“Not really a terribly good idea,” a high ranking psychological warfare official noted.

A telegram went out to a foreign correspondent named Delmer, then in Lisbon. He had established contacts with Britain’s cloak-and-dagger intelligence community.

“Suggest you return earliest possible,” the wire read. “...Important job awaits you.”

Delmer returned to London to take charge of SO1 in October, 1940. From that time, British “black” radio operations took on a new look, one which made them stand out from the rest of the clandestine propaganda stations of the war.

Delmer’s new twist was what he called psychological judo, exploiting the impetus of the enemy’s own ideological preaching to turn it against the Nazis. He also broke with tradition by creating stations which seemed not to be directed to the general listening audience. German listeners were supposed to get the idea that they were eavesdropping on “insider” two-way communications.

The SO1 chief recalled how he sometimes had, by chance, tuned in the salty conversations of ships’ captains talking over the high-seas maritime radiotelephone. He intended to make the German listener believe

he was hearing radio talk not intended for his ears.

“As he twiddled the knobs of his set,” Delmer explained in his postwar memoirs, “(the listener) would suddenly find himself tuned in to what sounded like the signals traffic of a clandestine military organization, sending ciphered instructions to secret cells all over occupied Europe.

“In between the cipher messages, a die-hard of the old Prussian school would use the transmitter to give members of the organization his caustic and salaciously outspoken views of what was going on—views which, while being spiced with plenty of inside information, would show him as loyal and devoted to the Fuhrer, but scathingly contemptuous of the ‘rabble’ that had seized control of the Fatherland in the Fuhrer’s name.”

The real message Delmer wanted to impart was a growing split between conservative, “old school” elements of the German army and the radicals of the Nazi party.

The crusty old radio personality he dubbed, simply, “der chief.” The station itself he called “Gustav Siegfried Eins.”

Gustav and Siegfried were just German military phonetics for the letters “G” and “S”; Eins means one. Delmer left it to his listeners’ imaginations to decide what those cabalistic initials signified.

Did it mean Geheimsender (secret transmitter)? Or Generalstab (general staff)? Or as one staff member suggested, Gurkensalat (cucumber salad)?

“I had no idea, and neither did anyone else,” Delmer said. “But we were soon to hear the most intriguing theories being reported back to us from Germany and elsewhere abroad.”

Delmer’s Special Operations 1 group operated from studios hidden away in a red brick cottage in the little English village of Aspley Guise, Bedfordshire. Der chief was played by an Army engineer, Cpl. Paul Sanders, and ex-mystery writer who had lived in Germany until 1938.

Gustav Siegfried Eins (GS1) went on the air for the first time on May 23, 1941. The first transmission began with supposed messages from GS1 to a totally imaginary “satellite” station, GS18.

In a low grade cipher that Delmer intended to be decoded by German monitors in the Reich Central Security Office, der chief instructed “Willy” to “meet Jochen, Friday, row five, parquet section, second performance, Union Theater.”

Delmer later said he imagined leather-coated Gestapo thugs attending every one of the hundreds of Union Theaters across Germany, looking for the nonexistent conspirators, Willy and Jochen.

But that was all secondary to the transmission that followed. Der chief began tearing apart various Hitler underlings, Heinrich Himmer, Nazi labor czar Fritz Sauckel and others, plus the Gestapo and the elite SS.

For an interval signal, GS1 used the second line of an 18th Century folk song by Ludwig Holty, played on an out-of-tune

piano. The first bars of the same melody were used as the tuning signal by the Nazis’ own radio, Deutschlandsender. GS1’s signature melody simply answered back with the next notes.

GS1 did its best, too, to widen a breach between Nazi Germany and its junior Axis partner, Italy. Der chief frequently grumped that German aid to the “weak sister Italians” was a waste of men and material. Italian forces in North Africa were scathingly referred to in the broadcasts as the “Macaroni Front.”

The real identity and location of Gustav Siegfried Eins was one of the war’s most closely held secrets for more than two years. In the press it was speculated that the station was the work of associates of Nazi official Rudolf Hess, who had flown to England on a self-styled peace mission.

Another writer, claiming inside information, asserted that GS1 “is located in Germany, that its whereabouts are known to the Gestapo, and that its operators cannot be arrested because the power behind them is a figure so prominent that his disgrace would cause a disastrous upheaval on the home front. This figure is, of course, Hermann Goering (head of the Luftwaffe).”

GS1 was so effective a “black” propaganda voice that the British became worried that their American allies would actually believe there were serious internal frictions between the Nazi party and the German army, and base policy on that misconception.

So Churchill told President Franklin Roosevelt the truth about Gustav Siegfried Eins. FDR found the story too good to keep to himself, it is said, and he told a confidant. Soon it was being whispered all over Washington.

It was clear that GS1’s days were numbered. So Delmer decided to finish off the clandestine station with a bang. A dramatic final program was staged in which Gestapo agents ostensibly broke into the GS1 studio in mid-program, “shooting” der chief to death.

It was a great finish, except for one problem—der chief died twice!

A transmitting engineer, knowing no German and unaware of the final nature of the program—complete with machine gun burst and a shout of “got you, you swine!”—followed his routine of replaying the transcription on a repeat broadcast later that day.

## Other Stations Emerge

Planning had begun nearly a year earlier, in December 1942, for two other stations. The first, which would be widely heard by American shortwave listeners, was Deutscher Kurzwellensender Atlantik (German Shortwave Radio Atlantic). It was part of a plan to step up the psychological warfare attack on the German Navy, particularly the submarine crews, with the assumption that if the U-boat men cracked, it would spread to other service arms.

The second SO1 radio was a medium wave operation targeting the German army,

Soldatensender Calais. It was a "black" news station, mixing truth and fiction calculated to weaken military morale.

Atlantiksender, as the Naval operation became known to sub crews and SWLs alike, went on the air initially on Feb. 5, 1943, after three weeks of off-the-air dry runs. Its tuning signal was a shrieking pipe melody, actually played on a Hammond organ by a studio engineer.

At first, Atlantiksender broadcast six half hour program segments each evening, originating from new studios in a two-story brick building at a place called Milton Bryan. At a casual glance, it seemed to be much like any of the new factory buildings in the area. But there was a 12-foot high chainlink fence around the building and, out of sight, a squad of special police officers armed with automatic weapons.

Atlantiksender first broadcast on 6,220 and 9,800 kHz, shortwave. By 1944, U.S. listeners were hearing it on a third frequency, 7,020 kHz. The station was heard in the United States from as early as 2145 GMT until sign off at 0700, with frantic German attempts to jam the signal evident.

The station's news style was new and ef-

fective, punchy, using the colloquial German, rather than the more formal approach of both the BBC's German programming and the Nazi's own official radio.

The latest German hit records were smuggled into neutral Sweden, then flown to England by RAF Mosquito bomber for Atlantiksender. Other records were made just for the station by Henry Zeisel's band, which had been captured by the Eighth Army in North Africa, where the musicians had been entertaining Rommel's troops. Even international stars such as Marlene Dietrich made records for the station.

To provide "cover" for the operation, Delmer's men periodically recorded Goebel's and Hitler's speeches from Berlin's Sports Palace, as broadcast by German radio, then realistically reaired them over Atlantiksender.

Mixed in neatly in the programs were what the SO1 boys called "dirt." Today's psywar experts would call it disinformation.

"It was amazing," Delmer marveled, "how many Germans were genuinely taken in and did believe it to be a German forces radio."

The powerful medium wave Soldaten-

sender Calais went on for the first time at 1800 GMT on October 24, 1943. Later, after the Allies invaded France on D-Day and Calais was taken, the station changed to Soldiers' Radio West, in German.

It went on the air with a crash of drums and a blare of trumpets, a boisterous military march, and an announcer who proclaimed: "Here is the Soldiers Radio Calais, broadcasting on wavebands 360 meters, 410 and 492 meters. It is linked to German Short-wave Radio Atlantic on wavebands 30.7 and 48.3 meters. We bring music and news for comrades in the Command Area West and Norway. Next, we shall play dance music..."

The station used what was described as a 600 kilowatt transmitting center in England, nicknamed "Aspidistra." It also was linked to a repeater, a low-powered, 500 watt mobile transmitter located on the coast near Dover, directly opposite Calais across the Channel. That little touch was for the benefit of German direction finding teams trying to get a fix on the location.

The Delmer operation regularly scooped legitimate broadcasting stations with war news. On June 6, 1944, at 4:50 a.m., Soldatensender was the first station to announce the Allied landing on Normandy's beaches. Genuine items of this sort added much credibility to the mixed "black" and "white" newscasts of the station.

Besides the military forces, much of the German civilian population tuned in. Before long, according to intelligence data reaching Delmer Soldatensender was one of the three most listened to stations in Germany.

The two clandestines continued on short and medium waves, nibbling away at German morale, until the war's end in the spring of 1945. The last broadcast was aired, and the stations went silent forever at 5:59 a.m., April 14.

"We made no announcement that we were closing," Delmer interestingly stated. "We just disappeared."

After the war, Delmer was made an Officer of the British Empire (OBE) for the contributions to the nation's war efforts of his broadcast trickery. He returned to journalism as chief foreign affairs writer for the London Daily Express.

For some 15 years, he kept mum about his WWII exploits, before finally publishing his memoirs. He also took time, in 1962, to travel to the U.S. Army's Psychological Warfare School at Ft. Bragg, North Carolina, to lecture a new generation of clandestine broadcasters about how it ought to be done.

Despite the several books he wrote, the public remained generally unaware of his clandestine broadcasting leadership role.

When Sefton Delmer died on September 6, 1979 at the age of 75, *The New York Times*, in its obituary, call him "one of Britain's best known foreign correspondents in the period between the World Wars."

But not a word was there about the master of "black" broadcasting, whose clandestine stations fooled the Nazis—and the world.

### UNSCRAMBLERS

FOR POLICE, FIRE & MEDICAL CODES  
SATISFACTION GUARANTEED  
SEND FOR COMPLETE INFORMATION  
**DNE, INC. — RT. 7, BOX 257C**  
**HOT SPRINGS, ARKANSAS 71901**  
**501-623-6027**

Please send all reader inquiries directly.

**RTTY RADIOTELETYPE FREQUENCY LISTS**

2000 WORLDWIDE RADIOTELETYPE STATIONS BY FREQUENCY...  
press, air, military, government, diplomatic, all utilities with calls, times, lomatic, plus other information 3 to 30 MHz.  
\$12.95 POSTPAID

World Press Services  
Frequencies & Manual.  
All press services,  
frequencies and transmission times. BOOK with 3 LISTS...  
\$8.95 ppd.

**UNIVERSAL ELECTRONICS**  
4555 Groves Rd. (Suite 3), Columbus, OH 43227

CIRCLE 50 ON READER SERVICE CARD

## INFO-TECH M-600 MULTI-MODE CODE RECEIVER



### DECODES:

Morse...5-60 wpm

Baudot RTTY...45 to 100 baud

ASCII RTTY...75 to 1200 baud

SITOR (TOR)...100 baud

Bit Inverted Baudot...45 to 100 baud

### FEATURES:

- Video and printer outputs
- Advanced RTTY demodulator with 3 fixed & 1 variable shift
- Separate Hi baud ASCII demodulator
- Solid state tuning "meter"
- Keyboard entry of mode, speed, shift & special feature commands
- Multiple scroll inhibit feature
- Built-in self-test system
- Screen Print feature
- Loop supply and Parallel printer options

Write For Information and Your Dealer's Name

**INFO-TECH**

Manufactured by:

**DIGITAL ELECTRONIC SYSTEMS, INC.**

1633 Wisteria Court • Englewood, Florida 33533

813-474-9518

**ELECTRONIC EQUIPMENT**

CIRCLE 27 ON READER SERVICE CARD

**QUALITY PARTS AT DISCOUNT PRICES!**

**SUB-MINIATURE D TYPE CONNECTOR**

SOLDER TYPE SUB-MINIATURE CONNECTORS USED FOR COMPUTER HOOK UPS

DB-15 PLUG \$2.75  
DB-15 SOCKET \$4.00  
DB-15 HOOD \$1.50  
DB-25 PLUG \$2.75  
DB-25 SOCKET \$3.50  
DB-25 HOOD \$1.25

**"PARALLEL" PRINTER CONNECTOR**

SOLDER STYLE 36 PIN MALE USED ON "PARALLEL" DATA CABLES

\$5.50 EACH

**KEY ASSEMBLY**

**5 KEY**  
\$1.00 EACH

CONTAINS 5 SINGLE-POLE NORMALLY OPEN SWITCHES. MEASURES 3 1/4" LONG

**6 KEY**  
\$1.25 EACH

CONTAINS 6 SINGLE-POLE NORMALLY OPEN SWITCHES. MEASURES 4 1/4" LONG

**SOLID STATE RELAYS**

**2 AMP**  
MOTOROLA #MP 120D2

RATED:  
CONTROL—3-6-6VDC  
LOAD—120VAC 2 AMPS  
T.T.L. COMPATIBLE  
SIZE: 1 1/2" x 3/4" x 1" HIGH

**\$3.50 EACH** 10 FOR \$32.00

**120V INDICATOR**  
NEON INDICATOR RATED 120 V 1/3 W MOUNTS IN 5/16" HOLE RED LENS  
**75¢ EACH** 10 FOR \$7.00  
100 FOR \$65.00

**BCD DIP SWITCH**

10 POSITION ROTARY SCREWDRIVER ADJUST. FITS 6 PIN DIP

**\$1.85 EACH**

**FREE! FREE! FREE!** SEND FOR **NEW 1984 48 PAGE CATALOG**

**MINIATURE TOGGLE SWITCHES**  
ALL ARE RATED 5 AMPS @ 125 VAC

**S.P.D.T. (on-on)**  
P.C. STYLE, NON-THREADED BUSHING  
75¢ EACH  
10 FOR \$7.00

**S.P.D.T. (on-on)**  
SOLDER LUG TERMINALS  
\$1.00 EACH  
10 FOR \$9.00  
100 FOR \$80.00

**S.P.D.T. (on-off-on)**  
SOLDER LUG TERMINALS  
\$1.00 EACH  
10 FOR \$9.00  
100 FOR \$80.00

**S.P.D.T. (on-off-on)**  
NON-THREADED BUSHING  
P.C. STYLE  
75¢ EACH  
10 FOR \$7.00

**S.P.D.T. (on-on)**  
P.C. LUGS, THREADED BUSHING  
\$1.00 EACH  
10 FOR \$9.00  
100 FOR \$80.00

**D.P.D.T. (on-on)**  
SOLDER LUG TERMINALS  
\$2.00 EACH  
10 FOR \$19.00  
100 FOR \$180.00

**EDGE CONNECTORS**

22/44 22/44 GOLD PLATED CONTACTS  
.156 CONTACT SPACING

**\$2.00 EACH** 10 FOR \$18.00

**5 STATION INTERLOCKING**

MADE BY ALPS  
3-2PDT AND 2-6PDT  
SWITCHES ON FULLY INTERLOCKING ASSEMBLY  
3 1/4" BETWEEN MOUNTING CENTERS.

**\$2.50 EACH**

**5 STATION NON-INTERLOCKING**

SAME AS ABOVE, EXCEPT EACH SWITCH OPERATES INDEPENDENTLY.

**\$2.50 EACH**

**ALL ELECTRONICS CORP.**

905 S. VERMONT • P.O. BOX 20408 • LOS ANGELES, CA 90008  
TOLL FREE ORDERS • 1-800-826-5432  
(IN CALIFORNIA: 1-800-258-6666)  
AK, HI, OR INFORMATION • (213) 380-8000

- QUANTITIES LIMITED
- MINIMUM ORDER \$10.00
- USA \$2.50 SHIPPING NO C.O.D.
- FOREIGN ORDERS INCLUDE SUFFICIENT SHIPPING
- CALIF RES ADD 6 1 2

CIRCLE 72 ON READER SERVICE CARD

# HOW TO SURVIVE 1984

## PROTECT YOUR PRIVACY

This palm sized system lets you know if anyone in the room is wearing a bug. With a series of lights the VL 34 even locates the source of transmission. It allows you to perform an electronic "sweep" with the same accuracy of professional systems. And it fits in your pocket to provide privacy wherever you go.

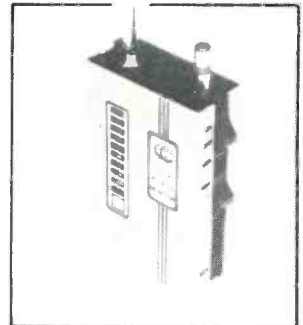

## FIND OUT WHO'S LYING

The VSA gives you a simple way to detect lies. It electronically analyzes a person's voice to detect tremors that the human ear can't even hear. A simple digital readout will help you identify who's lying — who's stealing — who your enemies really are!

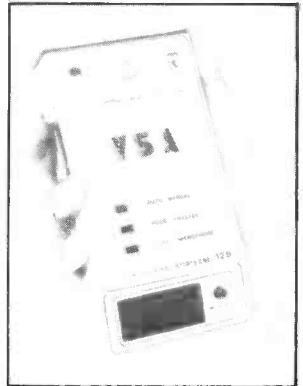

## INSURE YOUR TELEPHONE PRIVACY

One of the world's most sophisticated telephone privacy systems, the CC 7000 RC makes your conversation indecipherable to eavesdroppers. Every tenth of a second, the computer controlled CC 7000 RC automatically changes its own privacy codes. So interception is impossible. Only the legitimate speaking parties hear clear conversation.



Send \$50.00 for catalog and special report on how to protect yourself against bugging and wiretapping.

**CCS Communication Control Inc.** PopComm  
633 Third Ave., New York, NY 10017.

Enclosed is my \$50.00. Please send your literature.

Name \_\_\_\_\_

Address \_\_\_\_\_

\_\_\_\_\_ Zip \_\_\_\_\_

Phone \_\_\_\_\_

## CCS Communication Control Inc.

633 Third Ave., New York, NY 10017 212-697-8140 TX: 238720  
1010 Wisconsin Ave. NW, Washington, DC 20007 202-659-3432  
1435 Brickell Ave., Miami, Fla 33131 305-358-4336  
9465 Wilshire Blvd, Beverly Hills, Ca 90212 213-274-6256  
320 N. Michigan Ave., Chicago, Ill. 60601 (312) 726-0998  
6161 Savoy, Houston, Tx. 77036 713-781-0852

62 South Audley St., London W1 01-629-0223 TX: 8814709  
26 Place Vendome, 75001 Paris 297-56-00 TX: CCS 215524F

CIRCLE 67 ON READER SERVICE CARD

# PORTABLE ANTENNA

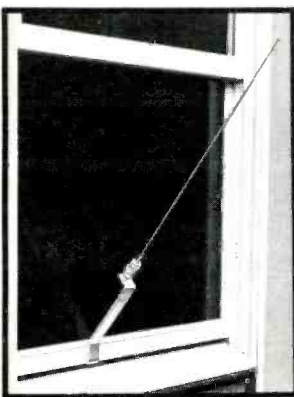

**SHORTWAVE LISTENING**

**MODEL ASW-5**

Designed for  
APARTMENTS  
MOTELS  
VACATIONS

PRICE  
**\$39.50**

Add \$2.00  
Shipping and Handling

The turn of a thumbscrew will install and remove this sturdy antenna and give you outdoor reception where conventional antennas are restricted. This window-mount antenna extends from 22 inches to 58 inches to provide coverage from 5 MHz to 100 MHz. Its 10 ft long coaxial cable connects to your shortwave or scanner receiver.

Write for more details and other B&W products



**ALL OUR PRODUCTS MADE IN USA**  
**BARKER & WILLIAMSON**

Quality Communication Products Since 1932  
At your Distributors. Write or call.  
10 Canal Street, Bristol, PA 19007  
**(215) 788-5581**



CIRCLE 33 ON READER SERVICE CARD

## INSIDE THE WORLD OF TVRO EARTH STATIONS

### Combating The Microwave Dilemma

It looks like 1984 is turning into an exciting year for the home satellite earth station industry. Sales projections for TVRO systems are placed at approximately 500,000 during the year's twelve months. Many of these systems are destined not for rural America, but rather for urban and suburbanites who wish to share in the satellite TV revolution.

Unfortunately, there is a significant problem awaiting would-be satellite earth station owners; interference caused by existing or future telephone microwave installations can degrade or even wipe out signals emanating from the satellites. Urban and suburban satellite earth station dealers and installers are already finding that terrestrial microwave interference presents the biggest obstacle to the successful completion of home earth station installations.

The average urban dweller probably doesn't even realize that he is bombarded daily by microwave signals originating from the center of our major metropolitan areas. These invisible information "highways" radiate outward from the communications "hub" to distant relay stations. During peak telephone traffic hours, these microwave

links are almost continually modulated by telephone calls or even business data transmissions. It is these communications transmissions which connect each city to countless other cities and towns across America and the world. While these signals are not strong enough to be a health hazard, they can wreak havoc upon your home satellite TV reception.

The problem exists today because both the satellites as well as America's telephone relay stations share the band of super high frequencies that lie between 3.7 and 4.2 GHz. If a telephone company's microwave signals pass through your backyard, they may be picked up by your antenna, amplified and passed on to your earth station receiver. In many cases, the interfering telephone carriers are significantly stronger than those emanating from the satellites, resulting in unacceptable interference to some or even all of the available transponders.

Any prospective earth station owner who lives in an urban or suburban environment is strongly urged to have a site survey conducted prior to purchasing a system. A local dealer can be employed to set up a portable

earth station on the same spot that the permanent installation would occupy. Then he or she can tune through the satellites to make sure that the reception will not be degraded by local telephone microwave traffic. In residential areas it is best to have the site checked during the evening hours, since this is the heaviest time for telephone use; in business areas, the site should be checked during business hours. If microwave interference should be discovered, in many instances the relocation of the antenna to a nearby spot will provide a marked improvement in satellite reception.

In some instances, there will be an unavoidable amount of telephone microwave interference at the site location and the owner will still want to obtain reception. We should also remember that many of today's TVRO systems could have a new relay system installed by a phone company sometime in the future, introducing interfering microwaves into your area. While commercial cable TV earth stations are licensed by the FCC to protect them from future interference from new telephone microwave facilities, the costs involved in licensing are too

- |   |   |
|---|---|
| <p>1 (H) Home Box Office (EAST). HBO is the most popular subscription television service available today. It has a wide selection of popular movies and special events.</p> <p>2 (V) The Nashville Network. Originates from Opryland and offers 24-hours-a-day of down-home entertainment, Nashville style. Much of the programming is centered around the country music industry, with shows like <i>Stars of the Grande Ole Opry</i>, <i>Off the Record Rack</i>, and <i>Nashville After Hours</i>. Country/western entertainment features game shows, sports, situation comedies, and live variety shows. Stereo.</p> <p>3 (H) HBO (WEST).</p> <p>4 (V) The Disney Channel (EAST). Walt Disney Productions offers 13-hours-a-day of family entertainment drawn from their extensive files of Disney movies, cartoons, and television programs. There are also new features created especially for the new cable services. The Experimental Prototype Community of Tomorrow (EPCOT) at Disney World provides a new Futureworld series that promises to open "new frontiers in entertainment, education, imagination, and discovery" for cable TV viewers nationwide.</p> <p>5 (H) Showtime. A 24-hour-a-day entertainment channel offering first-run movies, concerts, theater performances, and other special events.</p> <p>6 (V) Spanish International Network (SIN). Twenty-four hours of Spanish-language programming with feeds from Mexico, Spain, Argentina, Brazil, Chile, Puerto Rico, and Venezuela.</p> | <p>7 (H) Cable News Network (CNN). In-depth international news coverage with special sporting events and financial and weather reports.</p> <p>8 (V) CNN Headline News. A continually updated glance at the major news stories of the day.</p> <p>9 (H) Entertainment and Sports Programming Network (ESPN). Sporting events from around the world and related interviews and sporting news.</p> <p>10 (V) Showtime.</p> <p>11 (H) Continental Broadcasting Network (CBN). Christian family entertainment programming.</p> <p>12 (V) Home Team Sports.</p> <p>13 (H) C-SPAN. Live coverage of the House of Representatives in Washington, DC. It also covers related Congressional hearings and events.</p> <p>14 (V) The Movie Channel (WEST). 24-hour movie service.</p> <p>15 (H) WOR-TV. New York City's independent television channel 9.</p> <p>16 (V) The Movie Channel (EAST).</p> <p>17 (H) (TIME, INC.) Service unknown at press time.</p> <p>18 (V) WTBS. Turner Broadcasting Company's superstation from Atlanta, Georgia.</p> <p>19 (H) U.S.A. Network.</p> <p>20 (V) Galavision. Spanish language feature films, sports, and other special events.</p> <p>21 (H) Cinemax (EAST). Round the clock movies, family features, and special entertainment events.</p> <p>22 (V) (Westinghouse). Service unknown at press time.</p> <p>23 (H) (TIME, INC.) Service unknown at press time.</p> <p>24 (V) The Disney Channel (WEST). West coast edition of this service runs three hours behind the east coast feed.</p> |
|---|---|

Table 1

## Potential Antenna Interference Frequencies

Frequency (GHz)	Nature of Potential Offender	Frequency (GHz)	Nature of Potential Offender
0.960-1.350	Land-based air navigation systems	3.700-4.200	① Common carrier (telephone)
1.350-1.400	Armed forces		Earth Stations
1.400-1.427	Radio astronomy	4.200-4.400	Altimeters
1.427-1.435	Land-mobile: police, fire, forestry, railway	4.400-4.990	③ Armed forces
1.429-1.435	Armed forces	4.990-5.000	Meteorological—radio astronomy
1.435-1.535	Telemetry	5.250-5.650	Radio location (coastal radar)
1.535-1.543	SAT—maritime mobile	5.460-5.470	Radio navigation—General
1.605-1.800	Radio location	5.470-5.650	Maritime radio navigation
1.660-1.670	Radio astronomy	5.600-5.650	Meteorological—Ground based radar
1.660-1.700	Meteorological—Radiosond	5.650-5.925	Amateur
1.700-1.710	Space—research	5.800	Industrial and scientific equipment
1.710-1.850	Armed forces	5.925-6.425	② Common carrier and fixed SAT
1.990-2.110	TV Pick-up	6.425-6.525	Common carrier
2.110-2.180	② Public common carrier	6.525-6.575	Operational land and mobile
2.130-2.150	Fixed point-to-point (non-public)	6.575-6.875	Non-public point-to-point carrier
2.150-2.180	Fixed—omnidirectional	6.625-6.875	Fixed SAT
2.180-2.200	Fixed, point-to-point (non-public)	6.875-7.125	TV pick-up
2.200-2.290	Armed forces	7.125-8.400	Armed forces
2.290-2.300	Space—research	8.800	Airborne Doppler Radar
2.450-2.500	Radio location		
2.500-2.535	Fixed, SAT		
2.500-2.690	Fixed point-to-point (non-public)		
	Instructional TV		
2.655-2.690	Fixed, SAT		
2.690-2.700	Radio astronomy		
2.700-2.900	Armed forces		
2.900-3.100	Maritime radio navigation		
2.900-3.700	③ Maritime radio location		
3.300-3.500	Amateur radio		

*Interference frequencies listed in the order of occurrence on TVROs:*

- ① Telephone carrier spectrum co-located with TVROs.
- ② Widely distributed common microwave carriers.
- ③ Seldom occurring frequencies close to TVRO Band.

*Courtesy Microwave Filter Company, ASTI Handbook.*

high for the average TVRO owner to pursue. But if you find that terrestrial interference is encroaching upon your satellite TV reception, do not despair! There are ways of lowering or limiting the undesirable effects caused by terrestrial microwave interference. In fact, there is a new book that can answer almost any question that surrounds the microwave interference problem.

The Microwave Filter Co., of East Syracuse, NY, a firm dedicated to developing new and innovative techniques for the elimination of microwave interference, has produced a new book, *The Avoidance/Suppression Approach to Eliminating Terrestrial Interference at TVRO Earth Stations*. The *ASTI Handbook* is truly a godsend for TVRO technicians who are unacquainted with the field. Glyn Bostick, the founder, president, and chief engineer of the company has been designing filters for the suppression of interference in cable TV systems, industrial and defense communications equipment, and satellite earth stations since 1967. His pioneering series of articles which originally appeared in *CATJ* magazine have educated a whole generation of cable TV technicians to cope in a microwave saturated environment. Today, the Microwave Filter Co. is the main supplier of filters and microwave detection equipment for the private satellite earth station marketplace, as well as America's cable TV industry.

But how do you identify Terrestrial Interference? TI typically looks like weak reception, with the appearance of impulse noise

or "sparklies," in the video. Real strong terrestrial interference will totally blank out your TV screen, totally eliminating the incoming satellite signal. TI will usually affect some but not all transponders on a satellite. Depending on the direction of the incoming interference, TI will affect certain satellites, while others will be clear. TI will also show up heavier at certain times of the day, corresponding to peak telephone traffic periods. The following series of photographs reproduced from the *ASTI Handbook* illustrate the levels of interference which you may experience (See illustration).

The *ASTI Handbook* provides a detailed description of the various techniques used to identify and eliminate unwanted interference. Subjects discussed include: Sources of terrestrial interference; symptoms of terrestrial interference; selection of dish antennas and other TVRO equipment for the most rejection of Terrestrial Interference; earth station site location and installation tips; how to perform a microwave site survey; the use of artificial shield to block TI out of the dish; and the successful use of microwave filters, traps, and detection equipment. The book also provides an excellent introduction to satellite earth station reception techniques.

I would recommend this book highly to anyone seriously involved in today's home satellite earth station marketplace and to individuals who want to expand their technical knowledge in this area. For those who would like to obtain hands-on experience in

this field, the Microwave Filter Co., holds regular seminars at their facilities in New York. For further details, contact Bill Bostick, Associate Director, Microwave Filter Co., 6743 Kinne Street, East Syracuse, NY 13057. The phone number is 315-437-3953.

In last November's column, the launch of the Galaxy I satellite was discussed and a preliminary transponder assignment chart was provided. For the first few months of operation, activity on Galaxy I was limited to the SIN and Galavision services, with other transponders occasionally used for scrambling experiments by Home Box Office. Since the beginning of the year, several additional video services have relocated onto Galaxy, making the satellite a viable alternative to Satcom IIIIR for cable TV systems around the U.S. HBO and Turner Broadcasting have also announced plans to offer scrambled program services off of Galaxy direct to the home earth station owner for a monthly subscription fee. The Galaxy satellite is so powerful that noise-free reception of all transponders can be accomplished with the use of a six foot dish from locations throughout the continental U.S. Table 1 presents the program lineup as this article is being written.

If you would like to learn more about satellite television, *The World of Satellite Television* by Jeffrey Keating and Mark Long is available from Solar Electronics International, 156 Drakes Lane, Summertown, Tennessee 38483. The price is \$9.95. Please include \$1.00 for postage and handling.

# LISTENING POST

BY GERRY L. DEXTER

## WHAT'S HAPPENING: INTERNATIONAL SHORTWAVE BROADCASTING BANDS

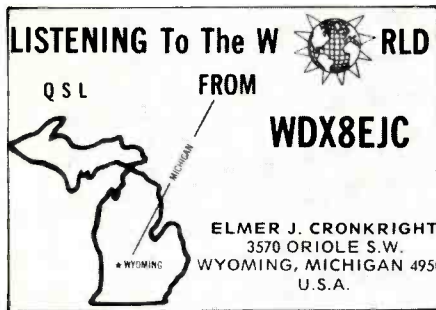

Elmer J. Cronkright sent us a copy of his SWL card which he designed himself.

Radio Marti begins regular broadcasts, we predict countermoves by Cuba—on medium wave, shortwave, or both.

In Honduras, Radio Landia at Comayagua has returned after an absence of several years. You'll find them during early mornings and local evenings on 4.965.

Guatemala's La Voz de Atitlan, near Lake Atitlan, has also returned to the air, although at present the station operates during local daytime only on 2.390 with just 500 watts. There may have been an expansion into evening broadcasts by now, but even so, reception won't be a snap.

### Club Notes

One of the best kept club secrets around is the Ontario DX Association, which will celebrate its tenth anniversary this summer. ODXA puts out an excellent monthly bulletin called *DX Ontario* that is devoted almost exclusively to shortwave broadcast. Well done feature articles and a nice list of loggings and other news make up the rest of the fare.

Subscriptions are \$20 per year in the U.S. (\$19 in Canada). Sample copies of the bulletin are \$1.50. Write to Cedric Marshall, Membership Secretary, P.O. Box 232, Postal Station Z, Toronto, Ontario M5N 2Z4, Canada, for more information.

The El Paso DX SWL Club sends along an invitation to all SWLs and "communications buffs" in the El Paso, Texas area to attend their meetings, which are held on the third Thursday of each month at the W5ES/El Paso Amateur Radio Clubhouse. For more information contact Herbert Gehring, Box 12553, El Paso, Texas 79913.

### Clandestine Confidential

The upsurge in interest in clandestine broadcasting over the past couple of years has lead to a new book with the above title. Authored by your editor, it should be available now from Universal Electronics and other SWL book distributors. It provides a full review of the clandestine scene with information on clandestine DXing and QSLing. We don't have a definite price yet. As a companion piece to the book, the *Clandestine Confidential Newsletter* is being published by ye ed every other month. The newsletter will provide the latest information on new stations, schedules, background information, addresses, and the like. Subscriptions are \$10.00 in the U.S., \$13.00 foreign from RR4, Box 110, Lake Geneva, WI 53147.

### Mail Call

Lots of letters again this month and that's good, because we always enjoy hearing from you.

The Voice of America QSLs a Cuba Inde-

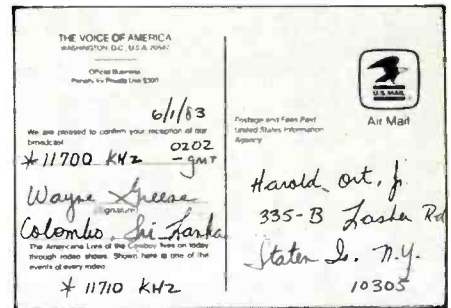

Harold Ort Jr's oddball VOA QSL.

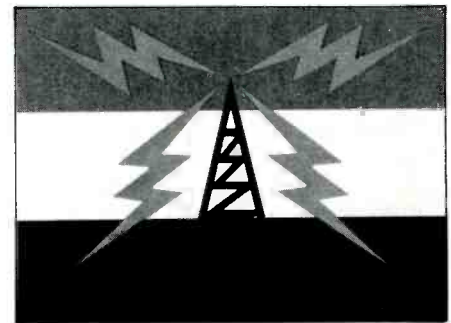

The QSL from Radio Vatan, one of the anti-Iranian clandestines.

pendiente y Democratica transmission?! Harold Ort of Staten Island, New York sent the VOA a report on the CID broadcast over Radio Clarin, "just for kicks." He was amazed to get a QSL back. Harold guesses the VOA didn't realize what they were responding to. They did correct the frequency though!

Jim Willett of Grimsby, England forwards a QSL from Radio Vatan, the anti-Iranian clandestine and notes that they sent him four of them. Yes Jim, that seems to be the practice. Some DXers report as "few" as three, others as many as six!

Kelly R. Masters of Roswell, New Mexico writes to defend the Voice of Free China against accusations of lengthy replies, saying he got his reply in less than two months and with it a whole package of goodies. Well, you've proved again, Kelly, that reply times from stations are highly variable. While a few are consistently fast or slow, most can take from a few weeks to several months.

Loy W. Lee checks in from Eastern Kentucky University where he is Assistant Manager of the university station, WEKU-FM. Loy's been in SWLing since 1958, has a variety of receivers and mentions that he gets together regularly with others in the area (including an old friend of ye editor's!) Area get togethers are great, Loy. They're always fun and often very educational.

Syria and Lebanon are so-far unlogged targets of John Dildy of New Orleans. As we noted, nobody's heard Syria on shortwave



for some years but that should change soon. As for Lebanon, try 9.660 or 11.955 around 0230 for English from Radio Lebanon. John also wants to know if they verify reports. Syria used to. Radio Lebanon is a fair replier. Just "Lebanese Broadcasting Station, Beirut, Lebanon" is all you really need for an address.

Strange goings on with Radio Havana Cuba are reported by Carl Gilkes of Brooklyn. He heard Havana at 0100 announcing 6.090 but actually on 5.995 interfering with the VOA. Later he heard them on 6.130, announcing 6.090 and again causing the VOA QRM. Perhaps the Radio Marti games have already started? Giving the frequency of 6.090 on the air would serve as a sort of "who, us?"

Tom Stovall, Jr., of Haleyville, Alabama wants to join a southern-based DX club. You might write to DX South Florida, 3156 NW 39th Court, Ft. Lauderdale, FL 33309, Tom. We're not sure if they're in a position to accept new members at the moment, but give them a try.

Jim Hall of Pittsburgh is a fan of Radio Earth International and points out that REI now has a weekly communications magazine show called "Dialogue," airing on Sunday nights local (Mondays, GMT) at 0400. REI is on the air nightly at 0400 to 0500 over WRNO on 6.185 MHz. Reports go to Box 69, Miami, Florida 33243.

Amateur operator Neil Swanson of St. Paul, Minnesota wonders about a BBC transmission he logged on 3.975 in the



*Avec les compliments de*  
**l'Office de Radiodiffusion et Télévision du Bénin**  
**ORTB**  
**LA VOIX DE LA REVOLUTION**  
 B. P. 366 - COTONOU (REPUBLIQUE POPULAIRE DU BENIN)

This attractive reply from Benin belongs to Harold Ort, Jr.

midst of the 75 meter amateur band. Neil wonders if this is legal. Sure is—3.900 to 4.000 is a legally designated broadcasting range (although not for stations in North America). The BBC, Swiss Radio, Radio Free Europe, The VOA (in Germany), and quite a number of Asian and African stations operate in this range. No transmissions are beamed to North America in this range, but a lot of the stations can be heard.

Rick Krzemien of Carol Stream, Illinois uses a Kenwood R-600 receiver with a Yaesu FRA-7700 active antenna. Rick likes listening to stations in the Middle East and Far East. Normally we don't use medium wave loggings Rick, unless there's some

kind of special connection to shortwave. That's the bottom of the bag. Let's hear from you next month!

### Listening Reports

- Here's what's on. (All times are GMT)
- Albania** Radio Tirana noted on 7.120 at 0245 with English to 0258. (Besal, VA)
  - Algeria** Radio Algiers was heard in English on 17.745 at 2000 with news and popular vocals at a very strong level. (Krzemien, IL) On 9.640 from 2000 to 2200 in French. Good signal. (Gagnon, Que)
  - Antarctica** Radio Nacional Arcangel San Gabriel from Base Esperanza logged in Spanish on 15.474 at 2300 with classical piano, several IDs. Weak. (Krzemien, IL)
  - Australia** Radio Australia on 11.790 at 1540 with English including news and stock exchange. Excellent. (Ort)

The new Sony ICF-2002 is here! From one of America's largest Sony SWL dealers.



Reg. \$249.95  
 INTRODUCTORY SPECIAL  
**\$224.95**  
 Plus \$3.00 UPS

**AVAILABLE NOW!**

## MAKE WAY FOR THE NEW LEADER IN SW!

After selling over 1,000 ICF-2001's we didn't think Sony could top this performer, but they did!

### FEATURES

- Ten memory channels • 12/24 hour quartz clock • PLL tuning for drift-free performance • Dual conversion Superheterodyne for high sensitivity • SSB/CW

### SPECIFICATIONS

- 150 kHz-30 MHz AM, 76-108 MHz FM • 1 uV sensitivity @ 6 dB S/N @ 10 MHz • 72 dB @ 10 MHz image ratio • 3 kHz @ -6 dB

Reg. \$179.95  
**Now only \$96.50**  
 plus \$3.00 UPS



### SONY ICF-6500W

- "The 6500W performs on a par with models in the \$200-300 price range" (World Radio TV Handbook)
- Digital LCD display for accuracy
- Dual Conversion Superheterodyne
- BFO for SSB/CW • 1 uV Sensitivity
- AFC for FM • AC/DC power

SONY		PANASONIC	
AN1	\$ 79.95 + (\$ 3 UPS)	RF9	\$ 89.95 + (\$2 UPS)
ICR4800	69.95 (\$ 2 UPS)	RFB50	139.95 (\$2 UPS)
ICF7600A	119.95 (\$ 2 UPS)	RFB300	229.95 (\$3 UPS)
ICF6800W	549.95 (\$10 UPS)	RFB600	499.95 (\$9 UPS)
AC9W	12.00 (\$ 2 UPS)	RF799	229.95 (\$3 UPS)
AC160W	14.00 (\$ 2 UPS)	RF1405	69.95 (\$3 UPS)
DCC127	29.50 (\$ 2 UPS)	RF3100	289.95 (\$5 UPS)

ICOM	
ICR70	\$639.95 (\$9 UPS)
DRAKE	
R7A	\$1479.00 (\$9 UPS)
AMECO	
PLF2 Preamp	\$52.95 (\$3 UPS)
EAVESDROPPER	
SWL Dipole	\$59.95 (\$3 UPS)
MFJ	
1020	\$79.95 (\$2 UPS)
752B	89.95 (\$3 UPS)
304	79.95 (\$2 UPS)
308	99.95 (\$2 UPS)

PUBLICATIONS	
(\$2 UPS 1st book, ea additional book add 50¢ UPS)	
World Radio TV Handbook, 1984 Edition	\$17.50
SWL Manual of Non Broadcast Stations	12.95
How to Tune the Secret Shortwave Spectrum	7.95
The Complete Short Wave Listeners Handbook	11.95
Short Wave Listeners Antenna Handbook	9.95
Whites Radio Log	4.95

Shipping charges in parenthesis are for continental U.S. only. International orders write for pro forma invoice. Illinois residents please add 7% sales tax.

Phone: (312) 848-6777



**SPECTRONICS, INC.**  
 1009 GARFIELD ST. OAK PARK, IL. 60304

Spectronics Sponsors "The World of Radio" With Glen Hauser on WRNO 05:30 GMT Fridays on 6.185 MHz.



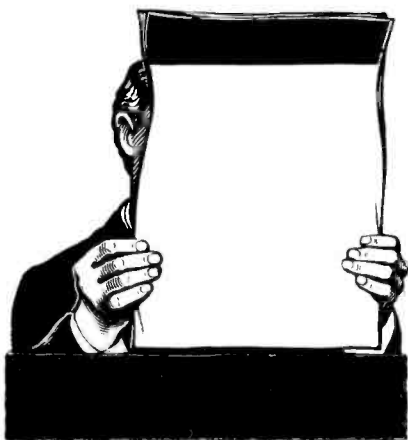

## The Clandestine Confidential Newsletter

A new publication devoted to clandestine stations and programs, *The Clandestine Confidential Newsletter* is designed to keep you up to date on this intriguing aspect of shortwave listening and DXing.

C-C-N will be published six times a year, beginning with the February, 1984 issue. It will contain the latest frequency and schedule information, monitoring data, background information, addresses, and features on new and old stations.

C-C-N will serve as a continuing updater to the new book *Clandestine Confidential*, being published by Universal Electronics.

Subscriptions to C-C-N are \$10.00 per year in North America, \$13.00 overseas, payable in cash, check or money order.

To subscribe, send your remittance to:

C-C-N,  
Gerry L. Dexter,  
RR4 Box 110,  
Lake Geneva, WI 53147, U.S.A.

# SWL

## DE RADIO ABIDJAN

**MERCI POUR VOTRE REPORT  
CONCERNANT NOTRE EMISSION**

A — a — b — c — d — X — Y — Z  
 B — a — b — c — d — X — Y — Z  
 C — a — b — c — d — X — Y — Z

**Heure GMT**

a — 06 h 00 à 00 h 00  
 b — 06 h 00 à 00 h 00  
 c — 06 h 00 à 00 h 00  
 X — FRANÇAIS  
 Y — VERNACULAIRE  
 Z — ANGLAIS

A = 11 920 kc/s 100 kW  
 B = 7 215 kc/s 1 kW  
 C = 4 940 kc/s 25 kW  
 D =  
 E =

B.P. V 191 ABIDJAN (COTE D'IVOIRE)

*We know people who've spent years trying to get a card like this. Harold Ort Jr. proves it can be done.*

NY) 11.790 and 9.580 from 1430 to 1600. (Stovall, AL) ABC Perth on 9.610 at 1220 with music and ads. (Gonzalez, SD) 9.580 with music at 1531. (Shakir, PA)

**Bangladesh** Radio Bangladesh, at 1230 in English with news and commentary on 17.800. (Krzemien, IL)

**Benin** Contonou found on 4.870 in French from 2215 to 2300. (Gagnon, Que)

**Brazil** Radio Nacional Amazonas, 11.780 heard at 2114 with Latin music. (Shakir, PA) Radiobras on 11.780 and 15.445 in Portuguese at 2100; 15.270 in French from 2000 to 2100. (Gagnon, Que)

**Bulgaria** Radio Sofia on 9.700 at 0021 to 0045 with "Midweek Mailbag," folk songs, and Bulgarian culture. (Tomasevich, IL) At 0023 with sports news. (Shakir, PA) On 7.115 in English with news at 0410. (Besel, VA)

**Cameron** Radio Yaounde, 9.745 at 2025 in French. (Gagnon, Que) Douala with interval signal and news in English 2102-2117. (Quaglieri, NY)

**Canada** CHNX on 6.130 at 1145 with music, time checks, weather, ads, pop music. (Paszkievicz, WI) Radio Canada International on 17.820 at 1600 with news and "Sunday Morning" program. (Ort, NY)

**Cape Verde** Voz do Sao Vicente, on approximately 3.931 at 2359 with a short identification, march, and sign off. (Quaglieri, NY)

**Clandestines** 5.700 unidentified from 0346-0351, all Spanish with prayer by woman over "Ave Maria," many mentions of Nicaragua, no ID at sign off. (Bergadano, NY) Probably La Voz de Nicaragua Libre, one of the ARDE stations. (Editor)

La Voz de Sandino, tentative 6.220 at 1253 sign off in Spanish. Revolutionary song, gunfire, and off. Possibly the one heard on 6.600 around 0304. (Bush, OH)

**Colombia** Radio Sutatenza, 5.095 at 0350 in Spanish. (Gonzalez, SD)

**Congo** RTV Congolaise, 9.715 in French at 2012. (Quaglieri, NY)

**Costa Rica** Radio Impacto, 6.150, at 1201 with frequent IDs, mentions of "Impacto." (Bush, OH) At 1105 with upbeat music and ads. Excellent signal. (Ort, NY)

Radio Columbia, 4.825 at 0325 with music and ads. Excellent signal. (Gonzalez, SD) 0238 with what was believed to be a political event. (Quaglieri, NY)

Radio Reloj, 4.832 at 0046 to 0104 with news in Spanish, mentions of "Nicaragua Liberté" and "amigos en Nicaragua." (Bergadano, NY)

**Czechoslovakia** Radio Prague's North American Service runs 0100 to 0157 and 0300 to 0357 on 5.930, 7.345, 9.540, 9.630, 9.740, and 11.990 (Besel, VA)

**Dominican Republic** Radio Clarin, 11.700 at 2200 with interval signal and ID. (Bush, OH)

**Ecuador** HCJB with "DX Party Line" at 0300 on 9.745. (Tomasevich, IL) Time station HD210A on 3.810 at 0812. (Shute, FL)

**Egypt** Radio Cairo, 9.805 at 2117 with news and music. (Shakir, PA)

**El Salvador** Radio El Salvador in English at 2306 on 11.985 with talk on Soviet aggression. Taped announcements saying it was their first English transmission although the same tape heard two days later. English to 2231, then into Spanish. (Shute, FL)

**Ethiopia** Voice of Revolutionary Ethiopia on 9.595 heard with march and short talk in local language at 1940. (Quaglieri, NY)

**France** RFI with Paris Calling Africa on 15.300 at 1640. ID and address of Box 9516, Paris. (Ort, NY) On 6.140 at 0100 in French. (Gagnon, Que)

**French Guiana** Radio Cayenne, in French at 0905 on 5.055 with U.S. and French pops. (Shute, FL)

**Gabon** Africa Number One on 4.810 in French at 2257 when it disappeared. (Ort, NY) At 2230 in French. (Gagnon, Que)

**Greece** The Voice of Greece in English on 9.865 from 0345 to 0350 with news. (Besel, VA)

**Guam** KYOI, 9.670 mentioning "shortwave from Los Angeles" at 1715 with rock, many IDs, announced as 24 hours a day. (Gonzalez, SD) It's programmed in Los Angeles. (Editor)

**Guinea** La Voix de la Revolution, Conakry, 15.310 believed the one here in French at 2358. (Shute, FL) At 1800 in French. Seeming news, music, talk program. Good level. (Ort, NY)

**Haiti** 4VEH on 4.930 from 2330 to 0300 in Creole and French. Very good audio. (Gagnon, Que)

**Iran** Voice of the Islamic Republic of Iran at 2230 on 9.022 in Arabic. (Shakir, PA) 15.084 in Farsi at 1315, then English announcement address and request for letters. (Krzemien, IL) Has anyone received those anti-U.S. postage stamps from Iran? (Editor)

**Iraq** Radio Baghdad in an unknown language at 2031 on 9.610. Frequent IDs by man and woman. Seemed German although that's not listed for Iraq in WRTVH. (Shute, FL)

**Italy** Italian Broadcasting Corporation, (pirate, Editor) on 7.310 at 1909 in Italian. (Quaglieri, NY)

**Ivory Coast** Radio Abidjan, 4.940 at 2231 in French. (Gagnon, Que) On 7.215 with French talk about the country's problems at 0648. (Quaglieri, NY)

**Lebanon** Radio Lebanon, on 11.955 at 0230 to 0300 in English with "Lebanon Today." (Conkright, MI)

**Liberia** ELWA, 4.765 at 2203-2215 with relay of VOA English news to 2209, then regional news followed by a religious program. Interference from the Cuban "Mayak" transmitter. (Bergadano, NY) On 11.755 at 2005, ID in English and French following Arabic segment. (Gagnon, Que)

ELBC, 3.255 with commercials at 2206. (Quaglieri, NY) Request program 2200 to 2300 with ad for Johnson prickly heat powder and rundown on LBS raffle prizes. (Conkright, MI)

**Malta** Radio Mediterranean, 6.110 at 2200 at 2230 in French. (Gagnon, Que)

**Mauritania** Radio Mauritania, 4.845 at 2215 in Arabic. (Gagnon, Que)

**Mexico** Radio Mexico, 11.770 at 0100 in Spanish. (Gagnon, Que) XEQM, 6.105 with U.S. pops, distorted audio, mentions of "Pantera" (pather, Editor) at 0224. (Quaglieri, NY)

**Monaco** Trans World Radio on 9.493 at 0800 in English, religious programming, "Your Worship Hour." (Krzemien, IL)

**Namibia** Radio Southwest Africa at 2244 on 3.270 with old pop tunes. German language ID at 2245. Not much talk. (Shakir, PA)

**Nepal** Radio Nepal, 5.005, weak but readable from 1147 to about 1240. (Quaglieri, NY)

**Netherlands** Radio Netherlands with English on 6.165 in parallel to 9.590 on 0319-0325 sign off. (Besel,

VA) "Happy Station" program on 11.740 at 1900 to 1920 sign off. (Shakir, PA)

**Nigeria** Radio Nigeria on 7.255 at 2130 in French. (Gagnon, Que)

Radio Nigeria, Kaduna, 4.770 from 0600 to 0617 with English news, list of Nigeria's new leaders who took over after the coup. (Bergadano, NY)

Voice of Nigeria, 15.120 at 2130 to 2140 with news in English. (Gonzalez, SD)

**Pakistan** Radio Pakistan on 15.565 at 1600 with world news in slow-speed English. Slow, deep fades. (Krzemien, IL)

**Peru** Radio Satellite, 6.725 at 0330 with Indian flute music and talk in Spanish. Off at 0402. (Shute, FL)

**Senegal** Radio Dakar, 4.890, at 2230 in French. (Gagnon, Que)

**Sierra Leone** Sierra Leone Broadcasting Service 5.980 at 2035 with ID and news in English at 2035. (Quaglieri, NY)

**South Africa** Radio RSA's "DX Corner" heard Saturday at 0200 on 9.615. (Tomasevich, IL)

**Spain** Time Station EBC at San Fernando logged at poor level at 1010 on 12.008. (Shute, FL)

**Sri Lanka** The VOA Colombo relay station on 15.395 at 1730 with news in special English and the "Magazine Show." (Krzemien, IL)

**Swaziland** Trans World Radio with interval signal on 9.730 at 0424, mixing with Havana. (Quaglieri, NY)

**Switzerland** Swiss Radio International on 15.430 at 1535 with English news and comment. Voice of America QRM. (Ort, NY) English schedule is 0145 on 6.135, 9.635, 9.725, and 11.715; 0430 on 9.725, 11.715; 0700 and 0900 on 9.560, 15.305, 21.520, 21.695; 1100 on 15.430, 17.795, 21.520, 25.780; 1315 on 21.570; 1530 on 11.805, 15.430, 17.830, 21.520; and 2145 on 15.570. Swiss Shortwave Merry Go Round still scheduled for the 2nd and 4th Saturdays. (Tomasevich, IL)

**Taiwan** Voice of Free China, via WYFR, 5.985 at 0516 with news, commentary in English, top pops in Taiwan to 0546. (Tomasevich, IL)

**Thailand** Radio Thailand, 9.650 instead of nominal 9.655 at 1200. News and "Saturday Evening Mailbag" in English. (Krzemien, IL)



This SWL card shows the attractive shack of Jim Willett in England.

**Togo** RTV Togolaise, 5.047 from Lome at 0621 in French. Very strong. (Bergadano, NY)

**Tunisia** Radio Tunis, 7.225 at 2100 in Arabic. (Gagnon, Que)

**Turkey** Voice of Turkey, 9.650 at 2205 with news, Review of the Turkish Press. (Bush, OH) Strong at 2215 with "Newsreel." (Shakir, PA) In English at 0330 with DX program, Letterbox. (Besal, VA)

**Uganda** Radio Uganda, 5.027 at 0405 with English news about Africa. RTTY QRM. (Paszkievicz, WI) At 0300 with pop music, news in English and vernaculars. (Conkright, MI)

**United Arab Emirates** Dubai Radio on 9.595 with English to North America at 0330. (Quaglieri, NY)

**United States** WINB, Red Lion, PA on 17.730 at 1930 in English. (Gonzalez, SD) 15.145 to western Europe and North Africa to 2345 and on to South America at 2347. (Tomasevich, IL)

Radio Earth via WRNO, 6.185 at 0400 to 0500. (Tomasevich, IL, and Paszkiewicz, WI)

WRNO, 15.420 with rock and commercials at 2000. (Tomasevich, IL)

**Uruguay** Radio El Espectador, 11.835 at 0023 in Spanish with talk, IDs, mention of Nicaragua. Abruptly off at 0030. (Paszkievicz, WI)

**USSR** Radio Tashkent, 9.600 at 1407 with news, music, interview to 1430 sign off. (Paszkievicz, WI) Radio Kiev, 15.240 at 0030 to 0100 with DX program on a Wednesday. (Stovall, AL) Both via Moscow facilities. (Editor)

**Venezuela** Radio Lara, Barquisimeto, 4.800 with Spanish DJ program and ID at 2254. (Ort, NY)

Radio Rumbos, 4.970 at 1018 with local ads and music, all Spanish. (Gonzalez, SD)

La Voz de Carabobo, 4.780 heard signing off at 2202. (Quaglieri, NY) Is that time correct? (Editor)

Radio Mara, tentatively heard on 3.275 in Spanish at 2236. (Shakir, PA)

**Vietnam** Voice of Vietnam, 12.035 at 2303, very weak with woman announcer speaking fairly rapidly. (Shakir, PA) On 15.010 at 1330 with world news and "Popular Music in Vietnam" in English. (Krzemien, IL)

**Yemen Arab Republic** Radio San'a, news in Arabic on 9.780 at 2000, fair. (Krzemien, IL) 9.780 and parallel to 4.853 at 2035. (Quaglieri, NY)

**Yugoslavia** Radio Belgrad, 9.620 at 2115 with a 15 minute newscast in English. (Krzemien, IL)

Don't forget, we'd love to hear from you with your reports, questions, shack photos, QSL copies, comments, schedules, and so on. We'll look for a letter from you soon.

Our thanks to: Al Quaglieri, Albany, NY; Rick Krzemien, Carol Stream, IL; Pierre Gagnon, Dorval, Quebec; Hassa Shakir, Monaca, PA; Bob Besal, Virginia Beach, VA; Michelle Shute, Pensacola, FL; Daniel Tomasevich, Berwyn, IL; Richard A. Gonzalez, Box Elder, SD; Elmer J Conkright, Wyoming, MI; Harold Ort Jr., Staten Island, NY; Tom Stovall Jr., Haleyville, AL; Sheryl Paszkiewicz, Manitowoc, WI; Bill Bergadano, Staten Island, NY; and Dave Bush, Sebring, OH.

Thanks to all of you. Til next month, good listening!

## ★ CAN YOU? ★

Electronically listen thru any wall? See in the dark cheaply? Read thru an envelope with a \$1.00 chemical? Obtain UNLISTED phone numbers? Open virtually any lock or safe in seconds? Tail anyone? Ditch a tail? Beat the lie detector? Run a driver's license or motor vehicle check? Trace anyone, anywhere? Save 30%-500% on surveillance gear? Get birth, death and real property records? Beat private detectives at their own game? Scramble any conversation? Defeat bug and recorder detectors?

HOW TO GET ANYTHING ON ANYBODY. By Lee Lapin...

An encyclopedia of CIA type tricks.

"The most dangerous book ever published"-NBC Newscaster. "One hell of a book, for the first time anyone can access intelligence secrets."-Nat News Service. "An A to Z handbook on all phases of undercover operations...A must for PI's, cops, agents..."-Popular Communications. "This book lives up to it's name....Key CIA type manual."-Police Times.

\$30.00 and well worth every cent!!!

Quaalude



380 Auto

**POLICE IDENTIFICATION GUIDE!**  
The First (and only) Guide To The ID Game; Photos, Drawings and Text show how to:

Figure speed and circumstances by skid marks, ID people, cars, tires, clothes, hats, bullet wounds and markings, drugs, hazardous materials and so on...

**Motor Vehicles:** Location of VIN numbers, motorcycle ID's, all state registration info, driver's license info (with photos) boat ID details...

Full color pill/drug guide for those things lying about, first aid guide, emergency situation guide, even Spanish/English phrases for emergencies!! By Police, For Police-New and Very Complete!!

We didn't write it, but we love it!! On the scene, in court, on the spot! \$26.00.

## CONFIDENTIAL!!!

"A through mastery of the materials herein will let you handle all normal police duties including major criminal investigations..."

Search a car-Find drugs  
Search a home-Act in court  
Collect evidence-Prepare a case  
Run legality checks-Question anyone  
Trick confessions-Analyze crimes

## THE LAW ENFORCEMENT HANDBOOK

"On initial contact...This statement implies you are not out to get him... If you feel any misgivings about using trickery...Remember that courts over the years have ruled...Are admissible as long as the tricks employed are not likely to have.... Never reveal all you know, you will need ammunition for...Consider searching these areas...On stopping the suspect vehicle...You may be able to search without a warrant...Here's how..." A Must In Every Glove Compartment!! Know your Rights! \$26!.



# ORDER TODAY BY MAIL OR TOLL FREE TELEPHONE!!

VISA, MC ORDERS ONLY: 800-662-8112 in PA 800-662-2444 or mail  
TOTAL + \$4.00 postage to Auburn-Wolfe Co. Box 623, Holmes, PA 019043 Dept 100

CIRCLE 68 ON READER SERVICE CARD

## THE EXCITING WORLD OF RADIOTELETYPE MONITORING

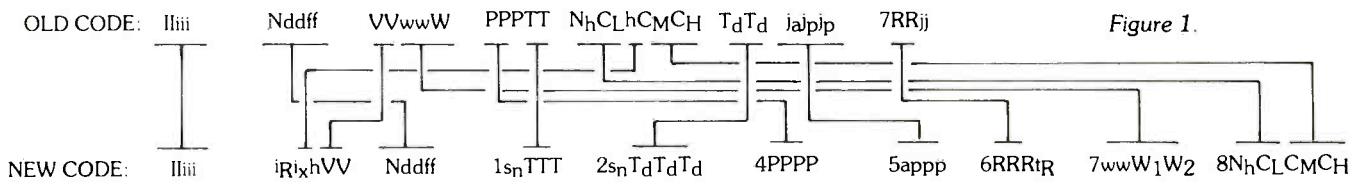

Figure 1.

A great deal of interest has been sparked over receiving weather RTTY information as evidenced by our reader response to our past column detailing the deciphering of RTTY weather codes. Also, as reader Thomas Van Kuihen correctly points out, the official weather codes have been modified somewhat. The amount of weather information has been increased and the corresponding line length increased. Another special phenomena group for reporting water temperature and the 5-digit code group position has been added. Refer to Figure 1 for the recent modified RTTY weather format as supported by the National Oceanic and Atmospheric Administration. The surface synoptic code is the first large scale change in the synoptic code form since it was introduced in 1949. This common code replaces all surface synoptic codes in use before 1983.

The first group will always be the station's index number IIiii. The World Meteorological Organization (WMO) assigns block numbers to individual countries and the countries will assign the specific station numbers. The first two digits (II) represent the block number and iii is the station number.

Volume A, WMO Publication No. 9, *Weather Reporting Observing Stations* is a list of all these index numbers in the world. *The Communications Handbook No. 4* lists only the index numbers for stations in North America, Central America, the Caribbean, and some stations in the Pacific.

The following list indicates location:

- Block numbers 70-Alaska, Alaskan Station numbers increase numerically from north to south and from west to east.
- Block number 71-Canada, St. Pierre, and Miquelon.
- Block number 72 and 74-United States.
- Block number 76-Mexico. The station numbers have been assigned so that they increase numerically from north to south and from west to east.
- Block number 78-Bermuda, Bahamas, Turks Island, Cuba, Central America, and the West Indies.
- Block number 91-Islands in the North Pacific Ocean. Station numbers in Block 91 increase from north to south and from west to east.

For example, New York Meteorological transmitters would be index number 74486 (J. F. Kennedy Int.) or 72503 (La Guardia).

New York can be found at 8130.0 kHz,

75 baud. Miami is denoted as 72202. Many of the meteorological RTTY sources use a 75 baud transmission rate. Miami can be found at 8140.0 kHz, 5925.0 kHz, 3235.0 kHz, 12175.0 kHz, and 4061.0 kHz.

Mobile Radio Alabama at 8707.0 kHz does not use Baudot as the others mentioned but forward error correction code or FEC. This is a seven bit code that uses a constant 4/3 work to space ratio. FEC allows errors to be reliably detected and corrected increasing the quality and integrity of the received RTTY data. Of course, the same weather numbers are used after being converted to FEC. The U.S. Coast Guard in Boston also uses FEC at 13020.0 kHz.

Boston has an index of 72509. The weather RTTY reception is usually quite good due to the omnidirectional antennas required for ship coverage. As contrasted with the typical 75 baud used in the U.S., we

find most foreign meteorological stations use 50 baud such as Warsaw Metro found at 7997.0 kHz. Don Saunders reports Miami Metro is found at 18763.0 kHz transmitting RTTY at 75 baud (100 WPM). Let us hear more information (frequency, shift, baud rate) from our weather RTTY DXers. Eugene Krolak writes to inform us that the *World Wide Marine Weather Broadcast Book* is now available from the Superintendent of Documents, stock number 003-017-00515-1 for \$8.50. Eugene also found non-standard shorthand used by the Coast Guard on 8455.0 kHz.

The five digit group following the station index is the precipitation group CrixhVV. The first number iR indicates if the precipitation data is included (1,2) or omitted (3,4). The transmitting station may be automatic or manned and ix indicates 1,2,3 for manned and 4,5,6 for automatic. Cloud

2	ZCZC WBC886
3	
4	SMVX1 KWBC 270000
5	
6	BBXX
7	
8	GRHP 27003 99265 71145 42498 12814 10184 2015/ 40137 57003 70200
9	
10	81100 22233 00205 20202 330// 40403=
11	
12	GCCU 27003 99164 51134 41598 20713 10265 20204 40116 56012 70200
13	
14	82200 22253 00262 20302 312// 40503 5////=
15	
16	
17	
18	
19	NNNN
20	
21	
22	ZCZC WBC887
23	
24	SMVF2 LFFW 270000 RTD
25	
26	BBXX
27	
28	SHIP 27004 99303 70449 42598 41013 10200 20176 40279 52013 70210
29	
30	822// 22223 00213 20302 304// 4//// 5////=
31	
32	FNVD 27004 99492 70040 41/97 82238 10085 20074 49869 5758917+360
33	
34	8//// 22213 00/// 2////=
35	
36	
37	
38	
39	
40	
41	
42	

Figure 2.

height and horizontal visibility follows. Determination of cloud height and horizontal visibility requires a detailed code table.

Most automatic RTTY stations are equipped with a temperature and pressure sensor and will transmit air temperature (1S<sub>n</sub>T<sub>T</sub>) in tenths of degrees Celsius and pressure (PPPP) in tenths of millibars. A three digit temperature, 2.3°C, would be encoded as 023. A four digit station pressure, 950.5 millibars would also be encoded (in tenths) as 9505. The second temperature group, 2S<sub>n</sub>T<sub>d</sub>T<sub>d</sub>T<sub>d</sub>, is the dew point temperature and the second pressure group, 4PPPP, is the sea level pressure value rather than the station pressure measured value.

The following group, 6RRRT<sub>R</sub>, may be included if any precipitation has occurred during the time covered by the group for that observation.

The actual amount of liquid precipitation or the water equivalent of solid precipitation is reported in millimeters. Code figure RRR will be in direct millimeters except 99X, where 9 refers to a trace amount (less than 1 MM) of precipitation. A code of 998 will correspond with .8 MM of precipitation. The group 7wwW<sub>1</sub>W<sub>2</sub> includes information about the weather at the time of the observation and the past weather since the last main synoptic observation. This is a detailed code "map" defining a large range of weather conditions and one should refer to the "Surface Synoptic Codes," *Federal Meteorological Handbook No. 2* pages C7-10 through C7-13. Last but not least, 8N<sub>h</sub>C<sub>L</sub>C<sub>M</sub>CH describes clouds and cloud formations.

Clouds are normally classified by their height and shape—low clouds, middle clouds, and high clouds. Again, we can refer to the above *Federal Meteorological Handbook No. 2* pages C8-5, 6, 7, 8, 9, 10 for cloud pictorial diagrams and related RTTY numerics.

Ship observations may be made from staffed ships or from automatic platforms. Data buoys are also commonly used and a different format is used for buoy observations. Keep in mind that the length of the RTTY message can be kept to a strict minimum by dropping out some groups if their information content is not available or the content is considered insignificant.

Instructions for making surface observations can be found in the latest editions of *Federal Meteorological Handbook No. 1* and IB (U.S. Air Force station). Coded observation instructions from ships are defined in the *Weather Service Observing Handbook No. 1*. Also in the *Federal Meteorological Handbook No. 1* are details on the different types of meteors, how to tell haze from smoke, what is a severe thunderstorm, etc.—a really good tutorial on weather phenomenon. Figure 2 is an actual printout of the 5 digit weather codes sent at 8140.7 kHz (75 baud) received in the early evening. A few data noise "hits" will be noticed, but this is fairly typical of what can be read on an inexpensive RTTY setup. Remember to keep the unshift on space (USOS) mode off since the 5 digit groups are numeric.

## MIZUHO AP-1D Audio Processor...

### WHAT IS AN AUDIO PROCESSOR?

The AP-1D Audio Processor picks up signals from sounds received through the speaker or headphone of the receiver or transceiver. The signals are deciphered, processed and reproduced automatically for improved SN by narrowing the bandwidth. This process is called an audio processor. AM, BCL, SSB and CW operators all agree that the results are outstanding.

#### SPECIFICATIONS

##### Filter

- Narrow band-pass filter (PEAK) 500-1000Hz variable
  - Band-pass filter (BAND PASS) 600-1500Hz fixed
  - Narrow band attenuator (NOTCH) 600-3000Hz variable
- Input impedance and level 2.5K ohm  
 - 30dB (RX 8 ohm SP terminal can be connected)  
 Output impedance and power supply 8 ohm 0.5W  
 Power Supply DC 13.5V 150mA

#### Dimensions and Weight

W200 × H66 × D153mm 1.1 kg

##### Selectivity

- A Narrow band-pass filter. Over 25dB at 1 oct relative to the center frequency
- B Band-Pass filter. Out-band attenuation 1 oct, over 10dB



**\$99.50**

Order today direct or from **HENRY RADIO (800) 421-6631**. To order direct include \$3.00 shipping/handling. From California add sales tax. VISA/MC orders welcome. We will pay shipping/handling charge for all prepaid orders. No C.O.D. PLEASE.

**ACE communications, inc.** 2832-D WALNUT AVENUE, TUSTI, CALIFORNIA 92680 (714) 544-8281  
 TELEX 655-306

CIRCLE 34 ON READER SERVICE CARD

**7 MILLION TUBES  
FREE CATALOG**

Includes all Current, Obsolete, Antique, Hard-To-Find Receiving, Broadcast, Industrial, Radio/TV types. **LOWEST PRICES**, Major Brands, In Stock.

**UNITY Electronics Dept. P.C.**  
**P.O. Box 213, Elizabeth, NJ 07206**

CIRCLE 69 ON READER SERVICE CARD

**AIRCRAFT - AIRPORT CAR RADIO!**

"LISTEN IN" TO AIRCRAFT - AIRPORTS - WORLDWIDE! 118-136 Mhz. Works in cars or with ALL home radios - NO HOOKUPS NEEDED! Self powered - Works everywhere. Complete \$29.95 (plus \$2.00 pstg) Call 1-308-236-5333 ANYTIME with credit cards or order by mail. Same day shipment. Free Information.

**WESTERN RADIO DEPT.-C KEARNEY, NEBR. 68847**

CIRCLE 30 ON READER SERVICE CARD

# IC-R71A

**The Best Just Got Better  
The Superior Grade Communications Receiver...  
at a price you can afford!**

**For your discount price on ICOM and other major brands call 812-422-0231, 0252**

**808 N. Main • Evansville, IN 47711 MON-FRI 9AM-6PM**  
**ICOM & WILSON Commercial Equipment Available SAT 9AM-3PM**

Please send all reader inquiries directly.

## NEW AND EXCITING TELEPHONE TECHNOLOGY

### *New Phone Frequencies Are Here*

**Y**ou read it here, folks, just over a year ago—telephones have now become one of the biggest electronic markets in the country with sales going from 20 million units to 35 million units this year. It's a billion dollar industry and, thanks to deregulation, we have everything to gain!

#### **New Cordless Channels At Last!**

First, let's take a look at those new frequencies. The FCC has just given cordless manufacturers the green light for tooling up on ten new additional "interim" frequency pairs in the 46 MHz/49 MHz area. This will undoubtedly give us longer range, clearer reception, and a cordless phone at a slightly higher price.

You won't see these new cordless phones until probably 60 days from when you read this. It takes that long for the industry and the Federal Communications Commission to get everything going in the right and legal direction. There will be no limitations for the sale or use of your present 1.7 MHz/49 MHz cordless phones. In fact, sales will still continue for this type of equipment until all the pipelines are clear in Japan and they completely switch over to the new frequency pairs.

The new frequency pairs will help cut down on some of that annoying power line noise that all cordless phone users experience—you know, the buzzing from neon lights, the hum from wall battery chargers, the buzz from your dimmer switches, smoke alarm whistles, and the growling from other noise sources that are generated in your AC house wiring. The new frequencies are independent of your AC house wiring, so range should increase.

Incidentally, several manufacturers have come up with some ingenious ways to greatly increase the range of your present 1.7 MHz/49 MHz cordless system. The extra range is achieved by adding adapters in between your AC outlet and the plug from your cordless phone base unit. This allows for external antennas to be rigged up and tuned out for maximum range. In some cases (in worst conditions) you can expect almost twice as much an increase when using some of these range addition systems. They really do work, but you still won't be able to hear your cordless phone at the end of the block.

On the new 46 MHz/49 MHz systems, there is a chance of one block coverage with external antennas. It's probably not 100 percent legal to add an external antenna system on these new sets, but nonetheless, I am sure everyone will. We will give you the very

latest details on how to get the best range out of your new 46 MHz/49 MHz cordless set just as soon as this equipment becomes available and legal for sale this fall. Before you buy, make sure that you are purchasing the newer frequencies if you really want the very latest in technology at a slightly higher price tag.

#### **Corded Phones**

The telephone market has literally exploded with new models, and not necessarily "el cheapo" sets either.

Phone Mate® has a great way of beating the present 5-channel congestion problem. Their new set, the digital Clearline Selectability unit, allows you to instantly dial in any one of the five present channels that will give you interference-free phone calls. This way you can always be assured of getting on another frequency than your neighbors on either side of you. The same set also gives you a choice of over 1,700 precise digital security codes. Although this phone and almost all of the recent new innovative phones still operate on the older 1.7 MHz/49 MHz frequencies, it's still an excellent value that assures you of not having to take it back for a re-channel job.

To restate the most common question about cordless telephones, no folks, there is no way to modify the existing units or even some of the new frequency units to give you more than one-block coverage. At 100 milliwatts, the radio waves just don't go any further! No matter how hard you try by adding all sorts of range-extending antenna systems, there is just no way that the cordless phone will transmit and receive further than a few houses down the street.

#### **Wired Phones**

This summer and fall, telephone retailers will be emphasizing the smart desk telephone with all sorts of sub-functions, as opposed to the cheap "disposable," all-in-the-handset \$10 phone. As long as you are going to take back your present telephone company owned phones and opt for a new phone that you own yourself, you might as well select one that does more than just talk and ring.

My overall favorite at the recent electronics show for a smart telephone system is the new Genesis® telephone system at AT&T Consumer Products. It's a phone system that will expand with your business or personal requirements. The basic system comes with memory number capabilities, a clock, an alarm, call timer, electronic ringer control, external speaker, and a host of other functions that you access via the membrane



*AT&T Consumer Products has introduced One-Touch Calling Module and a business cartridge for its Genesis® telephone system.*

keyboard. You can add several different packages that include additional memory numbers, a universal module that will memorize and automatically alphabetize your personal telephone directory, a business package all inside a cartridge that fits inside the phone, a security locking electronics network that lets you restrict dialing or completely lock out all outgoing calls, and a host of other features. In other words, all of these little add-on devices simply snap into the side or the back of the unit to allow the phone system to grow with you. It's an expensive little fellow—starting at just under \$350 for the basic package, but once that's under your belt, each additional cartridge isn't that expensive for the additional features you get. Several other companies produce office-type telephone systems that are designed for home or business use.

Some very interesting phones that are relatively new on the market include a cordless telephone that doesn't use radio frequencies, but rather light waves. Whistler Corpo-



*AT&T pocket dialers have just been brought onto the market.*



The U.S. Tron Pro-Line Danish Series.



The Command Dialer® from Audec.

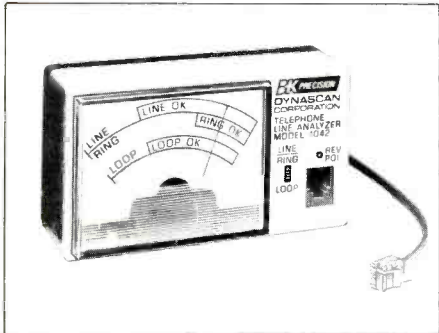

The B&K Dynascan Model 1042 Telephone Analyzer.

ration that produces radar detectors also produces a telephone that operates on infrared light frequencies, not radio frequencies, for security.

Some other innovative phones that you ought to know about that are available are the small "pocket dialers" that memorize up to 16 individual phone numbers that can instantly be recalled at any pay phone by simply holding up the device to the mouthpiece. This saves time in punching out the tones for your credit card number as well as the tones for the number you wish to dial.

For the vision-impaired telephoner, U.S. Tron, Inc., 125 Wilbur Place, Bohemia, New York 11716, offers a telephone desk set with huge key-pads so you can easily see what number you are stamping out.

If you are into the telephone business, you might consider the B&K Dynascan telephone line analyzer that plugs into any telephone jack. It will measure the line for proper voltages and levels to insure that the phone lines are in A-1 shape.

Here's one that I know you'll all want—a telephone that does the dialing by voice commands. The Command Dialer® from Audec Corporation recognizes your voice and automatically dials the number you ask for. No searching for the phone book and no codes to remember. Just pick up the receiver and state the name of the person you wish to talk with. This telephone device immediately searches its memory for the corresponding phone number, confirms your command, and then dials up the designated pre-programmed phone number. Just don't sneeze or cough!

Zoom Telephonics, Inc. sent us a sample "silencer cord" that works dandy. Flip the switch and your phone won't ring. I've had my switch flipped for the last three days and have never enjoyed the bliss so much! I just need to remember to flip it back on to start getting some messages.

Finally, as we mentioned last month, you do-it-yourselfers can write Firestik Antenna Company, 2614 E. Adams, Phoenix, Arizona 85034 for their informative book on how to hook up their new cordless telephone clip-on antenna system. This 20-page book gives pictorial diagrams of several popular cordless telephone setups and tells you precisely where to add the range-extending wires. If you're no good at soldering small components, forget about this operation. It's only for the serious minded cordless telephone buff that demands the very furthest range possible, and it takes the Firestik antenna system and magic box for this whole operation to work. Write them for more details.

One final note: several electronics experts are cautioning telephone sellers to be careful about their own particular industry—the telephone popularity might end up like the CB boom when prices began to plummet due to fierce competition. I don't see much analogy between CB radios and telephone sets, so simply reap the benefits of all these new innovative devices and pick a phone that suits you best.

Stop by your local telephone sales store and gawk at all the gadgets. See you next month!



Here's a quick way to silence that annoying telephone bell.

## Coming Soon In POPULAR COMMUNICATIONS

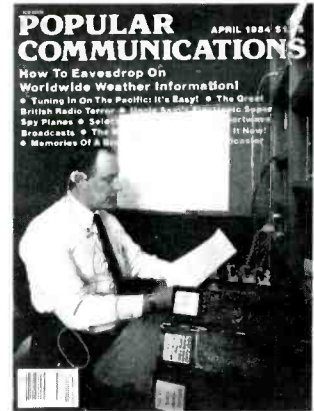

- Is ELF Able To Manipulate The Weather
- "Secret" Military Communications On Your Scanner
- Mobile Scanner Reception—Peculiar Problems
- They Call Her Auntie Beeb
- The Hindenburg And Its "Lost" Radio History
- Equipment Review: The Regency MX-5000 Scanner



### RADIO WORLD

Order Toll Free: 1-800-448-9338

Your Source For Shortwave Receivers, Antennas, RTTY Converters, Computers, Interfaces And Scanners.

Kenwood • Yaesu • Icom • Collins • Drake • Robot • Kantronics • AEA • Info-Tech • MFJ • Microlog • Grova • Commodore • Bearcat • Panasonic • Regency

### HAM RADIO WORLD

Oneida County Airport • Terminal Building  
Oriskany, New York 13424

1-315-736-0184

CIRCLE 60 ON READER SERVICE CARD

## Communicate . . . with electricity from the sun.

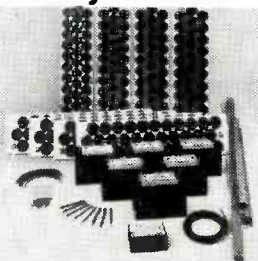

ARCO Solar photovoltaic systems have a number of outstanding advantages in powering remote communication equipment. Reliability. Independence. Modularity. Economy. Safety. ARCO solar is your best choice for communication power.

●REMOTE POWER ●FIELD DAY ●HAMFESTS  
●EMERGENCY STAND BY POWER

To get all the facts, send \$1.00 to

Springhouse Energy Systems, Inc.



Room 418  
Washington Trust Building  
Washington, Pa. 15301

412/225-8685

CIRCLE 21 ON READER SERVICE CARD

# SCANNER SCENE

BY CHUCK GYSI, N2DUP

## MONITORING THE 30 TO 900 MHz "ACTION" BANDS

**Y**ou readers have been super this month! We received so many letters here at Scanner Scene that we've decided to address as many of the letters as possible here. We also received some photographs of some really neat shacks for this month's column.

Joe Kohlhas of Buffalo, New York, asks a question I'm asked often in person by many radio hobbyists I know. He wonders whether the Wilson Citi-Com Plus programmable transceiver can be programmed to operate out of band. Wilson makes the keyboard-programmable transceivers for both VHF high band and UHF. Some hams I know have expressed an interest in operating such a unit both on the 440-450 MHz 3/4-meter band as well as business or General Mobile Radio Service channels on UHF. We did try programming one of the UHF units out of band and barely got the thing down to 449.900 MHz before it dropped off severely. The lowest usable frequency seemed to be about 449.950 MHz. The unit seems to program the entire T-band on UHF, but we really don't see any reason to take it above 512 MHz. The VHF high band unit operates in three bands from 135-174 MHz and you have to pick the model best for your use. Don't expect to be able to operate one on 151 and 173 MHz at the same time—it's just too much of a spread for the unit, although it probably will receive the frequencies.

For those who are unfamiliar with the Wilson programmable transceivers, basically you can program in the transmit and receive frequencies you want by a keyboard on the front of the radio. You also can program in the sub-audible tone. The radio resembles the Regency M-100 and M-400 scanners very much in appearance, and because of its low price it has become popular—especially by GMRS users on the 462 MHz band. The radio sells on the average for about \$450 to \$550. If anyone has specifically been able to program these units out of band for particular frequencies, we'd appreciate hearing about it.

Bill McEntire of Little Rock, Arkansas, says he has a Regency H-604 hand-held scanner and that the audio volume often is too low to hear above background noise. He questions whether there is an external speaker or amplifier that can give the audio a little punch. A lot of times, almost any external speaker made for scanner listening will give you that additional audio needed. If not, the unit that has impressed me the most is Capri Electronics' volume equalizer. This unit, which sells for \$49.50, plugs in between the scanner and an external speaker and becomes your volume control for the radio. For instance, if there is a frequency you listen to on which there is a soft-spoken dispatcher and a loud mobile operator, the vol-

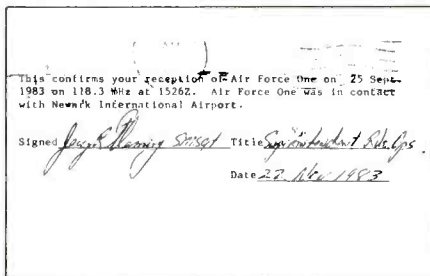

*This is a copy of the QSL Harold Ort received for monitoring Air Force One on 118.3 at Newark International Airport.*

ume equalizer automatically adjusts the volume so each is heard at the same level. In addition, this unit has a fourth-order 300-3000 Hz bandpass filter to eliminate noise outside the voice band. A change of 25 dB at the audio input results in only a 5 dB variation at the output with this unit. Capri also manufactures an external speaker that has the equalizer built in for \$61.45. For information, write to Capri Electronics, Route 1, Box 91-1J, Canon, Georgia 30520.

William Widman of Fremont, Ohio, writes in to note that the radio signals listed for the Ohio State Patrol in the May 1983 issue of POP'COMM are also used by the Ohio Turnpike Commission road maintenance trucks, toll gates, and service plazas on 156.135 MHz.

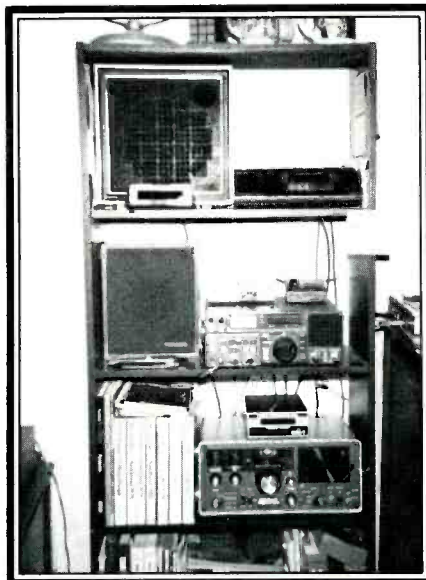

*This is Gary Hickerson's listening post at home in Fort Smith, Arkansas. On the top shelf are a Bearcat 220 with an external speaker and a 24-hour clock; on the middle shelf is an Icom IC-R70 shortwave receiver with an antenna tuner, external speaker and radio switch; and on the bottom shelf is a Yaesu FRG-7 shortwave receiver with a Gilfer GAR-7 digital readout unit.*

Gary Hickerson of Fort Smith, Arkansas, sent along a photograph of his listening post and notes he uses a Channel Master and Antenna Specialists Duo-Band ground plane antenna mounted 30 feet up on the roof. He says he can hear Tulsa (125 miles away), Little Rock, and Joplin and Springfield in Missouri. Although Gary says he has done more shortwave listening as opposed to VHF/UHF listening lately, the Bearcat 220 has served him well for four years. He also uses a Regency M100 while mobile with a Hustler four-band mobile antenna.

Jim Ingram of Aromas, California, sends along a list of frequencies for his area:

- 154.325 Santa Cruz County Fire Net red channel (used to dispatch 15 districts)
- 154.190 Santa Cruz County Fire Net yellow channel (tactical use/fireground)
- 154.415 Santa Cruz County Fire Net blue channel (tactical use/fireground)
- 154.280 Santa Cruz County Fire Net white channel (mutual aid)
- 154.370 Monterey County Fire Net
- 154.445 Watsonville City Fire Department
- 151.370 California Dept. of Forestry local net
- 151.445 California Department of Forestry regional net
- 151.295 California Department of Forestry green air net
- 151.285 California Department of Forestry car-to-car net

Harold Ort Jr., New York, passes along a neat souvenir—a QSL of Air Force One. Harold, POP'COMM's military consultant, heard the president's plane as it landed at Newark International Airport in New Jersey during a recent visit.

Ken Rohrer of Walkerton, Indiana, sends in several northern Indiana frequencies that he likes to listen to:

- 155.130 Base stations of most town and county police in northern Indiana
- 155.370 Base to base of town, county and state police
- 154.890 Mobile to base of most town and county units
- 42.42 State police base and state highways
- 42.26 State police mobile to base
- 42.12 State police mobile to mobile
- 42.16 State police special
- 154.250 Base and mobile of most Indiana towns for fire (also lower Michigan)
- 154.280 Base and mobile interdepartment fire
- 154.370 Fire base of many Indiana towns
- 155.475 ILEEN emergency police city to city
- 155.340 IHERN emergency ambulance base and mobile
- 155.205 Walkerton ambulance
- 155.775 Walkerton park and traffic direction
- 154.415 Tyner fire
- 154.130 Plymouth fire
- 155.235 Plymouth ambulance
- 155.160 Lakeville ambulance
- 155.025 Plymouth Civil Defense
- 47.66 Memorial Hospital, South Bend
- 155.280 Orthopedic Hospital, South Bend



463.175 Hospital to paramedics  
 468.175 Paramedics to hospitals  
 156.030 Indiana Toll Road police  
 158.910 Indiana Toll Road police

Daryll Symington, N8EBR, passes along a copy of his new *Scanner Frequency Directory* for Northwestern Ohio and Southeastern Michigan. The handy 8½-by-5½-inch directory includes details for Defiance, Erie, Fulton, Henry, Lucas, Ottawa, Sandusky, Williams, and Wood counties in Ohio, and Hillsdale, Lenawee, Monroe, Washtenaw, Wayne, Macomb, and Oakland counties in Michigan.

The book contains more than 5,000 frequencies in the categories of: police, fire, local government, aircraft, amateur repeaters, railroads, marine, medical, mobile telephone, utilities, and business users. The listings are also cross-referenced by callsign and frequency. Included are radio codes and unit numbering lists for several police and fire agencies. The 84-page book can be ordered for \$5.95 postpaid from: Midwest Software Services, P.O. Box 399, Holland, Ohio 43528.

Another new directory now available is the *Greater Philadelphia/South Jersey Guide*. The 130-page directory, which includes all of southern New Jersey, the Jersey shore, southeastern Pennsylvania, and northern Delaware, was edited by your columnist—Chuck Gysi, N2DUP. The guide includes all county, state, and municipal radio systems throughout the region, includ-



Here is Terry Lindley, WDX4KYX, of Birmingham, Alabama, in his shack. In addition to shortwave and computer gear, Terry has a Regency hand-held and a multiband tunable for VHF/UHF listening.

ing unit numbering lists and radio codes for every county and most larger municipalities. In addition to detailing the new 501 MHz police radio system in Bucks County and the 800 MHz police system in Delaware County, there are special sections on state agencies, mobile telephone, news media, amateur radio, regional agencies, railroads, marine, aircraft and airports, utilities, and many businesses. There also is a special section on monitoring casinos in Atlantic City. The book is available for \$12.95 plus \$2.50 for 1st Class postage (New Jersey residents add 6% sales tax) from East Coast News Ser-

vice, P.O. Box 1119, Flemington, NJ 08822-5019.

Monitoring the "insider" type federal frequencies continues to be one of the most fascinating aspects of the scanner scene. There's no question that agencies such as the Secret Service, FBI, Customs Service, Border Patrol, Immigration, BATF, Treasury, CIA, Federal Marshals, FAA, EPA, plus the military services offer unique and exciting monitoring the likes of which can't be found on any other frequencies. The authoritative guide to about 60,000 frequencies, locations, and callsigns of these stations throughout the USA is the giant (168 page) 5th Edition of Tom Kneitel's "Top Secret" *Registry of U.S. Government Frequencies*—the same book you saw highlighted on the CBS Evening News with Dan Rather last January 19th. The book is available at \$14.95 (postpaid by Book Rate Mail or add \$2 for First Class) from CRB Research, P.O. Box 56, Commack, NY 11725. This book has become the standard reference authority used by hobbyists, the news media, the communications industry, as well as public safety and many federal agencies.

Don't forget, this column seeks input from you—photos, frequencies, radio codes. What about sending in a photo of your listening post, or a dispatch center or transmitting tower in your area. Send to Chuck Gysi, N2DUP, Scanner Scene, Popular Communications, 76 North Broadway, Hicksville, NY 11801. See you next month.

## If You're In The Bugging Business

or happen to be one of our competitors, here comes some more "bad" news. Research Electronics, Inc. would like to introduce you to our new Telecom Security Unit (TSU 3000).



Based on military countermeasure technology with a unique blend of Research Electronics, Inc. experience and design, the TSU 3000 provides a realistic and effective approach to the problems of telephone communication security. Add to this ease of operation and twenty-four hour protection for your telephone line and you have one of the most advanced security units offered today.

\*\*For Private Use Or Export



1570 BROWN AVENUE, COOKEVILLE, TN 38501  
 Phone (615) 528-5756 Telex 786592

Call for information, or send \$10.00. for Catalog (refundable upon purchase)

CIRCLE 73 ON READER SERVICE CARD



**Scanner World, USA**  
 10 NEW SCOTLAND AVENUE  
 ALBANY, NEW YORK 12208  
 (518) 436-9606

**Super Special Package Sale!!**

## REGENCY HX-650

**Pocket Scanner — 6 Channels — 5 Bands**

Quality features included in the Regency HX-650 are 6 channels - 5 band coverage, lockout switches, manual step switch, scanning speed of 15 channels per second, long lasting LED's, volume & squelch controls, AC adapter/charger jacks.

**Scanner World's Special Package Deal includes the following:**

- Regency HX-650 Pocket Scanner
- MA-506 Carry Case with Steel Belt Clip
- Set of 4 AAA Nickel Cadmium Batteries
- 6 Monitor Crystals (specy frequencies needed sor we will include certificates for unknown frequencies)
- Flexible Rubber Ducky Antenna
- AC Adapter & Charger

**Scanner World Package Price**  
**\$109.99**  
 (Plus \$5.50 Shipping)

*To Order Call (518) 436-9606 or mail your order to Scanner World, USA, 10 New Scotland Ave., Albany, NY 12208. Payment may be made by VISA, MasterCard, Cashier's Check, Money Order, or we will ship your order C.O.D.*

**FREE CATALOG**

Send for your free 1984 Discount Catalog featuring the lowest prices anywhere on the most popular brands of Scanners such as Bearcat, Regency, Fanon, Jil & Fox plus all accessories and radar detectors.

CIRCLE 74 ON READER SERVICE CARD

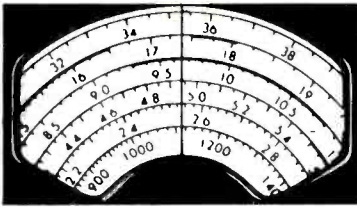

# COMMUNICATIONS CONFIDENTIAL

BY HARRY HELMS, KR2H

## YOUR GUIDE TO SHORTWAVE "UTILITY" STATIONS

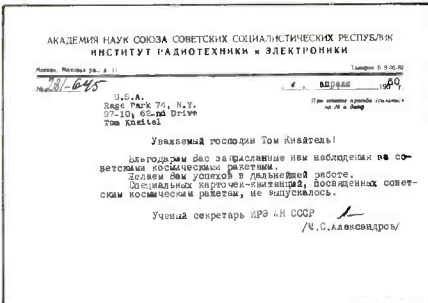

This curious "almost QSL" letter was in response to Tom Kneitel's 1959 reception report concerning the Soviet LUNA 3 space shot (1959 Theta 1, Catalog #21). Translated, it reads: "To worthy Tom Kneitel: We are thanking you for your observation facts regarding USSR Soviet Cosmic rockets. We wish you great success in your future work. A special table regarding USSR Soviet Cosmic rockets cannot be given out."

Several of you responded to my recent suggestions that direction finding efforts or calls to the FCC be made in an attempt to pin down the location of numbers stations and other mysterious stations. The best luck of all was had by David Batcho of New Mexico. David phoned in information at press time that FCC monitors told him that they had definitely traced some five-digit Spanish numbers stations as transmitting from a location near Havana, Cuba while four-digit Spanish stations were traced to a location near Washington, DC! Many thanks for the call, David! These results fit in nicely with the prevailing theory, mentioned in this column several times in the past, that five-digit Spanish numbers stations originate from Cuba while four-digit Spanish numbers stations originate from American sources.

Ken Navarre, Jr., of California was monitoring a four-digit Spanish numbers station on 6802 kHz around 0745 GMT. He called the FCC monitoring station at Livermore, California and spoke to the engineer on duty. The engineer on duty told Ken that he had the signal too. He and Ken discussed possibilities as to what the signal could be. The engineer suggested that Ken check out a publication called *Popular Communications* which amply covered such topics and signals! Ken also called the Fort Lauderdale, Florida FCC monitoring station and spoke with an engineer there who also had the signal and said it was very strong. Thanks for writing, Ken! And you FCC guys—don't just read this magazine, write in! I'll be glad to keep your names confidential.

Last month we told how Ron Weiss of Indiana did some very interesting direction finding for a numbers station on 4670 kHz. This month, Ron did similar direction finding on the four-digit station found at 5810-5812 kHz. Ron was able to get a clear bearing on this station toward the east. It's quite likely this station is located near Washington as well. Ron also sent along plans for his direction finding loop. This is a simple but effective design and you should be able to find all the components at any nearby electronics or radio/TV parts store. Our sincere thanks to Ron for sharing this design with fellow POP'COMM readers!

Several of you have written in volunteering to participate in coordinated direction finding efforts using loops. Several monitoring assignments have been sent out to participants and the results will appear in a future column.

### More Mysteries

E.R. Quackenbush of New York has been doing statistical studies of various numbers stations transmissions, particularly the four-digit variety. He has written a computer program to perform the analysis, and has found no difference between the five-digit groups and random numbers. He has an interesting hypothesis regarding the four-digit Spanish stations which open with a three-digit group repeated three times followed by a count of 1 through 0 in Spanish. He notes that the number of count preceding the groups is often repeated for several minutes. While he doesn't speak Spanish, he had no trouble copying the message after listening to the number count for several minutes. He wonders if there is any possibility that such messages could be intended for non-Spanish speaking recipients. That's a new idea on



Bob Leary (and children) shown at his very complete monitoring station in Akron, Ohio.



The listening post of George Schlack of Cranbury, New Jersey.



Henry Bartsch at his listening post in Vermont.

me, E.R., but could well be! Any further ideas, readers?

Rick Hadley of Iowa reports an unusual CW net on 3869 kHz in the 0100-0300 period. The traffic is encoded, usually in five-letter groups, and callsigns are of the tactical variety. Rick has been hearing this net for over a year, and suspects it is a Cuban or South American military training net of some sort. Thanks for the information, Rick. Can you other readers hear it or similar nets? I heard in 1978 similar activity around 3820 kHz in the 0500-0600 time period which would begin immediately after a Spanish five-digit station on 3820 kHz would sign off!

### Soviet Coastal Station Verified—Sort Of

A recent bulletin of the American Shortwave Listeners Club (ASWLC) reported that George Zeller of Ohio sent a report to CW station UJQ7, Kiev, USSR, for reception on 13055 kHz. Some 58 days later, he received a QSL card with the correct date, time, and frequency . . . but for the shortwave broadcaster Radio Kiev!

This reminds me of an incident back in

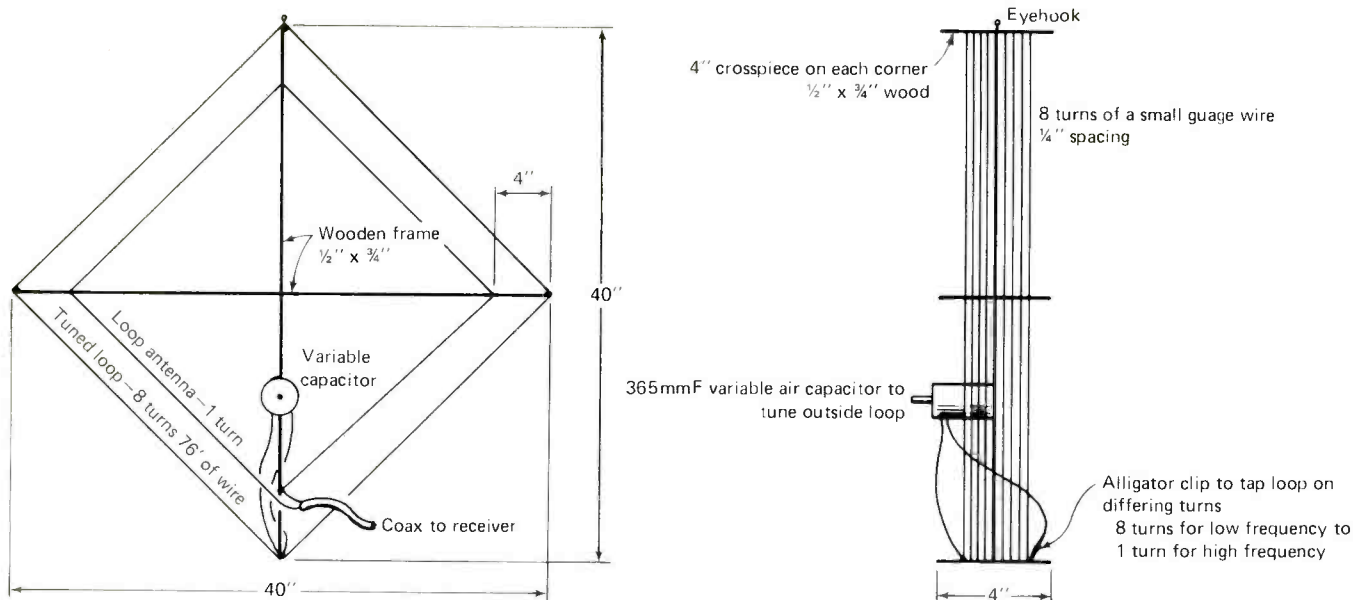

Ron Weiss, a reader in Indianapolis, Indiana, sent along this design for an inexpensive DF loop which will work between 100 kHz and 6 MHz.

1972 when a well-known DXer sent a report to the central transmitting station used by East Germany for overseas telephone communications. A few months later, he received a QSL from the East German facility with the time, date, and frequency of the numbers station transmission!

In both of these cases, the QSLs are doubtlessly the result of bureaucratic goofs rather than being actual proof of reception. However, they are certainly fascinating!

### In Memorium

H. John Clements, one of the founders of the Longwave Club of America (LWCA) and Editor of its "DX Downstairs" column, died of a heart attack on December 26, 1983. John was one of the pioneers in establishing hobby interest in monitoring the frequencies below 540 kHz. John was also the compiler for LWCA's *Beacon Directory*. He and his contributions to the hobby will be missed.

### The Case Of The Wandering Beacon

Craig Healy of Rhode Island edits the "Top End" column for the National Radio Club's bulletin. This column covers activity in the 1600-1800 kHz range. Craig has been noting a most unusual station identifying itself continuously in CW as "FRB." Craig first noted it on 1612 kHz around 0515. Then at 0600 on the same night it had moved up to 1637 kHz! A few nights later it was on 1647 kHz, and has been heard on several different frequencies in the 1600-1650 kHz range since. Anyone else heard this one or have a clue as to what's going on?

Craig also noted that a station could be heard on 1783 kHz sending 30 "pips" per minute around 0810. No identification was heard. If you'd like more information about the National Radio Club, write P.O. Box 118, Poquonock, CT 06064.

### From the Mailbag

Michael Harris of Ohio writes that he continues to hear a strange signal on 4705 kHz almost each evening around 0200. The signal consists of a "clicking" sound in the pattern of 11 clicks, a pause, then 22 clicks, another pause, and the pattern is then repeated. Michael wonders if this could be a propagation experiment of some kind. Has anyone also heard this one? Give it a try and remember to report the results to Communications Confidential!

Henry Bartsch of Vermont sends along a photo of his listening post. We welcome similar photos of you and your equipment; a clear black-and-white print works best. We're sorry that photos cannot be returned.

Harold Ort, Jr., *POP'COMM's* military consultant, sent along photocopies of some of his prized QSL cards. Thanks for sharing them, Harold! Why not share yours with other *POP'COMM* readers? Send photocopies, not the original QSLs, please.

This month I received numerous letters asking about receivers and other listening equipment. I don't like to suggest specific makes or models of receivers, since experienced DXers can have widely varying opinions about the same receiver. However, there are certain characteristics important in any receiver used to tune this sort of activity covered in this column. Tops on the list is accuracy in frequency readout. Fortunately, digital frequency readout receivers today are becoming less expensive and are within the price range of most serious listeners. Another feature I have found increasingly useful in my own listening is a receiver memory. This is especially useful when tracking down parallels of numbers stations or trying to correlate various signals with each other. Finally, the ability to copy SSB well is also useful.

Where do you find such receivers? The best place to start is the magazine you're now

reading, since virtually all companies specializing in the SWL/DX market advertise in *POP'COMM*.

### Listening Reports

Here are this month's listening reports. Some of the reports have been contributed by members of the American Shortwave Listeners Club (ASWLC) and the Longwave Club of America (LWCA). If you're an active listener, you'll find membership in these clubs an excellent investment. You can get a sample bulletin and membership details for \$1.00. Send your requests to ASWLC, 16182 Ballad Lane, Huntington Beach, CA 92649 and LWCA, 45 Wildflower Road, Levittown, PA 19057. Tell both that *POP'COMM* sent you!

Your reports are welcome. Use the format you see here and give all times in GMT and frequencies in kHz. Be sure to include enough details to make your report useful to others, such as languages and sex of speakers, number of digits in various groups, calls heard, location of stations, etc. Send your reports to Harry Helms, P.O. Box 157, Rockefeller Center Station, New York, NY 10185. And now to this month's reports...

**10:** Five successive tones in CW repeated continuously 1655...possibly OMEGA navigation? (Jerry Moyer, OK) Perhaps, or some sort of Soviet submarine navigation system. (Editor)

**60:** Dots followed by varying numbers of dashes 1635; steady tone in background and sometimes interrupted by fifteen seconds of silence. Is this WWVB? (Jerry Moyer, OK) Both WWVB and MSF, Rugby, England listed here for binary-coded decimal (BCD) time signal transmissions. (Editor)

**90:** Continuous scratching sound covering wide bandwidth 1650. (Jerry Moyer, OK) I really don't have any idea. Jerry. Readers??? (Editor)

**216:** CLB, Carolina Beach, NC, CW beacon 0528. (Scott Murphy, VA)

**236:** GNI, Grand Isle, NE, CW beacon and voice weather 0528. (Scott Murphy, VA)

**251:** ZQA, Nassau, Bahamas, CW beacon 0947. (Larry Mindel, WI/LWCA)

**271:** UVR, Varadero, Cuba, CW beacon 1103. (Robert Talbert, NJ/LWCA)

**352:** RG, Rarotonga, Cook Island, CW beacon 0955. (Art Peterson, CA/LWCA)

**360:** KIN, Kingston, Jamaica, CW beacon 1018. (Robert Talbert, NJ/LWCA)

**396:** ZBB, Bimini, Bahamas, CW beacon 0530. (Scott Murphy, VA)

**2500:** OMA/OLB5, Liblice, Czechoslovakia, 0350 with time signals and identification in CW every ten minutes. (George Osier, NY) Good catch, George! Unfortunately, this station will be more difficult now due to higher noise levels and ionospheric absorption at low frequencies as we approach summer. But keep this one in mind for next fall and winter. (Editor)

**2622:** AFE71, Cape Radio, Patrick AFB, FL, in contact with recovery vessel "Liberty" concerning its arrival time with recovered Space Shuttle boosters 0445. (Tom Lewandowski, NY)

**2690:** Five-digit German numbers station with female announcer 0345, "3/2" pattern. (George Osier, NY) As George points out, this is very low in frequency for a numbers station. (Editor)

**3039:** IDR8, Italian Navy, Rome, Italy. Sending VVV in CW at 0224. (Tom Kneitel, NY)

**3215:** Five-digit German numbers station with female announcer 0440. (George Osier, NY)

**3370:** Five-digit German numbers station with female announcer 2238. (Al Quaglieri, NY)

**3637:** "U" repeated continuously in the 0100-0400 period; sometimes five-digit CW traffic is heard on this frequency as well. (George Primavera, NJ)

**3810:** HD210A, Guayaquil, Ecuador, time signals and voice identification 0406. (George Osier, NY)

**3820:** Five-digit German numbers station with female announcer and tones noted most weekdays during the 2100-2300 period. (George Primavera, NJ)

**3885:** Christmas carols in AM played at 0138-0225. (George Osier, NY) This is a favorite frequency for hams still running AM and many hijinks can be heard. (Editor)

**4063:** WCM, Cincinnati, OH, working barge traffic on Ohio River in SSB 0120. (Thomas Buccì, VA)

**4407:** WOM, Miami, FL, traffic list in SSB 0630. (Ted Gurley, TX)

**4416:** English-speaking female calling "Zulu Five X-ray" in SSB 0515; probably military. (Robert Margolis, IL) Welcome to the column! (Editor)

**4476:** Five-digit Spanish numbers station with female announcer 0533, was in SSB. (Robert Margolis, IL)

**4500:** VNG, Lyndhurst, Australia, time signals with voice announcement 1125. Not audible on either 7500 or 12000 kHz. (Harold Ort, NY)

**4544:** Five-digit German numbers station with female announcer 2315; was in SSB. Signed off at 2317 with "ende" and a long beep. (E.R. Quackenbush, NY)

**4601:** "Red Fire" conducting radio checks with "Badger" 1410 in SSB. (Robert Margolis, IL) These are Civil Air Patrol stations. (Editor)

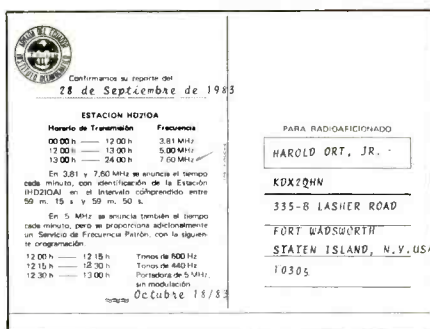

Harold Ort received this QSL from standard time station HD210A in Ecuador.

**4607:** "WCW9 DEFXL6 23 RS" repeated in CW 0210. (Ken Eichman, OH)

**4625:** VEB2, location unknown (but reported to be Canada), time pulses every two seconds 0340. (George Osier, NY) Are George and I the only people hearing this? (Editor)

**4626:** "Magnolia 153" in SSB 0100 calling the Louisiana wing net of the Civil Air Patrol. Later the Oklahoma CAP net was heard. This is a very active CAP frequency. (Dallas Williams, CO)

**4670:** Four-digit Spanish numbers station with female announcer 0200; was parallel to 5810 kHz. Most powerful numbers station ever heard...S9+50 dB! Full quieting, just like it was out my back door. (George Osier, NY) It's incredibly strong here too, George. (Editor) "Footsteps" sound, 96 per minute, from 0135 to 0152 tune out. Retuned 0211, four-digit Spanish numbers were being read by female announcer. "Repeta grupo 250" was announced, followed by a message consisting of 250 four-digit groups. At 0252, there were several rapid pulses, a short beep, more rapid pulses, and off with a long beep. (E.R. Quackenbush, NY) Also noted at 0340. (George Osier, NY) Four-digit Spanish numbers groups read by female 0340, powerful, no-fade signal; was like a local. (Frank Jerome, OK) Four-digit Spanish numbers groups read by female in SSB 0300; similar to previous logging. (E.R. Quackenbush, NY) Similar in AM 0310. (Tom Stovall, Jr., AL) Is this a popular frequency or what???? (Editor)

**4673:** Unidentified Russian language net in SSB 0545. (Charles Keilholz, APO NY/ASWLC)

**4705:** Irregular "pips" averaging 2.1 per second but ranging from 2.53 to 1.66 per second from 0114 past 0353. (E.R. Quackenbush, NY) Note under "From The Mailbag" that Micheal Harris of Ohio has noted the same

or a similar station on this same frequency in the same time period. (Editor)

**4712:** Russian language traffic net in SSB 0550, speech was scrambled but some portions were "in the clear." (Charles Keilholz, APO NY/ASWLC)

**4786:** Five-digit Spanish numbers station with female announcer 0140, was in SSB. (Thomas Buccì, VA)

**4835.5:** "Echo Three Whiskey" with female announcer working "Echo Four Charlie" with male announcer 0655 in SSB, both had British accents. (Robert Margolis, IL) Perhaps RAF traffic? (Editor)

**4840:** Five-digit German numbers station with female announcer 2025. (Al Quaglieri, NY)

**4865:** Russian language traffic net in SSB 0320, interference from Kallingrad broadcasting station. Apparently Soviet military traffic of some sort. (Charles Keilholz, APO NY/ASWLC)

**4990:** Five-digit German numbers station with female announcer 2215, used "3/2" system. (George Osier, NY) "3/2" means there is a distinct and apparently deliberate pause between the third and fourth digits of each group. (Editor) Similar station noted 2025. (Al Quaglieri, NY)

**5000:** ZUO, Olifantsfontein, South Africa, "ZUO" sent three times in CW and time in GMT every five minutes, also time signals in between. Conditions seemed disturbed. (George Osier, NY) Right, George. Conditions that disturb east-west propagation paths can weaken WWV/WWVH and allow other time signals located on north-south paths to sneak through. (Editor)

**5016:** Five-digit German numbers station with female announcer 0036; was in SSB. (George Osier, NY)

**5131:** "YWE5 DE QGH6" in CW 0854. (Chris Devendorf, CA) Any call beginning with "Q" is obviously spurious, since the QAA-QZZ block is reserved for international Q-signals such as QSL, QRM, etc. (Editor)

**5300:** Unidentified Spanish traffic in SSB 2300 between "Azul Quatro" and "Azul Dos." (Al Quaglieri, NY)

**5305.6:** "F" beacon repeating continuously in CW 0838. (Chris Devendorf, CA)

**5410:** Five-digit German numbers station with female announcer 1007. (Al Quaglieri, NY)

**5658:** Five-digit German numbers station with female announcer 0020. (Robert Comeau, NS)

**5695:** JG8, Atsugi, Japan working aircraft 0914 in English. (Chris Devendorf, CA)

**5810:** AFE71, Cape Radio, Patrick AFB, FL in contact with recovery vessel "Liberty" 1530 concerning search for Space Shuttle boosters. (Tom Lewandowski, NY)

**5812:** Four-digit Spanish numbers station with female announcer 0611. (Ted Gurley, TX) Also heard on 0415. (Robert Margolis, IL)

**5812.3:** "DAW RUU" repeated several times in CW 0900 followed by five-letter CW groups. (Robert Margolis, IL)

**5936:** Five-digit Spanish numbers station with female announcer 0705, was in SSB. (Robert Margolis, IL) Also heard at 0704 in AM. (Tom Stovall, Jr., AL)

**5982:** Five-digit Spanish numbers station with female announcer 0912, was apparently jammed by a pulsed carrier strong enough to cover the transmission. (Ken Navarre, Jr., CA)

**6102:** "VK30" sending a VVV marker in CW 1916. (Al Quaglieri, NY) One reader suggested this is really IAR30 being copied incorrectly. However, the reception times for this station are unlikely ones for trans-Atlantic propagation on this frequency. (Editor)

**6235:** "3/2" German numbers station with female announcer 0925. (Al Quaglieri, NY)

**6250:** Five-digit Spanish numbers station with female announcer 0430, some RTTY interference. (Tom Stovall, Jr., AL)

**6292:** Five-digit Spanish numbers station with female announcer 0908. (Frank Navarre, Jr., CA)

**6386.3:** HKC, Buenaventura, Columbia. Callsign marker in CW at 0205. (Tom Kneitel, NY)

**6390.3:** IDQ2/3/6, Italian Navy, Rome, Italy. Callsign marker in CW at 0213. (Tom Kneitel, NY)

**6395:** TBA3, Turkish Navy, Izmir, Turkey. VVV callsign marker in CW at 0217. (Tom Kneitel, NY)

**6621:** Five-digit Spanish numbers station with MALE announcer 0740. (Robert Margolis, IL) Male announcers on numbers stations are rare. (Editor)

**6761:** "Skyking" messages noted on this frequency at the rate of one each six to eight minutes between 0600-0750. (Ken Navarre, Jr., CA)

**6780:** XSG, Shanghai, China, CQ marker in CW 0801. (Chris Devendorf, CA)

**6790:** Four-digit Spanish numbers station with female announcer 0815, was in SSB. (Robert Margolis, IL)

Another major price breakthrough by STANO Components.  
We are a major supplier of night vision equipment to the public,  
the private business sector, and as a government contractor

AN/PVS-3 NIGHT VISION SIGHT  
HYPER-MINI



FEATURES:

- Ruggedized mil-spec combat oriented construction
- 18mm first generation Intensifier Assembly -- excellent condition
- 3X Optical System
- Unique quick range focus system
- Weights 3 lbs. complete (smallest of the military scopes)
- Range 400-600 meters (yards)

APPLICATIONS:

- Hunting
- Low-light level photography
- Stake out/surveillance
- Facility Security
- Anti-sniper or Terrorist countermeasure
- Nocturnal surveillance of wildlife
- Study of laser and infrared

LIMITED TIME ONLY

\$1,495.00

INCLUDES:

- Night Sight
- Front filter cover for daylight boresighting
- MIA/M14 and AR15/M16 adapter brackets
- Battery
- Manuals

Send \$4.00  
For Catalogs

Call or write:

STANO COMPONENTS

P.O. Box 6274  
San Bernardino, CA, USA, 92412  
(714) 882-5789  
Tlx: 675537 (STANO SBND)

CIRCLE 25 ON READER SERVICE CARD

**6791:** "Charlie India Oscar" repeated by woman 2246. into phonetic groups. (E. R. Quackenbush, NY)

**6802:** Four-digit Spanish numbers station with female announcer 0425, very strong signal. Opened with count from one through zero in Spanish, brief burst of RTTY-like sound, then "827" repeated followed by seven consecutive tones and into number groups. (Ted Gurley, TX) Four-digit Spanish numbers with female announcer 0710, was done live as announcer coughed while on the air! Heard in SSB until 0742. (Ken Navarre, Jr., CA)

**6803.5:** Four-digit Spanish numbers station with female announcer ending 0245; sound of tape flapping continued for a minute after the end of the message. (Jerry Winder, LA)

**6810:** Five-digit Spanish numbers station with male announcer 0440, each group sent twice. Switched to a 3/2 pattern just before ending at 0443. There was some interference from "pips" which preceded a five-digit Spanish numbers station with the usual female announcer on 6802 kHz. (Ken Eichman, OH)

**6833:** Five-digit Spanish numbers station with female announcer 0830; brief pause every five blocks of numbers. Off at 0838. At 0900, a carrier with two "clicks" each second came on the air; it ended at 0905. This same transmission was noted later at 1033 on 9082 kHz. (Ken Navarre, Jr., CA)

**6837:** Five-digit number groups, in columns of six, in RTTY 0430 850/66R. (Robert Margolis, IL)

**6840:** Four-digit English numbers station with female announcer 0502-0526. (Joseph Lemak, Jr., NY)

**6870:** Five-digit Spanish numbers station with MALE announcer 0005. (Dave Bush, OH)

**6875:** Five-digit English numbers station with female announcer 0230, was in SSB. (Thomas Bucci, VA)

**6889:** Five-digit Spanish numbers station with female announcer 0645. (Robert Margolis, IL)

**6900:** Five-digit Spanish numbers station with female announcer 1007. (Jonathan Scherf, WI)

**6923:** Four-letter/digit CW numbers station 0225-0242. Only letters A, B, D, E, N, T, U, V and numbers 4 and 6 used (obviously "cut" numbers of some sort). (Ron Weiss, IN) Male announcer yelling in Spanish 2247 in SSB, followed by a steady flow of RTTY. Breaks only lasted a few seconds. This pattern continued through the night until the early morning hours. (Thomas Bucci, VA)

**7000:** Five-digit Spanish numbers station with MALE announcer 0500, very strong. Same message was repeated at 0530. (Dave Bush, OH)

**7376:** Four-digit English numbers station with female announcer 0553, very weak signal. (Ted Gurley, TX)

**7395:** "U" repeated in CW 1220. (Ken Eichman, OH)

**7438:** Five-digit Spanish numbers station with female announcer 0935. (Chris Devendorf, CA) Similar station on 7440 kHz at 0933. (Ken Navarre, Jr., CA)

**7525:** Five-digit Spanish numbers station with female announcer 0522. (J. Lemak, NY) Also noted at 0310. (Carlton Greene, MD)

**7527:** Five-digit Spanish numbers station with female announcer 0311. (E. R. Quackenbush, NY)

**7532:** Five-digit German numbers station with female announcer 2335; was in SSB. Opened with flute-like tones and "Yankee Kilo." (Ken Eichman, OH) Also heard on 7533 kHz during same time period. (E. R. Quackenbush, NY)

**7605:** "Victor Lima Bravo Two" repeated by female in English from 0153 to 0200. (Robert Comeau, NS)

**7646:** KWS78, U.S. Embassy, Athens, Greece, QRA marker in CW 2150. (Al Quaglieri, NY)

**7652:** KRH50, U.S. Embassy, London, England, QRA marker in CW 2145. (Al Quaglieri, NY)

**7858:** Five-digit English numbers station with female announcer 0215; opened with "Alfa Charlie" repeated four times followed by a sound that was similar to that produced by a video game. (Thomas Bucci, VA)

**8040:** Four-digit Spanish numbers station with female announcer 0900, was in SSB. (Robert Margolis, IL)

**8053:** Five-digit Spanish numbers station with female announcer 1309, two women heard speaking in Spanish after end of transmission. (Tom Stovall, Jr., AL)

**8063:** Five-digit German numbers station with female announcer 0210, was in SSB. (Thomas Bucci, VA)

**8150:** Five-digit Spanish numbers station with MALE announcer 1142, opened with "atencion 786 95" repeated several times before number groups. Same message was repeated digit-for-digit on the same frequency and at same four times in the next eleven days! (Dave Bush, OH) Excellent bit of listening and persistence, Dave! (Editor) Four-digit Spanish numbers station with MALE announcer noted one day at 1208! (Dave Bush, OH) Since it now seems definite that the



0411 (11-60)



TO: WFB2QIN, Harold A. Ort Jr.

Thank you for your report of the reception of our signals on **HRE2 7970 KHz.** at 0830 GMT July 14/1968

This station is part of the Tropical Radio Telegraph Company's network of stations in the United States, Central America and Panama.

We appreciate your interest.

*C. A. Kirkconnally*  
C. A. Kirkconnally, Superintendent  
Tropical Radio Tele. Company Tegucigalpa

*HRE2 in Honduras sent Harold Ort this QSL in 1968.*

four-digit and five-digit stations are operated by "competitors," what are we to make of this? Is this just an unintended coincidence? Deliberate "jamming" or interference? A double agent? Will an interference complaint be filed with FCC? Can the ARRL do anything?? Stay tuned to future issues of POPCOMM for the answers... (Editor)

**8174:** Five-digit German numbers station with female announcer 2139. (Al Quaglieri, NY)

**8167:** LQB9, Buenos Aires, Argentina, time signals 2340-2350. "CQ LQB9" sent in CW 2340-2345, then time pulses until 2350 when "CQ LQB9" was sent again in CW, then off. (George Osier, NY) A good, rare catch! (Editor)

**8293:** This is an active frequency for maritime traffic involving tankers and tugboats. Traffic can be heard out of Halifax, Boston, and New York harbors in SSB. (Henry Bartsch, VT)

**8380.5:** "MSG FM LUPUS" in CW 0225, many numbers interspersed with such words as "maritider genova," "norfolk itons," "piano stiviggio eccles," etc. (Robert Margolis, IL) This is likely maritime transmission of some sort. (Editor)

**8441:** 70A, Aden, Peoples Democratic Republic of Yemen, CQ marker in CW 1900. (Ken Eichman, OH)

**8453.5:** KFS, San Francisco, CA, weather broadcast in CW 0605. (Robert Margolis, IL)

**8654:** JCS, Choshi, Japan, CQ marker in CW 1240. (Ken Eichman, OH)

**8759:** "Radio Buenos Aires transmitter" followed by a short Spanish transmission, in SSB 0345. Was repeated each minute, Spanish talk could be heard in background. (Thomas Bucci, VA) This is listed as LPL, General Pacheco Radio, Buenos Aires. (Editor)

**8812:** Phone patch traffic from aircraft 0535 through "high seas operator" 0535; bet those people would turn green if they knew they could be heard over half the world by anybody with a \$100 radio! (Dallas Williams, CO)

**8967:** CUW, Lajes Field, Azores, giving weather information to MAC 67953 in SSB 1117. (P. N. Davis, IL)

**9023:** "Uncle Sam," "Demolish," "Remodel," and "Sixpence" exchanging radio checks in SSB 1730. (P. N. Davis, IL)

**9050:** "L" repeated continuously in CW 0300. At 0305, a five-digit German numbers station with female announcer began, only to be replaced at 0307 by "L" beacon briefly, and then back to German numbers until 0311. (George Primavera, NJ)

**9124:** Five-letter CW groups, 0706, no calls, apparently cut numbers. (Chris Devendorf, CA)

**9325:** Letters in the international phonetic alphabet (fox-trot, tango, echo, etc.) read by female announcer 0100. At 0101, "message 29" said twice and then back to letters. At 0109, "end of transmission" was announced and

## Take a Closer Look



What do you want from a Ham magazine? News. Entertainment. Interviews. Projects. Reviews. Information. Great Reading.

Is that all?

Well, how about a WAZ Award Program, a Five Band WAZ Program, the two greatest World Wide DX Contests in the world, a DX Awards Program, two 160 Meter DX Contests, a USA-CA County Awards Program, a DX Hall of Fame. Twelve of the greatest achievement and operating programs in the Amateur Radio world. All from CQ.

 The Radio Amateur's Journal  
76 N. Broadway, Hicksville, NY 11801

Please send me CQ for  Life  3 Years  2 Years  1 Year  
 New  Renewal  Start with \_\_\_\_\_ issue

Name \_\_\_\_\_ Call \_\_\_\_\_  
Street \_\_\_\_\_  
City \_\_\_\_\_ State \_\_\_\_\_ Zip \_\_\_\_\_

Charge My Order To:  Payment Enclosed \$ \_\_\_\_\_  
 MasterCard  My account number is \_\_\_\_\_  
 VISA

3 Years (36 issues) ..... \$42.00  
2 Years (24 issues) ..... 29.00  
1 Year (12 issues) ..... 16.00



République Populaire Fédérative de Yougoslavie  
**COMMUNAUTE DES POSTES  
 TELEGRAPHES ET TELEPHONES  
 YUGOSLAVES**

BEOGRAD, le 27.3.68  
 Tél. 32-936, 31-224  
 Télex 01-031

Voire réf. o2-184/1  
 Notre réf.  
 O B J E T :

HAROLD ORT JR.  
 MEMBER: Firecrest WX Club  
 74 W. 8th Avenue  
 Gloversville, N.Y.  
 12078

Dear Sir,

We have received your letter of 16.II 1968 and we can confirm with pleasure that you have heard one of Yugoslav PTT stations working for oversea public radio traffic. In the same time we thank you for your information about emission.

The case you are writing about occurred on the 16.2.68 at 22,40 GMT and it was radio telephone emission A3a, on frequency 10958. The text you are quoted is for circuit adjustment purposes with certain corresponding station we are working with and we use beam antenna.

FOR TELEPHONE SERVICE  
 V. Ranković, ing. dipl.

A prized QSL letter from Yugoslav PTT received by Harold Ort several years ago.

transmission ceased. (George Osier, NY) Also heard from 0105-0108 and 0202-0210, no obvious grouping noted. (E. R. Quackenbush, NY) Heard later at 2151. (George Osier, NY)

**9891:** Five-digit numbers groups, sent in columns of six, at 1443 in RTTY 850/100N. (Robert Margolis, IL)

**10062:** Coded Spanish RTTY traffic from 0604. Mixture of Spanish words, numbers, and phonetics "de mike cero kilo" and others. During breaks in the traffic, a very weak and uncopiable reply could be heard from a station 500 Hz off frequency. 850/67. (Dallas Williams, CO)

**10177:** Numbers station with 5-digit groups in German read by a woman. USB mode. Heard at 2107. (Tom Kneitel, NY)

**10256:** KWS78, U.S. Embassy, Athens, Greece. QRA marker in CW 2205. (Al Quaglieri, NY)

**10494:** WGY903, Olney, MD. and WGY907, Kansas City, MO. exchanging technical talk at 1625 in SSB. Both stations are operated by the Federal Emergency Management Agency (FEMA). (George Osier, NY)

**10637:** KKN50, U.S. State Department, Washington, DC. QRA marker in CW 2217. (Al Quaglieri, NY)

**10638:** "Musical Marker" at 2230; E, fourth space, treble clef, then down to B, third line, treble clef. Each note of two seconds duration. Repeated for five minutes. (Robert Margolis, IL)

**10815:** AQP, Karachi, Pakistan, V marker in CW 1350. (Ken Eichman, OH)

**11207.7:** CW transmission consisting of 5 "dots" and a long "dash" repeated over and over at 2142. (Tom Kneitel, NY)

**11267:** "Dogmatic" with coded message to "Skyking" is SSB 2035 (Wayne Allen, ON) This is a SAC message, and "Skyking" refers to a SAC bomber aloft. (Editor)

**11448:** RLX, Soviet Embassy, located in Dublin, Ireland, with traffic in Russian 0030 in RTTY 850/66N. (Robert Margolis, IL)

**11497:** "Alfa Whiskey Tango," "Salt Lake," "Happy Hour," "Airborn," and "Players" among tactical calls

heard in SSB 2130. Possibly military, but the way some terms were used raised doubts. (Dallas Williams, CO) Pretending to be military tactical traffic is an old and proven excellent disguise for illicit activity, since the FCC knows that the military pops up anywhere without warning. (Editor)

**11532:** Four-digit Spanish numbers station with female announcer 2325. (Robert Margolis, IL) Another common channel for four-digit numbers traffic. (Editor) Four-digit Spanish numbers station with female announcer 0340, was in SSB. (Thomas Bucci, VA)

**11533:** "Acrobat" running radio checks in SSB 2229. (George Osier, NY)

**11533:** Four-digit Spanish numbers station with female announcer 1639. (George Osier, NY) Also heard in SSB 0230. (Henry Ponder, NC)

**11534:** Spanish numbers station with female announcer 0305 in SSB; a three-digit group was repeated twice followed by a ten-digit number. Then the sequence was repeated. (Thomas Bucci, VA)

**12328:** "U" repeated continuously in CW to 0323, then into a five-group, five-digit CW message, after which the "U" beacon resumed. (Ken Eichman, OH)

**12687:** OFJ, Helsinki, Finland, in CW at 2140 with marker tape reading "OFJ QX 16 MHZ K." (Tom Kneitel, NY)

**13000:** UBE2, Petropavlovsk, USSR, working UYCP in CW 2155. (Ken Eichman, OH)

**13072.5:** ZSD, Durban, South Africa, repeating its call in CW 2047. (Robert Margolis, IL)

**13135:** "This is a test transmission for circuit adjustment purposes. This is Tokyo Radio." This was followed by a short transmission in Japanese 0035 in SSB. The sequence was repeated every 30 seconds. (Thomas Bucci, VA) This is listed as JBO, Tokyo. (Editor)

**13438:** Y7A73, GDR Diplomatic Service, Berlin, East Germany, five-digit groups message apparently being sent to Washington 1700 in RTTY 425/66R. (Robert Margolis, IL)

**14358:** Five-digit groups, six groups per column, in RTTY 425/66N 1345. (Robert Margolis, IL)

**14393:** "CQ telephone pioneer, waiting and listening" repeated continuously in SSB 2330. (Thomas Bucci, VA) Anyone have an idea as to what the heck this is? (Editor)

**14968:** "UJVICI" and "RMBZ" calling CMU967, Santiago, Cuba, 1858. (Chris Devendorf, CA) CMU967 is the Soviet Navy; the other calls are apparently Soviet ships. (Editor)

**15945:** MKG, Royal Air Force, London, England, traffic 1505 in SSB. (Robert Margolis, IL)

**15967:** Spanish RTTY traffic 2143, appeared to be Cuban embassy as items were slugged "Embacuba Guyuana," 425/67. RTTY ended 2153, followed by very poorly sent CW until 2211. (Dallas Williams, CO)

**16420:** Five-digit Spanish numbers station with female announcer 1834, strong signal. (Tom Stovall, Jr., AL)

**16450:** Five-digit Spanish numbers station with female announcer 1720, numbers sent in a "3/2" pattern (pause between third and fourth digits of each five-digit block). Numbers ended at 1732, followed by "ticks" at the rate of one each 1.6 seconds until 1736; carrier remained on until 1742. (Dallas Williams, CO)

**16663:** EMLU calling UAI3 in RTTY 2239. 170/67. (Dallas Williams, CO) UAI3 is listed as being at Nakhodka, Dallas. (Editor)

**16925.4:** LSO3, Buenos Aires, Argentina, with following message in CW 0045: "In view of Great Britain's persistence of aggressive activity, any ships of English flag sailing through the South Atlantic and bound for operations area which might be liable to become a menace to national security be dealt with accordingly." (Robert Margolis, IL) !!! (Editor)

**17018:** ZSC, Capetown, South Africa, 1655-1700 with time pulses and ident in CW. (George Osier, NY)

**17370:** Five-letter groups in RTTY 1750, sent in blocks of 100 groups except for last block which was 52 groups. Signal was quite strong. 425/67. (Dallas Williams, CO)

**17371:** Y7L36, East German Embassy, Havana, Cuba, message consisting of five-digit groups in RTTY 425/66N 1649. (Robert Margolis, IL) Hmmm...the Soviets have all sorts of satellite links to and from Cuba, and it would certainly be more secure and reliable to route diplomatic traffic via them rather than radio. Unless, of course, Berlin wasn't the ultimate destination for this message. (Editor)

**18005:** "Skyking" SAC broadcast in SSB 0118 with phonetic letter traffic. (Dallas Williams, CO)

**18040:** ZRH, Fisantekraal, South Africa, calling NAU, U.S. Navy, San Juan, Puerto Rico, in RTTY 1806 850/67. (Dallas Williams, CO)

**19146:** KNY26, Hungarian Embassy, Washington, DC, calling HGX21 in Budapest, Hungary, in RTTY 1806 425/67. (Dallas Williams, CO)

**20186:** Several NASA stations noted here throughout a recent Space Shuttle mission. (Tom Lewandowski, NY)

**20191:** Several NASA stations noted here throughout a recent Space Shuttle mission, principally traffic between AFE71, Patrick AFB, and AFE83, Ascension Island. (Tom Lewandowski, NY) This frequency also used for rebroadcast of Space Shuttle transmissions, says Tom. (Editor)

**20193:** Unidentified station in SSB 1640, apparently an unauthorized relay of WEZY-FM, Cocoa, Florida. This frequency has been used for relays of Space Shuttle communications in the past. (Ken Modigan, NY)

**20198:** "Houston Control" giving progress reports on the Space Shuttle mission and also rebroadcasting Space Shuttle to ground communications. (Tom Lewandowski, NY) Many thanks for these loggings, Tom. Let's all keep an ear on these channels during future Shuttle missions! (Editor)

**20350:** NBA, U.S. Navy, Panama Canal Zone, testing in RTTY with RY marker 1750 850/100. (Dallas Williams, CO)

**20876:** KFK92, Observatorio Interamericano, Tucson, AZ working XQ8AFI, Observatorio Interamericano, Cerro Tololo, Chile, in SSB 2050. (Ken Eichman, OH)

**20958:** SAM47, Swedish Embassy, Beirut, Lebanon. SSB traffic at 1731. (Charles Keilholz, APO NY/ASWLC)

**30020:** Time pulses on the minute from 1652, no identification or voice announcement heard. (George Osier, NY) George, I'm stumped. Any clues, readers? (Editor)

Thanks for all of your support, and I'll see you next month.

# John J. Meshna Jr., Inc.

19 Allerton Street • Lynn, MA 01904 • Tel: (617) 595-2275

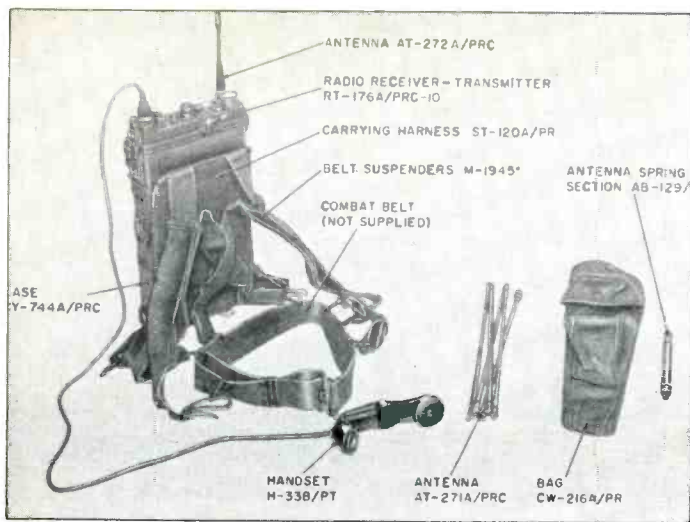

**U.S. RECEIVER TRANSMITTER RT 176/PRC 10 RADIOS**  
 Thru a very lucky purchase, we just got a small quantity of new, unused PRC 10 radios. They are just beautiful. Any collector would be proud to have one of these babies in his possession. These radios came bulk packed to us just the way they were shipped from the factory to Uncle Sam. They were never released into the field. We are selling these as complete sets. The picture below shows all accessories that will be shipped with each unit. **RT 176/PRC 10 feature:** voice communication, tuneable range of 38-55 MC, super heterodyne FM front end, .9 watt xmtr., range of 5 miles (may vary depending on antenna used & siting conditions), & total wt. w/accessories of only 16 lb. Each set will include at no extra cost operators manual, schematic, & 4300 KHz calibration xtal. We are selling these as complete sets as shown for \$100.00/set. Shpg. wt. 18 lb. The quantity is limited, so act fast. BA279 batteries for the PRC10 radios available. Shipping weight 10 lbs. \$15.00 each.

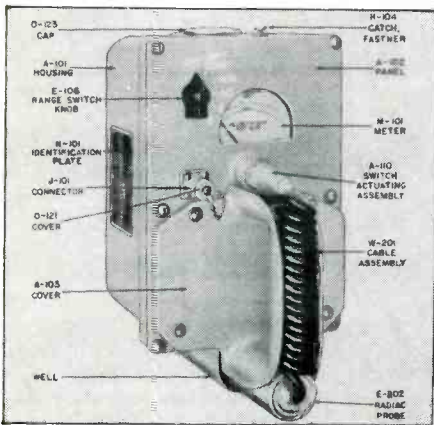

## PDR-27 NAVY RADIATION METER

Just released by the US Navy. They appear to be in excellent condition and include the fitted aluminum transit case. Batteries not furnished but are available in most electronic supply houses. 4 ranges 0.5 to 500 mr/hr. Removeable hand probe, detection of Beta and Gamma radiation. With today's world conditions and perhaps proximity to a nuke power station, it might provide a little insurance to own one of these instruments. With no facilities to check or test, we offer AS IS, visually OK Schematic provided with each. We have some accessories and offer as an option although not required for operation.

Shipping wgt. 22 lb. PDR-27 Rad Meter \$50.00

PDR-27 phones \$7.00

Hi Sensitivity GM tube \$10.00

Approx. 100 page Instr. Book \$10.00

Low Sensitivity GM tube \$5.00

The above listed tubes are already installed in the meter.

We are offering these as spares if desired.

**PHONE ORDERS accepted on MC, VISA, or AMEX No COD's. Shpg. extra on above.**  
**Send for free 72 page catalogue jam packed w/bargains. CIRCLE 70 ON READER SERVICE CARD**

## Paracclipse Midwest

Your Picture Window to the World



**High Performance  
Satellite Antenna**

STOCKING DISTRIBUTORS FOR

Paracclipse Luxor Bowman  
 Amplica MTI Drake  
 Chaparral DX General Instrument

**Guaranteed Lowest Prices**

SYSTEM PRICES STARTING AT

**\$1795.00**

**VIDEO ELECTRONICS INC.**

4416 Outer Loop  
 Louisville, Kentucky 40219

(502) 964-DISH

Outside Kentucky 1-800-55-VIDEO

CIRCLE 28 ON READER SERVICE CARD

## "TALKING" CW & RTTY

SPEAKS WORDS AS RECEIVED

ALSO

## SSTV & FAX

LIKE YOU'VE NEVER SEEN

WITH YOUR  
 TRS 80C OR TDP 100  
 COMPUTER  
 AND

## MAGNUM CMJ-IF & CMJ-TU SYSTEM

CONTACT:

**MAGNUM DISTRIBUTORS INC.**

1000 S. DIXIE HY. W. #3  
 POMPANO BEACH, FLORIDA 33060  
 305-785-2002

CIRCLE 22 ON READER SERVICE CARD

# PIRATES DEN

BY DARREN LENO, WD0EWJ

## FOCUS ON FREE RADIO BROADCASTING

### Pirate Radio Operator Sentenced

Victor G. Alcorn of Sayville, New York was sentenced late last year to 18 months of probation and ordered to pay a \$750 fine for operating an unlicensed FM radio broadcast station in violation of Section 301 of the Communications Act.

The sentence, handed down by Federal Magistrate David Jordan of the U.S. District Court for eastern New York, followed prosecution by the United States Attorney on evidence gathered by the FCC's New York District Office. Alcorn pleaded guilty to charges contained in a four count criminal offense filed against him. Alcorn faced possible penalties of four years in prison and a \$40,000 fine.

The charges were filed after Alcorn was arrested back in July, 1982 following an unlicensed broadcast. He had first been identified by the FCC New York Engineers in 1981 as the operator of an unlicensed FM radio station calling itself WBUZ, which was responsible for a complaint of interference to the instrument landing system at MacArthur airport in Islip, New York. Despite warnings and the imposition of monetary fines by the FCC, Alcorn continued to operate, even challenging the FCC to catch him, while attempting to avoid detection by repeatedly moving the location of his station and changing hours of operation. These efforts were to no avail, and Alcorn was identified on several occasions by FCC engineers using sophisticated direction finding techniques as being responsible for the unauthorized transmissions. Alcorn had generated considerable publicity for his pirate station, including news reports on commercial radio stations and newspapers.

The action against Alcorn was part of the FCC's continuing effort to take action against a growing number of unlicensed pirate radio stations. The operation of an unlicensed station is a violation of Federal Law, and occasionally causes interference to radionavigation equipment, home entertainment receivers, and other authorized users of the radio spectrum.

An FCC spokesperson emphasized that other pirate radio operators would face stiff penalties and fine when caught by FCC enforcement engineers.

### Pirate Bandscan

KPRC, the famous New York City area pirate, continues to be heard on 1616 kHz AM, 6240 kHz SW, and 91.5 MHz FM. This station has been known to pop up as early as 0300 GMT and continue transmissions until as late as 0700. This shortwave frequency

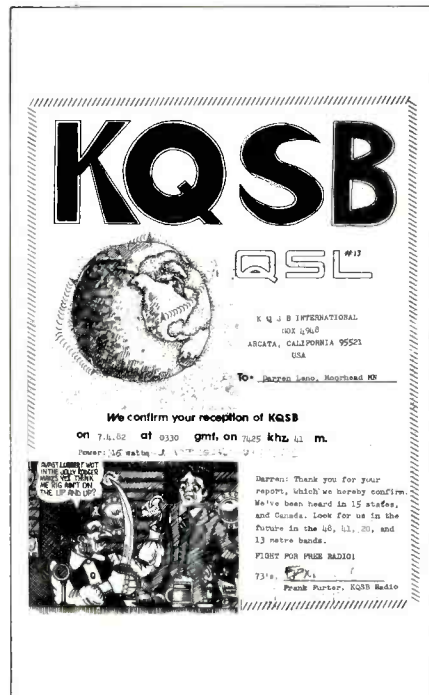

The impressive looking QSL from pirate KQSB International.

has enabled SWLs and DXers from around the country to hear the politically oriented programming this station offers. Station manager "Pirate Joe" can be contacted through PO Box 747, Exeter, NH 03833.

Another NYC pirate, PRN, also continues to operate a shortwave frequency of 7375 kHz in parallel with the AM frequency of 1616 kHz. PRN's new shortwave frequency has, not unlike KPRC's, become a popular target of listeners around the nation who cannot usually hear the AM frequency. Both KPRC and PRN seem to have found a very receptive new audience on shortwave.

KBIR has been popping up again lately on 3240 kHz. Arthur Pym of New York reports hearing ID's as "KBIR Clear Channel 1620." Evidently, the station was tuned on the second harmonic of its lower frequency. However, this is not the first time that KBIR has been noted on 3240 kHz.

KFAT has been heard by John Arthur of Hawaii on 7421 kHz. This is the only pirate on the bands today that I know of that plays Country & Western music. John noted some drifting of the KFAT's signal, as well as ID's by both male and female announcers.

Although some pirates like to tack the impressive word "International" to the end of their name or call letters, few have ever earned the right to do so like KQSB International. KQSB has been logged in Africa and several European nations. A taped program



Lucky listeners received this nice QSL card from Radio Confusion. The station, currently inactive, may be making a comeback.

of KQSB was even relayed by the famous English Free Radio station, Radio Apollo.

KQSB Int'l has of late been testing to Europe and Africa on a fairly regular basis. You may be able to hear one of these tests by tuning 15050 kHz (give or take 10 kHz) anywhere from 1900 to 0000 GMT. I'm sorry I can't be a little more specific with the time. KQSB utilizes the "hit and run" tactic for broadcasting, where the station never consistently operates at the same time on the same frequency. Of course, stations that use H&R are depriving themselves of a regular audience, but they may reach a larger audience in the long run. History has shown that pirates who become too predictable are often closed down by the FCC, whereas several H&R pirates (like R. Clandestine) sometimes go on for years and years.

Speaking of Radio Clandestine, it was noted on 7375 kHz by Grant Lochmiller of Iowa. Programming was said to be as professional and humorous as usual. R. Clandestine probably invented the H&R broadcasting method. You never know where this one will show up. A frequency directory compiled by Scott McClellan for A\*C\*E, showed that Radio Clandestine was heard last year on 4890, 7345, 7350, 7370, 7390, 7400, 7425, 9590, 9640, 9790, 11770, 15240, and 15400 kHz. Where they'll be this year is anyone's guess.

Kirk Baxter of Kansas caught Radio Free Insanity on 7430 kHz, from 2005 to 2026 GMT. Kirk said the station's format was to play three songs and then give the titles, along with an ID.

Radio Paradise Int'l, heard by Kirk Allen of Oklahoma, was recently on 6900 kHz from 2302 to 2358 GMT. Grant Lochmiller heard the station later on 6900 kHz, 0140 to 0215 GMT. R. Paradise claimed a mere 25 watts of power and said they could sometimes be heard on 6225 kHz.

Gary Criteser of Michigan reports hearing the Voice of Democracy from 0500 to 0800 GMT on 7300 kHz, with fair to excellent signals. Gary says, "The programming was very well done and very funny. They an-



nounced that would play 'Two forgotten melodies as played by the Dixie Capella', which was followed by two darned good Dixieland numbers." Telephone calls from listeners are a regular VOD feature. Other frequencies to check for this station are 6220, 6240, 7408, and 7430 kHz. This is a fun station to hear. Reception reports go to the Voice of Democracy, PO Box 982, Battle Creek, MI 49016-0982, although a QSL may not be returned for your report.

The controversial right-wing radical pirate The Voice of Tomorrow, often described as a clandestine, has been active on 6240 kHz, (usually around 0000 GMT) and 7410 kHz (from 0700 to 0800 GMT) according to Kirk Allen of Oklahoma. During the broadcast that Kirk tuned in, he noticed another pirate, WOIS, operating just below the VOT.

WOIS made a rare appearance on 7408 kHz from 0630 to 0738 GMT. This station has not been overly active in months past, and no one has the slightest idea if WOIS will be heard again—ever! If you're lucky enough to hear them, you can try for a QSL from the Battle Creek, Michigan address mentioned above. I've been waiting two years for mine.

The Voice of Venus, another station notorious for QSLs, is hoping to make it on the airwaves sometime soon. Station Manager Scott Wild hopes to present a series of actual interviews with members of minor U.S. political parties. "Too many people believe there are only two candidates in any election. The Voice of Venus hopes to make its voting age audience aware that they have more of a choice than they may know of," says Mr. Wild. However, plans are still tentative, and the station has been having its usual hard luck with transmitters, as it has throughout its six year history.

"Radio Rebel—KMA" sends word that they should be operating by the time you read this. Rebel Radio claims to be using an old Hammarlund transmitter and an 800 watt linear amplifier. Check 7410 kHz on GMT Monday after 0600. Reception reports are encouraged and welcomed at PO Box 3192, Joliet, IL 60434.

The Voice of Redemption is a new pirate radio organization being relayed over the facilities of Kiwi Radio in Hastings, New Zealand. Both VOR and Kiwi are exchanging programming and technical assistance. Although VOR does not own its own broadcasting equipment, they are engaged in a search to locate adequate transmitting facilities. Until further notice, check for the Kiwi relay on 5850 and 26050 kHz, GMT Saturdays from 1200 on. Reception reports go to PO Box 1411, Calumet City, IL 60409.

### Clandestines

**Nicaragua** Radio Miskus has been heard operating on 6965 kHz, from 0230 to 0330 according to Grant Lochmiller of Iowa. Programming, as usual, is in the native language of the Miskito Indians. You'll have to pay attention to positively I.D. this one.

I logged Radio Quince de Septiembre re-

cently on 7000 kHz, with transmissions lasting past 0500 GMT. George Zeller of Ohio notes that this station frequently operates a parallel frequency of 5565 kHz. Begin searching for this station around 0200.

La Voz de Sandino is active on 6210 kHz as early as 0000 GMT through 0500. Fred Oyster of California heard a male announcer talk about Costa Rica during an English segment of the broadcast. Tom Stovall, Jr. of Alabama has heard this station with good signals on 6215 kHz.

**El Salvador** Radio Farabundo Marti seems to have a hard time staying in one place, at least as far as frequencies are concerned. John Pascoe in Washington has heard this station on 6930, 6915, 6914, and 6900 kHz; check after 0100 GMT.

Radio Venceremos was heard by Paul Walkendorf of Michigan, as they jumped from frequency to frequency in an attempt to avoid jamming. You may find this station



operating between 6900 and 7000 kHz. Also watch 6500-6600 kHz.

**Libya** The Voice of the Libyan People, a station sponsored by the Nat'l Front for the Salvation of Libya, was heard by George Zeller of Ohio as they, too, were forced to avoid jamming by changing frequencies between 12649 and 12655 kHz. Check between 2000 and 2230 GMT. Programs were in Arabic.

### In Conclusion

Thank you to the people listed above, to the Association of Clandestine radio Enthusiasts, (A\*C\*E, PO Box 452, Moorhead, MN 56560) and all who have written in with their ideas and suggestions for this column. Your contributions and input are needed. Please send all material for the Pirates Den to: The Pirates Den, c/o Popular Communications magazine, 76 North Broadway, Hicksville, NY 11801.



**SW RECEIVERS**  
Call Today For Your Price



**IC-R71A**  
Call For Special Introductory Price



**Scanners In Stock**  
Call Today

## RTTY

**MFJ • AEA • KANTRONICS**  
**INTERFACES & SOFTWARE**



Prices and availability subject to change; please call for latest information  
RTE 286, PRESQUE ISLE PLAZA, PITTSBURGH, PA 15239  
CALL (412) 733-1555 MT&W 10-6 Th&F 10-8 Sat 10-2



CIRCLE 77 ON READER SERVICE CARD

*An incredible and unique opportunity from STANO Components!*

### AN/GSQ-151 (PSIDS) SEISMIC INTRUSION DETECTION SET

(THIS IS THE WIRELESS SET)

**Features:**

- Detects presence of people, animals, vehicles, etc.
- Rapid deployment
- Each detector/transmitter has a different tonecoded pulse for precise detection and identification
- Each detector/transmitter has the corresponding number of pulses embossed on the side for accurately implanting in total darkness
- Self-contained — detector/transmitters and receiver operate on 9V transistor radio batteries
- 100 hours continuous activation
- One mile transmission range
- 5 position sensitivity selection on each detector/transmitter
- Hand implanted above ground, buried, or placed in water
- Combat oriented ruggedized mil-spec construction



**NEW — NEVER USED**

**\$475.00**

**per set**

while supply lasts

(Mint condition. These are the best that have ever been available)

**INCLUDES:**

- (4) detector/transmitters with 8-feet of cable connected to geophone on each
- Compatible receiver with earphone
- Canvas carrying bag for entire set
- Manual

**APPLICATION**

- Home/camping/border patrol/facility security — perfect for any form of perimeter surveillance/security where precise intrusion detection and identification is desired

Call or Write:  
**STANO COMPONENTS**  
P.O. Box 6274  
San Bernardino, CA, USA, 92412  
(714) 882-5789

CIRCLE 29 ON READER SERVICE CARD

THE MONITORING MAGAZINE

May 1984 / POPULAR COMMUNICATIONS / 67

www.americanradiohistory.com

## ESTABLISHING SURVIVALIST COMMUNICATIONS SYSTEMS

### Signal Security Response

**R**ecently it was disclosed that the mysterious "Seaman Z" was retired businessman Robert D. Ogg of Kentfield, California. Ogg had used radio signals intercepted in San Francisco in 1941 to plot the eastward course of Japanese naval forces towards the Hawaiian Islands. The signals intelligence was passed on to the White House, although the actual identity of "Seaman Z," then a member of our Naval Intelligence, had remained hidden for decades.

Breaking enemy codes is nothing new. Throughout WWII our forces regularly monitored Japanese military traffic even though it was coded, just as the British broke the strategic code Hitler used to send high-level orders to his field commanders.

Effective protection of the information contained in communications generally means a combination of factors involving people, equipment, and systems. One important factor is that communications security is not something persons participating in tactical operations wish to put up with, finding it expedient to conduct their communications in the quickest, simplest, and most direct manner possible. This was a problem, for instance, in Vietnam where "possible" usually meant whatever superior officers were willing to permit in a given tactical situation. Therefore, the "people" component of the equation didn't improve until the chain of command fully appreciated the absolute need for very strict communications discipline. This appreciation grew in direct proportion to our realization of the threat involved as a result of poorly secured communications—compliance grew in proportion to the influx of new systems and equipment. But the problem was never fully resolved during the period of the war in Vietnam despite much effort and lots of new equipment. It is still a problem facing those involved in tactical communications, and that includes public safety agencies, military forces, survivalists, and others.

As pointed out by Lt. General Charles R. Myer, U.S. Army (Ret.) in his report entitled "Division Level Communications 1962-1973" (a Dept. of the Army document), "Along with the need to communicate as rapidly and directly as possible during combat, another factor worked against effective communications security: a soldier in the thick of battle feels the need for friendly assurance. This assurance can come from talking—to anyone else who has a radio. When this happens, chances are that little thought is given to what information is actually being transmitted." Indeed, monitoring the idle chit-chat of enemy forces has been known



Voice scrambling is a bonus if you want communications security. (Photo courtesy U.S. Army)

as a reliable and highly effective form of intelligence gathering and has often produced as much vital information as has been obtained after decoding encrypted "official" traffic.

Before various scrambling and other secure voice equipment was in general use, voice traffic needing security required being laboriously coded and manually decoded. The result was that coding was sometimes circumvented in favor of simplicity, expedience, and speed. What was needed was secure voice equipment.

In 1965 it was decided to attempt to make some use of 800 model KY-8 security devices in a stateside depot. Because no combat role had been assigned to the KY-8, the equipment wasn't made up with any mounting brackets or connecting cables. Nevertheless, the units were shipped off to Vietnam along with a team of communications experts to demonstrate their uses. That was the start of an evolutionary period during which applications and improvements progressed through several stages.

The KY-8's were distributed to field units for base, mobile, aero, and manpack use by 1968. This was not without problems, however, and equipment failure due to heat was one of the difficulties. The KY-8 had to be used away from direct sunlight and in a well

ventilated area. This was especially a problem during a presidential visit (1969) when a KY-8 temporarily conked out all secure voice communications between the Tan San Nhut HQ and an important field force! In another case, the commanding general of the infantry brigade HQ'd at Xuan Loc found that his secure FM net became unreliable because the KY-8 kept going on the fritz. He eventually discovered that it would work only when moved to a cooler location.

Other efforts to improve the KY-8's heating problem were not so effective. One operator put the KY-8 near a water bag to cool it down but it still ran too hot. It still overheated. Next, he took off the cover of the KY-8 which, while making it work, also violated the strict security regulations regarding the secrecy of the equipment itself.

By late 1968 infantry battalions began receiving PRC-77 transceivers mated to smaller KY-38 type scramblers; that permitted security between these battalions and the infantry companies. The PRC-77/KY-38 units, however, weighed in at more than 50 lbs., which meant transporting the two pieces of equipment separately or else having support aircraft fly it in for fixed-location operation.

In late 1969 secure narrow band FM equipment bearing the code name NESTOR was announced as being on the way. The KY-38, bulky as it was, and the generator-powered KY-8, were not being utilized as much as had been desired. In some instances, the larger KY-8 units were replaced with KY-38 scramblers in an effort to make the idea of using voice security more appealing.

When the NESTOR units arrived for use there was a shortage of the accompanying kits containing the cables and hardware for mounting the units in aircraft and vehicles;



Portable and mobile scramblers were great but didn't always work with a high degree of reliability.

as time went on, the lack of adequate mounting hardware and cables got more acute instead of better. Certain so-called "X-mode" cables for the KY-8 were also scarce. Another problem was recovering NESTOR units from vehicles and helicopters and the redistribution to other units; it was conducted in a rather haphazard manner. Moreover, losses and evacuation of aircraft that had been fitted for the equipment made the shortage even worse (most replacement aircraft didn't come with the kits installed).

The number of KY-28 keying (coding) devices for the NESTOR sets was sufficient when units were operating in one area, but when divisional units were dispersed there was a shortage of the keying devices. In 1969, a common keying (coding) list was developed for all units within the III Corps zone. In order to keep these scrambling codes compatible, codes had to be changed simultaneously. Midnight was selected—but it was the worst possible time since the greatest number of enemy engagements took place between 2200 and 0200. Furthermore, when several units shared the same coding device, having to move at night to change the scrambling instructions was inconvenient and dangerous; also it created reasons for not using the equipment. Later the changes were specified for 0600.

Voice security procedure codes were yet another problem. The early combat units were somewhat lax about communications security and the practice of using home-made codes and security measures became widespread. This was perceived as a dangerous practice even though it persisted throughout the war. One of its drawbacks was that it wasn't very effective but gave its advocates a false sense of security. It may well have been more dangerous than communicating in the clear! It was apparent that the need for more sophisticated codes was required. Upon request from the Army, the National Security Agency (NSA) prepared a series of preprinted codes to meet these needs. While they were not perfect, they were a great improvement, although getting the helicopter pilot or infantryman under fire to use them was a horse of a different color.

The ongoing need for convenient authentication and for a better means of sending limited classified traffic brought about the development of the KAL-55B authentication wheel, better known as the "whiz wheel." This was a circular authentication table prepared on a plastic disc.

This simplified communications security measures to a point where most users found them acceptable.

Signal security, especially in regard to voice traffic, was a huge problem throughout the war in Vietnam. Communicators (to one extent or another) were aware of the possibilities of enemy intercepts, analysis, and decoding—and of the need for encoding and authentication. The gap between this realization and actual practice, nevertheless, was immense. In Vietnam it looked at times to be a problem that could not be licked.

# Get Big Brother Off Your Back!

This is 1984, and Big Brother is watching you! Loompanics can show you *exactly* how he does it, too, with the most complete library of surveillance and countersurveillance books available. Here are just a few of the subjects covered in our incredible new catalog:

Electronic Surveillance  
Wiretapping  
Countersurveillance  
Mail Openings  
Spying & Shadowing  
Secret Codes

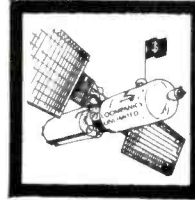

Gaining Privacy  
Concealing Valuables  
Financial Privacy  
Intelligence Gathering  
Alternate Identities  
"Beating the System"

**AND MUCH, MUCH MORE!**

We offer the world's most controversial and unusual books. Our new catalog has over 150 illustrated pages packed with detailed descriptions of more than 400 hard-to-find books. And you can order *every* book listed! You don't want to miss this unique source of suppressed information. To order your copy, send \$2.00 to the address below.

**Loompanics Unlimited**

Department 1984

P.O. Box 1197, Port Townsend, WA 98368

CIRCLE 78 ON READER SERVICE CARD

# USA-CA

Order one or two today and start collecting counties for one of amateur radio's most prized awards, USA-CA.

**\$1.25**



**POPULAR COMMUNICATIONS**

76 N. Broadway, Hicksville, NY 11801

Please rush me \_\_\_\_\_ copies of the USA-CA Record Book.

Enclosed is \$1.25 for each record book.

Total Enclosed \_\_\_\_\_

Name \_\_\_\_\_

Address \_\_\_\_\_

City \_\_\_\_\_ State \_\_\_\_\_ Zip \_\_\_\_\_

# WASHINGTON PULSE

## FCC ACTIONS AFFECTING COMMUNICATIONS

### **New Experimental Licenses**

The Commission Office of Science and Technology, Frequency Liaison Branch took the following actions:

**KE2XNA**, *Raytheon Service Co., Seattle, WA*. Developmental station to operate on 1636.5-1645.0 MHz to collect data needed to design Land Mobile Satellite Service looking to demonstrate alphanumeric communication for increasing spectrum efficiency via INMARSAT Satellite.

Granted the State of California to operate on 401.7895 MHz to collect data for use in prediction of fire, weather forecasting, and water run-off using GOES Satellite:

**KE2XNB** - Lee Vining, CA

**KE2XNC** - Kennedy Meadows, CA

**KE2XND** - Mount Shasta, CA

**KE2XNE** - Cartago, CA

**KE2XNF** - McCloud, CA

**KE2XNG** - Kennedy, CA

**KE2XNH** - Yosemite Village, CA

**KE2XNI** - Big Bend, CA

**KM2XQY**, *XTECH, Inc., Within Continental U.S.* Developmental station to operate on 173.2875 MHz for development of a timing device which could replace cable between start and finish points in a timed event.

**KM2XRC**, *Magnavox Advanced Products & Systems Co., Shipboard in Port of Los Angeles and approaching waters*. Developmental station to operate on 2900-3100 and 9300-9500 MHz bands to evaluate and prove new and existing marine radar systems.

**KM2XRD**, *Radiation Systems, Inc., Arcola, VA*. Research station to operate on various frequency bands to design, develop, and test antennas under U.S. Govt. contract.

**KM2XRE**, *Radiation Systems, Inc., Arcola, VA*. Same as above.

**KM2XRF**, *Astrotech Int'l Corp., Titusville, FL*. Research station to operate on various frequency bands to provide pre-launch test and support facility engineering and prelaunch operational data for spacecraft being launched from Cape Canaveral.

**KM2XRH**, *McDonnell Douglas Radio Services Corp., Southern California*. Research station to operate on 2315.0 MHz to evaluate, implement, and demonstrate an improved L-band/S-band frequency diversity telemetry system which will significantly reduce or eliminate data drop-outs due to multi-path interference.

**KM2XRI**, *Grumman Aerospace Corp., Calverton, NY*. Research station to operate on 400, 435, 450 MHz to demonstrate equipment as required by U.S. Government contract.

Granted developmental stations to Local Digital Distribution Company to assemble

and operate point to multi-point microwave (RAPAC) equipment in a city, metropolitan environment. The project will test and demonstrate the operation of equipment at the same time, it will verify the design and performance, improve design to demonstrate operation to potential customers and test and measure performance under various types of interference conditions; on various frequencies and locations as shown below:

**KM2XRJ**—10662.5 MHz, mobile within Montgomery County, Maryland.

**KM2XRK**—10664 MHz, Germantown, Maryland.

**KM2XRL**—10662.5 MHz, Rockville, Maryland.

**KM2XRM**—10596; 10597.5; 10599 MHz, Gaithersburg, Maryland.

**KM2XRQ**, *Navidyne Corp., Newport News, VA*. Developmental station to operate on various frequency bands for product testing of equipment and demonstration to prospective customers.

**KM2XRR**, *Navidyne Corp., Mobile Within Continental U.S.* Same as above with emissions and powers in accordance with Parts 81 and 83 of FCC Rules.

**KM2XRS**, *Northeast FM Repeater Assoc., Manhasset, NY*. Developmental station to operate on 902-928 MHz band to evaluate the use for point-to-point and some repeater application in the proposed WARC 79 for amateur radio operator use. To be used in conjunction with authorizations granted Eastern Amateur Repeater Linking Society.

**KM2XRT**, *Sperry Flight Systems, Albuquerque, NM*. Developmental station to operate on 915 MHz to flight test a data link and ranging system. Looking to develop a highly accurate ranging system with data link capability.

Granted developmental stations to Eastern Amateur Repeater Linking Society and various fixed and mobile locations to evaluate the use for point-to-point and some repeater application in the proposed WARC 79 for amateur radio operator use. To be used with authorizations granted Northeast FM Repeater Association.

**KM2XRU**—902-928 MHz, Mellville, NY and 50 mile radius

**KM2XRV**—902-928 MHz, North Creek, NY and 50 mile radius

**KM2XRW**—902-928 MHz, Lindenhurst, NY

**KM2XRX**—902-928 MHz, Mountain Lodge, NY

**KM2XRY**, *Northeast FM Repeater Assoc., Sherburne Township, Vermont*. Developmental station to operate on 902-928 MHz to evaluate the use for point-to-point application proposed in WARC 79 for amateur radio operator use.

**KO2XAB**, *Bell Telephone Laboratories, Inc., Mobile Continental U.S.* Developmental station to operate on various discrete frequencies and frequency bands for equipment development and engineering data needs supporting prototypes of new art and common carrier and related radio services; also for making field strength surveys by which operating companies can be assured that a system is capable of performing the work intended in the area of operation.

**KO2XAD**, *Bell Telephone Laboratories, Inc., Mobile Within Continental U.S.* Developmental station to operate on various discrete frequencies and frequency bands for demonstration of equipment to potential customers eligible for licensing in a service and to test equipment prior to filing applications for type approval or certification.

**KO2XAE**, *Bell Telephone Laboratories, Inc., mobile within Continental U.S.* Research station to operate on various discrete frequencies and frequency bands for use in studies of HF, VHF, UHF, and microwave technology and to use for communications essential to research projects and for technical demonstrations of technique and equipment to scientific and technical audiences.

### **New Public Local VHF Coast Station At Palmetto, Florida**

The Commission granted the application of James C. Pope for a new public local VHF coast station on 161.875 MHz at Palmetto, FL, provided he severs all relations with Gulf Coast Communications, Inc. (Public local VHF coast stations are common carriers which provide ship/shore radiotelephone service.)

In seeking to deny Pope's application, Marine Telephone Company, the licensee of public local VHF coast stations in Florida, Georgia, and North and South Carolina, maintained that because of his past involvement in Gulf Coast's conduct which caused it to lose its license for Palmetto station KUZ 383, Pope should not be an FCC licensee.

In 1972, Gulf Coast had threatened to report to the FCC certain derogatory information it had uncovered on a competitor, Dee Wetmore, unless she sold her public local VHF coast stations to Gulf Coast. The FCC Review Board subsequently determined that by not reporting the information to the Commission and attempting to use that information to coerce Wetmore into selling her stations, Gulf Coast was unfit to remain a licensee.

The Commission noted that Pope's principal employment at Gulf Coast was as a communications expert. The disqualifying activity occurred almost 10 years ago. Moreover, he apparently made few management

decisions while at Gulf Coast. Therefore, his limited involvement in the activities which led to Gulf Coast losing its license hardly is the type of behavior that would warrant denying his application for a new station.

However, the Commission said Pope would be required to sever all business and contractual relations with Gulf Coast and provide evidence to the Commission of his having done so within 90 days.

### **FCC Changes Use Of Marine VHF Channel 88A; Clarifies Eligibility Requirements; Deletes Emission Requirements**

The Commission discontinued use of simplex marine VHF Channel 88A (157.425 MHz) for commercial intership communications in Puget Sound waters within 75 miles of the Canadian border, but ships within this area will be allowed to use Channel 88 for public correspondence with Canadian coast stations.

There are 10 other channels which will remain available for commercial intership communications in the Puget Sound area.

It also clarified the eligibility requirements for Limited Coast and Marine Utility stations specifically to include companies servicing radio equipment on noncommercial vessels, and removed the A3A emission requirement for single sideband (SSB) radios. However, it noted that manufacturers of equipment having the A3A emission capability may continue to market these units and existing equipment will not be affected in any way.

### **Propose Setting Aside Certain Frequencies For Emergency Alarm Protection**

In response to the Central Station Electrical Protection Association's (CSEPA) rulemaking petition, the Commission proposed setting aside certain offset frequencies to accommodate transmission of electrical alarm signals.

CSEPA asked the Commission to set aside three pairs of 12.5 kHz offset frequencies in the 450-470 MHz band for nationwide use and three pairs for use within urban areas having a population of 200,000 or more. It also asked for authority to operate on these frequencies at antenna heights exceeding 20 feet above ground, but not more than 20 feet above man-made structures.

At 900 MHz, allocated for utility distribution systems and other multiple address systems, CSEPA requested that seven paired and four single frequencies be reserved exclusively for electrical alarm signaling use, in addition to a relaxation of frequency stability requirements at 952-960 MHz to keep remote units economically viable.

While the Commission declined to propose an exclusive allocation for this service at 900 MHz, it is requesting comments on

such an allocation. CSEPA's members, however, remain eligible for operations in the 928-929/952-960 MHz band with other Part 94 eligibles.

The Commission proposed amending its rules to permit CSEPA to coordinate the eight offset frequencies located between the five frequency pairs now allocated to it on a primary basis in the 450-470 MHz band. To prevent these offset frequencies from going unused, the Commission proposed subjecting CSEPA's use of them to the interservice frequency sharing provisions of the rules. In addition, existing licensees on these offsets would be grandfathered.

However, the Commission noted it was not proposing primary status for these offset frequencies because it felt the low-power, secondary status protected higher power uses on the primary frequencies and permitted system options not available on the primary frequencies. As a result of this secondary status, it would be possible to permit licensees on these eight offsets to exceed the 20-foot above ground antenna height limit.

### **Frequencies Available For Long Distance Industrial Communications**

On June 29, 1983, the Commission amended its rules to establish new licensing, technical, and operational requirements and procedures to provide certain Industrial Radio Service licensees with long distance (HF) capability.

Effective August 15, 1983, the Commission made available to specific classes of eligibles in the Power, Telephone Maintenance, Petroleum and Special Industrial

Radio Services the following frequency bands (kHz):

2107-2170	6763-7000	15450-16460
2194-2495	7300-8195	17360-17700
2505-2850	9040-9500	18030-18068
3155-3400	9775-9995	18168-19990
4000-4063	10150-11175	20010-21000
4438-4650	11400-11700	21750-21850
4750-4995	11977-12330	22720-23200
5005-5450	13360-14000	23350-24890
5730-5950	14350-14990	

On frequencies above 4650 kHz, transmissions from stations in motion are strictly prohibited. Only fixed or itinerant fixed operations are permitted.

Authorizations granted pursuant to the new rules (see Public Notice #5956, August 15, 1983) do not convey authority to operate on all frequencies in the bands. Only frequencies announced by Public Notice may be used under the provisions of Section 90.266 of the Commission's Rules. Authorizations will be issued for bands of frequencies and will be qualified with this note printed on the face of the license: *Only those frequencies identified by Public Notice are available for use.*

Applicants are reminded not to request specific frequencies in the frequency column of Form 574, but rather to indicate both the bands and number of frequencies in each band necessary to fulfill their communications requirements. Applicants are encouraged to consult a user data base in selecting the actual frequency of operation.

The following frequencies are available initially for use in accordance with rule provisions for long distance industrial communications (see Section 90.266 of the Commission's Rules) under the geographic and time-of-day limitations indicated in Table 1.

Frequency Carrier Assigned	Time of Day	Geographic Restrictions	Class of Station
2289.0	2290.4	-	United States and Insular Areas (USIA)
2292.0	2293.4	-	DO
2395.0	2396.4	-	DO
2398.0	2399.4	-	DO
3170.0	3171.4	-	DO
4538.6	4540.0	Nighttime Only	DO
4548.6	4550.0	DO	DO
4575.0	4576.4	-	DO
4610.5	4611.9	-	DO
4613.5	4614.9	-	DO
4634.5	4635.9	-	DO
4637.5	4638.9	-	DO
4647.0	4648.4	-	DO
5046.6	5048.0	-	East of 108 degrees West Longitude
5052.6	5054.0	-	DO
5055.6	5057.0	-	DO
5061.6	5063.0	-	West of 90 degrees West Longitude
5067.6	5069.0	-	USIA
5074.6	5076.0	-	East of 108 degrees West Longitude
5099.1	5100.5	-	USIA
5102.1	5103.5	-	DO
5313.6	5315.0	-	DO
6800.1	6801.5	Nighttime only	DO
6803.1	6804.5	-	DO
6806.1	6807.5	-	West of 90 degrees West Longitude
6855.1	6856.5	Nighttime only	West of the Mississippi River
6858.1	6859.5	DO	USIA
6861.1	6862.5	-	West of 90 degrees West Longitude
6885.1	6886.5	Nighttime only	USIA
6888.1	6889.5	DO	DO
7480.1	7481.5	-	DO
7483.1	7484.5	-	DO
7486.1	7487.5	-	East of 108 degrees West Longitude
7549.1	7550.5	Daytime only	USIA
7552.1	7553.5	-	DO
7555.1	7556.5	-	West of 90 degrees West Longitude
7558.1	7559.5	-	DO
7559.1	7560.5	-	DO
7562.1	7563.5	-	DO
7697.1	7698.5	-	USIA

**Table 1**

## **FCC Revokes Radio Station License Of Amateur**

FCC Administrative Law Judge Joseph Stirmer has revoked the license of Paul O. Overlock for amateur radio station N6BHC at Sepulveda, California, denied his application for a General Class operator license, and suspended his Technician Class Amateur Radio operator license.

Judge Stirmer found that *several years ago* Overlock had willfully violated the Citizen Band (CB) rules by using an unauthorized frequency, using non-type-accepted equipment, communicating over a distance of more than 250 kilometers and failing to identify his station.

As a licensed amateur, Judge Stirmer noted, Overlock was required to show knowledge of basic law and regulations, yet he operated on frequencies not authorized for either the CB or amateur services.

Despite Overlock's good conduct in operating his station since the violations occurred in 1979, the judge said, the type of violations could not be overlooked. However, Judge Stirmer recommended that Overlock be permitted to file a new license application within 90 days.

## **FCC Amends Special Emergency Radio Service Rules (PR Docket 81-416)**

The Commission amended its Special Emergency Radio Service (SERS) rules by eliminating the requirement that base stations operating on the MED 1-MED 8 channels (463.000/468.000-463.175/468.175 MHz) must use equipment wired and equipped to transmit/receive on at least four of these eight frequency pairs and by designating two additional SERS channels as MED-9 and MED-10 (462.950/467.950 and 462.975/467.975 MHz).

The Commission noted that more than half of the comments submitted in response to its Notice of Proposed Rulemaking favored relaxation of the multi-channel base station requirement. Most of the parties supporting the proposal indicated that their communication needs could be satisfied with base stations equipped to transmit/receive on less than four of the MED channel pairs. The Commission agreed with these commentators that the requirement for four-channel base stations may impose an unnecessary and undesirable expense, particularly for stations in rural areas.

The Commission noted that it received overwhelming support for designating the SERS frequency pairs used primarily for dispatching medical care vehicles and personnel as MED-9 and MED-10. The change will be strictly on a voluntary basis. Licensees will have the flexibility to refer to these two channel pairs in whatever way they determine to be most appropriate.

Noting that there is an ongoing proceeding considering all facets of the frequency coordination process for the private land mobile radio services, the Commission de-

clined to designate an official frequency coordinating committee for the MED channels for the present time. For now, applicants proposing to operate base stations which transmit/receive on less than four of the MED channel pairs will perform a field study to determine which frequencies will cause the least amount of interference to existing MED channel operations.

## **FCC Suspends Compliance Date For Existing Private Interconnected Systems Below 800 MHz**

The Commission suspended the January 1, 1984, compliance date contained in the first report and order in this docket (69 FCC 2d 1831 (1978)). Licensees of existing interconnected private land mobile systems operating below 800 MHz were to conform to the rules in the first report and order by January 1, 1984. The suspension enables licensees to continue present use pending the Commission's review of the private interconnection rules below 800 MHz.

The Commission said that many of these private interconnected systems have been operating for over five years and it does not expect their continued operation pending final review of the rules to cause significant harm to other users. It would place an unnecessary and unreasonable burden on these systems, the Commission concluded, to have required them to conform by January 1, 1984, when the rules may be amended in the near future.

## **New General Mobile Radio Service Rules**

The FCC clarified its updated General Mobile Radio Service (GMRS) rules which became effective October 16, 1983.

It also granted the American Telephone and Telegraph Company (AT&T) and the Personal Radio Steering Group (PRSG) partial reconsideration of its August 3, 1983, action adopting the new rules.

AT&T argued that the Commission's specification that "an entity may not have a base station or a mobile relay station for that entity's GMRS system within 64.4 kilometers (40 miles) of a base station or a mobile relay station for another GMRS system licensed to the same entity" went beyond the scope of this proceeding. They further stated that this rule should be removed, or existing systems which would violate the rule should be grandfathered.

While the Commission concluded that the "40-mile" rule was within the scope of the proceeding, it agreed that the rule change could work a hardship on existing stations that benefited under the older ambiguous rule, and, therefore, it would grandfather those stations which would otherwise be in violation of this rule.

The Commission said it also would amend Section 95.181 to clarify that tone-only paging is not allowed in the GMRS. AT&T had pointed out that this section was unclear regarding the propriety of using a

selective calling tone or tone-operated squelch for one-way paging.

Turning to PRSG's contention that the new rules now require determination of absolute signal levels, whereas under the old rules one needed only to measure relative signals, the Commission said this new burden had not been intended and it would be removed to permit measurement of relative signal levels for power measurement tests.

As for PRSG's request that non-system licensing be continued in the GMRS, the Commission pointed out that "system licensing" as used in the new rules merely minimizes the number of licenses issued and the number of call signs assigned to a given entity for various radio transmitting facilities. It does not constitute imposition of "system licensing" as known in the Part 90 Private Land Mobile Radio Services.

PRSG also contested required filing of Form 574-B by stations near U.S. borders as a substantive change having no basis in the former GMRS rules. The Commission noted that while the information submitted on this form is used to resolve interference disputes among licensees in different countries, the information had not been mandated previously and, therefore, the rule would be changed to advise submission of such information on Form 574-B for border stations, rather than requiring it.

## **Gulf Of Mexico Service Area In 216-220 MHz Band Proposed**

The Commission proposed adding the Gulf of Mexico to the authorized service area of maritime mobile systems operating in the 216-220 MHz band. This band is presently limited to systems on the Mississippi River System and the Gulf Intracoastal Waterway.

Waterway Communications System, Inc., a licensee of an island waterways communication system using this band, filed a petition requesting that the 216-220 MHz band be made available nationwide. It pointed out that, with the support of the United States, the 1979 WARC allocated the band for maritime communications in Region 2 which includes North and South America, and that the need for such an allocation was confirmed in Gen. Docket 80-1 which allocated the 216-220 MHz band, on a non-interference basis with television reception, for use by automated maritime communications systems on the Mississippi River and connecting waterways. Gen. Docket 81-822 added the Gulf Intracoastal Waterway to the authorized service area for such systems.

The Commission said that while it felt it would be premature to authorize these systems on a nationwide basis, it believed their service areas should be expanded at this time to include the offshore waters of the Gulf of Mexico. It noted that since the use of the 216-220 MHz band is currently authorized along the Gulf Intracoastal Waterway, expansion of service into the Gulf of Mexico would not involve potential television interference problems and would represent a logical extension of the existing service areas.

# POPULAR COMMUNICATIONS

# BOOK SHOP

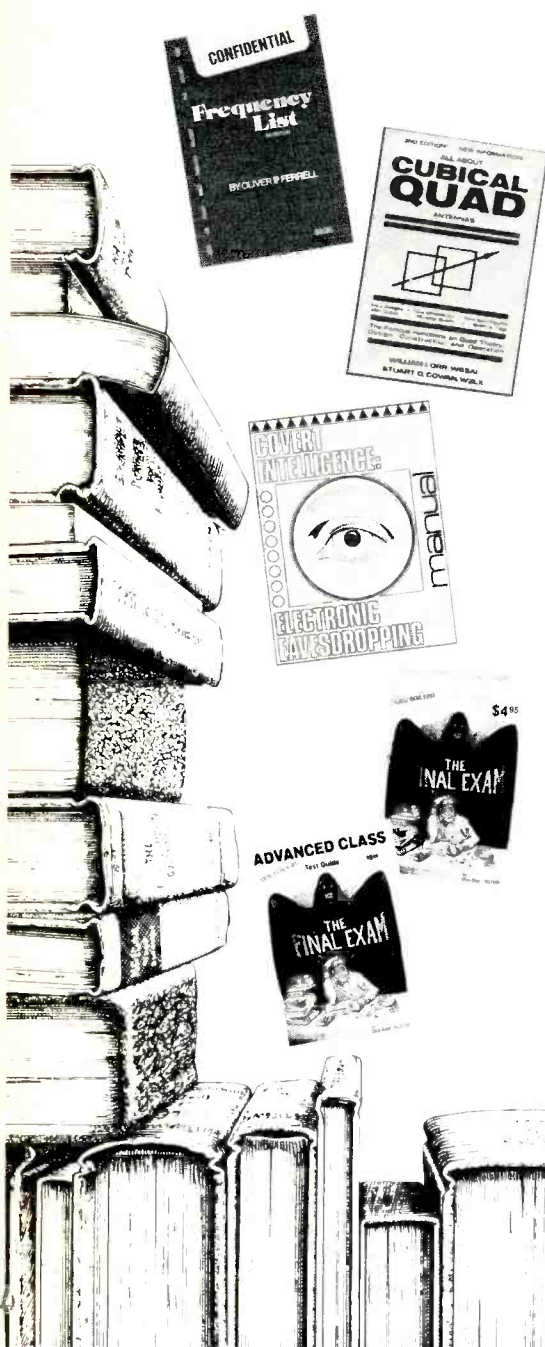

### Guide To RTTY Frequencies 2nd ed.

Details on 5500 RTTY stations/frequencies in two lists. "Real" press schedules, inside information on new RTTY techniques, etc. 192 pages, paperback, \$9.95. Order #G205.

### Radio Handbook, 22nd ed.

by Bill Orr, W6SAI  
A state-of-the-art, single-source reference on radio communications and theory for hams, professional ops, techs, and engineers. New coverage includes solid-state devices, Yagis and quads, and H.F. amplifier designs. A hands-on instruction manual, as well. 1168 pages, hardcover, \$39.95. Order #S197.

### The Radio Publications Group—The "Bill Orr Series"

These easy reading classics belong in the library of any active ham. Loaded with practical how-to information, with tables, charts, and formulas arranged for handy reference.

**Beam Antenna Handbook**, 200 pages, paperback, \$7.95. Order #R143.

**Wire Antennas**, 192 pages, paperback, \$7.95. Order #R144.

**Antenna Handbook**, 192 pages, paperback, \$7.95. Order #R145.

**Cubical Quad Antennas**, 112 pages, paperback, \$6.95. Order #R146.

**VHF Handbook**, 336 pages, paperback, \$11.95. Order #R147.

**Interference Handbook**, by W.R. Nelson, 247 pages, paperback, \$9.95. Order #R172.

### The Final Exam

by Dick Bash, KL7IHP  
Amateur radio license exam manuals proven highly successful in helping hams pass the FCC tests. Material for the books was obtained by interviewing actual applicants for the exams and collecting and researching the questions they had on the exams.

**General Class**, 123 pages, paperback, \$9.95. Order #B153.

**Advanced Class**, 108 pages, paperback, \$9.95. Order #B154.

**Extra Class**, 108 pages, paperback, \$9.95. Order #B155.

**Novice Class**, 104 pages, paperback, \$9.95. Order #B163.

### World Radio TV Handbook 1984

The world's only complete directory of international broadcasting and TV stations—the established, authoritative guide endorsed by the world's leading broadcasting organizations. A comprehensive country-by-country listing of short-, medium-, and long-wave stations revised and updated to reflect actual conditions. Also includes special features on shortwave receiver test reports and DX clubs and their programmes. 608 pages, paperback, \$17.50. Order #B097.

### Air-Scan, Directory of VHF Aero Band (108 to 136 MHz) Stations, 3rd ed.

by Tom Kneitel, K2AES  
More than 30,000 listings in U.S., Canada, and Mexico—Control Towers, Unicom, Multicom, Approach/Departure frequencies, Flight Service Stations, Air Route Traffic Control Centers, airline frequencies, search/rescue, etc. 80 pages, paperback, \$7.95. Order #C152B.

### Covert Intelligence: Electronic Eavesdropping Manual

Illustrated guide to using hidden transmitters and telephone taps for intelligence gathering, covering both theory and application. Detailed text enhanced by many graphs, charts, schematics, illustrations, field tests of equipment. Paperback, \$8.95. Order #C191.

### Covert Techniques For Intercepting Communications

A revealing inside look at how many federal agencies (some you never heard of) regularly "screen" phone, telex, and other "private communications." Here's the how, why, and "who" of it all. Most likely your own private communications have been checked by an intelligence computer or agent. Find out about it in this book. Paperback, \$8.95. Order #C192.

### World Press Services Frequencies

by Thomas Harrington  
A comprehensive manual covering the field of radiotele-type news monitoring—antennas, receivers, terminal units, monitors, and more. Contains 3 master lists of times of transmission, frequencies, plus ITU list of over 50 news services worldwide. 84 pages, paperback, \$8.95. Order #U173.

## POPULAR COMMUNICATIONS

76 N. Broadway, Hicksville, NY 11801

Order Date: \_\_\_\_\_

Name \_\_\_\_\_

Address \_\_\_\_\_

City \_\_\_\_\_

State \_\_\_\_\_ Zip \_\_\_\_\_

Check  MasterCard  VISA

Card No. \_\_\_\_\_ Expires \_\_\_\_\_

X \_\_\_\_\_

Signature required on all charge orders:



QTY. ORDER # TITLE PRICE TOTAL

QTY.	ORDER #	TITLE	PRICE	TOTAL

Shipping charges \$2.00 per order. Shipping charges waived on orders of \$50.00 or more. Books shipped best way. All orders are processed the day they are received, but please allow 30 days for delivery within North America.

**Book Total**  
**Shipping Charge**  
**Grand Total**

## Beaming In (from page 4)

news program mentioned it, but neglected to provide the frequency. Jack put his scanner into the search mode and located the frequency (146.265 MHz) himself. He speculates that there is, ultimately, an ulterior motive within the national news media about providing sufficient information on how to tune in on these and overseas broadcasts directed at listeners in North America. He suspects that if listeners could hear their news "live" and directly from its various sources, then maybe the public would decide to diminish its interest in the information provided by the news services, especially since it is sometimes late and not particularly objective. On the other hand, Jack points out that while there are persons who would like to get their news direct and "live," the general public (especially young people) is not particularly interested in news. As an instructor associated with people newly in the

military, Jack says he is "shocked" at the number of young people who never watch or listen to the news.

Jack also complains that shortwave receiving equipment looks rather complex to the average person and that it might appear less threatening if it were more readily available in local department stores rather than only by mail order or at shops specializing in electronics. He'd also like to see some very inexpensive shortwave receivers (\$20 price range) available in order to get people interested. His feeling is that telling someone who is thinking about getting started that a receiver is \$300 is akin to trying to convince someone about the joys of flight and then dropping on them the news that a good aircraft costs \$300,000. The door to aviation was opened a lot wider when it became possible to test your depth of interest by purchasing an ultralight for \$6,000 to \$8,000; could be the same with shortwave if a \$20 receiver could be marketed for rank beginners. It's the same with boating; most of the

folks who own \$30,000 Sea Rays started out with a \$6,000 outboard bowrider and just grew into something more formidable.

Ted Damick of Dublin, New Hampshire, "wholeheartedly agrees" that most of the programs beamed to North America "miss the boat" when it comes to programming time and program content. For instance, Ted says, he is a strong supporter of Israel Radio but they don't seem to realize that their programming at 0000, 0100, and 0200 GMT strikes out because it is forced to compete with American prime-time TV. Even though TV is mostly garbage, and the Israel Radio programs are exceptionally well done, persons who might well enjoy the programming somehow are never exposed to it because they're watching TV.

The BBC wrote too! A very informative lengthy letter arrived from Dr. Graham Mytton, Head of International Broadcasting and Audience Research, and he generally disagreed with a great deal of what was said in the January editorial, especially my opinions about the seeming lack of audience research and the size of the potential audience. The BBC and Radio Canada, Mytton pointed out, regularly conduct "large-scale, nationally representative surveys using face-to-face or telephone interviews . . . in addition, the BBC's International Broadcasting and Audience Research Department carries out regular postal surveys among World Service listeners. The BBC is well aware of the nature and preferences of its audience in the United States, as well as in many other countries in the world." Furthermore, reports Mytton, an accurate figure showing the size of the number of shortwave receivers is 11% of the adult population—and that translates into 16 million sets. A 1981/82 survey taken on behalf of the BBC shows that 2 million North Americans listen to the BBC World Service every week. Mytton's reported audience figures differ substantially from those which I had given (about 200,000 potential listeners to shortwave broadcasts) which were taken from a Radio Canada survey reported in the 1982 *World Radio TV Handbook*. Insofar as the appeal of the BBC programs to North American audiences, in fact I had singled out the BBC in my editorial as having many programs which are well tuned-in to the North American tastes.

This then is a round-up of views which arrived from the readers and these letters were representative of the overall opinions expressed. The general feeling from within the readers who were thoughtful enough to offer their comments was that—for whatever reasons—there are fewer listeners in North America than there might be or should be. No mail arrived from the North American listening audience which suggested that listeners were especially pleased with the majority of the broadcasts beamed this way, and none of the North American listeners thought that the size of the audience was as large as it might be if it weren't for the lack of information available to the public on the broadcasts and the equipment needed to hear the transmissions.

## HEAR THE NEW BANDS ON YOUR SCANNER



Converts out-of-band signals to vhf or uhf scanner bands. Cables provided. Simply plug into scanner.

### 5 MODELS AVAILABLE:

806-894 MHz New Land Mobile Band  
400-420 MHz Federal Government & FBI  
240-270 MHz Navy/Air Force Fleet Satellites  
135-144 MHz Weather & Geophysical Satellites  
72-76 MHz Industrial & Radio Control

Scanner Preamps also available

**ONLY \$88 + \$3 S & H**

Order by phone or mail. Use credit card, check, COD. Or send \$1 for complete catalog by return mail.

**hamtronics, inc.**

65-B MOUL ROAD  
HILTON NY 14468-9535  
Phone: 716-392-9430

CIRCLE 32 ON READER SERVICE CARD

# Unmatched

IS THE WORD



YAESU FRG-7700



ICOM R-70



TRIO-KENWOOD R-2000

**800-845-6183**



**GISMO**  
1039 Latham Dr.  
Rock Hill, SC 29730

Service Department  
Call 803-366-7158

CIRCLE 58 ON READER SERVICE CARD



# COMMUNICATIONS SHOP

**Advertising Rates:** Non-commercial ads are 30 cents per word including abbreviations and addresses; minimum charge \$6.00 per issue. Ads from firms offering commercial products or services are \$1.00 per word; minimum charge \$20.00 per issue. Leading key words set in all caps at no additional charge. All classified ads must be prepaid in full at time of insertion, a 5% discount is offered for prepaid 6 time insertions. All ads must be typewritten double spaced.

**Approval:** All ad copy is subject to Publisher's approval and may be modified to eliminate references to equipment and practices which are either illegal or otherwise not within the spirit or coverage scope of the magazine.

**Closing Date:** The 10th day in the third month preceding date of publication. Because the advertisers and equipment contained in Communications Shop have not been investigated, the Publisher of Popular Communications cannot vouch for the merchandise listed therein. Direct all correspondence and ad copy to: PC Communications Shop, 76 N. Broadway, Hicksville, NY 11801.

**ARMY FIELD RADIOS:** genuine Infantry mainstays from Korea to Nam. CPRC-26 Canadian Man-Pack Radio, compact, transmits-receives 42-54 MHz FM, 6 channels, with battery box, antenna, crystal: \$19.50 apiece, \$37.50/pair, good condition. PRC-510 Backpack Radio (Canadian version of American PRC-10), transmits-receives 38-55 MHz continuous tuning, with battery box, headset, antenna: \$39.50 apiece, \$77.50/pair, good condition. R-108 Field/Vehicular Receiver, 20-28 MHz FM: \$27.50 mint. VRC-7 Field/Vehicular Radio Set, includes RT-70 Transceiver, Audio Amplifier, Power Supply, antenna, vehicle mount, accessories, mint in original cartons: \$137.50. R-174 Receiver, tunes 1.8-18 MHz AM-CW-SSB, military, shortwave, amateur radio: \$27.50 good condition. ARC-27 Guard Receiver, single channel 220-250 MHz aircraft receiver: \$12.50 mint. 45 Day Replacement Guarantee. Add \$9.50 Shipping-Handling. Baytronics, Dept. PC, Box 591, Sandusky, OH 44870.

"FANTASTIC DISCOUNTS" Bearcat, Regency, Kenwood, Panasonic, Sony, Yaesu, CW/RTTY Decoders, Frequency Directories, antennas, much, much more. Free UPS shipping and insurance to 48 states. 25 page picture catalog \$1.00 (refundable). Galaxy Electronics, Box-1202, 67 Eber Ave., Akron, Ohio 44309 (216-376-2402) 9-5 p.m. EST.

**BACK AGAIN! WHITE'S RADIO LOG!** Famous since 1924 as the authoritative reference guide to American/Canadian broadcasting stations. All new fat 136-page edition lists every AM/FM/TV station according to frequency, call sign, location, plus worldwide shortwave according to frequency. No other DX book like it. Only \$4.95 plus \$1 First Class Mailing. CRB Research, P.O. Box 56, Commack, NY 11725.

**RF-204/U RF INTERFERENCE DETECTOR.** Locates hidden sources of RF such as bugs (see January *Popular Communications*) Unused, in box, including all accessories and transit case. \$85. Frank Moreland, 3748 Yosemite, San Diego, CA 92109.

**DANGER: Microwave and ELF Health Hazards.** Send \$2.00 for catalogue of books and sample Newsletter. Negeye Laboratories, Pennsboro, WV 26415.

**ELECTRONIC SPYING** is the name of the game. It's also the title of a startling book which reveals the closely guarded methods & equipment used by professionals & amateurs who eavesdrop on homes & businesses with (sometimes) legal and (usually) illegal bugs & wiretaps. Written in non-technical language everyone can easily understand. **ELECTRONIC SPYING** has photos & illustrations clearly revealing exactly how they do it & where they get the equipment (much of it inexpensive & easily available). Leaves nothing to the imagination! Latest techniques covered & offers an in-depth wealth of information on the ever increasing electronic invasion unavailable from any other source. This book is used by law enforcement agencies as a reference manual. Only \$7.95 (plus \$1.00 postage) per copy from CRB Research, P.O. Box 56, Commack, N.Y. 11725.

**SCANNER OPERATORS!** Are you registered? Be assigned your own personal monitoring ID letters inscribed on beautiful 2-color bordered certificate. Thousands already registered! Only \$5, ppd. from CRB Research, Box 56PC, Commack, NY 11725.

**COMPUTERIZED LOG BOOK** for scanner, SWL and ham operators. Now for Timex TI99/4A, VIC 20 and IBM. \$10.50 Postpaid. For free information, contact Kentronics, Inc., P.O. Box 586, Vernon, AL 35592.

**NEW! TOP SECRET REGISTRY OF U.S. GOV'T FREQUENCIES** by Tom Kneitel. Yes, it's finally here! The NEW 5th Edition is now 168 pages BIG in large 8 1/2" x 11" format (same page size as POP/COMM). Latest federal scanner frequency listings for FBI, FCC, Border Patrol, ATF, Immigration, Secret Service, CIA, Customs, Coast Guard, Armed Forces, and much more. Tens of thousands of call signs, frequencies, locations. The ultimate scanner directory also reveals many HF listings plus complete historic roster of all federal land stations authorized in 1923 (60 years ago)! New 5th Edition is \$14.95 postpaid by Book Rate Mail, or add \$2 if First Class Mailing wanted. Order your copy now! CRB Research, P.O. Box 56, Commack, NY 11725.

**SCANNER OWNERS** eliminate the dead air between transmissions with easily constructed controller that connects between scanner and recorder. Plans \$5. JFJ Projects, PO Box 152, Natrona Heights, PA 15065.

**TIMEX/SINCLAIR** Scanner operators. Custom scanner log for Timex computers. Super features, used by hundreds of scanner owners. \$9.95. SASE for info. Kentronics, Inc., P.O. Box 586, Vernon, AL 35592.

**TIMEX/TI99/4A**—Ham/SWL/Scanner logbook, and other programs. CW/RTTY for Timex! SASE for information. Kentronics, Box 586, Vernon, AL 35592.

**CB RADIO MODIFICATIONS!** Increase channels, range, privacy. Conversion hardware, books, plans, kits, repairs. Catalog \$2. CBCL, Box 31500PC, Phoenix, AZ 85046.

**FOR SALE REALISTIC DX-200** 1.5 kHz to 30 MHz. General coverage receiver, brand new. \$150.00. Joe Shaer, Box 49, Feeding Hills, MA 01030. Phone: 1-413-786-0584.

**NOSTALGIAPHILES. UNIQUE, FASCINATING, ENGROSSING WWII CASSETTES** from Axis-Allied sources. S.A.S.E. for details. Danrick/-Soundevents-PC, 213 Dayton Ave., Clifton, NJ 07011.

**LOWEST PRICES ON BEARCAT, REGENCY SCANNERS:** Trade-ins. Used Scanners at savings, Descramblers, Accessories. Free catalog! Spotlight Communications, Box 3047, Greenville, NC 27836-3047.

**SHORTWAVE ENGLISH BROADCASTS.** 40 page, 3000 item computerized tabulation. Latest issue \$3.00. Ferguson, Box 8452, South Charleston, WV 25303.

**COMMUNICATIONS SECURITY, DECEPTION,** Tactics. Unbreakable Codes. New 40-page How-To-Manual. Detailed, Easy \$11 Eustis Press, Suite 18, 751 Dunlap Circle, Winter Springs, FL 32708.

**PHOTOVOLTAIC POWER SYSTEMS** (solar electricity)—stand alone or standby power for your communications systems. Lightweight, rugged construction for decades of reliable power when and where you need it! Catalog \$2 (refundable), contact Current Alternatives, P.O. Box 166P, Northfield, VT 05663.

**WORLD'S MOST UNUSUAL Communications Books!** A large selection of outstanding titles covering scanners, "confidential" frequency registries, bugging, wiretapping, electronic surveillance, covert communications, espionage, monitoring, and more! New titles being added constantly! Ask for our large new FREE catalog. CRB Research, Box 56-PC, Commack, NY 11725.

**SURVIVAL!** Tom Kneitel's new *National Directory of Survival Radio Frequencies!* Unique book reveals the 5,000 most required radio frequencies 179 kHz to 470 MHz. State police, forestry, CD, highway maintenance, fish/game disaster, EMS, military, flood control, Indian Reservations, Air/Army National Guard, fed/state prisons, ports/harbors/bridges, clear channel broadcasters, severe weather, and lots more. National & state-by-state listings. An absolute must for every Survivalist and concerned citizen. A concise/handy key to knowing what's going on around you during a disaster or crisis, or for listening right now to hear what's taking place behind the scenes. Only \$7.95 by First Class Mail from CRB Research, P.O. Box 56, Commack, NY 11725.

**JOIN A RADIO listening club.** Complete information on major North American clubs for 25¢ and SASE. Association of North American Radio Clubs, 1500 Bunbury Drive, Whittier, CA 90601.

**TV GUIDES 1953-1984.** Every issue available. Any article located. Catalog \$5.00. TV Guide Specialists, Box 20 PC, Macomb, IL 61455.

**ANTIQUE RADIOS, speakers, tubes & literature,** write VRS(PC), 376 Cilley Rd., Manchester, NH 03103.

**CLANDESTINE CONFIDENTIAL** keeps you up to date on the latest in clandestine broadcasting. 6 issues per year \$10 in the U.S., \$13 foreign. G.L. Dexter, RR4 Box 110, Lake Geneva, WI 53147.

## CB MODIFICATIONS

Increase channels, range, privacy! We specialize in frequency expanders, speech processors, FM converters, PLL & slider tricks, how-to books, plans, kits. Expert mail-in repairs & conversions. 16-page catalog \$2

**CBC INTERNATIONAL, P.O. BOX 31500PC, PHOENIX, AZ 85046 (602) 996-8700**

Please send all reader inquiries directly.

## Shortwave Receivers, Antennas

Call 1-800-221-2683 Toll-Free US  
(212-925-7000 New York State)

### Barry Electronics

512 Broadway • New York, NY 10012  
Sales & Service Ham & Commercial Radio  
For 35 Years

CIRCLE 15 ON READER SERVICE CARD

## HOT ROD YOUR RECEIVER

YEARS OF SATISFIED CUSTOMERS

### Japan Radio

**NRD-515**  
\$950.00

**NVA-515** SPEAKER \$45.00      **NDH-518** 96 CH MEMORY \$235.00      **NCM-515** FREQ. CONTROLLER \$179.00

### Collins Filters Digital Displays Antennas

**3417 Purer Road Dept. PC Escondido, CA 92025 (619) 741-2891**



CIRCLE 51 ON READER SERVICE CARD

"RAIL-SCAN" by Tom Kneitel. New scanner frequency directory! Largest & most comprehensive railroad industry communications directory ever! 4,200 frequencies, 863 major RR's, short lines, narrow gauge, government, miniature, movie, museum, scenic, industrial traction, mass transit lines, private car owners, RR police, car/locomotive builders & service companies, regulatory agencies, accident/emergency channels, RR addresses, trackage data, lots more. Only \$7.95 (add \$1 for 1st Class Mail). Order now or ask for free info. CRB Research, Box 56-PC, Commack, NY 11725.

THE BOOTLEGGERS BIBLE. \$12.95 and other CB Radio Books, Kits, Modifications, Catalog \$1.00 refundable! APS, POB 263PC, Newport, RI 02840 (401) 846-5627.

NEW! JERROLD AND OAK CABLE CONVERTERS, Decoders. Catalog \$1.00 Refundable With Purchase. APS, POB 263PC, Newport, RI 02840 (401) 846-5627.

WANTED: CASH PAID FOR USED SPEED RADAR EQUIPMENT. Write or call: Brian R. Esterman, P.O. Box 8141, Northfield, IL 60093, (312) 251-8901.

SIDEBAND OPERATORS! Join the oldest/largest network of 27 MHz SSB operators. Now more than 100,000 strong! Send self-addressed stamped long (#10) envelope for FREE details and application (no obligation) SSB Network, P.O. Box 908, Smithtown, NY 11787.

WESTERN WIRELESS Inc. (415) 372-8805 Military Surplus specialties. Phone for catalog. Radios and accessories available. Electronic equipment of various types. Technician specializes in repair. (415) 372-8805.

MILITARY RADIO AND COMMUNICATIONS. Surplus Unlimited. Western Wireless Inc. (415) 372-8805. Send \$3.00 for catalog. 4840 Tahoe Circle, Martinez, California 94553.

WESTERN WIRELESS INC. (415) 372-8805 Surplus Unlimited. VRC, GRC, PRC, TRC, MRC. Surveillance PPS, GSQ, Night Vision PVS, PAS. Phone for catalog

**AD INDEX**

AEA . . . . . 1  
 Ace Communications . . . . . 55  
 All Electronics . . . . . 45  
 Auburn-Wolfe Pub. Co. . . . . 53  
 Barker & Williamson . . . . . 45  
 Barry Electronics . . . . . 75  
 CBC International . . . . . 75  
 CCS Comm. Control, Inc. . . . . 45  
 CRB Research . . . . . 23  
 Communications Electronics . . . . . 2  
 DNE Inc. . . . . 44  
 Digital Electronic Systems . . . . . 44  
 EGE, Inc. . . . . 40  
 Electra Co. . . . . Cov. III  
 Electronic Equipt Bank . . . . . 7, 31  
 G.I.S.M.O. . . . . 74  
 Grove Enterprises . . . . . 11  
 Ham Mastertapes . . . . . Cov. II  
 Ham Shack . . . . . 55  
 Hamtronics, Inc. . . . . 74  
 ICOM America, Inc. . . . . Cov. IV  
 J.I.L. . . . . 5  
 Loompanics Unltd. . . . . 69  
 MFJ Enterprises, Inc. . . . . 4  
 Magnum Distributors Inc. . . . . 65  
 Martin Engineering . . . . . 21  
 Meshna Inc., John . . . . . 65  
 Metz Communication Corp. . . . . 11  
 Micro Mart . . . . . 41  
 Morning Distributing . . . . . 21  
 PopComm Book Shop . . . . . 73  
 Radio West . . . . . 75  
 Radio World . . . . . 57  
 Research Electronics . . . . . 59  
 Scanner World, USA . . . . . 59  
 Spectronics, Inc. . . . . 51  
 Springhouse Energy Systems . . . . . 57  
 Stano Components . . . . . 62, 67  
 Unity Electronics . . . . . 55  
 Universal Electronics . . . . . 44  
 Universal Shortwave Radio . . . . . 11, 28  
 Video Electronics . . . . . 65  
 Viking International . . . . . 17  
 Westech Electronics . . . . . 67  
 Western Radio . . . . . 55

**To preserve  
 your copies of  
 POPULAR  
 COMMUNICATIONS**

A choice of handsome and durable library cases-or binders-for your copies of **POPULAR COMMUNICATIONS**. Both styles bound in dark blue library fabric stamped in gold leaf.

**Cases:** Each case hold 12 issues. Price per case \$5.95; three for \$17.00; six for \$30.00, postpaid.

**Binders:** Each binder holds 12 issues. Issues open flat. Price per binder \$7.50; three for \$21.75; six for \$42.00, postpaid.

*(Canadian and foreign requests should also include an additional \$2.50 per item for shipping costs.)*

**To: Jesse Jones Industries (Since 1843)  
 P.O. Box 5120, Dept. P-Com, Philadelphia, PA 19141**

I enclose my check or money order for \$ \_\_\_\_\_  
 Please send me \_\_\_\_\_ POPULAR COMMUNICATIONS  
 Files.  Binders. *Please allow approximately 4 weeks for delivery.*

*(Please Print)*

**Name** \_\_\_\_\_  
**Address** \_\_\_\_\_  
**City** \_\_\_\_\_  
**State** \_\_\_\_\_  
**Zip** \_\_\_\_\_

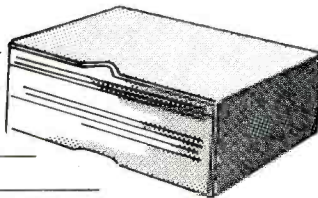

Reach this dynamic audience with your advertising message, contact either Herb Pressman, or Arnold Sposato, at (516) 681-2922.



# The Bearcat® DX1000 makes tuning in London as easy as dialing a phone.

Direct access keyboard tuning brings a new level of simplicity to shortwave radio. With the *Bearcat® DX 1000*, dialing in the BBC in London is as easy as dialing a telephone. And you can switch from the BBC to Peruvian Huayno music from Radio Andina instantly. Without bandswitching.

Featuring the innovative microprocessor digital technology made famous by *Bearcat* scanner radios, the *DX 1000* covers 10 kHz to 30 MHz continuously, with PLL synthesized accuracy. But as easy as it is to tune, it has all the features even the most sophisticated "DXer" could want. 10 memory channels let you store favorite stations for instant recall—or for faster "band-

scanning" during key openings.

The digital display measures frequencies to 1 kHz, or at the touch of a button, doubles as a two time zone, 24-hour digital quartz clock. A built-in timer wakes you to your favorite shortwave station. Or, it can be programmed to activate peripheral equipment like a tape recorder to record up to five different broadcasts—any frequency, any mode—while you are asleep or at work.

The *DX 1000* also includes independent selectivity selection to help you separate high-powered stations on adjacent

frequencies. Plus a noise blanking system that stops Russian pulse radar interference.

There's never been an easier way to hear what the world has to say. With the *Bearcat DX 1000* shortwave radio, you have direct access to the world.

For the name of your nearest retailer dial toll-free... 1-800-SCANNER.

**Frequency Range:** 10 kHz to 30 MHz continuously. **Tuning:** Direct keyboard entry, selectable 3 or 24 kHz per revolution knob tuning, or manual step tuning in selectable 1-99 kHz steps. **Sensitivity:** 1.0  $\mu$ V AM, 0.5  $\mu$ V CW/SSB/FM, 1.6-30 MHz. **Image and IF Rejection:** 70 dB or more. **Memory:** 10 frequency capacity. **Frequency Stability:** Better than 100 Hz after warm-up. **Modes:** AM/LSB/USB/CW/FM. **AGC:** Selectable Fast/Slow release times. **Filter Bandwidths:** 2.7 kHz, 6 kHz and 12 kHz. **Filter Selection Independent of Mode.**

CIRCLE 150 ON READER SERVICE CARD

## Bearcat® DX 1000 shortwave radio.

### Direct Access To The World.



© Copyright 1983, Masco Corporation of Indiana



Electra Company  
Division of Masco Corp. of Indiana  
300 East County Line Road  
Cumberland, Indiana 46229

# ICOM IC-751

## The New Standard of Comparison



ICOM is proud to announce the most advanced amateur transceiver in communications history. Based on ICOM's proven high technology and wide dynamic range HF receiver designs, the IC-751 is a competition grade ham receiver, a 100kHz to 30MHz continuous tuning general coverage receiver, and a full featured all mode solid-state ham band transmitter, that covers all the new WARC bands. And with the optional internal AC power supply, it becomes one compact, portable/field day package.

**Receiver.** Utilizing an ICOM developed J-FET DBM, the IC-751 has a 105dB dynamic range. The 70.4515MHz first IF virtually eliminates spurious responses, and a high gain 9.0115MHz second IF, with ICOM's PBT system, gives the ultimate in selectivity. A deep IF notch filter, adjustable AGC and noise blanker (can be adjusted to

eliminate the woodpecker), audio tone control, plus RIT with separate readout provides easy-to-adjust, clear reception even in the presence of strong QRM or high noise levels. A low noise receiver preamp provides exceptional reception sensitivity as required.

**Transmitter.** The transmitter features high reliability 2SC2904 transistors in a low IMD (-38dB @ 100W), full 100% duty cycle (internal cooling fan standard), 12 volt DC design. Quiet relay selection of transmitter LPF's, transmit audio tone control, monitor circuit (to monitor your own CW or SSB signal), XIT, and a high performance speech processor enhance the IC-751 transmitter's operation. For the CW operator, semi break-in or full QSK is provided for smooth, fast break-in keying.

**Dual** Dual VFOs controlled by a large tuning knob provide easy access to

split frequencies used in DX operation. Normal tuning rate is in 10Hz increments and increasing the speed of rotation of the main tuning knob shifts the tuning to 50Hz increments automatically. Pushing the tuning speed button gives 1KHz tuning. Digital outputs are available for computer control of the transceiver frequency and functions, and for a synthesized voice frequency readout.

**32 Memories.** Thirty-two tunable memories are provided to store mode, VFO, and frequency, and the CPU is backed by an internal lithium memory backup battery to maintain the memories for up to seven years. Scanning of frequencies, memories and bands are possible from the unit, or from the IC-HM12 scanning microphone. In the Mode S mode, only those memories with a particular mode are scanned; others are bypassed. Data may be transferred between VFO's,

from VFO to memories, or from memories to VFO.

**Standard Features.** All of the above features plus FM ur, high shape factor FL44A, 455K-z SSB filter, full function metering, SSB and FM squelch, convenient large controls, a large selector of plug-in filters, and a new high visibility multi-color fluorescent display that shows frequency in white or red, make the IC-751 your best choice for a superior grade HF base transceiver.

**Options.** External frequency controller, external IC-PS15 power supply, voice synthesizer, computer interface, internal IC-PS35 power supply, high stability reference crystal (less than ±10Hz after 1 hour), IC-HM12 hand mic, desk mic, filter options:

SSB: FL-70  
 CWN: FL-52A, FL-53A,  
 FL-32, FL-63  
 AM: FL-33

CIRCLE 75 ON READER SERVICE CARD

**The World System**

ICOM America, Inc., 2112-116th Ave NE, Bellevue, WA 98004 (206)454-8155 / 3331 Towerwood Drive, Suite 307, Dallas, TX 75234 (214)620-2780

All stated specifications are approximate and subject to change without notice or obligation. All ICOM radios significantly exceed FCC regulations limiting spurious emissions.

7514B4