

**POPULAR**

**AUGUST 2009**

# COMMUNICATIONS

Shortwave Listening • Scanning • AM & FM • Radio History

## Mexico On Edge

### Listening To Our Turbulent Neighbor

**A Short History Of  
Mexico's SW Stations, p. 18**

**Paul Harvey  
Remembered, p. 22**

**Tech Showcase: Uniden's  
Bearcat BC346XT Analog  
Handheld Scanner, p. 27**

Todas estas  
INSTALACIONES  
SON FINANCIADAS  
CON LOS  
IMPUESTOS DEL  
PUEBLO

**PLUS: Monitoring Along  
The Border • C. Crane's  
New CCRadio-2 For  
Great AM Reception**



1122

PC 277537 MAR 10 1  
SCH 3-DIGIT 600  
2088

# THE PROFESSIONAL STANDARD



- Continuous Frequency Coverage: 100 kHz ~ 2.6 GHz / LSB, USB, CW, AM-Narrow, AM, Wide AM, FM-Narrow, and Wide FM (cellular frequencies are blocked)
- 2000 Memory Channels / 100 Memory Groups
- Dual Receive
- Digital Signal Processing / Bandpass Filter, Noise Reduction, Notch Filter, Narrow CW Peak Filter (Optional DSP-1 requires)
- Real-Time Spectrum Scope
- World Clock with UTC/Local Settings
- Preset Shortwave Broadcast Station Memory Bank
- Extensive Scanning Capability/Smart Search™



## COMMUNICATIONS RECEIVER VR-5000

0.1 ~ 2599.99998MHz™  
LSB/USB/CW/AM-N/AM/  
WAM/FM-N/WFM  
\*Cellular blocked

### CARRY THE WORLD WITH YOU!

- Frequency coverage : 0.1-1299.99995 MHz
- Modes : NFM, WFM, AM, USB, LSB, CW
- Huge Memory Capacity: 1091 Channels
- Multiple Power Source Capability · Polycarbonate Case
- Real-Time 60-ch Band Scope Range  
6 MHz / Step 100 kHz
- Full Illumination For Display And Keypad
- Convenient "Preset" Operating Mode
- Front-end 20 dB Attenuator

## ALL-MODE WIDEBAND RECEIVER VR-500



For the latest Yaesu news, visit us on the Internet:  
<http://www.vertexstandard.com>

Specifications subject to change without notice. Some accessories and/or options may be standard in certain areas. Frequency coverage may differ in some countries. Check with your local Yaesu Dealer for specific details.

**YAESU**  
Choice of the World's top DX'ers™

Vertex Standard  
US Headquarters  
10900 Walker Street  
Cypress, CA 90630 (714)827-7600

# Universal Radio — Quality equipment since 1942.

## YAESU VR-5000



The Yaesu VR-5000 provides sophisticated wideband reception. Coverage is from 100 kHz to 2600 MHz (2.6 GHz) less cellular, in AM, FM-N, FM-W, LSB, USB and CW. This radio features a real-time bandscope and you get 2000 alphanumeric memories grouped into 100 banks. Optional aids such as a DSP unit, voice synthesizer and digital voice recorder are available. Jacks on the back panel include: Mute, 13.8 VDC input, External Speaker, 10.7 MHz IF Output, Antenna Input A (SO-239 50 ohm) & B (Hi Z 450 ohm), CAT Interface Jack (4800/9600/57600 bps). The VR-5000 comes with the PA28B 117 VAC adapter and a DC power cord. This radio is only 7.1 x 2.75 x 8 inches 4.2 Lbs. Please visit our website for full specifications, color photos and current price.

### ACCESSORIES

- #3545 DSP-1 DSP Notch/NR/Bandp. \$119.95
- #0560 DVS-4 Digital Voice Recorder 49.95

## YAESU

### VR-120D PKG



The VR-120D is a compact wideband receiver covering 100 kHz to 1299.995 MHz (less cellular and image gaps), in AM, FM-N and FM-W with 640 alphanumeric memories. Scan features include: Full Mem. Scan, Mem. Bank Scan, Selected Mem. Channel Scan, Band-Limit Mem. Scan, Smart Search, Priority Channel Watch and Dual Watch. Manual tuning is via the tuning knob. A built-in AM ferrite loop insures good AM performance. A Channel Counter feature measures the frequency of a strong nearby signal. With BNC antenna, wrist strap and belt clip. This new VR-120D "PKG" configuration now **includes** the FNB79 NiCad battery, CA34 sleeve, NC82 stand and PA30B 120 VAC adapter. Size: 2.3 x 3.8 x 1 inches 8 oz. Limited supply.

Order #4120 **\$139.98**

### ACCESSORIES

- #0384 CA34 Charging sleeve \$3.95
- #4332 CSC76 Carry Case 19.95
- #3646 EDC15 Cigarette lighter cord 36.95
- #0353 FNB79 Ni-Cad 2.4V 700 mA 9.95

## YAESU

### VR-500 PKG



The Yaesu VR-500 is the first to provide wideband coverage plus single sideband capability in such a small and capable package. Coverage is solid from 100 kHz to 1300 MHz (1.3 GHz) less cellular, in AM, FM-N, FM-W, LSB, USB and CW. You get 1000 regular memories (10x100) plus tuning steps from 50 Hz to 100 kHz. Other features include: backlit keypad, priority, power-off timers, adjustable battery saver, 60 channel bandscope, attenuator, dual watch, alphanumeric recall, bank scanning Smart Search™. The VR-500 operates from two AA cells. Includes BNC antenna, hand strap and belt clip. This new Yaesu VR-500 "PKG" configuration also **includes** the NiCd battery and wall charger. Only 2.3 x 3.7 x 1" 8 oz. Please call or visit our website for more information and current price.

### ACCESSORIES

- #4037 ADMS3 Win Software & PC cable \$37.95
- #4035 CSC72 Carry Case 19.95
- #1693 EDC5B DC Cable +Cigar Plug 23.95
- #3116 EDC6 DC Cable 6.95
- #0353 FNB79 NiCad Batt 2.4V 9.95
- #0594 NC60B AC Adapter 13.95

## YAESU

### FT-857D



**FREE** Yaesu orange mug with FT-857D/897D.

The Yaesu FT-857D is the world's smallest HF/VHF/UHF multimode amateur transceiver covering 160 m to 70 cm with 100 watts on HF. Now with 60 meters and DSP2 built-in.

### FT-897D



The Yaesu FT-897D is a multi-mode high-power base/mobile transceiver covering 160 m to 70 cm including 60 meters. Now with TCXO.

### FT-817ND



**FREE** black urban canvas case with FT-817ND.

The Yaesu FT-817ND is an improved, deluxe version of the hugely popular FT-817. It includes 60 meter coverage plus the new high capacity FNB-85 battery. This radio has an excellent shortwave receiver built-in and is a fully self-contained, battery-powered, low power amateur MF/HF/VHF/UHF QRP transceiver.



Universal Radio, Inc.  
6830 Americana Pkwy.  
Reynoldsburg, Ohio  
43068-4113 U.S.A.

☎ 800 431-3939 Orders & Prices  
☎ 614 866-4267 Information  
☎ 614 866-2339 FAX Line  
✉ dx@universal-radio.com

[www.universal-radio.com](http://www.universal-radio.com)

◆ Visit our website for more exciting new and used shortwave radios.

- Visa
- MasterCard
- Discover
- JCB
- Prices and specs. are subject to change.
- Special offers are subject to change.
- Returns subject to a 15% restocking fee.
- Prices shown do not include shipping.

# POPULAR COMMUNICATIONS CONTENTS

AUGUST 2009  
VOLUME 27, NUMBER 12

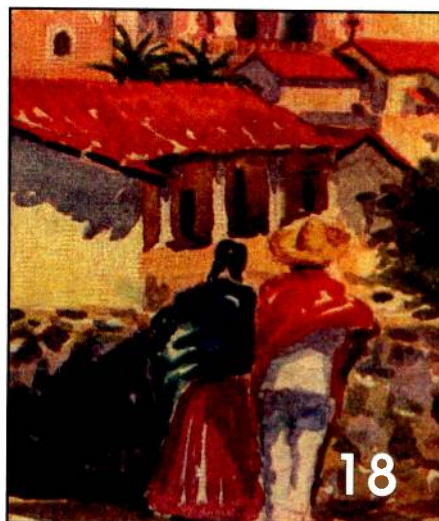
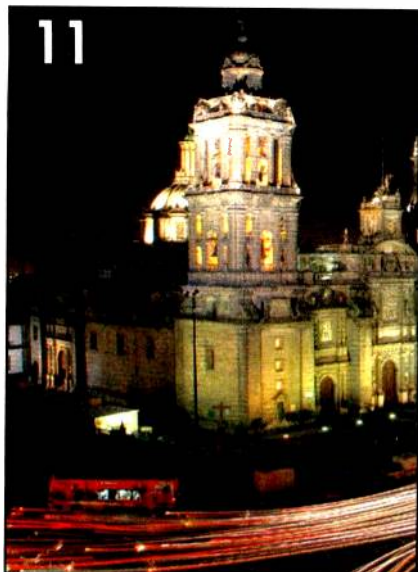

## COLUMNS

- 10 Horizons**  
Communications And News Delivery  
*by Rob de Santos*
- 42 World Band Tuning Tips**  
World News, Commentary, Music,  
Sports, And Drama At Your Fingertips
- 44 Global Information Guide**  
Radio Squatters And Radio Shufflers  
*by Gerry L. Dexter*
- 58 Homeland Security**  
Are Terrorists Really Using The  
Air Waves?  
*by Mitch Gill, NA7US*
- 61 Ham Discoveries**  
QRP—The New Norm?  
*by Kirk Kleinschmidt, NT0Z*
- 64 The Propagation Corner**  
Low Sunspots? You Can Still Work  
The World  
*by Tomas Hood, NW7US*
- 70 Military Radio Monitoring**  
Dover Air Force Base—The DoD's  
Biggest And Busiest Air Terminal  
*by Mark Meece, N8ICW*
- 74 The Wireless Connection**  
A Noise Generator Project  
*by Peter J. Bertini*
- 77 Utility Communications Digest**  
Utility's Back—Please Excuse The Dust  
*by John Kasupski, KC2HMZ*
- 84 The Loose Connection**  
The Dinosaur Drives A Wedge  
*by Bill Price, N3AVY*

## FEATURES

- 11 World Watch:**  
**An Ear Toward Mexico**  
Shaken By Earthquakes, Cartels,  
Germs, And More, Our Southern  
Neighbor Is Left Reeling  
*by Gerry Dexter*
- 18 A Short Stroll Through Mexico's  
Shortwave History**  
Soak Up Mexico's Radio Past, Then  
Become Part Of Its Present By  
Logging Its Fascinating Stations  
*by Dr. Adrian M. Peterson*
- 22 Remembering Paul Harvey**  
The Man Who Covered A Million  
Miles Of Main Street, 250 Watts  
At A Time  
*by Peter Hunn*
- 27 Tech Showcase**  
The Uniden Bearcat BC346XT  
Analog Handheld Scanner  
*by Jeffrey Reed*

## FEATURED COLUMNS

- 30 ScanTech**  
On The Borderline: Drug Wars,  
Influenza, And More To Monitor  
*by Ken Reiss*
- 54 Broadcast Technology**  
AM Radio: Alive And Well Received  
On The New CCRadio-2  
*by Bruce A. Conti*

## ON THE COVER

Mexico seems to be made up of equal parts of physical beauty, cultural depth, and turmoil—though it's the tumultuous component that has captured recent headlines. This issue focuses on our neighbor to the south and how to listen to its voices in these troubled times. (Cover photo is of a multi-purpose tower with TV and FM broadcast, two-way radio, and microwave communications antennas and was taken by Araceli Herrera in the state of Oaxaca during the civil unrest of 2006 when radio and TV stations were taken over by protesters, leading to a government crackdown and fatalities. The English translation of the sign is "All these facilities are paid for with the people's tax money and were used by and for the government and the industrialists. Now the people must take them back.")

## DEPARTMENTS

- 4 Tuning In**  
An Editorial
- 6 Newsworthy**  
Unwired, InfoCentral, And  
Washington Beat
- 40 Power Up**  
Radios & High-Tech Gear
- 57 Radio Fun**  
Trivia And Toons

# Tap into secret Shortwave Signals

Turn mysterious signals into exciting text messages with the MFJ MultiReader™!

MFJ-462B  
**\$199<sup>95</sup>**

Plug this self-contained MFJ Multi-Reader™ into your shortwave receiver's earphone jack.

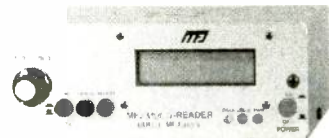

Then watch mysterious chirps, whistles and buzzing sounds of RTTY, ASCII, CW and AMTOR (FEC) turn into exciting text messages as they scroll across an easy-to-read LCD display.

You'll read interesting commercial, military, diplomatic, weather, aeronautical, maritime and amateur traffic . . .

## Eavesdrop on the World

Eavesdrop on the world's press agencies transmitting unedited late breaking news in English -- China News in Taiwan, Tanjung Press in Serbia, Iraqi News in Iraq -- all on RTTY.

Copy RTTY weather stations from Antarctica, Mali, Congo and many others. Listen to military RTTY passing traffic from Panama, Cyprus, Peru, Capetown, London and others. Listen to hams, diplomatic, research, commercial and maritime RTTY.

## Super Active Antenna

"World Radio TV Handbook" says MFJ-1024 is a "first-rate easy-to-operate active antenna...quiet... excellent dynamic range... good gain... low noise... broad frequency coverage." Mount it outdoors away from electrical noise for maximum signal, minimum noise. Covers 50 KHz-30 MHz.

Receives strong, clear signals from all over the world. 20 dB attenuator, gain control, ON LED.

Switch two receivers and auxiliary or active antenna. 6x3x5 in. Remote has 54" whip, 50 feet coax. 3x2x4 inches. 12 VDC or 110 VAC with MFJ-1312, \$15.95.

## Indoor Active Antenna

Rival outside twin wires with this tuned indoor active antenna. "World Radio TV Handbook" says MFJ-1020C is a "fine value... fair price... best offering to date... performs very well indeed."

Tuned circuitry minimizes intermod, improves selectivity, reduces noise outside tuned band. Use as a preselector with external antenna. Covers 0.3-30 MHz. Tune, Band, Gain, On/Off/Bypass Controls. Detachable telescoping whip. 5x2x6 in. Use 9 volt battery, 9-18 VDC or 110 VAC with MFJ-1312, \$15.95.

## Compact Active Antenna

Plug this MFJ-1022 compact MFJ all band active antenna into your receiver and you'll hear strong, clear signals from all over the world, 300 KHz to 200 MHz including low, medium, shortwave and VHF bands. Detachable 20" telescoping antenna. 9V battery or 110 VAC MFJ-1312B, \$15.95. 3/8x1 1/4x4 in.



MFJ-1020C  
**\$99<sup>95</sup>**



MFJ-1022  
**\$69<sup>95</sup>**

Listen to maritime users, diplomats and amateurs send and receive error-free messages using various forms of TOR (Telex-Over-Radio).

Monitor Morse code from hams, military, commercial, aeronautical, diplomatic, maritime -- all over the world -- Australia, Russia, Japan, etc.

Monitor any station 24 hours a day by printing transmissions. Printer cable, MFJ-5412, \$11.95.

Save several pages of text in memory for later reading or review.

## High Performance Modem

MFJ's high performance PhaseLockLoop™ modem consistently gives you solid copy -- even with weak signals buried in noise. New threshold control minimizes noise interference -- greatly improves copy on CW and other modes.

## Easy to use, tune and read

It's easy to use -- just push a button to select modes and features from a menu.

It's easy to tune -- a precision tuning indicator makes tuning your receiver easy for best copy.

It's easy to read -- front-mounted 2 line 16 character LCD display has contrast adjustment.

Copies most standard shifts and speeds. Has

MFJ AutoTrak™ Morse code speed tracking

Use 12 VDC or use 110 VAC with MFJ-1312D AC adapter, \$15.95. 5/4Wx2 1/2Hx5 1/4D inches.

## WiFi Yagi Antenna -- 15 dBi 16-elements extends range



16-element, 15 dBi WiFi Yagi antenna greatly extends range of 802.11b/g, 2.4 GHz WiFi signals. 32 times stronger than isotropic radiator. Turns slow/no connection WiFi into fast, solid connection. Highly directional -- minimizes interference.

N-female connector. Tripod screw-mount. Wall and desk/shelf mounts. Use vertically/horizontally. 18Wx2 1/4Hx1 1/4D inches. 2.9 ounces.

MFJ-5606SR, \$24.95. Cable connects MFJ-1800/WiFi antennas to computer.

Reverse-SMA male to N-male, 6 ft. RG-174. MFJ-5606TR, \$24.95. Same as MFJ-5606SR but Reverse-TNC male to N-male.

## Eliminate power line noise!



MFJ-1026  
**\$199<sup>95</sup>**

Completely eliminate power line noise, lightning crashes and interference before they get into your receiver! Works on all modes -- SSB, AM, CW, FM, data -- and on all shortwave bands. Plugs between main external antenna and receiver. Built-in active antenna picks up power line noise and cancels undesirable noise from main antenna. Also makes excellent active antenna.

## MFJ Antenna Matcher

Matches your antenna to your receiver so you get maximum signal and minimum loss. MFJ-959C \$119<sup>95</sup>

Preamp with gain control boosts weak stations 10 times. 20 dB attenuator prevents overload. Select 2 antennas and 2 receivers. 1.6-30 MHz. 9x2x6 in. Use 9-18 VDC or 110 VAC with MFJ-1312, \$15.95.

## High-Gain Preselector

High-gain, high-Q receiver preselector covers 1.8-54 MHz. Boost weak signals 10 times with low noise dual gate MOSFET. Reject out-of-band signals and images with high-Q tuned circuits. Push buttons let you select 2 antennas and 2 receivers. Dual coax and phono connectors. Use 9-18 VDC or 110 VAC with MFJ-1312, \$15.95.

## Dual Tunable Audio Filter

Two separately tunable filters let you peak desired signals and notch out interference at the same time. You can peak, notch, low or high pass signals to eliminate heterodynes and interference. Plugs between radio and speaker or phones. 10x2x6 inches.



MFJ-959C  
**\$119<sup>95</sup>**



MFJ-1045C  
**\$89<sup>95</sup>**



MFJ-752C  
**\$119<sup>95</sup>**

## MFJ Shortwave Headphones



MFJ-392B  
**\$24<sup>95</sup>**

Perfect for shortwave radio listening for all modes -- SSB, FM, AM, data and CW. Superb padded headband and ear cushioned design makes listening extremely comfortable as you listen to stations all over the world! High-performance driver unit reproduces enhanced communication sound. Weighs 8 ounces, 9 ft. cord. Handles 450 mW. Frequency response is 100-24,000 Hz.

## High-Q Passive Preselector

High-Q passive LC preselector boosts your favorite stations while rejecting images, intermod and phantom signals. 1.5-30 MHz. Preselector bypass and receiver grounded positions. Tiny 2x3x4 in.

## Super Passive Preselector

Improves any receiver! Suppresses strong out-of-band signals that cause intermod, blocking, cross modulation and phantom signals. Unique Hi-Q series tuned circuit adds super sharp front-end selectivity with excellent stopband attenuation and very low passband loss. Air variable capacitor with vernier. 1.6-33 MHz.

## MFJ Shortwave Speaker

This MFJ ClearTone™ restores the broadcast quality sound of shortwave listening. Makes copying easier, enhances speech, improves intelligibility, reduces noise, static, hum. 3 in. speaker handles 8 Watts. 8 Ohm impedance. 6 foot cord.



MFJ-956  
**\$69<sup>95</sup>**



MFJ-1046  
**\$119<sup>95</sup>**



MFJ-281  
**\$12<sup>95</sup>**

## MFJ All Band Doublet

102 ft. all band doublet covers .5 to 60 MHz. Super strong custom fiberglass center insulator provides stress relief for ladder line (100 ft.). Authentic glazed ceramic end insulators and heavy duty 14 gauge 7-strand copper wire.



MFJ-1777  
**\$59<sup>95</sup>**  
Ship Code A

## MFJ Antenna Switches

MFJ-1704 \$79<sup>95</sup> MFJ-1702C \$39<sup>95</sup>

MFJ-1704 heavy duty antenna switch lets you select 4 antennas or ground them for static and lightning protection. Unused antennas automatically grounded. Replaceable lightning surge protection. Good to 500 MHz. 60 dB isolation at 30 MHz. MFJ-1702C for 2 antennas.

## Morse Code Reader

Place this pocket-sized MFJ-461 MFJ Morse Code Reader near your receiver's speaker. Then watch CW turn into solid text messages on LCD. Eavesdrop on Morse Code QSOs from hams all over the world!

## MFJ 24/12 Hour Station Clock

MFJ-108B, \$21.95. Dual 24/12 hour clock. Read UTC/local time at-a-glance. High-contrast 5/8" LCD, brushed aluminum frame. Batteries included. 4 1/2Wx1Dx2H inches.



MFJ-461  
**\$89<sup>95</sup>**



MFJ-108B  
**\$21.95**

## Dealer/Catalog/Manuals

Visit: <http://www.mfjenterprises.com> or call toll-free 800-647-1800

• 1 Year No Matter What™ warranty • 30 day money back guarantee (less s/h) on orders direct from MFJ  
**MFJ ENTERPRISES, INC.**  
300 Industrial Pk Rd, Starkville, MS 39759 PH: (662) 323-5869  
Tech Help: (662) 323-0549  
FAX: (662) 323-6551 8-4:30 CST, Mon.-Fri. Add shipping.  
Prices and specifications subject to change (c) 2008 MFJ Enterprises, Inc.

# POPULAR COMMUNICATIONS

## EDITORIAL STAFF

**Edith Lennon, N2ZRW**, Editor

(E-mail: [editor@popular-communications.com](mailto:editor@popular-communications.com))

**Richard S. Moseson, W2VU**, Editorial Director

(E-mail: [w2vu@popular-communications.com](mailto:w2vu@popular-communications.com))

## CONTRIBUTING EDITORS

**Peter J. Bertini, K1ZJH**, Restoration/Electronics

**Kent Britain, WA5VJB**, Antennas And Accessories

**Bruce A. Conti**, AM/FM Broadcasts

**Rob de Santos**, Trends In Technology

**Gerry L. Dexter**, Shortwave Broadcast

**Richard Fisher KI6SN**, Capitol Hill News

**Mitch Gill, NA7US**, Homeland Security

**Tomas Hood, NW7US**, Propagation

**Shannon Huniwell**, Classic Radio

**John Kasupski, KC2HMZ**, UtilityComm/EmComm

**Kirk Kleinschmidt, NT0Z**, Amateur Radio

**Mark Meece, N8ICW**, Military Monitoring

**D. Prabakaran**, News

**Bill Price, N3AVY**, Humor/Communications

**Ken Reiss**, Technical/Scanning

**Dan Srebnick, K2DLS**, Computers And Radio

**Bob Sturtevant, AD7IL**, Puzzles And Trivia

**Tom Swisher, WA8PYR**, Civil Aviation

**Jason Togyer, KB3CNM**, Cartoons

**Gordon West, WB6NOA**, General Radio Comm.

## BUSINESS STAFF

**Richard A. Ross, K2MGA**, Publisher

**Arnold Sposato, N2IQO**, Advertising Manager

**Emily Leary**, Sales Coordinator

**Sal Del Grosso**, Accounting Manager

**Doris Watts**, Accounting Department

## CIRCULATION STAFF

**Melissa Gilligan**, Operations Manager

**Cheryl DiLorenzo**, Customer Service Manager

**Ann Marie Auer**, Customer Service

## PRODUCTION STAFF

**Elizabeth Ryan**, Art Director

**Barbara McGowan**, Associate Art Director

**Dorothy Kehrwieler**, Production Director

**Emily Leary**, Production Manager/Webmaster

**Hal Keith**, Technical Illustrator

**Larry Mulvehill, WB2ZPI**, Photographer

A publication of



CQ Communications, Inc.  
25 Newbridge Road  
Hicksville, NY 11801-2953 USA

Popular Communications (ISSN-0733-3315). Vol. 27, No. 12, published monthly by CQ Communications, Inc., 25 Newbridge Road, Hicksville, NY 11801. Telephone (516) 681-2922. FAX (516) 681-2926. Web Site: <<http://www.popular-communications.com/>> Periodicals Postage Paid at Hicksville, NY and at additional mailing offices. Subscription prices (payable in U.S. dollars): Domestic—one year \$32.95, two years \$58.95, three years \$85.95. Canada/Mexico—one year \$42.95, two years \$78.95, three years \$115.95. Foreign Air Post—one year \$52.95, two years \$98.95, three years \$145.95.

U.S. Government Agencies: Subscriptions to Popular Communications are available to agencies of the United States government, including military services, only on a cash with order basis. Requests for quotations, bids, contracts, etc. will be refused and will not be returned or processed.

Entire contents copyright © 2009 by CQ Communications, Inc. Popular Communications assumes no responsibility for unsolicited manuscripts, photographs, or drawings. Allow six weeks for change of address or delivery of first issue.

Printed in the United States of America.

POSTMASTER: Send address changes to Popular Communications, 25 Newbridge Road, Hicksville, NY 11801.

## EDITORIAL

Tuning In

# A Clear Choice: Declassify

by Edith Lennon, N2ZRW

[editor@popular-communications.com](mailto:editor@popular-communications.com)

Barack Obama ran on a platform that promised a “Transparent and Open Government.” And to that end, after taking office he publicly asked all Americans to submit their own ideas to the White House.

OK, sounds good; we’ll bite. And for our first course, we’d like the declassification of federal frequency assignments in the Government Master File (GMF), which was classified as secret in 1982.

It was “Cold-War Thinking” that led to President Reagan’s belief that our enemies would be thwarted from eavesdropping on us if our sensitive government radio communications frequencies were no longer published (and, of course, it was just easier to classify *everything*). Today, it’s “Post-9/11 Thinking” that provides the rationale, but the end result is the same: security through obscurity.

Prior to 1982, the GMF was public and readily available, and each year the radio hobby community got to gobble up that big, juicy list of federal frequency allocations, call signs, locations, etc. Yes, we had it good back then [sigh], but for the past 27 years, it’s been slim pickings, at least as far as *official* information goes.

You may think that the FCC regulates the use of all radio frequencies in the United States, but that’s not true; it only regulates the frequency use of *non-federal* entities. Virtually all federal government use of the radio spectrum—and it controls huge swaths of it—is regulated by a rather obscure government body called the Inter-departmental Radiofrequency Advisory Commission (IRAC), a division of the National Telecommunications and Information Administration (NTIA).

Like a mini domestic United Nations for radio, the IRAC seats representatives from dozens of government entities—from the Department of Agriculture to the Veterans Administration—all continually vying for their slices of the radio spectrum pie and working out allocation conflicts and interference issues among themselves. The FCC’s frequency allocations for non-federal entities are public and online, but unfortunately for radio hobbyists, the

IRAC’s federal frequency allocations are not public; they are classified and Freedom of Information Act-exempt. In other words, a Big Secret.

There’s been no recent public review of the necessity for this degree of secrecy, and the continued blanket classification of virtually all federal frequency assignments certainly constitutes obsessive and excessive information suppression. Security through obscurity works poorly at best, and nowadays federal entities that actually do require secrecy can and do use modern encryption technology.

The time has indeed come for a more “Transparent and Open Government.” One way to usher it in is for the GMF of federal frequency allocations to be made public once again.

Unconvinced? Consider this: As radio/scanner monitoring hobbyists we should not underestimate the public service we perform for our communities—and our nation—by keeping ourselves and others alert, informed, and safe. We do this best when equipped with one of our best tools: frequency information.

Call and write your senators and congressional representatives—and the White House. It’s time to lift this unnecessary radio secrecy. Our democracy will be better served and we’ll be all the safer for it.

## In Remembrance: WBCQ Program Director Michael Ketter

WBCQ international shortwave program director and broadcaster Michael Ketter passed away in Pittsburgh on May 17, 2009, as the result of an anoxic brain injury. He was only 48 and left behind a mourning radio community. “He died too young. He had a lot left in him and a lot to give,” said Tim “Timtron” Smith, WBCQ station engineer and a close friend. “He was one of the best radio people I ever met,” said Allan Weiner, WBCQ’s owner, adding, “He was a true Renaissance man. He always had a twinkle in his eye and a smile.” He is survived by his wife Gina. ■

# SEE More and HEAR More!

## With the SR2000A and AR8200MkIII from AOR

### SR2000A Color Frequency Monitor

The SR2000A is an ultra-fast spectrum display monitor that lets you SEE received signals in FULL color.

Using the power of FFT (Fast Fourier Transform) algorithms with a sensitive receiver covering 25MHz ~ 3GHz\*, the SR2000A features a color monitor that displays up to 40MHz spectrum bandwidth\*\*, a switchable time-lapse "waterfall" display or live video in NTSC or PAL formats.

Ultra sensitive, incredibly fast, yet easy to use with a high quality internal speaker for crisp, clean audio signals. Scans 10MHz in as little as 0.2 seconds! Instantly detects, captures and displays transmitted signals. PC control through RS232C serial port or USB interface. With 12 VDC input, it's perfect for base, mobile or field use.



### AR8200MkIII Handheld Receiver

From inter-agency coordination to surveillance, you can't know too much. The world-class AR8200MkIII portable receiver features a TXCO that delivers solid frequency stability and performance not found in most desktop units. With 1,000 alphanumeric memory channels, it covers 500 KHz ~ 3GHz\*. Improved RF circuits combine greater sensitivity, resistance to intermod and enhanced Signal to Noise ratio. It offers increased audio frequency response and includes NiMH AA batteries that can be charged while the unit is in use.

Optional internal slot cards expand the AR8200MkIII's capabilities. Choose from Memory Expansion (up to 4,000 memories), CTCSS Squelch and Search, and Tone Eliminator.

The AR8200MkIII offers "all mode" reception that includes "super narrow" FM plus wide and narrow FM in addition to USB, LSB, CW and standard AM and FM modes. It also features true carrier reinsertion in USB and LSB modes and includes a 3KHz SSB filter. The data port can be used for computer control, memory configuration and transfer, cloning or tape recording output.

A special government version, AR8200MkIII IR features infra-red illumination (IR) of the display and operating keys. The IR illumination function is selectable, allowing operation by users wearing night vision apparatus without removing goggles and waiting for the eyes to re-adjust. Ideal for military, law enforcement and surveillance operators.



Authority on Radio  
Communications

AOR U.S.A., Inc.

20655 S. Western Ave., Suite 112, Torrance, CA 90501, USA

Tel: 310-787-8615 Fax: 310-787-8619

info@aorusa.com <http://www.aorusa.com>

\* Government version, cellular blocked for US consumer version.

\*\*No audio is available when the frequency span is set to 20MHz or 40MHz.

Specifications subject to change without notice or obligation.

SEE more and HEAR  
more with AOR, the  
serious choice in  
Advanced Technology  
Receivers™.

# The Weirder Side Of Wireless

by Staff

## No Longer For The Birds

According to the BBC, a British digital radio station, which became unexpectedly popular with listeners by broadcasting only birdsongs for 18 months, has been taken off the air. The birdsong programming was intended as temporary filler after the DAB OneWord station closed, but it attracted nearly half a million listeners, with some fans even setting up Facebook fan sites. Its replacement, Amazing Radio, features songs from unsigned artists.

## Britain Joins Axis Of Evil?

A BBC 5 news announcer mistakenly said on national radio that the small town of North Yorkshire, England, had commenced illegal underground nuclear tests, it was reported on the Telegraph.co.uk website. The top news story was about worldwide disapproval of North Korea's recent nuclear tests, but the newsreader mistakenly declared: "There has been widespread condemnation of North Yorkshire's decision to carry out an underground nuclear test." A BBC 5 spokesman said: "We are aware of the occasional tensions between North and South Yorkshire, but clearly this was a slip of the tongue. We have no fears about the good people of North Yorkshire."

## Hugo Chavez's New Cell, Naughty Or Nice?

Venezuelan president Hugo Chavez has launched the Vergatario, one of the world's most affordable mobile phones—with a very controversial name. During his weekly radio and television show, "Hello President" Chavez showed off the new mobile phone called "El Vergatario." Costing about \$15, the Vergatario's name has its origins in a Venezuelan slang term for the male reproductive organ. Mr. Chavez, who nationalized the company that manufactures the phone, pronounced the Vergatario "light, beautiful, good and cheap." Despite its populist price, the phone has advanced features such as a web browser and MP3 player. "It is science and technology at the service of the people not the elites...the day will come when we manufacture phones for Cuba and

Latin America," Chavez said. "This telephone will be the biggest seller not only in Venezuela but the world. Whoever doesn't have a Vergatario is nothing." Chavez even telephoned his mother during the launch ceremony. Critics denounced the choice of name given to the phone as vulgar and in bad taste.

## For Verizon, It's Not All About The Network

An Ohio man was found unconscious and unresponsive after an intense search by Carroll County sheriff deputies. Sheriff Dale Williams organized the search party after deputies responded to a domestic 911 caller who said the man was destroying the house. But when deputies arrived, they were told the man had taken several bottles of pills and fled. Williams called the man's cell phone to help rescuers find him, but the man was behind on his bill and the Verizon operator refused to reconnect the phone unless the sheriff paid the overdue bill. After some strong words, Williams agreed to pay \$20 of the bill just to find the man. Deputies discovered the man just as Williams was preparing to make arrangements for the payment, however. "I was more concerned for the person's life," Williams said. "It would have been nice if Verizon had turned on his phone for five or ten minutes, just long enough to try and find the guy. But they would only turn it on if we agreed to pay \$20 of the unpaid bill. Ridiculous."

## Radio/TV-Starved Prisoners Go On Hunger Strike In Maine

As many as eight prisoners in the supermax unit of a state prison in Maine went on a hunger strike, demanding televisions and radios, which are prohibited in the supermax unit. One striking prisoner said in a letter to a newspaper reporter that he objected to the prison policy that only allows supermax inmates to have pen and paper, books and magazines in their cells, but no TVs or radios like the rest of the prison population. Another was quoted as saying most states recognize the need to have a TV or radio in order "to keep sane" in solitary confinement. Perhaps the prison should only let them watch The Food Network. ■



# Big Savings on Radio Scanners

## Uniden®

## SCANNERS



### Bearcat® 796DGV Trunk Tracker IV with free scanner headset

Manufacturers suggested list price \$799.95  
CEI Special Price \$519.95

1,000 Channels • 10 banks • CTCSS/DCS • S Meter  
Size: 6<sup>15/16</sup>" Wide x 6<sup>9/16</sup>" Deep x 2<sup>3/8</sup>" High

Frequency Coverage: 25.0000-512.0000 MHz., 806.0000-956.0000 MHz., (excluding the cellular & UHF TV band), 1,240.0000-1,300.0000 MHz.

When you buy your Bearcat 796DGV TrunkTracker package deal from Communications Electronics, you get more. The GV means "Great Value." With your BC796DGV scanner purchase, you also get a free deluxe scanner headphone designed for home or race track use. Headset features independent volume controls and 3.5 mm gold right angle plug. The 1,000 channel Bearcat 796DGV is packed with features to track Motorola Type III/III Hybrid, EDACS, LTR Analog Trunk Systems and Motorola APCO 25 Phase I digital scanner including 9,600 Baud C4FM and CQPSK. Also features control channel only mode to allow you to automatically trunk many systems by simply programming the control channel. S.A.M.E. weather alert, full-frequency display and backlit controls, built-in CTCSS/DCS to assign analog and digital subaudible tone codes to a specific frequency in memory, PC Control and programming with RS232C 9 pin port (cable not supplied), Beep Alert, Record function, VFO control, menu-driven design, total channel control and much more. Our CEI package deal includes telescopic antenna, AC adapter, cigarette lighter cord, DC cord, mobile mounting bracket with screws, owner's manual, trunking frequency guide and one-year limited Uniden factory warranty. For maximum scanning enjoyment, order magnetic mount antenna part number ANTMMBNC for \$29.95. For complete details, download the owners manual from the [www.usascan.com](http://www.usascan.com) web site. For fastest delivery, order on-line at [www.usascan.com](http://www.usascan.com).

### Bearcat® BCT8 Trunk Tracker III

Manufacturer suggested list price \$299.95

CEI Special Price \$169.95

250 Channels • 5 banks • PC Programmable  
Size: 7.06" Wide x 6.10" Deep x 2.44" High

Frequency Coverage: 25.0000-54.0000 MHz., 108.0000-174.0000 MHz., 400.0000-512.0000 MHz., 806.0000-823.9875 MHz., 849.0125-868.9875 MHz., 894.0125-956.0000 MHz.

The Bearcat BCT8 scanner, licensed by NASCAR, is a superb preprogrammed 800 MHz trunked highway patrol system scanner. Featuring TrunkTracker III, PC Programming, 250 Channels with unique BearTracker warning system to alert you to activity on highway patrol link frequencies. Preprogrammed service searches makes finding interesting active frequencies even easier and include preprogrammed police, fire and emergency medical, news agency, weather, CB band, air band, railroad, marine band and department of transportation service searches. The BCT8 also has preprogrammed highway patrol alert frequencies by state to help you quickly find frequencies likely to be active when you are driving. The BCT8 includes AC adapter, DC power cable, cigarette lighter adapter plug, telescopic antenna, window mount antenna, owner's manual, one year limited Uniden warranty, frequency guide and free mobile mounting bracket. For maximum scanning enjoyment, also order the following optional accessories: External speaker ESP20 with mounting bracket & 10 feet of cable with plug attached \$19.95. Magnetic Mount mobile antenna ANTMMBNC for \$29.95.



### Bearcat® BCD396T Trunk Tracker IV

Suggested list price \$799.95/CEI price \$519.95

APCO 25 9,600 baud compact digital ready handheld TrunkTracker IV scanner featuring Fire Tone Out Paging, Close Call and Dynamically Allocated Channel Memory (up to 6,000 channels), SAME Weather Alert, CTCSS/DCS, Alpha Tagging. Size: 2.40" Wide x 1.22" Deep x 5.35" High

#### Frequency Coverage:

25.0000-512.0000 MHz., 764.0000-775.9875 MHz., 794.0000-823.9875 MHz., 849.0125-868.8765 MHz., 894.0125-956.0000 MHz., 1240.0000 MHz., 1300.0000 MHz.

The handheld BCD396T scanner was designed for National Security/Emergency Preparedness (NS/EP) and homeland security use with new features such as **Fire Tone Out Decoder**. This feature lets you set the BCD396T to alert if your selected two-tone sequential paging tones are received. Ideal for on-call firefighters, emergency response staff and for activating individual scanners used for incident management and population attack warning.



**Close Call Radio Frequency Capture** - Bearcat exclusive technology locks onto nearby radio transmissions, even if you haven't programmed anything into your scanner. Useful for intelligence agencies for use at events where you don't have advance notice or knowledge of the radio communications systems and assets you need to intercept. The BCD396T scanner is designed to track Motorola Type I, Type II, Hybrid, SMARTNET, PRIVACY PLUS, LTR and EDACS\* analog trunking systems on any band. Now, follow UHF High Band, UHF 800/900 MHz trunked public safety and public service systems just as if conventional two-way communications were used. **Dynamically Allocated Channel Memory** - The BCD396T scanner's memory is organized so that it more closely matches how radio systems actually work. Organize channels any way you want, using Uniden's exclusive dynamic memory management system. 3,000 channels are typical but **over 6,000 channels are possible** depending on the scanner features used. You can also easily determine how much memory you have used and how much memory you have left. **Preprogrammed Systems** - The BCD396T is preprogrammed with over 400 channels covering police, fire and ambulance operations in the 25 most populated counties in the United States, plus the most popular digital systems. **3 AA NiMH or Alkaline battery operation and Charger** - 3 AA battery operation. The BCD396T includes 3 premium 2,300 mAh Nickel Metal Hydride AA batteries to give you the most economical power option available. You may also operate the BCD396T using 3 AA alkaline batteries. **Unique Data Skip** - Allows your scanner to skip unwanted data transmissions and reduces unwanted birdies. **Memory Backup** - If the battery completely discharges or if power is disconnected, the frequencies programmed in the BCD396T scanner are retained in memory. **Manual Channel Access** - Go directly to any channel. **LCD Back Light** - A blue LCD light remains on when the back light key is pressed. **Autolight** - Automatically turns the blue LCD backlight on when your scanner stops on a transmission. **Battery Save** - In manual mode, the BCD396T automatically reduces its power requirements to extend the battery's charge. **Attenuator** - Reduces the signal strength to help prevent signal overload. The BCD396T also works as a conventional scanner to continuously monitor many radio conversations even though the message is switching frequencies. The BCD396T comes with AC adapter, 3 AA nickel metal hydride batteries, belt clip, flexible rubber antenna, wrist strap, SMA/BNC adapter, RS232C cable, Trunk Tracker frequency guide, owner's manual and one year limited Uniden warranty. Not compatible with AGEIS, ASTRO or ESAS systems. Order on-line at [www.usascan.com](http://www.usascan.com) or call 1-800-USA-SCAN.

### More Radio Products

Save even more on radio scanners when purchased directly from CEI. Price includes delivery in the continental USA excluding Alaska.

Bearcat 898T 500 channel TrunkTracker III base/mobile.....	\$209.95
Bearcat 796DGV Digital 1,000 ch. TrunkTracker IV base/mobile.....	\$519.95
Bearcat BCD396T APCO 25 Digital scanner with Fire Tone Out.....	\$519.95
Bearcat 246T up to 2,500 ch. TrunkTracker III handheld scanner.....	\$214.95
Bearcat Sportcat 230 alpha display handheld sports scanner.....	\$184.95
Bearcat 278CLT 100 channel AM/FM/SAME WX alert scanner.....	\$129.95
Bearcat 248CLT 50 channel base AM/FM/weather alert scanner.....	\$104.95
Bearcat 244CLT 30 channel base AM/FM/weather alert scanner.....	\$94.95
Bearcat 92XLT 200 channel handheld scanner.....	\$105.95
Bearcat 72XLT 100 channel handheld scanner.....	\$89.95
Bearcat BR330T handheld shortwave/scanner with Fire Tone out.....	\$274.95
Bearcat BCT8 250 channel information mobile scanner.....	\$169.95
Bearcat 350C 50 channel desktop/mobile scanner.....	\$96.95
AOR AR16BQ Wide Band scanner with quick charger.....	\$199.95
AOR AR3000AB Wide Band base/mobile receiver.....	\$1,079.95
AOR AR8200 Mark IIIB Wide Band handheld scanner.....	\$594.95
AOR AR8600 Mark II Wide Band receiver.....	\$899.95
Deluxe Independent Dual Volume Control Racing Headphone.....	\$29.95
Scancat Gold For Windows Software.....	\$29.95
Scancat Gold For Windows Surveillance Edition.....	\$159.95

### Bearcat® BC246T Trunk Tracker III

Suggested list price \$399.95/CEI price \$214.95  
Compact professional handheld TrunkTracker III scanner featuring Close Call and Dynamically Allocated Channel Memory (up to 2,500 channels), SAME Weather Alert, CTCSS/DCS, Alpha Tagging. Size: 2.72" Wide x 1.26" Deep x 4.6" High

#### Frequency Coverage:

25.0000-54.0000 MHz., 108.0000-174.0000 MHz., 216.0000-224.9800 MHz., 400.0000-512.0000 MHz., 806.0000-823.9875 MHz., 849.0125-868.9875 MHz., 894.0125-956.0000 MHz., 1240.0000 MHz., 1300.0000 MHz.

The handheld BC246T TrunkTracker scanner has so many features, we recommend you visit our web site at [www.usascan.com](http://www.usascan.com) and download the free owner's manual. Popular features include **Close Call Radio Frequency Capture** - Bearcat exclusive technology locks onto nearby radio transmissions, even if you haven't programmed anything into your scanner. **Dynamically Allocated Channel Memory** - Organize channels any way you want, using Uniden's exclusive dynamic memory management system. 1,600 channels are typical but **over 2,500 channels are possible** depending on the scanner features used. You can also easily determine how much memory is used. **Preprogrammed Service Search (10)** - Makes it easy to find interesting frequencies used by public safety, news media TV broadcast audio, Amateur (ham) radio, CB radio, Family Radio Service, special low power, railroad, air-raft, marine, racing and weather frequencies. **Quick Keys** - allow you to select systems and groups by pressing a single key. **Text Tagging** - Name each system, group, channel, talk group



ID, custom search range, and S.A.M.E. group using 16 characters per name. **Memory Backup** - When power is lost or disconnected, your BC246T retains the frequencies that were programmed in memory. **Unique Data Skip** - Allows the BC246T to skip over unwanted data transmissions and birdies. **Attenuator** - You can set the BC246T attenuator to reduce the input strength of strong signals by about 18 dB. **Duplicate Frequency Alert** - Alerts you if you try to enter a duplicate name or frequency already stored in the scanner. **22 Bands** - with aircraft and 800 MHz. The BC246T comes with AC adapter, 2 AA 1,800 mAh nickel metal hydride batteries, belt clip, flexible rubber antenna, wrist strap, RS232C cable, Trunk Tracker frequency guide, owner's manual and one year limited Uniden warranty. For more fun, order our optional deluxe racing headset part #HF24RS for \$29.95. Order now at [www.usascan.com](http://www.usascan.com) or call 1-800-USA-SCAN.

### Buy with Confidence

### Order on-line and get big savings

For over 37 years, millions of communications specialists and enthusiasts worldwide have trusted Communications Electronics for their mission critical communications needs. It's easy to order. For fastest delivery, order on-line at [www.usascan.com](http://www.usascan.com). Mail orders to: Communications Electronics Inc., P.O. Box 1045, Ann Arbor, Michigan 48106 USA. Price includes \$30.00 UPS Ground shipping/handling/insurance per scanner to a street address in the continental USA excluding Alaska. Add \$20.00 shipping for all accessories. For shipments to Canada, Puerto Rico, Hawaii, Alaska, Guam, P.O. Box, APO/FPO, USPS Priority Mail or UPS 2 business day delivery, add \$30.00. Michigan residents add sales tax. No COD's. For Bearcat scanners your satisfaction is guaranteed or return item in unused condition in original packaging within 61 days for refund, less shipping charges. 10% surcharge for net 10 billing to qualified accounts. All sales are subject to availability, acceptance and verification. Prices, terms and specifications are subject to change without notice. We welcome your Discover, Visa, American Express, MasterCard, IMPAC or Eurocard. Order toll free, call 1-800-USA-SCAN or 1-734-996-8888 if outside Canada or the USA. FAX anytime, dial 1-734-663-8888. Dealer and international inquiries invited. Order your radio scanners from Communications Electronics today.

### For credit card orders call 1-800-USA-SCAN

e-mail: [cei@usascan.com](mailto:cei@usascan.com)

[www.usascan.com](http://www.usascan.com)

PO Box 1045, Ann Arbor, Michigan 48106-1045 USA  
For information call 734-996-8888 or FAX 734-663-8888  
Price schedule effective January 2, 2006 AD #10206 © 2006 Communications Electronics Inc.



**COMMUNICATIONS ELECTRONICS INC.**

Emergency Operations Center

Visit [WWW.USASCAN.COM](http://WWW.USASCAN.COM) • 1-800-USA-SCAN

## News, Trends, And Short Takes

by D. Prabakaran

### **WRMI To Produce AWR's Wavescan In Miami**

WRMI has announced that the Adventist World Radio DX program, "Wavescan," will be produced and distributed from its studios in Miami as of June, 2009. WRMI has broadcast "Wavescan" since its inception. For the past three years, the program has been produced at the AWR studio in Singapore. However, that studio was to be closed in June. As of the June 7 program, "Wavescan" will be written each week by Dr Adrian Peterson, AWR International Relations Coordinator in Indianapolis, Indiana, and produced at WRMI in Miami. WRMI will also distribute the program to the various stations in the AWR network around the globe. Peterson will be entirely in charge of the content of the program, but segments of regional DX news will continue to come from "Wavescan" correspondents in several Asian countries.

*(Source: WRMI)*

### **Mexico Wants AM Stations To Move To FM**

Radio World reports that the Mexican government wants to give the majority of AM stations in the country the opportunity to migrate voluntarily to the FM band, subject to availability of frequencies. However no FM frequencies have been awarded and the plan is bogged down in administrative complications. It's unclear when it will move forward. According to SCT, the agency that sets communications policy, a station that wished to move would have a year from the time of authorization to put an FM station on the air and another year to give up its AM frequency and turn in that license. It's been predicted that the majority of AM broadcasters in Mexico will shutter operations on that band within five years. There is a total of 1,580 radio stations in Mexico; 854 are AM and 726 are FM, according to the SCT.

*(Source: Radio Netherlands Media Network)*

### **BBC Mediumwave DRM Tests Reveal Problems After Dark**

The BBC's year-long test of digital mediumwave radio, dubbed Project Mayflower, proved that it worked well during daylight hours but disappointed volunteer listeners after sunset. Reception during daylight was good and most panelists rated the audio quality as comparable to FM, but not as good as DAB. However, at night there were serious problems with reception, with the signal breaking down entirely in some cases. The BBC said the problem could be solved, but would require it to replan its transmission network or build more powerful transmitters.

*(Source: guardian.co.uk)*

### **Panama Chooses IBOC Over DRM As Digital Broadcasting Standard**

After reviewing several digital radio technologies, the Republic of Panama has selected the HD Radio in-band, on channel (IBOC) system as its official digital radio standard. The Panamanian government stated that it selected IBOC technology after the country's Digital Broadcasting Technical Commission reviewed IBOC, Eureka 147 and DRM (Digital Radio Mondiale).

*(Source: Radio magazine online)*

### **Radio Free Europe/Radio Liberty Opens New HQ In Prague**

Radio Free Europe/Radio Liberty opened its new highly secured headquarters in Prague. The move was partly sparked by heightened Czech fears of terrorism following the attacks of September, 11, 2001. RFE/RL has in recent years reduced its activities in Central and Eastern Europe to focus on Russia, Belarus, Ukraine, the Caucasus, Central Asia, Afghanistan, Iran, and Iraq. The radio station with more than 1,000 journalists and correspondents broadcasts in 28 languages and has developed a range of websites.

RFE/RL, founded by the United States during the Cold War in the 1950s, moved to Prague from Munich, Germany in 1995, settling down in the former Czechoslovak parliament building at the top of the central Wenceslas Square. After 9/11, Czech authorities decided to move the radio station out of the center to a brand new headquarters that the station itself describes as one of the best-protected buildings in Europe.

*(Source: AFP)*

### **Radio Mada Reporter Freed After Detention In Madagascar**

Reporters Without Borders said Radio Mada reporter Evariste Ramanantsoavina was released from detention on May 20. He had been held since May 5, when soldiers arrested him to force him to reveal the location from which the station was broadcasting in defiance of a closure order. A court ordered his release after acquitting him on five charges, including "inciting revolt," and fining him 370 euros on a sixth charge of disseminating false information. Radio Mada supports the exiled former president, Marc Ravalomanana. After Ramanantsoavina was forced to reveal the secret location from which the station had been broadcasting since the change of government, soldiers dismantled its transmitter and seized equipment.

*(Source: AllAfrica.com)*

# Capitol Hill And FCC Actions Affecting Communications

## by Richard Fisher, KI6SN **Congress Calls For Study Of Amateur Radio EmComm**

A Texas congresswoman has introduced a bill in the 111th Congress calling for a “study of the uses of amateur radio for emergency and disaster relief communications, by identifying unnecessary or unreasonable impediments to the deployment of amateur radio emergency and disaster relief communications, and by making recommendations for relief of such unreasonable restrictions so as to expand the uses of amateur radio communications in Homeland Security planning and response.”

Sponsored by U.S. Rep. Sheila Jackson Lee (D-Tex.), H.R. 2160—The Amateur Radio Emergency Communications Enhancement Act of 2009—would examine “the uses and capabilities of Amateur Radio communications in emergencies and disaster relief” and report findings to Congress “not later than 180 days after the date of enactment of this Act.” Six other House members were listed as co-sponsors.

The bill directs the Secretary of Homeland Security to “utilize the expertise of the American Radio Relay League, representing the national amateur radio community and seek information from private and public sectors for the study.”

Citing the contributions of “the nearly 700,000” amateur radio operators in the United States, the bill’s initial findings said that “emergency and disaster relief communications services by volunteer amateur radio operators have consistently and reliably been provided before, during, and after floods, hurricanes, tornadoes, forest fires, earthquakes, blizzards, train accidents, chemical spills, and other disasters. These communications services include services in connection with significant examples, such as hurricanes Katrina, Rita, Hugo, and Andrew; the relief effort at the World Trade Center, and the Pentagon following the 2001 terrorist attacks; and the Oklahoma City bombing in April 1995.”

## **NAB “Respectfully Opposes” Suggestion To Shorten FCC License Terms**

The executive vice president of the National Association of Broadcasters said the organization “would respectfully oppose” any attempt to short-

en the broadcast license term from eight to three years, as suggested by acting FCC Chairman Michael Copps.

“Since we still need broadcasters to contribute to the democratic dialogue,” Copps said in remarks at a summit sponsored by the advocacy group Free Press, “we need clear standards that can be fairly but vigorously enforced. It is time to say ‘Good-bye’ to post card renewal every eight years and ‘Hello’ to license renewals every three years with some public interest teeth.”

In a statement posted on RadioWorld.com, NAB Executive Vice President Dennis Wharton said that “Congress wisely reformed license renewal terms to allow broadcasters to better compete against our pay platform competitors. Reducing a broadcaster’s term of license would actually harm localism by injecting greater uncertainty into a business model facing the worst advertising downturn in decades.”

Copps pointed out, however, that the FCC should not focus on making changes to license terms until a new FCC chairman takes office. President Obama has nominated Julius Genachowski to the post.

## **Daughter Of House Majority Whip Nominated To FCC By President Obama**

The daughter of U.S. House Majority Whip, Rep. James Clyburn, (D-SC), has been nominated by President Obama to the FCC, filling a seat being vacated by departing Commissioner Jonathan Adelstein. Mignon L. Clyburn, who has served on the South Carolina Public Service Commission, is currently chair of the Washington Action Committee of the National Association of Regulatory Utility Commissioners (NARUC). For 14 years, she was general manager and publisher of *The Coastal Times*, a weekly newspaper in Charleston. According to published reports, Obama described Ms. Clyburn as a “fine public servant” and “a welcome addition to my team as we work to put America on a path towards prosperity and keep our nation safe.”

Ms. Clyburn is a 1984 University of South Carolina graduate with a Bachelor of Science

*(Continued on page 82)*

# Communications And News Delivery

by Rob de Santos  
commhorizons@gmail.com

*"It's not frivolous to question if this makes Blackberry or iPhone fans the communications hobbyists of a new generation. I would argue that by the definitions of the past, they are!"*

When I first became a radio aficionado a main draw of the hobby was the ability to get news from the "source." No longer did I have to depend on the often unreliable or non-existent coverage of foreign events by the domestic press, I could get news straight from the country of origin, often "as it happened." I can recall hearing the sudden change of programming and music on Radio Moscow and knowing what none of my neighbors knew: the leader of the Soviet Union had died. The advent of the Internet gave me the perfect supplement to my shortwave radio and, over time, has replaced it to a great degree. I'm sure that I'm not alone in that.

The gradual demise of international broadcasting over the past several decades has made shortwave radio less important as a source of news and information, even in much of the Third World. The decisions of international broadcasters to reduce, discontinue, or to replace their newscasts probably marks the beginning of the sunset on the era where shortwave was the most important medium for the delivery of news. Will it ever return? Events may prove it otherwise, but right now it seems unlikely.

Similarly, we're seeing major newspapers in the Western world struggle for survival as the economic downturn coincides with the movement of "eyeballs" from the printed page to the glowing screen. These trends aren't just a reflection of bad business practices by the owners and management of newspapers, but perhaps represent a sea change in the entire means of delivery of news and information. Relatively few people under the age of 30 even purchase a newspaper.

What does the future hold for the delivery of news, and how will continuing development affect those of us in the communications hobby? Beyond the obvious, it seems that several trends are apparent: News will increasingly be delivered in smaller and smaller "bites," and "pull" technology will dominate over traditional "push" technology. For the hobbyist, our consumption of news may well be driven by these same trends.

We live in a "twitterized" world. Commercials are 10 seconds long. News headlines used to be 20 minutes; now we get it all in three. Today's hot news is forgotten in 72 hours. I read five to 10 stories in depth each day but consume 200 headlines of eight words each. Friends no longer ask if I have email, they want to know if I "text." In a society with such a short atten-

tion span, we now turn to media and delivery devices that cater to our "get it and forget it" lifestyle.

It's not frivolous to question if this makes Blackberry or iPhone fans the communications hobbyists of a new generation. I would argue that by the definitions of the past, they are! The devices are two-way radios. They can be customized and hacked. They have distinct fan followings and even collectors. If two readers of this magazine had used similar devices to communicate (miniaturization aside) 15 years ago no one would argue my point. There can be little doubt, therefore, that such devices will be increasingly central to news delivery, too.

Traditional news delivery was all "push." You listened or read; the source delivered the news. Little action was demanded on your part except to power up your device; i.e., tune the station or purchase the newspaper. Which news you consumed was entirely up to the news editor at the other end. You couldn't choose which stories this magazine or any news source would give you. The opposite is becoming true today.

Now, through the use of computers and communications devices like smart phones, we can obtain our news by picking and choosing or via customized searches. If we aren't grabbed by the headline, we move on to the next item. Tools like RSS, Twitter, blogs, and Google News make it our choice. This is fundamentally changing the delivery of news, and it means that the traditional business models, built around the old way of delivery, are failing.

It's probably obvious that as a columnist for a print magazine, I have a vested (if minor) interest in the traditional means of delivery. I don't think that printed newspapers or magazines will completely cease to exist. I also don't think that radio and television as a means of news delivery will cease either. However, the future of news delivery is probably going to be radically different from what it was just a decade or two ago. We will use much different devices to receive it; we will have more choice in the format in which we receive the news and in what we receive. The average size of each news item will decline. However, I also believe there is a limit beyond which the user fails to receive enough information for the news items to be truly useful. The need for in-depth information will still remain.

What do you think? What do you see as the way you'll get your news in the future? Drop me a line and let me know.

# World Watch: An Ear Toward Mexico

*Shaken By Earthquakes, Cartels, Germs,  
And More, Our Southern Neighbor Is  
Left Reeling*

by Gerry Dexter



“South of the border, down Mexico way, that’s where I fell in love when the stars above came out to play...” Well, maybe that’s taking the old song a bit too far. It was made popular in the 1940s by Gene Autry, with a significant assist from one of those great Roy Rogers-Dale Evans movies. Now, some 70 years later, that melody has seen better days. And, for that matter, in some respects perhaps has Mexico has also.

If we are to believe only what we hear in the news reports coming out of the seemingly always hyped media, Mexico is certainly a land of mucho trouble these days. Drugs are flowing across our southern border at something akin to the Rio Grande at full flood, and the cartel wars over the attendant profits have left a gruesome trail. And, of course, illegal (sorry, “undocumented”) immigrants also flow across the border and remain political a hot button.

At one time Mexico was the center of a highly sophisticated civilization that contributed significant developments in mathematics, the solar calendar, and medicine. In more modern times, elements of the society seem to have deteriorated into an almost pre-Colombian state. The drug world has recently reared its lawless head with a vengeance, and tales of kidnappings, murders, corruption, ruthless cartels and other horrors have grabbed headlines. That much of this is happening along our border highlights the need for greater security.

And if that weren’t enough to keep the locals awake at night, Mexico also garnered the unenviable title of Ground Zero

Gerry Dexter is *Pop’Comm’s* “Global Information Guide” columnist.

Puerto Vallarta radio masts,  
Jalisco, Mexico. (Photo by Stan  
Shebs via Wikimedia Commons)



Mexico City Metropolitan Cathedral. (Via Wikimedia Commons)

Then—for whatever reason—the situation began to reverse itself and from an almost flat-lined status the number of active stations climbed to a half dozen or so, albeit with a couple of them still barely active.

So don your sombrero and let's have a look at what's on (all the programming is in Spanish):

XERTS-Radio Transcontinental de America came on the air some years ago as a commercial operation. Initially it operated on 4810 (one reference still shows it there), but was beset by technical problems as well as a lot of interference. Sometime later the station moved down to 4800 where it resides today and is generally better heard, although it suffers occasional interference from Radio Buenas Nuevas in Guatemala (not to mention that devilishly annoying CODAR). XERTS operates from 1200 straight through to 0500 (0600 on weekends). Its contact info is: Gabriel Guerra 13, Col. Zona Escolar Oriente 07239, Mexico 75, D.F. Email to: Info\_xerta@yahoo.com.mx.

The next one up the dial is XEOI, (Nucleo) Radio Mil, on 6010. This one relays the large commercial station in Mexico City, which uses the same call and slogan on 1000 kHz, as it has for many years. Of course, XEOI has to battle any number of co-channel stations, among them Colombia's La Voz de su Concencia, Radio Bandierantes in Brazil, and several others (including the everpesky Radio Bahrain!). Despite this, a

for swine flu and what looked like the long-feared global pandemic. We still don't know if we've seen the worst of that. Adding to an almost Biblical level of bad luck, multiple earthquakes in the area have rattled buildings and nerves already worn raw.

Mexico is a democracy with a market economy, what we typically think of as all the ingredients needed for achieving success. But somehow the formula seems to be missing something. Perhaps corruption is too entrenched still, or too many bad decisions have been made by too many "me first" politicians, or maybe it's that for too long a period of time just one political party held the reins of power (the PRI from 1910 to 2000).

Nonetheless, despite its "grittier" aspects, our neighbor to the south has a lot going for it. It is superbly rich in history, culture, and natural beauty. People say Mexico is a great place to visit, so whadya say we do. But let's take the trip via radio—that way you won't need a passport and it'll be safe to drink the water!

## The Short And The Medium Of It

Shortwave from Mexico used to be hopping. There were successful shortwave outlets from several commercial broadcasters, such as XEWW-La Voz de la America Latina, La Voz de la Veracruz, Radio Novedades, and any number of others relaying their domestic AM or FM

outlets. Other memorable voices from those days include little Radio Huayacocotla, the low-power, non-commercial station down on 120 meters, and the government's own Radio Mexico International. Unfortunately, neither managed to have much of a run. The universities were also a significant radio factor, but even they ran into problems.

Mexican shortwave activity bottomed out several years ago and reached a point where there were almost no stations remaining on the plus side of the ledger.

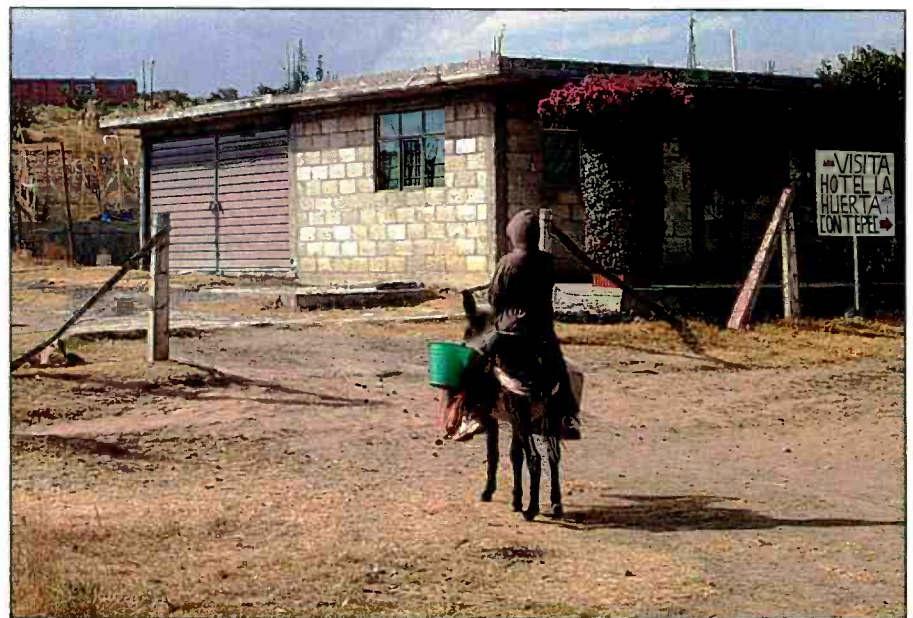

A world away from the turmoil of the border region, a boy rides a donkey over a dirt road in the farm state of Michoacan in western Mexico.



Radio Mil sticker.

few checks in the late night or post mid-night hours should bring you results. Contact info: Apartado Postal 21-1000, 04021, Mexico D.F. This station even has an online reception report form at: [ingenieria@nrm.com.mx](mailto:ingenieria@nrm.com.mx). Its website is at [www.radiomil.com.mx](http://www.radiomil.com.mx).

Radio Universidad-XEXQ, 6045, from San Luis Potosi is another one to search out. This station was reactivated last year after seeming decades when its only activity involved the paperwork needed to renew the license every few years. Then it managed to sputter back to life, albeit slowly and with barely enough power to tickle the antenna. It's using only 250 watts, but is supposedly on the air 24 hours a day, airing mostly classical music. This channel doesn't look to be quite so busy, so if and when XEXQ is active there should be opportunities during the late night hours, around local dawn, or even around sunset. Contact info: Apartado Postal 456,78001 San Luis Potosi, Mexico.

Rasa Onda Corta-XEQM, Merida (Yucatan), on 6105, is another 250 watt operation. It relays various Merida stations on a schedule seemingly known only to itself, so it's not what you'd call a regular in the average shack. In fact, you could classify it as rarely heard in the U.S. "RASA" is just an acronym for "Radiodifusora Asociadas S.A.," a Mexican radio network. One gets the feeling that only one person is in charge of its shortwave outlet—and that he maybe spends too much time guzzling Dos Equis! In other words, this seems to be another "sometime" effort, suffering from inadequate power and a congested frequency: the fearsome Family Radio operates here, as does the VOA at times. Contact info: Apartado Postal 117, 97001, Merida, Yucatan, Mexico.

Radio Educacion, XEPPM, 6185, Mexico City, is the gold standard, easily outdistancing the others when it comes to output power, stability, and longevity, not to mention professional production standards and quality program content.



Mexican army troops carry out a drug eradication mission in western Mexico.

XEPPM is heard regularly, operating from 0000 to 0600 nightly and is mostly alone on the channel. This one is definitely a class act that has been around for years. During the dark days when Mexican shortwave broadcasting barely had a pulse Radio Educacion was *it*. Contact info: Apartado Postal 44-227, 03100 Mexico D.F. Its general email address (there are several) is: [rmoreno@radioeducacion.edu.mx](mailto:rmoreno@radioeducacion.edu.mx). Website: [www.radioeducacion.edu.mx](http://www.radioeducacion.edu.mx).

Radio UNAM (National Autonomous University of Mexico), on 9600, is basically a carbon copy of 6045. It's affiliated with a (different) university and was once a regular. Now it's a shadow of its former self: sometimes active, sometimes comatose, in either condition it's always weak. It's supposed to be on the air 24 hours a day, but the frequency is so congested that it's difficult to determine a schedule. Even its relatively powerful 10 kW can't do much against Raul's Radio Havana Cuba, which also uses 9600. Actually, UNAM often unintentionally slips down to 9599 point "something," which can be an aid to identification, as is its classical music programming. Contact info: Adolfo Prieto 133, Colonia

del Valle, 0311 Mexico D. F. Email: [contacto@radio.unam.unam.mx](mailto:contacto@radio.unam.unam.mx).

By way of a kind of footnote, there are very occasional references to transmissions from drug smugglers, usually operating on the upper side of 6 MHz. We've seen 6227, 6644, 6732, 6840, and 6995 mentioned as possible channels, but transmissions could be anywhere in that range. Even if you're quite conversant in Spanish, chances are you probably wouldn't know such a transmission if you heard one, since they're reported to use many code words.

There are over 850 Mexican mediumwave stations, but due to their extremely low nighttime power, not many make it even as far north as the border. A few of the more powerful include XENK-620 (Radio 6-20), Mexico City, XENQ-640 (La Superstacion), Tulancingo, XEEY-660 (La Consentida), Aguascaliente, XEN-690 (La 69), XEX-730 (Estadio W), XEW-900 (Radio America-La Voz Pueblo), and XEOR-1030 (Radio Centro), all in Mexico City; and XEG-1050 (La Ranchera), Monterrey. These would probably offer the best chance for the casual DXer, using equipment of modest to intermediate level.

*"...there are very occasional references to transmissions from drug smugglers... We've seen 6227, 6644, 6732, 6840, and 6995 mentioned as possible channels, but transmissions could be anywhere in that range."*

# RADIOS FOR EVERYDAY ADVENTURES



SATELLIT 750

**GRUNDIG**

Available at:







FIELD RADIO GS350DL

GLOBE TRAVELER G3

BUZZ ALDRIN EDITION AVIATOR G6

TRAVELER II DIGITAL G8

etón  
CORPORATION

tune in: to life



Mobile medical center distributing facemasks, bottles of water, and information about the flu beside the Metropolitan Cathedral. (Via Wikimedia Commons)

Let's also not forget the famous XERF-1570, which back in my day, at least, announced its location as Del Rio, Texas, while battering you with commercial religion every night. (Write in for your autographed picture of John the Baptist!)

And while you won't hear the fallout unless you're an FM or TV DXer—or actually inside Mexico—it's interesting to note that some parts of the country are hotbeds of radioactivism of the community radio kind. The southern Mexican state of Oaxaca has recently witnessed a broadbased, popular uprising against the government and certain labor practices. In 2006 over a dozen radio and TV stations were taken over by school teachers, housewives, indigenous communities, health workers, farmers, and students. Authorities cracked down violently. Several unlicensed clandestine stations, such as UNOSJO in Talea de Castro, Oaxaca, have since appeared but are being jammed by the government.

## Ham Activity

Of course, Mexican amateur radio operators are easily heard, and provide one of the few opportunities to hear occasional English from that country. With a couple of exceptions, you'll find XE hams operating in the same general frequency ranges as we *gringos*. Take a listen in the following neighborhoods:

- 1.800–2.000 MHz
- 3.500–4.000 MHz
- 7.000–7.300 MHz
- 10.100–10.150 MHz
- 14.000–14.350 MHz
- 18.068–18.168 MHz
- 21.000–21.450 MHz
- 24.890–24.990 MHz
- 28.000–29.700 MHz

Most Mexican hams have callsigns that begin with XE1, XE2, or XE3, although the country's ITU allocated prefixes include XAA–XIZ, 4A–4C, and 6D–6J. Hams who live on, or are operating from, Mexico-administered islands use callsigns that begin with XF1, XF2, XF3, or XF4. Hearing an island call-sign, however, is far from casual. It's safe to say that most U.S. hams, proximity aside, have never heard one! Special-event or contest stations frequently sign 4A calls, which are easy to hear during large amateur radio contest weekends.



In addition to repelling off rock walls, Martin Pereda, XE2ML, of Durango, Mexico, is known for facilitating school-to-school ham radio sessions via amateur satellites or the international space station.

Internationally, Mexican hams are represented by the Federacion Mexicana de Radio Experimentadores (FMRE), founded in 1932. According to the Federation's website, [www.fmre.org.mx](http://www.fmre.org.mx), the current president is Victor Pinilla, XE1VP.

Mexican hams are licensed in one of four classes. The lowest two classes require no Morse code proficiency and limit operations to 50 or 150 watts on 40 and 2 meters. Second-class ops can run 500 watts on HF and 200 watts on VHF and up, while First-class licensees can boost their power levels to 1250 and 500 watts, respectively. Citizens must be at least 12 years old to test for a license.

Finding up-to-date information about ham radio in nearby Mexico is surprisingly difficult, especially in English. Despite its large population of more than 110 million citizens, the country sports only about 8,000 hams—only 68 hams per million citizens! For comparison, the U.S., which *isn't* the most ham-populated country on the planet (thanks to Japan), has some 2,300 hams per million citizens (about 700,000 total). Other regional states, such as Venezuela and Argentina, have about 425 hams per million citizens, which seems to be much closer to the geopolitical norm.

George Pataki, WB2AQC, a longtime ham known for his acerbic wit and globetrotting tendencies, recently visited hams near Mexico City. During his 14-day haricacion, local ops told Pataki that few new ham licenses have been issued in recent years, and that the amateur population is probably declining. According to Pataki, many XE hams work only locals (or other Spanish-speaking ops), on HF and 2 meters. Pataki and others have observed that amateur radio in Mexico is almost exclusively practiced by relatively wealthy citizens near the upper end of the country's socioeconomic strata.

Non-XE hams vacationing in Mexico and hoping to operate there should apply well in advance of their trips and be prepared for delays, currency, and payment hassles regarding the \$85 fee, and other "South of the Border" bureaucratic "issues."

### On The Web

For DXers, program hunters, and hams who have been disappointed in their efforts to pull Mexican signals out of the air, there are lots and lots of websites providing news hounds with the latest info

from and about Mexico. The best I've found is [www.mexicodaily.com](http://www.mexicodaily.com), which covers all aspects of the country, including many associated links. Another good one is [www.topix.net/world/mexico](http://www.topix.net/world/mexico). Also useful is [www.planeta.com](http://www.planeta.com). Regular perusal of any one of these three will have you on the way to becoming a Mexico expert faster than you can say "ay, carumba!"

### ¡Buena Suerte!

If you regularly "work" the shortwave

broadcast channels of the Mexican stations, you'll have success (eventually). Mediumwave success will depend more upon your location. Logging Mexican hams will be entirely up to chance, luck, persistence, and providence.

Good luck to Mexico in beating the cartels—and good luck to you in tuning them in! Ay, ay, ay! ■

(Many thanks to Kirk Kleinschmidt, NTØZ, for his assistance on the amateur radio info.)

For 45 years  
our volunteers have  
endured long hours  
and tough  
working conditions  
for no pay.



And 9 out of 10  
would do it again.

TO FIND OUT WHY  
contact

**REACT International, Inc.**

(301) 316-2900 • (866) REACT-9-9

5210 Auth Rd., Ste. 403, Suitland, MD 20746

[REACT.HQ@REACTintl.org](mailto:REACT.HQ@REACTintl.org)

[www.REACTintl.org](http://www.REACTintl.org)

# A Short Stroll Through Mexico's Shortwave History

***Soak Up Mexico's Radio Past, Then Become Part Of Its Present By Logging Its Fascinating Stations***

by Dr. Adrian M. Peterson

Ah, Mexico! It's a land of duality, of enchantment and turmoil, a country where the ancient and modern blend into delightful tourist attractions, but that's also witnessed more than its share of strife. Its timeless vistas lure wandering tourists from chillier climes up north to escape harsh winters and enjoy pleasantly warm weather on the edges of the rolling seas. In this land of contrast, luxury tourist accommodations stand next to ancient ruins that tell of mighty civilizations of long, long ago. Mexico also beckons another type of wondering tourist, the type that will travel from all over the world in search of something different and who is willing to penetrate deeply into varied forms of human endeavor.

In the same way, Mexico has a special appeal to radio aficionados who have a real interest in the history and the backgrounds of radio broadcasting in a (to some of us, at least) rather exotic country. During the era when the earliest experiments in wireless communication were developing in continental and islandic Europe, there were similar developments in the three countries of North America: Canada, the United States, and Mexico.

## Birth Of A Medium

The seminal wireless radio figure Guglielmo Marconi began his earliest electrical transmissions through unconnected space (hence wireless) in northern Italy in continental Europe in 1895. A few years later, he erected a huge wireless station at Poldhu in Cornwall in islandic Europe for communications across the Atlantic. These earliest wireless stations were so massive, in fact, that they had a circular antenna system with wooden towers 200 feet high or more.

Dr. Adrian M. Peterson is the DX Editor and Coordinator of International Relations, Adventist World Radio. He is also a member of the Board of Directors of the National Association of Shortwave Broadcasters, USA.

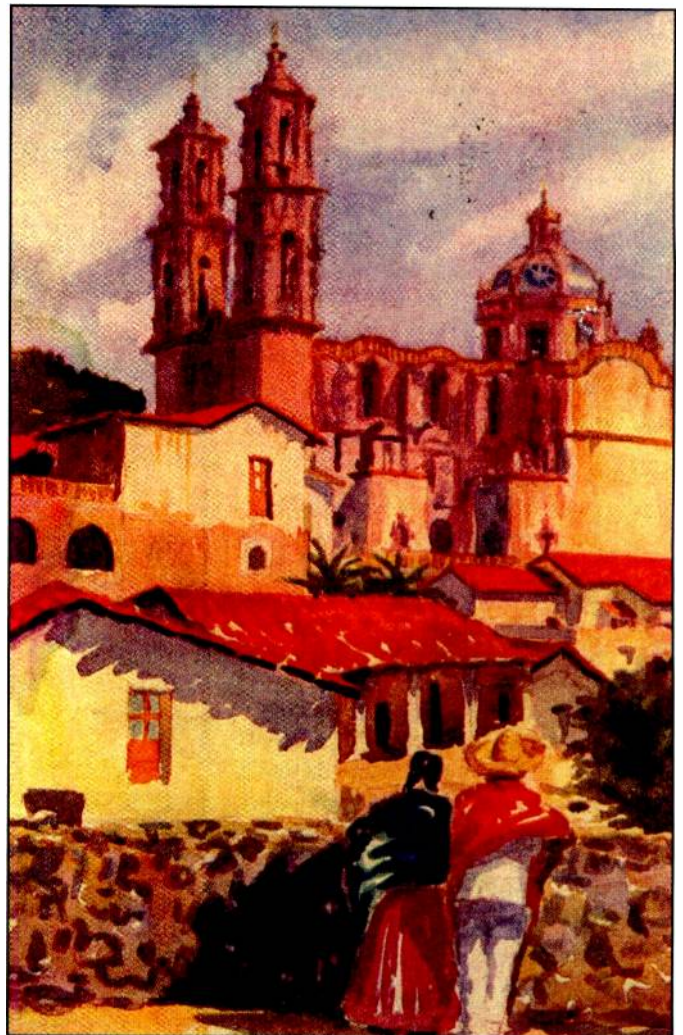

XEWW QSL card, dated February 24, 1946, 15160 kHz.

*“Over the years, station XERMX used a total of seven different shortwave transmitters with a power rating of 10 kW, 50 kW, and 100 kW, and its studios were moved four times.”*

Their transmission wires, which were an inch thick, whipped around almost uncontrollably when the power was applied, and there was a thunder-like crash that was literally deafening when the Morse code key was closed.

In Canada, the year 1901 is historic for the reception of the first wireless signal across the Atlantic. The simple letter S, indicated by the repetition of three consecutive dots in Morse code, was sent from the aforementioned Poldhu and received at Signal Hill in Newfoundland, a British dependency at the time, which was confederated into the Dominion of Canada 47 years later.

Simultaneously, wireless stations sprang up along the eastern coast of the United States in places like Cape Cod and North Truro in Massachusetts; Fort Meyer, Virginia; and Babylon and Sagaponack on Long Island, New York; among others.

All of these northerly wireless developments did not go unnoticed south of the

border, and the possibilities of wireless communications caught the imaginations of political leaders, business entrepreneurs, and scientific experimenters. Mexican radio history tells us that as early as the year 1904, the President of Mexico ordered his Secretariat to procure a set of Slaby wireless equipment from Germany for experimental purposes.

In 1908, experimental wireless transmitters were installed in the regional city of Monterrey, and on Chapultepec, a high hill on the edge of Mexico City. These early wireless events were followed by similar experiments soon afterwards with the implementation of several units in the area around Fresnillo.

It's considered that the earliest attempts at program broadcasting took place in Mexico City on September 27, 1921, when the first of a series of experimental transmissions were made from a station identified with the call letters JH, the initials of the experimenter, Jose de la Herran. The following year, a further series of experimental radio broadcasts was presented over what we would now consider the primitive radio equipment at station JH.

Interestingly, station JH in Mexico City was granted an official Mexican call-sign, CYB, in 1923, and in 1929 it became XEB under the new international regulations that granted Mexico the usage of radio call signs in the X series. Station XEB is still on the air today in Mexico

**ADVANCED SPECIALTIES INC.**  
 Orders/Quotes 1-800-926-9HAM  
**www.advancedspecialties.net**

**BIG ONLINE CATALOG**

BCD996T  
 6000 Channel Digital Trunking Scanner

**UNIDEN BEARCAT & GRE DIGITAL SCANNERS**  
 • CB • AMATEUR • RADIOS & ACCESSORIES

ALINCO • YAESU • GALAXY  
 • GRECOM • COBRA

(201)-VHF-2067  
 114 Essex Street, Lodi, NJ 07644

Closed Sunday & Monday

**MOVING?**

If you're planning a move in the near future, don't risk missing an issue of Popular Communications Please give us 6-8 weeks notice if you're planning on changing your address. Just write your new address and mail it, WITH YOUR SUBSCRIPTION MAILING LABEL, to:

**POPULAR COMMUNICATIONS**  
 25 Newbridge Road, Hicksville, NY 11801



City, with 100 kW on 1220 kHz. Its shortwave station was on the air under the call-sign XEBT. The era of the C callsign designation for Mexico lasted for about seven years, during which time a score of stations went on the air, mostly in Mexico City and some of the larger cities throughout the country.

### Shortwave Takes Shape

The earliest experiments in shortwave broadcasting in Mexico began in 1922. According to Pepe Gonzales, the noted shortwave historian in Mexico, a low-powered transmitter, around 100 watts or less, was installed in the Ideal Theatre in Mexico City and a series of test broadcasts with musical renditions was radiated on approximately 120 meters, 2500 kHz.

During the following year, one of the engineers from the 1922 tests installed a shortwave transmitter in a private home in Mexico City and conducted another series of test broadcasts with music programming.

Three years later again, a double set of radio equipment manufactured by General Electric was imported from the United States and installed in a government building in Mexico City. This event is noteworthy, because this station radiated on two channels simultaneously,





X1G QSL card for this amateur station that also broadcast programming, dated May 30, 1935.

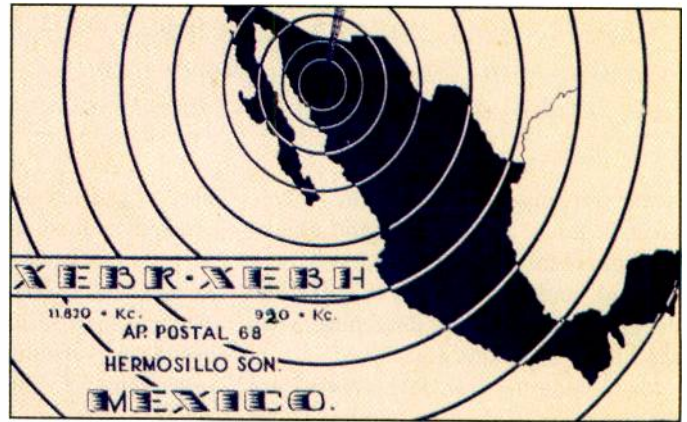

XEBR QSL card, 11820 kHz, dual mediumwave and shortwave is indicated on the card.

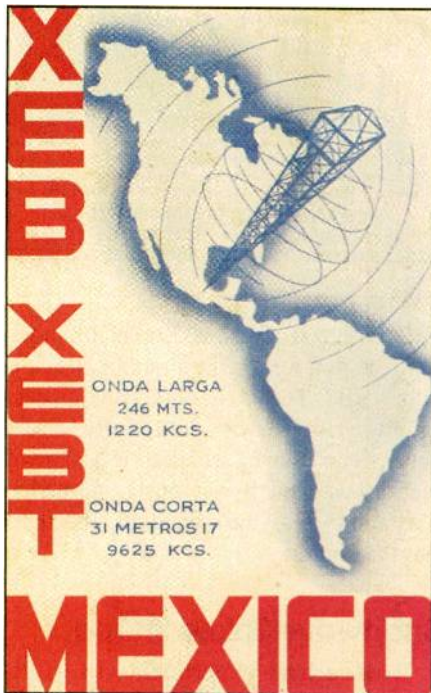

XEBT QSL card, 9525 kHz, dated May 4, 1947.

one in the mediumwave band and the other on shortwave. This procedure set a pattern for the development of radio broadcasting in Mexico and many of the subsequent radio stations installed two transmitters, mediumwave and shortwave, for local and wide area coverage.

According to the information available, mediumwave stations have been on the air in about 30 different locations throughout Mexico during the past 80 years or so. The decades from around the mid-1930s to the early 1990s saw the largest number of shortwave stations on the air at the same time, with anywhere up to 30 transmitting their signals simultaneously. The total number of different

shortwave stations on the air in Mexico over the years is close to 100.

Probably the best-known commercial shortwave station in Mexico has been XEW, "La Voz de la America Latina," which was launched on mediumwave on September 18, 1930. Its first shortwave transmitter was inaugurated seven years later under the callsign XEWW. Since that time, the station has built a small network of high-powered mediumwave outlets in some of the major cities of Mexico, and it has also been on the air with several shortwave transmitters under the XEWW callsign.

In actuality, the major purpose of the shortwave transmitters in Mexico has been simply to extend the coverage area of their mediumwave units. None of these numerous, generally low-powered shortwave units has presented a truly international broadcasting service. However, over the years, there have been three different attempts at creating a truly international shortwave broadcasting service.

In 1935, for instance, the Ministry of Foreign relations established station XECR in Mexico City, which operated with 20 kW on 7380 kHz. Due to financial problems, however, it was on the air for a little less than three years.

After the close of that first attempt at international radio broadcasting, another station, XEXA, was launched. Established in 1937, this facility was owned by the Department of Press and Publicity and operated on 6133 kHz and 11880 kHz with just 100 watts. Likewise, this station was closed due to financial problems.

The third attempt at international radio broadcasting from Mexico was the well-known XERMX, Radio Mexico International. This station made its inau-

gural broadcast on September 1, 1968, using a 10kW transmitter imported from the United States and tuned to 11720 kHz. Over the years, station XERMX used a total of seven different shortwave transmitters with a power rating of 10 kW, 50 kW, and 100 kW, and its studios were moved four times. The station radiated through three omni-directional discone and three rotatable log periodic antenna systems, and at one point it was receiving 200 listener letters a day.

In February 2004, however, the staff at Radio Mexico International was advised that the station was closing, due again to financial problems. Shortly afterwards, it went off the air.

## Have A Listen To History In The Making

These days, there are still just a few shortwave stations on the air in Mexico and just six are listed in the current edition of the *World Radio TV Handbook*, and even these are not always reliably on air (see Gerry Dexter's "World Watch: Mexico" elsewhere in this issue for how to listen).

Many of the QSL cards issued by the radio stations in Mexico are extremely appealing, with interesting designs, pictures, and layouts. In the case where there was a dual system, with both mediumwave and shortwave on the air, both callsigns are listed on the card.

Why don't you try to log the remaining shortwave stations on the air in Mexico and send them a reception report. You'll add a few exotic QSL cards to your collection from these unique shortwave stations and make yourself a part of the still-evolving radio landscape in this intriguing country of contrasts. ■

# RSGB Books from

View more  
RSGB books on our  
web site!

## Guide to VHF/UHF Amateur Radio



By Ian Poole, G3YWX

RSGB 2000 Ed., 112 pgs.  
Everything you will need to help you enjoy VHF/UHF to the fullest. Choosing the right transmitter, receiver, antenna, utilizing the correct part of each band and more!

Order No. RSGVUAR **\$16.00**



## HF Antenna Collection

RSGB, 2nd Ed., 2002. 252 pages.

A collection of outstanding articles and short pieces which were published in *Radio Communication* magazine. Includes single- and multi-element, horizontal and vertical antennas, extremely small transceiving and receiving antennas, feeders, tuners and much much more!

Order: RSHFAC **\$33.00**



## IOTA Directory

Edited by Roger Balister, G3KMA  
RSGB, 2007 Ed..

Fully updated, lists all islands that qualify for IOTA, grouped by continent, and indexed by prefix. Award rules and includes application forms.

Order: RSIOTA **\$18.00**

## Antenna Toolkit 2

By Joe Carr, K4IPV



RSGB & Newnes, 2002 Ed., 256 pgs.  
A definitive design guide for sending and receiving radio signals. Together with the powerful suite of CD software included with this book, the reader will have a complete solution for constructing or using an antenna; everything but the actual hardware!

Order: RSANTKIT2 **\$48.00**

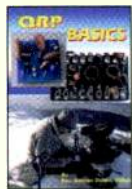

## QRP Basics

By Rev. George Dobbs, G3RJV

RSGB, 2003 Edition, 208 pages  
How to get the best results from a QRP station whether from home or outdoors. Explains how to construct your own station, including complete transmitters, receivers and some accessories.

Other sections include toroidal coils, construction techniques and equipping a workshop. You'll also find a listing of QRP contests and awards.

Order: RSQRPB **\$28.50**

## Low Power Scrapbook

RSGB, 2001 Ed., 320 pages.

Choose from dozens of simple transmitter and receiver projects for the HF bands and 6m, including the tiny Oner transmitter and the White Rose Receiver. Ideal for the experimenter or anyone who likes the fun of building and operating their own radio equipment.



Order: RSLPS **\$18.00**

## Practical Wire Antennas 2

By Ian Poole, G3YWX



RSGB, 2005 Edition, 176 pages  
This significantly expanded and fully revised edition includes designs for a wide range of practical wire antennas. You'll find just about every type of wire antenna you could possibly imagine with complete and easy to understand designs.

Order: RSPWA2 **\$23.50**



## The Antenna Experimenter's Guide

RSGB, 2nd Ed., 1996. 160 pages.

Takes the guesswork out of adjusting any home-made or commercial antenna, and makes sure that it is working with maximum efficiency. Describes RF measuring equipment

and its use, constructing your own antenna test range, computer modeling antennas. An invaluable companion for all those who wish to get the best results from antennas!

Order: RSTAEG **\$33.00**



## HF Amateur Radio

RSGB, 2007 Second Ed.

HF or shortwave bands are one of the most interesting areas of amateur radio. Guides you through setting up an efficient amateur radio station, equipment to choose, installation, the best antenna for your location and MUCH more.

Order: RSHFAR **\$23.00**

## Packet Radio Primer

By Dave Coomber, G8UYZ & Martin Croft, G8NZU



RSGB, 2nd Ed., 1995, 266 pages  
Detailed practical advice for beginners. Completely revised and greatly expanded to cover developments in this field and beyond bare basics into advanced areas such as satellite operations.

Order: RSPRP **\$16.00**

## The Low Frequency Experimenter's Hdbk

By Peter Dodd, G3LDO

RSGB, 2000 Ed., 296 pages.

An invaluable reference written to meet the needs of amateurs and experimenters interested in low power radio techniques below 200kHz.



Order: RSLFEH **\$33.00**

## Technical Topics Scrapbook 1985-1989

by Pat Hawker, G3VA

RSGB, 1st Ed., 1993, 346 pages  
A collection of popular 'Technical Topics' published in RadCom. Info, ideas, mods and tips for amateurs.



Order: RSVUDXB **\$18.00**

## VHF/UHF Handbook

Edited by Andy Barter, G8ATD

RSGB, 2nd Ed., 320 pages.  
This second edition guides you through the theory and practice of VHF/UHF operating and transmission lines. Includes info on getting started, antennas, constructing your own equipment, satellite ops, local nets and specialized modes.

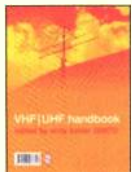

Order: RXVUH **\$29.50**



## Technical Topics Scrapbook 1995-1999

By Pat Hawker, G3VA

RSGB, 2000 Ed., 314 pages.

This third compilation of 'Tech Topic' articles is a fascinating collection of circuit ideas, antenna lore, component news and more!

Order: RSTTC99 **\$27.50**



## HF Antennas for All Locations

By Les Moxon, G6XN

RSGB, 2nd Edition, 322 pages  
Design and construction of hundreds of antennas. No matter what your location there's one for you!

Order: RSHFAAL **\$33.50**

Shipping & Handling: U.S. & Possessions-add \$7 for the first item, \$3.50 for the second and \$2 for each additional item. FREE shipping on orders over \$100 shipping to one domestic address.

All Foreign Shipping & Handling - calculated by order weight and destination and added to your credit card charge.

CQ Communications, Inc., 25 Newbridge Rd., Hicksville, NY 11801  
Call 800-853-9797 - Fax 516-681-2926 - www.cq-amateur-radio.com

# Remembering Paul Harvey

## *The Man Who Covered A Million Miles Of Main Street, 250 Watts At A Time*

by Peter Hunn

**W**hen ABC Radio commentator Paul Harvey passed away in February 2009, an irreplaceable piece of broadcasting died, too. And the fact that his death, at age 90, was so prominently covered by the youth-dominated online vehicles that are eroding the traditional media that brought Harvey to national prominence somehow seems to make his life's contribution especially poignant.

Harvey's intangible assets consisted of distinctive traits largely rejected by 21st Century electronic gatekeepers: a grandfatherly voice, a knack for what interests the average Midwestern American, a stubbornly positive conservative salesman's attitude, and the use something that normally scares the wits out of broadcasters—dead air. After having consistently attracted an uncommonly wide listener demographic for some 60 years, Harvey's sudden silence signaled an end to a brand of radio companionship that was arguably already gone.

### The Early Years

Born Paul Harvey Aurandt on September 4, 1918, the Tulsa native decided not to confuse listeners with a difficult to spell last name when, as a high school student, he hit the Oklahoma airwaves in 1933. His Tulsa police officer father had been gunned down by bad guys when Harvey was only three, leaving his mother to raise him and a sister. As an elementary school student, Harvey became infatuated with voices coaxed out of the ether via radio, and he built a crystal set in a cigar box chassis in order to hear them. He later liked to reminisce, "As a boy, I fell in love with words and ran away from home and joined the radio, and it was really something!"

That first gig at KVOO was done gratis. It represented a good investment in the future and resulted in an occasional chance to man the microphone while compiling a resume that soon opened radio studio doors in Abilene, Kansas; Oklahoma City; and St. Louis. At a station in that Missouri venue, Harvey fell in love with Lynne Cooper, a young education reporter who announced school news there. During a date, he told her she reminded him of an angel, an endearment that stuck, instantly proposed to her, and they were wed shortly thereafter, in 1940.

The former owner of several small market AM and FM stations, Peter Hunn teaches radio and television courses at the State University of New York at Oswego. He is also an administrator in the Syracuse, New York BOCES career and technical education high school. He can be reached at [phunn@ocmboces.org](mailto:phunn@ocmboces.org).



It was probably around 1935 that someone snapped this candid photo of a young Paul Harvey and associates near a KXOK microphone. Then again, because Harvey's national fame was still over 15 years away, the photographer might have been aiming at someone else on the St. Louis station's staff.

The couple moved to Kalamazoo, Michigan, where from 1941 to 1943, Harvey worked as WKZO's program director as well as news director for the Office of War Information throughout Indiana and Michigan. Harvey served in the Army Air Corp himself for three months during 1944, but received a discharge after cutting his foot in a training exercise. Some critics claimed that he got out of a possible combat assignment by obtaining a psychological exemption, but Harvey always maintained that he never consulted with any military psychiatrists and left the Army on good terms.

A civilian again, he relocated his bride to Chicago and scored a newscaster stint at WENR, the newly acquired 50,000 watt Windy City flagship (albeit a share-time operation with Sears' WLS) of the fledgling American Broadcasting Company. Among his listeners was a future U.S. president's father, Joseph Kennedy, landlord of the building from which WENR broadcast. In 1951, Kennedy suggested to struggling ABC brass that Harvey could help them generate more listeners for their third-



place network. They auditioned him as a substitute anchor, noted unusually complimentary feedback from affiliates, and soon gave him his own daily spot on the coast-to-coast schedule.

From that time until his recent passing, Paul Harvey entertained generations of radio listeners who would consider their day “normal” only after hearing his news and comment. ABC wisely ran the program for five minutes during the hurry-up morning drive-time (typically starting at 8:30 Eastern) and for a more leisurely quarter hour (12:30 to 12:45 p.m.) when local stations are especially happy to have help rounding out a lunch hour news block.

## A Trusted Voice

In many broadcast markets, especially small- and medium-sized cities-of-license, the local cutaways in Harvey’s program commanded a station’s highest spot advertising rates. Often, only the area’s best-heeled banks and car dealerships possessed the fiscal wherewithal to negotiate a yearly contract for airing a 60-second commercial during Paul Harvey’s news. At many a hometown Rotary, Kiwanis, or Lion’s Club meeting, banter

between the merchant class might include the kudos, “Hey, I heard your ad on Paul Harvey! Business must be good.” This would invariably trigger the response, “Business is good *because* I advertise on Paul Harvey.”

More than a few experienced radio sales people knew that when it came to filling slots on Harvey’s program, they served more as order takers for client’s hoping to rate a half-minute’s worth of precious airtime; it was for the rest of the broadcast day that they needed their powers of persuasion.

In May 1971, a young man named Jim Gebby felt on top of the broadcasting world. He’d just graduated with a community college radio and TV degree and netted a job at a small Southern AM/FM. He’d talked his way in by agreeing to sell spots each afternoon prior to doing a 6 to midnight DJ shift. To boost his confidence, the station owner tasked him to find a sponsor for a rare opening in the modest ABC affiliate’s Paul Harvey 8:30 a.m. newscast.

At the time, the normal cost for a minute spot on the AM outlet was just a bit over 4 dollars and about 3 dollars for FM. But Gebby says that, “During the

Harvey program, though, we simulcast him on our Country AM and Easy-Listening FM, charging \$12 for a :30-second spot. That added up to \$48 per minute total (\$24 for the AM and another \$24 for the FM)! And each broadcast had several local cutaways. Often, we’d run commercials for different sponsors on AM and FM so that lots of local merchants had the chance to get a valuable plug during Harvey’s show.”

It was a weekly contract for one of those half-minute FM (then, an “also-ran” band) slices that came Gebby’s way, and he didn’t even get the opportunity to make it onto Main Street before the proprietor of a one-man appliance repair shop got wind of the opportunity and phoned the station begging for the airtime. “I’d hardly had the chance to introduce myself,” Gebby now laughs, “when the guy interrupted with his pledge to bring cash to the studio immediately so he could sign the deal!” The most amazing thing, according to Gebby, was that “Harvey never used a music bed or jingles to draw attention to the content in his spots. It was all the province of a believable, trustworthy voice. That was Ronald Regan’s well-known secret, too.”

## Amassing The Masses

Depending on how one crunches the numbers, and for what era they’re crunched, Paul Harvey’s weekday audience ranged from 15 to 24 million. Collectively, these folks were tuned to some 1,200 U.S.-based stations and 400 transmitters that Armed Forces Radio operated around the globe.

The *Chicago Tribune*’s Phil Rosenthal mused that “back...in the 1960s and ’70s...when Harvey was on roughly 12 percent of the nation’s radio stations, you would have been hard-pressed to find a dot on the map where a local station didn’t air him. Sometimes he would air on both AM and FM in a town, sometimes on rock and country stations that had aired him when they had other formats and didn’t want to let go for risk of alienating listeners and boosting a rival.” Even if that “rival” was otherwise some poorly programmed hopelessly directional daytimer or rinky-dink rim-shot peanut-whistle, snagging the daily Paul Harvey feeds from a more powerful station looking to contemporize its format could represent a coup indeed! At least it would be a big score for the 20 minutes or so that Harvey broadcast.

One upstart northwestern FM on the



An aviation buff, Paul Harvey also plied his hobby in miniature as this 1974 *American Aircraft Modeler* magazine piece detailed.

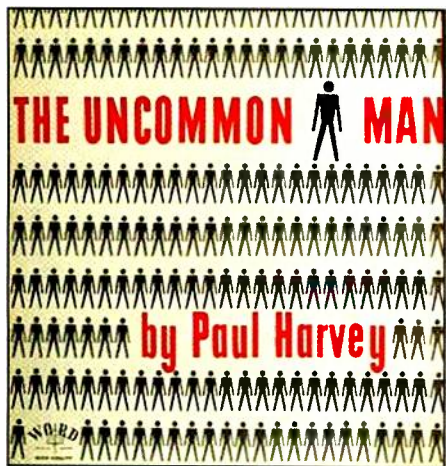

An album cover from one of several "spoken" records that Paul Harvey's family media business produced.

ultra-fringe of a larger market where Paul Harvey had been heard for over a decade convinced ABC to let it carry the commentator, too. As a sweetener in the deal, the FM owner agreed to carry all of ABC's other network programming and commercials, really chopping-up the fledgling facility's beautiful music format. No matter what the affiliate was, it was not uncommon for that station's promotional brochure/rate card to prominently boast, PAUL HARVEY NEWS & COMMENT, at the top of its bullet list of ratings-generating programming. That's just one reason why Rosenthal touted Harvey as "the most popular radio commentator of all time." Others dubbed him *the world's largest one-man network*. And he heartily appreciated any advertiser and station—small or large—that supported him. "I am fiercely loyal," he liked to quip, "to those willing to put their money where my mouth is!"

## Paul Harvey's Average Listener

Anyone who enjoyed Harvey's voice and message might consider him or herself representative of the commentator's typical audience. To be sure, his listeners often skewed older, or at least over 18, as younger ears were supposed to be in school during the time his 8:30 a.m. and noon hour "casts took to the air.

As a State University of New York (SUNY) professor, at the start of every semester I quiz my broadcasting undergrads on which radio and TV personalities they most admire. Whenever the students appear to need prompting, I'll break the tension by loudly enunciating, "HELLO AMERICANS...STAND BY FOR...NEWS!" Since the mid-1990s,

this has invariably caused several smiles, but only vague guesses as to the name of (as one of my more expressive students put it), "the old guy who always tells the news like a story with some kind of twist."

Though Harvey would likely have approved of that description from someone who hadn't regularly heard him, the commentator long considered his sister-in-law as his bull's-eye of target listeners. Writing in the *Encyclopedia of Radio*, author David Reese noted that Harvey extended his relative's persona onto an average listener named Aunt Betty onto whom "he applied the Aunt Betty test to his radio copy. Aunt Betty is your old-fashioned, Middle American housewife, and if [Harvey's] story content was perplexing for Aunt Betty, then he rewrote it using simpler words or threw it out entirely."

Not to toss overboard the youthful listeners exposed to Paul Harvey's voice coming through a mom's, dad's, or grandparent's kitchen radio, his most loyal audience was made up of the 25-plus crowd, with an emphasis on the *plus*. And up until last winter, many of this legion still tuned to his programs on small- and medium-market AM outlets, stations that some might consider the media equivalent of dead men walking. Then again Harvey kept stepping into an ABC studio long after most people born at the sunset of World War I had retired.

*The Los Angeles Times'* Dennis McLellan chronicled Harvey's typical day: "For years, he'd rise at 3:30 a.m. and be picked up by limousine in front of his 27-room house in suburban [Chicago]. At his office in downtown Chicago, he'd cull through material for his broadcasts from wire services, letters from his listeners and scores of newspapers. Then he'd write the scripts himself on an electric typewriter in large block type on yellow copy paper." Steve Zeigler, now a retired WIOD Miami engineer, recalls running the control board for Harvey when the famed newsman was on assignment in Florida sometime during the late 1970s. Zeigler says Harvey used 3x5 note cards to write his stories that day. "He arranged all of his cards in front of him—yellow ones for commercials, white for news." In recent years, Harvey was observed profitably using a word processor.

## Adapting An Old Sportscaster's Hyperbole

Though Paul Harvey was truly an American original, others provided him

with major elements of his trademark delivery. His biggest influence had to be Bill Stern. Already a national broadcaster while Harvey was still navigating a local radio career, Stern was best known for an NBC program series he debuted in the late 1930s, *The Colgate Sports Newsreel*. This show was filled with riveting stories of cliffhanger games and sports stars who conquered unbelievable odds. Anyone who recollects the saga of that one-legged, blind baseball pitcher in Woody Allen's classic *Radio Days* movie has seen a loosely disguised portrait of Stern's hyperbolic sporting tales. Stern delivered these epics with such expressive and convincing declaratives that even the most skeptical listener at least wished they were true.

Besides recognizing that radio audiences liked such fare because everybody "has a hunger for a little niceness," Harvey heard something else on Stern's program that he thought he could synthesize. The newsreel component in the sports show's name was supposed to conjure a visual aspect, as in the short newsreels theatergoers of this era were used to seeing at matinees. Stern transitioned from one group of stories to the next by prefacing with the words, "reel two," or "reel three," and so on. Harvey substituted individual pages of news copy for Stern's imaginary motion picture reels, transitioning from story to commercial or out of several stories into another group of stories with the cue announcement, "page two," etc.

With this basic framework in place, Harvey began "plucking a series of stories from any and all available sources," Rosenthal said, calling him "the world's first pre-Internet blogger." Then Harvey would "put his own spin and storytelling style on them, putting them in his voice and cadence." Unless he told listeners otherwise, his stories were always based upon fact.

## The Printed Page, Recording, And Video

With the help of his wife Lynne "Angel," and later assistance from his son, Paul Harvey, Jr., the ABC personality built a mini media empire of words and pictures. Even before he hit the national airwaves, Harvey's voice could be heard from sea to sea. His first big time exposure came in the form of narration for short, promotional films.

While doing research for my 2002 book, *The Vintage Culture of Outboard Racing*, I hit upon a brittle 16 mm news-

## Passport to World Band Radio



2009 Edition

The world's #1 selling shortwave guide! Have the world at your fingertips! You'll find in depth details on what to buy and where to tune.

Order No. PASS **\$22.95**

## The Complete DXer

Third Edition

The joy of the chase, the agony of defeat, the thrill of victory are the stuff of The Complete DXer, a book that is almost as seductive as the DX chase it describes. It excites, it entertains, it teaches!



Order: COMPDXer **\$19.95**



## MIL SPEC Radio Gear

Korean War To Present Day  
by Mark Francis, KI0PF

Detailed write-ups for many familiar sets: PRC-25/-77, RT-68, PRC-1099, GRC-106, GRR-5, R-392 and more Over 230 pages of operation, modification, and maintenance tips and information, including 200+ illustrations.

Order No. MILSPEC ~~\$27.95~~ **NOW \$25.00**

## Heathkit - A Guide to the AR Products

by Chuck Penson, WA7ZZE

This greatly expanded Second Edition is a must for collectors and Ham history buffs! Pick up this 328-page volume and you won't be able to put it down!



Order No. HEATHKIT **\$29.95**



## W6SAI HF Antenna Handbook

by Bill Orr, W6SAI

Inexpensive, practical antenna projects that work! Guides you through the building of wire, loop, Yagi & vertical antennas.

Order No. W6SAI **\$19.95**

## Understanding, Building & Using Baluns & Ununs

by Jerry Sevick, W2FMI

The successor to the popular and authoritative Baluns and Ununs. Great deal of new tutorial material, and designs not in previous book, with crystal clear explanations of how and why they work.



Order No. 2BU **\$19.95**

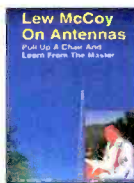

## McCoy on Antennas

by Lew McCoy, W1ICP

Unlike many technical publications, Lew presents his invaluable antenna information in a casual, non-intimidating way for anyone!

Order No. MCCOY **\$19.95**

## The NEW Shortwave Propagation Handbook

by W3ASK, N4XX & K6GKU

A comprehensive source of HF propagation principles, sunspots ionospheric predictions, with photos, charts and tables galore!



Order No. SWP **\$19.95**



## The Quad Antenna

by Bob Haviland, W4MB

A comprehensive guide to the construction, design and performance of Quad Antennas.

Order No. QUAD **\$19.95**

## The Vertical Antenna Handbook

by Paul Lee, N6PL

Learn basic theory and practice of the vertical antenna. Discover easy-to-build construction projects.

Order No. VAH **\$17.95**



## 2009 World Radio TV Handbook



Up-to-date information on mediumwave, shortwave, and FM broadcasts and broadcasters. Includes articles of interest to both listeners and DXers, reviews of the latest equipment, maps with SW transmitter sites and much, much more!

Order No. WRTH **\$29.95**

## Ham Radio Magazine on CD

Brought to you by CQ & ARRL

Enjoy quick and easy access to every issue of this popular magazine, broken down by years!



Three sets, each containing 4 CDs -

1968-1976 Order No. HRCD1 **\$59.95**

1977-1983 Order No. HRCD2 **\$59.95**

1984-1990 Order No. HRCD3 **\$59.95**

Buy All 3 Sets and Save **\$29.90!**

Order No. HRCD Set **\$149.95**

## 33 Simple Weekend Projects



by Dave Ingram, K4TWJ

Do-it-yourself electronics projects from the most basic to the fairly sophisticated. You'll find: station accessories for VHF FMing, working OSCAR satellites, fun on HF, trying CW, building simple antennas, even a complete working HF station you can build for \$100. Also includes practical tips and techniques on how to create your own electronic projects.

Order No. 33PROJ **\$17.95**

## The Short Vertical Antenna & Ground Radial

by Jerry Sevick, W2FMI

Small but solid guide walks you through the design and installation of inexpensive, yet effective short HF vertical antennas. If antenna restrictions are a problem? This book could keep you on the air!

Order No. SVERT **\$10.00**



## "Getting Started" DVD Paks

Our renowned Getting Started videos have been grouped together on DVDs!

### CQ Ham Radio Welcome Pak

Includes 3 programs:

Ham Radio Horizons  
Getting Started in Ham Radio  
Getting Started in VHF

Order # DVDHR



### CQ VHF Specialty Pak

Includes 3 programs:

Getting Started in Satellites  
Getting Started in VHF  
Getting Started in Packet

Order # DVDVHF



### CQ HF Specialty Pak

Includes 2 programs:

Getting Started in DXing  
Getting Started in Contesting

Order # DVDHF

1 Pak for \$24.95; 2 Paks for \$45.95;

3 Paks for \$65.95

Buy any combination and save!

## VHF Propagation

### A Guide For Radio Amateurs

by Ken Neubeck, WB2AMU & Gordon West, WB6NOA

A comprehensive source-book on VHF propagation by two great authors! Here's a sampling of what you'll find inside:

- Tropo Ducting • Aurora
- Meteor Scatter • TEP
- Sporadic-E • Combo Modes



Order VHFProp **\$15.95**

\*Shipping & Handling: U.S. & Possessions-add \$7 for the first item, \$3.50 for the second and \$2 for each additional item.

FREE shipping on orders over \$100.

All Foreign Shipping & Handling - calculated by order weight and destination and added to your credit card charge.

CQ Communications, Inc., 25 Newbridge Rd., Hicksville, NY 11801  
Call 1-800-853-9797 - FAX your order to 516-681-2926 - www.cq-amateur-radio.com

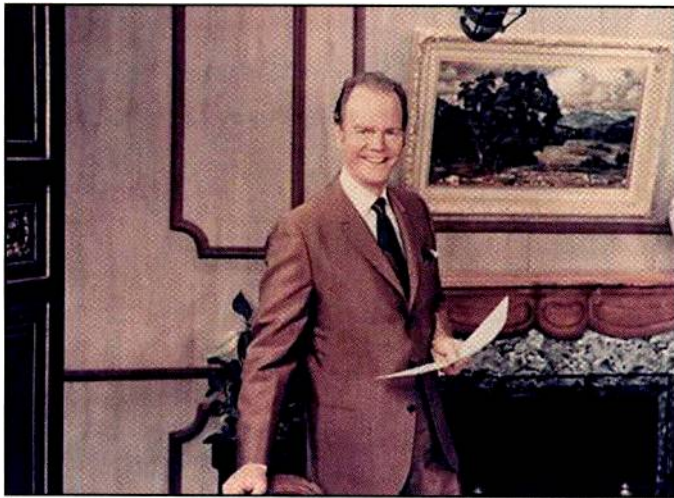

This photo appears to be a publicity shot from the Paul Harvey television editorial series. My “guesstimate,” to use a Harvey-coined term, is that it shows the Chicago-based set of an early 1960s version of the syndicated, five-minute program.

reel showing the 1949 Albany to New York boat race. To my amazement and delight, the film was voiced by a pre-ABC network Paul Harvey. And seconds into the little movie about small boats with tiny temperamental outboard motors buzzing down the Hudson River, I concluded that Harvey had also been commissioned to craft his own script. With obvious influence of Bill Stern and other exaggerated FDR-era announcers, it was pure prototype *News and Comment* all the way: “The mighty motors join in a thundering battle hymn,” Harvey dramatically intoned. “More than 5,000 horsepower is turned loose in a collective blast that rips up the river’s surface into shredded patchwork of foam and spray!”

Harvey Senior’s penchant for the pen resulted in a prolific body of anecdotal work that he converted into a syndicated newspaper column that ran in several hundred publications. Much of that wording Lynne edited into a roster of books, such as *You Said It, Paul Harvey*. While they never captured *New York Times*’ best seller crowns, they sold consistently enough—to the same steady and reliable demographic—for regular reprinting.

When, in 1976, Paul Harvey Jr. joined the family business by scripting for his famous dad a new five-minute human interest program called *The Rest of the Story*, additional recyclable media content was generated. An online *Time* article by Richard Corliss reports that “a book version of *The Rest of the Story*, first published in 1977, hit its 18th printing in four years.”

Throughout his ABC tenure, Lynne booked speaking engagements for her husband. Some sources say one of these after-dinner addresses would net the Harvey’s \$30,000. In addition to his radio work and speeches, adding to the family’s revenue stream were also LP record albums. Among his most poignant recordings was a parable Harvey always prefaced by admitting he didn’t know its origin. Though he’d co-opted the basic story, *The Man and the Birds* was otherwise obviously a Paul Harvey wordsmith product. The tale chronicled an honestly good dad who couldn’t bring himself to attend the Christmas Eve church service with his wife and kids. “I don’t believe in all that *God coming to earth as a baby* stuff,” Harvey’s main character confessed. “I’d feel too much like a hypocrite if I went with you.”

After his family left and the fellow settled down to read the paper, a sudden snowy wind pattered the house and knocked

some little birds off course, knocking them against his living room picture window. With this sad scenario sufficiently painted via Harvey’s skilled inflections, he told how the guy went outside to try, without success, to lure the stranded birds into the shelter of a backyard shed. “And then,” Harvey told listeners, the man “realized that they were afraid of him. To them, the fellow reasoned, I am a strange and terrifying creature. If only I could think of some way to let them know that they can trust me...That I am not trying to hurt them, but to help them. But how? Because any move he made tended to frighten them, confuse them. They just would not follow. They would not be led or shoed because they feared him.” Finally, Paul Harvey, his grandfatherly voice slowing perfectly and wavering with just the right touch of emotion, delivered the rest of what many of his listeners considered to be the greatest story he ever told:

“If only I could be a bird,” Harvey said the man thought to himself, “and mingle with them and speak their language. Then I could tell them not to be afraid. Then I could show them the way to safe, warm...to the safe warm barn. But I would have to be one of them so they could see, and hear and understand.” At that moment the church bells began to ring. The sound reached his ears above the sounds of the wind. And he stood there listening to the bells—*Adeste Fidelis*—listening to the bells pealing the glad tidings of Christmas. And he sank to his knees in the snow.

During the early 1960s, when television news was still in its snowy rabbit ears formative stage, Harvey added his face to the well-known voice by producing a five minute opinion vignette video package that local stations could feature in their fledgling newscasts. Paul Harvey’s TV segment ran in syndication (mostly in small and medium markets where his radio shows were big hits) until the Reagan-era’s frenzied use of new, on-the-scene/breaking news mini-cameras ate up the time once filled by slower-paced transcribed fare.

## A Mold Broken?

Upon learning that Paul Harvey had died, some of my SUNY colleagues and I speculated whether today’s media landscape might ever spawn another broadcast personality like him. One fellow suggested that Harvey had been operating primarily on legend for at least 15 years, and that if he had started his career in 2009, he’d probably be neither noticed nor accepted. “It’d be like trying to open up a new 250 watt AM station today,” he said.

I sided with several there who disagreed. We pointed to his 2000 re-upping with ABC in a \$100-million, 10-year contract, representing well over half of the income of ABC Radio Networks’ owner, Citadel Broadcasting. We also noted that the tiny AM analogy was an apples-to-oranges metaphor, as the radio station is a *platform* and Paul Harvey (or anyone aspiring to follow in his communicative footsteps) is media *content*, and content can march in any media platform’s parade.

Maybe Harvey himself had that in mind when Larry King asked him if he considered himself an influential newsmen. “I don’t think of myself as a profound journalist,” Paul Harvey told King. “I think of myself as a professional parade watcher who can’t wait to get out of bed every morning and rush down to the teletype and pan for gold.”

I suppose it’s possible that one day someone else will offer that same blend of enthusiasm, love of craft, distinctive voice, longevity, and inspirational words that can make people think positively. If so, then perhaps a modern multimedia platform will showcase a talented individual who may someday be compared to the otherwise inimitable Paul Harvey. ■

# Uniden Bearcat BC346XT Analog Handheld Scanner

by Jeffrey Reed

If you're a serious scanning enthusiast, and you haven't made the jump to purchasing a rig with Trunk Tracker technology, it's a good time to consider it. Monitoring without it is like conversing with outdated lingo on CB Radio with a 23-channel model. If you're in the market to purchase an analog trunking portable scanner, then check out the latest offering from Uniden: the Bearcat BC346XT handheld scanner with TrunkTracker III analog Trunk Tracker capabilities.

Sure, Uniden's Bearcat BCD396XT handheld unit and Bearcat 796DGV base unit both boast TrunkTracker IV, but the BC346XT also deserves a serious look for its myriad features.

## The Basics

My shack includes a Uniden Bearcat BC246T Trunk Tracker III handheld scanner, and let me tell you, Uniden has greatly improved on this unit with the newly released BC346XT. Never mind the seemingly endless specifications; one listen alone will tell you something about the quality of the BC346XT. It is, quite simply, the best-sounding handheld scanner in my shack.

Before getting into the juicier details, this sound is produced simply through an attached 24 ohm 0.8 watt max. (1.26 in.) internal speaker. There's a nifty Individual Channel Volume Offset feature, too. Controlling volume and squelch is done through a Function key at the unit's side and a top Volume/Squelch/Set control knob—very easy to use and efficient. The BC346XT includes a handy SMA-BNC adaptor so you can either screw in the stock rubber ducky or attach a conventional antenna via BNC. Even with using the included stock rubber ducky, reception was excellent.

A solid casing provides security and durability in the BC346XT handheld unit. It measures 5.35 x 2.4 x 1.22 inches (HWD) without antenna, and without antenna and batteries weighs 0.37 pounds. You have the option of powering this unit with three "AA" rechargeable Ni-MH batteries

Jeffrey Reed is a leading Canadian freelance journalist, and a life-long communications hobbyist.

(1800 mAh) or three "AA" Alkaline batteries, or an included 6 VDC 800mA regulated AC adapter. Of course, always be sure to remove the battery cover and select the proper battery type—rechargeable or Alkaline—with the included switch. The BC346XT allows you to set battery charging time (one to 16 hours, in one-hour increments), and includes a battery save feature, too.

Basic frequency coverage with the BC346XT includes 25–54 MHz, 108–174 MHz, 216–225 MHz, 400–512 MHz, 806–956 MHz (minus cellular bands) and 1240–1300 MHz. That's quite impressive coverage of VHF low, VHF high, VHF air, UHF, 800 MHz public service (less cel-

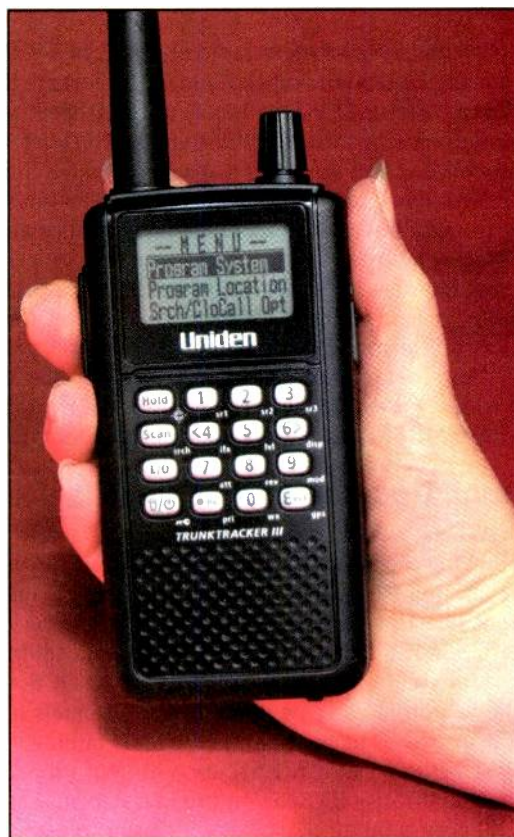

Tiny but mighty: Uniden's BC346XT Trunk Tracker III Scanner, weighing in at just 0.37 pounds, is a heavyweight in scanning power.



The Uniden BC346XT allows for both SMA and BNC antenna connections, providing plenty of flexibility in scanning.



PC Control/Programming allows you the option of remotely programming and controlling the BC346XT scanner.

ular), and even amateur radio on the 1.24-1.3 GHz band. You can edit the modulation and step for each band. Scan rate is 100 channels/second (conventional). I found that this scanner pulled in conversations much better than the BC246T model, and the produced sound via built-in speaker is much improved, too.

No doubt, Uniden has produced the BC346XT as an upgrade to the BC246T. Using its Dynamic Memory abilities, Uniden has now produced a handheld scanner with 9,000 channels (maximum), with 500 systems (maximum) available. Of course, there's Close Call RF Capture, too, so you can choose to be alerted if anyone keys up within a few hundred feet. There are 11 pre-programmed service searches—Police, Fire and EMS, Weather, News, Ham Radio, Marine, Railroad, Air, CB Radio, FRS/GMRS, Racing and Special Channel frequencies.

### Trunk Tracking With BC346XT

Where would scanner enthusiasts be today without Trunk Tracking technology? With the BC346XT, you receive third generation TrunkTracking III, supporting Motorola Systems Type I, II, III Hybrid, EDACS, and LTR Analog Trunk Systems. CTCSS/DCS Decode allows you to reduce interference when a system you want to hear uses CTCSS or DCS. Alpha Tagging allows you to assign a name to the Channels and Talk Group IDs for easier identification of who is talking. The BC346XT also features EDACS ESK support. With the BC346XT, you can use Priority ID Scan on trunked systems.

If programming a scanner with Trunk Tracking is new to you, beware: there is a learning curve, as has been deftly defined in previous articles here in *Popular Communications*. (The November 2005 and January 2006 issues of *Popular Communications* included excellent trunking information

from Uniden's Paul Opitz). Uniden includes a DVD for help with this chore, and there are many Internet websites offering easy-to-follow instructions. Furthermore, the BC346XT includes PC Control/Programming so you can remotely program and control the scanner using software. Uniden provides free demo software online, as well as a mammoth but easily comprehended 263-page PDF instructional booklet (visit [www.uniden.com/twiki/bin/view/UnidenMan4/ScannerManuals](http://www.uniden.com/twiki/bin/view/UnidenMan4/ScannerManuals)—yes, it's a lot to type, but it's worth it). You can clone all programmed data, including Memory Architecture, Menu settings and other parameters from one BC346XT to another, with the RS232C cable. If you're still learning the ins and outs of Trunk Tracking, just be patient: It's worth the wait.

### GPS And More!

Here's a great little offering of the BC346XT: a GPS/Remote Interface Jack (4-pin Mini Type). Of course, you'll need a compatible GPS to fully appreciate this feature, but what a feature it is. You can use GPS for location-based scanning, location alerts, and Crows-Flight Navigation. Uniden's GPS support feature with the BC346XT allows you to automatically control radio features that are based on location.

Another terrific, though sometimes underappreciated, feature of the BC346XT is the 64 x 128 pixel full dot matrix LCD display—it's crystal clear. The fully lit keypad is cool, too. The BC346XT also offers Fire Tone-Out, Band Scope (which graphically finds radio activity), Temporary Lockout, and

# CQ BOOKS

Back by popular demand!

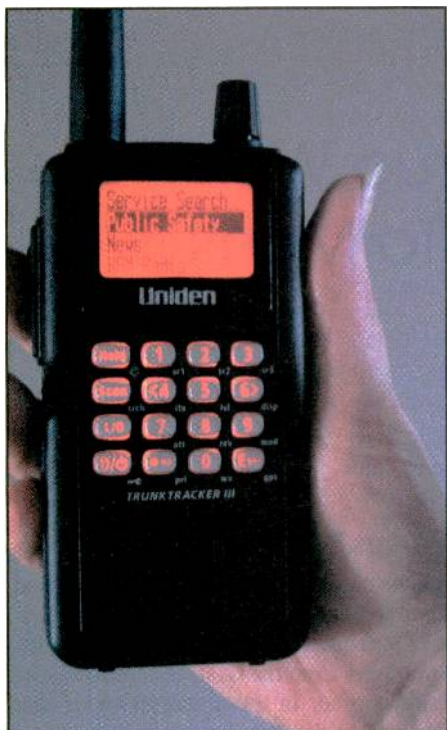

The BC346XT boasts a 64 x 128 pixel full dot matrix LCD display and a fully lit keypad.

Search with Scan features. S.A.M.E. Weather Alert is included, too. During a NOAA Weather or Emergency Alert, a code for your specific location will alert you to severe conditions in your immediate area. Uniden's BC-RH96 Remote Head is fully compatible with the BC346XT handheld scanner.

## It's An Amazing Analog Portable Scanner

I give an enthusiastic two thumbs up for Uniden's latest Trunk Tracking scanner. There are more bells and whistles with this handheld unit than James Bond could ever imagine. And with GPS support, Bond would approve. Remember: programming Trunk Tracking is not an easy task without first understanding its principles and reading instructionals. But once you get the hang of it, you won't want to live without it.

The BC346XT will remain in my shack and is now the big brother of the BC246T and entry-level models BC92XLT, and BC95XLT. That's a formidable quartet to make music to anyone's ears when scanning for the latest action. "Street price" for the BC346XT should be about \$249. Visit [www.uniden.com](http://www.uniden.com) for information. ■

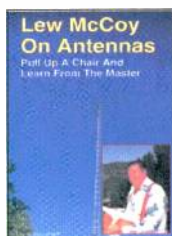

## Lew McCoy on Antennas

by Lew McCoy, W1ICP

Unlike many technical publications, Lew McCoy presents his invaluable antenna information in a casual, non-intimidating way for anyone!

Order No. MCCOY **\$19.95**

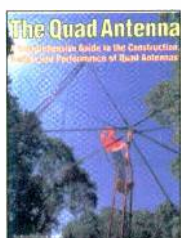

## The Quad Antenna

by Bob Haviland, W4MB

A comprehensive guide to the construction, design and performance of Quad Antennas. Chapter titles include General Concepts, Circular-Loop & Arrays, Rectangular & Square Loops, Multi-Element Quads, Delta Loops & Arrays, Design Variations, Optimizing a Quad Design and more!

Order No. QUAD **\$19.95**

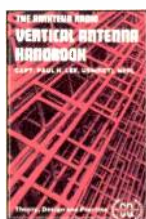

## The Vertical Antenna Handbook

by Paul Lee, N6PL

You'll learn basic theory and practice of the vertical antenna. Discover many easy-to-build construction projects.

Order No. VAH **\$17.95**

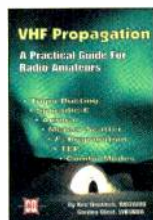

## VHF Propagation Handbook

The Practical Guide for Radio Amateurs

by Ken Neubeck, WB2AMU & Gordon West, WB6NOA

The combined ham radio experience of the authors represents many years of VHF observations and research. Tropo Ducting, Sporadic-E, Aurora, Meteor Scatter, F2 Propagation, TEP, Combo Modes, it's all here!

Order: VHFProp **\$15.95**



## 33 Simple Weekend Projects

by Dave Ingram, K4TWJ

Do-it-yourself electronics projects from the most basic to the fairly sophisticated. You'll find: station accessories for VHF FMing, working OSCAR satellites, fun on HF, trying CW, building simple antennas, even a complete working HF station you can build for \$100. Also includes practical tips and techniques on how to create your own electronic projects.

Order No. 33PROJ **\$17.95**

**Shipping & Handling:** U.S. & Possessions - add \$7 for the first item, \$3.50 for the second and \$2 for each additional item. \* **FREE shipping on orders over \$100.00** (merchandise only). Foreign-Calculated by order weight and destination and added to your credit card charge.



CQ Communications Inc.

25 Newbridge Rd., Hicksville, NY 11801

516-681-2922; Fax 516-681-2926 • Order Toll-Free 800-853-9797



# On The Borderline: Drug Wars, Influenza, And More To Monitor

by Ken Reiss  
radioken@earthlink.net

**W**hen our esteemed editor Edith (and since my column was late this month she's really "a-steamed") informed me that this issue would feature radio south of the Rio Grande, I thought it might be interesting to focus on the U.S./Mexico border, some of the controversy surrounding it, and how to listen in. Then the H1N1 strain of influenza broke out. While as of this writing, the feared worst-case scenario of pandemic has not materialized (thank heaven!), the virus is still out there and scientists are still looking to "Ground Zero" for clues. So, between drug wars, the ever-simmering political scene, and a lurking pathogen, I expect that this normally interesting

area will be even more abuzz for scannists for a long time to come.

## Virus Versus Borders

While most cases of the flu initially diagnosed in this country could be traced to tourists reentering the U.S. from Mexico through the airports, there are numbers from the CDC that indicate the outbreaks are higher in the southern states that border Mexico. At present, it turns out that there isn't much to monitor in terms of radio traffic at this time. Most of the outbreaks are handled through routine reporting and the patients are

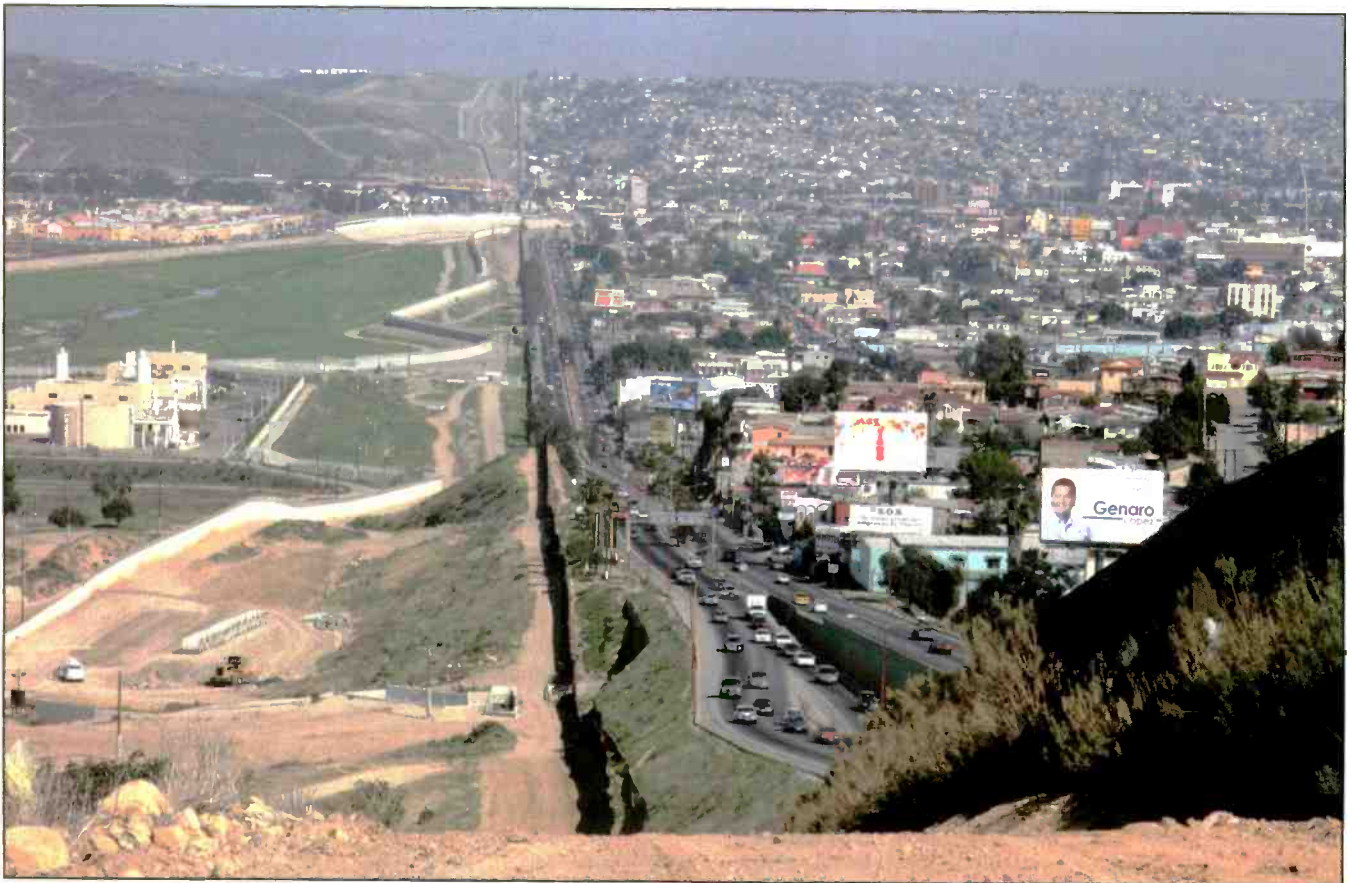

A small fence separates densely populated Tijuana, Mexico, right, from the United States in the Border Patrol's San Diego Sector. Construction is underway to extend a secondary fence over the top of this hill and eventually to the Pacific Ocean. (DoD Photo by Sgt. 1st Class Gordon Hyde)





The border fence is completed in southern California and reaches right to the ocean. Of course, people are able to just walk around the end of it when the tide is low, which is one of the reasons the effectiveness has been criticized. (Public domain photo by James Reyes)

treated at doctors' offices and hospitals like any other types of patients. If there's any radio traffic at all, it's probably going over a cell phone.

Of course, things may change, and only time will tell what might yet develop. We just hope and pray that all developments are of the good kind.

### Monitoring The Border

The controversy continues to rage over the border and controlling entry and exit

by illegal means. The Secure Border Initiative is the formal name given to the project by the Department of Homeland Security. Its effectiveness is subject to heated debate, and plans for expansion of the fence line are currently on hold.

The U.S. Border Patrol (now part of Homeland Security) is officially tasked with patrolling the border and controlling admission. There have been many stories of civilian groups assisting in the patrol of the fence and border, and in some cases crossing the line (literally and figurative-

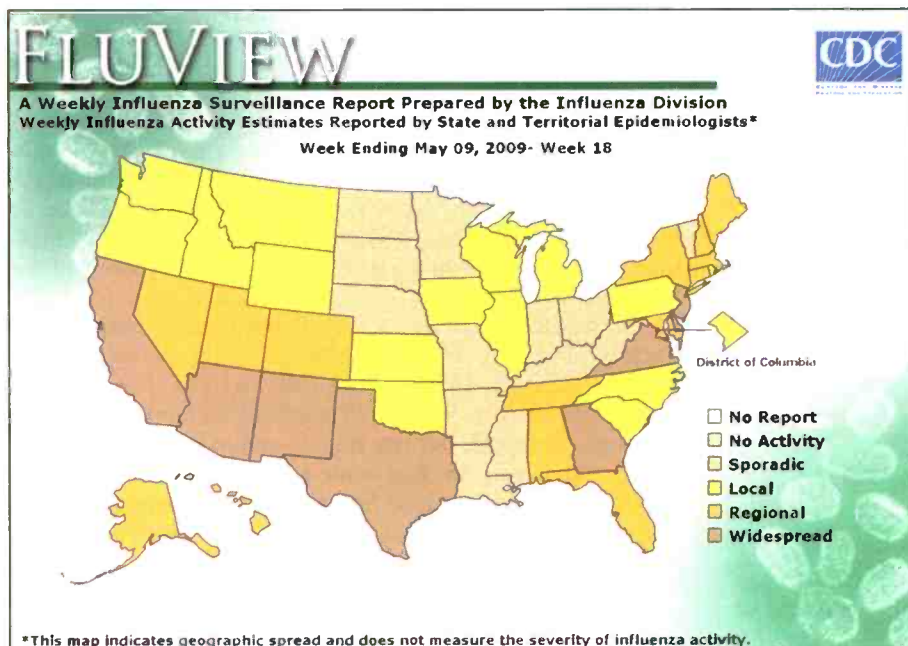

The southern states that border Mexico have been hit harder with outbreaks of the flu, although the first cases all came through airports. This could be more interesting as we get closer to fall and winter, so stay tuned! (Image from the Center for Disease Control)



### GearHarness

Hands free transport for your handheld and other gear.



### Leather & Neo Pouches

Custom sizes to fit your handheld.



### Radio Wallet

Travel case for your handheld and accessories.



831-427-8197 • KC6QLB  
www.powerportstore.com

## WorldRadio

is now part of the CQ family!



**Articles In August WorldRadio Online will include:**

- Trail-Friendly Radio • DX World
- Propagation

View the issue in its entirety - visit  
<<http://www.cq-amateur-radio.com>>  
Click on the WorldRadio Online link!

### WorldRadio Online

25 Newbridge Road  
Hicksville, NY 11801  
1-800-853-9797 FAX 516-681-2926

## Licensed Before 1984?

QCWA invites you to join with those distinguished amateurs licensed 25 or more years ago. Request an application from:

QCWA, Inc., Dept. PC  
PO Box 3247  
Framingham, MA 01705-3247  
USA



## Frequency Of The Month

Each month we ask our readers to let us know what they're hearing on our "Frequency Of The Month." Give it a listen and report your findings to me here at "ScanTech." We'll pick a name at random from the entries we receive and give that lucky winner a free one-year subscription, or extension, to *Pop'Comm*. Remember to include your address in case it's your name that's drawn! Good luck!

Our frequency this month will be **163.7125**. Have a listen and see what you can find. Let me know at radioken@earthlink.net or via more traditional methods at Ken Reiss, 9051 Watson Rd. #309, St. Louis, MO 63126. Even if you don't hear anything, we'll enter your name in the drawing. Send your entries, as well as suggestions and questions, to radioken@earthlink.net or via more traditional methods to Ken Reiss, 9051 Watson Rd. #309, St. Louis, MO 63126. Please note Frequency of the Month entries with the frequency on the envelope or email subject line for correct routing. And don't forget that address!

The winner of our most recent drawing is **Kenny Loatman** of **Bridgeton, New Jersey**. Kenny wrote in saying:

"Hi, 855.7125 is a trunk voice frequency for the state of New Jersey, State Police Troop A south. I have it programmed in my scanner and listen to it everyday."

Thanks for your submission, Kenny, and enjoy your free year of *Pop'Comm*!

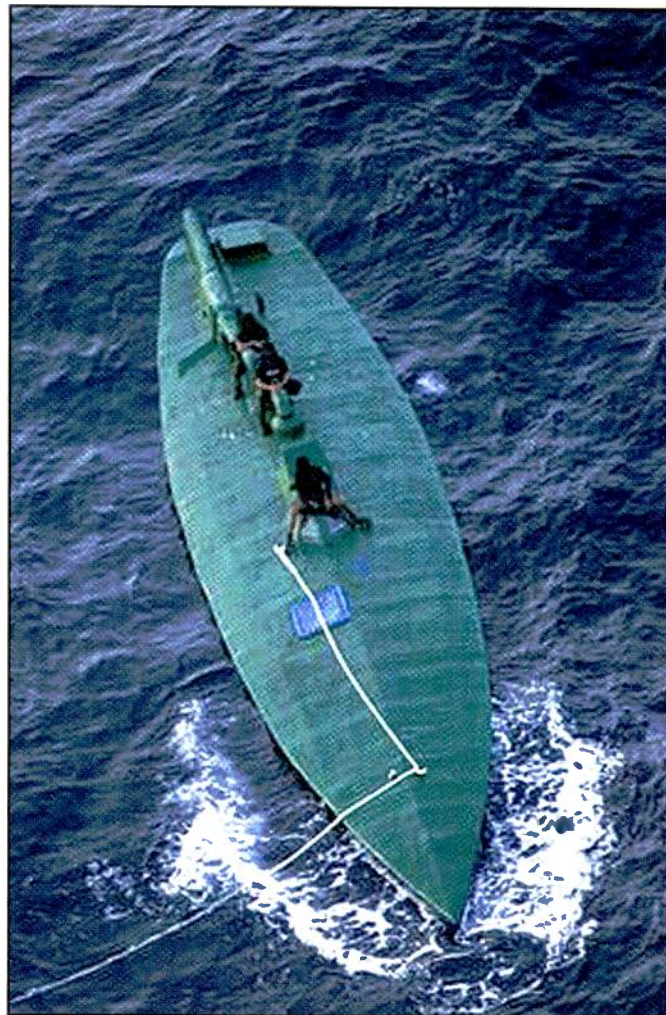

A 10 meter fiberglass semi-submersible (drug submarine or narco submarine) seized by the Mexican Navy, was loaded with cocaine. It was intercepted 200 miles southwest of the Oaxaca, Mexico coast. (via Wiki Commons)

## Pop'Comm Aug 2009 Reader Survey Questions

This month we'd like to ask how shortwave listening fits into your hobby. Please use the Reader Survey Card and circle all appropriate numbers. We'll pick one respondent at random for a free one-year subscription, or extension, to *Pop'Comm*, so don't forget your address. Thanks for participating.

### How important is shortwave listening to you?

- Not at all, I don't even have a SW receiver 1
- I'm moderately interested 2
- Pretty important, I tune in often 3
- It's a very big part of my hobby 4
- I'm an addict 5

### How many shortwave receivers do you own?

- None 6
- 1-3 7
- 4 or more 8

### If you don't have a SW radio, do plan to purchase one?

- Yes 9
- No 10
- Not sure 11

### Do you take a SW radio with you when you travel?

- Yes 12
- No 13
- I don't travel 14

### Have you ever monitored shortwave or other frequencies in a foreign country?

- Yes, shortwave 15
- Yes, scanner frequencies 16
- Yes, AM/FM broadcast 17
- Yes, TV(DXing) 18

(April Survey Highlights on page 38)

ly) when they find a violator. These groups are likely to use anything they have handy, from CB radio to the Family Radio Service (FRS) or even ham radios if they're licensed. You might also find some of their activity on the marine channels because the equipment is so easy to find, although the FRS has eliminated a lot of piracy on the marine band. Have a listen and see what you hear.

The border patrol has a very limited set of frequencies, namely: 162.825, 162.925, 163.625 (nationwide primary channel), 163.65, 163.675, 163.700, 163.725, 163.775, and 170.675 (Tactical). Since 9/11 much of its communications has been encrypted, but you might want to have a listen anyway to see if you can find some activity locally. And, since it's now part of Homeland Security, it may operate on other homeland security frequencies as well, though I've not seen any reports to indicate this.

We have a (legal) boatful of other frequencies for you to monitor, too, so let's dive right in. Check out the tables for suggestions on where to start scanning the southern action.

That's all—and it's quite a lot, isn't it?—for this month. Try tuning some of these frequencies and drop me a line describing your border catches. Until next time, good listening!

## State Agencies

### California Border Division

The Border division of the California Highway patrol provides state police services to most of the southern end of the state up through Orange County.

#### Border Division

##### Border Communications Center

Freq.	Tone	Description
39.4	162.2 PL	San Diego/Otay Mesa Offices
39.8	162.2 PL	Oceanside/Temecula/Rainbow/San Onofre Offices
39.6	162.2 PL	El Cajon Office
155.94	107.2 PL	Sig Alert (San Diego County)

##### El Centro Dispatch Center

Freq.	Tone	Description
42.92	162.2 PL	El Centro/Winterhaven/Calexico Offices

##### Indio Dispatch Center

Freq.	Tone	Description
42.44	162.2 PL	Blythe/Indio/Desert Hills/San Geronio Pass Offices

##### Orange County Communications Center

Freq.	Tone	Description
39.44	162.2 PL	Santa Ana Office
39.36	162.2 PL	San Juan Capistrano Office
39.72	162.2 PL	Westminster Office

### Public Safety - Mutual Aid

In case of a major event, California's Mutual Aid System would be pressed into service. Note that there's a lot of emphasis placed on fire mutual aid in the planning for the system.

#### California Law Enforcement Mutual Aid Radio System (CLEMARS)

Freq.	Tone	Alpha Tag
154.92	CSQ	CLEMARS 01
154.935	CSQ	CLEMARS 02
155.475	CSQ	CLEMARS 03
460.025	CSQ	CLEMARS 04
460.025	CSQ	CLEMARS 05
39.46	156.7 PL	CLEMARS 06
39.46	156.7 PL	CLEMARS 07
868.5125	156.7 PL	CLEMARS 08
868.5125	156.7 PL	CLEMARS 09
866.2	156.7 PL	CLEMARS 20
866.2	156.7 PL	CLEMARS 21
484.2375	156.7 PL	CLEMARS 22
487.2375	156.7 PL	CLEMARS 23

#### California Law Enforcement Radio System (CLERS)

Used primarily for Comm Center-to-Comm Center communication or one-way announcements to field units.

Freq.	Tone	Description
154.71	123.0 PL	MT. DIABLO - East Bay area
154.71	131.8 PL	JOAQUIN RIDGE
154.71	110.9 PL	BROCKWAY - Lake Tahoe
155.07	110.9 PL	BLUE RIDGE
155.07	110.9 PL	WOLF MTN - Nevada County
155.7	123.0 PL	HAMAKER
155.7	131.8 PL	ANTELOPE PEAK
155.7	110.9 PL	HORSE MTN
155.7	146.2 PL	HOADLEY
155.7	136.5 PL	LIKELY MTN

155.7	110.9 PL	SHAFFER
155.91	131.8 PL	GOVERNMENT PEAK - Northwest San Bernardino Co.
158.79	131.8 PL	CACTUS CITY - Eastern Riverside Co.
158.79	110.9 PL	SANTIAGO PEAK
453.675	123.0 PL	MT. LOWE
453.675	131.8 PL	RED MTN.
453.675	110.9 PL	CUYAMACA
453.675	136.5 PL	MT BULLION
453.875	110.9 PL	BLOOMER - Butte County
453.875	136.5 PL	TELEGRAPH
453.875	123.0 PL	FREMONT PK.
453.875	131.8 PL	MT TAMALPAIS - Marin County

#### Fire Department Mutual Aid

Freq.	Tone	Description
154.28	CSQ	Statewide Fire Tactical
154.265	CSQ	Statewide Fire Tactical
154.295	CSQ	Statewide Fire Tactical
868.9875	156.7 PL	
866.9125	156.7 PL	(NorCal Use ONLY)
154.16	CSQ	Statewide Fire Department Mutual Aid Coordination
154.16	CSQ	Statewide Fire Department Mutual Aid Coordination
154.16	CSQ	Statewide Fire Department Mutual Aid Coordination
154.22	CSQ	Statewide Fire Department Mutual Aid Coordination
154.22	CSQ	Statewide Fire Department Mutual Aid Coordination
154.22	CSQ	Statewide Fire Department Mutual Aid Coordination
154.22	CSQ	Statewide Fire Department Mutual Aid Coordination
153.83		Fire Tactical

### Arizona Emergency

Arizona features an emergency network in the 700 MHz range that operates in digital mode. It's listed as an Emergency and Military Affairs network although its use is unknown.

#### Emergency Management

Used by the Department of Emergency and Military Affairs Division of Emergency Management (APCO-25 Digital System)

Freq.	Description
764.05625	Emergency/Tactical Ops
764.06875	Emergency/Tactical Ops
775.99375	Emergency/Tactical Ops
794.05625	Emergency/Tactical Ops
794.06875	Emergency/Tactical Ops
805.99375	Emergency/Tactical Ops

#### Fire (Analog system)

Freq.	Description
151.4	State Fire Control

#### Arizona State Police

##### Highway Patrol

##### Districts

Freq.	Tone	Description
460.475	100.0 PL	Kingman; NW Area of State
460.025	100.0 PL	Flagstaff; N Central Area of State
460.3	100.0 PL	Holbrook; NE Area of State
460.4	100.0 PL	Yuma; SW Area of State
460.325	100.0 PL	Metro Phoenix Central Area
460.2	100.0 PL	Metro Phoenix East Area
460.3	151.4 PL	Metro Phoenix West Area
460.025	151.4 PL	Casa Grande; SE of Phoenix Metro
460.425	151.4 PL	Tucson; S Central Area of State

460.325	151.4 PL	Sierra Vista; SE Area of State
460.475	151.4 PL	Globe; E & NE of Phoenix Metro
460.425	100.0 PL	Prescott; N & NW of Phoenix Metro
460.15		WestTAC - Phoenix Area; Also Cross-patched as "INFO" channel during rush hour with EastTAC
460.175		EastTAC - Phoenix Area; also Cross-patched as "INFO" channel during rush hour with WestTAC

**Other Highway Patrol (Statewide)**

Freq.	Tone	Description
460.225	100.0 PL	DPS Statewide Operations
460.225	151.4 PL	DPS Statewide Tactical Operations
460.275	100.0 PL	DPS CID Channel 1 Statewide
460.5	100.0 PL	DPS CID Channel 2 Statewide
460.275	151.4 PL	DPS CID Channel 3 Statewide
460.5	151.4 PL	DPS CID Channel 4 Statewide
463.1	136.5 PL	DPS Air Rescue "Ranger Helos"

*New Mexico*

New Mexico's state police seems to handle most special operations in the state. There is a Border Authority, but it appears to be mostly concerned with the licensing and importing process as well as border crossings; there does not appear to be a separate radio system for its use.

**New Mexico State Police Districts**

**Districts 1-3-12**

Freq.	Tone	Description
155.565	127.3 PL	District 1 - Santa Fe
155.595		District 1 - Santa Fe Local
155.565	127.3 PL	District 3 - Roswell
155.565		District 12 - Deming

**Districts 2-10-11**

Socorro units often use Catron County Sheriff channels from the Quemado Socorro Sub District Office.

Freq.	Tone	Description
155.58	127.3 PL	District 2 - Las Vegas
155.58		District 10 - Farmington
155.58	127.3 PL	District 11 - Socorro
155.565	127.3 PL	District 2 - Raton Dispatch

**Districts 4-5-9**

Freq.	Tone	Description
155.52		District 4 - Las Cruces
155.52	127.3 PL	District 5 - Albuquerque
155.52		District 9 - Clovis

**Districts 6-7-8**

Freq.	Tone	Description
155.79	127.3 PL	District 6 - Gallup
155.79		District 7 - Espanola
154.935	110.9 PL	District 7 - Tres Piedras (Taos County)
155.79		District 8 - Alamogordo

**Statewide**

**Statewide Mobiles**

Freq.	Tone	Description
155.475		Statewide Mountain Relays to Headquarters in Santa Fe
155.55	127.3 PL	Statewide Law Enforcement Network (LEN) Car-to-Car
154.92	127.3 PL	Statewide Emergency
155.55	CSQ	Statewide Law Enforcement Network (LEN, 127.3 PL on input)

**New Mexico Mounted Patrol**

Freq.	Description
154.905	Mounted Patrol

*Texas*

Texas' southern border falls into two regions of the Division of Public Safety: Region 4 to the west and Region 8 to the east.

**Region IV Midland**

**DPS Midland**

Freq.	Tone	Description
155.4675	118 NAC	Midland - Dispatch
159.2175	111 NAC	Crane - Dispatch
155.5275	162 NAC	Gail - Dispatch
159.2175	137 NAC	Big Spring - Dispatch
155.37	CSQ	Midland
155.3775		Midland
155.445	162.2 PL	Midland
155.4525		Midland
155.46	162.2 PL	Midland
159.09		Midland
159.0975		Midland
159.21		Midland
155.505	162.2 PL	Midland
155.5125		Midland
159.21		Crane
159.21		Gail
159.2175		Gail
155.52		Gail
159.09		Penwell
159.0975		Penwell
155.46	162.2 PL	Seminole
159.09		Seminole
159.21		Seminole

**DPS Abilene**

Freq.	Tone	Description
155.4525		Abilene - Dispatch
155.4675		Brownwood - Dispatch
155.8875	123 NAC	Loraine - Dispatch
155.3775		Abilene
155.445	162.2 PL	Abilene
155.4525		Abilene
155.46	162.2 PL	Abilene
159.09		Abilene
159.0975		Abilene
159.21		Abilene
155.37	CSQ	Abilene
155.4675		Loraine
159.2175		Abilene
155.37	CSQ	Abilene (15 mi. SE)
155.3775		Abilene (15 mi. SE)
155.445	162.2 PL	Abilene (15 mi. SE)
155.4525		Abilene (15 mi. SE)
155.46	162.2 PL	Abilene (15 mi. SE)
155.4675		Abilene (15 mi. SE)
155.505	162.2 PL	Abilene (15 mi. SE)
155.5125		Abilene (15 mi. SE)
155.46	162.2 PL	Loraine
155.88	123.0 PL	Loraine
159.09		Loraine
159.0975		Loraine
159.21	123.0 PL	Loraine
159.2175		Loraine

**DPS El Paso**

Freq.	Tone	Description
155.4675		El Paso - Dispatch
159.2175		Mt. Franklin - Dispatch

159.2175		Quitman Mtn - Dispatch	159.21		Alpine (Santiago Peak)
159.15		Sierra Diablo - Dispatch	155.505	162.2 PL	Fort Davis (Mt. Locke)
155.37		El Paso	155.5125		Fort Davis (Mt. Locke)
155.3775		El Paso	155.73		Fort Davis (Mt. Locke)
155.46	162.2 PL	El Paso	159.09		Fort Davis (Mt. Locke)
159.09		El Paso	159.0975		Fort Davis (Mt. Locke)
159.0975		El Paso	159.21		Fort Davis (Mt. Locke)
159.21		El Paso	159.2175		Fort Davis (Mt. Locke)
159.2175		El Paso	158.82		Marathon (Glass Mtn.)
155.505		El Paso	155.595		Presidio (Chinati Mtn.)
155.505	162.2 PL	El Paso (Mt. Franklin)	155.505	162.2 PL	Presidio (Chinati Mtn.)
155.5125		El Paso (Mt. Franklin)	155.5125		Presidio (Chinati Mtn.)
159.21		El Paso (Mt. Franklin)	159.09		Presidio (Chinati Mtn.)
155.46	162.2 PL	Sierra Blanca (Quitman Mtn.)	159.0975		Presidio (Chinati Mtn.)
155.4675		Sierra Blanca (Quitman Mtn.)			
159.09		Sierra Blanca (Quitman Mtn.)			
159.0975		Sierra Blanca (Quitman Mtn.)			
159.21		Sierra Blanca (Quitman Mtn.)			
<b>DPS Ozona</b>					
<b>Freq.</b>	<b>Tone</b>	<b>Description</b>	<b>Freq.</b>	<b>Tone</b>	<b>Description</b>
155.46		Ozona - Dispatch	155.445		San Angelo - Dispatch
159.2175		Sanderson - Dispatch	155.46	162.2 PL	San Angelo
159.2175		Sheffield - Dispatch	155.4675		San Angelo
155.4675		Ozona	155.37	CSQ	Carlsbad
155.37	CSQ	Ozona (5 mi. E)	155.3775		Carlsbad
155.3775		Ozona (5 mi. E)	155.46	162.2 PL	Carlsbad
155.46	162.2 PL	Ozona (5 mi. E)	155.4675		Carlsbad
159.09		Ozona (5 mi. E)	159.09		Carlsbad
159.0975		Ozona (5 mi. E)	159.0975		Carlsbad
159.21		Ozona (5 mi. E)	159.21		Carlsbad
159.2175		Ozona (5 mi. E)	159.2175		Carlsbad
159.09		Sanderson			
159.0975		Sanderson			
159.21		Sanderson			
155.46	162.2 PL	Sheffield			
155.4675		Sheffield			
159.09		Sheffield			
159.0975		Sheffield			
159.21		Sheffield			
<b>DPS Pecos</b>					
<b>Freq.</b>	<b>Tone</b>	<b>Description</b>	<b>Freq.</b>	<b>Tone</b>	<b>Description</b>
155.4525		Pecos - Dispatch	155.46		McAllen - Dispatch
159.2175		Santiago Peak - Dispatch	159.21		Rio Grande City (La Gloria) - Dispatch
155.7375		Fort Davis - Dispatch	155.4675		McAllen
158.8275		Glass Mountain - Dispatch	155.37	CSQ	McCook
155.6025		Chinati Mountain - Dispatch	155.3775		McCook
155.37	CSQ	Pecos	155.445	162.2 PL	McCook
155.37	CSQ	Pecos (4 mi. SW)	155.4525		McCook
155.3775		Pecos	155.46	162.2 PL	McCook
155.3775		Pecos (4 mi. SW)	155.4675		McCook
155.445	162.2 PL	Pecos (4 mi. SW)	159.09		McCook
155.4525		Pecos (4 mi. SW)	159.0975		McCook
155.46	162.2 PL	Pecos (4 mi. SW)	159.21		McCook
155.46	162.2 PL	Pecos	159.2175		McCook
155.4675		Pecos	155.505	162.2 PL	Edinburg
159.09		Pecos (4 mi. SW)	155.5125		Edinburg
159.0975		Pecos (4 mi. SW)	159.09		Edinburg
159.21		Pecos (4 mi. SW)	159.0975		Edinburg
159.2175		Pecos (4 mi. SW)	155.505	162.2 PL	La Gloria
155.46	162.2 PL	Alpine (Santiago Peak)	155.5125		La Gloria
155.4675		Alpine (Santiago Peak)	159.2175		La Gloria
155.505	162.2 PL	Alpine (Santiago Peak)	155.505	162.2 PL	Rio Grande City
155.5125		Alpine (Santiago Peak)	159.09		Rio Grande City
159.09		Alpine (Santiago Peak)			
159.0975		Alpine (Santiago Peak)			
159.15		Alpine (Santiago Peak)			
159.1575		Alpine (Santiago Peak)			
<b>DPS San Angelo</b>					
<b>Freq.</b>	<b>Tone</b>	<b>Description</b>	<b>Freq.</b>	<b>Tone</b>	<b>Description</b>
155.445		San Angelo - Dispatch			
155.46	162.2 PL	San Angelo			
155.4675		San Angelo			
155.37	CSQ	Carlsbad			
155.3775		Carlsbad			
155.46	162.2 PL	Carlsbad			
155.4675		Carlsbad			
159.09		Carlsbad			
159.0975		Carlsbad			
159.21		Carlsbad			
159.2175		Carlsbad			
<b>Region VIII McAllen</b>					
<b>DPS Mc Allen</b>					
<b>Freq.</b>	<b>Tone</b>	<b>Description</b>	<b>Freq.</b>	<b>Tone</b>	<b>Description</b>
155.46		McAllen - Dispatch			
159.21		Rio Grande City (La Gloria) - Dispatch			
155.4675		McAllen			
155.37	CSQ	McCook			
155.3775		McCook			
155.445	162.2 PL	McCook			
155.4525		McCook			
155.46	162.2 PL	McCook			
155.4675		McCook			
159.09		McCook			
159.0975		McCook			
159.21		McCook			
159.2175		McCook			
155.505	162.2 PL	Edinburg			
155.5125		Edinburg			
159.09		Edinburg			
159.0975		Edinburg			
155.505	162.2 PL	La Gloria			
155.5125		La Gloria			
159.2175		La Gloria			
155.505	162.2 PL	Rio Grande City			
159.09		Rio Grande City			
<b>DPS Del Rio</b>					
<b>Freq.</b>	<b>Tone</b>	<b>Description</b>	<b>Freq.</b>	<b>Tone</b>	<b>Description</b>
155.4675		Del Rio - Dispatch			
159.21		Uvalde (Whites Mine) - Dispatch			
159.2175		Eagle Pass - Dispatch			
155.445	162.2 PL	Del Rio			
155.46	162.2 PL	Del Rio			
155.37	CSQ	Del Rio			
159.21		Del Rio			
155.37	CSQ	Carta Valley			
155.3775		Carta Valley			
155.445	162.2 PL	Carta Valley			
155.4525		Carta Valley			
155.46	162.2 PL	Carta Valley			

159.09		Carta Valley
159.0975		Carta Valley
159.21		Carta Valley
159.2175		Carta Valley
155.505	162.2 PL	Bracketville
155.5125		Bracketville
159.09		Bracketville
159.0975		Bracketville
159.21		Bracketville
159.2175		Bracketville
155.505	162.2 PL	Eagle Pass
155.5125		Eagle Pass
159.09		Eagle Pass
159.0975		Eagle Pass
159.21		Eagle Pass
155.46	162.2 PL	Whites Mine
159.09		Whites Mine

**DPS Harlingen**

Freq.	Tone	Description
155.445		Harlingen - Dispatch
159.2175		Bayview - Dispatch
159.2175		Falfurrias - Dispatch
155.3775		Harlingen
155.4525		Harlingen
155.46	162.2 PL	Harlingen
155.4675		Harlingen
159.09		Harlingen
159.0975		Harlingen
159.21		Harlingen
155.37	CSQ	Harlingen
159.2175		Harlingen
155.505	162.2 PL	Bayview
155.5125		Bayview
159.09		Bayview

159.0975	Bayview
159.21	Bayview
159.09	Falfurrias
159.21	Falfurrias

**DPS Laredo**

Freq.	Tone	Description
155.4525		Laredo / Webb County - Dispatch
159.2175		Valley Wells (Big Wells) - Dispatch
159.21		Hebronsville (Mirando City) - Dispatch
155.3775		Laredo
155.445	162.2 PL	Laredo
155.46	162.2 PL	Laredo
155.4675		Laredo
155.37	CSQ	Laredo (18 mi. N)
155.37	CSQ	Laredo
155.3775		Laredo (18 mi. N)
155.445	162.2 PL	Laredo (18 mi. N)
155.46	162.2 PL	Laredo (18 mi. N)
155.4675		Laredo (18 mi. N)
159.09		Laredo (18 mi. N)
159.0975		Laredo (18 mi. N)
159.21		Laredo (18 mi. N)
159.2175		Laredo (18 mi. N)
155.505	162.2 PL	Laredo
155.5125		Laredo
159.09		Big Wells
159.0975		Big Wells
159.21		Big Wells
159.2175		Mirando City

**State Health Department**

**Texas, State of Health Department**

Freq.	Tone	Description
155.04	151.4 PL	Comanche Peak, Somervell County

## "Getting Started" DVD Paks

Our renowned "Getting Started" videos have been grouped together on DVDs!

**CQ Ham Radio Welcome Pak**

1 DVD contains 3 programs:

- Ham Radio Horizons
- Getting Started in Ham Radio
- Getting Started in VHF

Order # HAMDVD \$24.95



**CQ HF Specialty Pak**

1 DVD contains 2 programs:

- Getting Started in DXing
- Getting Started in Contesting

Order # HFDVD \$24.95



Buy any combination of DVDs and save!

1 Pak for \$24.95;

2 Paks for \$45.95;

3 Paks for \$65.95

**CQ VHF Specialty Pak**

1 DVD contains 3 programs:

- Getting Started in Satellites
- Getting Started in VHF
- Getting Started in Packet

Order # VHFVDV \$24.95



**CQ DVD 3 Pak - one of each of the 3 DVDs above**

Order # 3DVD \$65.95

Shipping and Handling: US and Possessions - Add \$2.00 for a single DVD, \$2.50 for the second, and \$1 for each additional. FREE SHIPPING ON ORDERS OVER \$75.00 (merchandise only). Foreign - Calculated by order weight and destination and added to your credit card charge. Allow 3 to 4 weeks for delivery.



**CQ Communications, Inc.**



25 Newbridge Rd., Hicksville, NY 11801

1-800-853-9797 FAX 516-681-2926

## April Survey Highlights

(from page 32)

In our April survey we asked about hobby-related organized activities you participate in. Groucho Marx famously said, "I would never belong to a club that would have me as a member," and 37 percent of our readers apparently agree, though the majority of respondents felt otherwise. The top organized activities were scanner monitoring (35 percent), hobby-related group outings (32 percent), and amateur radio contests (28). SWL contests (17 percent) and building challenges (15 percent) got some votes, but foxhunting and geocaching saw little interest (7 percent and 4 percent, respectively, perhaps due to the winter weather). Concerning the importance of organized activities, readers were split pretty evenly among the four choices: very important (24 percent), moderately important (33 percent), not very (20 percent), and not at all (23 percent). But answers to the last question, "Are organized activities something you'd like to learn more about?" indicate that our readers are certainly interested, with 72 percent saying they'd like to hear more—something *Pop'Comm* will keep in mind for future issues. Thanks for the feedback.

The winner of a free subscription or extension to *Pop'Comm* this month is **Harry Kauffman** of **South Branch, Michigan**. Congratulations, **Harry!**

## Federal Agencies

### Homeland Security

Frequency assignments for the Department of Homeland Security

#### RADIO NET 1

163.65	168.8	171.6125	172.5125
167.15	168.85	171.6375	173.6625
167.2375	170.7125	172.2875	
167.4	171.175	172.45	

#### RADIO NET 2

166.9125	167.375	167.475	167.525
167.2125	167.425	167.5	167.725

#### RADIO NET 3

167.225	167.6	167.675	167.7875
---------	-------	---------	----------

#### BOATS

BOAT 1 169.6375	BOAT 2 169.3875
-----------------	-----------------

#### OTHER

166.6375	167.575	168.825	170.7375
167.55	168.375	170.0625	170.8375

### Itinerant

Just like commercial itinerant frequencies, these can be used any time and any place for a federal operation. They might be a good place to listen for info about the flu if a major outbreak occurs in your area.

163.7125	407.525	412.8875
168.6125	409.075	412.9
173.625	412.875	412.9125

### Family Radio Service

These widely available and inexpensive radios get used for just about everything. It's a good bank to have in your scanner if you have a spare.

Ch.	Freq.	Ch.	Freq.	Ch.	Freq.
1	462.5625	6	462.6875	11	467.6375
2	462.5875	7	462.7125	12	467.6625
3	462.6125	8	467.5625	13	467.6875
4	462.6375	9	467.5875	14	467.7125
5	462.6625	10	467.6125		

### Marine

Of course the Coast Guard plays a vital role in the border defense also. Much of the Coast Guard traffic takes place interacting with ships on the marine frequencies. If you're near water (even rivers and lakes) you should plug these in and see what you can hear.

Ch.	Freq.	Use
6	156.3000	Intership Safety
7	156.3500	Commercial
8	156.4000	Commercial
9	156.4500	Commercial
10	156.5000	Commercial
11	156.5500	Commercial
12	156.6000	Port Operations
13	156.6500	Navigational
14	156.7000	Port Operations
15	156.7500	Environmental
16	156.8000	Distress- Calling
17	156.8500	State Control

18	156.9000	Commercial
19	156.9500	Commercial
20	157.0000	Port Operations
21	157.0500	Coast Guard
22	157.1000	Coast Guard
23	157.1500	Coast Guard
24	157.2000	Marine Telephone
25	157.2500	Marine Telephone
26	157.3000	Marine Telephone
27	157.3500	Marine Telephone
28	157.4000	Marine Telephone
65	156.2750	Port Operations
66	156.3250	Port Operations
67	156.3750	Commercial
68	156.4250	Non-Commercial
69	156.4750	Non-Commercial
70	156.5250	Non-Commercial
71	156.5750	Non-Commercial
72	156.6250	Non-Commercial
73	156.6750	Port Operations
74	156.7250	Port Operations
75	156.7750	
76	156.8250	
77	156.8750	Oil Tankers
78	156.9250	Non-Commercial
79	156.9750	Commercial
80	157.0250	Commercial
81	157.0750	Coast Guard
82	157.1250	Coast Guard
83	157.1750	Coast Guard
84	157.2250	Marine Telephone
85	157.2750	Marine Telephone
86	157.3250	Marine Telephone
87	157.3750	Marine Telephone
88	157.4250	Commercial

## Good News for the VHF/UHF Enthusiast

The all-time favorite magazine for the VHF/UHF enthusiast, CQ VHF is better than ever and here to serve you!

By taking advantage of our subscription specials you'll save money and have CQ VHF delivered right to your mailbox. Only \$26 for four information-packed quarterly issues. Or better yet, enter a two or three year subscription at these special prices. As always, every subscription comes with our money back guarantee.



**DON'T MISS OUT CALL TODAY**

	USA	VE/XE	Foreign Air Post
1 Year	26.00	36.00	39.00
2 Years	52.00	72.00	78.00
3 Years	78.00	108.00	117.00

Please allow 6-8 weeks for delivery of first issue

Mail your order to:

CQ VHF • 25 Newbridge Road • Hicksville, NY 11801

Subscribe on line at [www.cq-vhf.com](http://www.cq-vhf.com)

FAX your order to us at 516 681-2926

Call Toll-Free 800-853-9797

# New, Interesting, And Useful Communications Products

by Staff

## Microsoft Adds HD To Zune

Microsoft has announced the next generation of its Zune portable media player, the Zune HD. This enhanced model, which is expected to be available in the U.S. this fall, is the first portable media player to combine a built-in HD Radio receiver, high-definition (HD) video output capabilities, organic light-emitting diode (OLED) touch screen, Wi-Fi, and an Internet browser.

Zune HD's built-in HD Radio receiver will let users listen to higher-quality sound than does traditional radio on the go. Users also will have access to the additional song and artist data broadcast by HD Radio stations as well as additional channels from their favorite stations multicasting in HD. Zune HD is Wi-Fi enabled, allowing for instant streaming to the device from the more than 5 million-track Zune music store, and will include a full-screen Internet browser optimized for multi-touch functionality. The bright OLED (organic light-emitting diode) touch screen interface allows users to flip through music, movies, and other content with ease, and the 16:9 widescreen format display (480x272 resolution) offers a comfortable viewing experience. The HD-compatible output lets Zune HD customers play back supported HD video files from the device through a premium high-definition multimedia interface (HDMI) audiovisual docking station (sold separately) direct to an HD TV in 720p.

For more information on Zune HD, visit [www.zune.net/ZuneHD](http://www.zune.net/ZuneHD).



Microsoft puts HD Radio in your pocket with its soon-to-be available Zune HD.



In addition to streaming stations from a wireless Internet connection, Cobra's CIR2000A Internet radio offers SD and USB slots for custom music inputs and a CD player with Gracenote media database technology.

## Internet Radios From Cobra

Cobra has added two tabletop Internet radios to its product line: the CIR1000A (MSRP \$179.95) and CIR2000A (MSRP \$289.95). Both models incorporate analog FM radio, stream more than 10,000 free Internet radio stations directly from your wireless Internet connection (802.11 b/g), and play PC-based music in the MP3, WMA, and Real Media formats. You can search for stations by country, region, or genre and stream podcasts, as well as wirelessly stream your music collection from your PC or Mac (excludes copy protected iTunes music downloads); a LAN cable connection is also provided. FM or Internet radio presets, clock, alarm, and sleep timer are included.

The mono one-piece CIR1000A features an 8-watt-peak speaker and built-in Wi-Fi; the three-piece CIR2000A offers two 20-watt-peak speakers in separate cabinets. The CIR2000A adds SD and USB slots for custom music inputs as well as a CD player with Gracenote media database technology that recognizes album and artist information for each song. The unit also offers a full-functioning remote control.

For more information, visit [www.cobra.com](http://www.cobra.com).

## VTech IS9181 Stereo Tabletop Radio

Also new to the table is VTech's IS9181 Wi-Fi Internet Radio. The IS9181 offers streaming



The VTech IS9181 is another feature-rich Internet radio. This one comes in at under \$200.



music across the 802.11 b/g Wi-Fi network with "Best-in-Class" range (broadband Internet service and home Wi-Fi network router required); access to over 11,000 stations with no monthly fee; access to Internet radio stations from the company's online site or from the device itself; ability to play music from any audio device (CD player, MP3 player, etc.); connection to any stereo system or powered speakers to access streaming Internet radio or music files stored on a PC or Mac; built-in FM radio tuner for local FM broadcast service.

The IS9181 hi-fidelity built-in 3 watt tuned stereo speakers and 10 watt subwoofer with class D amplifier offer full, dynamic sound. Other features include digital alarm clock, automatic clock set and adjustment via the Internet, battery-operation option, and remote control.

For more information on the VTech IS9181 (MSRP \$199.95), visit [www.vtechphones.com](http://www.vtechphones.com).

## MFJ Grab-and-Go Emergency Communications Center

The MFJ-706 is an Emergency Communications (EmComm) box that turns your ICOM IC-706 into an emergency communications center. It covers all HF, VHF, and UHF amateur radio frequencies available on the IC-706 and provides a full 100-watt SSB/CW signal simply by plugging into any available vehicle

cigarette-lighter socket or light-duty 10 to 15 amp, 12 VDC power supply. An MFJ PeakPowerBoost circuit delivers instantaneous SSB/CW power peaks using several Farads of super capacitance.

A built-in, full-range automatic antenna tuner turns any random wire or other antenna into a highly effective HF antenna. Simple automatic tuning is done with a single push of a button. An optional antenna mount lets you screw on a loaded whip (such as a Hamstick) for long-range HF communication or use a high-gain VHF/UHF antenna for local communications.

The IC-706 control head can easily be removed and placed in a convenient location while the larger MFJ EmComm box can be placed in the trunk, on the floor, or on the back seat of your vehicle. It is highly compact (4 1/2 x 6 3/4 x 13 1/2 inches HWD), and the handle is positioned so the box is balanced for easier carrying. Tough front and back covers secure and fully protect all the enclosed electronic gear. A convenient compartment stows a microphone and other small accessories.

The IC-706 speaker is fully exposed, so speech audio is loud and clear. The transceiver is well ventilated to prevent overheating, so you can provide continuous high-power communications. The MFJ-706 can be used horizontally, vertically, or at any other angle.

For more information on the MFJ-706 EmComm box (MSRP \$399.95), visit [www.mfjenterprises.com](http://www.mfjenterprises.com).



The MFJ-706 Emergency Communications covers all HF, VHF, and UHF amateur radio frequencies available on the ICOM IC-706 and serves as a complete "grab-and-go" communications center.

**WWW.SCANGAT.COM**

**ORDER TOLL FREE  
888-722-6228**

**COMBO CD SPECIAL**

ScanCat-Lite-Plus.....	Reg. \$29.95
Mr. Scanner FCC Public Safety.....	29.95
Nat-Com's FCC Scancat Files.....	9.95
Bonus Disk Of Frequencies.....	15.00
<b>NOW \$49.95</b>	\$84.85

**PLUS FREE** Scanning Magazine(s)  
*(With Purchase Of Special. While Supplies Last)*

**SUPPORT JUST ADDED FOR  
RADIOHACK PRO-106/PRO197  
UNIDEN BCD-34XT/BCD396XT**

**ScanCat-Lite-PLUS**

Reg. \$39.95 - Limited Time Special \$29.95

**Now It's Easier Than Ever To  
Use Your ScanCat Software.**

**FREE walk-you-through set up  
video to get you going fast.**

[www.scancat.com](http://www.scancat.com) **You Tube**  
Click on learn as you view.

**Scancat-Gold for Windows  
Version 8.50 \$99.95**

**Scancat-Gold for Windows-SE -  
\$159.95**

**Skysweep Decoder Software \$99.95**

**COMPUTER AIDED  
TECHNOLOGIES**

ORDERS: (318) 687-4444 FAX: (318) 686-0449  
Info/Tech Support: (318) 687-2555  
(9 a.m. - 3 p.m. Central M-F)

**WWW.SCANGAT.COM**

## Moving?



**For fast, accurate service,  
please remove the label used to  
address your magazine, and  
attach it to the Address Change  
Card or to any correspondence  
you send us regarding your  
subscription. Send it, along with  
your new address to**

**POPULAR COMMUNICATIONS**

25 Newbridge Road  
Hicksville, NY 11801  
Phone 516-681-2922  
FAX 516-681-2926

# World News, Commentary, Music, Sports, And Drama At Your Fingertips



This listing is designed to help you hear more shortwave broadcasting stations. The list covers a variety of stations, including international broadcasters beaming programs to North America, others to different parts of the world, as well as local and regional shortwave stations. Many of the transmissions listed here are not in English. Your ability to receive these stations will depend on time of day, time of year, your geographic location, highly variable propagation conditions, and the receiving equipment used.

AA, FF, SS, GG, etc. are abbreviations for languages (Arabic, French, Spanish, German). Times given are in UTC, which is five hours ahead of EST, i.e. 0000 UTC equals 7 p.m. EST, 6 p.m. CST, 4 p.m. PST.

UTC	Freq.	Station/Country	Notes	UTC	Freq.	Station/Country	Notes
0000	4451	Radio Santa Ana, Bolivia	SS	0400	6165	Radio Nationale Tchadienne, Chad	FF
0000	9545	Radio Republica, to Cuba	SS	0400	6010	La Voz de su Concencia, Colombia	SS
0000	9580	Radio Romania International		0400	4780	Radio Djibouti	AA
0030	9630	Radio Aparecida, Brazil	PP	0400	7175	Voice of the Broad Masses, Eritreavern; occ 7165	
0030	12095	Radio Thailand		0400	6110	Radio Fana, Ethiopia	Amharic
0030	4717	Radio Yura, Bolivia	SS	0400	3975	Magyar Radio, Hungary	HH
0030	11815	Radio Brazil Central	PP	0400	6973	Galei Zahal, Israel	HH
0100	6155	Radio Fides, Bolivia	SS	0400	7165	Voice of Peace and Democracy, Eritrea	Tigrinya
0100	5025	Radio Rebelde, Cuba	SS	0400	4960	Voice of America Relay, Sao Tome	
0100	4800	Radio Buenas Nuevas, Guatemala	SS	0400	6175	Voice of Vietnam, via Canada	EE, SS
0100	9870	All India Radio	HH	0400	9430	CVC International, Zambia	
0100	9440	Radio Slovakia International		0430	6140	Radio Havana Cuba	
0100	4755	Radio Immaculada Concieceao, Brazil	PP	0430	6290	Radio Cairo, Egypt	AA
0100	6200	Radio Prague, Czech Republic		0500	5005	Radio Nacional, Equatorial Guinea	SS
0100	3310	Radio Mosoj Chaski, Bolivia	SS	0500	3340	Radio Misiones Internacional, Honduras	SS
0130	7235	Voice of the Islamic Republic of Iran		0500	6185	Radio Educacion, Mexico	SS
0200	11710	Radio Argentina al Exterior	SS	0500	4770	Radio Nigeria	
0200	3280	La Voz del Napo, Ecuador	SS	0500	7255	Voice of Nigeria	
0200	9800	Radio Taiwan International, via French Guiana	SS	0500	6020	Radio Victoria, Peru	SS
0200	7200	Sudan Radio TV	AA	0500	4775	Trans World Radio, Swaziland	vern
0200	7270	Russian International Radio, via Armenia	RR	0500	4050	Radio Rossii, Russia, via Kyrgyzstan	RR
0200	9430	Radio Taiwan International		0530	6250	Radio Nacional, Equatorial Guinea	SS
0200	3985	Croatian Radio, Croatia		0600	5995	Radiodifusion du Mali	FF
0200	7280	Radio Farda, USA, via Germany	Farsi	0600	5446.5	AFN/AFRTS, Florida	
0300	4885	Radio Clube do Para, Brazil	PP	0600	5910	Marfil Estereo, Colombia	SS
0300	5010	Radio Madigasikara, Madagascar	Malagasy	0600	9625	Radio Bandierantes, Brazil	PP
0300	4800	Radio Transcontinental, Mexico	SS	0700	6010	Radio Mil, Mexico	SS
0300	4790	Radio Vision, Peru	SS	0700	6145	NHK World Radio, Japan	
0300	5915	Zambia National Broadcasting Corp.		0700	6145	Radio New Zealand International	
0300	4976	UBC Radio, Uganda		0800	4845	Radio Mauritanie, Mauritania	
0300	3220	Radio Sondergrense, South Africa	Afrikaans	0800	9635	RTV du Mali	FF
0300	7215	Trans World Radio, USA, via South Africa	Amharic	0900	4835	VL8A, Alice Springs, Australia	
0300	7475	Voice of Greece	Greek	0900	9541v	Solomon Islands Broadcasting Corp.	
0330	4915	Radio Difusora Macapa, Brazil	PP	0900	6160	CKZN, (Newfoundland), Canada	
0330	4905	Radio Nationale Tchadienne, Chad	FF	1100	15400	HCJB, Australia	II
0330	7110	Radio Ethiopia	Amharic	1100	9655	Radio New Zealand International	
0330	3345	Channel Africa, South Africa		1100	9615	Radio Veritas Asia, Philippines	Mandarin
0400	5865	Radio TV Algerienne, Algeria, via France	AA	1100	6110	Xizang PBS, (Tibet) China	Tibetan
0400	4985	Radio Brazil Central, Brazil	PP	1100	9550	FEBA Radio, via Rwanda	AA
0400	6020	China Radio International, via Canada		1130	3925	Radio Nikkei, Japan	JJ
0400	9885	Voice of America Relay, Botswana		1130	7140	Voice of Korea, North Korea	Mandarin
				1130	7370	KNLS, Alaska	RR
				1130	9670	CVC International, Australia	II

UTC	Freq.	Station/Country	Notes	UTC	Freq.	Station/Country	Notes
1130	3345	Radio Northern, Papua New Guinea	Pidgin	1500	9625	Channel Africa, South Africa	
1130	9910	Trans World Radio, Guam	Mandarin	1500	9955	Happy Station pgm, Taiwan, via WMRI, Florida	
1130	4790	Radio Republik Indonesia	II	1500	15560	RDP International, Portugal	PP
<b>1200</b>	9580	Radio Australia		<b>1530</b>	15275	Deutsche Welle/Voice of Germany, Rwanda Relay	GG
1200	13600	Radio Bulgaria	SS	1530	13730	Radio Dabanga, Sudan, via Germany	
1200	3950	Xinjiang Peoples Broadcasting Station, China	CC	<b>1600</b>	15345	Radio Argentina al Exterior	SS
1200	7360	China Radio International	Thai	1600	11615	Radio France International	
1200	3250	Radio Luz y Vida, Honduras	SS	1600	15215	Aso Radio, Nigeria, via Russia	Hausa
1200	9435	Kol Israel	HH	1600	9335	Voice of Korea, North Korea	KK
1200	3325	Radio Bougainville, Papua New Guinea	Pidgin	<b>1630</b>	12080	Deutsche Welle/Voice of Germany Relay, Portugal	RR
1200	7470	Radio Free Asia, USA, via Mongolia	Tibetan	1630	11840	Radio Farda, USA to Iran	Farsi
1200	7320	IBRA Radio, Sweden, via Russia	Mandarin	<b>1700</b>	11820	BBC Relay, Cyprus	AA
1200	3385	Radio East New Britain, Papua New Guinea	Pidgin	1700	15120	Voice of Nigeria	various
1200	5770	Myanmar Defense Forces, (Burma)	BB	1700	15170	RDP International, Portugal	PP
1200	5985	Radio Myanmar (Burma)	BB	<b>1730</b>	15085	VOIRI, Iran	various
1200	7185	Radio Taiwan International	Mandarin	<b>1800</b>	11880	Radio Australia	
<b>1230</b>	11775	Caribbean Beacon, Anguilla		1800	11745	BBC, via South Africa	FF
1230	9975	Trans World Radio, Guam	unid	1800	11945	NHK World Radio, Japan	
1230	15520	Voice of Turkey		1800	11510	Voice of Russia, via Armenia	
1230	5015	Turkmen Radio, Turkmenistan	Turkmen	1800	11735	Radio Tanzania-Zanzibar	EE/Swahili
<b>1300</b>	9475	Radio Australia	CC	<b>1830</b>	9420	The Voice-Africa, Zambia	FF
1300	13580	Radio Prague, Czech Republic		1830	11660	Adventist World Radio, via Austria	AA
1300	6070	CFRX, relay CFRB, Canada		<b>1900</b>	7465	Radio Tirana, Albania	
1300	5030	China National Radio	CC	1900	11990	Radio Kuwait	AA
1300	9605	BBC Relay, Singapore	CC	1900	17520	Voice of Biafra International, via WHRI	
1300	9935	RS Makedonias, Greece	Greck	1900	11620	Radio Exterior de Espana, Spain	SS
1300	9525	Voice of Indonesia		<b>2000</b>	7285	China Radio International, via Albania	
1300	9920	KFBS, Northern Marianas	VV	2000	11725	Radio New Zealand International	
1300	9965	North Korea Reform Radio, Taiwan	KK	<b>2030</b>	11840	Voice of Vietnam, via England	
1300	9920	FEBC Radio, Philippines	Asian lang	2030	7395	Radio Sweden, via Madagascar	
1300	9485	Family Radio/WYFR, via Russia	II	<b>2100</b>	7255	Radio Station Belarus	
1300	9900	Voice of Russia	Pashto	2100	9430	Radio Prague, Czech Republic	
1300	9990	Radio Free Afghanistan, USA, via Sri Lanka	Pashto	2100	9580	Africa Number One, Gabon	FF
1300	11940	Radio Romania International		2100	13680	Radio Nacional Venezuela, via Cuba	SS
1300	7365	Radio Thailand	CC	2100	12085	Radio Damascus, Syria	various
1300	9900	Voice of Russia	Pashto/Dari	2100	9330	Radio Damascus, Syria	various
1300	11975	Adventist World Radio, Guam	JJ	2100	11620	All India Radio	
1300	9475	Radio Australia		2100	9885	Voice of Russia	
1300	11710	Voice of Korea, North Korea		<b>2200</b>	12095	BBC Relay, Ascension Island	
1300	6065	China National (Business) Radio		2200	11780	Radio Nacional Amazonia, Brazil	PP
<b>1330</b>	9970	RTBF International, Belgium	FF	2200	15540	Radio Nederland, via Bonaire	DD
1330	9705	Voice of Pujiang, China	CC	2200	13680	NHK World Radio, Japan	JJ
1330	12090	Deutsche Welle, Germany, via Sri Lanka	Dari	2200	9810	Voice of the Islamic Republic of Iran	Bosnian
1330	9820	All India Radio, (Goa)	HH	2200	5860	Radio Nederland, via Philippines	II
1330	15735	Radio Sweden		2200	9830	Voice of Turkey	
1330	12035	Voice of Turkey		2200	13820	Radio Marti, USA to Cuba	SS
1330	15380	Broadcasting Svc. of the Kingdom, Saudi Arabia	AA	2200	15110	Radio Exterior de Espana, Spain	SS
1330	7130	Sarawak FM, via Malaysia	Malay	2200	9575	Radio Medi Un, Morocco	FF
1330	9760	VOA Relay, Philippines		2200	7300	Vatican Radio	Mandarin
<b>1400</b>	15140	Radio Sultanate of Oman	AA	2200	9830	Voice of Turkey	
1400	11540	Radio Sweden	Swedish	<b>2230</b>	5930	Cyprus Broadcasting Corp,	Greek, wknds
1400	5910	Shiokaze, Japan, to North Korea	KK	<b>2300</b>	6240	Radio PMR, Moldova	various
<b>1430</b>	7400	Radio Bulgaria	SS	2300	9875	Radio Free Asia, USA, via Germany	Tibetan
<b>1500</b>	13775	Radio Austria International	GG	2300	7285	Voice of Russia	RR
1500	13730	Radio Tirana, Albania		2300	6115	Radio Romania International	
1500	9625	CBC Northern Quebec Service, Canada	vern	<b>2330</b>	9855	Radio Kuwait	AA
1500	15190	Radio Africa, Equatorial Guinea		2330	7400	Radio Bulgaria	
1500	15650	Miraya FM, Sudan, via Slovakia					

# Radio Squatters And Radio Shufflers

by Gerry L. Dexter  
gdex@wi.rr.com

*“The clear-out of the 7.100–7.200 area isn’t quite complete...we’re still left with some of the old targets and a few familiar voices in their old spots. Enjoy this listening bonus while it lasts.”*

**R**ound up the usual suspects! The clear-out of the 7.100–7.200 area isn’t quite complete. As these words go into the laptop quite a few countries have ignored the abandon ship order, leaving us with a number of interesting targets still active where they’re not supposed to be. The EiBi listing for the current A-09 season shows considerable activity still present. Namely:

- 7100 Voice of Korea
- 7105 Nei Menggu PBS, China
- 7110 Radio Madagaskara, Madagascar  
China National Radio Radio Ethiopia  
UBC Radio, Uganda
- 7125 PBS Xizang and CNR-8, China
- 7130 Sarawak FM. Malaysia
- 7135 Belarus Radio, Radio Mahiliou, Belarus
- 7135 Radiodiffusion du Maroc, Morocco
- 7140 Voice of Korea, North Korea  
Radio Republika Sakha, Russia  
Radio Rossii, Russia
- 7145 Lao National Radio
- 7145 Radio Hargeisa, Somalia
- 7150 China Business Radio
- 7155 PBS Xinjiang, China
- 7155 Radio Pakistan
- 7160 Radio ICDI, Central African Republic  
China National Radio
- 7165 Nei Menggu PBS, China  
Voice of Peace and Democracy,  
(Opposition)  
Voice of Democratic Alliance,  
(Opposition)  
Voice of the Broad Masses, Eritrea  
Radio Ethiopia
- 7170 PBS Xizang, China
- 7175 Voice of the Broad Masses, Eritrea
- 7185 Firedrake Jammer, China  
SLBC, Sri Lanka
- 7190 All India Radio, Mumbai
- 7195 China National Radio  
UBC Radio, Uganda

In some respects the list is rather disturbing, from the point of the desire for law and order and

all that. From another angle, we’re still left with some of the old targets and a few familiar voices in their old spots. Enjoy this listening bonus while it lasts.

There may be a new Trans World Radio outlet on the air from Benin in another year or two. Word is that TWR plans to apply for a license there.

CVC has cut back its operating hours on 6070, apparently in deference to CFRX, a long-time res-

**The Issue of Abductions of Japanese Citizens by North Korea**

**For the Return of All of the Abductees**



**Headquarters for the Abduction Issue Government of Japan**

Rich D'Angelo received a QSL for his reception of Fursato no Kaze, based in Japan and beamed to North Korea from various sites. (The QSL didn't identify the people in the picture.)

## Help Wanted

We believe the "Global Information Guide" offers more logs than any other monthly SW publication (420\* shortwave broadcast station logs were processed this month!). Why not join the fun and add your name to the list of "GIG" reporters? Send your logs to "Global Information Guide," 213 Forest St., Lake Geneva, WI 53147. Or you can email them to [gdex@wi.rr.com](mailto:gdex@wi.rr.com). Please double-check your material before sending as logs that don't contain a frequency or a time cannot be used. Please also note that files sent as attachments do not always go through. See the column text for formatting suggestions..

*\*Not all logs get used. There are usually a few which are obviously inaccurate, unclear, or lack a time or frequency. Also discounted are unidentifieds, duplicate items (same broadcaster, same frequency, same site), and questionable logs.*

ident of 6070, the result being a stronger, cleaner signal out of Toronto.

If you've noticed Africa Number One has been down to a single frequency of late, that's because technical difficulties have forced the closedown of both 15475 and 17630. At least one of the two frequencies should be back in operation by the time you read this. The old 9580 standby remained active all along.

Radio Teilifis Eireann has begun a service for the Irish living and serving in Africa. It goes out via Meyerton, South Africa, daily from 1930 to 2030 on 6220.

## A Guide To "GIG-Speak"

Here's a partial list of abbreviations used in the "Global Information Guide":

(l)	listed
(p)	presumed
(t)	tentative
*	sign on/off time
//	parallel frequency
AA	Arabic
ABC	Australian Broadcasting Commission
AFN	Armed Forces Network
AFRTS	Armed Forces Radio TV Service
AIR	All India Radio
am	amplitude modulation
ancr	announcer
anmt(s)	announcement(s)
AWR	Adventist World Radio
BBCWS	BBC World Service
BSKSA	Broadcasting Service of the Kingdom of Saudi Arabia
CBC	Canadian Broadcasting Corp.
CC	Chinese
CNR	China National Radio
co-chan	co-channel (same) frequency
comml	commercial
CPBS	China People's Broadcasting Station
CRI	China Radio International
DD	Dutch
DJ	disc jockey
DW	Deutsche Welle/Voice of Germany
EE	English
f/by	followed by
FEBA	Far East Broadcasting Association
FEBC	Far East Broadcasting Company
FF	French
GBC	Ghana Broadcasting Corp.
GG	German
HH	Hebrew; Hungarian
HOA	Horn of Africa
ID	identification
IJ	Italian; Indonesian
Intl	International
IRIB	Islamic Republic of Iran Broadcasting
IRRS	Italian Radio Relay Service
IS	interval signal
JJ	Japanese
KBS	Korean Broadcasting System

KK	Korean language
Lang	language
LSB	lower sideband
LV	La Voz; La Voix
M	man
NBC	National Broadcasting Corporation (Papua New Guinea)
nf	new frequency
ORTB	Office de Radiodiffusion et Television du Benin
PBS	People's Broadcasting Station
PP	Portuguese
PSA	public service announcement
QQ	Quechua
RAE	Radiodifusion Argentina al Exterior
RCI	Radio Canada International
Rdf	Radiodifusora. Radiodiffusion
REE	Radio Exterior de Espana
RFA	Radio Free Asia
RFE/RL	Radio Free Europe/Radio Liberty
RFI	Radio France International
RHC	Radio Havana Cuba
RNZI	Radio New Zealand International
RR	Russian
RRI	Radio Republik Indonesia; Radio Romania International
RTBF	RTV Belge de la Communaute Francaise
s/off	sign off
s/on	sign on
SIBS	Solomon Is. Broadcasting Corp.
sked	schedule(d)
SLBC	Sri Lanka Broadcasting Corp.
SS	Spanish
TC	time check
TOH	top of the hour
TT	Turkish; Thai
TWR	Trans World Radio
unid	unidentified
USB	upper sideband
UTC	Coordinated Universal Time (= GMT)
UTE, Ute	utility station
v	variable
vern	vernacular (local language)
VOA	Voice of America
VOIRI	Voice of Islamic Republic of Iran
VOR	Voice of Russia
W	woman
ZBC	Zambian Broadcasting Corp.



Radio Farda—one of the services of Radio Free Europe/Radio Liberty—is beamed to the youth of Iran. (Thanks Rich D'Angelo)

We'll have to wait until late fall to have a shot at this one, considering the time and frequency involved.

Radio Jordan has apparently dropped its use of 11690, and 11960 and 15290 are the apparent replacements. Also, the English broadcasts seemed to have been cut back or eliminated completely.

A new one from Peru is Radio Rasuwilca, located in Ayacucho and operating on 4805. It seems to sign on around 1000.

Liberia's Star Radio, formerly relayed by Ascension, is no longer broadcasting on shortwave.

And Radio Sweden has eliminated its shortwave broadcasts in... Swedish! You can still hear Swedish on the Radio Sweden frequencies, but it'll be from the domestic broadcaster Sveriges Radio. That can be seen as an economic move. Radio Norway did the same thing years ago as it clung to its final months. Of course in their case the language was Norwegian.

## Reader Logs

Remember, your shortwave broadcast station logs are always welcome. But *please* be sure to double or triple space between the items, list each logging according to home country, and include your last name and state abbreviation after each. Also needed are spare QSLs or good copies you don't need returned, station schedules, brochures, pennants, station photos, and anything else you think would be of interest. And, c'mon, how about sending a photo of you at your listening post? It's your turn to grace these pages!

Here are this month's logs. All times are in UTC. Double capital letters are language abbreviations (SS = Spanish, RR = Russian, AA = Arabic, etc.). If no language is mentioned English (EE) is assumed.

**ALBANIA**—Radio Tirana, 7465 at 1940 on farming there and 13730 at 1525 on local elections. (Maxant, WV)

**ALGERIA**—RT Algerienne, 5865 via France at 0447 with Koran recital, long AA talk. The carrier cut out for about two minutes until Program Two returned with more Koran. (D'Angelo, PA)

**ANGUILLA**—University Network, 11775 at 1246 with Dr. Scott preaching. (Wood TN) 1620 with Melissa Scott preaching. (Maxant, WV)

**ARGENTINA**—RAE, 11710.7 at 0213 with EE news, contact info. Poor and barely audible by 0240. Noted again in FF at 0307 with

## In Times Past...

Here's your blast from the past for this month...

**Brazil**—Radio Educadora Sao Jose, Macapa, Brazil, ZYG461, 2400 kHz, in PP at 0215 on April 25, 1969. (Dexter, WI)

a good signal. (Alexander, PA) 15345 in SS at 1610. (Maxant, WV) 2234 in SS with M/W, some pops. (MacKenzie, CA)

**ASCENSION ISLAND**—BBC South Atlantic Relay, 6005 at 0421 with *The World Today*. (Brossell, WI) 9915 with interview, TS and ID at 2200, //12095. (Ronda, OK) 12095 heard at 2210 with M/W in conversation. (MacKenzie, DCA)

**AUSTRALIA**—Radio Australia, 9475-Shepparton at 1300 with CC news. (Ng, Malaysia) 9560 at 1330 with a very good jazz pgm. (Linonis, PA) 9580-Shepparton at 1220 interviewing the commander of the UN peacekeeping contingent in Rwanda. (Wood, TN) 11660-Brandon at 2144 with a variety of world news reports and pops. Also 12010-Darwin at 2242 with pops and conversation about fire responses, IDs and news at 2300. (Ronda, OK) 11880 at 1850 on a Melbourne investigation. (Maxant, WV) 15560-Shepparton at 2320 on Chinese gas production. (MacKenzie, CA)

ABC Northern Territories Service: 2310-Alice Springs at 1151 with *Saturday Night Country* pgm. (Taylor, WI) 4835 at 0755 with M, slow W vocal. In the clear but quite weak. (Parker, PA) 2325-Tennant Creek at 1150 interviewing several personalities. (Strawman, IA) 4910 at 0810 with local ballads, //4835-Alice Springs. Both poor in noise. (Alexander, PA)

HCJB-Australia, 15400 in II with Bible reading at 0025. (Ng, Malaysia)

**AUSTRIA**—Radio Austria International, 13775 via Canada at 1520 with M/W in GG on theater there. (Maxant, WV)

**BELARUS**—Radio Belarus, 7255 at 2000–2100 with EE news, local music. Fair level but muffled audio made it difficult to understand. Gave contact info at 2056, then covered by Nigeria at their 2100 sign on. (Alexander, PA)

**BELGIUM**—RTBF International, 9970 at 1344 with talks and songs in FF. (Brossell, WI)

**BOLIVIA**—Radio Eco, Reyes, 4409.8 at 0000 but difficult to copy under pulsating signal with a UTE also present. (Wilkner, FL)

Radio Santa Ana, Santa Ana del Yacuma, 4451.2 at 0000 irregularly noted from several Florida locations around this hour. (Wilkner, FL)

Radio Virgen de Remedios, Tupiza, 4555 noted with very weak signals at 0010 with occasional UTE QRM. (Wilkner, FL)

Radio Yura, Yura, 4716.5 at 0042 with vocals. (Strawman, IA) 0100 with domestic selections. Also 1000–1030 at varied sign on times. (Wilkner, FL)

Radio Lipez, Uyuni, 4796.4 at 1000 with vocals and deep fades. (Wilkner, FL)

Radio Pio Doce, Siglo Veinte, 5952.5 at 0150 with SS talk ID at 0225, River Kwai March signature tune at 0232 and SS anmts to sign off. Splatter from WYFR. (Alexander, PA)

Radio Fides, La Paz, 6155.2 monitored at 0105 with SS talk, ballads, comls. (Alexander, PA)

**BONAIRE**—Radio Nederland Relay, 15540 at 2226 in DD with anmts, national anthem and off the air at 2227. //17605. (MacKenzie, CA)

**BOTSWANA**—VOA Relay, 4930 at 0305 interview with the editor of *The Middle East Times*. (Parker, PA) 0400 with VOA news. //4960-Sao Tome. (Wood, TN) 9885 at 0410 with a report on the G-20 summit. (Ronda, OK)

**BRAZIL**—(All in PP) Radio Municipal da Cachoeira, Sao Gabriel, 3375.1 at 0940 with ancr and occasional music bridges. (Wilkner, FL)

Radio Imaculada Conceicao, Campo Grande, 4754.9 at 0550 with M and slow, sappy ballad, ID and jingle. (Parker, PA)

Radio Difusora do Amazonas, Manaus, 4805 at 0935 with M talk. (Wilkner, FL)



Radyo Pilipinas sent this QSL to Peter Ng in Malaysia for his reception on 15285.

Radio Alvorada, Londrina, 4865 at 0445 with M talk, under modulated. (Parker, PA)

Radio Difusora Roraima, Boa Vista, (p), 4877.5 weak at 2330. (Wilkner, PA)

Radio Clube do Para, Belem, 4885 monitored at 0347 with torrid Gypsy music. (Wood, TN) 0356. (Yohnicki, ON) 0410. (Parker, PA)

Radio Anhanguera, Araguaina, 4905 monitored at 2340 with music and M host. (Wilkner, FL)

Radio Difusora, Macapa, 4915 at 0312 with M hosting "grown up" pops. (Parker, PA) 0354. (Yohnicki, ON) 0356 with ID and MOR pops. (Wood, TN)

Radio Educacao Rural, Tefe, 4925.3 at 0213 with long talk by M. (Taylor, WI)

Radio Brazil Central, Goiania, 4985 at 0351 with M hosting pops. (D'Angelo, PA) 0433 with slow ballad, highlife, pops. (Parker, PA) 11815 at 0030 with possible sports commentary. (Strawman, IA)

Radio Aparecida, Aparecida, 9630 at 0015 with M ancr and pops. (Parker, PA)

Radio Nacional Amazonia, Brasilia, 11780 at 0121 with soccer match between Brazil and Paraguay. (Taylor, WI) 0453 with talks. (Brossell, WI)

**BULGARIA**—Radio Bulgaria, 13600 in SS heard at 1225. (Brossell, WI)

**CANADA**—Radio Canada International, 9615 with *Maple Leaf Mailbag* at 1615. (Maxant, WV) 9645-Sackville in SS at 0010. (Parker, PA) 11700 via China at 0040 with talk on the Canada Labor Congress. (Ng, Malaysia)

CBC Northern Quebec Service, 9625 in local language at 1540. (Maxant, WV)

CFRX, Toronto, 6070 at 1227 with *The Home Improvement Program*. (Wood, TN) 1530 with a magazine pgm. (Maxant, WV)

CHU, Ottawa, 3330, 7850 with EE/FF time signals at 1904. (Maxant, WV)

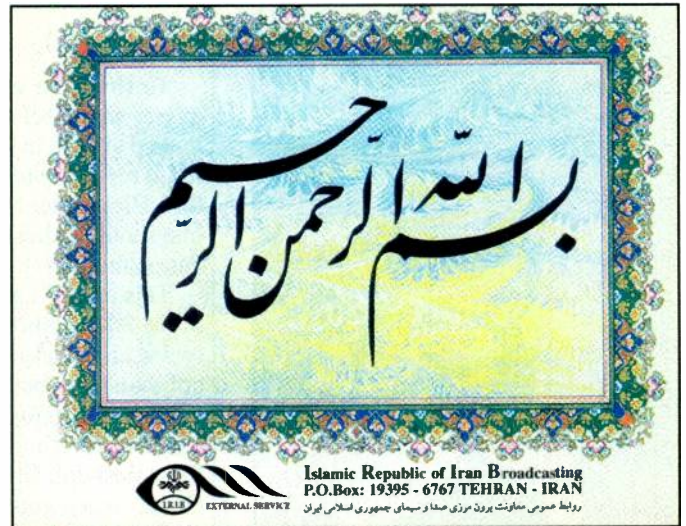

Our Iranian friends are issuing this QSL for the various IRIB broadcasts.

**CHAD**—R. Nationale Tchadienne, N'Djamena, 4905 at 0335 with slow, sappy music. (Parker, PA) 6165 at 0430 sign on with NA, opening FF ID, anmts and Afro-pops. (Alexander, PA)

**CHINA**—China Radio International, 6020 via Canada at 0433 with comments on China's economy. //6080 also via Canada. (MacKenzie, CA) 7180-Xi'an in RR at 1312. Also in RR via Urumqi on 7255 but not in parallel. Also 7285 via Albania at 2013 and 7360-Kunming at 1211 in (l) Thai. (Brossell, WI) 7220-Xi'an at 2315 in VV and 12085-Xi'an at 1230 very poor, maybe the Mongolian service. (Ronda, OK) 7290-Shijiazhuang at 1056 with traditional instrumentals, and news in RR. (D'Angelo, PA) 13640 at 2215 with pops and ancrs in JJ. (Barton, AZ) 13655 at 1215. (Fraser, ME)

China National Radio: Xinjiang PBS, Urumqi, 3950 in CC at 1220. (Ng, Malaysia) 5030-Beijing in CC at 1308. (Brossell, WI) Voice of Pujiang, Shanghai, 9705 in CC at 1322. (Brossell, WI) CNR-1, Lingshi, 9890 at 2319 with two men in Mandarin. (Ronda, OK) 13610-Naning at 1045 with long M/W in CC. (Barton, AZ)

**COLOMBIA**—La Voz de su Concencia, Puerto Lleras, 6010 at 0412 with IDs at 0423 and 0428 and lively SS music, anmts, SS talk. (Alexander, PA)

**CUBA**—Radio Havana Cuba, 6140 at 0438 with W and EE comments. (MacKenzie, CA)

Radio Rebelde, 5025 in SS at 0415. (MacKenzie, CA) 0605 with two M calling baseball game, several EE baseball terms used. (Wood, TN)

**CYPRUS**—Cyprus Broadcasting Corp., 5930 (ex-6180) at 2245 with talk in Greek. Abruptly off at 2244:30. //9760 was good, 7210 good but mixing with China. Schedule is Fri.-Sat.-Sun. (Alexander, PA)

**CZECH REPUBLIC**—Radio Prague, 6200 at 0100 news items re possible flooding there. (Fraser, ME) 9430 with *One on One* pgm at 2120. (Ng, Malaysia) 11600 with sports news at 2015. (Ng, Malaysia) 13580-Litomysl heard at 1305 on the Czech constitution. (Wood, TN)

**DJIBOUTI**—Radio Djibouti, 4780 at 0310 with Koran recitations under heavy CODAR. (Strawman, IA) 0346 with HOA vocals to ID at 0359. News in AA at 0400. (D'Angelo, PA) 0416 in AA. (Brossell, WI)

**ECUADOR**—La Voz del Napo, Tena, 3280 at 0956 with LA vocals, SS anmts, flutes. (D'Angelo, PA)

**EGYPT**—Radio Cairo, 6255 at 2000 with FF ID and presumed news, also 6290 at the same time with AA talks. (Brossell, WI) 6290 in AA at 0450. (Parker, PA)

**ENGLAND**—BBC, 5915-Skelton at 0257 open and anmt "This is the BBC. There is no program at this channel at present" and website URL. Time pips at 0300 and opening of Swahili service. (D'Angelo, PA) 6195 Singapore Relay at 1250 but just words and occasional sentences breaking through the noise. Clear BBCWS ID. (Ronda, OK) 9605 Singapore Relay at 1300 sign on in (p) CC. (Linonis, PA) 1319

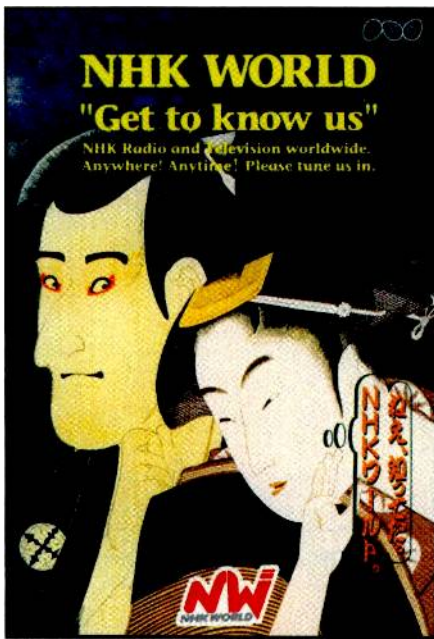

NHK World Radio's recent QSL, probably one of many designs.

in (l) Mandarin. (Strawman, IA) 11745 South Africa Relay in FF at 1825. (MacKenzie, CA) 11820 Cyprus Relay in AA at 1740. Off abruptly at 1745. Also 15420 South Africa Relay at 1821 on textile sales in Tanzania and Kenya. (Brossell, WI) 17640 Seychelles Relay with news at 0800. (Ng, Malaysia)

**EQUATORIAL GUINEA**—Radio Nacional Malabo, 6250 at \*0527 sign on, then continuous African vernacular, possible news at 0609. (Alexander, PA)

Radio Nacional Bata, 5005 at 0521 with Euro and Afro-pops, some periods of dead air and only an open carrier after about 0535. (Alexander, PA)

Radio Africa, 15190 noted as early as 1429 sign on and as late as 2258 close with EE religious pgms. (Alexander, PA) 1855 with a gospel pgm. (Maxant, WV)

**ERITREA**—Voice of the Broad Masses, 7175 (sometimes 7165), at \*0354 with IS/ID sequence and vernacular talk completely covered by a noise jammer. Moved to 7165, followed by jamming. (Alexander, PA)

**ETHIOPIA**—Radio Ethiopia, 7110-Gedja, \*0259 sign on with electronic keyboard IS, talk in (l) Amharic, HOA music, //5991.1 not on until 0322 and only a threshold signal on 9704.1. (Alexander, PA) 0332 with fairly long Amharic talk, HOA music and a continuous hum. (Taylor, WI) 0410 with HOA vocals and two men in Amharic. (D'Angelo, PA) 0416 in Amharic with what sounded like man-on-the-street interviews. (Wood, TN)

Radio Fana, 6110 at 0354 with HOA vocals, M in Amharic with ID over music f/by news. (D'Angelo, PA)

**FRANCE**—Radio France International, 7150 via South Africa in FF at 2004. 11615 with contest info at 1647. (Brossell, WI) 15605 at 1625. (Maxant, WV)

## This Month's Winner

To show our appreciation for your loggings and support of this column, each month we select one "GIG" contributor to receive a free book. Readers are also invited to send in loggings, photos, copies of QSL cards, and monitoring room photos to me at *Popular Communications*, "Global Information Guide," 25 Newbridge Rd., Hicksville, NY 11801, or by email to [gdex@wi.rr.com](mailto:gdex@wi.rr.com). The email's subject line should indicate that it's for the "GIG" column. So, come on, send your contribution in today!

This month's prizewinner is **Bob Fraser of Bedford, Maine**, who lands a copy of the 2010 edition of *Passport to World Band Radio*, courtesy of Universal Radio ([www.universal-radio.com](http://www.universal-radio.com)). You count on Universal Radio for all of your radio hobby needs (but, sorry, they don't issue QSLs!). You can have a copy of their mammoth catalog—free—just by calling them at (614) 866-4267 or sending an email to [dx@universal-radio.com](mailto:dx@universal-radio.com). Letter requests go to 6830 Americana Ave., Reynoldsburg, OH 43068. Please mention *Pop'Comm* and the "Global Information Guide" when you contact them.

**GABON**—Africa No. One, 9580 at 2120 with Afro-pops, many sung in FF, FF studio chatter. (Ronda, OK)

**GERMANY**—Deutsche Welle, 7205 via Petropavlovsk in RR at 2010, 11725 Rwanda Relay in GG at 1818, 12080 Portugal Relay in RR at 1649. Also 12090 Sri Lanka Relay in (l) Dari at 1333. (Brossell, WI) 9885 Sri Lanka Relay at 0045 with EE/GG lesson and 15650 Sri Lanka Relay in GG at 0810. (Ng, Malaysia) 11865 Portugal Relay in GG at 2218. (MacKenzie, CA) 15275 Rwanda Relay in GG at 1535. (Maxant, WV)

**GREECE**—RS Makedonias, 9935 in Greek at 1343. (Brossell, WI)

**GUAM**—Trans World Radio, Merizo (t), 9975 at 1236 with prayers and inspirational talk in an Asian language. Into EE language lessons at TOH. (Wood, TN)

**GUATEMALA**—Radio Buenas Nuevas, San Sebastian, 4799.8 at 0425, SS ID at 0425 and sign off at 0432, briefly swamping XERTA. (Parker, PA)

**HONDURAS**—Radio Luz y Vida, San Luis, 3250 at 0326 in SS with anmts, short music segments f/by long religious talk. (D'Angelo, PA) 1130 with EE translations of SS sermon. (Wilker, FL)

Radio Misiones Intl, 3340, Tegucigalpa at 0332 with SS vocals, EE IDs, M with SS songs, (D'Angelo, PA) 0510 with fast hip-hop type music not usually associated with this station. W with ID at 0521. (Wood, TN) 0720 with contemporary SS religious music, ID at 0730. (Alexander, PA)

**HUNGARY**—Hungarian Radio, 3975 at \*0400 with opening anmts, man in HH f/by news, then W hosting features. (D'Angelo, PA)

**INDIA**—All India Radio, 5010-Thiruvananthapuram in (p) Hindi at 1256, 7290-Chennai in (p) Hindi at 1320, 9425-Bengaluru in Hindi at 1324, 9820-Panaji (Goa) in (p) Hindi at 1334 and 11585-Delhi in presumed Hindi at 1332. (Brossell, WI) 9440 in (p) Hindi at 1230-1245 with EE pops. (Linonis, PA) 9455 with music from India at 1550 and 9870 with Indian music at 1904. (Maxant, WV) 9870-Bangaluru at 0124 with a variety of Indian

music. Exceptional strength during my local evening. (Ronda, OK)

**INDONESIA**—Voice of Indonesia, 9525v in EE at 1301 with *Indonesian Wonders* pgm at 1331, closing anmts at 1400 with IDs, contact info, and Malay would be next and it was at 1402. (Alexander, PA) 1302 with nearly an hour of armchair copy. *Today's History* at 1316. (Strawman, IA) 1335 with II songs, ID and frequency at 1400. (Ronda, OK)

**IRAN**—VOIRI/Voice of Justice, 7170 in listed Pashto monitored at 1316, off at 1327 per schedule. Also 7235 at 0205 fluttery in EE and US policy toward Iran, etc. and 9810-Kalamabad in (l) Bosnian at 2210. (Ronda, OK) 7235 on G-20 summit, several IDs and contract info to 0337 close. (Strawman, IA) 7320 at 2020 in EE on unemployment and inflation woes in Western countries. (Fraser, ME) 2016 with *Europe in the Past Week*. (Brossell, WI)

**ISRAEL**—Kol Israel, 9435 at 1210 with IS and into HH. Co-channel AA station QRM. (Linonis, PA)

Galei Zahal, 6973 at 0407 in HH with usual mix of eclectic music. (Wood, TN)

**ITALY**—NEXUS, 7290 at 1905 with speculation on Obama visiting Cuba. (Maxant, WV)

**JAPAN**—Radio Japan, 5960 via Canada in JJ at 0432, 9835 in JJ at 1815, 11945 via France in JJ at 1817, 13640 in JJ at 2235 and 13680 in JJ at 2202, //15265 and 13640. (MacKenzie, CA) 6120 via Canada in EE at 1212 on the first Japanese astronaut. (Fraser, ME) 11815-Yamata with EE news at 0905. (Ng, Malaysia) 15265 in unid Asian Lang at 2350 and IDs to sudden close at TOH. (Barton, AZ)

Radio Nikkei, 3925 in JJ at 1142 with semi-classical music. (Strawman, IA)

**JORDAN**—Radio Jordan, 11690 at 1550 in AA with woman talking and music. (Maxant, WV)

**KUWAIT**—Radio Kuwait, 9885-Kabd, 2355 with AA music. (Parker, PA) 11990 at 1910 with *Epic Hour* program. (Maxant, WV)

**MADAGASCAR**—Radio Madagaskara, 5010 at \*0302 sign on with IS, NA and into Malagasy talk, then instrumentals and



pops. (Alexander, PA) 0302 with W and end of opening anmts in Malagasy f/by music with lots of shouting and drums. (D'Angelo, PA)

**MALI**—RTV Malienne, 5995 at \*0801 sign on with flute IS, opening FF anmts local African music at 0802, listed //7285 not heard due to a strong digital transmission. (Alexander, PA)

**MAURITANIA**—Radio Mauritanie, 4845 at 0805 with two M with phone interview in vernacular. (Parker, PA) 2345 with W in AA and into vocals. (Ronda, OK)

**MEXICO**—XERTA, Mexico City, 4800 at 0414 with M in SS and slow ballads. (Parker, PA)

Radio Educacion, Mexico City, 6185 at 0540 with nice pgm of Mexican folk music with anc sounding very well versed in the music. Sign off at 0602 with ID, EE translations with website URL and requests for comments. (Wood, TN)

**MOLDOVA**—Radio PMR, Pridnestrovie, 6240 monitored at 2318 recalling the 1992 conflict with Moldova. (Fraser, ME)

**MYANMAR**—Myanmar Radio, 5985 at 1205 with talks and songs in Burmese. (Ng, Malaysia)

**NETHERLANDS**—Radio Nederland, 5860 via Tinang at 2213-2259\* in II. (D'Angelo, PA)

7530 at 1420 with *Earthbeat* pgm and 9390 via Philippines at 1325 with talk by M in DD. (Ng, Malaysia) 9450 via Portugal in SS at 0050 to Central America with various high-life selections. (Parker, PA) 9475-Tinang at 2245 in Indonesian on Islam there, Web and postal address at 2256. (Ronda, OK) 12045 at 1825 with a report on the discouraging lives of people in Zimbabwe. (Fraser, ME) 15105 at 1330. (Linonis, PA)

**NEW ZEALAND**—Radio New Zealand International, 6170 at 1009 with W with news, promo for *World of Books* pgm, weather forecast and M hosting pgm *Late Edition*. Also 9655 at 1112 with *Dateline Pacific* and ID at 1117. (D'Angelo, PA) 7145 at 1600 with an item about Fiji, also 11725 at 2015 mentioning Wellington. (Maxant, WV) 9765 at 1030 with music program to 1100 when they closed here and moved to 9660. (Linonis, PA) 9765 with *Pacific Beat*. (Barton, AZ) 15720 at 0143 on politics in New Caledonia and the Solomons. (Ronda, OK)

**NIGERIA**—Radio Nigeria, Kaduna, 4770 at 0525 with long reggae-type number. (Parker, PA) 0541 in EE, FF and vernacular with Afro-pops. Time signal and ID at TOH. (Wood, TN)

Voice of Nigeria, 7255 in (I) Hausa at 2239. (Brossell, WI) 9690 at 1015 with talk on agriculture and politics, anmt on HIV testing. (Alexander, PA) 1605 with W hosting local vocals. Also 15120 at 2015 discussing Nigerian culture and educational system there. (Maxant, WV) 1723 on university education in Nigeria. (Ronda, OK) 1824 with ID and *Impressions* pgm and promos for *Evergreen* pgm. (Wood, TN) 2058 with ID and close down routine. (Fraser, ME)

Aso Radio, 15215 via Samara, Russia, from 1600 open to 1630\*. Sign on with opening ID, anmts, talk in (I) Hausa. Some short breaks of African music. This is Mon.-Fri. only. (Alexander, PA)

**NORTH KOREA**—Voice of Korea, 7140-Kujang at 1125 with M/W in Mandarin. (Ronda, OK) 1220 in KK with W apparently explaining sections of an opera. (Taylor, WI) 9335 at 1315 extolling the virtues of North Korea. (Strawman, IA) 1322 on the socialist Korean economy. (Brossell, WI) 1745. (Barton, AZ) 11710 monitored at 1435 with M/W ancrs and opera. (Parker, PA) Poor at 1555 on Japanese people or individuals. (Maxant, WV)

**NORTHERN MARIANAS**—KFBS, 9920-Saipan in listed VV heard at 1212. (Strawman, IA)

**OMAN**—Radio Sultanate of Oman (p) 15140 at 1427 with pops usual theme and EE news at 1431. Too weak to hear a real ID. (Alexander, PA)

**OPPOSITION**—Voice of Peace and Democracy/Voice of Democratic Eritrea (to Eritrea), 7165-Gedja at 0400 with sign on and music, talk in Tigrinya. A "surging" noise thought to be jamming began at 0402. (Ronda, OK) 0405 in (I) Tigrinya with M anc and distinctive, pulsing music. ID 0414. (Taylor, WI)

Radio Xoriyo Ogadenia (to Ethiopia), 15350 via Samara at \*1700 with HOA music, talk in listed Somali, brief HOA breaks. Fairly well covered by noise jammer at 1701, //17870 not heard and also jammed. This is Monday and Friday only. (Alexander, PA)

Ginbot 7 (to Ethiopia), 15350 at \*1700-1739\* sign on with HOA music, open ID, talk in (I) Amharic, weak noise jammer, //17870. This is Tue., Thurs., Sat. only. (Alexander, PA)

Voice of Meselina Delina (to Eritrea), (t) 15350 at \*1730 with on with HOA music, opening anmts, instl music, unid language. This is Tues., Thurs., Sat. only. (Alexander, PA)

Radio Republica (to Cuba), 9545 at 0027 in SS with numerous IDs and music bits. (Parker, PA)

Voice of Biafra International (to Nigeria), 17520nf via WHRI at 1900 signing on with drums and opening EE ID and anmts. EE news at 1911, talk on poverty in "Biafraland." Difficult to copy due to accent. (Alexander, PA)

Denge Mesopotamia (to Iraq), 7540 via Ukraine at 2020 with talks in (I) Kurdish. (Brossell, WI)

North Korea Reform Radio, 9965 via Taiwan at 1317. Poor but audible with M/W in KK. (Ronda, OK)

Que Huong Radio (to Vietnam), 15680 at 1200 with a marching song and ID in VV. (Ng, Malaysia)

**PALAU**—Xi Wang Zhi Sheng over 9930-T8WH at 1322 with M/W in Mandarin. (Ronda, OK)

**PAPUA NEW GUINEA (North Solomons)**—Radio Bougainville, 3325 at 1220 poor with M talk in Pidgin, W talk at 1235 recheck. (Ronda, OK)

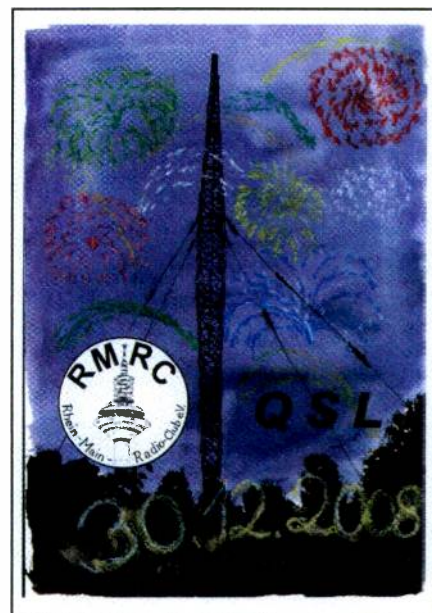

A QSL from the rarely received Rhein Main Radio Club broadcast on 9290 via Latvia. (Thanks Paul Gager, Austria)

**PERU**—Ondas del Huallaga, Huanuco, 3329.6 at 1920 with nice OA music. Weak, and bothered by CHU. (Wilkner, FL)

Radio Vision, Chiclayo, 4790 heard at 0458 with M in SS, music bridge and into usual fair of man preaching to a large crowd, but without the usual distortion. (Parker, PA)

Radio Rasuwilca, 4805 at 1035 with Andean flute, one brief ID and back to music. (Wilkner, FL)

Radio La Hora, Cusco, 4857.4 at 2350 with SS anc. Weak. (Wilkner, FL)

Ondas del Suroriente, 5120.2 at 1010 with domestic music, UTE covering so best heard using LSB. (Wilkner, FL)

Radio Tawantinsuyo, Cusco, 6173.9 at 1030 but weak with SS also on co-channel. (Wilkner, FL)

Radio Cusco, Cusco, 6195.8 at 0045 with SS talks and ballads, OA music. Poor and difficult reception. (Alexander, PA)

Radio Victoria, Lima, 9720 at 0425 with SS religious talk, phone talk, NA at 0500, light instrumental music at 0503. Very weak, much better on //6020. (Alexander, PA)

**PHILIPPINES**—FEBC, 9445-Iba at 2309 with M in (I) Cambodian. Also 9730-Bocau at 2315 with W singing, talk in listed Hmong-White/Daw. Flute and string music at 2327 and off at 2329. (Ronda, OK) 9920 at 1325 in listed Koho. (Brossell, WI)

Radio Veritas Asia, 9615 at 1127 with Mandarin pgm, EE ID at 1156 close. (D'Angelo, PA)

Radyo Pilipinas, 15285 with *Listeners International* at 1420. (Ng, Malaysia)

**PIRATES**—Dead Cat Radio, 6925u at \*0643 signing on with "Lonely Boy" song, various rock things, cat meowing and ID at 0734 sign off. Another day at \*0205 and later heard at 1528. (Alexander, PA)

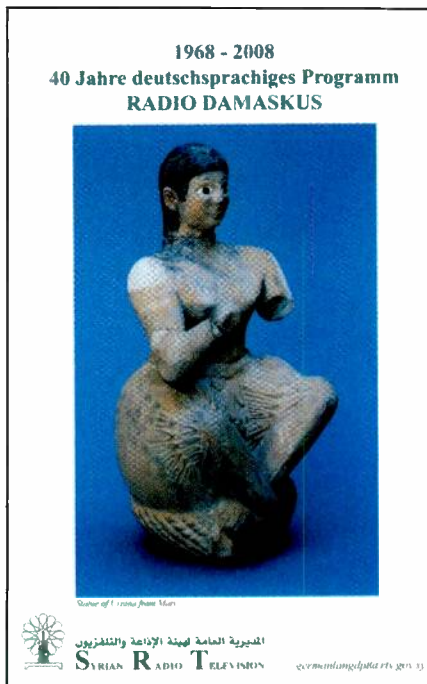

Radio Damascus may not be generating the best of signals these days, but the quality of its QSLs has certainly taken a turn for the better. (Thanks Paul Gager, Austria)

Radio Ga Ga, 6925u at 0115 running slow scan TV at tune in, rap number, ID at 0125 sign off. (Alexander, PA)

Voice of Doom, 6925u at 0215 with comment by M. Too weak to copy except for an ID monitored at 0224 sign off. (Alexander, PA)

WMPR-Micro Power Radio, 6924.9am monitored at 1454 with computerized disco and computerized IDs. (Alexander, PA)

Voice of Spike, 6925u at 0016. Apparent new one with a format of Spike Jones novelty tunes and M commenting that they are the only one with this format. Address ancd as voiceofspike@gmail.com. (Zeller, OH)

WBNY, 6925u variously at 1705-1710\*, 2052-2149\* and \*2006-2959\* with Commandeer Bunny and his Easter special pgm with Peter Rabbit and Peter Cottontail songs, numerous comedy bits. Belfast address. (Zeller, OH)

Radio First Termer, 6925u at 0130 with classic rock and several ad parodies until 0230 close. (Linonis, PA)

KPR, 6925u at \*0231-0250, Mr. Sandman at sign on, "KPR—we rock the oldies" (Alexander, PA)

(Euro) Radio Playback Intl, 6870 at 2215, 0000 with oldies pops, canned ID at 2226. Weak but fair level on peaks. (Alexander, PA)

Blue Ridge Radio, 6925u at 2330 with bluegrass things, ID. (Alexander, PA)

Barnyard Radio, 6925u noted 2205 and 2252. Ancr said he was getting drunk. Also IDed as "The Tijuana Donkey Show." Considerable profane talk directed as someone named Jennifer and other women with whom he was not happy. Mainly a pgm of

rock and punk rock with drunken profane rants that went on for nearly two hours. No address copied. (Zeller, OH) 2205 with barnyard sounds and rock. Also at 2154. (Alexander, PA)

MAC Shortwave, 6925u (variable), 1530 with rock/pop, several Eagles things. (Linonis, PA) 2157-2254\* and 2207-2252\* using the old Radio Prague IS, "Dick Danger Fireside Theater" sketch, old AM top 40 jingles, mac-shortwave@yahoo.com. (Zeller, OH) 0250 and 2215 in AM mode with various bubblegum rock. Frequency varied slightly. (Hassig, IL)

Voice of Chaos, 6925u at 0149 saying it was their first broadcast using their own transmitter. Used the *Get Smart* TV show theme, "A Boy Named Sue," some talk of amateur radio equipment and a mention of reception reports, but no address copied. (Zeller, OH)

Northwoods Radio/Northsea Radio, 6925u at 2337 to 0035 close. ID by "Mr. Savage" and various features, possible tape loop with many loon calls. Email for reports to: northwoodsradio@yahoo.com. Later Mr. Savage became Captain Savage and the station became Northsea Radio. (Wood, TN) Northsea Radio at 2100 with sounds of seagulls, IDs, "R" rated pirate songs. (Alexander, PA)

Green Spaghetti and Green Eggs, 6925u at 1940-2012 with multiple repeats of the theme from TVs *Rawhide* and much talk by M of green spaghetti and green eggs for Easter. No address announced. (Zeller, OH)

Radio Josephine, 6925u at 2347 with largely pop tunes by females. Said to be their first bcst. Slogan was "broadcasting from the big city." radiojosephine@gmail.com for reports. (Zeller, OH)

WTCR, 69254u at 0133 with rhythm and blues tunes. (Alexander, PA) 0210 with rock and pops. Address Box 1, Belfast NY 14711. (Hassig, IL)

Radio Free Euphoria, 6875.2 at 2328 with rock, rap, canned IDs, drug-oriented songs, talk about marijuana. (Alexander, PA)

Wolverine Radio, 6925u at 0030 with Beatles, Blood, Sweat and Tears. (Zeller, OH) 0108 with various rock/pop. (Hassig, IL)

Radio Jamba Intl, 6925.5u at 0010 with two or three repeats of "Black Betty" and into rock pgm, later an interview with Ultra Man of MAC radio. Some tech problems and garbled audio. (Zeller, OH)

POLAND—Polish Radio, 9450 via Germany at 1325 with pgm on women and jobs in the EU. (Brossell, WI)

ROMANIA—Radio Romania International, 7105 at 2325 on recent financial events there. (Brossell, WI) 11940 at 1315 in Romanian and EE. (Linonis, PA) 17770 with *Radio Newsreel* at 0530. (Ng, Malaysia)

RUSSIA—Voice of Russia, 4965 via Tajikistan in (l) Pashto/Dari at 1303, //4975. Also 6240 via Moldova to ECNA at 0457, also 9665 via Moldova in EE at 0005. (Parker, PA) 6245 via Moldova at 1950 in RR with RR rock, 7115-Moscow in RR at 1322, 7165-St. Petersburg in RR at 2006, 7250 via Armenia in RR at 0340 and 9900-Samara in (l) Pashto

at 1338. (Brossell, WI) 7285-Kaliningrad in RR at 2325 and 9890-Moscow at 2156 with tones, ID and news in EE. (Ronda, OK) 9900-Samara with listed Afgan service and apparent newscast at 1310. (Strawman, IA) 15510 via Armenia with *Music and Musicians* pgm at 1820. (Fraser, ME)

Radio Rossii, 4050 via Bishkek, Kyrgyzstan, in RR at 0532 with W anc and EZL-type music. Poor for the most part but faded up briefly. (Parker, PA)

Yakutsk Radio, 7345 in RR at 2020. (Brossell, WI)

SAO TOME—VOA Relay, Pinheira, 4960 in news at 0440. (Parker, PA)

SAUDI ARABIA—BSKSA, 15380 in AA at 1353. (Brossell, WI)

SLOVAKIA—Radio Slovakia International, 7345 with vocal, comment on the blue Danube River. (Parker, PA) 9440 at 0104 in EE to SA with *Slovakia Today* pgm. (Parker, PA)

SOUTH AFRICA—Channel Africa, 3345 at 0335. (Yohnicki, ON) 0327 with M anc playing jazz. (Parker, PA) 9625 at 1515 with interview on band and dance music. (Maxant, WV)

Radio Sondergrense, 3220 at 0320 in Afrikaans with pops and "grunge." (Wood, TN) 0327 with pop/rock. (Yohnicki, ON) 0330 with EZL and Afrikaans and EE anmts. (Ronda, OK) 0334 with usual contemporary folk/light rock. (Parker, PA)

SOUTH KOREA—KBS World Radio, 15160 with KK talk by W at 0950. (Ng, Malaysia)

SPAIN—Radio Exterior de Espana, 3350 Costa Rica Relay in SS at 0343 with M talk, classical music bridges. (Parker, PA) 11620 with ID, news at 1905. (Maxant, WV) 15110 in SS at 2238. (MacKenzie, CA)

SUDAN—Radio Omdurman, 7200 at 0232 with AA talk, Koran, talk and possible radio drama at 0245, time pips at 0301 f/by news. (Alexander, PA)

Radio Dabanga, 13730 via Wertachtal at 1715 to 1727 close. Vernacular talk. ID jingles, EE news at 1722-1726, weak but readable on //11500 via Madagascar. (Alexander, PA)

Miraya FM, 15650 via Slovakia at \*1459 sign on with African music, time pips, IDs and EE news at 1501. Into AA at 1513. (Alexander, PA)

SWEDEN—Radio Sweden International, 9895 via Madagascar at 2232 in EE. (Fraser, ME)

11540 in Swedish at 1427. (Brossell, WI) 15735 at 1330. (Ng, Malaysia)

IBRA Radio, 7320 via Novosibirsk at 1158 in Mandarin. Test tones to 1200, opening with M/W anc and into music. Very weak and unable to tell what language. (Taylor, WI)

SYRIA—Radio Damascus, 9930 at 2110 with EE news, local music, more news at 2125, anthem at 2159, and //12085 had strong carrier, hum but basically no audio. Off at 2204 but 9930 back at 2225 weak with SS. 12085 at 2134 in EE with local music, news brief at 2158. Poor, with low modulation; even lower on 9330. (Alexander, PA)

**SWAZILAND**—Trans World Radio, 4775 at 0424 with M and GG sermon, ID at 0429 and opening of EE pgm. (D'Angelo, PA) 0513 in presumed (I) Lomwe. Weak signal with M talking. (Parker, PA)

**TAIWAN**—Radio Taiwan International, 7185-Kouhu at 1200 with TS and into talk in Mandarin. (Ronda, OK) (p) 9800 via French Guiana in SS to SA at 0245 M/W with pop pgm, abrupt sign off at 0259. (Parker, PA)

Happy Station pgm, 9955 via WRMI at 1525. (Maxant, WV)

**TAJIKISTAN**—Tajik Radio, Yangul (p) 4765 at 0509 in Tajik with alternating M/W ancers and contemporary-sounding music. Fair to poor. (Taylor, WI)

**TANZANIA**—Radio Tanzania Zanzibar, 11735 at 1800 with "Spice FM" EE news to 1811, Swahili talk. Wobbly, distorted audio that continues to get worse every week. (Alexander, PA)

**THAILAND**—Radio Thailand, 7365 in CC at 1319. (Brossell, WI) 12085 monitored at 0030 with abrupt sign on and EE news in progress, ID at 0034, ads for yacht sailing and Thai airways, business news at 0037, then sports and weather. Gongs or chimes at 0100 and into Thai. (Alexander, PA)

**TURKEY**—Voice of Turkey, 9830-Emirler at 2206 ending EE news and into pgm on Turkey-Iraq relations. (Ronda, OK) 12035 at 1347 on private sector loans in Turkey. (Brossell, WI) 15520 with *Water Is Life* pgm at 1250. (Ng, Malaysia)

**TURKMENISTAN**—Turkmen Radio, 5015 monitored at 1256 with talks in (p) Turkmen. Weak under noise. (Brossell, WI)

**UGANDA**—UBC Radio, 4976 with Afro pops heard at 0304. (Brossell, WI)

**USA**—Voice of America, 9320 Philippines Relay with news items at 1216. (Brossell, WI) 9760 Philippines Relay at 1325 with *Jazz America* pgm. Interesting how reception along this path varies so greatly from inaudible to good. (Strawman, IA) 11705 at 1315 with *Jazz America*. (Linonis, PA)

AFN/AFRTS, 5446.5u, Key West at 0453 with news items and promos on "whistle blower" protection laws. (Wood, TN) 0624 on personal finance. (Parker, PA) 7811-Key West on baseball. (Maxant, WV)

Radio Free Asia, 7470 via Mongolia in (I) Tibetan at 1213. (Brossell, WI) 9875 via Lampertheim at 2328 with two W in (I) Tibetan. (Ronda, OK) 12140 at 1340 with M/W in Burmese. (Ng, Malaysia)

Radio Free Afghanistan, 9990 via Sri Lanka in Pashto and W with news items at 1310. (Ronda, OK)

Radio Farda, 7280 in Farsi at 0230 with ME techno-pop dance music, ID. (Alexander, PA) 11840 via England at 1656. (Brossell, WI)

Radio Marti, 13820-Greenville in SS at 2145. (MacKenzie, CA)

WEWN, Vandiver, 5810 in SS at 0420. (MacKenzie, CA)

WWCR, 3215 at 0405, 5070 at 0416, 5890 at 0425 and 5935 at 0430. (MacKenzie, CA)

Family Radio/WYFR, 9485 in II at 1330. (Ng, Malaysia) 9485 via Irkutsk in II at 1315. (Brossell, WI)

Adventist World Radio, 11980 with Christian music in JJ at 1320. (Ng, Malaysia)

Trans World Radio, 7215 via South Africa at 0339 in listed Amharic. (Brossell, WI) 0430 in (I) Orominya. (Ronda, OK) (*Language usage could vary by day.*—gld)

**VATICAN CITY**—Vatican Radio, 7250 at 0753 with two M in AA, theme music at 0800 and again at 0803 closedown and IS before off. (D'Angelo, PA)

**VIETNAM**—Voice of Vietnam, 6175 via Canada at 0442 in SS with M/W commenting. (MacKenzie, CA)

**VENEZUELA**—Radio Nacional, 13680 via Cuba in SS at 2147. (MacKenzie, CA)

**ZAMBIA**—Zambia National Broadcasting, 5915 at 0247 sign on with fishagle IS, anthem. Eventually blocked by the BBC at 0257. (D'Angelo, PA) 6165 at 0420 weak but in the clear with EE talk, local music. Covered by Chad at their 0434 sign on. (Alexander, PA)

CVC-The Voice-Africa, 4965 at 0228 with EE talk and music. (Yohnicki, ON) 9420 at 1830 in FF with music, talk. (Maxant, WV)

And that's the lot for this time! A mountain of thanks to all who submitted logs: Robert Wilkner, Pompano Beach, FL;

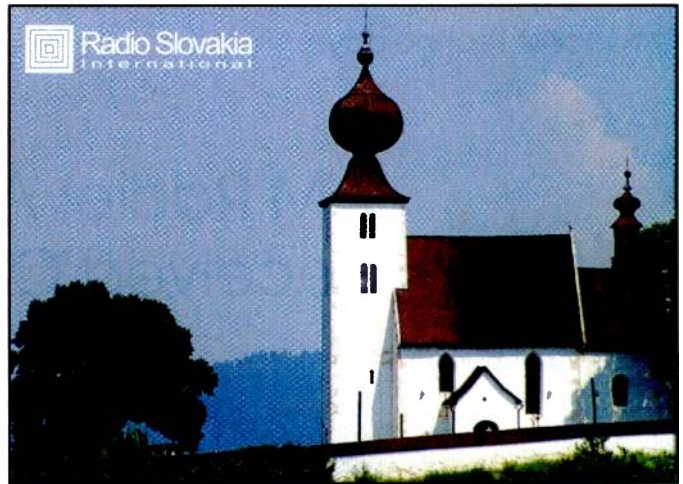

Radio Slovakia International QSLed Paul Gager for his reception on 6055 and 7345.

Brian Alexander, Mechanicsburg, PA; Jim Ronda, Tulsa, OK; Jerry Strawman, Des Moines, IA; Peter Ng, Johor Bahru, Malaysia; Mark Taylor, Madison, WI; Rick Barton, Phoenix, AZ; George Zeller, Cleveland, OH; Stewart Mackenzie, Huntington Beach, CA; William Hassig, Mt. Prospect, IL; Rich D'Angelo, Wyomissing, PA; Robert Fraser, Bedford, ME; Jack Linonis, Hermitage, PA; Robert Brossell, Pewaukee, WI; Joe Wood, Greenback, TN; Charles Maxant, Hinton, WV; Michael Yohnicki, London, ON; and Rich Parker, Pennsburg, PA.

Thanks to each one of you, and until next month, 73 and good listening!

**Listening is only half the fun...**

# POPULAR COMMUNICATIONS

**is the other half!**

The World's most authoritative monthly magazine for Shortwave Listening and Scanner Monitoring. Read by more active listeners world-wide.

You'll find features on scanner monitoring of police, fire, utility, and aircraft communications; international shortwave listening; CB radio; amateur radio; FRS; GMRS; monitoring radio digital communications including CW, RTTY, SITOP, etc; AM/FM commercial broadcasting; weather and communications satellites; telephone equipment and accessories; radio nostalgia; alternative radio; clandestine radio; and military radio.

	USA	Canada/Mexico	Foreign
1 Yr	32.95	42.95	52.95
2 Yrs	58.95	78.95	98.95
3 Yrs	85.95	115.95	145.95

**Popular Communications**  
25 Newbridge Road, Hicksville, NY11801  
Phone: 516-681-2922; Fax 516-681-2926  
Visit our web site: [www.popular-communications.com](http://www.popular-communications.com)

# AM Radio: Alive And Well Received On The New CCRadio-2

by Bruce A. Conti  
BAConti@aol.com

*“The addition of the 2 meter VHF amateur radio band is pure genius, setting the CCRadio-2 apart from any other portable of its kind.”*

The CCRadio from C. Crane was introduced more than 10 years ago in the November 1998 issue of *Popular Communications*. The CCRadio represented years of development by C. Crane Company in partnership with Sangean engineers, culminating in the design of a portable radio featuring superior AM performance. I was intrigued by the introduction of this new AM/FM receiver, simply because it was so unusual to find a manufacturer interested in providing a radio with a high-quality AM section. Back then I said it was a keeper, and until now nothing had replaced it at my bedside. Now C. Crane has done it again, introducing the new CCRadio-2.

## The Basics

The CCRadio-2 is a portable AM/FM clock radio reminiscent of the lunchbox-size portables of the 1960s and '70s, yet the retro design doesn't compromise the modern convenience of digital controls. Out of the box, it has an impressively solid and substantial feel, weighing in at nearly 5 pounds with four D-cell batteries installed. In addition to AM and FM broadcasts, the CCRadio-2 tunes in all seven of the NOAA Weather Radio broadcast channels and the 2 meter VHF ham band, which replaces the VHF

TV audio reception of the original CCRadio removed due to the television broadcast switch to digital. Extra features found standard in the CCRadio-2 include AC power, a stereo headphone jack, external stereo audio input/output jacks, and weather alert capability.

Although operation of the radio is relatively straightforward, the instruction manual is well written for quick access to information about the few more complex functions, such as setting the alarm clock, weather alert modes, VHF squelch control, selecting the audio auxiliary input, and timed operation. The status of all active digital functions is clearly indicated on a large front panel LCD with frequency and clock displayed by 1/2-inch numerals and three selectable levels of backlighting brightness.

Tuning is in steps by front panel up/down buttons or a right-side mounted rotary knob, or by auto scanning for a strong signal. A rotary volume control is also located on the side, while separate bass and treble knobs are on the front. Four front panel pushbuttons are dedicated to alarm clock and timer functions. Preset buttons prominently positioned on the top of the radio allow for instant access to five favorite frequencies on each band, just like on a car radio. The power switch, band/aux switch, and weather alert switch are pushbuttons also located on the top. A right-side locking slide switch disables all function switches to prevent accidental power up or loss of settings. A telescopic whip antenna for FM, weather band, and 2 meter reception completely collapses to protect against damage.

## Performance

First and foremost the strength of the CCRadio-2 remains in its AM reception. Company President Bob Crane says that engineers were able to get a couple more dB out of it, and it shows. The CCRadio-2 is built for the highest performance ever on AM, boosted by an internal 8-inch C. Crane Twin Coil Ferrite antenna. Balanced external antenna terminals located on the back of the radio are inductively coupled to the internal ferrite for connection to an outdoor or window-mounted antenna, such as a dipole,



The new CCRadio-2 is the “purr-fect” companion for a DX cat.

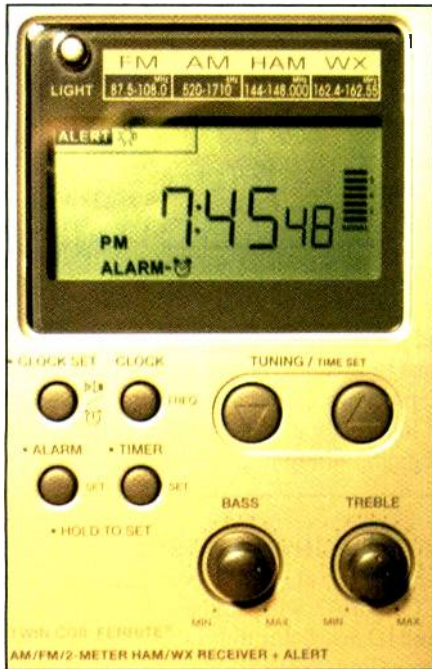

The CCRadio-2 front panel display and controls.

loop, unbalanced random wire and ground, or an optional external Twin Coil Ferrite if necessary for reception in a steel frame building. A section of the instruction manual is devoted to AM reception tips describing how to aim the radio and solve noise problems.

The AM frequency can be manually tuned from 520 to 1710 kHz in 1 kHz increments using the rotary tuning knob, or by channel in 10 kHz steps using the front panel up/down pushbuttons. AM reception is nothing less than outstanding and a noticeable improvement over the original CCRadio. Signals could be received on practically every domestic channel, day and night, without an external antenna. The fidelity of news/talk radio is enhanced by the radio's 5-inch 6 watt speaker and the C. Crane brand of audio specifically tailored to capture the full rich sound of the human voice.

Opposite conventional wisdom, FM seems almost an afterthought on the CCRadio-2. However reception is more than sufficient with a standard telescopic whip antenna that extends to 22 inches, but suffers from adjacent channel interference in the presence of strong local signals. For example, I could easily tune in distant stations at adjacent frequencies of 100.1, 100.3, and 100.5 MHz without interference, but reception of 100.9 and 101.3 was wiped out by a strong signal at 101.1 MHz. There's no provision for connecting an external FM antenna other than by attachment to the whip.

Five preset buttons are prominently positioned atop the retro style CCRadio-2.



On the other hand, NOAA Weather Radio reception seems improved to some degree. Stations received weak on the original CCRadio are heard much more clearly on the new CCRadio-2. The weather alert can be set to activate a warning light, turn on weather station audio, or sound an alarm when the weather service issues an all-hazards emergency bulletin. However the weather alert is not Specific Area Message Encoding (SAME)-compatible, so it doesn't allow for activation based on user-selected types of warning codes. When weather alert is active, the weather receiver is always on, so weather alert should only be used long-term on AC power or the batteries will be drained in a short period of time. When plugged into AC power the radio will automatically switch to batteries if a power failure occurs so weather bulletins won't be missed (and the alarm clock keeps on ticking).

The addition of the 2 meter VHF amateur radio band is pure genius, setting the CCRadio-2 apart from any other portable of its kind. Two meter reception covering 144 to 148 MHz with a resolution of 5 kHz complements weather alert by providing inside access to communications between civil defense amateur radio operators and emergency responders when other forms of communications are down. It's also fun listening in on local operators hamming it up about equipment, politics, or the day's events. The presets are loaded with five of the most popular frequencies, or you can change the presets to the most active repeater frequencies in your area. Quoting the instruction manual, "C. Crane salutes every Ham who has volunteered to be a part of emergency radio operations."

Needless to say the CCRadio-2 has taken the place of the old CCRadio, which has been relegated to my personal radio museum for posterity. If you liked the

original CCRadio, then you'll love the new CCRadio-2. Visit [www.ccrane.com](http://www.ccrane.com), where the CCRadio2 is advertised for \$159.95, or call 800-522-8863 to learn more about it. It's the radio for the next 10 years.

## Radio Is Not Dead!

The April edition of "Broadcast Technology" reported budget cuts at CBS-owned WBZ Newsradio 1030 that included the layoff of popular overnight talk show host Steve LeVeille. Well, the layoff was temporary as LeVeille returned to the airwaves a month later

## CCRadio2



### Designed for Even Better Long Range AM & Now Emergencies

- AM, FM, 2-Meter Ham, Weather Band and NOAA Weather Alert
- 2-Meter Scans Five Memories for Active Frequencies, Squelch
- Built-in Twin Coil Ferrite® AM Antenna for Max. Reception
- Signal & Battery Strength Meters

\$159<sup>95</sup>

**C. CRANE**

**Free Catalog**

**800-522-8863 • [ccrane.com](http://ccrane.com)**



WBZ's Steve LeVeille (www.wbz.com photo)

thanks to thousands of unsolicited public complaints sent to WBZ and posted over the Internet via websites like www.savewrko.com and www.bringbacksteve.com. In fact, it was so unsolicited that LeVeille was initially unaware of any of these efforts. It was a grassroots campaign to bring Steve back and was spearheaded entirely by loyal listeners.

"I'm stunned!" said LeVeille of the overwhelming outpouring of public support during his first night back on the air, "Radio is not dead!"

In a news release on www.wbz.com, News and Program Director Peter Casey said, "We always knew that the radio audience in New England and beyond has held WBZ to a higher standard than any other radio station and the local overnight programming was a part of that. WBZ is just a very different radio station than any other. We're happy to bring back Steve to his overnight midnight to 5 a.m. time slot."

The Steve LeVeille Broadcast can be heard weeknights beginning at midnight Eastern, over the airwaves on 1030 WBZ, and streaming online at www.wbz.com. LeVeille is a broadcast DXer too, so give him a call during "open forum" on his show to talk about radio. Lovell Dyett, the former community voice of Saturday night talk on WBZ, has also returned though he is now hosting public affairs talk early Sunday morning. So this still leaves WBZ listeners without local talk on Saturday nights, replaced with the nationally syndicated Kim Komando and paid programming until midnight when WBZ personality Jordan Rich takes the graveyard shift.

## Frequency Follies

Also in the April issue, it was reported that radio stations would reduce frequency to conserve cycles per second due to the economic recession. Many readers took this seriously, failing to see the humor in

## This Month In Broadcast History

*75 Years Ago (1934)*—Radio station 1010 WRNY New York began to broadcast scheduled experimental mechanical television programs that required a 240 rpm scanning disk for reception. Meanwhile inventor Philo Farnsworth provided the first public demonstration of his all-electronic television system in Philadelphia.

*50 Years Ago (1959)*—"I Want to Walk You Home" by Fats Domino topped the 1060 WNOE New Orleans music survey.

*25 Years Ago (1984)*—While the U.S. and Mexico came to an agreement in principle to allow graveyard channel AM stations to increase power from 250 to 1000 watts fulltime, Mexico continued to oppose post-sunset authorization for daytime-only stations. President Reagan was caught joking about the elimination of Russia during a radio sound check, saying, "We begin bombing in five minutes."



what was subsequently identified as an April Fools' joke. I guess I should leave the satire to fellow columnist Bill Price in his "Loose Connection." My bad!

## Broadcast Loggings

Although AM broadcast DXing isn't as popular a pursuit during the warm weather months due to the longer daylight hours and increased lightning noise, some die-hard listeners make it a year-round activity. The month of August can bring surprises as the days begin to get shorter and nighttime skywave propagation improves. Here are a few selected logs from our faithful DXers to inspire you. All times are UTC.

**555 ZIZ Basseterre, St. Kitts**, at 0410 very weak, relaying BBC World Service. (Chiochiu-QC)

**580 WKAQ San Juan, Puerto Rico**, at 0405 with ID, "WKAQ 580, la emisora (¿que te trae?) información y analisis." Very good with slight interference, mainly from co-channel WTAG in CFRA null. (Chiochiu-QC)

**600 CMKV Radio Rebelde, Urbano Noris, Cuba**, at 0403 fairly dramatic chatter in Spanish, sounded culture-related. Good but mushy signal with some fading and co-channel CKAT interference. (Chiochiu-QC)

**640 CMBC Radio Progreso, Guanabacoa, Cuba**, at 0407 talk about the city of Matanzas (a Havana suburb, east of the capital) followed by old-fashioned Cuban music. Briefly good, then faded to very poor with interference from co-channel WNNZ and/or CFYR. (Chiochiu-QC)

**1070 WINA Charlottesville, Virginia**, at 0200 heard with University of Virginia sports coverage, "...on Newsradio 1070 WINA." (Conti-NH)

**1134 Hrvatske Radio, Zadar, Croatia**, at 0100 caught on the CCRadio-2 with signature time marker and ID heard through 1130 WBBR splatter. (Conti-NH)

**1150 WAVO Rock Hill, South Carolina**, at 0039 heard with adult standards and oldies, "For the good times, WAVO 1150 and 1410." Decent signal fading in and out. (New-GA)

**1215 Absolute Radio, United Kingdom**, at 0012 "Everybody Wants to Rule the World" by Tears for Fears, Absolute Radio ID, contest promo to win 500 pounds; fair to good. (Connelly-MA)

**1350 KDZA Pueblo, Colorado**, at 0200 rock 'n' roll oldies, sometimes yielding out to co-channel political talker KABQ New Mexico. A good on-the-hour ID and other off-hour IDs heard. (Barton-AZ)

**1380 WYNF North Augusta, South Carolina**, at 0029 "ESPN 1380" with mentions of the NASCAR Camping World Truck Series Race at Lowe's Motor Speedway. Decent signal fading in and out of the mix. (New-GA)

**1390 XEKT Tecate, Mexico**, at 1259 with ID, "Súper Estación," into a very good music program. (Barton-AZ)

**1510 KCKK Littleton, Colorado**, at 0959 a solid clear ID as "Mile High Sports Radio AM 1510." This and a couple of other stations heard under the open carrier of local KFNN, this one with the antenna looped for general northeast-southwest reception. (Barton-AZ)

**1521 BSKSA Duba, Saudi Arabia**, at 0021 a man in Arabic; the best transatlantic signal, sometimes stronger than adjacent 1520 WWKB. (Connelly-MA)

Thanks to Rick Barton, Bogdan Chiochiu, Mark Connelly, and Bert New. Until next time, 73 and Good DX!

# Trivia And Toons

by R.B. Sturtevant, AD7IL

**Q.** What is a “burst transmission” and who first started using them?

**A.** A burst transmission is a transmission recorded at normal speed but sent at 30 or 40 times that speed. This is usually done to make it difficult to copy or even identify it as a transmission. The technique was first used by the Germans before World War I.

**Q.** General Patton moved the Third Army through Europe like a hot knife through butter. Was he assisted by SIGINTEL?

**A.** Yes, though in those days it was called COMINTTEL for Communications Intelligence and included both regular radio intercepts and the high-level Ultra cryptology efforts of the British decoders at Bletchley Park. And Patton got a lot of help from radio intercepts from both sources.

My information comes from a report written by Major Warrack Wallace, who was assigned to the Third Army as an Ultra Recipient in August 1944. Wallace’s job was to receive Ultra material from the Special Liaison Unit which got it from England and to return it to the SLU. (Ultra material could only be held for 24 hours and needed a hand receipt going both ways.) Every morning Patton and about 40 staff officers would be briefed by his Intelligence and Operations Officers. After the 0900 briefing was over everyone would leave except Patton and about seven senior officers, who would then receive the Ultra briefing.

Once, at Avaranches in France, Patton was informed by Ultra (and only Ultra) that five German Panzer Divisions were planning an attack. Patton was able to plan a successful defense because of the time and information Ultra had given him. On another occasion, at the city of Chalons, France, an Ultra message reached Patton at 0100 hours that the Germans were planning to hit his line at 0300. His troops were, in Patton’s words “spread thinner than the skin on an egg.” Yet, with only a short time to prepare, Patton mounted another successful defense.

**Q.** In the early days of Navy and Army radio, did the commanders of the radio operators know what they were dealing with and the problems that radio had in those days?

**A.** I don’t think that they did. The officers in direct command were usually people who had some amateur experience behind them. But above that level they didn’t seem to have a clue. And the Navy seems to have had the biggest problem, probably because a career Navy man had to have so many different areas of expertise that they couldn’t or didn’t learn wireless in the early days. An official order came down, which had to be posted in all Navy radio rooms in 1912, stating “Henceforth static disturbance will not be considered as an excuse for nonreception of a message.” Which was quickly shortened to “Henceforth there shall be no static!” This, of course, comes from having the idea that lazy and unskilled operators were using atmospherics as an excuse for their own failures. Try following this order the next time you transmit or receive on a radio. Records don’t show how long this policy was in force.

What actually improved Operator performance in wireless and a lot of other areas of the Navy was a serious use of competitions that pitted one ship or department against another with promotions as rewards. In time both Operators and Admirals learned what they could expect from radio communications. In time the equipment also improved which helped as well.

**Spurious Signals**

**By Jason Togyer KB3CNM**

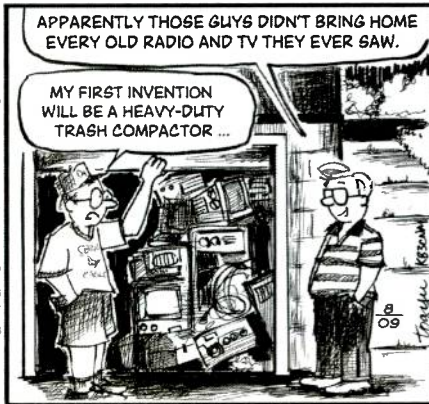
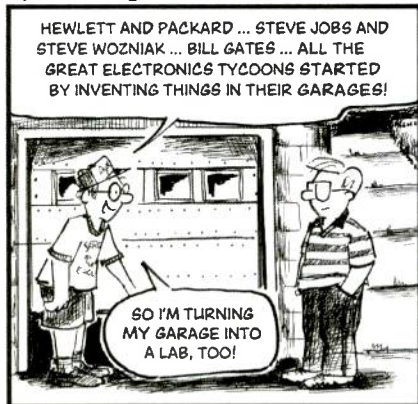

## Are Terrorists Really Using The Air Waves?

by Mitch Gill, NA7US,  
NA7US@yahoo.com

*“With ALE, anyone with a computer and a radio can send and receive all sorts of digital communications.”*

Because I’m a member of the Amateur Radio Relay League (ARRL) I receive a weekly email of interesting tidbits and small brief articles that deal with amateur radio. Normally I just breeze through most of them, but one recent piece really caught my eye. It was about a police department that was using ham gear without a license (see “FCC, Indianapolis Police Department...”). Why was I so interested? Because it made me wonder how long they had been using the ham frequencies without anyone knowing.

I was not interested in the fact that the incident involved a police department, which resolved the problem as soon as the FCC advised them about it, but it made me think about whether terrorists are using ham radio equipment illegally. I wanted to know whether there have been any known incidents of commercial or amateur radio HF radios being used and how it might be being used today.

### Learning From The Past

Looking back at past incidents can alert us to potential future areas to monitor. In 2002, when I was a member of the Amateur Radio Emergency

Services (ARES), the US Coast Guard briefed us on an incident that occurred locally.

Late one evening a control operator on a local repeater (145–148 MHz) heard a faint voice asking for help. The voice would come on the air only for a short time, giving small bits of information. The police and the Coast Guard were called when the person stated that he and his wife had been taken hostage on their boat by two Middle Eastern-looking men with large suitcases. One transmission stated that they were headed toward Bangor, our submarine base in the Puget Sound, which of course put the US Coast Guard and all federal agencies on high alert.

After huge costs were incurred, it was determined that there was no boat and no hostage-taking incident. Two possible explanations were discussed at the time: One was that it was someone who thought it would be funny to see the reaction, and the other was that it was someone testing our response. What the actual answer was we may never know.

### Terrorists Have Radios

My research led me to an article about an Australian company, Codan Limited, that unknowingly sold HF radios to an al-Qaida operative (see “Australian Firm Unwittingly Sells Radio Equipment to al-Qa’ida”). This particular sale was also mentioned by the Department of Homeland Security to illustrate that terrorists who may be in hiding could have HF radio capabilities. As recently as September 2007, the Times Online reported that HF was the only reliable communications that al-Qaida could use. Indeed, Osama bin Laden’s personal driver was found to have a series of pink numeric code cards inside his vehicle. These were used over HF radio to refer to an action (like placing a bomb), object (like C-4) and people (like Bin Laden).

After studying Codan’s radios I realized that they have automatic link establishment (ALE) as part of their offerings. For those of you not familiar with ALE, the website at <https://hfink.com> provides the following definition:

With the capability to call up a specific HF station, a group of stations, a net, or a networked station,



Like Codan, Harris Radio also utilizes ALE (see text). This radio is scanning channels waiting for an incoming message.





Any scanner or receiver can monitor and decipher PSK31 and other digital signals. The AOR AR-5000 is one of the best scanners out there, in my humble opinion.

Automatic Link Establishment is a versatile system for connecting radio operators for voice, data, text, instant messaging, Internet messaging, or image communications. A radio operator initiating a call can within minutes have the ALE automatically pick the best frequency that both stations have. It signals the operators on both ends, so they can begin communicating with each other immediately.

In this respect, it can eliminate the long-standing need for repetitive calling on pre-determined time schedules and monitoring static on HF radios.

In simple terms, this means that al-Qaida or others bent on causing us harm can send and receive messages worldwide and can be assured that they will be

received even if the person is not even at the radio at the time.

### ALE For The Good Guys

With ALE, anyone with a computer and a radio can send and receive all sorts of digital communications. For you, the

## Australian Firm Unwittingly Sells Radio Equipment to al Qa'ida

According to a report by the Australian Broadcasting Company, an Australian communications technology company sold communications equipment to an al Qa'ida operative in May 2001. Codan Limited, based in Adelaide, Australia, sold more than A\$32,000-worth (approximately US \$24,000) of remote-area long-distance communications equipment to Mohamedou Slahi, an al Qa'ida operative suspected of having been a contact for the Hamburg, Germany, cell that helped carry out the September 11, 2001, attacks in the United States.

The equipment was exported to Mauritania in May, 2001 and may have been diverted to Afghanistan. Osama bin Laden reportedly used information transmitted over the Codan radio network to escape, narrowly, a missile strike in late 2001.[1] Codan's managing director Mike Heard stated: "We've never ever had what I would call first-hand knowledge that a customer or a potential customer was a terrorist... unless we were a specialist security organization it would be very hard for us to accurately form that view." [2] Australian Foreign Minister Alexander Downer defended Codan, stating that the company did not violate any export control regulations and clearly did not know who was purchasing the equipment. He did ask other Australian companies to learn from the incident and "be very careful who you're selling equipment to, particularly in parts of North Africa and the Middle East." [3]

Sources: [1] Penelope DeBelle, "Adelaide Equipment 'Saved bin Laden,'" The Age, August 31, 2005, [www.theage.com.au/news/national/adelaide-equipment-saved-bin-laden/2005/08/30/1125302570157.html](http://www.theage.com.au/news/national/adelaide-equipment-saved-bin-laden/2005/08/30/1125302570157.html). [2] David Weber, "Al Qaeda Connection Prompts Company to Tighten Protocols," ABC NewsOnline (Australia), August 30, 2005, [www.abc.net.au/news/newsitems/200508/s1448892.htm](http://www.abc.net.au/news/newsitems/200508/s1448892.htm). [3] "Codan's Sale to Terrorists a Lesson For All: Downer," ABC NewsOnline (Australia), August 30, 2005, [www.abc.net.au/news/newsitems/200508/s1449432.htm](http://www.abc.net.au/news/newsitems/200508/s1449432.htm).

—International Export Control Observer, Issue 1, October 2005

TERRORISM FORCES  
US TO MAKE A  
CHOICE. WE CAN BE  
AFRAID. OR  
WE CAN BE READY.

**READY**

WWW.READY.GOV

1-800-BE-READY



## FCC, Indianapolis Police Department Address Unlicensed Operations

In response to an investigation by the FCC, the Indianapolis Metropolitan Police Department (IMPD) <http://www.indy.gov/eGov/IMPD/Pages/home.aspx> has taken action to prevent further use of Amateur Radio frequencies by unlicensed officers. Any Amateur Radio equipment in the cruisers of unlicensed officers was removed by order of IMPD Chief of Police Michael T. Spears.

According to the FCC, some IMPD officers were using the radios to supplement their normal communications channels, including using amateur frequencies for tactical communications during drug surveillance. As part of its inquiry, the FCC reminded the IMPD of the large number of tactical channels available on a secondary basis to police departments from the public safety pool of frequency allocations.

"We are pleased that IMPD has put a stop to this unlicensed activity," said ARRL Regulatory Information Manager Dan Henderson, N1ND. "The investigation by the FCC, coupled with the expedient cooperation and correction of the problem by the IMPD, eliminates a situation that had raised serious concerns in the amateur community."

The FCC stated they would monitor the situation and follow-up appropriately if needed.

—The ARRL Letter, Vol. 28, No. 14, April 9, 2009

reader, that means you would have the ability to easily receive and read digital signals. You simply add a connection from your speaker to the microphone connection on your computer using a stereo mini-plug and the software. Check out the

website at <http://ac6v.com/software.htm> #DIGITAL for free downloads of digital software and shareware. I recommend you try MixW first as it has several digital forms built into it.

Another excellent site is at [www.wb8nut.com/digital.html](http://www.wb8nut.com/digital.html). Here you can listen to what a particular digital signal sounds like. If you're monitoring inside or outside of the amateur radio bands, it's helpful to be able to distinguish between PSK31 and Hellschreiber or AMTOR and PACTOR, to name a few.

## How To Get Started

Begin by downloading and setting up PSK3 (make sure you get a manual, too). You'll see the digital image begins at the top and continues right off the screen, in what's referred to as waterfall. Depending on time of day and the conditions, the following PSK frequencies for the Amateur Radio bands will give you some practice in receiving digital signals: 3.580, 7.035, 10.140, and 14.070; all frequencies are upper sideband (USB).

PSK31 is the mode most widely used by hams today, and it will give you a chance to get your feet wet. Take your time, study, don't get frustrated, and you'll be rewarded with hearing signals from all over the world. Once you get comfortable with it, you can then start monitoring some of those digital signals on any frequency and will recognize what kind it is. Who knows what you'll find.

Until next time, soldier on! ■

## Collins Radio Repair & Tune-Up DVD Guides

*Restoring or repairing classic Collins S-Line equipment?  
These DVDs are like having an experienced  
professional right next to you!*

From Hi-Res Communications, Inc., these well-produced, authoritative DVDs cover all the most common repair and tune-up subjects on these classic radios.



### Collins KWM-2

Two disc set, 236 minutes total  
Order No. C-KWM \$89.95



### Collins 75S-3/32S-3

Two disc set, 226 minutes total  
Order No. C-75S \$89.95



### Collins 30L-1 -

Single Disc 61 minutes total  
Order No. C-30L \$39.95

**Shipping & Handling: US & Possessions**-add \$7 for the first item, \$3.50 for the second and \$2 for each additional item. **Foreign**-calculated by order weight and destination and added to your credit card charge.

CQ Communications, Inc. 25 Newbridge Rd, Hicksville, NY 11801  
[www.cq-amateur-radio.com](http://www.cq-amateur-radio.com) - 800-853-9797 - FAX us at 516 681-2926

## QRP—The New Norm?

by Kirk Kleinschmidt, NTØZ  
kirk@cloudnet.com

*“The QRP craze that started in the 1960s is still on the rise, meaning that, although there have never been more low-power ops or more low-power operating resources, the QRP trend hasn’t peaked yet!”*

I’d love to see a graph that accurately depicts the typical ham’s average RF power output over the past 50 years. In the 1960s, when this graph would begin, I imagine that the average power output would have been rather low (somewhere around 50 watts), but leading into the ’70s and ’80s, I figure 100 watts or so would probably have been the norm. In the ’90s, however, I bet the graph would have begun a downward slide, as real estate hassles, deed restrictions, and homeowner’s associations reared their ugly heads.

Since then, on average, it’s been a lot more difficult to enjoy ham radio by simply putting up a reasonable antenna in the backyard and using it to transmit an average 100 watts into the ether (like we did in the ’70s and ’80s). Ham radio has been under siege, and more and more ops have had to modify or even curtail their pursuit of the hobby.

Adaptations have been many, and they include stealth operation with hidden antennas, remote stations linked by the Internet or on

VHF/UHF (for the fortunate few), a shift to mobile and portable hamming, weekend contest operating at someone else’s shack, etc. Many of these “ways of operating” involve running a lot less than “the 100 watt average” when it comes to power output. Whether backpack portable or condo-bound, running 100 watts is probably impractical. It’s too difficult to lug around the required power for it, and running 100 watts to an indoor antenna is probably going to cause more problems than it fixes—for you and your neighbors.

As I’m sure my imaginary graph would show, hams don’t seem to be running as much power nowadays—and that’s not all bad.

Regardless of how we got to this point, take comfort in the fact that there’s still a lot of fun to be had running low (or lower) power. In fact, since the beginning of hobby radio, a small but dedicated cadre of hams has chosen to run low power simply for the challenge and the fun of it. Dubbed QRPers (from the ham radio Q Signal QRP, which used to mean “please reduce your

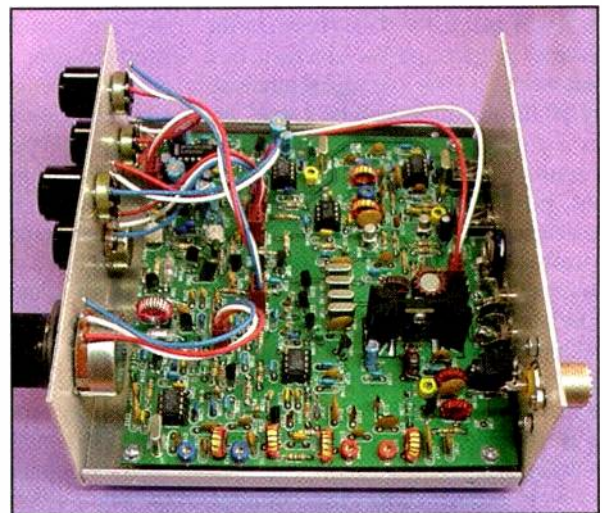
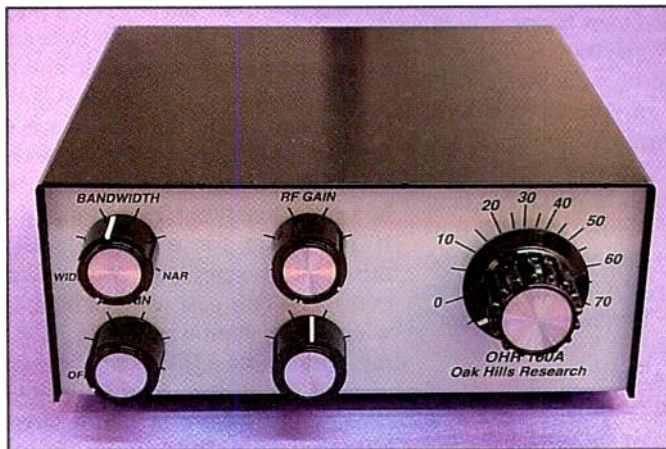

The OHR-100A, from Oak Hills Research, is a single-band QRP transceiver you can build yourself. At \$149 it’s not the least expensive kit on the block, but the ’100A is a tried and true design that traces its lineage to Doug DeMaw, W1FB, one of the all-time great QRP gurus. The ’100A puts out 5 watts on any band between 80 and 15 meters (it covers about 80 kHz of the CW subband, you choose before you build). It’s a stable superhet design with RIT, variable CW bandwidth and smooth, full-break-in T/R switching. See Oak Hills’ complete lineup at [www.ohr.com](http://www.ohr.com).

power”), these ops know the dirty little secret of radio propagation: 5 or 10 watts works just about as well as 100 watts in almost every situation.

True QRPers aren’t concerned in the slightest that other ops on the band are running 100 to 1000 watts or more. After they’ve logged a few low-power QSOs, the sky’s the limit (even if their power isn’t). So, let’s set aside deed restrictions and the like, including all the above-mentioned factors that might be forcing us to reduce our power, and let’s take a look at QRP operation from a bright and shiny perspective.

## The Golden Age of QRP Is Right Now!

Most ham rigs sold today—and in the past 30 years—put out 100 watts, which is about 20 times more power than the defined QRP power output level of 5 watts (5 watts for CW and digital modes, 10 watts PEP output for SSB). But running 5 watts—a “QRP full gallon”—isn’t even a challenge for the true believers, many of whom run 1 watt, 500 mW, 10 mW or even 1 mW of output power. “Microwatters,” the polite term for the crazies who run less than 1 mW of output power, are a breed unto themselves. Contacts can certainly be made while running a thousandth of a watt, but “puny power” QSOs are often scheduled, and casually calling CQ doesn’t create many pileups!

Even as a longtime QRP op, I have to wonder about the ultimate accuracy of certain claimed microwatt QSOs. Beware the QRPer who says he’s running 100 watts into a 50-dB attenuator placed between the transmitter output and the antenna. In a perfect world, a 100-watt signal attenuated by 50 dB would indeed be 1 mW, but in the real world, quite a bit of that 100-watt source signal could be coupled into the AC power mains, the shield braid of the antenna feed line, etc. Believe me, a few watts of RF coupled into the house wiring may transmit a *big* signal when compared to a milliwatt coupled to an actual antenna! I’m not trying to rain on the microwatters’ parade, I just want to keep it real. So, if you want to try your hand at running a milliwatt, start with a transmitter that puts out 250 mW or less.

As you explore QRP for yourself, you’ll be pleased to know that you’ll have a lot of company. Whether full time or part time, worldwide, there are at least 100,000 QRP ops who will graciously share the bands with you and welcome you to the party. Your 5-watt signal won’t

dominate the band, but with a little effort and a few tricks of the trade you can work all 50 states and a lot of DX, even with a “compromise” antenna.

The QRP craze that started in the 1960s is still on the rise, meaning that, although there have never been more low-power ops or more low-power operating resources, the QRP trend hasn’t peaked yet. I think of it as part of the Green Revolution we’re experiencing with cars, energy, and the like. QRP reduces your radio carbon footprint, for sure!

## The New Math

Here’s something the linear amplifier manufacturers don’t want you to know: A 1-watt signal is only 3 S-units weaker than a 100-watt signal. Yes, it’s true! If your 100-watt signal is about S-9, your 1-watt signal will be about S-6, which will put a lot of contacts in your logbook. You’ll listen more and call CQ less, perhaps. And persistence pays off, as does using the right approach. Beginning QRPers often call only the loudest stations. That’s not necessary, although it’s a good idea to have decent copy on the stations you do call. Some of those other, weaker, stations may be running low power, too. You never know until you give ’em a call.

## QRP Frequencies

As of the summer of 2009, we’re still at or near the bottom of the propagation doldrums that define the relative “dead spot” between sunspot cycles. In the Midwest, at least, 10, 12, 15, and 17 meters aren’t open very often, and when they are, signals are weak unless a strong sporadic-E or tropo event happens to be taking place. QRP operation is still possible, but it’s more of a challenge until propagation perks up. And when it does, these bands are daylight powerhouses. One solitary watt can work the world. Because I remember how good it’s going to get, I can’t wait! Below is a quick run-down on what you can expect from the bands, but don’t forget to keep a close eye on Tomas Hood’s “Propagation Corner” for monthly updates.

Twenty meters will benefit from increased sunspot activity—especially when it comes to staying open late into the night—but it’s a mainstay even now when it comes to QRP DXing. During the solar doldrums there’s a lot of competition on 20, so be prepared to work for whatever you scare up. It’s a good thing that plenty of ops have world-class antennas and station setups on this band. You

Band (Meters)	Calling Freq. (MHz)
160	1.810
80	3.560
40	7.040 (7.030)
30	10.106
20	14.060
17	18.080
15	21.060
12	24.910
10	28.060

can hear them, and they can almost always hear you.

Forty and 30 meters are excellent bands for stateside QRPing, especially when sunspots aren’t cooperating. They can even deliver a fair amount of DX in evening and overnight hours, especially if you live near one coast or another. Forty probably sports more QRPers per square mile than any other band, and many of them are home-brewers who like to build their own gear from kits or from scratch. Thirty meters is favored by many QRP ops because it’s quiet, uncrowded, and “open for business” nearly 24 hours a day, even if it doesn’t seem like it. Feel free to call CQ if 30 meters sounds dead. You’ll be surprised when your calls are answered.

Eighty meters is another good stateside QRP band; but it’s not as popular as 40 meters because propagation is usually not as good (except for close-in contacts). Eighty also has DX potential, but competition is fierce and the physics of propagation are working against you. Summertime noise can be a real killer on 80 and 160.

On Top Band, 160 meters, QRP contacts are possible, especially when the band is quiet, but because the other HF bands offer much easier hunting, 160 can be a pretty lonely band for casual QRPers. If you’re up for a jumbo challenge, though, 160-meter QRP contacts happen every day. This past winter I managed to work a KP4 station in Puerto Rico from my Minnesota QTH while running 5 watts CW. I was especially pleased because I was using an indoor antenna in my attic! To be fair, Illinois is usually good DX for my 160-meter QRP efforts.

## QRP Modes

Low-power ops run every conceivable mode, just like their QRO (high-power) cousins. But in a practical sense, some

modes work a lot better than others. Full-carrier AM (like a standard CB) probably takes the biggest hit, followed by SSB. For cheap-n-easy, Morse code is king of QRP. This is still the primary mode for QRPers worldwide, but PSK31 and a handful of newer, more exotic, digital modes have been making great strides. If you're not into CW (and you don't want to learn), PSK31 should be high on your list. Running 5 watts output with PSK31 may be QRP by definition, but it's not really low power for this amazingly efficient digital mode. Easy stateside and DX QSOs are the norm when your signal is so narrow.

## A Feast Of Teeny Gear Awaits

QRP rigs are everywhere nowadays. Look around, because you're likely to step on one if you're not careful! You can choose from classic QRP-only rigs made in years past by Heathkit and Ten-Tec; microscopic high-tech QRP rigs from ICOM, Yaesu, and Elecraft; kit radios galore from a hundred manufacturers (too many to assemble in one lifetime); and even entry-level transceivers from mainstream companies that can output RF from 1 watt to 100 watts (ICOM's versa-

tile and affordable IC-718, for example).

If you're thinking of building a low-power station from scratch, QRP is a great place to start. Hundreds of QRP construction articles have been published in every amateur radio magazine since 1975. The thrill of working other stations with a radio you built yourself is something every ham should experience.

If you don't want to invest in a dedicated QRP rig, it's relatively easy to reduce the power output of most modern solid-state rigs. The drive control can usually be used to trim the RF output to within acceptable QRP limits. And if it can't, you can almost always trick the radio into putting out QRP power by feeding a few volts of DC (from a 9-volt battery) to the radio's rear-panel ALC jack (which is used by an external amplifier to tell the transceiver to reduce its power output to prevent overdriving the amplifier's input circuits). Your rig's instruction manual will probably have more information.

## QRP Resources

Many clubs exist to serve the interests of QRPers and new ones seem to sprout weekly. One of the oldest and most prominent is the QRP Amateur Radio Club

International (QRP ARCI, [www.qrparci.org](http://www.qrparci.org)). Its members-only magazine, *QRP Quarterly*, has been around forever and is still going strong. Other clubs include the Michigan QRP Club ([www.miqrp.org](http://www.miqrp.org)), founded in 1978, and the G-QRP Club (<http://gqrp.com>), based in England (its publication, *Sprat*, can be hard to find here in the states, but it's a nice read if you can subscribe). On the G-QRP website you can order a CD-ROM that contains all of the magazine's back issues. A simple Google search of "QRP" will have you reading for days.

As for books on the subject, you need look no further than your favorite amateur radio products dealer. Look for titles on QRP operating and QRP gear/construction. Check out the ARRL's *Low-Power Communication: The Art and Science of QRP*, now in its 3rd edition, by veteran QRPer Rich Arland, K7SZ; and *QRP Basics*, by Reverend George Dobbs, G3RJV, the UK's best-known QRPer, for starters.

Despite a notorious bumper sticker that reads, "Life is too short for QRP;" don't be afraid to turn down the power. You'll have a blast and your carbon footprint will shrink, and that's a real double-whammy! ■

# If you enjoy Amateur Radio ...you'll enjoy **CQ**

It's a different kind of ham magazine. Fun to read, interesting from cover to cover, written so you can understand it. That's *CQ*. Read and enjoyed by thousands of people each month in 116 countries around the world.

It's more than just a magazine. It's an institution.



*CQ* also sponsors these world-famous award programs and contests: The *CQ* World-Wide DX Phone and CW Contests, the *CQ* WAZ Award, the *CQ* World-Wide WPX Phone and CW Contests, the *CQ* World-Wide VHF Contest, the *CQ* USA-CA Award, the *CQ* WPX Award, the *CQ* World-Wide 160 Meter Phone and CW Contests, the *CQ* World-Wide RTTY Contest, the *CQ* 5 Band WAZ Award, the *CQ* DX Award, *CQ* iDX Award, *CQ* DX Field Award, *CQ* DX Marathon and the highly acclaimed *CQ* DX Hall of Fame.

## SUBSCRIBE TODAY!

*CQ* The Radio Amateur's Journal  
25 Newbridge Road, Hicksville, New York 11801  
Phone: 1-516-681-2922

## For Fastest Service FAX 516-681-2926



	USA	VE/XE	Foreign
1 Year	<input type="checkbox"/> 36.95	<input type="checkbox"/> 49.95	<input type="checkbox"/> 61.95
2 Years	<input type="checkbox"/> 66.95	<input type="checkbox"/> 92.95	<input type="checkbox"/> 116.95
3 Years	<input type="checkbox"/> 96.95	<input type="checkbox"/> 135.95	<input type="checkbox"/> 171.95

# Low Sunspots? You Can Still Work The World

by Tomas Hood,  
NW7US, nw7us@arrl.net

*“ACE-HF PRO Version 2.05 includes some new analysis charts that enable you to compare different antennas...an easy ‘try-before-buy’ method when you are in the market for a new HF antenna.”*

This month, let’s take a fresh look at a unique corner of the exciting amateur radio hobby available to all amateur radio operators. Even though we are in period when the sun is very inactive, you can easily make two-way contacts around the world. This is especially true if you use highly efficient modes of communication to get your signal from your station to that distant “DX” station.

We’ve looked at this before (*Pop’Comm* June 2007), but let’s take a new look at a real-world situation from my location in western Montana, now that we’re at the very bottom of the solar cycle minimum. Since the 2007 article, there has been a steady increase in the popularity of an “antique” mode of communication. And, there’s been a growing craze for low-powered digital mode communication (QRP). Let’s find out why.

The illustrations for this month’s column are derived from the propagation prediction program, ACE-HF PRO, available at <http://hfradio.org/acehf/>. ACE stands for Animated Communications Effectiveness, a coverage display technique originally developed for U.S. Navy submarine communications.

ACE-HF’s advantage is that the effects of solar phenomenon and the day’s passage may be easily understood. ACE-HF shows when the HF bands will be open in different world areas. More accurately, the program is known as system simulation and visualization software, a powerful tool for an amateur radio operator that allows you to simulate a radio signal path between two points. The simulation includes the most current propagation modeling, and visually provides the results of your analysis.

I’ve used the ACE-HF PRO System Simulation & Visualization program to illustrate how useful propagation predictions can be to you as you begin this journey. Version 2.05 of ACE-HF, reviewed in the May 2006 edition of our sister publication *CQ*, has been called the “Cadillac of propagation programs.” That name isn’t surprising since the design derives from the professional ACE-HF Network software for government and commercial HF network operators, which is used by the military and commercial groups. This edition of ACE-HF has many features for the radio amateur, as well as powerful tools useful to short-wave listeners. (See <http://hfradio.org/ace-hf/> for

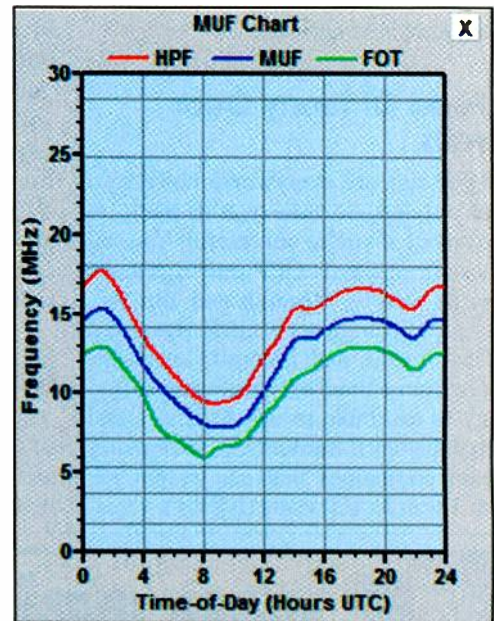

Figure 1. The Maximum Usable Frequency vs. time of day chart for the radio circuit between Missoula, Montana, and Chicago, Illinois, for August 2009 (SSN = 10). (All images were created by NW7US using ACE-HF PRO, version 2.05; see <http://hfradio.org/ace-hf/>)

my various reviews and application notes for ACE-HF PRO, version 2.05.)

To demonstrate how HF propagation works—and how HF circuits may be simulated—I used the NW7US-to-Chicago radio circuit shown in the following figures. ACE-HF is really a full-scale system simulation model, so I had to select some system parameters first. Specifically, I selected the transmitter’s power to be 200 watts, the maximum power permitted by the new rules for Technician class HF operation. I selected Isotropic antennas at each end of the circuit, with an assumed gain of +6 dBi (more about isotropic antennas later). I chose the month of August and selected the CW mode of operation since that’s the majority of what’s allowed on most of the newly available HF bands. This will work to illustrate how easy it is for you to get a handle on using the HF radio spectrum.

From within ACE-HF, I queried the Internet to learn what the predicted smoothed sunspot num-

ber is for August 2009. Next, I created my first prediction, the maximum usable frequency” (MUF) on the radio path between my home in Montana and Chicago (Figure 1). Simply stated, the MUF is the highest radio frequency that can be refracted back to Earth by the ionosphere. It changes from hour to hour and is correlated with the state of the ionosphere’s energy level.

The curves shown in Figure 1 are MUF predictions verses time of day. The blue curve is the median of the daily MOFs (maximum observed frequencies) over all days of the month at a given hour. The HPF (highest possible frequency) red curve gives values expected only 10 percent of the time. The FOT (from French for frequency optimum de travail and sometimes called OWF for optimum working frequency) green values are defined as the frequencies where the MOFs will be higher on at least 90 percent of the days of the month at that hour. The MUF chart also has a blue flashing line to indicate current time and horizontal lines showing the frequencies of each band. The band lines change automatically if a frequency change is made.

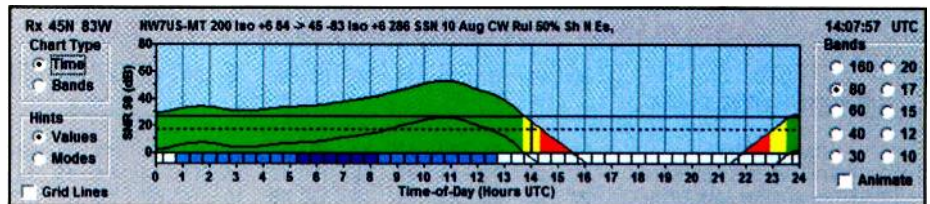

Figure 2. The Signal-to-Noise Ratio (SNR) chart for the radio circuit between Montana and Chicago on the 80 meter amateur radio band for August 2009 (SSN = 10).

Note that the curves in Figure 1 dip down during the nighttime hours, suggesting that the lower frequencies will be favored at night. But each specific circuit (for instance, a path between Montana and Australia rather than the Montana-to-Chicago path in Figure 1) has a different MUF prediction—you’re beginning to see why a prediction program is so valuable! This MUF chart is for SSN 10, the predicted smoothed sunspot number expected for August 2009. Later on we will see how the MUF changes as SSN varies, which is another reason to use software to predict your operation and assure successful HF contacts.

The MUF curves show how ionospheric propagation changes with time of

day and frequency, but they do not show how well your signals may be received. For that, you need a full-scale system performance prediction and must consider both predicted signal strength and noise, because it’s the signal-to-noise ratio (SNR) that determines your ability to hear the signal. It doesn’t matter how strong the signal level might be if it’s overwhelmed by noise (refer to last month’s column for more on SNR).

ACE-HF PRO is a system performance model with noise predictions that include interference from atmospheric noise (caused by lightning flashes), man-made noise and galactic noise. All this is computed automatically, but it’s different for every circuit, frequency, and time of

## The Ap Index And Understanding Propagation Terminology

The Ap index, or Planetary A index, is a 24-hour averaging of the Planetary K index. The Planetary K index is an averaging of worldwide readings of Earth’s geomagnetic field. High indices ( $K_p > 5$  or  $A_p > 20$ ) mean stormy conditions with an active geomagnetic field. The more active, the more unstable propagation is, with possible periods of total propagation fade-out. Especially around the higher latitudes and at the polar regions, where the geomagnetic field is weak, propagation may disappear completely. Extreme high indices may result in aurora propagation, with strongly degraded long-distance propagation at all latitudes. Low indices result in relatively good propagation, especially noticeable around the higher latitudes, when trans-polar paths may open up. Maximum K-index is 9, and the A-index can exceed well over 100 during very severe storm conditions, with no maximum.

Classification of A indices is as follows:

A0–A7 = quiet	A30–A49 = minor storm
A8–A15 = unsettled	A50–A99 = major storm
A16–A29 = active	A100–A400 = severe storm

**Solar Flux Index (SFI):** This flux number is obtained from the amount of radiation on the 10.7-cm band (2800 MHz). It is closely related to the amount of ultraviolet radiation, which is needed to create the ionosphere. Solar Flux readings are more descriptive of daily conditions than the Sunspot Number. The higher the Solar Flux (and, therefore, the higher the Sunspot Number), the stronger the ionosphere becomes, supporting refraction of higher frequencies.

**Ionosphere:** A collection of ionized particles and electrons in the uppermost portion of the Earth’s atmosphere, which is formed by the interaction of the solar wind with the very thin air particles that have escaped Earth’s gravity. These ions are responsible for the reflection or bending of radio waves occurring between certain critical frequencies, with these critical frequencies varying with the degree of

ionization. As a result, radio waves having frequencies higher than the Lowest Usable Frequency (LUF) but lower than the Maximum Usable Frequency (MUF) are propagated over long distances.

**Smoothed Sunspot Number (SSN):** Sunspots are magnetic regions on the sun with magnetic field strengths thousands of times stronger than the Earth’s magnetic field. Sunspots appear as dark spots on the surface of the sun. Temperatures in the dark centers of sunspots drop to about 3700° K (compared to 5700° K for the surrounding photosphere). This difference in temperatures makes the spots appear darker than elsewhere. Sunspots typically last for several days, although very large ones may last for several weeks. They are seen to rotate around the sun, since they are on the surface, and the sun rotates fully every 27.5 days.

Sunspots usually occur in a group, with two sets of spots. One set will have a positive, or north, magnetic field while the other set will have a negative, or south, magnetic field. The field is strongest in the darker parts of the sunspots (called the “umbra”). The field is weaker and more horizontal in the lighter part (the “penumbra”).

Galileo made the first European observations of sunspots in 1610. The Chinese and many other early civilizations have records of sunspots. Daily observations were started at the Zurich Observatory in 1749; continuous observations were begun in 1849.

The Sunspot Number is calculated by first counting the number of sunspot groups and then the number of individual sunspots. The Sunspot Number is then given by the sum of the number of individual sunspots and 10 times the number of groups. Since most sunspot groups have, on average, about 10 spots, this formula for counting sunspots gives reliable numbers even when the observing conditions are less than ideal and small spots are hard to see. Monthly averages (updated monthly) of the Sunspot Numbers show that the number of sunspots visible on the sun wax and wane with an approximate 11-year cycle.

For more information, see <http://prop.hfradio.org>.

## Optimum Working Frequencies (MHz) - For August 2009- Flux = 72, Created by NW7US

UTC	00	01	02	03	04	05	06	07	08	09	10	11	12	13	14	15	16	17	18	19	20	21	22	23
TO/FROM US WEST COAST																								
CARIBBEAN	21	21	21	20	18	17	15	14	13	12	11	11	11	13	15	17	18	19	20	20	21	21	21	21
NORTHERN SOUTH AMERICA	27	27	27	24	22	20	19	17	16	15	14	14	13	15	18	20	22	23	24	25	26	27	27	27
CENTRAL SOUTH AMERICA	27	25	23	21	19	18	16	15	15	14	13	15	14	17	20	22	24	26	27	28	28	29	29	28
SOUTHERN SOUTH AMERICA	25	21	19	17	16	15	14	14	13	13	12	12	14	17	19	22	23	25	26	27	28	28	27	27
WESTERN EUROPE	12	10	9	9	9	12	14	11	10	9	13	15	16	17	17	18	18	19	19	18	18	17	16	15
EASTERN EUROPE	9	9	8	8	12	14	13	10	9	9	9	12	15	16	17	18	18	17	17	16	15	13	10	9
EASTERN NORTH AMERICA	25	24	23	22	21	19	17	16	15	14	13	12	14	17	19	21	22	23	24	24	25	25	25	25
CENTRAL NORTH AMERICA	14	14	13	13	12	11	10	9	9	8	8	7	7	8	10	11	12	13	13	14	14	14	14	14
WESTERN NORTH AMERICA	7	7	7	7	7	6	6	5	5	4	4	4	3	3	5	5	6	6	7	7	7	7	7	7
SOUTHERN NORTH AMERICA	23	22	22	21	21	19	18	16	15	14	13	12	11	12	15	17	18	19	20	21	22	22	22	23
HAWAII	19	19	19	19	19	18	17	15	14	13	12	11	10	10	9	11	13	14	15	16	17	18	18	18
NORTHERN AFRICA	14	13	12	11	10	10	12	11	10	10	13	15	16	17	18	18	19	19	19	19	19	18	17	15
CENTRAL AFRICA	16	15	14	13	12	13	14	13	10	12	14	15	16	17	17	18	18	18	18	18	19	19	18	17
SOUTH AFRICA	17	16	15	14	13	13	14	14	13	13	12	13	17	19	20	22	23	23	24	24	23	21	19	18
MIDDLE EAST	11	11	10	11	14	15	13	10	9	9	9	13	15	16	17	18	18	19	18	17	16	14	13	12
JAPAN	19	20	20	20	19	18	18	17	15	13	12	11	10	10	11	12	11	10	10	13	15	17	18	19
CENTRAL ASIA	20	20	20	19	19	18	18	17	15	13	12	11	10	10	12	15	16	15	14	13	12	13	16	18
INDIA	16	16	17	17	17	16	15	13	10	9	9	8	12	9	8	8	8	8	10	13	14	15	16	16
THAILAND	16	18	19	19	19	18	17	16	15	12	11	11	10	10	14	16	17	16	15	14	13	12	12	14
AUSTRALIA	27	28	29	29	29	28	27	26	24	22	20	18	17	16	15	15	15	14	13	13	15	19	23	25
CHINA	18	19	19	19	18	18	17	16	15	13	11	10	10	13	14	13	12	11	11	10	11	14	16	17
SOUTH PACIFIC	29	29	29	29	28	27	25	21	18	17	16	15	14	14	13	13	12	12	20	24	26	28	28	28
TO/FROM US MIDWEST																								
CARIBBEAN	24	24	23	22	20	18	17	16	14	13	13	12	13	16	18	19	21	22	23	23	24	24	24	24
NORTHERN SOUTH AMERICA	25	25	24	22	20	18	17	16	15	14	13	12	12	15	17	19	20	22	23	23	24	25	25	25
CENTRAL SOUTH AMERICA	27	25	23	21	19	18	16	15	14	14	13	14	16	19	21	23	24	26	27	27	28	29	29	28
SOUTHERN SOUTH AMERICA	24	21	19	17	16	15	14	14	13	13	12	12	14	16	19	21	23	24	25	26	27	28	28	27
WESTERN EUROPE	15	14	11	10	12	12	11	10	10	11	14	16	17	18	18	18	18	18	18	18	18	17	17	16
EASTERN EUROPE	9	9	9	8	8	13	11	10	10	13	15	16	17	18	18	19	18	18	18	17	16	15	13	10
EASTERN NORTH AMERICA	18	17	17	16	15	13	12	11	11	10	9	9	11	13	14	15	16	17	17	18	18	18	18	18
CENTRAL NORTH AMERICA	8	8	8	7	7	6	6	5	5	4	4	4	4	5	6	7	7	8	8	8	8	8	8	8
WESTERN NORTH AMERICA	14	14	13	13	12	12	11	10	9	8	8	7	7	8	10	11	12	13	13	13	14	14	14	14
SOUTHERN NORTH AMERICA	16	16	15	15	14	13	12	11	10	9	8	8	9	11	12	13	14	15	15	15	16	16	16	16
HAWAII	22	22	22	22	21	19	18	16	15	14	16	15	14	13	12	11	11	13	15	17	18	19	20	21
NORTHERN AFRICA	18	16	15	14	13	12	12	11	10	10	13	15	17	18	19	19	20	20	20	20	20	20	20	19
CENTRAL AFRICA	16	15	14	13	12	12	12	11	10	10	13	15	17	18	19	19	20	20	20	20	20	20	20	18
SOUTH AFRICA	16	15	14	14	13	13	12	17	16	15	15	17	20	22	24	26	27	28	27	25	22	21	19	18
MIDDLE EAST	12	11	11	10	12	12	11	10	10	12	15	16	17	18	19	19	20	19	18	17	15	14	13	13
JAPAN	20	20	19	19	18	17	15	13	12	11	10	10	11	14	13	12	11	10	10	13	15	17	18	19
CENTRAL ASIA	20	19	19	18	18	17	15	13	12	11	10	10	13	15	16	18	16	15	14	13	12	13	16	18
INDIA	11	13	14	15	16	15	13	10	10	10	13	15	16	15	14	13	11	9	9	8	8	8	8	8
THAILAND	16	18	18	18	17	16	15	13	11	10	10	13	15	16	17	18	17	16	14	14	13	12	12	13
AUSTRALIA	27	28	29	29	28	27	25	23	21	19	18	17	15	15	16	15	15	14	13	13	16	20	23	25
CHINA	18	19	18	18	17	16	15	13	11	10	10	13	15	16	15	13	12	11	10	10	11	14	16	17
SOUTH PACIFIC	29	29	29	28	27	26	23	19	17	16	15	14	13	13	12	12	12	14	22	25	27	28	29	29
TO/FROM US EAST COAST																								
CARIBBEAN	19	19	18	17	15	14	13	12	11	10	10	10	12	13	15	16	17	18	18	19	19	19	19	19
NORTHERN SOUTH AMERICA	22	22	21	19	17	16	15	14	13	12	11	11	12	14	16	18	19	20	20	21	22	22	22	22
CENTRAL SOUTH AMERICA	26	24	22	20	18	17	16	15	14	14	13	15	17	20	22	23	24	25	26	27	27	28	28	28
SOUTHERN SOUTH AMERICA	24	20	19	17	16	15	14	14	13	13	12	12	16	19	21	22	24	25	26	27	27	28	28	26
WESTERN EUROPE	14	12	11	10	10	9	10	10	9	12	14	16	17	18	18	19	19	19	18	18	17	16	15	15
EASTERN EUROPE	10	9	9	8	11	11	11	10	10	13	15	17	18	19	19	19	19	18	18	18	17	16	15	13
EASTERN NORTH AMERICA	19	18	18	17	15	14	13	12	11	10	10	9	12	14	15	16	17	18	18	19	19	19	19	19
CENTRAL NORTH AMERICA	25	24	23	21	19	18	16	15	14	13	12	14	17	19	21	22	23	24	25	25	25	25	25	25
WESTERN NORTH AMERICA	19	19	19	18	16	15	14	13	12	11	10	10	11	13	14	16	17	18	18	19	19	19	20	20
SOUTHERN NORTH AMERICA	24	24	24	23	22	20	18	17	16	14	13	13	12	13	12	12	14	16	18	20	21	22	23	23
HAWAII	18	17	16	14	13	13	12	13	12	13	17	19	21	22	23	24	24	25	25	25	24	23	22	20
NORTHERN AFRICA	17	15	14	13	13	12	13	13	12	13	17	19	21	22	23	24	24	24	24	24	23	22	20	18
CENTRAL AFRICA	16	15	14	14	13	12	12	16	15	14	15	18	21	23	24	25	26	27	27	25	22	20	19	17
SOUTH AFRICA	15	14	13	13	12	12	11	10	10	12	15	16	18	19	19	20	20	21	21	20	20	18	17	17
MIDDLE EAST	19	19	18	17	15	13	12	11	11	10	10	14	15	13	12	11	11	10	10	13	16	17	18	19
JAPAN	19	18	17	16	14	12	12	11	10	10	13	15	17	18	18	17	17	17	16	15	13	11	9	9
CENTRAL ASIA	9	8	8	8	12	11	11	10	10	13	15	17	17	17	17	17	16	16	15	13	11	9	9	9
INDIA	15	17	17	15	13	12	11	10	10	13	15	16	17	18	19	19	18	16	15	14	13	12	12	12
THAILAND	28	29	28	28	26	24	22	20	18	17	16	15	14	17	16	15	14	14	13	13	17	21	24	26
AUSTRALIA	18	18	17	16	14	12	11	10	10	11	14	16	17	17	16	14	12	11	11	10	10	14	16	17
CHINA	29	28	28	27	25	23	21	16	15	14	13	13	12	12	12	12	11	11	18	23	25	27	28	28
SOUTH PACIFIC																								



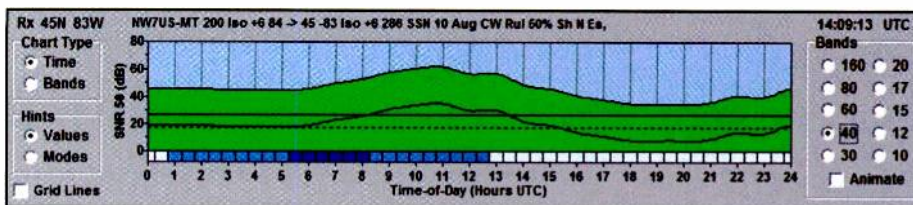

Figure 3. The Signal-to-Noise Ratio (SNR) chart for the radio circuit between Montana and Chicago on the 40-meter amateur radio band for August 2009 (SSN = 10).

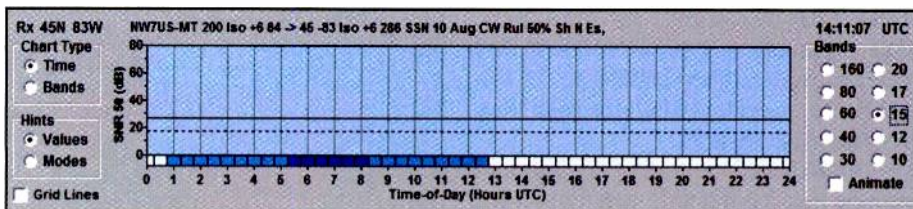

Figure 4. The Signal-to-Noise Ratio (SNR) chart for the radio circuit between Montana and Chicago on the 15 meter amateur radio band for August 2009 (SSN = 10).

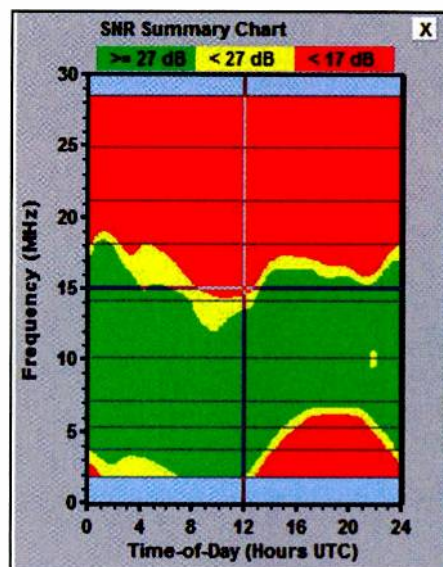

Figure 5. The Signal-to-Noise Ratio (SNR) summary chart for the radio circuit between Montana and Chicago for August 2009 (SSN = 10). Note how easily you can see the windows of “good” propagation for this radio circuit through the entire 24-hour period.

day. To illustrate how SNR varies throughout the day, the next three figures show SNR versus time of day for 80 meters, 40 meters, and 15 meters, assuming CW transmissions as permitted by the new Technician class rules.

The areas of these figures change color as the predicted SNR changes. A green area shows that the predicted SNR is above the minimum required SNR, called RSN. The yellow areas show SNRs within 10 dB of RSN, and the red areas show values that are less than 10 dB below RSN. Obviously, predictions that are in the green show the best times for making your contacts. Note that in the 80 meter predictions of **Figure 2**, there are times during the daylight hours when ionospheric propagation simply doesn't support this circuit to Chicago. So we know right away that a different frequency might be a better choice—or we may have to cool our heels until a time when the ionosphere decides to cooperate for 80 meter operation.

In **Figure 3**, 40-meter connectivity is seen to be much better than that on 80 meters. During the entire day, the SNR is above the desired RSN threshold. But in **Figure 4**, we see that CW operation at 15 meters doesn't work at any time of the day. At 10 meters, the chart is also blank (so we don't need to show it). Both bands are “dead” because of the very weak ionosphere at such very low SSN levels.

My favorite ACE-HF chart is shown in **Figure 5**, where a summary of SNR predictions is given as a function of both frequency and time of day. Here, we see

that the green areas (those where predicted SNR is above RSN) tend to follow the MUF curves, but this chart is much better to use because it illustrates all parameters of the system calculation.

Now, we begin to see the likelihood of making contacts in the various HF bands. The lower bands seem to work better and nighttime operation is favored, as was predicted by the MUF chart. But as the Summary Chart shows, the 15 and 10 meter bands aren't supported very well (because of the very low SSN level.) It can be seen that the sunspot level plays a significant role in HF propagation. During this period of the approximately 11-year solar cycle, operation in the higher HF bands doesn't work well over medium to long circuits, but as the years pass things will get better. The next few figures show how the other extreme of the solar cycle, where the SSN could rise to perhaps 130, will affect communications.

First, compare the MUF chart of **Figure 6** with the earlier one of Figure 1. The higher SSN level is the only thing that has changed. We readily see that the MUFs extend to include 15 meters, at least some of the time. This changing SSN value is a powerful influence on HF operation, and it affects us all the same way, whether you're a beginning Technician class ticket holder or a seasoned Extra class ham.

Let's repeat the 15-meter SNR versus time of day chart to show the difference caused by using an SSN of 130. **Figure 7** shows that 15 meters will support good activity, providing you choose the best

times of day. And it's interesting to see that at the higher SSN, the 15 meter band is better during daytime hours, at least for this circuit.

Now compare **Figure 8** with the earlier Figure 5, where again all we have altered is the predicted SSN level, changing it from the current value of 10 to the example maximum of 130. Now the green areas of good SNR extend to include the 15 meter band, and you can easily see when each band will be open. It's something to look forward to, and as time moves along and the higher bands get better, it's even more important to have a good HF system prediction model on your PC.

## The Antenna In The Mix

Earlier, I spoke of using generic isotropic antennas for these illustrations. Of course, such theoretical antennas don't really exist. We HF hams use practical constructions like horizontal dipoles, vertical monopoles, and even build elaborate arrays of highly directional antennas that can be pointed at desired countries. ACE-HFPRO includes many software models of HF antennas, but it is impractical to show them all in this article. The radiation patterns of all such antennas are handled automatically by the software, and your coverage will vary somewhat according to the antenna you select.

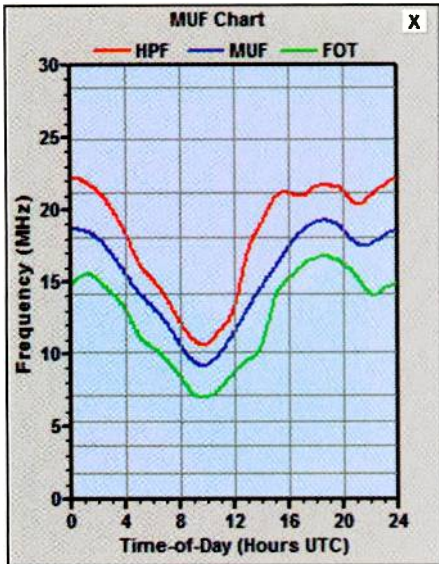

Figure 6. The Maximum Usable Frequency vs. time of day chart for the radio circuit between Missoula, Montana, and Chicago, Illinois, for August 2009 (SSN = 130). Compare this chart to Figure 1 and notice how much improvement on the higher frequencies occurs when the sunspot activity is higher.

ACE-HF PRO Version 2.05 includes some new analysis charts that enable you to compare different antennas, show their relative patterns and gains, and then use them in the system calculation to show their effectiveness—an easy “try-before-buy” method when you are in the market for a new HF antenna. Next month, we’ll begin a closer look at the critical role your antenna plays in how well radio propagation “works” for your station.

You can see that this is a most exciting time to gain HF operating privileges. Since Solar Cycle 23 is at its end and new Cycle 24 is just beginning, the next few years will see an ever-increasing improvement on the HF spectrum, since the sunspot activity will steadily rise. The ever-steady (even if slow) rise in the activity of the new solar cycle translates into a very strongly energized ionosphere. And that means around-the-clock HF propagation on most of the HF amateur bands. Now is the best time for you to raise an HF antenna, install your HF transceiver, and begin using the software tools to assist your on-air adventure.

## Current Solar Cycle Progress

The Dominion Radio Astrophysical Observatory at Penticton, BC, Canada, reports a 10.7-cm observed monthly

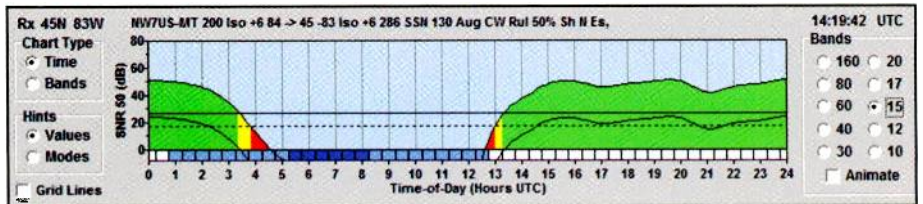

Figure 7. The Signal-to-Noise Ratio (SNR) chart for the radio circuit between Montana and Chicago on the 15 meter amateur radio band for August 2009 (if the SSN = 130). Compare this to Figure 4.

mean solar flux of 69.7 for April 2009. The 12-month smoothed 10.7-cm flux centered on October 2008 is 68.2. The predicted smoothed 10.7-cm solar flux for August 2009 is 72.

The Royal Observatory of Belgium reports that the monthly mean observed sunspot number for April 2009 is 1.2, up from March’s 0.7. Notice that the lowest monthly number during this current solar cycle minimum occurred in July and August of 2008, when the mean observed sunspot number for each month is 0.5. Solar cycle scientists are placing the end of Solar Cycle 23 statistically at December 2008 as a result. The lowest daily sunspot value of zero (0) was recorded on April 1–5, 7–20, and 23–28. The highest daily sunspot count was 8 April 29 and 30. The 12-month running smoothed sunspot number centered on October 2008 is 1.8. The forecast for August 2009 calls for a smoothed sunspot count of 8 to 17.

The observed monthly mean planetary A-Index ( $A_p$ ) for April 2009 is 4. The 12-month smoothed  $A_p$  index centered on October 2008 is 5.4. Expect the overall geomagnetic activity to be varying greatly between quiet to minor storm levels during August.

## August Propagation

Late August and early September are a difficult time of year for which to make accurate band predictions, because conditions can change drastically from day to day. On many days typical summertime conditions will continue much as they were during June and July. On other days conditions may be fall-like, with somewhat higher daytime usable frequencies and somewhat lower nighttime usable frequencies. When you add *equinoctial* (meaning pertaining to the equinox) conditions that can begin as early as late August, we often experience optimum openings between the Northern and Southern Hemispheres on the one hand, but periods of active to stormy conditions on the other.

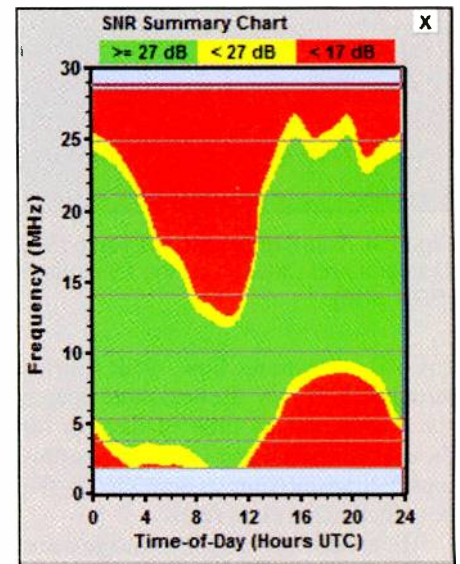

Figure 8. The Signal-to-Noise Ratio (SNR) summary chart for the radio circuit between Montana and Chicago for August 2009 (if the SSN = 130). Compare this to Figure 5.

Despite being at the very beginning of Solar Cycle 24 with low solar activity, during the daylight hours good DX conditions should be possible on 17 and 20 meters. Expect signals on these bands to peak approximately during the two-hour window immediately following sunrise and again during the late afternoon. These two bands will see openings for DX throughout the daylight hours. Fairly good DX openings should occur along an arc extending across central Africa, Latin America, and into the far Pacific area. Peak conditions should occur during the afternoon hours, but an increasing number of earlier openings should be possible by early September.

Between sundown and sunrise 20 meters is expected to be the best DX band. Openings might be possible to many areas of the world, some with surprisingly strong signal levels, especially when using digital and CW modes. Until midnight good DX conditions should be found for openings toward Latin

America, the far Pacific, and into Asia. You might even catch some activity on 17 or even 15. Fairly good conditions are also expected on 30, 40, 60, and 80 meters despite the high static level at times. Openings should be possible before midnight along an arc extending from northern Europe, through Africa, and into Latin America, the far Pacific, and Asia after midnight.

By late August it should be possible to work some DX on 160 meters during the hours of darkness. Conditions on this band, as well as on 40, 60, and 80 meters, will tend to peak just as the sun begins to rise on the light, or easternmost, terminal of a path.

For short-skip openings during August and early September, try 80 meters during the day for distances less than 250 miles, with 60 and 40 meters also usable. During the hours of darkness both 80 and 160 meters should provide excellent communications over this distance. For openings between 250 and 750 miles use 30 and 40 meters during the day for distances up to 500 miles, and 20 and 17 meters between 500 and 750 miles. At night, 40 and 30 meters should be the best bands for this distance until midnight, with 80 meters optimum from midnight to sunrise. Try 60 meters, as well. For openings between 750 and 1,300 miles, try 20 and 17 meters as they should provide optimum propagation during the hours of daylight. Optimum conditions should continue on these bands for this distance range after sundown and until midnight. Between midnight and sunrise the best band should be 40 meters, but check 60 meters, too. For openings between 1,300 miles and the one-hop short-skip limit of approximately 2,300 miles try 20 and 17 meters during the day, with 15 meters also usable. After sundown try 30, 40, and 60 meters, with 80 meters also providing good propagation conditions for this distance range.

### VHF Conditions

Sporadic-E ( $E_s$ ) propagation usually begins to taper off during August, but it should continue to occur fairly frequently. Some 6 meter  $E_s$  openings are expected during the month over distances of approximately 750 to 1,300 miles. During periods of intense and widespread  $E_s$  ionization, two-hop openings may be possible considerably beyond this range. Also check the 2 meter band for an occasional  $E_s$  short-skip opening between approxi-

mately 1,200 to 1,400 miles. While  $E_s$  short-skip openings may occur at any time, there is a tendency for them to peak between 8 a.m. and noon, and again between 6 and 9 p.m. local daylight time.

The Perseids meteor shower covers the period of late July to late August. The peak is expected to occur mid-August and will be most observable in the Northern Hemisphere. The maximum hourly visual rate should reach 100.

And let's not forget aurora. You'd think that aurora would not be a major player at this point in the lull between Cycle 23 and Cycle 24, but with the continued expulsion by the sun of coronal mass into the solar wind, we've been observing occasional moderate auroral activity in the highest latitudes. Auroral-scatter-type openings, on both 6 and 2 meters, can range from a few hundred up to about 1,000 miles, and they are usually characterized by very rapid flutter and Doppler shift on SSB signals.

The very patient can check the 6 meter band for possible trans-equatorial (TE)

openings between 8 and 11 p.m. local daylight time. This type of propagation favors openings from the southern tier states deep into South America, with the signal path crossing the magnetic equator at a right angle. TE openings during August are rare, but they can occur. Very weak signals and severe flutter fading usually characterize them.

### I'd Like To Hear From You

Be sure to check out the latest conditions, as well as the educational resources about propagation, which I have put together for you at <http://prop.hfradio.org/>. I also provide a WAP/WML resource for wireless devices. If you want the latest propagation information like the solar flux,  $A_p$  reading, and so forth using a cell phone or other WAP device, check out <http://wap.hfradio.org/>, the wireless version of my propagation site.

I hope to hear from you. Send a letter or an email.

Until next month, 73 de NW7US.  
Tomas Hood

## The NEW Shortwave Propagation Handbook

The single most comprehensive source of information on HF propagation is once again available from CQ!

- Principles of ionospheric propagation
- Solar cycle predictions
- Stunning photography
- Ionospheric forecasting
- Specific predictions for Cycle 23
- Analysis of HF propagation prediction software
- Unusual HF and VHF ionospheric propagation
- Expansive references and data sources
- How to access NOAA's geophysical databases
- "Do-it-yourself" propagation predictions/charts
- Scores of charts, tables, and summary information
- Overview of WWV and WWVH propagation services



**\$19.95**  
plus \$7 s.h.

**Order Today!!!!**

**CQ Communications, Inc.**

25 Newbridge Road, Hicksville, NY 11801  
Phone 516-681-2922 • FAX 516-681-2926



# Dover Air Force Base: The DoD's Biggest And Busiest Air Terminal

by Mark Meece, N8ICW  
ohioscan@gmail.com

 The Monster Mile is the nickname given to Dover International Speedway because its concrete surface has the tendency to eat the tires off the race cars traversing its one-mile oval. A mere four miles south on US Route 1 is the location of this issue's column subject, Dover Air Force Base, where it's the tires on some of the Air Force's largest aircraft that take a punishing.

## A History Of Change

Dover Air Force Base is situated in the center of the Delmarva Peninsula (Delaware, Maryland,

Virginia) two miles south of Dover, the capitol of Delaware. Construction was started in March 1941, and the facility opened in December of that year as Municipal Airport, Dover Airdrome. On December 7, 1941, Japanese forces attacked the naval base at Pearl Harbor in Hawaii, and weeks after the attack the facility was converted to an Army Air Corp airfield.

Over the next few years the base would go through a flurry of name changes. On April 8, 1943, it was renamed to Dover Army Airbase; two months later on June 6, 1954, it became Dover Subbase (when it was considered a subbase of



Aerial view of Dover AFB circa 1995. (Public Domain photo)



Dover's 13th and final C-17 Globemaster II arrives at the AMC Museum. (Photo Courtesy of Roland Balik/USAF)

Camp Springs Army Airfield, Maryland). The following year on February 2, 1944, it was changed to Dover Army Airfield. When the United States Air Force was established a few years after the end of hostilities of World War II, it was finally renamed Dover Air Force Base on January 13, 1948.

With the military requiring a training airfield, the facility first opened for operations on December 17, 1941, and construction commenced on the runways and hangars. The airfield's first assignment was to the First Air Force. The 112th Observation Squadron of the Ohio National Guard based at National Airport in Toledo, Ohio, was the first unit to arrive at Dover on December 20, 1941. The 112th OS would fly anti-submarine patrols off of the Delaware Coast. A few months later, in early 1942, three bomber squadrons flying the Mitchell B-25 arrived with the 45th Bombardment Group. The 45th BG was charged with patrolling the Atlantic Coast and assuming the anti-submarine mission.

On June 6, 1943 the anti-submarine mission came to an end. Almost immediately a huge upgrading project began and construction crews worked to lengthen the main runway to 7,000 feet. It was during this construction phase that Dover became a subbase of Camp Springs Army Airfield, a status that continued into June of 1944.

In September 1944 Dover returned to full operational status and welcomed the arrival of seven P-47 Thunderbolt squadrons for training before being deployed to the European Theater. The original operation training unit assigned to Dover was the 83rd Fighter Group, which was redesignated to the 125th Base Unit on April 10, 1944. On September 15, 1944, it was redesignated again to the 125th Army Air Force Base Unit.

As World War II came to a close and United States Forces began a drawdown, Dover Army Airfield was temporarily inactivated on September 1, 1946. The 4404th Base Standby Squadron remained at Dover as a housekeeping unit providing maintenance and upkeep of the base.

With the outbreak of the Korean War on June 25, 1950, and the expansion of the United States Air Force, Dover Air Force

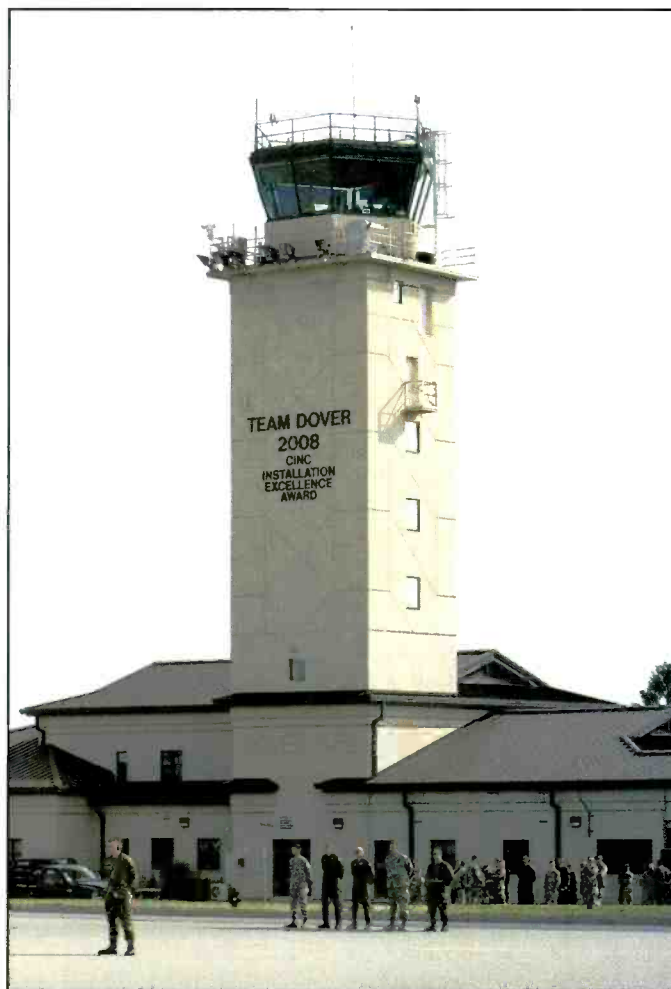

Team Dover leadership await the arrival of the final C-17, near the air control tower. (Photo Courtesy of Jason Minto/USAF)

## Scanning Dover Air Force Base (KDOV)

### Dover AFB Active Units

UNIT	NAME	AIRCRAFT	TAIL COLOR
436th AW			
3rd AS	Third But First	C-17A	Yellow
9th AS	Pelicans	C-5B, C-5M	Yellow
512th AW			
326th AS	Flying Bunnies	C-17A	Yellow
709th AS	C-5B, C-5M	Yellow	

### Dover Air Force Base (KDOV)

#### Aeronautical Operations:

118.875	Dover Ground
125.550	Clearance Delivery
125.900	VFR Only Approach
126.350	Dover Tower
132.425	Dover Approach/Departure
134.100	436th Command Post
135.050	ATIS
135.150	Dover Approach/Departure
142.200	Ground Controlled Approach
225.400	Dover Ground
257.875	Dover Approach/Departure
273.500	ATIS
279.625	Dover Tower
282.325	VFR Only Approach
289.400	Clearance Delivery
323.000	Dover Departure
342.000	METRO
349.000	AMC Command Post
372.700	Dispatcher

SYSTEM: Dover Air Force Base

TYPE: P-25 Standard

VOICE: APCO-25 Common Air Interface Exclusive

SYSID: 16A

#### FREQUENCIES:

381.42500a	381.73750c	381.95000a
385.62500a	386.06250	386.16250
386.35000	386.72500	

c= control channel

a-alternate control channel

#### TALKGROUPS:

DEC	MODE	USE
1	D	Fire/EMS
2	D	Gate Security
8	D	Avionics
10	D	Flight Line
11	D	Ramp control
13	D	Public works
14	D	Base Operations
16	D	Dover Tower
17	D	Fireground
32101	D	Security
32102	D	Security
32351	D	"Wild"
32404	D	Security

Base was brought back to active status on August 1, 1950. P-51 Mustangs marked the arrival of the 148th Fighter Interceptor Squadron from the Pennsylvania Air National Guard on February 1951.

By this time, however, many problems had developed with the base's infrastructure, which had been hastily built some 10 years earlier. Thus began a massive modernization of the base. Control of the base was handed over to the Military Air Transport Service (MATS) on April 1, 1952, and the host unit became the 1607th Air Transport Wing. Construction continued throughout the 1950s.

In 1958 a fully operational hospital was completed, and by 1961 base housing expanded to support 1,200 families. In further Air Force restructuring, the Military Air Transport Service was redesignated to the Military Airlift Command (MAC). The 1607th ATW was deactivated and replaced with the newly created 436th Military Airlift Wing (MAW) and the 436th MAW assumed the main mission at Dover.

Moving into the new decade of the 1970s the 436th MAW replaced its older C-141 Starlifters and C-133 Cargomasters with the new C-5 Galaxy. In 1973, after trading in the last of its C-141s to Charleston Air Force Base, South Carolina, Dover became the first base with an all C-5-equipped wing.

In 1992, the Military Airlift Command was dissolved and Dover Air Force Base was placed under the command of the newly established Air Mobility Command (AMC). The 436th Military Airlift Wing and its associated wing, the 512th MAW, were renamed as the 436th Airlift Wing, with the 436th AW known as "Eagle Wing" and 512th AW known as "Liberty Wing"; both are units of the Eighteenth Air Force headquartered at Scott Air Force Base. Both wings became major participants in Operation Enduring Freedom and Operation Iraqi Freedom after the 9/11 attacks. The first C-5 to land in Iraq at Baghdad International Airport in 2003 was from Dover's 3rd Airlift Squadron, and Dover's unit continues to support the operations in that theater.

### Today's Dover

Today Dover Air Force Base has modernized into the largest and busiest air terminal in the Department of Defense with two runways (14/32 and 1/19). The Charles C. Carson Center for Mortuary Affairs is the largest military mortuary in the Department of Defense. In addition to processing military personnel killed in both war and peacetime it has seen use from several historical events over the past 30 years. In 1978 it was used for the victims of the Jonestown Tragedy, for the Space Shuttle *Challenger* disaster in 1986, the Space Shuttle *Columbia* disaster in 2003, and for military personnel killed in the 9/11 attacks.

Since 2007 the 436th AW and 512th AW have been flying both the C-5 Galaxy and C-17 Globemaster III, some of the largest aircraft in the Air Force inventory. Details on these units can be found in the accompanying sidebar. In addition to aeronautical operations frequencies used at Dover Air Force Base (KDOV), the base uses a Project 25 digital trunk system; all this information is also in the sidebar.

### Air Mobility Command Museum

Dover Air Force Base is also home to the Air Mobility Command Museum. This museum is unique in that it offers visitors an inside look at the aircraft used for airlift operations.



Team Dover's first C-5M Super Galaxy arrives at the base. (Photo Courtesy of Jason Minto/USAF)

It's also the only museum devoted to air-lift and aerial refueling history.

If you plan a visit, it's nice to know that the museum offers free admission and parking. It's open to the public Tuesday through Sunday 9 a.m. to 4 p.m. and closed on Mondays and Federal holidays. Guided tours are available for groups of 10 or more. Check out its website at <http://www.amcmuseum.org/> for details.

And don't forget to program your scanner, and then write in to let us know if you find anything new.

## Loggings And Intercepts

Doug Bell from Ontario, Canada, writes in with his intercepts this month, if you would like to add your reports, whether on HF, VHF, or UHF, you can send them to the email address listed in the column header. Please try to follow the format you see here and we will include them in a future column.

**5616:** USB 1916Z CANFORCE 4129 (CC-150/8 WG, 437 SQN, CFB Trenton, Ontario) wkg Gander Radio with a full position report.

**0021Z** CANFORCE 4133 (CC-150/8 WG, 437 SQN, CFB Trenton, Ontario) wkg Gander Radio with a position of 50N 040W with fl 370.

**0046Z** STEEL 81 (KC-135R/171st ARW, 147th ARS, PA-ANG) wkg Gander Radio CPDLC at 030W. Flight performed a KQEH SELCAL check.

**5696:** USB 0220Z USCG 1702 (HC-130H7/CGAS Sacramento) wkg CAMSPAC-Point Reyes with an "ops normal," and a position of 39N 121W.

**8864:** USB 1523Z BOXER 45 (C-40C/113th WG, 201st AS, DC-ANG)

wkg Gander Radio CPDLC at 030W. Flight performed a LSPQ SELCAL check.

**1235Z** CONVOY 3882 (C-130T/ "Capital Express," VR-53, NAF Washington, D.C., Andrews AFB, MD) wkg Gander Radio with a position of 49N 040W.

**1923Z** SAM 4733 (C-32A/89th AW, 1st AS, Andrews AFB, MD) wkg Gander Radio CPDLC at 030W. Flight performed a MSFG SELCAL check.

**8918:** USB 2149Z CANFORCE 3607 (CC-177/8 WG, 429 SQN, CFB Trenton, Ontario) wkg New York Radio with a full position report at fl 340. Flight instructed to employ 5520 kHz for its next report.

**11175:** USB 1809Z DEATH 12 (B-2A/509th BW, Whiteman AFB, Mo.) wkg HF-GCS Station OFFUTT with a phone patch to SPIRIT CONTROL. Flight reported to be on time for the AR.

**1943Z** NAVY YB 007 (P-3C/ "Screaming Eagles," VP-1, NAS Whidbey Island, WA) wkg HF-GCS Station MCCLELLAN with a phone patch and flight data passed.

**2056Z** PELICAN 71E (P-3C/ "Pelicans," VP-45, NAS Jacksonville, FL) wkg HF-GCS Station PUERTO RICO with a phone patch and mission data passed.

**0049Z** RANGER 326 (EP-3E/"Batman," VQ-2, NAS Whidbey Island, WA) wkg HF-GCS Station MCCLELLAN with a phone patch and flight data passed.

**11232:** USB 2355Z NAVY LL 37 (P-3C/"The Pro's Nest," VP-30, NAS Jacksonville, FL) wkg TRENTON MILITARY with an unsuccessful phone patch. ■

# MIL SPEC RADIO GEAR

KOREAN WAR TO PRESENT DAY

by MARK FRANCIS, KIØPF



• Detailed write-ups for many familiar sets: PRC-25/-77, PRC-10, PRC-74, PRC-41, RT-68, PRC-1099, GRC-106, GRC-9, GRC-109, GRR-5, R-392, and more

• Over 230 pages of operation, modification, and maintenance tips and info, including 200+ illustrations

**CQ Communications, Inc.**

25 Newbridge Rd, Hicksville, NY 11801

(516) 681-2922 • Fax: (516) 681-2926

Web Site [www.cq-amateur-radio.com](http://www.cq-amateur-radio.com)

## Nifty E-Z Guide to PSK31 Operation

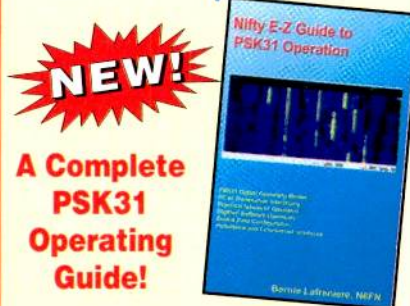

Using the very popular DigiPan software as a basis, a detailed step-by-step approach is used for configuring your interface hardware, software and computer system for PSK31 operation. Detailed instructions and computer screen shots are provided for several of the Windows operating systems, including Vista.

**Order yours today! \$12.95**

Shipping & Handling: USA-add \$7.  
Foreign- calculated by weight & destination  
and added to your total.

**CQ Communications, Inc.**

25 Newbridge Rd., Hicksville, NY 11801

1-800-853-9797 FAX 516-681-2926

## A Noise Generator Project

by Peter J. Bertini  
radiconnection@juno.com

Last month's column touted the benefits of using a noise generator for RF stage alignment. Just in case you missed it, I'm going to give a short recap before going ahead with this month's continuation of the topic.

Have you ever noticed that many sets suffer from significant oscillator pulling while the final touchup of the RF trimmer (antenna stage) for the highest shortwave frequency is being attempted? The common solution is to rock the tuning, or signal generator, back-and-forth over a range of several kHz in an (often futile) effort to keep the signal centered in the IF band-pass as you're trying to find the true peak for the antenna trimmer. [Sigh]. This interaction between the oscillator frequency and RF tuning is the nature of the beast for many inexpensive 1930s vintage consumer grade receivers. Here's how I align those radios using a broadband white noise signal generator.

*"Have you ever noticed that many sets suffer from significant oscillator pulling while the final touchup of the RF trimmer (antenna stage) for the highest shortwave frequency is being attempted?...Here's how I align those radios using a broadband white noise signal generator."*

The schematic for my homebrew noise generator is shown in the accompanying **Figure**. Similar circuits have been in circulation for many years, and my adaptation comes with no claims of originality.

### Noise Source

Here's how it works: A Zener diode (named in honor of Dr. Carl Zener, who first discovered the effect in 1934) is forward-biased to its breakdown region, which is 6.2 volts for the 1N3735. Zener diodes are intended to provide known reference voltages for electronic circuits; they also generate a broad spectrum of white noise when in the avalanche mode. While these noise products are very undesired artifacts for voltage references, here we're going to put that unwanted characteristic to good use!

An inexpensive 1N4735 6.2 volt Zener diode serves as the broadband noise source for our generator. You may substitute a Zener diode with a voltage rating of 5 to 6.6 volts if a 1N3735 type diode is readily not available. The value of the 1500 ohm resistor biasing the Zener diode can be tweaked to maximize the noise level. In a pinch, another 2N3904 transistor can be used as a noise source in lieu of a Zener diode. Connect the base to ground, leave the collector unconnected, and use the emitter as the "cathode" lead. The current limiting resistor must be changed from 1500 ohms to about 2700 ohms.

### The Circuit

The Zener diode noise source is followed by three cascaded transistor amplifier stages. The noise signal's output level is adjustable via a 1000

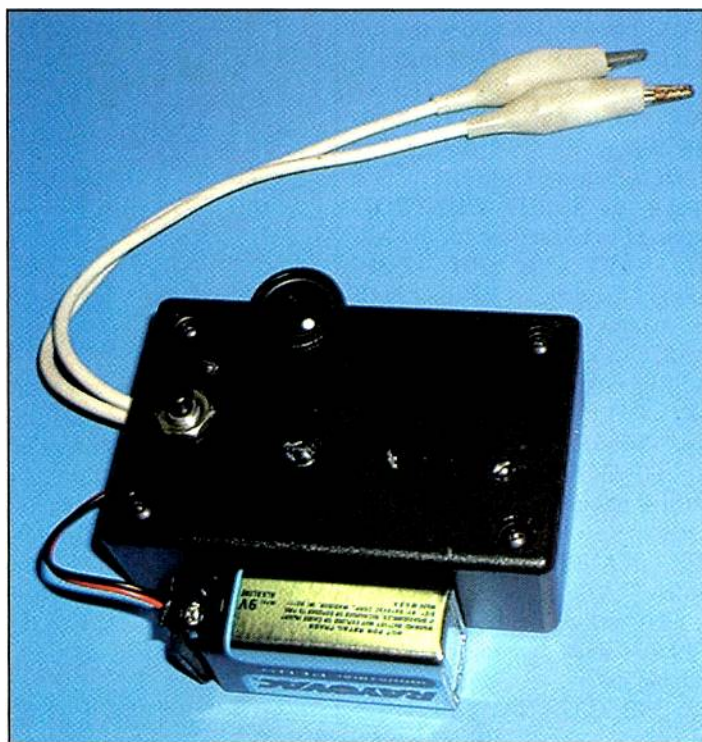

Photo A. An inexpensive plastic project enclosure houses the author's noise generator prototype. A metal or plastic box will serve equally well, so just use what you have.



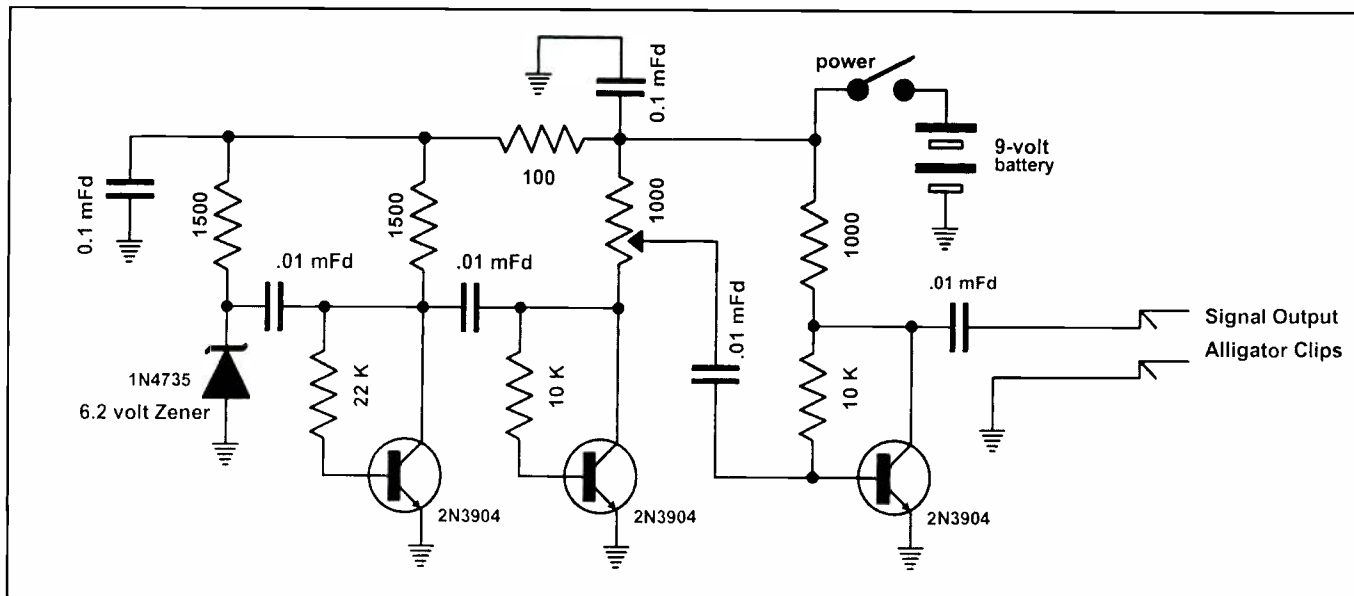

Figure. Noise Generator Schematic. A Zener diode generates the wide-band white noise, which is further amplified to a usable level by three transistor amplifier stages. This device facilitates shortwave band alignment in radios that suffer from severe oscillator pulling problems.

ohm potentiometer between the second and third amplifier stages.

The three silicon NPN transistors are common and inexpensive 2N3904 small signal devices. The 2N2222 transistor, as well as any other small signal transistor with an  $f_T$  (a unity gain parameter) of 300 to 400 MHz, makes good candidates for any of the three stages. I had a few NTE-123 transistors (from the NTE Electronics line of replacement parts) on the bench and they also worked fine. Metal- or plastic-bodied varieties may be used interchangeably.

### Part Values

In lieu of a parts list I'm going to give some general guidelines for what parts might be used to build this project. I'm going to assume that most builders will opt to use the materials they have on hand, rather than buying all of the small miscellaneous components at the local electronics emporium—even if one is lucky enough to find any locally that are still in business!

The resistors can be either carbon or metal oxide composition, and the wattage ratings are far from critical. One-quarter watt resistors will be fine. Use what you have. The capacitors can be ceramic, Mylar, or polyester-type dielectrics. Again, use what you have, but disc ceramic caps with lower voltage ratings will be less bulky and easier to work with. The potentiometer should be wired so that the potentiometer wiper arm, at full clock-

wise (CW) rotation, reaches the arm wired to the second transistor's collector. In other words, you want full noise output at full the CW setting.

A 9 volt transistor battery powers the project. I used a momentary push-button power switch to turn the generator on. It is a bit cumbersome, but I often end up with dead batteries in similarly powered devices because I forget to turn them off after use.

### Construction Ideas

I'm a tad embarrassed to share photos of how mine went together. As a feeble excuse I offer that the hastily cobbled up kludge you're about to witness was designed and assembled late on a Saturday evening, just prior to the column's Monday morning deadline. Ideally, the noise generator would be built on a printed board, using either through-hole mounted parts, or better yet, surface mount technology (SMT) construction. That would be the preferred, professional approach. If enough readers are interested I could investigate having a small run of through-hole PC boards made up. I offer other possible suggestions later in the column.

### Peter's Generator

Photo A is an exterior view of my noise generator. The enclosure is a very inexpensive, generic, plastic project box carried in the Philmore Electronics product line. I had it, so I used it. Everything seen came from the shop's junk box. That

being said, it was a tad small, and the 9 volt transistor battery is mounted externally using double-sided tape. Photo B shows the internal circuitry. It won't win any beauty contests, but remember this was a design prototype and was never meant to be the final, published product. I used miniature terminal strips for each of the three amplifier stages. This technique allowed adding or removing stages, as needed, during the design evaluation.

### Construction Techniques

In lieu of a printed circuit board I'd suggest using a perf-board, or better yet, what's known as "Manhattan-style" construction. Manhattan-style construction uses small sections (for example, one 1/4 inch by 1/4 inch) of PC board material hot glued to a PC board base. The sections serve as insulated solder-junction tie points for the component leads, while the copper substrate of the PC board base serves as a solder point for component ground and bypass returns. "Dead-bug" construction is also popular; for that technique the junctions are done in mid air, with the copper substrate of an unetched PC board being used for the ground return junction points. The component leads provide support for each other, and it works quite well, although it's a bit ugly to look at. Indeed, it has also been called "ugly-board" construction.

Both construction styles offer an excellent copper ground plane for RF circuits. Other techniques involve cutting

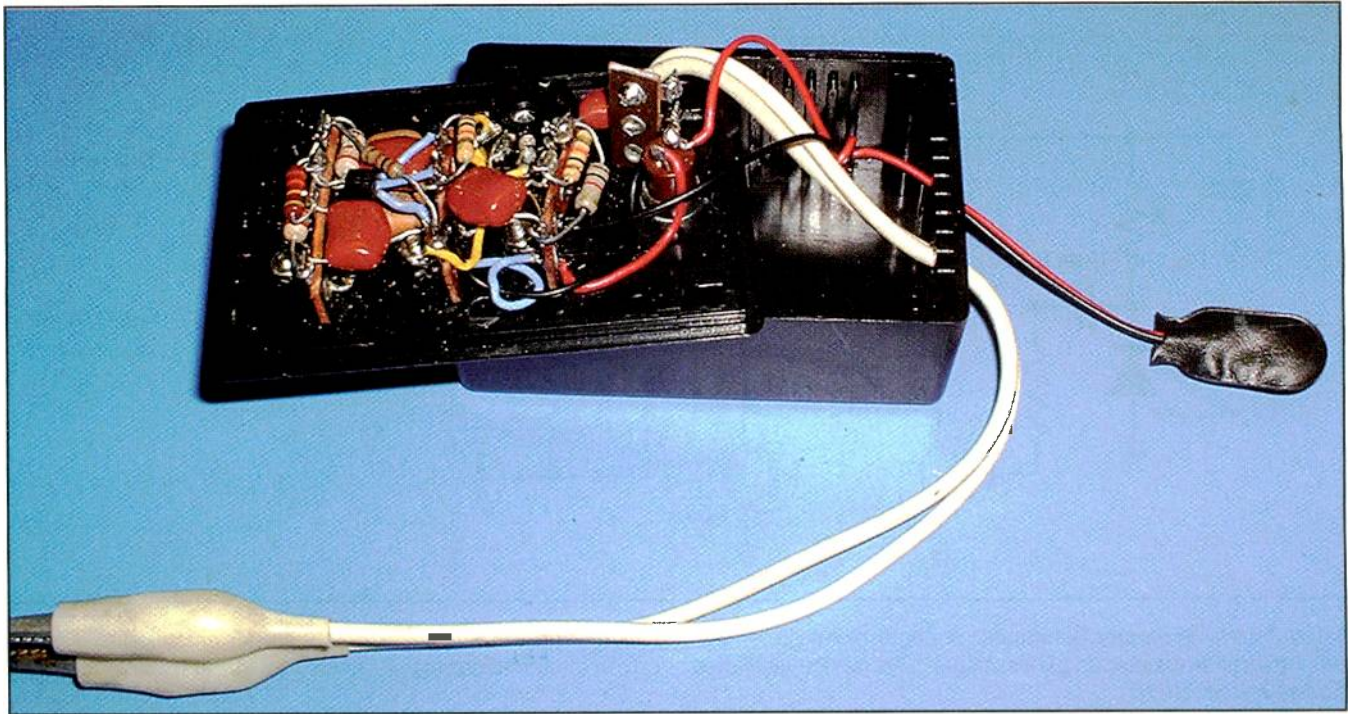

Photo B. This is an interior view of the circuitry in the author's prototype. The point-to-point wiring and sectionalized construction facilitated debugging and design changes as the circuit evolved.

isolated pads or runs on the copper substrate using various mechanical means. Regardless of the construction technique, this circuit is relatively foolproof and almost "has to work." If you have problems, first try a few simple voltage measurements for the initial troubleshooting. The cathode of the Zener diode should read the diode's working voltage. The bases of all three transistors will be at about 0.7 volts, while the collector voltages will run between 1 and 2 volts.

My Tek 465 scope measured a 0.8 VAC P-P noise level at full generator output. The waveform may go into clipping on both sides at full output. Remember that the max noise level displayed on the scope is mostly representative of the lowest frequency components of the generator's noise spectrum. The actual peak RF voltages in the HF region are in reality going to be much, much lower. Those more adventurous experimenters who can access a spectrum analyzer might consider optimizing the circuit design for a flatter and more uniform noise bandwidth spectra. If anyone comes up with improvements, I'd be pleased to share them in a future column.

Two flying test leads equipped with alligator clips provide the antenna connection. This is to accommodate radio receivers with either balanced or unbalanced antenna terminals. The generator

will work with receivers with low- or high-impedance antenna inputs.

### Using The Generator

Start by doing the receiver's shortwave alignment as you would normally do using the shop signal generator. If the upper shortwave band exhibits oscillator pulling, align the set as close as possible, with extra care to ensure the local oscillator is set correctly for high or low side injection. At that point, connect the noise generator and increase the output level until the receiver background noise increases to a noticeable level. As a final step, repeak the antenna trimmer (usually a small mica compression trimmer capacitor) for maximum background noise, recheck the calibration with a weak calibrated signal source, and you're done.

Note that there are going to be two possible peaks on the RF trimmer; one for the desired frequency, the other for the image (the image is only 910 kHz away for a set with a 455 kHz IF). Here's a quick check you can make to see if the RF is set on the correct side of the local oscillator. With the noise generator connected, you should find two peaks on the RF antenna trimmer. The lower peak is on the high side LO injection. The upper peak means the LO is on the low side of the signal source. Note that most of these early sets have very, very

poor image rejection much above 10 MHz! *When doing the final alignment take steps to ensure and verify that the LO is indeed set on the correct side and that the RF trimmer is peaked as closely as possible to maximize the image rejection.*

The generator can be used as a signal injector to find a defective receiver stage where the signal is lost. Start by injecting the noise at the audio stages and work back towards the antenna. Make sure that the generator is isolated with .01  $\mu$ Fd 630-volt caps on both test leads to prevent damaging the generator. I suggest you learn by practicing these techniques on a working receiver to learn the principles and what to expect before attempting to diagnose a dead radio.

The noise level should be ample enough to be heard by any but the most insensitive receivers. Note that the noise spectrum on this generator falls off rapidly as frequency is increased! Commercial noise generators are flat within a few dB from audio to many hundreds of MHz, or into the GHz range; while this unit's noise level falls off many dB per octave it was intended to be used for the upper 16 to 18 MHz shortwave band limits found on most 1930s consumer radios. I suspect this generator will be usable to at least 50 MHz.

Until next time, keep those soldering irons warm, and those old tubes glowing!

## Utility's Back... Please Excuse The Dust

by John Kasupski,  
KC2HMZ,  
kc2hmz@verizon.net

*“...some additions were made to the NASA mission and launch schedule, so those of you who enjoy monitoring NASA launch communications now have three events on the docket for this month.”*

This month, the “Utility” column returns to the pages of *Pop'Comm* following a temporary absence caused by your columnist taking some sorely needed time off. While I didn't travel, I did get to spend some extra time in front of the radios. I also did some work on my computers, and the one I do my writing on now sports a nifty new quad core CPU and a 1.5TB hard disk.

That's the good news. The bad news is that since we missed a few issues, we have a treasure of logs to catch up on, so this column will be cut kind of short to leave room for extra logs.

I also have to admit to having made an oversight in allowing my domain name registration for the website that supported this column to expire;

it was promptly snapped up by one of those vulture operations that grabs expired domain names in the hope of selling them back to the original holders (for a ridiculous fee, of course).

I want to stress that the “Utility Communications Digest” website was not an official site and was entirely my own responsibility, not that of the magazine or its publisher, so please don't send hate mail to anyone other than me. The oversight was entirely mine. I was the one who created and maintained the site, entirely on my own, as a sub-domain of my personal site and simply forgot to renew the domain name registration. In baseball terms, I committed an error.

In the future, I anticipate reviving the site,



Photo A. Reflected in the water of the Banana River at Kennedy Space Center, Space Shuttle *Atlantis* sits on Launch Pad 39A. (NASA photo by Ken Thornsley)

which will have an entirely new URL. This will occur as soon as I conjure up a new domain name, register it, and get enough spare time to rebuild the site.

## Catching Up With NASA

While I was enjoying my R&R, some additions were made to the NASA mission and launch schedule, so those of you who enjoy monitoring NASA launch communications now have three events on the docket for this month.

In the first of these missions, the Space Shuttle *Discovery* has a targeted August 6 as a launch date to blast off from pad 39A (Photo A) at the Kennedy Space Center. *Discovery* will carry experiment and storage racks to the International Space Station.

In the second mission, the STSS (Space Tracking and Surveillance System) Demonstrators Program for the Missile Defense Agency has a tentative August 17 launch date. The STSS Demonstrators Program is part of an evolving ballistic missile defense system. Its job is to track objects and provide trajectory information to other sensors and interceptors. NASA will launch the demonstrator for the Missile Defense Agency aboard a Delta II rocket from Launch Complex 17, Pad B, at the Cape Canaveral Air Force Station.

Finally, late August is also targeted for NASA's first test of the new Constellation launch vehicle, Ares I. The Ares I-X flight will provide NASA with an early opportunity to test and prove flight characteristics, hardware, facilities, and ground operations associated with the vehicle. It's slated to be launched from Pad 39B at the Kennedy Space Center.

As with all NASA activities, schedules are subject to change without notice. For example, the fall launch relative to the Kinetic Energy Interceptor (KEI) program disappeared from the schedule entirely this spring. The reason? The program itself was cancelled on May 7! The moral of the story is, keep an eye on the NASA website for updates. The page you want for launch schedule information is at:

[www.nasa.gov/missions/highlights/schedule.html](http://www.nasa.gov/missions/highlights/schedule.html)

## Monitor Station Registries, And Remembering Tom Kneitel

Also, while I was away I received a query from Spencer G. Sholly, KB5WQW, of Killeen, Texas, concerning the old Monitoring Station Registry

IDs that used to be more common than they are now. Spencer wrote, "Years ago from somewhere I sent off and got a Monitor Station Registry number (KUSØCJ) with a certificate, etc. Do these still exist and does anybody have any info on them?"

These Monitoring Station Registry IDs were issued by CRB Research Books, Inc., which was run by the late Tom Kneitel, W4XAA (ex-K2AES), and his wife, Judy, until Tom retired and closed the company. I had one—KNY2VS—and still have the certificate. This wasn't his first such endeavor, either. Tom (Photo B) also started the *Popular Electronics*-registered shortwave monitor program, which issued unofficial "WPE" call signs to active SWLs, when he worked for that magazine (as well as for *Electronics Illustrated*) back in the 1950s and 1960s. In fact, Tom touched many facets of the radio hobby, including ham, CB, and scanning, and wrote prolifically about these subjects, including some of the most authoritative reference works available.

And, of course, just in case you live in a cave, Tom was the founding editor of and creative force behind the magazine you're holding in your hand.

Unfortunately, Tom passed away a year ago this month, on August 22, at the age of 75—all too soon for us. And while I'm on the subject, I'd just like to observe that when Tom passed away, we all said he would be missed. We were right, and he is still being missed.

## Readers' Logs

That said, let's move right on to this month's logs. The folks who stepped up to the plate this month (since we're in the middle of the baseball season, we'll borrow another term from this most wonderful of sports) are the following: Al Stern, Satellite Beach, FL (ALS); Mark Cleary, Charleston, South Carolina (MC/SC); Steven Jones, Lexington, KY (SJ/KY); Chris Gay, Lexington, KY; Glenn Valenta, Lakewood, CO (GV/CO); and (because I actually found some time to spend with the radios while on vacation), even your columnist, John Kasupski, Tonawanda, NY (JK/NY).

There are a lot more logs than usual this month since they piled up while I was vacationing. I now have a backlog (no pun intended), so I'll be running a couple extra weeks' worth of logs each month until we get caught up. My sincere thanks for those who have hung in there and continued to send in their loggings!

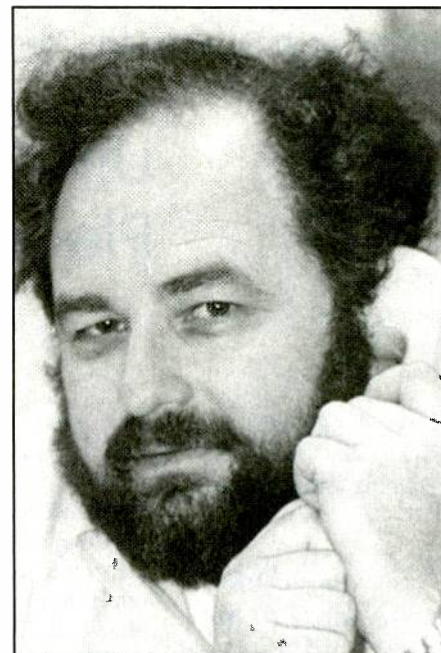

Photo B. Tom Kneitel, W4XAA/SK. "The King is gone, but he's not forgotten..."—Neil Young

**3026.0:** KINLOSS RESCUE in QSO with unheard station, advised him to meet a lady from Scottish TV and give her an infrared tape from a helicopter rescue mission. QRM from nearby broadcaster, in USB, at 2208Z. (CG/KY)

**3330.0:** CHU, Ottawa, Canada time station, in USB at 2002Z. (JK/NY)

**3455.0:** New York Radio wkg N50QJ for SELCAL check in USB at 2244Z. (ALS)

**3485.0:** New York VOLMET with Terminal Aerodrome forecast for Chicago-O'Hare, Milwaukee, Minneapolis, in USB at 0130Z. (ALS)

**4032.9:** U.S. Army MARS station AAT30L (net control) with AAA3VA, AAM3RE and many others in U.S. Army MARS Region 3 net in LSB at 1207Z. (MC/SC)

**4270.0:** E10 (ENIGMA designator) numbers station with 15 grp msg in USB at 1930Z. (CG/KY)

**4372.0:** 14P calling GIANTKILLER in USB at 2334Z. (MC/SC)

**4500.0:** USAF MARS stations AFA4BT, AFA4CD, AFA4LT, AFA4FQ, NNN0TWT and many others in USAF MARS Region 4 net in USB at 1302Z. (MC/SC)

**4718.0:** KINLOSS RESCUE in QSO with Rescue 12, Rescue 51 and Rescue 137; all 18 aboard a downed helicopter were rescued, in USB at 2030Z. (CG/KY)

**4736.0:** PAPA FOXTROT. DELTA. ECHO, INDIA in Link-11/16 coordination net, in USB at 1221Z. (MC/SC)

**5267.0:** 7 JULIET SIERRA, UNIFORM 9 VICTOR. Dolphin 1 in U.K. RAF Joint Maritime Course training exercise, passing info on "your hostile." "target," positions and

bearings, good signals in USB from 0419Z to 0437Z. (SJ/KY)

**5320.0:** USCG SECTOR NEW ORLEANS wkg USCGC MARLIN (WPB 87304) in USB at 2342Z. (MC/SC)

**5550.0:** New York Radio wkg Cactus 1188 for POSREP in USB at 2130Z; NY wkg Viking 1920 for POSREP and SELCAL check in USB at 2133Z; NY wkg Cactus 968 for POSREP (at JAINS); handed off to Jacksonville Center on UHF, in USB at 2134Z; NY wkg Speedbird 21MA for POSREP in USB at 2315Z. (ALS)

**6215.0:** USCG CAMSLANT, radio check with LANTAREA COMMAND CENTER, in USB at 1549Z. (MC/SC)

**6501.0:** USCG weather broadcast in USB at 2308Z. (ALS)

**6577.0:** RESCUE 2001 (USCG HC-130J, CGAS Elizabeth City) with position report to NEW YORK RADIO in USB at 1226Z. (MC/SC)

**6577.0:** New York Radio wkg JetBlue 774; they QSY to 3455 kHz, in USB at 2125Z. (ALS)

**6586.0:** New York Radio wkg American 1044 for SELCAL check in USB at 2258Z; NY wkg American 1764 for SELCAL check in USB at 2300Z. (ALS)

**6586.0:** New York Radio wkg Virgin 651 for POSREP in USB at 0346Z; NY wkg an Air France flight for POSREP, handed off to freq 3452 primary and 6535 secondary, in USB at 0405Z; NY wkg Aor Mexico 001 for POSREP in USB at 0455Z. (ALS)

**6586.0:** NY wkg Airliner 5361 for POSREP, handed off to freq 3455, in USB at 0458Z; NY wkg JetBlue 1765 for POSREP and SELCAL check in USB at 0506Z; NY wkg JetBlue 1751 for POSREP and SELCAL check in USB at 0527Z; NY wkg KLM 977 for POSREP and SELCAL check in USB at 0544Z. (ALS)

**6586.0:** NY wkg American 977 for POSREP in USB at 0602Z; NY wkg United 843 for clearance to Mach .80 in USB at 0607Z; NY wkg Delta 121 for SELCAL check in USB at 0617Z; NY wkg Delta 500; they QSY to 6577.0, then 3455.0, finally accomplish SELCAL check, in USB 2108Z. (ALS)

**6604.0:** New York VOLMET, Aviation WX for New York-Kennedy, Newark, Boston, Baltimore, Washington-Dulles, in USB at 0114Z. (ALS)

**6697.0:** BENEDICT (U.S. MIL) with EAM transmission in USB at 2240Z. (MC/SC)

**6733.0:** E3B in QSO with IDR, voice comms then into digital mode, in USB at 1302Z; OUF calling IDR with "normal ops" in USB at 1748Z; IDR calling 8NT for radio check, no joy, in USB at 1752Z. (CG/KY)

**6745.0:** Trenton Military VOLMET with Terminal WX for Bogotville, Trenton, Ottawa, etc. in USB at 0119Z. (ALS)

**6761.0:** Airborne refueling comms, ETHYL 54 (tanker) and REACH 3600 (receiver) coordinating 80k offload, in USB at 0012Z. (MC/SC)

**7642.0:** IOFN NN (USN MARS NNN0IOF) sounding in USB ALE at 1534Z. (MC/SC)

**8156.0:** CORAL HARBOUR BASE (Bahamas Defence Forces) clg C6WC in USB at 1458Z. (MC/SC)

**8337.6:** SHARK 05 wkg SHARK 47 9USCG assets) for ops and WX report in USB at 2352Z. (MC/SC)

**8379.0:** EIWF, ASPHALT SEMINOLE, 9,240-ton Ireland-registered chemical/oil products tanker w/MMSI and callsign in SITOR-A at 1430Z; C6PC6, AGAMEMNON, 23,433-ton Bahamas-registered bulk carrier repeating MMSI and abbreviated ID "NGEM" in SITOR-A at 1925Z; WDE3119, HOSNORTH STAR, two-month old U.S.-registered "new breed" offshore supply vessel w/MMSI, abbreviated ID "NRTH" and open text request for any msg traffic to the vessel, in SITOR-A at 0323Z. (SJ/KY)

**8381.0:** BUPB, CHANG HANG TAN SUO, 45,719-ton China-registered oil products tanker w/MMSI and abbreviated ID "CHTS" in SITOR-A at 2330Z. (SJ/KY)

**8605.0:** Unid. station w/extended apparent voice scrambling traffic. Station heard for 2 years now, originally transmitted series of 4 digital modes lasting 17 seconds including apparent scrambling every 135 seconds w/open carrier left on; now drops carrier between transmissions shortened to 14 seconds every 134 seconds. Traffic this time was two scrambled transmissions, each lasting several minutes, then back to standard sequence. Unknown mode from 2115Z-2143Z. (SJ/KY)

**8776.0:** TALLY HO (US MIL) with EAM transmission in USB at 2053Z. (MC/SC)

**8912.0:** OMAHA 46CS (P-3 AEW) wkg HAMMER for message relay in USB at 2313Z. (MC/SC)

**8912.0:** LNT (CAMSLANT) and TSC (US Customs Orlando, FL) calling F33 (USCG 2133, a CGAS Cape Cod HU-25C+) with no joy in USB ALE at 1534Z; CAMSLANT wkg CG2133, ALE-initiated QSO for POSREP (38.52N 073.42W), in USB at 1602Z. (JK/NY)

**8912.0:** OPB (OpBat Service Center, Bahamas) calls/raises J42 (USCG 6032) in ALE, followed by brief USB voice comms, in USB ALE then USB at 1611Z. (JK/NY)

**8933.0:** New York ARINC wkg EC-JRT (Gadair European Airlines) for phone patch to Skytour Dispatch; rqsts WX forecast for CYR (Goose Bay, Newfoundland); rqsts short approach to Toronto to save fuel, in USB at 2324Z. (ALS)

**8957.0:** Shannon VOLMET reciting weather; strong signal, in USB at 2014Z. (ALS)

**8965.0:** DHM91, Muenster, Germany, in QSO with German Air Force 442, who reported his departure time, in USB at 1316Z. (CG/KY)

**8983.0:** CG2113 (CGAS Cape Cod HU-25C+) calling CAMSLANT with no joy, I can hear both sides but they can't hear each other, in USB at 1903Z. (JK/NY)

**8983.0:** USCG CAMSLANT wkg CG-2005 (HC-130J, CGAS-Elizabeth City) in USB at 1622Z. (ALS)

**8992.0:** LL 82 (USN P-3C) radio check with Andrews HF-GCS in USB at 2025Z. (MC/SC)

**9007.0:** CANFORCE 85 passing ops normal report to TRENTON MILITARY in USB at 1320Z. (MC/SC)

**9025.0:** 591444 (KC-135) clg MCC (McClellan HF-GCS) in USB ALE at 0615Z. (MC/SC)

**10051.0:** Gander VOLMET aero WX bc, also heard weaker on parallel 13270.0, in USB, at 2000Z. (JK/NY)

**10493.0:** WGY901 (FEMA Region 1, Maynard, MA) wkg unheard station in USB at 2103Z. (MC/SC)

**10538.6:** SWORDFISH 13 (USCG HU-25) passing ops normal report to SECTOR KEY WEST in USB at 2135Z. (MC/SC)

**10780.0:** AMC 2021 in radio check with CAPE RADIO in USB at 1401Z. (MC/SC)

**10780.0:** FISHER (Cape Radio, Cape Canaveral AFS) wkg USN Vessel "0GK" ("Zero-Golf-Kilo"); 0GK passes Ops Normal msg; FISHER asks what buoy 0GK will be coming in on; FISHER will relay info to NOTU Control. In USB at 1120Z. (ALS)

**11175.0:** HF-GCS station CROUGHTON, all frequency call for FEMA 21 with request to "Contact any global station" in USB at 1417Z; HF-GCS station ANDREWS with Skyking FOXTROT "DGJ time 31 auth QO" in USB at 1533Z; ANDREWS with 6-char EAM "for Sweet Bay Tree" in USB at 1638Z; LAJES HF-GCS running p/p for WAFER 23 in USB at 1900Z. (CG/KY)

**11175.0:** ANDREWS with EAM of 6 chars (QPR4B4), in USB at 1811Z. (JK/NY)

**11175.0:** MAINE 85 (KC-135R, 132 ARS/101 ARW) obtaining latest EAM traffic, in USB at 1520Z. (MC/SC)

**11175.0:** HF-GCS Station LAJES (Azores) wkg SHARK 41 (Coronet Oak Mission C-130) for phone patch to SMASHER (SouthAF Flight Monitoring Facility); reports takeoff from TJSJ (San Juan PR) at 1206z; ETA KADW (Andrews AFB) 1715Z; position 21-33 North, 70-00 West; FL180; Heading 338; Mode 4: 3357; in USB at 1317Z. (ALS)

**11175.0:** SPAR 41 (YL) calls any HF-GCS station; no joy, in USB at 2358Z; McClellan HF-GCS wkg REACH 466 for radio check only, in USB at 2112Z; McClellan wkg VADER 26 (C-130H, Youngstown-Warren RAP JARS, AFRC 910AW) for radio check in USB at 2140Z; LAJES wkg REACH 122 for radio check in USB at 2149Z. (ALS)

**11175.0:** ANDREWS wkg REACH 003 (KC-10A #86-0027, McGuire AFB 305AMW) for phone patch to CP; reports inbound, in USB at 1334Z; HF-GCS Station PUERTO RICO wkg CONVOY 3302 for phone patch to Metro for current conditions and en route WX to NAS Norfolk in USB at 1349Z. (ALS)

**11175.0:** OFFUTT wkg LEGISLATE (US

MIL), they QSY to 11220 kHz, in USB at 2335Z. (ALS)

**11175.0:** McClellan wkg HANK 39 (C-130H, Maxwell AFB 908AW) for DSN phone patch to 908AW HANK OPS, passes 0345Z ETA, in USB at 0032Z; HF-GCS Station wkg BLUE 32 (Coronet Mission tanker) for phone patch to McGuire AFB Metro for EX at Hill AFB, in USB at 1512Z. (ALS)

**11175.0:** McClellan wkg TAZZ 71 (KC-135R, OH-ANG, Rickenbacker ANGB); rqsts current tfc; McClellan responds "CZMRRRA." In USB at 1506Z; McClellan wkg LD 894 (P-3C, Brunswick NAS VP-10 "Red Lancers") for radio check in USB at 1520Z; ANDREWS reciting EAM of 28 characters in USB at 1536Z. (ALS)

**11175.0:** OFFUTT calling SENTRY 07 (E-3 AWACS, Tinker AFB) in USB at 1736Z. (ALS)

**11175.0:** PUERTORICO wkg SHUCK 80 (E-3 AWACS, Tinker AFB); rqsts WX for Robins AFB and Tinker AFB at 0030Z; then phone patch to Ops who advises freq 6761 for contact w tanker, in USB at 1935Z. (ALS)

**11175.0:** HF-GCS Station wkg EXCITE 01 for DSN phone patch to "Apache Base" for WX at KHST (Homestead ARB), Naples & Nassau, in USB at 1943Z; ANDREWS wkg CONVOY 3302 for phone patch to North Island NAS Metro for 2230Z arrival WX at KNTD (Point Mugu), in USB at 1957Z. (ALS)

**11175.0:** HF-GCS Station wkg RANGER 410 (P-3, Whidbey VQ-2) in USB at 1953Z; HF-GCS Station wkg EXCITE 01 for DSN phone patch to "Apache Base"; gets WX previously requested for KHST (Homestead ARB), Naples & Nassau, in USB at 2011Z. (ALS)

**11175.0:** McClellan wkg REACH 5142 (C-17A #05-5142, March AFRB) for radio check in USB at 2255Z; PUERTO RICO wkg BRADY 13 (C-130H, 139AW, Rosecrans MAP) for DSN phone patch to Davis Monthan Metro for WX at KFLG (Flagstaff Pulliam A/p, Flagstaff AZ), in USB at 0029Z. (ALS)

**11175.0:** ANDREWS wkg JESSE 94 (C-130H, #86-1394, MO-ANG, Rosecrans MAP) for phone patch; no longer has problem, so returning to original itinerary from Guantanamo to Norfolk instead of RON at Homestead; after Norfolk, will continue to Andrews AFB, in USB at 1520Z. (ALS)

**11175.0:** McClellan wkg BK191 (P-3C, NAS Brunswick) for phone patch to NAS Brunswick TSC GOLDENHAWK, IDs as WAFER 21; passes Spare Group msg, in USB at 1539Z; LAJES wkg BK202 for DSN phone patch to GOLDENHAWK, IDs as WAFER 22, in USB at 1735Z. (ALS)

**11175.0:** HF-GCS Station wkg VIPER 01 for M&W phone patch to an Illinois area code) in USB at 1732Z; LAJES wkg EDGEWOOD (E-6B TACAMO acft) for DSN phone patch to Offutt AFB RF Orderwire Controller in USB at 1748Z. (ALS)

**11175.0:** LAJES wkg "Navy BK 105" for radio check in USB at 2347Z; ANDREWS wkg REACH 974 for phone patch to Scott

AFB HILDA OPS for comms regarding deicing, in USB at 1513Z. (ALS)

**11220.0:** OFFUTT wkg LEGISLATE (US MIL), rqsts 4-tone data transmission in USB at 2338Z; ANDREWS (same voice, changed ID) wkg LEGISLATE, for crypto will be using Alpha 11675, asynchronous, in USB at 2354Z; OFFUTT (changed ID back) wkg LEGISLATE, commencing transmission of data, in USB at 0005Z. (ALS)

**11226.0:** 210192 (C-17A, 437 AW) c/g AED (Elmendorf HF-GCS) in USB ALE at 2259Z. (MC/SC)

**11232.0:** ROCKY 19 (E-3 AWACS), p/p via TRENTON MILITARY to Radar Maintenance for troubleshooting, in USB at 1632Z. (MC/SC)

**11232.0:** TRENTON MILITARY wkg CANFORCE 2377 in USB at 1944Z. (ALS)

**11232.0:** TRENTON MILITARY wkg CANFORCE 2689 for SELCAL check, aircraft reports departed MYNN (Nassau IAP, Bahamas) at 1601Z; ETA MTPP (Port-au-Prince IAP, Haiti) at 1820Z; will then depart to TBPB (Grantley Adams IAP, Barbados); handed off to primary freq 9007 kHz, in USB at 1648Z. (ALS)

**11232.0:** TRENTON MILITARY wkg SENTRY 47 (E-3 AWACS, Tinker AFB) for phone patch, during which GOLIATH ALPHA (Mission crew c/s) rqsts freq and is passed 6714 kHz; GOLIATH ALPHA says they will contact Ops on UHF, in USB at 1918Z. (ALS)

**11232.0:** TRENTON MILITARY wkg ATLAS 39, which IDs as a C-130 conducting SAR training; asks for any tfc; no tfc waiting, in USB at 2011Z; TRENTON MILITARY wkg SENTRY 47 (E-3 AWACS, Tinker AFB), in Sector 8, for DSN phone patch to LOBO OPS in USB at 2003Z. (ALS)

**11232.0:** TRENTON MILITARY wkg CANFORCE 2386, reports ops normal; ETA EGVN (Brize Norton) 2230Z; rqsts latest WX forecast for EGVN (1950Z), EGPZ (Prestwick), & EINN (Shannon, Ireland), in USB at 2029Z. (ALS)

**11232.0:** TRENTON MILITARY wkg NIGHTSTAR (E-8C JSTARS, Robins AFB, in sector 6) for DSN p/p to (Northrop Grumman Integration Ops, Melbourne FL), in USB at 2037Z; TRENTON MILITARY wkg ATLAS 39 (self-IDed C-130); will be making PJ drop in a few minutes; no current tfc waiting, in USB at 2049Z. (ALS)

**11232.0:** TRENTON MILITARY wkg BING 79 (callsign spelled) for radio check in USB at 2140Z; TRENTON MILITARY wkg CANFORCE 2306 for SELCAL check in USB at 1754Z; TRENTON MILITARY wkg SENTRY 07 (E-3, AWACS, Tinker AFB, in Sector 9), for DSN phone patch, in USB at 1758Z. (ALS)

**11330.0:** New York Radio wkg Continental 1638 for POSREP and SELCAL check, in USB at 1558Z; NY wkg American 1937 for POSREP in USB at 1559Z; NY wkg American 1375 for POSREP in USB at 1603Z; NY wkg Delta 499 for POSREP and

SELCAL check in USB at 1604Z. (ALS)

**11330.0:** NY wkg JetBlue 718 for POSREP in USB at 2045Z; NY wkg Westjet 711 (at FL360) for POSREP in USB at 2047Z; NY wkg Cactus 968 for POSREP in USB at 2104Z. (ALS)

**11342.0:** New York Radio wkg N743QS (*this is a Gulfstream 200—jk*) for radio and SELCAL check in USB at 2137Z. (ALS)

**12479.0:** VRCU7, OOCL SOUTHAMPTON, 99,500-ton Hong Kong registered, 8,000 TEU class container ship w/MMSI and abbreviated ID "VRCU" in SITOR-A at 1745Z; ZCDJ4, ALTAMIRA EXPRESS, 40,845-ton Bermuda-registered container ship w/AMVER/PR, 100 miles northwest of Campeche, Mexico in SITOR-A at 1948Z; 3FWU7, SEA BAISEN, 26,613-ton Panama-registered bulk carrier w/ w/MMSI, abbreviated ID "SEAB" then full vessel ID in NBDP test message to China Ocean Shipping Group headquarters, included email address and named individual, in SITOR-A at 2350Z. (SJ/KY)

**12481.0:** Unid. vessel w/request in Spanish for equipment check on Digital Selective Calling freq, and OPR command in SITOR-A at 2342Z. (SJ/KY)

**12588.0:** KLB (ShipCom Seattle, WA), idling SITOR station with CW marker, in SITOR-A at 1805Z. (JK/NY)

**12701.5:** Unid 850 Hz RTTY, too weak to decode, assumed CKN (Vancouver Military), in RTTY at 1809Z. (JK/NY)

**12759.0:** WLO (ShipComm, Mobile, AL), idling SITOR station with CW marker, in SITOR-A at 1754Z. (JK/NY)

**12788.0:** NMG (USCG New Orleans, etc. remoted from NMC) with regularly scheduled WX FAX transmission, in HF-FAX at 1957Z. (JK/NY)

**13110.0:** WLO (ShipCom, Mobile, AL) with synth YL maritime WX BC, considerable QSB, also heard on parallel 13152.0, in USB at 1819Z. (JK/NY)

**13200.0:** Andrews HF-GCS with 3WEMT6, etc. 28-char EAM, also heard on parallel frequencies 15016, 11175, and 8992. In USB at 2006Z; Andrews with 3WO6GL, etc. 28-char EAM, parallel on at least 11175.0, in USB at 2013Z. (JK/NY)

**13306.0:** New York Radio working various aircraft in USB at 1830Z. (JK/NY)

**13914.0:** Unid comms in Spanish using NATO phonetics and Spanish numbers, in USB at 2207Z. (GV/CO)

**13927.0:** USAF MARS Operator AFA9PF (Los Angeles) wkg "Team 05" (KC-10A, McGuire AFB) for M&W phone patch to a Texas area code, in USB at 1748Z; AFA9PF wkg "Reach 115" over Indianapolis for M&W phone patch to a Washington, D.C. area code, states en route to D.C., in USB at 1817Z. (ALS)

**13927.0:** AFA9PF (Los Angeles) wkg "Sentry 61" (E-3B, AWACS, Tinker AFB) for phone patch; rqsts arrival weather, in USB, at 1810Z. (ALS)

**13927.0:** USAF MARS Operator "AFA5QW" (Greenwood IN) wkg "Excite

01" (poss MC-130, over Central America) for phone patch to DSN number at Homestead ARB re ETA 1900Z, also several M&W phone patches, in USB at 1725Z. (ALS)

**13927.0:** USAF MARS Operator AFA4DD (Texas) wkg EXCITE 01 (off coast of Honduras) for phone patch to DSN number at Homestead ARB, in USB at 1730Z; AFA9PF wkg KING 85 (EC-130H #73-1585, Davis Monthan AFB 355 Wing, over Texas) for DSN p/p to Barksdale Metro; rqsts 1830Z WX for KIAB (McConnell AFB), in USB at 1745Z. (ALS)

**13927.0:** AFA9PF wkg TUFF 91 for M&W phone patch to an Arkansas area code, in USB at 1718Z; USAF MARS Operator AFA4HF (Orange City FL) wkg CHILI 50 (C-5A, Kelly Field 433AW) for phone patch to DSN number at Tinker AFB; asks when OKIE 42 (KC-135R, Tinker AFB) will be airborne; in USB at 1653Z. (ALS)

**13927.0:** USAF MARS Operator AFA3CU wkg KING 58 (MC-130P, Moffett Field 129RQW) for DSN phone patch to Davis Monthan AFB Metro in USB at 2005Z; USAF MARS Operator AFA5RS (Shelbyville IN) wkg EXCITE 01 for DSN patch to "Command Post"; reports off the deck at 2016, in USB at 2045Z. (ALS)

**13927.0:** AFA9PF wkg HOBBY ## (C-130, Keesler AFB, MS) for phone patch to a Louisiana number, in USB at 1808Z; AFA6DD and AFA9PF wkg DERBY 86 (C-

130H, KY-ANG, Louisville KY); all have strong signals into my QTH but acft unable to hear, in USB, at 1835Z. (ALS)

**13927.0:** AFA9PF wkg HOBBY 28 (C-130, Keesler AFB, MS, over Texas) for M&W phone patch, in USB at 1842Z; AFA9PF wkg REACH 5142 (C-17A #05-5142, March AFB 452AMW) for phone patch attempt, acft is unable to hear MARS operators, in USB at 1949Z. (ALS)

**13927.0:** USAF MARS Operator AFA5QW (Greenwood IN) wkg SHARK 41 (Coronet Oak Mission C-130) for DSN phone patch to Patrick AFB Metro for 1700Z weather at Andrews AFB, in USB at 1435Z. (ALS)

**13927.0:** AFA5QW wkg SHARK 41 (Coronet Oak Mission C-130) for DSN phone patch to SMASHER (SouthAF Flight Monitoring Facility); no answer, in USB at 1443Z. (ALS)

**13927.0:** USAF MARS Operator AFA7HS (Leawood, KS) wkg SHARK 41 (Coronet Oak Mission C-130, over Bahamas) for DSN phone patch to "Mike-Charlie" at San Juan Coronet Oak Ops); had departed San Juan earlier; has maintenance issues with acft; Ops offers waiver to return to San Juan tonight, in USB at 1610Z. (ALS)

**13927.0:** AFA9PF wkg REACH 9015 (C-5A #69-0015, NY-ANG, Stewart ANGB NY) for radio check in USB at 1802Z; USAF MARS Operator AFA5RS (Los Angeles) wkg SHUCK 80 for DSN phone patch to RAF

Mildenhall Metro in USB at 1905Z; AFA9PF wkg SENTRY 50 (E-3 AWACS, Tinker AFB, over Tennessee) in USB at 1734Z. (ALS)

**13927.0:** USAF MARS Operator wkg RAVEN 36 (over NY City) for M&W phone patch to a Florida area code); reports landing time 1530L, in USB at 1720Z; AFA5QW wkg REACH 3276 (self-IDed C-130 over Indiana, 100 mi south of Goshen) for M&W phone patch in USB at 1745Z. (ALS)

**13927.0:** AFA9PF wkg SKULL 20 (B-52H Bomber, Barksdale AFB 2BW) for DSN p/p to Barksdale BLUE OPS, asks about tanker SOONER 81, in USB at 1745Z; USAF MARS Operator AFA5QW wkg BLUE 51 (Coronet Mission tanker) for p/p to Moody AFB Ops; arriving Moody with four A-10s, in USB at 1750Z. (ALS)

**13927.0:** AFA4HF wkg REACH 381 for DSN phone patch to (Ft. Hood TX); passes ETA "1210 Local"; says REACH 944 is 20 min in trail, REACH 874 is 50 min in trail, in USB at 1403Z. (ALS)

**14383.5:** US Navy/Marine Corps MARS station NNN0KRQ (net control) with NNN0OON in USN/USMC MARS phone patch net in USB at 2026Z. (MC/SC)

**17194.0:** Unid Spanish maritime comms, mentioned Zulu times, in USB at 0029Z. (GV/CO)

**17230.0:** Cerrato Radio with CW channel marker "CQ DE CWA QSX" and frequency list, good levels, in CW at 0011Z. (GV/CO)



# Monitoring Times

## ORDER TODAY!



Do you own a radio, a shortwave receiver, a scanning receiver, or a ham radio? Then Monitoring Times® is your magazine! Open a copy of MT, and you will find news, information, and tips on getting more out of your radio listening. In fact, it's the most comprehensive radio hobby magazine in the U.S.

MT Express - Not only do we offer a premium monthly printed magazine, but we also offer the popular MT Express digital version of Monitoring Times. This is the best way to get your magazine as soon as it's released, right from the internet! All you have to have is an internet connection with an e-mail address and you're ready for all the excitement of a truly interactive publication. For less than the cost of a printed subscription, you get the full magazine in pdf format with color photos throughout and active links to all web sites mentioned in the text.

Packed with up-to-date information concisely written by the top writers in the field, Monitoring Times® is your foremost guide to profiles of broadcasting and communications installations; home projects; and tips on monitoring everything from air, sea, and space to distant ports of call.

800-438-8155

828-837-9200 fax: 828-837-2216

WWW.GROVE-ENT.COM

order@grove-ent.com  
7540 Highway 64 West  
Brasstown, NC 28902



### Order today to start your monthly reference!

7540 Hwy. 64 W., Brasstown, NC 28902  
1-800-438-8155 US and Can., 828-837-9200; Fax 828-837-2216  
e-mail: order@grove-ent.com

	6 months	One Year	Two Years	Three Years
US Rates	<input type="checkbox"/> \$15.58	<input type="checkbox"/> \$28.95	<input type="checkbox"/> \$51.95	<input type="checkbox"/> \$76.95
US 1st Class	<input type="checkbox"/> \$80.00	<input type="checkbox"/> \$57.95	<input type="checkbox"/> \$112.00	<input type="checkbox"/> \$168.00
Canada Surface*	<input type="checkbox"/> \$20.50*	<input type="checkbox"/> \$29.50*	<input type="checkbox"/> \$52.95*	<input type="checkbox"/> \$78.95*
Foreign International*	<input type="checkbox"/> \$38.75*	<input type="checkbox"/> \$29.50*	<input type="checkbox"/> \$115.95*	<input type="checkbox"/> \$175.95*
Electron. Subscription	<input type="checkbox"/> \$19.95	<input type="checkbox"/> \$38.90	<input type="checkbox"/> \$72.85	<input type="checkbox"/> \$107.85

\*All payments must be in U.S. Funds drawn on a U.S. Bank!

Name \_\_\_\_\_ Address \_\_\_\_\_  
City \_\_\_\_\_ State \_\_\_\_\_ Zip \_\_\_\_\_ Country \_\_\_\_\_  
City \_\_\_\_\_ State \_\_\_\_\_ Zip \_\_\_\_\_ Country \_\_\_\_\_  
Exp. Date \_\_\_\_\_ CV# Code \_\_\_\_\_  
Signature \_\_\_\_\_  
E-mail address \_\_\_\_\_  
MasterCard, Visa, and Discover Card accepted

Or just go to [www.grove-ent.com](http://www.grove-ent.com) to order NOW!



## Popular Communications Caps, Shirts, Jackets & Duffels!

### PC T-Shirt & Cap

100% classic cut brushed cotton twill 6-panel cap with brass buckle and grommet, embroidered with the PC logo and a 50/50 blend shirt embossed with the PC logo.

← **Cap and T-shirt BOTH for only \$28**

Have your callsign embroidered on the front or back of the cap for only \$3 more!

Choose any shirt and cap colors you like!  
**Shirt colors:** Black, White, Navy, Grey & Natural  
**Shirt sizes:** S, M, L, XL, 2XL, 3XL, 4XL  
*(Please add \$3 for 2XL, 3XL or 4XL)*

**Cap colors:** Black, Navy, Mustard & Stone



### Adult Ring-Spun Cotton Pique Polo with Embroidered PC Logo

- \* 100% Ring-Spun Cotton
- \* Seamless design
- \* Well knit collar and sleeve bands
- \* Continental placket with horn bottoms
- \* Double-needle hem

**Colors:** Black, Forest Green, Sport Grey, Navy Blue, Royal Blue, White

**Sizes:** S, M, L, XL, 2XL, 3XL

Your callsign embroidered next to the PC logo (in black or white) for only \$3 more!



Polo with PC logo only \$23  
*(Please add \$3 for 2XL or 3XL)*

### Adult Fleece-Lined Coach's Jacket



100% nylon shell, 74% polyester/15% cotton/11% rayon fleece lining, embroidered with the PC logo. Hood and waist drawstrings with bell tips

← **Jacket with PC logo only \$32**

**Jacket colors:** Black, Navy Blue, Royal Blue, Burgundy and Forest Green

**Jacket sizes:** S, M, L, XL, 2XL, 3XL, 4XL  
*(Please add \$4 for 2XL, 3XL or 4XL)*

Your callsign embroidered next to the PC logo (in black or white) for only \$3 more!

### Crew Cap with Embroidered PC Patch

- \* 100% hypo-allergenic acrylic
- \* Super-dense knit
- \* Machine washable

**Colors:** Black, Navy, Grey

**Crew Cap with Embroidered PC Patch \$7.99**



### Large Duffel Bag with Embroidered PC Logo

- \* Size 28" X 14" X 13"
- \* 600-denier polyester ripstop fabric with 450-denier polyester bottom panel full double PU coating.
- \* Zippered main compartment with two zipper pulls.
- \* Zippered front pocket. Black web handles with self-fabric handle wrapper reinforced at stress points.
- \* Adjustable and detachable shoulder strap

**Colors:** Black/Black, Dark Green/Black, Gold/Black, Graphite/Black, Navy/Black, Purple/Black, Royal/Black



↑ **Large Duffel Bag w/Embroidered PC Logo only \$29.99**  
 Your callsign embroidered next to, beneath or above the PC logo (in black or white) for only \$3 more!

**Shipping & Handling: US & Possessions**-add \$7 for the first item, \$3.50 for the second and \$2 for each additional item. **Foreign**-calculated by order weight and destination and added to your credit card charge.

**Popular Communications**

25 Newbridge Rd., Hicksville, NY 11801

1-800-853-9797; Fax 516-681-2922

degree in Banking, Finance and Economics. Adelstein is leaving the FCC to head the Department of Agriculture's Rural Utilities Service.

## Copps: FCC Moving Aggressively On National Broadband Plan

In a May interview on cable network C-SPAN's *The Communicators*, acting FCC Chairman Michael Copps said he is "enthused as I can be that this country is finally, finally going to develop a national broadband plan." During the half-hour question-and-answer program hosted by C-SPAN's Peter Slen, Copps lamented that "we are probably the only industrialized country on the face of God's green earth that doesn't have some kind of a broadband strategy and a broadband plan. And again, we were in this mindset for too many years that, 'All this... will just take care of itself and the market will get broadband out everywhere and anywhere,' and that didn't happen.

"So now the President [and] the Congress have seen the need and directed the development of a plan," Copps said. "And better news for me, because I've been pushing this for so long—they've actually charged the FCC with being at the epicenter of putting this plan together." Copps added the nation is "coming into this late, we're way behind in broadband" and there's a need to take action now. A long term national strategy is the key.

Copps said he believes building a national broadband network is similar to previous national initiatives on rural electrification, universal phone service, and interstate highways. Building projects of such scale require cooperation between government and industry, he said. "That's the way we've always built infrastructure in this country — working together."

## New Amateur Radio "Enforcer" Named In Washington, D.C.

Filling a vacancy left by the 2008 retirement of Riley Hollingsworth, K4ZDH, Laura L. Smith has been named Special Counsel in the FCC's Enforcement Bureau with responsibility of rules enforcement in the amateur radio bands. Hollingsworth held the post for more than a decade as the FCC's enforcement watchdog in the amateur arena.

ARRL President Joel Harrison, W5ZN, said that "ever since [Hollingsworth] announced his retirement, we have met with the Enforcement Chief numerous times and corresponded with FCC Chairman Martin to ensure this position remains intact at FCC."

According to a report in the League's *ARRL Letter*, "Smith is not yet a licensed amateur. She said that she will get her license 'someday,' but that she did not want to get her license just because her job involves amateur radio: 'I didn't want to come into this job and become a ham, saying, 'I'm getting this job so I'm going to be a ham—not because I'm interested in being a ham, but because it looks better on paper.'"

Smith said eventually she will become a licensed radio amateur. Her father-in-law, when assigned to the FCC's Los Angeles Field Office, used to administer the Morse code test to prospective licensees. Smith said. "So he has challenged me that before I can become an amateur on any level, I must learn Morse code and I must pass the test with him administering the Morse code. So I have a challenge.

"I am going to begin learning Morse code this summer. He is going to start teaching me. so once I have sufficient proficiency, then he will let me take the [Technician] test." ■



## readers' market

**Advertising Rates for Readers' Mart:** Non-commercial ads are 30 cents per word, including abbreviations and addresses; minimum charge \$6.00 per issue. Ads from firms offering commercial products or services are \$1.00 per word; minimum charge \$20.00 per issue. Boldface words are \$1.20 each (specify which words). Leading key words set in all caps at no additional charge. All ads must be *pre-paid in full* at time of insertion; a 5% discount is offered for prepaid 6 time insertions. All ads must be typewritten double spaced.

**Approval:** All ad copy is subject to Publisher's approval and may be modified to eliminate references to equipment and practices which are either illegal or otherwise not within the spirit or coverage scope of the magazine.

**Closing Date:** The 10<sup>th</sup> day in the third month preceding date of publication. Because the advertisers and equipment contained in Readers' Market have not been investigated, the Publisher of *Popular Communications* cannot vouch for the merchandise listed therein. Direct all correspondence and ad copy to: Attention: Classified Dept., PC Readers' Market, 25 Newbridge Rd., Hicksville, NY 11801.

**SuperBertha.com** ULTIMATE LONG BOOM OWA YAGIS: Designed by WA3FET and K3LR. Scott W3TX. 814-881-9258.

**COMMUNICATIONS MONITORING ANTENNAS.** HF/VHF/UHF Super Discone \$49.75. AntennaCraft Scantenna \$47.70. 30-1200 MHz. 4-12 dB Log Periodic \$69.50, 806-900 MHz. 13 dB 9 element Yagi \$74.00, MURS/GMRS Dual Band Base \$48.95. All prices **INCLUDE** Priority S&H&I. See these antennas plus many, many more for Amateur, Business, CB, and Monitoring radio, plus cellular phone antennas on the web at: [www.antennawarehouse.com](http://www.antennawarehouse.com) MC/Visa Order line 877-680-7818. To help maintain our low pricing, we do not print catalogs.

**FOR SALE - DRAKE TR-7/TR-7A/R-7/R-7A Service kit.** Includes 13 Extender Boards and Digital Jumper Card. \$64.75 includes postage. See <http://wb4hfn.com/Services/W7AVK/tr7ext2.htm> Bob W7AVK, 5581 Panorama Drive, Moses Lake, WA 98837. w7avk@arrl.net, 509-750-7589.

**SuperBertha.com** CUSTOM ROTATING POLES: No guy wires, entire pole rotates, stack all your antennas, rotor at ground level, 50ft to 300ft high, EIA-TIA-222-G. Starting at \$37,799.00. Scott W3TX, 814-881-9258.

## ADVERTISERS' INDEX

Advertiser	Page #	Website Address
AOR USA, Inc. ....	5, Cov III	<a href="http://www.aorusa.com">www.aorusa.com</a>
Advanced Specialties .....	19	<a href="http://www.advancedspecialties.net">www.advancedspecialties.net</a>
C. Crane Company .....	55	<a href="http://www.ccrane.com">www.ccrane.com</a>
CQ Bookshop .....	25, 29	<a href="http://www.cq-amateur-radio.com">www.cq-amateur-radio.com</a>
Communications Electronics .....	7	<a href="http://www.usascan.com">www.usascan.com</a>
Computer Aided Technologies ....	41	<a href="http://www.scancat.com">www.scancat.com</a>
Eton Corporation .....	14, 15	<a href="http://www.etoncorp.com">www.etoncorp.com</a>
Grundig .....	14, 15	<a href="http://www.etoncorp.com">www.etoncorp.com</a>
Homeland Security .....	60	<a href="http://www.ready.gov">www.ready.gov</a>
ICOM America, Inc. ....	Cov. IV	<a href="http://www.icomamerica.com">www.icomamerica.com</a>
MFJ Enterprises, Inc. ....	3	<a href="http://www.mfjenterprises.com">www.mfjenterprises.com</a>
Monitoring Times .....	81	<a href="http://www.grove-ent.com">www.grove-ent.com</a>
Nifty .....	73	
PowerPort .....	31	<a href="http://www.powerportstore.com">www.powerportstore.com</a>
QCWA .....	31	<a href="http://www.qcwa.org">www.qcwa.org</a>
RSGB .....	21	<a href="http://www.cq-amateur-radio.com">www.cq-amateur-radio.com</a>
REACT International, Inc. ....	17	<a href="http://www.reactintl.org">www.reactintl.org</a>
Universal Radio .....	1	<a href="http://www.universal-radio.com">www.universal-radio.com</a>
Yaesu .....	Cov II	<a href="http://www.vxstdusa.com">www.vxstdusa.com</a>

Reach this dynamic audience with your advertising message, contact Arnie Sposato at 253-853-4080, FAX 253-853-4070, or e-mail: [advertising@popular-communications.com](mailto:advertising@popular-communications.com).

Listening is only half the fun...

## POPULAR COMMUNICATIONS is the other half!

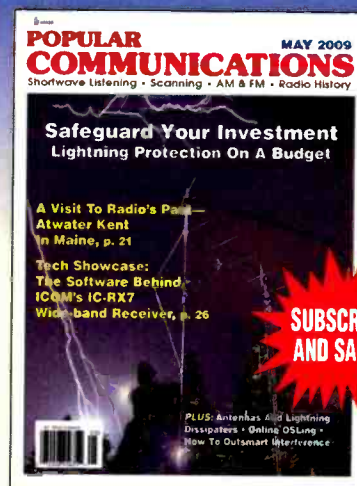

The World's most authoritative monthly magazine for Shortwave Listening and Scanner Monitoring. Read by more active listeners world-wide.

You'll find features on scanner monitoring of police, fire, utility, and aircraft communications; international shortwave listening; CB radio; amateur radio; FRS; GMRS; monitoring radio digital communications including CW, RTTY, SITOR, etc; AM/FM commercial broadcasting; weather and communications satellites; telephone equipment and accessories; radio nostalgia; alternative radio; clandestine radio; and military radio.

USA	Canada/Mexico	Foreign
1 Yr <input type="checkbox"/> 32.95	1 Yr <input type="checkbox"/> 42.95	1 Yr <input type="checkbox"/> 52.95
2 Yrs <input type="checkbox"/> 58.95	2 Yrs <input type="checkbox"/> 78.95	2 Yrs <input type="checkbox"/> 98.95
3 Yrs <input type="checkbox"/> 85.95	3 Yrs <input type="checkbox"/> 115.95	3 Yrs <input type="checkbox"/> 145.95

**Popular Communications**  
25 Newbridge Road, Hicksville, NY 11801  
Phone: 516-681-2922; Fax 516-681-2926  
Visit our web site:  
[www.popular-communications.com](http://www.popular-communications.com)

## The Dinosaur Drives A Wedge

by Bill Price, N3AVY  
chrodoc@gmail.com

*“When I drove a '66 Plymouth... I had a Lafayette “imported” speed key on the console, connected to an oscillator.”*

Once I was an active ham. I loved working CW, but I quickly lost interest in discussions of equipment, and weather, equipment and weather, and weather and equipment. I'd hoped to find someone on the CW bands with whom I'd have at least some common interests, but I didn't, so I swapped the transceiver for a receiver and never looked back. Now the same Internet that's decimated the king of hobbies provides me with the narrowest of categories: keeping me in touch with other armed harmonica players with pet rats. Some of them are even hams, which brings me to burning question: Why not CW over the Internet?

We can send still photos, movies, and audio files. We can chat over the net with cute mics and headsets or pay a few dollars (gasp!) and use VoIP, yet no one even bothers to offer a jack where I could plug in a key (if I hadn't given them all away). Maybe IBM isn't interested in that, but I'd like to think maybe MFJ would come up with an Internet-based CW system for those nights when the ionosphere is not co-operating.

In Coast Guard radio school, classrooms were connected by a CW intercom. It was odd to us at first, but after a while it seemed like the best way.

And what about those “push to talk” phones that connect you to anyone, anywhere, in an instant? A person would think they could at least offer a built-in keyer as an *option!*

When I drove a '66 Plymouth (something else that's discontinued due to lack of interest), I had a Lafayette “imported” speed key on the console, connected to an oscillator. I wanted to connect it to the horn, but my father warned me that the horn-relay would die an early death. I likely would have annoyed our friends in the law-enforcement community, too. I passed many hours and miles polishing my sending skills; hard turns and bumps took their toll.

Now all commercial and military ships have abandoned CW. They've told us we're dinosaurs. Gronk (to paraphrase Johnny Hart)—I've been called worse.

I was glad to see a video clip circulating on the Internet that showed a segment from *The Tonight Show* in which Jay Leno set up a “contest” between two young, annoying “text-messagers” and two mature, fine, upright CW operators. They were each given a message to pass to their associate. The CW guys won handily, but I'm afraid it's buggy-whips all over again. I wish they hadn't been wearing “sleeve garters” and green eyeshades.

My grandfather was a railroad telegrapher—a stationmaster, who sometimes took me to work with him. During the day, he sent and received traffic using the Continental (not our current “International”) Morse code. As the sounder clicked, he made up grand stories as to what was being sent, and I bought it all.

Meanwhile, back at my HPJIE\*, after finally figuring out how to make the new digital displays count out the revolutions of the three “drive-shafts” of our C-band satellite uplink by finally isolating the enormous motor-relays which had scrambled the readings, the now-isolated counters began to work nicely and I started to search the sky for those elusive satellites. A little up—a little to the west—aha! There's another one.

I soon had half the useable satellites located and their azimuth, elevation, and polarity settings recorded when the dish abruptly stopped moving up or down (high-tech name: “elevation”).

This 26-year-old dish (which came with an expected life of about 15 years) uses enormous mechanical couplers to connect enormous motors to the enormous worm gears. Did I mention that they were enormous?

From the ground, I could see that the half of the coupler on the motor was turning and the part on the worm gear was not. Without climbing, I found the manufacturer and part number in the manual and ordered a complete coupler. I anticipated having a rigger come to lift and position the motor—an expensive process.

But alas, when the parts arrived and I climbed to plan the installation, I saw that the real problem was that the set screws had loosened and allowed each half of the coupler to work away from the other. Naive fool that I am, I thought I could just loosen the set screws, push the coupler back together, and tighten the set screws. Wrong-o, satellite-breath—the coupling rings had seized over the years and were not going to be moved by normal means.

All my project planning and design happens while walking the aisle at the local “MegaHardware” store, and this one took several trips down the tool aisles until I came across a four-foot wrecking bar and a three-pound log-splitting wedge. *Viola!* (or is that Cello?)

By the way, I'm not supposed to climb or lift or raise my right arm because of a torn rotator cuff. Well, I climbed, lifted, and raised that arm very gently, used the wedge and an “engineering hammer” to drive one ring halfway toward its mate, then used the four-foot wrecking bar to move the other half till they were back as their maker intended. Of course, I now have an extra set of coupling rings, or typhoon-ready paperweights.

By the time you read this, I'll be recovering from my second rotator cuff surgery (yeah, I already *know* how bad it's gonna hurt) and I'll be using my south paw for a lot of things for a few weeks.

\*High-Paying Job In Electronics

*Pay no attention to the man behind the rotator cuff; rumor has it that he's bought an artificial scar from a Hollywood make-up artist and just wants some time off from work.—ed.*

# Want to SEE who is watching you?

## The **AR-STV** handheld receiver captures hidden video signals!

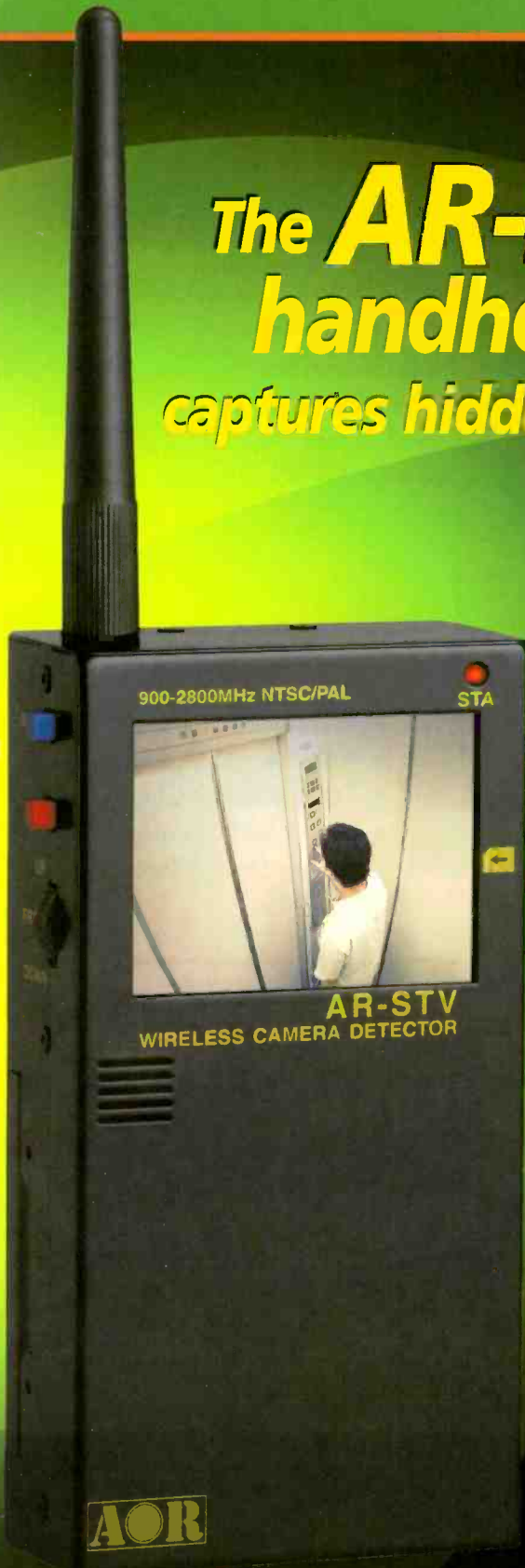

Now, with the AR-STV handheld wireless camera receiver from AOR, you can see who is watching you on wireless video surveillance cameras. It's a valuable addition to any security operation. This easy to operate receiver features a large 2.5 inch color LCD display, still picture recorder and sensor that captures video signals in real-time. The USB connector makes it easy to download stored images into a computer. And the AR-STV comes complete with an internal clock that allows captured images to be time-stamped. With an optional 4 GB SD memory card, the AR-STV can be used to store up to nearly 2000 images.

Add to the power of your security force with this pocket-sized video receiver from AOR!

- Receives and displays analog video signals on L-band (1.2 GHz) or S-band (2.4 GHz)
- 2.5 inch color LCD display
- Still picture recorder
- Can be set for continuous search between 900 ~ 2800 MHz
- Detects NTSC or PAL analog video signals in real-time
- Built-in clock allows captured images to be time-stamped
- USB connector makes it easy to download stored images into a computer
- Easy to operate
- Powered by four AA size batteries or external DC power
- NiMH batteries, belt clip and battery charger included
- Rubber duck antenna with SMA connector
- Optional 4 GB SD memory card can store nearly 2000 images

**Available from your favorite AOR dealer!**



Authority on Radio  
Communications

**AOR U.S.A., Inc.**  
20655 S. Western Ave., Suite 112, Torrance, CA 90501, USA  
Tel: 310-787-8615 Fax: 310-787-8619  
info@aorusa.com • www.aorusa.com

*Specifications are subject to change without notice or obligation.*

**Icom has the radio  
for the experts...**



**IC-R9500** ICOM'S ULTIMATE WIDE BAND RECEIVER

- 0.005 - 3335.000MHz\*
- USB, LSB, CW, FSK, FM, WFM, AM
- 1020 Alphanumeric Memory Channels
- P25 (Option UT-122)
- Five Roofing Filters and so much more!

**...or for those just  
getting started.**



**IC-R75** WIDE BAND RECEIVER

- 0.03 - 60.0 MHz\*
- Triple Conversion
- Twin Passband Tuning
- Digital Signal Processing (DSP)

**NEW IC-RX7**

STYLISH SCANNER WITH  
SMART INTERFACE

- 0.150 - 1300.000MHz\*
- AM, FM, WFM
- 1650 Alphanumeric Memory Channels
- Digital Signal Processing (DSP)
- IPX4 Water Resistant Rating



**IC-R5 SPORT**

COMPACT WIDE BAND

- 0.5 - 1300.0 MHz\*
- AM, FM, WFM
- 1250 Memory Channels
- CTCSS/DTCS Decode
- Weather Alert



**IC-R20**

ADVANCED WIDE BAND

- 0.150 - 3304.0 MHz\*
- AM, FM, WFM, SSB, CW
- 1000 Memory Channels
- Dual Watch Receiver
- 4 Hour Digital Recorder



**Now bundled with  
RadioCom 4.5**

Icom's black box radios now  
come bundled with Bonito's  
RadioCom 4.5 software.



**IC-R1500**

MOBILE OR PC CONTROL

- 0.01 - 3299.99 MHz\*
- AM, FM, WFM, USB, LSB, CW
- 1000 Memory Channels
- Fast Scan
- Optional DSP (UT-106)
- PCR Software Included
- Very Compact Design



**IC-R2500**

2 WIDE BAND RX IN 1

- 0.01 - 3299.99 MHz\*
- AM, FM, WFM, SSB, CW (Main)
- AM, FM and WFM (Sub)
- 1000 Memory Channels
- Optional D-STAR (UT-118)
- Optional P25 (UT-122)
- Optional DSP (UT-106)

**Contact your favorite Authorized Icom Dealer today!**



\*Frequency specs may vary. Refer to owner's manual for exact frequency specs.  
©2009 Icom America Inc. The Icom logo is a registered trademark of Icom Inc. All specifications are subject to change without notice or obligation. 30224