

# POPULAR COMMUNICATIONS

SEPTEMBER 2005

## The Osprey: Floats Like A Butterfly—Stings Like A Bee! A Pop'Comm Exclusive

- Stop Wondering—  
Start Listening: Satellite  
Radio's Secrets Revealed, p. 50
- Tech Showcase:  
Midland's 1001Z  
Mobile CB, p. 24

U.S. \$4.99 / Canada \$6.99



**PLUS:** Radio Past—And Radio Future,  
A Pep Talk, And Time Running Out To  
Hear Bhutan

# Tougher than Tough!



YAESU's rugged new VX-120/170 Series of 2-meter Hand-holds aren't just built tough. They're submersible, have a huge, easy-to-read LCD, and they provide big, bold audio (almost 3/4 of a Watt) from the huge internal speaker!



The VX-120/VX-170 are compact, high-performance FM hand-holds providing up to five Watts of RF power, along with big audio output (700 mW) and unmatched protection against the elements!

Protected against water ingress to IPX7 specifications (submersion for up to 30 minutes at a depth of 3 feet), the VX-120/170 feature long operating times, thanks to the supplied 1400 mAh NiMH Battery Pack. The 8-key VX-120 provides the utmost in operation simplicity, while the 16-key VX-170 includes direct keyboard frequency entry and direct DTMF input. And both models provide quick, one-touch access to YAESU's exciting and fun WIRELESS™ VoIP Internet Linking system!

5 W Submersible Full Featured 2 m Hand-Holds

## VX-120/VX-170

(8 key Version / 16 key Version)

- Ultra-rugged 5 W 2 m Hand-holds
- Expanded RX Coverage: 137-174 MHz
- Long-life 1400 mAh NiMH Battery Pack supplied
- Enhanced Paging and Code Squelch
- User Password protects against unauthorized use
- Dedicated Weather Band Channels with Severe Weather Alert Scan
- 200 Memories with Labeling and 10 Memory Groups
- Smart Search™ Automatic Memory Loading



### HANDHELD TRANSCEIVERS

5 W Ultra-Rugged,  
Submersible 6 m/2 m/70 cm  
Tri-Band FM Handhelds

#### VX-7R/VX-7RB



5 W Heavy Duty  
Submersible 2 m/70 cm  
Dual Band FM Handheld

#### VX-6R



5 W Heavy Duty  
2 m/70 cm  
Dual Band FM Handheld

#### FT-60R



1.5 W Ultra Compact  
2 m/70 cm  
Dual Band FM Handheld

#### VX-2R



Ultra-Rugged  
5 W Full Featured  
2 m FM Handhelds

#### VX-150/VX-110



**Free Original WIRELESS™ Cap**  
with V/UHF FM Transceiver or HRI-100 purchase

Buy a new VX-7R/VX-6R/FT-60R/VX-2R/VX-120/VX-170/FT-8900R/FT-8800R/FT-7800R/FT-2800M/HRI-100 between now and September 30, 2005 and receive an original WIRELESS™ Cap free! See your Authorized YAESU Amateur Products Dealer for details.

For the latest Yaesu news, visit us on the Internet:  
<http://www.vxstdusa.com>

Specifications subject to change without notice. Some accessories and/or options may be standard in certain areas. Frequency coverage may differ in some countries. Check with your local Yaesu Dealer for specific details.

**YAESU**  
Choice of the World's top DX'ers™

Vertex Standard  
US Headquarters  
10900 Walker Street  
Cypress, CA 90630 (714)827-7600

# Universal Radio — Quality equipment since 1942.

**ICOM**  
IC-R75



Universal Radio is pleased to continue to offer the ICOM R75 receiver. With full coverage from 30 kHz to 60 MHz; all longwave, medium wave and shortwave frequencies are supported plus extended coverage to include the 6 meter amateur band. Some of innovative features of the R75 include: Synchronous AM Detection, FM Mode Detection (but not the FM broadcast band), Twin Passband Tuning, Two Level Preamp, 99 Alphanumeric Memories, four Scan Modes, Noise Blanker, Selectable AGC (FAST/SLOW/OFF), Clock-Timer, Squelch, Attenuator and backlit LCD display. Tuning may be selected at 1 Hz or 10 Hz steps plus there is a 1 MHz quick tuning step plus tuning Lock. The front-firing speaker provides solid, clear audio. The back panel has a Record Output jack and Tape Recorder Activation jack. The supplied 2.1 kHz SSB filter is suitable for utility, amateur, or broadcast SSB. However, two optional CW/SSB filter positions are available (one per I.F.). The formerly optional **UT-106 DSP board** is now included and factory installed! A truly a great value. *Order #0175 \$549.95*

**AOR**

**AR7030 PLUS**



The AOR AR7030+ is the result of a combined project between the AOR Company of Japan and a designer group in England. The AR7030+ represents the very latest and best design featuring exceptional strong signal handling and is bristling with enhanced features. It offers greater than +35dBm IP3 and 104dB dynamic range (SSB, 2.2kHz, 20/40kHz spacing). This coupled with excellent selectivity, makes the AR7030 a strong choice for the shortwave broadcast listener or DX'er. Although performance is excellent, features have not been forgotten. You get: Synchronous AM, Passband Tuning, four levels of attenuation, dual VFOs and 24 hour clock-timer. The 400 scannable memories store frequency, bandwidth, PBS, Squelch and BFO settings plus alpha tagging. The mini headphone jack will accept a mono or stereo 3.5mm plug. The two line 48 character backlit LCD gives you the status of the receiver. The AR7030+ comes with four standard bandwidths. There is a 2.2 kHz filter for SSB. There is a Murata CFK455J 4.0 kHz for AM DXing (displays/sounds like 3.7 kHz in this radio) There is also a 5.5kHz AM filter and a 9.5 kHz filter for NFM. The *supplied* full-featured 32 button infrared remote provides access to virtually all facilities including: volume, tone, numeric keypad, memories, PBT, filter selection, etc. A remote RS-232 level port is also provided for computer control. Made in England. Includes 120 VAC wall adapter. We invite you visit our website or request a color spec sheet for options and further information regarding this impressive receiver. *Order #3396 \$1489.95*

**ELAD**

**FDM77**



The latest European technology is brought to the forefront by the cutting edge **ELAD FDM77**. This Italian-made, software defined shortwave receiver offers a host of advanced features coupled with exceptional performance. This multimode, continuous coverage receiver tunes 100 kHz to 60 MHz, employing a high dynamic range front-end with seven band preselection and preamplifier. Enjoy 1Hz to 1MHz tuning steps and keyboard direct frequency input. The triple conversion superheterodyne features IFs at 70 MHz, 455 kHz and 12 kHz. There are 10 kHz and 4 kHz ceramic and crystal filters on the 70 MHz and 455 kHz IF. Variable bandwidth on down to 500 Hz is supported on the 12 kHz IF. Modes of reception include AM, FM, CW, LSB, USB and DRM. Yes, DSP demodulators for all traditional DRM modes are provided. Support for DRM was engineered in from the beginning with a 12 kHz output to your PC sound card. See the Universal website for screen shots. The FDM77 system includes: the radio, ELAD Windows™ XP/2000 software CD, 120 VAC power supply, audio cable and USB 2.0 cable. Minimum and recommended PC requirements are: Pentium 700 MHz/ Pentium 4 @ 1.2 GHz, 128/512 MB RAM, 50 MB HD, 16-bit SoundBlaster compatible soundcard (Line or Microphone) without AGC, USB 1.0/2.0 and VGA 1024 x 768 pixel with 65,536 (16 bit) colors. *Order #0077 \$599.95*

## HUGE FREE CATALOG



Our new 2005-2006 catalog is the largest ever! Printed July 2005, it features 108 pages of everything for the radio hobbyist. Please call toll-free to request your free copy today. **1 800 431-3939**

**universal  
radio inc.**

**Universal Radio, Inc.**  
6830 Americana Pkwy.  
Reynoldsburg, Ohio  
43068-4113 U.S.A.

☎ 800 431-3939 Orders & Prices  
☎ 614 866-4267 Information  
☎ 614 866-2339 FAX Line  
✉ dx@universal-radio.com

**www.universal-radio.com**

◆ Visit our website for more exciting new and used shortwave radios.

- Visa
- MasterCard
- Discover
- JCB
- Prices and specs. are subject to change.
- Special offers are subject to change.
- Returns subject to a 15% restocking fee.
- Prices shown do not include shipping.

# Contents

## POPULAR COMMUNICATIONS

Volume 24, Number 1

September 2005



8

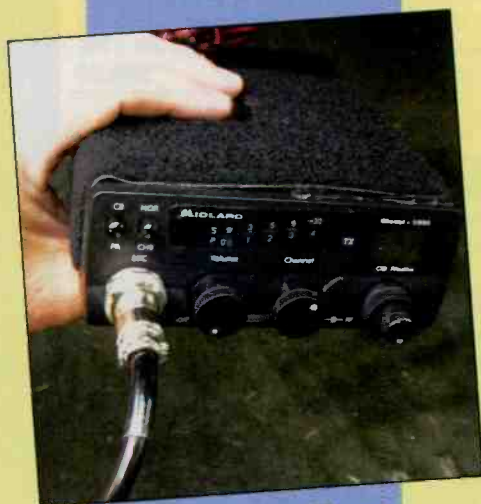

24

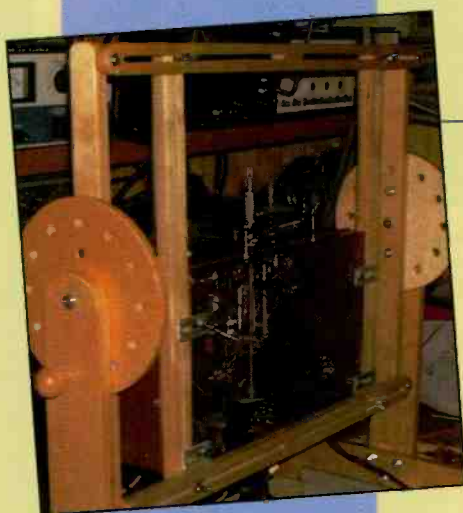

70

- 8 Inside The Osprey's Nest**  
The Scenario Is Fictional, But... by Steve Douglass
- 24 Technology Showcase: Midland's 1001Z**  
40-Channel Mobile CB by Harold Ort, N2RLL, Editor
- 53 On-The-Go Radio**  
How To Be Of Service To Your Community by Jock, Elliott, KB2GOM
- 20 Great DX On All Shortwave Bands Between Northern  
And Southern Temperate Regions The Propagation Corner
- 26 Time Running Out To Hear Bhutan Global Information Guide
- 36 Portable Mobile Mappers Go All U.S.A. Radio Resources
- 40 World News, Commentary, Music, Sports, And  
Drama At Your Fingertips World Band Tuning Tips
- 44 A Pep Talk Homeland Security
- 50 Digital Satellite Radio Is Hot—**  
**Here's What You Need To Get Started!** **Broadcast Technology**
- 56 The Striking Differences Between DOT And Jeppesen Charts Plane Sense
- 60 REACT, At Home And Offshore, Too REACT In Action
- 62 Radio Past—And Radio Future ScanTech
- 66 Ham History 101—Your Logbook! Ham Discoveries
- 68 Iran—The Next Nuclear Threat,  
Plus Some Readers' Letters Utility Communications Digest
- 70 A New Toy On Our Workbench—And A Definite "First!" The Wireless Connection
- 74 Software-Defined Radio—Part IV: How To Build An SDR,  
The Software Component Computer-Assisted Radio Monitoring
- 80 Why You Too Might Want An HPJIE\* The Loose Connection

### Departments

- 3 **Tuning In**—An Editorial
- 4 **Our Readers Speak Out**—Letters
- 16 **Washington Beat**—Capitol Hill And  
FCC Actions Affecting Communications
- 18 **InfoCentral**—News, Trends, And  
Short Takes
- 19 **V.I.P. Spotlight**—Congratulations To  
Charlie Van Sant, K7WLW!
- 35 **The Pop'Comm Trivia Corner**—Radio  
Fun, And Going Back In Time
- 42 **Power Up**—Radios & High-Tech Gear

### On The Cover

Bad Guys beware—the Osprey, loaded with troops and weapons, is one bird that's on your tail! Colonel Craig Olson, USAF V-22 Joint Program Manager says the Osprey is, "Twice as fast, three times the payload capacity, and six times the range of the aircraft it's replacing; the V-22 is not just evolutionary, it's revolutionary." Our "Utility Communications Digest" columnist, Steve Douglass, a resident of Amarillo, Texas—where the Osprey is built and tested—has an exclusive look inside the Osprey's nest, complete with monitoring tips and frequencies, beginning on page 8. (Photo by Steve Douglass)

Visit us on the Web: [www.popular-communications.com](http://www.popular-communications.com)

# Home Cookin' 101

Typically most folks don't have a personal problem with a loss of rights, or losing someone in a "war" (that *might* have been prevented had the troop been properly equipped in the first place), or having radios confiscated, or having to spend countless hours—and hundreds upon hundreds of dollars on legal fees—unless, of course, it happens too close to home. Then it really smarts.

The world we're living in today is so vastly different from our world of just 10 years ago—and light years different from when I was a growing up—that frankly, in many ways, I believe we've become so accustomed to the utter strangeness of the times that we can't remember what it was like to expect more from our leaders (both political and military), corporate CEOs, mainstream media, and, frankly, ourselves. Do you feel it, too? Our American Kitchen sometimes smells a whole lot like, "It's Not My Fault Soup—Eat It, And Don't Complain."

Whatever the concoction, it beats me how and where it all started to cook, but I always reflect back on when I'd hear folks say that you can't fight city hall. That was the 1960s, and it was surely a time when taking a stand sometimes meant standing alone.

I've always been a thorn in Uncle Sam's posterior, a troublemaker of sorts (well, that's probably one of the more endearing things I've been called) both in and out of the service. But, the fact is, all I've ever asked of my troops—and myself—was for them to do their jobs, take responsibility for their actions, and stand up against what they deemed inappropriate or just plain wrong. Play by the generally accepted rules, and no one goes home crying.

Part of being a patriotic American (notice I said nothing about party affiliation, shoe size, ethnicity, gender, or religious preference) is our duty to speak up to our elected officials and those charged with our safety, using appropriate channels. For example, to criticize—and offer solutions to—our esteemed Secretary of Defense Donald Rumsfeld for not taking responsibility for many of our troops not having two-way radios or other equipment is well within the purview of this magazine. Not only is it a radio issue, it's the patriotic thing to do.

To respectfully urge the FCC's Ms. Broadband Nirvana Abernathy to step down from her Commissioner's position is certainly appropriate given her very public cuddling up to the BPL industry. To do anything less falls far short of patriotism.

Now, I'm sure there are *still* those folks who believe she did no wrong, or that it's perfectly fine to give troops a mission without every possible ounce of protection that at least \$100 billion can give them. My guess is they're the same folks who, after reading our recent "On-the-Go" column about how some New York police have run afoul of federal law, *still* believe it's okay for ordinary law-abiding folks to have their radios confiscated. Can you hear the logic? "They must have done something wrong otherwise the cops wouldn't have taken their radios," or "It's okay because we're at war and anything we can do to prevent terrorism is fine with me."

Well, I sure don't buy it, and hope you don't either. I'll also bet a couple of donuts that the same folks that think I'm full of hot air and everything is hunky-dory on the U.S. block would soil their Levis if it happened to *them*. You see, that's the rub:

All's well with virtually any aspect of the insanity as long as that insanity doesn't creep into my living room, right? A soldier shouldn't complain about things—unless it's your son or daughter serving our great Nation. And ordinary law-abiding citizens, hams or not, aren't the enemy because they've got an antenna or two on their vehicles or can tune in the police.

Fact is, it doesn't matter whether you live near Albany, New York, as Jock Elliott reported, and are wrongly accused, or in Albany, Georgia. All that's required for this recipe is ignorance of the law and the fact that average folks like you and me just doesn't have the time or money to whiz away fighting baseless charges because their government, federal or local, took advantage of them. And by "ignorance of the law" I'm talking about the authorities—NOT our ignorance of the law.

But you see, once again, what happens in our upside-down world is that those charged with our protection and those politicians in high places can indeed turn the tables on you and me, placing the burden of digging out of overly aggressive policing on *our* shoulders. They laugh all the way to the courtroom. No excuses about officers *anywhere* not knowing the law. You and I are supposed to, so it's only fair and right that those who work *for us* should also.

What's happening here is merely something that's been coming at us all along. Where did the strangeness really begin? Beats me, but I *do* know that it has roots that go back further than Bill Clinton's presidency or even Nixon's. It isn't a Communist, Liberal, Democratic, Gay, Republican, or a Red or Blue state phenomena. It's just how we've evolved, like it or not.

Sadly, though, we don't learn from the past. The words "you're either with us or against us" are now being spoken aloud to us from lofty places. If you think for one moment that those words aren't echoed through federal, state, and local halls of enforcement and justice, you're probably living in another dimension or popping goof balls. Remember, when you hear them spoken, it's nothing we thinking Americans should be proud of, because at the *core* of such beliefs and words are serious, deep-rooted, problematic psychological issues. The intended audience isn't always foreigners.

Indeed, it's a strange world when you've got to either be a licensed ham in order to receive out-of-band frequencies on that mobile radio (and even that's no guarantee of not being wrongly accused) or, worse yet, carry a copy of a federal law in your glove compartment *just in case* you're stopped.

Are these incidents in New York isolated breaches of trust between those sworn to serve and protect us, or are they a sign of trouble ahead on Freedom's Road? I don't have the answer, but I do know that today it's still okay to fight city hall—but once you're engaged in the conflict, you had better be properly equipped.

And, oh yes, if you *are* stopped, please be careful opening the glove compartment to get your Papers. You don't want to be a statistic in someone's war. Besides, soup's on, and getting cold.

*Editor's Note:* Shannon Huniwell took a much deserved vacation this month, but she'll return with Shannon's Broadcast Classics next month.

## OUR READERS SPEAK OUT

Each month, we select representative reader letters for "Our Readers Speak Out" column. We reserve the right to condense lengthy letters for space reasons and to edit to conform to style. All letters submitted must be signed and show a return mailing address or valid e-mail address. Upon request, we will withhold a sender's name if the letter is used in "Our Readers Speak Out." Address letters to: Harold Ort, N2RLL, SSB-596, Editor, Popular Communications, 25 Newbridge Road, Hicksville, NY 11801-2909, or send e-mail via the Internet to popularcom@aol.com.

### Remembers Hanoi Hannah

#### Dear Editor:

I read Bob Sturtevant's article on Iva Toguri [July 2005] with much interest. Having been the son of a movie projectionist and once ham operator (now in my memories), I have probably seen every WWII movie made in the '50's and '60's. Almost every one of them has some mention of Tokyo Rose. I knew of Toguri, as my father had listened to her and the others that had done those broadcasts. He told me about them and his thoughts were not good about her; he believed she got what she deserved. It seems that this story might be a good one for the big screen. My father was unable to enlist due health but he told me about listening to shortwave and sometimes coded messages during the war.

Reading this story in *Pop'Comm* made me remember listening to the propaganda news and rock music of Hanoi Hannah. There were some rock songs that Armed Forces Radio was banned from playing because of the antiwar message. I served aboard the *USS Tutuila*, a repair support ship for the Brown River Navy during the Vietnam War. I can remember the rude comments we all made, but it would get quiet when the music came on. No one I knew ever took those broadcasts seriously. Enjoying your magazine.

Howard J. Allshouse, Jr.  
Via e-mail

### Biting A Ham

#### Dear Editor:

I was reading your comments in one of my favorite magazines (sorry, *Sky & Telescope* ranks pretty high, too) in "Taking A Bite Out Of A Ham" [July 2005, "Tuning In"]. Here's is another angle to it all that others might have not thought about.

I keep most of my paramedic and radio stuff low profile. Spare uniforms are inside a suit protector so some bad guy looking in the car won't get any bright ideas. Nothing on my car says who I am or what I do. Only when I am on duty does everything show. I know I am a target at work, but while off duty, being boring and hiding in plain sight is just fine.

Houses down here in the swamps have high rooflines and big attics to help dissipate heat. All of my antennas reside in the attic. That might reduce some of the performance, but there are no roof flags saying, "Amateur Radio Guy, Take Me Out First." Again, staying out of sight isn't such a bad plan. And I rarely take my radios out into public places because it draws undo attention.

It's sad to say, but you hit the spot with this article. The bad guys won't be able to take me or my radios out that easily, and why should I make it easy for them! I don't want to spend an hour explaining why I am listening to the police, although I rarely even listen to police frequencies since most stuff is pretty mundane. Fire and EMS is where most of the action is at!

Joseph "EM-Joe" Maurus, KA5TWS  
East Baton Rouge Parish EMS  
The Pumpkin Center Listening Post in  
Swampy Louisiana

### FRS Group In Central Pennsylvania

#### Dear Editor:

I live in Central Pennsylvania near Huntingdon and have always been very active in all parts of radio. I always wanted to have a radio net here. I just started putting out flyers for an FRS net because that seemed to be good place to start, because of the lake and campers, etc. I will offer weather and lake info and a chance to give radio a start. Is this a good idea or bad one? My only goal is to promote radio communications and to make friends and maybe help some people. I know FRS is a new band, but lots of people have these radios. The net will be run on FRS Channel 8 with check-ins in the evening. Maybe you could post this in your mag and people will do the same thing I am doing. I would be grateful. Write back and give me some feedback. I would love that, thanks.

Brandon Williams, SSB-141Y  
Operator of Central PA Radio Group

#### Dear Brandon:

*Thanks for your letter. If only your enthusiasm was contagious throughout the radio community. Readers, how about it? Why not start a similar "net" in your area on FRS, CB, or even MURS?*

## POPULAR COMMUNICATIONS

### EDITORIAL STAFF

Harold Ort, N2RLL, WPUD220, Editor

(E-mail: Popularcom@aol.com)

Tom Kneitel, K2AES/WQCU830, Senior Editor

Edith Lennon, N2ZRW, Managing Editor

Richard S. Moseson, W2VU, Online Coordinator

(E-mail: w2vu@popular-communications.com)

### CONTRIBUTING EDITORS

Rich Arland, K7SZ, Homeland Security

Peter J. Bertini, K1ZJH, Restoration/Electronics

Joseph Cooper, Computer-Assisted Radio

Gerry L. Dexter, Shortwave Broadcast

Steve Douglass, Utility Communications

Jock Elliott, KB2GOM, Mobile Communications

Richard Fisher, K16SN, Legislative Affairs

Bill Hoefer, KB0ULJ, Aviation Communications

Tomas Hood, NW7US, Propagation

Shannon Huniwell, Classic Radio

Kirk Kleinschmidt, NT0Z, Amateur Radio

Ron McCracken, React News

Bill Price, N3AVY, Humor/Communications

Ken Reiss, Technical/Scanning

Bruce Conti, AM/FM Broadcasts

Bob Sturtevant, KD7KTS, Puzzles and Trivia

Gordon West, WB6NOA, Radio Resources

### BUSINESS STAFF

Richard A. Ross, K2MGA, Publisher

Arnold Sposato, N2IQO, Advertising Manager

Emily Leary, Sales Assistant

Sal Del Grosso, Accounting Manager

Doris Watts, Accounting Department

Melissa Gilligan, Operations Manager

Cheryl DiLorenzo, Customer Service Manager

AnnMarie Auer, Customer Service

### PRODUCTION STAFF

Elizabeth Ryan, Art Director

Barbara McGowan, Associate Art Director

Dorothy Kehrwieler, Production Manager

Emily Leary, Assistant Production Manager

Hal Keith, Technical Illustrator

Larry Mulvehill, WB2ZPI, Photographer

A publication of



CQ Communications, Inc.  
25 Newbridge Road  
Hicksville, NY 11801-2953 USA

Offices: 25 Newbridge Road, Hicksville, NY 11801. Telephone (516) 681-2922. FAX (516) 681-2926. Web Site: <http://www.popular-communications.com/> Popular Communications (ISSN-0733-3315) is published monthly by CQ Communications, Inc. Periodical class postage paid at Hicksville, NY and additional offices. Subscription prices (payable in U.S. dollars): Domestic—one year \$28.95, two years \$51.95, three years \$74.95. Canada/Mexico—one year \$38.95, two years \$71.95, three years \$104.95. Foreign Air Post—one year \$48.95, two years \$91.95, three years \$134.95.

U.S. Government Agencies: Subscriptions to Popular Communications are available to agencies of the United States government, including military services, only on a cash with order basis. Requests for quotations, bids, contracts, etc. will be refused and will not be returned or processed.

Entire contents copyright © 2005 by CQ Communications, Inc. Popular Communications assumes no responsibility for unsolicited manuscripts, photographs, or drawings. Allow six weeks for change of address or delivery of first issue.

Printed in the United States of America.

Postmaster: Please send change of address to Popular Communications, 25 Newbridge Road, Hicksville, NY 11801.

# Big Savings on Radio Scanners

# Uniden®

# SCANNERS



## Bearcat® 796DGV Trunk Tracker IV with free scanner headset

Manufacturers suggested list price \$799.95

**CEI Special Price \$519.95**

**1,000 Channels • 10 banks • CTCSS/DCS • S Meter**  
**Size: 6.15" Wide x 6.91" Deep x 2.38" High**

**Frequency Coverage:** 25,000-512,000 MHz., 806,000-956,000 MHz. (excluding the cellular & UHF TV band), 1,240,000-1,300,000 MHz.

When you buy your Bearcat 796DGV TrunkTracker package deal from Communications Electronics, you get more. The GV means "Great Value." With your BC796DGV scanner purchase, you also get a **free deluxe scanner headphone** designed for home or race track use. Headset features independent volume control and 3.5 mm gold right angle plug. The 1,000 channel Bearcat 796DGV is packed with features to track Motorola Type I/II/III Hybrid, EDACS, LTR Analog Trunk Systems and Motorola APCO 25 Phase I digital scanner including 9,600 Baud C4FM and CQPSK. Also features control channel only mode to allow you to automatically trunk many systems by simply programming the control channel, S.A.M.E. weather alert, full-frequency display and backlit controls, built-in CTCSS/DCS to assign analog and digital subaudible tone codes to a specific frequency in memory, PC Control and programming with RS232C 9 pin port (cable not supplied), Beep Alert, Record function, VFO control, menu-driven design, total channel control and much more. Our CEI package deal includes telescopic antenna, AC adapter, cigarette lighter cord, DC cord, mobile mounting bracket with screws, owner's manual, trunking frequency guide and one-year limited Uniden factory warranty. For maximum scanning enjoyment, order magnetic mount antenna part number ANTMMBNC for \$29.95. For complete details, download the owners manual from the [www.usascan.com](http://www.usascan.com) web site. For fastest delivery, order on-line at [www.usascan.com](http://www.usascan.com).

## Bearcat® BCT8 Trunk Tracker III

Manufacturer suggested list price \$299.95

**CEI Special Price \$169.95**

**250 Channels • 5 banks • PC Programmable**

**Size: 7.06" Wide x 6.10" Deep x 2.44" High**

**Frequency Coverage:** 25,000-54,000 MHz., 108,000-174,000 MHz., 400,000-512,000 MHz., 806,000-823,985 MHz., 849,0125-868,985 MHz., 894,0125-956,000 MHz.

The Bearcat BCT8 scanner, licensed by NASCAR, is a superb preprogrammed 800 MHz trunked highway patrol system scanner. Featuring TrunkTracker III, PC Programming, 250 Channels with unique BearTracker warning system to alert you to activity on highway patrol link frequencies. Preprogrammed service searches makes finding interesting active frequencies even easier and include preprogrammed police, fire and emergency medical, news agency, weather, CB band, air band, railroad, marine band and department of transportation service searches. The BCT8 also has preprogrammed highway patrol alert frequencies by state to help you quickly find frequencies likely to be active when you are driving. The BCT8 includes AC adapter, DC power cable, cigarette lighter adapter plug, telescopic antenna, window mount antenna, owner's manual, one year limited Uniden warranty, frequency guide and free mobile mounting bracket. For maximum scanning enjoyment, also order the following optional accessories: External speaker **ESP20** with mounting bracket & 10 feet of cable with plug attached \$19.95. Magnetic Mount mobile antenna **ANTMMBNC** for \$29.95.



## Bearcat® BCD396T Trunk Tracker IV

Suggested list price \$799.95/CEI price \$519.95

**APCO 25 9,600 baud compact digital ready handheld TrunkTracker IV scanner featuring Fire Tone Out Paging, Close Call and Dynamically Allocated Channel Memory (up to 6,000 channels), SAME Weather Alert, CTCSS/DCS, Alpha Tagging. Size: 2.40" Wide x 1.22" Deep x 5.35" High**

**Frequency Coverage:**

25,000-512,000 MHz., 764,000-775,987.5 MHz., 794,000-823,987.5 MHz., 849,0125-868,987.5 MHz., 894,0125-956,000 MHz., 1,240,000 MHz.-1,300,000 MHz.

The handheld BCD396T scanner was designed for National Security/Emergency Preparedness (NS/EP) and homeland security use with new features such as **Fire Tone Out Paging**. This feature lets you set the BCD396T to alert if your selected two-tone sequential paging tones are received. Ideal for on-call firefighters, emergency response staff and for activating individual scanners used for incident management and population attack warning. **Close Call Radio Frequency Capture** - Bearcat exclusive technology locks onto nearby radio transmissions, even if you haven't programmed anything into your scanner. Useful for intelligence agencies for use at events where you don't have advance notice or knowledge of the radio communications systems and assets you need to intercept. The BCD396T scanner is designed to track Motorola Type I, Type II, Hybrid, SMARTNET, PRIVACY PLUS, LTR and EDACS analog trunking systems on any band. Now, follow UHF High Band, UHF 800/900 MHz trunked public safety and public service systems just as if conventional two-way communications were used. **Dynamically Allocated Channel Memory** - The BCD396T scanner's memory is

organized so that it more closely matches how radio systems actually work. Organize channels any way you want, using Uniden's exclusive dynamic memory management system. 3,000 channels are typical but **over 6,000 channels are possible** depending on the scanner features used. You can also easily determine how much memory you have used and how much memory you have left. **Preprogrammed Systems** - The BCD396T is preprogrammed with over 400 channels covering police, fire and ambulance operations in the 25 most populated counties in the United States, plus the most popular digital systems. **3 AA NiMH or Alkaline battery operation and Charger** - 3 AA battery operation - The BCD396T includes 3 premium 2,300 mAh Nickel Metal Hydride AA batteries to give you the most economical power option available. You may also operate the BCD396T using 3 AA alkaline batteries. **Unique Data Skip** - Allows your scanner to skip unwanted data transmissions and reduces unwanted birdies. **Memory Backup** - If the battery completely discharges or if power is disconnected, the frequencies programmed in the BCD396T scanner are retained in memory. **Manual Channel Access** - Go directly to any channel. **LCD Back Light** - A blue LCD light remains on when the back light key is pressed. **Autolight** - Automatically turns the blue LCD backlight on when your scanner stops on a transmission. **Battery Save** - In manual mode, the BCD396T automatically reduces its power requirements to extend the battery's charge. **Attenuator** - Reduces the signal strength to help prevent signal overload. The BCD396T also works as a conventional scanner to continuously monitor many radio conversations even though the message is switching frequencies. The BCD396T comes with AC adapter, 3 AA nickel metal hydride batteries, belt clip, flexible rubber antenna, wrist strap, SMA/BNC adapter, RS232C cable, Trunk Tracker frequency guide, owner's manual and one year limited Uniden warranty. Not compatible with AGEIS, ASTRO or ESAS systems. Order on-line at [www.usascan.com](http://www.usascan.com) or call 1-800-USA-SCAN.

## More Radio Products

Save even more on radio scanners when purchased directly from CEI. Price includes delivery in the continental USA excluding Alaska.

Bearcat 898T 500 channel TrunkTracker III base/mobile.....	\$209.95
Bearcat 796DGV 1,000 channel TrunkTracker III base/mobile.....	\$519.95
Bearcat BCD396T APCO 25 Digital scanner with Fire Tone Out.....	\$519.95
Bearcat 246T up to 2,500 ch. TrunkTracker III handheld scanner.....	\$214.95
Bearcat Sportcat 230 alpha display handheld sports scanner.....	\$184.95
Bearcat 278CLT 100 channel AM/FM/SAME WX alert scanner.....	\$129.95
Bearcat 248CLT 50 channel base AM/FM/weather alert scanner.....	\$104.95
Bearcat 92XLT1RH5 200 ch. handheld scanner with headset.....	\$119.95
Bearcat 92XLT 200 channel handheld scanner.....	\$109.95
Bearcat 72XLT 100 channel handheld scanner.....	\$99.95
Bearcat BCT8 250 channel information mobile scanner.....	\$169.95
Bearcat 350C 50 channel desktop/mobile scanner.....	\$104.95
AOR AR16BW Wide Band scanner with quick charger.....	\$199.95
AOR AR3000AB Wide Band base/mobile receiver.....	\$1,079.95
AOR AR5000A+3B Wide Band 10 KHz to 3 GHz receiver.....	\$2,599.95
AOR AR8200 Mark IIIB Wide Band handheld scanner.....	\$594.95
AOR AR8600 Mark II Wide Band receiver.....	\$899.95
AOR AR-ONE Government/Export sales only 10 KHz-3 GHz.....	\$4,489.95
Scantool Gold For Windows Software.....	\$99.95
Scantool Gold For Windows Surveillance Edition.....	\$159.95

## Bearcat® BC246T Trunk Tracker III

Suggested list price \$399.95/CEI price \$214.95  
**Compact professional handheld TrunkTracker III scanner featuring Close Call and Dynamically Allocated Channel Memory (up to 2,500 channels), SAME Weather Alert, CTCSS/DCS, Alpha Tagging. Size: 2.72" Wide x 1.26" Deep x 4.6" High**

**Frequency Coverage:**

25,000-54,000 MHz., 108,000-174,000 MHz., 216,000-224,980 MHz., 400,000-512,000 MHz., 806,000-823,987.5 MHz., 849,0125-868,987.5 MHz., 894,0125-956,000 MHz., 1,240,000 MHz.-1,300,000 MHz.

The handheld BC246T TrunkTracker scanner has so many features, we recommend you visit our web site at [www.usascan.com](http://www.usascan.com) and download the free owner's manual. Popular features include **Close Call Radio Frequency Capture** - Bearcat exclusive technology locks onto nearby radio transmissions, even if you haven't programmed anything into your scanner. **Dynamically Allocated Channel Memory** - Organize channels any way you want, using Uniden's exclusive dynamic memory management system. 1,600 channels are typical but **over 2,500 channels are possible** depending on the scanner features used. You can also easily determine how much memory is used. **Preprogrammed Service Search (10)** - Makes it easy to find interesting frequencies used by public safety, news media TV broadcast audio, Amateur (ham) radio, CB radio, Family Radio Service, special low power, railroad, aircraft, marine, racing and weather frequencies. **Quick Keys** - allow you to select systems and groups by pressing a single key. **Text Tagging** - Name each system, group, channel, talk group



LD, custom search range, and S.A.M.E. group using 16 characters per name. **Memory Backup** - When power is lost or disconnected, your BC246T retains the frequencies that were programmed in memory. **Unique Data Skip** - Allows the BC246T to skip over unwanted data transmissions and birdies. **Attenuator** - You can set the BC246T attenuator to reduce the input strength of strong signals by about 18 dB. **Duplicate Frequency Alert** - Alerts you if you try to enter a duplicate name or frequency already stored in the scanner. **22 Bands** - with aircraft and 800 MHz. The BC246T comes with AC adapter, 2 AA 1,800 mAh nickel metal hydride batteries, belt clip, flexible rubber antenna, wrist strap, RS232C cable, Trunk Tracker frequency guide, owner's manual and one year limited Uniden warranty. For more fun, order our optional deluxe racing headset part #HF2ARS for \$29.95. Order now at [www.usascan.com](http://www.usascan.com) or call 1-800-USA-SCAN.

## Buy with Confidence

### Order on-line and get big savings

For over 36 years, millions of communications specialists and enthusiasts worldwide have trusted Communications Electronics for their mission critical communications needs. It's easy to order. For fastest delivery, order on-line at [www.usascan.com](http://www.usascan.com). Mail orders to: Communications Electronics Inc., P.O. Box 1045, Ann Arbor, Michigan 48106 USA. Price includes \$30.00 UPS Ground shipping/handling/insurance per scanner to a street address in the continental USA excluding Alaska. Add \$20.00 shipping for all accessories. For shipments to Canada, Puerto Rico, Hawaii, Alaska, Guam, P.O. Box, APO/FPO, USPS Priority Mail or UPS 2 business day delivery, add \$30.00. Michigan residents add sales tax. No COD's. For Bearcat scanners your satisfaction is guaranteed or return item in unused condition in original packaging within 61 days for refund, less shipping charges. 10% surcharge for net 10 billing to qualified accounts. All sales are subject to availability, acceptance and verification. Prices, terms and specifications are subject to change without notice. We welcome your Discover, Visa, American Express, MasterCard, IMPAC or Eurocard. Order toll free, call 1-800-USA-SCAN or 1-734-996-8888 if outside Canada or the USA. FAX anytime, dial 1-734-663-8888. Dealer and international inquiries invited. Order your radio scanners from Communications Electronics today.

## For credit card orders call 1-800-USA-SCAN

e-mail: [cei@usascan.com](mailto:cei@usascan.com)

[www.usascan.com](http://www.usascan.com)

PO Box 1045, Ann Arbor, Michigan 48106-1045 USA  
 For information call 734-996-8888 or FAX 734-663-8888  
 Price schedule effective August 10, 2005 AD #081005PC © 2005 Communications Electronics Inc.

**COMMUNICATIONS ELECTRONICS INC.**  
 Emergency Operations Center

Visit [WWW.USASCAN.COM](http://WWW.USASCAN.COM) • 1-800-USA-SCAN

# RE-INVENTING RADIO

Through\_Innovation



## E1

AM/FM/Shortwave/Satellite Ready Radio \$500\*

Satellite radio brings premium music, news, and sports radio directly to you

- High-performance receiver for international and local radio listening
- User-defined station memory presets with customizable organization
- LCD screen displays frequency, battery life, signal strength and clock/alarm functions
- Direct frequency entry for all bands
- Shortwave range of 1711 – 29,999 KHz
- 1700 station presets with memory scan function

Dimensions: 13"W x 7-1/2"H x 2-1/2"D / Weight: 4 lb 3 oz. / Power Source: 4 "D" Batteries (not included); AC Adapter (included)

\*Prices do not include Shipping/Handling and applicable taxes. To order, please call us toll free at 1-800-793-6542



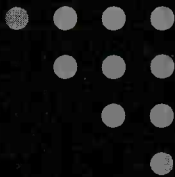

# E10

AM/FM/Shortwave Radio \$130\*

Intelligent Features, Strong Performance

- Shortwave range of 1711 – 29,999 KHz
- 550 programmable memories
- Memory page customization
- Manual & auto scan
- Direct keypad frequency entry, ATS
- Internally recharges included Ni-MH batteries
- Clock with alarm, sleep timer & snooze functions

Dimensions: 7-1/2"W x 4-1/2"H x 1-1/2"D / Weight: 1 lb. 1oz. / Power Source: 4 AA Batteries Or Included AC Adapter/Charger

# E100

AM/FM/Shortwave Radio \$100\*

Full-Size Features in Your Palm or Pocket

- Shortwave range of 1711 – 29,999 KHz
- 200 programmable memories
- Memory page customization
- Manual & auto scan
- Direct keypad frequency entry
- Clock with alarm, sleep timer & snooze functions

Dimensions: 5"W x 3"H x 1-1/4"D / Weight: 7 oz. / Power Source: 2 AA Batteries Or AC Adapter (not included)

\*Prices do not include Shipping/Handling and applicable taxes. To order, please call us toll free at 1-800-793-6542

# Inside The Osprey's Nest

## The Scenario Is Fictional, But....

by Steve Douglass

The clock is ticking. Insurgents have taken a high-ranking Iraqi official hostage. They promise to kill him if their demands aren't met, which includes the outrageous demand that all American troops leave the country and that Saddam Hussein be restored to power.

The lights burn long into the night inside the White House. "Unacceptable and completely insane," says the President. "But we can't just let them kill him. Not only will his death be a great tragedy for both our countries, but it will embolden the insurgency and cripple our efforts to set Iraq on the road to self rule."

"Sorry I'm late," says the Deputy Director of the C.I.A as he comes through the door, "but once you hear what we've just got I'll think you'll forgive my tardiness!" he said with a grin.

Opening a briefcase handcuffed to his wrist, the CIA director pulls out a folder containing photographs acquired during the last KH-12+ satellite pass over northern Iraq. "I have good news and bad news, Mr. President," the director says. "We know where they're holding him. An Iraqi informant gave us a tip and these photos confirm it."

The President and the Secretary of Defense closely examine the photos.

"And the bad news?" The President asks.

"It looks like they're preparing to move out. See these trucks in the compound? They've been loading them with weapons all day. My guess is that they'll be moving it into this city to the north and then they'll disappear, hidden among a deeply anti-American population of about 50,000.

"How much time do we have?" the Secretary of Defense asks.

"My best guess? Two maybe three hours." The CIA director replies.

"What about a rescue attempt? Do we have any forces in the area?" the President asks.

A military aide hands the Secretary of Defense a sheet of paper. The Secretary scans it, looks up from the document, smiles and says, "I think we're in luck."

He walks over to a huge map of Iraq and points to a small town northwest of where the insurgents are holding their hostage. "There's a Special Ops Detachment of Marines stationed here, Mr. President. By my calculations they're about 300 miles from the target. I'll have them notified and put on alert immediately."

The Secretary picks up a phone and begins dialing numbers. The President interrupts him.

"Aren't they too far to attempt a rescue? At helicopter speeds it will take them more than two hours to get to the target, and we'll need maybe 50 or more soldiers to take the compound. I don't see how we can do it in time."

The Secretary of Defense continued dialing. "Sir, they have Ospreys."

The expression on the President's face changes from one of deep concern to one of hope.

"Send in the Marines." He says confidently.

Four hours later the President addresses the nation. "Acting on a tip by intelligence operatives in the area, we were able to

<b>Powerplant</b> <ul style="list-style-type: none"> <li>Two Allison T406-AD-400 engines</li> <li>Max and Intermediate, shp (kW) - 6,150 (4,586)</li> </ul>	<p>83 ft 9.60 in</p> <p>38 ft 0 in (dia)</p> <p>21 ft 9.12 in</p> <p>17 ft 11.00 in</p> <p>21 ft 7.56 in</p> <p>57 ft 3.96 in</p>
<b>Rotor System</b> <ul style="list-style-type: none"> <li>Blades per hub - 3</li> <li>Construction - graphite/fiberglass</li> <li>Tip speed, fps (mps) - 661.90 (201.75)</li> <li>Diameter, ft (m) - 38.00 (11.58)</li> <li>Blade area, ft<sup>2</sup> (m<sup>2</sup>) - 261.52 (24.30)</li> <li>Disc area, ft<sup>2</sup> (m<sup>2</sup>) - 2,268.00 (210.70)</li> <li>Blade folding - automatic, powered</li> </ul>	
<b>Transmissions</b> <ul style="list-style-type: none"> <li>Takeoff [USMC], shp (kW) - 4,570 (3,408)</li> <li>Takeoff [USN], shp (kW) - 4,970 (3,706)</li> <li>Takeoff [USAF], shp (kW) - 4,970 (3,706)</li> <li>1 engine inoperative, shp (kW) - 5,920 (4,415)</li> </ul>	<b>Range</b> <ul style="list-style-type: none"> <li>Amphib assault, nm (km) - 515 (954)</li> <li>Max, self-deployment, nm (km) - 2,100 (3,892)</li> </ul>
<b>Performance</b> <ul style="list-style-type: none"> <li>Max speed, SL, kts (km/h) - 275 (510)</li> <li>Vert rate of climb, SL, fpm (m/m) - 1,090 (332)</li> <li>Max rate of climb, SL, fpm (m/m) - 2,320 (707)</li> <li>Service ceiling, ft (m) - 26,000 (7,925)</li> <li>Service ceiling, one engine inop, ft (m) - 11,300 (3,444)</li> <li>HQGE, ft (m) - 14,200 (4,328)</li> </ul>	<b>Crew</b> <ul style="list-style-type: none"> <li>Cockpit - crew seats - 2</li> <li>Cabin - troop seats/kiters - 24/12</li> </ul>
<b>Dimensions - Internal</b> <ul style="list-style-type: none"> <li>Length, max, ft (m) - 24.17 (7.37)</li> <li>Width, max, ft (m) - 5.92 (1.80)</li> <li>Height, max, ft (m) - 6.00 (1.83)</li> </ul>	<b>Dimensions - External</b> <ul style="list-style-type: none"> <li>Length, fuselage, ft (m) - 57.33 (17.48)</li> <li>Width, rotors turning, ft (m) - 83.33 (25.55)</li> <li>Width, stowed, ft (m) - 62.58 (19.08)</li> <li>Width, stowed, ft (m) - 18.42 (5.61)</li> <li>Width, horizontal stabilizer, ft (m) - 18.42 (5.61)</li> <li>Height, nacelles fully vertical, ft (m) - 21.76 (6.63)</li> <li>Height, vertical stabilizer, ft (m) - 17.65 (5.38)</li> </ul>
<b>Weights</b> <ul style="list-style-type: none"> <li>Empty, lbs (kg) - 33,140 (15,032)</li> <li>Takeoff, vertical, max, lbs - 47,500 (21,546)</li> <li>Takeoff, short running, max, lbs (kg) - 55,000 (24,948)</li> <li>Takeoff, self-deploy mission, lbs (kg) - 60,500 (27,443)</li> <li>Cargo hook, single, lbs (kg) - 10,000 (4,536)</li> <li>Cargo hook, dual, lbs (kg) - 15,000 (9,221)</li> </ul>	<b>Fuel Capacity</b> <ul style="list-style-type: none"> <li>Sponsons, gals (liters) - 1,228 (4,649)</li> <li>Wings, gals (liters) - 787 (2,979)</li> <li>Aux, self-deployment, gals (liters) - 2,436 (9,221)</li> </ul>

V-22 Fact Sheet, courtesy Bell Helicopter Textron.

locate the compound where the insurgents were hiding. With less than an hour's notice, a large contingency of Marines was able to fly 300 miles to the compound using MV-22 Osprey gun ships and was able to kill over 40 terrorists and rescue their hostage unharmed. Without the speed and troop capacity of the Ospreys, this mission could have never been accomplished in time."



Two XV-15s on the ramp at the NASA Dryden Flight Research Center at Edwards Air Force Base, California. (Photo courtesy NASA/Dryden Flight Research Center Archives)



A XV-15 on a test stand at Edwards Air Force Base. (Photo courtesy NASA/Dryden Flight Research Center Archives)



A rare photo of the beautiful "Silver Bird" sitting on the Amarillo ramp. It's thought that its silver coating is part of an active camouflage system to delay visual detection of the aircraft when in flight. (Photo by Steve Douglass)

This fictional account is just one of the scenarios envisioned by military planners when they asked Congress for the money to build for the Marine Corp and Air Force (Special Operations) an assault aircraft capable of landing, hovering, and taking-off like a helicopter and yet had the speed and large troop capacity of an aircraft.

The V-22 Osprey (the Air Force version; the MV-22 is the Marine version) is just such an aircraft, and they're already building them—hundreds of them—just a stone's throw from where I live in Amarillo.

## The Beginning Of Osprey

During the Vietnam War, the workhorse for Marine, Army, and Air Force expeditionary forces was the Bell UH-1 Huey helicopter. The multitasking Huey served as everything from a troop transport and air ambulance to assault chopper. Thousands of them were built and hundreds of them were shot down, still there are many Hueys flying today, some even doing duty in Southwest Asia.

But as good as the Hueys (and their modern-day equivalent, the UH-60 Blackhawk) are, they still have a major drawback that limits their effectiveness: helicopters just aren't very fast. They're limited by their very design—most of the power generated by their engines is geared to keeping them up in the air. The engines keep them aloft by turning a big rotor (which amounts to a moving wing) that creates tremendous upward lift. Only by tilting the rotor can the helicopter move forward.

A conventional airplane has a wing that provides the lift with a smaller propeller(s) out front that pulls it through the air. Since more of the engine's power is used to move the aircraft forward it can fly faster; however, at slow speeds, wing lift is lost and the aircraft stalls and falls. Because of this, an aircraft cannot hover like a helicopter.

Over the past 50 years, aerodynamicists have struggled to build an aircraft that embodies the best of both types of design. The advantages in having a fast flying transport or attack aircraft that can get to a target fast, deliver a good size force, and land anywhere like a helicopter are apparent to any military strategist. But until the advent of the XV-15 (the proof of concept aircraft for the V-22), they hadn't had much success.

You might ask, "What about the Harrier? Can't it float like a butterfly and sting like a bee?" True, the Harrier overcomes the difficulties of keeping a winged aircraft in hover mode by applying sheer brute strength in the form of powerful jet engines with dual jet exhausts aimed downward through a series of movable nozzles—and it works. But the Harrier is a fighter, not a transport, and providing jet-powered hovering capabilities in this way is not at all fuel-efficient.

NASA and Bell Helicopter thought they found the answer in the early 1970s with the invention and development of a tilting rotor winged aircraft called the XV-15.

Here's NASA's official history of the XV-15 program, reprinted with permission from the NASA/ Dryden website (<http://trc.dfrc.nasa.gov/gallery/photo/XV-15/HTML/EC80-13848.html>):

The development of the XV-15 Tiltrotor research aircraft was initiated in 1973 with joint Army/NASA funding as a "proof of concept," or "technology demonstrator" program, with two aircraft being built by Bell Helicopter Textron (BHT) in 1977. Ship number 1 was given NASA number 702, and ship #2 was 703. Aircraft development, airworthiness testing, and the basic "proof of concept" testing were completed in September 1979.

The aircraft are powered by twin Lycoming T-53 turboshaft engines that are connected by a cross-shaft and drive three-bladed, 25 ft diameter metal rotors (the size extensively tested in a wind tunnel). The engines and main transmissions are located in wingtip nacelles to minimize the operational loads on the cross-shaft system and, with the rotors, tilt as a single unit.

For takeoff, the proprotors and their engines are used in the straight-up position where the thrust is directed downward. The XV-15 then climbs vertically into the air like a helicopter. In this VTOL mode, the vehicle can lift off and hover for approximately one hour.

Once off the ground, the XV-15 has the ability to fly in one of two different modes. It can fly as a helicopter, in the partially converted airplane mode. The XV-15 can also then convert from the helicopter mode to the airplane mode. This is accomplished by continuous rotation of the proprotors from the helicopter rotor position to the conventional airplane propeller position. During the ten to fifteen second conversion period the aircraft speed increases and lift is transferred from the rotors to the wing.

Operating as a conventional airplane, the XV-15 can cruise for more than two hours. To land, the proprotors are rotated up to the helicopter rotor position and flown as a helicopter to a vertical landing.

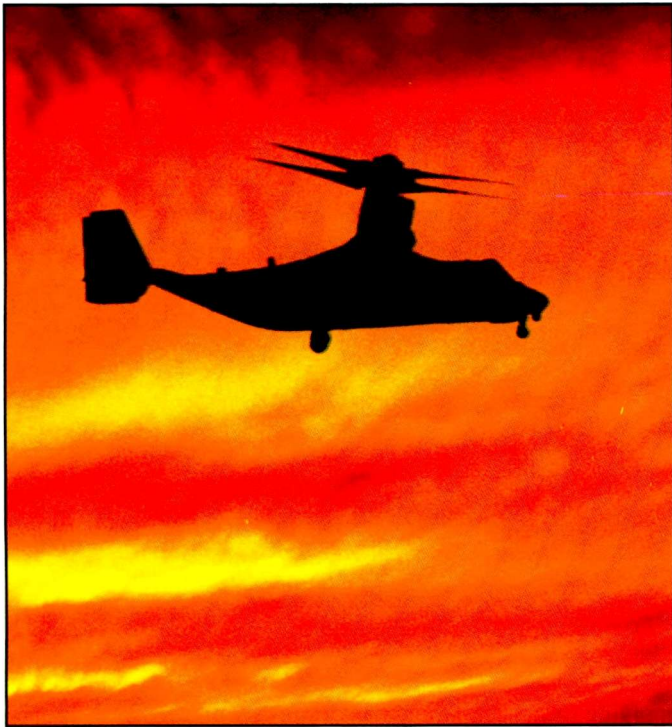

An MV-22 Osprey in hover mode. Notice how the twin engine swivels to transform the plane into a helicopter-like aircraft. (Photo by Steve Douglass)

The Osprey's tiltrotor concept has many advantages. The ease with which the aircraft can be converted from one flight mode to another enhances its maneuverability and permits it to be configured to meet various mission requirements. Operating as a VTOL (vertical takeoff and landing) aircraft, it can take off like a helicopter and deliver payloads on half the amount of fuel consumed by a helicopter when traveling distances greater than 185 kilometers.

Takeoff and landing terminals can be small, making tiltrotor aircraft ideal for intercity commuter travel. In the STOL (short takeoff and landing) mode, tiltrotor aircraft are ideal for long-distance transport of heavy cargoes into remote areas, where only short runways are available. The XV-15 has been the primary influence for Bell's V-22, the first production tilt rotor.

## Ospreys In Amarillo

When the Marine Corp and the USAF decided to buy hundreds of V-22s for use as troop carriers and Special Ops birds, Bell teamed with Boeing to fulfill the huge order. The problem was, neither Bell nor Boeing had the facilities to build the Osprey, so a search was begun to find a city that filled their needs. Criteria for cities applying to host the new Osprey plant were as follows:

- Wide open spaces near a major airport (but with not too much civilian or military traffic to inhibit flight operations)
- Large pool of skilled workers to choose from
- Close to a major interstate so supplies could be shipped to and from the plant with ease
- Aviation- and military-friendly city
- A community rich in cultural diversity with plenty of things to do (entertainment, shopping, etc.) serving to attract skilled workers (that can't be obtained locally) to the host city

- High standard of living, but with a low tax base
- Plenty of fair weather flying days

As it turned out, two Texas cities topped the Bell/Boeing short list of preferred sites: Ft. Worth and Amarillo.

Although civic leaders were ecstatic about being number two, they were not happy to see they would have to compete with metropolitan Ft. Worth, which already had a huge Bell helicopter facility. Although it looked like a long shot for Amarillo, our city did have a few advantages over Ft. Worth that the civic leaders did their best to promote.

First were Amarillo's wide-open spaces. Located on wide-open the Texas High Plains are hundreds of square miles of flyable airspace (for conducting test flights) away from populated areas, as opposed to the crowded skies of Ft. Worth and Dallas. There was plenty of space surrounding Amarillo International Airport on which they could build a huge plant. Existing facilities were also in place. On the far side of the airport were abandoned—yet usable—hangars and building space that once belonged to Bell Helicopter and was used to refurbish UH-1 helicopters during the Vietnam War. They stood empty, but were ready for immediate occupation.

Amarillo met the other criteria as well. Although not as bustling as Dallas/Ft. Worth, the area does have much to offer, such as large shopping malls, a new coliseum and concert-center, sporting and entertainment venues, plus natural wonders like Palo Duro Canyon State Park, located just south of the city. Amarillo is also located on I-40 and is just hours away from quality winter skiing in New Mexico or boating on huge Lake Meredith, 30 miles north of the city.

Another incentive drawing outside aerospace workers (mostly from California) is the high-quality, but inexpensive, standard of living. Real estate and construction costs are low in the area, so would-be homeowners could build a house about twice the size house for half the money it would cost them in Los Angeles. Plus aerospace workers in Amarillo would not have to deal with the long morning commutes, traffic snarls, and rising crime rates due to urban sprawl that beset Dallas/Ft. Worth.

Even with these pluses on Amarillo's side, the Amarillo Economic Development Committee offered Bell/Boeing huge tax breaks and deferments making it an offer they just couldn't refuse. When the decision came down and Amarillo was chosen to be the final assembly center for the V-22 Osprey, the



A look at the MV-22 assembly line inside the huge main building. (Photo by Steve Douglass)



Two huge MV-22 propellers wait for installation. (Photo by Steve Douglass)

town went wild. Celebrations and parties were held across the city welcoming Bell/Boeing management and employees. Bell flew in a V-22 Osprey prototype and invited the press and public to come out and see the aircraft that would soon become a familiar sight flying over the city.

Soon they broke ground and huge buildings went up on the south side of the airport. In less than a year, the first V-22s were rolling off the line.

## Monitoring The Osprey

When I heard we were getting the V-22 plant I was tickled pink. Not only as an aviation buff, but also because it would be a great opportunity to intercept communications involving test flights of this unique aircraft. Not long after the test flights began, I could be found at "the spot," watching the Osprey's take off and searching the bands for the frequencies used. It took me weeks, however, to find the actual flight test frequencies, though. Sure, it was easy enough to listen in on the local air traffic control and airport frequencies to know when the Osprey's were flying, but finding the channels used for flight test proved rather difficult.

One day when an Osprey was sitting on the ramp getting ready to go on a test hop, I heard it communicating with the airport control tower, saying it would be switching to their VHF company frequency. Using my ICOM R-3 in spectrum mode, I did a quick scan of the civil aviation band frequencies (108 to 136 MHz), and my receiver locked up on 123.100 MHz, where I heard the Osprey doing a test count and talking to the Bell/Boeing tower located right next to the main hangar. Since then, I've heard the tower controller asking for radio checks on 123.200, 123.300, and 123.400 MHz.

One frequency I was particularly interested in bagging was the UHF air-to-air frequency used between the Ospreys and a chase helicopter that sometimes accompanied the tilt rotors, either to monitor the flight or as a photo ship, taking publicity pictures over the lovely Palo Duro Canyon. That frequency eluded me until I heard the tower again asking for a comm check on 230.00 MHz. I was also able to find test telemetry data transmissions on 250.00 MHz.

Security at the plant is tight, since it's rated a DoD secure-facility, and is provided by Pinkerton Security and backed up by regular airport security. Security cameras are everywhere and if you park anywhere near the plant, security cops are soon dis-

patched to find out what you're doing in the area. Even if you're off airport property, video cameras and security patrols watch you closely. If, for some reason, they consider you or your actions suspicious, city police are dispatched to check you out.

The Pinkerton guards use 5-watt Motorola handheld-radios on 152.875 MHz. They don't use a repeater, so you can only monitor them within five miles of the plant. The main airport security frequency is 156.150 MHz. Sometimes (during high alerts) digital encryption is used on both frequencies.

## Bird Watching

Watching the Osprey's fly can be an exhilarating experience. Sometimes they do rolling takeoffs (like an aircraft from a runway), sometimes hovering takeoffs (like a helicopter), and sometimes a combination of the two. Watching it transition from hover to aircraft mode is pretty cool. When it lands, those huge rotors put out such a huge area of downdraft that the aircraft sometimes disappears in a cloud of dust.

The Osprey isn't very loud for an aircraft of its size, but it is unique. Even at night it's easy to tell when an Osprey flies over, with its engines sounding sort of like a light World War II bomber (like an F4U Corsair) combined with the thump-thump of a heavy helicopter (like a Chinook), except without the heavy bass vibration and with the thumps closer together.

Although there have been two much publicized crashes (neither in Amarillo), the Osprey looks like it's a very reliable and low-maintenance aircraft. Crashes have been blamed on software glitches and the huge ground effect caused by the rotors, which Bell/Boeing has spent considerable time and money correcting. I've monitored several IFEs (In-flight Emergencies) during test flights and, luckily, all the Ospreys made it home.

The problems seemed to be related to the hydraulic systems, which can be expected in new aircraft right off the assembly line. One day while I was listening to an Osprey on a test hop, the pilot complained he was showing low hydraulic pressure in the landing gear system. He notified the tower that he was returning to base and wanted to hover before landing so they could see if the gear was down and locked. They must have a heck of a video system in the tower because, when the Osprey was still more than 20 miles out, the tower radioed the pilot and said, "I

*(Continued on page 14)*



Close-up of the nose of an MV-22. (Photo by Steve Douglass)

# RE\_INVENTING RADIO

Through\_Innovation



## S350

AM/FM/Shortwave Radio \$100\*

High-Performance Field Radio

- Aeronautical design with rugged body
- Excellent AM, FM, & Shortwave reception
- Line-level input, separate bass, treble
- External antenna input
- Wide/narrow bandwidth filter controls
- Alarm and sleep timer functions

Dimensions: 10-3/4"W x 7"H x 3-1/2"D / Weight: 3 lb. 2 oz. / Power Source: 4 D Cells (not included) Or AC Adapter (included)

## YB550PE

AM/FM/Shortwave Radio \$80\*

Digital Expertise

- Shortwave range of 1711 - 29,995 KHz
- Autoscans, direct keypad, and scroll wheel tuning
- 200 customizable station presets
- Alarm and sleep timer functions
- AC adaptor and supplementary antenna inputs

Dimensions: 4-1/2"W x 6 1/2"H x 1 1/2"D / Weight: 10.4 oz. / Power Source: 3 AA Batteries Or AC Adapter (not included)



## G2000A

AM/FM/Shortwave Radio by F.A. Porsche \$80\*

Timeless Porsche Style

- Autoscans and direct keypad tuning
- 20 programmable station presets
- Dual alarm and sleep timer functions
- Snap-on protective case that converts to stand

Dimensions: 5-1/2"W x 3-1/2"H x 1-1/2"D / Weight: 13.8 oz. / Power Source: 3 AA Batteries Or AC Adapter (neither included)



\*Prices do not include Shipping/Handling and applicable taxes. To order, please call us toll free at 1-800-793-6542

# RE-INVENTING RADIO

Through\_Necessity



## FR300

AM/FM Radio with NOAA, TV-VHF, Flashlight, and Cell Phone Charger \$50\*

All-In-One Self-Powered Weather Alert Radio

- "Weather Alert" plus all 7 NOAA weather channels
- TV-VHF channels 2-13
- Hand-crank power generator
- Built-in cell phone charger

Dimensions: 3-1/2"W x 6"H x 2-1/2"D / Weight: 1 lb. 4 oz. / Power Source: Built-In Rechargeable Ni-MH Battery Pack; 3 AA Batteries (not incl.); Crank Power Alone; AC Adapter (not incl.). AC Adapter Can Recharge Built-In Ni-MH Battery Pack

## FR250

AM/FM/Shortwave Radio & Cell Phone Charger \$50\*

Self-Powered Radio and Flashlight

- Receives 7 international bands
- Hand-crank power generator
- Built-in cell phone charger
- Built-in flashlight and emergency siren
- Inputs for AC adaptor and earphones
- Rugged splash-proof ABS body

Dimensions: 6-1/2"W x 6"H x 2-1/2"D / Weight: 1 lb. 3 oz. / Power Source: Built-In Rechargeable Ni-MH Battery Pack; 3 AA Batteries (not incl.); Crank Power Alone; AC Adapter (not incl.). AC Adapter Can Recharge Built-In Ni-MH Battery Pack

## FR200

AM/FM/Shortwave Radio and Flashlight \$40\*

Emergency Crank Radio

- Hand-crank power generator
- Built-in flashlight
- 12 International shortwave bands
- Perfect for camping, hiking, and everyday use
- 5 colors: Metallic Red, Metallic Blue, Metallic Bronze, Yellow, and Sand.

Dimensions: 6-1/2"W x 5-3/4"H x 2-1/4"D / Weight: 1 lb. 2 oz. / Power Source: Built-In Rechargeable Ni-MH Battery Pack; 3 AA Batteries (not incl.); Crank Power Alone; AC Adapter (not incl.). AC Adapter Can Recharge Built-In Ni-MH Battery Pack



## FR100

AM/FM Radio and Flashlight with Blackout Alert \$30\*

Plug-In Radio with Blackout Alert

- Just unplug it for bright light and an AM/FM radio
- Plugs into the wall for continuous charging
- Illuminates automatically during a power failure
- Rechargeable Ni-MH battery (included) lasts up to 16 hours for LED light or up to 8 hours of radio use

Dimensions: 3"W x 5-1/4"H x 1-1/2"D / Weight: 10.1 oz. / Power Source: AC outlet charges internal, rechargeable Ni-MH battery pack. 72 hour full-charge



\*Prices do not include Shipping/Handling and applicable taxes. To order, please call us toll free at 1-800-793-6542

eton®  
RE-INVENTING RADIO  
www.etoncorp.com



Note the many antennas on the Bell MV-22 tower used to communicate with MV-22s on test flights. (Photo by Steve Douglass)

have you on video and from here it looks like the gear are down and locked.”

The pilot radioed back, “You can see the gear on video from 20 miles out? What kind of lens is on that camera?”

In the event that an Osprey has a hydraulic problem and the pilot can’t get the gear down, a huge inflatable bag is put out on the pad for the Osprey to land on so it will do minimal damage to the undercarriage. As far as I know, it has only been used in drills.

## An Invite Inside The Plant!

Finally after spending many hours outside the plant looking in, I got a chance to take a look *inside!*

On May 21, the public and media were invited to tour the plant. I would be the only reporter let in with a still camera. The public was not allowed to bring any photographic devices, including video cameras, digital cameras, and even cell phone cameras. Everyone entering the plant was asked if they had any recording devices on their persons; if they did, they weren’t allowed in. Coolers, bags, and purses were prohibited as well.

I approached the main gate with my camera bag over my shoulder and was immediately stopped by a guard before I got to the gate. I presented my press-pass and the guard radioed security base and said, “There’s a photographer here with a press I.D. named Steve Douglass wanting to enter the plant, shall I send him through?”

“No,” came the reply, “we’ll send along an escort.”

Five minutes later I was being escorted to the front of the main assembly building. I was introduced to the plant manager and the head of press relations for the plant and then given free rein to shoot anything and roam anywhere in the plant except in areas deemed off limits by security ropes and backed up by serious-looking guards.

Being in the main assembly plant is like standing inside an enclosed stadium, two football fields in length. Ospreys in various states of assembly are lined up neatly in two rows on both sides of the floor, with a wide expanse of floor space between for movement of heavy equipment. Along the ceiling are huge cranes for moving heavy assemblies. Huge tool and part boxes that would make Bob Villa green with envy are everywhere, as are signs warning all workers to be aware of FOD (foreign object debris) that can be sucked into an engine.

I hadn’t walked 50 feet when I was stopped by a security guard who, on seeing me raise my camera to take a shot of a propeller blade assembly, shouted, “Hey, you with the camera, no pictures allowed in here!”

I showed him my press pass and he said, “Sorry. I didn’t know they were allowing the press to take photos.”

I replied, “That’s okay. You were just doing your job. Glad to see you guys are on your toes.”

Over the next 15 minutes, security guards stopped me no less than a dozen times, each telling me I wasn’t allowed to take photos. Finally tired of being interrupted mid-photo, I said to one of the guards, “It might be a good idea to radio all of your security personnel and notify them there is a cleared photographer on the grounds who has been authorized to take photos. “Good idea!” he replied and did just that.

One of the areas I was not allowed to enter (and really wanted to) was the tower. I was also not allowed to enter another adjacent hangar used for maintaining the flyable aircraft, but its hangar doors were open and I was able to shoot some pictures through the doors. Inside this hangar was an Osprey with a mangled propeller on the left side. It looked like it had come in contact with the ground and had been chewed up. As I snapped some pictures my wandering eyes noticed another MV-22 tucked away and partially hidden in a corner. My eyes widened when I realized what it was.



Looking into an MV-22 Osprey through the open back doors. (Photo by Steve Douglass)





MV-22s fold up for compact storage on aircraft carrier decks. Note the mangled propeller on this Osprey. (Photo by Steve Douglass)

## The Silver Bird

The Osprey in the corner was the infamous "Silver Bird," a beautiful craft that I had only managed to catch a glimpse of outside on the ramp on one occasion.

I called it the Silver Bird because of its gleaming silver-blue paint job, which looked more like it belonged on a Ferrari or Lamborghini than on a ground pounding, heavy-duty piece of military hardware. The special paint job (I would subsequently find out through my contacts at *Aviation Week and Space Technology* magazine) was the same experimental coating being tested on F-22 Raptors in an attempt to make them harder to see. In other words, it was thought to be an advanced form of camouflage, or an active stealth covering to make the aircraft harder to detect visually.

Could it be the Silver Bird was an invisible bird? Time will tell—maybe.

## Hear The Busy Skies

With hundreds of Osprey's to build, it looks like they will be gracing Amarillo's skies for some time to come. The plant is growing by leaps and bounds, and not just to accommodate Osprey production. The civil version of the Osprey (BA609) will also be built here, as well as a tilt rotor UAV called the Bat. Bell also has plans to refurbish Navy AH-1Z Cobra helicopters here and to build a new version of the Huey helicopter (called the UH-1Y) as well. There are also rumors of a secret C-130-sized four-engine troop carrier version of the Osprey in the works as stealthy tilt-rotor aircraft.

The next presidential helicopter fleet will also be built in Amarillo. Bell Augusta recently landed the \$1.7 billion contract to build Marine One, the presidential helicopter. A fleet of 23 aircraft will be built in Amarillo, with another \$2.7 billion forthcoming in research funds.

There are currently 750 workers employed at the facility on Tiltrotor Drive, and that's expected to grow by as many as 305 new hires this year alone, ultimately reaching a work force of 1,700 employees by 2012.

If you're ever passing through Amarillo, plug in the frequencies listed above, keep your eyes to the skies (especially if you're driving along I-40 just east of the city), and maybe you'll get to see an Osprey leaving the nest! ■

# Radio YourWay LX

## AM/FM MP3 Player-Recorder

*Plays Podcasts Too!*

- Backlit LCD display
- USB, Line / Mic-in & microphone
- Frequency range: FM 87.50-108 MHz, AM 530-1710 kHz
- MP3, WMA, RFF playback
- Adjustable recording quality: 32k to 256k
- 128 MB internal flash
- SD card compatible



Radio YourWay LX - \$199.95

SD CARDS:

(2) 512 MB SD cards \$109.95 - SAVE \$20 when purchased with Radio YourWay LX

C. CRANE COMPANY

# FREE CATALOG!

800-522-8863 • [ccrane.com](http://ccrane.com)

New book from the publishers of  
**CQ Amateur Radio**

## MIL SPEC RADIO GEAR

KOREAN WAR TO PRESENT DAY

by MARK FRANCIS, KIÖPF

• Detailed write-ups for many familiar sets: PRC-251-77, PRC-10, PRC-74, PRC-41, RT-6B, PRC-1099, GRC-106, GRC-9, GRC-109, GRR-5, R-392, and more

• Over 230 pages of operation, modification, and maintenance tips and info, including 200+ illustrations

• HF Manpack, HF Mobile, HF Fixed, VHF Manpack, VHF Mobile, UHF Manpack

• Many useful hints and mods gathered from the author's personal experience you won't find in the tech manuals.

A few examples:

- ☞ Definitive cure for the PRC-1099 synthesizer Fming problem
- ☞ How to turn the power down on your GRC-106 so you don't fry it
- ☞ A simple way to adjust the transmit deviation on the FM GRC gear

• The HFpack Phenomenon – low-power HF portable operation

• How to find surplus; maintenance and troubleshooting



Price ONLY \$27.95  
\$5.00 S&H

CQ Communications, Inc.

25 Newbridge Road, Hicksville, New York 11801

Phone: (516) 681-2922 Fax: (516) 681-2926

## Capitol Hill And FCC Actions Affecting Communications

### FCC Offers Customized E-mail News Subscriptions

Subscribers to an "expanded and improved" e-mail service being offered by the Consumer & Governmental Affairs Bureau of the FCC will be able to receive customized information about the commission's actions on communications issues.

The Consumer Information Registry is "an Internet database that can be customized to deliver information on whatever topics the subscriber chooses," the commission said. "Whether it's digital television, telephone issues, telecommunications issues specific to people with disabilities, or anything else in the communications field, information on all these topics will be available through the Registry. Attorneys, consultants, engineers and individual consumers are among those who will benefit from subscribing."

There is a wide range of topic areas from which to choose, including Access to Emergency Information, Amateur Radio and Related Interests, Cable and Broadcast TV, Homeland Security, Internet, Voice over Internet Protocol, Satellite Radio/TV/Communications, and Emergency Management/E-911/Public Safety.

The service is free and registrants can unsubscribe at any time. To sign up or for more information, visit [www.fcc.gov/cgb/contacts/](http://www.fcc.gov/cgb/contacts/).

### ARRL Calls For Radio Amateurs To Take Political Action

Radio amateurs across the United States must take personal responsibility for raising the profile of ham-related issues before politicians, according to American Radio Relay League (ARRL) Hudson Division Director Frank Fallon, N2FF. "Political lobbying is something people don't really want to hear about," Fallon said. "But politics controls everything we get." When it comes to Congress, individual radio amateurs can help shape their own future."

The *ARRL Letter* said that Fallon used the Broadband over Power Line (BPL) issue as an example of "how politics can overcome logical, technical argument." "So, if we are hanging out in the basement and doing nothing but building rigs and working DX, we're going to be victims" of the political process, Fallon said.

"[The] ARRL, as a nonprofit IRS Section 501(c)(3) organization, must adhere to strict limitations on its lobbying activities," the *ARRL Letter* pointed out. For instance, it cannot endorse political candidates or contribute to political campaigns. But radio amateurs can make a difference, Fallon said, through letters, e-mails, faxes, or visits to U.S. representatives and senators.

"We've got to ratchet up our presence," League President Jim Haynie, W5JBP, said, adding that individual licensees also are voters, and lawmakers are aware that there are radio amateurs in their districts. "The focus of the ARRL Grassroots Lobbying initiative will be on measures that deal with FCC mat-

ters, because congress oversees the Commission," the *ARRL Letter* said.

### Florida Man Cited For Alleged Illegal Radio Operation

A hunter, who told FCC agents that he used a VHF marine radio on hunting trips because the CB band had too much interference, has been issued a \$10,000 Notice of Apparent Liability for Forfeiture by the Commission. Jeremy R. Riels, of Cross City, Florida, is alleged to be the unauthorized operator of a transmitter on 156.875 MHz after an investigation in December 2004 by agents from the FCC's Enforcement Bureau in Tampa.

Monitoring VHF Marine Channel 77, the agents "heard a conversation between hunters about the location of their hunting dogs in the forest." The agents used radio direction finding techniques to determine that the source of the signal was from a 1997 brown Silverado Chevrolet pickup truck in Dixie County, Florida. "The agents observed a radio transmitter installed in the vehicle. Mr. Riels, the driver and only occupant of the vehicle, was questioned and admitted to operation of the radio transceiver installed in his vehicle." Riels was given 30 days to respond to the notice, which was issued in May.

### One-day Course On Homeland Security Communications Introduced

A new course titled "The Telecommunicator's Role in Homeland Security" is being offered by APCO Institute as the first in a series of classes on the subject, the Association of Public-Safety Communications Officials International has announced.

"Terrorism events require specialized actions and telecommunicators will have to deal with a new set of circumstances, far different from the average structure fires, vehicle accidents and even HAZMAT incidents," the organization said. "This course will assist the telecommunicator in determining that a possible terrorist event has occurred and the appropriate response." The course is based on the U.S. Department of Homeland Security's National Incident Management System.

In its course description, APCO says the kick-off course covers modern terrorism threats, response to specific terrorism incidents, the anatomy of a terrorism incident and resource coordination during terrorism incidents. "The course also offers an Incident Command System module designed specifically for the telecommunicator," APCO reports. For scheduling, costs, locations, and more information, click on "Training and Certification" and "Course Descriptions" at [www.apcoinstitute.org](http://www.apcoinstitute.org).

### Alleged Jammer Released From Custody In California

Jack Gerritsen, who had been held by federal authorities for allegedly jamming Southern California radio transmissions,

(Continued on page 38)

# JRC NRD-545

*Legendary Quality. Digital Signal Processing. Awesome Performance.*



**With the introduction of the NRD-545, Japan Radio raises the standard by which high performance receivers are judged.**

Starting with JRC's legendary quality of construction, the NRD-545 offers superb ergonomics, virtually infinite filter bandwidth selection, steep filter shape factors, a large color liquid crystal display, 1,000 memory channels, scan and sweep functions, and both double sideband and sideband selectable synchronous detection. With high sensitivity, wide dynamic range, computer control capability, a built-in RTTY demodulator, tracking notch filter, and sophisticated DSP noise control circuitry, the NRD-545 redefines what a high-performance receiver should be.

**JRC** *Japan Radio Co., Ltd.*

Japan Radio Co. Ltd., New York Office —  
2125 Center Avenue, Suite 208, Fort Lee, NJ 07024  
Voice: 201 242 1882 Fax: 201 242 1885

Japan Radio Company, Ltd. — Nittochi Nishi-Shinjuku Bldg.  
10-1 Nishi-Shinjuku 6 chome, Shinjuku-ku, Tokyo 160-0023, Japan  
Voice: 81 3 3348 3858 Fax: 81 3 3348 3938

[www.jrc.co.jp/](http://www.jrc.co.jp/)

- LSB, USB, CW, RTTY, FM, AM, AMS, and ECSS (Exalted Carrier Selectable Sideband) modes.
- Continuously adjustable bandwidth from 10 Hz to 9.99 kHz in 10 Hz steps.
- Pass-band shift adjustable in 50 Hz steps up or down within a  $\pm 2.3$  kHz range.
- Noise reduction signal processing adjustable in 256 steps.
- Tracking notch filter, adjustable within  $\pm 2.5$  kHz in 10 Hz steps, follows in a  $\pm 10$  kHz range even when the tuning dial is rotated.
- Continuously adjustable AGC between 0.04 sec and 5.1 sec in LSB, USB, CW, RTTY, and ECSS modes.
- 1,000 memory channels that store frequency, mode, bandwidth, AGC, ATT, and (for channels 0-19) timer on/off.
- Built-in RTTY demodulator reads ITU-T No. 2 codes for 170, 425, and 850 Hz shifts at 37 to 75 baud rates. Demodulated output can be displayed on a PC monitor through the built-in RS-232C interface.
- High sensitivity and wide dynamic range achieved through four junction-type FETs with low noise and superior cross modulation characteristics.
- Computer control capability.
- Optional wideband converter unit enables reception of 30 MHz to 2,000 MHz frequencies (less cellular) in all modes.

# News, Trends, And Short Takes

## Spanish Commercial Network COPE Starts DRM Tests

The Spanish commercial radio network COPE has begun tests of DRM on mediumwave, following the example of public broadcaster RNE, which began testing DRM in January 2005. The current tests, being made in collaboration with the telecommunications company Axion and the University of Vigo, are to verify the viability of the simultaneous analog and digital transmissions on the same frequency. The Spanish Ministry of Industry is providing some of the funding. The tests are being carried out on 1269 kHz via the transmitter in Zamora.

## FCC Adopts Digital Radio Mondiale Standard For U.S. HF Broadcasting

The FCC has adopted the DRM standard for U.S. HF Broadcasting Service (HFBC) digital transmission. Adoption of the DRM standard was among several actions the FCC took in a wide-ranging Report and Order (R&O) in response to the World Radiocommunication Conference 2003 (WRC-03) in ET Docket 04-139.

The FCC authorized both digital audio broadcasting and datacasting. It said channels using digitally modulated emissions may share the same spectrum or be interleaved with analog emissions in the same HF broadcast band, provided the protection afforded to the analog emissions is at least as great as that currently in place for analog-to-analog protection.

The Commission authorized double-sideband (DSB), single-sideband (SSB), and digital transmissions in HF bands between 5900 and 26,100 kHz, and it set minimum HFBC power levels of 50-kW PEP for SSB. In the same proceeding, the FCC also reallocated the 7100- to 7200-kHz band to the Amateur Service on a co-primary basis and reallocated the 7350- to 7400-kHz band to the HFBC Service on a co-primary basis, with the fixed service until March 29, 2009, after which it will be allocated exclusively for broadcasting.

## Two Vatican Radio Executives Jailed For Electronic Interference

Two executives of Vatican Radio were given 10-day suspended jail sentences because of the radio's transmitters giving out too much interference. The sentences for Cardinal Roberto Tucci, the radio's president, and Director General Father Pasquale Borgomeo will be suspended only if the electronic interference ceases and the two officials agree to pay compensation, judge Luisa Martoni ruled. The transmitters are located in Cesano, north of Rome, where local people complained that electromagnetic pollution from them was causing serious health problems, including leukemia. An Italian environment ministry investigation in 2001 found that the magnetic fields were much higher than the permitted 6 volts per square meter in 11 out of 14 sites checked.

Vatican Radio slammed the ruling as "unjustified" and said it hoped the appeal would "clear all the shadows that have tarnished our good reputation and contributed to feeding baseless fears among the population." Last November, an Italian prosecutor asked for 15-day prison terms for Tucci and Borgomeo, demanding that the court order a suspended sentence only if the interference ceased.

## New French Website Of Digital Radio Mondiale Launched

A French version of the Digital Radio Mondiale (DRM) consortium website has been launched with the participation of the main actors of the consortium (broadcasters, manufacturers, network operators, research institutions, broadcasting unions, regulatory bodies, etc.). This new site, [www.drmfrance.com](http://www.drmfrance.com), will provide information on activities undertaken in France to promote digital radio on the French scene. It will also provide a platform for audio testing so surfers will be able to enjoy the sound of digital audio and compare it with that of analog sound. All ongoing transmission trials will also be listed.

## Radio Six International Launches New Saturday Transmission

Radio Six International, Scotland's independent international station, has launched a new Saturday transmission aimed at listeners across Europe. The schedule is 0600 to 0700 UTC on 15725 kHz from Milan; 9290 kHz from Ulbroka, Latvia; and a 24-hour Web feed at [www.radiosix.com](http://www.radiosix.com). There's another Web feed from 1500 to 1600 UTC and from 2300 to 2400 UTC. The station is on 5105 kHz along with another Web feed.

## BBC Announces Interactive Media Player Content Trial

BBC New Media has announced the next phase in the development of the BBC's interactive Media Player (iMP), an extensive three-month content trial that will begin in September 2005. iMP offers UK viewers the chance to catch up on TV and radio programs they may have missed for up to seven days after they have been broadcast, using the Internet to legally download programs to their home computers. (See also this month's "ScanTech" column.)

A technical trial took place in summer 2004 with a limited number of participants and a small amount of rights-cleared programs to test the concept of using peer-to-peer technology and digital rights management to protect rights holders. As part of the next phase of iMP's development, the BBC will now open up more of its radio and TV schedule—around 190 hours of TV programs and 310 radio programs, as well as local programming and rights-cleared feature films.

Five thousand people from all over the UK will take part in the pilot. They will be able to search for programs they want to

watch, sort programs by channel, select subtitles and, in the case of some series, collect and watch episodes they may otherwise have missed. Broadband users in the UK who would like to be considered for a place on the pilot can send an e-mail to [imprial@bbc.co.uk](mailto:imprial@bbc.co.uk) including their name, contact details, age, and postcode.

### Right-wing Flemish Political Party Vlaams Belang Launches DRM Service

On May 29, 2005, the right-wing Flemish political party Vlaams Belang of Belgium launched its own digital shortwave service, VB6015, broadcasting in DRM mode for two hours on Sundays on 6015 kHz from 0900 to 1100 UTC via Deutsche Telekom facilities at Juelich, Germany. The party advocates the secession of Flanders from Belgium and has plans to launch a full radio service in January 2006. It was formed at the end of 2004 following the disbanding of the Vlaams Blok, after the Belgian Supreme Court declared it a racist organization.

### STAR Radio Resumes Broadcasting In Liberia

The Liberian STAR radio has resumed broadcasting both on FM and shortwave. The independent news and information radio station is now on 104 MHz FM, and within a few weeks will also be on shortwave to Liberia and the sub-region.

Located at Mamba Point, Monrovia, Liberia, STAR radio had established itself as a primary source of independent and unbiased information for Liberians. It was forcibly closed by then-President Charles Taylor in 2000 and could not be reopened as long as he was in office. Taylor left Liberia for exile in Nigeria in August 2003, and in November of the same year, the ban on STAR radio was lifted by Gyude Bryant, the Chairman of the National Transitional Government, which replaced the Taylor regime.

STAR radio broadcasts are on the air daily from 0500 to 2200 UTC on 104 MHz FM for Greater Monrovia, as well as two hours per day on shortwave for rural Liberia and the sub-region. The frequency and shortwave schedule was not available at press time. STAR radio is a non-profit organization run by Liberians in partnership with the Hironnelle Foundation, an organization of journalists which sets up and operates media services in crisis areas. It is jointly funded by the European Commission, Switzerland, the Netherlands, Norway, and the United Kingdom.

### BBC World Service Receives Roosevelt Four Freedoms Medal

BBC World Service has been chosen by the Franklin and Eleanor Roosevelt Institute to receive a Roosevelt Four Freedoms Medal for its extraordinary history as a universal voice of freedom and to commemorate the 60th anniversary of the end of World War II.

The award is presented each year to men and women whose achievements show a commitment to the principles President Roosevelt, identified in 1941 as essential prerequisites of democracy: freedom of speech and expression, freedom of worship, freedom from want and freedom from fear. Former recipients of the award, which prior to 1982 was only given to American citizens, include U.S. Presidents John F. Kennedy, Harry S. Truman, Czech President Vaclav Havel, and the Dalai Lama. ■

## V.I.P. SPOTLIGHT

# Congratulations To Charlie Van Sant, K7WLW

## Our September Winner: Charlie Van Sant, K7WLW, Of Cincinnati, Ohio!

*Pop'Comm* reader Charlie Van Sant tells us,

I can never remember a time in my life when I was not fascinated by this thing we call "radio." I remember hearing the local shows in my hometown of Indianapolis on my Mom's Bakelite Zenith. As a youngster, I was often in my room "playing disc jockey" on my record player with some beat-up 45s. My studio was later enhanced with a battery operated reel-to-reel tape recorder. The shows were short, however—not much time on a three-inch reel!

When I was older, I hooked a 300-ohm antenna lead to an old Philco floor model radio that my Dad purchased in 1939. It was then that I was introduced to the world of shortwave and some sort of scrambled mess I later learned was "single sideband." I had discovered the 80-meter ham band.

My pursuit of radio continued with a radio-TV course in high school and a college degree in broadcasting. I have now been a commercial broadcaster for 30 years. It is my privilege to be the overnight news reporter for the granddaddy of them all, 700 WLW in Cincinnati. I finally earned my ham license in 1994.

I just wonder whatever happened to that old Bakelite Zenith! ■

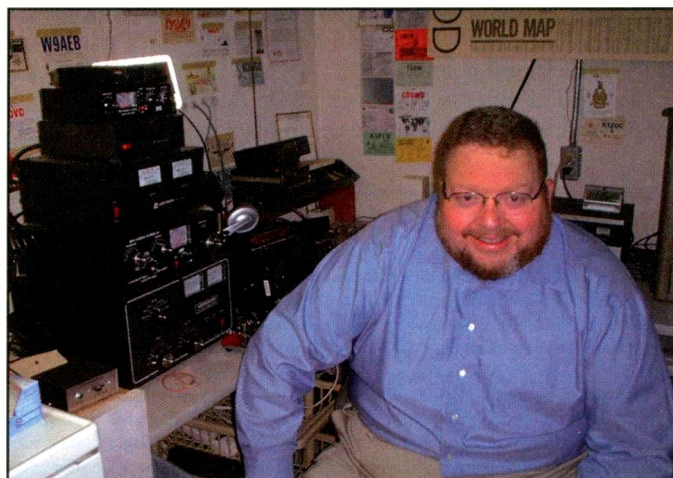

Here's Charlie Van Sant, K7WLW, of Cincinnati at his well-appointed radio shack.

*Popular Communications* invites you to submit, in about 300 words, how you got started in the communications hobby. Entries should be typewritten, or otherwise easily readable. If possible, your photo should be included.

Each month, we'll select one entry and publish it here. All submissions become the property of *Popular Communications*, and none will be acknowledged or returned. Entries will be selected taking into consideration the story they relate, and if it is especially interesting, unusual or even humorous. We reserve the right to edit all submitted material for length, grammar, and style.

The person whose entry is selected will receive a one-year gift subscription (or one-year subscription extension) to *Popular Communications*. Address all entries to: "V.I.P. Spotlight," *Popular Communications*, 25 Newbridge Road, Hicksville, NY 11801 or e-mail your entry to [popularcom@aol.com](mailto:popularcom@aol.com).

# Great DX On All Shortwave Bands Between Northern And Southern Temperate Regions

**A**utumn is right around the corner, a time of considerable improvement in HF radio propagation conditions. At the end of September, the Sun will be directly over the equator. On the Autumnal Equinox, everywhere in the world, the hours of daylight are equal to the hours of darkness.

This results in an ionosphere of almost similar characteristics over large areas of the world, making it the best time of the year for long DX openings between the temperate regions of the Northern and Southern Hemispheres on *all* shortwave bands. Expect some improvement on the higher frequencies (22 meters up through 11 meters), with more frequent short-path openings from mid-September through mid-October between North America and South America, the South Pacific, South Asia, and southern Africa.

Of course, the amount of improvement is not as great as during the years when we have a maximum of solar activity. Right now, we're close to the end of Solar Cycle 23, so there's just not a lot of energy on a daily basis to create a strong enough ionosphere able to support propagation on the higher frequencies. The strongest openings will occur for a few hours after sunrise and during the sunset hours.

Long-path openings also improve during the equinoctial periods. A variety of paths are opening up on 31 and 22 meters.

Expect a path from southern Asia around sunset, daily morning openings from southern Asia and the Middle East, expanding to Africa. Also look for signals from the Indian Ocean region via long-path over the North Pole. Afternoons will fill with South Pacific long-path, and then extend to Russia and Europe. Look for possible long-path openings on 31, 41, 49, 60, and 75 meters for an hour or so before sunrise and just before sunset.

The winter DX season is slowly approaching, making for exciting DX conditions. Many international shortwave broadcast stations will soon change from their summer schedule to a winter schedule, taking advantage of seasonal changes in propagation conditions. While the weather is still warm and fair, tighten hardware on your antenna system, check coax cables, and fine tune your radio station. Get ready to reap the DX, especially on the lower shortwave and the mediumwave bands.

## HF Propagation For September

Some days, propagation on 11 through 22 meters will be much like conditions during the summer. Other days (and more often), conditions will be more like those experienced during the winter season. With the 10.7-centimeter flux levels gener-

### The Ap Index And Understanding Propagation Terminology

The Ap index, or Planetary A index, is a 24-hour averaging of the Planetary K index. The Planetary K index is an averaging of worldwide readings of Earth's geomagnetic field. High indices ( $K_p > 5$  or  $A_p > 20$ ) mean stormy conditions with an active geomagnetic field. The more active, the more unstable propagation is, with possible periods of total propagation fade-out. Especially around the higher latitudes and especially at the Polar Regions, where the geomagnetic field is weak, propagation may disappear completely. Extreme high indices may result in aurora propagation, with strongly degraded long distance propagation at all latitudes. Low indices result in relatively good propagation, especially noticeable around the higher latitudes, when transpolar paths may open up. Maximum K-index is 9, and the A-index can exceed well over 100 during very severe storm conditions, with no maximum.

Classification of A-indices is as follows:

A0-A7 = quiet	A30-A49 = minor storm
A8-A15 = unsettled	A50-A99 = major storm
A16-A29 = active	A100-A400 = severe storm

**Solar Flux (SFI):** This flux number is obtained from the amount of radiation on the 10.7-cm band (2800 MHz). It is closely related to the amount of ultraviolet radiation, which is needed to create the ionosphere. Solar Flux readings are more descriptive of daily conditions than the Sunspot Number. The higher the Solar Flux (and, therefore, the higher the Sunspot Number), the stronger the ionosphere becomes, supporting refraction of higher frequencies.

**Ionosphere:** A collection of ionized particles and electrons in the uppermost portion of the Earth's atmosphere, which is formed by the interaction of the solar wind with the very thin air particles that have escaped Earth's gravity. These ions are responsible for the reflection or bending of radio waves occurring between certain critical frequencies, with these critical frequencies varying with the degree of ionization. As a result, radio waves having fre-

quencies higher than the Lowest Usable Frequency (LUF) but lower than the Maximum Usable Frequency (MUF) are propagated over large distances.

**Sunspot Number (SSN):** Sunspots are magnetic regions on the Sun with magnetic field strengths thousands of times stronger than the Earth's magnetic field. Sunspots appear as dark spots on the surface of the Sun. Temperatures in the dark centers of sunspots drop to about 3700° K (compared to 5700° K for the surrounding photosphere). This difference in temperatures makes the spots appear darker than elsewhere. Sunspots typically last for several days, although very large ones may last for several weeks. They are seen to rotate around the sun, since they are on the surface, and the sun rotates fully every 27.5 days.

Sunspots usually occur in a group, with two sets of spots. One set will have positive or north magnetic field while the other set will have negative or south magnetic field. The field is strongest in the darker parts of the sunspots (called the "umbra"). The field is weaker and more horizontal in the lighter part (the "penumbra").

Galileo made the first European observations of sunspots in 1610. The Chinese and many other early civilizations have records of sunspots. Daily observations were started at the Zurich Observatory in 1749; continuous observations were begun in 1849.

The sunspot number is calculated by first counting the number of sunspot groups and then the number of individual sunspots. The "sunspot number" is then given by the sum of the number of individual sunspots and 10 times the number of groups. Since most sunspot groups have, on average, about 10 spots, this formula for counting sunspots gives reliable numbers even when the observing conditions are less than ideal and small spots are hard to see. Monthly averages (updated monthly) of the sunspot numbers show that the number of sunspots visible on the sun waxes and wanes with an approximate 11-year cycle.

For more information, see <http://prop.hfradio.org>.



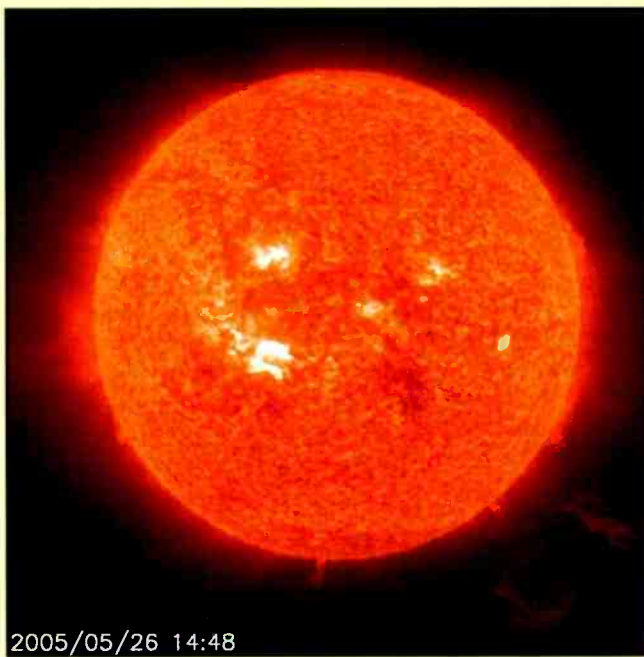

Within the space of minutes (and rarely seen in this 304-Angstrom wavelength of ultraviolet light), the Sun blasted out huge, swirling clouds of particles into space. SOHO (the Solar and Heliospheric Observatory, an international mission of NASA and the European Space Agency) was watching as an eruptive prominence—a floating cloud of gases above the Sun's surface—suddenly became unstable and rushed away from the Sun's lower right side. Minutes later, a small solar flare triggered a similar event near an active region (seen as a white area) just left of the Sun's center. The material can be seen as darker red strands crossing the Sun's surface to the right.

To get a sense of the scale involved here, in both cases the size of these strands is about 300,000 miles long or the equivalent of about 30 Earth diameters. The clouds of particles roared away at about half a million miles per hour. While these kinds of solar events occur fairly frequently, SOHO's instrumentation usually does not take images at this high rate of one image every 12 minutes. SOHO was fortunate to capture the event in this exquisite detail. (Source: SOHO/NASA)

ally on the low side (below 110 and probably averaging between 50 and 80) during September, openings on 11 through 22 meters will be spotty. But, when paths open, conditions will change fast, and vary greatly.

On the highest of these bands (11 meters through 15 meters), paths from Europe and the South Pacific as well as from Asia, into the North American region, will occur on days when the flux is higher than 80. However, few stations are using 11, 13, or 15 meters, as compared with the lower frequencies.

Sixteen meters, used by a larger group of broadcasters, will be the most reliable higher band, especially when the solar flux levels are higher during the month. This band will usually supply day-path propagation, even over the polar paths. A considerable improvement is expected, with the band opening shortly after sunrise and remaining open until after sundown. However, 16 meters will not stay open late into the night like it typically does during the spring season. Openings should be possible from all areas of the world, with conditions best from Europe and the northeast before noon, and from the rest of the world during the afternoon hours. Openings from the South Pacific, Australia, New Zealand, and the Far East should be possible well into the early evening, particularly when we have low geomagnetic activity combined with higher flux readings.

Conditions may be marginal during the month, but these higher bands are certainly coming alive. There will be less polar propagation as we move toward winter, though, making some parts of the world difficult to hear over these paths. To catch the openings over high latitudes, get on these bands shortly after sunrise, or watch for polar signals as they close for the evening.

The 19- and 22-meter bands compete with 16 for best daytime DX band this month. Look for 19 and 22 to open for DX at sunrise and remain open from all directions for a few hours. It should be possible to hear many areas of the world throughout the daylight hours, with a peak in the afternoon. Nighttime con-

ditions will favor openings from the south and tropical areas, but some openings will also be possible from other areas, especially during days of high sunspot numbers. Look for polar gray-line propagation from Asia. Long-path is common on 19 from southern Asia, the Middle East, and northeastern Africa, as well as from the Indian Ocean region via the North Polar path.

The 25- and 31-meter bands are all-season bands. Expect an incredible amount of activity on these two hot bands. Many broadcasters choose these, targeting their audiences during prime times (morning and early evenings). The conditions prevalent on 19 and 22 are more pronounced, and last much longer, on these bands. Look for exotic stations a few hours before sunrise through early morning, then again in the early evening before sunset, until around midnight.

Expect an improvement in nighttime DX conditions on 41, 49, 60, 75, 90, and 120 meters during September and October. This is due to the ever increasing hours of darkness and a seasonal decrease in the static level. Forty-one meters should be best for worldwide DX from sunset to sunrise. Forty-nine and 60 meters are used by a lot of the larger, stronger broadcasting stations, so you can always depend on hearing signals from early evening (from before sunset) to a few hours after sunrise. For exotic regional signals, check 75 through 120 meters during the hours of darkness, especially for an hour or so before local sunrise.

## Mediumwave

With the seasonal increase during the summer months in geomagnetic activity, mediumwave DX over the northern latitudes is severely attenuated. This can be a blessing for those trying to DX tropical AM broadcast stations and mid-latitude medium- and low-power stations, since the interference from strong over-the-pole stations is reduced. Signals below 120 meters will improve, with longer hours of darkness and the decline of noise-



producing weather. Seasonal static, which makes it difficult to hear the weak DX signals, is decreasing little by little as we move away from the Autumnal Equinox. Stretch out those beverage antennas and start looking for signals along nighttime paths.

## VHF Conditions

The sporadic-E season is winding down at this time of year. There may be a few openings possible this month, but tropospheric ducting propagation is a real possibility. Look for signals on paths crossing through stalled high-pressure zones in the mid-west, or along cool, wet air masses. Tropospheric conditions are generally very good for many of the VHF bands during September with the appearance of different weather fronts. This will be the primary mode for working up to 300 miles.

Meteor shower activity will be slim. Toward the end of September transequatorial propagation will begin to occur between southern North America and northern South America. Openings will generally occur in the late afternoon to early evening.

## Current Cycle 23 Progress

The Royal Observatory of Belgium reports that the monthly mean observed sunspot number for May 2005 is 42.6, a large increase over April's 24.4. The lowest daily sunspot value recorded on May 21 was 13. The highest daily sunspot count was 82 on May 11. The 12-month running smoothed sunspot number centered on November 2004 is 35.4, not even a full point below October's 35.9. A smoothed sunspot count of 16, give or take about 12 points, is expected for September 2005. (You can see that the worst case translates to about a sunspot count of three. That's pretty low, since we're so close to the end of this current cycle.)

The Dominion Radio Astrophysical Observatory at Penticton, BC, Canada, reports a 10.7-centimeter observed monthly mean solar flux of 99.5 for May 2005, just shy of January's 102.4, and the highest since. The 12-month smoothed 10.7-centimeter flux centered on November 2004 is 101.5, barely down from October's 102.1. The predicted smoothed 10.7-centimeter solar flux for September 2005 is 77, give or take about

16 points (with the low possibly being 58, still enough to support propagation on many paths between diverse regions).

The observed monthly mean planetary A-Index (Ap) for May 2005 is 20, jumping up from March and April's 12. The 12-month smoothed Ap index centered on November 2004 is 14.1, just a little over a point higher than in October. Expect the overall geomagnetic activity to vary greatly between quiet to active during most days in September, with some isolated periods of stormy activity.

## I'd Like To Hear From You!

If there's something you'd like me to cover in an upcoming issue, please write me an e-mail or drop a letter to me. Is the propagation information I am presenting helpful?

I look forward to hearing from you. If you're interested in up-to-the-minute space weather, check out my website at <http://propagation.hfradio.org/> (cell phone users may browse <http://wap.hfradio.org/>). Happy hunting those signals!

**ADVANCED SPECIALTIES INC.**  
 Orders/Quotes 1-800-926-9HAM  
[www.advancedspecialties.net](http://www.advancedspecialties.net)

**NEW!** **BIG ONLINE CATALOG**

**UNIDEN BEARCAT DIGITAL SCANNERS • CB • AMATEUR • RADIOS & ACCESSORIES**

ALINCO • YAESU • GALAXY  
 • RANGER • COBRA

(201)-VHF-2067  
 114 Essex Street, Lodi, NJ 07644

Closed Sunday & Monday



**FREE SAMPLE COPY!**

**ANTIQUE RADIO CLASSIFIED**

*Antique Radio's Largest-Circulation Monthly Magazine*

Articles - Classifieds - Ads for Parts & Services  
 Also: Early TV, Ham Equip., Books, Telegraph, 40's & 50's Radios & more...

**Free 20-word ad each month. Don't miss out!**

**VISA** 1-Year: \$39.49 (\$57.95 by 1st Class) **MasterCard**  
 6-Month Trial - \$19.95. Foreign - Write.

A.R.C., P.O. Box 802-T14, Carlisle, MA 01741  
 Phone: (978) 371-0512; Fax: (978) 371-7129  
 Web: [www.antiqueradio.com](http://www.antiqueradio.com)

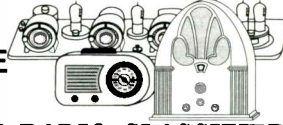

**ATOMIC TIME** 1010 Jorie Blvd. #332  
 Oak Brook, IL 60523

**Atomic Time 12" Modern Black**  
 918/3321.00 \$34.95

The black wall clock with arabic numerals is great for home or office use. This clock features the German made Hechinger radio-controlled movement.



**Atomic Time Analog Sport**

- < 065/1011 Black \$99.95
- < 065/1010 White \$99.95

German made atomic watch with readout for digital seconds. Can display any world time.



**Atomic Time Thermo-Calender**  
 < 306T21 \$29.95

This clock is able to display time in 12 hour or 24 hour format. It also shows the date, the day of the week, the temperature, and signal reception. Automatically adjusts for daylight saving.

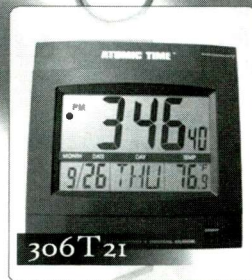

**Atomic Time Clock Radio ^ RCL-19 \$29.95**

AM/FM radio with dual alarms, temperature, and date display. Includes an AC adapter and an optional external antenna to help reception.



Tell time by the U.S. Atomic Clock - The official U.S. time that governs ship movements, radio stations, space flights, and warplanes. With small radio receivers hidden inside our timepieces, they automatically synchronize to the U.S. Atomic Clock (which measures each second of time as 9,192,631,770 vibrations of a cesium 133 atom in a vacuum) and give time which is accurate to 1 second every million years. Our timepieces even account automatically for daylight saving time, leap years, and leap seconds. \$7.95 Shipping & Handling. (Rush available at additional cost) Call M-F 9-5 CST for our free catalog.

**1-800-985-TIME**  
[www.atomictime.com](http://www.atomictime.com)

# Midland's 1001Z 40-Channel Mobile CB

Citizens Band. Just saying the words to *anyone*—general consumer or die-hard radio enthusiast—evokes a multitude of emotions and comments. Fact is, CB is alive and doing quite well. It's never going to replace cell phones, the Internet, or ham radio. But then again, *those* media aren't going to replace *CB*, at least not in our lifetimes! If you want to stay in touch with other drivers when traveling, or simply want good, reliable communications around town, CB could be for you.

Countless articles and books have been written on the subject over the years, but very simply, if you're a U.S. citizen you can use CB at home or in your vehicle. There is no license requirement, no test to take, and there are no airtime charges. The bottom line: For a minimal investment and a few minutes to "install" a CB (even temporarily) in your vehicle, you'll be rewarded with plenty of timesaving (and money-saving) travel information.

Midland has a lineup of six mobile CBs and two handheld models. Actually, one of those "handheld" models, the 822, available this fall, is a compact palm-sized CB that's more of a *mobile* radio, and we'll be reviewing it in the coming months. But for now, let's look at the 1001Z.

## Full-Featured, Yet Compact!

The 1001Z is just the right size CB for me. It weighs in at only 1 pound, 10 ounces and at 1 1/2 x 4 7/8 x 6 1/2 inches (HWD), it's a small radio, making it *much* easier to mount than some of the larger units on the market.

Since today's vehicles don't have those expansive metal dashboards that once allowed us to drill a couple of holes for a mounting bracket just about anywhere, if we want a radio in our vehicles we're usually limited in our mounting choices. I've mounted the 1001Z with some very heavy-duty hook-and-loop fastener. Is it the best mounting solution? Not by a long shot, *but* in my vehicle, there just isn't an option—also because I've reserved the small catch-all tray for my small ham radio. Everything has its place, and since I don't like to mess with what already works (Dad said if it works, leave it alone), the hook-and-loop is just fine if you use it correctly. The 1001Z does come with a very good quick-disconnect metal mounting bracket, but I didn't use it.

It's also important to know that you should never, ever, under any circumstances mount any radio on top of the dash: in a crash it becomes a lethal weapon. And if you're *going* to drill or cut into the plastic dash, be *absolutely* sure you're not going to puncture a cable or damage anything. Remember, that speedy drill bit has a way of going a little too far if you're not careful! I've also seen radios bungee-strapped to seats, consoles, and airbag covers. Don't do it.

The Midland 1001Z comes complete with a well-written manual, power cord (you've got to connect it to either a cigarette lighter plug or directly to your vehicle's battery), mounting bracket, and microphone. It's not rocket science to do the installation, just be sure to observe correct polarity when connecting the power cord to the vehicle. I found a fused cigarette lighter plug in my radio toolbox, soldered and taped the con-



Here's the Midland 1001Z mobile CB ready for mounting.

nection. As an added precaution, I also used heat-shrink tubing over the tape because after a while electrical tape gets sticky and sometimes falls apart.

Midland says the 1001Z has 4 watts of output "rated for maximum legal output power," a digital power meter that measures signal output strength, red TX (transmit) light, squelch control, CB/PA switch (for use with an optional public address speaker) and instant Channel 9 access.

Operation of this radio is a no-brainer. Connect the power cord, microphone, and CB antenna (magnetic-mount is my personal favorite), and you're in business. Adjust the squelch for what's pleasing to your ears. Open it up all the way and you'll



Mounted and ready to hit the road, the Midland 1001Z fits perfectly and is light enough to use heavy-duty hook-and-loop fastener.

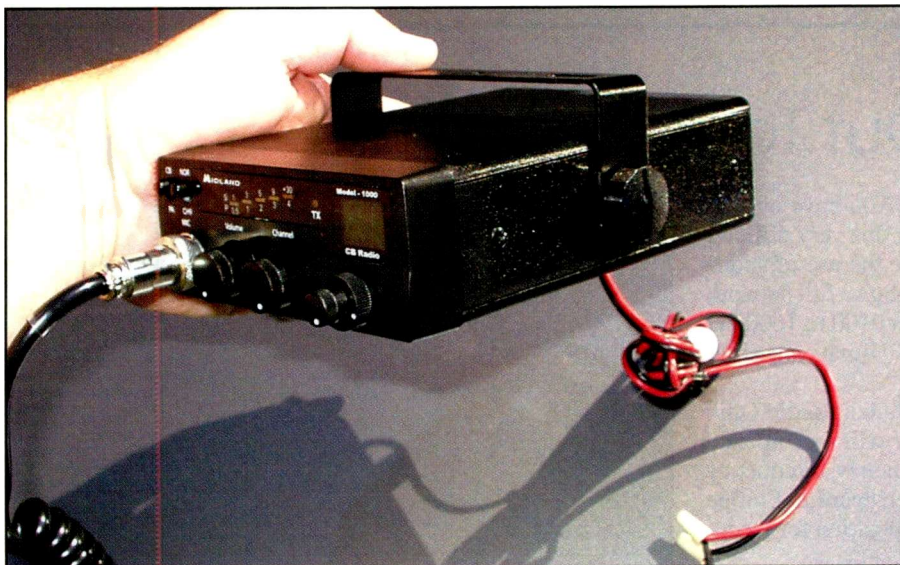

You can use the provided metal quick-disconnect bracket, but drilling holes in your vehicle might not be an option. Alternatively, I've seen mobile installations where folks have successfully rigged small cords around a small mounting bracket to mount a radio.

hear everything within range and a load of noise, or adjust it until the noise *just disappears* so only the stronger stations come through, then adjust the RF gain control for maximum signal. (On CB I keep the RF control at maximum; frankly, having an RF control on a mobile CB is unnecessary. It would be like having adjustable-size shoestrings on your shoes—there if you “need” it, but serving no real purpose, in my opinion.)

Power output of the Midland 1001Z is *actually* about 3.4 watts (I checked it out with my trusty MFJ wattmeter). The 4 watts most manufacturers tout is really meaningless; it's the measured output wattage that counts. By design they're all basically the same—full legal power output! For many years, companies said their CB power output was a “full 5 watts.”

Suffice it to say that whatever it measures with a meter, it's legal, very adequate for CBs intended local communications purpose, and frankly, you wouldn't know the difference between 3 watts and 10 watts anyway.

I made several contacts on Channel 19 during a recent trip to Rochester, New York using this Midland CB. For you beginners, in most areas, Channel 19 is where you'll find professional drivers (truckers) and other folks like you and me getting information on “bears” (cops with various forms of radar), accidents, and other road situations. Signal reports were all from nearby drivers on the Interstates, and they all said it was solid copy and good audio. Remember, you don't have to yell into the handheld microphone; just speak in a normal tone with the mic about

two or three inches from your mouth.

What I especially liked about the Midland 1001Z mobile was the receive audio. The loudness coming out of that bottom-mounted speaker sure lives up to Midland's “3-watt audio” advertised specs. You can also connect an in-vehicle (optional accessory) speaker and direct the audio where you want it. I've done this with my amateur gear and it makes a difference, especially in noisy environments. But you don't need to do it with the 1001Z; most of the time I kept the volume only cranked up about one-third of the way and it was plenty loud!

## Signal And Output Meters

The large channel readout on the Midland 1001Z is easy to read, even in bright sunlight. The “meter” is too, but like most meters on CB radios today, it's just one of those things that look pretty, but doesn't offer any real indication of signal strength. Well, it does, I *suppose*, in that the stronger the incoming signal the more lights light up. And, regarding output power, when you key the mic the colored lights extend all the way to the right, indicating full output power.

When I'm driving a vehicle, though, I don't bother with looking down at the radio's display or meter. If I can hear the other station, fine; if not, I try again in a minute or two to reach a station that's closer and stronger. My ears are my meter—if I can hear it, that's a good thing.

## It Gets A Solid Thumbs Up!

Unless you're looking for a CB with sideband, a larger, “classic” CB with lots of knobs and switches, or additional bells and whistles, you should consider the Midland 1001Z mobile CB. I've used it now for over two months with absolutely no problems.

The instant Channel 9 switch on the front panel, while an excellent feature, is seldom used in my vehicle (I'll listen to it periodically for activity, but am always on Channel 19). And the radio fits perfectly under the bottom left side of the dash without interfering with the steering wheel. It works for me, and it'll serve you well, too!

Midland's 1001Z 40-channel mobile CB has a three-year warranty and is \$44.95 direct from Midland's website at [www.midlandradio.com](http://www.midlandradio.com) or by contacting a Midland dealer. Please tell the folks at Midland that you read about the 1001Z in *Popular Communications*. ■

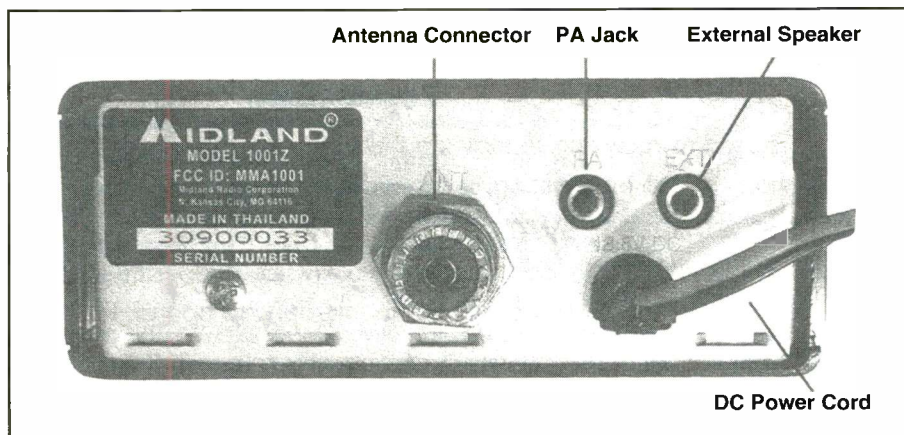

The rear of the 1001Z shows the power cord on the lower right, and simple, yet straight forward connections for your antenna, PA speaker, and external speaker.

## Time Running Out To Hear Bhutan

The clock is ticking for Radio Bhutan. You have only to the end of the year (at the most) to bag this very difficult catch. The station plans to discontinue the use of shortwave because the country is now covered through a full network of FM stations. Radio Bhutan uses **5035** from 0100 to 1600 but there have been few, if any, loggings of this Himalayan kingdom in North America.

Those elusive Coalition Maritime Radio (a.k.a. Radio One) broadcasts are now on **9133**, but apparently will—or already have—returned to their former **15500** frequency. Frequency 9133 is listed for 0300 to 1400, but it has been heard in Europe at 1700. Also in use is **6125**—an even worse position for reception in North America.

The Catholic Radio Network (CRN) in Vanimo, Papua New Guinea, seems to have finally taken to the air on **4960** with its “mighty” 1 kW. This will be best heard in the morning hours around dawn local time. Reception reports go to Wayne Wilson at [wwilsonteong.com](http://wwilsonteong.com).

Also from Papua New Guinea, the new Wontok Radio Light’s 1-kW signal is being heard more widely than initially expected. Check **7120** around your local dawn. The format includes some programming from HCJB, which is one of the partners in this venture.

Radio (TV) Estambul is a new one from Guayaramerin, Bolivia, now operating on **4498.1**. The address is Radiodifusora Estambul, Avenida Prinero de Mayo Esquina Loreto, Guayaramerin, Beni, Bolivia

The Gambia Democracy Project has launched a weekly half-hour program aimed at providing a source for news of Gambia other than the local media, which is under the control of the government (junta) there. The program will also include material from the Movement for the Restoration of Democracy in the Gambia as well as from other groups with similar interests. The initial schedule has them on **9405** from 2000 to 2030 via Julich.

Jamming by the Zimbabwe government has succeeded in forcing Short Wave Radio Africa off the high frequencies. Transmissions on shortwave ended the last day of May and are now conducted only on mediumwave as those signals seem to be getting through. Another factor in the decision was dwindling financial support. The overall future of the SWRA project is now in question.

Star Radio should be back on the air from Liberia by now. It was not well or widely heard in North America when it was last active some time ago. This new series of broadcasts will be aired through VT Merlin facilities, which should give us a better chance of hearing the station. So far, though, no frequencies or transmitter sites have been announced.

Another new religious broadcaster is the Trans World Broadcasting Ministry (not to be confused with Trans World Radio). TWBM airs over facilities of Taiwan’s Central Broadcasting System with programming in Mandarin. It’s on daily from 1300 to 1400 on slightly variable **11940**.

World Christian Broadcasting, which operates KNLS in Alaska, is currently expanding its efforts. They’ve begun construction of a new station in Madagascar. It will beam digital broadcasts in Mandarin, Russian, Chinese, English, and even-



*Rich D'Angelo received this attractive QSL from the China Huayi Broadcasting Company for reception on 4830kHz. (Thanks Rich D'Angelo, PA)*

tually even in Arabic. No target date for the new operation has been announced.

An old favorite from Russia is back on the air. Radio Station Tikhy Okean (Pacific Ocean) has been reactivated. Currently it's on **12065** from Vladivostok at 0835 to 0900.

Not only does the Vatican have problems with wayward priests, now the director of its radio station as well as a Vatican cardinal have been found guilty of “polluting” the atmosphere with Vatican Radio’s high-power broadcasts. Both were given 10-day suspended sentences and required to pay damages. The charges were based on a report from an Italian public health agency, which found abnormally high rates of leukemia in people who live near the station’s high-power shortwave site at Santa Maria da Galeria. Vatican Radio denies the accusations and plans to appeal. In an earlier trial, the judge ruled that Italian laws could not be applied to the Vatican since it is an independent state. The transmitter site, while separate from Vatican City, is considered a part of the Vatican. If this latest decision is upheld it could cost the Vatican hundreds of millions of dollars and would almost certainly mean a serious cutback in the radio broadcasts.

### Reader Logs

In last month’s loggings, Robert Brossell commented that WYFR seemed to be “everywhere.” We put our abacus to work the other day and tallied over 50 frequencies in use by WYFR during this current broadcast season! Even more surprising, WYFR is now broadcasting from over two dozen different sites worldwide, although most of the transmissions emanate from their home base in Okeechobee, Florida. So WYFR does at least seem to be everywhere. Chances are you’re going to come across them during a listening session, whether you want to or not!

Remember, your shortwave broadcast station logs are always welcome, but please be sure to double or triple space items, list them by country, and include your last name and state abbreviation after each log. Also much wanted are spare QSLs you don’t

## Help Wanted!

We believe the "Global Information Guide" consistently presents more short-wave broadcast loggings than any other monthly SW publication! (This month we processed 437\* loggings!) Why not join your fellow SWLs and let us know what you're hearing and become eligible for our monthly shortwave book prize as well! Send your logs to "Global Information Guide," *Popular Communications*, 25 Newbridge Rd., Hicksville NY 11801-2953. Or, e-mail them to Editor Harold Ort at popularcom@aol.com, or to your "Global Information Guide" columnist at gdex@genevaonline.com (please see column text for basic formatting tips.) So come join the party—we look forward to hearing from you!

*\*Not all logs get used; there are always a few which are obviously inaccurate, unclear, or lacking a time or frequency.*

need returned, station schedules, brochures, pennants, station photos, and anything else you think would be of interest. And how about sending a photo of you at your listening post? Step right up and get your 15 minutes of fame!

Here are this month's logs. All times are in UTC. Double capital letters are language abbreviations (SS = Spanish, RR = Russian, AA = Arabic, etc.). If no language is given, the broadcast is assumed to have been in English (EE).

**ALBANIA**—Radio Tirana, **6115** at 0343. (Brossell, WI) 0400 in Albanian. (Charlton,

## Abbreviations Used In This Month's Column

*	— (before or after a time) time the station came on or left the air	LSB	— lower sideband
(l)	— (after a frequency) lower sideband	LV	— La Voz, La Voix
(p)	— presumed	NBC	— National Broadcasting Corporation (Papua New Guinea)
(t)	— tentative	ORTB	— Office de Radiodiffusion et Television du Benin
(u)	— after a frequency (upper sideband)	PBS	— People's Broadcasting Station
v	— variable	PP	— Portuguese
//	— in parallel	PSA	— public service announcement
AA	— Arabic	QQ	— Quechua
ABC	— Australian Broadcasting Corporation	RCI	— Radio Canada International
AFN	— Armed Forces Network	Rdf.	— Radiodifusora, Radiodiffusion
AFRTS	— Armed Forces Radio TV Service	REE	— Radio Exterior de Espana
AIR	— All India Radio	RFA	— Radio Free Asia
Anmt(s)	— announcement(s)	RFE/RL	— Radio Free Europe/Radio liberty
Anncr	— announcer	RNZI	— Radio New Zealand International
AWR	— Adventist World Radio	RR	— Russian
BSKSA	— Broadcasting Service of Kingdom of Saudi Arabia	RRI	— Radio Republik Indonesia
CC	— Chinese	RTBF	— RTV Belge de la Communate Françoise
Co-chan	— co-channel (same frequency)	Relay	— transmitter site owned/operated by the broadcaster or privately operated f or that broadcaster
Comml(s)	— commercial(s)	relay	— transmitter site not owned by the broadcaster
CP	— Bolivia, Bolivian	SCI	— Song of the Coconut Islands (transition melody used by Indonesian stations)
CRI	— China Radio International	s/off	— sign off
DD	— Dutch	s/on	— sign on
DJ	— disc jockey	SIBC	— Solomon Is. Broadcasting corp.
DW	— Deutsche Welle/Voice of Germany	Sked	— schedule
EE	— English	SLBC	— Sri Lanka Broadcasting Corporation
ECNA	— East Coast of North America	SS	— Spanish
f/by	— followed by	TC	— time check
FEBA	— Far East Broadcasting Association	TOH	— top of the hour
FEBC	— Far East Broadcasting Company	TT	— Turkish
FF	— French	TWR	— Trans World Radio
GBC	— Ghana Broadcasting Corp	Unid	— unidentified
GG	— German	USB	— upper sideband
GMT	— Greenwich Mean Time	UTC	— Coordinated Universal Time (as GMT)
HH	— Hebrew, Hungarian, Hindi	UTE, ute	— utility station
HOA	— Horn of Africa	Vern	— vernacular (local) language
ID	— station identification	(via)	— same as "relay"
II	— Italian, Indonesian	VOAS	— Voice of America
Int	— international	VOIRI	— Voice of Islamic Republic of Iran
IRRS	— Italian Radio Relay Service	WCNA	— West Coast of North America
IS	— interval signal	ZBC	— Zimbabwe Broadcasting Corporation
JJ	— Japanese		
KK	— Korean		



*A bird's s-eye-view of the VOA Relay station at Pinheira, Sao Tome, is featured on some current VOA QSLs. (Thanks D'Angelo, PA)*

ON) 2326 in unid language. (Wood, TN) 0252. Also 7120 to Western Europe at 2140. (DeGennaro, NY)

**ANGOLA**—Radio Nacional, 4950 in PP monitored at 2310. (DeGennaro, NY)

**ANGUILLA**—Caribbean Beacon, 6090 with U.S. country at 0308. (DeGennaro, NY)

**ARGENTINA**—Radio Nacional, 6060 in SS at 0015. (Charlton, ON) 15345 in SS with live sports at 0202. (Jeffery, NY) RAE, 11710 in SS to North Africa and Europe in SS at 2248. (DeGennaro, NY) 2339. (Charlton, ON)

**ASCENSION IS.**—BBC Relay, 15400 at 1730. (Paradis, ME) 2032. (Charlton, ON) 2225. (MacKenzie, CA) 21470 heard at 1826. (Jeffery, NY)

**AUSTRALIA**—Radio Australia, 6020 in Pidgin/EE with news at 0941, 9475 at 1148, 9560 to East Asia and Pacific at 1155, 9580 to Pacific at 1000, 9710 in Pidgin/EE at 1025, 11880 to SE Asia at 1006 and 13630 in EE to Pacific and East Asia at 2348. (DeGennaro, NY) 9580 to Asia and Pacific at 1345. (Charlton, ON) 11740 with news at 1405. Also 12010 in CC at 1348. (Brossell, WI) 15240 at 0345 and 15515 at 2255 to 2300 close. (MacKenzie, CA) Voice Int., 13635 heard at 1710 with music, possible ID, this day in history feature, request for feedback and religious feature. (Burrow, WA)

**AUSTRIA**—Radio Austria Int., 9870 in GG at 0100. (Linonis, PA) 0057 ending broadcast to North America with ID in various languages. Also 13730 in GG to Europe at 1313. (DeGennaro, NY) 1339 with operatic vocals. (Wood, TN) 13775 at 1557 with waltz, IS and ID. (Charlton, ON)

**BELARUS**—Radio Minsk, 7210 in unid language at 0215. (Maxant, WV)

**BELGIUM**—RTBF, 9970 at 1950 with live sports in FF. (Brossell, WI) 17570 via Germany in FF to Central Africa heard at 1700. (DeGennaro, NY)

**BOLIVIA**—Radio Santa Cruz, Santa Cruz, 6134.8 in SS/QQ at 0948. (DeGennaro, NY) Radio Mosoj Chaski, Cochabamba, 3310 at 0125 in QQ with Andean music, rustic vocals. ID at 0200 and off at 0202. (Alexander, PA) Radio San Miguel, Riberalta, 4900.4 at 0120 with mostly constant SS talk to 0205 sign off. (Alexander, PA) Radio Minería, Oruro, 5926.8v at 2355 with clear "Radio Minería" ID. Ran to 0100. Previous two sign off times were 0003 and 0004. Are they on later on Sundays? (Wilkner, FL)

**BOTSWANA**—VOA Relay, 12080 in unid language at 2036 and 17895 in EE at 1619. (Charlton, ON)

**BRAZIL**—(Note: All in PP) Radio Difusora Acreana, Rio Branco, 4885 at 0144. (D'Angelo, PA) Radio Pioneira, Teresina, 5015 with religious message at 0902. (DeGennaro, NY) Radio Itatiaia, Belo Horizonte, 5910 with music at 0910. (DeGennaro, NY) Radio Rural, Santarem, 4765 at 0923. (DeGennaro, NY) Radio Brazil Central, Goiania, 11815 with religious program at 2354. (DeGennaro, NY)

Radio Difusora Roraima, Boa Vista, 4875 at 0223. (DeGennaro, NY) Radio Difusora, Londrina, 4815 at 0836. (DeGennaro, NY) Radio Difusora, Taubate, 4924.5 with religious talks at 0157. (DeGennaro, NY) Radio Cancao Nova, Cachoeira Paulista, 4825 with religious message at 0841, 6105 at 0805 and 9675 at 0036. (DeGennaro, NY) Radio Gaucha, Porto Alegre, 6020 with religion at 0754. (DeGennaro, NY) Radio Universo/Radio Tupi, 6060 with preacher at 0924. (DeGennaro, NY) Radio Cultura, Sao Paulo, 9615 at 0825. (DeGennaro, NY) Radio Anhanguera, Goiania, 4915 at 0847. (DeGennaro, NY) Radio Difusora, Pocos de Caldas, 4945 with local anmts and commls at 0731. (DeGennaro, NY) Radio Bandeirantes, Sao Paulo, 9645 with talks, anmts, commls at 2251. (DeGennaro, NY) Radio Marumby, Florinapolis, 9665 with news. ID at 2301. (DeGennaro, NY) Radio Brazil Central, Goiania, 4985 with music at 0856. (DeGennaro, NY) Radio Clube do Para, Belem, 4885 with music, anmts and time checks at 0948. (DeGennaro, NY) Radio Aparecida, Aparecida, 6135 with music and anmts at 0916. (DeGennaro, NY) Radio Clube Paranaense, Curitiba, 6040 with hymns at 0925. (DeGennaro, NY) Radio Guaruja Paulista, Presidente Prudente, 5045 with music at 0850. (DeGennaro, NY) Radio Congonhas, Congonhas, 4775 with music, preacher at 0905. (DeGennaro, NY) Radio Educacao Rural, Coari, 5035 with music at 0854. (DeGennaro, NY) Radio Educacao Rural, Campo Grande, 4755 at 0909 with music and religious messages. (DeGennaro, NY) Radio Nacional, Macapa, 4915 at 0133 with religious messages. (DeGennaro, NY) 0242 with talk by woman, music. (Jeffery, NY) Radio Nacional Amazonia, 6185 at 2348 and 11780 at 0007. (DeGennaro, NY) 2344. (Charlton, ON)

**BULGARIA**—7400/9700 in BB at 0128. (Charlton, ON) 9700//11700 at 0055. (Brock, PA) 9700 in BB at 0038, 11700 in BB at 1200, 13600 in RR at 2324 and 17500 in SS at 1656. (DeGennaro, NY) 11500 at 1730. (Paradis, ME) 2307 in SS. (Brossell, WI)

**BURKINA FASO**—Radio TV Burkina, 5030 at 2215 in unid language with music, bells and drums. (DeGennaro, NY) 2340 with a variety of Afro-pops, FF ballads and anmts. Off with national anthem at 2359. (Alexander, PA)

**CANADA**—Radio Canada Int., 5840 at 0230 via Sweden in AA to the Middle East. ID and opening in FF at 0230. 9390 via Sweden in FF at 2251, 11755 via Ascension in FF at 2258, 11825 in SS at 2314 and 15255 via UK at 1850. (DeGennaro, NY) 12035 via Japan with mailbag program at 2244. (Foss, Philippines) 13655 at 1220. (Northrup, MO) 15255 via UK at 1849. Signed off at 1858. (Jeffery, NY) CKZU, Vancouver (p) 6160 at 0945 with CBC and Voice of Russia programs. (Barton, AZ)

**CHILE**—Voz Cristiana, 5995 in SS at 0959 and 17680 in SS at 2032. (DeGennaro, NY) 2043 with music. (Charlton, ON) 21500 in SS at 2130. Not parallel to 17680. (Barton, AZ)

**CHINA**—China Radio Int., 6040 via Canada in EE at 1020, 7200 from Urumqi in FF at 2135, 7210-Beijing at 2200 sign on, 7285 at 2154 with "Real Time Beijing," 9640-Urumqi in SS at 2243, 9745 via Bonaire at 0035, 11660-Kashi in FF at 2132, 11975 via Mali in CC at 2340, 13650 via Cuba in PP at 2318 and 17490-Kashi at 1652. (DeGennaro, NY) 11640 via Mali in an African language at 1942. (Brossell, WI) 13740 via Cuba at 1500. (Paradis, ME) Voice of Pujiang, 9705 in CC at 1333. (Brossell, WI) CNR/CPBS, 7275 in CC at 1000. (Barton, AZ) 9890 in CC at 1408. (Brossell, WI) 11670 in CC at 1029. (DeGennaro, NY) 15500 in CC at 2308. (MacKenzie, CA) China Music Jammer, 9455 at 1845, //9540 and 13625. (MacKenzie, CA) 12040 at 1350. (Brossell, WI)

**CLANDESTINES**—Voice of the Tigray Revolution, 5500 with IS at 0358 and presumed ID at 0359. (Brossell, WI) Democratic Voice of Burma, 9435 via Germany in BB at 0024. (DeGennaro, NY) Radio Rhino Int., 17870 via Germany at 1500 opening with talk about Uganda politics, ID at 1513. Off at 1530. (Alexander, PA) Voice of Biafra Int., 7380 via South Africa at 2059 sign on with ID, frequency anmt, local music, ID, religious music. News at 2111. Off at 2159. (Alexander, PA) Radio Sedaye-e-Iran, 11630 via Moldova, with Middle Eastern music and talks in presumed Farsi at 1340. (Brossell, WI) Radio Free Asia, 11540 via Tajikistan in Asian language at 1325 and 11590 via Armenia in unid Asian language at 1330. Also 15510 via UAE in CC



Here's a look at the BBC Far Eastern Relay Station at Kranji, Singapore on a QSL received by D'Angelo, Pennsylvania.

at 2017 (Brossell, WI) **13670** via Northern Marianas at 1815 in unid Asian language. (Linonis, PA). Voice of Oromo Liberation, **15670** via Germany in unid language with rapid-fire speaker at 1749. (DeGennaro, NY)

**COLOMBIA**—La Voz de su Conciencia, Loma Linda, **5910** in SS with music and religious messages at 0909. Also **6009.8** Puerto Lleras at 0938. (DeGennaro, NY) Radio Lider, Bogota, **6140** with int. news heard at 1005. (DeGennaro, NY)

**CROATIA**—Croatian Radio/Voice of Croatia, **7285/9925** via Germany with music and anmts in Croatian at 0207. **9925** via Germany in Croatian at 2341 and **13830** at 2126. (DeGennaro, NY)

**CUBA**—Radio Havana Cuba, **6000** at 0210. (Brock, PA) **11760** in SS at 1330 and **15235** in SS at 1215. (Northrup, MO) **15230** in SS at 2109. (DeGennaro, NY) Radio Reloj, **6060** in SS with ticking clock at 0745. (Barton, AZ) Radio Rebelde, **5025** in SS at 0932 and **11655** in SS at 1142. (DeGennaro, NY)

**CYPRUS**—BBC Relay, **9410** with news at 2005 and **11820** in AA at 1337. (Brossell, WI)

**CZECH REPUBLIC**—Radio Prague, **6200** at 0153 in Czech with religious choir. (Moser, IL) **6200/7345** with EE sign on at 0100. (Linonis, PA) 7345 with report on a music conference at 0209. (Charlton, ON) 7345 in Czech to South America at 0149, **9880** in GG at 1016, **11600** in Czech at 2117 and **11615** in EE at 1033. (DeGennaro, NY) 11600 in EE at 2136. (Burrow, WA)

**DJIBOUTI**—RTV Djibouti, **4780** at 0300 sign on with instrumental music, anmts in vernacular and Koran at 0302. (Alexander, PA)

**ECUADOR**—HCJB, **9745** in SS at 0015 and **15140** in SS at 1342. (Charlton, ON) **11920** in PP at 2344, **12020** in PP at 2336 and **12040** in GG at 2332. (DeGennaro, NY) 12040 in GG at 2258. (MacKenzie, CA) La Voz del Napo, Tena, **3279** in SS at 0340. (Brossell, WI) Radio Quito, **4919** in SS heard at 0850. (DeGennaro, NY)

**EGYPT**—Radio Cairo/Egyptian Radio, **7260** in EE at 0214, **12050** in AA at 1842. (Charlton, ON) 7260 at 0200 sign on. (Moser, IL) 7260 to North America at 0316, **9990** in EE to Europe at 2123, **11665** in AA at 2138, **11755** in AA at 2358, **11790** in PP at 2308, 12050 in AA at 2333 and **15335** in FF at 2106. (DeGennaro, NY) 9990 in EE at 2200. (Burrow, WA)

**ENGLAND**—BBC, **6110** in SS at 0039 and **21470** via Ascension at 1620. (Charlton, ON) **6195** via Antigua (probably Fr. Guiana now—*gld*) to Central America at 1005, **7165** in Dari at 0030, 9740 via Singapore at 1025, **15225** in RR at 1845, **15400** via Ascension at 1907 and **17830** also via Ascension at 2037. (DeGennaro, NY) **11835** at 0453. (Brock, PA) **15195** with “Caribbean Magazine” at 1225. (Northrup, MO)

**ETHIOPIA**—Radio Ethiopia, **7110** heard at 0328 with instl. music, ID and anmts in Amharic. News at 0330. //9704.2. (D'Angelo, PA) Radio Fana, **9640** at 0315 in Amharic with talk, ID, HOA vocals. (D'Angelo, PA)

**FINLAND**—YLE/Radio Finland, **9600** in RR to Eastern Europe with presumed news at 1006. (DeGennaro, NY)

**FRANCE**—Radio France Int., **11665** in SS at 0004, **15605** in EE at 1603 and **17620** in FF at 1615. (Charlton, ON) **11670** in RR at 1830. (Linonis, PA) **11705** in FF at 2134, **12025**-Irkutsk in CC at 0953 and **15530** in PP to West Africa at 1725. (DeGennaro, NY)

**GABON**—Africa No. One, **9580** in FF at 2205 and **15475** in FF at 1718. (DeGennaro, NY)

**GERMANY**—Deutsche Welle, **9545** in GG at 0028, **11690** via Canada in GG at 2338 and **17800** in EE at 1915. (Charlton, ON) **9900** via Irkutsk in GG to Asia at 1022, **13780** in GG to the Middle East at 1317 and **15425** in RR at 1715. (DeGennaro, NY) **15275** in GG at 1730. (Paradis, ME) **15515** via Chita, Russia, in CC at 2300. (MacKenzie, CA)

**GHANA**—GBC/Radio Ghana, **4915** at 2211 with ID, news, music. (DeGennaro, NY) 2248 with non-stop music, brief EE ID heard at 2300. (D'Angelo, PA)

**GREECE**—Voice of Greece, **5865** at 0233, **7475** at 0204, **9375** at 0017, **12105** at 2329, **15630** at 1927 and **17705** via Delano at 1705, all in Greek. (DeGennaro, NY) 5865 in Greek at 0336. (Brossell, WI) **7275** in Greek at 0135. (Moser, IL) **15485** via Delano in Greek at 1932. (Chandler, ON)

**GUAM**—Adventist World Radio, **9385** at 1729 with ID, Christian music/talk program. (Burrow, WA) **15320** opening in EE at 2230. (Barton, AZ) Trans World Radio, **12130** in CC at 1354. (Brossell, WI)

**GUATEMALA**—Radio Verdad, **4052.5** in SS at 0330. (Brossell, WI) Radio Buenas Nuevas (p) **4800** with non-stop music (mainly soft vocals) at 0220. Usually noted on **4799.8**. (D'Angelo, PA)

**HAWAII**—World Harvest Radio/KWHR, **9930** with Jack Van Impe crusades at 1301. (Brossell, WI)

**ICELAND**—INBS/Ríkisvartpid, **12115** with two men talking in II to close at 2326. (DeGennaro, NY) AFN/AFRTS, **7590 USB** with news at 0209 and **9980 USB** at 0122. (DeGennaro, NY)

**INDIA**—All India Radio, **6165**-Delhi in HH at 1313, **9425**-Bangalore with string inst at 1324, **9470** in presumed Hindi at 1225 and **11585**-Delhi in HH at 1327. (Brossell, WI) 9425-Bangalore in HH at 0012, **9705**-Panaji (Goa) in EE to 0045 sign off, **9910**-Aligarh in EE at 2337, **10330**-Bangalore in HH at 0102, **11620**-Delhi in EE at 1138 and **13710**-Bangalore in EE at 1338. (DeGennaro, NY) **7410**-Delhi in EE at 1902. (Foss, Philippines) 11620-Delhi in EE at 0005. (Maxant-WV) **13605**-Bangalore in EE at 1800. (Charlton, ON) **15075**-Bangalore in unid language heard at 0210 with IS, talk by woman. (Jeffery, NY)

**INDONESIA**—RRI-Serui (Papua), **4605** in II at 1154 with up-tempo music. (Foss, Philippines) RRI-Jambi (Sumatera), **4925** in II with flutes, hand drums, strings at 1207. (Foss, Philippines) RRI-Ternate (Maluku), **3345** in presumed II at 1034. (Foss, Philippines) Voice of Indonesia, **9525** in II at 1329. (Brossell, WI) 2028 with talks, Western pops. Presumed news at 2040. (Burrow, WA)

**IRAN**—VOIRI, **9635//11650** in EE at 1530 with ID, anthem and sked. Also **9800/9925//11860** in EE at 1933. (Burrow, WA) **9650** in SS at 2036, **9905** in SS at 0117, **9935** in AA at 2346 and **15085** in FF at 1836. (DeGennaro, NY) **9855** in AA at 2047. (Chandler, ON) **9860** in Farsi at 0408. (Brossell, WI) Voice of Justice (VOIRI), **9495** at 0147 with EE IDs, sign off anmts at 0225 with sked, address, light instl music, //11875. Cuba not on 11875 on this occasion (Alexander, PA) 0211 in EE. Off at 0229. (Jeffery, NY)

**ISRAEL**—Kol Israel, **9345** in HH at 0020, **11585** in HH at 2114, **15615** in EE to 1925 sign off and **15640** in FF at 1930. (DeGennaro, NY) **7545** in HH at 0418. (Brossell, WI) **11585** in HH at 1850 and **11650** in HH at 1952. (Chandler, ON) 15640 in EE at 1731. (Burrow, WA) Galei Zahal, **6973** in HH at 2234 with US-style rock. (DeGennaro, NY)

**ITALY**—RAI, **9840** in II at 2323, **11800** in II at 0001, **11920** via Singapore in II at 1000 and **15380** in II to 1905 close. (DeGennaro, NY) 11800 in II at 0124 and **17780** in II at 1618. (Chandler, ON) **11895** in II to 2229 close. (Foss, Philippines) 17780 in II at 1400. (Paradis, ME) 1423 in II. (Moser, IL)

**JAPAN**—Radio Japan/NHK, **5960** via Canada in JJ at 0245, **6120**

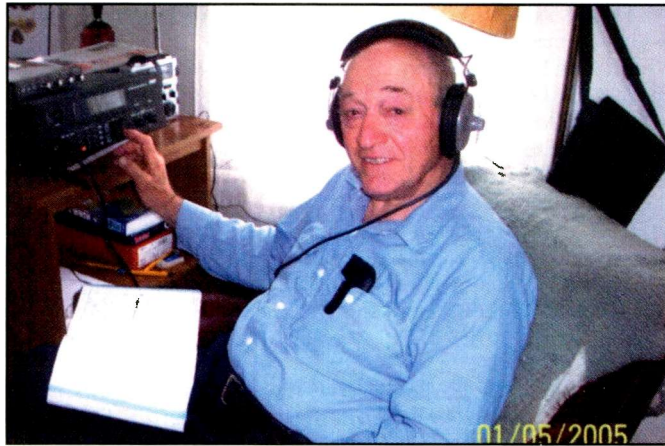

*And now for something completely different: an honest-to-goodness shack photo! It's none other than super reporter **Ciro DeGennaro** at his trusty **Drake R8** receiver.*

via Canada in EE at 1014, **9530** via French Guiana at 0955, **9540** in JJ at 0956, **9650** via UAE in JJ at 2213, **9710** in SS at 1006 and **11740** via Singapore in Burmese at 1048. (DeGennaro, NY) **6145** via Canada in EE at 0008, 9560 in EE at 0200 and **21630** via Ascension in JJ at 1621. (Chandler, ON) **11730** closing at 1600 and **13670** closing at 0700. (Barton, AZ) **11895** via French Guiana at 2227, **17825** in JJ at 2238, **21610** closing at 0359 and **21670** via French Guiana at 2140. (MacKenzie, CA) **15220** via Ascension in JJ at 2222. (Jeffery, NY) 21600 via French Guiana in JJ from 1700-1830. (Linonis, PA)

**JORDAN**—Radio Jordan, **9830** in AA at 2042, **11690** in EE at 1507 with old Western pops, "Radio Jordan—96.3 FM" ID. (Burrow, WA), **11810** in AA at 1403. (Brossell, WI) **15485** in AA at 2108. (DeGennaro, NY)

**KUWAIT**—Radio Kuwait, **9855** in AA at 2329, **15495** in AA at 1914 and **15505** in AA at 1917. (DeGennaro, NY) 9855 in AA at 1952. (Brossell, WI) 2348. (Charlton, ON) **11675** in AA at 0300-0330. (Linonis, PA)

**LIBYA**—(all frequencies via France) Radio Jamahiriya, **11635** in AA at 2008. (Chandler, ON) **15205** in AA at 1833 and **15660** in EE to 1738, then into FF. (DeGennaro, NY)

**LITHUANIA**—Radio Vilnius, **7345** in EE at 0145. (Chandler, ON) **9875** with news at 2329, **11690** in LL at 0009. (DeGennaro, NY) 11690 in EE at 0030. (Linonis, PA)

**MADAGASCAR**—Radio Nationale Malagasy, **5010** at 0316 with local vocal, talk in Malagasy. (D'Angelo, PA) Radio Nederland Relay, **12080** at 1400. (Brossell, WI)

**MALAYSIA**—Radio Malaysia, **5965** with Koran monitored at 1230. (Barton, AZ)

**MAURITANIA**—Radio Mauritanie, **4845** in AA at 2220. (DeGennaro, NY) 2245 with Koran. (Linonis, PA)

**MALI**—RTV Malienne, **4783** in FF at 2357, ID, military march and sign off. (DeGennaro, NY)

**MEXICO**—Radio Transcontinental, **4810** with ID and SS songs at 1215. (Brossell, WI) Radio Educacion, **6185** with ballads from the '30s and '40s at 1009. (DeGennaro, NY)

**MOLDOVA**—Voice of Russia relay, **9665** at 0111 in SS to South America. (DeGennaro, NY)

**MONACO**—Radio Monte Carlo, **6040** via Canada in AA at 0302. (DeGennaro, NY)

**MONGOLIA**—Voice of Mongolia, **12085** with pop/rock at 1010. (Foss, Philippines)

**MOROCCO**—RTV Marocaine, **5980** with radio drama in AA at 0336 and **15345** in AA at 2103. (DeGennaro, NY) 15345 in AA at 1811. (Chandler, ON) Radio Medi Un, **9575** in AA at 2331. (Wood, TN) 2337. (DeGennaro, NY) VOA Relay, **15230** at 2027. (Chandler, ON) **15235** in unid language at 1839. (Jeffery, NY)

**NETHERLANDS**—Radio Nederland, **9895** in DD at 1132. (DeGennaro, NY)

**NETHERLANDS ANTILLES**—Radio Nederland Bonaire Relay, **6165** at 0455. (Brock, PA) **9845** in EE at 0010, **17810** in EE at 1935. (Chandler, ON) **11675** at 1200. (Linonis, PA) 17810 at 2034. (DeGennaro, NY)

**NEW ZEALAND**—Radio New Zealand Int., **6095** with news at 1305. (Brossell, WI) **9870** with sports show at 1347. Also **15265** at 2020. (Chandler, ON) **9885** at 1018. (DeGennaro, NY) **11820** with current events at 0515. (Barton, AZ) **15720** at 2345. (Burrow, WA) 0100 with news and music program. (Paradis, ME) 0158 with time and frequency info and into news. (Jeffery, NY)

**NORTH KOREA**—Voice of Korea, **9335** ending EE at 1357, then IS until 1400 and opening in FF. (Brossell, WI) 1520 on "revolution and construction." (Burrow, WA) **11710** in EE at 1046. (DeGennaro, NY) **11735** in EE at 0115. (Linonis, PA) Hamgyong Broadcast Station, **3220** in KK monitored at 1721. (Foss, Philippines)

**NORTHERN MARIANAS**—VOA Relay, **9355** in CC at 1405 and **11995** in CC at 1345. (Brossell, WI)

**PAKISTAN**—Radio Pakistan, **11570** at 1559 with unmistakable IS, indistinct ID and into news at 1600. (Burrow, WA)

**PALU**—KHBN-Voice of Hope, **9965** with talks in CC at 1305. (Brossell, WI)

**PARAGUAY**—Radio Nacional, **9737** at 0023 in SS with Paraguayan harp music. (DeGennaro, NY) 0302 with news in SS f/by lively Latin vocals. QRM from DW on 9735. (D'Angelo, PA) **9738v** at 2339 with several mentions of Paraguay and Asuncion, lively LA music. Three pips and ID at 2359. (Wood, TN)

**PERU**—Radio Sicuani (t) Sicuani, **4826.5** with Andean music at 0230, SS talk and religious recitations. (Alexander, PA) Radio San Andres, **5544.7** at 0240 with OA music, ID, SS talk. Off at 0321. (Alexander, PA) Radio Altura, Piura, **5014.5** at 0220 with SS talk, ID, promos, ad string, OA music and SS pops. (Alexander, PA) Radio Andina, Huancayo, **4995.6** at 0237 with OA vocals, man and woman in SS talk, ID, anmts. Off at 0306. (D'Angelo, PA) Radio Cultural Amuata, Ayacucho, **4955** at 0218 with religious sermon in QQ f/by seeming close down anmts and SS ID by man and woman. Off at 0227 with no anthem. (D'Angelo, PA)

**PHILIPPINES**—FEBC, **9405** in CC at 1323. (Brossell, WI) **9435** at 2230 sign on in presumed Tagalog. (Linonis, PA) VOA Relay, **17740** at 2246. (MacKenzie, CA) Radio Philipinas, **15190** at 1853 with interview in Tagalog and female host. (Foss, Philippines)

**PIRATES**—NOAA Relay, **6925 USB** at 0030 carrying NOAA weather followed by "It must be the government controlling the weather." And then off. (Hassig, IL) American World Break, a.k.a. AWB R, **6925 USB** at 0004. Apparently a new station with long talk by man on how immigrants are running the country. Off at 0022 with no address given. (Zeller, OH) Derby Shortwave Radio, **6925 USB** at 0152-0206, 0254-0309 and 0333-0347. New station with a sports format. Sign on with the "call to post" bugle from a horse race, replayed the announcers call from the Kentucky Derby and a couple of banjo vocals of "My Old Kentucky Home." All three broadcasts were on the same evening. (Zeller, OH) WMPR (?), **6955.2** at 0155 with what seemed music from the movie *Koyanisqatsi*, then dance music. No ID given. (Hassig, IL) WHYP, **6925 USB** at 0207 but hard to copy. Some rock, mention of marijuana, several normal WHYP sound clips. Two clear IDs at 0226 sign off. (Zeller, OH) Ground Zero Radio, **6925.2** at 0110 with hard rock. QSL via Elkhorn, NE. (Hassig, IL) WHGW, **6925 USB** at 2150 with rebroadcast of CBS Radio Theater. Also at 2212 with a digital mode test. CW ID and an old time radio drama. Also at 0153 with a "Radio Mystery Theater" hosted by E.G. Marshall, then an ID for WSAO in San Antonio, commercial for Allstate, rock and some WHGW IDs. (Zeller, OH) 0125 with "CBS Mystery Theater." QSL via whgw6925@myway.com. (Hassig, IL) Radio Free Euphoria, **6925** at 0136 with rock, mentions of marijuana. Three or four definite IDs heard. (Zeller, OH) Grasscutter Radio/Sunshine Radio (joint broadcast) **6925 USB** at 0028 sign on with program of rock with multiple IDs by a man for Grasscutter and a young boy for Sunshine. Reports to grasscutterrado@yahoo.com. The transmitter "howls" at sign off. Grasscutter (alone) at 2004 sign on with soft rock, occasional IDs by a young boy and e-mail address (above) for reports. (Zeller, OH)





Iceland's Blue Lagoon, a geothermal spa, is pictured on an INBS QSL received by David Weronka, North Carolina.

Undercover Radio, **6925 USB** at 0313 with a drama discussion featuring Dr. Benway with William Burroughs also mentioned. Lost around 0340. Usual address of [undercoverradio@mail.com](mailto:undercoverradio@mail.com) for reports. (Zeller, OH) Voice of Laryngitis, **6925.3** at 0250 with a mix of old Laryngitis sketches and a few new touches. "Farty the Seal" did "Smoke on the Water" in his seal voice. Also parts of the "Pirate Busters" episode and some rock and other parodies. No address announced. (Zeller, OH) "The Crystal Ship," **6854** at 0314 various rock and punk things, ID at 0152 "You are tuned to the Crystal Ship and I am the Poet." Gave the Belfast, NY address. (Wood, TN) **6945** at 0050 with ad for "Big Lies Recovery Center" and rock. Belfast address or [tcsshortwave@yahoo.com](mailto:tcsshortwave@yahoo.com). (Hassig, IL) Radio Metalica World Wide relay, **6925** at 0001 with several IDs by Dr. Tornado as "RMWW" throughout but all mentioned **6955**. Also had a long discourse on pirate radio. (Zeller, OH)

**PORTUGAL**—RDP Int., **9715** heard at 0044, **11630** at 0000, **13660** at 2310 and **13700** to Brazil at 0008. (DeGennaro, NY) **11630** at 1945. (Brossell, WI) **15540** at 2012 and **17615** heard at 1614. (*All in PP—gld*)

**ROMANIA**—Radio Romania Int., **6135** in SS at 0345. (Brossell, WI) **7165** at 2151 to close at 2156, **11765** in FF at 1740 and **11940** in EE at 2345.

**RUSSIA**—Voice of Russia, **7125**-Moldova in RR at 0103, **7250**-Moscow at 0110, **7330**-Moscow in SS at 0143, **9725**-Armavir in RR at 0138, **9830**-Armavir in SS at 0047, **9880**-Armavir in RR at 0104, **12010**-Samara in PP at 2339 and **15455**-Armavir in FF at 1911. (DeGennaro, NY) **9830** in SS at 0016, **7125**-Moldova in SS at 0053 and **7180**-Moldova in SS at 0200. (Charlton, ON) **7250** with listener questions at 0130. (Moser, IL) **7370**-Yekaterinburg in RR at 1737. (Foss, Philippines) **9480**-Moscow in RR at 0204. (Jeffery, NY) **9665**-Moldova at 0110. (Brock, PA) **12055**-Chita with news at 1400. (Brossell, WI) Radio Rossii, **13665** in RR at 1305. (DeGennaro, NY)

**RWANDA**—Deutsche Welle Relay, **9545** at 0411. (Brossell, WI) **9655** at 0000. (Linonis, PA) **15145** at 1609 and **15205** at 2105. (DeGennaro, NY) **17860** in GG at 2136. (Charlton, ON)

**SAUDI ARABIA**—BSKSA, **11820** in AA at 2006. (Chandler, ON) **15380** in AA at 1327. (DeGennaro, NY) **17875** with Holy Koran at 1430. (Paradis, ME)

**SERBIA-MONTENEGRO**—Int. Radio of Serbia-Montenegro, **7115** via Bosnia in SS at 0155 and **9580** in EE at 0008. (Charlton, ON) 0428 with IS, ID, frequencies and into Balkan news. (Burrow, WA) **9580** in EE at 0003 and **9680** in SS at 2305. (DeGennaro, NY)

**SINGAPORE**—Mediacorp Radio, **6150** heard at 1458 with Western pops, ID, promos, time pips and into news. (Burrow, WA)

**SLOVAKIA**—Radio Slovakia Int., **5930** in FF at 0222. (DeGennaro, NY) **9440** at 0125. (Moser, IL)

**SOUTH AFRICA**—Channel Africa, **3345** with African news at 0320. (Brossell, WI) 0334 with interview, vocal, ID at 0342.

(D'Angelo, PA) **7240** at 0534 with music, political speech, ID, address, music. (Burrow, WA) **15285** at 1730 on health issues. (Linonis, PA) **15285** at 1701 and **15295** at 2039. (Charlton, ON) Radio Sondergrense, **3320** in Afrikaans at 2301. (DeGennaro, NY) 0320. (Brossell, WI) Adventist World Radio, **15365** in FF at 2015. (Brossell, WI)

**SOUTH KOREA**—KBS World Radio, **9650** via Canada at 1203 and **15360** via UK at 1852. (DeGennaro, NY)

**SPAIN**—Radio Exterior de Espana, **6155** in FF at 2354, **7275** in SS at 2148, **11625** in SS at 2124, **15110** in SS at 2100, **17715** in SS at 1709 and **17850** via Costa Rica in SS at 2041. (DeGennaro, NY) **9595** with listener letters at 2230. (Linonis, PA) SS/EE lessons at 2050 and **17850** (*Costa Rica—gld*) in SS at 1618. (Charlton, ON) **15110** in SS at 2250. (MacKenzie, CA) **15175** in SS at 1200. (Northrup, MO)

**SURINAME**—Radio Apinte, **4990** in DD heard at 0858. (DeGennaro, NY)

**SYRIA**—Radio Damascus, **9330** at 2005 opening with sked, EE news programs. Barely audible under WBCQ. (Alexander, PA) **12085** in SS at 2329. (DeGennaro, NY) **13870** in unid language at 1600. (Paradis, ME)

**SWAZILAND**—Trans World Radio, **3240** at 0338 in an African dialect. (Brossell, WI) 0344 with IS, ID—"You are tuned to the international voice of Trans World Radio." Repeated several times while alternating with the IS until off at 0348. (D'Angelo, PA)

**SWEDEN**—Radio Sweden, **6010** via Canada with talk on Laplanders at 0254 and **15240** at 1257 sign off. (DeGennaro, NY) **11625** in AA at 2005 and **15240** in EE at 1337. (Charlton, ON) **15245** in Scandinavian language at 1220. (Northrup, MO)

**TAIWAN**—Radio Taiwan Int., **5950** via Florida with news at 0220. (Charlton, ON) **15600** via Florida with "Discover Taiwan" program at 2223. (Mackenzie, CA) WYFR, **9280** in CC at 1218. (Brossell, WI)

**TAKIKISTAN**—Tajik Radio, **4635** with local music monitored at 1627. (Foss, Philippines)

**THAILAND**—Radio Thailand, **9830** with news at 1405. (Foss, Philippines) **11585** with talks in Mandarin and "You can listen to our program in Mandarin again tomorrow at 1300 on this same frequency." (Brossell, WI) **11870** in TT to Australia at 1010. (DeGennaro, NY) **15155** in EE at 1340. (Charlton, ON)

**TURKEY**—Voice of Turkey, **6020** with news at 0402. (Brossell, WI) **6140** to North America at 0258, **7270** at 0322 and **9460** in TT to Europe and ECNA at 0020. (DeGennaro, NY) **15155** ending EE heard at 1355 and into Turkish. (Charlton, ON)

**TUNISIA**—RTV Tunisienne, **7225** in AA at 2141 and **9720** in AA at 2041. (DeGennaro, NY) **9720** in AA with live sports at 1957. (Brossell, WI) **12005** in AA at 1640. (Charlton, ON) **17735** in AA at 1415. (Paradis, ME) 1430. (Moser, IL)

**UKRAINE**—Radio Ukraine Int., **7440** with domestic news at 0007. (Burrow, WA) 0158 in Ukrainian to NA. (DeGennaro, NY)



It's the man himself, Marconi, featured on this RAI International QSL contributed by Robert Charlton, Ontario.

**UNITED ARAB EMIRATES**—Emirates Radio, Dubai, **15435** in AA to Europe at 1644. (DeGennaro, NY) **21605** in AA at 1700. (Charlton, ON) Deutsche Welle (via), **17660** in GG at 2046. (Charlton, ON) Adventist World Radio (via) **15225** with religious message at 1553. (Burrow, WA) **17595** in AA with Christian music at 1800. (Linonis, PA)

**USA**—AFN/AFRTS Key West, **5446.5 USB** at 0744 and **12133.5 USB** at 2334. (DeGennaro, NY)

**UZBEKISTAN**—Radio Tashkent, **11905** with EE to Europe at 2134. (DeGennaro, NY) **17775** with news at 1330. (Paradis, ME)

**VATICAN**—Vatican Radio, **6185** in Polish at 0247, **7305** in SS at 0139 and **15570** in EE to Africa at 1729. (DeGennaro, NY) **11625** in EE at 2000. (Charlton, ON) **12055** in unid language at 1345 and off at 1359. (Brossell, WI)

**VENEZUELA**—Radio Nacional, via Cuba **11760** in SS at 2301. (DeGennaro, NY) 2342 in SS and **13660** via Cuba in SS at 2008. (Charlton, ON) Radio Amazonas, Puerto Ayacucho, **4939.7** in SS at 0950. (DeGennaro, NY) 0220 to 0303 close in SS with talks, ID, anmts. Choral anthem at 0301. (D'Angelo, PA) 0255 to 0311 close. (Alexander, PA)

**VIETNAM**—Voice of Vietnam, **6175** via Canada in EE at 0030. (Linonis, PA) 0139 in VV. (Charlton, ON) 0240. (Brock, PA) **9725** (via Austria—gld) with news at 1700. (Paradis, ME) **9840** at 2339 with IDs as "Radio Voice of Vietnam" and "Voice of Vietnam Radio." (Burrow, WA) **12020** in VV at 2230. (Foss, Philippines)

**ZIMBABWE**—ZBC, **3306** in unid African dialect at 0318. (Brossell, WI)

Let's have a monster round of applause for the good folks who came through for us this time: William Hassig, Mt. Prospect, IL; George Zeller, Cleveland, OH; Joe Wood, Greenback, TN; Rich Brock, Bridgewater, PA; Dave Jeffery, Niagara Falls, NY; Rick Barton, Phoenix, AZ; Stewart MacKenzie, Huntington Beach, CA; Jack Linonis, Hermitage,

## This Month's Book Winner

To show our appreciation for your loggings and support of this column, each month we select one "Global Information Guide" contributor to receive a free book. Readers are invited to send in loggings, photos, copies of QSL cards, and monitoring room photos to me at *Popular Communications*, "Global Information Guide," 25 Newbridge Road, Hicksville, NY 11801, or by e-mail to popularcom@aol.com. The e-mail's subject line should indicate that it's for the "Global Information Guide" column. So come on, send your contribution in today!

**Jerry Strawman** is our book winner this month. He's due to receive a copy of the 2006 *Passport to World Band Radio*—hot off the presses from our friends at Universal Radio. Have you sampled their catalog yet? If not you're really missing something! Request your free copy by calling 614-866-4267, e-mailing dx@universal.com, or dropping a note to them at 6830 Americana Parkway, Reynoldsburg, OH 43068.

PA; Charles Maxant, Hinton, WV; Howard Moser, Lincolnshire, IL; Robert Charlton, Windsor, ON; Robert Brossell, Pewaukee, WI; Ray Paradis, Pittsfield, ME; Marty Foss, Guinayangan, Philippines; Rich D'Angelo, Wyomissing, PA; Mark Northrup, Gladstone, MO; Brian Alexander, Mechanicsburg, PA; Robert Wilkner, Margate, FL; Ciro DeGennaro, Feura Bush, NY; and Jerry Strawman, Des Moines, IA. Thanks to each one of you. And until next month—good listening! ■

# Popular Communications September Survey Questions

**I think it's OK for the government to restrict what we're allowed to monitor on a scanner.**

Yes .....1  
No .....2  
Not Sure .....3

**I became a ham operator so I could use a mobile radio that receives out-of-band frequencies without being concerned about any local law saying it's illegal to monitor those frequencies.**

Yes .....4  
No .....5

**I've been licensed for many years, but if I were new to the hobby I would become licensed for this reason.....6**

**I've been stopped by the police or detained because of my mobile radios/antennas.**

Yes .....7  
No .....8  
I was stopped, but cited for another infraction. ....9

**I don't use any radios in my vehicle because I'm concerned about being stopped by the police.**

Yes .....10  
No .....11

**A close friend of mine had his/her mobile equipment confiscated by the police.**

Yes .....12  
No .....13

**Regarding the above question, the local newspaper covered the story.**

Yes .....14  
No .....15

**I use stealth mobile antennas to avoid problems.**

Yes .....16  
No .....17  
I'm considering doing so .....18

# Radio Fun And Going Back In Time

**Q.** What is ELF? Are there pixies and fairies on the radio spectrum, too?

**A.** Not really. ELF stands for Extremely Low Frequencies, and they figure in a project the Navy has been working with since the 1960s. Originally called Project Sanguine, its purpose is to communicate with submerged submarines of the Trident and Fast Attack varieties, both British and American. It tells them to come to the surface to receive more detailed messages. The signals travel so slowly that ELF can't be practically used for much else. It works between 30 Hz and 300 Hz from stations in Clam Lake, Wisconsin, and near Republic, on the upper peninsula of Michigan. In tests conducted in 1982, a submerged sub picked up a signal at a depth of 400 feet. The system has been operational since 1989. When tuned to 76 Hz, the wavelength is 2.452 miles long. The antennas must be *14 miles long*, and it takes at least two per transmitter. There is some talk of closing the station, but details are hard to find. Anyone wishing to work at those frequencies had better see their Navy Recruiter. SWLing in that neighborhood could lead to repercussions.

**Q.** When was the first radio broadcast made in Russia?

**A.** At the time of the Soviet Revolution in 1917, radio was only available using Morse code. The Soviet government used a great deal of research time, money, and talent to bring about transmission of the human voice. Lenin himself made it a priority. In 1921, a news program called "Spoken Newspaper of the Russian Telegraph Agency," which wasn't a real catchy title, got the "news" and propaganda out to the folks who couldn't read. Since receivers were expensive and hard to find, loudspeakers were set up to let the public hear. Viewed mostly as a tool of social control, Lenin wanted radios everywhere. He said, "That way our country will lead a life of highest political awareness, constantly knowing the actions of the government and views of the people ..." In 1922, Moscow had the most powerful radio station in the world on mediumwave. In 1925, Moscow also had the world's most powerful shortwave broadcast station.

**Q.** When General Eisenhower was planning D-Day he delayed it for 24 hours in order to get better weather. How did

he know, given the limited state of meteorology at the time, that the weather would improve?

**A.** Norwegian Resistance radio operators were sending in weather reports at least once a day throughout most of the war. Their reports allowed meteorologists to see the weather change coming. The Norwegians also reported on ship movements, which is why so many German ships were sunk by the British after they visited or passed Norwegian ports.

**Q.** When were Blacks first trained for the Signal Corps?

**A.** In May 1918, *The Wireless Age* magazine reported that the Army was setting up a class of Negroes to be trained as signal operators in wireless telegraphy for the Signal Corps. The training was to take place in Richmond, Virginia. The graduates would form the 325th Field Signal Battalion (Colored). The designation looks strange to us today, but that was how such segregated units were distinguished. Admission was to be limited to those who had registered for the draft but had not yet been called up. The plan had the backing of the Secretary of War and was to be implemented by the Federal Board of Vocational Education, which trained draftees. It would be interesting to know if anything came of this idea. Does anyone know?

## Looking Back...

### Five Years Ago In Pop'Comm

It's still hot, despite the fact that most folks have cable or satellite TV in their homes. Yes, there are many of us who enjoy TV DXing, and William Eckberg's article cited many excellent examples of how anyone can get in on the action. Got noise? As we've said before, some things never change, but Gordon West, WB6NOA, helped us track and eliminate mobile radio hash in our radios in his article on page 20 of our September 2000 *Pop'Comm*. Alinco's new DJ-X2 multi-mode communications receiver covered 522 kHz to 1 GHz.

### Ten Years Ago In Pop'Comm

New from AOR was the company's AR3000A, a 400-channel memory wideband receiver, covering 100 kHz to 2036 MHz. And Optoelectronics' latest entry on the radio scene was its OptoScan535, billed as, "the next generation in computer controlled interface boards for the Radio Shack series of scanners," featuring computer control of Radio Shack's 2035 scanner. U.S. cordless phone users got new channels, but those old phones were still quite a handful—many with antennas that are as large as the *phones* today!

### Twenty Years Ago In Pop'Comm

New was Yaesu's FRG-8800 receiver, which we reviewed in September 1985, reporting, "...tested in the lab gave results that substantially exceeded the manufacturer's specifications." And new from Regency was the Z60 tabletop scanner, a programmable 60-channel, eight-band scanner that also had an alarm clock!

## Reader Trivia

Here's something special from reader Sparky Voltz on the origin of the radio term, "73":

We "Old Timers" enjoy a look back at the dusty memories of earlier radio days. I've been a ham for over 35 years and a CBer longer than that. The "best regards" radio synonym "73" has been long in my standard sign-offs in both services.

I'd like to add to your historical assessment of the origin of "73." In Morse code, the combined numbers of 7 and 3 have a particular rhythm that sound very close to the word "best." It is my understanding that the phrase "best regards" was assigned the number 73 because of that similarity.

Here's more radio fun: Tap out or listen to "Ben's best bent wire" in Morse Code at 30-plus words per minute and see if you hear the almost drum-like "beat" to the phrase. It has a groove all its own, dig? (Yeah, Daddy-o, I'm a musician, too. Maybe that explains my love for working CW on the ham bands.)

# Portable Mobile Mappers Go All U.S.A.

As the price of portable GPS (Global Positioning System) mobile mappers comes down, more and more people are recognizing their value—not just as an in-vehicle navigational aid, but also as a personal driving assistant. Besides being preloaded with maps to help you get from here to there, many units come standard with a multitude of features, including directions to popular destinations, from restaurants and parks to service stations, and even car repair facilities!

The term “portable mobile mapper” refers to a car navigation 12-volt receiver with GPS-based, street-level mapping, plus thousands of “point of interest” electronic signposts. The GPS receiver is built into the hockey-puck sized antenna unit, and it works great just sitting on the dashboard, providing mapping cartography so detailed it can get you down to dirt roads and long private driveways! The equipment simply plugs into your vehicle’s 12-volt lighter socket.

Although the latest brands of visually detailed, color portable navigation receivers represent only a three-year-old market, adding roads to the 15-year-old marine electronics equipment has been common practice with manufacturers like Garmin and Lowrance. With them, the embedded large roads are referred to as land-based maps, but it was only a matter of time before Lowrance and Garmin would address the opportunities of a sim-

ilar type of readout for vehicles, improving on the base map all the way down to close-in street detail. Garmin was there first, with Street Pilot and the monochrome small screen.

## Ham Radio And APRS

Ham radio operators quickly brought Garmin equipment aboard their vehicles, tied it into their Kenwood APRS (automatic position reporting system) D-7 and D-700 equipment, and used the NMEA (National Marine Electronics Association) data stream out of their Street Pilots and other Garmin equipment to squawk their locations to other ham operators. Using a terminal node controller with bidirectional data exchange, operators could see callsigns come up on their screens.

Then, about three years ago, the portable small-screen mapping manufacturers nearly simultaneously switched from monochrome to daylight-viewable color screens and enlarged the screen size to *five inches* and even larger. No laptop was necessary, thanks to proprietary land mapping cartridges that could hold up to three or four states of detailed roads and point-of-interest databases on a 256-MB cartridge.

Each portable mapping manufacturer had its own scheme of how users would get additional geographic downloads—for



The Garmin GPSMAP with its color daylight viewable screen.



The AVMap tied into a Kenwood D700.

instance, purchasing new areas on a provided CD-ROM by buying the unlock code, sending back their cards to have them rewritten for a new area of the country—but it was clear to the end-user buying the portable device that there had to be a better way to get all of the United States without bringing an extra CD and your laptop along with the proprietary interconnect cable. Manufacturers were quick to realize RVers wanted portable mapping with *all* of the United States included. Oh yes, all this for under \$999.

## New GPS Goodies

So last January, two new approaches to portable mapping devices emerged: color mappers for under \$650 that contained about a third of the United States on a card; and color portable mappers for \$999 that included all of the United States, either on a proprietary 1- or 2-GB proprietary compact flash card pre-loaded with the entire United States and Canada, or on an internal hard drive where 10 GB could be allocated to digital mapping and the remaining 10 GB on the hard drive could be used for digital music recordings!

Among the offerings are the Lowrance iWay 500. With this 20-GB internal hard drive, it was a "Best New Mobile Electronics Product Show" winner at the Specialty Equipment Market Association show and has been recently seen selling for under \$999. Dual Electronics, connected with Namsung America, has previewed Nav Atlas, which covers all of the United States on a 1-GB card that also contains several million points of interest. The Magellan Roadmate 700, (reviewed in last month's *Popular Communications*) produced by Thales, has also dropped to the

under-\$999 level and offers detailed maps of all of the United States. And the Garmin Street Pilot 2620 includes a pre-programmed hard drive that stores city navigator detailed maps of North America, with no need to do any loading of area cartographic detail. Same thing with the Street Pilot 2660, Garmin's latest offering, as that company also bows to the customer's demand for a plug-and-play, out-of-the-box unit with absolutely no need for downloading specific cartographic regions.

For larger RVs, Lowrance can also offer bigger color screen readouts, running on their 20-GB internal hard drive, with their new iWay 700 7-inch-diagonal big-screen, or their iWay 800 with a 10.4-inch-diagonal mega-screen. But for most vehicles, vans, and camper applications, the most popular screen is the color, thin-film-transistor, daylight-viewable, 5.2-inch display, with Cobra offering its new GPS M-3000 that includes all of North America at street level and two million points of interest within the database without any need for an upload.

Another popular ultra-thin, 5.2-inch, thin-film-transistor, direct-sunlight color display is from marine electronics mapping giant C-Map Company, AvMap Navigation Division, with their all-United States, all-Canada, Hawaii, Alaska, and Puerto Rico already-installed mapping database in the Geosat 2 AvMap car navigator. For under \$999, this device has the largest, brightest screen in its class—a 5.6-inch-diagonal, which is about 30 percent larger than most of the competition.

And most important to ham operators, the Geosat 2 Satellite has an output plug specifically for Kenwood D-7 and D-700 transceivers for the tie-in to APRS. The Geosat can also output to the Alinco equipment with the optional TNC, as well as ICOM equipment with the optional TNC, and to the popular Byonics Tiny

videos  
videos  
videos  
videos  
videos  
videos

**Getting Started in Ham Radio** – How to select equipment, antennas, bands, use repeater stations, grounding, basic soldering.

**Getting Started in VHF** – Intro to VHF. Repeater usage, packet, satellites and more exotic VHF op modes.

**Getting Started in DXing** – Top DXers share experiences with equipment, antennas, op skills and QSLing.

**Getting Started in Packet** – De-mystify packet. Info on making contacts, bulletin boards, networks, satellites.

**Getting Started in Amateur Satellites** – How ops set up stations. Locate and track ham satellites.

**Getting Started in Contesting** – Advice and op tips from Ken Wolf, K1EA, K1AR and others!

**Ham Radio Horizons** – Step-by-step instructions for the prospective ham on how to get involved.

~~\$19.95 each~~ – Now **\$12.95 Buy more and save!**

**Buy 2 or 3 for \$11.95 each**

**Buy 4 to 6 for \$10.95 each**

**Buy all 7 for your Club for only ~~\$99.95!!~~**

**Now \$69.95!!**



Name \_\_\_\_\_  
 Address \_\_\_\_\_  
 City \_\_\_\_\_  
 State \_\_\_\_\_ Zip \_\_\_\_\_

Qty \_\_\_\_\_  
 \_\_\_\_\_ Getting Started in Ham Radio  
 \_\_\_\_\_ Getting Started in VHF  
 \_\_\_\_\_ Getting Started in DXing  
 \_\_\_\_\_ Getting Started in Packet Radio  
 \_\_\_\_\_ Getting Started in Ham Satellites  
 \_\_\_\_\_ Getting Started in Contesting  
 \_\_\_\_\_ Ham Radio Horizons  
 Total Videos X \$ \_\_\_\_\_  
 = \$ \_\_\_\_\_  
 Shipping/ handling \$ \_\_\_\_\_  
 Total \$ \_\_\_\_\_

Shipping & Handling: US & Possessions: add \$3 for first video, \$1 for each additional. Buy all 7 - and get FREE S&H. Foreign: Charges calculated by order weight & destination and added to you credit card.

Credit Card No. \_\_\_\_\_ Expiration date \_\_\_\_\_  
 Method of payment  Check  Money Order  Visa  MasterCard  Discover  American Express

**CQ Communications, Inc., 25 Newbridge Rd., Hicksville, NY 11801/516-681-2922; Fax 516-681-2926**



Here's a route created from Los Angeles to Arizona.

Nearest City			
Name	TO	DST	TTG
CORONA	128°	3.91	--:--
GYP SUM	246°	4.27	--:--
<b>NORCO</b>	<b>071°</b>	<b>4.50</b>	<b>--:--</b>
PORPHYRY	111°	5.22	--:--
PEPPER CORNER	130°	5.53	--:--
BEEKS PLACE	188°	5.74	--:--
HOME GARDENS	106°	6.20	--:--
LOS SERRANOS	320°	6.24	--:--
HOME GARDENS	103°	6.46	--:--
LOS SERRANOS	317°	6.71	--:--
EL CERRITO	126°	7.26	--:--
EL CERRITO	128°	7.38	--:--
LA SIERRA	080°	7.47	--:--
MIRA LOMA	049°	7.65	--:--

Select the nearest city from the list and you'll instantly see the bearing to that city and distance.

Trak inexpensive radio controller designed to receive and broadcast position reports from the AvMap equipment.

### More Good News!

The AvMap Geosat car navigator is noise-free, with none of the birdies, whistles, and other noise that can sometimes get into high-frequency and VHF/UHF ham equipment in your mobile. Many of the other mapping devices I tested were quite noisy to a nearby receiver, but the Geosat has special shielding on the inside to minimize noise. It's also the only

device that has a plug specifically for outputting the NMEA data stream.

And the equipment is so portable that well-known radio guru Don Arnold, WD4FSY, was seen walking around the Dayton Hamvention with a Kenwood D-7 and the AvMap not only squawking his position from the flea market, but also tracing his every step so he could go back and find that really precious goody! All the while, Kenwood's Amateur Radio Product Manager, Phil Parton, plus a host of onlookers were spotting WD4FSY throughout the acres of swap meet area, even tracking his walking speed.

(Kenwood equipment, tied into the AvMap navigation system, is also plug and play at its best).

The AvMap 2-GB compact flash card is a plug-in replacement for its original card, which didn't give you all of the United States down to street level. Any ham operator with an original card, or hams looking for the equipment and NMEA splitter cable set between the Kenwood and AvMap can contact Don Arnold at donarnold@skytel.com or call him at 423-400-4500. The latest version of AvMap for ham operators is sold by all Ham Radio Outlet stores throughout the country and includes the new 2-GB proprietary compact flash card preloaded with the United States, Canada, Hawaii, Alaska, Puerto Rico, and Guam, along with the included point-of-interest data by Info USA. All AvMap cartography is from Tele Atlas, based in San Jose, California.

If you're into flying, check with Don Arnold about the aeronautical version of AvMap. And if you're planning on going to Europe, it's a five-second card swap-out for the European database. And if you want to plug into Kenwood equipment, Don Arnold can be your answer man for that, too!

### WASHINGTON BEAT (from page 16)

was released from custody May 17 on \$250,000 bond and reportedly placed under house arrest at his home in Bell, California, near Los Angeles. Gerritsen, 69, was arrested May 5 without incident following an FCC investigation, which alleged he "often transmits his pre-recorded political messages and real-time harassment and profanity for hours at a time, often making it impossible for licensed radio operators to use the public frequencies."

The ARRL reported that Gerritsen had been convicted five years ago of "interfering with police radio transmissions and sentenced to 38 months in prison. After his release, he applied for a Technician class license and was granted KG6IRO. The FCC promptly rescinded the grant when it learned of his earlier conviction, however."

With his May 17 release, Gerritsen is subject to monitored home detention, is prohibited from possessing or using radio equipment, and his home is subject to search.

### FCC Chairman Names New Enforcement Bureau Chief

Kris Anne Monteith is being appointed to succeed David H. Solomon as chief of the FCC's Enforcement Bureau. FCC Chairman Kevin Martin made the announcement. Monteith has served as deputy bureau chief for outreach and inter-governmental affairs in the Consumer and Governmental Affairs Bureau, where she oversaw the FCC's interaction with local, state, and tribal governments. She also was responsible for consumer outreach to inform the public on FCC rules, policies, programs, and plans. Solomon left the FCC for a position in a private-sector law firm. Monteith has been with the commission since 1997. ■

### It's The GPS Generation

The future for portable navigational receivers with the GPS built into the hockey-puck-sized antenna is bright—just as bright as the daylight-viewable cartography now covering all of the U.S.A. without any downloading required, all for under \$999. It's an exciting market, indeed, for street-level mapping across the country. ■

# Tap into secret Shortwave Signals

Turn mysterious signals into exciting text messages with the MFJ MultiReader™!

Plug this self-contained MFJ MultiReader™ into your shortwave receiver's earphone jack.

Then watch mysterious chirps, whistles and buzzing sounds of RTTY, ASCII, CW and AMTOR (FEC) turn into exciting text messages as they scroll across an easy-to-read LCD display.

You'll read interesting commercial, military, diplomatic, weather, aeronautical, maritime and amateur traffic . . .

## Eavesdrop on the World

Eavesdrop on the world's press agencies transmitting unedited late breaking news in English -- China News in Taiwan, Tanjung Press in Serbia, Iraqi News in Iraq -- all on RTTY.

Copy RTTY weather stations from Antarctica, Mali, Congo and many others. Listen to military RTTY passing traffic from Panama, Cyprus, Peru, Capetown, London and others. Listen to hams, diplomatic, research, commercial and maritime RTTY.

Listen to maritime users, diplomats and amateurs send and receive error-free messages using various forms of TOR (Telex-Over-Radio).

Monitor Morse code from hams, military, commercial, aeronautical, diplomatic, maritime

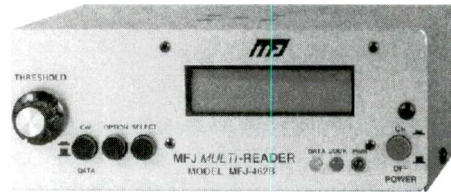

-- all over the world --  
Australia, Russia, Japan, etc.  
**Printer Monitors**  
**24 Hours a Day**  
MFJ-462B  
**\$179<sup>95</sup>**

MFJ's exclusive TelePrinterPort™ lets you monitor any station 24 hours a day by printing transmissions on an Epson compatible printer.

Printer cable, MFJ-5412, \$9.95.

## MFJ MessageSaver™

You can save several pages of text in an 8K of memory for re-reading or later review.

## High Performance Modem

MFJ's high performance PhaseLockLoop™ modem consistently gives you solid copy -- even with weak signals buried in noise. New threshold control minimizes noise interference --

greatly improves copy on CW and other modes.

## Easy to use, tune and read

It's easy to use -- just push a button to select modes and features from a menu.

It's easy to tune -- a precision tuning indicator makes tuning your receiver easy for best copy.

It's easy to read -- the 2 line 16 character LCD display with contrast adjustment is mounted on a brushed aluminum front panel for easy reading.

Copies most standard shifts and speeds. Has MFJ AutoTrak™ Morse code speed tracking.

Use 12 VDC or use 110 VAC with MFJ-1312B AC adapter, \$12.95. 5 1/4"Wx2 1/2"Hx5 1/4"D inches.

## No Matter What™ Warranty

You get MFJ's famous one year No Matter What™ limited warranty. That means we will repair or replace your MFJ MultiReader™ (at our option) no matter what for one full year.

## Try it for 30 Days

If you're not completely satisfied, simply return it within 30 days for a prompt and courteous refund (less shipping). Customer must retain dated proof-of-purchase direct from MFJ.

## Super Active Antenna

"World Radio TV Handbook" says MFJ-1024 is a "first-rate easy-to-operate active antenna...quiet...excellent dynamic range...good gain...low noise...broad frequency coverage." Mount it outdoors away from electrical noise for maximum signal, minimum noise. Covers 50 KHz-30 MHz.

Receives strong, clear signals from all over the world. 20 dB attenuator, gain control, ON LED.

Switch two receivers and auxiliary or active antenna. 6x3x5 in. Remote has 54" whip, 50 feet

coax. 3x2x4 inches. 12 VDC or 110 VAC with MFJ-1312, \$12.95.

## Indoor Active Antenna

Rival outside long wires with this tuned indoor active antenna. "World Radio TV Handbook" says MFJ-1020C is a "fine value...fair price...best offering to date...performs very well indeed."

Tuned circuitry minimizes intermod, improves selectivity, reduces noise outside tuned band. Use as a preselector with external antenna. Covers 0.3-30 MHz. Tune, Band, Gain, On/Off/Bypass Controls. Detachable telescoping whip. 5x2x6 in. Use 9 volt battery, 9-18 VDC or 110 VAC with MFJ-1312, \$12.95.

## Compact Active Antenna

Plug this compact MFJ all band active antenna into your receiver and you'll hear strong, clear signals from all over the world, 300 KHz to 200 MHz including low, medium, shortwave and VHF bands. Detachable 20" telescoping antenna. 9V battery or 110 VAC MFJ-1312B, \$12.95. 3 1/4"x1 1/4"x4 in.

## Eliminate power line noise!



MFJ-1026  
**\$179<sup>95</sup>**

Completely eliminate power line noise, lightning crashes and interference before they get into your receiver! Works on all modes -- SSB, AM, CW, FM, data -- and on all shortwave bands. Plugs between main external antenna and receiver. Built-in active antenna picks up power line noise and cancels undesirable noise from main antenna. Also makes excellent active antenna.

## MFJ Antenna Matcher

Matches your antenna to your receiver so you get maximum signal and minimum loss. MFJ-959C

Preamp with gain control boosts weak stations 10 times. 20 dB attenuator prevents overload. Select 2 antennas and 2 receivers. 1.6-30 MHz. 9x2x6 in. Use 9-18 VDC or 110 VAC with MFJ-1312, \$12.95.

## High-Gain Preselector

High-gain, high-Q receiver preselector covers 1.8-54 MHz. Boost weak signals 10 times with low noise dual gate MOSFET. Reject out-of-band signals and images with high-Q tuned circuits. Push buttons let you select 2 antennas and 2 receivers. Dual coax and phono connectors. Use 9-18 VDC or 110 VAC with MFJ-1312, \$12.95.

Dual Tunable Audio Filter

Two separately tunable filters let you peak desired signals and notch out interference at the same time. You can peak, notch, low or high pass signals to eliminate heterodynes and interference. Plugs between radio and speaker or phones. 10x2x6 inches.

MFJ-1045C  
**\$99<sup>95</sup>**

MFJ-752C  
**\$99<sup>95</sup>**

## MFJ Shortwave Headphones



MFJ-392B  
**\$19<sup>95</sup>**  
**New!**

Perfect for shortwave radio listening for all modes -- SSB, FM, AM, data and CW. Superb padded headband and ear cushioned design makes listening extremely comfortable as you listen to stations all over the world! High-performance driver unit reproduces enhanced communication sound. Weighs 8 ounces, 9 ft. cord. Handles 450 mW. Frequency response is 100-24,000 Hz.

## High-Q Passive Preselector

High-Q passive LC preselector boosts your favorite stations while rejecting images, intermod and phantom signals. 1.5-30 MHz. Preselector bypass and receiver grounded positions. Tiny 2x3x4 in.

## Super Passive Preselector

Improves any receiver! Suppresses strong out-of-band signals that cause intermod, blocking, cross modulation and phantom signals. Unique Hi-Q series tuned circuit adds super sharp front-end selectivity with excellent stopband attenuation and very low passband attenuation and very low passband loss. Air variable capacitor with vernier. 1.6-33 MHz.

## MFJ Shortwave Speaker

This MFJ ClearTone™ restores the broadcast quality sound of shortwave listening. Makes copying easier, enhances speech, improves intelligibility, reduces noise, static, hum. 3 in. speaker handles 8 Watts, 8 Ohm impedance. 6 foot cord.

MFJ-281  
**\$12<sup>95</sup>**

## MFJ All Band Doublet

102 ft. all band doublet covers .5 to 60 MHz. Super strong custom fiberglass center insulator provides stress relief for ladder line (100 ft.). Authentic glazed ceramic end insulators and heavy duty 14 gauge 7-strand copper wire.

## MFJ Antenna Switches

MFJ-1704  
**\$69<sup>95</sup>**

MFJ-1702C  
**\$24<sup>95</sup>**

MFJ-1704 heavy duty antenna switch lets you select 4 antennas or ground them for static and lightning protection. Unused antennas automatically grounded. Replaceable lightning surge protection. Good to 500 MHz. 60 dB isolation at 30 MHz. MFJ-1702C for 2 antennas.

## Morse Code Reader

Place this pocket-sized MFJ Morse Code Reader near your receiver's speaker. Then watch CW turn into solid text messages on LCD. Eavesdrop on Morse Code QSOs from hams all over the world!

## MFJ 24/12 Hour Station Clock

MFJ-108B, \$19.95. Dual 24/12 hour clock. Read UTC/local time at-a-glance. High-contrast 5/8" LCD, brushed aluminum frame. Batteries included. 4 1/2"Wx1Dx2H inches.

**Free MFJ Catalog**  
and Nearest Dealer . . . 800-647-1800

<http://www.mfjenterprises.com>  
• 1 Year No Matter What™ warranty • 30 day money back guarantee (less s/h) on orders from MFJ

**MFJ ENTERPRISES, INC.**  
Box 494, Miss. State, MS 39762  
(662) 323-5869; 8-4:30 CST, Mon.-Fri.  
FAX: (662) 323-6551; Add s/h  
Tech Help: (662) 323-0549

Prices and specifications subject to change. (c) 2004 MFJ Enterprises, Inc.

# World News, Commentary, Music, Sports, And Drama At Your Fingertips

This listing is designed to help you hear more shortwave broadcasting stations. The list includes a variety of stations, including international broadcasters beaming programs to North America, others to other parts of the world, as well as local and regional shortwave stations. Many of the transmissions listed here are not in English. Your ability to receive these stations will depend on time of day, time of year, your geographic location, highly variable propagation conditions, and the receiving equipment used.

AA, FF, SS, GG, etc. are abbreviations for languages (Arabic, French, Spanish, German). Times given are in UTC, which is five hours ahead of EST, i.e. 0000 UTC equals 7 p.m. EST, 6 p.m. CST, 4 p.m. PST.

UTC	Freq.	Station/Country	Notes	UTC	Freq.	Station/Country	Notes
0000	9665	Voice of Russia, via Moldova		0230	4995	Radio Andina, Peru	SS
0000	6060	Radio Nacional, Argentina	SS	0230	6175	Voice of Vietnam, via Canada	
0000	11780	Radio Nacional Amazonia, Brazil	PP	0230	3250	Radio Luz y Vida, Honduras	SS
0000	11630	REDP Int., Portugal	PP	0300	6090	Caribbean Beacon, Anguilla	Gene Scott
0000	11620	All India Radio		0300	7260	Radio Cairo, Egypt	
0000	9435	Democratic Voice of Burma, via Germany	Burmese	0300	4780	RTD Djibouti	AA
0000	13700	RDP Int., Portugal	PP	0300	4052.5	Radio Verdad, Guatemala	SS
0000	9580	Int. Radio of Serbia & Montenegro		0300	11675	Radio Kuwait	AA
0000	7440	Radio Ukraine Int.		0300	6040	Radio Monte Carlo, Monaco via Canada	AA
0030	9700	Radio Bulgaria	BB	0300	5010	Radio Nationale Malagasy, Madagascar	Malagasy
0030	11690	Radio Vilnius, Lithuania		0300	7270	Voice of Turkey	
0030	9705	All India Radio, Panaji (Goa)		0300	3320	Radio Sondergrense, South Africa	Afrikaans
0030	9460	Voice of Turkey	TT	0300	3345	Channel Africa, South Africa	
0030	15745	Sri Lanka Broadcasting Corp.		0300	3306	Zimbabwe Broadcasting Corp	unid
0100	9870	Radio Austria Int.	GG	0300	5925	Radio France Int., via South Africa	
0100	7345	Radio Prague, Czech Republic		0300	7120	BBC via South Africa	
0100	9980	AFN/AFRTS via Iceland	USB	0300	9880	Voice of Russia	
0100	11735	Voice of Korea, North Korea		0330	5025	Radio Rebelde, Cuba	SS
0100	15720	Radio New Zealand Int.		0330	6940	Radio Fana, Ethiopia	Amharic
0100	11800	RAI Int., Italy	II	0330	5865	Voice of Greece	GG
0100	9440	Radio Slovakia Int.		0330	7110	Radio Ethiopia	Amharic
0100	9590	Radio Budapest, Hungary		0330	3279	La a Voz del Napo, Ecuador	SS
0130	4915	Radio Nacional Macapa, Brazil	PP	0330	5980	RTV Marocaine, Morocco	AA
0130	3310	Radio Mosoj Chaski, Bolivia	QQ	0330	6135	Radio Romania Int.	SS
0130	7275	Voice of Greece	GG	0330	3240	Trans World Radio, Swaziland	
0130	9725	Voice of Russia	RR	0330	4965	Christian Voice, Zambia	
0130	7250	Voice of Russia		0330	6140	Voice of Turkey	
0130	9737	Radio Nacional Paraguay	SS	0400	5500	Voice of the Tigray Revolution	Tigrigana
0130	7115	Int. Radio of Serbia & Montenegro	SS	0400	7545	Kol Israel	HH
0130	4940	Radio Amazonas, Venezuela	SS	0400	9515	Radio Sultanate of Oman	
0130	9510	Radio Romania Int.		0430	6185	Radio Educacion, Mexico	SS
0200	6000	Radio Havana Cuba		0445	4775	Trans World Radio, Swaziland	
0200	9560	Radio Japan/NHK, via Canada		0500	4950	Radio Nacional, Angola	PP
0200	4800	Radio Buenas Nuevas, Guatemala	SS	0500	4930	VOA Relay, Botswana	
0200	9495	Voice of Justice/VOIRI, Iran		0500	7190	RT Tunisienne, Tunisia	AA
0200	7219	Radio Minsk, Belarus	unid	0530	7240	Channel Africa, South Africa	
0200	4955	Radio Cultural Amuata, Peru	SS	0600	4915	GBC/Radio Ghana	
0200	4780	Radio Cultural Coatan, Guatemala	SS	0600	9470	Voice of Croatia	
0200	4885	Radio Clube do Para, Brazil	PP	0700	4783	RTV Malienne, Mali	FF
0200	5970	Radio Belarus		0730	6060	Radio Reloj, Cuba	SS
0230	6115	Radio Tirana, Albania		0900	4755	Radio Educacao Rural, Brazil	PP
0230	5545	Radio San Andres, Peru	SS	0900	4919	Radio Quito, Ecuador	SS
0230	4810	Radio Transcontinental, Mexico	SS	0900	5015	Radio Pioneira Teresina, Brazil	PP



UTC	Freq.	Station/Country	Notes	UTC	Freq.	Station/Country	Notes
0900	4990	Radio Apinte, Suriname	DD	1730	17720	Radio Pilipinas, Philippines	
<b>0930</b>	6040	Radio Clube Paranaense, Brazil	PP	<b>1800</b>	13670	Radio Free Asia, via Northern Marianas	unid
0930	6135	Radio Santa Cruz, Bolivia	SS/QQ	1800	15345	RTV Marocaine, Morocco	AA
0930	6010	La Voz de tu Conciencia, Colombia	SS	1800	17595	Adventist World Radio, USA, via UAE	AA
0930	6160	CKZU, Canada		<b>1830</b>	21470	BBC Relay, Ascension Is.	
<b>1000</b>	6140	Radio Lider, Colombia	SS	1830	15235	VOA Relay, Morocco	unid
1000	12085	Voice of Mongolia		1830	15085	VOIRI, Iran	Farsi
<b>1030</b>	9740	BBC Relay, Singapore		1830	15190	Radio Pilipinas, Philippines	Tagalog
1030	11670	China National Radio/CPBS	CC	1830	12005	RT Tunisienne, Tunisia	AA
<b>1100</b>	15425	HCJB-Australia		<b>1900</b>	15190	Radio Africa, Equatorial Guinea	
<b>1130</b>	4605	Radio Republik Indonesia, Serui (Papua)	II	1900	15120	Voice of Nigeria	
<b>1200</b>	13655	Radio Canada Int.		<b>1930</b>	15485	Voice of Greece, via USA	GG
1200	9650	KBS World Radio, S. Korea, via Canada		<b>2000</b>	11625	IBRA Radio, Sweden	AA
1200	6150	Mediacorp Radio, Singapore		2000	11820	BSKSA, Saudi Arabia	AA
1200	9280	Family Radio/WYFR, USA via Taiwan	CC	2000	15365	Adventist World Radio via South Africa	FF
1200	9615	KNLS, Alaska		2000	15510	Radio Free Asia, USA, via UAE	CC
<b>1230</b>	7185	Bangladesh Betar		2000	11625	Vatican Radio	
<b>1300</b>	9930	World Harvest Radio/KWHR, Hawaii		2000	11655	Radio Nederland Relay, Madagascar	
1300	13665	Radio Rossii, Russia	RR	2000	15150	Voice of Indonesia	
1300	11540	Radio Free Asia, USA, via Tajikistan	unid	<b>2030</b>	17810	Radio Nederland Relay, Bonaire	
1300	9525	Voice of Indonesia	II	2030	17680	Voz Cristiana, Chile	SS
1300	11685	Radio Thailand	CC/EE	2030	15640	Kol Israel	HH
1300	9965	KHBN/Voice of Hope, Palau	CC	<b>2100</b>	15230	Radio Havana Cuba	SS
1300	13635	Voice International, Australia		2100	7380	Voice of Biafra Int., via South Africa	
<b>1330</b>	12010	Radio Australia via Singapore	CC	2100	12085	Radio Damascus, Syria	AA, others
1330	11820	BBC Relay, Cyprus	AA	2100	9780	Republic of Yemen Radio	AA
1330	12130	Trans World Radio, Guam	CC	<b>2130</b>	11600	Radio Prague, Czech Republic	
1330	11995	VOA Relay, Northern Marianas	CC	2130	9990	Radio Cairo, Egypt	
1330	9335	Voice of Korea, North Korea		2130	11705	Radio France Int.	FF
1330	9870	Radio New Zealand Int.		2130	17860	Deutsche Welle Relay, Rwanda	GG
1330	11585	All India Radio	Hindi	<b>2200</b>	15515	Radio Australia	
1330	9705	Voice of Pujiang, China	CC	2200	15220	Radio Japan/NHK via Ascension	JJ
1330	13730	Radio Austria Int.		<b>2230</b>	11710	RAE, Argentina	SS
<b>1330</b>	11630	Radio Seday-e-Iran, via Moldova	Farsi	2230	5030	Radio TV Burkina, Burkina Faso	unid
1330	15240	Radio Sweden		2230	9665	Radio Marumby, Brazil	PP
1330	15380	BSKSA, Saudi Arabia	AA	2230	17740	VOA Relay, Philippines	
1330	15155	BBC Relay, Thailand		2230	9435	FEBC Radio, Philippines	Tagalog
1330	17775	Radio Tashkent Int., Uzbekistan		2230	6973	Galei Zahal, Israel	HH
1330	12055	Vatican Radio	unid	<b>2300</b>	13600	Radio Bulgaria	SS
1330	6080	Radio Singapore Int.	CC	2300	12115	Rikisvtvarpid, Iceland	II
1330	15725	Radio Mi Amigo, via IRRS, Italy		2300	15515	Deutsche Welle, via Russia	CC
<b>1400</b>	11750	Radio Australia		2300	9855	Radio Kuwait	AA
1400	11810	Radio Jordan	AA	2300	9575	Radio Medi-Un, Morocco	AA
1400	12080	Radio Nederland Relay, Madagascar		2300	11760	Radio Nacional, Venezuela, via Cuba	SS
1400	17780	RAI Int., Italy		2300	9700	Radio Bulgaria	
1400	17735	RT Tunisienne, Tunisia	AA	2300	11815	Radio Brazil Central	PP
<b>1500</b>	11690	Radio Jordan		<b>2330</b>	9925	Voice of Croatia, via Germany	Croatian
1500	13740	China Radio Int., via Cuba		2330	12040	HCJB, Ecuador	GG
<b>1600</b>	17895	VOA Relay, Botswana		2330	9875	Radio Vilnius, Lithuania	
1600	11570	Radio Pakistan		2330	4845	Radio Mauritanie, Mauritania	AA
1600	13870	Radio Farda, USA via Sri Lanka	unid	2330	11975	China Radio Int., via Mali	CC
1600	17850	Radio Exterior de Espana	SS	2330	11690	Deutsche Welle, Germany, via Canada	GG
<b>1700</b>	17570	RTBF, Belgium, via Germany	FF	2330	11940	Radio Romania Int.	
1700	15530	Radio France Int	PP	2330	12133.5	AFN/AFRTS, Florida	USB
1700	15475	Africa Number One, Gabon	FF	2330	12140	VOA Relay, Kuwait	
1700	21605	Emirates Radio, Dubai	AA				
1700	13635	Voice International, Australia					
<b>1730</b>	15660	Radio Jamahiriya, Libya, via France	EE/FF				

# New, Interesting, And Useful Communications Products

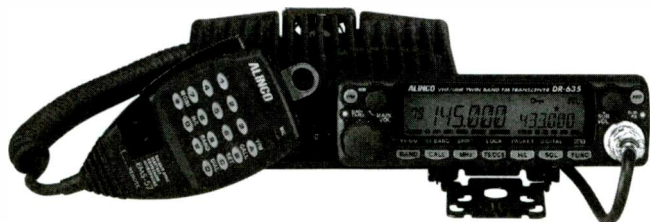

The new Alinco DR-635T mobile amateur transceiver is a full-featured radio that even receives aircraft frequencies.

## DR-635T 2-meter/440-MHz Mobile/Base Transceiver From Alinco

Alinco has announced a new dual-band mobile/base, the DR-635T. It features cross-band repeat, full duplex capability, a detachable remote mountable control head, as well as newly designed RF circuitry for increased resistance to interference from adjacent signals. The DR-635T also includes a new protection circuit designed to automatically engage when the internal temperature rises while operating in the high-power setting. By automatically changing the power setting to MID, this feature can help protect the radio when it is used for active cross-band repeater operation.

Included with the DR635T is Alinco's popular microphone, the EMS-57. In addition to basic microphone operation, the operator can use the backlit keypad to enter frequencies, switch from VFO to Memory operation (and back), select the transceiver's Call channel, recall SET mode, change operating bands, select the transmitter's power output setting, and temporarily defeat the receiver's squelch setting.

The DR-635T has a large, six-character alphanumeric display with selectable display color illumination available in blue, violet, or orange. It features 200 memory channels, ignition key on/off feature, theft alarm feature, CTCSS, DCS encode/decode, and DTMF encode functions along with European Tone Bursts. A variety of scan modes and extended receive capabilities are also available.

Similar in style and function to the DR-620, it shares the ability to operate with Alinco's optional internal packet boards. Digital operators can also order the optional EJ-50U packet board that fits inside the transceiver. With the board installed, 1200- or 9600-bps packet operations can be achieved by connecting a computer to the rear panel DSUB9 port that comes with the optional EJ-50U.

For more information on the DR-635T that retails for \$499.95, contact Alinco at [www.alinco.com](http://www.alinco.com). Please tell them you read about it in *Pop'Comm*.

## New Ameritron Eight-Position Automatic Remote Antenna Switch

Ameritron is now offering the RCS-12, an automatic control box used for switching remote antenna relays that is designed

to work with most ICOM, Yaesu, Kenwood, and other transceivers that have a band data output line. It will work with any relay box with up to eight positions, with voltages from 12 to 30 VDC. The switch reads information from the transceiver and selects pre-programmed antennas automatically. Programming is as easy as pushing a button.

Additionally, the RCS-12 can remember multiple antennas for one band, but selects the last antenna used for that band. It has a manual/automatic switch that allows manual selection of antennas as well. It has eight LEDs to indicate which antenna is selected and will not allow antennas to switch while transmitting. A user-programmable delay is used to give the relays enough time to switch, protecting the transceiver from "hot switching."

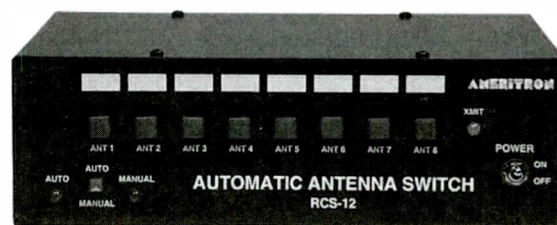

The Ameritron RCS-12 is an automatic control box used for switching remote antenna relays.

The RCS-12 also features a linear amplifier buffered relay line that prevents the amplifier from operating during an antenna changeover, an auxiliary input port that allows the switch-box to be operated from a remote location, an auxiliary output for controlling other devices in one of eight formats, and auto, manual, and transmit indicator LEDs. The unit measures 2 3/4 x 8 1/4 x 7 inches (HWD) and weighs 1.5 pounds.

For more information on the RCS-12, which sells for \$299, contact Ameritron at 800-713-3550 or visit them on the Web at [www.ameritron.com](http://www.ameritron.com).

## AOR Introduces SR2000 Frequency Monitor

The SR2000, new from AOR USA, is an ultra-fast spectrum display monitor with triple-conversion receiver. The unit puts the power of FFT (Fast Fourier Transform) algorithms to work in combination with a powerful receiver that covers 25 MHz to 3 GHz continuously. Featuring a full-color spectrum display, the SR2000 instantly detects, captures, and displays transmitted signals. It is extremely sensitive, fast, and easy to use.

Using a built-in 5-inch thin film transistor color display, the SR2000 offers a waterfall display function that tracks signals over time and uses colors to define their strength. With advanced digital signal processing, the SR2000 can display up to 10 MHz of bandwidth in real time. It covers AM, NFM, WFM, and SFM modes and uses digitally processed IF signals of the RF unit combined with FFT technology to enable spectrum analysis and high-speed signal detection in real time. The SR2000 can per-

AOR's SR2000 can perform a search of up to 10 MHz in as little as 0.2 second.



form a search of up to 10 MHz in as little as 0.2 second.

The keys and single control dial on the front panel of the SR2000 are designed to enable maximum versatility and simple operation. Monitored frequency and audio gain can be adjusted simply by using the main control dial. The SR2000 features 1,000 memory channels and 40 search bank memories, which can be easily be set up to suit individual monitoring requirements.

For more information on the SR2000 that retails for \$3099 and information about the FFT technology, contact AOR USA at [www.aorusa.com](http://www.aorusa.com).

### New Mio 269 GPS System

Mio Technology, Ltd., a leading worldwide supplier of mobile devices, has introduced the Mio 269 GPS navigation system to North America as part of a worldwide launch. The new device is a straightforward, easy-to-use GPS navigation system, combined with seamless, detailed maps of the Continental United States, Alaska, Hawaii, and Canada in a sleek, palm-sized chassis. The Mio 269 is designed for ease of use—all software and maps are already included on the unit's 2.5-MB hard disk drive, so it's ready to go right out of the box.

Requiring no setup fees or monthly charges, the Mio 269 is a perfect after-market alternative to today's expensive built-in automotive GPS systems. Powered by an Intel 300-MHz CPU, the unit provides both visual and verbal directions to the user's destination using an extra-sensitive GPS receiver and maps stored on the hard disk drive. Over a million points of interest (POI), including airports, ATMs, restaurants, gas stations, lodgings, and tourist attractions are also pre-installed. By simply selecting pre-programmed locations, the user can get directions to any destination with a simple click.

Other Mio 269 features include a fully integrated GPS antenna, rechargeable lithium ion battery that allows up to 4.5 hours of untethered operation on a single charge, 3.5-inch color display, 32 MB flash ROM and 64 MB SDRAM, touch screen keyboard (stylus pen), and a built-in one-inch loudspeaker.

The MSRP for the standard Mio 269 is \$799. In the United States and Canada, the Mio 269 is available through partnerships found on the Web at [www.miogps.com/where2buy.htm](http://www.miogps.com/where2buy.htm). Specifications are available at [www.miogps.com/products\\_269specs.htm](http://www.miogps.com/products_269specs.htm). ■



The new Mio 269 GPS system is \$799 and features a built-in one-inch loudspeaker, touch screen keyboard, and is compact enough to fit in your pocket.

## INFORMATION & ORDERING WWW.SCANCAT.COM

INTERNET DOWNLOADS AVAILABLE  
**ORDER TOLL FREE**  
**888-722-6228**

**SCANCAT®**  
Since 1989, The Recognized  
Leader in Computer Control



**Once you use SCANCAT with YOUR radio, you'll NEVER use your radio again WITHOUT SCANCAT!**

**ScanCat-Lite-PLUS**  
Limited Time \$29.95 Intro Special

**Program Your Scanner  
As Easy As 1-2-3-CLICK!**  
SC-Lite Supports PRO-83, PRO-95, PRO-96, BC246  
& over 15 more Trunking Scanners

**ScanCat-Gold for Windows**  
Version 8.50 \$99.95

Supports all radios in ONE program -  
share files with all radios.  
Two Scanning modules:  
A Simple Basic Module - for beginners  
**Plus**—An Advanced Scanning System  
for the "experts".

**ScanCat-Gold for Windows-SE**  
\$159.95

**All the features of our "Standard ScanCat" plus additional functions.**

- Long term logging of frequencies to hard drive.
- Record Audio to hard drive using sound card.
- Improved spectrum analysis with several great graphical analysis screens.

### Skysweep Decoder Software

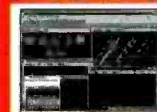

**Advanced Digital Signal Processing Software For HF/VHF Applications**  
All you need is any Windows® soundcard  
demo on our website

Order On Line \$99.95

### MAGIC for Windows

**If You're Not Using MAGIC, You're Only Enjoying Half The Hobby.**



**A Super File Conversion Utility—  
Reads & Writes to over  
10 database formats.**

• Creates databases from plain ASCII text.



### COMPUTER AIDED TECHNOLOGIES

P.O. Box 18285 Shreveport, LA 71138  
ORDERS: (318) 687-4444 FAX: (318) 686-0449  
Info/Tech Support: (318) 687-2555  
(9 a.m. - 3 p.m. Central M-F)

INTERNET DOWNLOADS AVAILABLE  
**INFORMATION & ORDERING**  
**WWW.SCANCAT.COM**

# A Pep Talk

**T**oday, as I write this column in mid June, the U.S. Forces' death toll in Iraq stands at 1,700. Seventeen hundred brave, young men and women of the United States military who have made the ultimate sacrifice to protect our country. Seventeen hundred of America's finest who have stood watch at the ramparts and paid a final price to protect our Constitution and our way of life. We should be humble and offer a prayer for their souls.

Lately I have heard a lot of whining and complaining from various areas within our society, including some of our elected officials, saying that we must disengage our forces and pull back from Iraq, that not one Iraqi is worth a single American life. While I might have agreed with this assessment early in our War on Terror, I no longer hold that opinion.

Currently my son-in-law, Kyle, is serving with the USAF in Iraq, doing things with radios, microwave links, crypto gear, and television that totally boggle the mind. His brother, Kevin, an Atlanta area cop, is over in Baghdad training Iraqis to become policemen in an effort to reclaim their country from the previously corrupt and totally evil regime of Saddam Hussein. Kevin's last class graduated with the highest overall grade point of any class of police cadets to date. I have several friends serving with the 109th ID, Mech who are involved with the day-to-day operations in getting Iraq back on its feet, stamping out terrorism, and helping bring about a free government, *elected* by the people of Iraq.

Also, the son of a good friend of mine recently returned from Iraq, where he was in charge of rebuilding the infrastructure of the country; the power generating stations, schools, waste disposal plants, housing, etc. Very few if any of these efforts are reported by the news media networks covering the events unfolding in that war-torn area. Instead they waste valuable air time focusing on the efforts of a few totally misguided individuals who, for the sake of their religion, are willing to become homicide bombers who, in turn, kill innocent Iraqi civilians and try to blame the Americans for their actions.

The good that the American and coalition forces are doing in Iraq far outweighs the ugly side of the war. One of the main reasons that opponents of our efforts in Iraq fight so intensely to counter our achievements is that they don't want a freely elected government to flourish in the Middle East. Should this concept catch on, it would spell the end of the sheikdoms and fiefdoms that have flourished for centuries in that area. A democratically elected government would erode power from a few chosen "elite" of the Islamic society and place that power squarely in the hands of the people. Man, what a concept!

Why am I "going political" in a radio hobby magazine? For one thing, our efforts in Iraq and our national will to see this through to the end have everything to do with Homeland Security, and that's the name of this column. We must adopt the proper mind set if we are to deal with terrorism, both at home and abroad. America must steel itself to "stay the course" as our forefathers would say. These terrorists are dedicated to bringing down the American way of life and they're not going to go away without one heck of a fight.

## Our Place In It All

As I have often said in this column, we, as radio hobbyists, have a unique place in the grand scheme of things when it comes to the security of our country and the War on Terror.

We are the extra eyes and ears of law enforcement and the intelligence community that can instantaneously report suspicious behavior or possible terrorist activity directly to police and federal law enforcement personnel. We have the ability to monitor the airwaves and snag bits of the puzzle out of thin air that might make the difference in thwarting an evil act of terror. Our on-air activities can aid law enforcement and intelligence gathering groups by our timely reporting of suspicious transmissions to the proper authorities. By receiving emergency communications (EmComm) training we are better prepared to help in times of natural or man-made disasters. In short, we

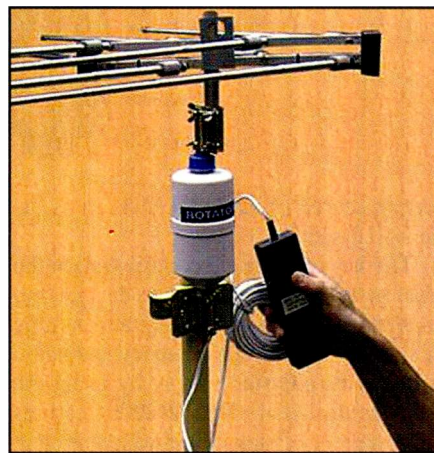

The K1CRA 6-volt antenna rotor runs on four-AA batteries and sells for \$49.95 from [www.k1cra.com](http://www.k1cra.com).

play a one-of-a-kind role in the War on Terror, but only if we take the job seriously, receive the proper training, and are willing to dedicate time in front of the radio to help win the war.

## A War Of Our Own

As if the War on Terror weren't enough for us to contend with, we are also faced with a war of our own. A war that ignorant, shortsighted legislators have invented. I am speaking about the six states that have Draconian laws on their books regarding the ownership and subsequent use of mobile radio equipment by law-abiding citizens. Jock Elliot, KB2GOM's July "On The Go Radio" column delved into the morass of confusion, misunderstanding, and misguided enforcement of New York State's Vehicle and Traffic Law, Section 397.

Jock did an excellent job of presenting some of the pitfalls of this piece of horrid legislation and the problems it has created in the recent past for law-abiding citizens. Many have been pulled over in simple traffic stops only to be challenged by law enforcement officers who are totally ignorant of Section 397 and the Federal law that allows duly licensed amateur radio (ham) operators to own, install, possess, and use a radio receiver/transmitter/transceiver that is capable of receiving police frequencies.

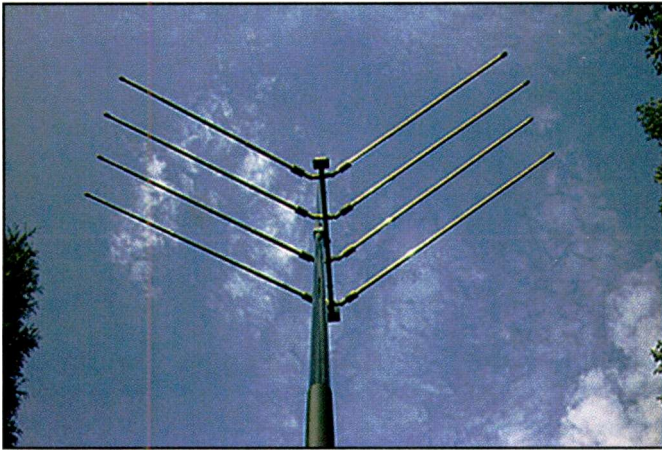

*The dual-band log periodic antenna has four elements on both 2 meters and 70 centimeters.*



*This is how Hurricane Ivan looked from the cockpit window of the WC-130 Hurricane Hunter aircraft from Keesler AFB, Mississippi.*

After acquiring a copy of David Stark, NF2G's excellent legal argument ("No Scanner for you? New York's Flawed Approach to Protecting Police Radio Communications from Misuse by Criminals," available on his website at [www.nf2g.com/scannist.VTL397.htm](http://www.nf2g.com/scannist.VTL397.htm) for \$5), I have come to the conclusion that we need to give cops, judges, legislators, city council members, mayors, and governors IQ tests before allowing them to hold any office of power within the local, county, and/or state government. No kidding, folks, Section 397 is so poorly written that to interpret it accurately is quite literally impossible. And forget common sense. That attribute has not been available in elected or appointed officials for at least 50 years!

Yes, New York State has a really bad law that is sometimes vigorously over-enforced by members of the local authorities, often to the detriment of the hapless law-abiding citizen. Judging from the brief that David has provided, if you have a scanner or VHF/UHF ham rig in your vehicle, you should remove it while traveling in New York State. Sad to say that I have been guilty (I know, ignorance of the law is no excuse) of traveling the highways of New York with at least two, sometimes three, radios that are in direct violation of this section of the vehicle and traffic laws. The fact that I work in the Justice System of the State of Pennsylvania, am a licensed ham radio operator, trained emergency communicator with county and state sanction, Department of Corrections/Pennsylvania State Police certified hostage negotiator, and member of the press, I have no doubt that I would be hard pressed not to have my radios confiscated if I were stopped by any member of law enforcement from New York State.

I find it extremely interesting and tremendously frustrating that, while a citizen is supposed to abide by the laws of the State and ignorance of said laws is not an excuse, law enforcement officials and judges *can* be ignorant of the *FEDERAL* law that preempts the targeting of duly licensed ham radio operators under Section 397! You see, while New York State (and others) can pass these utterly stupid, undecipherable, and totally Draconian anti-scanner/radio laws, the federal government specifically *authorizes* the monitoring of police, military, and other government communications (18 U.S.C. §2511 ¶2(g)(ii)(II)). Of course, there are specific limitations placed upon what can and cannot be discussed by individuals intercepting these communications (Section 705 of the Communications Act of 1934, 47 U.S.C. §605). However, the

bottom line is that the Fed says we can listen, so by God I'm going to listen! The last time I looked, federal statutes and laws trump state laws.

The point that needs to be made to law enforcement, and in some cases hammered into some very thick skulls, is that Section 397 does not apply to licensed ham radio operators. Once the officer sees proof of a valid FCC ham radio license that should be the end of the discussion. Apparently the zeal with which some of these officers jump on the hapless ham operator is extraordinarily disproportionate to the suspected infraction. Then there are the municipal judges who actually side with the cop making the "big bust." All this means that the law-abiding, duly licensed ham radio operator has to go to court, sometimes several times, in order to fight his ticket and *try* to get his gear back. From what I've read, all too often the confiscated gear is never returned. That basically translates to it's now in some cop's or judge's house or has been illegally destroyed.

Hmmmmm, maybe that's how I'll get more gear: I'll move to New York State, become a local cop, stop everyone who has more than one antenna on his car, confiscate the gear, and then, when the case is decided in my favor, take the gear out of evidence and take it home. It might take a couple of years, but I bet I could get a really nice ham shack/monitoring post set up all on the back of the taxpayers. Honest, folks, I don't know where all these outstanding ideas come from. They just well up inside of me and I have to share!

## **New York Is Not Alone!**

That's right—there are at least five other states (at last count) that have a massive case of "The Stupids" and have passed restrictive legislation preventing law-abiding citizens from owning/operating any radio equipment capable of receiving police communications in a vehicle. For those of you who are interested, point your browser to [www.afn.org/~afn09444/scans-laws/scanner5.html](http://www.afn.org/~afn09444/scans-laws/scanner5.html) for the full low-down on the states that currently have anti-scanner/radio laws on their books. Todd Sherman, KB4MHH, has an excellent website where you can become acquainted with the latest in scanning laws and how they may apply to you. I know that I certainly am going to start frequenting Todd's site, especially in light of the amount of dri-



The radar operator aboard the WC-13 Hurricane Hunter aircraft looks over the radar presentation of Hurricane Ivan. Notice the multicolored radar display.

ving my wife, Pat, and I do in the course of a year.

### All In The Family!

Thankfully, the beautiful and talented Patricia, my wife of 25 years, has finally successfully tested for her ham license. In April this year, she tested at the Timonium Hamfest near Baltimore and passed her Technician license test. Her call is KB3MCT and I am very proud of her accomplishment. Since both our respec-

tive vehicles are loaded down with radio gear capable of intercepting police communications, I can rest a little easier knowing that in the event she is ever stopped by an overzealous cop seeking to confiscate some radio gear, she has a slim chance of presenting her FCC license and possibly keeping her gear. Plan B: we both have our lawyer on speed dial on our respective cell phones!

### And The Storms Came

Last month I reiterated what a local meteorologist had told me about this year's hurricane season being bigger, meaner, and spawning larger, more destructive storms, likely causing millions or billions more in damages. Have you ever wondered how and why hurricanes form and how they mature from a tropical depression to a tropical storm and finally into a hurricane? Well, if you're inquisitive like I am, then you need to point your browser to [www.nationalgeographic.com/forcesofnature](http://www.nationalgeographic.com/forcesofnature). You'll be both entertained and enlightened by how hurricanes form and why they do what they do.

There is also plenty of storm tracking software available on the Internet, so why not do a search on "Storm Tracking Software," obtain same, load it on your favorite computer, and, when the next big blow comes up the Gulf or meandering up the Eastern seaboard, track it yourself. Not only will you be better prepared during hurricane season, your children will have something to share at school during "Show and Tell."

### WiFi Security...Again

Several months ago we did an entire column on computer security with an added emphasis on WiFi, or wireless fidelity—basically Internet without wires. Since that time I have had a number of requests for further information regarding WiFi security and how to implement it. That led me to do a search of various Internet sites to find some answers. I decided to Keep It Simple, and so ended up on the website of IT-savvy radio personality Kim Komando's website ([www.komando.com](http://www.komando.com)). Here I found a very good explanation of how to set up your WiFi system, including how to activate the encrypted security furnished with your wireless router.

It's interesting to note that most of us normally run a firewall when going on the Net; however, when you move up to WiFi, your wireless router now becomes your firewall (more properly called a "brick-wall"). Still, it never hurts to run your standard firewall in addition to the router. When configured properly, your router is all that is seen by the outside world, thereby keeping any computer information on the backside of the router, secure from prying eyes.

I have taken to listening to Kim's show on weekends on my local AM talk radio outlet, WILK 980, in Wilkes-Barre, Pennsylvania. Her show is full of interesting tips and tricks and features guaranteed to stimulate your interest in geek-a-zoid gadgetry. I have checked with Kim and she and her producers have given me permission to list her site for this special WiFi security segment. So, wander up there, take a peek and you never know, maybe you'll become a Kim Komando junkie like me!

### Edsel Murphy University— Communications 101

The American Radio Relay League's annual Field Day emergency communi-

*Listening is only half the fun...*



## POPULAR COMMUNICATIONS

*is the other half.*

The World's most authoritative monthly magazine for Shortwave Listening and Scanner Monitoring. Read by more active listeners world-wide.

If you enjoy radio communications you'll love  
**POPULAR COMMUNICATIONS**

	USA	Canada/Mexico	Foreign
1 Year	<input type="checkbox"/> 28.95	<input type="checkbox"/> 38.95	<input type="checkbox"/> 48.95
2 Years	<input type="checkbox"/> 51.95	<input type="checkbox"/> 71.95	<input type="checkbox"/> 91.95
3 Years	<input type="checkbox"/> 74.95	<input type="checkbox"/> 104.95	<input type="checkbox"/> 134.95

**Popular Communications**

**25 Newbridge Road, Hicksville, New York 11801**

**Phone: 1-516-681-2922**

**For Fastest Service FAX 516-681-2926**



Here's the complete set of ICOM "Bookcase" radios circa 1979-1984. All these little rigs seemed to be a bigger hit in Europe than here in the States. The three SSB/CW radios, the IC-402, 502, and 202 (from left, the second through fourth in the picture) are 3-watt PEP output on SSB and about 1.5-watt output on CW. The IC-215, the left-most radio, is a 1- to 10-watt, 2-meter FM transceiver that uses crystals and has 15 channels. This set was assembled for under \$300 by watching eBay and eHam.net and pouncing on bargains. These rigs are going to Field Day with me to provide the VHF/UHF station.

cations exercise is only two weeks away as I write this column. Last month, you may remember, I had planned on taking my WA3WSJ vertical fishing pole antenna, Elecraft KX-1 transceiver, and a battery pack into the field and do a 1B Battery entry for this year's event.

Under the heading of "The Best Laid Plans of Mice and Men..." those plans have been scrapped and I will be thrown in with the Eastern Pennsylvania QRP Group (EPA QRP), using the callsign N3EPA. I will be providing the VHF/UHF stations for the exercise. To wit: my main radios will be a trio of 25-year-old ICOM radios; specifically, an IC-202 (2M SSB/CW), IC-502 (6M SSB/CW), and IC-402 (70 centimeters SSB/CW). Backup for this mess will be by my old faithful Yaesu FT-817.

Antennas will consist of an MFJ three-element 6-meter Yagi, and a dualband (2-meter/70-centimeter) log periodic antenna (LPA). At the Dayton Hamvention this

year, I located a source of 6-VDC antenna rotors for under \$50. These tiny DC rotors look to be the perfect solution to turning small antenna arrays for "roving" during VHF/UHF contests and things like Field Day. Craig Anderson, K1CRA (www.k1cra.com), is furnishing the rotor and the dualband LPA for my use during Field Day. Craig told me in an e-mail that the LPA makes a great little scanner antenna due to its large frequency coverage, small physical size, and light weight. Well, now, we'll just have to see how that works! I will have an in depth report on these two items in an upcoming "Homeland Security" column.

### Till Next Time

That's all for now, gang. Its beautiful weather so get outside, take your radios, have some fun, and don't forget our mantra: *Preparedness is not optional.* ■

**TERRORISM FORCES  
US TO MAKE A  
CHOICE. WE CAN BE  
AFRAID. OR  
WE CAN BE READY.**

**READY**

**WWW.READY.GOV**

**1-800-BE-READY**



### RadioWallet travel case

Keep your HT and it's accessories in one place and protected in this tough, padded case. Big enough for your radio, extra antenna, battery and charger along with your repeater book. Zippered case comes in two sizes to fit any HT.

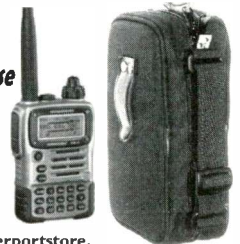

800 206-0115 www.powerportstore.

**Poor AM Radio Reception?  
This is the Solution!**

## Select-A-Tenna

For more than 34 years, this technically elegant but, simple-to-use device has significantly improved weak AM radio reception. The signal gain is as great as thirty times! And, no hook-up to your radio is required. Simply place it next to your radio and tune. It is already working! No batteries, no wires. It is powerful and really works. You'll be amazed!



**Model 541**  
\$59.95 plus shipping  
Satisfaction Guaranteed

Other models are available, see the complete story at our web-site

Intensitronics Corp  
PO Box 28  
Ashland, WI 54806  
800-382-4155 Toll-Free  
715-685-0474 Fax  
www.selectatenna.com  
Made in the USA

# Digital Satellite Radio Is Hot— Here's What You Need To Get Started!

## Editor's Note:

Popular Communications is pleased to welcome back Bruce A. Conti to our team of excellent writers. Bruce is—and I imagine always will be—a broadcast band DX enthusiast par excellence. When he's not listening to some transatlantic DX, he's most certainly listening to a distant U.S. station from his home in New Hampshire. Welcome back, Bruce!

**B**oth Sirius and XM Satellite radio services are growing at an amazing rate, by as many as 50,000 new subscribers a day. With commercial-free music channels now offered by both, Major League Baseball on XM and the National Football League on Sirius, plus Howard Stern abandoning AM/FM radio to escape FCC censorship, satellite radio is now more popular than ever. Here's an introductory look at what to expect if you've been considering satellite radio.

## Docking Receivers

Like cable and premium satellite TV, Sirius and XM satellite radio are available only by subscription. For one receiver, Sirius costs \$12.95 per month, XM \$9.99 per month, not including a one-time activation fee. Each additional radio is an additional subscription. Although discounts are offered for up to three radios on a single account, it can be rather expensive to have separate satellite radios in your cars, home, and office, never mind wholesale replacement of legacy analog AM/FM receivers to accommodate digital satellite radio.

Luckily there's something known as a docking receiver, an entry-level unit specifically designed to work around such issues, making the decision to sign-up for satellite radio a little easier. Docking receivers, also known as plug-and-play units, plug into base stations or "cradles" installed in the car, home, or wherever an AM/FM radio is available, providing the convenience and economy of being able to listen to satellite radio from any num-



ber of locations with just one receiver, one subscription, and without having to replace existing AM/FM radios.

A home dock will have line audio outputs for direct connection to a component stereo system to maintain the best audio quality. Some models are available with an optional "boom-box" docking kit to convert the docking receiver into a self-contained home stereo system, complete with amplifier and speakers. Docking receivers require an external antenna, usually provided with the receiver. The external antenna must be located next to a window for line-of-sight reception of the satellite signal or terrestrial booster signal.

A typical dock for the car will include a wireless FM modulator and wired cassette adapter to listen through any car radio. The FM modulator may also work with the home dock so you can listen on any FM radio in the house. Keep in mind, the FM modulator can be susceptible to drift, however, especially with temperature extremes in the car, and there will be at least some degradation of audio quality versus a wired connection.

Normally, a car dock and its antenna are mounted on the dashboard. Mounting can be done with custom hardware or with as unsophisticated an approach as Velcro fasteners. Signal drop-out is a common problem with this type of car installation, however. When a drop-out occurs, the audio will be muted until contact is reestablished, which can sometimes take a few seconds. Drop-outs are caused by signal blockage due to buildings and mountainous terrain, or sometimes it's simply a matter of vehicle and antenna orientation. The satellite services have attempted to minimize drop-outs by installing terrestrial boosters at strategic locations, but just like cell phones, not all dead spots have been eliminated. An optional magnet-mount roof antenna is

highly recommended for more reliable reception.

## In-Dash Car Receivers

Beware when looking for an after-market in-dash car radio. If a radio is advertised as Sirius or XM-ready, it *doesn't* mean that an internal satellite receiver is included. A satellite-ready receiver only has the front panel controls or "head" for Sirius or XM. You'll need to purchase a separate black-box satellite receiver, digital adapter, and antenna to plug into the back of the car radio for a complete system. For the car audiophile, this is far preferable to a docking receiver as it's less cluttered and offers the best audio quality. Everything is hidden behind the dash (except the antenna of course), and the digital-to-analog conversion is supported by superior circuitry.

Sirius-ready car audio systems by Alpine, Clarion, Eclipse, JVC, Kenwood, Pioneer, and Sanyo, and competing XM heads by Alpine, Kenwood, Panasonic, Pioneer, and Sony can be outfitted with satellite radio, usually for less than \$100. Some in-dash head units, like the new Alpine CDA-9855, will support Sirius and XM, but you still have to choose one or the other for the under-dash satellite receiver to complete the system.

## Portable Receivers

As the popularity of satellite radio has grown, the development of a new generation of receivers that look and feel more like traditional portable radios is on the horizon. Two models are on the forefront: the Delphi XM MyFi and the Etón E1 AM/FM/SW/XM radio.

The Delphi XM MyFi is a walkman-size receiver with a number of interesting features. For instance, the MyFi not only



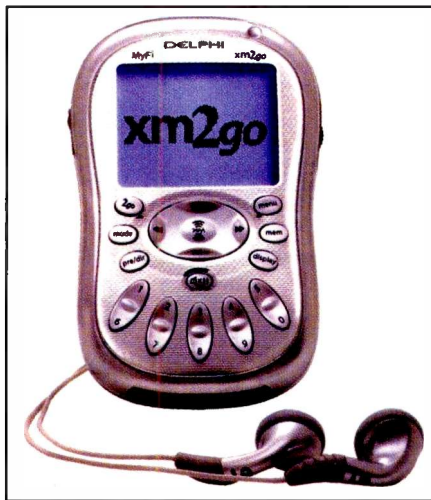

The Delphi XM MyFi.

receives live XM radio, it can be programmed to download into memory as much as five hours of content off the XM satellite. It's powered by an internal rechargeable battery and includes stereo headphones so you can take it anywhere, like a walkman. But, like a docking receiver, it plugs into a recharging stand that doubles as an interface for stationary home use. The stand includes audio output and external antenna connections.

The MyFi with its internal antenna is subject to drop-outs in poor signal areas and indoors, but reception can be improved significantly by an optional external clip-on antenna that plugs directly into the receiver or the charging stand. Of course, the drop-out problem can be eliminated by downloading programming before heading out on your daily walk or public transit commute.

If that weren't enough, the MyFi comes with a car docking kit, too, including wireless FM transmitter and wired cassette audio adapters, as well as a 12-VDC power adapter and optional magnet-mount car roof antenna. On the down side (if there is one), like docking receivers, the MyFi alone doesn't receive local AM/FM radio broadcasts.

The Etón E1 is the follow-up to the Grundig Satellit 900, with Drake circuitry inside and now XM ready. This radio has it all: continuous tuning from 100kHz to 30 MHz for LW/MW/SW reception, with selectable 7.0-, 4.0- and 2.5-kHz IF filters, AM, selectable sideband, and CW modes, 87- to 108-MHz FM stereo, and XM radio with an optional external satellite antenna module. It's powered by four internal D-cell batteries or by an external AC adapter. Although categorized as

portable, this receiver would just as easily serve as a tabletop model. Its bulk alone (at 13.1 x 7.4 x 2.6 inches and weighing over four pounds) might limit portability, but stereo audio line inputs and outputs, external antenna connections for outdoor aerials, and DX performance make the E1 equally at home in the den or radio shack.

It's worth noting that standalone receivers like the Delphi MyFi and Etón E1 are currently available only for XM. There's even a reference-grade XM receiver just introduced by Polk Audio ([www.polkaudio.com](http://www.polkaudio.com)). The Polk XRT12 is a rack-mountable component system XM receiver featuring top-of-the-line circuitry, optical and coaxial digital outputs, and a remote-controlled menu that can be displayed on your television monitor. Manufacturers have yet to make the same leap of faith beyond entry-level docking receivers and car stereo heads for Sirius.

### About Sirius And XM

Sirius Satellite Radio has over 120 channels of news and entertainment; XM Satellite Radio has over 150 channels. Both have commercial-free music channels to suit every taste, with Sirius available with 5.1 surround sound. Sirius scores big with play-by-play coverage of all NFL, NBA, and NHL games, plus sports talk from ESPN Radio and Sports Byline USA. XM carries all Major League Baseball games, in addition to sports talk from ESPN, Sporting News Radio, and Fox. News coverage is extensive on both, and includes ABC, Bloomberg, CNBC, CNN, C-Span, Fox, NPR, BBC World Service, World Radio Network, plus traffic and weather as well as local reports from a growing list of major metro areas.

Sirius and XM talk radio channels feature Air America Radio (where's Rush Limbaugh?), and ABC network programs headlined by Sean Hannity. Sirius carries the Midnight Trucking Radio Network, while XM has the Truckin' Bozo. XM might have the edge over Sirius with a wider selection of nationally syndicated talk radio hosts such as Matt Drudge, Michael Reagan, Bruce Williams, and Coast-to-Coast AM with George Noory, and Art Bell. Not to remain outdone, shock-jock Howard Stern joins Sirius in 2006, where even the commercials are guaranteed to have an uncensored edge.

Want to receive both Sirius and XM? You'll have to buy separate receivers for each because Sirius and XM use differ-

ent digital compression schemes, and with the exception of a few high-end car audio heads that support Sirius and XM, no single receiver is capable of decoding either service with the flip of a switch, at least not yet.

To learn more about satellite radio, visit Best Buy, Circuit City, RadioShack, or your favorite consumer electronics retailer for a demonstration. Additional information about satellite subscription services, receivers, and local retailers can be found online at [www.sirius.com](http://www.sirius.com) and [www.xmradio.com](http://www.xmradio.com). One thing's for sure, legacy AM and FM broadcasters are feeling the heat as satellite radio, along with podcasting and Internet streaming, continues to take an ever-increasing share of the listening audience. The slow start-up of AM and FM digital broadcasting may be too little too late. The future appears to be here for real via digital satellite radio.

### QSL Information

**870 KSKO McGrath, Alaska**, after receiving a no-detail note sometime back, I decided to send another report for my 2002 reception, but this time included a CD rather than the cassette. I got a much better detailed letter in 11 days, signed



**ELECTRIC RADIO MAGAZINE**

Tired of modern radios you can't work on and are hard to understand? ER is the monthly magazine for you! Send \$1 for a sample to:

**ER, PO Box 242,  
Bailey CO 80421-0242  
720-924-0171 or email:  
1Editor2@indra.com**

**WWW.ERMAG.COM**



4091 Viscount Street  
Memphis, TN 38118  
(901) 794-9494  
Fax: (901) 366-5736  
[www.majestic-comm.com/maco](http://www.majestic-comm.com/maco)

**ANTENNAS • POWER SUPPLIES  
• CABLE ASSEMBLIES**

**HIGH PERFORMANCE and MADE IN U.S.A.**  
ALL MACO BASE ANTENNAS are made of aircraft alloy 6063-TS aluminum tubing—.050 gauge.  
NOTE! To prevent fatigue failure, no holes are made in any boom or element.

**FREE**  
With First 100 Orders

**Maco 45 SWITCH BOX**

3 Position Coax Switch Handles 1kW  
\$20.00 Retail Value

With Purchase Of

**The MACO Comet**  
Space Saving, 6 el.  
Dual Polarity CB Antenna



Call or write for free catalog and name of reseller near you.

**[www.majestic-comm.com/maco](http://www.majestic-comm.com/maco)**

Timothy A. Terrell, News Director & Walt Gregg, GM. Address: PO Box 70, McGrath AK 99627. (Martin, OR)

**1150 WIMA Lima, Ohio**, a very nice QSL certificate, note, and bumper sticker received in 66 days for a taped report of DX test, signed Mark D. Gierhart, Dir. of Eng. Address: 667 W. Market St., PO Box 1128, Lima OH 45802-1128. Mentioned they were running 1 kW non-directional when I heard them. I am very pleased with this. Ohio stations are not that easy from Oregon these days. This is my 21st Ohio QSL and #2900 MW QSL in a bit over 40 years of QSLing MW stations. This made my day! (Martin, OR)

## Broadcast Loggings

**540 WWCS Canonsburg, Pennsylvania**, heard at 0200 top of the hour ID, "WWCS Canonsburg-Pittsburgh," into Radio Disney fare. Good signal for the brief second or two it appeared. (New, GA)

**540 WYNN Florence, South Carolina**, heard at 0130 Gospel music and an ad mentioning Darlington, SC. Dominant signal on top of WDAK in Columbus, Georgia, and WFLF in Pine Hills, Florida, but subject to fading from time to time. "Glory 98.5 and 540 AM." (New, GA)

**750 CMHV R. Progreso, Trinidad, Cuba**, with a newscast just shy of 0330 and then Latin music. Another newscast was delivered just shy of 0400. Radio Progreso was mentioned several times along with Havana. President Bush was mentioned in the newscast. Good, steady signal on both the Sangean ATS 909 and the Drake R8B with slight splatter from WJR on 760 in Detroit, Michigan. (New, GA) (*What happened to 750 WSB Atlanta?—bc*)



The Etón E1 LW/MW/SW/FM/XM portable receiver with external XM satellite radio antenna module.

**760 ZYH588 R. Uirapuru, Fortaleza, Brazil**, at 0020 a pop female vocal, then Portuguese talk with Uirapuru ID; fair. (Connelly, MA)

**780 YVMN R. Coro, Coro, Venezuela**, at 0128 rustic flute music, "en Coro" mention, phone numbers; dominant. (Connelly, MA)

**980 WFHG Bristol, Virginia**, heard at 0300 heard top of the hour ID, "Super Talk WFHG Bristol," into ABC News. Signal buried in the mix for the most part. (New, GA)

**1000 ZYK522 R. Record, Sao Paulo, Brazil**, at 0123 fast Portuguese talk including Sao Paulo store adverts; loud, way over WCMX and Venezuela. (Connelly, MA)

**1020.06 ZP14 R. Nanduti, Asuncion, Paraguay**, at 0112 lots of talk by a man, then a woman phone-in with an Asuncion mention; best copy in 1.8-kHz filter upper sideband which rendered Nanduti's audio clearer than the competing audio from 60-Hz-lower Margarita. (Connelly, MA)

**1060 HIRV R. Amanecer, San Pedro de Macoris, Dominican Republic**, at 0201 Spanish religious programming and jingle, "Radio Amanecer...la voz de la esperanza," over Brazil, KYW, others with WBIX seemingly off. Thanks to Mike Westfall (NRC) for ID help. (Connelly, MA)

**1100 ZYK694 R. Globo, Sao Paulo, Brazil**, at 0035 a good signal on the south Ewe antenna without phasing; excited talk in Portuguese, perhaps sports commentary, and signature Globo IDs. (Conti, NH)

**1160 VSB3 Hamilton, Bermuda**, at 0045 an excellent signal with BBC talk about African music and a performer from Mali. Audio was delayed a full 15 seconds from parallel 5975 kHz. (Connelly, MA)

**1620 WDHP Fredriksted, St. Croix, U.S. Virgin Islands**, at 0025 WDHP ID, Caribbean music; to good peak over Boston-area Haitian culture pirate. (Connelly, MA)

## It's YOUR Turn!

Thanks to Mark Connelly, Patrick Martin, and Ira Elbert New for their DX reports. Also thanks to columnists Randy Adams and Dave Schmidt for holding the fort while my real day job was getting the better of me. Now it's your turn. Ideas for future columns, questions, tips, and stories about your broadcast experiences are all welcome, as well as your DX achievements. 73 and Good DX! See you again next month. ■

## Ham Radio Magazine on CD-ROM

Finally, quick and easy access to back issues of Ham Radio Magazine!

These sets include high quality black and white scanned pages which are easy to read on your screen or when printed.

**30,000 pages in all!**

Enjoy this enormous stockpile of material including construction projects, theory, antennas, transmitters, receivers, amplifiers, HF through microwave, test equipment, accessories, FM, SSB, CW visual & digital modes. All articles, ads, columns and covers are included!

This collection is broken down into 3 sets - by year.

**Each set includes 4 CD-ROMs:**

1968 - 1976	Order No. HRCD1	\$59.95
1977 - 1983	Order No. HRCD2	\$59.95
1984 - 1990	Order No. HRCD 3	\$59.95

**Order all 3 sets and save \$29.95!**

**All 3 Sets - Order No. HRCD Set \$149.95**

Please add \$3 shipping & handling for 1 set; \$4 for 2 or more sets.

CQ Communications, Inc.

25 Newbridge Rd., Hicksville, NY 11801

**Order Today! 1-800-853-9797**



# Traffic Nets: One Way To Be Of Service To Your Community

**W**ant to do something that's really fun with radio that could be a terrific service to your community? Let me humbly suggest that you consider running a Ham Radio Commuter Assistance Network for your city, village, or town. For nearly 10 years now, I've been running just such a commuter assistance network in the Capital District of New York State.

Here's how it works. Every workday morning, I get up between 5 and 5:30 a.m. After taking care of a few household chores (like that all-important mug of coffee!), at 6 a.m. I fire up the radios and announce, "This is KB2GOM net control standing by." My main radio is an ICOM IC-706MKIIG, which is the workhorse of the network. I run it at about 20 watts into a simple omni-directional antenna. The main network frequency is 146.94, which feeds a repeater owned by the Telephone Pioneers of America and is located on Bald Mountain near Troy, New York. The repeater has very good coverage to the north, south, and west, from which directions tens of thousands of commuters pour into the Capital District.

There are two other radios that are important to the network. The first is an ICOM IC-V8 handi-talkie. I use this to run the network "mobile" while walking around the house and attending to various family activities. The second radio is a Galaxy DX2547 Citizens Band base station, which is fixed on CB Channel 9 (the emergency and travelers' assistance channel) and fed into a Shakespeare Big Stick on the roof. The only other equipment I need is a telephone, a pad of paper and a pencil, and a list of local law enforcement and emergency response agencies' telephone numbers.

The net runs most mornings from 6 until 8:15 a.m., although some days, when there's a winter storm or some other emergency (for example, one morning a fuel oil truck rolled over at the entrance to the New York State Thruway and caused chaos for hours), the net runs longer.

## Dual-Purpose Net

The net has two purposes: 1) to detect problems on the roadways and report them to the proper authorities; and 2) to share that information with net participants. During the time that the net is running, hams check in and out of the net as they commute to work. Some report problems they see on the roads; some ask about conditions along their route; and some relay information they've picked up from commercial radios or scanners.

When I first started the net, I would monitor law enforcement frequencies on a couple of scanners, but this proved too distracting while running the net and participating in the family's morning routine, so I stopped doing it. Fortunately, some of the hams who take part in the net help out by "filling in the gaps."

During the years the net has been running, nearly 150 different hams have participated in the network. Most years we handle about 1,000 calls for assistance, and most of these are



*The heart of the commuter net is made up of commuters like Mike Magin, N2XMO, who drive to work every day and report what they see. They make the Capital District Ham Radio Commuter Assistance Network a success. (Photo courtesy of Greg Magin)*



*This is what it's all about: A commuter's-eye view of the roadways. Thanks to community-spirited hams in New York's Capital District, the commuter assistance network has run for nearly a decade without dues, bylaws, or regular meetings. (Photo courtesy of Greg Magin)*



↑ Occasionally, CB Channel 9 calls for assistance come in on a Galaxy DX2547 Citizens Band base station.

These two radios, an ICOM IC-706MKIIG and an ICOM IC-V8 handi-talkie, are the workhorses of the network and have performed flawlessly. →



reports of disabled vehicles that are out of traffic, but we do get a substantial number of disabled vehicles that are in traffic, accidents, spin-outs, rollovers, debris, and other emergencies.

The net actually has an official set of triage rules; that is, a means by which we prioritize the importance of calls. Accidents with personal injury are at the top of the list. Next comes any vehicle or object in traffic or other hazards to navigation (these may include weather conditions, like snow, ice, freezing rain, or something spilled on the highway). Following that are potential hazards that are out of traffic, including disabled vehicles by the side of the road.

## A Good Report

Net participants know that location is the number one thing that must accompany every report. It's no good to say "There's an accident on the Thruway"—we also need to know which direction, which lane, and what milepost the incident is near. If it is on a local road, we need to know the nearest cross street or identifiable landmark. If it is an accident, the information provided needs to include whether it is in or out of traffic, the number of vehicles involved, and any injuries. If a vehicle is reported stopped by the side of the road, the report must include whether there are any indicators of distress; for instance, if the four-ways are on or the hood up is up.

When a report comes in, I evaluate it (as the net control) and when appropriate, I pass it on to the local authority with jurisdiction. I keep a list of the phone numbers for the local dispatchers near the net radios, and when needed, I keep notes of incidents on a pad. Throughout the morning commute, the net is punctuated by phone calls. Sometimes I call the Traffic Management Center in Albany, which has jurisdiction over the

interstate highways, to report incidents. Sometimes the dispatchers at the TMC call to update me on incidents. There is a nearly constant two-way flow of information.

In addition, Metro Networks, which does about 95 percent of the on-air traffic reporting on radio and TV, keeps a scanner locked on our net frequency. Sometimes the people at Metro Networks call for clarification on a report. Sometimes they call to update me, and occasionally I call them with a direct report by telephone.

## Working Together—Trained Observers!

I'm very grateful for the collaboration and participation of the folks from the TMC and Metro Networks (TMC and Metro also talk to each other by telephone). I believe that, working together, we do a better job than any of us could do separately. Metro Networks sometimes has a light plane observing traffic, and the TMC has a network of video cameras overlooking the major highways. These are both useful tools, but there have been a number of incidents where hams, driving to work and participating in the commuter network, have been able to provide vitals details necessary for handling an incident. On one morning, for example, neither the cameras nor the plane could figure out why traffic was bottled up on Rt. 787. It took one of the net participants, on the ground and eyeballing the scene in person, to report that there was a serious accident *under* one of the overpasses where it couldn't be seen by plane or camera.

A sharp reader might properly ask, "With the proliferation of cell phones, why bother running a ham radio commuter network?" I've talked with quite a few State Police dispatchers and they tell me that, while most cell phone users have the best inten-

tions, they often fall short in reporting an incident because they simply are not in the habit of carefully observing and collecting the information that is needed, like exact location, in or out of traffic, how many vehicles are involved, and so forth. By contrast, the participants in the Capital District Ham Radio Commuter Assistance Network are "trained observers." They know what to look for and what to report. These hams are the real heroes of the story, and I am deeply grateful to them. Without their active participation, I would be just another guy sitting at a radio with a cup of coffee. (I also specifically want to note that in the past year or so, June Kinerson, KB2JTG, the wife of one of the net participants, has provided invaluable help as net control on some afternoons when there was bad weather or on mornings when I couldn't be at the microphone.)

There have been a couple of incidents in which I know for certain that the network was responsible for getting critical help to someone who was in desperate trouble. In addition, it's a fair bet that the network has *prevented* scores of accidents by rapidly reporting disabled vehicles in traffic so they could be cleared by authorities. (If there is one thing I've learned while running the net, it's that if a vehicle remains disabled in traffic for very long, someone will hit it. It's not a question of "if" but "when.") We also help by warning people when certain heavily traveled commuter roads are clogged for one reason or another and by suggesting alternate routes.

I can also tell you that running the net is very satisfying for me, and that a number of net participants tell me it's the most fun they have in ham radio. By the way, calls for assistance on CB Channel 9, which were heavy at one time, have dwindled to an isolated call every few months.

### Are You A Net Candidate?

So what do you need to run your own ham radio commuter network for your community? Here's a quick checklist:

- Your ham license.
- A radio capable of solidly raising the repeater you want to use.
- Permission from the repeater owner to use the repeater at the time of your network.
- A list of phone numbers of local authorities so you can report incidents to them. (Using "911" usually isn't good enough; in some areas, 911 operators do

not consider a disabled vehicle in traffic worth reporting, but the local dispatchers do.)

- The time, the will, and the commitment to run the network. You need to be there all the time (during your net hours) so that you are ready, available, and practiced when things get bad.

- The participation of local hams. This may require going to local ham club meetings, giving a presentation on your

network, and inviting hams to check into the network.

- The cooperation of local authorities. You may want to briefly call them, explain what you're doing, and ask "What telephone number would you like me to use to report traffic incidents?"

If you start your own commuter assistance network, let me know! My e-mail is [lightkpr@nycap.rr.com](mailto:lightkpr@nycap.rr.com). ■

## When Disaster Strikes...



# REACT is Ready!

**REACT** Teams work with local, state, and national disaster response agencies. Often **REACT** plays a unique role in disaster relief because **REACT** is the only volunteer communications organization whose members are trained to use **all types of two-way communications** from CB to packet radio, Amateur radio to GMRS.

Fortunately, disasters don't happen every day. **REACT** Teams maintain their readiness and serve the public by monitoring emergency channels and by providing communications services for a variety of activities and community events.

Find out how **you** can be part of the **REACT** Team! Visit [www.reactintl.org](http://www.reactintl.org) to find a Team in your area – or information on starting your own Team.



**REACT International, Inc.**

(301)316-2900 or (866)REACT99  
5210 Auth Rd., Ste. 403 \* Suitland, MD 20746

# The Striking Differences Between DOT And Jeppesen Charts

**A**mong the things I've been attempting to do in the "Plane Sense" column is give you resources to help you track down as many frequencies as possible *and* to get information on what you're listening to. As a controller I've noticed that all ATC facilities I'm familiar with use only DOT (Department of Transportation)-produced charts and books, while many, if not most, pilots use Jeppesen charts.

Jep charts, as they're known in the industry, use the same information found in DOT charts, but with some differences. I tracked down some for the southeast United States—charts SE1 and SE2, 37 US (LO), 38 US (LO), 39 US (LO), 40 US (LO), 49 US (LO), 50 US (LO), 51 US (LO), and 52 US (LO). I also acquired Planning charts 1 and 2 US (FP/LO). All, except for the two planning charts, are basically equivalent to DOT charts L-14, 17, 18, 19, and 20.

## A Side-By-Side Comparison!

I then decided to do a side-by-side comparison of the Orlando area (my home city) from both IFR (Instrument Flight Rules) low en route charts, DOT L-19 and Jep 51 US/LO. The similarities are such that pilots who use one chart will have absolutely no problem using the other. But the differences between the two are striking (see illustrations).

The first thing you'll notice is that the Jeppesen chart appears to be a little easier on the eyes. It doesn't seem as cluttered, and the airway centerlines seem to be a little thinner. The DME (distance measuring equipment) information is a little bit difficult to read, however. An example is at the ODDEL intersection, which is south-southeast of the Orlando VORTAC (on airways V267/V295/V531) and west of the Melbourne VORTAC (on airway V441). The information on the DOT chart has the mileage inside a letter D with an arrow pointing at the intersection. On the Jep chart, you'll see that the same information shows the letter D with the distance following. Notice

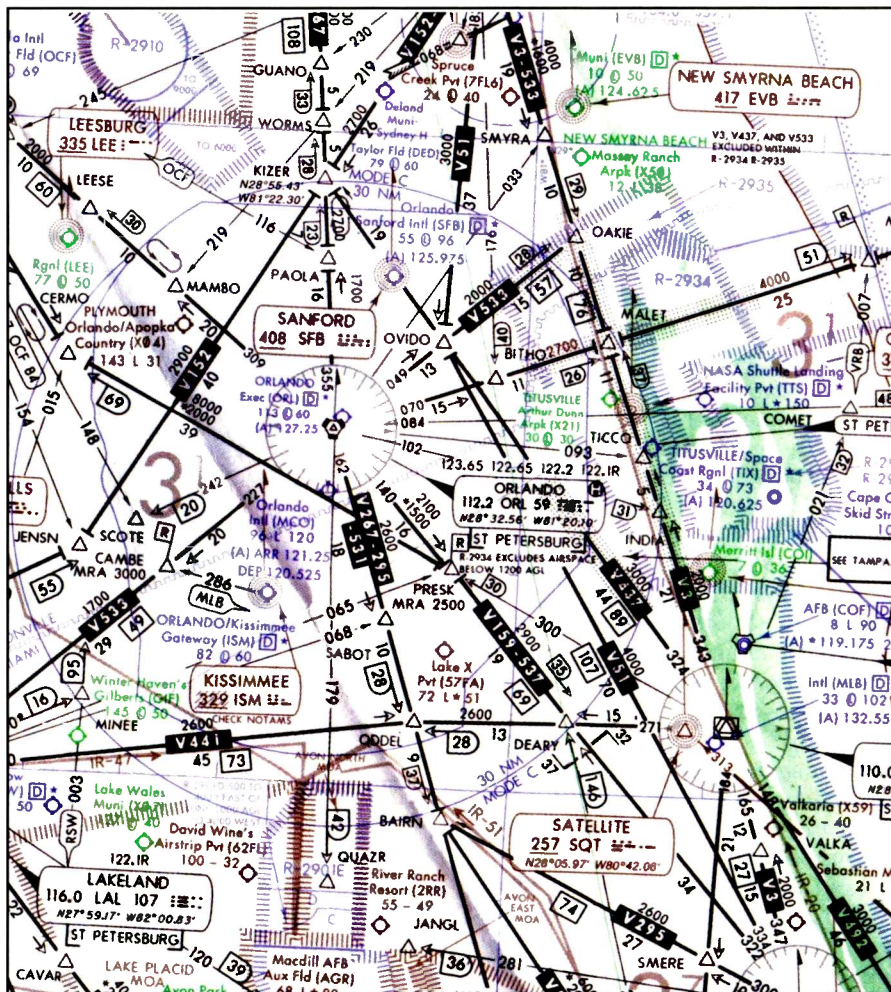

Here's a look at the DOT chart. Note: Not for navigational use.

that ODDEL (pronounced oh-dell) is 28 nautical miles from both Orlando and Melbourne.

NAVAID information is a little small on the Jep charts, but appears to be a little clearer. One thing I did observe on all the VORTAC blocks (and some NDB, or nondirectional beacon, blocks) on the DOT charts is the latitude/longitude for those NAVAIDs; this information is not on Jep charts. The information on the DOT charts is in degrees, minutes, and decimals of minutes, not seconds.

On the Jep charts, intersections with holding patterns (MAMBO on V159 northwest of Orlando, CERMO on V537

west of Orlando, and KIZER on V267 north of Orlando) are placed on the intersections themselves, instead of adjacent to them, as on the DOT chart.

## Restricted Areas And FSS Frequencies

Restricted areas, such as R-2901A-E south of Orlando and R-2933/2934 and 2935 at the Kennedy Space Center (Cape Canaveral), are much clearer on the Jep charts. Military Operation Areas (Marian MOA west of Vero Beach) are also much clearer. Similarly, the Orlando Class B area is strikingly clear on the Jep chart,

and almost invisible on the DOT chart.

Another thing I noticed quickly on the DOT chart is the availability of Flight Service Station (FSS) frequencies. I could not find these on the JEP charts. The FSS frequencies are located just above the VORTAC blocks; that is, just above the Orlando block you'll see 123.65, 122.65, 122.2, and 122.1R. The first three are simplex frequencies for transmitting and receiving on that specific frequency. The final one, with the "R" following, is duplex. It means that the pilot transmits on 122.1, but monitors the FSS on the VORTAC frequency located in the block. Pilots contacting FSS at Orlando would transmit on 122.1, but would need to turn up the volume on their VOR receivers and listen in on 112.2. You may notice the same 122.1R above the Lakeland VORTAC block. You may also notice that in a small open block beneath the Orlando and

Lakeland blocks is the name of the FSS that services that particular area, in this case St. Petersburg.

### Other Differences

There are a few additional things you need to notice about the JEP charts. The first is size. They tend to be a little smaller than the DOT charts, which is why it takes many more charts (52 Jeps versus 28 DOTs) to cover the lower 48. Also the paper is thinner and lighter in weight. Like the DOT charts, JEP charts are issued every 56 days, both on the same schedule. However, the JEP charts also place on the front of the charts all significant changes. Both charts give a listing of all air/ground (a/g) frequencies in columnar form. In this case, I have to give credit to the DOT charts: Each airport's information is much easier to read on the DOT chart and it gives

## Glossary Of Terms And Acronyms

**ARTCC (Air Route Traffic Control Center)**—A facility established to provide air traffic control service to aircraft operating on IFR flight plans within controlled airspace, principally during the en route phase of flight.

**ATC (Air Traffic Control)**—Means what it sounds like.

**FSS (Flight Service Station)**—Air traffic facilities that provide pilot briefing, en route communications and VFR search and rescue services. They also assist lost aircraft and aircraft in emergency situations, and relay ATC clearances.

**ICAO (International Civil Aviation Organization)**—Headquartered in Montreal, Canada, this agency of the UN develops the principles and techniques of international air navigation and fosters the planning and development of international air transport to ensure safe and orderly growth.

**IFR (Instrument Flight Rules)**—A set of rules governing the conduct of flight under instrument meteorological conditions.

**ILS (Instrument Landing System) Approach Plate**—Diagram published by the FAA and privately that depicts the procedure pilots need to follow to execute an ILS approach.

**NAVAID (Navigational Aid)**—Transmitter that helps pilots navigate from one point to another.

**NOTAM (Notices To Airmen)**—A notice of information that contains timely data concerning the establishment, condition, or change in any component (facility, service, or procedure of, or hazard in the National Airspace System) which is essential to personnel concerned with flight operations.

**UNICOM**—An aeronautical advisory station primarily for private aircraft.

**VFR (Visual Flight Rule)**—A set of regulations that a pilot may operate under when weather conditions meet certain minimum requirements. They are to be followed when there is sufficient visibility for aircraft to be seen and avoided.

**VORTAC**—The VOR system is the backbone of air navigation in the US and most other countries. It is composed of usually round buildings, about 30-feet in diameter, with a cone sticking out of the top. Many are painted in a red and white checkerboard pattern. VOR is an acronym for Very high frequency Omni Range. VORTAC is the same with TAC, standing for TACAN, a military designation for its distance information on a VOR signal.

**WSI (Weather Services International)**—Headquartered in Andover, Massachusetts with offices in Birmingham, England, WSI provides weather-related products and information to professionals in the energy, aviation, and media markets, as well as multiple federal and state government agencies.

## Full 800 MHz Scanners

**AOR AR-8600MKII**

**\$1199 US** Wideband mobile rx  
 - 0.1 to 3000 MHz  
 continuous. (unblocked)  
 All modes: NFM, WFM, NAM, WAM, USB, L/USB  
 - Alphanumeric memory  
 - Improved front end - Computer control - Improved TCXO  
 - 1000 memories - 20 banks x 50 mem - 40 search banks  
 - 2 VFO's - Up to 37 ch/second search - Optional cards



**ALINGO DJ-X2000**

**\$715 US** Intelligent Wideband Receiver  
 - 0.1 to 2200 MHz continuous. (unblocked)  
 - NFM, WFM, AM, USB, LSB & CW  
 - Flash Tune nearby signals - Transwreaper  
 - Channel scope  
 - 2000 memory channels  
 - Superb sensitivity  
 - Various scanning modes - Menu system



**ICOM IC-R5** (unblocked)

**\$289 US** "Compact wideband portable receiver!"  
 - Freq coverage, 1.1 to 1300 MHz  
 - Modes of operation AM, FM, WFM  
 - 1250 Alpha memory channels  
 - CTCSS and DTCSS tone squelch  
 - DC power jack - Large LCD Display



**OPTOELECTRONICS YUPITERU**

Guaranteed Delivery to USA.

[www.Radioworld.ca](http://www.Radioworld.ca)

Phone: **416-667-1000**  
 FAX: (416) 667-9995 sales@radioworld.ca  
 4335 Steeles Ave. W., Toronto, ON Canada M3N 1V7



Check out our Web site at:  
[www.popular-communications.com](http://www.popular-communications.com)

## IR REMOTE RADIO CONTROL

Remote control your Shortwave Receiver, Scanner, or ICOM transceiver from your easy chair with the SWL IR Remote and a Universal TV Remote control.

- SWL IR Remote for Drake R8/A/B..... **\$89.95**
- SWL IR Remote for ICOM IC-R75..... **\$79.95**
- SWL IR Remote for ICOM Transceiver.. **\$69.95**
- SWL IR Remote for Kenwood R-5000... **\$79.95**

[www.swl-remotes.com](http://www.swl-remotes.com)

**POWERPORT™ IC-T90**  
 Leather or Neoprene pouches



New for the ICOM IC-T90  
 Beautiful glove leather with a spring steel belt clip or sporty neoprene in red or black. Well padded with water proof material.

STARTING AT \$14.49 800 206-0115 [www.powerportstore.com](http://www.powerportstore.com)

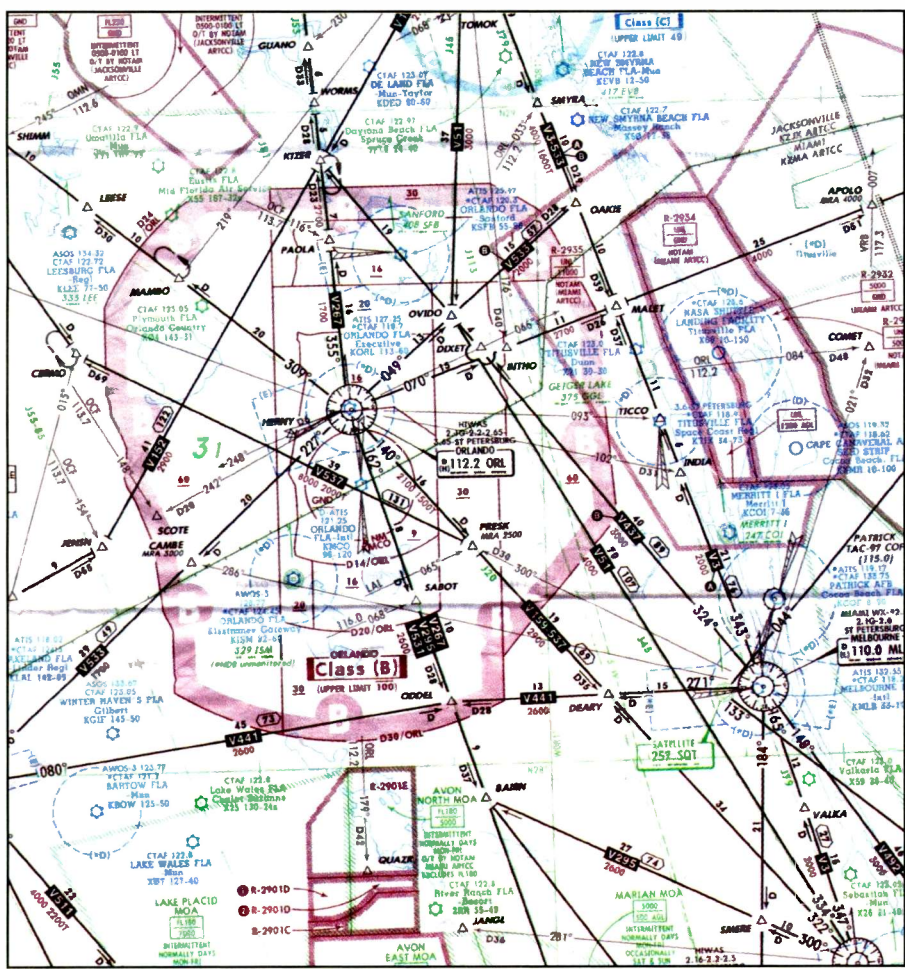

The Jeppesen chart is certainly different from the DOT chart. Note: Not for navigational use.

airports with Class C and B airspace and where fixed wing special VFR operations are prohibited.

Side 2 of this chart is worth its weight in gold-pressed latinum (okay, worth its weight in gold for you non-Trekkers). To get the charts and info found on this side would take numerous books or magazines, taking up much precious book shelf space. There are no less than 15 charts here, which most of you can use at your location.

Panel 1 on the left side of the chart has, from top to bottom, the format for Pilot Weather Reports (PIREPs), Aviation Weather Reports Key to Aerodrome Terminal Forecasts (TAFs), and Aviation Routine Weather Reports (METARs). There are examples of each with a sample decoded report. At the bottom of panel 1 is a chart of light gun signals used by local tower controllers to communicate, very basically, to pilots with missing or inoperative radios.

Panel 2 has basic transponder codes used by pilots, followed by the alphabet in both Morse code and ICAO phonetics. Panels 3 and 4 have a map of the lower 48 with stations utilizing the Enroute Flight Advisory Service (EFAS). A brief explanation of the EFAS system is located on panel 4.

Panels 5 and 6 have maps where winds and temperature aloft forecasts are available as well as aerodrome forecast locations. The information based on these maps is available from the various FSSes throughout the country. If you listen to the in-flight portion of an FSS you may notice pilots requesting VAD winds. This is because the winds from these facilities are forecasted, and, like most forecasts, can be wrong. VAD (rhymes with bad) is short for Velocity Azimuth Display. This is a measurement of actual real-world, real-

all airport IDs (not found on the Jep chart) and UHF frequencies for those of you who like to follow our military aircraft.

Lastly, the Jeppesen LO charts (at least all that I've found) are the same scale: 1 inch equals 10 nm, or nautical miles (I'm not sure, yet, about those in the northwest United States). The DOT charts, on the other hand, have a tendency to have varying scales, even on charts printed back to back. The charts covering Florida, Georgia, and South Carolina are a good example. L-19 is drawn so that 1 inch equals 16 nm; L-20, which is on the back side, shows 1 inch equaling 12 nm. Hats off to Jeppesen here.

**Recommended: PLANNING 1 And 2 US From Jeppesen**

However, if you normally get only the chart(s) covering your local area, whether you buy the DOT or the Jep chart, there is one other that I highly recommend. It is the PLANNING 1 and 2 US (FP/LO) from Jeppesen.

Side 1 has two maps on it. The large one is the complete low-altitude airway structure for the entire lower 48 states on one map. It's at a scale of 1 inch to 75 nm. Because of the complexity of the structure from Chicago to D.C. and New York, that information is placed in another map on side 1, at a scale of 1 inch = 40 nm. On that same side is a chart of all

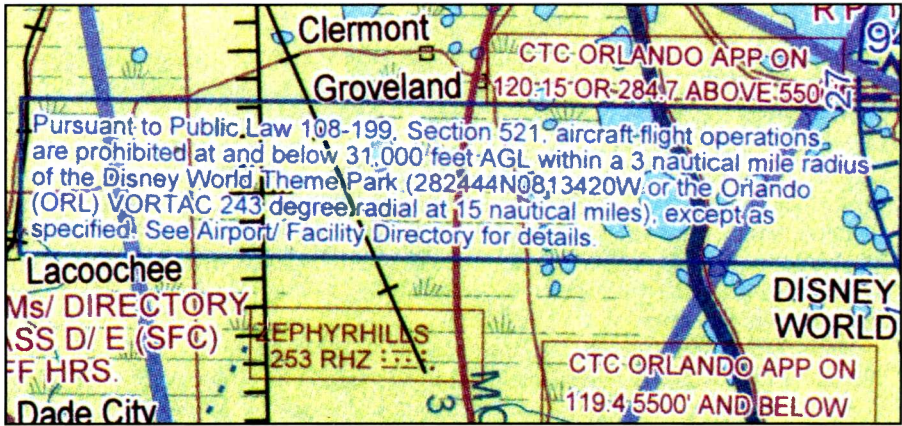

The Disney World 31,000-foot error. Note: Not for navigational use.



time winds, where Doppler radar picks up the movement of dust particles in the air and presents the information graphically for the FSS controller. The sites of VAD winds are the same for the winds aloft locations. The Aerodrome Forecast Locations map gives the airports that have a terminal forecast. These forecasts are only good within a five-mile radius of that particular airport. All other airports must use an area forecast.

Panels 7 through 9 give all airports in the lower-48 states that issue METARs and TAFs, along with the official airport names and the three-letter identifiers. Panel 9 shows, from top to bottom, basic Revision Data for the chart (this chart is also revised every 56 days), information concerning what the chart(s) is/are designed to do, a sample FAA Flight Plan form, a listing of aircraft equipment suffixes, recommended IFR position reporting procedures, and information concerning Daylight Saving Time throughout the country. Finally, on panels 2 through 9 is a distance chart for estimating mileage (in nm) for 100 airports in the 48 contiguous states.

The bottom line: If you can acquire this Jep chart at your local Fixed Base Operator (pilot training school/airplane rentals), do so.

## Turbulence?

We're now in the middle of the summer season and those of you who listen to pilot reports may hear some statements about turbulence. Before I give turbulence ratings (yes, turbulence, like icing, is rated), let me give you some facts concerning turbulence and flying:

- Generally air is smoother above the cloud tops and haze layers.
- Turbulence can be expected up to 20 miles from a thunderstorm.
- In-flight aviation weather includes alerts about convective and clear air turbulence.
- "Wave-like" or "herringbone" cloud patterns, as seen on satellite imagery, are often associated with mountain wave turbulence.
- In mountainous terrain, when winds aloft are 35 knots or greater, severe turbulence can and should be expected.
- Windshear and its accompanying non-convective turbulence are more intense above and downwind of mountain ranges.
- Clear air turbulence is often found in the vicinity of jet streams.
- Curving jet streams are more apt to have turbulent edges, especially jet streams that curve around a deep pressure trough.

Pilots reporting turbulence always give their type of aircraft. Turbulence (and icing, for that matter) that is reported as moderate to severe in a small aircraft, like a Cessna 150 or Piper Cherokee, could be considered light in an air carrier like a Boeing 757. When controllers relay PIREPs to pilots, it's almost certain that the type of aircraft is included in the report.

The ratings of intensity of turbulence are as follows:

*Light turbulence*—causes slight, erratic changes in altitude and/or attitude (pitch, roll, yaw).

*Light chop*—causes slight, rapid, and somewhat rhythmic bumpiness without appreciable changes in altitude or attitude. In both of these cases, the occupants may feel a slight strain against seat belts or shoulder straps. Unsecured objects may be displaced slightly.

*Moderate turbulence*—changes in altitude and/or attitude occur, but the aircraft remains in positive control at all times. It usually causes variations in indicated airspeed.

*Moderate chop*—causes rapid bumps or jolts without appreciable changes in aircraft altitude or attitude. Inside the aircraft, moderate turbulence can cause occupants to feel strains against their seat belts. Unsecured objects are dislodged.

*Severe turbulence*—causes large, abrupt changes in altitude and/or attitude. Large variations in indicated airspeed. Aircraft may be momentarily out of control. Occupants are forced violently against seat belts. Unsecured objects are tossed about.

*Extreme turbulence*—aircraft is violently tossed about and is practically impossible to control. It may cause structural damage.

The duration of turbulence is reported as occasionally (less than one-third of the time), intermittent (one-third to two-thirds of the time), and continuous (more than two-thirds of the time).

To get additional information concerning weather from the FAA, go to its website at: [www.faa.gov/ats/ars/arw/arw\\_home.htm](http://www.faa.gov/ats/ars/arw/arw_home.htm).

## Lakeland's Sun-n-Fun

This past April I was privileged to be a part of probably the last group of FAA controllers to man the Lakeland Temporary Flight Service Station for Sun-n-Fun. Among other things, we were giving pilots a complimentary copy of the 2005 Florida Aeronautical Chart, produced by the Florida Department of Transportation. It's a complete map of the state of Florida, published at a scale of 1:1,000,000, the same as the World Aeronautical Charts.

Since it's not published by the U.S. DOT or Jeppesen, it is to be used for planning purposes only, not for actual navigation. One glaring, if not humorous, error is found on the chart. Since shortly after September 11, numerous Temporary Flight Restrictions (TFRs) have been established throughout the country. Two have been set up over theme parks: Disneyland in Anaheim, California, and Walt Disney World, near Kissimmee, Florida. The restrictions prohibit pilots from flying below 3000 feet agl (above ground level) over these parks. However, the Florida-produced map gives the restriction over Walt Disney World as the surface up to 31,000 feet. Even President Bush doesn't get that much airspace above him.

## Spot The "Not"

Finally, here's my periodic "Spot the Not." Even though it's been nearly two years since the final *Lord of the Rings* movie came out, I decided to find some of the aviation intersections with names from the movies. Which one(s) of these are not fixes?

BILBO, FRODO, STING, GOLUM, PIPIN, MERRY, WIZRD, DWARF

Give up? There are three here that are not real: GOLUM, PIPIN, and MERRY. All the others are real. BILBO is eight miles from Oroville, California; FRODO is 16 miles from Huron, South Dakota; STING is 18 miles from Key West, Florida; WIZRD, is 12 miles from Wilmington, Ohio; and DWARF is 15 miles from Ketchikan, Alaska.

Thank you for reading "Plane Sense." I'll have a new column coming your way in November! ■

# REACT, At Home And Offshore, Too



**R**EACT Teams serve communities worldwide as well as across North America. Recently, marking their 40th Anniversary as part of REACT, REACTers from several Teams in the Caribbean nation of Trinidad and Tobago conducted a joint operation on very short notice

Forty-one REACT members, with less than a week to plan, provided logistical communications for “Sci-TechKnow-Fest,” a national science fair of higher learning. The fair extended over 12 days, so it was a mammoth task for the REACT Teams. Ten REACT personnel were on duty at all times throughout the science fair, with coverage provided in two shifts per day. Members’ own radios were supplemented with eight trunked portables, willingly loaned for the assignment by radio supplier Illuminat.

In addition to their communications responsibilities, REACT volunteers also staffed a REACT display area at the fair. They demonstrated the various types of radios and other equipment they use in support of their communities to keenly interested fair visitors.

When the event was over, REACT had contributed 1,318 man-hours to its success and had devoured 244 meals. The National Institute of Higher Education, Research, Science and Technology expressed its appreciation to REACT for its efforts. Each REACT operator received a small gift, and the Teams received a donation of \$1,130 to further their safety communications efforts.

REACT gained new respect for its capabilities from a government body.



*Time to relax. These Trinidad and Tobago REACTers unwind after 12 days of non-stop communications duties at the Sci-TechKnowFest higher learning science fair. The achievement highlighted their 40th anniversary celebrations as part of REACT worldwide.*

Teams also gained an excellent opportunity to work together and combine their skills in an important undertaking. REACT Trinidad and Tobago is ready and eager for its next challenge. What a great way to celebrate your 40th Anniversary as part of REACT!

## More Than Just Talk

Dallas County (Texas) REACT has been responsible for operating the Radio Communications Center for Dallas Area Red Cross since 1999. When massive flooding hit Dallas County, the Red Cross needed all of REACT’s expertise in “new technology” to cope with the disaster.

REACT was asked to install 28 wireless computers and get them fully operational. The computers were linked by satellite to a central Red Cross database in Virginia and were needed “yesterday.” The computers were soon working flawlessly, and Red Cross officials were amazed by the REACT Team’s flexibility. REACT service offers new opportunities for those with computer and other electronic skills. If you’re shy,

you may not need to talk on a radio at all—there are plenty of other ways to pitch in.

## REACT Month All Year

Wheeling, Illinois, police recently called Chicago Metro REACT to their headquarters. The Team naturally wondered what was up—especially when police said they needed the entire Team, *now*. No reason was given. When all the REACTers had assembled at police headquarters, their liaison officer escorted them into the training room.

As she opened the door, REACTers saw the entire Command Staff present, along with the Mayor and a village Board member. Police wanted to honor the Team for its many years of volunteer safety communications. The REACTers were astonished as each REACT member received a plaque to commemorate the occasion. Everyone then enjoyed a pizza party with the Team as guests of honor. It was a night to remember!

REACT Month comes in May, but sometimes a town just can’t wait for



REACT Mobile Command Post 246 proved its worth. Massillon Stark County REACT and several other Ohio REACT Council Teams used the Command Post to coordinate their efforts in support of police. The six REACT Teams assisted police with manual traffic light control on eight state high school playoff game days over a two-week period.

REACT Month to say, "Thanks, and well done" to their REACT Team. Congratulations to all!

### Yes, Officer

Police asked Massillon Stark County (Ohio) REACT for some help—and they got a lot more than they bargained for.

The Ohio State high school football playoffs were coming to town, and police wanted the REACT Team to control traffic lights manually on game days. However, the eight games were scattered over two weeks. Massillon REACT realized it couldn't handle the lengthy assignment alone.

A quick call went out from the Team to the Ohio REACT Council mutual aid officer. Help came—and how! Tri-City North, Great Lakes, Medina County, Flag City, and Central Ohio REACT Teams all responded.

The heavy traffic flowed smoothly on the eight game days, and police commended REACT later for its help. They were surprised to learn that six Teams had actually participated and functioned as such a fine-tuned unit.

What a great mutual aid exercise the State playoffs provided for REACT! These six Teams now know they can perform effectively together in any emergency that their area of Ohio may face.

### Got The Fever?

Has reading about these REACT Teams and their exploits got you thinking that the REACT life could be for you too? Check out the "Team Directory" on the REACT website at [www.react-intl.org](http://www.react-intl.org). You may find a Team nearby that could use your radio or electronics skills. If not, you can get details on the website about forming a Team to serve your community. Or, you can call REACT HQ at 866-REACT-9-9 for membership information. Remember to stop by again in November's *Pop'Comm* for more inspiring reports on REACT Teams' community service. ■

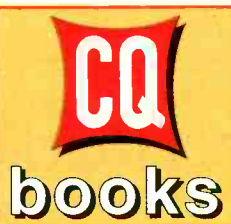

### McCoy on Antennas

by Lew McCoy, W1ICP  
Unlike many technical publications, Lew presents his invaluable antenna information in a casual, non-intimidating way for anyone!

Order No. MCCOY \$15.95

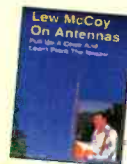

### VHF Propagation A Guide For Radio Amateurs

by Ken Neubeck, WB2AMU & Gordon West, WB6NOA

A comprehensive source-book on VHF propagation by two great authors! Here's a sampling of what you'll find inside:

- Tropo Ducting • Aurora • Meteor Scatter
- TEP • Sporadic-E • Combo Modes

Order No. VHFPROP \$15.95

### Contesting in Africa Multi-Multi on the Equator

by Roger Western, G3SXW and the Voo Doo Contest Group

A compelling array of contesting and DXing experiences from one of the most unique operating venues on earth - the African continent. The personal stories told by the world-renowned and witty personality, Roger Western, G3SXW, make this book a must have in any ham radio library.

Order No. AFRI \$19.95



### The Short Vertical Antenna and Ground Radial

by Jerry Sevick, W2FMI

This small but solid guide walks you through the design and installation of inexpensive, yet effective short HF vertical antennas. Antenna restrictions a problem? This book could keep you on the air!

Order No. SVERT \$10.00

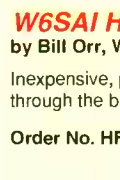

### W6SAI HF Antenna Handbook

by Bill Orr, W6SAI

Inexpensive, practical antenna projects that work! Guides you through the building of wire, loop, Yagi and vertical antennas.

Order No. HFANT \$19.95



### HR Anthologies \$19.95 ea.

Buy all 4 for only \$75

Now you can enjoy collections of the best material published in *Ham Radio* magazine, conveniently arranged by subject and original publication date. Choose your interest, your time period and choose your anthology!

- Homebrewing Techniques... Order # AHOME
  - Test Eqpt & Repair Techniques... Order # ATEST
  - Antennas - 1968 - 1972 ... Order # ANTS1
  - Antennas - 1973 - 1975 ..... Order # ANTS 2
- Get all 4 for \$75 + Free shipping ... Order # ASET

### Heathkit - A Guide to the AR Products

by Chuck Penson, WA7ZZE

This greatly expanded Second Edition is a must for collectors and Ham history buffs! Pick up this 328-page volume and you won't be able to put it down!

Order No. HEATHKIT \$29.95



Shipping & Handling: U.S. & Possessions - add \$5 for the first item, \$2.50 for the second and \$1 for each additional item. \* FREE shipping on orders over \$75.00 (merchandise only). Foreign - Calculated by order weight and destination and added to your credit card charge.

**CQ Communications Inc.**  
25 Newbridge Rd., Hicksville, NY 11801  
516-681-2922; Fax 516-681-2926  
Order Toll-Free 800-853-9797

# Radio Past, And Radio Future

First off, let me start by saying this isn't our normal "ScanTech" column. Not by a long shot. But if you'll permit me to digress for a bit, I think you'll find it a worthwhile read. I promise more VHF/UHF intrigue (or at least our normal babble) next month. There is a scanning connection, but you'll have to wait until the end to find out. Or cheat and read it now.

## Never Trust A Coincidence

This relatively true statement was uttered several times by the great fictional detective Nero Wolfe, the Rex Stout private detective that did a lot to establish the genre of fiction loosely called detective mystery today. Despite this caveat, three things came together that prompted me to write this month's column about radio past and radio future.

### MP3

Okay, so MP3 isn't particularly recent. I'd been watching this area for some time and, in fact, had talked with Harold several times about an article on Old Time Radio in MP3 format. I still have intentions of doing this, but we'll hold that thought for another time.

What's happened recently is the explosion of all kinds of content (audio, of course) available in MP3. If you're tuned into the Internet, you've seen MP3 every time you turn around. It does not seem to be slowing down any.

### Dayton Hamvention

I just got back from Hamvention 2005 in Dayton. If you haven't been there at least once, it's quite a weekend full of overindulgence in radio and overload of information in general. One of the frequent topics of conversation that I was eavesdropping in on the bus to and from the parking lot was about the attendance of this year's show.

Over the past several years, attendance seems to have fallen. The truth is that it was actually up by about 500 this year, to just over 20,000. But that's 13,000 less than the peak years in the early 1990s. That's a lot of missing folks.

The display area seemed to have wider aisles this year, indicating that there were fewer commercial vendors than in years past, and likewise the flea market outside had been reduced in size by about one third. That, probably more than any other factor contributed to the general buzz about low attendance.

What's happening? There's a lot of speculation by everyone concerned. Other interests are probably the real key, but there are some other contributing factors as well. There are simply more distractions than there used to be, particularly for young people looking for a lifelong hobby. People who find radio usually do so because they have a friend who introduced them, or because some world or local event caused them to become interested in shortwave reception or scanning. If there are fewer of us around to introduce others, then it's going to follow that fewer people are interested. Yet the number of licensed hams is not all that much different than it was 5 years ago. The number of

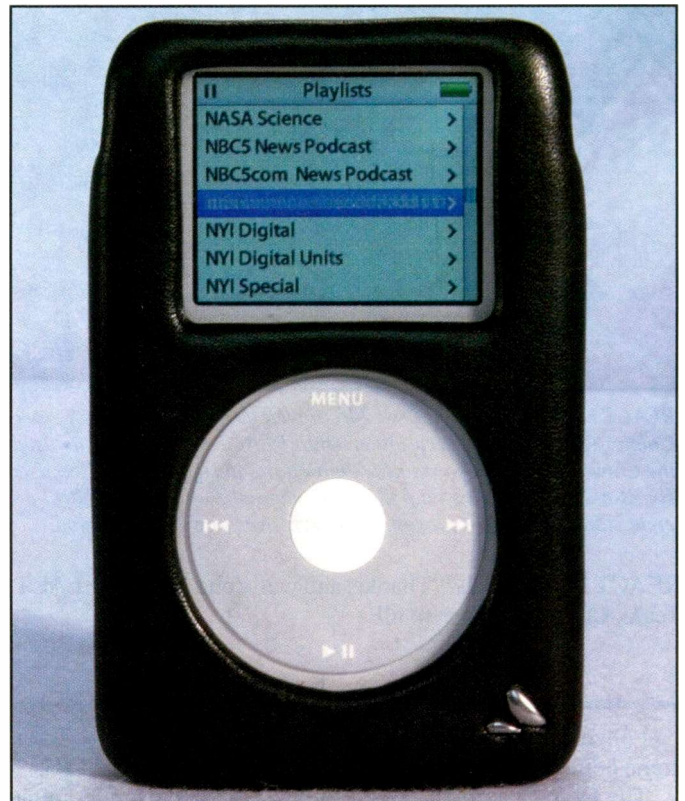

The term "Podcasting" comes from the iPod, the popular MP3 portable player, since many of the early "Podcasters" were involved with the iPod in one way or another. But you don't have to have an iPod to join in. Virtually any MP3 player will work, although some may require a bit more effort to get the files loaded onto your player.

listeners is harder to gauge, but I suspect it's probably not fallen much, although perhaps the type of listener has changed.

It also seems to me that people don't stick with a hobby as long as they used to. Perhaps because there are so many different things to try. When I first got started in radio, people used to talk about being bitten by the radio "bug" and getting addicted. For many of us, that's entirely true. It's a hobby that you can pick up and put down as time, interest, and finances permit, but does it ever go completely away?

The Internet gets blamed a lot. People are spending more time on the Internet or with computers and less time on the radio. And you can find anything you might need for your radio setup on the Internet faster than by taking a trip to Dayton. At one time people went to Dayton with shopping lists of parts they would need for the coming year. Antenna repair parts, new radios, spare parts, and even things to build projects with were all on the list. These days, I don't think many people build things at all anymore, and you're more likely to find a reliable Internet supplier and order what you need when you need it, rather than wait for an annual trip to anywhere.

Perhaps the economy is playing a factor, too. The market in a post 9/11 world is changed. Travel is not as easy or fun as it



Many major broadcasters are trying their hands at this with more to come. This BBC Download and Podcast trial was one of the things that made me realize just how seriously the broadcast industry is taking this.

used to be. Although we're being told that airline travel is finally back up to pre-9/11 levels, three and a half years is a long recovery time.

Whatever the reason, it's clear that the nature of the "listening hobbies," and ham radio in particular, is changing. Perhaps the long-term future doesn't include large hamfests, but rather more local events.

#### Podcasting

Here's where the coincidence comes in. Just after I returned from Dayton and was thinking about this month's column, I heard on broadcast radio a discussion of Podcasting and the perceived threat it poses to traditional broadcast radio as we know it today. If you're not familiar with the term, let me expound.

Podcasting refers to the current trend of producing MP3-based audio files intended for download from the Internet and then upload onto your favorite portable player to take along for the day. Since the Apple iPod has a corner on the market, it lent its name to the phenomenon and broadcasting to the iPod became simply Podcasting.

What makes this method unique from any of the hundreds of sites that you can download MP3 audio from is the addition of Really Simple Syndication, or RSS, which is a way of distributing information from a website that the user has complete control over.

For instance, if you find a website that has information of interest to you, you may choose to join its mailing list. If you have joined any of these e-mail lists, you know that you quickly start getting other e-mail that you didn't really want. Well, RSS puts the ability to subscribe and unsubscribe under the user's own control. The RSS client software on the user's computer has to go and get the "feed." If the user says "stop getting this information," it stops right then.

RSS does require a "reader" on your computer. Luckily, there are many out there that are free for download. The first version of RSS didn't get a whole lot of attention, because it was used mainly to distribute news and updates in text form. The relatively recent RSS 2.0, however, allows for attachments to be distributed as well, and that's where Podcasting comes back into the picture. The attachment can be an MP3 sound file.

The "Podcaster" sets up a website with an RSS 2.0 feed that includes the daily or weekly MP3 file as an attachment. More sophisticated RSS client software will take that MP3 attachment and transfer it right to your media player, so that a list of new Podcasts is ready for you whenever you care to listen. Plug in

your player to sync things up and your news or other Podcast information is ready and portable. Radio to go. Radio on demand, and by subscription—what you want, when you want it, and if you get bored you can switch to another play list and listen to your favorite tunes, or maybe a Nero Wolfe mystery audiobook instead.

Until recently, Podcasting a fairly obscure medium. Many Podcasts are nothing more than audio weblogs of what a person did or where they went that day. Not my idea of good entertainment. However, there are *now* many excellent programs available on the Web. Lots of commercial and public stations make programs available via streaming media, like Real Player or Windows Media player. NPR and the BBC have made many programs available this way in recent years.

That's great, and it certainly is better than not being able to hear the program at all, but I don't want to listen at home when I have an Internet connection. I want to be able to listen when I'm in the car and can't do much else.

### It's Catching On!

Over the past months, I've noticed that this idea seems to be catching on with many sites. Several pre-made programs are now available in both a streaming format and as an MP3 download. One very popular one is "Science at NASA" ([www.science.nasa.gov](http://www.science.nasa.gov)). You can subscribe to an e-mail list and receive a daily message with a link to a site for audio, which typically runs two or three minutes. But with this e-mail distribution, you have to remember to go get it, then move it from the download folder to your music player and then sync the player to get the information transferred. I usually did this about once a month and had a bunch of catching up to do all the time. Many of offerings are date-sensitive, so the information was lost.

"Science at NASA" recently added a Podcast to its arsenal, however. Now, *I don't have to go get it—it comes to me*. I just have to remember to hook the player up at night and it syncs over. So I can listen daily if I'm up to it. I have iTunes (my music player since I'm using an iPod) create a playlist, called Podcasts, which has things from the last 14 days that I haven't listened to. If I don't get to it in 14 days, I figure I probably won't at all, so it falls off the playlist. The only thing I have to remember now is to go through and clean out the old Podcasts from iTunes once in a while so I don't fill up the player with old archives.

There are lots of offerings coming online, from real content from major broadcasters to folks at home who know how to produce a show and everything in between. Some of them are quite enjoyable to listen to, some have entertainment or education value, and some are just terrible. The neat thing is that you can choose what you listen to and when you listen.

Many sites exist just to help you find Podcasts. A recent search on Google for the word Podcast yielded 10.7 million

### Frequency Of The Month

Let's have a look at the aviation band this month for a change. Plug **121.8** into your scanner and see what you hear. Send me an e-mail to [radioken@earthlink.net](mailto:radioken@earthlink.net) with 121.8 in the subject line and we'll enter you into the drawing for a one-year subscription to your favorite radio magazine. You can also reach me via traditional methods at Ken Reiss, 9051 Watson Rd. #309, St. Louis, MO 63126. Make sure to put 121.8 on the envelope if you're entering the drawing. Also, remember that you don't have to hear anything to enter!

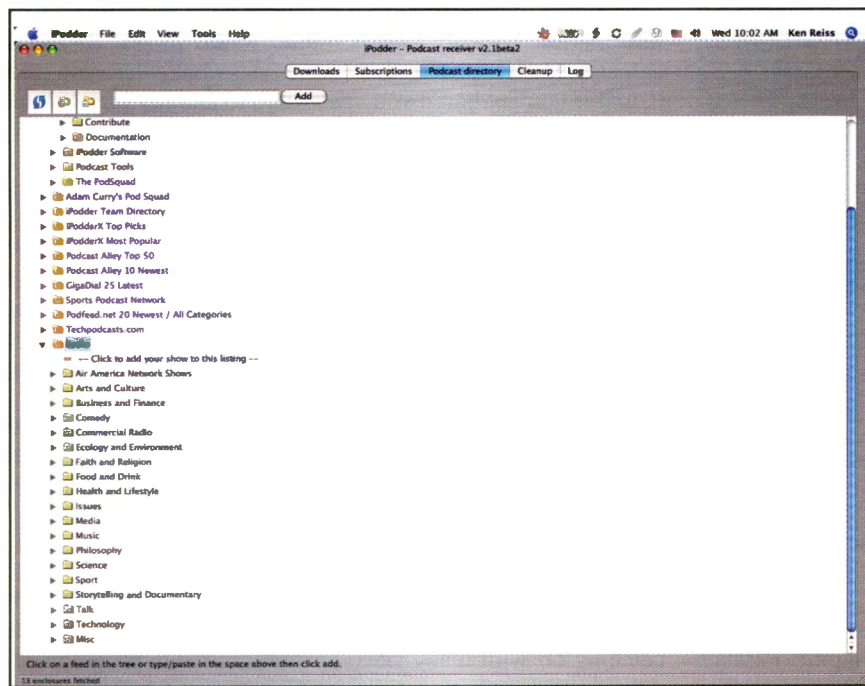

A long list of broadcasters is starting to appear on some of the Podcast directories. This is iPodder for the Mac, but it's one of the few programs that has both platforms available. You pick what you're interested in and tell it to subscribe. There are many applications available that will receive RSS 2.0 feeds (the engine that drives Podcasts) but the real magic is in those that automatically download the file and pop it into your player for you.



There are lots of other ways to listen. You can listen just on your computer, but the whole idea is to be mobile. The MP3 CD player is a great way to access a lot of content with very traditional tools. This particular model is now discontinued, but look for the magic "MP3" on any CD player that you're interested in.

hits. That's a lot of hits for an obscure geek trend.

## Now Back To That Podcasting Discussion

So now that you know what Podcasting is, we can talk about the show I heard. Unfortunately, I came in during the middle of it so I don't know exactly

what it was, but what caught my ear was the word Podcasting. They were discussing what a major impact Podcasting could have on broadcast radio. What? Really? They were also discussing the recent entry into Podcasting of major players like the BBC. That was news to me, too. ABC and NBC have both announced plans to at least experiment with the medium. Some major players are interested at this point, and according to the program, some of them are quite worried.

There's enough concern out there to warrant the discussion. I went to the BBC site and, sure enough, right on the front page was an announcement that the British behemoth was running a trial from May to December involving 12 programs—Podcasting! Many are live now, and most others probably will be by the time you read this. Check it out. If it's not still on the front page, do a search for Podcast once you get to the BBC site and you'll find it fairly quickly.

The BBC actually cited the availability of other distribution methods as part of the rationale for discontinuing the shortwave broadcasts to North America. Perhaps they've finally found one that will reach a large audience. World Service in your pocket? Could it really impact the broadcast world? I'm not sure, but it appears there is concern. Younger listen-

ers are not so interested in radio because they're used to controlling their own content. CD players, tapes, MP3 players, and many other gadgets make it possible for people to script their own programming for a day or longer.

Think about it: A 20-GB iPod can hold literally days' worth of music or other programming—all commercial free and all comprised of what someone is interested in listening to. Why would you put up with even FM radio and the never-ending stream of commercials and bad music when you can have your own favorites all day? Listen to the news you're interested in when you want, not just at the top of the hour. Refresh the content over night and start over if you like. It could really get interesting.

## Who Gets Paid?

One of the sticky issues with Podcasting so far is on the commercial side. How are the Podcasters who are producing commercial-quality programming, and doing it full time, going to pay the bills? So far, there are a few that are sponsored, with attendant commercials, but apparently there's some resistance on the part of the listener to much of this. I suppose it's going to depend on content.

If the sponsors can't advertise, then how about having the listener pay for the programming? That may have some merit for excellent content. Many NPR programs and several others are available from a service called Audible.com. Audible specializes in downloadable audiobooks, but they've got quite a few "subscription" publications as well. There's an audio version of *The New York Times*, *The Wall Street Journal*, "Your Mac Life," and several NPR programs—all on a pay-per-download basis. Perhaps the commercial Podcasters can jump on the bandwagon, or find a way to implement some nominal charge per program to help defray production costs. Either way, good programming probably won't remain completely free. But a few commercials might not be such a bad thing after all.

It appears that the seeds of change could well be taking root in the broadcast world, too. Perhaps radio as we know it is in a state of flux. But what would be new about that, really?

## The Scanning Connection

So what does all this have to do with scanning? I get at least one letter a month,

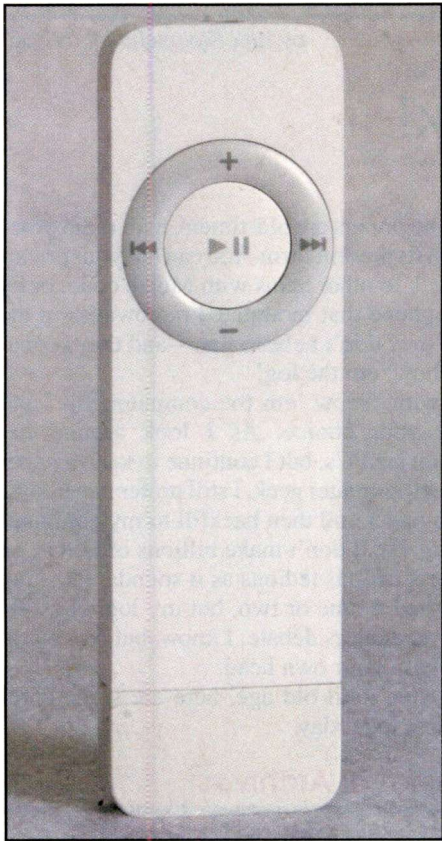

Flash base players like this iPod Shuffle hold anywhere from a couple hours worth of music to as much as a couple of days of programming in many of the spoken word formats. This player currently has a mixture of music and spoken content for about 14 hours worth, plus a few computer files as a flash drive. Capacities range from 128MB to 1GB now but 2GB soon will be common too. Even the lower memory and therefore cheaper players can hold quite a bit of content if you're interested in Podcasts or other spoken content.

often many more, with a question like, "What's the future of scanning?" or "Should I buy a new radio if scanning is going to switch to (insert whatever phrase you like here)?" The inserted phrase is reflective of the latest threat to our ease of listening. Trunking was the big threat for a while; now digital is it. But digital's been dealt with, too, at least to a large extent.

When I first got involved in scanning, well actually, listening (my first public safety radio didn't actually scan), the friend who got me started knew a couple of the local police officers. One day, one of the officers dropped the bomb that we wouldn't be able to listen after Friday because they were adding something called "Private Line." You're smiling because you know what we would soon find out about "Private Line." But for a week back then we were terrified that the

whole world of public safety communications was going to be gone.

Friday came, and I switched on the receiver the first thing in the morning to hear what kind of noise was going to replace the signals we were used to hearing. What I heard instead was business as usual. "Private Line," it turned out, was nothing more than tone squelch to help keep the transmitters from interfering with each other. It had nothing to do with receiving. Today, we have scanners with CTCSS (Continuous Tone Coded Squelch System) to help reduce interference and help us hear only the agencies we're interested in monitoring. Motorola's implementation of CTCSS is called "Private Line." So much for the scanner-killer technology.

But coming back to our future, will it be different? Yes. It takes a certain amount of sophistication and dedication to learn to program a trunking system into your scanner. The radios are making it easier all the time, and perhaps it won't be a big deal at some time in the future. But, for now, you need to be serious about scanning if you have a local trunked system.

Digital is a more interesting threat. On the surface, the recent introduction of APCO 25 scanners would seem to have slain that dragon, too. And to a large extent, I believe it has. Digital, however, can be more than APCO 25. It can be encrypted quite easily—and current scanning laws prevent efforts to unencrypt it. So while more systems will be switching to digital, and more scanners will have the capability to decode the standard digital signals, the door is open to the agencies to encrypt their communications if they feel the need for an extra level of security.

While that sounds a bit paranoid on the surface, if you think about recent history for a minute, it's probably not so bad. The agencies that use public safety radio have been fighting hard for the APCO 25 standard so that they can once again buy equipment from more than one manufac-

turer. Prior to that, once they had committed to a digital system, they were locked into that manufacturer's equipment and price increases. APCO 25 makes competitive bidding possible. It's likely that most of the agencies currently using analog systems will switch to APCO 25 systems the next time they do a major upgrade to their equipment. But it's equally unlikely that they'll want a proprietary encryption system unless they feel (with or without good cause) that their communications could be compromised by interception.

It's also not too much of a stretch to think about doing some time shifting of your own. We've talked in the past about recording off your scanner or shortwave receiver audio using programs like Total Recorder (Windows) or Audio Hijack (Mac). Pop those recordings into your mobile MP3 player and see what you missed last night. It's likely that the good stuff happens while you can't be listening anyway. Time shifted scanning would lose some of the "on-the-scene" feel, but it would also probably greatly increase the available time you have to listen. Of course, you'd need permission to use any of this audio for anything other than your own personal use. The Communications Act of 1934 is very clear on retransmitting or distributing audio not intended as broadcast radio. However, the owner of those communications can choose to do so. Who knows, perhaps some forward-thinking police official will be the first to Podcast police communications on a delayed basis. Once the delay is inserted, the threat of compromising an in-progress operation is completely removed.

## Part Of The Lure

Will communications change? Yes. And so will scanning, and the scanners that we use to follow it. That's what keeps the whole hobby interesting to those of us who have enjoyed it for so many years. Until next month, Good Listening! ■

The Adventures of Scammer Dweeb  
by M.A. Coletta

Wheat, whole, flakes  
fortified to 100% USRDA  
for eight vitamins & iron.  
Helps promote healthy  
scanning... all day long.

Fortified scanning

SS  
200 THRU WHOLE WHEAT  
LOW FAT  
scantes  
A Breakfast of Champions

Just add milk!

# Ham History 101: Your Logbook!

**W**arning! This month's column advocates the use of pencils, pens, and paper. And while recklessly following the suggestions herein may cause hand cramp, tendonitis, and profound symptoms of keyboard withdrawal, when applied with common sense, a lifelong warm and fuzzy feeling will ensue.

Let me explain! Years ago, when radio technology was a bit more cutting edge than it is today (and the government was a bit more "hands-on" with radio ops in general), the FCC insisted that hams keep detailed station logs, including date, time, mode, call signs, frequency, power output—the works. Every time a QSO occurred, the next blank line in the handy *ARRL Logbook* was carefully, painstakingly filled in. In addition to regular QSOs, hams even had to log unsuccessful CQ calls. Every transmission, no matter how brief, had to be logged!

Look at an old-timer's logbook and you'll see pages of unanswered CQ calls trailing down the page (well, hopefully not pages of unanswered calls). We don't have to get that detailed today. In fact, we aren't required to keep a log at all! But maintaining an accurate station log is still worthwhile today—and will be priceless tomorrow.

It's been almost 30 years since I made my first log entry, and I'm amazed at how just looking at my first logbook is like jumping into a ham radio time machine. Without the benefit of the log I can remember a few of my early QSOs, the QSOs that shaped my Amateur Radio career. With the log, however, I can remember those QSOs in great detail, as if I'm watching a big-screen movie in my mind's eye.

With my logbook scrawls and notations I can *hear* the CW coming from my first transceiver, my prized "first real radio" that I worked an entire summer to pay for. I can *feel* my trusty J-38 straight key—now unused for years—to which I added a drilled-out poker chip "knob enhancer." I can remember the thrill of working countless DX stations that I would have otherwise forgotten.

The simple act of keeping a station log has kept those memories fresh for two decades. And as long as I have those pages, they'll stay fresh for as long as I'm around. If you don't keep a station log for any other reason—and there are many present-day incentives for keeping an accurate log—keep it for your own future nostalgia.

When some of you beginners are old-timers, ham radio probably won't even exist in its present form. You can tell your grandkids, "Yep, I used to talk to other hams with Morse code, or by speaking into a microphone that modulated radiowaves in the MF/HF spectrum!" If they don't believe you—and they probably won't—you can show 'em the log!

You may counter with "show 'em the computer log," and that's okay if that's your choice. As I look around my office/shack, I can count six PCs, but I continue to keep a paper log. Even as a confirmed computer geek, I still prefer paper logs. Actually, I log first on paper and then backfill to my computer log for awards-tracking, etc. I don't make billions of QSOs, so the dual logging process isn't as tedious as it sounds. Plus, my computer log has crashed a time or two, but my logbooks are still going strong. It's an endless debate, I know, but one worth having, even if it's only in your own head.

To keep you motivated until old age, here are some compelling reasons to keep a log today.

## Personal Archives

We all have information and "benchmarks" we like to keep track of; for instance, states and countries worked and confirmed, information for awards, or the names and addresses of our on-the-air friends. A well-kept station log is invaluable in your quest for the Worked All States or DX Century Club (DXCC) awards. In addition to keeping a running list of states and countries, your logbook is the perfect place to keep detailed information on a wide range of subjects.

You can track modifications and changes to your equipment. Not only will the information be easy to find for future reference, it will be easier to note the effects of such changes by referencing contacts before and after. How does your new tri-band beam compare with your old trap vertical? Check out the signal reports in your logbook and you'll have a good idea!

DXers often refer to their logs when trying to work into specific parts of the worlds. When is the best time to work Japan in the winter? A quick check of last year's log entries will probably turn up the required information.

Feel free to note other changes in your log, too. When you upgrade, note it in your log. When you get a new rig, or put up

11-19-77												
06:15	X	WDS DZG	40m	579	569	7131	"	240	06:38	ROSEWELL N.M.	BILL	<input checked="" type="checkbox"/>
06:47	X	WDSEPY	40m	589	589	7126	"	"	07:01	SIM - DOUGLAS, TX		<input checked="" type="checkbox"/>
07:26	X	WAL SCR	"	569	559	?	"	"	07:42	TONY - CHINO, CA.		<input checked="" type="checkbox"/>
14:42	X	WD4EWW	15m	589	579	?	"	"	15:01	RAY - ASTATULA FLA		<input checked="" type="checkbox"/>
15:19	DA1KV	X	15m	459	449	?	"	"	15:30	Bill - BITBURG, GERMANY		<input checked="" type="checkbox"/>

*This is an excerpt from the first page of my first logbook. As a 15-year-old ham in an age long before the World Wide Web, working DA1KV in Germany was a life-altering event. When I look through that logbook I get a feeling that is definitely not produced by looking through my computerized log listings for that era!*



that long-awaited killer antenna, write it down. This is what logbooks are for, not just recording QSO information!

## Computer Logging

Computers and ham shacks are now inseparable, especially for contesters and DXers. If you have a PC in your shack, consider using it to keep your station log; just remember to back up the log data by making archival copies and/or by printing the log to paper. In 30 years, 3.5-inch floppies and FAT-encoded data files will be readable only in museums, but paper will still be paper.

Several excellent logging programs are available, and most packages have lots of handy bells and whistles. Check the ads in *CQ*, *QST*, and other amateur radio magazines. AC6V's exhaustive list of ham radio logging programs will set your head spinning. Point your Web browser to <http://ac6v.com/logging.htm>. Logging programs may also be available through your local club or computer user's group. If you're into programming (or are a bit masochistic), consider writing your own logging software.

I have used and perused several logging programs over the years. For most contesting stuff, I use the now-free ver-

sion of *CT*; for general logging (as mentioned a few issues back), I use *DXLab*. The latter is free for noncommercial use and is actively and *aggressively* updated by its author, Dave, AA6YQ.

If computerized logging isn't your thing, *The ARRL Logbook* is just what you've been looking for. Used by millions of hams over the years, the latest version is available from the ARRL for \$5 (or from your favorite amateur radio dealer). It has room for more than 1,200 QSOs and includes useful information such as Q signals, a time-conversion chart, the ITU phonetic alphabet, an RST chart, and international call sign prefixes. Visit [www.arrl.org](http://www.arrl.org), where you'll find it in the supplies section of the catalog section. ARRL's mini logbook and three-hole-punched logsheets are also available.

## Preserve Your Own History

Whatever you do, whatever your methods, be sure to keep some kind of station log. You'll be glad you did—sooner or later! That's all for this month. Send your QSL cards, questions, and letters to "Ham Discoveries," *Popular Communications*, 25 Newbridge Rd., Hicksville, NY 11801. ■

## Earn Your HAM RADIO LICENSE The Quick and Easy Way! No Morse Code Required!!



**GWTM**  
**\$15.95**  
+ \$6 S&H

Start earning your Technician ham license today! Get on the air and enjoy the fun hobby of amateur radio. Learn from the "Master" – Gordon West, WB6NOA. Study manual includes all possible test Q&A and more – or study at your PC using interactive practice exam software – **NCS \$39.95 + \$6 S&H.**



**GSTD**  
**\$19.95**  
+ \$6 S&H

*Getting Started in Electronics* is a complete electronics course in 128 pages! Forrest Mims teaches you the basics, takes you on a tour of analog and digital components, explains how they work, and shows how they are combined for various applications. 100 electronic circuits you can build and test!

## The W5YI Group

POB 565101 – Dallas, TX 75356

Order today on the web or call:  
[www.w5yi.org](http://www.w5yi.org) ♦ 800.669.9594

Want to know more about ham radio? Call us!  
Mention this ad to receive a free gift with your order!



## If you enjoy Amateur Radio you'll enjoy CQ

It's a different kind of ham magazine. Fun to read, interesting from cover to cover, written so you can understand it. That's *CQ*. Read and enjoyed by thousands of people each month in 116 countries around the world.

It's more than just a magazine. It's an institution.

*CQ* also sponsors these fourteen world-famous award programs and contests: The CQ World-Wide DX Phone and CW Contests, the CQ WAZ Award, the CQ World-Wide WPX Phone and CW Contests, the CQ World-Wide VHF Contest, the CQ USA-CA Award, the CQ WPX Award, the CQ World-Wide 160 Meter Phone and CW Contests, the CQ World-Wide RTTY Contest, the CQ 5 Band WAZ Award, the CQ DX Award, and the highly acclaimed CQ DX Hall of Fame. Accept the challenge, Join the fun. Read *CQ*.

Also available in Spanish language edition. Write for rates and details.

## SUBSCRIBE TODAY!

CQ The Radio Amateur's Journal  
25 Newbridge Road, Hicksville, New York 11801  
Phone: 1-516-681-2922

## For Fastest Service FAX 516 - 681- 2926



	<b>USA</b>	<b>VE/VE</b>
1 Year	□ 31.95	□ 44.95
2 Years	□ 57.95	□ 83.95
3 Years	□ 83.95	□ 122.95

	<b>Foreign</b>
	□ 56.95
	□ 107.95
	□ 158.95



# Iran—The Next Nuclear Threat, Plus Some Readers' Letters

A recent crash of a U-2 spy plane (that officials say was on a mission over Afghanistan, but military insiders hint was really flying over Iran) underscores the tensions that still exist between the United States and Iran ever since the pro-U.S. Shah of Iran was ousted from power and replaced with a fundamentalist and radical Islamic regime.

It is the opinion of many inside the U.S. intelligence agencies that, with most of the media's attention on North Korea's nuclear threat, Iran remains in the background, quietly building a nuclear industry, largely with Russian help.

According to GlobalSecurity.org, a website providing background information and breaking news of a security nature,

The focus of a considerable amount of controversy in the United States, the nuclear facility at Bushehr, Iran is being built under an agreement between the Russian and Iranian governments for \$800-million...There are two reactor buildings at Bushehr...Unit I, which is in an advanced stage of completion, Unit II...has not been worked on for some time and is not currently scheduled to be completed.

Although Iran is a signatory to the Nuclear Non-Proliferation Treaty, it has not ratified two additional protocols to the International Atomic Energy Agency's Program 93+2, which is designed to prevent states from developing nuclear weapons covertly despite IAEA inspections (as Iraq was able to do prior to the Gulf War). Iran maintains that it will not ratify 93+2 due to its being denied civilian nuclear technology for Bushehr despite its positive record with the IAEA.

Recently, a new nuclear agreement between Russia and Iran has come under attack in the west. According a BBC report, "Under this new deal Iran has to return spent nuclear fuel rods from the reactor, which was designed and built by Russia. The clause is a safeguard meant to banish fears that Iran might misuse the rods to build nuclear weapons, a concern of the US, Israel and others."

Russia had been insisting that no spent fuel should be diverted for the manufacture of weapons. Iran has repeatedly said its nuclear program is solely for the generation of power, but despite Iran's denials, diplomats said investigations showed Tehran had full possession of enrichment know-how for two decades, after acquiring the information from Pakistani nuclear scientist AQ Khan's black-market network.

Despite assurances from Iran and Russia, the United States is understandably very nervous about Iran's nuclear power program. Many U.S intelligence insiders say that, with their acquired nuclear knowledge, it would rather easy for the Iranians to set up a parallel black nuclear program without (or with) Russia's knowledge.

## Electronic Ears Turned Toward Iran

Soldiers returning from Iraq have talked about a National Security Agency listening post that has been set up near the Iran/Iraq border, with its massive antennas pointed not into Iraq but Iran. The occupation of Iraq has provided U.S. intelligence agencies with something they haven't had in the past: a U.S.-

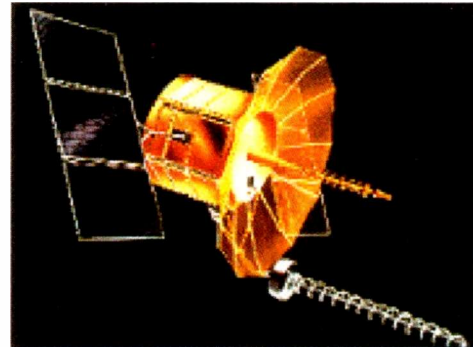

Artist rendering of a FLTSATCOM (Navy Fleet Satellite Communications) platform that many MILCOM monitors strive to intercept. FLTSATCOM frequencies are usually NBFM (narrow-band FM) and can be found in the 240- to 280-MHz range with some clear voice channels still reported in use, although most high-level secure communications have been moved to UFO (UHF Follow On Satellites) and MILSTAR communications satellites. (Photo courtesy U.S. Navy)

controlled chunk of high terrain next to Iran that lets them electronically peer into that closed and mysterious country.

U-2 and other spy aircraft engaged in ELINT and SIGINT and SAMP (nuclear sampling missions) can also be based closer to Iran than ever before because of the cooperation between the United States and other nations, such as Saudi Arabia, Qatar, and the United Arab Emirates.

The U-2 that crashed on June 23 was part of the 380th Expeditionary Wing based at the Dahfra air base near Abu Dhabi in the United Arab Emirates. When the crash occurred, however, Defense Department officials were mum about where it happened due to "host nation sensitivities," saying only that the crash occurred somewhere in Southwest Asia. The U.S. military said the plane was returning from a mission in support of Operation Enduring Freedom, which generally refers to U.S. military operations in Afghanistan. However, to get to Afghanistan, the U-2 could have flown over Iran. It is doubtful that even if the U-2 flight was flying primarily in support of Operation Enduring Freedom that it did not turn on its sensors when flying close to (or over) Iran.

In light of this, utility and MILCOM monitors might do well to keep their ears to the Middle East in general and to this area of growing of international concern in particular. No matter what you monitor, don't forget to send your intercepts to me here at *Pop'Comm* in care of this column!

## Dispatches: Your Questions Answered

*Old School/New School*

Roland J. Schwyn writes:

Your May 2005 article, "Back To Basics—Part V, Midrange Shortwave Receivers," was excellent! You asked for reader input and an answer to your question, "What serves you best?" My best two short-

wave radios are the Sony ICF-SW10 and the Radio Shack DX-440.

Both rate three stars in *Passport to World Band Radio*. The DX-440 is a real powerhouse when connected to an outside antenna. I enjoy worldwide reception (including the tropical bands) and even snagged a 3000-watt station on Tahiti!

As for antennas, I use an Alpha Delta Sloper, which rates a 4 to 5 on a 5-bar scale and includes excellent SSB and clear voice reception of Radio Club transmissions between all members in Pennsylvania.

My radio setup, by current standards, is rated in the PAST (old school-SD), with my dream radio being an NRD-345 SE.

Thanks Richard! I'm glad you enjoyed the series. How about sending us some loggings!

### Answering the Call

Steve, N2AMY, writes,

I've been silently reading your column for several years and will be making some new contributions to it in the future. After a long absence from SW listening, I've redeveloped an interest and it fits quite well with my current situation in that I work at home and have limited mobility, so it's a perfect distraction when there's nothing on TV.

I got started listening when I was about 13 on a tobacco farm in central Kentucky with an old Echophone/Hallicrafters tube receiver that a relative gave me and the hobby had a considerable impact on my life after that. To sum it up, it inspired me to learn about the world and leave the farm to go into academia, a plan which I later abandoned as I got closer to a Ph.D. when I realized the environment in universities was taking a turn I did not like.

Kentucky farm boys tend not to be "Politically Correct." I ditched academia in the late 1980s, returned from upstate New York to my roots in Kentucky and decided to go with a second career choice, which is my language capability. The choice has turned out to be a good one, and I've made a pretty good living for the past 21-plus years translating Chinese documents of all types into English, a better living than if I'd stayed in academia, actually. My learning Chinese was directly related to my hobby of SW listening and one of those things that you do when you're younger without realizing how it will eventually turn out (I'll be 54 this year).

Chinese/English translating (I work solely for the private sector now after 10 years on a U.S. government contract) tends to be seasonal, but I had unexpectedly good months last December and January, which are usually slow with the American and Chinese holidays. Since I made considerably more than I was expecting to, I decided to splurge and bought a Ten-Tec RX340 receiver and Universal M-8000 digital decoder and, with the help of a couple of friends and a chimney service, was able to get up a 100-foot hori-

zontal long wire at 35 feet with a top-quality coax dropped directly down an unused chimney to my receiver setup.

Even though I live downtown here in Lexington, circumstances worked pretty well in my favor—although I'll never approach the days when I was a kid and had 250 feet of wire up on top of a hill in a basically clean ambient RF noise environment out in the country.

Anyway, I have about three pages of utility monitoring intercepts from last April to date that I'd like to submit for your next column, but I thought I'd write you first before I sent them. I have them in a tabular format in an MS Word .doc file that would be easy for you to cut and paste from as you compose your column. I wanted to contact you first, though, because I'm always suspicious about e-mail with attachments coming from strangers, so you'd understand.

And I offer this for my bona fides. It was my first report to the "daddy" of *Popular Communications*, *S9 Magazine*, back in Tom Kneitel's heyday:

"I found mint condition bound volumes of *S9* for 1965 & 1966 on eBay, which was my heyday as a kid. I haven't scanned all of the reports I submitted yet, but especially after being given a Lafayette HA-230 (I still have it) for Christmas by my parents in 1965, I know I went full force into Utility listening. The additional modes that are used now are staggering and I'm still learning how to decode some of them. I hope to be a useful contributor to your column in the future."

Let me know the suggested mode of submission and I'll get something off to you for your next column.

Steve, send those loggings in using the format in the "Readers Logs" below!

*Readin' Writ'n' and 'Rithmetic—Wrong!*

Julius Gilcher, KB8DIE, writes us with these corrections:

I have read your fine articles for some time. All have been okay until now. The problem (in the July 2005 Pop'Comm article "Utility Communications Digest") is with your section "The NOT-SO Random Length Center-Fed Dipole Antenna." Your math is fine but the statement, "rounding that off to 70, which is how long, in feet, each element of your half-wave dipole antenna should be," is not correct.

The overall length of the dipole will be 70 feet if you divide 468 by the frequency of 6.739 MHz. To get the length of each element you divide 234 by the frequency in MHz, or divide your answer by 2.

Now for part two in the same article: You show a "dog bone" Insulator in the drawing, which is fine but your statement in the caption, "The 'dog bone' insulator, commonly referred to as an 'egg insulator,' supports each end of the antenna," is in error. A dog-bone insulator is correct for the drawing, but an egg insulator is another insulator altogether.

The egg insulator has the shape of an egg with two holes, one at each end and at 90 degrees to each other with grooves from them going to the opposite end to lay the wires in.

If you want to see one ask Gordon West, WB8NOA, or your editor Harold Ort, N2RLL, or any of the other hams you know.

Julius, you are absolutely correct on the math. We goofed—and the main office goofed on identification of the insulator. Thanks for helping to keep us on our toes!

## Readers Logs

To quote Uncle Sam, "We need you!" and your loggings. Seems that the summer time apathy bug has hit many of our regular contributors this month. This is a good chance for you novices (and experts) who have never sent in a logging to do so. Impress your friends and help others who depend on good frequency information by sending me your radio loggings at the e-mail address above.

**0000:** (Frequency MHz): STATION, Anytown, USA, summary of traffic heard in MODE at 0000Z. (Monitor/sometimes location)

**3150.0:** UNID YL/EE repeating "PCD2" in USB at 2005Z. (CG)

**4270.0:** UNID YL/EE with "PCD," then "message," "group 57," "text" then into 5-letter groups. Whole thing repeated. USB at 1800Z. (CG)

**5091.0:** UNID YL/EE with 5-letter groups in USB at 2110Z. (CG)

**6736.0:** Kinloss Rescue, RAF, in QSO with various stns such as Rescue 51, Rescue 52 and Rescue 122. USB at 1910Z. (CG)

**5422.0:** UNID YL/EE with 5-fig groups each twice. USB at 1820Z. (CG)

**7605.0:** UNID YL/EE repeating "KPA2" in USB at 1720Z. (CG)

**7758.0:** UNID with 5-fig groups (T=0) in CW at 1825Z. (CG)

**8189.0:** UNID with "555 555 555 161 161 161 2T," then into 5-fig groups. Ended with "93 93 2T 2T T T T" in CW at 1730Z. (CG)

**11175.0:** Offutt AFB with msg for Skyking in USB at 1713Z. (CG)

**12603.0:** UNID YL/EE with 5-fig groups repeated in USB. QRM from SVO in CW. 1530Z. (CG)

**12603.0:** SVO, Greece with beacon in CW at 1530Z. (CG)

**12649.5:** XSG, Shanghai, China with beacon in SITOR and CW at 1525Z. (CG)

**13375.0:** UNID YL/EE with 5-fig groups in USB at 1515Z. (CG)

**16811.5:** A9M, Bahrain with SITOR and CW beacon, then into SITOR t/c. 1455Z. (CG)

**16880.0:** XSQ, Guangzhou, China with beacon in SITOR and CW at 1448Z. Also on 12613 at 1528Z. (CG)

This month's star contributor was Chris Gay (CG). We'll see you again next month—and with a lot more loggings! ■

# A New Toy On Our Workbench, And A Definite "First!"

As this is being written, it's a beautiful, warm, breezy and sunny summer day, and here I sit meeting another deadline for taskmaster Harold! I've been a bit remiss on nitty-gritty technical features, but I have a few neat items for your approval. First, we have a new toy for the "Wireless" workbench, as well as some interesting news about the Carolinas Chapter of the Antique Wireless Association, contributed by correspondent Ron Lawrence (see sidebar). You might recall that it was Ron's extensive vintage radio collection that was the lead feature in our June 2005 issue.

## Building The Better Mousetrap— Steve Strong's Universal Chassis Stand!

Anyone who restores vintage sets suffers the same problem: positioning and holding a chassis undergoing restoration! We've all tried various means, such as judiciously placing rolls of solder or other handy items, to prop and steady a wobbly chassis. At best, the results are cumbersome; at worst, you'll end up doing some serious damage to tubes or other exposed components. I wish I had a dollar for every octal-based tube that bore the weight of a heavy inverted chassis and suffered a busted indexing pin as a result! Even worse, upending some radios like the Zenith Shutter Dial (12S232, 9S232, etc.) chassis series can seriously damage the exposed wafer switch for the tone control. Not many have survived their first encounter with a service call. Note the sad example shown in **Photo A**. Sigh. There has to be a better way to do things.

A year or so back I noticed favorable comments posted on Internet Usenet sites regarding a nifty chassis holder that had appeared at a vintage radio show in Oklahoma. Further investigation revealed that the product was the handiwork of Steve Strong. We contacted Steve, and he informed us that the chassis

holder is made in two sizes: one is a larger stand that should accommodate heavier military-type radios, and the other is a smaller stand intended to handle small-to-average-size vintage radios. I opted to order the larger model since I like big radios, and I eagerly anticipated its arrival.

## Assembly

Steve said that the idea for the design came from his uncle, Jerry Strong, a retired electronic technician. Steve also men-

*Photo A. The tone control wafer switch on a 1938 model Zenith Shutter Dial chassis can be damaged if the chassis is laid upside down on a workbench without proper support.*

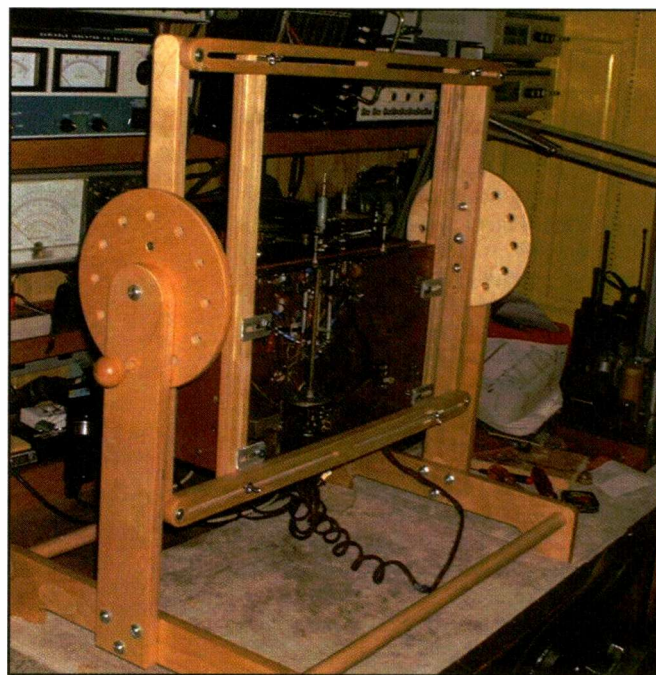

*Photo B. Here's the larger model chassis stand assembled and in use on my workbench. It ended up being a bit larger than I had anticipated!*

*Photo C. The chassis can be tilted over a full 360-degree-range and securely locked into the desired indexed positions using wood locking pins. The chassis stand is built from Baltic Birch and is finished in polyurethane. The stand is very sturdy and the quality is first rate.*

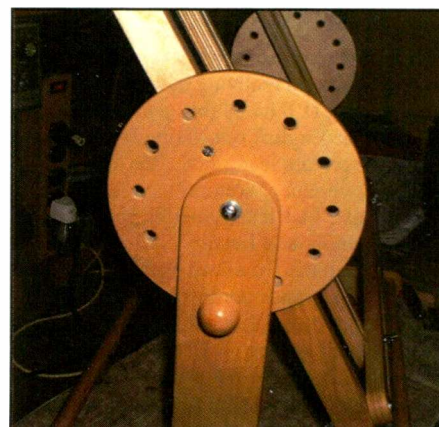

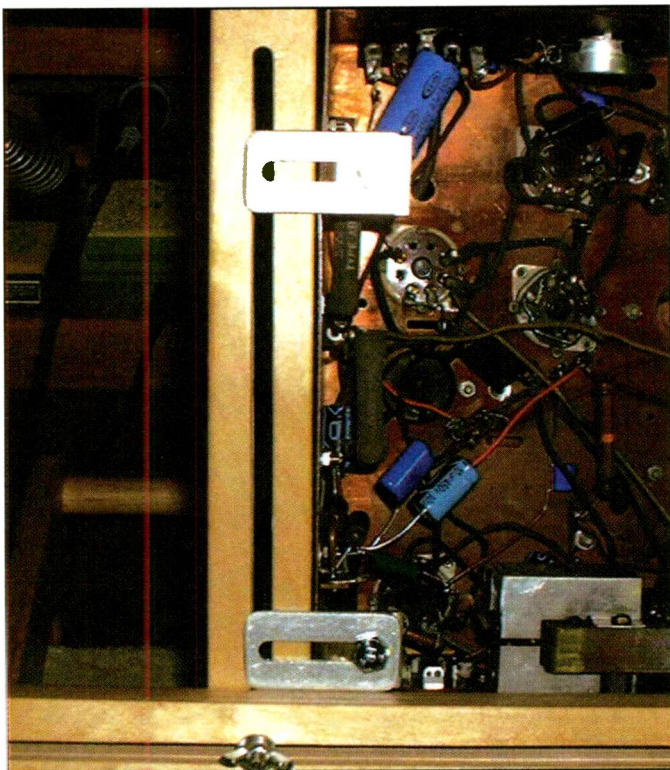

Photo D. The only issue I could find with the chassis stand was that the optional metal brackets were a tad shorter than needed when mounting this Zenith chassis. A larger set should be easy to fabricate as needed, using hardware store items.

tioned that he has some background in drafting and wood-working, and it shows. The assembly manual (actually a few stapled sheets) is clearly and profusely illustrated, and all of the materials are individually bagged in labeled polybags that are numbered to correspond with the various assembly steps. No big deal, everything went together quickly and without a hitch.

Photo B shows the stand assembled on my workbench. Did I mention this is the large model? The holder base measures about 18 inches deep and 26 inches wide. The maximum height needed is nearly 28 inches. Alas, that represents quite a bit of valuable bench real estate. To show how big the unit is, I placed a large Zenith 9S232 nine-tube chassis in the chassis jig, and as can be seen I suspect the smaller holder would be the better choice for most of us. That large Zenith chassis looks lost in the bigger stand! Did I mention the larger model is *really* big?

The stand is made from half- and three-quarter-inch Baltic Birch plywood and has a clear polyurethane finish. All edges are sanded smooth, and the product looks and feels professional in all regards. One nice feature is the indexing pin assembly that allows the chassis to be rotated (tilted) over a full 360-degree rotation while mounted in the stand. Photo C shows the locking index pin (one used on each side) that serves to firmly lock the chassis at the desired angle.

Photo D shows the optional metal brackets being used to mount the Zenith chassis to the cross braces. The chassis could be directly mounted to the cross braces, but the brackets provide open access to components mounted on the sides of the Zenith chassis. I did find one problem: the brackets should be at least 1 inch longer. As you can see, they aren't quite long enough to permit bolting the brackets to the wood cross arms.

## Monitoring Times

# ORDER TODAY!



Do you own a radio, a shortwave receiver, a scanning receiver, or a ham radio? Then Monitoring Times® is your magazine! Open a copy of MT, and you will find news, information, and tips on getting more out of your radio listening. In fact, it's the most comprehensive radio hobby magazine in the U.S.

**MT Express** - Not only do we offer a premium monthly printed magazine, but we also offer the popular

MT Express digital version of Monitoring Times. This is the best way to get your magazine as soon as it's released, right from the internet! All you have to have is an internet connection with an e-mail address and you're ready for all the excitement of a truly interactive publication. For less than the cost of a printed subscription, you get the full magazine in pdf format with **color** photos throughout and active links to all web sites mentioned in the text.

Packed with up-to-date information concisely written by the top writers in the field, Monitoring Times® is your foremost guide to profiles of broadcasting and communications installations; home projects; and tips on monitoring everything from air, sea, and space to distant ports of call.

# GROVE

800-438-8155  
828-837-9200 fax: 828-837-2216  
WWW.GROVE-ENT.COM  
7540 Highway 64 West  
Brasstown, NC 28902

### Order TODAY and use code MTSPECIAL to get all the great offers!

7540 Hwy. 64 W., Brasstown, NC 28902  
1-800-438-8155 US and Can.; 828-837-9200; Fax 828-837-2216  
e-mail order@grove-ent.com

	6 months	One Year	Two Years	Three Years
US Rates	<input type="checkbox"/> \$15.50	<input type="checkbox"/> \$28.95	<input type="checkbox"/> \$51.95	<input type="checkbox"/> \$76.95
US 1st Class	<input type="checkbox"/> \$30.00	<input type="checkbox"/> \$57.95	<input type="checkbox"/> \$112.00	<input type="checkbox"/> \$168.00
Canada Surface*	<input type="checkbox"/> \$20.50*	<input type="checkbox"/> \$39.50*	<input type="checkbox"/> \$75.95*	<input type="checkbox"/> \$112.95*
Foreign International*	<input type="checkbox"/> \$30.75*	<input type="checkbox"/> \$59.50*	<input type="checkbox"/> \$115.95*	<input type="checkbox"/> \$175.95*
Electronic Subscription	<input type="checkbox"/> \$19.95	<input type="checkbox"/> \$38.90	<input type="checkbox"/> \$75.85	

\*All payments must be in U.S. Funds drawn on a U.S. Bank!

Name \_\_\_\_\_ Address \_\_\_\_\_  
City \_\_\_\_\_ State \_\_\_\_\_ Zip \_\_\_\_\_ Country \_\_\_\_\_  
CC # \_\_\_\_\_ Exp. Date \_\_\_\_\_ CVV2 Code \_\_\_\_\_  
Signature \_\_\_\_\_  
Email address \_\_\_\_\_

MasterCard, Visa, and Discover Card accepted!

Or just go to [www.grove-ent.com](http://www.grove-ent.com) to order NOW!

## Support Your Local Club—Spotlighting The Carolinas Chapter Of The AWA

We're always pleased to provide coverage for local or national radio organizations; besides supporting our hobby, these groups usually sponsor regular swap meets. As I've noted in the past, these are the places to find those elusive radio treasures you've seen featured over the years in this column. They also let you experience the camaraderie among fellow collectors and historians.

Ron Lawrence has volunteered to give us the lowdown on the Carolinas Chapter of the Antique Wireless Association (CC-AWA). Following is what Ron has to say.

The CC-AWA, formed by a group of radio collectors who live in North and South Carolina, started hosting AWA Southeast meets in 1976. In the early 1990s, they organized and sought chapter status in the national organization of the Antique Wireless Association. Today, the CC-AWA hosts four Saturday morning swap meets, and their "Spring Meet in the Carolinas" Annual Conference is held each March in Charlotte, North Carolina. (We have included some photos of the 2005 March conference so you can see what you missed out on!)

The one remaining Saturday morning swapmeet for 2005 will be held this October at the City Lake Park in Jamestown, North Carolina. Admission for all Saturday morning swap meets is free. Details about all CC-AWA events can be found at our website at [www.cc-awa.org](http://www.cc-awa.org), or by contacting Ron Lawrence, KC4YOU, CC-AWA President & Conference Chairman, PO Box 3015, Matthews, NC 28106-3015; Phone: (704) 289-1166 (home); E-mail: [kc4yoy@carolina.rr.com](mailto:kc4yoy@carolina.rr.com).

### The 2005 Spring Meet In The Carolinas Meet: A Report

March 24 through 26 marked another great Charlotte CC-AWA Conference at the Sheraton Charlotte Airport Hotel. The Charlotte show has been on the fourth weekend in March for many years, and was only the second time since the early 1980s that Easter fell on this same weekend! I'm sure that this played a big part in the overall attendance being down a little this year. But it sure didn't put a damper on the enjoyment of everyone who did attend.

The Program/Forum sessions on Thursday afternoon were well attended. This was the second year that we've had a special Tube Collectors forum, and this year special guest host Ludwell Sibley, accompanied by his wife, drove all the way from Oregon to be with us. Lud and Kirk Cline did a great job of talking about Tube Testers and how to test unusual tubes. Robert Lozier did a slide show of some glass slides that showed early RCA tube production. Jim Oram put on a very interesting talk about German Enigma code machines and his effort to make exact reproduction parts for them. Jim's parts are so exact that they're used at the National Cryptologic Museum ([www.nsa.gov/museum](http://www.nsa.gov/museum)) to keep their Enigma machines running.

Thursday evening we had the first part of an estate auction that was consigned to us by the family of Larry Boyer, a retired RCA engineer. Larry, who went to work at the RCA labs in Camden, New Jersey, just after World War II, had had the foresight to collect early RCA artifacts before they could be destroyed. Along with a very nice collection of mostly '20s radios, the boxes and boxes that we found in Larry's attic were a time capsule of rare radio-related paper and catalogs, plus a lot of very rare tubes. The Thursday evening "Tube Paper & Ephemera" auction lasted four and a half hours and netted over \$14K in sales.

Friday morning we kicked off our first Flea Market session (Photo E) with our now traditional "LeMans Start," where there is no buying, selling, or trading allowed before 8 a.m. and everyone has to be out of the flea market area before the 8 a.m. start.

Friday afternoon was our second auction of the weekend (Photo F) with radios and other hardware going on the block. One highlight was a "one-of-a-kind" engineering prototype built by GE around 1922 with all the original engineers' handwritten notes and drawings. Another was a very rare Edison Concert 5-inch cylinder phonograph,



*Photo E. Tailgating flea market vendors at the Charlotte AWA Spring Meet offer a variety of intriguing wares. This small cross-section shows a few interesting early National communications receivers, a large GE tombstone radio, test equipment, and other items awaiting new homes.*



*Photo F. A variety of early televisions, horn speakers, battery sets, cathedrals, and cabinets awaits the auctioneer's gavel at the Spring Meet.*

with both playback and record heads in its original cover, and an Edison 5-inch wax cylinder—thoroughly enjoyed by the numerous members of the phonograph collecting community who were in attendance. Sales for the Friday afternoon auction totaled just over \$30,000, with over \$44,000 in sales for both.

The Annual Banquet was held Friday evening, followed by an open house to view the items entered in the Old Equipment Contest (see Photos G and H). Alfred H. Grebe, Jr., was a special guest speaker at the banquet. Al Grebe, the son of radio pioneer and manufacturer Alfred H. Grebe, is a good friend of the Charlotte show and has attended many times over almost 25 years.

Saturday morning activities started early. There was more of the Flea Market, followed by our traditional end-of-meet "Radio Rescue" auction—always a good way to find that last-minute bargain before heading home. The Conference wrapped up with our Saturday luncheon and contest report.

## Ordering Information

Steve custom makes each stand, so allow a week or two for your stand to be assembled and shipped. The current price is \$37.50 for the small stand and \$55 for the larger version. The bracket set is an additional \$2.50. Shipping charges depend on the zip code the stand is being shipped to. Preferred payment method is via USPS (postal) Money Order. Steve can be contacted by writing him at Steve Strong, 1200 South West 56th Street, Oklahoma City, OK 73109, or via e-mail at [scstrong1@cox.net](mailto:scstrong1@cox.net).



*Photo G. Old equipment contests are popular at many radio meets. One of the interesting contest entries for the March 2005 Springtime in the Carolinas meet was this like-new RME communications receiver, companion preselector, and supporting paperwork. This was entered by CC-AWA Vice President Richard Owens. It won a blue ribbon in its category and a special award for Best Presentation.*



*Photo H. Equipment contests bring out the best examples of vintage gear or communications apparatus and more! This exhibit features examples of early advertising ephemera for Sylvania receiving tubes. Each of these four radio store advertising cards is different and each has a wheel behind the card with names of different radio manufactures of the era. They date from about 1926. They were entered by Ron Lawrence and won second place in the advertising category.*

I'd like to thank all the folks who stepped up to help with making this event the success it continues to be. All the pre-planning is done by just a couple of people, but it takes many, many good friends to make it all happen during the show. Thanks to RL & Linda Barnett, Gerald Cromer, Ernie Hite and his son Everett Hite, Clare Owens, Tom Houghtaling, Ted Bryan, Ted Miller, Robert Lozier, AWA President Geoff Bourne, our auctioneer (who made it through three auctions), Brad Jones, Richard Wayne, Gary Carter, and many others whose names I just can't think of right now.

Look for us again next year on the forth weekend in March.

—73, Ron Lawrence, KC4YOY, CC-AWA President



*Photo I. During the Depression, people often had to make do with what was on hand. This tombstone dates from that era, and was crafted from an RCA model 100 speaker. The cast alloy speaker case has withstood the ravages of time, but the protective glass face that shielded the identity of the deceased did not survive the test of time. The marker is situated in a cemetery in South Hadley, Massachusetts.*

## Here's A "First"

Well, that's a wrap for this time around. But before I close out this month, I have one more tidbit to share. Take a look at the tombstone shown in **Photo I**, and compare it to the auction offerings shown in **Photo E**. Yep, that tombstone in the cemetery is indeed made from an RCA model 100 battery-set speaker from the 1920s! The speaker opening was once faced with clear glass to protect the paper showing the identity of the deceased, but time and weather has taken its toll and none of the historical data remains. My wife spotted the unique tombstone in a cemetery in South Hadley, Massachusetts, and suspects it marks the grave of a distant relative dating from the depression era!

We've talked about tombstone radios, but *this* tombstone speaker is a first. So, 73 for now, keep those soldering irons warm, those old tubes glowing, and keep writing in with suggestions and comments. ■

# Software-Defined Radio—Part IV

## How To Build An SDR, The Software Component

**A**s I've outlined in the past three columns, we're currently in the early stages of a technological revolution that's radically changing the way radio receivers and transmitters are being designed and built. This revolution has come about because of the availability of cheap and easy-to-use computerized components that allow engineers to create "virtual" radios through software programming. As a result, this new technology has come to be known as Software-Defined Radio (also referred to as SDR or SD radio).

SD radios operate in a way that is significantly different from the conventional (or Superhet) receiver that is currently the most popular receiving radio design. The primary design feature of the Superhet is that all frequencies that are received are first converted to single frequency, then amplified and detected.

What makes the SD radio different is that rather than taking one frequency off an antenna and converting it to a single frequency, the SD radio amplifies *all* the frequencies from an antenna over a very wide bandwidth and then converts *all signals found in those frequencies—man-made and natural*—from analog into digital form.

So, to use the proper terms employed with this new technology, an SD radio *samples* a broad bandwidth of the RF spectrum as it is received at the antenna, then digitizes it. Then, rather than simply amplifying one signal, an SD radio uses Digital Signal Processing (DSP) to *process the entire bandwidth* contained in the digitized sample of the RF spectrum.

Next, the intelligence (or information) found anywhere within the digitally sampled RF signal can then be detected using special DSP algorithms. More importantly, more than one source of intelligence can be detected at a time, allowing multiple stations to be monitored simultaneously.

Once that has been accomplished, the SD radio can then pass one or more sources of intelligence found in the sam-

pled RF signal to any number of digital devices. Once that has been done, that information can then be displayed or converted into analog modes, such as video images or audio sound.

### It's Really Not That Difficult

What's really interesting about this new technology is that while what can be accomplished with it can be very complex, the hardware requirements for an SD radio are actually very simple. In fact, most of the required components are available off the shelf and at reasonable prices.

To make an SD radio, all you really need is a broadband antenna, a good high-speed personal computer, a data acquisition card (DAC), and a computer sound card in order. You simply attach the antenna to the DAC, which then "samples" the voltage of the RF spectrum that it finds on the antenna. This sampled information is then processed through virtual radio circuitry created through DSP software running in the computer. Once the sampled signal is processed (which includes filtering and detection) it is turned back into an analog signal in the computer's sound card so it can be heard or passed on to another software program where it can be used to display text or graphics, depending upon the signal source.

### The Simplicity Of SDR

There is still a lot of experimentation and discovery taking place within the development of SDR at both the professional and hobbyist levels, although most of the mathematics providing the theoretical foundations were actually developed during the 1930 and '40s. In fact, one of the first electronic digital sampling devices was created in the late 1940s at the Research Laboratory of Electronics (REL) at MIT. During the 1960s and '70s this same group created some of the first virtual DSP circuitry using their TX-2 computer.



Interestingly, the first commercial experiments in DSP were undertaken in the 1950s by the oil industry in processing seismic data to find oil and gas deposits deep in the Earth. The broad commercial use of DSP technology emerged in telephone communications technology during the 1960s, with the development of the T-1 digital carrier system in 1962.

Later, thanks to the introduction during the 1980s of inexpensive high-speed CPUs and complete computers on a chip, such as Texas Instrument's TMS32010 and the Motorola 56000, it became possible to develop mass-produced DSP devices as consumer products. When this was combined with the development of the relatively low-cost personal computer with its high performance CPUs, a series of major breakthroughs in SDR technology began emerge from the laboratories, beginning in 2000. This trend has continued to this day.

We're now in a unique point of convergence where varied technologies, such as the Internet, high-speed digital communication and personal computing have reached a level of power and affordability that has placed SDR technology within the reach of the radio hobbyist. This has been brought about in great part due to the infusion of billions of dollars in research into SDR by the U.S. military, the benefits of which have trickled down to the general population. Today, SDR technology at the hobbyist level is in a



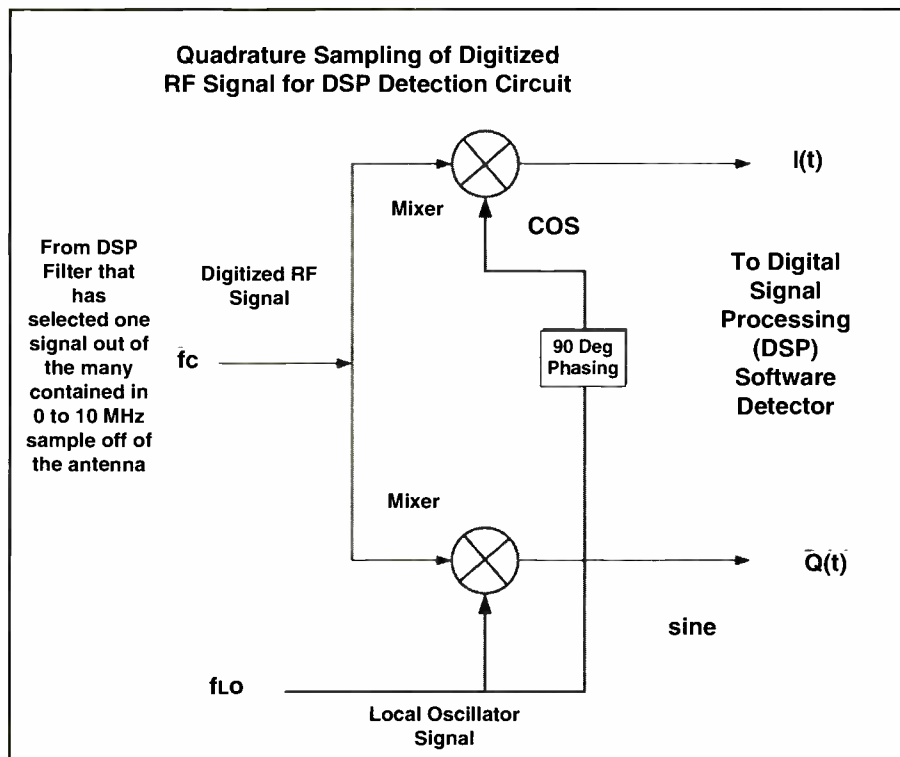

*This diagram shows the digital mixing circuit used to create the Q and I products necessary for a DSP-based detector to work.*

period of technological transition, with many designs being a hybrid of Superhet, DSP, and SDR.

Early design attempts have used an external hardware-based RF front-end that provides tuning and detection to a single IF frequency, which then is digitized for processing in a DSP circuit. However, the ultimate goal of many involved with the hobbyist design of SD radio is to make the design as simple as possible. To do this, they are attempting to eliminate the RF front-end, where the tuning of the signal takes place, and replace it with an analog-to-digital (A/D) converter that will sample a wide bandwidth of radio signals directly off the antenna.

The primary reason this minimalist approach to SDR design has not been widely undertaken is the lack of A/D converters with sufficient bandwidth to sample radio frequencies properly. However, this situation is changing, thanks to the introduction of the PCI-DAS4020 A/D card, which has provided the hobbyist and serious experimenter with an affordable "plug-and-play" device to place into their personal computers. This card can sample RF signals up to 10 MHz, allowing for the creation of a simple SD radio that will directly "tune" the LF, broadcast, and lower part of the shortwave band.

However, if you're willing to forgo the plug-and-play capability of PCI-DAS4020 you can experiment with a newly developed A/D converter from Analog Devices, the AD9430. This particular A/D card uses the fastest chip technology available today on the civilian market with a sampling rate of 210 MSPS (mega samples per second) with 12-bit resolution. More importantly, it has a bandwidth of 700 MHz, which will provide more than sufficient coverage of all of the LF, HF, and VHF frequencies that are popular with the amateur radio and monitoring hobbyists.

The big drawback with this particular card, though, is that it requires a solid background in engineering in order to get it to work. However, sometime in the very near future, someone with the time, money, and experience will tinker with it enough to make it an exceptionally wide-band SD radio that will be suitable for the hobby market.

### Getting The SD Radio To Work

So, assuming that you've installed the easier to use PCI-DAS4020 into your PC and hooked up your antenna to one of the

input leads on the card, how do you "tune" it to monitor a particular frequency and then listen to what you find there? The answer is that you'll need some sort of tuning, detecting, and processing software installed in that computer, along with a device in the computer to convert digital information back to analog so that you can listen to it. Luckily, that A/D converter is something that nearly all personal computers have today: a computer sound card. If you've ever played music or sound through your computer's speakers, then you've been doing A/D conversion (and probably didn't even know it).

Let's look at the software component of a personal SD radio. Now I don't promise to turn you into a computer programmer by the time you finish reading this, but you'll at least have a good idea of the theory involved and main components used to "build" such software.

Fortunately you can download from the Internet a fair amount of the software you need to create your own SD radio, thanks to the extensive amount of work done by computer geeks and dedicated radio monitoring experimenters. I hope this column will inspire you to try building an SD radio yourself, or at least to learn more about this fascinating technology. Frankly, it's really not all that hard once you set your mind to it. But first you'll need a plan to guide you, and that's what I intend to outline for you here.

### DSP Fundamentals

DSP is really very simple technology, but as with any simple technology, a lot of thought had to go into it to make it the way it is. An SDR really only performs three tasks: 1.) converts analog RF signals to digital data; 2.) processes that digital data so that the information it contains is tuned and detected in order to release the intelligence (music, speech, data) contained within it; and 3.) converts the detected intelligence from digital into analog form so we humans can understand it. All that's taking place within the computer to create the SD radio is something that is already well known in radio monitoring: DSP.

Today DSP technology is in use all around us, in sound cards, fax machines, modems, cellular phones, high-capacity hard disks, and digital TVs. (Here's an interesting bit of trivia: the first commercial DSP chip ever used was in Texas Instruments' "Speak & Spell" game from the late 1970s.)

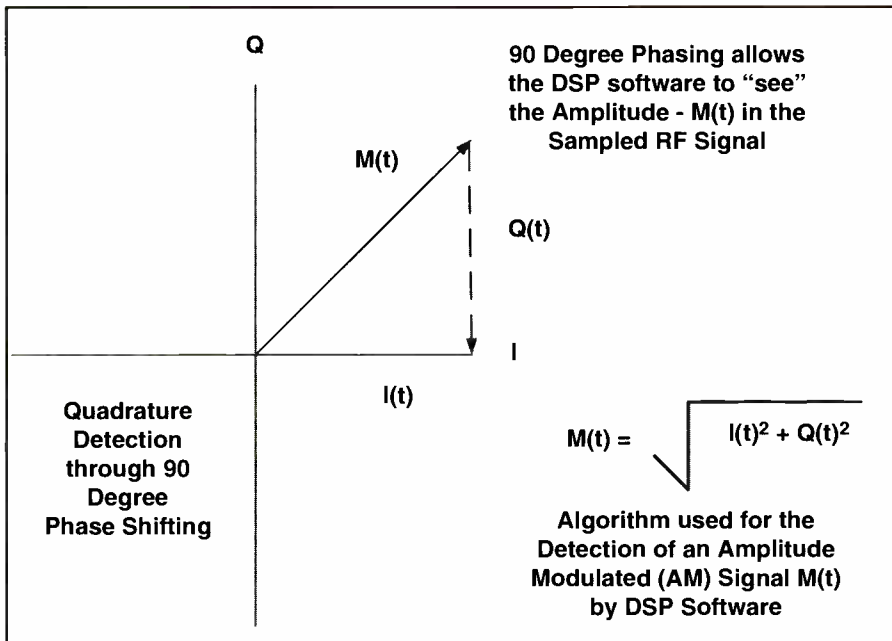

When the phased signal is sent to the DSP detector, it is able to determine the amplitude  $M(t)$  of the RF carrier as the product of an algorithm. Shown here is the formula used to determine the amplitude of the intelligence (music, voice, or data) contained in a digitized RF AM carrier. Other mathematical formulas are used in the detection of intelligence in other modes of communication. Once that value is determined, the DSP software can pass the result to the computer's sound card, where it is turned back into an analog signal that can be heard through speakers or earphones. This same information can also be used in other software programs to produce text or graphics.

Even if you're not interested in building an SD radio, you can still take a listen to DSP if you have a sound card installed in your PC. If you check the software that comes with that card, you'll most likely find that it can simulate the sound of a concert hall or create pseudo-surround sound when you play a music CD with your computer's CD player. That ability to change the original sound into something else is done through the processing of that digital information. This is accomplished through rapidly performing mathematical calculations on digitized signals that were originally analog in form (that is, voice or music).

There are many advantages to using DSP over conventional electronic circuits. Quite simply, electronic components are relatively large, take a fair amount of power to operate, and their values (resistance, capacitance and inductance) can change due to ambient temperature, age, and even just being bumped. However, DSP circuitry, because it is virtual, is not subject to any outside influences. It is simply comprised of mathematical equations, which are consistent under any and all conditions. This makes DSP ideal for any situation

where dependability and predictability are critical.

While these dependability and predictability factors are important, the primary reason DSP circuitry is so valuable is the programmability of the processing that takes place within it, allowing a number of parameters to be easily changed. I outlined a good example of this particular virtue of DSP circuitry in my series on Ten-Tec's RX-320 computer-controlled radio. One particularly powerful feature of the RX-320 is that it offers 34 IF bandwidths, ranging from 300 Hz to 6000 Hz, with the click of a mouse button.

Think about that while remembering what it used to be like to change bandwidths on older analog radios. With those old radios you may have had only four bandwidths to choose from; one for each mode the radio received. When you changed a bandwidth, you had to turn a mechanical switch, which was connected to various coils and capacitors. If you wanted more bandwidths, you needed more component space. Frankly, with all those mechanical devices, the actual results were not that good, unless you used a lot of very expensive components.

But, through the use of mathematical

calculations via the software in the DSP circuitry, the RX-320 can serve up its 34 values within an electronic component that is roughly one-inch square. The point of all this talk about DSP is that it is the heart of the SD radio.

When you create an SD radio all you're doing is turning your personal computer into an advanced digital signal processor that has several additional functions. Those functions include the ability to direct the flow of digital information from the A/D card to the computer sound card and to detect the intelligence found within the sampled and digitized RF signal being passed between those two devices.

So how is this done?

## "Building" The SD Radio In A Computer

When you use DSP technology you can create a virtual electronic circuit by describing the function of a virtual electronic component as a mathematical formula. Since an analog signal that has been converted into digital form is represented as a series of numbers, those numbers can then be processed through those mathematical formulas, with the result being the digital signal that will be changed or modified in the same way as an analog would be if it were passed through a "real world" circuit.

Conventional DSP circuitry has been successfully representing resistors, capacitors, and inductors in virtual form for many years now, and most of us have been using such circuits in our radio monitoring on a regular basis. Most of the time, though, that type of DSP has been applied to *audio analog circuitry*, so how do you then apply that to sampled RF signals? More specifically, how do you then "build" a detection circuit so you can demodulate AM, FM, SSB, or CW signals using DSP? It's not that different from the "real world" counterpart that would be used in a conventional circuit.

In its most fundamental form, radio is the application of a source of information (whether music, words, or codes) to a carrier wave that has been generated by electromagnetic forces that vibrate within a range we call "radio frequencies" or RF (roughly 10 kHz to well over 3000 MHz). A transmitter's RF energy, with this information contained within it, is released from an antenna out into the atmosphere. As this transmitted energy passes over other receiving antennas, they generate

internal voltages, which are then passed on to the radio receiver through a lead-in wire or coaxial cable.

In a conventional radio the RF voltages that enter the radio are passed through a tuning circuit which selects out a small set of frequencies while passing the remainder to ground. The low RF voltages of those selected frequencies are then amplified through any number of conventional techniques.

Once the RF signal is amplified, the next stage is to remove the RF component of the signal and to release from that signal the original intelligence that was placed on it. This is done through one of several methods of "detection," which can employ either a diode (solid state or a vacuum tube), a beat frequency oscillator and mixer (for CW or SSB), or through a discriminator circuit for FM.

In all of the above cases, the RF component is removed and the intelligence remains, which can then be amplified using audio amplification circuits. This intelligence can then be fed to an audio speaker, where it can be heard, or it could be used in other applications, such as radio teletype (RTTY) or telemetry circuitry to produce text or graphics.

This is all very fine and good, but how does this apply to our SD radio?

## Tuning A Digital Signal

In the SD radio the antenna is connected to the A/D converter (such as the PCI-DAS4020 card) via one of the connectors on that card. The card, which is plugged into one of the expansion slots in a personal computer, samples the voltages found on the antenna over a frequency range from 0 Hz to 10 MHz and converts this analog voltage to digital information.

A software program running in the personal computer containing the A/D card captures the data streaming out of that card and then passes it through a virtual DSP circuit that it has "constructed." This DSP circuitry creates a virtual radio which can then "tune" the desired frequency that one wishes to monitor, and then demodulate the intelligence found on that frequency by using a virtual detector.

In some contemporary radio designs, such as Ten-Tec's RX-320, an RF front-end produces an intermediate frequency, or IF, that is roughly 6 kHz in bandwidth. This IF frequency is then turned into a digital signal which may be processed with one of a series of 34 DSP IF bandwidth filters that range in size from 300 Hz to 6000 Hz. In the case of a SD radio, you perform much the same filtering function, but instead of filtering a fixed frequency you use the same DSP filter to "look" at the full 10-MHz worth of digital information and then take a virtual "slice" out of one small 6000-Hz part of it (as an example) for further processing. Frankly, you could reduce that slice down to 300 Hz or less if you wanted to, depending upon your requirements and software programming skills, and again take it out of any part of the sampled 10 MHz bandwidth you have to work with.

What's even more exciting about this technique is that you're not limited to only one "slice" (that is a single frequency) at time, such as you would be limited to with a conventional Superhet radio. Instead you can take multiple "slices" out of that sampled 10-MHz bandwidth and process them concurrently.

This technique of concurrent sampling and processing is already being used to great effect by the amateur radio community with computer-based software for digital modes such as PSK. Many software packages for communicating in the PSK mode allow you to hold multiple text-based conversations by



Here's the RFspace SDR-14, a 14-bit SDR receiver designed for the professional and advanced hobbyist. This unit samples the entire RF spectrum from 0 to 30 MHz and uses the same basic techniques to process sampled RF, as has been described in this column. Specifically, the unit converts sampled RF from its A/D converter into I and Q formats through phasing, and then sends the results to a PC via its USB port for detection using software algorithms and any further DSP processing that may be required. I will discuss this SD radio in more detail in next month's column. (Photo courtesy Universal Radio)

simply pointing and clicking on multiple signal sources displayed on the computer screen.

The only things that limit the number of "slices" that can be used by the software is the processing power contained in the computer's CPU and the amount of data processing bandwidth contained within the computer's data bus circuitry. As it stands, the PCI-DAS4020 A/D card is pumping 40 MB of data into the data bus *per second*, which the CPU has to process along with running the software that's creating the DSP circuitry you're using, as well as all of the "housekeeping" tasks required just to keep the computer running. So each time you take a slice out of the 40 MB of data you're adding more "overhead" to the operation of the computer; if you add too much, the computer will begin to slow down and possibly even stop working.

The bottom line is that if you want to get the most out of your SD radio, you must have as much processing power as you can get. Most of today's computers that use a Pentium 4 or equivalent CPU running above 2-GHz clock speed will do you just fine. So just use some common sense if you decide to build your own experimental SD radio; you may find that the early Pentium series of CPUs just won't cut it.

## Demodulating A Digital Signal

Once the software has chosen which "slice" of the sampled RF signal you will want to listen to, the intelligence contained within it, it will use it to generate text or graphics. This is accomplished by directing the "slice" of RF signal to a DSP demodulator circuit.

Frankly, I had to scratch my head a bit when it came to deciding how to describe the mathematical techniques used in making a DSP-based demodulator. I've decided to present the material about halfway between "trust me, it works!" and "don't you wish you paid more attention in your high school math class."

The starting point for any analog signal is the sine wave, which starts at a point of zero value, goes forward through time to a positive point, returns to zero, then goes through a negative point and returns to a zero value again. (What I just described

was one cycle). If the process is repeated, it's described in terms of cycles over a fixed period of time (such as per second). Sometimes when you are describing natural phenomena such as radio frequencies, those cycle measurements are given a special designation, such as Hz, MHz, and GHz to distinguish them from other cyclical phenomena, such as soundwaves (cps).

The only problem with this is that, while you can determine the frequency and amplitude with the information  $I$  just provided, it's difficult to know whether you are at the beginning, middle, or end point of the cycle. To determine that, you have to describe the characteristics of a sine wave using three properties: phase, frequency, and amplitude. The phase is a point in the cycle that is nearing either positive, negative, or zero; frequency is the rate of change of the phase; and amplitude is the maximum positive or negative value of the phase.

You are able to actually "see" the phase of a cycle by creating a virtual phase mixer within your DSP circuitry. With this device you can take the sampled RF signal and split it in half, with one half being held by half a cycle, and then re-mixing the out-of-phase sample with the original. This technique reveals the phase of a cycle through a mathematical algorithm, which allows for the detection of that phase at any given time. Once you have the phase information, you can perform an analysis of that sine wave as it passes through your DSP circuitry.

This phase analysis can be best explained by representing the sampled sine wave on a Cartesian graph, which has the horizontal axis labeled as  $I$  and the vertical axis  $Q$ . The mathematical algo-

rithm calculates the instantaneous values of  $I$  and  $Q$  on that graph, providing you with everything you need to know about the sampled signal in order to detect the intelligence contained within it. Once you have this phase information, you can "build" a "virtual detector" in the DSP circuitry through the use of an appropriate mathematical formula.

To give an example, a virtual diode for the demodulation of an AM signal is constructed using a simple formula that calculates the sum of the square of the cubed products of  $I$  and  $Q$ .

The product of these calculations then represents the intelligence contained within the digitally sampled RF signal, which (after any additional DSP filtering required) is passed along to the computer's sound card, where it is converted back to an analog form you can hear through a speaker. (Trust me, it works!)

### The Future Is Here

Again, this is the way of the future and, frankly, every single radio you now own that's based on conventional radio technology is already obsolete. At this moment, all services in the U.S. military are converting to SDR under the Joint Tactical Radio System (JTRS) Program, which is spending \$25 billion to achieve that goal.

As I said at the beginning of this series, it's wonderful to be sentimental about all the great radio technology we used during the past 50 years, and I will always appreciate how enjoyable those experiences were. However, it's time to move on, because, if we don't, the radio monitoring hobby will be superseded by the general computer user community in the

development of attainable and affordable SDR technology.

### Next Month

So now that we've looked at the theoretical side of the hardware and software components of SD radio, how do you actually put one together? Next month, I'll tell you how to get your hands on those components and I'll provide as much primary source information as you'll need to get started, including more information on affordable A/D cards and the necessary software. And for those of you not yet brave enough to build your own SD radio, I'll show you where can you get your hands on one that's already been built and tested so you can try it out?

I will also provide you with information on those groups that are working together to advance SDR technology at the hobbyist level, as well as those who are trying to influence the FCC to prevent this new technology from being crippled by too many needless government regulations. Stay tuned.

As always, I'm interested in any pictures you may have of your own computer-assisted monitoring station or stories about how you have built and run it. You can contact me via e-mail with any submissions or questions at [carm\\_popcomm@hotmail.com](mailto:carm_popcomm@hotmail.com). While I can't answer general questions on computers, I'll be more than happy to help you with any issues raised in the columns. You can also write to me at "Computer-Assisted Radio Monitoring," PMB 121 - 1623 Military Rd., Niagara Falls, NY 14304-1745. Also, on my personal webpage ([www3.sympatico.ca/joe\\_in\\_ey](http://www3.sympatico.ca/joe_in_ey)) you'll find a list of the columns I've done over the past two years, along with a summary of the content, and instructions on how to purchase back issues of *Popular Communications*. Remember that I cannot release previously published material as *Pop'Comm* owns the copyright.

Please also remember our troops overseas and give them your support. While the "Any Service Person" mail program has been suspended for security reasons, you should visit the U.S. Department of Defense's official webpage, "Defend America." They have a section, found at [http://www.defendamerica.mil/support\\_troops.html](http://www.defendamerica.mil/support_troops.html), which provides an amazingly wide range of practical and useful ways that you can directly help. Please take some time to check out the resources suggested on that webpage and put them to use.

See you again next month! ■

## Better Than Ever! CQ VHF is here!

The all-time favorite U.S. magazine for the VHF/UHF enthusiast CQ VHF - is here to serve you. You'll find more meaty reading for the really serious VHFer than ever before. That's what our surveys told us you wanted, and that's what you'll get.

Take a moment now and take advantage of our special offers on our one, two or three-year subscriptions. You'll save money and receive fast home delivery!

1 year - \$25.00    2 years - \$45.00    3 years - \$65.00

Canada/Mexico 1 yr \$35.00, 2 yrs \$65.00, 3 yrs \$95    Foreign - 1-yr \$38.00, 2-yr \$71.00, 3 yrs \$104.

Payable in U.S. dollars/ MasterCard/Visa/American Express/Discover Accepted

Mail your order to: CQ VHF Magazine, 25 Newbridge Road, Hicksville, NY 11801

Subscribe on line at [www.cq-vhf.com](http://www.cq-vhf.com)    FAX your order to us at 516 681-2926

Call Toll-Free 800-853-9797



# ADVERTISERS' INDEX

Advertiser	Page #	Website Address
AOR USA, Inc.	Cov III	www.aorusa.com
Advanced Specialties	23	www.advancedspecialties.net
Antique Radio Classified	23	www.antiqueradio.com
Atomic Time, Inc.	23	www.atomictime.com
C. Crane Company	15	www.ccrane.com
CQ Bookstore	61	www.cq-amateur-radio.com
Communications Electronics	5	www.usascan.com
Computer Aided Technology	43	www.scancat.com
Electric Radio Magazine	51	www.ermag.com
Grundig / Eton	6,7,12,13	www.etoncorp.com
Homeland Security	49	www.ready.gov
ICOM America, Inc.	Cov. IV	www.icomamerica.com
Intensitronics	49	www.selectantenna.com
Japan Radio (JRFC)	17	www.jrc.co.jp/
MFJ Enterprises, Inc.	39	www.mfjenterprises.com
MACO/Majestic	51	www.majestic-comm.com/maco
Monitoring Times	71	www.grove-ent.com
PowerPort	49,57	www.powerportstore.com
RSGB	79	www.cq-amateur-radio.com
REACT International, Inc.	55	www.reactintl.org
Radioworld, Inc.	57	www.radioworld.ca
SWL-Remotes	57	www.swl-remotes.com
Universal Radio	1	www.universal-radio.com
W5YI Group, The	67	www.w5yi.org
Yaesu	Cov II	www.vxstdusa.com

Reach this dynamic audience with your advertising message, contact Arnie Sposato at 253-853-4080, FAX 253-853-4070, or e-mail: [advertising@popular-communications.com](mailto:advertising@popular-communications.com).

## readers' market

**Advertising Rates for Readers' Mart:** Non-commercial ads are 30 cents per word, including abbreviations and addresses; minimum charge \$6.00 per issue. Ads from firms offering commercial products or services are \$1.00 per word; minimum charge \$20.00 per issue. Boldface words are \$1.20 each (specify which words). Leading key words set in all caps at no additional charge. All ads must be prepaid in full at time of insertion; a 5% discount is offered for prepaid 6 time insertions. All ads must be typewritten double spaced.

**Approval:** All ad copy is subject to Publisher's approval and may be modified to eliminate references to equipment and practices which are either illegal or otherwise not within the spirit or coverage scope of the magazine.

**Closing Date:** The 10<sup>th</sup> day in the third month preceding date of publication. Because the advertisers and equipment contained in Readers' Market have not been investigated, the Publisher of *Popular Communications* cannot vouch for the merchandise listed therein. Direct all correspondence and ad copy to: Attention: Classified Dept., PC Readers' Market, 25 Newbridge Rd., Hicksville, NY 11801.

**COMMUNICATIONS MONITORING ANTENNAS:** HF/VHF/UHF Super Discone \$49.75, AntennaCraff Scantenna \$47.70, 30-1200 MHz. 4-12 dB Log Periodic \$69.50, 806-900 MHz. 13 dB 9 element Yagi \$74.00, MURS/GMRS Dual Band Base \$48.95. All prices **INCLUDE** Priority S&H&I. See these antennas plus many, many more for Amateur, Business, CB, and Monitoring radio, plus cellular phone antennas on the web at: [www.antennaware-house.com](http://www.antennaware-house.com) MC/Visa Order line 877-680-7818. To help maintain our low pricing, we do not print catalogs.

Search for Panasonic H-1800 Scanner. In good condition and working. Very interested. Will pay in U.S. funds the price you ask for. Contact Jack in Quebec Canada. 450-347-0481

# RSGB Books

now available from



## IOTA Directory - 11th Edition



Edited by Roger Balister, G3KMA. RSGB, 2002 Ed., 128 pages  
This book is an essential guide to participating in the IOTA (Islands on the Air) program. It contains everything a newcomer needs to know to enjoy collecting or operating from islands for this popular worldwide program.

Order: RSIOTA **\$15.00**

## Low Power Scrapbook

RSGB. © 2001, 320 pages.  
Choose from dozens of simple transmitter and receiver projects for the HF bands and 6m, including the tiny Oner transmitter and the White Rose Receiver. Ideal for the experimenter or someone who likes the fun of building and operating their own radio equipment.



Order: RSLPS **\$19.00**

## HF Amateur Radio



RSGB, 2002 Ed.  
The HF or short wave bands are one of the most interesting areas of amateur radio. This book takes the reader through setting up an efficient amateur radio station, which equipment to choose, installation, and the best antenna for your location and MUCH more.

Order: RSHFAR **\$21.00**

## RSGB Prefix Guide

By Fred Handscombe, G4BWP. RSGB, 6th Ed., 2003. 48 pages.  
This book is an excellent tool for the beginner and the experienced hand alike. Designed with a "lay flat" wire binding for ease of use the new "Prefix Guide" is a must for every shack.



Order: RSPFXG **\$13.50**

## Antenna Topics



by Pat Hawker, G3VA  
RSGB, 2002 Ed. 384 pages. This book is a chronological collection of selections of G3VA's words over the years. Hundreds of areas and subjects are covered and many a good idea is included.

Order No. RSAT **\$29.00**

**Shipping and Handling:** US and Possessions - Add \$5.00 for the first book, \$2.50 for the second, and \$1 for each additional book. **FREE SHIPPING ON ORDERS OVER \$75.00** (merchandise only). Foreign - Calculated by order weight and destination and added to your credit card charge. **ALLOW 3 TO 4 WEEKS FOR DELIVERY**

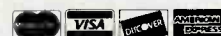

**CQ Communications Inc.,**  
25 Newbridge Rd.,  
Hicksville, NY 11801  
516-681-2922; Fax 516-681-2926  
Order Toll-Free 800-853-9797

Visit Our Web Site  
[www.cq-amateur-radio.com](http://www.cq-amateur-radio.com)

## Why You Too Might Want An HPJIE\*

Just a small sampling of my work-week will no doubt have you all clamoring (have any of you ever actually *clamored*) for a wonderful job such as mine.

Today I rose at 4 a.m. (okay, “rose” is a pretty loose term for what I did) and was on the road at 5:18 a.m. so that I could beat the dreaded Route 28 light-cycle delay which begins at about 6 a.m. just a few minutes down the road from my home. I was unaware that many new homes had been built (and occupied) since last week and now that same delay begins at about 5:17 a.m. I missed the commuter train I was trying for—and the next one—and arrived huffing and puffing in our nation’s capital in time to be contemplated by the bomb-sniffing dog that had just finished checking out the federal agency whose proceedings I was about to televise. These dogs and I have quite an affinity for one another and we always take the time to greet each other before going on about the rest of our day’s work. I’m not sure how the dog feels about it, but for me, it’s the high point of my day.

So I climb into my perch, a roughly six-foot-square former projection booth in a former movie theater now converted for well-attended meetings at one of our more interesting government agencies. I take my seat with three others, feeling very much like a navigator in a military aircraft, sitting among all the lighted dials and controls in a dark room with a glass window in front of me, watching the action ahead.

I test all of our video, audio, closed-captioning, recording, and fiber-optic equipment to the satisfaction of the people on the other end of a series of microwave, fiber-optic and computer mp2 links, and wait. My finger is at the ready on the record button of a DVD recorder. The gavel comes

---

***“It may take a while to get access to the roof, what with security like it is...”***

---

down and I press “record.” Sleep then comes quickly, but is interrupted by the electronic “ringing” of a telephone. One of the microwave links is being interfered with. What do I suppose it is?

What indeed? Ducks? Geese? Aliens with jetpacks? Aliens *without* jetpacks? O.J. Simpson soaring into a rental car? One of those pesky black helicopters spreading mind-control gas over our city? Certainly, boss, I’ll be glad to go up onto the roof and check it out. It may take a while to get access to the roof, what with security like it is...

My host and friend at the government agency rolls his eyes. He knows that he is the only person who can find the building manager and convince him to get the building engineer to grant me access to the roof, and he would really rather not do that just now. He is busy making sure the logistics of the meeting continue to run smoothly, but I am relentless in my plea. He knows that my boss will keep on me until I get to the roof and find out what, if anything, is interfering with our microwave path. I call my boss back and tell him there will be a delay as my host has other duties pressing before he can summon the building manager. We go for coffee.

We notice that the building manager has arrived for coffee at the same time and place as we have, and we mention that we would like to have access to the roof if he can arrange it for us. He calls his engineering department on the almost-antique 150-MHz walkie-talkie, and they will meet us at the freight elevator in about

15 minutes. We buy the building manager a coffee.

The freight elevator is hot. Our nation’s capital is normally hot at this time of year, but any part of a building that is not air-conditioned is stifling at this time. And it smells very much like a dumpster. A *hot* dumpster. We ride to the 15th floor and walk about as far as a person can walk on the 15th floor, then climb a short ladder to gain access to the roof.

The roof is even hotter than the elevator, but it does not smell. I find our microwave transmitter, looking for all intents and purposed like a large tom-tom hanging from a pole. I follow its path from the tom-tom head toward our relay point across the river, but my view is blocked by a crane. It is not a whooping crane, but a 16-story bright yellow construction crane, whose horizontal part is absolutely, as much as it possibly could be, directly in the path of our microwave link. I place a quick cell phone call to my boss and tell him that I can’t imagine how *any* of our signal is getting past the crane. He says he is not surprised. I tell him that there are some beautiful women swimming on a rooftop pool in an adjacent building, and he says he’ll be right over to check out the crane.

---

***“There is no pool; no women—just heat.”***

---

I got him on that one. There is no pool; no women—just heat. I know he won’t ask me about the pool, because he won’t admit that he was looking for it, yet he knows that I know that he was, and I know that he knows that I set him up. What neither of us knows is exactly why I’ve started to talk like Sam Spade. ■

\*High-Paying Job in Electronics

# AOR SR2000 Frequency Monitor

## Seeing is Believing!



**The SR2000 is an ultra-fast spectrum display monitor with a high quality triple-conversion receiver**

AOR puts the power of FFT (Fast Fourier Transform) algorithms to work in tandem with a powerful receiver covering 25 MHz ~ 3 GHz continuous.

The result is a compact color spectrum display monitor that's ultra-sensitive, incredibly fast, yet easy to use. The SR2000 is perfect for base, mobile or field use and can also be used in combination with a personal computer. It's another example of why so many Federal and State law enforcement, military units, surveillance agencies, government users, hospitals, RF labs, News Media and monitoring professionals rely on AOR, the Serious Choice in Advanced Technology Receivers.

**High Speed FFT Search**  
– Scans 10 MHz in as little as 0.2 seconds!  
Instantly detects, captures and displays transmitted signals.

- FFT (Fast Fourier Transform) high speed display
- Displays up to 10MHz of spectrum bandwidth
- 5 inch TFT color LCD display
- Waterfall (time) display function
- High speed FFT search quickly captures new signal transmissions
- Versatile color display uses state of the art digital signal processing
- Average or peak value readings
- Frequency coverage: 25MHz ~ 3GHz (no gaps)
- Ultra-stable, high-sensitivity triple-conversion receiver
- AM/NFM/WFM/SFM receive modes
- 1000 memory settings (100ch x 10 memory banks)
- Easy menu-driven operation
- PC control through serial port (or optional USB interface)

## SR2000

**Standard Accessories:**  
AC adapter, control cables



Authority on Radio Communications

® AOR U.S.A., Inc.  
20655 S. Western Ave., Suite 112, Torrance, CA 90501, USA  
Tel: 310-787-8615 Fax: 310-787-8619  
info@aorusa.com <http://www.aorusa.com>

Specifications are subject to change without notice or obligation. Product intended for use by government or authorized users in the USA, documentation required.

# The 'R75 is back - now with DSP standard!



**IC-R75** *Tune in the world!* • 30 kHz - 60.0 MHz • AM, FM, S-AM, USB, LSB, CW, RTTY • 101 Alphanumeric Memory Channels • Twin Passband Tuning (PBT) • Synchronous AM Detection (S-AM) • DSP with Noise Reduction Auto Notch Filter • Triple Conversion • Up to Two Optional Filters • Front Mounted Speaker • Large Display • Well Spaced Keys and Dials • PC Remote Control with Optional Icom RSR75 Software for Windows® • And Many Other Features



## Handheld Receivers

**IC-R3** • 500 kHz - 2.45 GHz\* • AM, FM, WFM, AM-TV, FM-TV • 450 Alphanumeric Memories • CTCSS with Tone Scan • 4 Level Attenuator • Antenna with BNC Connector • 2" Color TFT Display with Video and Audio Output Jacks • Lithium Ion Power

**IC-R5** • 150 kHz - 1.3 GHz\* • AM, FM, WFM • 1250 Alphanumeric Memories • CTCSS & DTCS Decode • Weather Alert • Dynamic Memory Scan • Icom's Hot 100 Preprogrammed TV & Shortwave Channels • Weather Resistant • AA Ni-Cds & Charger

**IC-R20** • 150 kHz - 3.3 GHz\* • AM, FM, WFM, USB, LSB, CW • 1250 Alphanumeric Memories • CTCSS & DTCS Decode • Dual Watch • Audio Recorder • Weather Alert • Dynamic Memory Scan • Icom's Hot 100 Preprogrammed TV & Shortwave Channels • Lithium Ion Power

All Icom receivers are PC programmable. See your dealer for details.



AMATEUR | AVIONICS | LAND MOBILE | MARINE | RECEIVER | [WWW.ICOMAMERICA.COM](http://WWW.ICOMAMERICA.COM)

**ICOM**®