

Raising The Standard for Toughness

Solid As A Rock



Actual Size

Yaesu's FT-1500M represents a technological breakthrough in radio transceiver design! New advances in power amplifier technology combine to provide you with 50 Watts of clean transmit power with enhanced current consumption efficiency. Yaesu's patent pending aluminum die-cast shell construction dissipates heat throughout the entire transceiver chassis and eliminates the need for a cooling fan. This allows the FT-1500 to fit in an incredibly small case size: less than 5 inches square X 1.4 inches high and offer superior operating specifications as well!

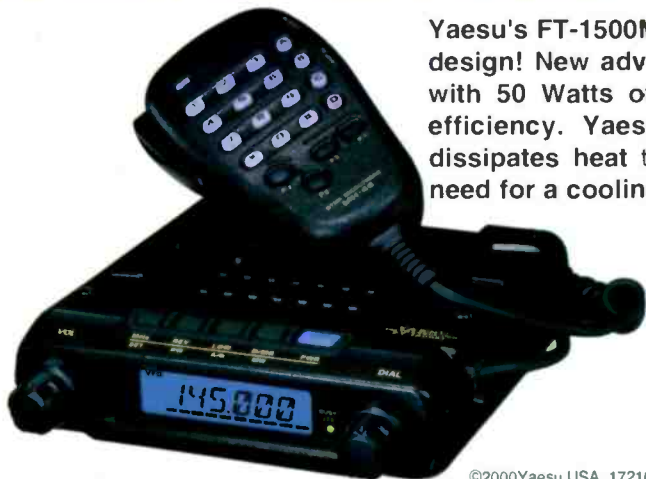

FT-1500M

50 W 2-m FM Mobile Transceiver

YAESU
Choice of the World's top DX'ers™

©2000Yaesu USA, 17210 Edwards Road, Cerritos, CA 90703. (562) 404-2700
Specifications subject to change without notice. Specifications guaranteed only within Amateur bands. Some accessories and/or options are standard in certain areas. Check with your local Yaesu dealer for specific details.

For the latest news, hottest products:
Visit us on the Internet! <http://www.yaesu.com>

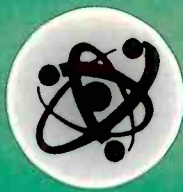

LENTINI

COMMUNICATIONS, INC.

Toll Free
1-800-666-0908
 In CT 860-666-6227

PCR1000



\$349.95
 Special Sale price w/ICOM coupon

Communications Receiver For Computer

- Covers .01-1300MHz.
- All Mode WFM, FM, AM, SSB, CW
- Employs Band-Tracking RF Filters.
- Connects to Your PC Extier.

NEW PCR1000, Similar to PCR1000 Less SSB \$199.95 SALE
 UPS Included

IC-R10



- Wideband, All Mode Receive Capability From 100 kHz to 1300 MHz.
- 1000 Memory Chan. With 8-Character Alphanumeric Names.
- Many Other Features!

\$299.95 Special Sale price w/ICOM coupon
 UPS Included

IC-R8500



Communications Receiver

- Wideband, All Mode Receive From 0.1 to 2000 MHz.
- Many Features Similar to IC-R10

CALL FOR PRICING!

ICOM



\$199.95
 UPS Inc.

Ultra Compact, Super Wide Band

- The New Mini-Sized Scanner From ICOM is Now Available.
- 500kHz-1.3GHz (Less Cellular) AM/FM/WFM.
- Loud And Crisp Audio, Backlit LCD.
- Triple Conversion, Built-In Attenuator.
- 400 Memories, 8 Banks of 50 Chan.
- CTCSS Tone Squelch and Tone Search.
- Includes 2 AA Size Ni-Cd Batteries and Charger.
- PC Programmable (Software and Connection Cable Optional).
- More!

IC-R2

IC-R75



\$689.95
 UPS Inc. w/ICOM Coupon

NEW IC-R75 HF Receiver

- Receives .03-60MHz, AM/FM/SSB/CW/RTTY
- Triple Conversion Receiver
- Synchronous AM detection
- Twin Passband Tuning
- Automatic Notch Filter
- Front Mounted Speaker
- Optional Digital Signal Processing
- Up to Two Optional Filters

SANGEAN

ATS505



- New Low Priced Shortwave Receiver with SSB Capability!
- AM/FM Stereo/SSB
- Lighted Display, 45 Mem.
- Incl Earbuds & Carrying Case
- More

\$129.95
 UPS Incl.

ATS909



- AM/FM Stereo/USB/LSB
- 306 Memory Presets, 29 Separate Pages
- RDS Reception
- Lighted LED, Clock with Alarm
- Incl/ Carrying Case,

\$259.95
 UPS Incl.

BC895XLT



\$219.95
 UPS Included

SC180 \$174.95
 SC200 \$199.95

BC245XLT

Handheld "TrunkTracker II"
\$219.95
 UPS Included

UPS included

AR8200B



- 5-2040MHz
- AM, NFM, WFM, SSB, CW
- Alpha-Num.
- Computer Prog.

ALSO AVAILABLE

NEW AR-16B
 Mini Handheld 500kHz - 1.36Hz (Cellular Blocked)
\$219.95

AR8000B ARD-2
 AR5000 + 3 AR3000A
 AR7030 Plus

FULL LINE OF AOR ACCESSORIES

CALL FOR MORE INFO & PRICING
 Unblocked versions available to qualified agencies

\$549.95

RANGER

RCI-6300/RCI-6900



RCI-6300/RCI-6900

- 10 Meter
- AM/FM AM/FM/SSB
- Low and High Power Models
- Built-In Frequency Counter
- High Sensitivity Receiver Design
- Variable Power Output
- More

CALL FOR LATEST PRICING

RCI-2950DX/RCI-2970DX



RCI-2950DX/RCI-2970DX

- New Dual 12 and 10 Meter Bands
- AM/FM/SSB
- Low and High Power Models
- Programmable Repeater Offset
- Receiver Clarifier
- Noise Blanking/ANL Circuitry
- More

VX-5R



Yaesu VX-5R Tri Band Handheld Transceiver

- Wide Band Receive RX: 0.5 - 15.995 MHz, 48-728.990 MHz, 800-998.990 MHz (Cellular Blocked) TX: 50-54 MHz, 144-148 MHz, 430-450 MHz
- 5W Power Output
- 220 Memories
- AM/NFM/WFM
- CTCSS Encode/Decode, Digital Coded Squelch (DCS)
- 8 Character Alpha Display.
- ADMS-1E Windows™ PC Programmable (Optional)
- Much, Much More

CALL FOR PRICING!

VR-500



- High Performance Miniature Communications Receiver
- Freq Range: 100kHz to 1300 MHz
- All-Mode! AM/WFM/NFM/LSB/USB/CW
- 1000 Memory Channels
- 8 Character Alpha Numeric Display.
- Direct Keypad Frequency Entry
- Dual Watch/Band Scope
- Much More!

Call For Availability and Pricing!

Drake Shortwave Radios	
RBB (new)	\$1159.95 • \$14 UPS
SW8	\$779.95 • \$10 UPS
SW1	\$199.95 • \$7 UPS
SONY	
ICF-2010	CALLS\$
ICF-SW67	CALLS\$
ICF-SW77	CALLS\$
ICF-7600G	CALLS\$
ICF-SW1000TS	CALLS\$
ICF-SW1005	CALLS\$
ICF-2010	CALLS\$
ICF-SC1	CALLS\$
ICF-SC1PC	CALLS\$
Luke	
DP-976	\$39.95

MAGNUM	
MAGNUM 257 30W 10 Meter Mobile	\$249.95
MAGNUM 357DX 150W 10 Meter Mobile	\$399.95
MAGNUM 457DX 200W 10 Meter Mobile	\$479.95
Galaxy CB	
DX949 AM/SSB Mobile	\$199.95
DX959 AM/SSB Mobile, Freq Counter	\$249.95
Galaxy 10 Meter	
DX33HML	\$219.95
DX55V	\$219.95
DX44	\$249.95
DX77HML	\$299.95
DX66V	\$329.95
DX73V	\$339.95
DX2517 Base	\$499.00
DX88HL	\$379.95
DX99V	\$399.95

GRUNDIG Shortwave

NEW!

Grundig Satellit 800

\$499.95
 \$15 UPS

Yacht Boy 400PE
\$199.00
 UPS Included

Yacht Boy 205 Analog Shortwave
SALE \$49.95

RELM

MS180

\$169.95
 UPS Included

HS200

\$199.95
 UPS Included

ALINCO

DJ-X10



- Wide Range Receiver
- Multi-Mode Reception From .1 to 2000MHz.
- Channel Scope.
- AM/WFM/FM/SSB/CW.
- 1200 Memories.
- Superb Sensitivity, Clear Sound.

\$349.95

HOURS: M-F 10am - 6pm SAT 10am-4pm UPS Ground (48 states)

Conn Sales Infor. & Tech Help 860-666-6227

Web Site: www.lentini.com

21 Garfield St. Newington, CT 06111

C.O.D.'s OK
 SAME DAY SHIPPING



CIRCLE 145 ON READER SERVICE CARD

Contents

POPULAR COMMUNICATIONS

Volume 18, Number 10

June 2000

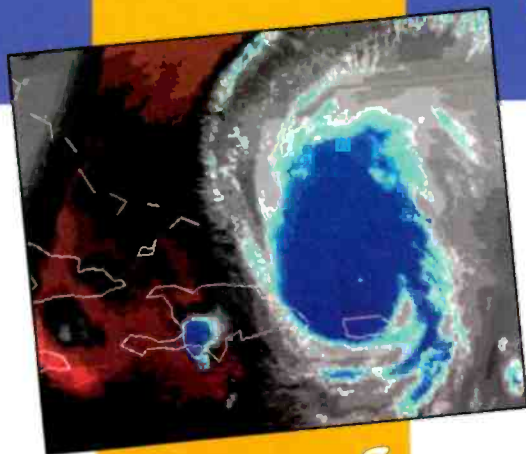

8



49



56

- 8 **Weather Alert! You CAN Be Ready**
Tips, Frequencies And The Inside Scoop To Stay Safe... by Peter Laws
- 19 **Early Broadcasting Fizzles: Radio Was An Amazing Fad, But Some Station Failed Anyway!**
 by Alice Brannigan

Product Spotlights

- 52 • **Palstar's R30 Shortwave Receiver** by Peter Bertini
- 54 • **Panasonic's 900 MHz KX-TC1800 Cordless Phone** by Harold Ort

- 22 *Going Mobile On High Frequency, Part 1: Your Rig And Operating Position* Radio Resources
- 26 *The Boy's First Receiver Contest Closes, And Adding A Tunable Notch Filter To Our Latest Project* The Radio Connection
- 32 *Applied Searching 101: John's Story From Western New York State* Scan Tech
- 37 *QSLs: The Right, And Easy Way* The Ham Column
- 40 *Navigating International SW BC Bands The Easy Way* World Band Tuning Tips
- 44 *Welcome To The First Utility Radio Review!* Utility Radio Review
- 49 *Radio Target: Hawaii* Broadcast DXing
- 56 *Art Bell Chats With Pop'Comm's Editor, And Free Flight Tracking With WebTrax!* Radio & The Internet
- 61 *Sectional Aeronautical Charts* Plane Sense
- 66 *Cherokee's Impressive CBS-2100 AM/SSB Base Station* CB Scene
- 70 **Liberia's ELWA On Shortwave, And Vanuatu Back On 7260!** The Listening Post
- 76 *CB Radio's 155 Mile Rule Petition Update* Washington Beat
- 80 *Surviving Life's Catastrophes* The Loose Connection

Departments

- 4 *Tuning In* — An Editorial
- 6 *Pop'Comm P.O.* — Letters
- 16 *How I Got Started*
- 42 *Product Parade*
- 79 *Readers' Market*

On The Cover

Each year hundreds of people die needlessly from lightning, hurricanes, tornadoes and flash floods. But with advance warnings and your radios, you and your family can be safe. Read Peter Law's article "Weather Alert! You CAN Be Ready" on page 8 for details. (Photo courtesy NOAA. Inset photo courtesy of the National Hurricane Center by Julio Ripoll, WD4JR)

Visit us on the Web: www.popular-communications.com

Universal Radio - Quality equipment since 1942.



**RX-340 H.F.
D.S.P.
RECEIVER**



The **TEN-TEC RX-340** communications receiver combines cutting-edge, state-of-the-art technology, with excellent ergonomics and esthetics. Digital signal processing (DSP) brings the performance and repeatability of expensive military grade communications receivers into the price range of top end commercial receivers for shortwave listeners. Tunable from 5 kHz to 30 MHz, it provides tuning steps and display resolution of 1 Hz. An astounding 57 bandwidths from 100 Hz to 16 kHz are included. All filters have a shape factor of 1.5:1 or better (6 to 60 dB). USB, LSB, ISB, CW, AM, Synchronous AM and FM modes are built-in. Four AGC modes are provided. A tunable Notch filter rejects unwanted signals in the passband. The receive front-end incorporates a built-in preselector with eight half octave bandpass filters. A switchable 10 dB preamp and 15 dB attenuator are also provided. The RX-340 also includes Built-in Test or "BITE". Memory and Scan functions fall into four categories: a scratchpad memory, 100 memory channels, memory scan and sweep (F1 to F2 scan). Separate volume controls are provided for the speaker and for the headphone. The front panel features a Lexan graphics overlay designed to last a lifetime. Made in Tennessee, U.S.A. Visit our website or request our 2000 catalog for full specifications. Under \$4000.

ICOM R3



What a cool idea this is! The new **ICOM R3** has incredible wideband coverage from .5 to 2450 MHz (less 824-849 & 869-894 MHz cellular) in AM, FM wide, FM narrow and TV. Yes, the R3 has a built-in 2 inch TFT **color TV** screen. You will receive regular TV, but that is only the beginning. Imagine being at a car race and seeing the video directly from the driver's seat or seeing ham fast-scan TV transmissions or wireless video cameras! The display can also be used as a spectrum bandscope and to display the various operational menus. There is even a second mono LCD display that can be used for conventional frequency display purposes when battery life is a concern. Plus you get a 450 alphanumeric memory system, 4-step attenuator, video and audio outputs, auto power off, a 4 position joy stick and BNC type antenna. A tone squelch system provides quiet stand-by. This radio comes with BP-206 Lithium Ion battery, charger, belt clip and antenna. Only 2.4 x 4.7 x 1.3 inches 11 oz. (61 x 120 x 33 mm 290 g). **NOTICE:** The R-3 has not been approved by the Federal Communications Commission. This device is not and may not be offered for sale or leased until the approval of the F.C.C. has been obtained.

HUGE FREE CATALOG

The **2000 Universal Communications Catalog** covers everything for the shortwave, amateur and scanner enthusiasts. This informative 104 page catalog is fully illustrated. Many new items are featured including the new **TEN-TEC RX-340**, **Grundig Satellite 800**, **ICOM R-3** and **Palstar R30** receivers. This catalog is **FREE** by bookrate or \$3 by Priority mail. Rising postage costs prevent us from sending this catalog out automatically so please **request your free copy today!**

Universal Radio, Inc.
6830 Americana Pkwy.
Reynoldsburg, Ohio
43068-4113 U.S.A.

☎ 800 431-3939 Orders & Prices
☎ 614 866-4267 Information
☎ 614 866-2339 FAX Line
✉ dx@universal-radio.com

**universal
radio inc.**

RADIO BOOKS

● Shortwave Receivers Past & Present *Third Ed.*

This huge 473 page guide covers over 770 receivers from 98 manufacturers, made from 1942-1997. Entry information includes: receiver type, date sold, photograph, size & weight, features, reviews, specifications, new & used values, variants, value rating & availability. 120 new pages. Become an instant receiver expert! #0003 \$24.95



● Passport To World Band Radio 2000 *New Edition*

Graphic presentation of all shortwave broadcast stations. Equipment reviews, too. 592 Pages! #1000 \$19.95

● World Radio TV Handbook 2000 *New Edition*

All shortwave broadcast stations organized by country with schedules, addresses, power, etc. #2000 \$24.95

● Pirate Radio *By A. Yoder With audio CD!*

Here is the incredible saga of America's underground illegal broadcasters (with audio CD). 326 pgs. #3038 \$24.95

● Discover DX'ing! *By J. Zondlo Second Edition*

Hear distant AM, FM and TV stations. #0019 \$5.95

● Shortwave Listening Guide *By Helms Second Ed.*

Here is understandable information on: selecting and operating a shortwave receiver, simple antennas, time stations, pirates and much more. 323 pgs. #2984 \$19.95

● Understanding ACARS. *By E. Flynn Third Edition*

Learn the ACARS aeronautical format. #0012 \$9.95

● Communications Receivers - The Vacuum Tube Era

By R.S. Moore Fourth Edition
Key facts, figures and photos for shortwave receivers of the Golden Era 1932-1981. 141 Pages. #2945 \$19.95

www.DXing.com

www.universal-radio.com

- Visa
- MasterCard
- Discover
- Prices and specs. are subject to change.
- Returns subject to a 15% restocking fee.
- Catalog & used list available on request.

tuning in

An Editorial

NAB: Their Nose In Anyone's Business (Except Their Own)

Money talks. We're finding that's especially true when it comes to the recently created Low-Power FM (LPFM) Service. But, of course, the National Association of Broadcasters is so knee-deep in political and lobbyist dung they couldn't walk a straight line if their lives depended on it. Just when I thought they had exceeded their "Nose in Anyone's Business" limits for the year, they file a comment about Alan Dixon's petition to eliminate CB Rule 13 regarding the 150-mile communications limit. Talk about NAB bull! The 150-mile rule is absurd and should be canned.

Since its inception in 1958, CBers have been using their radios to talk more than the FCC's maximum limit of 155.3 miles. I've done it and undoubtedly so have you. So lock me up and send the key to the NAB to swallow. My Mom did it back in the late '60s as we'd try to talk locally through the skip when I drove to and from work on snowy Upstate New York evenings. People still do. They're ordinary citizens who, because of the natural phenomenon known as ionospheric refraction—or skip—find themselves inadvertently communicating hundreds or even thousands of miles away. No linear necessary—just a regular 5-watt mobile or base CB. Makes me wonder what the FCC was thinking when they put what they envisioned as a short-range, personal radio service on a portion of spectrum that routinely supports long-distance communications. After all, for years hams had been using those frequencies to talk around the world with flea power!

And what about the folks who routinely violate the 150-mile rule by calling CQ and actively looking for long-distance contacts? Big deal, really. If they're not operating a kilowatt linear, what's the harm of talking to other 11-meter operators further away than 150 miles? Please don't tell me that we're crazy because we favor eliminating a useless, unenforceable rule, and at the same time stand by enforcement of the CB rule about over-powered, obnoxious loudmouths. These

are distinctly different rules and should be considered on their own merit. It's a point the legal staff at the NAB missed—again. CBers operating an otherwise legal station—mobile or base—should be legally permitted to use the service as they have for years: for personal and hobby communications. This harmless pursuit of radio fun deserves to be recognized by the FCC and Rule 13 should be eliminated from Part 95 of the Commission's rules. If Dixon's proposal, adopted by the FCC as **RM-9807** comes full circle, it will.

The NAB's Assertions

Now that we've factually established that the CB service is in an area of the spectrum that's naturally skip-prone, let's look at what the brilliant minds at the NAB had to say. In their comments on **RM-9807** filed on February 14, they made assertions that are seriously flawed. They state that consumers must be protected from CB transmissions that interfere with radio, television, and other electronic communication. Please, Mr. Bureaucrat, protect me from doing harm to myself and please protect the American Consumer from the wrath of those dirtbag CBers. You see, this age-old argument about CBers and interference to home entertainment equipment and NAB word posturing works if you don't know the truth. Fact is, it's incumbent on the manufacturer of home entertainment equipment and telephones to properly shield the equipment *before* offering it for sale to the consumer. So, I suppose you *could* say the NAB is correct about the fact that consumers *should* be protected from interference, but it seems to me the shoe is on the wrong foot! Certainly, CBers should operate their stations within the limits of the established law which means no high-power linears or out-of-band operation.

I've operated legal CB bases and mobiles for years. Parked in our driveway, my mobile CB wreaks havoc on two

(Continued on page 78)

BY HAROLD ORT, N2RLL, SSB-596

POPULAR COMMUNICATIONS

EDITORIAL STAFF

Harold Ort, N2RLL, SSB-596, Editor
(Internet e-mail: PopularCom@aol.com)
Tom Kneitel, K2AES/SSB-13, Senior Editor
(Internet e-mail: K2AES@juno.com)
Alycia Nicholse, Assistant Editor
Richard S. Moseson, W2VU, Online Coordinator
(Internet e-mail: W2VU@amsat.org)

CONTRIBUTING EDITORS

Richard "RD" Baker, Utility Communications
Ed Barnat, TCA-44, CB SSB
Peter J. Bertini, K1ZJH, Restoration/Electronics
Joe Carr, K4IPV, Antennas
Bruce Conti, AM/FM Broadcasts
Joseph Cooper, Projects and Broadcast Band
Gerry L. Dexter, Shortwave Broadcast
Alan Dixon, Legislative Affairs
Jock Elliott, SSB-734, Citizens Band
Eric Force, Radio and the Internet
Bill Hofer, Aviation Communications
Kirk Kleinschmidt, NT8Z, Amateur Radio
Ian Poole, SW Broadcasting
Bill Price, N3AVY, Humor/Communications
Ken Reiss, Technical/Scanning
Edward Teach, Pirate and Alternative Radio
J.T. Ward, Scanning
Gordon West, WB6NOA, Radio Resources

BUSINESS STAFF

Richard A. Ross, K2MGA, Publisher
Donald R. Allen, W9CW, Advertising Mgr.
Emily Leary, Sales Assistant
Sal Del Grosso, Accounting Manager
Ann Marie DeMeo, Accounting Department
Judith Erickson, Office Manager
Catherine Ross, Circulation Manager
Melissa Gilligan, Operations Manager
Denise Kells, Data Processing
Jennifer Cormagi, Customer Service

PRODUCTION STAFF

Elizabeth Ryan, Art Director
Barbara McGowan, Associate Art Director
Edmond Pesonen, Electronic Comp. Mgr.
Dorothy Kehrwieler, Production Manager
Emily Leary, Assistant Production Manager
Hal Keith, Technical Illustrator
Larry Mulvehill, WB2ZPI, Photographer

A publication of



CQ Communications, Inc.
25 Newbridge Road
Hicksville, NY 11801-2953 USA

Offices: 25 Newbridge Road, Hicksville, NY 11801. Telephone (516) 681-2922. FAX (516) 681-2926. Web Site: <http://www.popular-communications.com/> Popular Communications (ISSN-0733-3315) is published monthly by CQ Communications, Inc. Periodical class postage paid at Hicksville, NY and additional offices. Subscription prices (payable in U.S. dollars): Domestic—one year \$25.95, two years \$45.95, three years \$65.95. Canada/Mexico—one year \$35.95, two years \$65.95, three years \$95.95. Foreign Air Post—one year \$45.95, two years \$85.95, three years \$125.95.

U.S. Government Agencies: Subscriptions to Popular Communications are available to agencies of the United States government, including military services, only on a cash with order basis. Requests for quotations, bids, contracts, etc. will be refused and will not be returned or processed.

Entire contents copyright © 2000 by CQ Communications, Inc. Popular Communications assumes no responsibility for unsolicited manuscripts, photographs, or drawings. Allow six weeks for change of address or delivery of first issue.

Printed in the United States of America.
Postmaster: Please send change of address to Popular Communications, 25 Newbridge Road, Hicksville, NY 11801.

Tall, telescoping antenna with BNC connector.

Use the TFT color display:

- To show simple or advanced operation settings
- To scan for wireless cameras, like those found in race cars
- To catch your favorite TV shows
- In conjunction with a digital wireless camera to monitor babies, traffic, etc.

When the TFT color display is not needed, or if you just want to conserve power, use the mono LCD to display all necessary information.

4-way action joystick quickly moves you through settings.

Simulated picture

Lithium Ion Power

A long lasting Li-Ion battery offers easy charging, lightweight performance, and up to 27 hours of continual use on the mono LCD.

IC-R2 Excellent audio, tiny package

500 kHz - 1.300 GHz¹

AM, FM, WFM • 100 mW audio output • easy band switching • weather resistant • CTCSS tone squelch • 400 memory channels • backlit LCD • priority watch • includes Ni-Cd batteries and charger, or use alkalines • PC programming (optional)

IC-R10 Advanced listening excitement

500 kHz - 1.300 GHz¹

All mode • large, alphanumeric display • 1000 memory channels • band scope • 7 different scan types, including VSC (pauses only on voices) • easy mode • comes with rechargeable Ni-Cds and charger, or use alkalines • PC programming (optional)



Simulated picture

IC-R3* NEW FOR A LOOK BEHIND THE SCENES

ICOM wide band receivers always let you HEAR more of what's out there. With the new IC-R3, now you can SEE more, too! This pocket sized marvel receives from 0.5 - 2450 MHz¹, and sports a 2-inch TFT color display. Scan for wireless camera broadcasts. It's great for watching the action *behind* the scenes at sporting events. Or, just watch your favorite TV programs. A video/audio output terminal lets you display to a large monitor or recording device. All this, and advanced ICOM receiver features like 450 memory channels with alphanumeric names, CTCSS, attenuator, & more.

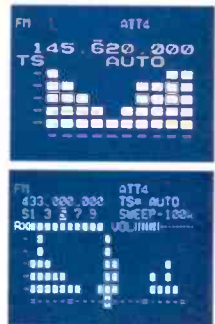

Signal strength (above) and band scope (below) functions assist in finding the action you want to hear...or see!

When you're looking for the best, keep your eye (and ear) on an ICOM receiver. Contact your authorized ICOM dealer today, or call for a free brochure:

425-450-6088

ICOM[®]
www.icomamerica.com

*This device has not been approved by the FCC. This device may not be sold or leased, or be offered for sale or lease, until approval of the FCC has been obtained.
¹Cellular blocked: unblocked version available to FCC authorized users only.
 ©2000 ICOM America, Inc. 2380 116th Ave NE, Bellevue, WA 98004 • 425-454-8155. The ICOM logo is a registered trademark of ICOM, Inc. All specifications are subject to change without notice or obligation. Questions? Contact your authorized ICOM dealer or contact ICOM America Tech Support on CompuServe's® HamNet forum at 75540.525 or send e-mail to 75540.525@compuserve.com. CompuServe is a registered trademark of CompuServe, Inc. RGPOP300

OUR readers SPEAK OUT...

Each month, we select representative reader letters for our "Pop'Comm P.O." column. We reserve the right to condense lengthy letters for space reasons and to edit to conform to style. All letters submitted must be signed and show a return mailing address or valid E-mail address. Upon request, we will withhold a sender's name if the letter is used in "Pop'Comm P.O." Address letters to: Harold Ort, N2RLL, SSB-596, Editor, *Popular Communications*, 25 Newbridge Road, Hicksville, NY 11801-2909, or send E-mail via the Internet to <popularcom@aol.com>.

Remembering Vincent's Ponzio's Letter

Dear Editor:

After reading Vincent Ponzio's vitriolic diatribe condemning the proposed changes in the amateur radio licensing structure, as well as those "liberals" who support the changes, I feel compelled to offer my views.

Let it happen; the sooner, the better. While other forms of hobby-type electronic communications have been growing by leaps and bounds, amateur radio has been stagnating. Relaxing the current licensing requirements will not "dumb down" our pastime. Quite the contrary; it will infuse ham radio with fresh, new blood eager to proudly carry the torch into the next century. The bar hasn't been lowered, its merely been modified.

One other thing: I'd like to express my appreciation to Mr. Ponzio for branding me a "liberal" for my views. That's a title I graciously accept, particularly when compared to what apparently passes as the alternative.

Marc Manis, K5NO
Winter Springs, FL

Bill's Birdcage Liner: An Opinion

Dear Editor:

The letter from Harry Horton, N6BWE, berating REACT in the February 2000 "Readers Speak Out" Section would have been much better served used as liner in someone's birdcage or as a wrapper for the Christmas turkey carcass. I was surprised that *Pop'Comm* would have even considered airing a letter so filled with innuendo, and unsubstantiated accusations. I was under the impression that the "American Way" involved being proven guilty of a specific crime prior to being punished, rather than pilloried by half truths and slurs. To print such a letter without offering the board a chance to respond is unlike the magazine and editor with whom I worked only a couple of years ago.

I have been involved with REACT on every possible level except as a member of the Board of Directors of REACT, International for the past eighteen years, and have worked directly with many of the board members during this time. The current members are easily the most accessible and open of all who have been in office during that time. The concept among the current board members is that they are in office to assist the teams and members in their efforts to be of assistance to the community and to encourage team growth. They make a point of not operating in secrecy, and have created E-mail accounts for all to contact the board members directly. Many opt to interface with one or more E-mail "lists" or discussion groups. They are as passionate con-

cerning REACT and the growth of REACT as anyone in the organization. All are active within their respective teams while serving on the board. Most are amateur radio operators, have GMRS licenses, and operate CB radio.

Mr. Horton's comment about "rubber-stamp numerous dues increases to 'Save REACT'" at the annual conventions borders on the ludicrous. The conventions are the site of the annual board meeting, and sufficient time to enter discussions is allowed all attendees. The entire membership has the option to attend, but choose not to do so. There are normally sufficient representatives from councils and teams to represent a cross section of the membership. I hardly think the approval of an increase in dues from the \$15 I paid in 1982 to the current \$20 annual dues represents a hardship for anyone nor could it be considered rubber stamping by either the Board or the attendees. All large corporations operate during the annual meeting using exactly the same method of member attendees to ratify Board decisions, or the Board to ratify member recommendations.

I would suggest that Mr. Horton's complaints would be better served by taking the time to contact the members of the current Board, rather than make unprovoked attacks in a forum which really allows no opportunity for the Board members to respond. I would also suggest that *Popular Communications* acted irresponsibly by printing Mr. Horton's letter without allowing the REACT Board the occasion to respond in the same column.

REACT, along with many other non-profit organizations not using paid management staff, has had problems over the past years. In 1998, at the convention hosted by the Wisconsin Council of REACT Teams, the Board and attendees took a giant step toward a successful future by reorganizing the Board of Directors to allow more direct representation for the membership. It will take time for the decisions made at that convention to demonstrate success. Letters filled with such venom and intentional vituperative are best left unread, unpublished, and in the circular file.

W.F. (Bill) Simpson,

Life Member 345 Past President, WI Council of REACT
Teams President, REACT Services Diversified, Team 4813
1998 Convention Chairman K40 Award 1986 Past Chair of
GMRS Task Group, Past Chair of CB Task Group Columnist
for REACTer

Dear Bill:

A "Letters" department in a magazine or newspaper is just that: letters to the Editor. We get lots of letters running the gamut; many even have little to do with radio! Do we print all the letters we receive? Hardly. Do we print letters with viewpoints different from our own? Certainly. We even get letters demanding publication (fat chance of that happening) and then there's your letter, which we've printed word for word in its entirety. (Looks like I'm having a good day — I need a refill on my cranky pills).

But please know that we don't make a habit of contacting the subjects of readers' letters. If we did I'd be on the phone to the ARRL every three weeks about a letter from an anti-code ham and giving Billy Tauzin a heads-up about my editorials. (Another fat chance). They're opinions, nothing more, nothing less. That's why people love reading the mail in Pop'Comm P.O. Thanks for writing, Bill!



The Best Just Got Better!



AOR has just improved its world-class AR8200 B portable receiver. The AR8200 Mark II B leaves others behind, with a new Temperature Compensated Crystal Oscillator that maintains frequency stability without regard to changing ambient temperatures. A new keyboard layout and improved illumination allow easy operation in a variety of conditions.

Discover why AOR receivers are the choice of many federal, state and local government agencies. Military users, laboratories and professional news-gathering operations also use AOR receivers.

When you're ready
to own the **best**,
you're **ready** for **AOR**.

NEW! AR8200 Mark II B

- New TCXO for greater stability – performance not found in most desktop units!
- Brighter backlit display for easy use anytime
- New telescopic antenna included for better reception
- New keyboard layout for easier operation
- Attractive new black case
- Now includes 1100 mAh high capacity Ni-Cd batteries
- 500 KHz ~ 2040 MHz * coverage
- 1,000 memory channels (20 banks)
- Computer control and programming. *(requires optional connection cable)*
- Download free control software from AOR web site!
- "All Mode" reception includes "super narrow" FM plus wide and narrow AM in addition to USB, LSB, CW and standard AM and FM modes
- True carrier reinsertion in USB and LSB modes.
- Includes 3 KHz SSB filter!
- Detachable MW antenna
- Optional internal slot cards expand the AR8200 MarkII B capabilities. Choose from Memory Expansion (up to 4,000 memories), CTCSS Squelch & Search, Tone Eliminator, Voice Inverter and Record Audio (saves up to 20 seconds of audio)
- Tuning steps programmable in multiples of 50 Hz in all modes
- 8.33 KHz airband step is correctly supported
- Noise limiter and attenuator
- Band activity "scope" display with "save trace" capability
- Four-way side panel rocker switch allows one-hand operation
- Large display includes A and B VFO frequencies and signal strength meter
- Battery Save function with Low Battery indicator
- Operates on 12 VDC external power
- 4 AA Ni-Cd batteries supplied, also uses standard AA dry cells
- BNC antenna connector
- Wide choice of accessories
- Patented design (U.S. Pat. No. 6,002,924)



AOR U.S.A., Inc.

20655 S. Western Ave.

Suite 112 Torrance, CA 90501

310-787-8615 Phone • 310-787-8619 Fax

www.aorusa.com

CIRCLE 156 ON READER SERVICE CARD

*Cellular frequencies blocked in compliance with USA regulations. Continuous coverage models available for authorized users/agencies; documentation required. AOR engages in ongoing efforts to improve its products. As such, design and performance parameters may change without notice or obligation on the part of the manufacturer and/or distributor(s).

Weather Alert! You CAN Be Ready

Tips, Frequencies, And The Inside Scoop To Stay Safe. . .

By Peter Laws, N5UWY

Each year across North America, hundreds of people are killed and thousands are injured by severe weather. Events include tornadoes, severe thunderstorms, flash floods, hurricanes, and blizzards. Little can be done to prevent these phenomena from occurring, but armed with information gleaned from listening to the radio spectrum, you can keep yourself and your loved ones safe from the storm.

NOAA: The National Oceanic And Atmospheric Administration

NOAA Weather Radio — The Voice of the National Weather Service — is perhaps the best known source of weather information in the radio spectrum. In 1994, Vice President Al Gore began an initiative to extend the reach of NOAA Weather Radio to fringe areas that previously did not have access to the broadcasts. He also set a goal of making weather radios “as common as smoke detectors” in American homes. Since that time, over 50 new transmitters have been installed through cooperative efforts with public sector organizations, such as local amateur radio clubs. NOAA’s 480 transmitters cover the 50 U.S. states, adjacent coastal waters, and many of the U.S. territories on 7 VHF channels (see **Table 1**). Roughly 95% of the U.S. population is within range of a weather radio transmitter and more transmitters are being added every year.

Programming on these stations originates from over 100 regional weather service forecast offices located strategically around the country. These offices create and broadcast a wide variety of weather products including local forecasts, climatological data, and recent observations.

Of course, most folks listen to NOAA Weather Radio for up-to-the-second severe weather information. When severe weather threatens an area, regular

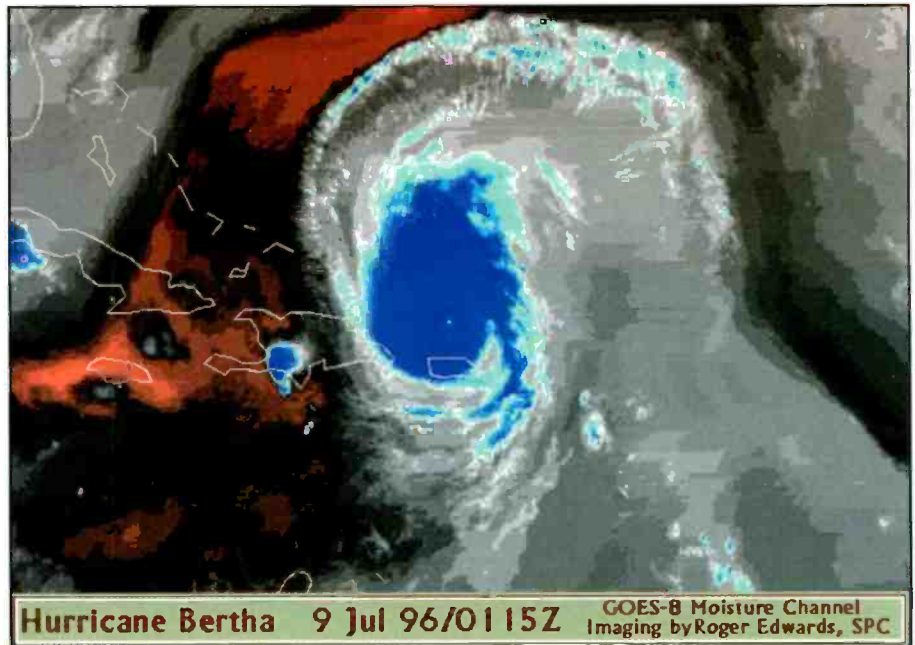

Hurricane Bertha north of Puerto Rico, as photographed by the GOES-8 weather satellite at 0115 UTC, July 9, 1996. The bright blue dot is the hurricane's eye.

programming is interrupted to bring listeners vital watches and warnings.

For many years, the NWS has used a 1050-Hz tone to alert listeners to approaching severe weather. While this feature is valuable, the inability of end-users to select the area of concern meant that many folks were awakened in the middle of the night for warnings affecting areas more than 50 miles away. To address this issue, the National Weather Service developed the **Specific Area Message Encoder, or SAME**. This digital technology allows forecasters to target the specific county or portion of a county that is under threat of severe weather. Furthermore, it allows weather service personnel to designate the exact type of threat (see **Table 2**). The data burst includes the geographical area threatened, the type of threat, as well as the expected duration (up to six hours). (See **Table 3** for SAME Specs.) Radios capable of decoding SAME messages have

been available for several years and prices have dropped steadily during that time (See this month’s “Product Parade” announcement about Midland’s new SAME weather receiver on page 42). Most can be programmed to allow reception of watches and warnings for multiple counties. This is helpful for storm spotters who may wish to receive advanced warning of severe weather moving towards their county.

In addition to weather information, the SAME system is part of the Emergency Alert System (EAS) and can be used by officials to disseminate vital information about non-weather-related events, such as chemical spills.

Listeners may also have noticed another change to NOAA Weather Radio: The elimination of human announcers! As part of the weather service’s multi-billion dollar modernization effort, the system has undergone some major changes. In years past, forecasters would type weath-

Table 1: NOAA Weather Channels

162.400 — WX2
162.425 — WX4
162.450 — WX5
162.475 — WX3
162.500 — WX6
162.525 — WX7
162.550 — WX1

er forecasts or storm warnings, then turn them over to personnel manning the weather radio studio. The text would then be read live on the air or recorded for repeated broadcast.

With the Console Replacement System, as the upgrade program is known, direct human intervention ends when the forecaster hits a key on his or her workstation. The computerized system then converts the written text to spoken words for relay to the various transmitters. The system is designed to reduce the number of personnel needed to broadcast the information. It is expected to reduce complexity in offices that may have many different transmitters covering different areas, each with unique programming. Most importantly, warnings will be delivered to listeners more quickly.

In addition to NOAA Weather Radio, the weather service also disseminates forecast products on a variety of MF, HF, and other VHF frequencies, primarily for the benefit of marine interests. NOAA forecast products can be heard via the facilities of the National Institute of Standards and Technology (NIST) and United States Coast Guard (USCG). See <http://www.nws.noaa.gov/om/rw/reachout/marine/home.htm> for complete details on how NOAA disseminates their marine data.

Station WWV

"At the tone, the time will be . . ." is what most radio hobbyists expect to hear on 2.5, 5, 10, 15, and 20 MHz. This is, of course, the National Institute of Standards and Technology's famous WWV time and frequency standard station. Usually, WWV's format is "all time, all the time," but at certain minutes during each hour, WWV transmits storm position data. At 9 and 10 minutes past each hour, storm position data for the Atlantic Ocean, Caribbean Sea, and Gulf of Mexico is broadcast. At minute 11, data for the Pacific Ocean is read. At minutes

Table 2: Weather and Environmental Threats

The NOAA Weather Radio Specific Area Message Encoder is able to indicate the following weather related messages. Also note that not all radios can decode all possible messages, but most are able to recognize that some type of alert has been transmitted and will open the weather radio's squelch.

Tornado Watch/Warning
Severe Thunderstorm Watch/Warning
Flash Flood Statement/Watch/Warning
Flood Statement/Watch/Warning
Winter Storm Watch/Warning
Blizzard Warning
High Wind/Dust Storm Watch/Warning
Hurricane Statement/ Watch/ Warning
Tropical Storm Watch/Warning
Tsunami Watch/Warning
Coastal Flood Watch/Warning
Special Marine Warning
Avalanche Watch/Warning
Volcano Watch/Warning
Immediate Evacuation Warning
Evacuation Immediate
Shelter In Place Warning
Severe Weather Statement
Special Weather Statement

Remember, a **WATCH** means that conditions are favorable for one of the above and a **WARNING** means that one of the above is occurring or is imminent.

48 through 51, Hawaiian sister station WWVH broadcasts data for Pacific storms. WWVH broadcasts on the same frequencies as WWV, with the exception of 20 MHz, and can be distinguished from its Boulder, Colorado counterpart by its female announcer's voice. The National Weather Service creates special reports for WWV and WWVH several times per day. (See Table 5 for more WWV Info.)

The U.S. Coast Guard

Several times each day, the Coast Guard broadcasts NWS weather forecasts from its coastal "master" stations around the USA and its territories. HF frequencies include **6501, 8764, and 13089 kHz** (see Table 6).

Various USCG districts also broadcast weather information on MF. After giving a call on **2182 kHz USB**, forecasts are read on **2670 kHz USB**. Unlike the HF broadcasts, which can be heard virtually worldwide, MF broadcasts are

usually only good out to about 150 nautical miles during the day and approximately double that at night. Regional broadcasts may also be heard on Marine Channels 16 (**156.8 MHz FM**) and 22A (**157.1 MHz FM**).

An interesting situation exists in Alaska, where National Weather Service forecast offices broadcast weather information directly, using **4125 kHz USB**. In addition to the broadcasts, mariners are encouraged to report conditions at their locations on the same frequency. The weather service monitors the frequency for these reports as staffing allows.

Environment Canada

The Meteorological Service of Canada, a service of Environment Canada, also provides weather services via radio. As in the U.S., forecasts are transmitted on 150 or so stations operating on the seven standard VHF weather channels (see Table 1). The service is known as WeatheRadio™.

In addition to voice broadcasts, Environment Canada transmits digital information to specially equipped receivers. Their system, known as WeatherCopy™ provides information on observations, watches and warnings, forecasts, and even bit-mapped images. DOS-based software can be downloaded that allows messages to be output to a printer in order to provide hard copy. The software can run on Intel-based hardware as old as the XT.

The Meteorological Service of Canada has undertaken an automation program to streamline broadcast operations. Canadian WeatheRadio™ listeners may have noticed that it seems like the same announcer is always on the air, 24 hours a day! Fortunately, this is not the case.

Beginning several years before their American counterparts, the Canadians also automated their weather broadcasts. Unlike the synthesized voice used in the U.S., the system north of the border uses digital samples of an actual human voice. The samples are strung together and the resulting speech is much more pleasing to the ear and much easier to understand than the synthesized voice of NOAA Weather Radio. Time will tell whether the Americans follow the technological lead of their Canadian colleagues. Interestingly, in addition to VHF, the Canadian service also transmits programming on about a dozen stations in the AM and FM broadcast bands. These stations, which use Canadian Broadcasting Corporation licenses, serve remote areas



Down and out in the Northeast! It takes more than a breath of fresh air to do this kind of damage. Stay on top of the weather at your monitoring post, and stay alive! (Photo by Jennifer Ort).

Table 3: SAME technical Data

The speed is 520.83 bits per second
 Logic zero is 1562.5 Hz (space)
 Logic one is 2083.3 Hz (mark)

Non-standard data rates and tones were chosen in an attempt to prevent false messages from being transmitted.

of Canada, such as Whitehorse, Yukon Territory (CBPY, 810 kHz AM), and Iqaluit, in the new Canadian territory of Nunavut (CIQA-FM, 93.3 MHz). A complete list is available at http://www1.tor.ec.gc.ca/nwsd/awps/wxrdo1st_e.cfm.

Local Severe Weather Nets

Each spring and summer, hundreds of tornadoes rip across the USA and Canada, causing untold damage and destruction. While it's unlikely that science will be unable to actually mitigate the strength of a thunderstorm, let alone a tornado any time soon, it has given us tools to keep out of harm's way.

Modern meteorologists rely on a wide array of state-of-the-art remote-sensing equipment. Doppler radar blankets the USA and new units are being installed across Canada, near space is filled with a variety of meteorological satellites, and sensors measuring ambient and dew point temperatures, wind speed and direction, as well as barometric pressure dot the

landscape. However, severe weather forecasters still rely on the most advanced sensor of all: the Mark I Human Eyeball!

Across North America, thousands of volunteers attend regular training and then spend hours scanning the skies of their neighborhoods looking for signs of meteorological mischief. These volunteers,

usually organized under the SKYWARN banner in the USA or CANWARN in Canada, are trained by weather service forecasters to be the eyes and ears (and skin) of the warning forecasters.

For the radio listener, SKYWARN provides a wealth of listening opportunities. Most storm-spotting traffic is heard in the **two-meter amateur band**, with the 70-cm and 222 MHz bands also gaining in popularity. Storm spotters are not always hams, however. Some nets are conducted on the GMRS UHF bands, often organized under the REACT banner. Other nets are run by public safety agencies, with law enforcement, fire, and EMS personnel functioning as storm spotters.

A sampling of severe weather net frequencies is included in **Table 4**. Nets are usually conducted on wide-area repeaters or linked systems, such as the West Texas Connection (<http://www.apex2000.net/nonprof/wtc/scanner.htm>), a linked repeater system centered on the Midland-Odessa area of West Texas.

Ham-based severe weather nets are often closely tied to National Weather Service forecast offices. Ham operators there either act as net control for the entire network or act as liaison between various weather nets and the forecasters. In either case, information from spotters flows easily to the forecasters, and spotters are

(Continued on page 15)

Table 4: SKYWARN Sampler

Chicago, IL — 145.21-, 145.35-, 442.975+
 Dallas-Fort Worth Metroplex, Texas — 146.88-, 146.76-, 146.94- (tone 110.9), 443.05+ (tone 103.5)
 Denver, Colorado — 146.94- (tone 91.5), 147.12+
 Huntsville, Alabama — 147.14+, 147.24+, 147.36+
 Kansas City, Missouri/Kansas — 146.82-, 146.91-, 146.79-, 158.82 (local gov't.)
 Little Rock, Arkansas — 146.94-
 Milwaukee, Wisconsin — 146.67-, 146.91-
 Minneapolis-St. Paul, Minnesota — 147.21+, 146.67-
 Nashville, Tennessee — 146.94-
 Oklahoma City, Oklahoma — 145.21-, 147.045-, 147.06+ (tone 141.3), 151.445 (local gov't), 462.675 (REACT GMRS)
 St Louis, Missouri — 145.13-, 145.33-, 146.67-, 146.94- (tone 123.0)
 Tulsa, Oklahoma — 146.88-, 146.94-, 443.85+ (tone 88.5)
 Toronto/Southern Ontario Net — 442.025+

Nationwide Storm Chasers: 146.55S Primary, 147.42S Alternate

National Severe Storms Laboratory Joint Mobile Research Facility — 163.100, 165.435

These frequencies were taken from an extraordinary list of U.S. storm spotting frequencies maintained by Keith Brewster, N0IAW. Keith has maintained his list on the Internet since 1992 — that's pre-world wide web! The current version is at <http://www.galstar.com/~kbrews/radio/spotfreq.html>.

More Canadian CANWARN frequencies may be found at <http://www.interlog.com/~jmckay/chaser.htm>

Today the World ... Tomorrow the Universe



GRUNDIG

GRUNDIG Tunes in the

The Millennium begins. The wait is over. The Grundig Satellit Legend continues. The Satellit 800 Millennium is your assurance of staying in touch with the world... Access radio programs the world over... fast-breaking news from the farthest corners of the globe... music from faraway countries.

CUTTING EDGE IN SPACE TECHNOLOGY

- You'll appreciate the smooth flowing design and functional control panel.
- Superbly appointed, fold away, easy grip handle for portability.
- Enter any station on the key pad, then tune up or down frequency or search specific meter bands.
- The tuner receives AM/FM and all shortwave frequencies from 100 to 30,000 KHz, FM from 87 to 108 MHz and VHF aircraft 118 to 137 MHz and locks onto broadcasts with digital accuracy...



World



"Performance ... exceptionally promising ..., Audio quality is delightful, superior to that of any other portable on today's market ..., This ergonomic radio is a cinch to operate straight out of the box"

Lawrence Magne,
Editor-in-Chief, Passport to World Band Radio

- Receives FM stereo with the included high-quality headphones.
- Superior audio quality for which Grundig is known.
- A direct input digital key pad combined with manual tuning.
- 70 user-programmable memories.
- Upper and lower sideband capability (USB/LSB).
- A large 6" by 3 1/2" multifunction LCD.
- Last station memory.
- Synchronous detector for superior AM and shortwave reception.
- Multi voltage (110, 220 V) AC adapter.
- Dual clocks.
- Low battery indicator.

Whether you are cruising offshore, enjoying the cottage, or relaxing on an extended vacation in some distant land, the Satellit 800 Millennium is the most powerful and precise radio in the World. Search the globe, you can discover the hottest news first hand... listen to and witness the ongoing fascination with our evolving world today... tomorrow the universe.

by **GRUNDIG**



The Ultimate in Digital Technology



The LCD

Big! Bold! Brightly Illuminated 6" by 3 1/2". Liquid Crystal Display shows all important data: Frequency, Meter band, Memory position, Time, LSB/USB, Synchronous Detector and more.

- For direct frequency entry: a responsive, intuitive numeric keypad.



The Signal Strength Meter
Elegant in its traditional Analog design, like the gauges in the world's finest sports cars. Large. Well Lit. Easy to read.



The Tuning Controls

- For the traditionalist: a smooth, precise tuning knob, produces no audio muting during use. Ultra fine-tuning of 50Hz on LSB/USB, 100Hz in SW, AM and Aircraft Band and 20 KHz in FM.
- For Fixed-step Tuning: Big, responsive Up/Down tuning buttons.

The Frequency Coverage

Longwave, AM and shortwave: continuous 100-30,000 KHz. FM: 87-108 MHz VHF Aircraft Band: 118-137 MHz.

The Technology

Today's latest engineering:

- Dual conversion super-heterodyne circuitry.
- PLL synthesized tuner.



The Operational Controls

Knobs where you want them; Buttons where they make sense. The best combination of traditional and high-tech controls.



The Many Features

- 70 user-programmable memories.
- Two, 24 hour format clocks.
- Two ON/OFF sleep timers.
- Massive, built-in telescopic antenna.
- Connectors for external antennas – SW, AM, FM and VHF Aircraft Band.
- Line-out, headphone and external speaker jacks.



The Sound

Legendary Grundig Audio Fidelity with separate bass and treble controls, big sound from its powerful speaker and FM-stereo with the included high quality headphones.



The Power Supply

A multi voltage (110, 220V) AC adapter is included. Also operates on 6 size D batteries. (not included)

Dimensions:

20.5" L x 9" H x 8" W

Weight: 14.50 lbs.

by **GRUNDIG**

Lextronix / Grundig, P.O. Box 2307, Menlo Park, CA 94026 • Tel: 650-361-1611 • Fax: 650-361-1724
Shortwave Hotlines: (US) 1-800-872-2228 (CN) 1-800-637-1648 • Web: www.grundigradio.net
CIRCLE 159 ON READER SERVICE CARD

Table 5: WWV Information

For more information on WWV, see the NIST's WWV Website at <http://www.boulder.nist.gov/timefreq/wwv/>.

For more information on NOAA's WWV services, see <http://www.nws.noaa.gov/om/rw/reachout/marine/wwv.htm>.

WWV Frequencies: 2.5, 5, 10, 15, 20 MHz at minutes: 9, 10, 11
Area: Atlantic, Pacific
Forecasts prepared at 0500, 1100, 1700, 2300

WWVH Frequencies: 2.5, 5, 10, 15 MHz at minutes: 48-51 (52)
Area: Pacific
Forecasts prepared at 0000, 0600, 1200, 1800

Hurricane Watch Net — Station W4EHW

Beginning in 1980, when University of Miami student Julio Ripoll WD4JR (ex-WD4JNS) hauled his ham gear to the National Hurricane Center to support the NHC's operations during Hurricane Allen, hams have played an integral role in collecting and disseminating hurricane and tropical storm-related information throughout the Caribbean Sea and Atlantic Ocean.

Current operations are centered at W4EHW, which is located inside the National Hurricane Center. Since abandoning their old building, which was damaged during Hurricane Andrew in 1992, the NHC has relocated to a new facility on the campus of Florida International University in Coral Gables. The NHC is part of the weather service's Tropical Prediction Center (TPC) and is responsible for maintaining a continuous watch on tropical cyclones over the Atlantic, Caribbean, Gulf of Mexico, and the Eastern Pacific from May 15 through November 30.

W4EHW was also significantly upgraded with equipment donated by Yaesu and other manufacturers. The current W4EHW is a far cry from the ancient Yaesu FT101EX that WD4JR would bring from his dorm room — and can now truly be called world-class!

During the hurricane season, which in the Atlantic, Caribbean, and Gulf of

kept up-to-date with radar and other meteorological data.

Other nets are run by Emergency Management agencies. These nets function in the same manner as those described above, but with local government as the net control. Both types of net exist for the same reason: to relay first-hand reports of severe weather to the National Weather Service and local Emergency Management agencies. While listening, keep in mind that this information is often "raw" and has yet to be correlated with other information gathered by the various agencies.

In Canada, CANWARN severe weather nets function in the same manner as their American SKYWARN counterparts. Ham operators at Environment

Canada offices fulfill the same role as hams in NWS offices, relaying observations from spotters in the field to the forecasters and, in turn, keeping the storm spotters up-to-date with information from the forecasters. CANWARN began as a pilot project in 1987 in the Windsor area (across the river from Detroit, Michigan) and has since expanded to cover most of Canada's "Tornado Alley" in Southern Ontario.

Lest anyone think that tornadoes only occur in Oklahoma and Texas, CANWARN, as well as improved service on Environment Canada's WeatherRadio™, are a result of the government report issued following the Barrie tornado of 1985, which killed 12 people and caused \$100 million in damage.

Table 6: U.S. Coast Guard HF Broadcasts

NMN, Chesapeake, Virginia
NMG, New Orleans, Louisiana
NMC, Pt. Reyes, California
NOJ, Kodiak, Alaska
NMO, Honolulu, Hawaii
NMV, Guam
4125 kHz NOAA broadcasts, Alaska
4316 kHz NMG
4426 kHz NMN, NMC
6501 kHz NMN, NOJ, NMO, NMV
8502 kHz NMG
8764 kHz NMN, NMC, NMO
12788 kHz NMG
13089 kHz NMN, NMC, NMO, NMV
17314 kHz NMN, NMC

NOAA broadcasts originate at various stations along the Alaskan coast.

Source: NOAA/National Weather Service

Table 7: Saffir-Simpson Hurricane Intensity Scale

Category	Wind Speed	miles/hour	knots km/h
Category One:	74-95	64-82	119-153
Category Two:	96-110	83-95	154-177
Category Three:	111-130	96-113	178-209
Category Four:	131-155	114-135	210-249
Category Five:	>155 mi/h	>135	>249

A Tropical Depression is an organized system of clouds and thunderstorms with a defined circulation and maximum sustained winds of 38 mi/h (33 kts) or less. A Tropical Storm is the same, but has winds of 39-73 mi/h (34-63 kts.) Hurricanes are the next step up and have winds of 74 mi/h and over. In the western Pacific, hurricanes are called "typhoons," while in the Indian Ocean, they are known as "cyclones."

Source: NOAA/National Hurricane Center

how I got started

Congratulations To Harold McNeal Of Florida!

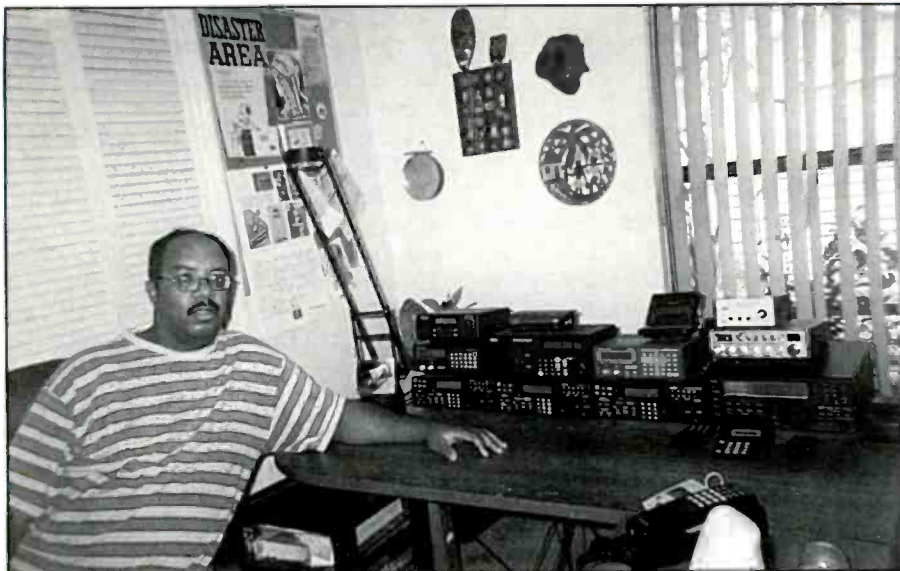

Harold McNeal of Florida at his listening post.

Popular Communications invites you to submit, in about 150 words, how you got started in the communications hobby. Entries should be typewritten, or otherwise easily readable. If possible, your photo (no Polaroids, please) should be included.

Each month, we'll select one entry and publish it here. Submit your entry only once; we'll keep it on file. All submissions become the property of *Popular Communications*, and none will be acknowledged or returned. Entries will be selected taking into consideration the story they relate, and if it is especially interesting, unusual, or even humorous. We reserve the right to edit all submitted material for length, grammar, and style.

The person whose entry is selected will receive a one-year gift subscription (or one-year subscription extension) to *Popular Communications*. Address all entries to: "How I Got Started," *Popular Communications*, 25 Newbridge Road, Hicksville, NY 11801 or E-mail your entry to popularcom@aol.com, letting us know if you're sending photos. If you're E-mailing photos, please send them in a separate E-mail with your name in the "subject" line.

Our June Winner

Pop'Comm reader, Harold McNeal of Kissimmee, Florida says, "My first receiver was a Harron Labs Coaxial Monitor tuned to Suffolk County, New York's Fire Dispatch (46.46 MHz). I then purchased a second Harron Labs Coaxial Monitor tuned to Nassau County, New York Fire Dispatch. Since then I've owned Patrolman PRO series single and dualband monitors, Bearcat and Sonar scanners.

I now have three Uniden BC9000XLT scanners, a Realistic PRO-2022, 2006 and a PRO-2052 scanner, a Drake SW2 receiver, ICOM IC-R8500 communications receiver, a Cobra 148 GTL ST SSB CB radio, and a RadioShack weather alert radio. I have a Novice ticket, KC4PLU, and am contemplating getting a ham rig. My specialty is civilian and military aircraft monitoring. I must say I couldn't have accomplished so much without the guidance of *Pop'Comm*. Thanks again." ■

**Table 8: Fujita Tornado
Damage Scale**

Developed in 1971 by T. Theodore Fujita of the University of Chicago

SCALE	WIND ESTIMATE (MPH)	TYPICAL DAMAGE
-------	---------------------	----------------

0 — < 73: Light damage. Some damage to chimneys; branches broken off trees; shallow-rooted trees pushed over; sign boards damaged.

1 — 73–112: Moderate damage. Peels surface off roofs; mobile homes pushed off foundations or overturned; moving autos blown off roads.

2 — 113–157: Considerable damage. Roofs torn off frame houses; mobile homes demolished; boxcars overturned; large trees snapped or uprooted; light-object missiles generated; cars lifted off the ground.

3 — 158–206: Severe damage. Roofs and some walls torn off well-constructed houses; trains overturned; most trees in forest uprooted; heavy cars lifted off the ground and thrown.

4 — 207–260: Devastating damage. Well-constructed houses leveled; structures with weak foundations blown away some distance; cars thrown and large missiles generated.

5 — 261–318: Incredible damage. Strong frame houses leveled off foundations and swept away; automobile-sized missiles fly through the air in excess of 100 meters (109 yds); trees debarked; incredible phenomena will occur.

IMPORTANT NOTE ABOUT F-SCALE WINDS: Do not use F-scale winds literally! These precise wind speed numbers are actually estimates based on observed damage and have never been scientifically verified.

Source: NOAA/Storm Prediction Center

Mexico runs from June through November, (See **Table 7** for hurricane info.) W4EHW's volunteer operators can be heard directing the Hurricane Watch Net on **14325 kHz USB**. This net has proved absolutely vital during hurricanes and has even allowed the NHC to stay in contact with other NWS offices when conventional communications were knocked out. In addition to the main 20-meter frequency, W4EHW may also be heard gathering information on the Water Way Net at **7268 kHz** or the Caribbean Net at **3815, 3950, or 3940 kHz**.

Roundup

Everyone is always talking about the weather! Now instead of talking about the weather, you can LISTEN instead. Power up your rig and see what's out there! ■

Early Broadcasting Fizzles

Radio Was An Amazing Fad, But Some Stations Failed Anyway!

By Alice Brannigan

Broadcasting officially began in late 1921, and within the first couple of years stations began flooding onto the airwaves. Some ran several thousand watts, but many were so-called *one-lung* stations operating with 100 watts or less. Despite the amazing popularity of broadcasting, it didn't take long for some of the early stations to go dark. Hundreds of early station operators had lost interest, gone broke, were bought out by other stations, or had been kicked off the air by the government because of rule violations. Fact is, many were bounced simply because the government had deemed them to be unnecessary.

It's true that many of today's broadcasters can trace a noble ancestry directly back to stations of the early 1920s. KDKA, WGN, WHA, WBZ, KCBS, WSM, and the like are revered as broadcast pioneers. Yet a host of stations from that early era came into existence and then left so quickly and quietly that they became unheralded and generally forgotten. Here are a couple of long lost stations.

50 Watts And A Dream

In 1924, the Coppotelli Brothers Music House (20 Illinois Street, Chicago Heights, IL) decided to put a modest broadcasting station on the air. Many stores selling phonograph records and radio receivers did this to attract neighborhood customers. A license was applied for, and in early May 1, 1924, the store was awarded the call letters WCBZ, granting 50-watt operation on 1210 kHz.

Using the slogan *Where the Lincoln and Dixie Highways Meet*, WCBZ operated only twice a week, playing recordings at 8:30 p.m. each Monday and Friday. In early 1925, it was relocated from the music store to 1721 Prairie Ave., Chicago Heights.

By late April 1925, after only a year of part-time broadcasting, the Coppotelli



This EKKO veri stamp from station WCBZ is a unique artifact relating to that obscure and short-lived one-lung 1920s station.

Brothers had spun their last wax platter over WCBZ. They sold their little station to the Neutrowound Radio Manufacturing Company. The new owners announced the station would soon be relocated to nearby Homewood, IL, a Chicagoland suburb.

Changes Ahead

As of late April 1925, WCBZ was shifted to 1380 kHz where it had to share time with Chicago's WFKB. Effective May 25, 1925, Neutrowound had dropped the call letters WCBZ and replaced them with WOK. The station left the air briefly for the move to Homewood, returning to the airwaves on July 20th, having increased its power from 50 to 500 watts. Two 85-foot tall steel masts were used to support a six-wire flat-top "T" antenna. The transmitter building was to one side of the antenna system. WOK's transmitter was powered by storage batteries. The station's license authorized it to increase its power to 5 kW on September 2, 1925.

The WOK studios were 18 by 24 feet

and located in the Terrace Gardens of the Morrison Hotel, Chicago.

These arrangements were short-lived. In the early months of 1927, the Neutrowound Radio Manufacturing Company (WOK's licensee) was acquired by Trianon, Inc., of 32 West Randolph Street, Chicago. As of June that year, WOK was shifted to 1190 kHz. These events would have major implications for WOK, for Trianon was a company with a story of its own to tell.

Trianon & Friends

The Trianon Ballroom, owned by the Woodlawn Theatre Company of Chicago, had put up a new broadcasting station of its own in March of 1925 atop its magnificent three story ballroom building at 6201 Cottage Grove Avenue, Chicago. The Woodlawn Theatre Co. owned not only the ballroom, but also the adjoining Woodlawn Recreation Co., which was a combination bowling alley and billiard parlor. Two steel lattice towers were erected atop the ballroom and a Western Electric 100-B transmitter was installed there. The call letters WMBB (standing for *World's Most Beautiful Ballroom*) were assigned, permitting 500 watt operation on 1200 kHz on a time-share basis with WGES, Oak Park, IL. The new WMBB first went on the air on April 15, 1925.

Within two weeks of WMBB's inaugural broadcast, its license was transferred to the American Bond and Mortgage Co., which simultaneously took control of the Trianon and Woodlawn properties.

In June of 1927, WMBB was ordered to shift to 1190 kHz and share time with WOK in Homewood. As of August 1927, the Federal Radio Commission authorized WMBB to increase its power to 5 kW. As of October that year, the FRC approved stations WMBB and WOK to merge. On November 1, 1927, WMBB was consoli-

dated with its time-share partner, WOK. A complex arrangement, to say the least.

Though both stations were under separate ownership and management and shared the same studios and studio staff at 6201 Cottage Grove Ave., in Chicago. WMBB's transmitting facilities were relocated to those of WOK at Homewood, where the stations began sharing the WOK transmitter and towers. Both call letters were used for one station with two licenses. In August 1928, Neutrowound Radio Manufacturing Co. changed its corporate name to Trianon, Inc. On October 22, 1928, WMBB and the merged WOK became one station with one owner, Trianon, Inc. using the hyphenated call letters WOK-WMBB.

The Irony Of Things

After all of the bobbing, weaving, merging, and hyphenated call letters, you'd think that things had finally gotten themselves worked out. Not so! In late 1928, WOK-WMBB routinely applied to the Federal Radio Commission for license renewal. For whatever reasons, the FRC rejected the renewal application, canceled the license, and ordered WOK-WMBB off the air. Most likely, the FRC had simply deemed the station to be unnecessary. In other words, in metropolitan areas, there were too many minor stations clogging the airwaves. That caused more interference than the FRC felt the stations were worth. Most inexpensive broadcast receivers had such poor selectivity they weren't able to separate stations using adjacent frequencies. So, along with time sharing, kicking stations off the air altogether became a common FRC approach when too many stations began clogging available local channels.

While the station was dark, Trianon appealed to various courts in order to obtain a renewal of the license. The FRC's action was upheld in 1931 by a federal court decision, thus writing the final chapter to the saga of WOK-WMBB.

Curiously, even with WOK-WMBB dark and denied a license renewal, rumors continued to make the rounds that the station would soon return to the air with 20 kW. Perhaps they were circulated by Trianon, Inc. with a dash of wishful thinking in the hopes of maintaining sponsor and listener interest. This was in hollow anticipation of winning its license renewal on appeal.

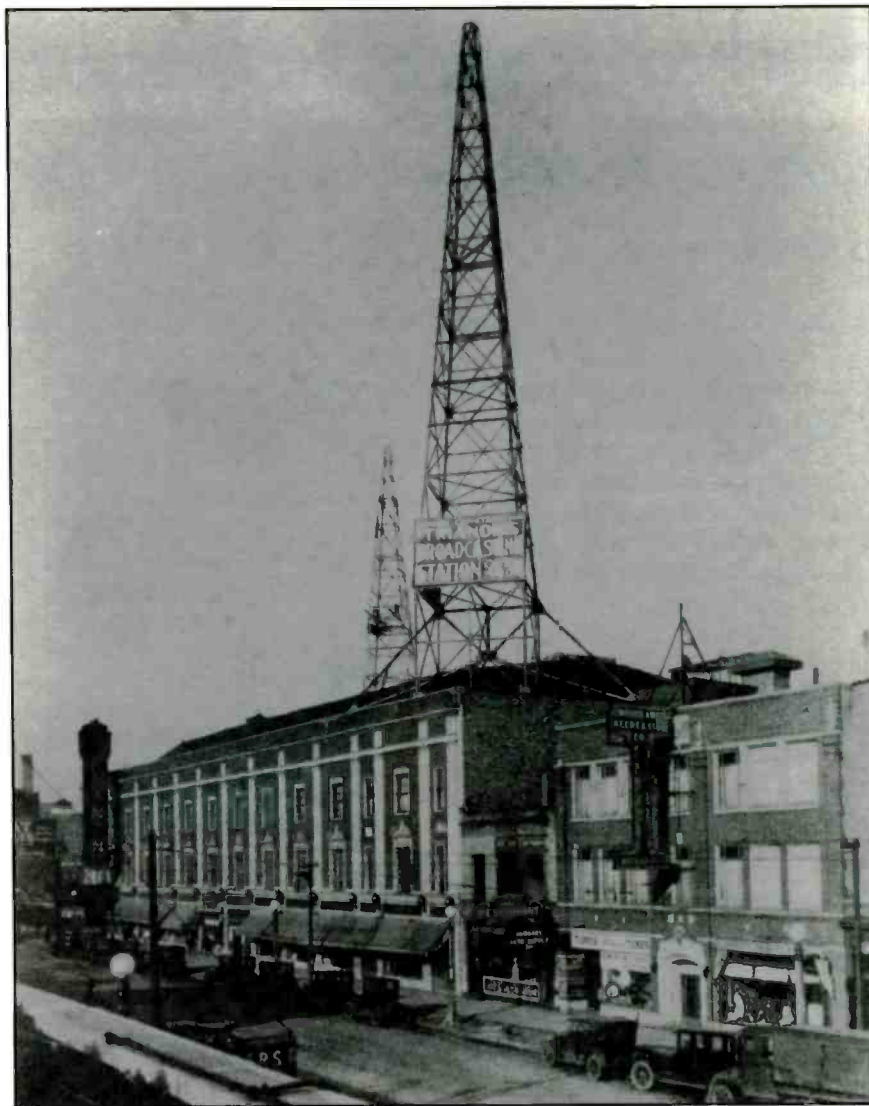

WMBB in all of its brief glory while at the beautiful Trianon Ballroom in 1925. You can almost hear Ted Weems playing the Charleston! (Photo courtesy Jan D. Lowry, Broadcast Pro-File, Calif.)

WCBZ, WOK, and WMBB were three minor stations that huddled together in order to survive. Yet they still went from here to oblivion in less than five short years. Now it's more than 70 years after the fact. We felt it's long past time to retrieve these lost gems from obscurity.

We have in our archives what must surely be the only remaining WCBZ-related artifact. Since 50-watt WCBZ existed for only one year, and that was many decades ago, our 1924 WCBZ EKKO verification stamp is likely all that remains relating to the station. We were lucky enough to obtain a rare photo of WMBB as it looked in 1925.

Our thanks go to Broadcast Pro-File for allowing us to extract information from

their reference files on WCBZ, WMBB, and WOK. BP-F is a professional research service that (for a nominal fee) can prepare a highly-detailed historic reference report on any American AM or FM broadcast station, past or present. Their catalog is \$1 and may be obtained from Broadcast Pro-File, 28243 Royal Road, Castaic, CA 91384-3028. Tell them Alice sent you!

We always appreciate input and feedback from readers, as well as material (old station QSL's originals or good photocopies), picture postcards, station lists, etc. Our snail mail address is Alice Brannigan, *Popular Communications*, 25 Newbridge Road, Hicksville, NY 11801. Our direct E-mail address is <Radioville@juno.com>.

Experience Events and Places Around the World...

...while in the comfort of your own chair.



Drake's world band communication receivers preserve their history of excellence, with something for every level of skill or interest. You will appreciate the high standards of craftsmanship, quality, and performance, built into each receiver.

R8B Communications Receiver



For the avid enthusiast, the top of the line R8B offers serious performance with Selectable Sideband Synchronous Detection and five built-in filters.

SW8 Worldband Receiver



For the listener on the go, the SW8 provides all the advanced features of a table top unit. It is battery powered and completely portable.

Order Now Risk Free! 15 Day Money Back Trial.

We are so confident you'll be impressed with the performance of our radios, we'll give you a full refund on your factory direct order, less shipping charges, if the receiver doesn't meet your expectations. Call for complete details.

Order Today, From Your Local Dealer or Factory Direct By Calling 1-800-937-2531.

The Finest Line of Products For The Shortwave Enthusiast.



R.L. Drake Company
phone: 513-746-4556

230 Industrial Dr.
fax: 513-743-4510

Franklin, OH 45005 U.S.A.
on-line: www.rldrake.com

CIRCLE 127 ON READER SERVICE CARD

DRAKE

radio resources

Interesting Thoughts And Ideas For Enjoying The Hobby

Going Mobile On High Frequency, Part 1: Your Rig And Operating Position

Now that it's relatively easy to pass the worldwide General class 5 wpm code test and straight-forward, multiple-choice theory exam, thousands of Technician class operators are upgrading and will consider putting a mobile station in their vehicle. There will also be thousands of brand new operators getting into ham radio and going for the General class license because the tough 13-wpm code test is now out the window.

This four-part discussion of a premiere high-frequency mobile station should also be of interest to old-time hams — even Extra class operators who may not be “up to speed” on the latest advancements about mobile automatic antenna tuners, mobile DSP noise-elimination circuits, and some new mobile “twists” in relatively small high-frequency whips that do an excellent job of putting out worldwide signals.

This series of mobile high-frequency articles will also confirm what some of the old-time, high-frequency mobile operators have known for years: Big signals come from big mobile antennas, and good signals come from almost any other smaller, properly mounted mobile antenna. We will also confirm that lousy signals come from even the best mobile antenna that's

improperly placed on a vehicle without regard to a good ground plane.

Part 1: The Rig

High frequency, 100-watt, 100-channel, 160-meter through 10-meter mobile transceivers start around \$700 and up. Add another \$100 if you also want 6 meters. Add another \$350 if you want 2 meters and 440 MHz.

If you already have a favorite dual-band or tri-band VHF/UHF transceiver in your vehicle, you might not want to choose the more expensive mobile HF transceiver with duplicate capabilities. The exception would be the worldwide equipment including VHF/UHF where these bands can also be operated multi-mode for some exciting 2-meter and 432 MHz SSB operation.

If you have absolutely no room to mount your mobile high-frequency transceiver in plain view of eyes-on-the-road, spend a little bit more and get a mobile HF with a detachable head. This allows you to bury the innards under the front seat, and put the remote head just about anywhere on the dash for a safe view of the radio and road ahead. Never place

your transceiver in an area that requires you to take your eyes off of the road. SAFE DRIVING IS A MUST when operating any type of ham set.

If you are remote-mounting the high-frequency transceiver, forget about keeping the black box innards in the trunk. This only adds length to the massive DC power cable run. You don't want massive red and black conductors running all the way to the back of the vehicle where they could get pinched and short out. You also don't want the remote-mounted HF box in the engine compartment because it would rapidly overheat and self-toast.

So look over all of the available rigs and give the knobs and buttons a twist and push to find the rig of your choice. All of the HF transceivers offered today have almost identical power outputs and receive sensitivity. It is the features that are different. It's up to you to decide what features you want — like an adjustable noiseblanker if you're driving a Ford. Or a motorized companion antenna system if you are driving an RV with an HF whip you can't easily reach. Or a display that has adjustable dimming at night when you drive to work and come home on the graveyard shift.



A remote head mounted too low (left) and one on top of dash near a GPS unit.

BY GORDON WEST, WB6NOA



The Yaesu FT-100 remote head.

Play with the knobs and look at the display. You'll find a big difference between individual manufacturer's radios. Each company seems to have its own way of displaying the frequencies, and giving you just the right feel for adjusting the knobs. I would be hesitant to buy any new mobile radio that I haven't actually had my hands on, so go to the next club meeting and sit in everyone else's car and give their radio equipment a thorough hands-on evaluation.

Buy the equipment from an authorized dealer that can also supply all of the antenna accessories. Build a relationship with one sales person that will take good care of you when you might need help. If you buy the radio from dealer A, and then buy the antenna from dealer B, and then get the coax from dealer C, and then get the alternator filters from dealer D, none of them will share the full responsibility of making sure you are a happy camper when part of the system may not be working up to expectation.

I like the remote head mounting for safety reasons. I use hook-and-loop fasteners all over the place so I can always play radio, whether I am driving or playing passenger, or in the back of the vehicle or riding in a van. HF mobile with a detachable head makes good safety sense!

Powering The Rig

You're going to need a good 12-volt source to power a 100-watt HF transmitter. Don't even THINK about using the cigarette lighter receptacle or the fuse box. Start looking around for a place that you can squeeze a pair of wires along with a whole bunch of other wires presently in place between the engine compartment and the passenger side of the vehicle. If

your only access is through a grommeted hole on the driver's side, make absolutely sure none of your wires will interfere with the gas or brake pedals. If you look hard enough in either the engine compartment or inside the vehicle, you will find an access hole where there are a whole bunch of other wires passing through. Your 12-volt DC cables won't interfere with their operation.

If you must lop off the in-line fuses to

pass the wires through the firewall, welcome to the club! This is just the way it is! You *will* put the fuses back on after you have run your wiring, right at the positive and negative battery terminals. If the fuses are anywhere else in line, they won't protect for an accidental short between the battery and the fuses. This is why you want your red and black DC cables fused *right at* the battery connection. The fuses won't do squat if they're inside the passenger compartment where you have ultimately mounted your high-frequency box.

Keep the red and black wires away from anything hot. Keep them away from alternator wiring, and electronic ignition modules. This will minimize induced noise pick-up.

Triple-inspect the area where the red and black wires pass through the firewall. If you have a real expensive set of wheels, maybe two firewalls. Make sure there is nothing sharp that could nick the wires and blow those two fuses you put on right at the battery terminals. (Oh yes, red to positive, and black to negative. I almost forgot to tell you that!) It is perfectly OK to cut off excess amounts of DC cable. But if you must *lengthen* the cable, you should go to the next wire size up.



synctime metallic mesh band, metal bezel mineral lens, hi-tech polymer case
\$179.95

a new millenium!
Time to be on time
.... atomic time!
with the world's most accurate time pieces, atomic clocks & watches from

ATOMIC TIME

- reliable convenient time pieces
- synchronized to the u.s. atomic clock, fort collins/co
- accurate to 1 second in 1 million years
- engineered in germany
- radio-controlled time

choose from our wide variety:
casual & sport watches
travel alarms • wall clocks
desk clocks • wood clocks
radios • weather stations
computer UTC clocks
industrial & commercial clocks

20% off second item

call for our free brochure:
(630) 472-9999

or go to www.atomictime.com
credit card orders call toll free
1-800-985-8463
send checks/money orders for the total amount incl. s&h \$7.00 to

ATOMIC TIME, INC.
1010 JORIE BLVD., #332
OAK BROOK, IL 60523



atomic dual alarm clock w. 2nd world time, 5x4-2 1/2" black arch design
\$59.95



atomic radio with 2 alarms and temperature, day, date, LCD
\$59.95



jumbo digit atomic clock w. temperature & humidity, wall or desk 8"x11"x1"
\$79.95



atomic digital alarm sport watch 2nd UTC 24hr time display, lap etc. • \$99.95



black arabic 12" wall clock for home or office • \$69.95 (wood \$89.95)

CIRCLE 62 ON READER SERVICE CARD



ICOM's IC-706 remote head.

Mounting The Box

The transceiver box needs to be mounted in an area where it can get a little ventilation. Keep the heat sinks clear for the internal fan (hopefully internal) to pull or blow air through. Avoid putting the transceiver in an area where a catalytic converter is going to heat up the floorboard area. If you are going with an all-in-one transceiver, you may wish to explore hump-mount kits sold to public safety agencies. For this mounting accessory, check out Galls Public Safety Equipment Buyer's Guide 2000, Phone 800-477-7766. You'll get their FREE catalog with numerous pages of radio mounts.

The all-in-one equipment needs to go where you can easily see the LCD display and easily reach the operating controls. Unlike VHF operating where every now and then you'll do channel changing off of the mike, high-frequency operation

regularly requires spinning the knob, adjusting the IF shift, and regularly fine-tuning the DSP and noiseblanking circuits. Unlike FM operation, your fingers are constantly on the controls.

Find a place to hang the microphone separate from your VHF/UHF mike. There's nothing worse than calling CQDX on 2 meters instead of 20 meters! I also recommend an external speaker. Mount this around shoulder level on your side of the vehicle. This way you're not cranking up the volume and driving your better half nuts. You will be glad you did this ahead of time before you next hit the road with worldwide radio. You normally *never* use squelch on high-frequency SSB.

Finally, turn on the equipment and look over your handiwork. You don't need that new high-frequency antenna system we will talk about in the next couple of months to double-check that the radio lights up and accepts frequencies you

punch into memory.

For high-frequency transceivers operated mobile, I always recommend putting in frequencies at the bottom of the band all the way up to the top of the band, 160 meters through 10 meters or 6 meters. I usually load the lower bands in the first 10 or 20 memories, then bands like 40 meters and 20 meters in the mid-memories, and then 15 and 10 meters in the upper-memory channels. This allows me to mike-cycle through the memories without having to take my eyes off the road. And if I find a band that is really hopping with activity, I reach down and push the memory to the variable frequency oscillator button that I have put dots on so I can feel them without looking.

Some high-frequency mobile transceivers may offer band-edge memory channels, which allow you to select a memory channel, and then spin the big knob with complete tuning from the upper and lower limits already stored in memory. This way you NEVER need to look down at the equipment and can safely keep your eyes on the road.

And when you start off memorizing, let's say up to 10 channels, stop the process and then start the vehicle with the radio turned on. Are your memory channels still there? On most newer equipment, the turned-on radio easily survives engine cranking. On older HF equipment, starting the engine will sometimes scramble the memories. If this happens, stay tuned in to upcoming parts of this high-frequency mobile discussion where I can tell you how to remedy the problem with starter-spike-filter networks that go in between your power cable and the battery.

So this month, go ahead and pick out your favorite mobile HF transceiver, and next month we'll go into where to mount the antenna and how to get worldwide reception on just a little bit of metal sticking above your bumper or trunk. The same steps for hams work quite nicely for shortwave reception, too. Even though you might not have your worldwide ham ticket yet, get this HF equipment in the vehicle and start monitoring the worldwide airwaves from 1 to 30 MHz. It's going to be fun! ■

Editor's Note: Coming in the next three issues of *Popular Communications* are Parts 2, 3, and 4 of Gordon's column; Tuned High-Frequency Whips, The Automatic Tuner and Stainless Steel Whip, and Debugging And Fine Tuning The Complete Mobile Station System.



Alinco's DX-77 (and DX-70) make great mobile HF transceivers.

Come With us On a Fascinating Journey to Explore the Excitement of Amateur Radio and the Mystery of Basic Electronics

Basic Technology for the Amateur Radio Enthusiast



Video & Book
\$39.95

Author:
Alice Narramore
Training Director
Alpha Delta
Communications, Inc.

Technical Consultant:
Don Tyrrell, WBAD
President
Alpha Delta
Communications, Inc.

The Alpha Delta *video/book* production "**Basic Technology for the Amateur Radio Enthusiast**" is a simple straightforward program that takes you on this journey, explaining the wonderment of the hobby along the way.



• The *video* shows how radio waves are formed and how electrons move to do work, and explains terms like voltage, current, power, resistance and other terms you'll hear relating to the hobby. You will even go with a miniature "*tour guide*" on

a walk through a receiver printed circuit board. He will show you how amplification, power supplies, radio frequency and audio amplifiers and other parts of a radio work. He will also explain what "semiconductors" are all about. Neither the video nor the book get into math or formulas--**we've kept it simple**

• The *book* is designed for the non-technical person interested in joining the hobby or the amateur operator who would like to know more about "what's behind the dials", and explains the fascination of the hobby in detail. The book is ideal as a support tool for someone who is being mentored by an "Elmer", and for amateurs involved with **school system programs**. The program was designed by our Training Director who formerly did college course development and was director of training for a major electronics company.

This **video/book program** is not a study guide for a specific license class but bridges the gap between study guides and programs that go into technical detail with formulas, math, circuits and theory. In fact, it is a great support program for license study guides, and the **new FCC License restructuring**. **Every aspiring or existing amateur should have this wonderful program in his or her collection!**

"Basic Technology for the Amateur Radio Enthusiast" video & book \$39.95

At your Alpha Delta dealer or direct plus \$5.00 s/h in the U.S., Exports quoted



ALPHA DELTA COMMUNICATIONS, INC.



P.O. Box 620, Manchester, KY 40962 • Phone (606) 598-2029 • Fax (606) 598-4413

Toll Free Order Line: 888-302-8777

Website: www.alphadeltacom.com

the radio connection

A Look Behind The Dials

The Boy's First Receiver Contest Closes, And Adding A Tunable Notch Filter To Our Latest Project

I am officially declaring the Boy's First Receiver contest closed as of June 1. Thanks to everyone who sent in photos or who took the time to write to us. If I receive more letters or photos, we will certainly consider running them in future columns, but sorry, no more subscriptions will be awarded after that date. Just to keep all of you in the building spirit, Harold and I will select two entries for the Lyonodyne crystal set, so send us some photos and tell us about your experiences building and using the set and you might win a complimentary one-year gift subscription to *Pop'Comm* or sub extension! As usual, entries by youngsters will get top billing.

Improving The Lyonodyne

Just in case you are new to our column, we've been discussing what is needed to build a version of the Lyonodyne crystal set over the past few issues. If you're just joining us, and are interested in duplicating the set shown here, you will need the April and May issues of *Popular Communications*. Half of my mail each month is answering readers about how to obtain back issues needed to complete one of our projects! Ordering information is given at the end of the column.

Crystal sets reputedly have notoriously poor selectivity; a strong station will often override weaker stations across a large portion of the set's tuning range. The set we are building is a tad better because it uses high Q components, in a circuit that uses variable ground coupling across the tuning range for an optimum tradeoff between selectivity for sensitivity. This month we will be adding a tunable notch filter to eliminate, or at least greatly reduce, the signals from strong local stations so you can hear signals that might have been previously missed.

The filter is simply a wave trap that tunes the broadcast band and is coupled into the crystal set's tuned circuit. As the filter or "wavetrapped" is tuned to the fre-

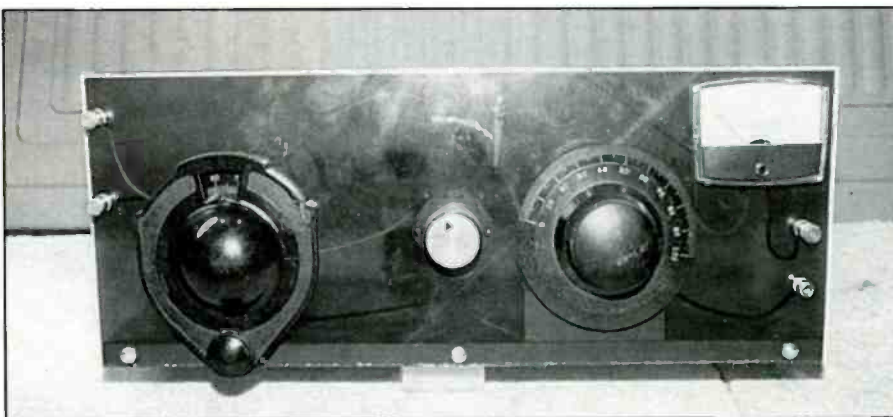

Lyonodyne 1: Front panel of the Lyonodyne crystal set with the added wavetrapped tuner. Vernier dial at left is the main tuning, knob at center selects the best antenna tap, and the large tuning knob at right is for adjusting the 365-pF wavetrapped tuning capacitor.

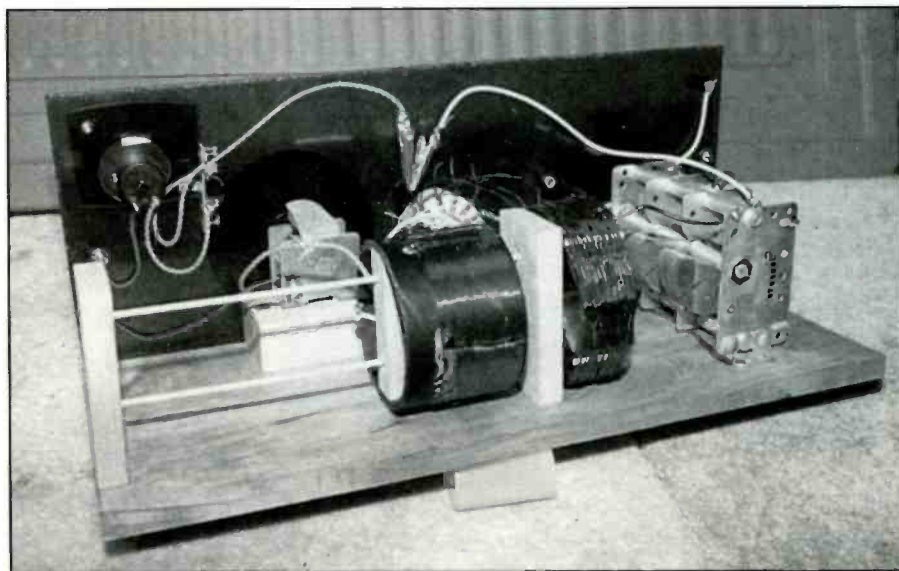

Lyonodyne 2: Rear shot of the Lyonodyne receiver shows the newly added wave-trap coil and tuning capacitor towards the left of the set.

quency of the interfering station, it absorbs the signal and reduces the amount of interference to adjacent stations with weaker signals. The degree of coupling between the coils is critical, so we need to come up with a means to vary the degree of coupling by moving the coils

closer together or further apart. The closer together, the greater the degree of coupling, and the more pronounced the effect of the wavetrapped becomes. In practice, the coupling is set to the minimum distance needed to reduce the interfering signal to a bearable level. Overcoupling will cause

BY PETER J. BERTINI <RadioConnection@juno.com>

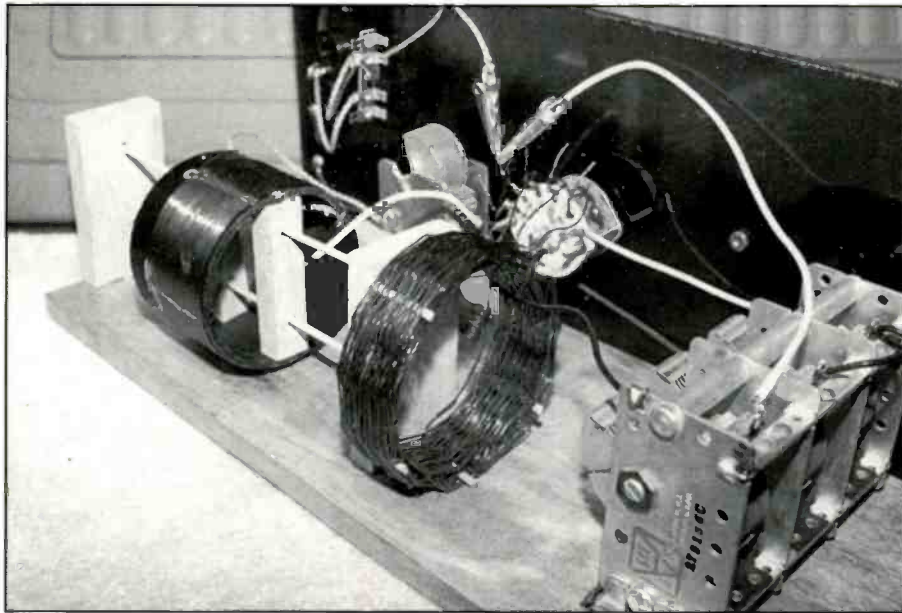

Lyonodyne 3: A close-up shot details the movable wavetrapped coil assembly.

the reduction of nearby desired signals, so some experimentation is needed to reach the desired effect. Also, the degree of coupling will vary across the band: typically the lower frequencies will require tighter coil coupling, while at the upper end of the band, the coils will be further apart.

Two Parts Needed

Only two parts are needed to add the wavetrapped — a coil and a variable 365-pF tuning capacitor with a knob. We will also need to build the mechanism that allows the distance between the two coils to be easily adjusted.

I didn't bother winding a basket-weave coil for the wave trap, instead the coil is wound "solenoid" fashion on a 3" diameter cardboard tube about 3" long. A solenoid winding is wound with each turn adjacent to each other, like a compressed spring, and with no overlapping windings. The coil is wound with 46 turns of number 20 gauge enamel-coated wire. I used wire from the same spool from Hosfelt Electronics that was used to wind the basket weave coil. The windings should be kept tight and evenly spaced. A few small drops of contact adhesive will help hold the finished windings in place. If you want to be a tad exotic, a basket-wound coil would work quite well in the wave trap circuit.

Before I wound the coil, I first dried the cardboard tube in an oven for several hours at low temperature to drive out any moisture. Afterwards I painted it black to

give it a "vintage" look and also seal it against moisture.

Building The Variable Coupler

In the original Lyonodyne design, the author used a wood dovetail slide arrangement to transport the wave-trapped coil towards or away from the main tuning coil. I didn't want to construct anything that elaborate, so I opted for a simpler system that has the movable coil sliding over two fixed wood dowels or

rails. First, two wood blocks are prepared that have a length equal to the inside diameter of the movable wave-trapped coil. Two holes, slightly larger than the wood dowels used for the rails, are drilled into each of the wood slide blocks. These are mounted on each end of the coil using brass or aluminum nails (ferrous metal would adversely affect the coil Q). The support dowels pass through two holes drilled into each of the blocks allowing the coil to move towards or away from the tuning coil. Two support blocks are used to suspend the wood dowel rails above the wood base of the crystal set. The dowels are glued into holes drilled to provide a snug fit for the dowel size used. All dowel holes must be drilled with care so the slide action is smooth without binding. The dowels must be kept perfectly parallel to each other. I drilled all four holes at one time on my drill press to ensure alignment, and I then enlarged the coil block holes as needed so they would freely slide on the dowels. I am not providing exact detailed measurements; the photos will give you some idea of what is needed. I used some 1/8" dowel stock I had on hand, but they're much too light and flimsy for this task. If you look at the photos closely, you see the doweling sagging under the weight of the coil. I don't like having metal near the coils, but in a pinch brass hobby tubing could be used in lieu of wood doweling.

Allow four or five inches of travel between the two coils or you may end up being over-coupled at the higher frequencies. My original breadboard was

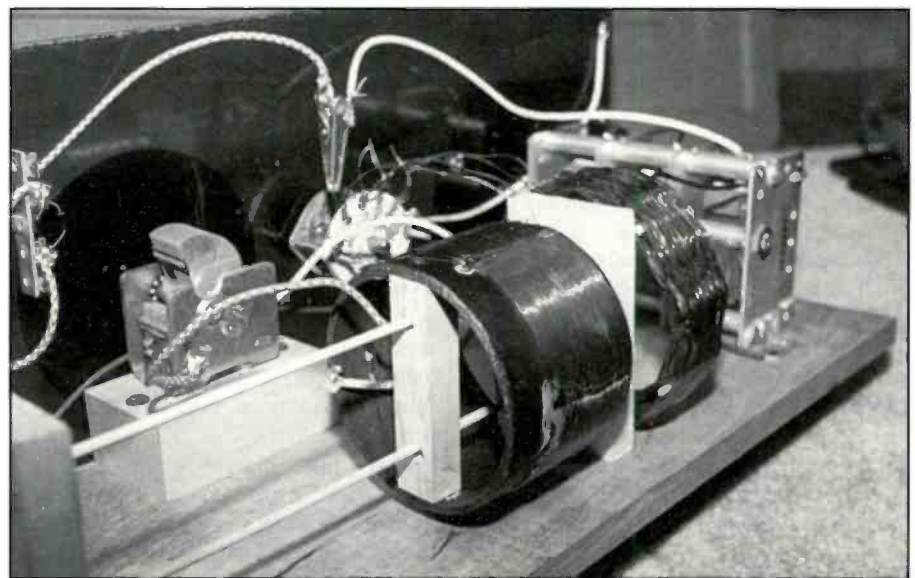

Lyonodyne 4: The movable wave-trapped coil rides on two wood dowels. The 1/8-inch dowels used by the author are a tad flimsy — 1/4-inch doweling would probably have made a more sturdy assembly.

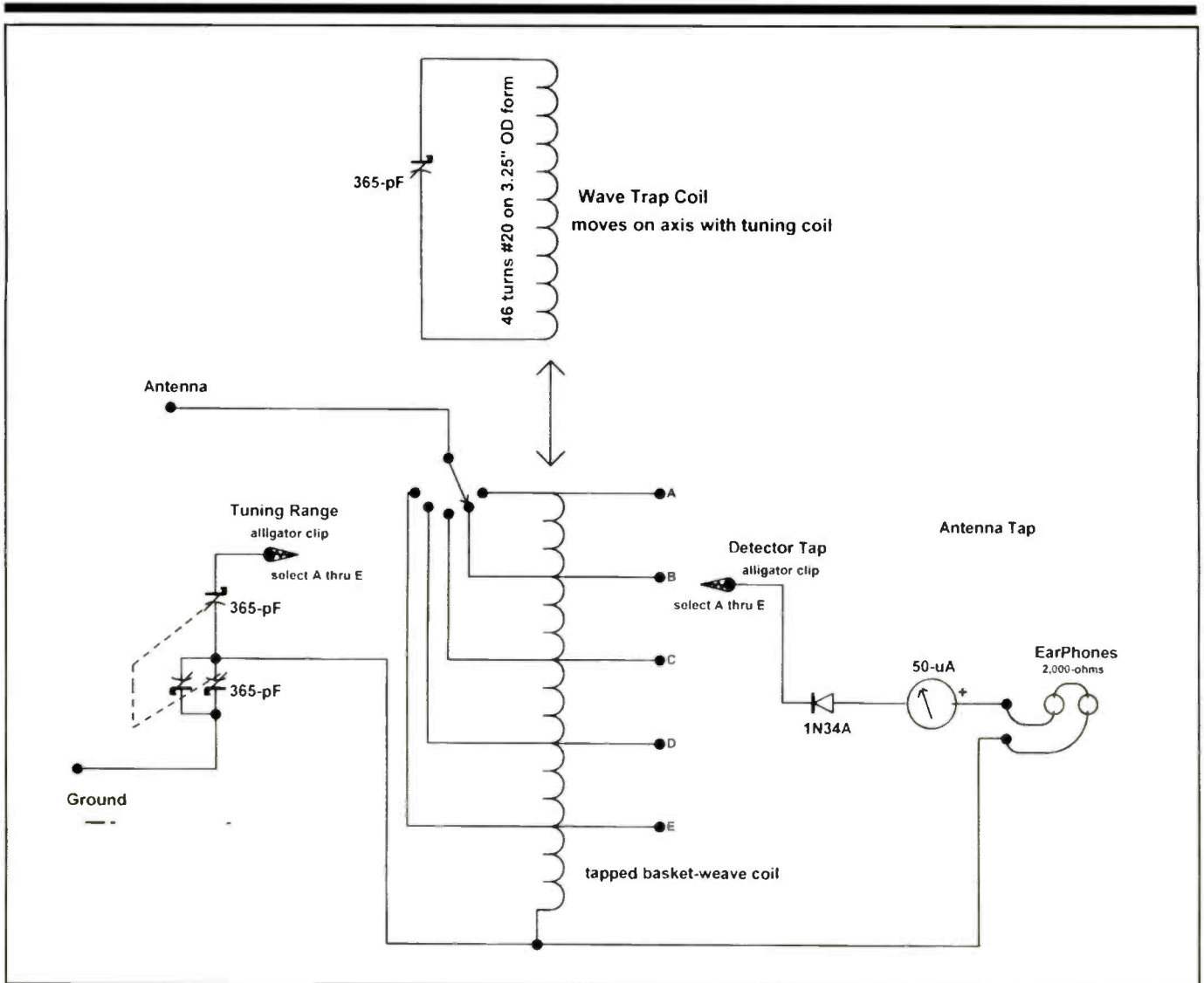

Figure 1: Schematic of the Lyonodyne with the wavetrapped filter.

larger than apparently needed to accommodate the wavetrapped circuit. The leads from the coil to the tuning capacitor are subjected to a considerable amount of flexing as the coil is moved. Solid gauge wire will eventually break, so flexible stranded wiring is used between the coil and tuning capacitor.

The wave trap is tuned using a 365-pF or slightly larger variable capacitor. I've listed several sources for these capacitors in the past few issues. Use either a large-sized knob or vernier dial for tuning the capacitor. The tuning is sharp! To minimize the effect of hand capacity when adjusting the coil, a 3" length of wood dowel could be added on the far end of the coil to serve as a handle.

Using The Wave Trap

Tune the set as you normally would, beginning with the coils placed close

together — the tighter coupling makes finding the dip much easier. Once the dip is found, use the minimum amount of coupling needed to reduce the interfering signal to a tolerable level. Once the strong station is nulled, carefully retune the set and search for weaker stations that may have been previously unreadable due to interference. If your set has the optional 50-uA signal meter, the needle should dip as the wavetrapped tunes across the offending signal. When not using the wave trap, keep the coils far apart and the wave trap tuning capacitor at either minimum or maximum capacity.

That just about wraps up the Lyonodyne. I have a few more simple mods I will show in our next column for getting a bit more selectivity when using ceramic or crystal earplugs. A couple of readers asked about adding an audio stage, or how to use the crystal set to drive an external audio amplifier. I'll give some

hints on doing so next time. In the meantime, I'll be anxiously awaiting your DX reports and photos!

Crystal Set Resources

Crystal sets have fascinated radio buffs from the earliest days of radio until today. If you have Internet access, sign on to *Yahoo!* and join or just visit the Yahoo Crystal Set Radio Club at the following URL: <http://clubs.yahoo.com/clubs/the-crystalsetradioclub>. This club is growing every day and currently has over 150 members. The members are a diverse, but friendly group of engineers, beginners, and experimenters all working to advance the art of crystal radio design while having a lot of fun in the process. Their past posts provide a vast library of crystal set lore. The club also sponsors an informal yearly crystal set DX contest. *Yahoo!* also provides the club with space for posting

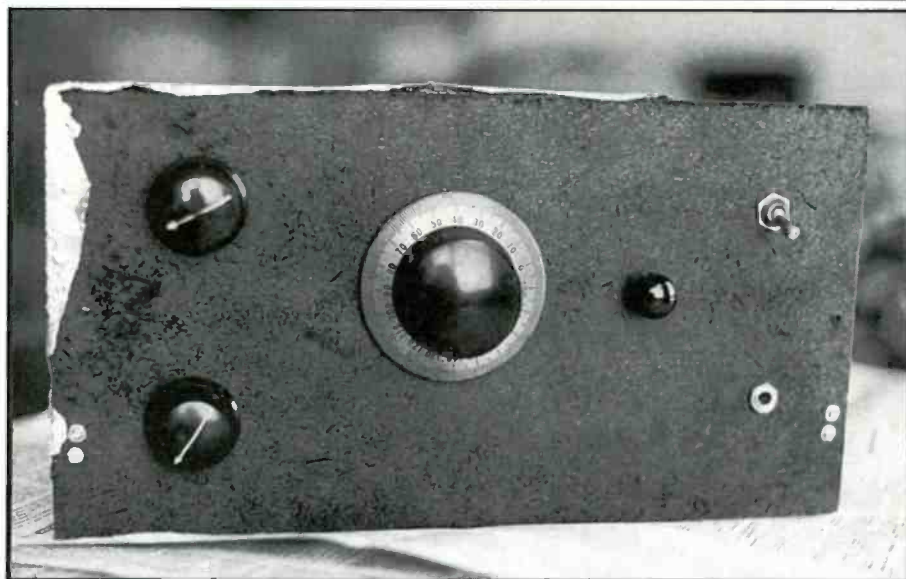

Front view of reader Joe Breczinski's one tube radio receiver.

photos of members' projects and circuit drawings. As a visitor, you can view all of the club posts, but you will have to become a member to post or view the photo sections. Membership is free and open to anyone interested in crystal radios.

Along the same lines, check the Web pages on crystal sets prepared by Ben

Toungue at this URL: <http://mars.superlink.net/bhtoungue>. Ben was a cofounder of the famous Blonder Toungue company which is still in existence; and his web pages features many of the early TV products pioneered by Blonder Toungue in its early days. Ben also provides hyperlinks to the Blonder Toungue company

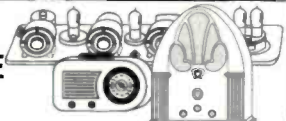

FREE SAMPLE COPY!



ANTIQUE RADIO CLASSIFIED

Antique Radio's Largest-Circulation Monthly Magazine

Articles - Classifieds - Ads for Parts & Services
Also: Early TV, Ham Equip., Books, Telegraph, 40's & 50's Radios & more...
Free 20-word ad each month. Don't miss out!

 1-Year: \$39.49 (\$57.95 by 1st Class)
 6-Month Trial - \$19.95. Foreign - Write.

A.R.C., P.O. Box 802-T14, Carlisle, MA 01741
Phone: (978) 371-0512; Fax: (978) 371-7129
Web: www.antiqueradio.com

FREE FREQUENCY LIST...

...with your catalog request!
(PLEASE enclose a self-addressed business size envelope with 55¢ postage.)

DWM Communications
P.O. Box 87-PC, Hanover, MI 49241

GET ON THE **MT EXPRESS**

Monitoring Times is Now On Line!

Now-Receive your subscription to Monitoring Times with no delays due to mailing, no lost or torn copies. Be the first to receive breaking news from the frontier of communications!

For less than the cost of a subscription in the U.S., you can be reading the entire *Monitoring Times* magazine anywhere in the world before U.S. subscribers receive their printed copies! Active utilities loggings, world hotbed frequencies, international broadcasting schedule changes, new product announcements! This is the exact same magazine that has gained a worldwide reputation for reliable radio information that's easy to understand, and products and projects of proven value.

For a mere \$19.95 U.S., **MT Express** gives you *Monitoring Times* magazine

- in PDF format viewable with free software
- delivered by FTP (10 MB file)
- viewable in brilliant color on your computer screen
- easily navigated by clicking on the Table of Contents
- printable using your own computer printer
- searchable to find every mention of a topic or station schedule
- compatible with software to convert text to audio for sight impaired listeners

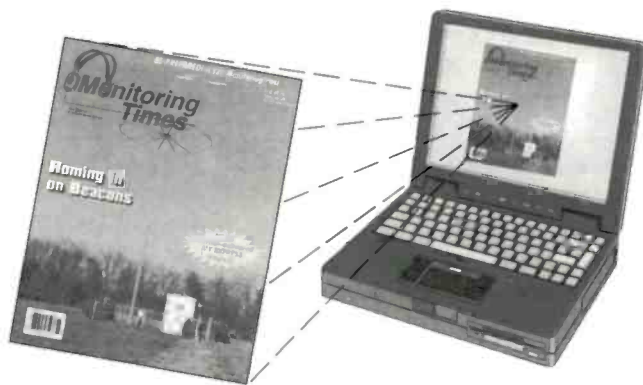

To find out if this new subscription is the delivery solution for you, you may download the August 1999 issue for free! Just go to <http://www.grove-ent.com> to find out how.

One year subscription to **MT Express**—only \$19.95 U.S., or for even greater savings, \$11 in addition to your printed subscription of \$24.95 in the U.S. Mastercard, Visa and DiscoverCard accepted. All payments must be in US funds drawn on a US bank.

ORDER NOW BY CALLING TOLL-FREE (800) 438-8155, OR E-MAIL order@grove-ent.com

Website. Seeing some of those early Blonder Tongue UHF converters was a trip down memory lane. Ben is a very proficient electrical engineer, and his papers on optimizing crystal set performance are the most detailed I have ever seen. Crystal set design from Ben's papers on headphones and crystal detectors are a must read. Don't worry if you don't have Internet access; we will be showing some of his circuits on headphone matching in an upcoming column.

The Crystal Set Society

The Crystal Set Society is dedicated to helping experimenters once again build and experiment with radio and electronics. The Society's newsletter helps support their goal of providing excellent quality technical books that encourage learning and building. Society members receive six bimonthly issues of the Society newsletter. If you want to join the Society or receive a sample newsletter, see the information at the end of the column. Our sample issue was the March 2000 issue, and packed into its fourteen pages were three construction projects, a Q&A section, and membership correspondence. The pro-

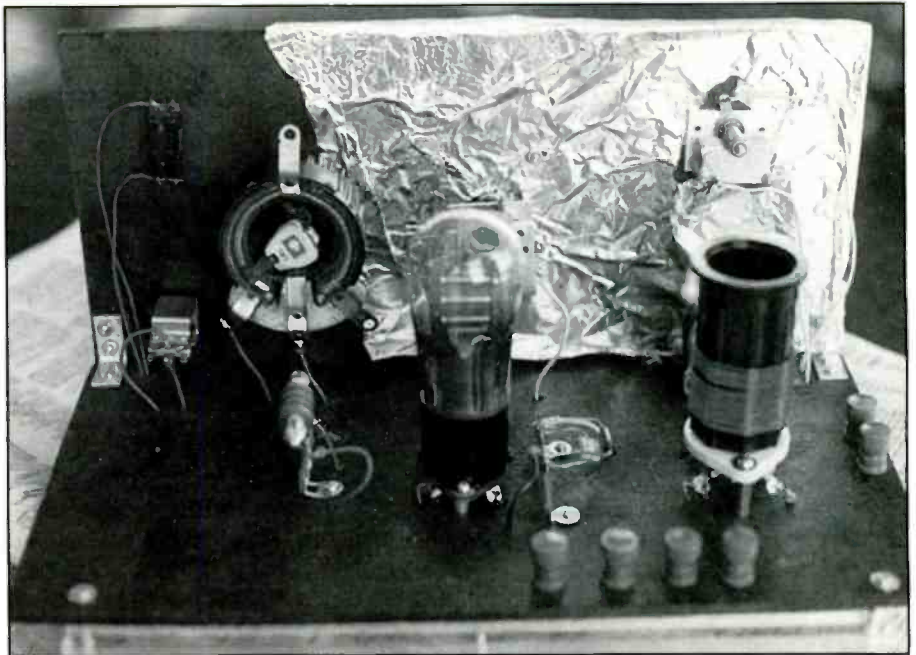

Rear view of the one-tube homemade regenerative receiver. Regeneration is controlled by a throttle capacitor. The aluminum foil on the back of the front panel is grounded, and provides a shield against hand capacity affecting the set while it is being tuning or adjusted.

jects were interesting, professionally illustrated and well-written. I might also add that some of them were very creative!

Besides the newsletter, the society also assists members by selling hard-to-find parts such as variable capacitors; and they also offer several interesting crystal set kits. We will be reviewing the Society's kits in a future column. Back issues of the newsletter are offered in booklet form, and the Society bookstore offers a wide variety of books on early radio.

Contact The Xtal Set Society at P.O. Box 3026, St. Louis, MO 63130, phone 314-725-1172 or FAX them at 314-725-7062. Their Website is at midnightscience.com or you can E-mail xtalset@midnightscience.com. Write or call for a sample of their newsletter. Membership is (USA) \$12.95. Canada: \$14 and foreign \$19 USD, postpaid.

Our Readers Write

Richard Barnes dropped us a note advising that he found the Lafayette manual for his receiver. A big thanks to everyone who wrote in. Richard is still looking for an early Lafayette HA-50 30- to 50-MHz tunable FM monitor receiver. If you can help, drop us an E-mail and we will get you and Richard together.

Joseph Breczinski writes: "Here are some photos of my one-tube regenerative

receiver; I built this using a schematic from the 1934 shortwave manual reprint by Linsey Books. I have left room on the chassis for the addition of an audio stage. I am 30 years old and finished building the set on Christmas day. I wound three coils for the 80, 40, and 10-meter bands. While the 40-meter coil works perfectly, the other two need some additional work. I have picked up Radio China, Taiwan, the BBC, two German stations, and Radio Canada. I love this little radio.

I built a crystal set with the help of a ham operator, Carl Herbert, W8CU, when I was seven years old. I still can remember cutting my fingers on the thin gauged wire we wrapped on the coil form. It saddens me that I no longer have that set—I took it and a bunch of radios apart that I should not have, including one that my dad built. I enjoy building radios and restoring Hallicrafters shortwave sets. Thanks. W8CU."

Joe, many thanks for the letter and photos. Your little radio is pretty cool! I see that the influence of your Elmer, Carl Herbert, has left a lasting impression on you, so it is fitting that you now hold his amateur radio call letters. I am sure he would approve.

Back issues of *Popular Communications* are \$4 each and can be ordered from *Popular Communications*, 25 Newbridge Road, Hicksville, NY 11801 or by calling 800-853-9797. ■

Lee Electronics
 Scanners, SW, FRS and More:
 AOR Cobra Bearcat BoyGen
 SANGEAN FREE PLAY uniden
 1-800-578-6006
 Tech: (724) 275-5822
 www.leeElect.com

Tubes • LITERATURE • Parts • Supplies
 www.tubesandmore.com

**Antique
 ELECTRONIC
 Supply**

Call for our FREE
 76 page catalog!

Phone Today! (480)820-5411
 Fax(480)820-4643 or (480)706-6789
 6221 S. Maple Ave • Tempe, AZ 85283

CIRCLE 61 ON READER SERVICE CARD

JRC NRD-545

Legendary Quality. Digital Signal Processing. Awesome Performance.



Japan Radio Raises the Standard by which High Performance Receivers are Judged.

Starting with JRC's legendary quality of construction, the NRD-545 offers superb ergonomics, virtually infinite filter bandwidth selection, steep filter shape factors, a large color liquid crystal display, 1,000 memory channels, scan and sweep functions, and both double sideband and sideband selectable synchronous detection. With high sensitivity, wide dynamic range, computer control capability, a built-in RTTY demodulator, tracking notch filter, and sophisticated DSP noise control circuitry, the NRD-545 redefines what a high-performance receiver should be.

- LSB, USB, CW, RTTY, FM, AM, AMS, and ECSS (Exalted Carrier Selectable Sideband) modes.
- Continuously adjustable bandwidth from 10 Hz to 9.99 kHz in 10 Hz steps.
- Pass-band shift adjustable in 50 Hz steps.
- Tracking notch filter, adjustable within ± 2.5 kHz in 10 Hz steps.
- Continuously adjustable AGC between 0.04 sec and 5.1 sec in LSB, USB, CW, RTTY, and ECSS modes.
- Built-in RTTY demodulator reads ITU-T No. 2 codes for 170, 425, and 850 Hz shifts at 37 to 75 baud rates. Demodulated output can be displayed on a PC monitor through the built-in RS-232C interface.
- High sensitivity and wide dynamic range achieved through four junction-type FETs with low noise and superior cross modulation characteristics.
- Optional wideband converter unit enables reception of 30 MHz to 2,000 MHz frequencies (less cellular) in all modes.

Japan Radio Quality. Synchronous Detection. Great Price.

NRD-345 JRC



- Synchronous AM, AMS, CW, SSB, and FAX modes.
- 0.1 to 30 MHz coverage.
- Dual IF filter bandwidths.
- High sensitivity and wide dynamic range. The RF amplifier and first mixer in the front-end incorporate four low-noise junction-type FETs with excellent cross modulation characteristics to ensure both high sensitivity and high dynamic range.
- Noise blanker.
- Clock/Timer.
- Memory scan and frequency scan functions.
- Personal computer control with optional RS-232C interface cable.

Only the NRD-345 offers Japan Radio Performance and Quality at a Surprisingly Affordable Price.

The NRD-345 delivers hour-after-hour of listening pleasure with synchronous AM detection to help tame fading, dual IF filter bandwidths (with a third optional), and high dynamic range. Compact, light, and refined, the NRD-345 offers advanced multifunctions, 100 memory channels, and even personal computer control. The NRD-345 brings shortwave listeners an outstanding value in a high-performance receiver for under \$1,000.

JRC *Japan Radio Co., Ltd.*

Japan Radio Co. Ltd., Seattle Branch — 1011 Klickitat Way #B-100 Seattle, WA 98134 Voice: 206 654-5644 Fax: 206 264-1168
Japan Radio Company, Ltd. — Akasaka Twin Tower (Main), 17-22, Akasaka 2-chome, Minato-ku, Tokyo 107, JAPAN Fax: (03) 3584-8878

CIRCLE 149 ON READER SERVICE CARD

scan tech

Trunking, Tips, Techniques, And Mods

Applied Searching 101: John's Story From Western New York State

We've talked in the past about the best ways to organize banks, and how to find new information. In fact, we've devoted several columns to those topics. However, one reader sent in such a compelling account of how to pull it all together, that I thought it might be worth another visit. I met John in an Internet Relay Chat (IRC) room, devoted to utility monitoring (#monitor). Here's John's story.

"Recently, we discussed on IRC the idea of my sending you a list of scanner frequencies from my listening area here in western New York State. Since this will be my first material contributed for your column, I suppose I should preface with some background information first.

I'm John Kasupski, registered monitor KNY2VS since February 6, 1988. I monitor from North Tonawanda, New York, which is a suburban city of 35,000 or so, located along the Niagara River between Buffalo and Niagara Falls, closer to Niagara Falls, and located in Niagara County along the Erie Canal which forms part of the border with neighboring Erie County.

My antennas are located approximately 400 yards from the east bank of the Niagara River, right across from Grand Island. Where Grand Island sits in the middle of the Niagara River, it splits the river into what are unofficially called the East River and the West River, so I'm basically right on the East River.

My first experience with monitoring public safety and other VHF/UHF radio was gained on [a] Ross multiband portable, the very same radio that also got me interested in SWL. Oddly, it was bought as a gift for my father, but he never did much with it other than listen to local FM broadcasters. For me, on the other hand, it led to a lifelong hobby."

John's mention of how he got started reminded me of just how amazing to me that initial spark can be. It's always interesting, no matter what it is, what gets people started in this hobby. In my case, it was a shortwave receiver that a friend's mother wanted out of her garage. Another friend introduced me to the world above 30 MHz and the rest, as they say, is history. In our esteemed (ahem) editor Harold's case, it was probably being there in the lab to help Marconi



John likes the RadioShack PRO-2045 shown here. Unfortunately, now discontinued, the 2045 is one of few scanners to offer tone squelch features. It's an excellent receiver, and still appears frequently on the used market. Of course, there are newer receivers that also have these and other features.

that "sparked" his interest. [Mine or Marconi's? — Ed.]

John continues, "While tuning around the VHF-Hi band, I stumbled on the Buffalo Fire Department's main dispatch frequency, which I later learned was 154.190. Of course, this radio wasn't very selective, and once you tuned 154.190, you could easily hear a strong signal on 154.130 without retuning. Well, guess what? The fire department here in North Tonawanda is on 154.130 and the first time I heard a call being dispatched for the equipment at the firehouse two blocks away, I nearly went through the roof (I was after all, only about 7 or 8 years old).

Eventually I 'graduated' to more sophisticated equipment. My first actual scanner was one of the RadioShack four-channel handhelds, crystal-controlled on VHF-Hi only. [Sounds pretty much like my first scanner — Ken] I had crystals for Buffalo Fire, North Tonawanda Fire, the county sheriff on 154.755, and the NY State Thruway Authority (since abandoned as they moved to UHF). I still have this radio, but it no longer works.

Today, I scan using a pair of PRO-2045s, an old Bearcat 210, a PRO-50, a Regency INF-10 that I power with a 3A supply as it runs on DC only, and a PRO-2024 whose case is literally falling apart, but which still functions perfectly.

My standard practice is to park the INF-10 on the local police frequency, the PRO-50 on the local fire frequency, and the BC-210 on Buffalo Fire. The PRO-2045s are programmed with various other things. One of

them is dedicated to military monitoring and a bank of marine VHF frequencies. The other is programmed with area law enforcement, fire, EMS, federal frequencies, as well as a bank with railroad frequencies that are active in my area.

Relative to [the ScanTech] column in the August issue, which talked about trading some of your capacity for detail, I've created a mixture of that idea and the multiple-radio school of thought. For me, more than one scanner is basically a must. I agree that you're going to miss a lot if you have one radio scanning 1000 channels or even 60 — literally, a fire call can be dispatched on your scanner's channel 1, and by the time that scanner gets back to channel 1 again the incident is over with and everybody's returning to the firehouses. It's happened to me. That's why I keep a scanner parked on the local FD during normal monitoring now, while my other scanners with more channel capacity are used for other things, switching banks in and out according to activity and my mood at any given time."

Officially, this concept is called "Dillo's first law of scanners." This dubious honor comes from the AOL Radio Listener's Conference (Thursday nights 9-11 p.m. ET in the Radio Forum Conference room. "WHAT is Dillo's first law, I hear you cry?" Why, "one can never have too many radios," of course. But back to our story.

He continues, "Incidentally, the scanners

BY KEN REISS <armadillo1@aol.com>



Many scanner nuts use more than one receiver (Remember Dill's first law). Dave D. from IL sent this photo of his well-equipped station. The lineup (clockwise) is basically an BC-895 (local trunked system), BC-9000 (mil/air and search), PRO-2026 (city PD & FD), BC-760 (suburban FD), PRO-2006 (ISP), PRO-2066 (city trunked system), PRO-2042 (counties), Opto OS-456/Probe (all local PD & FD), Opto OS535/Probe (searching and addl. scanning for major events), PRO-2050 (2nd local trunked). Various handhelds used based on type/freq. range of portable listening and finally an Opto Scout. Cool!

that are 'parked' on certain frequencies most of the time, do have the rest of the channels programmed with frequencies. The PRO-50 that sits on the local fire frequency, for example, also has the FD in it as well as the police and fire departments in a few neighboring cities and towns. If a major incident occurs in a nearby city or town, a few key presses is all that's necessary and I have the PRO-50 'parked' on the appropriate frequencies. The BC-210 and INF-10 pull similar duties.

And how would I find out about these major incidents? From the 60-channel PRO-2024 which has a cross-section of emergency/disaster frequencies which always light up during anything major. . . it's left running at low volume but is in my line of sight so that if it stops on any important frequency for any significant length of time, that will grab my attention and I'll turn the volume up so I can hear what's going on and adjust my other radios accordingly. The most important frequencies from this group are also kept in a bank in one of the PRO-2045s and that bank is never locked out. As a result of this setup, I don't miss any major occurrences, provided that I'm in my shack to hear them when the scanners light up with the activity."

How About Trying Computer Control?

It's an interesting idea. But it sounds like you might have to spend a fair bit of time looking at the "quiet" scanner to see what it was doing. Here's a place where

computer control would offer real advantage. Most computer control programs can be set to beep or make some other noise if certain frequencies go active. That should get your attention, so you could look up and respond accordingly. Now there's another project for you John.

John continues "Now, as to frequencies themselves. There are lists of the frequencies programmed into my two PRO-2045s. [See box] That covers somewhere between 300 and 400 frequencies programmed into the two 200-channel scanners. There's everything in there from military and a few federal frequencies, on through to the PD/FD/EMS stuff that most readers interested in Western New York freqs would be interested in, with some railroad and marine frequencies thrown in for good measure.

One thing should be noted regarding these lists. I keep at least two empty banks in the one scanner and several empty channels scattered about in both. The two empty banks aren't really usually empty, but the frequencies programmed into them are changed regularly. For example, if someone on the MilCom maillist sends a heads-up on military aircraft that will be passing through my area and he or she includes air-to-air frequencies for those aircraft, I'll put them in one of those 'empty' banks and activate that bank and see if I can catch those aircraft there as they pass through the area.

It's also a good place to put 'temporary' or 'unknown user' frequencies that I find during band searches, until I'm able to identify the source and transfer the frequency to a regular

bank or to another scanner as appropriate. The PRO-2045 can auto-program itself — you specify a frequency range and a bank of 20-channels, lock in the data skip, and start searching: the first 20 frequencies it finds active get auto-programmed into the bank you selected. This is the method I used to discover the Rural/Metro ambulance company's trunked 900 MHz system here way before anybody else around even knew that Rural-Metro HAD a 900 MHz system [in this area]. Actually, they have three that they are trying, with some difficulty, to integrate."

Grouping Geographically!

John continues, "These listings will cover most of Niagara and Erie counties, as well as activity on Wyoming, Orleans, and some stuff from a few other counties that I can routinely monitor parts of, namely Chautauqua, Cattaraugus, and Genesee counties.

The arrangement of how I have my banks set up on [one of the] PRO-2045s illustrates the point you made [in August 1999 "ScanTech"] about grouping things together geographically. On the other hand, taken as a whole, my use of six scanners to divide up listening chores among various radios is demonstrative of an entirely different school of thought. It's merely one man's method of organizing things into a system that works best for me. If, however, someone can get ideas from this that will

SE

SIGNAL ENGINEERING'S
High Performance CB & 10 Meter Antennas

SUPERHAWK

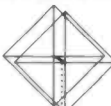

WHITE LIGHTNING
THE Four Element Antenna

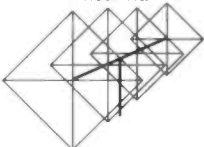

LIGHTNING 6

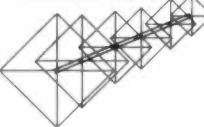

Goldenrod 45 Spyder A+
Broadband Hi powered MOBILE

THUNDER 8
Hi Gain Bi-Directional OMNI Electronically Steerable

And, also, NEW QUAD LIGHTNING 8
THE most POWERFUL CB base in the world today!

ALL SE PATENTED rotary beams are true quads and OUTPERFORM their counterparts (quad/yagl types). SE's patented SFS matching system makes SE QUADS the most technologically advanced antennas in the world today.
 If your dealer doesn't have SIGNAL ENGINEERING, write or call for full specs. DEALER inquiries invited.
 MasterCard, VISA, AMEX, Discover

SIGNAL ENGINEERING
 1172 Aster Avenue, #E, Sunnyvale, CA 94086
 Phone: (408) 247-2300
 Website: www.signalengineering.com

PRO-2045 Scanner #1 Program

FREQUENCY	DESCRIPTION	FREQUENCY	DESCRIPTION	FREQUENCY	DESCRIPTION
155.3700	Police Intersystem	460.5250	Niagara Falls FD F-2 (151.4 PL)	453.4750	NFTA Police
460.2750	Erie Co. Central Police Services	155.1600	Niagara Falls EMS (82.5 PL)	453.7750	NFTA Rail Maint.
155.5800	Erie Co. Central Police Services	155.5050	State Police Bases	453.6000	Buffalo Dept. Of Transportation (PVB) (151.4 PL)
155.7300	Erie Co. PDs Countywide Tactical	155.5350	State Police Cars (110.9 PL)	460.4500	Erie Co. Sheriff (151.4 PL)
460.4000	Erie Co. Sheriff Tactical	154.6650	State Police Car-To-Car (110.9 PL)	460.0750	Erie Co. Sheriff (151.4 PL)
46.3800	Erie Co. Fore Mutual Aid Net	155.4750	State Police Statewide Emergency	460.2000	Erie Co. Sheriff (151.4 PL)
155.7600	Erie Co. CD/Disaster Freq.	154.6950	State Police Statewide Alerts	460.1500	Lackawanna Police (151.4 PL)
155.7150	Erie Co. EMS Tactical	155.5650	State Police Bureau of Criminal Investigation (110.9 PL)	154.4300	Lackawanna Fire
47.4200	American Red Cross	155.0700	State Police, State Institutions	155.1900	Orchard Park Police (162.2 PL)
156.8000	Marine Ch. 16 Distress/Calling	155.6250	State Police (Also W. Seneca, E. Aurora, Orchard Park PDs)	154.1450	Orchard Park Fire
121.5000	Nationwide Aircraft Emergency	155.6850	State Parks Police (82.5 PL)	155.7900	Hamburg Police (114.8 PL)
243.0000	Nationwide Military Aircraft Emergency	156.1200	State Parks Police & Maint.	46.2000	Hamburg/Angola Fire
462.6750	GMRS Emergency Channel (Orange Dot)	159.2250	NYS Conservation Police (94.8 PL)	155.6100	Cheektowaga Police (151.4 PL)
123.4500	Aircraft VHF Informal Multicom	159.3750	NYS Conservation Police (Administrative)	155.6550	Lancaster Police (103.5 PL)
453.8250	Buffalo Airport F-1	453.5250	NYS Thruway Auth. & SP Troop T (123.0 PL)	46.2800	Cheektowaga/Lancaster/Depew Fire
460.1750	North Tonawanda Police (173.8 PL)	424.0250	Poss. NYS Power Auth. Security (151.4 PL)	155.6400	East Aurora Police (162.2 PL)
154.1300	North Tonawanda Fire	47.7400	NYS Power Auth.	46.2400	East Aurora/West Seneca Fire
460.5500	Twin City Ambulance (173.8 PL)	453.3500	Buff. State College Security	46.5000	Bowmansville Fire
145.3100	SKYWARN Primary	453.0500	UB Security (127.3 PL)	155.0100	Wyoming Co. Sheriff (1072 PL)
146.6400	SKYWARN Secondary	159.4350	Poss. NYS Cons. Police (127.3 PL)	46.1800	Wyoming Co. Fire
460.1750	North Tonawanda Police (173.8 PL)	460.5500	Twin City Ambulance (Disp.) (173.8 PL)	156.2100	Chautauqua Co. Sheriff
154.1300	North Tonawanda Fire	463.1375	Twin City Amb.	159.4050	Cattaraugus Co. Sheriff
151.1150	North Tonawanda DPW	463.1625	Twin City Amb.	46.0800	Orleans Co. Fire
35.7000	North Tonawanda City Schools	468.1375	Twin City Amb.	161.0700	Conrail Niagara Branch
151.7750	TNT Bus Service	468.1625	Twin City Amb.	160.8000	Conrail Main Line Disp.
460.2250	Tonawanda City Police (173.8 PL)	155.3400	Erie Co. MERSF-1(Hosp.-Amb. County)	160.3500	Conrail Car Dept.
46.4200	Tonawanda City Fire: Grand Island Fire	155.3250	Erie Co. MERS F-2 (Hosp.-Amb. City)	161.1300	Conrail Maint.
460.6000	Tonawanda City Fire TAC-1	462.9500	MED-9 Disp. 1	160.9800	Conrail Yard Bailey Ave.
154.9650	Tonawanda City DPW	462.9750	MED-10 Disp. 2	160.6800	Conrail Police
154.7400	Amherst Police (127.3 PL)	463.0000	MED-1	160.8600	Conrail Frontier Yard
46.2600	Amherst Fire	463.0250	MED-2	160.5900	Conrail Niagara Junction
153.8150	Amherst Hwy. Dept. (141.3 PL)	463.0500	MED-3	160.9350	CN Railroad
153.9800	Amherst Engineering Dept.	463.0750	MED-4	161.4150	CN Railroad
460.1000	Tonawanda Town Police (173.8 PL)	463.1000	MED-5	160.8150	Unidentified Railroad
46.3400	Tonawanda Town/Kenmore Fire F-1 (Mobiles)	463.1250	MED-6	160.4400	Norfolk & Southern Bison Yard
46.4600	Tonawanda Town/Kenmore Fire F-2 (Dispatch)	463.1500	MED-7	155.2800	Rural/Metro Amb. (Private Calls)
46.4800	Brighton Vol. Fire Co., Town of Tonawanda	463.1750	MED-8	939.0250	Rural/Metro Amb. Trunked
460.5000	Kenmore Police	424.3750	Buffalo Fire (Ambulance Dispatch) (141.3 PL)	937.1125	Rural/Metro Amb. Trunked
154.7550	Niagara Co. Sheriff (151.4 PL)	460.3250	Buffalo Police Ch. 1 (151.4 PL)	937.0625	Rural/Metro Amb. Trunked
46.0600	Niagara Co. Fire F-1 (Dispatch) (151.4 PL)	460.3500	Buffalo Police Ch. 2 (151.4 PL)	937.0125	Rural/Metro Amb. Trunked
46.2200	Niagara Co. Fire F-2 (Secondary) (151.4 PL)	460.4250	Buffalo Police Ch. 3 (151.4 PL)	937.1250	Rural/Metro Amb. Trunked
46.1600	Active Hose Co. (Town of Niagara)	460.4750	Buffalo Police Ch. 4 (151.4 PL)	939.1125	Rural/Metro Amb. Trunked
155.1750	Niagara Co. EMS (Amb.-Hosp.)	460.0250	Buffalo Police Ch. 5 (151.4 PL)	155.8800	Boston Rescue Squad
155.2200	Niagara Co. EMS (Tri-Town/Tri-Community Disp.) (131.8 PL)	423.8750	Buffalo Police Tactical	158.9550	Boston Vol. Amb. (136.5 PL)
45.8800	Intercounty Fire	424.3500	Buffalo Police (SecureNet Downtown) (Buffalo Place)	155.2509	West Seneca PD (162.2 PL)
155.2500	Lockport City PD (151.4 PL)	424.0750	Buffalo Police (Schools Security)	165.2375	U.S. Customs (100.0 PL)
46.4400	Lockport City Fire	424.0500	Buffalo Police (Engineering Dept.)	162.8250	Border Patrol Ch. 1 (100.0 PL)
158.9700	Lewiston Village PD	423.9250	Poss. BPD (Taps Heard)	162.9250	Border Patrol Ch. 2
460.3750	Niagara Falls PD F-1 (151.4 PL)	423.8250	Buffalo Fire (Electrical/Alarms)	163.6250	Border Patrol Ch. 3 (100.0 PL)
460.1250	Niagara Falls PD F-2 (151.4 PL)	425.2500	Possible BFD (Taps Heard)	163.6750	Border Patrol Ch. 4 (123.0 PL)
460.5750	Niagara Falls FD F-1 (151.4 PL)	154.1900	Buffalo Fire F-1 (Dispatch)	163.2000	Listed to U.S. Marshals Repeater
		154.3550	Buffalo Fire F-2 (Fireground)	417.2000	General Services Administration
		154.2950	Buffalo Fire	168.3500	U.S. Govt. All-Call
		453.2750	NFTA Rail Ops	163.1000	U.S. Govt. All-Call
				165.3750	CIA/Secret Service
				169.5500	Poss. U.S. Customs
				418.3000	U.S. Postal Inspectors SF RPTR/Simplex
				415.0500	U.S. Postal Inspectors BUF/SYR RPTR
				407.7250	U.S. Postal Inspectors Orange RPTR
				165.4125	FBI
				167.7625	FBI
				166.4625	U.S. Treasury Common

enhance their own scanning activities, then we will have both done our job."

Antennas In Use

John says the PRO-2045 that's used for the PD/FD/EMS/Railroad, etc. is on a RadioShack three-band groundplane up on the roof. The other PRO-2045 (used for military and marine monitoring) is on a discone, also from RadioShack, and is on a chimney-mount more or less next to the ground plane.

John says, "The old BC-210 — which by the way is an original Bearcat 210 made in Cumberland, Indiana, by Electra Corp. and has been with me since about 1977 — is fed by an MFJ-1022 LF/HF/ VHF active antenna that I power from one of those AC adapters that is commonly referred to as a wall-wart adapter. Since this radio is mainly programmed with VHF fire frequencies, this works out nicely. However, it also does fine picking up the city police on UHF despite the fact that the MFJ-1022 isn't designed for UHF at all.

The other three radios are equipped with the telescoping center-loaded whip antennas that Radio Shack sells for around \$10. The physical length of these antennas is easily adjustable to optimize signals for a particular band — fully extended for VHF-low, fully collapsed for UHF, and halfway extended for VHF-high. The handheld PRO-50 hears a lot of things with one of these antennas that it knows nothing about when using the rubber ducky that came with the radio. There's a 90-degree BNC adapter that RadioShack sells that allows use of these on a desktop scanner with the connector on the back panel, and that's what I use for the PRO-2024 and the INF-10. For the PRO-50, of course, it's simply a matter of removing the rubber duck and replacing it with the telescoping whip.

I'm located in an area that's saturated with RF. There is a trio of TV transmitters located just across the river, on UHF channels 17, 23, and 29. There is also a cell site less than half a mile away and enough paging signals to really raise havoc if I attempt to use something other than a triple-conversion radio on an outside antenna. The PRO-2045s of course are triple-conversion units and work quite well with the antennas on the roof — the use of the CTCSS boards doesn't hurt either. The CTCSS boards are installed in both of them although currently only the one that I use for PD/FD/EMS/Federal has many CTCSS tones programmed. As for the other radios, the indoor antennas provide sufficient reception of the desired signals without pulling in a lot of unwanted interference (is there any such thing as WANTED interference?) from pagers, intermod, and so forth."

Fire Department Update

Within a few days of sending all the info on his system, John followed up with

a major change in the operation of the Buffalo fire department. His quick research and searching techniques enabled him to find the new frequencies and continue listening almost uninterrupted — within one day!

"The Buffalo Fire Department began using a new radio system on UHF in a band that is authorized for public safety and business/industrial use within a certain radius of Buffalo and is part of the 70cm ham band in the rest of the USA," he says.

"I'm happy — it took me less than 24 hours to confirm all four frequency changes (three by BFD and one by the SecureNet downtown) as well as discover a new frequency for the campus security at Buffalo State — and I got a good night's sleep in that time as well.

A quick check of the FCC's Land Mobile Database to see what frequencies are licensed to the city that I haven't been monitoring regularly — cross-check with my own records to see which ones I can't account for, punch the leftovers into the scanner, and I'm listening for traffic.

Accessorize Your Portable!

Whatever your interest in hobby radio, **PRYME Radio Products** has an accessory item for you! We manufacture a full line of aftermarket products for all types of portable radios, from microminiature Family Radios, to scanning receivers, to amateur or commercial handheld radios. Our accessories are reliable, innovative, and affordably priced. We provide accessories for all major brands of radio including Motorola, Kenwood, Icom, Vertex, Uniden, and many, many more!

Audio Accessories

Our innovative audio products have made us famous. From the comfort of our SPM-400 mini-boom microphone to the low-profile of our EH-1 "invisible" ear phone and SPM-700 surveillance mic, we have the right accessory for the job!

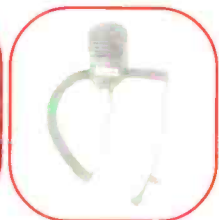

Antennas for Handhelds

Most stock antennas for scanners or portable radios are extremely poor. Upgrading to a better antenna can make a huge difference in performance. Our antenna products are specifically designed for maximum performance and durability.

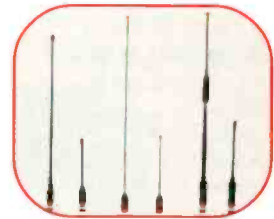

Batteries / Portable Power

We offer many models of rechargeable battery pack for today's most popular handheld radios, as well as a number of portable "power stations" for those who need "power to go."



Order on-line from our entire line of high quality, accessories. Visit our **on-line store** on the web at:

<http://www.prymebattery.com>

PRYME
Radio Products

by **PREMIER Communications Corp.**

480 Apollo St. #E • Brea, CA 92821

Phone: 714-257-0300 • Fax: 714-257-0600

Web: <http://www.adi-radio.com>

CQ Books

McCoy on Antennas

by Lew McCoy, W1ICP

This is truly a unique antenna book that's a must read for every amateur. Unlike many technical publications, Lew presents his invaluable antenna information in a casual, non-intimidating way for anyone!

Order No. MCCOY **\$15.95**

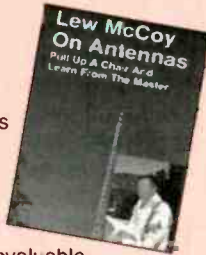

W6SAI HF Antenna Handbook

by Bill Orr, W6SAI

Nearly 200 pages filled with dozens of inexpensive, practical antenna projects that work! This invaluable resource will guide you through the construction of wire, loop, yagi and vertical antennas.

Order No. HFANT **\$19.95**

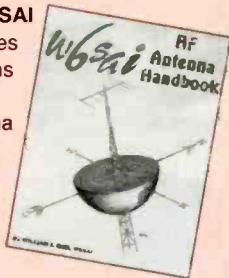

The Quad Antenna

by Bob Haviland, W4MB

Second Printing

You'll enjoy this authoritative book on the design, construction, characteristics and applications of quad antennas.

Order No.

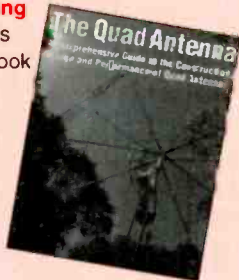

QUAD **\$15.95**



Please add \$4 shipping & handling
Free shipping & handling for orders \$50 and over

CQ Communications, Inc.
25 Newbridge Road
Hicksville, NY 11801
Phone: 516-681-2922
Fax: 516-681-2926

**or call toll-free
800-853-9797**

Last night, I punched in four frequencies that I couldn't account for. I found the Buffalo FD on two, and the downtown SecureNet on the third. This morning I checked the frequency I'd previously heard the downtown SecureNet on — and voila, there was the third new Buffalo FD frequency. They should all be this easy.

The portable radios for the new radio system were distributed to all companies and chiefs. The rig radios still have the old VHF channels and will not be changed over to the new radio system for several months, therefore they are simulcasting fire dispatching operations on the old 154.190 frequency."

The new frequencies, which John began using yesterday, are as follows:

Channel 1 — 424.225 (for the past 24 hours, all fire alarms have been dispatched here and simulcast on the old frequency, 154.190).

Channel 2 — 424.350 (apparently fire-ground use, as was the case with the old VHF radio system's channel 2 at 154.355. The old channel two will not be used ever again and has been disconnected from the fire alarm office.)

Channel 3 — 423.900 (I have heard this frequency this afternoon being used to dispatch fire apparatus as EMS units — sounds like they're separating the two dispatch functions with Channel 1 dispatching fire calls and Channel 3 dispatching EMS calls).

The downtown SecureNet used by police and security in the Buffalo downtown business district (such as the Main Place Mall, Buffalo Place market, etc.) formerly occupied the 424.350 frequency. This operation has apparently moved to 423.925 as I heard them there while hunting down the new FD frequencies. I also discovered 424.325 in use by the public safety and maintenance departments at the Buffalo State University College."

A few weeks after sending the initial information, John followed up with a change for the city of Amherst.

The Town of Amherst, NY, is now simulcasting fire comms from 46.26 on the frequency 425.400 and will probably change over to the UHF frequency once all the fire companies get new radios. Numerous volunteer companies provide Amherst's fire protection, so it may take them awhile to all get the new radios."

A special thank-you to John for providing this detailed monitoring plan and comments for our readers!

Web Sites For Research

There are a few Web sites worth knowing about if this type of change ever happens to you. In fact, it might be worthwhile to check once in a while for things in your area just to see if anyone has gotten licensed on a frequency you didn't know about. Sometimes departments add channels or services to relieve the load on the main system, but unless you're paying close attention, you might not notice the traffic was gone!

The first and easiest to use site is that of Percon Corporation, the official supplier of FCC data to the public. If you don't have one of their CD collections in your personal library, you should. It's an invaluable research tool, and their web site can help you keep up-to-date on changes in the licensing information since your CD was issued. They're at www.perconcorp.com.

The FCC is located at www.fcc.gov. It's a rather large site with tons of info on it. It's been recently upgraded and redesigned to make things a bit easier to find, so have a look and see if it will help your research efforts too!

Well, that should keep you busy until next month! Don't hesitate to reprogram and reorganize those scanners to take advantage of your own special interests. If you find some new frequency information, pass it along! And if you have a question related to scanning, don't hesitate to send it in. You can reach me at Ken Reiss, 9051 Watson Rd. #309, St. Louis, MO 63126 or via E-mail at armadillo1@aol.com. Until next month, Good listening! 73. ■

The Adventures of Scanner Dweeb by M. A. Coletta

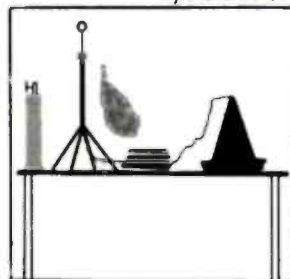

- 1) Attach hat to head
- 2) Attach coax connector to radio
- 3) Inflate balloon with bottled gas
- 4) Allow balloon to lift antenna to desired height unreeling coax slowly
- 5) Enjoy stronger signal radio reception

Who needs a mast?

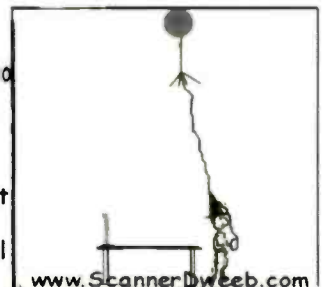

www.ScannerDweeb.com

the ham column

Getting Started As A Radio Amateur

QSLs: The Right, And Easy Way

Before we get started, I need to make a confession. I have a large pile of unanswered QSL cards sitting next to my radio. They're all from rabid 6-meter ops that desperately want to confirm my grid square. It's not that I don't want to answer them — I do! It's just that I don't have any up-to-date QSL cards on hand and I've been "too busy" to do much about it. At least the process of deciding how to produce my new cards prompted me to write this month's column. Here are a few dos and don'ts for producing and sending QSL cards.

Producing Or Printing Your QSL Cards

Many conventional QSL card printers advertise in CQ and QST. The larger companies have display ads — but don't forget to look in the classifieds. Spend a few dollars and send away for information kits and samples (or pop onto the Web and check out the online samples from those companies that offer them). Perusing QSL samples — online or in-hand — is fun and educational, but it can also make choosing a design more difficult, so be prepared.

Choosing a QSL card printer may be trickier than you think. Most commercial

printers produce "stock" cards — the only customized part is your name, callsign, and other personal information. Hundreds or even thousands of other hams may use the design of the card. If that's not a problem, you're in luck. Most beginning hams start this way. Stock cards are inexpensive, and you're sure to end up with a QSL card that contains all the necessary information — something that may not happen if you "go at it alone."

Whether you choose a standard card, a photographic card, or a one-of-a-kind masterpiece, make sure you don't buy too many right off the bat. Beginning hams have a habit of upgrading! And although the discount on 3,000 cards may seem attractive, buy with caution!

To reduce costs, consider putting together a group order with your friends or fellow ham club members. Or limit your cards to plain white stock and blank ink. Starting out with a plain vanilla QSL card is perfectly acceptable.

For a list of links to online QSL card printers, point your Web browser to www.ac6v.com/pageaac.html#QSL.

So far, we've talked about having a mainstream print shop produce your cards. If you're a do-it-yourselfer, feel free to produce your own. You can print master copies from your desktop pub-

lishing system and have cards printed at a local "quick printer," or you can even print your own cards from a suitable inkjet or laser printer. Several QSL card design programs are available for downloading from the Web. Try www.qsl.net/vk4wss/software.htm or <http://hfradio.org/wb8rcr/QSLMaker.html>.

Required Information

Here's the information that should appear on whatever card you choose: Callsign, name, mailing address, and your country. You may also want to include your county to please the many county-hunting hams you'll encounter on the air. And you may want to include your grid square designation if you're active on VHF/UHF.

The blanks where you fill in QSO information should be large enough to easily write in the other op's callsign, date, year, time (in UTC), band, mode, and signal report. Most hams also include a "PSE QSL TNX" line; circle either PSE or TNX to indicate whether you're requesting a card or responding to a received card. Feel free to include other personal data, too — but don't get too carried away. Junky, cluttered QSL cards

W D Ø B D A	
KIRK A. KLEINSCHMIDT	
1006 NORTH EAST EIGHTH STREET	
LITTLE FALLS, MINNESOTA 56345	
RADIO _____	CONFIRMING QSO OF _____ 19 _____
AT _____ G.M.T. UR _____	MC CW / AM / SSB SIGS RST _____
XMTR _____	WATTS INP _____
RCVR _____	ANT _____
REMARKS _____	
PSE QSL TNX _____	73, _____
MORRISON COUNTY	

My first card, printed in black and white by a discount printer, sports my first callsign, WDOBDA

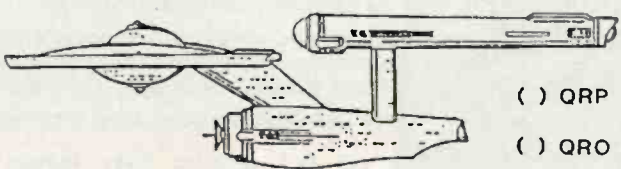
GRP ARCI # 5797		NTØZ	
		() QRP	() QRO
KIRK KLEINSCHMIDT		PSE QSL TNX	
160 SMITH STREET #3			
NEW BRITAIN CT 06053			
CONFIRMING QSO: _____		73, _____	
RADIO	DATE	UTC	MHz
RST	2x		SSB FM CW RTTY

Although this card shows a Connecticut address, it's really an updated version of my North Dakota "cheapie" homebrew card.

BY KIRK KLEINSCHMIDT, NTØZ

NTØZ 

OTH
 QRP 1 watt QRP 5 watts QRO watts Fixed Mobile/Portable

STATION	DATE	UTC	MHz	REPORT	2-WAY
	M D Y		<input type="checkbox"/> 3.5 <input type="checkbox"/> 21 <input type="checkbox"/> 7 <input type="checkbox"/> 28 <input type="checkbox"/> 14 <input type="checkbox"/> 144		<input type="checkbox"/> CW <input type="checkbox"/> SSB

GRP-ARCI 5797
EX-WD#BDA
GRID FN31

PSE QSL TNX ||

73, _____



KIRK KLEINSCHMIDT
746 EAST ST.
NEW BRITAIN, CT 06051
HARTFORD COUNTY

ONE OF THE ARRL HEADQUARTERS GANG

This QSL card (brightened to make it more readable in the magazine) was my ARRL-era card. My new card, which I need to send to that bunch of 6-meter grid hunters, hasn't been designed yet.

KJ6CA 

ROBERT J. RHOADS
9100 LA SERENA DR.
FAIR OAKS, CA 95628

PSE QSL TNX SACRAMENTO COUNTY 73 #5161

CONFIRMING QSO WITH	DATE	UTC	MHz	RST	2-WAY
	DAY MONTH YEAR				
					CW

This card, showing KJ6CA, was sent to me by Robert Rhoads of Fair Oaks, California. Robert, a QRP'er and vintage radio buff says, "Maybe you could run a couple of reader QSL cards sometime?" OK, OM, here's looking at your card!

complicate matters. Clean, straightforward designs work best. Be sensible about the artwork and forget about stuff that may be offensive or humorous. Something that's funny in sunny California may not play in Peoria — much less Persia! Think twice about graphic themes that are overly political, religious, or "visually stimulating."

Do yourself and your QSL recipients one last favor and make sure all QSO information is on the front side of your QSL card. Remember: The easier you make the QSL card process, the greater your chance of getting a card in return.

By the way, there are two ways to fill out a QSL card — perfect and wrong. Be careful, be accurate, and be neat. If you

make a mistake, toss the card into the trash and start over. Marked-over or altered cards — even if made in good faith — do not count for awards programs. What if you're that op's only New Hampshire contact?

Mailing/Sending Your QSLs

Want to improve your QSL return rate? Remember that hams in rare states (and rare places) are often inundated with QSL card requests. Make sure yours is sent with a self-addressed, stamped envelope. Being patient also helps, especially with cards sent overseas or via the QSL bureau.

In case you haven't used it yet, the "bureau" is an excellent, cost-effective

way to send and receive QSL cards to and from DX stations. Instead of going through the tedious and expensive process of sending QSL cards directly to overseas operators, you can simply sort your "outgoing" cards and send them to the ARRL Outgoing QSL Bureau for \$6 per pound (or 10 cards for \$1). Within a week or so of arrival, the Bureau forwards your cards to hundreds of other similar bureaus in most foreign countries. This route, while inexpensive, does take time (two months to two years), but it's quite popular among hams the world over. To use the Outgoing Bureau, U.S. hams must be ARRL members, but the services of its counterpart — the Incoming Bureaus — are available to members and nonmembers alike. Separate Incoming Bureaus are maintained for each callsign district in the U.S. and Canada. Cards arrive from overseas and are sorted by the first letter of the callsign suffix.

To get your cards, you send a few 5 X 7-inch SASEs to your bureau, which will forward cards to you every month or two, depending on your QSL card volume. The bureau system exchanges millions of QSL cards each year to hams almost everywhere. And with propagation picking up over the next few years, if you haven't yet, it's time you "QSL via the buro." For complete information on how to use the bureau system, point your Web browser to www.arrl.org/qs/qsout.html and www.arrl.org/qs/qsin.html.

Your suggestions, letters, and QSL cards are always welcome. Write to me at "The Ham Column," *Popular Communications*, 25 Newbridge Rd., Hicksville, NY 11801. See you on the bands — or at the print shop! ■

If you enjoy Amateur Radio, you'll enjoy CQ.

It's a different kind of ham magazine.

Fun to read, interesting from cover to cover, written so you can understand it. That's CQ. Read and enjoyed by over 90,000 people each month in 116 countries around the world.

It's more than just a magazine. It's an institution.

CQ also sponsors these fourteen world-famous award programs and contests: The CQ World-Wide DX Phone and CW Contests, the CQ WAZ Award, the CQ World-Wide WPX Phone and CW Contests, the CQ World-Wide VHF Contest, the CQ USA-CA Award, the CQ WPX Award, the CQ World-Wide 160 Meter Phone and CW Contests, the CQ World-Wide RTTY Contest, the CQ 5 Band WAZ Award, the CQ DX Award, and the highly acclaimed CQ DX Hall of Fame.

Accept the challenge. Join the fun. Read CQ.

Also available in the Spanish language edition. Write for rates and details.

	USA	VE/XE	Foreign Air Post	Visa, Mastercard, American Express, Discover accepted.
1 Year	27.95	40.95	52.95	Please send card number along with expiration date with your name, address, city, state.
2 Years	49.95	75.95	99.95	Please allow 6-8 weeks for delivery of first issue.
3 Years	71.95	110.95	146.95	

CQ Magazine, 25 Newbridge Road, Hicksville, NY 11801
Ph: 516-681-2922 FAX 516-681-2926

Tap into secret Shortwave Signals

Turn mysterious signals into exciting text messages with the MFJ MultiReader™!

Plug this self-contained MFJ MultiReader™ into your shortwave receiver's earphone jack.

Then watch mysterious chirps, whistles and buzzing sounds of RTTY, ASCII, CW and AMTOR (FEC) turn into exciting text messages as they scroll across an easy-to-read LCD display.

You'll read interesting commercial, military, diplomatic, weather, aeronautical, maritime and amateur traffic . . .

Eavesdrop on the World

Eavesdrop on the world's press agencies transmitting *unedited* late breaking news in English -- China News in Taiwan, Tanjung Press in Serbia, Iraqi News in Iraq -- all on RTTY.

Copy RTTY weather stations from Antarctica, Mali, Congo and many others. Listen to military RTTY passing traffic from Panama, Cyprus, Peru, Capetown, London and others. Listen to hams, diplomatic, research, commercial and maritime RTTY.

Listen to maritime users, diplomats and amateurs send and receive *error-free* messages using various forms of TOR (Telex-Over-Radio).

Monitor Morse code from hams, military, commercial, aeronautical, diplomatic, maritime

Super Active Antenna

"World Radio TV Handbook" says MFJ-1024 is a "first-rate easy-to-operate active antenna... quiet... excellent dynamic range... good gain... low noise... broad frequency coverage."

Mount it outdoors away from electrical noise for maximum signal, minimum noise. Covers 50 KHz-30 MHz.

Receives strong, clear signals from all over the world. 20 dB attenuator, gain control. ON LED.

Switch two receivers and auxiliary or active antenna.

MFJ-1024 6x3x5 inches. Remote has 54 inch whip, 50 feet coax, 3x2x4 inches. 12 VDC or 110 VAC with MFJ-1312, \$14.95.

Indoor Active Antenna

Rival outside long wires with this *tuned* indoor active antenna.

"World Radio TV Handbook" says MFJ-1020B is a "fine value... fair price... best offering to date... performs very well indeed."

Tuned circuitry minimizes intermod, improves selectivity, reduces noise outside tuned band. Use as a preselector with external antenna. Covers 0.3-30 MHz. Tune, Band, Gain, On/Off/Bypass Controls. Detachable telescoping whip. 5x2x6 in. Use 9 volt battery, 9-18 VDC or 110 VAC with MFJ-1312, \$14.95.

Compact Active Antenna

Plug this compact MFJ

all band active antenna into your receiver and you'll hear strong, clear signals from all over the world, 300 KHz-200 MHz including low, medium, shortwave and VHF bands.

Detachable 20 inch telescoping antenna. 9 volt battery or 110 VAC MFJ-1312B, \$14.95. 3 1/4 x 1 1/4 x 4 in.

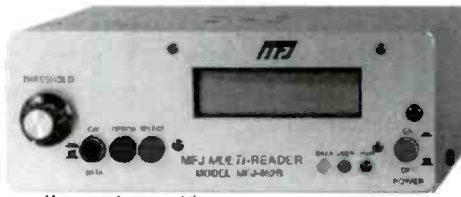

-- all over the world --
Australia, Russia, Japan, etc. MFJ-462B
Printer Monitors
24 Hours a Day
\$179⁹⁵

MFJ's exclusive TelePrinterPort™ lets you monitor any station 24 hours a day by printing transmissions on an Epson compatible printer.

Printer cable, MFJ-5412, \$9.95.
MFJ MessageSaver™
You can save several pages of text in an 8K of memory for re-reading or later review.

High Performance Modem
MFJ's high performance PhaseLockLoop™ modem consistently gives you solid copy -- even with weak signals buried in noise. New threshold control minimizes noise interference --

greatly improves copy on CW and other modes.

Easy to use, tune and read

It's easy to use -- just push a button to select modes and features from a menu.

It's easy to tune -- a precision tuning indicator makes tuning your receiver easy for best copy.

It's easy to read -- the 2 line 16 character LCD display with contrast adjustment is mounted on a brushed aluminum front panel for easy reading.

Copies most standard shifts and speeds. Has MFJ AutoTrak™ Morse code speed tracking.

Use 12 VDC or use 110 VAC with MFJ-1312B AC adapter, \$14.95. 5 1/4 x 2 1/2 x 5 1/4 inches.

No Matter What™ One Year Warranty

You get MFJ's famous one year No Matter What™ limited warranty. That means we will repair or replace your MFJ MultiReader™ (at our option) no matter what for one full year.

Try it for 30 Days

If you're not completely satisfied, simply return it within 30 days for a prompt and courteous refund (less shipping). Customer must retain dated proof-of-purchase direct from MFJ.

Eliminate power line noise!



MFJ-1026 \$179⁹⁵
New! Completely eliminate power line noise, lightning crashes and interference before they get into your receiver! Works on all modes -- SSB, AM, CW, FM, data -- and on all shortwave bands. Plugs between main external antenna and receiver. Built-in active antenna picks up power line noise and cancels undesirable noise from main antenna. Also makes excellent active antenna.

MFJ Antenna Matcher

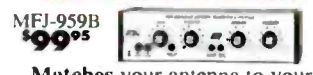

MFJ-959B \$99⁹⁵
Matches your antenna to your receiver so you get maximum signal and minimum loss.

Preamp with gain control boosts weak stations 10 times. 20 dB attenuator prevents overload. Select 2 antennas and 2 receivers. 1.6-30 MHz. 9x2x6 in. Use 9-18 VDC or 110 VAC with MFJ-1312, \$14.95.

Dual Tunable Audio Filter



MFJ-752C \$99⁹⁵
Two separately tunable filters let you peak desired signals and notch out interference at the same time. You can peak, notch, low or high pass signals to eliminate heterodynes and interference. Plugs between radio and speaker or phones. 10x2x6 in.

High-Gain Preselector



MFJ-1045C \$99⁹⁵
High-gain, high-Q receiver preselector covers 1.8-54 MHz. Boost weak signals 10 times with low noise dual gate MOSFET. Reject out-of-band signals and images with high-Q tuned circuits. Push buttons let you select 2 antennas and 2 receivers. Dual coax and phono connectors. Use 9-18 VDC or 110 VAC with MFJ-1312, \$14.95.

CW, RTTY, ASCII Interface



MFJ-1214PC \$149⁹⁵
Use your computer and radio to receive and display brilliant full color FAX news photos and incredible WeFAX weather maps. Also RTTY, ASCII and Morse code. Frequency manager lists over 900 FAX stations. Auto picture saver.

Includes interface, easy-to-use menu driven software, cables, power supply, manual and JumpStart™ guide. Requires 286 or better computer with VGA monitor.

High-Q Passive Preselector



MFJ-956 \$49⁹⁵
High-Q passive LC preselector boosts your favorite stations while rejecting images, intermod and phantom signals. 1.5-30 MHz. Preselector bypass and receiver grounded positions. Tiny 2x3x4 inches.

Super Passive Preselector



MFJ-1046 \$99⁹⁵
New! Improves any receiver! Suppresses strong out-of-band signals that cause intermod, blocking, cross modulation and phantom signals. Unique Hi-Q series tuned circuit adds super sharp front-end selectivity with excellent stopband attenuation and very low passband attenuation and very low passband loss. Air variable capacitor with vernier. 1.6-33 MHz.

Easy-Up Antennas

How to build and put up inexpensive, fully tested wire antennas using readily available parts that'll

bring signals in like you've never heard before. Antennas from 100 KHz to 1000 MHz.

MFJ Antenna Switches



MFJ-1704 \$64⁹⁵ MFJ-1702C \$24⁹⁵
MFJ-1704 heavy duty antenna switch lets you select 4 antennas or ground them for static and lightning protection. Unused antennas automatically grounded. Replaceable lightning surge protection. Good to 500 MHz. 60 dB isolation at 30 MHz. MFJ-1702C for 2 antennas.

World Band Radio Kit

Build this regenerative shortwave receiver kit and listen to signals from all

over the world with just a 10 foot wire antenna. Has RF stage, vernier reduction drive, smooth regeneration, five bands.

21 Band World Receiver

MFJ's MFJ-8121 new 21 Band World Receiver

lets you travel the world from your armchair! Listen to BBC news from London, live music from Paris, soccer matches from Germany and more! Covers 21 bands including FM, Medium Wave, Long Wave and Shortwave. Sony® integrated circuit from Japan, multicolored tuning dial, built-in telescopic antenna, permanent silkscreened world time zone, frequency charts on back panel. Carrying handle. Operates on four "AA"s. Super compact size!

Free MFJ Catalog

and Nearest Dealer . . . 800-647-1800

<http://www.mfjenterprises.com>

• 1 Year No Matter What™ warranty • 30 day money back guarantee (less s/h) on orders from MFJ

MFJ ENTERPRISES, INC.
Box 494, Miss. State, MS 39762
(601) 323-5869; 8-4:30 CST, Mon-Fri.
FAX: (601) 323-6551; Add s/h
Tech Help: (601) 323-0549

Prices and specifications subject to change. (c) 1998 MFJ Enterprises, Inc.

Pop'Comm's World Band Tuning Tips

June 2000

This listing is designed to help you hear more shortwave broadcasting stations. The list includes a variety of stations, including international broadcasters beaming programs to North America, others to other parts of the world, as well as local and regional shortwave stations. Many of the transmissions listed here are not in English. Your ability to receive these stations will depend on time of day, time of year, your geographic location, highly variable propagation conditions, and the receiving equipment used.

AA, FF, SS, GG, etc. are abbreviations for languages (Arabic, French, Spanish, German). Times given are in UTC, which is five hours ahead of EST, i.e. 0000 UTC equals 7 p.m. EST, 6 p.m. CST, 4 p.m. PST.

UTC	Freq.	Station/Country	Notes	UTC	Freq.	Station/Country	Notes
0000	11925	Radio Bandeirantes, Brazil	PP	0300	11950	Radio Nacional, Angola	PP
0000	11970	Radio Jordan	AA	0315	11730	BBC via Seychelles	
0000	13650	Radio Pyongyang, North Korea		0315	11885	Far East Broadcasting Assn., Seychelles	unid
0000	17675	Radio New Zealand		0330	7160	Radio Tirana, Albania	
0030	4515.7	Radio Amistad, Peru	SS	0330	7260	Voice of Vietnam, via Russia	
0030	6120	Radio Vilnius, Lithuania, via Germany		0330	9165	Radio Dada Gorgud, Azerbaijan	Azer
0030	6240	Trans World Radio, via Armenia	Kazakh	0330	9495	Radio Sweden	
0030	6485.5	AFRTS, Puerto Rico	SSB	0330	9835	Radio Budapest, Hungary	
0030	9022	Voice of Islamic Republic of Iran		0330	11970	Radio Taipei Int'l, Taiwan, via Florida	
0030	9400	Radio Bulgaria		0400	4819	La Voz Evangelica, Honduras	SS
0030	9620	SODRE, Uruguay	SS	0400	4835	Radio Tezulutlan, Guatemala	SS
0030	11585	Kol Israel	unid	0400	4850	Cameroon RadioTV	FF
0030	15460	Radio Thailand		0400	5500	Voice of the Tigray Revolution, Ethiopia	vern.
0100	3250	Radio Luz y Vida, Honduras	SS	0400	7180	Radio Polonia, Poland	
0100	3280	La Voz del Napo, Ecuador	SS	0400	7245	Radio Algiers, Algeria	AA
0100	4915	Radio CBN, Brazil	PP	0400	7300	Voice of Turkey	TT
0100	7115	Radio Yugoslavia		0400	9705	Radio Mexico Int'l	SS/EE
0100	7545	Kol Israel		0400	11690	Voz Cristiana, Chile	SS
0100	9885	Swiss Radio Int'l		0430	5035	Radio Centrafrique, Central African Republic	FF unid
0100	9915	BBC, England		0430	6210	Radio Fana, Ethiopia	unid
0130	9860	Voice of Russia	SS	0430	7180	Voice of Russia, via Moldova	
0130	11890	Radio Japan, via Sri Lanka	unid	0430	9730	China Radio Int'l, via Fr. Guiana	
0130	17685	NHK/Radio Japan		0430	9820	Radio Havana Cuba	
0200	3300	Radio Cultural, Guatemala	SS	0430	21700	UAE Radio, United Arab Emirates	AA
0200	4930	Radio Costena, Honduras	SS	0500	4770	Radio Nigeria	
0200	6000	Radio Havana Cuba		0500	4825	Radio Cancao Nova, Brazil	PP
0200	9565	Radio Universal, Brazil	PP	0500	4940	Radio TV Ivoirienne, Ivory Coast	FF
0200	11710	RAE, Argentina		0500	5047	Radio Lome, Togo	FF
0200	11785	Radio Guiaba, Brazil	PP	0500	6055	Radio Exterior de Espana, Spain	
0230	7120	Italian Radio Relay Service		0500	6110	NHK/Radio Japan, via Canada	
0230	17510	KWHR, Hawaii		0500	7135	Radio France Int'l	FF
0250	6265	Radio Zambia		0500	7210	Radiodiffusion du Benin	FF
0300	4800	Radio Lesotho		0500	7255	Voice of Nigeria	
0300	4830	Radio Tachira, Venezuela	SS	0500	9445	Voice of Turkey	TT
0300	4960	Radio Villa, Dominican Republic	SS	0500	12050	Radio Cairo, Egypt	AA
0300	6115	Radio Union, Peru	SS	0500	15215	Channel Africa, South Africa	
0300	9525	Channel Africa, South Africa		0530	5025	La Voix du Sahel, Niger	AA
0300	9735	Radio Wales Int'l, via England		0530	6015	Radio Austria Int'l, via Canada	
0300	9925	Croatian Radio, via Germany	Croatian				
0300	11620	All India Radio	unid				
0300	11665	YLE — Radio Finland					

UTC	Freq.	Station/Country	Notes	UTC	Freq.	Station/Country	Notes
0530	7175	Radio Tikhiy Okean, Russia	RR	1430	15345	RTV Marocaine, Morocco	AA
0530	13730	Radio Austria Int'l		1430	18960	Radio Sweden	
0530	15215	Channel Africa, South Africa	PP	1430	21745	Radio Prague, Czech Republic	
0600	3366	Ghana Broadcasting Corporation		1500	9910	Radio Free Asia, via Palau	CC
0600	4960	Radio Vanuatu	EE/FF	1500	11585	All India Radio	vern.
0600	5995	RTV Maliene, Mali	FF	1500	11600	Far East Broadcasting Assn., Seychelles	
0600	6080	Voice of America, via Sao Tome		1500	11730	NHK/Radio Japan	
0600	6185	Radio Educacion, Mexico	SS	1500	15310	BBC, via Oman	
0600	7125	RTV Ivoirienne	FF	1500	15460	Voice of America, via Thailand	
0600	7195	Voice of Russia		1500	15705	Radio Norway	NN
0630	4845	Radio Mauritania	AA	1600	15275	Deutsche Welle, Germany	GG
0630	9590	Radio Denmark, via Norway	DD	1600	15420	Voice of America, via Morocco	
0700	9560	YLE — Radio Finland	FF	1600	15435	Radio Jamahiriya, Libya	AA
0700	9595	Radio Tampa, Japan	JJ	1600	17570	RTBF, Belgium, via Germany	FF
0700	9860	Radio Rossi, Russia	RR	1600	17865	Radio Australia	
0700	12035	Radio Exterior de Espana, Spain	SS	1630	21700	Radio Exterior de Espana, Spain	SS
0700	15725	KHBN, Palau	CC	1700	17485	Radio Prague, Czech Republic	
0730	9780	HCJB, Ecuador		1700	17545	Kol Israel	HH
0800	3310	Radio Mosoj Chaski, Bolivia	SS	1730	15365	Radio Romania Int'l	
0800	6100	Radio Pyongyang, North Korea	KK	1800	11570	Radio Pakistan	Urdu
0800	9570	Radio Korea Int'l		1800	13675	UAE Radio, United Arab Emirates	AA
0900	4985	Radio Brazil Central	PP	1800	15495	Radio Kuwait	AA
0900	6045	Radio Santa Rosa, Peru	SS	1800	15545	RDP Int'l, Portugal	PP
0900	9870	Trans World Radio, Monaco		1800	15545	VOA via Botswana	
0930	4472	Radio Movima, Bolivia	SS	1800	15640	Kol Israel	HH
0945	5955	Caracol Villavicencio, Colombia	SS	1830	15475	Africa Number One, Gabon	FF
1000	7200	Yakutsk Radio, Russia	RR	1830	17695	Radio Vlaandaren Int'l, Belgium, via Germany	
1000	7260	Radio Netherlands		1830	21630	Radio Telefis Eirann, Ireland, via Ascension Island	
1000	7465	Radio Emisora Rural, Brazil	PP	1900	11710	Broadcasting Service of Kingdom of Saudi Arabia	AA
1030	3290	Radio Centro, Ecuador	SS	1900	11734	Radio Tanzania, Zanzibar	AA
1050	4824.5	La Voz de la Selva, Peru	SS	1900	15190	Radio Pilipinas, Philippines	
1100	3245	Radio Gulf, Papua New Guinea	Pidgin	1900	17660	HCJB, Ecuador	
1100	4463.7	Radio Norandina, Peru	SS	1900	17705	Voice of Greece, via Delano, CA	GG
1100	7295	RTV Malaysia		1930	17605	Radio Netherlands, via Bonaire	
1100	7445	Voice of Asia, Taiwan		2000	9745	Adventist World Radio, via South Africa	
1100	9525	Voice of Indonesia	Burmese	2000	12015	IBRA Radio, Sweden	
1130	4725	Radio Myanmar		2000	13770	RDP Int'l, Portugal	PP
1130	4754	Radio Republic Indonesia, Ujang Pandang	II	2100	9570	Radio Tirana, Albania	Alb
1130	5020	Solomon Islands Bc. Corp		2100	9625	CBC Northern Service, Canada	
1130	6130	Laos National Radio	unid	2100	9855	Radio Kuwait	AA
1130	9590	Radio Singapore Int'l		2100	9900	Radio Cairo, Egypt	
1130	9650	Radio Korea Int'l, via Canada		2100	9965	Voice of Armenia	
1200	4890	National Bc. Commission, Papua New Guinea		2100	15390	BBC, via Ascension	
1230	7130	Radio Taipei Int'l, Taiwan		2100	21740	Radio Australia	
1230	7184	Radio Bangladesh		2130	13690	Radio Canada Int'l	
1300	7365	KNLS, Alaska		2200	9870	Broadcasting Service of Kingdom of Saudi Arabia	AA
1300	12015	Voice of Mongolia		2230	9425	Voice of Greece	GG
1300	17775	Radio Tashkent, Uzbekistan		2230	9580	Africa Number One, Gabon	FF
1335	11755	Adventist World Radio, Guam		2230	13760	Radio Vlaandaren Int'l, Belgium, via Bonaire	
1400	6150	Radio Corporation of Singapore		2230	15190	Radio Africa, Equatorial Guinea	
1400	9375	Voice of Greece	GG	2300	9575	Voice of the Islamic Republic of Iran	unid
1400	9505	NHK/Radio Japan		2300	11705	Radio Nova Visao, Brazil	PP
1400	9530	Radio Thailand		2300	11735	Radio Transmundial, Brazil	PP
1400	9580	Radio Australia		2300	11800	RAI, Italy	II
1400	11960	Voice of the Islamic Republic of Iran	RR	2300	11820	Broadcasting Service of Kingdom of Saudi Arabia	AA
1400	12085	Radio Damascus, Syria	AA	2300	11820	Radio Veritas Asia, Philippines	EE/others
1400	15140	Radio Oman	AA	2300	11955	BBC via Singapore	
1400	15160	Radio Algiers, Algeria	FF	2300	17860	Deutsche Welle, Germany, via Rwanda	
1400	17560	Radio France Int'l, via F. Guiana		2330	17570	Radio Netherlands	
1400	21550	Voz Cristiana, Chile	SS				
1430	15245	Radio Nacional Congolaise, Dem. Rep of Congo	FF				

product parade

Review Of New, Interesting And Useful Products

Midland Introduces New SAME Weather/All Hazard Alert Monitor

Weather alert radios are now considered to be as important to have as smoke detectors in your home, school, or business. Midland Consumer Radio has introduced their latest weather/all hazard alert monitor, model 74-210. Using V1.2 Specific Area Message Encoder (SAME) technology, the 74-210 can be set to automatically switch to local NOAA broadcasts only when the alert tones are activated in the county, or range of counties specified by the user (up to 20). Alerts for other areas are ignored, which means you can rest assured without waking to false alarms. Repetitive watches and statements can also be silenced, if desired.

The 74-210 also receives the regular NOAA broadcast frequencies covering 95% of the U.S., for up-to-the-minute weather and hazard information 24-hours a day, and can be easily set to receive your entire broadcast area's alerts.

Most weather radios sound alerts, watches, and statements for areas three or four counties away, tempting users to shut off the radio and lose the benefit of early warning when alerts do effect their area. In addition to a multi-tone warning and voice alert, the 74-210 displays up to 56 messages on the front digital LCD panel, specifying the type of alert (Tornado, Hurricane, Flood, etc.), and three color LED indicators show at a glance if the alert is a statement, watch, or warning. Many areas now broadcast warnings of fires, earthquakes, chemical spills, or other hazards over the same frequencies. The 74-210 recognizes these also, so you can keep informed and move to safety. The telescopic fold-away antenna gives you a range of up to 50 miles from the broadcast transmitter, and with digital channel control, the tuning will never drift off frequency.

The 74-210 SAME Weather/Hazard Radio also features a built-in clock and FM radio with five memory settings, so you can listen to your favorite local FM broadcast stations. The 74-210 will automatically switch from FM radio to any

alert that sounds. Optional accessories, like an external antenna, strobe light, pillow vibrator, or X10 unit (all sold separately), are easy to add with the convenient accessory jacks. A standard AC power adapter is included, and battery backup allows operation during a power outage (4 AA batteries not included). It can also be powered from 12 volt vehicles or boats with Midland's model 18-235 adapter (not included).

The radio measures (HWD) 1-7/8" x 6" x 5-1/4," and is packaged in an attractive full color display box. The Midland 74-210 SAME Weather/Hazard Radio is a great value, with a suggested retail price of \$89.95.

In addition to being the industry leader in weather/hazard alert radios, Midland Consumer Radio is the oldest manufacturer of CB radios in the U.S. and was the first to introduce a 14 channel FRS radio. Since 1959, Midland has stayed on the forefront of two-way radio technology, offering the latest features at real value prices. They also offer marine radios and a complete line of antennas and accessories. For more information, contact Midland Consumer Radio, Inc. 1670 N. Topping Ave., Kansas City, MO 64120; (816) 241-8500; E-mail midlndcb@tfs.net, or visit Midland's Website at www.midlandradio.com.

Alinco Releases "Clear" DJ-V5 Models

Alinco USA has released new "clear" or "see-through" versions of its popular DJ-V5 VHF/UHF handheld transceiver. The new models are the DJ-V5TDC, powered by a transparent dry-cell battery pack and the DJ-V5TDH that comes with a black NiCd battery pack. The new radio is targeted to younger users who may want a bit more "style" and to "tekkies" who enjoy seeing some of the internal components in the new HT.

The DJ-V5TDC (H) has only faint coloration that appears as a part of the manufacturing process. Most people see it as a slight blue tinge to the outer case that reveals the placement of circuit board, display, lighting, speaker, keypad, switches, and more.



The Alinco DJ-V5T.

Alinco's DJ-V5T models are compact handheld transceivers designed to operate on the 2-meter and 70-cm amateur bands. The HT features alphanumeric display, up to five watts power output, 200 memories, an expanded receive capability offering coverage from 76-999.995 MHz (cellular blocked), narrow and wide FM receive modes along with CTCSS encode and decode.

Additional features include four scan modes, five programmable scan banks, automatic internal temperature protection, cable cloning, SMA antenna connector, 13.8 Vdc direct input, four different European tone bursts, autodial memories, input voltage display with over-voltage warning, MARS/CAP capability, adjustable AF audio tone, and more. There are no operational differences between the transparent body models and the existing black DJ-V5T transceivers. Alinco will continue to offer the black version of the radio in combination with the new transparent models.

For more information, contact Alinco USA at 438 Amapola Avenue, Suite 130, Torrance, CA 90501 or call 310-618-8616 or check them out on the Web at <http://www.alincousa.com>. Be sure to tell them you read about it in *Pop'Comm*.

BY HAROLD ORT AND R.L. SLATTERY

ClearSpeech™ Speaker

Am-Com's new ClearSpeech speaker is becoming a hit in the radio community. It removes up to 95% of the background noise from the receive side of any two-way radio communication. It's a high-tech, low-cost solution that enhances the audio quality of car and truck fleet, emergency vehicles, marine and ham radio communications. You'll listen to your comms with less fatigue and have greater concentration!

The new ClearSpeech speaker is easy to use and activates automatically when connected to your mobile radio and a 12-volt power supply. It mounts like a standard external loudspeaker and works on SSB, AM, FM, and CW. The new ClearSpeech speaker has an audio input impedance of 8 ohms and audio output, nominal power — 5 W, maximum, 10 W. The noise cancellation characteristics are 300 Hz to 3,400 Hz voice bandwidth, signal tone noise reduction ->50dB, white noise reduction ->12dB.

The suggested retail price is \$149 from Am-Com, P.O. Box 356, Lakeside, MT 59922 or call (for info only) 406-844-3252. You can order direct at 888-803-



Am-Com's ClearSpeech™ speaker will be a welcome addition to your radio shack.

5823. Be sure to check out their secure Website at amateurcommunications.com. And look for a review of the new ClearSpeech speaker in next month's *Pop'Comm!*

Amateur Radio, The First 100 Years

This great book tells the story of amateur radio, and it's a lavishly illustrated, limited edition. Many photographs not previously published are included.

This hardback coffee table book

includes selected photographs from the Radio Society of Great Britain's extensive photo-library. The book details the story of amateur radio since the first amateur station was set up in Woolwich Arsenal in London in 1898. It tells the fascinating story of how amateur radio developed over the years in picture and word demonstrating how amateurs showed their real pioneering spirit in making new developments against all the odds. It's an ideal purchase for anyone interested in the hobby. Each numbered copy of this limited edition is beautifully bound and gold blocked. Without a doubt, the "First 100 Years" book will become a valuable collector's item and serve as a particularly apt memento for the new Millennium of this outstanding story of achievement.

The 256-page book is published by the Radio Society of Great Britain, 1st Ed., 1999, ISBN: 1-872309-50-0. Contact the Radio Society of Great Britain, Lambda House, Cranborne Road, Potters Bar, Herts, EN6 3JE, England, Tel: 01707 660888 (+44 1707 660888) 24-hr. FAX 01707 645105 (+44 1707 645105), or E-mail to sales@rsgb.org.uk. Price \$46.50 to non-members, \$39.53 to members.

DEDICATED TO THE SCANNING AND SHORTWAVE ENTHUSIAST. WE'RE MORE THAN JUST SOFTWARE!

SCANCAT® GOLD for Windows "SE"

Since 1989, The Recognized Leader in Computer Control

Once you use SCANCAT with YOUR radio, you'll NEVER use your radio again WITHOUT SCANCAT!

SCANCAT supports almost ALL computer controlled radios by: AOR, DRAKE, KENWOOD, ICOM, YAESU and JRC (NRD) Plus PRO-2005/8/35/42 (with OS456/535), Lowe HF-150, and Watkins-Johnson.

SCANCAT GOLD FOR WINDOWS "SE" (Surveillance-Enhanced)

NOW SUPPORTS
RadioShack
PRO-2052

NOW SUPPORTS
UNIDEN BC-245 & BC-895
TRUNKTRACKER II
AOR AR16B - ARB200B
& TEN-TEC RX320

- Selective Sound Recording using PC-compatible sound card.
- "Point & Shoot" playback by individual hits.
- Demographic search for frequency co-ordination and 2-way Usage Analysis.
- Detailed logging to ASCII type files with DATE, TIME, Sig Str, Air Time.
- New sweep Analysis Functions.

- Exclusive "MACRO" control by frequency of Dwell, Hang, Resume, Sig. Threshold and even 6 separate programmable, audible alarms.
- Command line options for TIMED ON/OFF (Unattended) logging/searches.
- Run as many as 6 different Ct-V addressable radios as "Master/Slave".
- New! Scheduling/Recording Functions.

With Scancat Gold for Windows "SE," your spectrum never looked so good! Load virtually "any" database and Scancat "SE" will examine your database, plot each and every frequency, no matter what the range...and "paint" the entire analysis on your screen.

SEVERAL GRAPHICAL ANALYSIS MODES AVAILABLE

- By Signal Strength per frequency in a "histograph".
- By Number of hits per frequency in a "histograph".
- IF THAT ISN'T ENOUGH, try this...Multicolored, 3-D "Spatial/Landscape".

SCANCAT GOLD "SE"...\$159.95 + S & H*

UPGRADE SCANCAT GOLD V7.5.7 "SE"...\$59.95 + S & H* \$5 U.S. \$7.50 FOREIGN

SCANCAT'S WINDOWS FEATURES

- Unattended Logging of frequencies
- Scan Create Disk Files.
- Spectrum Analysis to Screen OR Printer.
- Supports PerCom, Mr. Scanner, and Betty Bearcat CD Roms.

- Scan VHF & HF Icom's Simultaneously.
- LINK up to 100 Disk files or ranges.
- MULTIPLE search filters for Diskfile Scanning.
- New - Programmable Favorite Frequency "Quick Buttons"

- Search by CTCSS & DCS tones with OS456/535 or DG440 (ICOM only).
- INCLUDES several large shortwave and VHF/UHF databases

All the features you EXPECT from a true Windows application such as:

- VERSATILE "Functional" spectrum analysis. NOT just a "pretty face". Spectrum is held in memory for long term accumulation. Simply "mouse over" to read frequency of spectrum location. "CLICK" to immediately tune your receiver. You can even accumulate a spectrum from scanning DISKFILES of random frequencies!
- DIRECT scanning of most DBASE, FOXPRO, ACCESS, BTRIEVE files WITHOUT "importing".
- UNIQUE database management system with moveable columns. Even SPLIT columns into doubles or triples for easy viewing of ALL important data on one screen.
- Exclusive SLIDE RULE tuner. Click or "skate" your mouse over our Slide-Tuner to change frequencies effortlessly! OR use our graphical tuning knob.

SCANCAT GOLD FOR WINDOWS (NON-"SE").....\$99.95 + S & H* UPGRADE TO V7.5\$29.95 + S & H* \$5 U.S. \$7.50 FOREIGN

MAGIC for Windows

PUT SOME ORDER
IN YOUR LIFE!

If You're Not Using MAGIC,
You're Only Enjoying Half The Hobby.

Magic is a super conversion utility that will read and write to over 10 database formats

- Creates databases from plain ASCII text.
- Finds single or multiple frequencies located anywhere in source files and creates perfectly aligned database files.
- Converts SCANCAT, ASCII text, comma delimited, HTML, DBase, ScanStar, RadioManager and ScannerWare.
- NEW WINRADIO. "WRM" files and PCR1000 ".MCH" files.

MAGIC for
Windows
\$34.95

(plus \$5.00 S & H)

LIMITED TIME OFFER!

Limited Time Thru 6/30/00

Scancat Gold for Windows	\$99.95
Magic for Windows	34.95
Disk of Frequency Files	15.00
Regular Price	\$149.90
SPECIAL	\$124.95
For "SE" Add:	\$59.95

"SPECIAL SCGM"

"UNI-VERSITILE" INTERFACE

- Supports ICOM/IC-R10, AR8000, AR16B, YAESU and SCOUT.
- Comes with 6 FOOT cable, and adapters to fit all units within a single package (Must Specify Yaesu)
- Unlike "single radio" adapters, can be used with ANY radio supported, simply change the adapter, then "Plug and Play."
- Expandable in future with a simple add on adapter.
- No external power required. Draws power from computer.
- Reaction Tune! scout with NO modifications to radio.



AR-8200B
Cables/Interfaces
—CALL!
BC-895 Cables
\$29.95

CAT-232C "UNIVERSITILE INTERFACE"
\$99.95 + s & h

FREE FREQ FILES

WEBSITE - www.scancat.com

E-MAIL - info@scancat.com

FREE DEMOS



SCANCAT is a registered trademark of Computer Aided Technologies

Order direct or
contact your
favorite dealer

COMPUTER AIDED TECHNOLOGIES

P.O. Box 18285 Shreveport, LA 71138

Phone: (318) 687-4444

FAX: (318) 686-0449

Info/Tech Support: (318) 687-2555 (9 a.m. - 1 p.m. Central M-F)

Toll-Free Orders
888-SCANCAT
888-722-6228

utility radio review

News, Information, And Events In The Utility Radio Service Between
30 KHZ And 30 MHZ

Welcome To The First Utility Radio Review!

As editor of the **Utility Radio Review** column, my personal mission will be to deliver to the readership of *Popular Communications Magazine* high-quality, comprehensive, and accurate information about the practices of utility radio. This is a new column and it will cover news, technical information, and educational facts about these radio services.

In this column, I will define a utility station as any radio station that does not direct their transmissions toward the general public. The method of transmission used by these stations will include point-to-point communication, information services, and automatic transmissions of data, to name only a few. Popular areas of interest, such as aeronautical, diplomatic, maritime, government, military, police, press, and digital (e.g. RTTY, etc.) will be covered in these pages.

The Column Mission

The mission of the column will be to inform and educate our readers about the background of a Utility Radio station or service, and how it is maintained and operated. Above all, we are interested in how the people connected to the operation of a utility radio station perform their work duties in order to operate or maintain their particular service.

In writing the column, my aim is to provide high quality information that you, the reader, expect when you pick up this magazine to read it. My aim will be to make your reading time worthwhile by providing you with the skills and knowledge you require in order to monitor utility radio transmissions effectively.

The column will also present, through news, personal stories and historical information, the background facts a reader will need to know in order to understand the important role of utility radio today. It is still an important medium of communication in the world. This fact is better understood if you are able to appreciate the



Joe Cooper at his monitoring/ham radio station, with a computer for receiving RTTY.

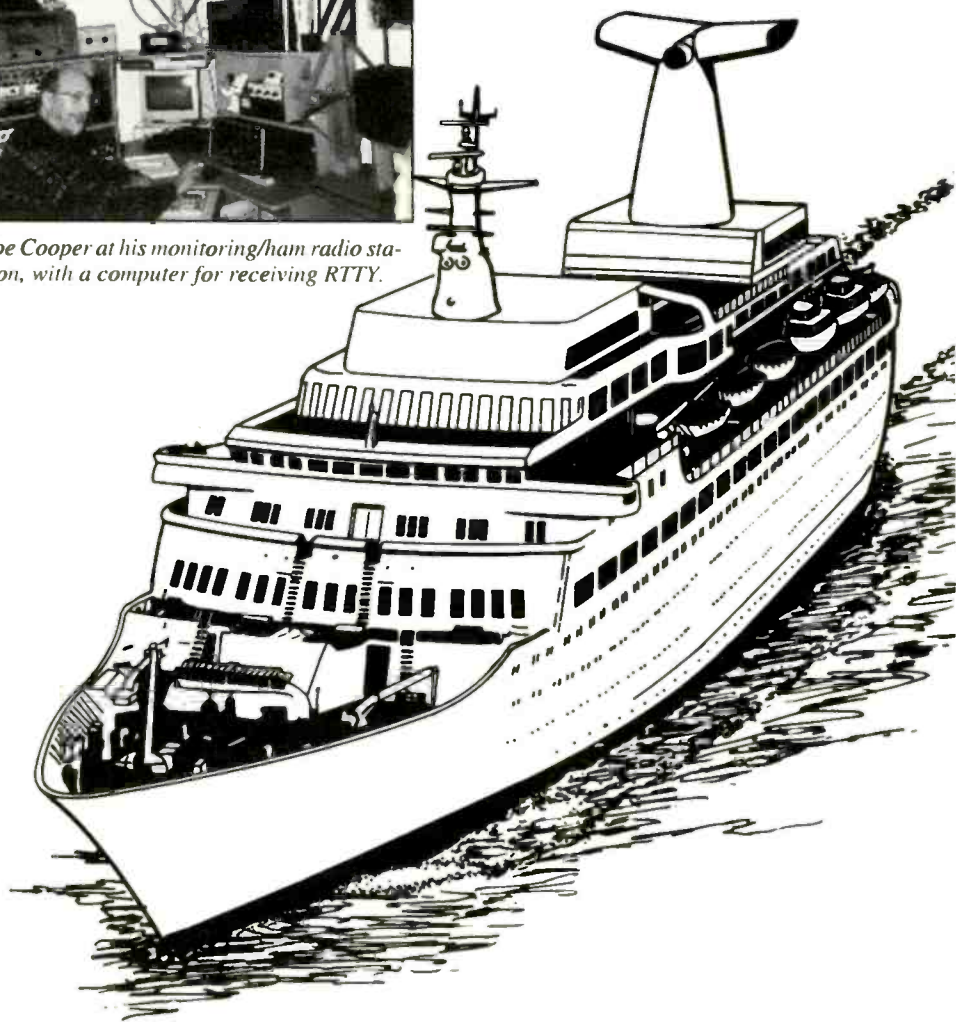

scope of the technology needed to make Utility Radio the success that it is.

Ethical Monitoring

The position of this column will always be that radio communications, particularly those made by Utility Stations, is significant for maintaining the safety and security of our nations and communities. Utility Radio is crucial to the efficient

operation of many of our social and economic infrastructures, such as transportation, power utilities, and government services. Radio as a service must never be taken for granted, nor treated with disrespect if we are to maintain its benefits to society.

As this column will focus on the monitoring of radio transmissions not intended for the general public, the writing here will always promote the ethical and legal

BY JOE COOPER <ur_review@provcomm.net>

monitoring of commercial/military communications. Due to this concern, the contents of all columns and loggings, as well as in correspondence with the readership, will never divulge the full contents of any communication without the permission of the originator and the intended recipient.

Likewise, no information will ever be provided in this column that will knowingly assist in the decoding of encrypted/encoded information, particularly that of any government agency. While I firmly believe that it is the right of any citizen in a democratic society to monitor the radio activity of those who use publicly owned radio frequencies, I also respect the need for government agencies, particularly the military and security services, to maintain privileged communications on those frequencies.

What Happens Next?

During the next few months, my first order of business will be getting to know the readership of this column. I want to know what you want to see written here, as well as find out what you don't want. After all, my main role is to be the custodian of these pages, and it's your reading needs that I have to satisfy in my role as column editor.

I also want to encourage commercial radio station owners, professional radio operators, and technicians to contact me as well. Part of my intention is to provide more "behind the scene" stories based on the experiences of people in the business. While listening to radio signals may be entertainment or excitement to those who listen as a hobby, it is a job for those who create and maintain them.

If possible, I would also like to cover news about achievements made by the manufacturers of commercial communication radio equipment. In this age of the microcomputer on a chip, radio equipment is going through many significant changes, particularly in the area of signal processing. Many new developments are taking place in radio technology, particularly in the field of utility radio, and its coverage would add to the understanding of where many radio services are headed in their development.

To achieve the goals that I have set out for this column, I want to make certain personal policies clear so that the content of the writing will stay on course. This column will always be written for the general reader of this magazine, rather than

for the semi-professional monitor. The best monitoring achievements of our readers will always be recognized, but there must be a balance too, so that the beginner and intermediate radio monitor will find topics of interest in these pages as well.

Working With You, The Reader

To get the best information for this column, I will be going to my best source —

you the reader. I will be building up a network of contacts amongst hobbyists, professionals, and the manufacturers/sellers of radio equipment in order to gather good quality information. My aim is to communicate with those readers who wish to share ideas, information, and news, logging and general comments.

Those who are interested in sharing their Utility Radio logging should contact me for a list of requirements, the reporting formats to be used, and the terms to be employed. To help make things easier, I have arranged for a unique E-mail



World's Most Powerful CB and Amateur Mobile Antenna*

**Lockheed Corp. Test Shows
Wilson 1000 CB Antenna Has
58% More Gain Than The
K40 Antenna (on channel 40).**

In tests conducted by Lockheed Corporation, one of the world's largest Aerospace Companies, at their Rye Canyon Laboratory and Antenna Test Range, the Wilson 1000 was found to have 58% more power gain than the K40 Electronics Company, K40 CB Antenna. This means that the Wilson 1000 gives you 58% more gain on both transmit and receive. Now you can instantly increase your operating range by using a Wilson 1000.

**Guaranteed To Transmit and Receive
Farther Than Any Other Mobile
CB Antenna or Your Money Back**
New Design**

The Wilson 1000 higher gain performance is a result of new design developments that bring you the most powerful CB base loaded antenna available.

Why Wilson 1000 Performs Better

Many CB antennas lose more than 50% of the power put into them. The power is wasted as heat loss in the plastic inside the coil form and not radiated as radio waves.

We have designed a new coil form which suspends the coil in air and still retains the rigidity needed for support. This new design eliminates 95% of the dielectric losses. We feel that this new design is so unique that we have filed a patent application on it. In addition, we use 10 Ga. silver plated wire to reduce resistive losses to a minimum.

In order to handle higher power for amateur use, we used the more efficient direct coupling method of matching, rather than the lossy capacitor coupling. With this method the Wilson 1000 will handle 3000 watts of power.

The Best You Can Buy

So far you have read about why the Wilson 1000 performs better, but it is also one of the most rugged antennas you can buy. It is made from high impact thermoplastics with ultraviolet protection. The threaded body mount and coil threads are stainless steel; the whip is tapered 17-7 ph. stainless steel. All of these reasons are why it is the best CB antenna on the market today, and we guarantee to you that it will outperform any CB antenna (K40, Formula 1, you name it) or your money back!

*Inductively base loaded antennas
**Call for details.

Lockheed - California Company
A Division of Lockheed Corporation
Burbank, California 91520

Wilson Antenna Company Inc.
3 Sunset Way Unit A-10
Green Valley Commerce Center
Henderson, Nevada 89015

Subject: Comparative Gain Testing of Citizen's Band Antennas
Ref: Rye Canyon Antenna Lab File #670529

We have completed relative gain measurements of your model 1000 antenna using the K40 antenna as the reference. The test was conducted with the antennas mounted on a 16' ground plane with a separation of greater than 300' between the transmit and test antennas. The antennas were tuned by the standard VSWR method. The results of the test are tabulated below:

FREQUENCY (MHZ)	RELATIVE GAIN (dB)	RELATIVE POWER GAIN (%)
26.985	1.30	35
27.015	1.30	35
27.065	1.45	40
27.115	1.60	45
27.165	1.50	41
27.215	1.60	45
27.265	1.75	50
27.315	1.95	57
27.365	2.00	58
27.405	2.00	58

**58%
MORE
POWER GAIN
THAN THE
K40**

Individual test results may vary upon actual use.

CALL TODAY
TOLL FREE: 1-800-541-6116
FOR YOUR NEAREST DEALER

Wilson 1000

Roof Top Mount.....59⁹⁵ Little Wil.....29⁹⁵
Trunk Lip Mount.....69⁹⁵ Wilson 2000 Trucker .59⁹⁵
Magnetic Mount79⁹⁵ Wilson 5000 Trucker .79⁹⁵
500 Magnetic Mount .59⁹⁵ Call About Fiberglass!!!
Wilson 5000 BaseLoad — NOW AVAILABLE!

Wilson
ANTENNA INC.

A Division of Barjan Products, L.L.C.
East Moline, IL 61244

address (ur-review@provcomm.net) to contact me at. I will make it a policy to reply to all e-mails and regular mail as quickly as possible, and answer any question in plain English wherever I can.

What's Going To Be Accomplished?

The goal of the column will be to help everyone gain a better understanding of past, present, and future practices found in utility radio. This will be done through the sharing of information and experiences of our readers on the subject of utility radio. I hope that those who work in

utility radio equipment will write in to introduce and explain to the readers the technology they employ in their particular fields.

Not all of the information presented about utility radio will be in the column. There are many fine radio clubs devoted to the understanding of many different types of radio services, and these will be brought to the reader's attention. There is a great deal of information out in the Internet, and this will be summarized and brought forward as well. Other sources of information, such as mailing lists, news releases, and even the regular media, will also be used.

Readers, who have news, information,

stories, personal experiences, or whatever, are all welcome to share them. We need subject experts who can lend their knowledge, skill, and experience to benefit others. Pictures, diagrams, FAX outputs, and QSL cards are also welcome (though please contact me first if you want to send an original so that arrangements can be made to return those items to you safely).

What About Logging Reports?

Yes, we will continue to carry the log reports, but with some significant differences. Rather than try and log large numbers of contacts over the entire RF spectrum, the focus will change to more tactical loggings.

The emphasis in a log will not be what you caught, but how you caught it. More emphasis will be placed on equipment, antennas, and distance as part of the logged information. How you received a particular signal, and why it was significant or different from others, will also be of importance in your reports.

The most important thing that a reader should take away with them after looking over the logs that are printed here is an understanding of how they can hear these transmissions themselves. We also want our readers to understand that you do not have to use the most expensive equipment, and the tallest antenna, to enjoy listening to utility radio stations.

Radio is the most democratic of all the media, and even with a \$50 dollar short-wave set and a wire strung around your room, you should be able to hear some good stations. I want to be able to post loggings from people who have never felt that they could contribute before because they didn't feel that they were good enough. Now I'm telling you that they are, so send them in. I can't guarantee that all will be listed, but I will tell you here that every log sent to me will be read and considered equally.

Where In The Spectrum Are We Looking?

The utility station activity that is going to be featured in this column takes place in the Low Frequency (LF) and High Frequency (HF) sections of the radio spectrum. For our purposes, this will be defined as being between 30 kHz to 30 MHz.

The primary locations of utility radio services will also be defined by the regional allocations made by the

When seconds count,
REACT
needs you....



...to summon for help for an injured motorist, an elderly woman trapped in a fire, a trucker stranded in a blizzard, a drowning child!



As a REACT volunteer radio monitor, you may be the only communication life-line for someone in serious trouble. You relay messages from those desperate for help to police, fire, or emergency services.



Your REACT team may also use CB, GMRS, Amateur, and other radio services to provide safety communications for events like parades, marathons, and even balloon races. The fellowship with other REACT members at team meetings and annual conventions is an added bonus, as is help with licensing, equipment advice, and radio training.

"The mission of REACT International is to provide public safety communications to individuals, organizations, and government agencies to save lives, prevent injuries, and give assistance wherever and whenever needed. We will strive to establish a monitoring network of trained volunteer citizen-based communicators using any and all available means to deliver the message."

Add a new, exciting challenge to your life.

Volunteer. Help save lives and property,

JOIN TODAY!

REACT INTERNATIONAL, INC.

Phone (301) 316-2900

Fax (301) 316-2903

Web: www.reactintl.org

5210 Auth Road, Suite 403

Suitland, MD 20746

• PROUD RECIPIENT OF THE PRESIDENT'S VOLUNTEER ACTION AWARD •

RADIO EMERGENCY ASSOCIATED COMMUNICATIONS TEAM



CIRCLE 71 ON READER SERVICE CARD

Utility Radio Frequency Allocation in the United States of America

LF (Low Frequency)			
59.95 to 30	Fixed and Maritime Mobile (Government)	7.300 to 8.195	Fixed and Maritime
60.05 to 59.05	Standard Frequency and Time signal (WWVB)	8.195 to 8.815	Maritime (Digital Modes)
70 to 60.05	Fixed, Maritime Mobile (Government)	8.815 to 9.040	Aeronautical
90 to 70	Fixed, Maritime Mobile (Government), Radio Navigation	9.040 to 9.500	Fixed
		9.900 to 9.995	Fixed
		9.995 to 10.005	Standard Frequency and Time Signals
110 to 90	Radio Navigation (LORAN C)	10.005 to 10.100	Aeronautical
130 to 110	Fixed, Maritime Mobile, Radio Navigation	10.150 to 11.175	Fixed
160 to 130	Maritime Mobile	11.175 to 11.400	Aeronautical
160 to 190	Fixed	11.400 to 11.650	Fixed
200 to 190	Aeronautical Navigation	12.050 to 12.230	Fixed
275 to 200	Radio Navigation, Aeronautical Mobile	12.230 to 13.200	Maritime Mobile
285 to 275	Aeronautical/Maritime Navigation	13.200 to 13.360	Aeronautical
285 to 300	Radio Navigation (aero/maritime)	13.360 to 13.410	Radio Astronomy
300 to 325	Radio Navigation (aero/maritime)	13.410 to 13.360	Fix and Mobile
325 to 335	Aeronautical Mobile	13.800 to 14.000	Fixed
335 to 285	Aeronautical/Maritime Navigation	14.350 to 14.990	Fixed
405 to 335	Aeronautical/Maritime Navigation	14.990 to 15.010	Standard Frequency and Time Signal
415 to 405	Radio Navigation, Aeronautical Mobile	15.600 to 16.360	Fixed
435 to 415	Aeronautical Navigation, Maritime Mobile	16.360 to 17.410	Maritime
495 to 435	Maritime Mobile	17.410 to 17.550	Fixed
505 to 495	500 kHz Maritime distress freq. and guard freq.	17.900 to 18.030	Aeronautical
510 to 505	Maritime Mobile	18.030 to 18.068	Fixed
525 to 510	Aeronautical Navigation, Maritime Mobile	18.780 to 18.900	Maritime
535 to 525	Aeronautical Navigation, Mobile	18.900 to 19.680	Fixed
		19.680 to 19.800	Maritime
		19.800 to 19.990	Fixed
		19.995 to 20.010	Standard Frequency and Time Signal
		20.010 to 21.000	Fixed
		21.850 to 21.924	Fixed
		21.924 to 22.000	Aeronautical
		22.000 to 22.855	Maritime
		22.855 to 23.000	Fixed
		23.000 to 23.200	Fixed and Mobile
		23.200 to 23.350	Aeronautical Mobile
		23.350 to 24.890	Fixed
		24.990 to 25.010	Standard Frequency and Time Signal
		25.010 to 25.070	Land Mobile
		25.070 to 25.210	Maritime
		25.210 to 25.330	Fixed and Maritime
		25.330 to 25.550	Fixed and Maritime
		25.550 to 25.670	Radio Astronomy
		26.100 to 26.175	Maritime Mobile
		26.175 to 26.480	Land Mobile
		26.480 to 26.950	Land Mobile
		26.950 to 26.960	Fixed
		26.960 to 27.230	Mobile
		27.230 to 27.410	Mobile
		27.410 to 27.540	Land Mobile
		27.540 to 28.000	Fixed and Maritime Mobile
HF (High Frequency)			
1.605 to 1.615	Mobile		
1.615 to 1.625	Radiolocation		
1.625 to 1.705	Radiolocation		
1.705 to 1.800	Fixed, Mobile, Radiolocation		
1.900 to 2.000	Radiolocation		
2.000 to 2.065	Mobile, Fixed, Maritime		
2.065 to 2.107	Maritime Mobile		
2.107 to 2.170	Mobile		
2.170 to 2.194	Maritime Mobile		
2.194 to 2.498	Fixed, and Maritime		
2.498 to 2.505	Standard Frequency and Time Signals		
2.505 to 2.850	Fixed and Maritime		
2.850 to 3.155	Aeronautical		
3.155 to 3.230	Fixed and Mobile		
3.230 to 3.400	Fixed, Mobile, Radiolocation		
3.400 to 3.500	Aeronautical Mobile		
4.000 to 4.063	Fixed and Maritime		
4.063 to 4.438	Maritime Mobile		
4.438 to 4.650	Fixed		
4.650 to 4.750	Aeronautical		
4.998 to 5.005	Standard Frequency and Time Signals		
5.005 to 5.060	Fixed		
5.060 to 5.45	Fixed and Mobile		
5.450 to 5.730	Aeronautical		
5.730 to 5.950	Fixed		
6.200 to 6.525	Maritime		
6.525 to 6.765	Aeronautical		
6.765 to 7.000	Fixed		

Source: U.S. Department of Commerce, NTIA
Office of Spectrum Management
March 1996

International Telecommunications Union (ITU) and the national allocations made by government licensing bodies such as the FCC in the United States.

As there are three international regions for frequency allocation, as defined by the ITU, there are variations in what one will find when one tries listening to some DX. Given that we are moving into an excel-

lent period in the current sunspot cycle for hearing distant stations, more target frequencies for European, Russian, and Asian (to name only a few) activities will be provided in the column.

The column is going to be looking at the activity of different groups of frequencies more closely in order to map out what will be found there. Over the next

year, I'm going to be starting at the bottom, so to speak, and work my way up. Starting with a survey of the low frequency utility services, each month a new block will be examined. Loggings in these targeted areas will also be encouraged, so keep an eye out for the schedule to be posted in the next column.

In the meantime, I'm listing the

"official" frequency list for ITU region 2 that I use when I go looking for utility stations to log. There are, of course, other frequencies that are unique to ITU regions 1 and 3 (such as the aeronautical service between 3.8 to 3.9 MHz in the 80-meter HAM band), and these will be noted in the column if there is activity worth targeting on them.

What Are We Going To Listen For?

The two main features of a signal that will distinguish it is the *mode* it is transmitted in and the *service* it provides. Unlike broadcasters, who come in only a few modes of transmission, utility radio uses a wide range of modes to carry many different types of data.

Along with the standard voice modes (AM, SSB, and FM), you can find a wide range of digital modes — though CW has all but disappeared for carrying information "traffic." Still, there are many modes of text and imaging transmissions that can be received. Radioteletype (RTTY) and FAX transmissions are very common, and easy to receive if you have the proper equipment.

Given the availability of inexpensive new and used personal computers, a renaissance is taking place in the monitoring of RTTY and FAX. No longer do you have to own complicated electronic decoders or large mechanical printers in order to view these transmissions. Today, all you need is either a serial port decoder, or a compatible sound card — along with the proper software — and you see the "public" messages being sent.

As mentioned before, our utility column will be providing information, in plain English, on ways to demodulate these signals. It is surprisingly simple to make the necessary cables and install the software now available. This will also include more

information on monitoring Automatic Link Establishment (ALE) signals using newly-developed computer software.

The column will continue to provide you with news and information on all of your favorite services, including those used by the military, Coast Guard, and aviation industry. There may be a few that are less utilized, but are still active residents of the spectrum to be monitored.

Here we need your suggestions for new topics to be covered that you feel need more exposure. For example, electrical power utilities transmit signals along their high-power transmission lines — would more information on this topic be of interest to you, the reader? Are there other services that have been of personal interest to you but you have not seen information about them? With your input to the column, these services could be covered here.

New Technology

One of the great developments that has taken place in the last year has been the recent availability of software demodulators on the Internet. These allow Windows™ and DOS-based computers to display many of the digital modes that were previously difficult and expensive to monitor. Today, all you need is a compatible computer sound card and an inexpensive 486/Pentium-based computer in order to monitor CW, RTTY, and FAX signals.

We will follow these developments in this column, and assist you in setting up an inexpensive, but efficient, digital monitoring station. However, as we stated earlier, we will not promote any software or hardware device that will compromise any privileged transmissions that are done in these modes. In saying that, there are many news, weather, and information stations that can, and should, be monitored using these new technologies.

Many other types of hardware and software will also be reviewed in this column. This will also include CD-based databases of frequency listings, logging software, DSP software that can be used by your computer sound cards, and other conventional toys of the hobby. New antennas, receivers, pre-amps, demodulator cards, or anything else that radio stores can sell us will be looked at — if they are really helpful in receiving utility stations.

Your experiences with your station, and its equipment, is again welcome information if you wish to share it with the readership. What works for you, when you try and dig out that weak signal? Is there a particular antenna configuration that you have found to work miracles cutting through the QRM, or is the answer to be found in DSP? Your contributions would be extremely helpful for other readers when they try and configure their monitoring stations.

Closing Comments

Next month, the column will talk about what is happening in the utility radio industry and on the radio waves — and nothing else. I thank you for your patience this month as I roll out the blue print for this column and share it with you. After all, you are a stake holder in the success of this undertaking, and I feel that it is only fair to include you, the reader, in the plans that I have for achieving that goal.

From here on in, we must now work together as partners in order to gather and share information about topics that we both like. Radio monitoring has been part of my life since I was 10 years old, and it has brought me hours of satisfaction. If this column can help someone else discover that enjoyment, my efforts will be on the right track. If people can hear more stations that are exciting to listen to on a regular basis through reading this column, then we are moving towards success. If a significant numbers of readers turn to these pages each month in anticipation, and come away from their reading with a sense of having learned something new, then it will be a success.

Please join with me in being part of this success story by becoming a regular contributor of logs, ideas, stories, and suggestions. Use whatever means is comfortable for you to write, and send your correspondence to either *Pop'Comm* or my E-mail address. If you are really curious, drop by my web page at: <http://www.provcomm.net/pages/joe/> where you can see the columns' schedule for the next year. ■

The book you've been waiting for...

CQ Amateur Radio Equipment Buyer's Guide

The CQ Amateur Radio Equipment Buyer's Guide lists practically every piece of Amateur Radio equipment currently offered for sale in the U.S., complete with specs and prices. It's all here — from top-of-the-line HF transceivers to the smallest accessories. The CQ Amateur Radio Equipment Buyer's Guide also includes the most comprehensive directory anywhere of Ham product manufacturers and dealers in the U.S., with phone numbers, FAX numbers, Web sites, and e-mail addresses.

Only \$15.95
Plus \$4.00 Shipping & Handling

ORDER YOURS TODAY!

For Fastest Service call 1-800-853-9797
FAX 516-681-2926

CQ Communications, Inc. 25 Newbridge Rd, Hicksville, NY 11801



Master Card VISA DISCOVER AMERICAN EXPRESS

broadcast dxing

DX, News And Views Of AM And FM Broadcasting

Radio Target: Hawaii

Unless you live on the U.S. Pacific coast, Hawaii is probably a dream catch on the AM broadcast band. KPUA Hilo on 670 and KAIM Honolulu on 870 are the islands' only full-time 50 kilowatt (kW) AM stations, but they both run with directional antenna patterns aimed away from mainland North America. However, your dream catcher may soon have another opportunity as KUAU Haiku on 1570 has applied for 50 kW daytime, 25 kW nights, non-directional. Hawaii does have a number of full-time non-directional 10 kW stations; KIPA Hilo on 620, KHNR Honolulu on 650, KQMQ Honolulu on 690, KGU Honolulu on 760, KHVH Honolulu on 830, KJPN Waipahu in Japanese on 940, and KUMU Honolulu on 1500 kHz. Give these a shot, and as one might say in Hawaii, "Hoo-manawa-nui," be patient, a necessary virtue for DXing any dream catches.

Station Swaps

The Sunshine State seems to want to be the leader when it comes to call letter swaps. It was just recently in the Tampa Bay area where WHNZ moved from 570 to 1250, and WDAE moved from 1250 to 620, formerly WSUN and WSAA. 570 became WTNB. Now WDAE is back on 1250, and WHNZ has moved to 620. In this month's call letter actions, you'll also find swaps between WBZT and WJNO, and WPCF moving from AM to FM, all in Florida. In addition, KAZW College Station, Texas, has changed to KZNE in preparation for start-up of their new x-band (expanded AM broadcast band) station on 1620; WSQV Berwick, Pennsylvania, is returning to the airwaves as WFBS simulcasting contemporary Christian WAAT "The Way" 750; and expect the former home of CBL Toronto on 740 to become radio active again. The speculation is that a foreign language broadcaster will fill the void on 740, perhaps bringing Indian film music to listeners out of range of CHIN on 1540 kHz.

In other x-band news, Gary Jackson

talked to the head of Freedom Communications regarding the status of KSXX Roseville, California, on 1690 kHz. They expect the new station to be on the air shortly if not already. Gary also reports that KNAX Clovis, California, has been testing on 1630 kHz.

QSL Information

Welcome to Michael Procop who joins our regular QSL reporters and writes, "I've been DXing since spring of 1999 and have never reported anything to *Popular Communications*. Lately, I have started to collect QSLs and a couple of stations have replied. After receiving their replies, I sent them postcards thanking them. I also told them that they could look forward to seeing their stations in an upcoming issue of *Popular Communications* in the 'Broadcast DXing' section."

Regarding the recent report that WCBS New York on 880 no longer QSLs, the policy is apparently the result of cost-cutting measures.

The all-news station has been continuing to down-

size their operations. Case-in-point, WCBS has just replaced three of their meteorologists with the forecasting services of The Weather Channel. Keep in mind that broadcasters are not required by law to respond to reception reports. If you receive a QSL, please remember to send a card or letter thanking the station for responding.

560 KBLU Yuma, Arizona, received letter and stickers in 13 days after follow-up from Wendy Adams-Kelley, Public Service Director. Address: 755 West 28th Street, Yuma, AZ 85364 (Martin, CA)

1130 CKWX Vancouver, British Columbia, full data QSL card mailed in envelope in 20 days for report and U.S. \$1 (returned), signed by CE. Address: 2440 Ash St., Vancouver, BC V5Z 4J6. (Griffith, CO)

1150 WIMA Lima, Ohio, received a QSL card and verification letter in nine days after E-mail for report on DX test, signed by Mark D. Gierhart, CE. The E-mail was a form made special for the DX test. Address: 667 West Market Street, Lima, OH 45801. (Procop, OH)

1180 WJNT Jackson, Mississippi, received bumper sticker and verification



BY BRUCE CONTI <BAConti@aol.com>

Pending

New Call	Location	Freq.	Old Call
KQRI	Lubbock, TX	90.9	KYFT
KXRI	Amarillo, TX	91.9	KYFA

Changes

New Call	Location	Freq.	Old Call
KESP	Modesto, CA	970	KANM
KMZT	San Rafael, CA	1510	KJQI
WBZT	Boynton Beach, FL	1040	WJNO
WJNO	West Palm Beach, FL	1290	WBZT
WHNZ	St. Petersburg, FL	620	WDAE
WDAE	Tampa, FL	1250	WHNZ
WPCF	Panama City Beach, FL	1290	WDLP
WKWH	Shelbyville, IN	1520	WOOO
WSJX	Terre Haute, IN	1300	WJSH
KCNB	Holdenville, OK	1370	KTLS
KREF	Norman, OK	1400	KNOR
WFBS	Berwick, PA	1280	WSQV
WLFJ	Greenville, SC	660	WESC
KZNE	College Station, TX	1620	KAZW
KHOM	Salem, AR	100.9	KSAR

New Call	Location	Freq.	Old Call
KMYX-FM	Arvin, CA	92.5	KBDS
KBDS	Taft, CA	103.9	KMYX-FM
WKNL	New London, CT	100.9	WTYD
WQJM	Panama City Beach, FL	100.1	WPCF-FM
KBSK	McCall, ID	89.9	KBPH
KBSQ	McCall, ID	90.7	New
WHCI	Hartford City, IN	88.1	New
WTCJ-FM	Tell City, IN	105.7	New
WLRS	Shepherdsville, KY	105.1	WLXO
KRKA	Erath, LA	107.9	KRXZ
KSAR	Thayer, MO	92.3	New
WSHK	Kittery, ME	105.3	WXBB
WSAK	Hampton, NH	102.1	WXBP
WGBZ	Cape May, NJ	102.3	WJSX
KBSJ	Jackpot, NV	91.3	New
WKSX-FM	Leland, NC	94.1	WAAV-FM
WOGH	Steubenville, OH	103.5	WRKY
KCNR	Coalgate, OK	105.5	KBNB
KSSM	Copperas Cove, TX	103.1	KOOV
KACE	Richfield, UT	97.5	KRFD
WFDT	Aguada, PR	105.5	WNNV
WNNV	San German, PR	91.7	WZGX
WPUC-FM	Ponce, PR	88.9	WEUC-FM

letter in four days after E-mail, signed by Stan Carter. CE. E-mail address: <email@WJNT.com>. (Procop, OH)

1430 KLO Ogden, Utah, received a very nice QSL letter on "Unforgettable KLO" stationary in 285 days for a report and \$1. Letter mentions that the station was 5 kW when I heard them but has since changed to 10 kW directional with a new transmitter site at Layton, Utah. It also states that the station is the second oldest in Utah signing on in 1924, and that morning show announcer Len Allen has worked for the station for 53 years! Signed Arlene Harris, Office Manager. Address: 4155 Harrison Blvd., Suite 206, Ogden, UT 84403. (Griffith, CO)

1470 XERCN Tijuana, Mexico, received verie letter in Spanish in 76 days from Sergio Golarte Quiros — Gerente de Promociones, along with stickers. Address: Gral. Manuel Marquez de Leon No. 950. Zona Rio. Tijuana B.C.N., Mexico. (Martin, OR)

1550 KUAT Tucson, Arizona, received QSL letter in 16 days from Lyle E. Kesterson — Radio Program Manager. Address: University of Arizona, Tucson, AZ 85721 (no street address or box number given). (Martin, CA)

Broadcast Loggings

This month's selected logs begin with an interesting report from Ron Gitschier, USN, shipboard on the Pacific Ocean off the coast of Central America. Among others, Ron heard Radio Marti, Marathon Key, Florida on 1180 kHz with a very good signal and clear audio. Ron listens on a Radio Shack DX-398 with the built-in ferrite antenna. "Sigh, this was my only pre-sunset USA station heard in a sea awash with Spanish," laments Ron on that particular day, "homesick and at sea (in perpetuity)." All times are UTC.

540 YNOW Radio Corporacion, Managua, Nicaragua, daytime saltwater path signal fair to strong. (Gitschier, 09N 90W)

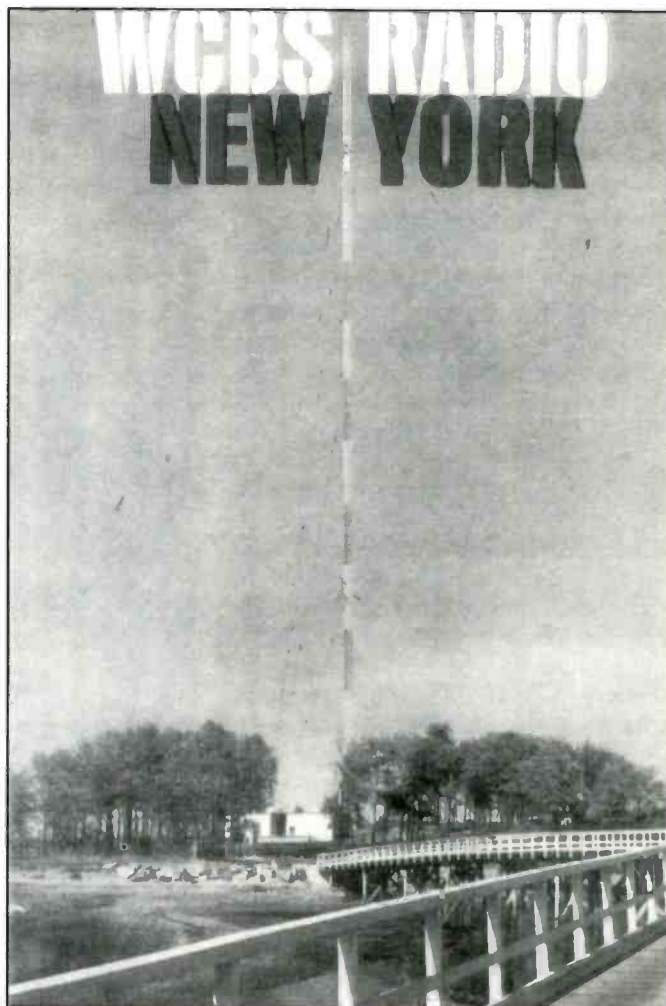

Vintage QSL card from WCBS, New York, on 880 kHz.

580 WTAG Worcester, Massachusetts, fair signal, "News-Talk 5-80" promotion and advertisements. (Procop, OH)

640 RFO Pointe-a-Pitre, Guadeloupe fair at 0450, man and woman in French parallel RFO Allouis, France on 162 kHz, over R. Progreso-Cuba. (Conti, NH)

650 CINT Saskatoon, Saskatchewan, presumed heard at 2201 (calls not heard), overnite forecast for minus 12 degrees and promo for Saskatchewan Indian Game Authority, slogans "NTR" and "News Talk Radio 6-50," under an unID Spanish station and in the null of WSM. (Griffith, CO)

720 RJR Kingston, Jamaica, fair at 0440, "Marketplace . . . on RJR 94 FM" and reggae music parallel 700, over WGN. (Conti, NH)

730 XEX Mexico City, Mexico, good and dominant signal, talk in Spanish, ID, and "equis buena" slogan at 0855-0901. (Procop, OH)

738 RNE1 Barcelona, Spain, at 0605 news in Spanish by a man and woman, fair sliding by CHCM and momentarily-blank WJIB carrier, and at 2358 parallel 855 kHz with Spanish political talk, to good peak over CHCM slop. (Connelly, MA)

756 DeutschlandRadio, Braunschweig/Ravensburg, Germany at 2356 man in German, then a version of "Spanish Harlem" that wasn't the original 1961 Ben E. King one, to good peak. Bits of 1422 kHz parallel noted, but 756 was much better. (Connelly, MA)

770 WVNN Athens, Alabama, fair signal, traffic, weather, and "Huntsville 770" slogan at 2259. (Procop, OH)

770 YVKK Valencia, Venezuela, fair under/over WABC, talk in Spanish, and "R-C-R" ID at 0734. (Procop, OH)

846 RAI Rome, Italy, at 0420 with Italian vocals parallel 6060 SW, poor in heavy interference from WEEL/WRMR on 850. (Conti, NH)

860 KKOW Pittsburg, Kansas, fair signal, news, and ID followed by high school basketball at 2338. (Procop, OH)

1035 R.Nacional, Lisboa, Portugal, at 2332 light Portuguese pops, poor in WBZ slop. (Connelly, MA)

1053 Talk Radio synchros, United Kingdom, at 2326 teletalk in English parallel 1089 kHz, slightly over Spain and a pile-up of others. (Connelly, MA) Has since changed format to sports talk.

1080 KGVY Green Valley, Arizona, fair on top of KRLD with nostalgia, announcer (sounded like local assist or locally done) with ID at 0100, "You are

tuned to KGVY Green Valley." Don't know if they went into news, but maybe — by then lots of KRLD interference. (Martin, CA)

1090 KKYN Plainview, Texas, heard well with XEPRS phased out, logged with ABC News and two local spots at 0101-0108, running 250 watts with a null in this direction at night. (Martin, CA)

1330 WZCT Scottsboro, Alabama, good signal with deep fades, gospel music and ID at top of the hour at 0600, only 38 watts! (Procop, OH)

1410 WLTV Mobile, Alabama, fair signal, Christian Connection promotion, and gospel music at 1035. (Procop, OH)

1450 KFIZ Fond Du Lac, Wisconsin, popped up with "News-Talk 14-50" ID at 1212. (Procop, OH)

1470 WRGA Rome, Georgia, fair signal, "the news station" slogan and ID at 1045. (Procop, OH)

1530 WSAI Cincinnati, Ohio, at 0004

(about 20 minutes prior to local sunset) "It's 62 degrees . . . I'm Jenny McCarthy, WSAI News" into "An Evening at the Pops" while looking for Voice of America-Belize. (Gitschier, 08N 93W)

1630 KNAX Clovis, California, testing carrier at 1100, strong with S-meter reading 45+. (Jackson, CA)

1660 KXOL Brigham City, Utah, heard airing one of their "We dominate the West at night" IDs during which they stated that they answer all E-mails. The address given was <KXOL@broadcast.net>. (Griffith, CO)

1690 WMDM Lexington Park, Maryland, at 0400 "Bay Talk;" heard with a RadioShack DX-390 receiver on the 15th floor of a glass-dominated apartment building. (Prather, MI)

Thanks to Mark Connelly, Ron Gitschier, Patrick Griffith, Gary Jackson, Patrick Martin, James Prather, and Michael Procop. 73 and good DX! ■

YOU AIN'T HEARD NOthin' BUT THE BEST

Since 1967, CRB Research has been the world's leading publisher and supplier of unique hobby and professional books and information including:

- Scanner Frequency Guides
- Shortwave Freq. Guides
- Military/Federal Comm.
- Broadcast Station Registries
- Undercover Communications
- & Other Related Topics!

New titles are constantly being added to our exciting catalog. If it's interesting and unusual, we've got it.

YOU'LL SEE.

CRB RESEARCH
P.O. Box 56, Commack, NY 11725
Ph: (631) 543-9169 FAX: (631) 543-7486
e-mail: sales@crbbooks.com
www.crbbooks.com

CIRCLE 11 ON READER SERVICE CARD

WOW!

Have you read Scanning USA, the ONLY scanning magazine? Get more out of your scanner with exclusive columns such as:

SCANNING USA

- Aviation
- Trunking
- Federal/Military
- Internet And Radio
- Railroad
- Product Reviews
- Beginners Corner
- And Much More!

Subscribe today!

VISA Call 1-800-651-0922

Sample \$3.00 8 Issues \$16.95
16 Issues \$33.95 26 Issues \$49.95

Scanning USA: 2054 Hawthorne Joliet IL 60435
Http://home.att.net/~scanningusa
Scanusa@compuserve.com FAX 815-722-0717

CIRCLE 72 ON READER SERVICE CARD

Rave Review Pop Comm April '96

SEE US ON THE WEB! www.vikingint.com

Professional 10 HOUR RECORDER

"BUILT LIKE A BATTLESHIP"

- Heavy duty commercial recorder - NOT improvised from consumer models
- 12, 14, and 16 hour models also available
- BUILT-IN voice activation (add \$30)
- Applications information included
- Dimensions: 11.5 x 7.0 x 2.75"

SPECIAL Pop Comm Price.. \$159

FREE SPECIAL EQUIP. CATALOG!

COO's OK. Calif. residents add tax. Sorry, no credit cards. Free catalog USA only, other countries \$5. Free Shipping to 48 Contiguous States on Prepaid Orders.

Viking Systems International 100 North Hill Drive #42, Brisbane, CA 94005
Factory Direct Phone: (415) 467-1220 • Fax: (415) 467-1221 "Since 1971"

CIRCLE 73 ON READER SERVICE CARD

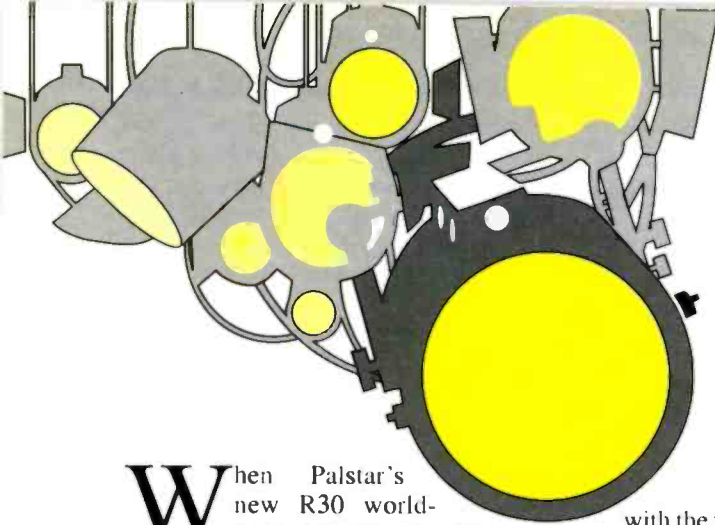

product spotlight

BY PETER BERTINI

POP'COMM REVIEWS PRODUCTS OF INTEREST

Palstar's R30 Shortwave Receiver

When Palstar's new R30 world-band shortwave receiver rocked the Dayton Hamfest last year, we knew it would be a winner! Our expectations have been met. The R30 firmly bridges the gap between low-cost entry grade sets, and the higher-end radios aimed at those with unlimited budgets.

Covering from 100 kHz to 30 MHz, the R30 features AM and both upper and lower sideband modes. Included is a true analog S-meter, and a large 6-digit back-light LCD display. Most of the controls perform dual functions, thus the front panel is surprisingly uncluttered. For the most part, basic operation is intuitive. The majority of the controls are momentary push-button style, some of which are used for dual functions when in the memory mode. Only two rotational, or linear, controls are present: these are for tuning and adjusting the volume level.

The radio powers up to the last monitored frequency. Variable-rate tuning detects when the operator is increasing the tuning speed, and the set automatically goes into a higher tuning rate to accommodate rapid frequency excursions. Depressing the tuning knob momentarily toggles the set between two tuning speeds: 20 Hz per step or 100 Hz per step. With 20 Hz steps selected, the fastest tuning speed is 100 Hz per step;

with the faster 100 Hz tuning step rate selected, the fastest tuning speed increases to 500 Hz per tuning step. Small push buttons allow you to do 1-MHz up or down steps; holding either MHz button automatically repeats the operation. If the tuning knob is depressed for more than two seconds, the frequency is locked and cannot be changed by any of the controls. The locked condition is maintained when power is removed, and the locked frequency is not lost. The radio is unlocked by depressing the tuning button for an additional two seconds. While locked, the digital display shows "LOCDIS."

Memory Functions

Unless you notice the memory (MEM) push button, you might be surprised to learn that the R30 can store up to 100 frequencies, along with all associated parameters for mode, bandwidth, AGC, and attenuation! Out of the box, the radio is in the normal mode — that is all tuning functions are controlled by the tuning knob and up/down buttons. The memory is enabled by pressing the MEM button. While in memory mode, the digital display can either show the Channel Number or frequency stored in that channel by depressing the tuning knob. Blank chan-

nels are not displayed. Memory channels are selected by turning the tuning knob or pressing the up/down push buttons. They serve the same purpose when selecting a channel position that is to be written to. To write to a memory, the radio must be in the memory store mode. This is done by depressing the MEM push button for two seconds. In the memory store mode, all channels are displayed whether programmed or not. A flashing "P" after the channel number indicates that data is being stored in that particular memory channel. When the channel to be programmed is selected, depressing the MEM button stores the information and returns the radio to its normal mode. It sounds more complicated than it really is: the R30 memory functions are very user-friendly, and once performed, it is unlikely you will have to reference the owner's manual again.

The two AGC ranges (Fast or Slow) can be selected regardless of the mode in use. An LED indicator shows when the Fast AGC is selected. The mode switch toggles between AM, LSB, and USB; the current mode is indicated by LED panel indicators. The two-bandwidth positions are normally determined by the mode selection. The AM filter is 6 kHz for North America (in European-exported sets the AM filter is 4 kHz.) A narrow bandwidth 2.5 kHz filter is normally used for SSB or CW, but either bandwidth is user selectable for either mode. The R30 is normally equipped with decent quality Murata ceramic filters. However, for a modest charge, either or both filters can be replaced with Rockwell International (former Collins Radio) mechanical filters at time of order. The filters are factory installed since soldering is required. For many, Collins mechanical filters are synonymous with high quality commercial and military radios. The mechanical filters offer much better stop-band attenuation; and a mechanical filter's shape factor — which determines how much the



The Palstar R30 receiver. The panel is uncluttered and all controls are convenient and easy-to-use. Note the nice large analog S-meter.

Table 1: 7-Pole Input Filter Ranges

100 kHz–1.0 MHz

1.0 MHz–2.0 MHz

2.0 MHz–4.0 MHz

4.0 MHz–8.0 MHz

8.0 MHz–16 MHz

Range 6: 16 MHz–30 MHz

filter bandwidth deteriorates under stronger signals — is also much better than the lower-cost ceramic filters.

The Audio

The R30 audio is rated for a hefty 3-watts into an 8-ohm speaker with less than 1% distortion. The R30's "full sounding" fidelity was a pleasant surprise. Unless you really need the extra skirt selectivity offered by the AM mechanical filter, the stock AM ceramic filter is best for full-fidelity AM BCB and SW monitoring. In my opinion, the best compromise is having the R30 equipped with the mechanical filter for SSB or narrow AM reception work (including exalted carrier), and the ceramic filter for AM reception. CW can be received by using either SSB mode with the narrow filter. The frequency dis-

play will be offset by the amount of the sidetone (several hundred cycles) when receiving CW signals.

Headphones can be connected to a jack on the front panel, and a rear-panel jack accommodates an external speaker. Other rear panel connections include an RCA jack for muting the R30 when it is used in conjunction with a transmitter. If you have a need for line-level audio for recording or other uses, a second RCA jack provides it. The tilt-bail is standard and allows easy viewing when the R30 is placed on a low table or nightstand.

Antenna Connections

There are two antenna connectors on the rear panel: the standard SO239 is used for Low Z coaxial-fed antennas; while high-impedance dipoles or wire-fed antennas are accommodated by two push-clip terminals. Higher Z antennas need a matching balun and that is included inside the set. Since SWLs are often limited to using active antennas due to space or other limitations, the R30 can also power active antennas connected to the SO239; a self-resetting fuse in the set protects this feature. Palstar's optional active antenna matcher, the AA30, permits the R30 to be used with a wire or whip antenna; while also offering tunable front-end selectivity and variable gain. We did not have an opportunity to review the AA30, but it lists for \$59 and can be seen on Palstar's Web pages.

Table 2: IF Filter Specs

Murata CFR455H AM filter

BW at 6 dB 6 kHz

BW at 70 dB 15 kHz

Rockwell 526-8636-010 AM filter

BW at 6 dB 5.5 kHz

BW at 60 dB 11 kHz max

Murata CFJ455K5 SSB filter

BW at 6 dB 2.4 kHz

BW at 70 dB 4.5 kHz

Rockwell 526-8635-010 SSB filter

BW at 6 dB 2.5 kHz

BW at 60 dB 5.2 kHz max

The R30 comes with a wall-cube type power supply. For camping, portable, or emergency operation, the set can be powered from an external 12 Vdc source or an internal battery pack. Removing the top cover accesses the internal battery tray that holds 10 "AA" alkaline batteries. Alkaline cells can power the set for three or four weeks of casual monitoring with headphones. AA NiMH cells will last for months, but they will need an external means for recharging. When operating on battery power, the display and meter lamps should be turned off by the rear panel switch to conserve battery power.

American Made

I was surprised to learn that while the R30 is both American made and engineered, it is more popular in Europe than in the States! In fact, our review set was delayed for several months while improvements suggested by European evaluators were being incorporated. European SW listeners face conditions that are far more demanding than in most of North America because of the proliferation of high-power SW transmitters throughout Europe.

What makes the R30 a standout performer? First, the set includes a bank of six preselection filters — see Table 1. These make the radio virtually immune to second order IMD products. For example, without the filters, any two frequencies, say a strong BCB at 1 MHz and a SW transmitter at 7 MHz, could overload the set and mix together producing phantom signals at 8 and 6 MHz. For extreme cases, 10 dB of attenuation can be switched in to further reduce or eliminate interference artifacts. Palstar claims a +12-dBm third order intercept point for the R30.

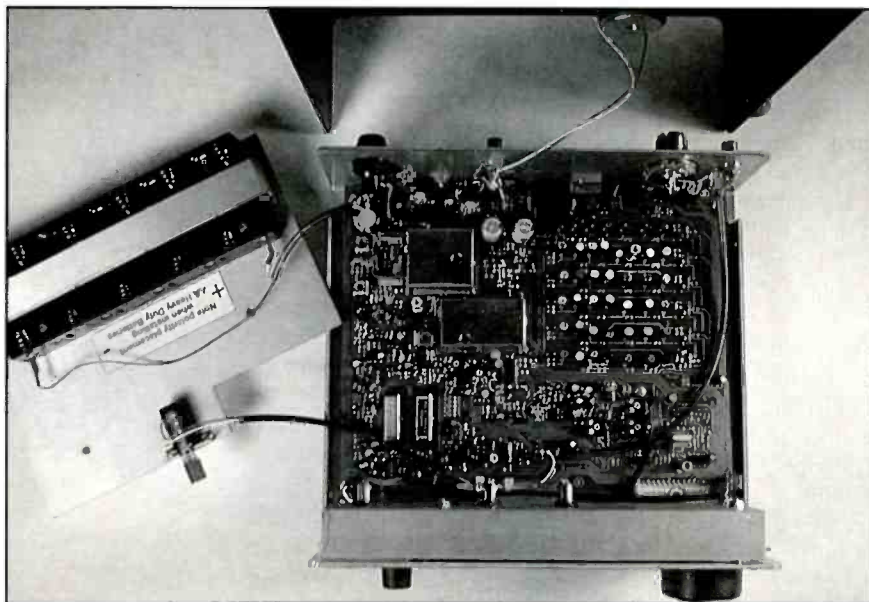

Interior view of the R30. At the left is the metal shelf for the battery holders. The main circuit board contains the RF and audio circuitry. The microprocessor and digital circuits are on a second PC board mounted parallel to the front panel.

Excellent! This is achieved by using custom high-current 1.5-dB NF J-FET devices in the critical first mixer stage. The active mixer is followed by two cascaded 45-MHz first IF monolithic crystal filters for four-pole filter performance. This places selectivity at the front of the receiver to protect subsequent mixer stages from strong off-channel signals.

The remaining mixers and IF amplifiers use low NF dual-gate MOSFETS; this means the R30 doesn't hiss like an errant steam engine while listening to a quiet channel. The majority of the analog RF and audio circuits are on one large PC board using a mix of surface mount and through-hole components. No schematic is included, and the surface-mount technology would most likely limit repairs to factory approved service centers.

Overall Impressions

The R30 rates an A+ for both ease of use and performance; the operation is intuitive and the controls are in the right positions. I liked the built-in tilt bail, the analog S-meter, and the backlighting on the meter and panel. I also like being able to upgrade the SSB or AM filters on an either-or basis. The Collins

filters are an additional \$50 per filter at time of ordering. The specs for the filters are shown in Table 2, but keep in mind our suggestion of using the standard ceramic filter for AM and the optional mechanical filter for SSB. Besides the optional filters, or the companion AA30 active preselector, there are no other options to worry about. The sturdy cabinet is all metal construction with a durable finish.

What is lacking? Well, there is no DSP processing, no variable IF bandwidth or passband tuning, and there is no notch filtering. Then again, this is a \$500 receiver, not one costing several hundred dollars or more. I've mentioned at the beginning that we feel the modestly priced R30 firmly bridges the void between low-cost entry sets and the high-end full-featured and costly SWL radios without compromising quality or performance. If you're a novice SWL or seasoned listener on a budget, the R30 definitely merits attention. The R30 is available factory direct or through distributors.

For more information on the R30, contact Palstar, Inc., 9676 North Looney Road, P.O. Box 1136, Piqua, Ohio 45356 or phone 937-773-6255, FAX 937 773-8003 or E-mail them at Palstar@erinet.com. You can also visit their Website at <http://www.palstarinc.com>. The R30 is in the \$499.99 price class. ■

Panasonic's 900 MHz Cordless Phone — KX-TC1800

BY HAROLD ORT

The phone's box says "Spread Spectrum Digital Gigarange" and the instructions say the unit operates in the frequency range of 905 to 926 MHz. So I checked the FCC's online database (at fcc.gov/oet/fccid/) using the phone's FCC ID number and found this particular phone operates from 905.22 to 925.55 MHz. Of course, the unit is running a sequential encryption code which chops up the transmission, and generally speaking, makes the conversations untunable.

My review of this new high-tech cordless phone was, frankly, prompted by a couple of letters we received. One, from a fellow on Long Island said, "... I decided to test it to be sure the phone lived up to its so-called technology, so I tuned in the 900-MHz portion ... called a friend and asked him to assist me in a test. ..." He continued, "To my surprise, I heard myself clear as day ..." He then suggested we tell folks considering purchasing a cordless phone to test it to "be sure it lives up to its claim."

Sounded like a good idea to me, so I contacted Panasonic and the phone arrived the following week for testing. Panasonic's news release dated May, 1999 says, "... we decided to extend the line to include 900-MHz 'GigaRange' Digital Spread Spectrum (SST) phones, which offer extended range and security over our standard 900 MHz analog phones." It continued, "... for added security, digital coding of the phones' transmissions help thwart potential eavesdropping."

After an overnight battery charge, I plugged the phone in and turned on both of my Opto near-field receivers — placed in the same room as the phone — made three phone calls, and heard nothing on *either* receiver. I tried a handheld scanner, searching through the spectrum and heard nothing. Once it stopped searching and I heard a short-duration fluttering, rumbling sound. Perhaps it was my phone, or possibly another nearby transmission. Either way, I repeated my test several times and heard nothing. Now that's not to say those folks with these phones didn't hear their phone on a scanner. It only means that on the phone I reviewed for many hours, I didn't. I would advise anyone buying any cordless phone to look at the bottom of the base unit for



Panasonic's KX-TC1800B cordless Gigarange phone.

the FCC ID number, go on-line and view the official paperwork filed with the FCC. It provides a multitude of information — including the all-important frequency information we talked about earlier.

Given the fact that this is the latest and greatest from Panasonic — and other companies with similar phones — and that seemingly everyone is looking for cordless phone security, I decided to check out this cordless phone, model KX-TC1800B even further.

Superb Range!

This was another product that I sure hated to return when the review period ended. Let's face it, it's a radio that happens to be a phone, so how can you resist a good cordless phone? This Panasonic cordless has all the features you'd expect on a cordless phone of this caliber; flash button that allows you to access special phone services such as call waiting and up to 10 phone numbers can be stored in the handset. Storing the numbers is simple: Press "program," enter a phone number, press "auto," and then a memory location (0 to 9). Dialing the stored number is easier; press "talk," "auto," and the memory number. Frankly, I really hate programming *anything*, but this was darned simple.

There's also a "direct" button where you can store one number that can be dialed at the touch of one button — you guessed it — the "direct" button. The handset's dialing buttons also light when any button is pressed or the handset is lifted from the base unit; it also flashes when a call is received. If you want, an optional headset connects to the handset.

Now, time for the big test. I called our "Radio Connection" columnist, Peter Bertini, while outside one afternoon. After a few minutes I asked him how the phone sounded. "Good — why?" he asked. After telling him it was one of those new Panasonic SST phones, I started walking down the street. And kept walking — and walking! Once, about 150 feet from the house (keep in mind the phone's base unit is on the second floor on the *back* of the house) the phone automatically changed frequencies; there was a momentary glitch and dropout and our conversation resumed. Near the end of the street, I'm forced to turn either turn around or walk up a hill onto someone's property in order to get to another street. I decided to turn around, but just as I did the signal dropped completely. Approximate distance: 450+ feet.

I don't know about you, but cordless convenience is great around the home, office, and out in the yard. But you just don't see lots of folks running around with cordless phones two blocks from their home!

If you're interested in a good, solid cordless phone with great range — and to the best of our knowledge a high degree of privacy, you owe it to yourself to check out the Panasonic KX-TC1800

that retails for \$99.95. There are other models that carry suggested retail prices up to \$239.95 with features like visual call waiting and Caller ID. Contact Panasonic's Customer Call Center at 800-211-7262 or visit their Website at www.panasonic.com for more information. As always, be sure to tell them you read about it in *Popular Communications*. We'd also like to hear about your cordless phone experiences. ■

CALL TOLL FREE
(800) 292-7711
Orders Only

Se Habla Español

C&S SALES

CALL, E-MAIL OR WRITE FOR OUR FREE

64 PAGE CATALOG (800) 445-3201

Digital Multimeters

<p>Elenco Model M-1740</p>  <p>\$39.95</p> <ul style="list-style-type: none"> • 11 Functions • Freq. to 20MHz • Cap. to 20µF • AC/DC Voltage • AC/DC Current • Diode Test • Transistor Test • Memory (1,134 safety codes) <p>Model M-1740 - \$24.95 (9 functions)</p>	<p>Elenco Model LCR-1810</p>  <p>\$99.95</p> <ul style="list-style-type: none"> • Capacitance 1µf to 20µF • Inductance 1µH to 20H • Resistance 0.1Ω to 2000Ω • Temperature 0°C to 700°C • DC Voltage 0 - 70V • Frequency up to 150kHz • Diode/LED Tester • Continuity Test • Logic Output Function • 3 1/2 Digit Display 	<p>Fluke 87III</p>  <p>\$319</p> <p>Features high performance AC/DC voltage and current measurement, frequency, duty cycle, resistance, conductance, and capacitance measurement</p>
--	---	--

Elenco Oscilloscopes

Free Dust Cover and x1, x2 Probes



2 year Warranty

S-1325	25MHz	Dual Trace	\$325
S-1330	25MHz	Delayed Sweep	\$439
S-1340	40MHz	Dual Trace	\$475
S-1345	40MHz	Delayed Sweep	\$569
S-1360	60MHz	Delayed Sweep	\$749
S-1390	100MHz	Delayed Sweep	\$995

Generators and Counters

<p>Elenco Sweep Function Generator with Built-in 60MHz Frequency Counter Model GF-8046</p>  <p>\$229</p> <p>This sweep function generator with counter is an instrument capable of generating square, triangle, and sine waveforms, and TTL, CMOS pulse over a frequency range from 0.2Hz to 30MHz.</p>	<p>Elenco Handheld Universal Counter 1MHz - 2.8GHz Model F-2800</p>  <p>\$99</p> <p>Features 10 digit display, 16 segment and RF signal strength bargraph. Includes antenna, McCad battery, and AC adapter. Resolution to 10Hz.</p>	<p>B&K Frequency Counter Model BK-1875</p>  <p>\$189</p> <p>50Hz - 2.8GHz 3 Channels</p> <p>Sensitivity: • ±0.5mv @ 100kHz • ±5mv @ 300kHz • ±7mv @ 1GHz • ±10mv @ 3GHz</p> <p>Ultra sensitive synchronous detector bargraph and RF strength</p>
<p>20MHz Sweep / Function Generator with Frequency Counter Model 4040</p>  <p>\$445</p> <ul style="list-style-type: none"> • 0.2Hz to 20MHz • AM & FM modulation • Burst Operation • External Frequency counter to 30MHz • Linear and Log Sweep 	<p>Elenco RF Generator with Counter Model SG-9500</p>  <p>\$225</p> <p>Features internal AM mod of 1000 Hz, Output 100W - 300W, Audio output 10W @ 1V RMS, SG-9500 (antenna, w/c counter) \$124</p>	<p>Elenco 10MHz - 1MHz Digital Audio Generator Model SG-9300</p>  <p>\$225</p> <p>Features built-in 150MHz frequency counter, low distortion and sine/square waves SG-9200 (w/c counter) \$124</p>

<p style="text-align: center; font-weight: bold;">Tekk Radios</p> <p>Pro-Sport FRS Two-Way Radio Model PRO-SPORT+</p>  <p>\$79 each or \$125 Set of 2</p> <ul style="list-style-type: none"> • 14 Channels • Battery Monitor • Key Lockout • Monitor Button • Lightweight • Palm Size • Large LCD Display • Removable Belt Clip • Removable Antenna • Two Radio Call Tones • Busy Channel Lockout • Accessory Connector • Highly Water Resistant <p>Talk up to 2 miles!</p>	<p style="text-align: center; font-weight: bold;">Four Functions in One</p>  <p>\$459 Model MX9300B</p> <p>Features:</p> <ul style="list-style-type: none"> • One instrument with four test and measuring systems • 1.3GHz Frequency Counter • 2MHz Sweep Function Generator • Digital Multimeter • Digital Triple Power Supply - 0-30V @ 3A, 15V @ 1A, 5V @ 2A
--	--

<p style="text-align: center; font-weight: bold;">Elenco Educational Kits</p> <table border="0" style="width: 100%;"> <tr> <td style="width: 50%; vertical-align: top;"> <p>Model AR-2N6K</p>  <p>\$34.95</p> <p>2 Meter / 6 Meter Amateur Radio Kit</p> </td> <td style="width: 50%; vertical-align: top;"> <p>Model AM-780K</p>  <p>\$11.95</p> <p>2 IC Radio Kit</p> </td> </tr> <tr> <td style="vertical-align: top;"> <p>Model M-1005K</p>  <p>\$19.95</p> <p>Digital Multimeter Kit</p> <ul style="list-style-type: none"> • 18 Ranges • 3 1/2 Digit LCD • Transistor Test • Diode Test </td> <td style="vertical-align: top;"> <p>Model RCC-7K</p>  <p>\$29.95</p> <p>Radio Controlled Race Car Kit</p> </td> </tr> </table>	<p>Model AR-2N6K</p>  <p>\$34.95</p> <p>2 Meter / 6 Meter Amateur Radio Kit</p>	<p>Model AM-780K</p>  <p>\$11.95</p> <p>2 IC Radio Kit</p>	<p>Model M-1005K</p>  <p>\$19.95</p> <p>Digital Multimeter Kit</p> <ul style="list-style-type: none"> • 18 Ranges • 3 1/2 Digit LCD • Transistor Test • Diode Test 	<p>Model RCC-7K</p>  <p>\$29.95</p> <p>Radio Controlled Race Car Kit</p>	<p style="text-align: center; font-weight: bold;">Guaranteed Lowest Prices</p> <p>UPS SHIPPING: 48 STATES 5% OTHERS CALL FOR DETAILS IL Residents add 8.25% Sales Tax</p> <p style="text-align: center; font-weight: bold;">SEE US ON THE WEB</p>
<p>Model AR-2N6K</p>  <p>\$34.95</p> <p>2 Meter / 6 Meter Amateur Radio Kit</p>	<p>Model AM-780K</p>  <p>\$11.95</p> <p>2 IC Radio Kit</p>				
<p>Model M-1005K</p>  <p>\$19.95</p> <p>Digital Multimeter Kit</p> <ul style="list-style-type: none"> • 18 Ranges • 3 1/2 Digit LCD • Transistor Test • Diode Test 	<p>Model RCC-7K</p>  <p>\$29.95</p> <p>Radio Controlled Race Car Kit</p>				

C&S SALES, INC.

150 W. CARPENTER AVENUE
WHEELING, IL 60090
FAX: (847) 541-9904 (847) 541-0710
<http://www.cs-sales.com>
e-mail: sales@cs-sales.com

15 DAY MONEY BACK GUARANTEE
2 YEAR FACTORY WARRANTY

PRICES SUBJECT TO CHANGE WITHOUT NOTICE

www.popular-communications.com

June 2000 / POP'COMM / 55

radio & the internet

Pop'Comm's Cyber Sleuth Checks Out Online Resources

Art Bell Chats With Pop'Comm's Editor, And Free Flight Tracking With WebTrax!

Pop'Comm's colorful editor, Harold Ort, was recently the principal guest on the "Art Bell Coast-to-Coast AM" radio show, which was aired simultaneously by over 400 radio stations. It was a most enjoyable and informative broadcast with Harold; Art and callers discussing a wide range of radio-related topics. If you missed the broadcast or would like to hear it again, it is available in RealAudio® format at <http://www.dobe.com/popcomm/Harold.htm>.

Also be sure to visit Art Bell's extremely popular web site where you can listen to his live broadcasts, previous shows, and much more. He's at <http://www.artbell.com/>.

Radio And Broadcast Technology

If you've ever wanted to know about the equipment and technology that goes into commercial broadcasting then Jim Hawkins' (WA2WHV) Radio and Broadcast Technology Page is for you. Walk along with Jim as he takes you on a personal, behind the scenes tour of several well-known broadcast stations. Containing over 300 original photographs and superb commentary, Jim's site is simply awesome! It's probably the closest many of us will ever get to the facilities and equipment used in commercial broadcasting both today and years gone by. And



It's thumbs up and all smiles with Art Bell after chatting with Pop'Comm's editor Harold Ort.

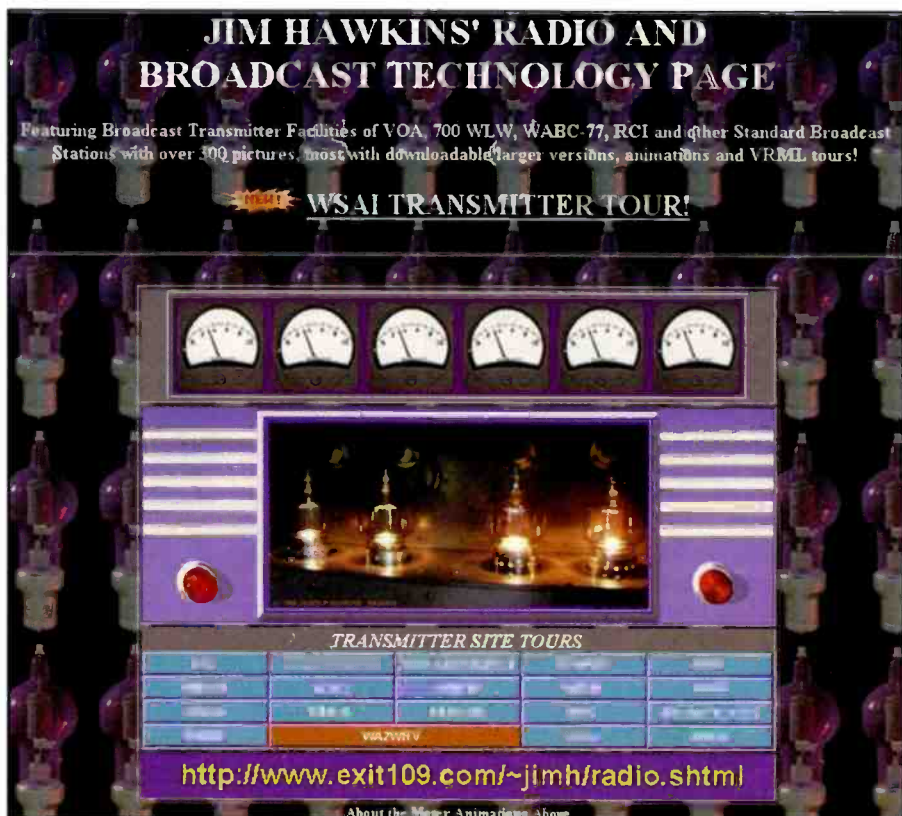

A MUST VISIT site! The Equipment and Technology of Commercial Broadcasting.

that's just the beginning! In addition to his incredible renderings and animations of electronic components, his "Radio and Technology Page" is just ONE of many fascinating, enjoyable, and educational radio resources he has assembled — each a masterpiece — each a DON'T MISS site! Some of his other outstanding "pages," accessible from the URL below, are: Jim's Ham Radio Corner, Jim's TV and FM Transmitter Page, and a Radio Calculators page which includes Java calculators for PI Networks, Air Inductors, Beam Antennas, and dipoles. Also available is a freeware Windows version of the PI Network and Air Inductor calculator. Grab some coffee (well, maybe not unless you like it cold), kick off your shoes, and enjoy one of the few (large and diversified) resources geared towards radio with

practically all original content. Visit and bookmark <http://www.exit109.com/~jimh/radio.shtml>.

Aircraft Scanning

There you are, scanning the sky, when you hear something like: "... Delta 1497 Level at Flight Level 280." Wouldn't it be neat if you knew a little more about that flight? Maybe where it came from, where it was going, where it is *right now*? Well, you can — complete with the aircraft's flight plan superimposed on a map with a marker to show the plane's current position. WebTrax, a new online service by FlyteComm of Florida, provides real-time aircraft position graphically and also returns departure and destination points, aircraft type, altitude, ground

BY ERIC FORCE <eric@dobe.com>



FLIGHT: DELTA AIRLINES 1497
 DEPARTING: NEWARK
 ARRIVING: CINCINNATI/COVINGTON
 DEPARTURE TIME 10:17 A.M. EST
 EXPECTED TO ARRIVE IN 0 HRS 38 MIN (11:37 A.M. EST)
 SPEED: 430 Knots, ALTITUDE: 28000 Feet

<http://www.flytecomm.com/>

WebTrax: Real Time Aircraft Positioning — one slick puppy!

speed, departure time, and ETA. WebTrax receives its data directly from the FAA based on real-time position reports. Numerous anomalies and errors in this data are corrected and the actual aircraft position is updated every minute.

And, it's FREE! If that weren't enough, FlyteComm of Florida invites you to make this slick service available on YOUR web site. Complete details, including the free WebTrax service, are available at <http://www.flytecomm.com/>.

Scanning With PerCon

Several months ago, we mentioned PerCon Corporation's online "DataFinder" resource. PerCon Corporation, as

you might recall, is a developer and publisher of government-related databases specializing in FCC, FAA data, and more. Their CDs and online database search capabilities are routinely used by those in the telecommunications, aviation, governmental, commercial, and hobby areas. At the time, it was quite a find. Today, it's a gold mine, given their greatly expanded (and FREE online) "DataFinder" lookup service. Available now are searchable databases covering U.S. Frequencies (millions of them), Aircraft identification by N-Number, U.S. Amateur Call Signs, Canadian frequencies and even a geographic FIPS code lookup section. By the time you read this, they will have probably expanded their service even more! This is *one* resource you'll want to visit

PerCon
 Corporation *Datafinder*

<http://www.perconcorp.com/datafinder/>

Visit the New & Improved PerCon DataFinder Page.

ELECTRONIC COMPONENTS

www.mouser.com

- Wire and Cable
- Connectors • Resistors
- Potentiometers
- Capacitors • Diodes
- Transformers
- Inductors
- Switches
- Speakers • Fuses
- Knobs
- Hardware
- Equipment
- Tools

800-992-9943

817-483-6828 Fax: 817-483-6899
catalog@mouser.com

958 North Main St., Mansfield, TX 76063

MOUSER
 ELECTRONICS

CIRCLE 69 ON READER SERVICE CARD

FACT:

Foot for foot, top-loaded antennas outperform base-loaded antennas.

FIRESTIK:

Firestik's top loaded coil design focuses more of your transmitted signal on the ground...where you need it most!

**FREE
 PRODUCT
 GUIDE**



FireStik

ANTENNA COMPANY

602-273-7151 • support@firestik.com

<http://www.firestik.com>

CIRCLE 67 ON READER SERVICE CARD



dialpad.com

Welcome to dialpad

Make unlimited free long-distance phone calls to anyone in the U.S. at dialpad.com. There's nothing to download or install—your web browser uses our Java-based technology to place calls while you're online. And dialpad.com is completely free!

user login

User Name
Your Name

Password

Forgot Password?

GO

join now what's dialpad?
help company info

Join Now

More than 3,500,000 people are using dialpad.com to make free long-distance calls

Sign Me Up Now!

<http://www.dialpad.com/>

Dialpad.com offers FREE and Unlimited Long Distance Telephony.

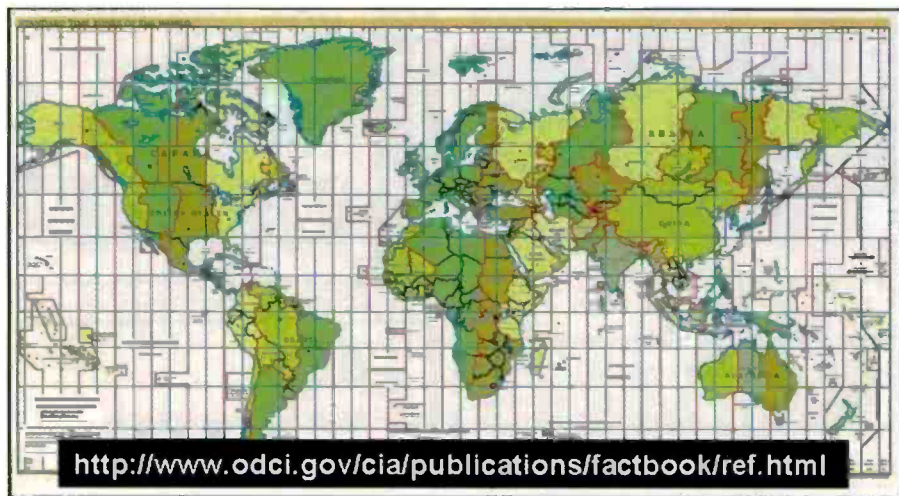

A Super World Time Zone Map from the CIA.

and bookmark! Percon is at <http://www.perconcorp.com/datafinder/>.

Free Long-Distance Calling

It's a rare occasion when we *don't* hear someone touting long distance calling at discounted rates. Well, here's one online source (dialpad.com) with a fairly good rate too — FREE! Based on my use of their service, I'd submit the quality is not on a par with standard telephony or as convenient. It's also subject to "drop outs" (like the hesitation often experienced when listening to a RealAudio® broadcast), echoing, and a few other quirks. But, all in all, for the price it's something you may want to explore. Currently, over 3.5 million people (according to the dialpad folks) subscribe to this service so it seems to be gaining in popularity.

When you use the service, your call is transmitted over the Internet to third-party Internet Protocol (IP) telephony gateways, then automatically relayed to the telephone number you're calling, just as if you had used your normal telephone to make the call — but *without* the charge! All you need is your standard Internet connection, a sound card, microphone, and speakers. However, a telephone headset or headphones is recommended to eliminate the potential for "echo feedback" to the party you are calling. Be *sure* to explore dialpad's "support/FAQ" page before using the service for the first time. A few minutes reading could save you considerable time and frustration in getting things to work properly. Using dialpad.com should also be a great way to keep your kids off the house phone. Check 'em out at <http://www.dialpad.com/>.

World Time Zones

One of the best sources for a "Standard Time Zones of the World" map can be found at the CIA's (Central Intelligence Agency) "World Factbook" site. What makes this map special is that they have made it available in Adobe's® PDF (Portable Document Format), as well as a normal JPEG image. If you have the Acrobat® PDF Reader, you can view the map in all it's beauty and detail. If you have a large format printer, the map can be printed (via the Acrobat® Reader) in its actual 22" x 17" format. If your printer handles color too, then you'll have one beauty of a map to hang as well! Other quality worldwide maps are also available.

What's Your Best Servicing Value? The magazine that makes money for you — *Electronic Servicing & Technology!*

Each month, *ES&T* brings you how-to service articles on TVs...VCRs...Computers... CD players... Microwaveovens... Audio products and more. It's the Information you need to do your job everyday.

Regular columns and special features from experts will make you more efficient — and more profitable — in no time. Plus, our monthly PROFAX, a FREE 8-page pull-out of popular TV, VCR and computer schematics, makes *ES&T* an even greater value.

SUBSCRIBE TODAY!!!

- | | |
|----------------------------------|-----------------------------------|
| 1-year, (12 issues) \$26.95 | 2-years, (24 issues) \$49.95 |
| 1-year \$36.95 | 2-years, \$69.95 |
| 1-year Foreign Air Post, \$44.95 | 2-years Foreign Air Post, \$85.95 |

When ordering by mail please include the following: Name, address, city, state, zip, renewal or new subscription. If you are charging please include credit card number along with expiration date.

Electronic Servicing & Technology
25 Newbridge Road, Hicksville, NY 11801 • Phone: 516-681-2922 • FAX: 516-681-2926



ENGLISH SHORTWAVE BROADCASTS TO NORTH AMERICA

<http://www.angelfire.com/wi/worldbandradio/>

An Outstanding SWL Resource provided by Daniel Sampson.

TRANSMITTER DOCUMENTATION PROJECT

<http://www.transmitter.org/>

SHORTWAVE TRANSMITTER AIR-TIME pool of 25 broadcasters with air-time offers on shortwave	SHORTWAVE BROADCAST ANTENNAS shortwave broadcast antennas supplier and specifications	SHORTWAVE TRANSMITTER COUNTRIES detailed SW transmitters info in each country of the world
DIGITAL SHORTWAVE RADIO info about digital shortwave radio and it's possibilities		SHORTWAVE RADIO DX CLUBS links to the websites of the 66 most experienced dx clubs
SHORTWAVE RADIO DX PROGRAMS SW radio dx programs are one of the best radio dx sources		TDP MAILING LIST subscribe to the TDP mailing list and receive our updates
SHORTWAVE RADIO STATIONS links to 315+ radio stations audible on a shortwave radio		BOOK TDP SW-98 the TDP SW-98 is the printed shortwave transmitter source
RADIO BROADCAST TRANSMITTERS radio broadcast transmitters suppliers and specifications	Copyright ©2000 TDP All rights reserved.	SHORTWAVE TRANSMITTER TUBES supplier and specifications of tubes for SW transmitters

A Super web site for WorldWide SW Transmitters.

Be sure to visit <http://www.odci.gov/cia/publications/factbook/ref.html>.

TIP: If you don't have the Adobe® Acrobat® Reader, GET IT! It's free and available at <http://www.adobe.com/products/acrobat/readstep.html>.

English Shortwave Broadcasts To North America

Whether you're looking for current English Language SW Broadcasts by time, country, or DX Media Program format, Daniel Sampson's "English Shortwave Broadcasts to North America" site has it superbly covered. And, that's just the tip of the iceberg! Also included are comprehensive and up-to-date pointers to radio-related as well as International Broadcast sites and more. Daniel borrows a slogan from his employer to describe his effort: "I want to be the best source for schedules." I think you'll agree Daniel has more than succeeded! Don't miss this outstanding SWL resource at <http://www.angelfire.com/wi/worldbandradio/index.html>.

Awesome Transmitter Documentation Project

From Belgium, the "Transmitter

Documentation Project" (TDP) by Ludo Maes, represents an awesome "one-stop-shop" for everything related to SW transmitters. Categories include: SW TRANSMITTER AIR-TIME: Pool of 25 SW broadcasters with air-time for sale, ALYX SW BROADCAST ANTENNAS: Suppliers and specifications, DIGITAL SW RADIO: Information about digital shortwave radio, SW RADIO DX INFORMATION: Everything related to SW DX, SW RADIO STATIONS: links to over 315 SW Radio Stations. RADIO BROADCAST TRANSMITTERS: Transmitter suppliers and specifications, and SHORTWAVE TRANSMITTER TUBES: Suppliers and specifications. Thanks to *Pop Comm* reader Richard McClung for the tip on this excellent resource. Check-it-out at <http://www.transmitter.org/>.

PC-Related Items: Scientific Calculator

Based on the number of calculator programs I've run across in my travels through cyberspace, it would seem many folks don't know about the nice calculator that comes with Windows®. To access it, left-click START, (lower left corner of your display) then place your cursor over PROGRAMS then ACCESSORIES then



Everhardt

SNGP-4 (4) Stainless Steel 3-Way Mount
SNGP-2-RM (32") Stainless Steel Roof Mount
SNGP-2WM (28") Stainless Steel Window Mount
NGP-1 (4) Fiberglass 3-Way Mount with Weatherband
SNGP-4-SM (4) Stainless Steel Side Mount 2" Ext. Bolts
NGP-1-SM (4) Fiberglass Side Mount 2" Ext. Bolts

TIGER "NO GROUND" PLANE

MARVEL COMMUNICATIONS
 6000-D Old Hemphill Road
 Fort Worth, TX 76134

COMING SOON
 As shown above Everhardt manufactures six types of "NGP" antennas for CB. Now in design is a new "NGP" not for CB but for 2 meter. 3db gain side body mount for fiberglass vehicles.

EVERHARDT ANTENNAS
 6000-D Old Hemphill Road
 Fort Worth, TX 76134
 Phone: 817-568-0177
 Fax: 817-293-4441
 Email: tigerever@aol.com

CIRCLE 66 ON READER SERVICE CARD

Full 800 MHz Scanners

AR-8200 (unlocked)
Wideband Portable receiver
 - 0.5 to 2040 MHz continuous.
 - NFM, WFM, NAM, WAM, USB, LSB & CW
 - Alphanumeric memory identification
 - Spectrum scan
 - Computer control
 - Flexible dynamic memory bank layout
 - Optional CTCSS & Extra memory boards

\$699 us

ALINGO DJ-X10 (unlocked)
Wideband Portable receiver
 - 0.1 to 2000 MHz continuous.
 - NFM, WFM, AM, USB, LSB & CW
 - Alphanumeric memory identification
 - Channel scope
 - 1200 memory channels
 - Supert sensitivity. Clear sound
 - Various scanning modes - Menu system

\$499 us

ICOM PCR-100-08
Wideband receiver for PC
 - PCR-100 can be used with your Desktop or Portable PC
 - 0.1 to 1300 MHz continuous.
 - Modes AM, FM & WFM
 - Built-in tone squelch
 - Multiple screens, multi-function control panel

\$229 us

AOR ICOM ALINGO OPTOELECTRONICS YUPITERU
Guaranteed Delivery to USA.

Radioworld

Phone: **416-667-1000**
 FAX: (416) 667-9995 Website Address: <http://www.radioworld.ca>
 sales@radioworld.ca - <http://www.radioworld.ca>
 4335 Steeles Ave. W., Toronto, ON Canada M3N 1V7

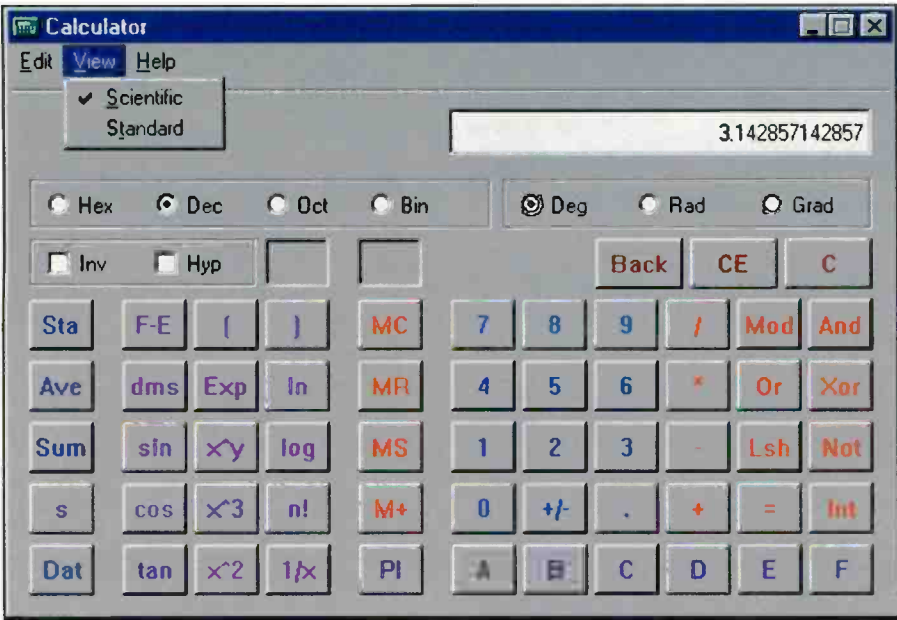

Need a nice calculator? You've already got this one!

left-click CALCULATOR. Left-clicking on "View" will toggle between standard and scientific modes. Click Help to learn more about the calculator and use of keyboard commands. I find it quite handy to MINIMIZE the calculator to the task bar where it will remain available whenever I need it via a single click. To minimize most ANY windows based application, just left-click the box in the upper right corner of the application with the " " (3rd block from the right)

Quick-N-Dirty Information Retrieval

Lurking behind the scenes in most of our PCs is an operating system called DOS (Disk Operating System). Yeah, I know, "DOS is Dead" or that's what most "modern day" programmers would have us believe. Well, it's *not*, and it can be put to good use if you're up to using your DOS prompt. "Way back" when windows meant glass panes and a mouse meant rodent, batch programs were written and used by just about every programmer out there for an amazing variety of tasks. The task we'll discuss here is incredibly simple to do but can be quite useful. The sample batch program shown in **Figure 1**, Items 1 through 3, provides an overview of the process with a couple of phone numbers but the same concept can be used for darn near any (TEXT) information you'd like to store and retrieve.

Step 1. Use Notepad (found under Programs, Accessories) to type in the text you want. Make sure the first line of your text reads: "@echo off" (without the quotes) then precede each additional line with the word "echo," (again without the quotes) a single space then your text.

Step 2. Save your file with the extension ".BAT" (without the quotes) in your Windows® directory. In the example, I used PHONE.BAT for the filename but you can use any name that has meaning

to you. Since this is DOS, limit your filename (prior to the .BAT extension) to a MAXIMUM of EIGHT characters.

Step 3. Drop to a DOS window — you should see an icon that reads "MS-DOS Prompt." If so, just double left-click it. If not, you should be able to access your MS-DOS prompt via your START, Programs menu. Once at the DOS prompt, (will look like C:\WINDOWS>) just type in the filename you used above. You can clear the screen, type CLS, then tap Enter. Minimize your DOS screen to the taskbar where it will be ready again when needed.

Like the calculator above, I usually open up a DOS window then minimize it to my task bar for quick access. If you don't want the DOS icon on your task bar, just type EXIT, and hit Enter. If you'll give it a try, I think you'll find these types of Batch files to be quite handy.

TIP: When using batch files, remember that each file, no matter how SMALL, will use several kilobytes (at least 4,000 characters worth and probably more) of disk storage. So, if disk space is at a premium, you may want to include several lines of text (i.e. several items, perhaps of a similar nature) in each batch file.

Well, that's it for this time. Thanks for joining me on this month's journey. Be sure to visit the *Pop' Comm* web site at <http://www.popular-communications.com/> for the latest radio news and keep those comments and suggestions coming!

Until next time, 73

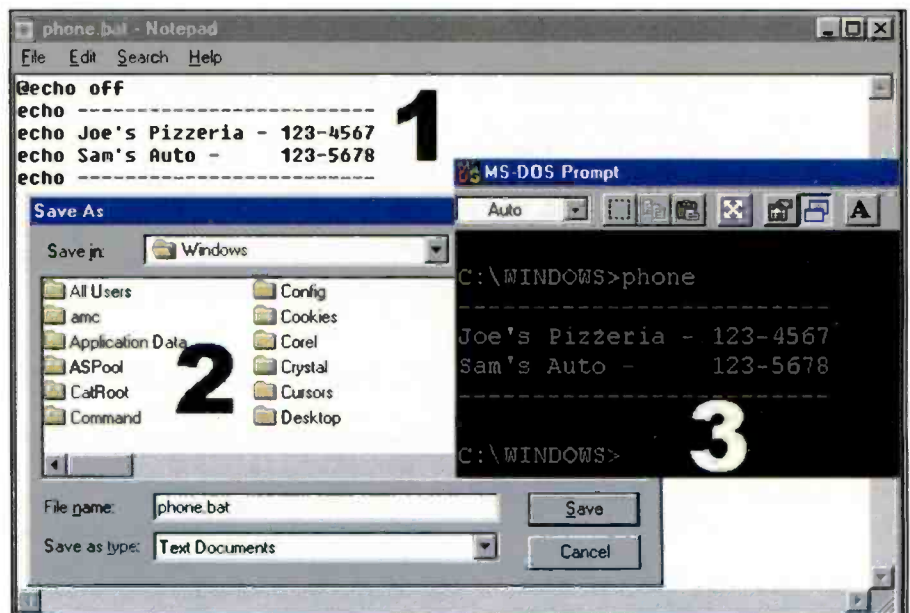

Figure 1: Use DOS Batch Files for Quick-N-Dirty Info Systems — Simple as 1-2-3.

plane sense

Your Link To Aviation Communications

Sectional Aeronautical Charts

With summer later this month and school ending soon, I know a lot of you will be traveling, taking that well-deserved vacation (or holiday in Canada) — many by plane. This month's resource will help you further your aviation scanning. I'm going to recommend three aviation maps that you can use. Actually, you really need only one of them, but the description of all three is almost the same.

When you picked up your airport/facility directory that I recommended in my first column last month you may have noticed some rather colorful maps. I recommend you pick up the **Sectional Aeronautical Chart** for your area. Before I go any further, here are the official definitions of the charts as found in the "Airman's Information Manual."

AERONAUTICAL CHART — A map used in air navigation containing all or part of the following: topographic features, hazards and obstructions, navigation aids, navigation routes, designated airspace, and airports. (Figure 1) Commonly used aeronautical charts are:

"a. Sectional Aeronautical Charts (1:500,000) — Designed for visual navigation of slow or medium speed aircraft. Topographic information on these charts features the portrayal of relief and a judicious selection of visual checkpoints for VFR flight. Aeronautical information includes visual and radio aids to navigation, airports, controlled airspace, restricted areas, obstructions, and related data.

"b. VFR Terminal Area Charts (1:250,000) — Depict Class B airspace which provides for the control or segregation of all the aircraft within Class B airspace. The chart depicts topographic information and aeronautical information which includes visual and radio aids to navigation, airports, controlled airspace, restricted areas, obstructions, and related data.

"c. World Aeronautical Charts (WAC) (1:1,000,000) — Provide a standard series of aeronautical charts covering land areas of the world at a size and scale convenient for navigation by moderate-speed aircraft. Topographic information includes

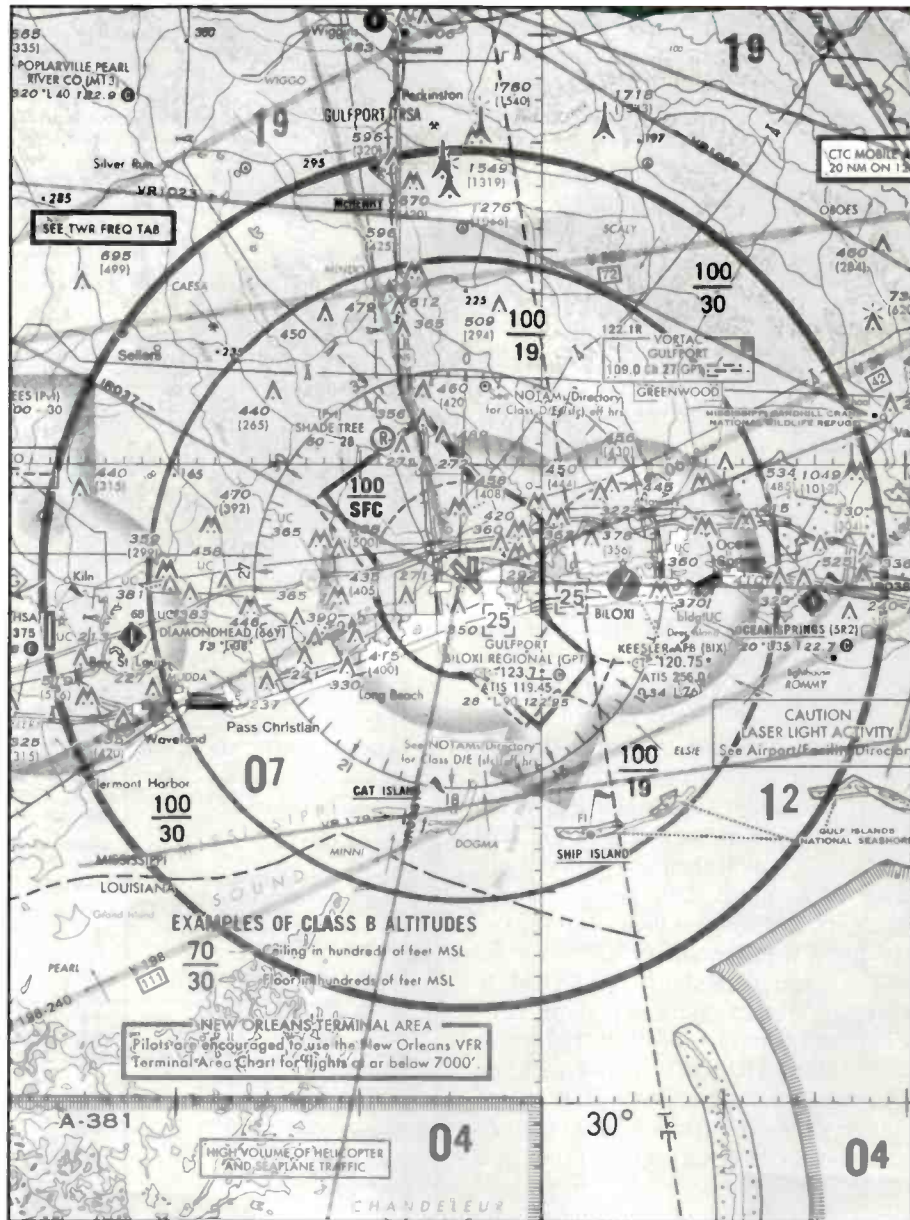

Figure 1: A sample of an aeronautical chart.

cities and towns, principal roads, railroads, distinctive landmarks, drainage, and relief. Aeronautical information includes visual and radio aids to navigation, airports, airways, restricted areas, obstructions, and other pertinent data."

Subparagraphs d through i deal with other charts, some of which I will discuss

in later columns. These are all just a series of detailed maps that most pilots use in their cross-country flying. The most used chart is the Sectional Aeronautical Chart, or just Sectional. It is in a 1 to 500,000 scale, or 1 inch equals 500,000 inches in real life. There are 38 different sectionals for the lower 48 states, Puerto Rico, and

the Virgin Islands, with 1 additional for Hawaii, Guam, and Samoa. They cost about \$7.50 each. There are also 16 Alaska sectionals, which retail for roughly \$4.40 each. Canada has a version of the sectionals called the "Canadian VFR Navigation Charts." There are 34 in this series and retail for roughly \$15 per copy in the U.S. Again you don't need to get all of them. (Plus to make a map of the entire country you would need to get two copies of each map as the north side of the area is printed on one side and the south is on the other).

I just put together a complete map of Florida for use at my Civil Air Patrol squadron in Clearwater. It took two copies each of the Miami, Jacksonville, and New Orleans sectionals. It was still over four and a half feet tall, and just as wide. You would only need two or more copies if you lived in an area of overlap and you wished to put the maps together on a wall.

How To Use Them

In Figure 2 you will find the legend for the sectionals, which by the way is virtually the same for the Terminal Area and World Aeronautical charts. The upper left section shows information on the airports, the layouts, if they have control towers, whether it is military or civilian, land or sea, or even if it is abandoned. The upper right block covers airport data. It gives the various frequencies that are in use, and much information about the airport itself; length of the runways, the elevation above sea level, and whether the airport or control tower is in operation 24/7.

The center block shows "Radio Aids to Navigation and Communication Boxes." Pilots and controllers call the radio aids as just "NAVAIDS." The frequencies you can monitor here are the VHF Omni Range, or "VOR" (pronounced "vee-oh-are," not "vor"), the VOR portion of a "VORTAC" (pronounced vortac) and those of the "Non-Directional Radio Beacon" or NDB. The VOR frequencies are found between 108.000 MHz and 117.950 MHz, or just above FM and below air traffic communications, which are from 118.000 MHz to 136.975 MHz.

The NDB frequencies are located below AM radio. TACAN information is basically unusable by anyone except military pilots, and DME is used by all pilots, but has little communication value. The "Communication Box" gives basic frequency info, the identifier of it, and the Morse Code identification. The Morse

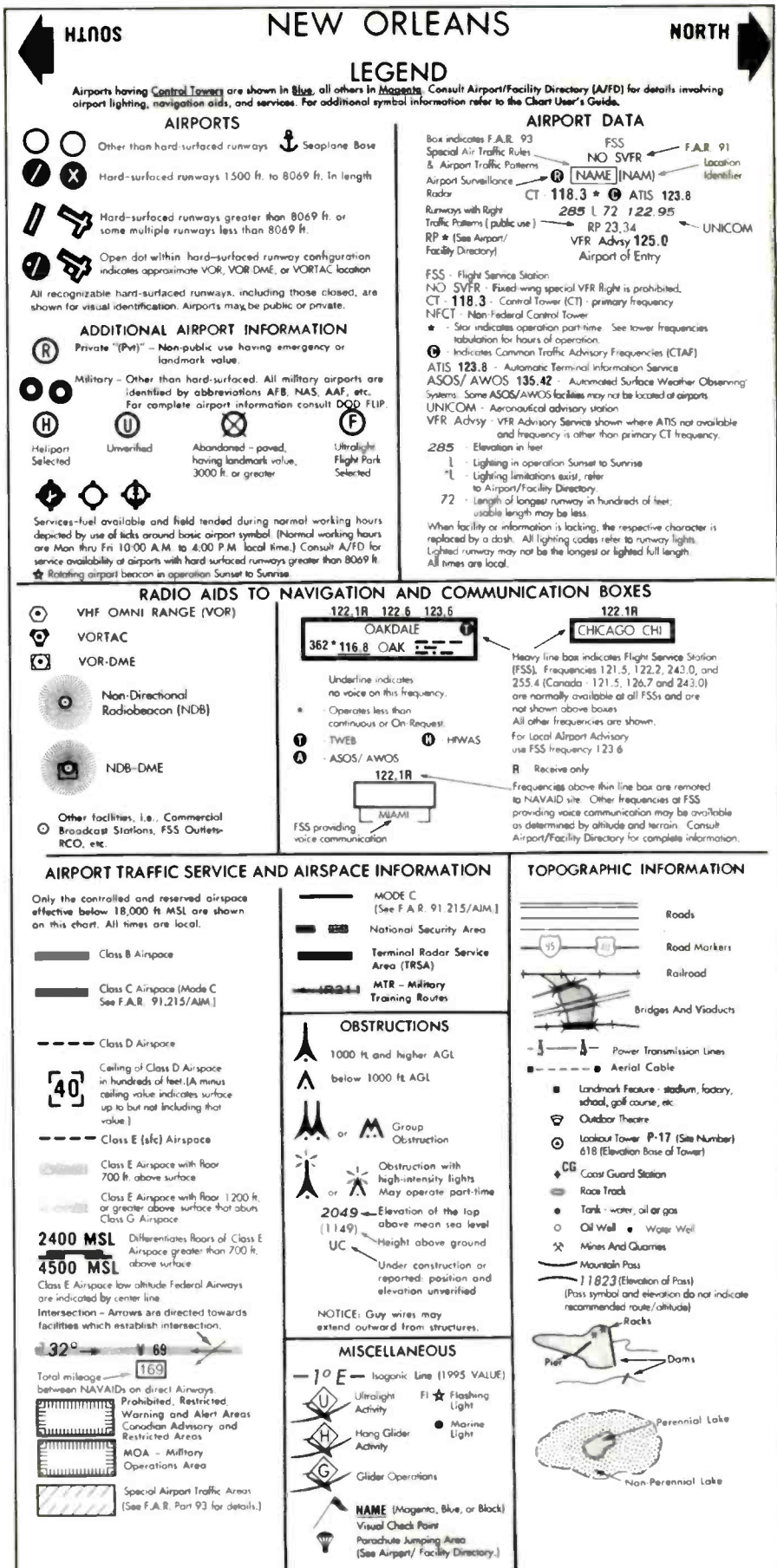

Figure 2: The legend for the sectional charts.

Cherokee's Impressive CBS-2100 AM/SSB Base Station

Life is always good when large boxes arrive from Wireless Marketing Corporation. Wireless, you'll remember, is the home of Cherokee™ brand citizens band equipment. Even though Wireless Marketing is a relative newcomer to the field — just a few years old — the firm has already won a richly deserved reputation for innovation, creativity, and excellence. So when my friendly local package delivery guy came loping up the sidewalk with an absolutely huge package perched on his shoulder, my first response was: "Whoa! What have we here?" The short answer is the box contained an engineering prototype for Cherokee's brand new **CBS-2100 base station**. After a few seconds work unzipping the package, I held in my arms the actual prototype that had been reviewed and approved by the FCC.

What a radio it is! It's big, solid, and gorgeous. It's also a radio that's bound to fuel the nonsense mills on the Internet when people get a look at the back panel. We'll get back to that in a little while, but first let's conduct a leisurely examination of this spanking new base station.

“... we found the CBS-2100 was comparable in every way to the Cobra 2000.”

The CBS-2100 is large: 19 inches wide by 6 inches high by 14 inches deep. It has “ears” and handles so that it can be rack mounted. The massive front panel has a brushed silver finish. The knobs, switches, and lettering are black, so the whole thing has a very clean, professional look. Most of the small knobs have soft rubber knurling that makes them pleasant to touch, and, where needed, they have a crisp white indicator stripe that clearly shows the position of the knob.

At the top left corner of the case is a light emitting diode that glows red when the rig is powered up. To the right of that is a large illuminated receive signal strength meter. Moving again to the right, there is a large illuminated meter for indicating transmit power or SWR reading. A



Cherokee's CBS-2100: the new Rolls Royce of CB base stations.

large LED display dominates the top center of the front panel. Large green LED digits show the channel number, and five smaller green LED digits indicate the frequency. By the way, the CBS-2100 is equipped with a true frequency counter, not a mere frequency *display*. Beneath the frequency readout are six red LED indicator lights for transmit, Clear Drive activation, and PA, AM, LSB, or USB mode.

At the upper right corner of the front panel is a large front-firing speaker. Beneath the LED display, you'll find a knob for selecting mode and a channel selector knob. To the left of these are four toggles switches. One activates a Roger Beep so that a beep tone sounds whenever the microphone is un-keyed. Another turns on the noise blanker and automatic noise limiter circuits. A third selects between SWR and calibration modes. The fourth switch activates the Clear Drive, which is Cherokee's trade name for its compander circuitry. What a compander does is COMPRESS the transmitted audio and EXPAND the audio on receive — hence the name, compander. A compander system works best when both stations that are in communication are using the compander. But the compander can *also* help in single station use. For example, compressing the transmitted audio can help to boost its punch for long-haul communications even when it is

received at a station that is not compander equipped. And using the compander on receive can help to pull a signal out of the noise. While Clear Drive is not a universal solution for all the problems of CB radio, it is a useful and valuable tool when the circumstances are right.

To the left of the four toggles switches is a push-button power On/Off switch. Below that, there is a four-pin microphone connector. Across the bottom of the front panel, there are eight knobs: SWR calibration, a Clear Drive level selector, microphone gain, RF gain, volume, squelch, and fine and coarse clarifier knobs. At the lower right corner of the front panel is jack for headphones.

It's the back panel of the CBS-2100 that will really get the rumor mill going on the Internet. In addition to the usual antenna connector, AC power input, external speaker jack, PA speaker jack, and recorder output jack, you'll find some unusual stuff. There is, for example, a DC jumper cable that runs from the power supply to a DC power jack. It's there so that you can unplug the jumper and go directly from DC power into the CBS-2100 if you wanted to use the rig anyplace that normal AC power is not readily available. I'm sure somebody out in the wastelands of the World Wide Web is going to look at it and declare it's a cable for hooking up a linear. It's not.

BY JOCK ELLIOTT

In addition, the CBS-2100 is the only commercially available CB that I know of that has a full-time cooling fan. The reason for that is the folks at Cherokee chose to use a modified computer power supply to deliver AC power to the CBS-2100. It keeps the power supply and the rest of the radio cool, but it is not, repeat NOT, designed so that you can reach in with a screwdriver and crank up the output power. I've talked with the people who designed this radio, and it just ain't so. It's designed for maximum reliability, not maximum power.

This new radio covers the 40 channels allocated to Citizens Band by the Federal Communications Commission. It offers a full four-watt power output in AM mode and 12 watt power output in single sideband mode, and it is not designed to be readily modifiable for operation outside the legal CB frequencies.

Newcomer To CB?

Now, if you're a newcomer to CB or perhaps an old hand that has never operated in anything but AM mode, you might rightly ask, "What's the big deal about sideband?" Good question. To get to the answer, we'll have to look for a moment at what constitutes an AM signal. An ordinary AM signal can be thought of as a kind of "electronic sandwich." In the middle of the sandwich is a carrier. On either side of the carrier, like the bread on a sandwich, are two sidebands—the upper sideband and the lower sideband. The sidebands contain the actual information in the signal; the sound of your voice, and the two sidebands are identical in that regard. So if you listen to one sideband, you'll hear the same information as you would if you listened to the other sideband. The carrier, however, contains no information whatsoever. It simply exists to provide the AM CB receiver at the other end of the conversation something to lock onto. It is much less expensive to build an AM-only CB than it is to build one that can receive sideband. That's why you can find cheap AM rigs for less than \$50 new, but you won't find sideband CBs that inexpensive. In addition—and here's the killer part—the carrier consumes 50% of the power of the signal. In other words, when you are communicating in AM mode, half of your power output is going to a carrier that delivers no information whatsoever at the other end of the line.

What a sideband CB allows you to do is to *eliminate* the carrier and to choose one of the sidebands to use for commu-



4091 Viscount Street
Memphis, TN 38118
(901) 794-9494
Fax (901) 366-5736
TM www.majestic-comm.com/maco

ANTENNAS • POWER SUPPLIES • CABLE ASSEMBLIES

HIGH PERFORMANCE and MADE IN U.S.A.

ALL MACO BASE STATION ANTENNAS are made of aircraft alloy 6063-T5 aluminum tubing—.050 wall. Elements are made of harder 6005 alloy.

NOTE! To prevent fatigue failure, no holes are made in any boom or element.

MACO

M106-C

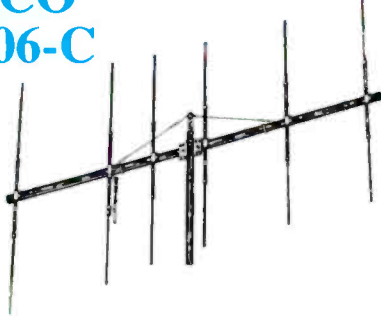

Dual Maximum Beam; 2 Beams on 1 Boom
10-11 METER VERTICAL/HORIZONTAL BEAMS
AVAILABLE IN 3-, 5-, 6-, 7-, AND 8-ELEMENT VERSIONS.

M105-C

Specifications:

Boom Length	31'
Boom OD	2"
Number Elements	6
Longest Radius	19'
Turn Radius	17'
Surface	
Area	10.21 (sq. ft.)
Wind Survival	90 mph
Tuning (MHz)	26.5-30
Gain	17 dB
VSWR	≤1.5
Power	
Multiplication	50X
Front-to-Back	
Separation	31 dB
Weight	39 lbs.

Call or write for free catalog and name of reseller near you.

CIRCLE 68 ON READER SERVICE CARD

nication. This has the effect of concentrating the power of your signal (to nearly four times the power), and most of the time you can talk nearly twice as far with a sideband rig as you can with AM. In addition, you'll find that sideband operators, by and large, have a different attitude. Instead of AM handles, they usually identify themselves with club identifier numbers (such as SSB-734) and their first names. Sideband operators frequently distinguish themselves with very classy operating habits and the use of Q-codes, much like those employed by ham radio operators. Sidebanders generally operate on channels 36 through 40, but that is a matter of custom, not FCC rules. There are literally hundreds of thousands of sideband operators around the world. For my part, I greatly enjoy operating on sideband. It's a lot of fun and always a pleasure to meet other sideband operators.

Like anything, there are, of course downsides to single sideband (SSB) operation: for it to work, you have to be talking to another sideband station which is operating on the same sideband (upper or lower) and the same channel. Because there is no carrier for the receiver to lock onto, a sideband rig is equipped with an

Wireless Internet & TV

WIRELESS CABLE • IFTS • MMDS
ATV • INTERNATIONAL • DIGITAL
Amplifiers • Antennas • Books • Compone'1s
• RF Frequency 2100-2700 Mhz
• SASE For "FREE" Catalog or Send \$1

PHILLIPS-TECH ELECTRONICS
P.O. Box 737, 607 Parker St., Trinidad, CA 95570
CATALOG/INFO: 707-677-0159
ORDER LINE: 800-880-MMDS
FAX LINE: 707-677-0934
WEBSITE: www.phillips-tech.com
E-MAIL: product@phillips.tech.com
Visa • M-C • AmEx • Discover • MC/MS • Quantity Pricing

CIRCLE 70 ON READER SERVICE CARD

Bill's 2 Way

CB Radio Equipment

uniden KENWOOD MIDLAND
CHEROKEE ICOM & Gbra
TEXAS RANGER maxon Galaxy

FREE CATALOG!

*"We are the DISCOUNT LEADER
in sales of scanners, FRS, CB,
GMRS radios and accessories."*

1-888-710-4094

Bill's CB & 2-Way Radio Service
PO Box 306, Morgan Hill, CA 95038-0306
Tech Line: (408) 782-0064 FAX: (408) 782-2985
e-mail: sales@bills2way.com
Website: <http://www.bills2way.com>

CIRCLE 63 ON READER SERVICE CARD

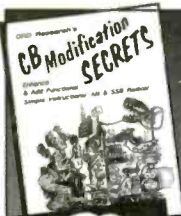

YOU AIN'T HEARD NOTHIN'.. YET



Since 1967, CRB Research has been the world's leading publisher and supplier of unique hobby and professional books and information including:

- Scanner Frequency Guides
- Shortwave Frequency Guides
- Military/Federal Communications
- Undercover Communications
- Survival Communications
- & Other Related Topics!



New titles are constantly being added to our exciting catalog. If it's interesting and unusual, we've got it. You'll see.

Ask For Big Free Catalog

CRB RESEARCH

P.O. Box 56, Commack, NY 11725
Phone: (631) 543-9169
FAX (631) 543-7486
e-mail: sales@crbbooks.com
www.crbbooks.com

CIRCLE 11 ON READER SERVICE CARD

additional control, called a clarifier, that allows the station operator to fine-tune the receive frequency. Without it, if the two stations are not exactly on the same frequency, the audio can sound like Donald Duck or Baby Huey. Finally, because of the extra circuits and controls needed for sideband operation. CBs capable of SSB cost more than AM-only rigs.

How Does It Perform?

Getting back to Cherokee's CBS-2100, as any hotrodder worth his salt knows, good looks is one thing; performance is another. So how does the CBS-2100 perform? The short answer: just great, thank you. My co-columnist Ed Barnat and I checked out the CBS-2100 in comparison with a radio that I call "the Gold Standard" — a completely stock, unmodified Cobra 2000 GTL. The 2000 GTL, which has not been manufactured for several years now, has long been regarded the Rolls Royce of CB base stations. In a head-to-head comparison, we found the CBS-2100 was comparable in every way to the Cobra 2000.

In my view, "ears" are everything in a CB transceiver. Almost anybody can build a transmitter that will perform adequately, but what really separates the heroes from the zeros is the quality of the receiver. You'll be glad to know that I found the CBS-2100 receiver to be exceptionally quiet in both AM and SSB mode. The noise blanker and automatic noise limiter circuits do an outstanding job of knocking out unwanted audio clutter. All the controls operate smoothly and efficiently.

On transmit, the CBS-2100 does equally well. In AM and SSB modes, Ed tells me, both the CBS-2100 and Cobra 2000 sound absolutely great, and the differences between the two are small and largely a matter of personal preference. The CBS-2100, therefore, gets top marks for audio quality.

The bottom line: If you are looking for the "new Rolls Royce" of CB base stations, look no farther than the Cherokee CBS-2100. The suggested retail price is \$499.95, although you can probably expect to pay less at discounters. For more information, contact Wireless Marketing Corporation at 800-259-0959 or visit www.wirelessmarketing.com.

CQ 33 Simple Weekend Projects

FUN FROM DAVE INGRAM, K4TWJ

"33 Simple Weekend Projects for the Ham, the Student, and the Experimenter" gives you a hint at the fun and satisfaction to be found between the covers of this little book. Dave Ingram, K4TWJ, has pulled together a wide ranging collection of do-it-yourself electronics projects from the most basic to the fairly sophisticated, and even touching on the frivolous. You'll find an interesting and very doable array of useful devices: station accessories for VHF FMing, working OSCAR satellites, joining the fun on HF, trying CW, building simple antennas, even a complete working HF station you can build for \$100. Add a measure of practical tips and techniques on how to build electronic projects yourself, and you've got an information-packed book that will keep the newcomer or the most experienced home-brewer busy for many a pleasant weekend.

Only \$15.95 + \$4. S&H

CQ Communications, Inc.
25 Newbridge Road, Hicksville, NY 11801
Phone: 516-681-2922/Fax: 516-681-2926
or call toll-free 800-853-9797

The "Special" You've Been Waiting For . . .

"Free Shipping - Big Savings"

Now thru April 15th - Jo Gunn will pay the shipping charges on any antenna that is UPS Shippable in the U.S.

All orders must be prepaid no COD's on "Shipping Special".

Orders must be prepaid by VISA, MasterCard, Discovery, AMEX, Cashiers Check, or Money Order.

Note: Shipping charges applies to UPS Ground Rate Shipping only. Any special shipping costs will be added to antenna cost. "Shipping Special" must be mentioned in order to receive the discount.

4 Star Excellent Local & DX Antenna

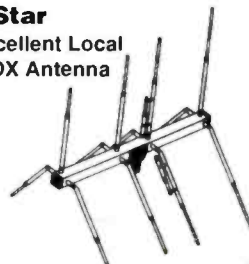

CALL FOR A FREE CATALOG

3138 County Road 30
Ethelsville, AL 35461
(205) 658-2229 • Fax: (205) 658-2259

Hours: 9 a.m. - 5 p.m. (CST) Tues - Friday
Answering System After Hours

Dealer Inquiries, please call.



Books, Videos, Calendars, Cards!

Visit Our Web Site
www.cq-amateur-radio.com

33 Simple Weekend Projects

by Dave Ingram, K4TJW

Do-it-yourself electronics projects from the most basic to the fairly sophisticated. You'll find: station accessories for VHF FMing, working OSCAR satellites, fun on HF, trying CW, building simple antennas, even a complete working HF station you can build for \$100. Also includes practical tips and techniques on how to create your own electronic projects.



Order No. 33PROJ.... **\$15.95**

Amateur Radio Equipment Buyer's Guide

This 144-page book is your single source for detailed information on practically every piece of Amateur Radio equipment and accessory item currently offered for sale in the USA complete with specs and prices. Also includes the most comprehensive directory of Ham product manufacturers and dealers in the USA.



Order No. EBG..... **\$15.95**

Building and Using Baluns and Ununs

by Jerry Sevick, W2FMI

This volume is the source for the latest information and designs on transmission line transformer theory. Discover new applications for dipoles, yagis, log periodics, beverages, antenna tuners, and countless other examples.

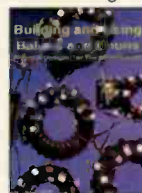

Order No. BALUN... **\$19.95**

The Vertical Antenna Handbook

by Paul Lee, N6PL

Learn basic theory and practice of the vertical antenna. Discover easy-to-build construction projects.



Order No. VAH..... **\$9.95**

McCoy on Antennas

by Lew McCoy, W1ICP

Unlike many technical publications, Lew presents his invaluable antenna information in a casual, non-intimidating way for anyone!

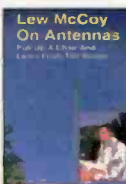

Order No. MCCOY..... **\$15.95**

The NEW Shortwave Propagation Handbook

by W3ASK, N4XX & K6GKU

A comprehensive source of HF propagation principles, sunspots, ionospheric predictions, with photography, charts and tables galore!

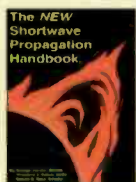

Order No. SWP..... **\$19.95**

The Quad Antenna

by Bob Haviland, W4MB

Second Printing

An authoritative book on the design, construction, characteristics and applications of quad antennas.



Order No. QUAD..... **\$15.95**

Keys, Keys, Keys

by Dave Ingram, K4TJW

You'll enjoy nostalgia with this visual celebration of amateur radio's favorite accessory. This book is full of pictures and historical insight.

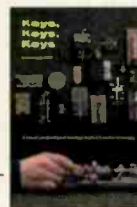

Order No. KEYS **\$9.95**

W6SAI HF Antenna Handbook

by Bill Orr, W6SAI

Inexpensive, practical antenna projects that work! Guides you through the building of wire, loop, Yagi and vertical antennas.



Order No. HFANT..... **\$19.95**

Getting Started Videos - "How-To," Tips, Techniques & More!

- Ham Radio Horizons: The Video .. Order No. VHOR
- Getting Started in VHF .. Order No. VVHF
- Getting Started in Ham Radio .. Order No. VHR
- Getting Started in DXing .. Order No. VDX
- Getting Started in Packet Radio .. Order No. VPAC
- Getting Started in Amateur Satellites .. Order No. VSAT
- Getting Started in Contesting .. Order No. VCON



Only \$19.95 each
Buy more and save!
Buy 2 or 3 for \$17.95; Buy 4 to 6 for \$15.95
Buy all 7 for your Club for only \$99.95

Fax us at 516-681-2926
Call us toll free at 1-800-853-9797

2000 Calendars



\$9.95

Fifteen month calendars
January 2000 through
March 2001

Please specify
Amateur Radio or
Classic Radio Calendar



CQ Award Pins

If you've earned any of CQ's Awards, you can also display the corresponding CQ Award pin. Available for WAZ, 5 Band WAZ, 160 Meter WAZ, CQ DX, CQ DX Honor Roll, WPX, WPX Honor Roll, and USA-CA awards. **ONLY \$5.00 EACH.**

Playing Cards

Top quality, plastic coated playing cards. **ONLY \$9.95 per deck**



FREE SHIPPING on orders over \$50*

Name _____ Callsign _____
Street Address _____
City _____ State _____ Zip _____

Qty	Item #	Description	Price	Total Price
U.S. and possessions - add \$4 shipping/handling. *FREE S/H on orders \$50 and over. Foreign - shipping/handling charges are calculated by order weight & destination. *A \$4 credit will be applied for Foreign orders over \$50.			Shipping/Handling	
			Total	

Method of payment Check Money Order Visa MasterCard Discover American Express

Credit Card No. _____ Expiration date _____

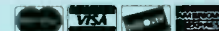

CQ Communications, Inc., 25 Newbridge Rd., Hicksville, NY 11801/516-681-2922; Fax 516-681-2926

the listening post

What's Happening: International Shortwave Broadcasting Bands

Liberia's ELWA On Shortwave, And Vanuatu Back On 7260!

“If at first you don't succeed . . . perseverance pays.” “The third time's a charm.” Obviously, the Sudan Interior Mission (SIM) is a great believer in these tried and true sayings. SIM's shortwave station in Liberia — ELWA — was destroyed in Liberia's civil war quite a few years ago. After peace was restored, SIM rebuilt ELWA and resumed broadcasting. Some years after that, ELWA was again destroyed in another civil conflict. Now ELWA, which first went on the air in the mid-1950s is back again! It's using its long time frequency of 4760 and if the past is anything to go by, it should be fairly easily heard, at least in the East and Midwest. Check for them at their **0600** sign-on (actually a couple of minutes before). If you want to send them a report, try ELWA, c/o SIM, Liberia, 08 BP 886, Abidjan 08, Ivory Coast.

In another bit of good news, **Radio Vanuatu** has reactivated its **7260** frequency, making it a bit easier to hear as opposed to its 60 meter band outlet. In fact, it may have replaced **4960** in favor of 7260. Check for this one around 0700.

The government radio in Congo-Kinshasa has reportedly taken delivery on a new 10 kW shortwave transmitter. That piece of news might be called an informational tickle. There's no word on when it will be active, or on what frequency. RTN Congolaise has a 100 kW transmitter (more or less!) which uses **15245** (now and then!) so it doesn't seem probable that the new unit would be a replacement for this. We'll have to wait and see.

On the minus side of things, Mike Miller in Washington noticed **11780** empty of any Portuguese language broadcasts, and we're hearing emptiness there, too. We don't find signals on the other frequencies normally used by the Brazilian government for its Radio Nacional/Radio Bras broadcasts either. There was a report sometime ago about the government having funding problems as well as in deciding who had control over what, so this may be the reason everything has clicked off. Let's hope the situation is only a temporary one!

Book reviews aren't normally a part of this column but in this case we can't resist the urge to say a few words about *On The Short Waves, 1923-1945*, by Jerome S. Berg. Sometimes those of us who have been tuning the bands for years tend to get a bit jaded; that special shortwave “feel” gets lost in the yelling of preachers and know-it-alls all over the dial. Or, like a treasured piece of jewelry that turns up under the sofa — it gets lost behind international stations trying to sound like the guys across town. Or it becomes a victim of Old Man Frustration when you can't hear that juicy piece of DX no matter how hard you try.

Subtitled “Broadcast Listening in the Pioneer Days of Radio,” *On the Short Waves* takes you back to radio's first days, to the early experimental shortwave stations, the first international broadcasters, the first QSLs, and other station collectibles (applause cards and Ekko stamps). Berg practically takes you shopping for a (then) new shortwave radio, introduces you to long-gone radio clubs and magazines, the secret stations and government propaganda that filled the airwaves in World War II. The book is filled with dozens and dozens of illustrations — stations, personalities, radios, QSLs, magazine covers, and more. It is, quite simply, a delight. The only negative is the high price (which, of course, was not the author's doing). You'll need \$42.50 plus \$4 shipping. Order direct from the publisher: McFarland & Company, 800-253-2187 or Box 611, Jefferson, NC 28640.

This month's book winner is David Jeffery of Niagara Falls, NY. Dave gets a year 2000 edition of the *World Radio TV Handbook* from **Universal Radio**. The WRTVH is just one of dozens of radio and related books in Universal's monster catalog which offers everything from state-of-the-art receivers to shirt pocket portables and every antenna/accessory imaginable. Get a copy by calling Universal at 614-866-4267.

The **Voice of Mongolia** is on with English from 1200-1230 on **12085**

ON THE SHORT WAVES, 1923-1945

Jerome S. Berg



On the Short Waves by Jerome Berg is an unbeatable nostalgia trip.

beamed to Australia: 1500-1530 to South Asia on **9720 and 12085** and 2000-2030 to Europe on those same frequencies. The 1200 segment is our best opportunity.

Radio Ukraine International airs English at 0100-0200 on **6030 and 9810** (to North America); 0100-0200 to Europe on **5905, 6020, 7205, 9560**; 0400-0500 to North America on **6030, 9810**; 0400-0500 to Europe on **4820, 6020, 7205, 9600**; 1200-1300 to North America on **9870** and to Australia on **21510**. Also 2200-2300 to North America on **6030 and 9810** and to Europe on **4820, 5905, 6020, 7205, and 9560**.

English from **All India Radio** airs from 0000-0045 on **7410, 9705, 11620, and 13625**. Also from 1000-1100 on **11585, 13700, 15020, 17485, 17840, and 17895**. And 1330-1500 on **8545, 11620, 13710**. Again at 1745-1945 on **7410, 9950, 11620, 11935, 13750, 15075, and 15200**. Also from 2045-2230 on **7150, 7410, 9650, 9910, 9950, 11620, and 11715** and lastly 2245-2359 on **7410, 9705, 9950, 11620, and 13625**.

BY GERRY L. DEXTER

**U.S. Department of Commerce
NATIONAL BUREAU OF STANDARDS
RADIO STATION WWV
FORT COLLINS, COLORADO**

2.5 MHz-40°40'55"N, 105°02'31"W 15 MHz-40°40'45"N, 105°02'25"W
5 MHz-40°40'42"N, 105°02'25"W 20 MHz-40°40'53"N, 105°02'29"W
10 MHz-40°40'48"N, 105°02'25"W

This is to confirm your reception report of WWV

on 150 MHz 2355-0030 UTC 31 Dec 1999-1 Jan 2000
Frequencies Time Date

Serial No **29295**

John B. Milton
Engineer-in-Charge

* GPO679-168



Ed Provencher caught the millennium change over on WWV and has this card to prove it. We're still issuing this card to regular "Listening Post" reporters.

Radio Tashkent, Uzbekistan, has English at 0100-0130 on **5955, 5975, 7105, 7285, and 9540**, 1200-1230 on **5060, 5975, 6025, 9715**, and 1330-1400 on **5060, 5975, 6025, and 9715**. And they're also on from 2030-2100 and 2130-2200 on **7105 and 9540**.

Remember that your reception logs are always welcome. Please be sure to list your logs by country, provide at least a double-space between each (so we can navigate scissors more easily) and add your last name and state abbreviation after each. And also, be sure to use only one side of the paper, otherwise some of your logs won't make it into the column. Other things we can put to good use in the column are spare QSL cards you don't need returned (or good quality copies), station photos and other items from stations, including schedules, brochures, etc. And, hey! How about a photograph of you at your listening post? As always, thanks so much for your continued interest and cooperation!

Here are this month's logs. All times are in UTC, which is five hours ahead of EST, i.e. 0000 UTC equals 7 p.m. EST, 6 p.m. CST, 5 p.m. MST, and 4 p.m. PST. Double capital letters are language abbreviations (FF = French, AA = Arabic, SS = Spanish, etc.). If no language abbreviation is included, the broadcast is assumed to have been in English.

ALASKA — KNLS, **7365**, 1302 with sign-on, ID, Bible stories, E-mail address. (Newbury, NE) 1305 experiencing technical problems. (Northrup, MO) 1300-1358 sign-off. (Silvi, OH)

ALBANIA — Radio Tirana, **7160** at 0330 with news. (Brossell, WI) 0335. (Burrow, WA; Newbury, NE) **9750** at 2127 in presumed

Albanian. Mentions of Tirana and Albania at sign-on. (Silvi, OH) Adventist World Radio, **9870** with religious program at 0900, //12070. (Alexander, PA)

ALGERIA — Radio Algiers, presumed, **7245** at 0410. Long song, AA announcements. (Paszkiwicz, WI) **15160** at 1412 in FF with talk by woman, music. (Jeffery, NY)

ARMENIA — Trans World Radio, **6240** with talks in Kazakh and into local music at 0039. (Montgomery, PA)

ANGOLA — Radio Nacional, **4950** at 0255 to past 0310 with PP pops, ballads, time pips at 0300, and talk. Very weak. Better on //11954.9. (Alexander, PA)

ANGUILLA — Caribbean Beacon, **6090** at 0328 with Gene Scott. (Newbury, NE)

ANTIGUA — BBC World Service relay, **5975** at 0000. **6195** at 1028. (Jeffery, NY) **15220** at 1309. (Newbury, NE)

ARGENTINA — RAE, **11710** at 0309 in FF with narrative and music. (Burrow, AZ) 0312 in FF. (Newbury, NE)

ASCENSION — BBC World Service relay, **15390** at 2114. (Jeffery, NY) **21660** at 1616 with music of Kenya. (Barton, AZ)

AUSTRALIA — Radio Australia, **9500** at 1129, **9580** at 1131 and **9710** (in Pidgin) at 0906. (Becker, WA) **9580** at 1435 and **11650** at 1210. (Miller, WA) **9580** at 1400 and **21740** at 2105. (Jeffery, NY) **9580** at 1508. (Newbury, NE) **9710** in Pidgin at 1017. (Barton, AZ) **21740** at 0000. (Wilson, MA)

AUSTRIA — Radio Austria Int'l, **6015** via Canada at 0530. **17865** via Canada at 1600. (Newbury, NE) 0645. Blue Danube Waltz at 0658. (Wilden, IN) **13730** at 0537 with news about Europe. (Foss, AK) **17865** at 1615. (Linonis, PA)

AZERBAIJAN — Radio Dada Gorgud, **9165** at 0343 with music and talk in Azerbaijani. Fluttery signal. Off at 0359. (Brossell, WI)

BELARUS — Belarusian Radio, 6190 with world news in RR at 1302. (Miller, WA)

BELGIUM — Radio Vlaanderen Int'l, 9925 at 0742 in DD. (Becker, WA) 2100 to

Abbreviations Used in Listening Post

AA	Arabic
BC	Broadcasting
CC	Chinese
EE	English
FF	French
GG	German
ID	Identification
IS	Interval Signal
JJ	Japanese
mx	Music
NA	North America
nx	News
OM	Male
pgm	Program
PP	Portuguese
RR	Russian
rx	Religion/ious
SA	South America/n
SS	Spanish
UTC	Coordinated Universal Time (ex-GMT)
v	Frequency varies
w/	With
WX	Weather
YL	Female
//	Parallel Frequencies

2158 in DD to Africa. (Silvi, OH) **11980** in EE (via Bonaire) at 0409; 0418. (Burrow, WA; Miller, WA) **13670** (via Bonaire) at 2239. (Wilden, IN) 2240. (Newbury, NE) **17695** via Germany at 1830 with EE to Africa. (Silvi, OH) RTBF International, **17570** (via Germany) at 1600 sign-on with EE/FF IDs and into FF. (Linonis, PA)

BENIN — Radiodiffusion du Benin, tentative, **5025** at 2145 in FF. U.S. pops. Weak with rapid fluttery-like fades. Not //7210.2. Off with anthem at 2200. (Montgomery, PA) **7210.3**, 2205-2237. Woman with talk, hi-life music, IDs. (D'Angelo, PA)

BOLIVIA — Radio Mosoj Chaski, **3310**, 0800 sign-on with opening ID, orchestra national anthem, and opening SS announcements. (D'Angelo, PA)

BOTSWANA — VOA relay, **9775** at 0445. (Newbury, NE) 9885 at 0300 sign-on. (Newbury, NE) **12080** at 0550. (Foss, AK) **15545** at 1750 in unidentified language. (Brossell, WI)

BRAZIL — Radio Bandeirantes, **9645** in PP at 0213. Mentions of Brazil, ID, jingle. (Paszkiwicz, WI) **1925** at 0015 in PP. (Newbury, NE) **0310** with PP talks, music. (Brossell, WI) Radio Universo, **9565** at 0212 with impassioned speech in PP. (Paszkiwicz, WI) Radio Pioneira, **5015** at 00298. U.S. pops and man announcer. Very poor. (Montgomery, PA)

BULGARIA — Radio Bulgaria, **9400** monitored at 0043 with pop/rock, ID, IS, sports. (Newbury, NE)

CAMEROON — RTV Cameroon, Yaounde, man, later woman announcer in FF. (Montgomery, PA)

CANADA — CBC Northern Service, **9625** at 2115, into CBC news. (Linonis, PA) Radio Canada Int'l, **9770** at 2107 with news. (Wilden, IN) **13690** at 2131 with news, mail-bag. (Jeffery, NY) **15325** with comedy show at 2208. (Barton, AZ)

CENTRAL AFRICAN REPUBLIC — Radio Centrafrique, **5035.2** in FF at 2207 with lively hi-life music, rap, male announcer, IDs. (D'Angelo, PA) **5035.0** with ID at 2200, into rap and African music. (Montgomery, PA)

CHAD — Radiodiffusion Nationale, **6165** at 2156-2204 close with vocals, FF talk by woman. Closed with orchestra national anthem at 2202. (D'Angelo, PA)

CHINA — China Radio Int'l, **7405** at 1443 with Western-style modern Chinese music. (Newbury, NE) **9730** (via French Guiana) at 0430. (Wilden, IN) Voice of the Strait (presumed) **4900** at 2216 with CC operatic vocals, talks by man and woman. (D'Angelo, PA) Central People's Broadcasting Station, **15710** in CC at 0437. (Foss, Philippines)

CHILE — Voz Christiana, **11690** at 0440 in SS with ID "La Voz Cristiana en Lima, Peru" several times, then religious rock. Also **21550** at 2250. (Newbury, NE) (*That must have been a program/studio ID as the transmitters are in Chile — Ed*) **21550.2** at 1410 in SS with contemporary Christian music. //17680.07. (Alexander, PA)

CONGO (Dem. Republic) — Radio Congo (tentative) **5985** in FF at 2148 with mix of talk and hi-life vocals. Fair until WYFR IS started at 2155. (D'Angelo, PA) **15245** at 1435 with news in FF. (Jeffery, NY)

COSTA RICA — RFP1, **6975** at 0556. (Newbury, NE) **15050** at 2051. (Jeffery, NY) **15495** at 2324. (Miller, WA) University Network (Gene Scott) **5030.1** at 0110, //6150, 7375, 9725, 13750. 11870 not heard. (Alexander, PA)

CROATIA — Croatian Radio, **9925** (via Germany) at 0306 with ethnic song, man in Croatian, woman with ID. (Newbury, NE)

CUBA — Radio Havana Cuba, **6000** at 0108 and 0245. (Wilden, IN) **9820** at 0445. (Newbury, NE)

CZECH REPUBLIC — Radio Prague, **7345** at 2230 with news, weather, "From the Weeklies," "Letter From Prague." (Burgess, MA) 0415 with financial news. (Barton, AZ) **21745** at 1445 closing program with Dvoarak. (Newbury, NE) 1700. (Linonis, PA)



**RADIO FREE EUROPE
RADIO LIBERTY**

RFE/RL INCORPORATED
1201 CONNECTICUT AVENUE, NW
WASHINGTON, DC 20036
TELEPHONE (202) 457-6900

LETTER OF VERIFICATION

Mr. Eldon Geiman

14 September, 1999

Dear Mr. Geiman:

Thank you for your reception report of Radio Liberty's program in Kazakh, heard on April 10, 1999, as follows:

1330 - 1400 UTC on 15255 kHz via Udorn, Thailand

Please accept this as full verification of your reception.

Yours truly,

David Epstein
Assistant Broadcast Operations Liaison

TO SEEK, RECEIVE AND IMPART INFORMATION AND IDEAS... REGARDLESS OF FRONTIERS
Universal Declaration of Human Rights

Eldon Geiman (PA) got this letter QSL from RFE/RL for the Radio Free Asia service broadcast via Thailand.

DENMARK — Radio Denmark, via Norway, **9590** at 0640 in Danish. (Becker, WA)

ECUADOR — HCJB, **9745** at 0630; **9765** in FF at 0634; **9780**, //9745 at 0635; **17795** in FF at 1915. (Becker, WA) **9745** at 0308. (Newbury, NE) 0738. (Wilden, IN) **17660** at 1928. (Jeffery, NY) Radio Centro, **3290** in SS at 1032 with long ad string, time check, economic talk, ID, and time check at 1047. (D'Angelo, PA)

EGYPT — Radio Cairo, **9900** at 2120 with news. (Wilson, MA) 2141 with Mideast news. (Burrow, WA) 2309 with info about QSLs. (Becker, WA) 0030 with clearest audio I've ever heard from them. (Silvi, OH) **12050** in AA at 0545 and 0747. (Foss, AK)

ENGLAND — Radio Wales Int'l, **9735** at 0300 with Celtic notes and contest info. (R.C. Watts, KY) BBC, **5975** (*Antigua — Ed*) at

0032. (Wilden, IN) **9410** at 0672 and **9415** at 0704. (Becker, WA) **9915** at 0107. **9590** (via Delano, CA) at 0000. **15400** at 2000. (Jeffery, NY) (Newbury, NE)

EQUATORIAL GUINEA — Radio Africa, **15184.8**, 2250 to 2303 sign-off. U.S.-produced EE religious programming from Washington, D.C. ID at 2257 followed by a four-minute announcement giving addresses in Cupertino, CA; Equatorial Guinea, Nigeria (2), Liberia, and Ghana. Off with national anthem. (Alexander, PA)

FINLAND — YLE/Radio Finland, **9560** in Finnish and //9940 at 0712; **9840** at 0737 in EE; **9940** in Finnish at 0707 and //9560. (Becker, WA) **9655** at 0312 and **11665** at 0302. (Burrow, WA) **11655** at 0325. Also at 1930 sign-off. (Miller, WA)

FRANCE — Radio France Int'l, **7135** in



Ed Turner's shack in Ohio. Feel free to drool over those neat old Hallicrafter sets!

FF at 0500. (Becker, WA) 11615 at 1610 with news. (Newbury, NE) 17620 at 2241 in FF. (Wilden, IN)

FRENCH GUIANA — Radio France Int'l relay, 17630 in SS at 1810. (Brossell, WI)

GABON — Africa Number One, 9580 with Afro-pops and ID at 0529. (Becker, WA) 2255 with laughter, rock. (Newbury, NE) 15475 at 1830 in FF. (Linonis, PA)

GERMANY — Deutsche Welle, 9545 in GG from 1915 to past 2110, listed //13780 not heard. (Silvi, OH) 15275 in GG at 1600. (Newbury, NE)

GHANA — Ghana Broadcasting Corp., 3366 at 2235 with mostly reggae music and some rap. (Montgomery, PA)

GREECE — Voice of Greece, 9375 at 1420 in Greek. (Northrup, MO) 9425 at 2240 in Greek with Greek music. (Newbury, NE) 17705 and 17565 with ID, narrative, and music. (Burrow, WA) 17705 via Delano, CA, with Greek folk music at 1925. (Barton, AZ) Voice of America relay, 15205 at 1421. (Jeffery, NY) Radio Liberty (RFE/RL — Ed) 7190 in RR with "Radio Svoboda" ID. (Becker, WA)

GUATEMALA — Radio Tezulutlan, 4835 in SS at 0400 with talk, possible religious music. (Linonis, PA)

GUINEA — Radio Conakry, 7125 in FF at 0605. (Becker, WA)

HAWAII — KWHR, 17510 at 0241 with call-in program. (Foss, Philippines)

HONDURAS — La Voz Evangelica, 4820 at 0421 with SS religious music. (Miller, WA)

HUNGARY — Radio Budapest, 9835 at 0330 sign-on. (Newbury, NE)

INDIA — All India Radio, 4850 Delhi, 0028 with Hindi vocals to EE ID followed by 3 plus 1 time pips at 0030 and news. Poor sig-

nal (D'Angelo, PA) 9545 at 1433. (Miller, WA) 9910 and 11715 at 2208 with news. Also 13750 at 1807. (Burrow, WA) 11585 in listed Baluchi at 1510, local instrumental music. (Newbury, NE) 11620 at 1850. (Linonis, PA) 11830 at 0300 in unidentified language. Many mentions of Pakistan and India. (Brossell, WI) Heard on 13620 at 0441 with woman in AA. (Foss, Philippines)

INDONESIA — Radio Republik Indonesia, Ujung Pandang, 4754 in II at 1400. (Miller, WA) 4753.30 with pop at 1330. (Barton, AZ) 2212 with vocals and talk. IS repeated 7 times at 2229 followed by 5 plus 1 time pips, news by man with remote reports. (D'Angelo, PA) RRI, Jambi, 4925 with continuous Islamic prayer to 2257, Song of Coconut Islands (SCI). Stopped at 2259, then man with talks. (Montgomery, PA) 2241 with brief talk, Koran recitation until SCI at 2359. (D'Angelo, PA) RRI Pekanbaru, 5040, 2238 with brief snippets of music, SCI at 2259, RRI ID and news. (D'Angelo, PA) SCI heard at 2301, talks and back to music. (Montgomery, PA) RRI Merauke, 3905 at 1154 with pops to 1200, SCI, RRI ID, apparent news. (D'Angelo, PA) Voice of Indonesia, 9525 at 1055 in CC. (Becker, WA)

IRAN — Voice of Islamic Republic of Iran, 7190 in EE at 1900. (Neubauer, OR) 9022 at 0033 with Islamic music, praise to Allah, news. (Burgess, MA) 9575 at 2320 in AA with music. (Becker, WA)

IRELAND — Radio Telefis Eirann (RTE), via England, 6155 at 0130 and 15315 at 1800. (Neubauer, OR) 13640 with 1830 sign-on. (Linonis, PA) 21630 at 1830 via Ascension Island. (Burrow, WA)

ISRAEL — Kol Israel, 7545 in HH at 0521. (Becker, WA) 11585 at 0033 in unidentified

language, pops. (Miller, WA) 11590 at 1845 in HH. (Linonis, PA) 15640 in HH at 1800. (Brossell, WI) 17545 at 1713 in HH. (Newbury, NE)

ITALY — RAI, 9760 at 1936 with news and frequencies. (Burrow, WA) 11800 at 2305 in II. (Newbury, NE) Italian Radio Relay Service, 7120 at 0220 with Nexus. 0755 with suppressed carrier USB. "Words of Life" religious program, ID at 0800. (Alexander, PA)

IVORY COAST — RdtV Ivoirienne, 4940 at 0515 in FF and vernacular. Weather, news, and commentary. (Linonis, PA)

JAPAN — Radio Tampa/NSB, 6055 in JJ at 0808, 6115 at 0745, and 9595 at 0715. (Becker, WA) Radio Japan/NHK — 6145 at 0800, into RR: 9505 at 1400; 11715 in RR at 0600; 13650 in CC at 2245; 17825 in JJ at 2221; 17835 in JJ at 0250; 17875 in JJ at 0247. (Becker, WA) 11730 at 1510. (Newbury, NE) 11910 at 0347 in JJ, in CC at 0351. 17685 at 0151 in JJ. (Foss, Philippines)

JORDAN — Radio Jordan, 11690 in AA at 1605. (Newbury, NE) 11970 in AA at 0008. (Becker, WA)

KUWAIT — Radio Kuwait, 9855 at 2110 in AA. (Newbury, NE) 15495 at 1800 in AA with talks and music. (Brossell, WI)

LIBYA — Radio Jamahiriya, 15435 in AA at 1625, pips at 1630. (Newbury, NE) 1755 in AA. (Brossell, WI)

LITHUANIA — Radio Vilnius, via Germany, 6120 at 0032 with news, E-mail address. (Newbury, NE) 0035 with news. (Wilson, MA)

MADAGASCAR — RTV Malagasy, 5009.7 at 0318 with long sermon by man, choir, brief prayer. ID by woman, brief talk by man and woman, gongs, and another Sunday morning religious program. (D'Angelo, PA)

MALI — Radio Malienne, 5995 with guitar SS at 0555. (Paszkiwicz, WI)

MAURITANIA — Radio Mauritanie, 4845 at 0055 to 0100 close. Koran, quick announcement and off. Also heard at 0632 with Koran. (Alexander, PA)

MALAYSIA — Voice of Malaysia, Kuala Lumpur, 6175 and 9750 monitored at 1700. Unidentified language. Narrative and local music. (Burrow, WA) RTV Malaysia, 7295 at 1123. Speech about Islam with commentary by woman, ID, music request program at 1130. (D'Angelo, PA)

MEXICO — Radio Educacion, 6185 in SS at 0741. (Becker, WA) Radio Mexico Int'l, 9705 at 0404 with "DXperience" in EE. (Burrow, WA)

MOLDOVA — Voice of Russia relay, 7125 at 0555. (Becker, WA) 7180 at 0440. (Newbury, NE)

MONACO — Trans World Radio, 9870 at 0913. (Becker, WA)

MONGOLIA — Voice of Mongolia, 9720 at 2001 with news, weather, music, and talk with U.S. visitor about U.S.-Mongolian cultural exchanges. Schedule and off at 2028. (Burrow, WA) 12015 at 1315 in either CC or Mongolian. Woman announcer and music. (Linonis, PA)

MOROCCO — RTV Marocaine, 15345 at 1447 in AA with music, talk. (Jeffery, NY) VOA relay, 7295 at 0602. (Becker, WA) 15240 at 1745. (Brossell, WI) 15420 at 1615. (Newbury, NE)

MYAMAR — Radio Myamar, 4725 at 1152 with talk by woman, short music segment at 1200 prior to ID and news. (D'Angelo, PA)

NETHERLANDS — Radio Netherlands, 5955 at 0807. News in DD (Newbury, NE) 11655 via Madagascar at 1930 with ID, news. (Becker, WA) 13700 at 1905 with "Sound Fountain." (Wilson, MA)

NETHERLANDS ANTILLES — Radio Netherlands via Bonaire, 17605 at 1929 with frequency info, ID, news, weather, "Sincerely Yours." "Dutch Horizons." (Jeffery, NY)

NEW ZEALAND — Radio New Zealand Int'l, 17675 at 0006 with "Cadenza." (Jeffery, NY) 0332 "A Question of Religion." (Burrow, WA) 0355 with rock, ID. (Newbury, NE) 1908 with "Morning Report." (Becker, WA)

NIGER — La Voix du Sahel, 5025 at 0530 in AA with music. (Linonis, PA)

NIGERIA — Voice of Nigeria, 7255 at 0455 sign-on with drums, ID, man, woman, more drums, music. (Newbury, NE)

NORTH KOREA — Radio Pyongyang, 9344 in unidentified language at 1012. (Barton, AZ) 9975 in RR at 0737. Also 11710 at 1930 with EE ID. (Becker, WA) 11735 at 2000. (Linonis, PA) 13650 at 0005 with news. (Newbury, WA)

NORWAY — Radio Norway, 7180 at 0703 and 9590 at 0714, both in NN. (Becker, WA) 15705 in NN at 1500. (Newbury, NE) 1805. (Brossell, WI)

OMAN — BBC relay, 15310 at 1525 with news. (Newbury, NE)

PALAU — KHBN, 15725 at 0706 in CC. (Foss, AK) Radio Free Asia via KHBN, 9910 at 1505 in CC. (Newbury, NE)

PAPUA NEW GUINEA — NBC, 4890 at 1339 with local pops. (Miller, WA)

PERU — La Voz de la Selva, 4824.5 at 1049. ID 1050, flute music. SS. (Montgomery, PA) Radio Municipal, 3172.8 at 1036. Tentative ID. SS. (Montgomery, PA) Radio Union, 6115 at 0252. SS, ballads, ID. (Paszkiwicz, WI) Radio Comas, 3250.8 at 1053 with rustic vocals, SS ID, commercials, more vocals. (D'Angelo, PA) Radio Norandina, 4463.7 at 1108 with rustic vocals and talk, ID, and TC. (D'Angelo, PA) Radio Amistad, 4515.7 at 0009 with woman hosting SS program of rustic Peruvian vocals, ID 0020. (D'Angelo, PA) Radio Tarma, 4775 at 1055, SS man hosting lively vocals with ID, TC. (D'Angelo, PA) Radio Sicuani, 4826.3 at 1022 with long SS talk, ID and TCs, vocals. (D'Angelo, PA) Radio Libertad, 5039.2 at 1040 with huaynos, IDs, TC. Clobbered by La Voz del Upano sign-on at 1056. (D'Angelo, PA) Radio Santa Rosa, 6045.4 at 0911. Two women in SS, numerous mentions of the station. (D'Angelo, PA) Radio San Miguel del Faique, tentative, 6895.4 at 0053. Peruvian vocals, man announcer, possible ID at 0123. Ute QRM. (D'Angelo, PA)

PHILIPPINES — Radio Pilipinas, 11730.3 at 1838 in Filipino. Narrative and ID at 1854. (Burrow, WA) 15190 at 1902-1930 close. Man talking, short group vocals, ID, and frequency announcement at 1918, more talk by woman to sign off ID "This is Radio Pilipinas, Philippine Broadcasting Company" and frequencies. Noted sked for 0230-0330 on 11885, 15120, and 15270. (D'Angelo, PA) Voice of America relay, 12040 at 1604. (Newbury, NE) 15425 at 1454. (Jeffery, NY)

POLAND — Radio Polonia, 7180 at 0400 with talk about the Pope. (Linonis, PA)

PORTUGAL — RDP Int'l, 13770 at 2008 with sports event in PP. (Newbury, NE) 15545 in PP at 1805. (Brossell, WI) Deutsche Welle relay, 7225 in GG at 0621. (Becker, WA)

PUERTO RICO — AFRTS, 6485.5 at 0025 with various features. (Newbury, NE)

ROMANIA — Radio Romania Int'l, 9510 at 0646 and 9530 at 0649. (Becker, WA) 11740 at 1708 with ID, news, sports, discussion. Also 11940 at 2000. (Burrow, WA) 15365 at 1750. (Brossell, WI)

RUSSIA — Voice of Russia, 6205 in RR at 2105. Man in EE with various types of music. (Montgomery, PA) 7260 at 1645 with music. (Barton, AZ) 7180 at 0556; 7195 at 0645 close; 15470 in EE at 0310; 15525 in RR at 0300; 15595 in RR at 0300; 17660 in RR at 0250. (Becker, WA) Radio Yakutsk, 7200 at 0805 relaying Radio Rossi and 1026 in RR. (Becker, WA) Radio Rossi, 7250 in RR at 0615 and 9860 at 0709. (Becker, WA) Radio Khabarovsk, 7210 in RR at 0611 relaying R. Rossi. Also in RR at 0710 and 1025. (Becker, WA) Radio Tikhiv Okean, 7175 in RR at 0556. (Becker, WA)

RWANDA — Deutsche Welle relay, 17860 at 2228 in GG. (Becker, WA) 2300 in GG. (Newbury, NE)

SAO TOME — VOA relay, 6080 with news at 0602. (Becker, WA)

SAUDI ARABIA — Broadcasting Service of the Kingdom of Saudi Arabia, 9870 in AA at 2254. (Newbury, NE) 11710 at 1900, possible radio drama. (Linonis, PA) 15435 at 1657 in EE with "Nostalgia" program of interviews. Into development program at 1716. "Shares" frequency with Libya. (Burrow, WA)

SEYCHELLE ISLANDS — Far East Broadcasting Association, 11600 at 1500 with "What a Friend We Have in Jesus" IS and EE sign-on. (Newbury, NE) BBC relay, 11730 at 0315. (Brossell, WI)

SIERRA LEONE — Sierra Leone Broadcasting Service, 3316 with news at 2226, restrictions on types of commercials carried on radio and TV, ID at 2231. (Montgomery, PA)

SINGAPORE — Radio Corporation of Singapore, 6150 at 1434 with mentions of QSL person's name, pop, rap. (Newbury, NE) BBC relay, 11955 at 2306. (D'Angelo, PA)

SLOVAKIA — Radio Slovakia Int'l, 7345 monitored at 1729 with ID, schedule, news. (Burrow, WA)

SOUTH AFRICA — South African Broadcasting Corp., 3320 at 2350, possibly Madonna. ID at 2351. (Montgomery, PA) BBC via Meyerton, 7125 at 0313. (Becker, WA) 15420 at 1755 with sports. (Brossell, WI) Channel Africa, 9525 at 0316 with news. (Newbury, NE) 15215 at 0506 with ID, African news, drum. (Paszkiwicz, WI) Adventist World Radio, 9745, in FF from 2000-2030, EE 2030-2059. (Silvi, OH)

SOLOMON ISLANDS — Solomon Is. Broadcasting Corp., 5980 (you mean 5020, Mike?) at 1240 with local country tunes. (Miller, WA)

SPAIN — Radio Exterior de Espana, 6055 at 0439, 0551; 11945 at 0010, all SS. (Becker, WA) 6055 in at 0508 with EE news. (Newbury, NE) 12035 in SS at 0746. (Foss, AK) 21700 in SS at 1630. (Linonis, PA)

RADIO NEDERLAND

PG

HILVERSUM NETHERLANDS

wish to convey to you their appreciation of your kind communication regarding the transmission of the

NETHERLANDS WORLD PROGRAMME

broadcast by PCJ, PHI and PGD.

PCJ's rotating beam aerial, which can be directed to every part of the world.

PCJ: Freq. 1522 Mc. - 1971 m. 6.59 Mc. - 3129 m.
PHI: Freq. 1777 Mc. - 1688 m. 1173 Mc. - 2557 m.
PGD: Freq. 602 Mc. - 4979 m.
Position: Latitude 52°17'52" N. Longitude 5°18'48" E.

As long as we're on a nostalgia kick, here's a repro of the famous PCJ — Netherlands QSL.

SRI LANKA — Deutsche Welle relay, **15275** in GG at 1851. (Becker, WA) Radio Japan relay, **11890** in JJ at 0159. (Becker, WA)

SWEDEN — Radio Sweden, **9495** at 0525 in SS. Off in mid-word at 0530. (Becker, WA) 0330 with news, weather in "60 Degrees North" program. (Burrow, WA) **18960** at 1447 with various features in EE. (Newbury, NE) IBRA Radio, via Moscow, 2029 with news, glockenspiel, ID, off. (Miller, WA)

SWITZERLAND — Swiss Radio Int'l, **9885** at 0123 with features, schedule, and URL. (Wilden, IN) 0420 with news, //9905. (Newbury, NE) 0752 (via French Guiana) with Swiss music. (Foss, AK) 0840 (via FG) with news analysis. (Barton, AZ) **9905** at 0305. (Burrow, WA)

TAIWAN — Radio Taipei Int'l, **5950** via WYFR at 0300; **7130** (direct) at 1253. (Newbury, NE) **9355** via WYFR at 2230. (Burgess, MA) **11970** at 0342. (Foss, Philippines)

THAILAND — Radio Thailand, **9530** at 1408 with political discussion. (Miller, WA) **13695** at 0048 with various features, ID, time, anthem? Into Thai at 0100. (Burrow, WA) **15460** at 0030. (Neubauer, OR) VOA relay, **11920** at 1620 with sports, //15240. (Newbury, NE) **15460** at 1505. (Jeffery, NY)

TURKEY — Voice of Turkey, **7300** at 0420 in TT. (Newbury, NE) **9445** and **9460** at 0521; **9835** at 0645, all TT. (Becker, WA)

UNIDENTIFIED — **9745**, audible the instant AWR via South Africa goes off at 2059. Sounds like Arabic. Alternating male/female talk, occasional music, mentions of "amen" and "alleluia" at the end of what sounded like a prayer. Possible mention of "...transmit Africa" and gave possible address. Still going after 2200. (Silvi, OH)

UNITED ARAB EMIRATES — UAE Radio, Dubai, **13675** at 0340 in EE. Koran teaching, EE ID, closing with "thank you for listening." (Newbury, NE) 1800 in AA. (Wilson, MA) **21700** at 0436. (Foss, Philippines)

UNITED NATIONS — UN Radio, **25930** USB in EE at 1545. Unidentified transmitter site. (Paszkiwicz, WI)

UZBEKISTAN — Radio Tashkent, presumed, **17775** at 1300 in Uzbek with news, commentary. (Linonis, PA)

VENEZUELA — Radio Tachira, **4830**, political speech in SS at 0345. (Linonis, PA)

VIETNAM — Voice of Vietnam, **7260** (via Russia) at 0330 with ID, news. (Burrow, WA) 0332 with "Welcome to the Voice of Vietnam." (Newbury, NE) **12035** (direct) at 0323 in presumed VV. (Foss, Philippines)

ZAMBIA — Radio Zambia, **6265** with carrier on at 0120, IS at 0235-0255, and ID by man in EE. Short, non-EE talk and into African music. (Montgomery, PA) 0246 sign-on with fisheagle IS, choral vocal music open-

ing at 0250, drums at 0252, and man with ID. (D'Angelo, PA)

A mighty roar of approval to the following good folks who did the good deeds this time: Pete Becker, Clarkson, Washington; Brian Alexander, Mechanicsburg, Pennsylvania; Mark Northrup, Gladstone, Missouri; Lee Silvi, Mentor, Ohio; Robert Montgomery, Levittown, Pennsylvania; Richard D'Angelo, Wyomissing, Pennsylvania (Logs by Montgomery and D'Angelo were made on a Dxpedition with three other DXers at a Pennsylvania state park); Sue Wilden, Nobelsville, Indiana; Jim Wilson, Worcester, Massachusetts; Ed Newbury, Kimball, Nebraska; Dean Burgess, Manchester, Massachusetts; Rick Barton, Phoenix, Arizona; Bruce Burrow, Snoqualmie, Washington; Marty Foss, Talkeetna, Alaska (also DXing from the Philippines); David Neubauer, Eugene, Oregon; David Jeffery, Niagara Falls, New York; Jack Linonis, West Middlesex, Pennsylvania; Sheryl Paszkiwicz, Manitowoc, Wisconsin; R.C. Watts, Louisville, Kentucky, and Mike Miller, Issaquah, Washington.

Thanks to each one of you! Until next month, good listening! ■

Getting Started Videos



Getting Started in Ham Radio—

How to select equipment, antennas, bands, use repeater stations, grounding, basic soldering.

Getting Started in VHF—Intro to VHF. Repeater usage, packet, satellites and more exotic VHF op modes.



Getting Started in Packet—

De-mystify packet. Info on making contacts, bulletin boards, networks, satellites.

Getting Started in Amateur Satellites—How ops set up stations. Locate and track ham satellites.



Ham Radio Horizons—Step-by-step instructions for the prospective ham on how to get involved.



Getting Started in DXing—Top DXers share experiences with equipment, antennas, op skills and QSLing.



Getting Started in Contesting—Advice and op tips from Ken Wolf, K1EA, K1AR and others!

\$19.95 each—

Buy more and save!

Buy 2 or 3 for \$17.95 each

Buy 4 to 6 for \$15.95 each

Buy all 7 for your Club for only \$99.95!!

Name _____
Address _____
City _____
State _____ Zip _____

Qty _____
 Getting Started in Ham Radio
 Getting Started in VHF
 Getting Started in DXing
 Getting Started in Packet Radio
 Getting Started in Ham Satellites
 Getting Started in Contesting
 Ham Radio Horizons
 Total Videos X \$ _____ = \$ _____
 Shipping/handling \$ _____
 Total \$ _____

Also available in PAL format.

U.S. and possessions - add \$4 shipping/handling. *FREE S/H on orders \$50 and over.

Foreign - shipping/handling charges are calculated by order weight & destination. *A \$4 credit will be applied for Foreign orders over \$50.

Credit Card No. _____ Expiration date _____
 Method of payment Check Money Order Visa MasterCard Discover American Express



**Call Toll-Free
1-800-853-9797**

washington beat

FCC Actions Affecting Communications

CB Radio's 155 Mile Rule Petition Update

The petition filed last fall to repeal the CB Radio Service 155 mile distance of communications rule (47 CFR 95.413(a)(9), CB Rule 13) has been assigned a docket number. It is now **RM-9807**, and was opened for a 30-day public comment period on January 14. The National Association of Broadcasters (NAB) and the American Radio Relay League (ARRL) filed formal comments against the repeal, citing concerns over possible increased use of illegal transmit power levels, among other matters. (See "Tuning In," this issue.) At least 17 other parties, mainly individuals, submitted late-filed comments electronically at the FCC Web site. Many of these filings were favorable toward RM-9807. There is no further indication at press time as to which direction the FCC may proceed on this matter. Stay tuned.

Would Congress Like To Do The FCC's Job?

Evidently, they feel qualified. The Federal Communications Commission used to be dominated by engineers and other technical types. Today, the Commission is top-heavy with lawyers. So is Congress. Why, then, even have an FCC? Think how much taxpayer money could be saved by having congressional committees doing such things as frequency planning, interference mitigation, and propagation studies. Let's look at how Congress is plying its hand in radio communications this month.

Here we go again. **H.R. 514 is back** — this time neatly tucked into **H.R. 3489**. To refresh everyone's memory, H.R. 514 was the latest anti-scanner legislation being pushed through Congress. It is still alive, though just barely. Since being passed by the House in 1999, it has languished in the Senate Commerce Committee with no action as of this writing. The newer bill, known as the Wireless Telecommunications Sourcing and Privacy Act, was introduced last November by Congressman Chip

Pickering (R-MS-3rd). It is co-sponsored by, of course, Telecommunications Committee Chair Billy Tauzin, as well as Heather Wilson, author of H.R. 514, among others. Using a well-known political tactic, language nearly identical to that of H.R. 514 has been placed as Sections 5 and 6 of the newer, and presumably more desirable H.R. 3489. The opening sections of the newer bill propose simplified taxation of wireless telephone service. Any simplification of taxation will likely be equated by many as *lowered* taxes, hence the desirability of the bill. Another provision of the bill would further emasculate the FCC by excluding it from having any jurisdiction over this taxation matter.

The first objective of H.R. 3489 is to essentially provide that mobile telephone subscribers be taxed only in their home jurisdiction, or "place of primary use." If enacted into law, mobile phone users would not have to fear being taxed while roaming both in the roaming jurisdiction and at home. Why *wouldn't* this concept be popular in an election year? Therein lies the danger. If the bill passes both houses of Congress as written, then consumers and radio hobbyists will radically have to change how they conduct their activities, or face severe consequences.

Both H.R. 514 and H.R. 3489 propose identical limitations on scanner manufacturing and importation. The language is vague at best, and veteran *Pop'Comm* readers are well aware of its implications. Still, the biggest threat is the fundamental change to Section 705 of the Communications Act (47 USC §605(a)(6)). Changing the word "and" to "or" in having it being unlawful to "intercept . . . and divulge" any radio communication, as proposed by H.R. 514, raises obvious new concerns. H.R. 3489 would leave "and" intact, but change the entire phrase to render it unlawful to "intercept any radio communication, and no person having intercepted such a communication shall intentionally divulge (it)." Either way, casual reception of many radio communications would be

" . . . casual reception of many radio communications would be illegal."

illegal. As with H.R. 514, the newer bill does allow reception of services and frequencies not already prohibited by the Electronic Communications Privacy Act (ECPA, 18 USC Ch. 119, §§2510, et seq.) How generous.

While H.R. 3489 could sail right through the House, it would still have to make its way through the Senate. There is however, already a Senate version of the bill, S. 1755. Interestingly, the Senate version contains none of the privacy provisions of H.R. 514. The Senate Commerce Committee had been reluctant to put H.R. 514 on the table, and they are reluctant to tack the language of H.R. 514 onto the Telecommunications Sourcing Act. Only time will tell if the House or Senate version of the Act, or a compromise version, will prevail if any prevails at all. Congress still had other tinkering to do, though.

They Want To Outlaw LPFM!

Are you fascinated by the coming new Low Power FM (LPFM) radio service recently authorized by the FCC in MM Docket 99-25? Well, you may not want to run out and spend any serious cash on setting up your new radio station just yet. Congress may have another idea here. **H.R. 3439**, the Radio Broadcasting Preservation Act of 1999, seeks to outlaw LPFM. There is no Washington doublespeak in this bill. It is short and to-the-point. Before it even gets off the ground, LPFM could have its plug pulled. In approving MM 99-25, the FCC exercised appropriate prudence while acting within the scope of its authority. The establishment of LPFM is a premiere example of the Commission actually responding to the requests of its constituents. It is not clear in the language of the bill why

BY ALAN DIXON, N3HOE <n3hoe@juno.com>

“Before it even gets off the ground, LPFM could have its plug pulled.”

Congress might want to ignore the voices of this constituency.

Congressman Oxley introduced H.R. 3439, which as of press time still sits waiting in the House Telecommunications Subcommittee. In spite of LPFM's proponents, some 113 representatives have signed on as cosponsors of this bill to overturn the FCC's action. This is certainly significant. If the bill makes it out of committee, it has a fair chance of passing a full House vote. Your *Pop'Comm* editorial staff will be watching to see what happens next with H.R. 3439.

Your State May Be At It, Too!

The people on Capitol Hill aren't the only ones interesting in micro-managing telecommunications affairs. Your elected *state legislators* may be at it too. A number of states are seriously considering banning the use of mobile telephones by drivers of moving vehicles. Some of us who do not use a cellular phone may find those that do, looking silly in an obsessed sort of way. The ironic thought of cellular addicts being deprived of their phones while stuck in traffic might bring a twisted gleeful smirk to our faces. But we telecommunications who feel that way might want to take a good long gander in the mirror. Political fallout, like nuclear fallout from a meltdown, knows few boundaries. While swinging the axe at telephoning drivers, a number of states' politicians find themselves thinking that if cellular phones are dangerous for drivers, then what makes CB radio, ham radio, and business dispatch radio any safer?

Yes, driver safety is said to be the issue. New bills designed to deal with phoning while driving have in recent months been popping up too quickly to be fully accounted for in this column. There have been literally dozens of these bills, with at least twelve in New York State alone. Some localities have organized citizens' lobbies to push for such restrictions. To listen to some of these groups, one gets the impression that a struggle exists between the cellular industry and the little guy, Joe Citizen. But it is not the industry driving mindlessly down the road with a phone crooked in the neck. It is Joe

Citizen himself. As of this writing, none of these anti-consumer state bills have yet passed. By the time you read this, it could be a different story, though.

What is most disconcerting, literally, is the utter lack of consistency among the various states' intentions. Some want to ban handheld phones while driving. Others want to ban all mobile phone use while driving, no exceptions. Some appear to propose banning cellular phones, but not PCS or SMR (trunked, telephone interconnected two-way radio) phones. Still others threaten to specifically outlaw mobile CB radio as well as mobile phone use by drivers, even as other states would specifically authorize the use of CB while outlawing cell phones. Louisiana H.B. 1151 would authorize cell phone use on school buses, while Virginia's H.B. 737 would prohibit cell phone use by school bus drivers. Arizona's pending S.B. 1017 (44th legis., 2nd reg. session) is so broad in banning

the use of electronic devices while driving, that it would outlaw the majority of cars on the road today. This is because Arizona's bill proposes not only to outlaw mobile phones and two-way radios, but also the use of computer processors in drivers' cars. And how many cars built in the last twenty years *aren't* equipped with microprocessor control circuits? Surely Arizona's late Senator Goldwater, K7UGA/SK, turns in his grave. Who's in charge of all this, anyway? Nobody. And that is the problem. No clear, consistent, national policy on this matter exists.

If you've had it with your elected officials thinking that they know better than you about how to conduct your affairs, then now is the time to contact your state and federal legislators and remind them who it is that they serve. That said, please keep yourself cool during the coming summer heat. Have a question? Let me have it at <n3hoe@juno.com>. See you next month!

Ranger Communications, Inc.

World's Most Reliable CB and Amateur Radios

CB Mobile and Base Applications



TR-296DX Mobile



TR-696F SSB Base

Amateur Mobile and Base Applications



RCI-2950 Mobile



RCI-2990 Base

Ranger now has over 25 models of radios for your choice:

Available at your favorite local dealer.

Ranger Communications, Inc.

Service & Parts:

3377 Carmel Mtn. Rd.

San Diego, CA 92121

1-800-446-5778

Attention Dealers:

Ranger Communications has a new factory-to-dealer only program. Provide your customers with better service with this new program. Please contact the sales department to see if your exclusive area is available.

Sales & Product Information: 1-877-536-0772

Tuning In (from page 4)

of our TVs and a telephone. There's no linear here. On my base, it's a similar story. I've installed a low-pass filter on the base, grounded the entire system, and the interference persists, so I operate when the TV is off and no one is on the phone. Let's face it, you can be a considerate operator, or be "blamed" for a situation that's really beyond your ultimate control. Operating on similar frequencies, hams have faced this problem for years. Please refer to page 12-18, Chapter 12 of the current American Radio Relay League (ARRL) *Operating Manual* (6th edition) which says — about *amateur radio transmissions*, "RFI — radio frequency interference — is a common complaint of owners of unshielded or poorly designed electronic entertainment equipment." (Interestingly, the ARRL is quick to point out how much poorly designed/shielded home entertainment equipment and telephones are problematic, but when it comes to CB operators they change their tune and speak of high-power operators and out-of-band operation — a vast *minority* of operators).

Since the NAB introduced the topic, let's talk more about the interference problem. While not an expensive undertaking for TV, stereo, and phone manufacturers to make quality equipment, the standards of compliance are *voluntary*. And since the public-at-large is ill-informed about consumer electronics, legal by-the-book CBers are frequently singled out and blamed for interference that is, in fact, beyond their control. Fact is, most consumers typically think "CB" when the offending transmission is from a local ham! With more than three decades of radio activity under my belt — OK, and a few chocolate donuts, too — I've heard police, taxi, aircraft, and unknown foreign language transmissions coming through stereos, TVs, telephones, and answering machines. I even heard then Radio Moscow coming through our stereo! I'm sure the NAB and politicians could think of a way to "blame" *someone* for that one, but in all my years in radio, I don't know who they could finger, but it isn't CBers.

Old-timers will remember the days when rumors of the FCC in town brought the fear of God in the hearts of the most upright citizen. No one would be on the air that week. And many of us remember when the use of "handles" was illegal and would make the FCC's blood boil, and when hobby operation on 11-meters was also illegal. All those outdated, useless rules have gone away. So should Rule 13, and with it, the NAB. ■

The National Association of Broadcasters And The ARRL: Whom Do They Serve?

By Alan Dixon, N3HOE <n3hoe@juno.com>

When the FCC assigned docket number RM-9807 to the petition to repeal the impractical CB Radio Service 155-mile distance of communications rule, both the National Association of Broadcasters (NAB) and the American Radio Relay League (ARRL) were moved to file formal comments in opposition. If you are the operator of legal, certified CB radio equipment, you may or may not feel that the Federal Communications Commission should attempt to place a regulatory limit on DX communications. Feeling as you may, you might wish to comment on any proposed deregulation that changes existing rules to that effect. That is your right, and your own business. In fact, such is the right of any party on any FCC matter open to comment.

But how fair or logical is it to comment on a matter that has no effect on you or your business? What interest has either the NAB or the ARRL in the affairs of legitimate CB radio operators? None that we can see. NAB states in its comments, "Consumers must be protected from illegal CB radio transmissions that interfere with . . . forms of electronic communication. In *early February*, the Commission issued its latest forfeiture order to a CB radio operator who was transmitting at a power level in excess of that permitted under the Commission's rules. This operator's transmissions were 'causing widespread interference to telephones and home electronic devices in the area.' It is operators like this one for which Section 95.413(a)(9) is needed." Just what does Section 95.413(a)(9) say, anyway? It reads, "(a) You must not use a CB station— (9) To communicate with, or attempt to communicate with, any CB station more than 250 kilometers (155.3 miles) away." Now, are we the only ones who can see no connection here? What has the use of illegal power levels have to do with authorizing type-accepted CB equipment to work DX skip farther than 155 miles? Did the NAB even *read* RM-9807? And how did this glaring oversight escape the attention of the law office that handled the NAB comments? Given this, why would legitimization of existing CB skip communications concern the NAB at all? Go figure.

The ARRL now actively purports to be "The National Association for Amateur Radio." Excellent. So why would RM-9807 concern the *amateur radio* community? In addition to being licensed hams, would anyone at the ARRL care to admit to being a CB radio operator? Then what business is it of the League? Among other things, the ARRL contends, "The Petition does not establish that there are instances in which CB operators have a legitimate need to exceed the distance limitation." Did not even the League actually *read* RM-9807? The petition states, "emergency communications should *never* be subject to any law, rule, or regulation inhibiting the immediate transport of such message to *any* station in a position to render aid or to forward such message." (*Emphasis original — Ed.*) How much clearer could this need be made? I don't know about Newington, but plain English works where we come from. And life safety matters, too.

We wonder if the bulk of ARRL members would appreciate the League expending its evidently limited resources acting as advocate, adversarial, or otherwise, for the CB community when there are tangible and direct political threats to the Amateur Radio Service. Covenant antenna restrictions and evolving laws to prohibit or restrict mobile use of communications devices could effectively kill ham radio. Allowing DX communications on 11-meters will not.

"Long distance HF communications are readily available in the Amateur Radio Service," the ARRL goes on. Hey, that's great. But that fact does nothing to help those of us trying to cope with 11-meter skip. The solution is not to throw our CB radios in the trash. The solution is a realistic regulatory framework in which to use CB radio.

advertisers index

ADI/Premier.....	35
AOR USA, Inc.....	7
Am-Com.....	68
Alpha Delta Communications.....	25
Antique Electronic Supply.....	30
Antique Radio Classified.....	29
Atomic Time, Inc.....	23
Bill's CB & 2-Way Radio Ser....	67
C. Crane Company.....	Cov III
C & S Sales, Inc.....	55
CQ Amateur Radio.....	38
CQ Amateur Radio Videos.....	75
CQ Merchandise.....	69
CRB Research.....	51,68
Computer Aided Technologies....	43
DWM Communications.....	29
Drake, R.L.....	21
Everhardt Antennas.....	59
Firestik Antenna Company.....	57
GRUNDIG.....	11-14
ICOM America, Inc.....	5
Japan Radio Corp.....	31
Jo Gunn Enterprises.....	68
Lee Electronics Company.....	30
Lentini Communications, Inc.....	1
Lextronix, Inc.....	11-14
MACO Mfg. /Majestic Comm....	67
MFJ Enterprises, Inc.....	39
Monitoring Times.....	29
Mouser Electronics.....	57
Optoelectronics, Inc.....	Cov IV
Phillips-Tech Electronics.....	67
REACT International, Inc.....	46
RadioWorld, Inc.....	59
Ranger Communications.....	77
Scanning USA.....	51
Signal Engineering.....	33
Universal Radio, Inc.....	3
Viking Systems International....	51
Wilson Antenna, Inc.....	45
Yaesu U.S.A.....	Cov. II

Reach this dynamic audience with your advertising message, contact Don Allen, W9CW at 217-344-8653, FAX 217-344-8656, or e-mail: PopComAds@aol.com

readers' market

Advertising Rates: Non-commercial ads are 30 cents per word, including abbreviations and addresses; minimum charge \$6.00 per issue. Ads from firms offering commercial products or services are \$1.00 per word; minimum charge \$20.00 per issue. Boldface words are \$1.20 each (specify which words). Leading key words set in all caps at no additional charge. All ads *must be prepaid in full* at time of insertion; a 5% discount is offered for prepaid 6 time insertions. All ads must be typewritten double spaced.

Approval: All ad copy is subject to Publisher's approval and may be modified to eliminate references to equipment and practices which are either illegal or otherwise not within the spirit or coverage scope of the magazine.

Closing Date: The 10th day in the third month preceding date of publication. Because the advertisers and equipment contained in Readers' Market have not been investigated, the Publisher of *Popular Communications* cannot vouch for the merchandise listed therein. Direct all correspondence and ad copy to: Attention: Alycia Nicholens, PC Readers' Market, 25 Newbridge Rd., Hicksville, NY 11801.

RADIO STUFF SALE: Books, magazines, club bulletins, radio station items, old time radio & more. \$1 for list. G. Dexter, 213 Forest St., Lake Geneva, WI 53147.

CB Tricks Books, Tricks I, II, or III. \$19.95 each. Repairs, tune-ups, amplifiers. Send Money Order to: Medicine Man, POB 37, Clarksville, AR 72830.

GROUND IT Ham Station Grounding Accessories. J. Martin Systems 35 Hilltop Avenue, Stamford, CT 06907. Voicemail/Fax 203-461-8768 [http:// www.jmsystem.com](http://www.jmsystem.com)

CB MODIFICATION SECRETS, big new 200-page guide by Kevin Ross, author of "CB Radio Hacker's Guide." More great easy-to-do AM/SSB CB equipment upgrades and enhancements applicable to Cobra, Realistic, Uniden, President, etc. Freq. expansion, VFO, clarifier unlock, VOX, Roger Beep, anti-theft device, receive signal preamp, much more. Only \$21.95, plus \$5 s/h (\$6 to Canada) from CRB Research Books, P.O. Box 56, Commack, NY 11725. NY residents add \$2.22 tax. VISA/MC orders call: (631) 543-9169.

SCANNER CRYSTALS FOR SALE. Send a long SASE for list and price to G.E. Jones, P.O. Box 467, Buckeye Lake, OH 43008.

LEARN CODE BY HYPNOSIS — <<http://www.qth.com/cweasy/>>; or call 1(800) 425-2552.

WANTED: 6502-based Hardware/Software/Literature, whatever. KIM's; SYM's; AIM's; OSI, anything & everything! John Rawley, 1923 Susquehanna Road, Abington, PA 19001, Phone: 215-884-9220, johnr750@aol.com

CB MODIFICATIONS! 10M, frequencies, sliders, amplifiers, FM, books, plans, kits, high-performance accessories. The best since 1976. Find out why! Catalog \$3. CBCL, BOX 1898A, MONTEREY, CA 93942. <www.cbclintl.com>.

CB MODIFICATIONS, REPAIRS, NEW PRODUCTS, CB RADIOS, EXPORTS, SCANNERS, POWER SUPPLYS, MIRCOPHONES, AMPS, ANTENNAS, MORE!! 15 yrs SAME LOCATION!! 6 PAGE PICTURE PRICE SHEETS \$1.00 (REFUNDABLE) GALAXY, BOX-1202, AKRON, OHIO 44309. [HTTP://MEMBERS.AOL.COM/GALAXYELC](http://MEMBERS.AOL.COM/GALAXYELC)

Tubes f/s - M/p of ge 6jb6a or 6146w & driver 38.00. M/p 6js6c & driver 70.00. Other amateur related tubes are available. Web site <http://www.jorsm.com/~n9tew>. E-mail: n9tew@jorsm.com. Bob Bieker 219-924-0945.

WANTED: X-BAND RADAR AND MICROWAVE EQUIPMENT. CIVILIAN, MILITARY — ALSO PARTS TM'S ETC. RADAR BOX 10215, PITTSBURGH, PA 15232.

Free Electricity. No more Electric Bills. Billion Dollar Industry. Reps Needed. Rhinish, 245239 Neptune Station, Brooklyn, NY 11224.

OLD TIME PROGRAMS. Over 100, 30 minute programs per computer CD (in MP3 or RealAudio) WWW.SCANCAT.COM 1-888-722-6228

SONY ICF-2010 NEW BOXED \$295.00. SONY ICF-2001 \$195.00. GRUNDIG YB 400 PE \$150.00 L.N. BOXED. SONY ICF-PRO-80 L.N. BOXED CALL JERRY, (954) 720-1972.

Y2K EDITION RCI/2950/2970/2990 SERVICE & MODIFICATION HANDBOOK. 160+ pgs Schematics/MicWiring/Parts/etc. \$38 HR2510/Lincoln Hdbk \$27, Spitfire/AH-100 Hdbk \$17, Galaxy Hdbk \$19. Radios & Accessories Catalogue \$3. MAXTECH, BOX 8086 NY, NY 10150 718-547-8244

Rick Mish/Miltronix R-390/R-390A/R-392 SERVICE Precision Alignment \$125.00. Repair, Lube, Align \$250.00. I.F. Strip Alignment \$25.00. Flat-rate + U.P.S. Don't settle for 3rd World performance any longer! Call/Fax: (419) 255-6220 today.

the loose connection

Radio Communications Humor

Surviving Life's Catastrophes

Along the crooked path I've taken to where I am today, there have been incidents ranging from little inconveniences to catastrophes, including a few that I thought might be "the big one, Elizabeth." As it turns out, I've survived them all, and for as many times as I rehearsed the voice-distress call *Mayday* and the Morse equivalent *SOS*, I've always fallen just short of the criteria; *imminent danger to life or property*.

Long before I ever operated a transmitter — in fact, I was about the size and age of *Ralphie* in Jean Shepherd's *Christmas Story* ("You'll shoot your eye out, kid!") when I began to imagine myself saving the day by taking over the radio transmitter on a sinking ship, or grabbing the wheel of a runaway school bus and bringing it safely to a stop at the bottom of some mountain pass. When I was thirteen, I really *did* chase a runaway '58 Ford whose parking-brake had slipped, and stopped it before it rolled into a small stream. I'm still waiting for my big chance, though.

It's not that way for those around me, though. I've probably made more heroes than a busy sandwich shop, just by getting myself into jams that would make *Lucy Ricardo's* life look dull and boring.

George Hosfeld used to regularly pull me out of knee-deep mud in some creek-bottom to sneak home in wet socks, hoping my mom would accept the notion of shoe-and-boot burglars in our neighborhood when I "couldn't find them" the next morning. Doug Quinn would regularly rescue me from running out of gas, finding myself in a restaurant with a date and no money, and often from the wrath of my parents, with his creative explanations of why we didn't get home on time.

Now that I find myself back in the communications field, I'm *Tonto* to *Kemosabe* Dave Bradley, the younger of the Bradley boys who you've read about on this very

page. I've become famous for my "911-pages" when I'm operating some broadcast facility and for some reason (almost always a switch in the wrong position) I can't get the signal to go where I want it to go. Dave always shows up, walks directly to the problem, and presses the necessary button, often with the flourishes and expression of *Oliver Hardy* freeing *Stan Laurel* from a certain death.

When I was young, I got myself stuck by climbing way too high in some tree, then *George Hosfeld* would show up and get me a rope or climb up and help me down. Now I get myself stuck on a rooftop by kicking the ladder away as I step onto the roof, and hope Dave knows where to look for me when I don't show up for our next project. If Dave had sailed on the *Titanic*, he'd have convinced the captain that he needed more lifeboats. If I were on board, I'd have nagged the recreation director to rearrange the deck chairs to compensate for the ships listing.

Dave has arrived "just in time" more times than I can remember. Twice, he helped extricate me from the inside of our satellite uplink dish — a place that's pretty tight for a person of normal girth — a real squeeze for me. I've gotten myself stuck, kneeling down in a tight space behind equipment racks, one knee in the rack and one out, where I waited with a steady charley horse 'til Dave showed up to go to lunch.

Perhaps the scariest situation was in our pickup — and old rustbucket with few options. Now, I've always had a girth problem, and when I'm sitting behind the wheel of just about any vehicle, if I drop something on the floor I have to stop, get out, retrieve the object, and get back in — something really inconvenient in traffic or on a high-speed highway. It would help you to know that the window cranks always fell off this thing, and we'd have to find one on the floor to roll down a win-

dow, but on this particular day, you'd factor in an old seat belt — lap-only — that jammed up tight on me, and an inside door-handle that fell off when I reached for it. No, the horn didn't work. No, our boss is way too — uh — frugal — to buy us cell-phones. Dave showed up as I was looking for a bit of parchment so I could stab my finger and write a will in blood.

When our TV station is short on personnel, I'm called upon to operate "Master Control," a job in which I play all the tapes, take all the live classes, play character generator screen-messages etc. I had made it through the day with only a few minor glitches — late cues, wrong slates for upcoming events, but all in all I'd kept it looking professional. Because ours is not a 24-hour station, we shut down and play the character generator overnight. We have certain remote controlled functions which we can "switch" using touch-tone phones, or computers and modems. Recently, I tried to transfer a call to someone in the back, I probably hit an incorrect sequence of numbers. Dave answered his 911-page pretty quickly, but all the other lines were already lit-up and ringing as he walked me through the process of taking off the slate that read, "The University is Closed Today due to Snow," and resume our normal broadcast programming.

Every one of those callers reminded me that it was August. Yes, there are more I haven't told you, but two of them involve a propane commode at our satellite uplink (one was a fire and the other was an explosion) but you're just going to have to use your imagination as to the details. *Kablam*. No, there was no fan in the room.

Stay tuned for more outlandish events starring *The Bradley Boys*, Norm, yours truly, and a cast of dozens. We also have a line on some information about our fearless editor, Harold "Look Out It's Gonna Blow!" Ort and his exemplary too-long military career. ■

BY BILL PRICE, N3AVY

MAKING BROADCAST HISTORY ... AGAIN



Introducing the New Sangean ATS505

A Lot More For A Lot Less!

- Continuous All Band SW Coverage
- Exceptional SSB
- 45 Memory Channels/ with Auto Memory Preset
- 9/10 kHz Switch
- AM/FM Stereo thru Headphones
- Dual Time Clock with Alarm
- Lighted LCD Display
- Carrying Case & Earbuds
- Size: 8-1/2" W x 5-1/4" H x 1-3/8" D

\$129⁹⁵ Includes U.S. Shipping



Sangean ATS909

The Last Shortwave Receiver You'll Ever Need to Buy!

- 306 Memory Presets, 29 Separate Pages
- True Upper and Lower SSB
- 5 Tuning Methods
- 42 World City Times
- RDS Reception
- AM/FM Stereo thru Headphones
- Built-in SW Antenna Jack
- Dual Time Clock with Alarm
- Lighted LCD Display
- Carrying Case, SW Ant., Earbuds

\$259⁹⁵ Includes U.S. Shipping



CCR radio 'Platinum Edition'

*The Best AM Radio Made Today & Now A Perpetual Radio!**

NEW!

- AM, FM, TV Audio, Weather Band + Alert
- Built-in 6V DC Input Jack & Charging Circuit
- Built-in LED Light Jack
- Audio Tuned for Human Voice
- 5 Memory Buttons Per Band
- Rotary Tuning Knob with 1KHz Fine Tuning
- Lighted Digital Display

\$159⁹⁵ Includes U.S. Shipping

*Optional Solar Kit Includes: Solar Panel, LED Light, 4 (4,000 mAh) Nicad Batteries and AC Charging Adapter
\$129.95 with purchase

CIRCLE 162 ON READER SERVICE CARD

SANGEAN
AMERICA, INC.

www.sangean.com

Broadcast Tower, Egypt



800-522-8863
ccrane.com

800-522-TUNE
FREE
CATALOG

NEW

CATCH IT. HOLD IT. TUNE IT.

Tuning your receiver will never be easier. Introducing the all new Mini Scout Reaction Tuner. With a .001 second measurement time, the Mini Scout will not miss even the briefest of transmissions. While

locking onto a frequency from up to 200 feet away (5w UHF), the Mini Scout automatically tunes the receiver* to the action using its patented Reaction Tune capability. No manual tuning necessary.



Patent No. 5,471,402

***Compatible Receivers:**

- ICOM**
7000, 7100, 8500, 9000, R10
- AOR**
8000, 8000B, 8200
- Optoelectronics**
Optocom, R11
- Radio Shack**
Pro2005/6 with OS456/Lite
Pro 2035/42 with OS535

No modifications necessary. Interface cables required.

Specifications Scout Mini Scout

10MHz - 1.4GHz	•	•
Reaction Tune	•	•
LCD Display	•	•
<3mV Sensitivity	•	•
Signal Strength Bargraph	•	•
Filter Mode	•	•
Capture Mode	•	•
Backlight	•	•
Beeper	•	•
Vibrator	•	•
400 Memories	•	•



Patent No. 5,471,402 AR8200 Not Included

**Scout Frequency Recorder
Reaction Tuner**

\$349

**Mini Scout
Reaction Tuner**

\$249



SPECIAL
DB32 & CC30 \$29

Place your Order anytime at the Optoelectronics Cyber Store www.optoelectronics.com



Are FM Broadcast signals a Problem?

Knock them out with the N100 Notch Filter. Blocks 88 - 108MHz, Connect between antenna and Scout or Mini Scout.....\$99

**OPTODIRECT•800-327-5912
OPTOELECTRONICS®**

5821 NE 14th Avenue • Ft. Lauderdale, FL 33334
Phone: (954)-771-2050 Fax: (954)-771-2052 E Mail: sales@optoelectronics.com

Prices and Specifications are subject to change without notice or obligation.

DB32 Antenna shown on Scout and Mini Scout sold separately. AOR, ICOM, Radio Shack are all registered trademarks