

ICD08635

POPULAR COMMUNICATIONS

MAY 2000

Airborne Action: The Sky's The Limit On What You Can Hear!

- **Alice On Stock Schemes
And Famous Radio Firsts**
- **Malawi and Antarctica
Back On Shortwave!**
- **In The Spotlight:
Nextel's i1000plus Cell Phone
Vectronic's VEC-1290K
AM Transmitter Kit**

**NEW COLUMN:
Plane Sense
Page 36**

U.S. \$3.99 /

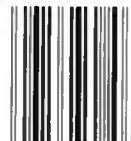

0 75470 08635 9

*****3-DIGIT 641
02 00380028 2102 200501AHU
MR. DAVID C STEARNS F00DAA
139 W 98 TER
KANSAS CITY MO 64114-4122

**olumn, Radio Resources,
tion And Much More!**

THE VR-500 BRINGS YOU THE WORLD!

CARRY THE WORLD WITH YOU!

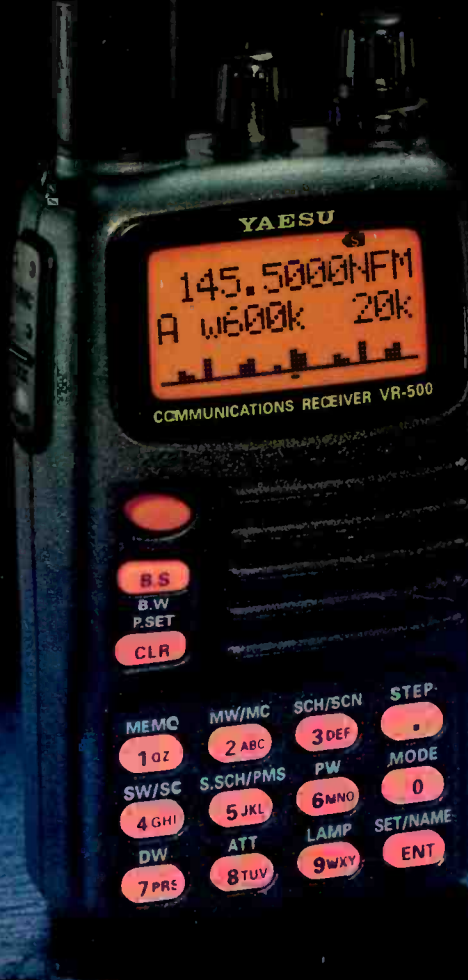

Ultra Compact Size!
58 mm x 24 mm x 95 mm
220 g (including Antenna / Battery)
 Simulated display / keypad illumination

Continuous Coverage:
100 kHz to 1299.99995* MHz!

*Cellular telephone frequencies are blocked and cannot be restored.

All Mode Reception:
FM, Wide-FM, USB, LSB, CW, and AM!

Huge Memory Capacity:
1091 Channels!

Actual Size

Features

- Multiple Power Source Capability
- Direct Keypad Frequency Entry
- Large High-Output Speaker
- Polycarbonate Case
- Real-Time 60-ch* Band Scope

*Range 6 MHz / Step 100 kHz

- Full Illumination For Display And Keypad
- Versatile Squelch / Monitor Key
- Convenient "Preset" Operating Mode

- Huge 1091-ch Memory System With Search & Scan
- Regular Memories (1000 ch)
- Search Band Memories (10 ch)
- Preset Channel Memories (19 ch +10 Weather Channels)
- Dual Watch Memories (10 ch)
- Priority Memory (1 ch)
- Smart Search™ Memories (11/21/31/41 ch)

Convenience Features

- 1 MHz Fast Steps
- Front-end 20 dB Attenuator
- RF Squelch
- Power On / Power Off Timers
- Adjustable Battery Saver
- Extensive Menu Customization
- Clone Capability
- Computer Control

COMMUNICATIONS RECEIVER

VR-500

All-Mode Wideband Receiver

YAESU
Choice of The World's top DX'ers™

For the latest news, hottest products:
 Visit us on the Internet! <http://www.yaesu.com>



LENTINI

COMMUNICATIONS, INC.

Toll Free
1-800-666-0908
In CT 860-666-6227

PCR1000



\$349.95
Special Sale price w/ICOM coupon

Communications Receiver For Computer
• Covers 01-1300MHz
• All Mode WFM, FM, AM, SSB, CW
• Employs Band-Tracking RF Filters.
• Connects to Your PC Exter.

NEW PCR100, Similar to PCR1000 Less SSB
\$199.95 SALE
UPS Included

IC-R10



• Wideband, All Mode Receive Capability From 100 kHz to 1300 MHz.
• 1000 Memory Chan. With 8-Character Alphanumeric Names.
• Many Other Features!

\$299.95 Special Sale price w/ICOM coupon
UPS Included

IC-R8500



Communications Receiver

• Wideband, All Mode Receive From 0.1 to 2000 MHz.
• Many Features Similar to IC-R10

CALL FOR PRICING!

ICOM

\$199.95
UPS Inc.



Ultra Compact, Super Wide Band

• The New Mini-Sized Scanner From ICOM is Now Available.
• 500kHz-1.3GHz (Less Cellular) AM/FM/WFM.
• Loud And Crisp Audio, Backlit LCD.
• Triple Conversion, Built-In Attenuator.
• 400 Memories, 8 Banks of 50 Chan.
• CTCSS Tone Squelch and Tone Search.
• Includes 2 AA Size Ni-Cd Batteries and Charger.
• PC Programmable (Software and Connection Cable Optional).
• More!

IC-R75



\$689.95
UPS Inc.
w/ICOM Coupon

NEW IC-R75 HF Receiver with free UT-106 DSP

• Receives .03-60MHz, AM/FM/SSB/CW/RTTY
• Triple Conversion Receiver
• Synchronous AM detection
• Twin Passband Tuning
• Automatic Notch Filter
• Front Mounted Speaker
• Optional Digital Signal Processing
• Up to Two Optional Filters

SANGEAN

ATS505



ATS505
• New Low Priced Shortwave Receiver with SSB Capability!
• AM/FM Stereo/SSB
• Lighted Display, 45 Mem.
• Incl Earbuds & Carrying Case
• More

\$129.95
UPS Incl.

ATS909



ATS909 Shortwave Receiver
• AM/FM Stereo/USB/LSB
• 306 Memory Presets, 29 Separate Pages
• RDS Reception
• Lighted LED, Clock with Alarm
• Incl/ Carrying Case,
• Much More

\$259.95
UPS Incl.

uniden

BC895XLT



"TrunkTracker"

\$219.95
UPS Included

SC180 \$174.95
SC200 \$199.95

BC245XLT



Handheld "TrunkTracker II"

\$219.95
UPS Included

UPS included

AOR

USA, Inc

AR8200B



NEW!

• 5-2040MHz
• AM, NFM, WFM, SSB, CW.
• Alpha-Num.
• Computer Prog.

\$549.95

ALSO AVAILABLE

NEW AR-16B

Mini Handheld 500kHz - 1.36Hz (Cellular Blocked)

\$219.95

AR8000B ARD-2
AR5000 + 3 AR3000A
AR7030 Plus

FULL LINE OF AOR ACCESSORIES

CALL FOR MORE INFO & PRICING
Unblocked versions available to qualified agencies

RANGER

RCI-6300/RCI-6900



RCI-6300/RCI-6900

• 10 Meter
• AM/FM AM/FM/SSB
• Low and High Power Models
• Built-In Frequency Counter
• High Sensitivity Receiver Design
• Variable Power Output
• More **CALL FOR LATEST PRICING!**

RCI-2950DX/RCI-2970DX



RCI-2950DX/RCI-2970DX

• New Dual 12 and 10 Meter Bands
• AM/FM/SSB
• Low and High Power Models
• Programmable Repeater Offset
• Receiver Clarifier
• Noise Blanker/ANL Circuitry
• More

YAESU

VX-5R



Yaesu VX-5R Tri Band Handheld Transceiver

NEW!
• Wide Band Receive
RX: 0.5 - 15.995 MHz, 48-728.990 MHz, 800-998.990 MHz (Cellular Blocked)
TX: 50-54 MHz, 144-148 MHz, 430-450 MHz
• 5W Power Output
• 220 Memories
• AM/NFM/WFM
• CTCSS
• Encoder/Decode, Digital Coded Squelch (DCS)
• 8 Character Alpha Display.
• ADMS-1E Windows™
• PC Programmable (Optional)
• Much, Much More

CALL FOR PRICING!

VR-500



\$329.95

High Performance Miniature Communications Receiver

• Freq Range: 100kHz to 1300 MHz
• All-Model AM/WFM/NFM/LSB/USB/CW
• 1000 Memory Channels
• 8 Character Alpha Numeric Display.
• Direct Keypad Frequency Entry
• Dual Watch/Band Scope
• Much More!

Call For Availability and Pricing!

Drake Shortwave Radios

R8B (new)\$1159.95 + \$14 UPS
SW8\$779.95 + \$10 UPS
SW1\$199.95 + \$7 UPS

SONY

ICF-2010CALL \$\$
ICF-SW07CALL \$\$
ICF-SW77CALL \$\$
ICF-7600GCALL \$\$
ICF-SW1000TSCALL \$\$
ICF-SW100SCALL \$\$
ICF-2010CALL \$\$
ICF-SC1CALL \$\$
ICF-SC1PCCALL \$\$

Luke

DP-976\$39.95

MAGNUM

MAGNUM 257 30W 10 Meter Mobile\$249.95
MAGNUM 357DX 150W 10 Meter Mobile\$399.95
MAGNUM 457DX 200W 10 Meter Mobile\$479.95

Galaxy CB

DX949 AM/SSB Mobile\$199.95
DX959 AM/SSB Mobile, Freq Counter\$249.95

Galaxy 10 Meter

DX133HML\$219.95
DX55V\$219.95
DX44\$249.95
DX77HML\$299.95
DX66V\$329.95
DX73V\$339.95
DX2517 Base\$499.00
DX88HL\$379.95
DX99V\$399.95

2 Year Factory Warranty on All Galaxy

GRUNDIG

Shortwave

NEW!

Grundig Satellit 800

\$499.95
\$15 UPS

Yacht Boy 400PE

\$199.00
UPS Included

Yacht Boy 205

Analog Shortwave SALE **\$49.95**

RELM

MS180

\$169.95
UPS Included

HS200

\$199.95
UPS Included

NEW!

ALINGO

DJ-X10



Wide Range Receiver

• Multi-Mode Reception From 1 to 2000MHz.
• Channel Scope.
• AM/WFM/FM/SSB/CW.
• 1200 Memories.
• Superb Sensitivity, Clear Sound.

\$349.95

HOURS: M-F 10am - 6pm SAT 10am-4pm UPS Ground (48 states)

Conn Sales Infor. & Tech Help 860-666-6227

Web Site: www.lentini.com

21 Garfield St. Newington, CT 06111

C.O.D.'s OK
SAME DAY
SHIPPING



Contents

POPULAR COMMUNICATIONS

Volume 18, Number 9

May 2000



22



52

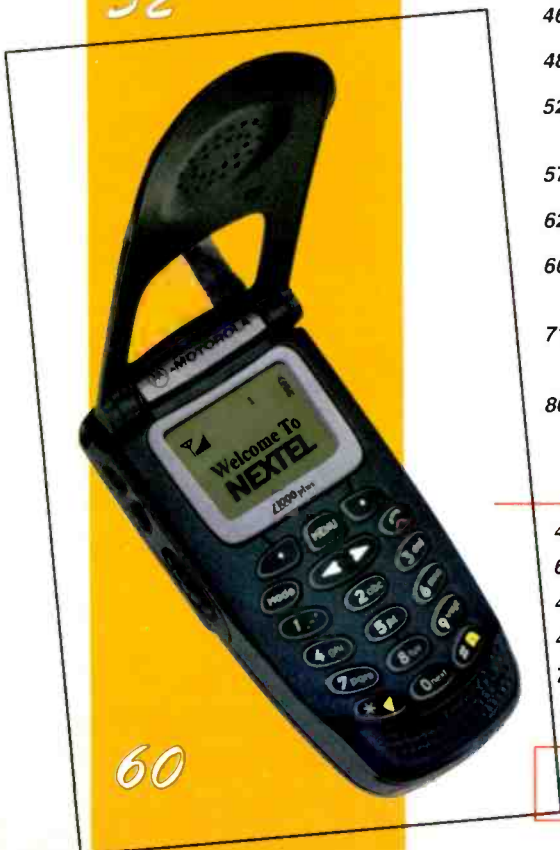

60

- 8 **In The Cockpit: Getting Started In Aviation Scanning**
You Don't Have To Live Near An Airport To Catch The Action! by Ken Reiss
- 16 **Stock Scheme Sparks Famous Firsts: America's First**
Wireless Company Left An Interesting Legacy by Alice Brannigan

Product Spotlights

- 31 • **Vectronics VEC-1290K AM Transmitter Kit** by Peter Bertini
- 60 • **Nextel's i1000plus Cell Phone** by Harold Ort

- 22 *Building A Selective Crystal Set* The Radio Connection
- 26 *The Restrained Two-Way TAD Radio* Radio Resources
- 28 *It Beats Me: Answer The Question And Win A Big Prize* CB Scene
- 32 *FCC Authorizes Low-Power FM, And Hot Canadian DX* Broadcast DXing
- 35 *Another Ethiopian Clandestine And Voice Of*
Tigray Revolution Is An Easy Catch Clandestine Communiqué
- 36 *Get This Book: Airport/Facility Directory* Plane Sense
- 40 *Navigating International SW BC Bands The Easy Way* World Band Tuning Tips
- 44 *No Shack? No Radio? No Problem!* The Ham Column
- 46 *One Voice Radio: A Multitude Of Topics* The Pirate's Den
- 48 *Learning About Scanner Features And Terms, Part III* Scan Tech
- 52 *Pop'Comm Readers Come Through, And*
A Super Online Air Traffic Control Site Radio & The Internet
- 57 *Firing Up A Six-Shooter* Antennas & Things
- 62 *Low-Power FM Radio Services Approved* Washington Beat
- 66 *Malawi's Radio One, And Argentine Antarctic Station*
Back On The Air! The Listening Post
- 71 *That Magical Mystery Tour Ends —*
RD Turns Over Helm To Cooper Communications Confidential
- 80 *Bill And Doug: Very Cool, Indeed!* The Loose Connection

Departments

- 4 *Tuning In — An Editorial*
- 6 *Pop'Comm P.O.— Letters*
- 42 *Product Parade*
- 47 *How I Got Started*
- 79 *Readers' Market*

On The Cover

A C-141 Starlifter approaches the refueling boom of a KC-135 Stratotanker. You can hear aviators make the connection and much more if you know where to tune. Check out this month's "In The Cockpit: Getting Started In Aviation Scanning" by Ken Reiss for tips and techniques on this fascinating aspect of radio monitoring on page 8. (Photo by Senior Airman Jerry Morrison, U.S. Air Force).

Visit us on the Web: www.popular-communications.com

Universal Radio - Quality equipment since 1942.

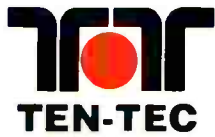

**RX-340 H.F.
D.S.P.
RECEIVER**



The TEN-TEC RX-340 communications receiver combines cutting-edge, state-of-the-art technology, with excellent ergonomics and esthetics. Digital signal processing (DSP) brings the performance and repeatability of expensive military grade communications receivers into the price range of top end commercial receivers for shortwave listeners. Tunable from 5 kHz to 30 MHz, it provides tuning steps and display resolution of 1 Hz. An astounding 57 bandwidths from 100 Hz to 16 kHz are included. All filters have a shape factor of 1.5:1 or better (6 to 60 dB). USB, LSB, ISB, CW, AM, Synchronous AM and FM modes are built-in. Four AGC modes are provided. A tunable Notch filter rejects unwanted signals in the passband. The receive front-end incorporates a built-in preselector with eight half octave bandpass filters. A switchable 10 dB preamp and 15 dB attenuator are also provided. The RX-340 also includes Built-in Test or 'BITE'. Memory and Scan functions fall into four categories: a scratchpad memory, 100 memory channels, memory scan and sweep (F1 to F2 scan). Separate volume controls are provided for the speaker and for the headphone. The front panel features a Lexan graphics overlay, designed to last a lifetime. Made in Tennessee, U.S.A. Visit our website or request our 2000 catalog for full specifications. Under \$400.

ICOM R3



What a cool idea this is! The new ICOM R3 has incredible wideband coverage from .5 to 2450 MHz (less 824-849 & 869-894 MHz cellular) in AM, FM wide, FM narrow and TV. Yes, the R3 has a built-in 2 inch TFT color TV screen. You will receive regular TV, but that is only the beginning. Imagine being at a car race and seeing the video directly from the driver's seat or seeing ham fast-scan TV transmissions or wireless video cameras! The display can also be used as a spectrum bandscope and to display the various operational menus. There is even a second mono LCD display that can be used for conventional frequency display purposes when battery life is a concern. Plus you get a 450 alphanumeric memory system, 4-step attenuator, video and audio outputs, auto power off, a 4 position joy stick and BNC type antenna. A tone squelch system provides quiet stand-by. This radio comes with BP-206 Lithium Ion battery, charger, belt clip and antenna. Only 2.4 x 4.7 x 1.3 inches 11 oz. (61 x 120 x 33 mm 290 g). Please call or see our website for further details, accessory list and pricing.

HUGE FREE CATALOG

The 2000 Universal Communications Catalog covers everything for the shortwave, amateur and scanner enthusiasts. This informative 104 page catalog is fully illustrated. Many new items are featured including the new TEN-TEC RX-340, Grundig Satellite 800, ICOM R-3 and Palstar R30 receivers. This catalog is FREE by bookrate or \$3 by Priority mail. Rising postage costs prevent us from sending this catalog out automatically so please request your free copy today!

Universal Radio, Inc.
6830 Americana Pkwy.
Reynoldsburg, Ohio
43068-4113 U.S.A.

800 431-3939 Orders & Prices
614 866-4267 Information
614 866-2339 FAX Line
dx@universal-radio.com

**universal
radio inc.**

RADIO BOOKS

Shortwave Receivers Past & Present *Third Ed.*

This huge 473 page guide covers over 770 receivers from 98 manufacturers, made from 1942-1997. Entry information includes: receiver type, date sold, photograph, size & weight, features, reviews, specifications, new & used values, variants, value rating & availability. 120 new pages. Become an instant receiver expert! #0003 \$24.95



Passport To World Band Radio 2000 *New Edition*

Graphic presentation of all shortwave broadcast stations. Equipment reviews, too. 592 Pages! #1000 \$19.95

World Radio TV Handbook 2000 *New Edition*

All shortwave broadcast stations organized by country with schedules, addresses, power, etc. #2000 \$24.95

Pirate Radio *By A. Yoder With audio CD!*

Here is the incredible saga of America's underground illegal broadcasters (with audio CD). 326 pgs. #303B \$24.95

Discover DX'ing! *By J. Zondlo Second Edition*

Hear distant AM, FM and TV stations. #0019 \$5.95

Shortwave Listening Guide *By Helms Second Ed.*

Here is understandable information on: selecting and operating a shortwave receiver, simple antennas, time stations, pirates and much more. 323 pgs. #2984 \$19.95

Understanding ACARS. *By E. Flynn Third Edition*

Learn the ACARS aeronautical format. #0012 \$9.95

Communications Receivers - The Vacuum Tube Era *By R.S. Moore Fourth Edition*

Key facts, figures and photos for shortwave receivers of the Golden Era 1932-1981. 141 Pages. #2945 \$19.95

www.DXing.com

www.universal-radio.com

- Visa
- Prices and specs. are subject to change.
- MasterCard
- Returns subject to a 15% restocking fee.
- Discover
- Catalog & used list available on request.

The Right Way, Wrong Way, and The BBG Way

Budget and personnel cutbacks in the government are nothing new, and like our fearless leader Bill Clinton has said in the past, we must all share the burden. But after a while, I frankly get tired of hearing the “we’re all in this together” and how we must all suffer because it’s the American way. Truth is, it’s the *American way of doing business*, not taking care of the people.

During my career with Uncle Sam, we faced countless budget ups and downs, but money saved by not building that last Apache helicopter or destroyer could outfit hundreds of thousands of troops or feed hungry American kids. But we all know that some things never change. The latest evidence of knee-jerk reaction and politics at its best comes from the hallowed halls of the VOA, courtesy the Broadcasting Board of Governors (BBG).

Specific cutbacks at the VOA are in the European Division, Lao Service, Brazilian Service, and news departments. In addition to services, a total of 51 folks will lose their jobs. A memo I received stated, “There was a clear wake-up call to several language services including Brazilian, Arabic, Russian, Kurdish, and Turkish . . . these services need to revitalize their programming and to prove their impact and effectiveness.”

Of course I realize that every part of the government can’t, and doesn’t, get everything they ask for, but for Heaven’s sake, look again at the language services being cut! You don’t have to be a Henry Kissinger to realize that Iran has again stepped up jamming of our broadcasts, the Middle East is constantly in turmoil, Russia is devastating Chechnya, and the Great Satan Himself, Saddam Hussein is still wreaking havoc on the Kurds. What’s wrong with this picture? Plenty. At a time when they need the VOA the most, the axe falls — you don’t need an accountant’s software program or a graduate degree in world history to figure out that something is very wrong with the VOA’s cutback process.

The worst slap in the face are these cutbacks: In the Albanian Service, 15 minutes of direct broadcasts will be eliminated, leaving 1.5 hours of direct radio broadcasts including a 30-minute radio/TV simulcast; in the Bulgarian Service, the 30-minute program will be converted to an Internet and affiliate feed service; Croatian Service daily broadcasts will be reduced by 30 minutes to a total of 1.5 hours, and in the Serbian Service, daily broadcasts will be reduced by 30 minutes to a total of two hours including a 30-minute radio/TV simulcast. Have they forgotten about the Serbs and what people died for last year? Remember Murder Milosevic, the indicted war criminal? He’s still at large, and like Saddam, probably always will be torturing people and a menace to society. We can’t mess his greasy hair if we don’t get in there and at least try! It can’t be done if the decision-makers are allowed to hang tough untouched by those they serve. The BBG works for *us*, but you’d never know it.

And The Survey Said . . .

The BBG learned many things from their surveys. But do *you* trust surveys? You *do* if they support what you want to hear. It’s the old, “Don’t confuse me with facts, my mind is made up, thank-you.” For example, the memo stated, “. . . Poland, Hungary, and the Czech Republic are now stable democracies and members of NATO.” Stable democracy? Really? All three were only admitted into NATO in *March 1999*. I’ve got socks older than that! I’m all for giving peace a chance, hugging and kissing former adversaries, but don’t you think we should hold hands first? How soon we forget. One wonders if we ever learn by past mistakes.

A show of hands, please. Who really believes these former Communist countries have completely washed their dirty hands of recent atrocities? I believe citizens want more, not less, radio from the VOA. One must ask, then, if there’s no

threat from our new “friends” why are 116,000 U.S. troops still stationed in and around Europe? Either we’re serious about doing the job right the first time, or we shouldn’t bother to suit up, and stay home. The average person on the street in many former Warsaw Pact countries is still living well below the poverty level and is still looking over their shoulder. The Broadcasting Board of Governors has clearly invested in shaded glasses if they believe otherwise.

To give you some perspective of the tons of hours they worked on this scheme, I just received a 16 page FAX explaining the rationale. (I’ll bet a non-bureaucrat could have condensed it into two pages, max). Therein lies a good part of the problem: The government trying to justify its existence. I’ve said it before, but for the most part — excluding my usual list of doofus Congressional reps and Senators — most government employees are hard-working and diligent Americans. Let’s wave the flag and salute the colors in their honor! Our thanks to them for a job well done.

But then you’ve got the hierarchy, the super government grades, if you will, that would do anything short of standing in front of a locomotive to save their jobs at the expense of the folks in the trenches. (Despite the fact that the folks in the trenches keep them afloat from month to month). So it’s not the majority I’m criticizing here, it’s the few weasels that know better, but frankly are future-challenged, or just don’t give a damn about tomorrow. After all, they’ll be retired.

Let’s talk a moment about radio and the Internet. Everything we read and see today is about the Almighty Internet — Dot-Com this, and Dot-Com that. But while the Internet is certainly the wave of the future and will, eventually keep us from having any meaningful verbal personal one-on-one interaction with people, and will (perhaps thankfully) keep me forever out of the supermarkets, it is still more or less experiencing phenomenal growth in major, developed countries

ity and reliable phone service is readily available, and people burn inordinate amounts of fossil fuels. But what about the family in the rice paddy in Laos? Radio is *still* the medium. And it will be for many years. What about the young Kurd family whose entire village was burned to the ground? Rest assured they'd welcome a VOA broadcast on a small portable battery-operated receiver. Most would probably welcome the receiver! Our Western view of the world and Internet is as foreign to them as sleeping with the sound of exploding mortar is to us. Walk a mile in their shoes and think. And pray for them.

The same VOA memo I mentioned earlier said, "... look beyond radio to other avenues such as TV and the Internet to deliver its product." That's fine for developed countries, but how many Chechnyans are running around with a TV in their backpack as they dodge advancing Russian troops?

I'm sure the memo's reference is intended to address TV Marti, a boondoggle that covers downtown Havana — and in the wee-hours when most people are asleep. Uncle spends \$11.2 million annually for TV Marti to broadcast from 3 to 6 a.m. daily, and it's not even heard throughout the island. The station's balloon antenna can't go up if the wind is over 30 mph. TV Marti is a total waste of money and doesn't serve a useful purpose in support of American policy. But it looks darned good on paper! Any idea why it's on at such a weird time of day? It's all about money, again. Our friends at the National Association of Broadcasters know why. Congress and the White House won't broadcast to Cuba on TV during *normal hours* because Fidel, it's feared, will jam Florida's commercial TV stations. We can't have that, so TV Marti clearly ends up being more of an irritant to Castro than an informative medium for the people. Enough already! The VOA should skip the TV and hold steadfastly onto radio; mediumwave, shortwave, or FM — whatever works in the target areas. (Pirate broadcasters could make some money advising Uncle Sam how to reach an audience with minimal investment).

Remember, in many countries, shortwave is still a mainstay. Remember too, that many third-world countries (and many high-tech nations) have less than quality phone lines necessary for a solid Internet connection. And they pay through the nose for even *local* phone service; often with per-minute charges. Imagine

the average Russian or Kurd sitting in the den with the computer on (don't forget outrageous electricity charges) using RealAudio to tune in the VOA. Dream on, BBG. Just because the Internet is the wave of the future *here* doesn't mean squat in many overseas target areas!

The powers-that-be at the BBG and Congress should spend a few weeks with the Kurds, Russians, Chechnyans, and the folks served by the Lao Service before making any more cutbacks. I'll bet they'd come away with different survey results.

A Plan

So in keeping with the fact that "simpler is better," here's my plan for the VOA decision-makers and those responsible for their budget. The top two folks at the VOA budget office could each chip in \$3 and take a local junior high school student to lunch at McDonald's. Bring a world map, pen, and two sheets of paper with the latest world news headlines from

(Continued on page 78)

BEYOND Family Radio!

Stay in touch with your family and friends!

The new PRYME Radio Products PR-460: SportConnect™ and PR-460: ClearConnect™ transceivers use frequencies in the **General Mobile Radio Service (GMRS)** to provide long range personal communications. Unlike half-watt FRS radios these new two-way radios provide a **full FOUR WATTS** output power.

The 8-channel PR-460: SportConnect™ model has a range of **up to 5 miles**, while the PR-460: ClearConnect™ has 23 channels including all GMRS **repeater frequencies** for a range of **up to twenty-five miles** or more!

Family Radio PLUS! Family Radio users upgrading to GMRS can still communicate with their existing FRS radios! Channels 1-7 in both our ClearConnect™ and SportConnect™ are the **same as Family Radio channels 1-7**, so you can still talk with any FRS radios in your group!

FCC License Required: Operation on the General Mobile Radio Service requires an FCC issued GMRS license. Information on obtaining a license is included with your transceiver. The FCC license fee is \$80 for five years, which breaks down to a little more than \$1.00 per month. One license covers you and everyone in your immediate family, including your children and parents.

PR-460: SportConnect

8 Channels up to 5 miles range!

\$199.95*

PR-460: ClearConnect

23 Channels including repeater operation for range up to 25 miles!

\$219.95*

Range may vary due to obstructions, weather, low battery, or other factors. Access to repeaters may require a fee.

* NOTE: The prices shown above are estimated street prices. Actual dealer prices may vary.

PRYME
Radio Products

by **PREMIER Communications Corp.**

480 Cicillo St. #E • Brea, CA 92821

Phone: 714-257-0300 • Fax: 714-257-0600

Web: <http://www.adi-radio.com>



- * **4 Watts Output Power**
- * **Just 4.25 inches tall!** (excluding antenna)
- * **Includes CTCSS** (38 tones)
- * **Communicate with the FRS Radios that you already have!**
- * **One touch access to the 462.675 MHz emergency channel**
- * **Up to 5 miles range.** Use the repeater mode on the ClearConnect model to increase your range up to 25 miles!

OUR readers SPEAK OUT...

Each month, we select representative reader letters for our "Pop'Comm P.O." column. We reserve the right to condense lengthy letters for space reasons and to edit to conform to style. All letters submitted must be signed and show a return mailing address or valid E-mail address. Upon request, we will withhold a sender's name if the letter is used in "Pop'Comm P.O." Address letters to: Harold Ort, N2RLL, SSB-596, Editor, *Popular Communications*, 25 Newbridge Road, Hicksville, NY 11801-2909, or send E-mail via the Internet to <popularcom@aol.com>.

Worldcom Technology: They're Gone

Dear Editor:

I purchased a device for my Realistic DX-390 shortwave radio called a Mini-booster, that was produced by a company known as Worldcom Technology. The radio now only works on the FM band and I have been trying to contact Worldcom before having the device removed. The last address that I have is no longer valid: P.O. Box 3364, Ft. Pierce, FL 34948. I would appreciate any information on this company you can provide.

John T. Driskell, III
Georgia

Dear John:

Unfortunately our efforts to contact Worldcom weren't successful either. They're clearly out of business and have provided us no forwarding address. If any of our readers can help, please contact our Pop'Comm office and we'll forward the note to John.

Henry Says: Take The Code Challenge!

Dear Editor:

Some years back, I was attending an open house at a National Guard air base. I talked to a young jet fighter pilot and asked him if flying the plane he was standing by was exciting. He said "no, it's extremely boring." I then asked him if he ever had an exciting flight, and he said "yes." He flew into a storm and lost con-

trol of his plane, his navigation and flight instruments gave false readings, but fortunately the storm pushed him back to its edge and he regained control.

Now if you as a ham radio operator want the excitement of challenging nature by sending your radio signal through its obstacles; local storms, distant storms, ionospheric instability, and sun-generated interference, you can fly into these unpredictable, rapidly changing rough conditions with a heavy duty military jet fighter plane (Morse code) and generally get through, or fly into it with an ultralight aircraft (voice, SSB) and observe its destruction. Obviously the real sport lies in the HF bands, with the use of Morse code. Take nature's challenge: Use your Morse code skills — go for the long haul.

Henry Hanpel
St. Louis, MO

Dear Henry:

The times, they are changing! But like they say: One man's jet fighter is another man's rubber-band windup plane.

Lighten Up, Please

Dear Editor:

The debate about the code/no-code requirement has been going on for a long time, but some common sense rather than emotions need to be applied. As a Navy Radioman, I spent the first five years in the service using nothing but CW, and I came to look at it as the premier method of communications. The last time I used CW officially was 1968, and then with a merchant vessel on 500 kHz. I was also one of the large group of radio operators who just knew that when World War III began and all the satellite and computers were knocked out, like white knights, we would save the day with CW, the most reliable method of communications ever developed. After all, wasn't the watchword Reliability, Security, Speed?

But let's get real. It just ain't so, and it isn't going to happen. Reading the "Communications Confidential" column every month is like being at a never-end-

(Continued on page 54)

POPULAR COMMUNICATIONS

EDITORIAL STAFF

Harold Ort, N2RLL, SSB-596, Editor

(Internet e-mail: PopularCom@aol.com)

Tom Kneitel, K2AES/SSB-13, Senior Editor

(Internet e-mail: K2AES@juno.com)

Alycia Nicholzen, Assistant Editor

Richard S. Moseson, W2VU, Online Coordinator

(Internet e-mail: W2VU@amsat.org)

CONTRIBUTING EDITORS

Richard "RD" Baker, Utility Communications

Ed Barnat, TCA-44, CB SSB

Peter J. Bertini, K1ZJH, Restoration/Electronics

Joe Carr, K4IPV, Antennas

Bruce Conti, AM/FM Broadcasts

Joseph Cooper, Projects and Broadcast Band

Gerry L. Dexter, Shortwave Broadcast

Alan Dixon, Legislative Affairs

Jock Elliott, SSB-734, Citizens Band

Eric Force, Radio and the Internet

Bill Hoefler, Aviation Communications

Kirk Kleinschmidt, NTØZ, Amateur Radio

Ian Poole, SW Broadcasting

Bill Price, N3AVY, Humor/Communications

Ken Reiss, Technical/Scanning

Edward Teach, Pirate and Alternative Radio

J.T. Ward, Scanning

Gordon West, WB6NOA, Radio Resources

BUSINESS STAFF

Richard A. Ross, K2MGA, Publisher

Donald R. Allen, W9CW, Advertising Mgr.

Emily Leary, Sales Assistant

Sal Del Grosso, Accounting Manager

Ann Marie DeMeo, Accounting Department

Judith Erickson, Office Manager

Catherine Ross, Circulation Manager

Melissa Gilligan, Operations Manager

Denise Kells, Data Processing

Jennifer Cormagi, Customer Service

PRODUCTION STAFF

Elizabeth Ryan, Art Director

Barbara McGowan, Associate Art Director

Edmond Pesonen, Electronic Comp. Mgr.

Dorothy Kehrrieder, Production Manager

Emily Leary, Assistant Production Manager

Hal Keith, Technical Illustrator

Larry Mulvehill, WB2ZPI, Photographer

A publication of



CQ Communications, Inc.
25 Newbridge Road
Hicksville, NY 11801-2953 USA

Offices: 25 Newbridge Road, Hicksville, NY 11801. Telephone (516) 681-2922. FAX (516) 681-2926. Web Site: <http://www.popular-communications.com/> Popular Communications (ISSN-0733-3315) is published monthly by CQ Communications, Inc. Periodical class postage paid at Hicksville, NY and additional offices. Subscription prices (payable in U.S. dollars): Domestic—one year \$25.95, two years \$45.95, three years \$65.95. Canada/Mexico—one year \$35.95, two years \$65.95, three years \$95.95. Foreign Air Post—one year \$45.95, two years \$85.95, three years \$125.95.

U.S. Government Agencies: Subscriptions to Popular Communications are available to agencies of the United States government, including military services, only on a cash with order basis. Requests for quotations, bids, contracts, etc. will be refused and will not be returned or processed.

Entire contents copyright © 2000 by CQ Communications, Inc. Popular Communications assumes no responsibility for unsolicited manuscripts, photographs, or drawings. Allow six weeks for change of address or delivery of first issue.

Printed in the United States of America.

Postmaster: Please send change of address to Popular Communications, 25 Newbridge Road, Hicksville, NY 11801.

Tall, telescoping antenna with BNC connector.

Use the TFT color display:

- To show simple or advanced operation settings
- To scan for wireless cameras, like those found in race cars
- To catch your favorite TV shows
- In conjunction with a digital wireless camera to monitor babies, traffic, etc.



7011
Simulated picture

When the TFT color display is not needed, or if you just want to conserve power, use the mono LCD to display all necessary information.

4-way action joystick quickly moves you through settings.



Simulated picture

Lithium Ion Power

A long lasting Li-Ion battery offers easy charging, lightweight performance, and up to 27 hours of continual use on the mono LCD.

IC-R3* **NEW**

FOR A LOOK BEHIND THE SCENES

ICOM wide band receivers always let you HEAR more of what's out there. With the new IC-R3, now you can SEE more, too! This pocket sized marvel receives from 0.5 - 2450 MHz¹, and sports a 2-inch TFT color display. Scan for wireless camera broadcasts. It's great for watching the action *behind* the scenes at sporting events. Or, just watch your favorite TV programs. A video/audio output terminal lets you display to a large monitor or recording device. All this, and advanced ICOM receiver features like 450 memory channels with alphanumeric names, CTCSS, attenuator, & more.

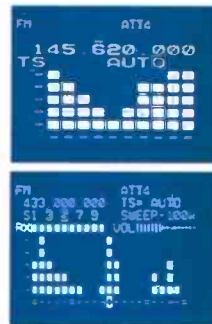

Signal strength (above) and band scope (below) functions assist in finding the action you want to hear...or see!

When you're looking for the best, keep your eye (and ear) on an ICOM receiver. Contact your authorized ICOM dealer today, or call for a free brochure:

425-450-6088

IC-R2 Excellent audio, tiny package

500 kHz - 1.300 GHz¹

AM, FM, WFM • 100 mW audio output • easy band switching • weather resistant • CTCSS tone squelch • 400 memory channels • backlit LCD • priority watch • includes Ni-Cd batteries and charger, or use alkalines • PC programming (optional)



IC-R10 Advanced listening excitement

500 kHz - 1.300 GHz¹

All mode • large, alphanumeric display • 1000 memory channels • band scope • 7 different scan types, including VSC (pauses only on voices) • easy mode • comes with rechargeable Ni-Cds and charger, or use alkalines • PC programming (optional)



*This device has not been approved by the FCC. This device may not be sold or leased, or be offered for sale or lease, until approval of the FCC has been obtained.

¹Cellular blocked; unblocked version available to FCC authorized users only.

©2000 ICOM America, Inc. 2380 116th Ave NE, Bellevue, WA 98004 • 425-450-8155. The ICOM logo is a registered trademark of ICOM, Inc. All specifications are subject to change without notice or obligation. Questions? Contact your authorized ICOM dealer or contact ICOM America Tech Support on CompuServe's® HamNet forum at 75540.525 or send e-mail to 75540.525@compuserve.com. CompuServe is a registered trademark of CompuServe, Inc. R3POP300

ICOM[®]
www.icomamerica.com

In The Cockpit: Getting Started In Aviation Scanning

You Don't Have To Live Near An Airport To Catch The Action!

By Ken Reiss <armadillo1@aol.com>

Aviation scanning, or more particularly "Air Band" scanning, is a bit of a specialty in the hobby. The transmissions tend to be very short and coded, and they use that blasted AM mode which some scanners don't even have available. Let's take a quick look at what it takes to get into this exciting part of the hobby, and what you might expect to hear if you do.

First, let's get a couple of things straight, so we all know what we're getting into. I'll admit right up front that I'm an airplane nut. Harold notes that even if I didn't like airplanes, I'd still be half right. I have been fascinated since I was a kid with anything that flew. Since I found out that scanners can receive that stuff, I've pretty much always had one radio dedicated to aviation listening.

Unfortunately, I've never been fortunate enough to live near enough to an airport that I could hear the tower. Actually, that's probably a good thing, because my interest in other forms of scanning might have ended right there. I can't tell you how many times I've taken the Drake SW-8 on a trip intending to spend some time DXing only to find out that I was within range of an airport tower. The radio never leaves the air band.

So What's To Hear?

Aviation monitoring is in many ways like public safety monitoring. Hours and hours of dull and routine comms interspersed with real-world high drama and excitement. You might actually find more excitement in the public safety area if that's what you're after. After all, the aviation industry works very hard to keep the excitement factor down to a bare minimum, and if you're a passenger on one of those flights, you'll no doubt appreciate their efforts.



Here's a rare photo opportunity from Ori Airlines. These pilots are so busy, since they can't carry many passengers at once, that they rarely park. When I asked about the apparent machine gun on the top, the pilot muttered something about writers who were late with columns, but then refused to comment further.

But the aviation monitor can listen to a wide variety of enroute communications. Some listeners even track flights on a regular basis, and if you're lucky enough to live near a major airport you can follow them all the way into or out of the airport on a trip. Many shortwave enthusiasts enjoy monitoring the overseas flights as they come across the ocean, and then transition to the VHF air band as they get closer into land once again. Aviation listening on HF is one of the very few services that looks like it's going to be on HF for a long time to come.

Air traffic controllers and pilots alike are trained to make all communications routine. When they break that training, it

can be some of the best listening on the air band, and often it's quite humorous. As an example, pilots try to minimize time on the radio and can leave out certain key words.

On a routine flight, a pilot called the ground control with the message "Grand Forks Ground, Golf Zulu Fox with Alpha, taxi for Fargo." What the pilot was saying was that his airplane whose tail number ended in GZF was ready to taxi and heading to Fargo. The pilot had listened to the repeating weather broadcast or ATIS and had that information coded "Alpha." So what we expect would be clearance to taxi. What we got instead from a controller who obviously wasn't

The ICAO (International Civil Aviation Organization) Phonetic Alphabet

This is also used by public safety agencies also, so it might not be new to you. However, most public safety agencies use the APCO (Association of Public Safety Communications Officers) alphabet which uses different words.

A	Alpha
B	Bravo
C	Charlie
D	Delta
E	Echo
F	Foxtrot
G	Golf
H	Hotel
I	India
J	Juliet
K	Kilo
L	Lima
M	Mike
N	November
O	Oscar
P	Papa
Q	Quebec (pronounced Kay-bek)
R	Romeo
S	Sierra
T	Tango
U	Uniform
V	Victor
W	Whiskey
X	X-Ray
Y	Yankee
Z	Zulu

busy was “Golf Zulu Fox, good day, you can taxi if you want, but it would be a lot faster to fly.”

ATIS: Automated Terminal Information Service

One of the first places a pilot tunes, and you can too, is to **ATIS**, the **Automated Terminal Information Service**. This repeating broadcast includes information about what runways are active, what the current weather is and what altimeter settings are plus any information about airport operations or things happening nearby that might be of interest or concern to all pilots operating in the area. The first broadcast of the day is called “Alpha” and then as it’s updated, the ID is changed so that everyone, particularly the pilots and ground crew know that the information



If you're close to a major airport, your local police helicopter will be in touch with them too. Sometimes, they reveal more about their location to air traffic control than they do on the police radio, since the police already know where they're going.

you have is the stuff that’s current. They simply step through the ICAO phonetic alphabet each time it’s changed and start over if they run out.

Often, the broadcast also includes frequency information for contacting ground or approach controllers depending on the airport. If not, this information is readily available in many publications, on the Internet, or just by searching for a few minutes. In fact, ATIS is one of the first things I look for when I’m in a new area because the transmitter is always on. If I can hear an ATIS broadcast, I can probably hear the tower too. It doesn’t take long to find active frequencies in your area and at least get a feel for the type of activity that frequency is being used for.

One of the key differences between aviation scanning and public safety scanning is that the information is so widely available. You can simply go visit your nearest pilot supply shop and come out with charts and books of all sorts that list frequency and usage information. Much is available on the Internet, and you may even find pilots who will give you old or outdated charts. They’re not legal to use for navigation anymore, but they don’t change frequencies that often. Visit a nearby pilot shop or flight training center and tell them what you’re looking for and why. If they don’t have any, I’ll bet you could talk someone into holding some for you the next time they expire for the price of a cup of coffee. They’re a wealth of

information and you’ll learn a bit about chart reading in the process.

Types Of Traffic

So let’s take a quick look at the types of traffic you’ll hear on a typical scan through the band. We’ve already covered ATIS, and mentioned Ground control. Ground control is responsible for the movements of the aircraft on the ground to and from the runways and terminals. Sometimes, the ground controller can have a worse traffic jam than the air controllers, and you just can’t pull a 747 off to the side and let a 767 pass.

Some of the larger airports also have a “ramp” controller. This controller will have responsibility for the immediate area around the gates and getting planes in and out of the “ramp.” So the ramp controller might be the first person a plane actually talks to start moving.

Often, also at larger airports, you’ll find a frequency used for “Clearance Delivery.” At smaller airports, the ground controller handles this function too, but as the ground controller gets busier at a larger airport, there isn’t time to read lengthy clearances back and forth. Clearance delivery will have the official clearance for the plane from Air Traffic Control based on their expectations. You might hear something like this:

“ATC clears Trans World 554 to Houston as filed. Climb and maintain

General Interest Aviation Frequencies

Some frequencies in the airband are nationwide. Put these in your scanner and see if anything interests you.

108–118 Navigation aids. You won't hear much voice down here (except for some automated weather and "talkthrough systems" where a remote flight service station transmits through a navigation aid's transmitter. For the most part, you can leave these out of your scanner.

121.5 The universal emergency frequency. **243.0** is the military equivalent. Not much traffic here, but what traffic is here is very important.

122.0 Flight Watch — Enroute weather and information for mostly private aircraft.

122.8 Unicom — Used at many smaller uncontrolled airports for pilots to talk and coordinate.

122.9 A second Unicom frequency

123.0 Unicom in some areas, sometimes used by helicopter operations.

123.025 Helicopter operations

123.45 Plane to plane (a sometimes very informal chat channel)

126.2 Military towers — Many military installations have restricted airspace around them and need a way to communicate with civilian aircraft. This frequency is used quite often for this purpose.

5000 feet, expect higher five minutes after departure."

Trans World 554 has filed a flight plan to Houston (or is a regularly scheduled flight, in which case they might have gotten their clearance from flight ops before they even get into the plane if nothing's irregular). However, for some reason, usually other planes that will be in the way, this clearance has been restricted to an altitude of 5000 feet, and they are telling him to expect a higher altitude 5 minutes after departure. If all goes well, the new clearance will come before he hits 5000 feet and the passengers will never know it was restricted. But the pilot cannot climb above that altitude until he receives further authorization.

After clearance delivery, ramp and/or ground control will provide instructions to get to the runway at which time they'll switch over to tower. Tower controls all the airspace around the airport but only out to a distance of five miles. After that, departure takes over.

Departure and approach can be on the same frequency if there isn't too much traffic in the area, or they may be segregated. There may even be more than one departure and approach frequency in use at an airport if there's lots of traffic. All traffic from the south will use one frequency, all traffic from the north will use another. If you listen to the tower, he'll



Lots of activity at almost any airport regardless of size. Of course, commercial flights generate the most interest and tend to be going further. Regardless of the flight distance or plane size, the communications are very similar.

tell the planes what frequency to contact departure on, and if you listen for a while, you may hear a couple of frequencies. If you listen long enough, you may also hear them give the approach frequency for some reason, so finding the frequencies shouldn't take long once you get started. But that's half the fun!

Once at a certain altitude or a certain distance from the airport, that departure controller will hand the plane off to an enroute controller. These are high-altitude con-

trollers that work in one of the 20 air route traffic control centers across the country. Don't be alarmed if there isn't an ARTCC in your neighborhood. They use remote transmitters all over the place to keep in touch with planes for a long distance. And even if you can't hear the ground, you can hear the planes for a very long way.

As the plane progresses on its flight, it will get passed from one controller to the next along the way. Often the same person will monitor both "sectors" but the

Today the World... Tomorrow the Universe



GRUNDIG

GRUNDIG Tunes in the

The Millennium begins. The wait is over. The Grundig Satellit Legend continues. The Satellit 800 Millennium is your assurance of staying in touch with the world... Access radio programs the world over... fast-breaking news from the farthest corners of the globe... music from faraway countries.

CUTTING EDGE IN SPACE TECHNOLOGY

- You'll appreciate the smooth flowing design and functional control panel.
- Superbly appointed, fold away, easy grip handle for portability.
- Enter any station on the key pad, then tune up or down frequency or search specific meter bands.
- The tuner receives AM/FM and all shortwave frequencies from 100 to 30,000 KHz, FM from 87 to 108 MHz and VHF aircraft 118 to 137 MHz and locks onto broadcasts with digital accuracy...



World



"Performance ... exceptionally promising ..., Audio quality is delightful, superior to that of any other portable on today's market ..., This ergonomic radio is a cinch to operate straight out of the box"

Lawrence Magne,
Editor-in-Chief, Passport to World Band Radio

- Receives FM stereo with the included high-quality headphones.
- Superior audio quality for which Grundig is known.
- A direct input digital key pad combined with manual tuning.
- 70 user-programmable memories.
- Upper and lower sideband capability (USB/LSB).
 - A large 6" by 3 1/2" multifunction LCD.
 - Last station memory.
- Synchronous detector for superior AM and shortwave reception.
- Multi voltage (110, 220 V) AC adapter.
- Dual clocks.
- Low battery indicator.

Whether you are cruising offshore, enjoying the cottage, or relaxing on an extended vacation in some distant land, the Satellit 800 Millennium is the most powerful and precise radio in the World. Search the globe, you can discover the hottest news first hand... listen to and witness the ongoing fascination with our evolving world today... tomorrow the universe.

by **GRUNDIG**

The Ultimate in Digital Technology



The LCD

Big! Bold! Brightly Illuminated 6" by 3 1/2". Liquid Crystal Display shows all important data: Frequency, Meter band, Memory position, Time, LSB/USB, Synchronous Detector and more.

- For direct frequency entry: a responsive, intuitive numeric keypad.



The Signal Strength Meter

Elegant in its traditional Analog design, like the gauges in the world's finest sports cars. Large. Well Lit. Easy to read.



The Tuning Controls

- For the traditionalist: a smooth, precise tuning knob, produces no audio muting during use. Ultra fine-tuning of 50Hz on LSB/USB, 100Hz in SW, AM and Aircraft Band and 20 KHz in FM.
- For Fixed-step Tuning: Big, responsive Up/Down tuning buttons.

The Frequency Coverage

Longwave, AM and short-wave: continuous 100-30,000 KHz. FM: 87-108 MHz VHF Aircraft Band: 118-137 MHz.

The Technology

Today's latest engineering:

- Dual conversion super-heterodyne circuitry.
- PLL synthesized tuner.



The Sound

Legendary Grundig Audio Fidelity with separate bass and treble controls, big sound from its powerful speaker and FM-stereo with the included high quality headphones.



The Operational Controls

Knobs where you want them; Buttons where they make sense. The best combination of traditional and high-tech controls.



The Many Features

- 70 user-programmable memories.
- Two, 24 hour format clocks.
- Two ON/OFF sleep timers.
- Massive, built-in telescopic antenna.
- Connectors for external antennas - SW, AM, FM and VHF Aircraft Band.
- Line-out, headphone and external speaker jacks.

The Power Supply

A multi voltage (110, 220V) AC adapter is included. Also operates on 6 size D batteries. (not included)

Dimensions:

20.5" L x 9" H x 8" W

Weight: 14.50 lbs.

by **GRUNDIG**

Lextronix / Grundig, P.O. Box 2307, Menlo Park, CA 94026 • Tel: 650-361-1611 • Fax: 650-361-1724
Shortwave Hotlines: (US) 1-800-872-2228 (CN) 1-800-637-1648 • Web: www.grundigradio.net

CIRCLE 159 ON READER SERVICE CARD

Air Route Traffic Control Centers (ARTCC)

ARTCC's handle planes at altitude as they travel between airports and criss-cross the country. Don't worry if there isn't one right in your backyard. You are still likely to hear one of their remote transmitter sites in your area.

Albuquerque
Atlanta
Boston
Chicago
Cleveland
Denver
Fort Worth
Houston
Indianapolis
Jacksonville
Kansas City
Los Angeles
Memphis
Miami
Minneapolis
New York
Oakland
Salt Lake
Seattle
Washington (DC)

frequency has to change to keep in contact with a close ground station. As the plane approaches its destination, the ARTCC will begin clearing the plane to lower and lower altitudes and will eventually hand it off to an approach controller, who in turn hands off to a tower, who hands it off to ground, who hands it off to the ramp once it has landed.

In addition to all the controller traffic, you'll also find company dispatch frequencies in the air band. Here's where a pilot can talk back to the mechanic or scheduling people for information or about problems in flight. There's some in-flight weather frequencies, including 122.0 the nationwide "Flight Watch" channel. On this frequency all across the country, you can hear weather reports and information passed.

There are also the **Unicom** frequencies. These are used at smaller airports that don't have a tower as community "advisory" frequencies. The most common is 122.8. A plane taking off will advise its intentions just in case someone else is landing. You'll also hear a bit of chit chat between planes. The frequency 123.025 is used nationwide for helicopter opera-

tions. There are lots of others, but those will get you started.

So Have A Listen!

Check out the air band (108.0 to 137 MHz with .025 MHz spacing) in your area. You might be surprised at just how active it is, even if you're not close to a major airport. The military air band (225-400 MHz) also has fascinating lis-

tening. Remember, though, that comms here are in the AM mode. Small airports actually generate more traffic, and sometimes more excitement because the pilots are in training or don't fly as a profession. Just listening to an ARTCC relay can be interesting to see what's passing overhead. And you can hear planes for a very long way even if the ground isn't audible. Check it out! You too may become an aviation scanner enthusiast! ■



World's Most Powerful CB and Amateur Mobile Antenna*

Lockheed Corp. Test Shows
Wilson 1000 CB Antenna Has
**58% More Gain Than The
K40 Antenna (on channel 40).**

In tests conducted by Lockheed Corporation, one of the world's largest Aerospace Companies, at their Rye Canyon Laboratory and Antenna Test Range, the Wilson 1000 was found to have 58% more power gain than the K40 Electronics Company, K40 CB Antenna. This means that the Wilson 1000 gives you 58% more gain on both transmit and receive. Now you can instantly increase your operating range by using a Wilson 1000.

**Guaranteed To Transmit and Receive
Farther Than Any Other Mobile
CB Antenna or Your Money Back**
New Design**

The Wilson 1000 higher gain performance is a result of new design developments that bring you the most powerful CB base loaded antenna available.

Why Wilson 1000 Performs Better

Many CB antennas lose more than 50% of the power put into them. The power is wasted as heat loss in the plastic inside the coil form and not radiated as radio waves.

We have designed a new coil form which suspends the coil in air and still retains the rigidity needed for support. This new design eliminates 95% of the dielectric losses. We feel that this new design is so unique that we have filed a patent application on it. In addition, we use 10 Ga. silver plated wire to reduce resistive losses to a minimum.

In order to handle higher power for amateur use, we used the more efficient direct coupling method of matching, rather than the lossy capacitor coupling. With this method the Wilson 1000 will handle 3000 watts of power.

The Best You Can Buy

So far you have read about why the Wilson 1000 performs better, but it is also one of the most rugged antennas you can buy. It is made from high impact thermoplastics with ultraviolet protection. The threaded body mount and coil threads are stainless steel; the whip is tapered 17-7 ph. stainless steel. All of these reasons are why it is the best CB antenna on the market today, and we guarantee to you that it will outperform any CB antenna (K40, Formula 1, you name it) or your money back!

*Inductively base loaded antennas
**Call for details.

Lockheed - California Company

A Division of Lockheed Corporation
Burbank, California 91520

Wilson Antenna Company Inc.
3 Sunset Way, Unit A-10
Green Valley Commercial Center
Henderson, Nevada 89015

Subject: Comparative Gain Testing of Citizen's Band Antennas
Ref: Rye Canyon Antenna Lab File #670529

We have completed relative gain measurements of your model 1000 antenna using the K-40 antenna as the reference. The test was conducted with the antennas mounted on a 16' ground plane with a separation of greater than 300' between the transmit and test antennas. The antennas were tuned by the standard VSWR method. The results of the test are tabulated below:

FREQUENCY (MHZ)	RELATIVE GAIN (dB)	RELATIVE POWER GAIN (%)
26.965	1.30	35
27.015	1.30	35
27.065	1.45	40
27.115	1.60	45
27.165	1.50	41
27.215	1.60	45
27.265	1.75	50
27.315	1.95	57
27.365	2.00	58
27.405	2.00	58

**58%
MORE
POWER GAIN
THAN THE
K40**

Individual test results may vary upon actual use.

CALL TODAY
TOLL FREE: 1-800-541-6116
FOR YOUR NEAREST DEALER

Wilson 1000

Roof Top Mount.....59⁹⁵ Little Wil.....29⁹⁵
Trunk Lip Mount.....69⁹⁵ Wilson 2000 Trucker .59⁹⁵
Magnetic Mount79⁹⁵ Wilson 5000 Trucker .79⁹⁵
500 Magnetic Mount .59⁹⁵ Call About Fiberglass!!!
Wilson 5000 BaseLoad — NOW AVAILABLE!

Wilson
ANTENNA INC.

A Division of Barjan Products, L.L.C.
East Moline, IL 61244

Stock Scheme Sparks Famous Firsts

America's First Wireless Company Left An Interesting Legacy

By Alice Brannigan

On November 10, 1899, the first wireless operating company in America was formed; the American Wireless Telephone & Telegraph Co., incorporated with a capitalization of \$5-million under the laws of the Territory of Arizona. AWT&T was a group of promoters headed by real estate and gold mine boomer, Dr. Gustav P.

Gerhing. The sudden rise to fame of Marconi had caused Gerhing and associates to seek out and acquire some nearly forgotten wireless patents taken out in 1884 by Dolbear. The stock was at first offered for \$1.50 per share, but gradually increased to \$8 per share.

AWT&T didn't exactly operate anything. It owned the patents, and divided

the entire nation into nine areas in which subcompanies were to operate. Each subcompany turned a large portion of its stock over to the parent company. The capitalization of the whole deal was \$50-million. AWT&T, as the holding company, claimed it was to design and manufacture the equipment to be used, and train the operators. The individual subcompa-



A 1905 postcard shows Santa Catalina station "A," together with its mast on a bluff above the beach.

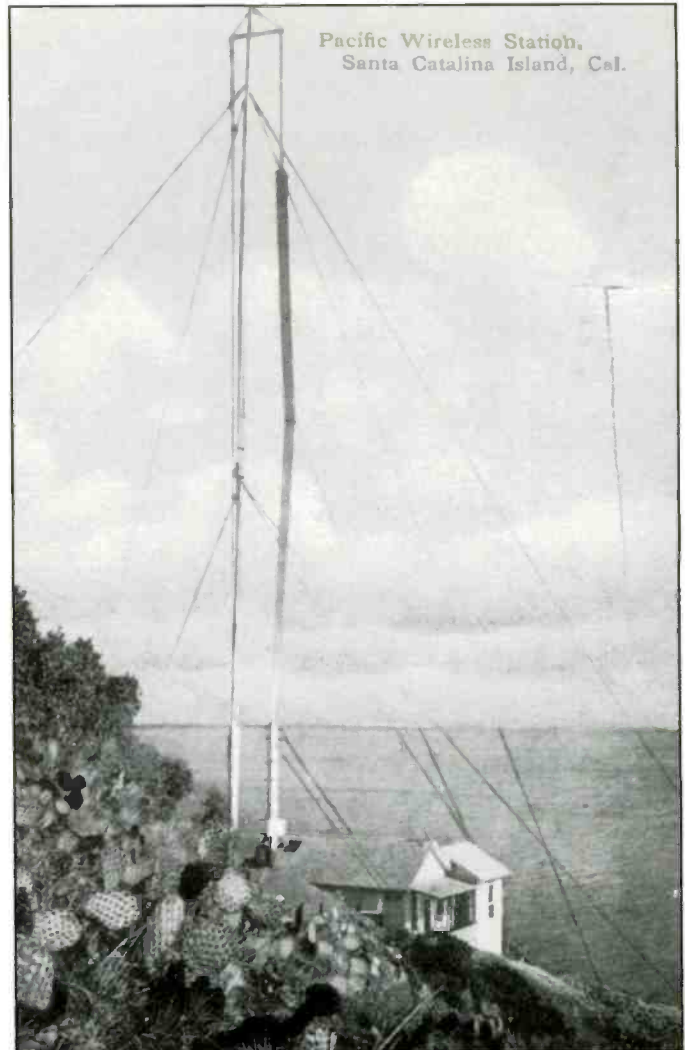

Another postcard view of station "A" from a slightly different angle offers a better look at the cage antenna system.

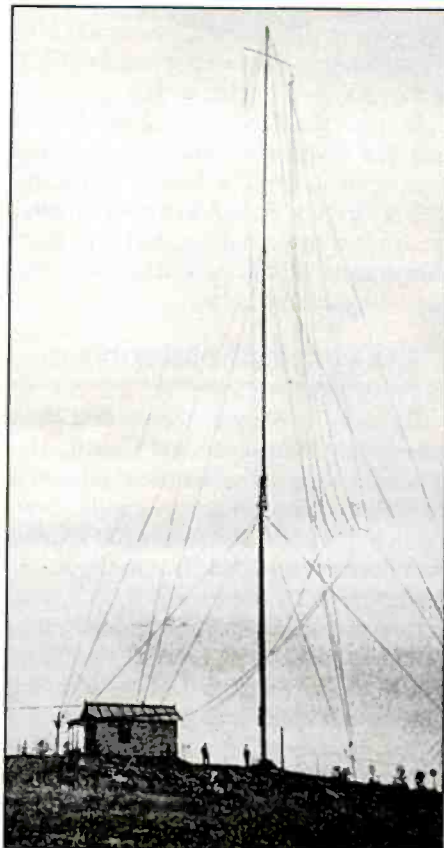

Pacific Wireless' station "G." located at San Pedro.

nies had their own officers, engineers, and a sales staff responsible for promoting the company to prospective investors.

Investors were hyped on the notion that eventually wireless stocks would substantially increase in value much the way telephone stocks had done before. Promoters pointed out that telephones were generally limited to city use, but wireless would extend to every rural area because no wires were needed. Investors had made plenty on telephone stocks, and wireless sounded as promising or better. In the early days, many invested in wireless.

Stations Are Built

As soon as Robert Marriott graduated from college in 1901, he joined AWT&T as an engineer. That's also when the company built three temporary stations in New Jersey, plus installed a temporary shipboard station for reporting the America's Cup yacht races. These stations were built for the sole purpose of demonstrating the future potentials of wireless in order to sell stock in AWT&T. They were not for handling messages. In fact, like many early wireless companies, AWT&T had questionable motives and was chiefly interested in selling stock in

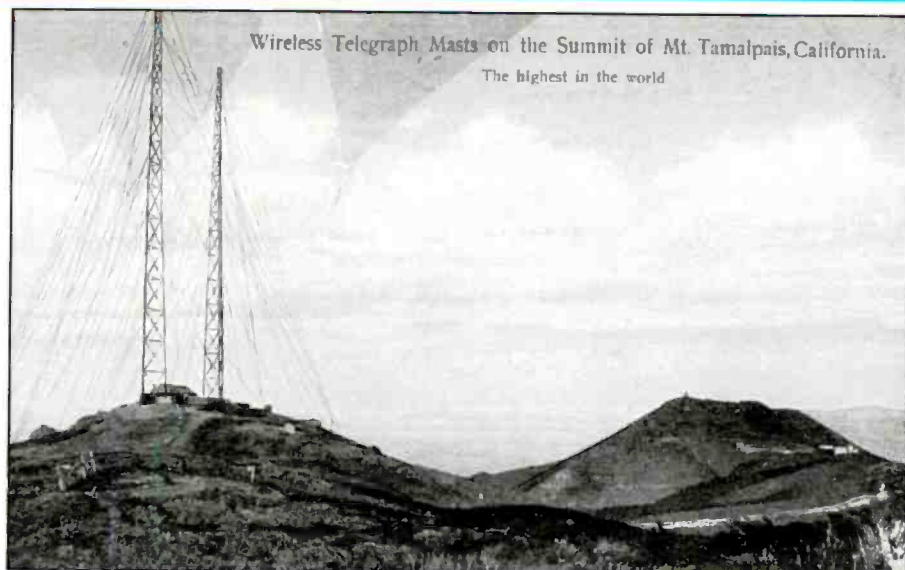

*Wireless Telegraph Masts on the Summit of Mt. Tamalpais, California.
The highest in the world*

The magnificent station Pacific Wireless built at the summit of Mt. Tamalpais was the highest in the world. It never went into service. This postcard was mailed in 1909, three years after the station had been dismantled.

itself rather than actually providing communications services.

By late 1901, Marriott had been promoted to Chief Engineer of the Pacific and Continental Wireless Telephone Companies. These two AWT&T sub-companies were operated from the same office in Denver.

Marriott, who was dedicated to communications, managed to convince the company that its first western stations should be located where an actual communications need existed. They agreed to construct two telegraph stations linking San Pedro, California, to Avalon, on Santa Catalina Island, about 26 miles offshore. Until then, the only contact between the mainland and the popular resort island had been a twice-daily ferry. Because AWT&T's proposed manufacturing facilities had not been set up, Marriott designed both stations, built the parts in Denver, and personally installed them at the two California locations. Marriott later noted that although several temporarily installed point-to-point commercial telegraph stations had been tried before that elsewhere, these were the first such stations in the United States intended to stay put.

The 2-kW station on Santa Catalina used the callsign "A." while the 2-kW one at White's Point, San Pedro, identified as "G." First radio telegrams were exchanged in July of 1902. The stations were said to be the first in the U.S., and probably the entire world, to handle commercial point-to-point traffic. Local residents on Santa Catalina were skeptical that messages

could actually be exchanged with this device and accused the operators of secretly using carrier pigeons.

By March of 1903, *The Los Angeles Times* had begun publishing a daily Avalon edition called *The Wireless*. Each edition's text was sent by wireless, then typeset and printed on Avalon.

Ultimately, in August of 1903, the Pacific Wireless Tel. & Tel. Company went bankrupt. The former PWT&T officers struck out on their own, promptly moving to Seattle to form the Pacific Wireless Telegraph Co., capitalized at \$5-million. Determined to actually make a go of communications, the first thing they did was purchase the two California stations for \$5,000. They also began construction of stations in Washington State at Friday Harbor, Fort Casey, Seattle, and Port Townsend. In 1905, they built stations at several additional California locations.

Super Station

The key link in this ambitious network was to be a magnificent super station 15 miles north of San Francisco. Two wooden towers over 500 feet tall were erected in early 1906 at the 2,600 foot high summit of Mt. Tamalpais. Each tower was 20 feet square at the base, tapering to four square feet at the top, and weighed 60 tons. Built in sections in Oakland, the towers were ferried across the bay, assembled on the ground, and raised as complete units. The cost of building and erecting these towers was \$50,000. At the time, this sta-



An early 1921 view of the site of Pacific Tel. & Tel. Station KUVX at Pebbly Beach, one mile from Avalon, Santa Catalina Island. This station exchanged telegraph and radiotelephone traffic with PT&T station KUXT on the mainland.

tion's location allowed it to claim the title of "the highest in the world."

The induction coil for the Mt. Tamalpais transmitter was designed to give a spark 15 feet long, with the secondary made of 2,000 miles of No. 30 silk covered wire, and to develop over 5-million volts. The station was intended for communication with Hawaii, the Philippines, and Japan, as well as points along the North American Pacific coast.

Curiously, this station was never completed and put into service. By late in 1906, the towers were reported as being down. One source claimed that several of the anchor bolts holding the guy wires had been deliberately cut with a hack saw.

Others said the towers had blown down, or come down in the (April 1906) great San Francisco earthquake. History does not record the specific reason for this station's fate.

Meanwhile, Back On Santa Catalina

Wireless telegraphy had flourished at Avalon, Santa Catalina Island. United Wireless (deForest) had opened a station there with the callsign "PI," for contacting the company's San Pedro station, "PJ." These later became known as KPI and KPJ after United was sold to Marconi in 1911. The U.S. Navy's telegraph sta-

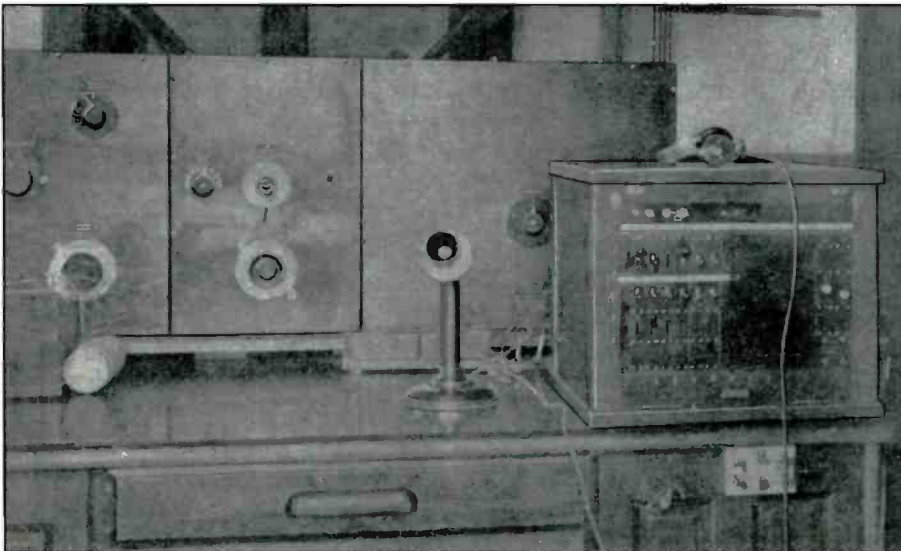

Operating console of radiotelephone station KUVX. The station was shut down in July 1923 because too many people were eavesdropping on the phone calls.

tion on the island (NZL) used 500 kHz for communicating with its station NPX in Los Angeles (Inglewood).

In time, the Pacific Wireless' Avalon and San Pedro operations split off and regrouped to become known as Pacific Tel. & Tel. Co. Robert Marriott, original designer of those stations, had kept them in operation right along. But he was working on something better.

The First Radiotelephone

By early 1921, the stations had been completely redesigned and rebuilt. The Santa Catalina station had been relocated to Pebbly Beach, about a mile from Avalon. It had the call letters KUVX and was licensed on 706 kHz. On the mainland, Marriott's station was KUXT, now relocated from San Pedro to Long Beach.

These stations provided radiotelephone service between the island and the mainland. Phones located in the island's stores, hotels, and homes could readily connect to any landline telephone in the United States, or vice versa. This is believed to be the first regularly established commercial point-to-point radiotelephone service in the world. The stations exchanged traffic for about 14 hours each day. While conversations were taking place, the two stations simultaneously exchanged telegraph traffic by means of superimposing a high-pitched harmonic on the signals. This didn't interfere with the voice traffic.

Evils Of Eavesdropping

This radiotelephone link was a technological triumph, but the popularity of broadcast radio receivers (starting in 1922) led to its demise in July 1923. As Robert Marriott recalled in the April 1926, issue of *Radio Broadcast*, "The use of telephony killed it, for too many uninvited people were able to listen in." An underwater cable was subsequently used to replace the radiotelephone link between the island and the mainland. Radio eavesdroppers had been denounced and foiled for the very first time! This was more than 60 years before the cellphone industry forced passage of the ECPA. Robert Marriott became the first President of the Institute of Radio Engineers.

We always appreciate and look forward to input from our readers. Our snail mail address is Alice Brannigan, *Popular Communications*, 25 Newbridge Road, Hicksville, NY 11801. Our direct E-mail address is <Radioville@juno.com>. ■

Are You Ready to Move Up?



AOR scanning receivers – for those who demand more.



AR8200B

Fact: AOR receivers are the choice of many federal, state and local government agencies. Military users, engineering laboratories and professional news gathering operations also purchase our receivers. Why? AOR engineering represents the state of the art in wide range receiver technology.

When you're ready to move up to superior quality, dependability and support, AOR has a portable or desktop receiver to suit your application.

Discover why AOR is The Serious Choice in Advanced Technology Receivers.™



AR5000/PLUS 3

AR8200B Incredible performance in a hand-held receiver!

- 500 KHz ~ 2040 MHz * coverage
- 1,000 memory channels (20 banks)
- Computer control and programming. (requires optional connection cable)
- Download free control software from AOR web site!
- "All Mode" reception includes "super narrow" FM plus wide and narrow AM in addition to USB, LSB, CW and standard AM and FV modes
- True carrier reinsertion in USB and LSB modes. Includes 3 KHz SSB filter!
- Detachable MW antenna with negative feedback
- Optional internal slot cards expand the AR8200B capabilities. Choose from Memory Expansion (up to 4,000 memories), CTCSS Squelch & Search, Tone Eliminator, and Record Audio (saves up to 20 seconds of audio)
- Tuning steps programmable in multiples of 50 Hz in all modes
- 8.33 KHz airband step is correctly supported
- Noise limiter and attenuator
- Band activity "scope" display with "save trace" capability
- Four-way side panel rocker switch allows one-hand operation
- Large display includes A and B VFO Frequencies and signal strength meter
- Battery Save function with Low Battery indicator
- Operates on 12 VDC external power
- 4 AA Ni-Cd batteries supplied, also uses standard AA dry cells
- BNC antenna connector
- Wide choice of accessories

AR5000/PLUS 3 High Performance Communications Receiver

A professional grade receiver with superior quality and selectivity

- 10 K-hz ~ 2060 MHz *
- 1000 memory Channels
- Triple Conversion IF stage
- Multiple IF bandwidths (3 KHz, 6 KHz, 15 KHz, 30 KHz, 110 KHz & 220 KHz)
- Solid Metal Cabinet
- Cyber Scan up to 45 channels/sec
- Provision for optional Collins mechanical filters
- Attenuator (10 dB)
- AM, FM, LSB, USB, CW modes
- Automatic electronic front end preselection
- Analog S-meter
- RS-232C port
- Alphanumeric channel labels
- 20 Search Banks
- N-Type and SO-239 Antenna Connectors
- Interfaces with SDU5500 Spectrum Display Unit
- TCXO standard for high stability
- Manual tuning dial
- AFC, Noise Blanker and Synchronous AM Detector

AOR U.S.A., Inc.

20655 S. Western Ave.
Suite 112 Torrance, CA 90501
310-787-8615 Phone • 310-787-8619 Fax
www.aorusa.com
CIRCLE 156 ON READER SERVICE CARD

* Cellular frequencies blocked in compliance with USA regulations. Continuous coverage models available for authorized users/agencies; documentation required.

AOR engages in ongoing efforts to improve its products. As such, design and performance parameters may change without notice or obligation on the part of the manufacturer and/or distributor(s).

the radio connection

A Look Behind The Dials

Building A Selective Crystal Set

For those of you reading "The Radio Connection" for the first time, we've begun building our latest project, a selective crystal set. Unlike simpler designs, this radio is surprisingly selective considering it's a single coil design. It owes most of its performance to a special high-Q coil-wound basket weave fashion, combined with the highest quality tuning capacitor we could find. A three-gang 365-pF tuning capacitor with (two sections paralleled) provides a method of variable ground coupling. For example, at the lower end of the BCB, ground coupling is at maximum, while at the higher end of the BCB the capacitance is at minimum. This gives the best compromise of selectivity versus sensitivity across the tuning range. This receiver is loosely based on an earlier design published by Mike Tuggle and dubbed the Lyonodyne. Mike's design was considerably more elaborate and used some special techniques to achieve an even higher degree of selectivity than our receiver is capable of achieving.

"This gives the best compromise of selectivity versus sensitivity across the tuning range."

If this project is something you would like to attempt building, you will need the April 2000 issue of *Popular Communications*. The April column shows how to wind the coil using a special 13-point homemade jig, and also lists resources for finding many of the parts used in this set. You can get back issues of the magazine (\$4.00 postpaid) by calling 1-800-853-9797 or faxing 516-681-2926.

Putting It All Together

This month we will put everything together. Over the next few columns, we'll investigate a few other designs with even better selectivity. Besides better selectivity, the more complex sets will also offer better immunity to shortwave station overload — a surprising short-

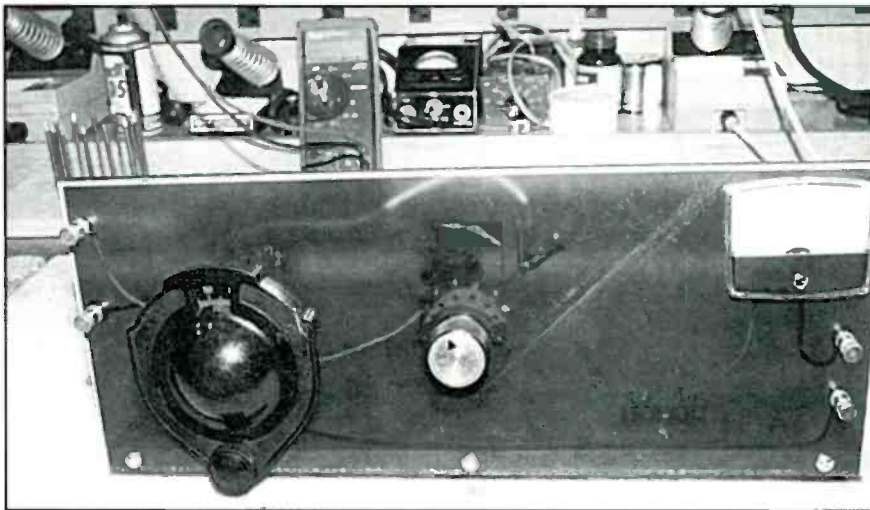

Here's the front view of our version of the Lyonodyne crystal receiver. The large vintage vernier tuning dial is at left, and the antenna matching switch knob is in the center.

coming of some single coil designs. With the Lyonodyne hooked to my 150-foot longwire antenna, WBCQ's 41-meter shortwave band booming signal from Monticello, Maine, was heard across the tuning range on most evenings!

As shown in the photos, the set is built breadboard fashion, using a piece of maple board for the chassis and a gray tinted Lexan front panel. A masonite front panel, spray painted black, would lend a more vintage feel to the set, but I

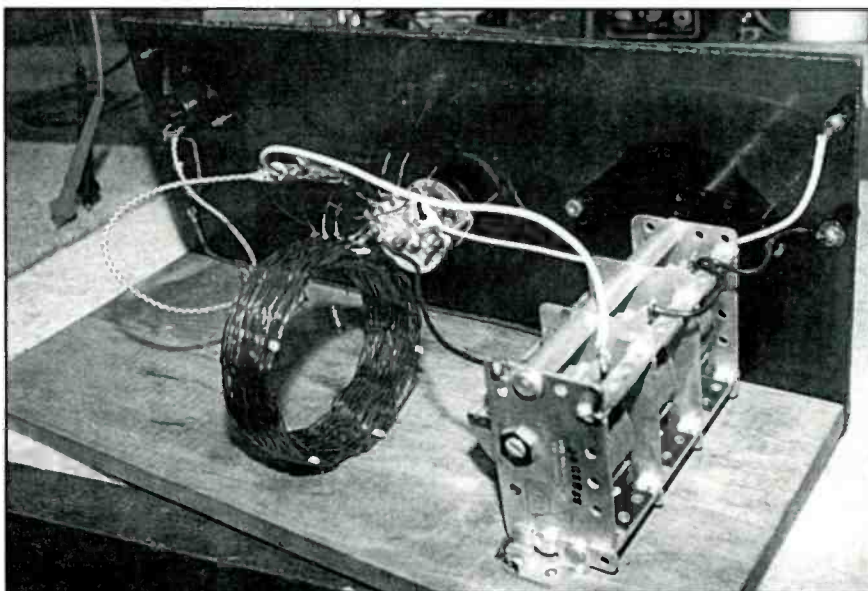

The rear of the receiver. The large three-gang 365pF-per-section variable is at the far right. The basket-wound coil is located on the center of the board, away from the detuning affects of nearby metal objects.

BY PETER J. BERTINI <RadioConnection@juno.com>

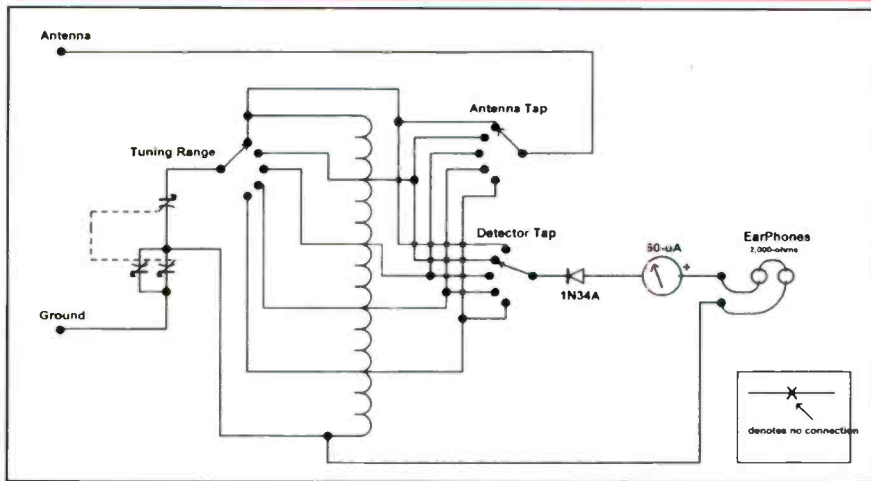

Figure 1. Schematic of the Lyonodyne receiver. The more complex design uses three switches.

had to make do with the materials on hand with short notice. The breadboard is slightly larger than needed, which was done for a good reason. Next month, we will be adding a notch filter to the set in that unused space to reduce the signal level of strong local interfering stations.

The basket-wound coil is tapped to permit selecting the best LC tuning range for the frequency of interest, and also for the best antenna matching and detector load. It would be nice to use three, 5-position rotary switches for this purpose: one to select the antenna tap, one for the detector tap point, and the last for the tuning capacitor. My junk box had a good quality ceramic wafer rotary switch that I used

to select the antenna tap. For simplicity and lower cost, I used alligator clips to select the tap positions for the detector and tuning capacitor. If you have them, three, 5-position rotary switches would be best: but the alligator technique — while certainly less elegant — gets the job done. Ceramic wafer switches with silver plate wipers are probably the most desirable in terms of loss and maintaining efficiency, in theory, but the less expensive phenolic wafer or plastic housing designs will do. The alligator clips are attached to tinned-wire lead pigtailed left on the switch terminals.

Where can you find inexpensive switches? Well, the ideal switch would be

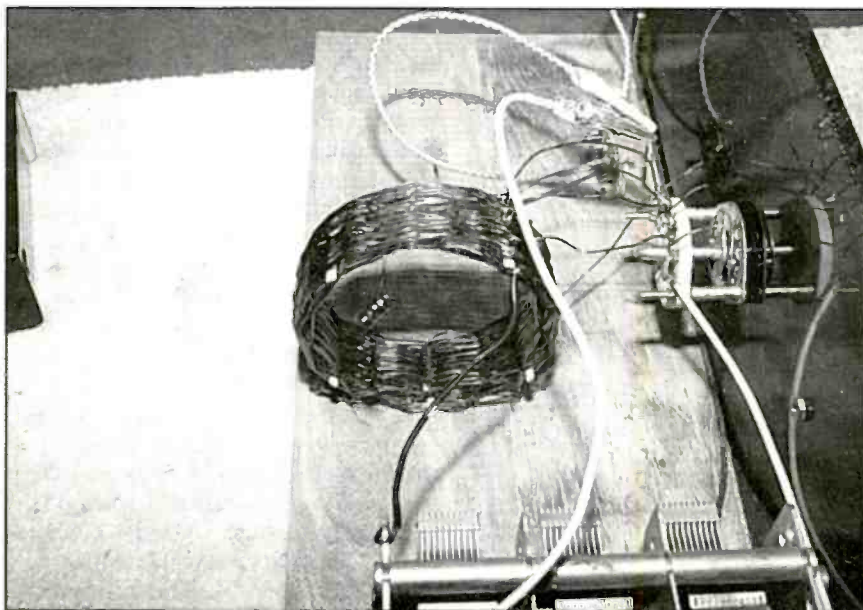

This rear-view shows more of the layout details. Note the use of alligator clips to make contact with coil tap positions for the detector and tuning capacitor.

FACT:

Foot for foot, top-loaded antennas outperform base-loaded antennas.

FIRESTIK:

Firestik's top loaded coil design focuses more of your transmitted signal on the ground... where you need it most!

**FREE
PRODUCT
GUIDE**



FireStik

ANTENNA COMPANY
602-273-7151 • support@firestik.com
http://www.firestik.com

CIRCLE 66 ON READER SERVICE CARD

WEATHER STATIONS



Professional-quality weather stations for home & industry.

Various models track temperature, wind, rain, evapotranspiration, heat-stress index, UV Index, degree-days, and more. Priced from \$150⁰⁰. POC0900

For a free catalog of our stations & accessories, call

1-800-678-3669

Davis Instruments

3465 Diablo Avenue, Hayward, CA 94545-2778 • www.davisnet.com

CIRCLE 65 ON READER SERVICE CARD

**FREE
SAMPLE
COPY!**



ANTIQUE RADIO CLASSIFIED

Antique Radio's Largest-Circulation Monthly Magazine

Articles - Classifieds - Ads for Parts & Services
Also: Early TV, Ham Equip., Books, Telegraph, 40's & 50's Radios & more...

Free 20-word ad each month. Don't miss out!

VISA 1-Year: \$39.49 (\$57.95 by 1st Class) **MC**
6-Month Trial - \$19.95. Foreign - Write.
A.R.C., P.O. Box 802-T14, Carlisle, MA 01741
Phone: (978) 371-0512; Fax: (978) 371-7129
Web: www.antiqueradio.com

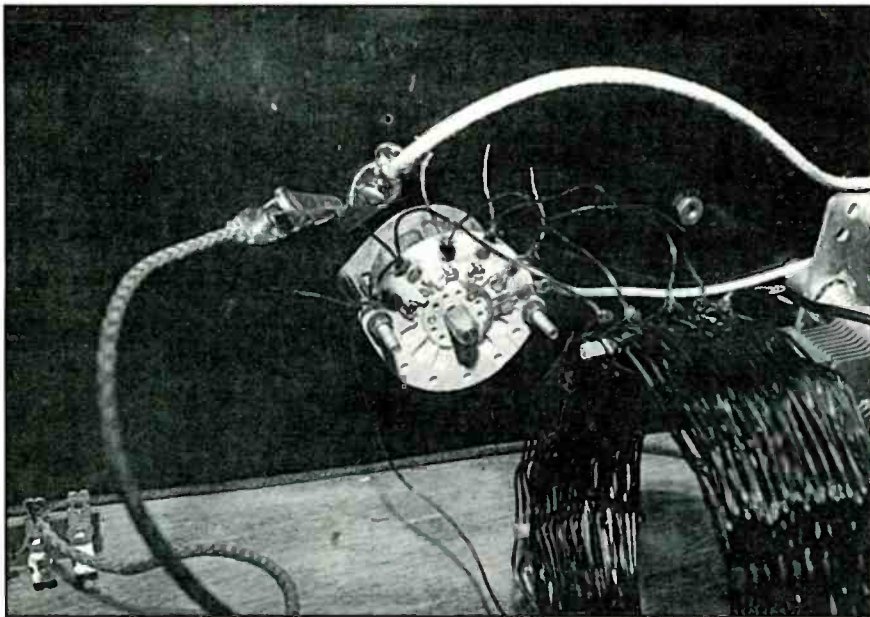

A close-up view details the ceramic antenna switch and how the alligator clips connect to various coil-tap configurations. Note the tie-strip (far left) with the IN34 diode.

a high-quality ceramic-wafer rotary switch with silver plated contacts. These are nearly impossible to find new these days, and certainly would be extremely costly if found! The best source is parts vendors at hamfests, or switches salvaged from early military surplus gear. For sources of new inexpensive rotary switches, check Mouser and the other suppliers we suggested last month.

The detector diode is a germanium type 1N34A. You can find 1N34 diodes on the shelf at your local RadioShack outlet, and the good news is that the RadioShack 1N34 diodes are reputedly excellent performers in crystal sets. My germanium diode was one of the two matched diodes

offered by the NTE Electronics line of replacement semiconductors; specifically the NTE110MP matched pair of germanium diodes. If you are experimentally inclined, you might want to try some small signal silicon diodes, such as the 1N914, but they will not be as sensitive as a good germanium diode. The diode was soldered to a terminal strip near the signal meter.

Adding A Signal Meter

The detector diode removes the audio component (an AC signal) from the RF carrier and the AM sidebands produced during modulation of the carrier. In theo-

ry, the carrier itself conveys no useful information. A byproduct of the detection process is a DC voltage produced by rectifying the RF signal, which is a high-frequency AC signal. Visualize the detector as working like a half-wave rectifier. When a radio station's carrier is detected, current will flow through the headphones, diode, and the tuning coil. Placing a sensitive microampere meter in series with the headphones will show relative signal strength. A 20- μ A meter is best; but these are scarce and expensive if purchased new. At one time, RadioShack's line of panel meters included an inexpensive 50- μ A meter movement that worked really well with crystal sets. They are no longer carried by RadioShack, so you will have to search the new and surplus equipment catalogs from various vendors to find a suitable candidate. My Ocean State Electronics catalog shows a small 50- μ A meter as their part number 60-165. Be careful here: Remember you need a 50 microampere, not 50 millampere, meter for this signal meter. A 50 millampere meter movement is far too insensitive.

The signal strength meter will only work with headphones with around 2000-ohms DC resistance. Ceramic or crystal earplugs have DC resistances that are nearly infinite, and will not pass sufficient current for the meter to operate. You should also add a 47k-ohm resistor across ceramic or crystal earplugs to provide a current path for the diode detector current.

Building The Radio

Pine, oak, poplar, or cabinet grade plywood will do for the breadboard. The board should be kiln-dried, and once cut to size, it needs a few good coats of stain followed by a lacquer or polyurethane finish to keep it from absorbing moisture.

The main tuning capacitor in my set is bolted directly to the breadboard using 10-32 screws and countersunk holes on the bottom of the board. Note that the frame of the capacitor is above ground potential in this receiver design. For minimum loss, the board must be free of excessive moisture.

A vintage vernier dial drive is used to turn the tuning capacitor. This provides a calibrated logging scale and a method for fine tuning stations. A large diameter knob — between three and four inches — could also be used. The five-position single-pole rotary switch mounted on the front panel near the vernier dial drive selects the antenna tap. This switch allows the operator to select the best

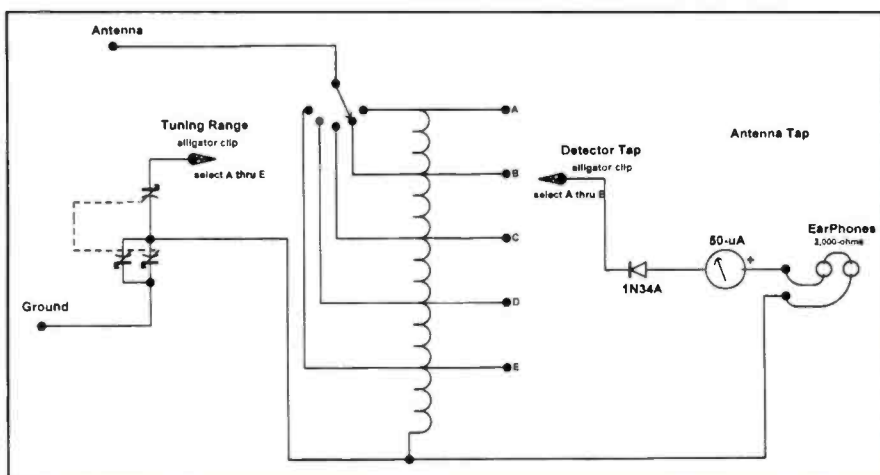

Figure 2. The simplest design uses one switch and two alligator clips for tap selections.

antenna tap point that yields the best signal strength to selectivity ratio. Two more similar switches could be used to select the desired detector and tuning capacitor tap points; But, for my set I used alligator clips to select the best tap positions for simplicity. The antenna coil is simply held in position by the wire leads from the tap positions and coil end wires. The coil should be positioned away from metal (especially ferrous) objects, such as the tuning capacitor, to keep the coil Q as high as possible. The ends of the coil wires, where attached to the switch contacts, are left about one or two inches long and tinned to provide points for attaching the alligator clips. My coil's five tap positions, along with the wire from the end of the coil winding, would logically dictate a six-position switch, but since my coil had too many turns, I simply left the last section of the coil unused. In practice, the more tap positions the better, especially if they resolve fewer turns on the antenna coil. Feel free to experiment. Use metal binding posts. Fahnestock clips, or inexpensive binding posts from RadioShack for the radio's antenna, ground and ear-phone connections.

Operating The Radio

The higher and longer the antenna the better! AM broadcast stations use vertical polarization, so best reception of local stations is obtained when the antenna is run as vertical as possible. Distant sta-



A 50- μ A meter shows the relative signal strength of most audible stations. The meter is very useful for fine-tuning and finding the most sensitive tap positions.

tions will arrive via various propagation methods, and their signal polarization will vary with conditions. Crystal set performance is highly dependent on your location and the antenna and ground system. Use as large gauge wire antenna as possible, and use high-quality porcelain or glass insulators as a first choice to minimize losses. The best ground requires radials laid on the ground like the spokes of a wheel, and running out several hundred feet from the hub, or operating position. I make do with a ten-foot commercial ground rod that is pounded into the earth outside my shack's window.

The "best" antenna tap position is the one that gives the best match between the antenna impedance and the tuned circuit. In general, shorter antennas will use tap positions closer to the "hot end" of the coil, or higher impedance point; while super

long wires will present a lower impedance that is best handled by the tap positions nearer the "ground" or "cold" end of the coil winding. I had good luck using very short antennas, about 25 feet placed over the house roof worked well during tests. The shorter antennas require the best ground systems. A long wire antenna will show wildly varying electrical characteristics across the band, so don't expect one antenna tap position to work the best for all stations.

Select the tuning capacitor tap position that gives the best coverage of the broadcast band. Too much coil will prevent tuning stations at the high end of the band, while too little coil will prevent reaching stations at the lower frequencies. The detector tap should be between the selected antenna tap and ground. The higher you place detector tap, the stronger the signal will become while the set becomes less selective. Experiment to find the best settings for any one station, and remember that every adjustment will interact with the others. When using a very long and efficient antenna, you may find disconnecting the ground lead will improve selectivity and prevent overload with no apparent loss of volume. Most audible stations will show some deflection of the signal meter, and the strongest stations at my location produce half-scale readings. For the very sharpest selectivity use crystal or ceramic earphones; but remember the signal meter will not work when very high-impedance phones are used. ■

\$139.95
plus S&H



STOP MISSING YOUR FAVORITE RADIO PROGRAMS...

Use Reel-talk™ radio timer recorders... Like A VCR For Radio!

Includes: AM/FM Radio • Digital Tuner • Digital Clock

- 4 Hour Timer Recorder (RT-101) or 1 Hour Timer Recorder (RT-201)
- Mic. Input Jack • 6" × 6" × 13" • LCD Display • Headphone Jack
- 20 Station Presets • And More.

ORDER NOW. CALL 1-800-723-4669.
30-DAY MONEY BACK GUARANTEE.

Reel-talk™ Inc.

1050-C Nine North Drive, Alpharetta, GA 30004

1-800-723-4669 FAX 678-393-9073

<http://www.reeltalk.com>

CIRCLE 79 ON READER SERVICE CARD

radio resources

Interesting Thoughts And Ideas For Enjoying The Hobby

The Restrained Two-Way TAD Radio

If you're a licensed ham radio operator, you can appreciate the flexibility of a programmable 2-meter or 440 MHz transceiver that can tune anywhere, transmit on any simplex or ham band split frequencies, and store 100 or more of your popular frequencies. Most single-band and dual-band ham sets are shipped with unrestricted (less cellular, of course) out-of-band receive coverage, turning the modern ham set into a powerful scanning receiver.

But there are some drawbacks with the synthesized VHF/UHF ham set for the tough commercial-like workplace. For one, a synthesized ham set is not permitted to transmit on any frequency outside of its upper and low ham band limits. About the only exception might be for Civil Air Patrol, Coast Guard Auxiliary, or MARS (Military Affiliate Radio System) authorized use. Running a transmit-modified ham set on, for example, your local VHF business channel is absolutely illegal.

Another problem with the ham radio in the commercial field is its susceptibility to downtown intermodulation interference. In order to achieve VHF extended receive reception of AM aviation frequencies, FM government channels below 144 MHz, and extended FM reception from 148 MHz through 179 MHz, ham manufacturers will leave out high Q band-pass and band-reject circuitry. The wideband receive capability is nice for tuning in your local airplanes and the VHF weather channels, but when listening to the 2-meter band in a downtown parking lot, chances are the receiver is going to be swamped with adjacent frequency powerful pager tones on 152 MHz and 157 MHz.

"Without some sort of mechanical filtering, most downtown kilowatt pager systems will numb the 2-meter reception of many ham radio mobile units and ham radio hand sets tuned to in-band 2-meter frequencies," comments Byron Grams, KC6YNG, a ham radio operator and radio communicator for his local city's disaster radio team. He continued, "I think wide-



The TAD radio is great for both business band and ham radio, plus CAP.

band multi-mode VHF scanner-type receiving is really a neat thing for a VHF 2-meter mobile, but the susceptibility to powerful VHF pager tones will sometimes wipe out my local 2-meter reception," specifically mentioning Los Angeles and San Francisco as major problem areas for intermod interference.

"For commercial applications, modified ham sets are strictly out, and FCC type-accepted radios are IN," comments Frank Strasser, WA7UOJ, with TAD Radio of Canada (P.O. Box 10160, Spokane, Washington 99209; 509-456-5885). "Our TAD M-10 offers 396 programmable channels of intermod-free reception, and it features tracking circuitry to specifically minimize intermod problems, yet still allow wideband FM reception," adds Strasser.

This VHF 30-watt mobile carries both FCC and Canadian acceptance numbers and could easily double as a 2-meter ham set as well as a VHF high-band mobile transceiver. Most interesting, it can be set up for proposed 6.25 kHz channelization, as well as the normal channel steps of 5

kHz. As our own FCC begins to chop channel spacing in half, this new equipment can take the 12.5-kHz channel pairs in stride.

For the non-ham operator, a simple radio set with minimum controls to get fouled up is a logical choice among professional communication system engineers. The TAD M-10 is PC—and field-programmable, and can be cloned almost anywhere in the field to another radio. For emergency communicators, this cloning capability has some terrific advantages that most mobile ham sets don't possess.

When we operated the equipment in Los Angeles, it was intermod-free. We programmed some of our VHF itinerant and high-band business channels with both CTCSS as well as DSC tones. And we also used the optional DTMF microphone to further expand the capabilities of the M-10.

During the programming process, we also detected a data burst; each set is capable of sending its own electronic serial number. This, along with a built-in theft protection, is one more margin of com-

BY GORDON WEST, WB6NOA



The TAD M-10 is computer programmable and offers a very tight receiver. Note the input port at the right for programming.

ment without accidentally pushing a button and putting the radio into la-la land. This is one of my biggest gripes against the new breed of dual-band and tri-band ham transceivers. Why do ham manufacturers insist on making the readouts, knobs, and buttons micro-small? I admit that our dashboards are getting smaller and smaller, but we still have room for a bigger and bigger control head on our ham equipment. We should follow the example of the professional land-mobile industry and get back to a logical sized control panel with a big LCD display.

Quite An Eye-Opener

It was an eye-opener to play with land-mobile equipment again. While there are restrictions on its programmability from under the dash, getting things programmed in ahead of time for specific channels is a good idea for driving safety. If you get a chance, call or write WA7UOJ at TAD and see all of the neat professional radio equipment they offer. The M-10 retails for \$695 (U.S.). Be sure to tell them you read about it in *Popular Communications*.

patibility with a land-mobile radio system. All of the 396 channels may also be named with an alphanumeric display.

TAD keeps up with any running changes by adding addendum sheets to the manual to ensure you have the very latest info.

But one of the best parts of a dedicated land-mobile-type receiver under the dash is the capability of using the equip-

Theft Protection?

Removing the power from the red lead for more than 15 seconds will cause the radio to revert to the theft-lock mode when this menu item is selected. You must enter a special lock number before the radio will work properly. If a wrong lock number is entered more than 10 times, the radio will display "Locked" and will stay totally locked until special software from the factory (over the phone) might get it back to normal. You don't see this in amateur radio gear.

The TAD radio uses an expensive RF amplifier transistor and first mixer stage to provide a high degree of selectivity against unwanted nearby signals. The first mixer combines the RF signal and the twin VCO oscillator output to provide a 21.6-MHz first IF. The first IF signal is fed via a matching network to the crystal filter, which has a very sharp band-pass characteristic to reject adjacent channel interference. We tested the equipment in downtown areas where 152 MHz and 157 MHz pagers pounded the receiver front end, and we couldn't detect any intermod or on-frequency desensitization.

And here is something that technical hams will appreciate: Each radio comes with a service manual that gives 100 pages of detailed service information and alignment procedures for the equipment. And

POWERPORT

WORLDPACK
P/N HMP
\$57.95
Designed to safely carry your ICOM-706 or other mobile radios into the field or carry onto a plane. Separate compartment for optional power supply and antennae. Complete, comfortable and compact.



VX-5R POUCH
P/N HI-51 **\$19.95**
Soft Glove quality leather pouch with rear pocket to hold extra antenna tips and secure full-sized belt clip. Easy access PTT and display. One of our many fine pouches for today's radios



FT-90 TRANSPORTER
P/N HM-90 **\$87.95**
Carry your FT-90 anywhere as a stand-alone unit. Sturdy padded nylon case securely holds your FT-90 and comes standard with 9 AH rechargeable power cell. Creates a complete 50W station that you can carry in one hand. Comes with automatic charger.



POWERSAFE
starting at **\$65.95**
You add the automotive or deep cycle battery and we supply everything else you need for extensive, long lasting power backup. AC models up to 600 Watts. Automatic charger can recharge your battery through your household wall socket, through your auto cigarette socket, or with our WorldPack solar rechargers. Five different models available.



ORDERS 800: 206-0115
CUTTING EDGE ENTERPRISES
1803 MISSION #PMB 546 SANTA CRUZ CA 95060
all other inquires 831: 429-5384 e-mail ce@ce@cutz.com









CIRCLE 82 ON READER SERVICE CARD

It Beats Me: Answer The Question And Win A Big Prize

What is the one thing that most CBers have in common? Aside from our common love of radio, the most common trait we share seems to be our lack of technical expertise. I guess that is not too surprising though. Let's face it, if we knew a lot about the intricacies and subtleties of the physical workings of radios and antennas, we probably wouldn't be CBers. We'd be amateurs, right? Well, on second thought, maybe not. Be that as it may, the fact remains, as non-technical a hobby as CB may be for most of us, there are still a certain number of technical problems that arise in our day-to-day pursuit of on-air happiness.

Often, when those puzzling technical questions come up, you — the reader of this column — put pen to paper or fingers to keyboard, and send them to me. And therein lies the problem. Guess what? I am a CBer! Yep, I am just a plug it in, turn it on, and hope to hell it works kinda guy. When it comes to the technical end of a radio, I am as lost as you are; perhaps even more so.

“Basics, however, often prove inadequate to the task of answering many of the profound questions you send in.”

I hope that I am not surprising or disillusioning you, but it is true. Yes, reluctantly, over these oh so many years, I have been forced to learn a few of the basics. Basics, however, often prove inadequate to the task of answering many of the profound questions you send in.

Frankly folks, my greatest fear is that there may not be answers to many of these questions. It is not that they are bad questions. They are not. They are great questions. While always phrased differently, they are very often the same question. The same question that I've been asking. The same question the people that I have been

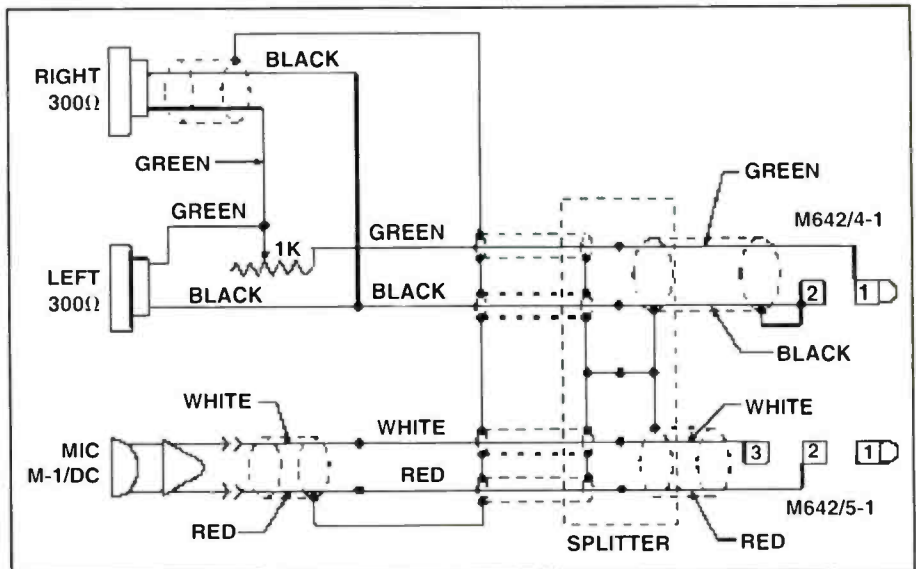

Luis' diagram mentioned in this month's column. How can he modify the headset?

asking have been asking. It is even the very same question that the people who were asked by the people I asked have been asking. And those people have been asking that question ever since CB was invented. Sadly, to this very day, nobody I know has ever found the answer. Now that's not to say that the answer doesn't exist. Rumors of the existence of an answer abound. That fact has been alluded to in newsgroups, talked about on nets, and openly bragged about by distant skip stations. I have heard from people who claim to have met somebody that knew somebody who knew. However, try as they might, they couldn't remember who.

No, I can't help thinking that somewhere, perhaps on an antenna farm way up in mountains of Montana, there is a shriveled up little old CBer-turned-amateur who knows what it is. But he won't tell anybody! Why? Because of being old and shriveled, not to mention an amateur. He gets extreme pleasure from prancing around at midnight in the bright Montana moonlight singing, "I know the answer, I know the answer!" And it is the joy pro-

duced by this odd ceremony that keeps him alive.

Fortunately for us, from time to time, he is known to shower and leave his retreat and attend coffee breaks and key downs in various parts of the country. There, he will sit in a dimly lit corner with his back against the wall. Surrounded by brown bottles and wearing his best "George W." -smirk, he gloats gleefully knowing that many in the room desire the knowledge only he possesses. It is times like these, after imbibing one too many of those brown bottles, he will get a little too daring and start dropping hints of his secret to one or more unsuspecting attendees. Occasionally, especially if he thinks he is not being believed, he will tell it all!

Perhaps you've met him and thought he was just a prattling old fool. Just maybe, unknowingly, you hold the very answer so many have sought for so long. Maybe you don't realize how important this information is. Perhaps you're not sure if you should tell anybody. You may not know how valuable this information is. Let me assure you it is extremely valuable. Who

ever possesses it not only holds the key to vast personal wealth but the ability to bring untold happiness to millions of current and future CB operators as well.

If you do know the answer, let me urge you, right here and now, to drop whatever it is that you are doing. Run, don't walk, to the nearest U.S. Patent Office and register the information. I think it is a safe bet to assume that our little old Montana Madman has not done that yet for fear that his secret would then be exposed. The moment you have it protected — your treasure with the official power of the government of the United States of America — write me. I have several major venture capitalists ready to bankroll production and marketing. Further, just to make sure that the news gets spread quickly, Jock Elliott will devote his entire product review in the very next "CB Scene" to you and your discovery.

"The question that has been plaguing CBers since the beginning of CB time is this: Where can I find the perfect antenna?"

Finally, if great wealth and fame aren't enough, let me add one final incentive. If you contact me with the desired information within the next 30 days, you will be granted exclusive rights to the CB channel of your choice for an entire year. That's right, any channel, any place to do with as you please for one full year!

Enough, Already! What's The Question?

The question that has been plaguing CBers since the beginning of CB time is this: Where can I find the perfect antenna? To be considered perfect, this antenna must minimally meet two criteria. First, it must be stealth enough to evade the prying eyes of the most stringent jack booted building supervisor, zoning inspector, or neighborhood association commissar. Second, it must provide suf-

"To be considered perfect, this antenna must minimally meet two criteria. . ."



4091 Viscount Avenue
Memphis, TN 38118
(901) 794-9494
Fax: (901) 366-5736

Visit our Website:
www.majestic-comm.com/maco

ANTENNAS • POWER SUPPLIES • CABLE ASSEMBLIES

HIGH PERFORMANCE and MADE IN U.S.A.

ALL MACO BASE STATION ANTENNAS are made of aircraft alloy 6063-T5 aluminum tubing—.050 wall. Elements are made of harder 6005 alloy.
NOTE! To prevent fatigue failure, no holes are made in any boom or element.

MACO Laser 400

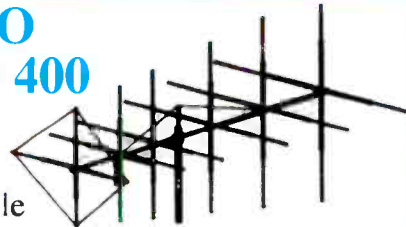

Switchable
Polarity
12 Element Beam

The 12 Element Laser is designed to achieve the maximum gain and front to back ratio using a Quad Reflector and Yagi Parasitic elements. There are six elements horizontal and six elements vertical, scientifically spaced on a 31 ft. boom. The 12 Element Laser is second only to the Super Laser 500 in performance.

Laser 400

Specifications:

Boom Length	31'
Boom OD	2"
Number Elements	12
Longest Radius	18'
Turn Radius	17'
Surface	
Area	10.5 (sq. ft.)
Wind Survival	90 mph
Gain	17 dB
Power	
Multiplication	50X
Front-to-Back	
Separation	40-44 dB
Weight	52 lbs.

Call or write for a free-catalog and name of reseller near you.

CIRCLE 69 ON READER SERVICE CARD



synctime metallic mesh band, metal bezel mineral lens, hi-tech polymer case \$179.95

a new millennium!
time to be on time
.... atomic time!
with the world's most accurate time pieces, atomic clocks & watches from

ATOMIC TIME

- reliable convenient time pieces
- synchronized to the u.s. atomic clock. fort collins/co
- accurate to 1 second in 1 million years
- engineered in germany
- radio-controlled time

choose from our wide variety:
casual & sport watches
travel alarms • wall clocks
desk clocks • wood clocks
radios • weather stations
computer UTC clocks
industrial & commercial clocks

20% off second item

call for our free brochure:
(630) 472-9999
or go to www.atomictime.com
credit card orders call toll free
1-800-985-8463
send checks/money orders for the total amount incl. s&h \$7.00 to

ATOMIC TIME, INC.
1010 JORIE BLVD. • #332
OAK BROOK, IL 60523



atomic dual alarm clock w. 2nd world time, 5x4x2 1/2" black arch design \$59.95



atomic radio with 2 alarms and temperature, day, date, LCD \$59.95



jumbo digit atomic clock w. temperature & humidity, wall or desk 8"x11"x1" • \$79.95



black arabic 12" wall clock for home or office • \$69.95 (wood \$89.95)



atomic digital alarm sport watch 2nd UTC 24hr time display, lap etc. • \$99.95

CIRCLE 60 ON READER SERVICE CARD

efficient gain to allow standard 12-watt PEP transmitters to dependably communicate with the average skip station. Ideally, this antenna should also be small, able to work indoors or taped to the out-

side of a window, easily converted for mobile or field work and if possible, cost less than \$75.

That is it. That is all there is to it. I'll be anxiously watching my mailbox, looking for your answer. In case of duplicate entries, the winner will be determined by earliest postmark. In case of duplicate postmarks, winner will be determined by random drawing. Assignment of exclusive channel is pending approval of the FCC. The decision of the judges is final. Good luck!

Luis, of San Juan, Puerto Rico, has a David Clark headset. He would like to modify it for use on CB. If possible, he would also like to create a "VOX" feature as well. Take a look at his diagram. How can he do it?

May And June Mixers

Looking for a little chatter on the CB? Then plan on attending the next, now regularly scheduled, on-air CB Mixer. They are held, wherever you are, on the last Saturday of the month (the next two will be on the 27th of May and 24th of June from 9 p.m. until 10 p.m. local time. SSB operators work channel 36 LSB. AM operators work channel 23. For complete guidelines, see the November 1998 issue of *Popular Communications* or drop me a note.

Well, that's it for now. Thanks for writing me here at the magazine or via the Internet where my address ed@barnat.com. And as always, if you can (especially May 27th and June 24th) — catch me on the radio! 73

The Alternate Question

OK, I agree that is a tough one. For those of you who don't know the answer, but would still like to win a prize, here is an easier one. The first 10 people who correctly answer this question will receive a genuine burnt screwdriver. This screwdriver's plastic handle has been customized by leaving it too close to a hot soldering iron, and its chrome-plated blade has been tastefully stained by the sparks from my last CB tune up.

Bill's 2 Way

CB Radio Equipment

uniden KENWOOD MIDLAND
CHEROKEE ICOM Gbra
TEXAS RANGER maxon Galaxy

FREE CATALOG!

*"We are the DISCOUNT LEADER
in sales of scanners, FRS, CB,
GMRS radios and accessories."*

1-888-710-4094

Bill's CB & 2-Way Radio Service
PO Box 306, Morgan Hill, CA 95038-0306
Tech Line: (408) 782-0064 FAX: (408) 782-2985
e-mail: sales@bills2way.com
Website: http://www.bills2way.com

CIRCLE 62 ON READER SERVICE CARD

The "Special" You've Been Waiting For . . .

"Free Shipping - Big Savings"

Now thru April 15th - Jo Gunn will pay the shipping charges on any antenna that is UPS Shippable in the U.S.

All orders must be prepaid no COD's on "Shipping Special".

Orders must be prepaid by VISA, MasterCard, Discovery, AMEX, Cashiers Check, or Money Order.

Note: Shipping charges applies to UPS Ground Rate Shipping only. Any special shipping costs will be added to antenna cost. "Shipping Special" must be mentioned in order to receive the discount.

4 Star
Excellent Local
& DX Antenna

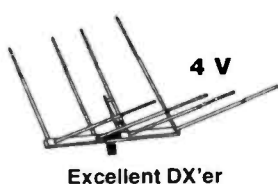
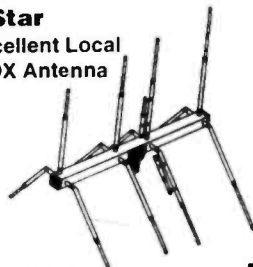

Excellent DX'er

CALL FOR A FREE CATALOG

3138 County Road 30
Ethelsville, AL 35461
(205) 658-2229 • Fax: (205) 658-2259

Hours: 9 a.m. - 5 p.m. (CST) Tues - Friday
Answering System After Hours

Dealer Inquires, please call.



CQ Ham Radio's Best Calendars Are Back

NEW 2000-01 editions!

Hot off the press, our widely acclaimed calendar series is back with CQ's new 2000 editions. You'll refer to your CQ calendar time after time as you search for the schedules of upcoming ham events and conventions. Public holidays and valuable astronomical information will be right by your side too!

Enjoy 15 months of use (January 2000 through March 2001) with this year's editions. Each month you will be treated to some of the greatest photography in all of amateur radio.



Only
\$9.95 ea.
+\$2 s/h

2000-2001 Radio Classics Calendar—Enjoy this year's selection of 15 magnificent images of some of the finest in Ham gear, vintage 1935-1968. Collins, Drake, Lyco, Gonset, Eldico, Harvey Wells, Lakeshore, Hammarlund, Hallicrafters, Globe, and more.

The 2000-2001 Amateur Radio Calendar—Features 15 terrific professional color photographs of some of the most interesting stations, the biggest antenna systems, the most famous operators and average hams throughout the USA.

Available directly from CQ and from your local dealer!

For Fastest Service call 1-800-853-9797 or FAX 516-681-2926

CQ Communications, Inc. 25 Newbridge Rd.,

Hicksville, NY 11801



product spotlight

BY PETER BERTINI

POP'COMM REVIEWS PRODUCTS OF INTEREST

The Vectronics VEC-1290K AM Transmitter Kit: AM MicroBroadcasting On A Budget

You've probably heard about folks who own and operate

their own radio stations on the AM broadcast band, but perhaps you didn't know that doing so is perfectly legal under Part 15 of the FCC Rules and Regulations governing these devices. Part 15 uses some pretty technical mumbo-jumbo to define just what signal you can radiate. For instance, a maximum field strength of 24000/fkHz uV-per-meter is permitted at a distance of 30 meters between 510 kHz and 1710 kHz. The regulations also limit the power and antenna size.

What this means is that while it is technically impossible to legally broadcast over a good-sized town, it is certainly possible to put out a good signal in your immediate neighborhood! I recently acquired a Vectronics VEC-1290K AM transmitter kit to rebroadcast vintage shows over the airwaves so I could enjoy listening to them on my collection of vintage radios. Low-cost transmitters for this purpose have been available for some time, but the VEC-1290K has about the best sounding modulation of any AM broadcast transmitter kit I have had the pleasure of listening to — the fidelity is outstanding!

The Transmitter

The heart of the transmitter is a multi-section CMOS IC that serves both as oscillator and buffer stage for the transistor final stage. The final is running Class C, permitting true high-level AM modulation. The modulator is an LM386 audio amplifier that is DC coupled to the final stage for maximum fidelity. I watched the modulation envelope while sweeping the audio input from 50 Hz to over 10 kHz; the transmitter output was remarkably flat over the entire range. The oscillator can be tuned to any clear frequency between 530 kHz and 1750 kHz. You'll probably find the unit gets out best at the higher frequencies, where the attached six-foot antenna is slightly more efficient. You shouldn't attach a 100 or 200 foot anten-

na since that would dramatically increase the transmitter range, and there is no guarantee that the suggested jumper settings would deliver a proper match without some experimentation. The modulation linearity is also excellent; the only shortcoming was a maximum modulation limit of about 75 or 80 percent. This is not a serious problem, and most likely results from having only the PA stage modulated. Solid-state AM transmitters usually require that some modulation be applied to the driver stage to achieve full 100 percent modulation. Several of my friends have built VEC-1290s on my recommendation, and they all have commented on the great audio quality.

Putting It All Together

To assemble the kit, you will only need some simple hand tools — a pair of nippers, screwdrivers, needlenose pliers, and soldering iron will do. Vectronics rates the VEC-1290K kit at Skill Level 1, placing it in the beginners category. The quality is A-One! The manual is extremely well-written and clearly illustrated. The introductory material is written with the novice builder in mind, and good alignment and troubleshooting sections follow. All of the parts are high quality, and the PC board is screened and masked making assembly and soldering a breeze. A beginner should be able to have the kit completed, tested, and on-the-air in one afternoon!

The little transmitter features both high and low-level inputs; making it suitable for a variety of program sources. You can use a CD player, mike, or tape deck. I use mine

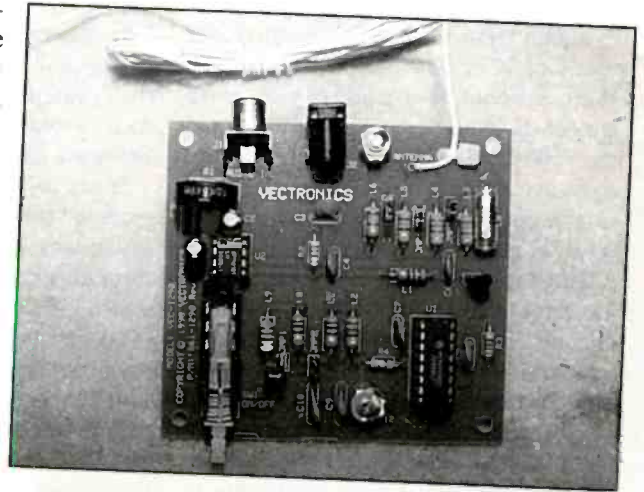

The new Vectronics VEC 1290K AM transmitter kit.

with the audio output from a satellite receiver to rebroadcast "Big Band" music service to my vintage AM sets. Or, you may opt to set up a home studio! Combine your CD player, tape deck, and mike with an inexpensive four or five channel mixer and you can be a budding DJ or talk show host. The mixer will keep your various program sources at the correct levels when switching from one to another.

You will need a small power pack capable of delivering 9 to 14 Vdc to operate the transmitter — remember the higher voltages will give increased power. The power pack should be capable of delivering at least 100mA and have a 2.1mm power plug with center positive. These inexpensive powerpacks can be found at your local RadioShack. An optional matching cabinet — the VEC-190KC — is available and features all-metal construction, decals, knobs, and rubber feet.

For more information on the Vectronics 1290K, call 662-323-5800 or to order it, call 800-363-2922. The price is only \$29.95. ■

broadcast dxing

DX, News And Views Of AM And FM Broadcasting

FCC Authorizes Low-Power FM, And Hot Canadian DX

The FCC has authorized a low-power FM (LPFM) broadcast service. Here are some of the details from the Mass Media Bureau. The new LPFM service will consist of two classes of radio stations with maximum power levels of 10 and 100 watts. The 10-watt stations would have a primary coverage area of about one to two miles radius, and the 100-watt stations approximately three and a half miles. These LPFM stations would operate throughout the present FM radio broadcast band.

The stations will be required to protect existing stations on the same channel (co-channel), the next or first adjacent channel on either side, and the second adjacent channel or two channels away. LPFM stations will not be required to protect existing stations three channels away. For example, under rules applicable to existing full power stations, where there is a station on 93.5 MHz, there is currently no station in the same geographic area on 93.7 (the first adjacent channel), 93.9 (the second adjacent channel), or 94.1 (the third adjacent channel). The new spacing criteria would allow a new LPFM station to be licensed on the third adjacent channel, or 94.1 MHz in this particular instance. (Note: FM broadcast frequencies in the U.S. are referred to as channels, beginning with channel 200 at 87.9 MHz and ending with channel 300 at 107.9 MHz, assigned at 0.2 MHz intervals.) FCC engineers have concluded that these protection standards will not produce unacceptable levels of interference with existing FM stations.

The new LPFM service will be exclusively *non-commercial*. In addition, current broadcast licensees or parties with interests in other media, including cable and newspapers, will not be eligible for LPFM stations. LPFM stations will be licensed exclusively to local entities for the first two years of license availability. Later, non-local entities will be eligible for licenses. Each licensee may own only one station in any given community, with

a maximum ownership of 10 radio stations nationwide.

Licensees will be subject to the same character qualifications as are currently applied to full power licensees. Unauthorized (pirate) broadcasters will be disqualified unless they certify that they ceased operations when notified of their violation of FCC rules or by February 26, 1999.

If mutually exclusive applications are received for the same LPFM stations in a given city, then they will be resolved through the award of points for established local presence (at least two years), proposed hours of service (at least 12 hours per day), and/or locally originated programming (at least eight hours a day). The point system would encourage mutually exclusive applicants to time-share their stations or assigned frequency. LPFM stations will be required to broadcast a minimum of 36 hours per week, the same as required of full power non-commercial educational licensees.

Applications will soon be available through the Mass Media Bureau Website at <www.fcc.gov/mmb/>. The FCC will provide 30 days public notice before accepting any applications. The entire FCC report on LPFM authorization is also available at the Website in a zipped Word 97 format.

Station Swaps

This month's list of call letter actions is evidence of more station swaps. Listeners in Albuquerque, New Mexico, have undoubtedly heard the KYJY/KQEO swap. In the Olympia, Washington, area, the KAYO/KGHO swap has people talking. In southernmost Florida, it looks like Radio Unica is transferring call letters to 106.3 and 107.9 FM, former sister stations of WRAU Miami Springs on 1700 kHz (now WAFN). The anticipated change of WARE 1250 call letters coinciding with the arrival of "La Mega" Spanish programming in Ware,

Massachusetts, hasn't occurred yet. Perhaps these unique call letters will be spared after all!

DX Across Canada

In response to "DXing the Contiguous 48" in the February 2000 *Popular Communications*, Jeff Kitz sends along these Canadian DX targets. (I added some embellishments.)

ALBERTA — Although they beam most of their signal away from the U.S., CFAC Calgary at 960 still breaks through the din. Jeff reports that CFAC blows out WFIR many nights at his listening post in Virginia.

BRITISH COLUMBIA — CBU at 690 and CKWX at 1130 from Vancouver have made it east on occasion.

MANITOBA — CBW Winnipeg at 990 covers much of North America with the exception of the coasts, especially the Atlantic and Gulf coasts where regional stations prevail.

NEW BRUNSWICK — Listen for CBA Moncton at 1070 with CBC Radio One and Maritime weather. This is one of the few CBC stations to remain on AM, serving fishing fleets and ships at sea.

NEWFOUNDLAND — The home of Marconi's historic transatlantic experiment that started it all, CHCM Marystown at 740 is the most likely to be heard from this distant province as long as CBL Toronto remains off the air. CHCM is on the VOCM/CFCB All Labrador-Newfoundland Radio Network. CBN at 640 was heard more widely before the frequency became congested with regionals.

NOVA SCOTIA — A number of targets are heard regularly along the Atlantic coast, including CFDR-780 "Kicks Country," CJCH-920, CHNS-960, and CKBW-1000. Unfortunately, like most of the Maritime Provinces, these are tough to hear inland.

ONTARIO — CJBC Toronto at 860 covers much of eastern North America with French-language CBC programs. This province is well represented across

BY BRUCE CONTI <BAConti@aol.com>

the dial by a number of other worthy targets including CKLW-800, CFRB-1010, CHUM-1050, and CHIN-1540. CBL Toronto at 740 used to be a favorite target before abandoning the frequency for FM. 740 remains dark.

PRINCE EDWARD ISLAND — Good Time Oldies CHTN, Charlottetown at 720 is heard up and down the East Coast. Interference from WGN, Chicago is a problem though.

QUEBEC — The flagship station of the French-language Radiomedia network, CKAC, Montreal at 730 covers most of places that Vancouver and Mexico don't. The new all-news stations from Montreal, CINF at 690 (in French) and CINW at 940 are your best bets. Old friend CBJ at 1550 is gone, another loss of CBC service to FM.

SASKATCHEWAN — CBK, Regina at 540 covers much of Canada, but the 150 kW Mexican station dominates the frequency across most of the U.S. CKBF-2 at 860 and CJGX at 940 kHz are possible alternatives.

YUKON — Jeff Kitze says, "Dream on!" Suggested targets; CFWH-570 and CKRW-610.

What about the new Inuit province that was separated from the Northwest Territories? As far as I know, the far northern reaches of Canada are inactive on AM. Finally, returning to the U.S., Jeff writes, "You left out my old friend 620 WTMJ (The Milwaukee Journal) from Wisconsin. How could you?" Jeff adds a few other suggestions I missed in the contiguous 48; WNAX (North American Experimental) at 570 from South Dakota, KFJR (K-Fire) at 550 from North Dakota, and KOMJ (formerly WOW) at 590 from Nebraska.

QSL Information

940 KCEE Tucson, Arizona, QSL letter in 28 days, signed Terry Daniels-KCEE Promotions Mgr. Address: 3202 N. Oracle Road, Tucson, AZ 85705. (Martin, CA)

1230 KBOV Bishop, California, friendly letter in seven days from John Dailey, Owner. Address: P.O. Box 757, Bishop, CA 93515. (Martin, CA)

1400 KTUC Tucson, Arizona, short letter in six days from Robert Malsbury — CE (also CE for KCUB-1290). Address: Slone Broadcasting, 575 W. Roger Road, Tucson, AZ 85705. (Martin, CA)

1450 KVSL Show Low, Arizona, very

friendly QSL letter with stickers in 16 days, signed Tom Troland-President/GM. Address: 3051 South White Mountain Road or P.O. Box 3000, Show Low, AZ 85901. (Martin, CA)

1600 KYBC Cottonwood, Arizona, another very friendly letter in seven days from David J. Kessel — GM. Address: Yavapali Broadcasting Corp., P.O. Box 187, Cottonwood, AZ 86326. (Martin, CA)

1630 KKWY Fox Farm, Wyoming, QSL card in 445 days, unsigned. (Martin,

OR) Full-data QSL card, signed Paul Montoya, one of the best looking cards I've seen. The station's address is 110 East 17th Street #205, Cheyenne, WY 82001. (Jackson, CA)

Broadcast Loggings

Here are our selected logs from across the country and around the world on AM. All times are UTC.

549 Les Trembles, Algeria, monitored

CALL TOLL FREE
(800) 292-7711
Orders Only
Se Habla Español

C&S SALES

Order On-Line @ www.cs-sales.com

CALL, E-MAIL OR WRITE FOR OUR FREE
64 PAGE CATALOG
(800) 445-3201

Digital Multimeters

<p>Elenco Model M-1740</p>  <p>\$39.95</p> <ul style="list-style-type: none"> • 11 Functions • Freq. to 20MHz • Cap. to 20µF • AC/DC Voltage • AC/DC Current • Beeper • Diode Test • Transistor Test • Meets IEC safety specs <p>Model M-2760 - \$24.95 (9 functions)</p>	<p>Elenco Model LCR-1810</p>  <p>\$99.95</p> <ul style="list-style-type: none"> • Capacitance 10f to 20µF • Inductance 1µH to 20H • Resistance 0.01Ω to 200kΩ • Temperature 0°C to 50°C • DC Volts 0 - 250V • Frequency up to 10MHz • Diode/Auto/Continuity Test • Signal Output Function • 3 1/2 Digit Display 	<p>Fluke 87III</p>  <p>\$319</p> <p>Features high performance AC/DC voltage and current measurement, frequency, duty cycle, resistance, conductance, and capacitance measurement.</p>
---	---	---

Elenco Oscilloscopes

Free Dust Cover and x1, x2 Probes



2 year Warranty

S-1325	25MHz	Dual Trace	\$325
S-1330	25MHz	Delayed Sweep	\$439
S-1340	40MHz	Dual Trace	\$475
S-1345	40MHz	Delayed Sweep	\$569
S-1360	60MHz	Delayed Sweep	\$749
S-1390	100MHz	Delayed Sweep	\$995

DIGITAL SCOPE SUPER SPECIALS

DS-203	20MHz/10Ms/s	Analog/Digital	\$695
DS-303	40MHz/20Ms/s	Analog/Digital	\$895
DS-603	60MHz/20Ms/s	Analog/Digital	\$995

Generators and Counters

<p>Elenco Sweep Function Generator with Built-in 60MHz Frequency Counter Model GF-8046</p>  <p style="text-align: center;">\$229</p> <p>This sweep function generator with counter is an instrument capable of generating square, triangle, and sine waveforms, and TTL CMOS pulse over a frequency range from 0.2Hz to 3MHz.</p>	<p>Elenco Handheld Universal Counter 1MHz - 2.8GHz Model F-2800</p>  <p style="text-align: center;">\$99</p> <p>Sensitivity: • 1mV @ 100kHz • 100µV @ 1MHz • 10µV @ 10MHz • 1mV @ 1GHz</p> <p>Features 10 digit display, 16 segment and RF signal strength bargraph, includes antenna, NiCad battery, and AC adapter. Resolution to 10Hz.</p>	<p>B&K Frequency Counter Model BK-1875</p>  <p style="text-align: center;">\$189</p> <p>50Hz - 2.8GHz 3 Channels</p> <p>Sensitivity: • 10 mV @ 100kHz • 100 µV @ 300kHz • 1 mV @ 1GHz • 100 µV @ 3GHz</p> <p>Ultra sensitive synchronous detector for bargraph and RF strength.</p>
--	--	---

Soldering Irons

Weller WLC100 LOW COST SOLDERING IRON



\$34.95

- Variable power control produces 5-40 watts
- Ideal for hobbyists, DIYers and students
- Complete with 40W iron

TEKK Radios

Pro-Sport FRS Two-Way Radio
Model PRO-SPORT+



\$79 each or \$125 Set of 2

- 14 Channels
- Battery Monitor
- Key Lockout
- Monitor Button
- Lightweight
- Palm Sized
- Large LCD Display
- Removable Belt Clip
- Removable Antenna
- Two Radio Call Tones
- Busy Channel Lockout
- Accessory Connector
- Highly Water Resistant

Elenco Educational Kits

<p>Model AR-2N6K</p>  <p style="text-align: center;">\$34.95</p> <p>2 Meter / 6 Meter Amateur Radio Kit</p>	<p>Model AM-780K</p>  <p style="text-align: center;">\$11.95</p> <p>2 IC Radio Kit</p>
<p>Model M-1005K</p>  <p style="text-align: center;">\$19.95</p> <p>Digital Multimeter Kit</p>	<p>Model RCC-7K</p>  <p style="text-align: center;">\$29.95</p> <p>Radio Controlled Race Car Kit</p>

TEKK Radios

Pro-Sport FRS Two-Way Radio
Model PRO-SPORT+



\$79 each or \$125 Set of 2

- 14 Channels
- Battery Monitor
- Key Lockout
- Monitor Button
- Lightweight
- Palm Sized
- Large LCD Display
- Removable Belt Clip
- Removable Antenna
- Two Radio Call Tones
- Busy Channel Lockout
- Accessory Connector
- Highly Water Resistant

Elenco Educational Kits

<p>Model AR-2N6K</p>  <p style="text-align: center;">\$34.95</p> <p>2 Meter / 6 Meter Amateur Radio Kit</p>	<p>Model AM-780K</p>  <p style="text-align: center;">\$11.95</p> <p>2 IC Radio Kit</p>
<p>Model M-1005K</p>  <p style="text-align: center;">\$19.95</p> <p>Digital Multimeter Kit</p>	<p>Model RCC-7K</p>  <p style="text-align: center;">\$29.95</p> <p>Radio Controlled Race Car Kit</p>

TEKK Radios

Pro-Sport FRS Two-Way Radio
Model PRO-SPORT+



\$79 each or \$125 Set of 2

- 14 Channels
- Battery Monitor
- Key Lockout
- Monitor Button
- Lightweight
- Palm Sized
- Large LCD Display
- Removable Belt Clip
- Removable Antenna
- Two Radio Call Tones
- Busy Channel Lockout
- Accessory Connector
- Highly Water Resistant

Elenco Educational Kits

<p>Model AR-2N6K</p>  <p style="text-align: center;">\$34.95</p> <p>2 Meter / 6 Meter Amateur Radio Kit</p>	<p>Model AM-780K</p>  <p style="text-align: center;">\$11.95</p> <p>2 IC Radio Kit</p>
<p>Model M-1005K</p>  <p style="text-align: center;">\$19.95</p> <p>Digital Multimeter Kit</p>	<p>Model RCC-7K</p>  <p style="text-align: center;">\$29.95</p> <p>Radio Controlled Race Car Kit</p>

TEKK Radios

Pro-Sport FRS Two-Way Radio
Model PRO-SPORT+



\$79 each or \$125 Set of 2

- 14 Channels
- Battery Monitor
- Key Lockout
- Monitor Button
- Lightweight
- Palm Sized
- Large LCD Display
- Removable Belt Clip
- Removable Antenna
- Two Radio Call Tones
- Busy Channel Lockout
- Accessory Connector
- Highly Water Resistant

Elenco Educational Kits

<p>Model AR-2N6K</p>  <p style="text-align: center;">\$34.95</p> <p>2 Meter / 6 Meter Amateur Radio Kit</p>	<p>Model AM-780K</p>  <p style="text-align: center;">\$11.95</p> <p>2 IC Radio Kit</p>
<p>Model M-1005K</p>  <p style="text-align: center;">\$19.95</p> <p>Digital Multimeter Kit</p>	<p>Model RCC-7K</p>  <p style="text-align: center;">\$29.95</p> <p>Radio Controlled Race Car Kit</p>

TEKK Radios

Pro-Sport FRS Two-Way Radio
Model PRO-SPORT+



\$79 each or \$125 Set of 2

- 14 Channels
- Battery Monitor
- Key Lockout
- Monitor Button
- Lightweight
- Palm Sized
- Large LCD Display
- Removable Belt Clip
- Removable Antenna
- Two Radio Call Tones
- Busy Channel Lockout
- Accessory Connector
- Highly Water Resistant

Elenco Educational Kits

<p>Model AR-2N6K</p>  <p style="text-align: center;">\$34.95</p> <p>2 Meter / 6 Meter Amateur Radio Kit</p>	<p>Model AM-780K</p>  <p style="text-align: center;">\$11.95</p> <p>2 IC Radio Kit</p>
<p>Model M-1005K</p>  <p style="text-align: center;">\$19.95</p> <p>Digital Multimeter Kit</p>	<p>Model RCC-7K</p>  <p style="text-align: center;">\$29.95</p> <p>Radio Controlled Race Car Kit</p>

TEKK Radios

Pro-Sport FRS Two-Way Radio
Model PRO-SPORT+



\$79 each or \$125 Set of 2

- 14 Channels
- Battery Monitor
- Key Lockout
- Monitor Button
- Lightweight
- Palm Sized
- Large LCD Display
- Removable Belt Clip
- Removable Antenna
- Two Radio Call Tones
- Busy Channel Lockout
- Accessory Connector
- Highly Water Resistant

Elenco Educational Kits

<p>Model AR-2N6K</p>  <p style="text-align: center;">\$34.95</p> <p>2 Meter / 6 Meter Amateur Radio Kit</p>	<p>Model AM-780K</p>  <p style="text-align: center;">\$11.95</p> <p>2 IC Radio Kit</p>
<p>Model M-1005K</p>  <p style="text-align: center;">\$19.95</p> <p>Digital Multimeter Kit</p>	<p>Model RCC-7K</p>  <p style="text-align: center;">\$29.95</p> <p>Radio Controlled Race Car Kit</p>

TEKK Radios

Pro-Sport FRS Two-Way Radio
Model PRO-SPORT+



\$79 each or \$125 Set of 2

- 14 Channels
- Battery Monitor
- Key Lockout
- Monitor Button
- Lightweight
- Palm Sized
- Large LCD Display
- Removable Belt Clip
- Removable Antenna
- Two Radio Call Tones
- Busy Channel Lockout
- Accessory Connector
- Highly Water Resistant

Elenco Educational Kits

<p>Model AR-2N6K</p>  <p style="text-align: center;">\$34.95</p> <p>2 Meter / 6 Meter Amateur Radio Kit</p>	<p>Model AM-780K</p>  <p style="text-align: center;">\$11.95</p> <p>2 IC Radio Kit</p>
<p>Model M-1005K</p>  <p style="text-align: center;">\$19.95</p> <p>Digital Multimeter Kit</p>	<p>Model RCC-7K</p>  <p style="text-align: center;">\$29.95</p> <p>Radio Controlled Race Car Kit</p>

TEKK Radios

Pro-Sport FRS Two-Way Radio
Model PRO-SPORT+



\$79 each or \$125 Set of 2

- 14 Channels
- Battery Monitor
- Key Lockout
- Monitor Button
- Lightweight
- Palm Sized
- Large LCD Display
- Removable Belt Clip
- Removable Antenna
- Two Radio Call Tones
- Busy Channel Lockout
- Accessory Connector
- Highly Water Resistant

Elenco Educational Kits

<p>Model AR-2N6K</p>  <p style="text-align: center;">\$34.95</p> <p>2 Meter / 6 Meter Amateur Radio Kit</p>	<p>Model AM-780K</p>  <p style="text-align: center;">\$11.95</p> <p>2 IC Radio Kit</p>
<p>Model M-1005K</p>  <p style="text-align: center;">\$19.95</p> <p>Digital Multimeter Kit</p>	<p>Model RCC-7K</p>  <p style="text-align: center;">\$29.95</p> <p>Radio Controlled Race Car Kit</p>

TEKK Radios

Pro-Sport FRS Two-Way Radio
Model PRO-SPORT+



\$79 each or \$125 Set of 2

- 14 Channels
- Battery Monitor
- Key Lockout
- Monitor Button
- Lightweight
- Palm Sized
- Large LCD Display
- Removable Belt Clip
- Removable Antenna
- Two Radio Call Tones
- Busy Channel Lockout
- Accessory Connector
- Highly Water Resistant

Elenco Educational Kits

<p>Model AR-2N6K</p>  <p style="text-align: center;">\$34.95</p> <p>2 Meter / 6 Meter Amateur Radio Kit</p>	<p>Model AM-780K</p>  <p style="text-align: center;">\$11.95</p> <p>2 IC Radio Kit</p>
<p>Model M-1005K</p>  <p style="text-align: center;">\$19.95</p> <p>Digital Multimeter Kit</p>	<p>Model RCC-7K</p>  <p style="text-align: center;">\$29.95</p> <p>Radio Controlled Race Car Kit</p>

TEKK Radios

Pro-Sport FRS Two-Way Radio
Model PRO-SPORT+



\$79 each or \$125 Set of 2

- 14 Channels
- Battery Monitor
- Key Lockout
- Monitor Button
- Lightweight
- Palm Sized
- Large LCD Display
- Removable Belt Clip
- Removable Antenna
- Two Radio Call Tones
- Busy Channel Lockout
- Accessory Connector
- Highly Water Resistant

Elenco Educational Kits

<p>Model AR-2N6K</p>  <p style="text-align: center;">\$34.95</p> <p>2 Meter / 6 Meter Amateur Radio Kit</p>	<p>Model AM-780K</p>  <p style="text-align: center;">\$11.95</p> <p>2 IC Radio Kit</p>
<p>Model M-1005K</p>  <p style="text-align: center;">\$19.95</p> <p>Digital Multimeter Kit</p>	<p>Model RCC-7K</p>  <p style="text-align: center;">\$29.95</p> <p>Radio Controlled Race Car Kit</p>

TEKK Radios

Pro-Sport FRS Two-Way Radio
Model PRO-SPORT+



\$79 each or \$125 Set of 2

- 14 Channels
- Battery Monitor
- Key Lockout
- Monitor Button
- Lightweight
- Palm Sized
- Large LCD Display
- Removable Belt Clip
- Removable Antenna
- Two Radio Call Tones
- Busy Channel Lockout
- Accessory Connector
- Highly Water Resistant

Elenco Educational Kits

<p>Model AR-2N6K</p>  <p style="text-align: center;">\$34.95</p> <p>2 Meter / 6 Meter Amateur Radio Kit</p>	<p>Model AM-780K</p>  <p style="text-align: center;">\$11.95</p> <p>2 IC Radio Kit</p>
<p>Model M-1005K</p>  <p style="text-align: center;">\$19.95</p> <p>Digital Multimeter Kit</p>	<p>Model RCC-7K</p>

Pending				New Call			
New Call	Location	Freq.	Old Call	New Call	Location	Freq.	Old Call
KTMM	Grand Junction, CO	1340	KQIL	KSSL	Wickenburg, AZ	105.3	KMYL-FM
WLWU	Dunedin, FL	1470	WTBL	KQPT	Colusa, CA	107.5	KPPL
KCBW	DeSoto, MO	1190	KHAD	KSMY	Lompoc, CA	106.7	KAKV
KKJY	Albuquerque, NM	1520	KYJY	WAXK	Stonington, CT	102.3	WVVE
WFBS	Berwick, PA	1280	WSQV	WMHS	Pike Creek, DE	88.1	WBMO
KNHT	Rio Dell, CA	107.3	KMGX	WRXR-FM	Rossville, GA	105.5	WLMX-FM
KMGJ	Grand Junction, CO	93.1	KQIX	WPWQ	Mount Sterling, IL	106.7	WLRT
WRAU	Key Largo, FL	106.3	WZMQ	WBNB	Rantoul, IL	95.3	WZNF
WRLA	Key West, FL	107.9	WVMQ	WFWR	Attica, IN	91.5	New
WDNB	Jeffersonville, NY	102.1	WVWH	WPFR-FM	Clinton, IN	93.9	WPFR
KAQX	Ilwaco, WA	103.9	KBKH	KXJH	Linton, IN	90.1	New
				WZTR	Salem, IN	98.9	WQSH
				KLLT	Spencer, IA	104.9	KIGL
				KXUL	Monroe, LA	91.1	KNLU
				WTPN	Brunswick, ME	98.9	WCLZ-FM
				WCLZ-FM	Topsham, ME	95.5	WXGL-FM
				KXBR	International Falls, MN	91.9	KBOG
				KKTR	Kirksville, MO	89.7	KBPP
				KNLN	Vienna, MO	90.9	New
				KTZZ	Conrad, MT	93.7	KEIN-FM
				KYLO	Livingston, MT	100.7	New
				KXLB	Livingston, MT	100.7	KYLO
				WEVC	Gorham, NH	107.1	WXLQ
				KFLH	Chama, NM	98.9	KYJY
				KQPD	Ardmore, OK	91.1	New
				KIZS	Broken Arrow, OK	92.1	KOAS
				WQFN	Forest City, PA	100.1	New
				KGDE	Fort Worth, TX	94.1	KLTY
				KLTY	Highland Village, TX	100.7	KRJT-FM
				New	West Odessa, TX	88.7	New
				KFNA	Roy, UT	107.9	KWKD
				KALO	Randolph, UT	102.3	KAIO
				KGHO	Mount Vernon, WA	91.7	New
				KAYO	Seattle, WA	96.5	KYCW
				KJTT	New Martinsville, WV	92.3	New
				KMPS	Romney, WV	104.1	WJGF
				KAQX	WRIT-FM	95.7	WZTR
				KBZG			

at 0135 poor, assumed this with string music and vocals, loud het against 550 domestics. Saudi Arabia is off at this time. (Conti, NH)

580 WKAQ San Juan, Puerto Rico, at 2337 Puerto Rico news in Spanish; mixed with another Spanish-language station (likely R. Monte Cristi, Dominican Republic per format) and a country music domestic (CJFX?). (Connelly, MA)

612 RTM Sebaa-Aioun, Morocco, at 2334 Arabic/Berber music, slightly over RTE 2FM Ireland. (Connelly, MA)

620 WTMJ Milwaukee, Wisconsin, with station ID, news, weather, traffic, and sports at 0030. (Gillespie, MI)

680 WAPA San Juan, Puerto Rico, at 2330 "Wapa" mention and talk in Spanish under WRKO (and bits of WPTF sneaking in also). It wasn't an auroral night, so

fill-in skip from WRKO was messing up the usually solid phase null of its ground-wave. (Connelly, MA)

950 KNFT Bayard, New Mexico, now satellite C&W, heard with spots after network news at 0906. on top of the channel, ID as "We don't have to be the best, but it helps, KNFT." (Martin, CA)

1090 KAAY Little Rock, Arkansas, fair under/over XEPRS with a preacher, at 0658 a man said "Here on KAAY," into a religious program. Haven't heard this in many years; if it wasn't for XEPRS, it would have been rock solid! (Martin, CA)

1100 ZDK St. John's, Antigua at 0040 good in WTAM null with soca and calypso music, once upon a time a regular visitor, now a rare catch. (Conti, NH)

1110 XEWR Ciudad Juarez, Mexico, booming in here this morning around 0630 in English with classic oldies for-

mat easily overpowering the usually dominant KFAB. (Griffith, CO)

1251 Tripoli, Libya, at 2358 poor with talk in Arabic, slopped by an unid Spanish station on 1250. (Connelly, MA) The Spanish was probably "La Mega" WARE, Ware, Massachusetts.

1380 KTSM El Paso, Texas, fair on top at 0631 with local news break, "News Talk 1380, KTSM" IDs, weather, etc. (Martin, CA)

1521 BSKSA Duba, Saudi Arabia, 2045 fade-up at good level, actually stronger before sunset than after it, 2249 Arabic vocal and talk; only fair, sometimes submerging under the SER Spain outlet running much less power. (Connelly, MA)

Thanks to Mark Connelly, Dan Gillespie, Patrick Griffith, Gary Jackson, Jeff Kitze, and Patrick Martin. 73

clandestine communiqué

Tuning In To Anti-Government Radio

Another Ethiopian Clandestine, And Voice Of Tigray Revolution Is An Easy Catch

There's yet another entry in the Ethiopian (and related) clandestine station ledger. **The Voice of the Democratic Path of Ethiopian Unity** has two broadcasts a week via German government transmitters: Sundays from 0800 to 0900 on **21550**, and Wednesdays from 1600 to 1700 on **11670**, all in Amharic. So far, we don't know who is doing the programming for this one, but the station says it seeks to promote democracy in Ethiopia, one of a long list of other noble causes it promotes.

The Voice of the Tigray Revolution is currently on the air from 0400-0500 and 1500 to 1630. Also check Monday through Friday from 0930 to 1030 and 1630-1900. Also listen Saturdays and Sundays from 0500-0900 and 1100-1500. All broadcasts are on **5500 and 7515**. The 0400/0500 broadcast is fairly easy to hear in North America. Sheryl Paszkiewicz in Wisconsin has heard this one on **5500** at 0413 with string instrumental music.

The Voice of Tibet is currently scheduled from 0100 to 0145 on **9920**, via Dushambe in Tajikistan; 1215 to 1300 on **9920** (sometimes **9910**) via Almaty in Kazakstan and 2315-0000 on **9920** via Almaty. The Tibetan language broadcasts are beamed at listeners in Tibet and Tibetans living outside the country. The Worldview International Foundation and the Norwegian Tibet Committee and several other human rights groups fund the station. Reception reports go to Welhavensgate 1, N-0166 Oslo, Norway.

"It seems the address being reported for the Voice of Sudan (16 Cameret Court, London) is a dud."

It seems the address being reported for the **Voice of Sudan** (16 Cameret Court, London) is a dud. Richard D'Angelo in Pennsylvania reports his report was returned, stamped "address unknown."

Bruce Alexander in Pennsylvania has heard Colombian clandestine **La Voz de la Resistencia** again. He noted the station on **6261.12** from 2205 tune-in until its sign-off (with anthem) at 2227. Bruce says the Spanish language programming featured Latin ballads and dance music. And he notes the station, though weak, has "been a regular lately."

The anti-Iranian **Radio International** is still in operation on **7520**, running from 1730 to 1800, transmitting in Farsi from somewhere in central Asia. Its address is BM Box 1499, London, WC1N 3XX, United Kingdom.

Voice of the Kurdistan Toilers is another fairly new station,

first reported late last year. It uses **4250** from 1600 to 1700 and again from 0400 to 0500. The first half-hour is in Kuridish, the second half is in Arabic.

The Voice of the Struggle of Iranian Kordestan also operates from 1600 to 1700, in Kurdish on **4290**. The broadcasts oppose the Iranian government.

The current schedule for **Radio Chechnya Svobodnaya** (Radio Free Chechnya) is:

0300-0500 on 5925, 5935, 7335
0500-0530 on 5925, 5935
0530-0600 on 5925, 5935, 15515
0530-0630 on 7335, 9470, 15515
0630-0700 on 7335, 9470, 11635, 15515, and 17665
0700-0730 on 9470, 11636, 15515, and 17665
0730-1100 on 9470, 11635, 15515, and 17665
1100-1130 on 9740, 11635, 17665
1130-1400 on 9740, 11635, 15605, and 17665
1400-1430 on 17665
1430-1500 on 7340, 7445
1500-1530 on 7340, 7445
1530-1800 on 7340, 7355, 7445
1800-1830 on 7340, 7445
1830-2100 on 7305, 7340, 7445

"Needless to say, the station broadcasts on behalf of the Russian government and against the opposition in Chechnya."

The broadcasts are transmitted from near Moscow (**5925, 7445, 9470**) and St. Petersburg (all other listed frequencies). Needless to say, the station broadcasts on behalf of the Russian government and against the opposition in Chechnya. Of course, those frequencies are highly susceptible to change. All programs are in Russian. Pete Becker in Washington has noted the station at 0618 on **7335** and 0701 on **9470**.

That will do it for this time. Keep in mind that your reports and other clandestine broadcast-related information are always welcome. Station schedules, copies of QSLs, info on the organizations and groups which sponsor such broadcasts, transmitter locations, and so on are all of great value.

Until next month, good hunting. ■

BY GERRY L. DEXTER

plane sense

Your Link To Aviation Communications

Get This Book: Airport/Facility Directory

I would like to thank Harold for giving me the opportunity to be the aviation editor for this fine magazine. We talked about it in detail last December and came to agreement on a series of columns about aviation frequencies. I'm writing this column in the dead of winter here in Florida and am awaiting the thaw of the orange juice concentrate can. If the outside temp gets down to the mid 40s again, I don't know what I'm going to do.

Harold gave you a brief bio of me in the April edition. I'm still doing air traffic control after almost 28 years and still loving it. I know many of you will have questions about what you've heard on your scanner from pilots and controllers. That being the case, please drop me an E-mail at flacap388@prodigy.net. I cannot make personal replies, but I will try to answer as many as I can in my column. There may be a few questions that for obvious security reasons I would not be able to answer. I will address those the best I can.

"Books with radio frequencies abound. . . many times the information is way out of date. . ."

I'll also do product reviews on scanners that cover aviation frequencies. Also in future columns, I will try to tell you what each type of air traffic control (ATC) facility does and show you why most of what you see in TV and the movies is far from accurate. As Obi-Wan told Luke, "Your eyes can deceive you. Don't trust them."

Books with radio frequencies abound and while they are good in their place, many times the information is way out of date when published, much less a year later when the next edition comes out. So my first recommendation about what you can get that will help you monitor the frequencies in your area can be obtained at your local airport. You can find the shop at the airport where you can get the AF/D by looking up "Aircraft Schools" or "Pilot

2 DIRECTORY LEGEND

SAMPLE

① CITY NAME

② AIRPORT NAME (ORL) ③ ④ ⑤

200 B 54 FUEL 100 JET A OR L 2, 3 TPA—1000(800) AOE ARFF Index A Not insa. JACKSONVILLE

⑨ ⑩ ⑪ ⑫ ⑬ ⑭ ⑮ ⑯ ⑰ ⑱

⑲ RWY 18-36: H1200x300 (CONC-GRVD) HREL
 RWY 18: (DIR. ALSFL, TDZL, REIL, PAPI/P2R)—GA 3.0° TCH 36'.
 Third displd 300'. Trees. Rgt. etc. Arresting device. 0.3% up.
 RWY 36: ALSFL. 0.4% down.
 RWY 05-23: H600x150 (ASPH-PFC) S-90, D-160, DT-300-PCN
 80 R/B/W/T HREL CL. 0.4% up E
 RWY 05: ALSFL. Trees. RWY 23: REIL. Rgt. etc.
WEATHER DECLARED DISTANCE INFORMATION
 RWY 05: TORA-6000 TODA-6700 ASDA-5700 LDA-5500
 RWY 23: TORA-6000 TODA-6000 ASDA-6000 LDA-5700

⑲ **AIRPORT REMARKS:** Special Air Traffic Rules—Part 93, see Regulatory NoGoes. Aftnwd 1200-0300Z; Parachute Jumping. CAUTION: Cattle and deer on aprt. Aclt 100,000 lbs or over ctc Director of Aviation for approval 305-894-9831. Fee for all airline charters, travel clubs and certain revenue producing acft. Flight Notification Service (ADCLUS) available.

⑳ **WEATHER DATA SOURCES:** AMOS-1 120.3 (302) 426-6000. LLWAS.

㉑ **COMMUNICATIONS:** CTRF 118.7 AGS APPR 127.25 DEP 134.025 (303) 342-0620 UNICOM 122.95
 NAME FSS (ORL) on aprt. 123.65 122.65 122.2.
 TF 1-800-444-8927. NOTAM FILE ORL
 NAME PCN 112.27 112.1R (NAME FSS)
 NAME APPREP COM 128.35 (1200-0400Z)
 TOWER 118.7 HFCT (1200-0400Z) GND COM 121.7 GCR 135.075 (ORLANDO CLWC) CLWC DEL 125.55
 PRE TAXI CLWC 125.5

㉒ **AIRSPACE CLASS 1:** See VFR Terminal Area Chart.

㉓ **RAIS ADS TO NAVIGATION:** NOTAM FILE MCO. VHF/DF ctc FSS.
 10 AIRBORNE 112.2 MCO Chan 59 N28°32.55' W81°20.12' at Rel. 1110/BE.
 Times avail 1300-0100Z; VOR unusable 050°-060° byd 15 NM bto 5000'.
 HERRY NDB (LWB) 221 OR N26°37.40' W81°21.05' 177° S. 4 NM to fld.
 ILS 109.9 I-ORL. Rwy 18. LOM HERRY NDB.
 ASAPM (1200-0400Z)

㉔ **COMMUNICATED REMARKS:** Emerg frequency 121.5 not avail at ter.

HELIPAD 01: H100x75 (ASPH)
 HELIPAD 02: H60x60 (ASPH)
HELIPAD REMARKS: Helipad M1 locd on general aviation side and M2 locd on air carrier side of aprt.
 187 TPA 1000(813)
 WATERWAY 13-36: 5000x300 (WATER)
SEAPLANE REMARKS: Birds roosting and feeding areas along river banks. Seaplanes operating adjacent to NE side of aprt not visible from ter and are required to ctc ter.

①

All Bearings and Radials are Magnetic unless otherwise specified.
 All mileages are nautical unless otherwise noted.
 All times are UTC except as noted.
 The horizontal reference datum of this publication is North American Datum of 1983 (NAD83), which for charting purposes is considered equivalent to World Geodetic System 1984 (WGS 84).

A look at the sample page of the Airport/Frequency Directory.

Supplies" in the Yellow pages. Get the "Airport/Facility Directory" or A/FD. It is published in seven volumes for the lower 48 states. Alaska and Hawaii have similar books. Each book covers from five

to 14 states, is issued every 56 days and costs about \$4.10 per book. Only professional pilots would even come close to needing a full set. Just get the one that covers your state. And even though it is updat-

ed every eight weeks, you don't need to get each edition when it comes out.

A Closer Look At The A/FD

Now that you know the first book I recommend, here's how to use it. Usually on page two is a sample directory listing. Look at **Figure 1**. I'll only list the items you as a scanner user would be interested in. Item 1 is the city name. Sometimes, it may be in listed as a different city. For example, both Kissimmee and Sanford, Florida, airports are located in the Orlando listings.

Item 2 is the location identifier for that airport. It is unique. No other airport in the country has that number. Officially, each airport in the lower 48 starts with a "K." For example Atlanta Hartsfield, Georgia, is "KATL." Grand Island, Nebraska, is "KGRI." The exceptions are Alaska and Hawaii, which start with a "P" and Puerto Rico and the Virgin Islands which start with a "T."

Item 5 gives the latitude and longitude of the airport in degrees, minutes, and hundredths of minutes, not seconds. Items 6 and 7 deal with other charts that the airport can be located on, which I'll discuss those in future columns. Item 8 is new to the A/FD, an airport diagram. Not all airports in the A/FD have them yet, but they will eventually. (Note: the Canadian version of the A/FD, The Canada Flight Supplement, which I will discuss in a later column already has these diagrams for each and every airport in Canada.)

Go down to item 20. Some, but not all, airports have an ASOS (Automated Surface Observation System) or AWOS (Automated Weather Observation System). These give automated and up-to-the minute weather information. The frequency is located here. A phone number next to it means you can acquire the same information over the telephone.

Item 21 is one of the main areas you'll be using. This gives the tower or local control frequency (the one you hear the pilots talking on within five miles of the airport), ground control (movement of aircraft on the taxiways, which at many airports is more difficult than local control), clearance delivery (what a pilot receives his instrument or special VFR clearance on), approach/departure control frequency (movement of aircraft usually within 40 or so miles from the airport; (an "R" in a circle indicates it is a RADAR controlled facility), UNICOM (a non-government air/ground radio communications facility used to provide general airport advisory services), and CTAF (Common Traffic Advisory Frequency; used at non-controlled airports for both vehicles and aircraft, and is usually the local control frequency when the control tower is closed).

Item 24 deals with radio aids to navigation, or NAVAIDS. I'll also talk about this in a later column. And lastly, item 25 deals with irregularities in communications. The example shows the emergency frequency is not available at the fictional airport in the sample. (Note: emergency frequency 121.5 MHz for civilian aircraft is monitored at all towers, approach controls, air route traffic control centers, and flight service stations.) The emergency frequency 243.0 MHz for military aircraft is also monitored at most of these facilities. You may notice that the military frequency is a harmonic of the civilian frequency. Most of the time when 1 of the 2 frequencies is in use, the other frequency may be picking up the transmission. This allows civilian radios to monitor military emergencies and vice versa.

Near the back of each book is a section of frequencies for **Air Route Traffic Control Centers** (we just call them centers) and **Flight Service Stations**. Listed with the centers are their remote

See You At Dayton - Booths 602 & 603

Am-Com Inc.

ClearSpeech™ Speaker

Digital Noise-Canceling Speaker for Two-Way Communications



This easy-to-use DSP speaker activates automatically and filters 95% background noise, static and other interference.

- Improves clarity & intelligibility
- Continuous, adaptive removal of background noise
- Listen with less fatigue & greater concentration
- Improves signal to noise ratio
- New: increased audio output and speaker jack added.

\$129.95
plus \$8.50 S&H
(Reg. Price \$149.00)

It Works!

Noisebuster™ Extreme!™ Headphone System

Electronically cancel low-to-mid frequency room noises generated by amplifiers, blowers, computers, fans, air conditioners, engines. For two-way radio or personal stereo systems. Use at home, portable, or on aircraft. Active noise cancellation 2-1500 HZ, better than 15 db between 15-300 HZ.



NEW
Regularly \$49
Am-Com's Price
\$44.95
(\$5.50 S&H)

We carry a complete line of NCT Noise Canceling Telephony Headsets, Cellular Telephone Headsets, proActive™ Industrial Noise Canceling Hearing Protectors and Communications Headsets.

For the Best Time... Radio controlled clocks from



\$49.95
(\$5.50 S&H)

WWVB Radio Controlled Time & Date

- Ideal for expeditions & field operation
- 12/24 Hour Format
- Indoor Temp (C & F)
- 2 Alarms w/Snooze
- 3-3/4" X 2" X 2"



\$99.95
(\$6.50 S&H)

World Time Center

- A must for the well equipped ham shack
- WWVB controlled accuracy
- 12/24 Hr, 2 Time Zones
- Indoor/Outdoor temp & RH with remote wireless sensor
- Battery Power, 11.8" X 1.22" X 8.8"

See website for clocks & weather stations

Protect your Hand-Held, GPS, Cellphone

- ABS plastic, shock absorbant shell, cushioning interior foam conforms to your phone shape
- Water resistant O-Ring seal
- Floats with contents weighing up to 1.5lbs
- Additional room for keys money, I.D. etc.
- Fits securely into a standard waterbottle cage
- Belt loop & hook for additional shoulder strap
- Ringing can be heard when Cell Safe is closed
- Inside dimensions 7.5" X 2.5", weight 6.5 oz.

\$24.95
(\$3.50 S&H)



NEW ATAS-100 Universal Controller

Use the Yaesu ATAS-100 with any transceiver

- Operates with any Transceiver
- Small & Compact, Mounts Anywhere
- Operates on 12VDC
- Low Cost
- Easy to Install
- Available Spring 2000

\$69.95
(\$6.50 S&H)

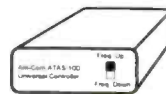

Unit shown is a prototype. Final product may vary in appearance. Size: 2-3/4" X 3-1/4" X 3". (Approx.)

Am-Com carries a complete line of Gap™ & Ham Stick™ Antennas & Accessories

Website: www.amateurcommunications.com
(Product Information & Secure Ordering)



Email: amcom@digisys.net
Phone Orders: 1-888-803-5823



Mail Orders To: Am-Com, Inc., 100 Bierney Creek Rd, Suite C, Lakeside, MT 59922

CIRCLE 61 ON READER SERVICE CARD

outlets. Obviously if you live in the southern area of the center, you won't be listening to frequencies in use at the northern areas. You will also notice that some of the frequencies are printed in plain text, some in bold. Pilots flying below 18,000 feet use those in plain text. Most single engine and slower aircraft use these altitudes along with aircraft making short hops between airports. Pilots flying larger 757's over long distances would only be using these frequencies near their

departure airport during climb, or their arrival airport during descent.

The frequencies in bold are used at and above 18,000 feet (which we call flight levels; 24,000 feet is flight level 240, 37,000 feet is flight level 370, etc.) This is where you will find the majority of the air carriers, business jets, and much of the military fighter/bomber/cargo traffic.

The Flight Service Station (FSS) Communication Frequencies follow those of the centers. Like the center, the remote

outlets can be found throughout the FSS area of coverage, with bold frequencies for high-altitude aircraft. You will notice some frequencies have a "T" or "R" following the actual frequency. A pilot flying near a NAVAID with voice capability calls the FSS on 122.1 MHz and turns up the NAVAID volume in his aircraft to monitor transmissions coming from the FSS. It is, basically, duplex, while all of the other frequencies are simplex.

While this looks like a lot of information, think of what the pilots use on a daily basis, especially when driving their aircraft to two, three, or even more airports every time they fly.

My recommendation is that you initially listen to all of the frequencies you may consider using during normal daytime and nighttime hours. After some monitoring, you will be able to pick out which frequency or frequencies can be monitored best from your area. I then suggest you stay on that frequency for most of your monitoring, when at a fixed location such as your house. I also recommend you put the emergency frequency in your scanner as a priority channel, for obvious reasons. You will find that much of the time pilots remain on one frequency, especially when talking to the tower.

Pilot Training

If you live in an area with high pilot training activity, such as near Daytona Beach, Sanford, Melbourne, or Vero Beach, Florida (I use these only because I know the activity near these airports), you will eventually pick up their training frequencies, ones the air traffic controllers don't use. But on federal holidays and days of inclement weather, those frequencies can be as dead as 10-meter ham frequencies during times of low sunspot activity.

I know that this is a lot to digest, but it is a start. The frequencies you find in the AF/D are as up-to-date as you can get in a publication. When you plan to take a trip and want to take a scanner along, just stop by where you bought the A/FD and pick up the one for the state you'll be visiting. You'll be receiving the most up-to-date information available.

Again, tell me what you think about this column, and most of all what you've heard on the aircraft frequencies. Any photos or QSLs you may have are also welcomed. Send your letters to me at *Popular Communications*, "Plane Sense," 25 Newbridge Road, Hicksville, NY 11801 or online to flacap388@prodigy.net. ■

When seconds count,
REACT
needs you....



...to summon for help for an injured motorist, an elderly woman trapped in a fire, a trucker stranded in a blizzard, a drowning child!



As a REACT volunteer radio monitor, you may be the only communication life-line for someone in serious trouble. You relay messages from those desperate for help to police, fire, or emergency services.



Your REACT team may also use CB, GMRS, Amateur, and other radio services to provide safety communications for events like parades, marathons, and even balloon races. The fellowship with other REACT members at team meetings and annual conventions is an added bonus, as is help with licensing, equipment advice, and radio training.

"The mission of REACT International is to provide public safety communications to individuals, organizations, and government agencies to save lives, prevent injuries, and give assistance wherever and whenever needed. We will strive to establish a monitoring network of trained volunteer citizen-based communicators using any and all available means to deliver the message."

*Add a new, exciting challenge to your life.
Volunteer. Help save lives and property,
JOIN TODAY!*

REACT INTERNATIONAL, INC.

Phone (301) 316-2900

Fax (301) 316-2903

Web: www.reactintl.org
5210 Auth Road, Suite 403
Suitland, MD 20746



• PROUD RECIPIENT OF THE PRESIDENT'S VOLUNTEER ACTION AWARD •
RADIO EMERGENCY ASSOCIATED COMMUNICATIONS TEAM

CIRCLE 73 ON READER SERVICE CARD

Tap into secret Shortwave Signals

Turn mysterious signals into exciting text messages with the MFJ MultiReader™!

Plug this self-contained MFJ MultiReader™ into your shortwave receiver's earphone jack.

Then watch mysterious chirps, whistles and buzzing sounds of RTTY, ASCII, CW and AMTOR (FEC) turn into exciting text messages as they scroll across an easy-to-read LCD display.

You'll read interesting commercial, military, diplomatic, weather, aeronautical, maritime and amateur traffic . . .

Eavesdrop on the World

Eavesdrop on the world's press agencies transmitting *unedited* late breaking news in English -- China News in Taiwan, Tanjung Press in Serbia, Iraqi News in Iraq -- all on RTTY.

Copy RTTY weather stations from Antarctica, Mali, Congo and many others. Listen to military RTTY passing traffic from Panama, Cyprus, Peru, Capetown, London and others. Listen to hams, diplomatic, research, commercial and maritime RTTY.

Listen to maritime users, diplomats and amateurs send and receive *error-free* messages using various forms of TOR (Telex-Over-Radio).

Monitor Morse code from hams, military, commercial, aeronautical, diplomatic, maritime

Super Active Antenna

"World Radio TV Handbook" says MFJ-1024 is a "first-rate easy-to-operate active antenna...quiet... excellent dynamic range... good gain... low noise... broad frequency coverage."

Mount it outdoors away from electrical noise for maximum signal, minimum noise. Covers 50 KHz-30 MHz.

Receives strong, clear signals from all over the world. 20 dB attenuator, gain control, ON LED.

Switch two receivers and auxiliary or active antenna.

MFJ-1024 \$139⁹⁵ 6x3x5 inches. Remote has 54 inch whip, 50 feet coax, 3x2x4 inches. 12 VDC or 110 VAC with MFJ-1312, \$14.95.

Indoor Active Antenna

Rival outside long wires with this *tuned* indoor active antenna.

"World Radio TV Handbook" says MFJ-1020B is a "fine value... fair price... best offering to date... performs very well indeed."

Tuned circuitry minimizes intermod, improves selectivity, reduces noise outside tuned band. Use as a preselector with external antenna. Covers 0.3-30 MHz. Tune, Band, Gain, On/Off/Bypass Controls. Detachable telescoping whip. 5x2x6 in. Use 9 volt battery, 9-18 VDC or 110 VAC with MFJ-1312, \$14.95.

Compact Active Antenna

Plug this compact MFJ

all hand active antenna into your receiver and you'll hear strong, clear signals from all over the world, 300 KHz-200 MHz including low, medium, shortwave and VHF bands.

Detachable 20 inch telescoping antenna. 9 volt battery or 110 VAC MFJ-1312B, \$14.95. 3 1/4 x 1 1/4 x 4 in.

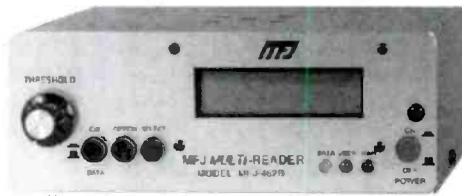

-- all over the world -- Australia, Russia, Japan, etc. MFJ-462B \$179⁹⁵

Printer Monitors 24 Hours a Day

MFJ's exclusive TelePrinterPort™ lets you monitor any station 24 hours a day by printing transmissions on an Epson compatible printer.

Printer cable, MFJ-5412, \$9.95.

MFJ MessageSaver™

You can save several pages of text in an 8K of memory for re-reading or later review.

High Performance Modem

MFJ's high performance PhaseLockLoop™ modem consistently gives you solid copy -- even with weak signals buried in noise. New threshold control minimizes noise interference --

Eliminate power line noise!



MFJ-1026 \$179⁹⁵

New! Completely eliminate power line noise, lightning crashes and interference *before they get into your receiver!* Works on all modes -- SSB, AM, CW, FM, data -- and on all shortwave bands. Plugs between main external antenna and receiver. Built-in active antenna picks up power line noise and cancels undesirable noise from main antenna. Also makes excellent active antenna.

MFJ Antenna Matcher



MFJ-959B \$99⁹⁵

Matches your antenna to your receiver so you get maximum signal and minimum loss.

Preamp with gain control boosts weak stations 10 times. 20 dB attenuator prevents overload. Select 2 antennas and 2 receivers. 1.6-30 MHz. 9x2x6 in. Use 9-18 VDC or 110 VAC with MFJ-1312, \$14.95.

Dual Tunable Audio Filter



MFJ-752C \$99⁹⁵

Two separately tunable filters let you peak desired signals and notch out interference at the same time. You can peak, notch, low or high pass signals to eliminate heterodynes and interference. Plugs between radio and speaker or phones. 10x2x6 in.

High-Gain Preselector



MFJ-1045C \$99⁹⁵

High-gain, high-Q receiver pre-selector covers 1.8-54 MHz. Boost weak signals 10 times with low noise dual gate MOSFET. Reject out-of-band signals and images with high-Q tuned circuits. Push buttons let you select 2 antennas and 2 receivers. Dual coax and phono connectors. Use 9-18 VDC or 110 VAC with MFJ-1312, \$14.95.

CW, RTTY, ASCII Interface



MFJ-1214PC \$149⁹⁵

Use your computer and radio to receive and display brilliant full color FAX news photos and incredible WeFAX weather maps. Also RTTY, ASCII and Morse code. Frequency manager lists over 900 FAX stations. Auto picture saver.

Includes interface, easy-to-use menu driven software, cables, power supply, manual and JumpStart™ guide. Requires 286 or better computer with VGA monitor.

High-Q Passive Preselector

High-Q passive LC MFJ-956 \$49⁹⁵



boosts your favorite stations while rejecting images, intermod and phantom signals. 1.5-30 MHz. Preselector bypass and receiver grounded positions. Tiny 2x3x4 inches.

Super Passive Preselector



MFJ-1046 \$99⁹⁵

New! Improves any receiver! Suppresses strong out-of-band signals that cause intermod, blocking, cross modulation and phantom signals. Unique Hi-Q series tuned circuit adds super sharp front-end selectivity with excellent stopband attenuation and very low passband loss. Air variable capacitor with vernier. 1.6-33 MHz.

Easy-Up Antennas

How to build and put up inexpensive, fully tested wire antennas using readily available parts that'll bring signals in like you've never heard before. Antennas from 100 KHz to 1000 MHz.

greatly improves copy on CW and other modes.

Easy to use, tune and read

It's easy to use -- just push a button to select modes and features from a menu.

It's easy to tune -- a precision tuning indicator makes tuning your receiver easy for best copy.

It's easy to read -- the 2 line 16 character LCD display with contrast adjustment is mounted on a brushed aluminum front panel for easy reading.

Copies most standard shifts and speeds. Has MFJ AutoTrak™ Morse code speed tracking.

Use 12 VDC or use 110 VAC with MFJ-1312B AC adapter, \$14.95. 5 1/4 Wx2 1/4 Hx5 1/4 D inches.

No Matter What™ One Year Warranty

You get MFJ's famous one year *No Matter What™* limited warranty. That means we will repair or replace your MFJ MultiReader™ (at our option) *no matter what* for one full year.

Try it for 30 Days

If you're not completely satisfied, simply return it within 30 days for a prompt and courteous refund (less shipping). Customer must retain dated proof-of-purchase direct from MFJ.

MFJ Antenna Switches

MFJ-1704 \$64⁹⁵ MFJ-1702C \$24⁹⁵

MFJ-1704 heavy duty antenna switch lets you select 4 antennas or ground them for static and lightning protection. Unused antennas automatically grounded. Replaceable lightning surge protection. Good to 500 MHz. 60 dB isolation at 30 MHz. MFJ-1702C for 2 antennas.

World Band Radio Kit

Build this regenerative shortwave receiver kit and listen to signals from all over the world with just a 10 foot wire antenna. Has RF stage, vernier reduction drive, smooth regeneration, five bands.

21 Band World Receiver

MFJ's MFJ-8121 new 21 Band World Receiver lets you travel the world from your armchair! Listen to BBC news from London, live music from Paris, soccer matches from Germany and more! Covers 21 bands including FM, Medium Wave, Long Wave and Shortwave. Sony® integrated circuit from Japan, multicolored tuning dial, built-in telescopic antenna, permanent silkscreened world time zone, frequency charts on back panel. Carrying handle. Operates on four "AA"s. Super compact size!

Free MFJ Catalog and Nearest Dealer . . . 800-647-1800

<http://www.mfjenterprises.com>
• 1 Year *No Matter What™* warranty • 30 day money back guarantee (less s/h) on orders from MFJ

MFJ ENTERPRISES, INC.
Box 494, Miss. State, MS 39762
(601) 323-5869; 8-4:30 CST, Mon.-Fri.
FAX: (601) 323-6551; Add s/h
Tech Help: (601) 323-0549
Prices and specifications subject to change. (c) 1998 MFJ Enterprises, Inc.

Pop'Comm's World Band Tuning Tips

May 2000

This listing is designed to help you hear more shortwave broadcasting stations. The list includes a variety of stations, including international broadcasters beaming programs to North America, others to other parts of the world, as well as local and regional shortwave stations. Many of the transmissions listed here are not in English. Your ability to receive these stations will depend on time of day, time of year, your geographic location, highly variable propagation conditions, and the receiving equipment used.

AA, FF, SS, GG, etc. are abbreviations for languages (Arabic, French, Spanish, German). Times given are in UTC, which is five hours ahead of EST, i.e. 0000 UTC equals 7 p.m. EST, 6 p.m. CST, 4 p.m. PST.

UTC	Freq.	Station/Country	Notes	UTC	Freq.	Station/Country	Notes
0000	7345	Galei Zahel, Israel	HH	0300	4828	Zimbabwe Broadcasting Corp.	vern.
0000	9400	Radio Bulgaria		0300	4830	Radio Tachira, Venezuela	SS
0000	9595	BBC, England		0300	5055	Faro del Caribe, Costa Rica	SS
0000	15215	Channel Africa, S. Africa	various	0300	7245	Radio Algiers Int'l, Algeria	FF
0000	17675	Radio New Zealand Int'l		0300	9495	Radio Sweden	
0030	6065	Voice of Islamic Republic of Iran		0300	9655	YLE Radio Finland	
0030	6090	Radio Tirana, Albania		0330	4832	Radio Reloj, Costa Rica	SS
0030	6120	Radio Vilnius, Lithuania		0330	6115	Radio Tirana, Albania	
0030	6165	Radio Netherlands, via Bonaire		0330	9835	Radio Budapest, Hungary	
0030	6480	Radio Altura, Peru	SS	0330	11885	Far East Bc. Assn., Seychelles	vern.
0030	6798	Radio Ondas del Mayo, Peru	SS	0400	4775	Radio Tarma, Peru	SS
0100	3280	La Voz del Napo, Ecuador	SS	0400	4819	La Voz Evangelica, Honduras	SS
0100	3360	La Voz de Nahuala, Guatemala	SS	0400	4919	Radio Quito, Ecuador	SS
0100	4940	Radio Amazonas, Venezuela	SS	0400	4980	Ecos del Torbes, Venezuela	SS
0100	4955	Radio Nacional, Colombia	SS	0400	6105	Radio Universidad, Costa Rica	SS
0100	4985	Radio Brazil Central	PP	0400	6115	La Voz del Llanero, Colombia	SS
0100	5025	Radio Rebelde, Cuba	SS	0400	7465	Radio Norway	NN
0100	5930	Radio Slovakia		0400	9570	Radio Romania Int'l	
0100	7115	Radio Yugoslavia		0400	11920	RTV Marocaine, Morocco	AA
0100	9560	Radio Budapest, Hungary		0400	11980	Radio Vlaanderen Int'l, Belgium, via Bonaire	
0100	9885	World Radio Switzerland		0400	15455	Voice of Russia	
0100	12015	HCJB, Ecuador		0430	6010	Voice of Turkey	
0100	15385	Radio Exterior de Espana		0430	7180	South African Broadcasting Corp.	Afrikaans
0130	5940	Voice of Russia		0430	7300	Voice of Turkey	TT
0130	6155	Radio Telefis Eireann, Ireland, via England		0430	7500	Radio Moldova Int'l	
0130	7335	Vatican Radio		0430	9820	Radio Havana Cuba	
0130	9570	China Radio Int'l, via Cuba		0430	9865	Radio Prague, Czech Republic	
0130	11675	Radio Kuwait	AA	0430	9905	World Radio Switzerland, via French Guiana	GG
0200	4960	Radio Vila, Dominican Republic	SS	0500	7180	Voice of Russia	
0200	6458	Armed Forces Radio via Puerto Rico	SSB	0500	7255	Voice of Nigeria	
0200	9475	Radio Cairo, Egypt		0500	12020	Voice of Russia	
0200	9737	Radio Nacional, Paraguay	SS	0530	4915	Ghana Broadcasting Corp.	
0200	11585	Kol Israel	unid	0530	6110	Radio Japan/NHK, via Canada	
0200	11710	RAE, Argentina		0600	5047	Radio Togo	FF
0200	15425	Sri Lanka Broadcasting Corp.		0600	5960	Radio Canada Int'l	
0230	3250	Radio Luz y Vida, Honduras	SS	0600	7125	Radio Guinee, Guinea	FF
0230	4992	Radio Apinte, Surinam	various	0600	9935	RS Macedonia, Greece	GG
0230	5678	Radio Ilucan, Peru	SS	0600	11640	Trans World Radio, South Africa relay	
0230	9655	Radio Austria Int'l		0630	4845	Radio Mauritania	AA
0250	6265	Radio One, Zambia					
0300	3320	Radio Sonder Grense, South Africa	Afrikaans				

UTC	Freq.	Station/Country	Notes	UTC	Freq.	Station/Country	Notes
0630	5995	RTV Maliene, Mali	FF	1500	11600	Far East Bc. Assn., Seychelles	
0630	6015	Radio Austria Int'l, via Canada		1500	11625	Adventist World Radio/ KSDA, Guam	various
0630	6070	Voz Cristiana, Chile	SS	1500	15435	Radio Jamahiriya, Libya	AA
0630	6185	Radio Educacion, Mexico	SS	1500	15590	Radio Netherlands, via Madagascar	
0630	7140	Radio Yakutsk, Russia	RR	1500	17535	Kol Israel	
0630	7250	Vatican Radio	Latin	1530	9405	Far East Broadcasting Company, Philippines	CC
0630	9530	Radio Romania Int'l		1600	15395	UAE Radio, Dubai	
0630	9670	Radio Canada Int'l		1630	11690	Radio Jordan	
0630	9670	RAI, Italy	II	1630	15475	Africa Number One, Gabon	FF
0700	4960	Radio Vanuatu		1630	21550	Voz Cristiana, Chile	SS
0700	6100	Radio Liberia Int'l		1700	15210	Radio France Int'l	
0700	7135	Radio France Int'l	FF	1700	17485	Radio Prague, Czech Republic	
0700	8000	JJY time station, Japan		1700	17680	RAI, Italy	II
0700	9510	Radio Korea Int'l, South Korea		1730	12045	All India Radio	Bengali
0700	9550	Radio Havana Cuba, relay Radio Reloj	SS	1730	15160	Radio Algeria Int'l	SS
0700	9560	YLE Radio Finland		1730	15555	World Radio Switzerland	AA/FF
0700	9580	Africa Number One, Gabon	FF	1800	11785	Voice of Indonesia	GG
0700	9775	Voice of Greece, via Delano, CA		1800	15335	Radio Pakistan	Urdu
0730	6055	Radio Tampa, Japan	JJ	1800	17705	Voice of Greece, via Delano, CA	GG
0800	6100	Radio Pyongyang, North Korea	unid	1830	17870	Channel Africa, S. Africa	
0800	7175	Radio Tikhoy Okean, Russia	RR	1900	15225	Radio Cairo, Egypt	AA
0800	7250	Radio Rossi, Russia	RR	1930	9605	UAE Radio, Abu Dhabi	AA
0800	9570	Radio Korea Int'l, S. Korea		1930	11975	Voice of America, Sao Tome relay	
0800	9870	Treans World Radio, Monaco		1930	17660	HCJB, Ecuador	
0930	4975	Radio del Pacifico, Peru	SS	2000	9685	Radio Baghdad Int'l, Iraq	AA
1000	6135	Radio Santa Cruz, Bolivia	SS	2000	15150	Voice of Indonesia	
1000	9865	KTWR/Trans World Radio, Guam		2000	15345	RTV Marocaine, Morocco	AA
1030	6155	Radio Fides, Bolivia	SS	2030	9525	Polish Radio	
1100	2410	Radio Enga, Papua New Guinea	Pidgin	2030	9870	Broadcasting Service of Kingdom of Saudi Arabia	AA
1100	4835	Radio Tezulutlan, Guatemala	SS	2030	11655	Radio Netherlands, via Madagascar	DD
1100	6105	Radio New Zealand Int'l		2030	17810	Deutsche Welle, via Antigua	
1100	11515	Voice of Hope, Lebanon	unid	2100	9780	Rep. of Yemen Radio	AA
1130	3925	Radio Tampa, Japan	JJ	2100	11955	Radio Nacional, Angola	PP
1130	5020	Ecos del Atrato, Colombia	SS	2100	15410	Deutsche Welle, via Rwanda	
1130	9645	Voice of America, Thailand		2115	9965	Voice of Armenia	
1130	9930	KWHR, Hawaii		2130	7415	Voice of America relay, Botswana	
1200	4725	Radio Myanmar, Myanmar (Burma) BB	BB	2130	9525	Voice of Turkey	
1200	4755	Radio Republik Indonesia, Ujung Pandang	II	2130	9570	Qatar Broadcasting Service	AA
1200	4890	National Bc. Commission, Papua New Guinea		2130	9735	Radio Oman	AA
1200	9740	BBC Singapore relay		2130	11605	Croatian Radio, via Germany	
1200	9780	Voice of America, Tinian relay		2130	13690	Radio Canada Int'l	
1200	15330	Radio Tashkent, Uzbekistan		2200	9615	Radio Cultura Sao Paulo, Brazil	PP
1215	9715	Radio Tashkent, Uzbekistan		2200	9810	Radio Ukraine Int'l	
1230	9965	Voice of Hope/KHBN, Palau		2200	11620	All India Radio	
1300	5940	Magadan Radio, Russia	RR	2200	15170	Radio Exterior de Espana, via Costa Rica	SS
1300	7365	KNLS, Alaska		2230	6010	RAI, Italy	II
1300	9515	BBC, via Canada		2230	7205	Cyprus Broadcasting Corp. (wknds)	unid
1300	9580	Radio Australia		2230	7535	Radio Bulgaria	
1330	9480	China Radio Int'l	CC	2230	9355	Radio Taipei Int'l, via WYFR	
1400	5995	Radio Australia		2230	9925	Radio Denmark, via Norway	DD
1400	9465	KFBS, Northern Marianas	RR	2230	15345	RAE, Argentina	SS
1400	9760	Voice of America, Philippines		2230	15540	Radio Portugal Int'l	PP
1400	9930	Radio Free Asia, Northern Marianas		2300	9900	Radio Cairo, Egypt	
1400	13620	Radio Kuwait	AA	2300	11550	Radio Australia, via Taiwan	
1400	17560	Radio France Int'l, via Gabon		2300	11655	RT Tunisienne, Tunisia	AA
1400	17770	Radio Cairo, Egypt	various	2300	11780	Radio Nacional Amazonas, Brazil	PP
1430	15140	Radio Oman	EE/AA	2300	11805	Radio Globo, Brazil	PP
1445	15500	Vatican Radio	GG	2330	9655	Voice of Turkey	
1500	9505	Radio Japan/NHK		2330	12020	Voice of Vietnam	
1500	9705	Radio Mexico Int'l	SS/EE				

product parade

Review Of New, Interesting And Useful Products

Pager Keeper

Tired of dropping your pager? The new Pager Keeper eliminates pager maintenance and replacements while providing comfort and style. As pagers continue to grow in popularity, more and more people are looking for the most convenient and secure way to carry these handy communications devices. Specialty Hardware, Inc. has the answer.



The Pager Keeper, by Specialty Hardware, Inc., is a unique, fashionable pager holder that provides security, style, and comfort.

The Pager Keeper is a top grain leather holder that snaps easily to a belt loop, purse strap, or sports bag. The flexible leather strap allows simple access to the pager display and the rigid snap keeps the holder firmly in place. It's the ideal solution for anyone who is tired of lost or dropped pagers, or clips breaking or pinching their skin.

Sized to fit any standard pager, the "patent pending" universal Pager Keeper is 5" tall by 1" wide. Custom leather colors and hot-stamped logos are available.

Pager Keepers are approved for consumer, corporate, and institutional use by Ameritech and other major telecommunication and blue chip stock companies.

Specialty Hardware, Inc., based in Cleveland, Ohio, designs, manufactures, and delivers cost-effective solutions for all handle and hardware requirements.

For more information, call toll-free 888-291-1161 or visit www.galaxymall.com/product/pagerkeeper.

MFJ's HamGear™ Tactical Chest Harness

Enjoy hands-free operation of your radio equipment with this rugged, easily adjusted chest harness by MFJ. It has adjustable Velcro closures to accommodate any radio width — it even has twin elastic antenna holders for short and long HT antennas!

Made of durable heavy-duty twill burlap, this interwoven fabric is water-resistant and will cushion your radio from blows and scrapes. It's perfect for rugged use for emergency radio operators and on-the-go hams. Use it at hamfests, while biking, hiking, and on DXpeditions. The adjustable shoulder straps are made of high-strength nylon with heavy-duty high-impact plastic shoulder strap adjustments. The harness is held firmly in place by a stretchable interwoven elastic belt with snap hook and adjustable sliders supported by nylon straps. One size fits all.



MFJ's new HamGear™ Tactical Chest Harness is perfect for DXpeditions, biking, and hiking.

Get the professional look you deserve with this radio harness that includes a 5" wide x 7" tall cargo pocket that holds another radio, maps, tools, compass, etc. Fully stretched out, the cargo pocket is 1 3/4" deep. MFJ's HamGear™ Tactical

Chest Harness even gives you a pen pouch.

For more information on the MFJ HamGear™ Tactical Chest Harness (MFJ-18) that sells for \$29.95, contact MFJ Enterprises, Inc., P.O. Box 494, Mississippi State, MS 39762 or call 601-323-5869. You can also FAX MFJ at 601-323-6551. Visit them on the Web at mfjenterprises.com.

MFJ Belt Radio Holder

Protect your radio from those everyday bumps and bruises with MFJ's new HamGear™ Belt Radio Holder. Made of strong, durable twill burlap, the MFJ-15 fits any size handheld radio. Your belt slides easily through the 2" x 3" heavily stitched loop and remains firmly locked in place. A strong elastic cord with Velcro closure easily stretches over your handheld radio.

Keep your HT close and secure with MFJ's new HamGear™ Belt Radio Holder that sells for \$14.95. We've been using one for months in every type of outdoor environment and absolutely love it!

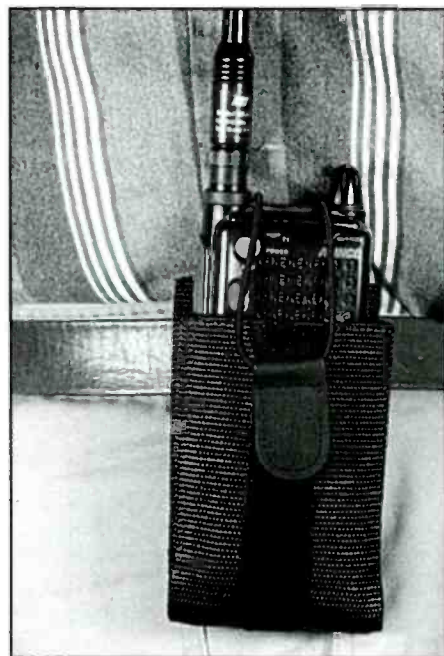

The new MFJ Belt Radio Holder, which sells for only \$14.95, is a must-have if you've got a handheld radio.

BY HAROLD ORT AND R.L. SLATTERY

Remember that MFJ's HamGear™ is also protected by MFJ's famous No Matter What™ one-year limited warranty. MFJ will repair or replace, at their option, your MFJ HamGear™ merchandise for one full year. Contact MFJ Enterprises at 601-323-5869 for more information about the MFJ-15.



Ten-Tec Announces New Receiver

TEN-TEC has done it again! The company announces the new RX-340 0 to 30 MHz receiver. For years TEN-TEC has competed in the so-called "black box" market (computer-control receivers) but now enters the shortwave market with the new RX-340. This radio, essentially their RX-331, repackaged in a different cabinet and with a front panel, has been exhaustively field-tested under rigorous conditions.

TEN-TEC officials, in announcing the new receiver report the best estimate of availability — if everything remains on

schedule — is that the RX-340 will be available for sale to hobby customers and the general public by the end of April, as you get this issue of *Pop'Comm*. Company officials told us, "... TEN-TEC has competed with Watkins-Johnson — their 8712 black box receiver, but until now has not competed with their 8711 (the HF-1000 is a hobby version) — the RX-340 fills that void"

The RX-340 will sell factory-direct and through selected worldwide radio dealers for just under \$4,000. For more information contact TEN-TEC at 1185 Dolly Parton Parkway, Sevierville, TN 37862

or call 800-833-7373 or send an E-mail to them at sales@tentec.com. Look for a "Product Spotlight" in *Popular Communications* in the coming months.

New Seiko R-Wave Radio-Controlled Wall Clocks

Seiko announces availability of their new radio-controlled clocks that keep time to within one second in one million years. They automatically adjust when daylight savings time occurs, then go back to standard time at the appointed hour. They are equipped to receive radio signals from the most accurate clock in the world, the cesium atomic clock at Fort Collins, Colorado.

Two models are offered, one with a dark brown solid wood case and Arabic numerals, the other with a light brown solid wood case and Roman numerals. Both have glass crystals and are 12 1/2" in diameter and 1 3/4" deep. The clock has a suggested retail price of \$95 from Seiko Corporation of America, 800-782-2510.

DEDICATED TO THE SCANNING AND SHORTWAVE ENTHUSIAST.

NOW SUPPORTS
Radio Shack
PRO-2052

WE'RE MORE THAN JUST SOFTWARE

SEE YOU AT DAYTON
BOOTH 634

SCANCAT GOLD for Windows "SE"

Since 1989, The Recognized Leader in Computer Control

Once you use SCANCAT with YOUR radio, you'll NEVER use your radio again WITHOUT SCANCAT!

SCANCAT supports almost ALL computer controlled radios by: AOR, DRAKE, KENWOOD, ICOM, YAESU and JRC (NRD) Plus PRO-2005/6/35/42 (with OS456/535), Lowe HF-150, and Watkins-Johnson

NOW SUPPORTS
UNIDEN BC-240 & BC-895
TRUNKTRACKER II
AOR APRIS - ARK2008
& TEN-TEC RX-340

SCANCAT GOLD FOR WINDOWS "SE"

(Surveillance-Enhanced)

FEATURES

- Selective Sound Recording using PC-compatible sound card. "Point & Shoot" playback by individual hits.
- Demographic search for frequency co-ordination and 2-way Usage Analysis.
- Detailed logging to ASCII type files with DATE, TIME, Sig Str, Air Time
- 6 New sweep Analysis Functions.
- Exclusive "MACRO" control by frequency of Dwell, Hang, Resume, Sig, Threshold and even 6 separate programmable, audible alarms.
- Command line options for TIMED ON/OFF (Unattended) logging/searches.
- Run as many as 6 different CI-V addressable radios as "Master/Slave".
- New! Scheduling/Recording Functions.

With Scancat Gold for Windows "SE," your spectrum never looked so good! Load virtually "any" database and Scancat "SE" will examine your database, plot each and every frequency, no matter what the range, and "paint" the entire analysis on your screen.

SEVERAL GRAPHICAL ANALYSIS MODES AVAILABLE

- By Signal Strength per frequency in a "histograph".
- By Signal Strength plotted in individual dots.
- By Number of hits per frequency in a "histograph".
- IF THAT ISN'T ENOUGH, try this... Multicolored, 3-D "Spatial Landscape".

SCANCAT GOLD "SE"... \$159.95 + s & h * UPGRADE SCANCAT GOLD V7.5.7 "SE"... \$59.95 + s & h *

SCANCAT'S WINDOWS FEATURES

- Unattended Logging of frequencies
- Scan Create Disk Files.
- Spectrum Analysis to Screen OR Printer.
- Supports PerCon, Mr. Scanner, and Betty Bearcat CD Roms.
- Scan VHF & HF Icom's Simultaneously.
- LINK up to 100 Disk files or ranges
- MULTIPLE search filters for Diskfile Scanning.
- New - Programmable Favorite Frequency "Quick Buttons"
- Search by CTCSS & DCS tones with OS456/535 or DC440 (ICOM only).
- INCLUDES several large shortwave and VHF/UHF databases

SCANCAT GOLD FOR WINDOWS (NON-"SE")... \$99.95 + s & h * UPGRADE TO V7.5.7... \$29.95 + s & h *

All the features you EXPECT from a true Windows application such as:

- VERSATILE "Functional" spectrum analysis. NOT just a "pretty face". Spectrum is held in memory for long term accumulation. Simply "mouse over" to read frequency of spectrum location. "CLICK" to immediately tune your receiver. You can even accumulate a spectrum from scanning DISKFILES of random frequencies!
- DIRECT scanning of most DBASE, FOXPRO, ACCESS, BTRIEVE files WITHOUT "importing".
- UNIQUE database management system with movable columns. Even SPLIT columns into doubles or triples for easy viewing of ALL important data on one screen.
- Exclusive "SLIDE RULE" tuner. Click or "skate" your mouse over our Slide-Tuner to change frequencies effortlessly! OR use our graphical tuning knob.

*\$5 U.S. \$7.50 FOREIGN

HOKA CODE-3 GOLD

"The Standard Against Which All Future Decoders Will Be Compared"

Many radio amateurs and SWLs are puzzled! Just what are all those strange signals you'll hear but not identify on the Short Wave Bands? A few of them such as CW, RTTY, Packet and Amtor you'll know - but what about the many other signals?

There are some well known CW/RTTY Decoders but then there is CODE-3 GOLD. It's up to you to make the choice, but it will be easy once you see CODE-3 GOLD. All units have an exclusive auto-classification module that tells YOU what you're listening to AND automatically sets you up to start decoding. No other decoder can do this on ALL the modes listed below - and most more expensive decoders have no means of identifying ANY received signals! Why spend more money for other decoders with FEWER features? CODE-3 GOLD works on any IBM compatible computer with MS-DOS with at least 640kb of RAM, and a VGA monitor. CODE-3 GOLD includes software and a complete audio to digital FSK converter.

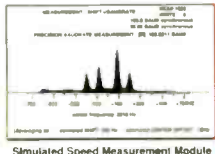

Simulated Speed Measurement Module

Modes Included in BASIC package	Modes included in STANDARD and PROFESSIONAL package	ADDITIONAL Modes included in STANDARD and PROFESSIONAL package
<ul style="list-style-type: none"> • Morse * • RTTY/Baudot/ Murray * • Sitor CCIR 625/476-4 ARO - Navtex * • AX25 Packet * • Facsimile all RPM (up to 16 gray shades at 1024 x 768 pixels) * • Hellsreiber - Synch/Asynch * • ASCII * • Factor * • VEFAX * 	<ul style="list-style-type: none"> • Autospec - Mk's I & II • DUP-ARQ Artrac • Twinplex • ARQ6-90/98 • SI-ARQ/ARQ-S • SWED-ARQ, ARO-SWE • ARO-E/ARQ1000 Duplex • ARO-N-ARQ1000 Duplex Variant • ARO-E3-CCIR519 Variant • POL-ARQ 100 Baud • Duplex ARQ 	<ul style="list-style-type: none"> • TDM242/ARQ-M2/4-242 • TDM342/ARQ-M2/4 • FEC-A • FEC1/90A/FEC101 • FEC-3 - FEC1000 Simplex • Sports Info 300 baud ASCII • Sitor - RAW (Normal Sitor but without Synch. • ARO6-70 • Baudot F788N • Piccolo • Coquelet • 4 special ARO & FEC systems: TORG-10/11, ROU-FEC/ RUM-FEC, HC-ARQ (ICRC) and HNG-FEC • SYNOP decoder

CODE-3 GOLD is the most sophisticated decoder available for ANY amount of money.

<p>CODE-3 GOLD VHF/SW DECODER \$450.00</p> <p>Includes PCSAG & ACARS Plus * Modes Options</p> <p>BASIC</p>	<p>CODE-3 GOLD VHF/SW DECODER \$595.00</p> <p>With ALL Modes/Options</p> <p>STANDARD</p>	<p>CODE-3 GOLD PROFESSIONAL \$795.00</p> <p>With ALL Modes/Options Plus Professional Analytical Package</p> <p>PROFESSIONAL</p>
--	--	---

Now Available - Stridsberg Engineering Multicouplers - "Call for Quantity Pricing" <http://www.scancat.com/multiplr.html>

FREE FREQ FILES

WEBSITE - www.scancat.com

E-MAIL - info@scancat.com

FREE DEMOS

Order direct or contact your favorite dealer

COMPUTER AIDED TECHNOLOGIES P.O. Box 18285 Shreveport, LA 71188

Orders Only 888-SCANCAT 888-722-6228

Phone: (318) 687-4444

FAX: (318) 686-0449

Info/Tech Support: (318) 687-2555 (9 a.m. - 1 p.m. Central M-F)

the ham column

Getting Started As A Radio Amateur

No Shack? No Radio? No Problem!

Is space at a premium? No room for a proper ham shack? Parents or spouses backed you into a corner — without a radio? Travel a lot? Can't afford a rig? Live in your car? Don't worry. You can still enjoy ham radio — even if you're sans radio or shackless. Where there's a will there's a way, my friends, and lots of enterprising hams have overcome similar hurdles. This month's column is about enjoying ham radio — no matter what. Who says ham radio is bound by tradition?

While you're sorting out the following possibilities (and perhaps building or arranging for a shack of your own), keep an open mind. Although they may be unconventional, any of the following radio activities could turn out to be your new favorite!

Club Stations

Unless you live in the outback, there's probably at least one club station in your area. Amazingly, it's probably lightly attended — just waiting for you to twist the knobs. Although popular in Europe, where some countries require a period of club station operation as a licensing requirement, club stations in the U.S. are often used primarily for license instruction and contesting. One club station in my vicinity has four transceivers, a large amplifier, a tall tower, several beams, and a bunch of wire antennas. Although nicely equipped, the station doesn't see much use. Whenever I've used it, I've had the place all to myself!

Search for club stations at colleges, universities, tech schools, and even high schools. You might have to join a club to gain access — but that's probably a step in the right direction anyway. Club stations are great for contesting and a great way to get on the air with other hams.

Mobile Operating

With the tiny size of modern mobile radios — most with similarly small price tags — chances are good that you can set up a shack in your car or camper if you

can't set up a shack at home. Unlike the bad old days, when mobile rigs were the size of beer coolers and required power supplies that were even bigger, today's mobile radios are small, small, small! They're also full-featured, perform well, and don't cost an arm and a leg. Because they run on 12 Vdc, you can also take them camping, use them for Field Day, or fly them to an exotic island.

Modern mobile rigs handle work AM, FM, SSB, CW, and data modes from 160 through 6 meters (or more), receive from DC to daylight, and can be remotely mounted (the radio lives in the trunk or under the seat while the "control head" and the mic mount to the dashboard). These little rigs are as flexible as their whip antennas.

Contests, Field Day, And Special Events

About 10 years ago I met a veteran ham who didn't own a station, yet operated almost every weekend. During the following week, I'd hear about his contest

exploits. This crafty fellow worked the world from his friend's "contest superstation," which was lavishly equipped and advantageously located outside the city limits. When I asked him why he didn't have a station of his own, he thought I was crazy. This was exactly his kind of ham radio. He wasn't missing out on anything by not having his own shack. This weekend warrior wasn't alone, either. I soon met others who took similar approaches. Some operated from friends' stations, some from university club stations — and one guy who got on the air only when he was vacationing in the Caribbean (which was pretty often)!

If this style of ham radio appeals to you — and you have generous friends or an available club station — you'll have plenty of operating opportunities, including Field Day and Special Events stations.

Foxhunting And Radiosporting

Foxhunting — finding hidden transmitters as part of a friendly competition



Are you tempted to save a few bucks by using bargain basement coaxial cable for your next antenna project? Well, don't! I can't stress that enough — and I'm speaking from experience in the School of Hard Knocks. When I was a teenager (and a rabid DXer), I fed my backyard antennas through a 150-foot length of bargain-brand RG-58-type coax. I don't even want to calculate the SWR losses — especially when I was using nonresonant antennas and a tuner. Let's just say that I was a QRP operator who ran 100 watts! When I moved to my present Minnesota QTH, I wanted to finally use decent feed lines (although I tried to get away with using a 50-foot length of crappy cable to feed my 6-meter beam). My experience with the discount brand RG-8 coax was so bad that I knew I had to break down and get the good stuff.

I settled on LMR-600 for my 6-meter beam and LMR-400 for my HF loop. Both are made by Times Microwave, and both are widely-available from ham radio distributors. Amazingly, the cable is priced about the same as the inferior generic stuff. You can check the specs at the company website, www.timesmicrowave.com, but a comment from Bill's Two Way, www.bills2way.com/equip/lmr400.html, where I found the photo reproduced above, pretty much sums it up: "This is the Best Coax you can buy. Don't be fooled by the claims of the others. This is the cable everyone is trying copy."

If you want to see just how low your coax losses can be, point your browser to www.timesmicrowave.com/cgi-bin/calculate, Times' web-based SWR loss calculator. Remember: The coax cable losses listed here (or anywhere) assume you're feeding a matched 50-ohm antenna. If you're feeding a nonresonant antenna through a shack-mounted antenna tuner, your SWR losses can be astronomically greater.

BY KIRK KLEINSCHMIDT, NT0Z

— is a popular weekend activity in many parts of the country (especially on both coasts and in larger metropolitan areas). Hams, usually radio club members and often grouped in age- or experience-related teams, gather to search for one or more hidden transmitters (foxes). The search area may be as small as a schoolyard or as big as a state!

On a typical foxhunt, competitors try to find all of the foxes in the least amount of time. Common frequencies are on 2 and 80 meters. Competitors use hand-held radios and compact directional antennas. Larger competitions may cover several square miles of forest or parkland and may require maps and orienteering skills.

In the “motorsport” variant, the hunters drive cars or off-road vehicles, the foxes are typically hidden on mountaintops or wayside rest areas, and the field of competition may cover several hundred square miles. Mobile foxhunters often use GPS navigation systems and sophisticated receiving gear, including multi-antenna Doppler arrays with computerized graphical displays.

Whether the atmosphere is casual or highly competitive, foxhunting has something for everyone — no shack required!

Public Service Comms

Providing communications at public events — parades, celebrations, etc. — is a long-held amateur radio tradition. Although FCC rules prohibit amateurs from relaying certain specific information about race leaders and other information on the progress of an event, hams may assist safety officials at aid stations, operations centers, checkpoints, and emergency vehicles.

To get involved, all you need is a hand-held transceiver. Most public service communications are handled on VHF and UHF frequencies because few activities spread out beyond repeater range. Two meters is most popular, but other bands are also used.

If you’re a member of a ham radio club, you’ve probably already been asked to help out at public events. If you aren’t in a club yet, or if your club hasn’t engaged in such activities, ask around on the air and check the local nets to hook up with service-minded hams in your area.

In addition to local club-provided communications, hams must be prepared to handle larger regional or national emergencies, such as floods, fires and earthquakes. Most of these emergencies are handled by members of the Amateur

Radio Emergency Service (ARES) and the Radio Amateur Civil Emergency Service (RACES). Other popular public service outlets include SKYWARN. Its local chapters spot and track tornadoes and often work closely with the National Weather Service. If you want to serve your fellow citizens, public-service comms will provide the opportunity — no home station required!

Radio Expeditions

You can’t be the first explorer to reach either of the poles, but you *can* take your radio gear to an infinite number of enjoyable “expedition destinations” that will definitely be appreciated by your fellow amateur ops.

Where might you go? Just about anywhere, really. How about camping, canoeing, or motorcycling? Or maybe fishing, hunting, or hiking. Don’t forget Field Day! With a compact mobile rig or an even smaller QRP transceiver, you can be on the air from just about anywhere. Stay in touch with friends and family, make new friends, or both!

During Field Day or the November Sweepstakes, for example, instead of operating from your home state (which probably has scads of hams), why not take your camper — and your radio gear — down the road a ways to a neighboring state where hams are scarce and sought-after? By working the contest from a rare state you’ll be “the DX station,” and others will be appreciative! Every year at least a few Alaska hams trek across the border to work Sweepstakes from Canada’s Yukon or Northwest Territories. Why? To *be* the DX, of course!

Your expedition activities don’t have to be limited to contests, either. You can set up at a scenic overlook at an out-of-the-way mountain pass to help other ops collect new grid squares, operate from a nearby island (inland or coastal) to work ops looking for Islands On The Air (IOTA) QSOs, and much more.

If you use your imagination, you’ll find ways to get on the air regardless of your present situation. And in the process of trying new things, you just might discover a facet of amateur radio you’d never otherwise uncover. So, get out there and operate — whatever it takes. Be reasonable. Stay safe. Don’t break the law. But use your imagination! I’ll see you on the air — and I’ll see you next month. Send your QSL cards, questions, and letters to “The Ham Column,” 25 Newbridge Road, Hicksville, NY 11801. ■

ELECTRONIC COMPONENTS

www.mouser.com

Wire and Cable
Connectors • Resistors
Potentiometers
Capacitors • Diodes
Transformers
Inductors
Switches
Speakers • Fuses
Knobs
Hardware
Equipment
Tools

800-992-9943

817-483-6828 Fax: 817-483-6899
catalog@mouser.com

958 North Main St., Mansfield, TX 76063

MOUSER
ELECTRONICS

CIRCLE 71 ON READER SERVICE CARD

SE SIGNAL ENGINEERING'S
High Performance CB &
10 Meter Antennas

SUPERHAWK

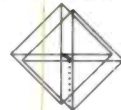

Goldenrod
45 Spyder A+
Broadband Hi
powered MOBILE

WHITE LIGHTNING
THE Four Element
Antenna

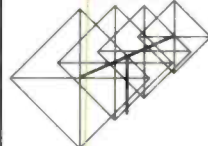

THUNDER 8
Hi Gain
Bi-Directional
OMNI
Electronically
Steerable

LIGHTNING 6

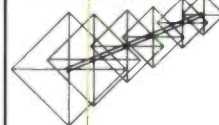

And, also,
NEW QUAD
LIGHTNING 8
THE most
POWERFUL
CB base in the
world today!

ALL SE PATENTED rotary beams are true quads and OUTPERFORM their counterparts (quad/yagi types). SE's patented SFS matching system makes SE QUADS the most technologically advanced antennas in the world today.

If your dealer doesn't have SIGNAL ENGINEERING, write or call for full specs. DEALER inquiries invited. MasterCard, VISA, AMEX, Discover

SIGNAL ENGINEERING

1172 Aster Avenue, #E, Sunnyvale, CA 94086
Phone: (408) 247-2300

Website: www.signalengineering.com

the pirate's den

Focus On Free Radio Broadcasting

One Voice Radio: A Multitude Of Topics

Step right up and get your pirate loggings! Have you sent in *your* loggings this month?

WHYP, 6955 USB at 0105 with country/western and Southeast Asian music. Says QSLs via E-mail only. Another day at 2155 "James Brownyard Memorial Station" and drifting down in frequency. (William Hassig, IL) 2301 with James mumbling and "music-ballroom Blitz and Word up." Also at 1425. Another day at 2303. ID by James. And at 2236 with rock numbers by various groups. Other loggings on various days at 0006, 0046, 0009, 0023, and 2230. Also at 1635. (Bill Finn, PA)

Radio Garbanzo, 6955 at 0116. "You are tuned to the maximum music orgy on Radio Garbanzo." And "down our antenna and up yours." Rock and X-rated ads. (Hassig, IL)

Radio Free Speech, 6955 at 0148 with commercial for Maplethorpe Portrait Studios. Also at 1317 with DJ "Bill O'Rights." Sign-on with theme from Twilight Zone and talk of microcasters, FCC and the law. (Hassig, IL) 0212 with ID, rock, comedy ads, funny version of the National Anthem. Also heard at 1314. They gave both the Blue Ridge Summit and Belfast addresses. (Dave Jeffery, NY)

WMOE, 69555 USB at 1000 to 1007 when they went off with Three Stooges music. Also at 2110 with a repeat of the previous day's program. Another day heard them at 0128. (Hassig, IL) 2100 with Celtic music, ID. QSL via wmoe6955@yahoo.com. Also heard at 2318. (Finn, PA) 2338 with music and IDs. (Lee Silvi, OH)

Ground Zero Radio, 6955 USB at 0100 with DJ Dave Gunn, Wagner's "Ride of the Valkyrie." (Hassig, IL) 0335 with E-mail given as gzrsw@usa.net. (Finn, PA)

WACK, 6955 USB at 2315 with rock. Was on top of another pirate broadcast. Playing back voice mail of callers to 1-888-959-8177. (Hassig, IL)

One Voice Radio, 6955 at 2115 with talk of co-generation, net metering, solar and wind power, household tips, recipe



This full-color, full-size QSL is sent out by KIPM. You probably don't have to understand it in order to get one.

for banana dessert. The tape ran a little fast. (Hassig, IL) 2112 discussing CCA-treated wood and gave ID. (Silvi, OH)

Blind Faith Radio, 6955 USB heard at 2205. Tinny audio. (Hassig, IL) 2210. (Silvi, OH)

Radio Azteca, 6955 USB at 2250 with Rocky and Bullwinkle interval signals. (Hassig, IL)

WFMQ, 6955.1v USB at 2300 with rock. (Hassig, IL) 2300. (Silvi, OH)

Radio Cobaine, 6954.9 USB at 0021 with tunes by Nirvana. (Hassig, IL)

Radio Bingo, tentative, 6954 at 1647 giving bingo numbers. (Silvi, OH)

Voice of Prozac, 6955 at 2028 with music and many IDs. (Silvi, OH)

Radio Tornado, tentative, 6955 monitored at 1622. Also tentative at 0038.

(Silvi, OH) **6955 USB** at 2254 with RMWW Dr. Tornado parody. Also at 2100 with usual clips of Dr. Tornado. Ended just in time for the "numbers lady" on 6960. (Finn, PA)

He-Man Radio, 6955 at 2353 with music and IDs. (Silvi, OH)

Radio Aesop, 6955 at 0103. He said he "was working on QSLs." (Silvi, OH)

Paint it Black (?) 6955 USB at 2000 and again 2321 playing "Paint it Black" by the Rolling Stones over and over. (Finn, PA)

Indira Calling, 6955 USB at 2345 with Harold Krishna playing Indian music and saying hello to George Zeller in Ohio. He gave Calcutta 02908 as a maildrop. (Finn, PA)

Jimmy The Weasel, 6955 USB at

BY EDWARD TEACH

2345. Sounded like Jimmy trying to get above the noise level by singing. He also told "sorry pirate listeners on this frequency to jump into the abyss." (Finn, PA)

Voice of Bono, 6955 at 2154 with Gary Daniels hosting a listener request program and saying the maildrop address had changed from Baltimore to Wellsville. (Finn, PA)

Crooked Man Radio, 6955 at 2031 and the next day at 2122. Many songs such as Jock James, You Keep Me Hangin', Hang on Sloopy, and Beatles songs. (Silvi, OH)

KAMP, 6955 USB at 0155. The host said to do the Batman or Bartman, Ren and Stimpy, "music for pirate listeners." (Finn, PA)

RBCN, 6955 USB at 0050. Radio Bo #21 — The best of Bob, re-airing Simpson's "We Do" song and the one with George Bush and Captain Picard in the secret society. (Finn, PA)

That cleans out the folder for this time. Keep those reports coming, please. You can mail reports to my attention at the magazine's Hicksville, NY, address or E-mail them to Editor Harold Ort at Popularcom@aol.com.

Catch you again next month! ■

how I got started

Congratulations To Bruce R. Burrow Of Washington!

Popular Communications invites you to submit, in about 150 words, how you got started in the communications hobby. Entries should be typewritten, or otherwise easily readable. If possible, your photo (no Polaroids, please) should be included.

Each month, we'll select one entry and publish it here. Submit your entry only once; we'll keep it on file. All submissions become the property of *Popular Communications*, and none will be acknowledged or returned. Entries will be selected taking into consideration the story they relate, and if it is especially interesting, unusual, or even humorous. We reserve the right to edit all submitted material for length, grammar, and style.

The person whose entry is selected will receive a one-year gift subscription (or one-year subscription extension) to *Popular Communications*. Address all entries to: "How I Got Started," *Popular Communications*, 25 Newbridge Road, Hicksville, NY 11801 or E-mail your entry to popularcom@aol.com, letting us know if you're sending photos. If you're E-mailing photos, please send them in a separate E-mail with your name in the "subject" line.

Our May Winner

Pop'Comm reader, Bruce R. Burrow, AB7WH of Snoqualmie, Washington, says, "My introduction to shortwave listening came in my childhood during the early '50s listening to my father's Hallicrafters receiver. Dad was a Merchant Marine officer and brought the old Hallicrafters home when his ship was in dry-dock. Ten years later, I joined the U.S. Army and served as a Morse Intercept Operator in the Army Security Agency in Thailand, South Vietnam, and Northern California between 1964 and 1968. After four years copying Morse code 10 hours a day, I swore I'd never listen to another dit or dah again!

However, in 1996 I was curious if I could still copy code. Remembering the exotic stations I picked up in Southeast Asia, I bought a RadioShack DX-394. With that basic receiver I rediscovered the fun of shortwave listening and eventually became interested in amateur radio. Thanks to my background in Morse code, I was able to rapidly advance from Tech Plus to Extra in five months. I now use an ICOM R71A for serious DXing, a Sony ICF-2010 for casual listening, and a Kenwood TS-680S for amateur communication. Since I recently retired, the radio hobby arrived just in time to become an important part of my life!" ■

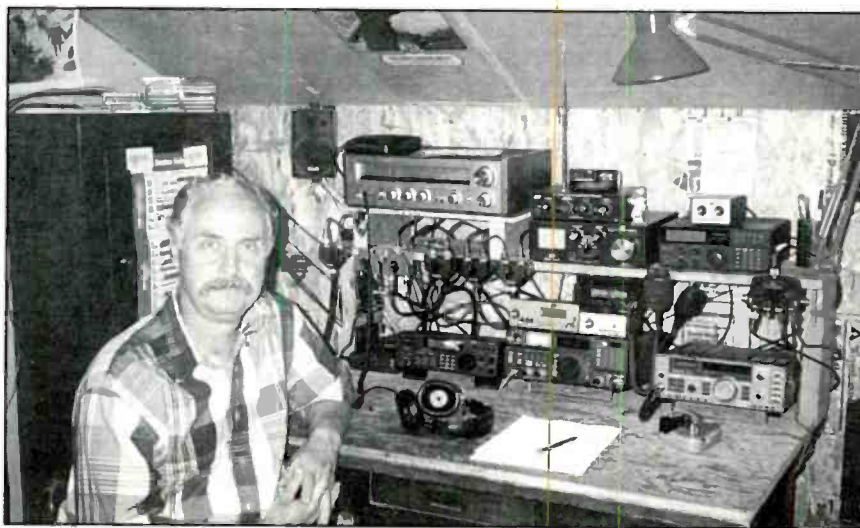

Pop'Comm reader, Bruce R. Burrow, AB7WH of Washington.

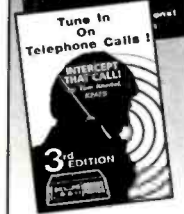
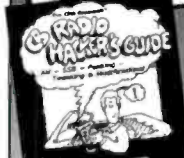
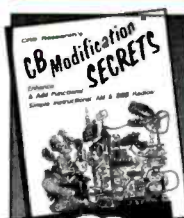

YOU AIN'T HEARD NOTHIN'.. YET

Since 1967, CRB Research has been the world's leading publisher and supplier of unique hobby and professional books and information including:

- Scanner Frequency Guides
- Shortwave Frequency Guides
- Military/Federal Communications
- Undercover Communications
- Survival Communications
- & Other Related Topics!

New titles are constantly being added to our exciting catalog. If it's interesting and unusual, we've got it. You'll see.

Ask For Big Free Catalog

CRB RESEARCH

P.O. Box 56, Commack, NY 11725

Phone: (631) 543-9169

FAX (631) 543-7486

e-mail: sales@crbbooks.com

www.crbbooks.com

CIRCLE 11 ON READER SERVICE CARD

scan tech

Trunking, Tips, Techniques, And Mods

Learning About Scanner Features And Terms Part III

Whew, I sure didn't know what I was biting off when I agreed to do successive columns on features and terms. I sure didn't expect it to run over into a third month (actually, I thought when I started that I was going to be doing well to fill up half of one month, but that's another story). Here's the third and last half, as promised.

Search Skip

When you're scanning along in your regular channels, and something comes along that you don't want to listen to, you can hit the "lockout" button, or invoke some sort of "memory skip" function on your receiver. However, when you're searching — going from one frequency to the next looking for activity, you might not have that convenience if you don't have a search skip or search lockout function.

Many newer scanners now have this feature which enables the lockout or skip of frequencies that are problematic during a search operation. For instance, once you find a pager frequency, you don't want to stop there again on your second pass through that frequency range. So you set it to skip, and hopefully, your second and subsequent passes will be much quieter.

Most of the radios that offer this function have a limit of about 100 frequencies that can be locked out at any one time. If you use the search function a lot in different parts of the spectrum, you might find that you have to clear it out from time to time. If you don't search much, or mostly search the same ranges looking for new activity, the 100-memory limit will probably be just fine.

Sound Squelch

The idea of a sound-based squelch as opposed to a signal or carrier-based squelch (the kind we normally have) is a great one. How effective it might be is another matter entirely. The idea is that there are certain frequencies that are going to lock up the scanner no matter what. Some are actually birdie frequencies generated within the radio, while others are interference coming from local radiating sources and still others are channel markers or other annoying beeps and buzzes that are intentionally transmitted to hold the channel as open or available.

What sound squelch does in its simplest form, is to look for changes in the audio. If it doesn't spot any after a certain delay, it assumes the channel is some form of static or interference and moves on. In practice, this works fairly well on birdies and locally generated noise that puts out a constant carrier or steady solid tone type of noise. But what about signals like pagers or control channels in trunk groups? These signals are actually changing; the modulation is changed in the data stream, and so it fools the simple sound squelch into thinking it's modulation, and it locks on the frequency.

Closely related to sound squelch is data squelch, which exists for precisely that reason. Most data squelch systems I've seen



Note the frequency step setting above the 7, 8, and 9 keys on this receiver. If your scanner doesn't have these adjustable step sizes, then it's set for you automatically by the scanner's internal system. Most of the time that works just fine, but there are times when an adjustable step comes in very handy.

tend to be optimized for trunked systems and work reasonably well for that application. Your mileage may vary depending on the signal you've found.

Tuning Steps

More appropriately called "adjustable step size," this refers to the ability of the scanner to change the distance between channels beyond some preset table. Every scanner has a built

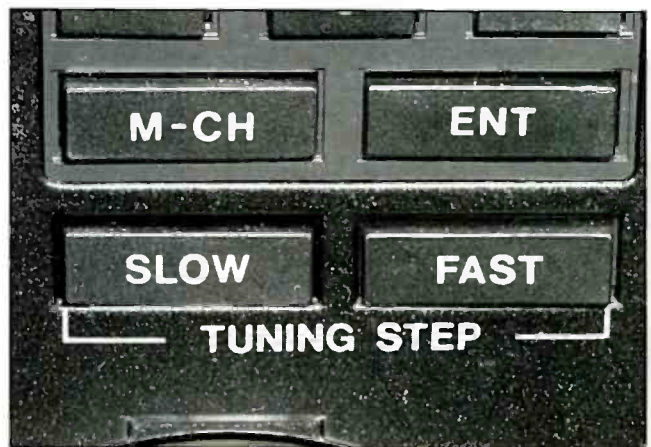

This receiver adjusts the step using SLOW and FAST keys to step through a wide range of available step sizes. Either method works fine.

BY KEN REISS <armadillo1@aol.com>



If you need trunking, that will limit the radios you have to choose from, but you'll be glad you got one! A trunktracker like this Uniden BC-245 makes following trunked systems much easier than with a conventional scanner.

in table of appropriate channel steps. On VHF-Hi for instance, channels are really 15 kHz apart, but if you use 5 kHz (a built in step in most radios), you'll be sure to hit every channel. On UHF, however, they're 12.5, 25, or 50 kHz apart. So if you use 12.5, you're sure to hit them all.

That works fine, but it means in a search operation that you're checking more frequencies than necessary. On higher end units, you can set a channel step to your liking, and search specific frequencies based on that setting. It's a handy function if you search a lot, or if something causes the band allocations to change, you might be able to use a different step to get to newly created channels.

For instance, the trend at the FCC is to put more channels between the existing channels. If the channels are 25 kHz apart now, the new ones will be on 12.5 kHz spacing. If they're on 12.5 kHz spacing now, the new proposal is to go to 6.25 kHz apart. Only communications receivers with continuously tunable VFO's are going to be able to hit those channels, but that might not be as big of a problem as it sounds. The filters on most of our scanners are designed for the 12.5 or 25 kHz steps. So if you're 6.25 kHz above or

below the actual transmission frequency, it might sound a bit off frequency, but you'll be able to hear it just fine.

Trunking Basics

This is probably one of those questions that needs to be answered before you ever start looking at specific models. Do I need trunking capabilities and if so, what type?

It wasn't all that long ago that this question was a moot point. Trunking scanners are only a couple of years old, but in that time, there have been numerous developments — far beyond our capability to explore here. I can almost hear Harold now: "You know, you really ought to do an article on trunking systems since you mentioned it," so I'm sure we'll explore this more fully soon. *(He's right! — Editor)* In the meantime, let's take a quick look at trunking.

Trunking means that instead of a service (like a police district, or fire dispatch) using a particular frequency, the frequencies available to the system are pooled and shared by a computer-controlled system. That means, unfortunately, that without a scanner that can follow the computer's instructions for which channel to go to and when, you'll only hear random bits of conversation.

That's not too bad late at night when only the police and fire services are operating. But during the day, or during a special event when you are trying to follow a particular conversation, it's frustrating. During the day, many trunked systems support not only the public safety operations, but all city functions including trash collection, animal control, parking control, towing operations, and EMS systems. You might be listening to an exciting multi-alarm fire dispatch and the next conversation you hear is about a stray cat stuck in a tree. Not exactly what we'd like to listen to at that point.

What a trunking scanner does is to follow the control information, just like the radios in use by the city officials, so that you can in fact follow just the conversation or conversations you are interested in monitoring. That makes life so much easier, and makes scanning much more fun if you happen to live in or near a city that is trunked. If not, then you don't need to be concerned about a trunking scanner and can concentrate on other features that interest you.

Unfortunately, I don't know of any universal way for you to find out. Many of the major cities have been searched and

Full 800 MHz Scanners

AR-8200 (unblocked)

Wideband Portable receiver

- 0.5 to 2040 MHz continuous.
- NFM, WFM, NAM, WAM, USB, LSB & CW
- Alphanumeric memory identification
- Spectrum scan
- Computer control
- Flexible dynamic memory bank layout
- Optional CTCSS & Extra memory boards

\$699 us



ALINCO DJ-X10 (unblocked)

Wideband Portable receiver

- 0.1 to 2000 MHz continuous.
- NFM, WFM, AM, USB, LSB & CW
- Alphanumeric memory identification
- Channel scope
- 1200 memory channels
- Superb sensitivity, Clear sound
- Various scanning modes - Menu system

\$499 us



ICOM PCR-100-08

Wideband receiver for PC

- PCR-100 can be used with your Desktop or Portable PC
- 0.1 to 1300 MHz continuous.
- Modes AM, FM & WFM
- Built-in tone squelch
- Multiple screens: multi-function control panel

\$229 us



AOR ICOM ALINCO
OPTOELECTRONICS YUPITERU

Guaranteed Delivery to USA.

Radioworld

Phone: **416-667-1000**

FAX: (416) 667-9995 Website Address:
sales@radioworld.ca http://www.radioworld.ca
4335 Steeles Ave. W., Toronto, ON Canada M3N 1V7

Lee Electronics

Scanners, SW, FRS and More:

AOR Cobra Bearcat BaGen
SANGEAN FREE PLAY uniden

1-800-578-6006

Tech: (724) 275-5822

www.LeeElect.com

Hand-Held Scanners!

MetroWest is your source for:

Hand-Held Scanners
Premium Battery Packs
Drop-In Chargers
Specialty Antennas
Books and More

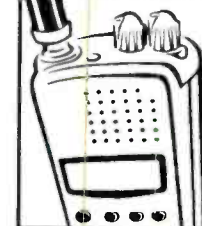

SEND OR CALL FOR A FREE CATALOG: **(708) 354-2125**

MetroWest Inc. 822 N. Spring LaGrange Park, IL 60526

ORDERS ONLY (800) 657-1475

CIRCLE 70 ON READER SERVICE CARD



This AR-8200 handheld has two VFO's and can switch back and forth between them quite easily. They act almost like temporary memories while you're working with the radio and are extremely convenient if you don't want to program something in, but just listen to it for a short time.

the information about their trunking systems is available on the Internet and through various publications. But if you're in a smaller town, or one that hasn't been explored yet, you might be on your own. It would be best to find someone who can tell you for sure if you need trunking and what type.

There are three main types of trunked systems: Motorola, GE's EDACS system, and Johnson LTR. Of these, Motorola and EDACS are by far the lion's share of trunking systems used by public safety agencies around the country, and Motorola has about 75 percent of those. Business users mostly use Johnson's system, although I understand there are new versions of that system in development in an attempt to break into the public safety market.

Once you know the type, you'll need to find a scanner that has those capabilities. Right now, there are very few scanners that do this — period — and the number is even more limited for EDACS systems. Motorola systems have a slight advantage in the number of radios and types of software systems out there to receive them, but that will change quickly.

Two Scanner Options For Trunking

You'll need a self-contained trunking scanner like the Uniden BC-245 or BC-895, or the other is a computer-assisted system. These range from self-contained systems, like the Optocom, which can run a variety of trunking software and track almost any mode, based on the software in use, to the ICOM and AOR series receivers which require additional hardware and software to trunk at all, but can

do a nice job once the system is assembled. Ask around to see if anyone close to you has a system you can look at, and evaluate carefully. You can do some neat things with systems like the Optocom and ICOMs if the software for what you want to do is available.

One more thought on trunking systems as it relates to delays. When we talked about delays, we mentioned that it might be important to delay and see if the reply to the conversation you're listening to comes back on the same channel. On some trunking systems, that is assumed as the normal mode of operation, and unless there is a lengthy pause between transmissions, they'll occur on the same frequency. On other systems, however, even though the repeater is held on, the reply conversation moves on (EDACS in particular is usually configured this way).

Using a conventional scan delay in the traditional mode would be a disaster in some of these situations. So the trunking scanner or trunk-following software should take this into account and use the appropriate method. Remember that the trunked system has additional information available to it on the control channel. So the delay function takes on a new meaning. Rather than delay the receiver on a particular frequency, turning on the delay function means waiting to see if there's a reply to this talk group before zipping off to find additional activity. It's much the same from a listening standpoint as the conventional delay on a conventional radio system, but the mechanics are a bit different.

Need A VFO?

VFO is an old ham radio term that means Variable Frequency Oscillator. You need one to make your scanner work, although these days, most of them are synthesized using solid state parts. What we're referring to in a receiver sense here is the ability of a receiver to be tuned by a knob or dial or some other method without having to put a frequency into memory.

In the old days, receivers only had one VFO and no memories: It was called the tuning dial. Then somebody got the bright idea that it would be handy to store the settings, or at least the frequency in use that might be of some interest later on, and memories were born. And then you put a bunch of memories together and check them for activity once in a while and you have — er — um — a scanner.

So it would seem we've come full cycle. Now, only high-end receivers and scan-

ners have VFO's so that you can just tune around at will and not have to store the frequency of interest in a memory. Another way to think of a VFO is as a manual search function. It only changes frequency when you turn the dial.

While in this day and age of thousand-channel synthesized scanners and high-tech communications receivers, a VFO is not nearly as useful as it once was, there are still times when it's handy. I use the VFO as a "scratch memory" so I can test frequencies without actually having to store them. One other note: Some radios keep the VFO frequency separate from any memories, so it's always available, while others simply let you tune up or down from any memory frequency as a starting point. Both are useful, but I prefer the ones that are stored for later use.

Weather Band Coverage

Many scanners these days have some type of weather function. These range from one-touch access to the NOAA weather radio channels, through sophisticated SAME Weather Notification systems on receivers. Weather alert is a very convenient function, if you'll use it. Originally, I think the idea was to come up with something for the scanner to do while you weren't using it, but it is an important and useful function.

Weather functions on scanners were a bit redundant until a few years ago. Oh sure, it was nice to have one button access to immediate weather data, but those who were interested in the weather had been programming their local NOAA weather broadcast into a channel and locking it out for years. Weather alert changed and enhanced that functionality.

When the scanner is off, but the weather alert function is on, the radio silently monitors the local NOAA channel. However, if NOAA has an important announcement, they broadcast a tone (which I'm sure you've heard if you listen to them at all). That tone causes your scanner to go into an ALARM mode that would wake the dead. Once alerted, and after you've climbed down off the ceiling, you can activate the weather channel and see what is coming your way — or somewhere three counties away. The problem is that there was only one tone and it covered the entire area served by the NOAA station. That can be half of a state sometimes.

The newest generation of scanners includes SAME, or Specific Area Message Encoding — a digital signal that

will notify only receivers set for that particular code. So instead of hearing alerts for three counties away, you hear alerts only for your area. It's up to the local national weather service office as to how they break down the encoding, but it has the potential to be a great asset. Unfortunately, we haven't had a chance to test any of the scanners equipped with this function yet, but stay tuned!

Wide-Band Receiver

Any receiver capable of receiving both shortwave and typical VHF/UHF communications is said to be a "Wide-band" receiver. For the most part, these receivers are a compromise between the needs of the dedicated scanner enthusiast and the needs of the dedicated shortwave listener. Many people find that having the extra coverage gets them interested in some of the other services; many people just like having the capability when the need arises.

Wide-band receivers tend to be at the high end of the receiver market. Unfortunately, they don't always perform equally well for both shortwave listeners and scanner folks, and so many people find they prefer having a dedicated, although somewhat cheaper, radio for each task. And in many ways, you can find combinations that will in fact give you better performance than many of the wide-band receivers.

One common disappointment I hear expressed is that a handheld wideband receiver just won't pick up the shortwave utility stations, or it can pick up some for-

eign broadcaster, but hears two others in the background. On handheld units in particular, the receiver just doesn't have the dynamic range, nor does it have enough antenna to do a good job. You're not going to hear six-megahertz signals on a 10-inch whip — at least not if they're weak.

These receivers definitely fall into the class of "having shortwave for convenience." You can hear the major broadcasters, and you'll hear a few of the stronger utility stations (if the radio has USB capability), but that's about it. Even that may require a longer antenna for the special purpose. They work well as scanners, but they're not for any kind of serious HF listening.

If you're interested in one, shop around, and ask lots of questions. Some of the receivers are built as scanners that also have shortwave, while others are built as shortwave receivers that happen to go above 30 megahertz. Which one you should choose, of course, depends entirely on what you expect out of the radio.

Next Month: Back To Normal "Scan Tech"

This concludes our "dictionary of features" series. I certainly hope you've found something new or useful along the way. Next month, we'll be back to "Scan Tech" as usual. In the meantime, if you've have a question or problem, don't hesitate to write. Send an E-mail to me at armadillo1@aol.com, or Ken Reiss, 9051 Watson Rd. #309, St. Louis, MO 63126. Until next time, Good Listening!

The Adventures of Scanner Dweeb by M.A. Coletta

This new feather weight scanner sure is nice....



It's so light when it's clipped to your belt you hardly know it's there....



Packin power

until you add the extra power pack... then your pants fall down....



www.ScannerDweeb.com

A special welcome to Mike Coletta and his "Scanner Dweeb" comics in *Pop'Comm*! Mike's handiwork can also be viewed at his fascinating website, <http://members.aol.com/ScannerDweeb>.

The book you've been waiting for...

CQ Amateur Radio Equipment Buyer's Guide

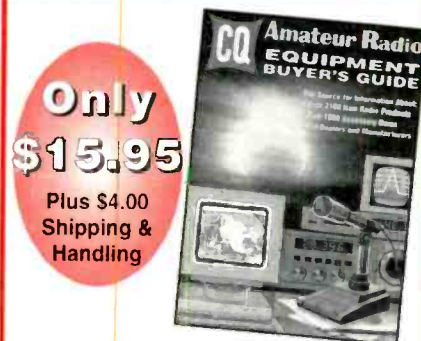

Only \$15.95

Plus \$4.00 Shipping & Handling

This information-packed book is your most reliable, unbiased source for detailed information on practically every piece of Amateur Radio equipment and every accessory item currently offered for sale in the United States. From the biggest HF transceiver to Ham computer software, it's in the CQ Amateur Radio Equipment Buyer's Guide, complete with specs and prices. There are over 2100 product listings (3100 including transceiver accessories!).

Product listings cover: HF Transceivers, VHF/UHF Multi-Mode Transceivers, VHF/UHF Base/Mobile Transceivers, Handheld Transceivers, Receivers and Scanners, HF Linear Amplifiers, VHF/UHF Power Amplifiers, Transceiver Accessories, Repeaters, Packet and RTTY Equipment, Amateur Television, HF Antennas, VHF/UHF Antennas, Accessories for Antennas, Antenna Rotators, Towers and Masts, Antenna Tuners, Measurement and Test Equipment, Ham Software, Training Tapes, Publications, and Miscellaneous Accessories. Thousands of products are described; many are illustrated.

The CQ Amateur Radio Equipment Buyer's Guide also includes the most comprehensive directory anywhere of Ham product manufacturers and dealers in the USA, complete with phone numbers, FAX numbers, Web sites, and e-mail addresses. Dealer and Manufacturer listings include major products manufactured or sold, and service and repair policies, where applicable, with 475 dealers and manufacturers listed. These listings alone are worth their weight in gold.

The CQ Amateur Radio Equipment Buyer's Guide is jam-packed with solid information and great reading. In addition to being an incredible source of insight into the current state of Ham Radio technology, it will continue to be a reliable Ham equipment reference source for many years to come.

For Fastest Service call

1-800-853-9797

FAX 516-681-2926

CQ Communications, Inc.
25 Newbridge Road
Hicksville, NY 11801



radio & the internet

Pop'Comm's Cyber Sleuth Checks Out Online Resources

Pop'Comm Readers Come Through, And A Super Online Air Traffic Control Site

Many thanks to Frank J. Kelly, Ted Cohen — N4XX and Bill Harrison — KK4XO for their help in my quest for a copy of the U. S. Army Technical Manual TM 11-666, "Antennas and Radio Propagation." I hope to have the manual reproduced and available on-line for all *Pop'Comm* readers by late summer. Thanks again guys — I really appreciate your assistance!

Air Traffic Control

Air Traffic Control Center, from XAVIUS Software, is a highly realistic simulation of actual radar sectors in the New York, Chicago, and Los Angeles Air Traffic Control Centers. You take the position of the radar controller, guiding both small and large aircraft into and out of some of the busiest airports in the world. This program is intended not so much as a game, but as an accurate simulation of actual air traffic situations that exist hour-by-hour in the crowded skies. Whether you are using this simulation as a training tool for a career in air traffic control, or you just want to see what it's like in the controller's chair, Air Traffic Control Center will let you experience one of the most mentally challenging occupations in the world.

Because of the high degree of realism of ATCC, unless you're already a controller, you *will* need to read the included manual to know what all the blips, lines, and numbers on the radar scope mean, and what commands you will need to issue to aircraft in your sectors. The comprehensive manual also provides an excellent overview of the Air Traffic Control System. An enormous amount of additional ATC information is also available at the XAVIUS website. See if you have what it takes to be an air traffic controller. Download your FREE copy of ATCC at <http://www.xavius.com/>.

IMPORTANT Note: When you run ATCC for the first time, you will be asked for your employee ID. Enter your Initials



Have YOU got what it takes to be an air traffic controller?

(two letters) and PRESS "N" (for New) WHILE the red error box is STILL on screen. DO NOT escape back to the sign-in screen because you'll never get logged in. When I visited the XAVIUS site there was a note indicating the FCC was hiring — full information was at the bottom of the XAVIUS main page.

Pirate Radio

If you've never heard a pirate radio broadcast or would like a sampling of

what's out there, check out "Bill's Shortwave Pirate Audio Page." In addition to many broadcasts (RealAudio format), you'll find a nice section of links to Pirate Radio Station Web pages, Pirate QSL Cards, and other areas of interest to the SWL community. Caution: You may find some of the archived broadcasts to be offensive, so listener discretion is advised. Although Pirate broadcasts can be found most anywhere, Bill lists the following frequencies as being a good starting point for your own listening:

Bill's Shortwave Pirate Audio Page

Listen to actual pirate radio broadcasts.

BY ERIC FORCE <eric@dobe.com>

A daily newsletter for the latest software releases.

1710-1780 a.m., 3500-3700, 7300-7400, 6950-6960, and 13900-13920 kHz. It's at <http://members.xoom.com/billfinn/audio/>.

Also be sure to checkout another super resource from Bill Finn: "Bill Finn's (Shortwave) Radio Page" at <http://www.geocities.com/Athens/Academy/4187/>.

Software Express Daily

With well over a million subscribers (yours truly is one of 'em), the Ziff-Davis "Software Express Daily" is a VERY popular newsletter. Every day, after subscribing, you'll receive listings of the hottest PC-based programs added to the Ziff-Davis collection — with an expanded edition every Thursday. Included in this daily newsletter are Editors' Picks, LaunchPad events, links to other Ziff-Davis resources, and ZDNet Exclusives. If you want to keep up with the latest-greatest PC software releases, "Software Express Daily" is for you — and it's FREE! Check it out. Visit <http://www.zdnet.com/downloads/lists/express/subscribe.html>.

Shortwave Listening

What do you get when you combine the incredible ICOM™ PCR-1000 receiver with some solid "C" and Java programming and the Internet? Why Kjell "Kelly" Lindman's, (SM0NHC) "JavaRadio" of

course. "JavaRadio" is a remotely controlled PCR-1000 with an amazing frequency span of 100 kHz to 1300 MHz — and YOU are in control. Home based in Stockholm, Sweden. "JavaRadio" features live audio and many features such as Chat, Frequency lists, filter and radio modes, etc. For those of us in the states, several other PCR-1000/100 owners have joined Kelly's JavaRadio Network by setting up similar facilities in Washington, D.C., Alexandria, VA, Kansas City, MO, San Diego, CA — all accessible from the "JavaRadio" home page. Thanks to *Pop' Comm* reader Jason Redmond for the tip on this slick resource. Visit <http://www.javaradio.com/>.

MAC Users Rejoice!

A few months ago, I mentioned two of Black Cat Systems' websites as superb resources for Pirate and "Spy" radio. Had I researched a little further at the time, I would have found that they also offer several radio-related programs for Mac users, including "MultiMode," the only Mac-based SSTV/FAX/RTTY/CW/ACARS/ decoding and transmitting package I know of. Even though I'm a PC guy, I can tell you there aren't too many websites dedicated to Mac software in general, much less software written specifically for hams and other radio enthusiasts. Consequently, this site

WOW!

Have you read Scanning USA, the ONLY scanning magazine? Get more out of your scanner with exclusive columns such as:

SCANNING USA

- Aviation
- Trunking
- Federal/Military
- Internet And Radio
- Railroad
- Product Reviews
- Beginners Corner
- And Much More!

Subscribe today!

VISA Call 1-800-651-0922

Sample \$3.00 8 Issues \$16.95
16 Issues \$33.95 26 Issues \$49.95

Scanning USA: 2054 Hawthorne Joliet IL 60435
[Http://home.att.net/~scanningusa](http://home.att.net/~scanningusa)
Scanusa@compuserve.com FAX 815-722-0717



CIRCLE 74 ON READER SERVICE CARD

Wireless Internet & TV

WIRELESS CABLE - IFTS - MMDS
ATV - INTERNATIONAL - DIGITAL
Amplifiers • Antennas • Books • Components

- RF Frequency 2100-2700 MHz
- SASE For "FREE" Catalog or Send \$1

PHILLIPS-TECH ELECTRONICS
P.O. Box 737, 607 Parker St., Trinidad, CA 95570
CATALOG/INFO: 707-677-0159
ORDER LINE: 800-880-MMDS
FAX LINE: 707-677-0934
WEBSITE: www.phillips-tech.com
E-MAIL: product@phillips.tech.com

CHALLENGER SYSTEM
31-Channel Composite 1240
Other Systems Available
5 Year Warranty
FREE SHIPPING

Visit • M.C. • AmEx • Discover • COD • Quantity Pricing

CIRCLE 72 ON READER SERVICE CARD

FREE FREQUENCY LIST...

...with your catalog request!
(PLEASE enclose a self-addressed business size envelope with 55c postage.)

DWM Communications
P.O. Box 87-PC, Hanover, MI 49241



Welcome to the JavaRadio
By Kjell Lindman, Lindman IT AB
P.O. Box 1087, s-411 22 Huddinge, Sweden.
ContactJavaRadio.com

The Ultimate Web Receiver 100 kHz - 1300 MHz
Now 4491 members

The JavaRadio applet



Click on the radio to login
[Apply for free membership!](#)
[Join the network and download software](#)
[The New product JavaRadio](#)

Access other JavaRadios around the world

Stockholm	Eastern Sweden
Borlax	Southern Sweden
Washington DC	Alexandria, VA, USA
Kansas City	Kansas City, MO, USA
San Diego	San Diego, CA, USA
Bombay	Targu Mures, Transylvania
Australia	Perth, WA

If you have an Icom PCR-1000/100 you can be a part of the network too!
[Just follow this link](#)
[Sign the Guestbook](#)

What is this?
This is a remotely controlled radio with the amazing frequency span of 100 kHz to 1300 MHz. You are in control of an Icom PCR-1000 receiver. You have live audio and many features such as Chat, Frequency lists, filter and radio modes etc.

[Technical info](#)
[The JavaRadio Network](#)

Take the incredible ICOM™ PCR-1000 for an on-line spin.



Receive Satellites with your Scanner!

Shuttle / Space Station / Military / etc.

Call for FREE brochure describing easy techniques to hear and see satellites.
Complete frequency guide with all orders!
1-888-FLGHT-LN
(1-888-354-4856)
Flightline Engineering, Inc.

CIRCLE 67 ON READER SERVICE CARD

Our Readers Speak Out (from page 6)

ing funeral to the Code. Station after station closing down, the latest being Globe Wireless. And nobody is buying back-up CW capable transmitters — just in case. CW is rapidly becoming an anachronism, and regardless of how much we love it, like all things, it too will pass away.

Amateur radio is first and foremost a hobby, regardless of the very useful and dedicated community service aspect. And hobbies are primarily here to be enjoyed. I am sure the amateur radio community is big enough to accommodate both code and no-code licensees, and that there are enough frequencies available to handle it. To say that no-code licensees would detract from circuit discipline is not quite true. There are bad operators in all modes of communications, just as there are bad drivers in all age groups or types of cars . . . the old guard will always try to keep the status quo, that is human nature. Hang on to what you got and stiff everyone else. But the old guard, and I am one of them, won't be around much longer.

Amateur radio needs to attract young people today. The Internet will probably do more to keep young people away from radio than any code/no-code requirement. Keep in mind, when radio began it was the hottest thing on the horizon with very little competition from anything other than a lot of dull books. The same is not true today. Come on, gents, lighten up. Declining membership may give you less crowded circuits, but it makes one thing inevitable: reallocation of frequency spectrum to other users.

Peter Warncke
Vallejo, CA

Renegade Foreign Broadcasts

Dear Editor:

Don't these foreign broadcasting stations have any restriction on operations policy? They are all over the 40-meter band. As amateurs, we're ruled by the FCC. Our band is not that wide. Are they not ruled by any rules?

O.D. Sewell, W5BAD

Dear Sewell:

Yes, they are regulated, but many choose to ignore the rules. By international agreement, they're supposed to broadcast within well-defined frequencies. I find it's often interesting to take stock of those countries that don't play by the radio rules: chances are they're the same ones not playing by other "rules" set forth for the good of their people, and their neighbors.

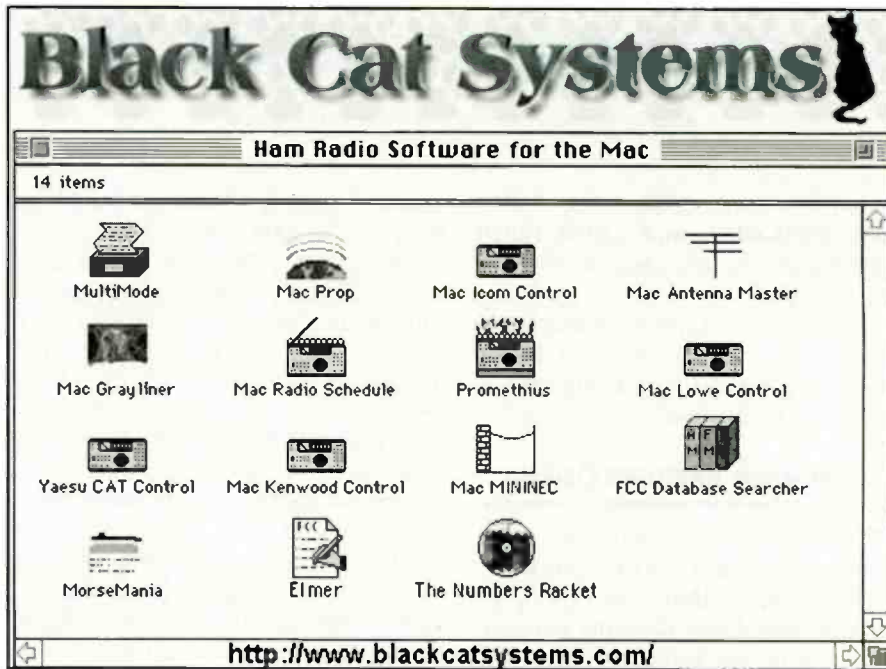

Radio-related software for the Macintosh computer.

should be of considerable interest to Mac users. All of Black Cat's software can be downloaded and tested prior to purchase so you'd have nothing to lose but a little time in checking out their products. Visit <http://www.blackcatsystems.com/>.

Get Precise Latitude/Longitude Coordinates

Probably the best known and most awarded website for providing accurate interactive maps and driving directions,

as well as extensive information on services and products near a user's address or travel route is Vicinity Corporation's MapBlast.com. Perhaps less known is that the exact Latitude and Longitude, in decimal degrees, of a displayed map's center is automatically provided for addresses which cover the United States and Canada. From the MapBlast! main page, simply click "MAP — Create, Print, Publish, E-mail, or Save Maps" then enter your address information on the subsequent screen. While there are many on-line resources providing approximate geographic coordinates

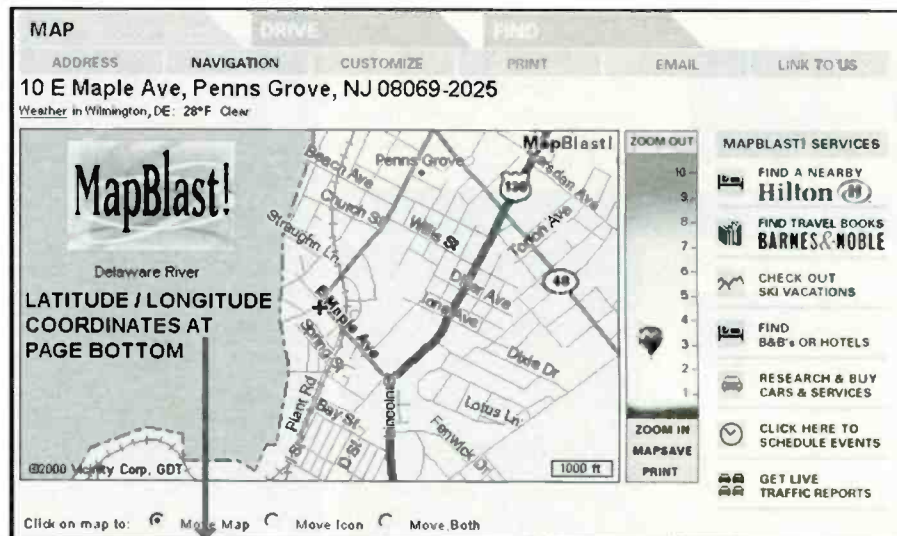

MapBlast! "The" source for finding latitude & longitude coordinates on-line.

zipinfo.com

[Click here to see our Online Product Catalog](#)

Free ZIP code Lookup

For any valid ZIP code, find the city and state, plus:

- county name and FIPS code area code
 time zone latitude and longitude
 MSA/PMSA congressional district

Enter a ZIP code, city, or city and state

08069

Go

Data Source: [ZIPList5 Product Line February 2000](#)

based on zip codes, etc., MapBlast! is the best (and most easy to use) on-line resource I've found for pinpointing and obtaining Latitude/Longitude values for specific street addresses. Visit <http://www.mapblast.com/mblast/index.mb>.

MW DX Time Zone Resource

ZipInfo.com provides quality (Zip Code) programs and databases at bargain

prices and has quickly become a leading supplier of ZIP code databases to Fortune 500 companies. While they hope you'll subscribe to one of their databases for off-line use, they also provide a really nice on-line and FREE zip code lookup service. What separates this resource from the crowd is the additional time zone and Latitude/Latitude information provided plus you don't need to know the actual zip code — just enter the city and state.

MW DXers should find the time zone information particularly useful in determining the local time of a received (U.S.) station. Check 'em out at <http://www.zipinfo.com/search/zipcode.htm>.

International Amateur Radio Information

Produced by Geoff Brown, GJ4ICD/G4ICD, the "International Amateur

← Find latitude/longitude, time zones, and more at ZipInfo.com.

Amateur radio information's main page — I'd call it "Everything Radio." ↓

International Amateur Radio Information



Produced by Geoff Brown, GJ4ICD/G4ICD

The works on Amateur Radio, including: EME, MS, IOTA, SSTV, ATV, Packet, Beacon News, VHF News, HF News, Cluster, Beacon lists, WWV, Satellite News, SWL Information, etc. In fact everything on Radiol! And Here is a full listing of everything to do with Amateur Radio on the Internet! New SSTV section! Jan 2000

Over 30,000 hits per week!!

Quicklooks!

50MHz Cluster	144MHz Cluster	432MHz Cluster	Input Form
DX Cluster	R.S.G.B. News	RSCB News Extra	HF News
WWV Figures	Solar Data	Live Aurora	Boulder

50MHz Information

GET ON THE *MT EXPRESS*

Monitoring Times is Now On Line!

Now-Receive your subscription to *Monitoring Times* with no delays due to mailing, no lost or torn copies. Be the first to receive breaking news from the frontier of communications!

For less than the cost of a subscription in the U.S., you can be reading the entire *Monitoring Times* magazine anywhere in the world before U.S. subscribers receive their printed copies! Active utilities loggings, world hotbed frequencies, international broadcasting schedule changes, new product announcements! This is the exact same magazine that has gained a worldwide reputation for reliable radio information that's easy to understand, and products and projects of proven value.

For a mere \$19.95 U.S., *MT Express* gives you *Monitoring Times* magazine

- in PDF format viewable with free software
- delivered by FTP (10 MB file)
- viewable in brilliant color on your computer screen
- easily navigated by clicking on the Table of Contents
- printable using your own computer printer
- searchable to find every mention of a topic or station schedule
- compatible with software to convert text to audio for sight impaired listeners

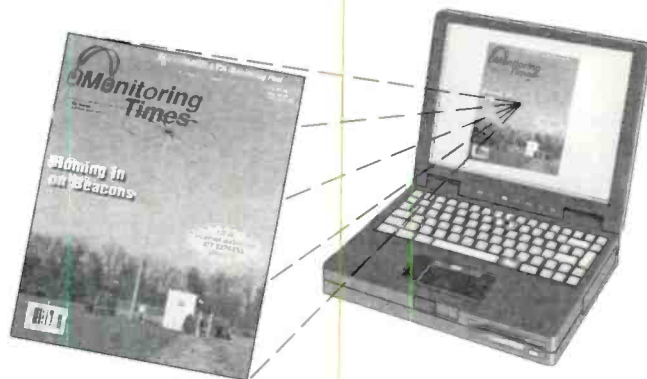

To find out if this new subscription is the delivery solution for you, you may download the August 1999 issue for free! Just go to <http://www.grove-ent.com> to find out how.

One year subscription to *MT Express* — only \$19.95 U.S., or for even greater savings, \$11 in addition to your printed subscription of \$24.95 in the U.S. Mastercard, Visa and DiscoverCard accepted. All payments must be in US funds drawn on a US bank.

ORDER NOW BY CALLING TOLL-FREE (800) 438-8155, OR E-MAIL order@grove-ent.com

Radio Information" website, covers EME, MS, IOTA, SSTV, ATV, Packet, Beacon News, VHF News, HF News, DX Cluster, Beacon lists, WWV, Satellite News, SWL information, and MUCH more! If it deals with Amateur Radio, Geoff has got it more than covered! What more can I say? Don't miss this outstanding resource at <http://user.itl.net/~equinox/>.

Note: That's a lower-case "L," NOT a numeral one in the "itl" part of the URL. Phonetically: India, Tango, Lima.

Another Great Amateur Radio Site

The "Kilo One Delta Whiskey Uniform" Website by John Woodstock, K1DWU, is another resource that just blows me away. Start with over 4,500 Ham Links, comprehensively indexed and VERIFIED WEEKLY, add current Ham Radio, Wireless, Science, Space, and Business News then include an FCC Part 97 reference and Ham Events section and, well, I'm speechless. Here's another guy trying to put the old Sleuth out of business! By the way folks, that "Links Verified Weekly" is extremely rare for a small site let alone one with several thousand pointers! It's really a pleasure to visit a site and have every link clicked work! Bravo John! Definitely another *don't miss* resource. Visit <http://www.k1dwu.net/>.

Please note: (I'm smiling) This time, it IS the numeral one in the URL. Phonetically, lower-case Kilo, One Delta, Whiskey, Uniform.

Scanning Info

Dave's New Jersey and New York City frequency page covers just about every conceivable aspect of radio communications in the NJ/NYC area. But it doesn't stop there. You'll also find tons of other pointers to live scanner broadcasts, Area Sky Cams, Weather Radar, and much, much more. Although the site (in my opinion) is a little heavy on banner advertising and animated graphics, (which increase page load times) it's well worth a visit — even if you're not in the NJ/NYC geographical area. Check it out <http://www.maxpages.com/frequencies?cart=1e873887362b>.

Rounding out this month's column is an E-mail I recently received from a good friend. Other than removing references to specific governmental agencies, here it is in its entirety.

K1DWU

Kilo One Delta Whiskey Uniform

February 1st, 2000

Home

K1DWU Section

- ▣ [In memory of my Dad](#)
- ▣ [4300+ Ham Links](#)
- ▣ [Ham News](#)
- ▣ [Web Site Registration](#)
- ▣ [Feedback](#)

Other News Feed Section

- ▣ [Wireless](#)
- ▣ [Top Stories](#)
- ▣ [Science News](#)
- ▣ [Top Business News](#)

Space

- [Space News](#) - Source: Amsat
- [2 Line Keys](#) - Source: Amsat
- [Long Keys](#) - Source: Amsat
- [News Service Bulletin](#) - Source: Amsat
- [Summary of Space Weather Observations](#) - Source: Amsat

Reference

- [Part 97](#) - Source: FCC

Events

- [Hamfest Calendar](#) - Source: ARRL
- [N.E. Public Service List](#) - Source: KD1SM

Ham Radio News

- [MILLENNIUM BALLOON EXPERIMENT](#)
VC7YTB - 01-31
- [The Hudson Loop # 162](#)
Hudson Communications Foundation, Inc. - 01-31
- [Daily Digest January 31](#)
FCC - 01-31
- [DX LISTENING DIGEST 00-19, January 31, 2000](#)
Glenn Hauser - 01-31
- [AMSAT NEWS SERVICE BULLETIN 030.01](#)
AMSAT - 01-31
- [Ohio/Penn DX Bulletin No. 446](#)
BARF-80 BBS Cleveland, Ohio - 01-30
- [DX LISTENING DIGEST 00-19](#)

Another super amateur radio resource — and NO dead links!

"I don't know if this is true, but . . . sometimes it DOES take a rocket scientist. U.S. scientists have developed a gun built specifically to launch dead chickens at the windshields of airliners, military jets, and space shuttles — all travelling at maximum velocity. The idea is to simulate the frequent incidents of collisions with airborne fowl in order to test the strength of the windshields.

Engineers from one of our allies heard about the gun and were eager to test it on the windshields of their new high-speed trains so arrangements were made to borrow the gun.

But when the gun was fired, the engineers stood in shock, as the chicken hurtled out of the barrel, crashed into the

shatterproof windshield, smashing it to smithereens, crashed through the control console, snapped the engineer's backrest in two, and embedded itself in the back wall of the cabin. Horrified, they sent our scientists the disastrous results of the experiment, along with the designs of the windshield, and asked for suggestions.

Our scientists' response was just one sentence: "Thaw the chicken."

Thanks for joining me on this month's journey into cyberspace. Be sure to visit the *Pop'Comm* website at <http://www.popular-communications.com/> for the latest greatest and keep those comments and suggestions coming!

Until next time. 73

Powered by **Max Pages**

- [About this Site](#)
- [Vote for this Site](#)
- [Visit My Chat Room](#)
- [Free Web Space](#)
- [Live Feeds](#)

Live

- [Live Radios](#)
- [Area Sky Cams](#)
- [Weather Radar](#)

NJ Countys

- [Morris County](#)
- [Bergen County](#)
- [Monmouth County](#)
- [Warren County](#)
- [Atlantic County](#)
- [Cape May County](#)
- [Cumberland County](#)



New Jersey and New York City
Frequencies + More

Why Does She Get So Mad?

A super scanner frequency resource page.

antennas & things

Simple Antennas And Accessories For Signal Improvement

Firing Up A Six-Shooter

I don't know why they call these antennas "Six-Shooters," but they do. Perhaps the name came from Bill Orr, W6SAI, in his popular *Radio Handbook*. Perhaps the name came from elsewhere, like from the fact that there are six elements in the antenna (more or less). But regardless, we're going to call them all "Six-Shooters."

The Six-Shooters (Figs. 1 and 2) are variations of what are called "broadside arrays." The version shown in Fig. 1 is basically a small "Sterba curtain" array, larger versions of which are often used by high-power international shortwave broadcasters. Both antennas can be fed with either 300-ohm twin-lead, or with 75-ohm coaxial cable if a 4:1 balun transformer is provided at the feedpoint.

These antennas can be built of wire or of aluminum tubing, although the wire option is probably the most popular. An advantage of these six-shooters is that they can be built for frequencies in the 6- to 7-MHz range (where wire construction is preferred), if you have enough room, and also well into the VHF region (in which case aluminum tubing construction is preferred).

Another advantage of these antennas is their considerable gain: 6 dB in the case of Fig. 1 and 7.5 dB in the case of Fig. 2. The signal is bi-directional, and is broadside to the array (in and out of the page as you view Figs. 1 and 2).

There are two uses for gain in antennas. First, antenna gain makes weak signals stronger by their own gain factor, without the added noise that a preamplifier introduces. Indeed, if all you have money for is either an antenna or a preamplifier, go for the antenna nine times out of 10. On most receivers, these antennas cause a signal to be about one S-unit stronger than the same signal received on a dipole (plus or minus a little bit). While one S-unit is not very much to write home about at S9, it can be critical at S1.

Second, the gain is achieved by re-focusing the pattern so that the maxima are broadside to the array, and there are nulls off the ends. These nulls can be positioned to reduce the signal level of an

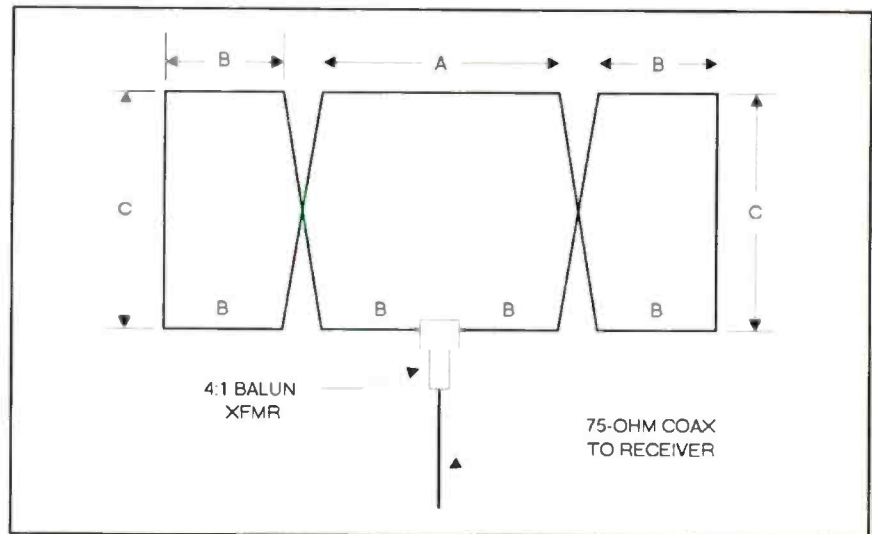

Fig. 1. Type-I ("micro-Sterba") Six-Shooter.

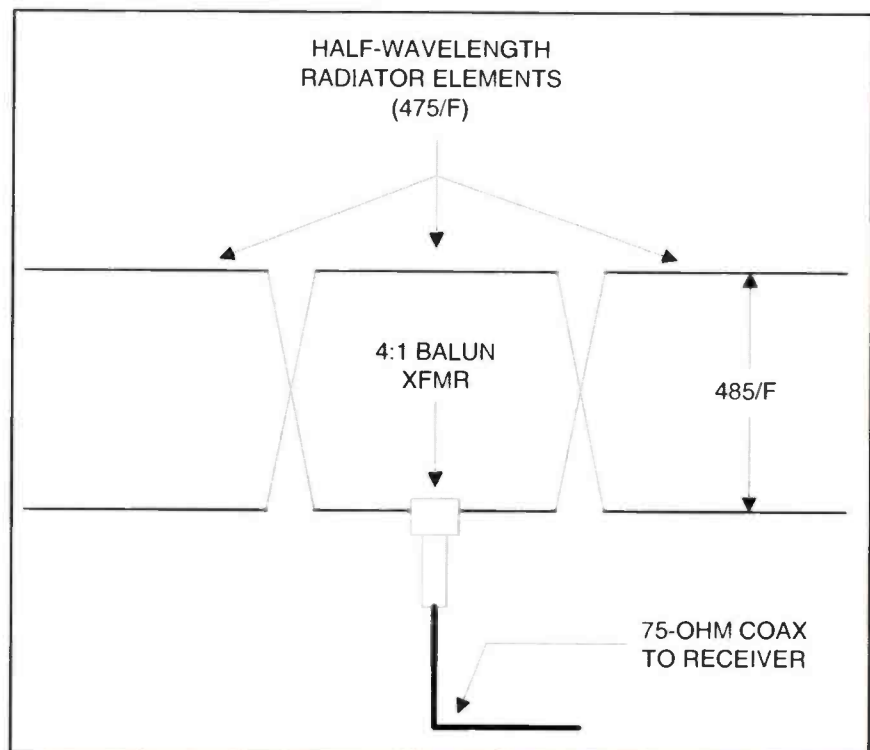

Fig. 2. Type-II Six-Shooter.

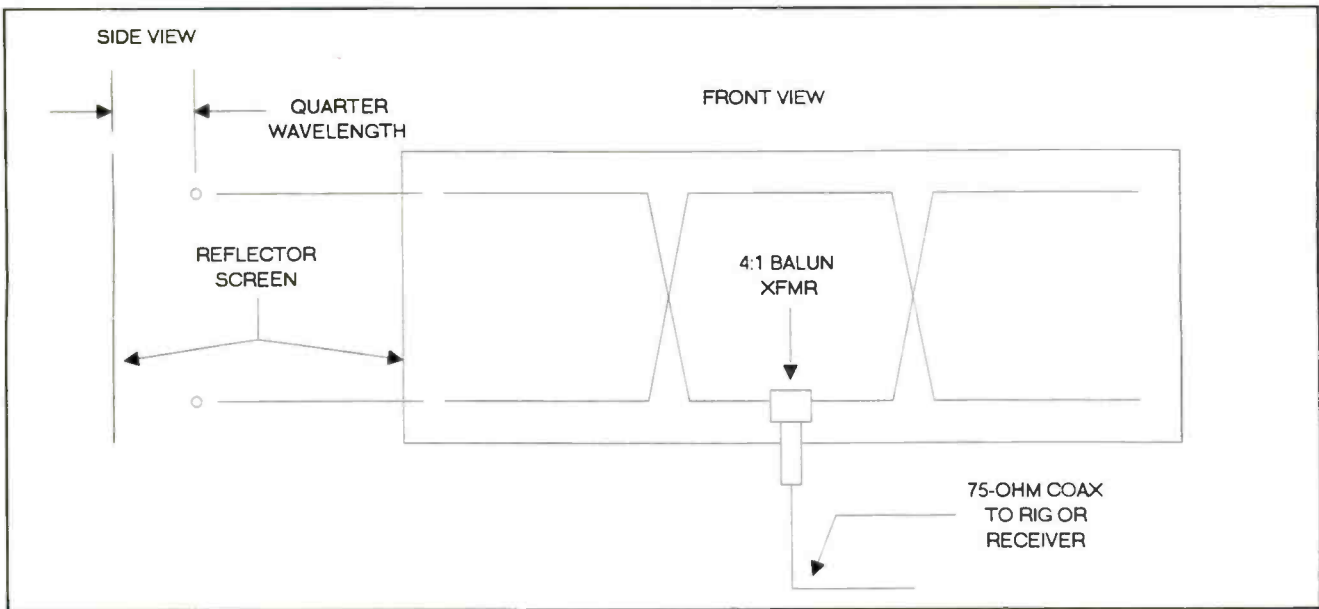

Fig. 3. Type-II Six-Shooter with a shield behind.

interfering signal on the same, or adjacent, channel. This may be the most important aspect to a directional gain antenna. The problem is one of signal-to-noise ratio (indeed, one of my college professors said that everything about receiv-

ing a signal is a matter of managing SNR!). The nulls are sharper and deeper than the peaks, so it's possible to null the interfering signal more than the desired signal. So even if the maxima is not aimed directly at the desired signal, the overall

performance is enhanced if the null is dead on the interfering signal.

The Six-Shooter in Fig. 1 (our micro-Sterba) uses elements of three different lengths, labeled A, B, and C. These lengths (in feet) can be calculated from:

Getting Started Videos

Getting Started in Ham Radio



Getting Started in Ham Radio walks the viewer through setting up the station, including the antenna, and goes over the 100 dB

Getting Started in Ham Radio—

How to select equipment, antennas, bands, use repeater stations, grounding, basic soldering.

Getting Started in VHF—Intro to VHF.

Repeater usage, packet, satellites and more exotic VHF op modes.



Getting Started in VHF

A video guide to all aspects of the exciting world of VHF, from CQ's award-winning 100 dB for the high level of learning.



Getting Started in DXing—

Top DXers share experiences with equipment, antennas, op skills and QSLing.

Getting Started in Packet Radio



Getting Started in Packet Radio shows you how to set up the hardware, software and how to get on the air and track the packets...all the nuts and bolts of how to do it!

Getting Started in Packet—

De-mystify packet. Info on making contacts, bulletin boards, networks, satellites.

Getting Started in Amateur Satellites—

How ops set up stations. Locate and track ham satellites.

Getting Started in Amateur Satellites



A new video guide through the excitement, the techniques and the fun of satellite communications.

Getting Started in Contesting



Getting Started in Contesting—

Advice and op tips from Ken Wolf, K1EA, K1AR and others!



Ham Radio Horizons—

Step-by-step instructions for the prospective ham on how to get involved.

\$19.95 each—

Buy more and save!

Buy 2 or 3 for \$17.95 each

Buy 4 to 6 for \$15.95 each

Buy all 7 for your Club for only \$99.95!!

Name _____
 Address _____
 City _____
 State _____ Zip _____

Qty

_____ Getting Started in Ham Radio	_____ Getting Started in Contesting
_____ Getting Started in VHF	_____ Ham Radio Horizons
_____ Getting Started in DXing	_____ Total Videos X \$ _____
_____ Getting Started in Packet Radio	_____ = \$ _____
_____ Getting Started in Ham Satellites	Shipping/ handling \$ _____
	Total \$ _____

Also available in PAL format.

U.S. and possessions - add \$4 shipping/handling. *FREE S/H on orders \$50 and over.
 Foreign - shipping/handling charges are calculated by order weight & destination. *A \$4 credit will be applied for Foreign orders over \$50.

Credit Card No. _____ Expiration date _____
 Method of payment Check Money Order Visa MasterCard Discover American Express



Call Toll-Free
 1-800-853-9797

$$A_{\text{feet}} = \frac{490}{F_{\text{MHz}}}$$

$$B_{\text{feet}} = \frac{A}{2}$$

$$C_{\text{feet}} = \frac{477}{F_{\text{MHz}}}$$

At 16 MHz, these lengths work out to be A = 30.6-feet, B = 15.3-feet and C = 29.8-feet. At 162 MHz, A = 3-feet, B = 1.5-feet and C = 2.9-feet.

The horizontal distance between horizontal elements should be 4 to 6 inches. In wire antennas, an ordinary end insulator placed between two elements will usually suffice.

The lengths of the elements in Fig. 2 are calculated as shown in the figure. The horizontal elements are each calculated from:

$$\text{Length}_{\text{feet}} = \frac{475}{F_{\text{MHz}}}$$

While the vertical separation between the two rows of horizontal elements is calculated from:

$$\text{Length}_{\text{feet}} = \frac{485}{F_{\text{MHz}}}$$

These two antennas are relatively easy to construct of either wire or tubing, and should be considered whenever you want gain on the cheap.

A third type of six-shooter antenna is merely the second type made unidirectional by the addition of a reflector shield quarter-wavelength in the direction of the minima (behind the radiator elements) (Figure 3). This shield can be constructed of solid aluminum on VHF/UHF bands, but it can also be made of chicken wire or other forms of screening. The only criteria are:

1. The screen be about ten percent larger than the dimensions of the antenna, and
2. The spaces in the antenna are at not larger than one-twelfth wavelength at the lowest frequency of operation.

Safety First!

Every now and then someone contacts me over my E-mail address (carrjj@aol.com) and asks something about antennas. One fellow (not a *Pop'Comm* reader!) very carefully gave me details of his plan to erect a wire "top-hat Tee" antenna for the high frequency shortwave bands. In his description, he mentioned that he was going to use a wrench as a weight to toss

The Best Just Got Better!

The Eavesdroppers™ now includes our new Zap Trapper™ Electronic Gas Tube Lightning Arrestors. Receive-only design shunts damaging transients to ground at only 1/7th the voltage buildup of the available 200 watt transmit-type arrestors, providing maximum solid state receiver protection.

Protect your investment - combine an excellent shortwave receiving antenna with the best receiver protection money can buy.



- Completely assembled and ready to use
- Only 42' overall length
- 8 trap circuits permit reception on all shortwave bands, 11-90 meters.
- All connections soldered and enclosed in ultrasonically-welded, hermetically-sealed trap covers
- Includes 50' of 450 lb. test nylon rope

- Model T includes 100' twinlead feedline
Model C includes weatherproofed center connector for your coax & coax sealant
- Either model \$79.95
 - UPS for lower 48 states \$6.00
 - COD add \$5.00, IL add 8.25% sales tax
 - Foreign shipping quoted

Also Available:

- Eavesdropper™ Sloper - End-fed, coil-loaded receive-only antenna with underhung parallel element. Includes our Gas Tube Lightning Arrestor, 67 ft. overall length, \$79.95
- RCVR/T - Receive-only Gas Tube Lightning Arrestor for twinlead-fed antennas, two gas tube design, \$19.95
- RCVR/C - Receive-only Gas Tube Lightning Arrestor for coax-fed antennas, single gas tube design, \$19.95

Please Call For More Information.

Antenna Supermarket

P.O. Box 563 Palatine, IL 60078 Tel (847) 359-7092 Fax (847) 359-8161
At your dealer or direct • Visa & Mastercard accepted

a rope over the AC power lines coming into his home, and then pull the antenna wire over using insulated gloves. My reply: DON'T DO IT! IT WILL KILL YOU. Always keep well away from power lines. They may look insulated, but **the antenna wire can cut power line insulation even when it's new.** You have to be dumber than a box of rocks to try any variant of this often-fatal maneuver!

Plan Yes, But DO IT!

A lot of people I talk to tell me that they want to erect that absolutely most perfect antenna possible, and they plan, and plan and plan and plan. Some of their arguments sound like those I heard against buying the (then new-fangled) calculators that came on the market when I was in college. My approach was to survey what was available in scientific calculators within my price range, and then go buy the thing. A friend of mine sneered that I'd paid too much for my TI SR-50

because "... next year they're comin' out with something that'll do more and cost less." Yep, that's the way the electronics industry worked. But when we were seniors, he was still looking for the magical, cheaper calculator in the sky and solving problems on a clumsy slip-stick ("slide rule" to the non-cognizent or younger readers); I had spent the last three years solving the same problems on a nice little calculator.

The point of this little analogy is that sometimes one has to "fish or cut bait." While you're planning, an awful lot of good listening is going by the wayside.

What was so odd about the planner I told you about above is that his receiver did not warrant a whole lot of antenna. Once you get past a certain quality level, and start listening to weaker and harder to detect signals, then one can worry about fine differences between antennas. Until then, put something up and start listening. There's plenty of time to upgrade later on. ■

product spotlight

BY HAROLD ORT,
N2RLL, EDITOR

POP'COMM REVIEWS PRODUCTS OF INTEREST

Nextel's i1000plus™ Cell Phone

You can't hear them on your scanner — if you search on an older cell-capable scanner it'll sound like a pulsating, rumbling noise — with no discernable audio. And while diehard monitors might frown in disbelief, I recently tested a pair of these cell phones and it was indeed a sad day when they were boxed up and returned to Nextel after an all-too-short review period.

I first heard about the Nextel i1000plus phones from a friend who uses them in his business. Fred owns a small manufacturing company and can call back to his warehouse — 50 miles away — check on the status of an order using the two-way radio feature, and immediately place a call to a customer confirming the order is on the loading dock. You see, they're more than just an ordinary cell phone, they're also a two-way radio — with plenty of solid coverage. Nextel calls the two-way, walkie-talkie feature Nextel

Direct Connect®. This completely digital wireless system combines digital cellular, the two-way feature of Direct Connect® (a digital two-way connection for instant private and group conversations), text/numeric paging, and wireless Web-based services — all in one phone!

A Cellular Phone With Mega Features

The small phone is lightweight and is easily tucked away in a shirt pocket or purse, or with the provided clip, attached to your belt. The small plastic attachment used to holster the phone takes some getting used to; at first I looked like I was trying to tear my belt off in public — not a pretty sight — but after a few tries, the wireless wonder was a cinch to remove. I'll admit that it didn't spend a lot of time on my belt or in my shirt pocket. We gave it quite a workout.

Features of this phone include a multitude of bells and whistles. It stores the last 10 numbers you've received and sent; you press "menu," then "calls" for access. Turbo Dial™ is Nextel's speed dial; press and hold any key (1-8) and it dials a stored number. (If you think your home phone's speed dialing is fast, you need to try this!) The "missed call" indicator automatically shows you the number of missed calls. And a great convenience is the phone's ability to store private IDs. Simply press "store," enter the name, and press "store" again.

Other great features include call forwarding, Voice Mail (with the flip cover open) which allows you to scroll through your voice messages and listen — either with the phone at your ear or using the speakerphone feature. (Did I say these phones are loaded with features?) We even tested the text and numeric paging feature — great for folks on the go. At your home or office computer, send an E-mail to another Nextel customer through the Nextel online system (www.nextel.com) and instantly the recipient gets the message on the i1000plus! (You can also

send a test message from the phone, but this feature wasn't up in our area, so it couldn't be checked out). But if it works as flawlessly as the computer-to-phone E-mail messaging system, it's nothing short of outstanding.

The Nextel messaging service (Short Messaging Service or SMS) even allows you to send messages to entire work-groups — receive verification of receipt, maintain a log of your messaging activity, and send messages to groups and individuals using non-Nextel paging products. The paging service includes an instant notification feature that alerts you to new messages!

Believe me, with a pair of these phones you're never out of touch with work, home, or Aunt Mildred in Cleveland. Each phone comes with a large instruction manual that *must* be read — and appropriate parts highlighted for future reference. The phones are relatively easy to use; however you do need to take some time to read the manual.

Setup is as easy as 1-2-3. Attach the battery to the back of the i1000plus phone and plug in the provided Motorola adapter. We charged the phones overnight after a hard workout everyday, but the small standard battery never pooped out in our extensive tests. Turn the unit on by simply pressing and holding a button on the top of the phone. A set of icons and "Welcome To Nextel!" message appears on the easy-to-read display. Your phone number and the message "Please Wait" will appear while the phone connects to the Nextel National Network. In a couple of seconds, the display will read "Phone Ready."

At this point, you can either use the phone function or — our favorite — the two-way feature with either the flip-top cover open or closed. With it closed, press the button under "Mode" until you see "Prvt Ready." Press the button under "List" until you see the person's name you've programmed. Press and hold the PTT button, wait for the courtesy beep, and talk away. To listen, just like an ordinary HT, release the PTT button.



Nextel's i1000plus cell phone with Direct Connect® feature.

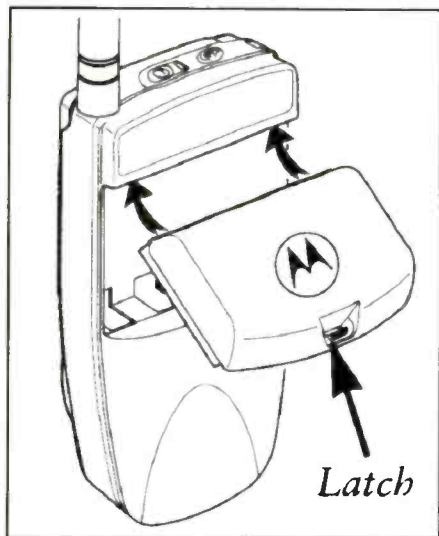

The small battery attaches with a firm click.

You can send a Call Alert the same way. It's a loud beep that the person you've called can't ignore! Or you can make a group call by pressing the button under "Mode" until you see "Group Ready." Press the button under "List" and use the volume/list control buttons on the left side of the phone to scroll to the desired talkgroup. Press the PTT and you're instantly in touch with the entire group of folks.

I especially liked the display icons. Sometimes I think the people that sit for hours planning and designing icons we see on phones and radios failed kindergarten. The Nextel icons make sense; think about it: a battery strength indicator that looks like a battery, a voice mail icon that looks like the two reels of a tape recorder, and small up/down arrows indicating there's more text to read above, below or above and below the current screen!

Audio Quality And Solid Coverage

It's no secret that cell phones, like our ham radios using a repeater, can drop out temporarily — although it happens more frequently, in my experience, with cell phones: you're talking and suddenly the service has let you down. During our solid month of testing these phones in the suburban New York area, signal drops were infrequent, and when they occurred, it was usually because my daughter was in Penn Station or entering a New York subway. Consider for a moment the sheer volume of users at rush hour coupled with the harsh radio environment.

The Direct Connect® two-way feature of these Nextel phones is superb! Looking at the small phones (the unit

measures 4.5 x 2.2 x 1.2 inches and weighs just six ounces with the included standard lithium-ion battery) you might expect basement volume, but even I had to turn the volume *down* in a noisy outdoor street environment. Using the Direct Connect® feature is as easy as using a CB or ham transceiver. Key the rubberized push-to-talk switch on the side of the unit; wait a brief second for a short courtesy beep, then talk. If you're too eager to talk and don't wait for that courtesy beep your first couple of words will be clipped, forcing you and your radio partner to play Keystone Cops until you slow down and learn how the two-way feature works. And works, it does!

My brother-in-law, Wes, isn't exactly a two-way radio person. He's got his own cell phone, car alarm, home alarms, VCR, microwave, and wireless remote car keys, but believe me, he's also got all the manuals and "quick-start" pamphlets for each of these devices at arms length. Off he went to a large north Jersey shopping mall one Saturday morning with the i1000plus in his pocket after I briefly explained the basics of the two-way feature from the comfort of our living room. Around noon, my Nextel phone beeped and there he was, safe and sound in Paramus.

"Can you hear me," he asks. He sounded like he never left the living room where I sat comfortably on the couch. We talked for a few minutes about the traffic, weather, and bargains he was shopping for, then decided to leave the units on so he could call later that afternoon. Later, his voice — unclipped and very loud — came through extremely clear with no distortion.

From the Big Apple, my daughter and I tested the phones every day for nearly a week. While there were some signal dropouts, with patience — and understanding the tremendous volume of calls on the system — we thought the Direct

Connect® feature worked quite well. I imagine the results would be similar in other coverage areas. All in all, the two-way feature is an excellent addition to an already outstanding cell phone.

An example of the coverage area, for those of you who know the New York/New Jersey area: The Nextel New York Area Coverage includes all of the metro New York City area, (including all of Long Island) all the way up the New York Thruway (Interstate 87) to Kingston, into a large portion of Connecticut and a sizeable portion of south-central Massachusetts near Springfield off Interstate 91, at least 80 percent of north and central New Jersey down to Trenton.

Nextel's coverage plans vary depending on your location. Here in central New Jersey, plans that include unlimited talk time on the Direct Connect® feature range from \$49.95 to \$159.95 a month. There are no roaming charges on the nation's only guaranteed all-digital national network by Nextel.

If you're considering entering the new millennium in style and want to stay in touch 24/7, the i1000plus is for you! (Nextel also offers the i500plus™ with a few less bells and whistles, and the i700plus, a new ruggedized version, both of which also include the Direct Connect® feature). Please keep in mind that the Direct Connect® two-way feature won't allow you to talk from Florida to New York or Texas to California; it's obviously a regional two-way radio system.

To learn more about the Nextel i1000plus, call 800-639-8359 or on the Internet visit <http://www.nextel.com>. You can also write to Nextel Communications, Inc., 2001 Edmund Halley Drive, Reston, VA 20191. Be sure to tell them you read about it in *Popular Communications* magazine. ■

Rave Review
Pop Comm
April '96

SEE US ON THE WEB!
www.vikingint.com



Professional 10 HOUR RECORDER

"BUILT LIKE A BATTLESHIP"

SPECIAL
Pop Comm
Price..

\$159

FREE
SPECIAL EQUIPMENT
CATALOG!

- Heavy duty commercial recorder - NOT improvised from consumer models
- 12, 14, and 16 hour models also available
- BUILT-IN voice activation (add \$30)
- Applications information included
- Dimensions: 11.5 x 7.0 x 2.75"

COD's OK. Calif. residents add tax. Sorry, no credit cards. Free catalog USA only, other countries \$5. Free Shipping to 48 contiguous States on Prepaid Orders.

Viking Systems International

Factory Direct Phone: (415) 467-1220 • Fax: (415) 467-1221 "Since 1971"

100 North Hill Drive #42, Brisbane, CA 94005

washington beat

FCC Actions Affecting Communications

Low-Power FM Radio Service Approved

The Federal Communications Commission has finally approved the new and long awaited Low-Power FM Radio Service. You may wring your hands and salivate in anticipation imagining that very soon, just about any wanna-be deejays or radio hobbyists like you will be able to put their very own FM radio station on the air, right from home. Or will they? Whatever LPFM Report and Order MM Docket 99-25 (FCC 00-19) did, it did not legitimize home pirate broadcasters. Nor is it an amateur broadcasting of, specifically, existing noncommercial and educational broadcasting as described by federal statute (47 USC §397(6)). The R&O, adopted on January 20 this year, authorizes two LPFM services. The first is known as LP100, for stations operating 50 to 100 watts of power, with an estimated service radius of 3.5 miles. The other is LP10, for stations running only one to 10 watts, and an estimated service radius of one to two miles.

The FCC did commit to keeping these services *noncommercial*, and imposed limits on the number of stations any one entity could own. These actions shut out the prospect of clusters of automated LPFM stations becoming a cellular system of broadcast commercial mills. The Commission's stated goal for LPFM is to enhance community-oriented radio broadcasting. Such a statement implies that community-oriented broadcasting exists, thus supporting the notion that LPFM will differ little from existing noncommercial broadcasting. The FCC claims that these new services will foster diversity in radio broadcasting. And it will fill local community needs in a "focused manner," whatever that means. So why can't just anyone apply for an LPFM license, and set up a studio and transmitter at home? Well, one *could*, but it's a bit more complicated than that. Applicants must meet certain eligibility requirements. Licensees must meet the criteria for noncommercial educational broadcast stations of Section 397(6), cited above, or be a government agency,

in essence. Public agencies; nonprofit private foundations, corporations, or associations; and public or private nonprofit educational institutions and organizations are among entities that may be eligible for LPFM licenses. *Individuals are not*. If you want to operate an LPFM station from home, you will probably have to incorporate or become a limited liability partnership. This process varies from state to state, costs fees that are hefty for an individual who will never see a return on the investment, and usually involves the services of an attorney. Incorporation usually involves two or three individuals to be named as officers or partners, depending on the state and the type of charter. And it appears that this *may* have to be done before applying for an LPFM license, with no guarantee that such license will be issued. Any party considering applying for an LPFM license should contact the FCC's Mass Media Bureau for specific clarification on this eligibility issue. Regardless, don't expect to find too many home amateur FM broadcasters or reformed pirates operating LPFM stations.

And what of pirate broadcasters who want to go "legit," even with all that is involved? The LPFM docket has provided special amnesty, if I may call it that, for pirates. Those broadcasters wishing to pack away the Jolly Roger and hoist the Stars and Stripes with the FCC's blessing may do so, subject to one of two conditions. Former "illegal broadcast" operators must certify that they "voluntarily ceased engaging in the unlicensed operation of any station no later than February 26, 1999, without specific direction to terminate by the FCC." Or they "ceased engaging in the unlicensed operation of any facility within 24 hours of being advised by the Commission to do so." Former pirates meeting one of these criteria may then be eligible to apply for an LPFM license.

Not surprisingly, there are a number of conditions and regulations affecting LPFM applicants and operations. The LPFM docket is 124 pages long, so I will

mention only selected major points here. The FCC will impose co-first and second-adjacent station separation in an effort to prevent interference. Both LP100 and LP10 stations will be required to meet minimum station separation distances to protect service contours of authorized FM stations "of all classes," existing FM translators and boosters, and LP100 stations, as well as certain proposed FM facilities. LPFM licenses are to be authorized throughout the FM band, not restricted to channels customarily reserved for use by noncommercial educational radio stations. Existing broadcasters and other media entities can have no ownership interest nor enter into programming or operating agreements with LPFM stations.

For the first two years of LPFM license eligibility, no entity may operate more than one LPFM station in a given community. During this period, any such entity must be essentially physically located, or have 75% of their board members residing within ten miles of the station in question. Licenses will be valid for eight-year renewable terms, and four-letter call signs with the letters "LP" appended will be issued. At press time, the Commission says it will subsequently announce designated filing windows, first a five-day window for LP100 stations and a later window for LP10. Barring any possible extensions of time, these windows will have passed by the time you read this, however. LPFM stations will have to broadcast at least 36 hours per week. They will be held to statutory rules regarding sponsorship identification, political programming, prohibitions on obscene or indecent programming, and periodic station identification by call sign. Yes, LPFM stations will have to participate in the Emergency Alert System.

FCC rules about main studio, ownership reports, and public file requirements will not apply to LPFM however, according to a FCC press release. For more information, the FCC has set up a special Web page at <www.fcc.gov/mmb/prd>.

BY ALAN DIXON, N3HOE <n3hoe@juno.com>

lpfm> or you may telephone the FCC at 888-225-5322.

FCC Establishes Minimum Standards For Inside Telephone Wiring

Third Report and Order CC Docket 88-57 (FCC 99-405) sets minimum quality standards for telephone wiring on the customer premises side of the telephone network, for "consumers and small businesses." This ruling is to ensure that consumers have adequate wiring to better accommodate Internet, facsimile, and "advanced broadband services" traffic over telephone wiring. The new rules in FCC Part 68 (68.213(c)) require solid, 24-gauge or thicker twisted pair. Such wiring must meet Category 3 ANSI/EIA/TIA standard 570-91. Conductors must have insulation with a minimum 1500-Volt rms minimum breakdown rating, subject to specified testing and measurement techniques. This ruling is set to take effect June 21 of this year. Builders and contractors will have to meet or exceed these standards when installing new telephone wiring after that date. This wiring must be marked at one foot intervals, as "CAT 3" or a symbol consisting of the letter "C" with a numeral "3" appearing within the "C." Again, check the FCC Website for details.

Universal Licensing System Forms Are Required

Did you know that Universal Licensing System (ULS) forms are now required for all amateur license filings? Effective this past February 17, the FCC no longer accepts any amateur license filings on forms 610 and 610V. Individual hams now have to use FCC form 605, either hard copy, or on-line. For vanity call sign applications requiring a fee, you will need to order or print out form 159 to mail in with your payment. Payment can be made electronically if you have Netscape browser software supporting 128-bit encryption. Existing amateur licensees have been required to register in the ULS since last summer. Registering is a simple task on the Web. License applications, upgrades, renewals, and administrative changes require a dial-in modem connection, however. This can be a bit intimidating for users accustomed to the ease of Internet connections. FCC Public

Notice DA 00-270 explains the procedures for both hard copy and on-line filing. This time visit the FCC at <www.fcc.gov/wtb/uls> for needed information. Or do it the old fashion way with the new paper forms. Call 1-800-418-FORM to get yours. The Commission says that applications filed on pre-ULS forms, with the exception of club, military, recreation, or RACES licenses using form 610B, will be dismissed without prejudice. So there!

Uncle's Budget

The FCC has submitted its annual budget request for fiscal year 2001 to Congress. The Commission is looking for \$237,188,000. This budget will support a staffing ceiling of 1975 full-time personnel equivalents. The figure above shows an increase of \$27,188,000 over the fiscal year 2000 appropriation of \$210,000,000, at the same "equivalent" staffing level. The FCC is looking to increase salaries and benefits, and to replace outmoded computer equipment and information technology systems, among other things.

The Revolution Advances

As the wireless revolution advances, the FCC remains busy. If you are not aware of the state of the wireless art and technology, you should be. The latest market trend in telecommunications is convergence, the union of handheld wireless phones with Internet E-mail and Web browsers, and even video devices. These devices, some existing, and many more to come, will operate on many bands in many transmission modes. All require regulatory approval and certification, even those that are unlicensed Part 15 devices. There is so much going on that we cannot possibly report it all here in the pages of *Pop'Comm*. That is why I encourage everyone to browse the FCC Website. If you don't have a computer at home, or have no Web access, go to your local library and browse there. The better educated we are about issues affecting us as electronics consumers and as radio hobbyists, the better we can express our needs to our elected and appointed officials, and to the electronics industry. Never forget that among other things, we are the customer to all these parties. They are to respond to us. See you next month, under the summer sun! ■

If you enjoy radio communications you'll love....

POPULAR COMMUNICATIONS



The World's largest, most authoritative monthly magazine for Shortwave Listening and Scanner Monitoring. Read by more active listeners than all other listening publications combined!

SUBSCRIBE TODAY!

POPULAR COMMUNICATIONS Ph: 516-681-2922

25 Newbridge Road, Hickville, NY 11801

SAVE UP TO 54%

Get fast home delivery of *Popular Communications* and save \$21.93 a year over the newsstand price. Save even more on 2 or 3 year subs.

- 1 year - 12 issues **\$25.95**
(Save \$21.93)
- 2 years - 24 issues **\$45.95**
(Save \$49.81)
- 3 years - 36 issues **\$65.95**
(Save \$77.69)

Canada/Mexico—One year \$35.95, two years \$65.95, three years \$95.95; Foreign Air Post—one year \$45.95, two years \$85.95, three years \$125.95.

Payable in US dollars only

Name _____

Street _____

City _____

State _____ Zip _____

Bill to Mastercard • VISA
• AMEX • Discover

Account number: _____

Exp. date: _____

Note: Allow 6-8 weeks for delivery of first issue.



A view of Vatican Radio's production center.

and other books. If you want a copy, drop 'em a line at sales@crbbooks.com or call 516-543-9169 or request a copy by writing them at P.O. Box 56, Commack, NY.

Remember that your reception logs are always welcome. Please be sure to list your logs by country, provide at least a double space between each (so we can navigate scissors more easily) and add your last name and state abbreviation after each. And also, be sure to use only one side of the paper — otherwise some of your logs won't make it into the column. Other things we can use in the column are spare QSL cards you don't need returned (or good quality copies), station photos and other items from stations, including schedules, brochures, etc. And, how about a photograph of you at your listening post? As always, thanks so much for your continued interest and cooperation!

Here are this month's logs. All times are in UTC, which is five hours ahead of EST, i.e. 0000 UTC equals 7 p.m. EST, 6 p.m. CST, 5 p.m. MST and 4 p.m. PST. Double capital letters are language abbreviations (FF = French, AA = Arabic, SS = Spanish, etc.). If no language abbreviation is included the broadcast is assumed to have been in English.

ALASKA — KNLS. 7365 at 1306 with religious music and general features, including "Radio Century." (Jeffery, NY)

ALBANIA — Radio Tirana. 6090 heard at 0053 in Albanian. Into Italian at 0102. (Ziegner, MA) 6115 at 0030 with news. (Brossell, WI) 7160 at 0340. Covered by BBC. (Burrow, WA)

ALGERIA — Radio Algiers. 11715 and 15160 (best) at 1720 in SS with music, tentative ID. (Burrow, WA) 15160 at 2000–2100 with news, jazz, press review, local pops. //11715 which was very weak under an unidentified station. (Alexander, PA)

ANGOLA — Radio Nacional. 11955 in PP at 2100 with clear ID, talks, and music to 2120 fade. (Brossell, WI)

ANTIGUA — BBC relay 5975 at 2350, 6195 at 1100, 9700 at 0106, 18710 at 2030 and 17840 at 1600. (Newbury, NE) 5975 at 0000, 0258, 0357, and 0500. (Jeffery, NY)

ARMENIA — Voice of Armenia, on 9965 signing on at 2115 with IS, national anthem, schedule, address, and news. (Alexander, PA)

2128 with program preview, music. (Jeffery, NY)

ARGENTINA — RAE. 11710 at 0230 with English and Spanish language, news, and music. (Gale, NC) 0315 with clear ID in French. (Brossell, WI)

AUSTRALIA — Radio Australia. 5995 at 1400. 9580 at 1300. (Newbury, NE) 9580 at 1258. (Jeffery, NY) 1322. (Wilden, IN) 1330. (Northrup, MO)

AUSTRIA — Radio Austria Int'l. 6015 (via Canada) at 0628 with sports in GG. (Miller, WA) 0646. (Becker, WA) 0620 with "Report From Austria." (Barton, AZ)

BELGIUM — Radio Vlaanderen Int'l. 9925 with English from 1830–1900. Dutch from 1900–1956. 17695 (via Antigua) in Dutch from 1900–2000 (Silvi, OH) 11980 (via Antigua) at 0411. (Burrow, WA)

BOTSWANA — Voice of America relay. 7415 at 2136. Audible until 2158 when WBCQ signed on the same frequency. (Jeffery, NY)

BRAZIL — Radio Nacional Amazonia. 11780 in PP at 0722. (Becker, WA) 2250. (Miller, WA)

BULGARIA — Radio Bulgaria. 7375/9400 at 0304 with news. (Burrow, WA) 7535 at 2231 with feature. ID, music. (Jeffery, NY) 9400 at 0007. (Newbury, NE) 13595 at 1501; very faint and distorted. (Wilden, IN)

CANADA — CFVP, relay CKMX, Calgary, Alberta, at 1835. (Becker, WA) CKZU. 6160 relay CBU, Vancouver, at 1847. (Becker, WA) 0700. (Silvi, OH) CHNX. 6130 (relay CHNS, Halifax). ID in passing, oldies. (Paszkievicz, WI) Radio Canada Int'l. 5960 at 0045 and 13655 at 1425. (Wilden, IN) 9670 at 0624. (Becker, WA) 13690 at 2130 with ID, frequencies, news update, weather, sports news, and mailbag. (Jeffery, NY) 15325 at 2213 with program on the arts in Canada. (Miller, WA)

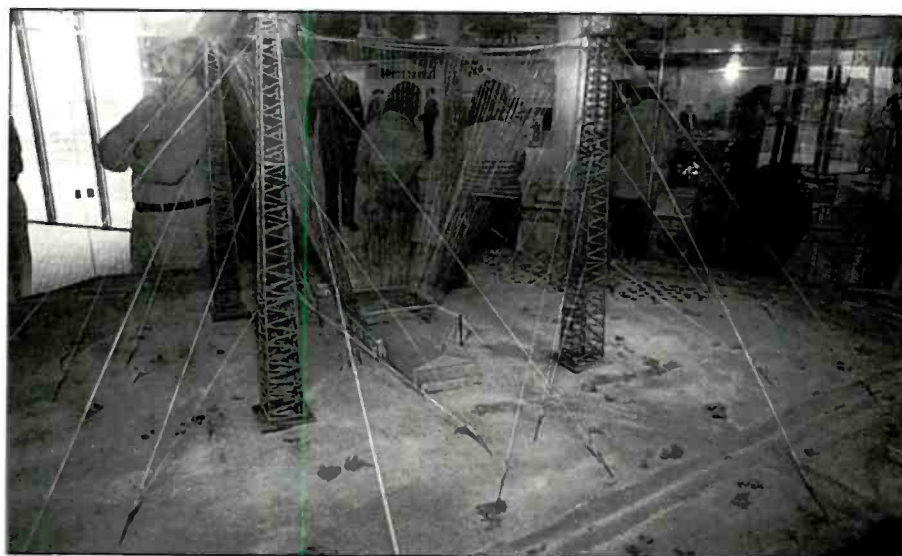

This is a model of Marconi's first transmitting station, at the Marconi National Historic Site, Glase Bay, Cape Beaton Island, Nova Scotia. Who could have imagined what it would bring? (Thanks to Gary Hubert, ON)

Abbreviations Used in Listening Post

AA	Arabic
BC	Broadcasting
CC	Chinese
EE	English
FF	French
GG	German
ID	Identification
IS	Interval Signal
JJ	Japanese
mx	Music
NA	North America
nx	News
OM	Male
pgm	Program
PP	Portuguese
RR	Russian
rx	Religion/ious
SA	South America/n
SS	Spanish
UTC	Coordinated Universal Time (ex-GMT)
v	Frequency varies
w/	With
WX	Weather
YL	Female
//	Parallel Frequencies

		AMÉRICA •																									
		1-norte / 2-centro / 3-sur																									
UTC		0	1	2	3	4	5	6	7	8	9	10	11	12	13	14	15	16	17	18	19	20	21	22	23	24	
1	16 m																										
	19 m																										
	19 m																										
	31 m																										
	31 m																										
	49 m																										
	49 m																										
	49 m																										
	13 m																										
	16 m																										
19 m																											
19 m																											
25 m																											
25 m																											
31 m																											
31 m																											
49 m																											
49 m																											
90 m																											
13 m																											
13 m																											
16 m																											
19 m																											
25 m																											
25 m																											
31 m																											
31 m																											
49 m																											
49 m																											
90 m																											

Radio Exterior de Espana's schedule for broadcasts to the Americas.

CHILE — Voz Cristiana, 6070 at 0631 with SS religious broadcast. (Miller, WA) 21550 at 1627 in SS. (Jeffery, NY)

CHINA — China Radio Int'l, 7405 at 1600. 9570. via Cuba, at 0125 and 1307. 11675 at 1700 in unidentified language. (Newbury, NE) 9480 at 1335 in CC. (Northrup, MO)

COSTA RICA — University Network on 5030.1 at 0420 to past 0800. Parallels on 6150, 7375, 9725. (Alexander, PA) RFPI, 15050 at 2106. (Becker, WA) 2115. (Wilson, MA) 2211. (Miller, WA)

CROATIA — Croatian Radio, 9925 (via Germany) at 0415 ending a news bulletin, ID, and into presumed Croatian. (Burrow, WA) 11605. via Germany, at 2148. (Miller, WA)

CUBA — Radio Havana Cuba, 9550 at 0710 in SS relaying Radio Reloj. (Becker, WA) 9820 at 0335 with news. ID, "Time Out," and DX show. (Jeffery, NY) 0450 to closing at 0500. (Newbury, NE)

CYPRUS — Cyprus Broadcasting Corp., 7205 at 2225 with a radio drama in an unidentified language. (Wilson, MA) (These broadcasts are weekends only — Ed) BBC relay, 21470 at 1621 with "Friday Fast Track." (Jeffery, NY)

CZECH REPUBLIC — Radio Prague International, 17485 at 1702 with news. (Burrow, WA)

DENMARK — Radio Denmark via Norway, 9925 monitored at 2249 in DD. (Miller, WA)

ECUADOR — Radio Quito, 4919 at 0415 with news in SS. (Miller, WA) HCJB, 9745 at 0700 with time check, station ID. (Hill, ID) 9745//12015 at 0000-0145 with special report on the government crisis. (Silvi? No reporter name) 17660 at 1930 with ham radio program. (Wilson, MA; Jeffery, NY)

EGYPT — Radio Cairo, 9475 at 0200-0257 with nice music but muffled audio again. (Silvi, OH) 9888 at 2046. (Miller, WA) 9900 at 2300 sign-on with local music and news. Strong. with good, clean audio. (Alexander, PA) 1800. (Italian? Editor)

(Becker, WA) 15255 at 1900 in AA and African language. (Ziegner, MA)

ENGLAND — BBC, 6175 via Delano, CA, at 0500. (Becker, WA) 0636. (Miller, WA) 0700. (Hill, ID) 9410 at 1700. (Northrup, MO) 9515 (via Canada) at 1311 and 15400 at 2015. (Wilden, IN) 6175 (Delano) at 0400; 9515 (Canada) at 1300; 9915 at 2358 and 15400 at 1959. (Jeffery, NY) 9515 (Canada) at 1400. (Newbury, NE) 9595 at 0000. (Ziegner, MA)

FINLAND — YLE/Radio Finland, 9655 heard at 0304 with news. "Nordic Report." (Burrow, WA)

FRANCE — Radio France Int'l, 6175 monitored at 2134 in FF. (Jeffery, NY) 7125 at 0654 in FF; 11700 at 0644 in FF; 12000 at 2006 in FF. (Becker, WA) 7135 at 0701 with FF news. (Miller, WA) 11615 and 15210 in EE at 1716. (Burrow, WA) 17560 in EE at 1413. (Silvi, OH)

FRENCH GUIANA — World Radio Switzerland/Swiss Radio Int'l relay, 9905 at 0435. (Newbury, NE)

GABON — Africa Number One, 9580 at 0628 in GG and 0705 in FF. (Becker, WA) 15475 at 1627. (Newbury, NE) News in FF at 0502. (Paszkievicz, W1)

GERMANY — Deutsche Welle, 9640 heard at 0303 with news. (Becker, WA) 11765 (probably via Portugal — Ed) and 15135 (via Rwanda) at 1933 with African news. (Wilson, MA) 11840 (via Sri Lanka) at 2203 in GG. Also 15275 via Rwanda. (Miller, WA) 15105 (Antigua) at 0000 and 15285 (via Canada) in GG monitored at 1504. (Wilden, IN) Bayerischer Rundfunk, 6085 in GG at 0515 with news from Wiesbaden and political talk. (Paszkievicz, W1)

GREECE — Voice of Greece, via Delano on 9775 at 0721. (Becker, WA)

GUAM — KTWR, 9865 at 1020 with DX schedules. (Barton, AZ)

GUATEMALA — Radio Tezulutlan, 4835 at 1125; SS and local music. (Barton, AZ)

GUINEA — RTV Guineenne, 7125 at 0604 sign-on to past 0700. Abrupt sign on with FF talk. ID as "Ici Conakry." Variety of Afro pops, local folk music, FF pops and many "Radio Guinee" IDs. Another time at 0600 sign-on. Also heard in late afternoon, 2200-0000. (Alexander, PA) 0638 with FF Afro pops. (Becker, WA)

HAWAII — KWHR, 9930 at 1145 with religious discussion. (Barton, AZ)

HONDURAS — La Voz Evangelica, 4819 heard at 0413 with religious programs in SS. (Miller, WA)

HUNGARY — Radio Budapest, 9835 at 0330 with news. (Burrow, WA)

INDIA — All India Radio, 7410 at 1932 with music and comment. (Wilson, MA) 11610 at 2159 with world news. (Miller, WA) Tentative on 12945 at 1750 in Bengali. (Ziegner, MA)

INDONESIA — Voice of Indonesia, 11785 monitored at 1806 in GG. (Becker, WA) RRI Ujung Pandang, 4755 at 1255 in II. (Miller, WA)

IRAN — Voice of the Islamic Republic of Iran, 6065 at 0040 with Silk Road discussion. (Ziegner, MA) 9022 at 0030 with ID, schedule, prayer, and news. (Gale, NC)

IRELAND — Radio Telefis Eirann, 12160 via WWCW monitored at 1930. (Ziegner, MA) (The relays over WWCW have apparently been discontinued and are now aired only from England via the Merlin Communications transmitters — Ed)

ISRAEL — Kol Israel, 7475 with news at 0511. (Paszkievicz, W1) 7545 monitored at

0444 in HH. (Becker, WA) 11585 at 0206 in unidentified language. (Miller, WA) 15650/17535 at 1500 with news of Israel. (Wilson, MA) 17545 at 1635. (Newbury, NE)

ITALY — RAI, 6010 at 2257 in II. Talk and music. (Jeffery, NY) 9670 at 0637 in II. (Becker, WA)

JAPAN — JYJ time station, 8000 at 0655. (Becker, WA) Radio Tampa, 6055 and 6115 at 0735 but not in parallel. Also 9595 at 0725 and 9760 at 0734. All in Japanese. (Becker, WA) 6095 at 1538 in JJ. (Miller, WA) Radio Japan/NHK, 6110 via Canada at 0553. 11705 (Canada) at 2221 in JJ; 11715 at 0606; 11840 at 0620 in EE; 12030 in SS at 0513. (Becker, WA) 9505 and 9535 at 1500; 11705 via Canada at 0019. (Newbury, NE) 9505 to WCNA at 1440. (Silvi, OH)

JORDAN — Radio Jordan, 9830 heard at 1800 in AA to Western Europe. (Hill, ID) 11690 at 1640 in EE. (Newbury, NE) 1707 with news in EE. (Burrow, WA) 15435 at 1506 in AA with prayers and talks. (Wilden, IN) (Not Libya?)

KUWAIT — Radio Kuwait, 9855 at 2057 in AA with talks, music. (Jeffery, NY) 11675 at 0126 in AA. (Newbury, NE) 0211 with call to prayer. (Miller, WA) 13620 in AA at 1440. (Barton, AZ)

MADAGASCAR — Radio Madagasikara, 5009.7 with IS at 0255. (Paskiewicz, WI)

MALAYSIA — Radio Malaysia, Kuching (Sarawak), 4895 at 1419 in unidentified language. (Miller, WA)

MAURITANIA — Radio Mauritania, 4845 at 2320 in AA. Also noted at 0200 and 0645. (Alexander, PA)

MEXICO — Radio Educacion, 6185 at 0600 in SS. (Newbury, NE) 0600-0620. Much interference before 0600 and some from Vatican after 0620. (Silvi, OH) 0637. SS blues. (Miller, WA) 0651. (Becker, WA) Radio Mexico Int'l, 9705 at 1505 with news in EE. (Gale, NC)

MOLDOVA — Radio Moldova Int'l, 7000 at 0430-0455 with news in EE, commentary, ID. Good level but the usual poor audio. (Alexander, PA)

MOROCCO — RTV Marocaine, 11920 at 0415 with all AA programming. (Brossell, WI) 15345 at 2025 with music and male announcer in AA. (Wilson, MA)

NETHERLANDS — Radio Netherlands, 6105 at 0053. (Wilden, IN) 9855 at 1138 with "Newslines." (Jeffery, NY) (Probably via Germany — Ed) 11655 via Madagascar at 2042 in DD. (Becker, WA) 15590 via Madagascar with news at 1539. (Barton, AZ)

NEW ZEALAND — Radio New Zealand Int'l, 6105 at 1100. The other 6 MHz frequency had QRM from Korea and RNZI's other frequencies were inaudible. (Silvi, OH) 6105 at 1105; 11675 at 0045 and 1710. (Newbury, NE) 6145 at 1542. (Miller, WA) 17675 at 0005 with weather, "Cadenza." (Jeffery, NY)

NIGERIA — Voice of Nigeria, 7255 at 0505 with "Wave Train." (Jeffery, NY)

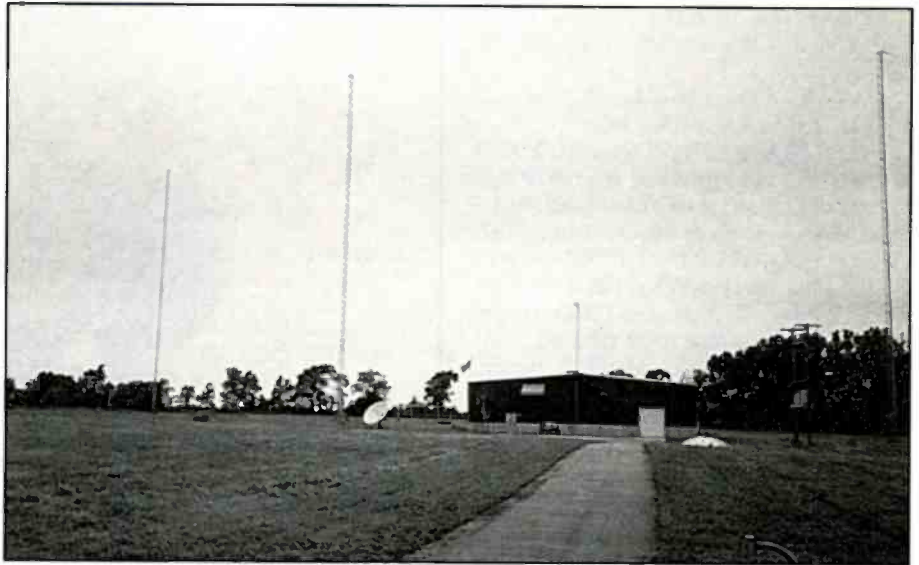

The transmitter site of WHRI, Noblesville, Indiana.

NORTHERN MARIANAS — KFBS, 9465 at 1400-1459 in presumed RR. (Silvi, OH) Voice of America, Tinian, 9780 at 1217 with news. (Jeffery, NY)

NORTH KOREA — Radio Pyongyang, on new 6100 at 0800-0900 and past. Weak, but definite IS at 0800 and 0900. Talk in unidentified language. //9344.94. Korean listed for 0800 and Mandarin at 0900. (Alexander, PA) 7144.9 with sign-on at 1010. (Barton, AZ)

NORWAY — Radio Norway, 7465 at 0405 in NN. (Brossell, WI)

OMAN — Radio Oman, 9735 at 2141 in AA. (Miller, WA) 15140 in EE at 1437 with features, rap. Into AA at 1503. (Ziegner, MA)

PARAGUAY — Radio Nacional, 9735 at 0253 in SS with Latin music. (Miller, WA)

PERU — Radio Ilucan, 5678 at 0225 with SS announcements, Peruvian music. Off with ID at 0247. (Alexander, PA) Radio Altura,

6479.65 at 0055-0406 close. SS announcements, Peruvian folk music, ID, abrupt sign-off. (Alexander, PA) Radiodifusora Huancabamba, 6535.76 at 0055 to 0113 close. Usual Peruvian SS programming. Abrupt sign off. (Alexander, PA) Radio Super Nueva Sensacion, 6673.98 at 0050 to past 0100. SS ID at 0100, commercials, echo effects. (Alexander, PA) Radio Ondas del Rio Mayo, 6797.63 in SS at 0045 to past 0100. (Alexander, PA)

PHILIPPINES — Radio Pilipinas, 11730 monitored at 1855 in Tagalog. Over Radio Japan. (Miller, WA) Far East Broadcasting Company, 9405 in CC at 1535. (Northrup, MO) Voice of America relay, 9760 at 1401 with news. 17820 at 0047 with Special English. Presumed on 17735 at 0030 in unidentified language. Also presumed on 17765 at 0035 in CC. (Jeffery, NY)



Whoever took the photo for this Voice of America QSL did so on a day the country was in mourning for someone. Note the flag at half-mast.

PORTUGAL — Radio Portugal, 15540 monitored at 2228 with soccer coverage in PP. (Miller, WA)

QATAR — Qatar Broadcasting Service, 9570 at 2137 in AA. (Miller, WA)

ROMANIA — Radio Romania Int'l, 9530 at 0634. Poor audio. (Becker, WA) 9570 with "World of Culture" at 0420. (Brossell, WI)

RUSSIA — Voice of Russia, 5940 at 0137. (Wilson, MA) 7125 at 0423. (Newbury, NE) 7260 at 1858. (Becker, WA) 7180 at 0208 and 0423. (Wilden, IN) 0527. And 12020 at 0516. (Becker, WA) 12020 at 0300. (Burrow, WA) 15455 at 0416 with "New Market." (Barton, AZ) Radio Yakutsk, 7140 at 0625, 7200 at 0805 with Radio Rossi relay, and 7345 at 0612, all in RR. (Becker, WA) Radio Khabarovsk, 7210 at 0700 carrying Radio Russi. (Becker, WA) Radio Rossi, 7250 at 0815 in RR. (Becker, WA) Radio Tikhly Okean, 7175 in RR at 0815. (Becker, WA) Magadan Radio, 5940 at 1311 in RR, over Vatican Radio. (Miller, WA)

RWANDA — Deutsche Welle relay, 15410 at 2122. (Becker, WA)

SAUDI ARABIA — Broadcasting Service of the Kingdom of Saudi Arabia, 9555 at 2134 in AA with Middle East music. (Miller, WA) 9870, presumed, at 2040 in AA. (Silvi, OH)

SINGAPORE — Broadcasting Corporation of Singapore, Kranji, 6150 at 1534. Relay of local FM. (Miller, WA) BBC relay, 6195 at 1505, 7120 at 1723, 7160 at 1720, 7205 at 1727 in presumed Hindi. (Becker, WA) 9740 at 1208. (Jeffery, NY)

SLOVAKIA — Radio Slovakia Int'l, 6055//7345 at 1729. ID, news, schedule. (Burrow, WA) 7345 at 1732 with mailbag. (Becker, WA) 5930//9440 at 0100-0130. 5930 suffers from moderate interference; 9440 has bad interference and 7300 totally blocked. (Silvi, OH)

SOUTH AFRICA — South African Broadcasting Corp., 7185 in Afrikaans at 0430. (Brossell, WI) Channel Africa, 17870 with EE and other broadcasts from 1700-1852. (Silvi, OH) 1717 with news. (Burrow, WA) 1800. (Hill, ID)

SOUTH KOREA — Radio Korea Int'l, 9510 at 0657 in KK. (Miller, WA) 9570 at 0800-0900 with EE commentary, local music, "Technical Corner." (Alexander, PA) 9650 via Canada at 1130 with ID, time/frequency info and news. (Jeffery, NY)

SPAIN — Radio Exterior de Espana, 6055 with news at 0506. (Barton, AZ) 0539 with EE discussion followed by SS lessons. (Burrow, WA) 15110 via Costa Rica in SS at 2212. (Miller, WA) 15110 at 2020 in SS and 15170 via Costa Rica at 2300. (Becker, WA)

SRI LANKA — Sri Lanka Broadcasting Corp., 11905 at 0210 in Hindi, with subcontinental music. (Paszkievicz, WI) 0232 in unidentified language. Oriental music. (Miller, WA) 15425 at 0200 with ID, news. (Gale, NC)

SWEDEN — Radio Sweden, 9495 at 0329

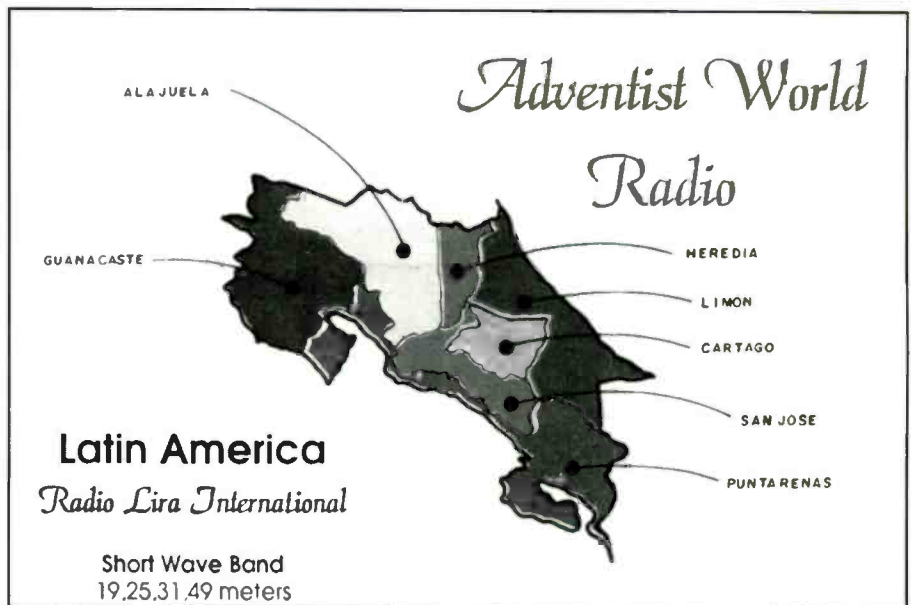

Adventist World Radio produced a series of QSLs featuring the coat of arms of each of the political districts of Costa Rica. Unfortunately, Radio Lira International/AWR Costa Rica no longer exists.

with IS and into "60 Degrees North." (Miller, WA; Burrow, WA)

SWITZERLAND — World Radio Switzerland (*Guess that's what they want to be called now—but why?*—Ed) 9885 at 0115 with news. (Wilson, MA) 9905 via French Guiana, in GG at 0430. (Newbury, NE)

TAIWAN — Radio Taipei Int'l, 5950 at 0700. (Hill, ID) 9355 at 2230. (Wilson, MA) 0615 in CC. (Becker, WA) New 9465 heard at 0005. Not there the next night. (Alexander, PA) 9680 at 0302. (Miller, WA)

THAILAND — Radio Thailand, 9535 at 1900. (Burrow, WA) Voice of America relay, 9645 at 1156. Suddenly overpowered by an unidentified station at 1201. (Jeffery, NY) BBC Relay, 17790 at 0400. (Jeffery, NY)

TURKEY — Voice of Turkey, 6010 at 0440 in EE with pops. (Brossell, WI) 7300 monitored at 0438 in TT with Turkish music, IDs. IS. (Newbury, NE) 9445 at 0000 and 9460 at 0525. (Becker, WA) 9525 in EE heard at 2130. (Miller, WA) 9655 at 2322 in EE. (Burrow, WA)

UNITED ARAB EMIRATES — UAE Radio, Abu Dhabi, 9605 at 1955 in AA. (Jeffery, NY) 11945 in AA at 0420. (Brossell, WI) UAE Radio, Dubai, 13675 at 1605 with EE program on Islam. (Gale, NC) 15395 at 1620 in EE; //13675. (Newbury, NE)

VATICAN — Vatican Radio, 7250 at 0641 with Latin mass. (Becker, WA) 15500 in GG at 1457. (Barton, AZ)

VENEZUELA — Ecos del Torbes, 4980 in SS at 0400. (Newbury, NE)

VIETNAM — Voice of Vietnam, 12020 monitored at 2336 in EE with news, economics. (Burrow, WA)

YEMEN — Republic of Yemen Radio

(presumed) 9780 in AA at 2100 when it became free of QRM to sign-off at 2211 after a presumed anthem. Sounded like a call-in program from 2100-2115. (Silvi, OH) 0504 with AA pop vocals. (Paszkievicz, WI)

YUGOSLAVIA — Radio Yugoslavia, 7115 at 0117. (Newbury, NE)

ZAMBIA — Radio Zambia, 6265 at 0005 with EE talk, local folk music, and talk in vernacular, local chants. (Alexander, PA)

ZIMBABWE — Zimbabwe Broadcasting Corp., 4828 at 0300 sign-on with choral version of national anthem, talk in vernacular, traditional church music, local music, EE talk. (Alexander, PA)

And that does it! A mile high pile of thank-yous to the following good folks who shared their results this month: Tricia Ziegner, Westford, Massachusetts; Bruce Burrow, Snoqualmie, Washington; Bruce Alexander, Mechanicsburg, Pennsylvania; Robert Brossell, Pewaukee, Wisconsin; Ed Newbury, Kimball, Nebraska; Dave Jeffery, Niagara Falls, New York; Dave Gale, Newland, North Carolina; Sue Wilden, Nobelsville, Indiana; Mark Northrup, Gladstone, Missouri; Michael Miller, Issaquah, Washington; Rick Barton, Phoenix, Arizona (Welcome back, Rick!); Lee Silvi, Mentor, Ohio; Pete Becker, Clarkson, Washington; Kenneth Hill, Mountain Home, Idaho; Jim Wilson, Worcester, Massachusetts and Sheryl Paszkievicz, Manitowoc, Wisconsin. Thanks to each one of you!

Until next month, good listening! ■

communications confidential

Your Guide To Shortwave "Utility" Stations

That Magical Mystery Tour Ends — RD Turns Over Helm To Cooper

Long before the Beatles took the tour, we had our own magical mysteries, which is the utility hobby we know today. Noises that go "bump" in the night that magically appear as text when the correct decoder mode and baud rate is applied. Chilling coded messages being sent worldwide that might signal the start of World War III or maybe just a retelling of *Doctor Strangelove* or *How I Learned to Love the Bomb*. High seas action with a tableside seat to the Coast Guard or your own military rescue service doing "a hoist" to pluck some lucky sailor from the deck of his sinking ship. There are the hours of fascination in tracking transoceanic flights traveling across the Atlantic or the Pacific and checking in at various waypoints. Mysterious "numbers" broadcasts emanating from the Central Intelligence Agency, the Russian facility at Lourdes, Cuba by Russian military intelligence (GRU) and the Federal Agency for Government Communications (FAPSI), the Israeli MOSSAD and many, many others worldwide. Or perhaps some very realistic war-gaming from a carrier battle group. It's all there every day of the year.

These are some of the things that drew me to the hobby back in 1969. I was lucky enough to write and QSL more than 1500 utility stations in those years, including more than 500 warships from eight countries. These stations were good enough sports to write me back and "QSL" that I had heard them. The more I heard, the more I learned about what I was hearing. Now, more than 30 years later, I am still learning! Having learned much about the hobby from my predecessor Don Schimmel, we signed on to fill his shoes more than three years ago. About six months back, I almost gave up the column due to some serious changes in my life that brought about a new work status for me. Thanks entirely to the efforts of Mike Fink and the MidAtlantic DX'er (Mid prefers to remain unknown), I was able to stay on, as they did the bulk of the work and research on each month's column. Unfortunately, we cannot keep going. This

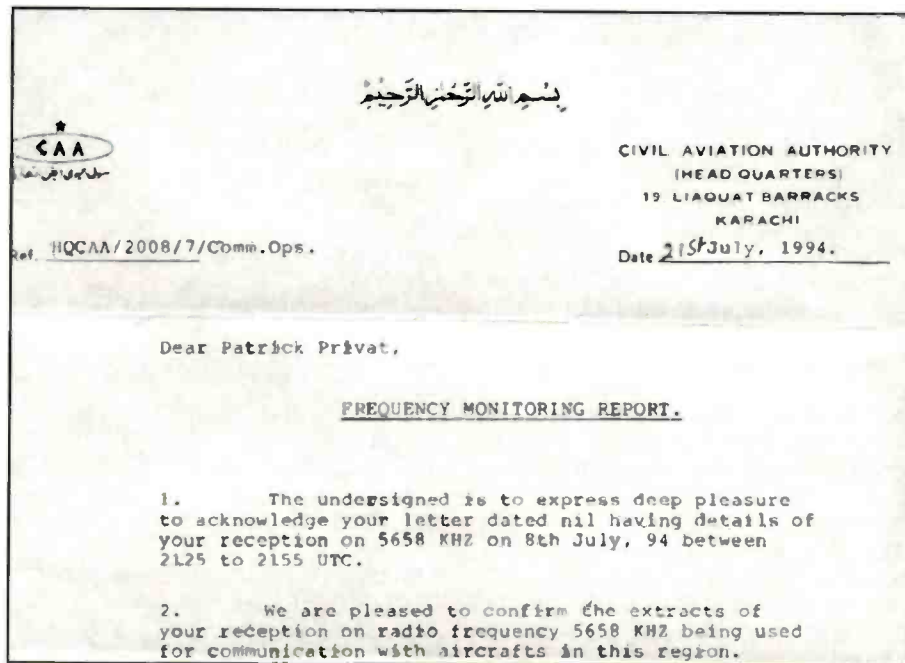

Here's a QSL letter from the collection of Patrice Privat, France, from the Civil Aviation Authority for reception on 5658 kHz.

is my last column before turning the helm over to Joe Cooper (joe@provcomm.net).

I certainly want to thank all of the contributors over the years who supported this column with logs, pictures, and graphics. I am partially happy to have seen our worldwide base of readers increased from being almost 90% from the U.S. to having logs from an average of five other countries each issue. We have five countries represented this issue. This gives everyone some exciting DX to target and expands our horizons. I plan to stay involved in the hobby although it may be some distance down the road before things began to become normal again as far as having some time goes. I also have a backlog of snail mail I must get caught up on, for which I apologize. But we will get caught up soon! We must also say thanks to many people behind the scenes, who mostly prefer to remain nameless, for their contributions in the forms of infor-

mation or confirmation of info from their own specialty fields of knowledge. These sources greatly added to the information we were able to give out.

Reader Mail

An anonymous reader sent the following internet links: <<http://jitic.fhu.disa.mil/it/hf.htm>>, <<http://jitic.fhu.disa.mil/>>, <<http://jitic.fhu.disa.mil/nitf/interop.htm>>, <<http://jitic.fhu.disa.mil/tadil>>, and <<http://jitic.fhu.disa.mil/tadil/schedule.htm>> of interest to listeners of military HF traffic.

Note that in this month's logs, we have two new USCG discrete frequencies found; both in the 10-MHz range. The frequency 10538.6 was found in use by Activities Baltimore by Ron Perron (MD), while 10993.6 was found in use by Group Key West, FL, by Jeff Jones (CA). Now on with the show.

BY RICHARD "RD" BAKER <CommConf@concentric.net> and MIKE FINK <mikef@apk.net>

UTE Loggings SSB/CW/DIGITAL

60: MSF, Timesignal station Rugby, w/timesignals in CW at 2142. (AB-NL)
 75: HBG, Observatoire de Neuchatel, w/timesignals in CW at 2238. (AB-NL)
 77.5: DCF77, PTB Braunschweig (tx Mainflingen) w/timesignals in CW at 2143. (AB-NL)
 85: DECCA station Puckeridge (chain 5B) w/pulses in CW at 2250. (AB-NL)
 100: LORAN-C stations w/pulses in CW at 2143. (AB-NL)
 113.3: DECCA station Shotisham (chain 5B) w/pulses in CW at 2258. (AB-NL)
 127.5: DECCA station East Hoathley (chain 5B) w/pulses in CW at 2256. (AB-NL)
 129.1: DCF49, ERF Berlin (tx Mainflingen) w/Ripple control in ASCII 200bd at 2211. (AB-NL)
 139: DCF39, ERF Berlin (tx Mainflingen) w/Ripple control in ASCII 200bd at 2215. (AB-NL)
 144.7: Datatrak stations w/databursts at 1317. (AB-NL)
 147.3: DDH47, Hamburg Meteo, RY in RTTY 50 bd at 2213. (AB-NL)
 296: GR, Goeree Lightvessel (still on the air) in CW at 1502. (AB-NL)
 303: YPP, unid in CW (JR-MA)
 323: UWP, Argentia, CAN in CW. (JR-MA)
 326: LLS, NDB Lelystad in CW at 1533. (AB-NL) FC, Fredericton, CAN in CW. (JR-MA)
 327: MVC, NDB Merveille in CW at 1533. (AB-NL)
 330: BE, Unid in CW. (JR-MA)
 332: NV, NDB Nieuwkoop in CW at 1534. (AB-NL)
 336: BU, Columbus, OH in CW. (JR-MA)
 336.5: NIK, NDB Nicky in CW monitored at 1618. (AB-NL)
 338: DRY, Manchester, NH in CW. (JR-MA)
 341: YYU, Kapuskasing, CAN monitored in CW. (JR-MA)
 344: CL, Cleveland, Oh in CW. (JR-MA)
 345: LI, Unid in CW. (JR-MA)
 347: YG, Charlottetown, CAN in CW. (JR-MA)
 350: ROT, NDB Rotterdam in CW at 1535. (AB-NL)
 351: YKQ, UNID in CW. (JR-MA)
 352.5: DD, NDB Oostende in CW at 1536. (AB-NL)
 359: AS, Nashua, NH in CW. (JR-MA)
 360.5: MAK, NDB Mackel in CW at 1536. (AB-NL)
 363: RSB, UNID in CW. (JR-MA)
 365: FIT, Fitchburg, MA, in CW. (JR-MA)
 LJ, NDB Koeln in CW at 1603. (AB-NL)
 365.5: BC, NDB Brasschaat in CW at 1604. (AB-NL)
 366: YMW, Maniwaki, CAN in CW. (JR-MA)
 368: IMR, Marshfield, MA in CW. (JR-MA)
 369: PS, NDB Heenvliet in CW at 1536 UTC (AB-NL)
 375: OO, NDB Oostende in CW at 1602 UTC (AB-NL)
 376: WP, NDB Muiden in CW at 1602 UTC (AB-NL)

377: YRR, UNID in CW. (JR-MA)
 378: RJ, Roberval, CAN in CW. (JR-MA)
 380: LQ, UNID in CW. (JR-MA)
 386: STD, NDB Stad aan het Haringvliet in CW at 1537. (AB-NL)
 387: ING, NDB St. Ingelvert in CW at 1538. (AB-NL)
 388.5: CH, NDB Buiten Kaag in CW at 1537. (AB-NL)
 390: JT, Stevenville, CAN in CW. (JR-MA)
 392: ML, Charlevoix, CAN in CW. (JR-MA)
 393: DEN, NDB Dender in CW monitored at 1559. (AB-NL)
 395: OA, NDB Assendelft in CW at 1538. (AB-NL)
 397: EHN, NDB Eindhoven in CW at 1541. (AB-NL)
 399.5: ONO, NDB Oostende in CW at 1542. (AB-NL)
 404: MRV, NDB Merveille in CW at 1543. (AB-NL)
 404.5: RR, NDB Rotterdam in CW at 1543. (AB-NL)
 406.5: BOT, NDB Bottrop in CW at 1551. (AB-NL)
 410: EK, UNID in CW. (JR-MA)
 414: BC, Baie-Comeau, CAN in CW. (JR-MA)
 418: MK, NDB Calais in CW monitored at 1550. (AB-NL)
 431: ONT, NDB Kleine Brogel in CW at 1546. (AB-NL)
 518: OST, Oostende Radio Navtex w/id T at 2310. CROSS Corsen, Navtex w/id A at 0800. EJM, Malin Head Radio, Navtex w/id Q? at 2243. GCC, Cullercoats Radio, Navtex w/id G at 2155. GNI, Niton Radio, Navtex w/id S at 2300. GNI, Niton Radio, Navtex w/id K at 2140. LGQ, Rogaland Radio, Navtex w/id L at 2148. OST, Oostende Radio, Navtex w/id M at 2200. PBK, Netherlands CG, Navtex w/id P at 2155. SDJ: Stockholm Radio (loc Gislovshanmar), Navtex w/id J monitored at 2128. (AB-NL)
 855: North Korean/NL nbrs hrd in AM at 1500. Started w/ "Red Flag Song" for three mins. then into nbrs 1/6.21 0657 11702 // 720 // 3250 11 6399 kHz. At 1512 weird music started additionally /13320 // 6250. (TY-JP)
 2044: HLY, Yosu Radio, South Korea, w/short melody mirror of Beethoven's 9th Symphony "Ode to Joy" between PIP in USB at 1317. (TY-JP)
 2066: Scrambled voice comms hrd in powerful USB at 0922, poss speech inversion type, North Korea? (TY-JP)
 2500: BPM, Xian, TSS, China, w/clear time pips and CW ID at 1350. (TY-JP)
 2507: HLN, Kunsan Radio, South Korea, w/short melody mirror of Beethoven's 9th Symphony "Ode to Joy" between PIP in USB at 1205. (TY-JP)
 2598: Canadian Coast Guard Port-au-Basques (Stephenville) at 0217 in USB w/MIB. (RP-MD)
 3092: Kinloss Rescue (G) at 1906 in r/c w/Rescue 177. (AG-UK)
 3123: CAMSPAC (USCG Communications Area Master Station Pacific) wkg RESCUE 1702 (HC-130) w/radio checks after QSY

Abbreviations Used For Intercepts

AM	Amplitude Modulation mode
BC	Broadcast
CW	Morse Code mode
EE	English
GG	German
ID	Identification/led/location
LSB	Lower Sideband mode
OM	Male operator
PP	Portuguese
SS	Spanish
tfc	Traffic
USB	Upper Sideband mode
w/	With
wx	Weather report/forecast
YL	Female operator
4F	4-figure coded groups (i.e. 5739)
5F	5-figure coded groups
5L	5-letter coded groups (i.e. IGRXJ)

from 5696. Comms related to Alaska Airlines MD-80 crash. (Baker, OH)

3307: USS Stennis battle group w/players CHARLIE-BRAVO and PAPA in net comms. at 0547 in USB. (JJ-CA)

3390: Unid stn HMA, rptng V and CQ mkr in chirpy CW at 1318. (TY-JP)

3440: Unid stn 6PXJ, rptng "V ABYZ DE 6PXJ over and over in CW at 1410, //114567 // 5600 //6785kHz. (TY-JP)

3458: Beijing Volmet, China, w/avian wx info in distorted USB and accented EE at 1322. (TY-JP)

3485: NY Volmet w/OM in EE w/aviation wx for variou's cities along the eastern seaboard at 0240 in USB (RK-NY)

3496: Unid, stn L8BM rptng callsign over and over in CW at 1200. (TY-JP)

4156: USS Stennis battle group w/players KILO, DELTA, and LIMA in net comms at 0543 in USB. (JJ-CA)

4178: OULD2, M/T Lone Wonsild at 0741 in ARQ ETA for Mumbles Head via OXZ. (HOOD)

4217: OST, Oostende, Belgium, w/channel marker at 0242 in USB (RK-NY)

4227: IGJ42, Italian Navy Augusta, I w/RTTY, 100/850 marker at 0315. (RP2-TX)

4372: MIKE 3 VICTOR, Hotel 4 Romeo and others in usual USN, "alligators in the playground" net at 0145. (RK-NY) GIANT KILLER req LF1 relay pp# to 5ZK at 0130, 5ZK is to contact HC2. (MF-OH) All in USB
 4560: YHF, Mossad, Israel, hrd in USB at 2000. (TY-JP)

4605: Unid stn UDQB sending CQ mkr in hand-sent CW at 1005. (TY-JP)

4625: The Buzzer, Russia, hrd in faint AM at 1450. (TY-JP)

4739: FIGHTING 742 passing spr-grp t/c to GOLDENHAWK at 0224. WAFER 741 passing spr-grp 4 to GOLDENHAWK at 0233. (MF-OH) All in USB

4819.6: CG Activities Baltimore at 1931 in USB w/CG 41359 in communications checks. (RP-MD) (nice catch, the 41359 is a Coast Guard 41 foot small boat — Ed)

4955: Very weak stn here — could only pick up carrier in AM at 0245. (RK-NY)

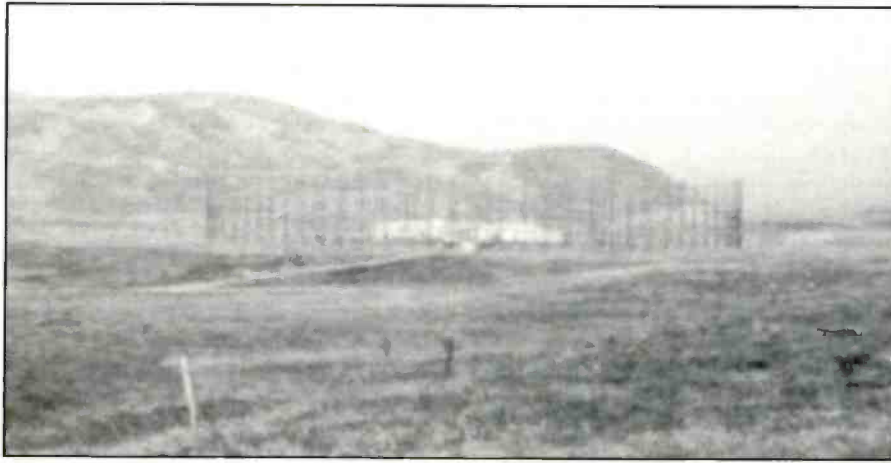

Bill Farley of New Mexico sent this picture of an antenna site near Adak, Alaska, taken a few years ago. According to sources, this is a Wullunweber (aka Circular Disposed Antenna Array) at Adak, and was removed in the mid-'90s.

5154: Russian Single Letter HF CW channel mkr "K" at 1440, is Petropavlovsk-Kamchastky in the north side of Khabarovsk. (TY-JP)

5190: Shuttle solid rocket boosters (SRB) recovery vessels *Freedom Star* and *Liberty Star* at 1901 in USB w/ann re Shuttle STS-99 countdown will continue down to built-in hold at T-9 minutes. Then announces mission scrub and 24-hour turnaround for launch tomorrow. Launch window will be 1744z-1948z. (ALS)

5211: WGY908 (FEMA Region 8, FRC Denver) at 0333 w/unid stn. 908 adv they were activated on Tues and looking forward to first "rollover" in Australia. (RP-MD) (A Y2K worry, the "rollover" was New Years — Ed) WGY908, WGY912, and WGY942: FEMA Denver, CO, Washington, D.C., and Albany NY, USA at 0752 w/Y2K New Year rollover checks. Mentioned about ringing up the CA EOC via ALE and they were just about ready at their end. (IJ-NZ) All in USB

5277: HERC 04, HERC 17, 10 CHARLIE, 61 ALPHA, PANTHER, and PANTHER 400 engaged in the tracking of and pursuit of a smuggling vessel w/all comms in the clear. (RMC-GA) (I heard parts of this well after 0700 UTC, just a small sample of the counter-drug activity work done in the Caribbean daily — Ed) CG 6010 (H-60, CGAS Clearwater) at 0516 w/PANTHER w/position report 2059N/7447W operations normal. PANTHER checking w/CG District 7 (Miami) on posn of vessel. At 0522 the 6010 reports over the vessel w/PANTHER asking to be advised when the pumps have been delivered to the vessel. CG 34CHARLIE (HH-60, 6034 CGAS Elizabeth City-deployed) at 0217 w/PANTHER (DEA, Bahamas) reporting RTB due to problems with their aircraft. (RP-MD) All in USB.

5320: CG Activities Baltimore at 1915 in USB w/CG 41359 (41-ft patrol boat) in communications checks. Also//communications checks also on VHF 157.15 (channel # 23). (RP-MD)

5328: Y/L (EE) passing 5F groups starting

"count 118" then each group given as three digits, pause then 2 digits monitored at 0222 in USB. (RP-MD)

5407: ZKST, ZKST11, ZKHQ Civil Defense net Southern Zone HQ Christchurch, Nelson and National HQ Wellington New Zealand at 2132 in USB w/radio checks. (IJ-NZ)

5431.3: Unid, stn L9CC rptng "V CP 17 0 E L9CC" over and over in CW at 2200. On another day, this stn hrd on 5438 at 1250. This stn hrd a lot in 40 amateur band at East Asian midnight. (TY-JP)

5435: ART, Mossad, Israel, hrd in USB at 2000. (TY-JP)

5471.6: VL8IPS, IPS Radiosonde Darwin, NT Australia at 0940 in CW w/DE, VL8IPS marker. (IJ-NZ)

5505: Shannon Volmet w/aviation wx for various European cities at 0409 in USB. (SW-IN)

5530: MIW2, Mossad, Israel, at 1515. (TY-JP)

5616: AIR FORCE ONE wkg Gander radio, gave altitude as FL 310 at 0045. (JK-NY)

5673: Beijing Volmet, China, hrd in USB and accented EE at 1040. (TY-JP)

5680: YANKEE 71 w/Sweden Air Rescue at 1451. VORTEX 011 at 1254 in r/c w/Kinloss, adv a Puma helo, ab from Aldergrove. VORTEX 454 at 1345 in r/c w/Kinloss. Coastguard LIMA CHARLIE at 1120 w/Kinloss. FOUR MIKE KILO at 1237 w/Kinloss re has received a Mayday from Supply Vessel "Seaward" at posn 5621.5N, 0527.4E, man overboard, rqst contact Danish RCC and ask for winch capable helo. German Navy 4864 at 1258 in r/c w/Glucksburg Rescue (D). PC 597 at 1259 in r/c w/Glucksburg. Glucksburg Rescue at 1105 in r/c w/Kinloss. Coningsby (RAF Coningsby I presume) at 1519 in r/c w/Kinloss. ABBOT I at 1349 in r/c w/Kinloss. MRCC Bremen at 1123 in r/c w/Kinloss. KILO 596 at 1835 w/Kinloss. Kinloss at 1918 wkg Rescue 125 re a Jumbo jet has crashed at Stansted, 3 pob, fire under control, suggest they offer assistance to Stansted. Ijmuiden Rescue (HOL) at 1558 wkg Rescue 125, sug-

gest they search until dark and if no results RTB. (AG-UK) CB and CN passing t/c in ANDVT and clear at 2155, re; fisheries and safety violations. CN req CB secure radio guard at 2222. (MF-OH) All in USB mode.

5687: JAWS 51 clg JAWS 52 at 0200, nothing heard. JAWS 51 clg PLANTATION OPS at 0255, re: PINT?. WISE 87 clg PLANTATION OPS at 0302. (MF-OH) FOLIO 11 CLG PLANTATION OPS, (Hurlburt Field, FL) at 0134, tells PLANTATION OPS he has just taken off from Hurlburt and that SEMINOLE OPS (Hurlburt AFSOC) has passed him the Satellite freqs. Plantation confirms the freqs are correct and that FOLIO 11 should use the 105 West bird (Satellite). (ALS-FL) All in USB (PLANTATION OP's is reportedly the 16th Special Operations Wing at Hurlburt Field, FL while SEMINOLE OP's (as in the Florida Seminole's), is Hurlburt Field Command Post — Ed)

5696: RESCUE 2125 wkg Group Galveston at 0530 for instructions on and passing info on a working SAR. 2125 handling guard for HH-65 and reporting various debris sighted. (RMC-GA) CG6009 and 1719 rep flt-ops normal to CAMSLANT at 0029. CG2126 flt-ops to CAMSLANT at 0035. (MF-OH) At 0346, AIR FORCE RESCUE 60212 (HC-130) (later shortened to 212) wkg RESCUE 1702 (USCG HC-130) app acting as on-scene commander at crash of Alaska Airlines MD-80. 212 is enrt to the scene, ETA 0440z and has a USAF helo with him. CAMSPAC (USCG Communications Area Master Station Pacific) wkg the 1702 afterwards re if both AirSta San Diego's HH-60's need to remain on scene all night. (Baker, OH) All in USB.

5841: CG 63A (HH-65, CGAS Atlantic City-deployed): 0037 w/PANTHER who advises that CG 10C is also on this frequency. Tells 63A to put down at Foxtrot to conserve fuel. (RP-MD) 63A clg PANTHER, ANDVT followed at 0220. 33C passing flt-ops to PANTHER at 0017. PANTHER clg RESCUE 6033 at 2347, at 2354 6033 passes flt-ops and pos to PANTHER. 6033 again w/flt-ops rep at 0004. 34A passing pos rep to PANTHER at 0002. 61A passing pos rep to PANTHER at 0220. (MF-OH) All in USB.

6224: ZLM, Taupo Radio, New Zealand, hrd in USB at 0900. YL opr w/long wx BC for ships in area. (TY-JP)

6270: ULX, Mossad, Israel, hrd in USB at 1430. (TY-JP)

6304: UIUO, TOBAGO (BI-1624) at 0732 in RTTY 50/170 msg to UDK2 (is ex YLJR). (HOOD)

6305: UAZN, KAPITAN ROGOZIN (MI-1637) at 0740 in RTTY 50/170 admin to RLK7. (HOOD)

6306: UCFT, MALAKHOV (ME-0365) monitored at 0823 in RTTY 50/170 admin to UDK2. (HOOD)

6357: SAA, Karlskrona Radio, Sweden, at 1806 in CW ID tape "...qxs 500, 4195.0, or 6292.5, happy new year." (HOOD)

6370: SYN2, Mossad, Israel, hrd in USB at 1545. (TY-JP)

- 6379:** 4XZ. Israeli Navy: Haifa, Israel, sending V mkr in CW at 1516. (TY-JP)
- 6386.5:** USO5, Izmail Radio at 1814 w/CW crew TG to UTFK: TKH RENDI. (HOOD)
- 6399:** North Korean/YL nbrs, hrd in powerful AM at 1500. Started w/"Red Flag Song" for 3 mins, then into nbrs, // 621 // 657 // 702 // 720 // 855 // 3250. At 1512 weird music hrd additionally // 3320 // 6250. (TY-JP)
- 6465:** Unid in CW w/msgs to ships at 0015. UWS, Kiev shown here, but lots of what looks like "KALININGRAD" in various messages. (RP2-TX)
- 6484.5:** XSV, Tiajin R, China, rptng "QRZ? DE XSV PSE UP 44.3 UP 43 EE" in CW at 1525. (TY-JP)
- 6494:** Unid HFFAX w/wx chart at 0115 in USB. (SW-IN) (*This is Canadian Forces stn CFH, Halifax Military, Canada on the actual center frequency 6496.4 kHz. -Ed.*)
- 6501:** NRV, U.S. Coast Guard, Bamigada, Guam, w/navigation warnings in USB at 0900. (TY-JP)
- 6575:** HNC6, Mossad, Israel, hrd in USB at 1445, Mossad lady rptng "Hotel November Charlie" SW for five mins. HNC is a deep cover and a mission specific Mossad BC. Usually Pyongyang's carrier beaming to Europe is very busy at this time. (TY-JP)
- 6651:** Rescue 51 at 1244 w/Karup Rescue (DNK). Karup Rescue at 1245 in r/c w/Rescue 277. Rescue 51 at 1316 w/kg Karup re man was picked up by fishing vessel serial RI275, call-sign OXHB at posn 5622N 0529E". (AG-UK)
- 6658:** C102, Mossad, Israel, hrd in USB at 1845. (TY-JP)
- 6679:** Hong Kong Volmet, w/Volmet in USB at 1215. (TY-JP)
- 6688:** CAPITOL, FAF Taverny France at 0750 in USB w/selcal check. (IJ-NZ)
- 6739:** OFFUTT w/EAM, good levels here, also hrd 11175/8992 weak/unreadable at 0150. OFFUTT w/6-char. EAM XAMAQJ at 0153. OFFUTT w/FAIRLY FOXTROT, followed by 30-char. EAM XAMAQJ at 0154. Note same preamble as 6-char transmission from a minute earlier. (JK-NY) All in USB
- 6745:** KPA2, Mossad, Israel, hrd in USB at 1415. (TY-JP)
- 6761:** Unid GHFS ground stn at 0520 running pp for unid a/c (partial callsign 03, could hear numerics only). YL op on gnd stn w/DTMF tones, then OM giving wx to the OM on the a/c. First time I've heard a GHFS ground station (or what sounded like one) on 6761 in a LONG time. (JK-NY) (*besides Andrews VIP/Mystic Star use, a number of USAF command posts both in the Continental U.S. and in Europe who have aerial refueling wings make use of 6761 but may have been used as discrete freq. - Ed*)
- 6765:** HSA, Bangkok Radio, Thailand, w/wx in EE, Thai and USB at 1200 (TY-JP)
- 6815.6:** GANTSEC req H4E's "Benchmark" at 0215. R6S passing unid t/c to GANTSEC at 0217. GANTSEC clg Z4Y at 0225. ANDVT followed at 0227. SHARK 11 clg GANTSEC at 0255, ANDVT followed. GANTSEC clg COASTAL BANDIT at 2355, who answers and relays t/c about SATCOM problems. GANTSEC passes t/c concerning (Unid) territorial waters at 0003. COASTAL BANDIT reports they are 12nm out from territorial waters. GANTSEC req COASTAL BANDIT contact them via landline at 0015. All in USB. (MF-OH)
- 6885:** CC/YL nbrs. Guangzhou, poss CC Intelligence, hrd in powerful AM at 1530 YL opr frequently, rptng. "All stns, this is Guangzhou. We are waiting for your messages," in Mandarin Chinese. Not heard parallel 10750. (TY-JP)
- 6913:** Several MARS stns w/AAA and AAR callsign prefixes at 0120. (JK-NY)
- 6986:** ART, Mossad, Israel, hrd in USB at 1500. (TY-JP)
- 6993:** NAVY 515 w/kg Andrews VIP at 0123 in USB. (JJ)
- 7337:** Lincolnshire Poacher nbrs British M16, Cyprus, hrd in USB at 1900, // 9251 kHz. Unable to find one more LP. (TY-JP)
- 7514:** Unid in SITOR B at 0210, Copied 1 'SIC JPL' which talks about shipping container adrift in North Atlantic. Second 'SIC JPL' talks about distress signal received 121.5 and 243 MHz, 53-14 N 17-46 W. Keep sharp lookout, report anything to MRCC, Falmouth right before abrupt sign-off saw a phone # 415-669-2047. (RP2-TX)
- 7605:** Abnormal Mossad best hrd in USB Mossad lady rptng "MIWTIC1" in phonetics for more than 60 mins at 1315 It 8127. On another day, Mossad lady rptng "MIWI" In phonetics for more than 20 mins at 1417. On different day, usual MIW2, Mossad, hrd in USB at 1515, but transmission was suddenly off in progress at 1517. (TY-JP)
- 7612:** ZERO ALPHA, 10, 40 and 60 w/Australian Army Relief OPs net PNG at 0802 in USB w/radio checks and trying to send data. (IJ-NZ)
- 7670:** RCC76, Moscow Meteo. RUS w/wefax 120/576 at 0130. (RP2-TX)
- 7686:** Unid, Stations Fiji at 0905 in USB w/2 OMs in Fijian. Mentioned Suva and Lautoka. (IJ-NZ)
- 7710:** VICTOR 92 w/kg PNGDF at 0832 in USB w/OM in Pidgin EE. Mentioned about Admin and trying his best. (IJ-NZ)
- 7811:** SYN2, Mossad, Israel, hrd in USB at 1345. (TY-JP)
- 7831.6:** 5ST, Antananarivo, Malagasey (sp?) AFTN (ASECNA?) in 48 hd ARQ-E3 w/"CH" message on cct TNC (to Nairobi?) at 1940. (JD-UK)
- 7872.5:** VL8IPS, IPS Radiosonde Darwin, NT Australia at 0943 in CW w/DE VL8IPS marker. (IJ-NZ)
- 7918:** YHF2, Mossad, Israel, hrd in USB at 1430. (TY-JP)
- 7961:** Unid three-channel Piccolo heard at 1745. (JD-UK)
- 8025:** C102, Mossad, Israel, hrd In USB at 1345. (TY-JP)
- 8026:** PACOM 01, CINCPAC a/c at 1356 in USB clg ANDREWS. (MADX)
- 8032:** SAM 204 w/kg Andrews with a signal check at 1906 in USB. (JJ)
- 8069:** Fishing boats *New Zealand* at 0815 in USB 2 OMs w/chit-chat. Mentioned about checking out fishing spots. (IJ-NZ)
- 8118:** Unid, Stations Pacific Islands at 0730 in USB w/YL and OM in a Pacific Island language. Possibly a Telecom link. (IJ-NZ)
- 8127:** Abnormal Mossad best hrd in USB at 1315. Mossad lady rptng "MIWTIC1" in phonetics for more than 60 mins., // 7605. On another day VLB2, Mossad, Israel, hrd in USB at 1330. (TY-JP)
- 8131:** Unid, three-channel Piccolo (ch 3 idle) all day today. (JD-UK)
- 8340:** YKBX, M/V BARADA at 0901 w/CW msg to ljmuiden pilots via unknown station (4935dwt gen cargo vsl). (HOOD)
- 8341:** 7THF, M/V TEBESSA at 0920 w/CW msg (eta for Oran) via 7TF (3499dwt ro-ro cargo vsl). (HOOD)
- 8341.5:** 9HXP5, M/V DIVA at 0654 w/CW crew TG to Kherson address via unknown station (is ex Volgo-Balt 186). (HOOD)
- 8446:** A4M, Muscat Radio, OMA in CW marker at 1330. Also heard on 12675.5 about the same time, a couple of days later. (RP2-TX)
- 8450:** 5AB, Benghazi Radio LBY w/CW marker at 0200. (RP2-TX)
- 8452:** Unid in CW at 1245, UHP, St. Petersburg Radio RUS shown here, likely. (RP2-TX)
- 8357.5:** UZYT, TKH SLAVUTICH 2 at 0733 in CW msg to Italy via UWS3. (HOOD)
- 8362.5:** P3WU6, TR PROLIV DIANY at 0803 in CW admin to UIW. (HOOD)
- 8465:** Abnormal Mossad BC hrd in USB at 1410. Mossad lady rptng phonetics for more than 10 mins. (TY-JP)
- 8367:** ENEU, TKH YASHA GORDIYENKO at 0832 in CW psn rpt (from 36.03N 10.46E) to USO5 (2180dwt gen cargo vsl). (HOOD)
- 8377:** ESDX, M/V VILSANDI at 0851 in ARQ msg (eta for Muuga) via GKE login 56761 ESDX. (HOOD)
- 8379.5:** SJYV, M/T DALANAS at 0900 in ARQ msg via SAB login 26490 DALANS. (HOOD)
- 8381:** CSBQ, M/T GALP FARO at 0815 in ARQ eta for Falmouth via CUL (5990dwt LPG carrier). (HOOD)
- 8385.5:** 3EUW8, M/V TRAMARCO TRADER at 0855 in ARQ request for wx to HEC opr (9662dwt bulker). MVQN8: M/V CAPE AGULHAS 0817 ARQ AMVER msg login 45596 MVQN8. (HOOD)
- 8397:** UIJP, TKH PIONER BELORUSSII at 0804 in ARQ msg to Solchart, Helsinki via UCE. UCPE, TKH PIONER LITVY 0833 ARQ admin from Km Bokarev to UCE. (HOOD)
- 8399.5:** J8LL7, TR ALEXA at 0812 in RTTY 50/170 crew TGs to UIW (sends as "ALEKSA," but is "ALEXA" in Lloyds). (HOOD). UALO, MALTSEVO (SRTM-8102) at 0742 in RTTY 50/170 admin from Km Stogniy to UIW. (HOOD)
- 8402:** UCUG, KIREYEVSK (MG-1323) at 0833 in RTTY 50/170 catch rpt to UDK2. (HOOD)
- 8402.5:** UCVK, UPS KRUZENSHTERN at

Books, Videos, Calendars, Cards!

Visit Our Web Site
www.cq-amateur-radio.com

33 Simple Weekend Projects

by Dave Ingram, K4TWJ

Do-it-yourself electronics projects from the most basic to the fairly sophisticated. You'll find: station accessories for VHF FMing, working OSCAR satellites, fun on HF, trying CW, building simple antennas, even a complete working HF station you can build for \$100. Also includes practical tips and techniques on how to create your own electronic projects.

Order No. 33PROJ.... **\$15.95**



Amateur Radio Equipment Buyer's Guide

This 144-page book is your single source for detailed information on practically every piece of Amateur Radio equipment and accessory item currently offered for sale in the USA complete with specs and prices. Also includes the most comprehensive directory of Ham product manufacturers and dealers in the USA.

Order No. EBG..... **\$15.95**



Building and Using Baluns and Ununs

by Jerry Sevick, W2FMI
This volume is the source for the latest information and designs on transmission line transformer theory. Discover new applications for dipoles, yagis, log periodics, beverages, antenna tuners, and countless other examples.

Order No. BALUN... **\$19.95**

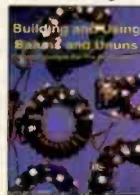

The Vertical Antenna Handbook

by Paul Lee, N6PL
Learn basic theory and practice of the vertical antenna. Discover easy-to-build construction projects.

Order No. VAH..... **\$9.95**



The NEW Shortwave Propagation Handbook

by W3ASK, N4XX & K6GKU

A comprehensive source of HF propagation principles, sunspots, ionospheric predictions, with photography, charts and tables galore!

Order No. SWP..... **\$19.95**



The Quad Antenna

by Bob Haviland, W4MB
Second Printing
An authoritative book on the design, construction, characteristics and applications of quad antennas.

Order No. QUAD..... **\$15.95**

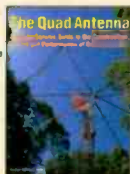

Keys, Keys, Keys

by Dave Ingram, K4TWJ

You'll enjoy nostalgia with this visual celebration of amateur radio's favorite accessory. This book is full of pictures and historical insight.

Order No. KEYS **\$9.95**



McCoy on Antennas

by Lew McCoy, W1ICP
Unlike many technical publications, Lew presents his invaluable antenna information in a casual, non-intimidating way for anyone!

Order No. MCCOY..... **\$15.95**

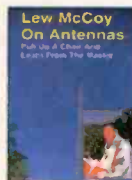

W6SAI HF Antenna Handbook

by Bill Orr, W6SAI
Inexpensive, practical antenna projects that work! Guides you through the building of wire, loop, Yagi and vertical antennas.

Order No. HFANT..... **\$19.95**



Getting Started Videos - "How-To," Tips, Techniques & More!

- Ham Radio Horizons: The Video . . . Order No. VHOR
- Getting Started in VHF . . . Order No. VVHF
- Getting Started in Ham Radio . . . Order No. VHR
- Getting Started in DXing . . . Order No. VDX
- Getting Started in Packet Radio . . . Order No. VPAC
- Getting Started in Amateur Satellites . . . Order No. VSAT
- Getting Started in Contesting . . . Order No. VCON

Only \$19.95 each
Buy more and save!
Buy 2 or 3 for \$17.95; Buy 4 to 6 for \$15.95
Buy all 7 for your Club for only \$99.95



Fax us at 516-681-2926
Call us toll free at 1-800-853-9797

2000 Calendars



\$9.95
Fifteen month calendars
January 2000 through
March 2001
Please specify
Amateur Radio or
Classic Radio Calendar



CQ Award Pins

If you've earned any of CQ's Awards, you can also display the corresponding CQ Award pin. Available for WAZ, 5 Band WAZ, 160 Meter WAZ, CQ DX, CQ DX Honor Roll, WPX, WPX Honor Roll, and USA-CA awards. **ONLY \$5.00 EACH.**

Playing Cards

Top quality, plastic coated playing cards. **ONLY \$9.95 per deck**



FREE SHIPPING on orders over \$50*

Name _____ Callsign _____
Street Address _____
City _____ State _____ Zip _____

Qty	Item #	Description	Price	Total Price
U.S. and possessions - add \$4 shipping/handling. *FREE S/H on orders \$50 and over. Foreign - shipping/handling charges are calculated by order weight & destination. *A \$4 credit will be applied for Foreign orders over \$50.			Shipping/Handling	
			Total	

Method of payment Check Money Order Visa MasterCard Discover American Express
Credit Card No. _____ Expiration date _____

CQ Communications, Inc., 25 Newbridge Rd., Hicksville, NY 11801/516-681-2922; Fax 516-681-2926

0812 in RTTY 50/170 crew TGs to UIW (training barque). (HOOD)
8406: UCFT, MALAKHOV (ME-0365) at 0837 in RTTY 50/170 admin to UDK2. (HOOD)
8431.5: UAT, Moscow Radio at 0647 in ARQ msg to UHLR, TKH MIKHAIL SHOLOKHOV. Same at 0738 w/ARQ msg status rpt to UHLR. (HOOD)
8432.5: UFN, Novorossiysk Radio at 1712 in ARQ msg status rpt to UDGB: TK GRIGORIY NESTERENKO. Same at 1649 w/crew TGs to UFJA: TK LIPETSK. Same at 1217 w/crew TGs to UEUK: TKH DYURSO (5885dwt sea-river cargo vsl). (HOOD)
8451: UBF2, St Petersburg Radio at 0801 w/CW t/c list abd QXS 12554.5/8370.5/4197. (HOOD)
8471: Unid in CW at 1200, EQZ, Abadan Radio, IRN shown here. (RP2-TX)
8607: Unid in CW at 1205, USU, Mariupol Radio UKR shown here, likely. (RP2-TX)
8705.5: PKC, Palembang R, Indonesia, w/"CQ mkr and QRU?" in CW at 1200. (TY-JP)
8743: HSA, Bangkok Radio, Thailand, w/wx into in EE, Thai and USB. (TY-JP)
8803: OHG, Helsinki Radio at 0822 in USB wkg 9HZK5: M/V GIRVAS (is ex Volgo-Don 5081). (HOOD)
8971: SCORPION 08 wkg CHARLIE, completed search area and requesting to RTB from JIATF East. CHARLIE passes on RTB approved and SCORPION RTBs w/14 POB, indicating that SCORPIONS are most likely P-3s. 31 CHARLIE clg SEABREEZE several times with no joy. Selected wrong frequency perhaps? (RMC-GA) SCORPION 03 wk BLUE STAR established contact then switched to ANDVT, then back to USB giving an ETA and ducking the question when asked to give his position. (JK-NY) DAGGER 11 (probable P-3C) at 0503 w/BLUE STAR (TSCC Roosevelt Roads, PR) in ANDVT and clear checks. DAGGER 11 passes encoded posn, course and speed. 11 adv to pass his info on the Indian Ridge circuit, apparently tries it (not heard) as BLUE STAR returns adv didn't receive anything. BLUE STAR at 0104 calling LOOKOUT 06, adv that DAGGER 10 has an emergency; then asks if lookout 06 able to go XAE. 06 unable to go XAE. At 0108 LOOKOUT 06 reports on station, ops normal Mike Bravo-1, HF and SATCOM w/4 POB. Note that 4 POB indicates that the 06 is probably not a P-3C or C-130; unless they are not flying w/full crew. SCORPION 08 (P-3C) at 2127 w/BLUE STAR in r/c then switch to ANDVT. (RP-MD) Weird, whale, sounding noises here any ideas? at 0212. (RK) *(discussed in my April 1999 column "Thar be Whales Ahoy, Matey" and also thoroughly covered including audio samples in the WUN Clubs 1999 Frequency Guide Plus, Vol. 2 CD-ROM <<http://www.wunclub.com/cd2.html>>, these noises are most likely high noise levels in remote transmitter lines. They always crop up on/near U.S. military frequencies — Ed)*
8980: CAMSLANT wkg pp for CG2131 to D7 (Miami Ops) at 2337 in USB. (MF-OH)

WAVERIDER and STACY (USN) at 0928 in USB w/going green, no joy and mentioned switch to Uniform. (IJ-NZ)
8983: CG A8K (possible HU-25) at 2212 w/CAMSLANT reporting airborne from parent command CGAS Miami enrt to "somewhere" near Key West, FL, w/5 POB. CG 2140 (HU-25 CGAS Miami) at 2003 req relay to District 7 (Miami) that they are on scene and have 1-1/2 hours on-scene time before they have to depart. (RP-MD) CAMSLANT req CG 2131 switch 8980 pp to D7 at 2333, C0R passing flt-ops and pos to CAMSLANT at 2216, C0R req CAMSLANT secure guard at 2227. RESCUE 1501 req CAMSLANT secure guard at 2233. CG2112 passing flt-ops and posn to CAMSLANT at 2246. RESCUE 1713 req CAMALANT relay to D7, that they are off scene at 2339. (MF-OH) All in USB.
8992: STOCKMAN (strong level) at 0150 w/Thule in pp w/DSN 339-XXXX for station Culminate, passes AKAC-369 msg: N5B PCL BZA 4AG FIQ N75 NVI 5MS, at 0155 clg SATURDAY (not heard) then switch to Z175. Z205 is secondary. FAP Lisboa (Hqs, Portuguese Air Force) at 2136 w/unid a/c in posn report. (RP-MD) MAYBERRY clg Hickam GHFS at 0248 w/pp req to MacDill CP. Tells MacDill they are trying to raise the MacDill Global Station (GHFS). MAYBERRY is obviously unaware that the MacDill GHFS Station has been long shut down. (ALS-FL) All in USB.
9016: STOCKMAN at 0157 w/Saturday (not heard). (RP-MD) RED RONIN, GIGANTOR, AKIRA, CASSHAN, others in NATO could have been Japanese as these are all names of "famous anime cartoons at 1025." (RK-NY) NET LOSS wkg Hickam at 0220 with msg for relay (maybe for AUTODIN/DMS injection, wasn't paying close attn). Hickam later advised that some parts were garbled and that he would call NET LOSS via STU III to fill in the garbles. (JJ) All in USB.
9018: SHADOW 91 and another unid station at 1835 in USB. (JM-KY)
9027: (F146) Andrews wkg pp for SAM 306, switched to unid freq. AIRCRAFT 217 clg any stn for r/c at 2233, both in USB. (MF-OH)
9120: NAVY 49676, DV-2, on the deck NAS North Island at 0331 in LSB wkg Andrews VIP re msg relay to Jacksonville NAS. Also found on 9120.0 and 11059.0 USB. (JJ)
9130: EZI, Mossad, Israel, hrd in USB at 2230, also noted on 6840. (TY-JP)
9135: Unid three-channel Piccolo. w/crypto on Ch 2, idle on Ch 1 and 3, has been there all day today (Sunday) and at least part of yesterday. (JD-UK)
9156.2: Unid Station at 0920 in ARQ w/encryption. (IJ-NZ)
9183.3: Unid Station at 0900 in ARQ w/encryption. (IJ-NZ)
9251: Lincolnshire Poacher nbrs British M16, Cyprus, hrd in USB at 2000, // 6959 // 11545. (TY-JP)
9270: Abnormal Mossad BC w/Mossad lady rptng "VLB2" for more than 30 mins in USB at 1430. Rare Mossad BC on this freq. (TY-JP)

9320: SAM 204 wkg Andrews VIP at 0204 in USB re on the deck in 20 mins. (JJ)
9328: The CIA counting nbrs hrd in AM at 1300 // 10529. (TY-JP)
9340: RCH72. Tashkent Meteo at 2132 w/FAX 90/576 w/moderate signal. QRM from decoder prevented good read on image. (MADX)
10125: Abnormal Mossad best hrd in USB at 1340, Mossad lady rptng "Charlie India Oscar One" for more than 10 mins. This is a WARC amateur hand. (TY-JP)
10355: 4XZ, Haifa, Israeli Navy, Israel, w/V-mkr in CW at 1525. (TY-JP)
10493: MOONBEAM at 1410 w/WGY 912 (FEMA HQ, Berryville, VA) checking into FEMA net. (RP-MD) BACK COUNTRY and THREE GEESSE at 1751 w/H211750 message. (JK-KY) All in USB.
10529: The CIA Counting nbrs hrd in powerful AM at 1300, also noted on 9328. (TY-JP)
10538.6: CG Activities Baltimore at 1947 in USB w/CG 41359 in comm checks. (RP-MD)
10583: E5, The Counting Station at 2127 in AM w/5FGs (3/2) already in progress. (MADX)
10765: OVC, Danish Navy Groennedal, Greenland in CW wkg warship OWEV. Later two stations (presumably the same two) w/encrypted 75/170 RTTY at 1830. (JD-UK)
10802.4: Unid Station at 0902 in ARQ w/encryption. (IJ-NZ)
10822: Unid stn 4XML rptng "VVV BFR7 DE 4XML" over and over in CW at 2215. A couple of years ago this stn sending "V BFR7 DE 4XML0" (TY-JP)
10993.6: BRAVO-6-ECHO clg DARK 17 with no joy at 0259 between lots of "broken" ANDVT sounds. Coast Guard Group Key West wkg "Coast Guard Aircraft GHOST" at 0305 for a signal check. Both in USB. (JJ)
11059: SAM 206, inbound Andrews, wkg Andrews VIP, re: ramp freezes at 0009. (JJ-CA) Navy 150515 (VIP aircraft) at 2214 clg Andrews on F365. Was also w/Andrews on 11175. (RP-MD) All in USB.
11175: Thule wkg pp for REACH 17 Little Rock Ops at 2103. S4JG r/c w/Thule at 2110. Andrews w/pp for OCEAN 50 to DSN#636 number at 2108, then pp to commercial number at 2111. Ascension w/pp for TRIDENT 01 to BLUESTAR at 2145, re: spare grps rep and posn. THULE w/pp for TRIDENT to DSN#831 (BLUESTAR) re; spare grp msg rep and posn. Andrews w/pp for BANDIT 69 to Hilda East and meteo at 2257. McClellan w/pp for REACH 5244 to Hilda East and meteo at 0032. Hickam w/pp for JESSE 92 (#61392) to AMC TACC at 0125. (MF-OH) SCARS 57 (possible C-130) at 0217 w/Ascension in pp w/CAMPER at DSN #317-626-XXXX (Anchorage ANGB) requesting confirmation of "setup" since they are going to Anchorage and the pax think they are going to Elmendorf. AIRCRAFT 55 (callsign missed) at 1619 in pp w/Trenton Metro w/wx for Iqualit and Goose Bay. STAG HOUND (spelled-fair level-has TACAMO sound) at 1758 w/Offutt requesting primary/secondary

working freqs for MUD DUCK. Offut passes freqs as Z150 (5800) and Z205 (11494) and says that MUD DUCK is currently up. MOONBEAM calling Mainsail for r/c at 2144 also asking Mainsail for r/c at 2143. (RP-MD) REACH 221 (C-5) wkg Avaino via Thule for cargo to offload wanted to know wx there and at ZGB (maybe Zagreb, Croatia?) at 0230. (RK-NY) All in USB.

11178: FALCON 01 (Dutch Navy P-3C, Curacao) at 1747 w/PJC (Dutch Navy, Hato Curacao) w/posn and status report. CHARLIE 3 (Dutch Navy vessel, Curacao) at 1815 clg FALCON 01 w/no response. FALCON 01 at 2148 w/PJC reporting off station at 2130Z and ETA at Hato, Curacao of 2240Z. PJC relays QSL time from PJK (Dutch Navy, Suffisant Curacao). All in USB. (RP-MD)

11181: SONGBIRD wkg McClellan w/data at 2152. (JJ-CA)

11212: Unid in CW at 0200. (RP2-TX)

11214: SPAR 76 wkg Andrews for a FAX msg at 0216. (JJ-CA) SHUCK 77 (E-3B AWACS, Tinker AFB) at 2059 w/Trenton Military in pp (number missed) that does not answer. Switched here from 11232. Tries pp to DSN 450-XXXX w/no answer. Tries second pp to 450-XXXX Keflavik CP who identifies self as RAYMOND-85. SHUCK-77 ID's self as BANDSAW XRAY and asks them to get discrete HF frequency for voice comms, also adv RAYMOND-85 that they are now on NORAD Satcom. Keflavik CP adv them to call HUNTRESS and they will pass them through. Shuck 77 cannot contact anyone and asks Keflavik to patch them through. This is the first time I've heard RAYMOND-85. (RP-MD) Trenton Mil wkg pp req for SHUCK 77 at 2121. re; 18 large pizzas. SHUCK 77 req another pp at 2138 to Keflavik CP. SHUCK 77 w/long pp to LOKIE. coord data link. crypto, voice and data freqs at 2210. LOKIE passed UHF only no HF, passed UHF freq (325.7). (MF-OH) All in USB.

11220: SAM 206 wkg Andrews VIP re: on the deck in about 30 min. at 0006 (JJ-CA) Andrews wkg pp for SAM 306, switched to F-146. (MF-OH) All in USB.

11226: TROUT 99 wkg Offutt for pp at 1839 in USB. (JJ)

11229: SNACK BAR wkg Andrews with data and then trying 13242 or 18006 and gone at 0307. (JJ-CA)

11232: Trenton Military wkg RESCUE 242 (CANFORCE) at 0158. (JK-NY) Canforce 4208 (C-130, 8th Wing CFB Trenton) at 1939 w/Trenton Military in pp w/Trenton Dispatch reports take off from Gander at 1950 w/destination of RAF Lyneham. Selcal is GH-AJ. Trenton Military at 1805 w/Challenger (CC-144, 7th Wing Ottawa) in r/c. Trenton Military: 2130 USB w/unheard Canforce aircraft w/wx for Montreal/D'or Val; Quebec City; Montreal/Mirabel; Trenton; and Ottawa. Trenton Military w/ASCOT 9213 (RAF VC-10 or L-1011) w/wx forecast at 2211. (locations missed) Canforce 4109 w/Trenton Military in pp w/Trenton Ops reporting crew member hospitalized at Gander at 2147. They

are at Gander and will leave soon enroute to Trenton. (RP-MD) Trenton Mil wkg pp for RAZOR 33 to DSN#497-2808 at 2049. CANFORCE 4209 req wx for St. Johns and Gander from Trenton Mil at 2133. Trenton Mil wkg CANFORCE 2960, 2960 passed A/D rep and req wx at 2121. (9007 passed as secondary.) (MF-OH) All in USB.

11244: EXTENSION w/MUD DUCK. MUD DUCK passes freqs as primary Z205 and secondary Z150 at 1925. TRUCK MAN w/EAM (YFFWYN) at 1958. All in USB. (RP-MD)

11342: New York (ARINC) at 1832 in USB w/Iberia 9606 discussing options for diverting. 9606 is bound for Barcelona but is considering diverting to Madrid due to wx. (RP-MD)

11545: Lincolnshire Poacher nbrs, British M16. Cyprus hrd in USB at 1900 // 8959 // 9251. (TY-JP)

11565: EZI, Mossad, Israel, hrd in USB at 1430 // 13533. (TY-JP)

12443.5: UYAX. TKH ANDREY BUBNOV at 0912 w/CW eta for Kherson via UWS3. EOTW, TKH VLAS CHUBAR at 0859 w/CW psn rpt to UWS3. (HOOD)

12459: UFXV. BMRT NAVIGATOR 0918 CW clg UDK2. (HOOD)

12478: UFHG. TKH MEKHANIK TYULENEV at 0816 w/ARQ msg to UCE. UCNT, TKH KAPITAN MOCHALOV at 0836 w/ARQ crew TG to UCE. (HOOD) XU7HJ: M/V SOYANA at 0945 w/ARQ eta for Arkhangelsk to UCE (is ex Aleksandr Pankratov, UCMW). (HOOD) 9HX14: TKH KAPITAN LUS 0837 ARQ admin from Km Averin to UCE. (HOOD)

12551: CAWS, KONOTOP (AG-1339) at 0820 in CW clg RLK7. UUII, TKH YURIY DVUZHLNIY at 0922 in CW clg USU. (HOOD)

12554: UAZB, MIKHAIL BORONIN (MB-0011) at 0844 in RTTY 50/170 crew TGs to UDK2. (HOOD)

12562.5: UAUU, TR YANTARNYA ZEMLYA at 0903 in RTTY 50/170 crew TGs to UIW (previously listed as BMRT, but this header gave type as TR). (HOOD)

12615: USU. Mariupol Radio at 0727 w/ARQ msg to UTJK: TKH KATYA ZELENKO for Km Korablev. (HOOD)

12735: URL, Sevastopol Radio. UKR w/CW marker at 1315. (RP2-TX)

12760: Unid in CW at 1400. UUI, Odessa Radio UKR, shown here. (RP2-TX)

12788: NMN, USCG Chesapeake, Virginia w/computerized high-seas forecast for the North Atlantic Maritime region at 2348 in USB. (SW-IN)

12824: GYU. Royal Navy Gibraltar, GIB w/RTTY 75/170 at 1145. Two numbers and a letter pattern. (RP2-TX)

12855: UBF2. St. Petersburg Radio at 0855 in CW clg UBFQ: TKH REFRIZHERATOR 609. (HOOD)

12877.5: UIW, Kaliningrad Radio, RY w/tape in RTTY 50bd at 1518. (AB-NL)

12966.5: A7D, Doha Radio. QAT w/CW marker at 1440. (RP2-TX)

12997.5: Unid in CW w/msgs of "storm warn-

ing" to ship(s) at 1200. Could be UUI, but 'MAE IUPOL' found in text. (RP2-TX)

13060: Unid in CW at 1345, suspect UFJ, but only logged about three lines before they signed off. (RP2-TX)

13146: Monaco Radio monitored at 0800 w/ships SSSS Fast Trader (Egyptian Cargo), YKMP Hadil (Syrian), YKAN Arwad (Syrian). At 0930 wx for Atlantic zones: Madeira, Faraday, Meteor, Guinea Gulf, South Canary, Pointe Noire Altair, Alice, Josephine, and Sierra Leone. (PP-FR)

13200: Army aircraft 112 (unid) at 1924 in USB clg Mainsail for r/c. (RP-MD)

13204: RAZOR 33 clg MAINSAIL, then tried Trenton Mil at 1926 in USB. Mentioned "triple 1" probably on wrong freq. (MF-OH) Whiteman 509BW based B-2 bomber "DEATH 41" up here at 1504 wkg CP re difficulties establishing comms on UHF Secure. 13204 is a known 509th Bomb Wing discrete. (ALS) TEAL 10 (also used Air Force 967) wkg Ascension for pp re ops, presumed pp to Keesler AFB, at 0043. (JJ) All in USB.

13206: FOLI0 11 clg PLANTATION OPS at 2010 in USB. req ammo, maint, and hot cargo. (MF-OH)

13211: BACK PAGE wkg Andrews re: comms extended DOWNTOWN at 2217 // 11460.

13242: SHADOW 47 wkg McClellan for pps. adv they were cruising at 18 knots and would be "back in port (Hawaii) on the twenty..." (op caught himself) at 0209 in USB. (JJ-CA)

13257: Bandsaw Golf (E-3B, AWACS, Tinker AFB) at 1933 w/Trenton Military trying to establish contact w/no response. Switched here from 11232. Trenton Military at 1828 w/Canforce 4210 (not heard) w/wx for Stephenville, St. Johns, Keflavik, and RAF Lyneham. (RP-MD) All in USB.

13264: Shannon Volmet at 1606 in USB w/wx. (RP-MD)

13270: New York Volmet w/wx at 1441 in USB. (SW-IN)

13273: Tokyo Aeradio. Japan. wkg various a/c in USB at 0452. (TY-JP)

13330: New York Radio at 1607 in USB w/TWA 843 w/SIGMET. Also Saudia 003 in pp w/Arabic conversation confirming ETA at destination. (RP-MD)

13339: O/M (Canadian FF) at 1503 in USB w/aircraft (O/M Canadian FF) w/aircraft status report and wx for Val Cartier airport. Probable LDOC. (RP-MD)

13440: SAM 300, outbound Pago Pago for Sydney, wkg Andrews VIP re: trying F-300 (15707.0). The Andrews op advised that she did not have that freq in her list. SAM 300 passed the freq at 0011 in USB. (JJ-CA)

13533: EZI, Mossad, Israel, hrd in USB at 1430. // 11565. (TY-JP)

13564.9: Unid station, unid mode: four tones spaced 200 c/s; 195.2 bd. This has been reported on many freqs, all ending in ".9" at 1515. (JD-UK)

13906: The CIA Counting stn. hrd in AM at 1200. // 15732. (TY-JP)

14139: The CIA Counting stn. hrd in AM at 1300. // 16198. (TY-JP)

14397: SHARES Net w/KGD 34 (Net Control) at 1418 in USB w/net check ins. Stations heard: AAC2KYA (NG Kentucky); WGY 955 (State EOC, Illinois); Red Fox 81 (CAP, Illinois). (RP-MD)

14677.3: "V5G" MFA Bucharest Rumania in ROU-FEC 164.5 bd at 1115. In plain-language Rumanian; signed off on CW "QRU QRX BYZZ GB 73/88 ar sk." Looks as if BYZZ was a coded time, ending in "00;" as a matter of interest, back in 1997 I logged the mysterious "A2A," also believed to be in Romania, signing off with "QRX YPZZ." apparently the same (or a similar) code. (JD-UK)

14686: FLINT 814 (DEA aircraft) at 1625 w/ATLAS (DEA contract communications center, Iowa) requesting ETA of 40 minutes be passed to FLINT 211 at 767-XXXX. (RP-MD) FLINT 902 w/(fc for FLINT 912 at 2011 re; Case #. FLINT 912 clg FLINT 913 for an "ATLAS" check, 913 calls ops normal at 2032. (MF-OH) All in USB.

14779.9: Unid 4-tone mode 195.2 bd — note, freq ends in .9 again at 1430. (JD-UK)

14873.2: RFLIG, French Forces, Cayenne, GUF w/ARQE3, 192/400 at 0009 w/DE RFLIGS, then at 0013 w/"BONNE ANNEE A TOUS ET MEILLEURS VOEUX" at 0000. (RP2-TX)

Tuning In (from page 5)

a month's worth of *The New York Times*. Ask the kid to put an "x" on the countries that could benefit from continued broadcasts. If they feel really energetic, bring along a college accounting major and an abbreviated version of the upcoming fiscal year budget proposal. Guaranteed it doesn't take countless late-night meetings and dozens of hours of head scratching to come up with a common-sense plan. A VOA representative told me that the cutbacks are more a "reorganization of priorities" — it's high time they got their priorities straight.

What about all the *talk* about budget surplus? Hello, Congress? Time to wake up, cut the BS politics-as-usual, and get off the potty and move some of that cash out of your pockets and into programs that *need* the money. Four or five million bucks is certainly a lot of money by anybody's standards, but in the grand budget scheme, it's a virtual drop in the bucket — a bucket that should be carried over pronto to the VOA.

The unfortunate lessons of cutbacks such as those recently implemented at the VOA might not be known for years, but by then hopefully those "good old boy" bureaucrats will be long gone, replaced by thinking, caring, honest human beings concerned more about our global community than Beltway politics. In the meantime, please think of the family dodging the mortar. ■

14931: 8BY, French Intelligence, France, sending "VVV 8BY followed by 3FG3's separated by a slant bar." in CW at 0845. // 18415 // 20946. (TY-JP)

15016: SUMO 71, inbound Wake, wkg Hickam at 0142 in USB. (JJ-CA)

15707: SAM 300 wkg Andrews VIP re: checking F-171 at 0223 in USB. (JJ-CA)

15732: The CIA Counting stn, hrd in AM at 1200. // 13906. (TY-JP)

15962: NET LOSS w/EAM traffic and then wkg KEG NAIL re coming upon EHF... "unable at this time." Hrd at 2331 in USB. (JJ)

16198: The CIA Counting stn, hrd in AM at 1300. // 14739. (TY-JP)

16670: EMLP. KAPITAN BUGA at 0827 in CW wkg URL (1810dwt fact trawler, rgd at Ilychovsk). (HOOD)

16693.5: ELTN8, M/V ATLANTIC FOREST at 1636 w/ARQ AMVER msg via WCC (is ex Aleksey Korygin). (HOOD)

16786.5: ENBE, TR PROLIV SANNIKOVA at 1046 in RTTY 50/170 crew TGs to URL. UYDV, RKTS MORE SODRUZHSTVA at 1631 in RTTY 50/170 crew TGs to URL. (HOOD)

16801: USLB, RTMA ORLINOYE at 0907 in RTTY 50/170 admin to URL. (HOOD)

16807.5: GKE, Portishead Radio, G w/SITOR B at 1300 w/tfc list. (RP2-TX)

16829: USU, Mariupol Radio at 1022 in ARQ msg (in EE) to UZMP: TKH NIKOLAY SHCHUKIN for Km Mogylevkin. (HOOD)

16839.5: UFN, Novorossiysk Radio at 0853 in ARQ msg to UICJ: TK POBEDA. (HOOD)

16904: UDK2, Murmansk Radio at 1028 w/ARQ ID marker (c/s and KYKY). (HOOD)

16945: XVG7, Haiphong Radio at 1030 w/CW ID marker. (HOOD)

17015: UTQ, Kiev Radio, UKR w/CW at 1500 w/msg to ship. (RP2-TX)

17079: HLF, Seoul Radio at 1034 w/ARQ ID marker. (HOOD)

17138: LYL, Klaipeda Radio at 1038 in RTTY 50/170 msg to P3YF7: ARAS I. (HOOD)

17360: HLS Seoul Radio, South Korea, w/short melody mirror of Beethoven's 9th Symphony "Ode to Joy" between PP in USB at 1213. (TY-JP)

17410: EZI, Mossad, Israel, hrd in USB at 0930. // 19715. (TY-JP)

17499: Abnormal Cherry Ripe nbrs. British MIS, Guam, hrd in USB CR lady didn't transmit a characteristic Cherry Picker tons at usual 1100, suddenly nbra started in progress at 1112, after that normal best hrd. // 123461 kHz was a normal operation. In recent such an abnormal CR best hrd occasionally malfunctioning? Really rare for these guys to mess up. (TY-JP)

17825: Unid FAPSI signed on clg WDS at 0805 — no RTTY traffic but someone (Bob, I think) reported this one a day or two ago as 8003.8. (JD-UK)

18012: Circus Vert (CFAP Hqs Villacoublay) at 1656 in USB w/COTAM 4002 (sounds like) who passes flight info. Aircraft mentioned Evreux and Villacoublay during flight chatter. Aircraft was weak and Vert was overmodulated-hard to understand. (RP-MD)

18397.4: SAM 300 wkg Andrews VIP (on tentatively ID'ed F-171) for pp to Sydney re: 0825 wx at 0230 in USB. (JJ-CA) (*that's a couple new Foxtro ID's this month — Ed*)

19745.1: Unid FAX charts both 60/576 and 120/576 w/much Cyrillic printing on charts but I haven't seen the ID yet. (JD-UK) (*see the April 1999 column and chart captured by Peter Thompson, UK. It is ID'ed as from Atlantic Scientific-Research Institute of Marine Fisheries and Oceanography (Kaliningrad) and was probably sent by Kaliningrad Radio, UIW — Ed*)

20474: Cherry Ripe nbrs, British M16, Guam, hrd in US 8 at 1000. // 23461. (TY-JP)

20946: 8BY, French Intelligence, France, sending "VVV 8BY followed by 3FG's separated by a slant bar" in CW at 0840. // 14931 // 18415. (TY-JP)

22108: Cherry Ripe nbrs, British M16, Guam, hrd in USB at 0000 // 17499. (TY-JP)

22371.5: LYCZ, BARRUNGAS at 1041 in RTTY 50/170 RYs to LYL then QSY for same on 16801.5 (1518dwt fact trawler). (HOOD)

22380.5: CBV, Valparaiso Radio at 1141 w/ARQ ID marker. (HOOD)

22563.5: 9AR, Rijeka Radio at 1200 w/CW ID marker and announcing closing CW at 2400 UTC on 31 Dec 1999. (HOOD) (*sad to see another one bite the dust — Ed*)

22610.5: CLA, Havana Radio at 1204 w/CW ID marker. (HOOD)

23461: Cherry Ripe nbrs, British M16, Guam. Hrd in USB at 1000 // 20474. (TY-JP)

23740: EZI2, Mossad No. station at 0801 in USB w/YL repeating EZI2. (IJ-NZ)

Contributors: (AB) Ary Boender, NL; (AG) Alan Gale, UK; (ALS) Allen Stern, FL; (HOOD) Robin Hood, UK; (IJ) Ian Julian, NZ; (JD) John Doe, UK; (JJ) Jeff Jones, CA; (JK) John Kasupski, NY; (JM) Jack Metcalf, KY; (JR) Jerry Rogich, MA; (PP) Patrice Privat, FR; (RK) Rich Klingman, NY; (RMC) Roland "Mac" McCormick, GA; (RP) Ron Perron, MD; (RP2) Ray Prestridge, TX; (SW) Sue Wilden, NY; and (TY) Takashi Yamaguchi, Japan. Thanks to all and goodbye!

[Editor's Note: This will be RD Baker's last "Communications Confidential" column for Pop'Comm. My sincere thanks to him for a job well done. Next month, our new columnist, Joe Cooper takes the helm. Please remember, this is YOUR column; your loggings, charts, photos, QSLs, and input go a long way in making any column in Pop'Comm what it is today. Joe is not a newcomer to the hobby; he has been a SWL since the '60s and a licensed ham since 1970. I encourage you to talk with him — he welcomes your input. Joe is online at Joe@provcomm.net or can be reached by mail to our Hicksville, NY, address. Thank you.] ■

advertisers index

ADI/Premier	5
AOR USA, Inc.....	21
Am-Com	37
Antenna Supermarket	59
Antique Radio Classified.....	23
Atomic Time, Inc.....	29
Bill's CB & 2-Way Radio Ser.....	30
C. Crane Company.....	Cov III
C & S Sales, Inc.....	33
CQ Amateur Radio Calendars	30
CRB Research.....	47
Computer Aided Technologies.....	43
Cutting Edge Enterprises	27
DWM Communications.....	53
Davis Instruments.....	23
Firestik Antenna Company	23
Flightline Engineering, Inc.	53
GRUNDIG.....	11-14
ICOM America, Inc.	7
Jo Gunn Enterprises.....	30
Lee Electronics Company.....	49
Lentini Communications, Inc.	1
Lextronix, Inc.	11-14
MACO Mfg. /Majestic Comm.....	29
MFJ Enterprises, Inc.....	39
MetroWest, Inc.	49
Monitoring Times	55
Mouser Electronics	45
Optoelectronics, Inc.....	Cov IV
Phillips-Tech Electronics	53
REACT International, Inc.....	38
RadioWorld, Inc.....	49
REEL-Talk	25
Scanning USA	53
Signal Engineering	45
Universal Radio, Inc.....	3
Viking Systems International.....	61
Wilson Antenna, Inc.	15
Yaesu U.S.A.....	Cov. II

Reach this dynamic audience with your advertising message, contact Don Allen, W9CW at 217-344-8653, FAX 217-344-8656, or e-mail: PopComAds@aol.com

readers' market

Advertising Rates: Non-commercial ads are 30 cents per word, including abbreviations and addresses; minimum charge \$6.00 per issue. Ads from firms offering commercial products or services are \$1.00 per word; minimum charge \$20.00 per issue. Boldface words are \$1.20 each (specify which words). Leading key words set in all caps at no additional charge. All ads *must be prepaid in full* at time of insertion; a 5% discount is offered for prepaid 6 time insertions. All ads must be typewritten double spaced.

Approval: All ad copy is subject to Publisher's approval and may be modified to eliminate references to equipment and practices which are either illegal or otherwise not within the spirit or coverage scope of the magazine.

Closing Date: The 10th day in the third month preceding date of publication. Because the advertisers and equipment contained in Readers' Market have not been investigated, the Publisher of *Popular Communications* cannot vouch for the merchandise listed therein. Direct all correspondence and ad copy to: Attention: Alycia Nicholens, PC Readers' Market, 25 Newbridge Rd., Hicksville, NY 11801.

RADIO STUFF SALE: Books, magazines, club bulletins, radio station items, old time radio & more. \$1 for list. G. Dexter, 213 Forest St., Lake Geneva, WI 53147.

CB Tricks Books, Tricks I, II, or III. \$19.95 each. Repairs, tune-ups, amplifiers. Send Money Order to: Medicine Man, POB 37, Clarksville, AR 72830.

GROUND IT Ham Station Grounding Accessories. J. Martin Systems 35 Hilltop Avenue, Stamford, CT 06907. Voicemail/Fax 203-461-8768 <http://www.jmsystem.com>

CB MODIFICATION SECRETS, big new 200-page guide by Kevin Ross, author of "CB Radio Hacker's Guide." More great easy-to-do AM/SSB CB equipment upgrades and enhancements applicable to Cobra, Realistic, Uniden, President, etc. Freq. expansion, VFO, clarifier unlock, VOX, Roger Beep, anti-theft device, receive signal pre-amp, much more. Only \$21.95, plus \$5 s/h (\$6 to Canada) from CRB Research Books, P.O. Box 56, Commack, NY 11725. NY residents add \$2.22 tax. VISA/MC orders call: (631) 543-9169.

MILITARY RADIOS: Easily made battery adapters for military radios & other electronics. Get **POWER UP!** Big new 96-page manual of instructions, diagrams. Use readily available commercial batteries in PRC-6, -8, -9, -10, -25, -28, -47, -74, -77, TRC-77, AN/PRC-9, AN/PRT-4, RT-77, URC-68, more; also mine detectors, night scopes, radars, field telephones, etc. Only \$14.95, plus \$5 s/h (\$6 Canada). NYS residents add \$1.53 tax. CRB Research Books, Box 56-PC, Commack, NY 11725. VISA/MC accepted. Phone (631) 543-9169.

SCANNER CRYSTALS FOR SALE. Send a long SASE for list and price to G.E. Jones, P.O. Box 467, Buckeye Lake, OH 43008.

LEARN CODE BY HYPNOSIS — <<http://www.qth.com/cweasy/>>; or call 1(800) 425-2552.

WANTED: Yaesu FRG-7 shortwave receiver. Must be in good shape cosmetically and electronically. Call (908) 874-2328.

WANTED: 6502-based Hardware/Software/Literature, whatever. KIM's: SYM's: AIM's: OSI, anything & everything! John Rawley, 1923 Susquehanna Road, Abington, PA 19001, Phone: 215-884-9220. johnr750@aol.com

CB MODIFICATIONS! 10M, frequencies, sliders, amplifiers, FM, books, plans, kits, high-performance accessories. The best since 1976. Find out why! Catalog \$3. CBCI, BOX 1898A, MONTEREY, CA 93942. <www.cbciintl.com>.

CB MODIFICATIONS, REPAIRS, NEW PRODUCTS, CB RADIOS, EXPORTS, SCANNERS, POWER SUPPLYS, MICROPHONES, AMPS, ANTENNAS, MORE !! 15 yrs SAME LOCATION!! 6 PAGE PICTURE PRICE SHEETS \$1.00 (REFUNDABLE) GALAXY, BOX-1202, AKRON, OHIO 44309. [HTTP://MEMBERS.AOL.COM/GALAXYELC](http://MEMBERS.AOL.COM/GALAXYELC)

Tubes l/s - M/p of ge 6jb6a or 6146w & driver 38.00. M/p 6js6c & driver 70.00. Other amateur related tubes are available. Web site <http://www.jorsm.com/~n9tew>. E-mail: n9tew@jorsm.com. Bob Bieker 219-924-0945.

WANTED: Panasonic RF2200 portable shortwave receiver, must be in good shape cosmetically and electronically. Call (908) 874-2328.

DRAKE R8B, MINT CONDITION, OUTBOARD SPEAKER AND MANUAL, ORIGINAL BOX, \$700. TIMEWAVE DIGITAL SIGNAL PROCESSOR, DSP 59+, WITH POWER SUPPLY, \$125. CALL CHUCK 847-577-1853.

WANTED: X-BAND RADAR AND MICROWAVE EQUIPMENT. CIVILIAN, MILITARY — ALSO PARTS TM'S ETC. RADAR BOX 10215, PITTSBURGH, PA 15232.

Free Electricity. No more Electric Bills. Billion Dollar Industry. Reps Needed. Rhinish, 245239 Neptune Station, Brooklyn, NY 11224.

OLD TIME PROGRAMS. Over 100, 30 minute programs per computer CD (in MP3 or RealAudio) WWW.SCANCAT.COM 1-888-722-6228

the loose connection

Radio Communications Humor

Bill And Doug: Very Cool, Indeed

I often wish my readers could share with me the joys of writing for publication. Particularly this morning, when my alarm went off at 4:45 (that's a.m.) so I could write yet another missive of the strange effects that electronic communications have had on me throughout the years.

First radio-related thought of the day: If that damned cat knocks one more thing off my bureau, I'll rip all his whiskers out — one at a time. Note how radio components (in this case, cat's whiskers) are a major part of my life. For those of you who think that the lovely and talented *Norm* is my only friend, today I'll introduce Doug (his real name). Doug was my best friend when I was growing up. Since (my wife assures me) I'm not completely grown up, it would stand to reason that he still is.

Doug's '65 Mustang and my '64 MGB had CB radios. They made us look cool. We would tell girls that we were on secret missions and would have to check in with "headquarters" from time to time. Doug used a telephone handset on his radio when car-phones were pure fantasy. We'd often call each other with important-sounding (and often specially-coded) messages at pre-determined times. Now that we're older and much more aware of what really goes on in women's minds, we wince at the thought of what they might have told their friends after dating us: "You wouldn't believe this weirdo I was out with! He had an old tube-type CB radio in an MG — you can imagine how much legroom I had — and he and his buddy kept calling each other just when things were getting interesting. They'd make up all these stupid spy-messages to sound like they're secret agents or something. The guy on the other end even called himself 'Q.' Any worthwhile special agent would have at least spent a couple bucks on some burgers."

Doug lives about 250 miles from me now, but our wives have our numbers — just like the young ladies of the sixties did — and like them, our wives still let us believe we're cool.

Doug and I barely knew which end of

the mike to talk into, but our lives have always contained more than our share of electrons. Doug now uses a power-wheelchair to get around, and I still say things like, "Here — let me have a look — I'm sure I can fix that . . ."

A while back, I arrived at Doug's house with pizza and pickled eggs (a bag of cheese-popcorn would have made it a perfect meal) and let myself in. I found him sitting, facing the corner of the kitchen, his wheels tight against the walls.

"Were you bad?" I asked.

"This @\$*&! chair-control has lost its mind!" he said, "it started spinning me in circles 'til I ended up here and the circuit-breaker tripped when the wheels jammed against the wall."

I was able to pull the chair away from the corner and reset the breaker, but the moment he touched the joystick-control, the chair began making three-foot circles on the kitchen floor, and headed for the corner again.

I tripped the breaker and opened the joystick control as Doug pondered the pizza. A stuck-microswitch was at fault, and some now-banned trichloroethene had him moving in a straight line once again. While I'm relegated to shortwave, ham, and scanner bands, Doug now has Mahlon — an electronic servant, if you will. Mahlon recognizes his name when Doug calls, and handles a variety of switching functions ranging from closing the garage door and arming the burglar alarms to adjusting the angles of his bed. I have yet to find Doug folded in half like a hasty ham-sandwich in that bed, but I warn him not to offend Mahlon when he's there alone. Doug's wife Linda (oh, she'll be upset to find herself defamed here) — maybe I'll call her *Minda*. Doug's wife, Minda told me of some recent trouble she'd had with their alarm system — how it would sound the internal alarm — the one that sounds only inside the house — every night at two minutes after midnight. Several calls to the alarm-monitoring company ended in frustration when they told her everything was operating normally, but they'd be glad to send a technician out in the morning — for



a fee. She and Doug stared at the ceiling 'til the alarm stopped sounding — at two minutes after one — and let them go back to sleep.

Eventually, a different technician answered the phone when Minda called shortly after midnight. He asked if she'd take the cordless phone from room to room, looking for where the alarm was loudest. Dutifully, she did. Her search ended in the living room, listening to the digital clock that sat atop their television. Yes, it was an alarm clock. It had become "set" when it experienced a brief power-outage. The alarm tech told her it was "no problem," and that it had been a boring evening anyway.

In a fast-changing world where few things can be counted on, Doug can. There's not much different today when we re-hash the story of his releasing the clip on his 102" whip so it would smack the hood of the guy sitting behind him at a light — a not-so-subtle reminder to dim those high-beams, dammit. Doug and I now communicate regularly via E-mail — something I talked him into because I hate the telephone (and the bills that come with it). Our golf clubs are rusting; our guitars (mine) and drums (his) are "in the attic," and our final output tubes are aging. We're lucky that our wives collect interesting relics. Say good night, Doug. ■

BY BILL PRICE, N3AVY

MAKING BROADCAST HISTORY ... AGAIN



Introducing the New Sangean ATS505

A Lot More For A Lot Less!

- Continuous All Band SW Coverage
- Exceptional SSB
- 45 Memory Channels / with Auto Memory Preset
- 9/10 kHz Switch
- AM/FM Stereo thru Headphones
- Dual Time Clock with Alarm
- Lighted LCD Display
- Carrying Case & Earbuds
- Size: 8-1/2" W x 5-1/4" H x 1-3/8" D

\$129⁹⁵ Includes U.S. Shipping



Sangean ATS909

The Last Shortwave Receiver You'll Ever Need to Buy!

- 306 Memory Presets, 29 Separate Pages
- True Upper and Lower SSB
- 5 Tuning Methods
- 42 World City Times
- RDS Reception
- AM/FM Stereo thru Headphones
- Built-in SW Antenna Jack
- Dual Time Clock with Alarm
- Lighted LCD Display
- Carrying Case, SW Ant., Earbuds

\$259⁹⁵ Includes U.S. Shipping



CCRadio 'Platinum Edition'

*The Best AM Radio Made Today & Now A Perpetual Radio!**

NEW!

- AM, FM, TV Audio, Weather Band + Alert
- Built-in 6V DC Input Jack & Charging Circuit
- Built-in LED Light Jack
- Audio Tuned for Human Voice
- 5 Memory Buttons Per Band
- Rotary Tuning Knob with 1KHz Fine Tuning
- Lighted Digital Display

\$159⁹⁵ Includes U.S. Shipping

*Optional Solar Kit Includes: Solar Panel, LED Light, 4 (4,000 mAh) Nicad Batteries and AC Charging Adapter
\$129.95 with purchase

CIRCLE 162 ON READER SERVICE CARD

SANGEAN

AMERICA, INC.

www.sangean.com

Broadcast Tower, Egypt



800-522-8863
ccrane.com

800-522-TUNE
FREE
CATALOG

THE ALL NEW MULTICOUNTER

\$399



TA100S Antenna Included
U.S. Pat. No. 5,471,402

Optoelectronics presents the **NEW Multicounter** CD100 Counter / Decoder. The **Multicounter** combines a frequency counter and tone decoder in one handheld package. As the **Multicounter** locks onto a nearby RF signal, the frequency along with either **CTCSS, DCS, LTR,** or **DTMF** is instantly shown on the two-line LCD display. Like the popular Optoelectronics Scout, the **Multicounter** also **Reaction Tunes** many radios for instant monitoring of the frequency captured.

ORDER NOW

The **Multicounter** is so easy to operate that it is ideal for quick radio checks by a two-way radio technician or the hobbyist looking for unknown frequencies and tones.

See Us
At Dayton
Booths 76 & 77

FEATURES

- 10MHz - 1GHz Frequency Range
- Measures frequency and tone in < 1 second
- Decodes CTCSS, DCS, LTR, and DTMF
- LTR displays Area code, Go to Repeater, Home Repeater, ID, and Free repeater
- Built-in .5ppm TCXO for accurate frequency measurement
- Reaction Tune the ICOM R10, R7000, R7100, R8500, R9000, AOR AR8000, AR8200, OS456/Lite, OS535, Optoelectronics R11, and Optocom.
- Two Line LCD Display with EL backlight
- Internal memory for frequency / tone measurement
- Download memory to PC with optional Optolinx PC interface
- Patented Digital Auto Filter



Reaction Tune
Scanner Not Included

CIRCLE 158 ON READER SERVICE CARD

OPTODIRECT 800-327-5912
OPTOELECTRONICS

5821 NE 14th Avenue • Ft. Lauderdale, FL 33334 • Visa • MasterCard • C.O.D. •
Prices and Specifications are subject to change without notice or obligation

Tel: 954-771-2050 Fax: 954-771-2052 Email: sales@optoelectronics.com Internet: www.optoelectronics.com