



# Design and Verify Circuits. Fast.

DOs and Windows & Mac versions available

## Electronics Workbench®

**NEW** Version 3

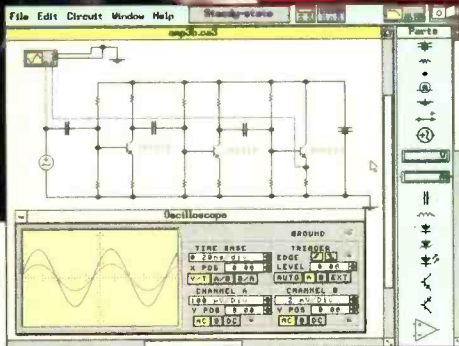

### Analog Module includes:

- complete control over all component values
- ideal and real-world models for active components
- resistors, capacitors, inductors, transformers, relays, diodes, Zener diodes, LEDs, BJTs, opamps, bulbs, fuses, JFETs, and MOSFETs
- manual, time-delay, voltage-controlled and current-controlled switches
- independent, voltage-controlled and current-controlled sources
- multimeter
- function generator (1 Hz to 1 GHz)
- dual-trace oscilloscope (1 Hz to 1 GHz)
- Bode plotter (1 mHz to 10 GHz)
- SPICE simulation of transient and steady-state response

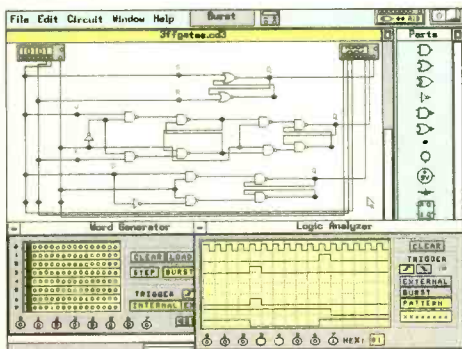

### Digital Module includes:

- fast simulation of ideal components
- AND, OR, XOR, NOT, NAND and NOR gates
- RS, JK and D flip-flops
- LED probes, half-adders, switches and seven-segment displays
- word generator (16 eight-bit words)
- logic analyzer (eight-channel)
- logic converter (converts among gates, truth table and Boolean representations)

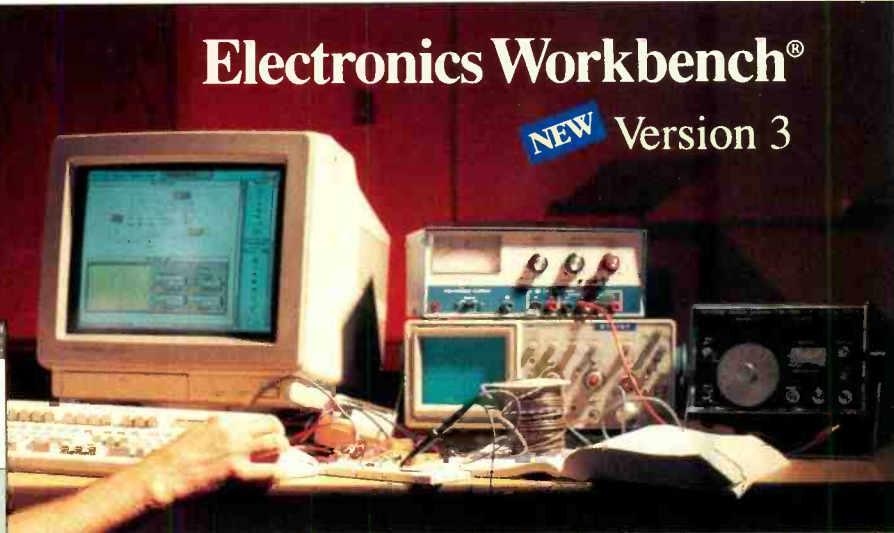

## Complement Your Test Bench

Here's why Electronics Workbench belongs on *your* test bench: Wires route themselves. Connections are always perfect. And the simulated components and test instruments work just like the real thing. The instruments are indestructible and the parts bin holds an unlimited supply of each component. The result: thousands of electronics professionals and hobbyists save precious time and money. **Over 90% would recommend it to their friends and colleagues.** Electronics Workbench: the ideal, affordable tool to design and verify your analog and digital circuits before you breadboard.

And now the best is even better - Electronics Workbench Version 3.0 is here. It simulates more and bigger circuits, and sets the standard for ease of use. Guaranteed!

### **NEW** Features in Version 3

- new components include JFETs, MOSFETs, voltage-controlled and current-controlled sources and manual, time-delay, voltage-controlled and current-controlled switches
- real-world models for opamps, BJTs, JFETs, MOSFETs and diodes - over 100 models available
- MS-DOS version now supports up to 16 MB of RAM for simulation of bigger circuits
- new Microsoft® Windows™ version available
- technical support now also available on CompuServe™

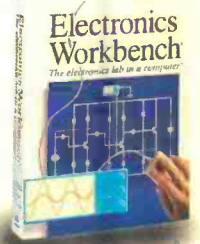

**Just \$299!**

## Electronics Workbench®

*The electronics lab in a computer™*

**Call: 800 263-5552**

INTERACTIVE IMAGE TECHNOLOGIES LTD.  
908 Niagara Falls Blvd. #068, North Tonawanda, NY 14120-2060  
Telephone: (416) 361-0333 FAX: (416) 368-5799

\*30-day money-back guarantee.

Prices in U.S. dollars, shipping \$15. Offer valid in U.S. and Canada only.  
All trademarks are the property of their respective owners.

**CIRCLE 157 ON FREE INFORMATION CARD**



# Popular Electronics®

THE MAGAZINE FOR THE ELECTRONICS ACTIVIST!

## CONSTRUCTION ARTICLES

<b>BUILD A RADIO-CONTROLLED CAR</b> .....	William Sheets and Rudolf F. Graf	31
<i>Learn how radio-control circuits work as you put together this fun-to-use R/C system</i>		
<b>AN AIR-CONDITIONER MONITOR FOR YOUR CAR</b> .....	Anthony J. Caristi	43
<i>Protect your car's air-conditioning system while you save money and the environment</i>		
<b>BUILD THE MOTION MEMORY</b> .....	Scott Edwards	63
<i>Animate the world around you with some common hobby servos and this joystick recorder</i>		

## FEATURE ARTICLES

<b>ALL ABOUT RADIO CONTROL</b> .....	Marc Spiwak	39
<i>Get in on the fun of one of this country's most popular hobbies</i>		
<b>POLICE CARS GO HIGH-TECH</b> .....	Bill Siuru	59
<i>Heads-up displays, nightvision viewers, and more help the police get the jump on the bad guys</i>		
<b>AN INTRODUCTION TO FILTER CIRCUITS</b> .....	Robert A. Young	69
<i>Learn how to design and use filter circuits for almost any application</i>		

## PRODUCT REVIEWS

<b>HANDS-ON-REPORT</b> .....		18
<i>Logisym logic-simulator software</i>		
<b>PRODUCT TEST REPORT</b> .....	Len Feldman	21
<i>Sharp MiniDisc player</i>		
<b>GIZMO</b> .....		47
<i>Including ProPhone CD-ROM Telephone Directories, Audio-Technica Multimedia Speakers, Sony MiniDisc Recorder, and much more</i>		

## COLUMNS

<b>MULTIMEDIA WATCH</b> .....	Marc Spiwak	6
<i>Multimedia gets "Reel"</i>		
<b>THINK TANK</b> .....	John Yacono	24
<i>Motion-detection circuits</i>		
<b>ANTIQUE RADIO</b> .....	Marc Ellis	73
<i>Good-bye to the NBS crystal set</i>		
<b>COMPUTER BITS</b> .....	Jeff Holtzman	76
<i>Bits and pieces</i>		
<b>CIRCUIT CIRCUS</b> .....	Charles D. Rakes	78
<i>Inductive transmitters</i>		
<b>DX LISTENING</b> .....	Don Jensen	84
<i>The money crunch</i>		
<b>HAM RADIO</b> .....	Joseph J. Carr	86
<i>An all-band antenna</i>		
<b>SCANNER SCENE</b> .....	Marc Saxon	88
<i>Scanning surveillance operations</i>		

## DEPARTMENTS

<b>EDITORIAL</b> .....	Carl Laron	2
<b>LETTERS</b> .....		4
<b>ELECTRONICS LIBRARY</b> .....		10
<b>NEW PRODUCTS</b> .....		16
<b>ELECTRONICS MARKET PLACE</b> .....		82
<b>POPULAR ELECTRONICS MARKET CENTER</b> .....		93
<b>ADVERTISER'S INDEX</b> .....		132
<b>FREE INFORMATION CARD</b> .....		133

Popular Electronics (ISSN 1042-170X) Published monthly by Gernsback Publications, Inc., 560-B Bi-County Boulevard, Farmingdale, NY 11735. Second-Class postage paid at Farmingdale, NY and at additional mailing offices. One-year, twelve issues, subscription rate U.S. and possessions \$21.95, Canada \$28.84 (includes G.S.T., Canadian Goods and Services Tax Registration No. R125186290), all other countries \$29.45. Subscription orders payable in U.S. funds only. International Postal Money Order, or check drawn on a U.S. bank. U.S. single copy price \$3.50. © 1994 by Gernsback Publications, Inc. All rights reserved. Hands-on Electronics and Gizmo trademarks are registered in U.S. and Canada by Gernsback Publications, Inc. Popular Electronics trademark is registered in U.S. and Canada by Electronics Technology Today, Inc. and is licensed to Gernsback Publications, Inc. Printed in U.S.A.

Postmaster: Please send address changes to Popular Electronics, Subscription Dept., P.O. Box 338, Mount Morris, IL 61054-0332

A stamped self-addressed envelope must accompany all submitted manuscripts and/or artwork or photographs if their return is desired should they be rejected. We disclaim any responsibility for the loss or damage of manuscripts and/or artwork or photographs while in our possession or otherwise.

As a service to readers, Popular Electronics publishes available plans or information relating to newsworthy products, techniques, and scientific and technological developments. Because of possible variances in the quality and condition of materials and workmanship used by readers, Popular Electronics disclaims any responsibility for the safe and proper functioning of reader-built projects based upon or from plans or information published in this magazine.

**Larry Steckler**

*EHF, CET*

*Editor-In-Chief and Publisher*

## EDITORIAL DEPARTMENT

**Carl Laron**

*Editor*

**Robert A. Young**

*Associate Editor*

**John J. Yacono**

*Associate Editor*

**Teri Scaduto**

*Assistant Editor*

**Evelyn Rose**

*Editorial Assistant*

**Marc Spiwak**

*Editorial Associate*

**Joseph J. Carr, K4IPV**

**Marc Ellis**

**Len Feldman**

**Jeffrey K. Holtzman**

**Don Jensen**

**Charles D. Rakes**

**Marc Saxon**

*Contributing Editors*

## PRODUCTION DEPARTMENT

**Ruby M. Yee**

*Production Director*

**Karen S. Brown**

*Production Manager*

**Kathy Campbell**

*Production Assistant*

## ART DEPARTMENT

**Andre Duzant**

*Art Director*

**Injae Lee**

*Illustrator*

**Russell C. Truelson**

*Illustrator*

**Jacqueline P. Cheeseboro**

*Circulation Director*

**Michele Torrillo**

*P-E Bookstore*

## BUSINESS AND EDITORIAL OFFICES

Gernsback Publications, Inc.

500-B Bi-County Blvd.

Farmingdale, NY 11735

1-516-293-3000

Fax: 1-516-293-3115

President: **Larry Steckler**

**Subscription**

**Customer Service/Order Entry**

1-800-827-0383

7:30 AM – 8:30 PM EST

**Advertising Sales offices listed on page 132**

Cover by Loewy Design,  
Photo Illustration by Yves Courbet



Since some of the equipment and circuitry described in POPULAR ELECTRONICS may relate to or be covered by U.S. patents, POPULAR ELECTRONICS disclaims any liability for the infringement of such patents by the making, using, or selling of any such equipment or circuitry, and suggests that anyone interested in such projects consult a patent attorney.

## AN ISSUE FOR ALL SEASONS

Summer is now in full swing, and this month **Popular Electronics** turns its attention to just about everyone's favorite season.

For instance, walk through any park on a nice summer day and you are bound to see "kids" of all ages taking part in one of this country's most popular and fastest-growing hobbies—radio control. Whether it's RC cars, planes, boats, or you name it, everyone seems fascinated with these devices. In two articles, "Build a Radio-Controlled Car" and "All About Radio Control," we examine, in depth, how you can get in on the fun, how commercial R/C devices work, and how you can build your own radio-control system. These stories begin on pages 31 and 39.

But Summer also has an unpleasant side, especially if you find yourself cooped up in a car on one of those "wonderful" 90+ degree days. The only thing that makes that bearable is your car's air conditioner. In "An Air-Conditioner Monitor for your Car" we look at a simple monitor circuit that makes sure your system is ready when you need it most. What's more, by spotting early signs of trouble, it can help you save money, and even help save the environment. The story begins on page 43.

Of course, after Summer comes Fall, and then Winter. If you're the type that likes to look ahead, we have a project that can make your next Halloween or Christmas a lot more fun. In "Build the Motion Memory" we present a simple circuit that can animate your holiday displays, or anything else. Imagine a pumpkin that has rolling eyes, or a Santa's workshop full of busy elves. The only limit to its uses are your imagination. The story begins on page 63.

Carl Laron  
Editor

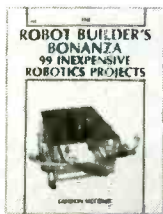

2800P \$17.95

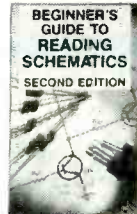

3632P \$10.95



3671P \$18.95

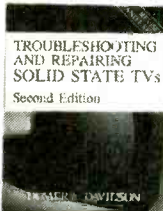

3700H-XX \$36.95  
Counts as 2/Hardcover

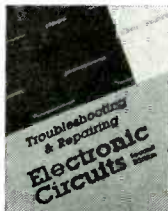

3258P \$19.45

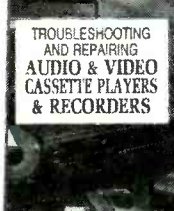

3795P \$19.95

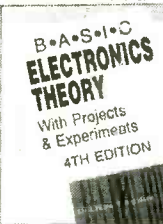

4261H-XX \$35.00  
Counts as 2/Hardcover



3438H-XX \$36.95  
Counts as 2/Hardcover



4243P \$9.95

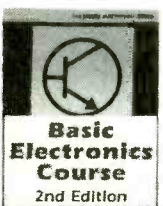

2613P \$19.95



2724P \$17.95

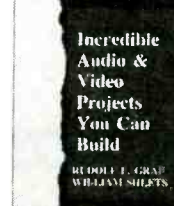

4325H-XX \$39.95  
Counts as 2/Hardcover

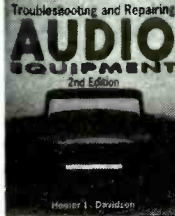

4112H-XX \$29.95  
Counts as 2/Hardcover

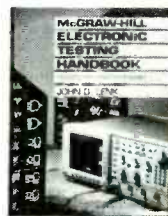

D376026H-XX \$39.50  
Counts as 2/Hardcover

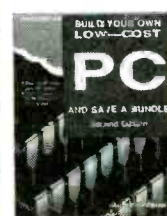

4209P \$19.95

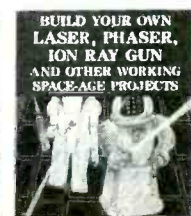

1604P \$17.95

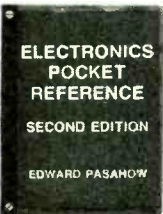

0487375P \$24.95

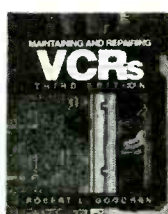

4204H-XX \$39.95  
Counts as 2/Hardcover



3765P \$19.95



4179H \$28.95  
Hardcover



3711P \$19.95



58E354H-XX \$39.00  
Counts as 2/hardcover



2790P \$17.95

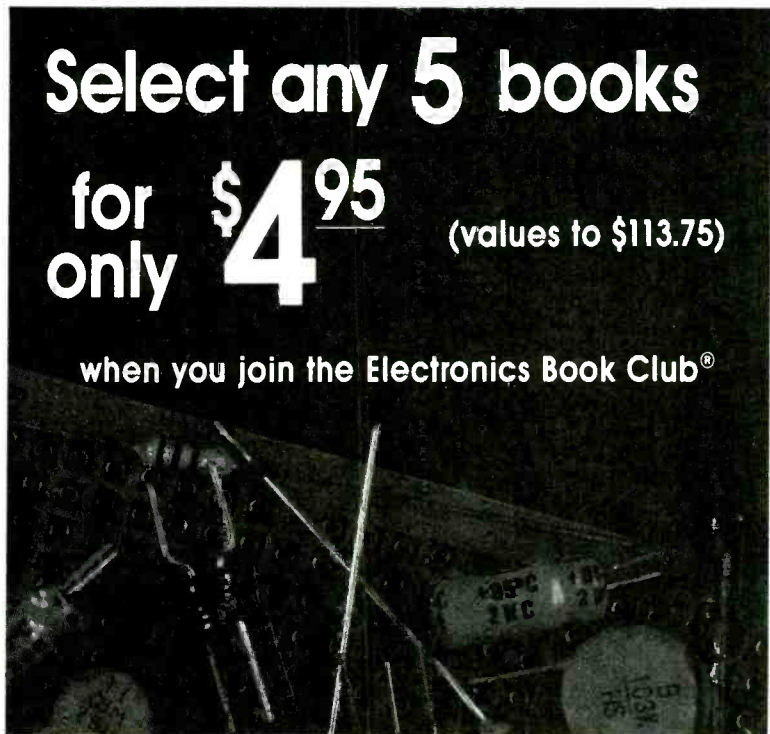

Select any 5 books  
for only \$4<sup>95</sup> (values to \$113.75)  
when you join the Electronics Book Club®

**As a member of the Electronics Book Club . . .**

... you'll enjoy receiving Club bulletins every 3-4 weeks containing exciting offers on the latest books in the field at savings of up to 50% off regular publishers' prices. If you want the Main Selection do nothing and it will be shipped automatically. If you want another book, or no book at all, simply return the reply form to us by the date specified. You'll always have at least 10 days to decide. And you'll be eligible for **FREE BOOKS** through our Bonus Book Program. Your only obligation is to purchase 3 more books during the next 12 months, after which you may cancel your membership at any time.

Publishers' prices shown. All books are softcover unless otherwise noted. If you select a book that counts as 2 choices, write the book number in one box and XX in the next. A shipping/handling charge & sales tax will be added to all orders.

©1994 EBC

If coupon is missing, write to:  
Electronics Book Club, Blue Ridge Summit, PA 17294-0810

**Your most complete and comprehensive source for the finest electronics books**

**Electronics Book Club®** Blue Ridge Summit, PA 17294-0810

**YES!** Please send me the books listed below, billing me for just \$4.95 plus shipping/handling & tax. Enroll me as a member of the **Electronics Book Club** according to the terms outlined in this ad. If not satisfied, I may return the books within 10 days without obligation and have my membership cancelled.

\_\_\_\_\_

If you select a book that counts as 2 choices, write the book number in one box and XX in the next.

Name \_\_\_\_\_

Address \_\_\_\_\_

City/State \_\_\_\_\_

Zip \_\_\_\_\_ Phone \_\_\_\_\_

Valid for new members only, subject to acceptance by EBC. Canada must remit in U.S. funds drawn on U.S. banks. Applicants outside the U.S. and Canada will receive special ordering instructions. All books are softcover unless otherwise noted. Publishers' prices shown. A shipping/handling charge & sales tax will be added to all orders. PE894

## "HOW TO SPLIT A POWER SUPPLY" CORRECTION

In the June 1994 issue, an error appeared in Fig. 2 of the article "How to Split a Power Supply." During the preparation of the article, a line connecting the bases of Q1 and Q2 to their emitters crept in. It should be omitted. Many thanks to the several sharp readers who caught the error. We apologize for any inconvenience it might have caused.—Editor

## SAFETY FIRST

Being a model-rocket enthusiast, I read with interest the article "Time-Delayed Model Rocket Launcher" (*Popular Electronics*, May 1994). I would like to point out one very important safety factor. It is highly recommended that the hobbyist be at least 15 feet from the launch pad for safety. The author indicated that he had just three feet between the project and the launch pad. Should a rocket or launch-system mal-

function occur while a person is that close, serious injury could result!

Also, as the author recommended, always unplug the phone plug for the igniter from the jack. I would suggest using a 12-volt battery for the system as it provides for better ignition with today's igniters.

K.B.  
Fullerton, CA

## SCA ADAPTER CORRECTIONS

Please note that there are two errors in the schematic of the SCA demodulator as it appears on page 45 of the June 1994 issue of *Popular Electronics*. First, there should be a solid connection between the junction of C6 and R14 and ground. Second, the junction of R22 and

R23 should go to +15 volts rather than to ground.—Don McCormick

## LOVES THE LOGIC PROBE

I want to tell you how much I enjoyed building and using the 125-MHz Logic Probe, which was described in the February 1994 issue of *Popular Electronics*. In the past I had used an oscilloscope to test circuit functionality, but I have found this logic probe to be considerably quicker, in part because the audible tone allows me to keep my eyes on the board instead of moving back and forth between the circuit board and the oscilloscope screen. I have been working on hardware random-number generation (very important for ultra-secure

secret codes), using an array of 16 crystal oscillators, each of which operates up to 80 MHz, so I especially appreciate the 125-MHz bandwidth of the logic probe.

Keep up the great work!  
T.S.P.  
Holland, PA

## HAVES & NEEDS

I have all of the first 255 FactCards published in *Hands-On Electronics* and *Popular Electronics*. I am willing to give them away to the first person who asks for them and pays the postage (\$2.90). Anyone writing for the FactCards should include a stamped, self-addressed envelope so that I can return the stamps to those who were too late.

After more than 50 years as an electronics professional and hobbyist, I also have a very large junk box that I need to get rid of.

ROY A. NORMAN  
223 Shangri La Avenue  
Brunswick, GA 31525-1923

I am in need of the schematic for my Hyundai HCM-1420 monitor, made in 1991. I will pay any reasonable amount for this information, and will answer any replies. Thank you.

EDWARD TAFFE, W2IGR  
222 Third Street  
Palisades Park, NJ 07650

I am retired and disabled. I'm most impressed with *Popular Electronics*; it keeps me in touch with the present world.

I am looking to acquire a schematic for an old Revere 8mm movie projector, model 777. I believe the company is no longer in business. Over the years the projector has been repaired and modified. I would like to restore it to its original condition, but I need the schematic to help me identify parts. Your help shall be greatly appreciated.

WILLIAM C. MERZ  
7659 Vienna Lane  
Port Richey, FL 34668

# LETTERS

Heathkit Heathkit Heathkit Heathkit Heathkit

## PC Servicing

Now, a Quality, Affordable, and Value-Packed Course

A Heathkit Exclusive. We deliver a true multi-media learning adventure. Not only do you get a better computer, but you get the only Computer-Aided Instruction software available as part of a self-study course.



### What You'll Learn:

- PC Upgrading and Maintenance
- Preventive Maintenance Procedures
- How to Identify and Repair Problems
- Installing Memory, Drives, Expansion Boards, Microprocessor Upgrades
- How to Configure for Performance
- MS/DOS® & Windows®

### And Learn About Computers at the Electronics Level:

- DC Electronics
- AC Electronics
- Semiconductor Devices
- Electronic Circuits
- Digital Techniques
- Microprocessor Programming

•Heathkit Educational Systems •433 Riverside Drive •Boston Harbor, MA 02111-1288

Compare this course with any others. You'll find that Heathkit offers you 2-3 times the value and quality of education. Many additional courses are available for TV, VCR, Camcorder Servicing, Electronics, etc.

For a Full-Line Catalog of Electronics Courses, call 1-800-44-HEATH

When calling, please mention this code: 107-026

CIRCLE 155 ON FREE INFORMATION CARD

## Introducing a New Era In Technical Training.

World College, an affiliate of the Cleveland Institute of Electronics, was created to provide a four year, independent study, technical degree program to individuals seeking a higher education. The Bachelor of Electronics Engineering Technology Degree, offered by World College, prepares students for high-paying careers in electronics, telecommunications, electrical power, computer and control systems. World College's curriculum is taught in an effective, time-proven, independent study environment. With World College's flexible study schedule, students have the opportunity to work or spend time with their family without having to worry about rigid scheduling residential colleges offer.

### A Quality Education with a Flexible Schedule.

In a world heavily dependent on electronic equipment, people who understand electronics will have no problem putting their knowledge to work... in high-paying careers. The staff and faculty of World College have invested over ten years developing, what we believe to be, the finest independent-study, baccalaureate degree program available. World College's mission is to instill in each student the knowledge, education, and training that employers are seeking for the many technical positions available today. It's a program created to provide the best education and training possible with a flexible schedule to match your busy lifestyle.

World College is currently seeking approval to confer the Bachelor Degree from the Virginia Council of Higher Education.



# Earn A Bachelor of Electronic Engineering Technology Degree from



**WORLD COLLEGE**  
*Bringing Technology Home!*

Lake Shores Plaza  
5193 Shore Drive, Suite 113  
Virginia Beach, VA 23455-2500

### Send For Your Free Course Catalog.

Take the first step towards a new start in life. Send for World College's Free Independent Course Catalog today and discover how easy and affordable it is to get started on your Bachelor Degree.

World College is affiliated with



## Complete the Entire Degree Program Under One Roof. Yours!

Only World College offers an independent study, four year technical degree which can be completed through one school. All lab equipment\*, parts, and software are included in your tuition and the program's 300-plus laboratory experiments can be completed in your own home.

### You Pay Only For Time Actually Used.

World College not only provides a means to earn a Bachelor Degree while fulfilling current obligations, but there are no restrictions on how fast you can complete the program. At World College, you pay tuition only for the actual upper-level semesters it takes to graduate. The quicker you complete the program, the less you pay in tuition. It's an effective way to keep you motivated in order to complete the course and move on to a better paying position as quickly as possible.

Currently not available in Ohio.

\* Student must have access to a personal computer system.

**YES!** Please send me World College's Free Course Catalog detailing the full curriculum.

Name: \_\_\_\_\_

Address: \_\_\_\_\_

Apt: \_\_\_\_\_

City: \_\_\_\_\_

State: \_\_\_\_\_ Zip: \_\_\_\_\_

Phone: ( \_\_\_\_\_ ) \_\_\_\_\_

Age: \_\_\_\_\_

Return to: WAH11  
World College  
Lake Shores Plaza  
5193 Shore Drive, Suite 113  
Virginia Beach, VA 23455-2500

# MULTIMEDIA WATCH

By Marc Spiwak

## Put some "ReelMagic" in your PC

In the past couple of years, video has become a really big item on the desktop. More than likely, the next multimedia software package you buy will include real-time video, either in the form of AVI (Microsoft's Video for Windows format) or QTW (Apple's Quicktime for Windows format) files. Both of those formats, however, leave a lot to be desired, especially when you try to play the video in a window of any substantial size. They are pretty good for viewing video in a small window, but when you blow it up to, say,



A ReelMagic card and an MPEG title allow your machine to show miraculous video.

full-screen size, the video becomes jerky, leaving out many video frames that the computer wasn't fast enough to display. Full-screen video contains just too much information for any current PC to keep up with.

Enter the Motion Picture Experts Group and the MPEG format. This video-

compression scheme allows full-screen video playback at 30 frames-per-second, and up to 72 minutes of video can be squeezed onto a single CD-ROM. Such compression ratios are possible because the MPEG scheme discards unnecessary information. A simple example of unnecessary information would be a blue background that stays blue for many consecutive video frames. Much of the information present in a video signal is repeated from frame to frame, so by dropping redundant information, there's less to store on the disc and less for the computer to process and display on-screen.

The problem with the MPEG format is that special hardware is needed to decode the information—hardware that is currently not present in most PC's. That problem can be quickly solved by popping the ReelMagic card from Sigma Designs into an empty PC expansion slot. The only other requirement to use the ReelMagic is that your VGA card have a VESA-compatible feature connector—basically just a header on the card for use with video accessories. The feature connector is fairly standard on newer video cards, but might be absent on older ones. You must make sure that your video card has that connector before you invest in a ReelMagic. An audio output on the back of the ReelMagic card lets you directly con-

nect headphones, amplified speakers, or a patch cable for inputting ReelMagic audio into the auxiliary input of your sound card.

The ReelMagic has built-in 16-bit digital sound processing, a CD-ROM interface, and CD audio connectors, so that it can take the place of a sound card and CD-ROM controller. That lets you keep as many slots free as possible for other cards. The ReelMagic board has a list price of \$449 by itself, but it is also available in a multimedia-upgrade package which includes the ReelMagic, a 2x CD-ROM drive, speakers, and five MPEG titles for \$799. This package lets you jump right into all multimedia software, including MPEG applications. A third option, if you already have a sound card, is ReelMagic Lite, which is basically the same as the ReelMagic but without built-in audio capabilities and a list price of \$349—why should you pay for the audio if you don't need it?

In short, the video produced by the ReelMagic is very impressive, and the stereo audio is CD-quality. A demo disc included with the card contains a bunch of sample MPEG clips that effectively demonstrate the power of MPEG. One MPEG title was also included with the ReelMagic: *Dragon's Lair* from Readysoft Corporation. MPEG compression brings the sharp images and fluid animation of the original laser-disc based



game (a huge arcade hit in the 1980's) to the PC. In it, you guide "Dirk the Daring" through a maze of demons, snakes, fire, falling rocks, and more to reach and rescue a princess held in the Dragon's Lair. The game is very entertaining, and at times it seems like you're playing out a role in a cartoon more than a game.

Other MPEG titles were supposed to be included with the ReelMagic card, but apparently they were not ready to ship. (At the time of this writing, there was a shortage of available MPEG material, but that situation is supposed to change shortly—probably by the time you read this.) A voucher for an MPEG version of *Return to Zork* was included in the ReelMagic package; the voucher is good for a free copy of the disc as soon as it's ready.

A handful of discs with MPEG material are already

available from Aris Entertainment, but they aren't enough by themselves to justify the purchase of a ReelMagic card. The only other title I've seen containing MPEG material is the MPEG version of *Compton's Interactive Encyclopedia*. It is identical to the regular version of the disc, except the video clips are in the MPEG format and can be viewed on a full screen—admittedly the video is much better than on the regular version.

With a company like Compton's New Media supporting the ReelMagic, I'm sure it won't be long before I'm deluged with MPEG material for use with the ReelMagic. MPEG video on a PC is just too impressive to be ignored, and I'll bet that the ReelMagic card and MPEG in general are going to be real winners.

#### NEW STUFF.

At the same time I was

# hello, max...



**We would like to introduce you to the Max-100A Frequency Counter, because great things really do come in small packages.**

- Full 8-digit display covers 100 MHz range
- Completely automatic-no front panel controls
- Extra large .43" display
- Battery or AC powered
- Automatic decimal point
- Input overvoltage protection
- Automatic overflow indication
- Automatic low battery indicator
- 1 Hz resolution to 100 MHz



**GLOBAL SPECIALTIES** • (800) 572-1028  
70 Fulton Terrace, New Haven, CT 06512  
(203) 466-6103 • Fax: (203) 468-0060  
CIRCLE 13 ON FREE INFORMATION CARD

**an Interplex Industries company**

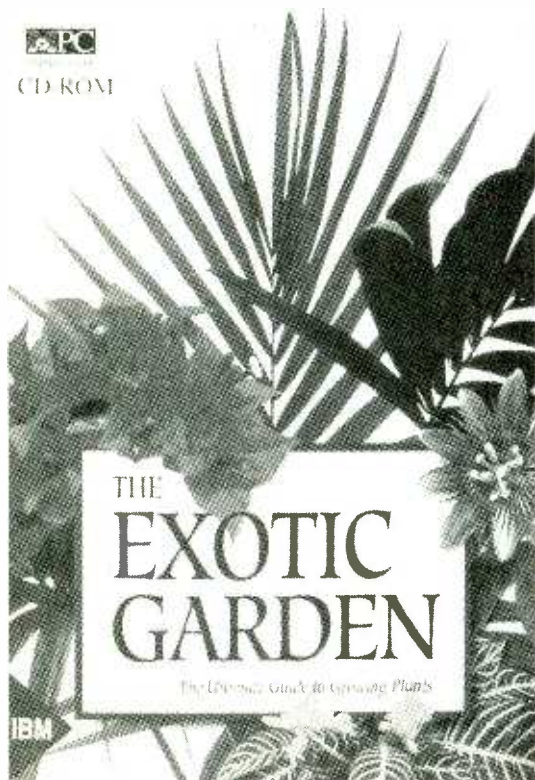

The Exotic Garden is a CD-ROM devoted entirely to plant lovers.

playing with the MPEG version of *Compton's Interactive Encyclopedia*, I also took a look at the latest release, 2.0, of the regular version. It is one fantastic package of information, useful for research or just plain fun. All the text you would find in the printed version of *Compton's Encyclopedia* is included on this single disc, but with the powerful search capabilities of a PC added. The disc also contains plenty of audio and video clips—stuff that can't be included in the printed version. One new feature is "InfoPilot," which informs the user of many additional topics all relating to the original focal point. All information pertaining to a particular topic can quickly be located, whether it's directly related to the original

topic or even barely related. This \$395 disc is a worthwhile investment for the entire family.

Also useful for research and entertainment is the *Time Traveler CD* from New Media Schoolhouse. This disc puts the user in a virtual time machine. You just pick a year from 4000 BC to the present and press the "Go" button. Instantly you are "in" the chosen year and able to study any important event that occurred in that year. Color and black-and-white photos, video, music, and speeches are included. If you are bored with the present time, why not check out the past?

Two new titles came to me from Deep River Publishing. One of them, *EVERYWHERE USA Travel Guide* is useful if you are



CD-ROMIX!, a comic book on CD-ROM, is an excellent example of what multimedia is all about.

planning any trip in the United States and don't want to miss any important sights or attractions. Pick a location, and this disc makes it easy to search for aquariums, museums, fairs, festivals, historic sights, national parks, theaters, and so on. This \$49.95 disc will certainly add more than \$49 worth of value to your next trip. The other title, *Complete House*, is a must for anyone building or remodeling a house. Not only does this disc help you decorate, it also lets you plan room layouts with its built-in CAD/FP floor-plan software. This makes it easy to plan a new layout for a room, and change things on the fly. It's a real time-saver.

If you're an enthusiast of horticulture, then you must check out *The Exotic Garden* from VT Productions. The disc features narrated time-lapse photography of plants growing and flowering, over 500 color photos, and information on each plant pictured. The user can search for plants by their common or Latin name, plant type, ease of growth, plant preferences, and so on. The disc is also helpful in figuring out why a certain plant is not doing well. This \$49.95 disc is perfect for

anyone, with or without a green thumb.

If you are more into wine than horticulture, *Wines of the World* from Multicom Publishing contains everything you could ever want to know about different wines from all over the world. A database on this CD-ROM contains information on over 20,000 different wines. This \$59.95 disc will have you drinking in no time—just kidding!

If adult entertainment is something you enjoy (and not everyone does), New Machine Publishing has several multimedia CD-ROM titles available that may be of interest. You can choose from still photos, full-length videos, and interactive games, all adult-oriented.

I've always liked watching the *Honeymooners* on TV. I think the show is so funny I can watch the episodes over and over again. I guess most people do too, as the show is still on and new episodes haven't been made in many years. As a fan of the *Honeymooners*, I just got one disc that's a keeper. *The Honeymooners Funniest Moments* CD-ROM from MPI Multimedia features clips from the "lost episodes" of the TV show. Anyone who likes the antics of Ralph and Norton ought

## Where to Get It

7th Level, Inc.  
P.O. Box 832190  
Richardson, TX 75083-2190

Aris Multimedia Entertainment  
310 Washington Boulevard,  
Suite 100  
Marina del Rey, CA 90292  
Tel. 310-821-0234

Compton's New Media  
2320 Camino Vida Roble  
Carlsbad, CA 92009  
Tel. 619-929-2500

Conexus, Inc.  
5252 Balboa Ave., Suite 605  
San Diego, CA 92117  
Tel. 619-268-3380

Context Systems, Inc.  
2935 Byberry Road  
Hatboro, PA 19040

Davidson & Associates, Inc.  
19840 Pioneer Ave.  
Torrance, CA 90503  
Tel. 310-793-0600

Deep River Publishing  
P.O. Box 9715-975  
565 Congress St., Ste. 200  
Portland, ME 04104  
Tel. 207-871-1684

MPI Multimedia  
15825 Rob Roy Drive  
Oak Forest, IL 60452  
Tel. 708-687-1914

Multicom Publishing  
1100 Olive Way, Ste. 1250  
Seattle, WA 98101  
Tel. 206-622-5530

New Machine Publishing  
2040 Broadway  
Santa Monica, CA 90404  
Tel. 310-453-5068

New Media Schoolhouse  
P.O. Box 390  
69 Westchester Ave.  
Pound Ridge, NY 19576  
Tel. 800-672-6002

Readysoft  
30 Wertheim Court, Ste. 2  
Richmond Hill, Ontario,  
Canada L4B 1B9

Sigma Designs, Inc.  
47900 Bayside Parkway  
Fremont, CA 94538  
Tel. 510-770-0100

Virgin Games  
18061 Fitch Ave.  
Irvine, CA 92714  
Tel. 714-833-8710

VT Productions  
P.O. Box 339  
Soquel, CA 95003  
Tel. 408-464-1552

to check out this disc.

If your children are constantly being told "Don't touch that!" then *Tuneland* from 7th Level is a CD-ROM they'll appreciate. It takes children to a land where they can click on almost anything they see without inhibition. *Tuneland* consists of a number of locations (Ol' McDonalds farm, a train station, Grandma's house, etc.) where the curious child can click-away at whatever's there and be rewarded with music and animation. A cute bear named Howie (whose voice is performed by Howie Mandel) hides in each location. Our 3-year-old "test toddler" ate the game up.

Another children's CD-ROM, *The Family Circus Our House* CD-ROM from Context Systems is a little off the beaten path. In the program, there's a house you can explore room by room and object by object. However, unlike an ordinary house, you can find out what the historical background and possible future of each object or room is. The *Family Circus* characters appear in wait screens during CD-ROM updates, but are not animated. When animation is used, it is restricted to explaining objects. If your child is a big history buff, this disc will be of interest.

Youngsters learning to read can benefit from a CD-ROM called *Sound it out Land* from Conexus. In the program, there are four characters (a dog, a robot, a toucan, and an owl) that play two games each. The eight games teach skills that are important for reading, such as the vowel sounds and simple-word pronunciation. On the first run, our very active test kid played every game without losing interest.

(Continued on page 26)

Now Available . . . the Most Complete, Single-Volume Amateur Radio Reference

# Tune Into the Exciting and Fast-Growing Hobby of Amateur Radio

- Packed with tips, techniques and applications for immediate use
- 1,000 entries arranged alphabetically with complete cross-references for related topics
- Over 700 illustrations including circuit designs
- Written by a top-class ham radio operator and award-winning author

Learn new technologies . . . build your own accessories . . . upgrade your license . . . explore new amateur radio applications and options . . .

Do it all with the **AMATEUR RADIO ENCYCLOPEDIA** — the comprehensive reference that no ham or radio hobbyist should be without. Here, in one single resource you'll find everything you want to know about shortwave listening antennas, amateur television, military affiliated radio service, amateur satellite communications and much, much more.

Try the **AMATEUR RADIO ENCYCLOPEDIA FREE** for the next thirty days — and we'll even send you a free gift — that's yours to keep. Call toll-free, 1-800-822-8158 or mail the attached order form to TAB/McGraw-Hill, Inc., Blue Ridge Summit, PA 17294.

**Easy enough for beginners . . .**  
detailed enough for experts!

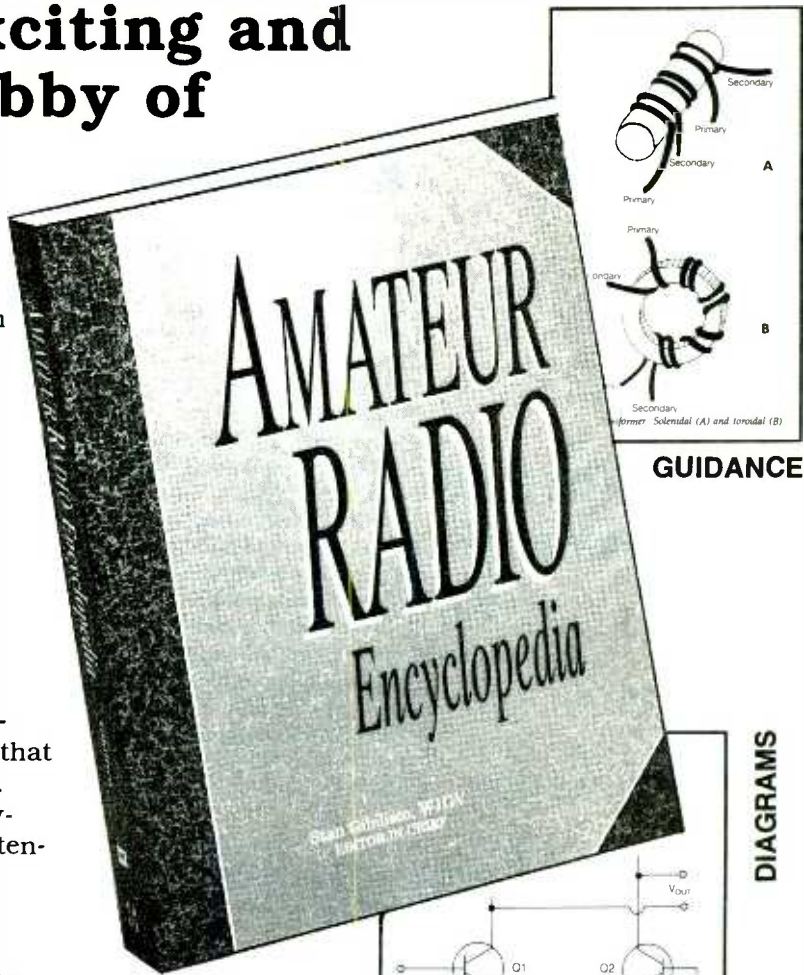

**GUIDANCE**

**DIAGRAMS**

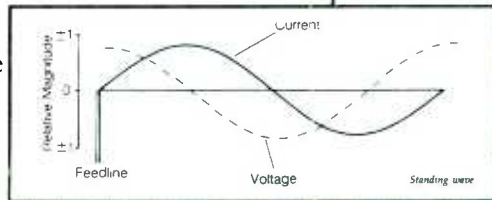

**DESIGNS**

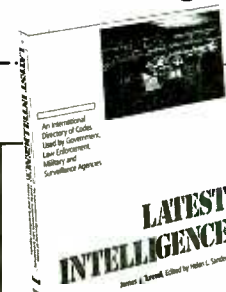

**FREE!**

Crack the "secret" radio codes used by law enforcement and surveillance agencies . . . even military codes . . . with Latest Intelligence — your **FREE** gift just for looking at the **AMATEUR RADIO ENCYCLOPEDIA**.

**YES!** I want to examine the **AMATEUR RADIO ENCYCLOPEDIA** (#023561-9) for 30 days — absolutely **FREE**. Within that time, I will either return the book or pay your invoice for \$49.95 plus \$4.95 s/h and applicable taxes. Whatever I decide, the code-breaker book, Latest Intelligence, is mine to keep.

Name \_\_\_\_\_

Address \_\_\_\_\_

City \_\_\_\_\_ State \_\_\_\_\_ Zip \_\_\_\_\_

Signature \_\_\_\_\_

(offer invalid without signature)

Code = SP84PV4

**Mail to: TAB/McGraw-Hill, Inc. Blue Ridge Summit, PA. 17294**  
**For Fastest Service, Call Toll-Free ☎ 1-800-822-8158**

# ELECTRONICS LIBRARY

## The BBS Construction Kit

by David Wolfe

There are currently 350,000 bulletin-board systems (BBS's) in the United States alone, with such wide-ranging audiences as motorcycle "bikers," chefs, women's groups, Boy Scouts, teachers, entrepreneurs, scientists, and engineers. The Internet can be viewed as a global network of BBS's, and there are an estimated 10 million BBS users worldwide.

This book gets readers involved with bulletin-board systems by giving them the tools they need to turn any PC into a fully operational BBS in just one day. It provides all the tips, tricks, and techniques re-

users to those 21 and older, how to protect against viruses, whether and how to set up a fee structure, and what types of hardware and software to choose for specific types of BBS's. It also explains how to give a BBS a "personality" that will keep people calling, by choosing a focus and using graphics and animation.

The book comes with a disc that contains GAP BBS software to install a 20-active-user BBS, a game called Global Wars, a complete on-line e-mail package called Online, an ANSI drawing and animation utility called TheDraw, and a quick door converter for running games and other software on the BBS.

*The BBS Construction Kit book with diskette costs \$27.95 and is published by John Wiley & Sons, Inc., 605 Third Avenue, New York, NY 10158-0012.*

**CIRCLE 85 ON FREE INFORMATION CARD**

### THE ARRL SATELLITE ANTHOLOGY, Third Edition

from The American Radio Relay League

As amateur satellite technology has progressed, more hams have been able to enjoy satellite communications even with modest equipment. Satellite operating is neither difficult nor expensive, and you might already own the equipment necessary for satellite communications. Now you can learn about all the active satellites from OSCAR 10 through OSCAR 27, and beyond, with this collection of the best satellite articles from *QST* magazine.

The articles explain how to track satellites, work satellite DX, explore the Microsats, and use the Russian "easybirds."

*The ARRL Satellite An-*

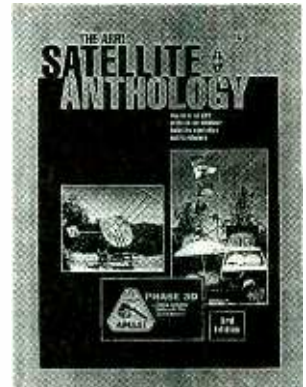

*thology, Third Edition costs \$10 and is published by The American Radio Relay League, 225 Main Street, Newington, CT 06111; Tel. 203-666-1541; Fax: 203-665-7531.*

**CIRCLE 86 ON FREE INFORMATION CARD**

### MAKING TELECOMMUTING HAPPEN: A Guide for Telemanagers and Telecommuters

by Jack M. Nilles

When Jack M. Nilles coined the phrase "telecommuting" back in the early 1970's—defining it as "moving the work to the workers instead of moving the workers to the work"—few people imagined that working from home via computers and telephone lines would become so widespread so quickly. Yet the explosive growth of telecommunications networks, faxes, and low-cost home computers has made his idea a reality for roughly 8-million U.S. workers to date. And Nilles believes that "three out of five Americans are potential telecommuters, at least part of the time, because they're information workers."

This book examines all aspects of telecommuting, from useful techniques for informa-

All the Software and Expert Advice You Need to Start Your Own BBS Today

**The BBS CONSTRUCTION KIT**

**Disk includes:**

- ✓ GAP BBS Software
- ✓ Utilities
- ✓ Screen drawing program
- ✓ Other important stuff

**David Wolfe**

quired to start, run, and maintain a successful BBS. The book answers a host of frequently asked questions, including how to limit the age of

tion workers who want to justify their "work-at-home" status, to management methods and the "bottom" line for company managers. It also provides a comprehensive "get-started" guide to help businesses and government conserve time, energy, and money by moving work out of a central office. The book offers step-by-step guidelines for developing a successful telecommunications program, delving into supporting technologies, personnel issues, work flows, and management techniques.

*Making Telecommuting Happen costs \$24.95 and is published by Van Nostrand Reinhold Publishing Company, 115 Fifth Avenue, New York, NY 10003; Tel. 212-254-3232; Fax: 212-475-2548.*

**CIRCLE 87 ON FREE INFORMATION CARD**

## 1994 GENERAL CATALOG

from Contact East

Hundreds of new test instruments and tools can be found in this 244-page catalog. Aimed at engineers, managers, technicians, and hobbyists, it features quality, brand-name products for assembling, testing, and repairing electronic equipment. New product highlights include digital multimeters and accessories, custom tool kits, EPROM programmers, power supplies, soldering tools, ELF meters, breadboards, scope meters, datacommunications tools and testers, and portable and bench-top digital-storage scopes. The catalog also includes full lines of communications test equipment, static-protection products,



ozone-safe cleaners, inspection equipment, and cases. All products are fully guaranteed, and orders placed by 4 PM are shipped by 5 PM.

*The 1994 General Catalog is free upon request from Contact East, 335 Willow Street South, North Andover, MA 01845-5995; Tel. 508-682-2000; Fax: 508-688-7829*

**CIRCLE 88 ON FREE INFORMATION CARD**

## HANDS-ON INTERNET: A Beginner's Guide for PC Users

by David Sachs and Henry Stair

The eight on-line tutorial sessions presented in this book are designed to teach readers how to actually use the Internet. Each session contains up to eight hands-on activities that lead readers step-by-step through subjects including sending e-mail, participating in Internet mailing lists and news-

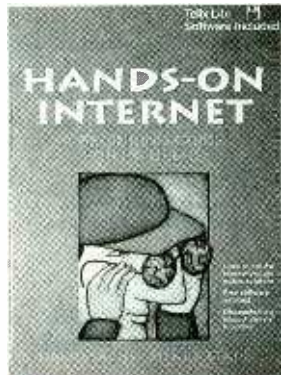

groups, and accessing files on computers around the world. The book explains how to use the Internet to access State Department travel information; obtain long-range forecasts, earthquake reports, and ski conditions from the Weather Underground; learn the latest findings on Project Magellan from the National Space Science Data Center; and access a geographic name server with phone numbers, Zip Codes, population statistics, telephone area codes, and time zones.

All that's required of the reader is a PC and a modem, and those who don't already have a modem will find information on how to buy one. The book includes free commercial com-

# SURVEILLANCE & SECURITY

## FM TRANSMITTERS MINIATURE (KITS)

- 3-VOLT FM XMTR, up to 300 ft. indoors, 1500 ft. outdoors
- PHONE XMTR, range to 500 ft., uses phone-line power
- Sound-Activated XMTR, range to 500 ft.
- 2-STAGE XMTR, 9-Volt, very powerful

All above require simple soldering at 2 to 4 places. Broadcast on std FM band. Assemble in less than 5 minutes. Any of the above **\$29.95\*\***

**TELE CALL FORWARDER.** Transfers incoming calls to any number you select. **\$99.00\***

**CALLER ID.** Registers incoming number and stores to 50 numbers. **\$99.00\***

**TEL REGISTER WITH PRINTER.** Records dialed number, duration, and prints record. 16-digit display with security lock control. Stores up to 40 calls. **\$149.00\***

**TEL REGISTER W/O PRINTER.** Records dialed number and time. 16-digit display. Holds up to 145 numbers in memory. **\$99.00\***

**12-HOUR LONG-PLAY RECORDER.** Modified Panasonic. Records 6 hrs. on each side of 120 tape (supplied). Compatible with VOX and Tel Rec Adapter. **\$119.00\***

**VOX VOICE-ACTIVATED SWITCH.** Makes recorder self-activating with voices or other sounds. Great for radios and scanners. Provisions for external mike and/or patch cord. **\$28.50\*\***

**TELEPHONE RECORDING ADAPTER.** Records incoming and outgoing calls. Use of handset controls recorder and records both sides of conversation. **\$28.50\***

**TELEPHONE SCRAMBLERS.** Over 51,000 separate codes; impossible to break code. Assures utmost privacy. **\$295.00\***

**VOICE CHANGER.** Changes man's voice to lady's and vice versa. 4 separate settings. Ideal for disguising voice. **\$29.95\*\***

## RF BUG DETECTORS, AND MUCH MORE

For Shipping and Handling add \*\$5.00 and \*\*\$2.00 per item. Colo. residents add sales tax. Mail Order. VISA, M/C, COD's o.k. Inquire for dealer prices. Free catalog

**TOLL FREE 1-800-926-2488**

## A.M.C. SALES, INC.

193 Vaquero Drive  
Boulder, CO 80303  
Tel: (303) 499-5405  
Fax: (303) 494-4924

Mon-Fri 8 a.m. - 5 p.m. Mtn. Time

**CIRCLE 151 ON FREE INFORMATION CARD**

munications software called Telix Lite, an easy telecommuncations package designed for DOS platforms. Also included are money-saving coupons offering discounts from Internet Service Providers.

*Hands-On Internet: A Beginning Guide for PC Users (including diskette) costs \$29.95 and is published by Prentice Hall Professional Technical Reference; 113 Sylvan Avenue, Route 9W, Englewood Cliffs, NJ 07632; Tel. 515-284-6751; Fax: 515-284-2607.*

**CIRCLE 89 ON FREE INFORMATION CARD**

## DESIGNING AND BUILDING ELECTRONIC FILTERS

by Delton T. Horn

Virtually every kind of electronic application and system contains filter circuits, which allow some frequencies to pass while blocking others. This book serves as a complete workbench guide to filter theory and practice. It clearly explains the required math, providing specific examples for each of the equations

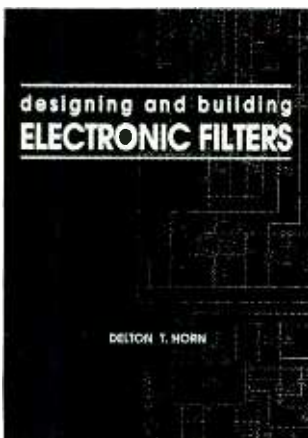

used. The book contains practical circuit plans that show you how to build a variety of filters, including passive low- and high-pass, active low- and high-pass, active band-pass, active band-reject, state-variable and all-pass, and voltage-controlled filters, and even sophisticated digital filters. For each filter, the book lists its characteristics, uses, specifications, and substitution values. The book also includes 12 projects that can be used in your own designs.

*Designing and Building Electronic Filters costs \$14.95 and is published by Tab Books Inc., Blue Ridge Summit, PA 17294-0850; Tel. 800-233-1128.*

**CIRCLE 98 ON FREE INFORMATION CARD**

## 1994 NEW PRODUCT TEST ACCESSORIES CATALOG

from ITT Pomona

More than 100 new products, including logic-analyzer test accessories, IEC1010-compliant probes, and banana jacks, are introduced in this 36-page, full-color catalog. Highlighted are a new logic-scope probe, insulated scope probes, DMM test



leads, fused probe kits, grabbers, cable assemblies, adapters, test strips, and laboratory power supplies. Also featured are test clips and adapters for the latest IC devices.

*The 1994 New Product Test Accessories Catalog is free upon request from ITT Pomona, Customer Service, 1500 East Ninth Street, Pomona, CA 91766-3835; Tel. 909-469-2900; Fax: 909-629-3317.*

**CIRCLE 90 ON FREE INFORMATION CARD**

## STAN VEIT'S HISTORY OF THE PERSONAL COMPUTER

by Stan Veit

Written by the Editor-in-Chief Emeritus of *Computer Shopper*, this book chronicles the personal-computer revolution, from the Altair (which had to be assembled by hand) to today's state-of-the-art PC's. The book discusses computers that made

## STAN VEIT'S HISTORY OF THE PERSONAL COMPUTER



From Altair to IBM:  
A History of the PC Revolution  
Stan Veit  
Editor-in-Chief Emeritus  
Computer Shopper

it big, and others that never made it out of the factory. It also offers behind-the-scenes stories of the savvy entrepreneurs and enthusiastic amateurs who made the personal-computer revolution happen. The book describes the rise (and the occasional fall) of computer companies including Apple, Heath, IBM, Ohio Scientific, Commodore, North Star, Morrow, Vector Graphic, Atari, and Radio Shack.

*Stan Veit's History of the Personal Computer costs \$19.95 and is published by World-Comm Press, 65 Macedonia Road, Alexander, NC 28701; Tel. 704-252-9515.*

**CIRCLE 91 ON FREE INFORMATION CARD**

## 1994 TECHNICAL SUPPLIES CATALOG

from Hub Material Company (HMC)

HMC's 1994 full-line catalog is a detailed, fully-illustrated buying guide of electronic tools, test equipment, and technical supplies for the assembly, testing, and repair of electronic prod-



ucts. It features a large selection of brand-name, competitively priced items including precision hand tools, test instruments, datacom/telecom equipment, tool kits, soldering/desoldering systems, lamps and magnifiers, static-control products, work stations, PC-board handling equipment, industrial chemicals and adhesives, and measurement and inspection instruments. The catalog offers comparison tables of product features.

*The 1994 Technical Supplies Catalog is free upon request from HMC, 33 Springdale Avenue, Canton, MA 02021; Tel. 617-821-1870; Fax: 617-821-4133.*

**CIRCLE 92 ON FREE INFORMATION CARD**

## CATALOG NUMBER 15

from Small Parts Inc.

This book-style catalog contains 320 pages filled with components, material, and precision tools for electronics engineers, technicians, and hobbyists. Fifty-one new product lines have been added, and 28 exist-

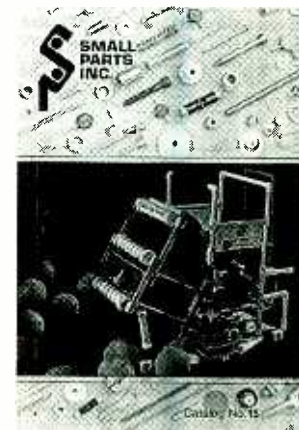

ing product categories have been expanded. Designed to be user friendly, the catalog features an extensive Table of Contents; in addition, new items are clearly marked, and inch and metric parts are easily differentiated.

*Catalog No. 15 is available from Small Parts Inc., 13980 N.W. 58th Court, P. O. Box 4650, Miami Lakes, FL 33014-0650; Tel. 305-557-8222; Fax: 800-423-9009.*

**CIRCLE 93 ON FREE INFORMATION CARD**

## Just like these Fully Trained Electronics Professionals



"Thanks to CIE I have tripled my previous salary, and I am now in a challenging and rewarding new field where only the sky is the limit."

Daniel Wade Reynolds  
Industrial Electrician  
Ore-Ida Foods



"CIE was recommended to me by my boss. It was appealing since I could study at my own pace at home and during business travel."

Dan Parks  
Marketing Manager/Consumer Products  
Analog Devices, Inc.



"I loved the flexibility CIE offered. It was the only way I could continue both school and my demanding job."

Britt A. Hanks  
Director of Engineering  
Petroleum Helicopters, Inc.



"I liked the way the school was set up with laboratory assignments to enforce conceptual learning. The thing which impressed me the most about CIE's curriculum is the way they show application for all the theory that is presented."

Daniel N. Parkman  
Missile Electro-Mechanical Technician  
U.S. Air Force



"Completing the course gave me the ability to efficiently troubleshoot modern microprocessor based audio and video systems and enjoy a sense of job security."

Tony Reynolds  
Service Manager/Technician  
Threshold Audio & Video

# Graduate with an Associate Degree from CIE!

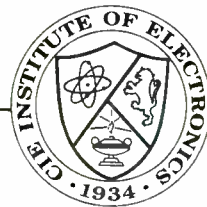

CIE is the best educational value you can receive if you want to learn about electronics, and earn a good income with that knowledge. CIE's reputation as the world leader in home study electronics is based solely on the success of our graduates. And we've earned our reputation with an unconditional commitment to provide our students with the very best electronics training.

Just ask any of the 150,000-plus graduates of the Cleveland Institute of Electronics who are working in high-paying positions with aerospace, computer, medical, automotive and communications firms throughout the world. They'll tell you success didn't come easy...but it did come...thanks to their CIE training. And today, a career in electronics offers more rewards than ever before.

### CIE'S COMMITTED TO BEING THE BEST...IN ONE AREA...ELECTRONICS.

CIE isn't another be-everything-to-everyone school. CIE teaches only one subject and we believe we're the best at what we do. Also, CIE is accredited by the National Home Study Council. And with more than 1,000 graduates each year, we're the largest home study school specializing exclusively in electronics. CIE has been training career-minded students for nearly sixty years and we're the best at our subject...**ELECTRONICS... IT'S THE ONLY SUBJECT WE TEACH!**

### CIE PROVIDES A LEARNING METHOD SO GOOD IT'S PATENTED.

CIE's AUTO-PROGRAMMED® lessons are a proven learning method for building valuable electronics

career skills. Each lesson is designed to take you step-by-step and principle-by-principle. And while all of CIE's lessons are designed for independent study, CIE's instructors are personally available to assist you with just a toll free call. The result is practical training...the kind of experience you can put to work in today's marketplace.

### LEARN BY DOING...WITH STATE-OF-THE-ART EQUIPMENT AND TRAINING.

CIE pioneered the first Electronics Laboratory

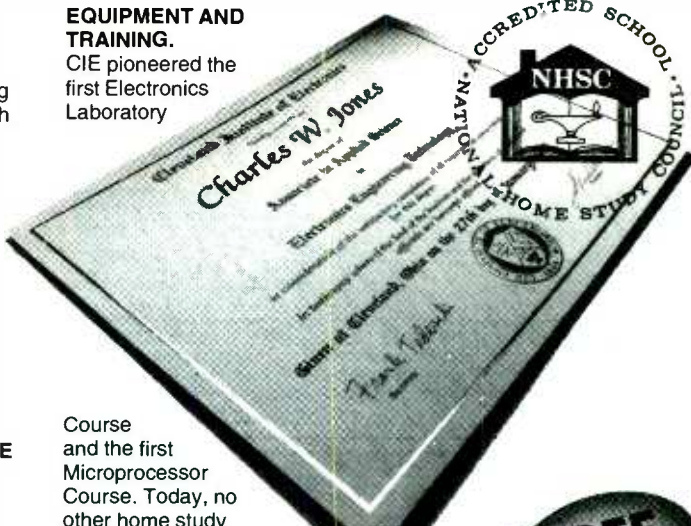

Course and the first Microprocessor Course. Today, no other home study school can match CIE's state-of-the-art equipment and training. And all your laboratory equipment, books and lessons are included in your tuition. It's all yours to use while you study and for on-the-job after you graduate.

### PERSONALIZED TRAINING...TO MATCH YOUR BACKGROUND.

While some of our students have a working knowledge of electronics others are just starting out. That's why CIE has developed twelve career courses and an A.A.S. Degree program to choose from. So, even if you're not sure which electronics career is best for you, CIE can get you started with core lessons applicable to all areas in

electronics. And every CIE Course earns credit towards the completion of your Associate in Applied Science Degree. So you can work toward your degree in stages or as fast as you wish. In fact, CIE is the only school that actually rewards you for fast study, which can save you money.



## YES!

I want to get started. Send me my CIE course catalog including details about the Associate Degree Program. (For your convenience, CIE will have a representative contact you - there is no obligation.)

Please Print Clearly

AH56

Name \_\_\_\_\_

Address \_\_\_\_\_

City \_\_\_\_\_

State \_\_\_\_\_ Zip \_\_\_\_\_ Age \_\_\_\_\_

Phone No. \_\_\_\_\_

Check box for G.I. Bill Benefits.

Veteran

Active Duty

Cleveland Institute of Electronics, Inc.  
1776 East 17th Street  
Cleveland, OH 44114

A School of Thousands.  
A Class of One. Since 1934.

Send for CIE's FREE Course Catalog and See How We Can Help Your Career Too!

# NEW PRODUCTS

## Pen-Style Multimeter

The first member of the *Shoreline Instruments* family of meters, the *SI1000* pen meter combines the practicality of a standard digital multimeter with the comfort of a pen. The pen meter displays a total of 11 ranges of AC/DC volts, milliamps, and ohms on a 2000-count digital display. The *SI1000* can also test diodes and perform audible continuity tests. Its automatic shut-off feature extends the life of its 9-volt battery.

The *SI1000*, which measures  $9\frac{1}{8} \times 1\frac{3}{4} \times 1$  inch and weighs four ounces including battery, features a molded case that fits comfortably in any sized hand. To improve the grip and reduce rubbing, the body was designed



with notches to fit the user's fingers. To prevent cramping and fatigue after extensive use, the *SI1000* can be held either like a pen or in the palm, with the display facing up. The display appears directly above the examined circuit point. The range settings can be set by moving a slide switch with the thumb. A twist-on alligator clip attaches to the meter's ground probe, allowing the user to connect it to the circuit to make one-handed measurements.

The *SI1000* pen-style meter costs \$39.95. For further information, contact Shoreline Electronics, Inc., P. O. Box 378, Moffett Field, CA; Tel: 408-987-7773; Fax: 408-987-7735.

**CIRCLE 101 ON FREE INFORMATION CARD**

## SYNTHESIZED FUNCTION GENERATOR

Designed for applications where a number of exact frequencies, waveforms, and amplitudes have to be selected, *Global Specialties' Model 2003* menu-driven, digitally synthesized function generator can store up

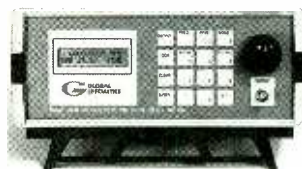

to 16 preset waveform configurations in memory, and recall them automatically. Its 32-character LCD readout allows precise setting of the desired frequency, with up to 11 digits of accuracy. It offers several modes of operation, including trigger, gated sweep, hop, burst, and external trigger and gate. Waveforms include sine, square, triangle, and positive and negative ramp. The Model 2003 can be used for repetitive testing, filter-response testing, and testing automotive and telecommunications systems.

The Model 2003 digitally synthesized function generator has a list price of \$499.95. For additional information, contact Global Specialties, 70 Fulton Terrace, New Haven, CT 06512; Tel: 203-466-6103; Fax: 203-468-0060.

**CIRCLE 102 ON FREE INFORMATION CARD**

## MOTION-CONTROL SYSTEM

*Cybermation's Motion-Control System*, complete with IBM-compatible software, is targeted at robotics, medical, industrial, and other OEM applications. The complete kit includes a  $4.5 \times 6$ -inch controller card, two stepper motors, a transformer, a wiring harness, documentation, and software written in Qbasic

and Gwbasic. The unit controls two multi-axis, 48-step motors per board. The boards are individually addressable, allowing the user to control up to 16 possible cards. Thus the system is expandable to 32 motors on one LPT (printer-port) interface. The input accepts a Centronics parallel interface, and board power input is via a 12-VAC C.T. 3-amp transformer. The system features a bi-directional, 8-bit read-and-write bus with address decoding, variable speed, step, range, direction, and on/off control. Relay cards, analog-to-digital cards, optically isolated input cards, timer controllers, and RS232 intelligent controllers, now in the final development stages, are compatible with the Motion-Control System.

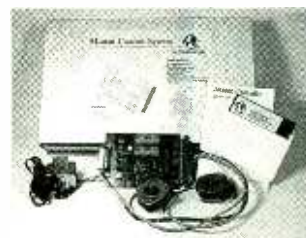

The Motion-Control System costs \$249.95. The compatible cards will be priced from \$149 to \$249. For more information contact Cybermation, 1943 Sunny Crest Dr., Suite 288, Fullerton, CA 92635; Tel.: 714-992-2266; FAX: 714-992-2082.

**CIRCLE 103 ON FREE INFORMATION CARD**

## 30-MHZ DUAL-CHANNEL OSCILLOSCOPE

*Hameg Instruments' HM303* is a 30-MHz dual-channel oscilloscope that offers a feature not usually found on oscilloscopes: a built-in component tester. The tester uses a stabilized measurement voltage to rapidly test active and passive circuit components at the push of a button.



The HM303 features improved vertical amplifiers with a sensitivity that goes down to 2 mV/div, with a broadband design that limits overshoot to 1%.

Probe-compensation adjustment is achieved through a built-in, dual-frequency, 1-kHz/1-MHz calibrator, which can be used to optimize probe-tip-through-display fidelity. The fastest sweep rate is 10 ns/div,

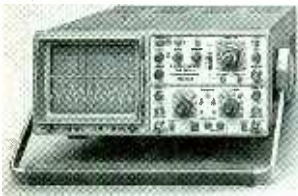

using the  $\times 10$  magnifier. The scope can trigger on signals greater than 100 MHz and on inputs less than one-half division. An active sync-separator allows the detailed examination of complex TV signals.

The HM303 dual-channel oscilloscope is priced at \$548. For additional information, contact Hameg Instruments, 1939 Avenida Plaza Road, Ocean-side, CA 92056; Tel: 800-247-1241; Fax: 619-630-6507.

**CIRCLE 104 ON FREE INFORMATION CARD**

### ENERGY-SAVING SURGE SUPPRESSOR

Designed to work with any PC or PC clone, *Tripp Lite's Isomiser* is a combination surge suppressor and screen monitor. It saves electricity by automatically turning off power-hungry computer monitors. Keyboard activity automatically restores the monitor to its prior screen. The Isomiser is a member of the EPA's "Energy Star" program, which recognizes power-saving computers and accessories. Monitor shut-off time can

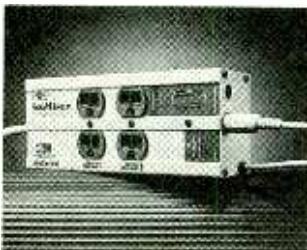

be adjusted between five and 60 minutes with a convenient slide control. By powering down the connected monitor, the Isomiser can provide savings up to \$190 a year per monitor, according to Tripp Lite.

The Isomiser is also a four-outlet Isobar surge suppressor that provides spike and line filtering, as well as RFI and EMI filtering. Isolated filter banks provide up to 720 joules of surge suppression while preventing interference between connected equipment.

The Isomiser screen monitor and surge suppressor has a suggested retail price of \$119.95. For more information, contact Tripp Lite, 500 North Orleans, Chicago, IL 60610-4188; Tel: 312-329-1777; Fax: 312-644-6505.

**CIRCLE 105 ON FREE INFORMATION CARD**

### CAR AMPLIFIERS

The *Mean Machines* line of car amplifiers from *Autotek* includes nine models with larger chassis for increased emphasis on power, aesthetics, and improved heat dissipation. For simplified installation and improved appearance, all controls and

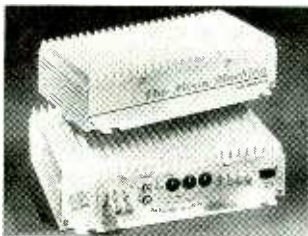

connections are located on the front panels of the two-channel amps. Gold-plated terminals are used for reduced resistance on power and speaker connections. The additional power capabilities are due to new circuit design and an exclusive transformer device that empowers a feature called Inductive Pulse Control.

The Mean Machines car amplifiers have retail prices ranging from \$279 to \$999. For additional information, contact Autotek, 855 Cowan Road, P.O. Box 4391, Burlingame, CA 94011-4391; Tel: 415-692-2444; Fax: 415-692-2448.

**CIRCLE 106 ON FREE INFORMATION CARD**

# 3M breadboards for less dough.

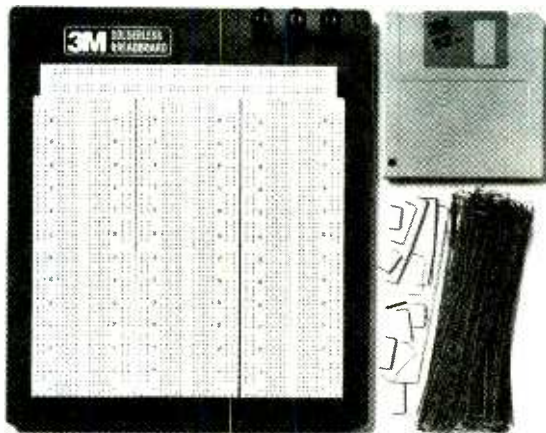

Lower prices, plus jumper wires and a diskette. No wonder interest is rising.

Remember, 3M Breadboards carry a lifetime warranty. For more information, call 1 (800) 328-0016, ext. 103.

© 3M 1994

**3M Reliability**

**CIRCLE 164 ON FREE INFORMATION CARD**



*THE MOST*  
**AN IMPORTANT PART  
OF YOUR PHOTOCOPIER  
ISN'T PART OF  
YOUR PHOTOCOPIER**

Having a machine may not permit you to photocopy books, journals, newsletters and magazines.

The Copyright Clearance Center CAN.

Contact us to find out how you too can COPY RIGHT!<sup>SM</sup>

**COPYRIGHT CLEARANCE CENTER**

222 Rosewood Drive, Danvers, MA 01923 □ Tel. (508) 744-3350 □ Fax (508) 741-2318

© 1993 Copyright Clearance Center



# LOGISYM V3.2 LOGIC SIMULATOR SOFTWARE

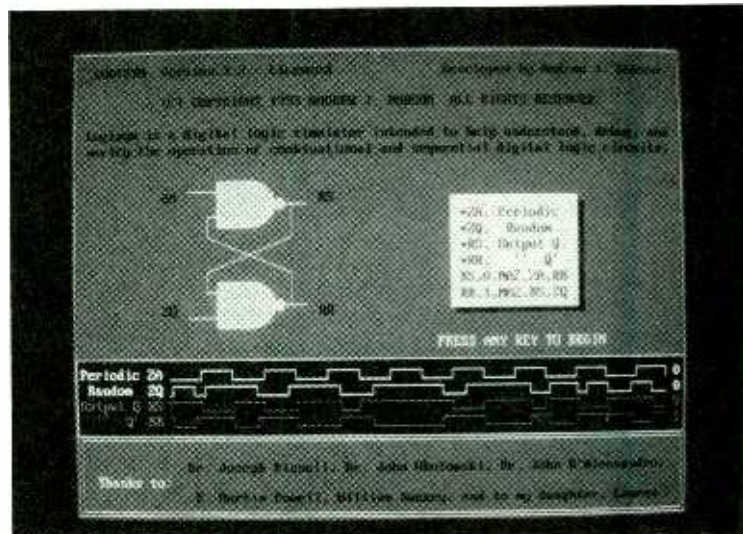

CIRCLE 119 ON FREE INFORMATION CARD

*Test logic circuits without heating your iron or using a protoboard.*

I've always been amazed by the fact that the easiest circuits to design are sometimes the hardest to implement. Logic circuits are an excellent example of "straightforward" designs that often go awry. Logic-circuit design should be a piece of cake, especially since it requires less math than analog-circuit design, but they can still be flaky. In fact, when a logic circuit fails to work as predicted, its surface-level simplicity only leads to complete consternation in the mind of the logic designer. If the validity of a truth table cannot be argued with, where's the problem?

One possible design flaw that leaps to mind (if only because it has snagged me before) is timing error due to propagation delay. Another, of course, is a flaw in the truth-table logic, that leads directly to a design error (face it, we're only human). One tricky problem that affects even the most "inhuman" designers is circuit racing; which occurs in sequential-logic circuits when a feedback loop is not fast enough, leading to circuit oscillation, or racing.

Well one item can spare us from both errors: a logic simulator. Furthermore, a logic simulator can help you do without multiple pieces of test

equipment, such as breadboards, pulse and data generators, oscilloscopes, and logic analyzers.

Logisym V3.2 is just such a software tool. It requires a PC compatible with 512k RAM, running MS-DOS 3.3 or higher, and VGA graphics. While DOS based, it comes with a program information file and icons that make it Windows friendly. It can handle both keyboard and mouse input (preferred), and generate printouts on both 9-pin Epson-compatible dot matrix and HP-compatible laser printers. The print feature is nothing to sneeze at, as it generates a complete report of what gate generated each signal. Now that you have some idea of whether it will work with your equipment, let's talk about features.

**Capability.** The software can monitor up to 16 points (commonly called "probes") in a circuit consisting of up to 650 nodes (or gate outputs). The circuit can be either sequential or combinational. To generate traces, the program requires PSPICE-like script files that describe the circuit. If you're not familiar with PSPICE, not to worry, the 20-page manual (including a tutorial) and 15 example scripts cover everything you'll need to know.

The simulator can handle buffers, inverting buffers, and AND, OR, NAND, NOR, XOR, and XNOR gates. The XOR and XNOR devices must be of the 2-input type, while the other gates can have up to eight inputs. The software can also accommodate positive-edge-triggered RS latches, and D and JK flip-flops.

It also comes with a variety of logic-signal generators to provide circuit stimulus. There's an eight-bit, variable-frequency, up/down counter; a four-bit, variable-frequency, up/down ring counter; and a four-bit, variable-rate, random data generator. In addition, the program also accepts 8-bits of real-time input (toggled high and low via 8 of the keyboard's function keys). Also, any unused gate inputs can be tied high or low as you desire. So, all totaled, there are 26 bit-value sources.

The program's only restriction is that it makes use of "unit-delay elements." What that means is the propagation delay of a simple gate is one "unit" long. The delay of more complex devices depends on how many simple gates inside the device a signal must pass through before it affects the output. Since the delay for a device cannot be manually set, it is assumed that all gates—simple or otherwise—are

of the same architecture (i.e., have the same delay per simple gate). This is most often a very good assumption. Even so, gates with longer delays can be simulated by placing one or more buffers at their output.

### Installation and Operation.

Installation for DOS operation is just a matter of copying the files from a disk to an appropriate sub-directory (provided you don't wish to run the simulator from a floppy, that is). Just a couple of additional steps are needed for windows operation: click and drag the programs PIF file into an appropriate window (from which you'll launch the application) and select one of the three provided icons using the properties command.

Once installed, you start the program by typing "logisym" at the DOS prompt or double-clicking its Windows icon. Then you're prompted for the name of a script file (which you could optionally have provided as a parameter from the DOS prompt). An opening screen is followed by a circuit-information screen, and then the program display when you hit a key.

The program display is a cross between a 16-trace logic analyzer and an oscilloscope; not only showing signals, but software-based control knobs and buttons as well. At the top there are also 6 commands, and another 4 at the bottom.

In the signal-display area, there is room for 16 signals, which are displayed like a typical logic-timing diagram, and a couple of blank traces. Each signal has its label to the left for easy identification. If a signal is generated by one of the internal clocks, its plot and label appear in yellow. If a signal comes from a gate, its plot and label appear in green. There is an area to the right of the displays where the current bit value (1 or 0) of each trace can be shown. If activated, that area is updated dynamically. By the way, to enhance comprehension, traces can be vertically separated into groups by requesting the presence of blank traces from within the circuit script.

Let's look at the program's controls next. The commands activate pop-up windows, the buttons turn simulator features on and off, and the knobs adjust simulation parameters over a range. Commands and buttons can be implemented by clicking on them with a mouse, or by typing in a letter. The appropriate letter appears in red in the command or button label on the screen. Knobs can also be controlled by typing in letters: pressing just a letter key turns a knob counter clockwise; if you simultaneously press shift, they turn clockwise. Alternatively, you may use a mouse by clicking near each knob — and + labels.

Taking the commands at the top of

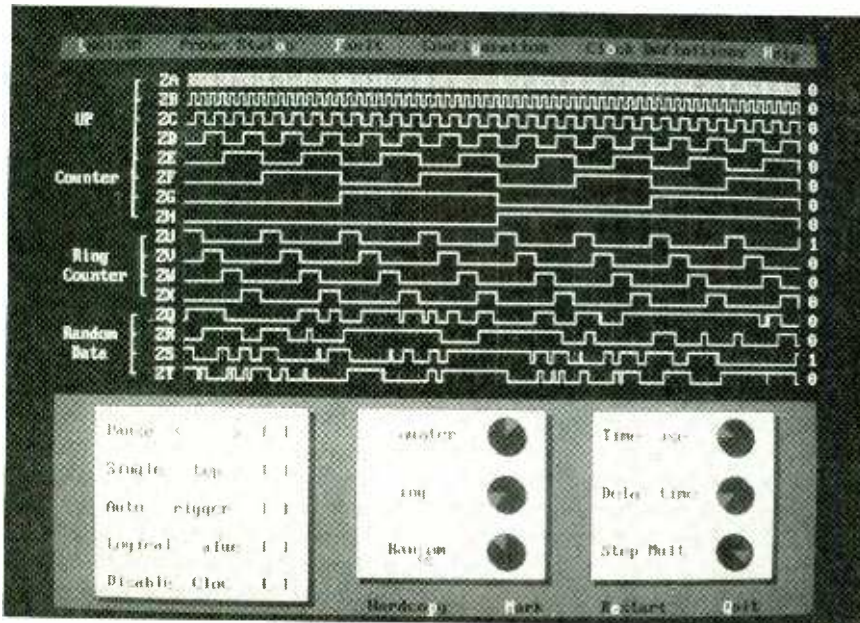

The bottom half of the Logisym interface, with its knobs and pushbuttons, emulates a piece of test gear. The top portion displays a state diagram just as a logic analyzer would.

## Earn Your B.S. Degree in ELECTRONICS or COMPUTERS



### By Studying at Home

Grantham College of Engineering, now in our 44th year, is highly experienced in "distance education"—teaching by correspondence—through printed materials, computer materials, fax, and phone.

No commuting to class. Study at your own pace, while continuing on your present job. Learn from easy-to-understand but complete and thorough lesson materials, with additional help from our instructors.

Our Computer B.S. Degree Program includes courses in BASIC, PASCAL and C languages — as well as Assembly Language, MS DOS, CADD, Robotics, and much more.

Our Electronics B.S. Degree Program includes courses in Solid-State Circuit Analysis and Design, Control Systems, Analog/Digital Communications, Microwave Engr, and much more.

An important part of being prepared to *move up* is holding the right college degree, and the absolutely necessary part is knowing your field. Grantham can help you both ways—to learn more and to earn your degree in the process.

Write or phone for our free catalog. Toll free, 1-800-955-2527, or see mailing address below.

Accredited by  
the Accrediting Commission of the  
National Home Study Council

**GRANTHAM**  
**College of Engineering**  
Grantham College Road  
Slidell, LA 70460



*Could this be the hobbyist lab of tomorrow—just a virtual-reality workstation? With products like Logisym, it does seem likely that in the future this is how most hobbyist projects will at least begin.*

the screen next, they are: Logisym, Probe Status, Configuration, Clock Definitions, and Help. Each calls up a window. Logisym just calls up a copyright-notice window. The Probe Status window shows the logic gate to which each probe is attached, the labels of that gate's inputs, and the current logic value of the signals. The configuration window is used to save and load the control knob, button, and printer settings to and from the configuration file (LOGISYM.CFG). The Clock Definitions window shows the

labels of all of Logisym's 26 internal clock signals, grouping them by source. The current value of each signal is also provided. The fault window allows you to set and hold any signal high or low to simulate a circuit fault. The "fault" may be removed by selecting Clear in that window. The Help window presents a menu of help topics on knobs and controls and the commands at the top of the screen (except the Logisym command).

Next, let's deal with the switches and knobs before getting to the remaining commands. The Pause button (which, unlike the other controls, can be operated by the space bar instead of a letter) starts and stops the simulator, and thus the plotting of signals. The program will automatically pause after plotting a certain number of steps if the Single Step button is on. The Auto Trigger button allows screen after screen of data to be produced if on; if off, the simulator will pause after one screen of data is plotted. The Logical Value button enables the dynamic display of signal values to the right of the signals, as mentioned earlier. As you might expect, the Disable Clock button freezes the operation of all the clocks when on, and allows them to proceed when off.

Now let's consider the knobs, which can be divided into two groups: those that affect the trace display (Time

Base, Delay Time, and Step Multi), and those that affect the signal generators (Counter, Ring, and Random). The Time Base control sets the number of unit delays that will fill one screen (i.e., the data resolution). The time-base values are 128, 256, 512, 1024, 2048, and 4096. The Delay-Time control determines how fast a plot is made. It permits you to adjust the plotting speed for your computer. The Step Multi knob adjusts the number of steps the simulator executes after each press of the space bar in single-step mode. The possible values are 1, 2, 4, 8, 16, and 32.

All the knobs that control the signal generators affect their frequency of operation. To the left of each knob label there is a tiny symbol (either a triangle or square) that, if clicked on, modifies the operation of its signal generator. The Counter-knob's symbol toggles the counter between upward and downward counting. The Ring-knob's symbol sets the direction of the pulse around the ring. The Random-knob's symbol determines whether the random generator is allowed to generate brief asynchronous pulses. That's an excellent way to test the effects of noise on a circuit.

The commands at the bottom of the screen are Hardcopy, Mark, Restart, and Quit. Hardcopy, as you might expect, initiates printing, but first asks whether you'll be using a laser or dot-matrix printer. Mark places a dashed vertical line through all the traces at the current position. Restart starts a simulation over again. Quit allows you to exit the program.

**Conclusion.** As you can probably tell from the list of features and controls, this is quite a flexible program. It is also very easy to use and, for only \$25, it's certainly worth checking out. If you're shy about spending anything for the software, you should at least check out Logisym V3.0, which is offered as a shareware product. The shareware version lacks blank traces, the manual (needed to fully understand the script-file language), print capability, detailed error messages during script loads, and the top-screen commands except Logisym and Clock definitions. For more information, contact Andrew J. Dobson, 106 W. Mowry St., Chester, PA 19013, or circle No. 119 on the Free Information Card. ■

### Satellite Images On Your PC



### PC HF Facsimile 7.0 \$99

SSC has interfaces and software to allow you to receive vivid satellite images on an IBM PC computer. Just plug the interface into the serial port of a PC and into the audio output of a shortwave receiver. The package includes the interface, manuals, schedules and software. SSC also makes systems for reception with VHF scanners. Call or write for our free catalog. **Visa and MASTERCARD accepted**

### Software Systems Consulting

615 S. El Camino Real, San Clemente, CA 92672  
Tel: (714)-498-5784 Fax: (714)-498-0568

# PRODUCT TEST REPORTS

By Len Feldman

## Sharp Model MD-D10 MiniDisc Player

**W**hile Sony is the acknowledged inventor of the new MiniDisc format, Sharp must be credited for coming up with one of the smallest and lightest MiniDisc players available to date. Their model MD-D10 measures only  $3\frac{1}{16} \times 4\frac{5}{16} \times 1\frac{1}{16}$  inches and weighs just 11.6 ounces!

### MINIDISC BASICS

For those who are not familiar with the MiniDisc format, let us quickly review its characteristics. MiniDiscs, or MD's, measure only  $2\frac{1}{2}$  inches in diameter and yet

because they are below the so-called "threshold of human hearing" or because they are masked by other sounds, are not recorded onto an MD. That allows the elimination of up to  $\frac{4}{5}$  of the digital data that would normally be recorded on a CD or a DAT tape.

MiniDiscs come in two forms: prerecorded discs and recordable MD's onto which you can record your own selections from whatever source (CD, radio, tapes, etc.) you choose. MiniDisc hardware, generally intended for portable or car use, can come either as a recorder/player or as a play-only device. The Sharp MD-D10 falls into the latter category, and can play back either prerecorded MD's or MD's you may have made on a home or portable MD recorder.

### FEATURES

While the most outstanding feature of the MD-D10 is its small size, this player has a lot more going for it. The unit features a three-second shockproof memory that eliminates skips if the unit is jarred. In it, the system stores three seconds of digital information into a memory buffer so that even if the laser pickup is momentarily caused to mistrack, music is not interrupted while the pickup returns to its correct position.

The MD-D10 also features a dot-matrix LCD display (10-characters-per-line) and uses a scroll function to

display disc and track titles that software manufacturers add to their prerecorded MD's. (If you also own an MD recorder, you can add your own text to the recordings you make, and these would also be displayed on the MD-D10.)

Sharp has incorporated digital processing in a noise-control circuit that reduces the audible leakage of high-frequency tones that often disturb others nearby when using headphones. Also incorporated is a switchable "X-Bass" system that amplifies tones in the lower bass range to produce more powerful bass.

With the digital MiniDisc format, users have instant access to any track on a disc. A microcomputer in the player allows fast access to any track and, additionally, a search function with fast-forward/reverse enables users to audibly scan to a specific segment of a song.

The MD-D10 can operate from any of three power sources: an included rechargeable battery, an included AC power adapter/recharger, or an optional power cord for the car. The adapter/recharger lets you recharge the battery from an AC power source even while listening to the player. Additional accessories supplied with the MD-D10 include a soft carrying case, a cable containing a mini-stereo plug at one end and a pair of phono-tip jacks at the other (for con-



Circle 120 ON FREE INFORMATION CARD  
*The Sharp Model MD-D10 portable MiniDisc player.*

are able to contain up to 74 minutes of recorded material. That amazing storage capacity arises from a low bit-rate encoding scheme that uses two psychoacoustic principles. Essentially, sounds that would not normally be heard by humans, either

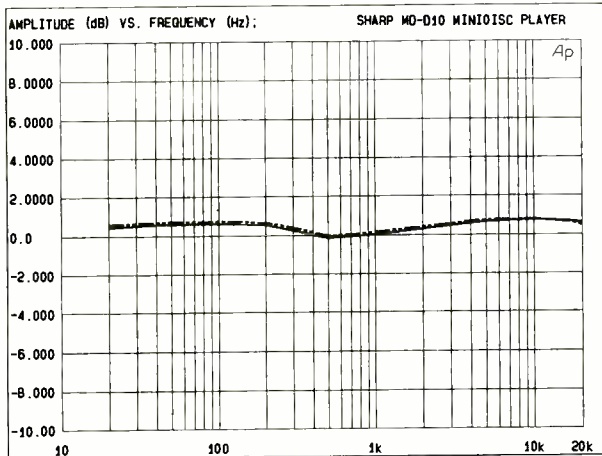

The frequency response of the MD-D10 varied by no more than +0.6, -0.0 dB over the range from 20 Hz to 20 kHz when operating in the "normal" mode.

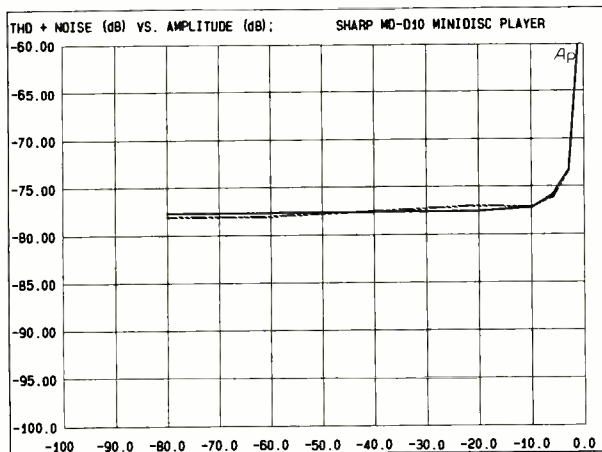

At recording levels of -10 dB or lower, distortion-plus-noise was around 78 dB (relative to the maximum recorded level of 0 dB), which corresponds to a distortion-plus-noise percentage of less than 0.02%.

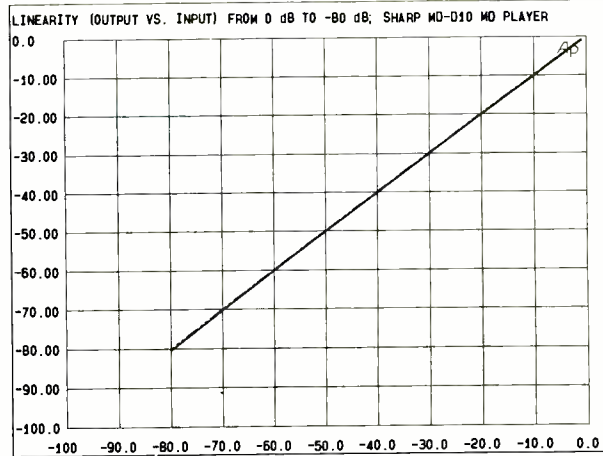

As can be seen in this plot, linearity from 0 to -80 dB was nearly perfect.

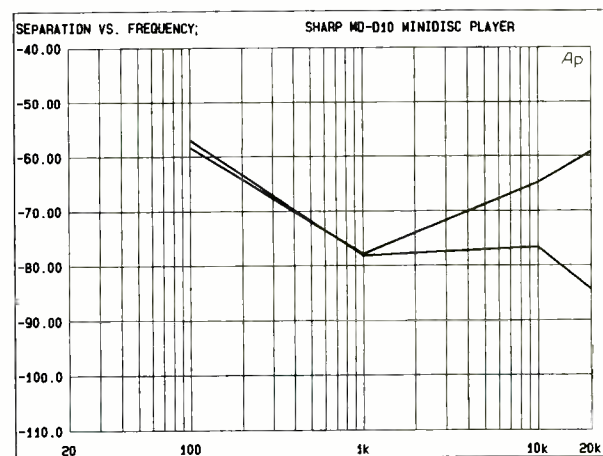

At the high-end of the audio spectrum, the left channel showed better separation than the right one.

necting the player to a home stereo system when headphone listening is not desired), and a set of stereo headphones.

### CONTROLS

A "hold" switch is found along the upper edge of the player, near the LCD display area. When activated, that switch prevents accidental operation of other controls while you're listening to the player. A "display" button activates the text display of the disc title, track title, and whatever additional text the producer of the MD has added (such as the artist's

name, etc.). A second press of that button changes the display to read track number and total playing time or elapsed time of the current track. Below the display button is a second button that, when pressed repeatedly, first activates the bass-boost circuitry and then the noise-control circuitry described above. A third press of the button restores normal (flat response) reproduction.

Forward and reverse "skip/search" buttons are also found along the top surface of the player, as are a "stop/off" button (one push stops play, a second

push turns off power), and a "play/repeat/random" button. If that button is pushed during play, the repeat-play function is activated. If pressed a second time, random play of tracks is initiated, while a third press causes the player to switch back to normal playback.

A DC jack (for powering the unit by means of the AC adapter) is located along the left side of the player, while the "phone/line" output jack is found along the rear edge of the unit. A thumbwheel-type volume-control knob is located along the right-side edge of the player. Depressing a spring-loaded tab near the front of the top surface opens the unit so that you

can insert a MiniDisc, while access to the battery compartment is found on the underside of the player. Looking at the player and all its controls, one wonders how Sharp managed to find room for the complex electronics, motor, and laser pickup that are required for a MiniDisc player to work!

### LAB MEASUREMENTS

When we knew that we would be testing an MD player we were stricken with a bit of panic. While we had previously had access to an MD recorder/player, that unit was no longer in our lab, having been returned to its manufacturer. What were we going to use

## TEST RESULTS—SHARP MODEL MD-D10 MINIDISC

Specification	Mfr's Claim	PE Measured
Frequency response	20 Hz - 20 kHz, $\pm 1$ dB	+0.6 dB, -0 dB
Power source		
Battery	4.8 VDC	Confirmed
AC adaptor	6.0 VDC (120V AC input)	Confirmed
Power consumption	9W	Confirmed
Headphone output power	15 mW/channel	Confirmed
Line output level	850 mV	1.083 volts
THD, battery operation	0.07%	Confirmed
Signal-to-noise ratio	N/A	90.74/92.55 dB
Stereo separation	N/A	78 dB @ 1 kHz
Battery performance	100 minutes	95 minutes
Recharge time	5 hours	Confirmed
Dimensions		
(W $\times$ L $\times$ D, inches)	3 <sup>5</sup> / <sub>16</sub> $\times$ 1 <sup>1</sup> / <sub>16</sub> $\times$ 4 <sup>5</sup> / <sub>16</sub>	Confirmed
Weight (incl. battery)	11.6 ounces	Confirmed
Suggested retail price	\$599.00	

for a test-signal MiniDisc if we no longer were able to make our own from a test CD? Fortunately, the day before the MD-D10 arrived in our lab, we received a newly produced, pre-recorded MD test disc from Sony Corporation. That disc contained all the test signals we would need for testing MD players or, for that matter, player/recorders.

The frequency response of the MD-D10 when operating in normal mode (neither X-Bass nor Noise Control turned on) varied by no more than +0.6, -0.0 dB over the range from 20 Hz to 20 kHz, which was well within the  $\pm 1.0$  dB claimed by the manufacturer. We next looked at how harmonic-distortion-plus-noise varied as a function of frequency when playing back spot frequencies recorded at maximum digital-record level. At mid-frequencies, distortion plus noise measured between 0.04% and 0.05%, rising to around 0.1% at the extreme bass frequencies and to 0.15% at 10 kHz. While these levels of distortion and noise are virtually insignificant, it is interesting to note that at lower recorded levels, (from around -10 dB or lower) distortion-plus-noise was considerably lower.

To separate the actual harmonic distortion components from the residual noise, we used spectrum analysis to examine the harmonics of a steady-state 1-kHz signal at maximum recorded level. The peaks at every odd and even harmonic up to around 20 kHz offered confirmation that the numbers obtained from the earlier measurements were essentially due to actual harmonic distortion rather than random noise.

We next did a plot of output versus input to examine the linearity of the D/A converter of this player and its associated circuitry. While our test disc contained signals from 0 dB (maximum recorded level) down to -90 dB, our test equipment was only able to register linearity down to -80 dB, probably due to random noise. Nevertheless, linearity was just about perfect over the range from 0 dB to -80 dB, which suggests that Sharp is using an excellent D/A conversion system in this portable player.

The new Sony MD test disc enabled us to measure the stereo-channel-separation capabilities of this MD player over the frequency range from 100 Hz to 20 kHz. While we were somewhat surprised to note that separation decreased at the

bass-frequency end of the spectrum (to less than 60 dB), that's still more than enough stereo separation for enjoyable listening. At the high-frequency end of the audio spectrum, the left channel exhibited better separation (as much as 84 dB at 20 kHz) than did the right channel (59 dB at 20 kHz). Again, we should stress that stereo effects were excellent, whether we listened via headphones or via loudspeakers. Normally, even 20 or 30 dB of separation is all that one needs to obtain a full stereo effect in a typical set up.

Finally, playing a "no signal" track of the test disc, we measured the signal-to-noise ratio of the player. The single-reading, A-weighted S/N measured 90.74 dB for the left channel and 92.55 dB for the right channel. To investigate the distribution or content of the residual noise, we used spectrum analysis to plot noise level versus frequency. That test was conducted using the AC adaptor to power the unit, which explained why there were some peaks in noise (actually minute amounts of hum) at the power-line frequency of 60 Hz and at its third harmonic (180 Hz). No doubt battery operation would have resulted in the elimination of these "bumps" and in even lower readings at the bass frequencies. For all of that, however, even when using the AC adaptor, the "worst" peaks were still some 90 dB below maximum recorded level and hence are totally inaudible under normal listening conditions. A summary of our lab measurements can be found elsewhere in this report, along with comparisons (where applicable) to the manufacturer's claimed specifications.

## HANDS-ON TESTS

The MD-D10 is truly a pleasure to use. All controls worked as claimed and confirming "beeps" that sound when using some of these controls assure the user that the control has responded. The LCD display is well positioned for legibility and, as we learned during our listening tests, you can actually change the contrast of the display to suit lighting conditions. You simply hold down the display button for more than three seconds, at which point the word "Contrast" is displayed. Then pressing the forward-skip button darkens the display, while pressing the reverse-skip button lightens the display. Sharp seems to have thought about everything, when it comes to convenient operation of this tiny MD player.

As for sound quality, we have already collected several prerecorded MD's and Sharp was kind enough to send along a sampler that contained both popular and classical selections. We listened to several selections via headphones, as well as by connecting the line-output jack to our reference stereo system. While Sony stoutly maintains that MD sound quality is not quite equal to CD sound quality, we would be hard-pressed to tell the difference unless we were able to do an instantaneous A/B comparison test of the same material recorded on an MD and on a CD. To us, the sound quality of the MD-D10 was superb, with not a hint of any background noise, good dynamic range, and inaudibly low distortion. What more could one ask for in a portable MD player.

One additional point  
(Continued on page 87)

# THINK TANK

By John J. Yacono

## A Beginner's Course and Motion-Detecting Alarms

This month, we'll look at some letters about light and infrared detecting alarms. First, I'd like to discuss something of interest to beginners in electronics: the *Basic Electronic Components* course (Model ECK-10) from Elenco Electronics (150 W. Carpenter Ave., Wheeling, IL 60090; Tel. 708-541-3800), selling for \$16.60. Unlike most electronics courses, this one is truly for the first-time electronics student, so I thought it would be of value to very young readers (whom I always strive to help) and those trying to help youngsters develop an interest in electronics.

The course introduces the student to resistors, capacitors, inductors (including

transformers), and semiconductors (including diodes, bipolar and field-effect transistors, and integrated circuits), and even mechanical parts (which include PC boards, solder, connectors, switches, and mounting hardware). A labeled bag of parts is included for each of those categories to assist the first-time student in developing parts-identification and marking skills.

The course discusses what each part does, their construction, the different types available (for example, the section on resistors describes wire-wound, carbon-composition, carbon-and metal-film, and variable types), and their value and markings. At the end of each section there is a thorough examination, which includes a theory quiz, a practice exercise, and an extra-credit item. By the end of the course, the student should be able to explain how each component looks and behaves, and read a component's value from its body.

What makes the course valuable in my mind is the fact that all the parts are described using entirely mechanical analogies. Based on the flow of water through a pipe, the analogies are easily understood by the neophyte. The inclusion of real-world parts helps reinforce learning and makes the components discussed more than just theoretical items "out there somewhere."

The printed material and overall course design are of sufficient quality for classroom use. The scope of the

material is just right as part of a beginner's electronics course or late-elementary/junior-high science course.

### MOMENTARY DEVICE

Passive-Infrared (PIR) motion detectors that control exterior house lights are pretty popular these days for security applications. I wanted to be able to tell if my light was ever triggered during the night, so I modified it by adding a simple

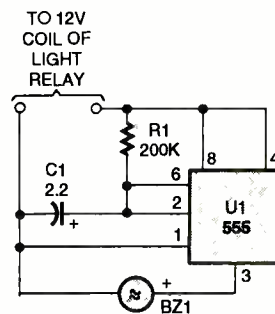

RADIO SHACK #273-065

Fig. 1. This outdoor security-light add-on chirps to let you know when the outside light has been activated. That way you can monitor your backyard in a more direct fashion.

audio-output device.

My circuit, shown in Fig. 1, takes advantage of the fact that PIR-light controllers generally have a low-voltage (typically 12-volt) relay to switch 117 volts to the lights. When the light is activated, the power that operates the light's relay also powers my add-on circuit. With the indicated values of R and C, the simple 555 timer circuit turns on a piezo buzzer for approximately 0.4 seconds. I ran a length of small-gauge, 2-conductor, stranded wire from the light unit to the circuit (located in



Elenco's *Basic Electronic Components* course shows how to identify many common components, and teaches what they do. As you can see, example devices are provided.



a bedroom of the house).

Please use caution when using your voltmeter to determine the pins for the relay coil. I hope that this circuit will earn me one of your books!

—Ron Sharpe, Regina, Saskatchewan, Canada

While the circuit might be simple, your application definitely entitles you to a book. It should go without saying that readers should mechanically secure all connections inside the lamp. Use whatever method is appropriate to the lamp case (wire ties, grommets, epoxy, etc.). The method should prevent the two leads from coming loose even if yanked hard. You don't want a stray wire carrying AC into your circuit, or worse yet, to you.

#### LATCHING UNIT

I'm a 15-year old electronics hobbyist. I've come up with a motion-detector alarm circuit that once triggered will remain on until power is interrupted.

The circuit, as you can see from Fig. 2, is very simple. It's built around a single general-purpose transistor and one general-purpose SCR. The transistor, Q1, is used as a switch. When light is present, photocell R1 shorts almost all current from the base of the transistor to ground, so the transistor is off. When there is no light present, R1 develops a high resistance between its terminals, so current flows into the base of the transistor. The transistor turns on and current from its emitter turns on LED1 and SCR1, which turns on the load. To reset the circuit, just interrupt power for a second.

To set the circuit, place it in the area to be monitored and turn R2 to its lowest resistance, which turns Q1 and the LED on. Then slowly

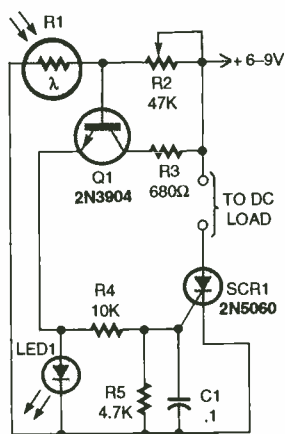

Fig. 2. The motion detector shown here relies on changes in ambient light to sense activity. It is capable of latching a wide variety of DC loads via SCR1.

raise the resistance of R2 until the LED just turns off. Turn off the power, connect the load, and turn the power back on. Passing your hand in front of the photoresistor, about one foot away, should trigger the circuit.

The area to be monitored should have some source of ambient light and the load should be about 1000 ohms or less. If the load has a higher resistance, then place a 500- to 1000-ohm resistor between the anode of the SCR and the positive side of the power supply.

—Bernardo Venerio, Miami, Florida

Thanks for the loading tip as well as the circuit. What I like most about the circuit is that the load is up to the builder. It could be a DC buzzer or a relay that operates an AC device.

One idea that would be neat is to use a simple FM transmitter as the load. The transmitter could be connected to a tone generator and broadcast an alarm tone when activated. The tone could be picked up and reproduced by an FM radio used as an enunciator. When the alarm is tripped, the transmitter

# ATTENTION! ELECTRONICS TECHNICIANS



**EARN YOUR  
B.S.E.E.  
DEGREE  
THROUGH HOME STUDY**

Our New and Highly Effective Advanced-Placement Program for experienced Electronic Technicians grants credit for previous Schooling and Professional Experience, and can greatly reduce the time required to complete Program and reach graduation. No residence schooling required for qualified Electronic Technicians. Through this Special Program you can pull all of the loose ends of your electronics background together and earn your B.S.E.E. Degree. Upgrade your status and pay to the Engineering Level. Advance Rapidly! Many finish in 12 months or less. Students and graduates in all 50 States and throughout the World. Established Over 40 Years! Write for free Descriptive Literature

**COOK'S INSTITUTE  
OF ELECTRONICS ENGINEERING**

 4251 CYPRESS DRIVE  
JACKSON, MISSISSIPPI 39212

CIRCLE 14 ON FREE INFORMATION CARD

# 45,296

## ELECTRONIC COMPONENTS

Whether you order 1 part or  
all 45,296...MOUSER stocks  
and...ships same day!!

**CALL...**  
**(800) 992-9943**



for your  
**FREE  
CATALOG**

2401 Hwy 287 N.  
Mansfield, TX 76063

# MOUSER

## ELECTRONICS

Sales & Stocking Locations Nationwide

CIRCLE 163 ON FREE INFORMATION CARD

sends the tone to the monitoring station without the need for wires, which are messy, hard to install, and easy to tamper with.

### HOME-BREW IR UNIT

The circuit in Fig. 3 is simple yet useful for anyone who wants an area "watched" by an alarm. The best thing about the circuit is that it contains no exotic parts, except for maybe the IR module, but that is available from Radio Shack.

Here's how the circuit works: The IR-transmitter section (Fig. 3A) contains a 555 timer/oscillator set-up for astable (oscillator) operation that, when correctly adjusted, can drive the infrared-emitting diodes at 40 kHz. The IR module in Fig. 3B picks up the beam, producing a low at its output. That low is fed to U2-a, which inverts the low, sending a high to a set/reset (RS) flip-flop consisting of U2-b and U2-c.

When the beam is momentarily broken, the output of the IR module goes high. That signal is inverted by U2-a and used to set the RS flip-flop. The result is a high at the output of U2-b, which turns on the 2N2222 transistor, sounding the buzzer. When the reset button is pushed, the RS flip-flop is reset, the buzzer shuts off, LED3 is lit, and the circuit is ready to be triggered again.

The capacitor connected from the output of the module (pin 1) to ground is used to absorb noise. (Noise increases with the distance between the receiver and transmitter because distance weakens the IR beam.) Despite the capacitor, the reaction time of the alarm is still very fast.

The receiver and transmitter should be encased in two separate enclosures. You can try enclosing the

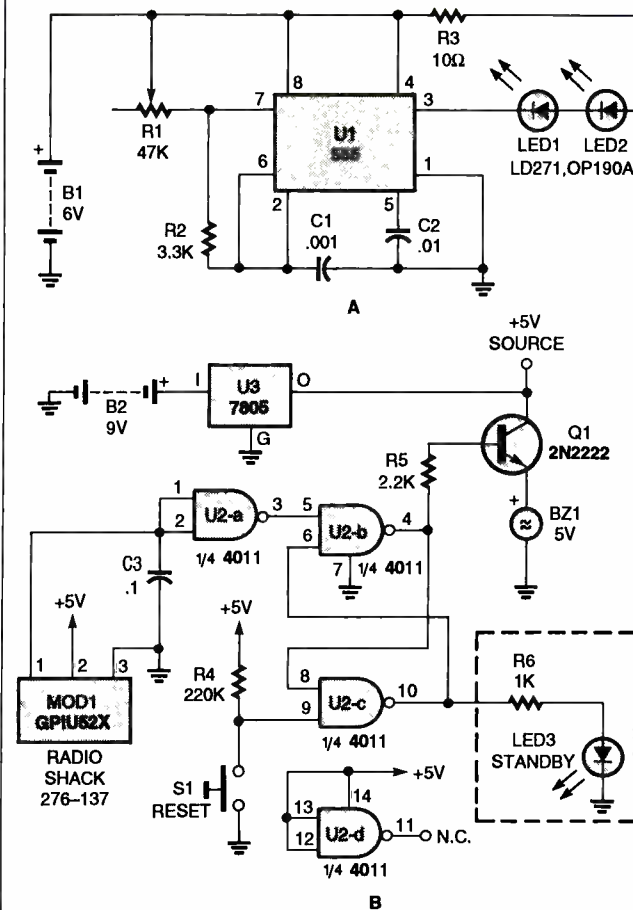

Fig. 3. This infrared transmitter (A) and receiver (B) pair can monitor a passageway. If the modulated IR beam between the circuits is broken, the buzzer will sound.

transmitter and receiver in the same case, using a mirror to reflect the beam, but the working distance will be cut in half. The transmitter LED's should be placed side-by-side about ¼ inch to 1 inch from each other.

By the way, please don't use LED's with a dispersion angle of more than 20 degrees. If you do, the beam will spread out too much, and the working distance of the two units will be greatly reduced.

Before this system will work, the 47k trimmer potentiometer connected to pin 7 of the 555 (Fig. 3A) should be adjusted so that the IR module responds with a steady low output. The working distance is about 20 feet, but that can

be increased by adding a lens on the receiver, or increasing the output of the transmitter.

—Jeremy Miller, Mandan, ND

Note that the use of a modulated IR carrier makes this alarm harder to defeat than a plain IR-detector/emitter circuit. To interrupt the beam without tripping the alarm, a thief would have to have a source of 40-kHz-modulated IR, not just any old IR source!

That's all the letters we have for this month. Next month, I'll present more letters dealing with alarm circuits and a new introductory topic. Until then, please write me here at *Think Tank*, **Popular Electronics**, 500-B Bi-County Blvd., Farmingdale, NY 11735.

### MULTIMEDIA WATCH

(Continued from page 8)

One new disc I examined is great fun for kids young and old. I thoroughly enjoyed it, and I'm sure a child would, too. The disc is one of many CD-ROMIX! multimedia comic books from Davidson & Associates. The one I looked at is *Freex #1* (pronounced freaks). This is the first story in the Freex series from Malibu Comics' Ultraverse line. These are comic books that you could buy at a newsstand skillfully transferred to CD-ROM. The story is brought to life using brilliant graphics, real voices, visual effects, music, and sound effects. While each disc contains only one comic "book," CD-ROMIX! are certainly worth their list price of only \$24.95. This is the kind of application that multimedia is all about.

I've been playing an excellent interactive game that's new to me only. *The 7th Guest* from Virgin Games takes place in an eerie 22-room haunted mansion. It's up to the player to solve the mystery of the house and its deceased owner, a twisted toy maker named Henry Stauf. This 2-disc game will keep you in suspense for weeks on end. It has a list price of \$99.99 and is often greatly discounted. The 7th Guest has been out for a while, and a sequel, *The 11th Hour*, is due out shortly—probably by the time you read this.

That's all for this time. See you again next month. In the meantime, if you have any multimedia-related questions, comments, or observations, you can send them to me at Multimedia Watch, **Popular Electronics**, 500-B Bi-County Blvd., Farmingdale, NY 11735.

# Start a money-making career in video/audio servicing!

Only NRI gets you started fast with real-world training designed around state-of-the-art equipment you keep!

NRI's newly expanded training covers all the latest advances in home entertainment electronics, then takes you inside today's high-tech equipment as you learn to troubleshoot, diagnose, and service the complete home entertainment system included in your course: 13" color TV, programmable VCR, and integrated audio rack system. Only NRI makes it so easy to start a new career, earn part-time income, even start a video/audio servicing business of your own!

**Billions of dollars of video/audio equipment means big opportunity for you**

There's never been a better time to get involved in home entertainment electronics. Experts predict that consumers of video/audio equipment will spend over \$26 billion by 1995 as product manufacturers race to fill the demand for increasingly sophisticated technology.

This explosive acceleration of new product innovation means new opportunities for you in video/audio servicing. And NRI prepares you to take advantage of those opportunities by giving you the skills to troubleshoot and service a full range of TV, video, and audio equipment.

**The most advanced, most complete video/audio training ever offered!**

You start with lessons that give you a strong foundation in electronics fundamentals, mastering the basic circuits and components at the heart of today's video/audio equipment.

Then you build on that foundation as you explore the high technology of digital controls, CDs and digital audio tape players, advanced TV systems, cable TV, VCRs and camcorders, even microprocessors.

Best of all, you're prepared for the technology of today and tomorrow with hands-on training designed to give you invaluable practical experience.

**Hands-on training with this incredible array of home entertainment equipment gives you the skills you need for success.**



**State-of-the-art equipment included in your training makes theory come to life**

Only NRI gives you so much real-world equipment ... all yours to train with and keep! Get hands-on experience as you work with a complete, high-tech home entertainment system: a 13" color TV with remote, a programmable VCR, and an integrated remote-controlled audio system including AM/FM tuner, 100 watt amplifier, CD player, dual cassette player, turntable, speakers, and audio rack cabinet.

Theory comes to life as you learn to perform component-level diagnosis and service on advanced technology audio equipment ... conduct in-set demonstrations of TV circuits and components ... and discover first-hand how to maintain and service today's commercial VCRs.

Plus, NRI custom-produced videos

show you in close-up detail how to test, troubleshoot, and service TVs and VCRs like a pro.

**No experience necessary ... NRI builds it in**

You need no previous experience in electronics to succeed with NRI. Step by step, you accumulate the knowledge and practical experience that will make you uniquely qualified for today's opportunities in home entertainment electronics.

You learn at your own pace and on your own time. And all throughout your training, you have the full support of your personal NRI instructor and the entire NRI technical staff.

**FREE catalog tells more**

If the coupon is missing, write to NRI Schools, McGraw-Hill Continuing Education Center, 4401 Connecticut Avenue, NW, Washington, DC 20008.

**SEND TODAY FOR FREE NRI CATALOG**

**NRI Schools**

McGraw-Hill Continuing Education Center  
4401 Connecticut Avenue, NW, Washington, DC 20008

For Career Opportunities approved under GI Bill  
 check for details



Check one FREE catalog only

- |  |  |
|--|--|
| <input type="checkbox"/> TV/Video/Audio Servicing        | <input type="checkbox"/> Desktop Publishing & Design |
| <input type="checkbox"/> Microcomputer Servicing         | <input type="checkbox"/> Electronic Music Technology |
| <input type="checkbox"/> Computer Programming            | <input type="checkbox"/> Home Inspection             |
| <input type="checkbox"/> Telecommunications              | <input type="checkbox"/> Automotive Servicing        |
| <input type="checkbox"/> PC Applications Specialist      | <input type="checkbox"/> Basic Electronics           |
| <input type="checkbox"/> Programming in C++ with Windows | <input type="checkbox"/> Bookkeeping & Accounting    |

Name \_\_\_\_\_ (Please print) \_\_\_\_\_ Age \_\_\_\_\_

Address \_\_\_\_\_

City \_\_\_\_\_ State \_\_\_\_\_ Zip \_\_\_\_\_

18-0894



# GET THE LATEST ADVANCES IN ELECTRONICS

SUBSCRIBE TO—

# Electronics NOW



## ENJOY THE WORLD OF ELECTRONICS EACH MONTH!

Subscribe to the best informed electronics magazine—the one that brings you the latest high-tech construction projects, feature articles on new technology, practical troubleshooting techniques, circuit design fundamentals, and much more.

**Electronics Now** looks to the future and shows you what new video, audio and computer products are on the horizon. You'll find helpful, monthly departments such as Video News, Equipment Reports, Hardware Hacker, Audio Update, Drawing Board, Computer Connections, New Products, and more. All designed to give you instruction, tips, and fun.

### Electronics Now gives you exciting articles like:

- Buyer's Guide to Digital Oscilloscopes
- Build A Scanner Converter
- Single-Chip Voice Recorder
- Build A MIDI Interface for your PC
- Troubleshoot Microprocessor Circuits
- Build A High-Power Amplifier for your Car
- Add Music On Hold to your Phone
- All About Binaural Recording
- VGA-to-NTSC Converter



FOR FAST SERVICE CALL OUR TOLL-FREE NUMBER!

# 1-800-999-7139

## DON'T DELAY — SUBSCRIBE TODAY!

If you prefer, just fill out the order card in this magazine and mail it in today.

# Build A Radio-Controlled Car

*Design and build radio-control system that works just like the ones used in commercially available RC cars.*

BY WILLIAM SHEETS AND RUDOLF F. GRAF



There are many applications for a radio-control (RC) system; for instance, an RC system might be used to control model cars or planes, toys, and even household devices. In this article, we'll describe the theory, construction, and interfacing of a RC transmitter/receiver system to a model car. The RC system that we'll present here is based on a pair of companion IC's specifically designed for simple remote-control applications. One chip—along with its external support components—performs the needed encoder/transmitter functions. The second chip, along with its support components, provides receiver/decoder functions. The receiver (which operates from nominal 6-volt DC supply) is a crystal controlled superhet design that can be easily interfaced to small DC motors or directly connected to standard pulse-type hobby servo motors. The receiver-to-DC motor interface we'll discuss provides on-off and direction-of-rotation control functions.

The receiver system can work with four channels, two digital and two analog. The two analog channels can be independently controlled to perform separate functions. In our circuit, only one of the analog outputs is used, although both channels are supported by hardware. The extra channel can be used to perform some other remote function if desired. The two digital output channels are

used for simple on-off and direction (forward/reverse) control.

Our system uses two separate variable-width 1- to 2-ms pulses for its analog channels, and 1 to 4 fixed-width 1-ms pulses for the digital channels.

**Generally Speaking.** A block diagram of the RC system is shown in Fig 1. The basic system is comprised of a pair of special-purpose chips: the LM1871 RC encoder/transmitter and its companion, the LM1872 RC receiver/decoder. A third chip, the LM18293 4-channel push-pull driver (which is controlled by the LM1872) is used to control the drive motor.

The LM1871 (see Fig. 1A) contains 4.6-volt regulator, a frame timer, a pulse timer, an encoder, and channel-add logic circuitry. The LM1871 generates an encoded pulse-width encoded waveform that is amplified, amplitude modulated, and fed to an antenna for transmission.

The receiver (see Fig. 1B) is a single-conversion superheterodyne circuit that is built around an LM1872 RC receiver/decoder. The LM1872 contains a local oscillator, voltage regulator, a mixer, IF circuitry with AGC, a detector, sync circuitry, and logic circuitry (which is used to decode the demodulated signal). It has a total of six output pins—two analog (pins 11 and 12,

CH1 and CH2, respectively) and four digital (CHA at pins 7 and 8, and CHB at pins 9 and 10).

The receiver (which operates from a 5- to 6-volt supply) has a single tuned network in its front end. The network feeds a mixer, where the signal is mixed with the output of the crystal-controlled local oscillator (LO). (The crystal is cut for 455 kHz below or above the desired radio frequency.) Since there is only one tuned circuit used for RF pre-selection, the receiver's image rejection is about 6 to 10 dB, but image interference is not a problem.

The mixer output is fed to the IF stage, whose output is kept constant by the chip's AGC circuit. The output of the IF is then used to drive the detector/decoder-logic circuitry. The receiver's analog outputs (pulse-width signals emitted from pins 11 and 12) can be used to directly drive a standard pulse servo.

However, in our application, the A and B digital outputs of the LM1872 are fed to an additional IC—an LM18293 four-channel push-pull driver (setup in an H-bridge configuration), which is, in turn, used to control the drive motor. One of the LM1872's two digital outputs (CHB) is fed directly to the enable input of the LM18293 to provide on/off control of the motor. The other digital output (CHA) is fed directly to one leg of the H-bridge circuit. A simple inverter, connected to the CHA output, inverts that signal,

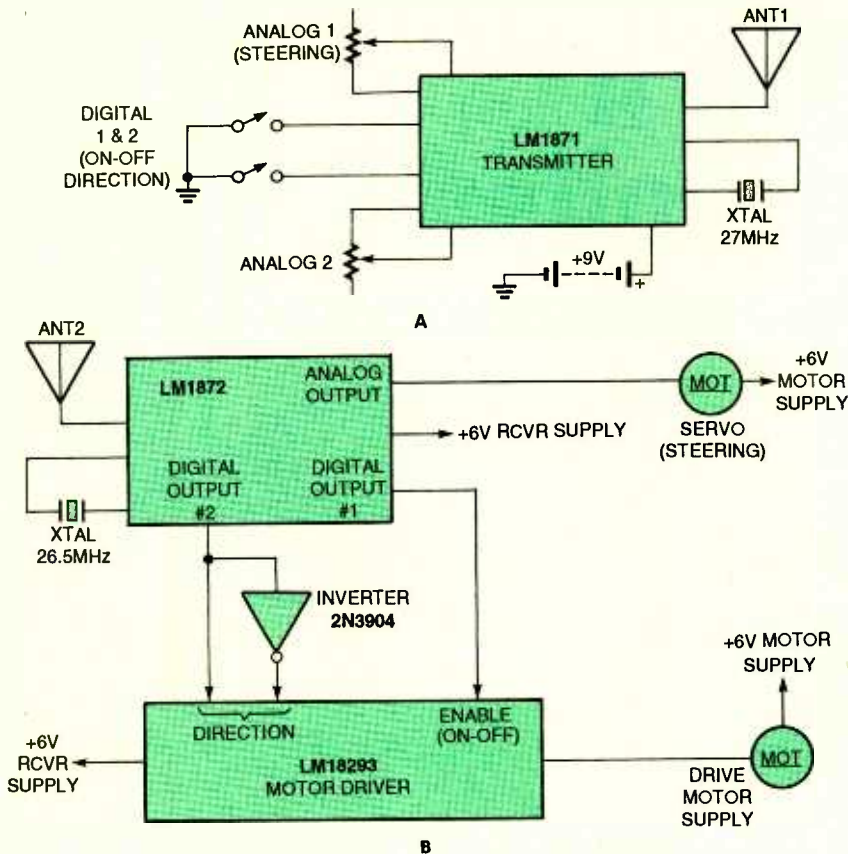

Fig. 1. The RC system is comprised of a pair of special-purpose chips, which perform both the encoder/transmitter functions and the receiver/decoder functions. A third chip, under command of the receiver/decoder, is used to control the motor.

which is then fed to the other leg of the H-bridge driver. In that way, the output from CHA is used to rotate the motor in either direction (backward or forward), depending on the logic level output by the receiver chip. The LM18293 can handle loads of up to 1 amp without overloading.

**Encoding.** The LM1871's encoding scheme is best understood with the aid of the control waveforms shown in Fig 2. As that illustration shows, the encoded signal (a stream of pulses) is output during a 20-ms period called the frame time, denoted  $T_f$ . At the beginning of each frame, there is a period (the modulation time, denoted  $T_m$ ) during which the output signal goes to zero for a fixed duration—500  $\mu$ s (0.5 ms). After  $T_m$ , the signal goes high for a variable duration called the channel time ( $T_{ch}$ ). Note that  $T_n$  (the width of a recovered channel pulse) is the sum of  $T_m$  and  $T_{ch}$ . In the first analog channel,  $T_{ch}$  has a pulse width of 0.5 to 1.5 ms, making  $T_n$  equal to between 1 and 2 ms—i.e.,  $0.5(T_m) + 0.5-1.5(T_{ch})$ —which appears at the CH1 output.

The first analog channel's  $T_n$  signal is followed by another-fixed-0.5-ms low ( $T_m$ ) and a second analog-channel

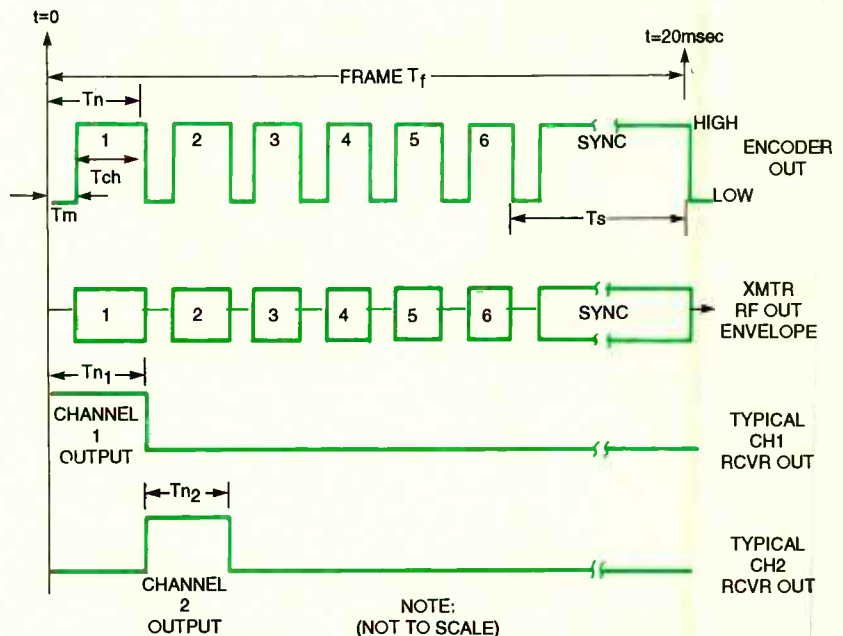

Fig. 2. The LM1871 outputs an encoded signal (a stream of pulses) during a 20-ms period called the frame time, denoted  $T_f$ . The frame time is broken down into several key segments; the modulation time ( $T_m$ ), the channel time ( $T_{ch}$ ), the a recovered channel pulse ( $T_n$ ), which equals the sum of  $T_m$  and  $T_{ch}$ .

pulse, which forms the second analog-channel signal.

Next is another 0.5-ms low and a fixed 0.5-ms high, which forms a third pulse. After that, there are up to three more fixed pulses, depending on the states of the two digital channels. After the last pulse is transmitted, another 0.5 ms low is produced followed by a long pulse to fill up the remainder of the 20-ms frame. That long pulse (called the sync time and designated  $T_s$ ) varies inversely to with the total of the channel times. Those pulse widths were chosen to ensure compliance with FCC bandwidth regulations, which state that all sidebands 10 kHz or more away from the carrier must not exceed 500 mV per meter at 3 meters from the antenna.

**Transmitter Operation.** The LM1871's  $T_f$  and  $T_{ch}$  waveforms are generated internally by the circuit in Fig. 3A. The comparator senses the rising voltage on the timing capacitor (C8) as it charges through a resistor (R1). The values of R1 and C8 are chosen to obtain a suitable  $T_f$ . When a voltage level of about  $\frac{2}{3}$  of the internally regulated voltage (4.6 volts) is reached, the comparator switches, turning on an internal transistor that discharges the capacitor to ground, or in the case of the channel timing

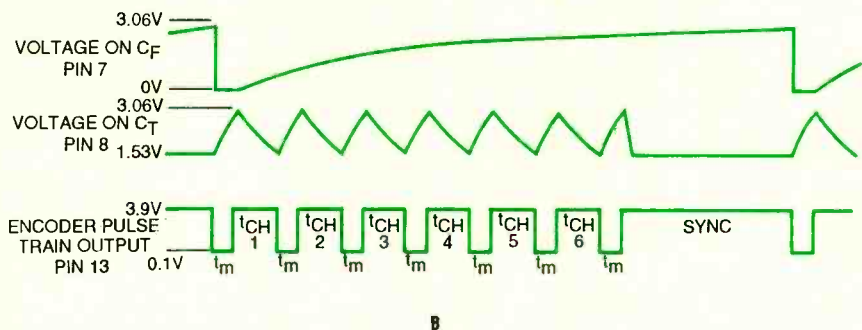
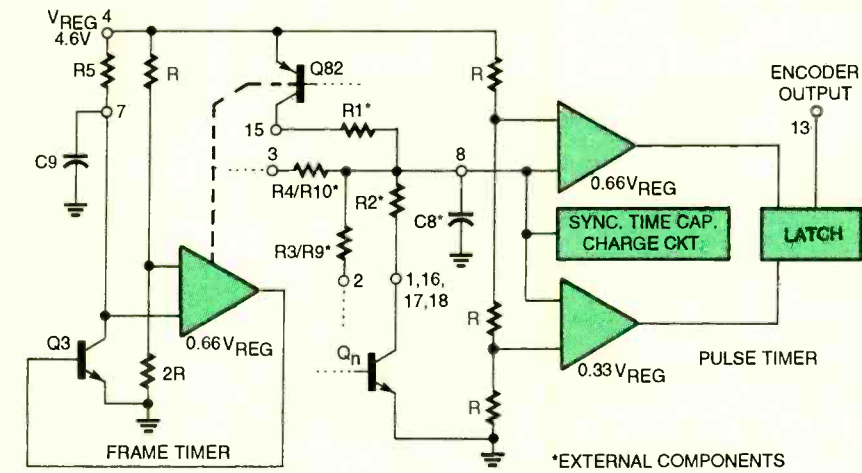

Fig. 3. Here's a simplified diagram of the LM1871's internal timing circuits.

pulses, to about  $\frac{1}{3}$  of the regulated voltage.

The six channel pulses are generated by discharging the timing capacitor ( $C_T$ ) through one of several external resistors (connected to pins 1, 2, 3, 16, 17, or 18), which is selected by an internal logic circuit, allowing independent control of the channel pulse widths. In our circuit, only the CH1 and CH2 times need to vary, so discharge paths are provided via R3, R4, R9, and R10. Since all the channel pulses for CH3 to CH6 (pins 1, 18, 17, and 16, respectively) are the same length, a single resistor (R2) is used for those four channels.

Figure 4 shows a schematic diagram of the RC system's transmitter section, which is comprised of the LM1871, U1, and a few support components.

Period  $T_m$  (as well as  $T_{CH}$  of the digital channel pulses) is determined by the values of R1 and C8, which for the specified values is 0.5 ms. The value of R3 and the R9 setting determine the pulse width ( $T_{CH}$ ) for analog channel 2; the value of R4 and the R10 setting

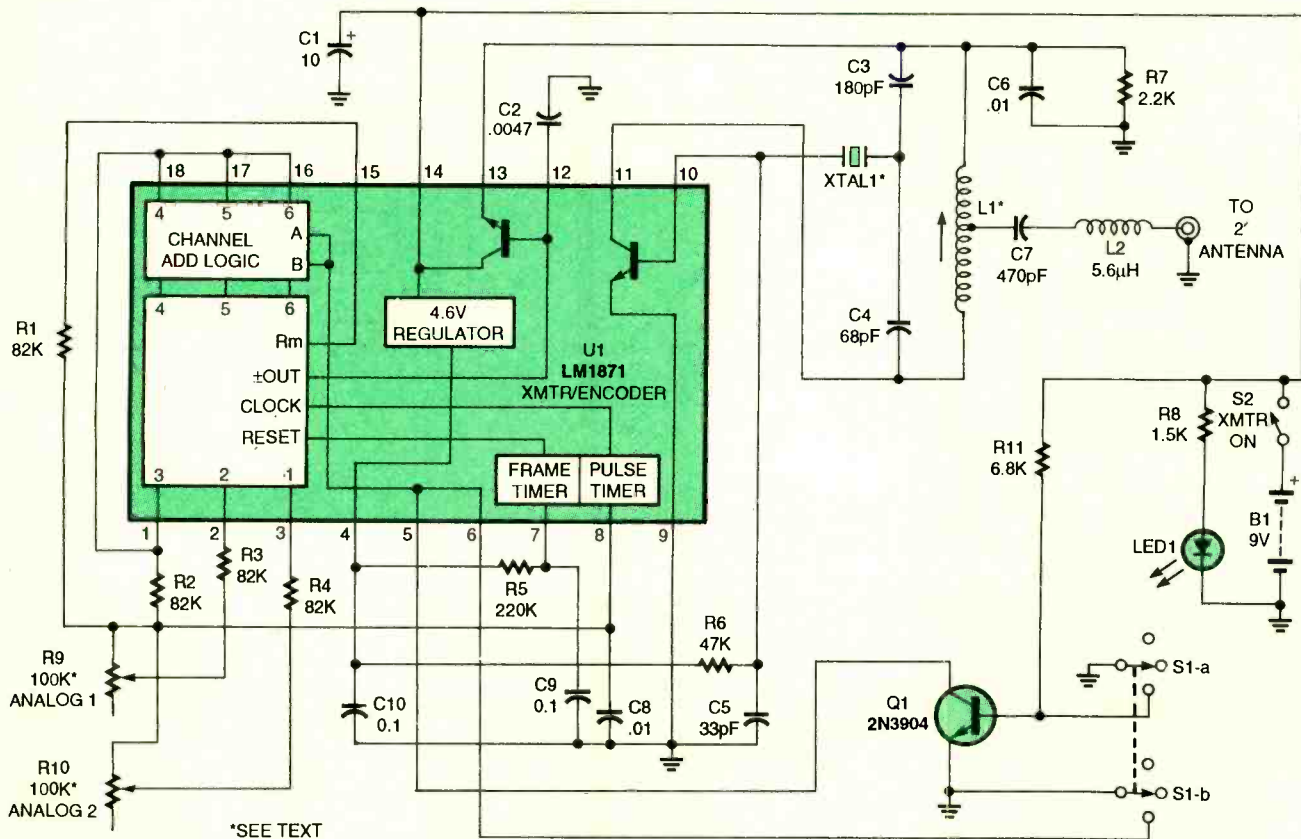

Fig. 4. The RC system's transmitter section is comprised of the LM1871 and a few support components.

determine the analog channel 1  $T_{ch}$ .

The regulated 4.6-volt DC bias voltage output at pin 4 of U1 is applied to an internal transistor (that is part of the crystal oscillator) via R6. That regulated DC bias also supplies current to the frame-timing components (R5 and C9), whose values produce a  $T_f$  of 22 ms. There are two channel-add logic inputs at pins 5 and 6, representing CHA and CHB, respectively. To initiate forward rotation, pin 5 is pulled low via Q1 and pin 6 left floating. For reverse pin 5 floats high and pin 6 is low.

The outputs of the frame timer circuit and the channel pulse-timing circuit comparators are pulse waveforms. Those two sets of pulses are combined in a logic circuit, and is output at pin 12 (see Fig. 4), which is the input to an internal emitter follower. A capacitor, connected from pin 12 to ground, is used to remove high-frequency components from the waveform. The encoder output modulates the 4.6-volt DC regulated supply and the voltage appearing at pin 13 of U1. The output of U1 at pin 13 is used to supply the transmitter's crystal oscillator. Strictly speaking, it is not usually recommended that a crystal oscillator be modulated, since doing so can result in an output may contain spurious FM signals and/or a distorted envelope. Resistor R7 is used as a pull-down resistor while C6 is used as an RF bypass.

An internal transistor (with its collector available at pin 11, the base at pin 10, and its emitter connected to pin 9) along with C4, C3, XTAL1 (connected to the junction of C4 and C3), and L1 form an oscillator circuit, with L1 used to tune the oscillator. Resistor R6 provides base bias to the internal transistor, while C5 is part of the feedback circuit.

The collector of the internal transistor (at pin 11) is connected to the high side of the tank circuit (formed by L1, C4, and C3). Capacitor C7 is used to couple the oscillator signal to the antenna. Inductor L2 is used to improve impedance matching for optimum power transfer. Inductor L4 is tapped at about 30% to provide a low impedance point. The RF output is about 350–400 mV into 50 ohms (or about 2 mW). Inductor L1 is tuned for best output consistent with good keying characteristics.

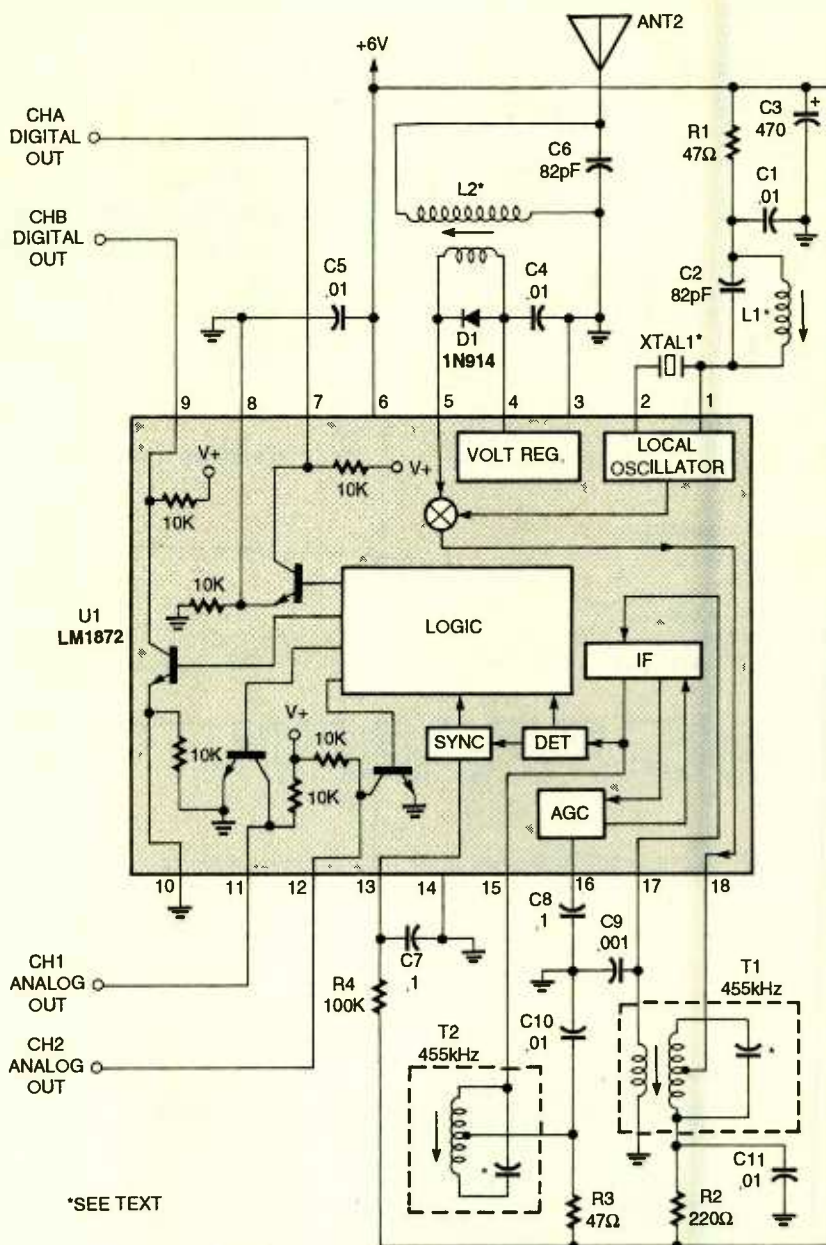

Fig. 5. The receiver section of the RC system—which is used to manipulate an optional driver—is comprised of the LM1872 and a handful of support components. The LM1872 decodes the received signal to determine which of its outputs (either digital or analog) should be activated or deactivated.

**The Receiver.** Figure 5 shows a schematic diagram of the receiver. Signals picked up by the antenna are fed to an LC circuit comprised of L2 and C6, which is tuned to 27 MHz. The signal is fed through L2 across D1 to pins 4 ( $V_{bias}$ ) and 5 (the mixer input) of the LM1872. The signal is bypassed for RF by C4. Diode D1 is included in the circuit to protect U1 from electrostatic discharge. The operating frequency of U1's internal local oscillator is controlled by XTAL1. A DC voltage is fed to the oscillator tank circuit (comprised of L1 and C2) via a decoupling net-

work consisting of R1 and C1. Capacitor C5 is used to bypass the supply voltage.

The mixer output at pin 18 (consisting of the sum and difference of the LO and RF-input frequencies, as well as the LO and RF-signal components) is fed to T1 (a 455-kHz transformer), which passes only the difference frequency (our 455-kHz IF). The difference frequency is fed to U1's internal IF amplifier at pin 17. The amplified output (which can range from about 10 mV to 100 mV) at pin 15 is fed to T2 (a tuned IF circuit). Transformer



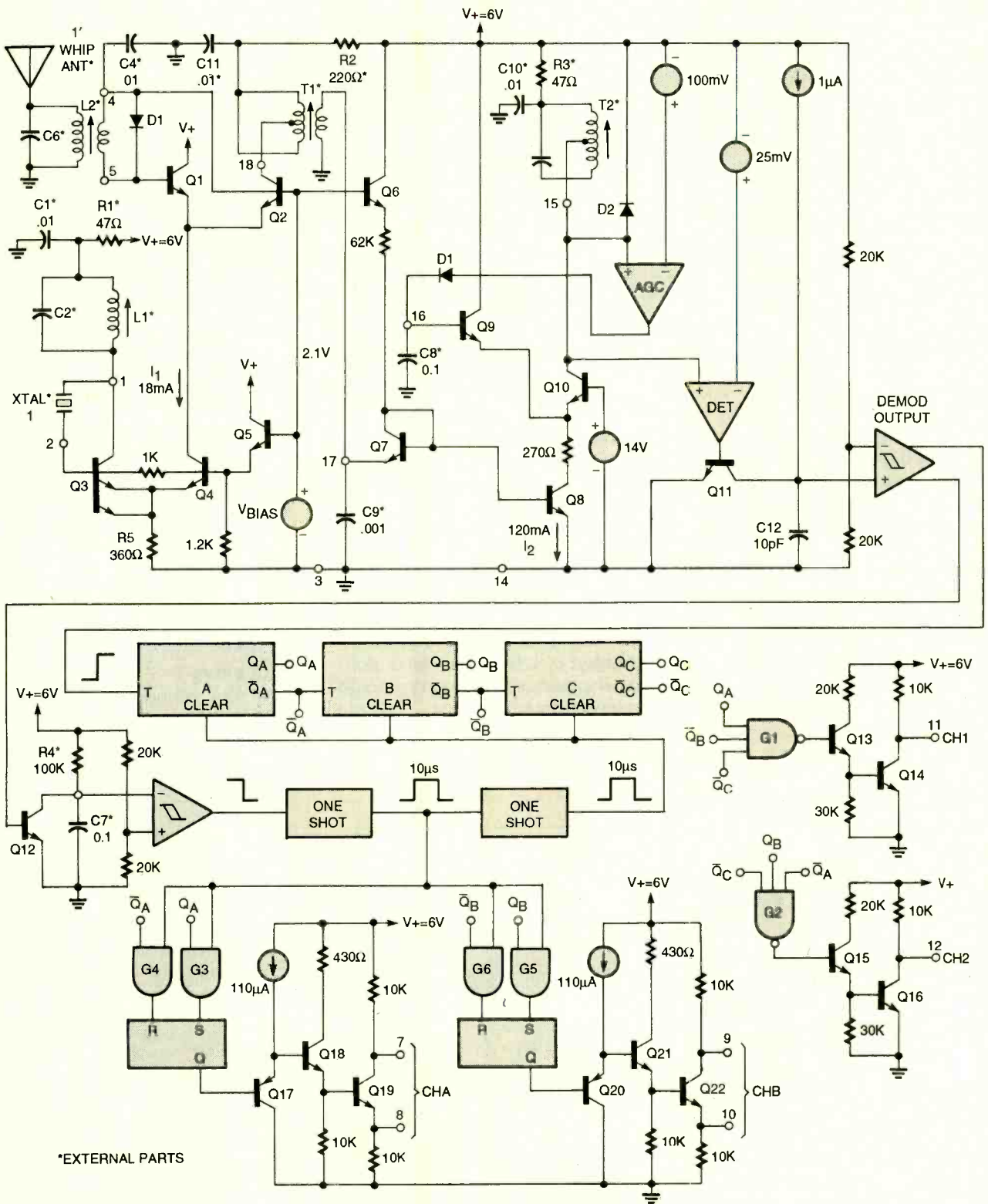

Fig. 6. Here is a schematic diagram of the LM1872's internal organs, which will give you some idea of the complexity harnessed within its small black silicon package.

T2's secondary is not used, but is brought out on the PC board as a test point for observing the IF signal.

Components C8-C10 are bypass capacitors. Resistors R2 and R3 feed

DC to the mixer and IF stages. Components R4 and C7 are used in conjunction with the chip's decoder circuit (comprised of a high-gain precision comparator and a precision

25-mV reference). The IF amplifier has an internal automatic-gain-control (AGC) circuit that helps to keep the IF amp's output constant. The output of the IF stage is fed to a detector. The

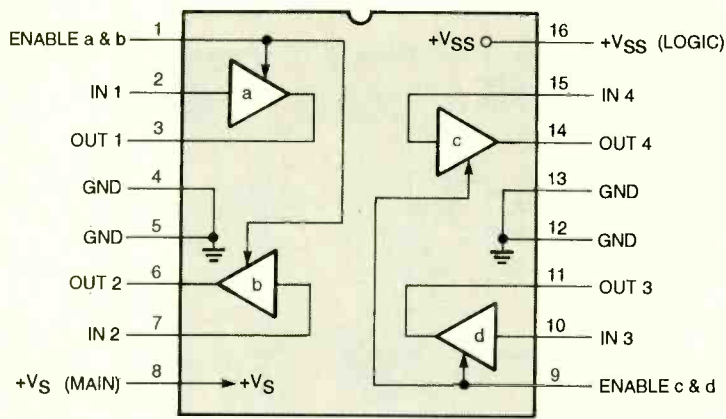

Fig. 7. Here is a block pinout diagram of the LM18293 4-channel push-pull driver. Two drivers (tied together through a common thread—the enable input) are used to form an H-bridge driver.

detector stage recovers the modulation on the received signal. When the IF carrier exceeds 25 mV, the comparator output discharges an RC timing circuit (that has a delay of 30 microseconds).

Referring to Fig. 6—a schematic diagram of the LM1872's internal circuitry—when the IF carrier exceeds 25 mV, the comparator produces an output that is fed to a Schmitt trigger (which conditions the input waveform). The demodulated output of the

Schmitt trigger is, in turn, fed to a decoder (essentially a 3-stage binary counter, consisting of three flip-flops, denoted A, B, and C), and a sync-timing circuit (comprised of Q12, R4, C7, and another Schmitt trigger).

At  $T_m$ , when the RF carrier drops for the first modulation pulse, the counter advances. During that interval, the sync-timing capacitor (C7) is held discharged by Q12. As the carrier starts to swing positive, C7 begins to charge toward a threshold of  $V_{supply}/2$ , but

cannot reach that level before the carrier goes low again. At the end of  $T_{ch}$ , the counter advances one count, and the cycle repeats.

A pair of 3-input NAND gates (G1 and G2), used to decode the analog channels, examine the counter's binary output in order to identify the time periods that correspond to the analog channels. The gate outputs (which are pulses equalling the sum of  $T_m$  and  $T_{ch}$ ) are fed to Darlington output circuits that can be used to drive standard hobby servos.

As mentioned earlier, following the transmission of the two variable analog channels, a variable of one to four

## PARTS LIST FOR THE RC TRANSMITTER

### SEMICONDUCTORS

- U1—LM1871 RC encoder/transmitter, integrated circuit (National Semiconductor)
- Q1—2N3904 or 2N2222 general-purpose silicon NPN transistor
- LED1—Light-emitting diode, any color

### RESISTORS

- (All fixed resistors are 1/4-watt, 5% units.)
- R1-R4—82,000-ohm
- R5—220,000-ohm
- R6—47,000-ohm
- R7—2200-ohm
- R8—1500-ohm
- R9, R10—100,000- to 500,000-ohm potentiometer
- R11—6800-ohm

### CAPACITORS

- C1—10- $\mu$ F, 16-WVDC, electrolytic
- C2—0.0047- $\mu$ F, Mylar
- C3—180-pF NPO, ceramic-disc
- C4—68-pF NPO, ceramic-disc
- C5—33-pF NPO, ceramic-disc
- C6—0.01- $\mu$ F, ceramic-disc (GMV)
- C7—470-pF, ceramic-disc
- C8—0.01- $\mu$ F, Mylar
- C9, C10—0.1- $\mu$ F, Mylar

### ADDITIONAL PARTS AND MATERIALS

- L1—See text
- L2—5.6-mH RF choke
- S1—DPDT center-off, momentary-contact switch
- S2—SPST toggle switch
- XTAL1—3rd overtone (HC49 or 18 case) crystal
- Printed-circuit materials, enclosure, 9-volt battery, battery holder and connector, antenna, antenna jack, knobs, wire, solder, hardware, etc.

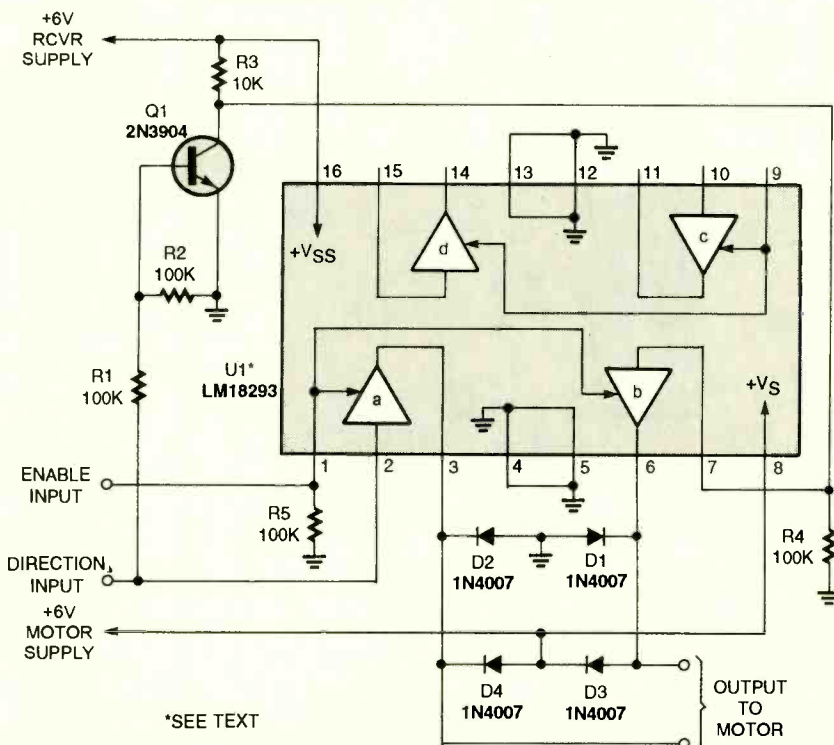

Fig. 8. This motor-driver circuit (which is only necessary where high-current loads are to be handled) is built around another of National Semiconductor many products: an LM18293 four-channel push-pull driver.

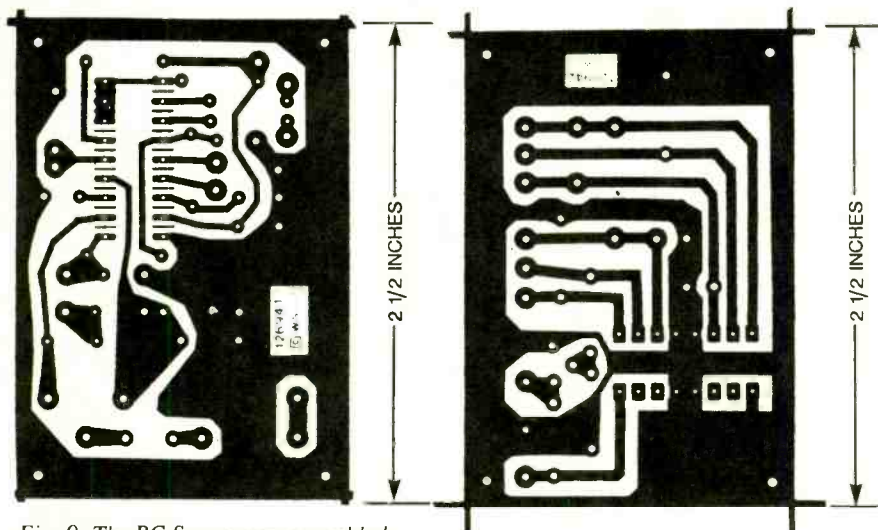

Fig. 9. The RC System was assembled on three printed-circuit boards; a full-scale template of the transmitter (which was mounted in a small aluminum box) is shown here.

fixed-width pulses of 500  $\mu$ s (containing the digital channel information) is transmitted. Until the end of  $T_r$ , the decoder responds as if the signals were analog pulses, but delivers no output. At the end of  $T_r$ ,  $T_s$  is sent. Since  $T_s$  is made longer than the sync-timer period ( $T'_s = 3.5$  ms), the sync timer provides a sync signal to the first of two cascaded oneshots.

The first one-shot enables AND gates G3–G6 to read the A and B flip-flops of the counter into two RS latches. The state of flip-flop A is then stored in one

Fig. 11. Here is a full-scale template of the RC System's final subassembly—the optional motor-driver board.

of the latches and buffered to drive up to a 100 mA load at the CHA digital output. The same is done for flip-flop B to drive digital output CHB. At the end of the 10  $\mu$ s read pulse, the second one-shot is triggered, and its output is used to reset the counter to be ready for the next frame.

**Motor-Driver Circuit.** The optional motor-driver circuit is built around half of an LM18293 four-channel push-pull driver IC. The other half of the LM18293 could be pressed into service for something else if needed. A

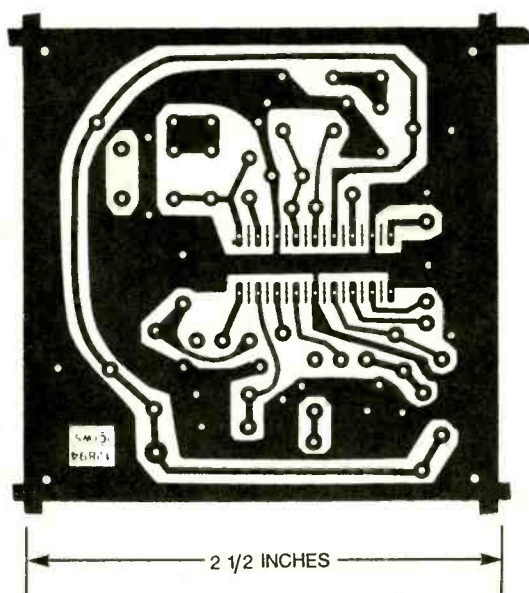

Fig. 10. A full-scale template of the receiver's printed-circuit board is shown here. It's recommended that the system, particularly the receiver be laid out on G-10 PC material (0.031 or 0.062 thick).

## PARTS LIST FOR THE RC RECEIVER

### SEMICONDUCTORS

U1—LM1872 RC receiver/decoder, integrated circuit (National Semiconductor)

D1—1N914 or 1N4148 general-purpose silicon diode

### RESISTORS

(All fixed resistors are 1/4-watt, 5% units.)

R1, R3—47-ohm

R2—220-ohm

R4—100,000-ohm

### CAPACITORS

C1, C4, C5, C10, C11—0.01- $\mu$ F, ceramic-disc

C2, C6—82-pF NPO, ceramic-disc

C3—470- $\mu$ F, 10- to 25-WVDC, electrolytic

C7, C8—0.1- $\mu$ F, Mylar

C9—0.001- $\mu$ F, Mylar

### ADDITIONAL PARTS AND MATERIALS

L1—See text

L2—See text

T1—455-kHz IF (Toko p/n RMC 202313)

T2—455-kHz IF (Toko p/n RMC 4025030)

XTAL1—See text

Printed-circuit materials, enclosure, power source, wire, solder, hardware, etc.

block pinout diagram of the driver IC is shown in Fig 7. Two drivers (which have a common enable input) are used to form an H-bridge driver (which is similar to the bridged output commonly used in audio-power amplifiers). Since the drivers are non-inverting, the required push-pull drive signal is derived from a phase inverter (Q1), as shown in Fig. 8.

The CHA output from the LM1872 is fed to pin 1 of the LM18293. When pin 1 is at logic high, the two drivers used are enabled; that function is used as a motor on-off control. When pin 1 is at a logic zero, both drivers are disabled and placed in a floating three-state condition, cutting off DC to the motor. The unused half of the IC is disabled by grounding pin 9. The pin-2 driver input is used as a direction control. Applying a logic high to pin 2 causes pin 3 to go high, which (in turn) causes the first driver to output nearly 6 volts to one leg of the motor. At the same time, the pin-2 signal is fed to Q1 (which is used as an inverter) through

## PARTS LIST FOR THE MOTOR-DRIVER BOARD

### SEMICONDUCTORS

- D1-D4—1N4007 1-amp, 1000-PIV rectifier diode  
 U1—LM18293 4-channel push-pull driver, integrated circuit (National semiconductor)  
 Q1—2N3904 or 2N2222 general-purpose silicon NPN transistor

### RESISTORS

- (All fixed resistors are 1/4-watt, 5% units.)  
 R1, R2, R4, R5—100,000-ohm  
 R3—10,000-ohm  
 Printed-circuit materials, enclosure, clip-on heatsink for 16 pin DIP IC, reversible DC drive motor, wire, antenna, power source, wire, solder, hardware, etc.

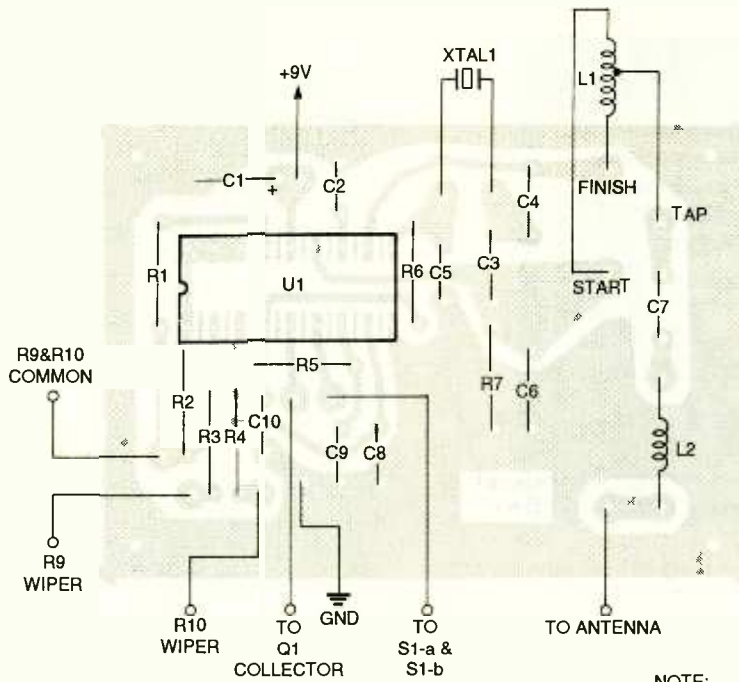

NOTE:  
 THESE PARTS NOT ON BOARD:  
 R8, LED1, R9  
 R11, Q1, R10

Fig. 12. This parts-placement diagram corresponds to printed-circuit layout of the transmitter shown in Fig. 9.

tial) and Q1 is cut off, raising Q1's collector voltage via R3. That high is applied to the input of the second driver, causing its output to rise to 6 volts, which is applied to the motor to rotate it in the opposite direction.

The driver circuit is powered by two 6-volt sources. One source is provided by a four C-cell power pack, and is used exclusively to drive the servo and drive motors. The other 6-volt source, which is used to power the receiver and driver logic, is derived from another battery pack consisting of four AA cells. That is done to prevent loss of control under stalled-motor conditions that can load the supply voltage enough to cause the receiver to malfunction. It also helps to sidestep RFI problems that a could result if a common battery supply were used.

The 6-volt motor supply is applied to pin 8 of U1. Diodes D1 through D4 are used as clamping diodes. Pull-down resistors R4 and R5 can be omitted if desired but they are handy for testing and necessary when the associated input is open circuited.

**Construction.** The RC System was assembled on three printed-circuit boards; full-scale templates of the transmitter (which was mounted in a small aluminum box), receiver, and motor-driver boards are shown in Fig. 9, 10, and 11, respectively. The system was assembled in three phases to allow the end user as much flexibility as  
*(Continued on page 90)*

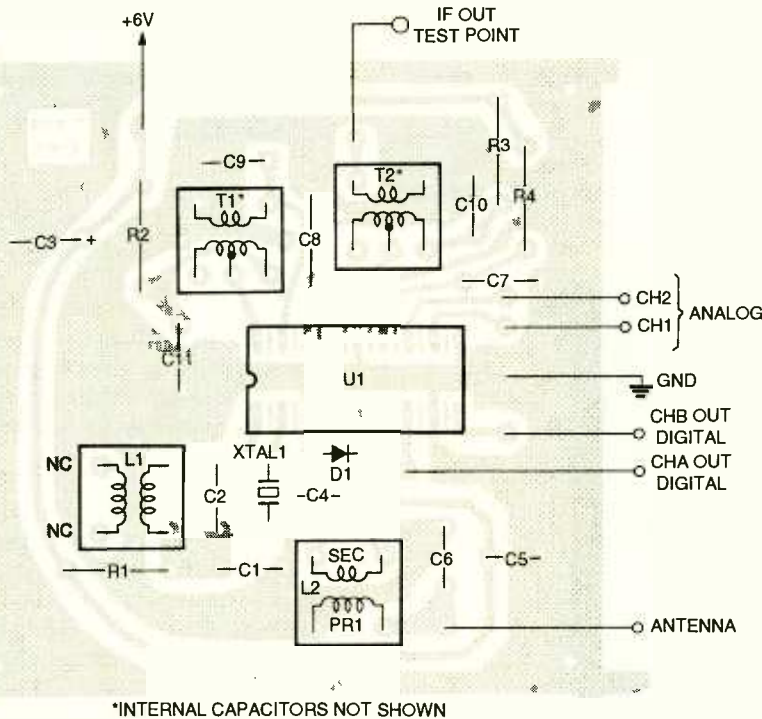

\*INTERNAL CAPACITORS NOT SHOWN

Fig. 13. Assemble the receiver portion of the system using this parts-placement diagram as a guide.

R1, turning Q1 on and pulling its collector to ground. That pulls the input to the second driver (at pin 7) low, forcing its output to ground; in effect, grounding the second leg of the

motor. That causes the motor to rotate in the forward direction.

When the input to pin 2 is low, the opposite happens. Now the output of the first driver is low (at ground poten-



# ALL ABOUT RADIO CONTROL

*Any reader of this magazine who hasn't dabbled in radio control is missing out on a lot of fun.*

BY MARC SPIWAK

**R**adio control is among the most popular hobbies in this country. That's not surprising, considering that in the radio-control hobby of today, one can find a toy to tickle any fancy. There are radio-controlled planes, gliders, helicopters, powerboats, sailboats, submarines, cars, motorcycles, tractors—you name the vehicle, and there is a radio-controlled version of it for your fun and amusement. More than likely, there is also a magazine out there that's entirely devoted to the particular type of RC vehicle you enjoy.

Years ago the RC hobby was dominated almost entirely by gas-powered vehicles. Miniature gas engines have evolved, and today you can buy them in 2-stroke, 4-stroke, multi-cylinder, radial piston, water-cooled, and even Wankel (rotary) models. You could spend anywhere from \$100 to several thousand dollars on just the engine!

However, by the late 1970's, electric power started to take the industry by storm due to advances in both motor and battery technology. While gas power is again gaining speed, since this is **Popular Electronics**, I'll concentrate on electric-powered RC models in this article.

**My Preference.** I have to be hon-

est—I'm no pilot, and have never flown an RC plane. A tremendous amount of time, although not necessarily money, must be invested in learning to fly an RC plane. Of course in learning, planes do crash, which can be all the more frustrating. To fly a plane you need a huge isolated area, devoid of trees and other obstacles. In many cases, you need a permit to fly RC planes, as a 20-pound plane in a dive at 100 miles per hour (actual speed!) with dual props chewing away at the air can easily kill someone. I'm not trying to dissuade anyone from flying RC airplanes, and I hope to try it myself sometime, but you do need the space, patience, and skill. Also, while boats can be fun, and although I once owned one, they are not my favorite RC toys. Too many swims to fetch a boat that snagged on a plastic bag or stalled for some other reason led me to direct my energies elsewhere.

I do however have years of experience with RC cars. I like RC cars not only because I like real cars, but also because cars can be easily worked on and tested indoors, and you need nothing more than the street or a backyard to have a lot of fun with them.

**Classes of Cars.** I group RC cars into

four categories. The first is the kind that won't even run on a carpet. The second kind comes preassembled and can be a lot of fun, but only for a short time. The problem with those is that once they break, they're often impossible to repair for many reasons. The third category is the kind that you build from a low-end kit. While they are easy to repair, you will find yourself having to repair one nearly every time you use it because it lacks the performance and quality associated with the next category: high-end kits. Cars built from more expensive kits are extremely durable, can be easily repaired if necessary, and are popular enough for there to be a wide range of aftermarket hop-up parts available.

**Class 3 and 4 Experiences.** You can expect to spend between \$200 and \$300 for the bare minimum that you'll need to get started with a decent-quality RC car, and even more if you want something of high quality. I bought my first car—a model from the third category—from a local hobby shop. It came as a package deal with everything I needed for about \$200. The package included the car kit, a radio, a battery pack, and a charger. That's the bare minimum you need. I paid extra for a charger that could be



*This inexpensive charger, while it can't be plugged into an AC outlet, is all you need (not including a car battery) to charge batteries in the field.*

plugged into a wall outlet, which is more versatile than an inexpensive charger that must be connected to a 12-volt car battery.

The first car had good intentions—it looked great, and performed well—but it lacked in durability and performance. In addition, it had too many small parts that kept breaking or popping off in a crash, and a cheap plastic chassis that cracked after a couple of months of use. While a replacement chassis wasn't too expensive, the car had to be completely taken apart to use it. Soon after the chassis was replaced, it cracked again. Also, while the car was intended for off-road use, it had relatively poor traction because it was only a two-wheel drive model. I decided that I liked the hobby enough to buy a better car—one that wouldn't break so easily, that wouldn't wear out so quickly, and that would greatly outperform the first one.

The second car I bought, another off-road model, had belt-driven four-wheel drive, a full set of ball bearings, front and rear differentials, an aluminum chassis, oil-filled shocks with graphite shock towers, sway bars, and a whole assortment of features not found on the first car. Even though I spent about \$230 on just the car, it was worth it, as I have had it for years and it still runs great. That's not to say that I haven't had to replace anything on it, but it has been much more of a plea-

sure to own than the first one. As an example, a \$50, 50,000-RPM motor I added quickly chewed up the gear-box when I used a 7-cell battery pack and a poorly chosen gear ratio. Fortunately, high-performance gears were also available as aftermarket items, so I could continue to use the motor.

Still, you should have seen that car go—almost 40 miles per hour on pavement! (Cars that are meant to race on pavement are not usually four-wheel drive, and they can dou-

ble the speed of my off-road model.) What this four-wheel drive car will do in the dirt, where it is intended to be used is even more amazing. Now let's take a look at the technology behind controlling an electric car remotely.

**Low-End Receivers and Transmitters.** Cars are usually controlled from a 2-channel radio—one channel for steering and the other for the throttle. My first radio was a 2-stick, 2-channel unit with a separate battery pack to power the receiver and servos.

Each stick, or gimbal, is connected to a potentiometer inside the transmitter. An encoder chip pulse-width modulates pulses onto a carrier frequency based on the position of each stick, or more precisely the resistance of the potentiometers. See Fig.



*In addition to a decoder chip, a servo contains a motor, gearbox, and output shaft. The servo can hold or adjust the position of its output shaft based on the signal from the transmitter.*



*This rechargeable Ni-Cd pack has 6 cells. You can purchase 7-cell packs for even more punch.*

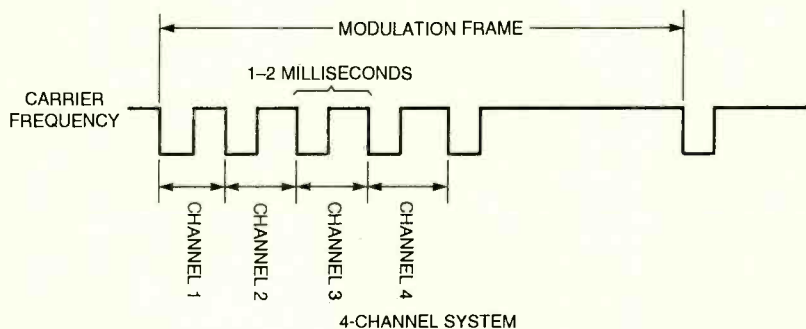

Fig. 1. Pulses modulated onto a carrier frequency are varied in width from 1 to 2 milliseconds. When a stick is centered, the pulse corresponding to that channel is 1.5 milliseconds long. When a stick is pushed fully to one extreme, the pulse width shrinks down to 1 millisecond, and when it's pushed to the other extreme, the pulse increases to 2 milliseconds.

1 for some example pulses. When a stick is centered, the pulse corresponding to that channel is 1.5 milliseconds long. When a stick is pushed fully to one extreme, the pulse width shrinks down to 1 millisecond, and when it's pushed to the other extreme the pulse increases to 2 milliseconds. A trim control for each stick adjusts the position of the potentiometer with respect to the stick to provide for centering or trim adjustment out in the field.

The carrier frequency is picked up by a receiver unit, which decodes the pulses and sends them to their respective servos. A servo is a small device containing a motor, gearbox, and output shaft. The motor is driven from a small PC board inside the servo that contains a decoder chip. The decoder chip generates a reference pulse based on the position of an internal potentiometer connected to the output shaft of the servo. The decoder chip compares the incoming pulses to the reference pulses and

tries to make them match in width by adjusting the position of the servo's output shaft. That's how the servo can hold or adjust its position based on the signal from the transmitter. In operation, it almost seems like magic.

To steer a car, the output shaft of a servo is connected via some kind of linkage to the front wheels of the car. The front wheels are adjusted so that they are pointing straight ahead when the steering servo is at rest (a 1.5-millisecond incoming pulse).

Most cars, except the very high-end ones, will come with a mechanical speed controller. That is basically a switch connected to two low-impedance, high-wattage shunt resistors. A linkage connected to the throttle servo puts both resistors in series with the motor for slow speed, one in series for medium speed, and none in series for high speed. A fourth switch position, accessed by turning the throttle servo in the opposite direction, reverses the polarity of the power going to the

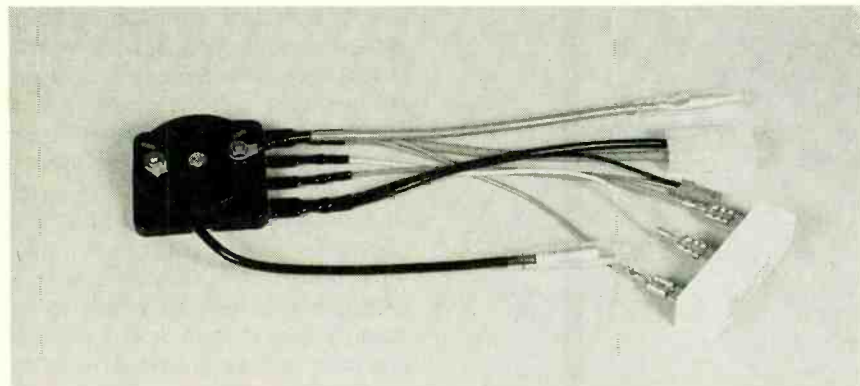

A mechanical speed controller is basically a switch connected to two low-impedance, high-wattage shunt resistors. Both resistors are switched in series with the motor for slow speed, one in series for medium speed, and none are used for high speed. A fourth switch position reverses the polarity of the power going to the motor.

## On The Cover

The Kyosho *Outlaw Ultima Truck*—an excellent first-time RC vehicle—pictured on the cover is a 2-wheel drive model. However, what it loses in traction (not being 4-wheel drive) is made up for in clearance. The large tires enable it to clear most obstacles, and it has no trouble running in deep grass. That's a problem for 2-wheel drive cars with low clearance. While most of the truck's parts are plastic, they are glass-reinforced, which makes them light in weight yet very durable. Four oil-filled shocks provide long-travel independent suspension, and a real gear-type differential helps increase traction. A good-quality mechanical speed controller is included, although I substituted an electronic controller.

The truck took me about two nights to build, not including the time it took to finish the body. The body is made of lexan, a clear, flexible plastic. The body is painted on the *inside* with special paint that bonds to the lexan and remains flexible after drying. That makes for a permanent finish that can't scratch off in a crash.

The *Outlaw Ultima* can be bought mail order for about \$130. For it you'll also need a 2-channel radio, a battery pack, and a charger. However, the truck can be bought in a package deal that includes a 2-channel radio, a battery, and charger for about \$200. However, the radio does not include an electronic speed controller, and the charger is DC only and can't be plugged into a wall outlet. A better approach would be to get the truck alone, and purchase an AC/DC charger (about \$50), a battery pack (about \$20), and a radio that includes an electronic speed controller (about \$90) separately. Sure that's about \$90 more than the base-package price, but I think having the more versatile charger and electronic speed controller are worth the extra expense. (I never said this was an inexpensive hobby.) However, you can certainly get by with any base package.

Keep in mind that those are mail-order prices and you will pay more at a local hobby shop—how much more depends on how reputable the shop is. However, paying slightly more can be a good thing if the local hobby-shop owner is also happy to lend a hand if you need one—something you don't get by mail.

If you are at all interested in RC cars, do yourself a favor and read an issue or two of *RC Car Action* (Air Age, Inc., 251 Danbury Rd., Wilton, CT 06897) before you buy anything. It's always good to be familiar with a product line before you invest in it. Otherwise get your hands on a copy of Tower Hobbies' catalog (PO Box 9078, Champaign, IL 61826; Tel. 800-637-4989). You can then order whatever you want from them or at least know what a fair price is for a given product. ■

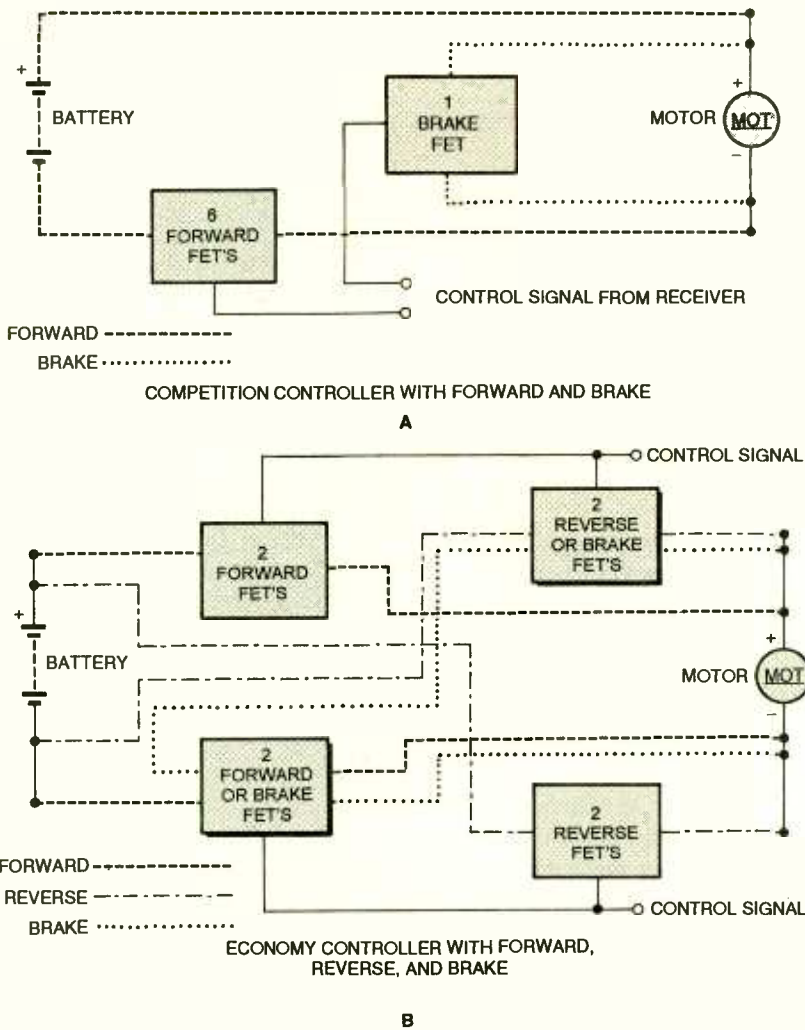
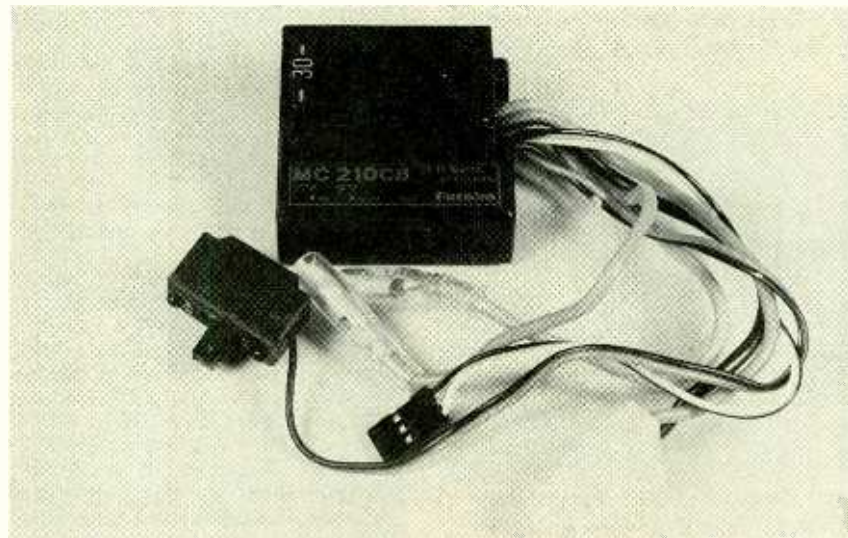

Fig. 2. Here we show a competition controller (A) with forward and brake capabilities and an economy controller (B) with forward, reverse, and brake functions. Both use paralleled FET's that are pulsed on and off at a variable rate to supply power to the motor. The more FET's in parallel, the less the voltage drop across the controller, and the greater the power supplied to the motor.



An electronic speed controller has no moving parts and eliminates the need for a throttle servo.

motor and makes the car go backwards.

There are drawbacks to both the receiver and speed controller in this sort of set up. For one, while the receiver's battery pack would be required for a gas-powered car, it only adds extra weight to an electric car, which already has a beefy Ni-Cd pack powering the motor. As for the speed controller, one problem is that there are only three speeds (instead of fully variable speed). Also, they are prone to jamming when dirt gets into them (which always leads to disaster), and any power shunted through a resistor is simply wasted as heat.

**High-End Receivers and Transmitters.** When I purchased my second car, I decided to go with an electronic speed controller. That device uses paralleled FET's that are pulsed on and off at a variable rate to supply power to the motor (see Fig. 2). An electronic speed controller plugs right into the receiver, eliminating the need for—and weight of—a throttle servo. The speed controller can sell for about \$60 by itself, but I bought it in a package that comes with the speed controller, a pistol-type radio (with a steering wheel to steer and a trigger for the throttle), and one servo for steering, all for about \$100. The new radio also included circuitry that eliminated the need for a separate battery pack for the receiver—a requirement for the new car, which had no place to put the extra battery pack. The new radio also replaced the steering stick with a wheel, which makes driving a car more realistic.

The speed controller included with the radio was basically a low-end one with reverse and dynamic braking. (For dynamic braking, a direct short is placed across the motor leads, which brings the car to a halt.) The high-end electronic controllers, intended for competition, don't usually include reverse, which would only add weight and decrease the efficiency of the controller. To win a race, it would make more sense to use as many FET's as possible for forward, which would decrease the voltage drop due to the controller and supply more power to the motor.

Electronic speed controllers have to handle a lot of current. The control-

(Continued on page 81)





# Build an Air-Conditioner Monitor for your Car

*Keep your auto's air-conditioning system in tip-top shape with this simple monitoring circuit.*

BY ANTHONY J. CARISTI

**D**id you know that the air-conditioning system in your pre-1994 vehicle contains an environmentally dangerous chlorofluorocarbon (CFC) that by law can not be manufactured in the United States after December 31, 1995? As a result, the price of refrigerant, called Freon 12 or R12, will soar through the roof. The cost of replacing lost gas, which eventually happens to all vehicular air conditioners, will continuously rise. A recharge can easily cost you more than \$100.00, with no upper limit in sight.

The reason for the steeply rising price of R12 refrigerant is the 1987 Montreal Protocol on Substances which Deplete the Ozone Layer. That international agreement mandates the total phase out of certain CFC's due to their propensity to destroy the ozone layer, which protects the earth. As a result, only recycled R12 will be available for servicing the 140-million existing air-conditioned vehicles on the road. Until supplies of new R12 are depleted, it is subject to a hefty federal excise tax, which adds to its steadily rising price.

As the owner of a vehicle, you'll be faced with three choices: Keep your vehicle's air-conditioning system in good repair, junk your vehicle and

purchase a 1994 model with CFC-free air conditioning, or sweat it out during the summertime. A fourth option, retrofitting the vehicle's A/C system for the replacement refrigerant HFC134A, is not really a viable choice for most cars when you consider the cost—which can run \$1000.00.

That's where the *Automotive Air Conditioner Monitor* described in this article comes in. This simple, low-cost electronic device will continuously monitor the performance of a vehicular air-conditioning system. When the system's performance degrades over time due to refrigerant loss (as eventually happens to all automotive air conditioning systems) a warning light is activated. Some luxury cars come equipped with that feature; why not yours?

The advantage of having such an electronic device installed in your air-conditioned vehicle is the early warning that will be automatically generated when the A/C refrigerant charge becomes less than optimal. Loss of refrigerant gas over time is normal, and it will degrade A/C performance long before you notice a decrease in cooling.

When the warning light is activated, you can take your vehicle to a professional who can determine the cause

of the loss of refrigerant and repair any possible leak. As a result, you may have to pay only for the relatively small amount of refrigerant that was lost (plus labor), and you certainly will be doing the environment a favor. Without the early warning, the A/C system can lose most of its charge before you realize, on a hot day, that something isn't right.

## **Automotive A/C Fundamentals.**

Figure 1 is a simplified diagram of a modern automotive air-conditioning system. High-pressure, high-temperature refrigerant gas is pumped by the compressor into the condenser, where it loses some of its heat and changes to liquid. The liquid refrigerant then passes through an expansion device and into the evaporator where it boils as it absorbs heat from the passenger compartment of the vehicle.

A pressure switch, or thermostat, is placed on the low pressure (evaporator) side of the system to cycle the compressor on and off in accordance with the cooling demand on the system. Older vehicular A/C designs use a continuously operating compressor. In such systems, an evaporator/pressure regulator prevents freeze up of the coils.

Most automotive air conditioners manufactured today operate with a "flooded" evaporator, meaning that not all of the liquid refrigerant in the cooling coils is converted to gas. The excess liquid is stored in a canister called an accumulator where it vaporizes before it returns to the compressor, to repeat the cycle.

A properly operating, fully charged automotive air-conditioning system, with some liquid refrigerant present in the evaporator, has a cold return pipe (that will assume a temperature of possibly 35 to 45°F) while the compressor is active. Systems that do not use an accumulator also have similar evaporator return-pipe temperatures, as evidenced by the normally cold suction-line hose that returns to the compressor-inlet port.

The temperature of the evaporator return pipe, therefore, is a valid parameter that can be monitored to verify that the refrigerant charge in the system is correct. Should the refrigerant charge be low, the evaporator coil return pipe will be warm, even though there will be some cooling of the passenger compartment. The rise in temperature of the evaporator return pipe is sensed by the Air Conditioner Monitor, which activates an LED alarm signal.

**About the Circuit.** Refer to the schematic diagram in Fig. 2. Power for the Air Conditioner Monitor is derived from the +12-volt power lead that feeds the magnetic clutch of the air-conditioning compressor. Thus, the circuit is active only when cooling is demanded of the A/C system.

Diode D1 protects the circuit from any possible reverse-voltage transients that occur when the compressor cycles on and off. Integrated circuit U1, a fixed-voltage regulator, reduces the 12-volt supply to the 8-volt

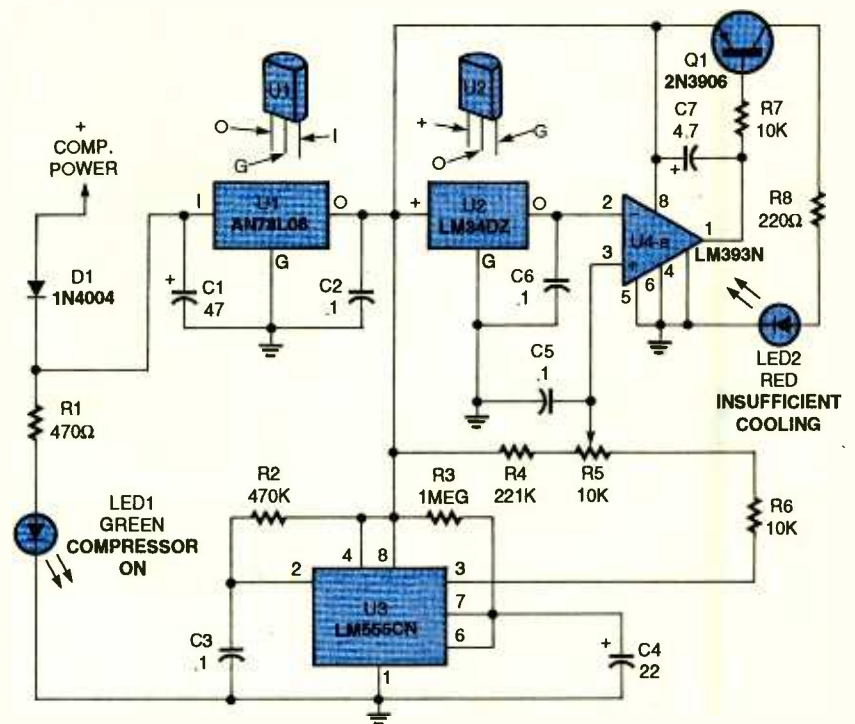

Fig. 2. Power for the Air-Conditioner Monitor is derived from the +12-volt power lead that feeds the magnetic clutch of the air-conditioning compressor.

level required to operate the monitor.

The heart of the circuit is U2, a factory-calibrated 3-terminal temperature-sensing IC that is designed to deliver an output voltage of 10 millivolts (mV) per degree Fahrenheit. The sensor, which is driven by the regulated 8-volt supply, is physically attached to the A/C evaporator-coil return pipe so that it accurately senses its operating temperature. Its temperature-dependent output voltage, which is proportional to the sensed temperature, is fed to the negative input terminal U4-a (half of an LM393N voltage comparator) at pin 2. A voltage comparator is a dedicated circuit that compares one voltage to another, and acts like an operational amplifier without external feedback. The output voltage of the comparator always as-

sumes a logic level of zero or  $V_{cc}$ , depending on which input terminal (+ or -) has the greater voltage level. The output of U4-a can thus be used to determine if the operating temperature of the evaporator return pipe is above or below a predetermined level.

The positive input of the comparator is driven by a voltage divider composed of R4, potentiometer R5, and R6. That allows the trigger voltage level of U4-a to be set slightly higher than the normal operating temperature of the A/C evaporator return pipe, with about 0.4 to 0.5 volts, representing 40 or 50 °F.

In order to avoid a false alarm caused by the warm evaporator return pipe each time the cycling A/C compressor starts, a time delay (composed of U3—a 555 oscillator/timer—and its associated components) is included in the circuit. The 555 timer is connected as a one-shot or monostable multivibrator that has an output pulse width of about 25 seconds as determined by R3 and C4.

When compressor power is applied to the Monitor, U3 is automatically triggered by a momentary low-going voltage, generated by R2 and C3, which is applied to its pin-2 input terminal. Once triggered, U3 generates

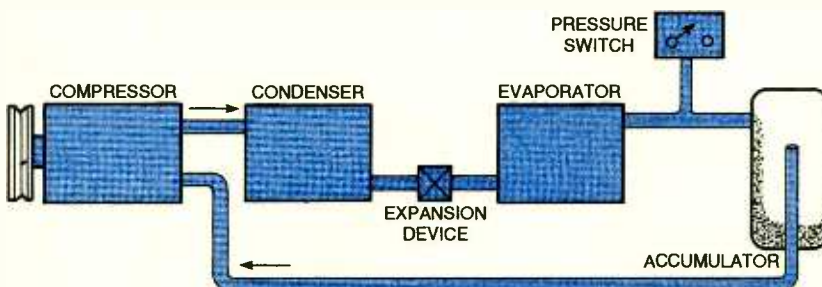

Fig. 1. Here is a simplified block diagram of a modern automotive air-conditioning system.

## PARTS LIST FOR THE AUTOMOTIVE AIR-CONDITIONING MONITOR

### SEMICONDUCTORS

- Q1—2N3906 or similar general-purpose PNP silicon transistor  
 DI—1N4004 1-amp, 400-PIV silicon rectifier diode  
 LED1—Green light-emitting diode (2 volts at 20 mA)  
 LED2—Red light-emitting diode (2 volts at 20 mA)  
 U1—AN78L05 8-volt 100-mA fixed voltage regulator, integrated circuit  
 U2—LM34DZ temperature sensor, integrated circuit (National Semiconductor)  
 U3—LM555CN oscillator/timer, integrated circuit  
 U4—LM393N dual voltage-comparator, integrated circuit

### RESISTORS

- (All fixed resistors are 1/4-watt, 5% units, unless otherwise noted.)  
 R1—470-ohm  
 R2—470,000-ohm  
 R3—1-megohm  
 R4—221,000-ohm, 1%, metal film  
 R5—10,000-ohm, cermet, PC mount, trimmer potentiometer  
 R6—10,000-ohm, 1%, metal film

- R7—10,000-ohm  
 R8—220-ohm

### CAPACITORS

- C1—47- $\mu$ F, 25-WVDC, radial-lead electrolytic  
 C2, C3, C5, C6—0.1- $\mu$ F, ceramic disc  
 C4—22- $\mu$ F, 25-WVDC, radial-lead electrolytic  
 C7—4.7- $\mu$ F, 25-WVDC, radial-lead electrolytic

### ADDITIONAL PARTS AND MATERIALS

Printed-circuit materials, enclosure, IC sockets, wire, solder, hardware, etc.

**Note:** The following parts are available from A. Caristi (69 White Pond Road, Waldwick, NJ 07463): PC board at \$10.95; U1 at \$2.25; U2 at \$8.75; U3 at \$2.25; U4 at \$2.50; Q1 at \$2.00; set of two metal-film resistors at \$1.00. New Jersey residents please add appropriate sales tax. Please add \$4.00 to all orders for postage/handling.

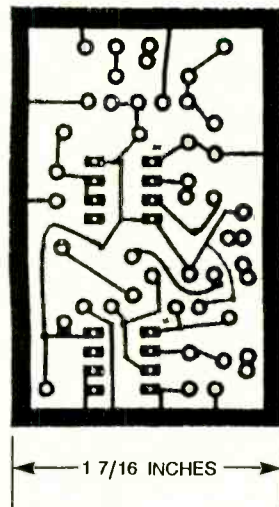

Fig. 3. Although the circuit could have been hard-wired on a perfboard, the author chose to assemble his unit on a printed-circuit board.

driver. To this end, the best location of the circuit board is in the engine compartment of the vehicle, next to the firewall.

Although the circuit is not critical and can be hard wired on a perfboard if desired, a full-size layout of the unit's printed-circuit board is shown in Fig. 3. That template can be used to etch your own printed-circuit board, or one can be obtained from the source given in the Parts List.

Figure 4 shows the parts-placement diagram for the author's printed-circuit layout. When assembling the board, be sure to note the orientation of the polarized components. It is important that each is placed correctly in the board; if not a non-working circuit will result. It is rec-

a positive output voltage at pin 3, which raises the voltage at the positive input (pin 3) terminal of U4-a to 8 volts. That causes the open-collector output transistor within U4-a to be cut off. No base current flows to Q1, and LED2 will not light.

At the end of the timed cycle of U3, U4-a is ready to monitor the evaporator temperature. Should the temperature be above the limit set by R5, the output of U4-a is pulled low. That allows base current to flow to Q1, turning it on and illuminating the warning LED (LED2). As mentioned earlier, a warm evaporator return pipe is a symptom of loss of refrigerant or other problems with the air-conditioning system. A light-emitting diode, LED1, has been included in the circuit as a visual indication as to the operation of the air-conditioner compressor, which normally cycles on and off in most vehicles except during periods of high heat load on the system. Should the refrigerant charge be extremely low, the compressor will cycle rapidly, alerting the driver to an almost total loss of refrigerant.

**Construction.** In the author's prototype, all of the components—except U2 and the LEDs—that comprise the A/C Monitor were installed on a small single-sided printed-circuit board. The temperature sensor must be attached to the evaporator return pipe, and the LEDs are placed in the passenger compartment of the vehicle where they can be seen by the

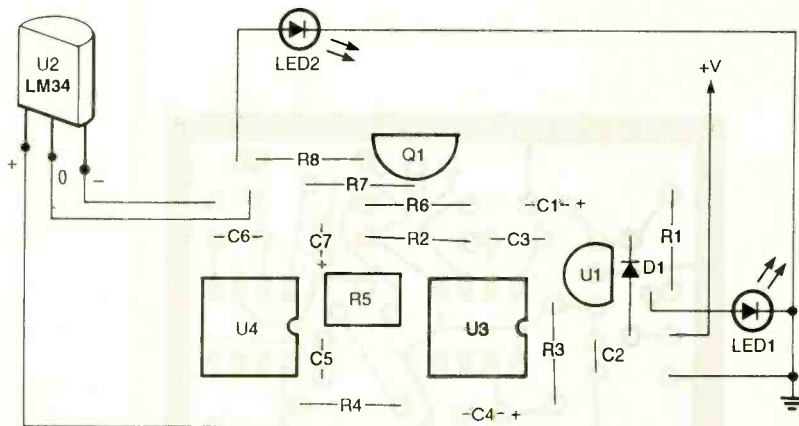

Fig. 4. Here is a parts-placement diagram corresponding to the author's printed-circuit layout.

ommended that sockets be used for U3 and U4 to allow ease of service should it ever be necessary. It is very difficult to remove a soldered multi-pin chip from a PC board without damage to the board or chip.

The sensor, U2, is connected to the board via three wires, which should be kept as short as possible. Figure 5 is pinout diagram of the LM34 (U2), and is provided to aid in wiring U2 into the circuit. The three wires should be soldered directly to the leads of U2, and each insulated with shrink tubing to avoid any possibility of a short circuit to each other or any metal part of the vehicle. Be sure to use stranded wire;

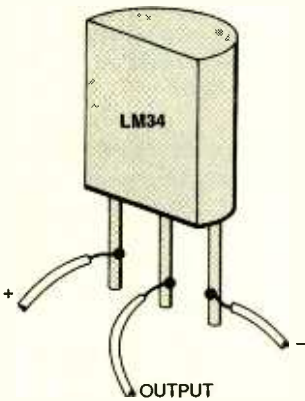

Fig. 5. A pinout diagram of the LM34 (U2) is provided here to aid in wiring U2 into the circuit.

solid wire has a tendency to break. It is recommended that three different color wires be used to avoid misconnections.

If desired, the circuit can be housed in a small plastic or metal enclosure to protect it from the dirt and grease that is prevalent in the engine compartment of any vehicle. If a metal enclosure is used, be sure to use rubber grommets to will allow the sensor, LED,

and power leads to come through the wall of the enclosure without shorting to the metal.

When you have completed assembling and wiring the circuit, examine it very carefully for poor solder connections and short circuits, especially between adjacent IC terminals. It is much easier to correct problems at this stage rather than later on should you power up the circuit and find that it does not work.

**Preliminary Test.** Before installing the A/C Monitor in your vehicle, it should be checked for proper operation. That's easily accomplished using any well-filtered, 12-volt DC supply, or a 12-volt battery, as the power source, and a DC voltmeter. Refer to Fig. 3 for the external connections to the circuit board. Sensor U2 should be prewired to the circuit board for the test, and the two LED's should be connected to the circuit to verify proper operation. The cathode of each LED may be temporarily soldered to circuit ground.

Apply power to the circuit (observing proper polarity); measure the output voltage of U1 at the emitter of Q1 or any other convenient point. You should get a reading of 7.6 to 8.4 volts, and LED1 should be illuminated. If you do not obtain the correct voltage or LED1 is extinguished, troubleshoot the circuit before proceeding. Check the orientation of D1, C1, U1, and LED1. Be sure the power source is delivering about 12-volts DC to the circuit. Check the circuit board for any possible shorts, opens, or cold solder joints, which may appear as dull blobs of solder.

If you get the proper (8-volt) reading, check the range of R5 by rotating it while measuring the voltage at pin 3

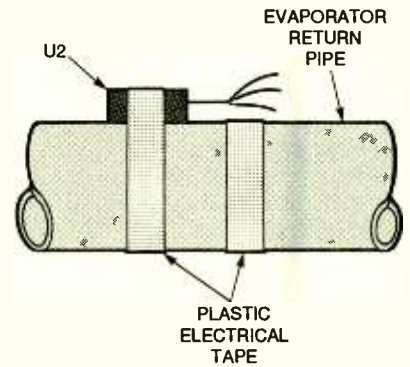

Fig. 7. The temperature sensor, U2, should be physically attached to the metal evaporator-return pipe, as close to the firewall as possible.

of U4; it should indicate an adjustable range of about 0.33 to 0.66 volts. If so, set R5 for a voltage of 0.5 volts. Allow at least 30 seconds after power has been applied for U3 to complete its timed cycle. LED2 should then be illuminated.

Disconnect power and reapply it to the circuit; LED2 should be extinguished and remain so for about 25 seconds. Then it should illuminate. With power applied to the circuit and LED2 illuminated, take an ice cube and hold it against the plastic body of U2. After a few seconds, LED2 should extinguish. Remove the ice cube. After a few seconds the LED should come on. That completes the preliminary test.

If the circuit fails to perform as indicated, check the orientation of all polarized parts, especially U2, U3, U4, Q1, and the LED's. Be sure all components are of the proper value. If possible, try new IC's. Check the circuit board carefully for shorts, opens, or cold solder joints.

**Installation.** Refer to Fig. 6. Locate the circuit board near the evaporator return pipe, next to the firewall of the vehicle. Secure the board so that no part of it can short out to any metal part of the vehicle. The 12-volt connection to the circuit board is made to the hot lead of the air-conditioner clutch coil. The ground return may be made to any metal part of the vehicle chassis. If you cannot identify the hot lead of the air-conditioner clutch, operate the air conditioner and use a DC voltmeter to determine the correct wire.

(Continued on page 92)

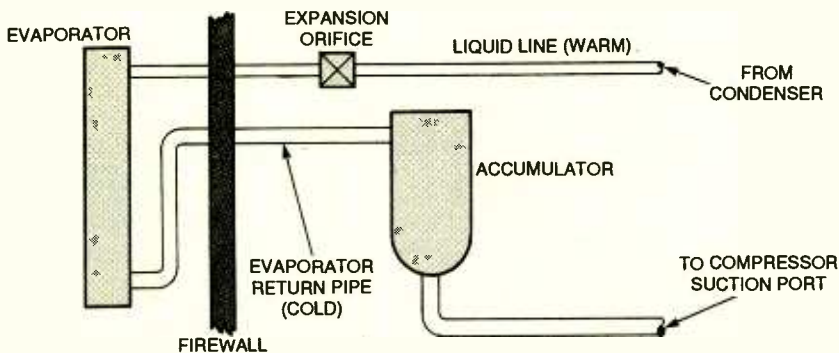

Fig. 6. The monitor's printed-circuit board should be mounted near the evaporator-return pipe, next to the firewall of the vehicle.

# GIZMO

AUGUST 1994

VOLUME 10,  
NUMBER 8

A CHRONICLE OF CONSUMER ELECTRONICS

## Mini Disc-covery

**MD WALKMAN PLAYER RECORDER  
MODEL MZ-R2.** Manufactured by Sony  
Corporation, 1 Sony Drive, Park Ridge,  
NJ 07656; Price: \$749.95.

For centuries, the American motto has been "The bigger the better." In the last couple of decades, however, that has been changing. People have been scaling back, living in smaller homes, having smaller families, driving smaller cars. Nowhere is such "downsizing" more evident than in audio components. Bookshelf stereos are as popular as full-sized components, 12-inch LP's have been replaced by 5-inch compact discs: floor-standing speakers are being edged out by unobtrusive speaker cubes, and the portable Walkman has revolutionized the way we listen to music.

Thanks to advances in digital technology and microelectronics, quality need not be sacrificed when size is reduced. It can even be enhanced, as more functions and data are jammed into ever more compact packages. Today, the new motto could be "Smaller is smarter."

Perhaps the ultimate in audio downsizing to date is the MiniDisc, or MD. The MiniDisc is smaller than the compact disc, measuring about 2½ inches in diameter, and is packaged much like a microfloppy (3½-inch) computer disk. Like the CD, the MiniDisc offers quick and convenient track access, is read by a laser, and can hold 74 minutes of music, but the MiniDisc offers several features that the CD does not. At the top of the list, the MiniDisc is not merely a playback medium—it can be recorded and re-recorded on a million times without degradation of sound quality. Pre-recorded MD's provide information about the artist and recording that can be viewed on an LCD readout on the MD player, and some MD recorders allow users to label their own homemade recordings. (Home-recorded discs can hold only about ¼ of the subcode information that fits on pre-recorded discs, however.) Finally, the MD is a more portable medium



than the CD in terms of both size and anti-shock resistance.

Given the amazing success of the Walkman, and the growing acceptance of and demand for digital sound, a format like MiniDisc seems like a sure winner. You might wonder how Sony managed to get that much material on such a small disc? In short, they also "downsized" the amount of digital information being recorded by leaving out those sounds that are inaudible to the human ear. Even so, the resulting sound quality is far superior to the standard recordable medium—analogue cassettes—although it is not quite up to CD standards. For full details on the inner workings of the MiniDisc format, see the box entitled "MiniDisc Technology" elsewhere in this article.

We took a look at Sony's second-generation portable MD player/recorder, the *MD Walkman Model MZ-R2*. Measuring less than 3½ × 4¼ × 1¼ inches, and weighing just 10.9 ounces with battery, the MZ-R2 is 60% smaller and 55% lighter than its predecessor. But it is no lightweight: It has a substantial look and a comforting solidity that belie its compact size.

The upper-right portion of the MZ-R2's LCD readout is a nine-character display

that shows the disc title and artist when a prerecorded MD is inserted. When a track begins to play, the full title scrolls across the display; for the remainder of the song, the first nine characters are displayed and below it the elapsed track time. Pressing the DISPLAY button once changes the display to show the remaining time of the current track. Another press brings back the title and artist along with the remaining time of the disc; a third press brings up the time and date that the disc was recorded.

At the far left of the display is a bargraph volume-level meter. Next to it is an MD icon that "spins" when a disc is being played. A battery icon shows the battery power remaining. At the bottom right corner, a bass indicator shows what level of bass-boost has been activated, if any.

The most commonly used functions—PLAY, SEARCH FORWARD, SEARCH BACK, PAUSE, and STOP—are accessed using a group of buttons located at the bottom-right side of the front panel. Immediately to the left are the VOLUME UP/DOWN buttons. Tucked away in a hidden compartment (we would never have guessed that the MD Walkman logo panel slid open if we hadn't read about it in the manual) are three buttons used during recording: TRACK MARK, END SEARCH, and ERASE.

## MiniDisc Technology

The MiniDisc was developed by Sony "to be a durable and highly reliable sound-recording format, virtually unaffected by external magnetic fields, and that retains its inherent quality despite repeated recording and playback." Sony believes that because of the quick random access and data storage advantages of MiniDisc, "the era of tape as an audio medium will eventually come to an end."

The MiniDisc is only a fraction of the size of a compact disc, and can hold only about 1/3 the amount of data that a CD can (140 megabytes as compared to about 660 megabytes). Nevertheless, a MiniDisc can hold up to 74 minutes of audio—the same as a CD—with quality approaching that of a CD. Digital compression is what makes it possible. The compression system that Sony developed for MiniDisc is called ATRAC, which stands for Adaptive Transform Acoustic Coding.

### ATRAC DATA COMPRESSION

ATRAC relies on the psychoacoustic principles of masking and the ear's threshold of hearing (which varies according to frequency) to reduce the amount of data that needs to be stored on the disc. MiniDisc does not record sounds that would be masked by other sounds that are close in frequency.

The sensitivity of the ear depends on frequency, being most sensitive at 4 kHz, and least sensitive at higher frequencies. ATRAC encoding ignores sounds that would fall below the threshold of hearing to reduce the amount of data that needs to be stored.

On a compact disc, all sound is stored equally. Ten seconds of Beethoven's Fifth and ten seconds of silence requires the same number of bits. That is not true on a MiniDisc. Instead, the number of bits that are used to encode the audible sounds are varied adaptively, based on the sound's audibility and on whether the quantization noise would likely be heard. (Quantization noise is created by the digitizing of audio signals.)

ATRAC endeavors to "hide" the quantization noise in areas of the audio spectrum where there are high signal levels corresponding to a lot of musical activity. It does that by breaking the music signal into 52 frequency bands and determining the sensitivity of each of those

bands to quantization noise. The sensitive regions—which could be, for example, a violin solo—are recorded very accurately because quantization noise would be very obvious on playback. The remaining regions are recorded less accurately. The width of the frequency bands varies with the frequency because of the way our ears perceives sounds.

ATRAC also encodes audio differently depending on whether the audio is changing rapidly or slowly. When the music is changing quickly, the encoder splits time up into blocks of only 1.45 or 2.9 milliseconds. For slowly changing music, the time is split into blocks of up to 11.6 milliseconds.

### DISC TYPES

The MiniDisc consists of a 64-mm disc housed in a rigid protective cartridge similar to a 3½-inch microfloppy diskette. Two kinds of discs are available. First is a playback-only disc for pre-recorded music, which is manufactured using the same process as that for compact-disc manufacturing. Second is a recordable magneto-optical MiniDisc for home recording.

Recordable MiniDiscs are significantly different from pre-recorded discs. They contain a "pre-groove" that covers the entire disc recording area. The pre-groove enables tracking and spindle-servo control during both recording and playback. The pre-groove has wobbles that serve as address markers. Track addresses are stored in a user table of contents (UTOC) after a lead-in area at the beginning (inner area) of the disc.

Because the recordable MiniDiscs are recorded differently from playback-only discs, the MD pickup has to be different from a conventional CD pickup as well. Data on pre-recorded discs are encoded on a series of pits on the disc, which either reflect light or don't. On a recordable MiniDisc, however, the data is encoded magnetically. The magnetic polarization of a spot on the disc affects the direction in which the light will be reflected. A polarization beam splitter varies the distribution of the reflected light to two photodetectors in accordance with the polarization direction. The differences in the electrical output of the photodetectors is used to recreate the digital signals. ■

Three slide switches found on the bottom edge of the MZ-R2 are used to begin recording, open the MD compartment, and lock the controls of the recorder so that unintentional button pushes are ignored. The headphone jack is also located on the bottom edge.

The headphones feature a remote control, located on the cord, that can be con-

veniently clipped onto a pocket for easy access to basic functions when listening to a disc. (Unlike its play-only counterpart, the MZ-E2, the MZ-R2 doesn't offer a remote control with its own LCD. Pre-programmed recording and playback information is displayed on the MD Walkman's LCD readout.) The remote control is handy when you're carrying the

### MAGNETO-OPTICAL RECORDING

Data is recorded on a recordable MiniDisc by heating a spot on a magnetic layer with a laser beam until it reaches the Curie temperature, which is the temperature at which the magnetism of a material dissipates. (This temperature varies with the material, which in an MD is terbium ferrite cobalt.) A magnetic head at the opposite (rear) side of the disc then orients it to either north or south polarity. Once the spot cools, the recording is virtually permanent—unless the disc is re-recorded with a combination of a laser and recording head.

Sony has tested recordable MiniDiscs and found that they can be re-recorded one-million times without an increase in data-error rates. Interestingly, although MiniDisc is widely regarded as a non-contact medium, that's true only on playback. During recording, the magnetic head, which is encased in a low-friction material, makes contact with the disc.

### SHOCK-RESISTANCE

Another benefit of all MiniDisc players is their shock-resistance. That is made possible by a buffer memory that permits the audio to continue playing even if the laser pickup mistracks. It works this way: Data is read off the disc at the same rate as it is off a CD (1.4 megabits per second) and fed into the buffer memory. The data rate required for MiniDisc playback is only 300 kilobits per second, however, and that is the rate at which the buffer empties. If the laser mistracks during playback, the buffer almost always affords sufficient time for the laser to return to the proper location.

Shock resistance isn't the only way that the buffer memory is used. It is also used to allow data to be stored discontinuously, much like files on a computer disk. Let's say that you want to change the third track of a recordable disc and replace it with another, longer one. The recorder would fill up the area occupied by the original track 3, and then continue somewhere else on the disc where there was room. During playback, the buffer would be used to continue audio playback without interruption as the head was moving between the discontinuous areas. ■

MD Walkman in the included case, although the case's clear-plastic front panel does allow you to read the LCD and push the control buttons when the MZ-R2 is in the case.

The headphone's remote-control buttons include volume, play, search, pause, stop, track mark, and hold (which locks the controls of the remote controller to

avoid accidentally pressing them). Also found on the headphone remote is the AVLS on/off switch. AVLS stands for Automatic Volume Limiter System, and is intended to prevent hearing damage by setting a low peak volume. When listening to a Walkman in noisy areas, it's possible to set the volume to a potentially damaging level without realizing it. AVLS eliminates that possibility by setting a safe maximum volume level. However, we don't imagine that AVLS would be a popular feature with the MD's intended audience of teens and Generation X'ers. Regardless of volume level, the on-ear headphone pads are comfortable even for extended listening sessions.

You can power the unit in several different ways. The second-generation MD Walkman uses a rechargeable lithium-ion battery, which is smaller and lighter than a NiCd battery. The rechargeable battery provide up to 2½ hours of listening time or two hours of record time when used alone. When used in conjunction with three AA batteries, the maximum play time is extended to 6½ hours and record time to 4½ hours. The MZ-R2 also comes with an AC power adapter; an automotive cigarette-lighter adapter is optional.

A DC-in jack on the top edge of the MZ-R2 is used for the AC or DC power adapter and to connect the battery case that holds the three AA batteries. The rechargeable battery slides into a compartment accessed from the left edge of the MD Walkman. Also on the left edge are the BASS BOOST button, line-out and optical line-in jacks, and a microphone jack.

Playback on the MD Walkman is virtually the same as on a portable CD player. Like CD's, MD's provide instant track access. You can search forward or backward through a track while listening or without listening by holding down one of arrow buttons while in either play or pause mode. The arrow buttons, when pressed once, bring you to the beginning of a next or preceding track. You can play an MD from beginning to end, or take advantage of three repeated play modes—repeat all, single repeat, or shuffle repeat—by using the PLAY MODE button located next to the LCD.

There are two major differences between listening to the MD Walkman and listening to a portable CD player: sound quality and shock resistance. The former will probably be transparent to anyone but an avowed audiophile, at least when listening to professionally recorded MD's. We're not crazed audiophiles, but we do consider ourselves "experienced listeners," and we had difficulty distinguishing between prerecorded MD's and CD's when using the MD Walkman as it is intended to be used—as a portable listening device. In A-B tests, with a quality ampli-



**The MZ-R2 MD Walkman fits comfortably in the palm of a hand. The recordable MiniDiscs are just 2½ inches square.**

fier playing through full-size speakers, slight differences could be discerned between CD's and MD's. It is difficult to pinpoint precisely what was different, but the MD sound did not seem quite as distinct as that from a CD.

The difference in shock resistance, on the other hand, will be readily apparent to anyone who has tried to use a portable CD player while exercising. The MZ-R2 has a 10-second buffer memory that ensures smooth playback even if the device is jarrred. (See "MiniDisc Technology" for a technical description of the buffer.) We used the MZ-R2 while fast-walking, jogging, cycling (with AVSL turned on, of course), roller blading, stair stepping, and dancing, all without a skip. Next we tried dropping it from about a foot onto a desk, from about 3 feet onto a sofa—it didn't miss a beat. We tried shaking it as you would a bottle of juice—*nada*. We thought we got it to skip when we juggled with it (sorry, Sony), but it turned out we'd accidentally pressed the PAUSE button. The only way we could make it skip was to flip and drop it simultaneously.

That didn't really surprise us, since we'd been treated to a bone-shaking ride in the Sony Jaminator at a recent Consumer Electronics Show. The Jaminator is a simulator ride in which passengers in a custom minibus experience a roller coaster ride, speeding through hairpin curves on a mountain road, and other dipping, rattling, and rolling thrills through video, audio, and the shaking motion of the Jaminator itself. The soundtrack—on MiniDisc, of course—was unrattled by all the jarring motions.

Of course, the biggest difference between the CD and MD formats is that MD is recordable. According to Sony, the MZ-R2 is the world's smallest optical disc-based recording system. It offers three recording modes, and the ability to record from a variety of sources.

You can record continuously from the beginning of a MiniDisc. You can select the point on the disc at which to begin recording. Or you can opt to begin recording in the first available unrecorded section of the disc. Such non-sequential recording makes efficient use of disc space. However, the one recording mode that we would have most appreciated is not offered on the MZ-R2. You cannot replace one track in the middle of the disc without erasing all the following tracks!

Recording is a simple process. With the PAUSE button depressed, the REC switch is slid to the on position. The source is started, and the PAUSE button pressed again to begin recording. One caveat: The anti-shock buffer is not in effect while recording, so be careful not to move the MZ-R2 while creating your discs.

Using an optional digital cable, it's possible to make a direct digital recording from a digital source—a CD or a prerecorded MiniDisc, for instance. (Although you can make unlimited digital copies of a prerecorded MD or CD, you cannot make a digital copy of that copy, due to the Serial Copy Management System, or SCMS, that's incorporated in every MD recorder.) The stereo mini-jack input supports recording from analog devices. Finally, a microphone (also optional) can be used to record live performances.

When making a direct digital recording from CD or another MD, the track divisions from the original are copied onto the new disc. During analog recordings, silent pauses of more than two seconds cause track marks to be inserted automatically. It's possible to add track marks either while recording or during playback, simply by pressing the TRACK MARK button on the remote control at the appropriate spots. Track marks can be erased by moving to its position on the MD and then pressing TRACK MARK. When you erase a track mark, the tracks immediately preceding and following that mark will be combined, and all subsequent track numbers will change to reflect the deletion.

It's also possible to erase a track from an MD by pressing the ERASE button, which is hidden safely away under a sliding compartment door on the front panel. The display will repeatedly flash "Erase OK?" followed by "Push Erase." Pressing STOP will cancel the process, pressing ERASE will delete the current track. The remaining tracks will be renumbered.

(Continued on page 57)

# GIZMO NEWS

## AUTOMATIC CLOCK SETTING

The Public Broadcasting System (PBS) is transmitting a signal through its member stations that permits the clock in special VCR's to be set automatically. The signal works through Extended Data Services, a portion of the same signal that delivers closed captioning. Extended Data Services is a voluntary technical standard (EIA-680) established by the Electronic Industries Association for the transmission of data by television broadcasters. It allows for the broadcast of station- and network-identification, program names and description, weather alerts, and more.

The FCC granted authority for stations to broadcast the information last year. The first commercial devices developed to take advantage of the signals are two new Sony VCR's that will contain an auto clock-set feature. Every time the VCR is turned off, it will update the clock setting. Perhaps it will put an end to the flashing-12:00 syndrome that afflicts many VCR owners, and reduce the anxiety level when daylight savings time begins.

## SCRAMBLED FOOTBALLS

The National Football League is making many satellite-dish owners unhappy with its plans to scramble all NFL feeds. Previously, virtually all games televised by CBS, NBC, and ABC were available "in the clear" or unscrambled. Satellite-dish owners could watch games from anywhere in the country, with the crystal-clear quality of TVRO reception. As an added bonus, the "backhauls"—the signals sent from the stadium back to the network—were often in the clear, so that games could be watched commercial-free.

That will all change beginning with the 1994 season, when all football feeds will be scrambled and available only by subscription to the NFL Sunday Ticket service, which will be transmitted on eight adjacent channels on a single satellite (Telstar 303, channels 1 through 8). TVN, the satellite pay-per-view service, is leasing the transponders to the NFL for the games. Subscribers will need VideoCipher II Plus descramblers to view the games.

According to the NFL, the service is being offered for the convenience of the dish owner: Instead of searching from one satellite to the next, and even from one band to the next, the dish owner will know where all the games are. (If that were true, we would imagine that the NFL would leave the backhauls and fronthauls in the

clear, and still provide the scrambled service to those viewers who wanted the convenience—at a cost of about \$140 for the season.)

Sports bars will be charged subscription fees based on their size. They will probably appreciate having all the games available on a single satellite because it should reduce their equipment costs.

Game days will begin at 11:30 AM Eastern Time, with NFL Films' host Steve Sabol guiding subscribers through the day's lineup on each transponder. He will introduce special pre-game programming produced for dish owners, such as a variety of local coaches' shows, the syndicated weekly series "This Is The NFL," and NBC and Fox pre-game shows. Early games begin at 1PM Eastern, followed by several more games at 4PM Eastern. The breaks during the games, which would normally be filled by the local broadcast station, will contain additional programming for dish owners. Subscribers to the package will receive a full schedule of all the games in the mail prior to the first Sunday of the season. VideoCipher descramblers can be turned on and off by Zip Code, allowing local games that haven't sold out to be blacked out in their areas.

Nobody we talked to was willing to predict the program's success, but we know that we won't be subscribing.

## NEW DISC FORMAT

Sony's MiniDisc is for more than just music, now that the company introduced the first MD Data drive. The drive, which is available to OEM customers, can be used with MD Data magneto-optical discs to store up to 140 megabytes of data.

The drive accepts three kinds of media: rewritable, read-only, and a hybrid that contains both read-only and rewritable sections. Sony expects the drive to be "widely accepted as a standard in removable storage."

The 2½-inch diameter MD Data discs have about the same capacity as 100 high-density floppy disks. The drive has a data transfer rate of 150 kilobits per second, and an average access time of 300 milliseconds. Sony has hinted that a new universal file system allows MD Data discs to be used interchangeably between IBM-compatible machines and Macintosh computers. Leading software developers, including Lotus Development Corp., Claris Corp., and Traveling Software have expressed support for the new format. Microsoft has agreed to support Sony's MD Data volume and file structure, and is assisting Sony in developing MD Data file systems for Windows and future Microsoft operating systems such as Chicago.

## CD-ROM HITS 100 MILLION

CD-ROM manufacturing is growing at an annual rate of 150%, according to the Optical Publishing Association. Last year, about 100 million discs were produced worldwide. North America had an installed base of about 7.5 million CD-ROM drives.

Most of the discs that were sold were multimedia-games, educational, or reference products. However, they only accounted for about 20% of the \$1.5 billion in sales. The majority of revenue in the CD-ROM arena still comes from relatively high-ticket database, professional, and corporate products.

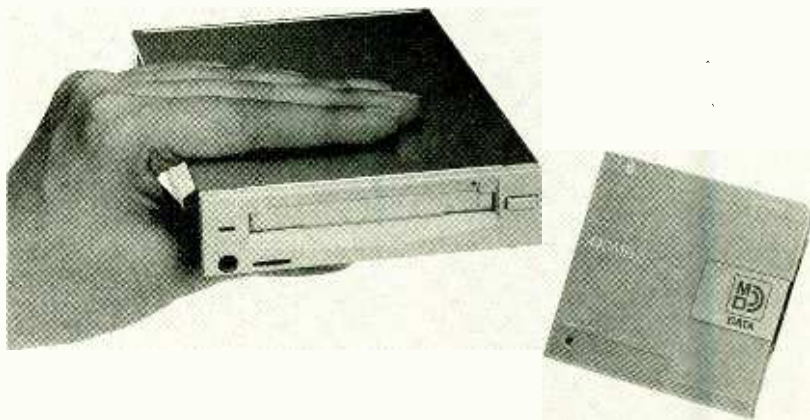



## CONTACTS AND MANUFACTURERS

Electronic Industries Association  
2001 Pennsylvania Ave., N.W.  
Washington, DC 20006-1813

MCI Telecommunications Corp.  
Consumer Markets  
1200 S. Hayes Street  
Arlington, VA 22202

NFL Enterprises  
410 Park Avenue  
New York, NY 10022

Optical Publishing Association  
P.O. Box 21268  
Columbus, OH 43221

PBS  
1320 Braddock Place  
Alexandria, VA 22314

Sony Electronics Inc.  
1 Sony Drive  
Park Ridge, NJ 07656



## PHONE AWAY FROM HOME

A new telephone calling card promises to make it easier than ever to make phone calls. Called MCI PhoneCash, the card is prepaid and is available in "denominations" of 10, 30, and 60 units. Each unit provides one minute of calling time anywhere in the U.S. The 10-, 30-, and 60-unit cards sell for \$4.50, \$13.50, and \$27, respectively. That's \$0.45 per minute for calls in the U.S.

Unlike other prepaid phone cards in use around the world, the PhoneCash card itself contains no "smarts" or data of any kind. The back of the card simply has the 800 number to call, and a unique PhoneCash number. The amount of credit left "in the card" is stored on a central computer.

To use the system, the caller dials the toll-free number and enters the eight-digit code on the card. He then dials the number he wants to reach. At the start of each call, voice instructions tell the caller how many units are left on the card. If the caller is at a

rotary phone or a COCOT (customer-owned, coin-operated telephone) that cuts off the touch-tone pad after a call is made, an operator will complete the call.

Calls to other countries consume more than one unit per minute. For example, calls to Canada, the United Kingdom, and Caribbean Zone 1 (area code 809) consume 3 units per minute. The most expensive calls are to Asia (except Japan), which consume 5 units per minute. Calls to Japan, Australia, Mexico, Latin America, Europe, Africa and the rest of the Caribbean are priced at 4 units per minute.

## Number, Please

**PROPHONE CD-ROM TELEPHONE DIRECTORIES.** From Pro CD Inc., 8 Doaks Lane, Little Harbor, Marblehead, MA 01945; Tel. 800-99-CD-ROM; Fax: 617-631-9299; Price: **directPHONE**, \$149; **selectPHONE**, \$299; **freePHONE**, \$49.

Have you ever wondered what became of your high-school sweetheart, but her parents have retired to some unknown destination and you have no way of tracking her down? Have you lost touch with your college roommate, even though you thought that friendship would last a lifetime? Perhaps you've considered organizing a family reunion, but don't have a clue about how to reach all those obscure branches of the family scattered across the country.

Now there's an easy way to locate all those "missing" people, using **directPHONE**, one of the **ProPHONE** series of CD-ROM phone books from **Pro CD**. With a database that includes the contents

of every white-pages directory in the United States, it allows you to find listings for 72-million residences and 8-million businesses. Each listing provides name, full address, and telephone number. Searches are done by name, and can be limited by Zip Code, city, street address, or state.

Perhaps you own a small business and would like to send out personalized mailings or make telephone solicitations to select locations. A marine-maintenance company might want to limit its advertising to the owners of waterfront homes, for instance, or a firm specializing in Victorian home restoration items might like to target homes in historic districts or areas undergoing "gentrification." A mail-order company specializing in lawn care might like to avoid wasting postage by deleting city-dwellers from its mailing list, while those same urbanites might be considered prime customers for a company selling high-tech home-security products.

**selectPHONE** provides the same database as **directPHONE** but allows much more leeway in searching. **ProPHONE** calls it a "national criss-cross re-

verse directory" because its multi-indexing allows you to search using any combination of name, address, phone number, Zip Code, area code, and business heading or Standard Industrial Classification (SIC) code. The owner of that marine-maintenance company could use a local map to learn the names of every waterfront street in the area, and then search for the names and phone numbers of the people living on those streets. A landscaper could drive around looking for homes that look as if they could use a spring or fall cleanup, jot down the addresses, and call the owners directly to offer his services.

If you prefer not to pay for phone calls when you can avoid it, **freePHONE** provides the complete AT&T Toll-Free Directory on CD-ROM. The listings are organized under 1000 separate business headings, and you can search by name, address, phone number, and business heading or SIC code. As virtually every major airline, hotel or motel chain, and car-rental agency offers toll-free reservations numbers, **freePHONE** is a particularly handy tool for travel planning.

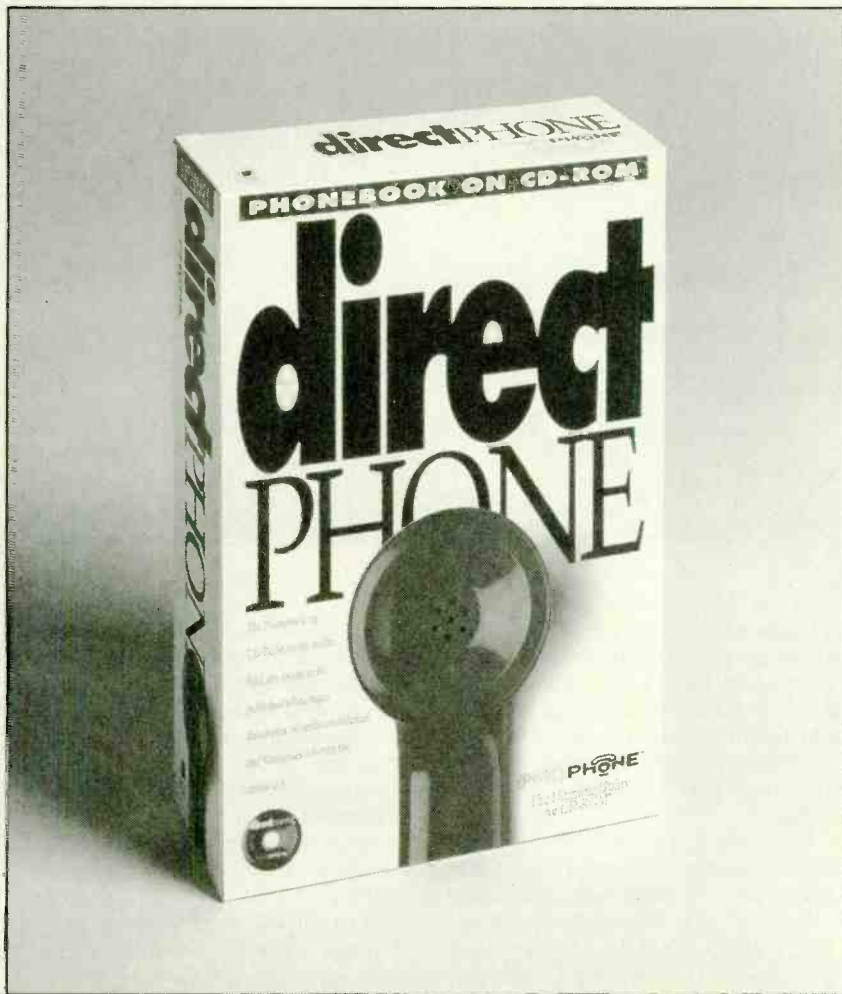

All ProPHONE CD-ROM's require a 386 or better IBM-compatible PC with 4-megabytes RAM, a hard disk with 2 megabytes free, and a CD-ROM drive. The same software is used to access and manipulate any of the databases mentioned here, as well as *CanadaPHONE*, which contains the complete Canadian white and yellow pages on one disc, and *EuroPAGES*, a European business directory distributed by Pro CD. A feature called "Jericho" searching allows you to search across multiple databases to create a single sorted result. Each of the programs comes with a free Windows upgrade; the Windows version is expected to be available shortly.

Installation takes less than a minute: Insert any one of the ProPHONE discs (directPHONE comes with one residential and one business disc, selectPHONE with four regional discs, and freePHONE with one disc) in the CD-ROM drive and type "install" to transfer the search software to your hard disk. Typing "Prophone" calls up a screen that's divided into three boxes, two small ones on top and a large one below. The top left screen is the data-entry window, in which the search parameters are entered. The bottom screen displays all

the listings that the search turns up. The currently highlighted listing appears in its entirety (including Zip Code, which printed phone books omit) in the upper-right listing-display window. When using selectPHONE to look up business listings, the type of business and approximate number of employees are also displayed.

We started out with directPHONE, by searching for our own last names and those of our friends and relatives. To initiate those searches, we simply typed the last name into the name field in the data-entry window. Our searches turned up few surprises—common names resulted in hundreds of listings scattered across all 50 states, while the more ethnic-sounding names brought forth only a handful of entries often concentrated in one or two areas. One friend's very Italian surname name could be found listed only in New York and New Jersey. We found a couple of other friends' surnames in geographical clusters—one in and around New Orleans, another throughout Virginia—although neither friend was aware of any relatives in those areas.

That surname-searching was intriguing—in fact, we dare anyone who buys directPHONE to *not* look up his name

immediately after installing the program! Although the fun wore off after several searches, we weren't through using the database just yet.

We live and work on the borderline of two counties, in the suburbs of a New York City. Our day-to-day business and personal calls frequently include numbers in Nassau and Suffolk counties on Long Island, as well as Manhattan and the other four boroughs of New York City. NYNEX will provide free white pages upon request, but we simply don't have the room to store seven phone books, each several inches thick. We would also rather not spend time searching through seven phone directories to find all the listings in our immediate area. With directPHONE, we can look up listings in those areas by searching by the three area codes—516, 212, and 718—that cover Long Island and all five boroughs of New York City.

directPHONE offers two different types of searches: lookup and restrictive. A lookup search is one in which information is entered into only one field. By entering information into another field, the search is restricted to only those listings that match the information in both fields.

The program searches for any listing in which that field begins with the specific string of characters that has been input; it assumes that a "wild card" is tacked to the end of the string. For instance, if you were searching for people with the last name "Williams," the program would also retrieve "Williamson" listings. By leaving a space before typing a name, a wild card is added to the beginning of the name string, allowing a search to be made for both



selectPHONE allows users to "reverse search" (use the address to find the name and phone number) every listing in the residential and business white pages for the entire United States.



**freePHONE puts every 800-number in the national AT&T toll-free directory at your fingertips.**

“Shea” and “O’Shea,” for instance. It’s also possible to search for a first name or for a word in the middle of a business name by leaving a space before inputting the information.

When the selected listings appear in the scan window, you can scroll through them using the cursor keys, or PG UP and PG DN keys. You can tag a listing by pressing the space bar when that listing is highlighted. Those tagged listings are then grouped together and can be viewed separately by pressing the F4 key when you have finished tagging them.

It’s also possible to export the tagged listings (or individual listings) to different applications, including Word, WordPerfect, Excel, dBase IV, FoxPRO, Lotus 1-2-3, Quattro Pro, and many other popular programs. You can also output listings to a printer or disk in various formats: galley (list), mailing label, delimited ASCII, business card, or fixed length. Because we’re not very good at keeping up-to-date phone books (we generally have the correct phone number jotted down somewhere, but rarely the address, and almost never the Zip Code), we wouldn’t mind using directPHONE to find all the people on our Christmas-card list, for instance, and then to print out all of the mailing labels.

When using directPHONE, all searches must include the name, whether or not you choose to restrict the search by entering information in another field. When using either selectPHONE, freePHONE, or CanadaPHONE, it’s also possible to conduct a lookup search on the phone number, address, city, state, Zip Code, or SIC code.

Typing in all or part of the SIC code (for instance, “book”), generates a list of business headings that include that string

of characters. In this case, 17 categories were listed, including “Accounting & Bookkeeping Systems Wholesale,” “Blankbook Looseleaf Binder & Device Manufacturing,” “Book Publishing,” “Book Stores Retail,” “Bookbinders Machinery Manufacturing,” and “Used & Rare Book Dealers Retail.” The user can select the appropriate category or categories to be searched.

Zip-Code searches are a boon for any company that relies heavily on mailing lists, because it is possible to learn a lot about potential customers by researching their Zip Codes. Information such as average family income is available by Zip Code, allowing businesses to target their goods and services to the appropriate areas.

selectPHONE, freePHONE, and CanadaPHONE allow you to limit searches to business records, residential records, or all records. Those programs also offer a third type of search, called sort, which allows a highlighted listing to be sorted by name, address, or telephone number. Name sort positions the highlighted name within the name index. Telephone sort displays the phone numbers adjacent to the highlighted listing, and address sort displays all the neighbors of the highlighted listing. That could come in handy if, for instance, your company has just finished an eye-catching remodeling job on a home and you wanted to take make sure all the neighbors knew whose work it was, and that you’d be more than happy to offer a free estimate on their next home-improvement project.

If you prefer to use the telephone, ProPHONE will even use your modem to dial it for you.

Because people and businesses move so frequently, the entire ProPHONE line is updated quarterly. Annual subscriptions are available for both directPHONE (\$299) and selectPHONE (\$399); both offer the first upgrade free. Pro CD also offers licensing agreements for “Workgroups”—multiple users within an office that have access to the ProPHONE databases. ProPHONE for Workgroups allows directory listings to be transferred to another computer or terminal, or to be accessed over a local area network. Prices vary according to the number of workstations involved, ranging from \$100 for groups of 2–5 users to \$400 for groups of 16–20 users.

The information provided by the ProPHONE directories was once available only to businesses, and at great expense. The ProPHONE discs offer a national telephone directory to anyone, and at a modest price. “We’re living in the Information Age” might be a hackneyed expression, but ProPHONE is a good example of how true it is. ■

## Timely Zapper

**CMD-40B WRIST CONTROLLER WATCH.** Manufactured by Casio, Inc., 570 Mt. Pleasant Avenue, Dover, NJ 07801; Tel. 201-361-5400; Price: \$129.95.

Who knew, back in our school days, that one of the skills we’d need as adults was “juggling?” Juggling our time so that neither our families nor our jobs are neglected. Juggling our money so that we can pay the mortgage, save for college and retirement, and still put food on the table. And, when we have a few hours of time just to relax, we spend it juggling the collection of remote controls needed to operate our audio/video systems—and that’s assuming that we’re able to unearth them all from under the sofa cushions or last Sunday’s newspapers.

Casio comes to the rescue with the *Model CMD-40B Wrist Controller Watch*. The multi-function wristwatch doesn’t just tell time: It can also control your TV, cable box, and one other video or audio component. While that might not resolve your scheduling or budget dilemmas, the watch does provide an alarm function to remind you of appointments and a calculator function to help you with finances and other arithmetic.

The Wrist Controller looks like an ordinary digital watch with a calculator function—it has a digital LCD readout and a numeric keypad. Setting it apart from any other watches that we’ve used are an infrared signal emitter at the top of the watch face and buttons along the right side of the face for the volume-up and -down, TV/video switching, and power on/off. The keys that are used for multiplying and adding when in the calculator mode double as channel-up and -down controls. Three buttons used for selecting and setting the watch’s various modes and functions are located along the left side of the watch face.

The watch’s display is divided horizontally into three sections. The time is displayed on the bottom of the screen, and the date at the top. A thin strip across the middle contains mode indicators as well as the letter “P” to indicate PM. Even people with <sup>20</sup>/<sub>20</sub> vision might have difficulty making out the tiny letters inside each mode icon; we soon found ourselves relying on the relative position of each instead of trying to read the labels—TV toward the left, Cable at the center, and Learn toward the right.

The print in the manual—a booklet that measures less than 2½ × 3 inches—is also terribly small, though legible. The manual clearly walks the user through the steps

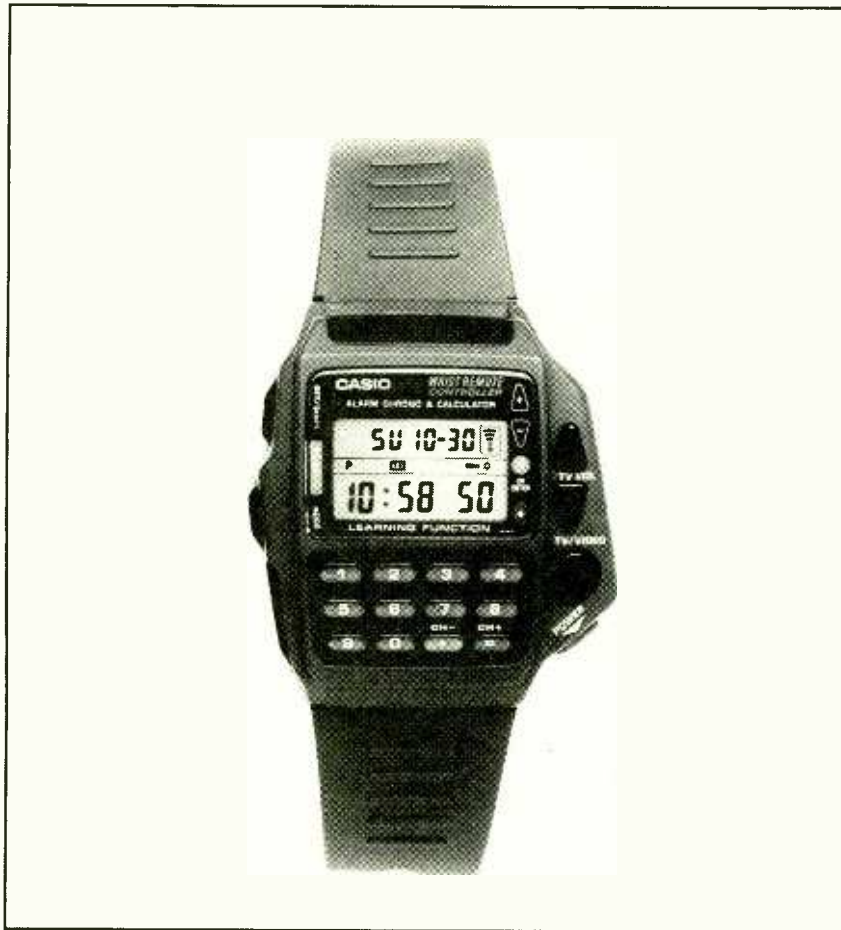

needed to set the time and date, use the watch in its other modes, and program the remote-control functions.

The bottom button ("C") on the left-hand side of the watch switches it between time-keeping, calculator, alarm, and stopwatch modes. The calculator works as you would expect, although the tiny keys are somewhat awkward to press. An alarm can be set to beep once daily. The stopwatch mode can measure elapsed time, split times, and two finishes; it has a range of 23 hours, 59 minutes, and 59 seconds.

The middle button ("B") is used when in the time-keeping mode to select the TV, Cable, or Learn "sub-modes." Casio calls them sub-modes because all of their functions can be accessed without leaving the main time-keeping mode. Before the CMD-40B can control any devices, however, it must be programmed to recognize those devices.

In general, "universal" remote controls use one of two programming methods. In the first, the basic functions for most major brands of equipment are factory pre-programmed into the unit. The user, by entering special codes supplied in the manual, lets the replacement remote know which brands of equipment it is to control. The second method requires the user to "teach" the new remote all or some of the

functions offered by the original remote(s). One at a time, each old remote is aimed at a "learning window" on the universal remote. (That window houses an IR detector that sometimes shares space with the remote's IR emitter.) The universal remote is then set in its learning mode. When the user presses a function button on the original remote and the corresponding button on the universal remote, the new remote "learns" to operate that function. The Wrist Controller combines both programming methods.

Nineteen brands of TV's and five cable-box brands can be set using a list of manufacturer codes. However, only basic functions are preprogrammed; advanced functions are not available. As programmed, the watch can turn a TV on or off, change channels by scanning up or down or by directly inputting the channel number, and raise or lower the volume. It can also control the same functions on a cable box.

To control a third device or to implement advanced features, the CMD-40B must be taught. The learning method of programming is more time consuming, but allows you to access more functions—up to 16. You could program it to operate your VCR's rewind, fast-forward, play, stop, pause, frame-advance, and record func-

tions, for instance, by assigning each of those functions to one of 16 available keys on the watch face.

No consumer-electronics gizmo can be said to simplify the consumer's life if it is impossible to use. That's why we let a technically challenged friend do the first tests of the CMD-40B.

She had some trepidation, but no trouble at all, setting the time and date, or using the alarm, stopwatch, and calculator functions. Problems arose, however, when she discovered that her living-room television, manufactured by Zenith, was not represented on the compatible-brands list. She was able to set the Wrist Controller to operate another TV (manufactured by Panasonic) and a Jerrold cable box in a matter of minutes. She ran into one problem "teaching" the CMD-40B to control a VCR—it easily learned every function she required, except power on/off.

Most learning-remote manufacturers anticipate some such set-up problems—even though the devices are generally quite easy to program—and supply a toll-free number to call with questions. There's no such number listed in the Casio manual. There is a troubleshooting guide included, and it listed our problem: "Some remote control functions do not work." Unfortunately, none of the three possible causes listed in the manual ("Improper pointing of the signal emitter," "Use of button on the watch for which the TV/cable box does not have a corresponding function," and "Direct sunlight shining on the emitter port") was true in our case.

She never did resolve that particular problem, and we weren't able to figure out what went wrong. We did manage, however, to instead program the Wrist Controller's TV/VIDEO button to turn the VCR power on and off.

When the time came for our own tests, we took a few minutes and reprogrammed the Wrist Controller to operate the various components in our own video setup. Then we put the unit to work during an evening of viewing.

There's definitely something to be said for having a three-in-one remote controls always on hand ("on wrist"?), and never having to scrounge around to find three separate ones. There is a trade-off for that convenience in terms of functionality: unless you are willing to tackle the programming, the CMD-40B controls only the most basic TV and cable-box functions. Although, let's face it, when you're frantically searching for the missing remote control, it's usually because you want to change the channel before you miss the opening monologue in *Seinfeld*, or lower the volume so that you can answer the phone—not because you have an overwhelming need to adjust the picture contrast immediately. ■

## Speaking of Multimedia ...

**MMS557 MULTIMEDIA SPEAKERS.**  
From Audio-Technica U.S., 1221 Commerce Drive, Stow, OH 44224. Tel. 216-686-2600. Price: \$149.95.

Each of the last several years has been touted by one or another computer-industry observers as "the year of multimedia." Well, it seems that multimedia has truly hit the big time. There's not a single computer manufacturer that hasn't jumped firmly into multimedia—at least no manufacturer who will be in business next year. Judging from the number of multimedia discs that cross our desks, we're not surprised that the total retail value of CD-ROM titles sold in 1993 was near \$1.5 billion.

Multimedia CD-ROM's are only one reason for the growing importance of audio for personal computers. The excitement level in games can be increased dramatically by good sound effects. More musicians are composing at their computer keyboards, creating MIDI tracks. Even business presentations are increasingly moving away from flip charts and slides to multimedia.

A number of speaker manufacturers have discovered the importance of multimedia, too. One example is *Audio-Technica*, which has introduced the *MMS557*, a new active speaker system that is designed primarily for multimedia.

Because the speakers are intended to be placed by your computer monitor, they are magnetically "shielded" or compensated so that they will not produce any video distortion. They also won't corrupt the data on floppy disks that you might carelessly leave on top of them. However, because the magnetic field from the speakers can't be eliminated entirely, the manual recommends *not* leaving disks on top. Because any flat surfaces in the vicinity of our computers seem to gather more diskettes than dust, we chose to mount the speakers on the metal stands that are supplied with the system. The stands tilt the speakers up from the desktop, to aim them at your ears. The tilt is enough to cause disks just to slide off the top.

The stereo amplifier for the speaker system is contained within the speaker box for the right channel. Line-level audio inputs are fed to that speaker via two RCA-type phono jacks on the back of that speaker. (An adapter cable included with the system has phono plugs on one end, and a mini stereo phone jack on the other, so it mates directly with most computer sound cards.) The left speaker receives its amplified signal from the first through a two-conductor speaker wire that is perma-



nently attached to the right speaker/amplifier. It connects to the second speaker through spring-loaded terminals. The wire is clearly marked to help ensure that the phasing is correct.

The right speaker contains the power switch for the system, the volume control, and bass and treble tone controls. (The left speaker contains the Audio-Technica logo and model number in the same location.) An LED behind the right speaker's grille serves as a power-on indicator.

The system does not offer any balance control, which shouldn't be much of a problem because of the intended application of the speakers, placed relatively close together on a desktop. However, on our sample set of speakers, we could have used a balance control because the volume

potentiometer was not perfectly calibrated between the right and left channels. That is, when we wanted to listen at the lowest volume levels possible, we couldn't get equal volume levels in the two speakers.

The speakers are housed in attractive cream-colored plastic cabinets (9 × 5½ × 6 inches) with metal grilles. The bass-reflex (ported) enclosures help to provide a frequency response rated from 80 to 20,000 Hz. The drivers in each speaker are a 4-inch woofer and 3.4-inch tweeter. Speaker sensitivity is rated at 89 dB (1 watt, 1 meter).

The MMS557's are unlike most speaker systems being sold as "multimedia" speakers—they sound good. Ten watts per channel is quite a bit of power for a desktop

(Continued on page 57)

## Just Say It

**VOICE ORGANIZER.** From Voice Powered Technology, Inc., 19725 Sherman Way, Canoga Park, CA 91306; Tel. 800-743-2000; Price: \$199.95.

Today's busy people are becoming increasingly dependent on personal organizers to help them keep track of their business and personal appointments. Of course, before any electronic organizer can do its job—storing phone numbers, appointments, and the like—its owner must input a lot of information: names and phone numbers, meeting dates, and reminders. Sized to fit in a pocket or purse, most organizers have tiny keypads that are used to input information. Typing all that data into a time-saving, convenience device is—surprise!—time-consuming and inconvenient.

There are exceptions to the keypad-based organizers. Last year Apple introduced its Newton and Casio, Tandy brought out their Zoomer pen-based organizers (see Gizmo, March 1994), and Voice Powered Technology came out with the VOICE Organizer (a portable electronic organizer that is operated entirely by voice).

Measuring 4 × 2.33 × .7 inches, the VOICE Organizer fits easily into a shirt pocket, briefcase, or pocketbook, and weighs only 3 ounces with batteries. The device comes with Ni-Cd button cells installed, and with its own recharging stand. A full charge requires eight hours and provides several days use, depending on the number of messages recorded and played back each day. The manufacturer suggests storing the Organizer in its base when it isn't being used, as you would a portable phone, to make sure it's always charged. Backup batteries are provided to protect the data stored in memory.

The VOICE Organizer looks more like a pager than a personal organizer. Its front (top) panel features an LCD readout that usually displays the date, time, and day of the week. Just below the LCD are a microphone and a speaker, and soft controls labeled PLAY, PREV, NEXT, and STOP. Four other buttons—TRAIN, SAVE, ERASE, and EDIT—complete the front-panel controls; another four buttons—TIME, PHONE, SELECT, and RECORD—are spaced across the top of the device. A volume dial is found on the side of the unit.

As with any personal organizer, information must be input before the device can be used. We've always hated having to type in our entire Rolodex of business contacts as well as the phone numbers of our friends and family members. That chore is eliminated with the VOICE Organizer—it doesn't even have a keypad. To input infor-

mation, you simply *tell* the unit what it needs to know.

Before you can begin inputting data, however, you must train the Organizer to recognize your voice. Pressing the TRAIN button brings up the first of a list of words for you to speak. Holding the Organizer a few inches from your mouth, you hold down the TIME button and then speak each word as it appears on screen, using your normal tone of voice. The word list includes numbers 0 through 9, the days of the week, "no," "AM" and "PM," and a few others. You must read through the list twice to complete the voice-recognition training.

The initial training process takes just a couple of minutes. The Organizer is likely, however, to misunderstand at least a word or two when you first begin to use the device. In our case, it had difficulty interpreting the word "four." It's possible to retrain the device to recognize a single word or the entire word list.

Once the Organizer is able to recognize

your voice, it is ready to start working, albeit in a somewhat limited fashion. The device does not offer the full functionality of some of the top-of-the-line personal organizers on the market today: It doesn't store addresses, or provide an on-screen weekly or monthly calendar. It does offer the basics—storing memos, storing reminders to be recalled at certain times, doing calculations, and storing phone numbers—all easily accessible by voice.

To store a memo, for instance, you simply press the RECORD button and begin speaking. The display will say "recorded" and show the time of recording; on the left side of the screen, the memo number will also appear. At a press of the PLAY button, you will hear the memos you've recorded, beginning with the most recent one. During playback, you can skip forward or backward through your messages using the NEXT and PREV buttons, or delete it by holding down the ERASE button.

Basically, reminders are memos to which you've attached a time and date:

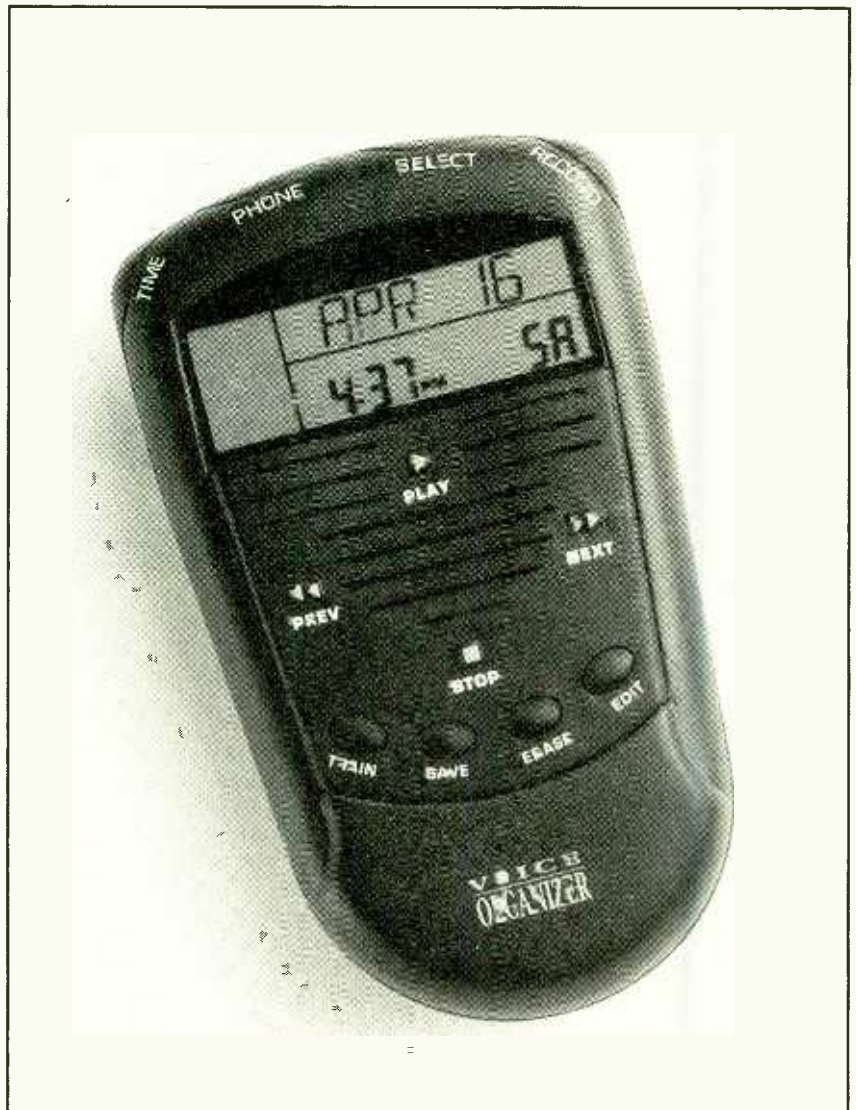

"Call Joan, 5PM," for instance. The Organizer will beep at the appropriate time to let you know there's a reminder waiting. To turn a memo into a reminder, you can add the necessary time and date by pressing the TIME button and speaking the hour, the quarter-hour (15, 30, or 45) if necessary, AM or PM, and the day and date. When you hear the Organizer beep, pressing PLAY will activate the reminder, and then pressing STOP (or simply waiting 30 seconds) will erase it.

If the unit beeps and you don't press play, it will continue to beep at regular intervals (every five minutes for the first 15 minutes, every 15 minutes for the first two hours, and every hour for the first 12 hours) until you do "pick up" your message.

It's also possible to set recurring reminders by speaking the word "recurring" at the end of the time-setting procedure. If you've entered only the time ("Pick up Tommy, 3:30PM"), the Organizer will remind you to get to the day-care center every day. If you've entered time and the day of the week ("Staff meeting, 11 AM Monday"), it will beep once a week. If you've entered the time, month, and day ("Pay mortgage, 8 AM, 1, 10,"), it will remind you to write that check the first thing in the morning on the 10th of each month.

Although it is not possible to view a weekly or monthly calendar on the small LCD, the Organizer can let you know what you have scheduled for a certain day. The Calendar mode can be accessed either verbally or manually. You can hold down the TIME button and tell the Organizer what day you would like to review, either by saying the day of the week or the numerical date (month and day). Or, from the basic clock display, you can press SELECT four times. Once in the Calendar mode, pressing PLAY will recall the first message; the PREV and NEXT buttons can be used to scroll through the rest of the previously recorded reminders.

Phone numbers can only be entered verbally. The Phone mode is divided into five alphabetic sections (A-D, E-I, J-M, N-R, S-Z), to make it easier to retrieve numbers. To enter a number, you must press the PHONE button repeatedly, until you've reached the appropriate alphabetic section. Then hold the EDIT button until a double beep sounds, hold the PHONE button while speaking the number, and then press the SAVE button. The Organizer then prompts you to speak the person's name, and to indicate if the number is for business, home, fax, or other. Only ten digits can be entered for each number; the manual recommends using the "other" category to store extensions. To retrieve a phone number, just speak the person's name while holding the "phone" button. The phone number will be displayed on the



**The voice organizer looks and feels more like a pager than an electronic organizer.**

screen, and the Organizer confirms that it's the correct one by playing back the person's name (which you recorded after recording the phone number).

The Calculator mode is also operated by voice only. After pressing the SELECT button five times to reach the Calculator mode, you hold down the TIME button and then speak the calculation—"One plus one equals . . ."—and then release the TIME button. The correct answer will appear on the screen. You must remember to say each digit: "two, pause, one" instead of "twenty one."

We found holding down the TIMES button to be fatiguing, particularly when using the Organizer as a calculator. In fact, we'd have preferred pressing tiny buttons on a down-sized numeric keypad to holding down one tiny button while enunciating every digit in a complex (or even a simple) calculation.

For folks who worry about privacy, the VOICE Organizer offers two means of security. First, because it has been programmed to recognize its owner's distinct voice, it has difficulty recognizing anyone else's. It's, for the most part, a one-man personal organizer. For added security, however, the Organizer also offers password protection.

Once the VOICE Organizer is programmed to recognize your voice, and you have your phone book up-to-date, the device is very easy to use. It might not offer the full functionality of other personal organizers but, then, neither does it increase the complexity of its owner's life, as some of those keypad-based organizers have been known to do. The functions it does offer are those most likely to be used on a regular basis, and its compact size and easily recharged batteries ensure that you'll be carrying it around on a regular basis. ■

## SONY MINIDISC

*(Continued from page 49)*

The aural differences between an original CD and an analog-recorded MD copy of it are apparent in A/B playback tests to the critical ear. Even so, the MD copy is far superior to the best analog cassette-tape copy you could create, in sound quality and also in durability and playback convenience.

Although MiniDisc was originally conceived as a portable medium, Sony and several other manufacturers are now offering home and automotive MD decks. If you own the MZ-R2, however, you can put it to use at home or on the road. You can use the supplied line cable to connect the MD Walkman's line-out jack to an analog speaker or to a pair of powered speakers, or the SRS-58 active speakers, available from Sony as an MD option. Sony also offers the CPM-MZR2K car-mount kit that lets you play back discs via the car's cassette player.

No matter how you choose to use the recordable MD Walkman, the device represents a giant leap forward in the audio evolutionary scale. The ability to make your own digital recordings on a durable, almost infinitely reusable optical disc is a development long awaited by many audio enthusiasts. ■

## MULTIMEDIA SPEAKERS

*(Continued from page 55)*

computer sound system. It's power that is not offered by battery-powered multimedia speakers or speakers that are powered by wall-mounted transformers. (The MMS557 system plugs right into the wall—the power supply is contained in the right speaker cabinet.)

The speaker system is not, of course, one that we would choose for serious music listening. However, it is a surprisingly good performer. Because we often listen to audio CD's when working at our computer, we had ample opportunity to listen to a wide variety of music as well as multimedia applications. From Stravinski to the Spin Doctors, the MMS557's packed some punch! Their only significant sonic shortcoming was the lack of deep bass, which is typical of small speakers.

The active speaker system is good enough that it could serve in a pinch in a stereo system in limited-space situations. A student might appreciate them in a dorm room. There's no way he could put them in the window and entertain everyone in the quad, but in his room he could connect his portable CD player or tuner and get adequate performance with a small investment in both space and dollars. ■

# ELECTRONICS WISH LIST

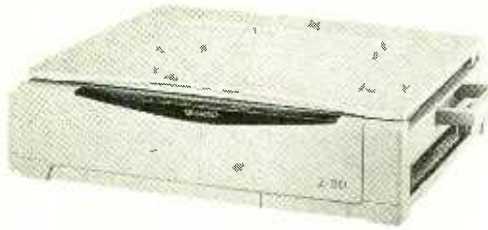

Sharp Compact Personal Copiers



Goldstar 4-Head Hi-Fi VCR



Koss Sonic Boom Computer Headsets



58 Ryka Universal Slim Design Computer Case

## Compact Personal Copier

According to Sharp Electronics Corporation (Sharp Plaza, Mahwah, NJ 07430-2135), their Z-20 (pictured here) and Z-27 personal copiers are the smallest and lightest personal copiers available. Each measures just 14.3 × 13.9 × 3.9 inches, and weigh only 14.8 pounds, making them easy to move or store. Designed to make the transition from office product to consumer item, the copiers offer time-saving features such as Auto Start, which allows the copy-mode settings to be adjusted during the warm-up period when the machine is first powered up. The copiers also offer a warm-up time of less than 20 seconds, a first-copy time of 19 seconds, auto power shut-off and a cartridge-exchange system for easy maintenance. The Z-20 has a single-page feeder and a copy speed of three copies per minute. The Z-27 offers continuous copying, with space for 50 sheets in its multi-feed tray. Both models are designed to minimize ozone emissions and power consumption. Prices: Z-20, \$549.99; Z-27, \$749.99.

## Four-Head Hi-Fi VCR

Goldstar Electronics International's (1000 Sylvan Avenue, Englewood Cliffs, NJ 07632) Model GVR-D465 four-head, hi-fi, VHS VCR features an auto head cleaner, on-screen programming and function displays in English, Spanish, and French, and "high quality plus luminance signal noise-reduction circuitry." The VCR also offers digital auto tracking, a VHS index-search system, a multifunction, multi-brand remote control, and a 10-minute backup timer. Price: \$429.95.

## Computer Headset

In response to the growing popularity of multimedia, voice-activated, and voice-recognition computer programs, Koss Corporation (4129 North Port Washington Avenue, Milwaukee, IL 53212) has introduced a line of three boom microphone/stereophones designed specifically for hands-free use with computers. Each Sonic Boom stereophone model features a lightweight dynamic microphone that requires no external power source. The unique microphone design provides optimized pick-up pattern that allows flexible microphone placement. The headphones provide accurate sound reproduction and maximum clarity. The SB/30 is a closed stereophone with leatherette earcushions that isolate the user from ambient noise. For those who prefer to keep an ear on the world around them, the SB/20's foam earcushions provide an open, hear-through sound. The SB/10 is an ultra-lightweight model that also allows ambient sounds to be heard. Prices: SB/30, \$49.99; SB/20, \$39.99; SB/10, \$19.99.

## Soft-Sided Computer Case

Computer carrying cases tend to be either too large and heavy, or not roomy enough for carrying all the essentials. The Model NB-510 Universal Slim Design is designed specifically for people who want a lightweight, carry-all case. It weighs only 1 pound, 11 ounces and is just 3 inches thick, yet it can accommodate a laptop computer, power source, mouse, and cables. An adjustable, padded divider custom fits the computer securely in place. The case also has room for files, pens, and business cards, and provides dust-protected disk storage. Its shock-protection system uses lightweight plastic inside to provide twice the protection without adding extra weight. Price: \$69.95.



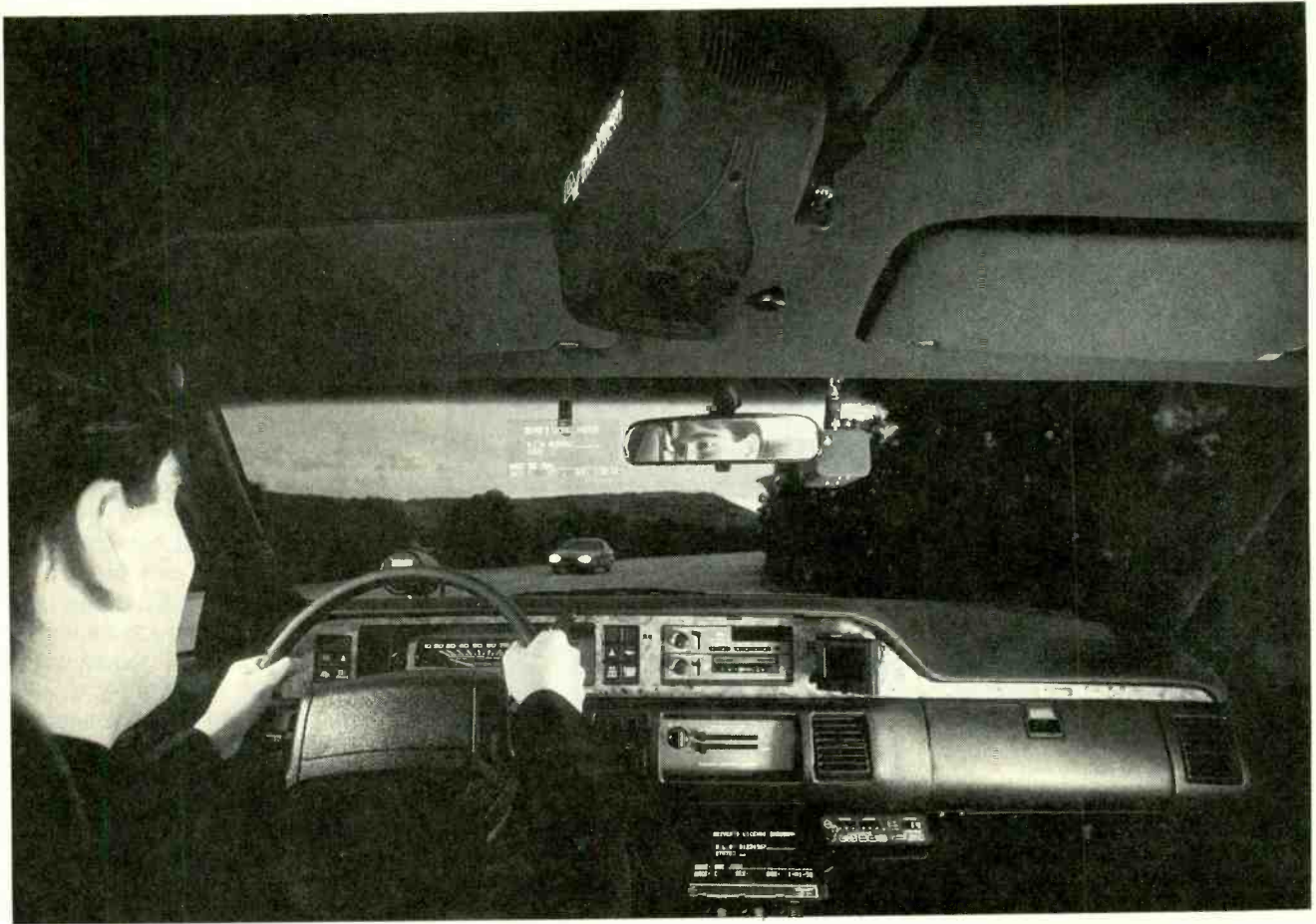

# Police Cars go High-Tech

*Find out how advanced technology is helping to fight crime.*

BY BILL SIURU

**T**he police cruiser without headlights moves slowly towards the street corner where several individuals are involved in suspected drug deals. Not aware that they are seen, the dealers continue to make deals under the cloak of darkness. However, their activities are not only being observed, but also recorded. The officer is watching everything on the Head-Up Display (HUD) mounted on the windshield. The scene on the HUD is almost as clear as if the deals were going down in broad daylight.

The officer calls into the dispatcher at precinct headquarters for back up before going in to make an arrest. The dispatcher calls up a computer display showing the location of all police

cars currently on duty, then dispatches several of the closest cruisers via their Mobile Data Terminals (MDT's).

This is not "gee-whiz" technology for the 21st Century. It represents the level of technology that, once only practical for the defense and aerospace community, is now used by some police departments.

**HUD's in Police Cars.** New high-tech equipment like mobile data terminals, radar/laser speed sensors, video cameras, and even low-light television (LLTV) in police cars means officers can do their jobs better and more efficiently. The advanced electronics also increase the workload. Officers, who usually ride alone, have to

watch for suspicious criminal activities, follow suspect vehicles, read information on MDT's, monitor radar/laser speed guns, view surveillance sensors, communicate by radio, and at the same time drive—sometimes in hot pursuit!

Indeed, the workload level is reaching that facing a fighter pilot engaged in combat. Therefore, it isn't surprising that police cars are now being fitted with the modern fighter pilot's key tool, the HUD. A HUD allows a fighter pilot to fly without having to look down into the cockpit to read instruments. With a HUD in a police car, crucial information can be superimposed in the driver's field of view. There it can be read without the need to

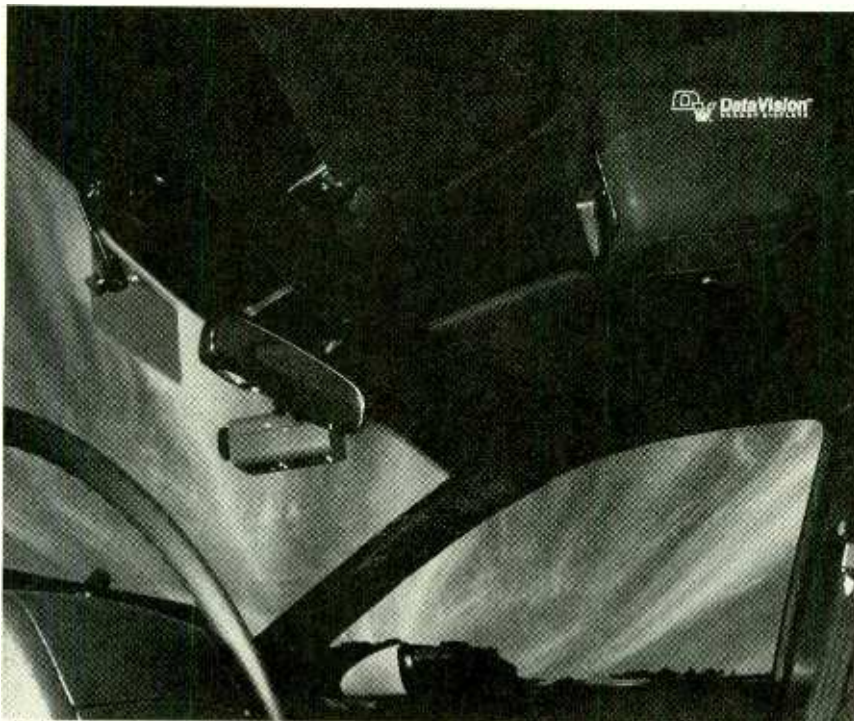

*This is an internal view of the DataVision HUD installation. Note the video camera to the right of the rearview mirror, the combiner to its left, and the roof-mounted projector.*

move eyes off the road ahead, or the suspect.

GM Hughes Electronics, a company that has supplied HUD's for the most advanced military jets, has adapted this display technology and is now making it affordable for law enforcement. In fact, its new DataVision HUD is being tested and demonstrated in police vehicles used by a dozen law enforcement agencies in California, Florida, Illinois, Indiana, Nevada, Texas, and Ontario, Canada. It is also now available to other law-enforcement agencies from several suppliers around the country.

DataVision consists of three main components. First, there is a small, see-through glass projection screen or "combiner" that is located on the windshield just to the left of the inside rearview mirror. While in the driver's field of view, the transparent view-screen does not detract from the ability to see the road ahead. The optics in the combiner give the impression that the image is floating in space. The optics are set up so the driver does not have to refocus his eyes to read it. The combiner screen can display 12 lines of information with 40 characters on each line. Full ASCII uppercase and lowercase letters plus special characters can be displayed.

Next, there is a projector mounted on the car's ceiling in front of the combiner that projects the image onto the viewscreen. Finally, a remote electronic unit supplies the image to the projector via a cable.

The initial DataVision system is specifically designed to work in conjunction with MDT's used throughout the law-enforcement community. With modifications, they could also display information from a radar/laser unit, video monitor, onboard computer, or anything else that can be sent via an RS-232 data port.

Currently, the system reproduces images from a monochrome liquid-crystal display (LCD). In the future, high-definition color LCD's could be added so that moving maps, or the output of an onboard navigation system could also be viewed. As we will see in a bit, it can also be used with thermal (infrared) sensors for nighttime surveillance.

DataVision is easy to interface with most MDT's, and adapters are available so they can be installed in Chevrolet Caprices and Ford Crown Victorias—the most commonly used police cars in the U.S. According to GM Hughes Electronics, it takes less than two hours to install and can be easily transferred between different

vehicles in the fleet. The projector is mounted magnetically or via a through-the-roof attachment. It is mounted well out of the way in case the airbags should be deployed. The combiner is attached to the windshield using a removable adhesive bond.

**Night Vision.** Police departments in Dallas and Highland Park, Texas; Los Angeles; St. Louis; Portland, and Ottawa, Ontario are testing Thermal Imaging (TI) technology that allows officers to see in complete darkness. The police departments are testing the Nightsight Thermal Vision System developed by Texas Instruments Inc. and GM's Hughes Electronics.

Nightsight uses TI, also known as infrared (IR) imaging because it operates in the IR band. TI should not be confused with another night-vision technique called image intensification (or II), which is commonly used in law enforcement to detect criminals and criminal activity at night. Thermal vision, which requires no light to function, is effective even when it is too dark for image intensifiers, which need minimal light such as from the moon. That's because TI equipment senses the heat generated by virtually all objects.

Since TI takes advantage of inherent infrared energy, it is passive, so only the user knows when it is in operation, not the criminal. It can detect temperature differences of as little as one-tenth of a degree to render heat images of vegetation, people, machinery, etc. on a screen. Also, TI can not only see through the night, but fog, mist, or smoke as well. It is especially useful in penetrating almost any type of camouflage.

Like HUD's, thermal imaging is another military technology being transferred to civilian use. For example, Forward-Looking Infrared (FLIR) systems have been used for years in fighters, helicopters, tanks, and armored vehicles. Nightsight, in particular, is based on technology developed by the U.S. Army, and allowed Coalition Forces to "own the night" during the Persian-Gulf War.

In the Nightsight system, a 6 × 8-inch TI camera is mounted on the roof of the cruiser. A motorized mount moves the camera up or down or sweeps it through a full 360-degree

circle. The officer controls the camera's motion with a joystick. He or she can view the scene on the HUD or on an LCD in the instrument panel.

Night vision is ideal for law-enforcement work because officers can approach dangerous situations without alerting the bad guys with, for instance, headlights. Also, officers can search dark corners without leaving the security of the police cruiser. They can even use thermal vision in full daylight to locate criminals who might be hiding in bushes. It can also locate a recently driven car in a full parking lot by identifying its still-hot engine.

The success stories are already coming in from the test trials around the country. Nightsight has been used by Ottawa constables to pick-up fleeing break-in suspects by distinguishing fresh footprints in the snow from a number of older ones. Dallas law-enforcement officials were able to detect a concealed firearm being carried under clothing. In one case, a drug dealer was caught "red handed" when he threw little baggies of cocaine out of his car window. The flying baggies, still warm from the dealer's body heat, showed up on the Nightsight system and were an affirmative link between the drugs and the dealer.

The Nightsight night-vision enhancement system could be commercially available by late next year. While prices have not been established, the target cost is in the neighborhood of a police-radar unit or video camcorder.

**Automated Vehicle Locating.** One of the initial applications of Intelligent-Vehicle/Highway System (IVHS) technology, called "Automated Vehicle Locating" (or AVL), is already being used by law-enforcement dispatchers. Basically, dispatching involves determining the current location of all the units in the fleet and their availability for "duty." So, when an emergency occurs, the closest available unit can be guided to the scene of the incident by the shortest route.

AVL decreases response times and allows more efficient use of limited law-enforcement resources. It does that by replacing time-consuming, sometimes garbled, two-way radio communications with automatic data

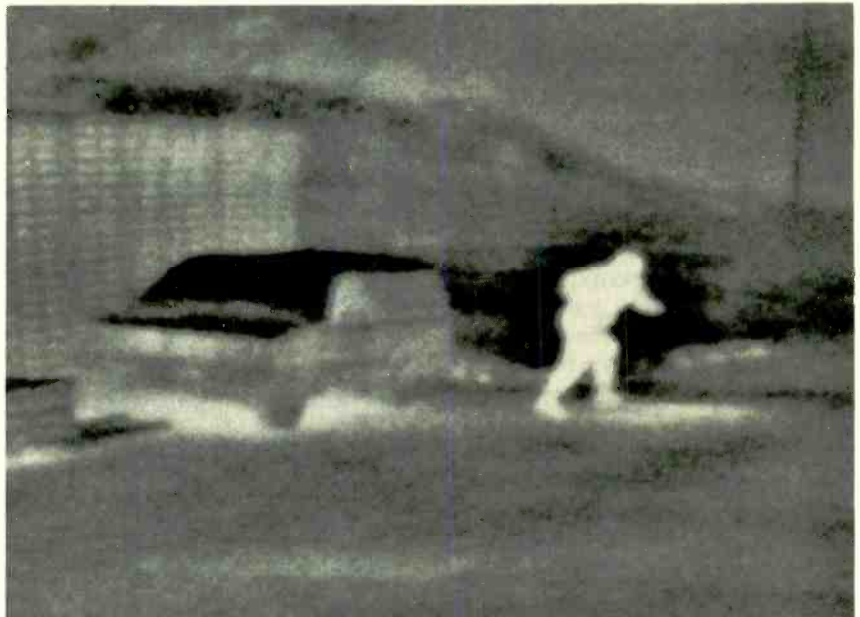

*This is what an officer can see on the head-up display or television monitor in a cruiser equipped with the Nightsight system. Notice the extreme visibility of a perpetrator.*

transmission between police cars and the dispatch center. At "dispatch" the data is entered into a computerized database. That allows location, availability, and other information to be displayed in various forms. The most common and useful way is with a

multi-color map display on a computer screen.

One example of AVL technology is the Vehicle Tracking System (VTS) from Il Morrow, Inc. Each vehicle using VTS is equipped with a Position Sensor and Radio Interface Unit (both usually located in the trunk), and a dashboard-mounted Status Panel. The Position Sensor receives data from the Government's Loran C transmitters. Automatic triangulation of the Loran signals is then used to determine the unit's current position. Position data along with the unit's unique ID number is transmitted via radio to the dispatch center. The availability of the unit, established by the driver pressing a button on the Status Panel, is also transmitted. Eight or 16-button units are offered that can be tailored to individual agency requirements and there is an emergency "red" button to trigger an alarm at the dispatch center.

At the dispatch center, a Radio Communication Controller is the link between the incoming radio signals and the Map Workstation. The latter is an IBM-compatible computer that displays the current location and status of each vehicle in the fleet on an on-screen map. After deciding which unit to dispatch, the dispatcher sends instructions to the mobile unit via radio.

While VTS does not automatically

#### Names and Addresses

**CMI/MPH**  
316 East Ninth Street  
Owensboro, KY 42303  
Tel. 800-835-0690, 502-685-0690  
FAX: 502-685-6268

**GM Hughes Electronics**  
Automotive Electronics Development  
P.O. Box 92426  
Los Angeles, CA 90009  
Tel. 800-DATA-HUD, 310-334-1665

**Il Morrow**  
2345 Turner Road  
Salem, OR 97302-2000

**Impact Solutions/XPEDITOR and XPEDATA**  
Tel. 619-224-5877

**MobileData Communications, Corporation**  
10850 N. 24th Avenue, Suite 101  
Phoenix, AZ 85029  
Tel. 602-678-3788; FAX 602-678-4471

**RCI**  
5983 Ford Court  
Brighton, MI 48116  
Tel. 313-229-0122, 800-963-2580  
FAX: 313-229-0124

**Texas Instruments Incorporated**  
34 Forest Street  
Attleboro, MA 02703  
Tel. 508-699-1520

guide the vehicle to the spot, it continually transmits the unit's location to the dispatch center. The dispatcher can follow the vehicle's path on the map to help the driver navigate. Like most of the new computer-based technology, VTS is user-friendly with menu-driven software. Most commands are executed using a mouse. There is also a zoom capability to look at specific areas in greater detail while simultaneously displaying a small window containing the full-area map in miniature for reference purposes.

The advantage of the II Morrow VTS, and comparable systems from several other companies, are their simplicity and low cost, especially for the components installed in vehicles. As proof of that, the systems are already being used by police departments in several states, plus ambulance services, delivery services, mass-transportation companies, and even trash collectors.

"Smart" vehicles are already on the street, with the City of Detroit leading the way. Detroit has developed an integrated system that includes three main components. First, is the II Morrow AVL system described above. Each vehicle is also equipped with a ElectroCom Mobile Display Terminal



*The center console in a Cruiser holds a laptop computer, a closed-circuit monitor, a cellular phone, a two-way radio, and more high-tech electronics.*

(MDT). Finally, dispatching is done using a Computer-Aided Dispatch (CAD) system developed by Unisys Corporation. While normally information is transmitted by both voice and

datalink, it is possible to send all information via the MDT if a "silent" run is desired.

Detroit's system has been in operation for about five years, with nearly 1000 vehicles now equipped. That includes not only police vehicles, but fire and Emergency Medical Service (EMS) vehicles as well. Of course, the greatest number are found in police vehicles with 95% of the fleet equipped. The remaining 5% are under-cover type vehicles, which are unequipped for obvious reasons. Detroit uses eight CAD-equipped police-dispatch centers, and four each for the fire and EMS departments.

According to Chuck Gray of the Detroit Police Department's Information Systems Division, police officers were a bit leery of the system initially. Mainly because they thought that "big brother" could monitor their every move. But with training and experience, most now appreciate the system's advantages including the elimination of the need to write things down while listening and perhaps even driving. Also, information transmitted is retained in the database for latter reference, for example when writing up a report.

However, Detroit has experienced a few technical problems, but they are being solved with even more advanced technology. For example, the AVL system uses Loran C, which can "go south" in the presence of major power lines or tall buildings. Thus, Loran C will be replaced or augmented by position information from the Global Positioning System (GPS). That will eliminate the powerline problem, but not the tall-building trouble because GPS uses line-of-sight transmissions. Detroit is looking at a dead-reckoning navigation system to cure the latter problem.

### **Computers and Video Cameras**

Today there is a proliferation of computerized law-enforcement-oriented software that instantly provides officers with a wealth of information on criminals and their M.O.'s. Other software is aimed at reducing the beat officer's workload. Studies show officers spend about 60% of their time on paperwork.

Case-management software like Impact Solutions' Xpeditor can reduce that chore by 25 to 50%, and  
(Continued on page 81)

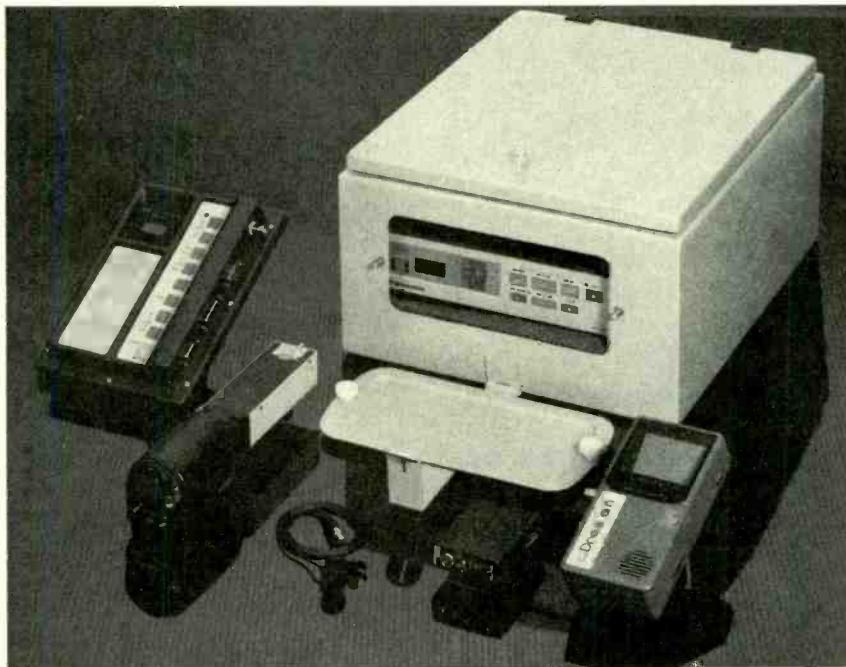

*From the left to right the components of the CMI/MPH DocuCam video camera system are the control panel, the camera, the Panasonic recorder in its environment-controlled enclosure. On the far right is the Sony 3-inch B&W monitor. Finally, there's the wireless microphone worn by the officer, which can record any audio within 1500-feet of the car.*

# BUILD THE MOTION MEMORY

*Animate the world around you with this joystick recorder and common hobby servos.*



BY SCOTT EDWARDS

**W**ant special effects for your home-video production, animated Christmas display, light show, model railroad layout, Halloween costume, or museum exhibit? Build the *Motion Memory* described in this article, and you'll have a tireless automated assistant that can record and play back motion sequences on cue.

The Motion Memory is an inexpensive (\$35) project that interfaces a joystick to a pair of hobby servos—the same inexpensive, rugged, and reliable mechanisms used in remote-control planes, boats, and cars. Move the joystick and the servos move. Press the trigger, and the controller records up to 21 seconds of motion in digital memory. Set the unit for playback, and the servos will repeat the recorded motions, either on cue, or continuously.

**How it works.** Hobby servos are small, motorized positioners that respond to a control signal consisting of 1- to 2-millisecond positive pulses repeated 40 to 60 times per second.

The angle of a servo's output shaft is proportional to the width of the pulse, and typically covers a 90-degree range of motion. A servo's mechanical power ranges from 12 to more than 48 inch-ounces—enough to reliably lift and lower a four-pack of D-cell batteries. Servos are designed to operate from an unregulated 4.8- to 6-volt DC supply consisting of four series-connected cells.

The Motion Memory reads the position of the two potentiometers of a PC-style joystick and translates their resistance into proportional servo pulses. If the user presses the joystick trigger, the unit writes position data into its 1024 bytes (1k) of memory. Recording stops when the user presses the joystick thumb button, or the memory is filled.

On playback, the recorder retrieves data from memory and uses it to regenerate the servo pulses, ignoring the joystick. If the recorder is set for one-shot mode, playback stops at the end of the motion sequence. In loop mode, the sequence plays continuously until the mode is changed or the power is turned off.

That's the abridged version of the Motion Memory's operation. Let's look at the system in greater detail, starting with U2 in Fig. 1.

**Down to Details.** Referring to Fig. 1, U2 is a PIC 16C55 microcontroller, which is a close relative of the type of microprocessor found in PC's. Internally, they perform many of the same functions, such as math and logic. Externally, however, microcontrollers and microprocessors are very different. A microprocessor has connections for memory and input/output (I/O) devices. Related groups of connections are known as buses. Microprocessors generally have buses for address, data and control, and built-in commands for orchestrating their operation.

A microcontroller also has external connections, but uses them directly for I/O. It has no buses for convenient connection of external memory or other devices, and no built-in commands for bus operation. From that description, it's easy to think of a microcontroller as something less than a microprocessor. For general-purpose computing, that's true. But in the case of stand-alone devices that just need a little bit of intelligence, microcontrollers make sense.

Microprocessors not only allow the connection of external memory, they need it in order to function. Microcontrollers don't. They have a single program permanently stored in internal read-only memory (ROM) or erasable/programmable ROM (EPROM). To carry out their program, they have a limited amount of internal random-access memory (RAM). The PIC16C55 microcontroller used in this project has EPROM storage for a 512-instruction program, 32 bytes of RAM, and 20 I/O lines. The I/O's are used to read the joystick, communicate with the electrically erasable programmable ROM's (EEPROM's), provide pulses for the servos, read switches, and light the LED's.

The PIC's programming coordinates all of those activities. Its steps are

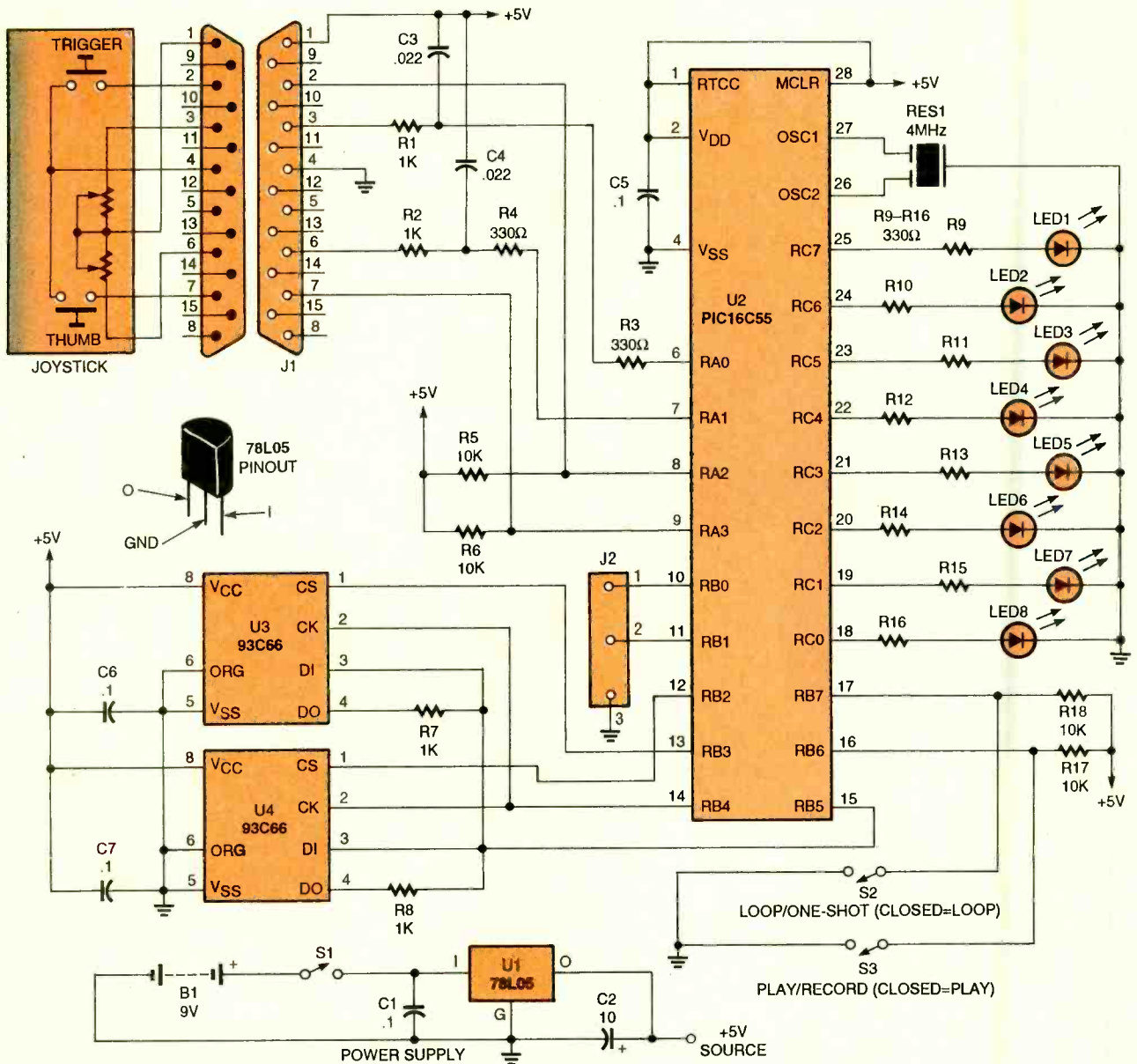

Fig. 1. The Motion Memory is a joystick interface comprised of a pair of 93C66 512-byte serial EEPROM's (U3, and U4), a PIC16C55 microcontroller (U2), a 78L05 5-volt, 100-mA voltage regulator (U1), 8 red light-emitting diodes (LED1-LED8), and a handful of additional components

executed in sync with an internal clock oscillator whose frequency is set to 4 MHz by ceramic resonator RES1. Every fourth tick of the 4-MHz clock, the PIC executes another instruction; that's 1-million instructions per second (MIPS). In our circuit, the PIC's primary functions are reading the joystick potentiometers, generating servo pulses, and communicating with the EEPROM's. Let's take a closer look at each of those jobs, starting with the joysticks.

PC-compatible joysticks consist of a pair of potentiometers coupled to a

swiveling handle, and couple of push-buttons, generally arranged as a trigger and a thumb button. The potentiometers' full-scale resistance is approximately 140,000 ohms (140k). To determine the resistance of a joystick potentiometer, the PIC measures the time required for it to charge a capacitor.

Look at C3 in Fig. 1 and imagine this series of events: The PIC puts a low onto pin RA0, effectively grounding point X. Any charge on the capacitor R2 is rapidly drained through resistor R2 until X is near 0 volts. At that point, the

PIC changes RA0 to an input. In that state, the RA0 pin floats, neither supplying current to nor taking current from the capacitor. It just watches the voltage at point X, which is initially 0. The PIC sees that logical 0 as an answer of "no" to the question, "Is there a voltage on RA0?"

As C3 charges through the combination of the joystick resistance and R1, that voltage rises. How fast it rises depends on the resistance of the joystick potentiometers; low resistance = fast, high = slow.

Meanwhile, the PIC counts the

passing microseconds, waiting for the answer to its voltage question to come back "yes" (a logical 1). That happens when the voltage on the RA0 terminal reaches approximately 1.5 volts, a level known as the logic threshold. Then, the counting stops. That count indicates the resistance (and therefore the position) of one axis of the joystick.

Although that method of reading a potentiometer is effective and cheap, it is susceptible to noise. The noise can be in the form of AC hum or radio-frequency noise picked up by the unshielded joystick cable, or noise generated by the PIC's own clock and coupled to the power supply. Since all of those noise sources are higher in frequency than the desired joystick motions, all that's required to eliminate them is a low-pass filter.

The PIC performs the filtering task by using simple arithmetic. For each new joystick value, it computes a weighted average, giving greater weight to the old joystick value. To explain, let's say that the new joystick value is 200 and the old value was 190. The program computes  $(\frac{3}{4} \times \text{old}) + (\frac{1}{4} \times \text{new}) = 142 + 50 = 192$ . (The program's integer math drops the fractional parts of computations, so  $\frac{3}{4} \times 190 = 142$ , not 142.5.)

If the joystick value stays at 200, it will take several joystick readings for the new value to catch up. In fact, the value will never actually reach 200; it will stall out at 197. That isn't important in this application because the numbers are a means to an end; i.e., smooth, proportional motion of the servos. If noise on the joystick lines causes the readings to jitter between 200 and 202, the computation is  $150 + 50 = 200$ ; the servos stay rock solid.

To turn the joystick data into timed pulses for the servos, the PIC goes through another counting process. As an example, let's say the PIC must send a 1.5-millisecond (ms) pulse to servo 1. The PIC first writes a 1 to RB0, raising the voltage on that pin from 0 to 5 volts. The PIC then loads a number—say, 150—into a counter, and begins the following two-step operation:

- Step 1: Subtract 1 from the counter (counter = counter - 1)
- Step 2: If the counter is not 0, go to Step 1. If the time required to perform

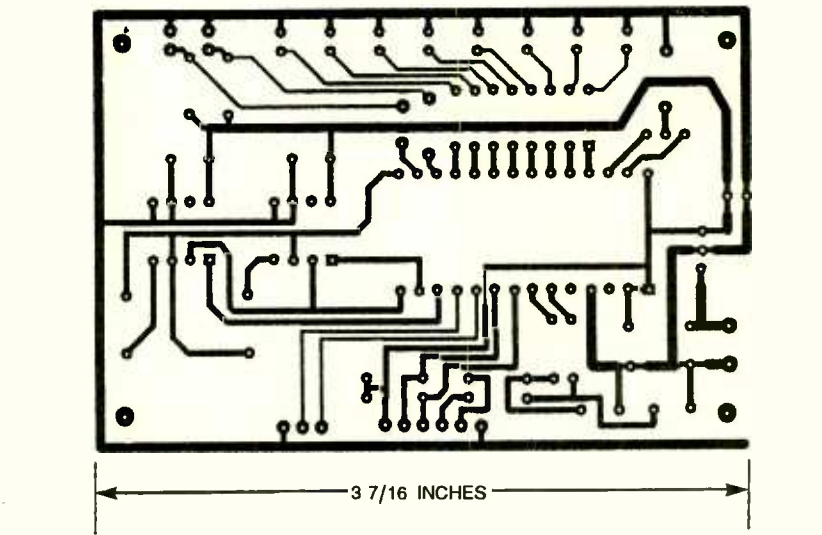

Fig. 2. The Motion Memory was assembled on a small printed-circuit board (shown here full-scale) measuring about 3 7/16 by 2 5/16 inches.

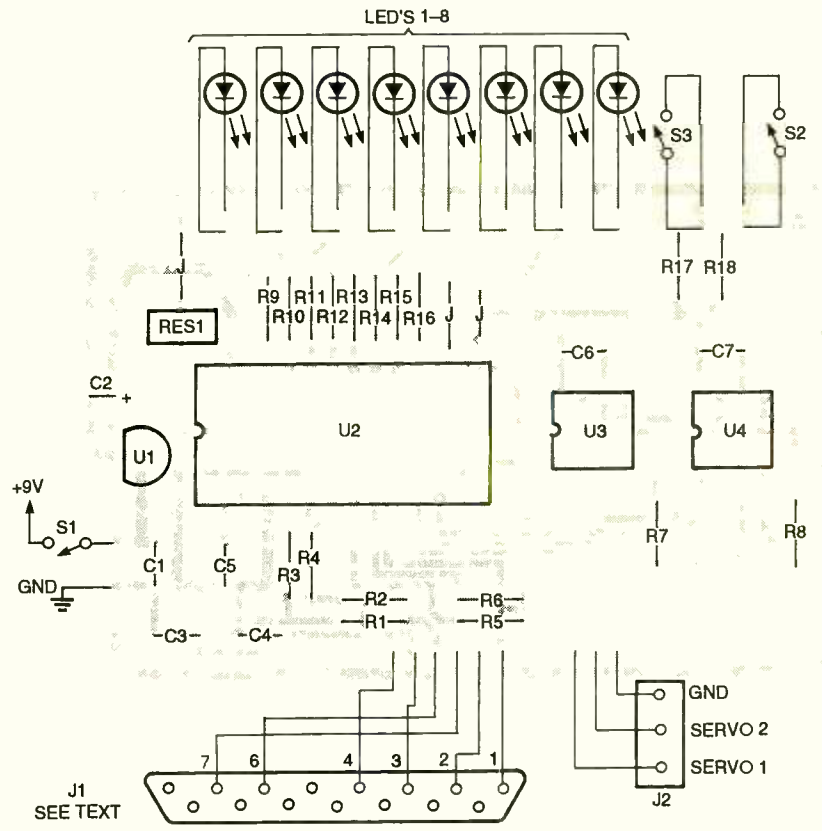

Fig. 3. Assemble the Motion Memory's printed-circuit board following this parts-placement diagram. It is recommended that sockets be provided for U2-U4. Don't forget to pay close attention to the orientation of the polarized components.

steps 1 and 2 is 10 microseconds, and the counter is initially 150, how long does it take the counter to reach 0? The answer is  $150 \times 10 \text{ microseconds} = 1500 \text{ microseconds} = 1.5 \text{ milliseconds}$ .  
 When the count reaches 0, the program ends the servo pulse by writing a

0 to RB0. That's called a "timing loop" and it's a common feature of microcontroller programs. Designers who use controllers try to convert every possible input or output into some kind of timing function, because time is free! External components that measure or produce analog voltages

or waveforms cost money—often more than the controller itself. So, to make the servos move in response to the joystick, the PIC measures the joystick position in terms of the time required for a capacitor to charge. It uses the resulting number to determine how many trips to take through a timing loop in order to generate the servo pulses.

Of course, the Motion Memory controller's unique feature is its ability to record joystick motions for later playback. That's where U3 and U4, the serial EEPROM's, come into play. EEPROM's retain data even with the power removed. They are used in many systems to allow the user to update the programming or change calibration data. Some telephones use them to store speed-dial numbers. Many laser printers keep number-of-copies data in EEPROM's.

The 93C66 EEPROM's used in the Motion Memory can each hold 512 bytes of data and communicate with the PIC over a serial interface. While slower and more complicated than their parallel counterparts, serial peripherals have been gaining popularity in the world of controller hardware. The reason for their success is simple; space. A parallel-interface EEPROM with 512 bytes of storage would require 8 pins for data, 9 pins for address, 2 pins for power, and at least 3 control pins for compatibility with

common buses; that's 22 pins in all. But, the 93C66's used in this project have just 8 pins.

Certainly, there's a tradeoff in program complexity. It takes about 100 PIC instructions to control the EEPROM's. A parallel EEPROM might require 10 instructions. There's also speed to consider. Parallel memory can make eight bits of data available in 400 nanoseconds or less, whereas the serial device must first receive a 3-bit read instruction and a 9-bit address before it can return 8 bits of data. Since its fastest communication rate is 2-million bits per second, that takes at least 10 microseconds.

There are two other issues related to EEPROM's regardless of the type of interface: erase/write speed and longevity. An EEPROM internally generates a high programming voltage to erase and write data. The process takes a few milliseconds per byte written. That's much slower than conventional RAM, which can accept new data in 100 nanoseconds or less; 10,000 times faster! EEPROM's may be read at speeds comparable to regular EPROM's or RAM.

It is possible to speed up the erase/write cycle with higher programming voltages, but then we run afoul of issue two: longevity. The higher the programming voltage, the greater the stress on the memory cell. Each erase/write operation wears away at a

portion of the memory cell known as the tunnel dielectric. That thin insulator corrals the electrons that determine a memory cell's state. When electrons are trapped on the gate side of the tunnel dielectric, the cell holds a 1. When electrons are held away from the gate, the cell holds a 0.

In order to change the state of a memory cell, a high voltage is used to create a strong electric field. That field drives electrons through the tunnel dielectric to the other side. Eventually, the dielectric begins to break down and becomes a less effective barrier. When it can no longer hold enough electrons to one side or the other for the gate to reliably tell the difference between 1 and 0, the memory cell is worn out.

Ideally, an EEPROM would tolerate 2 million erase/write operations before wearing out. However, flaws (like cracks in a wall) in the tunnel dielectric, accelerate the process. Heat and fast programming processes also reduce an EEPROM's life expectancy. In the Motion Memory, the EEPROM's should be good for 100,000 recordings. Playback causes no wear, so the average user will probably never have to replace the EEPROM's.

To record a motion sequence in the EEPROM's, the record/play switch is put into the record position and the trigger on the joystick is pressed. The PIC continues to convert joystick resis-

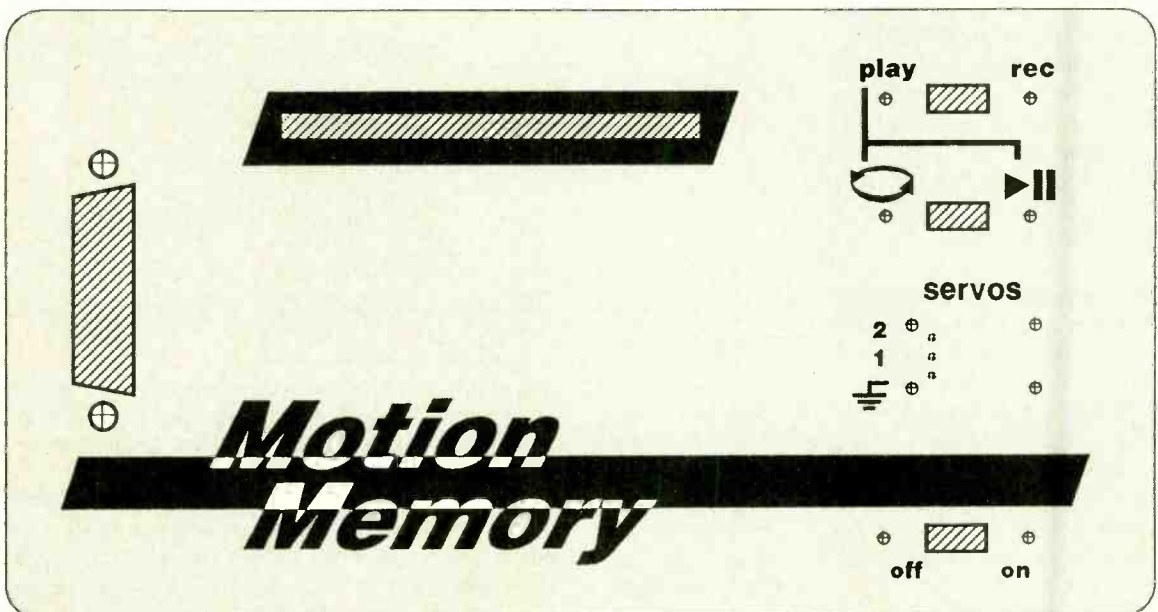

Fig. 4. The front-panel layout of the author's unit, which was housed in a plastic enclosure measuring approximately 6-inches long, 3-inches wide, and 2-inches high, is shown here to give you an idea of how you might design yours.



## PARTS LIST FOR THE MOTION MEMORY

### SEMICONDUCTORS

- U1—78L05 5-volt, 100-mA voltage-regulator, integrated circuit  
 U2—PIC16C55 microcontroller, integrated circuit  
 U3, U4—93C66 or 93LC66 512-byte serial EEPROM, integrated circuit (Microchip, Digi-Key part 93LC66/P-ND)  
 LED1—LED8—Red light-emitting diode (T1-3/4 package)

### RESISTORS

- (All fixed resistors are 1/4-watt, 5% units.)  
 R1, R2, R7, R8—1000-ohm  
 R3, R4, R9—R16—330-ohm  
 R5, R6, R17, R18—10,000-ohm

### CAPACITORS

- C1, C5—C7—0.1- $\mu$ F ceramic disc  
 C2—10- $\mu$ F 16-WVDC tantalum electrolytic  
 C3, C4—0.022- $\mu$ F ceramic disc

### ADDITIONAL PARTS AND MATERIALS

- RES1—4-MHz ceramic resonator with integral capacitors (Panasonic PX-400, Digi-Key)  
 S1—S3—Miniature SPST slide switch

- J1—DB-15 solder-type, panel-mount, female connector  
 J2—3-terminal breadboarding connector (tie-point block)  
 B1—9-volt transistor-radio battery  
 Printed-circuit materials, enclosure (Radio Shack 270-223 or similar), IC sockets, 9-volt battery holder and connector, 2-56 machine hardware, circuit-board standoffs, hookup wire, scrap of 1/4" tinted acrylic plastic, hot-glue gun and glue sticks, PC-compatible joystick, hobby servo(s), 4-battery C or D-cell holder, solder, hardware, etc.

**Note:** A partial kit of parts, consisting of U2 (the programmed PIC16C55 controller), RES1 (4-MHz resonator), U3 and U4 (the 93LC66 EEPROM's), is available for \$25 postpaid from Scott Edwards Electronics, 964 Cactus Wren Lane, Sierra Vista, AZ 85635. An etched and drilled printed-circuit board is available for \$10 postage paid. Check or money order only, please. Arizona residents receive a discount equal to the state sales tax.

tances into data, and to use that data to generate servo pulses about 50 times a second. But now it also writes every second byte of that data into sequential addresses of the EEPROM's, starting with address 1. Servo 1's data goes into U3; servo 2's into U4.

When the recording is over, either because you pressed the thumb switch or the PIC reached the end of the EEPROM memory, the PIC writes the length of the recording to address 0 of the EEPROM's. Since that value is 9-bits long, the lower eight bits go to address 0 of U3, while the 9th bit goes into address 0 of U4.

When you switch to playback and press the joystick trigger, the PIC reads the address-0 contents of U3 and U4 to reassemble the length of the recording. Starting with address 1 of the EEPROM's, it reads a position value and sends a pulse of that length to the appropriate servo. Since the PIC recorded only every second byte of position data to the EEPROM's—25 samples for each second of recording versus the 50 required to keep the

servos properly updated—it now has to replace the missing data. To do that, it simply computes weighted averages of successive position values, and low-pass filtering smoothes

off the rough edges created by the missing data samples.

When the PIC reaches the end of a recorded sequence, it checks the positions of the mode switches. If the record/playback switch (S3) has been moved to the record position, the program goes back into record-standby. If it is still in playback mode, then the LOOP/ONE-SHOT switch (S2) determines what the unit will do next. If it is set to one-shot, the program will wait for the user to press the trigger to start another playback. If it is in the loop position, playback starts again from the beginning.

During both the record and playback cycles, the PIC sequences the LED's to indicate its position in the EEPROM memory. Each LED is on for approximately 2.5 seconds. Now that we've learned how the Motion Memory's works, let's build it.

**Construction** The BASIC program listing used by the author to burn his microcontroller can be plucked from the Gernsback Bulletin Board at 516-293-2283, for those who have the tools, skills, and desire to burn their own microcontroller. Those with the skills and desire, but not the tools can obtain the necessary equipment from Parallax Inc. (3805 Atherton Road, Rocklin, CA; Tel. 916-624-8333). A pre-programmed PIC is also available as part of partial kit of parts from the source given in the Parts List.

The first step in building the project

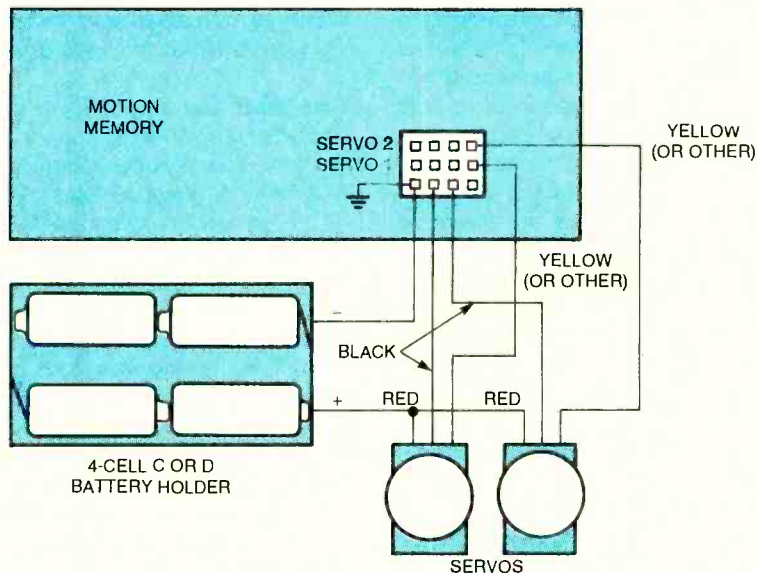

Fig. 5. To test the Motion Memory, plug a joystick into J1; afterward, connect a pair of servos to J2 (as illustrated here).

is to etch or purchase the board (an etched or drilled board is, again, available from the source given in the Parts List). Once that is done, assembly is just a matter of soldering the board-mounted components in place where indicated in Fig. 3. Install sockets for U2, U3, and U4, but do not install the IC's just yet.

When the board is assembled, but before inserting the IC's, apply a 9-volt power source to the board and measure the voltage between pins 4 (ground) and 2 (supply) of U2's empty socket. It should read 5 volts, plus or minus 0.1 volt. If it doesn't, double-check your wiring. Be certain that the flat side of U1 is oriented as shown in the parts-placement diagram.

If you plan to install your Motion Memory in a project box, now would be a good time to mount switches S1 through S3 and jacks J1 and J2. That way, you can wire the board to those parts with just the right amount of slack to make a neat job, but still permit disassembly. Figure 4 shows the author's front-panel layout. If you're using a plastic box and find it hard to make the rectangular holes for the slide switches and LED slot, drill out as much material as you can. Then, using a very sharp wood-carving knife, carve out the rest. Be careful. If you find yourself applying too much pressure to the plastic, sharpen the blade or take a smaller cut.

To mount the printed-circuit board in the box without drilling holes in the front panel, try this: Get four 1/4-inch diameter tubular standoffs about 1/2-inch long, four 2-56 x 1/2-inch machine screws and nuts, and a hot-glue gun. Being careful not to burn yourself, squirt a little hot glue into one of the standoffs. Push the head of the machine screw into the standoff, leaving about 3/16 inch of the threaded part of the screw protruding. Do that for the remaining three standoffs and screws.

When the glue has set, put the threaded posts through the holes at the four corners of the circuit board and secure them with nuts. The standoffs should protrude from the component side of the board. Put another dab of hot glue on the ends of the standoffs and press them against the inside of the project-box cover. Before the glue sets, adjust the board to align the LED's with the slot.

To dress up the prototype, the author made a viewing prism for the LED opening. Using a hand saw, cut a 2 1/8 by 3/8 inch piece out of a 1/4-inch thick scrap of tinted acrylic plastic. Then sand the cut edges with progressively finer wet sandpaper, and polish them with toothpaste. After that, temporarily remove the circuit board from the project-box cover and press the acrylic piece into the LED viewing slot. That blacks out the LED's when they are off. When they're on, they have a somewhat magnified, squared-off appearance.

You can substitute any type of connector or screw-terminal arrangement that you prefer for the specified J2 connector. If you use the specified block, solder wires to its connecting tabs before installing it on the front panel. To mount it, thread the wires through the holes, and press the legs of the connector into the four corner holes. From the back side of the panel, apply a dab of glue to each of the legs.

Once the enclosure has been prepared, wire the switches and connectors to the assembled board. Using antistatic precautions (a grounded work surface or wrist strap) install U2, U3, and U4 in their sockets. Note that the parts (part 93LC66/P-ND) specified in the Parts List for U3 and U4 are available from Digi-Key, and under no circumstances should parts with the same part numbers from other manufacturers be substituted; they are not compatible. Connect a 9-volt battery to the clip, and you're ready for a test drive.

**Checkout and Use.** Plug a joystick into J1 and connect a couple of servos (one source for suitable servos is ACE R/C, 116 West 19 Street, PO Box 472, Higginsville, MO 64037-0472; Tel. 800-322-7121) to J2, as illustrated in Fig. 5. Put PLAY/RECORD switch S3 into the record position. The position of LOOP/ONE-SHOT switch S2 is not important. With everything connected, turn on the Motion Memory circuit and apply power to the servos. Their output shafts should immediately rotate to roughly the center of their range. Move the joystick. The servos should move in response. If they don't, turn off the power and re-inspect your work.

Once you have the servos moving, try making a recording. Switch S3 to

record and press the joystick trigger button. The first LED will light. Move the joystick around. When you are done, press the thumb button on the joystick. If the LOOP/ONE-SHOT switch (S2) is set to loop, playback will begin immediately. If it's in the one-shot position, you'll have to press the joystick trigger to start playback.

Once you've recorded a sequence, it will remain in memory until you record over it. If you want a sequence to begin playing when you first turn on the unit, set the record/playback switch (S3) to playback before switching the power on. If the unit is in one-shot mode, the recording will play once, then stop. If it's in loop mode, playback will begin immediately and continue until you switch the unit off or change the mode to record.

When using the Motion Memory, don't forget that you can attach more than one servo to an output channel. The channel-sharing servos will move in perfect synchronization. You can also connect other switches (mechanical or electronic) to the joystick port to trigger the motions. For example, say you want a motion to play whenever someone presses a button. Wire a normally open, momentary-contact button between pins 4 and 2 of a male DB-15 connector. Plug that into the joystick port. Put S2 and S3 of the Motion Memory into one-shot and playback, respectively, and turn it on. The motion sequence will play through once, then wait for a push of the button.

Finally, if you need to drive more than two servos for your application, build additional Motion Memory circuits. Connect their ground and joystick button inputs together (pins 2, 4, and 7 of the DB-15). Pressing any of the joystick triggers will start all of the units recording or playing back, depending on how the mode switches (S2 and S3) are set.

Now that you can animate almost anything that moves, what should you do first? Here are some ideas: At Halloween, a pumpkin with rolling eyes would be a real scream. At Christmas, show your spirit by making toy-building elves that hammer and saw. Make a home-video version of Jurassic Park with model dinosaurs. Animate your model train layout. Use your imagination and have fun! ■

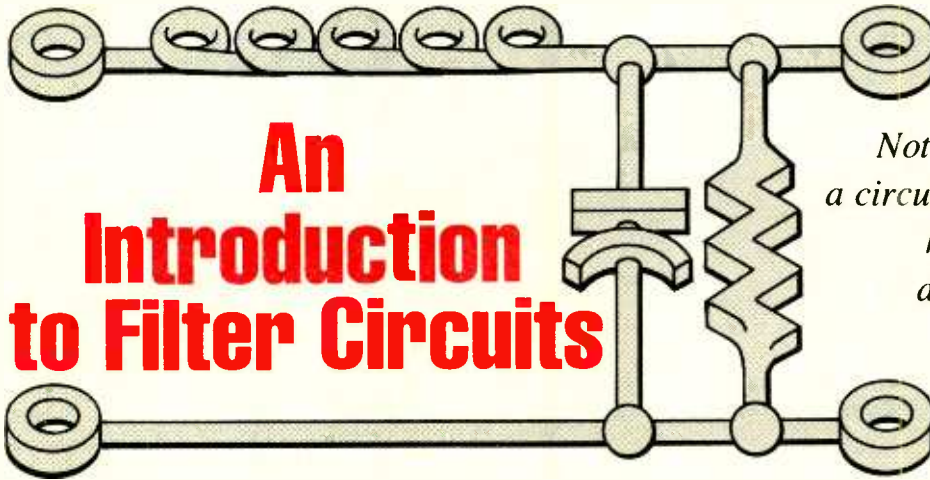

# An Introduction to Filter Circuits

*Not every signal that enters a circuit is welcome, but if you know the secrets of filter design, you can eject the offending signal*

**A** filter is a frequency-selective electronic network that alters the amplitude and/or phase of a signal. Filters are most often used in electronic systems to emphasize a signal or group of signals within a specific frequency range, while rejecting frequencies that fall outside of that range. In this article we'll look at some simple filter-circuit basics. Note that much of our discussion will be based on information taken from National Semiconductor's Switched-Capacitor Handbook, although all the circuits will be based on resistors, capacitors, and inductors.

We'll start our discussion by referring to Fig. 1. Let's say that a desired signal, which we'll call  $f_1$ , has been contaminated by an unwanted signal, which in this example we'll refer to as  $f_2$ . If the contaminated signal— $f_1 + f_2$ —is passed through a filter network that has a high gain at  $f_1$ , but a very low gain at  $f_2$ , the undesirable signal will be output at levels so low as to be effectively removed from the output, while the desired frequency is retained.

Note, that we have not specified the signal gain at any frequency other than  $f_1$  and  $f_2$ . In our example, as long

as  $f_2$  is sufficiently attenuated compared to  $f_1$ , the performance of the filter is considered effective. However, a filter's affect on complex signals (consisting of more than one frequency) may be specified at various frequencies.

In filter design, we are most often concerned with a filter's affect on continuous sinewaves, especially the gain delivered to signals of various frequencies. Knowing the filter's gain at different frequencies allows you to determine how well the filter will perform in a given application. Because of that, plots of gain versus frequency or phase versus frequency are commonly used to illustrate filter characteristics. The most widely used filter illustrations are based on frequency, and are described mathematically by the filter's transfer function—an equation that specifies a filter's output-to-input signal ratio at any frequency.

The comparison of a filter's gain to frequency is referred to as the filter's amplitude response. In audio applications, the same comparison is often referred to as frequency response. Similarly, the phase response of the filter gives the amount of phase

shift introduced to a signal with respect to frequency. Since the phase change in a signal also represents a

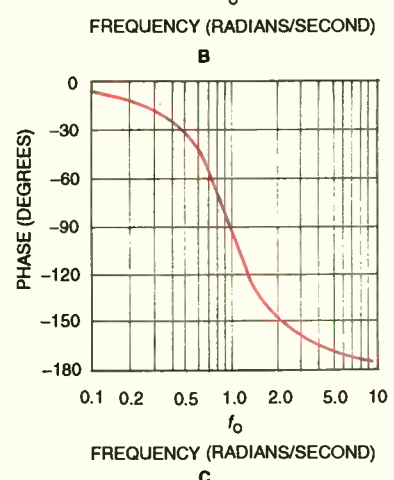
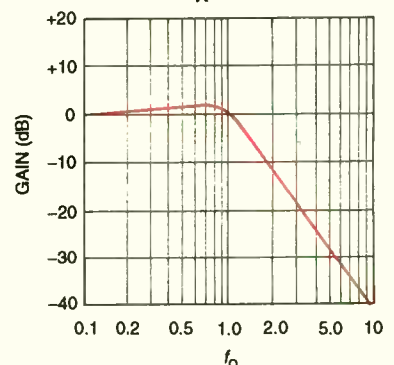
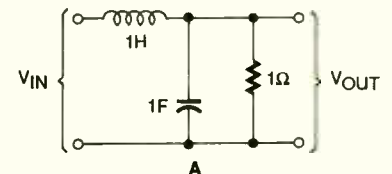

Fig. 2. A low-pass filter (like that shown in A) is designed to pass signals that are below a certain (cut-off) frequency, while rejecting those that are above that value. The gain-versus-frequency (B) and phase-versus-frequency (C) response curves show that.

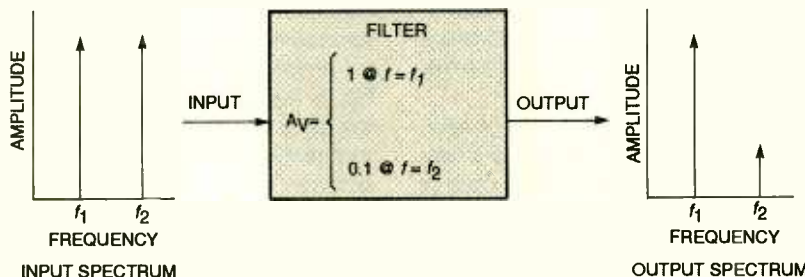

Fig. 1. Filters are most often used to emphasize a signal or group of signals within a specific frequency range, while rejecting frequencies that fall outside of that range as illustrated here.

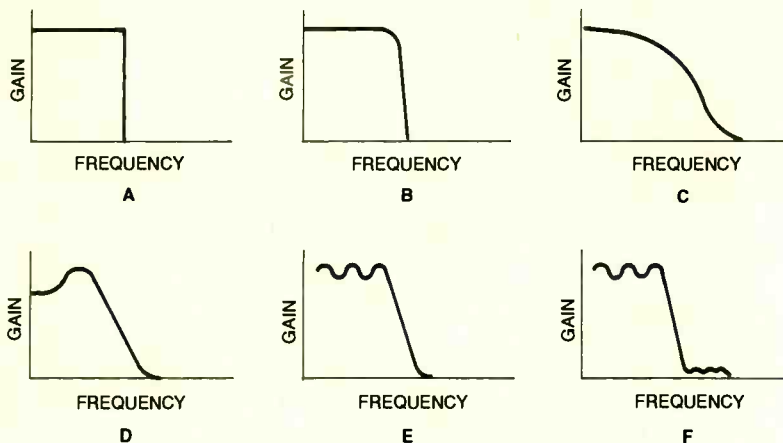

Fig. 3. The curve in A represents the ideal low-pass response; however that response is nearly impossible to achieve, but it can be approximated to varying degrees, as illustrated in B through F.

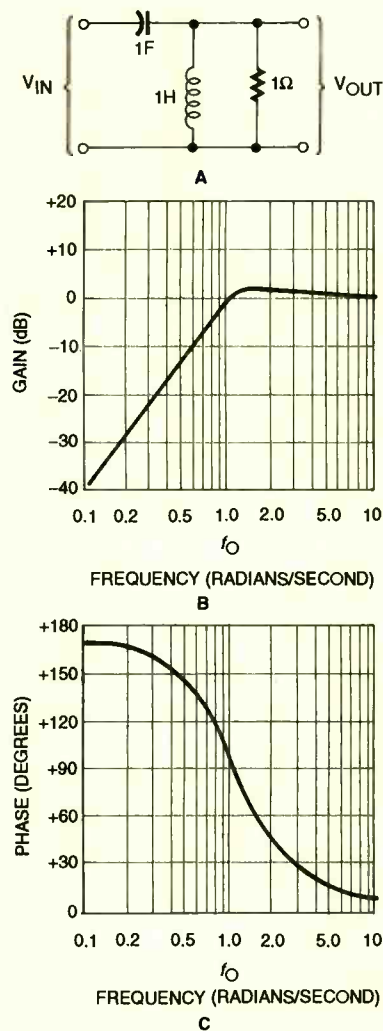

Fig. 4. The high-pass filter (functionally the inverse of the low-pass filter) is designed to pass signals above a certain frequency, while rejecting those that fall short of its design parameters (see A). Note that the amplitude response (A) of the high-pass filter mirrors that of the low-pass filter, while the phase-response curve (B) is identical.

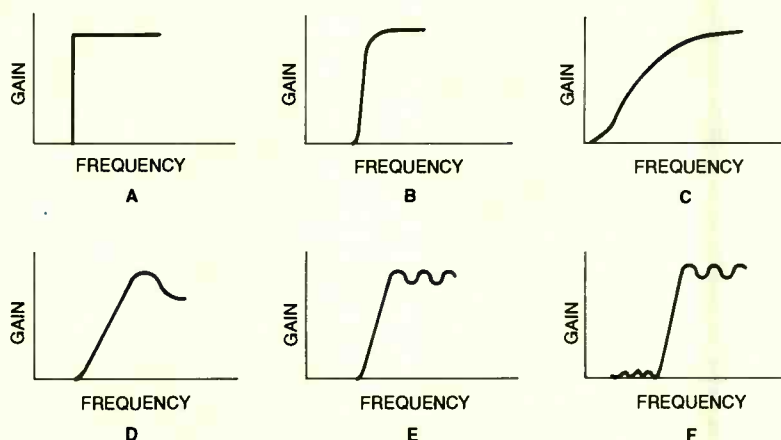

Fig. 5. Other examples of high-pass filter responses are shown here. The ideal response is shown in A with various approximations shown in B through F.

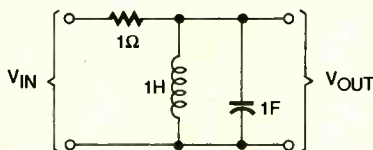

Fig. 6. Band-pass filters are designed to pass signals within a selected frequency band, while attenuating all others as much as possible.

change in time, the phase characteristics of a filter are especially important when dealing with complex signals where the time relationships between different frequencies are critical.

There are five basic types of filter: low-pass, high-pass, band-pass, notch or band-reject, and all-pass or phase-shift filters. Let's look at these next.

**Low-Pass Filters.** The low-pass filter, as might be expected, is designed to pass signals that are below a certain

(cutoff) frequency, while attenuating those that are above it. Figure 2A shows an example of a low-pass filter, while its gain- and phase-response curves are shown in Figs. 2B and 2C. Note from the plot in Fig. 2B that the gain of the input signal drops off as the frequency goes up. That means that low-pass filters can be used where high-frequencies must be removed from a signal.

For example, one application for a low-pass filter might be in a light-sensing instrument that uses a photodiode, where light levels are low and the output of the photodiode is very small, allowing its output to be partially obscured by noise gener-

ated by the sensor and/or its amplifier (the spectrum of which can extend to very high frequencies). If a low-pass filter is placed at the output of the amplifier, and provided its cutoff is abrupt enough to allow only the desired signal frequencies to pass, the overall noise level can be reduced, allowing the desired signal to be extracted from the input.

The number of possible response curves for the low-pass filter are infinite, but they all share the same basic form; several examples of low-pass filter amplitude response are shown in Fig. 3. The curve in Fig. 3A represents the ideal low-pass response; however that response is nearly impossible to achieve, but it can be approximated to varying degrees.

**High-Pass Filters.** The high-pass filter (functionally the inverse of the low-pass filter) is designed to pass signals above a certain frequency, while re-

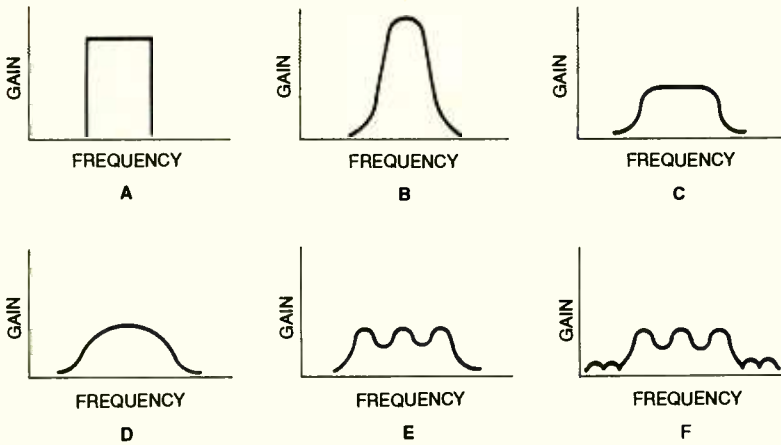

Fig. 7. The number of possible response curves for a band-pass filter is infinite, but they all share the same basic form; several examples of band-pass amplitude-response curves are shown here.

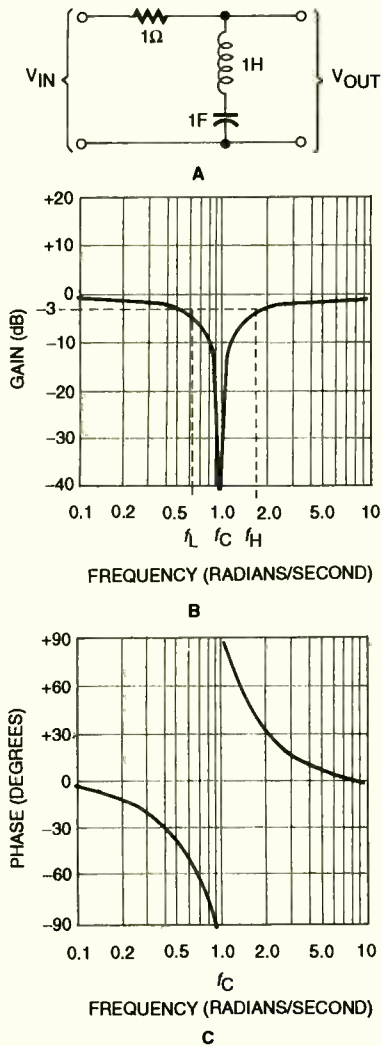

Fig. 8. An example of the band-reject or notch filter is shown in A, while its gain-verses-frequency and phase-verses-frequency curves are shown in B and C, respectively.

jecting those that fall short of its design parameters. Such a filter is shown

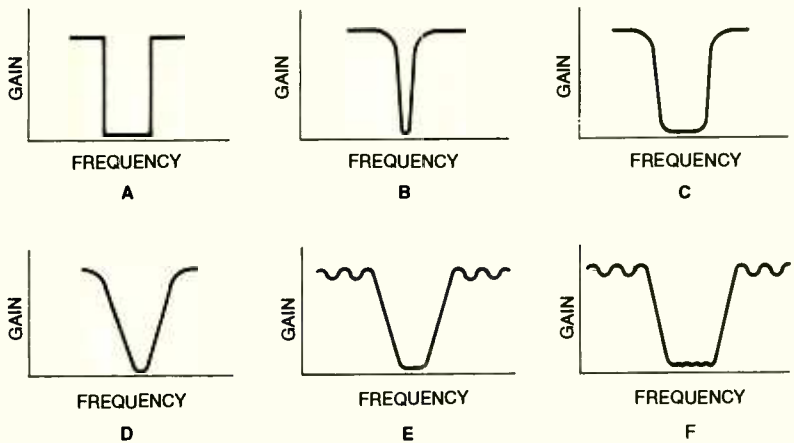

Fig. 9. As with other filter networks, the number of notch-filter amplitude-response curves are infinite; several possible amplitude-response curves for the notch filter are shown here.

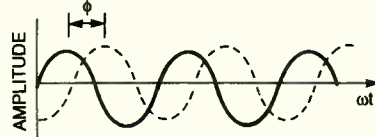

Fig. 10. The phase relationship of the input (represented by a solid plot) to output signal (shown as a dashed curve) of a phase-shift filter is illustrated here. Note that the two sinusoidal waveforms are identical except that their peaks and valleys occur at different times, indicating that the output signal has undergone a delay or a phase shift relative to the input signal.

in Fig. 4A. The amplitude- and phase-response curves for the high-pass filter are shown in Figs. 4B and 4C, respectively. Note that the amplitude response of the high-pass filter (Fig. 4B) mirrors that of the low-pass filter, while their phase-response curves are identical.

As with the low-pass filter, the number of possible response curves

are infinite; several examples of high-pass amplitude-response curves are shown in Fig. 5. The ideal response is shown in Fig. 5A and various approximations shown in Figs. 5B through 5F. Like the ideal response of the low-pass filter, that response can be approximated to varying degrees by real filters, but is next to impossible to achieve in practice.

High-pass filters are used in applications requiring the rejection of low-frequency signals; for instance, in high-fidelity loudspeaker systems. Consider that music contains significant energy in the low-frequency (100-Hz to 2-kHz) range and high-frequency drivers (tweeters) can be

damaged if a low-frequency audio signal of sufficient power is applied to them. Placing a high-pass filter between the wideband audio source and the tweeter prevents low-frequency signals from reaching and possibly damaging the tweeter. When high-pass and low-pass filters (and possibly other filter classes) are used in combination, they are referred to as crossover networks.

**Band-Pass Filters.** The schematic diagram of the basic band-pass filter is shown in Fig. 6. The circuit in Fig. 6 is designed to pass a signal at the "center frequency," while attenuating signal frequencies above and below the center frequency. Such a filter could be used to reject unwanted signals at frequencies that lie outside of the "pass band," so it could be used where the frequency of interest must be extracted from a signal that has

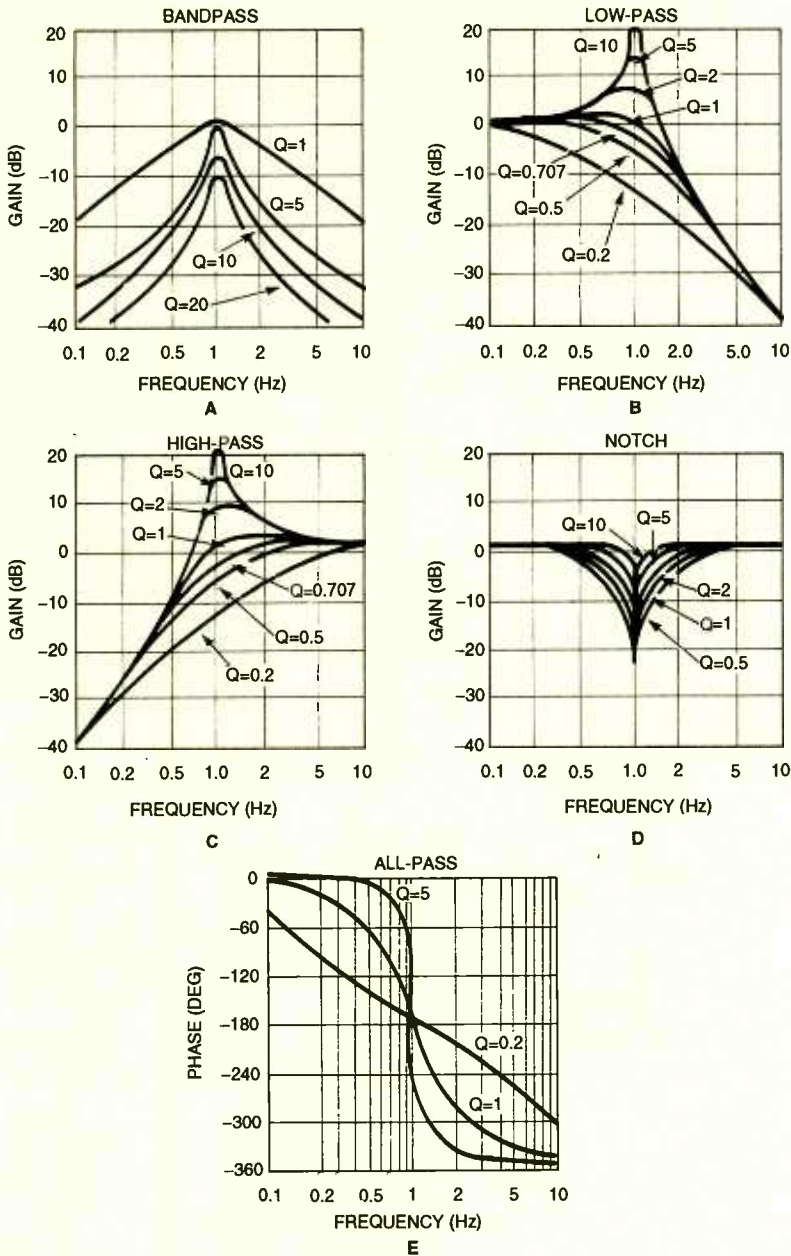

Fig. 11. The  $Q$  of a filter, which determines the shape of the amplitude response, is useful in describing its behavior. Shown here the response curves for second-order band-pass (A), low-pass (B), high-pass (C), notch (D), and all-pass (E) filters with various values of  $Q$ .

been contaminated by a number of different frequencies.

The number of possible response curves for such a filter is infinite, but they all share the same basic form; several examples of band-pass amplitude-response curves are shown in Fig. 7. The curve in Fig. 7A represents the ideal band-pass response—showing absolutely constant gain within the pass-band region, with zero gain outside of the pass band, and abrupt boundaries between them. That response characteristic is next to

impossible to achieve in practice, but it can be approximated to varying degrees by real filters.

The curves in Figs. 7B through 7F are examples of a few amplitude-response curves that approximate the ideal curve with varying degrees of accuracy. Note that while some curves are very smooth, others have ripple in their pass bands, while others have ripple in their stop bands as well. The stop band is the range of frequencies over which unwanted signals are attenuated.

Band-pass filters have two stop bands: one above and one below the pass band. The frequency at which the stop band begins is usually defined by the requirements of a given system—for example, a system specification might require that the signal be attenuated at least 35 dB at 1.5 kHz. That would define the beginning of a stop band at 1.5 kHz.

**Notch or Band-Reject Filters.** The band-reject or notch filter is effectively the opposite of the band-pass filter. An example of a band-reject or notch filter is shown in Fig. 8A, while its gain- and phase-response curves are shown in Figs. 8B and 8C, respectively. As can be seen from the curves, the quantities  $f_c$ ,  $f_L$ , and  $f_H$  that were used to describe the behavior of the band-pass filter are also appropriate for the notch filter. As with other filter networks, the number of notch-filter amplitude-response curves are infinite; several possible amplitude-response curves for the notch filter are shown in Fig. 9.

Notch filters are used to remove an unwanted frequency or band of frequencies from a signal, while affecting all other frequencies as little as possible. One possible application for the notch filter is to clean-up an audio source that has been contaminated by 60-Hz power-line hum. In such instances, a notch filter with a center frequency of 60 Hz would be used to remove the hum without significantly affecting the desired audio signal.

### All-Pass or Phase-Shift Filters.

Ideally, all-pass or phase-shift filters have no effect on the amplitude of a signal of any frequency; instead, such filters are designed to alter (shift) the phase of the signal. The effect of an all-pass filter is shown in Fig. 10. Note that in the illustration there are two sinusoidal waveforms; one shown as a solid curve (representing the input signal) and the other dashed (representing the output signal). The two curves are identical except that their peaks and valleys occur at different times—i.e., the output signal has undergone a delay or a phase shift relative to the input signal.

One application of all-pass filters is to introduce phase shifts into signals in order to cancel or partially cancel

(Continued on page 92)

# ANTIQUE RADIO

By Marc Ellis

## NBS Post Scripts

Last month's column saw the completion and testing of the NBS crystal-set project. For those who may not have read the earlier columns, this receiver was designed by the National Bureau of Standards in the early 1920's. Planned so that almost every one of its components could be built from scratch with a few simple hand tools, the radio was intended to be a starter project for budding electronics enthusiasts.

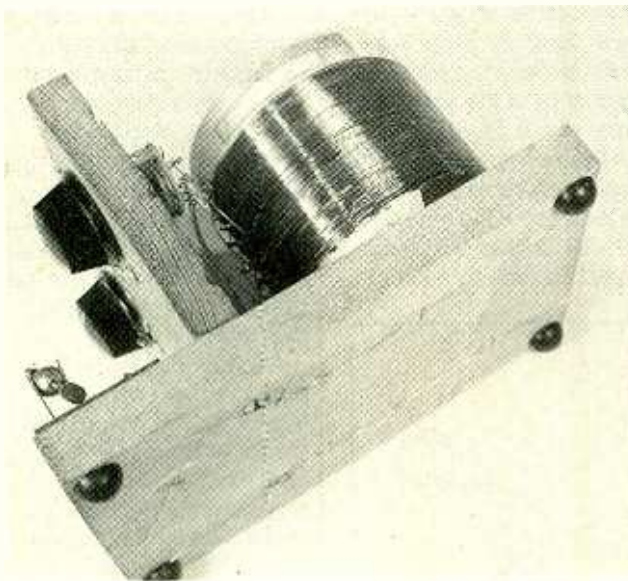

Here's a farewell, and never-before-seen, view of the NBS set featuring the underside of the base. The nail-in rubber bumpers provide clearance for wiring.

### A BLAST FROM THE PAST!

As the readers who have been following this series know, I didn't *entirely* follow in the footsteps of those 1920's builders, choosing to use modern rotary switches and a reproduction crystal holder instead of building my own. Even so, as I put this little receiver together, I felt more than an echo of the romance and excite-

ment that the early constructors must have experienced.

I don't exactly understand why that should have been. The performance of a simple 1920's crystal set, even when connected to a good outside antenna, couldn't be anything but pathetic compared with the cheapest modern pocket transistor. Yet I was able to enter the mindset of those early radio experimenters without even trying.

As I wound magnet wire on the Quaker Oats canister and screwed Fahnestock clips to the wooden baseboard, I found myself speculating about the faint, faraway signals that would flow through my creation. The results were exciting. Though I could only hear a few local broadcasts, it was easy to imagine how the 1920's constructors must have felt as they pulled in signals for the very first time.

As reported last month, I was able to tune in stations (broadcasting on about 800, 1160, and 1600 kHz) on just the bottom three of the six "coarse tuning" tap positions (right-hand knob). The top three taps brought in only a jumble of weak signals. The stations that did come in could be fine-tuned nicely using the "vernier" (left-hand) knob.

### PERFORMANCE POST MORTEM

From my point of view, the NBS crystal-set project worked out quite well. I was able to experience some of the satisfaction the early set builders must have felt as they crafted working radios

from crude household materials. The finished radio is quite charming in an ungainly sort of way and looks like an authentic period piece. Operating the set offers a taste of the excitement and the frustrations connected with DX'ing the broadcast band some 70 years ago.

A number of theories could be advanced to explain why the receiver doesn't tune on all the coil taps. The most obvious one relates to the difference in insulation thickness between the double-cotton-covered wire (now very difficult to obtain) specified in the original construction article and the enamel-covered wire actually used.

I think I have that one covered because, enamel-covered wire being thinner, I used a slightly larger gauge than the one originally specified. As things turned out, the length of the completed coil (one of the key factors in determining inductance) was very close to specification.

A more plausible theory concerns differences in antenna systems. A resonant circuit without its own tuning capacitor would have to be quite sensitive to the inherent capacitance of the antenna to which it is connected. Because of antenna differences, some readers might get better results than others.

Another possibility that can't be ruled out is faulty set design. The introduction to the original construction article stated that this was a "... re-creation of the famous Bureau of Standards receiver, brought up to

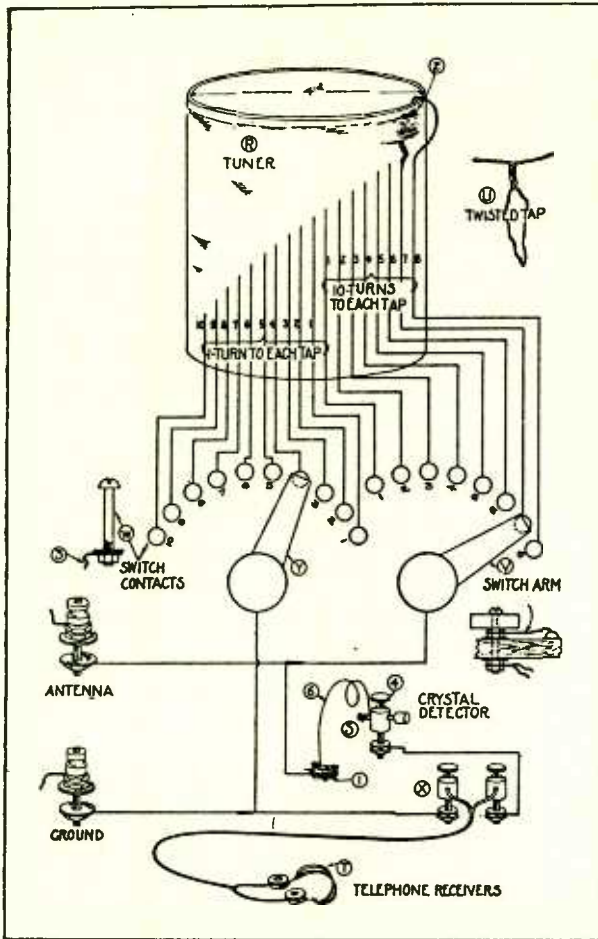

Semi-schematic view of the earlier NBS set that Jim Cihler called to our attention (see text).

date with a suitable wavelength range." However, it's not clear who modified the circuit: the NBS or the author. Perhaps something was lost in the translation.

### AN EARLIER NBS DESIGN

Following up on the point just made, I recently received a letter from Jim Cihler (Fair Oaks, CA) with a copy of a crystal-set construction article from *Radio For Everybody* by Austin C. Lescarbourea (Scientific American Publishing Company, 1922). That one, Jim pointed out, uses a 4-inch diameter coil form—which is the same size as a Quaker Oats canister (at least in the smaller product size). Readers who have been following this series will recall that the design I

be described has been designed by the Bureau of Standards at the request of the States Relations Service of the United States Department of Agriculture, for the use of boys and girls radio clubs." Since Jim's book was published a couple of years prior to the publication in which my set appeared, I have to assume that the design shown in the book is closer to the one that my author "brought up to date with suitable wavelength range."

The set in Jim's article is said to have a range of 500 to 1500 kHz. That comprises most of the broadcast band we have today, and it might be interesting to try the design and see if it tunes better than the version I built. I'm including the schematic and physical drawings of the set for anyone who is interested.

The wire specified for the coil is the same as that specified for the set I built: No. 24 double cotton covered. So an enamel-

every 10th turn thereafter until you have wound on 70 turns. Then wind on 10 additional single turns placing a tap after each. The top eight taps, connected to the right-hand switch in the schematic diagram and physical drawings, are used for coarse tuning; the bottom 10 (left-hand switch) are used for vernier tuning.

### CRYSTAL SET COMMENTS

Reader James Collins (Redmond, WA) calls our attention to a good-looking crystal radio-construction project published in **Popular Electronics** back in October, 1989. It was written by Stanley A. Czarnik. James is also interested in building the NBS set, but can't locate a "Quaker Quick Grits" canister. Those who have that problem should look for a Quaker Oats cornmeal product that also comes in a 3½-inch canister. Or they might like to try the design just sent in by Jim Cihler, which can be built on a normal Quaker Oats container.

As a boy during the Depression, Lloyd F. Thomas (Oxnard, CA) was responsible for keeping the family coal bin filled. Noticing crystals in some of the lumps, he found a way to mount them and discovered that they worked quite well as radio detectors.

Durrell R. Roth of Antique Audio (5555 N. Lamar Blvd, Suite H-105, Austin, TX 78751), a company that specializes in parts and supplies for crystal-set builders, was kind enough to pass along a copy of the instruction manual for the Quaker Oats premium crystal set discussed earlier in this series. The set is very similar to the one we built, except that it uses a slider instead of tap switches. It's

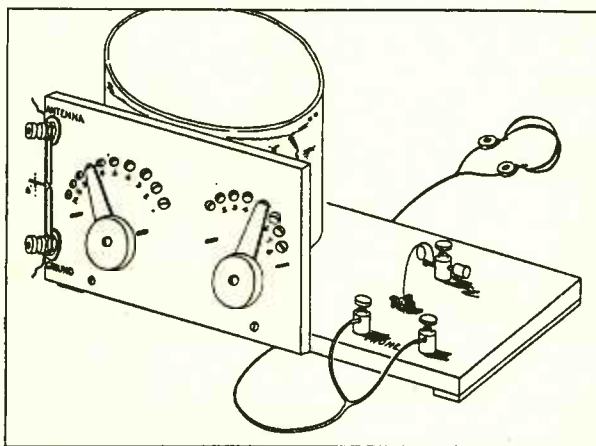

The physical layout of the earlier NBS set. The headphone jacks and the crystal are placed off to the side, rather than in front of the panel as in the version that we built.

used specified a 3½-inch form—so I had to settle for the even smaller Quaker Quick Grits canister.

In perusing the introduction to the article Jim sent, I was startled to read the following: "The set about to

covered wire close to the size I used (No. 22) should be appropriate. Construction of the coil is similar, except for the number and location of the taps.

Bring out a tap at the top of the winding and after



interesting to note, given my previous antenna comments, that the manual advises: "your aerial may have too much or too little wire ... Excess wire in aerial causes broadness in tuning."

Craig Fiedler (22253 Pheasant Court, Hutchinson, MN 55350)—at least as of last December when his letter was received—has a home-built vintage crystal set for sale. It includes a coil with several taps and a couple of sliders as well as some circa-1914 Western Electric phones. Include a self-addressed, stamped envelope with your inquiry.

John Beal (Lompoc, CA) remembers building his first crystal set in the early 1930's. He'd like to pass along a hint for winding spaced (as opposed to close-wound) coils. Just select some monofilament fishing line of the appropriate diameter to give the desired spacing and wind it side-by-side with the coil wire. Secure the wire and plastic line in place with some Duco cement.

### POTENT PUBLICATIONS

Several months ago, I received the latest edition of Don Diers' (4276 North 50th St., Milwaukee, WI 53216-1313) electronics catalog. Don's newest collection of surplus and close-out goods includes many hard-to-find items of interest to the antique-radio hobbyist, and he writes them up in a chatty style that's all his own. The entertainment value is well worth the \$3.00 cost (\$5.00 to overseas locations), and the catalog includes a \$1.00 rebate coupon on your first order.

Need a BC348 with the original dynamotor? A command set radio system for a Flying fortress? How about a complete field-

telephone switchboard? No problem! Just check with "The Signal Corps" (3583 Everett Rd., Richfield, OH 44286), a company specializing in military-communications equipment of the World War II era.

The Signal Corps' catalog is another publication that's worth its price (\$2.00 U.S./Canada; \$5.00 foreign) for browsing value alone. Sam Hevener, the proprietor, is a long-time ham and served for three years in the Army Signal Corps. He began seriously collecting military-communications gear in the mid-1980's, turning the hobby into a part-time business in 1991. The response since then has been quite encouraging, and if you need something in World War II communications gear, Sam is looking forward to helping you find it!

Finally, how about a good word for my own monthly periodical *The Radio Collector*. It's an eight-page, newsletter-style publication dedicated to providing basic information for the beginning antique-radio hobbyist. Publication began last January, and the magazine includes a front-page feature article as well as monthly columns presenting reviews of vintage books and publications, histories of classic companies, radio-repair lore, and reader questions and answers. Classified ads are free to subscribers.

Interested? Yearly subscriptions are \$20.00 in the U.S., \$21.50 (U.S. Funds) in Canada, and \$35.00 (U.S. funds) in other countries. Send your check to *The Radio Collector*, P.O. Box 1306, Evanston, IL 60204-1306. Your money will be refunded in full if you are not satisfied with the first issue. ■

## Be a computer repair expert!

CAREER-LEVEL HOME STUDY



Learn PC repairs, troubleshooting, servicing, upgrading, installation. Increase your value as an employee or open your own business.

No expensive instruments, no high-tech electronics. Over 90% of PC repairs and service involve easy mechanical procedures or parts replacements. Send or call for free literature.

# 800-223-4542

Name \_\_\_\_\_ Age \_\_\_\_\_  
Address \_\_\_\_\_ Phone ( ) \_\_\_\_\_  
City \_\_\_\_\_ State \_\_\_\_\_ Zip \_\_\_\_\_

### The School of PC Repair

6065 Roswell Road  
Dept. JJJ341, Atlanta, Georgia 30328

CIRCLE 159 ON FREE INFORMATION CARD

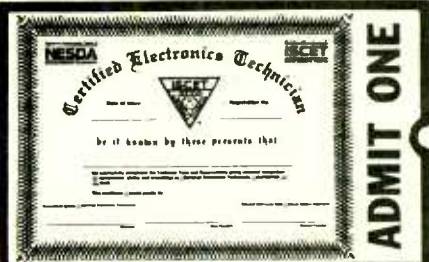

## Your Ticket To

# SUCCESS

Over 28,000 technicians have gained admittance worldwide as certified professionals. Let your ticket start opening doors for you.

ISCT offers Journeyman certification in Consumer Electronics, Industrial, Medical, Communications, Radar, Computer and Video. For more information, contact the International Society of Certified Electronics Technicians, 2708 West Berry Street, Fort Worth, TX 76109; (817) 921-9101.

Name \_\_\_\_\_  
Address \_\_\_\_\_  
City \_\_\_\_\_  
State \_\_\_\_\_ Zip \_\_\_\_\_

Send material about ISCT and becoming certified.

Send one "Study Guide for the Associate Level CET Test." Enclosed is \$10 (inc. postage).

# COMPUTER BITS

By Jeff Holtzman

## Odds And Ends

This month, I have numerous product cameos to provide. Rest assured that I've used everything discussed here, and that I heartily and enthusiastically recommend each. This is my personal "best of" list. The selection includes DOS programs, Windows programs, and some books.

### DOS DIRECTORY LISTER

*Pocket D* is an incredibly powerful shareware tool for DOS command-line jockeys. You can use *Pocket D* as a fancy directory lister, with color coding and numerous sort options. You can also use it as a powerful file management tool, for copying, deleting, and

incredible things with the program. Look no further.

### PERSONAL FINANCE SOFTWARE

After years of using the DOS-based *Managing Your Money*, I got fed up with MECA's snide attitude and switched to *Quicken for Windows* from Intuit Inc. I've never looked back. This program has quite simply the best user interface of any PC product I have ever used. Nearly every conceivable thing has been done that could be done to make things easier on the user. The only functional capability that I find lacking is the budgeting module. I'd like to see a full-fledged spreadsheet with symbolic access to quantities like total amount spent on groceries last year. Failing that, full-blown DDE links to Excel would suffice.

### WINDOWS PROGRAM LAUNCHER

*DashBoard* from Hewlett-Packard's PC Software Division is an inexpensive yet powerful Windows front end. It can do stand-in duty for both Program Manager and Task Manager. *DashBoard* allows you to put your most frequently used programs on a button bar; it also provides all sorts of ways to customize operation to your taste. In addition, it includes a DOS-like command-line processor that allows you to launch Windows and DOS programs, copy and delete files, get directory listings, etc. *DashBoard* is no match for powerhouses like Norton Desktop for Windows or PC Tools, but it's fast in, fast out,

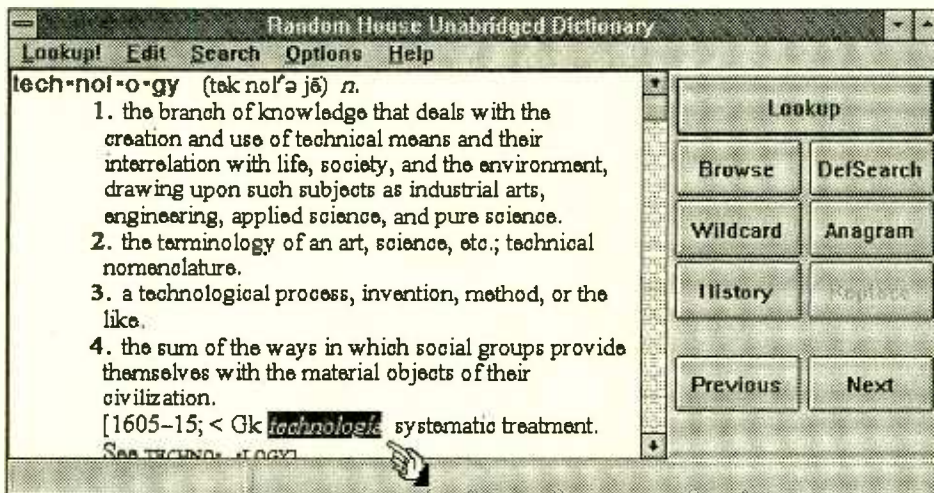

The *Random House Unabridged Dictionary* has several useful lookup modes. At under \$80, it's a bargain.

### DOS COMMAND LINE PROCESSOR

Microsoft has improved COMMAND.COM with versions 5 and later of DOS. But COMMAND is still no match for the shareware program *4DOS*, which provides a vastly expanded command set, a much more powerful batch language, compiled batch files (compiler included), on-line help, and much more. If you find window-based file managers cumbersome, you'll love *4DOS*. Versions are available for DOS, OS/2, and Windows NT. The DOS version runs fine under Window 3.x, as well as DOS sessions under OS/2.

finding files. The author is Jeff Rollason, of PocketWare. Contact him on CompuServe at 100031,3537. *Pocket D* is available through most BBS's. I'll post a copy on the Gernsback BBS (516-293-2283).

### DOS TEXT EDITOR

The *SemWare Editor* (TSE) from SemWare Corporation is it. As detailed here in the past, TSE provides a powerful text-processing engine, along with a simple means of customizing the user interface (menus and keystrokes), and an elegant Pascal-like macro language that lets you do

economical on disk space, and gets the job done.

## WINDOWS PRINT UTILITY

*ClickBook*, from Bookmaker Corporation, installs as a Windows printer driver. When you print to it from any application, it will reformat output to fit miniature pages just right for address books, day planners, flyers, program notes, and so on. *ClickBook* is simple to operate, yet offers a wealth of options. It can print on both sides of a page; it even prints a page in the middle

## VENDOR INFORMATION

**4DOS 5.0**  
JP Software  
P.O. Box 1470  
East Arlington, MA 02174  
800-368-8777  
617-646-3975

**The SemWare Editor**  
SemWare Corporation  
4343 Shallowford Road  
Suite C3A  
Marietta, GA 30062-5022  
404-641-9002

**Quicken for Windows**  
Intuit Inc.  
P.O. Box 3014  
Menlo Park, CA 94026  
800-624-8742  
415-858-6095

**DashBoard**  
Hewlett-Packard Co.  
PC Software Division  
974 E. Arques Avenue  
Sunnyvale, CA 94086  
800-752-0900

**ClickBook**  
Bookmaker Corporation  
625 Emerson Street  
Suite 100  
Palo Alto, CA 94501  
800-766-8531

**Random House Unabridged Dictionary**  
Random House Reference  
and Electronic Publishing  
201 East 50th Street, Third  
Floor  
New York, NY 10022-7703

**Paint Shop Pro**  
JASC, Inc.  
10901 Red Circle Drive  
Suite 430  
Minnetonka, MN 55343  
612-930-9171

of the print run showing you how to reload the stack to get the other side printed with the right orientation. *ClickBook* will print on small page sizes, or on large page sizes, where it will provide cut lines. An Xacto knife, a straight edge, and a stapler are all it takes.

## FULL FEATURED DICTIONARY

Random House Reference and Electronic Publishing has published the *Random House Unabridged Dictionary* on CD-ROM. A single disc contains the entire dictionary, plus access software for DOS, Windows, and Macintosh. This is the best, reasonably priced dictionary available in digital form; it lists for less than \$80. The Oxford English Dictionary is also available on disc, but costs ten times as much, and is more suited for language scholars. I'd prefer the American Heritage dictionary, but in the meantime, the RHUD is a good compromise. It has terms like Ethernet—but not Token Ring. The definitions contain some etymological background, which I love. The program provides some extra features, including a nicely designed browse mode.

## WINDOWS IMAGE PROCESSOR

If you deal at all with bitmap images, you know that there is a plethora of file formats out there. The Shareware program *Paint Shop Pro* (from JASC, Inc.) costs only about \$50, but it provides most of the functions of much more expensive programs. PSP can convert files among different bitmap formats, as well as convert color images to gray scale, apply various filters, reduce color depth, and lots more. Most

of the screen shots you see printed in this column are captured, processed, and printed by PSP.

## BOOKS

A while back, I asked for suggestions on a short, sweet introductory book on database design. One of the better responses came from Windcrest/McGraw-Hill books with *The Relational Database Advisor*, by Kimberly Maughan Saunders. Subtitled *Elements of PC Database Design*, the book strikes a reasonable balance between technical detail and density of prose. If you need to create relational databases, but doing so is not your main line of work, you'll find this book useful.

*The Computer Dictionary*, Second Edition by Microsoft Press is easily the best of its type on the market. It has

more terms, and more detailed definitions, than any comparable work. It also has many illustrations.

Hypertext and Hypermedia (Academic Press Professional), by Jakob Nielsen, provides an excellent introduction to what's going on in that rapidly changing field. The extensive, annotated bibliography gives you plenty of trails to start pursuing topics of interest in depth.

Sequoia Publishing's *Pocket PC Ref* compresses tons of useful tabular data into a very small book. You'll find printer codes (but no PostScript), DOS and BASIC commands, hard-disk specifications, and quite a bit more. I'd like to see network information (maximum segment length, nodes per segment, etc.) included in the next release. ■

**The professional weather station for people curious about the weather.**



Haven't you always wanted a weather station? The Weather Monitor II makes a state-of-the-art weather monitoring system affordable enough for home use!

**FEATURES INCLUDE:**

- Inside & Outside Temps
- Wind Speed & Direction
- Barometer
- Time & Date
- Inside Humidity
- Wind Chill
- Alarms
- Highs & Lows
- Rainfall Option
- Instant Metric Conversions
- Outside Hum. & Dew Point Option
- Optional PC Interface

Order today:  
**1-800-678-3669**

M-F 7 a.m. to 5:30 p.m. Pacific Time • PE644E  
FAX 1-510-670-0589 • M/C and VISA  
One-year warranty • 30-day money-back guarantee

**DAVIS INSTRUMENTS**  
3465 Diablo Ave., Hayward, CA 94545

CIRCLE 162 ON FREE INFORMATION CARD

# CIRCUIT CIRCUS

By Charles D. Rakes

## Inductive Transmitters

If you're an avid experimenter, stay tuned; this Circus visit is especially aimed your way. Even if you're not in the building mood right now, take a look at the following inductive-transmission circuits. You just might want to try one in a future project.

It's possible to transmit audio by "inductive coupling" (without an FCC license or permit). The method is certainly not a new one, but it is an interesting and useful way to move audio signals through the air without involving an RF transmitter or receiver. Just about any audio frequency between 100

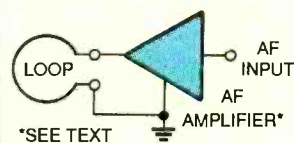

Fig. 1. An inductive transmitter consists of an audio-frequency power amplifier and a coupling inductor or loop.

Hz and 15 kHz can be used. In fact, digital information on an audio carrier may also be transmitted via the inductive method.

The block diagram in Fig. 1 shows an audio amplifier with the output connected to a loop. The loop, in this case, is a single turn of wire routed around the inside of a large room or an entire building. The audio amplifier can be just about any device that can supply a low-impedance, medium- to high-power audio signal to the loop.

All that's needed to receive the audio signal is a pick-up loop, an audio amplifier, and a pair of

headphones. In fact, when a high-powered audio amplifier is used to drive the transmitter loop, the audio signal can be received in close proximity to the loop with the headphones connected directly to the receiving loop.

### TWO-STAGE RECEIVER

Our first audio-induction receiver circuit is shown in Fig. 2. The transformer action between the transmitter loop and the re-

ceiver loop produces an audio signal that is fed to the base of Q1, a common-emitter audio-amplifier circuit. The amplified audio signal is then passed on to the input of U1, an LM386 audio power amplifier IC, to increase the audio level sufficiently to drive the headphones. A single 9-volt battery supplies power to the receiver circuit.

The construction of the receiver's loop isn't too critical and either of the

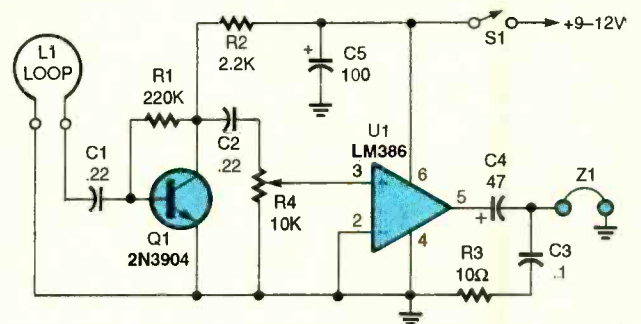

Fig. 2. This two-stage receiver has a discrete transistor preamp and an integrated power amplifier. The included volume control (R4) allows you to adjust for varying coupling conditions.

### PARTS LIST FOR THE TWO-STAGE RECEIVER (Fig. 2)

#### SEMICONDUCTORS

Q1—2N3904 NPN transistor

U1—LM386 audio, power amplifier, integrated circuit

#### CAPACITORS

C1, C2—0.22-µF, ceramic-disc

C3—0.1-µF, ceramic-disc

C4—47-µF, 25-WVDC, electrolytic

C5—100-µF, 25-WVDC, electrolytic

#### RESISTORS

(All fixed resistors are ¼-watt, 5% units unless otherwise indicated.)

R1—220,000-ohm

R2—2200-ohm

R3—10-ohm

R4—10,000-ohm potentiometer

#### ADDITIONAL PARTS AND MATERIALS

S1—SPST toggle switch

Z1—Low-impedance headphones

L1—See text

Perfboard, integrated-circuit socket, solder, wire, etc.

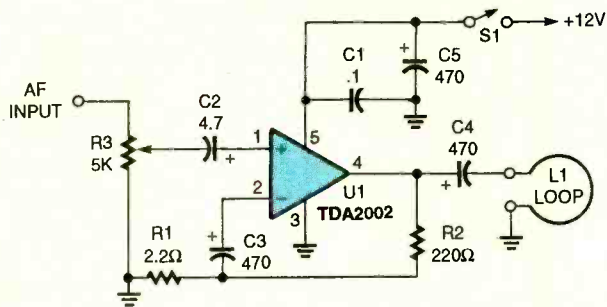

Fig. 3. Based on the TDA2002 power amplifier, this transmitter packs plenty of punch. The amplifier is capable of driving heavy current into the loop.

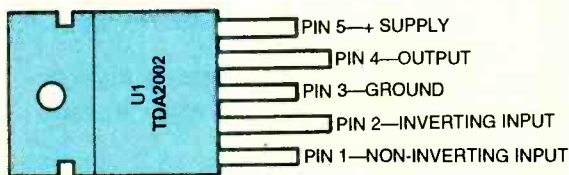

Fig. 4. The TDA2002 comes in a high-power case, ready-made for a heat sink. Be sure to use one and double-check your connections with this diagram before powering the chip up.

following two loops will perform just fine with the circuit: The simplest and most efficient loop may be wound on a ferrite rod removed from an old AM receiver. Usually they are about 1/4 to 1/2-inch in diameter and up to 6 inches in length. Jumble wind about 300 turns of No. 30 wire over the length of the rod and cover with electrical tape. A large loop may be wound on any 6- to 12-inch diameter, non-metallic form, such as wood or plastic. Jumble wind about 100 to 150-ft of No. 30 wire on the form and hold it in place with electrical tape.

Your results can best be improved by experimenting with the design of the transmitter and receiver loops. The basic coverage area is set by the inside area of the transmitter loop. So, the simplest way in which to increase the coverage area is to increase the diameter of the transmitter loop. Increasing the audio power that's fed into the transmitter loop will also increase the coverage area.

### HEAVY-DUTY TRANSMITTER

Our next item (see Fig. 3) is a general-purpose, 8-watt loop-driver/amplifier circuit. The power amplifier can boost the low audio-output levels of small portable radios, cassette players, CD's, and TV's to a level sufficient to drive the inductive transmitting loop.

A TDA2002 8-watt 5-pin T0-220 packaged IC (see Fig. 4) is the heart of the simple power amplifier cir-

cuit. The IC is tough enough to supply full power to low-impedance loads with low output distortion. The IC is also current limiting and thermally protected. It requires only a few external components, although its power source should be capable of supplying currents up to 4 amps on peak output signals.

### REMOTE-CONTROL TRANSMITTER

Inductive coupling can also be used as a medium for remote control. An audio-tone encoder can be

used to drive the transmitter amplifier and a selective frequency decoder can be used at the receiver.

A single-tone encoder/transmitter is shown in Fig. 5. A 567 tone decoder IC (U1) is connected as a single-tone encoder. The tone frequency is determined by the values of C3, R2, and the frequency-control potentiometer, R4, and may be set to any desired frequency between about 500 Hz and 8 kHz.

The encoder's square-wave output is taken from pin 5 of U1 and fed to one side of S2, a normally open, pushbutton switch. When S2

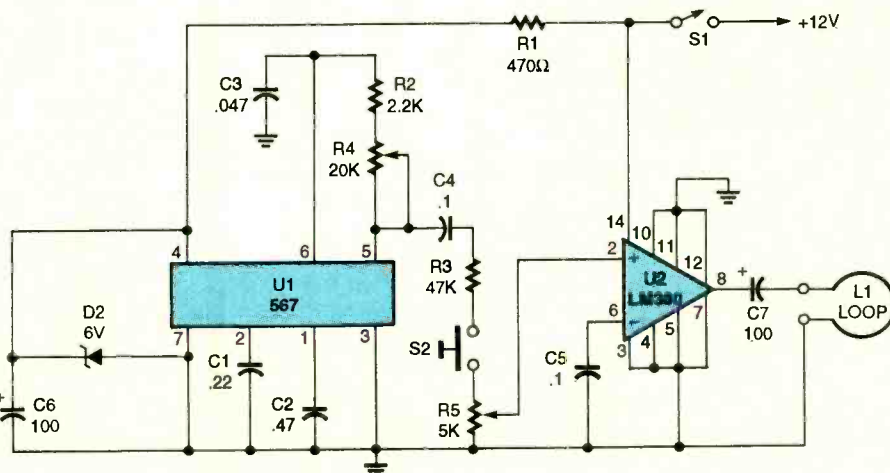

Fig. 5. This transmitter circuit generates a single tone and drives it into a loop for pickup elsewhere. It's ideal as a remote-control transmitter.

### PARTS LIST FOR THE HEAVY-DUTY TRANSMITTER (Fig. 3)

#### CAPACITORS

- C1—0.1- $\mu$ F, ceramic-disc
- C2—4.7- $\mu$ F, 25-WVDC, electrolytic
- C3, C4, C5—470- $\mu$ F, 25-WVDC, electrolytic

#### RESISTORS

(All fixed resistors are 1/4-watt, 5% units unless otherwise indicated.)

- R1—2.2-ohm
- R2—220-ohm
- R3—5000-ohm potentiometer

#### ADDITIONAL PARTS AND MATERIALS

- L1—See text
  - U1—TDA2002 8-watt audio-power amplifier, integrated circuit
  - S1—SPST switch
- Perfboard, solder, wire, etc.

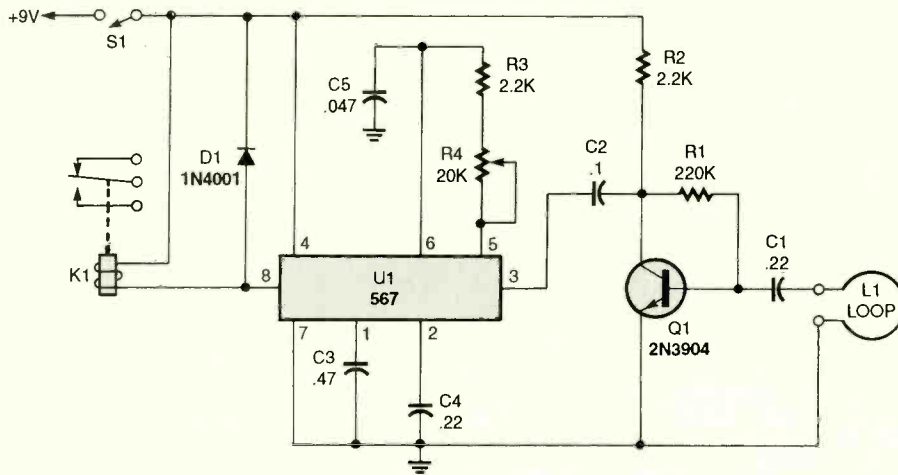

Fig. 6. Acting as an inductive receiver, this circuit has Q1 as a preamp and U1 as a tone decoder. When the appropriate signal is received, K1 is activated.

input (pin 3) of the single-tone PLL decoder IC, U1. The 567 tone decoder should be tuned to the same tone frequency as the transmitter by adjusting R4. A relay is connected to the decoder's output at pin 8 and battery positive so it can activate whatever circuit you have in mind.

When U1 receives the correct audio tone, the IC's output at pin 8 goes low, closing the relay. The relay will remain closed as long as the tone is received.

**A LOW-PASS FILTER**  
To improve the circuits

**PARTS LIST FOR THE REMOTE-CONTROL TRANSMITTER (Fig. 5)**

**SEMICONDUCTORS**

- U1—567 tone decoder, integrated circuit
- U2—LM380 2-watt, audio-power amplifier, integrated circuit
- D1—6-volt Zener diode

**CAPACITORS**

- C1—0.22-µF, mylar or similar
- C2—0.47-µF, mylar or similar
- C3—0.047-µF, mylar or similar
- C4, C5—0.1-µF, ceramic-disc
- C6, C7—100-µF, 25-WVDC, electrolytic

**RESISTORS**

- (All fixed resistors are ¼-watt, 5% units unless otherwise indicated.)
- R1—470-ohm
  - R2—2200-ohm
  - R3—47,000-ohm
  - R4—20,000-ohm potentiometer
  - R5—5000-ohm potentiometer

**ADDITIONAL PARTS AND MATERIALS**

- L1—See text
- S1—SPST switch
- S2—Normally open, pushbutton switch
- Integrated-circuit sockets, perfboard, solder, wire, etc.

**PARTS LIST FOR THE REMOTE-CONTROL RECEIVER (Fig. 6)**

**SEMICONDUCTORS**

- U1—567 tone decoder, integrated circuit
- Q1—2N3904 NPN transistor
- D1—1N4001 rectifying diode

**CAPACITORS**

- C1, C4—0.22-µF, mylar or similar
- C2—0.1-µF, mylar or similar
- C3—0.47-µF, mylar or similar
- C5—0.047-µF, mylar or similar

**RESISTORS**

- (All fixed resistors are ¼-watt, 5% units unless otherwise indicated.)
- R1—220,000-ohm
  - R2, R3—2200-ohm
  - R4—20,000-ohm potentiometer

**ADDITIONAL PARTS AND MATERIALS**

- L1—See text
- S1—SPST switch
- K1—Low-current, 6-12-volt relay
- Integrated-circuit socket, perfboard, solder, wire, etc

**PARTS LIST FOR THE LOW-PASS FILTER (Fig. 7)**

- C1—100-pF capacitor, ceramic-disc
- C2—680-pF capacitor, ceramic-disc
- L1—See text
- L2—2.5-mH, radio-frequency choke
- Perfboard, solder, wire, etc

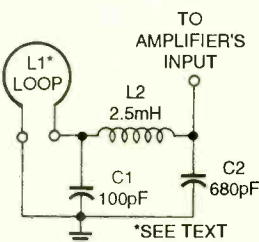

Fig. 7. The low-pass filter shown here filters out any high-power or close-by AM-broadcast interference to improve performance.

is closed, the signal is coupled to the input of an LM380, 2-watt, audio, power-amplifier IC (U2). The amplifier's output drives the transmitting loop. Potentiometer R5 sets the output power level.

**REMOTE-CONTROL RECEIVER**

A remote-control receiver/decoder circuit (the companion to the previous

transmitter) is shown in Fig. 6. The receiver loop (the same loop as used in Fig. 2) is connected to a single-stage, common-emitter, amplifier circuit. The amplifier's output is fed to the

presented, the low-pass filter circuit shown in Fig. 7 can be used between the receiver loop and receiver circuitry. It filters out any high-power or close-by AM-broadcast interference. ■

## POLICE CARS GO HIGH-TECH

*(Continued from page 62)*

significantly decrease errors that can result in loss of conviction. At the end of the shift, reports and other information can be transferred from the officer's laptop to the main computer in the station house. At that time, a state's CIC or the FBI's databases, arrest and citation records, vehicle/license data, stolen-car and wanted lists, and so forth can also be called up on the laptop. Other programs range from software for helping in case investigations to accident reconstruction.

One example of the computer power that is being installed in police cruisers is MobileData Communications, Corporation's MDC-386i. The system's MobileMap information system replaces bulky maps and hard-to-handle notebooks.

The MDC-386i's flat-panel LCD display shows the address a cruiser is dispatched to along with a map to get there. With a keystroke, the officer can zoom-in on the street map to show increasing levels of detail. The detail can include building floor layouts, apartment-building plans, trailer-park layouts, the location of burglar alarms, lock boxes, potentially hazardous areas, etc. The MDC-386i can be used as a MDT to display details on a particular incident whether it be a burglary or drive-by shooting. The MobileMap can be ordered with an optional AVL system.

With its touch screen, the MDC-386i is extremely user friendly, even to those officers who are not computer literate. Having a 386SL processor, up to 20MB of RAM, and a 200-MB hard drive, it can run a plethora of software including word processing, report-preparation programs, and databases available to the law-enforcement community.

Video cameras, usually located outside in the over-head lightbar or inside on an over-head console, are also becoming common in police cars. Connected to a screen on the console, the video camera gives the officer an extra set of eyes. Even more important, when connected to a VCR, the video camera records vital information especially admissible evidence needed for courtroom proceedings. The system usually includes

a wireless microphone for audio recording. The system can be rigged up so the camera starts rolling when the emergency lights are activated, or it can be switched on manually.

For example, the officer can record a complete DUI/DWI stop including the erratic driving considered the "probable cause" and the behavior of the driver after the stop. Other important information needed to get a later conviction, such as proper subduing of a violent suspect or reading of the suspect's rights, can be captured on tape. The tape recordings can also be used for training. For example, to point out dangerous and improper techniques, such as an officer turning his back on a suspect or letting several suspects get out of a car at the same time.

**Cruisers.** All this electronic gear in the front seat of a police car can create logistical, ergonomic, and safety problems. With police cars like the popular Ford Crown Victorias and Chevrolet Caprices, both now equipped with dual airbags, each piece of gear could become a dangerous missile should the airbags deploy in a collision.

To solve that problem, RCI of Brighton, Michigan is offering its Cruiser concept. Slipping inside a Cruiser you immediately see the center console securely holding items like a cellular phone, communications equipment, laptop computer, video recorder, scanner, radar readout, switches for lighting, and so forth. The overhead console contains more switches for items like sirens and overhead lights, a 2-way radio speaker, interior lighting, and a video-camera mount. All that will stay in place should the airbags inflate in a blink of an eye. ■



## ALL ABOUT RADIO CONTROL

*(Continued from page 42)*

ler used in the truck shown on the cover has a 30-amp fuse installed, and the FET's themselves are rated for continuous maximum current of 142 amps and a maximum instantaneous current of 568 amps. At those current levels, and even at much lower ones, the name of the game is low impedance. Ideally you would like to have a

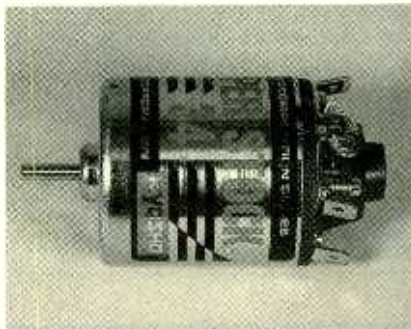

*This "stock" motor is included with the Outlaw Ultima Truck. High-performance motors can be substituted.*

direct short between the motor and the battery pack, but even high-quality FET's have some impedance, which robs the motor of power. However, the more FET's that are paralleled, the lower the resistance becomes. So, depending on the application, a balance must be found between the size and weight of the controller, the number of FET's, and the price.

Depending on the price of a car, the motor included with it will be worth anywhere from \$5 to \$25. These motors are generally matched to the requirements of the car they come with. As I discovered, upgrading to a more powerful motor can damage the parts of the car not designed to handle such stress, so those must be upgraded, too. The power of a motor is determined by the number of turns in its winding and, thus, the amount of current it draws. The more current and RPM's a motor can handle, the more expensive it will be.

That's about it for the basics behind electric RC cars. While I haven't gotten into the special motors, wires, tires, screws, batteries, chargers, conditioners, and so on, I have provided enough information so that you should feel confident if you want to get into the hobby. ■

# ELECTRONICS MARKET PLACE

## FOR SALE

**CABLE test chips.** Jerrold, Tocom, S.A., Zenith. Puts cable boxes into full service mode! \$29.95 to \$59.95. 1 (800) 452-7090, (310) 902-0841.

**SECRET cable descramblers!** Build your own descrambler for less than \$12.00 in seven easy steps! Radio Shack parts list and free descrambling methods that cost nothing to try, included. Send \$10.00 to: **INFORMATION FACTORY**, PO Box 669, Seabrook, TX 77586. For COD's (713) 922-3512 any time!

**300 Experimenters Circuits** — Complete in 6 practical books using diodes, relays, FET's, LED's, IC 555's, and IC CA3130's for building blocks. Only \$33.00 plus \$5.50 for shipping, USA and Canada only. US funds. **ETT, INC.**, PO Box 240, Massapequa Park, NY 11762-0240.

**CABLE descramblers** and test turn-on kits available for most makes and models. We also carry bullet stoppers. No catalog, no 800 number equals your lowest prices. Call others, then compare our prices! Cash paid for cable equipment. No Florida sales. (305) 425-0751.

**GREAT idea!** We do documentation right! **PAT DOCUMENT SERVICES**, PO Box 200, Ellisville, MS 39437. (601) 477-3875.

**DESCRAMBLE** cable with simple circuit added to Radio Shack RF modulator, and using cable ready VCR as tuner. Instructions \$8.00. **TÉLCOM**, Box 832P8, Brusly, LA 70719.

**REASONABLE** board service. See our full ad, now in Market Center under Plans-Kits-Schematics. **FIRST PROTO**, (407) 392-8677.

**SCULLYS**, (2) mono, (1) 2 trk. Ampex (1) 2 trk 350 playback only (op-amps). Chuck Irwin. **UNIQUE SYSTEMS INC.**, (914) 693-2860.

## CLASSIFIED AD ORDER FORM

To run your own classified ad, put one word on each of the lines below and send this form along with your check to:

**Popular Electronics Classified Ads**, 500-B Bi-County Boulevard, Farmingdale, N.Y. 11735

**PLEASE INDICATE** in which category of classified advertising you wish your ad to appear. For special headings, there is a surcharge of **\$11.00**.

( ) Plans/Kits ( ) Business Opportunities ( ) For Sale  
( ) Education/Instruction ( ) Wanted ( ) Satellite Television

Special Category: \$11.00

**PLEASE PRINT EACH WORD SEPARATELY, IN BLOCK LETTERS.**

(No refunds or credits for typesetting errors can be made unless you clearly print or type your copy.) Rates indicated are for standard style classified ads only. See below for additional charges for special ads. **Minimum: 15 words.**

1	2	3	4	5
6	7	8	9	10
11	12	13	14	15 (\$23.25)
16 (\$24.80)	17 (\$26.35)	18 (\$27.90)	19 (\$29.45)	20 (\$31.00)
21 (\$32.55)	22 (\$34.10)	23 (\$35.65)	24 (\$37.20)	25 (\$38.75)
26 (\$40.30)	27 (\$41.85)	28 (\$43.40)	29 (\$44.95)	30 (\$46.50)
31 (\$48.05)	32 (\$49.60)	33 (\$51.15)	34 (\$52.70)	35 (\$54.25)

We accept MasterCard and Visa for payment of orders. If you wish to use your credit card to pay for your ad fill in the following additional information (Sorry, no telephone orders can be accepted.):

Card Number

Expiration Date

PRINT NAME

SIGNATURE

**IF YOU USE A BOX NUMBER YOU MUST INCLUDE YOUR PERMANENT ADDRESS AND PHONE NUMBER FOR OUR FILES. ADS SUBMITTED WITHOUT THIS INFORMATION WILL NOT BE ACCEPTED.**

**CLASSIFIED COMMERCIAL RATE:** (for firms or individuals offering commercial products or services) \$1.55 per word prepaid (no charge for ZIP code)...**MINIMUM 15 WORDS.** 5% discount for same ad in 6 issues within one year; 10% discount for 12 issues within one year if prepaid not applicable on credit card orders. **NON-COMMERCIAL RATE:** (for individuals who want to buy or sell a personal item) \$1.25 per word, prepaid...no minimum. **ONLY FIRST WORD AND NAME** set in bold caps at no extra charge. Additional bold face (not available as all caps) 30¢ per word additional. Entire ad in boldface, \$1.85 per word. **TINT SCREEN BEHIND ENTIRE AD: \$1.90 per word. TINT SCREEN BEHIND ENTIRE AD PLUS ALL BOLD FACE AD: \$2.25 per word. EXPANDED TYPE AD: \$2.05 per word prepaid.** Entire ad in boldface, \$2.45 per word. **TINT SCREEN BEHIND ENTIRE EXPANDED TYPE AD: \$2.55 per word. TINT SCREEN BEHIND ENTIRE EXPANDED TYPE AD PLUS ALL BOLD FACE AD: \$2.95 per word. DISPLAY ADS: 1" x 2 1/2" — \$205.00; 2" x 2 1/2" — \$410.00; 3" x 2 1/2" — \$615.00.** General Information: Frequency rates and prepayment discounts are available. **ALL COPY SUBJECT TO PUBLISHERS APPROVAL. ADVERTISEMENTS USING P.O. BOX ADDRESS WILL NOT BE ACCEPTED UNTIL ADVERTISER SUPPLIES PUBLISHER WITH PERMANENT ADDRESS AND PHONE NUMBER.** Copy to be in our hands on the 18th of the fourth month preceding the date of issue (i.e., Sept. issue copy must be received by May 18th). When normal closing date falls on Saturday, Sunday or Holiday, issue closes on preceding work day. Send for the classified brochure. Circle Number 49 on the Free Information Card.

Look to the Future  
With Your Own  
Cable Converter & Descrambler!

1-800-228-7404



**NU-TEK  
ELECTRONICS**

**FREE CATALOG!**

3250 Hatch Rd.  
Suite 1 C  
Cedar Park, TX 78613

**ALL MAJOR  
BRANDS**



**THE Case Against Patents.** Thoroughly tested and proven alternatives that work in the real world. \$28.50. **SYNERGETICS PRESS**, Box 809-C, Thatcher, AZ 85552. (602) 428-4073. Visa/MC.

**CABLE equipment!** Jerrold, Zenith, Pioneer, Oak, Scientific Atlanta & more! Our prices are below wholesale! **CABLE MASTER**. 1 (800) 480-9888.

## CB RADIO OWNERS!

We specialize in a wide variety of technical information, parts and services for CB radios. 10-Meter and FM conversion kits, repair books, plans, high-performance accessories. Thousands of satisfied customers since 1976! Catalog \$3.

**CBC INTERNATIONAL, INC.**  
P.O. BOX 31500PE, PHOENIX, AZ 85046



**NEW!** Universal descrambler upgrade, improve, modification, repair parts/instructions. Delivers better picture, performance. \$15.00. **ROBERT SNOW**, 22049 Lansdowne, Saint John, Canada E2K4T7.

**CABLE TV converters/descramblers** 2 year warranties on Jerrold, Zenith, Tocom. Scientific Atlanta. We service most converters. Money back guarantee. **NATIONAL CABLE SERVICES** (219) 935-4128.

★ **1994 CATALOG** ★  
**OF THE WORLD'S MOST FAMOUS**  
**CB ANTENNAS & ACCESSORIES**

— FIRESTIK ANTENNA —  
 2614 E. Adams · Phoenix, AZ 85034  
 Write or Call, 602-273-7151

### PLANS & KITS



**60 Solderless Breadboard Projects** in two easy-to-read pocket books. Complete with circuit descriptions, schematics, parts layouts, component listings, etc. Both books (BP107 & BP113) only \$11.90 plus \$3.50 for shipping. USA and Canada only. US funds. **ETT, INC.**, PO Box 240, Massapequa Park, NY 11762-0240.

**SCHEMATIC** design program. Free brochure. Write Dept. P, **SCHEME-ADDICT**, 8622 W. 44th Place, Wheat Ridge, CO 80033.

**FASCINATING** kits! Lasers, voice changers, gas sensors, and more! Send \$1.00 for catalog. **LNS TECHNOLOGIES**, 20993 Foothill Blvd., Suite 307P, Hayward, CA 94541-1511.

**LASER** plans. Build your own laser. Diagrams, construction tips, part sources. \$6.00. Satisfaction guaranteed. **K. HARRIS**, PO Box 290729, Phelan, CA 92329.

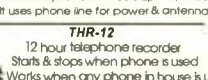
**Telephone Listening & Recording Devices**

<b>MA-100</b> FM Transmitter	<b>MA-100</b> Crystal clear reception on FM radio up to 1/4 mile. Snap! kit uses phone line for power & antenna.	<b>THR-12</b> 12 Hr phone recorder
		
<b>THR-12</b> 12 hour telephone recorder. Starts & stops when phone is used. Works when any phone in house is used.	<b>\$25.95</b> free shipping Visa/MC (214) 255-7490 <b>\$99.00</b>	
Seymour-Radix Inc. Box 166055 - PE Irving, TX 75016		

### SATELLITE TELEVISION

**LEARN** how to buy satellite systems at wholesale prices. Kingviper \$629.00. Tracker 10 plus \$769.00. Monterey 95 \$1,099.00. Get free subscription of Onsat and Satellite TV Week. \$29.95. **SATTRONICS**, Box 832P, N. Highlands, CA 95660.

## THE BURNING MUST STOP NOW!

96,000 acres of rain forest are burned every day. You can help stop this senseless destruction by joining The National Arbor Day Foundation and supporting Rain Forest Rescue.



Call Rain Forest Rescue.  
**1-800-255-5500**

The National Arbor Day Foundation

Rapidly growing manufacturer of automotive electronics needs the following permanent positions filled: • **Purchasing Manager** • **Electrical Engineer** • **Electronics Engineers** • **R.I.S.C. Assembly** • **Micro-Chip Programmers** • **P.C. Board Layout Specialist**. O.C. Power Supply Specialist a definite plus. Both Digital and Analog. Excellent opportunity for advancement for the proper employees. Send resumes to: **500 N. Baird St., Midland, Texas 79701. Jacobs Electronics** is an Equal Opportunity Employment at Will Company.

### BUSINESS OPPORTUNITIES

**MAKE \$75,000.00 to \$250,000.00 yearly.** Learn IBM monitors repairs (solutions most brands). New home based business program. Software available. Information: **USA-Canada \$3.00** cash (no checks). Dealers wanted worldwide (\$35.00) US funds. **RANDALL DISPLAY**, PO Box 2168-H, Van Nuys, CA 91404, USA.

**GOVERNMENT** seized cars, trucks, boats, computers, televisions. Surplus bargains galore! Your area. Information: 1 (800) 601-2212 Ex.SP7930.

**EASY work!** Excellent pay! Assemble products at home. Call toll free 1 (800) 467-5566 ext. 5730.

**START** your own technical venture! Don Lancaster's newly updated **Incredible Secret Money Machine II** tells how. We now have autographed copies of the Guru's underground classic for \$18.50. **SYNERGETICS PRESS**, Box 809-C, Thatcher, AZ 85552. (602) 428-4073. Visa/MC.

### INVENTIONS

**FREE Invention package: DAVISON & ASSOCIATES** offers customized development, patenting, and licensing for new products and ideas. Proven results: 1 (800) 677-6382.

### TELEVISION VIDEOS

**INEXPENSIVE, proven, colorbar generator alternative!** Crosshatch, dot matrix, and more on high grade VHS. 30 minutes. Only \$23.95. **DLD DISTRIBUTORS**, 429 Cessna Road, Concord, NC 28025.

### EDUCATION/INSTRUCTION

**ELECTRONIC engineering.** 8 volumes complete. \$109.95. No prior knowledge required. Free brochure. **BANNER TECHNICAL BOOKS**, 1203 Grant Avenue, Rockford, IL 61103.

**VCR Repairs You Can Do.** Save\$. Make\$. 403-page textbook used by national correspondence schools. \$Back-guarantee. Over 40,000 sold. 704 illustrations + tool. Mail \$24.95 to **WORTHINGTON PUBLISHING**, Box 16691N, Tampa, FL 33687-6691.

**BECOME** an electronics engineer! Money for college available. Call (609) 266-2887 ext. 112 for recorded message.

**"VIDEO Game Secrets of the Orient"** — Genesis/Super-Nint, etc... Yes, game recording machines do exist! Any game \$1.00, incredibly accessible to anyone worldwide, described in detail. Also, outrageous savings, products, sources, more! Highly revealing information game companies don't want you to know. 6 years researched. \$15.00. **DEL WORLD PUBLICATIONS**, 2390 Crenshaw Blvd., Dept. 8PE, Torrance, CA 90501.

**BECOME** an amateur radio operator ham. Information how \$3.00 **D&S INT.**, PO Box 73560, Metairie, LA 70033-3560.

**DIGITAL electronics,** learn at home or college for digital computers, full color illustrations 360 pages. Send \$29.95 to **PJ ENTERPRISES**, 26551 Sparks St., Highland, CA 92346.

**ELECTRICITY.** Electronics training series used by US military. 24 volumes, other courses available. Free info: **FEDERAL TECHNICAL PUBLISHERS**, Box 1218 E, Glen Lake, MN 55345.

**SCIENCE:** astronomy to zoology. Newsletter. **INTERNATIONAL AMATEUR SCIENCE NETWORK**, 2410 Norton Road, Stow, OH 44224.

## Learn VCR repair!

Home study. Learn high-profit repairs without investing in high-tech instruments. **FREE BOOKLET: 800-223-4542.**

Name \_\_\_\_\_ Age \_\_\_\_\_  
 Address \_\_\_\_\_  
 City \_\_\_\_\_ State \_\_\_\_\_ Zip \_\_\_\_\_  
 The School of VCR Repair, Dept. VRJ341  
 6065 Roswell Road, Atlanta, Georgia 30328



## BEST BY MAIL

Rates: Write National, Box 5, Sarasota, FL 34230  
 OF INTEREST TO ALL

**SPORTS FANS:** CALL 1-800-PLAY-ISC to see what you are missing!

**INVENTORS. HOW TO** Invent; Protect; Sell! Free Report. Randolph, Box 92972, Lakeland, FL 33804.

**MODERN DAY REVIVAL?** Eternal Security? Send for FREE Bible Studies. Light, St. Maries, ID 83861.

**CASH FOR COMMON** Canceled Stamps. Instructions \$1.00. (RWIN, Box 2096-(PE), Baytown, Texas 77522.

**MASTER PSYCHIC DURRAN** brings money, love fast! Results assured. (714) 647-7277.

**2nd CREDIT CHANCE.** Start New File. Free Information: 212-592-3939 anytime.

**RUSSIAN LADIES, TRULY** beautiful, seek relationships. Free color brochure! Russia191. POB 888851, Atlanta, GA 30356. (404) 458-0909.

**GUARANTEED: LOANS, MASTERCARD, VISA, \$1,500 Credit Line.** Mortgages. Income. 212-465-3311.

## ANTIQUE RADIO CLASSIFIED

Free Sample!

Antique Radio's



Largest Circulation Monthly. Articles, Ads & Classifieds.

6-Month Trial: \$16.95. 1-Yr: \$31.95 (\$47.95-1st Class). **A.R.C., P.O. Box 802-L12, Carlisle, MA 01741**



## RECEIVING TUBES

**OVER 3000 TYPES IN STOCK!**

Also hard-to-find transformers, capacitors and parts for tube equipment.

Send \$2.00 for our 32 page catalog.

**ANTIQUE ELECTRONIC SUPPLY**  
 6221 S. Maple Ave. • Tempe, AZ 85283 • 602-820-5411

MAY THE  
 SOURCE  
 BE WITH  
 YOU.

Don't let the dark forces of ignorance defeat you. Right in this galaxy, you can tap into the source — the free **CONSUMER INFORMATION CATALOG**. It lists more than 200 free and low-cost government publications on a variety of important topics. So dispel the darkness and send for the source. Just send your name and address to:

**Consumer Information Center**  
 Department Source  
 Pueblo, Colorado 81009

# DX LISTENING

By Don Jensen

## The Money Crunch!

It doesn't seem to matter where in the world you look, some shortwave broadcaster is having problems. That's true of both the major and minor players in world-band radio. But, it wasn't too many years ago when money seemed to be no object to many international broadcasters. They got into a one-upmanship game, installing higher and higher powered SW transmitters.

Fifty kilowatts of power, then 100 kW, were considered more than ample to deliver a listenable signal across the oceans. But when everybody had them, a "louder-shouter" was deemed necessary, and so 250-kW, 300-kW, and 500-kW units came on line. Now some of those power-house transmitters are being shut down, or their transmitting hours are being curtailed for economic reasons. Some stations also are eliminating or cutting back on some of their foreign-language services. Staff reductions are also a common answer to tighter SW-broadcasting budgets.

Consider the Czech Republic's *Radio Prague*. Late last year, that longtime SW-broadcast operation learned that its annual budget for 1994 would be cut drastically, from 90 million crowns (\$3 million U.S.) to 51 million crowns (\$1.6 million). Its broadcast staff—programmers, technicians, and all the rest—was chopped from 124 to 65. Also axed was all programming in the Slovakian language.

External service programming in English, French, German, Spanish, and, of course, Czech for expatriates continues. However, their 19.5 hours of daily programming was cut by three hours.

In other shortwave developments:

Estonia, one of the Baltic nations that regained independence with the breakup of the ex-Soviet Union, reactivated its *Estonian Radio* foreign SW service earlier this year. It has been reported operat-

ing on 5,925 kHz, from 2030 to 2130 UTC, with broadcasts in German, Swedish, and English. But the station is having trouble meeting its operational and electrical costs, and with its 45-year old Russian-made transmitter limping along, the situation could be brighter for Estonian Radio.

In nearby Lithuania, a crisis was avoided at the start of this year when the government decided it would continue to pay Russia about a quarter million dollars in 1994 to rent a shortwave transmitter at Krasnodar. Without that powerful Russian SW transmitter, *Radio Vilnius* would have had to end its SW transmissions to North America. Even without the money problems, Lithuania, which like Estonia split from the former USSR, is reluctant to entrust the future of its SW operations to Russia.

Will these Baltic nations join together in a new joint SW transmitting complex? Maybe, but again the problem is money. However, a \$2 million grant from Switzerland is pending. Stay tuned.

For many years, the Organization of American States, the regional association whose members included most Western hemisphere nations, broadcast a daily 45-minute program via airtime leased from the *Voice of America*. Those programs, in Spanish, were aimed at promoting a better understanding among the OAS countries. But, like the *United Nations* and *American Forces Radio-TV Service* programs also once aired by the VOA,

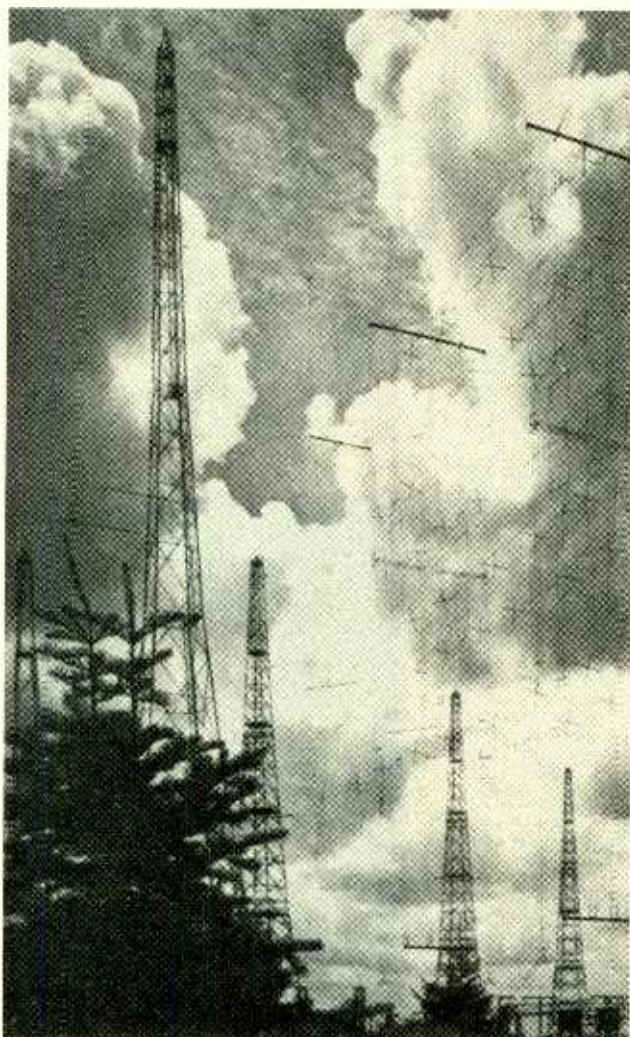

A dramatic photo of part of the antenna complex of Germany's *Radio Deutsche Welle*, which is often heard with a good signal during its news about Germany at 0140 UTC.

the *Voice of the OAS* also has departed. Its last SW broadcasts were heard in January.

## THE BRIGHTER SIDE

Among the shortwave broadcasters of West Africa, the *Voice of Nigeria* used to be heard widely and well. Now, though, only one of its five shortwave transmitters at Ikorodu, near the capital of Lagos, still works. However, the Nigerian government recently established a rehabilitation fund for the *Voice of Nigeria*, which will provide for better maintenance of the existing broadcast facilities.

Also in Africa, the Zimbabwe government has announced that it hopes to return to shortwave after five years of silence. The *Zimbabwe Broadcasting Corporation* is supposed to get three new SW transmitters. However, even though SW is considered the most effective way to reach audiences within the country and those in other southern African countries, here too, money is a problem, so who knows when these transmitters will go on the air.

Better news is that now Hawaii now can be heard on SW, thanks to *KWHR*, World Harvest Radio, the same religious broadcaster that operates *WHRI* in Indiana. It began regular transmissions last Christmas, programming mostly to Asia. This one is scheduled round the clock on various frequencies including 7,425,

\*Credits: Jim Clar, NY; Richard D'Angelo, PA; John Lyon, MN; Daniel McCarthy, GA; T.A. Mitchell, ONT; Jerry Osborn, ONT; Martin Peck, NY; Doug Robertson, CA; Peter West, ONT; North American SW Association, 45 Wildflower Road, Levittown, PA 19057; Ontario DX Association, P.O. Box 161, Station A, Willowdale, Ontario M2N 5S8

9,930, 13,625, 13,720, 17,510, and 17,555 kHz.

The *Singapore Broadcasting Corp.*, whose old shortwave outlets on 5,010 and 5,052 kHz were not easy to hear in the U.S., has recently installed replacement 250-kW powerhouse transmitters. As of this writing, the only frequency that I can suggest is 11,940 kHz during the afternoon hours.

## MAIL CALL

I recently got a postcard from Harry Jaspers, Sioux Falls, SD, with just a single sentence: "What can you tell me about getting up-to-date shortwave information on computer bulletin-board systems?"

Happily, Brian Boulden, writing recently in the North American SW Association's *The Journal*, covered that subject nicely. "By use of the on-line services," Boulden noted, "the avid shortwave listener can be in contact with many other SWL'ers as well as many stations worldwide. America Online," he continues, "is one of the newest on-line services today. It, like many other on-line services, operates an SWL area within their ham-radio sections."

He quotes system operator Terry Stader as saying "Here is where the SWL'er, or even the curious, can get a chance to interact in real-time with others who might have his or her interests. We have built up the library to support many of the same radio schedules found on the major news groups from the Internet."

Computer enthusiasts can try America Online for 10 free hours with no obligation by calling 800-827-6364, Extension 6285.

"Compuserve," Boulden says, "is the largest of the pay on-line services. . . . The Compuserve Shortwave Ra-

dio area is one part of the HamNet Forum. As with other on line services, this area includes all types of radio communications, such as Ham, SWL, RTTY. . . . Once inside the shortwave area, one can discuss all aspects of the hobby. Most of the shortwave area deals with discussions on equipment used by listeners. Very little of the area is used to discuss loggings, QSL's, and other more-current information."

"Genie Services, a division of General Electric Co., offers one of the finest selections of materials for the shortwave listener," says Boulden. "The information for the SWL is complete and extensive. The RADIO RT (for Round Table) is run by Larry Ledlow (whose personal interests in SW date back 25 years) and who is an avid listener to anything under the sun."

Of special interest, perhaps, is the Round Table Conference on-line for SWL's, scheduled each Sunday at 9 PM EST. Genie is available on a trial basis with 10 free hours, Boulden notes. Call 800-638-9636 for information.

Unlike those on-line systems, the Shortwave Fido Net is free. It's carried by many local BBS systems, says Boulden. The SWL Fido Net is run by Fred Hatfield. Many well known SWL's participate and there is much current activity of interest to listeners. For more information, Boulden suggests that you contact your local BBS system operator. Also, *Computer Shopper* carries monthly listings of BBS's around the country, and those listings indicate which ones echo Fido Net.

I hope that helps, Harry. Many thanks to Brian and NASWA for the info! If you have questions or comments on SWL'ing, or want

to tell the world what you've been hearing lately—please include frequencies and times—drop me a line, *c/o DX Listening, Popular Electronics*, 500-B Bi-Country Blvd., Farmingdale, NY 11735.

## DOWN THE DIAL

Here are some of the shortwave stations being logged by listeners:

**ALASKA**—7,367 kHz. *KNLS* at Anchor Point, Alaska, is noted in English at 0800 UTC (for those not familiar with it, Universal Time, which is equal to EDT + 4 hours, CDT + 5, MDT + 6, or PDT + 7), with a mailbox segment, music, identification, and Bible reading.

**AUSTRIA**—9,870 kHz. *Radio Austria International* was heard at 0130 UTC with English news and a talk about Austria's role in the European Economic Community.

**GERMANY**—6,085 kHz. Germany's *Radio Deutsche Welle* often is heard with a good signal during its news about Germany at 0140 UTC.

**PHILIPPINES**—9,520 kHz. *Radio Veritas Asia*, the Vatican's voice in the Far East, was logged with an English identification and announcing as "broadcasting from Quezon City, Philippines," at 1157 UTC. Programming continued in an Asian language.

**UGANDA**—4,976 kHz. *Radio Uganda* is scheduled on this frequency at 0405 UTC with an English-language newscast.

**UZBEKISTAN**—6,025 kHz. *Radio Tashkent* still operates in English at 1200 UTC, when it was logged with the national anthem, interval signal, identification, frequencies, news, and commentary. The station can be heard on a parallel frequency of 9,540 kHz as well.

# HAM RADIO

By Joseph J. Carr, K4IPV

## An All-Band Delta-Loop Antenna

If you've been paying attention to recent ham ads, you've no doubt noticed that there are a lot of large loop antennas on the market. A "large loop" is any loop over about  $0.2\lambda$ , although most of them are  $0.5\lambda$ ,  $1\lambda$ ,  $1.5\lambda$ , or  $2\lambda$  long. Loops smaller than  $0.2\lambda$  are used for radio-direction finding and to receive signals in the lower bands (where they can help to diminish perceived QRM and QRN).

The loop antenna that we'll discuss this month is based on a half-wavelength delta loop. The name "delta loop" is derived from the fact that the loop has a triangular shape

(Fig. 1), resembling the upper-case Greek letter delta ( $\Delta$ ). The delta loop can be used for most of the ham bands, ranging from 3.5 MHz to 21.45 MHz: 3.5 MHz, 7 MHz, 10.1 MHz, 14 MHz and 21 MHz. It can also be used on 160-meters (1.85 MHz), but because it becomes terribly inefficient on "top-band," it isn't recommended for operation there.

### DELTA LOOP

The multi-band delta loop is based on a design of Scottish amateur operator GM3AXX. The basic design of the antenna, see Fig. 1, uses two conductors to form the shape (points

ABC and DEF) both of which are made of #14 copper-weld wire cut to 33 feet. The bottom side of the antenna is mounted at least four feet above ground, but as high as ten feet is recommended.

The reason for that is twofold. First, a wire that is only four feet off the ground is hard to see, and as such it is a trap for any unwary pedestrian. Common sense and ordinary decency suggest keeping the wire above the point where people can hit it. Unless you have 7-foot NBA players in your neighborhood, place the wire seven feet (and as much as ten feet) off the ground. The other reason for keeping the antenna base high is that under certain operating conditions, high RF voltages (reaching a maximum at points "C" and "D") may be present along the base.

When the  $\Delta$  is made equilateral, each sloping section is 22 feet long, and each horizontal section is 11 feet long ( $22 + 11 = 33$ ). The feedpoint of the antenna—which should be 20 to 35 feet off the ground, depending on where the base is placed—is at the apex of the loop. The antenna is fed through a 75-ohm coaxial cable connected to a 1:1 BALUN transformer (connected at points A and F in Fig. 1) at the top of the mast. No antenna tuning unit is needed at the feedpoint, but as usual, at least a "line flattener" is recommended at the transmitter end (especially if the rig has solid-state final amplifiers).

It is best to make the

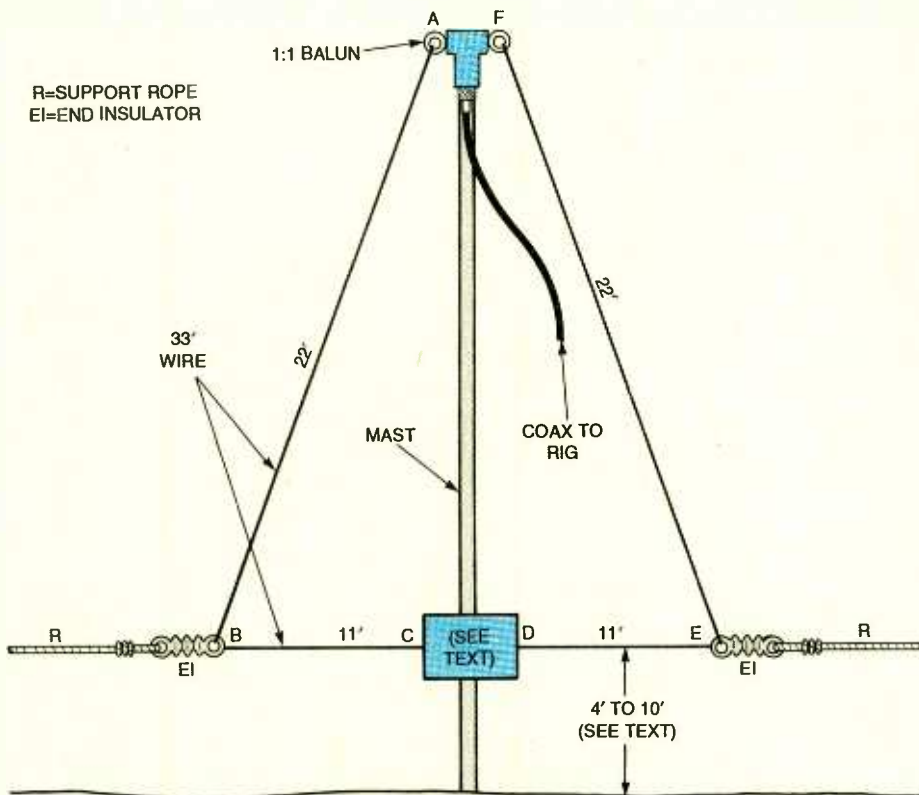

Fig. 1. The "delta loop"—whose name is derived from the fact that the loop resembles an upper-case Greek letter delta ( $\Delta$ )—can be used for most of the ham bands (from 3.5 MHz to 21.45 MHz).

three sides of equal length so the top of the mast will be at 29 feet when the base is 10 feet off the ground. The two lower points of the triangle (B and E) are supported by end insulators and a support rope. The rope can be attached to any stationary object, such as a building, tree, mast, fence post, or whatever will give the needed strength and the stability (as well as the height off ground).

### NETWORKING

A band-changing and matching network is used along the base of the delta-loop antenna. The band-changing and matching network (connected between points C and D) should be installed in a weather-proof box and mounted with gasket-sealed beehive insulators.

Figure 2 shows the composition of the band-changing and matching network. For operation on 40 meters (7–7.3 MHz), the two switches are left open, and the antenna operates in a manner similar to that of a bent inverted-vee dipole. Likewise, the switches are left open for operation on 15 meters (21–21.45 MHz), in which case it is a 3  $\lambda/2$  inverted-vee dipole. (Note: In general, 40-meter half-wavelength antennas can work on 15 meters, but the pattern has four main lobes rather than the two lobes that are characteristic of a dipole). On 20 meters (14–14.4 MHz), switch S1 is closed, making the antenna into a full-wave loop at that frequency.

The antenna can be operated on 10.1 and 3.5 MHz by connecting an inductor across points "C" and "D," as shown Fig. 2, and using S2 to switch the inductor into and out of the circuit. While some experimen-

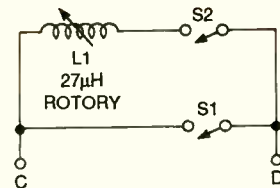

Fig. 2. A band-changing and matching network, such as that shown here, can be used in conjunction with the delta-loop antenna.

tion is needed to find the correct inductance for any given band, using a 18- $\mu$ H or 27- $\mu$ H variable inductor (both common values) will allow the inductance to be adjusted as needed. Ocean State Electronics—P.O. Box 1458, 6 Industrial Drive, Westerly, RI, 02891; Tel. 800-866-6626 (orders), 401-596-3080 (inquiries), or FAX 401-596-3590—lists variable and fixed air-core inductors in their catalog. The inductor can be remotely adjusted using a low-voltage (e.g. 6- DC or 12-volt DC) RPM motor.

The switches are a bit of a problem. For manual band changing, RF switches of the sort used in high-power amplifiers for band changing can be used. For low-power operation, you can substitute ordinary 117-volt AC power-line light switches. However, under no circumstances should "silent," "mercury," or "dimmer" switches be used; only true mechanical switches are suitable.

For remote operation, relays can be used. Again, high-power RF relays, coaxial relays, or others capable of handling the RF power and voltage levels present across C and D should be used. The same restrictions that apply to ordinary mechanical switches also apply to mercury-wetted relays and must be enforced. Mercury switching at high RF-power levels is dangerous and could be

an environmental and health hazard (mercury, especially mercury vapor, is poisonous).

The antenna can also be operated on 18 MHz, 24 MHz, and 28–30 MHz by using a variable capacitor in place of the inductor in Fig. 2. However, only high-power transmitting variables are suitable in this application; in fact, it might be appropriate to use a 1000-pF vacuum variable. Fair Radio Sales—P.O. Box 1105, 1016 E. Eureka, Lima, OH 45802; Tel. 419-227-6573; FAX 419-227-1313—offers motor-driven vacuum variables for a relatively low price (as well as surplus rotary inductors suitable for low power).

The vacuum variable that I bought from Fair Radio has a motor rated for 24-volts DC, but it ran well at 6 volts. For both the coil and the capacitor, a VSWR meter, or SWR analyzer, such as the MFJ-247 or MFJ-249—from MFJ Enterprises, Inc., Box 494, Mississippi State, MS, 39762; Tel. 800-647-1800 (nearest dealer/orders), 601-323-5869 (voice); FAX 601-323-6551—can be used to find the correct settings. I prefer the MFJ VSWR analyzers because they use ultra-low power from an internal signal generator, rather than transmitter power, and as such are inherently more polite (and more legal) to use when making tests.

While you're at it, ask for MFJ's catalog . . . they sell some useful accessories. One of their products is a half-wave vertical antenna that operates on 40 meters, 20 meters, 15 meters, 10 meters, 6 meters, and 2 meters without radials (product MFJ-1796). By the way, when you contact firms mentioned in this column, please mention **Popular Electronics**.

### CONCLUSION

Large loop antennas, such as the delta loop shown in Fig. 1, are a reasonable means to get on a large number of HF bands at low cost, and with minimal space demands. While the antennas rarely perform as well as dipoles or quads, they work nearly as well . . . and are possible in cases where other antennas (or multiple antennas) are not. If you have a favorite "non-traditional" antenna, then please let me know. I can be reached at P.O. Box 1099, Falls Church, VA 22041.

### PRODUCT TEST REPORTS

(Continued from page 23)

must be emphasized: Having become accustomed to "instant access" to tracks on CD players, one of the most welcome features of any MD player (including this one from Sharp) is its instant access capability. It is that feature, we feel, that places the MD format ahead of any digital-tape format, whether it be DAT or DCC. As for the "shock-proof" feature of the player, we were literally able to toss the player up into the air and catch it without interrupting the music we were listening to!

For more information on the MD-D10, contact Sharp (Sharp Plaza, Mahwah, NJ 07430-8200) directly, or circle No. 120 on the Free Information Card.

AMERICAN HEART  
ASSOCIATION  
MEMORIALS & TRIBUTES



1-800-AHA-USA1

 American Heart Association

This space provided as a public service.  
©1993, American Heart Association

# SCANNER SCENE

By Marc Saxon

## Scanning Sky-High Surveillance Operations

The Radio Shack PRO-2027 desktop scanner has a 100-channel memory, grouped in ten-channel storage banks. In addition, there are monitor memories that allow you to save up to ten channels located during a search.

Coverage of the PRO-2027 runs from 30–45 MHz, 137–174 MHz, 380–512 MHz, and 806–960-MHz (minus the cellular bands). It also receives the 108–137-MHz VHF aeronautics band.

second rate if you want. When searching, Hyperscan works at 50 channels per second.

The scanner is designed around IF frequencies of 10.7 MHz and 455 kHz. Selectivity at  $\pm 10$  kHz is  $-6$  dB; at  $\pm 20$  kHz, it's  $-50$  dB. Sensitivity below 54 MHz is  $0.5 \mu\text{V}$ ; in the VHF aeronautics and 800-MHz bands, it is  $2.0 \mu\text{V}$ ; and on the other operational frequencies, it is  $1.0 \mu\text{V}$ .

The (Realistic) PRO-2027 scanner is available at all Radio Shack retail stores. In case you haven't heard yet, Radio Shack is phasing out the name Realistic. Products will be offered under the brand name "Radio Shack."

### EYE IN THE SKY

Aircraft have been a mainstay of surveillance for quite some time. Police often catch highway speeders by clocking them from fixed-wing aircraft and helicopters. We have monitored some of that activity on 122.9 MHz.

Criminal activity may be spotted from surveillance aircraft. In that connection, aircraft are often used for tracking the vehicles, boats, and aircraft used by law breakers. In addition, aircraft are ideal for finding carefully concealed locations being used for illegal operations. Federal agencies, in particular, use aircraft for surveillance purposes.

Among federal agencies, the following scanner frequencies have been

reported as being used for surveillance: the FBI on 120.425, 120.45, 120.475, and 167.5625 MHz; the U.S. Coast Guard on 166.3475, 166.4625, and 353.9 MHz; U.S. Customs on 120.325, 132.05, 165.7375, 166.4375, 166.4625, 269.0, 281.4, 282.425, 290.2, and 353.9 MHz; and the DEA on 120.375 and 120.775 MHz.

In general, 166.4625 MHz is a frequency common to all branches of the Treasury Department. As such, it is in heavy use, and often activated for surveillance purposes. It is a simplex channel; no repeaters are in operation. Many of the units monitored there thus far appear to be low-power mobiles or portables. Anything that you hear there would most likely be within a few miles of your location.

### NO-SEE TV

Tim MacKenna, of Upper Darby, Pennsylvania, tells us that he is a trucker who hasn't ever owned a scanner. Now he wants to get a scanner that can pick up the action bands and NOAA weather broadcasts, but it needs to do something extra. What Tim wants to know is if any scanners can also receive VHF- and UHF-channel audio, so that he can at least listen to his favorite shows while he's on the superslabs.

Some scanners are suited to the task, but you'd have to be certain that the scanner you select can be switched to receive signals in wide-FM (WFM) mode.



The Radio Shack PRO-2027 desktop scanner offers "Hyperscan" rapid scanning.

A nice feature of the PRO-2027 is Radio Shack's "Hyperscan" rapid scanning, which can zip through scanning at 25 channels per second. You can switch to a slower 8-channel-per-

Most two-way FM communications are in narrow-FM (NFM) mode, and the majority of scanners will receive FM only in its NFM form. The Realistic PRO-2006, for instance, is one example of a scanner that can be switched to receive either NFM or WFM.

Next, frequencies for the TV audio signals must be dealt with. The TV-audio signals for Channels 2 through 13 cover 59.75 through 215.75 MHz; Channels 14-69 span 475.75 to 805.75 MHz. The video signals are mixed in there too. Most scanners have a coverage gap between 512 and 806 MHz. That eliminates the possibility of picking up audio from TV channels 22 through 69, the major portion the UHF-TV spectrum.

Scanner owners who would like to experiment with this can try Channel 2 audio on 59.75 MHz, Channel 3 on 65.75 MHz, Channel 4 on 71.75 MHz, Channel 5 on 81.75 MHz, Channel 6 on 87.85 MHz, and Channel 7 on 179.75 MHz. That will cover those stations in all areas of North America. Remember, too, that at times TV signals on Channels 2 through 6 open for excellent long-haul skip reception.

Of course, all of the foregoing is meaningful only if your scanner is receiving TV audio direct from an antenna picking up signals out of the air. If you hook your scanner to a cable-TV system, never mind. Nothing written here would apply to cable TV.

### CUT OFF IN MID-WORD

A reader in Florida writes to comment that he enjoys tuning in the cellular band, and can pick up more than 20 calls per hour loud and clear. What he wants to know is why he sometimes

hears a short buzz and then the call abruptly cuts off. He complains that this is annoying and can happen right in the middle of a call.

That is normal with cellular phone calls, indicating that the moving vehicle has passed out of range of the cell site that you were monitoring. The buzz is a data burst that instructs the cellular phone to automatically switch to a different channel because the call is being instantaneously handed off to another cell site. The persons engaged in conversation don't notice a thing, but an outsider with a scanner is left high and dry. It might be possible to search the band to see if the call can be located again on its new frequency, assuming that the scanner is within range of that cell site. One call can change frequencies in this manner several times when a vehicle is moving.

### QUESTIONS, WE GET QUESTIONS

Jerry, of Detroit, asks if we know that city's police channel where major crimes are handled. Try 453.325 MHz, Jerry.

The car-to-car channel for the Maine State Police radar units is the request of Martin Wolfe, of that state. Try 154.935 MHz.

Lee Howard, who hails from Chicago, wants to hear the parking-enforcement operations and asks for those frequencies. Monitor 453.825 MHz. Police towing units are on 453.775 MHz. Those two channels should have enough traffic to keep things lively.

That's it for this month. Please send in your comments, frequencies, and scanner questions to *Scanner Scene*, **Popular Electronics**, 500-B Bi-County Blvd., Farmingdale, NY 11735. ■

## VCR Cross Reference

**NOW Find the right Part  
for your VCR**



**With the  
IS CET VCR  
CROSS REFERENCE**

This 270-page reference contains both model and part-number cross-references updated to include 1992 units.

VCR's are made in a few factories from which hundreds of different brand names and model numbers identify cosmetically-changed identical and near-identical manufactured units. Interchangeable parts are very common. An exact replacement part may be available only a few minutes away from you even though the manufacturer supplier is out-of-stock. You may be able to cannibalize scrap units at no cost!

The IS CET VCR Cross Reference is pre-punched for standard loose-leaf binding. . . \$38.00 plus \$3.00 for shipping for each Reference.

**Clagg Inc.  
VCR CROSS REFERENCE OFFER  
P.O. Box 4099  
Farmingdale, New York 11735**

Name \_\_\_\_\_

Business \_\_\_\_\_

Address \_\_\_\_\_

City \_\_\_\_\_

State \_\_\_\_\_ Zip \_\_\_\_\_

Phone \_\_\_\_\_

Enclose \$38.00 for the Third Edition of the IS CET VCR Cross Reference and \$3.00 for shipping for each Reference.

The total amount of my order is \$ \_\_\_\_\_

Check enclosed—do not send cash.

or please charge my credit card.

Visa  MasterCard Exp. Date \_\_\_\_/\_\_\_\_/\_\_\_\_

Card No. \_\_\_\_\_

Signature \_\_\_\_\_

New York State residents must add applicable local sales tax to total.

## RADIO-CONTROLLED CAR

(Continued from page 38)

possible. It's recommended that G-10 printed-circuit board material (0.031 or 0.062 thick) be used. Avoid paper-base phenolic printed-circuit material; it is brittle and is easily cracked or broken.

Corresponding parts-placement diagrams for the RC System's printed-circuit layouts are shown in Figs. 12, 13, and 14. Note that the coil (L1) used in the transmitter is a home-made unit, consisting of 10.5 turns of #22 enameled wire wound on 1/4-inch diameter, slug-tuned coil form tapped at 3.25 turns from the starting end. (Use a coil form that is intended for 20–50 MHz operation; an old TV set or CB radio is a good source of such forms.) The completed coil should have a nominal value of  $0.6\mu\text{H}$ , a  $Q$  of about 70, and a  $\pm 20\%$  adjustment range. The crystal for the transmitter circuit must be chosen according to the desired operating frequency.

Coils L1 and L2 on the receiver board are also home made. To make L1, wind  $11\frac{1}{2}$  turns of #22 enameled wire on an 8-32 screw. When that's done, remove the screw and replace with an 8-32 threaded ferrite slug (again, the slug material should be suitable for 20–50-MHz operation). Coil L2 is identical, except that a secondary winding consisting of  $3\frac{1}{2}$  turns of #24 insulated hook-up wire must be added. The completed coils should have a nominal inductance of  $0.4\mu\text{H}$ , a  $Q$  of about 60, and should have an adjustment range of  $\pm 20\%$ .

If you wish to avoid winding your own coils for L1 and L2 on the receiver board, you can use TOKO KXNA 4434 DZ coils instead (note that those coils come in standard 10mm shielded cans and that the PC board is laid out to accommodate them; also note that the parts-placement diagram in Fig. 13 shows the connections for the TOKO coils). If you elect to use the TOKO coils, you will have to change the values of C2 and C6 to 47 pF. The receiver IF coils (T1 and T2) are standard types and are best purchased ready made (see the Parts List for details).

A 12-inch length of music wire with a plastic ball on the end was used for the receiver antenna. (**Do not** over-

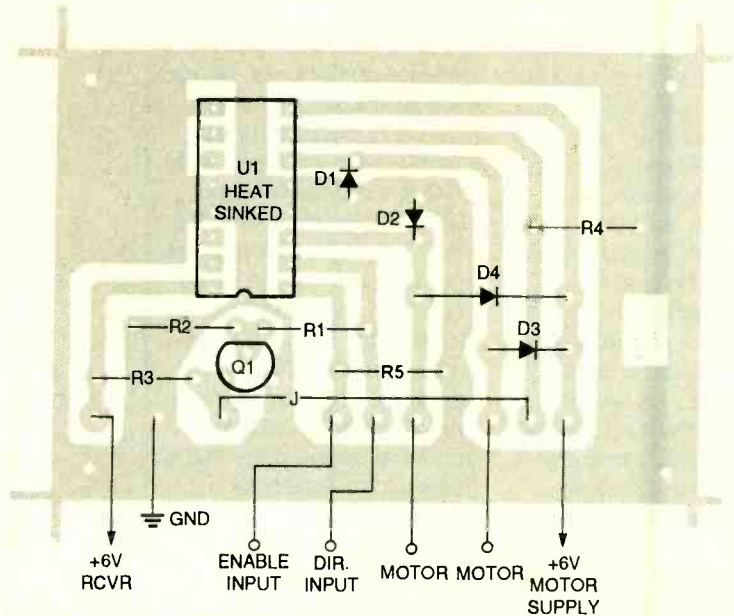

Fig. 14. Here is the motor driver board's parts-placement diagram. When assembling this portion of the system, don't forget to attach a clip-on heat sink to the LM18293, as it may be called upon to deliver significant amounts of current.

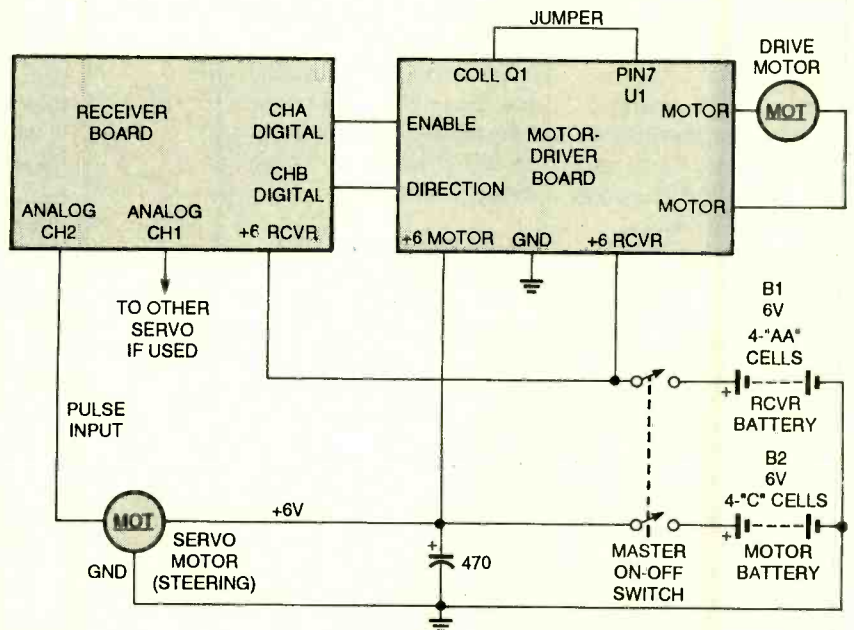

Fig. 15. With just a few simple inter-wiring connections, the receiver and motor-controller boards can be linked to one another, in preparation for your application.

look the ball as the music wire is sharp and can give you a serious eye injury.) The receiver crystal, XTAL1, is a 3rd-overtone unit (housed in an HC49 or HC18 case) cut for desired receive frequency minus 455 kHz; a CB-channel receive crystal is okay.

The receiver and motor controller sections of the system were installed in a non-functioning radio-controlled model car. Its electronics and servo were removed, leaving the chassis, steering mechanism, wheels, and

drive motor and wheel assembly. You can, of course, build your car from the ground up, from a kit, or use an entirely different vehicle such as a boat.

After gutting the vehicle—whose chassis contained a battery holder that was used to hold the "AA" cells for the receiver—a piece of unetched printed-circuit material and a DPDT switch (for on-off control) was attached to the chassis. The printed-circuit material was used to provide a level mounting platform for the re-



ceiver and driver boards. In addition, the copper surface makes a good ground plane. A little work was done to fit a servo to the steering mechanism. The four "C" cells (which were used to provide power to the motors) were too large to fit, so they were installed in a separate battery holder that was mounted to the top of the chassis. The PC board interconnections are shown in Fig. 15. The "master on-off switch" is a single DPDT switch used to disconnect both power sources; in some cases the model's own on-off switch can be used. Note the presence of a 470 $\mu$ F, 15 WVDC electrolytic or tantalum capacitor between +6 volts and ground; it is there to reduce motor noise and might not be needed in your application.

Once all three printed-circuit boards have been completed, it's a good idea to check for construction errors; cold solder joints, and incorrect component placement or orientation; pay close attention to the interwiring between boards. The final step is to align the transmitter and receiver boards.

**Transmitter Alignment.** The system tuneup starts with the transmitter. An oscilloscope is recommended but not necessary if you have a shortwave receiver that can cover 27-MHz or a CB transceiver. In either case, set R10 and R9 to about 1/2 rotation. The slug of L1 is then set fully into the winding. If you have an oscilloscope, connect it to pin 13 of U1 (the LM1871). The scope should be set for a horizontal deflection of 1ms/cm, vertical 2 volt/cm, negative triggering, and DC coupling. Connect a 9-volt DC source between S2 and ground, and close S2; pulses should be seen on the oscilloscope. Examine the waveform and note effect of R9, R10, and S1-a and S1-b. Check the scope display against the waveforms shown in Fig. 3 to verify correct operation.

If you don't have an oscilloscope with a bandwidth of over 27 MHz, skip the following step. Connect the scope to the junction of C7 and L2. Using only a non-metallic tool, adjust the slug of L1 until the RF envelope shown in Fig. 2 is seen. Then back the slug out until a peak is reached. At that point screw the slug back in for a 10% drop in RF level. Make sure the RF envelope is keying properly (as illus-

trated in Fig. 2). You may have to compromise on the output somewhat to achieve the near ideal.

If no scope is available, you can tune the transmitter using a CB or shortwave receiver. Begin by tuning the receiver or CB to the frequency of your transmitter (the crystal frequency). Turn on the transmitter. Back out the slug of L1. At some point, you should hear a loud buzz. Keep backing out until the buzzing ceases. Then screw the slug back into L1 until the buzz returns, then 1/4 turn more. Next operate R9, R10, and S1-a and S1-b. Each should change the buzzing sound slightly. If all okay so far, you can be reasonably sure that the transmitter is working. If, on the other hand, no buzz is heard, check your work. Also, check for a 4.6-volt DC source at pin 4 of the LM1871.

**Receiver Alignment.** The receiver alignment consists of simply peaking all the coils for maximum response to a signal from the transmitter. In order to peak the coils, some sort of monitoring device is required. An oscilloscope or signal tracer is ideal but, in a pinch, a receiver tuned to 455 kHz can be used. Not much gain or sensitivity is needed since the RC receiver IF output is in the 10 to 100 mV range. The detector can be coupled via a small capacitor (10 pF to 100 pF) to pin 15 of the LM1872 and ground. If the scope has a low-capacitance probe, the capacitor is not needed.

Before starting, check all wiring and component placements and their orientation. Once everything is verified, connect a 6-volt DC source to the receiver. With the indicator device connected to pin 15, turn the transmitter on, and adjust the L1 slug until the signal can be seen or heard on the monitoring device. Turn the transmitter off momentarily to verify that the received signal is the genuine article. A shortwave receiver tuned to the RC receiver's crystal frequency can be used to verify the operation of the RC receiver's oscillator is working if no scope is available. A frequency counter can be used if coupled lightly to pin 1 of the IC.

Next, peak L2, T1, and T2 for their maximum responses. The antenna should be connected to the receiver. Use as little signal as possible by keeping the transmitter a suitable distance

away. Be sure to use non-metallic alignment tools and do not force anything—the slugs in T1 and T2 are easily cracked. Once that is done, check the channel outputs for proper operation by activating the transmitter controls and observing the channel responses. Alternately, you can simply hook up the receiver to the device to be controlled and see if everything works as expected.

The motor driver can be checked by hooking a motor to it, and connecting a 6-volt source to the enable and direction inputs to see if the motor can be turned on, off, and reversed. When everything checks, a clip on heat sink should be attached to the LM18293.

**Conclusion.** You can use the RC system in your intended application and experiment as you see fit. This article was intended as an introduction to RC devices and their application, and should serve well either as a stand alone system or as the core of a more powerful system. ■

**IF COLLEGE IS IN YOUR  
CHILD'S FUTURE,  
U.S. SAVINGS BONDS  
SHOULD BE IN YOUR  
PRESENT.**



Ask your employer or banker about saving for college with Savings Bonds. Or write: U.S. Savings Bonds for Education, Department of the Treasury, Washington, DC 20226.

For a recorded message of current rate information, call 1-800-4US BOND • 1-800-487-2663



A public service of this magazine

## FILTER CIRCUITS

(Continued from page 72)

any unwanted phase shifts previously imposed on the signals by other means. The phase-shift filter offers unity gain at all frequencies, but the phase-shift for each signal is a function of its frequency.

**Filter Order.** Filters are characterized by filter type, order, pass-band gain, center frequency, and  $Q$ . We have dealt with filter type; now let's look at the other characteristics.

The rate of attenuation (or slope) at the edge of a response curve differs from one filter to another. The slope is usually expressed in dB/octave (an octave is a factor of 2 in frequency) or dB/decade (a decade is a factor of 10 in frequency). The slope depends on the "order" of the filter; higher-order filters have steeper slopes. So, the higher the order of the filter, the more effectively the filter discriminates between signals of different frequencies. Filter order is usually determined by

the total number of capacitors and inductors in the designed circuit.

The  $Q$  of a filter determines the shape of the amplitude response. As  $Q$  increases, the response becomes more abrupt (sharp). Low- and high-pass filters exhibit peaks in their responses when  $Q$  becomes large. Figure 11 shows the response curves for second-order band-pass (Fig. 11A), low-pass (Fig. 11B), high-pass (Fig. 11C), notch (Fig. 11D), and all-pass (Fig. 11E) filters with various values of  $Q$ .

There is a great deal of symmetry inherent in those graphs. For instance the band-pass and notch-filter amplitude-response curves are symmetrical around  $f_o$ . That means that their gains at  $2f_o$  will be the same as their gains at  $f_o/2$ , their gains at  $10f_o$  will be the same as their gains at  $f_o/10$ , and so on.

The high- and low-pass filter response curves also exhibit symmetry, but with each other rather than with themselves. They are effectively mirror images of each other about  $f_o$ . Thus, the high-pass filter's gain at  $2f_o$  equals that of the low-pass filter at  $f_o/2$ . The

similarities between the various filter functions prove to be quite helpful when designing filters, because it allows the use of similar design guidelines for all filter types.

As the curves for the various filter types imply, the number of possible filter-response curves that can be generated is infinite. The filter responses within a single filter type can vary with respect to their characteristic frequencies, filter order (or roll-off slope), and flatness of the pass-band and stop-band regions. The transfer function chosen for a given application often results from a trade-off between those characteristics. ■



## AIR-CONDITIONER MONITOR

(Continued from page 46)

The two LED's should be mounted on or under the dashboard of the vehicle where they can readily be seen by the driver. To make the connections, run a pair of stranded wires from the circuit board to the LED assembly, one for each indicator. The grounded leads (cathodes) of the LED's can be connected to any metal part of the vehicle.

**Mounting the Temperature Sensor.** Refer to Fig. 7 for the following discussion. It is mandatory that U2 be physically attached to the metal evaporator-return pipe, as close to the firewall as possible. The evaporator-return pipe is one that has the larger diameter, and is connected directly to the accumulator or suction side of the compressor. That pipe is normally cold to the touch when the compressor is operating normally.

The flat side of U2 should be placed

directly against the pipe, being careful that none of the leads can accidentally short to it. Once in place, use some plastic electrical tape to secure the sensor and insulate the leads. Obtain some self-adhesive thermal-insulation material, available from do-it-yourself outlets, and wrap it around the sensor and pipe several times to thermally isolate the sensor from the hot ambient air of the engine compartment. In that way the sensor will respond only to the operating temperature of the pipe.

**Operation.** The Air-Conditioner Monitor is automatically placed in operation each time the compressor is activated. The green LED will be lit only when the compressor is on. In most vehicles, it is normal for the compressor to cycle on and off during mild weather. Under very hot conditions, the compressor should operate just about continuously.

The red LED should not light unless there is a low refrigerant charge or there is some other problem with the

air-conditioning system. If in doubt, have the vehicle examined by a professional air-conditioning technician to verify that the charge is correct or to add refrigerant if necessary. The technician will be able to measure the normal operating temperature of the evaporator return pipe, with the system fully charged.

The trip point of the circuit has been set to 50°F (0.5 volts at the wiper of R5) as adjusted during the preliminary test procedure. If necessary, the adjustment can be set higher or lower to accommodate your vehicle. It is recommended that the trip point be set as low as possible, but not so low as to cause false alarms. In that way, the Monitor will be sensitive to a very small loss of refrigerant.

If the red LED comes on at anytime during operation of the air conditioner, have the system checked as soon as possible. That way, you'll avoid losing a great part of the refrigerant charge should a minor leak develop, and help protect the planet in the bargain. ■

# Market Center™

## Paperback Books

GREAT PAPERBACKS AT SPECIAL PRICES

**COMPUTER HOBBYISTS HANDBOOK—BP251—\$8.95**

Subjects covered include microprocessors and their register sets; interfacing serial, parallel, monitor, games and MIDI ports; numbering systems, operating systems and computer graphics. While the book is aimed at the computer hobbyist, it should also prove useful to anyone who intends to use a computer to follow their interests.

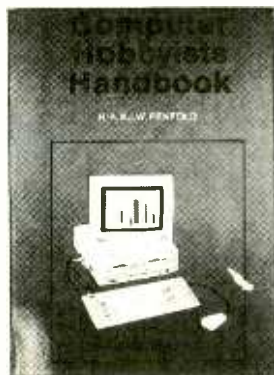

**INTERNATIONAL RADIO STATIONS GUIDE—BP255—\$9.95**

Provides the casual listener, amateur radio DXer and the professional radio monitor with an essential reference work designed as a guide for the complex radio bands.

Includes coverage on Listening to Short Wave Radio, ITU Country Codes, Worldwide Radio Stations, European Long Wave and Medium Wave Stations, Broadcasts in English and more.

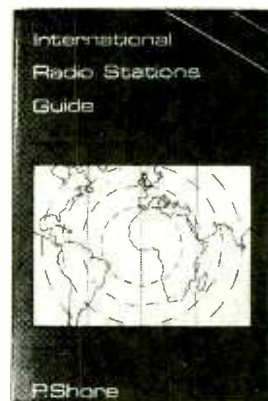

**Further Practical Electronics Calculations and Formulae**



**FURTHER PRACTICAL ELECTRONICS CALCULATIONS—BP144—\$9.00**

450 pages crammed full of all the formulae you are likely to need. Covers Electricity, Electrostatics, Electromagnetism, Complex Numbers, Amplifiers, Signal Generation and Processing, Communications, Statistics, Reliability, Audio, Radio Systems, Transmission Lines, Digital Logic, Power Supplies. Then there's an appendix of Conversion Factors, Mathematical Formulae and more.

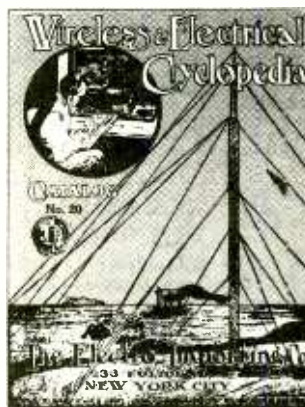

**WIRELESS & ELECTRICAL CYCLOPEDIA—ETT1—\$5.75**

A slice of history. This early electronics catalog was issued in 1918. It consists of 176 pages that document the early history of electricity, radio and electronics. It was the "bible" of the electrical experimenter of the period. Take a look at history and see how far we have come. And by the way, don't try to order any of the merchandise shown, it's unlikely that it will be available. And if it is, the prices will be many times higher.

**ELECTRONIC TECHNOLOGY TODAY INC.**  
P.O. Box 240, Massapequa Park, NY 11762-0240

Name \_\_\_\_\_  
Address \_\_\_\_\_  
City \_\_\_\_\_ State \_\_\_\_\_ Zip \_\_\_\_\_

PE894

**SHIPPING CHARGES IN USA AND CANADA**

\$0.01 to \$5.00	.....	\$1.50
\$5.01 to \$10.00	.....	\$2.50
\$10.01 to \$20.00	.....	\$3.50
\$20.01 to \$30.00	.....	\$4.50
\$30.01 to \$40.00	.....	\$5.50
\$40.01 to \$50.00	.....	\$6.50
\$50.01 and above	.....	\$8.00

**SORRY No orders accepted outside of USA & Canada**

Total price of merchandise	.....	\$ _____
Shipping (see chart)	.....	\$ _____
<b>Subtotal</b>	.....	\$ _____
Sales Tax (NYS only)	.....	\$ _____
<b>Total Enclosed</b>	.....	\$ _____

**All payments must be in U.S. funds**

Number of books ordered

# ALFA ELECTRONICS

HIGH QUALITY TEST EQUIPMENT  
BEST PRICE



**DMM 89 \$199.95**  
**Most Advanced DMM**  
*All Purpose & Communication*  
-80.7 to 81.4 dBm with 4Ω-1200Ω  
20 reference impedances  
True RMS  
Frequency counter: 0.01Hz-10MHz  
Capacitance: 1pF-50,000μF  
Measure AC volt to 20kHz  
5000 counts, 0.1% accuracy  
Auto/manual range, fast bar graph  
Min/Max/Ave/DH/Relative/Zoom  
Auto power off  
Input warning  
Splash proof  
Volt, amp, ohm, logic, diode, continuity  
Ruggedized case  
Rubber holster included



**DMM 2360 \$119.95**  
**DMM+LCR Meter**  
*Very Versatile DMM*  
Inductance: 1μH-40H  
Capacitance: 1pF-40μF  
Frequency: 1Hz - 4MHz  
Temperature: -40-302 °F  
TTL Logic Test: 20MHz  
Diode, Continuity  
Volt, Amp, Ohm  
3999 count display  
Auto power off  
Ruggedized case  
Rubber Holster \$8.00  
Temperature probe \$7.00



**DMM 21 \$74.95**  
Inductance: 1μH-40H  
Capacitance: 1pF-200 F  
Frequency: 1Hz-1MHz  
Volt, amp, ohm, diode, continuity  
3999 count display  
TTL logic, HFE  
Peak hold  
Ruggedized case  
Rubber holster \$8.00  
  
Full line of DMMs, economy, compact, ruggedized, solar cell, automotive, heavy duty, industrial starts from \$15.95

**Fluke Multimeter**  
Fluke 12 \$84.95  
Holster C-10 \$10  
Fluke 70 II \$67.5  
Fluke 73 II \$94  
Fluke 75 II \$129  
Holster C-70 \$16  
Fluke 77 II \$149  
Fluke 79 II \$169  
Fluke 29 II \$169  
  
Fluke 83 \$225  
Fluke 85 \$259  
Fluke 87 \$267  
  
Fluke 97  
Scope Meter \$1785



**LCR Meter 131D \$229.95**  
**Most Advanced LCR**  
Dual display: L/Q or C/D  
Inductance: 0.1μH-1000H  
Capacitance: 0.1pF-10,000μF  
Impedance: 1mΩ-10MΩ  
0.7% basic accuracy  
Dissipation factor & Q factor  
Serial & parallel mode  
Relative mode for comparison and to remove parasitics  
Statistics, tolerance  
Best for design, incoming testing & production  
SMD and chip component test probe \$25.00



**LCR Meter 814 \$189.95**  
**Best Resolution LCR**  
Inductance: 0.1μH-200H  
Capacitance: 0.1pF-20,000μF  
Resistance: 1mΩ-20MΩ  
1% basic accuracy  
Dissipation factor indicates leakage in capacitor and Q factor in inductor  
Zero adjustment to reduce parasitics from test fixture  
Best for high frequency RF and surface mount components  
SMD and chip component test probe \$25.00, Deluxe carrying case \$5.00

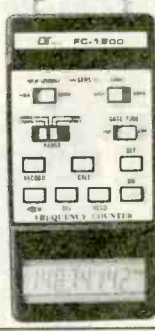

**Frequency Counter FC-1200 \$129.95**  
Frequency: 0.1Hz-1.25GHz  
Display: 8 digit LCD  
Period: 0.1μs-0.1s  
Records Max/Min/Average  
Data hold, relative mode  
Telescoping antenna \$8.00  
Deluxe case \$5.00  
  
Also Available:  
AC/DC clamp meter, Light meter, Thermometer, pH meter, High voltage probe, Digital caliper, Anemometer, Electronic scale, Force gauge, Tachometer, Stroboscope, Humidity & EMF adapter, Sound level meter, Frequency counter, SWR/field strength/power meter, Dip meter

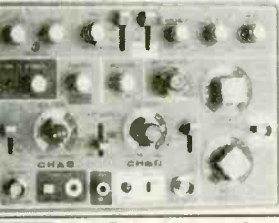
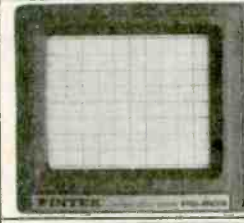

**20 MHz Oscilloscope with Delay Sweep PS-205 \$429.95**  
Dual Trace, Component test, 6" CRT, X-Y Operation, TV Sync, Z-Modulation, CH2 Output, Graticule Illum, 2 probes each has x1, x10 switch. Best price with delay sweep.  
PS-200 20 MHz DUAL TRACE \$339.95  
PS-400 40 MHz DUAL TRACE \$494.95  
PS-405 40 MHz DELAY SWEEP \$589.95  
PS-605 80 MHz DELAY SWEEP \$769.95  
Scope Probe: 60MHz x1, x10 \$13, 100MHz x1, x10 \$22

**20 MHz Digital Storage Oscilloscope DS-203 \$729.95**  
Switchable between digital and analog modes  
2 K word per channel storage  
Sampling rate: 10 M sample/sec  
8 bit vertical resolution (25 Level/div)  
Expanded Timebase 10ms/div - 0.5 s/div  
Refresh, Roll, Save all, Save CH2, Pre-Trig  
Plotter Control  
250MHz x1, x10 \$29, 250MHz x100 \$39

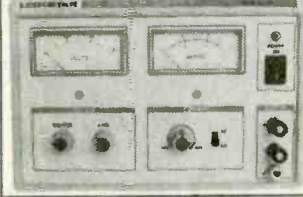

**DC Power Supply PS-303 \$159.00**  
**0-30 VDC, 0-3A output**  
Constant voltage & constant current mode  
0.02% + 2mV line regulation  
0.02% + 3mV load regulation  
1 mVrms noise and ripple  
Short circuit and overload protected  
PS-8200 with digital voltmeter \$179.00  
Also available: 30V/5A, 60V/3A, 60V/5A, 16V/10A, 30V/10A

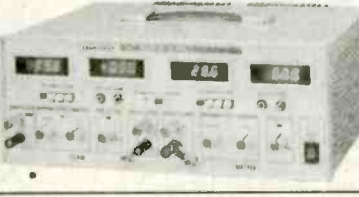

**DC Power Supply Triple Output PS-8202 \$499.95**  
Two 0-30 VDC, 0-3A outputs  
One fixed 5VDC, 3A output  
Capable of independent or tracking operation  
Constant voltage and constant current mode  
Four digital meters for volt and current display  
Excellent regulation and low ripple  
Short circuit and overload protected  
Also available: 30V/5A, triple output \$549.95  
Dual tracking 30V/3A, 30V/5A, 60V/3A, 60V/5A



**RF SIGNAL GENERATOR SG-4160B \$119.00**  
100 kHz-150MHz sinewave in 6 ranges  
RF Output 100mVrms to 35 MHz  
Internal 1kHz, External 50Hz-20kHz  
AM modulation  
Audio output 1 kHz, 1 Vrms

**AUDIO GENERATOR AG-2601A \$119.00**  
10Hz - 1MHz in 5 ranges  
Output: 0-8Vrms sinewave  
0-10Vp-p squarewave  
Synchronization: ±3% of oscillation frequency per Vrms  
Output distortion:  
0.05% 500Hz - 50kHz  
0.5 % 50Hz - 500kHz  
Output impedance: 600 ohm

**FUNCTION GENERATOR FG-2100A \$169.95**  
0.2 Hz - 2 MHz in 7 ranges  
Sine, square, triangle, pulse and ramp  
Output: 5mV-20Vp-p  
1% distortion, DC offset ±10V  
VCF: 0-10V control frequency to 1000:1  
  
**FUNCTION GEN./COUNTER FG-2102AD \$229.95**  
Generates signal same as FG-2100A  
Frequency counter 4 digits  
Feature TTL and CMOS output

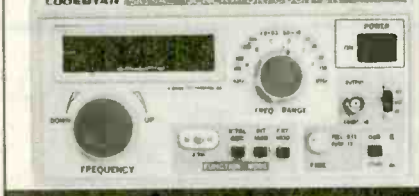

**RF SIGNAL GEN./COUNTER SG-4162 AD \$229.95**  
Generates RF signal same as SG-4160B  
Frequency counter 1Hz - 150 MHz for internal and external source  
Sensitivity <50mV

**AUDIO GEN./COUNTER AG-2603AD \$229.95**  
Generates audio signal same as AG-2601A  
Frequency counter 1Hz-150MHz for internal and external sources  
Sensitivity <50mV

**SWEEP FUNCTION GEN./COUNTER \$329.95**  
0.5Hz to 5 MHz in 7 ranges  
Sweep: Linear 10:1/Log 10:1 20ms to 2s  
AM Modulation  
Gated Burst, Voltage Control Generator  
Generator Control Voltage & 6 digit counter  
1Hz-10MHz for internal & external sources

**ALFA ELECTRONICS**  
741 Alexander Rd., Princeton, NJ 08540

(800) 526-2532/(609) 520-2002 15 DAY MONEY BACK GUARANTEE. 1 YEAR WARRANTY  
FAX: (609) 520-2007 CALL OR WRITE FOR FREE CATALOG AND BEST OFFER.  
Visa, Master Card, American Express, COD. Purchase Order Welcome



# Electronic Chemicals

## for Manufacturing, Maintenance & Service

### The Next Generation Contact Cleaners, Conditioners and Preservatives

Even the finest equipment cannot guarantee noise-free operation. One "dirty" connection anywhere in the signal path can cause unwanted noise, distortion and signal loss. Considering the hundreds (if not thousands) of connections in electronic equipment today, it is only a matter of time before they begin to fail.

**ProGold** and **DeoxIT** increase the performance and reliability of electrical components and equipment. They provide long-lasting protection, reducing the expense of repeated cleaning with expensive ozone-depleting solvents. As a general rule, use **ProGold** for best performance and protection on plated surfaces and **DeoxIT** as a general purpose treatment.

### ProGold™ Conditioner & Preservative

**ProGold** outperforms all other contact cleaners, enhancers and lubricants. Due to its unique properties, not only does it deoxidize and clean surface contamination, but it penetrates plated surfaces and molecularly bonds to the base metals. This increases conductivity and contact surface area and reduces arcing, RFI, wear and abrasion - the major cause of intermittent signals, distortion and signal loss. **ProGold** is the only product that conditions & protects plated surfaces and their base metals.



### DeoxIT™ & PreservIT™

#### Deoxidizes, Seals & Protects Electrical Connections

**DeoxIT** is a fast-acting, deoxidizing solution that cleans, preserves, lubricates & improves conductivity on all metal surfaces. Use as a general treatment for connectors, contacts & other metal surfaces.

**PreservIT** seals, lubricates and preserves metal surfaces for protection from oxidation and contamination. For use on clean/new surfaces or those pre-cleaned with **DeoxIT**.

Both have excellent migration properties that coat the surfaces and protect them from future oxidation & contamination. These formulas contain improved deoxidizers, preservatives, conductivity enhancers, anti-tarnishing compounds, arcing & RFI inhibitors and provide extended temperature range.



### OpticALL™ StaticALL™

**OpticALL** cleans, polishes and eliminates static electricity on optical viewing surfaces. **OpticALL** is also recommended as a general purpose antistatic cleaner on plastic, glass and metal surfaces. **StaticALL** neutralizes static build-up caused by friction & low humidity conditions. Use on carpets, floors, clothing & other static generating surfaces.



### DustALL™ FreezALL™

**DustALL** quickly & safely removes dust, lint & particles from sensitive electronic equipment, computers, lab equip., optical grade surfaces & other mechanisms & equipment. **FreezALL** quickly and safely cools circuits to -54°C. Locates intermittent components due to heat failure and hairline cracks on PCBs.



### MechanicALL™

High Penetrating Anti-Corrosive Anti-Tarnishing Cleaner & Lubricant. Lubricates & Protects. Displaces Moisture, Stops Squeaks, Migrates & Coats Entire Surface.



### ElectricALL™

Rejuvenating Solution For All Electrical Applications. Cleans, Preserves, Improves & Protects Connections, Removes Corrosion & Oxidation, Reduces Wear, Abrasion, Arcing & RFI.



### CaiKleen® 41

Approved Freon TF replacement. Cleaning solvent for equipment and parts. Harmless to metal and most plastics & elastomeric parts. No residue, non-flammable, HCFC blend.



### CaiKleen® TRP

For degreasing, cleaning & defluxing equipment and parts. Removes oil, grease, dirt and contaminants including rosin flux from PCBs, components and metal parts. Biodegradable.

### CaiKleen® IPA

Ultra-pure Isopropyl alcohol. Cleaning & degreasing solvent for removal of oil, grease & dirt from instruments, equipment & parts. Use on tape heads, discs, guides, switches, connectors, relays, and other parts for general cleaning.

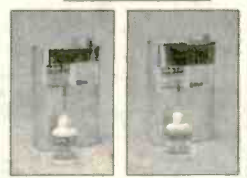

### CaiLube® 360

Finest quality cutting and lubricating oil for use on various materials; cast-iron, stainless, titanium, gold, platinum, non-ferrous metals, synthetics, etc..

### CaiLube® X-10S Instrument Oil

Contains silicone. Finest quality instrument oil for use on rubber, plastics and metals. Non-gumming, rust inhibiting, long lasting lubrication.

### CAIG Products ... used by those who demand the best!

- |                    |                 |                    |
|--------------------|-----------------|--------------------|
| Boeing             | Honeywell       | Switchcraft        |
| Dolby Laboratories | John Fluke Mfg. | Tektronix          |
| E.I. Dupont        | McIntosh Labs   | Texas Instruments  |
| Federal Express    | Motorola        | Wayne-Dresser      |
| General Electric   | Nakamichi       | Xerox Corp.        |
| Hewlett Packard    | RCA             | ... and many more! |

Since 1956  
  
 16744 West Bernardo Drive  
 San Diego, CA 92127-1904  
 TEL: (619) 451-1799  
 FAX: (619) 451-2799

**1-800-CAIG-123**

CIRCLE 31 ON FREE INFORMATION CARD

www.americanradiohistory.com

August 1994, Popular Electronics

# AMAZING Electronic and Scientific Products

## Mystery Levitating Device!



Remember War of the World? Objects float in air and move to the touch. Defies gravity, amazing gift, conversation piece, magic trick or great science project.

ANT1K Easy to Assemble Kit / Plans ..... \$19.50

## Laser Ray Gun

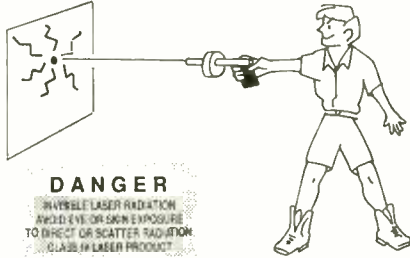

Advanced project produces a burst of light energy capable of burning holes in most materials. Hand-held device uses rechargeable batteries. 500 joules of flash energy excite either a neodymium glass, yag or other suitable 3" laser rod. This is a dangerous CLASS IV project (individual parts/assemblies available).

LAGUN1 Plans ..... \$20.00  
LAGUN1K Kit / Plans ..... Price on Request

## Extended Play Telephone Recording System



READY TO USE! Automatically controls and records on our X-4 extended play recorder, taping both sides of a telephone conversation. Intended for order entry verification. Check your local laws as some states may require an alerting beeper.

TAP20X Ready to Use System ..... \$129.50



## Shocker Force Field/Vehide Electrifier

Neat little device allows you to make hand and shock balls, shock wands and electrify objects, charge capacitors. Great payback for those wise guys who have wronged you!

SHK1KM Easy to Assemble Electronic Kit ..... \$24.50



## Blaster Pulsar

Pocket-sized wand produces 100,000 watts of power for personal defense, field and lab use, etc. BLS3 Plans ..... \$10.00  
BLS3K Kit / Plans ..... \$69.50

## Homing / Tracking Transmitter

Beeper device, 3 mile range. HOD1 Plans ..... \$10.00 HOD1K Kit / Plans ..... \$49.50

## Listen Through Walls, Floors

Highly sensitive stethoscope mike. STETH1 Plans ..... \$8.00 STETH1K Kit/Plans ..... \$44.50



NEW!

## INFINITY TRANSMITTER++

### Room Monitor / Phone Line Grabber

ALL NEW! The Ultimate in Home or Office Security & Safety! Simple to Use! Call your home or office phone, push a secret tone on your telephone keypad to access either: A. On premises sounds and voices; or B. Existing telephone conversation with break in capability for emergency messages. CAUTION: Before assembly or use, check legalities with your state Attorney General's office as you may require "beepers" or other 3rd party alerts.

TELEGRAB1 Plans Only ..... \$10.00  
TELEGRAB1K Kit / Plans ..... \$99.50

## Ultrasonic Blaster

Laboratory source of acoustical shock waves. Blow holes in metal, produce "cold" steam, atomize liquids. Many cleaning uses for PC boards, jewelry, coins, small parts, etc.

ULB1 Plans ..... \$10.00 ULB1K Kit/Plans ..... \$69.50



## 100,000V Intimidator / Shock Wand Module

Build an electrical device that is affective up to 20 feet. May be enclosed for handheld, portable field or laboratory applications. ITM2KM Easy-to-Assemble Electronics Kit ..... \$49.50  
ITM2 Plans only, credit-able to kit ..... \$10.00



## Ion Ray Gun

Projects charged ions that induce shocks in people and objects without any connection! Great science project as well as a high tech party prank. IOG3 Plans ..... \$8.00  
IOG3K Kit/Plans ..... \$69.50

## Invisible Pain Field Generator

Shirt pocket size electronic device produces time variant complex shock waves of intense directional acoustic energy, capable of warding off aggressive animals, etc. IPG7 Plans ..... \$8.00 IPG7K Kit/Plans ..... \$49.50  
IPG70 Assembled ..... \$74.50



## 1000 Ft++

## Potato Cannon

NOT A TOY. Uses electronic or piezo ignition. CAUTION REQUIRED! POT1 Plans ..... \$10.00 (Dangerous Product)

## FireBall Gun

Shoots flaming ball - two shot capacity Great for special effects and remote fire starting. CAUTION REQUIRED! FIREBALL Plans (Dangerous Product) ..... \$10.00



## TV & FM Jocker / Jammer

Shirt pocket device allows you to totally control and remotely disrupt TV or radio reception. Great gag to play on family or friends. Discretion required. EJK1KM Easy to Assemble Electronic Kit ..... \$24.50



## Visible Beam Laser

High brightness red HeNe laser visible for miles. Produce your own light show! Projects a visible beam of red lite clearly visible in most circumstances. Can be used to intimidate by projection of a red dot on target subject. Also may be used to "listen in" using our laser window bounce method #LLIS1 below. Easy to build module makes A working visible laser!

LAS1KM Kit w/1mw Laser Tube, Class II ..... \$69.50  
LAS3KM Kit w/2.5mw Laser Tube, Class IIIa ..... \$99.50



## "Laser Bounce" Listener System

Allows you to hear sounds from an area via a lite beam reflected from a window or other similar objects. System uses our ready-to-use LATR1 Laser Terminator gun site as the transmitter. The receiver section is supplied as an easy-to-build kit, including our cushioned HS10 headsets. LLIST2 Plans ..... \$20.00  
LLIST1K Kit of Both Transmitter and Receiver ..... \$199.50  
LLIST20 Assemble with Laser Gun Site ..... \$299.50

3mw Visible Red Pocket Laser Utilizes our touch power control! VRL3KM Kit / Plans ..... \$74.50



## Electronic Hypnotism

Puts subjects under control using highly effective electronic stimuli. Useful for parties and entertainment but must be used with caution. Includes valuable text book reference and plans. EH2 Plans and Text Book ..... \$19.50

## Pocket Sized Night Viewer

Uses Low Level Starlight to See in the Dark! • Low Cost • Ultra-Hi Lite Amplification! • Auto Brightness Control • Limited Amount Available • Made in USA • Night surveillance • Animal studies, etc. Can be used to fly an airplane or drive a car! PKV7 Plans ..... \$15.00  
PKV7K Easy to Assemble Kit ..... Price on Request  
PKV70 Ready to Use ..... Price on Request



## 3 Mi FM Wireless Microphone

Subminiature! Crystal clear, ultra sensitive pickup transmits voices and sounds to FM radio. Excellent for security, monitoring of children or invalids. Become the neighborhood disk jockey, or go "under cover" using our sunglasses FM radio (see catalog). FMV1 Plans ..... \$7.00  
FMV1K Kit and Plans ..... \$39.50  
SUGL10 Sunglasses with built in FM Radio ..... \$29.50



## Telephone Transmitter - 3 Mi

Automatically transmits both sides of a telephone conversation to an FM radio. • Tunable Frequency • Undetectable on Phone • Easy to Build and Use • Up to 3 Mile Range • Only transmits during phone use. VWPM7 Plans ..... \$7.00  
VWPM7K Kit/Plans ..... \$39.50

CATALOG With many more items! Free with Order or send \$1 P&H

Order by Mail or by 24 Hour Orders-Only Phone 800-221-1705

Dept PEM16, Box 716, Amherst, NH 03031  
Phone: 603-673-4730 FAX 603-672-5406  
MC, VISA, COD, Checks accepted Please add \$5.00 Shipping & Handling

INFORMATION UNLIMITED

# Simply A Superior 1.3 GHz Spectrum Analyzer

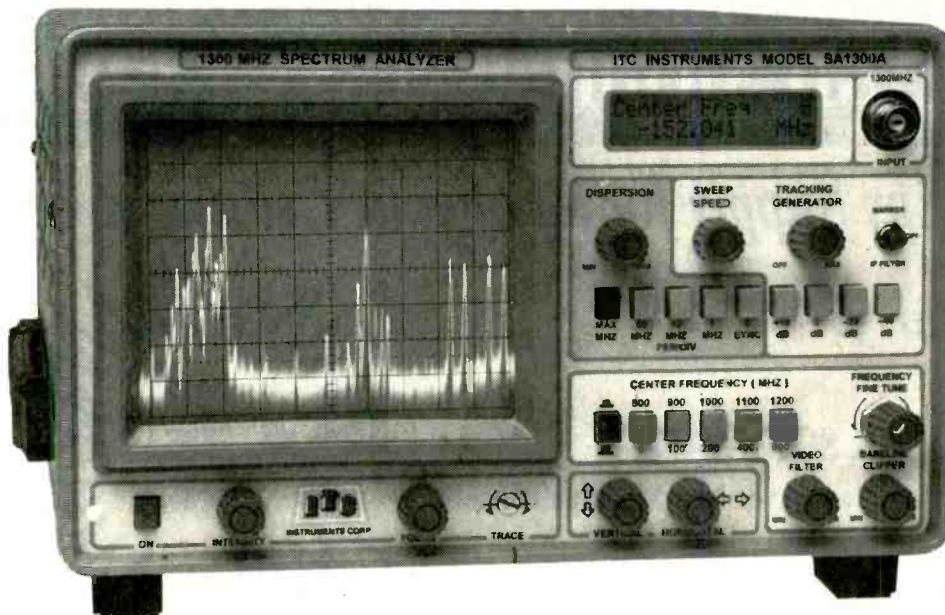

**1-1300 MHz *In One Sweep* \$1,895.**

**MADE IN USA** -10KHz Resolution Band Width -7 Digit Center Frequency Display

MARINE, TWO-WAY, HAM, AM FM SW BROADCAST RADIO - CATV, SATELLITE. SYS., SURVEILLANCE  
TUNE DUPLEXERS, AMPS, FILTERS, SECURITY TRANS, & RECEIVERS - EMI, RFI, FCC, TESTING

**EXCLUSIVE DISPERSION ZOOM**  
ITC SA Series exclusive Dispersion Zoom lets you zoom in on **any Center Frequency** signal, from any one of five calibrated Dispersion positions. Preset at >140 MHz, 50MHz, 10MHz 1MHz and zero MHz per division. The SA1300A displays greater than 1300 MHz on the screen at one time yet allows instant zoom to any Dispersion Scan Width as low as zero MHz per div. Allowing for total control over all **Dispersion Scan Widths** settings.

**80 dB ON SCREEN**

130 dB total Dynamic range **110 dBm Sensitivity**. At Narrow and Wide Band Width settings. Performance you would expect only from a \$10,000 Analyzer.

**ULTIMATE LOW COST ANALYZER**  
ITC Spectrum Analyzers are the best performance to price ratio Analyzers on the market today. No other low cost Analyzer comes close to the Superior performance and quality of an ITC Analyzer. **Total flexibility and ease of operation.** SA1300A gives you full control over the Resolution Band Width and Freq. Span widths. Plus Vertical Position, Baseline Clipper, Sweep Speed, Video Filter, 4 Input Attenuator settings, 10 Frequency Select settings.

**MODEL SA1800B 1800 MHz**  
Covers 1-1300 MHz and 850-1850 MHz in one sweep. Ideal for Satellite service. The **SA1800B** has the same general specifications as the model SA1300A.

**INTRODUCTORY OFFER**  
**SA1300A & OPT.s 1, 3, 6**  
**ONLY \$1895.00** note 1

**SA1800B & OPT.s 1, 3, 6**  
**ONLY \$2295.00** note 1  
\$1995.00 Opt. 1, 6 ONLY

SA1300A	\$1995.00
SA1800B	\$1895.00
OPT. 1 50MHz MARKER	\$200.00
OPT. 3 +/- 5KHz Res B.W	\$350.00
OPT. 5 1000 MHz Tracking Generator	\$250.00
OPT. 6 7 Digit Center Frequency Display	\$300.00

Note 1: Introductory Price for limited time only.

**TAKE ADVANTAGE**  
**CALL 1-800-566-1818**

To: Order - For Information & Special Intro. Offer  
Terms MC, VISA, AE, Check, COD, PO (OAC), LC, Transfer

**DISTRIBUTED BY: ADVANTAGE INSTRUMENTS CORP.**

3817 S. CARSON ST. # 818 CARSON CITY NV. 89701  
1-800-566-1818 702-885-0234 FAX 702-885-7600

PRICES & SPECIFICATIONS SUBJECT TO CHANGE WITHOUT NOTICE OR OBLIGATION. F.O.B. CARSON CITY NV. NV. RESIDENTS ADD SALES TAX. 97

CIRCLE 138 ON FREE INFORMATION CARD

# CELLULAR SOFTWARE AND MODIFICATION GUIDES

*Call Spy Supply for all of your Cellular needs!*

*We Carry:*

## CELLULAR SOFTWARE

(We have the software to do New Motorola Phones)

## CELLULAR CABLES

(For the Motorola, Panasonic, and Nokia Phones)

## CELLULAR MODIFICATION GUIDES

(Covers all cellular manufacturers)

## CELLULAR PHONES

(We carry a complete line of cellular phones)



## FREE TECHNICAL SUPPORT!

We now offer Cellular Phones cloned with your existing number! Buy a handheld, transportable or car mounted phone ready to go and have only one monthly bill!

### *Don't Get Ripped Off!*

Before you buy our competitor's manual, call and ask if they offer **FREE TECHNICAL SUPPORT**

### **SPY SUPPLY**

Find out why the  
CIA - FBI - DEA -  
SECRET SERVICE

Have ordered from our catalog  
To receive yours, send \$5.00 to:

### **SPY SUPPLY**

1212 Boylston St. #120  
Chestnut Hill, MA 02167

**SPY SUPPLY, 1212 Boylston St. #120, Chestnut Hill, MA 02167**

**(617) 327-7272**

*Sold for educational purposes only*



# NEW OPTOSCAN 456

Computer Interface for the PRO-2005/6 Scanner



Why spend \$1300\* to get a scanner with a computer interface? For only \$299 make the outstanding PRO-2005/6 from Radio Shack the top performer under computer control.

*A new standard for scanning is here now!*

#### Features:

- High Speed 25 Channels per Second Scanning!
- CTCSS & DCS Controlled Scanning and Logging
- DTMF Decode & Log with Channel and Time
- PC Software for Computer Log, Scan & Search
- RS-232C CI-V Interface with Multi-Radio Capability
- No Drill or Solder Installation Video

It's a well known fact that the microprocessor made it possible to develop the programmable scanner in 1974. Virtually all programmable scanners could have had (many feel should have had) a computer interface. It's as if the scanner manufacturers had a secret meeting on some deserted island and agreed to put computer interfaces on only a few of the most expensive radios. Why are they trying to limit the number of computer controlled scanners? What don't they want you to listen to or to find?

Well they didn't invite Optoelectronics to the big secret meeting. We don't agree to keep computer scanning expensive! The OptoScan 456 makes computer controlled scanning available at half the price with unbeatable performance and features.

The OptoScan 456 includes every thing you need to easily convert the superb Realistic PRO 2005/6 scanners into computer controlled screamers. Hardware, cables and software for the PC is included for the introductory price of \$299. Step by step video instructions show installation details without drilling, cutting or soldering. Simple hand tools are all you need.

Features such as CTCSS, DCS, and DTMF decode give the OS456 superior performance.

#### Why Computer Controlled Scanning?

The computer makes the scanner *really* perform, simply and effortlessly. Even when you are not around the computer can continue to search out those frequencies you want to listen to and record them into virtually unlimited numbers of memory channels. The OptoScan 456 becomes a relentless monitor of the VHF/UHF frequency spectrum searching out illusive signals. The OptoScan software makes using the PRO-2005/6 easier and much less confusing than using the front panel controls. Complex store, search, and scan features are more easily accessible through software menus.

#### Why Decode CTCSS Tones and DCS Codes?

Virtually all non-trunked VHF/UHF two way radio uses squelch tones or codes for privacy and efficiency. These sub audible tones and codes are identifying signatures that can aid in following transmissions across channels. The OS456 decodes tones, codes and touch-tone characters to provide the Radio Monitoring Enthusiast with a powerful new tool in sorting out who is talking, accessing a repeater and in general what is going on. Like the computer interface, tone decode should have been built into the radio but wasn't. Optoelectronics has produced the OptoScan 456 to make the PRO-2006 family radios perform to a new standard that no one else can match for any price!

Complete Installation Kit, Model OS465, includes the assembled and tested controller board, mounting hardware, cables, OptoScan 456 software for the PC and the installation video

Introduction Price  
**\$299**

Complete OptoScan 456 modified PRO-2006 with software and cables is available from the Electronic Equipment Bank and other radio and scanner dealers. Call for price and availability. 1-800-368-3270, 703-938-3350 • 323 Mill Street NE, Vienna VA 22180

# OPTOELECTRONICS

In FL: 305-771-2050 FAX: 305-771-2052 • 5821 NE 14th Avenue, Fort Lauderdale, FL 33334  
5% Ship/Handling (Max \$10) U.S. Canada. • 15% outside continental U.S. • Visa, Master Card, C.O.D., Cash or Money Order only.

Order Toll Free

## 1-800-327-5912

CIRCLE 43 ON FREE INFORMATION CARD

# LATEST TECHNOLOGY

- DESCRAMBLERS
- CONVERTERS
- COMBINATION UNITS

**WE'LL BEAT ANY PRICE!**

## LATEST DESCRAMBLER MODELS

Add On Descrambler for all JERROLD Systems (Except Base Band) Guaranteed to Work Anywhere Coast to Coast. (Model JD-3)

~~\$125~~  
**\$89** 6-10  
 \$119 1-5

Add On Descrambler For All PIONEER Systems. Guaranteed to Work Anywhere Coast to Coast. (Model PD-3)

~~\$125~~  
**\$89** 6-10  
 \$119 1-5

Add On Descrambler For All SCIENTIFIC ATLANTA Systems (Except 8570, 8590, 8600). Guaranteed to Work Anywhere Coast to Coast. (Model SAD-3)

~~\$125~~  
**\$89** 6-10  
 \$119 1-5



**BRAND NEW 1 YEAR WARRANTY**

### SCIENTIFIC ATLANTA 8580

- Features*
- Wireless Remote Control
  - Favorite Channel Recall
  - Parental Lockout

**\$259** 6-10

**BRAND NEW 1 YEAR WARRANTY**

**\$289** 1-5

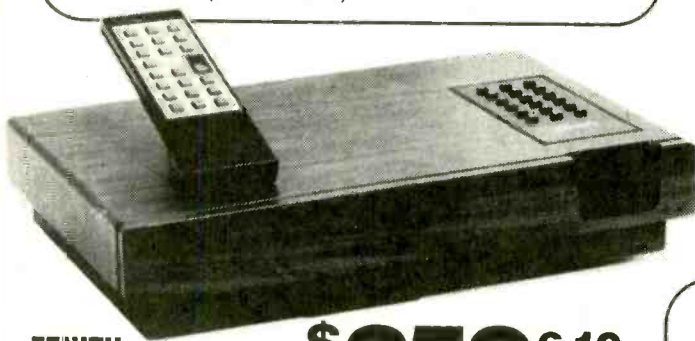

### ZENITH

*Features*

- Wireless Remote Control
- 550MHz (99 Channel) capacity
- Volume Control
- Parental Lock-Out
- Programmable Favorite Channel Memory

**\$259** 6-10

**\$289** 1-5

## ADD ON DESCRAMBLERS

	1-5	6-10
FTB-3	49.00	39.00
TVT OR TBI	55.00	47.00
SA-3	59.00	49.00
KN12-3	59.00	49.00
MLD1200-3	49.00	39.00

## CONVERTERS

	1-5	6-10
PANASONIC 1453G	79.00	69.00
JERROLD DQN7-3	75.00	65.00
STARGATE 2001	75.00	65.00

*Call for other models*



**DPV7 & DBB7  
 8590 & 8600**  
 Call for availability & prices



1470 OLD COUNTRY ROAD,  
 SUITE 315 - P.E.  
 PLAINVIEW, NY 11803  
 NO NY SALES

**FREE COLOR CATALOG!**  
**1-800-950-9145**

Model Close Out  
Reg. \$59.95  
**Sale \$24.00\***  
Item # X3800 ▶

**Full Range DMM**

- 5 DCV ranges  $\pm 0.5\%$
- 5 ACV ranges  $\pm 0.8\%$
- 7 DCA ranges  $\pm 0.5\%$
- 7 ACA ranges  $\pm 1\%$
- 6 OHM ranges  $\pm 0.8\%$
- Diode Tester
- Trans. Tester
- Continuity Buzzer
- Highly Visible Yellow Color
- 1 Year Warranty

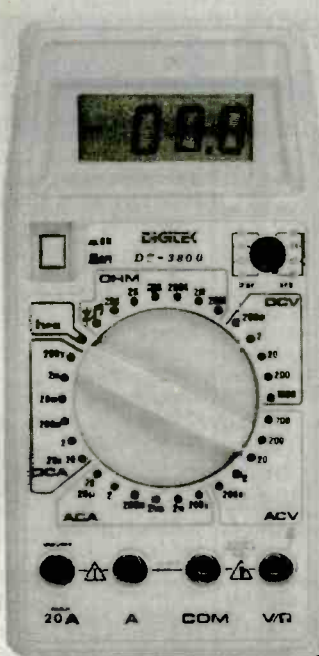

Reg. \$105.95  
**Sale \$89.00\***  
Item # X3500 ▶

**Auto-Range DMM  
w/Capacitance**

- CPU controlled with auto power off function
- 3.75 digit jumbo LCD (max reading 3999)
- 42 segment high speed bar graph
- Full auto-ranging measurement
- Offset adjustment
- Data hold and data memory function
- MIN/MAX hold function
- Auto capacitance measurement 1pF to 40 $\mu$ F in 5 ranges
- Auto frequency measurement up to 1 MHz in 5 ranges
- Safety design according to IEC Publication 348
- 1 Year Warranty

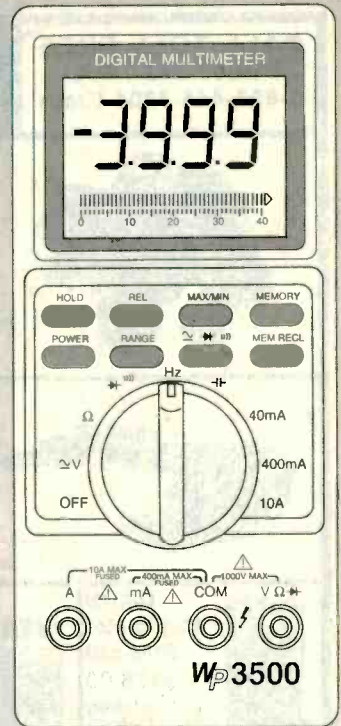

Reg. \$45.95  
**Sale \$29.00\***  
Item # X2600

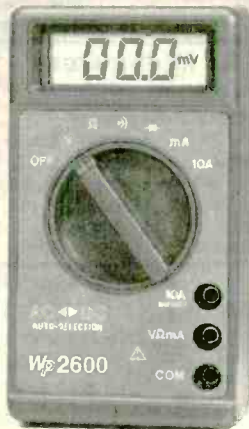

**Affordable  
Auto-Ranging**

- Automatic AC/DC Mode Selection
- DC voltage 0.2V to 1000V in 5 ranges
- AC voltage 2V to 700V in 4 ranges
- DC and AC current 200mA and 10A
- Audible continuity check & Diode Tester
- Yellow Case
- 1 Year Warranty

Reg. \$39.95  
**Sale \$29.00\***  
Item # X1000



**Shoreline  
INSTRUMENTS**

- 2000 Count Digital Display
- 11 Ranges - AC/DC V, mA,  $\Omega$
- Diode Tester and Continuity Beeper
- Auto Shut-off
- Alligator Clip for Easy Measuring
- 1 Year Warranty
- Attractive Gray Case

**Versatile DMM  
w/ Capacitance**

- Large LCD Display
- DCV accuracy 0.5%
- Diode test, continuity check with buzzer sound
- Transistor hFE test
- All ranges overload protected
- Rugged case, drop proof
- Capacitance measurement, 1pF-2 $\mu$ F in 5 ranges
- Resistance measurement up to 200M
- Auto power off
- Yellow Case
- 1 Year Warranty

Reg. \$54.95  
**Sale \$39.00\***  
Item # X3910 ▶



Orders Only Please  
**800-597-5929**  
24 hours a Day

Technical/Product Line  
800-470-WIND (9463)  
24 Hour Fax Order Line  
408-987-7735

or send Check or Money order  
\* CA customers please add Sales Tax  
\* Shipping & Handling \$4.00  
\* Meters are shown about 1/2 Size

\* Quick Delivery via U.S. Priority Mail  
\* All Fax Orders -Free Shipping  
Include: Name, Add., Ph#, Card#, Exp. Date, Item #

Don't Pay Out of This World Pricing for  
Your Next Voltage Meter..... Call Windward First

**Windward  
Products**

We Stand Behind our Products  
Satisfaction Guaranteed

P.O. Box 378 , Moffett Field, CA. 94035

**CALL TOLL FREE**  
1-800-292-7711  
1-800-445-3201 (Can)

# C&S SALES

## EXCELLENCE IN SERVICE

**WRITE FOR  
FREE CATALOG**



**Line Tracker  
MV-963  
\$52.95**  
(Infra-red Sensor)  
The robot follows  
a black line  
on white paper  
Preassembled PCB



**Dual-Display  
LCR Meter  
w/ Stat Functions  
B+K Model 878  
\$239.95**  
Auto/manual range  
Many features  
with Q factor  
High Accuracy

**Electronic Tool Kit Model TK-1000**  
A professional organizer tool kit at affordable prices. No student should be without this unique tool kit that holds all the tools you need.  
Including:

- Diagonal Cutter
- Long Nose Pliers
- 6" Wire Stripper
- Solder 60/40
- 6" Screwdriver
- 6" Phillips Driver
- Safety Goggles
- IC Puller
- 3pc Nut Drivers
- Iron 25W
- Iron Stand
- Solder Wick
- Desoldering Pump
- 5 pc Solder Ease Kit
- 6pc Precision Screwdrivers



**\$39.95**



**Robotic Arm  
Y-01  
\$49.95**  
(Wired Control)  
Movement grabs  
& releases,  
lifts & lowers,  
pivots from side to side



**Stereo Cassette Player  
Kit  
Model  
TR-18K  
\$16.95**  
Headphones  
Included



**Digital  
Multimeter  
EDM-83B  
\$175.00**  
Almost every  
feature available  
Bargain of  
the decade



**Digital  
Multimeter  
DVM-638  
\$39.95**  
11 Functions  
with case



**Digital  
Capacitance  
Meter  
CM-1555  
\$49.95**  
Measures capacitors  
from .1pf to 20,000µf



**Digital  
LCR Meter  
LCR-680  
\$79.95**  
3-1/2 Digit  
LCD Display  
Inductance  
1uH to 20MΩ



**Function  
Generator  
FG-801  
\$149.95**  
Square,  
Triangle  
Sine wave  
Freq range



**3-3/4 Digit Multimeter  
BK-390  
\$139.00**  
0.1% DCV accy  
Analog bar graph  
Auto/manual ranging  
Capacitance meas  
Temperature probe



**Digital  
Multimeter Kit  
w/ Training Course  
M-2665K  
\$49.95**  
Full function 34 ranges  
Ideal school project  
**M-2661 (Assembled) \$55.00**



**Frequency Counter  
F-1225  
\$225.00**  
8 Digit LED display  
Wide meas range  
High sensitivity  
Data hold function  
Input impedance 1MΩ or 50Ω  
10:1 input attenuation function

**Fluke Multimeters  
(All Models Available Call)**

<b>Scopemeters</b>	<b>70 Series</b>
Model 97 \$1,795	Model 70II \$69.95
<b>10 Series</b>	Model 73II \$97.50
Model 10 \$62.95	Model 77II \$149
Model 12 \$84.95	Model 79II \$175
<b>20 Series</b>	<b>80 Series</b>
Model 29II \$175	Model 87 \$289



**Triple Power  
Supply  
XP-620  
By Elenco  
\$75.00**  
3 fully regulated supplies; 1.5-15V @ 1A, -1.5 to -15V @ 1A or 3-30V @ 1A & 5V @ 3A **Kit XP-620K \$49.95**



**Quad Power  
Supply  
XP-581  
By Elenco  
\$79.95**  
Four supplies in one unit; 2-20V @ 2.5A, 5V @ 3A, -5V @ .5A and 12V @ 1A. All regulated and short protected



**High Current DC  
Power Supply  
BK-1686 \$169.95**  
3 to 14 VDC Output  
12A @ 13.8V  
For servicing high  
power car stereos,  
camcorders, ham radios, etc.  
Connect 2 or more in parallel



**Wide Band  
Signal  
Generators  
SG-9000  
\$124.95**  
RF Frequency 100K-450MHz  
AM modulation of 1KHz Variable  
**SG-9500 150MHz \$239.00**

**Telephone Kit  
PT-223K  
\$14.95**  
Available  
Assembled  
PT-223  
\$15.95



**Function Generator  
Blox  
#9600  
By  
Elenco  
\$29.95**  
Kit \$26.95  
Sine, Triangle, Square Wave



**Learn to Build & Program  
Computers with this Kit**



**MM-8000  
By Elenco  
\$129.00**  
From scratch you build a complete system. Our Micro-Master trainer teaches you to write into RAMs, ROMs and run a 8085 microprocessor, which uses similar machine language as IBM PC.

**Digital/Analog Trainer  
Complete Mini-Lab For Building,  
Testing, Prototyping Analog and Digital**



By Elenco  
in U.S.A.  
**XK-525  
\$159.95**  
Kit  
**XK-525K  
\$129.95**

**AM/FM Transistor  
Radio Kit  
with Training Course  
Model AM/FM 108  
\$27.95**  
14 Transistor, 5 Diodes  
Easy to build because  
schematic is printed on the PCB  
Makes a great school project  
Model AM-550 AM Only \$17.95

**Telephone Line  
Analyzer  
Kit TT-400K \$19.95  
Assembled TT-400 \$26.95**



**WE WILL NOT BE UNDERSOLD**  
UPS SHIPPING: 48 STATES 5%  
IL RES 7.5% TAX (\$3 min \$10 max)  
OTHERS CALL

**C&S SALES INC.**  
1245 ROSEWOOD, DEERFIELD, IL 60015  
FAX: 708-520-0085 (708) 541-0710



**15 DAY MONEY BACK  
GUARANTEE  
FULL FACTORY WARRANTY**  
PRICES SUBJECT TO CHANGE WITHOUT NOTICE

**FREE PROBES  
WITH ALL  
SCOPES**

**ELENCO ♦ HITACHI ♦ B+K  
SCOPES  
AT GUARANTEED LOWEST PRICES**

**WRITE FOR  
FREE  
CATALOG**

**QUALITY - ELENCO OSCILLOSCOPES**

**2-YEAR WARRANTY**

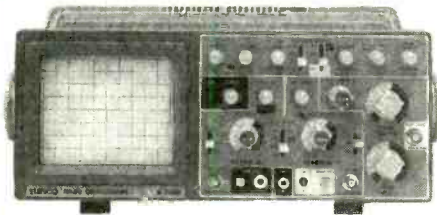

**60MHz**

**S-1360 \$775**

Delayed Sweep

**S-1365 \$849**

Cursor Readout

- ♦ Voltage, Time
- ♦ Frequency differences displayed on CRT

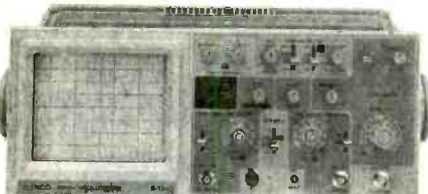

**40MHz**

**S-1340 \$495**

2- Channel

**S-1345 \$575**

Delayed Sweep

- ♦ Beam Find
- ♦ Component Tester

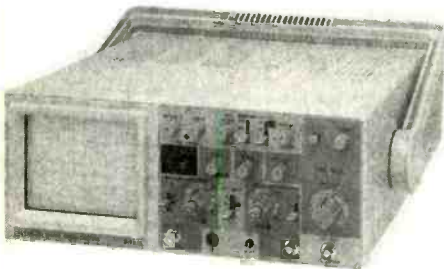

**25MHz**

**S-1325 \$349**

2- Channel

**S-1330 \$449**

Delayed Sweep

- ♦ Beam Find
- ♦ Component Tester

*Dependable Equipment at Affordable Prices*

**B+K 20MHz**

2 Channel

**Model 2120 \$389.00**



Delayed Sweep

**Model 2125 \$539.95**

**40MHz DUAL -TRACE**

**Model 1541B**

**\$749.95**

- 1mV/div sensitivity
- Video sync separators
- Z axis input
- Single sweep
- V mode-displays 2 signals unrelated in frequency

**60MHz DUAL-TRACE**

**Model 2160**

**\$949.95**

- 1mV/div sensitivity
- Sweep to 5ns/div
- Dual time base
- Signal delay line
- Component tester
- V mode-displays 2 signals unrelated in frequency

**100MHz THREE-TRACE**

**Model 2190**

**\$1,379.95**

- 1mV/div sensitivity
- Sweeps to 2ns/div
- Dual time base
- Signal delay line
- 19kV accelerating voltage
- Calibrated delay time multiplier

**20MHz ANALOG with  
DIGITAL STORAGE**

**Model 2522A**

**\$869.95**

- 20MHz analog bandwidth
- 20MS/s sampling rate
- 2k memory per channel
- 20MHz equivalent time sampling

**HITACHI POPULAR SERIES**

V-212 - 20MHz, 2 Channel	\$425.00
V-222 - 20MHz, DC Offset	\$695.00
V-422 - 40MHz, Dual Trace	\$849.00
V-522 - 50MHz, Dual Trace	\$975.00
V-523 - 50MHz, Delayed Sweep	\$995.00
V-525 - 50MHz, w/ Cursor	\$1,069.00

**HITACHI COMPACT SERIES SCOPES**

V-660 - 60MHz, Dual Trace	\$1,375.00
V-665A - 60MHz, DT, w/cursor	\$1,449.00
V-1060 - 100MHz, Dual Trace	\$1,549.00
V-1065A - 100MHz, DT, w/cursor	\$1,695.00
V-1085 - 100MHz, QT, w/cursor	\$2,125.00
VC-6045A - 100MHz, Digital Stor	CALL
VC-6025A - 50MHz, Digital Stor	CALL

**Elenco DS-203 20MHz, 10MS/s  
Digital Storage Oscilloscope**

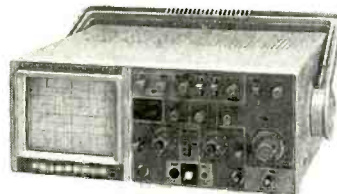

**\$749**

2K Word Per Channel • Plotter Output  
8 Bit Vert. Resolution • 2048 Pts Hor.  
Resolution • Much More.....

**FLUKE SCOPEMETERS**

A handheld instrument that combines a 50MHz, 25MS/s dual channel digital storage oscilloscope with feature-packed 3000 count digital multimeter.

**Model 93 - \$1,225**

**Model 95 - \$1,549**

**Model 97 - \$1,795**

- Autoset, automatically sets voltage, time & trigger
- Multimeter display; 3-2/3 digits (>3000 counts)
- True RMS volts; AC or AC+DC up to 600V



**C&S SALES INC.**

1245 ROSEWOOD, DEERFIELD, IL 60015  
FAX: 708-520-0085 (708) 541-0710

**CALL TOLL FREE**

**1-800-292-7711**

**1-800-445-3201 (Can)**



**15 DAY MONEY BACK GUARANTEE**

**FULL FACTORY WARRANTY**

**ALL PRODUCTS ARE FACTORY NEW**

PRICES SUBJECT TO CHANGE WITHOUT NOTICE

CIRCLE 32 ON FREE INFORMATION CARD

**TOTAL COST FOR SHIPPING OF ANY ONE, OR AS MANY OF THE FOLLOWING ITEMS BY AIR MAIL IS \$15**

**FOUR CHANNEL UHF REMOTE CONTROL KIT**

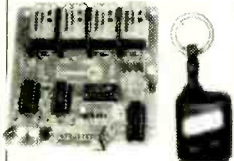

Features a 3 channel transmitter which is small enough to fit onto a key ring. The fourth channel can be accessed by a second transmitter. For example each of the two transmitters could have two common channels and one individual channel. The compact receiver employs a ready made and prealigned (30.4MHz) UHF receiver "front end" module. Over 100 meters range, has 12A SPDT relay contact outputs, has a user programmable security code with 6561 combinations, easy to construct, is expandable, etc. **Transmitter: \$13. Receiver: \$46. TWO TRANSMITTERS AND ONE RECEIVER: \$68**

The operating frequency of the system is adjustable but you should check local regulations with regards to using this very low power remote control system.

**FM TRANSMITTER MK1 KIT**



This unit has most of the features of our FMTXMK2 transmitter, but is much smaller. The complete transmitter PCB (Miniature microphone included) is the size of a "AA" battery, and is powered by a single "AA" battery. We use two "AA" battery holder (provided) for the case, and a battery clip (shorted) for the switch. Estimated battery life is over 500 hours! **SAME PRICE AS OUR FMTXMK2: \$8**

**SOLID STATE "Peltier Effect" COOLER - HEATER**

These are the major parts needed to make a solid state thermoelectric cooler - heater. We can provide a large 12V-4.5A Peltier effect semiconductor, two thermal cut-out switches, and a 12V DC fan for a total price of:

**\$32**

We include a basic diagram - circuit showing how to make a small refrigerator - heater. The major additional items required will be an insulated container such as an old portable cooler. Two heatsinks, and a small block of aluminium.

**FM TRANSMITTER KIT - MKII**

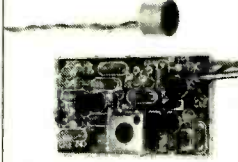

This low cost FM transmitter features pre-emphasis, high audio response as it can easily pick up normal conversation in a large room, a range of well over 100 meters, etc. It also has excellent frequency stability. Specifications: Tuning range: 88-108MHz, Supply voltage 6-12V, current consumption @ 9V: 3.5mA, Pre-emphasis: 7.5uS, Frequency response: 40Hz to greater than 15KHz, S/N ratio: Greater than 60dB, Sensitivity for full deviation: 20mV, Frequency stability with extreme antenna movements: 0.03%, P.C.B. dimensions: 1" x 1.7" Construction is easy and no coil winding is necessary. The coil is preassembled in a shielded metal can. The double sided, solder masked and screened PCB also makes for easy construction. The kit includes a PCB and all the on-board components, an electret microphone, and a 9V battery clip.

**\$8**

**PASSIVE NIGHT VIEWER**

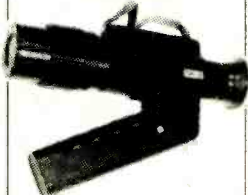

This is a completed commercial monocular hand held night viewer, that employs an image intensifier tube. The viewer is of a USSR military standard (model T3C-2), and will produce useful images in very low ambient light. Has adjustable low light objective lens, adjustable eyepiece, and is supplied with a carry case.

**\$280**

**INFRA RED FILTER**

A very high quality IR filter and a RUBBER lens cover that would fit over most torches including MAGLITES, and convert them to a good source of IR. The filter material withstands high temperatures and produces an output which would not be visible from a few meters away and in total darkness. Suitable for use with passive and active viewers.

**\$11**

For the filter and the rubber lens cover.

**ALL PRICES ARE IN U.S. DOLLARS**

**IR "TANK SET"**



**ON SPECIAL** is a set of components that can be used to make a very responsive Infra Red night viewer. The matching lens tube and eyepiece sets were removed from working military quality tank viewers. We also supply a very small EHT power supply kit that enables the tube to be operated from a small 9V battery. The tube employed is probably the most sensitive IR responsive tube we ever supplied. The resultant viewer requires low level IR illumination. Basic instructions provided.

**\$85**

For the tube, lens, eyepiece and the power supply kit. When ordering specify preference for a wide angle, or a telescopic objective lens.

**MIRACLE TV ANTENNA KIT**



This combination of proven circular antenna design, and a wideband low noise amplifier produces remarkable results on VHF, UHF, and FM frequencies. Based on an IC with 20dB of gain, a bandwidth of 2GHz and a noise figure of 3dB. Can be used as a masthead amplifier on existing antennas. The cost of the complete kit of parts for the masthead amplifier PCB and components, the power and signal combiner PCB and components, a balun core and the tinplate for the antenna is priced at only:

**\$18**

Requires a DC supply (Plugpack etc.) 7V-20V DC at approximately 25mA. Extra reinforcement for the tinplate antenna is also required.

**FIBRE OPTIC TUBES**



These US made tubes are "pulled" from equipment, in excellent condition. Have 25/40mm diameter, fibre-optically coupled input and output windows. The 25mm tube has an overall diameter of 57mm and is 60mm long. The 40mm tube has an overall diameter of 80mm and is 92mm long. The gain of these is such that they would produce a good image in approximately 1/7 moon illumination when used with suitable "fast" lens, but they can also be IR assisted to see in total darkness. The superior resolution of these tubes would make them suitable for low light video preamplifiers, wild life observation, and astronomical use. **INCREDIBLE PRICES:** Each of the tubes is supplied with a 9V-EHT power supply kit. **INCREDIBLE PRICES:**

**\$85** For the 25mm intensifier tube and supply.

**\$130** For the 40mm intensifier tube and supply.

Three of these tubes can be cascaded to make a very high gain image intensifier! We should have a kit and instructions available to make these. Approximately \$195 for 25mm and \$320 for 40mm, three stage kits. Resellers enquiries welcome.

**MISCELLANEOUS ITEMS COMPONENTS AND KITS**

- High Voltage Diodes: 8KV-3mA, \$0.80; 10KV-20mA, \$1.40
- High Voltage Disc Ceramics: 0.01uF-3KV, \$0.80; 0.01uF-5KV \$1.30, 1000pF-15KV, \$3.50
- Electric Fence Kit: PCB and components, \$28
- Garage-Door-Remote Control Kit: Tx \$13; RX \$56
- Laser Beam Communication Kit: TX, RX, plus IR Laser, \$39
- Plasma Ball Kit: PCB and components kit, needs any bulb \$18
- IEC Extension Leads: 2 meters long \$3.50, High Intensity Led's: 550-1000mCD output at 20mA, .5mm diameter, 10 for \$2.80.
- Triacs: 60A-600V Stud mounted THOMPSON type TGA606 \$7.20.
- Ultrasonic Transducers: Murata brand (Japanese), 40KHz TX-Rx Pair, \$1.50

**UNIVERSAL SOLAR CHARGER KIT**



Two 6" x 6" amorphous glass solar panels, and a PCB and all on-board components kit for a solid state inverter. In normal sunlight, the combination can deliver a charging power of over 1.4 Watts into 5-12V batteries. EG 6V-230mA, 9V-150mA, 12V-120mA. The glass panels need to be terminated and have their rear waterproofed. Simple to do, instructions included.

**\$20**

For the two panels, PCB and components, terminating clips and the instructions.

**IMAGE INTENSIFIER TUBE AND SUPPLY**

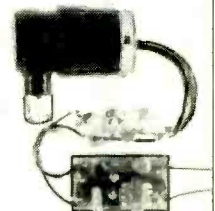

These are the key components needed for making a **PASSIVE NIGHT VIEWER**. The small prefocussed Russian image intensifier tube only requires a low current EHT power supply to make it operational, which we provide in kit form. Draws 20mA from a small 9V battery. With a suitable low light objective lens (not provided) the resultant viewer will produce useful pictures in sub-moonlight illumination, and it can also be IR assisted. **INCREDIBLE PRICE:**

**\$105**

for the Russian image intensifier tube and an EHT power supply kit! All that is needed to make a complete passive night viewer is a lens, an eyepiece, a 9V battery, a case and a switch. We can supply a matching lens and eyepiece: **\$68 for the pair.**

All our kits are provided with high quality fibreglass, silk screened and solder masked, printed circuit boards

**OATLEY ELECTRONICS**

5 LANSDOWNE PDE., OATLEY, SYDNEY, NSW, AUSTRALIA 2223

**PHONE ORDERS**

East Coast between 7 pm and 2 am  
West Coast between 4 pm and 11 pm  
**011 62 579 4985**

**FAX ORDERS**

**011 61 2 570 7910**  
Mastercard - Viscard with Telephone or Fax Orders

International Bank Drafts and Money Orders with Mail Orders  
If possible include contact phone and fax number

# Unbeatable Discount Prices

1 YEAR WARRANTY  
15 DAY MONEY BACK GUARANTEE

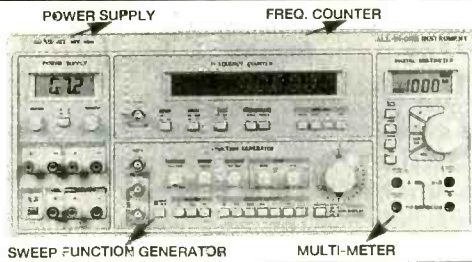

**MT-100**

Reg. \$595.

**\$399.00**

## Four Instruments in One Instrument

### 1 Function Generator

- Sine, Square, Triangle, Pulse, Skewed Sine, Ramp, TTL
- 0.02 Hz ~ 2MHz

### 3 Power Supply

- 3-1/2 Digit LCD
- Triple output: #1. 0-50V, 0.5A MAX #2, 15V, 1A #3. 5V, 2A

### 2 Frequency Counter

- 8 Digit LED
- 1 Hz ~ 100MHz
- ± (1 Hz + 1 dgt. + Time Base Error)

### 4 Digital Multimeter

- 3-1/2 Digit LCD
- DCV, ACV, Ω, DCA, ACA
- ± (0.5% + 2 dgts)

## BEST BUY! O'SCOPES

2 Yr. Parts/Labor Warranty



### 25 MHz Dual

Reg. \$525.

**\$299.00**

### 25 MHz Dual w/Component Test

Reg. \$595.

**\$379.00**

### 40 MHz Dual/Delay

Reg. \$695.

**\$499.00**

### OS-3304/3324, 25 MHz

- DC to 25 MHz. Dual Channel
- 6" Rectangular CRT with Internal Graticule 10x8cm (Phillips P31)
- Uncalibration LED.
- High Sensitivity 1 mV/div to 20V/div X-Y modes, Z Axis (intensity modulation)
- Rise time 14n Sec. or less.
- Full TV Trigger for TV-V & TV-H
- Acceleration Potential 2kV

### OS-3315, 40 MHz Sweep Delay

- DC to 40 MHz. Dual Channel
- Delayed Sweep 100nS to 1 Sec.
- 6" Rectangular CRT with Internal Graticule 10x8cm (Phillips P31)
- Uncalibration LED.
- High Sensitivity 1 mV/div to 20V/div X-Y modes, Z Axis (intensity modulation)
- Rise time 8.5nS or less.
- Full TV Trigger for TV-V & TV-H
- Acceleration Potential 12kV

### GoldStar Oscilloscopes

- OS-7020A. 20MHz Dual Reg. \$525. **\$395.00**
  - OS-902RB. 20MHz Dual/Read Out Reg. \$795. **\$595.00**
  - OS-9040D. 40MHz Delay Dual/Read Out Reg. \$695. **\$575.00**
  - OS-904RD. 40MHz Dual/Read Out Reg. \$895. **\$695.00**
  - OS-8100. 100MHz 8 Trace Reg. \$1,395. **\$1,145.00**
- Other Models Call for Price

### FG-150

Reg. \$395. **\$229.00**



### 2MHz Sweep / Function Generator w/Built-in Frequency Counter

- 4 Digit LED Display
- 0.2 Hz ~ 2.0 MHz
- Sine, Square, Triangle, Pulse, Skewed Sine, Ramp, TTL
- Linear or Logarithmic Sweep
- Variable DC Offset Control
- 10 MHz Frequency Counter

### Best Buy!

### 1.0 GHz Counter FC-200

Reg. \$395. **\$199.00**



### High Resolution Frequency Counter

- 1.0 Hz ~ 1.0 GHz
- 8 Digit LED Display
- Auto & Manual Range
- Measured Value Hold
- 4 Selectable Gate Times
- Below 20mV Input Sensitivity
- 1mΩ & 50Ω Input Impedance
- 10:1 Input Switchable Attenuator

### Reg. \$199. **\$119.00**



### RF Signal Generator, SG-310

### 100KHz - 150MHz

- 100KHz ~ 150MHz, 6 Ranges.
- Accuracy: ± 5%
- RF Output: 100 m Vrms (Up to 35MHz Unloaded)
- Modulation
  - Int. 1KHz (AM) 30%
  - Ext. 50Hz ~ 20KHz
- Audio Output: 1KHz Min 2 Vrms

### Reg. \$199. **\$119.00**



### Audio Generator, AG-350

### 10Hz ~ 1MHz

- 10Hz ~ 1MHz, 5 Ranges.
- Accuracy: 5% ± 2
- Output Impedance: 600Ω
- Sine Wave Output
  - Range: 10Hz ~ 1MHz
  - Output Voltage: 8 Vrms
- Square Wave Output
  - Range: 10Hz ~ 100KHz
  - Output Voltage: 15Vp-p

### Reg. \$249. **\$159.00**

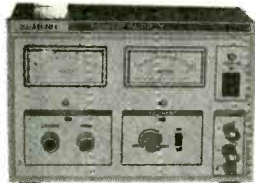

### DC Power Supply, PS-500

### 0-30VDC, 0-3A

- 0 ~ 30VDC Continuously Variable
- Regulation: ≤ 0.01% + 3mV
- Ripple Voltage: p-p ≤ 2m Vrms; ≤ 1mV
- 0.1A ~ 3A Constant Current
- Regulation: ≤ 0.2% + 3mA
- Ripple Current: ≤ 3m Arms
- Short Circuit Overload Protection w/Indicating Lamp

### Reg. \$399. **\$289.00**



### DC Power Supply, PS-500

### 0-16VDC, 0-10A

- 0 ~ 16VDC Continuously Variable
- Regulation: ≤ 0.01% + 3mV
- Ripple Voltage: p-p ≤ 2m Vrms; ≤ 1mV
- 0.1A ~ 10A Constant Current
- Regulation: ≤ 0.2% + 3mA
- Ripple Current: ≤ 3m Arms
- Short Circuit Overload Protection w/Indicating Lamp

### Oscilloscope Probes

### Switch Selectable

### X1 / X10



HP-9060, 60MHz  
Reg. \$29. **\$15.00**

HP-9150, 150MHz  
Reg. \$49. **\$22.00**

HP-9250, 250MHz  
Reg. \$59. **\$29.00**

### Auto Bargraph w/Holster



DM3200

Reg. \$99.

**\$59.00**

- Auto & Manual
- 3-1/2 Digit
- 32 Seg. Bargraph
- Diode Test
- Continuity Beeper
- Data Hold
- Auto Power Off
- Low Battery Mark
- Over Range Mark
- Holster

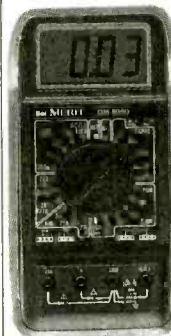

DM3000

Reg. \$69.

**\$44.00**

DM3050

Reg. \$99.

**\$54.00**

DM3100

Reg. \$99.

**\$54.00**

### Multimeter

### Multi-Function w/Holster

- 3-1/2 Digit
- 1.5" Big LCD
- Heavy Duty, 20A
- Capacitance
- TR-hFE
- Diode
- Low Battery Mark
- Over Range Mark
- Protective Holster
- Tilt Stand

DM3050 Only

- Frequency
- Continuity Beeper

DM3100 Only

- Temperature w/Optional Probe

Reg. \$15 **\$8.00**

- Continuity Beeper

**BMC** Your Best Source for  
High Standard Electronics

13700 Alton Pkwy., Ste. 154-282  
Irvine, CA 92718

Order & Free Catalog

**800-532-3221**

(714) 586-2310 Fax (714) 586-3399



# B. G. MICRO

P. O. Box 280298 Dallas, Texas 75228  
 (214) 271-5546  
 FAX (214) 271-2462



## LCD DISPLAYS

- OPTREX 2x16-DMC 16207H-8 Bit ASCII Input  
Dim. 3 1/4x1 3/4x3/8 Char. Height 19" ..... **\$5.99**
- OPTREX 2x20-DMC 20261-8 Bit ASCII Input  
Dim. 4 7/16x1 7/16x3/8 Char. Height 19" ..... **\$7.99**
- OPTREX 1x16 "Backlit"-DMC 16187-  
8 Bit ASCII Input Dim. 3 1/4x1 3/8x7/16  
Char. Height 11" ..... **\$9.95**
- OPTREX 1x20-DMC 20171-8 Bit ASCII Input  
Dim. 7 3/16x1 5/16x1/2 Char. Height 42" ..... **\$9.95**
- OPTREX 2x40-DMC 40218-8 Bit ASCII Input  
Dim. 7 3/16x1 5/16x1 3/32 Char. Height 19" ..... **\$9.95**

**VERY EASY TO INTERFACE TO ALMOST ANY MICROPROCESSOR!!!!!!**

## STEREO AUDIO AMP

This 20 watt per channel, open frame, stereo audio amp comes completely assembled and tested. It also includes a self contained plug-in power supply. Less than .1 % distortion for you real "audio buffs". You supply the speakers and we will supply some of the cleanest audio you have heard. Unit includes volume, tone, and balance controls. Front panel measures 9"x3".

**A steal at ..... \$12.95**



## SWITCHING POWER SUPPLIES

### DELTA Switching Power Supply

Heavy duty switcher—A full 280 watts completely enclosed w/fan—UL and CSA approved— + 12V @ 7 amps— + 5V @ 37 amps  
 -5V @ .75 amps—  
 -12V @ .75 amps.  
 Measures 8 1/2"x  
 5 15/16"x7 3/8"

**\$17.95**

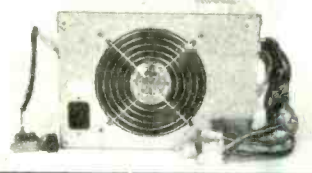

## SIRENS

Simply apply 12 volts to this little baby, then you had better hold your ears. Very loud!

**\$5.95**

Great for car and intrusion alarms



## DTMF

- SSI-202 Decoder **2.25**
- 8870 Decoder **2.25**
- 5087 Generator **2.00**
- 5089 Generator **1.25**

## UART

- NS16450 ..... 6.50
- 16550 ..... 10.95
- TR1602B  
(COM 2017) .... 1.75
- IM6402 +5v High speed  
AYS-1013 pin out 2.45
- INS 8250 ..... 2.95

## STATIC RAM

- 2016-2KK8 200 n.s. .... 1.00
- 2101-1 - 256X4 500 n.s. .... .75
- 21L02-1 350 n.s. .... .65
- 2102AL-4 L.P. 450 n.s. .... .49
- 2111-1 256X4 500 n.s. .... 1.00
- 2112A-2 ..... 2.50
- 2114L-3 1KK4 300 n.s. .... .45
- 2125A-2 1KK1 70 n.s. .... 1.00
- 2147 4KX1 ..... 1.00
- 2148 ..... 1.00
- 6116P-4 ..... 1.00
- 6117 ..... 1.20
- 6264 ..... 1.40
- 62256 32KX8 ..... 5.00
- 128KX8 ..... 15.00

## EPROM SPECIAL

We bought a large quantity of 2708s, 2716s, 2532s, 2732s, 2764s, 27128s, 27256s and 27512s from a computer manufacturer who re-designed their boards. We removed them from sockets, erased and verified them, and now we offer the savings to you. Complete satisfaction guaranteed.

- Your Choice
- 2708 ..... 1/20 10/8.00
  - 2716 ..... 1.75 10/15.00
  - 2532 ..... 2.00 10/17.50
  - 2732 ..... 2.00 10/17.50
  - 2764 ..... 2.00 10/17.50
  - 27128 ..... 2.50 10/20.00
  - 27256 ..... 3.00 10/25.00
  - 27152 ..... 4.75 10/40.00
  - 1 Meg ..... 8.50 10/77.50

## DYNAMIC RAM

- 2108-4 8KX1 ..... 1.50
- 2118-4 16KX1-5Volt ..... .70
- 4027-4KX1-250 n.s. .... .80
- 4116-16KX1-250 n.s. .... .40
- 4116-16KX1-200 n.s. .... .75
- 4116-16KX1-150 n.s. .... .90
- 4128 Piggyback ..... 2.00
- 4164-150 n.s. .... 49or9/3.50
- 4164-120 n.s. .... 1.10
- 4164-100 n.s. .... 1.40
- TMS4416-16KX4-15 n.s. .... 2.75
- 4464-150 n.s. .... 1.40
- 4464-120 n.s. .... 1.45
- 4464-100 n.s. .... 1.45
- 4464-80 n.s. .... 1.45
- 41256-150 n.s. .... 1.25 or 9/9.95
- 41256-120 n.s. .... 1.30 or 9/10.99
- 41256-100 n.s. .... 1.30 or 9/10.99
- 41256-80 n.s. .... 1.30 or 9/10.99
- 41256-60 n.s. .... 1.85
- 1 Meg - 100 n.s. .... 4.40
- 1 Meg - 80 n.s. .... 4.40
- 414256-80 n.s. 256 x 4 ..... 4.60

## EPROM

- 8741 ..... 7.00
- 8742 ..... 7.00
- 8748 ..... 7.00
- 8749 ..... 7.00
- 8751H ..... 12.95
- 8755 ..... 7.00

## PROMS

- 82S123 ..... 1.49
- 82S126 ..... 1.49
- 82S153 ..... 1.75

## FANS

**SANYO—BRUSHLESS**  
 12 Volt DC at .07 Amps—  
 7 Blades  
 60 MM—2 3/8"x2 3/8"x1"  
**\$5.95**



**TECHIDYNE—Brushless**  
 12 Volt DC at .12 Amps—  
 7 Blades  
 80MM—3 1/8"x3 1/8"x1"  
 This size commonly used in  
 Computer Power Supplies  
**\$5.90**

**PANAFLO—Brushless—12 Volt DC at**  
 .2 Amps 5 Blades—  
 119MM—4 11/16"x4 11/16"x1 1/2"  
**\$5.99**

## 8000/80000

8001	5.20	8237	1.90	8088-2	3.25	8257	1.50
8002	\$2.50	8237-5	2.80	8155	2.25	8259A	1.85
8010	4.95	8243	1.75	8156	2.25	8259C-5	2.10
8031	2.95	8250	2.95	8202A	8.00	8275	10.95
8032	3.95	(16450)	6.50	8212	1.25	8279	2.25
8035	1.00	(16550)	10.95	8214	2.00	8284	1.49
8036	4.95	8251	1.10	8216	1.25	8286	3.50
8039	1.00	8253-5	1.75	8224	1.25	8287	2.49
8085	1.55	8254	1.80	8228	1.75	8288	3.50
8086	1.55	8255	1.50			8530	3.00
8088	2.20	8255-5	1.75				

**TERMS:** (Unless specified elsewhere) Add \$3.25 postage, we pay balance. Orders over \$50.00 add 85¢ for insurance. No. C.O.D. Texas Res. add 8 1/4% Tax. 90 Day Money Back Guarantee all items. All items subject to prior sale. Prices subject to change without notice. Foreign order - US funds only. We cannot ship to Mexico or Puerto Rico. Canada, add \$7.50 minimum shipping and handling. Countries other than Canada, add \$15.00 minimum shipping and handling.

NEW ITEMS! NEW PRICES! NEW ITEMS! NEW PRICES! NEW ITEMS! NEW PRICES! NEW ITEMS!

NEW PRICES! NEW ITEMS! NEW PRICES! NEW ITEMS! NEW PRICES! NEW ITEMS!



**KELVIN**  
ELECTRONICS

10 HUB DRIVE, MELVILLE, NY 11747

(800) 645-9212  
(516) 756-1750  
(516) 756-1763/FAX

Established 1945

M/C & VISA <sup>120 Minimum Order</sup>

**KELVIN CATALOG \$3**  
Stock No. 650412



150 LE - Student 200 LE - Technician 300 LE - Auto-Range 400 LE - Engineer

**Standard Features** ● AC & DC VOLTAGES ● DC CURRENT  
● RESISTANCE ● CONTINUITY TESTER - Buzzer ● DIODE TEST  
● 10M ohm INPUT IMPEDANCE ● ACCURACY +/- 0.5% RDG

**TRANSISTOR BATTERY TEST DC CURRENT 10 Amp**

**FREQ COUNTER up to 20MHz CAPACITANCE from 1pF to 20uF**

**AUTO RANGE with 3200 counts AC CURRENT DC CURRENT ANALOG BAR 10 Amp**

**INDUCTANCE Resolution 1uH FREQ COUNTER up to 20MHz CAPACITANCE from 1pF to 200uF AC/DC CURRENT TRANSISTOR DUTY % 20 Amp**

**150 LE**  
Stock # 990122  
**\$29<sup>95</sup>**

**200 LE**  
Stock # 990123  
**\$49<sup>95</sup>**

**300 LE**  
Stock # 990125  
**\$49<sup>95</sup>**

**400 LE**  
Stock # 990124  
**\$79<sup>95</sup>**

**KELVIN 100 Basic**  
# 990087 **\$19<sup>95</sup>**

- AC & DC VOLTAGES
- DC CURRENT
- RESISTANCE
- 3 1/2 Digit LCD
- CONTINUITY TEST
- -Buzzer
- LOW BATTERY INDICATOR
- DIODE TEST ● BATTERY TEST



**CAPACITANCE KELVIN METER 250 LE \$59<sup>95</sup>**  
# 990126

- 0.5% ACCURACY
- RANGES: 20mF, 200uF, 200uF, 20uF, 2uF, 200nF, 20nF, 2000pF, 200pF
- Zero Adjust
- Safety Test Leads
- Test Socket for Plug-in Components



Designed to meet IEC-348 & UL-1244 safety specifications.

**Protective Cases**

For Models 100 Basic, 150LE, 200LE, 300LE  
..... \$4.<sup>95</sup> (#990088)

Case For Model 400LE ..... \$9.<sup>95</sup> (#990116)

**2 Year Warranty (Parts & Labor)**

**The Ultimate Meter**  
TRUE RMS - LCR - Hz - dBm

Popular Electronics (Reviewed - May 1993)

"Not only does the Kelvin 94 boast alot of features ... the features go the extra distance."

"If we had to run into a burning building to do some emergency trouble-shooting and could carry in only one piece of equipment, the Kelvin 94 would be it!"

**12 INSTRUMENTS IN ONE -**

DC VOLTMETER, AC VOLTMETER, OHMMETER, AC CURRENT, DC CURRENT, DIODE TESTER, AUDIBLE CONTINUITY TESTER, dBm, FREQ COUNTER, CAPACITANCE METER, INDUCTANCE METER, LOGIC PROBE

- 0.1% ACCURACY ON DC VOLTAGES
- TRUE RMS ON AC VOLTAGES & CURRENT
- FREQUENCY COUNTER TO 20 MHz
- LARGE EASY-TO-READ 3 3/4 DIGIT LCD DISPLAY
- AUTO SLEEP & AUTO POWER OFF BUILT-IN TO SAVE BATTERY LIFE with Bypass
- SHOCK RESISTANT HEAVY DUTY CASE WITH YELLOW RUBBER HOLSTER & TILT STAND
- WATER RESISTANT SEALED CASE
- 30 DAY MONEY BACK SATISFACTION GUARANTEE

**\$199<sup>95</sup>** MODEL 94 #990111

COMES COMPLETE WITH YELLOW HOLSTER, PROBES, BATTERY, FUSE, STAND

0.1% ACCURACY on DC Voltages Water Resistant

Freq Counter to 20 MHz

**Protective Cases for Model 94**

Regular Padded Zippered ..... \$9.<sup>95</sup> (#990116)  
Deluxe Padded Zippered ..... \$14.<sup>95</sup> (#990115)

Meter is designed in accordance with safety requirements specified in IEC-348, UL-1244 VDE-0411.

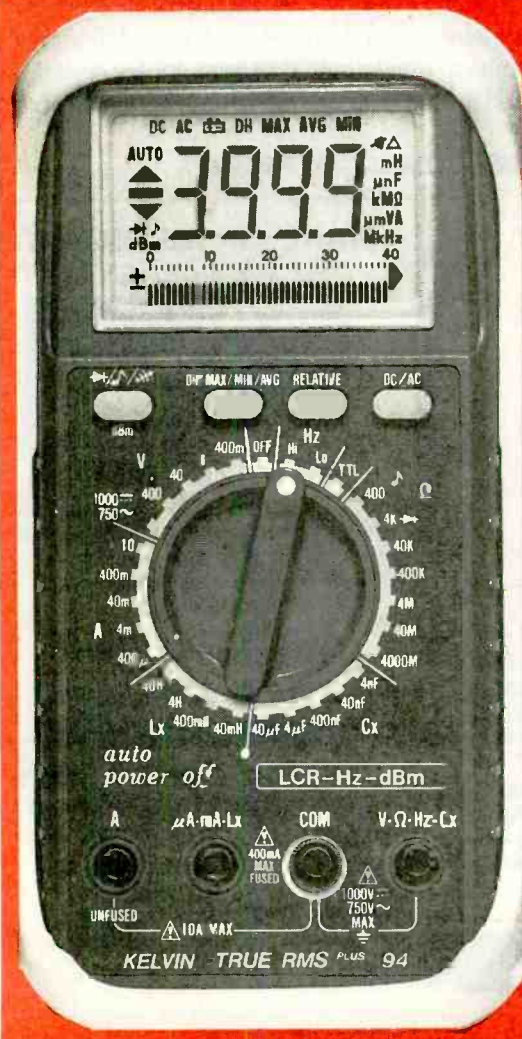

August 1994, Popular Electronics

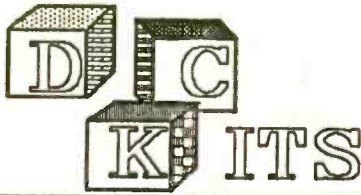

TOLL FREE ORDER  
HOT LINE  
1-800-423-0070

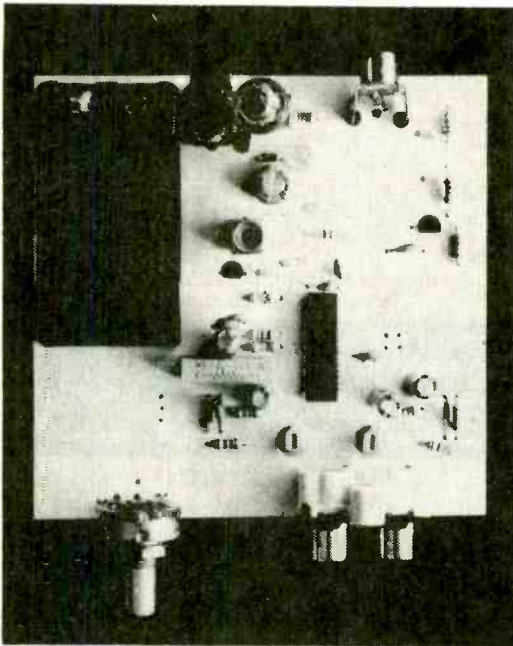

## ALL NEW--IMPROVED STEREO FM TRANSMITTER

### LOADED WITH FEATURES

- \* RF AMPLIFIER
- \* FRONT PANEL FINE TUNING
- \* STABLE OPERATION
- \* INPUT LEVEL ADJUSTMENTS
- \* WORKS WITH DIGITAL TUNED RADIOS
- \* 38KHz CRYSTAL MULTIPLEX CIRCUIT

DC'S all new FM Stereo Transmitter Kit based on the unique BA1404 Stereo Broadcaster Integrated Circuit that includes all the complex circuitry to generate the stereo signal. We've added an RF amplifier circuit to provide excellent transmit range. Additional features like electronic fine tuning, voltage regulation, 38KHz multiplex crystal, input level adjustment makes the Stereocaster the top of the line Stereo FM Transmitter.

ORDER STEREOCASTER \$29.95

### FUNCTION GENERATOR KIT ORDER FG2 KIT \$19.95

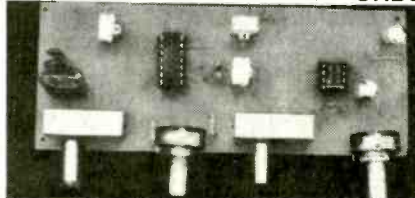

A great project to enhance your bench. This handy little function generator has a built-in buffer amplifier, a 3-decade range selector switch that covers 15 Hz to 25 kHz, output level control and function switch to select sine, square, or triangle.

### POWER SUPPLY KIT PS-1 \$16.99

Output of this power supply is continuously adjustable from 1.2 to 25V DC. The LM317T voltage regulator provides excellent regulation and ripple rejection. Includes a 1 A transformer, PC board, LM317T, 2 binding posts, and all small parts.

### MORE KITS

3 DIGIT LED DVM ONLY 3" X 3" READS 0 TO 100 V DC ORDER DVM3 \$19.95  
FM WIRELESS BROADCASTER FMI \$ 9.95  
8038 FUNCTION GEN. KIT FGI \$ 9.50  
SEQUENCER PROJECT SEQKIT \$ 9.50  
**CHRISTMAS TREE PROJECT**  
Build this unique seasonal project and have an unusual conversation piece. Powered by two D cells, 17 LEDs flash in a seemingly random fashion. Kit includes everything except batteries. ORDER XMASKIT \$16.95

### MAKE CIRCUIT BOARDS THE NEW, EASY WAY



### WITH TEC-200 FILM

#### JUST 3 EASY STEPS:

- Copy circuit pattern on TEC-200 film using any plain paper copier
  - Iron film on to copper clad board
  - Peel off film and etch
- convenient 8 1/2 x 11 size  
With Complete Instructions

ORDER TEC200-10 (10-SHEETS) \$5.95

### UNIVERSAL DECODER IC'S

REFER TO RADIO ELECTRONICS MAY 1990

CD22402E	7.95	CD4040	.65
LM733	.99	CD4053	.59
LM7805	.50	LM7812	.50
CA3126E	1.95	LM7905	.50
74C00	.50	3.58 MHz	1.00
NE564	2.29	18 Uh	.39

**DC ELECTRONICS**

SEND MAIL ORDERS TO:

PO BOX 3203 SCOTTSDALE, AZ 85271



ADD \$4.00 S&H

# ALL ELECTRONICS CORP.

QUALITY PARTS • DISCOUNT PRICES • FAST SHIPPING

## JUMBO LEDS JUMBO SAVINGS

Liton # LTL 327C - 8MM

Ideal for eye-catching indicators and displays. A recent quantity purchase of these BIG, 8mm diameter, red diffused LEDs enables us to provide some very special pricing. The leads on these devices have been trimmed to 0.325", leaving plenty of room for soldering. Normally these parts would sell for more than twice our price.

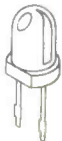

CAT # LED-23

5 for \$1.00

100 for \$15.00  
1000 for \$120.00

## ELECTRET MIKE WITH VISOR CLIP

Miniature electret condenser microphone designed for use with cellular phones but could be used in other audio applications. Black 0.3" diameter X 0.43" mike and 12 foot flexible cord with 3.5 mm mini-plug. Includes chrome-plated alligator clip which can be used for attachment to auto visor or clothing.

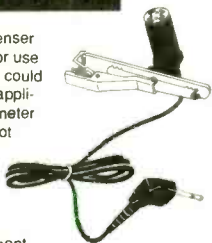

CAT# MIKE-14

\$4.50 each

## 4 POSITION SCREW CLAMP



Four position, dual screw terminal strip for surface mounting. Screw-clamp terminals accept up to AWG 16 wire. Black thermoplastic housing. UL listed. Terminals and mounting holes are on 0.35" centers.

4 for \$1.00

CAT # TER-41

100 for \$15.00

Futaba # M202SD08GL

Two rows of 20 characters displayed in a 5 X 7 dot matrix. Bright green 5mm X 3.5mm characters. On board CPU, driver and DC-DC converter simplifies hook-up and interfacing. Operates on 5 Vdc. Displays 215 different characters including alphanumeric and other symbols. ASCII configuration. Module overall dimensions: 6.1" X 1.7" X 0.7" thick.

These displays were modified somewhat from original specifications and we do not know the exact nature of the modifications. They work fine in the test mode, but we don't know if the original interface is the same. We supply a data/hook-up sheet for the pre-modified device which, hopefully, provides most of the information necessary to use the display.

## VACUUM FLUORESCENT DISPLAY

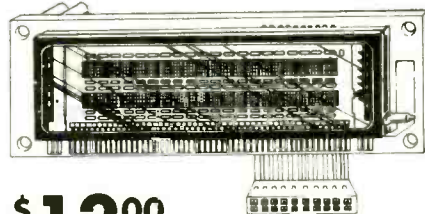

\$12.00 each

CAT# VFM-2

## PHOTOVOLTAIC DETECTOR



Centralab # EA7

Miniature glass encapsulated hermetically sealed silicon solar cell. Converts light impulses directly into electrical charges which can easily be amplified, using a transistor for example, to activate a control mechanism. Unlike a conventional photo diode or transistor, it generates its own power and does not require any external bias. Includes spec. sheet and application notes.

75¢ each

CAT# PVD-1

10 for \$5.00

## LONG LIFE MAGNESIUM BATTERY



Rayovac #  
BA-4386/  
PRC-77/  
PRC-25

Built for military communications equipment including PRC-77 and PRC-25 radios. Output jacks for 14.4 volts and 3 volts. Extremely long shelf life, should be good for 15 years storage. Ideal for emergency applications. 6 pin output jack can be used with banana plugs. 9.375" X 3.57" X 2.07" cardboard jacketed case. 3 lbs.

CAT # MB-4386

\$4.00 each

## 5 Volts, 20 Amps POWER SUPPLY

RTE Power/Mate# EVS-5F  
Input: 115/230 Vac.  
Output: 5 Vdc, 20 amps.

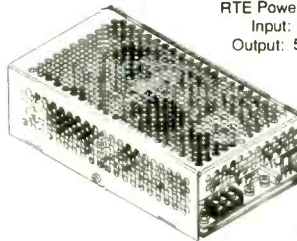

CAT# PS-520

Brand new switching power supply enclosed in vented aluminum cabinet. Over-voltage, over-load, short-circuit protection. Fuse protected. Adjustable output voltage and current limiting. Inrush current limiting. Screw terminals for input and output. UL and CSA listed. 8.5" X 4.9" X 2.45"

\$15.00 each

## 9 Vdc @ 200 ma. WALL TRANSFORMER

**SPECIAL!**



CAT# DCTX-9200

Three prong grounded plug. 6 foot long cord terminates to three color-coded pigtail leads.

100 for \$180.00

\$2.00 each

MANUFACTURERS - We Purchase EXCESS INVENTORIES... CALL, WRITE OR FAX YOUR LIST

CALL, WRITE or FAX For A Free 64 Page CATALOG Outside the U.S.A. send \$2.00 postage.

ORDER TOLL FREE 1-800-826-5432

MAIL ORDERS TO:  
ALL ELECTRONICS CORP  
P.O. Box 567  
Van Nuys, CA 91408

FAX (818) 781-2653  
INFO (818) 904-0524

Minimum Order \$10.00 • All Orders Can Be Charged To Visa, Mastercard Or Discover Card • Checks and Money Orders Accepted By Mail • California, Add Sales Tax • No C.O.D. • Shipping And Handling \$4.00 for the 48 Continental United States • All Others Including Alaska, Hawaii, P.R. and Canada Must Pay Full Shipping • Quantities Limited • Prices Subject to change without notice



CIRCLE 28 ON FREE INFORMATION CARD

www.americanradiohistory.com

# DATA ACQUISITION

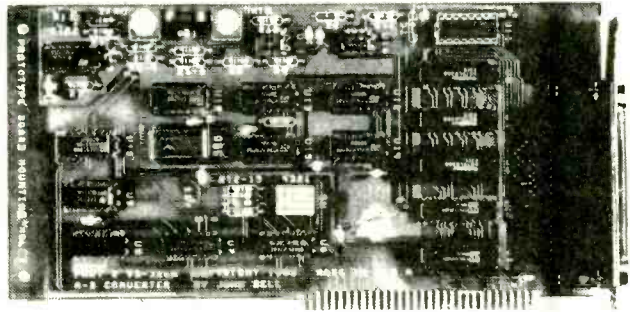
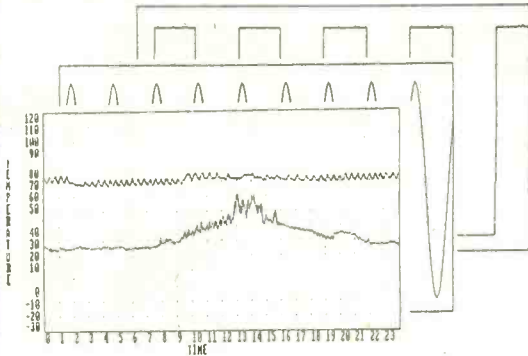

## 12 Bit 8 Channel Analog to Digital Converter + I/O

Specifications: IBM 486, 386, 286, 8088 PC compatible interface board.

12 Bit 8 Channel multiplexed Analog to Digital Converter. Input Voltage 0 to 2 volts (data 0 to 4095) .00048 volts per count. 12 Bit conversion time is less than 1ms. Accuracy is better than +/- 2 counts Linearity better than +/- 1%. Over Voltage, the counter is a 15 bit counter and this board will handle twice the normal input voltage. MODS: This board can be modified to convert 8 bits to 14 bits. This board also has one 8 bit TTL output port and one 8 bit TTL input port. All I/O is through a 37 pin D connector. A Disk with BASIC programs is included. Programs include a low frequency Oscilloscope, Data logger, Temperature measurement using a Radio Shack Thermistor and Voltage measurement. This board also has mounting holes for a Prototype board to be added.

Order Part Number 93-326A \$149.95 + Shipping (\$6.00 for 2 day air or \$4.00 for 8 day ground)

Circle my number on the FREE INFORMATION CARD to get more info on my other Interface Boards.

John Bell - 1381 Saratoga Street - Minden, NV 89423 - (702) 267-2704

CIRCLE 137 ON FREE INFORMATION CARD

## TONY TALLI'S ORIGINAL TELEVIEW DISTRIBUTORS

WHERE OUR VALUED CUSTOMERS'

*BUSINESS*

IS HONESTLY APPRECIATED

**OUR PRICES**

**1 800 847 3773**

*Call Us Today*

**90 DAY + GUARANTEE**

**SCIENTIFIC ATLANTA**

**JERROLD PIONEER**

**OAK HAMLIN**



HRS. M - F 9-4 PST NO NV. SALES



**Are you overpaying . . .**

**. . . your cable company?**

**You are if . . .**

**. . . you are leasing their equipment.**

- Forest Electronic, Inc. offers a complete line of New Cable Equipment that is fully Compatible with your cable system.
- All systems come with: Remote Control, & Parental Guidance Feature. Volume Control is also available.
- All Equipment is fully guaranteed & comes with a 30 day money back option.

For More Information Call Us At:

**800-332-1996**

FAX: 708-860-9048

**DC/CAD**  
introducing...

## THE TERMINATOR

Super High Density Router  
(Complete with Schematic & PCB EDITOR)

Features the following powerful algorithm & capability:

- Rip - up and Retry
  - Pre-routing of SMT components
  - Real-Time via minimization
  - Real-Time clean up passes
  - User defined strategies
  - Window 3.0 capability as DOS Task
  - 1-mil Autoplacer and Autopanning
  - Two-way Gerber and DXF
  - Automatic Ground Plane w/ Cross-Hatching
  - Complete w/ Schematic & Dolly Libraries
  - Optional simulation capability & protected mode for 386 users
- \* PCB LAYOUT SERVICE AT LOW COST \***

Call for  
**DC/CAD - \$95**  
(available for students only)  
normal price range  
\$295 - \$2500

LEASE PROGRAM & SITE LICENSE AVAILABLE



Design  
Computation

1771 State Highway 34  
Farmingdale, NJ 07727  
(908) 681 - 7700 • (908) 681 - 8733 (FAX)

"DC/CAD... The focal point of future CAD market"

## CONTROL ANYTHING FROM YOUR COMPUTER SERIAL PORT!

**115200 BAUDS SMART BOARDS DO NOT REQUIRE PROGRAMMING!** The I/O-232 boards understand simple commands, e.g. PRA [Enter] reads Port A. Results are sent back to the computer as an ASCII string allowing the use of PROCOMM, MAC240, or your own programs. In addition to interfacing, the I/O-232 boards have the following embedded functions:

- All standard Baud rates (300-115KB) supported.
- Bin, Hex or Dec formats.
- 24 I/O lines configurable individually as Inputs or latched Outputs.
- 8 or 10 bits, 10 channels Analog to Digital converter.
- 10-10,000 Hz, 0-100% Pulse Width Modulation output.
- 3 EASY to use stepper motor logic interfaces (Muxable to more).
- Relative resistance or capacitance measurements using an RC network (ideal to read temperatures using a thermistor).

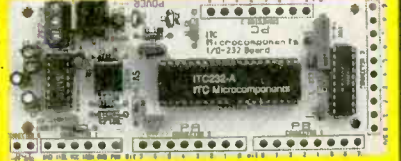

- I/O-232-8A ( 8 bit ADC) Assemb. Only US\$109
  - I/O-232-8K ( 8 bit ADC) Kit. Only US\$ 89
  - I/O-232-10A (10 bit ADC) Assemb. Only US\$125
  - I/O-232-10K (10 bit ADC) Kit. Only US\$ 99
- Add \$10 for manuals + Shipping & Handling

ITC MICROCOMPONENTS INC.

18440-57 Ave, Edmonton AB, T6M 1Y2,  
Canada. Phone & Fax: 1 (403) 486 2377

# MCM ELECTRONICS<sup>SM</sup>

## High Technology Without The High Price

★ Over 21,000 items stocked and shipped within 24 hours

- Pocket DMMs to 1GHz Spectrum Analyzers
- Computer Components from Keyboard Covers to Motherboards
- Over 8000 Semiconductors and Consumer Electronic Repair Parts
- New Line of Amateur and GMRS Radio Products and Accessories

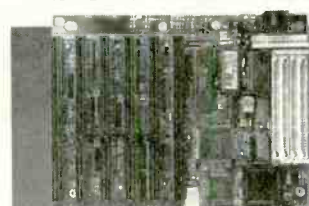

286, 386 and 486 Motherboards  
at Factory Direct Prices



**TENMA**  
The World's  
Most Affordable  
Test Equipment



Complete  
Line of  
Technicians  
Aids

Wide Variety  
of Speaker  
Components  
Including Over 140  
Different Woofers

MCM is now an RCA/GE  
Premier Distributor



**FREE  
CATALOG**

FREE 288 Page Catalog, CALL...

**1-800-543-4330**

For Product Questions... Call 1-800-824-TECH(8324)



MCM ELECTRONICS<sup>SM</sup>  
650 CONGRESS PARK DR.  
CENTERVILLE, OH 45459-4072  
A PREMIER Company

SERVING YOU COAST TO COAST! DISTRIBUTION CENTERS IN DAYTON, OH AND RENO, NV

POP-09

CIRCLE 142 ON FREE INFORMATION CARD

www.americanradiohistory.com

EASY TO FABRICATE  
DESIGNED FOR SMALL LOT  
PRODUCTION

# SHEET METAL BOXES FOR CONSTRUCTION

ALL ITEMS STOCKED  
FOR QUICK DELIVERY  
SHEET METAL BOXES SHIPPED FLAT



## DUAL SLOPE METAL CABINETS

MODEL	DESCRIPTION MAJOR DIM. SECONDARY DIM. W x D x H (inches) \$1 x \$2 x D1 (in)	PRICE \$
DS-1	4 x 6 x 4 x 1.2 x 1.9 x 2.4 x 1.6	59.00
DS-2	6 x 6 x 4 x 1.2 x 1.9 x 2.4 x 1.6	63.25
DS-3	8 x 6 x 4 x 1.2 x 1.9 x 2.4 x 1.6	67.50
DS-4	10 x 6 x 4 x 1.2 x 1.9 x 2.4 x 1.6	71.50
DS-5	12 x 6 x 4 x 1.2 x 1.9 x 2.4 x 1.6	76.00
DS-6	16 x 6 x 4 x 1.2 x 1.9 x 2.4 x 1.6	81.00
DS-7	4 x 8 x 6 x 2 x 3.1 x 3.5 x 1.9	69.00
DS-8	6 x 8 x 6 x 2 x 3.1 x 3.5 x 1.9	73.00
DS-9	8 x 8 x 6 x 2 x 3.1 x 3.5 x 1.9	78.00
DS-10	10 x 8 x 6 x 2 x 3.1 x 3.5 x 1.9	82.75
DS-11	12 x 8 x 6 x 2 x 3.1 x 3.5 x 1.9	87.75
DS-12	16 x 8 x 6 x 2 x 3.1 x 3.5 x 1.9	100.75

## EXTRUDED SERIES

MODEL	DESCRIPTION W x D x H (inches)	PRICE \$
ET-1	4.52 x 4.35 x 1.57	10.00
ET-1B	4.52 x 4.35 x 1.37	10.00
ET-2	4.52 x 6.00 x 1.57	24.00
ET-2B	4.52 x 6.00 x 1.37	24.00
CCET	PLASTIC CARRYING CASE	18.00



PANELS ARE .063" ALUMINUM

## RACK CHASSIS

MODEL	DESCRIPTION W x D x H (inches)	PRICE \$
1RU5	19 x 5 x 1.75	30.85
1RU7	19 x 7 x 1.75	33.10
1RU10	19 x 10 x 1.75	35.25
2RU5	19 x 5 x 3.5	33.10
2RU7	19 x 7 x 3.5	35.25
2RU10	19 x 10 x 3.5	37.80
3RU5	19 x 5 x 5.25	41.90
3RU7	19 x 7 x 5.25	44.10
3RU10	19 x 10 x 5.25	46.30

## SHEET METAL PUNCHES

MODEL	MOLE SIZE & SLOPE	PRICE \$
PUNCH 1	3/8" ROUND	9.95
PUNCH 2	7/16" ROUND	9.95
PUNCH 3	1/2" ROUND	9.95
PUNCH 4	9/16" ROUND	12.95
PUNCH 5	5/8" ROUND	12.95
PUNCH 6	11/16" ROUND	12.95
PUNCH 7	3/4" ROUND	12.95
PUNCH 8	13/16" ROUND	12.95
PUNCH 9	7/8" ROUND	12.95
PUNCH 10	1" ROUND	13.95
PUNCH 11	1-1/16" ROUND	13.95
PUNCH 12	1-1/8" ROUND	13.95
PUNCH 13	1-3/16" ROUND	13.95
PUNCH 14	1-1/4" ROUND	14.95
PUNCH 15	1-3/8" ROUND	14.95
PUNCH 16	1-1/2" ROUND	16.95
PUNCH 17	1-5/8" ROUND	21.95
PUNCH 18	1-3/4" ROUND	24.95
PUNCH 19	2-5/8" ROUND	61.95
PUNCH 20	1 1/16" SQUARE	32.95
PUNCH 21	3/4" SQUARE	36.95
PUNCH 22	1" SQUARE	46.95
PUNCH 23	2 1/2" x 1 5/16" RECT.	46.95
*PUNCH 24	*THURST RACES	10.95



PANELS ARE .063" ALUMINUM

## METAL CABINETS

MODEL	DESCRIPTION W x D x H (inches)	PRICE \$
MC-1A	4 x 5 x 2	16.50
MC-2A	6 x 3 x 2	18.75
MC-3A	8 x 3 x 2	20.95
MC-4A	4 x 4 x 3	18.75
MC-5A	6 x 4 x 3	20.95
MC-6A	8 x 4 x 3	23.15
MC-7A	4 x 7 x 4	20.95
MC-8A	6 x 7 x 4	23.15
MC-9A	8 x 7 x 4	25.75



PANELS ARE .060"  
ALUMINUM AND ARE FIELD REMOVABLE

## HEAVY DUTY RACK CHASSIS

MODEL	DESCRIPTION W x D x H (inches)	PRICE \$
3RU7 HD	19 x 7 x 5.25	115.00
3RU10 HD	19 x 10 x 5.25	121.00
3RU14 HD	19 x 14 x 5.25	134.00
4RU7 HD	19 x 7 x 7.0	121.00
4RU10 HD	19 x 10 x 7.0	129.00
4RU14 HD	19 x 14 x 7.0	134.00
5RU7 HD	19 x 7 x 8.75	126.00
5RU10 HD	19 x 10 x 8.75	133.00
5RU14 HD	19 x 14 x 8.75	143.00

## HAND TOOLS

MODEL	DESCRIPTION	RANGE (mm)	PRICE \$
MD-1	MICRO REAMER	1.0-5.5	16.50
MD-2	REGULAR REAMER	3.0-12.0	26.00
MD-3	LARGE REAMER	10.0-25.0	48.00
RT-1	RETHREADER	3.0 x 0.5	10.50
AD-1	DRILL BIT ADAPTER FOR POWER SCREWDRIVER		6.50

## NEW FOR 1994

RACKEM 'N' STACKEM™ SERIES  
A NEW 1/4" RACK SYSTEM WITH ITS  
OWN TABLE-TOP RACK  
AVAILABLE IN CLEAR, BLACK AND  
GOLD FOR A GREAT PRESENTATION

ORDERS (800) 634-3457  
FAX ORDERS (800) 551-2749

\$610.00  
(shipped within  
48 states)



## BRAKE & SHEAR

CUTS METALS, PLASTIC, ETC. TO .063" THICK AND  
7 7/8" WIDE AND BENDS UP TO 90°. GREAT SHOP TOOL.

TECH LINE (702) 565-3993 M - Th 8 am TO 4 pm (Pacific Time)

Line will only be answered by our technician:  
if no answer, please try at another time  
OFFICE (702) 565-3400  
FAX (702) 565-4828

SESCOM, INC.

2100 WARD DRIVE  
HENDERSON, NV 89015 USA



CALL OR WRITE FOR YOUR FREE 24 PAGE CONSTRUCTOR'S CATALOG!  
PREPAID ORDERS SHIPPED GROUND AT NO CHARGE (48 STATES)



CIRCLE 48 ON FREE INFORMATION CARD

# SMALL MIRACLES



## NEW MICRO TX2000 KIT

**\$59.95**  
-SMALLEST 120 MW FM VOICE/PHONE TRANSMITTER  
-88-110MHz ON ANY BROADCAST RECEIVER  
-ROCK SOLID TUNING, DOESN'T DRIFT  
-5 MIN. ASSEM., HEAR A WHISPER UP TO 2 MILES  
-SMT PARTS PREASSEMBLED  
-INCLUDES TXMTR, MIC, ANTENNA, BATTERY CLIP,  
TUNING TOOL, AND INSTRUCTIONS



## VOICE SCRAMBLER/DESCRAMBLER KIT

**\$69.95**  
**2 FOR \$129.95**  
-WORLDS SMALLEST AUDIO SCRAM/DESCRAM.  
-TALK IN PRIVACY ON AUDIO, SPKR. OR MIC LINE  
-HEAR THOSE GARBLED SCANNER VOICES  
-SMALL SIZE 1"x7/8"x1/4"  
-CRYSTAL CONTROLLED DIGITAL SPEECH INVERSION  
-7-15 VOLT DC SUPPLY  
-LOUD HALF WATT AUDIO AMPLIFIER  
-EXCELLENT AUDIO QUALITY  
-INCLUDES FULL DOCUMENTATION  
-DUPLEX SCRAMBLE & DESCRAMBLE  
AT THE SAME TIME

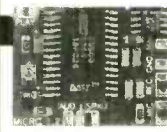

## MICRO 1.2 VOICE RECORDER

**\$69.95**  
-SMALL SIZE 1-1/4"x15/16"x1/4"  
-HUNDREDS OF APPLICATIONS  
-EXCELLENT AUDIO QUALITY  
-60 SECONDS REC/PLAY  
-8 OHM SPEAKER OUTPUT  
-7-15 VOLT DC SUPPLY  
-100 YEAR MEMORY WITHOUT POWER  
-INCLUDES MIC, SWITCHES AND FULL  
DOCUMENTATION



## MICRO 2B VOICE RECORDER

**\$109.95**  
**MICRO 2B FEATURES**  
SAME AS 1.2 PLUS:  
-MULTI MESSAGES (UP TO 600 MEM.)  
-SMALL SIZE 1-5/16"x1-5/8"x1/8"  
-VARIABLE AUTO PLAY TIMER  
-5 VOLT KEY OUT DURING PLAYBACK

ORDER BY PHONE OR MAIL  
IN U.S.A. ADD \$5 FOR S&H  
C.D.D. CHARGES APPLY  
NY'S RESIDENTS ADD 7% SALES TAX  
TECH. SUPPORT: 518-381-1057  
TECH. FAX: 518-381-1058



1145 CATALYN STREET  
SCHENECTADY, NY 12303

TO ORDER: CALL 1-(800)-588 4300



# FOTRONIC

## QUALITY ELECTRONIC TEST EQUIPMENT

Sales • Service

- Specialists in - Fluke, Hewlett Packard, Tektronix
- NIST Traceable/Mil Spec 45662A Calibration Available

We buy surplus  
Electronic Equipment  
FAX your list!!!

### TECHNICAL SUPPORT

#### Oscilloscope Specials

Tek 465	100 MHZ	\$489.00
Tek 465B	100 MHZ	\$589.00
Tek 475	200 MHZ	\$649.00
Tek 475A	250 MHZ	\$749.00

**ALL EQUIPMENT SOLD WITH WARRANTY**

For more GREAT VALUES Call, Write, or FAX  
P.O. Box 708, Medford, MA 02155  
**(617) 391-6858 FAX (617) 391-6903**

# Are Cable Companies Sucking You Dry?



**FREE  
Catalog!**

**All Major  
Brands!**

Take a Bite out of High Rental Fees  
with your own

## Converters & Descramblers



Everquest • Panasonic • Jerrold • Zenith • Pioneer  
Scientific Atlanta • Oak • Eagle • Hamlin • Tocom



Order  
Toll-Free **1 800 624-1150**

Call today for a FREE catalog!

# MD Electronics

875 S. 72 Street • Omaha, NE 68114



# BUILDING BLOCK

FOR YOUR  
CONTROL & MONITORING  
NETWORK SYSTEMS



## DINEX

DISTRIBUTED  
INTELLIGENT  
NETWORK  
CONTROLLER

BY PLUGGING DINEX INTO YOUR PC  
RS-232 YOU CAN CONNECT ALMOST  
UNLIMITED I/O.

**DIO-STD-SM \$69.95**  
5 TTL DIGITAL I/O

**ADFC-SM \$96.65**  
4 CHANNEL 8 BIT 0-5V A/D  
1 CHANNEL FREQ INPUT

**D-M232-SM \$79.95**  
RS-232 TO 485 INTELLIGENT  
CONVERTER

LIMITED TIME

**INTRODUCTORY OFFER:**

**\$199.95/kit** +S/H

P/N SM-KIT including:  
DIO-STD-SM/ADFC-SM/D-M232-SM, POWER  
ADAPTER, NETWORK PHONE LINE SOFTWARE,  
DEVICE DRIVER, AND UTILITY. OVER \$450 VALUE.

ALSO AVAILABLE:

8 CH. 12BIT A/D, 12 BIT D/A, STEPPER MOTOR  
SERVO, DISPLAY, CODE INPUT, NETWORK  
CONTROLLER...ETC.

PLS CONTACT FACTORY FOR DETAIL.

NO ORDER CALL:

15 DAYS MONEY BACK GUARANTEE  
VISA, MASTER CARD ACCEPTED.

NO CONTROLS CORPORATION

359 V. FOOTHILL BLVD, AZUSA, CA 91702

**(818) 812-5333 FAX: (818) 812-5332**

Radiotelephone - Radiotelegraph

# FCC Commercial License

## Why Take Chances?

Discover how easy it is to pass the exams. Study with the most current materials available. Our Homestudy Guides, Audio, Video or PC "Q&A" pools make it so fast, easy and inexpensive. No college or experience needed. The new commercial FCC exams have been revised, covering updated Aviation, Marine, Radar, Microwave, New Rules & Regs, Digital Circuitry & more. We feature the Popular "Complete Electronic Career Guide" 1000's of satisfied customers

Guarantee to pass or money back. Send for FREE DETAILS or call

**1-800-800-7588**

WPT Publications

7015 N.E. 61st Ave Dept. 10  
Vancouver, WA 98661

Name \_\_\_\_\_

Address \_\_\_\_\_

City \_\_\_\_\_ St. \_\_\_\_\_ Zip \_\_\_\_\_

**1-800-800-7588**

# CABLE TV DESCRAMBLERS

Best Prices in the U.S.A.! Guaranteed to Work!

**WE WILL BEAT ANY PRICE!**



JERROLD, SCIENTIFIC ATLANTA, PIONEER, FTB-3, SA3

## THE NEWEST & THE LATEST

- TVT-3K - Jerrold Impulse & Starcom series
- SA3-DFA - Scientific Atlantas incl. 8536/+, 8580, Drop-field
- PN-3A - Pioneer systems

PANASONIC TZPC145G 99 Channel Wireless Cable Converters

ZENTEK XL2100 99 Channel Wireless Cable Converters

FAST SHIPMENTS FREE CATALOG 30 DAY MONEY BACK GUARANTEE

**1-800-772-6244** M-F: 9-6 EST  
U.S. Cable TV, Inc. Dept.: KPE084

4100 N. Powerline Rd, Bldg. F-4 Pompano Beach FL 33073

NO FLORIDA SALES!



Whether you wish to save money, boldly go where no guitarist has gone before or simply have fun building electronic gadgets designed for your musical pleasure, then read

## Electronic Projects for GUITAR

Some of the add-on guitar gadgets you can build are:

**\$12<sup>95</sup>**

- Preamplifier • Headphone Amplifier • Soft Distortion Effects Unit • Compressor • Auto-waa • Waa-waa Pedal • Phaser • Dual Tracking Effects • Distortion Unit • Expander • Dynamic Treble Booster • Direct Injection Box • Dynamic Tremelo • Thin Distortion Unit • and Guitar Tuner.

Anyone with some previous electronic project building experience should have no problem assembling the projects.

ELECTRONICS TECHNOLOGY TODAY INC.  
P.O. Box 240, Massapequa Park, NY 11762-0240

Yes, send my copy of ELECTRONIC PROJECTS FOR GUITAR by RA Pentfold to the address at right. I am enclosing \$12.95 plus \$2.95 for shipping charges in USA and Canada. All payments must be made in US funds. Sorry, no orders accepted outside of USA and Canada. New York State residents add local sales tax. Allow 6-8 weeks for delivery.

Check enclosed

Please charge my  Visa  MasterCard

Signature \_\_\_\_\_

Account No. \_\_\_\_\_ Expir. Date \_\_\_\_\_

Name \_\_\_\_\_

Address \_\_\_\_\_

City \_\_\_\_\_ State \_\_\_\_\_ ZIP \_\_\_\_\_



# B & S SALES

Call (313) 566-7248 • FAX (313) 566-7258 24 hrs.

Hours: Monday through Friday 8 am to 6 pm EST  
51756 Van Dyke St. #330, Shelby Township, MI 48316

WE SPECIALIZE IN QUANTITY PRICING 5, 10, 20 LOTS

*Make Your Best Deal!*

JERROLD	SA	PIONEER	HAMLIN	TOCOM	ZENITH
DRX-3-DIC	8590	BA 6110	CR 6600-3M	5507 VIP	1600
DPBB	8580	BA 5135	CR 6000-3M	5503 VIP	
DPV-5,7	8570				
	8550				

**NEW PAN**  
PIONEER  
GREEN E LITE  
BA 5000 > SERIES  
BA 6000

**NEW PAN**  
SA-8500 SERIES  
(BUT ALL BASE BAND)  
THE PREMIER

**NEW PAN**  
JERROLD  
PINK PAN

## PANASONIC TZ — PC 1453G2

By far the best basic converter on the market today. 550 MHz (1 to 99) parental control, sleep timer, remote batteries, contrast and remote control range.

*Superior to all other converters*

**NO MICHIGAN SALES**

MINI TVT:  
THE 1/4 POUNDER  
LITTLE 4x4  
SECOND ONLY TO TVT  
GOLD IN POPULARITY

OWN YOUR OWN

SA-3  
M-80

SAVE \$

NEW REMOTE CONTROL AB  
SWITCH FOR DUAL SYSTEMS  
(WITHOUT LEAVING THE  
COMFORT OF YOUR CHAIR)

TVT GOLD ORIGINAL  
FOR MOST  
JERROLD SYSTEMS,  
LEADING SELLER  
OF ALL PANS

TNT  
MLD

OWN YOUR OWN

SAVE \$

FILTERS  
POST & NEG  
SUBCONTRACTORS  
& DEALERS  
ONLY QUANTITY

We are now offering a 6-month warranty. In order for warranty to be in effect, this form must be signed and returned.  
FOR VCR, SECOND, THIRD, ETC. HOOK-UPS.

Yes, I agree all units are to be used or resold in compliance with Federal and State laws.

Signature \_\_\_\_\_ Date \_\_\_\_\_

Name \_\_\_\_\_ Phone No. ( ) \_\_\_\_\_  
Address \_\_\_\_\_  
City \_\_\_\_\_ State \_\_\_\_\_ Zip \_\_\_\_\_

It is not the intent of B & S Sales to defraud any pay television operator and we will not assist any company or individual in doing the same.

CIRCLE 140 ON FREE INFORMATION CARD

Serving the public since 1981



**XANDI ELECTRONICS**

201 E Southern # 205, Tempe AZ 85282 - 5140

**SATISFACTION GUARANTEED!**

**BUY WITH CONFIDENCE FROM XANDI**

• 30-DAY REFUND POLICY

• TECH SUPPORT NUMBER

(602-894-0992)

- Smallest FM transmitter anywhere!
- Tunes 88-108 MHz.
- Powerful 2 stage audio amplifier.
- Sensitive, picks up sounds at the level of a whisper.
- Up to 1 mile range.

**SUPER-MINIATURE FM TRANSMITTER**

World's smallest FM transmitter. Use with any FM broadcast receiver. Easy to assemble, all chip (SMT) parts are pre-assembled to the circuit board.

**XST500 (E-Z) Kit .....\$44.95**

- Smallest Phone transmitter anywhere!
- Tunes 88-108 MHz.
- No batteries required, powered by phone line.
- Up to 1/4 mile range.
- Attach to phone line anywhere in house, even inside phone

**SUPER-MINIATURE PHONE TRANSMITTER**

World's smallest FM phone transmitter. Use with any FM broadcast receiver. Easy to assemble, all chip components are pre-assembled to the circuit board.

**XSP250 (E-Z) Kit .....\$34.95**

- Uses sensitive microwave transistor amplifier.
- Covers 1 to 2,000 MHz.
- Compact hand held unit.
- Includes miniature loud speaker for audio indication of detected signals.

**SUPER SENSITIVE BUG DETECTOR**

When the XBD200 intercepts a signal in the 1 to 2,000 MHz range, it emits a growl that increases to a high pitched squeal as the signal strength increases.

**XBD200 (C) Kit .....\$49.95**

- Transmit high quality stereo to any FM stereo receiver.
- Built-in output level monitor for quick and easy tuning.
- Ideal for use with personal CD player.

**FM STEREO TRANSMITTER**

Transmit full-bodied Hi-Fi stereo to any FM stereo receiver. Separate left and right inputs and gain controls. Includes an output booster stage for greater range.

**XFS-CASE KIT .....\$13.95**

**XFS108 (C) KIT .....\$41.95**

- Dial your phone from anywhere and listen to the sounds inside your home.
- Two digit Touch Tone code for secure operation.

**TELEPHONE SNOOP**

The latest in home or office security. Call home from anywhere, enter a two digit security code, and hear the sounds in your home. Automatically turns on without ringing the phone. Verifies code, then activates for one and a half minutes.

**XPS-CASE KIT .....\$13.95**

**XPS1000 (C) KIT .....\$49.95**

- Transmits a continuous beeping tone.
- Adjustable from 88 to 108 MHz.
- Up to 1 mile range.
- Works with any FM broadcast receiver.

**TRACKING TRANSMITTER**

Only 0.7 by 2.4 inches, the XTR100 operates at voltages of 3 to 18 Volts and is ideal for use in locating lost model rockets, bicycles, automobiles, games of hide and seek, and contests.

**XTR100 (C) Kit .....\$33.95**

- Works with any FM broadcast receiver.
- Turns off when phone is not in use to extend battery life.
- Adjustable from 88 to 108 MHz.
- Up to 1 mile range.

**LONG RANGE PHONE TRANSMITTER**

Similar to our very popular XSP250, the XTT100 is battery powered for greater range. It plugs into any phone jack and transmits both sides of conversations on that line.

**XTT100 (C) Kit .....\$32.95**

- Use with any FM broadcast receiver.
- Hear every sound in an entire house!
- Up to 1 mile range
- Powerful 2 stage audio amplifier.

**MINIATURE FM TRANSMITTER**

The XFM100 has a super sensitive microphone and is capable of picking up sounds at the level of a whisper and transmitting them to any FM broadcast receiver.

**XFM100 (C) Kit .....\$32.95**

- Digital voice changing: male to female, female to male, adult to child, child to adult.
- Anonymity on any call.
- Button for normal operation.
- 16 levels of voice masking.

**VOICE CHANGING TELEPHONE**

STOP THOSE ANNOYING TELEPHONE CALLS! Sound older and tougher when you want to. Not a kit. Fully assembled. Single phone operation only.

**TRANSITION 2000 .....\$89.95**

- Digital voice changing: male to female, female to male, adult to child, child to adult.
- Use with any modular phone.
- 16 levels of voice masking.
- Connects between handset and phone.

**VOICE CHANGING ACCESSORY**

STOP THOSE ANNOYING TELEPHONE CALLS! Sound older and tougher when you want to. Not a kit. Fully assembled. Use with single or multi-line phones.

**TRANSITION 2001 .....\$59.95**

- Uninterrupted coverage of 800 to 950 MHz.
- Works with any scanner that can receive 400 to 550 MHz.

**800-950 MHz SCANNER CONVERTER KIT**

If your scanner can receive 400-550 MHz, just add the XLC900 for uninterrupted 800-950 MHz coverage. It converts all 800-950 MHz signals down to 400-550 MHz so your scanner can receive them! Add our custom case kit for that "Professional" look.

**XLC-CASE KIT .....\$13.95**

**XLC900 (C) KIT .....\$49.95**

- Works with most any scanner.
- 10 TO 1000 MHz.
- 10 dB typical gain.
- 3 dB typical noise figure.

**10 -1000 MHz AMPLIFIER**

Designed to help scanners with poor sensitivity pull in those weak signals. Includes OFF/BYPASS switch for returning to normal operation and front panel gain control. Add our custom case kit for that "Professional" look.

**XLA-CASE KIT .....\$13.95**

**XLA1000 (C) KIT .....\$24.95**



WE ACCEPT VISA, MC, MO, C/D SHIPPING & HANDLING EXTRA

**TOLL FREE ORDER LINE**  
1-800-336-7389  
ASK FOR FREE CATALOG OF OUR PRODUCTS

SEND MAIL XANDI ELECTRONICS  
ORDERS TO: BOX 25647  
TEMPE, AZ 85285-5647

CIRCLE 134 ON FREE INFORMATION CARD

**Learn MICROCONTROLLERS and EMBEDDED SYSTEMS with the AES-10**

The AES-10... a complete learning system, a complete embedded control system. Extensive manuals guide you through your 8051 development project. Assembly, BASIC, and C programming. All hardware details, complete schematics. Learn to program the LCD, keypad, digital and analog I/Os for your applications.

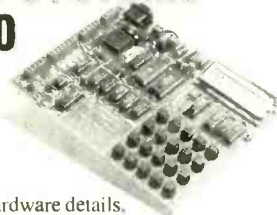

**80C32 Computer/Microcontroller board with:**

- 32K ROM , 32K RAM
- 2 by 16 Liquid Crystal Display
- 4 by 5 Keypad
- Digital, A/D , D/A, and PWM, I/O
- Built in Logic Probe
- Power supply, (can also be battery operated)
- Extended AES BASIC and AES Monitor in ROM
- Built-in routines for LCD, Keypad, A/D, D/A and Digital I/O ports
- See 80C32 registers while you Step
- See all memory locations and data on LCD
- See memory contents in dec, hex, and binary
- RS-232 cable to connect to PC for programming
- 8051/52 DOS Cross Assembler
- Program disks with well documented examples
- User's Manual, Language Manual, and Text

\$365 . Money Back Guarantee  
Free Brochure, M/C Visa  
800 - 730-3232  
714 - 744-0981  
Fax 714 - 744-2693

**AES**  
Advanced Educational Systems  
1407 North Batavia Street, Orange, California 92667, USA

**Professional Electronic Engineering Software**

**"Best bargain in the country"**

**Linear AC/DC Circuit Analysis**

Active & Passive ckt's. 50 nodes, 225 elements max. Models for active devices. Calc, Plot & Print AC voltages & currents. Calc DC current, voltage & power. More

**Linear Transient Circuit Analysis**

10 Input Transients. Active, passive ckt's. 50 nodes, 225 elements max. Models for active devices. Calc, plot and print output Transient voltages. Calc dc current, voltage, pwr. more.

**Active Filters Design & Analysis**

Design & Analyze active LPF, BPF, HPF & All pass filters. Calc, plot Mag/ Phase. More.

**Transient System Analysis**

Calc, plot transient response of system H(s). 14 Input Transients. Inverse Laplace. More

**Control Systems analysis**

Calc and Plot Root Locus, Nyquist, Bode of any H(s). Determine gain and Phase Margins/stability. More

**Mag & Phase Graphics**

Calc, plot mag/ phase of H(s). more

**Function Graphics**

Calc, plot, edit any of 87 common math functions as desired. More.

**Data Graphics**

Plot up to 400 data points in 9 formats. Linear, log, semi, etc. more.

**Polynomial Operations**

Calc Roots, Product & Coefficients.

**News! Circuit Schematic Draw: Both Stand-alone & Integrated**  
Cut, Copy, Move, Merge, Check, Grid, Label, List, 128 symbols, 300 elements, more..

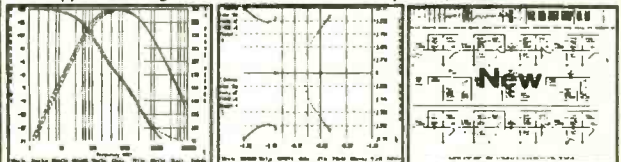

- ◆ Extremely Easy to use
- ◆ Dot Matrix/Laser/Mouse Support
- ◆ Outstanding Graphics & Menus
- ◆ 200 page User's Manual Included

**100% Satisfaction Guaranteed**

Introductory Offer: 9-program package (without Schematic Draw) \$79.99  
Complete 10-program package (with Schematic Draw) \$129.99

VISA/MC accepted. Add \$5.95 for shipping. CA add 7.25% Tax  
To order or info call 1(800)645-6806 or send check or money order to:  
**Geoban Engineering, PO Box 658, Ridgecrest, CA 93556**

**Powerful Integrated Digital and Analog (Berkeley Compatible Spice)  
Circuit Design and Simulation Software for Microsoft Windows™ (network compatible)**

**Includes 4 Integrated Modules: LogicDesigner + WinSpice3 + WinProbe3 + SymbolEditor**

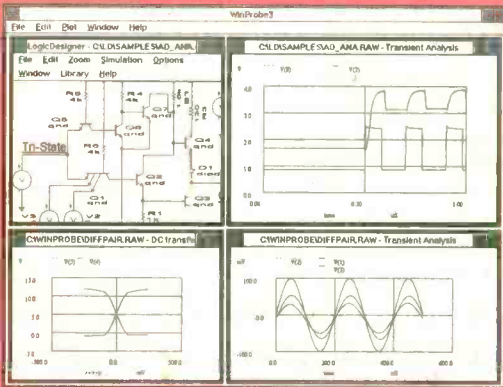

Comes with a Spice library plus 5 more libraries of active digital devices CMOS, 74xx, 74xxx, ALUs, counters, MUX, FFs etc. Plus a passive symbol library of microprocessors and more. Use the symbol library editor to design your own symbols and symbols for subcircuits, true bussing, buss pins can be assigned a unique name, parts billing list, legends, nested subcircuits for hierarchical top down or bottom up design, checks fan out violation and electronic rules, device unit numbers/chip pinouts automatically added as per data books, spice netlist generation, continuous zoom in/out, cut/copy/paste, multiple rotatable fonts, rotatable symbols, multipage zoomed in/out printouts to any windows printer/plotter.

**LogicDesigner Digital Simulation/Schematic Capture Module**

Interactive digital simulation and schematic capture, with glitch detection, single step mode, variable speed simulation, printable timing diagram output, truth table generation, binary to 7 segment displays, hex keypads, clock sources, logic probes. Built in logic analyzer can be set up to generate breakpoints during simulation from user defined AND/OR combinations of circuit signals and sequential events to help debug circuit timing/logic/race conditions. Simulates tri state, open collector & don't care logic, RAM/ROM, one shot, carry look ahead, shift reg, pull up/down.

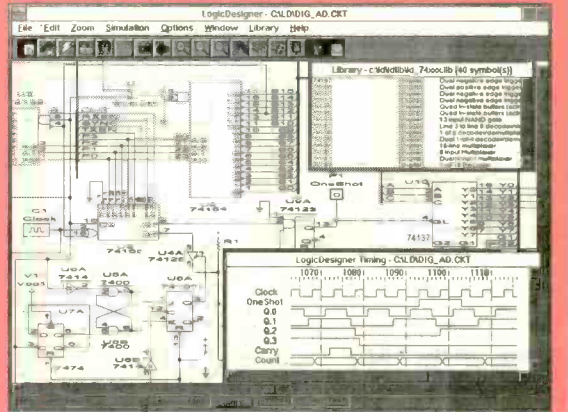

**WinSpice3 Simulator & WinProbe3 Data Analyzer Modules**

DC, AC, Transient, pole-zero, noise, sensitivity and transfer function analysis. Spice library includes MOSFET, MESFET, GaSFET, BJT, DIODE, controlled, independent, dependent and arbitrary sources, transmission lines, current and voltage controlled switches, more. Each with user modifiable models. Plots linear, logarithmic, smith chart type plots, more. Multiple plot windows. Zoom in/out on plot waveforms. Plots math expressions using plot variables as arguments: Ex: plots  $\text{COS}(V_1)/V(2)*10$ , derivatives, + more.

\$69.00 (one month only!!! reg \$179.99)  
(Univ & student pricing avail) VISA/Mastercard

**ISLAND LOGIX INC.**

IRIE MAN  
920 South West 95 Terrace  
Pembroke Pines, Florida 33025 U.S.A.  
PH/FAX: (305) 435-7665



CIRCLE 145 ON FREE INFORMATION CARD

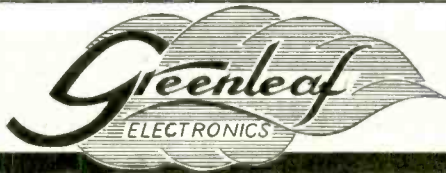

**CABLE TV  
Converters & Descramblers**

Compatible with  
**Jerrold, Scientific Atlanta,  
Pioneer, Oak, & Hamlin  
Equipment**

**BRAND NEW!  
90-DAY GUARANTEE  
LOWEST PRICES**

Volume Control & Parental Lockout Available

**Greenleaf Electronics  
1-800-742-2567**

**NO ILLINOIS SALES**

It is not the intent of Greenleaf Electronics to defraud any pay television operator and we will not assist any company or individual in doing the same.

**Make your projects  
speak for themselves...  
Ours do!**

**DIGITAL VOICE RECORDERS**

- Record up to 218 seconds
- 1 to 8 messages
- High quality speech 12 bit
- Switch-closure actuation
- Sample rates up to 20Khz
- On-board backup
- Direct speaker output
- Wide operating range
- Small size 2.6" X 2.6"
- Made in U.S.A.

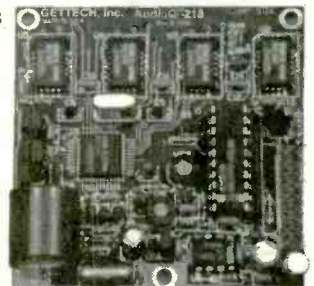

MODEL AudioQ™-218

Call or write for more information  
OEM price and delivery available  
Custom designs and enclosures  
Single unit price \$149.00 plus s+h  
Quantity pricing as low as \$99.00

**GETTECH, Inc.**

402 Riley Road, New Windsor, NY 12553  
(914) 564-5347

Specifications and price subject to change.

August 1994, Popular Electronics

AMERICAN RELIANCE

## Introducing the AMREL Analog and Digital Power Supplies...

**EITHER CHOICE PLACES MORE FEATURES ON YOUR BENCH—SAVES YOU MONEY!**

**3 YEAR WARRANTY**



### AMREL LPS-100 Series—For Performance That Sets New Industry Standards!

- Low Output noise rating less than 0.3mV.
- Line/load regulation rated at low 0.01% + 1mV.
- Transient response time of 50µ Sec.
- Overload protection.
- Output enable/disable
- Coarse and fine voltage/current adjustment.
- Auto series/parallel operations for triple output supplies.
- 3 year full warranty—not 1 or 2 years.

**2 YEAR WARRANTY**

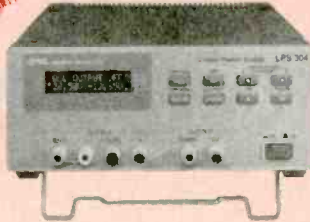

### AMREL LPS-300 Series—Offer Features And Prices That The Competition Can't Beat!

- Microprocessor controlled.
- User friendly keypad data entry.
- Low output noise rating less than 1mV.
- Line/Load regulation rated less than 2mV.
- Output enable/disable and Power-off memory.
- 2 year warranty.
- Optional RS-232 interface capability.

Model	LPS-101	LPS-102	LPS-103	LPS-104	LPS-105	LPS-106	LPS-301	LPS-302	LPS-303	LPS-304	LPS-305
Rating	30V/1A	30V/2A	30V/3A	+30V/1A -30V/1A 3-6.5V/3A	+30V/3A -30V/3A 3-6.5V/3A	60V/1A	15V/2A(H) 30V/1A(L)	15V/4A(H) 30V/2A(L)	30V/3A	+30V/1A -30V/1A 5V/2A	+30V/2.5A -30V/2.5A 3-3.5V/3A
Retail Price	\$195	\$225	\$295	\$395	\$495	\$245	\$249	\$299	\$369	\$399	\$599

**PRINT**<sup>™</sup>  
Product International Inc.



Call For Sale Price: **1-800-638-2020**



8931 Brookville Road • Silver Spring, Maryland 20910 • Fax: 800-545-0058 •

CIRCLE 46 ON FREE INFORMATION CARD

## AFFORDABLE DATA ACQUISITION



**MODEL 30 ..... \$79.00**

- PLUGS INTO PC BUSS
- 24 LINES DIGITAL I/O
- 8 CHANNEL-8 BIT A/D IN
- 12 BIT COUNTER
- UP TO 14K SMP/SEC



**MODEL 45 ..... \$189**

- RS-232 INTERFACE
- 8 DIGITAL I/O
- 8 ANALOG INPUTS
- 2 ANALOG OUTPUTS
- 2 COUNTERS-24 BIT



**MODEL 70 ..... \$239**

- RS-232 INTERFACE
- 18 BIT A/D
- 5.5 DIGIT
- UP TO 60 SMP/SEC



**MODEL 150-02 .. \$179**

- RS-232 INTERFACE
- TRMS, 20 AMPS
- 12 BIT A/D
- OPTO-ISOLATED
- CHANGE RANGES, AC/DC, VIA RS-232

### Prairie Digital, Inc.

846 17th Street • Industrial Park • Prairie du Sac, WI 53578  
(608) 643-8599 • FAX: (608) 643-6754

CIRCLE 47 ON FREE INFORMATION CARD

## Low Cost CAD Software for the IBM PC and Compatibles Now In Windows<sup>™</sup>

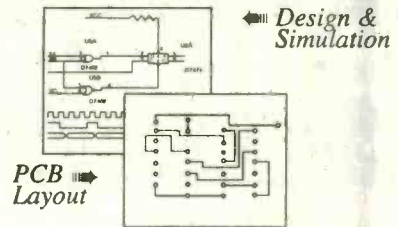

- Easy to use schematic entry program (SuperCAD) for circuit diagrams, only \$149. Includes netlisting, bill of materials, extensive parts libraries, More parts, and automatic wiring available in enhanced CAD package (SuperCAD+) for only \$249.
- Powerful, event-driven digital simulator (SuperSIM) allows you to check logic circuitry quickly before actually wiring it up. Works directly within the SuperCAD editor from a pulldown menu and displays results in "logic analyzer" display window. Starting at \$149 this is the lowest cost simulator on the market. Support for PALs, a larger library, and a separate interactive logic viewer are available in full-featured SuperSIM+ for only \$399. Library parts include TTL, CMOS and ECL devices.
- Circuit board artwork editor and autorouter programs (SuperPCB), starting at \$149. Produce high quality artwork directly on dot matrix or laser printers. You can do boards up to 16 layers including surface mount. Includes Gerber and Excellon file output. Autorouter accepts netlists and placement data directly from the SuperCAD schematic editor.
- Low cost combination packages with schematics and PCB design: 2-layer for \$399, 16-layer for \$649.
- DOS version available.

Write or call for free demo disks:

**MENTAL AUTOMATION**<sup>™</sup>  
5415 - 136th Place S.E.  
Bellevue, WA 98006  
(206) 641-2141

# Double Your Income! Own your own computer repair business or add computer repair to your existing business.

TechServ can put you into your own computer repair business quickly, economically and efficiently. Research indicates that during a recession, computer repair businesses will grow at twice the rate of hardware sales. TechServ's complete support program gives you the opportunity to be a part of this fast growing industry.

## • Proven Marketing Plan

## • Recognition

Nationally recognized trademarks and logos give you immediate recognition as a professional computer repair specialist in your area.

## • Training

- Level 1 286/386/486/586  
Troubleshooting, upgrades, advanced diagnostics
- Level 2 Networking/Novel/Unix/Multi-user/  
Multi-tasking configuration/Installation/  
Maintenance. Prepare for C.N.E.  
(Certified Network Engineer) test

## • Parts and Board Repair

Single source for OEM/generic parts and board repair. Order 7 days a week/24 hours a day. \$45 million in parts in stock, ready to ship any where, overnight if required.

## • Documentation

We provide manuals, documentation and advanced diagnostic software.

## • New Hardware

We provide new hardware for IBM, Compaq, Apple and compatibles at huge discounts. Custom build your own systems.

## Over 300 dealers worldwide

Find out why the Wall Street Journal and Fortune Magazine call computer repair the business opportunity of the 1990s.

**Call TechServ at (212) 967-1865**

or fill out coupon below and mail to:

**techserv** AUTHORIZED DEALER  
SM

**America's largest chain of independent,  
licensed computer repair centers**

253 West 28th Street, New York, NY 10001

NAME \_\_\_\_\_

ADDRESS \_\_\_\_\_

CITY \_\_\_\_\_ STATE \_\_\_\_\_ ZIP \_\_\_\_\_

TELEPHONE \_\_\_\_\_ [PE 2/93]

CIRCLE 130 ON FREE INFORMATION CARD

Tap into a World of...

## FREE ELECTRICITY

Our 150+ page *Self-Reliance Catalog*  
IS JUST LOADED WITH DC to AC  
ENERGY INDEPENDENCE ...

We offer:

- Solar, Wind & Hydroelectric energy systems. True Sine Wave DC to AC Inverters.
- Electric Boat & Car kits.
- Portable power packs.
- Solar Lighting & Cooling systems. Solar Pool Heaters.
- Solar Battery chargers. Solar Books & Toys. DC Appliances.
- Active & Passive Solar Air & Water Heating Systems.
- Composting Toilets. Hydroponic, Fish-Farming, Solarium & Greenhouse Systems. Water Testing, Treatment, & Pumping Systems.
- Emergency Food & H<sub>2</sub>O Kits. High Efficiency AC/DC Refrigeration + More...

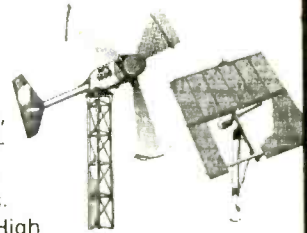

A LOT OF INFORMATION FOR ONLY \$5.75 ...

SEND CHECK or MO TO:

**Self-Reliance Company Inc.**  
**P.O. Box 306, Florissant, MO 63032**

## EPROM+ PROGRAMMING SYSTEM USES PARALLEL PORT

**EPROMS** (24,28,32 & 40 PIN\*) FLUS 27CXXX  
1702\*, 2708, TMS2716\*, 32,32A, 64, 64A, 128, 128A  
256, 512, 513, 011, 010, 101, 1001, 1060, 1024, 210, 020  
2001, 220, 2048, 4001, 040, 240, 4096 25XX, 68764/66  
**FLASH EPROMS** 28F256, 28F512, 28F010  
28I020, 29C257, 29C010, 29F010  
**EPEPROMS & NVRAMS** (18,24 & 28 PIN+CXX)  
2210, 2212, 2804, 2816, 2816A, 2817, 2864, 2865, 28256  
28C010, DS1220, DS1225, DS1230  
**SERIAL EPEPROMS\*** (8 & 14 PIN PLUS CXX)  
KR1400, M58657, 2401, 02, 04, 08, 16, 2444, 59C11  
9306, 46, 56, 66, 8572, 82, 92  
**BIPOLAR PROMS\*** (16 THROUGH 24 PINS)  
74SXXX AND 82SXXX FAMILY  
**MICROCONTROLLERS\*** 8741, 42, 48, 49, 8751  
C51, 8752, 87C52, 87C5XXX, 87C751, 87C752, 68705  
68HC705, 68HC711E9, PIC16C5X, TMS7742  
\*ADAPTER REQ'D - DIAGRAMS INCLUDED



SYSTEM INCLUDES:  
PROGRAMMING UNIT  
PRINTER PORT CABLE  
POWER PACK, MANUAL  
AND SOFTWARE.

**\$289**

ADD \$5.00 SHIPPING  
\$5.00 C.O.D.  
VISA/MASTERCARD

**SOFTWARE** - READ, VERIFY, PROGRAM, COPY  
DISK FILE LOAD/SAVE, CHECKSUM, FULL  
SCREEN BUFFER EDITOR W/20 COMMANDS  
**READS** HEX, S RECORD AND BINARY FILES  
**FAST DEVICES** PROGRAM IN UNDER 60 SEC  
**RUGGED** (8"X7"X3") ENCLOSURE W/HANDLE  
**MADE IN USA - 1 YEAR WARRANTY**

**ANDROMEDA RESEARCH, P.O. BOX 222, MILFORD, OH 45150**  
(513) 831-9708 FAX (513) 831-7562

# SUPPORT RESEARCH.

It Works Wonders.

American  
Heart  
Association





**CONSUMERTRONICS**  
2011 Crescent Dr., P.O. Drawer 537  
Alamogordo, NM 88310

**Voice:** (505) 434-0234, 434-1778;  
8AM - 8PM MST, Mon-Sat  
**Fax:** (505) 434-0234 (orders only; if you get  
answering machine, any time enter #111)

24-hour, 7 days/week  
**Free Tech Support** (must relate directly to your  
order or prospective order): **Tues. and Thurs. only.**

Add \$5 total SH (US, Canada). All items in stock. **VISA**,  
**MCARD OK** (\$29 min.). No CODs or "bill me's". New Catalog  
(150+ offers) is \$2 w/order, \$4 w/b (no free catalog).  
In business since 1971. As seen on TV, etc. John Williams - former  
Lockheed Senior Engineer, NMSU Computer Science Professor,  
Navy, Air Force Weapons Engineer, NIH Health Physicist.

\*All software supports all IBM-PC compatible  
x86 systems (8086-Pentium)

**Off-The-Shelf HARDWARE**  
Van Eck Systems, Automated Tempest Module, Xx Radar  
Emitter, Carjacking Follower, Personal Body Alarm,  
Voice Disguiser, Hearing Assistant, Shrek Module, EM  
Countermeasure, Omnimax TENS, 6th Sense Communi-  
cator, many nifty Phone Boxes, Bumper Beeper, Sub-  
liminal Mixer/Amp, Super MW, Rifle Device, Neuro-  
phone, Hieronymus Machine, Magnetometer, Data Card  
Reader/Writers, Dwelling Security System, Levitator,  
Vortex Generator, Ultrasonic Jammer & Receiver,  
Long-Range Eavesdropper, Noise Cancellation System,  
Unknown Presence Detector, Electronic Downer, Auto-  
matic Pet Feeder, Stealth Paint - more! See our Catalog.

**CELLPHONE MODIFICATIONS**  
See our Catalog for our infamous cellphone modification  
guide (\$69) - detailed, comprehensive, covers all makes -  
10 times more info than competitor's "guides". (Do Special  
Projects (below) for up-to-date hardware/software).

**SPECIAL PROJECTS**  
We design, build, repair, modify, maintain and/or consult  
on any device, system, process or project - electrical,  
electronic, computer, phone, mechanical, optical, auto-  
motive. Invention prototyping. Confidentiality guaranteed.  
Describe and include \$25 pre-engineering fee (does not  
obligate you). Time and cost estimates in 7-10 days.

**VOICE MAIL HACKING**  
How Voice Mail Box (VMB) systems are used and the  
specific ways they are hacked. Includes ASPEN, MES-  
SAGE CENTER, BIX, GENESIS, EZ, SYONEY, PHONE  
MAIL, AUDIX, CINDY, CENTAGRAM, SPERRY LINK,  
RSVP, etc. Absolutely required for all users, sysops and  
security personnel \$29.

**PBX HACKING**  
How PBXs are hacked to the tune of \$ Billions/yr!  
While "VOICE MAIL HACKING" details how VMS are  
hacked for "phun" and profit - including VMS methods  
for hacking PBXs themselves - "PBX HACKING" ad-  
dresses ALL issues relating to PBX hacking, including  
countermeasures! Can your business or agency afford a  
\$30,000 phone fraud loss (the average loss due to  
hacked PBXs)? As described in Forbes Magazine. \$39.

**PHREAKING CALLER ID & ANI**  
Details on how they work and dozens of effective ways  
of defeating Caller ID, ANI, #69, #57, and Call Blocking  
& #67. Also describes Caller ID, Orange, Beige,  
Cheese and CF Boxes, SS7, E-911, various  
CLASS services, CWA, NON PUB DA, CAMA, DNR,  
800-EOR, Diverters, LD Extenders, Genrex - more. \$29.

**PHONE COLOR BOXES**  
As designed by Phone Phreaks! 15 phone color boxes  
described. Dozens of circuits, simulator programs. Plus  
call-forwarding, conferencing, phreak history, 50 useful  
and legal phone circuit plans - more. \$29.

**ROBOFONE AUTODIALER**  
Powerful, versatile, menu-driven "Wargames" autodialer  
lets you dial any quantity (up to 10K) or mix of lo-  
cal-long distance numbers in any order, over any length  
of time, whether busy or answered (your choice) and  
logs the times, commands and results to monitor, printer  
and/or disk. Quick-dial directory of up to 600 numbers.  
BUSY redial options. Direct remote command and con-  
trol. All Result Codes, including VOICE and RINGING.  
Optional shell to terminal program upon CONNECT. Exit  
to menu or DOS (for batching). Manual + Disk \$29.

**COMPUTER PHREAKING**  
TROJAN HORSES, VIRUSES, WORMS, etc. and  
countermeasures. Includes disk with 360K of hacker  
text files and utilities, and legendary FLUSHOT+ pro-  
tection system (Editor Choice, PC Magazine). Dozens of  
computer crime and abuse methods and countermea-  
sures. How systems are penetrated. BBS advice, pass-  
word defeats, glossary - much more! Manuals +  
Disks \$39.

**BEYOND VAN ECK PHREAKING**  
Lavesdropping on TV and Computer video signals using  
an ordinary TV! Includes security industry reports. Range  
up to 1 KM. Plans include both the Consumertronics and  
the original Top Secret Van Eck designs! \$29.

**CRYPTANALYSIS TECHNIQUES**  
Five powerful menu-driven crypto programs (in COM  
and their .BAS sources) to analyze, decrypt "secure" ci-  
pher texts. Worked-out examples. Recommended in pres-  
tigious "Computers & Security". Manual + Disk \$29.

**By an ORDER of the MAGNITUDE**  
The most comprehensive, hard-hitting, hi-tech sur-  
vival book ever written! Topics include electronics,  
computers, energy, weapons, concealment, revenge,  
alarms, etc. to survive today's dangerous world. We all  
face increasingly financially and physically brutal times!  
Field-expedient use of technology in various threat and  
conflict environments and scenarios. \$49.

**STOPPING POWER METERS**  
As reported on CBS "60 MINUTES": How certain de-  
vices can slow down - even stop - watt-hour meters -  
while loads draw full power! Device simply plugs into  
one outlet and normal loads into other outlets. Also de-  
scribes meter creep, overload droop, etc. Plans \$29,  
i.g. **MANUAL**: External magnetic ways (applied to the  
meter itself) to slow down and stop watt-hour meters  
while drawing full loads. Plans. \$19. **KW-HR**  
**METERS**: How watt-hour meters work, calibration,  
error modes (many), ANSI Standards, etc. Demand and  
Polyphase Meters. Experimental results to slow and  
stop meters by others. \$19. Any 2. \$38. All 3. \$59.

**AUTOMATIC TELLER MACHINES**  
ATM crimes, abuses, vulnerabilities and defeats ex-  
posed! 100+ methods detailed, include: Physical, Reg,  
E, cipher, PIN compromise, card counterfeiting, mag-  
netic stripe, false front, TEMPEST, Van Eck, tapping,  
spoofing, inside job, super-cool, vibration, pulse, high  
voltage - others. Case histories, law, countermeasures,  
detailed security checklist, labeled internal photos, fig-  
ures. ATMs contain up to \$250,000 in cash! Recent  
\$350,000 ATM crime spree still unsolved! \$39.

**CREDIT CARD SCAMS**  
Cardholders, merchants, banks suffer \$ Billions in  
losses annually because of credit card fraud. Describes  
every known means of credit card fraud and scams.  
Protect yourself! \$29.

**CONS & SCAMS**  
Cons & scams fleece Americans of \$100+ Billion per  
year! The most comprehensive survival manual on cons &  
scams of all kinds - from the classic to hi-tech. De-  
tails on 100s and their many variations. Protect your-  
self! \$29.

**HIGH VOLTAGE DEVICES**  
HV devices plans: Stun Gun, Taser, Prod, Cane,  
Flasher, Blaster, Zapper, Audio/Radar Jammer,  
Jacob's Ladder, Plasma & Van de Graaf Gens., Fence  
Charger, Beizer Counter, Ozone Gen., Fish Stunner,  
Plant Stim., Kirlian, more! Shocking! \$29.

**UNDER ATTACK!**  
Electromagnetic Interference and Electronic Weapon  
Attacks cause: Cancer, birth defects, and profound psy-  
chological, neurological, cardiovascular and immune  
system disorders! Destructive to people, animals,  
plants - equipment! Includes **ACTUAL CASES OF EM AT-  
TACKS ON PEOPLE** (we investigated!) Includes how to  
verify and pinpoint EMI and electronic attack sources,  
and specific countermeasures. \$29. **EM BRAIN-  
BLASTER**: Tutorial and plans for powerful  
**ELECTROMAGNETIC WEAPONS and LAB DEVICES**.  
Optimum circuits, freqs, waveforms, duty cycles, intensi-  
ties. Thorough. \$29. Both \$49.

**RADIONICS MANUAL**  
Containing electrical, electronic and electromagnetic ther-  
apeutic, diagnostic and preventive devices (mostly ex-  
perimental). History, descriptions, plans (dozens), avail-  
abilities of Radionics Devices from early to modern.  
While drugs cost \$ Hundreds, electricity costs pennies!  
\$29. **HEAL THYSELF**: Plans for 3 major elec-  
tronic therapeutic devices of types approved by FDA.  
\$19. Both \$39.

**HARD DRIVE MANUAL**  
Covers all hard drive and controller implementations  
(emphasis on PCs). How to select, interface, initialize,  
set up, use, maintain, troubleshoot and repair them.  
How to protect them from mistakes, sabotage, prying  
eyes and sticky fingers. How to recover damaged and  
lost files. How to prevent crashes. Includes software re-  
views. Loaded with information, advice, tips. \$29.  
**DISK SERVICE MANUAL**: Maintain, trouble-  
shoot, repair, adjust, align floppies without special  
equipment or software. 3.5"/5.25", PCXTAT386/  
486, Apple, Commodore, etc. systems. All floppies need  
occasional upkeep. \$29. **DISK DRIVE TUTO-  
RIAL**: Theory, practical facts on floppy drives, disks,  
including many tips, recommendations, formatting, in-  
terfacing, FDC, etc. \$24. Any 2. \$49. All 3. \$69.

**SOFTWARE PROTECTION SYSTEM**  
Unique system that highly discourages costly software  
piracy while not interfering with legit archival copies. No  
known way to defeat. No special equipment required.  
Simple and automatic to install on your distributed soft-  
ware. Compatible with all copy-prevention systems.  
Manual + Disk \$59.

**STEALTH TECHNOLOGY**  
Police radar is fascinating! It also has error rates of 1-  
20%! Every known error mode - stealth method and ma-  
terial used to minimize radar reflections - tactic and  
strategy to fight unjust radar tickets (that cost you  
\$100s in Insurance and risk cancellation) - methods to  
detect and jam signals - fully described! \$29.

**SECRET & SURVIVAL RADIO**  
Optimum survival and Security radio equipment, meth-  
ods, freq allocations and voice/data scrambling/encod-  
ing. Includes small receivers/transmitters, telemetry, an-  
tenna optimizations, remote monitoring and control, se-  
curity, surveillance, and ultrasonic, fiber-optic and infra-  
red commo. 70+ circuit plans, tables. \$29.

**ULTIMATE SUCCESS MANUAL**  
Underpaid? Harassed or abused? Manipulated?  
Taken for granted? Stuck in a dead-end job? Can't find a  
good job? Expect to be laid off, fired or transferred soon?  
The ultimate no-holds-barred, looking-after-#1  
Machiavellian techniques to find, obtain, optimize and  
keep top jobs, pay and benefits. **THE RULES OF THE  
GAME FOR A GAME WITHOUT RULES!** From first re-  
sume to CEO. \$29.

**ROCKET'S RED GLARE**  
How to design and build solid-propellant amateur and  
survival rockets. Emphasis on formulation, manufacture,  
installation of propellants, motors, igniters, etc. Includes  
list of commonly available materials, and the design of  
launch pads and test beds and their electronics. \$29.  
Please Order Today! (505) 434-0234  
Sold for educational purpose only.

**JAN Crystals**

**FREE 1994 Catalog  
of General Purpose Crystals  
Now Available**

<b>FOR FREQUENCY CONTROL:</b>	
<b>FUNDAMENTAL MODE CRYSTALS</b> 1.001-30.0 MHz HC6/U, HC33/U HOLDERS	<b>FROM \$11.00</b>
<b>FUNDAMENTAL MODE CRYSTALS</b> 2.0-30.0 MHz HC25/U, HC18/U MINIATURE HOLDERS	<b>FROM \$11.00</b>
<b>THIRD MODE CRYSTALS</b> 18-75. MHz ANY HOLDER	<b>FROM \$11.00</b>
<b>FIFTH MODE CRYSTALS</b> 52-125. MHz ANY HOLDER	<b>FROM \$13.00</b>
<b>SEVENTH MODE CRYSTALS</b> 110.5-150. MHz ANY HOLDER	<b>FROM \$18.00</b>

*Quantity Prices Available  
On Request*

**FOR MICROPROCESSORS:**  
...low E.S.R....close tolerance...long-term stability...  
frequency deviation from 0° to 70°C max. ± 100 PPM...  
tolerance at 25° ± 50 PPM.

HC49/U	
3.0-3.5 MHz	\$5.00
3.5-18.432 MHz	\$5.00
19.6608-24. MHz	\$5.00

*When Ordering Please Specify MP-Crystal*

*Your reliable source for a  
world of crystal clear communication*

**Order Toll-Free  
1-800-JAN-XTAL  
FAX ORDERS: 1-813-936-3750**

**EXPEDITED ORDER SERVICE AVAILABLE  
CALL OR WRITE FOR FREE CATALOG  
P.O. Box 60017 Ft. Myers, FL 33906**



PRICES SUBJECT TO CHANGE WITHOUT NOTICE

CIRCLE 37 ON FREE INFORMATION CARD

# Don't Despair...REPAIR!

Here's how to troubleshoot and repair your electronics successfully!

## You Can Be Your Own Repair Expert!

For VCRs, camcorders, audio equipment, TV equipment, computer hardware, office equipment, home appliances, automobile electronics, and outdoor equipment.

- Pinpoint and analyze problems quickly.
- Successfully complete repairs with hands-on troubleshooting instructions.
- Become skilled understanding flowcharts and schematic diagrams.
- Confidently use test equipment such as oscilloscopes, frequency counters, and video analyzers.
- Keep your equipment in top condition with effective preventive maintenance techniques.

## Continue to Broaden Your Repair Expertise!

You'll receive quarterly supplements, up to 160 pages, with new step-by-step repair and maintenance instructions, valuable schematics and new repair techniques. Learn how to repair a growing variety of appliances with hands-on repair projects that will keep you up-to-date with later models and technology. You'll be thrilled with your ability to repair a growing list of electronic equipment! Supplements may be returned or cancelled at any time.

**SAVE \$10**

Call our toll-free number, pay by credit card, and mention this ad. We'll deduct \$10!

We'll also waive shipping and handling.

**Order today for your 30-day, no-risk review of The Electronics Repair Manual.**

**For Faster Service Call TOLL-FREE  
1-800-222-WEKA**

**Or Fax To: 1-203-622-4187**

CIRCLE 133 ON FREE INFORMATION CARD



## One Source For All Your Repair Needs!

Better organized than a magazine, more current than a book.

- 900-page manual
- easy-to-follow, detailed instructions
- trouble analysis flowcharts
- safety precaution checklists
- comprehensive replacement parts list
- directory of manufacturers



**Order your copy today!**

### MONEYBACK GUARANTEE

There's no risk in trying the **ELECTRONICS REPAIR MANUAL** to see if it's right for you. If you are not delighted, simply return the manual after the 30-day trial period and receive a prompt refund.



97 Indian Field Rd.  
Greenwich, CT 06830

**YES!** Please rush me a copy of the new Electronics Repair Manual for only \$59.95 + \$5.50 shipping and handling. I understand that if I am not satisfied I may return the manual within 30 days for a complete refund. Supplements are sent quarterly for 25¢ per page (never more than \$30) and may be returned or cancelled at any time.

My payment is enclosed  Bill me later  
 Charge my  Visa  MasterCard

Acct. No. \_\_\_\_\_ Exp. Date \_\_\_\_\_

Signature \_\_\_\_\_

Phone ( ) \_\_\_\_\_ Signature and phone number are required for all orders.

Name \_\_\_\_\_

Address \_\_\_\_\_

City \_\_\_\_\_ State \_\_\_\_\_ Zip \_\_\_\_\_

All payments must be in U.S. funds. Canada add \$10. All other countries add \$15. CT residents add 6% sales tax.

Mail to: WEKA Publishing, 97 Indian Field Rd.,  
Greenwich, CT 06830

400077

## Electronics made Easy with UCANDO



### Complete Course in Basic Electronics

Includes 6 one hour videos and 6 workbooks.

Everything you need to learn basic electronics. You will learn about Direct Current, Alternating Current, Semiconductor devices, Power supplies, Amplifiers, and Oscillators. These videos are **100% computer animated**, they make learning electronics easy and fun. Don't waste any more of your valuable time reading and re-reading the same material to try and understand these simple concepts when you can **"see it happen."** These videos will ... teach you more in less time ... allow you to learn at your own pace ... help you remember more of what you learn ... give you years of quality use ... become a valuable source of reference material ... make your understanding of electronics more complete ... and help you build your future today. **Your future is too important to gamble with**, so order your course in Basic Electronics Today.

**Call Now ...** ask about our other popular UCANDO videos in Digital, AM Radio, FM Radio, and Fiber Optics. These videos are currently being used by Tech-Schools, CET's, Military branches, Ham Operators, Industries, and are sold in six foreign countries. After you have seen your first UCANDO video you will understand why UCANDO is .....

***"Changing The Way The World Learns Electronics".***

Part 1 DC .....	\$44.95
Part 2 AC .....	\$44.95
Part 3 Semiconductors ....	\$44.95
Part 4 Power Supplies .....	\$44.95
Part 5 Amplifiers .....	\$44.95
Part 6 Oscillators .....	\$44.95
<b>SAVE ... buy all six for only \$240</b>	

**Call toll free 1-800-678-6113**

CIRCLE 136 ON FREE INFORMATION CARD

# EARN MORE MONEY!

## Be an FCC LICENSED ELECTRONIC TECHNICIAN!



No costly school. No commuting to class. The Original Home-Study course prepares you for the "FCC Commercial Radiotelephone License." This valuable license is your professional "ticket" to thousands of exciting jobs in Communications, Radio-TV, Microwave, Maritime, Radar, Avionics and more...even start your own business! You don't need a college degree to qualify, but you do need an FCC License.

**No Need to Quit Your Job or Go To School** This proven course is easy, fast and low cost! **GUARANTEED PASS**—You get your FCC License or money refunded. **Send for FREE facts now. MAIL COUPON TODAY!**

Or, Call 1-800-932-4268 Ext. 240

### COMMAND PRODUCTIONS

FCC LICENSE TRAINING, Dept. 240  
P.O. Box 2824, San Francisco, CA 94126  
Please rush FREE details immediately!

NAME \_\_\_\_\_  
ADDRESS \_\_\_\_\_  
CITY \_\_\_\_\_ STATE \_\_\_\_\_ ZIP \_\_\_\_\_



## MEMBRANE SWITCH KITS!

These highly durable water resistant flat-panel keypads can be assembled in minutes with YOUR legend! Available in 4, 12, 16, 24 & 40 Key models. Steel "clickdomes" optional. Connector and bezel included.



Call for free brochure:

Sil-Walker 880 Calle Plano, Unit N,  
Camarillo, CA 93012  
(805) 389-8100 FAX (805) 484-3311

## \* THE BEST \* 8085 MICROPROCESSOR TRAINING SYSTEM JUST GOT BETTER

Are you interested in Single Board Computers and Microprocessor based systems? If the answer is yes and you want to know more about these fascinating subjects the PRIMER Trainer is the place to start. The PRIMER teaches more and is easier to use than other comparably priced trainers. The over 100 page Self Instruction manual takes you from binary number systems to processing interrupts. At the end of the manual are working examples of using photocells, temperature sensors, making a waveform generator, programmable timer with alarm, and a new motor speed control lab using back EMF. The PRIMER comes with everything you need

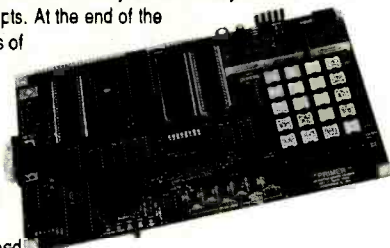

to start programming in machine language. Continue on to program in Assembler, Forth or BASIC with optional upgrade and software. Upgrade includes: RS232 serial port, a serial cable and, 32K of battery backed RAM.

THE PRIMER IS ONLY \$119.95 QUANTITY 1 IN KIT FORM. THE PRIMER ASSEMBLED & TESTED BY EMAC IS \$169.95. ORDER NOW AND RECEIVE ONE FREE POWER SUPPLY WHEN YOU MENTION THIS AD. PLEASE ADD \$5.00 FOR SHIPPING.

# EMAC, inc.

618-529-4525 FAX: 457-0110 BBS: 529-5708  
P.O. BOX 2042 CARBONDALE, IL 62902

IN THE FOREST. KINDLE YOUR SPIRIT.  
NOTHING MORE.



ONLY YOU CAN PREVENT FOREST FIRES.



A PUBLIC SERVICE OF THE USDA FOREST SERVICE AND YOUR STATE FORESTERS.

## CABLE CONVERTER SPECIALS

	1	5	10+
<b>Sigma 550</b> NEW — 86 channel O & I compatible Last channel recall — lightning protection 1 year warranty	99.95	75.00	70.00
<b>Timeless 550 P/C</b> Same as above, different manufacturer with parental lockout. HRC switchable 1 year warranty	99.95	75.00	70.00
<b>Northcoast Excell</b> American manufactured!! 70 channel Fine tuning — Standard HRC tuning through remote, sleep timer. Green LED w/dimmer Parental lockout. Deluxe! A/B twinline available. . .	109.95	85.00	75.00



### United Electronic Supply

P.O. Box 1206-RE  
Elgin, IL 60121

708-697-0600

No Illinois Sales

### NEW ITEM

Zenith Universal Remotes  
Fully Programmable  
New Program / Learn Type  
Combines both functions  
for  
VCR / Cable / TV / Stereo  
All in remote.

As low as \$19.95

Hours: Mon - Fri: 8:30 — 5:00 pm CST

24 Hour Answering Machine for orders

# INSTEK Test & Measuring Instruments

## DC POWER SUPPLIES

### PR-Middle Series (Analog/Digital)

ISO 9002  
CERTIFICATION  
#934163



MODEL #PR6030D (Digital)  
Regular \$500.00  
Sale \$399.95

MODEL #PR6030 (Analog)  
Regular \$379.00  
Sale \$299.95

- Continuous or Dynamic load for internal selectable
- Low ripple and noise
- 0.01% high regulation
- Overload and Reverse polarity protection
- Constant voltage and constant current modes
- 3½ Digits 0.5" LED display (Digital type only)

	Model	Output Volts (V)	Output Amps (A)	Weight (kg)
Analog	PR-6030	0-60	0-3	11.5
Digital	PR-6030D	0-60	0-3	11.5



**Products International**

Test Instruments, Equipment and Tools, Training and Supplies for Electronic Maintenance and Repair  
8931 Brookville Road \* Silver Spring, Maryland 20910 \* 800-638-2020 \* Fax 800-545-0058



TOLL FREE  
800-638-2020

NEW 84 PAGE CATALOG!!!  
Call Today For Your FREE Copy  
Of The 1994 Print Test  
Equipment Catalog!

CIRCLE 143 ON FREE INFORMATION CARD

## NOW Find the Right Part for Your VCR!



### with the **ISCET VCR CROSS REFERENCE**

**NEW!** The Fourth Edition is contained on a diskette for IBM PC AT/XT compatibles, DOS 2.1 or higher. The disk software allows technicians to search by manufacturer for model numbers and description of part numbers. A parts editing sequence gives an on-screen view of all substitutes for parts entered. With the diskette, the technician can update files by adding model and parts

The 320-page, Fourth Edition of the VCR Cross Reference contains both model and part number cross references. Over 1300 new parts and 360 new models have been added.

VCR's are made in a few factories from which hundreds of different brand names and model numbers identify cosmetically-changed identical and near-identical manufactured units. Interchangeable parts are very common. An exact replacement part may be available only a few minutes away from you even though the original brand-name supplier is out of stock. Also, you may be able to cannibalize scrap units at no cost.

crosses of future models. The Fourth Edition can be printed on pages completely from the diskette.

The ISCET VCR Cross Reference, Fourth Edition, is on 8½ × 11-in., pre-punched pages and sells for **\$36.00**. The 3½ inch diskette sells for **\$69.95** and you can view listings from a monitor or printed page.

Only **\$36.00** for pages  
**\$69.95** diskette

Claggk Inc.  
VCR CROSS REFERENCE OFFER  
P.O. Box 4099  
Farmingdale, New York 11735

Name \_\_\_\_\_  
Business \_\_\_\_\_  
Address \_\_\_\_\_  
City \_\_\_\_\_  
State \_\_\_\_\_ Zip \_\_\_\_\_  
Phone \_\_\_\_\_

Enclosed \$36.00 for the ISCET VCR Cross Reference, Fourth Edition.

Enclosed \$69.95 for the diskette containing the ISCET VCR Cross Reference, Fourth Edition. Please specify:

5¼ Diskettes (2) 3½ Diskette (1)

Include \$3.00 for shipping each Cross Reference (Pages or Diskette)

The total amount of my order is \$ \_\_\_\_\_

Check enclosed—do not send cash.

Visa  MasterCard Exp. Date \_\_\_\_/\_\_\_\_/\_\_\_\_

Signature \_\_\_\_\_

New York State residents must add applicable local sales tax to total.

# Satellite Television

Order Your **FREE** Catalog/Buyers Guide Today!



The World Supplier of Satellite T.V. Products. . . "Down To Earth Prices"



### Satellite Analysis and Antenna Aiming Software

An extremely valuable tool for designing and installing TVRO's, tailored for ease of use by professionals and dealers as well as by technically orientated TVRO owners. Demonstrates how changing parameters such as dish size or LNB noise temperature affect picture quality. The program performs both TVRO system analysis and antenna aiming. The analysis subcomponent, is especially useful for predicting performance when viewing signals from a particularly weak satellite. The aiming subcomponent calculates azimuth and elevation angles and range to all satellites within "view" of a TVRO. The names and latitudes of all world-wide C and Ku-band broadcast satellites, presently in service or to be launched by 1995, are listed. The user simply enters TVRO site latitude and longitude.

5.25" disk ..... \$49.95  
3.5" disk ..... \$49.95



### SATELLITE SYSTEM DO-IT-YOURSELF INSTALLATION VIDEO

"Now You Can Watch It Being Done"

Install or "Tune up" your satellite system in no time flat with this professional video.

VHS or Beta (45 Min.) ..... \$33.95

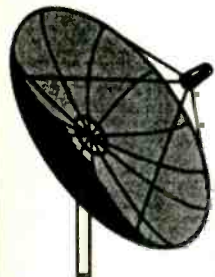

### MESH DISHES by ORBITRON

Quality Demonstrated by Performance

Orbitron antennas ("size for size") are known the world over for their superior reception and picture quality.

7ft dish & polar tracking mount ..... \$259  
8.5ft " " " " ..... 319  
10ft " " " " ..... 369  
10ft H.D. " " " " ..... 449  
12ft " " " " ..... 649

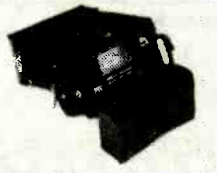

Pico dish Tuning Meter



Bulz-I-Tuning Meter Now with audio alert



## TUNE YOUR DISH TO IT'S MAXIMUM!

Dish tuning meters are a must for the serious dealer or satellite system owner. Saves time, frustration and money. Use when installing a new system, moving your dish, re-alignment of a dish that has been moved by wind, frost heaves etc., gets you right on the satellite belt for the best possible pictures!

Pico meter (meter tuning) ..... \$89.95  
Bulz-I-IV meter (meter & audio alert) ..... 154.95

New Powerful Satellites = Smaller Dishes  
Smaller Dish = Less \$\$\$

### KU-BAND SYSTEM

Package **INCLUDES** all of this:

- 3ft Quality alum dish
- Pansat BR 1100 Receiver
- Polar tracking mount
- Polarity switching feed
- Low Temperature LNB
- 100ft All in one ribbon cable
- Site data coordinate sheet

\*Complete System  
**Only \$499**

### C-BAND SYSTEM

Package **INCLUDES** all of this:

- 7ft ORBITRON mesh dish
- uniden 4400 IRD
- Polar tracking mount and motorized arm
- Chaparral Polarity switching feed
- 25°Low Temperature LNB
- 100ft All in one ribbon cable
- Optional Decoder module

\*All you need to supply is ground pole to mount dish on. (3.5" O.D.)  
\*Complete System  
**Only \$859**



LNBs  
New Lower Temp's

Hermt Technology Commercial Grade

35° LNB C-band 4GHz ..... \$ 79  
25° LNB ..... 95

0.9dbLNB Ku-band 12GHz ..... \$ 89  
0.7dbLNB " " ..... 99  
0.6dbLNB " " ..... 119

All Major Credit Cards Accepted

## Skyvision Inc.®

1048 Frontier Drive, Fergus Falls, MN 56537 - Toll Free 800-334-6455  
Mail in coupon or call today for the SKYVISION Satellite TV Product Catalog/Buyers Guide Delivered free to your mail box in U.S. and its possessions.

- Send Free Domestic Satellite TV Products Catalog  
 Send International Satellite Catalog (For International Catalog add \$8.00 to cover S&H)

Name \_\_\_\_\_ Phone ( ) \_\_\_\_\_

Address \_\_\_\_\_

City \_\_\_\_\_ State \_\_\_\_\_ Zip \_\_\_\_\_



Install A System, Upgrade & Repair Yourself And Save SSSS

Call Toll Free 800-334-6455 International 1-218 -739-5231 Fax 218-739-4879

# KASCO DISTRIBUTING

Your Source for Electronic Tools and Technical Aids

12338 Martin Alexander Rd., Sardinia, Ohio 45171

**FREE CATALOG**



**Computer Care Kit**  
 5 1/4" disk #00648400 \$14.70  
 3 1/2" disk #00648395 \$14.70  
 Includes mini vacuum w/ 3 attachments, cleaning disk, head cleaning fluid, cleaning cloth, spray pump, cotton swabs & carrying case.



**System Power Center**  
 #01878805 \$28.50  
 Protect your system from damaging power surges & spikes. Five power switches & master control switch. 15 AMP circuit breaker. 12"(W) x 13"(D) x 2"(H).



**PC Pocket Reference**  
 #12148430 \$14.90  
 Handy reference book for the computer technician. Codes & numeric translation, video standards, keyboard scan codes, port pinouts and much more!



**Deluxe 22 Piece Tool Kit**  
 #06248325 \$33.80 (above)  
 Zippered carrying case includes diagonal pliers, crimper, soldering iron, screwdrivers/nutdrivers, tweezers & more. Call for more details.  
**Economy 11 Piece Tool Kit**  
 05947245 \$10.90

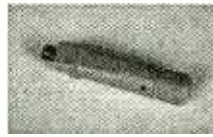

**Deluxe Punch Down Tool**  
 #04647595 \$36.80 (above)  
 Adjustable pressure regulator with slow compartment



**Universal Modular Crimp Tool** (above)  
 #05446515 \$79.80  
 Cut-Strip-Crimp - all in one!  
 Handful plugs (4 pin) RJ11 112 (4 & 6 pin), DECAAG offset (6 pin) RJ45 (6 pin) & 10 pin plugs. Cushioned hand grips. Tough steel construction.  
**Basic Crimp Tools**  
 #05446495 \$12.50

**Simcheck Memory Tester**  
 09747205 \$895.00  
 Identifies bad memory chips. Easy to use. Tests all SDRAM & SRP memory modules 64Kx8/16, 256Kx8/16, 2Kbit, 4Kbit/8bit, 16Mbit/32bit. LCD display, AC adaptor.

**Modular Flat Telephone Wire**  
 1-69ft. 100-499 500+ Item No.  
 4 cond. .08¢ .07¢ .06¢ #02744400  
 8 cond. .13¢ .12¢ .10¢ #02744405  
 8 cond. .13¢ .12¢ .10¢ #02744425  
 10 cond. .20¢ .18¢ .16¢ #02747995

**10% OFF**  
 For New Customers  
 Offer expires 7/31/94



Order Toll Free  
**1-800-575-2726**  
 24HR FAX (513) 446-2781

**30 Day Money Back Guarantee!**

CIRCLE 144 ON FREE INFORMATION CARD

## CABLE TV DESCRAMBLER KITS

"New & Improved Version"  
**Universal Descrambler**  
 Includes all the parts and an etched & Drilled PC Board. Not included is AC adaptor or enclosure.....\$69.00

**Tri-Mode Descrambler**  
 Includes all the parts and an etched & drilled PC board & AC adaptor. Not included is the enclosure.....\$49.00

**SB-3 Descrambler**  
 Includes all the parts & an etched & drilled PC board & AC adaptor. Not included is the enclosure.....\$39.00

**Call Toll Free 1-800-886-8699**  
 Visa, MasterCard & COD.

M & G Electronics, Inc. 2 Aborn Street, Providence, RI. 02903

*It is not the intent of M & G Electronics, Inc. to assist any individual to defraud any pay TV operator or to violate any state or federal laws regarding the use of the descrambler kits. You must understand the kits being purchased for educational and or experimental use only.*

Popular Electronics, August 1994

**CABLE DIRECT**

Now you can tune-in to your favorite cable TV programming and **SAVE 100's—EVEN \$1000's** on premium

**CABLE TV EQUIPMENT**  
 Converters • Descramblers • Filters

FREE Cable TV Catalog

**MODERN ELECTRONICS**  
**1-800-906-6664**  
 100% MONEY BACK GUARANTEE! • 30 DAY FREE TRIAL!

**CABLE TV CHANNELS**  
 EQUIPMENT **GUARANTEED**

→ The nationwide source for cable TV equipment.

**FREE 30 DAY TRIAL**

"BUY WHERE THE DEALERS BUY."

**FREE** TV Cable Descramblers and Converters Catalog. Open Every Day!

**MEGA ELECTRONICS**  
 VISA • MC C.O.D. **1-800-676-6342** SAVE 1000's

21 South Main Street, Winter Garden, FL 34787

Dumont Model 190 two channel, 50 MHz solid state, delayed timebase, modular construction, built to military specs. includes 225 page manual, 30 money-back guarantee  
 Your cost: **\$250**

Hewlett-Packard Model 180A two channel solid state, 50 MHz delayed timebase. Remanufactured, original cost was over \$6,000 Your cost: **\$290**

Price includes 225 page service manual with schematics. 30 day unconditional guarantee 80 day parts and labor. Remanufactured. Two cabinet styles available.

**VIDEOSPECTRA**  
**(800) 835-8335**

P.O. Box 755  
 Agoura, CA 91301



### PRIAM 330MB SCSI DRIVE

Model 738, with DTC3280 controller, cable and software. Formatted, used. (94C017)

**\$349.00 each**

Many more hard drives in stock. Check our BBS for current inventory.

### RODIME 5180ST

SCSI, 134 MB, half-height, formatted, used. (94C020) **\$119.00 each**

### MAXTOR XT-1085

MFM, 69.3 MB, formatted, full-height, 5.25", used. (94C021) **\$69.00 each**



### 101-KEY ENHANCED KEYBOARD

XT-AT switchable. "Turbo" key gives programmable repeat rates, buzzer on/off, and keyboard lock functions. (94C012) **\$24.95**

### MICROSOFT WINDOWS 3.0

New, in box 5.25" disks. (94C018) **\$4.95 each**

### LATTICE-NET CONCENTRATOR

Synoptics model 2500-01 or 2510-01E. New, in box, complete with power supply and documentation. (94C018) **\$79.00 each**

### MOUSE

Microsoft and Mouse Systems compatible for IBM compatible systems. Works with all major application software. Dynamic resolution and fast tracking speed. Opto-mechanical encoder. (93C019) **\$9.95 each**



**SUMMER SPECIAL!** When you order the above mouse, get a mousepad FREE! (94C004) **Reg. 99¢ each**

### LITHIUM BATTERY 3V

Popular PC mount type. Approx 1" dia. by 0.125" thick. General Electronics #CR2430. (92E018) **2 for \$2.95**



### LIQUID CRYSTAL DISPLAY

2 line by 40 characters. Specs included. (94L005) **\$14.95 each**

### CAPACITORS

All new lytics, tants, discs, computer grades. All kinds of caps. A good variety. (92P088) **5 Lbs. for \$5.00**

### MOTOROLA MRF454

2-30 MHz, 12.5 V, 80W, 0.510 flange package. (94S005) **\$17.50 each**



### TRW PT4273

House numbered part. Ratings: 28 MHz, 12.5 V, 100W (package will handle 50 W in continuous duty), 0.380" flange package. (94S006) **\$15.00 each - 2 for \$27.50**

**New Lower Prices!**

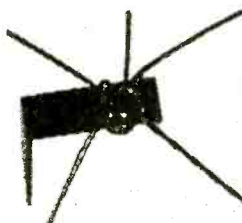

### GROUND PLANE ANTENNA KITS

Mounting Bracket and Connectors Included.

**144 MHz (92A008) \$9.95**

**220 MHz (92A009) \$8.95**

**440 MHz (92A010) \$7.95**

(Use the 144 MHz Model for Scanners)

### STEPPER MOTORS

Assortment of ten. (92M001)

**\$16.95**



### SANYO STEPPER MOTOR

Model 1103-49021-1, 4.3, 0.9°/step. Measures 39mm square by 16mm deep, 5mm shaft. (94M003) **\$14.95 each**

### RAPIDSYN STEPPER MOTOR

9VDC, 3A, 1.8°/step. 82mm square. 62mm deep, 10mm shaft. Model 34D-9106A. Used. (94M004) **\$24.95 each**

### 9V TWO-STAGE FM TRANSMITTER

Our most powerful FM "bug" to date. Easy to build and tune in the upper part of the FM band. Reaches up to 1 km in the open. Uses RF transistor for its final stage. Uses a 9V battery. Proven circuit. Top quality PCB and components. Full circuit schematic provided. (Kit #32) **\$12.99 each**

### CIRCUIT WORKS



• **CONDUCTIVE PEN** Makes instant silver conductive traces on most surfaces. Dries in minutes at room temperature. Valved pen tip for easy application. Solderable at low temperatures. Use where conductive electronic traces are needed. (93Z002) **\$9.49 each**

• **OVERCOAT PEN** Draws from point to point on circuit boards, components and delicate electronics to insulate against shorting and arcing. Protect against moisture, abrasion, chemicals, fungus and other environmental hazards. Use to repair solder mask and improve the reliability and safety of circuit board modifications and repairs. Clear. P/N 3300. (94Z011) **\$8.95 each**

### PELTIER JUNCTION

Thermoelectric heat pump. Use to cool that '486, build a drink cooler, etc. Up to 65° temperature differential. Size 1.1875" x 1.1875" x 0.125". With spec sheet. (93U004) **\$24.95 each**

### RESISTOR RIOT

1/8, 1/4, 1/2 Watt, power, precision, fixed, adjustable, etc. Thousands of pieces. (92P023) **5 lbs. for \$4.95**

### BOOM MIKE

Electret condenser type. This versatile microphone may be wired for Handy Talkie, telephone, base station, aircraft radio, CB radio, motorcycle intercom, etc. An earphone or miniature speaker may be installed in either or both muffs. The microphone unit can be easily removed and installed on another headset or helmet. (92A001) **\$4.95 Each**



### MINI FLAT PM SPEAKER

Great for use in Boom Mike (shown above). Applications include model railroad sound systems, radios, test equipment and more. Only 0.9" dia. by 0.2" thick. 40 Ohm coil, rated at 20 mW has 6" wire leads. BRAND NEW! (92A007) **\$1.49 Each**



### BATTERY HOLDERS

- BH1AA (1 AA Cell, Flat) **\$0.49**
- BH2AA (2 AA Cells, Flat) **\$0.52**
- BH3AA (3 AA Cells, Flat) **\$0.68**
- BH4AAS (4 AAS Cells, Flat) **\$0.90**
- BH4AAF (4 AAF Cells, Block) **\$0.90**
- BH6AA (6 AA Cells, Block) **\$1.00**
- BH8AA (8 AA Cells, Block) **\$1.15**
- BH2C (2 C Cells) **\$1.00**
- BH4C (4 C Cells) **\$1.20**
- BH2D (2 D Cells) **\$1.25**
- BH4D (4 D Cells) **\$1.45**
- BS19 (One 9V Battery Snap) **\$0.35**
- BH19 (1 9V Battery Holder) **\$0.60**
- BH2032 (Lithium Battery Holder) **\$1.50**
- BH2325 (Lithium Battery Holder) **\$1.50**

### TARZAN FAN

High quality, thermally protected, 115VAC, 60 Hz, 85W. 6.875" x 6.875" x 4.25". Rotron model #TN3A2. (93F001) **\$19.95**

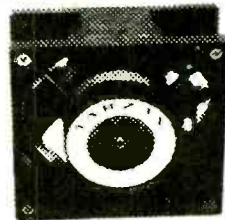

### PLUG-IN WALL TRANSFORMER ASSORTMENT

Various output voltages and currents. (94E004) **Ten for \$14.95**

24-Hour BBS  
**(408) 943-0622**  
9600 Baud • N-8-1  
On-Line Ordering

**ALLTRONICS**  
2300 Zanker Road • San Jose, CA 95131  
Phone (408) 943-9773 • Fax (408) 943-9776

Visa, MC, AmEx cards accepted.  
Minimum order \$15.00.  
CA & OH residents add local sales tax.  
Shipping additional on all orders.



# MACHINE YOUR DREAM!

## THIS IS THE MACHINE YOU'VE BEEN WAITING FOR!

Have you ever dreamed of manufacturing and marketing your own products? If so, the Neuractor CNC-4 Desktop Manufacturing System may be just the edge you need! This fourth-generation CNC machining center can automatically drill, mill and route three-dimensional products in wood, plastic and light metals DIRECTLY FROM YOUR CAD DRAWINGS! You've seen the rapid-prototyping and "Santa Claus" machines that cost thousands of dollars, but did you know that as an electronic technician you can build one yourself from this inexpensive kit? Utilizing patent pending technology the Neuractor CNC-4 kit provides you with everything you need to machine products in three dimensions with a resolution of .001". All mechanical components are pre-fabricated, pre-machined, plated and painted. Includes four 83 oz/in CY-MOTORS, interface card, 5 amp power supply, 10 pitch steel lead screws, 4 proprietary Slide Block actuator mechanisms, 4 aluminum linear actuator channels, polished steel guide-rods, Dremel bracket, hardware, etc.. (You provide Dremel or flex-shaft router and work surface.) It's a complete kit! All you do is put

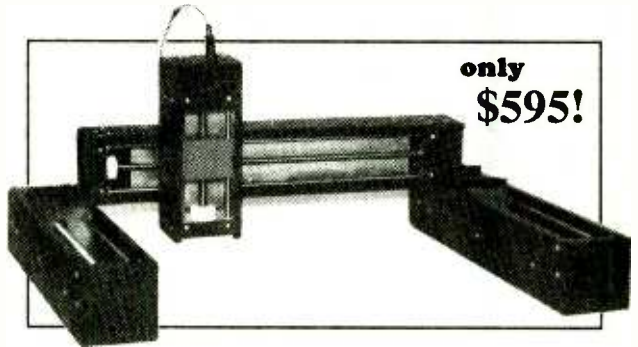

only  
**\$595!**

it together and calibrate it! Using 32 screw-type micro-calibrators, you calibrate your machine and then TURN IT LOOSE! Designed to be used with a Dremel MotoTool(tm), or flex-shaft router for more cutting power, the Neuractor translates your 3D CAD files directly into actual working parts! IF THAT'S NOT EXCITING ENOUGH, WE'RE THROWING IN A FREE, FULL-FEATURED 3D CAD/CAM SOFTWARE PACKAGE WITH EACH UNIT! Imagine using your new Neuractor to experiment with different product designs and concepts BEFORE taking the business plunge! By working out your product's design and Desktop Manufacturing processes, you can virtually automate the "proof-of-concept" phase of your projects! Built-in fonts for custom sign-making and panel engraving, 18"x18"x4.6" cutter travel for crafts, electronics, and printed circuit board drilling, not to mention model-making, mold-making, and painting. These are but a few opportunity areas others are already exploring with their Neuractors. You build it, you calibrate it, you customize it for your applications! Don't miss out on your chance to cash-in on your own at-home business! Get started by ordering your own Neuractor CNC-4 today! ACT NOW! Kit \$595 +\$24.95 UPS S/H. Allow 4-8 wks for delivery. U.S. CYBERLAB, 14786 Slate Gap Rd., West Fork, AR 72774 (501) 839-8293



## PE MARKET CENTER CLASSIFIEDS

### MISCELLANEOUS ELECTRONICS FOR SALE

**ADD EXCITING** surround sound to your stereo system, **decoder** includes audio patch cables, requires second stereo amplifier. Only \$39.95 plus S&H, fully guaranteed, 1 (800) 768-7530.

**THE Case Against Patents.** Thoroughly tested and proven alternatives that work in the real world. \$28.50. **SYNERGETICS PRESS**, Box 809-C, Thatcher, AZ 85552. (602) 428-4073. Visa/MC.

**NEW SURPLUS ELECTRONIC PARTS.** Call or fax anytime for catalog #P11. Voice 1(800) 290-2694. Fax (916) 823-0643. **CCSNOW ELECTRONICS.**

**VIDEO GAME** training videos for NES, Super NES and SEGA Genesis, tools, parts, schematics. Send SASE for free catalog. **Irata Systems**, 2562 East Glade Ave., Mesa, AZ 85204-6208.

**SENCORE VC93 ALL FORMAT VCR ANALYZER** for sale. Includes test leads and operating manual. Excellent condition. \$1,800.00 (419) 531-8249.

**Quality Microwave TV Antennas**

**WIRELESS CABLE - IFTS - MMDS - Amateur TV**  
Ultra High Gain 50db(+) • Tunable 1.8 to 2.7 Ghz.

- 55-Channel Dish System \$199.95
- 36-Channel Dish System \$149.95
- 20-Channel Dish System \$124.95

• Optional Commercial Grid Antenna (not shown) Add \$50.00  
• Vtg Antennas, Components, Custom Tuning Available  
• Call or write (SASE) for "FREE" Catalog

**PHILLIPS-TECH ELECTRONICS**  
P.O. Box 8533 • Scottsdale, AZ 85262  
(602) 947-7700 (\$3.00 Credit all phone orders)  
MasterCard • Visa • American Express • C.O.D.'s • Quantity Pricing

Dish System  
**LIFETIME WARRANTY**

### REPAIRS-SERVICES

**VCR REPAIR** course, learn at home. Fun, easy. Kengo Video, PO Box 2460, Longview, WA 98632.

**WOOFER ROT?** Quality re-coning, refoaming, restorations and parts for all speakers. World's largest speaker catalog, 200 pages \$10.00. Tri-State Loudspeaker, 650 Franklin, Aliquippa, PA 15001. (412) 375-9203.

**Satellite-TV**

**SAVE 40% - 60%**  
800-334-6455  
218-739-5231 Int'l  
218-739-4879 Fax

**Skyvision Inc.®**  
1048 FRONTIER DRIVE • FERGUS FALLS, MN 56537

See full page ad in *The Market Center*

**FREE Catalog**

### SATELLITE EQUIPMENT

**VIDEOCIPHER II** Descrambling manual. Schematics, video and audio, \$18.95. Software, \$25.00. Videocipher II 032, \$15.00. Videocipher II Plus, \$20.00. VCII Plus software, \$30.00. Cabletronics, Box 30502PE, Bethesda, MD 20824.

**100 FREE channels.** Complete 3' Ku-band satellite TV system only \$399.00. Free info. (303) 344-3507. Minisat, PO Box 202331, Denver, CO 80220.

### BUSINESS OPPORTUNITIES

**EASY WORK!** Excellent pay! Assemble products at home. Call toll free 1 (800) 467-5566 ext. 5192.

**GREAT EXTRA income!** Assemble products at home. Easy and fun to do. Guaranteed! 1 (800) 377-6000 ex7930.

**FREE 900# S.** Computerized equipment managers and brokers wanted. Unlimited income potential. For information call (914) 573-2067.

**START** your own technical venture! Don Lancaster's newly updated **Incredible Secret Money Machine II** tells how. We now have autographed copies of the Guru's underground classic for \$18.50. **SYNERGETICS PRESS**, Box 809-C, Thatcher, AZ 85552. (602) 428-4073. Visa/MC.

**GUIDE TO home employment.** Rush \$1.00 and SASE for information: Melody Bush, 119-A Bay Berry, Elizabeth City, NC 27909.

**AMAZING WAY** to support your hobby. Send SASE to BK ASSOC., 7227 Winchester #271, Dept. 10, Memphis, TN 38125.

**ELECTRONIC TECHNICIANS:** Circuit City Stores Inc. is now hiring experienced consumer electronic technicians. Our technicians earn above average wages and enjoy excellent benefits including: medical, dental, life, disability, merchandise discounts, employee stock purchase, retirement plan. Candidates must have 4 years hands-on experience in component level repair. Lou Garcia, 1 (800) 274-8958 ext. 214.

**EARN FINANCIAL INDEPENDENCE** through direct mail from your own home. Send SASE for information to Timberline Industries, PO Box 446, Chimacum, WA 98325.

**Cable Test**

Orders only **Aids** Information  
1-800-452-7090 (310)902-0841

*Test chips for JERROLD, TOCOM, ZENITH, S.A. & more. Puts cable boxes in full service mode. Easy installation. Zenith only \$39.95. Most others under \$50ea. FAX: (310)902-0851. Quantity prices available. No Co. miles. Not for use in cable co. owned equip. For use as a test aid only.*

### CABLE TV

**"BULLET" BUSTER.** Protect your cable box against the infamous cable "bullet." The "Bullet" Buster acts as an electronic shield. Installs in-line in seconds. Don't wait until it's too late! \$19.95 + \$3.00 S&H. **Electroman**, Box 24474, New Orleans, LA 70184. (504) 482-3017.

**CBTV DOCTOR** Stop the Bullet and ID signal in cable lines. Send \$20.00 to: R.R. Enterprise, PO Box 3532, Easton, PA 18043.

**CABLE UNSCRAMBLED.** Everything you want to know, but are afraid to ask. \$10.00. **Electroman**, Box 24474, New Orleans, LA 70184. (504) 482-3017.

**CABLE — SAFE.** Guarantee cable privacy. The one way valve for your cable TV signal. \$29.95, + \$3.00 S&H. **Electroman**, Box 24474, New Orleans, LA 70184. (504) 482-3017.

**DESCRAMBLER SCHEMATICS REVEALED.** A powerful guide to descrambling schemes. \$10.00. **ELECTROMAN**, Box 24474, New Orleans, LA 70184. (504) 482-3017.

Infiniter™

## Laser Pointer

Attracts the attention of your audience

**\$68** Black or Silver

**\$88** Gold

2 "AAA" Batteries included

1 year warranty

FDA APPROVAL  
PATENTED

For:

- \*Conferences
- \*Presentations
- \*Marketing Sales
- \*Lawyers \*Doctors
- \*Real Estate Brokers
- \*Lectures \*Teachers
- \*Executives \*Engineers
- \*Scientists \*Inspections

Please Call 800-520-8435

**Quarton USA, L.T.D. CO.**

7042 Alamo Downs Parkway, Suite 250,  
San Antonio, Texas 78238-4518

Tel: (210)520-8430 Fax: (210)520-8433



### Model 1010 Synthesized Digital Sweep/Function Generator S289

- .1 Hz to 8 MHz sawtooth and ramp
- DC to 8 MHz square and sine wave
- AM and FM modulation
- ±25 ppm frequency accuracy
- Log or linear frequency sweeping with automatic or user programmed markers
- Programmable Pulse width and repetition rate. Programmable burst mode
- 10 year nonvolatile memory storage of up to 100 user programmable setups

(Optional RS-232 remote, ±2 ppm accuracy, rechargeable battery operation, 30 day trial, 1 year factory parts and labor price and availability subject to change w/o notice)

### Videospectra

P.O. Box 755 Agoura, CA 91301

(818) 889-9072 (800) 835-8335

FAX (818) 889-9085



# Put an electronics lab in your computer with CircuitMaker

## Need to debug?

With the exclusive CircuitMaker Trace feature, the state of every node is indicated in color as the simulation runs.

## Test equipment provided!

The data sequencer can produce streams of up to 1024 eight-bit words. The logic probe and scopes monitor waveforms. You can even set breakpoints!

## Make your own fully functional devices!

The unique CircuitMaker macro feature enables you to create, save and reuse your own customized IC's and devices. With CircuitMaker, creating your own functional device library is a quick and easy task!

## Never burn out another device!

CircuitMaker's parts are indestructible. Included with the program are libraries containing TTL, CMOS and generic devices, all with programmable propagation delays. Also included are many powerful I/O devices.

## Layout and design is fast and easy!

Advanced features like device rotation, functional page connectors, busses, smart wires and rubberband moves make CircuitMaker easy to learn and use. No special computing skills are needed.

## Your satisfaction is guaranteed!

We're so sure CircuitMaker will win you over, that we are offering a no-risk guarantee. If you're not delighted with CircuitMaker, just return it within 30 days of your purchase. The purchase price will be fully and cheerfully refunded.

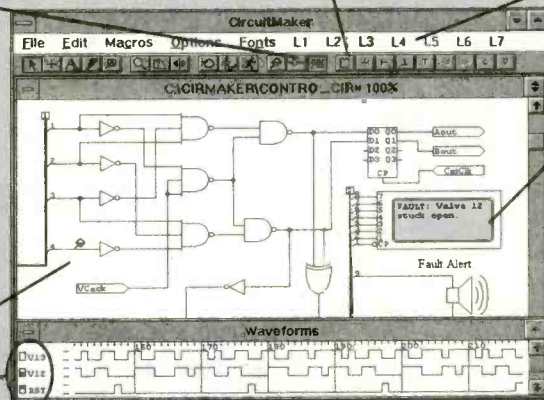

## Unlimited experimenting!

CircuitMaker provides you with a safe, cost effective, computerized electronics lab, where circuit design and digital simulation is fast and easy. With CircuitMaker, you can expand your understanding and unleash your creativity.

**FREE FUNCTIONAL DEMO VERSION**

available on CompuServe or \$10 s&h for demo disk

# CALL 1-800-419-4242

MicroCode Engineering

1943 N. 205 W. Orem, UT 84057

Fax orders to (801) 226-6332

Phone (801) 226-4170

**Only \$199**



CIRCLE 42 ON FREE INFORMATION CARD

## PE MARKET CENTER CLASSIFIEDS

### CB-SCANNERS

RCI-2950 MODIFICATION Manual \$20.00 pre-paid money order, \$25.50 COD. Scott, PO Box 510408, St. Louis, MO 63151-0408. (314) 846-0252.

### AUDIO-VIDEO-LASERS

LASER POINTER \$49.99. Powerful 4" long, 1.5 ounces, 2 N-size batteries, 2-week delivery. Check, Visa, MC, Disc, include expiration date. Laser, 6780 Vermar Terrace, Eden Prairie, MN 55346.

### EDUCATION

NEW! ADAPT-11 microcontroller module plugs right into your solderless breadboard! Test drive your 68HC11 designs instantly! Included software and serial cable make it a breeze to program with any PC! Re-useable thousands of times! Ideal for students, hobbyists, and experimenters! Only \$74.95! TECH ARTS, Suite 1704, 1644 Bayview Ave., Toronto, ON, M4G 3C2.

### PUBLICATIONS

FREE PROGRAMS, games, information from local computer bulletin boards. "A Guide to Computer BBSing," 87 pages explains, \$11.95. Imprint Publications, 35775 Schmid #103, New Baltimore, MI 48047.

### COMPUTER HARDWARE

TAKE PICTURES with your PC and a video camera. VIDEO DIGITIZER 640X480, 256 grays, connects to printer port, image processing software supports popular file formats, printers, ONLY \$89.00! Demo disk \$3.00. CHROMAGIC DEVELOPMENT, POB 6106, Penacook, NH 03303-6106, (603) 228-6695.

### COMPUTER SOFTWARE

OHM'S LAW CALCULATOR PC software. Calculates: volts, amps, resistance, power. Prints results, displays standard resistor values. Requires mouse. Specify disk format. Send \$17.50 (includes P&H) to APS, POB 58252, Raleigh, NC 27658.

## Universal Programmers

RCE-GDI Is Never Undersold!

- \$1389 DATA I/O CHIPLABS 4800
  - \$ 799 DATA I/O CHIPLABS 3200
  - \$1869 LOGICAL DEVICES 5000
  - \$ 579 EETOOLS ALLMAX
  - \$ 479 EETOOLS PROMAX
  - \$ 489 XELTEK SUPERPRO II
  - \$ 350 XELTEK SUPERPRO (R)
  - \$ 499 LOGICAL DEVICES 3000
  - \$ 499 ADVANTECH PC-UPROG
  - \$ 779 DATAMAN S4
  - \$ 499 AMERICAN RELIANCE 9860
  - \$ 699 NEEDHAMS SA-20 8-GANG
  - \$ 139 EETOOLS 1 GANG
  - \$ 199 EETOOLS 4 GANG
  - \$ 129 XELTEK ROM MAX
  - \$ 159 SUNSHINE 4 GANG
  - \$ 399 SUNSHINE 8 GANG
  - \$ 599 JDR MICRO E-MUP
- Largest Selection In The World!**  
**(408) 241-7376 Fax 241-6375**

We Buy  
& Trade



## PROFESSIONAL SURVEILLANCE EQUIPMENT Used By Law Enforcement Agencies

VHF-FM CRYSTAL CONTROLLED TRANSMITTERS  
 A - 139MHz, B - 139.970 MHz, C - 149 MHz, D - 149.450 MHz  
 All kits assemble in less than 5 mins.

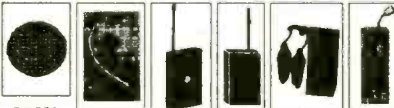

SD-200 Smoke Detector Camera w/Audio 400 lines .03 lux 10-14 VDC \$330	CX-102 Miniature Camera w/Audio 240 lines 2 lux 7-14 VDC \$235	AD-700 Mic Range: up to 5 Mile Power 750MW \$247	AD-600 Mic Range: up to 5 Mile Power 15MW \$125	AD-500 Tel. Range: up to 5 Mile Power 15MW \$115	AD-400 Mic Range: up to 2.5 Mile Power 400MW \$155
--	---	---	--	---	---

We sell a variety of cameras, bug detectors, night vision equipment, video transmitters, time lapse recorders, remote video monitoring systems, and many more...

### A&D ELECTRONICS

P.O. Box 601, Monsey, NY 10952  
 914-356-7541 • Fax 914-356-7505  
 Call for FREE catalog. Credit Cards accepted

## Smart Battery Charger

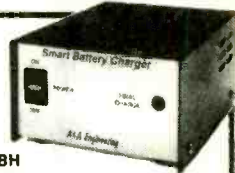

JUN 87 QST  
 BY WARREN DION N18BH

FOR GEL-CELLS or LEAD ACID BATTERIES.  
**Features:** Precision temperature tracking voltage reference & three mode charging sequence. Standard kit is for 12V @ 1/2 or 1 Amp, user selectable. Can be connected to the battery indefinitely, will not overcharge. Weighs 2 pounds and measures 4"W x 5 1/2"D x 2 1/2"H. Finished enclosure included in kit.

**Complete Kit Only ..... \$59.95**  
**Assembled & Tested ..... \$79.95**

CA Residents add 7.75% sales tax. S&H: \$5.00 (insured). Foreign orders add 20%. For more info or price list; send legal size SASE (52¢) to:

**A&A Engineering**   
 2521 W. La Palma #K • Anaheim, CA 92801  
 (714) 952-2114 • FAX: (714) 952-3280

## MARYMAC® The New Realistic® PRO-43 Scanner

# Radio Shack®

### PHONES

Our 18th year of DISCOUNTS

**Toll Free 800-231-3680**

PRO-43 List \$349.95

**Our Delivered Price \$288.00**

**IF ON SALE, WE ARE CHEAPER!**

*We discount everything in the RS catalog*

22511 Katy Fwy.

Katy (Houston), TX 77450

1-713-392-0747 FAX 713-574-4567

## Surface Mount Chip Component Prototyping Kits— Only \$49.95



CC-1 Capacitor Kit contains 365 pieces. 5 ea. of every 10% value from 1pf to .33µf. CR-1 Resistor Kit contains 1540 pieces; 10 ea. of every 5% value from 10Ω to 10 megΩ. Sizes are 0805 and 1206. Each kit is ONLY \$49.95 and available for Immediate One Day Delivery!

Order by toll-free phone, FAX, or mail. We accept VISA, MC, COD, or Pre-paid orders. Company PO's accepted with approved credit. Call for free detailed brochure.

**COMMUNICATIONS SPECIALISTS, INC.**  
 426 West Taft Ave. • Orange, CA 92665-4296  
 Local (714) 998-3021 • FAX (714) 974-3420  
**Entire USA 1-800-854-0547**

# REACH FOR THE POWER. TEACH.

No other profession has this power. The power to wake up young minds. The power to wake up the world. Teachers have that power. Reach for it. Teach.

For information call:

**1-800-45-TEACH.**



Recruiting  
New Teachers, Inc.

# SUPPORT RESEARCH.

American Heart Association

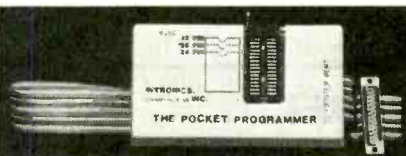

## The Pocket Programmer

The portable Eeprom programmer that uses the printer port of your PC instead of an internal card. The software has 24 easy to use functions and programs 27/25/28/68764 & Cmos for 16K (2K × 8)—2M (256K × 8) Eeproms (32 pin socket, UpGradeable to 8Meg). Adapters available for MCU's, 40-Pin Eeproms, 5-Gang and Eeprom Emulator to 32K × 8.

**\$129.95**

INTRONICS, INC.  
 Box 13723  
 Edwardsville, KS 66113  
 (913) 422-2094

Add \$3.00 for shipping.  
 Add \$3.75 for COD.  
 Visa/Master Charge

## \$129 Laser Light Show

This kit displays animation, text, drawings, & music! Includes 2 Galvos, VCO, Computer Interface, Manual & Software listing. Works from parallel printer port.

## Computerized Motors \$39\*

Includes: 2 Stepper or 4 DC servo motors, Computer interface kit, 32 page training manual & Software listing. Works from parallel printer port.

\* Add \$5 for shipping. Computer and Laser not included.

Call for **FREE** Flyer

**SVS**  
 Light &  
 Motion  
 in kit form

1273 Industrial Pky. W#460  
 P O Box 55125  
 Hayward CA 94545-0125  
**510-582-6602**



# PE MARKET CENTER CLASSIFIEDS

## !! BROADCAST & SURVEILLANCE !!

70-120MHz FM Transmitters & RF Amplifiers  
RF Power/SWR Meters, Stereo Generator, DC Power  
Supplies, Audio Limiters, Electronic & RF  
Components, Plans, Kits, and more! Send \$2 for  
complete information, get \$2 discount on first order.

**Progressive Concepts** 1434 N. MILLS AVENUE, B  
(909) 626-4969 CLAREMONT, CA 91711

## PLANS-KITS-SCHEMATICS

**BUILD — FIVE**-digit, ohms, capacitance, frequency, pulse, multimeter. Board and instructions \$9.95. Bagnall Electronics, 179 May, Fairfield, CT 06430.

**ALL-IN-ONE** catalog. AM/FM/ham/spy, transmitters, amplifiers, receivers. Voice scramblers/disguisers, audio, TV, Tesla coils, plans, "secret" books, kits, imports, exports and more. Start your own licensed or unlicensed radio station. 60 full pages for \$1.00. **PAN-COM INTERNATIONAL**, PO Box 130-H8, Paradise, CA 95967.

**FM STEREO TRANSMITTER** kit broadcasts any audio signal to FM stereo radios throughout your home. Uses unique BA1404 IC. Complete kit: PC board/components — \$24.00. Visa/MC. **TENTRONIX**, 3605 Broken Arrow, Coeur d'Alene, ID 83814. (208) 664-2312.

## BUGGED??

**EAVESDROPPING** is unbelievably widespread! Electronic Devices with amazing capabilities can be monitoring your telephone and room conversations **RIGHT NOW!** Are you sure you're safe? **FREE CATALOG** tells you **fast!** Includes **Free Bonus** details on fantastic opportunities now open in Counter-Surveillance field. Exciting, immensely interesting and **EXTREMELY** profitable (up to \$250/hr) full/part-time income. Call Now! **1-800-732-5000**

**TIRED OF IRONING?** Prototype service for hobbyists & engineers. Single/small quantity ss PCB's. No setup fee. \$10.00 minimum, most boards \$25.00. We scan magazine artwork free! Get out your back issues! **FIRST PROTO**, (407) 392-8677.

**SILENT SAM**. Patented vehicle turn signal reminder. Outshines others. Brief, timely alerting signal doesn't bug you. Kit complete w/case \$15.00. Visa/MC. 1 (800) 398-5605 literature. Also, \$22.00/\$27.00 wired models. Silent Sam, 1627 Basil Dr., Columbus, OH 43227.

**PROJECTS**. \$2.00 gets flyer, 100 piece grab bag. Lynn Johnson Electronics, Box 51268, San Jose, CA 95151-1268.

**MINI-FM** transmitter. Buy parts at Radio Shack. Complete plans \$3.00. Lynn Johnson Electronics, Box 51268, San Jose, CA 95151-1268.

## Prototype it..... FAST!

with ProtoQuick 8051 or Z8

- Complete single board computers
- Up to 32K EPROM and 8K RAM
- 12 ss in. plated through holes area
- RS232 C serial port w/ DB25 cone
- Op. sys. in EPROM w/ source code
- Assembly, ready to run. 5v. only
- MS-DOS cross-assembly included

ProtoQuick Z8 and 8051  
**\$99.00** each

Software Science  
12700 Redwood Road  
Claremont, OH 45214 USA  
(513) 561-2060

Run prototype applications or experimental hardware from the serial port... **WITHOUT PROGRAMMING!**

**75W + 75W** stereo amplifier kit. Excellent sound quality constructed by you. Refine your electronics talent hands-on. Assembly plans and 5"x6" nickel-plated PC-board \$49.95. Send check or M.O. to: **JAFCO AMPS**, PO Box 17563, Hattiesburg, MS 39404-7563.

**THE ONLY CATALOG NEEDED!** Kits, plans, surveillance, test, radios, more! Part locating. Best prices! Send \$1.50 (refundable) **NEUTRONICS**, 4 Croydon Ct., Englishtown, NJ 07726.

**NINE BAND** shortwave receiver kit. See March 1994 Popular Electronics \$59.95 plus \$3.75 shipping ch/mo to Dan's Small Parts and Kits, 1935 So. 3rd. West #1, Missoula, MT 59801. Cat. 2 stamps.

## SURVEILLANCE

& COUNTERSURVEILLANCE Electronic Devices

Bugging/Phone Tapping Detectors • Caller ID • Covert Video  
• Phone Scramblers • Voice Changers • Shotgun Mics • Vehicle  
Tracking • Transmitter Kits • Locksmithing • AND MORE!

7-Hour Telephone Recording System  
Tapes phone calls automatically. \$125.00



FOR CATALOG SEND \$5.00 TO...

P.O. Box 337, Buffalo, NY 14226 (716) 691-3476

**CABLE DESCRABLERS** Build your own, SSAVI, gated sync, sinewave. \$14.95. Cabletronics, Box 30502PE, Bethesda, MD 20824.

**HOBBYIST CIRCUITS** — Remote room monitor, tone decoder, long distance circuit control and more. Simple experiments for the beginner. **CATALOG** \$2.00 — Garrett Plans, Box 155, Jamesburg, NJ 08831.

**SURVEILLANCE TRANSMITTER** kits. 65 to 305 MHz. **Quick & Easy**. Partially assembled units. Five minutes completion. 110-volt duplex receptacle, room battery types, and telephone. Counter-surveillance. Catalog: \$2.00. **SHEFFIELD ELECTRONICS**, PO Box 377940-B, Chicago, IL 60637-7940.

**WAVEFORM VIEWER**. RF applications use monitor TV to view sine square. Build RF filters circuits \$19.95 book. Waveform Viewer, PO Box 142042, Gainesville, FL 32614-2040.

**THERMAL ANEMOMETER** \$12.00 for board and plans using Radio Shack parts. \$52.00 assembled and calibrated. One board per customer please. Discount for 10 or more assembled units. Eshleman Engineering, PO Box 12527, Gainesville, FL 32604.

**ELECTRIC DOG DOOR**, entrancing LED clock, cool rocket launcher, computer clocks, awesome phones, plans, kits and more. **FREE CATALOG**, **CAMPBELL ENTERPRISES**, 27955 Terrace PE8, North Olmsted, OH 44070.

**TURBO CHARGE** your amplifier! Guide to increase wattage of your existing power amps. Send \$7.50 for complete book. JAM Electronics, 7391 Hwy 78, Gratiot, WI 53541.

## MUSIC & ACCESSORIES

**MUSICAL INSTRUMENTS**, electronic, acoustic, free catalog. Freepost Music, 41A Shore Drive, Huntington Bay, NY 11743.

## DIGI-FIELD FIELD STRENGTH METER

Are you worried about electromagnetic radiation, TV coax distribution loss, poor antenna performance, or EMU/RFI? The DIGI-FIELD field strength meter will put you at ease. With its frequency response of DC up to 12 GHz, it readily detects potential electromagnetic radiation hazards. It is an excellent tool for measuring TV coax distribution loss. In addition DIGI-FIELD can easily find 60-Hz AC-line interference, as well as RFI/EMI instrumentation disrupting set-ups. Sensitivity: @ 100 MHz Model A: 150 nano Watts. Model B: 2 nano watts.

**\$139.95** Plus \$6.50 s/h

Software Science  
12700 Redwood Road  
Claremont, OH 45214 USA  
(513) 561-2060

To order call - (800) FIELD 58 (343-5358)  
**I.C. Engineering**, 16350 Ventura Blvd.  
Suite 125, Encino, CA 91436 PH (818) 345-1692 • 818-345-0517 Fax



# Motorless Motion!



Includes Complete Plans

Create direct linear action with Muscle Wires<sup>SM</sup>— they actually contract up to 5% when powered! Use them in robots, planes, railroads — anywhere you need small, strong all-electric motion.

## Q&A

### What are Muscle Wires?

Muscle Wires are highly processed strands of a nickel-titanium alloy called *nitinol*. At room temperature they are easily stretched by up to 5% of their length. When conducting an electric current they return to their original "unstretched" shape with a force *thousands of times* their weight.

### How strong are Muscle Wires?

This varies with the wire's size. A single wire can lift from 35 to 930 grams (over 2 lbs)! For more strength, use several wires in parallel.

### How fast can Muscle Wires activate?

They contract as fast as they are relaxed — as quickly as 1/1000 of a second. To relax, the wire must cool again. Rates of many cycles per second are possible with active cooling.

### Flexinol Muscle Wire Specifications

Wire Diameter (µm)	50	100	150	250
Resistance (Ω/2m)	510	150	50	20
Contract Force (grams)	35	150	330	930
Typical Current (mA)	50	180	400	1000

### How much power do Muscle Wires need?

Power varies with wire diameter, length, and surrounding conditions. Once the wire has fully shortened, power should be reduced to prevent overheating.

### What are the advantages of Muscle Wires?

Small size, light weight, low power, very high strength-to-weight ratio, precise control, AC or DC activation, long life and direct linear action and much more!

Get our new 128 page **Muscle Wires Project Book** with full plans for Boris and 14 other **motorless motion** projects, and our **Deluxe Sample Kit** with one meter each of 50, 100 and 150 µm dia. Muscle Wires — everything you need to get moving today!

24-hour Voice Order Line — VISA MasterCard

**800-374-5764**

Request our FREE Muscle Wires Technical Brochure

## Mondo-tronics

524 San Anselmo Ave. #107-62  
San Anselmo, CA 94960

Questions: 415-455-9330  
Fax: 415-455-9333  
Internet: mondo@holonet.net

New Book & Deluxe Kit only

**\$59.95**  
Plus \$5.00 P&H  
CA orders add tax

International Orders Welcome! First Class P&H: \$11.00

# ADVERTISING INDEX

POPULAR ELECTRONICS magazine does not assume any responsibility for errors that may appear in the index below.

Free Information No.	Page	Free Information No.	Page
164	3M	137	John Bell
—	A&A Engineering	—	JP Video
—	A&D Electronics	144	Kasco Distributing
—	Agrelo Engineering	38	Kelvin Electronics
26	Alfa Electronics	—	M&G Electronics
28	All Electronics	—	Marymac Industries Inc.
—	Allen Engineering	142	MCM Electronics
27	Alltronics	—	MD Electronics
151	AMC Sales	—	Mega Electronics
—	Andromeda Research	—	Mental Automation
—	Antique Electronics Supply	42	MicroCode Engineering
—	Antique Radio Classified	—	Modern Electronics
140	B&S Sales	—	Mondo-tronics
30	Bel Merit	163	Mouser Electronics
139	BG Micro	—	NRI Schools
—	CBC International Inc.	—	Nu-Tek Electronics
—	C&C Specialties	—	Oatley Electronics
32	C&S Sales	43	Optoelectronics
31	Caig Labs	—	Phillips Tech
—	CLAGGK Inc.	47	Prairie Digital Inc.
—	CLAGGK Video	46	Print
—	Cleveland Inst. of Electronics	143	Print
—	Command Productions	—	Progressive Concepts
—	Communication Specialists	—	Quarton USA
—	Consumertronics	—	RCE GDI
14	Cook's Institute of Elec. Eng.	—	The School of PC Repair
—	Copyright Clearance Center	159	The School of VCR Repair
162	Davis Instruments	—	Self-Reliance Co. Inc.
141	DC Electronics	48	Sescom Inc.
—	Design Computation	—	Seymour-Radix Inc.
—	EDE	—	Sil Walker
—	EMAC	—	Silicon Valley Surplus
—	Firestick II	—	Skyvision (Small)
—	Forest Electronics	—	Skyvision Inc.
—	Fotronics	—	Software Science
—	GeoBan Engineering	—	Software Systems Consulting
—	Get-Tech Inc.	—	Spy Supply
13	Global Specialties	—	TAB Books
—	Grantham College of Engineering	—	TAB Books
—	Great Southern Security	130	Tech Serv.
—	Greenleaf Electronics Inc.	—	Tele View Distributors
155	Heath Company	136	UCANDO Videos
—	I.C. Engineering	—	United Electronic Supply
—	I/O Controls Corp.	—	US Cable (Zentek)
—	ISCET	—	US Cyberlab
—	Information Unlimited	—	Video Spectra
157	Interactive Image Technologies	—	Video Spectra
—	Intronics	158	Voice Powered Technology
145	Island LogIX Inc.	133	Weka Publishing
138	ITC Instruments	—	Windward Electronics
—	ITC Microcomponents	—	World College (Div. of CIE)
—	Jacobs Electronics, Inc.	—	WPT Publications
37	Jan Crystals	134	Xandi Electronics

## ADVERTISING SALES OFFICE

**Gernsback Publications, Inc.**  
500-B Bi-County Blvd.  
Farmingdale, NY 11735  
1-(516) 293-3000

**Larry Steckler, EHF/CET**  
President

**Christina Estrada**  
Assistant to the President

**For Advertising ONLY**  
516-293-3000  
Fax 1-516-293-3115

**Larry Steckler**  
publisher

**Arlene Fishman**  
advertising director

**Denise Mullen**  
advertising assistant

**Kelly Twist**  
credit manager

**Subscription/  
Customer Service/  
Order Entry**  
1-800-827-0383  
7:30 AM - 8:30 PM EST

## ADVERTISING SALES OFFICES

### EAST/SOUTHEAST

**Stanley Levitan**  
Eastern Sales  
1 Overlook Ave.  
Great Neck, NY 11021  
1-516-487-9357, 1-516-293-3000  
Fax 1-516-487-8402

### MIDWEST/Texas/Arkansas/ Oklahoma, Colorado, Arizona

**Ralph Bergen**  
Midwest Sales  
One Northfield Plaza, Suite 300  
Northfield, IL 60093-1214  
1-708-446-1444  
Fax 1-708-559-0562

### PACIFIC COAST/Mountain States

**Mike Brooks**  
Hutch Looney & Assoc., Inc.  
1800 North Highland Avenue  
Suite 717  
Hollywood, CA 90028  
1-213-462-2700  
Fax 1-213-463-0544

# Countersurveillance

**Never before has so much professional information on the art of detecting and eliminating electronic snooping devices—and how to defend against experienced information thieves—been placed in one VHS video. If you are a Fortune 500 CEO, an executive in any hi-tech industry, or a novice seeking entry into an honorable, rewarding field of work in countersurveillance, you must view this video presentation again and again.**



**CALL NOW!**

**1-516-293-3751**

**HAVE YOUR  
VISA or MC CARD  
AVAILABLE**

*Wake up!* You may be the victim of stolen words—precious ideas that would have made you very wealthy! Yes, professionals, even rank amateurs, may be listening to your most private conversations.

*Wake up!* If you are not the victim, then you are surrounded by countless victims who need your help if you know how to discover telephone taps, locate bugs, or “sweep” a room clean.

There is a thriving professional service steeped in high-tech techniques that you can become a part of! But first, you must know and understand Countersurveillance Technology. Your very first insight into this highly rewarding field is made possible by a video VHS presentation that you cannot view on broadcast television, satellite, or cable. It presents an informative program prepared by professionals in the field who know their industry, its techniques, kinks and loopholes. Men who can tell you more in 45 minutes in a straightforward, exclusive talk than was ever attempted before.

## Foiling Information Thieves

Discover the targets professional snoopers seek out! The prey are stock brokers, arbitrage firms, manufacturers, high-tech companies, any competitive industry, or even small businesses in the same community. The valuable information they filch may be marketing strategies, customer lists, product formulas, manufacturing techniques, even advertising plans. Information thieves eavesdrop on court decisions, bidding information, financial data. The list is unlimited in the mind of man—especially if he is a thief!

You know that the Russians secretly installed countless microphones in the concrete work of the American Embassy building in Moscow. They converted

what was to be an embassy and private residence into the most sophisticated recording studio the world had ever known. The building had to be torn down in order to remove all the bugs.

## Stolen Information

The open taps from where the information pours out may be from FAX's, computer communications, telephone calls, and everyday business meetings and lunchtime encounters. Businessmen need counselling on how to eliminate this information drain. Basic telephone use coupled with the user's understanding that someone may be listening or recording vital data and information greatly reduces the opportunity for others to purloin meaningful information.

The professional discussions seen on the TV screen in your home reveals how to detect and disable wiretaps, midget radio-frequency transmitters, and other bugs, plus when to use disinformation to confuse the unwanted listener, and the technique of voice scrambling telephone communications. In fact, do you know how to look for a bug, where to look for a bug, and what to do when you find it?

Bugs of a very small size are easy to build and they can be placed quickly in a matter of seconds, in any object or room. Today you may have used a telephone handset that was bugged. It probably contained three bugs. One was a phony bug to fool you into believing you found a bug and secured the telephone. The second bug placates the investigator when he finds the real thing! And the third bug is found only by the professional, who continued to search just in case there were more bugs.

The professional is not without his tools. Special equipment has been designed so that the professional can sweep a room so that he can detect voice-activated (VOX) and remote-activated bugs. Some of this equipment can be operated by novices, others require a trained countersurveillance professional.

The professionals viewed on your television screen reveal information on the latest technological advances like laser-beam snoopers that are installed hundreds of feet away from the room they snoop on. The professionals disclose that computers yield information too easily.

This advertisement was not written by a countersurveillance professional, but by a beginner whose only experience came from viewing the video tape in the privacy of his home. After you review the video carefully and understand its contents, you have taken the first important step in either acquiring professional help with your surveillance problems, or you may very well consider a career as a countersurveillance professional.

## The Dollars You Save

To obtain the information contained in the video VHS cassette, you would attend a professional seminar costing \$350-750 and possibly pay hundreds of dollars more if you had to travel to a distant city to attend. Now, for only \$49.95 (plus \$4.00 P&H) you can view *Countersurveillance Techniques* at home and take refresher views often. To obtain your copy, complete the coupon or call,

**CLAGGK INC.** PE  
P.O. Box 4099 • Farmingdale, NY 11735

Please rush my copy of the Countersurveillance Techniques Video VHS Cassette for a total cost of \$53.95 each (which includes \$1.00 postage and handling)

No. of Cassettes ordered \_\_\_\_\_  
Amount of payment \$ \_\_\_\_\_  
Sales tax (N.Y.S. only) \_\_\_\_\_  
Total enclosed \_\_\_\_\_  
Bill me  VISA  MasterCard  
Card No. \_\_\_\_\_  
Expire Date \_\_\_\_ / \_\_\_\_ / \_\_\_\_  
Signature \_\_\_\_\_  
Name \_\_\_\_\_  
Address \_\_\_\_\_  
City \_\_\_\_\_ State \_\_\_\_\_ ZIP \_\_\_\_\_

All payments in U.S.A. funds. Canadians add \$1.00 per VHS cassette. No foreign orders.

Now You'll Never Forget Anything Ever Again!

# Introducing The New Voice Organizer™!

Finally, it's this simple: If you can talk, you can stay organized!

Whether you're in a plane or your car, at home or in a hotel, the amazing Voice Organizer™ reminds you *who, what, where* and *when*...in your own voice!

Thanks to voice recognition technology, you can throw away your notepads, forget about making tickler files, and stop fumbling with miniature keyboards. All you have to do is talk into your friendly Voice Organizer to hold and organize the facts, figures, phone numbers, ideas and appointments you need to remember.

## Manage Your Business Day Just By Talking!

The real value of your friendly Voice Organizer becomes obvious the first time you use it! Simply tell your easy-to-use Voice Organizer what information to keep...then, retrieve it whenever you want it.



*Who* was I supposed to call?



*What* was that idea I had for my presentation?



*Where* was I supposed to pick up those reports?



*When* did I reschedule that meeting?

With 4-Megabits of memory, the pocket-sized Voice Organizer easily remembers:

- Your personal phone directory of up to 400 numbers for up to 100 names. To enter a number, just say: "Bob Jones" and the number...then, when making a call, just say "Bob Jones" and your Voice Organizer will display it: "800-555-1212."
- Your personal appointment calendar...All you do is say: "Meeting with George, 12/17, 2 P.M."...then, to review all your events for that day, just say: "12/17."
- 99 individual notes...All you do is say: "Develop New Sales Proposal" and that thought is readily accessible whenever you want to hear it.

## Now...Try Your Own Voice Organizer RISK FREE For 30 Days!

Order your friendly Voice Organizer now and use it for 30 days with *no obligation*. We'll bill \$199.95 (plus shipping, handling and applicable sales tax) to the credit card of your choice. If you decide to return it within 30 days, you'll receive full credit.

- 99 reminders that alert you to every event you schedule -- in your own voice...*even up to a full year later*...and all you do is say: "Staff Meeting, Monday, 9 A.M."

Manufactured by the world leader in voice recognition products, your Voice Organizer holds a charge for 7 days. A plug-in recharging stand is also included!

Take advantage of the easiest way to remember everything instantly. The amazing Voice Organizer is not available in any store. To order yours now, have your VISA, MasterCard, Discover or American Express ready and Call Toll-Free Now For Immediate Delivery:

## 1-800-998-2900, Dept. 62

Or, send a check or money order for \$199.95 (plus \$9 shipping and handling) to:  
Voice Powered Technology International, Inc.  
19725 Sherman Way • Canoga Park, CA 91306.  
California residents please add applicable sales tax.

**VOICE POWERED TECHNOLOGY**  
INTERNATIONAL, INC.

The World Leader In Voice Recognition Products.