

ANTENNA AMPLIFIERS YOU CAN BUILD

Popular Electronics[®]

FEBRUARY 1993

MAKE YOUR OWN SUBLIMINAL TAPES

Stop smoking, lose weight, gain confidence, and more with subliminal self-improvement tapes that you can make yourself using our easy-to-build project



HERE'S DCC
A hands-on review of the first DCC deck

THE GAS GAUGE GETS SMART

Build an "intelligent" idiot light that accurately monitors your car's fuel level



ALL ABOUT PHOTO CD

Learn about the new technology that may revolutionize the way we view and save our family snapshots

3 NEW FactCards
IN THIS ISSUE



A
GERNSBACK
PUBLICATION

\$3.50 U.S.
\$3.95 CANADA

#BXBDCC***** 5-DIGIT 60506
#60506DHM997GA006# FEB93 P14



ROBERT DAHM

RESP
087

997 GRAND AVE
AURORA IL

60506-2513

EVOLUTION IN ELECTRONICS

IF YOU ARE LOOKING FOR INNOVATION

IN CONSUMER ELECTRONICS AND

RELATED TECHNOLOGIES, LOOK INTO:

SIGHTS & SOUNDS.

EVERY WEEK, WE

FEATURE REPORTS ON THE

LATEST MARKETPLACE TRENDS,

PRODUCT REVIEWS AND INSIGHTFUL

INTERVIEWS WITH THE INDUSTRY'S

MOVERS AND SHAKERS.

JOURNEY WITH US

SATURDAY, DECEMBER 19TH,

AS WE EXPLORE NEW FRONTIERS IN

INTELLIGENT PHOTOGRAPHY, DIGITAL

SCANNING TECHNOLOGY AND MORE.



The Minolta Maxxum® xi Series

Saturday December 19th we will take a look at the world's most advanced auto-focus single-lens reflex cameras – Minolta's Maxxum xi Series.

Feature for feature, no other auto-focus single-lens reflex comes close to the speed and precision of the Maxxum xi Series.

(201) 825-4000

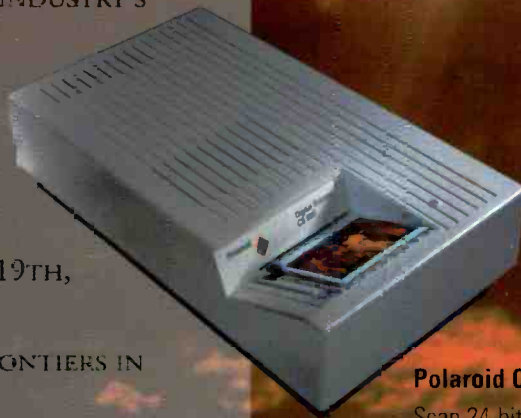

Polaroid CS 500 Digital Photo Scanner

Scan 24-bit color photographs into your computer in as little as three seconds with a Polaroid digital photo scanner.

(800) 225-1618

The evolution is here.

SIGHTS & SOUNDS

Saturdays at 4:30 E.S.T. on CNBC.

Popular Electronics®

THE MAGAZINE FOR THE ELECTRONICS ACTIVIST!

CONSTRUCTION ARTICLES

BUILD A SMART GAS GAUGE	Jonathan Gordon	35
<i>Build intelligence into your car's fuel-measurement system</i>		
MAKE YOUR OWN SUBLIMINAL TAPES	James Melton	53
<i>Build a simple circuit that allows you to create your own self-improvement tapes</i>		
BUILD THE WATER TAP	Marc Spiwak	61
<i>Add the dimension of sound to your fish tank with this one-evening project</i>		
BUILD A FOUR-ELEMENT TWO-METER QUAD	Larry R. Luchi	63
<i>You can build an inexpensive antenna that will both educate and entertain you</i>		

FEATURE ARTICLES

ALL ABOUT PHOTO CD	Brian Fenton	31
<i>Photographic film enters the digital era with Kodak's new compact-disc format</i>		
ANTENNA AMPLIFIERS THAT YOU CAN BUILD	Joseph J. Carr	43
<i>Explore a number of VLF, AM, BCB, MW, SW, and VHF/UHF designs</i>		
PROGRAMMING PARALLEL PRINTER PORTS	John J. Yacono	47
<i>Learn how to control and program your computer's parallel port, and interface it to your own projects</i>		
ALL ABOUT MICROPROCESSORS	Timothy D. Green	56
<i>Explore the internal operation of microprocessors one step at a time</i>		
KEYBOARD CLEAN UP	Marty Knight	65
<i>Restore your computer's keyboard to a like-new appearance</i>		

PRODUCT REVIEWS

GIZMO		5
<i>Including: Tandy Digital Compact Cassette Deck, Kodak Photo CD, and much more!</i>		
HANDS-ON REPORT		22
<i>Colorado Memory Systems Jumbo 250 Tape Backup</i>		
PRODUCT TEST REPORT	Len Feldman	24
<i>JVC HR-DX42 Video Cassette Recorder</i>		

COLUMNS

ANTIQUÉ RADIO	Marc Ellis	67
<i>The readers speak</i>		
COMPUTER BITS	Jeff Holtzman	69
<i>Fun with computer graphics</i>		
CIRCUIT CIRCUS	Charles D. Rakes	71
<i>A little something for everybody</i>		
THINK TANK	John Yacono	74
<i>Chips and test gear</i>		
DX LISTENING	Don Jensen	77
<i>She sells "Seychelles" down by the seashore</i>		
HAM RADIO	Joseph J. Carr	79
<i>Antenna tuners</i>		
SCANNER SCENE	Marc Saxon	81
<i>Monitoring two-way radio</i>		

DEPARTMENTS

EDITORIAL	Carl Laron	2
LETTERS		3
FACTCARDS		49
POPULAR ELECTRONICS MARKET CENTER		50A
FREE INFORMATION CARD		51
ELECTRONICS LIBRARY		86
NEW PRODUCTS		88
ELECTRONICS MARKET PLACE		95
ADVERTISER'S INDEX		98

Popular Electronics (ISSN 1042-170X) Published monthly by Gernsback Publications, Inc., 600-B B-County Boulevard, Farmingdale, NY 11735. Second Class postage paid at Farmingdale, NY and at additional mailing offices. One year twelve issues, subscription rate U.S. and possessions \$21.95, Canada \$28.84 (includes U.S.S.T. Canadian Goods and Services Tax Registration No. R125166280), all other countries \$29.45. Subscription orders payable in U.S. funds only, International Postal Money Order, or check drawn on a U.S. bank. U.S. single copy price \$2.95. © 1992 by Gernsback Publications, Inc. All rights reserved. **Hands-on Electronics** and **Gizmo** trademarks are registered in U.S. and Canada by Gernsback Publications, Inc. **Popular Electronics** trademark is registered in U.S. and Canada by Electronics Technology Today, Inc. and is licensed to Gernsback Publications, Inc. Printed in U.S.A.

Postmaster: Please send address changes to **Popular Electronics**, Subscription Dept., P.O. Box 336, Mount Morris, IL 61054-8932.

A stamped self-addressed envelope must accompany all submitted manuscripts and/or artwork or photographs if their return is desired should they be rejected. We disclaim any responsibility for the loss or damage of manuscripts and/or artwork or photographs while in our possession or otherwise.

As a service to readers, **Popular Electronics** publishes available plans or information relating to newsworthy products, techniques, and scientific and technological developments. Because of possible variances in the quality and condition of materials and workmanship used by readers, **Popular Electronics** disclaims any responsibility for the safe and proper functioning of reader-built projects based upon or from plans or information published in this magazine.

Larry Steckler

*EHF, CET
Editor-In-Chief and Publisher*

EDITORIAL DEPARTMENT

Carl Laron

Editor

Robert A. Young

Associate Editor

John J. Yacono

Associate Editor

Byron G. Wels, K2AVB

Associate Editor

Teri Scaduto

Assistant Editor

Kathy Terenzi

Editorial Assistant

Marc Spiwak

Editorial Associate

Joseph J. Carr, K4IPV

Marc Ellis

Len Feldman

Jeffrey K. Holtzman

Don Jensen

Chris F. O'Brian

Charles D. Rakes

Marc Saxon

Contributing Editors

PRODUCTION DEPARTMENT

Ruby M. Yee

Production Director

Karen S. Brown

Production Manager

Marcella Amoroso

Production Assistant

Lisa Rachowitz

Editorial Production

ART DEPARTMENT

Andre Duzant

Art Director

Injae Lee

Illustrator

Russell C. Trelson

Illustrator

Jacqueline P. Cheeseboro

Circulation Director

Michele Torriolo

P-E Bookstore

BUSINESS AND EDITORIAL OFFICES

Gernsback Publications, Inc.

500-B Bi-County Blvd.

Farmingdale, NY 11735

1-516-293-3000

Fax: 1-516-293-3115

President: Larry Steckler

Customer Service/Order Entry

1-800-827-0383

7:30 AM - 8:30 PM EST

Advertising Sales offices listed on page 98

Composition by
Mates Graphics



Since some of the equipment and circuitry described in POPULAR ELECTRONICS may relate to or be covered by U.S. patents, POPULAR ELECTRONICS disclaims any liability for the infringement of such patents by the making, using, or selling of any such equipment or circuitry, and suggests that anyone interested in such projects consult a patent attorney.

HIGHWAY TO THE FUTURE

In the recent election, the Clinton-Gore Presidential ticket placed a great deal of emphasis on rebuilding this country's infrastructure. Linked with that was mention of building a "data superhighway" that could give every citizen access to the kinds of information and services that until recently were available only to large institutions and government agencies over a system called Internet.

Familiar to many computer users, Internet currently is a frustrating, chaotic system that's been pieced together over the past 20 years. It is composed mainly of military, research, university, and other networks and bulletin boards. The system has a multitude of problems that have limited its usefulness: It crashes often, it is slow by today's standards, it is confusing to use, it lacks central control, its standards are informal, the system lacks structure, and so on.

The idea of a data superhighway had long been pushed in Congress by Vice President Gore. Prior to the election, President Clinton had said that Gore would be in charge of building the superhighway. Gore wants to use a portion of the 20-billion infrastructure fund proposed by Clinton to seed network projects. The government would give the system structure and promote commercial expansion.

The long-term goal is to reach every home in America with a high-speed, fiber-optic network that's able to handle huge amounts of data, including full-motion video. (Internet currently is too slow to even accommodate multimedia.) Undeniably, that's an expensive proposition, although Gore thinks that interim technology can be used to bring services to homes less expensively and in a relatively short time.

As nice as that is, even more important to this country are the commercial applications of such a system. Commercial use of Internet was first allowed in 1991. Despite the system's problems, commercial users exceeded all others by July of that year. With a true data superhighway, the ability to exchange information and to trade at lightning speed could open up new markets, even in geographically isolated areas, and create new jobs. Because of that, I believe that such a data superhighway is an investment that our country must make.

Carl Laron
Editor

NAMELY, BECKMAN INDUSTRIAL

We at Beckman Industrial thought that your article on our new DM10XL DMM (**Popular Electronics**, October 1992) was excellent. To correctly promote our products, however, we would appreciate your discontinuing the practice of abbreviating the Beckman Industrial name by referring to us as "Beckman" as was done in that article. The trade name "Beckman" is owned by a different company. It is important that we always be referred to as "Beckman Industrial." Thanks for your cooperation and your continued support of Beckman Industrial products.

James M. Bordyn
VP-Marketing
Beckman Industrial
San Diego, CA

A.S. POPOV RE-EXAMINED

I would like to express my heartfelt gratitude to **Popular Electronics** and James Rybak for the August 1992 article on A. S. Popov, a Russian scientist who was at the cradle of radio. I appreciate Mr. Rybak's effort to remain objective and true to his words, "We present the facts so you can decide for yourself."

Unfortunately, some historians in Russia and abroad are mistaken in saying that on May 7, 1895, Popov demonstrated a lightning discharge receiver. The fact of the matter is that there are documents proving that on that date, at the meeting of the Russian Physical and Chemical Society, Popov demonstrated wireless transmission and reception of artificial signals, generated by Hertz's vibrator, not by lightning discharges. It is difficult to suppose that during the meeting, the time of which had been announced in advance, a storm conveniently broke out.

Five days after the historical demonstration, the newspaper *Cronstadt's Herald* (No. 54, 1895) wrote: "Respected teacher A.S. Popov ... has constructed a peculiar portable apparatus reacting to electrical vibration as ordinary electrical bell does and sensitive to

Hertz's waves in the open air to a distance of 30 sajens (64 meters) ... All these experiments were the outcomes of the theoretical possibility of sending signals to a distance wirelessly in the way similar to optical telegraphy but with the help of electrical beams."

It is quite clear for everyone that there is no sense in detecting lightning discharges at a distance of 64 meters.

The official minutes of the meeting were published in the August 1895 issue of the society's journal, and the gave a sufficiently full description of the receiver and its operating principles. Although both of the above-mentioned documents also tell about Popov's study of atmospheric electricity, his scientific article dated December 1895 and published in the January 1896 issue of the *Journal of the Russian Physical and Chemical Society* leaves no doubt about what Popov actually demonstrated at that meeting. The introductory remarks point out that the article repeats Popov's May 7, 1895 report and "only test results obtained at the Institute of Forestry have been added."

The article contains the scheme of the receiver, which fully matches the receiver's description given in the minutes, and has the following essential details: "In combination with a 2.5-meter vertical wire the apparatus responded in the open air to the oscillations produced, 30 sajens away, by a large Hertz's vibrator (square metal sheets with 40 cm sides) with a spark in oil."

Thus, there is no doubt that on May 7, 1895, Popov demonstrated a radio-communication system rather than a lightning detector. Popov notes in his article that "the apparatus responds to single oscillation with short rings and continuous coil discharges result in quite frequently repeated rings with nearly the same time intervals."

Popov discovered that the re-

ceiver was sensitive to atmospheric discharges in the very first experiments. This finding gave him the grounds to proceed with his research in two directions, using, on the one hand, artificial electromagnetic radiation sources such as electrophoruses and vibrators (including the "large Hertz's vibrator and a small Righi vibrator similar to that used by Marconi in 1896) and, on the other hand, "electromagnetic perturbations occurring in the atmosphere." In the latter case, the apparatus design was somewhat changed: An electromagnetic recording device of Richard Brothers was put in parallel with the bell and, in addition to the antenna, an Earth ground "connection through the running water pipe" was provided. The rest of the components of the schemes of the electromagnetic wave receiver and the atmospheric discharge detector were the same. The mere replacement of the recording device by a Morse telegraph apparatus could convert the lightning detector into the telegraph signal receiver (which later was done by Popov). That is the reason that during priority defending, both A.S. Popov and his contemporaries did not emphasize the difference between the receiver and the lightning detector—the difference that became crucial in our time.

Both devices, the lightning detector and the receiver, have survived and are now kept in the A.S. Popov Central Communications Museum in St. Petersburg. Anyone can see them and be satisfied that the two devices were intended and used for different aims. By the way, the term "lightning detector" was not used by Popov himself until the end of 1897.

Marconi obtained English patent No. 12,039 under the title "Improvements in Transmitting Electrical Impulses and Signals, and In Apparatus Therefore" (date of application 2nd June

1896; complete specification left 2nd March 1897; accepted 2nd July 1897). However, his priority was called in question by some members of the English and American press.

When discussing who was first, one should recall that when Marconi applied for a patent in Germany, France, and Russia, his claims were denied on the grounds that Popov's articles already had been published.

The matter of priority was officially examined in 1908 in Russia, when the commission of the Physical and Chemical Society studied all the available documents and came to the conclusion that Popov should be nominated the inventor of wireless telegraphy. The decision was written in the Society's journal, along with the answers of E. Branly and O. Lodge to the question the commission asked them. Lodge wrote, "I have always thought highly of Professor Popoff's [*sic*] work in connection with wireless telegraphy ... Popoff was the first to make the signal itself actuate the tapper-back; and I think is the novelty we owe to Popoff. It was speedy adopted by Marconi and others..."

At the same time, it is necessary to emphasize the major role of Marconi in the creation of the practical radio-communications systems. His achievements were recognized not only by Popov but by the Nobel Prize Committee as well, the latter awarding him and the German scientist K.F. Braun with the 1909 Nobel Prize in Physics for work connected with the creation of the wireless telegraph. The premature death of A.S. Popov did not allow him even to be considered as a candidate for that most prestigious award.

V. A. Urvalov
*Head of the Historical Section,
A.S. Popov Science and
Technology Society for
Radio, Electronics, and
Communications
St. Petersburg, Russia*

LETTERS

Electronic Paperbacks at Special Prices

□ **BP325—A CONCISE USER'S GUIDE TO WINDOWS 3.1 . . . \$7.95.** Come to grips with Windows 3.1 in the shortest and most effective way. Learn how to manipulate Windows screens and DOS by Windows graphics interface. Master its word processor, Paintbrush and data base along with Notepad, Macro Recorder, PIF Editor, and Calculator.

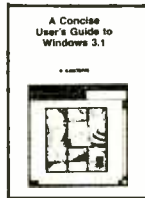

□ **BP311—AN INTRODUCTION TO SCANNERS AND SCANNING . . . \$7.95.** Radio scanners have opened a realm of exciting radio listening. Understand radio wave propagation, types of transmissions, antennas, band assignments—the straight dope on what to hear and where to hear it! Comes complete with index, glossary of important terminology.



□ **BP287—A REFERENCE GUIDE TO PRACTICAL ELECTRONICS TERMS . . . \$8.95.** More than just a dictionary of practical electronics terms, the book goes a step further in getting down to fundamentals. A reference volume that can be read casually by a reader seeking knowledge.

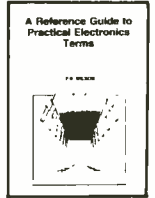

□ **BP248—TEST EQUIPMENT CONSTRUCTION . . . \$5.95.** Details construction of simple, inexpensive, but extremely useful test equipment. AF Gen, Test Bench Ampl, Audio Millivoltmeter, Transistor Tester and six more.



□ **BP267—HOW TO USE OSCILLOSCOPES AND OTHER TEST EQUIPMENT . . . \$6.95.** Mastering the oscilloscope is not really too difficult. This book explains all the standard controls and functions. Other equipment is also described.



□ **BP265—MORE ADVANCED USES OF THE MULTI-METER . . . \$5.95.** Use these techniques to test and analyze the performance of a variety of components. Also see how to build add-ons to extend multi-meter capabilities.



□ **BP256—INTRO TO LOUDSPEAKERS AND ENCLOSURE DESIGN . . . \$5.95.** We explore the variety of enclosure and speaker designs in use today, so the reader can understand the principles involved.

□ **CMOS1—CMOS POCKET GUIDE 1 . . . \$18.95.** Works like the TTL Guides but covers all commonly used CMOS standard devices. Six major sections. The first shows the device schematic. Next is a brief description of the component and is followed by full operating details. The fourth section lists major applications, while the 5th and 6th sections present essential data for that device and a list of the relevant manufacturers. The final two sections are a valuable cross-reference.



□ **BP299—PRACTICAL ELECTRONIC FILTERS . . . \$6.95.** Presents a dozen filter-based practical projects with applications in and around the home or in the constructor's workshop. Complete construction details are included.



□ **BP249—MORE ADVANCED TEST EQUIPMENT CONSTRUCTION . . . \$6.95.** Eleven more test equipment construction projects. They include a digital voltmeter, capacitance meter, current tracer, etc.



□ **BP245—DIGITAL AUDIO PROJECTS . . . \$5.95.** Practical circuits to build and experiment with. Includes A/D converter, input amplifier, digital delay line, compander, echo effect and more.



□ **BP247—MORE ADVANCED MIDI PROJECTS . . . \$5.95.** Circuits included are a MIDI indicator, THRU box, merge unit, code generator, pedal, programmer, channelizer, and analyzer.



□ **BP257—INTRO TO AMATEUR RADIO . . . \$6.95.** Amateur Radio is a unique and fascinating hobby. This book gives the newcomer a comprehensive and easy to understand guide to the subject.

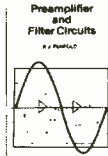

□ **BP309—PREAMPLIFIER AND FILTER CIRCUITS . . . \$6.95.** Provides circuits and background info for a range of preamplifiers, plus tone controls, filters, mixers and more. All are high-performance circuits that can be built at a reasonable cost.

□ **BP303—UNDERSTANDING PC SOFTWARE . . . \$6.95.** This book will help you understand the basics of various types of business software in common use. Types of software covered include word processors, spelling checkers, graphics programs, desktop publishing, databases, spreadsheets and utilities.



□ **BP251—COMPUTER HOBBYISTS HANDBOOK . . . \$8.95.** A wrapup of everything the computer hobbyist needs to know in one easy to use volume. Provides a range of useful reference material in a single source.



□ **PCP115—ELECTRONIC PROJECTS FOR HOME SECURITY . . . \$10.00.** 25 projects ranging from a single-door protection circuit that can be completed in an hour or two, to a sophisticated multi-channel security system. Each project is described in detail with circuit diagrams, explanations of how it works, instructions for building and testing, and how to adapt circuits to meet special requirements.



- **BP190—ADVANCED ELECTRONIC SECURITY PROJECTS . . . \$5.95.** Includes a passive infra-red detector, a fiber-optic loop alarm, computer-based alarms and an unusual form of ultrasonic intruder detector.
- **BP235—POWER SELECTOR GUIDE . . . \$10.00** Complete guide to semiconductor power devices. More than 1000 power handling devices are included. They are tabulated in alpha-numeric sequence, by technical specs Includes power diodes, Thyristors, Triacs, Power Transistors and FET's.
- **BP234—TRANSISTOR SELECTOR GUIDE . . . \$10.00.** Companion volume to BP235. Book covers more than 1400 JEDEC, JIS, and brand-specific devices. Also contains listing by case type, and electronic parameters. Includes Darlingtons transistors, high-voltage devices, high-current devices, high power devices.
- **BP117—PRACTICAL ELECTRONIC BUILDING BLOCKS—Book 1 . . . \$5.75.** Oscillators, Timers, Noise Generators, Rectifiers, Comparators, Triggers and more.
- **BP195—INTRODUCTION TO SATELLITE TV . . . \$9.95.** A definitive introduction to the subject written for the professional engineer, electronics enthusiast, or others who want to know more before they buy. 8" x 10 in.

- **BP239—GETTING THE MOST FROM YOUR MULTIMETER . . . \$5.95.** Covers basics of analog and digital meters. Methods of component testing includes transistors, thyristors, resistors, capacitors and other active and passive devices.
- **BP97—IC PROJECTS FOR BEGINNERS . . . \$5.50.** Power supplies, radio and audio circuits, oscillators, timers, switches, and more. If you can use a soldering iron you can build these devices.
- **RADIO—100 RADIO HOOKUPS . . . \$3.00.** Reprint of 1924 booklet presents radio circuits of the era including regenerative, neutrodyne, reflex & more.
- **BP42—SIMPLE LED CIRCUITS . . . \$5.50.** A large selection of simple applications for this simple electronic component.
- **BP122—AUDIO AMPLIFIER CONSTRUCTION . . . \$5.75.** Construction details for preamps and power amplifiers up through a 100-watt DC-coupled FET amplifier.
- **BP92—CRYSTAL SET CONSTRUCTION . . . \$5.50.** Everything you need to know about building crystal radio receivers.

□ **BP255—INTERNATIONAL RADIO STATIONS GUIDE . . . \$7.95.** Provides the casual listener amateur radio DXer and the professional radio monitor with an essential reference work designed to guide him or her around the more than ever complex radio bands.

CHECK OFF THE BOOKS YOU WANT

ELECTRONIC TECHNOLOGY TODAY INC.
P.O. Box 240, Massapequa Park, NY 11762-0240

SHIPPING CHARGES IN USA AND CANADA

SORRY No orders accepted outside of USA & Canada

Number of books ordered

Name _____
Address _____
City _____ State _____ Zip _____

\$0.01 to \$5.00	\$1.50
\$5.01 to \$10.00	\$2.50
\$10.01 to 20.00	\$3.50
\$20.01 to 30.00	\$4.50
\$30.01 to 40.00	\$5.50
\$40.01 to 50.00	\$6.50
\$50.01 and above	\$8.00

Total price of merchandise . . . \$ _____
Shipping (see chart at left) . . . \$ _____
Subtotal \$ _____
Sales Tax (NY State only) \$ _____
Total Enclosed \$ _____

All payments must be in U.S. funds

PE 293

GIZMO

FEBRUARY 1993

VOLUME 6,
NUMBER 2

A CHRONICLE OF CONSUMER ELECTRONICS

D(igital) C(hange) C(oming)

OPTIMUS DCT-2000 DIGITAL COMPACT CASSETTE RECORDER: From Tandy Corporation, 1800 One Tandy Center, Fort Worth, TX 76102; Price: \$699.95.

If you're a regular Gizmo reader, you've known about Digital Compact Cassettes (DCC) for quite some time now. The first prototype DCC decks were demonstrated at the 1991 Winter Consumer Electronics Show—two full years ago. The first actual DCC decks to be purchased in America were sold on September 17, 1992 at the grand opening of Tandy's Incredible Universe stores.

For those of us who are anxiously waiting to try out a new technology, of course, the prototype-to-product time frame seems interminable. We were quite happy to receive our review sample of Tandy's *Optimus DCT-2000* just a week or so after the first unit sold to the public, and couldn't wait to put it through its paces.

We suppose it's fitting that the DCT-2000 looks like a cross between a standard tape deck and a CD player. The usual tape well is replaced by a tray that slides out smoothly with the push of a button. You never actually see the tape heads; they're hidden inside the unit. To the left of the well is a large vacuum-fluorescent display, which would look more at home on a CD player. It provides a wealth of information about prerecorded DCC tapes and more limited information about analog cassettes. To the right of the tape tray is a row of large buttons used for ordinary tape-deck functions—OPEN/CLOSE, RECORD, PAUSE, DIRECTION, PLAY, and STOP. Underneath each of those buttons is a smaller button for less-frequently used tape functions—REV MODE, REC MUTE, and buttons labeled with arrows for fast forward, rewind, and Automatic Search Music System (ASMS) functions. Hidden behind a flip-down panel are the



controls used to operate advanced digital recording functions, to select the proper input, and to select the information you'd like to see on the display. For use in playing back analog tapes, there is a switch to select Dolby-B or -C noise reduction (Dolby isn't relevant to DCC playback or recording). For recording using analog inputs, there are also knobs for setting the recording level and balance. At the bottom right side of the front panel is a headphone jack, along with a volume-control knob for headphone listening.

The DCT-2000's rear panel has four line-level phono jacks for analog audio signals (an input and an output for each channel); standard, shielded audio cable is used for analog connection to an amplifier. Of course, digital connection to a CD player—which allows you to record from CD to DCC without digital-to-analog conversion, resulting in what are theoretically exact duplicates of digital recordings—is preferred. The DCC deck provides two sets of digital jacks—coaxial and optical. One 75-ohm coax cable is required to connect the DCT-2000's coaxial input jack to

the CD player's coaxial output (or vice versa if the CD player has only a digital input jack). To use the DCC deck's optical jacks, you must use a JAE-standard fiber-optic cable and connectors, available at some audio specialty shops (at prices starting at \$40 and going higher than \$80 in our area) or by special order from Radio Shack's computer mail-order centers.

A small remote control—5 inches long by 1½ inches wide—can be used to operate the deck's main functions—play, pause, stop, fast forward, rewind, record, record mute—as well as to select the tape direction and what type of information you'd like to see displayed.

Each pre-recorded digital compact cassette includes a sub-band of non-musical information. The DCC deck is able to "read" the information, which can be shown on the 12-character display and includes the album title, the track title, and the recording artist's or group's name. Pressing the MODE key on the remote or the front panel changes the text category.

If you prefer, one of four timer modes can be displayed instead. Repeatedly

TURN PAGE FOR CONTENTS

This month in GIZMO®

Tandy Optimus DCT-2000 Digital Compact Cassette Deck	pg. 5
Digital Compact Cassette: An Overview	pg. 7
Kodak Photo CD Model PCD-870	pg. 10
Luxman Integrated Components	pg. 13
Look Power Zoom Binoculars	pg. 18
Sharp Nice & Easy Microwave Oven	pg. 19
Arkon Electronic Reminder	pg. 20
Casio Ladies Sports Watch	pg. 20
Headline Harry History-Lesson Program	pg. 20
Phone Care Emergency Communication System	pg. 20

Gizmo is published by Gernsback Publications, Inc., 500-B Bi-County Blvd., Farmingdale, NY 11735. Senior Writers: Chris F. O'Brian and Teri Scaduto. ©Copyright 1992 by Gernsback Publications, Inc. Gizmo is a registered trademark. All rights reserved.

pressing the **TEXT** key toggles the display between text and timer modes. Once in the timer mode, pressing the **MODE** key scrolls the display between total elapsed time, total remaining time, track time elapsed, track time remaining, and a tape counter that shows the current tape position as a number between "000" and "999." (The tape counter automatically resets whenever the cassette compartment is opened and can be reset manually using the front-panel **RESET** key.) When in any of the timer modes (but not in the text modes), the track number is displayed. In either text or timer mode, the display also indicates the tape direction, the autoreverse setting (single-side, full-tape, or continuous play), and whether a digital or analog tape is in

use. At the bottom of the display is a horizontal bar-graph signal-level indicator, so that you can monitor the left- and right-channel levels during playback and recording.

When playing back a prerecorded or homemade analog tape—and playback is all you can do because no DCC deck can record onto analog tapes—the display is a lot simpler. Again, it shows the signal-level indicator, the direction of play, and the auto-reverse mode, and in the top right corner it says "analog." The only possible display mode, however, is the tape counter; track numbers are not displayed. The ASMS system, which flawlessly advances the tape to the start of the next track on prerecorded DCC tapes, advances to blank spaces (silences) on analog cassettes. That means that it is sometimes stymied by pauses or very soft passages within a song, although it does work well in general.

ASMS is not needed, however, on digitally recorded cassettes that include ID markers. The DCC deck is able to find the beginning of a song by looking for the ID marker—a much more accurate method than ASMS. The ID markers also allow you to set a programmed track sequence; that is, you can select which tracks you'd like to hear, and in what order. To do so, you must use the controls in the front-panel compartment. Pressing **PROGRAM** starts the process. Then you use the **FAST FORWARD** or **REVERSE** buttons to move to the beginning of each track that you want to hear, in the order of preference, and press **PLAY** after each one. When you've selected all of the tracks that you'd like to hear, you can review the sequence on the display. If it's okay, another press of the **PROGRAM** key stores the sequence to memory—but only until the tape tray is opened, the power is turned off, or the **PROGRAM** button is pressed again.

When making digital recordings, the process can be as easy or as complicated as you like. To make a basic digital tape, which doesn't record track numbers or total elapsed time, involves virtually the same method you're accustomed to from using standard, analog cassette decks—loading the tape and pressing **RECORD**, setting up the source material and hitting **PLAY** on both the tape deck and the source. To display the recording time, you must press **COUNTER/DISPLAY RESET** before you begin the recording. The only differences in basic DCC recording are that you must, first, set the DCC tape to allow recording (using the "protect" slide switch found on each digital tape); and second, choose between analog, digital, and optical inputs (actually, the optical input is also digital). When either digital input is used, there is no need to adjust the record level or balance controls. That in itself should allow *anyone* to make quality tapes.

If the digital source material is copy protected, "SCMS" appears on the display, and you can only record the material using the analog inputs. The analog information is still recorded digitally.

It's when you decide to get fancy, with "advanced" DCC recording techniques, that things can start to get a bit complicated—and that you know you've left the world of analog recording behind. There are, of course, some decided advantages to taking the trouble: The total elapsed time and the current track number of a digital recording can be displayed, and you can add your own ID markers and renumber the tracks.

There are three different types of ID markers that you can add to homemade DCC recordings. Each gives you more control over the completed tape by letting you quickly find the beginning of a track or the end of a side. The "start" marker signifies the start of a track, and each one is automatically assigned an associated track number. The deck will automatically include the start markers in either basic or advanced recordings, but you can also write them in manually, for instance, to mark the beginning of a favorite passage within a song. The "reverse" ID marker indicates the place on the tape where the playback direction automatically switches from side A to side B. It can be written only on the A side of a DCC tape; the end of side B is marked with a "home" ID marker. The "skip" ID marker tells the deck to fast forward over the taped material until it recognizes the next "start" ID. That could come in particularly handy if you've recorded a radio program on a commercial station—you could "skip" over each commercial break and hear only the program material. For each of those three ID markers, there are a pair of buttons located in the front-panel compartment. Marked **WRITE** and **ERASE**, they are used to manually insert or delete the ID markers.

Two types of ID markers are automatically inserted by the DCT-2000: the "lead-in" and the "home" ID markers. The former marks the start of an advanced user-recorded tape; the latter marks the end of an advanced recording and is only recognized in playback, search, or append modes.

The append functions are used to add more tracks to an unfinished tape and to record over a previously used DCC tape. Doing so involves several additional steps to ensure that the ID markers are correctly inserted.

It's also possible to erase unwanted ID markers. When you play back a DCC tape that you've made, the ID indicator on the display lights up whenever the deck recognizes a marker. That makes it easy to spot any unwanted markers.

The DCT-2000 assumes that each start marker it encounters signals the start of a selection, and numbers the tracks accordingly. If you record a DCC in more than one session, however, it begins the track numbering for each session with Track 0. Not surprisingly, you can frequently end up with tracks that are incorrectly numbered. Renumbering the tracks makes it easier to find your way around the tape during playback. The process is a quick one—press the RENUMBER button and the tape rewinds to the beginning and then fast forwards until it finds the first start ID marker, which it rennumbers as Track 1. The DCC deck keeps fast forwarding and renumbering until all the tracks are correctly numbered. (The renumbering process works only on tapes that have been recorded on both sides.)

All of the above might seem somewhat complicated—and it is. Actually, we had no trouble inserting “start” and “reverse” ID markers. We never mastered the art of inserting the “end” markers, however, and were unable to figure out from the manual what we did wrong. Nor were we able to make digitally recorded tapes that would indicate track time or total time, or any timing information, for that matter. We hope that subsequent models will be easier to use.

Despite the troubles we experienced with the end ID's, the tapes we created were the best we've ever made. We made digital recordings of several selections from various compact discs. (We used fiber-optic cables for connection.) Using the Luxman A/V receiver reviewed elsewhere in this issue of *Gizmo*, we were able to quickly switch between the two sources for our subjective A-B listening tests.

Armed with our knowledge of how PASC encoding works, we expected that DCC would perform very well on our favorite rock-and-roll selections, which are “noisy” and don't have a wide dynamic range, and are therefore forgiving of poor recording. We expected to be able to hear the difference on classical recordings. Their generally wide dynamic range can task recording media, and symphonic music contains many varied sounds of distinct frequencies that are not masked by raucous guitars and vocals.

Despite our pre-existing suspicions, in blind tests we were unable to distinguish any differences between the original CD and the DCC copy regardless of the music we recorded—from Wagner to the Clash. We invited friends and family members to perform the same test, with the same result.

We were, however, able to distinguish between DCC and analog compact cassettes almost without fail.

The DCT-2000 is not perfect. A few
(Continued on page 18)

THE ABC'S OF DCC

In the world of consumer electronics, there has always been a tug-of-war between the desire to cling to the familiar gear in which we've invested so much money, and the desire to leap into the future by embracing exciting new technologies. Although it takes time for emerging product categories to take hold, eventually the lure of the new generally overcomes the comfort of the familiar—as long as the change represents a real improvement, that is. Just think of all those collections of LP's that are gathering mold in basements, casualties of the compact-disc invasion. The sometimes sad reality is that the old must make way for the new.

Must it really? Not according to some manufacturers, most notably, Philips—a company with a huge investment in the past, the present, and in the future. At least not immediately. Philips invented the original audio compact cassette format. Although it was originally intended for use in dictation systems, and it took years for it to become accepted as a high-fidelity audio medium (and was *never* accepted by some purists), the compact cassette went on to become the most successful format in audio history. Philips also pioneered the compact disc, which managed for the first time in 1991 to achieve a higher market share than the compact cassette (see chart). Not surprisingly, Philips is anxious to preserve that admittedly obsolescence-bound format for as long as possible, as are all the manufacturers of personal cassette players, automotive cassette players, home decks, and blank and prerecorded tapes. Now Philips has managed to look toward the future—but keep the past and present alive—with a new technology called Digital Compact Cassette, or DCC.

DCC bridges the gap between the familiarity of the standard audio cassette and the sound quality and convenience of the compact disc—and allows consumers to make their own high-quality digital recordings. All DCC decks are “backward compatible”—that is, they can play and record digital compact cassettes, and they also can play back standard cassettes. That's good news for a lot of people, since, according to some estimates, the average household in the U.S., Europe, and Japan owns 60 of them. (We thought that figure was a bit high, until we did a quick count of cassettes in the *Gizmo* offices, and came up with about 150—and we've never liked cassettes!) Some 2.6 billion new cassettes—60% blank and 40% prerecorded—are purchased each year. There are over a billion cassette players in use worldwide, and folks are buying about 180 mil-



THE DCC TAPE LOOKS QUITE DIFFERENT from the standard compact cassette. No moving parts (tape or tape hubs) are exposed on the flat DCC tape; a sliding-metal cover keeps them safely hidden.

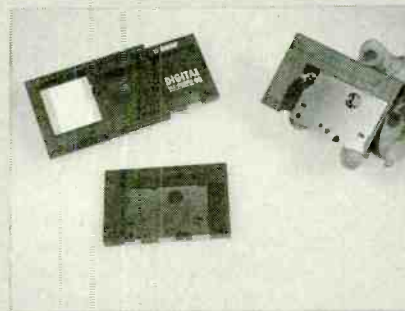

FOR RECORDING AND PLAYBACK, THE DCC'S sliding steel cover is pushed back by a mechanism inside the DCC deck to expose the tape and spindles.

lion new ones every year. The switch to DCC can be accomplished without future shock; consumers can continue to enjoy their analog tapes on DCC decks, as they begin to amass a library of DCC tapes. The superior sound and convenience features of DCC are sure to speed that transition along.

Like analog cassettes, DCC tapes come in 60- and 90-minute lengths, and both tapes have the same external dimensions, but that's where the similarities end. The digital compact cassette is flat; regular cassettes get fat where the tape head enters because when they were first invented and standardized, the technology needed to make the heads any smaller didn't exist. The top side of the DCC is completely covered, and pre-recorded DCC tapes will have album art in that spot. The holes in the base of the DCC for the tape-drive spindles, and in front of the tape for the tape head, are protected by a sliding steel cover similar to that on a 3½-inch floppy disk. Because the spindles can be accessed only from the rear of the cassette, the tape can't be flipped over for reverse play, so DCC players will always have auto-reverse operation. The closed-cover design, in which the only time the tape or the spindles are exposed is when the tape is inside the deck, also makes DCC tapes more durable for portable applications. Although their outer cases provide some extra protection, for use in cars the outer case

could be omitted, allowing easy one-hand access to DCC tapes while driving. What's really different about DCC tapes, however, is on the inside—digitally coded magnetic tape that affords both the superior sound and precise track access of compact discs.

SOUND PRINCIPLES

In nature, sound is analog. Until recently, sound reproduction also was analog in nature, consisting either of converting sound waves to movements of a phonograph needle over the grooves on a record or transforming them into magnetic patterns on tape.

There are problems inherent in analog recordings, which suffer from noise and distortion (most caused by the recording process itself) that become inextricably mixed with the wanted sounds during the recording process. Efforts to improve the sound quality of analog recordings have focused on minimizing signal distortion or on compensating or filtering the signal. Although some purists disagree, when you add to that the problems of surface defects in LP's and ambient hiss in audio cassettes, analog recording never could provide a totally faithful reproduction of the original sound.

Digital recording, developed in the 1970's by Philips and Sony and first used commercially in the 1982 introduction of the compact disc, represented a completely new approach to sound reproduction. In digital recording, the original analog signal is converted to digital data—discrete "bits" of information that are represented by "ones" and "zeros," like the language used by computers. A computer chip inside the CD player converts the digital signal back into sound by creating a waveform from the coded numbers. In digital recording, the original audio signal is duplicated exactly, with no additions or

losses. Noise signals generated in the recording process can be removed from the digital signal. In fact, the recording technique even makes it possible to "correct" imperfections in the source material, such as those caused by scratches. And while audiophiles originally feared that this "chopping up" of the signal would detract from the listening experience, most now agree that digital recording has been a major advance in fidelity.

The digital recording technique used for compact discs, called PCM (pulse-code modulation) coding, is a straightforward, linear method that involves "sampling" the analog signal and then measuring and recording in bits the amplitudes of each individual sample point. The technique, based on the ability of the human ear to discriminate a maximum 16-bit resolution per sample, results in terrific sound reproduction.

Unfortunately, the sheer amount of data sampled makes PCM coding incompatible with the compact cassette format. Using PCM coding to digitally record magnetic tapes compatible with the compact cassette format, in which music is stored along longitudinal "tracks" that run the length of the tape, would require about four times more tape moving at four times the speed. The tape needed for a 90-minute recording simply wouldn't fit in the compact cassette case, and existing tape-transport mechanisms wouldn't work. A more efficient coding method was needed to fit a CD's worth of digitally recorded music into a compact cassette format.

ENTER DCC

Philips met that challenge, using a bit of digital-data doctoring and acoustic corner-cutting to get rid of extraneous bits, while retaining the stationary head and the longitudinal track arrangement for back-

ward compatibility with analog cassettes. The DCC coding technology is called PASC for Precision Adaptive Sub-band Coding. In PASC, the audio spectrum is divided into "sub-bands." Bits that have been assigned to one sub-band might sometimes go unused, because there is no sound at that sub-band's frequency. Those bits can be reassigned to other sub-bands. (Thus the *precision* of the sub-band encoding *adapts* to the sound being recorded.) Efficiency is further increased by giving more bits to prominent sounds, and fewer to barely audible sounds. In addition, PASC, modeled on the hearing mechanism of the human ear, digitizes audio signals according to the way we hear. In particular, it takes advantage of a psycho-acoustic phenomena known as "masking," in which soft sounds are audibly hidden ("masked") by simultaneous loud sounds of similar frequency. The sounds that cannot be heard because of masking are simply removed from the recording. Similarly, the PASC technique removes those soft high- or low-frequency sounds that are above or below the threshold of human hearing. Only about one-quarter of the digital data on compact discs is audible. PASC actually removes the other three-quarters, making the sophisticated coding method four times more efficient than PCM coding.

While audio purists worry that the removal of those extraneous sounds will degrade the recording quality, according to Philips, the sound quality of digital compact cassettes is at least equal to—and possibly surpasses—that of compact discs. The average listener will not be able to distinguish DCC from CD. (We also were initially skeptical. But the quality of the digital recordings that we were able make during our tests of the Optimus DCT-2000 quickly convinced us.)

The tape-to-head speed is the same in DCC and analog decks, allowing playback of standard cassette tapes. The head itself is different however. The DCC deck uses a stationary "thin-film" head, named for its manufacturing technique: thin-film deposition. That's the same technique used for making some integrated circuits. The DCC tape heads are similar to the thin-film heads used in computer disk drives.

In addition to superior sound compared to regular cassettes, DCC tapes provide some of the convenience features to which CD converts have become accustomed—and at least one new feature. Besides music, prerecorded DCC tapes contains "control information" recorded in a sub-code channel, as is done on CD's. That information enables such features as direct track access in both directions. (Actual access time is longer on DCC tapes than on CD's, and will depend on the winding speed of individual DCC decks.) Other

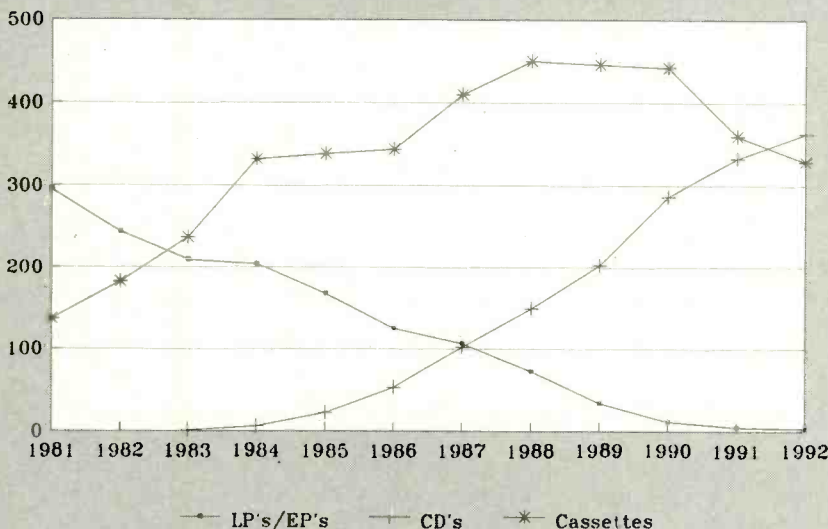

Fig. 1. Sales of compact discs surpassed those of audio compact cassettes for the first time in 1991.

information on prerecorded DCC tapes—including album title, track title, and such album credits as the recording artist's name—is "read" by the DCC deck, and appears as text in the unit's display. There's room on a DCC for full song lyrics, but that's up to the record producer to include. (Compact discs have the potential for such textual information, but, unfortunately, the means of displaying it was never standardized, as it has been for DCC.)

That non-musical data cannot be copied when you dub prerecorded DCC's onto blank DCC tapes. It's possible, however, when making recordings on blank DCC tapes, to insert ID marks at the beginning of each track for direct track access on custom tapes.

Providing consumers with digital sound and convenience, backward compatibility with their existing cassette collections, and the ability to make their own digital recordings. DCC sounds like a sure winner—doesn't it?

FUTURE FORMAT, OR DIGITAL DETOUR?

So far, we've discussed the consumer benefits inherent in the DCC format. In fact, the Digital Compact Cassette has several benefits from the industry standpoint, as well.

First, DCC has the backing of the recording industry (the lack of which hampered the acceptance of Digital Audio Tape, or DAT). In 1991, a compromise agreement between audio manufacturers and the recording industry was reached, in which the manufacturers agreed to pay royalties on digital audio-recording hardware and blank media, and to use a copy-limiting system. That system, called SCMS for serial copy-management system, limits the number of generations of direct copies that can be made (usually to one). In other words, you can copy a CD onto as many different DCC tapes as you like, but you can't make a digital copy (a "second generation" tape) of any of those home-brewed DCC tapes. That restriction might be a moot point, as it has been suggested that multiple generation DCC tapes would suffer from the effects of repeated use of data-compression techniques. In any case, single-generation taping covers most consumer uses. (We'd prefer to see unrestricted home recording, but if we had to make a choice between digital with limitations or no digital at all, we'll grudgingly accept the restrictions.) Recording industry support means that there will be software in the form of prerecorded DCC's to accompany the DCC decks that are being introduced.

Second, the longitudinal track arrangement on DCC tapes means that they can be duplicated at high speeds, lowering production costs. In addition, their close sim-

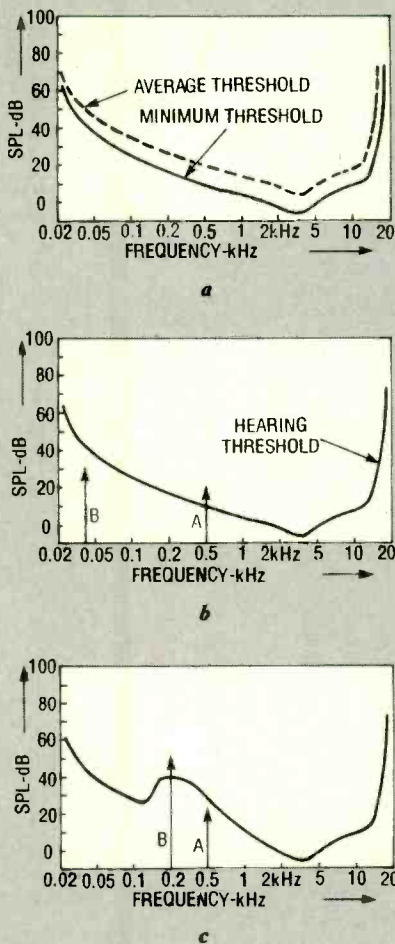

Fig. 2. PHILIPS' PASC ENCODING ignores sounds that are below the hearing threshold (a). Of the signals shown in b, only A would be recorded because B, below the hearing threshold, would not be heard. The hearing threshold, however, varies dynamically depending on what other signals are present. In c, signal B has altered the threshold, making A inaudible ("masking" signal A).

ilarities to standard audio cassettes makes it possible to manufacture DCC tapes at existing tape-manufacturing plants with very little adaptation.

Third, it's only a matter of time until Digital Audio Broadcasting becomes the norm on our airwaves. That's sure to boost sales of any digital recording format.

Finally, as mentioned above, DCC will prolong the life of the analog cassette—a format in which a great many manufacturers have an interest, and which has begun its final decline.

So, what could go wrong?

Some folks would argue that the audio cassette—analogue or digital—already is obsolete, and that the future belongs to optical recording media. They see DCC, at best, as an interim format that will disappear as soon as recordable CD's—which are under development by several man-

ufacturers—become a consumer reality.

Meanwhile, Sony has already introduced a competing recordable optical format—the Mini Disc, or MD. The 2½-inch magneto-optical discs each can store up to 74 minutes of digital audio information, which is recorded in a similar way as in CD's, but which uses a data-compression scheme similar to DCC's. (Keep watching these pages in upcoming months for a hands-on evaluation of Mini Disc.) MD's, however, are not compatible with CD players, and are intended primarily as a portable digital medium. Is there room on the market for two recordable digital-audio formats, besides the CD?

Another potential problem with DCC is price. When the first DCC prototypes were demonstrated at trade shows two years ago, DAT was just being introduced. To position the new product in the digital-audio tape market, DCC manufacturers were emphasizing its affordable price—DAT was to be the audiophile choice and DCC represented digital audio for the masses. The first DCC decks were to be sold for under \$500 (and we all know what happens to prices as a format catches on). DCC tapes, too, were to be priced along the lines of standard audio cassettes. But as the first units are hitting the shelves, they're carrying price tags of \$700 and up—particularly expensive when compared to today's low-end CD players and cassette decks, which are frequently sold for less than \$150, sometimes as low as \$99. We'll have to see DCC prices drop quite sharply before they can be truly competitive in the mainstream mass market.

The Digital Compact Cassette format has a lot going for it—recordability, sound quality, convenience, durability, recording-industry support, backward compatibility, portability, and reasonable manufacturing costs. While we don't pretend to have a crystal ball—or even any great insights into the vagaries of consumer demand—we'd like to see the format succeed. One thing's for sure: The next several years will see a shakeup in the digital-audio field. We're as curious as you to see what ends up on top. ■

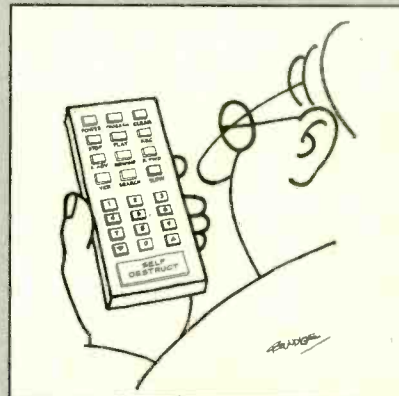

Electronic Photo Album

PHOTO CD PLAYER MODEL PCD-870:
From Eastman Kodak Company, 343
State Street, Rochester, NY 14650-0519.
Price: \$549.

Photography is an extremely popular pastime in this country. Americans own more than 100 million 35-mm cameras, and last year they took more than 15 billion photos. Unfortunately, a large percentage of those snapshots end up "filed" in shoe boxes.

For most of us, photographs are more than mere mementos. Pictures of new babies, weddings, family vacations—evoking memories of some of the happiest moments in life and comprising a visual family history—are often among our most cherished possessions. Yet, all too often, those photographs never make it into albums. Instead, we quickly glance through them as we walk from the developer's back to our car, examine them more closely once we get home, and pass them around to family and friends once or twice. Then they get stashed away in a drawer or closet, still in the envelope from the developer, rarely to be seen again. Even those photos that are mounted in albums are difficult for more than one person at a time to view.

Kodak, the venerable old granddaddy of photographic companies, has introduced a new way to store and view photographs. Called *Photo CD*, the system merges 35-mm picture taking with state-of-the-art digital technology. The Photo CD Player closely resembles an audio CD player (and can, in fact, play compact discs). It displays on a TV or monitor photographic images that have been digitally "developed" onto a Photo CD disc, which looks like a gold-colored compact disc.

From the photographer's end, picture-taking hasn't changed—the same camera, lenses, lights, and film can be used. And, increasingly often, even the same developer might be used. The photos are even developed and printed with traditional methods. The first major change comes after development, when the Photo CD process adds an important step. The film negatives are scanned, digitized, and then transferred at full resolution to a compact disc. At this early stage, Photo CD developers across the country can send the film for processing to one of about 25 locations equipped for Photo CD. As the format catches on, however, Kodak expects local processing labs to be so equipped, eventually allowing one-hour Photo CD development. (For a complete technical description of the digitization



CIRCLE 51 ON FREE INFORMATION CARD

process, along with discussions of professional and industrial uses of the format, see the article "All About Photo CD" elsewhere in this issue of *Popular Electronics*.)

When you opt to have your photos placed on disc, you also receive a set of prints and the negatives. The cost of digital developing, at least initially, is higher than for prints-only: about a dollar per image. Up to 100 images can be placed on each disc; you can bring a partially full disc back to the developer and have new photos added to it. It's also possible to bring in your old slides and negatives to be placed on a Photo CD disc. And Kodak promises that, in the near future, you also will be able to have audio, graphics, and text added to your Photo CD discs. To help you keep track of all those photos, each image is assigned an index number, and each disc comes with a full-color "proof sheet" that slides into the front cover of the jewel-box Photo CD case (in place of the liner notes that come inside audio CD cases).

The next major change—and the most important one, as far as most consumers are concerned—is in the viewing process, which, of course, requires a Photo CD (or compatible) player. Kodak, which stands to make most of its Photo CD profits in development fees, is not looking to corner the player hardware market. Under Kodak's active encouragement, several other companies plan to market Photo CD players. In addition, Philips' CD-I players can play back Photo CD's. (Philips worked with Kodak to develop Photo

CD—no pun intended—and actually manufactures the Kodak units.)

We used the *PCD-870 Photo CD Player* from Kodak. As mentioned above, the unit closely resembles an audio CD player, although it has a few more controls than most CD players. The disc drawer is at the left side of the front panel. The center of the front panel is devoted to a two-color vacuum-fluorescent screen. Below the display is a row of buttons that execute basic commands in both Photo and audio CD modes—OPEN/CLOSE, PLAY, PREVIOUS, NEXT, PAUSE, and STOP. To the right of the display are two more rows of buttons, most of which are used exclusively for one mode or the other (although they seem to be rather randomly placed instead of logically grouped by mode). Rounding out the front panel is a headphone jack.

More sophisticated functions are operated using the remote control, which also replicates virtually all the front-panel controls. The remote adds a numeric keypad for directly selecting audio tracks or photos, as well as keys used for on-screen "image manipulation."

Once the Photo CD player is hooked up to your current audio/video setup (which is as easy as connecting a VCR), you can display your pictures simply by placing a disc in the tray, and pressing PLAY. The resolution is as good as that of your television set, and the image is large enough for the whole family to view at once. To view another photo, you can use the NEXT or PREVIOUS buttons or the numeric keypad on the remote. The AUTOPLAY button is

Take Any **3** PROFESSIONAL BOOKS for only \$**9.95**

when you join the **ELECTRONICS ENGINEERS' BOOK CLUB**

Values to \$162.40



9255-XXX \$105.00
Counts as 3



003961 \$39.95



003957-XX \$49.95
Counts as 2

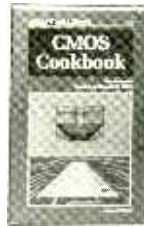

9244P \$18.95
Softcover



585261-XX \$52.00
Counts as 2

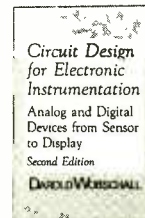

071231 \$57.95



020975-XXX \$104.50
Counts as 3



3147-XX \$38.95
Counts as 2

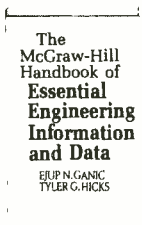

022764-XX \$92.50
Counts as 2

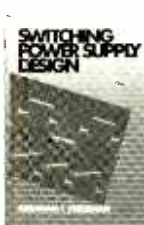

050806 \$54.95

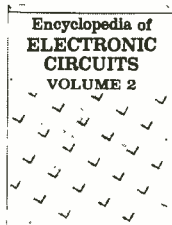

3138-XX \$60.00
Counts as 2



3279 \$36.55

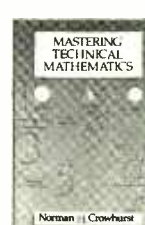

3438 \$39.95



3710 \$32.95



3321P \$16.95
Softcover



3837 \$27.95



3151 \$42.95



2962P \$17.95
Softcover



3212-XX \$39.95
Counts as 2



025354 \$29.95



10010P \$22.95
Softcover

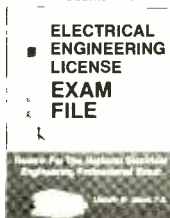

585247-XX \$31.95
Counts as 2



3365P \$24.95
Softcover



3991 \$39.95



3102-XX \$49.95
Counts as 2



2672 \$49.50

As a member of the Electronics Engineers' Book ClubSM . . .

. . . you'll enjoy receiving Club bulletins every 3-4 weeks containing exciting offers on the latest books in the field at savings of up to 50% off of regular publishers' prices. If you want the Main Selection do nothing and it will be shipped automatically. If you want another book, or no book at all, simply return the reply form to us by the date specified. You'll have at least 10 days to decide. And you'll be eligible for **FREE** books through our **NEW Bonus Book Program**. Your only obligation is to purchase 3 more books during the next 2 years, after which you may cancel your membership at any time.

All books are hardcover unless otherwise noted. Publishers' prices shown. ©1993 EEBC
A shipping/handling charge and sales tax will be added to all orders.

If coupon is missing, write to:
Electronics Engineers' Book Club, Blue Ridge Summit, PA 17294-0860

ELECTRONICS ENGINEERS' BOOK CLUB

Blue Ridge Summit, PA 17294-0860

YES! Please send me the book(s) listed below for just \$9.95, plus shipping/handling & tax. Enroll me as a member of the **Electronics Engineers' Book Club** according to the terms outlined in this ad. If not satisfied, I may return the book(s) within ten days and have my membership cancelled. A shipping/handling charge & tax will be added to all orders.

--	--	--

If you select a book that counts as 2 choices, write the book number in one box and XX in the next
If you select a Counts as 3 choice, write the book number in one box and XXX in the next 2 boxes

Name _____

Address _____

City/State _____

Zip _____ Phone _____

Valid for new members only, subject to acceptance by EEBC. Canada must remit in U.S. funds. Applicants outside the U.S. and Canada will receive special ordering instructions. PPIF293

used to automatically scroll through all the pictures (or just your favorites) at selectable intervals of 2, 4, or 8 seconds.

You can do much more than just look at the pictures, however. Photo CD allows you to customize the photo presentation by skipping those pictures that you don't want to see, panning to show hidden parts of the picture, enlarging a portion of a picture, creating and storing different versions of a picture, and rotating an image. The changes that you make can be stored, so that your custom presentation can be viewed every time you play that disc on the same Photo CD player. None of those features permanently affects the original images—you can't erase a photo (accidentally or purposely) using a Photo CD player. And all of the features are clearly explained both in the owner's manual and on the included demo disc.

We'd guess that SKIP will be one of the most frequently used buttons. Just think of all those photos you've appeared in over the years that you'd prefer no one would see—flabby bathing-suit shots, weird facial expressions, embarrassing moments, etc. Add to those all the shots that just didn't quite make it—overexposed, underexposed, blurred, etc. When the unwanted picture is on the screen, a single press of the SKIP button makes it disappear. The next picture comes up on the screen, and from then on, that picture is not included in your favorite-picture-selection (FPS) lineup. That means that it will no longer be shown, unless you specifically call it up using the numeric keypad. Once on the screen, a press of the KEEP button restores it to its original place in the FPS list.

The aspect ratio of television sets is different from that of photographs, so the outer edges of the images are hidden from view in the "normal" (full-screen) mode. To see the entire photograph, a press of the FULL key on the remote controls displays a reduced-size version. When you return to normal, full-screen size (with a press of the NORM key), the PAN buttons let you move a picture up, down, left, or right to reveal those hidden portions. The pan function is especially handy when viewing pictures that were shot vertically. You can use the ROTATE button to spin a picture clockwise or counterclockwise in 90° increments. Once a vertical picture has been rotated into horizontal position, it doesn't quite fit—it's too narrow to fill the width of the screen, and too tall to fit completely on the TV screen. You can use the PAN button to reposition the photo; pressing KEEP stores the new version.

Not many amateur photographers are masters of composition. You're likely to have a few pictures that could benefit from a bit of on-screen "cropping." Photo CD lets you "frame" the desired portion of a picture. Pressing the FRAME button super-

imposes a rectangular frame over the picture. The PAN button can be used to position the frame over the desired portion of the picture. Pressing TELE enlarges the area within the frame to two times its original size, filling the entire screen and effectively cropping out the unwanted areas. Pressing NORM restores the original composition. To store the cropped photo in the FPS list, you must press the KEEP button. It's even possible to store different versions of the same photograph. Framing works only on previously unaltered pictures, however; you can't frame an enlarged or rotated image, for instance.

Finally, you can change the viewing order of the pictures, using the INSERT key. You first go to the position on the disc at which you'd like to place the photo, then hit the INSERT key, then use the numeric keypad to select the picture to be moved. When that picture comes up on screen, a press of the KEEP button both moves it and stores that new position into FPS memory.

All of those features allow you to set up television "slide" shows that aren't guaranteed to hold your audience enthralled, but at least promise to be less dull than old-fashioned projected slide shows, thanks to your judicious use of the SKIP, PAN, ROTATE, and FRAME keys. Keep in mind, however, that it isn't possible to "edit" a Photo CD disc and then send it to someone else who owns a Photo CD player. Only the player on which the favorite-program-selections were made will recognize the disc's FPS list. You can still send edited video photos to friends or relatives, however, by videotaping your slide shows. (Why wait for Photo CD audio capability? You can add voice-over narration to your videotape as well.)

We'd seen all of those features demonstrated at press events, we'd read all the literature from Kodak, and we'd played with the included demo disc. None of that prepared us for the sheer *fun* of being able to, first, see photos of our own friends, family, pets, and vacations on our TV; and, second, to be able to improve on the images we'd captured. We found ourselves playing around with even those pictures whose composition was close to perfect as is. It's great to be able to zoom in on a particular area of a photo. We learned, however, that when you're playing around with your own photos, as opposed to the "picture-perfect" shots on the demo, sometimes it's best to leave well enough alone. Imperfections that are not obvious in the normal mode occasionally become painfully clear in the "tele" mode.

When you're not in the mood to sit around looking at photographs on your TV, the PCD-870 won't sit idle—you can use it to play compact discs. The audio portion of the Photo CD player holds no

audible or convenience surprises for those who are accustomed to using CD players. Bitstream technology, a one-bit digital-to-analog conversion process, is said to offer "excellent phase linearity, to reduce phase distortion and minimize group delay that can change the tonal quality and timbre of music." In other words, you get the superior sound expected from CD's. In terms of convenience features, the PCD-870 allows you to program the order in which the tracks are played, store your preferred program in memory ("favorite track selection"), scan the first ten seconds of each track, and search forward or backward within a particular track to locate a specific musical passage. The audio portion also provides "shuffle" play (random playback of tracks) and a feature called "time edit" that lets you tell the PCD-870 what length tape you are using when recording a CD. In time-edit mode, the unit will not allow a partial track to be recorded.

If you're not in the mood for your own photos or for listening to music, you can also play prerecorded interactive Photo CD discs. The one that we got to sample was a specially made Kodak demo—the Photo CD companion to a Natural Geographic book titled *From Alice to Ocean*, which chronicles the 1700-mile solo trek of a young woman, starting from the town of Alice, Australia, across the outback desert, to the ocean. The disc contains narration, in the woman's own voice, along with photographs that don't appear in the book. The story is fascinating and uplifting; the photography, exquisite. What makes the disc "interactive" is the user's ability to skip around in the story, replay certain portions, and even use the panning, framing, and zoom functions of the Photo CD player. The discs move much more quickly and smoothly than CD-I discs (which cannot be played on Photo CD players), and you can move the action along even faster by pressing the NEXT key. Philips is just one of the companies that will be producing interactive Photo CD discs.

The model PCD-870 represents the middle of Kodak's introductory line of Photo CD players. At the lower end is the model PCD-270 (\$449), which lacks the zoom and framing functions, the headphone jack, and the audio favorite-track-selection and time-edit functions. The top-of-the-line model PCD-5870 (\$649) is identical to the PCD-870, but adds a five-disc carousel and an on-screen display of the index number. Personally, we'd opt for the carousel version, having become used to the convenience of multi-disc CD changers.

But the PCD-870 is certainly no slouch. It performed quite well—in fact, remarkably so for the "first" item in a brand new
(Continued on page 19)

Convenient Quality

LUXMAN RV-371 A/V RECEIVER, D-351 CD PLAYER, and K-351 CASSETTE DECK. Manufactured by: Luxman, 199145 Gramercy Place, Torrance, CA 90501. Prices: \$1500 (RV-371), \$600 (D-351), \$600 (K-351).

When it comes to consumer electronics, convenience and quality are what make or break a product or even an entire product category. Consider the analog compact cassette and the compact disc. The convenience of both music carriers have made them as popular as they are today. Similarly, the convenience of TV/VCR combinations have made them the fastest growing segment of the video industry. Yet quality is what inspires brand loyalty. And it's quality that keeps audio components and Dolby Pro Logic audio/video receivers selling, even in these recessionary times.

Luxman, who's been manufacturing quality audio devices for almost 70 years, thinks that a quality audio-component system doesn't have to preclude convenience. We looked at their RV-371 Pro Logic A/V receiver, D-351 CD player, and K-351 cassette deck. All of the components were equipped with Luxman's System Bus, which allows the separate components to act as a single unit.

The RV-371 is the heart of the system. The Dolby Pro-Logic A/V receiver features two 70-watt amplifiers for the front channels, and three 50-watt amplifiers for the center and surround channels. The RV-371 is an attractive receiver, featuring black cabinetry and a black front panel with gold-colored labels that are easy to read.

The D-351 compact-disc player, on the outside, looks like a fairly basic unit. Its clean front panel hides a host of special internal circuits that make it anything but basic. The K-351 auto-reverse cassette deck also looks fairly standard on the outside. But again, we'll see that appearances can be deceiving.

The RV-371, like other Luxman amplifiers, features what the company calls "Ultimate Power"—that is, power reserves to deal with the dynamics encountered in music. Such amplifier design would always be good practice. But a modern digital-audio system, with its wide dynamic range, produces powerful transients that make sufficient amplifier output-current capability essential for distortion-free performance. Your amplifier can distort because your speakers present a low impedance to your amplifier more often than you might think. That's because



CIRCLE 52 ON FREE INFORMATION CARD

the impedance that a typical "8-ohm" speaker presents to an amplifier is anything but flat with respect to frequency. An amplifier output is approximately a constant-voltage source, delivering, for a given input, a constant voltage across the speaker terminals. That's true regardless of the load. So if the load that the speaker presents drops from eight ohms to four ohms, the amplifier is called on to double its output power—or increase its output current by a factor of two.

Other circuitry, called "Duo-Beta," is an innovative way of applying negative feedback to its amplifier. Negative feedback is used in amplifiers to reduce nonlinearities; it can correct individual waveform distortions as well as frequency-response fluctuations. A rapidly changing signal—one having high-frequency components—can typically overdrive the input stages of an amplifier designed to operate with the gain reduction inherent in negative feedback. (Such overload is called TIM or transient intermodulation distortion.) The Duo-Beta circuitry actually provides two feedback paths. One is a low, negative-feedback loop that operates through the entire frequency range of the amplifier. The second is a high negative feedback loop that operates on signals from 5 hertz down to DC.

Designing an amplifier with adequate bandwidth before the feedback should allow high-frequencies to travel through the amplifier fast enough to avoid problems that would otherwise occur with negative feedback. (It requires an amplifier with an adequate slew rate.) If Duo-Beta helps to widen that bandwidth, improve the slew rate, and, in Luxman's words, "improve the transient response while maintaining DC balance and tight control over subsonic woofer motion—a necessity most other manufacturers overlook," then we're all for it. Our subjective tests sug-

gest that it does. But we wouldn't expect TIM to be a problem with any well-designed amplifier.

The high negative feedback at the lower end helps to improve the amplifier's damping factor, which is specified as 120 for the front stereo channels (measured at 50 Hz into 8 ohms). That gives the amplifier tight control over speaker-cone motion, theoretically increasing the accuracy of reproduction: you can think of it as something akin to the way a car's shock absorbers damp bouncing.

The RV-371 offers other techniques to improve performance. "Star Circuit" layout topology is said to "eliminate interstage and unwanted common-ground signal couplings while shortening all signal transfer paths to minimize group delay." Eliminating unwanted signal coupling is, by definition, a good thing. You wouldn't want, for example, power-supply hum to get into your audio. Group delay—the rate of change of phase of the response of the amplifier as a function of frequency—can be heard as a loss of precision in musical transients so that they are "smeared" over time. Anything done to reduce it is desirable. Keeping signal paths short is a sensible way of achieving that result. Another feature, voltage-driven amplification or VDA, is claimed to "preserve the warmth and transparency associated with great vacuum tube amplifiers."

Well, the RV-371 is a high-end component, and we suppose that that in itself gives Luxman the right to make such claims. Although you might note a hint of skepticism in some of our comments (we haven't heard any modern amplifier where TIM was an audible problem, for example, and tests whose results we believe have shown that amplifier damping is of little consequence in controlling or enhancing speaker sound). Nevertheless, the amplifier proved able to deliver very realistic



reproduction. Its ability to handle demanding musical peaks without distortion was impressive. The amplifier's *sound*, of course, depends so much on the attached speakers that we won't comment any further on its sonic quality.

The D-351 CD player also features VDA, Duo-Beta, and STAR Circuit layout topology. In addition, it contains internal trimmer potentiometers that are used to hand-calibrate the resistors for the most significant bit of the 18-bit digital-to-analog converters. The intent is to reduce crossover (or zero-cross) distortion, which can be audible.

The K-351 cassette deck also features VDA, Duo-Beta and STAR circuitry, and adds in Hexalam heads, Dolby -B and -C noise reduction, and HX-Pro headroom extension. The Hexalam heads, are said to allow for higher recording levels without saturation, and to provide lower noise and lower distortion performance. HX-Pro is a Dolby-licensed technology that permits recording high-level, high-frequency sounds cleanly and accurately without expensive metal tapes. (The results can be heard on any cassette deck, whether it's equipped with HX-Pro or not.)

The features we've mentioned—and we didn't mention them all—make up the quality portion of the equation. But what about convenience?

Luxman's System Bus allows the three components to act as an integrated system. A simple two-conductor cable (included) with subminiature phono plugs on either end ferries control signals back and forth between the system components. The result is a system of components that act in harmony. If you tire of listening to the tuner and instead want to listen to a CD, simply hit the CD selection button on the receiver's front panel. Not only will the receiver switch into the CD-amp mode, but the CD player will automatically begin to play.

The same thing happens with the cassette deck—choose TAPE 1 from the receiver's front panel, and the deck automatically enters its play mode. It's even possible to have two System Bus-equipped cassette decks in a single system;

a rear-panel switch identifies a deck as No. 1 or No. 2. Similarly, pressing the play button on either the CD player or cassette deck automatically switches the input of the amplifier to that component.

Best of all, to tune in a given station, you don't have to press the TUNER function button, and then the station-preset memory for the station you want to hear. Pressing a memory preset (20 are provided) automatically puts the receiver in its tuner mode. (Although you can scan through pre-stored stations with the remote, direct memory access is not possible.)

The CD Synchro feature makes recording compact discs onto cassette tapes easier, especially for people who normally have trouble putting their tapes together. A single press of the front-panel CD SYNCHRO button puts the cassette deck into its record mode, and starts the CD player. Although we normally don't think that CD Synchro is all too useful a feature, we did find it useful to assemble a tape from selections from various CD's. We could program the CD player to play, for example, the two tracks from the first disc in which we were interested, press CD SYNCHRO, and walk away. We knew that when we returned, the tracks would have been recorded, and the tape player would be in its stop mode. We could then repeat the process with the next disc. It turned out to be a sensible way of making tapes.

An optional accessory available for the

RV-371 is the RC-505 in-wall keypad. The keypad is intended to mount in a two-gang outlet box of the type used in electrical construction to mount two light switches. Four-wire telephone-type cable connects the keypad to the receiver. The keypad, with its 31 buttons, gives you control over source selection and operation of any System Bus-connected component. Despite the rather large number of buttons, the keypad is clear, and easy to use. In addition, it accepts signals from the system remote control; signals from other remote controls (a VCR, for example) can be passed by the keypad to another optional device, the RC-503 remote command repeater.

The one function that we found to be missing from the keypad, and also from the remote control that's supplied with the receiver, is the ability to choose which front speakers you wish to listen to. The RV-371 can support two pairs. So although it's possible to mount the keypad and a pair of in-wall speakers in your living room, and keep the rest of the gear mounted in your home theater, you can't use the keypad to switch on the living-room speakers.

The convenience features provided on the cassette deck and CD player are rather standard. We liked the ability of the K-351 cassette deck to search, for example, the fourth track on a tape. Pushing the fast-forward button three times will advance the tape three selections. The D-351 can be programmed to play a maximum of 24 tracks in any order. A random mode is also provided. A convenient "Edit Play" mode lets you select and divide CD tracks on the basis of timing. It's useful for making clean cassette tapes of a single CD. Program "30 minutes" into the player, and it will divide the tracks into two 30-minute groups for recording on a C-60 cassette.

Although we spent most of our time with the RV-371 listening to music, it's important to remember that it's an audio/video receiver with Dolby Pro-Logic capability. Video connectors are provided

(Continued on page 18)



Training includes AT-compatible computer system with hard drive and AutoSketch® CAD software!

Be today's complete drafter.

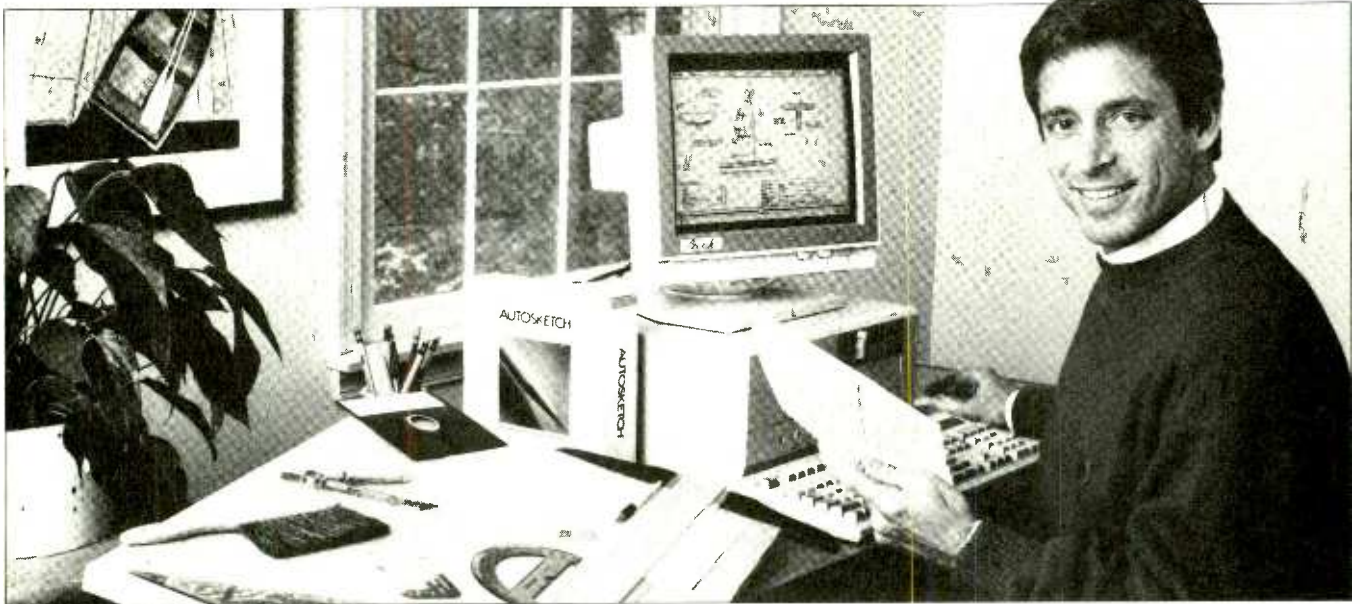

Now with NRI, you can get in on the ground floor of CAD, the new revolution in drafting!

Transforming rough sketches and calculations into accurate working drawings, drafters have always been the key link in the chain of creative people who envision, design, and build the world's products. And today, thanks to the computer revolution, a career in drafting offers more job security — and opportunity — than ever before.

It's true! People with computer-aided drafting (CAD) skills are achieving breakthrough success on design teams in all areas of business and industry. In fact, employment experts predict that manufacturers will hire some 300,000 of these computer-savvy drafters over the next decade!

Now, with NRI at-home training, you can get the hands-on skills and equipment you need for a fast start as today's *complete* drafter, equally comfortable with both manual and computer-aided drafting techniques.

Only NRI gives you an AT-compatible computer and CAD software you train with and keep

Working with a full array of drafting tools, you first master the techniques required to create detailed drawings by hand. Then, with a firm foundation in traditional methods, you move on to do the same kinds of drawings with greater speed and accuracy — using the high-powered PC and software also included with your course.

Only NRI gives you this priceless, practical experience ... with a complete computer system that's yours to train with and keep! You learn to create precision drawings using a fully IBM PC/AT-compatible system that includes a full meg of RAM, hard disk drive, high-density floppy drive, mouse, and 14" monitor. But that's just the beginning.

AutoSketch CAD software turns your computer into a high-tech drafting tool

Using your AutoSketch CAD software, you learn to draft objects with a variety of computer-generated drawing tools — from lines, arcs, and circles to fillets, ellipses, and pattern fill areas. And, once you've discovered how to draw an object, you learn how to quickly stretch it, scale it, copy it, rotate it at any angle, or change its dimensions.

You find out how fast and easy it is to manipulate your work with a single keystroke — moving or adding features such as wheels, doorways, and circuitry on your mechanical, architectural, and electrical drawings.

NRI Discovery Learning Method means no experience necessary

NRI's unique training method helps you learn by doing as you build a complete understanding of today's revolutionary drafting techniques.

Bite-size lessons expand your knowledge one step at a time while hands-on Discovery Learning projects give you practical drafting experience. You learn at home, at your own pace, guided by your personal NRI instructor from the basics of drafting to more advanced computer techniques.

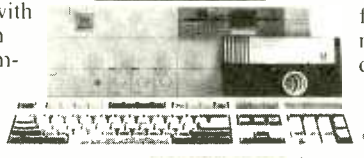

Soon you have the skills and confidence you need to draft detailed renderings of sprockets, homes,

circuit boards — indeed, virtually anything you'll be called on to produce on the job — at the drafting table or your computer terminal.

Send today for your FREE NRI catalog

Whether you want to change careers, advance on the job, or make good money in a business of your own, you can count on NRI hands-on training to give you the fast start you need to succeed. Send today for your free catalog describing NRI's new course in Computer-Aided Drafting.

If the coupon is missing, write to NRI Schools, McGraw-Hill Continuing Education Center, 4401 Connecticut Avenue, NW, Washington, DC 20008.

AutoSketch is a registered trademark of Autodesk, Inc., makers of AutoCAD®, IBM, PC, and AT are registered trademarks of IBM Corp.

Send Today For FREE Catalog!

NRI Schools

McGraw-Hill Continuing Education Center
4401 Connecticut Avenue, NW
Washington, DC 20008

- Check one FREE catalog only
- COMPUTER-AIDED DRAFTING
- Computer Programming
- Microcomputer Servicing
- Desktop Publishing and Design
- Home Inspection
- Programming in C++ with Windows

NAME (please print) AGE

ADDRESS

CITY

STATE

ZIP

18-0293

Accredited Member, National Home Study Council

CONVENIENT QUALITY

(Continued from page 14)

for switching two generic audio/video sources as well as for two VCR's, a laser-disc player, and a TV.

An on-screen display is also provided through the composite-video connectors. (The S-video connectors don't support the display.) The surround-mode display helps you set the surround mode, rear-channel delay time, master volume, and center and rear channel volume. An A/V-selector display helps you make your input and record-output selections.

Like any other Pro-Logic decoder, a test signal is available to aid in setting the proper level of each channel. Unlike most others, the RV-371 permits both automatic and manual switching of the signal.

One feature that we missed on the system was a clock. Although we realize that timer functions on audio systems are not very popular features, we find them important for unattended recording operation, and more. There were also a couple of things we found inconvenient. For example, the cassette player can be put into its pause mode, and the receiver can be muted only from the remote control.

Otherwise, we were very impressed with the convenience of the Luxman system. The quality of the components could be seen and heard—if anything it was over-designed. Even if our ears top out at less than 20 kHz, we can't argue with an amplifier whose frequency response is specified as 8 Hz–120 kHz (–1 dB)! ■

DDC PLAYER

(Continued from page 7)

standard tape-deck features are missing, most notably, a microphone input. An intro-scan function like that found on many CD players, which lets you hear a few seconds of each track, would also have been appreciated. Our biggest gripe, however, was with the difficulty we encountered learning to use the ID markers. After all, one of the biggest draws of DCC is supposed to be its ease of use. Granted, the manual could be a bit clearer. But we usually can figure out most component functions intuitively, and we are rarely stymied by even the most advanced features after studying a manual!

Of course, the DCT-2000 is one of the first models of the first generation of DCC decks, and some bugs and kinks are to be expected. We look forward to seeing future models, and to seeing DCC car decks and portable DCC players. Because if the DCT-2000 is any indication, the new format has a lot going for it. ■

Look Sharp!

LOOK POWER ZOOM BINOCULARS.
From: Copitar, 17 Renwick Avenue,
Huntington, NY 11743. Price: \$229.

Electronics has certainly changed the way we do things, and it's dramatically changed the things we buy. Everything from our kitchen ranges and dishwashers to our bedroom clock radios to our automobiles are under some sort of electronic control. We sometimes wonder whether someday *everything* will contain some electronics.

That thought was in the forefront of our mind when we received a phone call from Copitar asking us if we'd like to take a look at a new pair of electronic binoculars. How could we say no? Electronic binoculars sounded as if they'd be perfect for coverage in Gizmo! Without getting any details about the binoculars, we said we'd be happy to try them out. How, we wondered, had they turned binoculars into electronic devices?

Later that week, Copitar's Look binoculars arrived as promised. The literature touted "advanced electronically driven zoom binoculars made simple with touch-button control ... the perfect union of form and function ... [with] irresistible appeal!" The binoculars, according to the literature, "combine high technology and ease of use." Our interest piqued, we tore

open the box, installed the two "AAA" batteries, and took a look at what they did that made them electronic.

As it turns out, the Look binoculars offer a motorized zoom feature that lets you change the magnification from 7× to 15×. We were disappointed because that's all that's electronic about them. We had expected something a little more high-tech—perhaps a high-resolution digital zoom or electronic image stabilization. Despite our initial disappointment, we did want to give the binoculars a workout as we pursued our hobby of bird watching.

When purchasing binoculars, there are a few specifications that are important to understand. You'll usually find a specification something like "8×20mm." The number before the × signifies the power of magnification. If you were to view an object at a distance of 200 feet with such 8× binoculars, it would appear to be only 25 feet away. The number after the × indicates the diameter of the objective lens—which is the lens through which light enters.

The higher the magnification, the larger objects at a distance will seem. High-power binoculars are not always desirable, however. First, it's difficult to hold high-power binoculars steady. Second, it's more difficult to find what you're looking for—if you move the binoculars a quarter of an inch, you can miss your subject by several feet or more.

The diameter of the objective lens is the

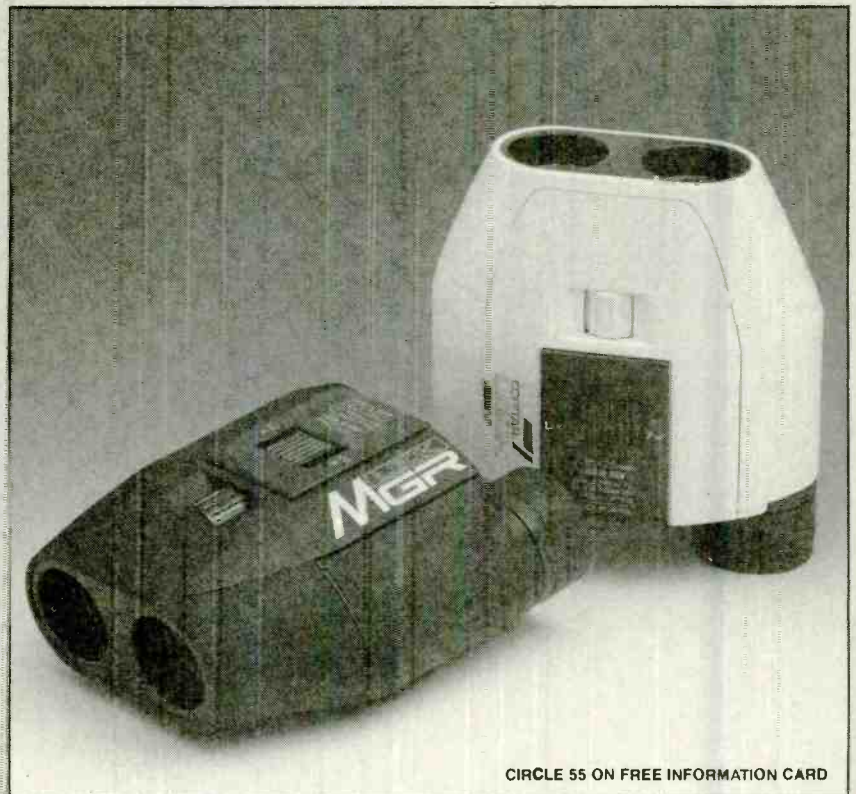

CIRCLE 55 ON FREE INFORMATION CARD

factor that determines how much light can enter the binoculars. While a small objective lens allows for compact binoculars, it also means that the low-light capability will be reduced. That's important if you are planning to watch wildlife at dusk, or in a shaded forest.

Another important binocular specification is the field of view. It's normally expressed something like "500 feet at 1000 yards." What that means is that when focused at a distance of 1000 yards, your horizontal field of view will be 500 feet wide. Sometimes the specification will also be given in degrees. Wide angle binoculars make it easier to find objects of interest.

Does the "perfect" pair of binoculars exist? Perhaps. But we've always needed two pairs for our hobby activities. One is a 10x50mm that provide good magnification and excellent low-light ability. A second pair, 8x21mm are very compact, but not ideal for low-light viewing. It is easier to sight an object using them, though.

The Look binoculars offer a 25-mm objective lens, and continuously variable magnification from 7x to 15x. They are reasonably compact and weigh just over 11 ounces. They are very sleek and come in either black or white. The zooming is controlled by a slide switch on the top of the binoculars. Slide the switch in one direction and you can zoom in on a subject. Slide the switch in the other direction and you pull back.

Despite our initial disappointment with the not-too-electronic electronic binoculars, we found the zoom feature to come in handy, mainly for sighting an object in the 7x mode, and then zooming in to get a better view. It was especially useful in siting fast-moving terns darting above the water in search of food. Although we're certainly not experts when it comes to optical components, the multi-coated lenses seemed to deliver sharp and bright images.

The field of view of the Look binoculars is 90.82 meters at 1000 (with the magnification set at 7x) and 61.11 m (at 15x). That corresponds to a range from 5.2 degrees to 3.5 degrees. In using the binoculars, we found that field of view to be a little narrow for our tastes; sighting subjects sometimes seemed difficult even at minimum magnification.

The internal lens focusing helps increase the binocular's shock resistance. That feature makes it more resistant to dirt as well.

Will electronics change the way we buy binoculars? Perhaps for some of us. The Look power-zoom binoculars seem well suited for the customers of The Sharper Image, one of the outlets through which they are available. Believe it or not, however, even though we enjoyed using the Look binoculars, and even though we usually like anything "electronic," we at Gizmo will go back to our no-battery-required models. ■

PHOTO CD

(Continued from page 12)

product category—both visually and audibly. The format is familiar to anyone who's used compact discs, and the player is a snap to use. When integrated in a home audio/video system in place of a standard CD player, the Photo CD spends very little time sitting around unused. At the moment, Photo CD players cost much more than comparably equipped compact-disc players, but prices are sure to fall as Photo CD becomes more popular.

The Photo CD format has a lot going for it. Viewing your own photos on a 27-inch television screen is a thrill that we don't think will wear off as the novelty does. And, while all those photographic prints are gathering dust in the closet, you can have digital copies safely and conveniently on hand in the entertainment center, with pictorial indexes to keep them all organized at a glance. You can even rescue old favorites, as long as the slides or negatives are available. The future promise of adding graphics, text, and sound is icing on the cake. (And any computer buffs who might be reading this should turn to the Photo CD article elsewhere in this issue of **Popular Electronics** to learn what can be done with a PC, a CD-ROM XA drive, and Kodak's Photo CD software!) Photo CD certainly has what it takes to be the next wave in photography. ■

For more information on any product in this section, circle the appropriate number on the Free Information Card.

ELECTRONICS WISH LIST

Smart Cooker

Busy folks are likely to rely on a microwave to speed food preparation, and the *Smart & Easy* microwave from *Sharp Electronics Corporation* (Sharp Plaza, Mahwah, NJ 07430-2135) makes cooking easier as well. The name says it all—you don't have to input cooking or reheating times, or even the power level. The oven makes all those choices automatically. The 900-watt *Model R-5H84* uses Electronic Sensory Processors (ESP) that allow the oven to adjust to the appropriate cooking times and power levels by measuring the amount of humidity and vapor emitted from the food as it cooks. The Sensor Defrost System allows one-touch defrosting. The oven also features raised and rounded one-touch keys for cooking popcorn, beverages, and dinner plates. For homemade soups and sauces, the Cook & Simmer feature automatically determines the time required to boil, and then reduces the power level for a simmer time. A child-safety lock allows parents to deactivate the front panel to prevent accidental misuse. The 1.6-cubic foot microwave has a 16-inch carousel. Price: \$439.95.

CIRCLE 56 ON FREE INFORMATION CARD

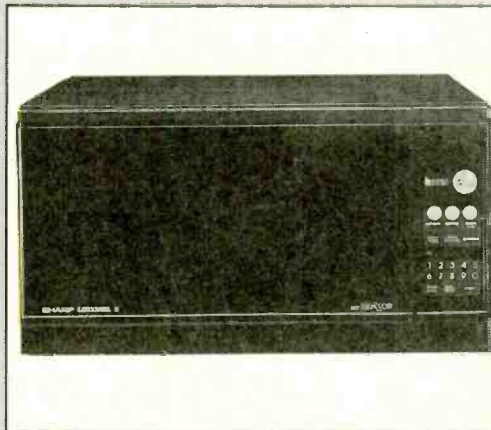

Sharp Nice & Easy Microwave Oven

ELECTRONICS WISH LIST

For more information on any product in this section, circle the appropriate number on the Free Information Card.



Phone Care Emergency Communication System

Emergency Communication System

Intended to provide peace of mind, the *Phone Care* emergency communication system from *Personal Communications Systems, Inc.* (353 Jonestown Road, Suite 114, Winston-Salem, NC 27104) is aimed at active senior citizens, people with chronic health problems, the physically challenged, post-operative patients, and anyone who lives alone and is concerned about safety and security. The system provides direct, 24-hour emergency notification to a friend, neighbor, relative, doctor, or local emergency-response center. It gives critical information, such as name, address, and medical history, and provides two-way communications through the built-in speaker phone. The remote control and speaker phone can even be used as a hands-free way to answer the phone. The Phone Care system requires no installation or monthly service fees. Its compact design allows it to be used on vacations or during extended visits. Price: \$299.

CIRCLE 57 ON FREE INFORMATION CARD



Arkon Electronic Reminder

Electronic Reminder

For all those people you know who continually leave their briefcase at the office, as well as those who want to protect their valuables from thieves, *Arkon Resources, Inc.* (11627 Clark Street, Suite 101, Arcadia, CA 91006) offers the *Electronic Reminder*. The two-piece system provides an automatic, invisible link to protect a briefcase, camcorder, cellular phone, notebook computer from loss or theft. The tiny transmitter can be attached to the briefcase or other valuable, and the receiver carried in a pocket or on a keychain. The transmitter emits a signal with a 6-10-foot target distance to the receiver. When the receiver strays beyond the target distance, it sounds a 110-dB warning beep. Both pieces feature built-in NiCd batteries that provide power for a full day's monitoring. The system can be recharged overnight in the included charger stand. Price: \$69.95.

CIRCLE 58 ON FREE INFORMATION CARD

History Lessons

History is the subject of *Headline Harry and the Great Paper Race*, a fast-paced learning game for Apple Macintosh computers from *Davidson & Associates, Inc.* (19840 Pioneer Avenue, Torrance, CA 90503). The player (aged 10 to adult) joins *Headline Harry*, ace reporter for the *U.S. Daily Star*, in investigations of story topics covering politics, sports, arts, entertainment, and science in America from 1950 through 1990. Apple QuickTime video clips enhance the experience with colorful full-motion video and realistic sounds. Video clips from the NBC News archives provide clues about the player's lead story. In four progressively difficult levels of play, players work against a deadline in their search for facts and try to scoop the *Diabolical Daily's* staff of five yellow-sheet reporters, who will write anything to sell newspapers. To file a story, the player must compile key words, names, dates, places, events, and other facts into an on-screen notebook. The program then automatically writes the story and publishes it on the front page of the *U.S. Daily Star*. Apple QuickTime is required. Price: \$59.95.

CIRCLE 59 ON FREE INFORMATION CARD



Casio Ladies Sports Watch

Splash Time

In the fitness-conscious days of the nineties, more women than ever are doing aerobics, swimming laps, jogging, power walking, and participating in various sports. Add to that the time she spends running—to and from work, after the kids, shopping, and the rest—and there's no question that she needs a watch that can keep up, not just keep time. For the "superwoman" on your list, *Casio, Inc.* (570 Mt. Pleasant Avenue, P.O. Box 7000, Dover NJ 07801) offers the *LAW-16-6EV* sports watch. It provides both analog and digital time, digital day and date, daily alarm, an hourly time signal, a stopwatch, and is water-resistant to 50 meters. Price: \$59.95.

CIRCLE 60 ON FREE INFORMATION CARD

1-800-831-4242

Your Resource for Value. Only a Phone Call Away.

ENTER YOUR KIT, AND WIN!

Send us your original electronics kit concept. If selected, we'll offer it in our catalog and you'll win \$300.

We reserve all rights for approval of entries. All entries become the property of Jameco and will not be returned.

Call Jameco for complete contest details at 1-800-831-8020.

JAMECO KITS

VOICE SCRAMBLER KIT

Transmit voice messages with complete privacy and security. The Voice Scrambler Kit converts intelligible human speech into unrecognizable garble for recording or transmitting over standard media. The descrambler mode restores the signal to fully intelligible speech. Operate with a cassette tape recorder or build a secure telephone system using a separate kit at each end of the line.

Audio Power Output: 0.5 Watts
Resolution: 8 bits (companded, Mu-Law)
Sample Rate: 8 kHz
Power Supply: +5 & -5 VDC @ 25 mA, +12 VDC @ 250 mA; (recommend power supply 2P73613- right)

Dimensions: PCB is 3.55" x 3.10" (LxW)
Part No. **Price**
 2P70519.....\$34.95



TWO-DIGIT VOLTMETER KIT

Now you can build a versatile, practical, high-performance digital panel voltmeter. Finished kits deliver ±2% accuracy at full scale. Its basic input range of 0.0 to 9.9 VDC is easily scaled for any application.



Input Impedance: 82K ohm with 9.9 VDC range
Displays: 0.3" red MAN74A type
Power Supply: +5 VDC, regulated, 100 mA; (recommend power supply 2P20360- right)
Dimensions: 4.3" x 2.2" x 1.3" (LxWxH)

Part No. **Price**
 2P70527.....\$24.95

See our Catalog for more kits

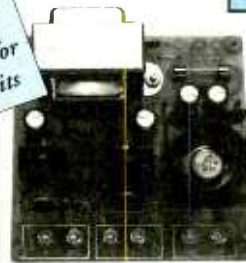

REGULATED POWER SUPPLY KITS

Build the power supply you've been needing for years. Ideal for home or instructional use. Select from three different versions. Each kit is complete with printed circuit board, electronic components, and user assembly instructions.

Part No.	Product No.	Input Voltage (VAC)	Output Voltage (VDC)	Current (mA)	Dimensions (L x W x H inches)	Price
2P20360	JE200	120	+5	1000	3.5 x 5.0 x 2.0	\$14.95
2P20626	JE215	120	+5 to +15 -5 to -15	750 to 175 750 to 175	3.5 x 5.0 x 2.0	19.95
2P73613	JE225	120	+5 fixed +3 to +12 -3 to -12	1000 100 100	5.12 x 5.12 x 2.25	29.95

EPROMS

Part No.	Product No.	Price
2P33611	TMS2716.....	\$5.95
2P39909	2708.....	4.95
2P40002	2716.....	3.95
2P40125	2732A-25.....	3.49
2P40230	2764A-20.....	3.75
2P39829	27C64-15.....	3.95
2P74688	27C64-20.....	3.75
2P39933	27128-25.....	7.75
2P39968	27128A-20.....	4.75
2P39984	27128A-25.....	3.75
2P39677	27C128-15.....	5.75
2P40037	27256-15.....	5.49
2P40061	27256-25.....	4.89
2P39714	27C256-15.....	5.95
2P39722	27C256-20.....	5.49
2P40150	27512-20.....	6.75
2P39781	27C512-15.....	6.95
2P65699	27C020-15.....	17.95
2P43692	68766-35.....	4.95

Linear ICs*

Part No.	Product No.	Price
2P33241	TL082CP.....	\$5.59
2P23579	LM317T.....	.59
2P23683	LM324N.....	.35
2P23771	LM336Z.....	1.09
2P23851	LM339N.....	.45
2P27422	NE555V.....	.29
2P24328	LM556N.....	.49
2P24467	LM723CN.....	.49
2P24539	LM741CN.....	.29
2P23131	LM1458N.....	.39
2P23157	LM1488N.....	.45
2P23181	LM1489N.....	.45
2P34278	ULN2003A.....	.69
2P24230	LM3914N.....	2.49
2P27385	NE5532.....	1.19
2P51262	7805T.....	.45
2P51334	7812T.....	.45

*Name brand IC's in stock

IC Sockets

Part No.	Product No.	Description	Price
2P51570	8LP	8-pin low profile	\$.10
2P37161	14LP	14-pin low profile	.11
2P37372	16LP	16-pin low profile	.12
2P39335	24LP	24-pin low profile	.19
2P40301	28LP	28-pin low profile	.22
2P41110	40LP	40-pin low profile	.28

Connectors

Part No.	Product No.	Description	Price
2P15114	DB25P	Male, 25-pin	\$.65
2P15157	DB25S	Female, 25-pin	.75
2P15085	DB25H	Hood	.39
2P15106	DB25MH	Metal Hood	1.35

Transistors And Diodes

Part No.	Product No.	Description	Price
2P28628	PN2222	TO-92 case	\$.12
2P28644	PN2907	TO-92 case	.12
2P35991	1N4004	DO-41 case	.10
2P38236	2N2222A	TO-18 case	.25
2P36126	1N4735	DO-41 case	.25
2P38359	2N3904	TO-92 case	.12
2P36290	1N751	DO-35 case	.15
2P38421	2N4401	TO-92 case	.15
2P36038	1N4148	DO-35 case	.07
2P38308	2N3055	TO-3 case	.69

Switches

Part No.	Product No.	Description	Price
2P21936	JMT123	SPDT, on-on (toggle)	\$.15
2P38842	206-8	SPST, 16-pin (DIP)	1.09
2P26622	MS102	SPST, momentary (push-button)	.39

*Additional components available

Memory

Part No.	Product No.	Function	Price
2P41398	41256-120	256K DIP	120ns.....\$1.69
2P42251	511000P-80	1MB DIP	80ns.....5.99
2P41523	41256A9B-80	256K SIMM	80ns.....16.95
2P41718	421000A9A-80	1MB SIPP	80ns.....54.95
2P41769	421000A9B-80	1MB SIMM	80ns.....54.95

LEDs

Part No.	Product No.	Description	Price
2P34761	XC556G	T1 3/4, (green)	\$.16
2P34796	XC556R	T1 3/4, (red)	.12
2P34825	XC556Y	T1 3/4, (yellow)	.16

Order toll-free
1-800-831-4242



Call or write for your
FREE 1993 Annual Catalog:
1-800-637-8471

JAMECO
ELECTRONIC COMPONENTS
COMPUTER PRODUCTS

1355 Shoreway Road
Belmont, CA 94002

FAX: 1-800-237-6948 (Domestic)
FAX: 415-592-2503 (International)

For International Sales, Customer Service, Credit Department and all other inquiries: Call 415-592-8097 between 7AM-5PM P.S.T.

CA Residents please add applicable sales tax.

\$30.00 Minimum Order

Terms: Prices subject to change without notice. Items subject to availability and prior sale. Complete list of terms/warranties is available upon request.

© 1993 Jameco 2/93 All trademarks are registered trademarks of their respective companies.





COLORADO MEMORY SYSTEMS JUMBO 250 TAPE BACKUP

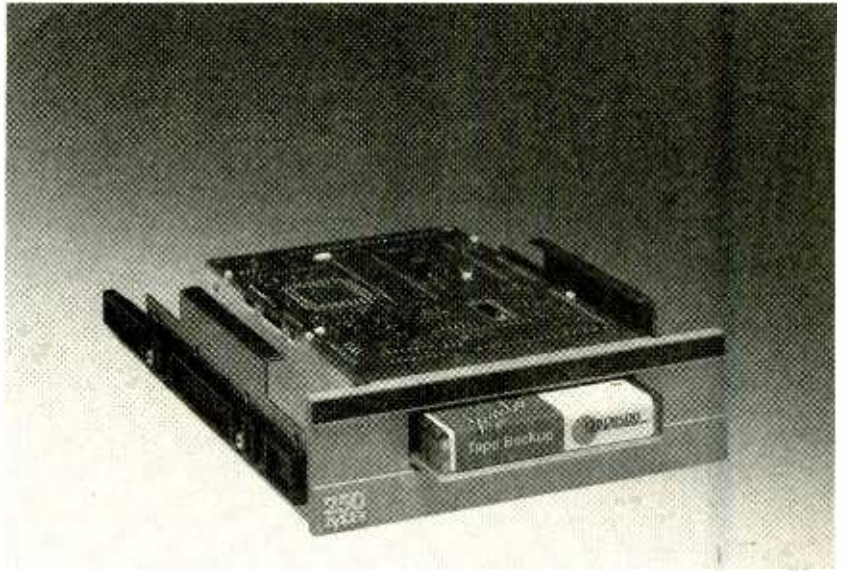

CIRCLE 119 ON FREE INFORMATION CARD

*If you don't have a tape backup for your computer yet,
then now's the time to get one.*

We'll bet that most of our readers who own a home computer don't have a tape backup for it. Sure there have been many reasons in the past not to get a tape backup, such as high prices and the temperamental nature of such backup units, however software is expensive to replace and your work might be impossible to replace.

The Colorado Memory Systems' Jumbo 250 tape backup can save you from such grief with little expense. The internal model has a suggested retail price of \$350, but sells for as little as \$250 via mail order, and can store as much as 250 megabytes on one tape cartridge. At that price and capacity, how can you go wrong? The DC 2120 tape cartridges that the unit uses sell for about \$25 in single quantities. Lots of accessories are available for the Jumbo 250, including kits that let you mount the unit externally. The kits start at \$159.95 but, again, that's the suggested list price and you can probably do better by mail. Colorado Memory Systems (800 S. Taft Avenue, Loveland, CO 80537; Tel.

303-635-8000) also makes a Jumbo 120 tape backup that stores 120 megabytes and sells for as little as \$180.

Data Loss. The most likely cause of data loss is human error. We've all inadvertently reformatted a disk, typed "N" instead of "Y," or overwritten a file at one time or another. Hard-disk failure is always a threat, although failures are less common with the newer hard-disk drives. Power loss, power spikes, fire, and theft can also cause data loss.

There are reasons other than data loss for owning a tape backup. For one, the tape cartridges provide an easy way to carry around extremely large files—quite common these days. A tape backup can also extend the usefulness of a smaller hard disk. With a tape backup, you can save all of your old data and seldom-used software on tape in case you need it in the future, and then delete it from your hard drive.

A tape backup can even help speed up a full hard disk without deleting any files. "How could it possibly

do that?" you might ask. When you have an empty hard disk, files are stored in single blocks of memory on the disk. When you ask the computer to retrieve the file, it's all in one place and the heads don't have to do much traveling across the disk. However, deleting files from your hard disk leaves empty spaces here and there. Once there's not enough room on the disk to store a file in a single block of data, the file is broken up into little pieces that are stored in the empty spaces on the disk, and a record is kept of where all the pieces are and how they go together. This *disk fragmentation* has the tendency to slow down a disk because the heads must move all around the disk and the disk may have to spin several times while it pieces together the parts of a file. When you do a backup, the files are reconstructed before being recorded on the tape. Then, if you do a restore operation, the files are put back on the hard disk whole.

There have always been alternatives to using tape backups. There's lots of software, including DOS, that lets you back up data to floppy disks.

Backing up to floppies was practical in the old days when your hard disk held only 10 or 20 megabytes and didn't require too many floppy disks. But with new systems containing 200-megabyte hard disks, backing up to floppies is impractical to say the least.

A second hard disk, although not portable, is another way of backing up your files, but hard disks that hold 250 megabytes are still a lot more expensive than the Jumbo 250. Also, the data on a second hard disk will disappear if your computer is stolen or damaged in a fire, while a tape cartridge can be stored in a safe place.

The Jumbo 250. The Jumbo 250 is a QIC-80 approved tape backup, meaning that it is certified to be compatible with the QIC-80 standard. QIC-80 is a standard that allows a tape recorded on any QIC-80 drive to be read on any other QIC-80 drive. Also, any brand of software that adheres to the QIC-80 standard can run any QIC-80 drive. QIC-80 doubles the storage capacity of its predecessor, the QIC-40 standard, by packing twice as much data on the same tape. The Jumbo 250 actually uses DC 2120 tapes formatted to 120-megabytes, and roughly doubles that to about 250 megabytes using software compression. The Jumbo 120, which is a QIC-40 drive, formats the same tape to 60 megabytes and doubles it to 120 with compression.

We installed the Jumbo 250 in a Gateway 2000 486DX2/50 computer in a vacant half-height bay. The tape drive is installed in the same way as a floppy drive, and is connected to the floppy controller with an included adapter cable. A spare power connector inside the computer plugs into the back of the tape drive. When the mechanical installation is complete, it's time to install the software.

The software installs in a snap after asking you some very basic questions such as what drive to install the software on and whether or not you have a color monitor. The software can even be installed from Windows, and run from its own icon. Colorado recommends that you not use the Windows option if you are running Norton Desktop For Windows.

Note that at the time of this writing, the software was not a true Windows program in that it goes out to DOS

when it runs. The feature is mainly for computer "greenhorns" who are more familiar with Windows than DOS. Besides, it's best to back up in a non-multitasking environment like DOS because open files can't be backed up. And an operating system like Windows usually has several files open at once. Even so, Colorado Memory Systems hopes to be able to include true Windows software with the Jumbo 250 by the time you read this. The present software is compatible with Novell, Netware, and 3Com networks.

During installation, you will have to select either the "unattended backup facility," which will automatically run a backup procedure at specified intervals, or normal (manual) backup. Because the computer we installed the Jumbo 250 in isn't powered up at specified intervals, we decided not to use the feature. When our software installation was complete, the computer let us know that the operation was successful. We were finally ready to do a backup.

There are three backup options: selective, total, and modified files only. A selective backup lets you pick and choose which files and directories should be backed up. A total backup backs up everything. A modified-files-only backup will only back up files that have been modified (written to disk) since the last backup. Because this was our first backup, we decided to do a total backup.

We had the option of adding password protection to the backup tape, but chose not to. Next we had to choose between no compression (120MB on one tape), optimize-space compression (about 250MB on one tape), or optimize-time compression (something less than 250MB but more than 120MB, depending on what you are backing up). We chose to optimize space, which would take the most time.

Our hard disk had about 150 megabytes on it, which took roughly 40 minutes to back up. To be fair, though, we did it on one of the fastest PC's you can buy, so it may take longer to back up the same amount of data on a slower machine. The screen kept us informed as to the progress of the backup, while continually adjusting its predictions as to how much longer it would take.

The same types of operations avail-

able to backup operations are available to restore operations. For example, you can restore a single file, a group of files, a single directory, or an entire disk. There is a suitable restore operation to cure just about every conceivable type of blunder.

Although we had no problems with the Jumbo 250, we did have some questions that needed to be answered for our review, so we called Colorado's technical support department. They were extremely helpful, knowledgeable, and courteous. Concerning the Jumbo 250, as well as Colorado Memory Systems, we have absolutely nothing to complain about.

If disaster ever strikes us, we're ready for it with our Jumbo 250 tape backup. If you have a hard disk of considerable size holding lots of valuable data, you should back it up soon before disaster strikes. For more information on the unit contact Colorado Memory Systems directly, or circle No. 119 on the Free Information Card in this issue. ■



Be an FCC LICENSED ELECTRONIC TECHNICIAN!

Earn up to \$30 an hour and more!

Learn at home in spare time. No previous experience needed!

No costly school. No commuting to class. The Original Home-Study course prepares you for the "FCC Commercial Radiotelephone License." This valuable license is your professional "ticket" to thousands of exciting jobs in Communications, Radio-TV, Microwave, Maritime, Radar, Avionics and more...even start your own business! You don't need a college degree to qualify, but you do need an FCC License.

No Need to Quit Your Job or Go To School This proven course is easy, fast and low cost! **GUARANTEED PASS**—You get your FCC License or money refunded. **Send for FREE facts now. MAIL COUPON TODAY!**

COMMAND PRODUCTIONS
FCC LICENSE TRAINING, Dept. 100
P.O. Box 2824, San Francisco, CA 94126
Please rush FREE details immediately!

NAME _____
ADDRESS _____
CITY _____ STATE _____ ZIP _____

PRODUCT TEST REPORTS

By Len Feldman

JVC HR-DX42 Video-Cassette Recorder



The JVC HR-DX42 four-head VCR is a moderately sophisticated unit that, among other things, offers on-screen menus.

What appears at first to be a fairly basic, 4-head video-cassette recorder is, in fact, a moderately sophisticated unit that offers such features as on-screen menus for ease of use. In addition to the more common functions, the on-screen menus are used for such things as selecting between broadcast and cable channel frequencies, memorizing channels, selecting AFC, setting the time and date, and even selecting the language of the displays (users can select either English or Spanish).

Other important features include digital tracking, a full-function TV/VCR unified remote control, a 181-channel cable-compatible frequency-synthesized tuner, 8-event programming (over a full one-year period), instant timer recording, fast shuttle search, and a counter memory function. Additional automatic features include an

auto-reset real-time tape counter, auto power-on (when a tape is inserted), auto play, auto rewind, and automatic power-off/eject. Also notable is a pair of front-panel audio/video connectors. These enable quick connection of a second video deck or a camcorder for dubbing without having to go around to the back of the unit. Those frequently used connectors are gold plated to prevent oxidation.

Although this is a mono unit, the VCR is equipped with dual audio-output jacks for connection to a stereo TV or a hi-fi audio system (of course, the sound will still be monophonic). A built-in head cleaner automatically cleans the video heads and head drum each time you load or eject a tape. And speaking of video heads, this VCR has four of them in a double-azimuth system that provides noiseless still-frame and slow-motion viewing.

CONTROLS

JVC has kept the number of front-panel controls on the HR-DX42 to a minimum. Besides the usual power on/off button there are fast-forward, rewind, play, and stop/eject buttons. Smaller buttons initiate the on-screen menu modes, start the recording function, and step up or down through the TV channels. The previously mentioned audio and video jacks are found at the lower-right corner of

the front panel, while an easy-to-read display occupies much of the width of the panel, just below the tape slot.

The rear panel of this VCR is equipped with the usual F-type connectors for hooking up an antenna or a CATV cable lead, and for the connection between the VCR and a TV monitor or receiver (a cable is supplied for that interconnection). Also found on the rear panel are video/audio input and output jacks and a Channel 3/4 RF-output selector switch.

The supplied remote control has buttons that duplicate all the control functions found on the front panel. In addition, there are volume, tape-speed (SP/EP), and TV/video selection buttons; numeric buttons for direct channel access; and all the buttons necessary for working with the on-screen menus, programming the timer, and selecting timer operation.

We found that operating the VCR with the remote was actually easier than trying to operate it using the front-panel controls. This mode of operation was also more convenient, since it enabled us to sit comfortably across the room from the VCR and its associated TV monitor.

TEST RESULTS

All of the recordings and measurements made by APEL for this test report were made at the SP tape speed. Under those condi-

Graduate as a Fully Trained Electronics Professional!

If you want to learn about electronics, and earn a good income with that knowledge, then CIE is the best educational value you can receive.

CIE's reputation as the world leader in home study electronics is based solely on the success of our graduates. And we've earned our reputation with an unconditional commitment to provide our students with the very best electronics training.

Just ask any of the 150,000-plus graduates of the Cleveland Institute of Electronics who are working in high-paying positions with aerospace, computer, medical, automotive and communications firms throughout the world.

They'll tell you success didn't come easy...but it did come...thanks to their CIE training. And today, a career in electronics offers more rewards than ever before.

CIE'S COMMITTED TO BEING THE BEST...IN ONE AREA...ELECTRONICS.

CIE isn't another be-everything-to-everyone school. CIE teaches only one subject and we believe we're the best at what we do. Also, CIE is accredited by the National Home Study Council. And with more than 1,000 graduates each year, we're the

largest home study school specializing exclusively in electronics. CIE has been training career-minded students like yourself for nearly sixty years and we're the best at our subject...ELECTRONICS...BECAUSE IT'S THE ONLY SUBJECT WE TEACH!

CIE PROVIDES A LEARNING METHOD SO GOOD IT'S PATENTED.

CIE's AUTO-PROGRAMMED® lessons are a proven learning method for building valuable electronics career skills. Each lesson is designed to take you step-by-step and principle-by-principle. And while all of CIE lessons are designed for independent study, CIE's instructors are personally available to assist you with just a toll free call. The result is practical training... the kind of experience you can put to work in today's marketplace.

LEARN BY DOING..WITH STATE-OF-THE-ART EQUIPMENT AND TRAINING.

CIE pioneered the first Electronics Laboratory Course and the first Microprocessor Course. Today, no other home study school can match CIE's state-of-the-art equipment and

training. And all your laboratory equipment, books and lessons are included in your tuition. It's all yours to use while you study and for on-the-job after you graduate.

PERSONALIZED TRAINING...TO MATCH YOUR BACKGROUND.

While some of our students have a working knowledge of electronics others are just starting out. That's why CIE has developed twelve career courses and an A.A.S. Degree program to choose from. So, even if you're not sure which electronics career is best for you, CIE can get you started with core lessons applicable to all areas in electronics. And every CIE Course earns credit towards the completion of your Associate in Applied Science Degree. So you can work toward your degree in stages or as fast as you wish. In fact, CIE is the only school that actually rewards you for fast study, which can save you money.

SEND FOR YOUR CIE COURSE CATALOG AND WE'LL SEND YOU A FREE 24-PAGE CIE ELECTRONIC SYMBOLS HANDBOOK.

FREE!

SEND FOR YOUR CIE HOME STUDY COURSE CATALOG AND RECEIVE A FREE 24 PAGE CIE ELECTRONIC SYMBOLS HANDBOOK!

Includes hundreds of the most frequently used electronic symbols. Published exclusively by CIE for our students and alumni. Yours free when you request a CIE Course Catalog.

electronics



YES! I want to get started. Send me my CIE course catalog including details about the Associate Degree Program. (For your convenience, CIE will have a representative contact you - there is no obligation.)

AH37

Please print clearly

Name _____

Address _____

City _____ State _____

Zip _____ Age _____

Phone No. (____) _____

Check box for G.I. Bill Benefits

Veteran Active Duty



1776 East 17th Street
Cleveland, Ohio 44114

*A School of Thousands.
A Class of One. Since 1934.*

DIGITAL VIDEO STABILIZER ELIMINATES ALL VIDEO COPYGUARDS



While watching rental movies, you will notice annoying periodic color darkening, color shift, unwanted lines, flashing or jagged edges. This is caused by the copy protection jamming signals embedded in the video tape, such as Macrovision copy protection. THE DIGITAL VIDEO STABILIZER: RXII COMPLETELY ELIMINATES ALL COPY PROTECTIONS AND JAMMING SIGNALS AND BRINGS YOU CRYSTAL CLEAR PICTURES.

WARNING

THE DIGITAL VIDEO STABILIZER IS INTENDED FOR PRIVATE HOME USE ONLY. IT IS NOT INTENDED TO COPY RENTAL MOVIES OR COPYRIGHTED VIDEO TAPES THAT MAY CONSTITUTE COPYRIGHT INFRINGEMENT.

FEATURES

- Easy to use and a snap to install
- State-of-the-art Microchip technology
- 100% automatic
- Compatible to all types of VCRs and TVs
- The best and most exciting Video Stabilizer in the market
- Light weight (8 ounces) and compact (1x3.5x5")
- Uses a standard 9 Volt battery (last 1-2 years)
- Fast UPS delivery
- Air shipping available
- UNCONDITIONAL 30 day money back guarantee
- 1 year warranty

(Dealers Welcome)
FREE 20P Catalog

To Order: \$59.95 ea + \$5 for p & h
Visa, M/C, COD Mon-Fri: 9-6 EST
1-800-445-9285
ZENTEK CORP. DEPT. CPE293
3670-12 WEST OCEANSIDE RD. OCEANSIDE, NY 11572

CIRCLE 11 ON FREE INFORMATION CARD

CABLE TV DESCRAMBLERS How You Can Save Money on Cable Rental Fees Bullet Proof

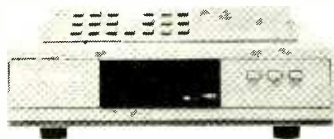

1 Unit 5+

BEST Super Tri-Bi Auto/
Var. Gain Adjustment \$119.95...\$85
Jerrold Super Tri-Bi... \$109.95...\$79
Scientific Atlanta \$109.....\$79
Pioneer \$109.....\$79
Panasonic TZPC145... \$99.95...\$79
Stargate Converter..... \$95.....\$69
Digital Video Stabilizer. \$59.95...\$29
Wireless Video Sender..\$59.95...\$49.95

**US Cable'll Beat
Anyone's Price
Advertised in
this Magazine!**

30 Day Money Back Guarantee
FREE 20 page Catalog

Visa, M/C, COD or send money order to:
U.S. Cable TV Inc. Dept. KPE293
4100 N. Powerline Rd., Bldg. F-4
Pompano Beach, FL 33073

1-800-772-6244

For Our Record

I, the undersigned, do hereby declare under penalty of perjury that all products purchased, now and in the future, will only be used on Cable TV systems with proper authorization from local officials or cable company officials in accordance with all applicable federal and state laws. FEDERAL AND VARIOUS STATE LAWS PROVIDE FOR SUBSTANTIAL CRIMINAL AND CIVIL PENALTIES FOR UNAUTHORIZED USE.

Date: _____

Signed: _____

No Florida Sales!

CIRCLE 12 ON FREE INFORMATION CARD

tions, the video frequency response was better than average for VCR's in this price category, exhibiting an attenuation of only -0.98 dB at 2.0 MHz. The luminance signal-to-noise ratio ranged from 41.7 dB to 42.1 dB, depending upon the reference luminance level used by APEL to make the measurement. The chroma (color) AM signal-to-noise ratio measured 43.2 dB, while the chroma PM signal-to-noise ratio was an acceptable 41.7 dB.

stereo receivers. Backing off by -10 dB, distortion decreased to 0.67% for a 1-kHz test signal. The audio signal-to-noise ratio measured 51.2 dB, which is just about average for the audio section of a VCR that uses edge-track audio recording. About the only thing we might criticize concerning the audio performance of this VCR would be its rather high level of wow-and-flutter, which measured an average of 0.38% with peak readings

TEST RESULTS—JVC HR-DX42 VCR

Specification	Video Section	PE Measured
Frequency response		-0.98 db @ 2.0 MHz
Signal-to-noise ratio		
Luminance level		
100 IRE		42.1 dB
50 IRE		42.0 dB
10 IRE		41.7 dB
Chroma AM		43.2 dB
Chroma PM		41.7 dB
	Audio Section	
Output at 0 db (1 kHz)		0.54 volts
THD at 0 db (1 kHz)		2.84%
Flutter		
Average		0.38%
Peak		0.42%
Signal-to-noise ratio		51.2 dB
Frequency response (-3 dB)		110 Hz to 12.0 kHz
Record/play THD @ -10 dB		0.67%
	Additional Data	
Power requirements		14.0 watts
Weight		9.5 lbs.
Fast-forward time (T-120 tape)		4 min. 43 sec.
Fast-rewind time (T-120 tape)		4 min. 58 sec.
Dimensions (H x W x D, inches)		3½ x 14¾ x 12
Suggested price:		\$349.95

As for the audio performance of this VCR, frequency response extended from 110 Hz to 12 kHz for the -3 dB roll-off points. We regard this as being better than average for a VCR that uses conventional edge-track audio recording (as opposed to hi-fi recording). At a 0-dB reference level, audio output measured 0.54 volts at 2.84% total harmonic distortion. That output level is more than enough to drive the high-level inputs of stereo amplifiers or integrated

of 0.42%. When listening to sustained musical tones, this amount of wow-and-flutter is audible, though it caused no problems with spoken dialog or rapidly changing musical material. Additional data, as measured by APEL, can be found in the Test Results table that is elsewhere in this report.

HANDS-ON TESTS

We recorded several programs using this VCR; in addition, we made some "live" recordings by connecting our camcorder to

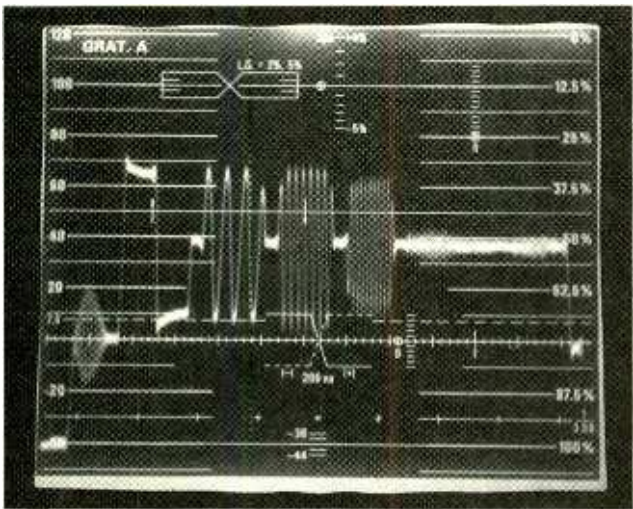

With an attenuation of only -0.98 dB at 2.0 MHz, the video frequency response at the SP tape speed was better than average for a VCR in this price category.

the front panel audio and video inputs. We should mention that when a video/ audio program source is connected to the front-panel jacks, the rear panel audio and video jacks are disconnected. That posed no problem during our hands-on tests, but users should be aware of this arrangement.

We were particularly pleased with the on-screen menu system offered by this relatively low-cost VCR. Considering the number of comedian's jokes that have been leveled at people who seem unable to program a VCR (let alone set the clock so that it stops flashing "12:00, 12:00, 12:00 . . ."), we found it easy to program and initialize the VCR thanks to the easy to follow on-screen menu selections. As a youngster of

our acquaintance has put it, "even an adult can figure it out."

We were impressed by the small size of this unit, as well as by its many features. It should fit nicely where other VCR's might not. Still picture and slow-motion playback were virtually noise-free, as claimed, and that was true for both the SP and the EP tape speeds. All things considered, JVC has managed to incorporate more features and better performance than one would normally expect to find in a VCR whose suggested retail price is only \$349.95.

For more information on the JVC HR-DX42 VCR, contact the manufacturer (JVC, 41 Slater Dr., Elmwood Park, NJ 07407) directly, or circle no. 120 on the Free Information Card.

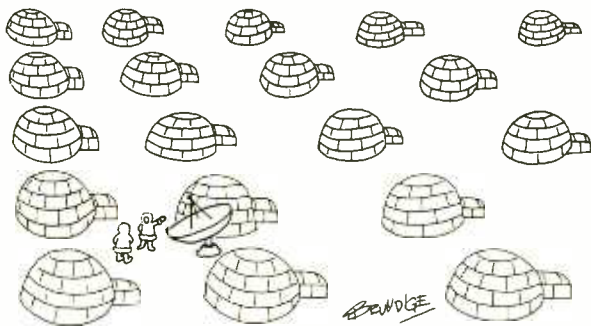

"My new antenna doesn't work that well—I'm getting a lot of snow"

Learn VCR repair at home!

MAKE GOOD MONEY IN YOUR OWN FULL- OR PART-TIME JOB



Professional-level home study course. You will master easy-to-learn, high-profit repairs *without* investing in high-tech instruments or a costly workshop. Want more independence and higher income? Send or call today!

**Free career kit:
800-223-4542**

Name _____
Address _____
City _____ State _____ Zip _____

The School of VCR Repair
2245 Perimeter Park Drive
Dept. VB341 Atlanta, Georgia 30341

CIRCLE 6 ON FREE INFORMATION CARD

SUPER 12 HOUR RECORDER CALL TOLL FREE



Modified Panasonic Slimline. 6 hrs per side.
120 TDK tape furnished.
AC/DC Operation.
Quality Playback.
Digital Counter.
Durable Lightweight Plastic.

\$119.00*

PHONE RECORDING ADAPTER

Starts & Stops Recorder Automatically When Hand Set is Used.
Solid State!



\$28.50*

VOX VOICE ACTIVATED CONTROL

Solidstate Adjustable Sensitivity. Voices & Sounds Activate Recorder. Adjustable Sensitivity. Provisions for Remote Mike.



\$28.50*

*Add for ship. & handling. Phone Adapter & Vox \$2.00 each. Recorders \$5.00 each. Colo. Res. add tax. Mail Order, VISA, M/C, COD's OK. Money Back Guar. Qty. Disc. available. Dealer inquiries invited. Free data on other products.

ALL MAIL TO: Box 20100, Boulder, CO 80308
AMC SALES INC., 193 Vaquero Dr.,
Boulder, CO 80303
Phones (303) 499-5405 • 1-800-926-2488
FAX (303) 494-4924 • Mon-Fri 8-5 MTN. TIME

CIRCLE 8 ON FREE INFORMATION CARD

Enter A World Of Excitement with a Subscription to

Popular Electronics®

Get the latest electronic technology and information monthly!

Now you can subscribe to the magazine that plugs you into the exciting world of electronics. With every issue of Popular Electronics you'll find a wide variety of electronics projects you can build and enjoy.

Popular Electronics brings you informative new product and literature listings, feature articles on test equipment and tools—all designed to keep you tuned in to the latest developments in electronics. So if you love to build fascinating electronics, just fill out the subscription form below to subscribe to Popular Electronics... It's a power-house of fun for the electronics enthusiast.

EXCITING MONTHLY FEATURES LIKE:

- CONSTRUCTION**—Building projects from crystal sets to electronic roulette
- FEATURES**—Educational training on digital electronics, Ohm's Law, Antennas, Communications, Antique Radio, Simplified Theory
- HANDS-ON-REPORTS**—User test comments on new and unusual consumer products
- SPECIAL COLUMNS**—Think Tank, Circuit Circus, Computer Bits, DX Listening, Antique Radio, Amateur, Scanner Scene

PLUS: ALL OUR GREAT DEPARTMENTS!

You'll get 12 exciting and informative issues of Popular Electronics for only \$18.95. That's a savings of \$23.05 off the regular single copy price. Subscribe to Popular Electronics today! Just fill out the subscription order form below.

CREATE A HIGH-VOLTAGE MINIATURE TORNADO
MAY 1992
Popular Electronics

NEW GEAR COMING AT YOU
Get your first look at wide-screen TV's, recordable video-discs, "full-motion" picturephones, "shock-proof" CD players, and the rest of the new generation of high-tech electronic products

POP UP OUTDOOR LIGHTS
Build a walkway lighting system that ducks out of your way for mowing and other gardening chores

WIRE BEAMS: GAIN ON THE CHEAP
These antenna designs work where others fail

BUILD YOUR OWN HIGH-VOLTAGE CAPACITORS
Can't find or afford that special capacitor for your Tesla coil or other high-voltage project? Then build your own using our easy-to-duplicate, low-cost designs

Product Reviews

- Sansui A-V Amplifier
- Memorex Extended-Play Personal Stereo
- Plug 'N Power Computer Interface
- Zenith 27-inch Surround-Sound TV
- And More

Save **55%**
Off The Regular
NEWSSTAND
Rate

FOR FASTER SERVICE CALL TODAY

1-800-827-0383

(7:30AM-8:30PM)
EASTERN STANDARD TIME

Popular Electronics® SUBSCRIPTION ORDER FORM

APEB3

P.O. Box 338, Mt. Morris IL. 61054

YES! I want to subscribe to Popular Electronics for 1 Full year (12 Issues) for only \$18.95. That's a savings of \$23.05 off the newstand price.

(Basic Subscription Rate—1 yr/\$21.95)

Payment Enclosed Bill me later

Please charge my: Visa Mastercard

Acct. #

Signature _____

Exp. Date _____

PLEASE PRINT BELOW:

NAME _____

ADDRESS _____

CITY _____

STATE _____

ZIP _____

Allow 6 to 8 weeks for delivery of first issue. U.S. Funds only.

In Canada add \$6.98 Postage (Includes G.S.T.) All Other Foreign add \$7.50 Postage



ALL ABOUT PHOTO CD

Photographic film enters the digital era with Kodak's new compact-disc format.

BY BRIAN FENTON

Kodak is calling its new Photo CD format "The future of memories." We prefer to think of it as the marriage of film and digital photography. Not only does Photo CD give consumers an interesting new format for viewing their photographs, it promises to open up a brand new era of desktop publishing.

By the time this report hits the newsstands, most consumers will have a pretty good handle on the basics of Photo CD—Kodak promises to let everyone know through a pre-Christmas advertising campaign. We'll review the basics here. Then we'll talk about

some of the lesser-known benefits of Photo CD and the technical details behind the new format.

What is Photo CD? Photo CD is a system that digitizes photographic images and stores them on a write-once compact disc. The images are then played back by the consumer on his Photo CD player, which is hooked up to a video monitor or television set for display.

Kodak is the only manufacturer currently making Photo CD players (which also play back audio CD's). But CD-I (compact disc-interactive) play-

ers, such as those from Philips, can also play back Photo CD discs, and Kodak is encouraging other manufacturers to make hardware supporting the Photo CD format. Computers with CD-ROM XA drives and the right software can also access the images; we'll look at that in detail later in the article.

For consumers, Photo CD is a reasonably simple process. You take 35-mm pictures the way you always have, using the same 35-mm silver-halide film that Kodak invented, makes, processes, and sells. And when when you bring the film in for

processing, you still get your prints and negatives returned. But if you request Photo-CD processing, you also get back a compact disc.

The standard Photo-CD disc, known as a Photo CD Master disc, looks similar to an audio compact disc. But instead of being silver-colored, it's golden. And instead of the liner notes that normally accompany an audio disc, there's a photographic index print that shows as many as 40 thumbnail images of the disc's contents. Up to 100 35-mm images can fit on a disc; when you develop another roll of film, you can bring your disc back and have the new images added. You can even have old pictures added from slides or negatives. When you bring the disc home, you pop it into your Photo CD player and enjoy watching the still images on your TV.

Photo-CD players will let you program the order in which the images are displayed, and even alter their size, orientation, and cropping. For a detailed look at what the first generation of Photo CD players from Kodak can do, turn to GIZMO* (that section begins on page 5) for a review of their PCD-870. Undoubtedly, as the format becomes more popular, Photo CD players with even more features will become available.

If you want to get prints made of the images on a Photo CD Master disc, just bring the disc back to your pro-

cessor—you don't need the original negatives. Kodak claims that there will be no loss of resolution. As far as we can tell from the prints that we've seen, there isn't; with enlargement, the grain of the film becomes visible before any pixelization does.

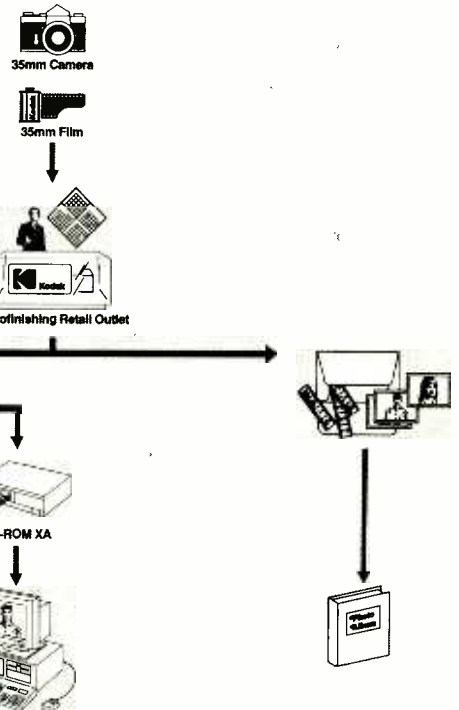

The Photo CD process starts with standard photo developing. The customer gets his prints and negatives and a Photo CD optical disc, which can be played back on a Photo-CD player, a CD-I player, or on a computer equipped with a CD-ROM XA drive.

What's on the disc? A Photo CD Master disc actually stores much more than 100 images. That's because each image is stored in 5 different resolutions. The minimum-resolution images, which are used for the thumbnail index prints, are stored with a 192 x 192-pixel resolution. The base video images (those that appear on your TV screen) are 768 x 512. To ensure that the system will work with high-definition TV, a 4Base (4 times the resolution of the base) image with a resolution of 1536 x 1024 is provided. A 16Base image (3072 x 2048) is provided for high-quality digital printing. A 384 x 256 resolution—half that of the base video resolution—is also on disc.

Why is it necessary to store so many different resolutions on a Photo CD Master disc? Strictly speaking, it's not necessary at all. Kodak could have chosen to store only the highest resolution, and thus gain space for more images per disc. Sometimes, however, a lower-resolution image is better. Let's take the example of viewing a picture on a TV. If a Photo CD player had to import the highest-resolution image, it would need 16 times the processing power to handle the images



Even before Photo CD hit the streets, Kodak announced four new enhancements to the format: Pro Master discs permit large-format image storage. Portfolio discs allow the addition of sound and graphics. Medical discs provide medical-image storage, and Catalog discs can store up to 8000 low-resolution pictures.

with the same speed—and you wouldn't gain any noticeable video quality. The difference is even more important for desktop-publishing applications where processing time is expensive. If you need to reproduce a small picture, you can get by with lower-resolution images without compromising the visual quality.

What the Processor Does. At the introduction of Photo CD, (late summer, 1992) there were more than a dozen photofinishers that could create Photo CD Master discs. Kodak claimed that by the end of 1992, they expected nearly 90 percent of all photofinishing drop-off points to offer the transfer from film to Photo CD. They wouldn't necessarily offer it in-house, however.

Any photofinisher who wants to supply in-house Photo CD capability will need—in addition to standard film-processing equipment—at least five additional pieces of equipment. First is a Kodak film scanner that digitizes 35-mm color or black-and-white negatives or slides at "full photographic resolution." The result for a 35-mm slide—which measures about 35 × 22 mm, an area less than two square inches—is an 18-megabyte file.

The scanned image is sent to a Kodak PCD Data Manager S200 (which is a specially adapted Sun SPARCstation computer) where color correction and density correction are performed. The image is then compressed according to an algorithm proprietary to Kodak; the resulting file is about 4.5 megabytes. Some proprietary Kodak hardware is also contained in the S200.

The SPARCstation outputs to an index printer that produces the thumbnail index prints. Data is also fed to a Photo CD disc writer that is made by Philips. The disc writer records the pictures on a write-once CD, which is then given to the customer. The customer picks up his prints and negatives as usual, along with the Photo CD Master disc.

The fifth piece of equipment that photofinishers will require is a PC equipped with a CD-ROM-XA drive for additional processing.

New Photo CD Formats. Even before Photo CD was introduced to the

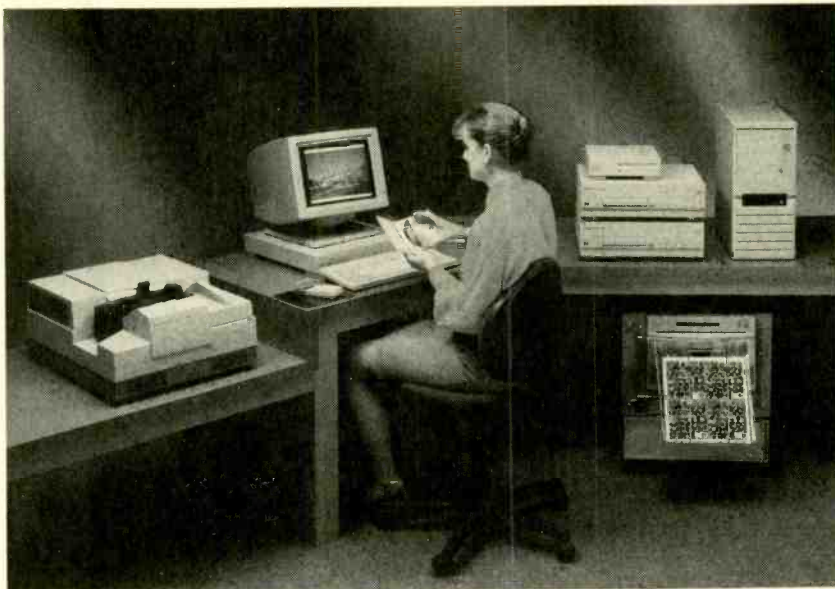

One of Kodak's imaging workstations is shown here. The 35-mm film scanner is at the left. Two Photo-CD disc writers and a CD-ROM XA drive are stacked to the right of the system operator. A thermal printer sits on the floor.

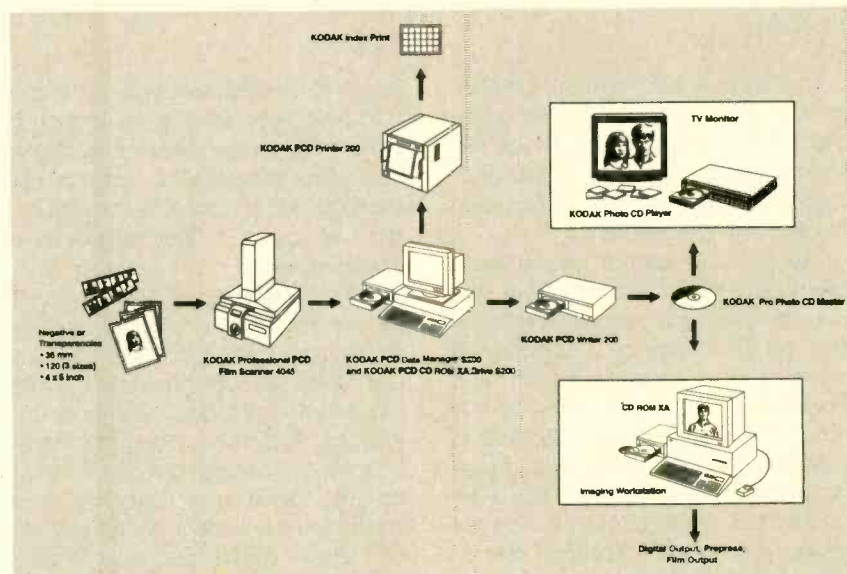

The photofinisher scans negatives or transparencies and imports the files to an imaging workstation. The workstation outputs to a thermal printer and a Photo CD optical disc writer.

public, Kodak was hard at work developing new uses. Beginning later this year, Kodak processors will be able to produce more than just Photo CD Master discs. One new disc type is the Kodak Pro Photo CD Master. The difference is that while the regular Master disc can store only 35-mm images, the Pro Master will be able to store photographs taken on a variety of film sizes. That includes the 120, 70-mm, and 4 × 5-inch formats that are favored by professional photographers. (Most Popular Electronics cover photographs are taken

in the 4 × 5-inch format.) Although the Photo-CD format will support even larger formats, including 8 × 10 inch images, Kodak's current scanners cannot.

In addition to being able to handle "professional" formats, the new discs can include copyright identifiers, watermarks, and encryption. That will help professionals protect their on-disc images against unauthorized use. The disc's capacity depends on the types of images it contains. If all the images are in the 35-mm format, the capacity remains at 100.



One of the most important benefits of Photo CD is the ability to import photographs into personal computers. CorelDraw is the first graphics software package to support the format.

Another new disc format is the Photo CD Portfolio. The Portfolio disc is created from either a Master or Pro Master disc. In addition to the photographs, text, graphics, audio, and "branching" are possible.

The Portfolio format allows for a great amount of creativity. One simple example is a slide show of a vacation trip with voice-over narration. A more creative example might be a Portfolio family tree, where the branching feature could be used to navigate the tree. Audio from those family members who were still living could be included to create a disc of lasting memories. A Portfolio disc of your family might let you move through, for example, all the birthday photographs, year by year, of one or the other of your children. Portfolio discs are also expected to be used for business presentations, and perhaps in informational kiosk applications.

Who will create these Portfolio discs? Consumers will, with help from photofinishers. Kodak envisions minilabs equipped with authoring software that will enable customers to assemble their presentations from their Master or Pro Master discs and audio selections. Portfolio discs can contain full-resolution photographs. The higher the image resolution, however, the less audio and graphics can be included, so lower-resolution stor-

age is an available option. (If the disc is to be used strictly for viewing on TV, storing higher resolution doesn't give you better images.) The capacity of a Portfolio disc is up to 800 images or 1 hour of sound, or any proportional combination.

Yet another type of new Photo CD format is called the Catalog disc, which can hold as many as 6000 images. On-disc software, called Kodak Browser, is used to branch through the images. A clothing company could create a Catalog disc that would contain sections for children's shoes and men's sweaters. More specific branching could lead you to photographs of women's purple winter hats.

That sort of specific branching might be even more important for other applications. A magazine art director looking for a photograph of an African-American couple on a beach with a sunset in the background might be able to automatically find selections from a stock photo catalog.

The final new format announced by Kodak is Photo CD Medical. The Medical discs can store film-based medical photographs, and such digital diagnostic images as CT (computerized tomography) scans or MR (magnetic-resonance) images. In the future, it may be possible to store such data as patient reports as well.

One important feature to remember is that all Photo CD discs, regardless of the particular format—Master, Pro Master, Portfolio, Catalog, or Medical—can be displayed on a monitor or TV with a Photo CD player or on a computer equipped with a CD-ROM-XA drive.

Photos and the PC. The potential computer applications of Photo CD are the most exciting part of the new format. Handling photographic images on desktop-publishing equipment has always posed problems. We've tried digital cameras for computers; in general, they just don't provide high enough quality for serious applications.

Of course, scanners can digitize standard photographs for computer input. For many desktop uses—company newsletters, advertising fliers, church bulletins, and the like—the current crop of desktop scanners are adequate. But for professional applications, scanners have always been expensive.

But not any more!

It's expected to cost about \$20 to put a roll of 24 35-mm pictures onto a Photo CD. While 35-mm images might not be considered acceptable to the most critical users, Photo CD certainly brings the promise of professional quality photographic publishing to the desktop level.

The main component required for access to Photo CD images is a CD-ROM XA drive. There are some XA drives on the market now from Sony, Philips, and NEC. Expect more to follow. For example, as this was being written, Sony announced a new XA-compatible drive for consumer applications, the model CDU31A, at a suggested list price of \$499.95.

The main reasons an XA drive is necessary is because Photo CD's are written in multiple sessions—once each time a roll of film is added to a disc. When CD's were developed, there wasn't any thought that the format could be made recordable; by definition, it was a write-once medium. The CD format requires that the end of the disc is expressly defined on the disc. (Note that if you take a directory of a CD-ROM, your computer will report that there is no room left on the disc—regardless of how much data it

(Continued on page 97)



Build intelligence into your car's fuel-measuring system by installing an indicator lamp that flashes when your fuel supply falls to a user-defined level.

BUILD A "SMART" GAS-GAUGE

BY JONATHAN GORDON

Whether you have a 1930–1950's vintage car, a 1960–1970's stock car that's been rebuilt into a musclecar, or a modern 1980–1990's car that has an engine computer, the *Smarter Gas Gauge* described in this article will accurately monitor the changing gas level in the tank—without affecting the operation of your factory installed gas-gauge in any way. Although your car may already be equipped with an in-dash low-fuel indicator, sometimes called an *idiot light* (which uses a factory preset, gas-level-sensing switch), such switches offer no manual control over the fuel level at which the idiot-light illuminates.

But, that's not the case with the Smarter Gas-Gauge. The Smarter Gas Gauge lets you electronically set the fuel-level trip point to $\frac{3}{4}$, $\frac{1}{2}$, $\frac{1}{4}$ full, almost empty, or any level in between. And the trip point that you set remains valid, even during periods of extreme agitation like when you quickly accelerate or take a tight turn. When the gas level reaches your preset trip-point, the low-fuel indicator illuminates.

But before we get into the operation of the circuit, a quick discussion of fuel-level indicators is in order.

Fuel-Gauge Systems. There are three types of fuel gauges found on automobiles: The magnetic, balanced-coil fuel gauge, the bi-metallic, heated-coil fuel gauge, and an electronic fuel-level bargraph or digital display.

Figure 1 shows the magnetic fuel-gauge system that's used in a 1972 Olds Cutlass convertible, which, incidentally, acted as the test platform for this project. The car's original gas-gauge was working fine but had become blocked from the driver's view by a modified steering-wheel column.

Inside the magnetic gauge is a set of balancing coils labeled L1 and L2, which are electromagnetic inductors that are wound around a plastic core at right angles to each other. The gauge needle is attached to a metal armature on which the two electromagnetic coils act. A series DC current flows through limiting-coil L1, then through operating-coil L2, and finally to ground.

Limiting-coil L1 exerts a constant

magnetic pressure on the gas-gauge needle that pulls it toward the empty-tank position; while operating-coil, L2 exerts a variable magnetic pressure that pulls the gauge needle toward the full-tank position. In such systems, the direction of the needle's movement depends on how much current is shunted away from L2 to ground via tank-rheostat R1 (which is usually called a sender).

Because coil L2 has more windings than coil L1, a small resistor, R2, is added to the winding resistance of L1 so that the resistance between the two coils is balanced.

Now let's suppose that ignition-switch S1 is turned on and sender R1 is in the full-tank position. Most of the current flows to ground through the gas gauge via coils L1 and L2; minimal shunt current flows to ground through the high-resistance path of sender R1, which is in parallel with coil L2. Operating-coil L2 builds up a stronger magnetic field than limiting-coil L1, and the pointer is pulled to the full position.

Now suppose that sender R1 is in the empty-tank position. Most of the current flows through the gas gauge via coils L1, and the low-resistance path

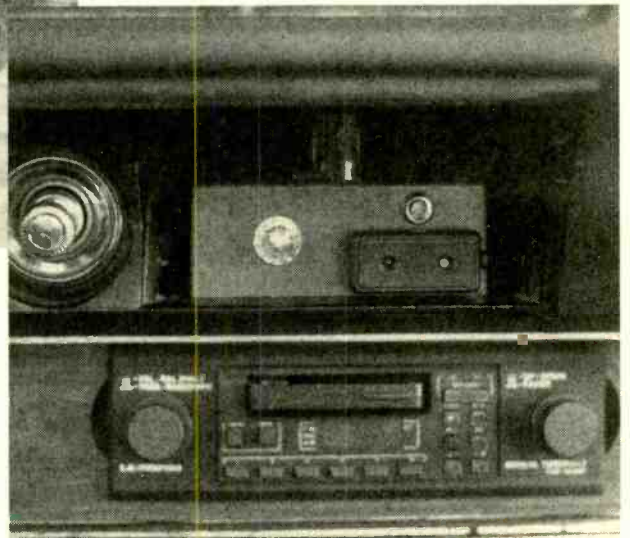

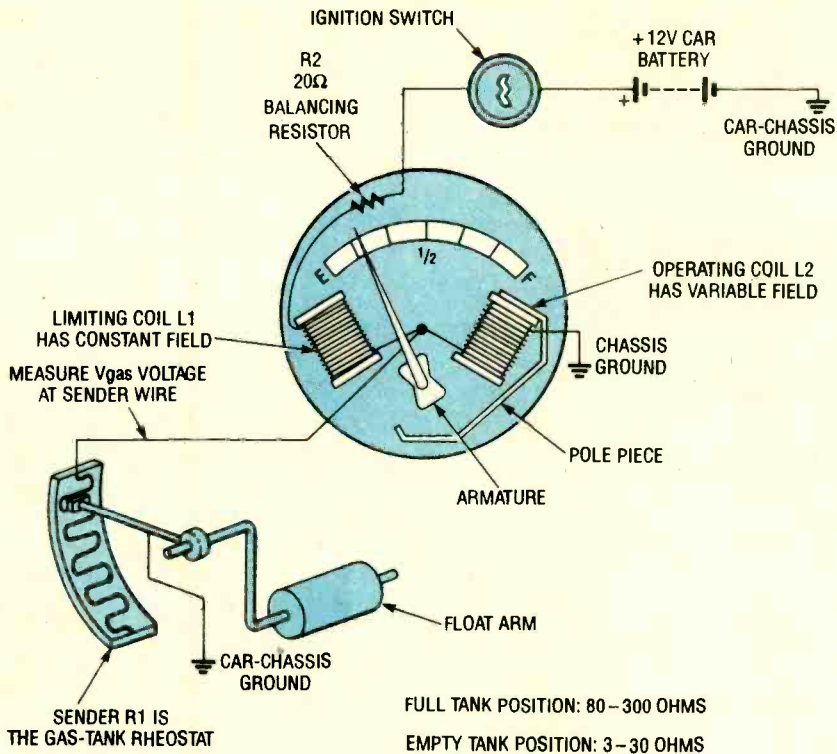

Fig. 1. There are two types of magnetic balanced-coil gauge systems; the one shown here uses a set of electromagnetic coils, L1 and L2, and a sender, R1, that shunt's coil L2.

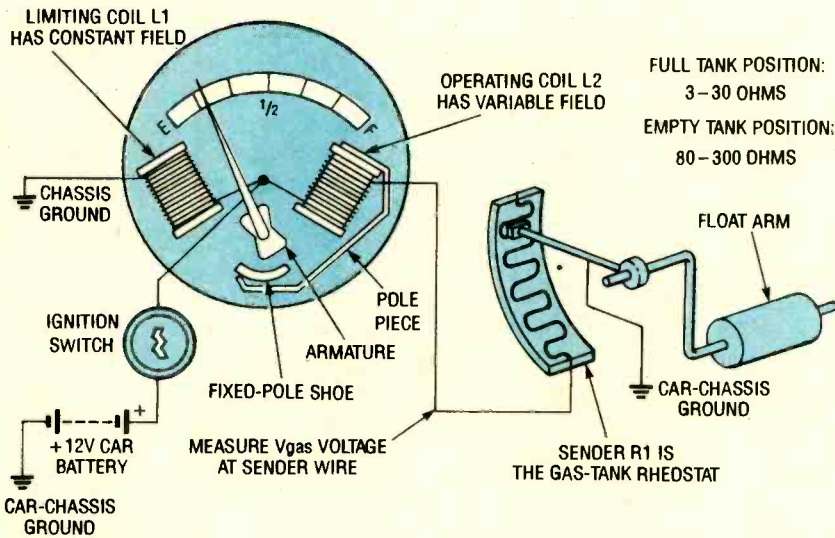

Fig. 2. Here is the second type of magnetic balanced-coil gauge system; this one uses a set of electro-magnetic coils L1 and L2, and a sender R1, as with the previous one. But, instead of the sender shunting L2, the sender is in series with coil L2.

to ground through sender R1, which shunts current around coil L2. Limiting-coil L1 builds up a stronger magnetic field than operating-coil L2, and the pointer is pulled to the empty position.

Figure 2 shows another version of the magnetic, balanced-coil, fuel-gauge system. In this version, limiting-coil L1 exerts a constant magnetic

pressure that pulls the gauge needle toward the empty position. Operating-coil L2 exerts a steady magnetic pressure that pulls the gauge needle toward the full position, but the magnetic strength depends upon the amount of current flowing through the series circuit formed by coil L2 and sender R1. When R1 is in the empty

position, the resistance is high, which reduces the series current, so that the magnetic pull developed by coil L2 is weak. When sender R1 is in the full position, the resistance is low, which increases series current, so that the magnetic pull developed by coil L2 is strong.

The magnetic fuel-gauge systems in Figs. 1 and 2 work differently. The gauge in Fig. 1 uses a shunt circuit, consisting of operating-coil L2 and sender R1, while the one in Fig. 2 uses a series circuit of operating-coil L2 and sender R1. In addition, sender R1 in Fig. 1 has a low resistance in the empty position and a high resistance in the full position; while sender R1 in Fig. 2 has just the opposite, a high resistance in the empty position and a low resistance in the full position.

Figure 3 shows another type of fuel-gauge system; a bi-metallic, heated-coil type. In that system, sender R1 influences the series current flow by way of a coiled heating element that's wound around a bi-metallic bar in the gauge. When the tank is full, sender R1 has a low resistance, allowing maximum current to flow through the coiled heating element, which causes it to heat. As the bi-metallic bar heats, it begins to bend because

A BRIGHT IDEA

The author wishes to thank Bob Manfred of SK Technologies, Inc., Boca Raton, FL, who is an expert on 1972 Cutlass convertibles in particular, and musclecars in general. It all started when Bob asked the author to design an instrument that would flash a light when his car was in need of fuel. The author admits that the whole idea sounded a lot like the idiot light (that most cars already had in abundance) that flash to signal everything from an alternator malfunction, low fuel, battery problems, door ajar, you name it. But Bob wanted no ordinary idiot light; what he wanted was a smarter light. The old fashioned idiot light that just illuminates when the gas gauge reads near empty wasn't good enough. Bob wanted to manually set the light's trip point for any gas needle position, from empty to full. And the light had to be an extremely bright incandescent lamp, an LED just wouldn't do. That's how the bright idea for the Smarter Gas Gauge got started, and one week later the author's prototype was installed in Bob's 1972 Olds Cutlass. The Smarter Gas Gauge has since become a fool-proof warning system and a conversation piece for everyone who comes along for a ride.

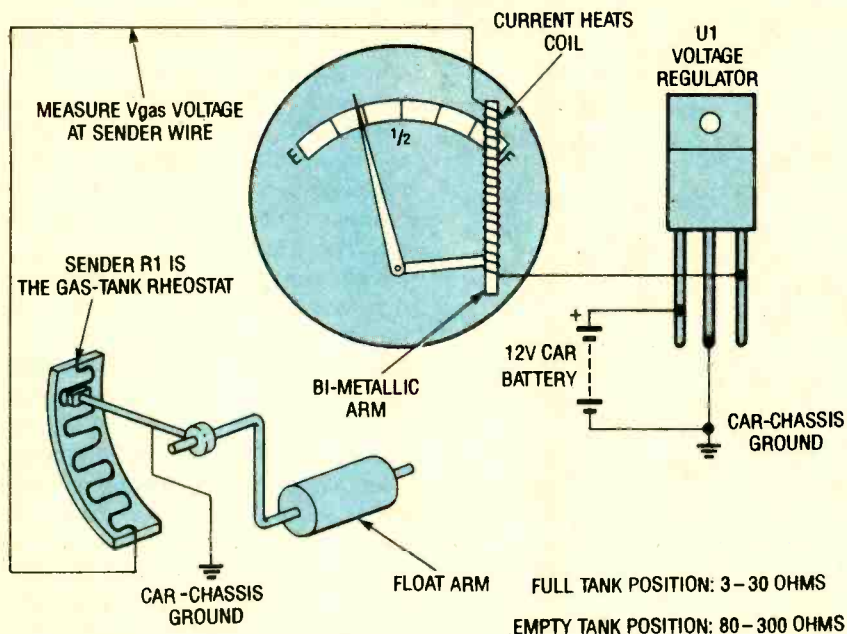

Fig. 3. The bi-metallic heated-coil gauge system uses a heating coil wound around a bi-metal bar, and a sender (R1) that's connected in series with the heating-coil wire.

of the difference in temperature expansion properties between the two bonded metals. Consequently, the gauge needle moves to the full position. When the tank is empty, sender R1 has a high resistance so minimum current flows through the coiled heating element. The bi-metallic bar cools, bending back to the original position, and the gauge needle moves to the empty position.

Voltage regulator U1 assures that any changes in current through the coiled heating element is caused by changes in resistance originating at the sender. Because the bi-metallic strip heats and cools slowly, sudden fuel-level changes caused by fuel sloshing in the tank are dampened so that a steady reading of the average fuel level in the tank is indicated. That is in contrast to the magnetic, balanced-coil gauge, which responds to sloshing fuel and gives a noticeable swing to the gauge needle.

Figure 4 shows an electronic fuel-level gauge that uses a bargraph display (digital readout). Notice that the gas-tank rheostat R1 (sending unit) is the same as that used by the electromechanical needle-type gauges. The sender consists of a float arm and variable resistor. As the fuel level changes, the sender's resistance also changes, which, in turn, places a varying voltage across the sender.

The electronic control module (or ECM) senses the voltage across the

sender and converts it into a bargraph or digital readout that indicates fuel-gallons remaining. For example, a typical General Motors sender has 90 ohms when the tank is full and 0 ohms when empty. Therefore, every decrease of 6 ohms would decrease the display one segment if it is equipped with a 16-segment bargraph gauge and a 16-gallon tank.

Figure 5 shows how a typical sending-unit is situated in the fuel tank. The rheostat assembly works just like a potentiometer. The resistive element is inside a metal housing that is lowered into the tank. The float arm is attached to a brush that contacts the resistive element. As the fuel level changes, the float arm moves and the rheostat then converts that linear up-and-down motion into a changing resistance. That varies the current flow through the fuel gauge so that the pointer needle moves.

Typical sender-resistance values are: 0-ohm empty to 90-ohms full for most GM vehicles; 73-ohms empty to 8-12-ohms full for Ford and Chrysler; 240-ohms empty to 33-ohms full for AMC, Stewart Warner senders, and marine applications.

Now that we've established that the sender resistance depends on the fuel level in the tank, it stands to reason that by measuring the voltage across sender R1 a unique voltage is recorded for each fuel level in the tank from empty-to-full.

In fact, a table can be created by measuring the voltages—which we'll call V_{gas} —at various fuel levels. Table 1 shows the V_{gas} voltage rising as the tank is being filled for the fuel gauge in Fig. 1. Tables 2 and 3 show V_{gas} levels falling as the tank is being filled for the fuel gauges in Figs. 2 and 3, respectively. By monitoring the V_{gas} level, we'll always know exactly how much fuel is in the tank. Now let's go through the procedure to measure V_{gas} and record the data.

Measuring V_{gas} . To measure the V_{gas} level, you'll need to perform the following steps: Turn the ignition switch to the on position (powering up the fuel-gauge system); disassemble the dash to locate the fuel-gauge plug; and hookup a DVM to measure the V_{gas} voltage that's across the sending unit.

A typical ignition switch with four positions—LOCK, ACC, ON, and START—is

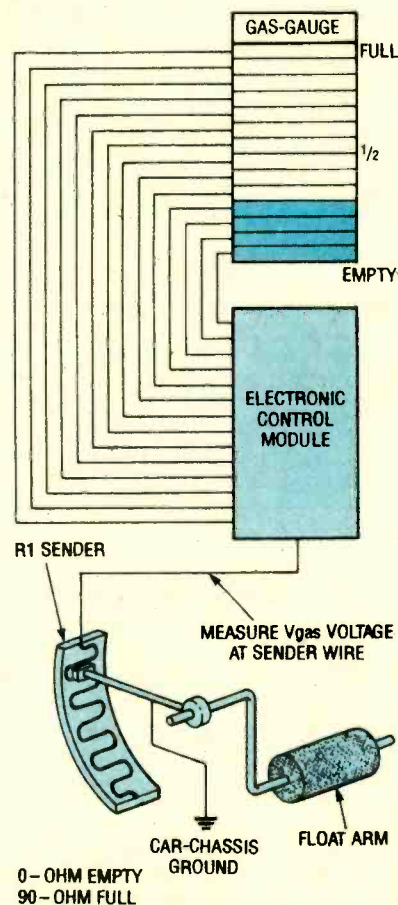

Fig. 4. This electronic, fuel-level, bargraph-display system uses an Electronic Control Module (ECM), a 16-segment LED display, and a sender R1.

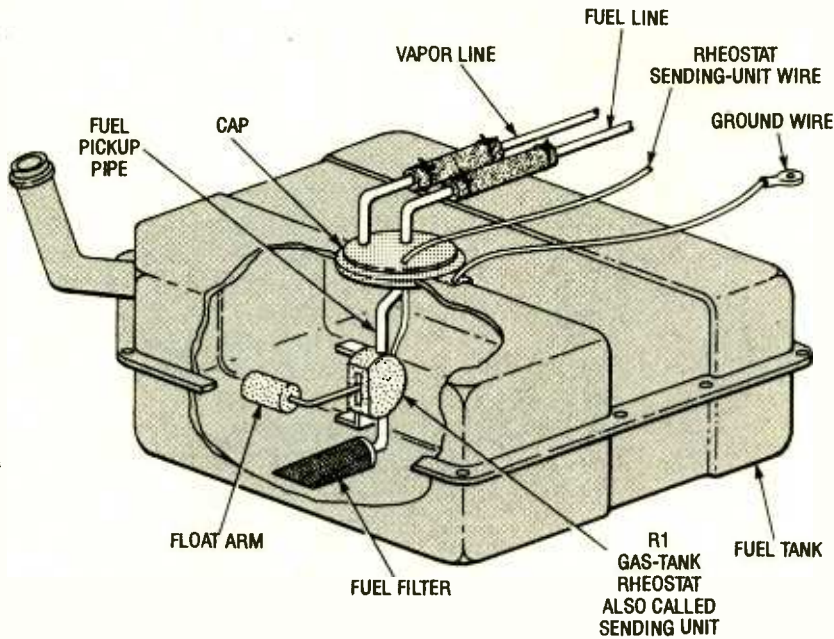

Fig. 5. The sending unit is effectively a rheostat that is controlled by a float arm, which senses the gas level in the fuel tank.

TABLE 1—
DATA FROM FIG. 1 GAS GAUGE

Fuel Level	V_{gas}
Full	7.7
$\frac{3}{4}$	6.7
$\frac{1}{2}$	6.2
$\frac{1}{4}$	5.2
Empty	4.5

TABLE 2—
DATA FROM FIG. 2 GAS GAUGE

Fuel Level	V_{gas}
Full	4.1
$\frac{3}{4}$	5.2
$\frac{1}{2}$	6.0
$\frac{1}{4}$	6.7
Empty	7.5

TABLE 3—
DATA FROM FIG. 3 GAS GAUGE

Fuel Level	V_{gas}
Full	1.5
$\frac{3}{4}$	2.8
$\frac{1}{2}$	3.9
$\frac{1}{4}$	5.3
Empty	6.4

shown in Fig. 6. The first step is to start the engine by turning the ignition switch to the **START** position. Release the key when the engine turns over. With the engine running, the alternator and DC regulator supply the electrical power necessary to operate the

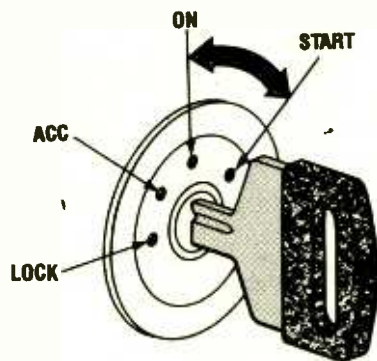

Fig. 6. Most ignition switches have four positions: **LOCK**, **ACC** (accessory), **ON**, and **START**, as shown here.

fuel gauge and other instrumentation.

The ignition switch may also be turned to the **ON** position without starting the engine. In that case, all the high-current electrical systems (like the fuel gauge, heater, and windshield wipers) will function normally except the battery will be supplying all the power. If left in the **ON** position for a lengthy period, the battery can become discharged.

When the ignition switch is in the **ACC** position, only the low-current devices (such as the radio and some of the warning buzzers, like door ajar will function), but the high-current devices (like the fuel gauge) will not be supplied with power.

For now, it's important to understand the ignition switch so that you can

take V_{gas} voltage measurements with confidence. Begin by turning the ignition switch to the **ON** position to power the fuel-gauge system. The next step is to disassemble the dash and remove the instrument cluster to get to the fuel gauge plug. In the 1972 Olds Cutlass, that means that the fuel-oil-gen-temp cluster gauge must be removed. Connected into the back of the cluster gauge is the fuel-gauge plug.

The third step is the most difficult because you'll have to locate the sending wire that is surely among several dozen other wires that all look alike. Turn on the ignition-switch and hook a voltmeter's positive lead to the wire coming from the sender, and the voltmeter's ground lead to the car chassis. If you don't know which wire in the fuel-gauge plug comes from the sender, don't be intimidated. Take a good look at the back of the cluster gauge: locating the fuel-gauge plug will be obvious.

Just study the plug and take an educated guess as to which wire comes from the sender. The wire is often color-coded green, brown, or striped. Now stick the voltmeter probe into the terminal (wire) you've picked. The probe's tip should be ground to a pointy spike that can be jabbed into the insulation of a harness wire.

There are just so many wires in the plug and sooner or later you'll hit on the right one. Make a splice into the sending wire and you're ready to take some measurements. Be advised, however (if you don't already know), that even shop manuals (like Chilton, etc.) are poor references when it comes to plug-connector diagrams.

A fool-proof method for locating the sending wire is to assemble a jabbing test-probe like that in Fig. 7. You'll need a sharp sewing needle or hat pin, a 10-watt, 10-ohm resistor, some hook-up wire, and an alligator clip. The probe's lead length should be several feet. The idea is quite simple. Hook the alligator clip to ground, turn the ignition switch to the **ON** position, and start jabbing the sewing pin into one wire at a time while watching the fuel gauge. When you hit the sending wire, the gas-tank rheostat (sender) will now be shunted by a 10-ohm resistor. Because any two resistors in parallel will reduce the total resistance, the fuel gauge thinks the rheostat resistance has changed and the gauge

needle will swing. It's fast, it's simple, and it works every time.

When your tank is about empty, drive to a gas station and have the attendant fill up your car. While the attendant goes for the gas hose, you should turn the ignition-switch to the

on position to power up the instrument gauges; but do not start the engine. As the tank is being filled, watch the fuel-gauge pointer move toward the full position, and record the voltage measured for each 1/4 tank of gas.

There are three reasons why you might not get a V_{gas} voltage reading; two of which are bad news. One bad reason could be that the fuel gauge is completely inoperative and burnt out—no current can flow through the gauge to get to the sender. The other bad reason might be that the sender is broken, or maybe the connecting wire is broken or intermittent. In either event, you'll have to do some electrical checking to diagnose why there's no V_{gas} voltage.

The third reason isn't so bad and may even surprise you. When the gauge is lifted out of the dash on some musclecars, the electrical ground is lost and the gauge becomes inoperative; the V_{gas} voltage may also be lost. The fix for that is simple: Use hook-up wire to jump the gauge's ground wire or terminal to the car chassis.

as in Table 1, or falls from an empty-to-full as in Tables 2 and 3.

Let's take a look at two examples: Suppose V_{gas} rises in the manner indicated in Table 1. In that instance, V_{gas} goes to pin 2 (the inverting input) and V_{ref} goes to pin 3 (the non-inverting input). Let's set the indicator lamp to illuminate when the tank is 1/4 full.

According to Table 1, V_{gas} is 5.2 volts, so V_{ref} —which serves as the trip point—should be manually set to 5.2 volts via potentiometer R2. When the tank is more than 1/4 full, the V_{gas} level will be above 5.2 volts, causing U1-a's output at pin 1 to be driven to ground. The output of U1-a, which is fed through S2, reverse biases transistor Q1, causing lamp I1 to stay off. However, when the tank is less than 1/4 full, the V_{gas} dips below 5.2 volts, causing U1-a's output at pin 1 to swing to the positive rail, forward biasing Q1 and turning I1 on.

Now let's suppose that V_{gas} falls as indicated in either Tables 2 or 3; in that case, the V_{gas} level is fed to U1-a's non-inverting input at pin 3 and V_{ref} is routed to U1-a's inverting input at pin 2. Let's set the indicator lamp to illuminate when the tank is 1/4 full. According to Table 2, V_{gas} is 6.7 volts, so V_{ref} should be manually set to 6.7 volts (the trip point for this example) via potentiometer R2.

When the tank is more than 1/4 full, V_{gas} will be below 6.7 volts and U1-a's output at pin 1 will be driven to ground, which reverse biases transistor Q1, causing I1 to stay off. How-

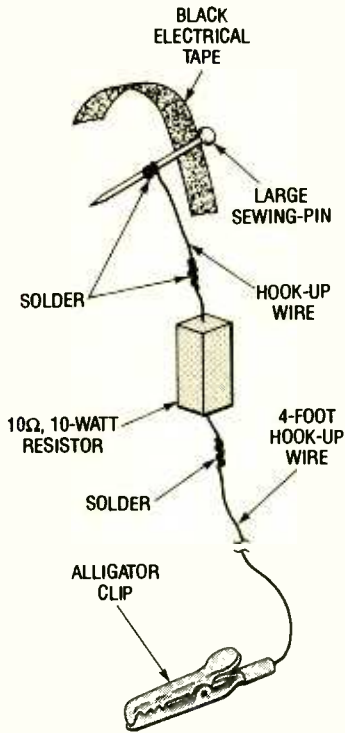

Fig. 7. A home-made test probe—like this one made from a 10-ohm, 10-watt resistor, a large sewing needle, an alligator clip, and some hook-up wire—can be used to locate the lone sending wire amongst the jumble of wires behind the dashboard.

Circuit Theory. A schematic diagram for the Smarter Gas Gauge is shown in Fig. 8. In that circuit, a single op-amp, U1-a—1/4 of an LM324N quad op-amp, configured as a comparator—is used to compare the V_{gas} input to a reference voltage (V_{ref}). Switch S1 is used to reverse the V_{gas} and V_{ref} inputs to U1-a, depending on whether V_{gas} rises from empty-to-full

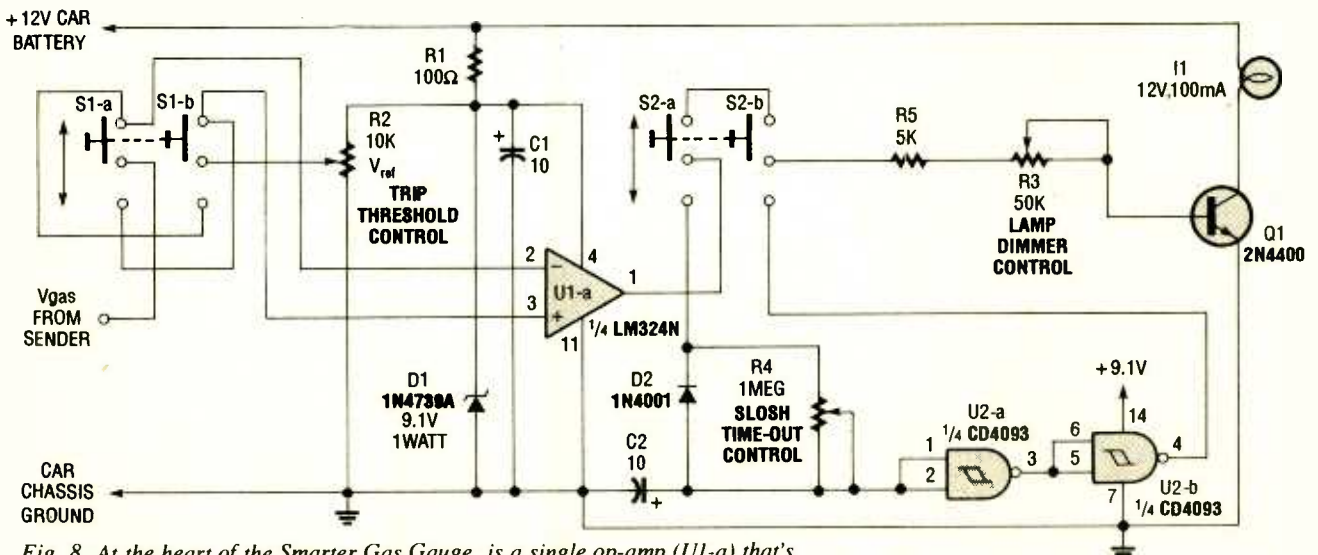

Fig. 8. At the heart of the Smarter Gas Gauge, is a single op-amp (U1-a) that's configured as a comparator. The output of the op-amp toggles high when the gas tank needs to be refilled, which forward-biases transistor Q1, causing I1 to light.

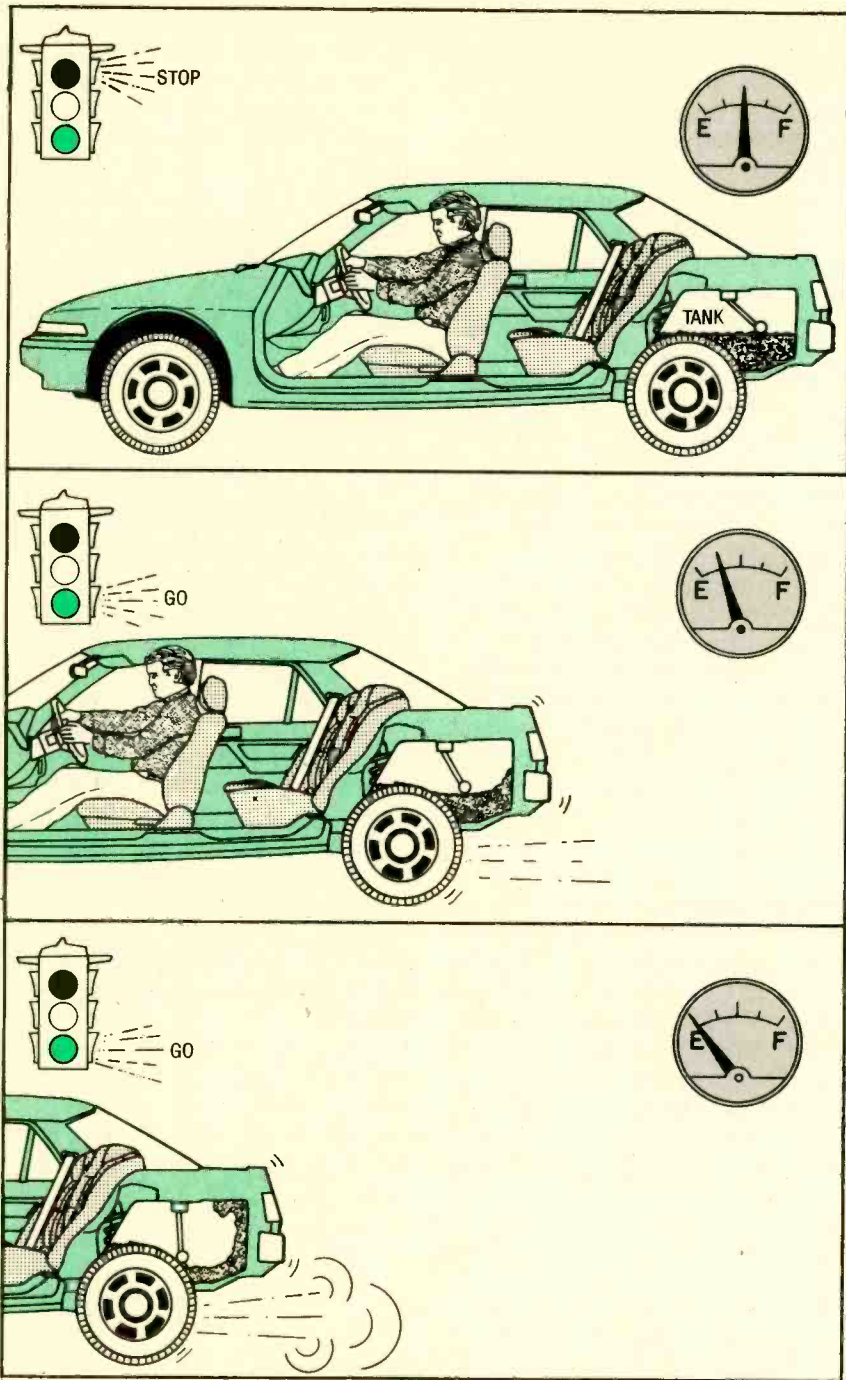

Fig. 9. When the car accelerates, gasoline within the fuel tank begins to slosh around. The float arm follows the gasoline, causing the gas-gauge needle to move toward empty, giving a false indication. Some float arms have a calibrated friction brake to prevent gasoline wave-motion from oscillating the float arm.

ever, when the tank is less than $\frac{1}{4}$ full, V_{gas} rises above 6.7 volts, causing U1-a's output at pin 1 to swing to the positive rail. That forward biases Q1, which, in turn, causes I1 to light.

Switch S2 can route U1-a's output in either of two directions. In one direction, the output of U1-a is fed straight to the base of Q1 (as we've just seen). In the other direction, the output of U1

is routed to an RC, gas-sloshing, time-out circuit (comprised of R4/C2).

Let's discuss how the time-out circuit functions. When the gas level is at the comparator's trip point and the car accelerates, the sloshing gas causes V_{gas} to oscillate above and below V_{ref} . That causes the output of U1-a at pin 1 to also oscillate high and low. When the output goes high, capaci-

PARTS LIST FOR THE SMARTER GAS GAUGE

SEMICONDUCTORS

- U1—LM324N quad, low-power op-amp, integrated circuit
- U2—CD4093, quad 2-input NAND Schmitt-trigger, integrated circuit
- Q1—2N4400 small-signal, general-purpose NPN silicon transistor
- D1—1N4739A 9.1-volt, 1-watt, Zener diode
- D2—1N4001 general-purpose silicon rectifier diode

RESISTORS

- (All fixed resistors are $\frac{1}{2}$ -watt, 5% units.)
- R1—100-ohms
 - R2—10,000-ohm linear-taper potentiometer
 - R3—50,000-ohm linear-taper potentiometer
 - R4—1 megohm linear-taper potentiometer
 - R5—5,000-ohm

ADDITIONAL PARTS AND MATERIALS

- C1, C2—10- μ F, 35-WVDC, tantalum capacitor
- I1—12-volt, 60–175-mA incandescent lamp
- S1, S2—DPDT slide switch
- Printed-circuit materials, enclosure (optional), 2-amp 3GA-type fuse, crimping tool and connectors, in-line fuse holder, hookup wire, wire ties, solder, hardware, etc.

Note: The following items are available from Jonathan Gordon, 74 Berkshire, Apt. C, West Palm Beach, FL 33417; a kit of parts containing the printed-circuit board and all components (except an enclosure) for \$69.95; the fully assembled and tested Smarter Gas Gauge for \$89.95. Please add \$4.00 to all orders for shipping and handling. Florida residents please add 6% sales tax.

for C2 charges through resistor R4 (together R4 and C2 form an RC time constant).

The voltage across C2 rises only for the time that the output of U1-a is high, which is usually for less than a second. Eventually, the slosh reverses itself and the output of U1-a goes low, which immediately discharges C2 through diode D2. The C2 charging-cycle must now start all over again. Notice

that V_{gas} can now swing above and below V_{ref} yet the indicator lamp remains off. When C2 has charged enough to trigger U2-a ($\frac{1}{4}$ of a 4093 quad CMOS NAND Schmitt-trigger), I1 illuminates.

There are two reasons for using a CMOS Schmitt-trigger for U2: CMOS gates offer a high input-impedance that won't interfere with the charging rate of C2, and because the voltage across C2 is slow-rising voltage, that's far too long a time for most digital gates. Digital gates like fast rise-time inputs (at the least a few milliseconds) or they'll get confused and the output will oscillate while trying to figure out if the input voltage is actually rising or falling past the gate's trip-point.

A Schmitt trigger has two separate trigger points—one for rising voltages and another for falling voltages—and can, therefore, toggle on the slowly-rising voltage across C2 without oscillating.

The circuit is powered from a 12-volt source that is tapped off the vehicle's battery. The 9.1-volt power source for the IC's is provided through a conventional Zener-regulator circuit consisting of D1 and its current-limiting resistor, R1.

Slosh Time-Out. When the 1972 Olds Cutlass (mentioned earlier) accelerates from a stop, the gas-gauge needle swings toward empty. In Fig. 9, when the tank is about $\frac{1}{2}$ full and the car lurches forward, there's plenty of room in the tank for the gas to slosh back-and-forth like an ocean surf. When the float arm that's attached to the rheostat rides the surf to the tank's bottom, the rheostat thinks the tank is empty and the gauge needle swings all the way to "E" (empty).

The V_{gas} voltage will vary with the rocking gas-tank sender every time that the car accelerates quickly, takes a tight turn, or hits a road bump. That presents no problem until V_{gas} approaches the comparator's trigger point (the V_{ref} voltage). Points a and b in Fig. 10 show that every time V_{gas} oscillates above and below V_{ref} , U1-a's output toggles (as shown in Fig. 10 at point c), which causes the lamp to flash (see point d).

If U1-a's output is routed to the slosh time-out circuit, C2 charges on the positive pulse (see Fig. 10, point e). Because there is not insufficient time

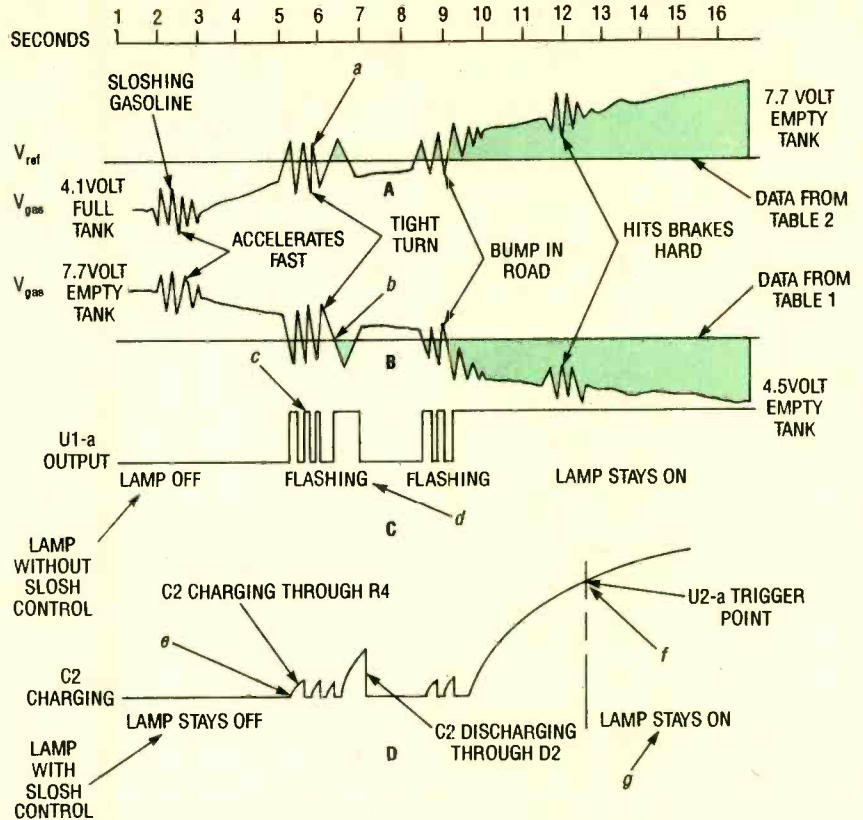

Fig. 10. The low-fuel indicator flashes when gasoline within the tank sloshes around the threshold trip-point. The RC circuit ($R4/C2$ in Fig. 8), operating in much the same manner as a switch-debouncer, prevents the lamp from flashing as gas sloshes about the fuel tank.

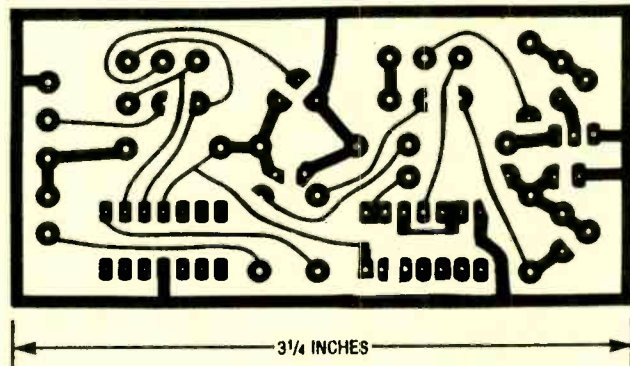

Fig. 11. The author's prototype was assembled on a small printed-circuit board that measures about $3\frac{1}{4}$ by $1\frac{1}{16}$ inches. A full-size template of that printed-circuit pattern is shown here.

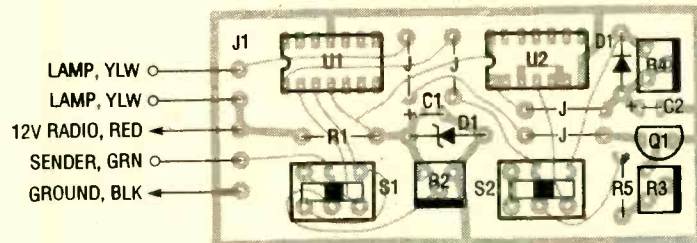

Fig. 12. Here's the printed-circuit board's parts-placement diagram. Careful attention should be paid to component orientation, which will prevent most construction errors.

to charge C2 to U2-a's trigger point, the lamp remains off. Ultimately, after

driving for some time, the tank gets so low that the float arm cannot swing

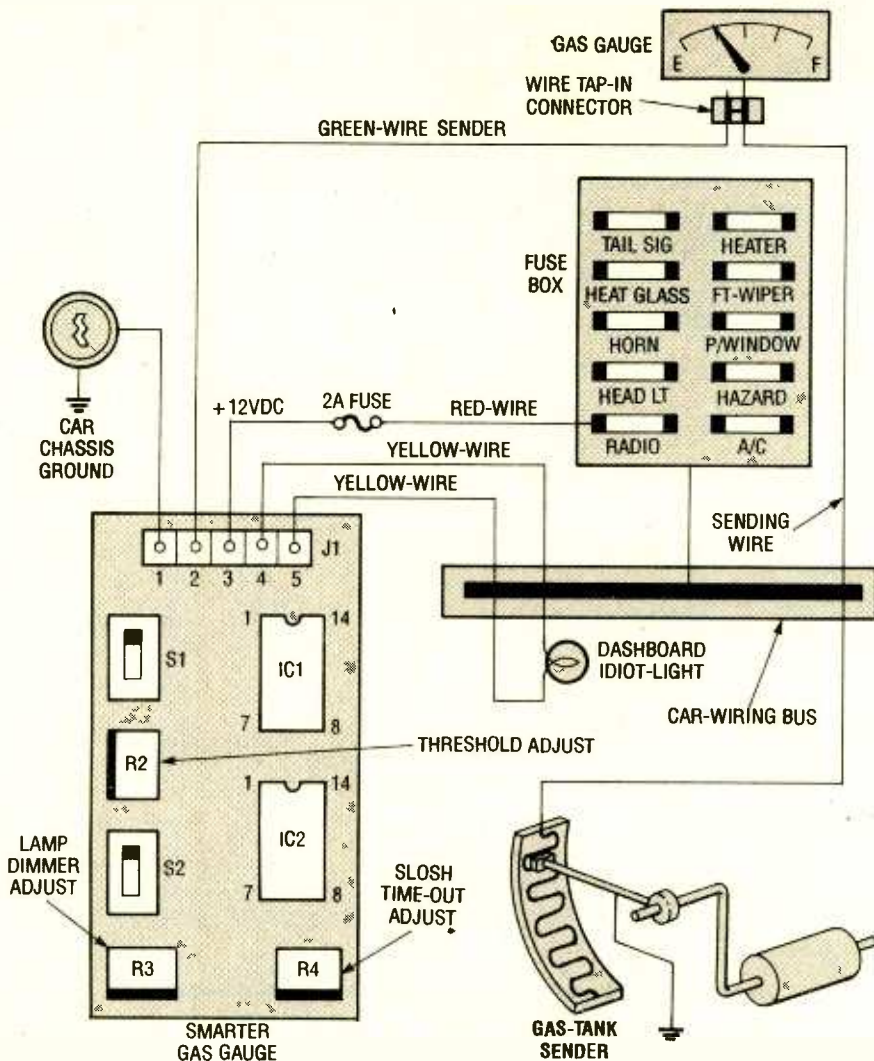

Fig. 13. Here's the musclecar hook-up diagram. To make installing the Smarter Gas Gauge a bit easier, use a different color wire for each connection: It's also a good idea to plan your installation carefully before starting.

high enough to oscillate V_{gas} around V_{ref} . When that happens, C2 has time to charge (see Fig. 10 point f), and trigger U2-a, which causes I1 to turn on continuously (see point g).

There is, of course, always the possibility that a wild screeching turn will rock the float arm enough to push V_{gas} to the V_{ref} level. That causes U1-a's output to go low, discharging C2. When that happens, I1 turns off, and requires another 5 seconds or so before turning on again. But the lamp will not flicker or flash.

A flashing lamp sure gets your attention though, possibly because the flash rate is somewhat non-repetitive—sometimes flashing quickly and at other times quite slowly—depending on how the gas sloshes in the tank. Although for many, a flashing light that goes crazy when the car accelerates is a perfect attraction,

not everyone loves a flashing light. And if you prefer a lamp that just comes on and stays on when the gas level exceeds the trip threshold, then the answer is to use the slosh time-out circuit.

Construction. The Smarter Gas Gauge was assembled on a small printed-circuit board that measures about $3\frac{1}{4}$ by $1\frac{1}{16}$ inches. A full-size template of that printed-circuit pattern is shown in Fig. 11, with the corresponding parts-placement diagram appearing in Fig. 12. The electronic components are simple and should tolerate all but the most severe abuses.

There are no delicate oscillators or touchy amplifier feedback loops to worry about, no ultra-fast computer clocks that wreck havoc with every wire that comes near them, and no

delicate transistor betas to worry about when the temperature gets too hot or too cold.

What you should do, however, is to make absolutely sure that U1 and U2, D1 and D2, Q1, and C1 and C2 are installed with the proper orientation. If Zener diode D1 is put in backwards, the 9.1-volt power source used to operate U1 and U2 just won't be available. Remember, reverse-biased Zener diodes act like regular rectifier diodes. The means that if D2 is installed backwards, R4 will be shorted out and the R4/C2 time constant won't function at all—C2 will charge and the lamp will be lit continually.

If the voltage at U1-a pin-1 is high and the lamp isn't lit, check Q1, make sure that R3 is wired correctly, and check the continuity through switch S2.

Once assembly is complete, carefully inspect your work for solder shorts (bridges) between pads and lands, cold solder joints (characterized by dull blobs of solder) and touch up those that look suspicious. Finally, label all wires going to the car as either G for ground, S for sender, or +12V for battery.

Installation. First we'll take a look at the original prototype installation in the aforementioned 1972 Olds Cutlass. For a proper installation, you'll need the right tools and the know how to do the following: disassemble the dash; drill a hole here or there; run a wiring harness up and around corners; find the sending wire in the back of the dash at the fuel-gauge plug; make good splice connections using a crimping tool or soldering iron; know how to take voltage measurements using any DVM or VOM; and use metal brackets and other hardware for a secure installation.

Before beginning your installation, study the car's dash and decide what kind of installation you want. If your dash has a low-fuel "idiot" light, you'll have to disconnect the two wires from the lamp's socket. That usually means cutting the wires unless there's a simple crimp terminal to pull off. Just tuck those wires away. Now wire the in-dash light to the appropriate pads on the Smarter Gas Gauge's printed-circuit board. An incandescent lamp can be connected directly to the cir-

(Continued on page 92)

Antenna Amplifiers that you can Build

BY JOSEPH J. CARR

We explore a number of working VLF, AM BCB, MW, shortwave, and VHF/UHF designs.

Recently my radio experimenting has taken me into a number of different areas where small amplifiers of reasonably good gain was required. Examples include various outdoor-antenna preamplifiers, loop amplifiers, amplifiers for indoor antennas, and active antennas. In this article we will take a look at some of the different circuits that I have tried with a view towards helping you find solutions for some of your own radio problems.

Construction. Although the circuits described in this article are different from each other, there is a strong similarity in the way each is constructed. All of these circuits can be built on perforated board stock, with or without printed tracks. I used both the Vector brand perfboard (0.100-inch on-center holes), as well as the little Radio Shack pre-printed circuit boards of various types. Both yielded good results. The Radio Shack products come in two general categories (in different sizes). One class has traces for use with dual in-line package (DIP) integrated circuits, while the other just has simple circular pads of copper to facilitate circuitry without IC's. The latter is preferred.

All of the circuits must be built inside a shielded enclosure. So use either die-cast or sheet-metal enclosures, not the plastic or nylon kind. If sheet-metal enclosures are used, make sure that you buy the kind that has an overlapping lip or flange to better shield the circuit from outside influences. The

kind of sheet-metal box that uses only dimples or notches to join the two halves are not suitable for radio-frequency circuits.

The input and output connectors can be SO-239 UHF coaxial connectors, BNC coaxial connectors, "phono connectors" (except at VHF/UHF), or any other connectors that you desire.

If the preamplifier is intended to be mounted outdoors, then the enclosure must be weatherproofed. You can either buy weatherproof enclosures, such as those used in TV-antenna systems, or weatherproof a regular "indoor" box. That can be done by sealing all edges and con-

nectors with silicon seal or caulk prior to installation.

All of the circuits in this article are wideband, but can be made either narrower or single-frequency by the addition of suitable input and output LC tuning circuitry.

Wide/Multi-Band Preamplifier.

Figure 1A shows an integrated-circuit preamplifier that can be used on any frequency, or band of frequencies, from near-DC to daylight (well, 1000 MHz in some models and 2000 MHz in others). I've used the circuit for a 60-kHz VLF WWV receiver, for a medium-wave loop-antenna preamplifier, in the HF band, on the six-meter ham

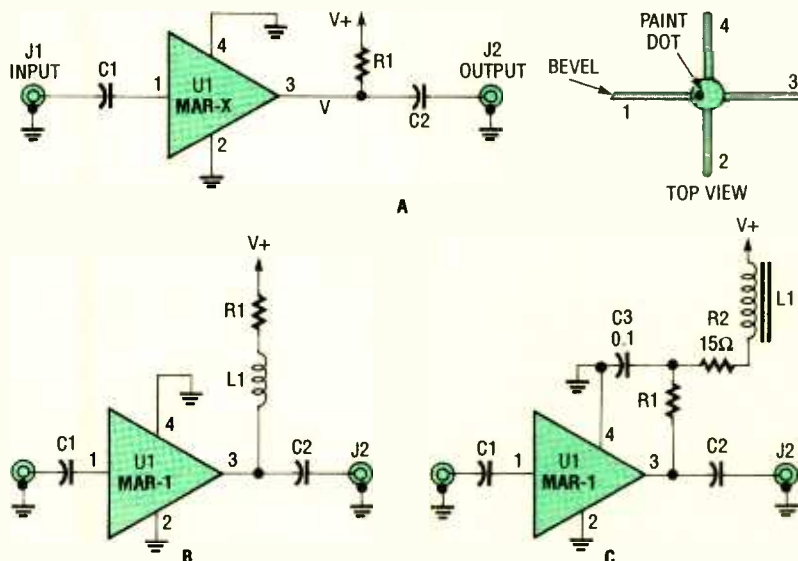

Fig. 1. All these preamplifier circuits can be built from the MAR-1 MMIC device. In fact the only difference between the circuits is the output connection of the IC.

band, and throughout the VHF/UHF bands. The central element is a special monolithic microwave integrated circuit (MMIC) device labeled MAR-X in the drawing. That is not the designation of a real part, but is meant to denote a family of parts (MAR-1, MAR-2, etc.) from Mini-Circuit Laboratories (P.O. Box 350166, Brooklyn, NY 11235-0003). Various versions provide from 15 to 23 dB of gain at frequencies to 2000 MHz (i.e., 2 GHz). The one that I've used most frequently is the MAR-1, which operates to 1000 MHz with around 20 dB of gain. One of the nice things about the MAR-1 device is that it inherently has input and output impedances of 50 ohms.

Input and output coupling is provided by capacitors C1 and C2. Those capacitors should have the same value. The value depends on the operational frequency range: for operation below 100 kHz, use 1- μ F units; from 100–500 kHz, 0.47- μ F types will do; between 500 and 3000 kHz try 0.1- μ F capacitors; from 3 to 30 MHz, 0.01 μ F is called for; operation between 30 and 100 MHz requires 0.001- μ F units; a 100–500-MHz preamplifier needs 100-pF devices; and for operation in the 500–1000-MHz range, 33-pF components are needed. Those values are guidelines only, and you will be successful with any values close to them. Also, at VHF/UHF frequencies above about 100 MHz the capacitors should be surface-mount chip types; at all other frequencies ceramic-disc capacitors are sufficient.

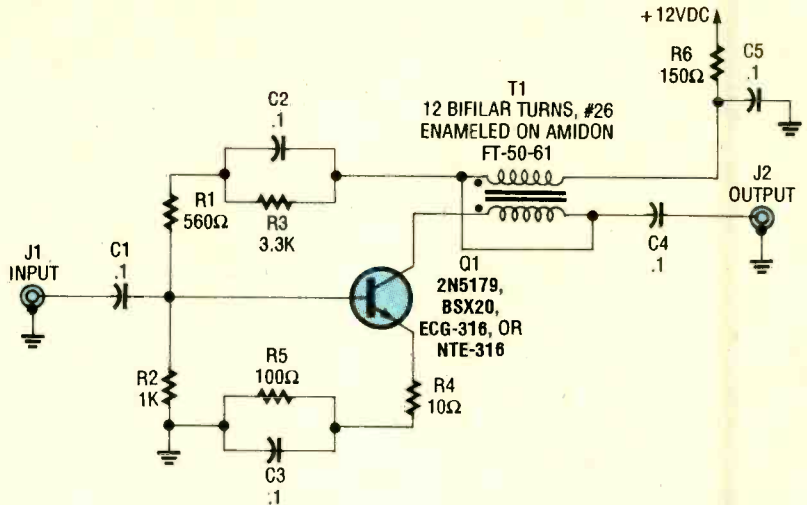

Fig. 3. This feedback amplifier will work well for 3–30 MHz signals. Note the partially RF-bypassed emitter network that improves performance.

The DC power source for the MAR-1 device should be less than 7 volts DC. Power is applied through the output terminal (lead number 3). The rated current drawn by the device is on the order of 15 mA. The value of the resistor, R1, is determined by the desired operating voltage, V, which must be 4.5 to 7 volts, and the supply voltage (V+) according to this relation:

$$R1 = (V+ - V) / 0.015$$

For example, to get an operating voltage of 5 volts from a 9-volt power supply, the value of R1 is:

$$(9 - 5) / 0.015 = 267 \text{ ohms}$$

In this case, a standard 270-ohm, quarter-watt resistor is indicated.

Figures 1B and 1C are two variations

on the output circuit scheme that will prove useful in some cases. Note that the ground connections (leads 2 and 4) have been left out to promote clarity. The circuit of Fig. 1B uses a radio-frequency choke (L1) as a peaking coil to improve the high-frequency response. The value of the coil depends on the operating frequency. Use 2.5 mH below 1000 kHz, 1 mH from 1000 kHz to 3 MHz, 100 μ H in the HF band, and lower values in the VHF/UHF band. I've successfully used 5 μ H units in the 144-MHz ham band.

The circuit in Fig. 1C can be used to keep outside signals from affecting the preamplifier circuit. The coil (L1) should be selected according to the operating frequency, but in general, interference from an AM-broadcast station should be blocked by a 2.5-mH coil, from a ham station in the HF bands use a 1-mH unit, and from an FM or TV broadcasting station L1 should be 100- μ H.

Amidon Associates (P.O. Box 956, Torrance, CA 90508) can provide toroid and solenoid bobbin-style cores for making coils to suit any frequency range from 50 MHz to 300 MHz. The MAR-1 is a little hard to come by in single units, but readers can obtain them from me at P.O. Box 1099, Falls Church, VA 22041, for \$4.95 postpaid (VA residents must add tax).

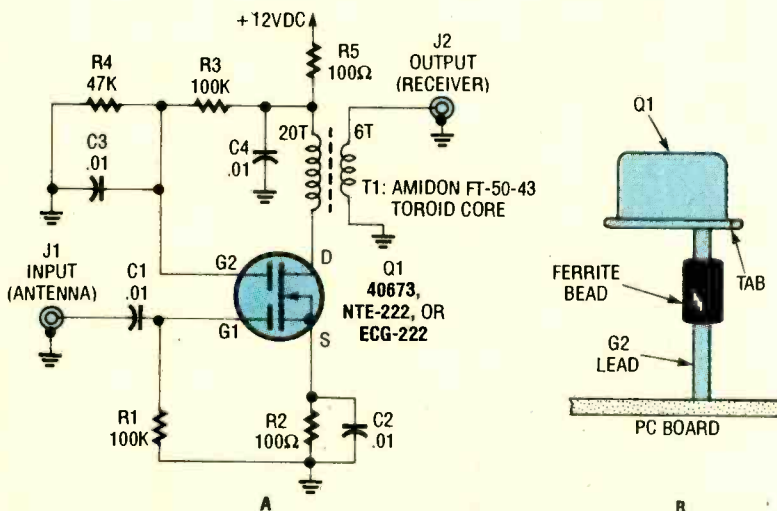

Fig. 2. This is a general-purpose HF preamplifier based on the 40673 MOSFET device. As shown, a ferrite bead should be placed on the G2 lead of Q1 to eliminate several possible problems.

HF Preamplifiers. The preamplifier circuits in this section are intended for use in the HF bands from 3 MHz to 30 MHz, although they can also be used in adjacent bands at reduced gain. The circuit in Fig. 2 is based on the

40673 dual-gate MOSFET transistor, and provides as much as 44 dB of gain. That device is relatively easy to obtain, but in case you have difficulty there are two replacement-line transistors that are identical: the ECG-222 and NTE-222. Those devices are usually available from local parts distributors.

The input circuit consists of a 100k resistor to ground and a 0.01- μ F capacitor connected to gate 1 (G1 in the figure) of the MOSFET transistor. Bias to the transistor is provided by a 100-ohm resistor (R2) from the source (labeled S) to ground. The 0.01- μ F capacitor shunted across R2 is used to keep the source terminal of the MOSFET at a low impedance to ground for RF, while keeping it a little above ground for DC. Bias to gate 2 (G2) is provided by a resistor voltage divider made of R3 and R4. Gate 2 is decoupled by a ceramic-disc capacitor to ground (C3) and a ferrite bead that is installed on the G2 lead of the transistor (see the detail inset in Fig. 2). The ferrite bead keeps the transistor from oscillating at a high frequency, as well as serving to prevent those frequencies from entering the transistor. Amidon FT-73-201 is an appropriate bead for this circuit.

The output circuit consists of a toroidal transformer. I've used toroids made of type 2, type 6 and type 43 material in various projects. Types 2 and 6 are powdered-iron cores, while the type 43 is a nickel-zinc ferrite material. In a version of the circuit that I built, and which produced 44 dB of gain throughout most of the HF band, the core selected was an FT-50-43 wound with 20 turns of No. 26 enameled wire in the primary, and 6 turns of the same wire in the secondary.

A wideband preamplifier circuit based on a bipolar NPN transistor is shown in Fig. 3. That circuit is widely used in amateur-radio circles both in the USA and Europe, and is based on an original circuit by Les Hayward. The transistor used in this circuit is a 2N5179, or a similar European device called the BSX20. For those readers who must buy from local parts distributors, the 2N5179 device can be replaced by an ECG-316 or NTE-316, which seem to be satisfactory. These devices are low-noise (4.5 dB at 450 MHz), high-gain NPN transistors for use up to UHF frequencies.

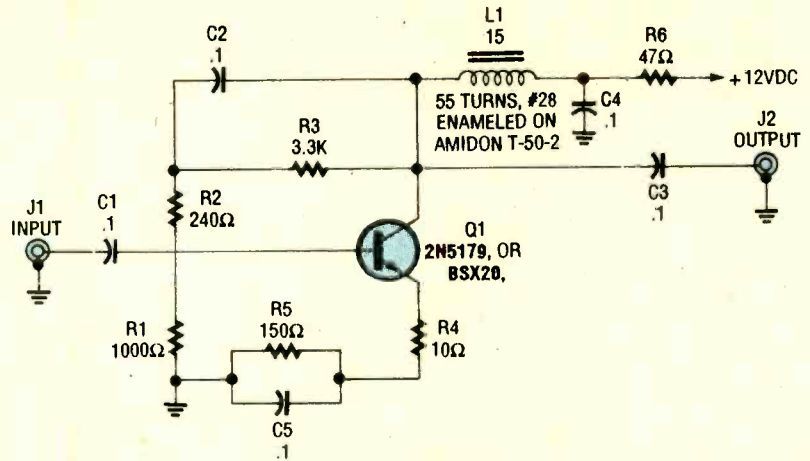

Fig. 4. This is a variation on the theme of Fig. 3. The emitter network is the same, but the feedback and power-supply decoupling circuits are different.

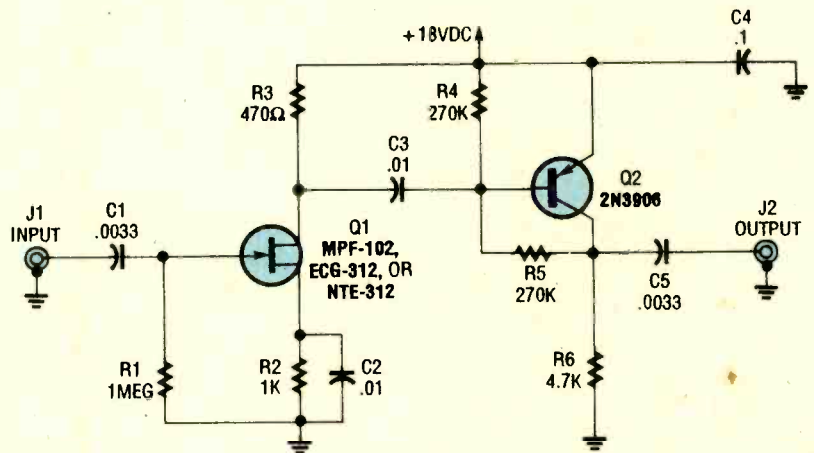

Fig. 5. This cascade preamplifier circuit is useful for low-frequency applications. Both transistors in the circuit are readily available, non-critical components.

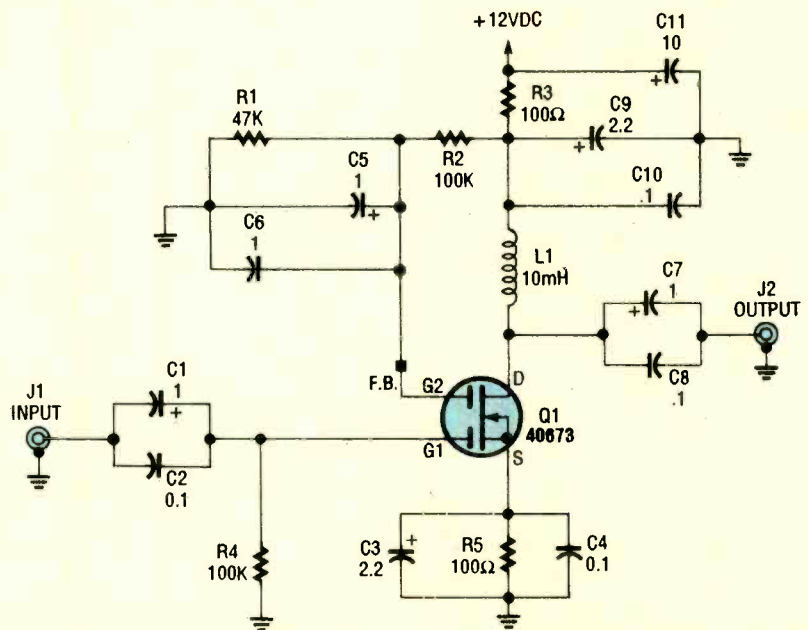

Fig. 6. If you like to experiment with very-low frequency applications, then you might want to use this preamplifier circuit based on the 40673 MOSFET.

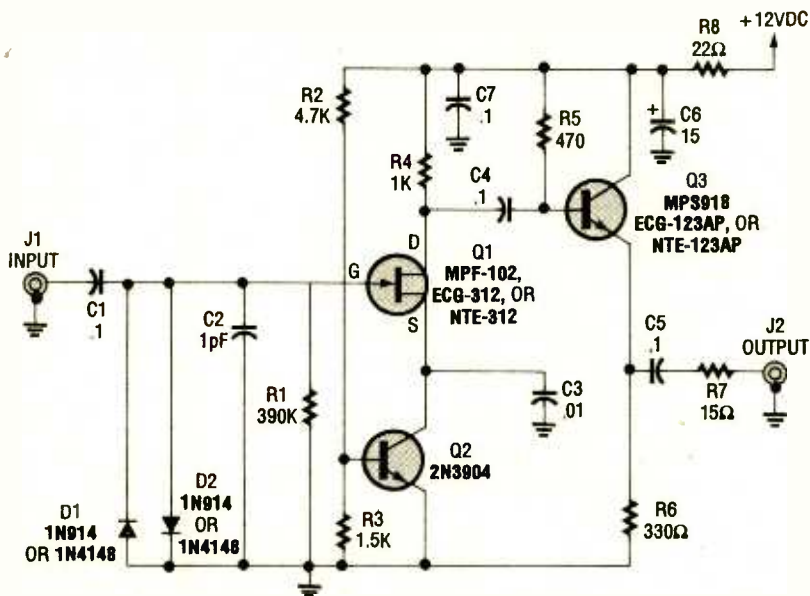

Fig. 7. This cascade JFET AM broadcast band preamplifier circuit has diodes to protect its input from overload. The diodes can be eliminated if swamping is not a problem.

The output circuitry is based on a 4:1 ratio BALUN transformer. You can buy those transformers for the low-VHF region, but must wind them yourself for HF-band use. A successful BALUN can be wound on the Amidon FT-50-61 core using 12 "bifilar" turns of No. 26 enameled wire. A bifilar transformer is wound so that every other turn belongs to the same wire—the two coils are in a sense interlaced. The easiest way to build such a transformer on a toroidal form is to twist the two pieces of wire together (about 5 to 10 twists per inch seems right), and then treat the twisted pair as a single entity when you wind the twelve turns on the core. The dots on T1 indicate the same ends of the two windings.

A variation on the circuit of Fig. 3 is shown in Fig. 4. This circuit does not use an output transformer as in Fig. 3, but rather is capacitor coupled. The collector load for RF frequencies consists of a radio-frequency choke (L1). For the HF frequencies, this choke can be made from 55 turns of No. 28 or 30 enameled wire on an Amidon T-50-2 (red) core.

A point of interest in both Figs. 3 and 4 is the emitter circuit. Notice that the emitter load resistance is made up, in both circuits, of two resistors. One is bypassed for RF, while the other (a 10-ohm resistor) is not bypassed. The un-bypassed resistance portion provides a small amount of negative feedback

to stabilize the amplifier and provide better performance.

A cascade preamplifier is shown in Fig. 5. That circuit is based on a pair of transistors: the input device (Q1) is an MPF-102, or the service replacements ECG-312 or NTE-312, while the output device is a PNP general-purpose silicon transistor. The input and output circuits are capacitor coupled, and the two stages use capacitor coupling between them. The values of capacitance shown in Fig. 5 are suitable for the HF bands, but for lower frequencies increase the values of the capacitors to 0.01 or 0.1- μ F.

VLF, AM, and Low/Medium Wave.

The circuits in the previous section are designed for use in the HF shortwave bands, although some will also work at lower frequencies. In this section we will take a look at circuits for the frequencies below the HF band. The medium-wave frequencies are those in the 1000 kHz to 3000 kHz region, although the frequencies to about 6000 kHz have similar properties for radio purposes. The AM broadcast band extends from 530 kHz to 1630 kHz, so it overlaps the medium-wave bands a bit. The VLF bands are those frequencies less than 530 kHz.

The circuit in Fig. 6 shows a variant of the earlier MOSFET circuit (see Fig. 2) that will operate over a wide range of frequencies from 10 kHz (dare we call

it "ULF" for Unbelievably Low Frequency?) to the upper end of the medium-wave band. The basic circuit is the same as for the previous version, so the discussion will not be repeated here. The differences are in the capacitor coupling and decoupling circuitry, and in the output circuit.

The capacitors used for coupling (C1-C10) are doubled up: a 0.1- μ F ceramic-disc capacitor is used for higher frequencies, while a tantalum electrolytic is used for the lower frequencies. Be sure to observe the polarities on the electrolytics (on tantalum units, the "+" lead is usually marked, but be careful or you will destroy the capacitor).

The drain load for RF is provided by an RF choke (L1). In this case, the value selected for L1 is 10 mH, which reflects the fact that the circuit was intended for VLF use. For higher frequencies, you can reduce that to 1 mH or 100 μ H, but only at the expense of gain at the lower frequencies.

With the values shown, the gains realized were 15.6 dB at 10 kHz, and up to 44 dB at 330 kHz. Gain at lower frequencies can be enhanced by increasing the value of L1 to as much as 88 mH, and by increasing the values of the electrolytic capacitors in the source, gate 2, and drain circuits. The G2 capacitor (C5) can be increased to 4.7 μ F, and both C3 and C9 can be increased to 15 μ F or more for operation at lower frequencies (or more gain). In that case, capacitor C6 should be increased to 47 μ F.

An AM BCB preamplifier is shown in Fig. 7. That multistage, cascaded preamplifier uses an MPF-102 junction field-effect transistor (JFET) or its equivalent (NTE-312 or ECG-312) as the amplifier (Q1), with a general-purpose NPN transistor (Q2) serving as a current source for the JFET. A second NPN device (Q3) is used as an output-buffer/amplifier.

The overload diodes used in the front-end of the circuit (D1 and D2) prove useful in the AM broadcast band. Those diodes clip very strong signals, which can occur in the AM BCB, as well as high-voltage transients that might be induced in the circuit by any nearby lightning. However, the diodes can cause harmonic generation and distortion if the signal is too strong, or lasts too long, so some people prefer not to have them. ■

Programming

Parallel

Printer Ports

Learn how to control and monitor the parallel ports on your computer so you can interface it with your own computer projects.

BY JOHN J. YACONO

An awful lot of electronics enthusiasts nowadays have a personal computer. And, if any of them are like me, it would seem pretty natural for a typical computer/electronics bug to want to build and connect all sorts of projects to their computers. Luckily, a PC's parallel printer ports are perfect for hobbyist-level interfacing because they use standard TTL voltages (0-volts is a low, 5-volts is a high). That makes designing a computer project simple.

Unfortunately, unless they own a technical-reference manual for their system, they'll soon discover that the necessary programming information is scarce. There are many books on building and connecting all kinds of interfaces, even building your own expansion boards, but (sigh) few of them actually tell you which bit in the computer corresponds to which pin receptacle on a parallel-port connector.

In this article, I'll endeavor to do just that for the three parallel printer ports you may find on a typical IBM-compatible PC/XT/AT. If you want to learn how to control or read the logic level of the pin holes on a parallel port from a program, this was written for you.

For the sake of brevity, I'll assume you have at least a little knowledge of programming (like what a statement

is, what memory is, what a port is, etc.) Further still, I won't be discussing the typical function of the lines on the ports, as you'll just assign them a function of your own anyway. If you still really want to know more about parallel ports signals and dealing with their practicalities, read "All About Parallel-Port Signals" (*Popular Electronics*, January, 1992) and "Troubleshooting Parallel Connections" (*Popular Electronics*, February, 1992).

Using Addresses. As you probably know, all programs, no matter how simple, temporarily store data in the computer's memory. A computer's memory is broken up into small pieces called bytes, and each byte is given its own address to help identify it. It's sort of like marking distinct numbers (addresses) on a bunch of boxes (bytes) so you can refer to the stuff inside each box (data) by using the number of the box it's in (the address). If you want to store (or "write") a byte of data, you can tell the computer to place it in a certain box (address). If you want to look at (read) some already stored data, you can ask the computer to retrieve it from the appropriate box (address).

Data addresses—unlike residential addresses, which identify a house by number, street, city, and state—are

simply just numbers. However, most of the time we humans don't write programs containing actual addresses to store and retrieve data. Instead we use variables—various combinations of letters and numbers, which are more descriptive and thus more intuitive for us to use. When asked to store or retrieve data related to a particular variable (like "Total" or "Customer"), a computer translates the variable name into its appropriate address at some point before performing the task.

However, there are certain times when writing an address numerically is better. Typically, numerical addresses are written in a number system called "hexadecimal." The hexadecimal system contains 16 digits (0–9 and A–F) rather than two (as in binary) or ten (as in decimal). For the rest of this article, when we refer to any address we will use hexadecimal numbers.

In BASIC, to indicate a number is written in hexadecimal you type the prefix "&H" in front of the number. For example, the hexadecimal number "A" (which is 10 in decimal form), would have to be typed "&HA."

So far we've loosely discussed how to write to and read from memory using addresses. Fortunately, reading incoming data from, and writing out-

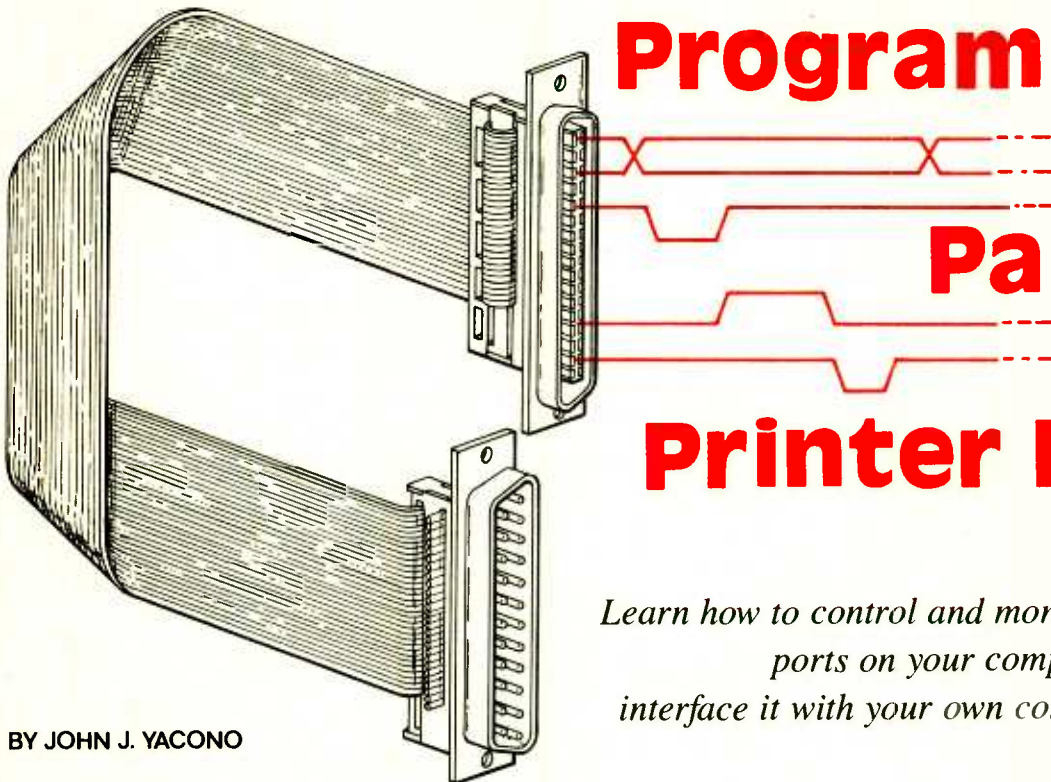

going data to a port is done in much the same way; in a program, you refer to a port by specifying the address of that port. In basic, to send data to a port you would use a statement of the form:

```
OUT address,data
```

where *address* is the address of the port, and *data* is the actual data you wish to send or a variable name that represents the address where the data is stored. Note the customary program line number has been dropped for clarity. For example, to send the decimal number 5 to a port with the hexadecimal address E1, a program must contain the statement:

```
OUT &HE1,5
```

If the number 5 had been stored in an address with the symbolic name NUMBER, the statement could've been written:

```
OUT &HE1,NUMBER
```

To process this statement, the computer will send the data located in the address corresponding to the variable NUMBER to the port with hexadecimal address E1.

In BASIC you can use the following function statement to get data from a port:

```
variable = INP(address)
```

where *address* is the address of the port, and *variable* is the name of the variable (which the computer will translate into a memory address) you want the data to be stored under. For example, to grab data from a port with the hexadecimal address 5D, and store it in the address used by the variable PORTDATA, a program must contain the statement:

```
PORTDATA = INP(&H5D)
```

The statement sets the value contained in the variable PORTDATA equal to the data contained in the port that has the hexadecimal address 5D.

Parallel-Port Addressing. Each of the three possible parallel ports (normally referred to as LPT1:, LPT2:, and LPT3: in DOS documentation), is supported by three addresses (see Table 1). For example, bytes 3BC through 3BE are associated with LPT1:. Each address contains one byte of information and each bit in each byte

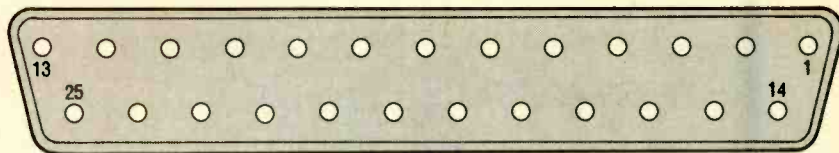

Fig. 1. If you look at the back of your computer, you should find at least one female connector that looks like this. Many of the holes correspond to bits in the computer that can be used to control or read their logic value.

TABLE 1—BYTES, BITS, AND PINS

Port Addresses in Hexadecimal			Bit in Byte (N)	DB-25F Pin	Input or Output
LPT1:	LPT2:	LPT3:			
3BC	378	278	0	2	Output
			1	3	Output
			2	4	Output
			3	5	Output
			4	6	Output
			5	7	Output
			6	8	Output
3BD	379	279	7	9	Output
			0	NA	—
			1	NA	—
			2	NA	—
			3	15	Input
			4	13	Input
			5	12	Input
6	10	Input			
3BE	37A	27A	7*	11	Input
			0*	1	Output
			1*	14	Output
			2	16	Output
			3*	17	Output
			4	NA	—
			5	NA	—
6	NA	—			
			7	NA	—

*The data in these bits is inverted

performs a certain job. Some bits reflect the logic state of input lines, others can be used to control the logic state of output lines, and the remainder are not applicable to our discussion.

The pin receptacles listed in Table 1 can be found on the female DB-25 connector used for the parallel port(s) on most IBM-compatible computers. See Fig. 1.

The second byte for each port (3BD, 379, or 279) is used to indicate the status of the input lines (at pin holes 10, 11, 12, 13, and 15). For example, lets say you wanted to find the status of the input pin holes for LPT1: from a basic program. The program would have to contain a statement to get input from the second byte that controls LPT1: (address 3BD), like this:

```
PARADAT = INP(&H3BD)
```

After a program executes this state-

ment, the value of the variable PARADAT will equal the byte stored in address 3BD. That byte can then be analyzed to determine which bits are high and which are low. With the exception of bit 7 (which is inverted), if a bit is logic 0, the corresponding input is being held low, if a bit is logic 1, the corresponding input is high. Since bit 7 in the byte is inverted, if that bit is logic 0, pin 11 is high, if that bit is logic 1, then pin-hole 11 is low.

To analyze a byte and determine if a particular bit is high, you just take the logical AND of the byte with two raised to the number of the bit you are testing (0-7). For example, this statement checks to see if bit N is high in a variable called PDAT:

```
TORF = PDAT AND 2^N
```

(The caret ^ indicates that what follows it—in this case N—is an expo-

(Continued on page 93)

Make Your Own

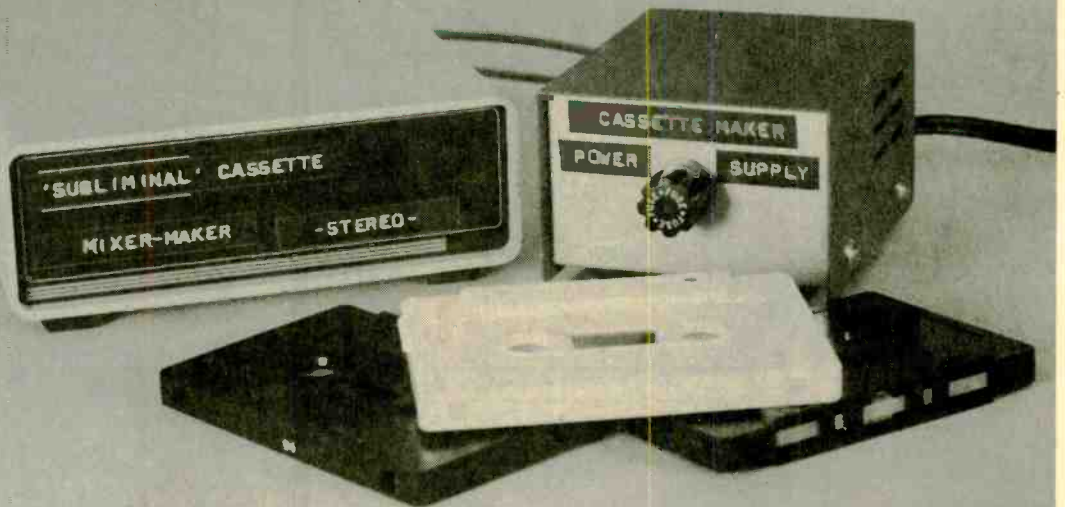

Subliminal Tapes

Build a simple circuit that allows you to experiment with one of the most controversial forms of self-improvement systems

BY JAMES MELTON

Subliminal tapes are on sale everywhere: bookstores, record stores, health stores, and even by mail-order through magazine ads. The topics range from stopping smoking, losing weight, and improving memory to gaining greater self confidence or becoming more influential. Do they work? The jury is still out on that question. Is it fun to experiment with the idea? Definitely!

The tapes are based on the fact that your subconscious mind can receive and process information that your conscious mind is completely unaware of. There are numerous examples that your subconscious mind is at work when you are not consciously aware of it. For example, a baby crying at night will wake up a parent, but other adults in the same house will sleep on (assuming the baby is not crying too loud). Even if you are in a sound sleep, the smell of smoke will generally wake you up. Strange bumps in the night will awaken your wife, while you sleep right on through if given the chance.

While the examples of awakening from a sound sleep due to external stimuli are the most straightforward, there is evidence that suggests that the same processing occurs on a subconscious level while you're awake. That's the theory behind subliminal tapes.

In application, a reduced-volume subliminal message is mixed with a bland musical background and tape recorded. Then the tape is played back when you have time to listen; the subconscious mind receives and processes both the recorded music (which could have some intelligence to it, but is usually specifically chosen not to) and the subliminal message.

The music must be chosen so that it does not become the dominant feature (so that you do not concentrate on it too much). For that reason, music with lyrics is usually avoided, because during playback the subconscious mind would have to decode the two language streams, and that would place an unnecessary and perhaps confusing burden on it. Therefore,

bland natural sounds are preferred. Ocean surf, chirping birds, the shore at a lake, or even the winds blowing during a storm are good examples of bland natural sounds. You can also use music that does not demand your full attention (for example, soft instrumentals), but the natural sounds are probably better suited for this application.

The subliminal message should always be upbeat and forward thinking. Good results (whether you're concerned about the conscious or the subconscious) are far easier to obtain with positive reinforcement—such as "I'll feel better as I lose weight," or "I can wait another hour for a cigarette," and so on—than with the use of negatives—such as "I am fat," and other such put downs.

The best part of making your own tapes is that you can phrase the messages to suit your needs. You control the content of the tapes; you can make them single purpose or multi-purpose. The more you listen, the more reinforcement you get, and the

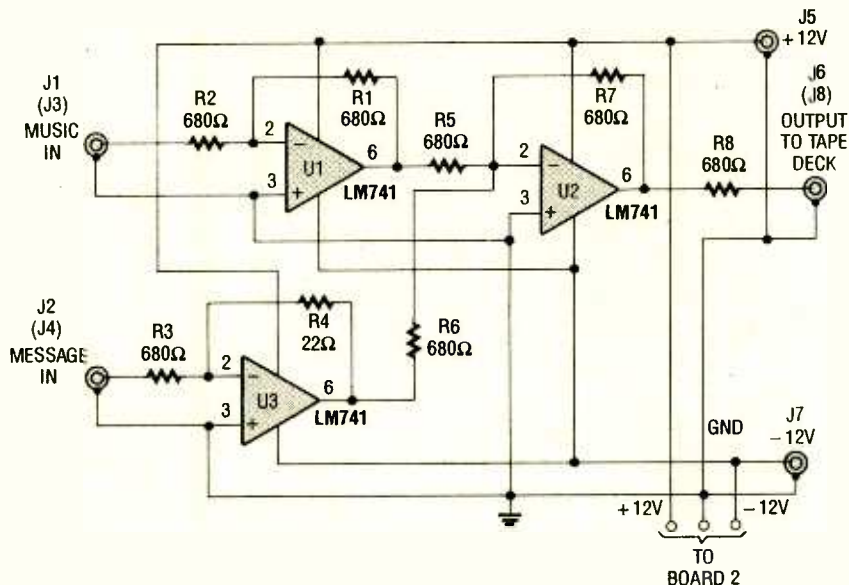

Fig. 1. Built around three LM741 general-purpose op-amps, the Subliminal Tape Mixer is designed to be completely goofproof—there are no adjustments to be made.

results will be faster, stronger, and longer lasting.

Circuit Theory. The tape mixer (see Fig. 1) is designed to be completely goofproof—there are no adjustments to be made. The main music input is passed through the mixer with no amplification and sent to the tape recorder, while the subliminal track is attenuated by 30 dB. At those levels, it is possible to hear some of the subliminal message if the music is off (like during quiet passages) and the playback volume is high. But when the regular music is on, you'll not be able to tell if the subliminal is on or off.

If the sound being slightly in the background is objectionable, then you can adjust the signal level of the message so that the information is recorded, but you cannot hear it on a conscious level, even during the silent periods between songs. That's the reason continuous sound, such as surf or the sound of rain is chosen. The more constant the main signal source, the louder you can have the subliminal source.

Since most users will want to use the mixer with stereo systems, two boards will be required. Because both are identical, we've shown only a single channel, while indicating which lines must be tied to the second board. The main channel is applied to the circuit at J1 (J3 is the main channel for the second board). The input signal is buffered by R2, which presents a load

of approximately 600 ohms to the line. A 741 op-amp (U1) in conjunction with feedback resistor R1 form the active part of the buffer.

The subliminal feed is applied to the circuit via J2 (J4 on the second board). Resistor R3 presents the 600-ohm load to the input line, and R4 along with U2 (another 741) form an attenuator for the subliminal line. In this case, R4 (a 22-ohm unit) together with R3 (680 ohms) provides just slightly more than 30 dB of signal reduction. If you feel that some other input level would be preferable, or you just want to experiment, see Table 1. Table 1 gives various resistor values (and their attenuation factors) that can be used for R4.

Note: in order to be realistic about the amount of dynamic range available on the typical cassette system, you should not have to go more than 40 dB lower in any stretch of music/voice over combinations.

The outputs of U1 and U2 are fed to final mixer-amp U3 (another 741) through R5 and R6. Op-amp U3 algebraically adds the outputs of U1

TABLE 1—ATTENUATION

R4 Value	Attenuation Factor
680Ω	none
480Ω	3 dB
340Ω	6 dB
240Ω	9 dB
120Ω	15 dB
68Ω	20 dB
6.8Ω	40 dB

THE SUBLIMINAL CONTROVERSY

The use of subliminal advertising has been controversial since its first use. As far as visual subliminal suggestion is concerned, there is no doubt that a picture of items flashed on a movie screen for as little as one frame can increase sales at the concession stand of a theater. That kind of advertising, in particular, has been banned in the US.

The controversy is that on one hand there are numerous studies that prove that it cannot be detected, and therefore cannot work, while on the other hand, the FCC has deemed it illegal to use subliminal advertisements to sell things without notifying the recipient that subliminal suggestions are being used!

Several books have been written on the subject of subliminal advertising, with perhaps the most outspoken books being the ones written by Wilson Bryan Key: "Media Sexploitation" and "The Clam Plate Orgy" are two of the books he has authored. In them, Key outlines many examples of subliminal advertising that he claims sneak past the FCC. His opinion (and he argues his case very persuasively) is that the advertisers use subliminal suggestion to help you overcome fear of being overweight in order to sell candy, or help you lose your fear of cancer in order to sell cigarettes.

Since the idea of audio subliminal suggestion has neither been proven nor disproved, the ultimate use of the tape maker presented here is up to you. There are studies that track the amount of shoplifting that occurred in a store that had background music playing with a subliminal suggestion that said "I am honest, I will not steal. Shoplifting is wrong," and so on. The amount of shoplifting with the subliminal suggestion was measurably less than with just the background music. And again, there are also studies that show there is no difference!

The audio subliminal technique used here will allow you to make your own subliminal tapes, containing your own messages. You can then reach your own conclusions and make your own decisions. One note of caution; other people will not appreciate being experimented on without their prior consent or knowledge, so use the tape on well-informed and willing volunteers.

and U2, and passes them through to the output via R8, which provides the nominal 600-ohm output necessary for impedance matching to the input of a tape deck.

Power for the project was originally supplied by batteries. However, it was soon discovered that as the batteries began to go (which did not take long)

distortion—which was not immediately noticeable—got into the recording. Therefore, the battery supply was abandoned in favor of a dual polarity (+/-12 volt) DC power supply, based on 7812 and 7912 (positive and negative, respectively) three-terminal regulators. Both units can supply up to 1.5 amp each, obviously more than enough current to power six 741 op-amps.

Construction. The author's unit was assembled on two printed-circuit boards, measuring about 3⁹/₁₆ by 1³/₁₆ inches, both of which were etched on a single copper-clad slug; one each for the left and right channels. However, there is no reason that two separate boards could not be used; particularly, since either way, the two sets of circuit-board traces must be hard-wired together in three places as you'll see in the parts-placement diagram. A template of the single printed-circuit pattern is shown in Fig. 2. Remember, you'll need two such boards.

To avoid having to drill holes in the circuit board for the component leads, the author surface-mounted regular components to the copper side of the board. Refer to Fig. 3 for the locations of the components. The components are installed on the board from the centerline outward, using a very-fine-tipped soldering iron. Because direct-soldered IC's are almost impossible to remove and direct soldering can (and often does) damage IC's, the use of sockets for U1-U3 is highly recommended. After installing the IC sockets, install the resistors. The resistors leads are easily secured to the board by depositing a glob of solder on one pad and then melting one lead of the resistor onto the glob. After that, you can secure the other end of the resistor.

Next, solder appropriate lengths of small-gauge stranded wire to the circuit-board pads marked for the input, output, and power-supply connections. Note: It will be necessary to make jumper connections between the -12-volt (J7), the +12-volt (J5), and the ground pads on the two boards. Then connect lengths of wire to the appropriate circuit-board pads on both boards for connection to a bank of eight RCA phono jacks, which will be mounted to the rear of the proj-

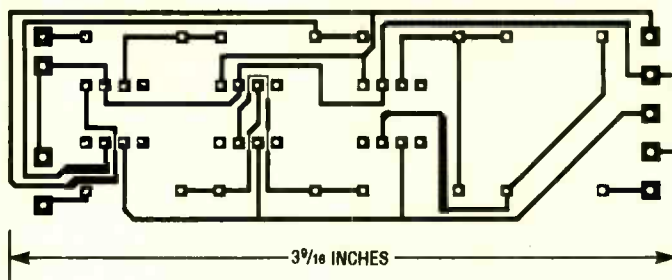

Fig. 2. When preparing the printed-circuit board for the Subliminal Tape Mixer, remember that you'll need to duplicate the printed-circuit pattern shown here twice... either on two separate boards or on a single board as the author did.

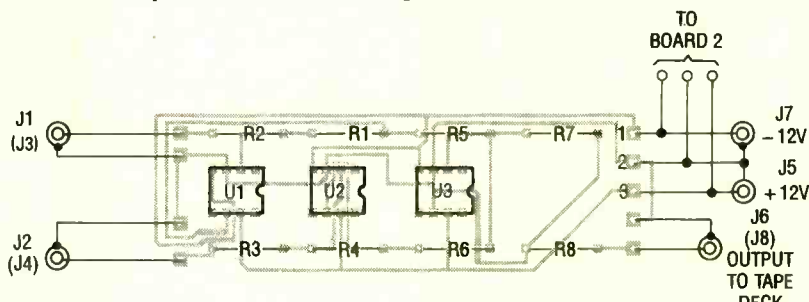

Fig. 3. To avoid having to drill holes in the circuit board for the component leads, the author surface-mounted regular components to the copper side of the board. Refer to this diagram for the locations of the components; the inter connections between the circuit board patterns; and the wiring of the off-board components.

PARTS LIST FOR THE SUBLIMINAL TAPE MIXER

- U1-U3—LM741 general-purpose op-amp, integrated circuit
- R1-R3, R5-R8—680-ohm, 1/4-watt, 5% resistor
- R4—22-ohm, 1/4-watt, 5% resistor
- J1-J8—RCA phono jack
- Printed-circuit materials, enclosure, +/-12-volt power source, wire, solder, hardware, etc.

Note: An etched, printed-circuit board (two channels) is available for \$12.00; a 5-minute, 1000-Hz tone tape is available for \$5.00. Contact James Melton, SW Books, 2747 Wentworth Drive, Grand Prairie, TX 75052. Please add \$2.00 for postage and packaging per order. Texas residents please add appropriate sales tax.

ect's enclosure. Note that J3, J4, and J8 are on the second board, and are indicated by the jack numbers in parenthesis.

The circuit can be housed in an enclosure of your own choosing, so long as it can accommodate the circuit board(s). Prepare the enclosure by making a cutout in the rear panel of the enclosure large enough to accommodate the bank of phono jacks. Since the circuit needs no adjustment,

there is no need to prepare the front panel for controls. After making the rear-panel cutout, mount the bank of jacks, and begin making connections between circuit board(s) and jack bank. Once completed, check your work for possible wiring errors, particularly the inter-board connections. If everything looks OK, install the IC's in their sockets, with the proper orientation (as shown in the parts placement diagram).

Using the Subliminal Tape Mixer.

To initially set up your tape recorder for this project, you'll need a master-volume tape—a tape on which you've recorded a 1000-Hz tone (at a 0-dB level) on both channels using your best recorder. If you do not have the equipment to make the tape, a source for one is listed in the Parts List.

You'll also need a background source (a tape containing the natural sounds or music—perhaps classical—mentioned earlier); the subliminal message tape recorded at normal volume, and three player/recorders.

Connect the tape player for the subliminal tape to the main input jacks; J1 and J3, and a high-quality recorder to the output jacks (J6 and J8).

(Continued on page 91)

ALL ABOUT MICRO PROCESSORS

This month we explore the internal operation of microprocessors in a step-by-step fashion.

BY TIMOTHY D. GREEN

Last month we looked at the microprocessor's control unit and set-up a simple 8-bit microprocessor. This month we will cover some examples of the microprocessor's instructions and how they are executed. We will also look at some special instructions and features.

Incrementing the Accumulator.

Suppose that the microprocessor has an instruction that increments the accumulator register. Since this instruction works with the accumulator alone, it will take only one eight-bit instruction code to represent it.

Suppose that the program counter and the address latches have the address of the increment instruction in them already. With this information, the control unit is ready to perform the increment instruction. Look at Fig. 1 as we explain the steps of the process.

First, the control unit activates the external read and memory control lines, sets the data buffer controls to receive input, and enable the buffer's output (remember the blocks connected to the internal bus are three-state circuits). Those steps bring the instruction from external memory into the external data bus, and, in turn, onto the internal data bus.

With the instruction on the internal bus, the control unit activates the latch control of the instruction latch and at the same time activates the clear-counter control of the control unit counter (not shown in Fig. 1 as it is a part of the control circuit's architecture). The instruction code to increment the accumulator register is now

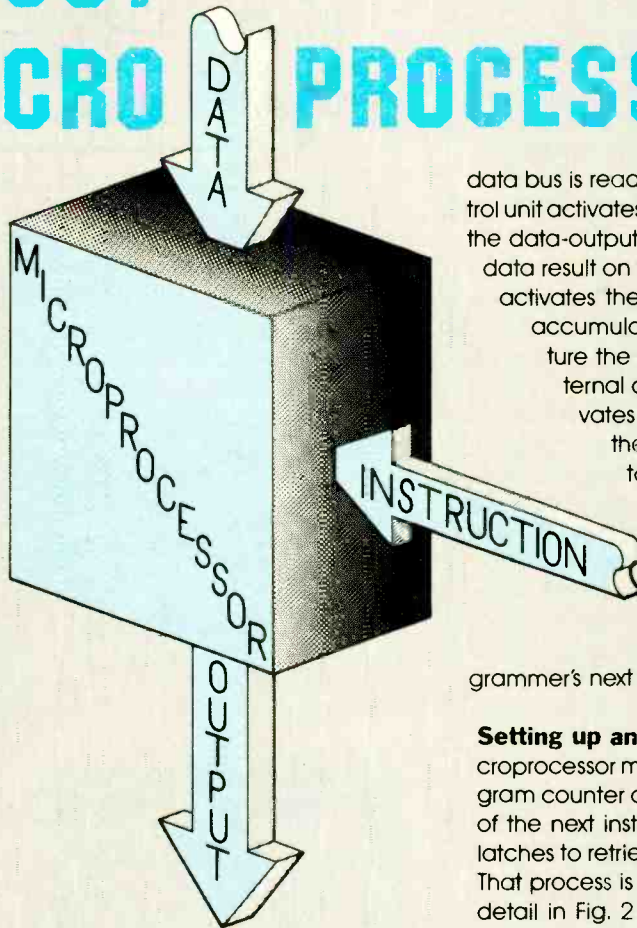

in place and ready to be processed.

The control unit now deactivates the control lines for the instruction latch, the control unit counter, and the external read and memory control lines. It also disables the data-buffer outputs to free-up the internal data bus. Then it activates the output enable of the accumulator register so that the accumulator's data is placed on the internal data bus, and it sends an increment input #1 command to the ALU as well.

When the ALU has done its job, the control unit activates the latch controls for the data output register and the external status register. The external status register is used since the ALU's operation was used to fulfill a programmer's instruction. Next the latch controls for the data-output register and the external status register are deactivated followed by the controls for the accumulator's output enable and the ALU's command lines.

At this point, the data result is in the data-output register and the internal

data bus is ready for use. So the control unit activates the output enable of the data-output register to place the data result on the internal data bus, activates the latch control of the accumulator register to capture the data result for the internal data bus, and deactivates the output enable of the data-output register to clear the internal data bus. The operation is now complete, so the microprocessor's control unit must set-up the programmer's next instruction.

Setting up an Instruction. The microprocessor must increment the program counter and place the address of the next instruction in the address latches to retrieve the next instruction. That process is shown in abbreviated detail in Fig. 2 and is as follows: The control unit places the low-half of the program counter's data onto the internal data bus, commands the ALU to increment input #1, and latches the results in the data-output register and the internal status register. The internal status register is used because this operation was requested only by the control unit, not the programmer.

The incremented low-half results from the data-output register are then sent back to the low-half of the program counter. The high-half of the program counter's data is then placed onto the internal data bus and the ALU is commanded to add any carry bit from the previous (low byte) addition to input #1, and latch the result in the data-output register. That data is the high-half result that is picked up by the high-half register of the program counter under command from the control unit. Finally, the low and high halves of the program counter are sent to the low and high halves of the address latches, respectively. At this point, the microprocessor is ready to process the next instruction.

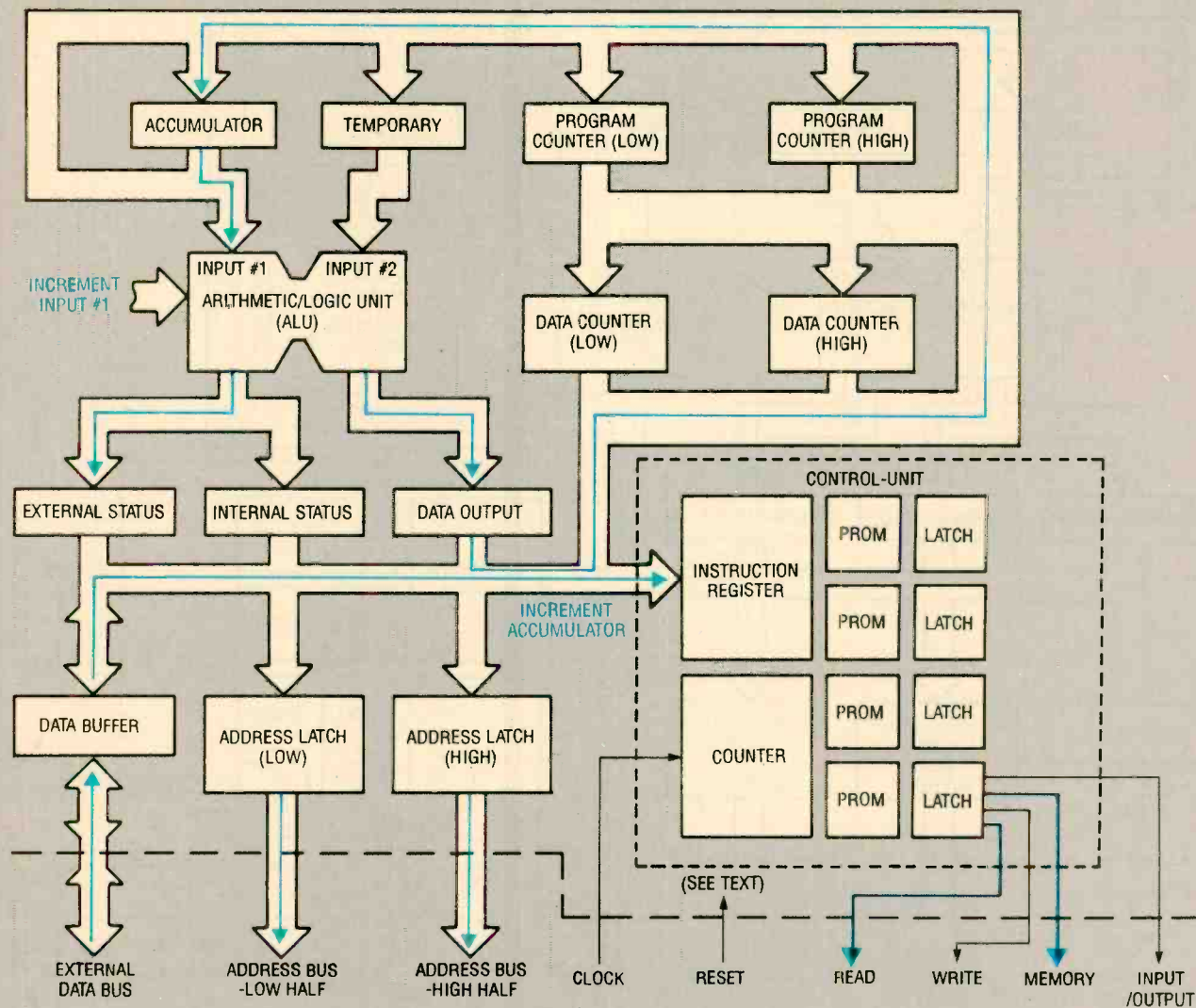

Fig. 1. To increment the value in the accumulator, first the address of the accumulate instruction is latched into the instruction register via the data buffer, then the controller processes the instruction by coordinating the ALU and the external-status, data-output, and accumulator registers.

Handling a Jump. In another example, consider the instruction "jump to a new address." A jump instruction is a programmer's command to go to a new section of external memory to do another part of the program there. That is, instead of incrementing the program counter to the next address to do the next instruction, the program counter is loaded with a different address contained within the jump instruction.

Unlike the last two examples, the jump instruction is coded in multiple parts. That is part of the trade-off between a control unit and a microprocessor. It shows the limitations and the advantages of using sequential, "indirect" instruction steps to perform a programmer's tasks, as we discussed

last month. The limitation is slower execution speed. The advantage is greater complexity and versatility.

The jump instruction is coded in three parts, which must be sequentially retrieved from external memory. The first part is the jump-instruction code itself, which tells the control unit to read-in the next two parts and transfer them to the program counter as the next address. The two parts are the low-half and high-half of the address of the instruction the processor must jump to. The order of the two halves of the address (whether the low comes before the high or not) depends on the microprocessor.

The sequence of steps used to process the jump instruction is shown in abbreviated detail in Fig. 3 and is as

follows: As for any instruction, the control unit activates the external read and memory lines, latches the jump-instruction code into the data buffer, enables the data buffer's output, and clears the control-unit counter. This places the jump instruction on the microprocessor's internal bus.

Now the control unit runs the sequence to increment the program counter to get the low-half address for the jump from memory. The microprocessor reads the new low-half address from external memory and temporarily stores it in the low-half of the data counter. The same steps are performed to get the high-half of the address for the jump from external memory and temporarily store it in the high-half of the data counter.

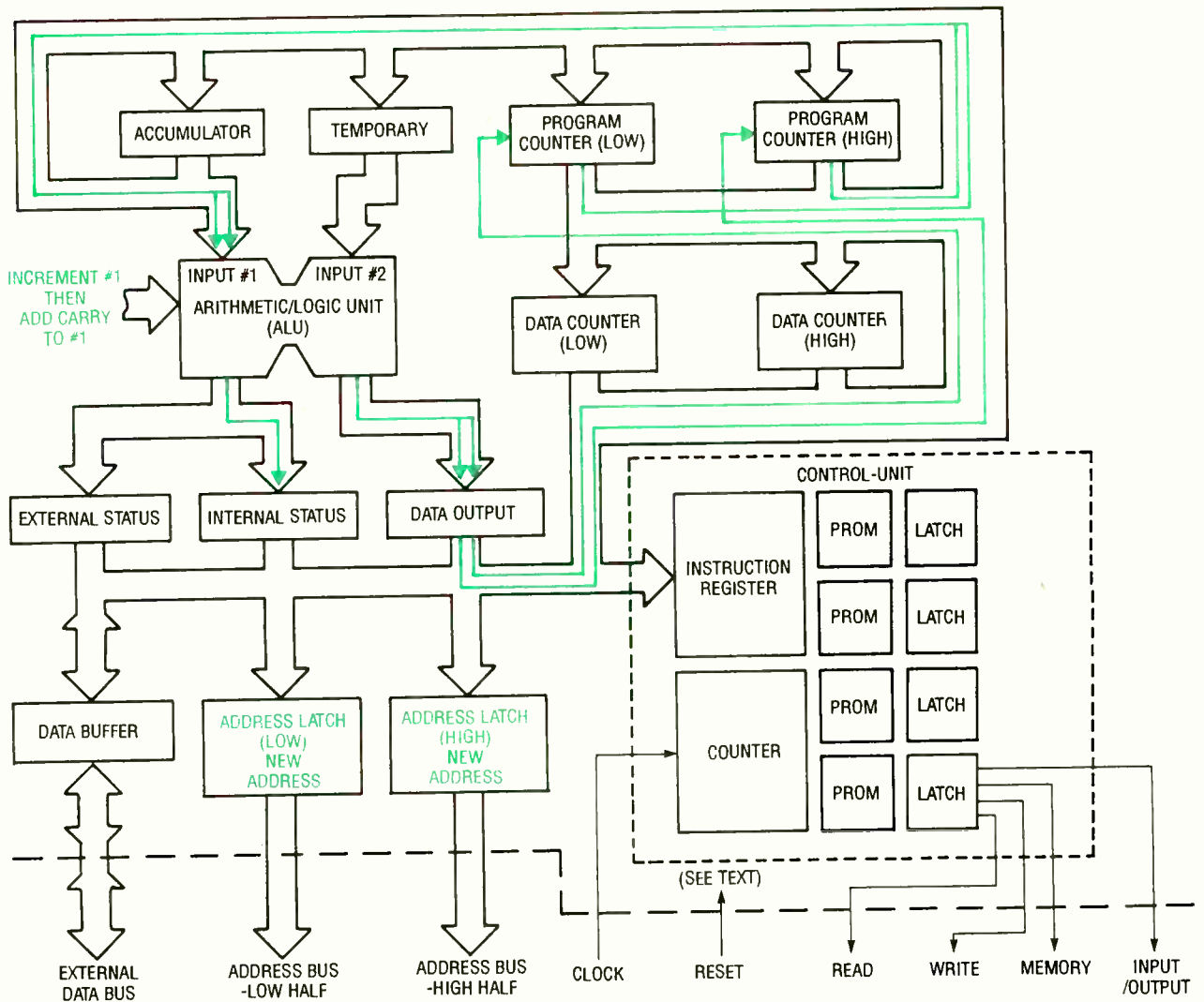

Fig. 2. Between each instruction the microprocessor's control unit must do some housekeeping to ready itself for the next instruction.

To finish up, the control unit sends the new low and high halves of the address in the data counter to the low and high halves of the program counter. Then it sends the low and high halves of the program counter to the low and high halves of the address latches to set-up the programmer's next instruction.

An Addition. As a last example, suppose that there is an instruction that adds the value in the accumulator to a value in memory and stores the result in memory. This instruction, like the jump instruction, would be composed of three parts. The first part is the add instruction code, which will cause the control unit to read-in the next two parts and execute the instruction. These two parts are the low and high halves of the external RAM address of

the word to add to the accumulator value. That same address is where the result will be placed.

The sequence of the add instruction is shown in abbreviated detail in Fig. 4 and works as follows: To begin, the system runs the same first five steps as the jump instruction. That is, get the add instruction code and load the data counter with the address given in the last two parts of the instruction. Then send the address in the data counter to the address latches to prepare to read and write data at this address.

The data from that memory address is then written into the temporary register. The accumulator data and the temporary-register data are then presented to the ALU's inputs. The control unit next commands the ALU to add input #1 and input #2 and

store the results in the data-output register and the external status register. With the result in the data-output register, the register's output is enabled the external write and memory-control lines are activated to write the data result into the external RAM. The controller then follows up by running the sequence to increment the program counter, as before, setting up the programmer's next instruction.

Conditional Instructions. A conditional instruction is one that is executed only when one of the status register's status bits is at the appropriate logic level. Examples of these instructions are "jump if carry bit is set" and "jump if the zero bit is reset."

The control unit cannot run conditional instructions in its present form. It must be modified to include the sta-

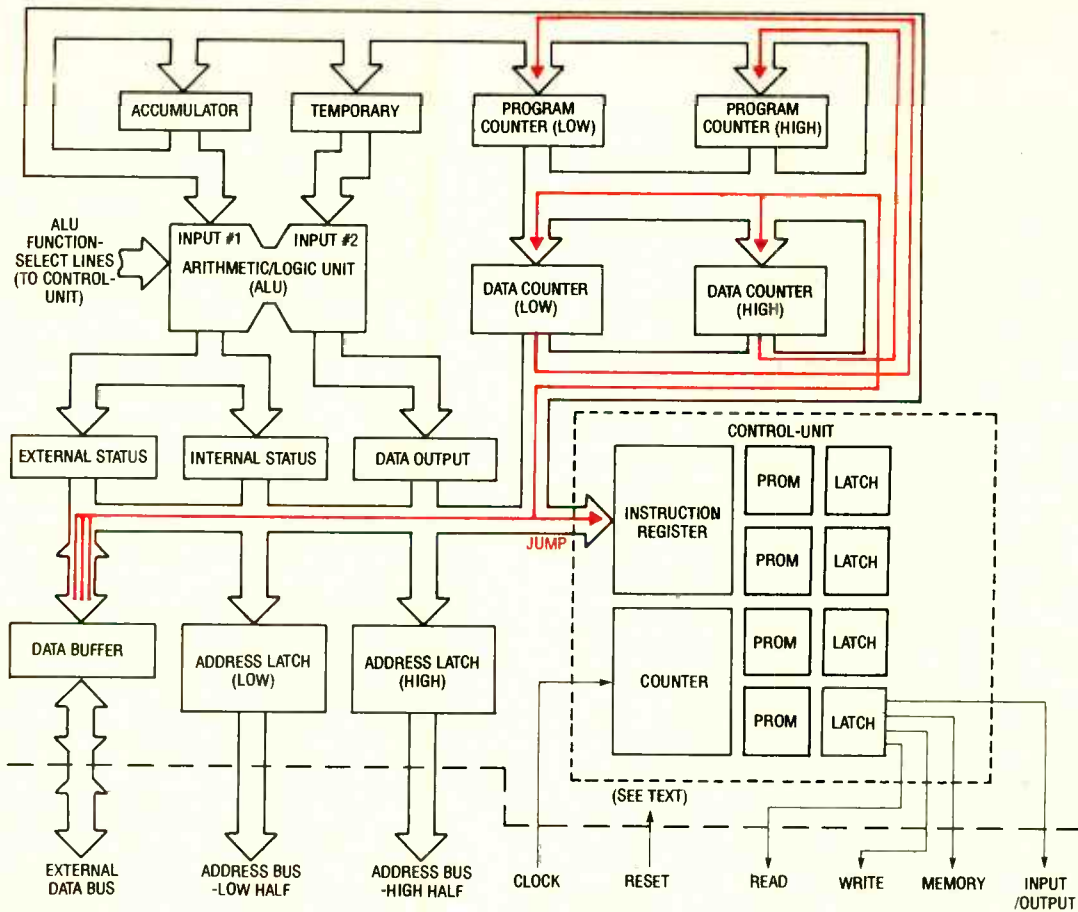

Fig. 3. To process a jump instruction, a microprocessor must receive the jump instruction, and the low half and high half of the address to jump to.

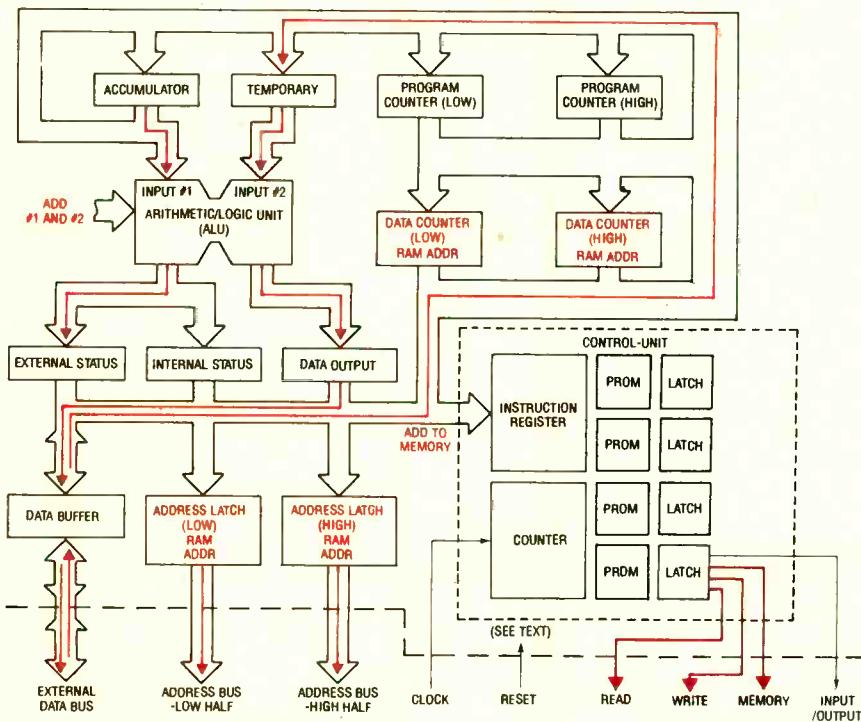

Fig. 4. To perform an addition to memory, the address and then the contents of a memory location must be pulled into the microprocessor. It is then added to the accumulator value and the result is latched out.

tus bits in its controlling processes.

The status registers must be modified so that the three-state outputs are tied to the internal data bus through a buffer, rather than using the three-state outputs of the latch. That is shown in Fig. 5. This allows the control unit to use the status information without interfering with the operation of the internal data bus.

In Fig. 5, the status bits are fed into a 16-to-1 multiplexer that selects a single input's value to appear at the output when it is given a binary-coded selection code by the control unit. One of the inputs to the multiplexer comes from the lowest bit of the instruction latch. The output of the multiplexer is fed to the control unit's PROMs on the same line that was fed by the lowest bit of the instruction latch. That allows the control unit to select status bits to be included in determining a control process to execute. One of two different control sequences will be executed depending on the output of the 16-to-1 multiplexer.

These control sequences must have

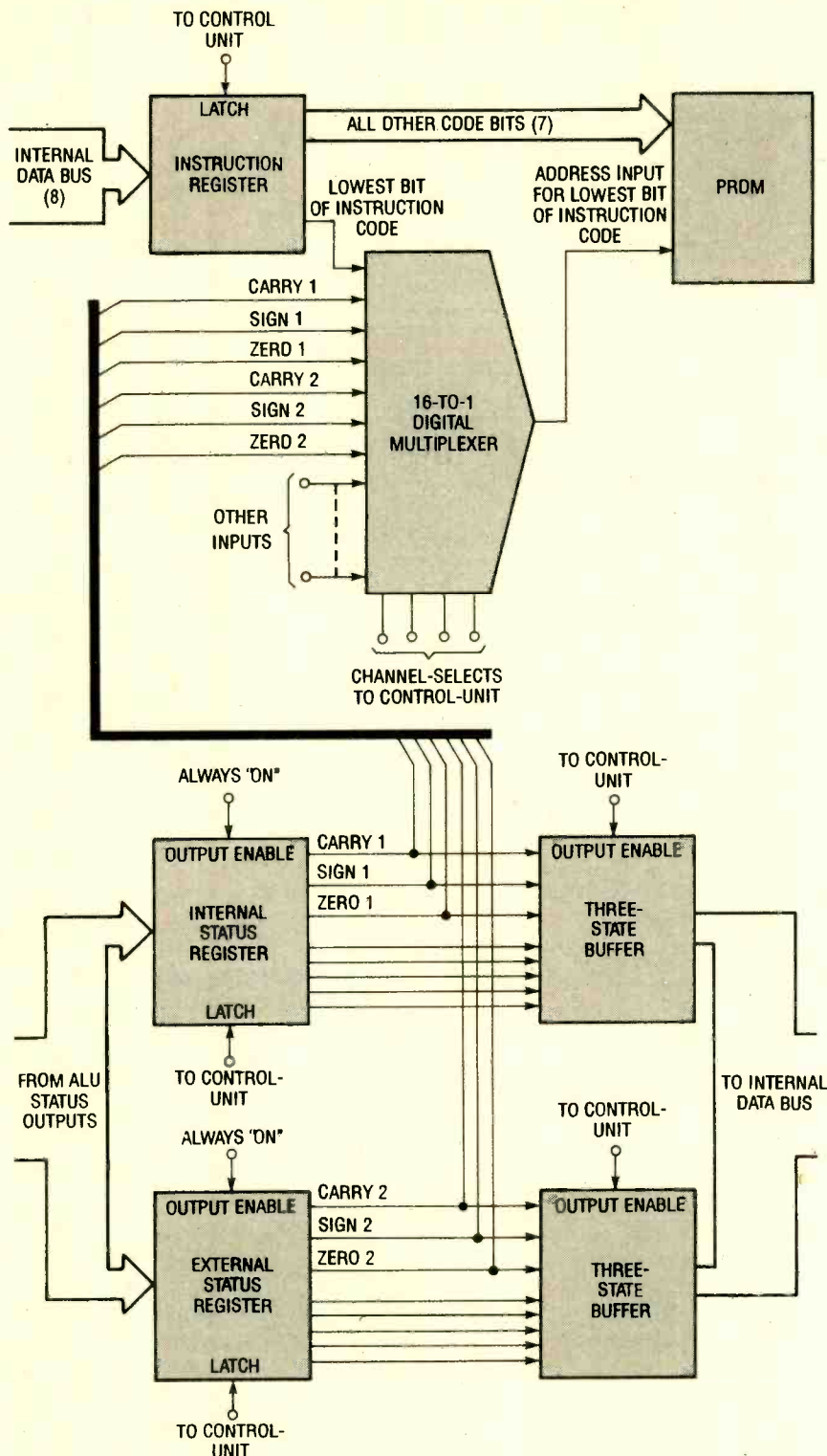

Fig. 5. To process conditional instructions (like jump if a result is zero, or decrement a number if it is not equal to zero, etc.) the control unit uses the contents of the status registers to help select the right PROM address.

overlapping code to prevent any signal mismatch that may occur when the multiplexer is switched. An instruction that is not conditional must have the control unit select the lowest bit of the instruction latch to send to the

PROM's. When any instruction is finished it must do the same.

One example of a conditional instruction is the "jump if carry bit is set" instruction. The control unit will direct the multiplexer to select the external

References

Bipolar Microprocessor Logic and Interface 1985 Data Book, Advanced Micro Devices, 1985

Bit-Slice Design: Controllers and ALU's, D.E. White, Garland STPM Press, 1981

Microprogramming and Firmware Engineering Methods, Edited by Stanley Habib, Van Nostrand Reinhold, 1988

Elements of Microprogramming, by J.K. Banerji and J. Raymond, Prentice-Hall, 1982

status register's carry bit and send it to the PROM's at the start of this instruction. If the carry bit is reset, the control sequence will increment the program counter to the start of the next instruction after the jump. If the carry bit is set, the control unit will run the jump instruction sequence.

Microprocessor Reset. The microprocessor must have an orderly starting sequence when the power is turned on. This is the purpose of the microprocessor's reset line as shown back in Figs. 1 and 2. One instruction code, such as all zeros, could be reserved to act only when the reset line is active. More hardware would be needed to clear the instruction latch and the control-unit counter when the reset occurs.

Some microprocessors start by clearing all of the registers, including the program counter, so that the programmer's programs will start at address zero. Other microprocessors start the program counter at some preset value.

Conclusion. A microprocessor is an extension of the control unit that runs it. The control unit, the registers, and the ALU form a more complex "controller" that is called a microprocessor.

The type of control unit and microprocessor we've explored is called a "microprogrammed" design. Microprogramming is not the same as programming a microprocessor; microprogramming uses a one-to-one correspondence of the control line and the device it controls. Programming a microprocessor does not. For more information about microprogramming and computer design, see the books mentioned in the boxed text entitled "References." ■

BUILD THE WATER TAP

Add the dimension of sound to your fish tank with this one-evening project.

BY MARC SPIWAK

Ideas for projects don't grow on trees—usually they're the result of wanting to do something that can't be done without some unique gadget. That's exactly how the idea for this project came about. You see, I have a rather large freshwater fish from the Cichlid family known as a "Jack Dempsey" (in Latin it's called *Ciclasoma octofasciatum*). The fish is of a rather violent nature, even more so than most Cichlids (hence the name Jack Dempsey). He can't be kept in a community aquarium among peaceful fish, so he has his own tank.

Besides being able to swallow smaller fish whole, the Jack Dempsey can also swallow whole food pellets. These food pellets are "crunchy" when dry, and "Jack" swallows them as soon as they hit the water. One day while feeding him, I could swear I heard a sort of "crunch, crunch" sound just after he swallowed a pellet. Now although the pellets seem like they would be hard for a fish with no teeth to pulverize, apparently he can do just that.

Thinking about the faint yet strange sounds, I wished that I could somehow amplify them. I had an amplifier circuit with an electret microphone attached to it, but electret microphones shouldn't be placed underwater. If only there were some easy way to waterproof the microphone, then it would be easy to amplify the underwater sounds—or to at least to test the idea.

So I wrapped the microphone in

cellophane, plunked it into the fish tank, and powered up the amp. It worked, but at first all I heard was the filter bubbling away—although much louder than usual. After shutting off the filter, it sounded very much like what you hear when you swim underwater. So then I dropped in a food pellet, and there was that crunching sound, loud and clear.

After listening for a while, static started to replace the nautical theme. The problem was that the cellophane had somehow leaked, and the microphone was actually exposed to water.

Clearly the microphone would need better waterproofing. Let's discuss the method I used to protect the microphone, and the amplifier circuit in greater depth so you can build your own.

The Water Tap. The amplifier circuit is shown in Fig. 1. It's based on a 2-watt TBA820M op-amp, but as you can see from the Parts List, there are a few other chips that are pin-for-pin compatible replacements for it. The circuit is powered from a 9-volt battery. Instead of making a PC board for the

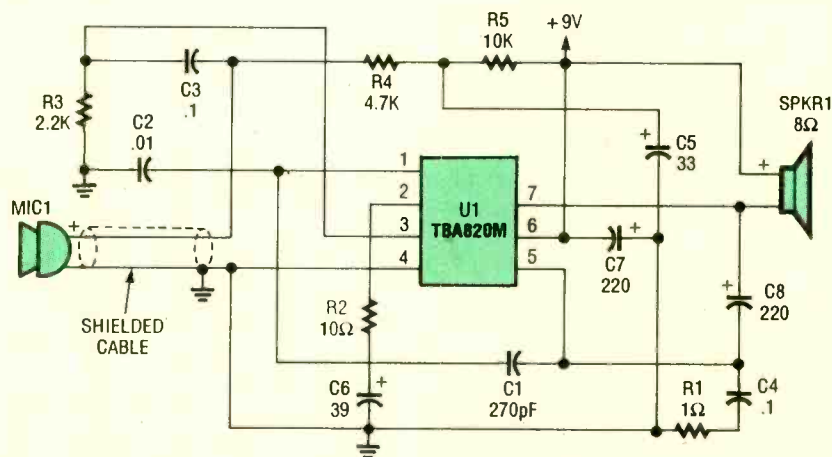

Fig. 1. The amplifier circuit is based on a 2-watt audio op-amp, and powered from a 9-volt battery. Perfboard and point-to-point wiring was used to make the circuit.

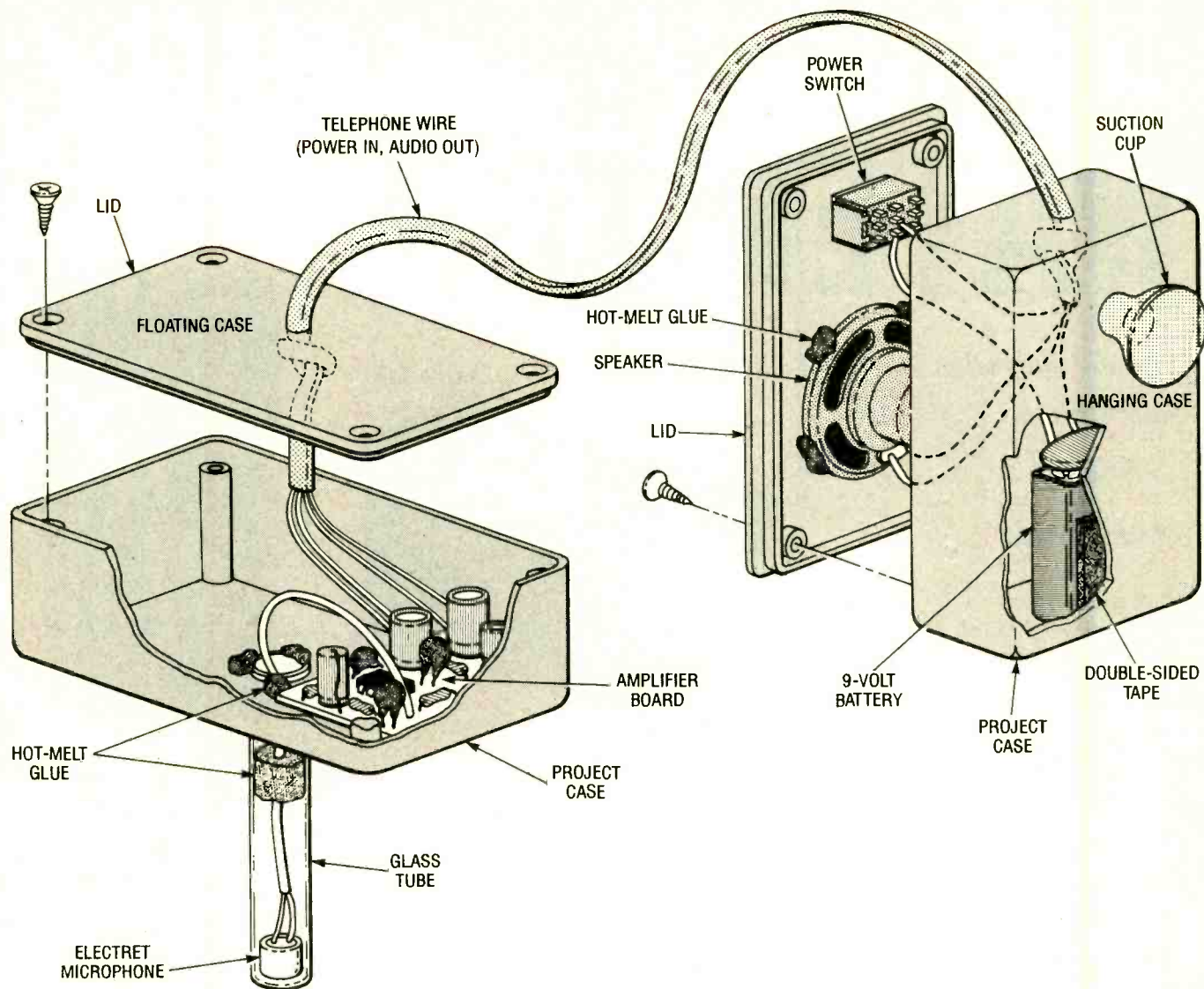

Fig. 2. The microphone and amplifier board are mounted in one floating project case, and the battery, speaker, and on/off switch are mounted in another case.

project, simple perfboard and point-to-point wiring was used.

The microphone was connected to the circuit with a 3-inch shielded cable. The amplifier is so sensitive that, during the initial tests, the speaker had to be attached to the cable via a 2-foot wire—otherwise the circuit squealed uncontrollably with feedback. Fortunately the wire can be shortened for the final Water Tap design.

It was decided that the microphone and amplifier board would be mounted in one floating project case (since the microphone's shielded cable shouldn't be too long), and that the battery, speaker, and on/off switch would be mounted in another project case that could be stuck to the side of the fish tank with a suction cup.

Figure 2 shows how the two sections

are interconnected. Since four wires are needed to connect the two sections together, a piece of 4-conductor telephone wire a little over a foot long was used. You can use four separate wires twisted together, but telephone wire has a neat finished appearance.

A glass test tube was used as a waterproof case for the microphone. It was reasoned that glass would probably result in better sound pickup than plastic, but you can experiment on different microphone covers if you like. The test tube was included in a fish-tank ammonia test kit. If you can't find a suitable test tube, or something similar, buy a cheap test kit (they should only cost two or three dollars) from an aquarium-supply store and use the one that comes with it.

The figure also shows how the floating case is laid out. A hole exactly the

same size as the test tube must be drilled in the bottom of the case. The tube then hangs out of the bottom of the case, making a tight fit in the hole. The joint between the case and the test tube must then be sealed with hot-melt glue or RTV (room-temperature vulcanizing) silicone to ensure a completely watertight seal. The microphone then slides down to the bottom of the tube, and more hot-melt glue or RTV silicone plugs up the top of the tube to further isolate the microphone from the outside air. Another hole is drilled in what is now the top of the case for the telephone wire to pass through. Make the hole as small as possible—seal the hole if it's much wider than the wire to help prevent water from getting inside the case.

The circuit board is then centered
(Continued on page 93)

Build a Four-Element Two-Meter Quad

You can easily build an inexpensive
transceiver antenna that's
both fun and
educational.

BY LARRY R. LUCHI, W7KZE

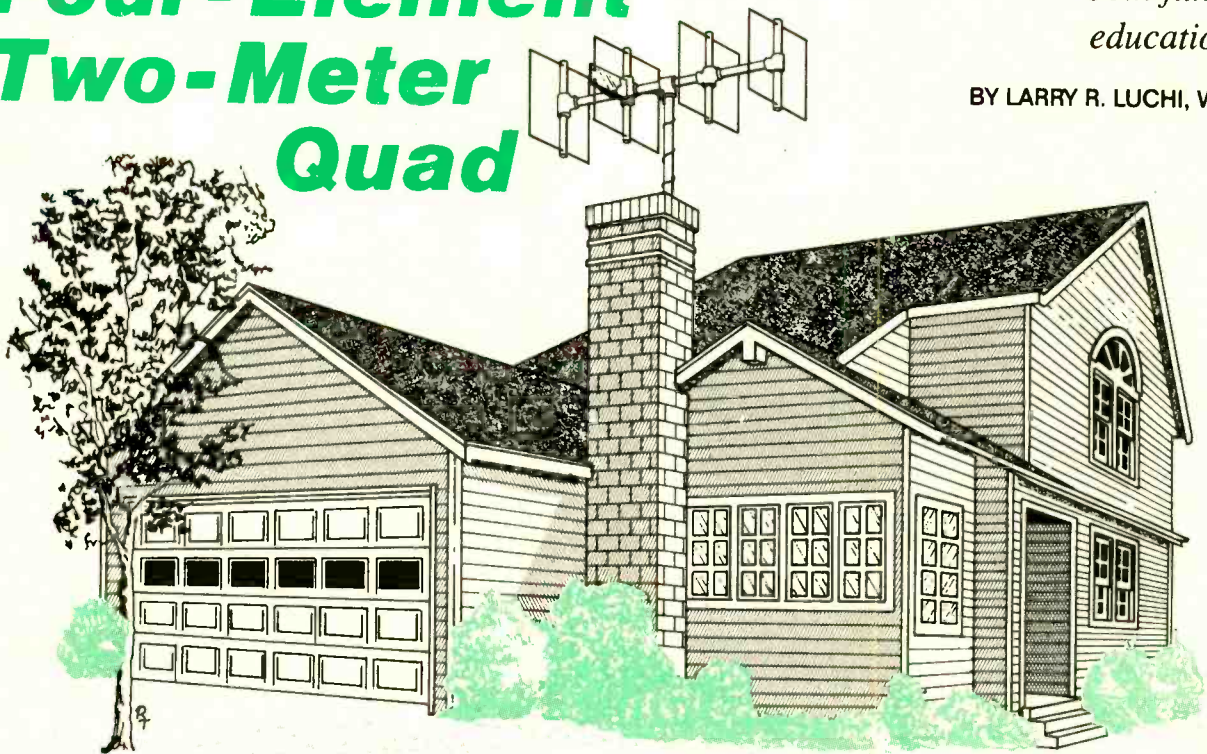

I really enjoy my work in the Electronics Technology Program at the Sno-Isle Skills Center where I teach. The Center is a vocational high school with twenty-two programs of instruction. During the second semester of each year, I teach amateur radio to junior and senior high school students. As part of their instruction, I have each of my students build an AM/FM superheterodyne receiver.

Of course, we also cover antenna design. So as a group, we had also constructed a half-wave dipole for two-meters. Two-meters gave us the compact size and also allowed me to demonstrate vertical and horizontal polarization.

As I explained the half-wave dipole antenna to my students, they appeared puzzled as if to ask "how can that work?" After the demonstration, some of these bright young minds came to life and started to ask ques-

tions out loud: "How can a full wave fit into a half-wave length of wire?" "If a gallon of milk is a gallon of milk and we drink a glass is it still a gallon?" My excitement increased with each question; they were obviously very intrigued by antennas.

So it Started. Since antennas were obviously a point of interest to the class, I searched for my *ARRL Antenna Book* (my personal favorite) and started to look for a two-meter quad antenna that could be easily constructed with little cost to the students. With the book in hand, I went to the faculty lounge to discuss my quad-antenna project with some of the staff.

I showed our welding instructor the drawings of a portable 144-MHz, 4-element quad. It turned out that he was the right man to speak to as he had a large quantity of 1/8-inch braz-

ing rods that we could use for the loops. (For your information, No. 8 aluminum ground wire will work just as well, but using the brazing rods kept student cost to a minimum.) Our plastics instructor had the needed PVC supports (spreaders) and a PVC boom. Our machine-trades instructor suggested he have his students drill all of the holes needed in the PVC supports and boom.

Now I would have to do some number crunching before we went further. The element spacing for quad antennas found in literature ranges from 0.14λ to 0.25λ (where λ is the wavelength). Factors such as the number of elements in the array and the parameters to be optimized (front/back ratio, forward gain bandwidth, etc.), determine the optimum element spacing within this range.

The other characteristics obey these relations:

Reflector length = $1046.8/f_{\text{MHz}}$
 Driven element = $985.5/f_{\text{MHz}}$
 Directors = $937.3/f_{\text{MHz}}$

where f_{MHz} is the frequency of interest and the lengths are measured in inches. The 4-element quad we built in class was designed for 146.58-kHz operation, so the reflector was 86-inches, the driven element was 81-inches, and the directors were 77-inches. With that out of the way, it was time for the students and I to roll up our sleeves and get to it.

Building the Quad. Construction began with two, 10-foot, 1/2-inch PVC pipes. From that stock, the boom was cut to 42 inches in length with allowances given for two PVC tees to be fitted at each end (see Fig. 1); one for the reflector and one for the first director. Those tees were not permanently installed at that time.

Construction of the elements began by cutting the PVC stock for the spreaders and drilling 1/8-inch holes in the ends of each piece to accommodate the brazing rods. The reflector spreader was initially cut to be 22 1/2 inches long, with holes drilled to be 10 3/4 inches from the center of the boom. The driven spreader was first cut to 21 1/4 inches long with holes drilled so that they'd be 10 1/8 inches from the center of the boom. The directors were then cut to 20 1/4 inches long with holes drilled to place them 9 5/8 inches from the center of the boom.

At this point, each spreader was cut

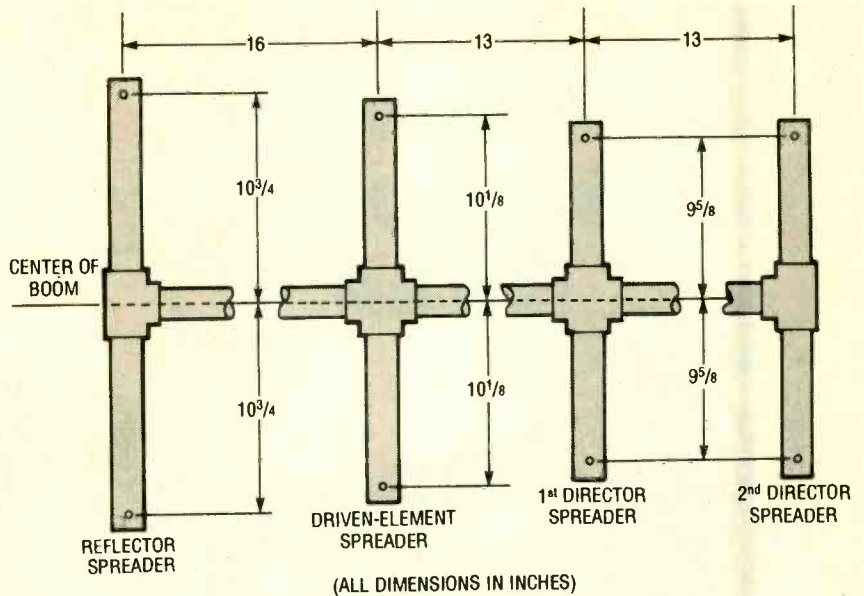

Fig. 1. This is the boom/spreader assembly for the quad antenna. Note that the locations of the holes are measured from the center of the boom.

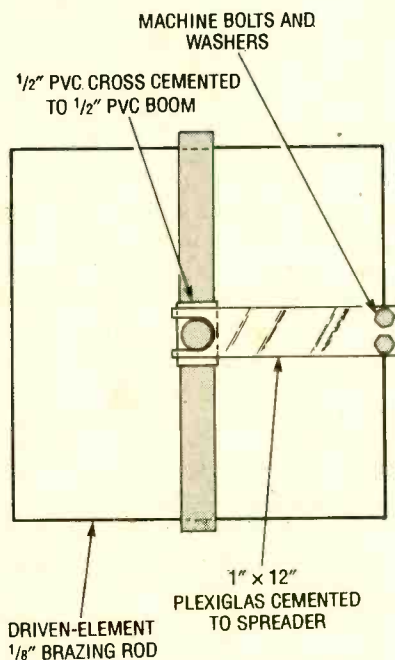

Fig. 2. A Plexiglass strip was used as a support for the feed point. It was cemented to the driven-element spreader.

in half (i.e., the reflector was cut at 11-1/4 inches). Then the reflector and first-director spreaders were glued (using Nova Weld P cement) to their tees, which were in-turn glued to the ends of the boom. The driven-element and the middle-director spreaders were glued into two PVC crosses that had been cut in half and glued to their measured places on the boom.

The driven element required extra preparation as the coax feed-point

MATERIALS LIST FOR THE 4-ELEMENT 2-METER QUAD

- 2 10-foot lengths of 1/2-inch PVC
- 1 x 12-inch Plexiglass plate
- 2 pounds of 1/8-inch oxy-acetylene brazing rods
- PVC cement
- RTV cement
- 2 Solder lugs for No. 8 hardware
- 2 No. 8 nut/bolt pairs
- 2 1/2-inch PVC tees
- 5 1/2-inch PVC crosses
- A length of 52-ohm feedline

needs to be adequately supported. We used a 1 x 12-inch Plexiglass plate to support the coax feed line, as shown in Fig. 2. One end of the Plexiglass plate was cut to fit around the boom, where it was epoxied. At the other end of the Plexiglass plate we drilled two holes 3/4 of an inch apart.

To begin making the feed-point connections, a 52-ohm coax feedline was terminated in solder lugs. Then two brazing rods were taken and a loop was formed in one end of each. A bolt was passed through each loop, solder lug, and hole in the Plexiglass and secured with a nut. The junctions were then soldered and sealed with RTV cement. From there, the cable was routed directly to the mast and down.

Three more brazing rods (two of
(Continued on page 93)

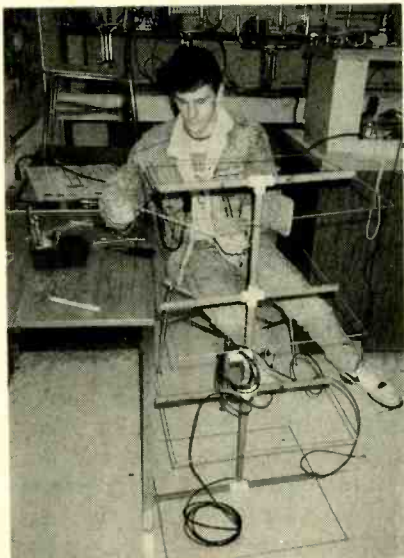

As each brazing rod was added to a given loop, its ends were simply soldered to those already in place.



KEYBOARD CLEAN-UP

Is your keyboard a disgrace?

Don't replace it, clean it up using these simple techniques.

BY MARTY KNIGHT

Take a good look at your computer's keyboard. Do you remember those lovely ivory-colored keys, some gray, pristine when you purchased the keyboard? Look at what time, lunch, and dirty fingers have done to them.

If your keyboard appears as mine did, you see dirty, greasy smears on the keys and the surrounding plastic frame. What was once a sparkling delight is now a monument to dirt. Are you ashamed to let someone use your computer or terminal? Short of buying a new keyboard, what can you do?

Clean the keyboard. It's easy!

Forget about lack of computer knowledge and little electronic experience. Cleaning a computer keyboard so that it appears new again is a simple task. Here's how you go at it.

Getting Started. Before you disassemble the keyboard, there are a couple of steps you should take to make the eventual reassembly easier. First, it is a good idea to keep a log of everything you do. That way, if your memory fails, you just need to follow your noted comments in reverse order to complete reassembly. It is also a good idea to photocopy the keyboard layout so that you know where the keys belong when it comes time

to reassemble the unit. That is more important with older units as their keys may fall out upon disassembly. It is also a good idea to keep a container or dish on hand to hold the miscellaneous hardware. If you do that, everything will be there when you need it.

Now, let's get to the disassembly. Be sure your computer is turned off, then unplug the keyboard from the computer's rear apron by grasping the plug and gently wiggling it as you pull it out of its socket. Notice the position of the connector's keyway so that reinstallation of the plug will be a snap.

Move the keyboard to a clean table top. The kitchen table is a good idea because you'll need to use a sink later. Spread an old table cloth over the table or use some cardboard from a large box to prevent scratching either the keyboard or table surface. Place the keyboard upside down on the table and remove the screws that hold the bottom section to the top section. While removing the bottom section you might have to disengage some tabs that hold it to the top. Do so with care.

What you find inside will depend on the age and make of your keyboard. Our keyboard, an original IBM unit made in 1984, used discrete key

switches. The internal assembly included a metal retaining plate for the switches, a bottom protective plate, and a circuit board. In the interest of simplifying mass production, most newer keyboards use one-piece integrated key-switch assemblies. Regardless of the type of assembly, disconnect the keyboard cable and lift the assembly from the case.

If you are dealing with a keyboard with discrete switches and you wish to do a thorough cleaning, the next thing to do is to remove the retaining plate. Usually that entails the removal of several screws. This is where the headaches come in. When the retaining plate on our keyboard assembly was removed, several of the switches came loose and fell out (that's why we told you to photocopy the keyboard layout earlier). On other older keyboards, the key switches may fall out even as you lift the assembly from the plastic frame.

Newer, "one-piece" keyboards should present less of a problem. With those, the individual key switches stay in place.

In any event, once the keyboard assembly is removed from its case, it is time to move on to the next step.

Soap and Water. Plastics are funny

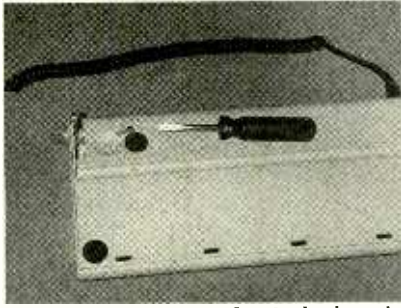

To begin disassembly, flip the keyboard upside down and remove the screws that hold the bottom in place.

materials. Looking at them can only tell you their color and shape. What effect strong chemicals will have on a plastic object is not discovered until after they meet, and then the results are usually catastrophic for the finish of the plastic surface.

Fortunately, ordinary facial soap is all you need in the way of chemicals. A nail brush, toothbrush, wash cloth, and other cleaning items may come in handy. Do not use steel-wool products or scouring pads that contain metal or abrasive particles. The simplest criterion is if you wouldn't use it on your face and hands, don't use it on the keyboard.

Sometimes it becomes necessary to wet the electronic components in the keyboard (for example, if you elect not to remove the key-switch retaining plate). It won't hurt a thing, provided that you take some precautions. The foremost precaution is that you do not immerse the electronics. Just allow the water to run over the surface. Dunking is not allowed! We'll discuss the other precautions when we talk about drying the electronics and the other parts.

The kitchen sink is the best place to clean the keyboard parts. Allow a gentle stream of lukewarm water to flow over the parts as you brush the



With the bottom removed, all of the dirt trapped within the keyboard comes into view. Shake and brush away the particles.

surface with a nail brush. An old toothbrush can reach into most corners and crannies to dig out the dirt. I have a long-stemmed brush used to clean glass tubing. It's great for getting under the keys and into corners. Be careful of brushes that have wire stems. They may scratch if you are not careful. Flat surfaces are best cleaned with a face cloth or soft sponge.

After the initial soaping and scrubbing, wash the soap and dirt away with

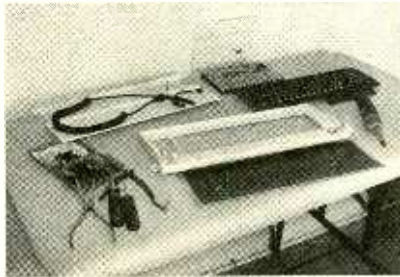

Here's the disassembled keyboard. Newer keyboards use a simpler design, making cleaning easier.



Here's a headache! We completely disassembled all 82 keys of our old IBM keyboard for cleaning. If you are not comfortable doing this, limit your disassembly and increase your drying time.

with a gentle flow of lukewarm water. Again, do not immerse the electronic parts. If your sink has a spray attachment, use it. When the parts appear clean and rinsed, inspect them carefully. Inspect the sides of the keys for stubborn dirt. Check the inside corners of the plastic frame. Use the soap again until the cleaning is complete. Deep scratches and cigarette burns are scars that cannot be removed. Do not attempt to file or sand them. The results are usually worse than the scar. The final rinse should be thorough.

The coiled connecting cord between the keyboard and the computer may be cleaned using soap and a soft sponge. Run your fingers between the coils to increase the soaping ac-



The results were well worth the effort. The keyboard looked good and worked well.

tion. Rinse the cord (do not submerge it) in flowing water trying not to get too much water on the connectors. Shake the cord dry and roll it in a face towel to dry it further. Hang up the cord to dry, with the connectors hanging down.

Dry Up. The next step is pure common sense. Dry the parts using a lint-free cloth or good-grade paper toweling. Be patient. Get into the tight spaces, corners, and between the keys. Blot the printed-circuit board if it made contact with water. Be careful not to damage the parts that you are drying.

After the parts are hand dried, tie them to a string and suspend them near a window where a gentle breeze can play on them for 24 hours. If it's cold outside or the humidity is high, an electric fan positioned a few feet away will do the job. Place a few old newspapers on the floor in case some water drips from the parts. If the key-switch assembly uses foam cushioning material it will require a longer drying period—at least about 48 hours.

Stay away from ovens and other methods of quick drying. It doesn't take much to over-cook your keyboard. And forget about using a hair dryer. You don't know about the plastic's heat sensitivity or the temperature of the blower. Those gadgets can burn hair, so your keyboard may not stand a chance when heated.

Putting it Together. Generally speaking, reassembly should produce few problems, although putting together a completely disassembled discrete-key keyboard can be a daunting task. If you aren't sure that you are up to it, limit your disassembly

(Continued on page 98)

ANTIQUÉ RADIO

By Marc Ellis

The Readers Speak!

This month, I'll put the Sky Buddy restoration project on hold for a bit so that we can deal with the overflowing reader mailbag. As is often the case when we get involved in a long-term project, the mail quietly accumulates on my study shelf until—much to my surprise—I suddenly have a very large pile containing missives dating back several months. Without further

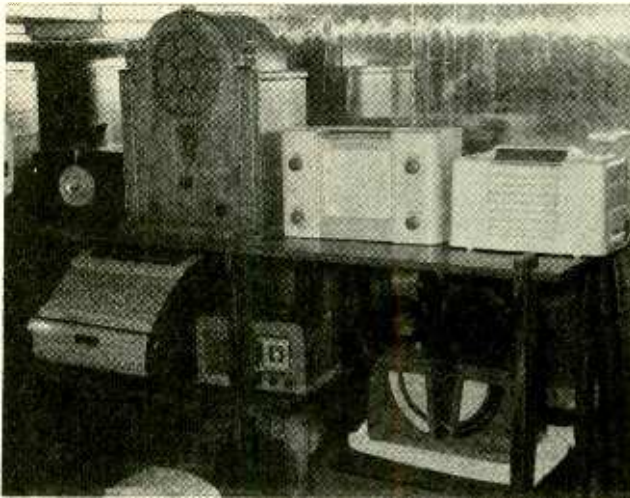

Here's a small part of Terry Schwartz's extensive collection. Note the Northland cathedral on the top shelf, for which documentation is needed (see text).

ado, then, and with apologies to those who have been waiting awhile, let's get to it!

INFORMATION WANTED

We'll begin with the ever-popular "Information Wanted" category. The following folks are looking for schematics and/or general information on specific sets. If you can help, please get in touch using the address given.

Arturo M. Castro (Apdo, Postal #1173, Toluca, 50 909 Mexico), *Andrea Model 30G6*; *John Clark* (P.O. Box

2204, Thomasville, GA 31799), *Atwater Kent Model 40*; *William P. Dube* (3209 Imperial Palm Dr., Largo, FL 34641), application schematics for RCA 902-A cathode-ray tube; *Raymond Newman* (Ferndale Rd., Jersey Side P. Bay, Newfoundland, Canada) and *Albert J. Padula* (409 N. George St., Rome, NY 13440), *Hallicrafters SX-99*.

David Batchelor (4016 Texana Way, Beale AFB, CA 95903), *Atwater Kent Model 20*; *Ray S. Hanson* (Apartment 45, 254 Palin Ave., Galt, CA 95632), dial-cord stringing diagram for Allied Radio Model #2682; *Charles R. Byram* (16905 Herigstad Rd. NE, Silverton, OR 97381), *Hallicrafters Super Skyrider*. *Don Rapp* (745 Gettinger, Ste. Genevieve, MO 63670), schematic of a *McMurdo Silver* signal generator similar to the one shown in *Larry Kenan's* collection (January, 1992 issue).

INFORMATION PLUS A HELPING HAND

The following readers have asked for specific pieces of information but, judging from the tone of their letters, may be newcomers to the hobby or inexperienced in some phase of it. In addition to the information, they would probably welcome some in-depth advice concerning their projects.

K.R. Harding (2989 Lida Lane, Sparks, NV 89431), advice on equipping a *Sylvania Type 132* oscilloscope with probes and operating same; *W. Yancey Sanford* (211 Smith St., Petal, MS 39485), help with dating

his first two acquisitions: a *Firestone Air Chief Stock S7406-7/Code F-C-58* manufactured by *Farnsworth Television and Radio Corp* (#73-2011), and a *Sonora Radio-Phono Model WBRU-2391*; *Sean Stryker* (P.O. Box 1513, Mariposa, CA 95338) advice on disposing of an antique radio (make and model not mentioned); 12-year-old *Justin DePolis* (581 S.E. La Palma, Anaheim, CA 92807) information on the *Hallicrafters S-38*.

Tom Corbitt (31 Augusta Dr., Yaupon Beach, NC 28465), operating and technical manuals for *Eico Tube Tester Model 625*; *Phyllis Hicks* (96 Crichton St., Ottawa, Ontario, Canada K1M 1V9), local repairman to fix antique set of great sentimental value; *Fred Botner, Jr.* (8480 NW 185 St., Hialeah, FL 33015), advice on constructing shortwave coils, laying out printed-circuit boards; *Dan Alexander* (3700 Elizabeth Ave #54, Olympia, WA 98501), how to get started restoring an old *Brunswick*; *Randy Eckl* (Box 2394, Canmore, Alberta, Canada T0L 0M0), advice on restoring a *Westinghouse Model 813*; *Mike Brixius* (635 Hamilton Ave, Eugene, OR 97404), documentation and restoration information for *Weston Model 310* Wattmeter.

INFORMATION PLUS PARTS

The following readers are looking for information about their sets and/or parts to restore them. *Shayne Trowsse* (RR3, Box A3, Casselman, Ontario, Canada K0A 1M0), who was



Carlos Queiroz's very well-organized basement shop. On the bench are a Zenith Trans-Oceanic and a Phillips Matador. On the shelf is a Pilot Model 203 tombstone.

a winner in our "With the Collectors" contest, sends a shot of a very slick yellow plastic Air King set. He'd like to know the model number of the set (it's stamped "1936" inside) and could use three authentic Air King knobs (8-sided with yellow center). Shayne is also looking for sources of information and schematics for radios made in Canada.

Alan A. DuBarson (67 Peggy Ann Rd., Queensbury, NY 12804) needs a replacement output transformer (or a substitution suggestion for same) for his Model 41-295 Philco. The transformer works with push-pull type-42 tubes and has a feedback tap in the primary.

Stephen Shaw (P.O. Box 1404, Randfontein, 1760, South Africa) is restoring a pulse generator made by Datapulse of Englewood, CA. He needs the "fine" control knob (made by "Baka-Ware" of Chicago). It's deep red in color and takes a 1/4-inch shaft.

SHOW AND TELL TIME

Terry Schwartz (340 Oakwood Dr., Shoreview, MN 55126), who received an honorable mention in our recent "With The Collectors" contest, sent along several photos featuring a portion

of his collection. I'm running the one showing a Northland cathedral (top row, second from left) because Terry could use some help determining the model number and locating a schematic.

Carlos S. Queiroz (Cx. Postal, 1064, Belo Horizonte-MG 30.160, Brazil) sends along some compliments for the column (thanks, Carlos!) and a nice shot of his basement restoration shop. Note the WPE shortwave listener certificate (WPE2QGQ) on the wall to the left; Carlos received it in June, 1968 while stationed in Yonkers, NY. Carlos has a number of tubes, parts, and schematics from the 1930's and '40's that he'd be happy to share for the cost of shipping. Contact him if interested.

Another old WPE'er, Sam Hevener (3583 Everett Rd, Richfield, OH 44286) received his call letters (WPE3WH) about 1959. If you have a P.E. backfile, look for Sam's photo in the shortwave column for March, 1962. Sam buys, sells, and trades WWII surplus military sets. Contact him if you have any leads!

Harry Alenick (Hawthorne, CA) enjoyed seeing the pictures of his collection that we ran in a recent

column. As of last August, he had just picked up four new radios (Philco 625 and RCA 6T-2 tombstones and two G.E. floor models) at the Southern California Antique Radio Society swap meet, bringing his total count to 34 sets—mostly floor models.

THIS 'N THAT

A couple of readers are working with sets that have been restored or discussed in previous columns. Keith Perry (384 S. 48th St., Spring-



Shayne Trowsse's slick yellow plastic "Air King." Shayne needs information and parts (see text).

field, OR 97478) is restoring an Echophone EC1 and needs documentation. Boyd Foster (120 Centre St., Hereford, TX) wants to fire up a Crosley 50, and needs similar information.

Both sets have been covered in some detail on these pages. (See July, September, October and November, 1987 issues for the EC1; January and February, 1988 issues for the Crosley 50). But if you can help Keith or Boyd by sharing your own experiences, be sure to contact them.

Michael Jones (P.O. Box 191, Fortson, GA 31808) has a Heathkit DX-100 ham transmitter (operates AM or CW on the 160- through 10-meter bands) for sale. It's in the original steel cabinet. This golden oldie can be yours for \$50.00 (pickup) or

\$75.00 (crated and sent freight collect). Mike also has several boxes of blank 8-track tapes available for the cost of shipping only. First come first served.

Thanks to Jon Hauko (Acworth, GA) for his kind words about this column; to David Mliot (Valley Stream, NY) and Tim Jagers (San Jose, CA) for adding to my store of theremin information; to Lloyd Thomas (Oxnard, CA) for the interesting article on antique radios from the American Association For Retired People Newsletter for May, 1992; and to Clinton Wills for his analysis of the Sky Buddy's circuit oddities.

Speaking of the Sky Buddy, a reader who owns one (but who'd like to remain nameless) offers a hint for rejuvenating the black crackle finish. Just polish it with two or three applications of Windex. That seems to bring back the old luster and even brighten up the silk-screened lettering without causing any damage.

CAPACITOR COMMENTS

William Robinson (Odessa, TX) is restoring a 1969-vintage English tube-type guitar amp and has purchased some replacement electrolytic filter capacitors for it. The overseas supplier suggested powering up the amp slowly to give the new capacitors a chance to "form." Bill's local amp technician called this suggestion "hog-wash"; new capacitors don't need that step. Noting that I've always recommended forming when powering up long-unused equipment for the first time, Bill wondered what I advised.

Here's what I think: The forming process should be completely unnecessary for (Continued on page 70)

COMPUTER BITS

By Jeff Holtzman

Fun With Computer Graphics

I recently discovered the Computer Art forum on CompuServe (GO COMART). And I haven't had as much PC fun in years. Hidden away in section 16 is a gem of a program—"Povray"—for creating surrealistic graphics. POV stands for Persistence of Vision, the name of the group that developed the program and RAY stands for Ray Tracing, a technique for rendering high-quality 3D images on a 2D computer screen.

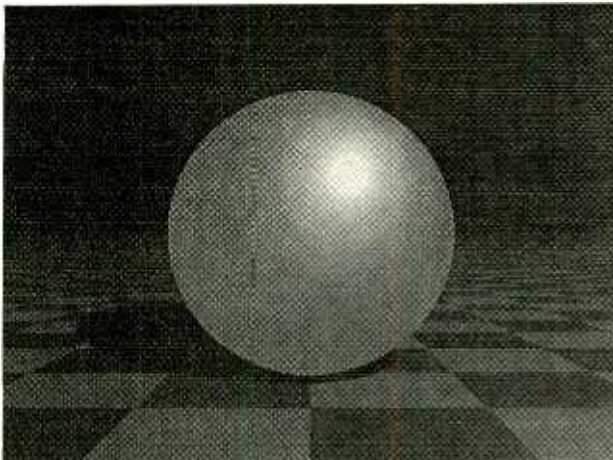

Create your own fantastic 3D graphics using a freeware program called Povray. The image shown here does not do justice to the 24-bit color images that you can create. Read the article for information on how to obtain samples and the program.

Povray is a "freeware" program that is available in ready-to-run versions for PC's, Macintoshes, and Amigas; the source code is also available to compile and run the program on various UNIX-based machines.

HOW YOU USE IT

Povray is more like a compiler for a programming language than a drawing or painting program. To create an image, you prepare an ASCII text

file that specifies the size, shape, orientation, texture, and location of one or more objects in a 3D space defined by X (horizontal), Y (vertical), and Z (into the page/screen) axes. Then you place light sources at the desired positions, and a camera that "records" the scene. It's from the point of view of the camera that your image appears.

You can view the image from different points by merely "moving" the camera or changing the point that the camera is focused on. Then you run Povray on that text file. The size of the image need not match the resolution of your video monitor, and may range as high as 4096 by 4096. The program then creates a 24-bit color rendition of the image, optionally displaying the image line-by-line as it processes it, and saves it in a Targa-format file.

But, why 24-bit color? It's because 24 bits provides "true color" or "photorealistic" results that allow lifelike displays of "real" photographs, and that provide stunning results with computer graphics. The value 24 comes from using eight bits each for the red, green, and blue electron guns in a CRT.

OBJECTS AND TEXTURES

Povray lets you create various simple and complex geometric objects, and to combine various simple objects into composites. Simple objects include boxes, spheres, and planes. Complex objects include quadrics (cone, cylinder, paraboloids, hyperboloid),

quartics (donut or torus), "blobs," and more. You can combine objects using unions, intersections, and differences.

Every object has a texture. Povray includes a wide variety of textures, including any 24-bit color, patterns like checkerboard and candy cane, metallic, mirror, wood, marble, granite, water, various "bump" patterns, countless variations on all of them, and the ability to create your own. You can also "stack" textures for special effects.

After you define an object and its texture(s), you put it somewhere in 3D space using a translate command; you can also rotate your objects. Then you add one or more light sources and spotlights, each of which has its own color (and for spotlights, other properties). Povray works by "tracing" the path of light rays from the light sources to the objects, and based on the ability of the latter to absorb and reflect light, allows the rays to continue bouncing around. The program creates realistic-looking shadows in the process. The math involved does get hairy, but fortunately you don't need to understand the details to use the program.

SYSTEMS REQUIREMENTS

You'll need the best video system and fastest CPU that you can get your hands on. On my 8MB, 25-MHz 486DX, small (160 × 120) simple images typically take about two minutes to render, and larger versions (640 × 480) take about half an hour.

VCR Cross Reference

**NOW Find the right Part
for your VCR**



**with the
ISCRET VCR**

CROSS REFERENCE

This 272-page reference contains both model and part-number cross-references and now includes the FREE 56-page 1991 updates.

VCR's are made in a few factories from which hundreds of different brand names and model numbers identify cosmetically-changed identical and near-identical manufactured units. Interchangeable parts are very common. An exact replacement part may be available only a few minutes away from you even though the manufacturer supplier is out-of-stock. You may be able to cannibalize scrap units at no cost!

The ISCRET VCR Cross Reference and 1991 Update pages are pre-punched for standard loose-leaf binding....\$38.00 plus \$3.00 for shipping for each reference.

**Electronics Technology Today Inc.
VCR CROSS REFERENCE OFFER
P.O. Box 240,
Farmingdale, New York 11735**

Name

Business

Address

City

State Zip

Phone

Enclose \$38.00 for the ISCRET VCR Cross Reference and 1991 Update Reference and \$3.00 for shipping for each reference.

I have ordered ISCRET VCR Cross Reference(s).

The total amount of my order is \$

Check enclosed—do not send cash.

or please charge my credit card:

Visa MasterCard Exp. Date

Card No.

Signature

New York State residents must add applicable local sales tax to total.

Complex images can take hours and literally days. One sample image claims a 40-hour rendering time on an Amiga!

On a PC, Povray runs well under Windows (the program does require a 386 or better, and a math coprocessor speeds things up tremendously). Typically, I open a DOS window and run a "compile" in the background, while doing something else (e.g., printing samples, writing articles). When the compile completes, I load the resulting image file into a shareware program called Paint Shop Pro (PSP). Then, if I want to keep the image, I use PSP to reduce the number of colors to 256, which matches the capability of my video driver, and produces better results than when Windows does the color reduction itself.

I then save the file in a common format (BMP, RLE, PCX, or TIFF). The advantage of RLE over BMP format is that often it's possible to save an RLE file in 10% of the space of a BMP.

The process of converting a 24-bit color image to a black-and-write laser-printed version and subsequent processing for publication leaves a lot to be desired. For that reason, I'll post several sample RLE files on the Gernsback BBS Center—Tel. 516-293-2283, 8N1—(SPHCHRX.RLE, STEINER.RLE, BLOB.RLE). All display well on a 640 × 480 × 256 VGA screen.

In addition, look for the Povray files, including POV-IBM.ZIP (executable code), POVDOC.ZIP (documentation), and POVSCN.ZIP (sample scenes). The three ZIP files are also available on CompuServe, where you should look to obtain the latest versions. Last, I've also posted a version of Paint Shop Pro, PSP10.ZIP. ■

ANTIQUE RADIO

(Continued from page 68)

an electrolytic that is genuinely new. However, newly-manufactured electrolytics in the voltages needed for tube equipment are hard to find today; there just isn't that much of a demand for them. Many units that appear to be brand-new are really NOS (new old stock). Those should be treated as old units and powered up slowly when first used.

Bill's caps, particularly if they are exact replacements for those in his old amp, may well be NOS. So, Bill, I'd recommend following the supplier's advice.

While we're speaking of electrolytics, I want to be sure to mention the letter I received from Gregory S. Lindsay (Jacksonville, FL). Gregory doesn't believe in forming as a way to extend the life of an old electrolytic. Though he concedes that the process works for a while, the electrolytic may still fail suddenly and without notice, taking with it the rectifier tube and, perhaps, a hard-to-replace power transformer.

Greg won't work with a newly-acquired antique until he has replaced not only the electrolytic, but also all cardboard-cased tubular paper capacitors, with new units. While the latter are more stable than electrolytics, he feels that most had a useful life of ten years, after which they became leakier and leakier, degrading the performance of the radio, until outright failure occurred. As substitutes for the paper-cased units, Greg suggests a modern ceramic-coated type, such as Sprague's "orange-drop" units. With that, my space is just about gone. I'll respond to Greg's comments next month. ■

CIRCUIT CIRCUS

By Charles D. Rakes

A Little Something For Everybody

This time around we've got a variety of circuits that we're going to share with you. So, without further ado, let's see what this month's electronics grab-bag has to offer.

AUDIBLE AUDIO-SIGNAL TRACER

If you've ever had to trace an audio signal through a maze of wires that wind a wayward path through either the attic or basement, you are well aware of how a simple job can turn into a nightmare. The *Audible Audio-Signal Tracer* shown in Fig. 1 is designed to ease the pain

of inverting input of U1-a (half of a 1458 dual op-amp), where it is amplified by a factor that's determined by R1 and R7. The amplified output of U1-a is then applied to U1-b (the second half of the 1458 op-amp) through R7, which serves as a gain control for the second op-amp (in addition to its gain-determining duties). Op-amp U1-b increases the signal level sufficiently (about 33 times) to drive a set of low-impedance headphones, Z1.

The pick-up coil consists of 75 to 100 turns of #30 enamel-coated copper wire wound on a 1¼-inch length of ¼-inch diameter ferrite rod. The coil, which can be jumble wound over the length of the ferrite rod, can be located several feet from the circuit and connected to it through a shielded cable.

The best ferrite material to use for the coil's core is one that offers a high permeability. Amidon Associates (P.O. box 956, Torrance, CA 90508) offers a number of ferrite rods—such as #33, which has a permeability of 800—that are designed for audio-frequency use. The #33 material is a good choice for the pick-up, but the smallest diameter in the series is 0.5 inches. To use the larger diameter material just reduce the number of turns to about 50 to 75. However, before spending money for rod material try what you have on hand. I've used several different materials of unknown permeability and they all seemed to work just fine.

Using the tracer is easy; simply locate the signal-carrying wire and position the pick-up next to the wire

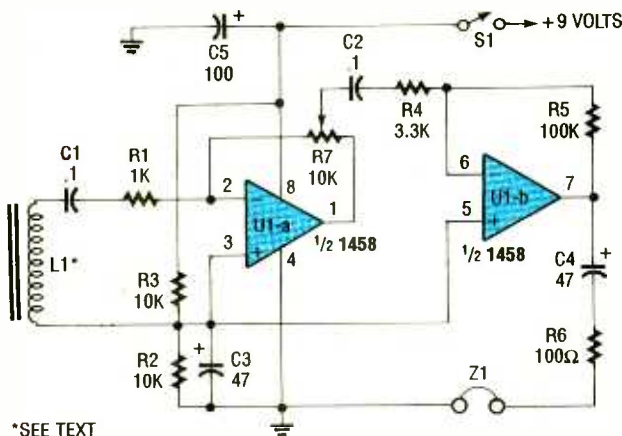

*SEE TEXT

Fig. 1. The Audible Audio-Signal Tracer is designed to help you to trace an audio signal through a maze of wires that wind a wayward path through either the attic or basement.

and make the job of signal tracing an enjoyable experience.

The operation of the Audible Audio-Signal Tracer is really quite simple. A homebrew induction coil, L1, is used as the pick-up device. When L1 is brought near a wire carrying an audio signal, the audio signal is induced into the coil. From L1, the signal is fed to the

PARTS LIST FOR THE AUDIBLE AUDIO-SIGNAL TRACER

RESISTORS

(All fixed resistors are ¼-watt, 5% units.)

- R1—1000-ohm
- R2, R3—10,000-ohm
- R4—3300-ohm
- R5—100,000-ohm
- R6—100-ohm
- R7—10,000-ohm potentiometer

CAPACITORS

- C1, C2—0.1-μF, ceramic-disc
- C3, C4—47-μF, 16-WVDC, electrolytic
- C5—100-μF, 16-WVDC, electrolytic

ADDITIONAL PARTS AND MATERIALS

- U1—1458 dual op-amp, integrated circuit
- L1—Pick-up coil (see text)
- Z1—Low-impedance headphones
- S1—SPST toggle or slide switch
- Perfboard materials, enclosure, 9-volt power source, wire, solder, hardware, etc.

in the position that produces the greatest audio output and trace away.

PC-BOARD SIGNAL TRACER

The next circuit is a slightly different type of signal tracer; this one is designed to track audio signals along a circuit-board trace or through a short piece of wire by touching two probes to the signal carrying conductor. Rather than using a pick-up coil as in the previous circuit, this one uses a pair of sharp needles as probes to penetrate wire insulation and the protective (conformal) coating found on some circuit boards.

Figure 2 shows a schematic diagram of the *PC-Board Signal Tracer*. The two probes sample the audio signal along the circuit trace and feed the signal to the input of a 741 op-amp (U1), which provides a gain of about 50. The amplified output of U1 is fed to a 386 low-voltage, audio-power amplifier through R7, which serves as volume control. Power amp U2 increases the signal level enough to drive a 4-ohm speaker, SPKR1.

Diodes D1 and D2 are

included in the circuit to protect op-amp U1 from an input overload should the probes happen to be placed across two different traces carrying a large signal voltage.

LIGHT DETECTOR

The next entry, see Fig. 3, is a simple *Light Detector* that's designed to help visually-impaired persons pinpoint a light source; for

example, to locate a light that may have been turned on for a sighted guest.

The circuit consists of only four components—a cadmium-sulfide light-dependent resistor (R1), a piezo sounder (BZ1), push-button switch (S1), and a 9-volt battery—which are connected in series.

A cadmium-sulfide light-dependent resistor (R1) detects light and adjusts its

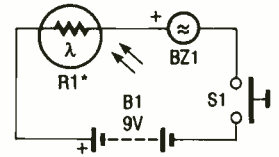

*R DARK = 500K
R LIGHT = 3K TO 20K

Fig. 3. This *Light Detector*, which consists of only four components that are connected in series, is designed to help visually-impaired persons pinpoint light sources.

PARTS LIST FOR THE PC-BOARD SIGNAL TRACER

SEMICONDUCTORS

- *U1—741 general-purpose op-amp, integrated circuit
- U2—386 low-voltage audio-power amplifier, integrated circuit
- D1, D2—1N914 general-purpose small-signal silicon diode

RESISTORS

(All fixed resistors are 1/4-watt, 5% units.)

- R1, R2—1000-ohm
- R3, R4—10,000-ohm
- R5—47,000-ohm
- R6—10-ohm
- R7—10,000-ohm, potentiometer

CAPACITORS

- C1, C2—0.25- μ F, ceramic-disc
- C3—0.1- μ F, ceramic-disc
- C4—0.05- μ F, ceramic-disc
- C5—4.7- μ F, 16-WVDC, electrolytic
- C6—100- μ F, 16-WVDC, electrolytic
- C7—220- μ F, 16-WVDC, electrolytic

ADDITIONAL PARTS AND MATERIALS

- SPKR1—4-ohm speaker
- Perfboard materials, enclosure, IC sockets, 9-volt power source, wire, solder, hardware, etc.

TELEPHONE HOLD

Our next entry, see Fig. 4, is a simple *Telephone Hold* circuit that allows you to hang up one phone without losing the call and move to another room or area and pick up a different phone (connected to the same line) and continue your conversation.

When a telephone is on-hook, the voltage across tip and ring (that's telephone lingo meaning the two phone wires) is about 48 to 50 volts DC. When the receiver is taken off-hook, that voltage falls to a level somewhere between 6 and 15 volts, depending on the distance between your phone and the central office.

The operation of the Telephone Hold circuit is simple.

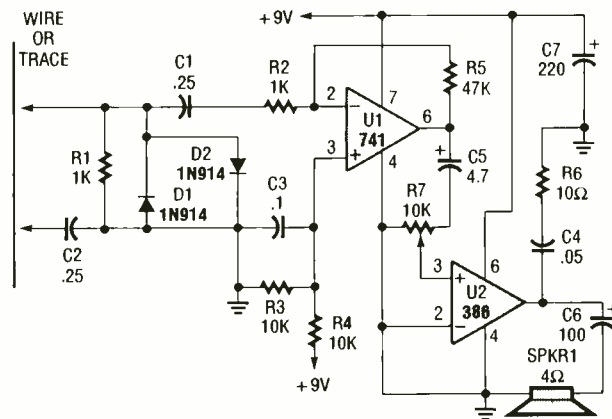

Fig. 2. The *PC-Board Signal Tracer*, rather than using a pick-up coil as in the previous circuit, uses a pair of sharp needles as probes to penetrate wire insulation and the protective (conformal) coating found on some circuit boards.

resistance in proportion to the light intensity. That varies the amount of current available to drive the piezo sounder (BZ1), which, in turn, indicates the relative intensity of the light striking R1. Pushbutton switch S1 activates the detector.

To give the *Light Detector* directivity, R1 should be mounted in one end of a 4- to 6-inch opaque tube facing out through the full length of the tube. If you happen to have a light-dependent resistor in your junkbox, there's a good chance that it will work in the circuit.

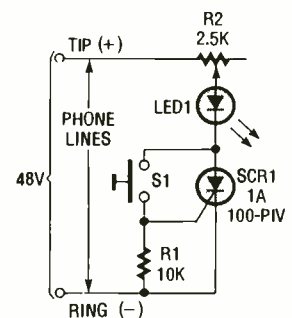

Fig. 4. The *Telephone Hold* circuit allow you to hang up one phone without losing the call and move to another room or area and pick up a different phone (connected to the same line) and continue your conversation.

PARTS LIST FOR THE LIGHT DETECTOR

R1—Cadmium-sulfide, light-dependent resistor (Mouser #338-76C348)
 BZ1—Piezoelectric buzzer (with built-in oscillator)
 B1—9-volt transistor-radio battery
 S1—Normally-open pushbutton switch
 Perfboard materials, enclosure, battery holder and connector, wire, solder, hardware, etc.

PARTS LIST FOR THE TELEPHONE HOLD

LED1—Light-emitting diode (any color)
 SCR1—1-amp (or less), 100-PIV, silicon-controlled rectifier (see text)
 R1—10,000-ohm, ¼-watt, 5% resistor
 R2—2500-ohm potentiometer
 S1—Normally-open pushbutton switch
 Perfboard materials, enclosure, wire, solder, hardware, etc.

A silicon-controlled rectifier, SCR1, is connected in series with LED1 and a variable current limiter, potentiometer R2, and the whole thing is tied across the telephone line. As long as SCR1 is off, no current flows through the circuit and the phone line remains unchanged. Pressing S1 fires SCR1, lighting LED1, and placing a load on the phone line that draws about the same amount of current as a standard phone. Pressing S1 while hanging up the receiver places the phone on hold, and lights LED1. When S1 is released, LED1 should remain lit.

When an extension phone is taken off-hook, the current through SCR1 dips below its holding level, which causes it to turn off, allowing the phone to be used in a normal manner.

LED1 is included in the circuit as an indication that SCR1 has latched in the on condition, which shows that the hold circuit is functioning. If it does not, repeat the

operating procedure and adjust R2 until LED1 remains on. With R2 properly set, picking up any phone on the same line will reset the hold circuit and turn off the LED. The trick is to set R2 so that when a phone is taken off-hook, the extra load on the line pulls the current through the SCR lower than its minimum holding current.

LINE IN-USE INDICATOR

Our next circuit, a *Line In-Use Indicator*, can be a handy item to have around, especially if you have several extension phones and one or more teenagers in the house. A schematic diagram of the circuit is shown in Fig. 5.

At the heart of the Line In-Use Indicator is an N-channel hexFET (Q1) whose gate and source terminals are connected across the telephone line. That hexFET is used to sense the telephone line's condition. If all the phones connected to the line are on hook, the

voltage across the phone line will be about 48 volts DC. That voltage, which is applied to the gate of Q1, biases it on. With Q1 turned on, the voltage at its drain is pulled to near ground potential (zero volts). The output of Q1 at its drain feeds the base of Q2 (a 2N3904 general-purpose NPN silicon transistor). The near ground output of Q1 holds Q2 off. With Q2 turned off, the LED connected in its collector

which, in turn, provides a ground path for LED1, causing it to light. When the phone is placed back on hook, the voltage applied to the gate of Q1 is again sufficient to bias it on, which again diverts current away from the base of Q2. That causes Q2 to turn off, extinguishing LED1.

To use the circuit, simply connect it to the phone line (as shown in the schematic) somewhere near the phone.

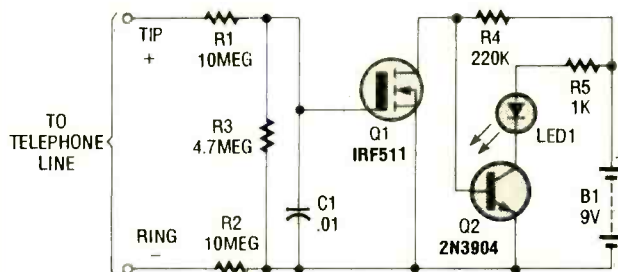

Fig. 5. The Line In-Use indicator which can be a handy item to have around, especially if you have several extension phones and one or more teenagers in the house.

PARTS LIST FOR THE LINE IN-USE INDICATOR

SEMICONDUCTORS

Q1—IRF511N-channel hexFET
 Q2—2N3904 general-purpose NPN silicon transistor
 LED1—Light-emitting diode (any color)

RESISTORS

(All fixed resistors are ¼-watt, 5% units.)

R1, R2—10-megohm
 R3—4.7-megohm
 R4—220,000-ohm
 R5—1000-ohm

ADDITIONAL PARTS AND MATERIALS

B1—9-volt transistor-radio battery
 C1—0.01-μF, ceramic-disc capacitor
 Perfboard materials, enclosure, battery holder and connector, wire, solder, hardware, etc.

circuit is also held off.

If any phone connected to the line is taken off-hook, the voltage applied to Q1's gate will be insufficient to hold it on. With Q1 turned off, no current flows through it to ground. Instead, current now flows through R4 to the base of Q2, turning it on,

TOUCH-ON/TOUCH-OFF CIRCUIT

Our next entry is a simple *Touch-On/Touch-Off* circuit, see Fig. 6. In that circuit, half of a 4001 CMOS quad 2-input NOR gate (U1-a and U1-b) is configured as a simple latch (or flip-flop) cir-

(Continued on page 94)

THINK TANK

By John J. Yacono

Chips And Test Gear

Over the last few months, I've received a number of test-equipment contributions from you readers. Since it seems to be a topic with broad appeal, I've gathered all the letters together so that I could devote a series of columns to them, starting with this month's edition.

But, before we get to those letters, I'd like to

duction into integrated circuits and a summary of today's logic families would at least get people's feet wet. Perhaps it'll make folks less hesitant about cracking the binding of a book or two on the topic. With that in mind, let's shove-off with this new topic (which will span a few issues).

IC'S IN GENERAL

Integrated circuits (IC's) are circuits composed of up to millions of components (resistors, capacitors, transistors, etc.) formed on an incredibly small wafer (or chip). The circuits are housed in either plastic, ceramic, or metal cases.

Since handling the micro-fine wires coming off the chip is impossible without the aid of a powerful microscope, the cases (or packages) have manageable-size leads on them to connect vital points on the tiny chip to the outside world.

Most of the IC's that hobbyists deal with come in only a few different packages (see Fig. 1). The most common case is the Dual In-Line Package, or DIP, shown in Fig. 1A. If you pick up a European text, you might find this package referred to as a DIL instead.

Although the case style shown is a 20-pin package, DIP IC's can have as few as four to as many as 64 leads. The space between adjacent leads (leads on the same side of the chip as opposed to across the body of the chip) is a constant .01-inches (or 10 mils) center to center regardless of the number of pins. The distance between the two

rows of pins varies with the number of pins, as IC's with a lot of pins tend to be wider than IC's with just a few pins.

Another popular case style, called the TO-220, is shown in Fig. 1B. There are many variations on the style (some with rounded corners, different widths, more pins, without notches in the heatsink, etc.), all with their own designations. However, in hobby electronics, you are most likely to come across cases like the one shown, as they are commonly used for voltage-regulator IC's.

By the way, there are some discrete—one-component as opposed to integrated—devices that come in similar cases. Triacs and SCR's use a case called the MU27 style that looks almost like the TO-220. Try not to confuse them with IC's just because they have the same or similar packages.

Another enclosure commonly used for regulator IC's called the TO-3 is shown in Fig. 1C. Cases like that are typically used for devices that must dissipate large amounts of heat. Power transistors are also commonly packaged in that form, but again, a transistor is a discrete component, not an IC. To accommodate IC's that have more than three leads, there are case styles that look similar to the TO-3 type but have more pins.

The last case, shown in Fig. 1D, pops-up in test equipment from time to time. Three- and four-lead versions of this case are often used for transistors,

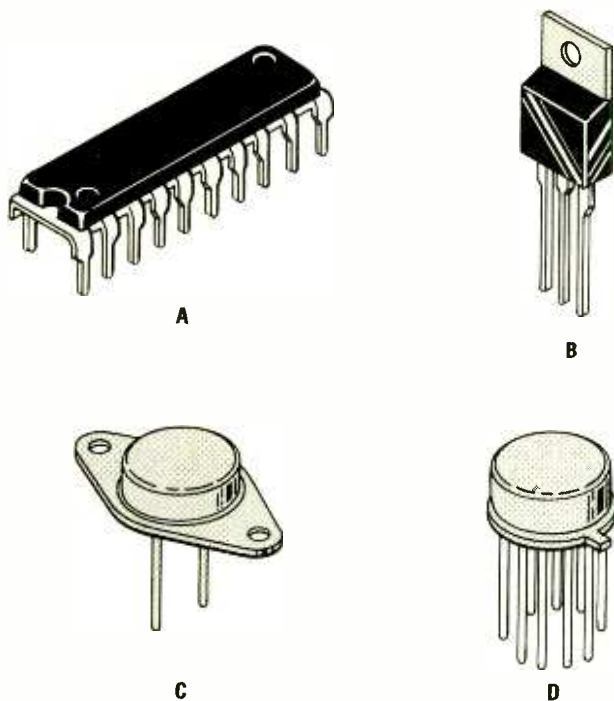

Fig. 1. Among the more common IC packages are the DIP (A), TO-220 (B), TO-3 (C), and TO-100 (D) styles shown here.

launch a new topic for the beginning of this column: integrated circuits. It would appear from the mail that there are many tube-era hobbyists that have been absent from the field for some time now and would like to learn more about today's chip technology so that they can catch up.

While it's obvious that I can't fill-in all the gaps, I thought that a brief intro-

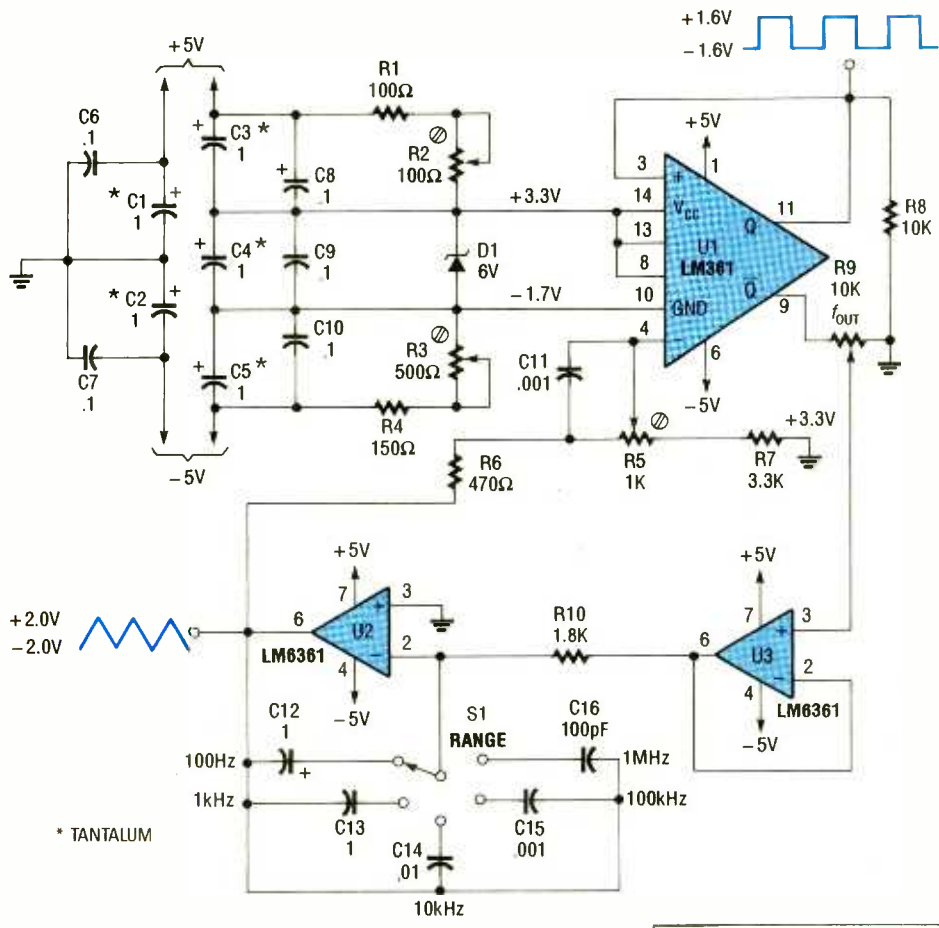

Fig. 2. Note how U3 supplies reshaped feedback (in the form of a triangle wave) to U1 via R5 and C11. That little trick causes the output waveform to be very accurate.

but if you see more than four leads on this sort of case, the chances are that you're looking at an IC. High-speed voltage comparators and op-amps are the IC's that you're most likely to come across in this case style.

We'll continue this discussion next month. For now, let's get to the letters and our new letters topic: home-made test equipment.

FUNCTION GENERATOR

Hello again, John. Thank you very much for your nice presentation of my "Sine-wave Converter" in your November 1991 column. Here's another unusual circuit built with advanced design tactics (see Fig. 2).

This circuit was designed to be used as a building

block for high-speed analog circuitry. It's easy-to-build, simple-to-operate, and produces squarewave and triangle-wave outputs from about DC to 1 MHz. An added bonus is that the frequency-control (R9) rotation is linear with the change in frequency. Thus, the high frequencies don't "bunch up" at one end of the scale.

The heart of the circuit is U1, an LM361 high-speed differential comparator with complementary TTL outputs, which are level-shifted by R1 to R4 to provide a +1.6-volt output. The non-inverting output provides hysteresis to the non-inverting input, while the inverting output supplies a variable-voltage squarewave to buffer U2, an LM6361 super-high-speed

op-amp. That IC drives the op-amp integrator composed of U3, another LM6361, whose output is a triangle wave that is precisely controlled by U1 via the feedback path through R6.

Construction isn't super critical, but keep the lead lengths short, especially for R9 and S1. Resistor R9 is a standard linear potentiometer (not wirewound), and R2, R3, and R5 are single-turn trimmers.

Capacitors C1 through C10 are bypass units. Note that each 1-μF tantalum unit (C1 to C5) is placed in parallel with a 0.1-μF ceramic-disc unit (C6 to C10) for superior noise suppression. Mount them near the IC's.

Capacitors C12 through C16 should be polystyrene or similar in quality, and C11 can be a 0.001-μF ceramic disc. By the way, the LM361

Over 750,000 readers of earlier editions of

The Forrest Mims Engineer's Notebook

agree—nobody knows practical IC applications like Forrest Mims! This newly-revised edition contains hundreds of proven, tested circuits—hand-drawn by Forrest—using today's most popular linear, TTL, and CMOS ICs. Forrest gives you full data for each device and circuit—pin numbers, logic tables, supply voltages, and signal waveforms—so you can quickly duplicate each circuit. There's also practical information on construction methods, troubleshooting, and interfacing different IC families. If you work with ICs you gotta get this book!

Only \$14.95 at bookstores or electronic parts dealers. Or order direct from HighText! Add \$3 shipping (\$4 to Canada, \$5 elsewhere). CA please add sales tax. U.S. funds only please.

HighText 7128 Miramar Road Suite 151 San Diego, CA 92121

and LM6361 IC's are available from Digi-Key. (701 Brooks Ave. South, P. O. Box 677, Thief River Falls, MN 56701-0677; Tel. 800-344-4539).

Calibration is simple: Set R2, R3, and R5 to mid-rotation, then turn on the power. Adjust R2 for +3.3 volts at the cathode of D1 (a 6-volt Zener diode); trim R1 if needed. Adjust R3 for -1.7 volts at the anode of D1; trim R4 if needed. Set the frequency at about 10 kHz, put your scope probe on pin 11 of U1, and fine tune R2 and R3 for a symmetrical squarewave, while maintaining 5 volts across D1. Put your scope probe on pin 6 of U3 and adjust R5 for a +1-2.0-volt triangle wave. Note that R9 yields a 0 to 1 multiplication factor on the range switch.

Combine this circuit with my sinewave converter mentioned earlier and you'll have a full-blown function generator. The wave shape is excellent! (Inquiries Welcome.)

—Skip Campisi, South Bound Brook, NJ

What a nice companion to your sinewave shaper. This, like the triangle generator that you originally submitted with your sine-wave shaper, feeds some of the output signal back to the initial oscillator, which I find a fascinating technique. More times than not in hobbyist circuits the feedback loop of a device contains only passive components. Your circuits, on the other hand, actively reshape a waveform before sending it back to the first stage; that's neat.

By the way, thank you for welcoming comments from the readers. Those interested in contacting Skip can write to him at 143 Cedar St., South Bound Brook, NJ 08880.

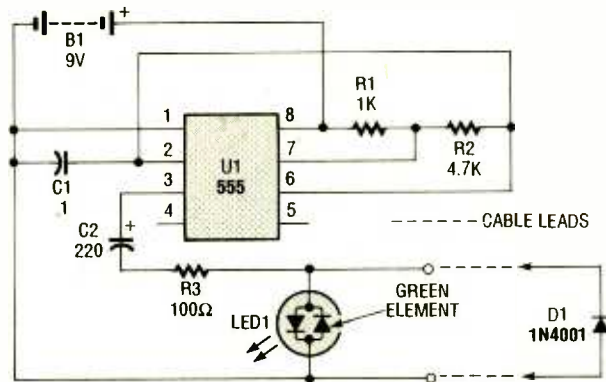

Fig. 3. This handy device tests 2-conductor cables and helps ring them out in one easy step. The LED will inform you of a shorted or open lead, and lead identity by its color.

CABLE CHECKER

As a computer-cable designer/installer, I have designed a simple but effective circuit for testing two-wire cables. The circuit (shown in Fig. 3) consists of two parts: a tri-state LED connected across a squarewave oscillator and a diode that is used to short-out the positive or negative swing of the squarewave generator's output.

When the two sections are connected across a cable, the LED will be in one of four possible states: If the negative half of the squarewave has been shorted by the diode, only the green component of the LED will light. If the positive half of the squarewave was shorted by D1, only the red element in the tri-color LED lights. If the LED is orange, neither half of the squarewave was shorted out, thus the LED alternately lights green and red at a rate that blends the two colors into orange, indicating that the cable is open. If the LED doesn't light, the squarewave has been totally shorted out.

By the way, using a momentary pushbutton in series with the battery (not shown) as a power switch helps conserve battery life.

—Ron Rogers, Kansas City, MO

So basically if the LED is dark, there's a short in the cable; if the LED glows orange with the diode in place, the cable is an open circuit; but if the LED is either red or green the leads of the cable are fine and the LED's color helps you ring them out. I particularly like how the electrolytic capacitor acts as a battery when the 555 output (pin 3) goes low to pull current through the LED in the reverse direction.

ZENER TESTER

Is your junkbox full of unmarked Zener diodes? If so, then this circuit (see Fig. 4) can help you to test Zener diodes rated as high as 20 volts, provided that you own a low-current (100 mA) wall-mount transformer or another DC supply rated that high. I built my own unit to test my extensive collection of Zener diodes. I used

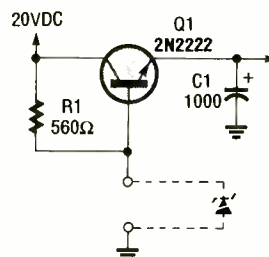

Fig. 4. Identifying unmarked Zener diodes (or just testing the voltage specification of suspect units) is a breeze with this universal test fixture.

a zero insertion-force IC socket as the test pad for the Zeners.

If an unknown Zener diode is placed in the IC socket with 20 volts DC applied to the collector of transistor Q1, then a small current through resistor R1 and the transistor's base causes the unknown diode to conduct, applying its voltage to the emitter of the transistor. Capacitor C1 filters out any emitter fluctuations so that you can measure the Zener's reference voltage. If you are tired of the tester, you can place any Zener diode up to 20 volts in it and use it as a power supply.

—Joseph Anie, Tema, Ghana

That's a pretty simple device to build provided that you have a power supply (which shouldn't be any problem for most of the readers of this column). In this application, note that the transistor acts as an active current limiter to protect the Zener diode under test.

JFET TESTER

As a full-time biomedical technician and part-time electronics experimenter, I am always interested in quick and dirty component testers. Many books and magazines offer testers for bi-polar transistors, but I've never seen anything simple for testing JFET's. Usually you have to use a curve tracer or mess around with an ohmmeter.

That led me to try a homemade tester of my own (see Fig. 5). I'll skip the basic JFET theory (which can be found in any self-respecting textbook) and only explain the N-channel half of the circuit, since the P-channel portion works the same way.

When a good N-channel (Continued on page 90)

DX LISTENING

By Don Jensen

She Sells "Seychelles" Down By The Seashore



Here is Jorge Zambrano, host of the popular "Musica del Ecuador" program from HCJB in Quito, Ecuador.

That updated version of the old tongue twister merely serves as a reminder that this is a good time of year to tune for the several shortwave outlets in this tiny island republic in the warm Indian Ocean.

The Seychelles, formerly a British crown colony (which gained its independence in 1976), consists of a small group of islands east of

coral reef, a kilometer offshore, according to the station's audience-relations director, Roger Foyle. Here are seven towers supporting 11 stacked-dipole, curtain-array aerials that can be computer switched in various combinations to beam the FEBA's signals to different target areas, from Malaysia to Madagascar.

The FEBA has fraternal links to the longtime Philippine-based religious organization, *Far East Broadcasting Co.* The station has three shortwave transmitters located at Anse Etoile, on the northeast coast of Mahe, only about two miles from the Seychelles capital, Victoria. The transmitters are rated at a healthy 100 kilowatts.

The station offices and a pair of program studios are at San Suci, an attractive location in the hills south of the capital city. The FEBA broadcasts, mostly pre-recorded religious programs, in nearly two-score different languages, from Amharic and Azeri to Tamil and Urdu.

The FEBA, however, has only a single international program in English each day. On Tuesdays through Saturdays, it is on from 1500 to 1600 UTC on frequencies of 9,810 and 15,330 kHz; and until 1540 UTC on a third channel (as of this writing), 11,690 kHz. On Saturday, the latter frequency operates in English from 1500 to 1615 UTC; on Sunday, only until 1555 UTC.

While most of the programming is produced off-island, some of the English broadcasts originate in the Seychelles studios. English news broadcasts also are

picked up by the FEBA from the FEBC in Manila, and from the BBC, *Voice of America* and *All India Radio*.

While not exactly an everyday SW catch, you should have a fairly good opportunity to hear the FEBA during the 1500-UTC transmission during the week on 15,330 kHz. If you do, you can send your reception reports to: FEBA, Box 234, Mahe, Seychelles. Since this is a privately run station, if you ask for a QSL card in reply, a \$1 bill for return postage would be appreciated.

The British Broadcasting Corporation's Indian Ocean station operates pretty much like any of the other BBC shortwave relay stations around the world, bringing better quality signals to areas of the globe not well serviced by transmitters in the United Kingdom. It's transmitting base is located at Grand Anse, another coastal area on Mahe island, according to Bill Kurrasch, author of the "African Destinations" column in the "North American SW Association's Journal."

Since a number of the BBC relays share the same frequencies at different times of the day and night, be careful not to misidentify one relay for another. A partial schedule for the Indian Ocean outlet includes: 6,005 kHz during the 1700 to 2200 UTC period; 9,630 kHz from 1615-1745 and 1830-2030 UTC, and 0300-2030 UTC on 15,420 kHz.

Some U.S. SWL's suggest trying at around 2000 UTC

Tanzania. It's been called a tropical paradise, one of the loveliest spots in the world. Now that's a nice thought on an icy February morning!

Its location also makes the Seychelles an excellent transmitter base for shortwave broadcasting both to south Asia and east Africa. And two major SW organizations have located here: the *Far East Broadcasting Association* and the *British Broadcasting Corp.* Both the FEBA and the BBC Indian-Ocean relay are located on 58-square-mile Mahe, the largest of the Seychelles.

The FEBA's antenna system, however, is built on a

on 9,630 kHz or 0400 UTC on 15,420 kHz.

WHAT TO LOOK FOR IN A RECEIVER

That's a commonly asked question. Here are some tips from Larry Magne, publisher, editor, and shortwave-receiver reviewer of the well-known annual, *Passport To World Band Radio*.

"An accurate frequency readout is important. Will you be able to find a station easily? Nowadays, most advanced world-band radios provide digital-frequency readouts that are accurate to the nearest kilohertz or better to tell you precisely where you are tuning. A low-cost compromise involves "bandsread" analog-frequency readouts, but that technique is dying out

"Other tuning aids include programmable channel memories, up/down pushbutton or scan-frequency slewing, and keypad frequency entry. Whether or not those features are of interest to you is a matter of taste. Remember to look for a tuning knob or a high-tech alternative, not simply a pair of one or two-speed slow up/down buttons.

"With a digital-frequency readout, you can use an accurate shortwave reference to set your radio immediately to what you wish to hear There are literally thousands of signals on the air, so sorting them out is no mean feat A radio should cover the complete shortwave spectrum from 2.3 to 30 MHz, or at least 3.2 to 26.1 MHz.

"Multiple conversion, usu-

ally double conversion, helps reduce the presence of *images*, false signals that create unnecessary interference to what you're trying to hear. Demand it if you value your hearing and sanity."

You can find more of Magne's pull-no-punches ideas on buying a shortwave receiver, including his evaluations of most sets on the market today, in *Passport to World Band Radio*. The book is available from many book stores and SWL suppliers. Or send a stamped, self-addressed envelope to Passport, Box 300, Penn's Park, PA 18943, for the name of a dealer near you.

IN THE MAIL

Bob Ernst of Boise, MT, has a query about record keeping. "I think I should keep track of the SW stations that I'm hearing. Do you think this is a worthwhile idea and do you have any suggestions?"

It's an excellent idea, Bob. Most experienced DX'ers do keep a running log of their listening activities. There are several very good reasons for doing so. First, it is always interesting, at a later time, even months or years afterward, to look back at what you were logging back then. It allows you to mentally replay some of your listening highlights of the past. And it can also jog your memory as to when you last heard a particular station.

Reception patterns are seasonal; there are longer cycles as well. Knowing, for example, that lower powered Indian and

*Credits: Brian Alesander, PA; Jim Clar, NY; Ross Comeau, MA; Rich D'Angelo, PA; Mark Humenyk, ONT; Marie Lamb, NY; Tony Orr, VA; North American SW Association, 45 Wildflower Road, Levittown, PA 19057.

Pakistani outlets were coming through with decent signals last year from mid-December to the end of January, can be a clue that similar patterns may prevail now.

Your logbook can be an inexpensive notebook or diary. Or you might wish to get printed SW logbook pages. Tiare Publications, P.O. Box 493, Lake Geneva, WI 53147, and Gilfer Shortwave, 52 park Ave., Park Ridge, NJ 07656, are two sources for them.

Minimally, a log should record the station, the date, time, and reception conditions, plus any other notations you think might be useful when you turn back the pages on your shortwave listening at some later date.

TUNING AROUND

Here are some stations being logged by your fellow DX'ers recently. Give them a try!

LESOTHO—4,800 kHz.

Radio Lesotho, a southern African station, has been reported with good signals at 0500 UTC, with English-language commercials, identification, and news.

RUSSIA—11,880 kHz.

Radio Galaxy is one of the new shortwave voices from the former USSR. Radio Galaxy, broadcasting from Moscow, and has been reported with commercial, English programming at 1948 to 2029 UTC.

SAUDI ARABIA—21,505

kHz. Listen for the *Broadcasting Station of the Kingdom of Saudi Arabia* with its Arabic-language programming at 1555 UTC, with a commentary and the Islamic call to prayer.

SOUTH AFRICA—5,960

kHz. *Radio RSA*, although no longer the dominant SW presence that it was before cutbacks, it's still there to be heard in English at about 0400 UTC. ■

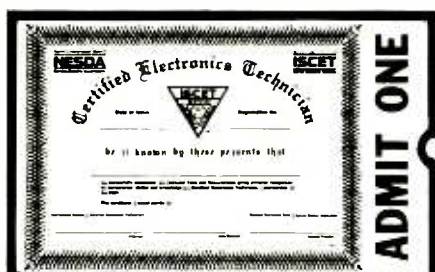

Your Ticket To SUCCESS

Over 28,000 technicians have gained admittance worldwide as certified professionals. Let your ticket start opening doors for you.

ISCET offers Journeyman certification in Consumer Electronics, Industrial, Medical, Communications, Radar, Computer and Video. For more information, contact the International Society of Certified Electronics Technicians, 2708 West Berry Street, Fort Worth, TX 76109; (817) 921-9101.

Name _____
Address _____
City _____
State _____ Zip _____

Send material about ISCET and becoming certified.

Send one "Study Guide for the Associate Level CET Test." Enclosed is \$10 (inc. postage).

HAM RADIO

By Joseph J. Carr, K4IPV

Are Antenna Tuning Units Necessary?

The subject of this column may surprise some readers, but it is nonetheless serious. The simple fact is that the antenna tuner is an often overlooked station accessory that has several important uses. Some people swear by antenna tuners, while others swear at them. Some people haven't a clue as to what they are used for, while others have some pretty fuzzy ideas about the matter. But because of its usefulness, the



The Deluxe Versa Tuner II, from MFJ Enterprises, Inc., uses a "crossed needles" VSWR meter, which allows you to clearly see the increase in forward power vs. the decrease in reflected power (which represents VSWR).

antenna tuner should be fondly regarded by all amateurs.

ANTENNA TUNER USES

Perhaps the most common use for an antenna tuner is to match the output impedance of a transmitter to the impedance of the transmission line. If the antenna is not matched to the line, the mismatch will be reflected back to the transmitter. The purpose of the antenna tuner is to flatten the standing-wave ratio (VSWR) on the line so that the transmitter won't be bothered.

Most modern transmitters have a protective VSWR shutdown circuit that cranks down the output power level as the VSWR goes up.

Once the VSWR reaches 1.5:1, a significant decrease in power is seen, and at something between 2:1 and 3:1, the transmitter is putting out a power level that's decimal dust compared to the rated output power.

The standard antenna tuner does not really tune the antenna—only changing the lengths of the radiating elements will really do that job. What the antenna tuner does is to match the impedance of the antenna at its feedpoint to the characteristic impedance of the transmission line (if the tuner is placed at the antenna feedpoint).

On the other hand, if the tuner is placed between the antenna transmission line and the output of the transmitter, it will match that reflected impedance. Such tuners are sometimes called "line flatteners," and are, perhaps, the most commonly used today. Antenna tuners can be used to match some really difficult antenna systems to the 52-ohm output typically found on radio transmitters.

At one time, most rigs used vacuum tubes in the final RF power amplifiers, which were equipped with relatively wide-range pi-network output circuits that would do a good job of suppressing harmonics and matching impedances. But today's solid-state rigs typically use broadband bandpass filters in their output circuits, which means that the rig wants to see a matched impedance, or close to it. As a result, when antenna mismatches occur, they must be handled ex-

ternal to the transmitter by way of an antenna-tuning unit.

If the antenna tuner has a balanced output, it can be used to match tuned feeders, parallel transmission lines, twin-lead transmission lines, etc. And if it has a single-ended high-impedance output (often labelled "Hi-Z" or something similar), it can be used to match the impedance of random-length wire antennas. (For several years while I was in college, a random-length wire served me well for operating on 75 and 40 meters.)

REDUCING HARMONICS

An antenna tuner can also be used to prevent harmonic radiation. Harmonics are, if you recall, integer multiples of the operating frequency. That is, if f is the operating frequency, $2f$, $3f$, $4f$, $5f$,... nf are the harmonics. In addition to harmonics, modern transmitters are often afflicted by other spurious output products resulting from the heterodyning (mixing) of several internal signals.

All mixing circuits produce some spurious signals in the output, although there are profound differences between several varieties. The mixing products tend to not be harmonically related, although they can be calculated if you know the rig's IF frequency, VFO frequency range, operating frequency, and the frequencies of any crystal oscillators or other frequency sources used in the process.

If the antenna tuner is inherently a bandpass or lowpass filter, it will permit neither transmitter harmonics nor mixing products to reach the antenna. Unfortunately, because there are several different antenna-tuner designs, the amateur will often select a unit that does some of the job, but not all of it.

the lowpass filter into the line and attempt to adjust the antenna tuner. See whether it works as advertised. Then raise the power closer to the full rated power and check the operation again. If all is OK, connect the output of the tuner to the transmission line from the antenna and try it—at low power—into

the antenna, or to a coaxial switch that allows you to operate into either the live antenna or a dummy load. A multiple coax switch can be used to connect the ATU to several different antennas as well as the dummy load.

ANTENNA TUNERS

MFJ Enterprises, Inc. (Box 494, Mississippi State, MS 39762; Tel. 601-323-6551) makes a couple of antenna tuners for the ham bands. One of them, the Deluxe Versa Tuner II (which is of a tried and true traditional design), has been around for a long time. The Deluxe Versa Tuner II uses the "crossed needles" form of VSWR meter. Older models either have a single meter with a "forward-reverse" switch to select the direction of measurement or use

tempts, I found it very resettable from one operating session to another. I found that once the settings were known, and without any changes in the antenna connected to the tuner, resetting it to "preset" points prior to going on the air resulted in a very nearly perfectly tuned situation almost without fail.

The rear panel of the Differential-T Tuner will accommodate two coaxial antennas (COAX1 and COAX2), an external dummy load (so no external coax switch is needed), and a parallel transmission line (which also implies a single-wire line if one side of the parallel output is tied to ground). I am a firm believer in antenna tuners, and have used one on every station that I've put together since the mid-1960's.



The Differential-T Tuner, which also uses a "crossed needles" VSWR meter, seems a little odd to use at first, but once the settings were known (absent any changes in the antenna connected to the tuner) resetting it to "preset" points prior to going on the air resulted in a very nearly perfectly tuned situation.

For example, one coaxial line-flattener design (essentially a highpass filter) does a really good job of matching coaxial transmission lines to the coax output of a transmitter. While that keeps the transmitter from balking at the impedance mismatch, it does nothing at all for harmonic suppression. If the antenna tuner is not a good bandpass filter or it's an out-and-out highpass filter, then it is a good idea to explore the possibility of using a fixed-frequency lowpass filter in the transmission line between the transmitter and the antenna tuner. But, try it on low power before committing the rig to full-bore! The characteristics of filters change if they are not terminated in their design impedance, which can cause some strange things to happen.

Using a dummy load instead of the antenna, insert

the real antenna with all of its mismatches and ghostly gremlins. Don't turn up the power until you are sure that the thing will work correctly.

In the typical high-frequency (160 through 10 meters) station configuration, the output of the transmitter feeds the input of a lowpass filter (LPF), which should have a cut-off frequency in the 32- to 40-MHz region if all bands in the HF spectrum are used. If only one or two bands are used, then select a filter with a cut-off frequency that is approximately midway between the operating band and the next higher ham band. For example, if you only operate 40 and 20 meters, then use a filter with a cut-off frequency about 18 or 19 MHz. The antenna-tuning unit (ATU) is fed from the output of the lowpass filter, and the output of the ATU is fed either directly to

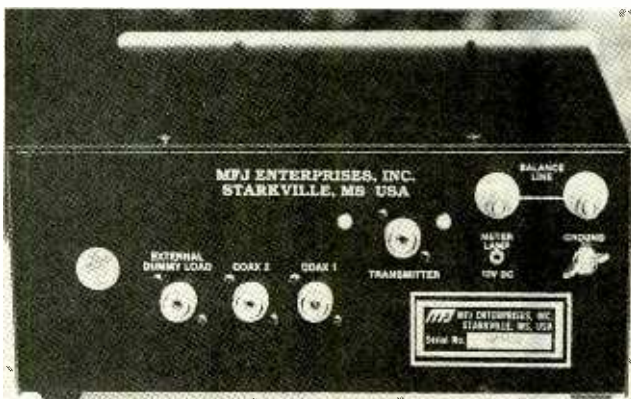

The rear panel of the Differential-T Tuner can accommodate two coaxial antennas (COAX1 and COAX2), an external dummy load (so no external coax switch is needed), and a parallel transmission line.

a pair of meters (one forward, one reverse). The Deluxe Versa Tuner II's crossed-needle design allows you to easily observe the rise in forward power while the reflected power (which represents VSWR) decreases.

Another unit, the Differential-T Tuner, which uses a different design, is the type that I use in my ham station. It's a little odd to use at first, but after a couple at-

NEW TEXT

Unfortunately, we have come to the end of our allotted space for this month. Incidentally, by the time this article reaches you, my new antenna book, *Receiving Antenna Handbook* should be ready. To find out where to get your copy, you can contact HighText Publications, 7128 Miramar Road, #15, San Diego, CA, 92121; 619-693-5900.

SCANNER SCENE

By Marc Saxon

Monitoring Two-Way Radios

Looking here, there, and everywhere for frequencies to find interesting or unusual stations, scanning enthusiasts sometimes overlook places that aren't really all that far off the beaten path.

One example is the 49.82–49.90-MHz band. That band is the one to listen to for those low-power, two-way radios usually offered as "hands-free



This Maxon 49-FX five-channel transceiver operates in the 49.82–49.90-MHz band. Have you ever monitored there?

49-MHz" sets. The units don't require FCC licenses, but their range can be more than a quarter of a mile. Many companies are now producing equipment for that band, and it can be purchased in places ranging from sporting goods specialty shops to general-merchandise department stores, as well as electronics shops.

The 49.82–49.90-MHz band isn't divided (by the FCC) into specific channels,

as is the CB band. All of the transceivers thus far produced for this band are handhelds or intended to be worn on a belt. For the most part, they operate on a single channel somewhere (anywhere) within the band. The exact frequency is left up to the manufacturer. As long as two sets sold as a pair share a common channel, the specific frequency isn't important. Deluxe units are capable of operating on as many as five different frequencies, selectable by the user.

Who can be monitored in this band? Many different businesses make heavy use of those two-way radios, including private security patrols, private detectives, construction companies and other job sites, and warehouses. I know of several police forces that use these sets for surveillance work because the frequencies are so seldom monitored by scanner owners!

Naturally, these radios have dozens of recreational applications, including camping, hiking, biking, boating, motorcycling, fishing, ultralight flying, and on-field use during sporting events.

It's certainly worth your time to search/scan the 49.82–49.90-MHz band (in 5-kHz steps, if you can) to see what it might produce for you. And, while you're at it, you might as well give a listen on the other frequencies that appeal to many of

the same types of users. Those frequencies require FCC licenses, and primarily include: 151.625, 154.57, 154.60, 464.50, 464.55, 469.50, and 469.55 MHz.

WHITHER WEATHER?

There's always a lot of interest in monitoring weather information, and some scanners now come with the ability to scan the NOAA's seven weather-broadcast channels. Those are: 162.40, 162.425, 162.45, 162.475, 162.50, 162.525, and 162.55 MHz. Just about all areas of the United States (except perhaps a few remote areas of Alaska) are within monitoring range of at least one of the NOAA stations. Listeners in some areas, especially if they have a decent outside antenna, can normally receive several NOAA stations.

It's worth pointing out that the NOAA stations present scanner owners with signals of known strength that are (usually) operating constantly. That means that if you think you're having trouble with your scanner's antenna system, or perhaps the scanner itself, the first thing to do is punch up one or more NOAA stations that are familiar to you. Listening to the way that they are coming through gives you a quick check on how your station is functioning. If you used to be able to hear the NOAA station 100 miles away, and now you can no longer copy it, then you have confirmed your suspi-



- * **COMPUTERS** *
- * **VIDEO** *
- * **STEREO** *
- * **TECHNOLOGY** *
- * **SERVICE** *

Electronics NOW®

Each month, *Electronics Now* presents articles on new technology, electronics construction, video, audio, computers, and more. It's a magazine for the electronics professional who truly enjoys electronics and for whom electronics is more than just a job. It will be sought out in your library for reading . . . reference . . . research.

1 year \$19.97, 2 years \$38.97

cions that something isn't doing its job properly.

Don't forget, too, that there are other frequencies around the country where weather data can be copied. Those are two-way frequencies used by pilots to exchange weather information with ground stations. When the weather gets tricky, those frequencies can get very busy and quite exciting.

You won't be in receiving range of activity on every one of these frequencies, but you'll certainly be within range of the action on a minimum of two or three. These are all AM mode: 122.0, 124.675, 126.625, 127.625, 128.475, 132.725, 133.025, 133.675, 133.775, 133.925, 134.175, 134.525, 134.725, 134.825, 135.425, 135.475, 135.675, 135.7, 135.9, 239.8, 342.5, 344.6, 375.2, 135.475, 135.675, 135.7, 135.9, 135.925, 239.8, 342.5, 344.6, and 375.2 MHz. Note that 122.0 MHz is called the "Flight Watch" frequency, and is active throughout the U.S. The frequencies between 124 and 136 MHz are all used by high-altitude aircraft exchanging weather data with FAA ground stations around the country. At least one of those frequencies should be active in your area. The UHF frequencies are used for weather data at many military air bases. You should be able to copy activity on one or two of the UHF channels.

FROM OUR READERS

It seems like every couple of weeks we get a letter from Greg Pruitt of Alpharetta, GA, complaining that he wrote to us but he didn't get a response, although he wishes us a nice day, anyway. Greg didn't have any specific question or comment regarding scanners, or any frequencies to

share. He just wants a response. OK, Greg. We have responded, and we hope this is what you wanted.

Stephen Kalista (9 Maple Drive, Jim Thorpe, PA 18229) has a 16-channel Tennelec Memory Scan MS-2 scanner, but he doesn't have the book with the programming codes, nor does he know where to obtain one. He is hoping that we can help him locate one of those books. That could be a problem. That was one of the very first programmable scanners ever to appear. It must have come out in the 1970's, and it was neither very good nor particularly successful.

The MS-2 picked up many frequencies, but they had to be programmed into the unit by binary codes that were listed in the manual. If you wanted to monitor 155.37, for instance, you looked up that frequency and it told you to program in something like "1100101." If you wanted to hear 151.655, you programmed in something like "0101100." There was a code for each frequency. Without the book, the set could not be programmed. It had more birdies than the San Diego Zoo.

The company that made the MS-2 long ago left the scanner field, or went out of business altogether. The books became impossible to get after a while, unless some MS-2 owner was kind enough to copy one for a fellow enthusiast. If you have one of those books, maybe you can help Steve out.

Why not drop us a card or letter with your favorite frequencies, or scanner questions and comments? Write to us at *Scanner Scene*, **Popular Electronics**, 500-B Bi-County Blvd., Farmingdale, NY 11735.



1367P \$29.95
Softcover



3672P \$18.95
Softcover



2790P \$15.95
Softcover

Select any 5 books

for only \$4.95

(values up to \$187.70)

plus 1 book FREE upon prepayment

when you join the **Electronics Book Club**™

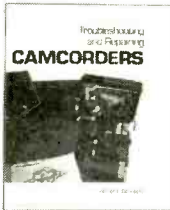

3337-XX \$35.95
Counts as 2



2613P \$17.95
Softcover

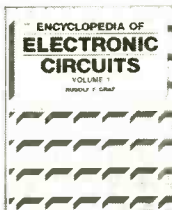

1938-XXX \$60.00
Counts as 3

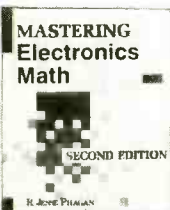

3589 \$27.95

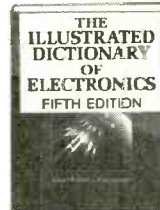

3345P-XX \$21.95
Counts as 2/Softcover



3475P \$17.95
Softcover



3765 \$29.95



3777-XX \$32.95
Counts as 2



3485-XX \$27.95
Counts as 2



3258-XX \$28.95
Counts as 2

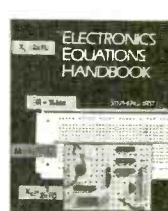

3241P \$16.95
Softcover

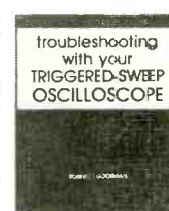

3669 \$27.95



3671P \$18.95
Softcover

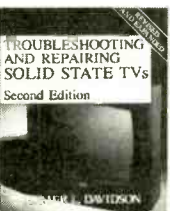

3700-XX \$36.95
Counts as 2

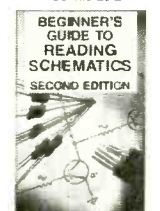

3632P \$10.95
Softcover



3888 \$26.95

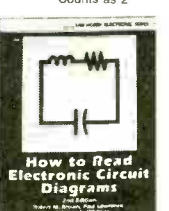

2880P \$14.95
Softcover

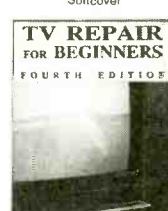

3627 \$29.95

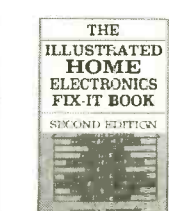

2883P \$18.95
Softcover



3886 \$22.95

As a member of the Electronics Book Club . . .

. . . you'll enjoy receiving Club bulletins every 3-4 weeks containing exciting offers on the latest books in the field at savings of up to 50% off of regular publishers' prices. If you want the Main Selection do nothing and it will be shipped automatically. If you want another book, or no book at all, simply return the reply form to us by the date specified. You'll have at least 10 days to decide. And you'll be eligible for **FREE** books through the **NEW Bonus Book Program**. Your only obligation is to purchase 3 more books during the next 12 months, after which you may cancel your membership at any time. ©1993 EBC

A shipping/handling charge and sales tax will be added to all orders. All books are hardcover unless otherwise noted. (Publishers' Prices Shown) If you select a book that counts as 2 choices, write the book number in one box and XX in the next. If you select a Counts as 3 choice, write the book number in one box and XXX in the next 2 boxes. PE293



586168-XX \$24.95
Counts as 2

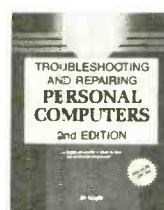

3677-XX \$34.95
Counts as 2

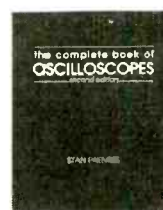

3825 \$26.95

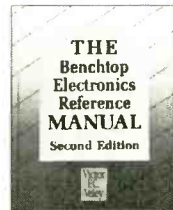

3414-XX \$39.95
Counts as 2



3457 \$29.95

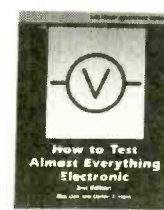

2525P \$10.95
Softcover



3438 \$39.95



3540 \$26.95

Your most complete and comprehensive source for the finest electronics books.

If card is missing, write to: Electronics Book Club, Blue Ridge Summit, PA 17294-0810

ELECTRONICS LIBRARY

Electronic Projects for Guitar

by R.A. Penfold

Written for guitarists on a budget, this book includes 16 guitar and general-purpose effects devices that you can build yourself at a fraction of the retail price. Projects include a guitar pre-amplifier, a headphone amplifier, a soft distortion unit, a compressor, a "waa-waa" pedal, a treble booster, a dynamic tremelo, a guitar tuner, an expander, and more. You don't need any previous experience with electronics to build the proj-

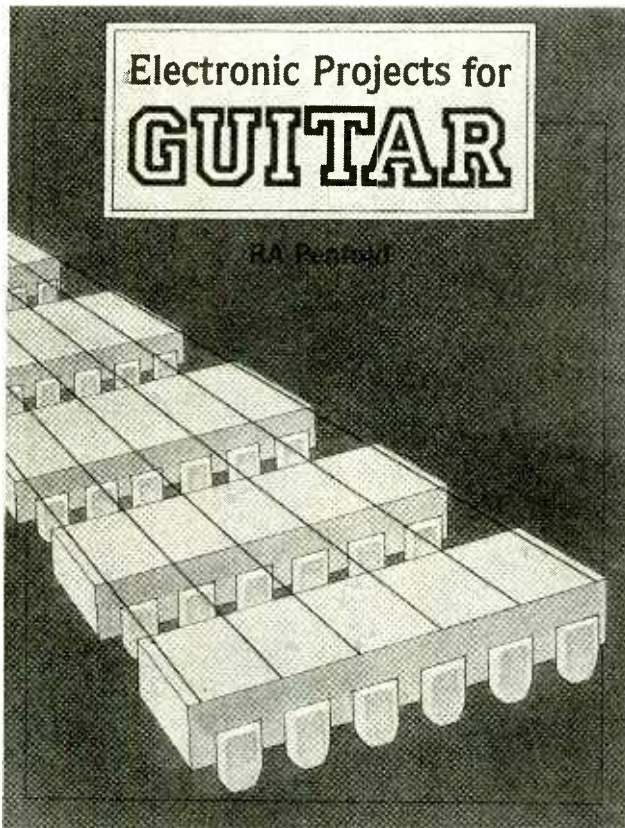

ects, and no expensive test equipment is required. Each project includes an introduction, an explanation of how it works, complete assembly instructions, a circuit diagram, and notes on how to set up and use the device.

Electronic Projects for Guitar is available for \$12.95 plus \$3.50 shipping and handling from Electronics Technology Today Inc., P.O. Box 240, Massapequa Park, NY 11762-0240.

CIRCLE 97 ON FREE INFORMATION CARD

PURGE THE SURGE SCOURGE

from Liebert Corporation

This 14-page guide details the causes and effects of, and solutions for, power surges. The easy-to-follow brochure includes a glossary, charts on required ANSI/NFPA (National Fire Protection Association) applica-



tions, and industry codes and standards (UL, ANSI, IEEE, etc.) for voltage-surge suppressors. Diagrams give examples of industrial and residential circuits, and industrial, hospital, and commercial applications of transient voltage surge suppressors.

Purge the Surge Scourge is free upon request from Liebert Corporation, 1050 Dearborn Drive, Columbus, OH 43229.

CIRCLE 90 ON FREE INFORMATION CARD

AIR-WAVES: THE AVIATION MONITOR'S HANDBOOK

by Laura E. Quarantiello

You can experience the call of

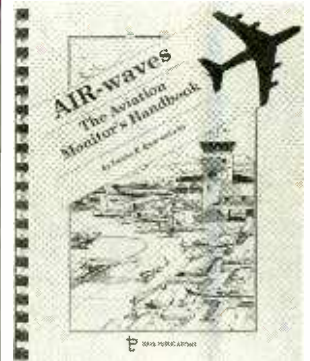

the "wild blue yonder" while keeping both feet firmly on the ground, by tuning your scanner to the aeronautical bands. Whether you're a newcomer to monitoring aeronautical communications or have been doing it for years, this book will help you better understand what is being said and why. The entire field of VHF/UHF aeronautical communications is covered, from airport identifiers to runway numbering. Readers are introduced to the daily routines of airports and flights, with clear, often chatty descriptions of air-traffic control, a flight from take-off to touchdown, a typical day on the field at an airport, how airspace is divided and arranged, departure and arrival communications with the tower, the Air Route Traffic Control Center, emergency communications, aviation weather, monitoring air-to-ground telephones, and reading aviation charts. Plenty of purely practical information is included in the appendices, such as navigation aid identifiers, navigation equipment suffix codes, airport abbreviations, aeronautical frequency ranges, VHF frequency log, international civil aircraft tail code prefixes, a list of related magazines and books, and a pilot/controller glossary.

AIR-Waves: The Aviation Monitor's Handbook is available for \$17.95 plus \$2 shipping and

handling (\$3 foreign) from Tiare Publications, P.O. Box 493, Lake Geneva, WI 53147; Tel: 414-248-4845.

CIRCLE 91 ON FREE INFORMATION CARD

CIRCUIT DESIGN & ANALYSIS

Featuring C Routines

by C. Britton Rorabaugh

Aimed at anyone who is involved in electronic-circuit design, this book provides an array of computer-aided analysis and synthesis techniques. Technicians and advanced hobbyists can use their PC's and this book/diskette package to harness the same professional-level diagnostic tools used by engineers to design and evaluate complex circuitry. Unlike

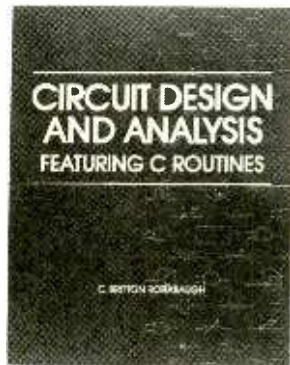

prepackaged general-purpose analysis programs, the ready-to-compile C routines presented in the package allow readers to configure customized, streamlined programs with a power and flexibility that "canned" programs can't match. The book opens with an extensive review of circuit-analysis fundamentals. That is followed by methods for solving circuit equations, techniques for implementing "end-to-end" design strategies, special analysis techniques for non-linear circuits, and other powerful routines. The book includes an IBM-compatible 5¼-inch source-code disk, and complete listings for users of non-IBM compatible computers.

Circuit Design & Analysis Featuring C Routines costs \$34.95 and is published by TAB Books, Division of McGraw-Hill Inc., Blue Ridge Summit, PA 17294-0850; Tel. 1-800-822-8138.

CIRCLE 98 ON FREE INFORMATION CARD

TEST INSTRUMENTS CATALOG

from B + K Precision

This catalog (No. BK-93) details B + K's complete line of electronic test instruments and accessories for use in engineering, maintenance and repair, field service, education, production-line testing, quality-control programs, and research and development. Included in its 64 pages are signal and function generators, IC testers, oscilloscopes, spectrum analyzers, component testers, digital multimeters, video test gear, probes, and the accessories designed to optimize the functions of those instruments.



The catalog's detailed listings include complete specifications, summaries of key product features, and selected product applications. To help users select the right instrument for a given job and to provide an educational training aid, the catalog also features easy-to-use comparison charts and a glossary of terms.

Test Instruments Catalog (BK-93) is free upon request from B + K Precision, 6470 West Cortland Street, Chicago, IL 60635; Tel: 312-889-1448; Fax: 312-794-9740.

CIRCLE 92 ON FREE INFORMATION CARD

TROUBLESHOOTING & REPAIRING AUDIO & VIDEO CASSETTE PLAYERS AND RECORDERS

by Homer L. Davidson

Cassette players, both audio and video, have found their place in everyone's life—in every room of the home, in the office, in the car, and carried on

the go. This book is intended to help homeowners, hobbyists, tinkerers, and electronic students learn how each player works and how to make simple repairs using just one piece of test equipment—a digital multimeter. The book opens with a chapter titled "Cassette Player Basics" that includes discussions of basic troubleshooting techniques, IC and transistor tests, signal tracing, head-azimuth and current tests, tape-head cleaning and demagnetizing, speed adjustments, and even instruction on how to build



your own test equipment—a sine/squarewave generator, an IC audio signal tracer, a white-noise generator, a 1-kHz audio generator, and a speaker load. Subsequent chapters are each devoted to a specific type of cassette player: personal cassette players, boom boxes, portable AM/FM Cassette/CD players, microcassette recorders, car-stereo cassette players, autocasette/CD players, dual-well cassette decks, VCR's, home-stereo cassette decks, compact cassette players, and camcorders. Line drawings, photographs, and schematics accompany the text. Rounding out the book are a manufacturer's list and a complete glossary.

Troubleshooting & Repairing Audio & Video Cassette Players & Recorders costs \$19.95 and is published by TAB Books, Division of McGraw-Hill Inc., Blue Ridge Summit, PA 17294-0850; Tel. 1-800-822-8138.

CIRCLE 98 ON FREE INFORMATION CARD

ATTENTION! ELECTRONICS TECHNICIANS

EARN YOUR **B.S.E.E. DEGREE**

THROUGH HOME STUDY

Our New and Highly Effective Advanced-Placement Program for experienced Electronic Technicians grants credit for previous Schooling and Professional Experience, and can greatly reduce the time required to complete Program and reach graduation. No residence schooling required for qualified Electronic Technicians. Through this Special Program you can pull all of the loose ends of your electronics background together and earn your B.S.E.E. Degree. Upgrade your status and pay to the Engineering Level. Advance Rapidly! Many finish in 12 months or less. Students and graduates in all 50 States and throughout the World. Established Over 40 Years! Write for free Descriptive Literature

COOK'S INSTITUTE OF ELECTRONICS ENGINEERING



4251 CYPRESS DRIVE
JACKSON, MISSISSIPPI 39212

CIRCLE 5 ON FREE INFORMATION CARD

NEW PRODUCTS

AM Communications Interceptor

A modern version of the crystal-detector radio, the *Model R20 AM Communications Interceptor* has microwave diodes and transistors replacing the chunk of galena. Unlike a conventional radio receiver or scanner, the Interceptor responds to any strong signal present, and is stabilized by the signal it is receiving. That means that the Interceptor doesn't have to be tuned to a frequency to receive a signal. Any AM signal from 0.5 MHz to over 2.5 GHz can be intercepted without any coverage gaps. The page-sized unit is completely automatic for



hands-free operation. A ten-LED bargraph provides a relative signal-level display, using 3-dB steps, for all RF signals that are detected. The detected audio output is amplified and processed using automatic level circuitry, which replaces the need for an external volume control and also protects the listener from strong signals that might produce uncomfortably loud transients. An earphone can be used to monitor the detector output.

The Interceptor can be used

to check two-way radios for RF output, make RF signal-strength measurements, locate stuck transmitters, test microwave ovens for leakage (even those within the radiation leakage standards will indicate on the R20), locate RF "bugs," and listen to any AM signal including CB and two-way aircraft transmissions. Because it has no internal oscillators, it doesn't radiate any signals that could interfere with sensitive navigation or communication equipment aboard aircraft. When sweeping a room for concealed listening devices, more LED's will light on the bar-graph as the source of RF is approached.

The Interceptor costs \$119. For further information, contact Optoelectronics Inc., 5821 NE 14th Avenue, Fort Lauderdale, FL 33334; Tel: 800-327-5912 or 305-771-2050; Fax: 305-771-2052.

CIRCLE 102 ON FREE INFORMATION CARD

DIGITAL MULTIMETER

Following the idea that "smaller is better," *Beckman Industrial* has introduced the *Model DM2*, the company's most compact, low-cost, full-function DMM. The DM2 weighs just seven ounces and is about the size of a deck of cards, fitting easily into a shirt or pants pocket. The unit measures low-level DC current with 0.1- μ A resolution, DC volts to 1000 volts, AC volts to 500 volts, and resistance to 2 megohms. It can be used for diode testing, and provides up to 200-mA fused DC measurements. DC voltage ranges include 200 mV, 2V, 200V, and 1000V; AC ranges include 200V and 500V. Designed for quick measurements, the DM2 is well suited for field service and facilities maintenance, as well as for use by hobbyists and students.

The Model DM2, complete with test leads, an owners manual, a spare fuse, and a one-



year warranty, has a list price of \$27.95. For additional information, contact Beckman Industrial Corporation, 3883 Ruffin Road, San Diego, CA 92122-1898; Tel: 619-495-3218.

CIRCLE 103 ON FREE INFORMATION CARD

PRINTER-SHARING SYSTEM

As many as 40 personal computers can share a single printer with the *GT100 PrintShare* system from *L-com Data Products*. The system is easy to use and install, and no software or external power is required for operation. Each PrintShare adaptor plugs directly into the parallel port of a PC, and connections are made over four-conductor, flat telephone wire. Printer access is on a first come, first served basis. The system features automatic switching, a unique collision-avoidance technology, and user-adjustable time-out. It also has printer-unavailable and connection-error status indicators. PrintShare operates in both Windows and DOS environments. It supports high-speed data transmission of 10,000 characters per second over a combined distance of 1200 feet.

An individually packaged PrintShare adaptor, which comes with a 25-foot, four-wire modular cable, costs \$89.50. As an introductory offer, a starter kit that contains two transmitters, one receiver, and



PORTABLE NTSC SIGNAL GENERATOR

Offering capabilities usually found only in benchtop models, *B + K Precision's Model 1221* portable television/video signal generator produces 14 patterns of stable video signals for comprehensive testing, servicing, and adjustment of virtually all types of television and video equipment—including color or monochrome video monitors, VCR's, television receivers, closed-circuit television systems and components, and cable television systems. Suitable for field or shop use, the Model 1221 is small enough to fit into a field-service kit. Its lightweight-aluminum housing provides exceptional RF shielding and ruggedness.

two 25-foot cords is also available. For more information, contact L-com Data Products, 1755 Osgood Street, North Andover, MA 01845; Tel: 1-800-343-1455; Fax: 518-689-9484.

CIRCLE 104 ON FREE INFORMATION CARD

VIDEO MICROPHONE

Aimed at amateur videographers, the *Model ECS-440* from *Azden Corporation* is a stereo/monaural directional microphone intended for use with camcorders. The ECS-440 comes with a camera-shoe mount as well as a metal stand for use in a conference setting. The appropriate cables for both purposes also are included. The microphone features a stereo/mono switch, and an on/off switch with an LED for battery checks.



The Model ECS-440 stereo/mono directional microphone has a suggested retail price of \$69.95. For additional information, contact Azden Corporation, 147 New Hyde Park Road, Franklin Square, NY 11010; Tel: 516-328-7500; Fax: 516-328-7506.

CIRCLE 105 ON FREE INFORMATION CARD

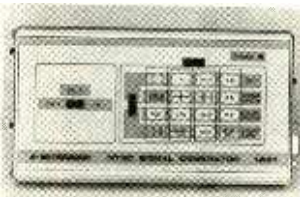

The 14 patterns include standard NTSC color bars with and without IWQ, full-field IWQ, split-field color bars with reverse bars; red, green, blue, and black rasters; and six convergence patterns. Chroma can be turned off to display the luminance level only (monochrome). A 1-kHz subcarrier audio tone also can be switched on or off. Outputs include composite video, IF (45.75 MHz, crystal-controlled), and CH3 and 4 (crystal-controlled). A 9-pin, D-type connector provides an RGB output for testing CGA computer monitors. The user can select either interlaced or progressive scan, TTL or low-level (analog level) for RGB outputs, and can output composite sync through pin 7 of the D-connector.

The Model 1221 NTSC signal generator, complete with manual, output cable, and AC adapter, has a list price of \$369. For more information, contact B + K Precision, Division of Maxtec Corporation, 6470 West Cortland Street, Chicago, IL 60635; Tel: 312-889-1448; Fax: 312-794-9740. ■

CIRCLE 106 ON FREE INFORMATION CARD

Earn Your B.S. Degree in ELECTRONICS or COMPUTERS



By Studying at Home

Grantham College of Engineering, now in our 42nd year, is highly experienced in "distance education"—teaching by correspondence—through printed materials, computer materials, fax, and phone.

No commuting to class. Study at your own pace, while continuing on your present job. Learn from easy-to-understand but complete and thorough lesson materials, with additional help from our instructors.

Our Computer B.S. Degree Program includes courses in BASIC, PASCAL and C languages — as well as Assembly Language, MS DOS, CADD, Robotics, and much more.

Our Electronics B.S. Degree Program includes courses in Solid-State Circuit Analysis and Design, Control Systems, Analog/Digital Communications, Microwave Engr, and much more.

An important part of being prepared to *move up* is holding the right college degree, and the absolutely necessary part is knowing your field. Grantham can help you both ways—to learn more and to earn your degree in the process.

Write or phone for our free catalog. Toll free, 1-800-955-2527, or see mailing address below.

•
Accredited by
the Accrediting Commission of the
National Home Study Council

•
GRANTHAM
College of Engineering
Grantham College Road
Slidell, LA 70460

THINK TANK

(Continued from page 76)

device is connected to the terminals correctly, the JFET is biased on and D3 drops approximately 0.6 volt. So, by virtue of Kirchoff's voltage law, 0.6 volts appears at the gate. The brightness of the LED gives an approximate indication of I_D , while R3 protects the LED and D3 should the drain and source leads be accidentally shorted together. An AC signal generator or home-made signal source is then connected to the BNC connector and is used to provide an alternating gate voltage after being half-wave rectified by D1. That voltage acts to pinch off the channel and turn off

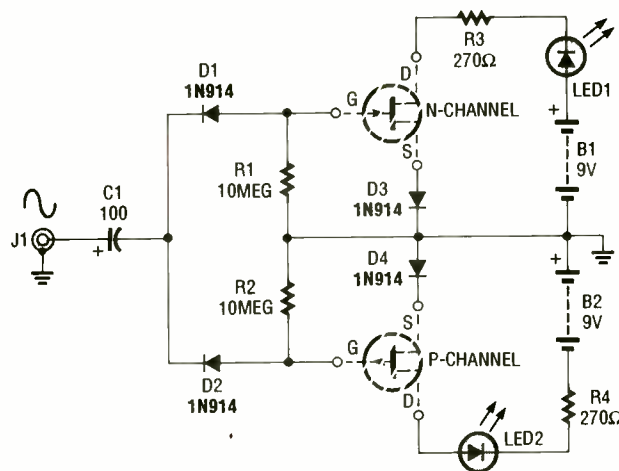

Fig. 5. Just pop an N-channel JFET in the top position or a P-channel JFET in the bottom position, apply an AC signal to J1, and the health of the JFET will be indicated by one of the LED's.

the LED. A sinewave or triangle-wave input of approximately $8 V_{pp}$ at 15 Hz gives a linear indication of the channel being pinched off, while a square-

wave gives the device's switching characteristic.

—C. Daykin, Rochester, NY

Very nice, your book is on the way. I took the liberty of

attempting to reduce the number of parts almost in half by adding a switch to toggle the unit between N- and P-channel operation. Unfortunately, it would have to be quite a switch. I like the approach that you used much better.

Well that's all the room we have for this month. If you'd like to be a participant of this column, please write to **Think Tank, Popular Electronics**, 500-B Bi-County Blvd., Farmingdale, NY 11735. All entries that make these pages will be rewarded with a "Think Tank II" or other book. Until next month when we'll continue our discussion on chips and look at some more of your test-equipment circuits and letters, may your iron be forever warm.

FACTCARDS



Jampacked with information at your fingertips

■ ALL YOU NEED to know about electronics from transistor packaging to substitution and replacement guides. FACTCARDS numbers 34 through 66 are now available. These beautifully-printed cards measure a full three-by-five inches and are printed in two colors. They cover a wide range of subjects from Triac circuit/replacement guides to flip-flops, Schmitt triggers, Thyristor circuits, Opto-Isolator/Coupler selection and replacement. All are clearly explained with typical circuit applications.

■ WANT TO EXPAND your knowledge of electronics? Do it the easy way

by studying the Electronics Fact Cards. Do you travel to and from your job each day? Drop a handful of cards in your pocket before you leave, and the bus becomes a schoolroom! At home, you can build some of the projects and not only have fun building and using them, but learn how they work at the same time.

■ YOU'LL BE AMAZED both at how rapidly you learn with these cards, and how easy it is to understand. These new cards are available right now. Don't miss out. Send your check or money order today.

FACTCARDS—Facts at your fingertips for Experimenters and Project Builders!

Please send one copy of FACTCARDS at \$3.50. Shipping \$1.00 (U.S. and Canada only).

Please send _____ copies of FACTCARDS. Total cost is sum of copy price and First Class postage and handling cost multiplied by number of card sets ordered.

New York residents add sales tax to total cost of each order.

Please print

Allow 6-8 weeks for the material to arrive.

(Name)

(Street Address)

(City)

(State)

(Zip)

Detach and mail today:
CLAGGK Inc.
P.O. Box 4099
Farmingdale, NY 11735

All Payment must be in U.S. Funds!

SUBLIMINAL TAPES

(Continued from page 55)

Place the 1000-Hz tone tape in the machine connected to the main input. Set the output machine to record, and then turn the volume up or down on the subliminal machine until the VU meter on the output machine reads 0 dB. Once you get the proper reading, move the subliminal machine connections from J1/J3 to J2/J4 without changing its setting. The volume from that machine will be down 30 dB.

Note: If you prefer a lower level, or for some reason a higher volume level, then set the VU meter accordingly. For example, if you prefer a -40-dB level, adjust the volume of the subliminal machine until the VU meters on the output machine reads -10 dB. That way, when you move that machine's connections to the -30-dB inputs (J2/J4), the total attenuation of the mixer for that channel will be the desired -40 dB.

Next, attach the music machine to

J1/J3, turn off the subliminal player, and put the 1000-Hz tape into the main player and turn it on. Adjust its volume control so that the output machine again reads 0 dB. That concludes the setup and level adjustment.

Now, place the background music tape in the main machine (the one connected to J1/J3), your subliminal-suggestions tape into the -30 dB machine (the player connected to J2/J4), and put a blank tape into the output recorder. Start by placing the output machine in the record mode, then put the music machine in the play mode, and finally start the subliminal-message machine. Let all of the tape machines run to the end of the tapes. When you are through, you'll have a tape with nice pleasant music in the foreground and the subliminal message(s) of your choosing in the background.

There is a chance that when you're making your subliminal suggestions tape, that you will not be able to think up 30 or more minutes of something

to say. Don't panic! Endless-loop tape (available from Radio Shack and elsewhere) lets you record a shorter message that will repeat over and over.

Conclusion. To use your subliminal tapes, it's suggested that you listen at home or anytime you are relaxing. Remember that the purpose of subliminal message tapes is for self-improvement—if you are also thinking of your goals while you're listening a tape, it can do no harm, and will almost certainly help.

One final suggestion: If you are able to listen to music during the day, it is perfectly reasonable to put the Subliminal Mixer in the line between the tuner and amplifier. The improvement cassette can then be played through the -30 dB channel and mixed with the input from the tuner. The output will contain the subliminal messages that you have prepared. Again, only you can be the judge of whether or not they work! Let me know if you have any verifiable successes!! ■

Train at HOME to be an Electronics Technician!

As the demand for computers and microprocessors in business, manufacturing and communications continues to grow, so does the need for qualified technicians. It's not unusual for experienced technicians to earn from \$30,000 to more than \$40,000 a year.* Now through Peoples College of Independent Studies you can train for this exciting field without interrupting your job or home life.

Choose From Five Programs of Study

- Electronics & Microprocessor Technology
- Industrial Electronics & Microprocessor Technology
- Communications Electronics with Microprocessor Technology
- Computer Servicing & Electronics Technology
- Specialized Associate Degree In Electronics Technology

Professional Equipment Is Included

Depending on the program you select, you'll perfect your skills using this advanced equipment, included in the price of tuition:

- IBM-Compatible Personal Computer
- Digital Multimeter
- Digital Logic Probe
- Elenco Oscilloscope
- Portable Cellular Telephone

(* Source: U.S. Bureau of Labor Statistics)



Exclusive Extras That Enhance Your Training

Peoples College introduces some training firsts to make your learning experience more complete:

- Accelerated Learning System — a scientifically proven study system that helps you learn faster and easier than ever before.
- Video Tutor Training Tapes — give you a permanent, visual record of informative lectures and close-up demonstrations.
- Experience Labs — professionally designed experiments that give you hands-on "bench" experience.
- Industry Certification Training Guide — provided with four of our programs. Prepares you for examinations you may take for your professional license or certification.

Easy Payment Plans — No Finance Charges

To help you get started on your education, Peoples College has reduced tuition rates and offers low monthly payment plans with no finance fees. So don't delay, call or write for more information today!

For COLOR CATALOG Mail Coupon or Call TOLL FREE 1-800-765-7247

Programs offered only in United States, Canada, Puerto Rico and Virgin Islands. No Obligation. No sales person will call.

Our programs are accredited by the Accrediting Commission of the National Home Study Council

YES! I would like to know more about your training programs. Send a catalog to:

Name _____

Address _____

City _____

State _____ Zip _____

Phone # _____

PEOPLES COLLEGE
OF INDEPENDENT STUDIES

233 Academy Drive • P.O. Box 421768
Kissimmee, FL 34742-1768

Member, D.L. Peoples Group

E293

CIRCLE 10 ON FREE INFORMATION CARD

GAS GAUGE

(Continued from page 42)

circuit board. If, however, the in-dash idiot light is an LED, it will be necessary to use a 1000-ohm current-limiting resistor in series with driver transistor Q1 and the LED. (Check to see if there isn't already a limiting resistor.)

If your car is an early model, then you might not have an idiot light that was factory installed and integral to the instrument cluster. In that case, you'll want to install your own idiot light; it can be either mounted directly in the dash or in a separate enclosure as you prefer.

Although you could mount all three potentiometers (trip threshold, lamp dimmer, and slosh control) in the dash, the trip-threshold potentiometer is the one that you'll be adjusting the most. The other two controls can be left on the circuit board, adjusted once, then left alone.

The grounding wire should be terminated with an eyelet (ring lug) and attached to the car chassis anywhere under the dash using a sheet-metal screw or rivet. It's better to ground the circuit directly to the car chassis rather than to another wire that seems to be grounded. Very often, wires that seem to be grounded are actually disconnected when the ignition switch is in one position or another; going directly to the chassis ground takes most of the guess work out of the installation procedure.

The 12-volt wire should go to the radio fuse in the car's fuse box, either solder the joint or use a mechanical twist connector. Also, don't forget to place a 2-amp, in-line fuse in series with the positive supply lead of the Smarter Gas Gauge. If you're in a rush, just jam the Gas Gauge's positive lead wire against the radio fuse and push them both into the fuse box. The fuse clip will hold the wire pretty tightly. It's fast and it works.

Lastly, the V_{gas} lead wire should be connected at the gas gauge to the sending wire using a wire tap-in connector.

Quick connect, snap-n-splice, or wire tap-ins are trade names for a connector that's designed to make an electrical connection between two wires without having to cut, twist, or solder them together. First select



The author's finished prototype of the Smarter Gas Gauge, though small, is uncluttered.

the wire-tapping connector of the appropriate wire gauge for your installation. Place the sending wire and connecting wire into the wire-tap connector, then fold and squeeze with pliers until the metal insert bottoms out; that will force the metal insert to pierce the insulation of both wires thereby making electrical contact without cutting the conductors.

What if your gas gauge is broken? Maybe the gas needle is stuck in the full or empty position. If so you can still use our Smart Gas-Gauge, but you'll have to bypass your broken gauge. That's because series current must flow from the battery through the gas gauge then through the sender to ground. Any broken wire internal to the gauge will open the series circuit and no current will be able to reach the sender.

The idea is to disconnect the gauge wiring and install a 100-ohm, 10-watt, bypass resistor (such as Radio Shack's P/N 271-135 wire-wound resistor). You can leave the gauge in place to retain the dash aesthetics.

Calibration. Here's one method to calibrate the threshold at which the gas level in the tank turns l1 on. Drive your car until the gas tank is well below $\frac{1}{4}$ tank and pull up to a gas pump at any gas station. Turn the ignition key to the ON position, which will leave the fuel-gauge system on, but the engine off. For the calibration to work you'll need to watch the gas-tank needle move as the tank is being filled. When the gas-station attendant starts the pump, adjust R2 (the TRIP-THRESHOLD CONTROL) so that the lamp is illuminated. The second the gas gauge shows exactly $\frac{1}{4}$ tank, back off on the trip threshold until the lamp extinguishes. That's all there is to it. Now you've set the lamp to come on when your tank

is $\frac{1}{4}$ full. Then adjust R3 (LAMP-DIMMER CONTROL) to achieve the desired lamp brightness.

You could also fill up the tank yourself to the exact gas-gauge indication, say $\frac{1}{2}$ full, then go back into your car and adjust the trip-threshold potentiometer so that the lamp just turns on. Any additional gas pumped into the tank will immediately turn the lamp off, as the tank fills up.

The bi-metal, heated-coil, fuel gauge requires a minute or so to accurately reflect the gas level in the tank. That's because the bi-metal takes that long to heat up and bend to the correct position. So give the gauge a minute to stabilize before adjusting the trip threshold. Magnetic-type gauges, which display the correct gas level in the tank right away, don't have that problem.

Even though bi-metal gauges take their time to respond to the correct gas-level reading, the Smarter Gas-Gauge reads the sender voltage immediately, and is therefore immediately accurate.

Calibrating the trip threshold while driving on the open road is easy, too. When the gas tank reads about $\frac{1}{4}$ full, adjust the trip-threshold potentiometer so that the lamp just comes on. When you adjust the trip threshold, you're actually adjusting V_{ref} . As the gas sloshes in the tank, V_{gas} varies above and below V_{ref} and that will cause the lamp to flash while you're driving. You, therefore, might want to re-adjust the trip threshold several times until you get a feeling for the lamp's flashing rate.

Accelerating quickly by stepping down hard on the gas peddle or turning tight corners at screeching speeds may also light the lamp, again, because the gas is rolling in the tank. A steep hill or incline may also turn on the lamp. Stopping the lamp from flashing is easy: Adjust potentiometer R4 (the SLOSH TIME-OUT CONTROL) until the lamp stops flashing, then tweak R4 a little more in the same direction for good measure.

Of course, the beauty of the Smarter Gas-Gauge is that you can adjust the lamp to illuminate at any gas level in the tank; whether $\frac{3}{4}$ full, $\frac{1}{2}$ full, $\frac{1}{4}$ full, almost empty, or anywhere in between. You'll quickly find that resetting the controls only takes a second. ■

PRINTER PORTS

(Continued from page 48)

nent.) If TORF is high, then bit N in PDAT was high, if TORF is low, then bit N in PDAT was low.

The first and third bytes that support each parallel port can be used to set the logic state of the outputs. With the exception of bits 0, 1, and 3 in the third byte, if one of those bits is set high, its corresponding pin output will go high, if any of those bits is brought low, its corresponding output will go low. Bits 0, 1, and 3 in the third byte are inverted so when they're low, their associated pin receptacles are high, and when those bits are high, the pin outputs are low. As an example, to set bit N (and its associated output) in the first byte of LPT3: high, you could use a statement like this:

OUT &H278, 2^N

There is one drawback to this statement however: All bits except N will be set low when this statement is processed. If some bits were set high before this statement was executed, and you wanted to keep them that way, this statement would mess things up. On some PC-compatible computers it is possible to rectify the situation by reading the value of the byte before adjusting it to make sure you preserve the high bits when you modify the byte. For example, you could first use:

BITSET = INP(&H278)

to copy the data already stored in hexadecimal address 278 into the address of variable BITSET. Next, you could logically OR those bits with the value of the bit you want to set high:

NEWBITS = BITSET OR 2^N

which leaves all the old bits except for bit N as they were. Finally, you could send the updated data to the port using:

OUT &H278, NEWBITS

If your computer doesn't allow you to read the output bytes (the first and third bytes) then you must write your program so it keeps track of the bits that have been set in the course of operation and preserves them as appropriate. In other words, your program must update the value of variable you use in place of BITSET in the equation for NEWBITS. ■

BUILD THE WATER TAP

(Continued from page 62)

PARTS LIST FOR THE WATER TAP

RESISTORS

(All resistors are 1/4-watt, 5% units.)

R1—1-ohm

R2—10-ohm

R3—2200-ohm

R4—4700-ohm

R5—10,000-ohm

CAPACITORS

C1—270-pF, ceramic-disc

C2—0.01-μF, ceramic-disc

C3, C4—0.1-μF, ceramic-disc

C5—33-μF, 10-WVDC, electrolytic

C6—39-μF, 10-WVDC, electrolytic

C7, C8—220-μF, 10-WVDC, electrolytic

ADDITIONAL PARTS AND MATERIALS

U1—TBA820M audio-amplifier integrated circuit, (SN76001, MCE820, NTE1294, or equivalent)

MIC1—Electret microphone

SPKR1—8-ohm speaker

Shielded cable, telephone wire, 9-volt battery and clip, glass test tube, two project cases, suction cup, hot-melt glue or RTV silicone, double-sided tape, wire solder, etc.

over the tube so that the assembly floats as level as possible.

The other section contains the 9-volt battery with the power switch in series, which supplies power to the floating section via two strands of the telephone wire. The battery is held in place inside the case with a piece of double-sided tape. Holes are drilled in the lid of the case for the speaker sound to pass through. The speaker is then secured to the lid with hot-melt glue. The speaker is connected to the amplifier board with the two remaining telephone wires. The telephone wire exits the top of the case. A suction cup is mounted on the back of the case to hang it on the outside of the fish tank.

When the adhesive (hot melt glue or RTV silicone) is completely dry, the Water Tap is ready to listen in on your fish. You can probably think of many other unusual uses for this bizarre gadget. Perhaps you might want to listen for submarines at your local seashore! ■

QUAD ANTENNA

(Continued from page 64)

which were snaked through the spreader holes) were used to complete the driven-element loop and soldered together. The other loops were assembled in the same fashion, feedpoint not withstanding.

An electrician's copper-wire clamp placed on the reflector was used to tune the quad. We pointed the reflector toward a handheld two-watt transceiver and tuned for minimum signal into the transceiver.

The antenna provided very good performance, with a reasonable SWR over the entire 144-MHz band. We used a watt meter to measure the reflected power, and found that with 100 watts of output, less than a 1/2 watt was reflected.

So my students now know the difference between a full-wave and half-wave antenna. Our next classroom project is to build a PVC-based ten-meter quad. Hope to work you on ten meters. ■

*** NOW PRESENTING ***

All Available Television Channels!

with **CABLE TV**

DESCRAMBLERS

Featuring: *Scientific Atlanta, Oak, Jerrold, Hamlin, Stargate*

- Overnight Delivery
- Competitive Pricing
- Long-Term Warranties
- Visa and Mastercard Accepted

Video Dimensions

1-800-952-5197

401 Fairmount Ave., Ste. 208 Oakland, CA 94611



Let's close the book
on forest fires.



A Public Service of This Magazine
& The Advertising Council



CIRCUIT CIRCUS

(Continued from page 73)

cuit. The circuit is triggered by skin contact between two sets of metal plates, labeled S1 and S2, which serve as switches.

When the two S1 contacts are bridged via skin resistance, a small voltage is applied to the bridged inputs of U1-a (which is configured as an inverter), causing its output at pin 3 to go low. That low is applied to the bridged inputs of U1-b (also set up as an inverter), causing its output at pin 4 to go high. That high is applied to both inputs of the two remaining gates (U1-c and U1-d), which like the previous gates are wired as inverters, but connected in parallel. That forces the outputs of the two gates (at pins 10 and 11, respectively) to go low, causing LED1 to light.

The circuit remains latched in that circuit condition until the S2 contacts are bridged. Bridging the S2 contacts forces the output of U1-b low. That low is applied to the input of the parallel-connected gates (U1-c and U1-d), causing their outputs to go high, extinguishing LED1.

The LED can be replaced with an optoisolator/coupler or a relay, allowing the circuit to control just about any higher-powered device.

DIODE TESTER

The *Diode Tester*, see Fig. 7, is comprised of a 9-volt battery, two switches, two resistors, and two LED's (which are parallel connected and reverse polarized).

In operation, with a diode connected to the circuit as shown, the diode's anode is connected to the negative side of the battery through S1-b and S2. Con-

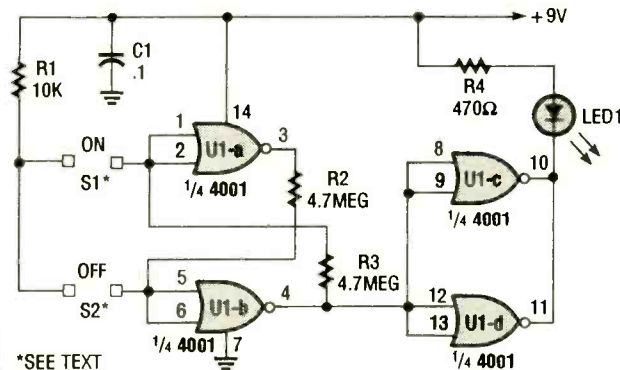

Fig. 6. The Touch-On/Touch-Off consists primarily of a latch (R-S flip-flop), built around half of a 4001 CMOS quad 2-input NOR gate (U1-a and U1-b). The remaining two gates of that CMOS chip (U1-c and U1-d) are wired as inverters and connected in parallel.

PARTS LIST FOR THE TOUCH-ON/TOUCH-OFF CIRCUIT

RESISTORS

(All fixed resistors are 1/4-watt, 5% units.)

R1—10,000-ohm

R2, R3—4.7-megohm

R4—470-ohm

ADDITIONAL PARTS AND MATERIALS

U1—4001 quad 2-input NOR gate, CMOS integrated circuit

LED1—Light-emitting diode (any size)

C1—0.1- μ F, ceramic-disc capacitor

S1, S2—Dual-contact touch-plate (see text)

Perfboard materials, enclosure, IC socket, 9-volt power source, wire, solder, hardware, etc.

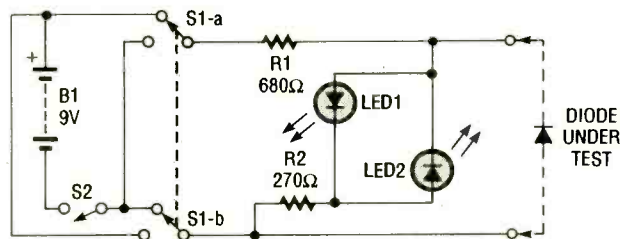

Fig. 7. The Diode Tester shown here is comprised of a 9-volt battery, two switches, two resistors, and two LED's (which are parallel connected and reverse polarized).

PARTS LIST FOR THE DIODE TESTER

LED1, LED2—Light-emitting diode (any color)

R1—680-ohm, 1/4-watt, 5% resistor

R2—270-ohm, 1/4-watt, 5% resistor

B1—9-volt transistor-radio battery

S1—DPDT toggle switch

S2—SPST toggle switch

Perfboard materials, enclosure, battery holder and connector, wire, solder, hardware, etc.

nected in that manner, the diode under test (DUT) as well as LED2 are reverse-biased and therefore do not conduct, while LED1, which is forward-biased, lights. With S1 is placed in the opposite position, the anode of the DUT is tied to the positive side of the battery, causing it to conduct. Under that condition, neither LED will light. That's because current follows the path of least resistance (the combination of LED and resistor offer greater opposition to current flow than does the diode alone).

If the DUT is connected with an opposite orientation to the way it is shown in Fig. 7, and S1 remains as shown, the DUT conducts, preventing both LED's from lighting. If, on the other hand, S1 is flipped to the other position, LED2 lights to indicate the position of the test diode's anode.

If the diode is shorted, neither LED will light regardless of the polarity of the applied voltage, because all current will be shunted around the LED circuit.



One tree can make
3,000,000 matches.



One match can burn
3,000,000 trees.



A Public Service of The Magazine
& The Advertising Council

ELECTRONICS MARKET PLACE

FOR SALE

LASER & solar energy products. Lasers from \$9.95. We specialize in laser and solar energy products for commercial, and hobbyist applications. Free catalog: **DESIGN IMAGES**, Dept. P7, Box 292125, Lewisville, TX 75029. (214) 221-9711.

CABLE DESCRAMBLERS! Build your own descrambler for less than \$12.00 in seven easy steps. **Radio Shack** parts list and free descrambling methods that cost nothing to try included. Send \$10.00 to: **HARRY WHITE**, PO Box 1790, Baytown, TX 77522.

SITELINE LASERS, INC. is offering its 5 — 8 milliwatt He-Ne lasers and power supplies for sale at manufacturers pricing. Supplies can be purchased in Do-It-Yourself kits. Send SASE and phone number for free catalog, or call (206) 481-9490.

HUGE 100 page communications catalog of shortwave, amateur and scanner equipment. Antennas, books, and accessories too. Send \$1.00 to: **UNIVERSAL RADIO**, 6830 Americana Pkwy., Dept. PE, Reynoldsburg, OH 43068.

CLASSIFIED AD ORDER FORM

To run your own classified ad, put one word on each of the lines below and send this form along with your check to:

Popular Electronics Classified Ads, 500-B Bi-County Boulevard, Farmingdale, N.Y. 11735

PLEASE INDICATE in which category of classified advertising you wish your ad to appear. For special headings, there is a surcharge of \$11.00.

() Plans/Kits () Business Opportunities () For Sale
() Education/Instruction () Wanted () Satellite Television

Special Category: \$11.00

PLEASE PRINT EACH WORD SEPARATELY, IN BLOCK LETTERS.

(No refunds or credits for typesetting errors can be made unless you clearly print or type your copy.) Rates indicated are for standard style classified ads only. See below for additional charges for special ads. **Minimum: 15 words.**

1	2	3	4	5
6	7	8	9	10
11	12	13	14	15 (\$23.25)
16 (\$24.80)	17 (\$26.35)	18 (\$27.90)	19 (\$29.45)	20 (\$31.00)
21 (\$32.55)	22 (\$34.10)	23 (\$35.65)	24 (\$37.20)	25 (\$38.75)
26 (\$40.30)	27 (\$41.85)	28 (\$43.40)	29 (\$44.95)	30 (\$46.50)
31 (\$48.05)	32 (\$49.60)	33 (\$51.15)	34 (\$52.70)	35 (\$54.25)

We accept MasterCard and Visa for payment of orders. If you wish to use your credit card to pay for your ad fill in the following additional information (Sorry, no telephone orders can be accepted.):

Card Number _____ Expiration Date _____

PRINT NAME _____

SIGNATURE _____

IF YOU USE A BOX NUMBER YOU MUST INCLUDE YOUR PERMANENT ADDRESS AND PHONE NUMBER FOR OUR FILES. ADS SUBMITTED WITHOUT THIS INFORMATION WILL NOT BE ACCEPTED.

CLASSIFIED COMMERCIAL RATE: (for firms or individuals offering commercial products or services) \$1.55 per word prepaid (no charge for ZIP code)...**MINIMUM 15 WORDS.** 5% discount for same ad in 6 issues within one year; 10% discount for 12 issues within one year if prepaid not applicable on credit card orders. **NON-COMMERCIAL RATE:** (for individuals who want to buy or sell a personal item) \$1.25 per word, prepaid...no minimum. **ONLY FIRST WORD AND NAME** set in bold caps at no extra charge. Additional bold face (not available as all caps) 30¢ per word additional. Entire ad in boldface, \$1.85 per word. **TINT SCREEN BEHIND ENTIRE AD:** \$1.90 per word. **TINT SCREEN BEHIND ENTIRE AD PLUS ALL BOLD FACE AD:** \$2.25 per word. **EXPANDED TYPE AD:** \$2.05 per word prepaid. Entire ad in boldface, \$2.45 per word. **TINT SCREEN BEHIND ENTIRE EXPANDED TYPE AD:** \$2.55 per word. **TINT SCREEN BEHIND ENTIRE EXPANDED TYPE AD PLUS ALL BOLD FACE AD:** \$2.95 per word. **DISPLAY ADS:** 1" x 2 1/2" — \$205.00; 2" x 2 1/2" — \$410.00; 3" x 2 1/4" — \$615.00. **General Information:** Frequency rates and prepayment discounts are available. **ALL COPY SUBJECT TO PUBLISHERS APPROVAL. ADVERTISEMENTS USING P.O. BOX ADDRESS WILL NOT BE ACCEPTED UNTIL ADVERTISER SUPPLIES PUBLISHER WITH PERMANENT ADDRESS AND PHONE NUMBER.** Copy to be in our hands on the 18th of the fourth month preceding the date of issue (i.e., Sept. issue copy must be received by May 18th). When normal closing date falls on Saturday, Sunday or Holiday, issue closes on preceding work day. Send for the classified brochure. Circle Number 49 on the Free Information Card.

Cable TV DESCRAMBLERS

**30-day
Money Back
Guarantee**



- The Most Complete Line of Descramblers
- Friendly, professional service
- FREE Catalog

ORDER NOW!





1-800-228-7404

Go to the Source

NU-TEK ELECTRONICS

3250 Hatch RD
Cedar Park TEXAS 78613

300 EXPERIMENTERS CIRCUITS — Complete in 6 practical books using diodes, relays, FET's, LED's, IC 555's, and IC CA3130's for building blocks. Only \$33.00 plus \$5.50 for shipping. USA and Canada only. US funds. **ETT, INC.**, PO Box 240, Massapequa Park, NY 11762-0240.

TOCOM-Jerrold Impulse-Scientific Atlanta converters, two year warranties, also test modules for your converters. Contact **NATIONAL CABLE**, (219) 935-4128 full details.

WANT to make your own cable TV "test chips". Send a SASE to **ES, 5765-F Burke Centre Parkway**, Suite 317, Burke, VA 22015.

CB RADIO OWNERS!

We specialize in a wide variety of technical information, parts and services for CB radios, 10-Meter and FM conversion kits, repair books, plans, high-performance accessories. Thousands of satisfied customers since 1976! Catalog \$2

CBC INTERNATIONAL
P.O. BOX 31500PE, PHOENIX, AZ 85046

Quality Microwave TV Antennas



WIRELESS CABLE - IFTS - MMDS - Amateur TV
Ultra High Gain 50db(+)* • Tuneable 1.9 to 2.7 Ghz.

- 55-Channel Dish System \$199.95
- 36-Channel Dish System \$149.95
- 20-Channel Dish System \$124.95
- Optional Commercial Grid Antenna (not shown) Add \$50.00
- Yagi Antennas, Components, Custom Tuning Available
- Call or write (SASE) for "FREE" Catalog

PHILLIPS-TECH ELECTRONICS

P.O. Box 8533 • Scottsdale, AZ 85252
(602) 947-7700 (\$3.00 Credit all phone orders)
MasterCard • Visa • American Express • C.O.O.'s • Quantity Pricing

Dish System

LIFETIME WARRANTY

**CABLE TV DESCRAMBLERS
★ CONVERTERS ★
and ACCESSORIES.**

**SAVE MONEY.
DON'T RENT!**

PANASONIC,
PIONEER, JERROLD, OAK,
SCIENTIFIC ATLANTA
AND MORE. LOWEST PRICES.
FREE CATALOG.
(800) 234-1006
CABLE READY COMPANY

PRINTED circuit boards — etched, drilled, tin plated. Single sided \$1.25/sq. inch. No setup charge. **CHELCO ELECTRONICS**, 61 Water Street, Mayville, NY 14757. 1 (800) 388-8521.

ATTN. VCR servicers. 1600 VCR symptoms/cures by make and model printout \$45.00. IBM disk \$85.00. **VCR TUNE UP CENTER**, 2610 Bay Rd., Redwood City, CA 94063. Visa Mastercard on phone orders 1 (800) 777-7883.

FREE CATALOG

FAMOUS "FIRESTIK" BRAND CB ANTENNAS AND ACCESSORIES. QUALITY PRODUCTS FOR THE SERIOUS CB'er. SINCE 1962
FIRESTIK ANTENNA COMPANY
2614 EAST ADAMS
PHOENIX, ARIZONA 85034

TEST-Aids for testing units in full service mode. Starcom VII, \$40.00; Starcom VI, \$30.00; Starcom DPBB, \$50.00; Pioneer clears error codes E2-E5, \$60.00; Pioneer cubes, will not alter internal serial #, \$125.00; Tocom VIP 5503/5507, \$25.00; Tocom mapping, \$40.00; S.A. 8500, \$25.00; 8550, \$30.00; 8580, \$40.00; 8570/90, \$50.00; Zenith, \$25.00; security bits and remotes. **N.E. ENGINEERING**, (617) 770-3830.

CABLE T.V. descramblers, converters, lowest prices, guaranteed, best quality, free catalog. **CNC CONCEPTS INC.**, Box 49503, Minneapolis, MN 55449. 1 (800) 535-1843.

USED "Sweet Art" computer cake decorating machine. Can reproduce photos using edible food color on cakes. Widow must sacrifice. Make offer. (619) 944-7244.

CABLE test chips. Jerrold, Tocom, S.A., Zenith. Puts cable boxes into full service mode! \$29.95 to \$59.95. 1 (800) 452-7090, (310) 867-0081.

WANTED

PROTECT and market your new product ideas! Call **THE IDEA EXCHANGE** — Fast, professional, confidential: 1 (800) 272-6875.

PLANS & KITS

HOBBY/broadcasting/ham/CB/surveillance transmitters, amplifiers, cable TV, science, bugs, other great projects! Catalog \$1.00 **PANAXIS**, Box 130-H2, Paradise, CA 95967.

FASCINATING Electronic Devices! Dazers! Lasers! Transmitters! Detectors! Free energy! Tesla! Kits/Assembled! Catalog \$4.00. (refundable) **QUANTUM RESEARCH**, 17919-77 Avenue, Edmonton, Alberta T5T 2S1.

DESCRAMBLER kits. Complete cable kit \$44.95. Complete satellite kit \$49.95. Add \$5.00 shipping. Free brochure. No New York sales. **SUMMIT PE**, Box 489, Bronx, NY 10465.

SURVEILLANCE transmitter kits tune from 65 to 305 MHz. Mains powered duplex, telephone, room, combination telephone/room. Catalog with **Popular Communications, Popular Electronics and Radio-Electronics** book reviews of "Electronic Eavesdropping Equipment Design," \$2.00. **SHEFFIELD ELECTRONICS**, PO Box 377785-A, Chicago, IL 60637-7785.

BUILD 0-50 volt regulated dual tracking power supply. Complete schematics and instructions \$5.95. **SMS ENGINEERING** 5932 West Bell Road, Suite D106, Glendale, AZ 85308.

AUTOMOTIVE electrical monitor. Complete kit \$6.95. Assembled \$9.95. \$3.00 S/H. NY residents add tax. **VR ELECTRONICS CORPORATION**, 47-30 196 St., Flushing, NY 11358.

TELEPHONE LISTENING DEVICE



Record telephone conversations in your office or home. Connects between any cassette or tape recorder and your telephone line. Starts automatically when phone is answered. Records both sides of conversation. Stops recorder when phone is hung up.

\$19.95 EACH Qty. Disc. Avail.



Super Powerful FM TRANSMITTER
Many times more powerful than other transmitters. Transmits up to 1/4 mile to any FM radio. Easy to Assemble Kit — up to 9V battery (not incl.)
For catalog of Transmitters, Voice Scramblers and other specialty items, enclose \$2.00 to USI Corp.

Call 407-705-1900 or send \$19.95 — \$1.00 shipping per item to: USI Corp., P.O. Box 11-208-2, Melbourne, FL 32902, 0000 V.C.R.

60 SOLDERLESS Breadboard Projects in two easy-to-read pocket books. Complete with circuit descriptions, schematics, parts layouts, component listings, etc. Both books (BP107 & BP113) only \$11.99 plus \$3.50 for shipping. USA and Canada only. US funds. **ETT, INC.**, PO Box 240, Masapequa Park, NY 11762-0240.

SURVEILLANCE — Counterspy equipment! Guaranteed low prices! Catalog \$5.00. **SURVEILLANCE COUNTERMEASURE TECHNOLOGIES**, Box 520013-B, Salt Lake City, Utah 84152.

SILENT submarine drive, MHD plans send \$11.95 to **DNS RESEARCH**, 2314 W. Harrison, Chandler, AZ 85224.



Great kit project for Electronic buffs. **Silent Sam** reminds you when you forget. SSTS (turn signal reminder) beeps 3 seconds after 15 seconds and repeats until cancelled. Unobtrusive, resets when braking. Easy installation. Parts, case, PCB, schematic, instructions \$15; 2/\$25; 3/\$30 PPD. Also, pre-wired units \$20; 2/\$35; 3/\$45 PPD VISA/MC. 1-800-398-5605. Send SASE for more information.
Silent Sam, 1627 Basil Dr., Columbus, OH 43227.

BUGGED? Phonedapped? Free catalog counter-surveillance equipment tells you fast! 1 (800) 732-5000.

SUPER electronic and scientific devices. Some never seen before by the public. T-lasers, alarms, surveillance devices, H. voltage devices, electronic projects, tubes, plans, and etc. at low prices. Catalog \$3.00. **CM FALCO**, Box 217, Rahway, NJ 07065.

ACTIVE Filter Handbook: Easily design/build filters for most applications. Send \$10.95. **EE-Z-SOFT**, 9001 Swigert, Loveland, OH 45140.

VIDEOCIPHER II / surveillance / satellite / scanner / cable / amateur / cellular. Catalog — \$3.00. **TELECODE**, PO Box 6426-PE, Yuma, AZ 85366-6426.

HIGH tech, high quality plans. Digital delay \$9.95, 24Ch mixer \$14.95, duophonic synthesizer \$9.95, stereo crossover \$7.95, 10Ch equalizer \$5.95, computerized DJ lighting \$14.95, IBM lasershow kit. Does endless patterns, text, animation. With software. \$99.95 **GEBHARDT**, Box 754, Anaconda, MT 59711. (406) 563-7506.

BEST BY MAIL

Rates: Write National, Box 5, Sarasota, FL 34230

OF INTEREST TO ALL

YOU TOO CAN import from Taiwan and Hong Kong. Free information. Box 661, Dallas, GA 30132.

ELECTRONIC ENGINEERING. 8 volumes complete. \$109.95. No prior knowledge required. Free brochure. **BANNER TECHNICAL BOOKS**, 1203 Grant Ave., Rockford, IL 61103.

RECYCLE PERSONAL COPIERS Cartridges. Instructions \$14.95. Charles Bruns, Box 543, Applegate, CA 95703.

MUSICAL INSTRUMENTS

TELL EVERY MUSICIAN You Know We're Looking For Unknown Amateurs For Possible Recording Contract. Call Jack. 1-800-926-9559. Free Call. Recorded Message. Day/Night. No Obligation.

MONEYMAKING OPPORTUNITIES

EARN \$50-\$300 DAILY Using Your Camcorder. Free Information: **WCE**, Box 9803, Fountain Valley, CA 92728.

UP TO \$10,000 Monthly — Own Your Own 900# With No Investment — Free Details. Box 1123, Phelan, CA 92371.

SATELLITE TV

FREE Catalog — Lowest prices world wide. **KYVISION**, 1048 Frontier, Fergus Falls, MN 56537. 1 (800) 334-6455. (See full page ad The Market Center).

SATELLITE TV — Do It Yourself, major brands discounted. We'll beat everyone's price. call **LARRY**, (609) 596-0656.

SUPER low satellite prices. Free U.S. and International catalog. **SATMAN**, (309) 692-4140 (Int'l), 1 (800) 472-8626 in U.S.

ANTIQUE RADIO CLASSIFIED
Free Sample!

Antique Radio's
Largest Circulation Monthly.
Articles, Ads & Classifieds.
6-Month Trial: \$15. 1-Yr: \$27(\$40-1st Class).
A.R.C., P.O. Box 802-L8, Carlisle, MA 01741

BUSINESS OPPORTUNITIES

YOUR own radio station! Licensed/unlicensed. AM, FM, TV, cable. Information \$1.00 **BROADCASTING**, Box 130-H2, Paradise, CA 95967.

MAKE \$75,000.00 to \$250,000.00 yearly or more fixing IBM color monitors. No investment, start doing it from your home (a telephone required). Information, USA, Canada \$2.00 cash for brochure, other countries \$10.00 US funds. **RANDALL DISPLAY**, Box 2168-H, Van Nuys, CA 91404, USA. Fax (818) 990-7803.

HOME assembly work available! Guaranteed easy money! Free details! **HOMEWORK-P**, Box 520, Danville, NH 03819.

FEDERAL loans for small businesses now available. 1 (800) 777-6342 for free details.

FREE information! Research engineer earns living with stocks safely. **HILL**, PO Box 48194, Niles, IL 60648.

DISTRIBUTORS needed — High profits, untapped markets. Mini satellite antennas for homes, RVs & business use. As low as \$361.00. 24 hrs. 1 (800) 886-5008.



LEARN COMPUTERS!
 Home study; become an expert with the personal computer for home or business use. Free literature; call 800-223-4542.
 Name _____
 Address _____
 City _____ State _____ Zip _____
 School of Computer Training, Dept. KB341
 2245 Perimeter Pk., Atlanta, Georgia 30341

EASY work! Excellent pay! Assemble products at home. Call toll free 1 (800) 467-5566 ext. 5730.

IF you own, rent or can borrow a computer, you can make money with it. Send SASE for info: **DEWORKS**, PO 98-C, Milltown, MT 59851.

EDUCATION/INSTRUCTION

LEARN assembly language for IBM PC and compatibles. Disk \$5.00. Book \$18.00. **ZIPFAST**, Box 12238, Lexington, KY 40581-2238.

VCR repair. Save money — make big profits! Learn how from *How to Keep Your VCR Alive*. "This detailed, step-by-step manual enables anyone with no previous knowledge or experience to fix most VCR problems easily, quickly, and inexpensively with a few simple tools." — *Small Press Review*. Highly recommended by *Electronic Servicing and Technology*, *Modern Electronics*, *Popular Electronics*, *Popular Communications*, *Videomaker*, *Video*, *Nuts and Volts*, and many other electronics and video magazines "Far better than Viejo at 1/7 the cost." 403 page book, with 704 illustrations, plus professional head-cleaning tool. Obtain from B. Daltons or send \$24.95 to **WORTHINGTON PUBLISHING**, 6907-202H Halifax River Drive, Tampa, FL 33617. Publisher pays S&H. Money-back satisfaction guarantee!

"PERMANENT Magnet Materials Short Course." Complete history, materials listing, glossary, specifications, applications, design criteria, sources. Details \$2.50, order refundable. **SJL PUBLISHING**, Dept. A004PE, Hanna, IN 46340-0152.



RECEIVING TUBES
OVER 3000 TYPES IN STOCK!
 Also hard-to-find transformers, capacitors and parts for tube equipment.
 Send \$2.00 for our 32 page catalog.
ANTIQUE ELECTRONIC SUPPLY
 6221 S. Maple Ave. • Tempe, AZ 85283 • 602-820-5411

PERSONAL CODE EXPLORER

NEW! Exciting! Easy-to-use Personal Code Explorer copies digital radio signals — fax, morse, RTTY, ASCII, SITOR, packet and more on your IBM/PC screen. Free brochure. Call, write, MC/VISA. \$129.00 plus \$4.00 shipping. **MICRO-CRAFT**, Box 513PE, Thiensville, WI 53092. (414) 241-8144.

BE A GOOD NEIGHBOR
 Volunteer.
 **American Heart Association**

PHOTO CD
(Continued from page 34)

contains.) New "multi-session" drives know enough to look past the "end of the disc" to see if there is another session's worth of data.

When CD's and CD-ROM's were invented, it was always thought that they would contain only one kind of data. XA drives support interleaved data, so they can read discs that have intermixed audio and video—such as Portfolio discs. Even MPC's (multi-media PC's) can't read both data types *at the same time*

Strictly speaking, an XA-drive isn't essential. Some drives, called "Mode 2 Form 1" are compatible with Photo CD, but they can read only the first session of data. We tried one such drive, the Magnavox CDD 461. (We reviewed the drive in GIZMO one year ago; it has a list price of \$549, including four CD-ROM software titles, but we've seen it on the street for about \$300.) Another drive, the Sony CDU 535 with CDB X10 controller is also said to be compatible, although not multi-session. A new multi-session CDD-461 is said to be in the works.

Just having the drive isn't enough; you also need the right software. We used a Beta version of Kodak's Photo CD Access software, which let us pull images off the disc and call them up on our PC's. The editing and exporting functions were disabled on the Beta version.

Other software is sure to also provide compatibility with the Photo CD file format. The first to do this is Corel-Draw version 3.0, a comprehensive graphics package that runs under Windows.

The Corel Photo-Paint module of the program lets you retouch and edit the photos. You can, for example, change colors, shapes, and backgrounds. Tools include a paintbrush, paint roller, airbrush, sprayscan, eyedropper, and much more. Automatic retouching filters can alter the photo's brightness and contrast, or add such special effects as motion blur. The imported images can be exported in one of several file formats.

Market Success? Regardless of whether consumers take to watching their photographs on TV, Photo CD is

sure to be a success because there are so many potential uses for the format. Of course, it is possible that consumers will become enamored to the new format itself. First, Photo CD players aren't priced extraordinarily high—the low end Kodak player was introduced at \$449, with street prices of about \$375—and they can play back audio compact discs.

The success of the CD-ROM and of Philip's CD-I formats will also play a large role in whether Photo CD catches on with consumers. But Kodak's marketing strategy means that consumers can take their time in deciding. Photo CD will be around for commercial applications.

The Kodak Picture Exchange is an on-line network of images that will start up in the middle of this year. It will attempt to link distributors of images (stock photo houses and photographers) with image users such as graphic designers and publishers. Users will call up the service and conduct searches of images using key words. They will be provided with low-resolution thumbnail images. When they decide what images they want to see in hard copy, the Picture Exchange will alert the image suppliers.

One company that has signed on to the Picture Exchange is *Homes & Land* magazine, the largest publisher of real-estate magazines in the U.S. The publisher expects to use Photo CD images extensively in its magazines.

Rarely has the introduction of a new "product" meant so much to so many businesses, consumers, computer users, and publishers. (Photo CD was even used during the Republican convention to display still images of President Bush and his family on four giant TV screens.) We have to wonder, however, who other than Kodak would have come up with a revolutionary way of handling photographs that is firmly based in the century-old technology of silver-halide film? ■



KEYBOARD CLEAN-UP

(Continued from page 66)

work and increase the drying time. In any event, if problems do arise, the log we suggested you keep can prove invaluable.

Some Basic Precautions. Use only a pure facial soap with no additives. Ivory is pretty good (no plug intended). Avoid soaps with deodorant additives or cleansing creams. The additives are corrosive. Avoid the use of liquid soaps, powders, etc. Most of them are very difficult to flush away in the rinse. Deposited soap will eventually cause corrosion of electronic parts and conductors.

The rinse and drying period are very critical. Flush all parts carefully and fully. Don't cut the drying period short because the surfaces are dry. Water has a knack of hiding in the nooks and crannies that you can't see and can take weeks to evaporate, causing corrosion or sticking of mechanical parts, and may entrap dust where it can cause the most problems. In warm climates mildew will grow, adding to your grief if drying is not complete.

The Final Touch. Now you are ready to plug in the keyboard and turn on the computer. Everything should work fine. Press each key to be sure it feels good and works properly. If key switches were removed or fell out, check that they are reinstalled in their correct positions.

Now stand back and admire your handiwork. One thing you're sure to notice, it's time to clean your computer chassis and monitor case! ■

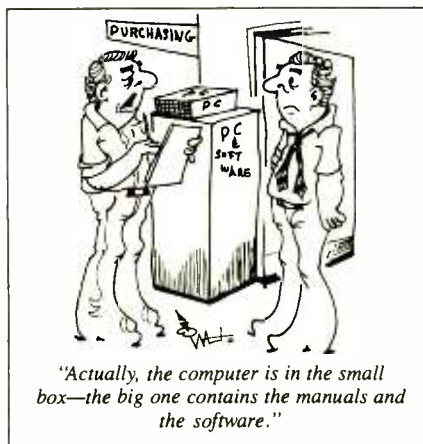

"Actually, the computer is in the small box—the big one contains the manuals and the software."

ADVERTISING INDEX

POPULAR ELECTRONICS magazine does not assume any responsibility for errors that may appear in the index below.

Free Information No.	Page
8	AMC Sales 29
—	Antique Electronic Supply 97
—	Antique Radio Classified 96
—	CBC International 95
—	CIE 27
—	Cable Ready Company 96
—	CLAGGK Video Offer CV3
—	Command Productions 23
5	Cook's Institute 87
—	Electronic Tech. Today 4, 70
—	Electronics Book Club 11, 85
—	Firestik II 96
—	Grantham College of Engineering 89
—	HighText Publications, Inc. 75
—	ISCET 78
9	Jameco 21
—	NRI Schools 17
—	Nu-Tek 95
—	P.E. Fact Cards 90
10	People's College 91
—	Phillips Tech 95
7	Radio Shack CV4
—	Silent Sam TSR Co. 96
6	The School Of VCR Repair .. 29, 97
12	U.S. Cable 28
—	USI Corp. 96
—	Video Dimensions 93
—	WTDT TV CV2
11	Zentek Corp. 28

ADVERTISING SALES OFFICE

Gernsback Publications, Inc.
500-B Bi-County Blvd.
Farmingdale, NY 11735
1-(516) 293-3000

Larry Steckler
President

Christina Estrada
Assistant to the President

For Advertising ONLY
516-293-3000
Fax 1-516-293-3115

Larry Steckler
publisher

Arline Fishman
advertising director

Denise Mullen
advertising assistant

Kelly McQuade
credit manager

Customer Service/Order Entry
1-800-827-0383
1-800-892-0753
7:30 AM - 8:30 PM EST

SALES OFFICES

EAST/SOUTHEAST

Stanley Levitan
Eastern Sales Manager
1 Overlook Ave.
Great Neck, NY 11021
1-516-487-9357, 1-516-293-3000
Fax 1-516-487-8402

MIDWEST/Texas/Arkansas/ Oklahoma, Colorado, Arizona

Ralph Bergen
Midwest Sales Manager
One Northfield Plaza, Suite 300
Northfield, IL 60093-1214
1-708-446-1444
Fax 1-708-559-0562

PACIFIC COAST/Mountain States

Mike Brooks
Pattis/3M
1800 North Highland Avenue
Suite 717
Hollywood, CA 90028
1-213-462-2700
Fax 1-213-463-0544

PE Market Center

Nicki Van Suydam
Pattis/3M
1800 North Highland Avenue
Suite 717
Hollywood, CA 90028
1-213-462-2700
Fax 1-213-463-0544

Countersurveillance

Never before has so much professional information on the art of detecting and eliminating electronic snooping devices—and how to defend against experienced information thieves—been placed in one VHS video. If you are a Fortune 500 CEO, an executive in any hi-tech industry, or a novice seeking entry into an honorable, rewarding field of work in countersurveillance, you must view this video presentation again and again.



CALL NOW!

1-516-293-3751

HAVE YOUR VISA or MC CARD AVAILABLE

Wake up! You may be the victim of stolen words—precious ideas that would have made you very wealthy! Yes, professionals, even rank amateurs, may be listening to your most private conversations.

Wake up! If you are not the victim, then you are surrounded by countless victims who need your help if you know how to discover telephone taps, locate bugs, or “sweep” a room clean.

There is a thriving professional service steeped in high-tech techniques that you can become a part of! But first, you must know and understand Countersurveillance Technology. Your very first insight into this highly rewarding field is made possible by a video VHS presentation that you cannot view on broadcast television, satellite, or cable. It presents an informative program prepared by professionals in the field who know their industry, its techniques, kinks and loopholes. Men who can tell you more in 45 minutes in a straightforward, exclusive talk than was ever attempted before.

Foiling Information Thieves

Discover the targets professional snoopers seek out! The prey are stock brokers, arbitrage firms, manufacturers, high-tech companies, any competitive industry, or even small businesses in the same community. The valuable information they filch may be marketing strategies, customer lists, product formulas, manufacturing techniques, even advertising plans. Information thieves eavesdrop on court decisions, bidding information, financial data. The list is unlimited in the mind of man—especially if he is a thief!

You know that the Russians secretly installed countless microphones in the concrete work of the American Embassy building in Moscow. They converted

what was to be an embassy and private residence into the most sophisticated recording studio the world had ever known. The building had to be torn down in order to remove all the bugs.

Stolen Information

The open taps from where the information pours out may be from FAX's, computer communications, telephone calls, and everyday business meetings and lunchtime encounters. Businessmen need counselling on how to eliminate this information drain. Basic telephone use coupled with the user's understanding that someone may be listening or recording vital data and information greatly reduces the opportunity for others to purloin meaningful information.

The professional discussions seen on the TV screen in your home reveals how to detect and disable wiretaps, midget radio-frequency transmitters, and other bugs, plus when to use disinformation to confuse the unwanted listener, and the technique of voice scrambling telephone communications. In fact, do you know how to look for a bug, where to look for a bug, and what to do when you find it?

Bugs of a very small size are easy to build and they can be placed quickly in a matter of seconds, in any object or room. Today you may have used a telephone handset that was bugged. It probably contained three bugs. One was a phony bug to fool you into believing you found a bug and secured the telephone. The second bug placates the investigator when he finds the real thing! And the third bug is found only by the professional, who continued to search just in case there were more bugs.

The professional is not without his tools. Special equipment has been designed so that the professional can sweep a room so that he can detect voice-activated (VOX) and remote-activated bugs. Some of this equipment can be operated by novices, others require a trained countersurveillance professional.

The professionals viewed on your television screen reveal information on the latest technological advances like laser-beam snoopers that are installed hundreds of feet away from the room they snoop on. The professionals disclose that computers yield information too easily.

This advertisement was not written by a countersurveillance professional, but by a beginner whose only experience came from viewing the video tape in the privacy of his home. After you review the video carefully and understand its contents, you have taken the first important step in either acquiring professional help with your surveillance problems, or you may very well consider a career as a countersurveillance professional.

The Dollars You Save

To obtain the information contained in the video VHS cassette, you would attend a professional seminar costing \$350-750 and possibly pay hundreds of dollars more if you had to travel to a distant city to attend. Now, for only \$49.95 (plus \$4.00 P&H) you can view *Countersurveillance Techniques* at home and take refresher views often. To obtain your coupon, complete the coupon or call.

PE

CLAGGK INC.
P.O. Box 4099 • Farmingdale, NY 11735

Please rush my copy of the Countersurveillance Techniques Video VHS Cassette for a total cost of \$53.95 each (which includes \$4.00 postage and handling)

No. of Cassettes ordered _____
 Amount of payment \$ _____
 Sales tax (N.Y.S. only) _____
 Total enclosed _____
 Bill my VISA MasterCard
 Card No. _____
 Expire Date ____/____/____
 Signature _____
 Name _____
 Address _____
 City _____ State _____ ZIP _____

All payments in U.S.A. funds. Canadians add \$4.00 per VHS cassette. No foreign orders.

THE PARTS PLACE SM

NEW! Autoranging LCD Digital Multimeter

Convenient autoranging and auto-polarity at a low price. Select the function—meter does the rest. Diode-check, continuity buzzer. Measures to 1000VDC, 750VAC, 10A AC/DC current, 2 megohms. Fuse protected, UL 1244 listed. #22-184 49.99



TECHLINE™ Tools—The new standard in strength and precision!



- Precision-crafted with top-quality materials
- Designed for long life and ease of use
- Backed by Radio Shack's 1-Year Limited Warranty

New TECHLINE tools represent Radio Shack's uncompromising dedication to quality. Each is precision-crafted of long-lasting, hard-working materials and employs the latest design innovations for comfort and ease of use. And, each is backed by our full 1-year limited warranty.

Speedy service and low prices on thousands of parts and accessories!



- FREE delivery to Radio Shack on orders \$5 and up
- Semiconductors and ICs ■ Hard-to-find batteries
- CB and scanner crystals ■ Long-life vacuum tubes
- Phono cartridges/styli ■ SAMS® service books

Why pay more for mail-order? Your Radio Shack stocks 1000 electronic components, and another 15,000 are available fast from our special-order warehouse. Ordering is easy! Bring in the exact part number (or old part). We'll check availability and order by phone. Delivery time to your nearby Radio Shack for most items is a week.



NEW! Circuit Breaker Identifier. Timesaver! Plug transmitter into outlet. Wireless receiver lights and beeps when placed near that circuit's wiring, breaker or fuse. #61-2721 29.95

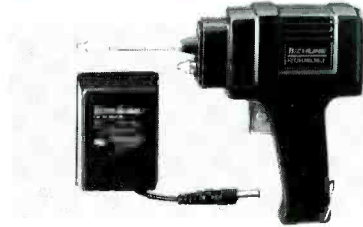

TECHLINE Rechargeable Soldering Gun. Great for autos, boats and campers—solder up to 250 joints on one charge. Trigger-activated light. UL listed AC charger, case. #64-2194 39.95

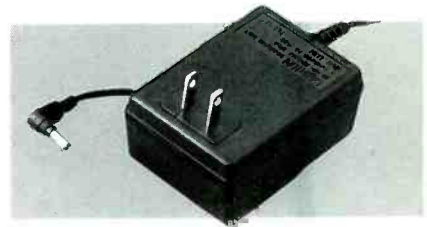

CD Player AC-to-DC Voltage Adapter. Saves batteries! Connect to your portable CD player's DC jack and plug into wall outlet to play from 120VAC. 3VDC regulated output. UL listed. #273-1659 16.95



TECHLINE™ 18-Piece Hex Key Set. Ideal for engine and machinery work. Heavy-duty steel alloy. Standard sizes. #64-1816 4.99

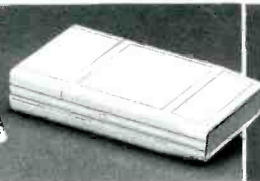

IR Transmitter Project Case. For beeper or remote. 9V battery compartment. Molded 7/8 x 2 3/8 x 4 1/4" enclosure. #270-294 4.49



Infrared Sensor Card. Detects normally invisible infrared to confirm output from remotes, IR LEDs or lasers. #276-099 5.95

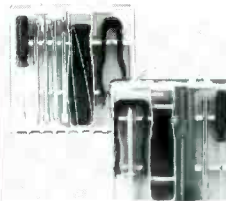

14-Piece PC Tool Kit. Includes screwdrivers, chip extractor and inserter, tweezers, nut-driver, parts tube, case. #64-1972 14.95



Brushless 12VDC Fan. Excellent for cooling car stereo amps, Ham equipment. 27 CFM. 3 5/32 x 4 1/16 x 1 1/2". #273-243 14.95

Radio Shack SINCE 1921

AMERICA'S TECHNOLOGY STORE SM

Prices apply at participating stores and dealers

CIRCLE 7 ON FREE INFORMATION CARD