

A THEFT ALARM FOR HANDHELD CALCULATORS

Popular Electronics®

WORLD'S LARGEST-SELLING ELECTRONICS MAGAZINE

MARCH 1976/75c

EXCLUSIVE

Build the "PENNYWHISTLE" MODEM

**FOR TELEPHONE-
TO-DATA SYSTEM COMMUNICATIONS**

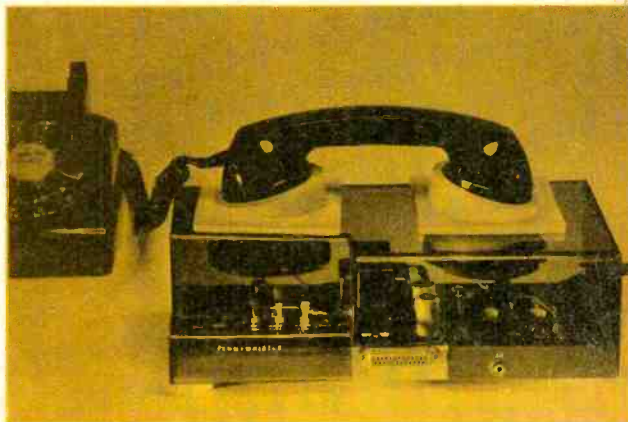

How to Minimize Scope-Probe Combination Errors



The Care & Feeding of NiCd Batteries

A LED-Readout Audio Power Meter

**REVEALS POWER LEVELS
FROM AMPLIFIERS**

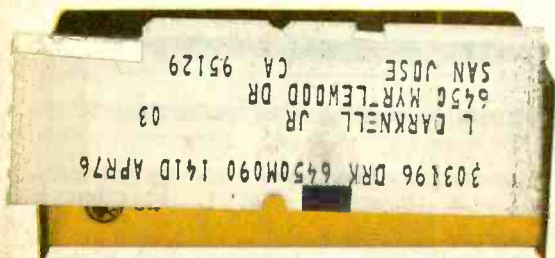

TEST REPORTS:

AUDIO: Marantz 5220
Front-Load Cassette Deck
Onkyo TX-220
AM/Stereo FM Receiver

GB: Midland 13-882B
Mobile AM Transceiver

PLUS: Heathkit GB-12D1
7-Function Stop Watch

Retailers: Notice of display-allowance plan is within last three pages.





We don't just talk quality

We build quality. That's why Cobra CB radios are engineered and built to operate at peak performance under all conditions. But we don't stop there. Our concern for quality assures you of performance that makes using your CB more enjoyable. And our dealers and distributors are concerned about customer service. All this—because, like you, we're serious about CB.



Cobra
Products of Dynascan

1801 W. Belle Plaine Ave., Chicago, Illinois 60613 (312) 327-7270

CIRCLE NO. 13 ON FREE INFORMATION CARD

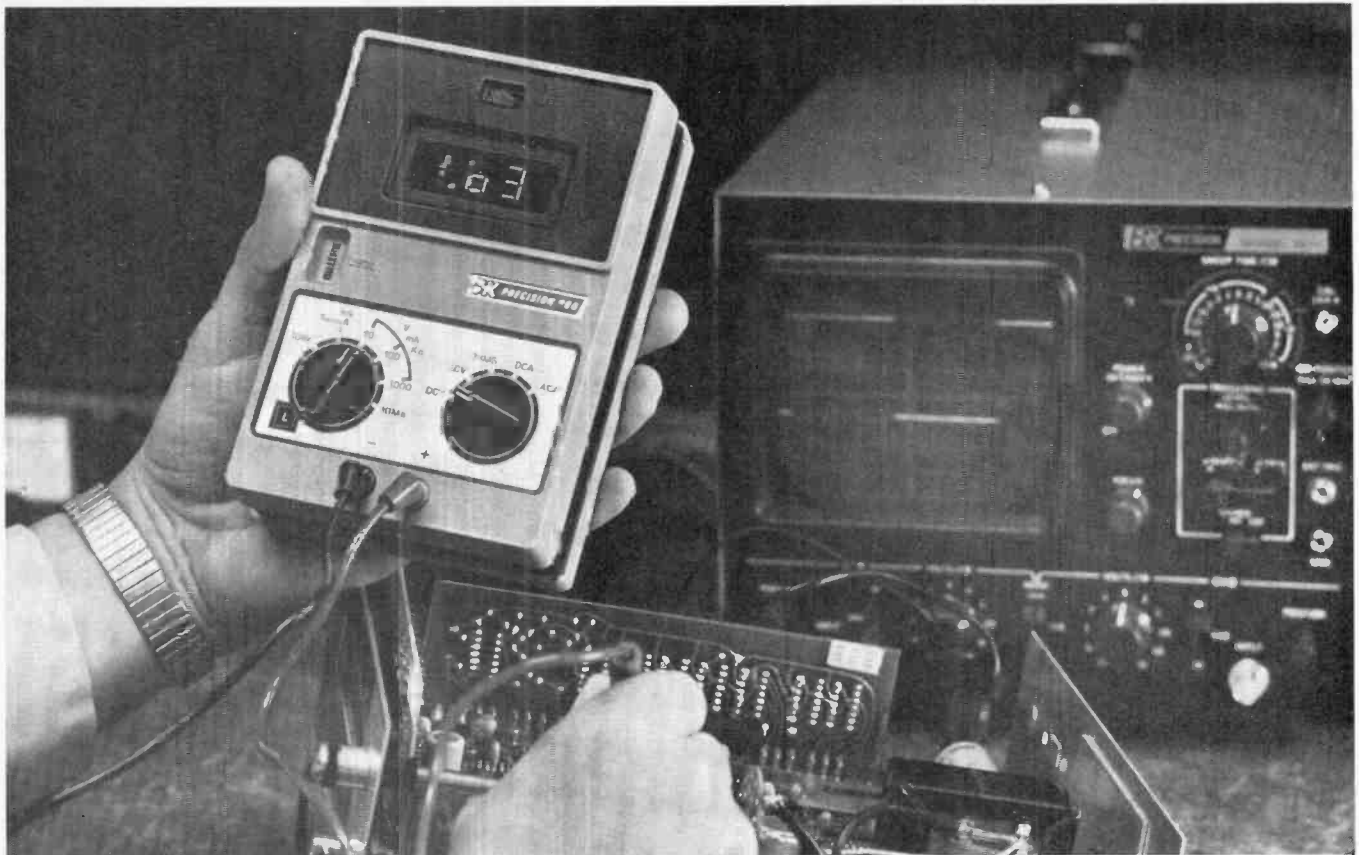

Why is the 280 at \$99⁹⁵ our fastest selling multimeter ever?

Ever since we introduced the 280 last year, sales have been breaking records.

The reasons are easy to understand. The 280 is a battery-operated portable, full-feature digital multimeter at less than the price of a pre-

cision analog meter. The 280 features a large three-digit LED readout, automatic polarity indication, automatic decimal point placement and out-of-range indication. The 280 is fully overload protected for reliability and has an industry-standard input impedance of 10 megohms for all voltage ranges.

It has High/Low power ohms ranges for accurate in-circuit measurements, not available on most analog meters. And digital accuracy (1% typical for DCV; 2% for ACV and ohms, except 2.5% on highest ranges) and digital resolution (1mV, 1 μ A, 0.1 ohm)—not available on any analog meter.

No compromises on range either—DC and AC voltage ranges to 1000V, DC and AC current ranges to 1000mA and ohms ranges to 10 megs.

Our fastest seller ever? We're not surprised. *In stock at your distributor.*



BK PRECISION

PRODUCTS OF DYNASCAN

1801 W. Belle Plaine • Chicago, Illinois 60613 • (312) 327-7270

Who builds the best value in electronics today?...

YOU DO!

When you build any of the over 400 superb Heathkit electronics products described in our new catalog. You add the element so clearly lacking in many ready-made products... careful craftsmanship. And you work with world-renowned Heathkit assembly manuals – a step-by-check instruction method that leaves absolutely nothing to chance. Your time and your care go into each Heathkit product you build, along with Heath Company's outstanding design, engineering and quality components. And when you finish, you'll have something that's uniquely yours; a product that will give you far more satisfaction and pride than any ready-made unit you can buy.

Read all about it in this big, NEW Heathkit Catalog!



HEATH	Schlumberger	Benton Harbor, Michigan 49022 Dept. No. 10-15
Please rush me my FREE Heathkit Catalog		
Name _____		
Address _____		
City _____	State _____	Zip _____
CL-591		

◁ IT'S FREE ▷

Complete, accurate descriptions of over 400 kits...test instruments, marine and fishing gear, auto tuneup and accessories, Amateur and SW radio, Radio Control devices, hi-fi-components, color TV, digital clocks and weather instruments, more!

SEND FOR IT TODAY!

Heath Company, Dept. 10-15, Benton Harbor, Michigan 49022

Popular Electronics®

WORLD'S LARGEST SELLING ELECTRONICS MAGAZINE

FEATURE ARTICLES

THE CARE & FEEDING OF NiCd BATTERIES	Alex Burr	39
<i>How they work and how to use them correctly.</i>		
HOW TO MINIMIZE SCOPE/PROBE COMBINATION ERRORS	Thomas R. Sear	54
<i>Choosing the right probe for a particular application.</i>		
HOW MULTIPLEXED LED DISPLAYS SIMPLIFY CIRCUITS	Patrick J. Delaney III	62
<i>Reduce size and complexity of seven-segment readouts.</i>		
ENGLISH-LANGUAGE SHORTWAVE BROADCASTS FOR MAR. & APR. 1976	Richard E. Wood	92

CONSTRUCTION ARTICLES

AN LED-READOUT AUDIO POWER METER	Tim Henry	35
<i>Checks amplifier output, speaker balance and efficiencies.</i>		
THEFT ALARM FOR HANDHELD CALCULATORS	Tommy N. Tyler	42
BUILD "PENNYWHISTLE"—THE HOBBYIST'S MODEM	Lee Felsenstein	43
<i>Interface for digital data transmission and reception.</i>		
A BCB LOOP ANTENNA FOR DX'ING	Norman Fallon	51
<i>Increases reception range of inexpensive AM radios.</i>		
CURVE TRACER CHECKS SEMICONDUCTOR QUALITY	Samuel Lyle	58
<i>Used with a scope, it indicates conditions from breakdown voltage to Beta.</i>		

COLUMNS

STEREO SCENE	Ralph Hodges	20
<i>Tone Controls, Plain and Fancy.</i>		
SOLID STATE	Lou Garner	80
<i>Opting For Op Amps.</i>		
TEST EQUIPMENT SCENE	Les Solomon	83
<i>Using Your Oscilloscope.</i>		
COMPUTER BITS	Robert Marsh	88
<i>Computer Users Tape System.</i>		
DX LISTENING	Glenn Hauser	91
<i>Shortwave News From All Over.</i>		
CB SCENE	Ray Newhall	95
<i>Is Your Station Ready For an Emergency?</i>		
HOBBY SCENE Q&A	John McVeigh	97
EXPERIMENTER'S CORNER	Forrest Mims	100
<i>Percussion Instrument Synthesizer.</i>		

PRODUCT TEST REPORTS

MARANTZ MODEL 5220 STEREO CASSETTE DECK	68
ONKYO MODEL TX-220 AM/STEREO FM RECEIVER	70
MIDLAND MODEL 13-882B MOBILE AM CB TRANSCEIVER	72
HEATHKIT MODEL GB-1201 DIGITAL STOPWATCH	73
TRI-STAR "TIGER SST" CD IGNITION SYSTEM	78

DEPARTMENTS

EDITORIAL	Art Salsberg	4
<i>New-Project Stumbling Blocks.</i>		
LETTERS		6
NEW PRODUCTS		12
NEW LITERATURE		18
NEWS HIGHLIGHTS		33
OPERATION ASSIST		98
ELECTRONICS LIBRARY		99
ADVERTISERS INDEX		119

POPULAR ELECTRONICS, March 1976, Volume 9, Number 3. Published monthly at One Park Avenue, New York, NY 10016. One year subscription rate for U.S., \$6.98; U.S. Possessions and Canada, \$7.98; all other countries, \$8.98. Second Class postage paid at New York, NY and at additional mailing offices. Authorized as second class mail by the Post Office Department, Ottawa, Canada and for payment of postage in cash. Subscription service and Forms 3579; P.O. Box 2774, Boulder, CO 80302.

POPULAR ELECTRONICS including ELECTRONICS WORLD, Trade Mark Registered. Indexed in the Reader's Guide to Periodical Literature.

COPYRIGHT © 1976 BY ZIFF-DAVIS PUBLISHING COMPANY. ALL RIGHTS RESERVED.

Ziff-Davis also publishes Boating, Car and Driver, Cycle, Flying, Modern Bride, Popular Photography, Skiing and Stereo Review.

Editorial correspondence: POPULAR ELECTRONICS, 1 Park Ave., New York, NY 10016. Editorial contributions must be accompanied by return postage and will be handled with reasonable care; however, publisher assumes no responsibility for return or safety of manuscripts, art work, or models.

Forms 3579 and all subscription correspondence: POPULAR ELECTRONICS, Circulation Dept., P.O. Box 2774, Boulder, CO 80302. Please allow at least eight weeks for change of address. Include your old address, enclosing, if possible, an address label from a recent issue.

EDGAR W. HOPPER
Publisher

ARTHUR P. SALSBERG
Editorial Director

LESLIE SOLOMON
Technical Editor

JOHN R. RIGGS
Managing Editor

ALEXANDER W. BURAWA
Feature Editor

EDWARD I. BUXBAUM
Art Director

JOHN McVEIGH
Associate Editor

ANDRE DUZANT
Technical Illustrator

PATRICIA BROWN
Editorial Assistant

LOU GARNER
GLENN HAUSER
JULIAN D. HIRSCH
RALPH HODGES
ART MARGOLIS
FORREST MIMS
JERRY OGDIN
WILFRED M. SCHERER
Contributing Editors

JOSEPH E. HALLORAN
Advertising Director

JOHN J. CORTON
Advertising Sales

LINDA BLUM
Advertising Service Manager

PEGI McENEANEY
Executive Assistant

STANLEY NEUFELD
Associate Publisher

ZIFF-DAVIS PUBLISHING COMPANY
Popular Electronics
Editorial and Executive Offices
One Park Avenue New York, New York 10016
212-725-3500

Hershel B. Sarbin, President
Furman Hebb, Executive Vice President
Vincent Perry, Financial Vice President and Treasurer
Phillip T. Heffernan, Senior Vice President, Marketing
Edward D. Muhlfeld, Senior Vice President, Sports Division
Philip Sine, Senior Vice President
Frank Pomerantz, Vice President, Creative Services
Arthur W. Butzow, Vice President, Production
Lawrence Sporn, Vice President, Circulation
George Morrissey, Vice President
Sydney H. Rogers, Vice President
Sidney Holtz, Vice President
Al Traina, Vice President
Philip Korsant, Vice President
Paul H. Chook, Vice President, Market Planning
Charles B. Seton, Secretary
Edgar W. Hopper, Vice President, Electronics Div.

William Ziff, Chairman
W. Bradford Briggs, Vice Chairman

Midwestern Office
The Pattis Group, 4761 West Touhy Ave.,
Lincolnwood, Illinois 60644, 312 679-1100
GERALD E. WOLFE, THOMAS HOCKNEY

Western Office
9025 Wilshire Boulevard, Beverly Hills, CA 90211
213 273-8050; BRadshaw 2-1161
Western Advertising Manager, BUD DEAN

Japan: James Yagi
Oji Palace Aoyama; 6-25, Minami Aoyama
6 Chome, Minato-Ku, Tokyo 407-1930/6821,
582-2851



The publisher has no knowledge of any proprietary rights which will be violated by the making or using of any items disclosed in this issue.



Editorial

NEW-PROJECT STUMBLING BLOCKS

There are a handful of exciting construction projects that we've wanted to present to you for the past two years or so. Unfortunately, we couldn't—due to one stumbling block or another.

For example, we've had many electronic games in our hands for use with conventional TV receivers. However, we "blinked" on this one because Magnavox, which claims some fifty patents in this area, initiated a string of infringement law suits (against some manufacturers). Finally overcoming this problem, we faced a second one—Class I device requirements by the FCC.

According to the reg's, one cannot simply remove TV antenna leads and substitute a device to supply a modulated r-f carrier signal directly to the receiver's antenna terminals. The premise here is that many people would not bother to remove the antenna leads, possibly causing reception interference on neighbors' receivers. Furthermore, any old transfer switch may not have sufficient isolation to prevent the minuscule radiation demanded by the FCC.

It was interesting to observe the efforts of one author trying to get type approval of a Class I device for a TV game. Isolation of 60 dB must be provided by the switch, he learned. (A typical toggle switch is lucky to have -10 dB at 60 MHz, and a slide switch might reach -20 dB.) It turned out that there's only one switch that will provide the required -60 dB isolation. The kicker here is that the switch company won't do business for less than a 10,000-quantity purchase. He wound up designing his own! Next, he learned that the device must be clean from 10 kHz to 1000 MHz. How can one be sure that there isn't a tiny 16-microvolt glitch at 999 MHz? Easy. Buy a \$23,000 spectrum analyzer (or rent one).

The Class I device mentioned above has been submitted to the FCC for type approval—along with the required \$1500 filing fee. If it's accepted, there's a \$500 grant fee. If not, there goes \$1500.

We don't question the need to protect the consumer from someone transmitting a TV game signal up and down the block. However, the cost for type approval of a device that might sell for about \$20 is inordinately high, greatly exceeding charges made by private test laboratories. Moreover, there's a long waiting list in Washington, D.C. for official approval.

Considering all this, we've decided not to wait any longer! So next month we'll publish two electronic TV games—with or without r-f, depending on what happens in the interim period. If type approval isn't received, readers will have to go directly into the TV receiver's video stage to be on the legal side of things.

Another project area that we've been holding back on concerns interconnecting devices to telephones. The FCC has noted that the Carterfone Decision placed the burden of proof of harm to telephone installations by interconnect equipment upon the carriers, not the users. This applies equally to devices which have direct electrical connection. Happily, for hobbyists, the latest FCC pronouncement (Docket No. 19528) covers a registration program for interconnect devices, spelling out technical requirements. The certification program is simple (and free).

An FCC registration number is issued to the applicant, who must notify the telephone company of plans, including the FCC registration number issued. This would be for telephone company informational purposes, not approval. So good-bye acoustic couplers! And to authors out there, let's see those hard-wire telephone innovations that we formerly rejected.

WHY SETTLE FOR LESS— THAN A COMPLETE 6800 SYSTEM

MEMORY—

All static memory with selected 2102 IC's allows processor to run at its maximum speed at all times. No refresh system is needed and no time is lost in memory refresh cycles. Each board holds 4,096 words of this proven reliable and trouble free memory. Cost—only \$125.00 for each full 4K memory.

INTERFACE—

Serial control interface connects to any RS-232, or 20 Ma. TTY control terminal. Connectors provided for expansion of up to eight interfaces. Unique programmable interface circuits allow you to match the interface to almost any possible combination of polarity and control signal arrangements. Baud rate selection can be made on each individual interface. All this at a sensible cost of only \$35.00 for either serial, or parallel type

PROCESSOR—

"Motorola" M6800 processor with Mikbug[®] ROM operating system. Automatic reset and loading, plus full compatibility with Motorola evaluation set software. Crystal controlled oscillator provides the clock signal for the processor and is divided down by the MC14411 to provide the various Baud rate outputs for the interface circuits. Full buffering on all data and address busses insures "glitch" free operation with full expansion of memory and interfaces.

POWER SUPPLY—

Heavy duty 10.0 Amp power supply capable of powering a fully expanded system of memory and interface boards. Note 25 Amp rectifier bridge and 91,000 mfd computer grade filter capacitor.

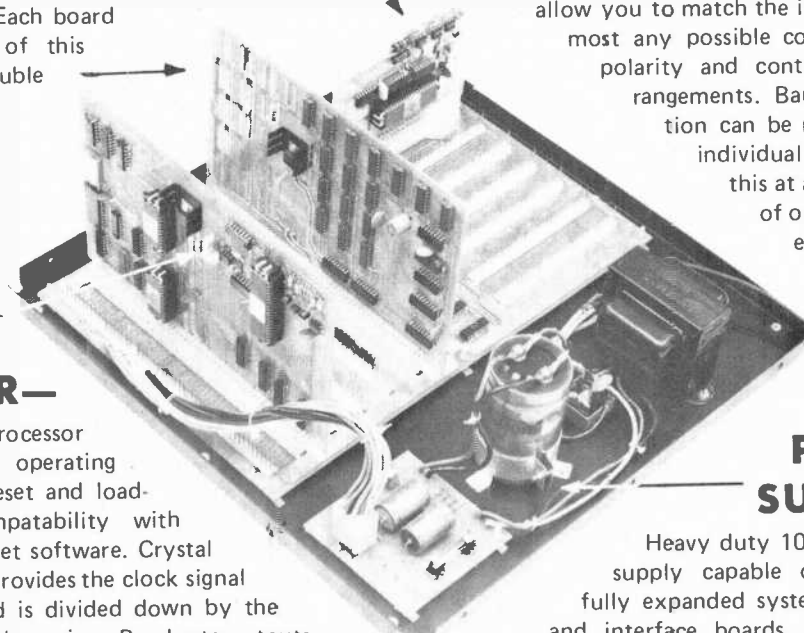

DOCUMENTATION—

Probably the most extensive and complete set of data available for any microprocessor system is supplied with our 6800 computer. This includes the Motorola programming manual, our own very complete assembly instructions, plus a notebook full of information that we have compiled on the system hardware and programming. This includes diagnostic programs, sample programs and even a Tic Tac Toe listing.

Mikbug[®] is a registered trademark of Motorola Inc.

SwTPC 6800
Computer System

with serial interface and 2,048 words of memory. \$395.00



Enclosed is \$395 for my SwTPC Computer Kit Send Data

or BAC _____ # _____

or MC _____ Ex Date _____

NAME _____

ADDRESS _____

CITY _____ STATE _____ ZIP _____

Southwest Technical Products Corp., Box 32040, San Antonio, Texas 78284

Crown The Known Value...

at an uninflated price!

An honest value isn't hard to find, if you know an honest supplier. CROWN's reputation for providing more recorder value for your dollar is as old as our company. Nothing would ever cause us to change that.

CROWN recorders offer you day-in, day-out worry-free reliability, plus brilliant performance. Both result from simple, rugged design, with only a few moving parts. The CROWN belt drive and massive flywheel almost completely isolate the capstan drive from any vibration or rumble.

CROWN electronic circuits are carefully designed for maximum reliability, and electronic components are thoroughly tested before assembly. Oversize meters and easy-to-handle-controls make operation simple. The result? A professional tape deck, used to produce quality recordings in many a studio.

Each CROWN transport has undergone 100 hours of testing. Each CROWN recorder has its own performance report, signed, not stamped, by a CROWN inspector. And each CROWN recorder is backed by a one-year full warranty on parts and labor; and an additional two-year limited warranty on parts only. We put the CROWN name on these recorders proudly - we believe they've earned it.

Why not talk to your nearby CROWN dealer about the long-term values of a CROWN recorder. And the uninflated price. It could be the year's best buy.

Write us for his name. CROWN, Box 1000, Elkhart, IN 46514



CROWN
WHEN LISTENING BECOMES AN ART

CIRCLE NO. 12 ON FREE INFORMATION CARD



Letters

MORE CB JARGON

In "How to Use CB Radio 'Buzz' Words" (CB Scene, January 1976), I found some important words missing and some words misused. Below I have listed some of these missing words and definitions, as culled from my own "ratchetjawing" and from friends on the air:

- Beaver—any female.
- Seatcover—a female in a car.
- Ratchetjaw—one who often talks on radio.
- Portable parking lot—a truck transporting cars.
- Beams—any directional antennas.
- Stick—any nondirectional antenna.
- Turn the house around—rotating a beam antenna to copy better.
- Copy—hear a transmission.
- Copy the mail—just listening to the radio with very little talking.
- 88's—kisses and hugs (for a woman, a sign of affection).
- 44's—hugs to the little ones.
- My goodness!—a pause with no meaning.
- Four wheeler—a car.
- Eighteen wheeler—a truck.
- Junk—a nonderogatory term for radio equipment (i.e. "We may run junk, but we run superior junk!").
- Pull the plug—shut off the radio.
- Re Linear—one doesn't say he uses a linear, but he may imply it by indicating he's wearing sneakers.
- Candyman, Federal Candy Co., Candy Paper—the first two refer to the Federal Communications Commission (FCC), the last to the tickets it issues.
- Green stamps—dollars.
- Grasser—low in signal strength.

—Allan S. Adelman, Philadelphia, Pa.

BRODDINGNAGIAN IC'S?

I was very interested in building "A Wireless Audio System For Remote Speakers" (January 1976). After looking at the etching and drilling guides for the transmitter and receiver, it appears that you goofed and printed enlargements.—E. Taffe, W2IGR, Palisades Park, N.J.

Yes, the guides were mistakenly published two times actual size. If you're making your own boards and are not equipped to photographically reduce the guides, send a self-addressed, stamped envelope to POPULAR ELECTRONICS and we'll send you the proper-size guides.

AN ALTERNATE APPROACH

In the "Negistor" article (December 1975), it was stated that oscillation was obtained from an npn transistor with open base under reverse-bias conditions. I have obtained similar results from the same type of circuit and also from forward-biased pnp germanium transistors. One of my pnp circuits is shown below. To test for negative

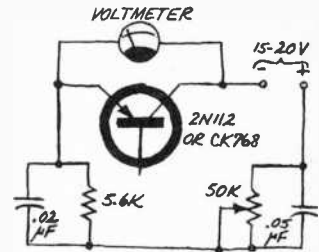

resistance, I adjust the setting of the potentiometer so that the voltmeter's pointer rises to a peak indication and then begins to fall back toward the zero index. The oscillations I have observed with such a circuit have a sinusoidal waveform and a 0.5-volt peak at about 7000 Hz.—I. Queen, Brooklyn, N.Y.

OCTAL VERSUS HEXADECIMAL

I take exception to the statement in the November 1975 Computer Bits column that only "pockets" of programmers still use octal notation. On the contrary, octal notation is currently in widespread use. In fact, I wouldn't hesitate to say that it is more widely used than hexadecimal notation. The reason is that there are more computers of all types (particularly micro's and mini's) designed for eight-bit octal documentation than there are 16-bit hexadecimal machines.—Don R. Walters, Ann Arbor, Mich.

CREDIT WHERE CREDIT IS DUE

"Programming the Altair 680" (December 1975) was erroneously bylined by Paul Van Baalen and me. The credit for writing this article rightly belongs to William H. Gates.—H. Edward Roberts, Albuquerque, N.M.

MISSING CIRCUIT

The diagram below should have appeared in the February Letters column with John Hanson's suggestion for a simple current-limiting circuit for pass-transistor regulators.

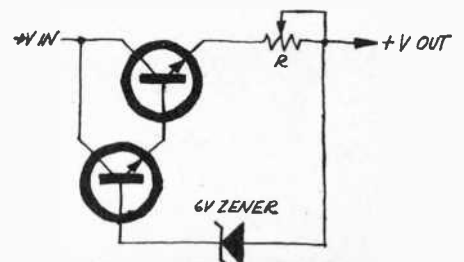

For the \$400-class CB customer Realistic has what's really new and 4000 places to find it.



Reading time 48 seconds:

Not everyone has four C-notes to lay out for hobby or business equipment. But on the other hand, the new Realistic Navaho TRC-57 actually costs no more than a basic 35mm SLR camera. And for 399.95* you get an AM/SSB base/mobile transceiver with everything you'd expect — plus a lot you wouldn't. + Digital phase-locked synthesizer and crystal lattice filter for unusual selectivity. + Automatic modulation gain control for full power always, whether you talk loud or soft. + ANL and blanker for chopping out noise. + LED-indicator AM/USB/LSB mode lights. + Separate SWR and S/RF power meters that turn red on transmit. + Precise LED-readout clock switchable for 12 or 24-hour time. And of course it's FCC Type Accepted and UL listed. The new Navaho. You get something more by accepting nothing less!

*Retail price may vary at individual stores and dealers.



FREE! NEW 1976 RADIO SHACK CATALOG

164 PAGES • OVER 2000 ITEMS

Get your copy today at our nearest store or dealer. Or write:

Radio Shack
P.O. Box 1052
Fort Worth, Texas 76101

686

(Please Print)

Name _____ Apt. # _____

Street _____

City _____ State _____ Zip

SOLD ONLY WHERE YOU SEE THIS SIGN:

Radio Shack®

A TANDY CORPORATION COMPANY



Just Say
"Charge It!"
at participating stores

Where do the pros get their training?



Almost half of the successful TV servicemen have home study training and with them, it's NRI 2 to 1. It's a fact! Among men actually making their living repairing TV and audio equipment, more have taken training from NRI than any other home study school. More than twice as many!

A national survey*, performed by an independent research organization, showed that the pros named NRI most often as a recommended school and as the first choice by far among those who had taken home study courses from any school. Why? Perhaps NRI's 60-year record with over a million students . . . the solid training and value built into every NRI course . . . and the designed-for-learning equipment originated by NRI provide the answer. But send for your free NRI catalog and decide for yourself.



25" Diagonal Color TV... And 4-channel Quadraphonic Stereo.

As a part of NRI's Master Course in color TV/Audio servicing, you build a 25" diagonal solid state color TV with console cabinet. As you build it, you perform stage-by-stage experiments designed to give you actual bench experience. And you get a Quadraphonic system with 4 speakers. NRI's



instruments are a cut above the average, including a transistorized volt ohm-meter, triggered

sweep 5" oscilloscope, CMOS digital frequency counter and digital integrated circuit color TV pattern generator. They're top professional quality, designed to give you years of reliable service. You can pay hundreds of dollars more for a similar course and not get a nickel's worth extra in training and equipment.

Widest Choice of Courses and Careers.

NRI doesn't stop with just one course in TV/Audio servicing. You can pick from five different courses (including an advanced color course for practicing technicians) so you can fit your training to your needs and your budget. Or, you can go into Computer Technology, learning on a real, digital computer you build yourself. Communications with your own 500 channel digitally-synthesized VHF transceiver. Aircraft or Marine Electronics. Mobile radio, and more.

Free Catalog... No Salesman Will Call.

Send the postage-paid card for our free color catalog showing details on all NRI electronics courses. Lesson plans, equipment, and career opportunities are fully described. Check card for information on G.I. benefits. No obligation, no salesman will call. Mail today and see for yourself why the pros select NRI two to one!

If card is missing, write,

*Summary of survey results upon request.

Two Famous Educators... NRI and McGraw-Hill.

NRI is a part of McGraw-Hill, world's largest publishers of educational material. Together, they give you the kind of training that's geared for success . . . practical know-how aimed at giving you a real shot at a better job or a business of your own. You learn at home at your convenience, with "bite-size" lessons that ease learning and speed comprehension. Kits designed to give you practical bench experience also become first-class professional instruments you'll use in your work.



NRI SCHOOLS
McGraw-Hill Continuing Education Center
3939 Wisconsin Avenue,
Washington, D.C. 20016

The \$750 alternative.

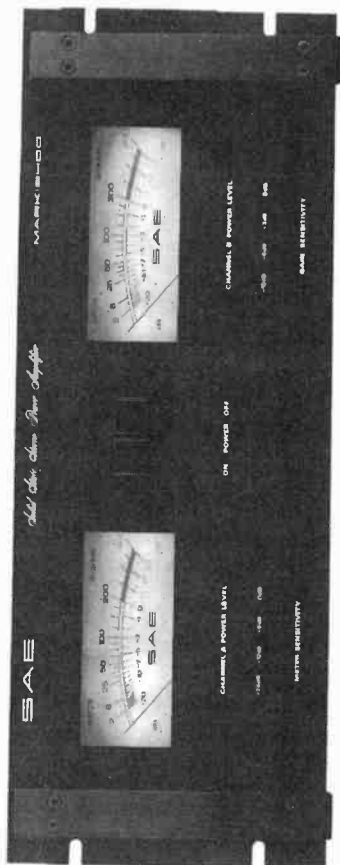

SAE 2400 Professional Dual-Channel Power Amplifier

- 200 Watts RMS, per channel, both channels driven into 4 or 8 Ohms from 20Hz to 20KHz at no more than 0.05% Total Harmonic Distortion.
 - 0.05% IM into 4 or 8 Ohms
 - (signal to noise) greater than 100dB
 - plug-in board modules
 - forced air cooling
 - only 11" deep
 - weighs less than 42 lbs.
 - superb construction using only the finest materials and component parts
 - available in black rack mount (as shown) or our traditional satin gold and black
- You'd have to look a long time to find a power amplifier that delivers this much value.



Scientific Audio Electronics, Inc. PE-376
P.O. Box 60271, Terminal Annex
Los Angeles, California 90060

Please send me the reasons (including available literature) why the SAE 2400 Professional Amplifier is the "\$750 Alternative."

NAME _____
ADDRESS _____
CITY _____ STATE _____ ZIP _____

CIRCLE NO. 47 ON FREE INFORMATION CARD

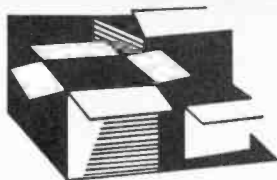

New Products

Additional information on new products covered in this section is available from the manufacturers. Either circle the item's code number on the Reader Service Card inside the back cover or write to the manufacturer at the address given.

FOUR-DRIVER SPEAKER SYSTEM

Bertagni Electroacoustic Systems, Inc. now has a four-driver speaker system which incorporates no-cone, no-piston technology and nonenclosure styling, the Model d120. With a sound-radiating area of 1700 sq. in., it is the largest of the Geostatic™ line but measures only 3¾" front-to-back. Thinness is achieved by exciting a

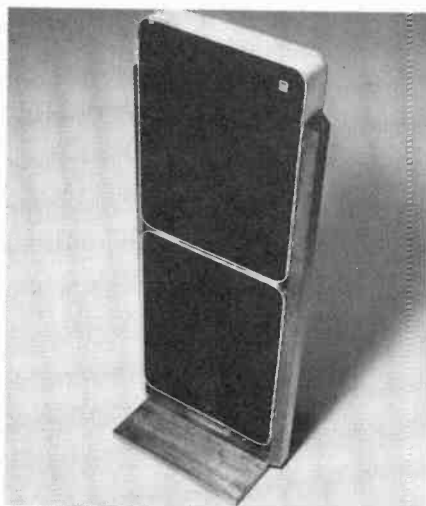

tension-flexed diaphragm; separate areas of the diaphragm are activated by multiple drivers to produce high, middle, and low frequencies. Claimed frequency response is 25 to 20,000 Hz ±2 dB, HD is 1.2% measured with 90 dB, 80-Hz tone at 1 meter. The d120 will handle up to 250-W rms, but operates on power as low as 25-W rms. \$499.00.

CIRCLE NO. 84 ON FREE INFORMATION CARD

PACE CB TRANSCEIVER WITH WEATHER CHANNELS

Pace's new Model CB 145 mobile transceiver provides synthesized 23-channel coverage, as well as receive capabilities on the two NOAA vhf weather channels. Features 4-W r-f output, delta tune, noise blanker, anl, r-f gain control, S/r-f meter, and switch-selected PA operation. Also has indicator lights for transmit and receive, as well as cb, wx-1, and wx-2 operating modes. Comes with a dynamic PTT mike. \$209.95

CIRCLE NO. 85 ON FREE INFORMATION CARD

ECONOTRACE CURVE TRACER

Lab Science's Model EC-101 Econotrace displays semiconductor characteristic curves on any scope having an external horizontal input. The device has switches for polarity selection, base current per step in microamps, and also has two transistor sockets on the front panel. The display is sized using the scope's vertical gain control. Leakage, noise, saturation voltage, linearity, breakdown, and beta can be measured. The Econotrace operates from a 9-volt battery which has a normal operational lifetime of one year. Current limiting and low test voltages protect the device under test. Measures 4" x 2⅞" x 1⅞" (10.2 x 7.3 x 4.8 cm), weighs 2 lb (0.91 kg). \$39.50

CIRCLE NO. 86 ON FREE INFORMATION CARD

MOBILE TRANSCEIVER LOCK

Shur-Lok Manufacturing's Model CB 700 is designed to discourage the theft of your mobile transceiver. The locking bracket is made of heavy gauge metal stampings and is electroplated flat black. The lock, according to Shur-Lok, has tempered shackles, a pick-proof barrel, and two keys. It can be adjusted to fit up to the largest AM/SSB mobile transceiver currently on the market. \$14.95

CIRCLE NO. 87 ON FREE INFORMATION CARD

REALISTIC MOBILE PA AMPLIFIER

Radio Shack announces its new Realistic Model MPA-10 mobile PA amplifier. Designed to operate from 12-volt dc sources, the solid-state amplifier is rated at 10W rms output into 8 ohms. Claimed frequency response at full power is 200 to 10,000 Hz. Has tone and volume controls and push-button selection of MIC or AUX inputs. Measures 6½" x 4⅞" x 1½" (16.5 x 10.5 x 3.8 cm) and comes with a dynamic mike, hanger, and mounting hardware. \$39.95

CIRCLE NO. 88 ON FREE INFORMATION CARD

REMOTE-READING RAIN GAUGE

An Electronic Digital Rain Gauge (No. 72,165) for gardening hobbyists, farmers, homeowners, and weather buffs empties



POPULAR ELECTRONICS

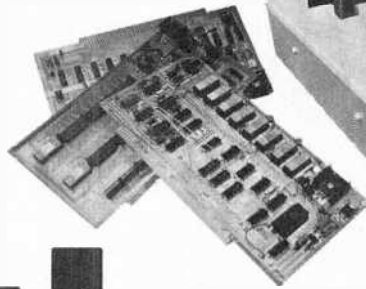

Now, you can buy an Altair 8800 or Altair 680 computer kit right off the shelf. Most all Altair options, software and manuals are also available. The MITS Dealer List below is just the beginning:

off the shelf

ARROWHEAD COMPUTER CO.
 (The Computer Store)
 11656 W. Pico Blvd.
 Los Angeles, CA 90064
 (213) 478-3168

BYTE'TRONICS
 5604 Kingston Pike
 Knoxville, TN 37919
 (615) 588-8971

THE COMPUTER SYSTEMCENTER
 3330 Piedmont Road
 Atlanta, GA 30305
 (404) 231-1691

COMPUTER KITS
 1044 University Ave.
 Berkeley, CA 94710
 (415) 845-5300

COMPUTERS & STUFF
 1092 S. State St.
 Orem, UT 84057
 (801) 224-2066

GATEWAY ELECTRONICS
 2839 W. 44th Ave.
 Denver, CO 80211
 (303) 458-5444

GATEWAY ELECTRONICS
 8123-25 Page Blvd.
 St. Louis, MO 63130
 (314) 427-6116

MARSH DATA SYSTEMS
 5405-B Southern Comfort Blvd.
 Tampa, FL 33614
 (813) 886-9890

MICROSYSTEMS
 6605A Backlick Rd.
 Springfield, VA 22150
 (Washington DC area)
 (703) 569-1110

CTI DATA SYSTEMS
 3450 East Spring St.
 Long Beach, CA 90806
 (213) 426-7375

BYTE SHOP
 1063 El Camino Real
 Mountain View, CA 94043
 (415) 969-5464

RIDGWAY EAST
 Retail Computer Center
 161 Bell St.
 Chagrin Falls, OH 44022
 (Cleveland) (216) 247-4845

THE COMPUTER STORE, INC.
 PO Box 2621
 Framingham Center, MA 01701
 (617) 877-6984

NOTE: Altair is a registered trademark of MITS, Inc.

MARCH 1976

CIRCLE NO. 31 ON FREE INFORMATION CARD

itself; is said to accurately record rainfall up to 100 feet away, by tenths of an inch, to 999.9". Accumulated total inches of rainfall for any period (hour, day, week, etc.) can be recorded; the counter can be reset to start a new count period. The hermetically sealed outdoor collector includes 30 ft. of waterproof wire. A 9-V transistor battery powers the device. Edmund Scientific Co. markets the unit at \$44.95.

CIRCLE NO. 89 ON FREE INFORMATION CARD

DC REGULATED POWER SUPPLY KIT

GC Electronics' Calectro Division has a ready-to-assemble dc regulated power-

supply kit, Cat. No. G2-100. It can be used in place of batteries in radios, tape recorders, and other electronic devices using 2 to 25 V, up to a current drain of 500 mA. Voltage output remains constant, even when output load varies from zero to full load. The kit comes with an illustrated, step-by-step instruction booklet.

CIRCLE NO. 91 ON FREE INFORMATION CARD

3M/WOLLENSAK CASSETTE DECK

The new Model 4766 by 3M/Wollensak is a stereo cassette deck with a direct-drive transport. It also has a bias switch to match

the deck for use with ferric-oxide, chromium-dioxide, or ferri-chrome tape. Peak indicator lights monitor transients while recording and VU meters monitor average signal levels. Dolby noise reduction circuitry is built-in. \$429.95.

CIRCLE NO. 92 ON FREE INFORMATION CARD

TENNELEC MEMORYSCAN MONITOR

Tennelec's Memoryscan Model MS-2 allows the listener to monitor 16 channels in the vhf LO and HI bands, as well as the uhf band. Frequencies assigned to these channels may be changed at any time without installing new crystals. To program the scanner for any of the 4000 public service channels listed in Tennelec's special code book, the number sequence corresponding to the desired frequency is punched into the scanner. The Memoryscan can receive on up to 16,000 frequencies, has FET r-f stages, automatic or manual scan control, channel lockout switches, and squelch. \$339.95.

CIRCLE NO. 93 ON FREE INFORMATION CARD

GUTTER-MOUNT CB ANTENNA

A low-profile 27-MHz CB antenna, designed to be installed on any vehicle rain gutter, is now available from Breaker Corp. Known as the "Independence" (Model 10-245), it is 28 inches long; the top whip is

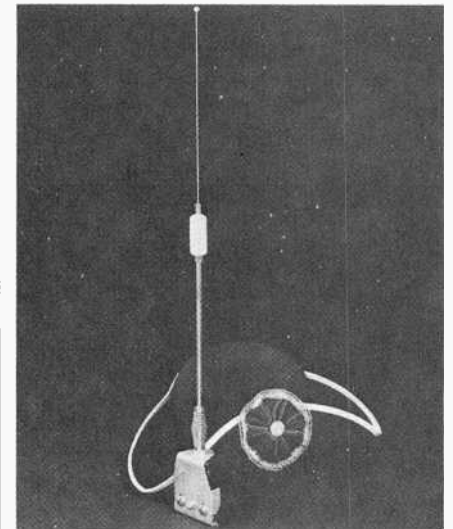

stainless steel and the base chrome-plated brass. The whip includes a static arrester and has a pre-tuned heavy-duty ABS-encapsulated center load coil; an autoflex, stainless-steel spring relieves whip shock. The antenna comes packaged with Allen wrench for fine tuning, 10-ft coax cable with PL-259 plug, and complete instructions. \$22.95.

CIRCLE NO. 94 ON FREE INFORMATION CARD

TEKTRONIX SINGLE-TRACE OSCILLOSCOPE

Tektronix's Model T921 oscilloscope is a single-trace unit with mono time base. Vertical bandwidth is dc to 15 MHz, with 2

POPULAR ELECTRONICS

THE NEW

3-WAY SYSTEM

handic cb



IT'S A
**BASE
MOBILE
PORTABLE**

You're looking at an authentic CB first from Handic... Innovators of the "no-frills, no-gimmicks" dependable CB designed for Sweden's tough operating conditions. Now, Handic offers the first truly personal CB system that works 3 ways... Portable, Mobile and Base. With it comes advanced electronic design featuring: 0.5µv sensitivity; 0.003% crystal freq. tolerance; automatic noise limiting; AVC; low current drain; and rugged construction. Here's how it works:



IT'S PORTABLE... Power-packed, anytime versatility for off-the-road action — hunting, fishing, skiing or on the job! Your Handic personal CB system starts out as a portable — in 2, 3, 4 or 6 Chs. (1 to 5W. input). Each operates on Nickel Cadmium batteries, easily rechargeable with our unique "PowerPack" sleeve... the secret behind Handic's 3-Way System.

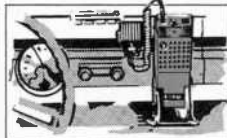

IT'S MOBILE... Every Handic portable slips easily into the optional "PowerPack". Automatically, this gives you a portable CB with a functioning, external power supply. And, with the Models 43C & 65C, you connect to your auto, truck, van or marine CB antenna. Now, you've got an operating mobile unit that stows easily to guard against theft. That's not all...

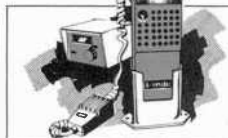

IT'S A BASE... An hour ago, you worked your Handic portable as a mobile. It can easily become a base! And, that holds for each unit! To operate, keep portable in its "PowerPack". This time, couple to our optional 110V. AC adapter. With the model 43C & 65C connect the radio to your base antenna. Now, you've got a quality base that goes the distance!

There it is. Handic ingenuity. In a practical, money-saving, 3-way system that's portable, mobile or base! Complete with crystal; and impact-resistant case featuring Handic's orange color — symbol of CB excellence. From approx. \$60. Handic CB radios include: mobile/base transceivers; hand-held personal portable CB systems; scanners with FM radio option; selective call; microphones; antennas; and a full line of accessories.



handic U.S.A. inc.

14560 N.W. 60th Ave., Kennedy Bldg., Miami Lakes, Fla. 33014 (305) 558-1522
In Canada: Scotcomm Radio Inc., Chomedey, Laval, Quebec

CIRCLE NO. 22 ON FREE INFORMATION CARD.

Send for FREE Catalog!



SWEDEN'S DEPENDABLE CB

IMSAI

The IMSAI 8080 can be configured with optional Mother Board to provide a full 22 slots. (shown)

Front panel plugs into Mother Board, thus eliminating the work of soldering all the wires from the front panel to the Mother Board.

Special PIO Board configured with LEDs to monitor each bit of each of the 4 ports.

Extender Board available

Sturdy Card Cage

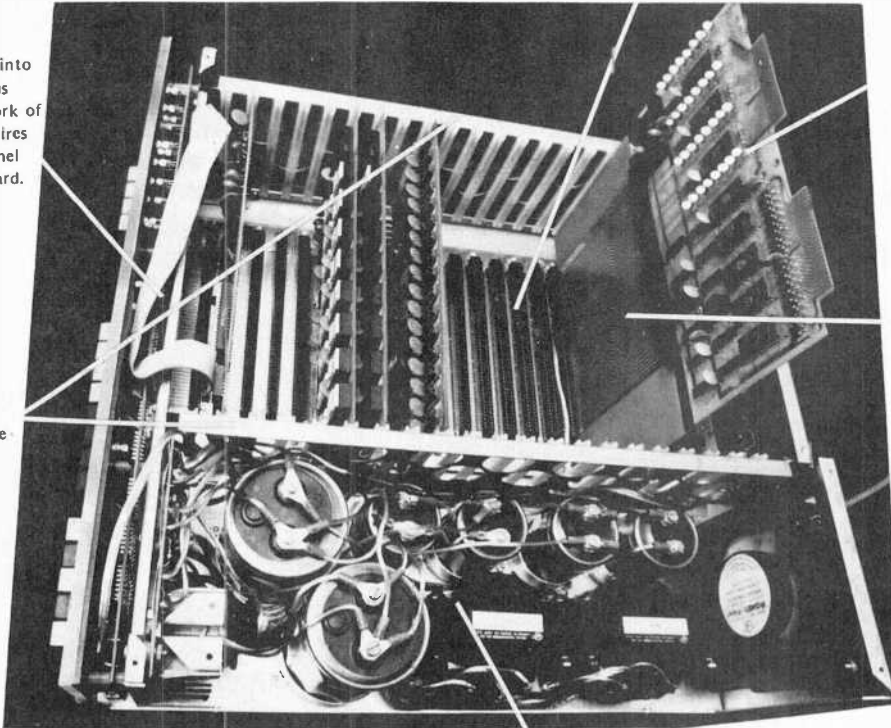

Heavy duty power supply (optional dual power supply shown.)

The IMSAI 8080 is designed using the full Intel family of large scale integration chips, thus providing high reliability and greater flexibility.

Front panel hosts a photographic legend to produce a clear, concise, easy-to-read format that can be configured for either hexadecimal or octal. (It won't wear off!)

8 additional program controlled LEDs.

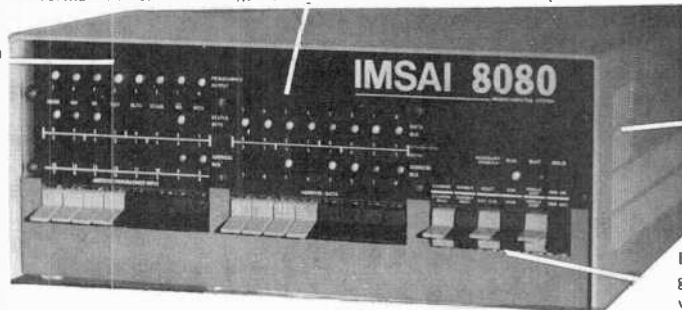

Commercial grade cabinet

Easy-to-use commercial grade paddle switches—very crisp and solid.

Front panel unplugs, so unit can be used in a turn key system.

COMING SOON: Free BASIC and extended BASIC for registered IMSAI 8080 owners, followed shortly by Fortran IV and PLM.
 TERMS: Check or money order, BankAmericard, Master Charge, 25% deposit on COD orders. On all orders under \$1,000, add 5% for handling. On orders over \$10,000 subtract 5%. California residents add 6% sales tax.

SEND FOR FREE CATALOG OF IMSAI MICROCOMPUTER PRODUCTS
 SPECIAL NOTICE TO ALTAIR 8800 OWNERS:

DEALER INQUIRIES INVITED

If you would like to step-up to the superior quality of an IMSAI 8080, you will be pleased to know that your ALTAIR 8800 boards are "plug-in" usable—without modification—in the IMSAI 8080 cabinet. Furthermore, by acquiring IMSAI's unique Memory Sharing Facility, your ALTAIR MPU board and IMSAI MPU board can co-exist in the same cabinet, operate in parallel with each other, and share all memory in common. This is the technology that laid the foundation for IMSAI's powerful HYPERCUBE Computer and Intelligent Disk systems (recently featured in Computerworld, Datamation and Electronics magazines.)

IMS ASSOCIATES, INC., 1922 REPUBLIC AVENUE, SAN LEANDRO, CA 94577

(415) 483-2093

PIONEER INTRODUCES AN AMPLIFICATION SYSTEM THAT WILL FORCE YOU TO TAKE A HARD LOOK AT YOUR SPEAKERS.

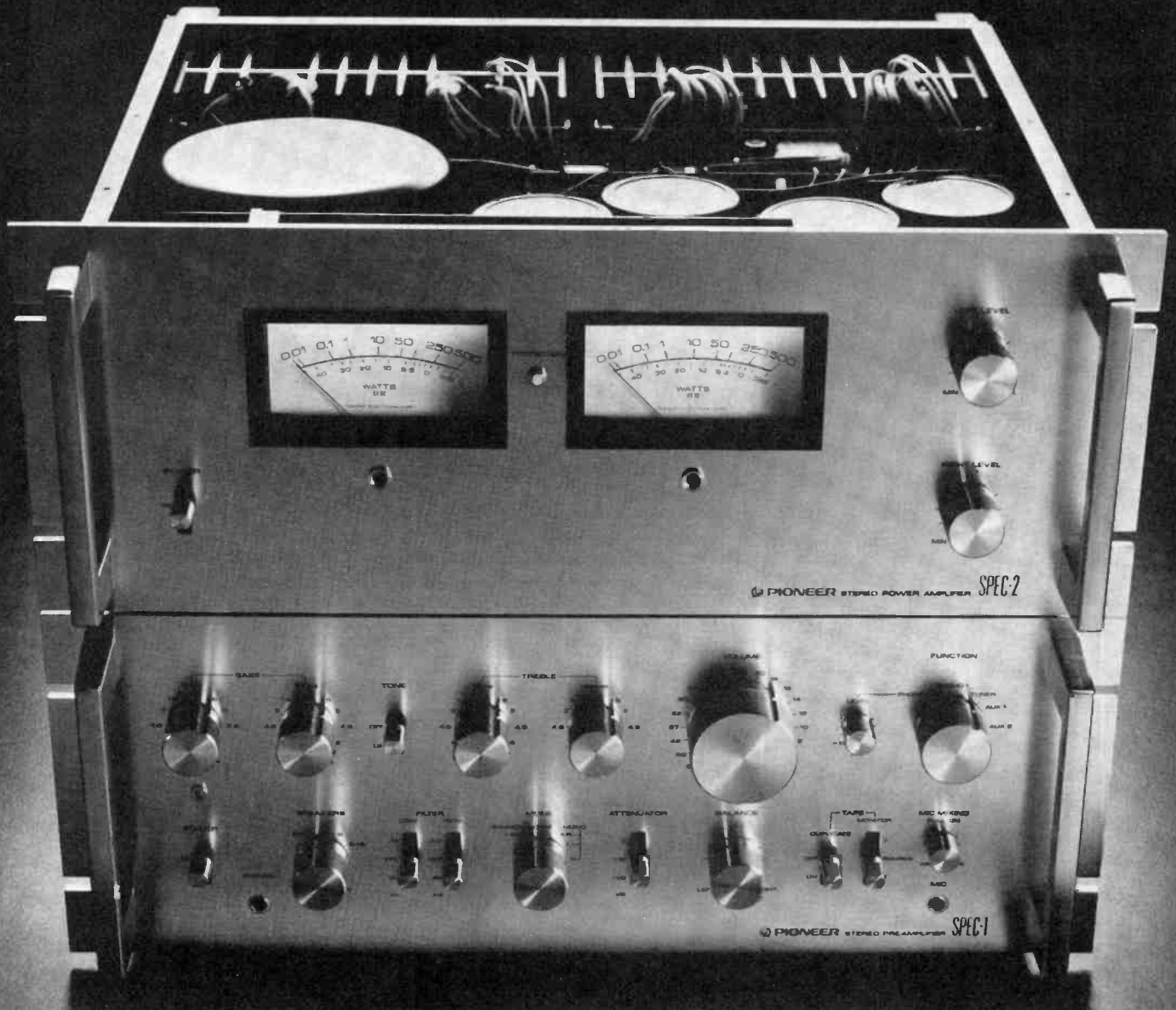

Pioneer's new Spec 1 and Spec 2 are capable of producing a level of high-quality sound most speakers are simply incapable of reproducing.

So, unless you're willing to listen to Spec 1 and Spec 2 at something less than their full potential, don't make the decision to invest in them if you're not prepared to invest in a new pair of speakers.

SPEC 2: 250 GOVERNMENT-APPROVED WATTS A CHANNEL

Spec 2 was the first power amplifier designed to deal with the new F.T.C. power regulations. It has a continuous power output of 250 watts per channel minimum RMS. At 4 or 8 ohms. From 20 to 20,000 Hz. With no more than 0.1% harmonic distortion.

Other power amplifiers that used to claim a lot more power can't do that anymore.

WHO NEEDS ALL THIS POWER AND WHY

When you listen to a live performance it can have an average sound level of 84 dB. Which most high fidelity systems can reproduce with half a watt of power. But a sudden musical peak of 110 dB takes four hundred times as much power. Which means you need 200 watts of power to reproduce that peak. If your amplifier doesn't have that much reserve power, you get "clipping." Which doesn't happen during a live performance.

So, if you want your system to be able to give you all the power, all the sheer presence of live performance, you need an

amplifier with all the reserve power of the Spec 2.

STATE-OF-THE-ART DESIGN

Spec 2 not only produces an uncompromising amount of sound; it does so in a totally uncompromising manner.

For example, Spec 2 uses an advanced toroidal coil power transformer. It's a more expensive transformer than most amplifiers use. But a more efficient transformer. And one that keeps magnetic flux leakage to an absolute minimum.

Also unlike many power amplifiers, Spec 2 doesn't use fans. Because fans can cause noise. Instead, Spec 2 has massive heat sinks and special Pioneer-developed protective circuitry to keep the operating temperature under control.

Spec 2 even has wattage meters that indicate music output

compensate for any deficiencies in program material or listening area.

And, so you can make sure you've made all the right adjustments, Spec 1 has a "tone off" switch that lets you compare your setting with a completely flat setting.

Spec 1 even has its own microphone amplifier, with its own volume control. So you can mix into any program material without touching the main volume control.

THE BEAUTIFUL SOUND OF NOTHING

One thing Spec 1 doesn't do is add anything to the sound it reproduces. The phono section has a completely inaudible signal-to-noise ratio of 70 dB (IHF, short-circuited A network). All other inputs are rated at 90 dB. Which is even more inaudible. And it has a total harmonic distortion of no more than 0.03%. Which is five times under what your ear is capable of detecting.

DESIGNED FOR EIA MOUNTING

Both Spec 1 and Spec 2 are 19" wide. So you can place them in any standard EIA laboratory rack.

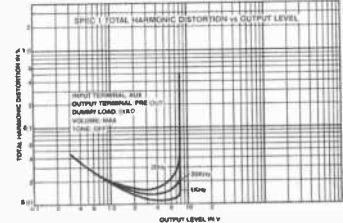
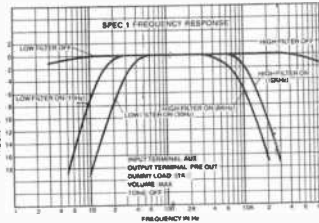
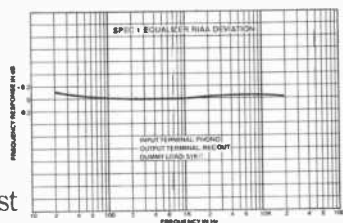
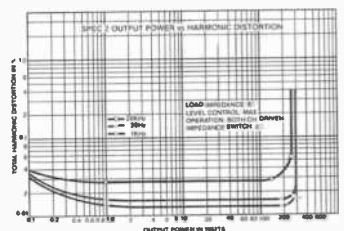
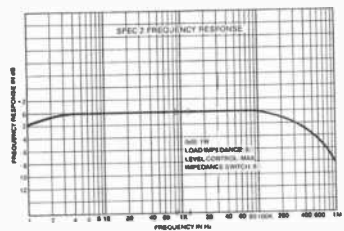
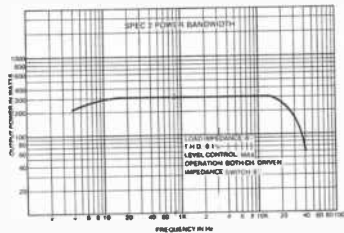

in RMS watts at 8 ohms. These had to be specially designed, too. Because conventional VU meters couldn't give an accurate enough power reading.

SPEC 1: TWICE THE CONTROL OF MOST PREAMPLIFIERS

Most preamplifiers have two tone controls. Some have three. But Spec 1 has four. Each of which is calibrated in 1.5 dB clickstops. All together, they give you a total of 5,929 ways to

Or you can stack them like conventional home entertainment components.

Which they definitely are not.

**SPEC 1
SPEC 2
PIONEER®**

U.S. Pioneer Electronics Corp.
75 Oxford Drive, Moonachie, New Jersey 07074

mV/cm minimum sensitivity. Fastest sweep rate is 20 ns/cm using the 10X sweep expander. Features an 8 x 10 cm CRT with 12 kV anode supply, beam finder, single knob trigger control, a delay line for viewing the leading edge of a waveform, automatic selection of TV line or frame display, and color-coded controls. A 10X probe is included, and a scope stand, camera, and rain jacket are available as options. Measures 19" x 10" x 7" (48.3 x 25.4 x 17.8 cm) and weighs 15 lb (6.8 kg). \$695.00

CIRCLE NO. 95 ON FREE INFORMATION CARD

SOUND/IR/SOUND XMTR

Revox Corp. has released a number of

Beyer Dynamic components for sound-to-infrared-to-sound transmissions. The system consists of the IS76 infrared transmitter with ten transmitter diodes in line, specially equipped with back reflectors; IE76 receiver, designed to be used with existing headphones; DT444 infrared receiving headphone; and charging unit for IE76 and DT444. The system can be used for TV, radio, and hi-fi sound pickup where cable-free listening is desired. Carrier frequency is 95 kHz with FM modulation; max. deviation is 30 kHz at 30 mV/100,000 ohms; frequency range is 40-10,000 Hz. IS76 \$92.50; IE76 \$76.00; DT444 \$119.50; charging unit \$12.50.

CIRCLE NO. 96 ON FREE INFORMATION CARD

GET FAMILIAR WITH MICROCOMPUTERS AT MICROCOST.

The EBKA FAMILIARIZOR is a complete microcomputer system. No expensive terminal is required. Everything is built-in to a single PC board, including a hexadecimal keyboard and display.

Easy-to-understand Hardware and Programming Manuals guide you every step of the way. You will gain a practical knowledge of microprocessing, plus invaluable "hands-on" experience. All at microcost.

The heart of the EBKA FAMILIARIZOR is a MOS TECHNOLOGY 6502 Microprocessor, an eight bit processor that can address up to 65K bytes of memory. On-board memory consists of 1K bytes of RAM for user programs and two eight bit ports (one input and one output). A 256 byte monitor program, supplied in one 1702A erasable PROM, enables you to load, examine, run, debug and modify your own programs. Each function can be implemented at any address in memory. Breakpoints can be entered at any location in your program to display internal registers or branch to a separate routine.

You may also expand the capabilities of your FAMILIARIZOR in easy, inexpensive stages. To store your own programs in PROM, the PC board is designed to accept three additional 1702A PROMS (768 bytes). A low cost PROM programmer is also available. The system bus allows easy expansion. Add-on memory, interface and special function cards are available.

Whether you're a beginner or an experienced engineer, EBKA offers you a microcost way to get familiar with microcomputers. Order your EBKA FAMILIARIZOR today.



ORDER FORM

Please send me:

- Complete 6502 FAMILIARIZOR Kit\$229
- Assembled.....\$285
- IC Socket Kit.....\$14.50
- Power Supply\$58
- Check here if you wish to receive literature on the complete EBKA line.

Oklahoma residents, add sales tax.

Make payable and mail to:

EBKA INDUSTRIES INC.

6920 Melrose Lane 405/787-3671
Oklahoma City, Oklahoma 73127

- Enclosed is my check or money order for \$ _____
- Charge my Bank Americard or Master Charge exp. date _____

Account No. _____

M.C. Bank No. _____

Signature _____

Name _____

Address _____

City, State, Zip _____

CIRCLE NO. 65 ON FREE INFORMATION CARD

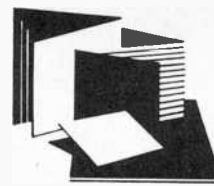

New Literature

LITTELFUSE INDICATOR LIGHT GUIDE

Littelfuse's line of indicator lights (Littellites) is highlighted in a six-page, four-color product guide. It contains information on cartridge lamps and lampholders, subminiature and miniature lampholders, and snap-mount Plastic Lites. Address: Littelfuse, Inc., 800 E. Northwest Highway, Des Plaines, IL 60016.

METRIC STANDARDS BIBLIOGRAPHY

Up-to-date information on the availability of metric standards is provided in a new edition of the "Bibliography of Metric Standards" of the American National Standards Institute. Among the areas covered are machinery and hardware. More than 1000 standards, recommendations, and amendments are listed. Single copies of ANSI's "Bibliography of Metric Standards," Special Publication 11b, are available on request. Address: ANSI, Sales Dept., 1430 Broadway, New York NY 10018.

MICROPHONE SELECTION & APPLICATION GUIDE

Tips on how to select and use microphones plus guidelines for on-stage miking are compiled in a new brochure, "The Music-Maker's Manual of Microphone Mastery" from Shure Brothers Inc. In nontechnical terms, the booklet describes how to mike voices and instruments, with techniques for handling troublesome sound pick-up situations. Also featured are recommended microphones for specific instrumental and vocal styles, positioning hints, and descriptions of accessories that can be helpful. Address: Shure Brothers Inc., 222 Hartrey Ave., Evanston, IL 60204.

1976 RADIO SHACK CATALOG

Radio Shack's 1976 Electronics Catalog #263, contains 164 pages (100 in full color) describing the company's complete line of products. Among the new items are a special limited-edition bicentennial radio, a 23-channel CB two-way radio with a telephone-type handset, a new line of Radio Shack pocket calculators priced from \$16.95, a digital multimeter, a precision belt-drive manual turntable and a new line of Realistic stereo tape cassette recorders. Also included is a coupon for the purchase of a \$1.00 Radio Shack metric slide-rule calculator for 25¢. Address: Radio Shack, Dept. R-19, 2617 W. Seventh Street, Fort Worth, TX 76107.

SBE Formula D

The state-of-the-art in fifty states

Stated simply, the SBE Formula D transceiver is in a class by itself. It's the one full-feature CB radio with frequency synthesis and digital locking. It covers all 23 channels with a single crystal. Phase-locked-loop circuitry holds each channel right "on target." Audio comes through clean and crisp. And there's plenty of power for the built-in PA system.

And that's just the beginning. Formula D is designed to give you superb sensitivity and signal-to-noise ratio to master weak signal reception. Plus such exceptional features as audio tone control, local distance switch (to prevent overload from strong signals), delta tune, automatic noise limiter, back-lighted monitor meter and dynamic microphone with coil cord.

For the perfect ending to the story, see and hear Formula D for yourself. You'll love the way it all comes out.



SBE Better Communications through Creative Technology

For information write: SBE, Inc., 220 Airport Blvd., Watsonville CA 95076

INTERNATIONAL OFFICES: E.S. Gould Marketing Co., Ltd., 10E Montee de Lisse, Montreal, Quebec, Canada H 4T 1S9 • Unirac Systems S.A., 5 Rue des Alpes, P.O. Box 163, 1211 Geneva 1, Switzerland

CIRCLE NO. 48 ON FREE INFORMATION CARD

AmericanRadioHistory.Com

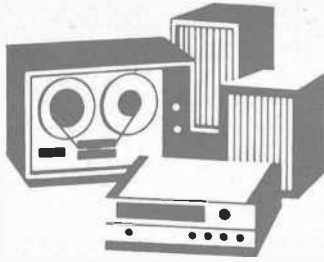

Stereo Scene

By Ralph Hodges

TONE CONTROLS, PLAIN AND FANCY

ONCE again a number of high-quality preamplifiers is being offered without tone controls. The philosophy of the manufacturers involved is, this time, both practical and purist. "You wouldn't want the simplistic bass and treble knobs we'd have to use to keep the design and cost of the product under control," they suggest. "Instead, buy our basic, unadorned preamplifier that contains nothing that will foul up the signal. Then, if you still feel you want tone controls, add a quality equalizer for the desired flexibility." And, of course, as often as not an appropriate equalizer is already on the drawing board of the manufacturer.

Bass and Treble Controls. I can find no fault with the above argument, but as these products fall into my hands from time to time, I realize that I sorely miss the old bass and treble knobs. They helped to provide a frame of reference in a world where equalization of recordings is going in every direction at once. An investigative twitch of the bass control has become almost routine; sometimes there's an additional octave or so of usable low frequencies hiding at the bottom of the spectrum. More often, after a minute or two of listening I'll want to trim the high frequencies in some way, or even run the treble control up full to get a better idea of the noise levels on the recording or the distortion characteristics of a particular phono cartridge. For these purposes, tone controls are cheap and easy. Furthermore, sometimes they are capable of bringing about a genuine sonic improvement in a recording. I am mindful of the purist's admonition against tampering with the sound of the original, but the fact is that the vast majority of commercial recordings come pre-tampered. If you listen only to your own recordings miked in a perfect replication of a Venetian cathedral you

can afford to set pretty lofty standards. However, those of us who buy regularly from the major labels need all the help we can get.

Some of the hostility that simple tone controls arouse is understandable. The technically minded note that, since most controls operate within one of the preamplifier's feedback paths, they affect the distortion of the device. The enthusiast who worships at the altar of high fidelity considers them a blatant form of cheating. Often the average listener has found them useless in many situations and so has ignored them. This last is symptomatic of a misunderstanding of what tone controls are likely to be good for, and what they are not.

Occasionally, tone controls are recommended for matching a speaker system's response to the acoustic conditions of the listening room. I have my doubts about this. If the speakers have been placed with reasonable care, a simple shelving of the midrange and treble response to match the bass output should be all that is required. The controls on the speakers should be able to accomplish this, and do it better than most tone controls. For more persistent problems (including a poor speaker to begin with), a tone control's action is usually too gross or too unspecific to make a good correction.

I have always felt that a treble control should be able to ameliorate high-frequency distortion problems that can develop from several sources, but I've never been able to put this theory to work. By the time I've turned down the treble enough to have some effect on the distortion, all traces of musical high frequencies have disappeared. In short, if the music sounds harsh because it is seriously distorted, I wouldn't look to tone controls for a satisfactory remedy.

Bass boost is often useful and often not. Many recordings lack bass be-

cause the lows have been sharply rolled off somewhere in production. The typical bass control cannot begin to complement the steep attenuation slope used. Even if the slope is not so steep, the bass control is likely to begin acting at too high a frequency, generating an obnoxious midbass hump in the response. Furthermore, with disc recordings, the low-frequency noise levels that are common will have you playing tag with acoustic feedback as soon as you start advancing the bass knob much beyond its midpoint. Nevertheless, a moderate amount of bass boost can really bring certain recordings to life. Bass cut, on the other hand, is rarely wanted or tolerated except with program material having a restricted frequency response—an unaccompanied male voice, for example.

The opposite is true of the treble control. Turned down, it may be capable of taming many of the over-bright recordings (the British call them "chromium plated") that are always cropping up. Turned up, the treble control generally inundates you with noise—a cure worse than the disease.

Matching the Music. In my experience, tone controls are most useful for "correcting" sins of recording equalization that have been committed by similar circuits. How useful they are in every circumstance is another question. Shown in Fig. 1 is the spectral balance typical of a commercial symphonic recording during a loud orchestral passage. Steady percussion has raised the upper midrange levels somewhat, and the recording is on the bright side, but the overall shape of the curve is representative. Figure 2 shows the same kind of data for a typical pop recording.

(Continued on page 26.)

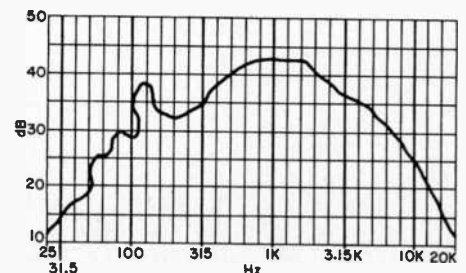

Fig. 1. Dynamic spectrum of a classical recording, measured on a real-time analyzer.



At TEAC, our fundamental mandate for any new product is performance and reliability. First and finally. Qualities that are measurable in terms of mechanical stability and inherent design integrity.

These are essentials. Because our technological resources established the cassette deck as a true high fidelity component. So we demand that a new product possess that measure of TEAC quality.

And that's what distinguishes the A-170. Compare it with other inexpensive cassette decks with Dolby, please. Just call (800) 447-4700* for the name of your nearest TEAC retailer. We think you'll agree it's a value you can rely on.

*In Illinois, call (800) 322-4400.

A-170

TEAC performance and reliability...

how can you really afford anything less?

TEAC.

The leader. Always has been.

Dolby is a trademark of Dolby Laboratories, Inc.

TEAC Corporation of America/7733 Telegraph Road, Montebello, Ca. 90640 ©TEAC 1975



Is there a little of the Thomas Edison in you?

As a kid, were you one of the first in your neighborhood to make a walkie-talkie out of a couple of tin cans and a length of string—or give your folks early gray hair with the experiments you tried with your chemistry set?

Does it all sound kind of familiar? If so, then your inquiring mind is much like that of another fellow who, years ago, did some pretty fascinating things in electricity and electronics. His name was Tom Edison.

So if, indeed, there's a little of the Thomas Edison in you, you're just the person who'd get the most out of Bell & Howell Schools' self-instruction programs in electronics.

How would you like to build and experiment with a 25"-diagonal color TV with advanced digital features—or an FM/FM-stereo tuner and 4-channel amplifier? Or maybe delve into areas like two-way radio or modern industrial electronics? Whatever, Bell & Howell Schools offers programs you can follow at home—without giving up your job!

Tom Edison learned by doing and experimenting rather than just by reading—and you can, too!

Like Edison, you'll be using the "hands on" method to learn. Because that's just how our new program works!

You begin by performing your first experiments with the Lab Starter Kit we send you. Next, you build and use a laboratory that includes a design console, a digital multimeter, and a solid-

state, "triggered sweep" oscilloscope! This "Electro-Lab®" electronics training system leads you through the Fundamentals of Electronics.

And once you've done that, Bell & Howell Schools offers a wide selection of programs, so you can continue in the field or fields that interest you most. And just look at the range of fascinating electronics specialties available to you!

Now Bell & Howell Schools gives you a choice of Communications, Digital/Industrial, and Audio or TV Home Entertainment Electronics!

Let's say you're interested in the field of TV Home Entertainment Electronics. You may choose it as your first specialty, and learn it in the most exciting way imaginable. You'll build a 25"-diagonal color TV with your own two hands! Actually probe into the circuitry behind features such as time and channel numbers that flash right on the screen! How's that for training? And Home Entertainment Electronics is just one of the ways you can travel!

You may decide to specialize in fields like Digital/Industrial, and Communications Electronics, too! Never before has a home-

learning program offered such freedom and flexibility.

Only Bell & Howell Schools offers you all this... and more!

We've told you about the satisfaction, the convenience, and the choices that are yours for the asking. What we haven't mentioned is that the programs you follow at home actually provide the same quality and content as if you had taken them at any of our eight resident schools! Proof? Our dramatic new approach to self-instruction allows you to transfer to our resident school technician program without any loss of credits!

But, remember, learning electronics at home doesn't mean learning electronics entirely by yourself. Our toll-free number is yours to use when you need it. So are the weekend "help sessions" we hold in 50 major cities at various times of the year.

Of course, no school can guarantee income opportunities. But our programs could help when you look for a job in electronics, in moving ahead in the job you may already have, or as a base for more advanced programs.

So, if there's still a little of the Thomas Edison in you, why not use it? You'll do a whole lot more than make a walkie-talkie out of two tin cans and a piece of string.

Mail the postpaid card for full details... today!

Note: When taken for vocational purposes, this program is approved by the state approval agency for Veterans' Benefits.

Simulated TV test pattern



If card has been used, write to:
An Electronics Home Study School
DEVRY INSTITUTE OF TECHNOLOGY

ONE OF THE
BELL & HOWELL SCHOOLS
4141 Belmont, Chicago, Illinois 60641

"Electro-Lab®" is a registered trademark of the Bell & Howell Company.

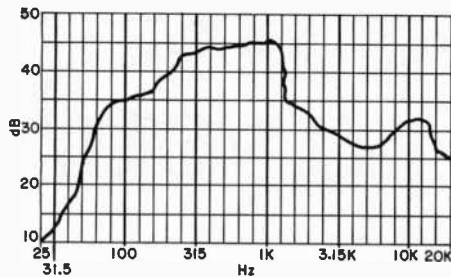

Fig. 2. Dynamic spectrum of a popular recording, measured on the same analyzer as Fig. 1.

At first glance, the family of curves usually available from simple tone controls (Fig. 3) seems like it would fit in well with the classical material if smooth shaping of the final response curve is the object. The pop selection looks too chopped up to be predictable. However, having heard these two recordings, the tone-control correction I'd choose for them would be: do nothing to the treble of the pop selection (which was, after all, meant to sound a little strange and electronic), but add a moderate boost to the deepest bass (which might be handled by the sliding inflection point of the bass control's characteristic). For the classical record, I'd want to tame down the upper register of the violins, which is somewhat strident. Unfortunately, I couldn't do this without applying a greater cut to the extreme high frequencies and losing the attractive sparkle of the percussion. In this case the available tone-control characteristics suit the pop selection better than the classical.

Figure 4 shows the tone-control results for one prominent product on

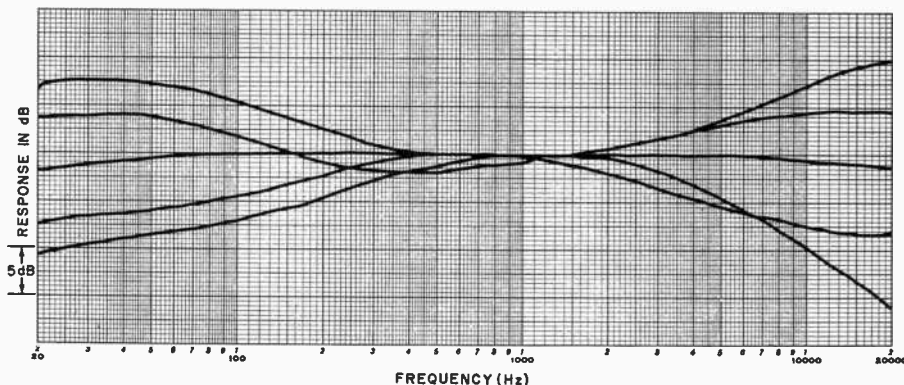

Fig. 3. Typical tone controls affect upper bass and moderate highs as well as extremes.

which a great deal of designer concern was lavished. The philosophy was to concentrate most of the controls' effects at the frequency extremes. As you can see (particularly in the treble), the greatest influence occurs at 30 and 20,000 Hz. Sliding inflection points are used for both bass and treble, so that moderate settings leave the range from 100 to 3000 Hz virtually untouched, while greater adjustments move farther and farther into the midrange. During my experience with these controls, I found they

the frequencies above 10,000 Hz are not further reduced, so that much of the sparkle remains. This sort of characteristic will do wonders on, for example, many of the old Bruno Walter recordings from Columbia and its subsidiary labels. At the low frequencies, you can obtain a reasonably sharp bass cut (to reduce rumble and similar noises), but it affects nothing above 60 Hz. If fact, the bass control is generally more satisfactory than the unit's rumble filter for this purpose.

On the boost side, things are less

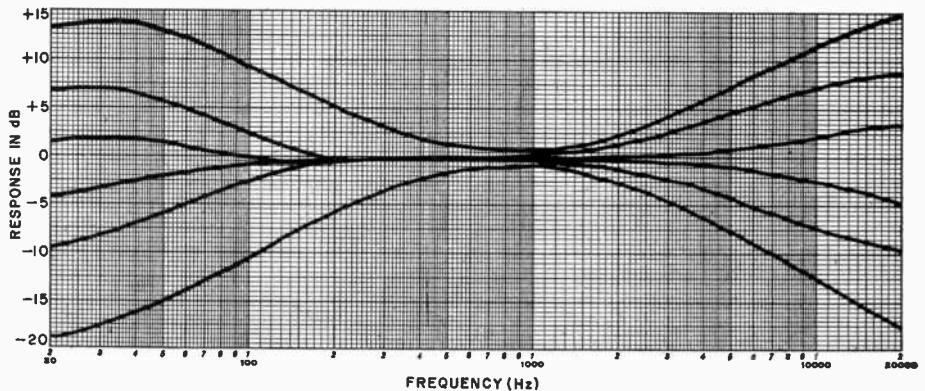

Fig. 4. Tone controls giving these characteristics were designed for maximum effect at frequency extremes.

were at their best in providing boost. Treble response could be tilted upwards slightly without a great increase in noise between 5000 and 10,000 Hz. But reduced treble was just not as satisfactory, having a muting effect on the extreme highs rather quickly.

Another manufacturer follows a different route. His controls really shine when it comes to reducing bass and treble. With a moderate reduction, the treble control ignores the midrange region, but really acts sharply from 2000 to 10,000 Hz to quash the stridency of violins and other high-pitched instruments. At the same time

happy. The treble control may readily introduce stridency when all you want is a bit of top-end "tizz," while the bass has excessive effect above 100 Hz.

More Knobs. While some manufacturers are eliminating tone controls, others—especially those in Japan—are giving us more and more. Along with bass and treble knobs, a mid-range control (usually centered at about 1000 Hz in its action, and not of a great deal of use in my view) is not unusual. Many tone controls now have switchable inflection or "turnover" frequencies. Perhaps the most useful innovation in terms of precise response shaping is the dual tone-control system, with bass and treble controls for relatively broad-band effect as well as for the frequency extremes (in other words, a total of four controls).

With more controls comes more flexibility but also more complexity of operation, until we get to the paragon, the multi-band equalizer. New equalizers have been appearing in phenomenal numbers of late, and still the surface of design possibilities has barely been scratched. Most current consumer products provide control over fixed frequency bands spaced

(Continued on page 32.)



state-of-the-art in receiver design...

**engineer's
triumph...
operator's
dream.**

Improving what is already the best is the ultimate challenge for the engineer. And the ultimate reward for the discerning CB operator. In the new Messenger 323A you can experience the incredible interference rejection of the only *dual cascaded crystal filtering* system available in any CB radio. Plus the exceptional noise rejection of both an efficient RF-type noise blanker and a new fully-automatic noise limiter system that adjusts itself for the cleanest, clearest reception possible. Equally important are the features we *didn't* change — the large, easy-to-read meter, easy-to-handle control knobs, built-in electronic speech compression, P.A. function, and rugged steel cabinetry. It's the dream rig you can own for \$249.95.



JOHNSON

E. F. Johnson Company, Waseca, Minn. 56093

In Canada: A. C. Simmonds & Sons, Ltd.

COPY NO. 33 ON FREE INFORMATION CARD

What are your opportunities in the electronics field?

Here are some eye opening facts from ETI.

Q. What about the job market in electronics?

A. It's good. In fact, it seems to be one of the few fields that stays relatively steady in bad times. Today, for example, estimates indicate that several thousand jobs will be opening up for electronics technicians each year, for years to come. One reason for this is the fact that electronics are the basis of almost all communications, and this is a communications-oriented nation.



Q. What kind of jobs are you talking about?

A. For example, there are jobs available in electronic/industrial automation, electronic equip-

ment repair and servicing, in the broadcast and radio telephone communications field, at airports, and even in medicine and in hospitals, where electronics is rapidly increasing in importance. And there are hundreds of other jobs opening up as electronics continues to make great strides, in new ideas and developments.



It's a growing field, and you can grow with it through Electronics Technical Institute.

Q. Can such a complicated subject as electronics be successfully taught by the home-study method?

A. Of course it can. ETI has proven that beyond a shadow of a doubt. Our graduates are working in practically every phase of electronics. This is largely due to the kind of instruction provided by ETI.

For example, while learning the Fundamentals of Electronics, the student advances rapidly through the use of an exclusive teaching system called *Autotext*. And throughout all courses the student is thoroughly monitored and carefully guided by a licensed instructor, whose professional and personal interest is to see that he masters every bit of information presented to him. Of course, we must give a lot of the credit to our students themselves. They know that no matter how good the instructor may be, *they* have to make it work. So most of them apply themselves diligently, and they find the more they learn, the more they *want* to learn.

Q. But I have a job, and as much as I would like to get into electronics, I can't afford to take time off. How do I get around that?



A. You don't have to take time off from your job. You study at home, in your free time. We do advise, however, that you set aside a certain time for your study schedule and stick to it, even if it's only a couple of hours a day. The beauty of the ETI way of learning is that you work at your own pace, making sure you've completed your assignment thoroughly and completely. We think you'll find, as you go along, that learning the ETI way can be fun.



Q. How do my assignments come to me?

A. They are sent to you one at a time. You work on each in the comfort of your home, at a pace that is comfortable and convenient to you. If you feel you need more time, you can go back over the material until you've mastered every point of information. Then you take a brief exam, which helps you to fix the information even more firmly in your mind. This exam is mailed back to ETI, where your instructor reviews it, and makes comments and suggestions that will be particularly valuable when you take up your next assignment.

Q. How long does all this take?

A. If your instructor receives your examination in the morning, in most cases he will have graded it, added his comments and have it on the way back to you that same afternoon. Service like this helps speed up your learning process—keeps your interest high—and puts you closer to your goal, the coveted ETI diploma.

Q. But I was never very big on books and study. I like to work with my hands.

A. With your ETI course, you'll get plenty of work with your hands. In fact, the ETI system of teaching combines hands-on work with study, so that you actually learn by doing. As you move along developing your technical knowledge, you will use, in many phases, specially developed Project Kits. So you apply your knowledge in logical, hands-on sequences, from the first step through completion of basic units.

Q. It all sounds very interesting and inviting. But I wouldn't want to commit myself before knowing more.

A. We wouldn't want you to. In fact, we insist that you check it out first. All you do is fill out the card or coupon and mail it to us. We'll send you a colorful new 48-page ETI Career Book that will give you the facts and the many opportunities ETI can open up for you. If you like electronics, you'll enjoy reading this book.

Q. Do I obligate myself in any way by sending for your book?

A. Absolutely not. The ETI Career Book is free, and it involves no responsibility on your part, nor will a salesman call on you. All we want to do is to be sure you have all the facts about ETI and what it can mean to your future. And you can get these facts and complete information about ETI's 18 different courses and programs in electronics by filling out and mailing the card or coupon to us today. We'll send you ETI's Career Book by return mail. We think it will be a real eye-opener for you. Mail the card or coupon today.

Electronics Technical Institute

Division of Technical Home Study Schools

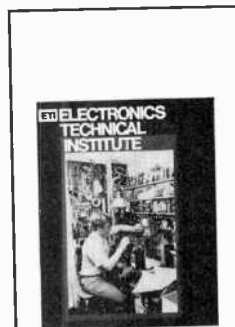

Get all the facts. It's your future, and it's important. There's no obligation of any kind. Send for your exciting free Career Book today!

Electronics Technical Institute • Dept. 2-473-036
Little Falls, New Jersey 07424

Send my free Career Book!

Tell me how I can get ahead in Electronics through ETI. I've checked the fields of special interest to me.

- | | | |
|--|---|--|
| <input type="checkbox"/> TV/Audio Servicing | <input type="checkbox"/> Computers | <input type="checkbox"/> Business and Engineering Electronics |
| <input type="checkbox"/> Black & White Color Solid State CATV | <input type="checkbox"/> Digital Electronics Computer Programming | <input type="checkbox"/> Electronics Fundamentals |
| <input type="checkbox"/> Closed Circuit Video Recorders Radio Hi-Fi Stereo | <input type="checkbox"/> Communications | <input type="checkbox"/> Electronics Drafting Industrial Electronics Advanced Electronics Industrial |
| | <input type="checkbox"/> FCC License Aircraft Marine Mobile Two-Way Microwave | <input type="checkbox"/> Instrumentation Electronics Technology Medical Electronics |

Check here for Veteran information.

Name _____ (please print)

Address _____

City _____ State _____ Zip _____

CIRCLE NO. 19 ON FREE INFORMATION CARD

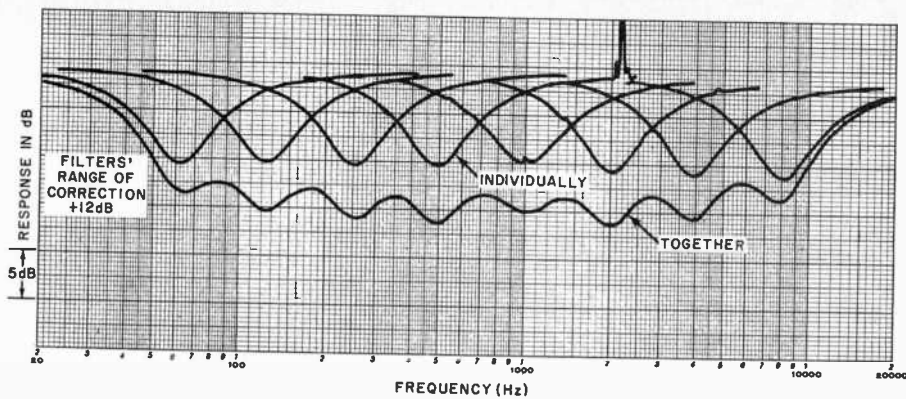

Fig. 5. Combining filters used individually and in concert. Note that the effect of all controls exceeds that of only one.

anywhere from two octaves to 1/3 octave apart, but Technics has demonstrated a prototype with variable band centers and bandwidths. You just tune in on the frequency aberration you want to correct and zap it.

Equalizers are very good in their way—incomparable, in fact, for the purpose for which they are designed. I do not personally find them that much more useful for correcting most individual recordings than simple tone controls. Also, they are much more arduous to use in that application, requiring the finicky adjustment of at least five slide pots for each channel. Most of their appeal lies in the possibility of fine-tuning the loudspeaker/listening-room interaction and making precise, permanent alterations of a system's frequency response. For this sort of use, the simple five-band units with two-octave spacings are rarely versatile enough. The octave-band devices begin to approach the necessary resolution, but the 1/3-octave equalizers are considered much better in most cases.

The more elaborate equalizers (or "filter sets," as they are often aptly called) come in a variety of types: band pass, band rejection, active, passive, boost and cut, cut only, etc. Not all of these are ideally suited to sound-system equalization, but between those that are there is an important distinction to be made: the difference between so-called "graphic equalizers" and the equalizers that use "combining" filters.

The graphic equalizer is the most common type in the consumer area. It apparently got its name because the response curve it introduces can be read roughly from the control settings on the front panel. If the controls are slide pots, their positions form a

frequency-response graph that can be interpreted at a glance. The sets with combining filters, of which the best known to consumers is probably the Altec Acousta-Voicette, may look identical to the graphic devices, but their control settings give only the vaguest idea of what's going on inside. Combining filters are intended to interact liberally with neighboring filters, with the result that a variety of slopes, degrees of attenuation, and center frequencies can be obtained by the proper finagling of adjacent filters. This means that even a very complicated response curve can be "dialed in" in great detail. However, the adjustment of the filters is a painstaking process involving careful monitoring with appropriate instruments. A combining-filter set is likely to frustrate even the most expert attempts to use it "by ear." In contrast, the graphic equalizer has fixed center frequencies, and predetermined slopes, and is generally limited to the extremes of boost and cut for each band given in the specifications. Figure 5 shows the effects of combining filters used one at a time and simultaneously. Note that the combining filters together can produce more drastic attenuation than any one filter used individually, and that there is a slight indication in the ensemble curve of the slope variations combining filters can achieve. Figure 6, an actual equalization curve for a sound system, gives a much better idea of how closely a combining filter set can "track" a desired frequency-response curve. A standard graphic equalizer could manage only a very rough approximation.

A final note on elaborate equalizers: they can be enormously useful in "tuning" the overall loudspeaker/listening-room response, as adver-

tised, but they can only be predictably useful under certain well-defined conditions. In a room large enough to support a stable reverberant field (that is, a sound field in which levels and frequency response are almost perfectly uniform throughout), they can equalize that reverberant field with excellent results. Unfortunately, no conceivable home listening room is large enough to qualify.

Conversely, in a smallish room, such as a recording-studio control room, they can equalize the monitoring loudspeakers for any desired response at the ears of some fixed listener. Usually the listener is seated at the mixing console, which is rather close to the speakers; and usually the speakers are quite directional, so that most of their output is beamed right at the head of the listener, with reflected sound contributing very little to what he hears. Should he move away from his favored spot at the mixing desk, chances are excellent that he will hear a significantly different frequency balance, and the same would be true for you at home with your equalized system. This is not to say that equalization can't make great improvements in a

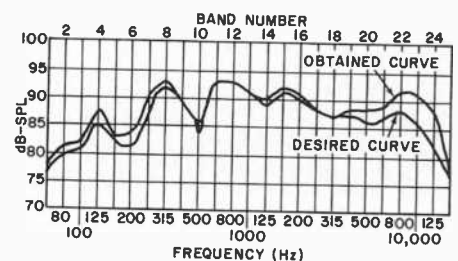

Fig. 6. The interaction of combining filters enables the resulting curve to closely resemble the desired curve.

home sound system. Often it can. But it is in the home environment that it encounters severe limitations.

Syn-Aud-Con. I am indebted to Don Davis for giving me an appreciation of the many nuances of sound equalization. Recently, I attended Mr. Davis's three-day Syn-Aud-Con (Synergistic Audio Concepts) seminar. It is evident that professional sound people are developing some powerful tools in their quest for optimum performance. My hope is that we listeners at home will be able to use these developments to our own benefit. ♦

NEWS HIGHLIGHTS

Digital Watch/Calculator

Time Computer, Inc. has come out with a combination Pulsar quartz timepiece (hours, minutes, seconds,



month, and date) and microminiature IC calculator. The calculator is capable of providing answers totaling up to 12 figures, displaying the first six significant digits. It has a complete calculator keyboard that enables the wearer to add, subtract, divide, or multiply. It also has a built-in memory, floating decimal point, and percentage key. The

unit can be switched from calculator to timepiece at the touch of a single key. The miniature calculator is operated by touching the keys with the retractable plastic tip of a 12-kt gold-filled pocket pen packaged with the unit. The unit is powered by four energy cells, which the company estimates will provide power for as many as 25 calculations and 25 time checks a day for one year. Initial production, limited to a hundred 18-kt gold models, carried a price tag of \$3,950. Future models, in less elaborate cases, are planned to sell for considerably less.

Teac To Use dbx NR

Teac has signed a license agreement which will permit it to incorporate dbx noise reduction in its machines in all three tape formats. The system will be the same 2:1 double-ended compression/expansion system presently being marketed by dbx as an outboard accessory and will be compatible with dbx noise-reduction systems now in use.

Back-Up Warning Device

A Japanese firm has developed a vehicular warning device—R-Phone—which talks. Consisting of an IC, waterproof housing, and a plastic speaker, the unit is about the size of an automobile horn. It is designed to be mounted to the rear under-section of any vehicle (motor home, camper, van, auto, truck) and hooked up to the back-up light circuit. When the gearshift lever is put into "reverse," an endless tape repeats the warning, "Watch out, this car is backing up." The device is being imported by Klir, Inc. of Santa Ana, California and will be offered through chain-store outlets and auto accessory stores.

"Instant-On" TV

Beginning January 1, 1977, "instant-on" television receivers will be banned in New York State under a bill Gov. Carey recently signed into law. Designed as an energy-conservation measure, the law applies to units manufactured on or after that date.

Fire Detection Systems

A recent market study by Frost & Sullivan predicts that annual sales of residential alarm devices will grow from \$68 million in 1974 to \$302 million by 1985. Smoke detectors will be the fastest growing product line, from \$12.6 million in 1974 to \$107 million by 1985. Other trends include the combination of fire and burglar alarm devices into a single system, the advent of wireless systems and the growing use of solid-state components. Government is stimulating this trend. More and more states are requiring early-warning fire detection devices in new homes. Federal safety standards will soon make smoke detectors mandatory in all new mobile homes. Also, homes underwritten by FHA-sponsored loans must now be protected by smoke detectors.

In a related area, the Protectowire Company (Hanover, Mass.) has developed a line-type detector that is actuated by both radiant and convected heat. The sensor consists of two energized wires encased in a heat-sensitive material. The application of heat anywhere along the line causes the material to yield, and the wires make contact. The resultant current change energizes or releases one or more relays which in turn activate warning devices. Various sensitivities are available: 155°, 190°, and 280° F (65.2°, 87.5°, and 137.6° C).

Wireless TV Remote Control

A Canadian company, the Keeble Selectra Corp. Ltd., has developed a wireless remote control tuning system which can tune up to 32 vhf channels (including special "cable" channels). The channel control emits an ultrasonic signal (which Keeble claims won't bother your pet), and is roughly the size and weight of a pocket calculator. It can switch a television receiver on or off and change channels from a distance of 20 feet (6 m) and from 45° angles. The receiver unit, called a translator, which sits atop the television, directs the chosen signal from its own tuner to the television's antenna terminals. The translator contains three elements: a mixer, a tuner, and a pc board carrying digital logic and a voltage selector to route the signal to the television. The hand held "channel control" transmitter is battery operated.

Computerized Speech Synthesis

Scientists at the Naval Research Laboratory have developed a computer program that translates English text into synthetic speech. The program applies a limited set of letter-to-sound rules to individual words, and "sounds" them out the way a child does. Thus, it does not require a separate, dedicated computer system, separate storage for a large data base, or computer time to break up and attempt to understand sentences. In an average sample of English text, the system pronounces correctly about 95% of the words, and most errors are obvious enough to be detected by the human operator. In the current system, a commercial speech synthesizer is used.

The Black Watch kit

At \$29.95, it's

★**practical**—easily built by anyone in an evening's straightforward assembly.

★**complete**—right down to strap and batteries.

★**guaranteed.** A correctly-assembled watch is guaranteed for a year. It works as soon as you put the batteries in. On a built watch we guarantee an accuracy within a second a day—but building it yourself you may be able to adjust the trimmer to achieve an accuracy within a second a week.

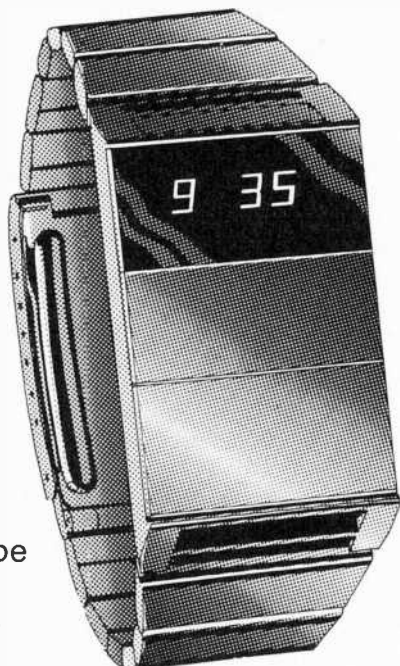

The Black Watch by Sinclair is unique. Controlled by a quartz crystal . . . powered by two hearing aid batteries . . . it's also styled in the cool prestige Sinclair fashion: no knobs, no buttons, no flash . . . just touch the front of the case to show hours and minutes and minutes and seconds in bright red LEDs.

The Black Watch kit is unique, too. It's rational—Sinclair have reduced the separate components to just four. It's simple—anybody who can use a soldering iron can assemble a Black Watch without difficulty. From opening the kit to wearing the watch is a couple of hours' work.

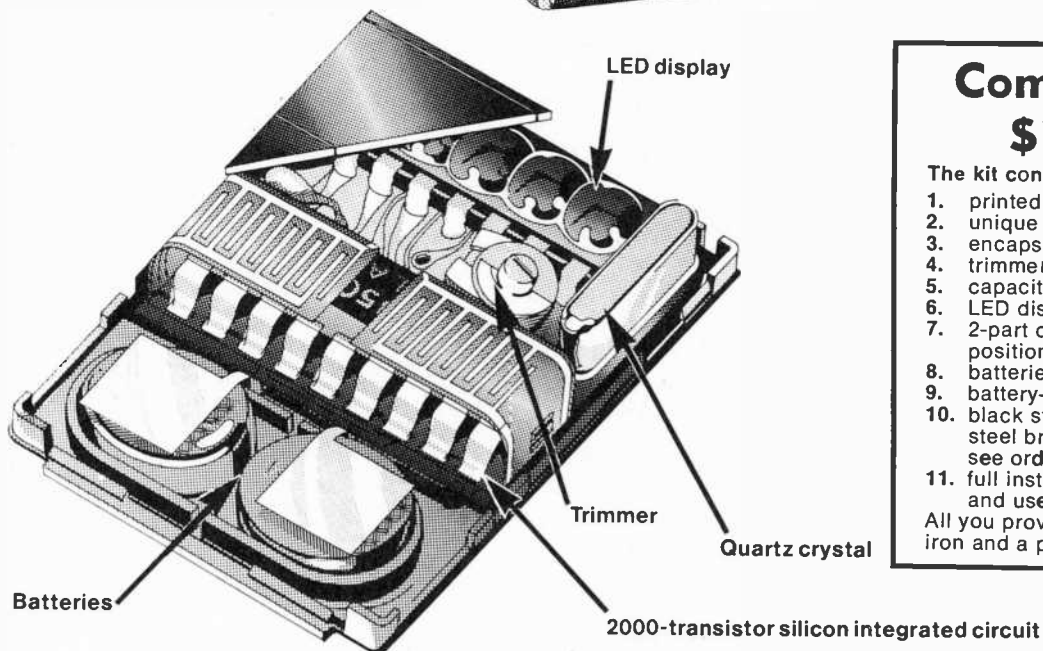

Complete kit \$29.95!

The kit contains

1. printed circuit board
2. unique Sinclair-designed IC
3. encapsulated quartz crystal
4. trimmer
5. capacitor
6. LED display
7. 2-part case with window in position
8. batteries
9. battery-clip
10. black strap (black stainless-steel bracelet optional extra—see order form)
11. full instructions for building and use.

All you provide is a fine soldering iron and a pair of cutters.

Take advantage of this no-risks, money-back offer today!

The Sinclair Black Watch is fully guaranteed. Return your kit within 10 days and we'll refund your money without question.

sinclair
SINCLAIR RADIONICS

375 Park Avenue
New York, N.Y. 10022
Tel. 212-688-6623

Please send me _____ Sinclair Black Watch kit(s) at \$29.95 (Plus \$2.50 per unit, shipping and handling). Stainless steel band \$4.00.

Enclosed is my check for _____

Name _____

Address _____

City _____

State _____ Zip Code _____

Mail to: Sinclair Radionics Inc., 375 Park Ave., New York, N.Y. 10022
N.Y. Residents add sales tax.



CONSTRUCTION

An LED-Readout Audio Power Meter

BY TIM HENRY

Measures amplifier output, indicates speaker balance, compares speaker efficiencies, and doubles as a VU meter with easy-to-read displays.

HOW MUCH power does your audio amplifier really put out? How is your stereo channel balance? Which is the more efficient speaker in your unmatched set? These are just a few, among many, questions that are difficult to answer unless you have some very specialized test equipment.

With the audio power meter described here, however, you can get the answers to many questions about your audio system—at a reasonable cost. The meter has an easy-to-read LED display and can also be used as a VU meter. The 11 LED's (light emitting diodes) are arranged in a row and are identified from 1/16 to 64 watts, with each succeeding LED indicating a doubling of audio output power. This means that the lights come on in sequence at 3-dB intervals. (A 3-dB increase means a doubling of power.) Since the human ear has a logarithmic sensitivity, 3 dB is about the minimum change that can be detected.

The meter is capable of operating with 4-, 8-, or 16-ohm speakers simply by changing the values of two resistors. The 0-dB point, or reference, was arbitrarily set at 1 watt.

System Operation. The meter (Fig. 1) is a form of analog-to-digital converter in that it takes the instantaneous voltage across the speaker (an analog signal) and converts it to digital indication to light the LED's. The only difference between this system and conventional A/D conversion is that here there is a nonlinear (logarithmic) relationship between the input and output. The 11 levels are used to create a 2048:1 change, rather than a 11:1 range if the system were linear.

The voltage measured across the speaker terminals is converted to power by using the nonlinear equation $P = E^2/R$, where E is the measured voltage and R is the speaker resistance. Then the 11 stages are designed to turn on their respective LED's at the desired power level. Table 1 shows the related values of voltage and power for the 11 steps used in this meter and for three difference speaker resistances. Note that, as the impedance doubles, the voltage values shift up one line. This means that a specific value of voltage, say 2.00, corresponds to a power level

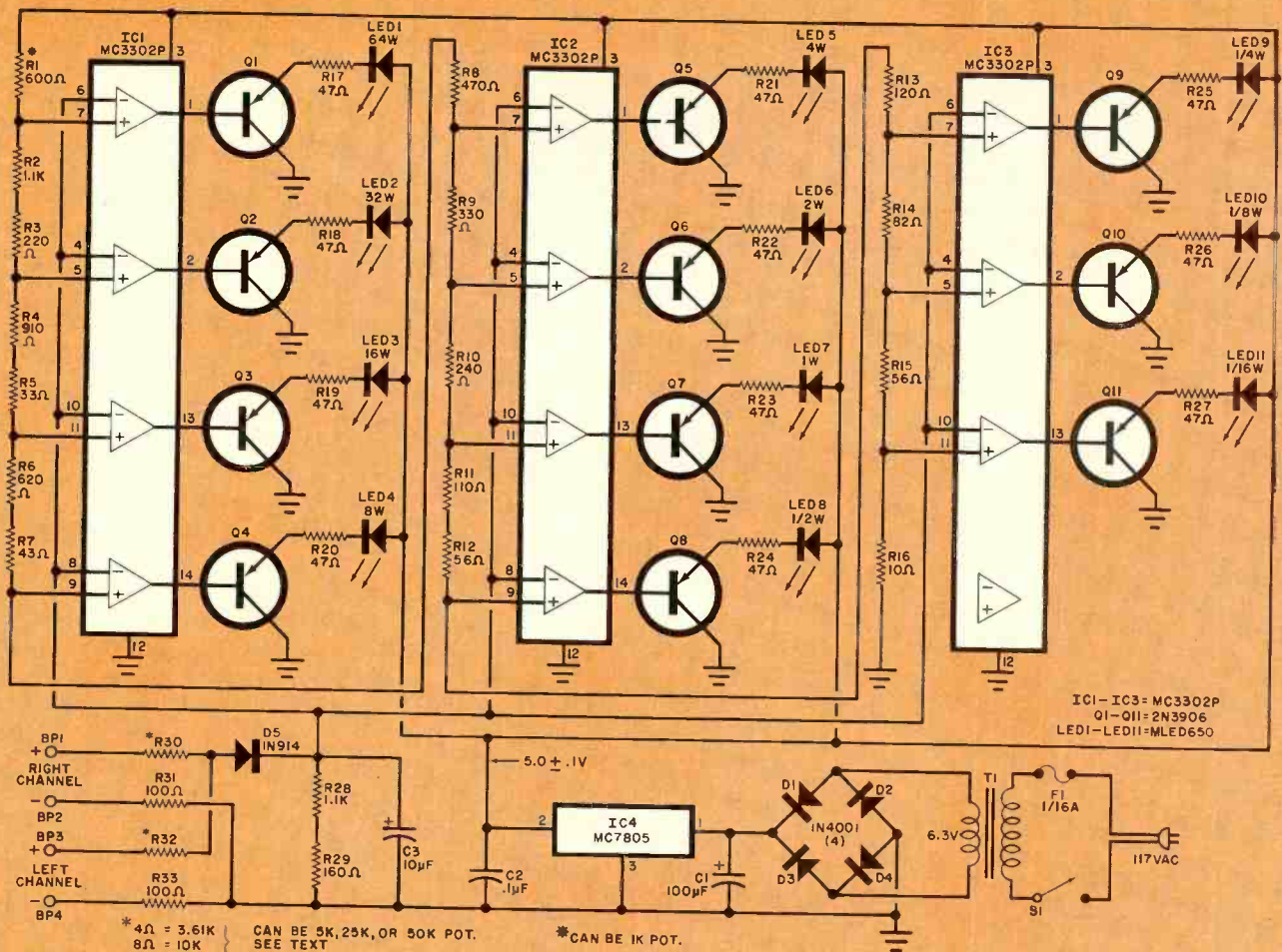

PARTS LIST

BP1 to BP4—Five-way binding post (two red, two black)
 C1—100- μ F, 25-V electrolytic capacitor
 C2—0.1- μ F, 100-V ceramic capacitor
 C3—10- μ F, 15-V electrolytic capacitor
 D1 to D4—Diode (1N4001 or similar)
 D5—Diode (1N914 or similar)
 F1—1/16-A fuse and holder
 IC1 to IC3—Quad comparator (Motorola MC3302P)
 IC4—5-volt regulator (Motorola MC7805CP)
 LED1 to LED11—MLED 650 (or similar)
 Q1 to Q11—Transistor (2N3906 or HEP715)

Following resistors are 1/2-W, 5% unless otherwise specified:

R1—600 ohms (see text)
 R2, R28—1100 ohms
 R3—220 ohms
 R4—910 ohms
 R5—33 ohms
 R6—620 ohms
 R7—43 ohms
 R8—470 ohms
 R9—330 ohms
 R10—240 ohms
 R11—110 ohms
 R12, R15—56 ohms
 R13—120 ohms
 R14—82 ohms

R16—10 ohms
 R17 to R27—47 ohms
 R29—160 ohms
 R30, R32—See schematic
 R31, R33—100 ohms
 S1—Spst switch
 T1—6.3-V filament transformer (Stancor P-6465 or similar)

Misc.—Suitable cabinet, line cord, grommets for LED's, press-on type, mounting hardware, etc.

Note—The following are available from MITS, Inc., 6328 Linn, N.E., Albuquerque, NM 87108: printed circuit board only, \$6.50; complete kit of parts including pc board but not case, \$38.

Fig. 1. As signal input voltage doubles, 11 comparators turn on their associated LED's.

of 1 W across 4 ohms, 1/2 W across 8 ohms, and 1/4 W across 16 ohms. Thus the same circuitry can be used for any of the three impedances simply by changing the values of the input resistors (R30 and R32).

About the Circuit. The input circuit consists of resistors R30 through R33, diode D5, and an RC filter consisting of R28, R29, and C3. The filter has a time constant of about 80 Hz. Resis-

tors R31 and R33, in the common (-) inputs, allow the circuit to be used with amplifiers that do not have a common ground for both channels. They provide a low-impedance reference for the circuit but have no effect on the bias of the amplifier.

Resistors R30 and R32 reflect a high impedance to the program source because their values are insignificant in parallel with the few milliohms of output impedance of most amplifiers.

These resistors take the algebraic average of the voltage across each of the speakers, which causes the power meter to indicate the average power being delivered by the amplifier. This could be extended to use on a four-channel system by adding two more resistors, with all four at 20,000 ohms to maintain a 5:1 ratio.

Diode D5 prevents the negative half of the audio signal from bringing the comparator inputs below ground and

causing possible damage. The diode also rectifies the signal so that the meter can indicate a somewhat average power rather than peak power, which the 80-Hz (low-pass) filter provides. The filter was selected to give good LED response and still provide a reasonably slow LED switching time for the eye to follow.

The eleven differential comparators in *IC1* to *IC3* deliver logic outputs based on the states of their inputs. If a noninverting (+) input is higher than the associated inverting (-) input, the comparator output is high, and vice versa.

The inverting inputs of all comparators are connected together and driven by the input signal. The noninverting inputs are threshold voltages determined by the voltage divider made up of *R1* through *R16*. The divider values are based on the desired power-level increments. Since the inputs to the comparators should not be higher or lower than the supply voltage, the input circuit forms a 5:1 ratio and the corresponding thresholds are similarly reduced. As the output of each comparator switches from high to low, its associated transistor is turned on, causing the LED to glow.

Each LED requires about 20 to 40 mA, while the comparators can sink only 2 mA. Thus the transistors must be used, with series resistors (*R17* to *R27*) to limit the LED current. If more brightness is required, the series resistors can be reduced to 22 ohms.

The power supply is a conventional transformer-diode-filter combination with a voltage regulator (*IC4*) to provide 5 volts. Capacitor *C2* is used for transient suppression.

Construction. The meter circuit can be assembled on perforated board or a pc board (Fig. 2) can be used. Note that the 11 LED's are not mounted on the board. They are connected to the appropriate pads on the board by lengths of insulated wire.

Before installing the comparators (*IC1* to *IC3*), build and test the power supply. (The transformer is not on the board.) Install *IC3*, and the 1/16-watt LED (*LED11*). Connect the positive lead of one of the meter inputs (*BP1* or *BP3*) to the 5-volt dc line and tie the other input leads to ground. When power is supplied, *LED11* should light. If it does not, it may be connected backwards. Remove power from the circuit and install the other two IC's and the remainder of the LED's. The

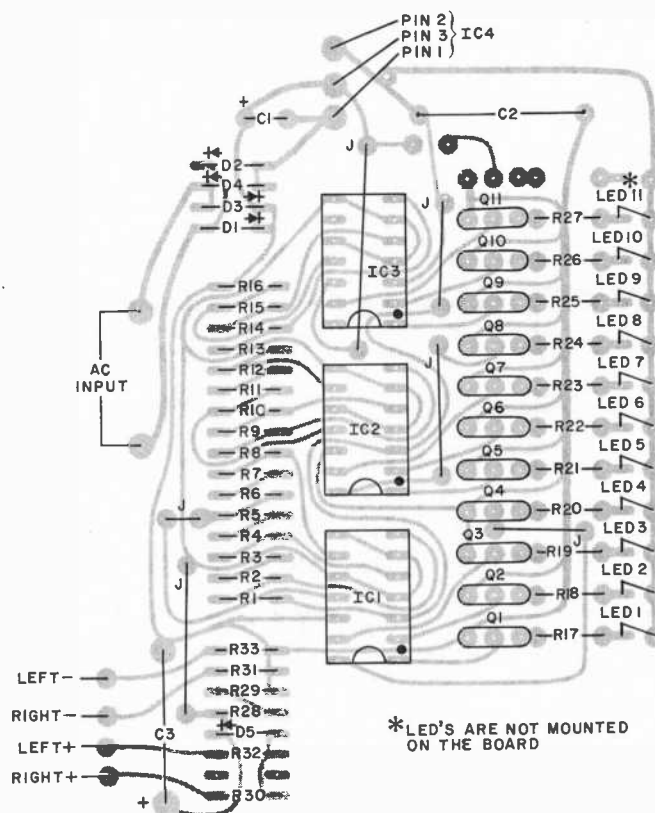
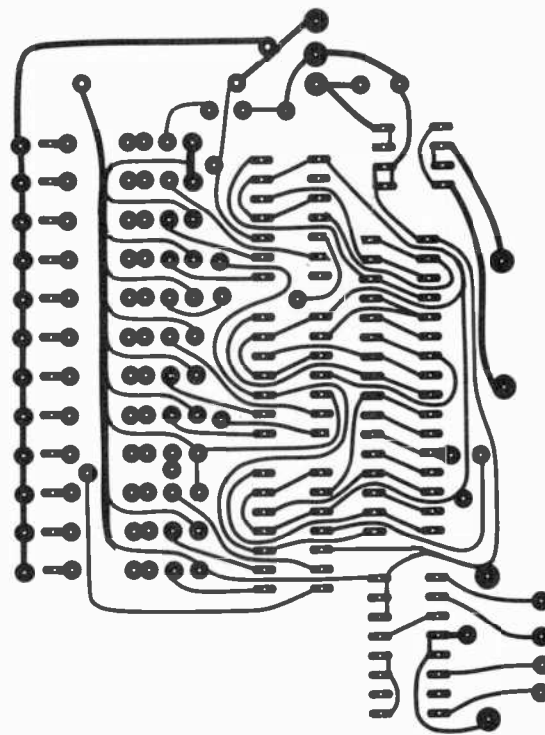

Fig. 2. Foil pattern (top) and component layout for the audio power meter.

leads for the LED's should be long enough for them to be mounted on the front of the chassis selected.

With one of the positive inputs to the meter connected to the 5-volt supply, the lowest four LED's should glow. With both positive inputs connected to 5 volts, the lowest six LED's should

light. This test indicates whether or not the circuit is operating properly. If desired, the threshold voltages can be checked with Table II, which gives the ideal values—though a 5% tolerance is permitted.

The basic accuracy of the system is directly related to the input divider

TABLE I—VOLTAGES FOR SELECTED POWER LEVELS

Power (watts)	Voltage (across 4 ohms)	Voltage (across 8 ohms)	Voltage (across 16 ohms)
1/16	0.5	0.707	1.00
1/8	0.707	1.00	1.41
1/4	1.00	1.41	2.00
1/2	1.41	2.00	2.83
1	2.00	2.83	4.00
2	2.83	4.00	5.66
4	4.00	5.66	8.00
8	5.66	8.00	11.3
16	8.00	11.3	16.0
32	11.3	16.0	22.6
64	16.0	22.6	32.0

ratio and the voltage levels of the respective thresholds. With 5% resistors, the system has an absolute accuracy of 5%. A potentiometer can be used for *R1* for calibration adjustment. This allows correction for the input divider adjustment of the power supply threshold reference voltage, and setting any particular threshold to its exact value. To calibrate the meter with a potentiometer at *R1*, adjust the

pot until the voltage at pin 7 of *IC2* is precisely 0.436 volt. All of the other thresholds should then have an accuracy of 2.5% or better.

If 5% (or even 2.5%) accuracy does not sound good enough, keep in mind that this is a power meter which indicates the continuously changing output of an audio system. It is not a laboratory-grade instrument.

Using the Meter. Besides being used to indicate the instantaneous output of an amplifier, the meter can also indicate channel balance, and response of bass and treble controls. It will also serve as a VU meter for recording and for comparing speaker efficiencies.

Connect the input leads across the amplifier outputs, noting the polarities. If one set of leads is reversed, the LED's will indicate the difference in power being supplied to each channel. This can be used as an indicator of channel balance and/or channel separation.

In bass response testing, the meter will indicate the amount of boost or

TABLE II—IDEAL THRESHOLD VOLTAGES

IC	Pin	Voltage
1	7	0.011
1	5	0.070
1	11	0.153
1	9	0.270
2	7	0.436
2	5	0.670
2	11	1.001
2	9	1.470
3	7	2.133
3	5	3.070
3	11	4.395

cut provided by the bass control. For treble control testing, a single frequency should be applied to the amplifier. This is because most of the power is in the lower frequencies, and the presence of higher frequencies in the bass test is insignificant.

Relative efficiencies of speakers can be checked by connecting the meter across the amplifier output and measuring the output power required to deliver a certain "standard" listening level. ♦

THE COMPLETE DVM



\$348

FOR FASTER, MORE RELIABLE MEASUREMENTS

A NEW STANDARD IS BORN

High accuracy you can trust
Versatile measuring capabilities
An efficient, easy to operate meter
All at an affordable price
That's the DVM38 . . . The complete DVM that sets new performance standards in 4 key areas.

A NEW ACCURACY STANDARD

The 3½ digit, .1% accuracy is backed by a 15 meg Ω input impedance, compared to 10 meg Ω input of conventional DVM's, which guarantees up to 50% greater accuracy with 1/3 less circuit loading on every measurement for high accuracy you can trust.

A STANDARD IN CAPABILITIES

The DVM38 is more accurate in MORE circuits with these versatile ranges: 100 μ V to 2000V DC, 1KV AC; .01 Ω to 20 meg Ω ; 0.1 μ A to 2A . . . Plus

HI and LO ohms and a 50KVDC range with accessory Hv probe.

A NEW STANDARD IN SPEED AND EASE OF OPERATION

Large pushbuttons and callouts — no need to hunt and peck. Large .4" L.E.D.'s with direct readout, down to V and mV indicators. SINGLE STEP AUTO-RANGING for maximum resolution and efficiency. 2KV DC protection minimizes downtime.

THE AFFORDABLE STANDARD

There are few .1% DVM's less expensive—there are none as complete in this price range, plus backed by a LIFETIME guarantee against factory workmanship errors.

THE DVM38 A NEW STANDARD IN DVM'S FOR SPEED, VERSATILITY AND ACCURACY.

DVM38 BACKED BY SENCORE'S 100% MADE RIGHT LIFETIME GUARANTEE

SENCORE 3200 Sencore Drive, Sioux Falls, S.D. 57107 Phone: 1-605-339-0100 TWX: 910-650-0300

CIRCLE NO. 50 ON FREE INFORMATION CARD

NEW LOW COST KITS!

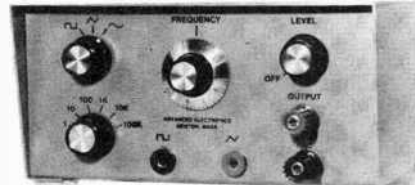

A. E. CORP.

P.O. Box 63
Newton, MA 02161
(617) 449-3142

\$5995

FUNCTION GENERATOR—Simultaneous sine, square and triangle wave outputs from 1 Hz to 1 MHz \pm 5% accuracy, stability \pm 200 PPM and sinewave distortion 2%. TTL compatible square wave output with rise and fall times 100 nsec. Adjustable output 0 to 20 Vpp. 105-125 VAC 5 Watts.

FACTORY WIRED AND CALIBRATED \$89.95



\$4995

PULSE GENERATOR—Pulse width continuously adjustable from .1 sec to 100 nsec. (5 Hz to 5 MHz Frequency Range) with 20 nsec rise and fall times, 0 to + 5 volts output (10 TTL fanouts). Input power 105-125 VAC 60 Hz at 5 watts. Size 6" x 4" x 3" and weight 1 lb.

FACTORY WIRED AND CALIBRATED \$79.95

—15 DAY FREE TRIAL PERIODS—
* MASTER CHARGE HONORED

CIRCLE NO. 1 ON FREE INFORMATION CARD

The Care & Feeding of NiCd Batteries

How they work and how to use them correctly

NICKEL-CADMIUM batteries are becoming ever more popular in cordless consumer products and electronics building. Although initial cost may seem to be high, nickel-cadmium cells can be recharged so often that their per-unit-of-use performance actually makes them less expensive than almost any other type of battery in the long run. Aside from rechargeability and reasonable cost, these batteries can often directly replace ordinary disposable carbon-zinc cells.

Just as there are differences between bipolar and field-effect transistors (although they are both transistors), there are basic differences between nickel-cadmium cells and other types. Indeed, there are different types of nickel-cadmium batteries, too. Just what are the differences? How do nickel-cadmium batteries work? And where are they best put to use? These and other questions will be explored.

General Details. The energy that a nickel-cadmium battery supplies is stored in the chemical compounds formed in the cell. The active material in the cell is nickel hydroxide in the positive plate and metallic cadmium in the negative plate. During discharge, the cadmium metal supplies electrons to the external circuit and becomes oxidized to cadmium hydroxide, while the nickel hydroxide accepts electrons from the circuit and goes to a lower valence state. The reverse pro-

cess occurs during the recharging.

Both processes take place in an electrolyte of potassium hydroxide. The cell has a long useful life because the active plates remain as solids and do not dissolve while undergoing charging and discharging. During overcharge, when both plates have all their active metal storing as much energy as they can, gaseous oxygen is released at the positive and gaseous hydrogen at the negative plates.

The manner in which the gases are

handled distinguishes the two major types of nickel-cadmium batteries from each other. In *vented* cells, the gas is simply released into the outside air. However, not just gas is released; so is some of the water from the cell. Consequently, more water must be added to the cell eventually, creating a maintenance problem.

The maintenance problem is eliminated in *sealed* cells, but at the price of lower energy density and higher internal resistance. The cells must be cap-

Discharge characteristics for a typical AA cell. They apply, in general, to other NiCd cells also.

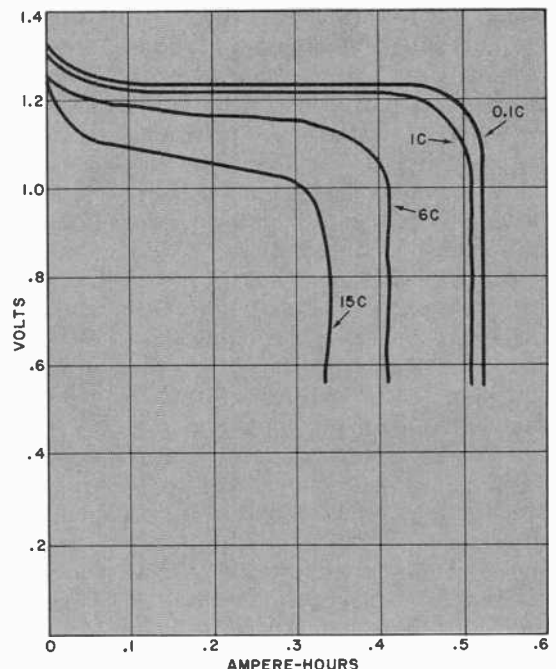

TABLE I—TYPICAL CHARACTERISTICS

Size	Capacity (AH)	Internal Resistance (milliohms)	Max. Charge Rate (mA)	1C Rate (A)
AA	0.5	35	50	0.5
C	1.0	10	100	1
D	1.2	7	100	1.2
D*	4.0	5	350	4

*High power.

able of sustaining an overcharge because there is no convenient way of determining when they are fully charged (and also because people who use rechargeable cells tend to forget to turn off the chargers).

In sealed cells, the gas problem is solved by making the negative plate's capacity higher than that of the positive plate. When the positive plate is fully charged and releasing oxygen, the negative plate has not yet come up to full charge. The oxygen is permitted to migrate over to the negative plate, where it combines with that plate and prevents it from further charging. Thus, hydrogen gas is never released, and the oxygen is completely used up. This procedure can continue indefinitely as long as it proceeds slowly enough to allow the oxygen time to get to the negative plate. Most sealed cells have an emergency high-pressure relief valve to prevent a heavily overcharged cell from bursting.

For the purposes of this article, our discussion will be limited to the sealed type of nickel-cadmium cell. It is this type of cell that is in most use in electronics.

Sizes and Capacities. There are several varieties of sealed cells. Some are designed to operate over wider temperature ranges than others, some have larger capacities, and others permit faster charging rates. However, all nickel-cadmium cells of the sealed variety are very similar in the general details of their care and use.

The most popular sizes of nickel-cadmium cells and some of their characteristics are listed in Table I. The information given here is very useful, but it does require some clarification. While the AH (ampere-hour) figures listed under "Capacity" might imply that any product of current in amperes and time in hours will yield the correct AH figure for a given cell, this is not strictly the case. A number of variables (like temperature, end voltage, current, and duty cycle) have an effect on the number used to repre-

sent the capacity of a cell. Fortunately, these effects are usually very small and can be ignored.

A procedure often used for measuring capacity is to select 0.5 V as the potential at which the cell is declared fully discharged and then select a current that will discharge the cell in one hour. This is termed the 1-hour rate and that current is called the 1C rate, which is the rate to which all other rates are referred.

The AA cell in Table I has a 0.5-AH capacity, which means that the terminal potential will be 0.5 V after a 1-hour drain at the rate of 500 mA. The 1C rate in this particular case is 500 mA. Ideally, this figure would mean that (for example) you could get 1 A from the cell for a half hour before the potential drops to 0.5 V. But, as we shall see, this is not quite correct.

If you selected 1 V as the cutoff potential (the voltage at which the cell is considered to be completely discharged), you would expect to obtain less energy from the cell than if cutoff was at 0.5 V. Furthermore, 1 V appears to be a more practical cutoff point than 0.5 V. So, why not use 1 V? The answer is that the voltage characteristics of the cells are such that the 0.5-V figure produces a more reliable number than does a higher cutoff voltage.

Information on how a higher discharge rate and higher cutoff voltage affect the capacity of a typical nickel-cadmium cell is given in Table II. As an example of how to use this table, consider an AA cell that is to supply 5 A until its terminal potential is reduced to 1 V. From Table I, the discharge rate for an AA cell is 500 mA. Therefore, our rate is 10C. Moving along the 10C row in Table II until we get to the 1.0-V column, we find that, at a 10C discharge rate to 1.0 V, 10% of the cell's capacity is not available. We can expect to get only 0.45 AH (about 5 minutes of energy at this high rate) from the cell under these conditions. Because Table II is given in terms of multiples of the 1C rate, it can be used with

all sizes of sealed nickel-cadmium cells. The table clearly shows that you can use nickel-cadmium cells at a 10C rate to an end potential of 1.0 V with very little reduction in capacity.

Discharge Characteristics. One of the welcome characteristics of nickel-cadmium cells is their excellent discharge characteristic. Their terminal potential remains a fairly steady 1.2 V until the cell is almost completely discharged, after which it drops off rapidly. The details of the discharge characteristics for an AA cell are shown in the diagram (previous page), which displays the voltage versus AH delivered at various discharge rates. While the plots are for a typical AA cell, they also give the main characteristics of the discharge curves for any sealed nickel-cadmium cell.

Note from the graph that the terminal potential reduces to 0.5 V when the cell has delivered 0.5 AH at the 1C rate. (Because the 1C rate is 500 mA for the AA cell, this will take 1 hour). At the 0.1C rate, which is 50 mA for an AA cell, you will obtain about 0.525 AH, or somewhat more than 10 hours of use because the cell will deliver more power at that slower rate. Similar calculations can be made from the curves for the other cells listed in Table I. The main feature illustrated by the curves is that the terminal voltage of any cell is about 1.2 volts for most of the time it is supplying (a wide range of) current.

TABLE II—INACCESSIBLE CELL CAPACITY AS A PERCENTAGE OF TOTAL CAPACITY TO 0.5 VOLT

Discharge Rate	Cutoff Voltage (V)		
	0.5	1.0	1.1
0.1C	0	3	5
1C	0	3	5
2C	0	4	7
5C	0	5	9
10C	0	10	30-40

Charging Characteristics. Sealed nickel-cadmium cells can be charged under a wide variety of conditions, but the chemical processes do place some limitations on the charging process. A little oxygen is generated at the positive electrode during charge and a lot during overcharge. This oxygen puts both an upper and a lower limit on the charge rate.

Sealed cells are designed to get rid of the oxygen generated during overcharge as quickly as it is generated, as

long as the charge rate is kept below 0.1C, which means that current at the rate of 0.1C or lower can be supplied indefinitely to the cell. Higher current rates—up to 20C in special applications—can be accommodated as long as the positive plate of the sealed cell is not overcharged. It is difficult (but not impossible) to tell just when overcharging sets in. (Fast-rate chargers are complicated and expensive to build, which precludes them from this discussion.)

The amount of oxygen generated before the cell is fully charged is small, but it does compete with the desired oxidation of the nickel hydroxide. It is this reaction that defines the minimum charge current that will effectively charge a cell. A charge rate lower than 0.01C results in more current being used to generate oxygen than is used to convert the active material. Hence, currents smaller than 0.01C produce little increase in the charge contained in the cell.

Most chargers supply current at the 0.1C rate. This represents the rate that will recharge the ordinary cell in the least possible time without endangering the life of the battery if accidentally left connected for a long time. It is important to note that, while current at the 1C rate will discharge the cell in 1 hour, more than 10 hours are required to charge it at the 0.1C rate. The oxygen generated and losses in the cell's internal resistance are two reasons. In general, at the 0.1C rate, one must put in about 140% of the energy that the cell can store before a completely discharged cell can be considered fully charged.

There are several other facts about charging nickel-cadmium cells that are useful to know. If you charge at a 1C rate, only about 120% of the cell's capacity can be supplied before overcharging commences. If a 0.05C rate is used, the cell will be difficult to charge above 75% of its capacity. Allowing the temperature of the cell to reach about 50° C will cause difficulties when attempting to charge above 75% of capacity, even with a charge rate of 0.1C. Full charge is assured at 25° C. At very low temperatures, like 5° C, some hydrogen is generated at the negative plate of the cell during charging. There is no rapid recombination reaction to rid the cell of this gas, so it tends to increase the pressure inside the cell. If the cell must be recharged at low temperatures, the only way to overcome this problem is to derate the

maximum permissible overcharge rate to 0.02C at -20° C.

Failure Modes. Because nickel-cadmium cells use active materials that are highly insoluble in their alkaline electrolyte, failure modes are few. Most sealed cells are guaranteed for 500 to 1000 charge/discharge cycles. This might appear to be a limited number, but when you consider 1000 cycles at a rate of two cycles per week, these cells will last 10 years.

In the case of sealed cells, the quality of materials used in making them has a marked effect on their useful life. Although failures are rare, they do occur (catastrophically) for two major reasons: internal shorts and loss of electrolyte.

Internal shorts develop when time and temperature cause decomposition of the materials that separate the positive and negative plates of the cell. Shorts are generally a low-charge phenomenon.

Loss of electrolyte reduces the capacity of the cell and increases its internal resistance. The electrolyte is usually lost in some combination of two ways. Even the best of hermetic seals will allow some hydrogen and oxygen to escape. In the case of high-quality seals, 10 years or more will elapse before an appreciable amount of electrolyte is lost. If the cell is abused by excessive overcharging or reverse charging, excessive gas in the cell will cause the safety valve to vent the excess pressure into the atmosphere. Needless to say, the hermetic seal is now broken and evaporation of the electrolyte will be much faster. Even if the safety valve is resealable (quite common), a significant amount of vapor will escape with the excessive pressure and eventually cause the cell to dry out with continued venting.

There are also non-catastrophic failures common to nickel-cadmium cells. These, however, are reversible so that the cell can be restored to full capacity.

One reversible failure mode is due to long and continued overcharging (as when a standby power supply is kept on float charge for a month or more without discharging it). The effect is accentuated by high temperatures. The second reversible failure mode appears in cells used in a regular cycle. If a group of cells is regularly called upon to deliver, say, 25% of their full capacity and then recharged,

they will eventually "memorize" that only 25% of capacity will be required of them and become incapable of supplying the remaining 75% of capacity. This phenomenon is most likely to occur if a cell is rarely overcharged, the rate of discharge is great, and/or the temperature is high.

Non-catastrophic failures can be reversed by completely discharging the cell at a low discharge rate and then recharging it at a 0.1C rate for 20 hours at 25° C (80° F). One or two reconditioning cycles like this are generally all that is needed to restore a cell to its full capacity.

Storage Characteristics. Sealed nickel-cadmium cells readily lend themselves to prolonged storage, whether in a partially or fully charged state or completely discharged. If stored in a charged state, the cell will self-discharge, at a rate that depends on cell design and storage conditions. In general, a cell will lose about 1% of its charge per day so that at the end of about three months an initially fully charged cell will be completely discharged. If stored at high temperatures (50° C or higher), the cell will lose up to 5% of its charge per day, with the charge lasting less than a month.

The lack of a charge in a cell when it is put into storage has no effect on the cell's life. The cell can be put back into service after one or two charge/discharge cycles. Over a wide range of temperatures (-50° C to 50° C), nickel-cadmium cells can be stored for years with no significant degradation in performance.

Closing Comment. Sealed nickel-cadmium cells have a number of outstanding characteristics that make them good first choices for everyday use. They are reusable, permitting up to 1000 charge/discharge cycles. Their terminal voltage during discharge holds relatively constant. And they require no special care.

There are, of course, some minor disadvantages. High initial cost is one, although it is counterbalanced by the fact that the cells are reusable. Another is that the typical nickel-cadmium cell, when compared with the same-size carbon-zinc cell, has a lower capacity and a lower terminal voltage (1.2 V as opposed to 1.5 V for the carbon-zinc cell). The balance, however, is in the nickel-cadmium cell's favor when it comes to long life, convenience of use, and reliability. ♦

THEFT ALARM FOR HANDHELD CALCULATORS

BY TOMMY N. TYLER

HANDHELD calculators are a prime target for thieves because they can be quickly picked up and tucked out of sight. Though you could physically fasten the calculator to your desk, this defeats the purpose of its portability. Here's another approach—an audible alarm that sounds off when the calculator is unplugged from its charger.

The Alarm Circuit. Simplicity is the key feature of this alarm. It is inserted between the charger and the calculator, as shown in Fig. 1, and draws a nominal amount of power from the charger. As long as a trickle charging current (at least 100 μ A) flows into the calculator, silicon diode *D1* conducts. The forward voltage drop across it keeps germanium transistor *Q1*

turned on. Transistor *Q2*, which can be almost any pnp device, is cut off, and the Sonalert alarm is silenced.

However, if the calculator is unplugged, *Q1* turns off, *Q2* turns on, and the Sonalert starts to howl. Obviously, if the charger is unplugged, the alarm will not operate. So, it's important either to hide the charger or secure it in some way so that the thief will not disconnect it. To prevent the alarm from becoming obvious (when it is silenced!), it's a good idea to build the alarm and the charger into one small enclosure.

Two variations on the circuit are shown in Figures 2 and 3. The relay contacts can be used to trigger a remote signalling device. Install diode *D2* to prevent destruction of *Q2* by inductive voltage spikes generated by

keying the relay. Figure 3 shows a small transistor oscillator which can be used in place of the Sonalert. It can be assembled from junk box parts. (Note *R2* is changed to 2200 ohms.)

Construction. Take care in wiring jack *J1* and plug *P2*, observing correct polarities. Although *D1* will prevent damage to the calculator from reverse current, the unit's batteries will never charge! And, of course, be sure that *P2* and *J1* are the same types as those on the charger and calculator. Either pc or perforated board may be used. Both parts placement and the selection of semiconductors are not critical. Just be sure that *D1* is rated to handle the charger's maximum output (in the event that *P2* is accidentally shorted), and *Q1* is a germanium device. ♦

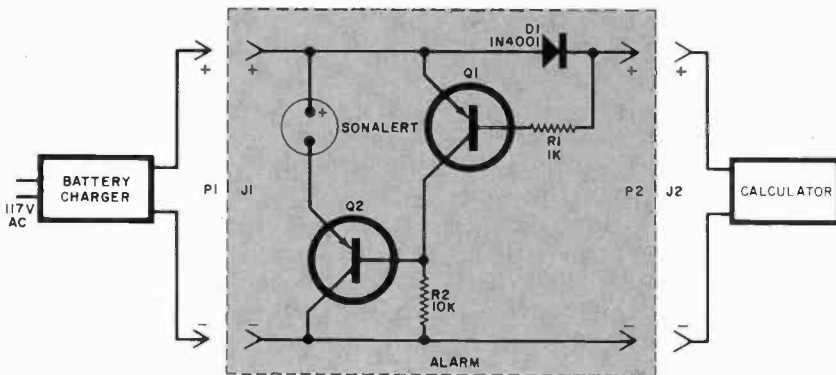

Fig. 1. When trickle current through *D1* stops, Sonalert is activated.

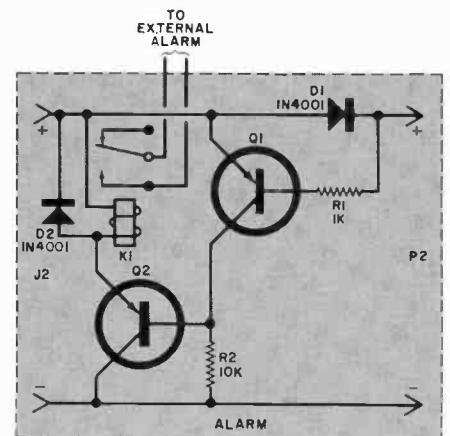

Fig. 2. For a remote alarm, use a relay instead of Sonalert.

PARTS LIST

- C1*—1- μ F, 15-volt electrolytic capacitor
- D1, D2*—1N4001 rectifier
- J1—Calculator-type power jack
- K1*—6-9 volt, 500-ohm relay (Radio Shack 275-004 or equivalent)
- P2—Charger-type power plug
- Q1—General-purpose germanium pnp transistor
- Q2—General-purpose pnp transistor
- R1—1000-ohm, 1/2-W, 10% resistor
- R2—2200-ohm or 10,000-ohm, 1/2-W, 10% resistor (see text)
- Sonalert—Mallory SC628P
- Spkr*—3.2-ohm dynamic speaker.
- T1*—500- or 1000-ohm/3.2-ohm audio transformer
- Misc. Perforated or pc board, hookup wire, solder, suitable enclosure, machine hardware, etc.
- *Optional. See text.

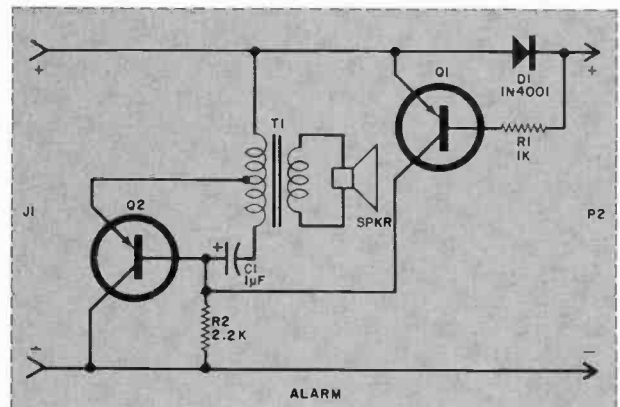

Fig. 3. Audio oscillator can also be used to provide an audible signal.



Build “PENNYWHISTLE” The Hobbyist’s Modem

*Under-\$100 interface for digital data transmission/reception
over channels such as telephone or cassette tape.*

TO TRANSMIT and/or receive digital data—as between two computers, between terminal and computer, etc.—over telephone lines and other limited-bandwidth channels, you need a modem (an acronym for *modulator/demodulator*). Most such channels cannot cope with the steep-sided, flat-topped digital pulse without distorting it, much less pass the high baud rate (bits per second) used in computers. The modem translates the pulses into a usable form.

MARCH 1976

Digital pulses going into a modem at one end emerge as different frequency audio tones that are fed into the transmitting channel. At the other end, another modem translates the tones back to the appropriate digital pulses.

Modems can operate in one direction only (half duplex) or in both directions (full duplex). The under-\$100 Pennywhistle modem project presented here offers the user both modes with the flip of a switch.

Although some modems can operate at up to 9600 baud over telephone lines, full-duplex operation usually restricts the maximum speed to 300 baud, or 30 characters/second. Modems in this speed range generally operate with frequency-shift keying (FSK), using four frequencies in two “bands.” The 1070-to-1270-Hz low band is used for transmission from a terminal to a central system, while the 2025-to-2225-Hz high band is for transmission in the opposite direc-

Fig. 1. The modem receiver uses noise-reducing active filtering before its PLL detector and delivers both 20-mA and EIA-compatible outputs. Transmitter accepts either EIA or 20-mA current to modulate two-frequency, two-band oscillator. Also shown here are the power supply and active hybrid for direct telephone-line connection.

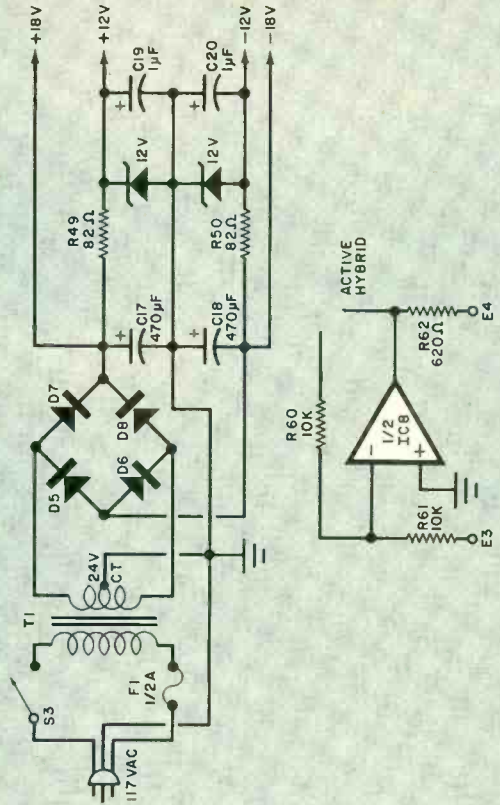
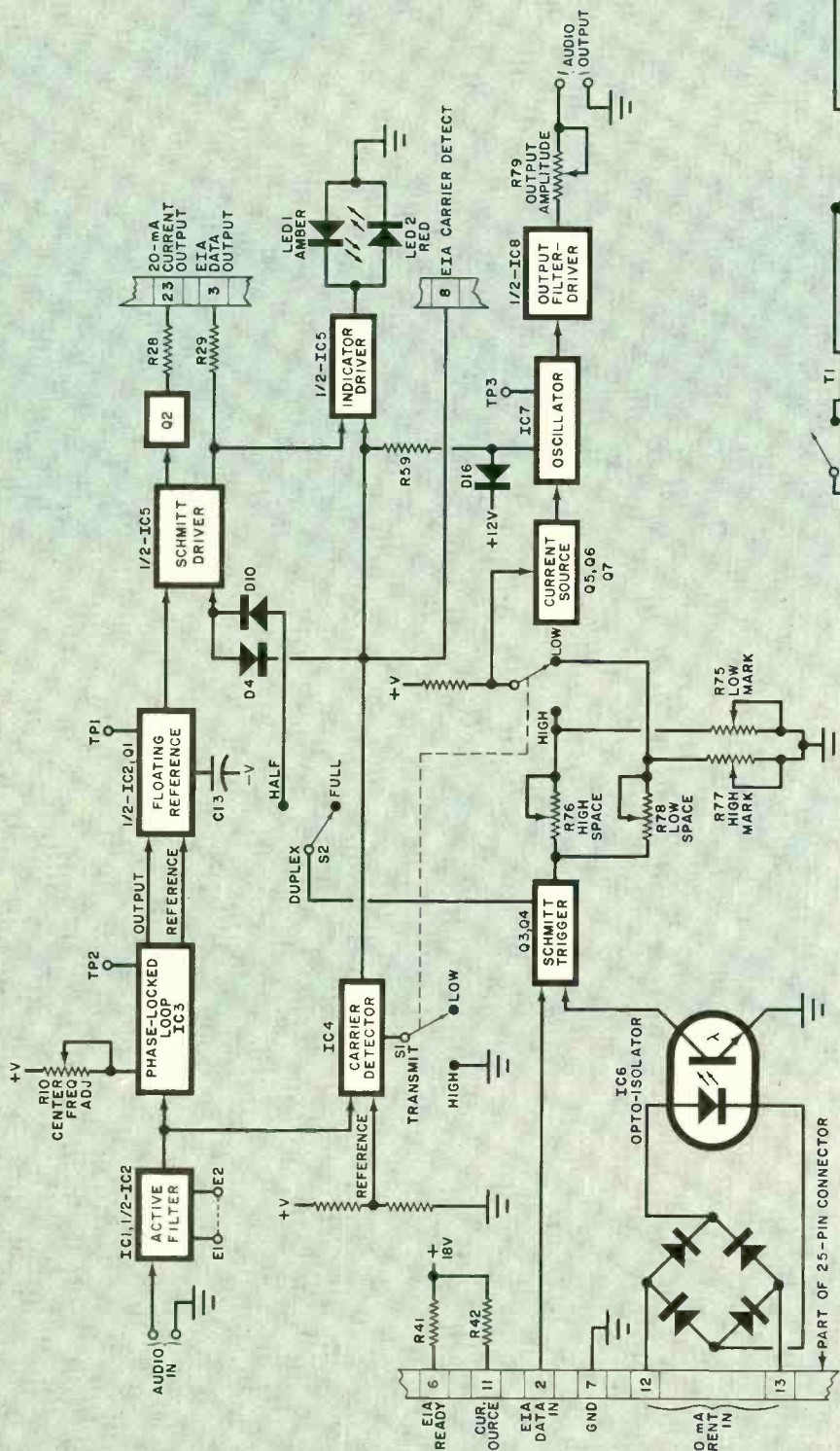

PARTS LIST

- A1, A2, A4, A5, A8—MC1458 (dual 741-type) operational amplifier IC (Motorola)
- A3—565V phase-locked loop IC
- A6—4N26 optoisolator
- A7—555 timer IC
- C1—390-pF, 5% silver-mica capacitor
- C2, C7, C10, C12, C21, C25—0.1- μ F, 10% polyester film capacitor
- C3, C4—0.0047- μ F, 10% polyester film capacitor
- C5, C14, C15, C22—0.01- μ F, 10% polyester film capacitor
- C6—0.001- μ F, 10% polyester film capacitor
- C8—0.033- μ F, 10% polyester film capacitor
- C9—620-pF, 5% silver-mica capacitor
- C11—1800-pF, 5% silver-mica capacitor
- C13—22- μ F, 25-volt electrolytic capacitor
- C16, C19, C20—1- μ F, 25-volt electrolytic capacitor
- C17, C18—470- μ F, 25-volt electrolytic capacitor
- C23, C24—270-pF, 5% silver-mica capacitor
- D1 to D4, D9, D10, D15 to D24 — IN4148 low-leakage diode

D5 to D8, D11 to D14—1N4001 rectifier diode
 F1—3AG, ½-ampere slow-blow fuse with pigtails
 LED1, LED2—Light-emitting diode (one red, one amber)
 J1, J3—Two-conductor, closed-circuit miniature phone jack
 J2—Two-conductor, open-circuit miniature phone jack
 P1—No. DB25S connector plug
 Q1, Q2, Q4, Q5—2N2907 transistor
 Q3, Q6, Q7—2N2222 transistor
 Following resistors are ¼-watt, 5% tolerance, except as noted:
 R1, R51, R80—6800 ohms
 R2, R3, R9, R17, R18, R19, R45, R47, R54, R55, R59, R60, R61, R63—10,000 ohms
 R4, R5—150,000 ohms
 R6, R25, R26—330,000 ohms
 R7—20,000 ohms
 R8, R14—18,000 ohms
 R11, R70—2200 ohms
 R12, R13, R53—4700 ohms
 R15, R16, R22, R57, R64 to R69—1000 ohms
 R20, R21—5100 ohms
 R23, R24, R33—15,000 ohms
 R27, R40, R46, R48, R58—3300 ohms
 R28, R41, R42—1000 ohms (½-watt)
 R29, R30, R31—680 ohms (½-watt)
 R32—680 ohms
 R34—68,000 ohms
 R35, R72, R73—220,000 ohms
 R36—4300 ohms
 R37—1.5 megohms
 R38—24,000 ohms
 R39—180,000 ohms
 R43—8200 ohms
 R44, R56—100,000 ohms
 R49, R50—82 ohms (½-watt)
 R52—22,000 ohms
 R62—620 ohms
 R71—470,000 ohms
 R74—47 ohms
 R10, R77—5000-ohm trimmer potentiometer (CTS No. 360S502B or similar)
 R75—20,000-ohm trimmer potentiometer (CTS No. 360S203B or similar)
 R76, R78—100,000-ohm trimmer potentiometer (CTS No. 360S104B or similar)
 R79—1000-ohm trimmer potentiometer (CTS No. 360S102B or similar)
 S1, S2, S3—PC-type dpdt toggle switch
 T1—24-volt center-tapped, 600-mA power transformer
 Z1, Z2—12-volt, 1-watt zener diode (1N4742 or similar)
 Misc.—Printed circuit or perforated board and solder clips; sockets for IC's (optional); 2¼"-diameter, 8-ohm loudspeakers (2); suitable enclosure; three-conductor line cord with plug; line cord strain relief; metal spacers; hookup wire; machine hardware; solder; etc.
 Note: A complete kit of all Pennywhistle modem parts, including cabinet, is available for \$97.50 from M&R Enterprises, P.O. Box 1011, Sunnyvale, CA 94088. Add \$1.50 if ordering from Canada. California residents, please add 6% sales tax. Allow 15 days for delivery after receipt of order. Send SASE to above address for free copies (8" x 11") of schematic, etching and drilling guide, and component layout guide.

tion. Modems that transmit on the low and receive on the high band are termed "originate-mode" devices, since they are usually used by a local terminal to call into a remote central computer.

In either band, digital data is translated from 1's and 0's (marks and spaces) to high and low frequencies. Don't confuse this with high and low band terminology. The receiving modem translates the tones back to 1's and 0's. Note that the high and low frequencies used in FSK are only 200 Hz apart.

Most originate modems, including the Pennywhistle, employ acoustic coupling to the telephone line via the telephone handset. (Some modems are, however, designed to be directly wired into the phone line.) Acoustic couplers obviate the need for the user to pay installation and rental charges for the devices the telephone company requires for direct-line hookups. The main disadvantage of the acoustic coupler is that it can cause an increase in distortion problems that can increase the error rate.

It is important that you bear in mind that modems do not process the data passed through them. They merely accept a stream of serial bits at one end and deliver the same bit information at the other end. The translation that takes place in between merely makes it possible to have remote-point communication. Also, modems do not generally have UART's built into them; they are designed to be connected to outboard UART's, such as those designed into computers.

Circuit Operation. A block diagram of the modem is shown in Fig. 1, which we will use to explain system operation. (The schematic diagram and etching and drilling and component placement guides are too large to fit on these pages. They are available FREE by sending a stamped, self-addressed 8" x 11" envelope to the source given in the Parts List.)

The audio input to the modem is first applied to a three-stage filter consisting of both parts of IC1 and half of IC2. This prevents most noise and harmonics from passing through the system. The filtered signal is then passed to the IC3 phase-locked loop, which contains a variable-frequency oscillator and comparator. The PLL always attempts to lock the frequency of its internal oscillator to the incoming signal frequency. The correction vol-

tage supplied by the comparator to the oscillator provides a measure of how far off the incoming signal frequency is from a preset center frequency.

It is difficult for a PLL to discriminate between an input signal of the proper frequency and one of its harmonics or subharmonics. Since the high-band frequencies are almost twice those of the low band, this can present a problem for some modems, which is the reason for preceding the PLL with the three-stage active filter in the Pennywhistle. Potentiometer R10 is used to set the PLL's center frequency. The PLL itself delivers two outputs: one is a fixed reference voltage from the internal voltage divider, and the other is the actual output of the stage.

One of the lesser problems associated with a loop is that voltages drift with changes in temperature. The Pennywhistle tackles this problem with the floating reference circuit made up of half of IC2 and Q1. This circuit takes advantage of the fact that in asynchronous data transmission, the serial data signal returns to the "mark" condition between every character sent. The floating reference circuit detects the mark and resets its voltage accordingly. If the data goes to and remains at a "space" condition, the circuit slowly readjusts itself and, in about 2 seconds, will claim the new level as a "mark." It readjusts much faster in the opposite direction to correct such a mistaken impression quite rapidly.

The floating reference is fed to IC5, a Schmitt trigger, while the data is fed to the other input. The output of IC5 is an EIA data output which, in turn, drives Q2 to deliver a 20-mA current output.

The IC4 circuit is used to detect the presence of an adequate signal level for reliable loop operation. The output of IC4 provides a positive EIA-type "carrier present" signal to turn on external terminals and hold the data output to the terminal at a mark condition when insufficient carrier is present. Indicators LED1 and LED2 are driven by IC5. A positive output from the IC turns on LED2, while a negative output turns on LED1. When no carrier is present, the output of IC5 is normally negative. With a carrier present, it is positive. Hence, the LED's will alternately light when data is being received, providing a useful indication of modem operation.

The carrier detect signal turns on

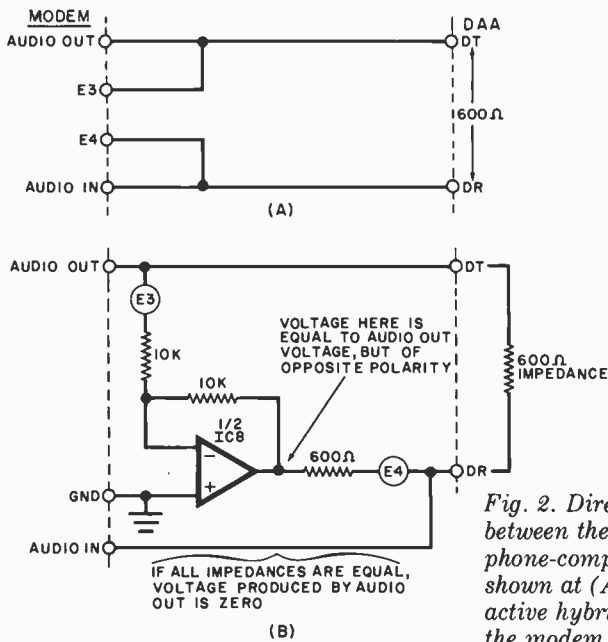

Fig. 2. Direct line connection between the modem and the phone-company supplied DAA is shown at (A). Use of the active hybrid connection between the modem and DAA is shown at (B).

transmitter oscillator IC7 via R59. The TRANSMIT switch (S1) has a section that simulates a received carrier to turn on the oscillator. Data is "looped back" from the transmitter to the receiver when DUPLEX switch S2 is in the HALF duplex position. This provides an echo of data originated at the terminal without requiring that the data travel to the other end and return. Some time-share services require half-duplex operation, which is one reason for including this feature in the Pennywhistle. Another is that it provides a self-test capability for the terminal and modem.

The transmitter is built around IC7, a 555 timer chip. The output of IC7 is fed to the output filter (half of IC8), which smooths out the waveform to reduce harmonics and provides enough power to drive a small speaker or the telephone line.

The frequency at which IC7 operates is determined by Q5, Q6, and Q7, which form a symmetrical current source that keeps the "on" and "off" periods of the oscillator equal, regardless of the operating frequency. Potentiometers R77 and R75 set the mark frequency, while R76 and R78 determine the space frequency.

The Q3-Q4 Schmitt trigger circuit accepts data from either the EIA data input (positive or negative levels) or from optoisolator IC6, which can be tied into a standard 20-mA teleprinter current loop. Mark data has a negative voltage level at the EIA input or a current of 15 mA or more at the current-loop input. Space data is a positive voltage level at the EIA data input or no

current at the current-loop input. With nothing connected to either input, the modem "sees" a space.

TRANSMIT switch S1 is used to select either the high- or the low-tone band. Normally left in the LOW position, for tape recording or unit-to-unit transmission, it is switched to HIGH.

Construction. The modem lends itself equally well to either printed-circuit or perforated-board wiring. Since the design of the system provides for maximum flexibility, both current-loop and EIA circuits are provided. However, you can omit either of these circuits, depending on the needs of your system.

Capacitors C2, C7, C8, C10, C12, and C22 must operate with a relatively high degree of stability in the circuit. So, it is important that you use only Mylar, polystyrene, or other high-stability capacitors where these are called out.

Do not use wire-wound potentiometers. They can be difficult to adjust with a high enough degree of accuracy. Transistor types are not critical, but it is good policy to use only complementary pnp and npn types for Q5 and Q6. All transistors in the system must be good-quality silicon switching types.

Any 741-type operational amplifier IC will operate in the modem's circuit. The only restriction here is that the op amp you select must be able to operate with a short-circuited output indefinitely with ± 18 volts dc applied to the positive and negative pins of the IC. Not all op amps can meet this re-

quirement; check this out on the IC specifications sheet before you buy. Most quad op amps will not meet the requirement. Type 3900 op amps will not work in this circuit because of the radical design changes required.

After wiring the circuit board assembly, mount the two soft-rubber acoustic "muffs" on the cover of the enclosure. Note that all parts, except the muffs and J1, J2, and J3, mount on the pc board. The case supplied with the kit has a stepped area through which the toggles of the switches protrude and holes through which the LED's are visible. Connector P1 fits along the edge of the board and is held in place by soldering its pins to the foil pads. The connector is then secured to the metal base plate that forms the bottom of the enclosure with machine hardware through its tabs. Mount J1, J2, and J3 in holes in the base plate near P1 and wire them to the board. Secure the power cord with a strain relief after soldering its conductors to the appropriate points in the circuit.

If you buy your parts locally, you'll have to fabricate your own acoustic coupler from a pair of small loudspeakers (see Parts List) and some commonly available materials.

To do this, apply a thin bead of silicone adhesive/sealing compound around the entire front edge of one of the speakers. Make sure the bead is no more than $\frac{1}{8}$ " (3.2-mm) thick and doesn't bleed onto the cone. Place this speaker, front down, on a square of wax paper atop a flat, level surface. Gently press the speaker so that the silicone cement bead spreads out. Allow the speaker to remain like this for at least 24 hours to permit the silicone cement to cure. At the end of this time, slowly and gently peel away the wax paper. Trim the silicone cement flush with the outside perimeter of the speaker and check that the silicone provides a tight seal to the microphone of a telephone handset.

From a piece of resilient polyurethane foam, cut a "donut" to fit over the rear of this loudspeaker. Solder lengths of stranded hookup wire to the speaker's lugs. Route the wires through the hole in the plastic foam, and cement the latter to the rear of the speaker with silicone adhesive.

Two $2\frac{5}{8}$ " (6.7-cm) diameter tin cans can be used as "wells" in which to mount the speakers to make good contact with the telephone handset. The cans should be mounted $5\frac{3}{4}$ " (14.6) apart, center to center, and

FREE...

the world's largest selection of superb electronics products in easy-to-build kit form

Amateur Radio



SB-104 Digital Broadbanded, SSB Transceiver — plus CW, SWL, 2-meter, everything for the Ham

Digital Electronics



Wind Speed and Direction Indicator ID-1590 — plus Clocks, Temperature Monitors, Car Tach and Timer, Programmable Stopwatch,

Radio Control

Unique Frequency-Plug-In Pack 17™ Systems — plus Systems and Accessories for beginners or pro's



Automotive



CO-2500 Professional Ignition Analyzer plus Timing Lights, Tuneup Meters, Battery Chargers, Testers

Hi-Fi Components



The Revolutionary Modulus™ System — plus Stereo and 4-channel Components for every taste and budget

Home & Hobby Kits

Treasure Finder GD-348 plus Ultrasonic Cleaner, Intercoms, Model Railroad Control, Lamp Dimmer, Security Systems

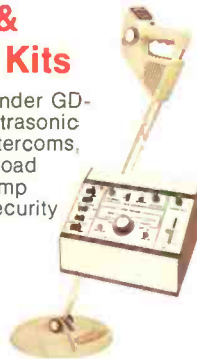

Color TV's

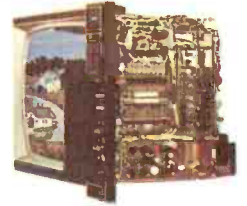

The 25" Diag. Digital Readout GR-2000 — plus advanced design color TV's in 4 other screen sizes

Test Instruments

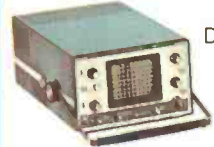

IO-4550 Dual-Trace Scope plus VOM's, DMM's, Counters, Generators, Chart Recorders, Design Breadboard and Experimenters, Power Supplies



WE GUIDE YOU EVERY STEP OF THE WAY:
Each Heathkit Assembly Manual is a masterpiece of careful instruction, guiding you step-by-step through complete kit assembly. And personal technical help, if you need it, is a phone call or a letter away. We won't let you fail!

Every kit contains:

- Complete Kitbuilder's Guide
- Famous Heathkit Assembly Manual
- ... and all the parts are there!

FREE!
Send for it today!

HEATH
Schlumberger

FREE!



Please rush me my FREE copy of the NEW Heathkit Catalog.

Name _____

Address _____

City _____

State _____ Zip _____

Popular Electronics

CL-590

FREE!

THE WORLD'S LARGEST ELECTRONIC KIT CATALOG!

96 pages...complete, accurate descriptions and specifications of over 400 easy-to-build electronic kits including:

- Test Equipment
- Auto Tuneup
- Marine and Fishing Gear
- Amateur and Shortwave Radio
- Stereo and 4-Channel
- Radio Control
- Color TV
- Calculators
- Digital Devices
- PA System



Heath Company, Dept. 10-152, Benton Harbor, Michigan 49022

PLACE
STAMP
HERE

Heath Company

Dept. No. 10-152

Benton Harbor, Michigan 49022

IT'S FREE

Send Card Today!

Imagine... an auto ignition analyzer that brings professional diagnosis within the reach of 'most anyone... a stereo preamplifier with incredible specifications at an equally incredible low price... a radio control system with instant plug-in frequency change... a model railroad throttle power supply that adds amazing realism to any line... a stereo/4-channel tuner/preamp of almost limitless versatility... new 'scopes that do more for the money... an important new Digital IC Tester... just a few of the many new and interesting products in the Heathkit line... read all about them in this bright new catalog!

should have 3/16" (5-mm) thick polyurethane foam lining their sides. Punch a hole in the bottom of each can to allow wires to pass through for connecting the speakers into the circuit. Fashion two circular wedges of polyurethane foam to fit into the bottoms of the cans, where they will hold the speakers the correct distance away from and at the proper angle to assure firm contact with the handset when the handset is placed in the cans. You may have to experiment a bit to get the right wedge shapes. Punch a hole through each wedge. Route the speaker wires through the holes in the wedges and the cans, and silicone cement the wedges in place. Then connect the wires from the speaker with the silicone "gasket" to the output and the wires from the other speaker to the input terminals of the modem.

If you prefer, you can use an inductive pickup at the receiving side of the modem. To do so, you'll have to lower the value of *R19*, (which determines the gain of the last stage of the active filter) to compensate for the lower gain of the pickup. In this way, you eliminate the possibility of external noise pickup.

Test and Adjustment. Set TRANSMIT switch *S1* to LOW and DUPLEX switch *S2* to FULL. Temporarily connect a jumper wire from pin 2 of the 25-pin connector to a voltage source of about -12 volts dc. This can be found at the negative side of *C2*. Connect a frequency counter to test point *TP3* (at *IC7*) and temporarily connect a jumper across *D16*. This will turn on the transmitter. Now, adjust *R77* for a frequency of 1270 Hz, ± 5 Hz. Remove the jumper from pin 2 of the connector and power supply, and adjust *R78* for a frequency of 1070 Hz, ± 5 Hz.

Set the TRANSMIT switch to HIGH and replace the jumper from pin 2 of the connector to the negative voltage supply. Adjust *R75* for a frequency of 2225 Hz, ± 10 Hz. Remove the jumper and adjust *R76* for a frequency of 2025 Hz, ± 10 Hz.

The output of the modem must now be set for -15 dBm (0.14 V rms or 0.39 V p-p) on the telephone line when the handset is in position in the modem's acoustic coupler by adjusting *R79*. Assuming you don't have a standard modem test instrument to perform this adjustment, carefully follow the procedure below.

First, make no measurements of the voltage on your phone line until you have dialed and have a party on the other end. Next, be very careful not to short the telephone terminals, and use an ungrounded meter to make all measurements. If your meter doesn't have an OUTPUT jack, place a 0.1- μ F capacitor in series with one of its test probes.

Set the TRANSMIT and DUPLEX switches to the LOW and FULL positions, respectively. Turn on the transmitter by jumpering *D16*. Place the telephone handset into the acoustic coupler. (Make sure the handset is correctly oriented.) Then connect the meter to the telephone connector block. (Do not attempt to use a "key-set" telephone that has lighted pushbuttons.) Adjust *R79* for -15 dBm, 0.14 V rms, or 0.39 V p-p.

Connect a 1000-ohm resistor between the audio input terminal to the active filter and ground. With a 100,000-ohm resistor connected in series with the signal or "hot" output, connect a signal generator to the audio input terminal and the generator's ground lead to the modem's common ground.

Monitoring the output with a frequency counter, set the generator's frequency for 1170 Hz. Connect the

counter between *TP3* and ground and a dc voltmeter between *TP1* (floating reference) and ground. Adjust *R10* through its entire range, observing where the monitored voltage swings smoothly between positive and negative. This is the lock range of the PLL. Adjust *R10* so that the meter indicates zero within the lock range. Perform this adjustment several times to be sure you haven't adjusted outside the lock range; false indications are possible there.

Direct-Line Hookup. To wire the modem directly to the telephone line, the telephone company requires that you use a DAA (Direct Access Arrangement) to isolate the two. The lowest-cost system available, generally renting for \$2 to \$5 a month, is the CDT (1001A) coupler. It has a switch that cuts the telephone out and the coupler in when turned on. The wiring diagram for this setup is shown in Fig. 2A.

When the CDT is used, *IC8* is wired as an "active hybrid" circuit that can subtract the output of the transmitter from the input of the receiver, as shown in Fig. 2B. Terminal E3 is connected to the output of the modem, which is also connected to one side of the phone line. E4 goes to the input terminal of the modem and the other side of the phone line. Ideally, *R62* should be the same resistance as the line impedance, specified by the telephone company as 600 ohms, when a DAA is used. However, this resistor's value can be trimmed if "balancing out" adjustments are needed.

Tape Recorder Connections. The phone jacks, *J1*, *J2*, and *J3*, permit the use of the modem with a tape recorder to record data from the terminal or from the phone line, and to play the data back to the terminal for the phone line, or both.

The jacks are wired into the modem as shown in Fig. 3A. Jack *J1* then connects to the transmitting speaker and serves as the interconnect for the microphone input to the tape recorder. Jacks *J2* and *J3* connect between E1 and E2 and ground. (Make sure you break the foil between E1 and E2 on the circuit board if you use this mode.) Jack *J2* goes to E1, which is the output of the first stage of the filter, and also feeds the microphone input of the tape recorder when *J2* is used. Jack *J3* breaks the connection between E1 and E2 and allows the tape recorder to

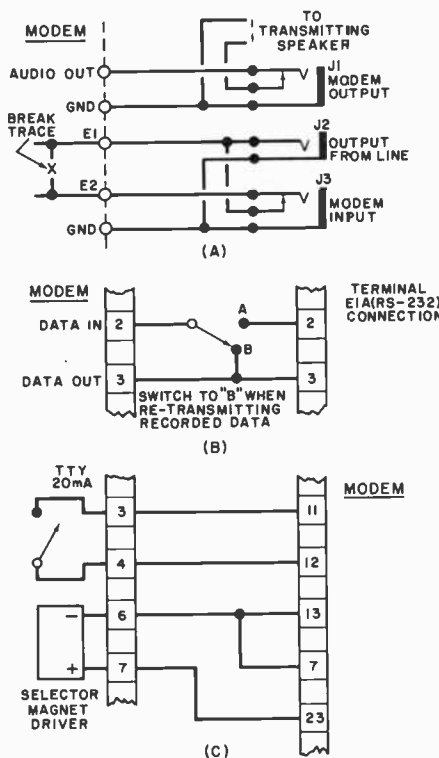

Fig. 3. Ways to connect the modem to tape recorder, an EIA terminal, or a Model 33 TTY Teleprinter.

feed a signal into the second stage of the filter.

To record local terminal data, plug the tape recorder's microphone input into *J1* and set the TRANSMIT switch to HIGH. Run the recorder and input data from the terminal.

To record line data, plug the recorder's microphone or auxiliary input into *J2*. Run the recorder for the duration of the desired output. Record a 5-second leader of no-data carrier on the tape before the data.

To play data back to a local terminal, plug the recorder's speaker output into *J3*. Then play the tape. The modem will track with any desired speed variations from the tape. The first point of failure for speed change will occur when the timing of the signal into the terminal goes beyond the limits of its serial receiver circuit.

To play data back to the line, connect a switch between pins 2 and 3 of the 25-pin connector on the modem and pins 2 and 3 of the terminal as shown in Fig. 3B. Using the terminal, set up the proper conditions in the system to receive the data. Make sure that you start the tape in the no-data carrier leader area. Plug the recorder cable

into the tape recorder and throw the switch to connect pins 2 and 3 of the connector. Plug the other end of the recorder cable into *J3*. Data will now be feeding into the modem's receiver, looping back to the transmitter section. Simultaneously, the data will appear on the terminal.

Current-Loop Hookup. Teleprinters handle data on a current loop, where 20 mA of current represents a 1 or "mark" and no current represents a 0 or "space." The wiring between the modem and a Model 33 Teletype (TTY) are shown in Fig. 3C. If you have an older teleprinter that has bare coils, use a reed relay between pins 23 and 7 (ground) on the modem. Connect a diode between pin 23 and ground, with the cathode going to pin 23. This diode will prevent inductive "kickback" voltages from damaging current-source transistor *Q2* inside the modem.

Teleprinter keyboards consist of switches that open and close according to a set pattern to control an externally supplied current. Pin 11 of the modem is a source of 18 mA of maximum current. Connect pin 11 to

pin 12 and the teleprinter keyboard from pin 13 to pin 7.

EIA Interface. The EIA standard relevant to the modem is RS232C. Any terminal wired according to this specification will mate with the Pennywhistle modem.

EIA signals in the RS232C standard are always more than 3 volts in amplitude and always less than 25 volts open circuit (15 volts when connected). They are positive or negative, depending on the data. Negative is a data 1 (mark), positive a data 0 (space). Control lines are active with a positive signal. EIA signals are not required to drive a load of less than 3000 ohms, but they must be protected from ground and each other.

Final Remark. To communicate between two Pennywhistle modems, the TRANSMIT switch must be set to LOW for receiving, HIGH for transmitting. Keep the DUPLEX switch in the FULL position, and your receiver will come back with what you're transmitting. Bear in mind that communication can be in only one direction when using this scheme. ♦

3 GOOD REASONS FOR BUYING AN EMPIRE CARTRIDGE

1. YOUR RECORDS WILL LAST LONGER. Unlike ordinary magnetic cartridges, Empire's variable reluctance cartridges have a diamond stylus that floats free of its magnets. This imposes much less weight on the record surface and insures much longer record life.

2. YOUR RECORDS WILL SOUND BETTER. Empire sound is spectacular.

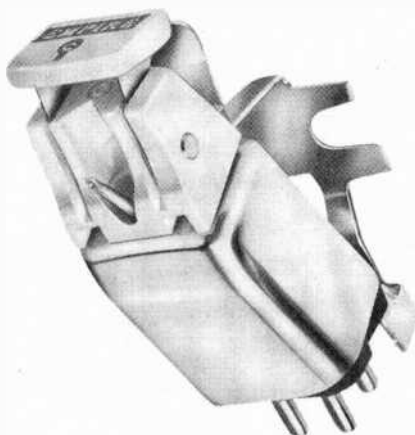

Distortion at standard groove velocity does not exceed .05%. Instruments don't waver; channel separation is razor sharp.

3. MORE CARTRIDGE FOR YOUR MONEY. We use 4 poles, 4 coils and three magnets in our cartridge (more than any other brand). Each cartridge must pass rigid tests before shipment.

For more good reasons to buy an Empire cartridge write for your free catalogue: EMPIRE SCIENTIFIC CORP., Dept. Z, Garden City, N.Y. 11530.

EMPIRE

POPULAR ELECTRONICS

IF YOU'RE anxious to hear distant stations on the AM Broadcast Band—say, to catch blacked-out home-town sports events—then the Broadcast Band Loop is just what you need! When coupled to a good AM transistor radio with a built-in ferrite bar antenna, it will bring in lots of stations you could never copy before—be they TA's (transatlantics), rare "locals," or clear-channel stations from distant cities. It is easy to build and use, fairly small, and inexpensive—total parts cost is about \$15 to \$20!

About the Loop. The use of a loop antenna is not new, but its advantages are timeless. It has good directivity, and can be easily rotated. Further, the loop works only with the magnetic

combination can be tuned to resonance. Its nominal directional pattern (Fig. 1) is a figure eight, with maximum response in the plane of the loop. Turning the antenna broadside to a station will cause an appreciable drop in signal strength.

Selectivity is another loop characteristic. The antenna favors signals at the resonant frequency at the expense of those nearby. Its response gets progressively narrower as its Q increases (which varies directly with the C/L ratio). For our purposes, we'll want as high a Q as possible.

We have adapted the loop to better serve our purpose by eliminating the direct connection between the Loop and the receiver. Experience indicates that unwanted signal pickup occurs

out bothering others around you, and vice versa.

To accomplish this, audio will be coupled from the earphone jack on the receiver to jack J3 by a short patch cord. Make use of the new crop of high-sensitivity, lightweight (Mylar transducer) stereo headphones, which require only a few milliwatts of drive.

It's also wise to use battery power rather than an ac battery eliminator, as hum problems can arise. Of course, if you don't want to use phones or already have a mono miniature/stereo phone jack adapter, the audio circuit can be ignored.

Physical Construction. The Loop's frame will be assembled first, using

A BCB LOOP ANTENNA FOR DX'ING

Increases reception range of inexpensive AM radios by inductive linking.

BY NORMAN FALLON

portion of the radio wave (which contains both electric and magnetic fields), so it is inherently quieter than higher-gain long-wire outdoor antennas. The loop contains no fragile semiconductors and requires no power supply, unlike the "amplified loops" that some MW DX'ers are now using.

A simple loop antenna is shown in Fig. 1. It's an electrically short loop consisting of turns of wire with a total length much less than a wavelength. Medium waves are fairly long, e.g. 500 m (1640 ft) at 600 kHz! Obviously this loop or an outdoor longwire are the only real options.

The loop is really an inductor. When shunted by variable capacitor C, the

when a transmission line is used to couple signals to the receiver's antenna input jack (if there is one). In this design (Fig. 2), signals are coupled inductively, simply by positioning the built-in ferrite bar close to the loop base. This offers the advantage of being able to adjust the degree of coupling between the coils to suit variations in signal strength. Operating the loop and ferrite bar in tandem will yield a cardioid directional pattern due to interaction between the coils.

Further flexibility is afforded by a switch which shorts out one turn of the Loop when closed. This is often desirable when working the high end of the MW band, since a decreased L requires more C for resonance. The result is a higher Q, and slightly less gain. In most cases, though, the effect on signal strength will not be noticed—but the sharpened tuning will be greatly appreciated. It's easy to see that the L1 and the ferrite bar in the receiver act as an r-f transformer. The "audio circuit" has been included as an operator convenience. To best work DX, headphones should be used. They are more sensitive than loudspeakers, so it will be easier to hear weak signals. The acoustic isolation from background noise will also come in handy—you'll be able to listen with-

doweling, two pieces of hardwood, aluminum tubing and aluminum U-channel. Refer to Fig. 3.

First, take two pieces of 1/2-inch (1.3-cm) ID seamless aluminum tubing, 34" (86.4 cm) long, and flatten the center 1 1/2" (3.8 cm) in a vise as shown in step 1. (Steps are shown in Fig. 3.) Drill a 7/32-inch (5.6-mm) hole in each tube at the center point. Then drill two 5/32-inch (4-mm) holes 6" (15.2 cm) from the center point on each length of tubing. Next, drill two 1/8-inch (3.2-mm) holes 16.5" and 15" (41.9 and 38.1 cm) from the center point on each length of tubing.

Center-drill 1/2-inch (1.3 cm) holes 1/4 inch (6.4 mm) deep on each of three 2 5/8-inch (6.7-cm) lengths of 3/4-inch

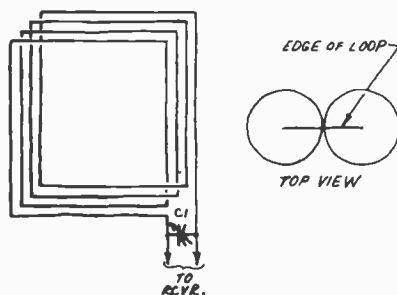

Fig. 1. Loop acts as an LC parallel circuit.

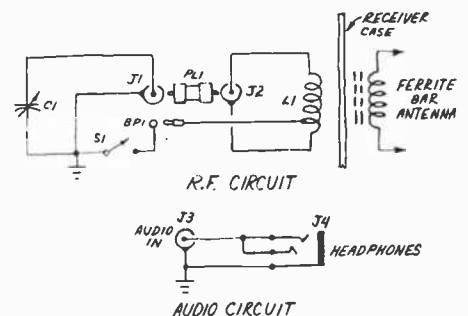

Fig. 2. Schematic shows how loop and radio antenna form r-f transformer.

(1.9-cm) doweling. File six grooves $\frac{3}{8}$ " (9.5 mm) apart on the dowels, spacing the outer ones $\frac{3}{8}$ " (9.5 mm) from each end. Take a $12\frac{1}{4}$ -inch (31.1-cm) length of $\frac{1}{2}$ -inch (1.3-cm) doweling and drill two $\frac{1}{8}$ -inch (3.2-mm) holes $1\frac{1}{4}$ " (3.2 cm) and $2\frac{3}{4}$ " (7cm) from one end. Repeat four times. Then, glue the dowels together to form three T-shaped wire supports as shown in Step 2. Save the remaining dowel for later use.

Form a cross by overlapping the two lengths of tubing. Line up the center holes and secure with a $\frac{1}{4}$ -20 \times 1 inch bolt, flatwashers, and wing nut. Slide the Tee's into ends B, C, and D of the cross until the holes line up. Secure the Tee's in the tubing with $\frac{1}{4}$ -inch self-tapping sheet metal screws (Step 3). Form four support braces from 9-inch (23.9-cm) lengths of $\frac{1}{2}$ " \times $\frac{1}{2}$ " (1.3 cm \times 1.3 cm) aluminum U-channel. Drill two $1\frac{1}{64}$ -inch (4.4-mm) holes $\frac{1}{4}$ " (6.4 mm) from each end. Then fasten the braces to the cross by lining up holes and using 6-32 \times 1 inch machine screws, flatwashers, and nuts. Two lengths of channel should be on opposite sides of the tubing at each juncture.

Now prepare the fourth Tee by center drilling a $\frac{1}{2}$ -inch (1.3-cm) hole $\frac{1}{4}$ " (6.4 mm) deep on one long side of a 4 " \times $1\frac{1}{4}$ " \times $\frac{3}{4}$ " (10.2 cm \times 3.2 cm \times 1.9 cm) block of hardwood (Step 4). Drill a $\frac{3}{16}$ -inch (4.8-mm) hole $\frac{7}{8}$ " (2.2 cm) from one end of the block for the center conductor pin of J2, an SO-239 coaxial connector. Then drill a $\frac{3}{16}$ -inch (4.8-mm) hole $\frac{9}{16}$ " (1.4 cm)

away on each side of the center conductor hole for two securing screws. File seven grooves $\frac{3}{8}$ " (9.5 mm) apart, spacing the HOT END groove $\frac{5}{16}$ " (7.9 mm) from the edge of the block. Drill a $\frac{1}{8}$ -inch (3.2-mm) hole in the center of both the HOT and GROUND END grooves. Then drill a $\frac{3}{16}$ -inch (4.8-mm) hole $\frac{3}{8}$ " (9.5 mm) to the right of the HOT and GROUND END holes on the top (un-grooved) side of the block. Mount solder lugs above each hole, using No. 6 \times $\frac{1}{2}$ " wood screws.

Referring to Step 5, prepare an SO-239 coaxial jack, cutting two corners with a hacksaw to fit the hardwood block. Solder one end of a 6-inch (15.3-cm) length of hookup wire to the center conductor pin of J2, and thread it through the center conductor hole. Then secure J2 to the wood block using No. 6 \times $\frac{1}{4}$ " wood screws, looping one end of a 4-inch (10.2-cm) length of hookup wire under the head of the screw nearest the GROUND END groove. Thread the other end through the hole in this groove and attach to the nearest solder lug (above J2). Trim excess. Attach the free end of the center conductor wire to the other solder lug, trimming excess.

Glue the hardwood block to the remaining $12\frac{1}{4}$ -inch (31.1-cm) dowel to form the fourth Tee. Insert the Tee into the remaining corner of the cross (A), lining up the holes. Secure with $\frac{1}{4}$ -inch self-tapping sheet metal screws. Then drill a $\frac{3}{16}$ -inch (4.8-mm) hole $\frac{7}{8}$ " (2.2 cm) above the bottom of the vertical tubing (above corner A).

Make the hole slightly more than $\frac{3}{8}$ " (9.5 mm) deep.

Take one end of a 74-foot (22.6-m) length of 18- or 16-gauge (solid or stranded, bare or insulated—enamel or plastic—almost anything will do!) copper wire, thread it through the HOT END hole and solder it to the HOT END solder lug (trimming excess). Then tightly wind the wire around the cross, using the Tee grooves as guides to make six turns in all. Thread the free end through the GROUND END hole and solder to the lug, trimming excess. Remove the insulation (if any) from the wire near corner A on the fifth turn. Solder one end of a 4-inch (10.2-cm) length of hookup wire to this point. Leave the other end free for the moment.

Control Panel Construction. We'll now assemble the Loop's Control Panel. It should be fashioned from a 4.75" (12.1-cm) square piece of $\frac{1}{16}$ -inch (1.6-mm) aluminum plate. Physical layout is flexible, but use Fig. 4 as a guideline. Form a support bracket from aluminum stock, or use a commercial aluminum angle about $2\frac{1}{2}$ " \times $1\frac{1}{2}$ " \times $1\frac{1}{2}$ " (6.4 cm \times 3.8 cm \times 3.8 cm). Install the bracket centered along one side of the aluminum panel. Then drill mounting holes for an SO-239 coaxial jack—this should be set back 1" \times 1" (2.5 cm \times 2.5 cm) from the corner nearest the notched side of the bracket—and for the main tuning capacitor, switch S1, binding post BP1, and the RCA phono and head-
phone jacks (if desired).

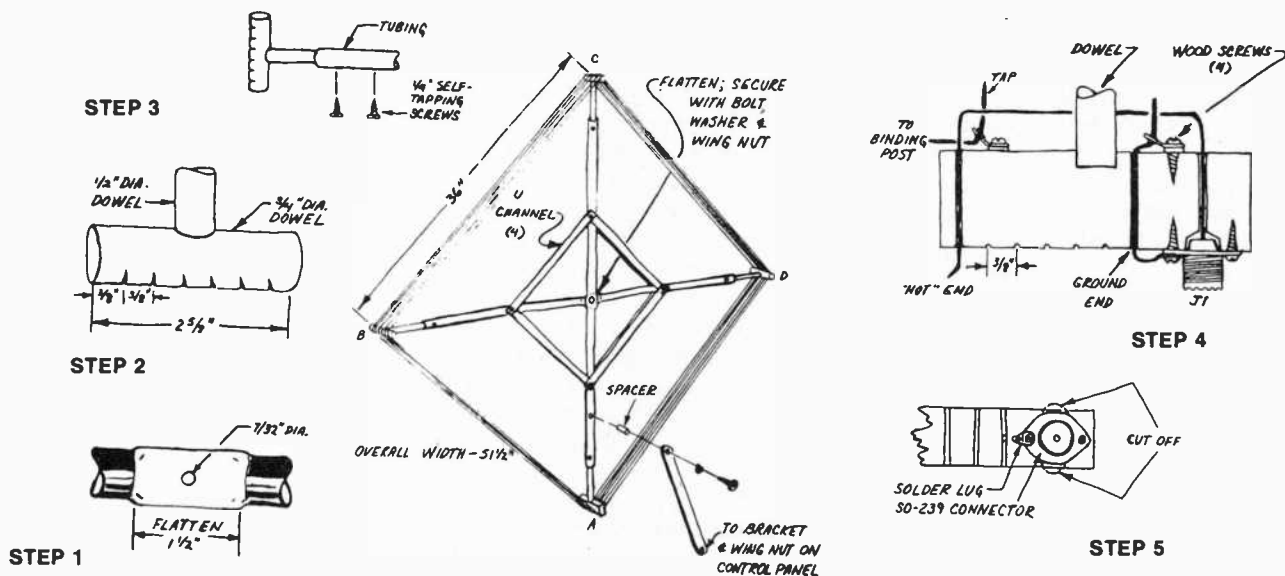

Fig. 3. Above are directions for constructing the frame for the loop. Aluminum tubing, U-channel, and wood dowels are used. Steps 1 to 5 are referred to in the text.

A note about capacitor *C1*—any surplus, multi-gang variable capacitor may be used. Total maximum capacitance should be about 1200 pF. As of press time, Fair Radio Sales, Box 1105, Lima, OH 45802, has several suitable models, with an approximate cost of \$3.00. If you have trouble finding a capacitor on the surplus market, buy three 365-pF AM tuning capacitors and gang their shafts together. After installing all components, wire the Control Panel in accordance with the schematic (Fig. 2) using 18-gauge solid hookup wire. Try to keep all leads as short as possible.

The Control Panel should be mounted in a cutout on a rotatable platform—a lazy susan arrangement. The platform should be big enough to accommodate your AM receiver also, since it must be rotated in step with the Loop.

Once the Panel is mounted, drill a $7/32$ -inch (5.6-mm) hole in the support bracket $3/8$ " (9.5 mm) down and 1" (2.54 cm) over from the un-notched top corner. Then drill $7/32$ -inch (5.6-mm) holes along the center line $3/8$ " (9.5 mm) from each end of an $11\frac{1}{4}$ " \times 1" \times $3/8$ " (28.6 cm \times 2.5 cm \times 9.5 mm) hardwood strip. Attach one end of the strip to the support bracket using a 10-20 \times 1" hex head bolt, a hex nut as a spacer between the strip and bracket,

FRAME BILL OF MATERIALS

- 2—42 inch lengths of $1/2$ " ID thin-wall aluminum tubing
- 4—14-inch lengths of $1/2$ " wood doweling
- 3—2 $3/8$ -inch lengths of $3/4$ " wood doweling
- 4—12-inch lengths of $1/2$ " \times $1/2$ " aluminum U-channel
- 1—Block of hardwood 4" \times $1\frac{1}{4}$ " \times $3/4$ "
- 1—Strip of hardwood $11\frac{1}{4}$ " \times 1" \times $3/8$ "
- 1—10-32 \times $1\frac{1}{2}$ " bolt and washer
- 1— $3/4$ -inch spacer to fit above.
- 1— $1/4$ -20 \times 1" bolt, washers, and wing nut
- 4—6-32 \times 1" machine screws, flatwashers, and nuts
- 4—No. 6 \times $1/2$ " wood screws
- 8— $1/4$ " self-tapping sheet metal screws

PARTS LIST

- BP1—5-way binding post
- C1—1200-pF (total) multi-gang variable capacitor
- J1, J2—Uhf coaxial jack, SO-239
- J3—RCA phono jack
- J4—Open-circuit stereo headphone jack
- L1—6 turns of 16- or 18-gauge copper wire wound on loop frame
- PL1—Double male uhf coaxial adapter (Amphenol 83-877, Lafayette 42 69064 or equivalent)
- S1—SPST switch
- Misc.—4.75" square 1/16-inch aluminum plate, tuning knob, machine hardware, hookup wire, solder, etc.

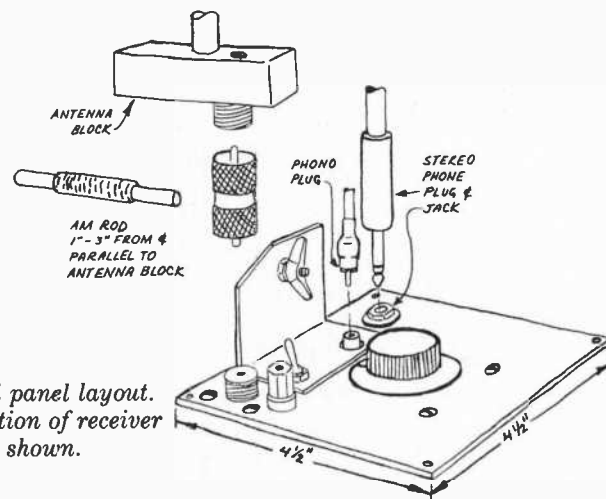

Fig. 4. Control panel layout. Proper orientation of receiver rod antenna is shown.

and wing nut. Keep the wing nut relatively loose. Now secure the other end of the strip to the Loop frame using a 10-32 \times $1\frac{1}{2}$ " bolt, washer, and a $3/4$ " (1.9 cm) spacer. Use the $3/16$ -inch (4.8-mm) hole previously drilled above the bottom of the vertical tubing.

Attach the Loop frame to the Control Panel using PL1, a double male uhf coaxial adapter (Amphenol 83-877), between jacks J1 and J2. Then connect the free end of the hookup wire from the loop to binding post BP1. Tighten the hardware holding the hardwood strip. Leave S1 open, and position your AM receiver below the Loop, orienting its rod antenna as shown in Fig. 4. The two coils should be about 1" to 3" (2.5 cm to 7.6 cm) apart.

Using the Loop. Tune the receiver down to the low end (540 kHz) of the AM Broadcast Band. Turn C1's tuning knob so that the plates are fully meshed. Then, carefully tune in an audible signal using the receiver's tuning capacitor. Slowly unmesh C1's plates (reduce capacitance) until the signal peaks strongly. You have now tuned the Loop to resonance at this frequency.

It's possible that loading effects by the Loop may "pull" the receiver off its dial calibration. If this occurs, just continue to adjust both C1 and the receiver's tuning capacitor for maximum intelligibility. You'll probably find that the two controls interlock, but with a little practice you'll be quickly zeroing in on the station you're after. Try rotating the loop to get an even stronger signal. Best results will be obtained when the plane of the loop extends in the direction of the desired signal. You can also use this directivity to null out an interfering station on the same frequency—

turn the loop broadside to the offending signal.

With S1 open, the Loop can be tuned just about to 1600 kHz. It also has maximum gain in this position. But there are times when a bit more selectivity is desirable over gain—for example, when two fairly strong stations are a few kHz apart. This is particularly true when trying to work the "splits"—foreign stations operating on odd frequencies not multiples of 10 kHz. In situations like this, close S1. This shorts out the bottom turn of the loop, giving a higher Q. It also gives you a bit more "room" on C1 at the top end of the band.

Other Suggestions. The "pulling" action mentioned earlier can cause you to get "lost" in terms of frequency. To prevent this, prepare a list of strong signals in your area, noting them by call letter and frequency. You can then use them as frequency markers to chart your way across the band. It's also a good idea to get a complete list of North American AM stations—especially if you want to DX the band. Several are available, listing stations by call letters, power output, frequency, and geographical location.

Another system variable is the amount of coupling between the Loop and the rod antenna. This should be varied to suit signal strength, but cannot accurately be predicted without experience with your particular receiver. While it should vary between 1 and 3 inches, experiment for best results.

To make tuning easier, a vernier (0 to 100) tuning knob can be used with C1. Once you have properly tuned a station in, record its frequency, direction toward which the Loop is turned, position of S1, and the amount of capacitance needed. Keep all this information for future reference. ♦

HOW TO MINIMIZE SCOPE / PROBE COMBINATION ERRORS

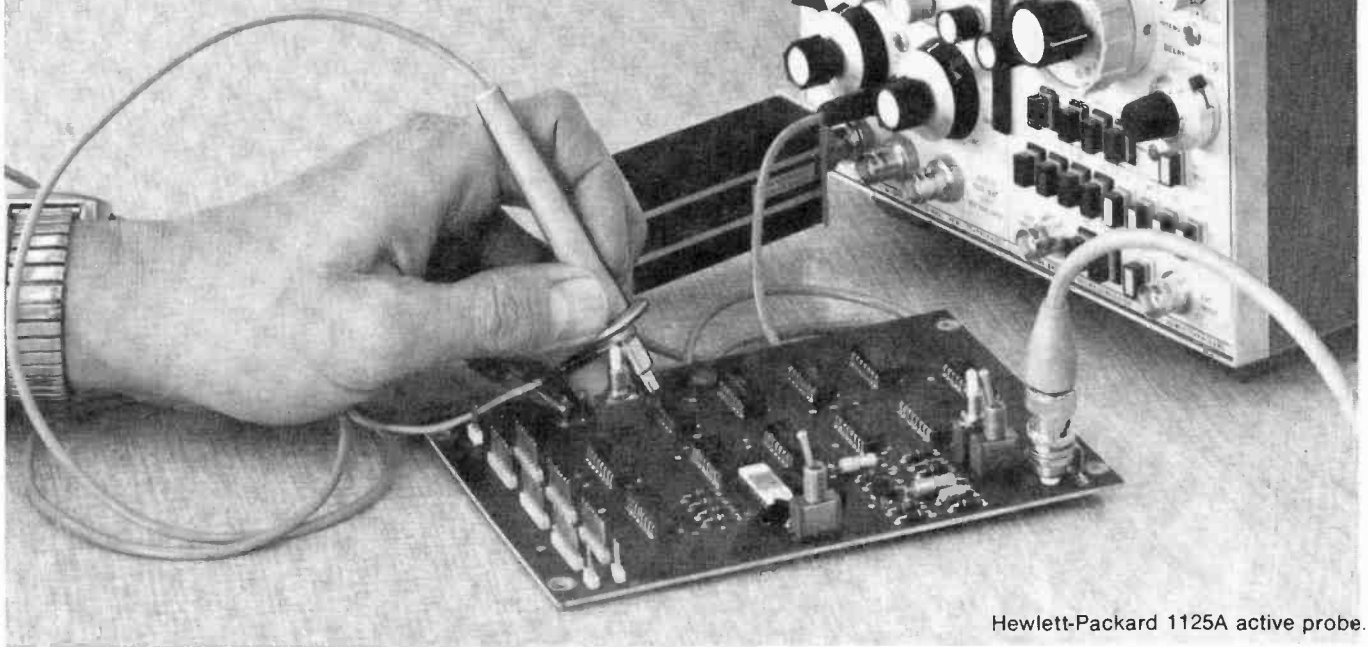

Hewlett-Packard 1125A active probe.

*Choosing the right probe for a particular application
can reduce measurement errors 50% or more.*

BY THOMAS R. SEAR

MOST of us tend to assume that an oscilloscope display is a "perfect" representation of what is occurring in a given circuit. Actually, when you apply a signal to the input of a scope, you can lose a large percentage of what is really there if the signal source is not carefully matched to the scope's input impedance. Since the main reason for paying big money for

a wideband scope is that you need the bandwidth, it is important that nothing be allowed to compromise its performance—least of all something as "simple" as a probe connected to the input.

If you select the wrong type of probe for a given measurement, the signal that reaches the scope may not have some of the characteristics that are of

interest to you. Unless certain precautions are observed, especially at high frequencies, getting the signal to the input of the scope may become the most critical part of any measurement you are making.

There are times when a plain piece of wire will suffice for coupling a signal to a scope. Also, the passive types of attenuator probes that are sold with

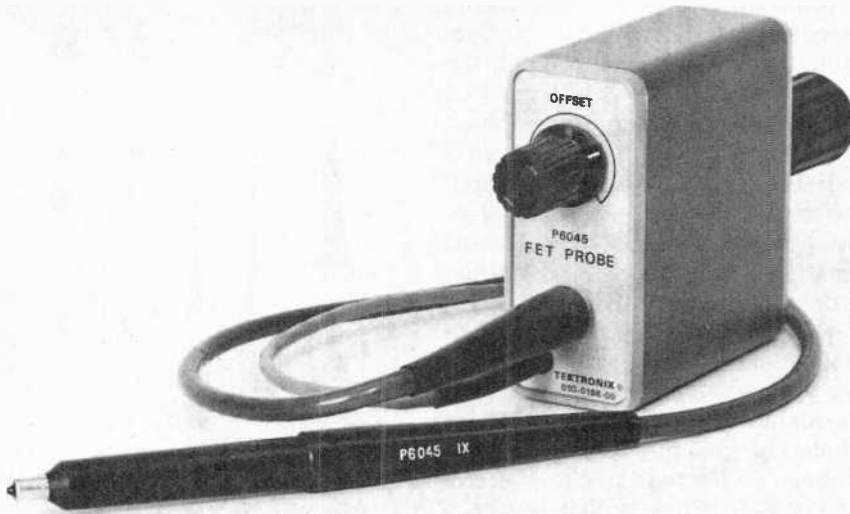

The Tektronix P6045 probe, with FET isolation stage, provides signal attenuation of 1:1, 10:1, or 100:1 with 1.5-ns rise time.

most new scopes do a fine job most of the time. However, the broad bandwidths of modern scopes and the sophisticated uses to which they are put make it absolutely necessary to match scope to probe if you want accurate and meaningful measurements. Failure to match probe and scope can result in measurement errors of 50% or more.

Impedance Effects. The scope vertical input to which you connect the probe will have either a high impedance or an impedance of 50 ohms (Fig. 1A). In either case, the impedance is a resistance in parallel with a capacitance (values approximately those in the diagram). Any probe can also be represented by a parallel RC circuit (Fig. 1B).

To estimate the effects that a given scope/probe combination will have on the signal, the combination can be simplified schematically as shown in Fig. 1C. Note that the values here are those that would be "seen" from the probe tip. That is, the series resistance of R_p and R_s is typically about 10 megohms (R_{IN}); and the series equivalent of C_p and C_s is about 6.7pF.

As R_{IN} decreases, more current is drawn from the circuit being tested. When R_{IN} approaches the impedance of the signal source, significant errors result because of resistive loading. The amount of error in per cent is $100Z_G/(Z_G + Z_{IN})$, where Z_{IN} is the parallel combination of R_{IN} and the impedance of C_{IN} .

Small amounts of loading decrease the signal amplitude only slightly.

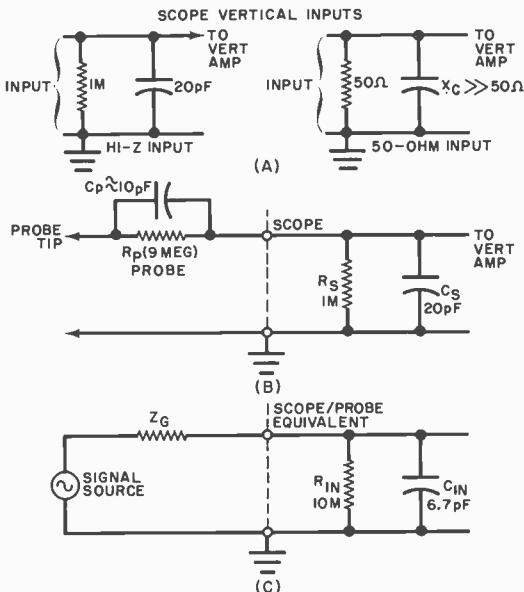

Fig. 1. Typical scope inputs: (A) for high- and low-impedance scopes; (B) with a passive divider probe; (C) equivalent circuit of combination in (B).

Fig. 2. A pulse source connected to the scope/probe combination in (A) results in equivalent at (B) for rise-time analysis.

Heavy loading, however, may draw so much current from the signal source that the circuit will saturate, become nonlinear, or stop operating completely.

So the first rule for selecting scope/probe combinations is:

Rule 1: To insure that resistive loading errors are less than 1%, select a scope/probe combination with R_{IN} at least 100 times greater than the source impedance.

The probe capacitor can be troublesome in two ways. First, if not properly adjusted to provide frequency compensation, slight errors will be introduced into your measurements. Second, consider the effects of the combined capacitance (C_{IN}) as a function of frequency. At 1000 Hz, C_{IN} (Fig. 1C) has an impedance of about 23.8 megohms, with no effect on signal measurement. But at 2375 Hz, its impedance will equal R_{IN} and have a definite effect on the signal. Down at 1 MHz, the impedance is only about 24,000 ohms and may load the circuit heavily.

The results of shunt capacitance variations can be amplitude attenuation and abnormal circuit operation. Furthermore, it can cause phase shift, excessive source loading, pulse perturbations, and errors in rise time and propagation-delay measurements.

The effects of shunt capacitance can become a factor almost before you know it. At 100 MHz, impedance of shunt capacitance can be less than 80 ohms for some scope/probe combinations—practically a short circuit in some cases. So, the second rule for probe selection is:

Rule 2: To minimize errors related to frequency, select a scope/probe combination with a shunt capacitance value that is as small as possible.

Rise-Time Error. We have considered the effects of resistance and

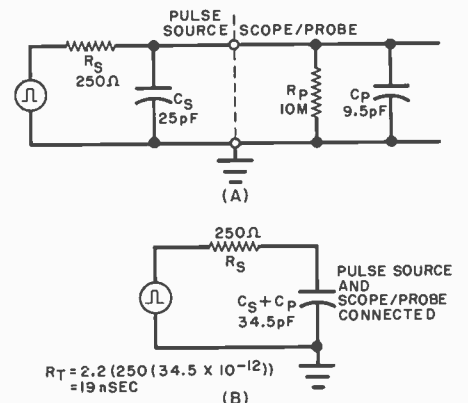

capacitance. Now what is their combined effect? Figure 2A shows a typical pulse source, with an internal impedance of 250 ohms and shunt capacitance of 25 picofarads. Assuming a pulse signal with a rise time of zero, the source output rise time would be approximately $2.2R_sC_s$, or 13.8 nanoseconds. The equivalent circuit for the scope/probe and source combination is shown in Fig. 2B. Since R_p is so much larger than R_s , the former can be ignored. The rise time of the signal reaching the scope input will now be about 19 nanoseconds. The loading effect of the probe is the percentage change in rise time or about 37.7%. This is directly related to the difference in capacitance (9.5/25 or 38%) caused by the addition of the probe. So to determine how much error in rise time you are going to introduce by adding a probe, determine the ratio of the capacitances involved.

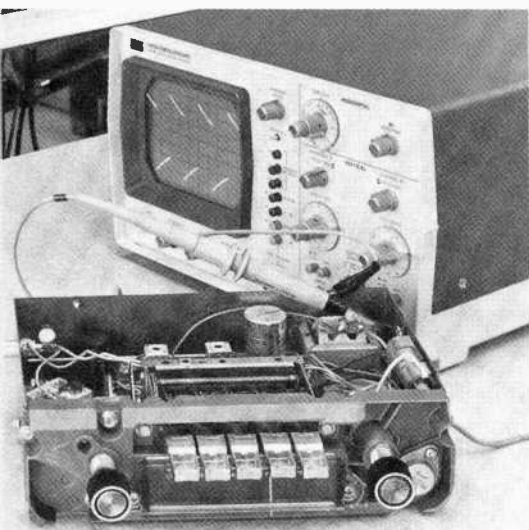

Hewlett-Packard's 10001A passive probe is rugged and easy to use.

Phase-Shift Error. In making measurements, source impedance is the key parameter. Accuracy requires that the source impedances of the two points being measured be on the same order of magnitude. For example, referring to Fig. 3, consider the effects of various probes on phase measurements between the input and output of the amplifier. The source impedance of the input is 50 ohms; while, for the output, it is 2000 ohms.

If 10-megohm, 10-picofarad scope/probe combinations are connected to the input and output of the amplifier, the source impedances will not be changed and a phase measurement error of about 49 degrees will result.

However, if 1000-ohm, 1-picofarad scope/probe combinations are connected to the input and output, the source impedances will become 47.5 and 667 ohms, and the phase measurement error will be only about 2 degrees. Thus, by loading the input and output circuits of the amplifier, the phase error has been almost eliminated; but the resistive loading error is on the order of 67%.

When phase and amplitude are both of interest, it is necessary to perform two tests—one for phase (using low-impedance probes) and another for amplitude (using high-impedance probes). So the third rule is:

Rule 3: To minimize phase errors, use low-impedance scope/probe combinations.

Types of Probes. In general, there are three basic types of probes available commercially. The types and their characteristics are as follows:

• **High-Resistance Passive.**

- Minimum resistive loading.
- Subject to capacitive loading at frequencies above 200 kHz.
- High input impedance from dc to about 200 kHz.
- High dynamic range (500-600 V).
- Least expensive type.

• **Miniature Passive Divider.**

- Load source more than high-resistance types, but load remains constant to about 100 MHz so loading is easy to predict.
- Minimum capacitive loading.
- Most useful when resistive loading is not a consideration.
- Fastest rise time.
- Widest range of voltage division (to 100:1 with changeable divider tips).
- Maximum signal voltage less than high-resistance types.
- Best for measuring fast rise time, phase relationships, and high frequencies if resistive loading is not important.

• **Active Probes.**

- Very little resistive loading.
- Minimum capacitive loading.
- Limited dynamic range (50 V maximum signal).
- Highest input resistance of all types.
- Lowest input capacitance of all types.
- Excellent for high-frequency, low-level signals.
- Best general-purpose probe within its limited dynamic range.
- Slightly greater pulse perturbations than passive-type probes.
- Large physical size.
- Most expensive type.
- Requires some form of external power.

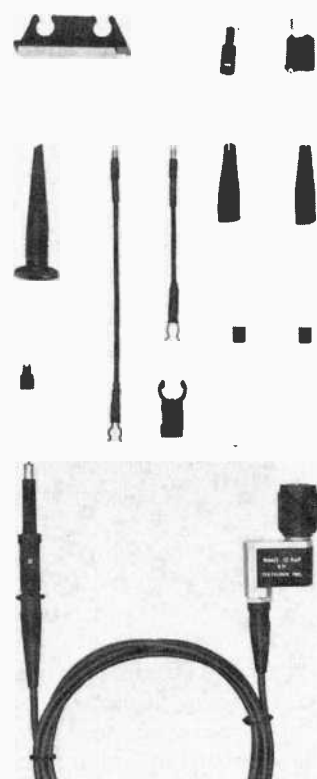

Tektronix active probe has switch to actuate trace-identity function on scope—good for dc to 250 MHz.

Of course the active probe is the "in thing" these days—primarily because it has the least possible effect on the test circuit. It is generally used with scopes having 50-ohm inputs; but it can't really be considered a general-purpose probe since it is expensive and is liable to damage from misuse.

There is a fourth type of probe that doesn't fit any of the other categories. Called a "current" probe, it is ideal for measurements involving very high source impedances, where other probes would put too much load on

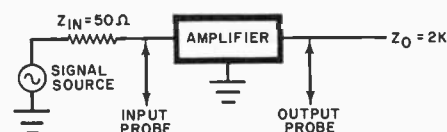

Fig. 3. Scope/probe combination can affect phase-error measurements.

the circuit. The current probe clips around the wire (or component) carrying a signal so that it does not actually contact the circuit. There is a small amount of insertion impedance (about 0.1 ohm) reflected into the circuit being tested, but this merely means that the source impedance must be at least 5 ohms to minimize errors in amplitude measurement. ♦

DEPENDABLE PERFORMANCE

He is fast on his feet. A great run. He scores...A dependable performance based on ability. And then a great feeling: Victory

You always score with PACE CB. PACE CB radios offer you dependable performance. When you're encountering an emergency on a lonely road. When you wonder about road or traffic conditions up ahead.

Or, when you're looking for a camp ground. And we're able to serve you coast to coast with our Warranty/Service Stations.

You'll feel great...being able to say: "I own a PACE CB."

**When you've got a Pace,
you've got the world by the ears.**

NEW!

CB 166

**((p))
PACE**



PACE CB 166-23 channel Mobile CB with digital synthesizer · Phase Lock Loop · Excellent Selectivity · S/R/F meter for monitoring incoming signal strength and relative power output · Transmit and receive mode indicator lights · Squelch control for quiet standby · PA function with front panel control · Noise Blanker Control for suppressing pulsing noise · Automatic Noise Limiter control for suppressing basic external noise · External speaker and PA jacks · Dynamic plug-in mic.

The PACE CB 166 operates on 12 V DC, (+) or (-) ground.

((p)) PATHCOM INC. PACE TWO-WAY RADIO PRODUCTS

24049 S. Frampton Ave., Harbor City, CA. 90710

Available in Canada from Superior Electronics Inc.
Export (all other parts of the world): 2200 Shames Dr., Westbury, N.Y. 11590.
CIRCLE NO. 40 ON FREE INFORMATION CARD

02102

CURVE TRACER Checks Semiconductor Quality from Breakdown Voltage to Beta

A SIMPLE go/no-go tester will tell you if a transistor will operate, but it will not tell you the quality of operation. For this, you need a curve tracer, which is usually an adapter designed to be used with an oscilloscope. The Experimenter's Assistant tracer/tester described here can test virtually any type of discrete semiconductor device, classify it according to type (npn or pnp) and material (silicon or germanium), and check reverse and forward breakdown voltages and leakage. It can also provide a rough indication of a transistor's beta.

In addition to semiconductor devices, the tester can also check capacitors and inductors. With a little imagination, it can also be used for in-circuit testing. To make testing conditions as safe as possible, the maximum test current is limited to slightly less than 4 mA.

Circuit Operation. The tester provides a simple means of depicting the voltage/current behavior characteristic of the component under test, graphically displaying the characteristic on an oscilloscope screen. The basic circuit shown in Fig. 1 consists of transformer *T1*, resistors *R1* and *R2*, switch *S1*, and component attachment jacks *J1* and *J2*. Note the three connections that must be made from the tester to the oscilloscope's horizontal and vertical inputs and ground. The remainder of the circuit is used for actual semiconductor testing and is connected to the basic circuit by plugging *P1* into *J1* and *P2* into *J2*.

With *S1* open, the 12.6 volts rms at *T1*'s secondary provides the sweep for the scope. Because the input impedance of the scope is virtually infinite, relative to the value of *R1*, the full transformer swing of ± 17.82 volts peak-to-peak is applied to the horizontal input of the scope. Since no effective current flows through *R1*, no signal appears at the scope's vertical input. The result is a horizontal trace on

the CRT, with the right and left ends of the trace representing $+17.82$ and -17.82 volts, respectively.

If test leads are connected to *J1* and *J2* and their test tips are shorted together, the full secondary voltage of *T1* will appear across *R1*, while no voltage is applied to the scope's hori-

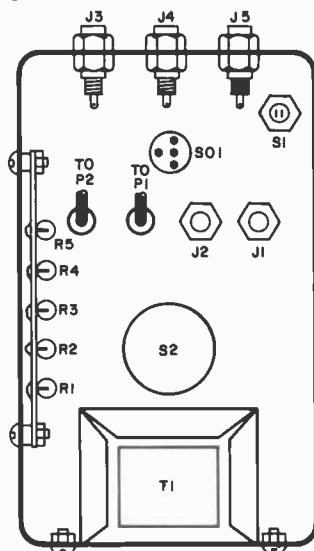

A typical layout for the curve tracer.

zontal input. This results in a vertical trace on the CRT, with the top of the trace representing a current of 3.8 mA ($17.82 \text{ volts}/4800 \text{ ohms} = 3.8 \text{ mA}$).

Removing the short between the test leads and depressing *S1* places *R1* and *R2* in the circuit. Now, the scope will display a 45° trace, assuming the horizontal and vertical input channel gains of the scope are properly set. Resistor *R2* and switch *S1* are used for balancing the channel gains. Once the channel gains have been set to display a 45° trace, any component whose resistance is greater than 4700 ohms will produce a more nearly horizontal trace, while component resistances of less than 4700 ohms will produce a more nearly vertical trace. The actual slope of the trace is directly related to $R1/R_{\text{TEST}}$, where $R1 = 4700$ ohms and R_{TEST} is the resistance of the

component connected across the *J1/J2* test probes.

Construction. You can assemble the tester in any enclosure of a convenient size using a point-to-point wiring technique. Use a terminal strip to mount the five resistors. The best place to mount *SO1*, *S1*, *S2*, *J1*, and *J2* is on the cover of the enclosure.

Connect one end of a 12" (30.5-cm) length of flexible test lead to the C lug on *SO1*, tie a knot in it to serve as a strain relief, pass the free end through a rubber-grommet-lined hole in the top of the case, and terminate the cable with a banana or tip jack (to mate with *J1*). Repeat this procedure with a cable connected to the E lug on *SO1*. These two cables, when plugged into *J1* and *J2*, allow transistors plugged into *SO1* to be tested. For in-circuit tests of transistors and diodes and out-of-circuit tests of transistors that do not fit into *SO1*, separate test cables must be plugged into *J1* and *J2*. Prepare these with appropriate plugs at one end and standard test probes at the other end.

Mount *J3*, *J4*, and *J5* on the rear wall of the case. Prepare three 36" (about 1-meter) test cables with plugs (*P3*, *P4*, and *P5*) to match these jacks on one end and plugs to match the input connectors on your scope at the other end. These last jacks and cables are for interconnecting the tester with a scope. Alternatively, you can connect the cables directly to the appropriate points in the tester circuit and have them exit the case through grommet-lined holes and eliminate *J3*, *J4*, *J5*, *P3*, *P4*, and *P5*.

After wiring the circuit and assembling the case, label the jacks, plugs, switches, and test socket.

Using the Tester. If an "ideal" diode is connected between *J1* and *J2*, it will act as a short circuit for one-half of the ac cycle when forward biased. During the other half-cycle, it will be

5 WAYS TO STOP WASTING TIME IN ELECTRONICS.

1. Stop wasting your time soldering. Save hours of soldering, desoldering, re-soldering with QT sockets and bus strips. Connect and disconnect resistors, capacitors, transistors, IC's etc., literally as fast as you can push in—or pull out—a lead. Make instant interconnections with short lengths of wire. And interlock sockets and bus strips for infinite expandability on bench, chassis, plug-in cards, etc. At \$2.00-12.50*, you'll wonder how you've done without them!

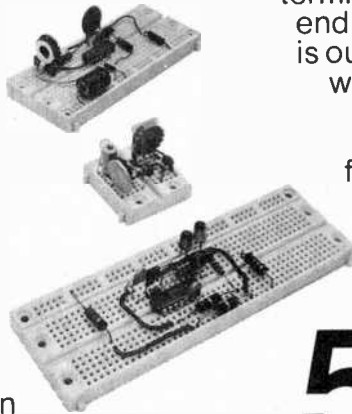

popular solderless breadboarding system ... our Proto-Board® line. For just \$15.95*, you can have our PB-6 Proto-Board kit. Takes about 10 minutes to assemble, and gives you 630 solderless QT terminals. On the other end of the spectrum is our giant PB-104, with 3,060 solderless terminals for \$79.95*, or only 2.6¢ apiece! You can choose from a variety of models, with or without regulated power supplies.

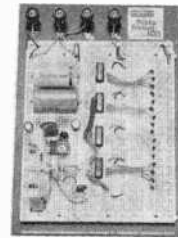

2. Stop wasting your time designing circuits. Design Mate™ 1 will help, by providing you with QT hookup versatility (see above), a continuously-variable 5-15V, 600mA 1%-regulated supply, and a voltmeter to monitor supply or circuit. Plug it in, turn it on and start designing more by soldering less. At \$49.95*, you can afford to.



5. Stop wasting your time testing. You can own the test gear you need at economical prices. Our Design Mate 2, for instance, gives you a 3-waveform function generator—sine, square and triangle—from 1 Hz to 100 kHz... for just \$64.95*. Design Mate 3 R/C bridge provides 5%-accurate measurements of unknown resistors and capacitors from 10 ohms to 10 meg and 10 pF to 1 uF, with built-in LED null indication. Price is a "micro" \$54.95*. And as you're reading this, we're busy adding new low-priced, high-quality Design Mates.



3. Stop wasting your time testing. On DIP IC's, finding the lead you want—and making sure you don't short others—can be as delicate as surgery. Until you discover our handy Proto-Clip™ ... the instant, short-proof way to test IC's up to 24 pins. Available without cable or with cable, they're the most economical and foolproof IC test aids on the market.

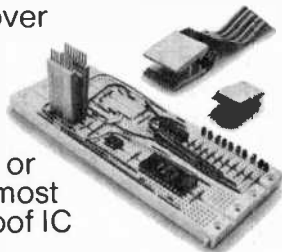

4. Stop wasting your time breadboarding. Small budgets or big requirements are no obstacle to owning and enjoying today's most

Stop wasting your time reading. Send for the complete CSC catalog and distributor list... and start making more of your time in electronics.

*Manufacturer's recommended retail.

CONTINENTAL SPECIALTIES CORPORATION



44 Kendall Street, Box 1942
New Haven, CT 06509 • 203-624-3103 TWX: 710-465-1227
West Coast office: Box 7809, San Francisco, CA
94119 • 415-421-8872 TWX: 910-372-7992
Canada: Len Finkler Ltd., Ontario

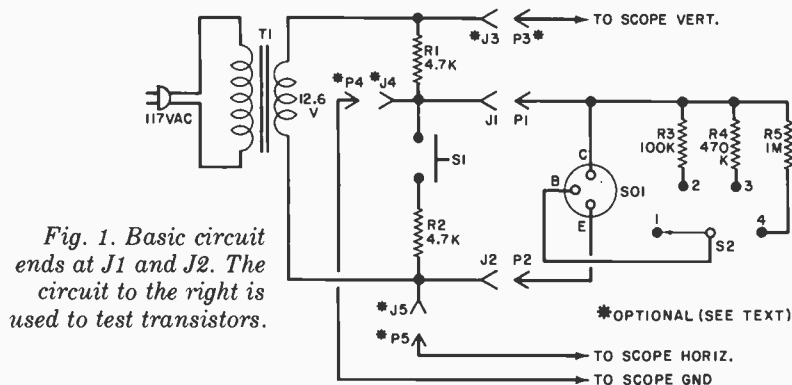

Fig. 1. Basic circuit ends at J1 and J2. The circuit to the right is used to test transistors.

PARTS LIST

- J1 to J5—Banana or tip jack (J3, J4, J5 optional—see text)
 P1 to P5—Banana or tip plug to match jacks (P3, P4, P5—optional—see text)
 R1, R2—4700-ohm, ½-watt, 1% resistor
 R3—100,000-ohm, ½-watt, 1% resistor
 R4—470,000-ohm, ½-watt, 1% resistor
 R5—1-megohm, ½-watt, 1% resistor

- S1—Normally-open pushbutton switch
 S2—4-position, nonshorting rotary switch
 SO1—Transistor socket (chassis mount)
 T1—12.6-volt filament transformer
 Misc.—Line cord with plug; flexible test-lead cable; control knob; test probes (2); jacks for scope input (3); case (such as Radio Shack No. 270B098—6½" × 3¾" × 2"); lettering kit; machine hardware; rubber grommets; hookup wire; solder; etc.

trace will be displayed as shown in Fig. 2D.

For most transistors, β can be determined by rotating S2 until the trace is close to 45°. For the component values shown in Fig. 1, and a trace slope of 45°, the β is approximately 21 in position 2 of S2, approximately 100 in position 3, and approximately 213 in position 4.

Other Uses. If you connect a good capacitor across the test leads connected to J1 and J2, an elliptical trace will be displayed. This trace will result because of the phase shift at 60 Hz between the vertical and horizontal inputs of the scope due to the RC network. A trace shape approaching a circle is obtained when the capacitive value under test is approximately 0.5 μ F. Inductors will produce similar

reverse biased and will seem to be an open circuit. Hence, the trace observed on the scope's CRT will form a right angle with one leg horizontal and the other vertical. The intersection of the two legs will be centered on the screen.

Few things in nature are perfect, the diode is no exception. A silicon diode requires about 0.6 volt forward bias before it begins to conduct, germanium about 0.2 volt. Illustrated in Fig. 2A are the differences in forward conduction voltage as "offsets" in expanded horizontal traces. Hence, the tester can identify a diode under test as either silicon or germanium.

If you connect a 5-volt zener diode between the test probes connected to J1 and J2, the resultant waveform will appear as shown in Fig. 2B. Note that the zener's impedance and breakdown voltage can be obtained from an expanded horizontal trace. The zener impedance is equal to the change in voltage divided by the change in current within the linear breakdown region of the trace. Snap-recovery and tunnel diodes also produce their own characteristic traces.

In testing transistors, it is useful to visualize them as variable resistors whose emitter-to-collector resistances are controlled by a minute base current. Within a transistor's operating range, the collector current will approximately double if base current is doubled. The "resistance" of the transistor, as "seen" by its associated circuit components, will decrease by a factor of approximately two.

To use the tester as a transistor checker, the SO1 portion of the circuit

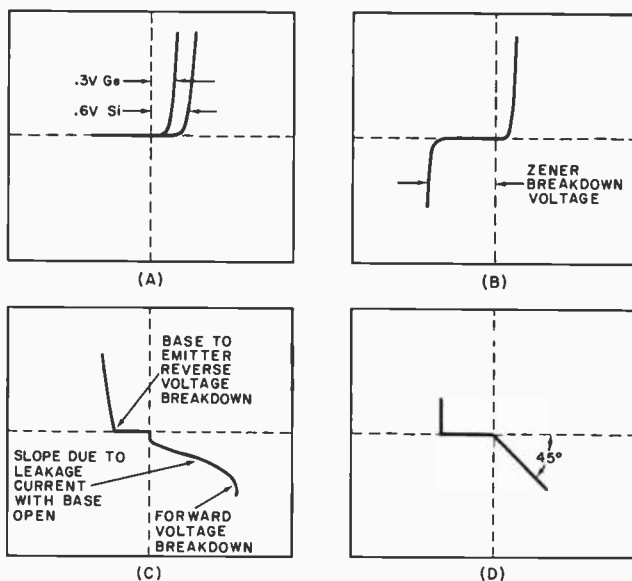

Fig. 2. Typical scope traces: (A) identification of silicon or germanium junction; (B) zener diode reverse curve; (C) transistor with leakage, forward breakdown voltage, reverse breakdown; (D) transistor with a gain of 100.

in Fig. 1 must be plugged into J1 and J2 or the separate test leads must be plugged into the jacks. Assuming the former, if a transistor is plugged into SO1 and S2 is set to position 1, the trace observed should be a continuous horizontal line. (With no base current, the transistor should have an infinite emitter-to-collector resistance.) The trace will be off the horizontal only if there is leakage current within the transistor or the transistor's breakdown voltage is exceeded. These traces are depicted in Fig. 2C.

To perform a beta (β) measurement of a transistor, start with no transistor plugged into SO1. Depress S1 and adjust the scope's controls for a 45° slope to the trace. Insert the transistor in the test socket, observing the proper lead basing, and set S2 to position 3. If the transistor's β is 100, a 45°

traces, and the tester can also be used to match inductances of home-made toroidal transformer coils.

Since the current through the probes is limited to less than 4 mA, the tester can be used to check most in-circuit components. Connect the test leads across an in-circuit semiconductor, and the resultant trace shape and slope will be determined by the various resistances and reactances associated with the semiconductor. Although the waveform displayed can be greatly distorted, you can check junction operation by looking for the telltale junction discontinuity that is typical at the zero axis. Not only can you check semiconductor junctions, you can also check the qualities of other components such as resistors, capacitors, and inductors that are common to the transistor stage. ♦

WORLD NEWS is breaking fast!

HEAR IT AS IT HAPPENS...

Get that news direct from the source of the action ... and listen to a world of music direct from the concert hall ... with a



DRAKE Short Wave RECEIVER



The R. L. Drake

SSR-1 RECEIVER

is great for
short wave
listening...

- 500 kHz to 30 MHz continuous—no extra crystals to buy • Direct reading dial with excellent calibration—dial your station, and there it is!
- Product detector for SSB/CW • Built-in AC supply for 110/220 Volts, 50/60 Hz, and provision for internal battery pack for portable operation
- Excellent Sensitivity • Telescoping whip antenna included
- For reduced current drain on DC, dials do not light up unless red pushbutton on panel is depressed.

The performance, versatility, size and low cost of the SSR-1 make it ideal for use as a stand-by amateur or novice-amateur receiver, short wave receiver, CB monitor receiver, or general purpose lab receiver.

- **Synthesized**
- **Solid State**
- **General Coverage**
- **\$350.00**

Now at your Dealer. Write for brochure on this and other Drake radio communications products.

R. L. DRAKE COMPANY



540 Richard St., Miamisburg, Ohio 45342
Phone: (513) 866-2421 • Telex: 288-017

See us at Dayton Hamvention

CIRCLE NO. 67 ON FREE INFORMATION CARD

How Multiplexed LED Displays Simplify Circuits

BY PATRICK J. DELANEY III

The use of digital multiplexing greatly reduces the number of parts and the size of a digital counter. It also means that inexpensive AND gates can be substituted for seven-segment decoder IC's; low-cost surplus multi-decade readout blocks can be used; and there is lower current drain on the power supply. The amount of wiring required can also be reduced.

How Multiplexing Works. Display multiplexing is based on a time-sharing technique which is shown in a simplified form in Fig. 1. If switches *S4* and *S5* are driven from a common shaft, they carry "on" and "off" information from *S1*, *S2* and *S3* to lamps *I1*, *I2*, and *I3* sequentially, so that the lamps respond to the position of each associated switch. That is, *I1* responds only to *S1*, *I2* responds only to *S2*, and *I3* responds only to *S3*.

If *S4* and *S5* were made to switch very rapidly, it would appear to the eye that the lamps were either constantly on or constantly off depending on the position of the controlling switches. (When LED's are used, thermal lag in lamp filaments, which would have some import in incandescent lamps, can be disregarded.)

The actions of the mechanical switches can be duplicated with digi-

A CONVENTIONAL digital readout system for LED's consists of a counter to generate a BCD (binary coded decimal) output and drive a seven-segment decoder for each of

the seven segments. For several decades of readout, requiring a counter/decoder combination for each digit, the cost and circuit complexity can be very high.

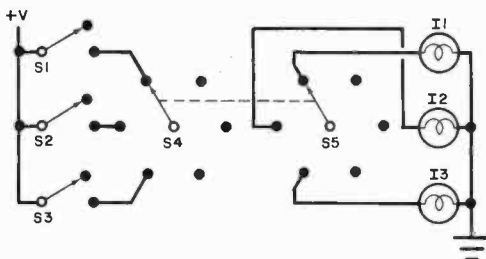
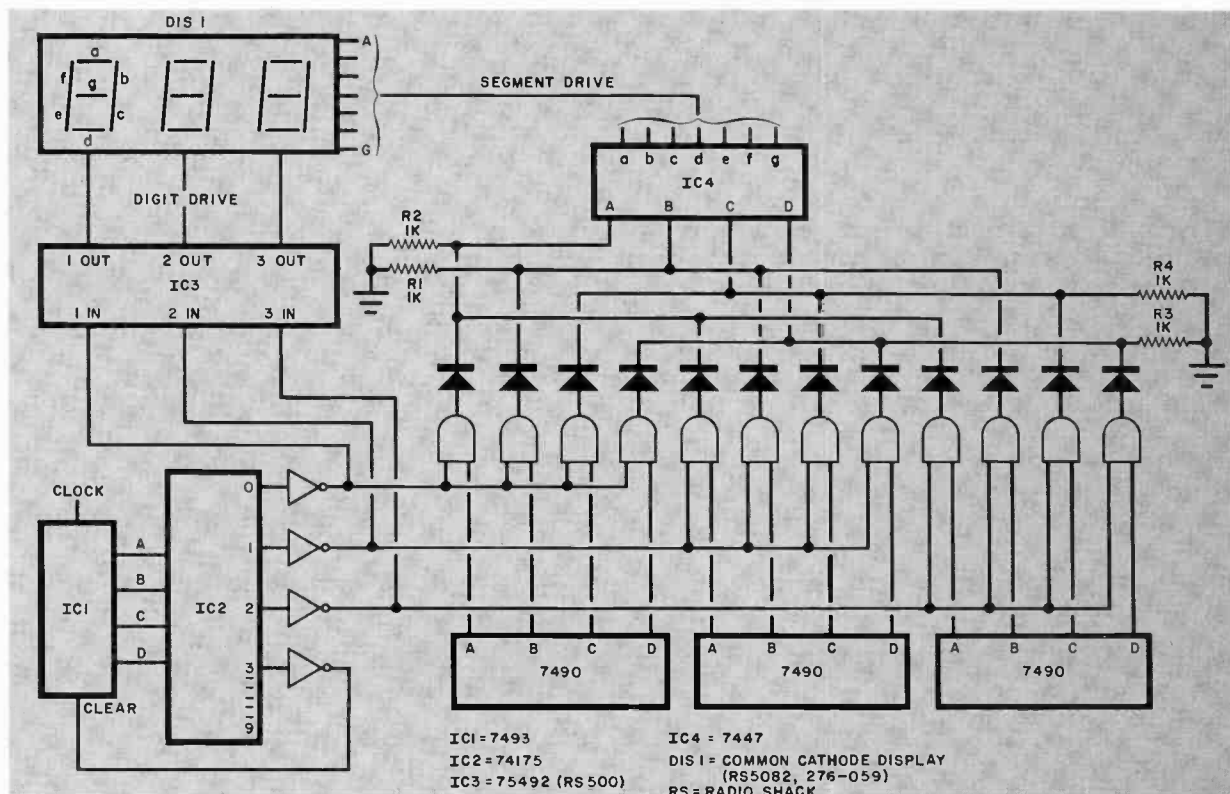

Fig. 1. Basic principle of mechanical multiplexing is a time-sharing scheme.

Fig. 2. Electronic multiplex can be used to experiment with multi-digit LED readouts—as many as nine digits.



tal electronic circuits as shown in Fig. 2. The components in this circuit can be bought from almost any "blister package" rack. The three 7490 decade counters represent the output stages of a digital instrument. Although only three decades are shown, the circuit can be easily expanded to six decades simply by adding AND gates and diodes or to nine decades by duplicating IC3.

In Fig. 2, IC1 and IC2 act as the rotary switches of Fig. 1. They are driven by IC1, which gets a clock pulse to determine the multiplex rate. Each output of IC2 turns on a single digit of the multi-digit readout by shunting a cathode to ground through IC3. Simultaneously, the output signal from IC2 turns on its set of AND gates to transfer the associated decade counter's BCD output to the common BCD-to-seven-segment decoder IC4.

In the digital readout block, all the similar segments are connected in parallel so that (for example) if segment A is driven, all A segments are driven. However, the digit driving circuit has activated only one digit so only the A segment of that digit will glow. The clock pulses then cause IC2 to switch to its next output so that the second digit is activated. If the clock rate to IC1 is high enough (above 200 Hz), each digit is strobed rapidly so that the display appears to be motionless. When the states of the 7490 IC's change, the readouts change accordingly.

As a rule, the output of a TTL gate is intended to drive the input of another gate. If the outputs are tied together, it is possible that, when one gate has a high output, one of the others may have a low output. The latter will then try to "sink" the output currents. This causes one gate to overheat and possibly malfunction. The diodes on the outputs of the AND gates in Fig. 2 prevent this problem by isolating the outputs. Resistors R1 through R4 provide a return path to ground to insure that the inputs of IC4 are low if no positive input is present.

The clock signal for IC1 can be obtained from any source of pulses whose frequency is greater than 200 Hz. If more than three decades are required, select an output from IC2 that is one digit higher than the number of digits to be displayed. Then invert this signal and apply it to the clear input of IC1. Expand the circuit by coupling the diodes to the BCD inputs of IC4. Each IC3 can handle six digits. ♦

MARCH 1976



Attention Hobbyists!
Get your 1976 CALECTRO HANDBOOK NOW!

More than 80 pages of tips, products, projects, charts, and scores of facts and data for hours of fun--plus, FREE National Directory of where to buy. Send \$2.00 for book, directory, postage, and handling to:

CALECTRO/GC ELECTRONICS
P. O. BOX 355
Argo, Illinois 60501

NAME: _____
STREET: _____
CITY: _____ STATE: _____ ZIP: _____

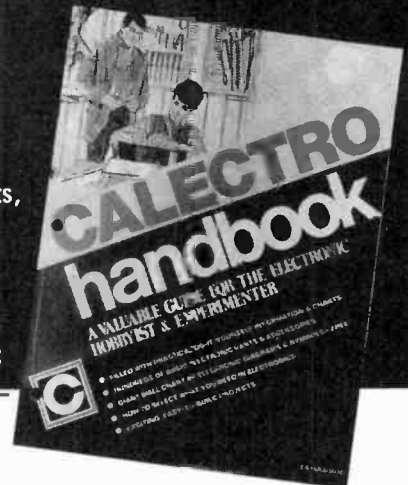

FREE

McIntosh CATALOG and FM DIRECTORY

Get all the newest and latest information on the new McIntosh Solid State equipment in the McIntosh catalog. In addition you will receive an FM station directory that covers all of North America.



MX 113

FM/FM STEREO - AM TUNER AND PREAMPLIFIER

SEND TODAY!

McIntosh Laboratory, Inc.
East Side Station P.O. Box 96
Binghamton, N.Y. 13904
Dept. PE

NAME _____
ADDRESS _____
CITY _____ STATE _____ ZIP _____

If you are in a hurry for your catalog please send the coupon to McIntosh. For non rush service send the Reader Service Card to the magazine.

CIRCLE NO. 30 ON FREE INFORMATION CARD

The better the training the better you'll

Send for
FREE
illustrated
career
guide

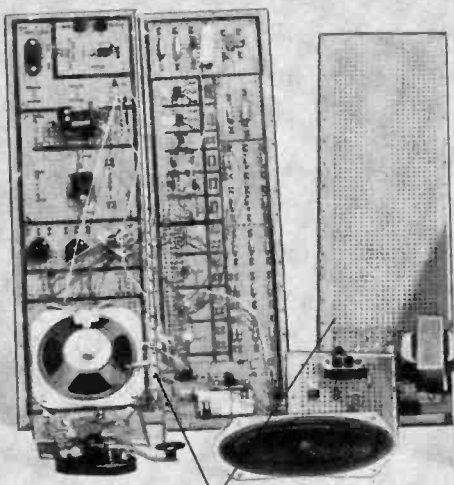
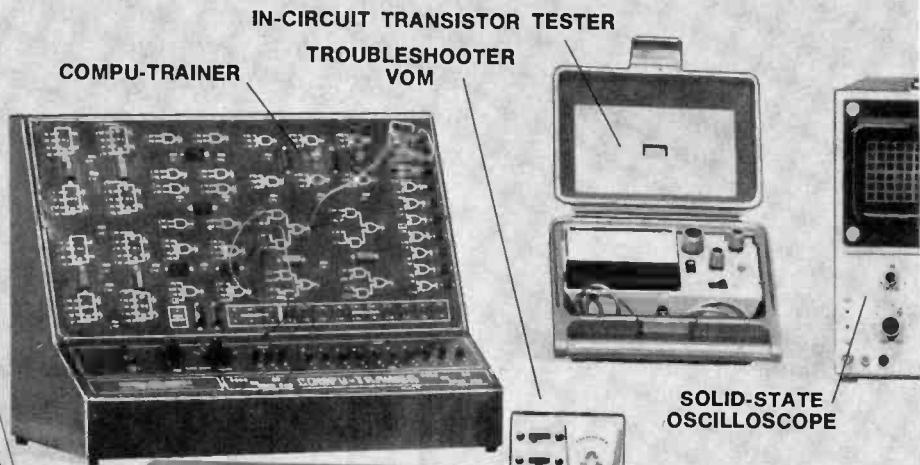
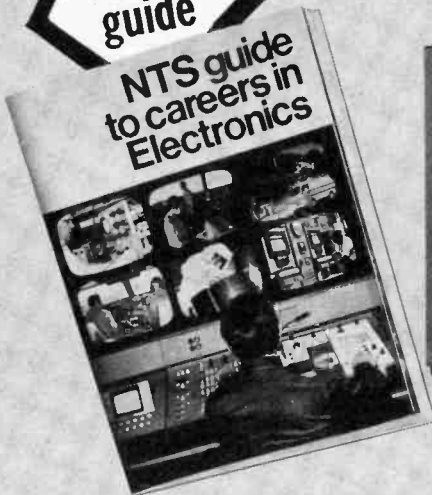

As an NTS student you'll acquire the know-how that comes with first-hand training on NTS professional equipment. **Equipment you'll build and keep.** Our courses include equipment like the **NTS/Heath Digital GR-2000 Solid State color TV** with first-ever features like silent varactor diode tuning; digital channel selection, (with optional digital clock), and big 315 sq. in. ultra-rectangular screen.

Also pictured above are other units — 5" solid state oscilloscope, vector monitor scope, solid-state stereo AM-FM receiver with twin speakers, digital multi-meter, and more. It's the kind of better equipment that gets you better equipped for the electronics industry.

This electronic gear is not only designed for training; it's field-type — like you'll meet on the job, or when you're making service calls. And with NTS easy-to-read, profusely illustrated lessons you learn the theory behind these tools of the trade.

Choose from 12 NTS courses covering a wide range of fields in electronics, each complete with equipment, lessons, and manuals to make your training more practical and interesting.

Compare our training; compare our lower tuition. We employ no salesmen, pay no commissions. You receive all home-study information by mail only. All Kits, lessons, and experiments are described in full color. Most liberal refund policy and cancella-

and the equipment be equipped.

**COMPARE OUR
KITS AND LESSONS.
COMPARE OUR
TUITION.**

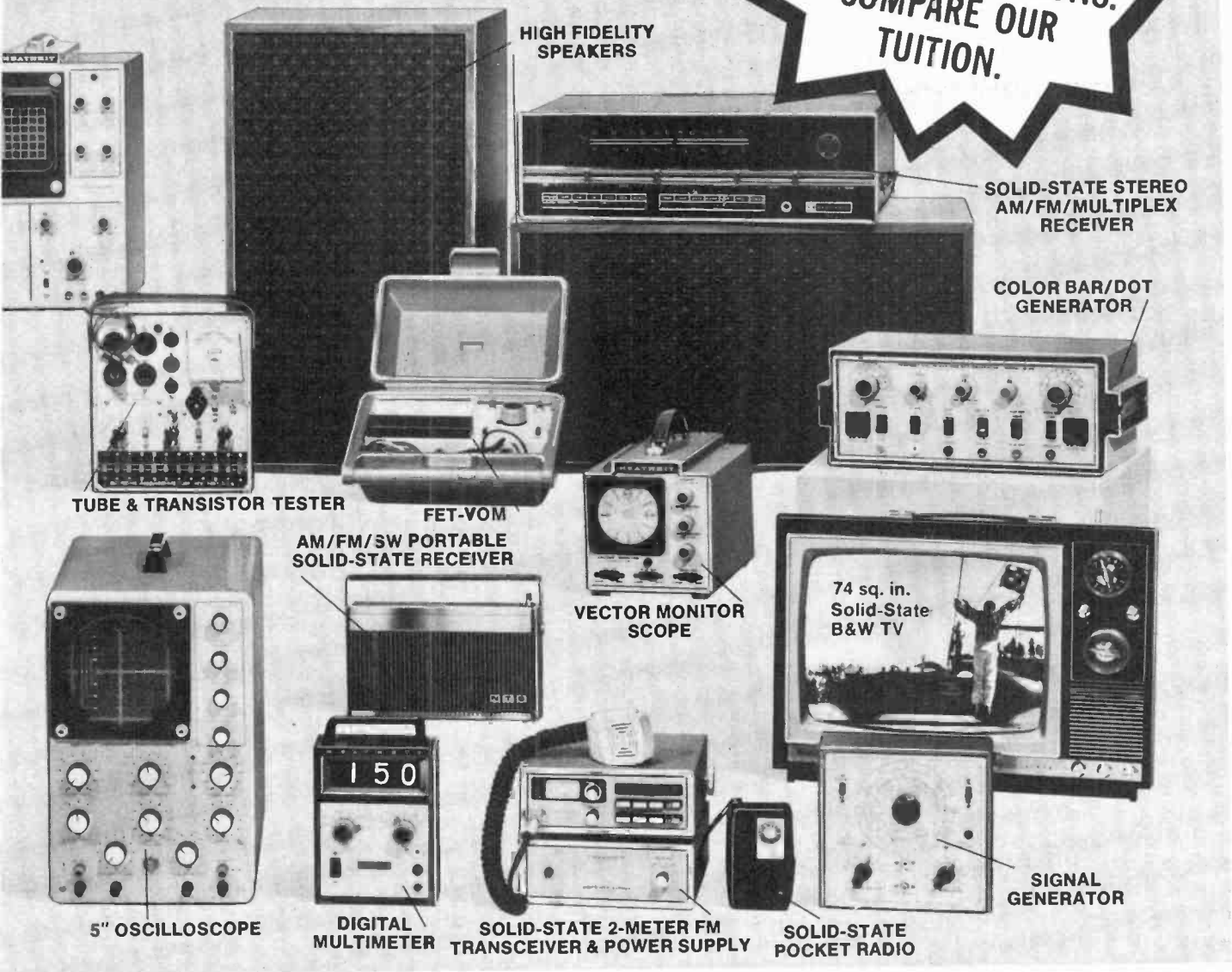

tion privileges spelled out. Make your own comparisons, your own decision. Mail card today, or clip coupon if card is missing.

NO OBLIGATION. NO SALESMAN WILL CALL
APPROVED FOR VETERAN TRAINING
 Get facts on new 2-year extension

NATIONAL TECHNICAL SCHOOLS
 TECHNICAL-TRADE TRAINING SINCE 1905
 Resident and Home-Study Schools
 4000 So. Figueroa St., Los Angeles, Calif. 90037

NATIONAL TECHNICAL SCHOOLS Dept. 205-036
 4000 South Figueroa St., Los Angeles, Calif. 90037
 Please send FREE Color Catalog and Sample Lesson.
 NO OBLIGATION. NO SALESMAN WILL CALL.

Color TV Servicing
 B & W TV and Radio Servicing
 Electronic Communications
 FCC License Course

Electronics Technology
 Computer Electronics
 Basic Electronics
 Audio Electronics Servicing

NAME _____ AGE _____

ADDRESS _____ APT # _____

CITY _____ STATE _____

Please fill in Zip Code for fast service _____

Check if interested in G.I. Bill information.
 Check if interested ONLY in classroom training in Los Angeles.



Product Test Reports

ABOUT THIS MONTH'S HI-FI REPORTS

One of the more versatile models in the new Marantz line of cassette decks is the front-loading 5220, which can also be used to decode Dolby FM broadcasts. It is equipped with bias and equalization selectors for all three basic tape formulations (ferric-oxide, chromium-dioxide, and ferrichrome).

The Onkyo Model TX-220 AM/stereo FM receiver, though relatively low-priced, compares favorably in performance with others costing more—and has most of the same features. It is rated for lower power than some more deluxe units, but there are many compact speakers that it can drive to room-filling levels without strain.

—Julian D. Hirsch

MARANTZ MODEL 5220 STEREO CASSETTE DECK

Front-load tape deck combines fine performance with luxury features.



The Marantz Model 5220 is a front-loading cassette deck whose styling

matches that of other audio components in the company's line. More than half of the satin-gold front panel is devoted to a blackout area that corresponds to the dial portion ordinarily found on tuners and receivers. When the power is on, two level meters, (illuminated in blue and red), become visible behind the blackout window.

The cassette compartment occupies the left portion of the panel and is internally lighted to permit visibility of the cassette while playing or recording. The compartment is covered by a tinted plastic window that swings open for inserting or removing the tape and closes by operating a lever near the cassette well.

The deck measures 16 $\frac{3}{8}$ "W × 12 $\frac{1}{2}$ "D × 5 $\frac{3}{8}$ "H (41.6 × 31.8 × 13.7 cm) and weighs 19 $\frac{1}{2}$ pounds (8.9 kg). Price is \$349.95.

General Description. The deck's control section includes an index counter for the tape, accompanied by pushbuttons to reset the counter and engage a MEMORY feature. When the latter is engaged, the tape automatically stops when the counter reaches 000 in the rewind mode. This is convenient when you want to return to a previously selected point on the tape.

Six levers provide control of the tape transport. They are labelled EJECT, REC, REW, FF, STOP, and PAUSE. Except for REC, any control can be operated at any time without first stopping the tape. At the end of the tape, or if the cassette jams or breaks, the mechanism shuts off and disengages automatically in any operating mode.

Slide-type controls provide a means for separately adjusting the recording levels for each channel from the microphone and line sources. (The two can be mixed.) A single slide potentiometer serves as the master level control. The playback level is normally fixed, but it can be adjusted via

screwdriver controls located in the rear of the deck. The two MIC jacks are located below their level controls, and a stereo jack for 8-ohm headphones is below the power switch.

The deck's remaining functions are controlled by seven pushbutton switches located below the gain controls. Two switch in and out the Dolby FM decoding system for listening to broadcasts with the benefits of noise reduction and correct frequency balance. Screwdriver controls on the deck's rear are provided for calibrating the Dolby circuits to a standard level tone transmitted by the FM station by setting the meter pointers to the Dolby (+2-dB) marks on the scales. A slide switch on the rear of the deck can be used to insert a compensating network to convert the normal 75- μ s tuner deemphasis to the 25- μ s used in Dolby transmissions. (If your tuner has its own 25- μ s deemphasis network, this switch should be left in the 75- μ s position.)

Another pushbutton turns on and off the Dolby circuits themselves for FM decoding or for recording and playing tapes. Separate pushbuttons for NORMAL (low-noise ferric-oxide tapes), CrO₂, and FeCr tape formulations simultaneously select the correct bias and equalization required for each type of tape. The final pushbutton engages a recording LIMITER that goes into operation at levels above 0 dB to prevent tape saturation and distortion from unexpected high input levels. A red PEAK light, located between the meters, flashes when instantaneous recording levels exceed "safe" limits. A REC light glows red when the deck is in the recording mode.

The tape transport employs a servo-controlled dc motor for driving the capstans and tape hubs. Plug-in circuit-board assemblies are used in the deck for easy serviceability, and extra shielding and bias traps keep the 100-kHz bias oscillator signal out of the line outputs when recording. The deck's circuits, including the Dolby noise reduction section, are built with discrete components to reduce distortion at high signal levels. Ferrite tape heads provide long life and wide frequency response.

Laboratory Measurements. The playback frequency response was measured with both 120- and 70- μ s test tapes for the NORMAL and CrO₂/FeCr tape selector settings. The

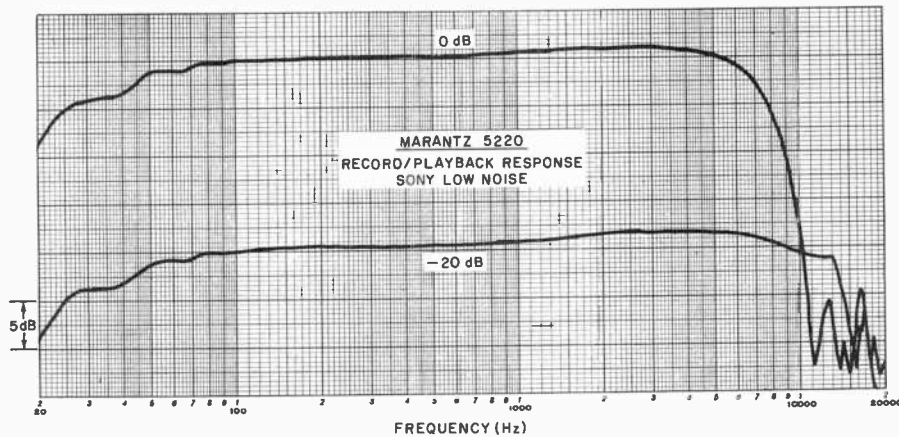
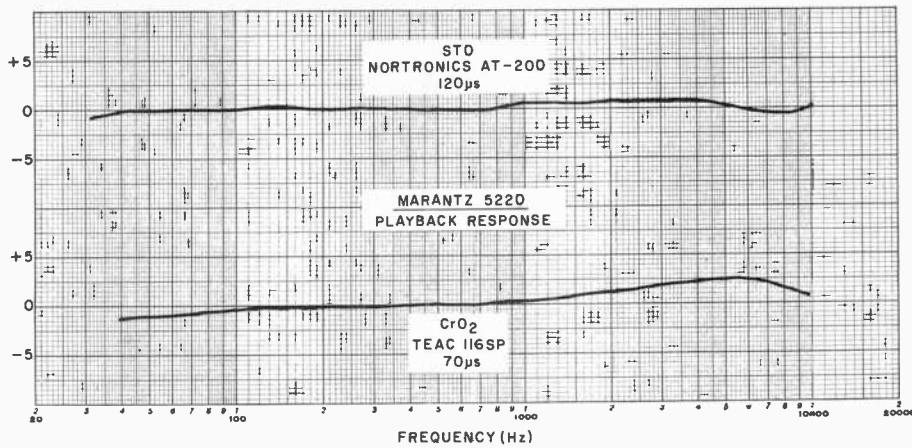

120- μ s response was flat to within ± 1 dB from 31.5 to 10,000 Hz. The 70- μ s response rose slightly in the several thousand hertz range but was within ± 2 dB from 40 to 10,000 Hz.

The record/playback frequency response was checked with the three tapes for which the deck had been specifically adjusted. Sony Low Noise (LN) was used as a NORMAL tape, Sony CRO for chromium-dioxide tape and Sony FeCr for the ferrichrome. Response checks were also made with other standard tapes to verify compatibility: Maxell UD and Scotch Classic. (Most CrO₂ tapes have very similar magnetic properties.)

The Sony LN tape yielded a frequency response within ± 2 dB from 45 to 13,500 Hz. The CrO₂ tape, as expected, produced a slightly extended response: ± 3 dB from 22 to 14,500 Hz. The best response was obtained with the ferrichrome tape: ± 3 dB from 23 to 16,500 Hz. The recorder was evidently slightly under-biased for Maxell UD tape, since the response had a gentle upward slope above 1000 Hz. However, it was still quite usable with the NORMAL tape setting. The Scotch Classic ferrichrome has different properties from the Sony ferrichrome,

and its output was emphasized below 1000 Hz compared to the high-frequency level. It was still within ± 4 dB from 20 to 14,000 Hz.

All response measurements were made at a -20-dB level. At 0 dB, high-frequency response suffers due to tape saturation, with the high-frequency performance improving markedly as we progressed from LN to FeCr tape.

A line input of 58 mV or a microphone input of 0.16 mV was needed for a 0-dB recording level at 1000 Hz. The microphone input overloaded at a very high 95 mV. The playback output depended on the tape used, varying from a low of 0.65 volt with Sony LN to a high of 0.81 volt with CrO₂. The meters had ballistic characteristics close to those of professional VU meters, indicating about 95% of steady-state levels on a 0.3-second tone burst. A Dolby level tape played back with meter indications within 0.5 dB of the Dolby markings.

The NORMAL tapes had the lowest distortion and greatest recording headroom at 1000 Hz. Both Sony and Maxell tapes were quite close in their performance, with the Sony LN having 1.8% distortion at 0 dB and reaching

the 3% reference distortion level at +6 dB. Corresponding figures for Maxell UD were 1.6% and +7 dB. The CrO₂ tape saturated at a much lower level, with 3% distortion occurring at +1 dB. The two ferrichrome tapes reached 3% distortion at +2 dB. Since the PEAK light flashed at +7 dB, it can be used as an overload indicator only with ferric-oxide tapes. Other tapes would be driven into saturation long before the lamp would flash.

The signal-to-noise (S/N) ratio was measured with the three tapes relative to the recording level that gave 3% playback distortion. Measurements were made unweighted (wide-band), with IEC "A" weighting to reduce the effect of less audible low and high frequencies, and again with the Dolby system switched in. The three S/N figures for Sony LN tape were 50.8, 56.0, and 62.5 dB. With Sony CRO tape, they were 50.5, 56.0, and 61.5 dB, and with Sony FeCr tape, they were 50.0, 55.0, and 60.5 dB. The Scotch Classic ranked close to the Sony FeCr and the Maxell UD was similar to the Sony LN in their distortion and noise characteristics.

Through the microphone inputs at maximum gain, the noise increased by only 4.5 dB, which is considerably less than the noise added by most cassette recorder microphone amplifiers. The combined unweighted rms wow and flutter was 0.11% in playback only and 0.13% in a combined record/playback measurement. The tape transport required 93 seconds to wind a C-60 cassette in the fast speeds. The recording limiter had a very fast attack and a slow decay. Although it had no effect on signal levels below 0 dB, it virtually eliminated all possibility of overload distortion. (Even a 50-volt input signal, at maximum gain, was held to safe levels.) The headphone output was too low to be really useful with high-impedance (200 ohms) phones, which are much more common these days than the 8-ohm phones for which the recorder was designed. The Dolby circuits tracked well, affecting the overall record/playback response by less than 2 dB at any frequency, at recording levels of -20 and -30 dB.

User Comment. Our tests confirmed the specifications for the tape deck. The Model 5220 is extremely versatile in its ability to use different tape formulations, mix signal sources, and properly decode FM Dolby transmissions with any type of tuner.

We liked the front-loading feature. The cassette can be seen clearly in the compartment if it is close to eye-level. Below eye-level, however, there may be some fumbling encountered in seating the cassette in its support. When the EJECT lever is operated, the door swings up and the cassette slides down to the front of the compartment for easy removal.

Although the meters are accurate and have good ballistic response, their illumination is rather dim. The low-level blue light used for the "safe" portion of the scale provides almost no contrast with the meter pointer. On the other hand, once the level has been set, there is little need to refer to the meter, especially if the limiter is

used. When the limiter is switched out, the flashing PEAK light is visible anywhere in the room.

From our distortion and S/N measurements, we conclude that a good low-noise ferric-oxide tape, such as the Sony LN, gives the most satisfactory overall results with this recorder. The distortion and noise for LN were marginally better than for CrO₂ and FeCr tapes, but its frequency response was not quite as wide. These differences are not significant. What we consider important is the extra 4 to 6 dB of recording "headroom" of the ferric-oxide tape. This allows the recording gain to be set for maximum program levels of 0 to -3 dB, with an occasional flash of the PEAK light indi-

cating when a +7-dB level has been reached. With the other tapes, the average maximum recording level should be reduced to between -5 and -8 dB, at which time, the PEAK light conveys no useful information since the tape distortion could be excessive before the light would flash.

Used independently of the transport, the built-in FM Dolby decoder worked very well. Once the level calibrations have been made with the aid of broadcast test tones, they should not require re-adjustment unless a different tuner is used.

All in all, the laboratory and listening results reveal that the Model 5220 represents good value for the money.

CIRCLE NO. 80 ON FREE INFORMATION CARD

ONKYO MODEL TX-220 AM/STEREO FM RECEIVER

Moderately priced unit for budget audio systems.



Although it is relatively low powered, the Onkyo Model TX-220 offers several design

and operating features not commonly found in AM/stereo FM receivers in its price range. Selling for only slightly more than the lowest priced stereo receivers on the market, the Model TX-220 has integrated circuit (IC) output amplifiers that deliver a conservative 12 watts of power per channel into 8-ohm loads over a frequency range of 50 to 20,000 Hz at less than 1% total harmonic distortion (THD). The outputs can be switched to either or both of two pairs of speaker systems. If the second pair of speakers is placed in the back of the room, a MATRIX 4CH position on the speaker selector switch allows the receiver to drive them with an L-R difference signal to simulate 4-channel programs from a stereo source.

The receiver measures 16%¹/₂"W × 13%³/₄"D × 5%¹/₂"H (42.2 × 35 × 14.3 cm)

and weighs 19 pounds (8.6 kg). \$219.95.

General Description. The receiver has a bronze satin-finished front panel and gold-colored knobs. Behind a "black-out" window are AM and FM tuning scales, the latter linearly calibrated at 0.25-MHz intervals; a dial pointer that lights up in red; and a single meter for center channel tuning on FM and relative signal strength on AM.

Except for the large TUNING knob to the right of the dial area, the receiver's operating controls form a single row across the lower portion of the front panel. To the right of the SPEAKERS switch and headphone jack are the BASS and TREBLE tone controls and the concentric VOLUME and BALANCE controls. (The BALANCE control is a ring around the VOLUME knob.)

Four pushbutton switches are for the LOUDNESS compensation, mono/stereo MODE, and TAPE MONITOR functions. The last is for two tape decks.

Programs can be dubbed from TAPE 1 to TAPE 2 while you are monitoring the playback from recorder number two.

Used in conjunction with the MIC jack on the front panel, a MIC MIXER control allows the output of a dynamic microphone to be mixed with the selected program so that both appear at the speaker outputs. When the MIC MIXER knob is pulled out, the signal also appears at the tape recording outputs.

The last front-panel control is the program, or source, selector. It has positions for AM, FM AUTO, PHONO, and AUX inputs.

On the rear apron of the receiver are located binding post output terminals for four speaker systems, all input and remaining output jacks, and AM and FM antenna terminals. A nonadjustable ferrite rod AM antenna is mounted inside the receiver's cabinet.

The receiver comes with a walnut-grained vinyl-clad metal cabinet.

Laboratory Measurements. The receiver's audio amplifiers clipped at 13.3 watts/channel with both channels driven into 8-ohm loads and a 1000-Hz test signal. The 4-ohm output was 16.4 watts/channel, while the 16-ohm output was 8.4 watts/channel. The receiver easily met its 12-watt/channel FTC output rating. Harmonic distortion measured between 0.1 and 0.2% from 70 to 8500 Hz and less than 0.5% from 40 to 20,000 Hz. At lower levels, the distortion was slightly less, measuring typically less than 0.1% at most frequencies and output power levels.

The 1000-Hz THD, at less than 1-watt

POPULAR ELECTRONICS

output, measured below the noise level. It was about 0.08% from 3 to 10 watts, and reached 0.6% at 14 watts output. The IM distortion was between 0.1% and 0.2% between 0.1 and 9 watts output, reaching 0.33% at 12 watts. It also rose at very low power levels, achieving 1% at a few milliwatts output.

The input sensitivity for 10 watts output was 145 mV through the AUX inputs, 2.1 mV through the PHONO inputs, and 4.5 mV through the MIC input. The respective noise levels were -77.5, -76.1, and -62.5 dB. The PHONO input overloaded at 50 mV, an adequate figure for most cartridges. Microphone overload occurred at a very safe 180 mV.

The characteristics of the TREBLE control were hinged at 1000 Hz, and the BASS control had a sliding turn-over frequency that permitted effective compensation at very low frequencies with negligible effect on the response at higher frequencies. The LOUDNESS compensation boosted the low and high frequencies at low VOLUME control settings.

The RIAA phono equalization was accurate to within ± 1 dB from 50 to 15,000 Hz, with a slight low-frequency roll-off to -3 dB at 20 Hz. There was only a minor interaction with cartridge inductance, which increased the output by 1 to 2 dB at frequencies between approximately 8000 and 20,000 Hz.

The FM tuner section had a usable sensitivity in mono of 12.8 dBf, equivalent to 2.4 μ V. This is much better than the rated 3.0- μ V sensitivity specified by Onkyo. In stereo, the sensitivity was determined essentially by the automatic switching threshold of 23 dBf (7.8 μ V), the 50-dB quieting sensitivity

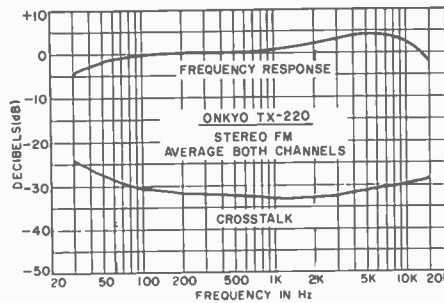
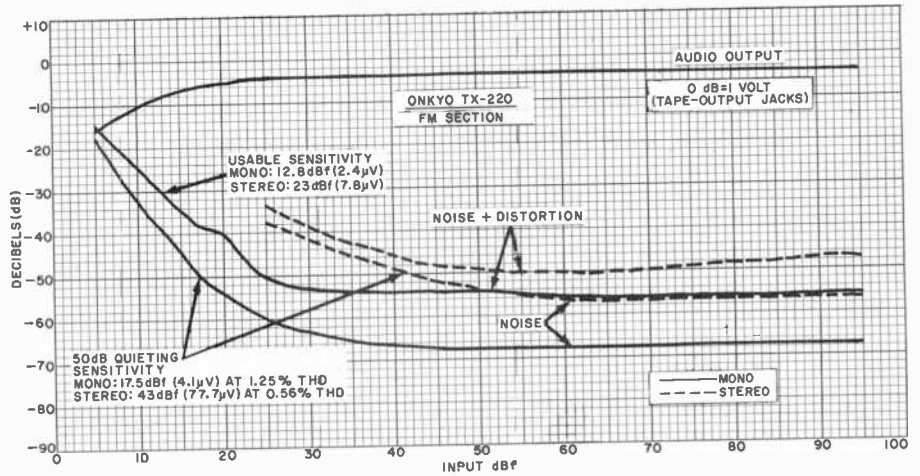

very good 66 dB. Image rejection measured 52.4 dB, bettering the 50-dB rating.

Alternate-channel selectivity, which was almost perfectly symmetrical about the signal frequency, was 53.5 dB, slightly short of the 60-dB rating. The automatic stereo/mono transition occurred smoothly over an input range of 17 to 25 dBf (4 to 10 μ V). The 19-kHz pilot carrier leakage was 51 dB down.

The FM tuner was not equipped with interstation noise muting. The AM frequency response was down 6 dB at 70 and 1700 Hz.

in mono was 17.5 dBf (4.1 μ V) with 1.25% THD. In stereo, it was a rather high 48 dBf (77.7 μ V) with 0.56% THD. The distortion was very low for a receiver in this price range, measuring 0.16% in mono and 0.32% in stereo. (The rated values are 0.4% and 0.8%.)

The FM frequency response was ± 4 dB from 30 to 15,000 Hz. There was a high-frequency emphasis and a reduced bass response. The channel separation was good at an almost constant 30 to 33 dB from 85 to 8500 Hz. It was better than 25 dB over the full audio range. The FM capture ratio at a 45-dBf (100 μ V) input was 1.8 dB, which was slightly better than the rated 2 dB. The AM rejection was a

User Comment. When used with moderately efficient speaker systems, the Model TX-220 proved to be a very smooth handling and generally fine-sounding receiver. However, it cannot be expected to drive low-efficiency speakers to satisfactory volume levels. The slightly accentuated high-end response in the FM mode added a touch of brightness and was no doubt partially responsible for the 56.5-dB stereo S/N measurement we obtained,

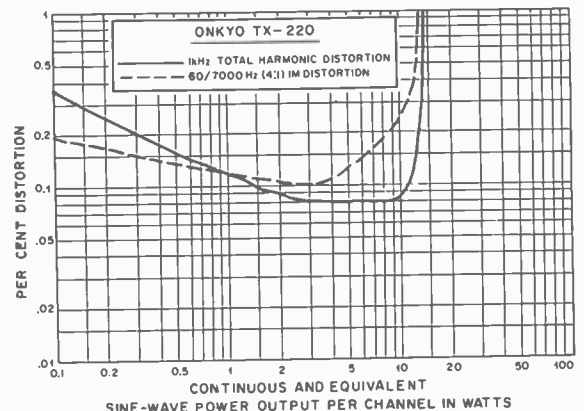
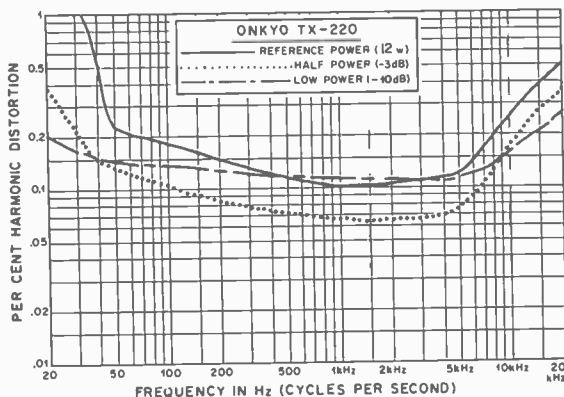

since it tended to exaggerate the tuner's background hiss.

The calibration of the FM dial was very accurate, limited only by the width of the pointer (about 100 kHz wide). We missed having an interstation noise muting circuit, but recognize that the design of such a modestly priced receiver must make some trade-offs. Fortunately in this case, the basic high-fidelity performance characteristics were not sacrificed. In addition, the full control facilities pro-

vided for two tape decks and a microphone input that can be used for recording as well as driving the outputs are not often found in this price range. Judging from the "feel" of the tuning, the FM tuner had a small amount of non-defeatable afc, of which no mention was made in accompanying literature.

We didn't evaluate the MATRIX 4CH mode, which operates in a manner similar to other ambience-recovery schemes we have tested in the past.

This feature is the least expensive way to enjoy some of the benefits of quadraphonic reproduction by simulating the rear channels from the out-of-phase information contained in many stereo programs. It costs nothing but the simple addition of an extra pair of speaker systems.

The Model TX-220 could certainly serve as the basis for a satisfactory music system for those with limited funds available.

CIRCLE NO. 81 ON FREE INFORMATION CARD

MIDLAND MODEL 13-882B MOBILE AM CB TRANSCEIVER

Boasts high voice intelligibility and antenna-mismatch indicator lamp.



THE MIDLAND Model 13-882B mobile CB transceiver is designed for AM operation on all 23 channels. Its special feature is a lamp that warns the operator in the event of a mismatch or defective antenna system that might result in damage to the r-f output transistor or cause instability.

Full 23-channel coverage is obtained through the use of a frequency synthesizer. Among the other features to be found in this transceiver are: S/r-f meter, adjustable squelch, switchable noise limiter, Delta tune, external speaker jacks, built-in bottom-facing speaker, nominal 12.6-volt dc (negative- or positive-ground) operation, supply line filter, and dynamic microphone.

The transceiver measures 7 $\frac{7}{8}$ "D \times 6 $\frac{3}{8}$ "W \times 2 $\frac{1}{4}$ "H (20 \times 16.2 \times 5.7 cm) and weighs 3.8 lb (1.7 kg). It comes complete with mobile mounting hardware. \$179.95.

The Receiver. Conventional double conversion is employed in the receiver. The stage complement includes a diode-protected grounded-base r-f amplifier, bipolar transistor first mixer, diode second mixer, ceramic filter, two i-f amplifiers, diode

detector and agc, anl, and a three-stage a-f amplifier section that terminates in a push-pull output amplifier.

The measured receiver sensitivity was 0.5 μ V for 10 dB (S+N)/N at 30% modulation with a 1000-Hz test signal. Adjacent-channel rejection was nominally 50 dB. The overall audio response was 550 to 3800 Hz at 6 dB, and the maximum audio power available for both receiving and PA operation at the start of clipping with a 1000-Hz test tone was 3 watts at 5% distortion into 8 ohms and 3% distortion into 16 ohms.

Rounding out our receiver measurements, the agc was quite flat, holding the audio output to within 6 dB with an 80-dB r-f input signal change at 1 to 10,000 μ V. A 50- μ V signal level produced an S9 meter indication. The squelch threshold range was 0.25 to 500- μ V. Unwanted- or spurious-signal response was 45 dB down, and measured -50 dB at several points within \pm 3 MHz of the 11-meter band. Image and i-f signal rejection were 80 and 60 dB, respectively.

Frequency Control. The frequency synthesizer is of conventional design, employing 10 crystals that are com-

bined in specific pairs to produce a local oscillator signal of around 38 MHz at the first mixer that, in conjunction with the CB signal, results in an 11.275-MHz first i-f. A second i-f of 455 kHz is generated by heterodyning the first i-f signal against an 11.730-MHz crystal-controlled signal.

On transmit, the on-channel carrier is generated by heterodyning the synthesizer's output with an 11.275-MHz crystal-controlled signal at a transmitter mixer, using the difference frequencies. Triple-tuned bandpass filtering circuits at both the synthesizer- and transmitter-mixer outputs minimize spurious-signal responses.

The Transmitter. The usual lineup of predriver, driver, and power amplifier with a multi-section 50-ohm output-matching network make up the transmitter. An adjustable TVI trap is included in the design. Collector modulation of the driver and power amplifier stages by the audio section includes automatic modulation control (amc), which is obtained in the usual manner with negative feedback. The functions of each stage are controlled by electronic switching.

Using a 13.8-volt dc source, we measured a 3.75-watt r-f carrier output power. A sine-wave modulation envelope was attainable at 100% modulation with 8% distortion using a 1000-Hz test tone. Raising the microphone input level by 10 dB over that required to initially produce 100% modulation held the distortion to 10% with no evidence of over-modulation.

Under the above conditions, and using a 2500-Hz test tone, the adjacent-channel splatter was 50 and 35 dB down, respectively. With voice signals, the "attack" time was a little slow before the amc took hold, enabling the peaks on the initial rise to

slightly square off. Nevertheless, splatter was held to -55 dB or better.

The audio response was 600 to 7000 Hz at 6 dB. The frequency tolerance of the transmitter on any channel was within 225 Hz at 80° F.

The ANT. WARNING lamp is driven by an SWR-sensing circuit. When SWR is greater than about 2.5:1, which may be due to an open or shorted transmission line or to antenna mismatch, a reflected voltage derived from the sensing unit turns the lamp on.

User Comment. The edgewise meter movement used in the transceiver is fairly large and easy to view, due to a high level of illumination. It is quite lively in its action, with indications starting at about a 1- μ V signal level.

As may be noted from the audio response measurements for both the receiver and transmitter, the low-frequency rolloff commences at a somewhat higher frequency than usual. This results in a very crisp signal, with the voice energy accentuated where it is needed for high intelligibility.

The DELTA TUNE control has three detented positions. It shifts the receiver frequency in one fixed amount of about 1000 Hz to either side of center.

The anl's performance was very good. It attenuated impulse noise by roughly 50 dB and its effectiveness was most pronounced when receiving weak signals.

CIRCLE NO. 82 ON FREE INFORMATION CARD

HEATHKIT MODEL GB-1201 DIGITAL STOPWATCH

Handheld clock provides seven types of timing functions.



THE NEW handheld digital stopwatch from Heath offers unusual timing versatility. It has the multifunctions, range, and accuracy needed for any split-second timing application one can think of—rallies, photo work, track events, efficiency studies, etc.

The Heathkit Model GB-1201 provides seven timing functions, two of which are programmable. It is housed in a hand-contoured black plastic case and comes with detachable sun shield, neck lanyard, felt-lined Naugahyde® carrying case, built-in rechargeable nickel-cadmium battery pack, and battery charger/eliminator—all for \$99.95 in kit form.

The digital stopwatch measures approximately 5 $\frac{1}{3}$ " x 2" x 2" (13.5 x 5.1 x 5.1 cm) without sun shield in place. It weighs about 8 oz (0.23 kg).

General Description. The stopwatch is built around an eight-digit, seven-segment LED display consisting of 0.15" (3.8-mm) high numerals. Tens and units of hours and tens and units of minutes are displayed in the upper row, while the lower row indicates tens and units of seconds and tenths and hundredths of seconds from left to right. (Heath also includes a modification that converts the display to read in hours, minutes, and tenths and hundredths of minutes for special applications.)

As configured, the display has a timing range of 99 hours, 59 minutes and 59.99 seconds. With the modification, the timing range is 99 hours, 59.99 minutes, in which case the display employs only six of the eight digits.

There are two miniature slide switches. One is for turning on and off the POWER. The other switch, labelled DISPLAY, allows the user to select a constantly on display or to disable the display (without interrupting the time counting cycle) to conserve battery power when timing long-period events. Two more switches round out the front-panel complement. One of these is the rotary function switch labelled clockwise from 1 to 7. The other is a momentary-action push-button switch marked RESET/ (LOAD).

FREE EICO CATALOG

346 Ways To Save On Instruments, Burglar Alarms, Automotive & Hobby Electronics!

The more you know about electronics, the more you'll appreciate EICO. We have a wide range of products for you to choose from, each designed to provide you with the most pleasure and quality performance for your money. The fact that more than 3 million EICO products are in use attests to their quality and performance.

"Build-it-Yourself" and save up to 50% with our famous electronic kits.

For latest EICO Catalog on Test Instruments, Automotive and Hobby Electronics, Eicocraft Project kits, Burglar-Fire Alarm Systems and name of nearest EICO Distributor, check reader service card or send 50¢ for fast first class mail service.

**EICO—283 Malta Street,
Brooklyn, N.Y. 11207**

*Leadership in creative electronics
since 1945.*



CIRCLE NO. 16 ON FREE INFORMATION CARD

If you can't go to college for your career in electronics -read this!

CREI brings college-level training to you with eight educational advantages, including special arrangements for engineering degrees

The best way to qualify for top positions and top pay in electronics is obviously with college-level training. The person with such training usually steps more quickly into an engineering level position and is paid considerably more than the average technician who has been on the job several years.

A regular college engineering program, however, means several years of full-time resident training—and it often means waiting several years before you *can even start your career*. This, of course, is difficult if you must work full time to support yourself and your family.

If your career in electronics is limited without college-level training, take a look at the advantages a CREI home study program can offer you.

1. Convenient Training

CREI brings the college to you. Through the convenience of home study, you receive exactly the same level of training you will find in any college or university offering programs in electronic engineering technology. With CREI, however, you can “go to college” whenever you have spare time at home or on the job.

2. Specialized Programs

With CREI, you enjoy the advantage of *specialized* training. That is, your program will include only those courses directly applicable to your career in electronics. We omit such courses as English, social studies and other subjects, which are usually required in resident schools. Therefore, with CREI, you move ahead faster to the more interesting and useful part of your training.

3. Practical Engineering

CREI programs give you a *practical engineering* knowledge of electronics. That is, each part of your training is planned for your “use on the job.” By using your training, you reinforce the learning process. And by demonstrating your increased knowledge to your employer, you may qualify for faster career advancement.

4. Engineering Degrees

CREI offers you a number of special arrangements for earning engineering degrees at recognized colleges and universities. You can earn college credit while you are taking your CREI program or apply later, whatever is best for your career plans.

Career Training at Home

5. Unique Laboratory

Only CREI offers you the unique Electronic Design Laboratory Program. This complete college laboratory makes learning advanced electronics easier and it gives you extensive practical experience in many areas of engineering, including design of electronic circuits. No other school offers this unique program. It is a better "Lab" than we have found in many colleges. And the professional equipment included in the program becomes yours to keep and use throughout your professional career.

6. Wide Program Choice

CREI gives you a choice of specialization in 14 areas of electronics. You can select exactly the area of electronics best for your career field. You can specialize in such areas as computer electronics, communications engineering, microwave, CATV, television (broadcast) engineering and many other areas of modern electronics.

7. Prepared by Experts

Experts in industry and technical organizations of government develop CREI programs. Each part of your training is developed by a recognized expert in that area of electronics. That means you get the most up-to-date and practical instruction for your career.

8. Industry Recognition

That CREI training is recognized by industry and government is evident from the fact CREI provides training to advanced technical personnel in over 1,700 technical organizations. Many subsidize the training of their employees with CREI. If there is any question about the advantages of CREI training for you, ask your employer or any engineer to evaluate the outline of a CREI program for you.

Other Advantages

Of course, there are many other advantages to CREI training. For example, throughout your training, CREI's staff gives you personal instruction for each step of your program. And in many industrial areas, both in the U. S. and abroad, CREI Field Service Representatives provide a number of important personal services for your training and your career.

FREE Book

There isn't room here to give you all of the facts about career opportunities in advanced electronics and how CREI prepares you for them. So we invite you to send for our free catalog (if you are qualified). This fully illustrated, 80 page catalog describes in detail the programs, equipment and services of CREI.

Qualifications

You may be eligible to take a CREI college-level program in electronics if you are a high school graduate (or the true equivalent) and have previous training or experience in electronics. Program arrangements are available depending upon whether you have extensive or minimum experience in electronics.

Send for this **FREE Book** describing your opportunities and CREI college-level programs in electronics



Mail card or write describing qualifications to

CREI **CAPITOL
RADIO
ENGINEERING
INSTITUTE**

McGraw-Hill Continuing Education Center
3939 Wisconsin Avenue Northwest
Washington, D.C. 20016

Accredited Member National Home Study Council

GI Bill

CREI programs are approved for training of veterans and servicemen under the G.I. Bill.

The timing functions available take some explaining to understand how they differ from each other. Let us take a function-by-function look at them.

In function 1, the stopwatch is used as a start/stop elapsed time indicator. It can be used to time any one or more events, displaying the time it takes for each successive event to complete while counting the total elapsed time of all events separately. Only the particular event being timed is normally displayed. Then you press a button to display the total elapsed, excluding any times out or delays between events. This mode is excellent for timing periods in basketball games.

In function 2, the stopwatch becomes a sequential timer. This lets you time each part of a given continuous event, such as separate lap times in an auto race or the times between hand-offs in relay footraces. Meanwhile, the stopwatch times the period of the overall event.

Function 3 is for total activity timing. This function is similar to the first, displaying the elapsed time for a series of events, minus times out between events. Where it differs is that, with the press of a button, you can also display total elapsed time, *including* the times out.

In function 4, the stopwatch operates in a split mode. The display gives the cumulative time to each "split" point in an event while timing the overall event separately.

Setting the function switch to position 5 sets the stopwatch up as a stop/start activity timer. In this mode, the stopwatch gives separate times for each event as well as the total time of all events.

Functions 6 and 7 are unique. They let you count up to or down from a preprogrammed time, respectively, over a 9 hour, 59 minute, 59.99 second range. To operate in these modes, the

display must be set to the reference time by first operating the RESET switch to display all zeros. Then the function switch is set to each of positions 1 through 5 and simultaneously with the pressing of the S/S (start/stop) and F/S (final stop) switches located on the left and right of the case. Once the reference time is established on the display, you switch back to function 6 to operate the RESET/(LOAD) switch to program the internal counter.

After loading the program, you either stay in function 6 to count up from zero to the reference time or switch to function 7 to count down from the reference time to zero by pressing the S/S switch. When the stopwatch completes the counting cycle, all counting stops. If a signalling device is plugged into the alarm jack at the top of the case, an alarm will sound at the termination of the count. (The kit's assembly manual provides full details for connecting various types of alarm devices.)

There are two more jacks on the top of the case. One is for plugging in the battery charger/eliminator, and the other is for operating the start/stop function remotely (either manually or by automatic trip devices). The start/stop jack is wired in parallel with the S/S switch.

Two PMOS LSI chips are used inside the stopwatch for all counting operations. A quartz crystal provides an accurate, stable time-base reference.

About the Kit. The stopwatch ranks as a one-evening kit project for the experienced kit builder. Even a newcomer can assemble and start using the stopwatch in little more than seven or eight hours. This is possible because all of the complex circuits are contained in the two counter IC's. There are very few discrete compo-

nents to be wired to the two screened, double-sided printed-circuit boards.

The LED displays come in lensed DIP cases, and they and the IC's plug into sockets. This eliminates the possibility of heat damage during soldering and makes it easy to troubleshoot and replace defective components should the need arise.

There are no critical steps to perform during assembly. However, because the LSI chips are MOS devices, safe-handling precautions must be exercised (see assembly manual).

User Comment. Heath claims an accuracy of $\pm 0.006\%$ when the stopwatch is adjusted without instruments and better than $\pm 0.003\%$ with instruments. We tried both ways and obtained better than $\pm 0.003\%$ in both cases. Just as important, the long- and short-term stabilities were excellent. We used a 15-minute short-term test and observed no significant drift. At the end of a 25-hour (long-term) test, operating the stopwatch on the battery charger/eliminator, we observed a difference of 4.31 seconds when compared against a WWV calibrated timer.

These results were obtained with the stopwatch aligned without instruments. After aligning with instruments and repeating the 25-hour test, there was a discrepancy of less than 1 second between the stopwatch and reference timer, which in all likelihood was due to reaction time lag when both were started and stopped.

This is a very easy stopwatch to use and operate. With the S/S and F/S buttons located on either side of the display, it is not limited to either right- or left-handed operation. Also, the grasp is comfortable. A nice final touch is the sun shield, especially useful when reading the LED display under high ambient lighting conditions.

CIRCLE NO. 90 ON FREE INFORMATION CARD

TRI-STAR "TIGER SST" CD IGNITION SYSTEM

Capacitive-discharge kit system for autos.

MANY different circuits have been designed to increase the performance of automotive engines by upgrading the ignition system. One of these is the capacitive-discharge system (CDI) which boosts the voltage applied to the primary of the ignition coil. The Tri-Star "Tiger SST" is such a CDI circuit. It is triggered by the existing breaker points and is fully compatible with stock as well as "breakerless" ignition systems.

The Tiger SST is available factory-wired for \$42.95 and in Simpli-Kit form for \$31.95.

General Description. The ignition system utilizes a two-transistor multivibrator whose operating frequency is set at about 8000 Hz. This frequency is high enough to prevent the synchronization problems that plagued earlier CDI system designs.

The multivibrator converts the 12-

volt vehicle electrical system potential to a square-wave ac signal. A transformer then steps up this signal and passes it to a full-wave rectifier-diode bridge to convert it to pulsating dc. Following the bridge is a 2.2- μ F storage capacitor that begins to charge up from the bridge's output signal.

A signal from the vehicle's breaker points triggers an SCR in the CDI system. This permits the storage capacitor to discharge its stored 400

volts through the car's ignition coil. A special RC network in the CDI system prevents the SCR from triggering during contact bounce.

With 400 volts applied to the ignition coil's primary, the output potential across the coil's secondary can reach 45,000 volts at idle and 30,000 volts during cranking and at high engine speeds. The duration of the spark is about 310 μ s, and about 0.15 joule of energy is contained in each pulse. This assures a very hot, short-duration spark that provides reliable ignition and long life for the vehicle's points, capacitor (condenser), and spark plugs.

The system has a built-in switch that allows the user to select CDI or standard ignition.

About the Kit. It took us about an hour to assemble the kit version of the Tiger SST. This time included preliminary voltage checks.

The multivibrator transistors arrived already riveted to a metal plate that serves as their heat sink. This plate assembly must be force-fitted into a channel at the top of the system's case. The heat-sinking action with this

setup allows the transistors to operate very cool. All other components, except the STD/CDI switch, mount on one printed circuit board. The switch comes already riveted to one of the end plates of the case. Exiting through the same end plate is a four-conductor ribbon cable.

Installing the system into an automobile required only a few minutes of work. First, we had to drill four holes, which permitted us to mount the compact 5"D x 4 1/2"W x 4 1/2"H (12.7 x 11.4 x 11.4-cm) unit on the engine side of a wheel well with self-tapping sheet metal screws. We then made the five necessary connections to make the system functional. The case of the unit was connected to chassis ground.

After this, we wired conductors from the CD ignition system to a +12-volt point in our car's electrical system, the vehicle's points, and to the positive (+) and negative (-) terminals on the car's ignition coil.

Performance Results. The difference between the standard and capacitive-discharge systems was quickly evident. (We installed the system in a 1974 car that has a full com-

plement of anti-smog devices that rob power and make operation balky.)

With the CDI system installed and switched on, our car's engine turned over immediately and warmed up quickly. Putting the transmission in gear, the engine seemed to call upon power reserves we never knew it had. And the engine began to run more smoothly than it had previously.

Having lived with the Tiger SST CD ignition system for over a year, we can make some long-range observations. We noted some increase in fuel economy, but we must caution that this will not necessarily occur with all cars or all drivers.

The car has now been driven with the CDI system switched in for more than 20,000 miles. Points and plugs are still in excellent condition, and the ignition coil and condenser have been given a clean bill of health. Moreover, the car's engine "catches" in less than a second of cranking, even after overnight exposure to wet weather and winter temperatures. Also, the engine never balks under load, even in high gear and on hills with moderately steep grades.

CIRCLE NO. 83 ON FREE INFORMATION CARD

You don't have to buy a new car to get an electronic ignition.

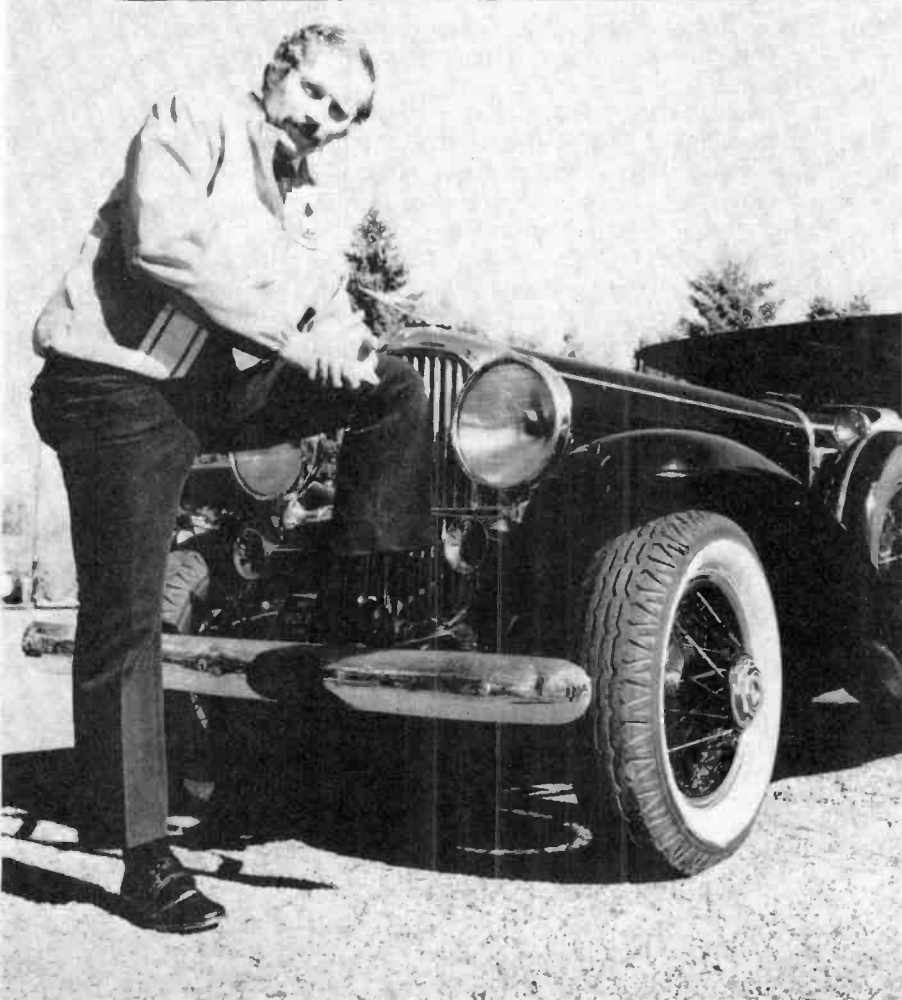

Most of you know the evaluation of automotive electrical systems . . . an evaluation characterized only occasionally by efficiency and performance. I know that, and that's why I use the Delta Mark Ten B CDI on all my cars, new and old. And believe me, you don't have to have a new car to appreciate the best electronic ignition available today. Study these features and you'll know what I mean.

1. Mark Ten and Mark Ten B Capacitive Discharge Ignition Systems are manufactured by Delta Products, Inc., a company with a conscience, and with a proven record of reliability both in product and in customer relations.
2. The Mark Ten CDI's really do save money by eliminating the need for 2 out of 3 tune-ups. Figure it out for yourself. The first tune-up or two saved pays for the unit, the rest is money in your pocket. No bunk!
3. Because the Mark Ten CDI's keep your car in better tune, you actually can save on expensive gasoline.
4. With a Mark Ten, spark plugs stay clean and last longer . . . fouling is virtually eliminated.



No matter what kind of car you drive, it too can use a Delta quality lift.

I want to know more about Mark Ten B CDI's. Send me complete no-nonsense information on how they can improve the performance of my car.

Name _____
 Address _____
 City _____ State _____ Zip _____



DELTA PRODUCTS, INC.

P.O. Box 1147, Dept. PE, Grand Junction, Colo. 81501
 303-242-9000

Mark Ten B, assembled	\$64.95 ppd	Standard Mark Ten, assembled	\$49.95 ppd
Mark Ten B, kit	\$49.95 ppd	Deltakit®	\$34.95 ppd

CIRCLE NO. 14 ON FREE INFORMATION CARD

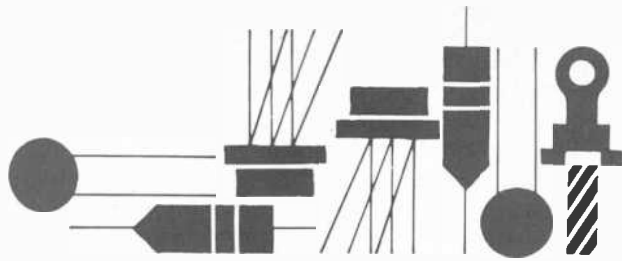

Solid State

By Lou Garner

OPTING FOR OP AMPS

CONSIDERED as a class, operational amplifiers are perhaps the most versatile of all integrated circuits. Depending on terminal interconnections, feedback, load, and similar factors, they can perform many different tasks. Op amps typically appear as differential amplifiers, voltage comparators, phono and microphone preamps, clippers, control amplifiers, voltage followers, pulse-width modulators, phase inverters, function generators, instrumentation amplifiers, multivibrators, pulse generators, summing amplifiers, integrators and differentiators, active filters, voltage or current regulators, peak detectors, buffers, sample-and-hold circuits, logarithmic converters, anti-log generators, and VCO's. And that's not a complete list!

These devices were among the first linear IC's to be produced commercially in large quantities. Although introduced back in the mid-sixties, many of the 'first generation' types are still available and have, to a degree, become industry standards. Semiconductor manufacturers often describe their newer devices by comparing them with such familiar old-timers as the 741. Teledyne Semiconductor's latest quad op amp, the 836, for example, is offered as an inexpensive, wide-band replacement for four 741's with similar general specifications, but more than twice the operating speed (i.e., slew rate).

When first introduced, op amp IC's were quite expensive, often costing more than similar circuits duplicated using discrete devices. Today, however, manufacturer's surplus types are available for less than a dollar, with even greater savings possible through the use of multiple units, such as quad devices (see "Applications for Quad Op Amps," "Experimenter's Corner," POPULAR ELECTRONICS December, 1975). Despite the relatively low cost of many popular general-purpose op amps, one can still invest a handful of cash in these units. If you want a very low-noise,

high-gain, extremely stable precision device with low drift and a broad temperature range (such as National Semiconductor's LH0044A), you could pay as much as thirty to forty dollars, or more, for a single op amp!

Interestingly, there are a number of applications in test and control instrumentation as well as in medical electronic equipment where the use of such expensive devices can be justified. Typically, precision op amps are used in strain-gauge bridges, thermocouple amplifiers, and ultra-stable reference amplifiers.

There are a number of excellent sources for op amp application data, including magazine articles and standard reference texts. Among the top sources are the technical specification bulletins and application notes issued by the various semiconductor manufacturers. For example, the five op amp applications illustrated in Figs. 1 and 2, can be found among a total of twenty-seven in the 12-page data bulletin for the 844/846 Series, published by Teledyne Semiconductor (1300 Terra Bella Ave., Mountain View, CA 94043). Among the other applications offered in the bulletin are clipping, instrumentation, and summing amplifiers; Wien bridge oscillators; an anti-log generator; integrators and differentiators; a bandpass filter; and several current sources.

Available in 8-lead TO-type metal cans, plastic miniDIP's, and standard 14-lead ceramic DIP's, the 844/846 devices are general-purpose op amps fabricated on a single monolithic silicon substrate using planar epitaxial technology. Suitable for use as plug-in replacements for such popular types as the 741, 107, and 101, the devices offer a guaranteed slew rate of $1.0\text{V}/\mu\text{s}$ (min.), an input bias current of 30 nA max., maximum input offset current of 5 nA , and offset voltage of 2 mV . The 844 is internally compensated, but the 846 is not, permitting the user to tailor the circuit's frequency response to meet application requirements. Both devices offer typical large-signal voltage gains of 300 V/mV and can supply output voltage swings of better than ± 12 volts with a ± 15 -volt dc source. Internal power dissipation ratings range from 500 mW with metal can packaging to 670 mW for the ceramic DIP version.

Typical Circuits. With potential applications in audio systems, electronic music, test equipment, and radio transmitters and receivers, the gain-controlled amplifier illustrated in Fig. 1A employs a 2N5163 n-channel FET in conjunction with an 844/846 op amp. (Note: for both circuits of Fig. 1, a 30-pF compensation capacitor is required if the type 846 is used). Pin connections are identified for the TO-type can and miniDIP packages, with the bipolar 12-volt supply connections made to pins 4 (-) and 7 (+). The circuit's gain control characteristics are determined by the size of the feedback resistor, which can range in

Fig. 1. Op amp applications: (A) gain-controlled amplifier; (B) notch filter.

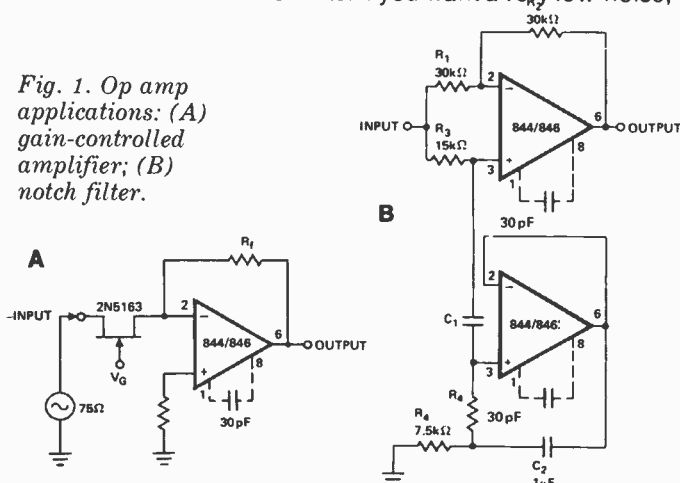

value from 10 to 47 kilohms. With a value of 10 kilohms, overall gain will vary from approximately 5 to 38 dB as the FET's gate voltage is shifted from -0.5 to -5.0 volts. With 47 kilohms, the range is from 20 to 52 dB using a similar control voltage.

The notch filter circuit given in Fig. 1B employs the 844/846 op amp as a gyrator. It can be used in audio test circuits, electronic music instruments, and similar applications. The filter's center frequency is determined by C_1 , ranging from about 20 Hz with a $1.0\text{-}\mu\text{F}$ capacitor to 2 kHz with $0.0001\text{ }\mu\text{F}$.

An astable multivibrator and low frequency square-wave generator employing the 844 are shown in Figs. 2A and 2B, respectively. The two circuits are designed for operation on bipolar 15-volt dc supplies. In addition to the op amp, the square-wave generator utilizes a pair of zener diodes (D_1 and D_2) to provide a clamped output signal. In both designs, the operating frequency is determined by C_1 .

Finally, a sine-wave oscillator using a pair of 846 op amps is illustrated in Fig. 2C. With a specified distortion level of less than 0.4%, this circuit could be used as an audio-signal generator, as a tone source for electronic music, or any similar application. The oscillator's output frequency is determined by R_3 and the values of feedback capacitors C_1 and C_2 . If $0.47\text{-}\mu\text{F}$ capacitors are used, the minimum and maximum frequencies are 18 and 80 Hz, respectively. With $0.1\text{-}\mu\text{F}$ capacitors, the coverage is 80 to 380 Hz, while $0.022\text{-}\mu\text{F}$ components will provide a 38-

Fig. 2. An op amp used as an astable multivibrator (A); square-wave generator (B); and sine-wave generator (C).

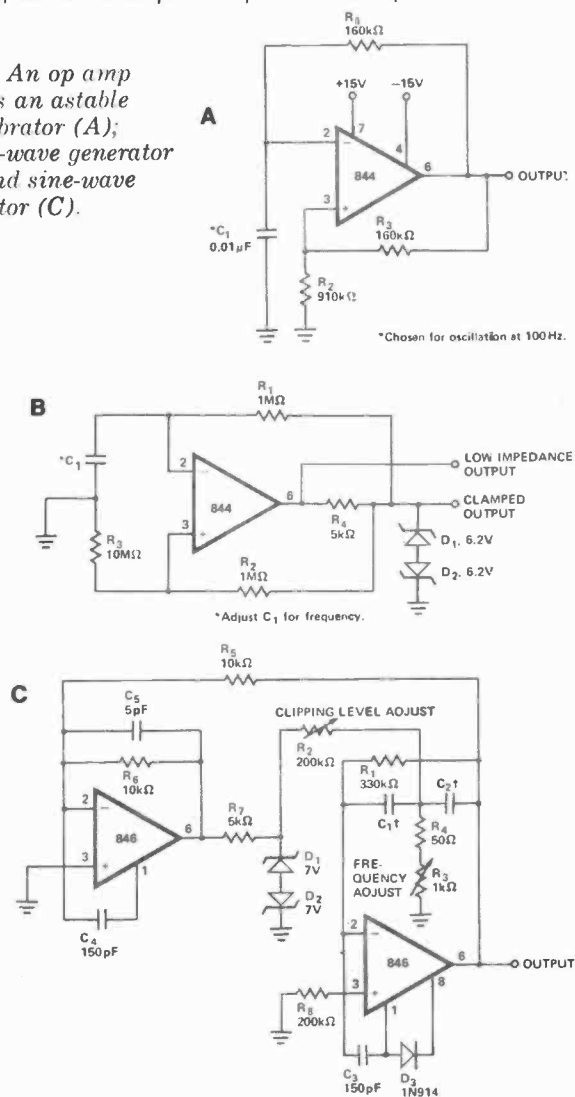

number one cb antennas by a country mile!

One reason why Antenna Specialists' CB antennas are the world's most popular is that it doesn't take a mechanic and three engineers to install 'em.

Our model M-176 Quick Grip,[®] for instance. Solderless connections. No holes to drill. Clamps to your trunk lid in seconds, yet it's a clean permanent installation with cable completely concealed.

And if you don't have a trunk, there are other A/S models equally simple to install for every vehicle known to man.

... all with the same highest quality components and workmanship that insure maximum range and long life.

**the antenna
specialists co.**



© "Stripes of Quality"
a member of The Allen Group Inc.
12435 Euclid Ave. Cleveland, Ohio 44106
Export: 2200 Shames Drive, Westbury, L.I., N.Y. 11590
Canada: A.C. Simmonds & Sons, Ltd.

**"look for the
stripes of quality"**



CIRCLE NO. 51 ON FREE INFORMATION CARD

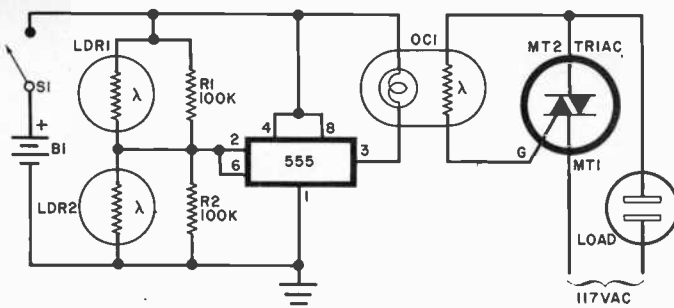

Fig. 3. An opto-coupler controls triac gate current.

1700-Hz range. Increasing the operating frequency is easily accomplished by further reducing capacitance.

Reader's Circuit. Add a dash of imagination and chances are you can think of a hatful of projects for the light-controlled switch shown in Fig. 3. Contributed by reader Ted Reiter (1442 Brook Dr., Titusville, FL 32780), the circuit utilizes a number of different solid-state devices—light-dependent resistors (LDR's), a 555 IC timer, an opto-coupler and a power triac. When activated by external light sources such as a flashlight or the sun, the circuit can be used for remote control applications as an intruder alarm or an automatic light or appliance switch (hot coffee with the rising sun, perhaps?).

The 555 serves as a bistable switch controlled by a pair of light dependent resistors, *LDR1* and *LDR2*. When the IC is in its high state, output terminal 3 is connected to the dc source, but in the low state, pin 3 is grounded. The battery-powered control circuit is effectively isolated from the ac line by *OC1*.

In operation, light striking one of the LDR's will switch the 555 from a high to a low state, or vice versa. If high initially, light striking *LDR1* causes a positive input pulse which switches the IC, activating *OC1* which in turn supplies a gate signal to the triac, switching this device on and applying ac power to the external load. If the IC is low, light striking *LDR2* will switch the device to high, deactivating *OC1*, thus removing the triac's gate signal and switching off the load.

In describing his circuit, Ted did not specify the type numbers of the LDR's or triac installed in his original model, indicating that a variety of devices can be used. Obviously different applications require varying sensitivity, while load requirements will vary with the nature of the switched device. Depending on the nature and intensity of the light source, either CdS or CdSe photocells could be used as sensing elements, but identical types should be used for both *LDR1* and *LDR2*. Ted suggests that a standard 100-V, 8-A triac is more than adequate for most applications, but it should be heat-sinked if used near its maximum ratings. Resistors *R1* and *R2*, are used to balance the LDR characteristics but if the LDR's are closely matched, the resistors will not be needed. At the user's option, either a 6- or 12-volt dc source can be used with the control circuit.

Neither lead dress nor layout is critical and the circuit can be assembled on pc or perf board or even on a small chassis. Some care is required in placing and mechanically mounting the LDR's, of course, so that both are not activated simultaneously by the light source. Small tubes, opaque shields, masks, or lenses can be used, depending on the specific application.

Device/Product News. Responding to the increasing

use of microprocessors and memory IC's, the Vector Electronic Co., Inc. (12460 Gladstone Ave., Sylmar, CA 91342) has developed a new DIP plugboard designed specifically to accommodate those devices. The board accepts two supply voltages, is copper clad on both sides for shielding and to supply primary power (positive on one side, negative on the other), with interwoven zig-zag lines (also on both sides) to facilitate power distribution. Designated as the Model 4350, the board will hold 63 14- or 16-pin DIP's or five 24-pin microprocessors and 45 DIP's. The 4350 is priced at \$14.95 each in unit quantities and is available from both local and mail order outlets.

A lever-actuated solid-state switch of interest to experimenters and hobbyists is now available from Optron, Inc. (1201 Tappen Circle, Carrollton, TX 75006). Identified as the type OPS 100 Optical Limit Switch, the device does not use mechanical switch contacts. Instead, the lever arm operates a shutter which interrupts a light beam between a GaAs infrared LED and an npn phototransistor, the latter generating an output signal (See Fig. 4). It can be used as either a normally open or normally closed spst switch, depending on a simple mechanical adjustment. A dc source is required for the LED.

The Fairchild Camera and Instrument Corp. (464 Ellis St., Mountain View, CA 94042) has announced a 2048-bit static n-channel RAM ideally suited for use with microprocessors. The new product, type 3539, is organized as 256 x 8 bits, and is available in two versions with maximum access times of 650 and 500 ns. Two separate chip-select inputs allow direct expansion to 512 bytes of memory. The device has a power dissipation rating of less than 500 mW, requires a single 5-volt power supply. It comes in a standard 22-pin DIP. The 3539 also features TTL-compatible inputs and outputs.

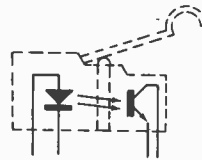
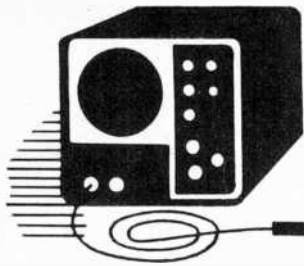

Fig. 4. Optron's OPS 100 optical limit switch provides bounceless electronic switching.

Fairchild's East Coast Imaging Systems Division (300 Robbins Lane, Syosset, NY 11791) has developed a third-generation charge-coupled-device (CCD) television camera offering considerably improved resolution over earlier models. The Model MV-201 has 244-line resolution and a bandwidth of 1.86 MHz. It is sensitive to as little as 0.000125 footcandle of illumination at the CCD elements. The camera weighs only 12 ounces and is 2" H x 2.5" W x 3.75" L. Interfacing directly with conventional TV monitors, the MV-201 requires only 4 watts at 12 volts.

If you're interested in the design and assembly of electronic musical instruments, you'll find it worthwhile to investigate the standard IC's offered by American Microsystems, Inc. (3800 Homestead Road, Santa Clara, CA 95051). Among the interesting devices available are the S2555 and S2556 top-octave synthesizers, the S2566 rhythm generator ROM, the S8890 rhythm generator, the S2567 resettable rhythm counter, the S2470 six-stage frequency divider, the S50240 series of top-octave synthesizers, and the S2193 seven-stage frequency divider. Unit prices range from \$4.50 for the frequency dividers and S2567 resettable rhythm counter to \$22.50 for the S8890.



Test Equipment Scene

By Leslie Solomon

USING YOUR OSCILLOSCOPE

MUCH of my mail has to do with questions about oscilloscopes and their use. Here are some common problems and, hopefully, their solutions.

Rise Time. How do you determine the rise time of a scope to find out how well it will work in making measurements in digital circuits?

First, you have to find the upper frequency at which the scope is 3 dB down. This can be done either by checking the manufacturer's specifications in the user's manual or by applying a signal and, after determining a graticule level at some intermediate frequency, raising the input frequency until the display is about 30% smaller. This will be the approximate 3-dB point.

Assume that the scope has a bandpass of about 5 MHz at 3 dB down. Since the period is the reciprocal of the frequency ($T=1/f$), the period comes out to 0.2 microsecond at 5 MHz, and a third of this at the 3-dB down point or 0.06 microsecond. This means that the scope will display a rise time of 0.06 microsecond. So you can see why most people want a scope that will go to about 10 MHz.

Ring and Overshoot. Some people apply square waves to an oscilloscope to try to establish the rise time. However, they notice "spikes or wobbles" along the upper and lower portion of the waveform. This effect is called "overshoot" or "ringing." In many cases, overshoot is followed by ringing, but not always. Other times, overshoot occurs only at one edge. However, no matter how you slice it, overshoot and ringing produce signal distortion.

The amount of overshoot can be determined by making a calculation based on the type of trace shown on your scope. With a square-wave input at some known value (as measured on

the scope), determine the overshoot level. Divide the amount of overshoot by the main signal level and multiply by 100 to find the per cent of overshoot. The scope with the smallest overshoot is the best.

Amplifier square-wave response may often show overshoot coupled with ringing, overshoot with tilt, and overshoot with both ringing and tilt. In many cases, overshoot is the price paid for trying to improve the rise time, while ringing is usually caused by inductance in the signal path (such as occurs with peaking coils in broadband amplifiers). In many low-cost scopes and many TV receivers, the high-frequency response of an amplifier is extended by inductors.

Linearity. What if the vertical and horizontal amplifiers in your oscilloscope don't "work" together the way they should? This is particularly important when checking phase relationships with Lissajous figures.

To find out, connect the scope ground to an audio signal-generator ground. Then connect the hot lead of the signal generator to both the vertical and horizontal inputs (use external horizontal input on the scope). Adjust the scope's vertical and horizontal gains for a balanced diagonal line around the graticule zero crossing. If this line is straight, the scope amplifiers are linear and can be used for phase measurements. If, however, the line has a bend in it, the scope amplifiers are nonlinear, and this fact can affect phase measurements.

Light Emitting Diodes. Changing the subject slightly, we have also been asked whether it is possible to use a LED as a voltage dropper in a piece of test equipment instead of a conventional diode.

The idea, of course, is to obtain the voltage-dropping function and, at the same time, have a power-on pilot light. This can be done, but there is a small catch. What is the drop across the LED?

To find out, assemble a series circuit of a 5-volt dc power supply, a couple of 100-ohm resistors for current limiting and a holder for inserting an LED. Measure the voltage across the LED when it is glowing. (You may have to vary the series resistor to get the amount of glow you want.) Try this on several different LED's from different manufacturers and of different colors. You will note that the voltage drop can be as high as 3 volts. ♦

the PROFITMETER

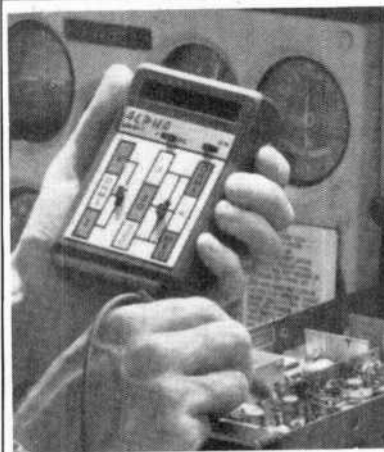

AUTO ZERO/POLARITY 3½ DIGIT MULTIMETER KIT WITH BRIGHT RED LED DISPLAY

On the Service Bench or in the Field. Wherever and whatever the job, you'll need its battery operated portability and its high accuracy: .1% DCV & OHMS, 1% Current and ACV.

\$79.95 +2.95 P & H
LESS TEST LEADS
& BATTERIES



ALPHA ELECTRONICS
DEPT 1 PO BOX 1005
MERRITT ISLAND, FLA. 32952

TO ORDER OR FOR INFORMATION
CALL
305 - 636 - 6951

Have you ever asked yourself, "Can I make it in Electronics?"

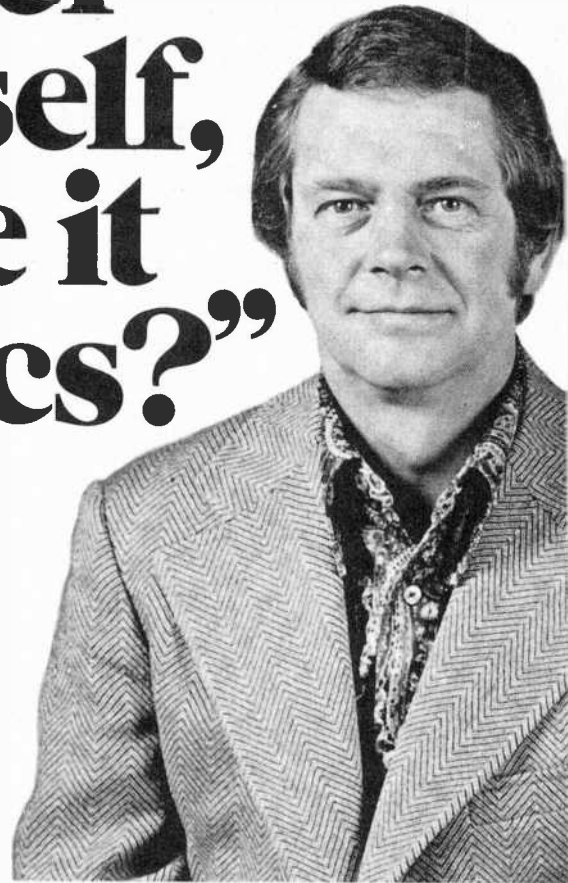

CIE may be the answer if you have a technical aptitude and a serious desire to get ahead.

Right now, you're reading a technical magazine with articles that require a certain amount of electronics know-how. And that says a couple of things about you.

First, you're involved in Electronics . . . on the job, or as a hobby.

Second, you obviously realize the importance of staying up-to-date on the latest technical applications and developments. Reading a technical magazine *helps*, but it takes more than that to get you where *you* want to be . . . if you're serious about Electronics.

How can you afford

. . . *not* to continue with your electronics training?

You know the answer to that as well as we do.

To achieve continuing success, you have to keep building more knowledge into the Electronics background and experience you already have. You have to sharpen the tech skills you've already got and add new ones.

And one of the most logical ways for you to get what you need is to seriously consider an in-depth electronics training program that could help you achieve your ambitions in Electronics.

How can you afford

. . . the time and trouble of going back to school?

An excellent and *convenient* way for you to develop and expand your electronics knowledge is to "let the *school* come to *you*."

CIE's independent education plan does just that. Because we can effectively train you with an "education by mail" electronics training program that makes sense. And it makes sense for these reasons:

You can master *career* Electronics without missing one day of work. Without sacrificing one paycheck! Because you study in your free time . . . setting the study pace that best fits your schedule. *You* decide when and where *you* want to study. So you can go right on enjoying your leisure time because there are no *rigid* classroom schedules to be met. *You're* in control!

How can you afford

. . . the expense of the additional education you need?

A lot depends on which CIE course best fits your educational goals and background. We have a variety of electronics courses at beginner, intermediate, and advanced college-level. And there's a convenient payment plan available for every course. But, one way to evaluate your investment in CIE is this . . . you can *graduate* from CIE for about the cost of one year's tuition at some colleges or universities.

How can you afford

. . . to learn Career Electronics from anyone other than an electronics *specialist*?

If you are *serious* about your career in Electronics, you owe it to yourself to investigate *the* home study school that devotes its entire curriculum and instructional efforts to Electronics. That's CIE — Cleveland Institute of Electronics.

We have *specialized exclusively* in Electronics education-by-mail for more than 40 years. Just Electronics. Nothing else. And, the courses we offer today are the result of these years of teaching experience and proven methods of training . . . all based on the expert guidance of our



specialized Electronics Instruction Staff. Our lessons reflect this specialized experience. No frills. No unnecessary fancy stuff. Instruction is thorough . . . designed to meet the demands of electronics employers.

Each CIE course is built on the principle that the best way for you to *learn* and *retain* what you've learned is to *explain*; then to *check* your understanding; then to *reinforce* your comprehension with practical applications. In some courses, you will perform experiments and tests with your CIE Experimental Electronics Laboratory using authentic electronic components and gear. And, if you select a course that includes Color TV technology, you will not only build and keep a big screen Color TV which features digital circuitry . . . you'll also learn how to troubleshoot your TV.

The course you select will be a complete educational program, designed by *experts* to give you the best in Electronics independent home-study education. It will not be a "snap" course. No easy exams. It will make you work . . . and think. So that when you've earned your CIE Diploma, you'll *really* know your stuff.

In education just like in the "real world" of Electronics, your success depends on you and the effort you make. That's a real plus in CIE independent home-study . . . you build a strong foundation of self-discipline. And *that* pays off!

How can you afford . . . to stop now?

There is a lot more to CIE than this advertisement can tell you. And because you're looking for the *best*, we think it's well worth your while to find out what CIE is

all about. Detailed Courses of Study outlines. In-depth training programs in Electronics Technology, Broadcasting, Industrial, Color TV, Engineering, and 1st Class FCC License preparation. Special CIE Student Services.

All this information is available to you, FREE, when you mail the card or coupon to us. For your convenience, we'll try to have a school representative contact you to review the benefits of CIE training and assist in course selection. And as soon as we hear from you, we'll mail a complete package of information, including our school catalog, G. I. Bill details, special FCC License information. All the facts you need to start your Electronics career program with CIE.

Send TODAY for CIE'S FREE information.

CIE **Cleveland Institute of Electronics, Inc.**
 1776 East 17th Street, Cleveland, Ohio 44114
Accredited Member National Home Study Council

Yes, I want your FREE school catalog and career information package today.

I am especially interested in: PE-94

Electronics Technology Industrial Electronics
 FCC License Preparation Electronics Engineering
 Color TV Maintenance Other _____
 Mobile Communications _____

Print Name _____

Address _____ Apt. _____

City _____

State _____ Zip _____ Age _____

Check box for G.I. Bill information. Veteran On Active Duty

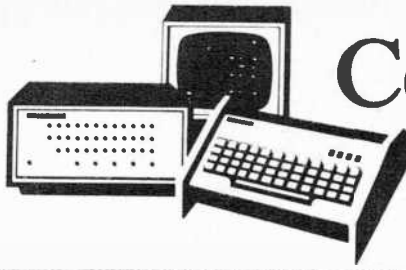

Computer Bits

By Robert M. Marsh

the simplest way of recording data, where data "1" is the presence of a tone and data "0" the absence of a tone, as shown in Fig. 1B. Because this system is basically an amplitude-modulation scheme, and very susceptible to noise, reliability suffers above 150 bits per second.

Pulse-width modulation may be recorded in its pure form (Fig. 1C) or as a burst of tone with varying duration, as used in the HIT system (Fig. 1D). Both methods are self-synchronizing and are highly independent of speed and amplitude variations. However, in the original HIT proposal, data was recorded synchronously so that each data word had to follow the previous word immediately, thus making HIT impractical for use with stand-alone asynchronous terminals such as TV typewriters and teleprinters. In addition, "pure" pulse-width modulation is patented as a data recording method, which might be seen as a drawback by manufacturers.

Ordinary *frequency shift keying* (FSK), shown in Fig. 1E, is by far the most common method used to transmit data over phone lines and radio links. It would be a useful feature of a cassette recorder interface if it could transmit data over phone lines as if it were a FSK Bell-103 compatible modem. However, while FSK is fairly insensitive to AM noise and level changes, it is susceptible to loss of data when overall frequency changes exceeding $\pm 5\%$ of the nominal value occur. The 5% frequency, or speed tolerance is not sufficient for reliable data storage on many cassette re-

COMPUTER USERS TAPE SYSTEM

THE LACK of standardization is the bane of many industries. For example, three basic four-channel audio systems (SQ, QS, and CD-4), instead of a universal system, have impeded progress in that field. The same holds true for computer hobbyists, where a host of methods for exchanging programs or data have been introduced, including the HIT system published in POPULAR ELECTRONICS, September 1975.

Rather than stifle this user-created "program explosion," a group of hobby computer manufacturers and other interested parties (POPULAR ELECTRONICS, among them), met in Kansas City, MO, last November to explore standardization in general and hopefully to agree on a single method of recording data. There was general agreement that cassette tape represented the best route to go for a hobbyist computer-data exchange system. These tapes are low-cost and widely available, and cassette machines are owned by most people.

The use of inexpensive cassette recorders was not viewed as a serious limitation as long as the record/playback exchange method adopted allowed for certain inherent machine deficiencies. The two most common considerations with low-cost cassette machines are: (1) the automatic level control incorporated in some machines, and (2) variations in average speed, nominally $1\frac{1}{8}$ inches/second. Both drawbacks could be easily overcome, it was decided.

Another important consideration in using low-cost cassette tapes is that some tapes would likely cause drop-outs (momentary loss of signal) due to a lack of uniform distribution of oxide particles. At this time, the user would have to "certify" the best tape brand and model for him to use. There are also "data cassettes" certified by tape manufacturers. Prices are not too much higher than those for consumer premium tapes.

Cassette Data Recording Methods. Various methods have been used by computer enthusiasts and manufacturers to record data on audio cassette recorders. These fall into five categories: (1) simple tone burst, (2) pulse-width modulation such as used in the POPULAR ELECTRONICS HIT program, (3) frequency shift keying (FSK) as used in radio-teletypewriter or phone-line communications modems, (4) double-frequency pulse recording as used in most floppy disc systems, and (5) phase encoding as used in ANSI standard magnetic tape transports of all major computer manufacturers.

Most of these methods record data serially; that is, one bit after another. Serial recording requires a conversion from parallel to serial form (and vice versa) when used with a computer. Fortunately, most computers and terminals already have a standardized serial communications channel that transmits in a form called "non-return to zero" (NRZ), shown in Fig. 1A.

Tone-burst (or cw) recording may be

Fig. 1. Methods of recording data on cassette recorders.

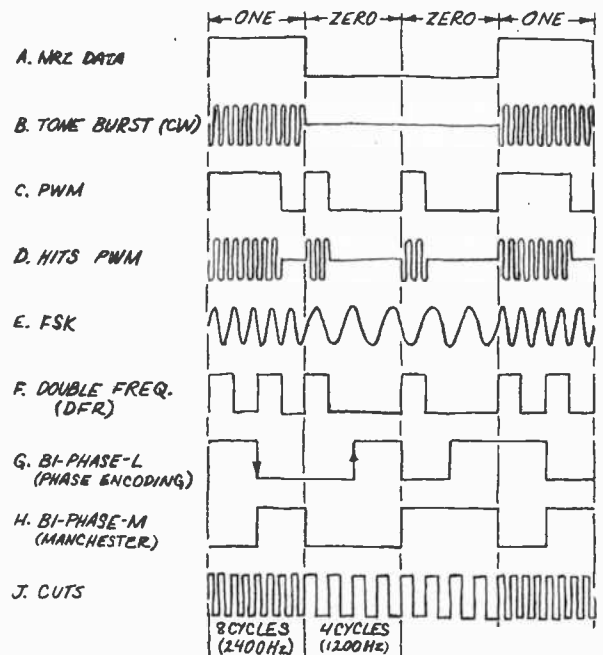

corders. In addition, FSK is more expensive to implement than many other methods.

Double-frequency recording (DFR), shown in Fig. 1F, is often used on disc memories at high data rates. When used on a cassette, however, it requires a relatively high bandwidth for a given data rate. This method is insensitive to speed variation since each bit is self-clocked, but it is only moderately free from problems created by noise and amplitude changes. DFR is, therefore, not as reliable as other methods at data rates higher than 500 bits/second, making future expansion and improvement difficult.

Phase encoding has many variants and has been in use in many different types of magnetic tape data systems for many years. The most common forms are Bi Phase-L, usually called "phase encoding," and Bi Phase-M, often called "Manchester" code. Both methods are self-clocking and, at first

glance, resemble simplified FSK. In fact, phase modulation does create a form of frequency modulation. All phase-encoded methods are independent of frequency changes over a wide range, and can be made highly resistant to AM noises and level shifts.

Bi Phase-L is shown in Fig. 1G. You can see that there is a transition in the middle of each bit cell and that the polarity of the transition determines whether the bit is a logic 1 or 0. Bi Phase-M, or Manchester, shown in Fig. 1H, has a transition at the beginning of each bit cell. Logical 1's have another transition in the middle of the cell, whereas logical 0's do not.

Manchester code is extremely easy to generate, decode, and synchronize, and is the basis for the CUTS (Computer Users Tape System) recording method proposed as an outgrowth of the meeting in Kansas City.

The CUTS method employs a variation of the Manchester code in which a

COMPARISON CHART

	Level, Noise Tolerance	Frequency, Speed Tolerance	Self clocking	Cost*	Future Upgrading**	Remarks
CW (Fig. 1B)	Poor	Poor	No	Very Low	No	Susceptible to noise. Reliability suffers over 150 baud.
PWM (Fig. 1C)	Good	Very Good	Yes	Low	To 1500 Baud	Patented. Requires higher bandwidth than Bi-phase for same baud rate.
HITS (Fig. 1D)	Good	Very Good	Yes	Low	To 600 Baud	Requires higher bandwidth than CUTS for same baud rate (see PE, Sept. 1975).
FSK*** (Fig. 1E)	Very Good	Poor-Fair	No	Moderate	To 450 baud (with Bell 103 tones)	Can be transmitted over phone lines to any modem.
DFR (Fig. 1F)	Moderate	Good	Yes	Low to Moderate	To 800 Baud	See "Computer Hobbyist" Vol. 1, No. 5, 6, 1975.
Bi-Phase-L (Fig. 1G)	Very Good	Very Good	Yes	Low to Moderate	To 1500 Baud	Proposed ANSI standard. Subject to phase inversion.
Bi-Phase-M (Fig. 1H)	Very Good	Very Good	Yes	Low to Moderate	To 1500 Baud	Widely used. Easily decoded.
CUTS (Fig. 1J)	Very Good	Very Good	Yes	Low	To 1200 Baud	Very easily decoded. Can be transmitted by phone to other CUTS units.

*Cost is estimated for devices which do not require a CPU for reading and writing. Cost may be quite low if CPU decodes mostly by software.

**Future upgrading implies minimal hardware modification at low cost.

***Especially Bell-103 compatible.

MARCH 1976

THE BOOK



Now available for \$25

Thousands of copies of our innovative book on microprocessors, published in 1974, were purchased by engineers and designers around the world . . . for \$75 each. Now **Microcomputer Design**—revised, expanded, and reprinted in paperback—is available for \$25! Over 400 pages on quality white text paper, including:

- 8080 circuits, theory of operation
- Vectored interrupts, for all 8-bit CPUs
- Efficient bus structure design
- Interfacing to timers, A/D converters, keyboards, digits, and other I/O
- Plus much more!

SPECIAL—The **MIKE 2 Manual** is a complete guide to our 8008-based micro, with schematics, theory, and software listings for the **MONITOR 8** operating system. Over 150 pages long, the Manual normally costs \$25. Now, **Microcomputer Design**, plus this Manual, only \$30! Applies to prepaid orders received before April 1, 1976.

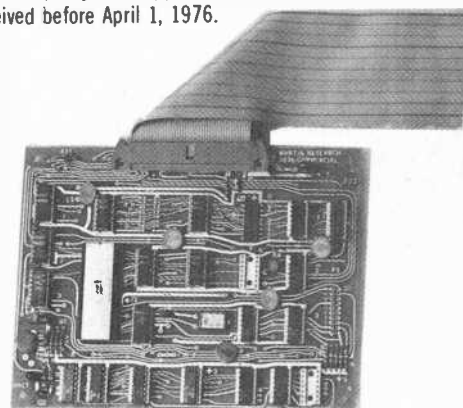

The **MIKE 3** typifies the modular micros from Martin Research: an optimal small system, yet fully expandable. The AT813 includes the 471 CPU board with 8080A; memory board with Monitor PROM, 512 bytes RAM; keyboard and six LED digits . . . only \$395. More memory? AT405-4 RAM board, with 4K of 450 ns high-speed RAM, now only \$195. All first-quality parts; all units assembled, tested, and guaranteed.



martin research

3336 Commercial Ave.
Northbrook, IL 60062
(312) 498-5060

Bank Americard, Master Charge accepted.
U.S. prices; foreign delivery extra.

Now: available through Semiconductor Specialists!

CIRCLE NO. 32 ON FREE INFORMATION CARD

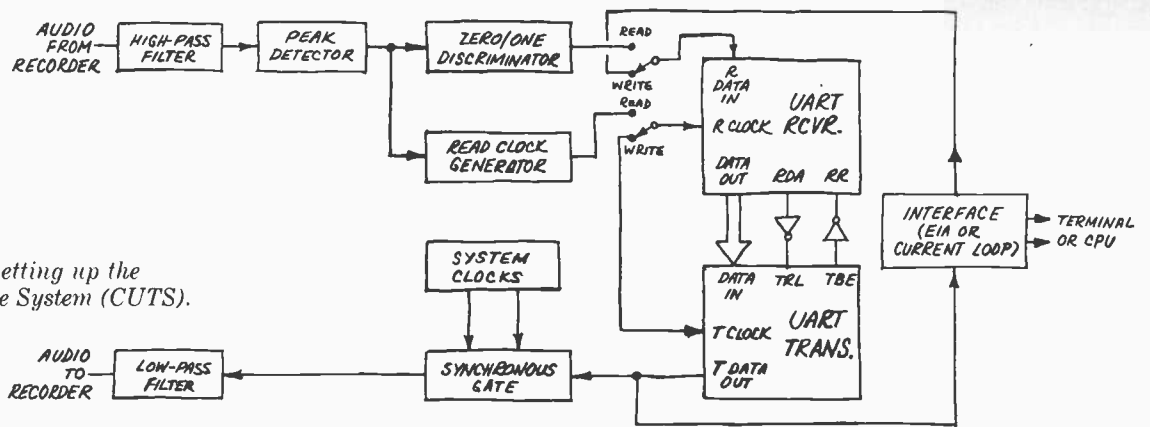

Fig. 2. One way of setting up the Computer Users Tape System (CUTS).

logical 1 consists of eight cycles of 2400 Hz, and a logical 0 is four cycles of 1200 Hz. A 4800-Hz clock is derived from the recorded data itself as the tapes are read, and is used to clock a UART (Universal Asynchronous Receiver Transmitter) which performs the serial/parallel and parallel/serial conversions necessary to interface with the computer's data bus. It is not necessary to use a UART. Also, in some simple applications, a less expensive circuit can be used.

The standard data rate is 300 bits/second, and can be expanded to 600 or even 1200 bits/second with slightly higher error rates. Each bit is self-synchronizing because every bit time frame starts with a positive transition and contains an even number of tone cycles. Each data character is resynchronized by a logic 0 start bit that precedes the data bits. Therefore, data can be transferred asynchronously from any computer, terminal or modem with a serial data channel, as long as the serial channel is set up for 300 bits/second, eight data bits, and two "stop" bits.

Recording Method. The following specifications were adopted with the goal of optimizing versatility, reliability, low cost, and future expandability.

Mode: asynchronous by character.

Character Format: 11 bits; one start bit (a 0); least significant data bit first (if less than 8 bits are used as with Baudot 5-level code, then all bits not specified by the code will be set to 1). The interval between characters, if any, will be 1's.

Modulation Method: 1's will be 8 cycles of 2400 Hz; 0's will be four cycles of 1200 Hz tones. Sine-wave signals are preferred, although not always necessary.

Leader: Five seconds of continuous 2400 Hz (all 1's) will precede any block of valid data. At least 30 seconds of

continuous 2400 Hz should be recorded at the beginning of each cassette. When multiple blocks are recorded, there will be a 5-second gap between them.

Motor Control: The interface should provide for switching the tape recorder motor so that the computer can start and stop the machine under program control.

Basic Circuit. One suggested approach to mechanizing the CUTS system is shown in Fig. 2. In the write mode, data is accepted from a terminal EIA/current loop interface and converted from serial to parallel by the UART receiver. The parallel data is transferred to the UART transmitter when a complete data character is received. The UART transmitter then converts the signal to serial form to gate either a 2400-Hz tone for 1's or a 1200-Hz tone for 0's. The tones are then passed through an output filter which rounds off the waveform and reduces the output level to about 0.5-volt peak-to-peak. This signal is then passed to the tape recorder auxiliary (or microphone) input for recording on the cassette.

In the read mode, the output from the recorder earphone jack is filtered to remove any low-frequency noise, and the waveform is squared up and synchronized with the system clock by the zero/one discriminator. The clock signal for the UART receiver is derived from the recorded information itself by the read clock generator. Parallel data from the UART receiver is transferred to the UART transmitter when a complete character is received. The reconverted serial data is then coupled to the terminal or CPU via the appropriate EIA or current loop.

Data transmitted from the computer or terminal could be sent directly to the synchronizing gate during write operations, but successive serial/

parallel and parallel/serial conversions guarantee an accurate 300 bits/second data rate. This type of conversion and reconversion effectively eliminates the possibility of cumulative speed errors when duplicating tapes, and makes for a cleaner and more precise signal whether reading or writing.

Based on observations made at the meeting, most manufacturers agreed to shelve their personal systems for the good of the industry, although some might still offer their systems, with CUTS made available as an alternative.

More Hobbyist Clubs. Here are additional computer hobbyist clubs reported to us.

California

Bay Area Microprocessor Users Group, 4565 Black Ave., Pleasanton, CA 94566.

29 Palms Area, Sgt. Wesley B. Isrigg, 74055 Casita Dr., 29 Palms, CA 92277 (address change).

Colorado

Denver Amateur Computer Society, P.O. Box 6338, Denver, CO 80206.

Georgia

Atlanta Area Microcomputer Hobbyist Club, Jim Dunion, Pres., 421 Ridgecrest Rd., Atlanta, GA 30307.

Illinois

Computer Hobbyist Exchange, P.O. Box 36, Vernon Hills, IL 60061

New Jersey

Amateur Computer Group of New Jersey, Union County Technical Institute, 1776 Raritan Road, Scotch Plains, NJ 07076

New York

Long Island Computer Club, c/o Popular Electronics, One Park Ave., New York, NY 10016

Texas

El Paso Computer Group, Jack O. Coats, Jr., 213 Argonaut, Apt. 27, El Paso, TX 79912. ♦

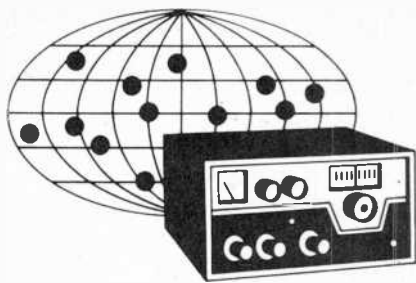

DX Listening

By Glenn Hauser

SHORTWAVE NEWS FROM ALL OVER

DX LISTENERS in western North America have long felt frustrated by their inability to hear one of the nearest radio countries—Turks & Caicos Islands (in the Bahamas chain). VSI Radio's afternoon show on 4.788 MHz—in a band requiring darkness between transmitter and receiver—usually ends not later than 0030. (All times are GMT.) But now, Marlin Field in Michigan reports a morning program around 1130, when propagation is possible to the farthest shores of the Pacific. Whether 750 watts will cut through the QRM is another matter.

Radio Swan de Honduras started out on 6.185 MHz, but Jack Jones who discovered them, reports a switch to 6.000 MHz—obviously to strengthen their tenuous ties to the original Radio Swan, which used that channel. Radio Swan may be just the vanguard of growing SW activity in that country. Visiting Honduras, Scott Reeves learned that a leading Honduran presidential candidate was planning to add 6.145 MHz to his Radio Ceiba outlet early this year, and put his other stations on SW too. Jones reports another Honduran on 4.870 MHz.

Colombia-watcher Adam Gaffin of Brooklyn, N.Y., says the Colombian government is cracking down on what was once one of the most free-wheeling broadcasting scenes in Latin America. If the 60-meter band becomes a bit tamer, it may be because Colombian stations have been forbidden to criticize government or church officials.

Mexico, *Colombia* and *Venezuela* have all staked out channels on the 19-meter band, but only *Venezuela* has shown signs of a truly international approach, with an occasional Arabic program at 1300-1400, and English at 2200-2300 on Radio Nacional, 15.400 MHz. *Colombia* relays its official domestic program on 15.336 MHz; and *Radio Mexico*'s English pro-

gramming on 15.384 MHz has been limited to appeals for reception reports. John Fischer, Jr., of New York theorizes they do this from time to time to prove to their funding agency that they have an audience abroad. Meanwhile, reception reports pile up, unanswered, as a contact of John Tuchscherer's found when he visited the station.

Brazil has big plans for international broadcasting. Eight 250-kW transmitters are being built in strategic locations, and Brazilian commercial stations expect to have to turn over some of their frequencies to Radio Nacional—Brasilia. So far, RNB has only one on the air at 11.780 MHz (with 15.245 and 9.605 MHz as alternates) with an English hour at 2100. Among the feature programs are: Mon. Science on the March; Tue., Travelling Through Brazil; Wed., The Versatile Guitar; Thurs., Strange & Curious Aspects of Brazil; Fri., People & Events; Saturday Special; Sun., Retrospective—per a schedule sent to David Snyder in Brooklyn.

New Zealand also is contemplating going big time with 250 kW instead of 7.5 kW—but, even so, Radio New Zealand is surprisingly well heard on their beam toward Hawaii and Alaska at 0500-0745 on 9.540 and 11.780 MHz. Check for the Mailbag program, Fridays at 0615. Times change to an hour later in March.

Belgium has announced plans to cease broadcasting to the western hemisphere after the first week in March. Although the 20-minute English program was just a token successor to their 1958's World's Fair Radio, and was hard to receive in the interior, Jackie Marshall's friendly voice will be missed. But we've already gained a new English broadcast to North America, from the Voice of Greece—also tough to hear, but try for 15 minutes at 1215, 1515, 0015 or 0215 on 9.520 MHz.

Those who prefer English-language programs must sometimes make do with language lessons from stations not otherwise broadcasting in English—such as Algeria, which has "Brush Up Your English" Wednesdays around 1420 GMT on 17.825, 11.910 and 9.510 MHz—all frequencies likely to vary greatly. For Spanish from Algiers, tune to the clandestine "Voz de la Resistencia Chilena" program at 2300-2400 on 7.1431 MHz.

North Korean clandestine "Voice of the Revolutionary Party for Reunification" ambitiously has begun English broadcasts at 0530-0600 and 2300-2330 on 4.5515 MHz, as monitored by Kouji Yamada in Tokyo, but not likely to be heard here. Realizing that 1230-1250 is an ideal hour to reach North America, VRPR has a Thursday program for "our compatriots in the US", also on 4.115 MHz—in Korean.

Tirana's tirades make it a station most Americans avoid with a passion. But Kim Andrew Elliott of Minneapolis has found a way to enjoy listening to Radio Tirana! He recommends the musical portions of the incomprehensible Albanian-language program at 0030-0100 on 6.200, 7.300 or 9.790 MHz—especially *Tosk* music, raspy a *cappella* chanting, not to be confused with more conventionally Balkan Geg music.

DX-Program aficionados find Soviet-bloc versions rather dull. Unlicensed SWL'ing and DX'ing is suspect, so DX programs from the USSR, Bulgaria and Romania take the amateur angle—which is licensed and permitted. But Radio Budapest exercises more freedom, reading lists of DX loggings, including even evangelical stations. Though admitting its main aim is political, Radio Kiev encourages listener feedback on programs, and hopes to expand to daily English broadcasts, says Mike Barracough of England who paid them a visit. Try for the Kiev DX program on the second Monday of each month (following Tuesday GMT). Radio Tashkent, Uzbek SSR, is reported to have begun a ham-type DX program on the second Sunday of the month at 1215—currently on 6.025, 9.540, 9.600 and 11.925 MHz.

Another DX program you're likely to miss if you aren't careful is from Deutsche Welle. Strangely, their one English segment is broadcast during its *German* transmissions, in consecutive translation. Check the second Saturday of the month at 2350 on

FREE catalog

over 2000



unique tools,
handy kits,
precision
instruments,
technical
supplies.

Our 23rd year of service to the World's finest craftsmen and technicians.

A carefully selected and tested assortment of unique, hard-to-find tools, clever gadgets, precision instruments, bargain kits. One-stop shopping for the technician, craftsman, hobbyist, lab specialist, production supervisor. Many tools and measuring instruments available nowhere else. One of the most unusual and complete tool catalogs anywhere. Get your copy of the NC FLASHER today.



National Camera

2000 West Union Ave., Dept. GGA
Englewood, Colorado 80110
(303) 789-1893

CIRCLE NO. 35 ON FREE INFORMATION CARD

free

BA 1976 catalog



244 PAGE
RADIO, TV &
ELECTRONICS
CATALOG

Your buying guide for Everything in Electronics ... Stereo, Hi-Fi, TV's, Radios, Tape Recorders, CB, Kits, Tools, Books and Electronic Parts.

**WRITE FOR YOUR
FREE COPY NOW!**

burstein-applebee

DEPT. PE PE-3 3199 MERCIER ST.
KANSAS CITY, MO. 64111

NAME _____
ADDRESS _____
CITY _____
STATE _____ ZIP _____

6.145 MHz and many others, repeated at 0350 on 6.085 and 9.605 MHz, among others.

Odds and Ends. If you're just getting started in SWL'ing, most of your questions are answered in the new book, *DX According To NASWA*. You can order it postpaid for \$3.00 (in North America) from North American Shortwave Assoc., Box 13, Liberty, IN 47353.

Updating some items in the 1976 Communications Handbook: Now there's evidence the Spanish numbers spout from Cuba, rather than the USA. Several DX'ers report hearing the ciphers mixed with Radio Habana audio, which points to a common transmitter site—unless ionospheric cross modulation is involved. And the "4Y" Ocean Weather Stations have been closed down. ♦

ENGLISH-LANGUAGE SHORTWAVE BROADCASTS FOR MAR. & APR.

By Richard E. Wood

TO EASTERN NORTH AMERICA

TIME—EST	TIME—GMT	STATION	QUAL*	FREQUENCIES, MHz
6:00-6:30 a.m.	1100-1130	Tirana, Albania	F	9.48, 11.985
6:00-7:00 a.m.	1100-1200	London, England	G	15.07
6:00-9:00 a.m.	1100-1400	**VOA, Washington, U.S.A.	G	5.955, 9.73
6:15-7:15 a.m.	1115-1215	Montreal, Canada	G	5.97
6:15-7:45 a.m.	1115-1245	Melbourne, Australia	G	9.58
7:00-7:30 a.m.	1200-1230	Jerusalem, Israel	F	15.10, 17.815
7:00-7:55 a.m.	1200-1255	Peking, China	F	11.685
7:00-8:15 a.m.	1200-1315	London, England	G	15.07
7:15-7:30 a.m.	1215-1230	Athens, Greece HCJB, Quito, Ecuador	P G	9.52 11.745
7:30-8:00 a.m.	1230-1300	Stockholm, Sweden	G	15.305
7:30-11:30 a.m.	1230-1630	HCJB, Quito, Ecuador	G	11.745, 15.115
8:15-8:45 a.m.	1315-1345	Berne, Switzerland	G	15.14
9:00-9:30 a.m.	1400-1430	Stockholm, Sweden Helsinki, Finland	G G	15.305 15.185
10:00-11:15 a.m.	1500-1615	London, England	G	17.84 (via Ascension)
3:00-3:55 p.m.	2000-2055	Jerusalem, Israel	G	5.90, 7.395, 9.815
4:15-5:45 p.m.	2115-2245	London, England	G	9.58 (via Ascension), 11.78, 15.26 (via Ascension)
4:30-5:50 p.m.	2130-2250	Hilversum, Holland	G	9.715, 11.73 (Sun.: Dutch)
5:30-6:00 p.m.	2230-2300	Vilnius, U.S.S.R.	G	5.94, 7.31, 7.355, 7.44 (Sat./Sun.)
5:30-6:20 p.m.	2230-2320	Johannesburg, S. Africa	G	5.98, 9.585, 11.90, 11.97
5:45-11:30 p.m.	2245-0430	London, England	G	5.975, 7.325, 9.58 (via Ascension)
5:55-6:15 p.m.	2255-2315	Brussels, Belgium	G	9.73 (subject to cancellation)
6:00-6:30 p.m.	2300-2330	Stockholm, Sweden	F	6.035, 9.605, 11.705
6:00-7:30 p.m.	2300-0030	Moscow, U.S.S.R.	G	5.94, 7.105, 7.115, 7.15, 7.205, 7.355, 7.40, 7.44, 12.05, 15.14, 15.18, 15.455, 17.72
6:45-7:45 p.m.	2345-0045	Tokyo, Japan	F	15.27, 15.30
7:00-7:25 p.m.	0000-0025	Tirana, Albania	G	7.065, 9.78
7:00-7:30 p.m.	0000-0030	Oslo, Norway	P	6.18 (Sun.)
7:00-7:55 p.m.	0000-0055	Peking, China Sofia, Bulgaria	F F	11.945, 15.06, 15.52, 17.673 9.70
7:00-9:00 p.m.	0000-0200	**VOA, Washington, U.S.A.	G	6.13, 9.65, 11.71, 15.205
7:15-7:30 p.m.	0015-0030	Athens, Greece	P	9.52
7:30-8:00 p.m.	0030-0100	Kiev, U.S.S.R.	G	6.02, 7.15, 7.26, 9.78, 12.05, 15.14, 15.18, 15.455 (Mon./Thu./Sat.)
		Vilnius, U.S.S.R.	G	5.94, 7.355, 9.53, 9.685 (Sat./Sun.)
		HCJB, Quito, Ecuador	G	6.095, 9.56
7:40-8:00 p.m.	0040-0100	Brussels, Belgium	G	6.08 (subject to cancellation)
8:00-8:15 p.m.	0100-0115	Vatican City	G	5.995, 6.165, 9.605
8:00-8:20 p.m.	0100-0120	Rome, Italy	G	6.01, 9.575
8:00-8:45 p.m.	0100-0145	Berlin, Ger. Dem. Rep. Madrid, Spain	P F	9.73 6.065, 11.925
8:00-8:55 p.m.	0100-0155	Peking, China	G	7.12, 9.78 (via Tirana), 11.685, 11.945, 15.06, 15.52
		Prague, Czechoslovakia	G	5.93, 7.345, 9.54, 11.99
8:00-9:00 p.m.	0100-0200	Montreal, Canada	G	6.085
8:00-9:00 p.m.	0100-0200	Moscow, U.S.S.R.	G	5.94, 6.07 (via Sofia), 7.105, 7.15, 7.205, 7.355, 7.44, 9.505, 9.53, 9.78, 11.86, 12.05, 15.14, 15.455

8:00-10:30 p.m.	0100-0330	Havana, Cuba	G	11.725, 11.93
8:00 p.m.-12 mdt.	0100-0500	HCJB, Quito, Ecuador	G	6.095, 9.56, 11.91 (includes some Eskimo)
8:30-8:50 p.m.	0130-0150	Cologne, Ger. Fed. Rep.	G	6.01, 6.04, 6.10 (via Malta), 9.565, 9.69, 9.745, 11.865 (via Malta)
8:30-8:55 p.m.	0130-0155	Tirana, Albania	G	6.20, 7.30
		Vienna, Austria	P	6.155, 9.77
8:30-9:25 p.m.	0130-0225	Bucharest, Rumania	F	5.99, 9.57, 9.68, 11.775, 11.94
8:45-9:15 p.m.	0145-0215	Berne, Switzerland	G	5.965, 6.135, 9.725, 11.715
9:00-9:30 p.m.	0230-0230	Budapest, Hungary	G	3.00, 7.22, 9.833, 11.91 (Ex. Sun.)
		Lisbon, Portugal	F	6.025, 11.935
		Oslo, Norway	P	6.18 (Sun.)
9:00-9:45 p.m.	0200-0245	Madrid, Spain	F	6.065, 11.925
9:00-9:55 p.m.	0200-0255	Peking, China	F	11.965, 12.055, 15.06
9:00-10:00 p.m.	0200-0300	Moscow, U.S.S.R.	G	5.94, 6.07 (via Sofia), 7.105 7.115, 7.205, 7.26, 7.355, 7.44, 9.61, 9.78, 11.86, 12.05, 15.14
9:00-10:20 p.m.	0200-0320	Hilversum, Holland	G	6.165 (via Bonaire)
9:00-10:30 p.m.	0200-0330	Cairo, Egypt	G	9.475
9:00-11:00 p.m.	0200-0400	Warsaw, Poland	P	6.095, 6.135, 7.27, 9.675, 11.815 (mixed Polish/English)
9:30-10:00 p.m.	0230-0300	Beirut, Lebanon	P	9.545 (subject to change)
10:00-10:30 p.m.	0300-0330	Budapest, Hungary	G	6.00, 7.22, 9.833, 11.91
		Kiev, U.S.S.R.	G	5.98, 6.02, 7.245, 7.26, 7.40, 9.78, 11.86 (Mon./Thu./Sat.)
10:00-10:45 p.m.	0300-0345	Madrid, Spain	F	6.065, 11.925
10:00-10:55 p.m.	0300-0355	Peking, China	G	7.12, 9.78 (via Tirana)
10:00-11:00 p.m.	0300-0400	Buenos Aires, Argentina	G	9.69 (Mon.-Fri.)
		Prague, Czechoslovakia	G	5.93, 7.345, 9.54, 11.99
		Moscow, U.S.S.R.	G	5.94, 6.07 (via Sofia), 7.115, 7.205, 7.355, 7.44
10:30-10:55 p.m.	0330-0355	Tirana, Albania	G	6.20, 7.30
		Vienna, Austria	P	6.155, 9.77
10:30-11:30 p.m.	0330-0430	London, England	G	5.975, 9.58 (via Ascension)
10:30-11:50 p.m.	0330-0450	Havana, Cuba	G	11.725, 11.76, 11.93
11:00-11:15 p.m.	0400-0415	Budapest, Hungary	G	6.00, 7.22, 9.833, 11.91 (Tue./Fri.)
11:00-11:25 p.m.	0400-0425	Bucharest, Rumania	F	5.99, 9.57, 9.68, 11.775, 11.94
11:00-11:30 p.m.	0400-0430	Oslo, Norway	P	6.18, 9.61 (Sun.)
11:00-12 mdt.	0400-0500	Moscow, U.S.S.R.	G	5.94, 7.115, 7.15, 7.205, 7.355, 7.40, 7.44
11:50 p.m.-1:00 a.m.	0450-0600	Havana, Cuba	G	11.725, 11.76
12 mdt. 12:15 a.m.	0500-0515	Jerusalem, Israel	G	5.90, 5.950, 7.395, 9.009
12 mdt.-2:00 a.m.	0500-0700	HCJB, Quito, Ecuador	G	6.095, 9.56

TO WESTERN NORTH AMERICA

TIME-PST	TIME-GMT	STATION	QUAL*	FREQUENCIES, MHz
4:00-5:30 a.m.	1200-1330	London, England	G	5.99 (via Sackville) (opens 1300 Sun.)
4:15-4:30 a.m.	1215-1230	HCJB, Quito, Ecuador	G	11.745
4:30-8:30 a.m.	1230-1630	HCJB, Quito, Ecuador	G	11.745, 15.115
5:00-5:15 a.m.	1300-1315	Tokyo, Japan	G	5.99
5:00-8:00 a.m.	1300-1600	**VOA, Washington, U.S.A.	G	6.11, 9.76, 11.715
5:57-8:54 a.m.	1357-1654	Manila, Philippines	F	9.58 (closes 1554 Sun.)
6:00-6:30 a.m.	1400-1430	Tokyo, Japan	G	5.99
7:00-7:30 a.m.	1500-1530	Tokyo, Japan	G	5.99
7:00-8:15 a.m.	1500-1615	London, England	G	17.84 (via Ascension)
8:00-8:15 a.m.	1600-1615	Tokyo, Japan	G	9.505
8:00-8:30 a.m.	1600-1630	Oslo, Norway	P	11.895 (Sun.)
8:42-8:51 a.m.	1642-1651	Hilversum, Holland	G	11.82, 15.19 (via Bonaire; mixed English/Dutch)
9:00-9:15 a.m.	1700-1715	Tokyo, Japan	G	9.505
9:00-10:30 a.m.	1700-1830	London, England	G	15.365 (via Sackville)
10:00-10:15 a.m.	1800-1815	Tokyo, Japan	G	9.505
10:00-10:30 a.m.	1800-1830	Oslo, Norway	F	11.895 (Sun.)
11:00-11:15 a.m.	1900-1915	Tokyo, Japan	G	9.505
12 noon-12:15 p.m.	2000-2015	Tokyo, Japan	G	9.505
12 noon-12:55 p.m.	2000-2055	Jerusalem, Israel	F	9.815, 11.645
1:00-1:15 p.m.	2100-2115	Tokyo, Japan	G	9.505

MARCH 1976

**"Why I chose
Western Auto
over other
well-known
national
franchises."**



JEWEL SHIPMAN, owner,
Western Auto Associate Store
Mountain View, Arkansas

"To begin, Western Auto has no contract or franchise fee; they don't charge sales royalties. I make the full gross. They want to profit from my success."

A franchise pioneer, Western Auto is time-tested and has a proven plan for growth and success. More than 4,000 owners located in the United States.

Western Auto has a "total" program that includes training, advertising, display, bookkeeping, time payment and may be able to help you with your financing, if you qualify. Mail the coupon below for your first step towards owning your own business. Or Call TOLL FREE day or night 7 days per week

1-800-821-7700 Ext. 818
Missouri Residents Call
1-800-892-7655, Ext. 818
—for action today.

Mail to: R. T. Renfro, V.P.,
Western Auto
2107 Grand Avenue,
Kansas City, Mo. 64108



I'd like to know more about owning my own Western Auto store. Please send free information.

Name _____
Address _____
City _____ State _____ Zip _____
Phone _____ Dept PE-376

WESTERN AUTO

OVER 4,000 ASSOCIATE STORES IN 40 YEARS.
CIRCLE NO. 62 ON FREE INFORMATION CARD

WHAT'S HAPPENING TONIGHT?



~~\$179.95~~ now \$132.50

The BEARCAT IV. The ultimate scanning monitor. Hear any eight channels of action, excitement and information from the nation's four public service frequency bands!

Please send me _____ Bearcat IVs @ \$132.50 ea.

Please send me _____ Crystal Certificates @ \$3.25 ea.

(Minimum order \$10.00.)

(COD's require 20% deposit)

Send check or money order to:

BETA ELECTRONICS

P.O. BOX 5869

PITTSBURGH, PA 15209

Name _____

Address _____

City _____ State _____ Zip _____

CIRCLE NO. 9 ON FREE INFORMATION CARD

GENERATION-III



FROM: **PAIA**

THIRD GENERATION MUSIC SYNTHESIZER KITS from PAIA feature state-of-the-art design still at incredibly low prices.

Have you seen "POLYPHONY"? The PAIA User's Group magazine. Information for musicians, from musicians. Write today for your free sample Issue.

24 HR. DEMO LINE (405) 843-7396

FREE CATALOG

PAIA ELECTRONICS, INC.

DEPT. 3-P

1020 W. WILSHIRE BLVD.

OKLAHOMA CITY, OK 73116

CIRCLE NO. 39 ON FREE INFORMATION CARD

1:15-3:00 p.m.	2115-2300	London, England	G	15.26 (via Ascension)
2:00-2:15 p.m.	2200-2215	Tokyo, Japan	G	15.105
3:00-3:30 p.m.	2300-2330	Tokyo, Japan	G	15.105
3:00-4:30 p.m.	2300-0030	London, England	G	6.175, 9.51 (via Sackville), 9.58, 15.26 (via Ascension)
		Moscow, U.S.S.R.	G	12.05, 15.21, 17.72, 17.775, 17.90
4:00-4:15 p.m.	0000-0015	Tokyo, Japan	G	15.105
4:00-6:00 p.m.	0000-0200	**VOA, Washington, U.S.A.	G	11.76, 15.21, 17.79
4:30-7:30 p.m.	0030-0330	London, England	G	6.175 (via Sackville), 9.51 (via Greenville), 9.58, 15.26 (via Ascension)
5:00-5:15 p.m.	0100-0115	Tokyo, Japan	G	15.105
5:00-5:30 p.m.	0100-0130	Moscow, U.S.S.R.	G	12.05, 15.21, 17.72, 17.775, 17.90 (via Soviet Far East)
5:00-5:55 p.m.	0100-0155	Peking, China	G	11.945, 11.965, 12.055, 15.06, 15.52
5:00-7:00 p.m.	0100-0300	Melbourne, Australia	G	15.32, 17.795
5:00-9:00 p.m.	0100-0500	HCJB, Quito, Ecuador	G	6.095, 9.56, 11.91 (includes Eskimo)
5:30-6:00 p.m.	0130-0200	Moscow, U.S.S.R.	G	12.05, 15.21, 17.72, 17.90 (via Soviet Far East)
5:30-6:30 p.m.	0130-0230	Tokyo, Japan	G	15.195, 15.235, 17.725, 17.825
6:00-6:15 p.m.	0200-0215	Tokyo, Japan	G	15.105
6:00-6:55 p.m.	0200-0255	Peking, China	G	11.455, 11.965, 12.055, 15.06, 17.855
6:00-7:00 p.m.	0200-0300	Moscow, U.S.S.R.	G	12.05, 15.21, 15.245, 17.72, 17.90 (via Soviet Far East)
6:00-8:50 p.m.	0200-0350	Taipei, Taiwan	F	11.86, 15.125, 17.72
6:15-6:30 p.m.	0215-0230	Athens, Greece	P	9.52
6:30-7:00 p.m.	0230-0300	Stockholm, Sweden	P	9.695, 11.705
7:00-7:15 p.m.	0300-0315	Tokyo, Japan	G	15.105
7:00-7:30 p.m.	0300-0330	Seoul, Korea Kiev, U.S.S.R.	P G	15.335 12.05, 15.21, 15.245, 17.72 (Sat./Mon./Thu.) (via Soviet Far East)
7:00-7:45 p.m.	0300-0345	Madrid, Spain	P	6.065, 11.925
7:00-7:55 p.m.	0300-0355	Peking, China	G	7.12, 9.78 (via Tirana), 11.445, 12.055, 15.06, 15.385, 17.735, 17.855
7:30-8:15 p.m.	0330-0415	Berlin, Ger. Dem. Rep.	P	5.955, 6.08, 9.73
7:30-8:30 p.m.	0330-0430	London, England	G	6.175 (via Sackville), 9.58 (via Ascension)
7:30-9:30 p.m.	0330-0530	Moscow, U.S.S.R.	G	7.17, 7.18, 7.26, 9.54, 9.58, 9.735, 11.69, 15.14 (via Soviet Far East)
8:00-8:15 p.m.	0400-0415	Tokyo, Japan	G	15.105
8:00-8:30 p.m.	0400-0430	Sofia, Bulgaria Budapest, Hungary	P F	9.70 6.00, 7.22, 9.833, 11.91 (Tue., Fri.)
8:00-9:00 p.m.	0400-0500	Montreal, Canada	G	6.135, 9.655
8:30-9:00 p.m.	0430-0500	Lisbon, Portugal Berne, Switzerland Vienna, Austria	P F P	6.025, 11.935 6.045, 9.725 6.015
9:00-9:15 p.m.	0500-0515	Tokyo, Japan Jerusalem, Israel	G F	9.505 7.412
9:00-10:00 p.m.	0500-0600	Montreal, Canada	F	6.135, 9.655
9:00-10:20 p.m.	0500-0620	Hilversum, Holland	G	6.165, 9.715 (via Bonaire)
9:00-11:00 p.m.	0500-0700	HCJB, Quito, Ecuador	G	6.095, 9.56
9:30-9:50 p.m.	0530-0550	Cologne, Ger. Fed. Rep.	F	6.10 (via Malta), 6.185, 9.545
9:30-11:30 p.m.	0530-0730	Moscow, U.S.S.R.	G	7.15, 7.17, 7.26, 9.54, 9.58, 9.61, 9.735, 9.78 (via Soviet Far East)
10:00-10:15 p.m.	0600-0615	Tokyo, Japan	G	9.505
10:00-10:30 p.m.	0600-0630	Oslo, Norway	P	9.645, 11.87 (Sun.)
10:00-11:00 p.m.	0600-0700	Buenos Aires, Argentina	G	9.69 (Mon.-Fri.)
10:30 p.m.-12 mdt.	0630-0800	Havana, Cuba	G	9.525
11:00-11:15 p.m.	0700-0715	Tokyo, Japan	G	9.505
12 mdt.-12:15 a.m.	0800-0815	Tokyo, Japan	G	9.505
1:00-1:15 a.m.	0900-0915	Tokyo, Japan	G	9.505
2:00-2:15 a.m.	1000-1015	Tokyo, Japan	G	5.99
2:00-2:50 a.m.	1000-1050	Pyongyang, D.P.R. Korea	G	9.415, 9.535
3:00-3:15 a.m.	1100-1115	Tokyo, Japan	G	5.99

*Reception quality, East Coast (West Coast) location: G-good, F-fair, P-poor

**Not intended for North America, but receivable satisfactorily

Frequencies are accurate as of press time, but subject to change.



CB Scene

By Ray Newhall

IS YOUR STATION READY FOR AN EMERGENCY?

MUCH has been written about the public safety potential of the many CB radio stations spread across the country. Equally publicized is how CB'ers have responded to past large- and small-scale disasters. But a well-executed assist does not "just happen." It is planned in advance and is practiced over and over until both equipment and operators are ready to handle the emergency when it occurs.

Hundreds of CB clubs have organized emergency communications systems, and many of the more successful organizations have expanded to nationwide scope. REACT, ALERT, and REST Marine are typical of these emergency networks. However, in spite of these admirable efforts, many CB'ers are still not equipped to handle emergency communications. Are you?

What's an Emergency? The FCC defines an emergency that deserves channel priority as one which, "involves . . . the immediate safety of life . . . or the immediate protection of property." Only when a situation meets these requirements can the band be cleared for priority traffic or the international distress signals (MAYDAY for voice transmissions) be used. Then operating restrictions can be abandoned *if necessary* to initiate and direct rescue operations. However, misuse of priority or distress procedures can result in very heavy fines, imprisonment, or both—not to mention widespread confusion!

Less grave situations do not qualify for priority or distress traffic, but they may be conducted on the emergency channel 9, or any of the other 21 "free" class D channels. Channel 11 should be avoided, if possible, as it is set aside for contact ("call and switch") transmissions only. But in any event, as soon as contact is made on either channel 9 or 11, you should move to another one to keep these calling channels open.

Being Prepared. Public safety communications facilities should have reliable equipment, local maps and a list of needed phone numbers, a telephone, and most of all trained and dedicated operators.

Every CB'er is aware of equipment requirements—a good transceiver and a high-performance antenna. The rig should be checked regularly to make sure it's in top shape and to be certain that all channels are on frequency. Preventive maintenance schedules should be followed. To make a transceiver truly useful for emergency, it should be provided with a power source independent of the commercial power lines. For mobile units, which are powered by the car battery or alternator, there's no problem. But base stations are a different story. Obviously, if a real disaster occurs which knocks out the power lines, you won't be able to do much with a dead base transceiver.

Many transceivers, especially those of the "base/mobile" variety, will accept 12 volts dc as well as 117 volts ac. With such equipment, fully-charged automotive storage batteries will provide the back-up power you might need. But the batteries must be charged. A trickle charger permanently attached to the power line will keep the battery topped up.

A relay can be used for automatic, instantaneous switching when the ac

line fails as shown in the diagram. For extended operations, more than one battery might be required. If needed, the additional batteries can be simply placed in parallel with the primary battery. But be sure to observe standard safety procedures for handling and charging lead-acid storage batteries. For ac-only base transceivers, a battery/ac inverter combination or an emergency generator will be needed.

Although not required, auxiliary equipment will be useful. This includes a vhf/FM scanner with local Public Service channels and (if you live near the shore) vhf/FM marine channels 2, 16, and 22. A tape recorder and a phone patch might also prove handy, but I hardly ever use my patch unless the band is unusually quiet. This equipment should also have a back-up power source.

Other items that should be included are:

- Pencils, notepads and a logbook.
- Land-line phone within easy reach.
- City street listing and maps of your monitoring area.
- Telephone numbers for all local public safety agencies.

Training Yourself. As I mentioned earlier, all this equipment is of little value unless the operator is properly trained and can use it efficiently. In emergency communications, effectiveness is essential. The guidelines for emergency traffic handling can be summed up in the "Four C's."

Be Calm. No matter what the emergency, a calm, professional attitude will help cool the situation and instill confidence. Remember that the person reporting the emergency is likely to be excited, and might even be abusive or irrational in his anxiety.

Be Courteous. Persons seeking assistance sometimes expect the

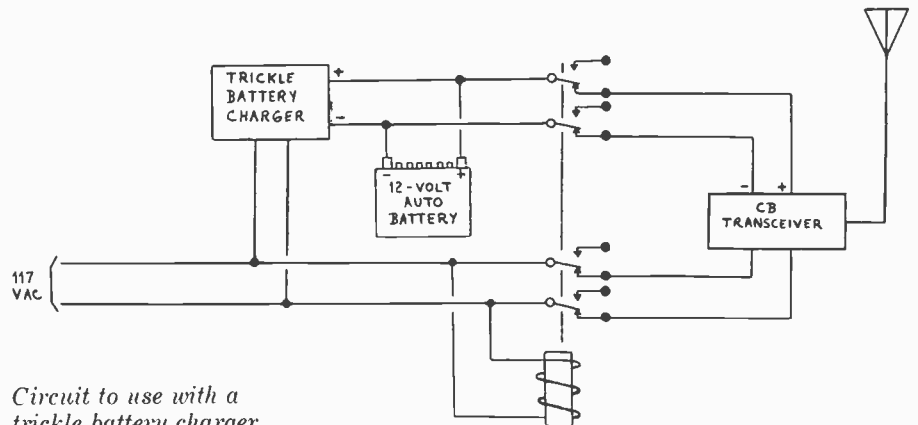

Circuit to use with a trickle battery charger.

INTRODUCING VDM-1



VIDEO DISPLAY MODULE

- ultra high-speed intelligent display
- generates 16, 64 character lines of alpha-numeric data
- displays upper and lower case characters
- full 128 ascii characters
- single printed circuit card
- standard video output

The VDM-1 is an ultra high-speed intelligent display on a single printed circuit card. The new card generates 16, 64 character lines of Alpha-numeric data in upper and lower case characters from a 1K Byte memory.

The VDM-1 configuration allows you to build a powerful terminal, with a standard video output into your Altair Processor.

Price: \$160.00

SPECIAL FREE OFFER!

Scientific Notation Software Package with Formatted Output

With the purchase of (1) VDM-1 and
(1) 4KRA Memory:

Just \$299.00

(Offer expires 2-1-76)

The floating point math package features 12 decimal digits with exponents from +127 to -127; handles assigned and unassigned numbers. With it is a 5 function calculator package; $+$ $-$ \times \div & square root. It includes 3 storage and 3 operating memories and will handle chain and column calculations.

For more details on these and other 8800 plug-in compatible modules, write to:

P Processor Technology
2465 Fourth Street
Berkeley, Ca. 94710

service of a professional operator. Try to act the part. No matter what the provocation, you *must* be courteous.

Be Concise. When you receive an emergency message, jot down all the essential data needed to identify the nature of the incident, its exact location, the number and identity of persons or vehicles involved, and the nature and extent of injuries, if any. Make your transmissions as brief and clear as possible.

Be Correct. Before you relay a message, try to get confirmation from a second source, if possible. Note the call signs of reporting stations, vehicle registration numbers, etc.—any information which will identify the victim(s) and the caller. Be particularly careful to confirm the exact location of the incident. Excited informants are often confused about their exact whereabouts. Keep in mind that your information can do more harm than good when you direct emergency teams to the wrong location!

It's not easy to follow these four commandments in the heat and excitement of an emergency, but that's precisely the time when they are most necessary to get the message through. Play it cool. Keep all emotion out of your voice. Remember—this takes self discipline and *practice*.

Whom to Notify. Generally, when you receive an emergency call at your base location you will be asked to relay a message to police or marine safety agencies. But you must know the jurisdictions of each organization so you can alert the proper one. For example, don't deliver a message to your *local* police concerning an accident on an interstate highway patrolled by state authorities. However, if you need an ambulance, a call to your local police (or to the 911 emergency service if available) may be your best bet.

If you monitor marine activity, you should know what marine safety groups are active in the area. Do the local police maintain a marine patrol, or is there an active Coast Guard Auxiliary Flotilla in your area? If you call the Coast Guard directly, chances are that they will refer your call to one of these other agencies. Precious time will be lost in the process. The best way to find out whom you should call

for each situation is to visit these groups at their own bases of operations and see for yourself how they operate. Normally, they will appreciate your interest and efforts to learn. You will also find out which, if any, of the organizations operate CB equipment of their own and how they can be contacted directly on the Citizens Band. (Most are far too busy to maintain a continuous CB watch, but might monitor one individual channel.) This knowledge is of particular value when you are reporting an emergency from your mobile unit.

The best way to handle emergency communications on the local level is to organize a CB monitor-and-assist team. Even if you're not presently associated with the local REACT, it's good practice to know the other emergency operators in your area. Perhaps your local CB club has an organized net. If not, try and form one yourself. Through an organized approach, you can quickly establish a working relationship with public safety agencies and such groups as the Red Cross. Also, a local emergency net can hold drills and simulated emergencies to sharpen operating skills.

Channel Usage. Remember that channel 9 is to be used only for emergency traffic. Don't conduct simulated message relays over it, or use it for the *administrative* purposes of your local emergency team. Now that many truckers have moved their highway communications to channel 19, channel 9 is much less susceptible to heavy "bleed-over." But you might hear an emergency message about a highway accident first on channel 19 via the truckers. Marine messages might first be heard on channel 13, which is used by shipboard CB'ers.

If you are monitoring channel 9 and scofflaws are using it for non-emergency purposes, don't argue with them. The experienced operator avoids a confrontation of this sort because he knows that a response usually just compounds the problem. The FCC is stepping up its efforts to indict illegal operators, and will appreciate your efforts to provide them with positive identification. Sometimes, signals from Latin America will "skip" in on channel 9. These operators are not governed by U.S. regulations, and their transmissions are all quite legal. It's just one of the annoyances that CB'ers must tolerate. ◆



By John McVeigh

DIMMER RFI

Q. I replaced several of my wall switches with triac dimmers, but now experience severe interference to AM broadcasts. I tried a 0.1- μ F capacitor, which reduced but did not eliminate the noise. How can I lick this problem?

—William Conover, Clinton, TN

A. The fast switching action of thyristors produces voltage and current waveforms with abrupt on and off transitions, which contain loads of harmonics extending into the hf region. A lowpass filter will take care of the harmonics without defeating the

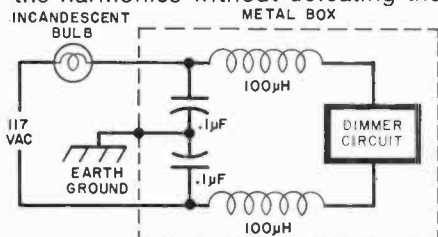

purpose of the dimmer. Construct two low-pass filters (one for each side of the line) from 100- μ H coils and 0.1- μ F, 200-V ceramic capacitors. Mount the filters and the dimmer inside a metal box, and bond the box to a good earth ground. That should clear up your AM reception.

DIGITAL IC DATA

Q. I am looking for a handbook on the 7400 series of digital integrated circuits. Is there any volume out that can serve as a basic reference guide?

—Galen Tackett, Newark, CA.

A. The 7400 Series Pinout Handbook will probably help you. It includes pin connections, functional specs, truth tables, and a cross-reference. It's available for \$2.95 plus \$0.30 postage from IMS Associates, 1298 E 14th St., San Leandro, CA 94577.

EUROPEAN/US AC CONVERTER

Q. I am serving with the Canadian Armed Forces in Europe and have purchased several appliances which I want to take home with me. Is there a simple way to convert the 50-Hz, 220-V ac power to 60-Hz, 110-V ser-

vice we have in North America?

—Keith L. Webber, Lahr, Germany

A. A simple 2:1 transformer will take care of the voltage problem, and it works both ways. If you want to convert 110 V to 220 V, take a transformer like the Thorardson Type 23V74, attach a power plug to the secondary and a receptacle to the primary. When 110 V is applied to the "secondary," 220 V will appear across the "primary." To step down 220 V to 110 V, reverse this procedure. It is *not* an easy job, however, to convert the 50 Hz to 60 Hz line frequency or vice versa.

You would have to rectify the ac to dc, and then use a dc/ac transistor converter running at the desired line frequency. A sample circuit was shown in PE, 5/69, page 65. We've had many inquiries about these dc/ac circuits, but they all share several disadvantages. They tend to be inefficient, require bulky, expensive transformers, or ones you have to roll for yourself. Most of them have limited power capacities, and their outputs are square-wave ac. This makes them unsuitable for use with induction motors, refrigerators, air conditioners, etc.



Introducing the Phase Linear System 200

A complete home stereo system built around a Phase Linear amplifier is now within the reach of every serious listener. The development of the new Phase Linear 200 power amplifier makes it possible. In combination with the advanced 2000 preamplifier, the 200 provides the nucleus of a fine, medium-powered stereo system with lower distortion, wider dynamic range, faster transient response and greater flexibility than a comparable receiver-based system — at a surprisingly reasonable cost. With a pair of quality bookshelf speakers and a good turntable, a Phase Linear 200 system can be assembled by your dealer for around \$7,000 — a fraction of the investment of many veteran audiophiles with sophisticated systems amplified by Phase Linear. You might as well start near the top.

The new Phase Linear 200 power amplifier is a handcrafted, reliable amplifier with outstanding sonic performance in the tradition of the famous 700B and 400 models. Power output is 105 watts per channel, minimum R.M.S. at 8 ohms from 20 Hz to 20 kHz, with no more than .25% total harmonic distortion. Light emitting diode displays give instantaneous display of power for each channel. Hum and noise: 100 dB below rated power.

The Phase Linear 2000 preamplifier is one of the quietest preamps ever made. Signal to noise ratio of 74 dB below 10 mV and total harmonic distortion of 0.1%. Variable ambience injection circuit recovers music lost with most preamps.

Phase Linear
The Powerful Difference

Manufactured in the U.S.A. Distributed in Canada by H. Roy Gray, LTD.

CIRCLE NO. 41 ON FREE INFORMATION CARD

DELUXE

MAGAZINE CASES...

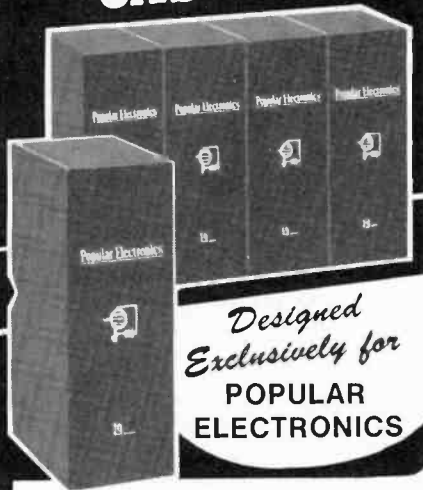

Designed Exclusively for
POPULAR ELECTRONICS

● It's the new look in magazine cases! The ideal way to save your valuable copies, keep them well-protected and make it easy for you to refer to any issue at any time. Both decorative and attractive to enhance the decor of any room—each case is designed to hold a full year's copies. Sturdily constructed to guard your magazines against soiling and tearing, these durable cases are covered in a rich-textured leatherette. They

are available in either all black or attractive maroon back with black sides. The gold-embossed back adds to its elegance and makes each case a welcome addition to your book shelf or cabinet.

Magazine cases are available for any of your favorite magazines. They're only \$5.95 each, 3 for \$15.50 in any combination of titles ordered. Prices include all postage and handling charges. Outside U.S.A. add \$1 per case ordered.

CHARGE YOUR ORDER TO YOUR AMERICAN EXPRESS, BANKAMERICARD, MASTER CHARGE OR DINERS CLUB ACCOUNT.



Ziff-Davis Service Division, Dept. JJ, PE-376
595 Broadway, New York, N.Y. 10012

Please send the Magazine Cases indicated below:

TITLE	QUANTITY
_____	_____
_____	_____
_____	_____

CHECK ONE: All Black
 Maroon Back, Black Sides

ENCLOSED IS \$ _____
 CHARGE: American Express BankAmericard
 Master Charge Diners Club

Account # _____ Exp. Date _____

Master Charge Interbank # _____
(4 numbers over your name)

Signature _____

Print Name _____

Address _____

City _____ State _____ Zip _____

Residents of Calif., Col., Fla., Ill., Mich., Mo., N.Y. State, D.C. and Tex. add applicable sales tax.

Operation Assist

If you need information on outdated or rare equipment—a schematic, parts list, etc.—another reader might be able to assist. Simply send a postcard to Operation Assist, POPULAR ELECTRONICS, 1 Park Ave., New York, NY 10016. For those who can help readers, please respond directly to them. They'll appreciate it. (Only those items regarding equipment not available from normal sources are published.)

Freed-Eisemann FM-AM radio chassis Model CH155, Schematic, Sylvania part #241-0002 horizontal scanning output choke. Need part. Charles L. Pierce, Hwy. 180, Suches, GA 30572.

RCA Institutes Multimeter. Schematic of ac section. 6.667 ohm/V ac shown on meter face. Tom Stanton, Box 224, 902 Bayshore Dr., Terra Ceia, FL 33591.

Lavoie Labs. WWV Receiver LA800D. Automatic Electric Intercommunication Type 1-A-T, Drg. No. GH78025-1. Operation and maintenance manuals. Julian A. Harris, Jr., 1900 N. Barcelona St., Pensacola, FL 32501.

Military AN/UPM-1 Radar Test Set, Instruction manual. John Landa, S. Tallulah Fls., Clarksville, GA 30523.

LeSabre 10-transistor AM-FM portable radio. Service manual with schematic. Dana G. Frisbee, 490 Commonwealth Ave., Boston, MA 02215.

Hallicrafters Model S-40 receiver. Schematic and/or service information. Mike Turner, Box 85, Fletcher, NC 28732.

Collins R105/ARR-15 (51H3) Radio Receiver. Air Force manual AN 16-30-ARR15. Felix M. Marshall, 9339 E. Magdalena St., Tucson, AZ 85710.

Avia FMR-150 Radio. Schematic and/or service manual. Richard Kindred, 902 Rainbow Dr., Blackwell, OK 74631.

Navy surplus receiver. Need transformer N17-T-73701-5366, UTC G-5551A, RCA 8889252-1, TF 1A 03 YY. Reynaldo Rodriguez, 8412 Georgian Dr., Austin, TX 78753.

Varo Receiver Model R-663A/TRC-42. Any information, Bernard Gnat, 1565 Hollywood N.E., Warren, OH 44483.

Precision Apparatus, Series EV-20 VTVM and Multi-Range Test Set. Schematic. Jesse G. Williams, 1833 Waycross Dr., Winston-Salem, NC 27106.

Magnecord Tape Recorder, Model PT6-A. Schematics of motor and amplifier sections. Robert Faris, Rt. 25, Brookfield, CT 06804.

Channel 11 mini-TV transmitter schematic needed. R. Greenwade, 211 Cherry Lane, Monmouth, OR 97361.

Monarch SA60 Stereo Amplifier. Schematic. John Mutchler Jr., Rte. 3, Box 304, Grand Rapids, MN 55744.

ITT 4-trace Oscilloscope Model KP-404, Serial No. 7027. Schematic and/or service manual. Sam Lay, 6771 Bonnie Dr., Huntington Beach, CA 92647.

Hammarlund HQ-129X Receiver. Schematic and/or service manual. James Smythe, 5158 W. 135th St., Hawthorne, CA 90250.

Surplus Transponder AN/APX-6A with Radio Receiver/Transmitter RT 279/APX-6A. Schematic. J.P. Vanags, 505-1111 Beach Ave., Vancouver, B.C. Canada.

Gibson Guitar Amplifier Model Minuteman GA-20RVT. Schematic and instruction manual. Carl McCormick, 1502 Debra, Bossier City, LA 71010.

Skyline Radiophone Model 1A30. Schematic and/or owner's manual. Fred Caughlin, 11094 71st Ave. N.E., Brooks, OR 97305

Vivitar Model ICR-007 FM-AM Radio. Schematic. Rico Liu, 110-19 65th Ave., Forest Hills, NY 11375.

Electro-Voice EVR-2A Stereo Receiver, Serial # 134,257. Schematic and/or operating manual. Henry L. Black, 2411 E. Gage Ave., Huntington Park, CA 90255.

Gorler Varactor FM Tuner No. 4-1969 312-0512. Schematic. Paul G. Kazmierski, 9146 Forrer, Detroit, MI 48228.

United Cinephone U.S. Army Signal Corps Test Oscilloscope TS-100/AP, Order #368-DAV-45-RA. Operator's manual, service information. Chester A. Browning, 219 Hanover St., Providence, RI 02507.

Revolutionary New Wiring "Pencil" Makes

Interconnections in 1/3 the Time!

- Create Finished Wired Circuits in Hours, Not Days
- For Breadboarding, Prototypes and Production
- Interconnects Circuit Elements in Digital and Analog Circuits

Easy for anyone — just hook up your components using the insulated "solder thru" wire (your choice of blue, red, green or clear). Wire feeds off a replaceable spool thru the P173 tool body and out of a steel tip so fine it easily routes wire around even the smallest I.C. lead. A touch of the iron, with solder, completes the joint.

Available accessory items include P179WS Wire Spacers for neat routing, tenth-tenth Micro-Vectorboards[®], circuit Padboards and frames, like the 3677-6 and 51X-1. Order a P173 Now! Supplied with two 200' spools of AWG solder thru wire (1 red, 1 green), complete instructions.

At your Vector distributor **\$9.50**

Mail orders, add \$2 shipping and handling charge. California residents add 6% sales tax.

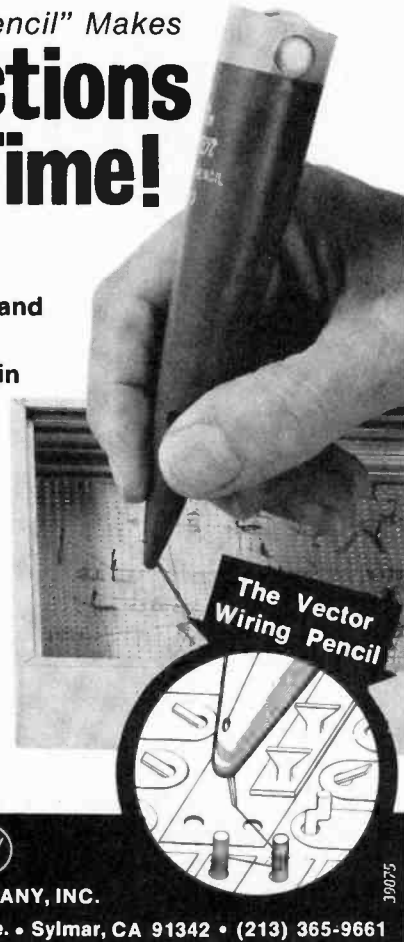

The Vector Wiring Pencil

Vector

W P DIVISION
ELECTRONIC COMPANY, INC.
12460 Gladstone Ave. • Sylmar, CA 91342 • (213) 365-9661



39075

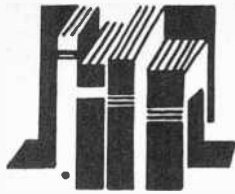

Electronics Library

INTERNATIONAL DICTIONARIES OF SCIENCE AND TECHNOLOGY: SOUND

edited by R.W. Stevens

Scientists and technologists of eight European nations and the USA have collaborated to produce this multilingual dictionary which provides coverage of the ways in which sound is important in modern technology. Included are physical concepts relating to mechanical vibrations as well as thorough treatment of such topics as architectural acoustics, audio circuits, disc, magnetic and optical recording, sound editing and broadcasting, telephony, ultrasonics, underwater and musical acoustics. There are also transliterations of entries into English, French, German, Italian, Portuguese, Spanish and Russian. Published by Halsted Press, Div. of John Wiley & Sons, Inc., 605 Third Avenue, New York, NY 10016. 853 pages. \$37.50 hard cover.

RCA SOLID-STATE DEVICES MANUAL

A manual on the theory and applications of solid-state devices, including discrete types and monolithic IC's, has been published by RCA. The Solid-State Devices Manual (SC-16), successor to the RCA Transistor, Thyristor, and Diode Manual, covers silicon diodes, bipolar transistors (low-, medium- and high-frequency types), MOSFET's, thyristors, and monolithic IC's (bipolar and COS/MOS types) for linear and digital applications. It provides information on basic operation, technology, ratings and characteristics, circuit applications, packages, and handling and mounting considerations, as well as an up-to-date listing of commercial types available from RCA. Many projects, including schematics, parts lists, and descriptions are included. Published by RCA Solid State Division, Box 3200, Somerville, NJ 08876. 752 pages. \$5.00 soft cover.

DM-1A DIGITAL INTEGRATED CIRCUITS MANUAL (THIRD EDITION)

This updated digital IC reference manual contains listings by type numbers (old and new), and by figure (pinout) numbers (old and new). Included are most IC's the hobbyist is likely to encounter in the TTL, DTL, ECL, MOS and C/MOS families. Covered are simple combinational gates, flip-flops, shift registers, RAM's and arithmetic chips. Published by Electronics, Box 127, Hopedale, MA 01747. 48 pages (8 1/2" x 11"). \$6.95 soft cover.

MARCH 1976

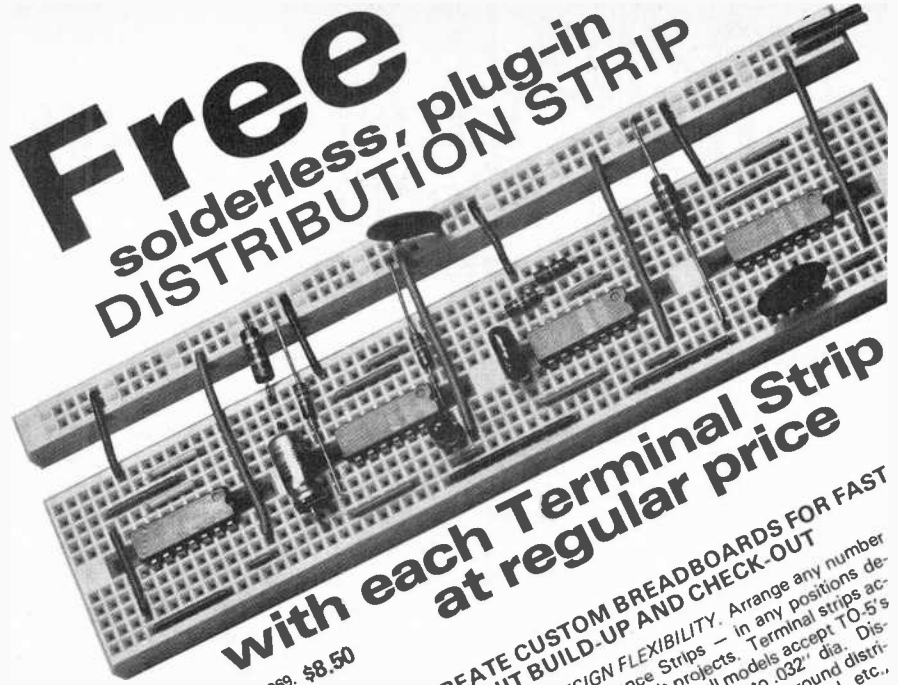

Free solderless, plug-in DISTRIBUTION STRIP

with each Terminal Strip at regular price

Model 234L Terminal Strip has 68 (5-tie point) terminals; holds up to 4 (16-pin) DIP's. P/N 923269. \$8.50

Two rows of 3 connected tie points

3.5"

Matching Distribution Strip has 2 buses of 24 tie pts

Buy this GET THIS FREE regular \$2.00

Model 248L Terminal Strip has 96 (5-tie point) terminals and holds up to 6 (14-pin) DIP's. Part No. 923265 \$10.00

4.8"

Matching Distribution Strip has 2 buses of 36 tie points

Buy this GET THIS FREE regular \$2.25

Model 264L Terminal Strip has 128 (5-tie pt.) terminals and holds up to 9 (14 pin) DIP's. P/N 923261 \$12.50

6.5"

Matching Distribution Strip has 2 buses of 48 tie points

Buy this GET THIS FREE regular \$2.50

CREATE CUSTOM BREADBOARDS FOR FAST CIRCUIT BUILD-UP AND CHECK-OUT

INFINITE DESIGN FLEXIBILITY. Arrange any number of these high-performance Strips — in any positions desired for your custom circuit projects. Terminal strips accept all DIP sizes. Additionally, all models accept 10.5" distribution strips are used for voltage and ground distribution, reset lines, clock lines, and may be linked if desired.

NO SOLDERING. Simply plug in your components where desired in .1" x .1" matrices. SAFE — no components overheated and ruined with soldering irons. REUSE components and strips in future circuits and breadboards.

NO SPECIAL PATCH CORDS. Interconnect anywhere with solid wire up to No. 20 A.V.G.

INSTANT MOUNTING. New, non-shorting "peel and press" backing permits building even large-scale breadboards in minutes. (Instant-removal mounting screws are also included for boards up to 1/8" thick where disassembly may be required.)

MATERIALS. Non-corrosive nickel-silver contacts; rugged acetal copolymer dielectric.

A P PRODUCTS INC. Box 110-H, Painesville, Ohio 44077

"FREE" offer expires March 31 1976

order today
Use convenient coupon below or order direct from your nearest A P Distributor.

TYPE OF ORDER		A P PRODUCTS INC.	
<input type="checkbox"/> CASH: A check or money order is enclosed.	<input type="checkbox"/> P.O.: (Attach coupon). F.O.B. factory; Net 30.	Box 110-H, Painesville, Ohio 44077	
<input type="checkbox"/> Charge B.A.	<input type="checkbox"/> Charge M.C.	Order date: _____ (Offer expires March 31, 1976.)	
ACCOUNT NUMBER _____	4 NO'S ABOVE NAME (MC) _____ GOOD THRU _____	Quantity	Part Number
SIGNATURE _____	PRINT NAME _____		\$ Each
ADDRESS _____	CITY _____ STATE _____ ZIP _____		\$ Total
All orders subject to acceptance at factory		923269	\$8.50
		923265	\$10.00
		923261	\$12.50
		SHIPPING/HANDLING	
		Merchandise Total	
		Sales Tax (OH & CA)	
		Shipping (see chart)	
		Total Amount Enclosed	

CIRCLE NO. 2 ON FREE INFORMATION CARD

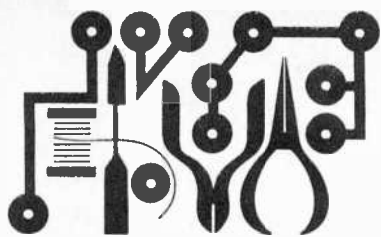

Experimenter's Corner

By Forrest M. Mims

PERCUSSION INSTRUMENT SYNTHESIZER

THANKS to John Simonton, and Don Lancaster, this magazine has featured articles on virtually every aspect of electronic music over the past several years.

Recently the electronic music bug bit me. Having tinkered with several of the basic circuits, I'm convinced that voicing circuits are by far the most challenging—and the most fun. Of course, they can be very difficult to implement, but the successful electronic synthesis of the unique "voice" or timbre of a particular musical instrument is quite rewarding.

Percussion instruments are among the simplest to simulate, so let's jump into electronic music by putting a per-

cussion synthesizer together. Since percussion instruments include the bell, gong, cymbals, triangle, xylophone, tambourine, and drum, a successful percussion synthesizer has lots of uses!

The first step of a successful design is to study the waveforms produced by the instrument to be synthesized. If you're new to electronic music, be prepared for a surprise! "Ordinary" musical instruments produce some very extraordinary waveforms. To make matters even worse, the amplitude (signal strength) of the waveform during the first 100 milliseconds or so is usually irregular and often unique. For example, the cello

has a gradual, slow amplitude rise time, but the tuba has a fast rise time in the form of a high-amplitude spike followed by the remainder of the sound "envelope." See Don Lancaster's article "Imitating Musical Instruments with Synthesized Sound" (POPULAR ELECTRONICS, August 1975, p. 37) for more information on the sound envelopes of these and other nonpercussion instruments.

Fortunately, percussion instruments produce a fairly orderly sound envelope. Figure 1 is a somewhat simplified version of the waveform

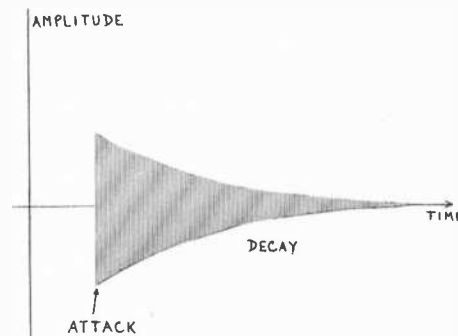

Fig. 1. In percussive waveform, rise is fast and decay slow.

produced by a typical percussion instrument. The waveform consists of a strong, fast rise-time "attack" followed by a gradual "decay." In the case of a bell, the attack is the initial high-amplitude sound produced when the bell is struck by its clapper. The decay is the ringing sound representative of the bell's natural resonant frequency.

Now that we've defined the frequency and amplitude relationships of the sounds we wish to simulate, we can start designing a circuit. Fortunately, our task is easy because "ringing," the effect we want to simulate, is a common and even pesky problem in many electronic circuits!

An active notch filter happens to make an excellent ringing circuit since it has a natural resonance frequency and can be adjusted to a critical point where oscillation can be externally stimulated and internally damped. As you may know, an active filter uses transistors or, better, one or more op amps to simulate a conventional filter. The active filter is superior to a passive filter since it has internal gain which replaces the losses of passive filters and since it can be made with a very high input impedance (very desirable) and a low output impedance (also very good).

NEW!
\$860

Announcing!! The world's most advanced, low cost, computer system available today!!

The MICRO-SPHERE 200



SPECIAL FEATURES:

- Completely Assembled and Tested (Ready to use; not a kit.)
- 4k RAM (EXPANDABLE TO 8k)
- CASSETTE LOADER
- Sphere Cassette Operating System (SCOS) supports file handling and Advanced Program Development, System, an aid for developing your programs.
- 16 Line by 21 Character Alpha Numeric Character Generator (128 by 128 B & W Dot Matrix Graphic System)
- Monte Carlo Games Package
- Operators Manual
- Attractive Mar-Resistant Plastic Case

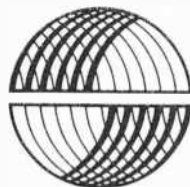

SPHERE CORPORATION
791 South 500 West Dept. 130 (801) 292-8466
Bountiful, Utah 84010

CIRCLE NO. 64 ON FREE INFORMATION CARD

ISO TIP

QUICK CHARGE

Recharges in 1/3rd the time of any other cordless iron.

Complete line of accessories available:

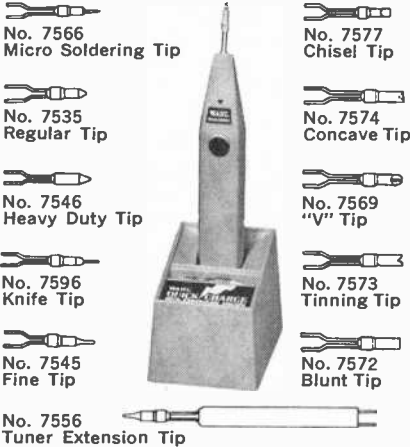

WAHL CLIPPER CORPORATION
 ORIGINATORS OF PRACTICAL CORDLESS SOLDERING
 Sterling, Illinois 61081 (815) 625-6525
 "Manufacturing Excellence Since 1919"

CIRCLE NO. 59 ON FREE INFORMATION CARD

ABOUT YOUR SUBSCRIPTION

Your subscription to POPULAR ELECTRONICS is maintained on one of the world's most modern, efficient computer systems, and if you're like 99% of our subscribers, you'll never have any reason to complain about your subscription service.

We have found that when complaints do arise, the majority of them occur because people have written their names or addresses differently at different times. For example, if your subscription were listed under "William Jones, Cedar Lane, Middletown, Arizona," and you were to renew it as "Bill Jones, Cedar Lane, Middletown, Arizona," our computer would think that two separate subscriptions were involved, and it would start sending you two copies of POPULAR ELECTRONICS each month. Other examples of combinations of names that would confuse the computer would include: John Henry Smith and Henry Smith; and Mrs. Joseph Jones and Mary Jones. Minor differences in addresses can also lead to difficulties. For example, to the computer, 100 Second St. is not the same as 100 2nd St.

So, please, when you write us about your subscription, be sure to enclose the mailing label from the cover of the magazine—or else copy your name and address exactly as they appear on the mailing label. This will greatly reduce any chance of error, and we will be able to service your request much more quickly.

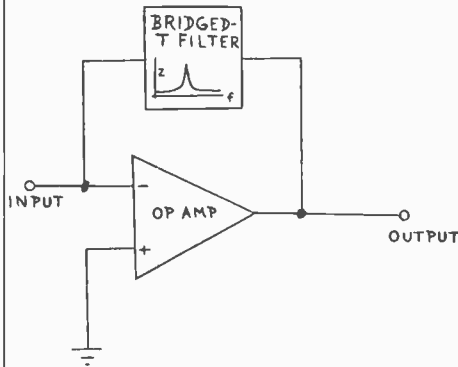

Fig. 2. Notch filter with maximum impedance at center frequency.

Figure 2 is the block diagram of a typical active notch filter which uses a single op amp, and Fig. 3 shows a working circuit. The filtering action takes place in the twin-T network formed by $R1$, $R2$, and their associated components. The twin-T notch filter is an old standby and is often used to block 60-Hz line noise in amplifiers and other circuits. The op amp provides restorative gain and interfacing to external circuits. You can operate the circuit as it is by connecting a miniature speaker to the output through a matching transformer (a unit with a 1000-ohm primary and an 8-ohm secondary), but you will have best results by connecting the circuit to an external audio amplifier.

The circuit works like this. The potentiometer is adjusted so that the filter just begins to oscillate and is then backed off until oscillation ceases. After this adjustment is made, a tiny input signal at pin 2 of the op amp will stimulate an oscillating attack followed by a gradual decay as the oscillation is dampened. How do you apply an input signal? Simple—just touch the touch plate (which can be a scrap of bare hookup wire) with a finger. The LM308, a precision op amp, has a typical input resistance of 40 megohms and readily accepts the small noise voltage from your body.

The frequency pattern of the circuit is very similar to Fig. 1, and the result is a very effective and realistic percussion simulator. You will probably have to make several adjustments of the pot for best results. If the circuit continues to oscillate without decaying, back off on the pot.

When $R1$ and $R2$ are about 100,000 ohms each, the circuit produces a very realistic bell sound when pin 2 is briefly touched. You can change the resonance frequency to simulate many other percussion instruments by

VIDEO PING PONG KITS

Tennis/Handball with on-screen scoring

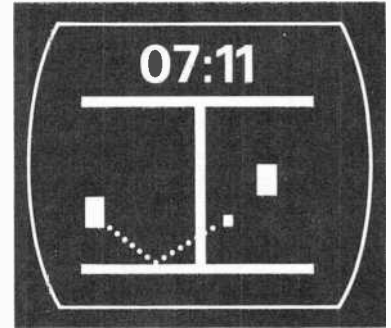

- Complete kit supplied, or any combination of plans, parts, PC board, etc.
- Anyone can build easily from concise instructions
- Attaches to TV antenna — no TV alterations required

IT'S THE HOTTEST ELECTRONIC GAME IN TOWN.

Send 50¢ for Info Pack—Refunded with Purchase.

INTERFAB
 27963 Cabot Road
 Laguna Niguel, California 92677 A

CIRCLE NO. 58 ON FREE INFORMATION CARD



Our volume buying power enables us to pass the savings on to you. Listen to us ... You can't go wrong.

Fill out this coupon and mail to address below for our latest Free Catalogs.

Name _____
 Address _____
 City _____
 State _____ Zip _____

AUDIO CATALOG

PE-3

STEREO DISCOUNTERS
 7A AYLESBURY ROAD □ TIMONIUM, MD. 21093
 [301] 252-6880

CIRCLE NO. 54 ON FREE INFORMATION CARD 101

ALTAIR 8800 VIDEO TERMINAL

Video Interface. Plugs into the Altair or IMSAI 8800 bus and connects to standard TV monitor (or modified receiver). 8-bit input connects to almost any keyboard. Characters are displayed as 16 lines of 64 or 32 characters each, in a 7x9 dot matrix. (64 character line requires a high resolution monitor or extensively modified receiver.) The character set includes 128 upper and lower case ASCII characters and 64 graphics characters for plotting a 48x128 (or 64) grid. Characters are stored in the onboard memory and may be accessed directly by the computer. The output is standard 525 line EIA RS170 video.

\$160 Kit \$230 Assem. and tested (Add \$25 for 64 character option) delivery 30 days

Analog Interface. This board is a complete interface for a CRT graphics display or an X-Y plotter, and provides 8 channels of software-controlled A/D conversion. There are 1 or 2 channels of analog output with 10-bit resolution (0-10v or $\pm 5v$ out), 6-bits of latched digital output, and 8 analog comparators.

1 channel (0-10v): \$135 Kit \$175 Assem. and tested
2 channels (0-10v): \$185 Kit \$235 Assem. and tested
(Bipolar option ($\pm 5v$) add \$8 for 1 ch., \$12 for 2) delivery 30 days

Micro Computer. A one board computer system containing an 8080 processor, 512 bytes RAM, space for 1-3K bytes PROM or ROM, and a serial I/O port (optional). Compatible with IMSAI and Altair memory and peripherals. Supports multiprocessing. (Avail. 1st Q. 1976)

Microcomputer System. A system based on our microcomputer and video boards. Includes motherboard, cabinet, power supply, and an operating system and monitor on PROM. (Avail. 1st Q. 1976)

All prices and specifications subject to change without notice. Prices are USA only - Calif. res. add 6% sales tax.

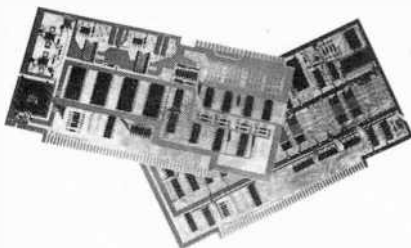

POLYMORPHIC SYSTEMS
P.O. Box 2207, Goleta, California 93018

CIRCLE NO. 44 ON FREE INFORMATION CARD

A Major Advance...



- 500ps Restrike Rate
- High Energy >1000mJ
- Programmable Duration
- High Output Arc Current
- Fast Rise Time

- *EFFICIENT ENGINE PERFORMANCE
- *REDUCED MAINTENANCE EXPENSE
- *1 YEAR GUARANTEE OF PRODUCTS

For those who need maximum firing potential, Labtronics offers the Multiple Restrike Ignition. The system produces a high energy repetitive spark on each power stroke which insures the greatest statistical chance for proper ignition. Dependable system triggering from breaker-points, magnetic pick-ups or the extremely accurate '13A1-xx' infrared triggering unit. Order your system and enjoy the economy and peak performance of an efficient engine.

LABTRONICS, INCORPORATED

3635 HILLSIDE DRIVE • YPSILANTI, MICHIGAN 48197

MULTIPLE RESTRIKE SYSTEM

[] Model VI	Programmable Duration	\$79.95
[] Model VI-B	Fixed Burst Duration	\$59.95
[] Model VI-C	Complete Optical System	\$79.95
HIGH ENERGY SYSTEM (Single Strike)		
[] Model V	Points Triggering System	\$29.95
[] Model V-C	Complete Optical System	\$47.95
TRIGGERING UNITS		
[] 13A1-xx	Optical Trigger Unit	\$24.95
[] 6129B	Magnetic Amplifier	\$ 4.95

CIRCLE NO. 29 ON FREE INFORMATION CARD

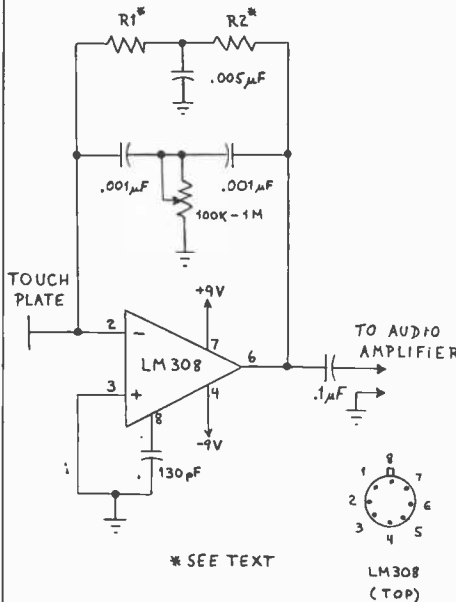

* SEE TEXT

Fig. 3. Damped percussive waveform appears at filter output when touch plate is "struck."

changing $R1$ and $R2$. Of course you will have to readjust the pot to obtain the best voice for each instrument. Try these values for various effects:

Instrument	$R1$ and $R2$
Triangle	33K
Small bell	47K
Medium bell	150K
Large bell	470K
Drum	1M

A narrow tuning range will help you adjust the circuit for optimum voicing, so you will want to use as small a value for the pot as possible. If 100,000 isn't enough, use values of up to 1M.

Incidentally, you can use various op amps in this circuit, but they may not respond to a touch input signal. If this occurs, just connect a resistance of a few thousand ohms between the positive power-supply lead and pin 2 of the op amp through a momentary contact spst (normally open) pushbutton switch. Press the switch to ring the bell, strike the drum, or whatever. For a ding-dong effect, insert a small (about 0.001- μF) capacitor in place of the resistor. Pressing the switch gives a sharp "ding" and releasing it gives a resonant "dong." This hookup makes a great doorbell circuit!

Finally, if this introductory project turns you on to electronic music, try building a complete percussion synthesizer from several filters adjusted to simulate various instruments. You can even build a realistic xylophone by building up a separate filter for each note.

SAVE!

MONEY • TIME • FREIGHT

- QUALITY STEREO EQUIPMENT AT LOWEST PRICES.
- YOUR REQUEST FOR QUOTATION RETURNED SAME DAY.
- FACTORY SEALED CARTONS—GUARANTEED AND INSURED.
- SAVE ON NAME BRANDS LIKE:
 - A.D.C. KLH
 - A.R. SHURE
 - DYNACO KOSS
 - SONY FISHER

PIONEER
AND MORE THAN 50 OTHERS
BUY THE MODERN WAY
BY MAIL—FROM

illinois audio

Department 217S
12 East Delaware
Chicago, Illinois 60611
312-664-0020

CIRCLE NO. 25 ON FREE INFORMATION CARD



12 REASONS YOUR CAR NEEDS TIGER CDI

Instant starting in any weather - Eliminates tune-ups - Increases gas mileage - Increases horsepower 15% - Improves acceleration and performance - Spark plugs last up to 70,000 miles - Reduces engine maintenance expense - Amplifies spark plug voltage to 45,000 volts - Maintains spark plug voltage to 10,000 RPM - Reduces exhaust emissions - Dual ignition switch - An Unconditional LIFETIME GUARANTEE Installs in 10 minutes on any car with 12 volt negative ground - No rewiring - Most powerful, efficient and reliable Solid State Ignition made.

SATISFACTION GUARANTEED or money back

TIGER 500 assembled \$53.95
TIGER SST assembled \$42.95
Post Paid in U.S.A.

Send check or money order with order to:

Tri-Star Corporation

P. O. Box 1727 C
Grand Junction, Colorado 81501

DEALER INQUIRIES INVITED
CIRCLE NO. 55 ON FREE INFORMATION CARD

Poly Pak's 100'S OF BARRELS PURCHASED! BUY 'EM FROM THE "BARREL" AND SAVE!

Your choice
of any kit

\$1.98



EXCLUSIVE 'BARREL' SALE

THE BIGGEST INFLATION-FIGHTING VALUE EVER!

TEST 'EM YOURSELF 'N SAVE!

Every kit carries money back guarantee.

For the first time anywhere, Poly Pak merchandisers introduce a new way in buying the economical way. Raw

stock from the "barrel". Remember the "good ole days"? They're back again. The same way merchandisers throughout the United States buy from various factories... their overruns in barrels. Poly Pak has done the same. Therefore you are getting the same type of material as the RE-TESTERS DO!

BARREL KIT #1 SN7400 DIP IC'S 75 for \$1.98 Marked 14 and/or with 16 pin dips, may include gates, registers, flip flops, counters. Who knows? GUARANTEED SATISFACTION! Cat. No. 2415 Untested.	BARREL KIT #2 LINEAR OP AMPS, DIPS 75 for \$1.98 Un- tested May include 709's, 741's, 703's, 560 series, 555 includes marked and unmarked. Cat. No. 2416	BARREL KIT #3 1N4148/9/14 SWITCHING DIODES 100 for \$1.98 You never saw this before. Imagine famous switching diodes at these prices! Cat. No. 2418 Untested.	BARREL KIT #4 "4000" RECTIFIERS 100 for \$1.98 These are the famous micro miniature rectifiers of the 1N4000 series. May include 25, 50, 100, 200, 400, 600, 800 and 1000 volters. Cat. 2417 Untested.	BARREL KIT #5 SCRS, TRIACS, QUADRACS 40 for \$1.98 All the famous plastic power tab type. Raw factory stock! All the 10 amp types. Cat. No. 2419 Untested.	BARREL KIT #7 VOLUME CONTROL BONANZA! 40 for \$1.98 100% good Singles, duals, variety of values, styles, big ones — small ones. Cat. No. 2421	BARREL KIT #8 SUBMINIATURE IF TRANSFORMERS 60 for \$1.98 100% good. Amazing. Includes 455kes, osc, antenna, who knows? From transistor radio manufacturers. No. 2422
BARREL KIT #10 ROMS-REGISTERS 50 for \$1.98 Un- tested 28 to 40 pin devices, marked, internal factory numbers, etc. No. 2424	BARREL KIT #11 POWER TAB TRANSISTORS 40 for \$1.98 NPN, plastic TO220 type. Assorted 2N numbers. Cat. No. 2425 Untested.	BARREL KIT #12 POWER TAB TRANSISTORS 40 for \$1.98 PNP, plastic TO220 type. Assorted 2N numbers. Cat. No. 2426 Untested.	BARREL KIT #13 RESISTOR NETWORKS 40 for \$1.98 Un- tested. By Corning Glass, in 1-1 pin dip paks. Cat. No. 2427	BARREL KIT #14 PRECISION RESISTORS 200 for \$1.98 100% good Marked and unmarked 1/4, 1/2, 2 watts. No. 2428	BARREL KIT #15 MOSFET TRANSISTORS 60 for \$1.98 AU 4 leadders TO-18 case, includes UIHF translators Cat. 2429 Untested.	BARREL KIT #16 DISC CAPACITORS 200 for \$1.98 Marked and unmarked. Red case type ass. values. Cat. No. 2430 100% good.
BARREL KIT #17 LINEAR & 7400 DIPS 100 for \$1.98 Un- tested Marked and unmarked, internal numbers of raw factory stock. No. 2431	BARREL KIT #18 ZENER-RECTIFIER MIX 100 for \$1.98 Subminiature. DO7's, includes ass't, zeners and rectifiers. It's mixed at the factory, we cannot separate. Un- tested. Cat. 2432	BARREL KIT #19 DIPPED MYLARS 60 for \$1.98 Finest capacitors made, shiny finish. Imagine factory dumping 'em in barrels. Cat. No. 2597 100% good.	BARREL KIT #20 LONG LEAD DISCS 100 for \$1.98 Factory distributor stock "auction sale". Prime, marked only. Long leads. Cat. No. 2598 100% good.	BARREL KIT #23 "RTL" IC'S 75 for \$1.98 100% good. All in TO-5 cases, brand new. May include 908, 911, 912, 913, etc. Cat. 2601	BARREL KIT #24 HIGH VOLTAGE RECTIFIERS 60 for \$1.98 Un- tested. Up to 12,000 volts, 4 mils, epoxy, axial leads. Cat. No. 2602	BARREL KIT #25 METAL CAN TRANSISTORS 100 for \$1.98 Un- tested. Includes TO-5, TO-18, etc., assorted 2N numbers, unmarked etc. Cat. No. 2603
BARREL KIT #26 PLASTIC TRANSISTORS 100 for \$1.98 Un- tested. Type TO-92 (TO-18), all manufacturers, variety of 2N #'s. Cat. No. 2604	BARREL KIT #28 CERAMIC CAPACITORS 200 for \$1.98 Not only do the barrels contain dogbones, but factory dumped, Eric Central, lab, molded types too! Cat. No. 2606 100% good.	BARREL KIT #29 VITAMIN Q CAPS 100 for \$1.98 100% good. Every type of oil-impregnated caps, same worth \$2. But the "ole barrel" sale gives you the bargain-of-a-lifetime. Cat. No. 2607	BARREL KIT #30 PREFORMED RESISTORS 200 for \$1.98 We got barrels of 1/4 and 1/2 watters for pc use. You'll get even amount, 100: 1/4, 100 1/2 watters. Cat. No. 2608 100% good.	BARREL KIT #31 METALLIC RESISTORS 100 for \$1.98 Made mostly by Corning. The finest resistor made. Mostly 1/2 watters, 1% to 5% tol. & a barrel of values. 100% good. No. 2609	BARREL KIT #32 TRANSISTORS WITH A HOLE IN IT 50 for \$1.98 Un- tested. Can't name factory but we bought barrels of 25 watt-em with mtg. hole in middle. PNP's and NPN's.	BARREL KIT #34 TUBE SOCKETS 100 for \$1.98 Good ole tube sockets, still in demand! Barrels and barrels of 4's, 5's, 7's, 9, even computer types. Cat. No. 2612 100% good.
BARREL KIT #35 NEON LAMPS 40 for \$1.98 100% good. Famous NE-2's. All prime, but factory made millions and barreled 'em. Your advantage. Cat. 2613	BARREL KIT #36 GERMANIUM DIODES 200 for \$1.98 Famous maker, popular item. Never grows old. But this is the way the RE-TESTERS buy 'em from the factories. Un- tested. Cat. 2614	BARREL KIT #37 1 AMP "BULLETT" RECTIFIERS 100 for \$1.98 Famous style, ass'd. voltages, silicon, axial includes all types of voltages to 1KV. Un- tested. Cat. No. 2615	BARREL KIT #38 2 AMP RECTIFIERS 75 for \$1.98 Un- tested. "CYLINDER" type, silicon. Mallory, includes all voltages up to 1KV. Axial leads. Cat. No. 2616	BARREL KIT #39 2N3055 HOBBY TRANSISTORS 15 for \$1.98 100% good. From factory to you, these fallouts of the famous 2N3055. We have 10 barrels. Cat. No. 2617	BARREL KIT #40 PNP HIGH-POWER TRANSISTORS 20 for \$1.98 Popular germanium TO-3 case units, now available at "good ole barrel" prices. Cat. No. 2618 100% good.	BARREL KIT #42 100 TIT "GLASS 4000" RECTIFIERS \$1.98 Un- tested. Just in! 1N4000 silicon rectifiers in epoxy, now in glass encased at barrel prices 50 to 1000v too! Cat. No. 2620
BARREL KIT #46 G.E. 3.5 WATT AMPLIFIERS 25 for \$1.98 Hobby type, factory fallouts, we purchased them in barrels. These are unknowns. No. 2624 Untested.	BARREL KIT #49 QUADSI QUADSI 50 for \$1.98 LM 3900 Un- tested. 4 mirror op amps in one package. Why the factory barreled these we don't know. Cat. No. 2627	BARREL KIT #50 SIGNAL SILICON DIODES 200 for \$1.98 Includes many, many types of switching, signal silicon types, all axial leads. Some may be zeners. Cat. No. 2628 Untested.	BARREL KIT #51 HOBBY OTO COUPLERS 30 for \$1.98 We got 1,000's unknown both the sensor or transmitter may be good, or both. WE DON'T KNOW! We don't know the types, 1500V isolation. No. 2629 Untested.	BARREL KIT #52 DISCS! 500 for \$1.98 No. 2630 100% good. The bargain of a lifetime! First time ever offered by Poly Pak for the economy-minded bargain hunters.	BARREL KIT #53 JUMBO RESISTOR PAK 100-pc. \$1.98 No. 2721 Assortm metal films, precision, carbons, metal oxide powers, from 1/2 watt to 7 watts. Color coded & 100% good. Worth \$10.	BARREL KIT #54 9 DIGIT READOUTS 10 for \$1.98 Un- tested. Bargain of a lifetime! All we got was 1 barrel — the "blister digit" types, Multiplexed. Cat. No. 2722
BARREL KIT #55 3 DIGIT READOUTS 15 for \$1.98 National cleaned it warehouse, now we have barrels of NSN-38 type Un- tested. Cat. No. 2723	BARREL KIT #57 HI-POWER RECTIFIERS 15 for \$1.98 50-Amp studs: 6, 12, 24, 48V. 100% material. Factory rectifier "line" rejects. Cat. No. 2725 100% good.	BARREL KIT #58 SLIDE SWITCHES 30 for \$1.98 All shapes, sizes, spat, dpot, momentaries, etc. Tremendous shop pak for 100's of switching projects. Cat. No. 2726 100% good.	BARREL KIT #59 POWER TRANSISTORS 40 for \$1.98 15 watt Bendix B-5000 pellet transistors, npn, all good, purchased from a pretester, have millions of 100% good. Cat. No. 2727	BARREL KIT #60 DTL'S IC'S 75 for \$1.98 Un- tested. This is prime barrel material. Who wants DTL's? 930, 936, 940's. Your gain is our loss. They're marked good. Cat. No. 2728	BARREL KIT #61 POLYSTYRENE CAPS 100 for \$1.98 100% good Finest caps made. As a gamble we bought 10 barrels from factory, mixed values; all good. Cat. No. 2729	BARREL KIT #64 6-DIGIT READOUTS 20 for \$1.98 Here's a bargain! This is a National "dumpy" inflation is stayed here! Cat. No. 2732 Untested.
BARREL KIT #65 MIXED READOUTS 30 for \$1.98 Factory returns — such numbers as MAN-4's, MAN-7's, MAN-3's, 11 barrels & no time to separate. Cat. No. 2733 Untested.	BARREL KIT #67 2-WATT AMPLIFIERS 50 for \$1.98 Un- tested. Buy from the barrel 'n save! LM-380 types in dip paks. Are they good? We don't want to find out we got millions. Cat. No. 2734	BARREL KIT #68 2-WATERS 100 for \$1.98 100% good. Nobody seems to want 'em! So many suppliers don't count, but throw 'em in the barrel. It's a jill gold mine. All marked. Cat. No. 2735	BARREL KIT #71 CAPACITOR SPECIAL 100 pcs. \$1.98 Emptied stockrooms into barrels of mylars, poly's, mess, multidecs, plastics, ceramics, discs, etc. Nifty 100% good. Cat. 2736	BARREL KIT #72 TERMINALS RECEPTACLES 150 for \$1.98 100% good Maker of these dumped in to barrels. You get 2, 4, 6 strips & receptacles. What a buy! Cat. No. 2739	BARREL KIT #73 TRANSISTOR ELECTROS 50 for \$1.98 It "bugs" us why the factories dump 'em in barrels. We don't wish to separate wide ass't voltages & values up to 300 mv. No. 2747	BARREL KIT #75 400MW ZENERS 100 for \$1.98 Factory out of biz! Amazing offer: 6, 8, 10, 12 to 15V. You test. Hermetically sealed glass pak. Double plug. Cat. No. 2740 Untested.
BARREL KIT #76 1-WATT ZENERS 100 for \$1.98 Un- tested. Factory same as 400-mw's. Never-to-use-again offer. 6, 8, 10, 12, 15V. under glass. Double plug. Cat. No. 2741	BARREL KIT #77 "BROWN" BODY TRANSISTORS 40 for \$1.98 G-E D-10 series; has hi-voltage. Darlington's, 20 current, npn's. Factory line discontinued. Power tabs. Cat. No. 2742 Untested.	BARREL KIT #78 "RED" BODY TRANSISTORS 40 for \$1.98 D-42 series. You test — go into your own biz! High current, hi-V. NPN. Cat. No. 2743 Untested.	BARREL KIT #79 DARLINGTON POWER TABS 25 for \$1.98 Un- tested. Brown body. Power tab Darlington's are mixed, raw factory stock. Why pay more? Cat. No. 2744	BARREL KIT #81 SUBMINI RESISTORS 100 for \$1.98 100% good. PC, upright type, color coded, 1/2 watt. Ass't values. Came to us in a barrel. Cat. No. 2746	TWIN PAK #1 LED READOUTS 20 for \$1.98 10 Man-3's, 10 Man-7's. Cat. No. 2826	TWIN PAK #4 ZENERS 100 for \$1.98 50 400-MW, 50 1-watt 6, 8, 10, 12 to 15V. Cat. No. 2829
BARREL KIT #82 8000 SERIES IC'S 50 for \$1.98 By National. From factory to you. Assortment of popular series factory fallouts, overruns. Un- tested. Cat. No. 2634	BARREL KIT #83 LM-340T VOLTAGE REGULATORS 15 for \$1.98 Un- tested. Factory rejected them for length of leads. May include 6, 8, 9, 12, 15, 18, 24 volts. Power tab. No. 2635	BARREL KIT #84 THE CLAW! 5V 15 mil LED hobby or experimental use, for understanding the working of "mini" or calculator readouts. A segment may be missing. No. 2679	BARREL KIT #86 HOBBY LEDS 40 for \$1.98 Un- tested. Wow! A Litronics dump of all kinds of mixed discrete LEDs, shapes, colors, good, poor, etc. Cat. 2859	BARREL KIT #87 NATIONAL IC BONANZA 100 for \$1.98 Factory dumps into barrels. Types 8000, 7400 series, DTL's, ROM's, registers, clock & calc. chips, linear, etc. Cat. No. 2860 Untested.	TWIN PAK #10 POWER RESISTORS 70 for \$1.98 40 Oxide 2-wattors, 30 Oxide 1-wattors. Cat. No. 2835	TWIN PAK #9 6 & 9-DIGIT READOUTS 15 for \$1.98 15 6-digit, 15 for 9-digit Hobby types, from calculator makers' glassouts. Cat. No. 2854
BARREL #91 SILVER MICAS 100 for \$1.98 For the first time silver micas so low in price! Axial, red case, variety of physical sizes & values. Big savings from distributor prices. Wt. 1 lb.	BARREL KIT #94 "BUBBLE" READOUTS 12 for \$1.98 DL-93B bubble magnifiers. Size missing. Truthfully so many of 'em we don't care. Un- tested, 3 oz.	BARREL KIT #99 PHOTO ELECTRIC CELLS 10 for \$1.98 Ass't. GE types, CDS types. Mixed by factory. Big job for us to separate. 100% good.	BARREL KIT #101 RESISTOR SPECIAL 200 for \$1.98 Includes: 1/4, 1/2, 1/2, 1, 2-wattors, carbon, 8 oz. 100% good.	BARREL KIT #104 SILVER VOLUME CONTROLS 10 for \$1.98 Used in hi-f, volume control maker unloads. Ass't values, what a buy. Worth \$1 ea. We've got barrels of 100% material.		

Terms: Add postage. Rated: net 30
Phone: Wakefield, Mass. (617) 245-3829
Retail: 16-18 Del Carmine St., Wakefield,
C.O.D.'S MAY BE PHONED

POLY PAKS MIN. Order \$4.00
□ 20c CATALOG on ICs, SEMI's, PARTS
P.O. Box 942E-3, Lynnfield, Mass. 01940

ELECTRONICS MARKET PLACE

NON-DISPLAY CLASSIFIED: COMMERCIAL RATE: For firms or individuals offering commercial products or services, \$2.00 per word (including name and address). Minimum order \$30.00. Payment must accompany copy except when ads are placed by accredited advertising agencies. Frequency discount; 5% for 6 months; 10% for 12 months paid in advance. **READER RATE:** For individuals with a personal item to buy or sell, \$1.20 per word (including name and address.) No minimum! Payment must accompany copy. **DISPLAY CLASSIFIED:** 1" by 1 column (2-1/4" wide), \$230.00. 2" by 1 column, \$460.00. 3" by 1 column, \$690.00. Advertiser to supply film positives. For frequency rates, please inquire.

GENERAL INFORMATION: First word in all ads set in caps at no extra charge. All copy subject to publisher's approval. All advertisers using Post Office Boxes in their addresses **MUST** supply publisher with permanent address and telephone number before ad can be run. Advertisements will not be published which advertise or promote the use of devices for the surreptitious interception of communications. Ads are not acknowledged. They will appear in first issue to go to press after closing date. Closing Date: 1st of the 2nd month preceding cover date (for example, March issue closes January 1st. Send order and remittance to **POPULAR ELECTRONICS**, One Park Avenue, New York, New York 10016, Attention: Hal Cymes.

FOR SALE

FREE! Bargain Catalog—I.C.'s, LED's, readouts, fiber optics, calculators parts & kits, semiconductors, parts. Poly Paks, Box 942PE, Lynnfield, Mass. 01940.

GOVERNMENT Surplus Receivers, Transmitters, Snooperscopes, Radios, Parts, Picture Catalog 25 cents. Meshna, Nahant, Mass. 01908.

LOWEST Prices Electronic Parts. Confidential Catalog Free. KNAPP, 3174 8th Ave. S.W., Largo, Fla. 33540.

ELECTRONIC PARTS, semiconductors, kits. FREE FLYER. Large catalog \$1.00 deposit. **BIGELOW ELECTRONICS**, Bluffton, Ohio 45817.

RADIO—T.V. Tubes—36 cents each. Send for free catalog. Cornell, 4213 University, San Diego, Calif. 92105.

AMATEUR SCIENTISTS, Electronics Experimenters, Science Fair Students Construction plans—Complete, including drawings, schematics, parts list with prices and sources Robot Man — Psychedelic shows — Lasers — Emotion/Lie Detector — Touch Tone Dial — Quadrasonic Adapter — Transistorized Ignition — Burglar Alarm — Sound Meter over 60 items. Send 50 cents coin (no stamps) for complete catalog. Technical Writers Group, Box 5994, University Station, Raleigh, N.C. 27607.

METERS—Surplus, new used, panel or portable. Send for list. Hanchett, Box 5577, Riverside, CA 92507.

MECHANICAL, ELECTRONIC devices catalog 10 cents. Greatest Values — Lowest Prices. Fertik's, 5249 "D", Philadelphia, Pa. 19120.

SOUND SYNTHESIZER KITS—Surf \$12.95, Wind \$12.95. Wind Chimes \$17.95. Electronic Songbird \$6.95. Musical Accessories, many more. Catalog free. **PAIA Electronics**, Box J14359, Oklahoma City, OK 73114.

BUGGED??? New locator finds them fast. Write, Clifton, 11500-L N.W. 7th Avenue, Miami, Florida 33168.

DISCOUNT PRICES

B&K, SENCORE, LEADER, RCA EICO, FLUKE, HICKOK, SIMPSON Test Equipment

ICC/ServiceMaster, RCA and Raytheon Tubes

Complete line of electronic supplies

Free Catalog

FORDHAM RADIO SUPPLY CO., INC.

558 Morris Ave., Bronx, N.Y. 10451 (212) 585-0330

YOU WILL SAVE BIG MONEY! Surplus, Clearouts, Bankruptcy, Inventory, Deals. Catalog \$1 (redeemable). **ETCOA Electronics**, Box 741, Montreal, H3C 2V2. U.S. Inquiries.

TELEPHONE "BUGGED"? Countermeasures Brochure \$1.00. Negeye, Drawer 547, Pennsboro, W. VA 26415.

HEAR POLICE/FIRE Dispatchers! Catalog shows exclusive directories of "confidential" channels, receivers. Send 10 cent stamp. Communications, Box 56-PE, Commack, N.Y. 11725.

CD IGNITIONS, VHF/UHF monitors, crystals, CB radios. Southland, Box 3591-B, Baytown, Texas 77520.

ALPHA/THETA BRAINWAVE biofeedback instruments. Analog instruments from \$125; digital processing systems from \$225. **BioScan**, Box 14168-E, Houston, Texas 77021.

SURPRISE! Build inexpensively, the most Unusual Test Instruments. Futuristic Gadgets using Numerical Readouts! Catalogue Free! **GBS**, Box 100A, Green Bank, West Virginia 24944.

LEARN DESIGN TECHNIQUES. Electronics Design Newsletter. Digital, linear construction projects, design theory and procedures. Annual subscription \$6.00, sample copy \$1.00. **Valley West**, Box 2119-B, Sunnyvale, California 94087.

TELEPHONES UNLIMITED, equipment, supplies. Catalog 50 cents. Box 1654E, Costa Mesa, Calif. 92626.

P-1

wanted **Citizens Band**

DEALER-DISTRIBUTORS

Send this ad with Letterhead to:

PAL ELECTRONICS CO.

2962 W. WELDON - PHOENIX, ARIZ. 85017

UNSCRAMBLERS: Fits any scanner or monitor, easily adjusts to all scrambled frequencies. Only 4" square \$29.95, fully guaranteed. Dealer inquiries welcomed. **PQO Electronics**, Box 841, North Little Rock, Arkansas 72115.

SURPRISE! SURPRISE! Digital Piano Tuning Device tunes musical instruments Accurately! Perfectly! Inexpensively! Construction-Instruction-Plans Complete \$12.95 Airmailed Postpaid! Moonlighting quickly repays \$40 electronics investment! **GBS**, Box 100P, Green Bank, West Virginia 24944.

PYROTECHNICAL chemicals, casings, fuse, tools, literature, supplies. Catalog-\$1.00, with samples — \$2.00. **Westech**, Logan, Utah 84321.

RECONDITIONED Test Equipment. \$0.50 for catalog. **Walter's Test Equipment**, 2697 Nickel, San Pablo, CA 94806.

FREE giant bargain electronic catalog listing thousands of components, tubes, transistors, IC's, kits, test equipment. **EDLIE'S**, 2700-PA Hempstead Tpke., Levittown, N.Y. 11756.

SAVE ELECTRIC POWER!

Save up to 80% electrical power with this unique, inexpensive, portable, permanent and legal method applicable for shops, homes, factories, businesses, farms, sites. 100% Refund Guaranteed if not scientifically sound or if it employs gimmicks.

Information \$1.00

CONSUMERTRONICS CO.

P.O. Box 1399 Alamogordo, N.M. 88310

FOR A New Electronic Experience, learn to control your brainwaves. **Aquarius Electronics**, Box 96ZE, Albion, CA 95410.

POLICE, Fire monitors, scanners, crystals discount priced. New crystal-less scanners. Box 19224, Denver, CO 80219.

TELETYPE EQUIPMENT for sale for beginners and experienced computer enthusiast. Teletype machines, parts, supplies. Catalogue \$1.00 to: **ATLANTIC SALES**, 3730 Nautilus Ave., Brooklyn, NY 11224. Tel: (212) 372-0349.

BUILD THAT ELECTRONIC ORGAN YOU ALWAYS WANTED AT A PRICE YOU CAN AFFORD. Third edition of "Organ Builder's Guide," pictured product kit line, circuits, block diagrams, design rationale using IC divider and independent generators with diode keying. \$3.00 postpaid. Also, free brochure on keyboards. **DEVTRONIX ORGAN PRODUCTS**, Dept. C, 5872 Amapola Dr., San Jose, CA 95129.

JAPANESE TRANSISTORS, all transistors original factory made. Free catalog. **West Pacific Electronics**, P.O. Box 25837, W. Los Angeles, CA 90025.

COMPUTER, PERIPHERAL, TECHNICAL Reports; Project Supplies; Kits. Catalog 751A, 50 cents. **E/S Lab**, Box 738, College Park, Maryland 20740.

It's about time...

A SOLAR POWERED DIGITAL WATCH



ONLY \$199.95

Fantastic new time computer. Accurate to within 5 seconds a month. Guaranteed minimum 3 years without battery replacement!

Amazing new solar powered quartz watch makes almost all standard digital watches seem obsolete. Handsome, sleek "20th Century Sundial" features bright L.E.D. display for easy 3-second reading of hour, minute, second at the press of its recessed button. Press it again for the self-correcting (except leap year) calendar to show the month and date. 9 silicon solar cells charge 2 sub-mini batteries (guaranteed for minimum 3-year life) to power the quartz control oscillator. No moving parts in mechanism. Unmatched dependability and performance. Works with incandescent light also. Once it's fully charged, will actually run for a full year at 25 actuations a day — without any light whatsoever. So just follow your normal routine. As if you could — ever again — with such an extraordinary timepiece. Order today with your BankAmericard, Master Charge or check. Return it in 30 days if you aren't delighted. Gold-plated "smart" watch says it's time for solar energy.

Stock No. 1675AVC . Only \$199.95 Ppd.

COMPLETE AND MAIL COUPON NOW

EDMUND SCIENTIFIC CO. 300 Edscorp Bldg., Barrington, N. J. 08007

Send me:

SEND FREE 172 PAGE CATALOG AVC

Charge my BankAmericard

Charge my Master Charge

Interbank No. _____

Card No. _____

Expiration Date _____

30-DAY MONEY-BACK GUARANTEE. You must be satisfied or return any purchase in 30 days for full refund.

City _____ State _____ Zip _____

Enclosed is check, m.o. in amount of \$ _____

Signature _____

Name _____ Please print

Address _____

GIANT FREE CATALOG!

NEW. 172 Pages. Over 4,500 Unusual Bargains for Hobbyists, Schools, Industry

EDMUND SCIENTIFIC CO.

300 EDSCORP BUILDING
Barrington, N. J. 08007

America's Greatest Science • Optics • Hobby Mart

JUST CHECK COUPON!

EDMUND SCIENTIFIC CO.

HELPING TO DEVELOP AMERICA'S TECHNOLOGY FOR OVER 30 YEARS.

CIRCLE NO. 17 ON FREE INFORMATION CARD

CONTINENTAL SPECIALTIES

PROTO BOARDS

Build & test circuits as fast as you think!

PB100	10 IC cap breadboard kit, 4.5 x 6.0 x 1.35"	\$19.95
PB101	10 14-DIP cap, 5-way post, 940 solderless tie points, 5.8 x 4.5"	\$29.95
PB102	12 14-DIP cap, like PB101 with 1,240 tie points, 7.0 x 4.5"	\$39.95
PB103	24 14-DIP cap, 4.5-way posts, 2,250 tie points, 6.0 x 4.9"	\$59.95
PB104	32 14-DIP cap, 3060 solderless tie points, 8.0 x 9.76"	\$79.95



PROTO-CLIP

For power-on/hands-off signal tracing. Bring IC leads up from PCB surface for fast troubleshooting.

PC14	14-pin	\$4.50
PC16	16-pin	4.76

LOGIC MONITOR

Simultaneously displays static and dynamic logic states of DTL, TTL, HTL or CMOS DIP ICs. Pocket size. \$84.95.

SOCKETS & BUS STRIPS

Plug-in, wire, test, modify or expand without patch cords or solder. Snap together to form breadboard needed.

PN/Description	L. Holes	Hole-to-Hole	Term's	Price
QT95B Socket	6.5"	6.2"	1B	\$12.50
QT95B Bus	6.5"	6.2"	20	2.50
QT47S Socket	5.3"	5.0"	94	10.00
QT47S Bus	5.3"	5.0"	16	2.25
QT18S Socket	4.1"	3.8"	70	5.50
QT35B Bus	4.1"	3.8"	12	2.00
QT18S Socket	2.4"	2.1"	36	4.00
QT12S Socket	1.8"	1.5"	24	3.75
QT8S Socket	1.4"	1.1"	18	3.25
QT7S Socket	1.3"	1.0"	14	3.00

7400N TTL

7400N	.12	7442N	.58	7497N	5.00	74164N	1.10
7401N	.15	7443N	.77	74100N	5.00	74165N	1.10
7402N	.14	7444N	.77	74104N	1.20	74166N	1.28
7403N	.15	7445N	.77	74105N	5.00	74170N	2.05
7404N	.16	7446N	.83	74107N	.33	74173N	1.34
7405N	.19	7447N	.72	74109N	.74	74174N	1.25
7406N	.29	7448N	.80	74110N	.72	74175N	.94
7407N	.29	7450N	.14	74111N	1.20	74176N	.90
7408N	.18	7451N	.14	74116N	2.00	74177N	.90
7409N	.20	7453N	.14	74121N	.36	74178N	.90
7410N	.16	7454N	.20	74122N	.38	74179N	2.50
7411N	.24	7459N	.10	74123N	.70	74180N	.80
7412N	.33	7460N	.14	74125N	.47	74181N	2.39
7413N	.44	7470N	.26	74126N	.53	74182N	.70
7414N	.95	7472N	.26	74128N	.74	74184N	1.84
7415N	.33	7473N	.27	74132N	1.10	74185N	2.20
7417N	.33	7474N	.32	74136N	.95	74188N	4.75
7418N	.25	7475N	.50	74141N	1.20	74190N	1.20
7420N	.13	7476N	.32	74145N	.91	74191N	1.20
7421N	.33	7481N	.48	74150N	.94	74192N	.96
7422N	.50	7481N	1.30	74148N	2.00	74193N	.95
7423N	.37	7482N	.98	74150N	1.00	74194N	1.10
7425N	.23	7483N	.70	74151N	.80	74195N	.74
7426N	.23	7485N	3.00	74159N	1.40	74196N	.99
7427N	.25	7485N	.90	74153N	.79	74197N	.78
7428N	.33	7486N	.34	74154N	1.40	74198N	1.60
7430N	.20	7489N	2.20	74155N	.97	74199N	1.60
7432N	.24	7490N	.48	74156N	.95	74200N	5.60
7433N	.35	7491N	.76	74157N	.74	74211N	1.50
7437N	.29	7492N	.49	74158N	1.60	74251N	1.75
7438N	.29	7493N	.49	74160N	1.24	74278N	2.45
7439N	.38	7494N	.72	74161N	.99	74279N	.94
7440N	.16	7495N	.60	74162N	1.25	74293N	2.40
7441N	.87	7496N	.70	74163N	.99	74298N	1.98

HIGH SPEED TTL

74H00N	.33	74H20N	.33	74H52N	.36	74H73N	.80
74H01N	.25	74H21N	.33	74H53N	.36	74H74N	.80
74H04N	.33	74H22N	.33	74H54N	.36	74H76N	.75
74H05N	.33	74H30N	.33	74H55N	.36	74H102N	.75
74H08N	.40	74H40N	.36	74H60N	.36	74H103N	.90
74H10N	.33	74H50N	.36	74H71N	.75	74H106N	.95
74H11N	.33	74H51N	.36	74H72N	.75		

LOW POWER TTL

74L00N	.24	74L10N	.24	74L51N	.34	74L90N	1.62
74L02N	.24	74L20N	.33	74L73N	.43	74L93N	1.51
74L03N	.39	74L42N	1.33	74L74N	.90	74L95N	1.62
74L04N	.33						

74LS

74LS00	.39	74LS27	.45	74LS109	.92	74LS163	2.25
74LS01	.56	74LS30	.39	74LS112	.65	74LS170	6.80
74LS02	.39	74LS32	.45	74LS113	.92	74LS174	2.20
74LS03	.39	74LS38	.53	74LS114	.92	74LS175	2.40
74LS04	.45	74LS51	.39	74LS138	1.89	74LS181	6.00
74LS08	.39	74LS54	.55	74LS139	2.00	74LS194	2.25
74LS09	.57	74LS55	.39	74LS151	1.55	74LS198A	2.25
74LS10	.39	74LS73	.65	74LS153	1.89	74LS199	2.76
74LS11	.42	74LS75	.65	74LS157	1.55	74LS251	2.06
74LS15	.57	74LS76	.65	74LS158	1.68	74LS253	2.42
74LS20	.39	74LS78	.92	74LS160	3.06	74LS257	1.89
74LS21	.56	74LS95	2.30	74LS161	3.06	74LS258	2.06
74LS22	.60	74LS107	.75	74LS162	2.25	74LS260	.55

SCHOTTKY TTL

74S00	.44	74S32	.80	74S113	1.80	74S174	3.30
74S01	.76	74S40	.68	74S114	1.20	74S175	2.90
74S02	.60	74S50	.76	74S133	.80	74S181	6.00
74S03	.75	74S51	.80	74S38	2.20	74S189	4.40
74S04	.55	74S60	.80	74S39	2.20	74S194	3.30
74S05	.76	74S64	.80	74S40	.80	74S195	3.30
74S08	.80	74S68	.80	74S51	2.20	74S251	2.20
74S09	.76	74S74	.90	74S53	3.40	74S253	2.40
74S10	.55	74S76	1.15	74S57	2.40	74S257	2.40
74S11	.65	74S78	1.16	74S58	2.00	74S268	2.40
74S15	.76	74S85	6.10	74S60	3.00	74S260	1.20
74S20	.65	74S86	2.50	74S61	4.70	74S280	5.70
74S21	.76	74S112	1.00	74S72	6.00	74S289	4.00
74S30	.80						

9300 SERIES

9300PC	\$1.00	9318PC	1.75	9366PC	1.75	93L18	3.50
9301PC	1.20	9321PC	2.30	93L00	1.50	93L21	1.50
9304PC	1.50	9322PC	1.60	93L22	.80	93L22	.80
9306PC	6.90	9324PC	2.00	93L08	3.20	93L24	3.80
9308PC	2.50	9328PC	2.50	93L09	1.80	93L28	2.70
9309PC	1.60	9334PC	2.95	93L10	2.80	93L34	6.00
9310PC	1.31	9336PC	3.00	93L11	1.10	93L36	4.20
9311PC	2.30	9340PC	5.00	93L12	1.80	93L40	4.50
9312PC	1.20	9341PC	1.00	93L14	1.70	93L41	6.50
9314PC	1.30	9342PC	1.15	93L16	3.20	93L60	3.00
9316PC	1.60	9360PC	.75	93L18	3.50	93L66	2.70

LINEAR IC'S

H-TO-5	N-DIP	M-MINI-DIP	D-CER-DIP	K-TO-3	
LM105H	3.90	LM311H	1.20	LM7101H	9.80
LM108H	4.90	LM313D	9.00	LM710CN	9.00
LM114H	3.00	LM313N	1.75	LM711CN	9.00
LM300H	1.20	LM312N	1.75	LM711CN	9.00
LM300N	1.20	LM318H	1.50	LM715CH	3.50
LM301AH	.50	LM318N	2.40	LM715CN	4.60
LM301AM	.80	LM324A	1.90	LM723CH	6.00
LM301AN	1.10	LM331N	1.25	LM723CN	.65
LM301M	.95	LM336K	2.40	LM725CH	1.50
LM302N	1.30	LM339N	2.20	LM725CN	5.00
LM302H	1.40	LM320-5K	2.90	LM733CH	1.40
LM304H	1.20	LM320-5T	2.50	LM733CN	3.50
LM305H	.85	LM320-12K	2.90	LM733CN	1.30
LM305AH	1.05	LM320-12T	2.50	LM741CH	4.00
LM305N	1.00	LM340-5K	2.50	LM741CN	1.25
LM306H	.95	LM340-6K	2.60	LM741CN	39
LM307H	.60	LM340-8K	2.60	LM747CH	75
LM307M	1.60	LM340-12K	2.60	LM747CN	90
LM308H	.85	LM340-15K	2.60	LM748CN	55
LM308N	.95	LM340-18K	2.60	LM777CH	2.15
LM308M	1.60	LM340-24K	2.60	LM777CN	2.10
LM308H	1.60	LM340-24K	2.60	LM3046CN	9.50
LM309H	1.75	LM3556CN	1.30	LM3054CN	1.50
LM309K	1.50	LM357CN	1.70	SC4501T	2.40
LM310H	.60	LM709CH	.75	SC4501N	2.40
LM310M	1.80	LM709CN	.75	LM5000K	7.50

C-MOS

P/N	1-9 10up	P/N	1-9 10up	P/N	1-9 10up
4000AE	.24 .23	4027AE	.55 .53	4070AE	.60 .59
4001AE	.24 .22	4028AE	.95 .88	4071AE	.25 .23
4002AE	.24 .22	4029AE	1.25 1.22	4072AE	.34 .31
4004AE	4.00 3.98	4032AE	.44 .40	4073AE	.38 .35
4006AE	1.20 1.20	4033AE	2.00 .94	4075AE	.38 .35
4007AE	.24 .23	4035AE	1.25 1.14	4076AE	1.24 1.22
4008AE	1.79 1.65	4040AE	1.58 1.50	4077AE	.70 .69
4009AE	.59 .51	4041AE	1.82 1.75	4078AE	.38 .35
4010AE	.50 .49	4042AE	.78 .75	4081AE	.25 .23
4011AE	.24 .22	4043AE	.85 .80	4082AE	.34 .31
4012AE	.24 .22	4044AE	.80 .75	4095AE	2.00 1.99
4013AE	.45 .40	4047AE	2.75 2.70	4098	

TV TERMINAL III \$134.95

Complete with plated boards, TTL, res, caps and 1K memory

Add 1.50 shipping, handling, insurance

NEW

BAUDOT to ASCII converter board \$29.95

ASCII to BAUDOT converter board \$34.95

Converts codes in parallel form. Includes encoded PROMs, TTL, res, caps, PC board. Special Altair model will be available.

Add \$1 shipping, handling, insurance

Write for info on new boards for Altair.

R-M TERMINAL includes solid state keyboard, custom converted to ASCII, power supply and case \$134.95

Shipping additional, UPS or Parcel Post. Shipping weight 60 pounds.



Send stamped self addressed envelope for prompt response

MiniMicroMart

1618 James Street
Syracuse, New York 13203
(315) 422-4467

CIRCLE NO. 34 ON FREE INFORMATION CARD

Planning to move?

Let us know 8 weeks in advance so that you won't miss a single issue of POPULAR ELECTRONICS.

Attach old label where indicated and print new address in space provided. Also include your mailing label whenever you write concerning your subscription. It helps us serve you promptly. Write to: P.O. Box 2774, Boulder, CO 80302, giving the following information:

- Change address only.
 Extend subscription. Enter new subscription.
 1 year \$6.98
 Payment enclosed (1 extra BONUS issue)
 Bill me later

0182

zip code

name please print address city state zip code

name please print address city state zip code

name please print address city state zip code

name please print address city state zip code

Add'l postage per year: Add \$1 for Canada; \$2 for all other countries outside the U.S.

CB RADIO, Scanners, Antennas. The best for less. Free List. Capitol Sound, Box 3523, Des Moines, Iowa 50322.

YOU WANT TO BUILD IT: WE WANT TO HELP. WE SELL CONSTRUCTION PLANS with an Engineering Service. TELEPHONE: Answering Machines, Speakerphones, Car-phones, Phonevision, Touch Button Dialers. TELEVISION: VTR, 1" Color TV Set, PONG, \$25.00 Camera, COLOR PROJECTION TV. HOBBYIST: Electron Microscope, \$75 software programmable computer. BROADCAST: Special Effects Generator, Chroma Key, Audio Board, DA's. COURSES: Telephone Engineering \$52.00. Detective Electronics \$29.50, IC Engineering \$65.00, PLUS MUCH MORE. NEW Super Hobby Catalog PLUS year's subscription to Electronic News Letter AIR MAILED \$1.00. Don Britton Enterprises, 6200 Wilshire Blvd., Los Angeles, Calif. 90048.

FREE CATALOG. Ultrasonic Devices, LEDs, Transistors, IC's, Keyboards, Digital Thermometers, Unique Components. Chaney's, Box 15431, Lakewood, Colo. 80215.

SEMICONDUCTOR AND PARTS Catalogue from the semiconductor specialists. J & J Electronics, Box 1437, Winnipeg, Manitoba, Canada. U.S. Inquiries.

ELECTRONIC Ignition: Pointless, Transistor, Capacitor. Vapor inductors. Auburn Sparkplugs. Information 10 cents. Anderson Engineering, Epsom, N.H. 03234.

TV PING PONG game. Plays through your set's antenna terminals: Plans \$3.25. ARS SYSTEMS, Box 1922, Sunnyvale, CA 94088.

6 MHZ CRYSTALS including schematic and info to generate 60 hz-12VAC to make your digital clock run on batteries. \$10.50 pp in US. Eastern Sales, Box 510, Raleigh, N.C. 27602.

FREE CATALOG. Kits and components. ELS Electronics, Box 581, Westbury, N.Y. 11590.

CB RADIO
\$9
CB RADIO

Oldest and largest CB Radio Magazine in the U.S.

Covers: CB NEWS
 SCANNERS
 CB PRODUCTS
 FCC REGULATIONS

SEND \$8.50 for one year subscription (12 issues) and receive a free 24 book of official FCC Part 95 CB regulations.

S9 / CB Radio 14 Vandeventer Ave.,
 Port Washington, NY 11050

DESCRAMBLERS: Several Professional Models that work with all Scanners. Tone Encoders/Decoders, Scanmate, AAPP, Radar Detectors, Big Ears, Alarms, Books, Kits, parts. Catalog 25 cents: KRYSTAL KITS, Box 445, Bentonville, Ark. 72712.

4K 8080 COMPUTER, 3 I/O Ports \$395 assembled. Kits from \$35. Details \$2.00 (refundable). VACOMP, Box 4733, Arlington, Virginia 22204.

CARBON FILM RESISTORS. Brand new as low as 1.7 cents. Discounts of 20%. Prompt delivery. FREE samples/specifications. COMPONENTS CENTER, Box 134P, N.Y., N.Y. 10038.

COMPUTER, 8 bit serial, complete, \$225. Scope display generator, 128 characters, parallel input, \$85. Brochure 10 cents. RAECO, Box 14, Readville, Mass. 02137.

KEYBOARDS, for synthesizers, organs. Three octave, two bud. \$65. Brinkwood Electronics, Box 26, Sandy Spring, MD 20860.

"HOLD-A-CALL." Hold button for single line phones (rotary or touch tone). Single line, \$29.95, double line \$39.95, with "music on hold" \$10.00 additional. Money back guarantee, catalog 25 cents. PCS, 92 Marcus Avenue, New Hyde Park, N.Y. 11040.

"BASIC TELEPHONE WIRING." Unique report gives complete details. \$3.50 postpaid. Queens Village Telephone Supply, Box 29002-Q, Queens Village, NY 11429.

COMPUTER HOBBYISTS! Learn how to program. Complete self-taught programming course. Details \$1.00. Creative Computer, Box 52, Palo Alto, CA 94302.

COMPUTER HOBBYISTS! Bargain hunt and sell via ON-LINE. 18 issues/year — \$3.75. Free sample issue from: ON-LINE, 24695 Santa Cruz Hwy., Los Gatos, CA 95030.

IMSAI AND ALTAIR OWNERS!!

IMSAI 8080 COMPUTER

ALL BOARDS COMPLETELY "PLUS COMPATIBLE" WITH ALTAIR 8800

BASIC COMPUTER INCLUDES: MPU FRONT PANEL CONTROL BOARD, LIGHTS AND SWITCHES, POWER SUPPLY, EXPANDER BOARD AND CASE. \$499 KIT... \$931 ASSEMBLED

SEE FULL PAGE AD IN THIS ISSUE FOR DETAILS INTERCHANGEABLE MPU-A, MEMORY & I/O BOARDS FULL IMSAI 8080/ALTAIR 8800 COMPATIBILITY. NO HARDWARE OR SOFTWARE MODIFICATIONS REQUIRED JUST PLUG IN!!!!

PART #	DESCRIPTION	KIT	ASSEMBLED
MPU-A	8080 MPU BOARD	\$181.00	\$390.00
RAM 4-4	4K RAM ON 4K BOARD	\$186.00	\$290.00
RAM 4-1	1K RAM ON 4K BOARD	\$88.00	\$139.00
PROM 4-2	2K EPROM ON 4K BOARD	\$176.00	\$344.00
EXT	EXTENDER BOARD	\$37.00	\$43.00
PIC-8	COMB. VECT. INT. & R.T. CLK.	\$118.00	\$238.00
PIO 4-1	PARALLEL I/O BOARDS: 8 BIT PORTS!!	\$88.00	\$140.00
PIO 4-4	SAME AS PIO 4-1, BUT 4 BYTES IN, 4 BYTES OUT.	\$149.00	\$299.00
SERIAL I/O BOARDS:	HANDLE BOTH SYNCH AND ASYNCH COMM. (RS-232 PLUS CONTROL LINES PLUS TTL PLUS TTY!)	\$88.00	\$140.00
SIO 2-1	ONE I/O CHANNEL	\$119.00	\$235.00
SIO 2-2	TWO I/O CHANNELS	\$149.00	\$299.00

NEW... UNIVERSAL CASSETTE RECORDER INTERFACE

JUMPER SELECT BETWEEN PE HITS SYSTEM AND NEW KANSAS CITY STANDARD... ALL ON ONE BOARD. FOR BOTH THE IMSAI 8080 AND THE ALTAIR 8800 KIT.....\$49 ASSEMBLED AND TESTED.....\$99

THE INTEL DATA BOOK

CONTAINS COMPLETE SPECIFICATIONS AND DATA SHEETS ON INTEL 8080 AND ALL ASSOCIATED INTEL MEMORY AND PERIPHERAL CHIPS. ALSO INCLUDES PRELIMINARY SPECS ON "COMING" INTEL CHIPS. 167 pages \$5.00

THE TTL DATA BOOK

CONTAINS COMPLETE ELECTRICAL SPECIFICATIONS FOR ALL 7400 SERIES TTL. THIS IS THE "BIBLE" 640 pages \$10.00

THE PINOUT HANDBOOK

COVERS ENTIRE 5400/7400 SERIES D.P. I.C.'S, PIN CONNECTIONS, FUNCTIONAL SPECS CROSS REFERENCE \$3.95

IMS ASSOCIATES, INC. 1922 REPUBLIC AVE. SAN LEANDRO CALIF. 94577
 TERMS: CHECK OR M.O. BANKAMERICAN, MASTERCARD, 25% DEPOSIT ON C.O.D.

ADD 5% POSTAGE AND HANDLING. (415) 488-2093 PRICES SUBJECT TO CHANGE WITHOUT NOTICE
 CALIF. RESIDENTS: ADD 6.5% SALES TAX
 IMSAI CIRCLE NO. 24 ON READER SERVICE CARD

GOV'T SURPLUS Electronic "Super-Buys"

Nationally Known-World Famous SURPLUS CENTER offers finest, Government Surplus electronic units and components at a fraction of their original acquisition cost.

STANDARD DIAL TELEPHONE

(ITEM #715) - 51d. commercial telephone. Same as used throughout U.S.A. Like new condition. Polished black. Use as extension phone or connect several phones together for local intercom system. Full instructions furnished. Wt. 9 lbs.

Original Cost \$24.50
\$7.39

STEP-BY-STEP TELEPHONE SWITCH

(ITEM #738) - Amazing selector switch makes great experimental item. When used with 2-wire telephone diol it will select any number from 10 to 100. Make private phone or intercom system, turn on remote lights, motors, etc. Complete with contact block. 13" x 6" x 5". (16 lbs.) **\$7.81**

(ITEM #700) - Telephone Dial For use with #738 switch **\$1.38** Cost Over \$90.00

SPECIAL SELF Correspondence Course In ELECTRICAL ENGINEERING

\$11.79 PREPAID IN USA
 \$12.79 PREPAID OUTSIDE USA

(ITEM #9-181) - Technical training of low cost Lincoln Engineering School suspended its Correspondence Courses because of rising costs. Limited number of Electrical Engineering courses (without examination grading service) available. Course consists of 15 lesson books with associated exams and standard answers. Home Experimental Lab Bench book included FREE!

BUILD ELECTRIC CARTS WITH UNIQUE MOTORIZED DRIVE WHEEL

(ITEM #5-936) - Permanent magnet field motor drives wheel through gear box for high torque. Operates on 6 or 12-volt storage battery. Reversible. 65 to 125 RPM. Swivels for steering. 4 1/2" diam. rubber tire wheel. Instructions **\$9.98**

ALL ITEMS F.O.B. LINCOLN, NEBR.
 Write For Catalogs Order Direct From Ad.
SURPLUS CENTER
 DEPT. PE-036 LINCOLN, NE. 68501

SIX DIGIT LED ALARM CLOCK KIT

Thousands of hobbyists have bought and built our original clock kit and were completely satisfied. But we have received many requests for an alarm clock kit with the same value and quality that you have come to expect from S.D. So, here it is!

THE KIT INCLUDES:

- 1—National MM5375 Alarm Clock Chip
- 6—Hewlett-Packard .30in. common cathode readouts
- 15—NPN & PNP Driver Transistors
- 1—Etched and drilled P.C. board
- 1—Step-Down Transformer
- 2—Push Button Switches for time set
- 2—Slide Switches for Alarm Set and Enable
- 1—Filter Caps
- 6—IN4002 Rectifiers
- 1—IN914 Diode
- 3—.01 Disc Caps
- 28—Resistors
- 1—Speaker for Alarm
- 1—LED Lamp for Pm indicator.

\$19.95
(Complete Kit. PPD.)

Please take note that we use only first run parts in our kits and include ALL the necessary parts. Not like some of our competitors who use retested readouts and chips or who may not even include switches in their kits.

INTEL 1702A 2K ERASEABLE PROM'S \$6.95

We tell it like it is. We could have said these were factory new, but here is the straight scoop. We bought a load of new computer gear that contained a quantity of 1702A's in sockets. We carefully removed the parts, verified their quality, and are offering them on one heck of a deal. First come, first served. Satisfaction guaranteed.

PROFESSIONAL QUALITY STEREO HEADPHONES

Here is the kind of super deal that S. D. is famous for. Treat your ears to a super sound at a super price. Soft padded ear cushions, lightweight, fully adjustable headband, long coiled cord, wide response. \$6 Post Paid - NEW IN ORIGINAL FACTORY BOXES

SALE ON CUT LEAD SEMICONDUCTORS

Leads were cut for PCB insertion. Still very useable. IN4148 Diode - 40/\$1 2N3904 (House #Transistor) - 25/\$1

INSTRUMENT KNOBS

Black with brushed aluminum insert. Medium size, very attractive style. **SPECIAL 5 FOR \$1**

SIGNETICS 1K P-ROM

82S129. 256 X 4. Bipolar, much faster than MOS devices. 50 NS. Tri-state outputs. TTL compatible. Field programmable, and features on chip address decoding. Perfect for microprogramming applications. 16 pin DIP. With specs. \$2.95 ea.

MV-50 TYPE LED's

by LITRONIX

10 for \$1

Factory Prime!

1AMP 1000 PIV SILICON RECTIFIERS
IN4007. Factory prime devices. 10 for \$1.00

741C OP AMPS

Prime, factory tested and marked. Full spec on all parameters. Not re-tested, functional only, units as sold by others. 741CH -TO-5 8 Lead Metal Can . . . 3/\$1
741CV - 8 Lead Mini Dip 4/\$1

SLIDE SWITCH ASSORTMENT

Our best seller. Includes miniature and standard sizes, single and multi-position units. All new, first quality, name brand switches. Try one package and you'll reorder more. *Special — 12 for \$1 (Assortment)*

SUBMINIATURE TRIMMER CAPS

Ultra stable. Range 3.5 to 18 PF 3 for \$1

FILTER CAPS

Dual section, 2000 MFD and 1500 MFD at 30 WVDC Twist Lock. 79c ea. 3 For \$2

NATIONAL VOLTAGE REGULATOR

Like 7805. 5VDC - 1 AMP output. Has TO-220 plastic power tab - 99c

IN4148 COMPUTER DIODES

Same as IN914. Factory prime. 20 for \$1

FULL WAVE BRIDGE

By G. I. 1.5 AMP 800PIV - 75c

2N706A 400MHZ. TRANSISTORS

Silicon NPN. 1 WATT. TO-18 Case. 5 For \$1

LARGE SIZE LED LAMPS

Similar to MV5024. Prime factory tested units. We include plastic mounting clips which are very hard to come by. *Special 5 for \$1*

MOTOROLA VOLTAGE REG

MC1469R. TO-66 9 Lead package. For 3 TO 30V Outputs. Provides 600 MA direct output or more by using an external power transistor. Reg. catalog \$4 ea. With specs. \$1.95 ea.

VERNIER DIAL

From a close out of metal detector manufacturer. 1/2 Turn, 8 to 1 ratio. Internal stops easily removed to make unit multi-turn.

LIMITED QUANTITY - \$99 EACH

DO YOU NEED A LARGE COMMON ANODE READOUT AT A FANTASTIC PRICE?



S. D. presents the MAN-64 by Monsanto - .40 inch character. All LED construction - not reflective bar type, fits 14 pin DIP. Brand new and factory prime. Left D.P.

\$1.50 ea. 6 for \$7.50

1000 MFD FILTER CAPS

Rated 35 WVDC. Upright style with P.C. leads. Most popular value for hobbyists. Compare at up to \$1.19 each from franchise type electronic parts stores. S.D. *Special 4 for \$1*

DRIVER TRANSISTORS
2N3904 - NPN
2N3906 - PNP
8 for \$1

12 DIGIT READOUTS — \$1.75

Mfg. by National Electronics. Big .40 in. char. size. Gas discharge type, for use in desk top calculators, frequency counters, clocks, etc. #NDP 1253-12. Originally cost a calculator mfg. \$16.77 ea. in quantity. S.D. *Price \$1.75 ea.*

HIGH V. TRANSFORMER for above readout. Primary 117V, two secondaries: 24 VAC 500 MA 175 VAC 100 MA. \$1.25 ea.

SUPER DEAL: Two 12 Digit Readouts w/transformer — \$5.00

FET'S BY TEXAS INSTRUMENTS — SPECIAL 5 for \$1

#TIS-75 but with an internal house number. TO-92 plastic case. N. Channel, Junction type FET.

FAIRCHILD BIG LED READOUTS

A big .50 inch easy to read character. Now available in either common anode or common cathode. Take your pick. Super low current drain, only 5 MA per segment typical.

FND - 510 Common Anode
FND - 503 Common Cathode

YOUR CHOICE
\$2 ea.

H.P. IS BACK!

No Rejects or Retests here — You Want Quality? You have it with this popular 0.3" L.E.D. by Hewlett Packard. Fits Standard I.C. Socket. Right hand DP.

5082-7740 — Common Cathode \$1.25

5082-7730 — Common Anode \$1.25

6 for \$6.00



5VDC 1 AMP POWER SUPPLY KIT

DC supply kit for TTL. Includes transformer, rectifiers, filter caps, voltage regulation IC, and schematic. Only \$3.95 (Kit) Add 50c postage. *Well Regulated and Short Circuit Protected!*

Signetics, TRI-State Hex Buffer. MOS

and TTL interface to TRI-State Logic.

Special: \$1 8T97B

936 DTL BY ITT

Prime, house numbered. Hex Inverter
10 For \$1

LM324 - QUAD 741 OP
AMP - 99c

NE555 - Timers - 49c

709CH - OP AMPS -
4 For \$1

GE SCR C106B1
4 AMP 200PIV. Sensi-
tive Gate. 59c

3 DIGIT LED ARRAY — 75c

by LITRONIX

DL33MMB. 3 MAN-3 Size Readouts in one package. These are factory prime, not retested rejects as sold by others. compare this price! 75c 3 for \$2.

MOTOROLA NEGATIVE VOLTAGE REG

MC1463R - Like our 1469R, except for negative voltage. Reg. catalog \$5. Our price \$1.95.

We do not sell junk. Money back guarantee on every item. WE PAY POSTAGE. No C.O.D. Texas Res. add 5% tax. Postage rates went up 30%! Please add 5% of your total order to help cover shipping. (Excluding Power Supply Kit)

S. D. SALES CO.

P.O. BOX 28810
DALLAS, TEXAS 75228

AMAZING cordless electric lawnmower. FREE information. No waiting plans \$10.00. Amonics, P.O. Box 1045, Norman, Oklahoma 73069.

SURPLUS Univac Computer Equipment: Univacors, key punches, card sorters, H. S. printers, card readers, card punches, cables, tapes, power supplies, boards, manuals & electronic parts at unbelievable prices. Midwest Electronics, Dept. 24, Pimento, IN 47866. (812) 495-6555.

SURPLUS receivers, transmitters, components, test equipment. Catalog free. Ed French, P.O. Box 249, Aurora, Illinois 60507.

ELECTRONICS parts, low prices, free flyer: DARTEK ELECTRONICS, Box 2460, Dartmouth, Nova Scotia, Canada. U.S. Inquiries.

LEGAL ASPECTS OF INTERCONNECTION
SIXES HARDBOUND

The complete reference book to your LEGAL RIGHTS as a telephone subscriber. Study customer-provided equipment, wiring, court hearings, tariffs and many more!

ALL TWENTY-FIVE OF OUR TELEPHONE-TYPE CONSTRUCTION PLANS PLUS 1000 MORE

19730 VENTURA BLVD., WOODLAND HILLS, CA 91364 USA

TV GAMES — Low cost one or two player Pong/Handball game with sound: Plans \$5.00. For the discriminating, a Super Pong game with variable ball speeds and angles, plus sound, plus color: Plans \$8.50. PC Boards and kits also available. ARS SYSTEMS, Box 1922B, Sunnyvale, CA 94088.

HOBBYISTS, CRAFTSMEN. Stainless nuts, bolts, screws. Catalog \$2.5. Caltronic Laboratory, 461 So. Cochran, Los Angeles, CA 90036.

AUDIO POWER AMPLIFIER ASSEMBLIES. 100W — \$50. 50W — \$35. Power supplies available. Details 25 cents. Progressive Sound Engineering, 357 Richfield No. 16, San Jose, Calif. 95129.

PRECISION, adjustable, solid state power supply, ±15VDC at 1-1/2 amps, regulated simultaneously with 10VDC at 3 amps unregulated, plus over 900 parts worth \$400.00. 120 transistors. Semiconductor characteristics, circuit diagrams included. New Cartrivision VTR electronic units. \$19.95 plus \$1.50 shipping. 50 cents for brochure. Madison Electronics Company, Inc., Box 369, D55, Madison, Alabama 35758.

CASSETTE interface for Altair 8800 users. Up to 540 Bytes/Sec on ordinary audio cassette recorder. Kit: \$100. Assembled: \$150. Manual: \$4. Tarbell, 144 Miraleste Drive No. 106, Miraleste, Calif. 90732.

SEMI-CONDUCTORS, Transistors, Rectifiers, Diodes, RF devices, IC's, FET's, Zeners, Free Flyer, send stamp. Prime Units, Aldelco, Box 341, Lynbrook, New York 11563.

TV-GAMES, construction plans: Pong series — 5 game set \$5.00, big 12 game set \$12.00. Jaws-2 and Space Race — both games for \$8.00. Pinball 1&2 — both for \$8.00. Full description and specs — \$1.00. ADVANCED ELECTRONICS, P.O. Box 1128, Cupertino, Calif. 95014.

WHOLESALE C.B. Scanners, Antennas, Crystals: Special cut, \$4.95. Monitor \$3.95. Send make, model, frequency. Catalog 25 cents. G. Enterprises, Box 461P, Clearfield, UT 84015.

END THE PIN-OUT HASSEL

For Engineers, PC Draftsmen, Servicemen and Hobbyists Avoid the frustration of small illustrations in handbooks. Get both top and bottom views for easy finding. Sets upright on bench or on PC Board, or lies flat. Playing card size. Ring binders. Top view in black, bottom view in red. 100 pinouts each at \$6 per illustration.

Set 1 TTL 7400 to 7488
Set 2 TTL 7489 to 74195

Send check or money order for \$5 per set to:

COMPUTRONICS ENGINEERING

7225 Hollywood Blvd., Hollywood, CA 90006
Satisfaction Guaranteed. Money returned within 10 days.
Postage included in price. Calif. residents add 6% sales tax.

THE AUDIO AMATEUR—A quarterly publication for the serious audio constructor. Free prospectus. The Audio Amateur, Box 176Z, Peterborough, N.H. 03458.

TV TECHNICIANS, SERVICEMEN, HOBBYISTS—Vista Model 740 Digital Crosshatch Generator. Compact crystal divider for lowest-priced ultra-stable 5x7 crosshatch or 56 dot patterns. AC powered. \$31.95 complete kit; \$41.95 assembled. Postpaid in USA, Canada. Information available free. Photolume Corporation, Dept. PE-36, 118 East 28th Street, New York, New York 10016.

SANTA CLARA, CALIFORNIA. Open door distributor. All types semiconductors. (408) 296-0667. Hardcore Electronics, 3233 Stevens Creek, Santa Clara, CA 95050.

DON'T LET VOLTAGE TRANSIENTS ZAP YOUR HI-FI. Solid state equipment protector plugs into outlet protects any transistorized equipment. \$6.95. Kopp Electronics, 1650 William St., Buffalo, N.Y. 14206. Free Brochure.

COMPLETE CONSTRUCTION PLANS—Telephone: Answering Device, Automatic Dialer, "Black Box", Conference Bridge, Call Diverter, Central Dial Exchange, Call Limiter, Call Transferer, Hold Button, Line Relay, Multifrequency Encoder Network (pushbutton tone box), Melodic Ringing Generator (for bell ringing signal), Recorder-Actuator, Remote Control, Speakerphone System, Stand- Alone Telephone Schematics, Teletalk Burglar Alarm, Toll-Charge Indicator, Unwanted Call Screener, Voice Scrambler. ELECTRONIC: Bio-Feedback Conditioner, Horticulture Stimulator (makes plants grow 300 per-cent faster). HOBBYIST: Photographic Pinhole Camera, Dodecahedron Speaker Enclosure (Twelve-Sided Cabinet), PRICE \$3.00 EACH. ALL OF THE CONSTRUCTION PLANS LISTED ABOVE ONLY \$24.95. "The Legal Aspects of Interconnection" book. (over 200 pages) \$29.95. ALL OF THE MERCHANDISE LISTED IN THIS AD ONLY \$49.95. PLUS a One Year Subscription to Telephone Electronics Line (TEL) \$6.00. TELETRONICS COMPANY OF AMERICA, P.O. DRAWER 3450, HOLLYWOOD, CALIFORNIA 90028 USA.

ELECTRONIC components, lowest prices. Send for free catalog. C. Stoute, 8241 Cure Clermont, Montreal HK 1X8, U.S. Inquiries.

PLANS: Build minicomputer for \$99. Including 1024 word memory and digital readouts! Parts readily available from many sources. Plans, diagrams, drawings, instructions \$5. Information \$1. Supertronics, 29790 Toley Creek, Sonoma, Calif. 95476.

ALTAIR 8800. Games — Startrek, Blackjack, Football, Centerfold Pictures. Real world interface kits — speed, sound, temperature. Business and Engineering programs. Send \$1 for samples catalog. Scientific Research, P.O. Box 83, Marcy, N.Y. 13403.

LIFE — a computer animation game program for 8080/6800 users (specify with order). Special price \$10. Other swell programs. Infm — 50 cents. KODIAK CODE CO., 1378 Sedgewick, Oakville, Ontario, Canada. U.S. Inquiries.

ELECTRONICS BARGAINS! New and surplus. Catalog 25 cents, refundable with order. ATLANTIS, Box 12654P, Tucson, Arizona 85711.

FREE PARTS

You can obtain electronic parts absolutely and unconditionally FREE, without buying anything, selling anything, and without any obligation whatsoever! Not surplus parts, but first quality new parts of your own choosing: 100-OP AMPS, D-A Converters, Transistors, LEDs, Digital Devices (MOS, TTL, ECL), etc. These parts are made by virtually every manufacturer like INTEL, TEX, INSTRUMENTS, NATIONAL, MOTOROLA, FAIRCHILD, and many more. I myself have obtained hundreds and hundreds of dollars of these parts absolutely FREE! I have designed my project using FREE parts, that I finally decided to write a brochure so that the electronics public could do as I have done and benefit from my knowledge and experience. I'll make you the following offer: If you can't obtain a minimum of fifty dollars worth of new parts of your own choosing within 30 days after receipt of my brochure, I'll return your money, no questions asked! If I fail, would you? You can receive my brochure for just One Dollar! There will be no further charges. Send One Dollar and ask for "FREE PARTS BROCHURE" #1. J.P. NELSON INTERNATIONAL, P.O. BOX 4438-V, THOUSAND OAKS, CALIFORNIA, 91359

QUALITY ELECTRONIC COMPONENTS — SAME DAY SERVICE —

NEW DISCOUNT SCHEDULE SAVES YOU EVEN MORE!

AMD 8080A \$39.95 **2102 \$2.65**

MICROPROCESSOR 1024 Bit Random Access Memory
0-70°C 480 ns Clock Period 500 ns Typical, 1000 ns Max Access Time

INTEGRATED CIRCUITS — TTL, CMOS, LINEAR & MOS

7400	21	7473	30	74174	98	4001	23	4073	23
7401	21	7474	30	74175	98	4002	23	4075	23
7402	21	7475	49	74176	79	4006	1.23	4081	23
7403	21	7476	32	74177	79	4007	23	4082	23
7404	21	7480	70	74180	70	4008	79	4502	79
7405	21	7482	70	74181	215	4009	44	4510	114
7406	25	7483	70	74182	79	4010	44	4511	109
7407	25	7485	89	74184	219	4011	23	4514	2.80
7408	21	7486	28	74185	80	4012	23	4515	2.80
7409	21	7489	219	74188	3.50	4013	40	4516	1.23
7410	21	7490	44	74189	3.50	4014	96	4518	1.14
7411	21	7491	70	74190	3.23	4015	96	4520	1.14
7412	21	7492	44	74191	1.23	4016	40	4527	1.68
7413	25	7493	44	74192	88	4017	1.05	4528	1.88
7414	89	7494	70	74193	88	4018	1.05	4585	1.23
7415	75	7495	70	74194	80	4019	1.14	LM309K	1.60
7417	25	7496	70	74195	88	4020	1.14	LM309AN	1.28
7420	21	74100	1.28	74196	88	4021	1.14	LM340T-5	1.25
7421	25	74107	30	74197	88	4022	96	LM340T-6	1.25
7423	35	74108	30	74198	1.49	4023	23	LM340T-8	1.25
7425	35	74121	35	74199	1.49	4024	84	LM340T-12	1.25
7426	25	74122	44	74201	1.09	4025	23	LM340T-15	1.25
7427	33	74123	61	74279	58	4026	1.68	LM340T-18	1.25
7428	28	74125	40	74365	67	4027	40	LM340T-24	1.25
7430	21	74126	40	74366	67	4028	89	LM3900N	88
7432	25	74132	70	74367	67	4029	1.14	NE530T	3.24
7433	30	74141	88	74368	49	4030	23	NE540L	2.04
7437	25	74145	70	75150	31	4033	1.31	NE555V	46
7438	25	74147	1.63	75150	88	4034	3.50	NE556A	88
7440	21	74148	1.30	75451	61	4035	1.14	NE560B	3.83
7441	88	74149	1.16	75452	61	4036	1.14	NE561B	3.83
7442	53	74151	70	75453	61	4041	79	NE562B	3.83
7443	63	74153	65	75454	61	4042	79	NE565A	1.28
7444	63	74154	1.03	75459	81	4043	70	NE566V	1.25
7445	70	74155	1.03	75459	81	4044	1.80	uA740CV	46
7446	70	74156	70	75493	1.09	4046	1.86	uA709CV	44
7447	70	74157	70	75494	1.19	4049	40	uA710CA	44
7448	70	74160	88	8093	40	4051	26	uA711CA	53
7450	21	74162	88	8095	67	4052	1.26	uA712CA	44
7454	21	74163	88	8096	67	4053	72	uA747CA	70
7460	21	74164	88	8097	67	4056	79	uA748CV	46
7470	30	74166	1.24	8098	67	4066	79	MC1458V	53
7472	30	74170	2.64	8252	219	4071	23	2102	2.65
		74173	1.42	4000	23	4072	23	8080A	49.95

AP SUPER STRIP II—Universal Breadboarding

Element with 840 Solderless Plug-In Tie-Points

\$17.00

IC TEST CLIPS

14 pin TC-14 \$4.50
16 pin TC-16 \$4.75
24 pin TC-24 \$13.85

We carry AP's Patch Cords, Terminal Strips, Distribution Strips and ACE's tool

BISHOP GRAPHICS Printed Circuit Drafting

Aids are now available from Dig-I-Key

ROCKWELL CALCULATORS

We stock a complete line from \$16.88 through \$99.95

Scientific Slide Rule \$89.95 with Case and Battery Charger

- 4-pin, low-profile DIP
- Leads on standard .10" (2.54 mm) grid
- 1 Amp at 40°C (t_l)

DIB DUAL IN-LINE BRIDGE

An integrated bridge rectifier in a miniature dual in-line package

VARO

LED DISPLAYS

Your Choice of RED, GREEN or YELLOW

0.3" High... \$1.90 ea.	0.6" High... \$3.50 ea.
XAN72 RED C.A.	XAN672 RED C.A.
XAN52 GREEN C.A.	XAN652 GREEN C.A.
XAN82 YELLOW C.A.	XAN682 YELLOW C.A.
XAN74 RED C.C.	XAN674 RED C.C.
XAN54 GREEN C.C.	XAN654 GREEN C.C.
XAN84 YELLOW C.C.	XAN684 YELLOW C.C.

CMOS DATABASE \$1.50

Specifications and pin-outs for 80 different 4000 series parts.

REED RELAYS

1.5 Amp SPST N.O. Contacts

1/4 WATT 5% FILM RESISTORS

5¢ each in multiples of 5 per value
\$1.70/100 of same value, 10 ohm to 1.0 meg

4.8V Coil \$1.70 \$125/C
6.0V Coil \$1.70 \$125/C
12V Coil \$1.70 \$125/C
24V Coil \$1.70 \$125/C

RESISTOR ASSORTMENTS

5 ea. all 10% 1/4 W. Val. from 1.2 to 2.2 meg (425 pcs) \$12.00
5 ea. all 10% 1/4 W. Val. from 1.0 to 5.6 meg (350 pcs) \$10.00

I.C. SOCKETS

8 Pin Solder Tab	17
14 Pin Solder Tab	20
16 Pin Solder Tab	22
18 Pin Solder Tab	29
24 Pin Solder Tab	38
28 Pin Solder Tab	45
40 Pin Solder Tab	63
8 Pin Wire-Wrap	24
14 Pin Wire-Wrap	26
16 Pin Wire-Wrap	30
18 Pin Wire-Wrap	30
24 Pin Wire-Wrap	36
28 Pin Wire-Wrap	1.23
40 Pin Wire-Wrap	1.80

SILICON DIODES

1N4148	40/10	3.50/C	1N40004	70/10	5.95/C
1N4001	64/10	5.50/C	1N4005	82/10	7.05/C
1N4002	66/10	5.40/C	1N4006	90/10	7.75/C
1N4003	68/10	5.80/C	1N4007	92/10	8.60/C

HARDWARE

2-56 1/4 Screw	99/C	2.20/M
2-56 1/4 Screw	99/C	7.65/M
4-40 1/4 Screw	55/C	2.60/M
4-40 1/4 Screw	60/C	4.05/M
6-32 1/4 Screw	65/C	4.00/M
6-32 1/4 Screw	75/C	4.85/M
8-32 3/8 Screw	90/C	8.85/M
2-56 Hex Nut	55/C	3.60/M
4-40 Hex Nut	55/C	3.75/M
6-32 Hex Nut	60/C	4.00/M
8-32 Hex Nut	60/C	4.15/M
No. 2 Lockwasher	85/C	5.75/M
No. 4 Lockwasher	85/C	3.00/M
No. 6 Lockwasher	45/C	3.00/M
No. 8 Lockwasher	45/C	3.00/M

VOLUME DISCOUNT SCHEDULE

Merchandise Total	Discount	Merchandise Total	Discount
\$ 0.00-5.99	...	NET \$ 100.00-599.99	LESS 15%
\$ 6.00-24.99	LESS 5%	\$ 600.00-999.99	LESS 20%
\$ 25.00-99.99	LESS 10%	\$ 1000.00+	LESS 20%

— Then Add the Standard Charge Below

STANDARD SHIPPING/HANDLING CHARGE

If your merchandise total after discount is between:

\$ 0.00-5.99	add \$2.00	\$ 50.00-99.99	add \$0.25
\$ 5.00-24.99	add \$0.75	\$ 100.00+	no charge
\$ 25.00-99.99	add \$0.50		

Includes shipping & insurance to USA & Canada

DIGI-KEY CORPORATION

P.O. Box 677 Thief River Falls, MN 56701

Send for free catalog or mail order service card.

"Only Quality Components Sold"

SILICON TRANSISTORS

MPF5918, MPF5930, MPF2222A, MPF2689A, MPF2712, MPF2907A, MPF3392, MPF3393, MPF3394, MPF3395, MPF3396, MPF3397, MPF3398, MPF3399, MPF3400, MPF3401, MPF3402, MPF3403, MPF3404, MPF3405, MPF3406, MPF3407, MPF3408, MPF3409, MPF3410, MPF3411, MPF3412, MPF3413, MPF3414, MPF3415, MPF3416, MPF3417, MPF3418, MPF3419, MPF3420, MPF3421, MPF3422, MPF3423, MPF3424, MPF3425, MPF3426, MPF3427, MPF3428, MPF3429, MPF3430, MPF3431, MPF3432, MPF3433, MPF3434, MPF3435, MPF3436, MPF3437, MPF3438, MPF3439, MPF3440, MPF3441, MPF3442, MPF3443, MPF3444, MPF3445, MPF3446, MPF3447, MPF3448, MPF3449, MPF3450, MPF3451, MPF3452, MPF3453, MPF3454, MPF3455, MPF3456, MPF3457, MPF3458, MPF3459, MPF3460, MPF3461, MPF3462, MPF3463, MPF3464, MPF3465, MPF3466, MPF3467, MPF3468, MPF3469, MPF3470, MPF3471, MPF3472, MPF3473, MPF3474, MPF3475, MPF3476, MPF3477, MPF3478, MPF3479, MPF3480, MPF3481, MPF3482, MPF3483, MPF3484, MPF3485, MPF3486, MPF3487, MPF3488, MPF3489, MPF3490, MPF3491, MPF3492, MPF3493, MPF3494, MPF3495, MPF3496, MPF3497, MPF3498, MPF3499, MPF3500, MPF3501, MPF3502, MPF3503, MPF3504, MPF3505, MPF3506, MPF3507, MPF3508, MPF3509, MPF3510, MPF3511, MPF3512, MPF3513, MPF3514, MPF3515, MPF3516, MPF3517, MPF3518, MPF3519, MPF3520, MPF3521, MPF3522, MPF3523, MPF3524, MPF3525, MPF3526, MPF3527, MPF3528, MPF3529, MPF3530, MPF3531, MPF3532, MPF3533, MPF3534, MPF3535, MPF3536, MPF3537, MPF3538, MPF3539, MPF3540, MPF3541, MPF3542, MPF3543, MPF3544, MPF3545, MPF3546, MPF3547, MPF3548, MPF3549, MPF3550, MPF3551, MPF3552, MPF3553, MPF3554, MPF3555, MPF3556, MPF3557, MPF3558, MPF3559, MPF3560, MPF3561, MPF3562, MPF3563, MPF3564, MPF3565, MPF3566, MPF3567, MPF3568, MPF3569, MPF3570, MPF3571, MPF3572, MPF3573, MPF3574, MPF3575, MPF3576, MPF3577, MPF3578, MPF3579, MPF3580, MPF3581, MPF3582, MPF3583, MPF3584, MPF3585, MPF3586, MPF3587, MPF3588, MPF3589, MPF3590, MPF3591, MPF3592, MPF3593, MPF3594, MPF3595, MPF3596

SPECIAL 4 DIGIT ALARM CLOCK KIT
\$15⁹⁵ Features the only LED direct drive clock chip on the market. Kit includes all parts (except X fmr) for a 4 Digit alarm clock kit. Uses .25 Inch LED (with PC Board) readouts.
CLOCK KIT TRANSFORMER \$2.00



3 DIGIT LED READOUT ARRAY
 Like Litronix DL-33 3 MAN-3 style readouts in one package. Factory new units Designed for calculators. Special \$1.39 (3 Digits).

FACTORY NEW LED'S



Jumbo Red-Like MV5024-8/\$1
 Jumbo Green-Like MV5222-5/\$1
 Jumbo Yellow-5/\$1
 Mini Red-Like MV50-10/\$1



LITRONIX DL707 READOUTS

.30 IN CHAR. Common Anode. SPECIAL - \$1.19



MONSANTO COLORED READOUTS

.27 IN. Character. Common Anode. MAN5 - GREEN - \$1.29
 MAN8 - YELLOW - \$1.29



DOUBLE DIGIT JUMBO READOUTS

New Litronix 727. Dual. Perfect for giant clocks, etc. \$3.95 each (2 DIGITS)



JUMBO LED READOUT

Twice the size of regular readouts. .65 inches. Like Litronix DL747. Outperforms and easier to read than SLA-3, only 20 MA per segment. Our best readout for digital clocks. \$2.95 ea. (6 FOR \$15) Common Anode.



6 DIGIT LED READOUTS

Brand new arrays by T. I. Common cathode, properly multiplexed. Six digits plus a negative sign. Perfect for calculators, mini-clocks, stop watches, etc. SUPER SPECIAL \$1.29 ea 3 for \$3.



7805 STYLE REGULATORS
 TO-220 Plastic Case 5VDC Regulator. Brand New by National .99c

MOTOROLA MJE3055
 Plastic version of 2N3055. NPN Silicon. 90 Watts 15 Amps. SPECIAL - .69c.

TTL IC ASSORTMENT
 Various types. Most are marked. Our best selling assortment. Untested but includes many usable devices. 200 PCS FOR \$3.95

TRANSFORMER SPECIAL #1
 Miniature size. Primary 115V AC Secondary 11V AC No Load. 8V AC with 400 MA Load. Perfect for clocks or calculators or small power supply. 99c

12VDC REED RELAY Sub-Mini.
 Coil is 500 OHM. SPST-No. \$1.49

MOTOROLA SCR
 2N4443 8 Amp 400PN, Plastic Power Case. .69c



PRIME TTL DIP IC'S

- | | | |
|----------|-----------|------------|
| 7400-16c | 7448-89c | 74151-75c |
| 7402-16c | 7453-16c | 74153-89c |
| 7404-16c | 7473-37c | 74154-95c |
| 7406-24c | 7474-37c | 74157-99c |
| 7808-16c | 7475-65c | 74161-99c |
| 7410-16c | 7476-39c | 74163-1.19 |
| 7413-49c | 7483-85c | 74164-1.89 |
| 7420-16c | 7490-69c | 74165-1.49 |
| 7427-24c | 7492-75c | 74174-1.29 |
| 7430-16c | 7493-75c | 74175-1.39 |
| 7437-39c | 7495-75c | 74181-2.75 |
| 7438-35c | 7496-75-c | 74192-1.25 |
| 7440-16c | 74121-38c | 74193-1.25 |
| 7442-69c | 74123-75c | 74195-79c |
| 7447-89c | 74150-70c | 74197-79c |

NEW PRODUCTS



METRIC MASTER: Adds, subtracts, multiplies, divides, takes percent. Addressable memory and recall, constant and chain calculation on all five functions. Plus metric conversion: pounds to kilograms, gallons or quarts to liters, miles to kilometers, yards or feet to meters, inches to centimeters, ounces to grams or cubic centimeters, Fahrenheit to Centigrade, cubic and square as well as powers, reciprocals, fractions and complex quotients. AC and rechargeable nicad batteries. UL approved charger. Molded protective cover.

Metric Master THIS IS NOT A KIT! 49.95

\$1⁰⁰ Bargain Bonanza

FORD SOLID STATE MODULES
 Mfg. by Conralab for Ford car radios. Each module contains 2 transistors plus other components. These modules were used as audio pre amps. We Include specs. 4 for \$1

TANTALUM CAPS
 By Srague. 4.7 MFD 10 VDC. Axial Leads. Perfect for timers. 10 for \$1

GE POWER DARLINGTON
 NPN, Plastic Power Tab Case, VCEO-30 HFE-30,000 TYP. Brand new units, but leads are slightly trimmed for P.C.B. #D40C1 SPECIAL 4 for \$1

IN4148 DIODES
 Brand New Units. Same as IN914. Full Leads. 24 for \$1

TTL SUPER SPECIAL
 74121 - ONE SHOT 4 for \$1

FILTER CAPS
 1000 MFD 16 VDC upright style. 4 for \$1

IN40004 RECTIFIERS
 1 AMP 400PIV SPECIAL 15 for \$1

FM TRANSFORMERS
 We bought a load coils and transformers that were used in Ford AM-FM car radios. Includes 19KHZ, 38KHZ, OSC. Coils, etc. All New. Perfect for experimenters or repairmen. 10PC Asst. .99c

COLOR ORGAN CONTROL MODULE
 Completely self-contained. Has SCR circuitry, AC line cord, etc. From a close out by a mfg. of color organs. New, unused. \$1.49

COMPUTER BOARD BONANZA
 We bought over 4 tons of assorted boards. Contains TTL, diodes, transistors, etc. 5 board asmt. with 150 to 250 IC's \$3.95.

LM309K
 TO-3 Case, 1 AMP 5 VDC Voltage Regulator. Brand New by National \$1.19



C-MOS

CD4000 24	CD4015 . . . 1.19	CD4026 . . . 1.49	CD4044 . . . 59
CD4001 . . . 24	CD4016 . . . 59	CD4027 . . . 59	CD4047 . . . 59
CD4002 . . . 24	CD4017 . . . 1.29	CD4028 . . . 99	CD4049 . . . 59
CD4006 . . . 1.49	CD4018 . . . 1.49	CD4029 . . . 1.39	CD4050 . . . 59
CD4007 . . . 24	CD4019 . . . 59	CD4030 . . . 49	CD4066 . . . 99
CD4008 . . . 1.15	CD4020 . . . 59	CD4032 . . . 24	CD4077 . . . 39
CD4009 . . . 59	CD4021 . . . 1.49	CD4033 . . . 1.49	74C02 . . . 29
CD4011 . . . 24	CD4022 . . . 1.19	CD4035 . . . 1.39	74C04 . . . 29
CD4012 . . . 24	CD4023 . . . 24	CD4040 . . . 1.59	74C107 . . . 1.29
CD4013 . . . 59	CD4024 . . . 99	CD4041 . . . 89	
CD4014 . . . 1.49	CD4024 . . . 24	CD4042 . . . 79	

RCA PHOTO DETECTOR SPECIAL POWER AMP - IC \$1.99

RCA CA3062 for photoelectric applications. Useful for intrusion alarms, counters, position sensors, etc. with complete spec sheets. Reg. \$4.84. SPECIAL - \$1.99



8008 "The COMPUTER ON THE CHIP"

Computer on a chip. 8 Bit Parallel CPU. Can address 16k x 8 bits of memory. With specs. Factory tested units \$24.95 2101-1K RAM's for above - \$4.95 or 8 for \$30.



NATIONAL MM5314

4-6 Digit Clock Chip, 24 pin DIP. Lowest Price in USA. \$3.95



DVM or Frequency Counter

Build your own with the MOS-4. Contains a complete 4 digit counter, including 4 decade counters, latches, multiplexing circuits, display decoders, etc. Complete with specs 28 pin DIP. SPECIAL \$12.50



CALCULATOR CHIP Bonanza

Chip #1 - 8 digit, constant, six function (+, -, x, =, %) Features: Direct LED segment drive, low power consumption, internal keyboard encoding, and floating decimal point. ONLY \$2.49



RCA 3043FM IC

IF Amp, Limiter, FM Detector, Audio Pre Amp 99c



8038 Function Generator

Voltage Controlled OSC. with sine, square wave, and triangular outputs. \$4.95



LINEAR IC SPECIALS

555V Timer 75c
 565A Phase Locked Loop 99c
 567V Decoder \$1.95
 723 CH Regulator 59c
 741CV OP. Amp 25c
 LM 324 4x741 OP. Amp \$1.19



U.V. ERASEABLE PROMS

New Prime units by National
 MM5203 2K \$14.95
 MM5204 4K \$19.95

LED DRIVER IC'S

75491 Quad segment dr. - 29c
 75492 Hex digit dr. - 39c

GE TRANSISTOR ASSORTMENT



One of the best mixed transistor lots we have seen. TO-98 Plastic cased. Includes Darlington's, SCR's, PNP, NPN, etc. Untested sample test shows very high yield. Satisfaction assured. 50 for 99c

SPECIAL: 6 BAGS FOR \$5

ALTAJ ELECTRONICS

P. O. Box 38544, Dallas, Texas 75238

TERMS: Check or money order. No COD.

Telephone (214) 278-3561

Texas Residents Add 5%



POCKET CALCULATOR

5 function plus constant — addressable memory with individual recall — 8 digit display plus overflow — battery saver — uses standard or rechargeable batteries — all necessary parts in ready to assemble form — instructions included.
 Kit with AC adaptor included
 Set of Alkaline batteries (disposable)



\$14.95
\$ 2.50

UNIVERSAL BREADBOARD

Silver plated copper circuit board 3-3/16" x 5-1/16", 2 rows of 27 holes for DIP IC's, space for transistors, resistors & capacitors. Versatile and simple for breadboarding IC circuitry \$1.50 ea.
 50 nec. 1.00 ea.



\$31.95

ALARM CLOCK KIT

4 Large Digits - AM-PM. Complete kit includes TMS 3834 chip — green fluorescent panel with .5" digits — PC board — alarm speaker — all necessary components — case — schematic and instructions.
 Shipped UPS or Parcel Post.



UV ERASABLE PROM

1702A — 2048 bit static PROM 256x8 elect. programmable & erasable TTL/DTL comp. \$14.95

MARCH SPECIALS

1/2 PRICE SALE

FACTORY MARKED — GUARANTEED FUNCTIONAL

7425	\$.13	7473	\$.17	74121	\$.21
7430	.10	7475	.28	74123	.42
7441	.49	7483	.39	74151	.39
7442	.38	7490	.29	74153	.49
7446	.46	7495	.39	74180	.45
7447	.44	7496	.39	74193	.60
7448	.52	74107	.20		

MARKED — NO FACTORY LOGO GUARANTEED FUNCTIONAL

7400	\$.07	7420	.08	7460	.08
7402	.07	7437	.17	7474	.17
7403	.08	7440	.08	7493	.30
7404	.09	7445	.44	7496	.39
7406	.17	7450	.08	74195	.44
7408	.09	7453	.08		
7410	.08	7454	.08		

8038 FUNCTION GENERATOR

Voltage controlled oscillator line, square, triangular output 16 pin DIP with data \$3.95

7001 CLOCK CHIP

44 digit, 12-24 hr. alarm, timer & date circuits with data \$6.95

MV5020 LED

Jumbo red dome .15

75491 SEGMENT DRIVER

MOS to LED quad segment driver — 50 ma sink capability per driver — high gain darlington circuits 14 pin DIP .49

DVM CHIP 4% DIGIT

MM 5330 — P channel device provides all logic for 4% digit voltmeter, 16 pin DIP with data \$14.95

MM5738

3.95

2102 2.95

2102-1 3.25

2102-2 3.25

5203 12.95

5262 2.95

TANALFUM CAPACITORS SOLID-DIPPED +20%

.1 mfd	35V	25 ea.	6.8 mfd	6V	.30 ea.
.33 mfd	35V	25 ea.	6.8 mfd	50V	40 ea.
1 mfd	35V	25 ea.	10 mfd	25V	40 ea.
2.2 mfd	20V	25 ea.	15 mfd	10V	40 ea.
2.2 mfd	35V	30 ea.	33 mfd	10V	40 ea.
4.7 mfd	16V	30 ea.	47 mfd	6V	40 ea.

LINEARS

546	AM radio receiver		
	sub. DIP	\$ 75	
733	DIH. video AMPL TO-5		.89
5556/			
MC1456	Int. compensated Op amp mDIP	1.59	
7525	Dual core mem. sense AMPL DIP	.98	
MC1310	FM stereo demodulator DIP	1.95	
CA3046	Transistor array 14 pin DIP	.89	

6 DIGIT LED CLOCK KIT

INCLUDES:
 MM314 clock circuit
 6 FND70 LED displays (.250" red 7 segment)
 All necessary transistors, resistors & capacitors
 1 double sided PC board accommodates LED's & clock circuitry
 Schematic & instructions
 Does not include 12V-300 ma transformer, switches & case \$12.95

MISC. DEVICES

2513	64 x 8 x 5 character generator	\$11.00
2602	1024-bit static RAM, N-channel DTL/TTL compatible	3.95
F93410	256 bit RAM	2.19
MV5020	Jumbo green XC209-R .125" red LED	.15
L100	Red LED	.15
L101	Red LED	.15

NEW ITEMS

TTL

74132	\$.89	74132	\$.97
74H101	.58	74LS00	.60
74H102	.58	74LS02	.60
74H103	.63	74LS04	.66
74H106	.63	74LS08	.68
74H108	.63	74LS10	.68
		74LS20	.66
		74LS32	.68
		74LS40	.45
		74LS42	.38
		74LS44	.45
		74LS48	.52
		74LS50	.38
		74LS51	.38
		74LS53	.52
		74LS54	.38

LOW POWER SCHOTTKY

74LS00	\$.38	74LS32	.38
74LS02	.45	74LS40	.45
74LS03	.38	74LS42	1.40
74LS04	.45	74LS44	.59
74LS08	.52	74LS90	1.30
74LS10	.38	74LS93	1.30
74LS20	.38	74LS95	2.09
74LS22	.38	74LS107	.59
74LS32	.52	74LS164	2.20
74LS52	.52	74LS193	2.50
74LS74	.38	74LS197	2.20

TTL

7400	\$.14	7492	.71
7401	.16	7493	.60
7402	.15	7494	.94
7403	.16	7495	.79
7404	.19	7496	.79
7405	.19	74100	1.30
7406	.35	74105	.44
7407	.35	74107	.40
7408	.18	74121	.42
7409	.19	74122	.45
7410	.16	74123	.85
7411	.25	74126	.63
7413	.55	74141	1.04
7416	.35	74145	1.04
7417	.35	74150	.97
7420	.16	74151	.79
7422	.26	74153	.99
7423	.29	74154	1.25
7425	.27	74155	1.07
7426	.26	74156	1.07
7427	.29	74157	.99
7430	.20	74158	1.79
7432	.23	74160	1.39
7437	.35	74161	1.25
7438	.35	74162	1.49
7440	.17	74163	1.39
7441	.98	74164	1.59
7442	.77	74165	1.59
7443	.87	74166	1.49
7444	.87	74170	2.30
7445	.89	74173	1.49
7446	.93	74174	1.62
7447	.89	74175	1.39
7448	1.04	74176	.89
7450	.17	74177	.84
7451	.17	74180	.90
7453	.17	74181	2.98
7454	.17	74182	.79
7460	.17	74184	2.29
7464	.35	74185	2.29
7465	.35	74187	5.95
7470	.30	74190	1.35
7472	.30	74191	1.35
7473	.35	74192	1.25
7474	.35	74193	1.19
7475	.57	74194	1.25
7476	.39	74195	.89
7483	.79	74196	1.25
7485	1.10	74197	.89
7486	.40	74198	1.79
7489	2.48	74199	1.79
7490	.59	74200	5.90

5% OFF ON ORDERS OVER \$50.00
 10% OFF ON ORDERS OVER \$100.00
 15% OFF ON ORDERS OVER \$250.00

LINEAR CIRCUITS

300	Pos V Reg (super 723)	TO-5	\$.71
301	Hi perl op amp	mDIP	.29
307	Op AMP (super 741)	mDIP	.26
308	Micro Pwr Op Amp	mDIP	.85
309A	5V 1A regulator	TO-3	1.39
310	V Follower Op Amp	mDIP	1.07
311	Hi perl V Comp	mDIP	.95
319	Hi Speed Dual Comp	DIP	1.13
320	Neg Reg 5, 12, 15, TO-3		\$1.39
320K	Neg Reg 5, 12 TO-3		1.39
324	Quad Op Amp	DIP	1.32
339	Quad Comparator	DIP	1.58
340K.	Pos. V. reg. (5V, 6V, 8V, 12V, 15V, 18V, 24V)	TO-3	1.69
340T	Pos. V. reg. (5V, 6V, 8V, 12V, 15V, 18V, 24V)	TO-220	1.49
370	ACC/Squelch AMPL	DIP	.71
372	AF-IF Strip detector	DIP	2.93
376	Pos. V. Reg	mDIP	2.42
380	2w Audio Amp	DIP	1.13
380-B	6w Audio Amp	mDIP	1.52
381	Lo Noise Dual preamp	DIP	1.52
550	Pre V Reg	DIP	.89
555	Timer	mDIP	.89
556A	Dual 555 Timer	DIP	1.49
560	Phase Locked Loop	DIP	2.48
562	Phase Locked Loop	DIP	2.48
565	Phase Locked Loop	DIP	2.38
566	Function Gen	mDIP	2.25
567	Tone Decoder	mDIP	2.66
709	Operational AMPL	DIP	.35
710	Hi Speed Volt Comp	DIP	.62
723	V Reg	DIP	.62
739	Dual Hi Perl Op Amp	DIP	1.67
741	Comp Op Amp	mDIP	.32
747	Dual 741 Op Amp	DIP	.71
748	Freq Adj 741	mDIP	.35
1304	FM Mulps Stereo Demod	DIP	1.07
1307	FM Mulps Stereo Demod	DIP	.74
1458	Dual Comp Op Amp	mDIP	.62
1800	Stereo multiplexer	DIP	2.48
3900	Quad Amplifier	DIP	.35
8038	V contr. osc	DIP	4.95
8664	9 DIC Led Cath Dvrr	DIP	2.25
75150	Dual Line Driver	DIP	1.95
75451	Dual Peripheral Driver	mDIP	.35
75452	Dual Peripheral Driver	mDIP	.35
75453	(3S1) Dual Periph. Driver	mDIP	.35
75491	Quad Seg Driver for LED	DIP	.71
75492	Hex Digit Driver	DIP	.80

MEMORIES

1101	256 bit RAM MOS	\$ 1.50
1103	1024 bit RAM MOS	3.95
2102	1024 bit static RAM	5.55
5203	2048 bit UV eras PROM	17.95
5260	1024 bit RAM	2.49
5261	1024 bit RAM	2.69
5262	2048 bit RAM	5.95
7489	64 bit ROM TTL	2.48
8223	Programmable ROM	3.69
74200	256 bit RAM 1st-time	5.90

CALCULATOR & CLOCK CHIPS

5001	12 DIG 4 funct fix dec	\$3.45
5002	Same as 5001 exc btry pwr	3.95
5005	12 DIG 4 funct w/mem	4.95
MMS5725	8 DIG 4 funct chain & dec	1.98
MMS5736	18 pin 6 DIG 4 funct	4.45
MMS5738	8 DIG 5 funct K & mem	5.35
MMS5739	9 DIG 4 funct (btry sur)	5.35
MMS5311	28 pin BCD 6 dig mux	4.45
MMS5312	24 pin 1 pps BCD 4 dig mux	3.95
MMS5313	28 pin 1 pps BCD 6 dig mux	4.45
MMS5314	24 pin 6 dig mux	4.45
MMS5316	40 pin alarm 4 dig	5.39

LED'S

MV108	Red TO 18	\$.22
MV50	Asial leads	.18
MV5020	Jumbo Vis. Red (Red Dome)	.22
	Jumbo Vis. Red (Clear Dome)	.22
ME4	Infra red diff. dome	.54
MAN1	Red 7 seg. .270"	2.19
MAN2	Red alpha num. .32"	4.39
MAN4	Red 7 seg. .190"	1.95
MAN5	Green 7 seg. .270"	3.45
MAN6	.8" high solid seq.	4.25
MAN7	Red 7 seg. .270"	1.19
MAN8	Yellow 7 seg. .270"	3.45
MAN6A	.4" high solid seq.	2.95
MAN66	.6" high spaced seq.	3.75
MCT2	Opto-iso transistor	.61

CMOS

4000A	\$.26	4017A	1.19	4049A	.59
4001A	.25	4020A	1.49	4050A	.59
4002A	.25	4021A	1.39	4068A	.44
40					

BURGLAR ALARMS

BURGLAR ALARM dialing unit automatically calls police. \$29.95. Free literature. S&S Systems, 5619-C St. John, Kansas City, MO 64123.

PRESSURE sensitive miniature cable for burglar alarm systems. Place under carpet in any contour for intrusion detection or secret switching. \$4.95 for twenty feet. Cable Switch Corp., Box 72-PE, West Long Branch, NJ 07764.

BURGLAR-FIRE alarm supplies and information. Free catalog. Protecto Alarm Sales, Box 357-G, Birch Run, Michigan 48415.

CALCULATORS

TEXAS INSTRUMENTS CALCULATORS DISCOUNT HOT LINE Toll Free (800) 638-8906. Phone us long distance free for the low discount price on the Texas Instruments Calculator of your choice: SR-50A, SR-51A, SR-16II, TI-2500II, TI-1500, TI-2550II, TI-5050. All of the great new Texas Instruments models. Capital Calculator Company, 701 East Gude Drive, Rockville, Maryland 20850. The discount super market for top brand name calculators. Mail and phone orders accepted. BankAmericard and Master Charge accepted.

HIGH FIDELITY

DIAMOND NEEDLES and Stereo Cartridges at Discount prices for Shure, Pickering, Stanton, Empire, Grado and ADC. Send for free catalog. LYLE CARTRIDGES, Dept. P, Box 69, Kensington Station, Brooklyn, New York 11218.

SAVE 50%. Build your own speaker systems featuring Norelco, Eminence and CTS. Famous brands from world's largest speaker factories at lowest wholesale prices. Write for free catalog of speakers and electronic accessories. McGee Radio & Electronic Corp., 1901 McGee Street, Kansas City, Missouri 64108.

DO-IT-YOURSELF

TELEPHONES. All Types. Equipment, Supplies, Keyed, Regular, Decorator. Catalog. 50 cents. Box 1654J, Costa Mesa, California 92626.

For
faster
service

USE
ZIP
CODE

on
all
mail

13.5 KV HIGH VOLTAGE POWER SUPPLY

This high voltage power supply is rated at 13.5 KV DC, @ 0.31 ma. Completely sealed. Ideal for CRT's, high voltage experiments, bug zappers, etc. Shipping weight 6 lbs.

STOCK NO. P5356

\$13.95 each, 2/26.00

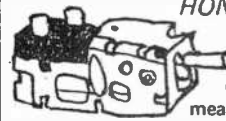

HONEYWELL HUMIDITY CONTROLLER

Made by HONEYWELL for automatic control of humidifiers or de-humidifiers.

Control range 10% RH to 60% RH, sensing by means of a nylon ribbon. Snap action switch with

240v AC contacts. Ideal for home lab, or greenhouse. 3 1/2 x 2 1/4 x 1 1/4. STOCK NO. P6263 1 lb. \$4.95 each, 3/14.00

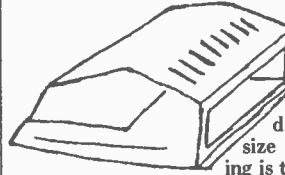

MOLDED PLASTIC CALCULATOR HOUSING

From a maker of desktop calculators. Molded in off white plastic, ideal for a display or other small project. Overall size 1 1/4" x 12" x 4" high. The front opening is trapezoidal, 1 1/2" wide x 2 1/2" high. With

cooling fins. 2 lbs. STOCK NO. P5354 \$4.75 ea, 2/9.00

1458, dual 741 type op-amp. 8 pin mini-DIP. Very versatile. STOCK NO. P3112 \$1.25 each, 5/5.00

650 WATT POWER TRANSFORMER

This versatile transformer has dual primaries, for 115v or 230v operation, or for isolation use. Each is also tapped for low or high line. Secondaries are 24v center tapped at 8 amps, 24v at 10 amps, and 24v at 10 amps! Possible combinations include 24v at 20 A and 48v center tapped at 10 amps. Shipping weight 13 lbs.

STOCK NO. P9898

\$14.95 each, 2/28.00

Send for new 88 page Catalog 15, bigger than ever. MASTERCHARGE



& BANKAMERICARD now accepted. Minimum cash order \$5, minimum charge order \$15. Phone orders accepted. Include sufficient postage, excess refunded.



DELTA ELECTRONICS CO.

BOX 1, LYNN, MASSACHUSETTS 01903

Phone (617) 388-4705

CIRCLE NO. 10 ON FREE INFORMATION CARD

CB SPECIALS—R.F. DRIVERS—R.F. POWER OUTPUTS—FETS

2SC481	1.85	2SC767	15.75	2SC866	5.85	2SC1449-1	1.60	40081	1.50
2SC482	1.75	2SC773	.85	2SC013	1.50	2SC475	1.50	40082	3.00
2SC495	1.10	2SC774	1.75	2SC1014	1.50	2SC1678	5.50	2SC608	4.85
2SC502	3.75	2SC775	2.75	2SC1017	1.50	2SC1679	4.75	SK3046	2.15
2SC517	4.75	2SC776	3.00	2SC1018	1.50	2SC1728	2.15	SK3047	3.75
2SC614	3.80	2SC777	4.75	2SC1173	1.25	2SC1760	2.15	SJ2095	3.50
2SC615	3.90	2SC778	3.25	2SC1226A	1.25	2SC1816	5.50	SK3048	3.25
2SC616	4.15	2SC797	2.50	2SC1237	4.50	2SC1908	.70	SK3054	1.25
2SC617	4.25	2SC798	3.10	2SC1239	3.50	2SC1957	1.50		
2SC699	4.75	2SC781	3.00	2SC1243	1.50	2SF8	3.00	2SK19	1.75
2SC710	.70	2SC789	1.00	2SC1306	4.75	HEP-S3001	3.25	2SK30	1.00
2SC711	.70	2SC796	3.15	2SC1306-1	4.90	2SD235	1.00	2SK33	1.20
2SC735	.70	2SC799	4.25	2SC1307	5.75	MRF8004	3.00		
2SC756	3.00	2SC802	3.75	2SC1307-1	6.00	4004	3.00	3SK40	2.75
2SC765	9.50	2SC803	4.00	2SC1377	5.50	4005	3.00	3SK45	2.75
2SC766	10.15	2SC839	.85	2SC1449	1.30	40060	1.25	3SK49	2.75

JAPANESE TRANSISTORS

2SA52	.60	2SB187	.60	2SC458	.70	2SC815	.75	2SC1569	1.25
2SA316	.75	2SB235	1.75	2SC460	.70	2SC828	.75	2SC1756	1.25
2SA473	.75	2SB303	.65	2SC478	.80	2SC829	.75		
2SA483	1.95	2SB324	1.00	2SC491	2.50	2SC830	1.60	2SD30	.95
2SA489	.80	2SB337	2.10	2SC497	1.60	2SC839	.85	2SD45	2.00
2SA490	.70	2SB367	1.60	2SC515	.80	2SC945	.65	2SD65	7.75
2SA505	.70	2SB370	.65	2SC535	.75	2SC1010	.80	2SD68	.90
2SA564	.50	2SB405	.85	2SC536	.65	2SC1012	.80	2SD72	1.00
2SA628	.65	2SB407	1.65	2SC537	.70	2SC1051	2.50	2SD88	1.50
2SA643	.85	2SB415	.85	2SC563	2.50	2SC1061	1.65	2SD151	2.25
2SA647	2.75	2SB461	1.25	2SC605	1.00	2SC1079	3.75	2SD170	2.00
2SA673	.85	2SB463	1.65	2SC620	.80	2SC1096	1.20	2SD180	2.75
2SA679	3.75	2SB471	1.75	2SC627	1.75	2SC1098	1.15	2SD201	1.95
2SA682	.85	2SB474	1.50	2SC642	3.50	2SC1115	2.75	2SD218	4.75
2SA699	1.30	2SB476	1.25	2SC643	3.75	2SC1166	.70	2SD300	2.50
2SA699A	1.75	2SB481	2.10	2SC644	.70	2SC1170	4.00	2SD313	1.10
2SA705	.55	2SB492	1.25	2SC681	2.50	2SC1172B	4.25	2SD315	.75
2SA815	.85	2SB495	.95	2SC684	2.10	2SC1209	.55	2SD318	.95
2SA816	.85	2SB507	.90	2SC687	2.50	2SC1213	.75	2SD341	.95
		2SB511	.70	2SC696	2.35	2SC1226	1.25	2SD350	3.25
				2SC712	.70	2SC1243	1.50	2SD352	.80
2SB22	.65			2SC713	.70	2SC1293	.85	2SD380	5.70
2SB54	.70	2SC206	1.00	2SC732	.70	2SC1308	4.75	2SD389	.90
2SB56	.70	2SC240	1.10	2SC733	.70	2SC1347	.80	2SD-390	.75
2SB77	.70	2SC261	.65	2SC733	.70	2SC1347	.80	2SD-390	.75
2SB128	2.25	2SC291	.65	2SC739	.70	2SC1383	.75	2SD437	5.50
2SB135	.95	2SC320	2.00	2SC715	1.75	2SC1409	1.25		
2SB152	4.50	2SC352	.75	2SC762	1.90	2SC1410	1.25	C106B1	.50
2SB173	.55	2SC353	.75	2SC783	1.00	2SC1447	1.25		
2SB175	.55	2SC371	.70	2SC784	.70	2SC1448	1.25		
2SB178	1.00	2SC372	.70	2SC785	1.00	2SC1507	1.25		
2SB186	.60	2SC394	.70	2SC793	2.50	2SC1509	1.25		

POWER-TRANSISTORS HIGH-VOLT. TV. TYPE

BU204	1300V	3.90	BU207	1300V	5.40	2SC1172B	1100V	4.25
BU205	1500V	4.70	BU208	1500V	6.25	2SC308	1100V	4.95
BU206	1700V	5.90	2SC1170	1100V	4.00	2SC1325	1100V	4.95

OEM SPECIALS

1N270	.10	2N960	.55	2N2219A	.30	2N2913	.75	2N3740	1.00	2N4401	.20
1N914	.10	2N962	.40	2N2221	.25	2N2914	1.20	2N3771	1.75	2N4402	.20
		2N967	.50	2N2221A	.30	2N2916A	3.65	2N3732	1.90	2N4403	.20
2N173	1.75	2N1136	1.35	2N2222	.25	2N3019	.50	2N3773	3.00	2N4409	.20
2N178	.90	2N1142	2.25	2N2222A	.30	2N3053	.30	2N3819	.32	2N4410	.25
2N327A	1.15	2N1302	.25	2N2270	.40	2N3054	.70	2N3823	.70	2N4416	.75
2N334	1.20	2N1305	.30	2N2322	1.00	2N3055	.75	2N3856	.20	2N4441	.85
2N336	.90	2N1377	.75	2N2323	1.00	2N3227	1.00	2N3866	.85	2N4442	.90
2N338A	1.05	2N1420	.20	2N2324	1.35	2N3247	3.40	2N3903	.20	2N4443	1.20
2N398B	.90	2N1483	.95	2N2325	2.00	2N3250	.50	2N3904	.20	2N4852	.55
2N404	.30	2N1540	.90	2N2326	2.85	2N3375	6.50	2N3905	.20	2N5061	.30
2N443	1.75	2N1543	2.70	2N2327	3.80	2N3394	.20	2N3906	.25	2N5064	.50
2N456	1.10	2N1544	.80	2N2328	4.20	2N3394	.17	2N3925	3.75	2N5130	.20
2N501A	3.00	2N1549	1.25	2N2329	4.75	2N3414	.17	2N3954	3.50	2N5133	.15
2N508A	.45	2N1551	2.50	2N2368	.25	2N3415	.18	2N3954A	3.75	2N5138	.15
2N555	.45	2N1552	3.25	2N2369	.25	2N3416	.19	2N3955	2.45	2N5198	3.75
2N652A	.85	2N1554	1.25	2N2484	.32	2N3417	.20	2N3957	1.25	2N5294	.50
2N677C	6.00	2N557	.15	2N2712	.18	2N3442	1.85	2N3958	1.20	2N5296	.50
2N706	.25	2N1560	2.80	2N2894	.40	2N3553	1.50	2N4037	.60	2N5306	.20
2N706B	.40	2N1605	.35	2N2903	3.30	2N3563	.20	2N4093	.85	2N5354	.20
2N711	.50	2N1613	.30	2N2904	.25	2N3565	.20	2N4124	.20	2N5369	.20
2N711B	.60	2N1711	.30	2N2904A	.30	2N3638	.20	2N4126	.20	2N5400	.40
2N718	.25	2N1907	4.10	2N2905	.25	2N3642	.20	2N4141	.20	2N5401	.50
2N718A	.30	2N2060	1.85	2N2905A	.30	2N3643	.15	2N4142	.20	2N5457	.35
2N720A	.50	2N2102	.40	2N2906	.25	2N3645	.15	2N4143	.20	C103Y	.25
2N918	.35	2N2128	.25	2N2906A	.30	2N3646	.14	2N4220A	.45	C103D	.40
2N930	.25	2N2218A	.30	2N2907	.25	2N3730	1.50	2N4234	.95	C106B1	.50
2N956	.30	2N2219	.25	2N2907A	.30	2N3731	2.75	2N4400	.20	C106D1	.75

SILICON UNIUNIONS

2N2646	.50	2N2160	.65
2N2647	.60	2N4870	.50
2N6027	.55	2N4871	.50
2N6028	.70	2N4891	.50
D5E37	.25	2N4892	.50
		2N4893	.50
		2N4894	.50
		MU10	.40

INTEGRATED CIRC.

UA703C	.40
709C OP. AMP.	.25
741C OP. AMP.	.25
7400	.15
7404N	.18
7430N	.19
74L00J	.35
74H55N	.35

RECTIFIERS

		10	100
IN4001	.60	5.00	
IN4002	.70	6.00	
IN4003	.80	7.00	
IN4004	.90	8.00	
IN4005	1.00	9.00	
IN4006	1.10	10.00	
IN4007	1.20	11.00	

7400N TTL

SN7400N	13	SN7453N	27	SN74148N	2.50
SN7401N	16	SN7454N	41	SN74150N	1.10
SN7402N	21	SN7455A	.45	SN74151N	1.25
SN7403N	16	SN7474N	.25	SN74153N	1.35
SN7404N	16	SN7475N	.45	SN74154N	1.25
SN7405N	24	SN7476N	.39	SN74155N	1.21
SN7406N	25	SN7477N	.69	SN74156N	1.30
SN7407N	25	SN7478N	.37	SN74157N	1.30
SN7408N	25	SN7479N	.32	SN74158N	1.30
SN7409N	25	SN7475A	.59	SN74159N	1.45
SN7410N	16	SN7476A	.32	SN74163A	1.35
SN7411N	30	SN7479A	.50	SN74164A	1.65
SN7412N	22	SN7480N	.50	SN74165N	1.65
SN7413N	85	SN7482N	1.75	SN74166N	1.70
SN7414N	70	SN7483N	1.15	SN74167N	5.50
SN7416N	43	SN7485N	1.12	SN74170N	3.00
SN7417N	43	SN7486N	.45	SN74172N	18.00
SN7418N	27	SN7487N	.20	SN74173N	1.20
SN7420N	31	SN7489N	3.00	SN74174N	1.95
SN7421N	39	SN7490N	.49	SN74175N	1.95
SN7423N	37	SN7491N	1.20	SN74176N	.90
SN7425N	33	SN7492N	.82	SN74177N	.90
SN7426N	31	SN7493N	.27	SN74180N	1.05
SN7427N	37	SN7494A	.91	SN74181N	3.55
SN7429N	42	SN7495N	.91	SN74182N	.95
SN7430N	26	SN7496N	.91	SN74184N	2.30
SN7432N	21	SN7497N	.31	SN74185N	2.30
SN7437N	47	SN74100N	1.00	SN74187N	6.00
SN7438N	40	SN74107N	.49	SN74190N	1.50
SN7439N	25	SN74121N	.46	SN74191N	1.50
SN7440N	21	SN74140N	.70	SN74192N	1.19
SN7441N	110	SN74123N	.70	SN74193N	.99
SN7442N	1.08	SN74125N	.60	SN74194N	1.45
SN7443N	1.05	SN74126N	.81	SN74195N	1.00
SN7444N	1.10	SN74132N	3.00	SN74196N	1.25
SN7445N	1.10	SN74135N	1.80	SN74197N	1.00
SN7446N	1.15	SN74141N	1.15	SN74198N	2.25
SN7447N	.79	SN74142N	4.00	SN74199N	2.25
SN7448N	96	SN74143N	4.50	SN74200N	7.00
SN7450N	26	SN74144N	4.50	SN74201N	2.50
SN7451N	27	SN74145N	1.15	SN74202N	6.00
SN7452N	.27	SN74147N	3.00	SN74205N	6.00

JAMES MARCH SPECIALS

Astrisk Denotes Items On Special For This Month

Special Requested Items

RC4184	Dual Track V reg	\$ 5.95	8N797	\$ 3.00	MK5007	\$10.95	MC4044	4.50
RC4195	=15V Track Reg	3.25	4024P	2.25	8263	5.95	LM3090P	1.95
P5388	Decoder	3.95	DM310	3.25	8267	2.75	MM5322D	19.95
LD110111	DVM Chip Set	28.00	9352	1.30	8298	1.15	4072AE	.45
CA3130	Super CMOS Op Amp	1.49	MCI-4016	56	8826	3.00	7422	5.00
MC140617	D/A	9.95	2525	8.00	8880	1.35	7497	5.00
F3341	FID	6.95	2527	5.00	4511AE	2.50	74186	5.00
MM5841	Character Gen.	18.00	CD4518	2.50	3443S	2.00	74279	.90

WE'LL BE HAPPY TO QUOTE ON YOUR SPECIAL PARTS—

74LS00 TTL

74LS00	39	74LS55	.39	74LS151	1.55
74LS02	39	74LS73	.65	74LS153	1.89
74LS03	39	74LS74	.65	74LS157	1.69
74LS04	45	74LS75	.78	74LS160	2.25
74LS05	45	74LS76	.65	74LS163	2.25
74LS08	39	74LS83	2.19	74LS164	2.25
74LS10	39	74LS86	.65	74LS181	3.69
74LS13	79	74LS89	1.29	74LS192	2.85
74LS14	219	74LS92	1.25	74LS191	2.85
74LS20	39	74LS93	1.25	74LS192	2.85
74LS26	39	74LS95	2.19	74LS193	2.85
74LS27	45	74LS96	1.89	74LS194	2.25
74LS28	49	74LS97	.65	74LS195	2.25
74LS30	39	74LS112	.65	74LS257	1.89
74LS32	45	74LS132	1.55	74LS260	.55
74LS40	49	74LS136	.65	74LS279	7.9
74LS51	39	74LS138	1.89	74LS279	5.95

OPTO ELECTRONICS

R - RED
G - GREEN
Y - YELLOW
O - ORANGE

DISCRETE LEDES

125" dia.	185" dia.	190" dia.
XC209R 5/51	XC256R 5/51	XC111R 4/51
XC209S 4/51	XC256G 4/51	XC111G 4/51
XC209Y 4/51	XC256Y 4/51	XC111Y 4/51
XC209O 4/51	XC256O 4/51	XC111O 4/51
XC22R 5/51	XC256S 5/51	MV50
XC22G 4/51	XC256G 4/51	.085" dia. Micro
XC22Y 4/51	XC256Y 4/51	red led
XC22O 4/51	XC256O 4/51	6/51

DIP SWITCH

These switches feature four SPST Racer Switches in a molded die. They are ideally suited for microprocessor applications. **\$1.95**

MINIATURE TOGGLE

DPST	DPST	1 Pole	2 Pole	3 Pole	4 Pole
100	100	100	100	100	100
100	100	100	100	100	100

PUSH BUTTON

Model 1 Quality net price
Number Each 2-9 10-29 30-99
PB-123 \$2.35 \$1.95 \$1.47 \$1.30

CMOS

CD4000	25	74C04N	.75
CD4001	25	74C01N	.65
CD4002	25	74C02	.65
CD4006	2.50	74C03	.65
CD4007	25	74C04	2.15
CD4009	1.90	74C07N	1.50
CD4010	59	74C04A	1.50
CD4011	.25	74C04B	3.00
CD4012	.25	74C04C	2.00
CD4013	.47	74C05N	1.25
CD4016	.46	74C05G	2.90
CD4017	1.35	74C05J	3.00
CD4019	.55	74C05K	2.15
CD4020	1.49	74C06G	3.25
CD4022	1.00	74C06J	3.00
CD4023	.25	74C06S	3.00
CD4024	1.50	74C07	3.25
CD4025	.25	74C08	2.60
CD4027	.69	74C09N	3.00
CD4028	1.65	74C09S	2.75

DISPLAY LEDES

FN0503	FN1070	DL707	MAN 2	MAN 3	MAN 4	MAN 7	DL747	DL747	DL747
TYPE	POLARITY	HT	TYPE	POLARITY	HT	TYPE	POLARITY	HT	TYPE
MAN 1	COMMON ANODE	270	MAN 74	COMMON CATHODE	300	MAN 74	COMMON CATHODE	300	MAN 74
MAN 2	5 x 7 DOT MATRIX	300	DL707	COMMON ANODE	300	DL707	COMMON ANODE	300	DL707
MAN 3	COMMON CATHODE	125	DL717	COMMON CATHODE	600	DL717	COMMON CATHODE	600	DL717
MAN 4	COMMON CATHODE	187	DL750	COMMON CATHODE	600	DL750	COMMON CATHODE	600	DL750
MAN 7	COMMON ANODE	300	DL750	COMMON CATHODE	600	DL750	COMMON CATHODE	600	DL750
MAN 7G	COMMON ANODE-GREEN	300	FN070	COMMON CATHODE	500	FN070	COMMON CATHODE	500	FN070
MAN 7Y	COMMON ANODE-YELLOW	300	FN053	COMMON CATHODE	500	FN053	COMMON CATHODE	500	FN053
MAN 7Z	COMMON ANODE	300	FN057	COMMON CATHODE	500	FN057	COMMON CATHODE	500	FN057

THUMBWHEEL SWITCHES

These switches are a 7 position, 8 pin position opto. rotary switch enclosed in a T.O-5 can. They have a standard 8 pin configuration and will mount perfectly on printed circuit board. **\$.99 ea.**

LINEAR

LM100H	15.00	LM1310N	2.95
LM105H	2.50	LM1351N	1.65
LM171H	3.75	LM1414N	1.75
LM212H	7.00	LM1458C	.95
LM300H	8.00	LM1458N	.95
LM301H*	31.00	LM1558N	1.85
LM301CN*	31.00	LM2111N	1.95
LM302H	7.5	LM2901N	2.95
LM304H	1.00	LM2902N	.95
LM305H	.95	LM2903N	.95
LM307CN	35	LM3905N	.60
LM308H	1.00	LM5558N	1.85
LM308CN	1.00	MC5558V	1.00
LM309H	1.10	LM7525N	2.90
LM309K	1.25	LM7528N	2.90
LM310CN	1.15	NE555*	2.20
LM311H	.90	NE555*	1.25
LM311N	.90	NE555*	4.95
LM318CN	1.50	NE568*	1.95
LM319N	1.30	NE568*	1.25
LM319D	9.00	NE567*	1.50
LM320K-5	1.35	LM703CN	.45
LM320K-12	1.35	LM703CN	.45
LM320K-15	1.35	LM703CN	.45
LM320T-5	1.75	LM703CN	.45
LM320T-12	1.75	LM703CN	.45
LM320T-15	1.75	LM703CN	.45
LM323K-5	1.60	LM703CN	.45
LM324N	1.80	LM703CN	.45
LM339N	1.70	LM703CN	.45
LM340K-5	1.95	LM703CN	.45
LM340K-12	1.95	LM703CN	.45
LM340K-15	1.95	LM703CN	.45
LM340K-24	1.95	LM703CN	.45
LM340T-8*	1.75	LM703CN	.45
LM340T-18*	1.75	LM703CN	.45
NE568*	5.00	LM1304N	1.19
NE568B*	5.00	LM1304N	1.19
NE568C*	5.00	LM1307N	.85

IC SOLDERTAILS - LOW PROFILE (TIN) SOCKETS

8 pin	1-24	25-49	50-100	24 pin	1-24	25-49	50-100
14 pin	5-17	16	15	24 pin	5-17	16	15
16 pin	22	21	20	24 pin	38	37	36
18 pin	29	28	27	24 pin	45	44	43
22 pin	37	36	35	24 pin	50	49	48
				24 pin	63	62	61

SOLDERTAIL STANDARD (TIN)

12 pin	\$.27	.25	.24	28 pin	\$.99	.98	.81
16 pin	.30	.27	.25	28 pin	1.19	1.26	1.10
18 pin	.35	.32	.30	40 pin	1.59	1.45	1.30
24 pin	.49	.45	.42				

SOLDERTAIL STANDARD (GOLD)

8 pin	\$.30	.27	.24	24 pin	\$.70	.67	.57
14 pin	.35	.32	.29	28 pin	1.10	1.00	.90
16 pin	.38	.35	.32	28 pin	1.75	1.40	1.26
				40 pin	1.75	1.50	1.45

WIRE WRAP SOCKETS (GOLD) LEVEL #3

10 pin	\$.45	.41	.37	24 pin	\$1.05	.95	.85
14 pin	.39	.38	.37	28 pin	1.40	1.26	1.10
18 pin	.43	.42	.41	36 pin	1.59	1.44	1.30
18 pin	.75	.68	.62	40 pin	1.75	1.50	1.40

ZENERS—DIODES—RECTIFIERS

TYPE	VOLTS	W	PRICE	TYPE	VOLTS	W	PRICE
1N4746	3.3	400m	41.00	1N4003	200 PIV	1 AMP	121.00
1N751A	5.1	400m	41.00	1N4004	400 PIV	1 AMP	121.00
1N752	5.6	400m	41.00	1N3600	50	200m	61.00
1N753	6.2	400m	41.00	1N4148	75	10m	151.00
1N754	6.8	400m	41.00	1N4150	25	10m	121.00
1N9505B	15	400m	41.00	1N4734	5.6	1w	28
1N5232	5.6	500m	28	1N4735	6.2	1w	28
1N5234	6.2	500m	28	1N4736	6.8	1w	28
1N5235	6.8	500m	28	1N4737	7.5	1w	28
1N5236	7.5	500m	28	1N4742	12	1w	28
1N456	25	40m	61.00	1N4744	15	1w	28
1N458	15.0	7m	61.00	1N1183	50 PIV	35 AMP	1.60
1N458A	160	10m	51.00	1N1184	100 PIV	35 AMP	1.70
1N4001	50 PIV	1 AMP	121.00	1N1150	250 PIV	5 AMP	1.80
1N4002	100 PIV	1 AMP	121.00	1N1168	400 PIV	35 AMP	3.00

KITS EXAR ICS

XR-2206KA SPECIAL \$17.95
Includes monolithic function generator IC, PC board, and assembly instruction manual.

XR-2206KB SPECIAL \$27.95
Same as XR-2206KA above and includes external components for PC board.

TIMERS

XR-555CP	1.80	STEREO DECODERS	
XR-520P	1.55	XR-1310P	\$3.20
XR-555CP	1.85	XR-1800P	3.70
XR-2556CP	3.20		
XR-2240CP	3.25	WAVEFORM GENERATORS	
		XR-205	8.40
		XR-2205CP	4.49
		XR-2207CP	3.85

PHASE LOCKED LOOPS

XR-210	5.20	XR-2211CP	6.70
XR-215	6.80	XR-2261P	3.79
XR-567CP	1.85		
XR-2567CP	2.99		

DATA HANDBOOKS

74

CRYSTALS

Part #	Frequency	Case Style	Price
CY1A	1,000 MHz	HC33/U	\$4.95
CY2A	2,000 MHz	HC33/U	\$4.95
CY3A	4,000 MHz	HC18/U	\$4.95
CY7A	5,000 MHz	HC18/U	\$4.95
CY12A	10,000 MHz	HC18/U	\$4.95
CY15A	15,000 MHz	HC18/U	\$4.95
CY22A	20,000 MHz	HC18/U	\$4.95
CY30B	30,000 MHz	HC18/U	\$4.95

— AVAILABLE IN THESE FREQUENCIES ONLY —

CLOCK CASES



Nicely styled cases complete with red bezel for use in such applications as desk clocks, car clocks, alarm clocks, instrument cases.
DIMENSIONS: W-4" L-4 1/4" H-2"
\$5.95

SEMICONDUCTOR SUPER SPECIALS

2M2222	Low Power 2N2222A	7/51.00
MJ3055	Same as T03 2N3055 with solder lugs on leads	.59
1N4308	Fast 1N4148 Si Switch	20/51.00
MC172	8i VPM Photo Trans. Opto Isolator	2.95
MW5025	4 MCD, 20 mA LED with Mounting	7.95
MV5377	Low Profile Yellow LED	3/51.00
XCS26R	RED 185" dia LED	7/51.00

DL728

The DL728 is a dual 0.5" common cathode red display. It is ideal for use with clock chips, as segments are already multiplexed.
\$2.95

CALCULATOR CHIPS AND DRIVERS

MM5725	8 DIGIT 4 FUNCTION	\$1.98
DM75491	SEGMENT DRIVER	.79
MM5736	6 DIGIT 4 FUNCTION	1.95
DM75492	DRIVER FOR 5736	.89
MM5738	8 DIGIT 5 FUNCTION	2.95
DM8864	DRIVER TYPE 1	2.00
DM8865	DRIVER TYPE 2	1.00
CLOCK CHIPS		
MM5311	6 DIGIT W/BCD	\$4.95
MM5312	4 DIGIT W/BCD	4.95
MM5313	6 DIGIT W/BCD	4.95
MM5314	6 DIGIT CLOCK	3.95
MM5316	ALARM CLOCK	4.95
CT7001	CALC/CLOCK CHIP	5.95

DIGITAL WATCH READOUT

FOR USE WITH WATCHES, OMMs, COUNTERS, ETC.
\$1.95

HP-5082-7300

HP 5082-7300
3" Dia Matrix type numeric readouts with decoder/driver/touch built on the chip. Only 8 bits (BCD n, DP, Latch, +5v, ground).
HP 5082-7300 **\$5.95**

HP 5082-7304

= 1 version of 7300 **4.95**

1 1/2" x 1 1/2" XFMRs

These were designed for clock type applications. 110 Vac primary @ 60 Hz. Secondaries: 8-10 Vac @ 10 mA-50 mA
50 Vac @ 30 mA-50 mA
Excellent for miniature power supplies & gas discharge displays
SPECIAL \$1.79

P.C. Mount



1/16 VECTOR BOARD

0.1" Hole Spacing V-Pattern

Part No.	Length	Width	Price
PHENOLIC			
64P44 062XXXP	4.50	6.50	1.72 1.54
169P44 02XXXP	4.50	17.00	3.69 3.32
64P44 062	4.50	6.50	2.07 1.86
84P44 062	4.50	8.50	2.56 2.31
169P44 062	4.50	17.00	5.04 4.53
169P44 062	8.50	17.00	9.23 8.26
169P44 062C1	4.50	17.00	6.80 6.12
EPOXY GLASS COPPER CLAD			

VECTOR WIRING PENCIL



Vector Wiring Pencil P173 consists of a hand held leather weight (under one ounce) tool which is used to guide and wrap insulated wire, fed off a self-contained replaceable bobbin, onto component leads or terminals installed on pre-punched "P" Pattern Vectorboards*. Connections between the wrapped wire and component leads, pads or terminals are made by soldering. Complete with 250 FT of red wire. **\$9.50 ea.**

REPLACEMENT WIRE — BOBBINS FOR WIRING PENCIL

W36-3-A-Pkg. 3	(Green)	\$2.40
W36-3-B-Pkg. 3	(Red)	\$2.40
W36-3-C-Pkg. 3	(Clear)	\$2.40
W36-3-D-Pkg. 3	(Blue)	\$2.40

9V BATTERY CLIP

STANDARD CLIP FOR USE WITH 9V TRANSISTOR BATTERIES WITH 4" LEADS **9/99**



TERMINAL STRIPS

THREE TERMINAL STRIPS, WITH CENTER TERMINAL USED FOR MOUNTING **15/\$1.00**

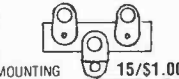

AMP TERMINAL PINS

TERMINAL PINS FOR MOUNTING COMPONENTS ALSO PERFECT FOR USE WITH BOARD CONNECTORS AND SUBASSEMBLIES **\$1.00/100 PCS.**



MICROPROCESSOR COMPONENTS

CENTRAL PROCESSOR UNITS

Each processor feature 2us instruction cycles, and are brand new from the manufacturer. The T15800 is and 2nd generation processor; and the AMD9080A/8080A is a 2nd generation processor.

T.1 8080

\$29.95

DIRECT REPLACEMENT FOR INTEL C8080

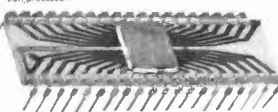

AMD 8080A

\$39.95

DIRECT REPLACEMENT FOR INTEL C8080A

CPU'S		RAM'S	
8006	8 Bit CPU	1101	256K1
8080	Super 8080	1103	1024K1
8080A	Super 8080A	2101	256K1
	SR'S	2102	1024K1
2504	1024 DYNAMIC	2107	4096K1
2518	HEX 32 BIT	2111	256K4
2519	HEX 40 BIT	7010	1024K1
2524	S12 DYNAMIC	7489	16K4
2525	1024 DYNAMIC	8101	256K4
2527	DUAL 256 BIT	8111	256K4
2529	DUAL 512 BIT	4.00	8599
2532	QUAD 80 BIT	9102	1024K1
2533	1024 STATIC	74200	256K1
3341	RIFO	8.95	256K1
74LS670	16K4 REG.	5.95	2048K1
	UART'S		PROMS
AY-5-1013	20K BAUD	\$4.95	1702A
	ROM'S		5203
2513	CHAR. GEN.	11.00	2048
7488	RANDOM BITS	3.50	8223
			3248
			1024
			FAMOS 15.95
			FAMOS 14.95
			BIPOLEAR 3.00
			STATIC 7.95

JOLT 159.95

ACCESSORIES

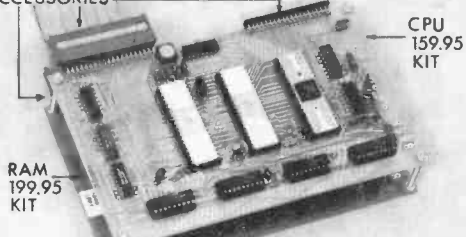

RAM 199.95 KIT

CPU 159.95 KIT

The JOLT system consists of a set of modular microcomputer boards which can be used singly or tied together to produce any desired microcomputer system configuration. The minimum system is one CPU board, which

JOLT INCLUDES SOFTWARE, HARDWARE AND ASSEMBLY MANUALS. AVAILABLE FOR IMMEDIATE SHIPMENT. \$159.95 in kit form... \$249 assembled.

JOLT SYSTEM DESCRIPTION

JOLT RAM Card — Fully static 4,096 bytes of RAM with 1 microsecond access time and on-board decoding. Hardware and assembly manuals included. AVAILABLE FOR IMMEDIATE SHIPMENT. \$199.95 kit... \$285 assembled.

JOLT Power Supply — Operates at +5, +12 and -10 voltages. Supports JOLT CPU, 4k bytes of RAM and JOLT I/O card — or, CPU and 8 I/O cards. Manual included. AVAILABLE FOR IMMEDIATE SHIPMENT. \$99.95 kit... \$145 assembled.

JOLT Accessory Bag — Contains enough hardware to connect one JOLT card to another. Such necessary items as flat cable, connectors, cord spacers, hardware, etc. AVAILABLE FOR IMMEDIATE SHIPMENT. \$39.95.

JOLT I/O Card (Peripheral Interface Adapter) — 2 PALS chips, 32 I/O lines, four interrupt lines, on-board decoding and standard TTL drive. Fully programmable. Manuals included. AVAILABLE FOR IMMEDIATE SHIPMENT. \$95.95 kit... \$140 assembled.

JOLT Universal Card — Same size (4 1/2" x 7 1/2"), same form factor as other JOLT cards. Completely blank, drilled to accept 14, 16, 24 or 40 pin sockets. Used for additional user memory or I/O control panels, TV interfaces, keyboards, LEDs, or other interface logic. AVAILABLE FOR IMMEDIATE SHIPMENT. \$24.95.

JOLT +5V Booster Option — Fits onto JOLT Power Supply card. Supports CPU, 16k bytes of RAM — or, CPU and 8k bytes RAM and 8 I/O cards — or, CPU and 4k bytes RAM and 16 I/O cards. 4 manuals included. AVAILABLE FOR IMMEDIATE SHIPMENT. \$24.95.

64 KEY BOARD

These high quality keyboards, which were originally made by a large computer manufacturer. Each keyboard has 64 keys, which are brought out on unenclosed pins. They utilize magnetic reed type switches, and are new in appearance. **\$29.95**



MD1165 Keyboard Encoder ROM **\$7.95**

WIRE WRAP WIRE

AWG	COLOR	25 FT. MIN.	50 FT.	100 FT.	1000 FT.
30 AWG	WHITE	\$2.10	\$2.75	\$3.50	\$24.00
30 AWG	YELLOW	2.10	2.75	3.50	24.00
30 AWG	RED	2.10	2.75	3.50	24.00
30 AWG	GREEN	2.10	2.75	3.50	24.00
30 AWG	BLUE	2.10	2.75	3.50	24.00
30 AWG	BLACK	2.10	2.75	3.50	24.00

RIBBON CABLE

Conductors	1-9ft/ft	10-24ft/h	25-99ft/ft	100ft
30	.39	.29	.25	.23
40	.59	.49	.45	.43
50	.79	.69	.65	.60
60	.99	.89	.85	.80
80	1.19	1.09	1.05	1.00

6" 2 CONDUCTOR POWER CORDS 125V @ 5A

NUMBER	LENGTH	AWG	O.D.	RATING	COLOR	PRICE
17236	6	18(41X34)	.265	1250W	BLACK Special	.79 ea.
17237	6	18(41X35)	.253	10A-125V/1250W	GREY	1.25
17238	8	18(41X34)	.265	10A-125V/1250W	BLACK Special	.99 ea.
17239	8	18(41X34)	.253	10A-125V/1250W	GREY	1.50
17000	4	18(41X34)	.253	10A-125V/1250W	BLACK	.59

Satisfaction Guaranteed. \$5.00 Min. Order. U.S. Funds. California Residents — Add 6% Sales Tax. Write for FREE 1976 Catalog — Data Sheets .25¢ each

JAMES

P.O. BOX 822, BELMONT, CA. 94002
PHONE ORDERS — (415) 592-8097

JE SERIES KITS

JE801 DVM

The JE801 is a three and one half digit, auto polarity digital voltmeter, in a kit form. It features several options not available in any commercial digital voltmeter. Its low cost is perhaps the most important feature, which is achieved by offering it in a kit form. A kit allows the unit to be used by small OEM's where cost effectiveness is an important factor, and by the hobbyist who has to be concerned with cost. The unit also features on card regulators, allowing it to be operated off a single plus and minus fifteen volt, unregulated power supply. The unit has a small size of three inches width, three and three quarters of an inch length, and one and a quarter inch height.

\$39.95 Per Kit printed circuit board

JE803 PROBE

The Logic Probe is a unit which is for the most part indispensable in trouble shooting logic families. TTL, DTL, RTL, CMOS. It derives the power it needs to operate directly off of the circuit under test, drawing a scant 10 mA max. It uses a MAN3 readout to indicate any of the following states by these symbols: (H) - 1 (LOW) - 0 (PULSE) - P. The Probe can detect high frequency pulses to 45 MHz. It can't be used at MOS levels or circuit damage will result.

\$9.95 Per Kit printed circuit board

JE700 CLOCK

The JE700 is a low cost digital clock, but it is a very high quality unit. The unit features a simulated walnut case with dimensions of 6" x 2 1/2" x 1 1/2". It utilizes a MAN72 high brightness readout, and the MMS14 clock chip. **\$19.95**

12 or 24 Hour
115 VAC — \$19.95 per kit \$29.95 assembled

JOYSTICK

These joysticks feature four 100K potentiometers, that vary resistance proportional to the angle of the stick. Slurdy metal construction with plastic components only at the movable joint. Perfect for electronic games and instrumentation. **\$9.95 ea**

ELECTRONIC ROULETTE

Complete kit with all components case and transformer **\$29.95 Per Kit**

115 VAC
Dimensions: 6 1/2" x 6 1/2" x 1 1/2"

ELECTRONIC CRAPS

Complete kit with all components case and transformer. **\$19.95 Per Kit**

Dimensions: 6 1/2" x 3 1/2" x 1 1/2"

CONTINENTAL SPECIALTIES \$15.95

PROTO BOARD 6
The PB-6 lets the user test and build circuits without soldering or patch cords. All interconnections between components are made with common #22 AWG hook-up wire. This quality breadboarding kit includes 830 component tie points at 855 than 2.5c each. It measures 6" long by 4" wide. Designed specially to Breadboard Microprocessor Circuits. **\$15.95**

PROTO BOARD 100
A low cost, big 10 IC capacity breadboard kit with all the quality of OT sockets and the best of the Proto Board series — complete down to the last nut, bolt and screw. Includes 2 OT-35S Sockets; 1 OT-35B Bus Strip; 2 5-way binding posts; 4 rubber feet screws; nuts, bolts, and easy assembly instructions. **\$19.95**

Bring IC leads from pc board for fast signal tracing and troubleshooting. Inject signals. Wire unused circuits into boards. Scope probes and test leads lace onto Dynagrip inset (see circle) for hands-off testing. Plastic construction eliminates springs & pivots. Non-corrosive nickel/silver contacts for simultaneous low resistance connections.
PC-14, 14-pin Proto Dip, \$4.90 ea.
PC-16, 16-pin Proto Clip, \$4.75 ea.
PC-24, 24-pin Proto Clips, \$8.00 ea.

URE FINDERS

FREE FACT-FILLED CATALOG! World's largest selection! Metal detectors starting at \$79.50. Two year guarantee! Three factories, U.S.-Canada. 1,200 dealers - Service Centers nationwide. Finest instruments at any price! Budget Terms. Dealer inquiries invited. Write: White's Electronics, Inc. Dept. PD6Q, 1011 Pleasant Valley Road, Sweet Home, Oregon 97386.

TREASURE FINDER locates buried gold, silver, coins, treasures. 6 powerful models. Instant financing available. Write or call for free catalog. Phone (713) 682-2728 day or night. Dealer inquiries invited. Relco, Dept. AA20, Box 10839, Houston, Texas 77018.

REAL ESTATE

280-PAGE CATALOG Free! Over 2,600 top values coast to coast! **UNITED FARM AGENCY**, 612-EP West 47th, Kansas City, MO 64112.

RECORDS

OLDIES. 45rpm. Free Catalog. Corny's Record Shop, Box 166TD, Mason, Ohio 45040.

FREE RECORD COLLECTION Reviewers wanted. Anyone qualifies. We ship you new records to review. You pay postage. Records are free. Applicants accepted "first come" basis. Write: Research PE, 6162 Washington Circle, Milwaukee, Wisconsin 53213.

PRINTING

PRINTING Type, Cuts, Ornaments. Your monogram cut and list \$1.00. Moneyback Guarantee. Superior, Box 487, Lee's Summit, MO 64063.

RUBBER STAMPS

RUBBER ADDRESS STAMPS. Free Catalog. 45 type styles. Jackson's, Dept. K, Brownsville Rd., Mt. Vernon, Ill. 62864.

INVENTIONS WANTED

INVENTORS: Manufacturers Need New Products. Free "Recommended Procedure," by a creative fee-based invention service company. Washington Inventors Service, 422-T Washington Building, Washington, D. C. 20005.

inventors
...Manufacturers Need New Products

If you have an idea for a new product, or a way to make an old product better, contact us, "the idea people." We'll develop your idea, introduce it to industry, negotiate for cash sale or licensing.

Send for our **FREE "Invention Kit."** It has a special "Invention Record Form," an important brochure, "Your Invention - Its Development, Protection & Marketing," and a **Directory of 500 Corporations Seeking New Products**. You'll learn how ideas become a reality!

RAYMOND LEE ORGANIZATION
 230 Park Avenue North, New York, NY 10017
 I'd like to find out how to take action on your idea. Send Free "Invention Kit No. A-112"

Name Please Print
 Address
 City State Zip

A Fee-Based Invention Service Company

FREE PAMPHLET: "Tips on Marketing Your Invention," from an experienced fee-based invention service company. Write United States Inventors Service Company, Dept. T, 1435 G Street NW, Washington, D. C. 20005.

PERSONALS

MAKE FRIENDS WORLDWIDE through international correspondence. Illustrated brochure free. Hermes, Berlin 11, Box 110660/ZD, Germany.

Ph.D.'S. MASTER'S. BACHELOR'S - official nonresident College Degrees easily acquired through mailorder Universities. Complete Revealing Directory - \$2. Counseling Connection, 5495 Claremont, No. BSG, Oakland, CA 94618.

NEW LUXURY CAR without cost! Free details. CODEX-DD, Box 6073, Toledo, Ohio 43614.

TUBES

RADIO & T.V. Tubes-36 cents each. Send for free Catalog. Cornell, 4213 University, San Diego, Calif. 92105

TUBES receiving, factory boxed, low prices, free price list. Translelectronic, Inc., 1365 39th Street, Brooklyn, N.Y. 11218A, Telephone: 212-633-2800.

TUBES "Oldies", latest. Lists free. Steinmetz, 7519 Maplewood, Hammond, Indiana 46324.

TUBES Send 10 cents for large conclusive list. Low Prices. T-J Specialties, Box 43, Bradley Beach, New Jersey 07720.

ELECTRICAL SUPPLIES & EQUIPMENT

PLATING Equipment, Portable Platers, Supplies and "Know-How." Build your own tanks for nickel, chrome, etc. Easy-to-install PVC liners. Rectifier components—all sizes. Schematics, parts lists, formulas, operating instructions for all plating. Guaranteed to save you 25%-75%. Some good used units for sale. Write for details. Platers Service Company, 1511-PE Esperanza, Los Angeles, Calif. 90023.

MAGNETS

PERMANENT MAGNET MOTION. Foucault Drives. Virtual Perpetual Motion. Details \$3.00. MAGNETRIKS, 6064 N. Paulina, Chicago, IL 60660.

MAGNETS. All types. Specials-20 disc, or 10 bar, or 2 stick, or 8 assorted magnets, \$1.00. Magnets, Box 192-H, Randallstown, Maryland 21133.

WANTED

QUICKSILVER, Platinum, Silver, Gold, Ores Analyzed. Free Circular. Mercury Terminal, Norwood, Mass. 02062.

THERE'S A NEW PLACE TO BUY COMPONENTS

INDICATOR LITES

Tinylite Indicator lites
 Five colors available - red, white, yellow, green and blue. Three voltages available -- 7VDC, 14VDC, 28VDC. Lamp replaceable from front of panel. Indicator lite includes lamp. Mounts in 7/16" dia. hole - Mounting hardware included.

Solder terminals	1-9	10-24	25-49
5126-022(7VDC)	\$1.25	\$1.18	\$1.06
5127-022(14VDC)	1.30	1.22	1.10
5128-022(28VDC)	1.60	1.48	1.33

specify lens color

FANS

Reduces heat, single largest cause of component failure. Compact, 4-11/16" square by 1-1/2" thick. All metal frame. Ball bearing or sleeve bearing. Same parts as used by major computer manufacturers. Fan is designed and manufactured in accordance with UL specifications. 115 Volt AC

P/N	Current (Amps)	Air Del. (cu ft/min)	Price
WS2107FL sleeve bearing	24	115	\$15.00
BS2107FL ball bearing	20	115	25.00
1)*WS2107FL-9 sleeve bearing	10	50	17.25

Accessories
 65-175 Finger Guard
 Fits all BS and WS models. 1.20
 69-174-1 36" Plug and Cord Set -
 Fits all BS & WS models. 1.20
 1) Extra Quiet version of WS2107FL - designed for HiFi equipment or any place minimal acoustical disturbance is required.

Spec sheets available on all fans and indicator lites at 25¢ ea. No charge for spec sheet with \$25.00 order.

CMOS

4000	.24	4018	1.44	4035	1.36	4072	.26
4001	.24	4019	.58	4040	1.60	4073	.26
4002	.24	4020	1.56	4041	.90	4075	.26
4006	1.50	4021	1.42	4042	.82	4081	.26
4007	.24	4022	1.18	4043	.67	4082	.26
4008	1.17	4023	.24	4044	.67	4502	1.26
4009	.64	4024	.96	4046	2.35	4511	1.60
4010	.64	4025	.24	4049	.52	4518	1.28
4011	.24	4026	1.67	4050	.52	4520	1.28
4012	.24	4027	.64	4051	.44	4527	2.00
4013	.50	4028	1.04	4052	1.44	4528	.90
4014	1.58	4029	1.36	4053	1.44		
4015	1.17	4030	.50	4060	1.67		
4016	.50	4033	1.67	4066	.90		
4017	1.26	4034	3.34	4071	.26		

RESISTORS

Carbon Film Resistors

1/4W 5% 120 resistance values - 10Ω thru 910KΩ
 1/2W 5% 145 resistance values - 10Ω thru 10megΩ
 1W 5% 145 resistance values - 10Ω thru 10 megΩ
 2W 5% 145 resistance values - 10Ω thru 10megΩ

	1-25	26-100	101-500	501-1000
1/4W 1/2W	.05	.04	.03	.0275
1W	.14	.12	.11	.10
2W	.21	.20	.19	.18

Shipping charges
 \$.00 to \$4.99. Add \$2.00
 5.00 to 24.99. Add .75
 25.00 to 49.99. Add .49
 50.00 to 99.99. Add .25
 \$100 and up. No charge

Minnesota residents add 4% tax
 Many other models available - send for our free catalog.



AND YOU SHOULD SEE WHAT ELSE WE HAVE!

North Star Electronics Corporation/P.O. Box 1190/Minnetonka, Minnesota 55343

ARIES brought you the first calculator kit, and the first digital clock kit... and now brings you three of the most innovative electronic kits ever made. The System 300 Electronic Music Synthesizer kit is the most advanced in the world today, regardless of price. The AR-781 is a space-age beauty for any decor. And the wholly solid state AR-830 does the work of a \$400.00 tape memory unit.



WARNING... if you're interested in a music synthesizer, don't make a move until you see our catalog first. It's more like a handbook than a catalog, with hundreds of in-depth photographs and descriptions to explain electronic music principles, and to show equipment to do the job. ARIES now offers a complete complement of modules, keyboards, and cases, matched to the most rigorous professional standards. Starter systems priced as low as \$395.00.

A clear, ruby-red cylinder shows off all six digits of this modern calendar clock. Easy-to-read numbers show the hours, minutes, and seconds, as well as the month and day every ten seconds.



Red LED 7-segment numerals are 0.33" high, in a sturdy cylinder 2-1/2" in diameter and 4-3/4" long, with finished hardwood ends. Time and calendar are controlled by 60 Hz line frequency, with a 12-month movement. Separate time and calendar adjustments. Includes all the components, PC boards, housing, and instructions. Shipping weight 2 lbs, AR-781 Clock Kit\$34.50

Add finger-touch operation to your old-fashioned dial telephone with an ARIES AR-830 Automatic Digital Telephone Dialer. This has the same layout and convenience as Ma Bell, plus other features she doesn't offer yet. For instance... AR-830 always remembers the last number you dialed, in case the line was busy and you want to try again later. Not only that, but the Dialer's memory can store as many as ten of your favorite numbers for one-touch dialing. AR-830 uses standard dialing and muting contacts; consult local tariffs before connecting. Sh. wt. 2 lbs. AR-830 Dialer Kit\$69.50



ARIES INC.

119 Foster Street
Peabody, Mass., 01960
(617) 532-0450

CIRCLE NO. 66 ON FREE INFORMATION CARD

GOVERNMENT SURPLUS

GOVERNMENT Surplus. How and Where to Buy in Your Area. Send \$2.00. Surplus 30177-PE Headquarters Bldg., Washington, D.C. 20014.

MANUALS for Govt Surplus radios, test sets, scopes. List 50 cents (coin). Books, 7218 Roanne Drive, Washington, D.C. 20021.

SURPLUS ELECTRONIC EQUIPMENT, government and manufacturers' Grab Box Assortment—diverse, useful new and used parts, assemblies, etc. Carton packed: 50 lbs. \$6.00; 100 lbs. \$10.00. F.O.B. Lima. Send for BIG Free Catalog! Fair Radio, Box 1105-E, Lima, Ohio 45802.

JEEPS, TRUCKS, Typically From \$52.40. Automobiles, Boats, Motorcycles, Airplanes, Oscilloscopes, Tools, Clothing, Sports, Camping, Photographic, Electronics Equipment. 200,000 Bid Bargains Nationwide Direct From Government. Low as 2 cents on Dollar! Surplus Catalog and Sales Directory \$1.00 (refundable first order). National Surplus Center, 240 Eastcass-PEL, Joliet, IL 60432.

VIDEO CAMERA KIT

A UNIQUE CAMERA KIT
FEATURING A... 100 X 100 BIT
SELF SCANNING CHARGED
COUPLED DEVICE

INCLUDES THE FOLLOWING
UNIQUE FEATURES...
FOUND IN FAR MORE
EXPENSIVE CAMERAS
IF AVAILABLE

- LOW VOLTAGE SUPPLY (OR BATTERIES) + 5 AND ± 15 VOLTS
- SENSITIVE TO INFRARED AS WELL AS VISIBLE LIGHT
- MAY BE USED FOR IR SURVEILLANCE WITH AN IR LIGHT SOURCE
- EXCELLENT FOR STANDARD SURVEILLANCE WORK BECAUSE OF ITS LIGHT WEIGHT AND SMALL SIZE
- ALL COMPONENTS MOUNTED ON TWO PARALLEL 3" X 5" SINGLE-SIDED BOARDS. TOTAL WEIGHT UNDER 2 LBS
- MAY BE WIRED BY PERSON WITH SOME TECHNICAL EXPERIENCE IN 4-8 HRS



ONLY
\$225.00
ADD \$2.00 POSTAGE AND HANDLING. PLUS \$6.00 FOR ALL IC SUPPLIES

MAY BE USED
WITH AMATEUR
RADIO FOR VIDEO

USED FOR CHARAC-
TER RECOGNITION
FOR COMPUTERS
WITH EXTERNAL
CIRCUITS

MAY BE USED IN
A VACUUM, UN-
DER WATER, HIGH
ALTITUDE, AND
IN MAGNETIC
ENVIRONMENT
BECAUSE THERE
IS NO HIGH
VOLTAGE OR
MAGNETIC
DEFLECTION

WE SUPPLY ALL
SEMICONDUCTORS,
BOARDS, DATA SHEETS,
DIAGRAMS, RESISTORS,
AND CAPACITORS

WE DO NOT SUPPLY
THE CASE, BATTERIES
(OR SUPPLY) THE LENS
(NOT SUPPLIED) DEPENDS
UPON THE USER

ADD \$2.00 POSTAGE AND HANDLING. PLUS \$6.00 FOR ALL IC SUPPLIES

F8 MICROPROCESSOR KIT

WE'VE GOT THE F8 MICROPROCESSOR KIT, ONE OF THE MOST ADVANCED MCU SYSTEMS ON THE MARKET TODAY FOR ONLY \$179.00

The three chip microprocessor system has the following advantages:

- 1) Driven by a +5 and -12 volt power supply
- 2) Two I/O ports on the CPU chip, and ROM, making 32 bidirectional lines
- 3) 64 bytes of fast RAM scratchpad built into the CPU chip
- 4) A built in clock generator and power on reset built into the CPU chip
- 5) A programmable internal timer built into the ROM chip
- 6) 60% of the instructions are 1 byte
- 7) TTL I/O compatibility
- 8) consumes less than 300mw of power per chip
- 9) A local interrupt with automatic address vector
- 10) expandable to 64K bytes (2 1024's) of memory

The F8 Kit has enough parts and instructions to demonstrate microprocessor programs up to 1K byte, and to debug those programs.

We supply

1. 3850 CPU
1. 3851 FAIR-BIG programmed storage unit, provides the programmer with all its I/O subroutine, and allows the programmer to display or alter memory, and register contents via a teletype terminal
1. 3853 Static memory interface
8. 2102-2 Plus CMOS gates and buffers, PC card, instruction manuals, programming guide, and time sharing guide

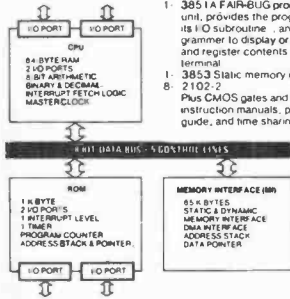

INTEL 8080 CPU	\$37.50
8008 8 BIT MICRO PROCESSING CHIP (with Data Book)	\$19.00
2102-2 1024 BIT RAM	\$ 2.95
5202A UV PROM	\$12.50
MM5203 UV PROM	\$12.50
1702A UV PROM	\$12.50
5204-4K PROM	\$24.95
MINIATURE TRIM POTS 100, 500	
5K, 10K, 25K, 50K, 100K, 200K	\$382.00
5.75 ea.	
MULTI-TURN TRIM POTS Similar to Bourms	
5204-4K PROM	\$5.00, 100, 500, 100,000 ohms
11.50 ea.	
3/4 \$4.00	
LIGHT ACTIVATED SCR'S TO-18 200V 1A	\$1.75

PRINTED CIRCUIT BOARD	
4 1/2" x 6" SINGLE SIDED EPOXY BOARD 1/16" track, unetched	\$9.50 ea.
5/82.20	
VECTOR BOARD 1" SPACING	
4.5" x 6.5" SHEET	\$1.50
4 WATT IR LASER DIODE \$7.95	
2N5480 P FET	\$.45
2N5457 N FET	\$.45
2N4891 UJT	\$.45
TIS 43 UJT	\$.35
ER 900 TRIGGER DIODES	4/51.00
2N 6028 PROM. UJT	\$.85

VERIPAX PC BOARD	
This board is a 1/16" single sided paper epoxy board, 4 1/2" x 6 1/2", DRILLED and ETCHED which will hold up to 21 single 14 pin IC's or 8. 16 or LSI DIP IC's with buses for power supply connector. \$5.25	

MV 5691 YELLOW-GREEN	\$1.25
MT-2 PHOTO TRANS	\$.80
RED YELLOW GREEN OR AMBER LARGE LED'S	ea. \$.20
14 PIN DIP SOCKETS	\$.35
16 PIN DIP SOCKETS	\$.38
MOLEX PINS	100/\$1.00
	1000/\$8.00
8 PIN MINI DIP SOCKETS	\$.30
10 PIN TO-5 TEFLON PC SOCKETS	\$.80
10 WATT ZENERS 3.9, 4.7, 12, 18 OR 22V	ea. \$.75
1 WATT ZENERS 4.7, 5.6, 10, 12, 15, 18 OR 22V	ea. \$.25

Silicon Power Rectifiers				
PRV 1A	3A	12A	50A	125A
100 06	14	30	80	
200 07	20	35	115	4.25
400 09	25	50	140	6.50
600 11	30	70	180	8.50
800 15	35	90	230	10.50
1000 20	45	110	275	12.50

REGULATED MODULAR POWER SUPPLIES	
+ -15VDC AT 100ma	
115VAC INPUT	\$24.95
5VDC AT 1A, 115VAC INPUT	\$24.95
12V 5A	\$24.95
IN 4148 (IN914)	15/\$1.00
1103, 1024 bit RAM	\$2.75
NEC 6003 2048 bit RAM	\$6.00
1101 256 bit RAM	\$1.40
7489 RAM	\$2.30
7 POLE 1 THROW TO-5 MINATURE ROTARY SWITCH	
5-30V LOW CURRENT	\$1.15

TRANSISTOR SPECIALS	
2N3585 NPN Si TO-66	\$.95
2N3772 NPN Si TO-3	\$1.80
2N4901 PNP Si TO-3	\$.85
2N1546 PNP GE TO-3	\$.95
2N5086 PNP Si TO-92	4/1.00
2N4898 PNP TO-66	\$.60
2N404 PNP GE TO-5	5/1.00
2N3919 NPN Si TO-3FF	\$1.50
MPS113 NPN Si TO-92	3/1.00
2N3767 NPN Si TO-66	\$.70
2N2222 NPN Si TO-18	5/1.00
2N3055 NPN Si TO-3	\$.80
2N3904 NPN Si TO-92	5/1.00
2N3906 PNP Si TO-92	5/1.00
2N5298 NPN Si TO-22D	\$.50
MPS112 NPN Si TO-22D	\$.55
2N3886 NPN Si TO-5	\$.75
2N3838 NPN Si TO-5	5/1.00
2N6517 NPN TO-92 S	3/1.00

CAPACITORS	
35V at 47 uF TANT	5/1.00
35V at 68 uF TANT	5/1.00
25V 33 uF TANT	\$.40
35V at 6.8 uF TANT	3/1.00
20V at 150 uF TANT	\$.40
6V 30 uF TANT	5/1.00
200V 4.7 uF ELECT	\$.30
CT7001 ALARM CLOCK CHIP	\$5.75
FPA 711-7 LEVEL Clode Array Optical Tape Readers	\$5.95
MM1402-3.20	MM5057-4.00
MM1403-3.20	MM5058-4.95
MM1404-2.50	MM5080-4.95
MM5013-7.75	MM5081-4.30
MM5016-3.50	MM5555-6.25
MM5017-4.75	MM5556-6.25
MM5055-4.00	MM5210-1.95
MM5056-4.00	MM5260-2.95

TTL IC SERIES	
7400-26	7476-35
7400-14	7480-48
7401-15	7483-75
7402-15	7485-105
7403-15	7486-34
7404-18	7490-49
7405-18	7491-79
7406-35	7492-49
7407-33	7493-49
7408-18	7495-74
7409-18	7496-79
7410-15	74107-34
7411-25	74121-38
7412-30	74125-74
7413-45	74125-54
7414-145	74126-54
7416-33	74150-92
7417-33	74151-69
7420-15	74153-79
7425-27	74154-105
7426-24	74155-105
7427-27	74157-75
7430-15	74161-95
7432-24	74164-110
7437-29	74165-110
7438-29	74173-135
7440-15	74175-95
7441-95	74177-75
7442-59	74181-230
7445-79	74192-110
7446-87	74193-110
7447-87	74194-115
7448-85	74195-74
7472-28	74196-95
7473-34	75324-1.75
7474-35	75491-1.10

ALCO MINATURE TOGGLE SWITCHES	
MTA 106 SPDT	\$1.20
MTA 206 DPDT	\$1.70

C/MOS (DIODE CLAMPED)			
74C02-26	4012-24	4026-1	90
74C10-30	4013-45	4027-55	50
74C157-1.75	4015-1.24	4028-95	95
4001-24	4017-1.15	4030-49	49
4002-24	4018-1.24	4035-51	50
4006-1.35	4019-50	4042-75	75
4007-24	4022-1.24	4046-2.75	2.75
4009-50	4023-24	4047-3.50	3.50
4010-50	4024-95	4050-49	49
4011-24	4025-24	4055-1.95	1.95

Full Wave Bridges		
PRV 2A	6A	25A
200 95	1.25	2.00
400 1.15	1.50	3.00
600 1.35	1.75	4.00

CD 110 LINEAR 256 XI BIT SELF SCANNING CHARGED COUPLED DEVICE \$125.00	
SANKEN AUDIO POWER AMPS	
Si 1010 G 10 WATTS	\$ 6.90
Si 1020 G 20 WATTS	\$14.95
Si 1050 G 50 WATTS	\$23.95

LINEAR CIRCUITS	
LM 309K 5V 1A REGULATOR	\$1.20
723-40 +40V REGULATOR	\$5.84
30174B Hi Perf Op. Amp.	\$.28
320T 5, 12, 15, OR 24V NEGATIVE REG.	\$1.50
741A or 741C OP AMP	\$.31
709C OPER AMP	\$.25
307 OP AMP	\$.25
CA 3047 HI PERF. OP AMP	\$.95
CA 3089 FM IF SYSTEM	\$3.25
340T-5, 8, 12, 15, 18, 24V POS. REG TO-220	\$1.20
101 OPER AMP HI PERFORM.	\$.75
LM 308 Oper Amp, Low Power	\$1.05
747-DUAL 741	\$.85
556-DUAL TIMER	\$.95
537-PRECISION OP AMP	\$2.60
540-70V POWER DRIVER	\$2.50
LM 3900-QUAD OP AMP	\$.49
LM 324-QUAD 741	\$1.50
560-PHASE LOCK LOOP	\$2.50
561-PHASE LOCK LOOP	\$2.50
565-PHASE LOCK LOOP	\$1.75
566 FUNCTION GEN	\$2.50
567-TONE DECODER	\$1.75
LM 1310 FM STEREO DEMOD	\$2.75
8038 IC VOLTAGE CONT OSC	\$3.90
LM370-AGC SQUELCH AMP	\$1.15
555-2 uS-2 HR TIMER	\$.53
553 QUAD TIMER	\$3.50
FCD 810 OPTO-ISOLATOR	\$.80
1458 DUAL OP AMP	\$.65
LM 380-2W AUDIO AMP	\$.95
LM 377-2W Stereo Audio Amp	\$2.50
LM 381-STEREO PREAMP	\$1.15
LM 382-DUAL AUDIO PREAMP	\$1.15
LM 311-HI PER COMPARTOR	\$.95
LM 319-Dual Hi Speed Comp.	\$1.10
LM 339-HI PER COMPARTOR	\$1.25

TRIACS SCR'S					
PRV 1A	10A	25A	15A	6A	35A
100 40	70	130	40	50	20
200 70	110	175	60	70	120
400 110	160	260	100	120	220
600 170	230	360	150	300	

Send 20¢ for our catalog featuring Transistors and Rectifiers
145 Hampshire St., Cambridge, Mass



SOLID STATE SALES

P.O. BOX 74A
SOMERVILLE, MASS. 02143 TEL. (617) 547 4005

WE SHIP OVER 95% OF OUR ORDERS THE DAY WE RECEIVE THEM

CIRCLE NO. 52 ON FREE INFORMATION CARD

Olson[®] ELECTRONIC PARTS AND ACCESSORIES



500-ft. Hookup Wire Kit	WW-579	1.69
3-6V DC Mini Hobby Motor, Kit/5	MO-333	.55
3-6V DC Midi Hobby Motor, Kit/4	MO-334	.79
3-6V DC Ass't'd. Hobby Motor, Kit/4	MO-335	.99
1 Amp. 200 PIV. Diode, Kit/50	DI-051	.69
IN4149 Switch Diode, Kit/10	XM-382	.59
1/4 - 1/2 - 1 Watt Resistors 1 lb. Kit	RS-239	.99
PNP Audio Transistors Kit/10	TR-445	.39
NPN Audio Transistors, Kit/10	TR-444	.39
C-60 Cassettes, Kit/5	TA-879	.99
8 Tr. 40-Min. Blank, Each	TA-854	.89
8 Tr. 80-Min. Blank, Each	TA-855	.99
IN4001 1A, 50 PIV Diode, Kit/5	DI-028	.39
IN4002 1A, 100 PIV Diode, Kit/5	DI-029	.39
IN4003 1A, 200 PIV Diode, Kit/5	DI-030	.39
IN4004 1A, 400 PIV Diode, Kit/5	DI-031	.39
SCR Assortment, Untested, Kit/25	TR-446	.99
7A. Pwr. Trans. NPN-like SK3054, Each		1.49
1A, 50 PIV Epoxy Diodes, Kit/50		1.00
5 Volt 1 Amp Regulator, Each		1.20
6.2 Volt Zener Diode, HEP 103		1.00
6500KV Color TV Rectifier		3 for 1.95
Colorburst Quartz Crystals		2 for 1.89
10 Ass't'd. Diodes IN34-IN48-IN50-IN54 Etc.		1.00

SILICON POWER RECTIFIERS

PRV	1 Amp.	3 Amp.	12 Amp.	50 Amp.
100	.06	.14	.30	.80
200	.07	.20	.35	1.15
400	.09	.25	.50	1.40
600	.11	.30	.70	1.80
800	.15	.35	.90	2.20
1000	.20	.45	1.10	2.75

TRIACS

PRV	1 Amp.	10 Amp.	25 Amp.
100	.40	.70	1.30
200	1.10	1.75	3.00
400	1.10	1.60	2.60
600	1.70	2.30	3.00

SCRs

PRV	1.5 Amp.	6 Amp.	35 Amp.
100	.40	.50	1.20
200	.60	.70	1.60
400	1.00	1.20	2.20
600	—	—	3.00

LM 703 CN Linear OP Amp	.45
LM 708 H Linear OP Amp	.29
LM 709 N Linear OP Amp	.29
LM 710 N Linear OP Amp	.79
LM 711 N Linear OP Amp	.39
LM 723 N Linear OP Amp	.55
LM 723 H Linear OP Amp	.60
Mini Numeric Nixie 170V DC, XM-107	6.00
3 1/2 Digit Liquid Crystal Display, XM-371	6.00
Fairchild 914 Type IC, Kit/2, TR-297	.60
Fairchild 717 Type IC, TR-294	.60
200 Bit Shift Register, Kit/5, TR-295	.60
Fairchild 909 Type IC, RE-131	.80
8-12 Amp Stud Rectifiers, Pkg. of 3, TR-443	.60
Low Voltage Electronics, Pkg. of 50, CD-407	2.70
D58R Numeric Indicator Tube, XM-338	1.20

DUAL IN-LINE IC'S

LOW AS **29¢**
 Made in U.S. These IC's are guaranteed against defects: With diagram, Shpg. wt. 1/4 lb.
 Type 7400 Quad 2-Input Pos. NAND Gate. High speed, diode-clamped inputs. 29¢
 TR-431.
 Type 7402 Quad 2-Input Pos. NOR Gate. Low-noise Propagation delay, 12 ns. 29¢
 TR-432.
 Type 7404 Hex Inverter. Low noise, low power dissipation. 29¢
 TR-433.
 Type 7410 Triple 3-Input Pos. NAND Gate. Low output impedance, diode-clamped inputs. 29¢
 TR-434.
 Type 7447 BCD to 7-Seg. ment Decoder/Driver. With common anode displays. 59¢
 TR-435.
 Type 7473 Dual J-K Master/Slave Flip-Flop. 39¢
 TR-436.
 Type 7474 Dual D-Type Edge Triggered Flip-Flop. 39¢
 TR-438.
 Type 7475 4-Bit Latch. Temp. stores binary coded info. 79¢
 TR-437.
 Type 7490 Decade Counter. Binary coded decimal counter with symmetrical divide. 79¢
 TR-439.



59¢ Gallium phosphide. Large red, high quality LED. Wt. 1/4 lb.
 PL-233.

ORDER TODAY! Send to Olson Electronics, 260 S. Forge St., Akron, Ohio 44327. Allow for postage. C.O.D. 20% Deposit. Ohio Residents Add 4% Sales Tax.

FREE
Olson
Catalogs
 Next 7 Issues FREE!

Olson electronics
 Dept. 1H 260 S. Forge St., Akron, Ohio 44327

NAME _____
 ADDRESS _____
 CITY _____
 STATE _____ ZIP _____

INSTRUCTION

LEARN ELECTRONIC ORGAN SERVICING at home all makes including transistor. Experimental kit—trouble-shooting. Accredited NHSC. Free Booklet. NILES BRYANT SCHOOL, 3631 Stockton, Dept. A. Sacramento, Calif. 95820.

LEARN WHILE ASLEEP. Hypnotize! Strange catalog free. Auto-suggestion, Box 24-ZD, Olympia, Washington 98501. DEGREE IN ELECTRONICS through correspondence. Free catalog. Grantham, 2000 Stoner Avenue, Los Angeles, California 90025.

INTENSIVE 5 week course for Broadcast Engineers. F.C.C. First Class license. Radio Engineering Incorporated, 61 N. Pineapple Ave., Sarasota, Florida 33577 and 2402 Tidewater Trail, Fredericksburg, VA 22401.

F.C.C. EXAM MANUAL

PASS FCC EXAMS! Memorize, study — "Test Answers" for FCC 1st and 2nd class Radio-Telephone licenses. Newly revised multiple-choice questions and diagrams cover all areas tested in FCC exams plus "Self-Study Ability Test." \$8.95 postpaid. Money-back Guarantee.

COMMAND PRODUCTIONS
 RADIO ENGINEERING DIVISION P.O. BOX 26348-P
 SAN FRANCISCO, CALIF. 94126

SCORE high on F.C.C. Exams Over 300 questions and answers. Covers 3rd, 2nd, 1st and even Radar. Third and Second Test, \$14.50; First Class Test, \$15.00. All tests, \$26.50. R.E.I., Inc., Box 806, Sarasota, Fla. 33577.

UNIVERSITY DEGREES BY MAIL! Bachelors, Masters, Ph.D.'s. Free revealing details. Counseling, Box 1162-PE3, Tustin, California 92680.

SELF-STUDY CB RADIO REPAIR COURSE. THERE'S MONEY TO BE MADE REPAIRING CB RADIOS. This easy-to-learn course can prepare you for a career in electronics enabling you to earn as much as \$16.00 an hour in your spare time. For more information write: CB RADIO REPAIR COURSE, Dept. PE036, 531 N. Ann Arbor, Oklahoma City, Okla. 73127.

NO FCC LICENSE? Tried every way but the right way? It's time for Genn Tech. Home Study. Free Catalog, 5540 Hollywood Blvd., Los Angeles, Calif. 90028.

FCC LICENSE STUDY GUIDE—new, 377 pages, includes 1465 FCC-type questions, with answers and discussions, covering third, second, and first class radiotelephone exams. \$8.95 postpaid. GSE, 2000 Stoner Avenue, Los Angeles, Calif. 90025.

BROADCAST STATION — Start your own at home, school, church, business. Free details. Broadcast Development, Box 5516-AB, Walnut Creek, CA 94596.

LEARN Basic Digital Troubleshooting by correspondence. Information Free. Educational Technologies, Box 224, Reynoldsburg, Ohio 43068.

AMATEUR Radio. Complete no-textbook correspondence code and theory license courses. Ron Reed Electronics Institute, 12217 Santa Monica Blvd., Los Angeles, Calif. 90025.

LEARN TO BUILD AND TEST ELECTRONIC CIRCUITS FOR FUN AND PROFIT. Complete Details Free. Chapel Company, Box 482, Erie, Pennsylvania 16512.

PASS FCC EXAMINATIONS! 532 questions—answers cover First, Second, Third. Proven method. \$7.00, Guaranteed. Exams, Box 5516-AB, Walnut Creek, Calif. 94596.

BOOKS AND MAGAZINES

FREE book prophet Elijah coming before Christ. Wonderful bible evidence. Megiddo Mission, Dept. 64, 481 Thurston Rd., Rochester, N.Y. 14619.

POPULAR ELECTRONICS INDEXES. Detailed and complete subject indexes available to magazine years 1974, 1973, and 1972. Hundreds of subject references to help you quickly find that special project, article or product test. 1972, 1973 and 1974 editions \$1.50 each. All three editions only \$4.00. INDEX, Box 2228, Falls Church, Va. 22042.

FREE CATALOG. Aviation and Space Books. Aero Publishers, 329PE West Aviation, Fallbrook, California 92028.

THE AUDIO AMATEUR—A quarterly publication for the serious audio constructor. Free prospectus. The Audio Amateur, Box 176P, Peterborough, N.H. 03458.

MUSICAL INSTRUMENTS

UP TO 60% DISCOUNT. Name brand instruments catalog. Freepost Music, 455N Route 110, Melville, N.Y. 11746.

WHOLESALE! Professional Guitars, PA Systems, Attec Speakers, 240W RMS Amplifiers. Free Catalog, Carvin, Escondido, Calif. 92028.

30% TO 50% DISCOUNT! Guitars, Amps, Drums, Free Catalog! Warehouse PE-4, Box 11449, Ft. Worth, TX 76109.

ACE OF THE MONTH SPECIALS

ASCII COMPUTER KEYBOARDS



These keyboards were manufactured for use on Texas Instruments line of Silent 700 series data terminals. They are fully encoded with TTL large scale integrated circuits (T.I. TMS-5000 in 28 pin socket). Additional IC's provide a parallel 7 bit, without parity, code plus a strobe signal indicating "valid" data and six other independent outputs for those special keys which are not encoded. The keys are read type with a format similar to typewriter. Internal circuitry provides for two key rollover and de-bounce. Output is on standard 10 pin double readout connector for data and power input. And 8 pin double readout connector for six special switch functions.

KB-6: Clare/Pandar 720627-1 New - tested \$39.95
 T.I. Part number 959327-1 Used - tested \$29.95
 A 56 key ASCII encoded Alphanumeric keyboard with six extra switch closures to ground marked HERE IS, PAPER ADV., BREAK, REPEAT, TAPE-, TAPE-.

KB-7: Clare/Pandar 720731-1 New - tested \$49.95
 T.I. Part number 959326-1 Used - tested \$39.95
 This is a 64 key full ASCII encoded keyboard.

All keyboards supplied with wiring diagrams, code tables, and other useful documentation.

MOLEX I.C. PINS

100/51 1000/6.95



Kynar 30 AWG Blue
 1000 FT. SPOOL 9.95

74S201N

13 ns 256 Bit RAM
 Three-State Output
 Plug In Replacement
 SN74200 and SN74S200
 \$3.95 ea. 10 for \$25.00

TMS5000 ASCII
 keyboard encoder
 with data \$17.95

2N5449 50v 800 ma
 6/\$1.00 100 for 12.50

BISMUTH ALLOY.
 Melts in boiling water
 4 oz. ingot \$3.95
 1 lb. ingot \$9.95
 Fun to play with

DUAL POWER SUPPLY



1N914B
 100 for \$7.90
 LM301AH
 100 for \$39.95

The power supply consists of two independent adjustable regulator circuits and a common power transformer. The VOLTAGE ADJUST trimpot has range from 10 volts to 16 volts. The short circuit current is limited to 250 ma. Wired & Tested \$24.95

TERMS We pay postage, unless otherwise specified include check or money order, no COD Texas residents add 5% sales tax. TWX 910-881-2411



ELECTRONIC PARTS
 3303 Mangum Road
 Houston, Texas 77018

CIRCLE NO. 3 ON FREE INFORMATION CARD

EMPLOYMENT OPPORTUNITIES

ELECTRONICS/AVIONICS EMPLOYMENT OPPORTUNITIES. Report on jobs now open. Details FREE. Aviation Employment Information Service, Box 240E, Northport, New York 11768.

CALIFORNIA companies hiring Engineers and Technicians. Current openings bulletin \$3. Dynamics, Box 1867-K, Covina, Calif. 91722.

HYPNOTISM

SLEEP learning. Hypnotic method. 92% effective. Details free. ASR Foundation, Box 23429EG, Fort Lauderdale, Florida 33307.

FREE Hypnotism. Self-Hypnosis. Sleep Learning Catalog! Drawer H400, Ruidoso, New Mexico 88345.

AMAZING self-hypnosis record releases fantastic mental power. Instant results! Free trial. Write: Forum (AA3), 333 North Michigan, Chicago 60601.

ADVERTISERS INDEX

READER SERVICE NO.	ADVERTISER	PAGE NUMBER
1	A.E. Corp.	38
2	A.P. Products	99
3	Ace Electronics	118
60	Adva Electronics	119
	Alpha Electronics	83
7	Altaj Electronics	111
8	Ancrona Corp.	107
61	Antenna Specialists Co., The	81
66	Aries Inc.	117
63	B & K Products of Dynascan	1
	Bell & Howell Schools	22, 23, 24, 25
9	Beta Electronics	94
	Burstein-Applebee	92
	CREI Capitol Radio Engineering Institute	74, 75, 76, 77
	Cleveland Institute of Electronics, Inc.	84, 85, 86, 87
13	Cobra, Product of Dynascan	SECOND COVER
11	Continental Specialties Corporation	59
12	Crown	6
10	Della Electronics Co.	113
14	Delta Products, Inc.	79
15	Digi-Key Corporation	110
67	Drake Company, R.L.	61
16	EICO	73
65	Ebka Industries Inc.	18
17	Edmund Scientific Co.	106
18	Edmund Scientific Co.	120
19	Electronics Technical Institute	28, 29, 30, 31
20	Empire Scientific	50
	G.C. Electronics	63
22	Handic U.S.A. Inc.	14
6	Health Company	2
5	Health Company	47, 48
23	IMS Associates Inc.	15
24	IMS Associates Inc.	108
25	Illinois Audio	102
27	International Electronics Unlimited	112
28	James	114, 115
29	Johnson Co., E.F.	27
23	Labtronics Inc.	102
30	McIntosh Laboratory, Inc.	63
31	MITS	13
32	Martin Research	89
34	Mini-Micro Mart	108
	NRI Schools	8, 9, 10, 11
35	National Camera Supply	92
	National Technical Schools	64, 65, 66, 67
36	New-Tone	113
37	North Star Electronics Corporation	116
38	Olson Electronics	118
39	PAIA Electronics, Inc.	94
40	Pathcom Inc.	57
41	Phase Linear Corporation	97
42	Pickering & Co.	THIRD COVER
43	Poly Paks	105
44	Polymorphic Systems	102
	Processor Technology Co.	96
46	Radio Shack	7
47	SAE, Inc.	12
48	SBE, Inc.	19
49	S.D. Sales Co.	109
50	Sencore	38
51	Sinclair Radionics Inc.	34
52	Solid State Sales	117
53	Southwest Technical Products Corporation	5
64	Sphere Corporation	100
54	Stereo Discounters	101
	Surplus Center	108
	TEAC	21
55	Tri-Star Corporation	102
56	U.S. Pioneer Electronics	16, 17
4	United Audio Products	FOURTH COVER
57	Vector Electronics	98
58	Video Games	101
59	Wahl Clipper Corporation	101
62	Western Auto	93

CLASSIFIED ADVERTISING:

106, 108, 110, 112, 113, 116, 117, 118, 119

PRO SPORTS ACTION FILMS

IT'S OUR 21ST BIRTHDAY BUT YOU SAVE DOLLARS and buy year-long film entertainment! MARCH SPECIALS (Good until April 1, 1976): 1975 Indy "500", 200' Super 8 Color film, regularly \$19.95 — now \$17.75 each PPD. You save 75 cents on postage. NFL Football Follies, 200' Super 8 Eastman Color, \$17.75 each PPD — you save \$2.00 + postage. Saving Strokes with Sam Snead — 200' B&W Standard or Super 8, \$4.95 each PPD. Ten 35mm Color Slides to Better Golf (Larry Hinson) — including a regulation ball — packed in plastic case, \$2.95 each PPD, no limit — a \$4.95 value. Or make your own selection from our Columbia, Castle or Sportlite order forms — 50 cents. SPORTLITE, Elect-3, Box 24-500, Speedway, Indiana 46224.

BUSINESS OPPORTUNITIES

I MADE \$40,000.00 Year by Mailorder! Helped others make money! Free Proof. Torrey, Box 318-NN, Ypsilanti, Michigan 48197.

FREE CATALOGS. Repair air conditioning, refrigeration. Tools, supplies, full instructions. Doolin, 2016 Canton, Dallas, Texas 75201.

MAILORDER MILLIONAIRE helps beginners make \$500 weekly. Free report reveals secret plan! Executive (1K3), 333 North Michigan, Chicago 60601.

PIANO TUNING LEARNED QUICKLY AT HOME! Musical knowledge unnecessary. Free information. Empire School, Box 450327, Miami 33145.

\$200.00 DAILY In Your Mailbox! Your opportunity to do what mail-order experts do. Free details. Associates, Box 136-J, Holland, Michigan 49423.

FREE BOOK "2042 unique proven enterprises." Work home! Hayling-B, Carlsbad, CA 92008.

P-2

wanted Citizens Band
DEALER-DISTRIBUTORS

Send this ad with Letterhead to:

PAL ELECTRONICS CO.

2962 W. WELDON - PHOENIX, ARIZ. 85017

GET RICH with Secret Law that smashes debts and brings you \$500 to \$5 Million cash. Free report! Credit 4K3, 333 North Michigan, Chicago 60601.

HIGHLY PROFITABLE ONE-MAN ELECTRONIC FACTORY

Investment unnecessary, knowledge not required, sales handled by professionals. Postcard brings facts about this unusual opportunity. Write today! Barta-DC, Box 248, Walnut Creek, CA 94597.

FM RADIO STATION. Start your own. Fantastic income. Frequencies still available. Complete information. \$3.00. Concept, Box 106, Lawrence, N.Y. 11558.

ASIA DIRECTORY — WORLD PRODUCTS INFORMATION. Both just \$1.00. World Trade Inquiries, Box 6224, Spokane, Washington 99207.

\$178 WEEKLY. Work one hour daily. Completely Guaranteed. Free. FAS, Box 13703-R, San Antonio, Texas 78213.

HOW TO MAKE \$2,000 WEEKLY at home using other people's money. Guaranteed. Free details. Richlieu Reports, Box 25277-F, Houston, Texas 77005.

MISCELLANEOUS

WINEMAKERS: Free illustrated catalog yeasts, equipment. Semplex, Box 12276P, Minneapolis, Minn. 55412.

DISCOUNTERS of Stained Glass Supplies. Send \$1.00 for catalog. Nervo Distributors, 650 University Ave., Berkeley, CA 94710.

FREE! CONSUMER SERVICE DIVISION CATALOG

Includes a wide variety of products associated with the special interests of readers of Ziff-Davis magazines—Psychology Today, Popular Photography, Stereo Review, Popular Electronics, Boating, Flying, Car and Driver, Cycle, Skiing.

Send for your free catalog today.
Consumer Service Div., 595 Broadway, N.Y. N.Y. 10012

FREE DATA SHEETS WITH EVERY ITEM, IC or FET's WITH \$5 & \$10 ORDERS.*

- MONEY-BACK GUARANTEE
- 24-HOUR SHIPMENT
- ALL TESTED AND GUARANTEED

TRANSISTORS (NPN)	
2N918 TYPE RF Amp & Oscillator to 1 GHz	3/\$1.00
2N3563 TYPE RF Amp & Osc to 1 GHz (pl. 2N918)	5/\$1.00
2N3565 TYPE Gen. Purpose Gain (TO-92/106)	5/\$1.00
2N3641 TYPE RF & GP Amp & Sw to 500 mA & 30 MHz	5/\$1.00
2N3866 TYPE RF Power Amp 1.5 W @ 450 MHz	\$1.50
2N3903 TYPE GP Amp & Sw to 100 mA and 30 MHz	5/\$1.00
2N3904 TYPE GP Amp & Sw to 100 mA hFE 100	5/\$1.00
2N3919 TYPE RF Power Amp 10-25 W @ 3-30 MHz	\$3.00
2N4274 TYPE Ultra-High Speed Switch 12 ns	5/\$1.00
2N5108 TYPE RF Power Amp 2 W @ 450, 1 W @ 1 GHz	\$2.50
MPS6515 TYPE High-Gain Amplifier hFE 250	3/\$1.00
Assort. NPN GP TYPES, e.g. 2N3694, 2N3903, etc. (15)	\$2.00
2N3638 TYPE (PNP) GP Amp & Sw to 300 mA	5/\$1.00
2N3906 TYPE (PNP) GP Amp & Sw to 30 MHz	5/\$1.00
2N4249 TYPE (PNP) Low-Noise Amp 1µA to 50mA	4/\$1.00

FET's:	
N-CHANNEL (LOW-NOISE)	
2N4091 TYPE RF Amp & Switch (TO-18/106)	3/\$1.00
2N4416 TYPE RF Amplifier to 450 MHz (TO-72)	2/\$1.00
2N5163 TYPE Gen. Purpose Amp & Sw (TO-106)	3/\$1.00
2N5486 TYPE RF Amp to 450 MHz (plastic 2N4416)	2/\$1.00
E100 TYPE Low-Cost Audio Amplifier	4/\$1.00
ITE4868 TYPE Ultra-Low Noise Audio Amp	2/\$1.00
TIS74 TYPE High-Speed Switch 4052	3/\$1.00
Assort. RF & GP FET's, e.g. 2N5163, MPF102, etc. (8)	\$2.00
P-CHANNEL:	
2N4360 TYPE Gen. Purpose Amp & Sw (TO-106)	3/\$1.00
E175 TYPE High-Speed Switch 12552 (TO-106)	3/\$1.00

SPECIALS:	
2N2222 NPN TRANSISTOR GP Amp & Switch	6/\$1.00
2N2907 PNP TRANSISTOR GP Amp & Switch	6/\$1.00
2N3553 RF Power Amp 5 W @ 150 MHz, 7 W @ 50 MHz	\$2.00
E101 N-CHANNEL FET Low Current, Low Vp Amp/Sw	3/\$1.00
MPF102 N-CHANNEL FET RF Amp-200 MHz	3/\$1.00
556 DUAL 555 TIMER 1 µsec to 1 hour (DIP)	\$1.00
723 VOLT. REGULATOR 3-30 V @ 1-200 mA (OIP/TO-5)	2/\$1.00
741 Op Amp, Freq. Comp., LM 741, µA741, etc. (MINI-OIP)	4/\$1.00
2740 FET Op Amp, Like NE536 and µA740 (TO-5)	\$2.40
µA7805 VOLTAGE REGULATOR 5 V @ 1 A (TO-220)	\$1.25
8038 WAVEFORM GENERATOR 0-1 Wave v/ckts	\$4.50
1N4001 RECTIFIER 50 V PIV, 1A	15/\$1.00
1N4154 DIODE 30 V/10mA-1N914 except 30 V	25/\$1.00
BR1 BRIDGE RECTIFIER 50 V PIV, 500 mA (DIP)	3/\$1.00
MM5314 DIGITAL CLOCK CHIP-With Specs/Schematics	\$4.95

LINEAR IC's:	
308 Micro-Power Op Amp (TO-5/MINI-OIP)	\$1.00
309K Voltage Regulator 5 V @ 1 A (TO-3)	\$1.25
324 Quad 741 Op Amp, Compensated (OIP)	\$1.50
340T Volt. Reg.-1 Amp-Specify 5, 6, 12, 15 or 24 V-w/ckts	\$1.75
380 2.5 Watt Audio Amplifier 34 dB (OIP)	\$1.29
555 Timer 1 µs to 1 hr. NE555, LM555, etc. (MINI-OIP)	\$.65
709 Popular Op Amp (DIP/TO-5)	\$.29
739 Dual Low-Noise Audio Preamp/Op Amp (OIP)	\$1.00
1458 Dual 741 Op Amp (MINI-OIP)	\$.65
741 Freq. Comp. Op Amp (OIP/TO-5)	3/\$1.00

DIODES:	
ZENERS—Specify Voltage 3.3, 3.9, 4.3, 5.1, 6.8, 8.2	400mW 4/\$1.00
9.1, 10, 12, 15, 16, 18, 20, 22, 24, 27, or 33V (±10%)	1 Watt 3/\$1.00
1N914 or 1N4148 TYPE General Purpose 100V/10mA	15/\$1.00
1N3893 TYPE RECTIFIER Stud Mount 400 V/12 A	2/\$1.00
O5 VARACTOR 5-50 W Output @ 30-250 MHz, 7-70 pF	\$5.00
F7 VARACTOR 1-3 W Output @ 100-500 MHz, 5-30 pF	\$1.00

*MAIL NOW! FREE DATA SHEETS supplied with every item from this ad. FREE ON REQUEST—741 Op Amp with every order of \$5 or more—749 Dual Op Amp or two E100 FET's with every order of \$10 or more, postmarked prior to 4/30/76. One free item per order.

ORDER TODAY—All items subject to prior sale and prices subject to change without notice. All items are new surplus parts—100% functionally tested.

WRITE FOR FREE CATALOG #7510 offering over 350 semiconductor carriers in stock. Send 13¢ stamp.

TERMS: Send check or money order (U.S. funds) with order. We pay 1st Class postage to U.S., Canada and Mexico. \$1.00 handling charge on orders under \$10. Calif. residents add 6% sales tax. Foreign orders add postage. COD orders—add \$1.00 service charge.

ADVA ELECTRONICS
BOX 4181 BL, WOODSIDE, CA 94062
Tel. (415) 851-0455

CIRCLE NO. 60 ON FREE INFORMATION CARD

Retail Display Plan

All magazine retailers in the United States and Canada interested in earning an allowance for the display and sale of publications of the Ziff-Davis Publishing Company are invited to write for details. Sales Manager, Select Magazines, 229 Park Avenue South, New York, New York 10003.

LIVE IN THE WORLD OF TOMORROW... TODAY!

And our FREE 164 PAGE CATALOG is packed with exciting and unusual values in electronic, hobby and science items — plus 4,500 finds for fun, study or profit... for every member of the family.

A BETTER LIFE STARTS HERE

WORLD'S SMALLEST ELECTRONIC CALCULATOR!

Small but mighty! 8-digit, 4-function *electronic* calculator does everything big ones do—even has automatic % key... for only \$19.95. Take it anywhere. Fits in your pocket— $\frac{2}{3}$ size of cigarette pack. $\frac{3}{2}$ oz. dynamo features floating decimal, constant key, lead zero depression, more! Includes plug-in rechargeable Ni-Cad battery pack. $2 \times 3\frac{1}{2} \times 9\frac{1}{16}$ " with plenty of room for most fingers. Another Edmund first with advanced technology.



Stock No. 1945AV \$19.95 Ppd.

SUPER POWER FOR ANY RADIO

New antenna assist turns a tiny transistor into a tiger, has pulled in stations up to 1000+ miles away! Just set beside radio (no wires, clips, grounding) and fine-tune Select-A-Tenna's dial to same frequency — "gangbusters"! Great for clearing weak signals in radio depressed areas, off-coast islands, crowded frequency stations. Solid state—uses no electricity, batts., tubes.



Stock No. 72,095AV \$15.95 Ppd.
ULTRA SELECT-A-TENNA
No. 72,147AV ("OVER 1000 MI.") \$22.95 Ppd.

50-150-300 POWER MICROSCOPE

Amazing Value—3 Achromatic Objective Lenses on Revolving Turret! Color-corrected, cemented achromatic lenses in objectives give far superior results to single lenses usually found in this microscope price range. Results are worth the difference! Fine rack and pinion focusing. Imported!



Stock No. 70,008AV \$45.00 Ppd.
MOUNTED 500 POWER OBJECTIVE:
Threaded achromatic lenses, 3mm F.L.
Stock No. 30,197AV \$9.75 Ppd.

SEE MUSIC IN PULSATING COLOR

New 3-Channel Color Organ adds to music listening pleasure, lets you modulate 3 independent strings of colored lamps with intensity of your music to create an audio "light show." They flash, vary in brightness related to music's rhythm, pitch, volume—pulsating lighting performance to music! Fully assembled & priced half that of others, the Edmund Sound to Light Control is a terrific value. Plug in, turn on!

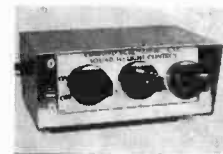

No. 42,309AV... (ASSEMBLED) \$17.95 Ppd.
No. 42,336AV... (UNASSEMBLED) \$13.95 Ppd.

WHEN YOU COME TO PHILADELPHIA BE SURE TO SEE
FREE BICENTENNIAL LIGHT SHOW
IN BARRINGTON, N.J. ONLY 10 MINUTES AWAY AT
EDMUND FACTORY STORE

PLUG IN 200,000 CANDLEPOWER!

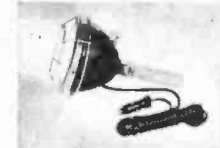

Powerful 12v emergency light projects big straight beam *visible for 2 miles*. Plugs into car's cigarette lighter; only $3\frac{1}{2}$ lbs. Great for motorists, outdoorsmen, emergency crews, security men, campers. Super bright 200,000 candlepower G.E. aircraft landing light in a

rugged weatherproof steel housing with baked enamel finish, steel lens grate, polished chrome-plated reflector, on/off switch. 15 ft. extension cord; $6\frac{1}{8}$ dia. x $11\frac{1}{8}$ ". Keep it handy!

Stock No. 72,093 AV \$22.95 Ppd.

CAN'T SLEEP, RELAX? TRY THIS!

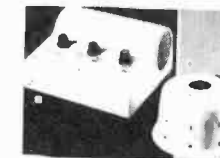

Electronic sound conditioner simulates 4 kinds of soothing sounds of ocean surf and rain. "White sound" helps mask unwanted noise, adds restful, intriguing background sound. Program the solid-state unit to your own need: 2 surf, 2 rain, or "white sound", proven by medical tests to have analgesic effects. Great for meditation, restlessness, sleeplessness psychology.

(A)-No. 71,997AV... ($7\frac{1}{2} \times 7 \times 3\frac{1}{2}$ ") 110V AC \$89.95 Ppd.

(B)-AS ABOVE, BUT "WHITE SOUND" ONLY
No. 71,980AV... ($6" \text{ Rd.} \times 3\frac{1}{2}" \text{ Hi}$) \$28.00 Ppd.

KNOW YOUR ALPHA FROM THETA!



For greater relaxation, concentration, listen to your Alpha-Theta brainwaves. Ultra-sensitive electrode headband slips on/off in seconds—eliminates need for messy creams, etc. Atch'd to amplifier, filters brainwaves, signals beep for ea. Alpha or Theta wave passed. Monitoring button stimulates Alpha sound; audio & visual

(L.E.D.) feedback. Reliable, easy-to-use unit comparable to costlier models. Completely safe. Comprehensive instruction booklet.

No. 1635AV ($8 \times 3 \times 4"$; 24 oz.) \$149.50 Ppd.

DELUXE "ON" TIME MONITOR—Measures and records %
No. 1652AV... ($15 \times 10 \times 6"$) \$299.50 Ppd.

No. 71809AV LOW COST "STARTER" UNIT \$55.00 Ppd.

DO-IT-YOURSELF KIT No. 61,069AV \$34.95 Ppd.

LOW COST 7X INFRA-RED VIEWER



For infra-red crime detection surveillance, security system alignment, I.R. detection, laser checking, nite wildlife study, any work req. I.R. detection & conv. to visible spectrum. Self cont. scope w/everything incl I.R. light source.

6v or 12v power, 6032 I.R. converter tube, f/4.5 objective lens, adjust. triplet eyepiece. Focuses from 10' to infinity.

No. 1659AV ($11 \times 14\frac{1}{4} \times 3"$) \$285.00 Ppd.

WITHOUT LIGHT SOURCE
No. 1663AV \$225.00 Ppd.

SOLAR CELL CONCENTRATOR PANEL



World's first! Takes up to 10 suns... without burning out (normal ones can't use over 3)! Specially designed panel (four 2×2 cm super cells) delivers .125 amps @ 1.5V w/1 sun; over 1 amp @ 1.5V w/ten! Requires concentration system (build

Crab Eye or mount on std. telescope drive.) Water-cooled, so it's also a hot water generator. Detailed instructions incl.

No. 61,103AV... ($6 \times 2 \times \frac{3}{4}"$) \$175.00 Ppd.

LARGE CONCENTRATION PANEL ($19 \times 2 \times \frac{3}{4}"$)
No. 72, 195AV... (30 CELLS; 15w) \$575.00 Ppd.



MAIL COUPON FOR GIANT FREE CATALOG!

164 PAGES • MORE THAN 4500 UNUSUAL BARGAINS

Completely new 1976 edition. New items, categories, illustrations. Dozens of electrical and electromagnetic parts, accessories. Enormous selection of Astronomical Telescopes. Unique lighting and ecological items. Microscopes, Binoculars, Magnifiers, Magnets, Lenses, Prisms. Hard-to-get-surplus bargains. Ingenious scientific tools. 1000's of components.

EDMUND SCIENTIFIC CO.
300 Edscorp Building, Barrington, N. J. 08007
Please rush Free Giant Catalog "AV"

Name, _____
Address _____
City _____ State _____ Zip _____

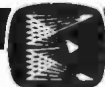

COMPLETE & MAIL WITH CHECK OR M.O.

EDMUND SCIENTIFIC CO. 300 Edscorp Building, Barrington, N.J. 08007

How Many	Stock No.	Description	Price Each	Total
<input type="checkbox"/>		PLEASE SEND GIANT FREE CATALOG "AV"		
<input type="checkbox"/>		Charge my BankAmericard		
<input type="checkbox"/>		Charge my Master Charge		

Interbank No. _____ Add Handling Chg.: \$1.00, Orders Under \$5.00, 50¢, Orders Over \$5.00

My Card No. is _____ I enclose check money order for TOTAL \$ _____

Signature _____

Card Expiration Date _____

30-DAY MONEY-BACK GUARANTEE. Name _____
You must be satisfied or return any purchase in 30 days for full refund. *\$15.00 minimum Address _____
City _____ State _____ Zip _____

Pick-A-Pickering



It's the least expensive way to make the greatest improvement in the sound of your system

Here it is. The easy and inexpensive way to upgrade the sound of your entire hi fi system. Simply add a Pickering cartridge. Know why a good cartridge will make such a difference in sound? Because the cartridge and stylus have *first contact* with the music on your record. It's your *cartridge* that picks up the highest highs and the lowest lows in your record grooves. Not by plodding along, round and round, but by performing an incredibly quick dance between the two small groove walls. Too quickly for your eye to see, but not for your ear to hear. **No matter how much you sink into the rest of your equipment, a poor quality cartridge can murder the sound — bend the record grooves out of shape and blur the music.**

But not Pickering cartridges. They have a feathery touch we call *tracAbility™*. A touch that lightly covers the whole range of musical tones on your record — giving you the type of sound you want to hear.

Upgrade your entire hi fi system the easy way, the inexpensive way. Just pick a Pickering cartridge, and you'll hear the difference.

For further information write to
Pickering & Co., Inc. Dept. PE,
101 Sunnyside Blvd., Plainview,
New York 11803

 **PICKERING**

"for those who can **hear** the difference"



The Dual 1249.

**It will give you
more reasons than ever
to own a Dual.**

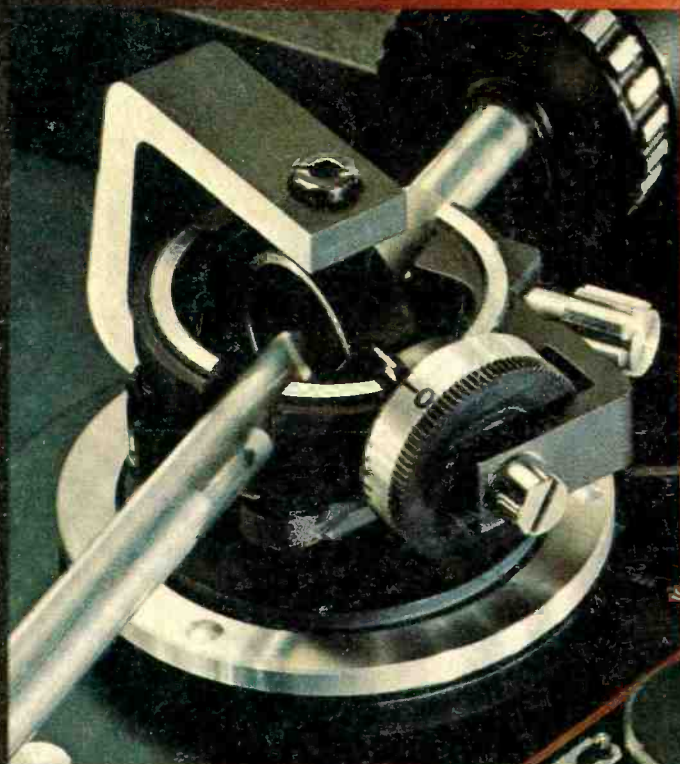

Tonearm of Dual 1249 pivots in four-point gyrosopic gimbal, suspended within a rigid frame. Each gimbal is hand-assembled, and special gauges assure that each will conform to Dual's stringent specifications.

For several years, independent surveys of component owners—audio experts, hifi editors, record reviewers, readers of the music/equipment magazines—have shown that more of them own Duals than any other turntable. This is quite a testimonial to Dual's quality performance, reliability and fully automatic convenience.

We believe the new 1249 will add even more serious music lovers to the roster of Dual owners, as it provides every feature, innovation and refinement long associated with Dual turntables plus some new ones. And all in a newly designed chassis that complements the superb design and meticulous engineering of the 1249.

The low-mass tubular tonearm pivots in a true four-point gyrosopic gimbal suspended within a rigid frame. All tonearm settings are easily made to the exacting requirements of the finest cartridges. The tonearm is vernier-adjustable for precise balance; tracking pressure is calibrated in tenths of a gram; anti-skating is separately calibrated for conical, elliptical and CD-4 styli.

Tracking is flawless at pressures as low as a quarter of a gram. In single-play, the tonearm parallels the record to provide perfect vertical tracking. In multi-play, the Mode Selector lifts the entire tonearm to parallel the center of the stack.

All operations are completely flexible and convenient—and they are foolproof. The tonearm can be set on the record manually or by using the viscous-damped cue-control or by simply pressing the automatic switch. You also have the options of single-play, continuous-repeat, or multiple-play.

The dynamically-balanced cast platter and flywheel are driven by an 8-pole synchronous motor via a precision-ground belt. Pitch is variable over a 6% range and can be conveniently set to exact speed by means of an illuminated strobe, read directly off the rim of the platter.

Of course, if you already own a current Dual, you won't really need a new turntable for several years. However, we would understand if you now feel you must have nothing less than the new 1249. Less than \$280, less base.

Still, we should advise you of two other models in our full-size, belt-drive series. The 601, single-play, fully automatic, less than \$250. (CS601, with base and cover, less than \$270.) The 510, single-play, semi-automatic, less than \$200.



United Audio Products, 120 So. Columbus Ave., Mt. Vernon, N.Y. 10553
Exclusive U.S. Distribution Agency for Dual

Dual[®]