

THE PROFESSIONAL MAGAZINE FOR ELECTRONICS AND COMPUTER SERVICING

# ELECTRONIC<sup>T.M.</sup>

Servicing & Technology

January 1997

Steps for PC preventative maintenance

Understanding comb filters

## Diagnostics software

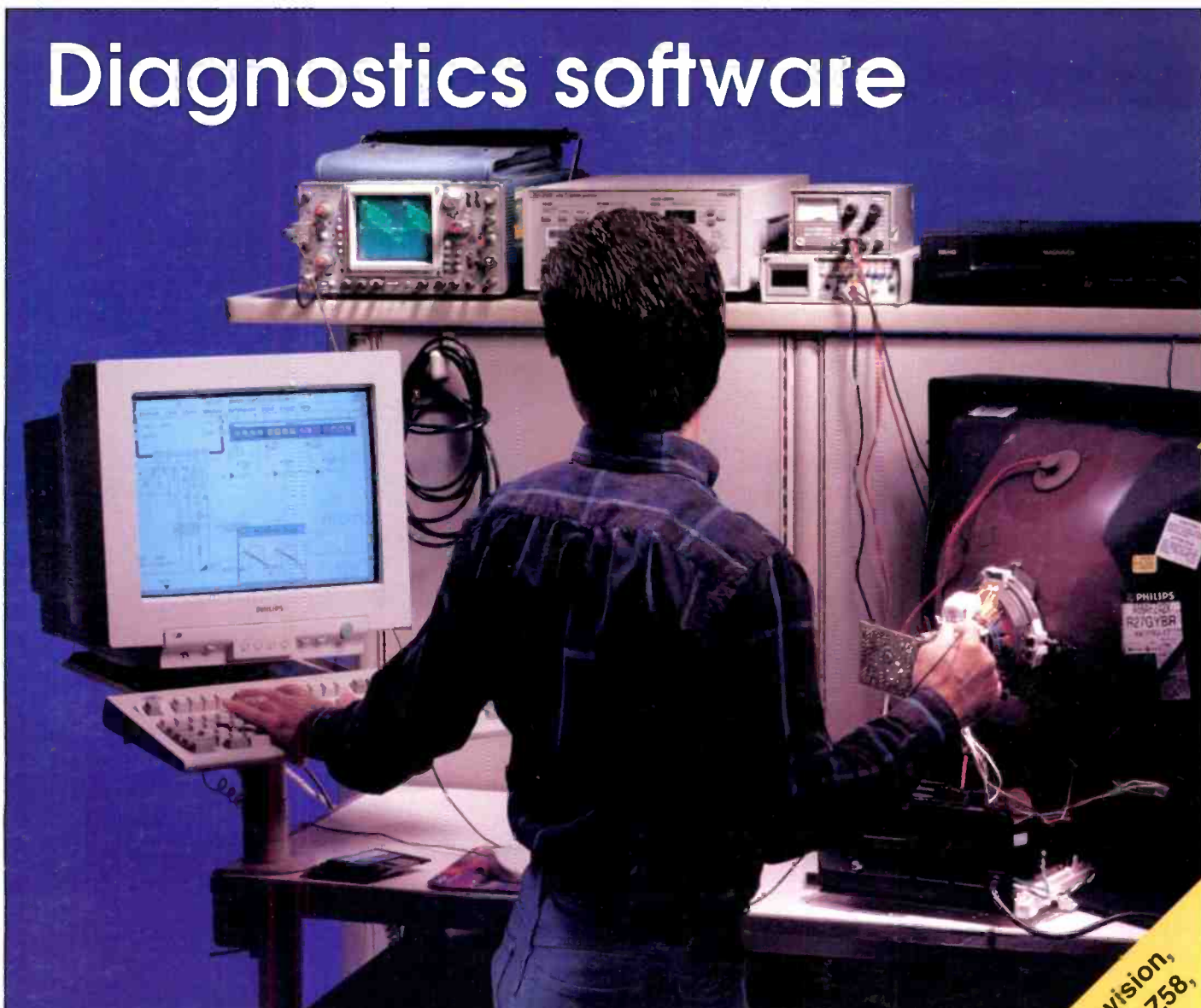

U.S. \$3.00



Hitachi color television,  
Models 35UX80B/CZ58,  
35UX70B/CZ57



Philips announces the end of manual labor.



Introducing **Force™**, the easy-to-use software that replaces all those service manuals cluttering up your shop. Now you can enjoy instant access to any Force-compatible manual. Once loaded, all the information you need is at your fingertips: drawings, adjustments, parts lists and printed circuit board layouts. For more information, call 1-423-475-0480, and put your old manuals in their proper place.

*Let's make things better.*



**PHILIPS**

© 1996 Philips Electronics North America Corporation

Circle (117) on Reply Card



# WANTED



**\$250**  
per head  
**Reward**

**We Are Putting A Price On Your Heads**

All you have to do is purchase any *SK Series* video head between January 1 and March 31, 1997, fill out a redemption form and send it in along with the numbered box top and your invoice. Simple as that. Some restrictions apply. Void where prohibited by law.

See your participating authorized  
Thomson Consumer Electronics  
distributor for details.



Circle (113) on Reply Card

# ELECTRONIC

Servicing & Technology

Volume 17, No. 1 January 1997

## Contents

### FEATURES

- 10 Steps for PC preventative maintenance**  
*By Stephen J. Bigelow*  
This article is intended to give PC owners a way to keep their system running trouble free, and technicians a sound procedure on which to base preventative maintenance service.
- 14 Diagnostics software**  
*By The ES&T Staff*  
This article provides information on how to use diagnostic software when working with PCs. It also includes a list of software manufacturers.
- 20 Understanding comb filters**  
*By Steven Jay Babbert*  
Comb filters are generally reliable, but like any component they can fail. This article will help you understand comb filters and make them easier to troubleshoot.
- 24 Servicing TV relay problems**  
*By Homer Davidson*  
There are many problems that can occur when a set has relay problems. A description of these problems and ways to troubleshoot them can be found in this article.

### DEPARTMENTS

- 4 Editorial**
- 5 News**
- 7 Literature**
- 8 Products**
- 22 Test Your Electronics Knowledge**
- 29 Profax**
- 41 Photofact**
- 41 Calendar of Events**
- 42 What Do You Know About Electronics?**  
What is true and what is false?
- 45 Books**
- 62 Classified/Reader's Exchange**
- 64 Advertisers' Index**

### Editorial Index

- ES&T presents its annual article, department, and Profax schematics 1996 indexes
- 49 Department Index**
  - 50 Article Index**
  - 52 Profax Index**

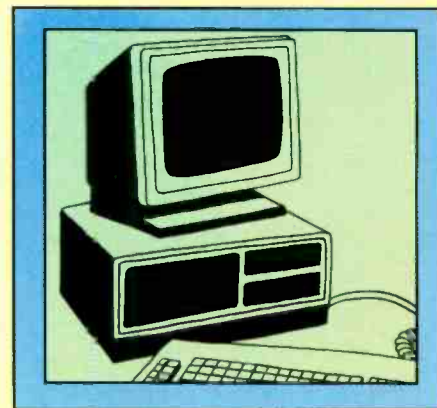

page 10

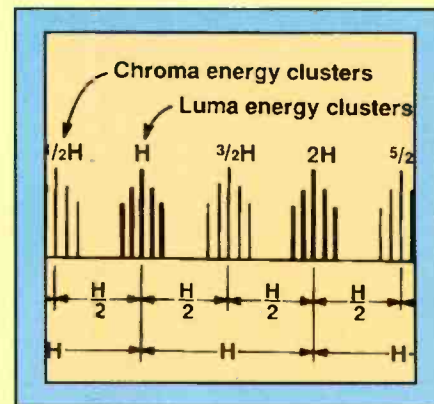

page 20

### ON THE COVER

Diagnostic software comes in a number of flavors. There's the software that's run in the computer to detect problems in the computer hardware or software. Then there is the software that contains reference information that the technician can use to diagnose problems in any product covered. Here's a little of both. (Photo courtesy Philips Software Development)

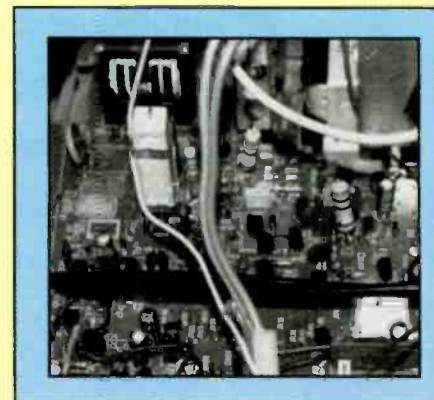

page 24



# THE POWER AND THE GLORY

UP TO 10A OF PURE CLEAN DC

LOW PRICE AND MADE IN USA



## NOW AND FOREVER

The power to perform virtually any electronic repair is yours with these easy-to-use, rugged, reliable DC power supplies from B+K. These compact units are cool running and fully protected for ultrasafe use. All are **MADE IN THE USA\*** and backed by B+K's **2 YEAR WARRANTY**. Technical telephone support is available. Call B+K if you have special requirements.

**More purchasing power!** These competitively priced units are in stock for immediate delivery from a nationwide network of distributors. Available exclusively from B+K Precision. . . leading supplier of test instruments and power supplies to the electronic servicing industry.

Output	Meter Type/No.	No. of Outputs	Load Reg.	Line Reg.	Ripple mV	Model Number	User Price
30V, 1A	Analog/2	1	0.01%	0.01%	1mV	1710	\$229
30V, 1A	Digital/2	1	0.01%	0.01%	1mV	1705	\$299
60V, 2A	Analog/2	1	0.01%	0.01%	1mV	1711	\$309
60V, 2A	Digital/2	1	0.01%	0.01%	1mV	1715	\$379
30V, 3A	Analog/2	1	0.01%	0.01%	1mV	1730	\$315
30V, 3A	Digital/2	1	0.01%	0.01%	1mV	1735	\$380
60V, 4A	Analog/2	1	0.04%	0.2%	1mV	1740	\$499
35V, 6A	Digital/2	1	0.04%	0.2%	1mV	1743	\$499
16V, 10A	Analog/2	1	0.04%	0.2%	1mV	1746	\$499
30V, 2A 5V, 5A	Digital/2	3	0.01%	0.01%	1mV	1760	\$649



**BK PRECISION**  
MAXTEC INTERNATIONAL CORP.

6470 W. Cortland, Chicago, IL 60635  
Phone: (312) 889-1448 Fax: (312) 794-9740

\*Manufactured in USA from domestic and imported parts.

Circle (119) on Reply Card

# Thanks for the feedback

**F**eedback is an important phenomenon. Without feedback, it's difficult to know if you are where you want to be. For example, have you ever heard someone singing along with music coming from earphones, with the volume turned up so loud that he can't hear himself. The effect is hilarious, the person sings at the top of his lungs, totally off key. Without being able to hear his own voice feeding back to his ear, he has no idea what he is singing, so it sounds terrible.

The same general effect occurs any time feedback is lost in a system that depends on feedback. The output wanders from the desired value, but without feedback, there's nothing to tell the system that adjustment is needed.

Even magazines need feedback. If the editors of the magazine aren't tuned in to the needs of readers, the output of the magazine may cease to be in sync with the information needs of the readers. The result is that the magazine loses its value to readers.

And keeping a magazine such as this one on track is already quite a challenge. Even though readers of **ES&T** have in common the fact that they all service consumer electronics products, different service centers place emphasis on different aspects of the business.

For example, some service centers concentrate almost exclusively on TV service, while others service mainly VCRs or microwave ovens. Some service centers today service personal computers and peripherals almost exclusively.

Further complicating the situation, different technicians may take very different approaches to the same task. Some technicians, especially those who have been through technical school may perform much of their service by observing symptoms, comparing their observations with the knowledge that they have developed through study, and in that manner arrive at a diagnosis.

Other technicians may prefer to rely on troubleshooting tips developed by themselves and others in the service center, or from the manufacturer, or another service center that has made a business selling tips that they have developed.

Because of this considerable diversity among our readers, we try to remain aware of their information needs by attending meetings, contacting service centers via mail, telephone and e-mail. We also conduct surveys in the magazine every month. The information we derive from these sources helps us stay on track and make sure that the articles that we publish are useful and informative.

We appreciate the fact that readers take the time to fill out these survey cards, and we know that many readers are interested in the results of these surveys. Here are the results of one such survey.

## **ES&T readers and the internet**

In June of 1996, we included a survey form in the magazine that solicited information from readers about their use of computers, the internet and e-mail. Once again a caveat is in order. The results of surveys such as this are not statistically relevant. We cannot say, for example, that because 90 out of 100 respondents to this survey answered the question in a certain way, then we can be confident that this applies to 90 percent of all readers. For one thing, the people who answered the survey selected themselves, so it is not a statistically valid sample. Furthermore, the sample is too small in any event.

Still, the survey tells us about those who responded, and combined with information gleaned in other ways suggests that a significant and growing number of service centers own computers and use them to connect to the internet, send and receive e-mail, and some have constructed their own websites.

In particular, of the 111 respondents to the survey, 10 told us that they do not own

computers at all, while 101 do own computers. Of the 101 respondents who own computers, nearly 60 are connected in one way or another to the internet. Slightly more than 40 respondents use their computers to send and receive e-mail. Very interesting was the fact that fourteen of these service centers report that they have a website on the internet.

We have learned from other means that many manufacturers and distributors have websites and that some service centers use these sites to learn about the products those companies offer, and even to order such things as replacement parts.

The computer and the internet are changing the way companies and other organizations do business. Here are just a few examples. You can now track your Federal Express packages via the internet. EIA has a setup on the internet so that anyone contacting the site can access a list of CES conferences, exhibitors and hotels. Individuals who plan to attend can even register on line.

Here at **ES&T** we have received articles via e-mail, and we regularly send material such as articles and even artwork back and forth electronically.

Please be assured that **ES&T** is not going to turn into a computer magazine, or an internet magazine. However, we do plan to remain abreast of, and report on, technology and the products of technology that one way or another affect consumer electronics service centers. At the moment, computers and the internet are having a profound effect on service centers, and we plan to provide as much useful information on those areas as we can.

Thanks again to those readers who took the time to fill out reader surveys on this subject, and for helping us keep this magazine on track and in tune.

*Nile Conrad Penam*



## Home systems in the spotlight at the 1997 winter CES

The neon lights of Las Vegas will be shining on the fast-growing home systems industry at the 1997 International Winter Consumer Electronics Show (CES), January 9-12, 1997. Home systems exhibits will be placed alongside home theater and multi-room entertainment exhibits at the Las Vegas Hilton, one of the four CES facilities—the Las Vegas Convention Center (LVCC), Sands Expo and Convention Center, and the Alexis Park Hotel are the others. Some home control products will be displayed at the Las Vegas Convention Center.

Show management—the Consumer Electronics Manufacturers Association (CEMA)—expects to attract over 80,000 attendees to Winter CES, making it the world's largest event showcasing consumer electronics products, including integrated home systems technology. Currently, the square footage of home systems exhibits at the 1997 Winter CES is double that of the '96 Show.

"For suppliers of home controls and services, Winter CES will offer a targeted audience of tens of thousands of installers, integrators, contractors, and retailers," said Robbi Lycett, Winter CES Show Director. "This year at the Hilton, CES is promoting the growing synergy of custom home theater products into integrated home systems by providing a one-stop venue to see these fast-growing products and services."

Independent research indicates that 55 percent of polled 1996 Winter CES attendees are interested in home systems products and services.

### Exhibitors enthusiastic for CES

"We are excited to show the new RCA Home Control at Winter CES," said Jack Nick, Vice President, Accessories & Component Business at Thomson Consumer Electronics. "Our home control product, operated by a standard universal remote control, starts at only \$49 and can control consumer electronics products in the home, in addition to other electrical products. By bringing the benefits of home control to the mass market, this product will help grow the entire home

control industry, and I expect the Consumer Electronics Show attendees will heartily embrace this concept."

Will West, President of PHAST added, "Winter CES will enable us to build excitement around our products—a full line of hardware and software which makes high-end automation truly practical. This is an essential show for us because CES is a key place for all our dealers to check out the latest in consumer electronics."

Attendees at the 1997 Winter CES will see some new companies on the exhibit floor. Among the first-time CES exhibitors are: AMP, AVSI, Dancraft Enterprises, Diablo Research, IES Technologies, Lutron Electronics, and PHAST.

### Conference program

CES is offering an extensive seminar program for 1997 Winter CES attendees, including a home systems track and home theater track.

- Home systems\*
  - Sources of Recurring Revenue
  - Consumer Trends in Home Systems
  - Home Systems Standards—Reality Check
    - An Incremental Approach: Selling Islands of Automation and Integration to Consumers
    - Working With Home Builders to Pre-Sell Systems
    - The Ultimate Integrator: A Winning Company Profile for the 21st Century
- Home Theater
  - How to Sell Home Theater
  - Home Theater Upgrade: Selling 5.1 Channel Audio
    - A New Customer: Working with Interior Designers
    - So You Want to Become A Custom Installer

\* The Home Systems track consists of six paid sessions for \$125, or \$30/session.

Lycett concluded, "We see home and building control as one of the fastest-growing segments of our industry. CES' commitment to this product category can be seen in the significant jump in exhibit space alongside home theater products, a comprehensive seminar track, and a major effort to attract system designers, installers, integrators, and retailers. Win-

ter CES has become an invaluable showcase for the home systems industry."

### Standard assures Americans free digital TV

In their reply comments of High Definition Television (HDTV) filed with the Federal Communications Commission (FCC) on August 12, 1996, the Electronic Industries Association (EIA) and its Advanced Television (ATV) Committee again advised the FCC to adopt the standard recommended by the Advanced Television System Committee and Consumer Electronics Manufacturers Association (CEMA) consider the adoption of the standard as critical for the success of FREE over-the-air digital television.

"Without a standard, digital picture quality, digital sound quality and digital data opportunities would be left only to fee-based service providers such as cable operators," said EIA President Peter F. McCloskey. "The industries such as PCS, cellular, DBS and MMDS that a small minority of companies used in their filings as examples of why a standard should not be set are all fee-based industries. The consumer must pay to receive any of those services. If the Commission wants to make sure that all Americans—not just 65 percent with cable services—have access to digital television, it must recognize that a standard is vital."

Television is an established, nationwide free service that most Americans rely on as a primary source of information. Preserving this national asset, while replacing the underlying technologies, requires clear national direction. The consequences of attempting to advance a new broadcast technology without uniform transmission standards can be seen by the failure of AM stereo. The Commission's decision to authorize competing AM stereo standards led to the widespread marketplace confusion.

Designed and developed by a myriad of industries and interested parties for more than a decade, the ATSC DTV standard is extraordinarily flexible and invites innovation and competition. The majority of commenting parties, including the National Telecommunications

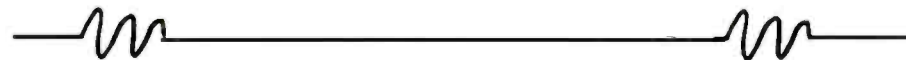

and Information Administration, consumer groups, unions, and members of the broadcasting, consumer electronics and motion picture industries, agree that the ATSC standard provides for interoperability with computers and alternative distribution media.

The concerns of the computer and movie industries were addressed during the consultative process that led to the adoption of the ATSC DTV standard. In fact, the computer industry's participation in the ATSC development process resulted in a standard that is primarily composed of progressive scan formats. Fourteen of the 18 Digital TV formats are progressive scan. The other four formats use interlace technology for the broadcast environment.

In regards to the aspect ratio for DTV, the ATSC format uses a 16:9 aspect ratio as supported by the Motion Picture Association of America (MPAA) and the Society of Motion Picture and Television Engineers (SMPTE). Cinematographers currently use a wide variety of aspect ratios, as a consequence, no single aspect ratio would be ideal for the display of all motion pictures. The 16:9 ratio was chosen because it can accommodate the variety of widescreen film formats as well as 4:3 film and video archival materials. Moreover, the 16:9 aspect ratio is now the preferred global format, having been endorsed by the international standards bodies in Europe and Japan.

By contrast, a receiver that supports a 2:1 aspect ratio (as favored by a minute minority of parties) may weigh 30-50 percent more and require a 12.5 percent larger tube size than a 16:9 set of the same picture height. The additional weight and screen-size required by a 2:1 aspect ratio would make such a receiver significantly more costly. Plus, a 2:1 aspect ratio would actually reduce DTV and computer interoperability because such an aspect ratio is not defined in the Video Electronics Standards Association Extended Display Identification Standard.

If the Commission wishes, as it has indicated repeatedly during the past decade, that DTV be available to consumers free and over-the-air, it must support a single standard. The ATSC standard will allow consumers to purchase TV receivers with

confidence that the receiver will operate as expected no matter where it is used in the United States. A single standard promotes familiarity with a product, facilitates ease of use, and gives consumers confidence in the longevity of their purchases. The ATSC standard is the United States answer for digital television. From P.S. Connections, October 1996 Volume 1, Number 4. A quarterly newsletter produced by the CEMA Product Services Department.

### Winter CES registration goes on-line

For the nearly 100,000 attendees that are expected at the 1997 International Winter Consumer Electronics Show (CES), registering can now be done on-line via the CES home page on the World Wide Web (<http://www.eia.org/CEMA>). Winter CES is the world's largest annual trade show for the broad-based consumer electronics market. The premier event, to be held January 9-12 in Las Vegas, is expected to attract retail buyers, distributors, manufacturers, financial and market analysts, importers/exporters and journalists who are anxious to find out what's hot in the consumer electronics market. The Consumer Electronics Manufacturers Association (CEMA), the sponsors and producers of Winter CES, have added this electronic method of registration to help save time and paper, and reduce errors in the registration process.

"Previously, attendees had the option to register by mail or by fax. Now they can register on the CEMA web site and help expedite the whole process," said Rob Lycett, group show director. "This is the first time we've offered registration for Winter CES on our web site, and if our attendees utilize this service, we will offer on-line registration for all of our shows."

Once an attendee enters the CES registration site, they will be asked to answer a few profile questions. They will then be provided with a registration form that they fill out and return electronically.

"In addition to registering for Winter CES, visitors to the CEMA/CES web site can find information on other CES events, press releases, conference schedules, exhibitor lists, membership information, consumer electronic product information and much, much more," said Lycett. ■

THE PROFESSIONAL MAGAZINE FOR ELECTRONICS AND COMPUTER SERVICING

# ELECTRONIC

Servicing & Technology

**Electronic Servicing & Technology** is edited for servicing professionals who service consumer electronics equipment. This includes service technicians, field service personnel and avid servicing enthusiasts who repair and maintain audio, video, computer and other consumer electronics equipment.

### EDITORIAL

Nils Conrad Persson, *Editor*  
(Internet e-mail: [cpersedit@aol.com](mailto:cpersedit@aol.com))  
Kirstie A. Wickham, *Associate Editor*  
(Internet e-mail: [kirstieest@aol.com](mailto:kirstieest@aol.com))  
Richard S. Moseson, NW2L, *On-Line Coordinator*

### CONSULTING EDITORS

Homer L. Davidson, *TV Servicing Consultant*  
Victor Meeldijk, *Components Consultant*  
John E. Shepler, *Audio Consultant*  
Sam Wilson, *Electronics Theory Consultant*

### PRODUCTION

Elizabeth Ryan, *Art Director*  
Barbara McGowan, *Associate Art Director*  
Edmond Pesonen, *Electronic Composition Mgr.*  
Dorothy Kehrlied, *Production Manager*  
Emily Kreutz, *Assistant Production Manager*  
Pat Le Blanc, *Phototypographer*

### BUSINESS

Richard A. Ross, *Publisher*  
Diane G. Klusner, *Associate Publisher*  
(Internet e-mail: [dianekest@aol.com](mailto:dianekest@aol.com))  
John Dorr, *General Manager*  
Frank V. Fuzia, *Controller*  
Simon Schatzmann, *Circulation Director*  
Catherine Ross, *Circulation Manager*  
Melissa Nitschke, *Operations Manager*  
Jean Sawchuk, *Data Processing*  
Denise Pyne, *Customer Service*

### SALES OFFICE

Electronic Servicing & Technology  
76 N. Broadway, Hicksville, NY 11801  
516-681-2922; FAX 516-681-2926

Diane G. Klusner, *Director of Advertising*  
Emily Kreutz, *Sales Assistant*

### EDITORIAL CORRESPONDENCE:

P.O. Box 12487  
Overland Park, KS 66212  
913-492-4857



Electronic Servicing & Technology (ISSN 0278-9922) is published 13 times a year by CQ Communications, Inc. 76 N. Broadway, Hicksville, NY 11801. Telephone (516) 681-2922. Periodical class postage paid at Hicksville, NY and additional offices.

Printed in the United States of America.

Postmaster: Please send change of address notice to Electronic Servicing & Technology, 76 N. Broadway, Hicksville, NY 11801.

Statement of Ownership, Management and Circulation 10-10-96, Electronic Servicing & Technology, 76 North Broadway, Hicksville, NY 11801.

Publication # 02789922, Issued 13 times a year, subscription price \$24.75 per year. Publisher: Richard A. Ross, Editor: Nils Conrad Persson, owned by CQ Communications Inc. Stockholders: Richard A. Ross, Alan M. Dorhoffer, Thomas Kniel, Arthur S. Salsberg. Circulation (Average of 12 Preceding Months): Net Press Run 22,436. Sales Through Dealers and News Agents 1,330, Mail Subscriptions 19,405, Total Paid 20,735, Free Distribution 544, Total Distribution 21,279, Copies not Distributed 871, Returns from News Agents 288, Total 22,436. Circulation (Single Issue Nearest Filing): Net Press Run 21,438, Sales Through Dealers and News Agents 1,164, Mail Subscriptions 18,684, Total Paid 19,848, Free Distribution 538, Total Distribution 20,386, Copies not Distributed 572, Returns from News Agents 480, Total 21,438. s./Simon Schatzmann, Circulation Director.



**GLOBAL SPECIALTIES**  
Innovative Products Short Form Catalog

<p><b>GSA 1000</b></p>  <p><b>Spectrum Analyzer Scope Adapter</b></p> <ul style="list-style-type: none"> <li>Converts any oscilloscope into an accurate, cost effective spectrum analyzer</li> <li>400kHz to 1000MHz frequency range</li> <li>250kHz bandwidth, variable scan width &amp; scan speed</li> <li>High accuracy (1.5dB typical), built-in calibration marker</li> <li>Wide dynamic range, -70dBm to 0 dBm</li> <li>Digital readout of center frequency</li> </ul> <p>Model GSA 1000 ..... P/N 105-1000</p>	<p><b>Model 5003</b></p>  <p><b>1.3 GHz Hand Held Frequency Counter</b></p> <ul style="list-style-type: none"> <li>5Hz to 1300MHz frequency range</li> <li>Very high sensitivity at all frequencies</li> <li>Frequency and period measurement, 0.001Hz resolution</li> <li>Reciprocal counting technique gives superior accuracy</li> <li>Push-to-measure function with auto power-down</li> <li>Large 8-digit display with full range of indicators</li> </ul> <p>Model 5003 ..... P/N 105-5003</p>
<p><b>Model 1520</b></p>  <p><b>AUTOSCAN True RMS Line Power Monitor</b></p> <ul style="list-style-type: none"> <li>True RMS measurements of voltage, current, power, volt-amps and frequency</li> <li>Unique scan mode enables continuous monitoring of all functions</li> <li>Separate function switch allows individual monitoring of each parameter</li> <li>Reads current up to 20 amps and wattage up to 2,000 watts</li> </ul> <p>Model 1520 ..... P/N 105-1520</p>	<p><b>1504 &amp; 1505 AC Power Supplies</b></p>  <p><b>Variable Line Supply Series</b></p> <ul style="list-style-type: none"> <li>Model 1504 single range: 0-150 VAC @ 4A</li> <li>Model 1505 dual range: 0-150 VAC @ 4A, 0-260 VAC @ 2A</li> <li>Triple isolated continuously variable AC output</li> <li>Power line leakage current measurement ready</li> <li>3 digit DPM for high accuracy</li> <li>Capacitive coupling less than 0.0005pF</li> <li>Galvanic leakage less than 10uA</li> <li>120dB attenuation for common mode noise</li> </ul> <p>Model 1504 ..... P/N 105-1504 Model 1505 ..... P/N 105-1505</p>

For Ordering Information Call 800-572-1028

## Product short form catalog

Global Specialties has introduced a new short form catalog featuring five new products and two existing products with additional features.

The 4-page catalog features the 1GHz spectrum analyzer scope adapter, which converts any standard oscilloscope, a handheld frequency counter, an autoscanning true RMS power line analyzer, a dual variable, triple isolated digital ac power source, a line of 10 Proto-Board surface mount design breadboards, two new versions of the Proto-Board design workstations, and much more.

Circle (20) on Reply Card

## Sencore News published

Sencore, Inc. has announced that Sencore News #176 is now available. This issue concentrates on functional analyzing, a method of troubleshooting expected to save 54% of your analyzing according to technical surveys. Functional analyzing and divide-and-conquer troubleshooting form the cornerstone of the company's line of instruments.

This is a technical publication printed six times a year designed to help electronic servicers (owners and operators) with informative articles and troubleshooting tips spread throughout each issue. The publication contains circuit descriptions, troubleshooting procedures, business support, and equipment applications.

Circle (21) on Reply Card

## Waveform generation instrumentation

Wavetek Corporation has introduced its new catalog of arbitrary waveform generators, function generators and VXI instruments. With its handy selection guide, buyers can choose the instrument to suit their needs. The catalog also includes a comprehensive listing of all the company's sales and service representatives worldwide.

Numerous instruments are appearing for the first time in this catalog. These include three new VXI models: The Model 1385 is a 50 MS/s Arbitrary Waveform Synthesizer with a floating main output and versatile intermodule triggering and phase control. The Model 1361 is a Kilovolt Digital Multimeter with 4-1/2 to 6-1/2 digit resolution and unique 1,000 Vrms measurements. The third, the Model 1396 is a 50 MS/s Arbitrary Waveform Synthesizer with advanced waveform sequencing and 16-bit digital output, plus versatile intermodule triggering, summing and phase control.

Models 296 and 29 are also making their debut in this catalog. The Model 296 is a Synthesized 50 MS/s Multichannel Arbitrary Waveform Generator with up to 4 independent channels, advanced waveform sequencing, ten standard functions plus arbitrary waveforms and versatile interchannel triggering, summing and phase control. The Model 29, offers extensive capabilities including standard and arbitrary waveforms and multiple unit phase locking.

Circle (22) on Reply Card

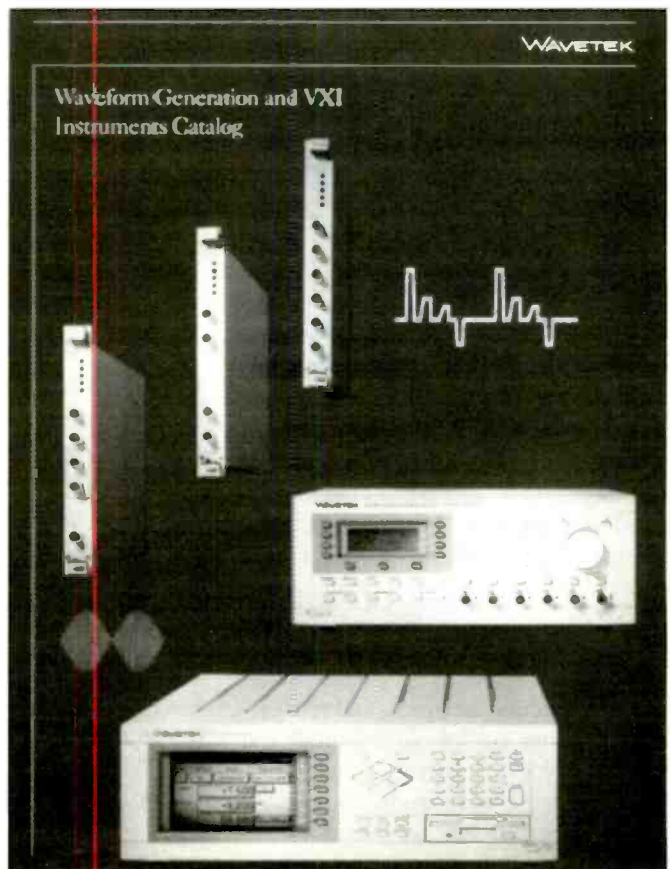

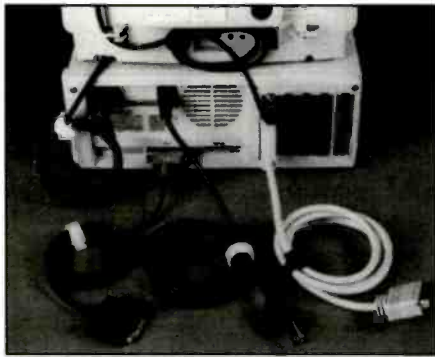

## Cable wraps

*Richo Plastic* introduces *Kwik Wrap*. The Velcro brand hook and loop fastener has been designed to wrap power cords, cables, peripherals, extension cords and more. The back to back polyethylene hook and nylon loop enable quick and secure bundling methods. The material allows for easy fastening and re-fastening to make an installation, a temporary alignment, or a permanent bundle.

The wraps are available in four sizes ranging from 6.0 inches to 15.0 inches with bundle diameters from 1.0 inches to 3.5 inches. Standard colors are black and white and other colors are available by special order.

Circle (46) on Reply Card



## Ozone-safe solvent

*Micro Care Corp* offers a new, planet-safe degreaser—"OS-20"—to aid in the transition from CFCs to environmentally progressive solvents, as directed by the Montreal Protocol ten years ago.

"OS-20" is a cleaner and degreaser, as effective as 1, 1, 1-TCA but completely ozone safe. It removes all grease and oil residues, silicone lubricants and refrigerants, uncured conformal coatings and many ink types. Relatively slow drying, it is easy-to-use, economical and safe for people. Because this solvent does not damage the environment in any way,

company officials state that, based on laboratory testing, "OS-20" may be one of the few ozone-safe alternatives to CFC's that can meet popular requirements decades from now.

Circle (47) on Reply Card



## Instructional video cassette

A new instructional video cassette has been released by *Electronix Corporation*, titled "An Introduction to PC Computer Repair." This 40 minute program covers troubleshooting and repair of common IBM compatible personal computers. Topics that are discussed include problems associated with power supplies, motherboards, RAM, floppy and hard disk drives, slot connectors, and more. It also covers the proper way to clean and lubricate 3.5 inch and 5.25 inch floppy disk drives. Common screen and CMOS error codes are also addressed, along with servicing tips and strategies. This presentation is a follow-up to "IBM Compatible Computer Assembly," which displays how to properly build and configure a PC from the motherboard up.

Circle (48) on Reply Card

## CAD software

*NTE Electronics, Inc.*, announces the availability of *WinDraft* schematic design and *WinBoard* PDB layout, two software programs from *IVEX Design International* that work with *Windows '95* to improve and simplify engineering and design of printed circuit boards. They also can be used with *Windows 3.1*, *Windows 3.11*, and *Windows/NT*.

Both programs require at least a 486/DX PC, 8Mbit RAM, 10 Mbyte hard disk space, and SVGA, and cost \$29.95 each. *WinDraft* requires *Win32s*, when used with *Windows 3.1*.

*WinDraft* can generate schematic designs within minutes of installation and provides everything needed for wiring,

drawing, printing, and finishing the design. It features a full graphical library editor and title block editor; capability to create new component libraries, or build upon existing libraries to design custom symbols; user-definable on-line ERC to identify problem areas in the circuit before final design; and the ability to track widths and isolations on the schematic.

Circle (49) on Reply Card



## DMM

The Model 85XT from *Wavetek* is a new, high resolution, 4 1/2 digit ( $\pm 1999$  counts), 0.05% superior accuracy digital Multimeter (DMM) with True-RMS measuring. It also measures frequency, duty cycle, diode test and continuity.

Features of the new meter include auto-power off, data hold/max hold, low battery annunciator, continuity beeper, spare fuse and large 0.7 inch high display digits.

Circle (50) on Reply Card

## Power supply

"A new low cost and compact, single-output dc power supply covering an output range from 0V to 30V, up to 5A, and featuring power-saving circuitry is now available from *HC Protek*.

The Model 3005 offers precise current and voltage level settings. It features two, 3-digit LED readouts for simultaneous monitoring of voltage and current plus an overload indicator. The instrument incorporates a special "energy-saver" circuit design for cooler, more efficient operation.

Circle (51) on Reply Card



# EIA/CEMA Hands-On Technical Training Workshops

For over seventy years, EIA has been the primary trade association representing all facets of electronics manufacturing. CEMA represents U.S. manufacturers of audio, video, home office and home automation, consumer information, accessories, mobile electronics, multimedia products, and assistive devices for people with disabilities. In addition to managing the International Winter Consumer Electronics Show, CEMA member manufacturers work to promote optimum servicing of consumer electronic products and foster interest in continuing education of electronics technicians through the Product Services Department.

The Consumer Electronics Manufacturers Association (CEMA), a sector of the EIA, will offer the following courses as outlined below. These 3-5 day technical workshops cover theory, hands-on training, and troubleshooting techniques. They fulfill the "training" requirements for preliminary service authorization for most major manufacturers.

### Video Laser Disc Technology & Servicing



- ◆ VLD Servo Systems
- ◆ Video Signal Path
- ◆ Laser Optics
- ◆ Troubleshooting Techniques

3 days 2.0 CEUs

VLD

### Computer Monitor Servicing



- ◆ Signal Formats
- ◆ Test Equipment
- ◆ Monitor Alignments
- ◆ Troubleshooting Techniques

3 days 2.0 CEUs

MON

### Color TV Technology & Servicing



- ◆ NTSC Signal Processing
- ◆ Test Equipment
- ◆ Receiver Alignments
- ◆ Troubleshooting Techniques

3 days 2.0 CEUs

CTV

### VCR Technology & Servicing



- ◆ VCR Servo Systems
- ◆ VHS Signal Processing
- ◆ Tape Transport Alignment
- ◆ Troubleshooting Techniques

5 days 3.5 CEUs

VCR

Courses are designed to upgrade the skills of both technicians and educators with electronics background. The workshops are provided by CEMA's Product Services Department for a minimal fee of \$50, except for the monitor training which is \$150. Anyone interested in attending should contact Product Services (703) 907-7656 for space availability and details. CEMA offers CEUs at a nominal fee.

### 1997 Technical Workshop Schedule

Workshop	Location	State/City	Date
VCR	EIA - Headquarters	Arlington, VA	Jan 27-31, 97
VLD	EIA - Headquarters	Arlington, VA	Feb 19-21, 97
CTV	EIA - Headquarters	Arlington, VA	Mar 4-6, 97
MDN	EIA - Headquarters	Arlington, VA	Apr 15-17, 97
CTV	Tampa Tech. Institute	Tampa, FL	Apr 8-10, 97
VCR	Tampa Tech. Institute	Tampa, FL	Jul 8-10, 97
MON	Tampa Tech. Institute	Tampa, FL	Oct 7-9, 97
VCR	Triton Comm College	River Grove, IL	Mar 24-26, 97
CTV	Triton Comm College	River Grove, IL	Jul 14-18, 97
MON	Triton Comm College	River Grove, IL	Oct 13-15, 97
CTV	Mt. San Antonio C.C.	Walnut, CA	Feb. 18-20, 97
VCR	Mt. San Antonio C.C.	Walnut, CA	Mar 24-27, 97 (4 days)
MON	Mt. San Antonio C.C.	Walnut, CA	Apr 22-24, 97
CTV	Mt. San Antonio C.C.	Walnut, CA	June 3-5, 97
MON	Mt. San Antonio C.C.	Walnut, CA	July 23-25, 97
CTV	Mt. San Antonio C.C.	Walnut, CA	Nov 11-13, 97

**Product Services, EIA/CEMA**  
2500 Wilson Boulevard,  
Arlington, VA 22201-3834  
(703)907-7670

Web Site: <http://www.cemacity.org>

Circle (77) on Reply Card



# Steps for PC preventive maintenance

By Stephen J. Bigelow

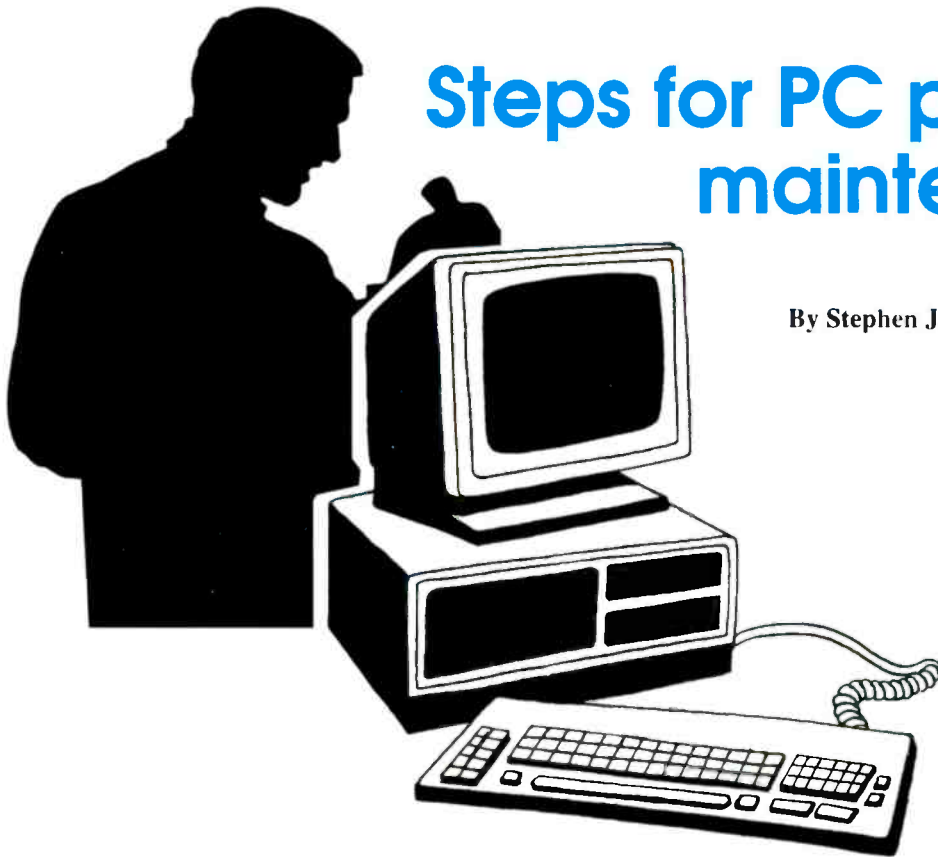

**A**s reliable as the PC may be, it also demands a certain amount of regular maintenance to ensure continued trouble-free service. Dust, debris, careless installations, and general wear can adversely effect a computer, as well as peripherals such as monitors and printers. A routine of preventive maintenance can extend the working life of a computer, and halt many problems before they start.

For the individual computer enthusiast, routine maintenance will help to keep your system out of the repair shop. For the service technician, routine maintenance is a valuable asset which can be offered free (performed after a repair), sold as a value-added service, or included with standard service contracts.

It is not uncommon for enterprising service shops to popularize themselves by providing "Preventive Maintenance" coupons in local papers. Still, there are no standards for preventive maintenance, and it is performed differently depending on the individual. This article is intended to offer a "standard" set of procedures for consistent preventive maintenance.

## Equipment and materials

Preventive maintenance of any product requires the use of tools, equipment and materials in order to complete the procedure thoroughly, effectively and safely. This is especially true when the product is as sophisticated as a personal computer. Here is a list of equipment and materials that I recommend to any service center that plans to perform preventive maintenance on personal computers.

*Static-safe vacuum cleaner.* If you plan to perform preventive maintenance seriously, invest in a static-safe vacuum cleaner. It can be purchased from a computer or electronics store. Most ordinary vacuums generate large static accumulations as air rushes into the nozzle. If the charged nozzle should come in contact with static sensitive circuitry, you may precipitate a failure in the computer without even realizing it. A static-safe vacuum will eliminate this danger.

*Basic hand tools.* You will need a selection of regular and Phillips-type screwdrivers for simple disassembly and reassembly tasks. Chances are that you already have these tools handy, but if you're still looking for a tool set, consider magnetized tools that will allow you to

keep screws on a tool without holding them—a real plus for delicate work in the crowded space of a computer chassis. Magnetized tools also allow you to pick up hardware that might accidentally be dropped into tight areas.

*Voltmeter.* You should have a simple voltmeter on hand to measure the outputs from a power supply. In practice, a low output may signal an overloaded supply (or a supply on its way to failure).

*Floppy drive cleaning kit.* Get a good-quality cleaning kit for 3.5" and 5.25" floppy drives. A typical cleaning kit is quite inexpensive, and consists of "cleaning disks" and a mild cleaning solution. You apply a bit of cleaning solution to the disk fabric, insert the cleaning disk, and run the drive for 30 seconds or so. This removes excess oxides or foreign matter from the drive's R/W heads. There are also "dry" cleaning disks, but these tend to be a bit more abrasive than the "wet" disks. From a practical standpoint, either type of cleaning kit should be adequate and safe for brief, periodic cleanings.

*Cleaning materials.* Round up a bottle of Windex (or some other mild household cleaner) and some paper towels. Avoid heavy or caustic cleaners. This is certain-

Bigelow is a technical author and computer consultant at Dynamic Learning Systems in Marlboro, MA.



ly not glamorous, but you'd be amazed what a squirt of Windex or other window cleaning solution on a paper towel will do for dirty enclosures.

### A preventive maintenance procedure

One way to speed up preventive maintenance, and to make sure that the work is performed thoroughly and effectively, is to establish a step-by-step procedure to be followed each time. Here is the procedure that I follow.

#### Step 1: Clean the enclosures

Start with a little cosmetic work. Spray a bit of cleaner on a paper towel, and clean the PC's front plastic housing. Clean the overall metal enclosure next. Don't waste time here—the procedure should take no more than 2 minutes. You could use fabric rags for this purpose, but rags get dirty quickly. So unless you want to do laundry too, use paper towels instead which are cheap and easily disposable.

Never, under any circumstances, should you spray cleaner onto the PC directly! When the cleaning is complete, remove the cleaned metal enclosure and set it

aside. Next, clean the monitor housing and CRT glass with a little cleaner on a paper towel. Once again, a mild household cleaner such as Windex is ideal.

Dry the CRT completely before continuing. If the CRT has an anti-glare screen, remove the screen and clean the CRT alone if necessary (do not wet the glare screen). Brush any dust or debris from the glare screen with a dry rag. Do not spray cleaner directly at the CRT, or into the vents on a monitor's housing!

#### Step 2: Vacuum inside the PC

Dust and airborne debris occur in every home and office. Eventually, accumulations of such contaminants will build up on fan blades, vent slots, dust screens, and drive mechanisms, as well as on expansion boards and cabling. Dust can clog vents and inhibit cooling, so the system runs hotter than necessary. Since dust is also conductive, enough dust can cause short circuits or circuit problems.

Once the PC is opened, use a static-safe vacuum to remove dust from fan blades, drives, and around the chassis. If there is a dust filter on the air intake fan, remove

Wire Color	Voltage Level
Black	Ground (0 volts)
Red	+5V
Yellow	+12V
White	-5V
Blue	-12V
Orange	("Power Good")+5V

Table 1. These represent typical motherboard power connections.

the filter and clean it (or replace it if necessary). If there is a great deal of dust in tight spaces, use a can of compressed air to blow out the dust.

#### Step 3: Vacuum the monitor vents

Ideally, you should remove the rear housing from the monitor and vacuum it as well, but monitor enclosures can sometimes be difficult and time-consuming to remove. Instead, vacuum the air inlets located at the bottom of the rear enclosure. This is where air enters the monitor, so this is where dust and debris are most likely to collect. Examine the exhaust vents on top of the rear enclosure. If you see

# PTS Electronics

Supplying the World of Electronics

## PTS Support

PTS has been supporting the electronic service industry for over three decades. By providing quality TV replacement Tuners and Mainboards, PTS has become a source you can rely on. Thousands of TV Tuners, Chassis, Mainboards, and Modules are in stock and available for immediate delivery. PTS stocks and services over 40 brands of direct replacements. PTS is a valuable resource which will keep you competitive in today's electronics industry.

**COMPUTER**  
Service On Monitors,  
Printers,  
System Boards



CORPORATE HEADQUARTERS

<b>INDIANA</b> BLOOMINGTON	<b>COLORADO</b> ARVADA	<b>TEXAS</b> LONGVIEW	<b>CALIFORNIA</b> TUSTIN
800-844-7871 TOLL FREE	800-331-3219 TOLL FREE	800-264-5082 TOLL FREE	800-380-2521 TOLL FREE
800-844-3291 FAX	303-422-5268 FAX	903-234-0441 FAX	714-258-0315 FAX

**The Nation's Largest Inventory of TV Tuners and Mainboards**

any dust obstructing the vents, vacuum there as well. When you are finished, all vents should be open and unobstructed.

#### Step 4: Check the drives

Check to see that all of the drives are bolted securely to the chassis. Loose drives will tend to rattle when they run. For sensitive drives (especially low-profile hard drives), such vibration can cause random data errors and premature drive failure. Tighten any loose screws, and install additional screws if necessary to secure the drive properly.

#### Step 5: Check the boards

Examine the motherboard and each of the expansion boards. Check to see that all of the screws holding the motherboard are secure. If the motherboard is not secure, it may not sit evenly, which can allow the motherboard to flex and fail prematurely, or allow expansion boards to slide out. Install any missing motherboard screws. Next, check to see that each of the expansion boards are properly seated their bus connectors. Each expansion board is held in place by a screw attached to a metal bracket. If that screw is missing, there is nothing to hold the board in place. This can prove to be especially tricky when installing or removing cables.

#### Step 6: Check power cables

See that the four-pin power connectors are attached securely to each drive. Loose power connectors can cause intermittent drive operation. If there are any "Y" power adapters in the PC, make sure they are also secure.

#### Step 7: Check signal cables

Next, examine each of the ribbon cable assemblies inside the PC, and see that each one is securely attached to its corresponding signal connector. You will find at least two ribbon cables, one from the floppy drive(s) to the floppy drive controller and one from the hard drive(s) to the hard drive controller. If there is a CD-ROM drive in the system, there will be a third ribbon cable from the CD-ROM to the CD-ROM controller.

#### Step 8: Check heat sinks

Look for heat sinks on motherboard ICs. Recent PCs will typically incorporate at least one heat sink to cool the CPU. If there is a heat sink in place, check to see that it is attached securely to the IC. To aid in heat transfer, there should also be a thin layer of thermal grease (a heavy white paste) between the CPU and heat sink. Tighten the heat sink (and apply a bit of thermal grease) if necessary.

#### Step 9: Clean the keyboard

Use a little cleaner on a paper towel and gently clean away any accumulations of grit from the keys and keyboard housing. To remove dust and debris from between the keys, you can vacuum between the keys with a very narrow nozzle, or use compressed air to blow it out.

#### Step 10: Clean the mouse

Remove the mouse ball from the mouse and clean the ball with some mild cleaner on a paper towel. Next, use some compressed air to blow out any dust or lint that may have built up inside the mouse assembly. Next, gently scrape off any accumulations of gunk that may be caked onto the "x" and "y" rollers (as well as the "pressure roller"). You may have to spin the rollers by hand and scrape the rollers clean all the way around. Once the rollers are clear, blow out any debris still in the mouse housing. Replace the mouse ball and secure it in place.

#### Step 11: Check the fans

Plug the PC in and turn the power on. Once power is applied, any fans in the PC should start spinning. Although every PC is different, there are five fans that you should look for (1) the power supply fan, (2) an air intake vent fan, (3) an air exhaust vent fan, (4) a CPU fan, and (5) a fan card in one of the expansion slots. Note that your particular system may not have all of these fans in place.

If a fan is not moving, try giving a blade a little shove with the tip of a pencil (not your finger). If this starts the fan, it is defective and should be replaced. When a little shove doesn't work, check the fan's power cable and see that it is attached securely. Finally, check for any fan "rattles" or "grinding" noises. These could indicate that the fan's motor is wearing out.

#### Step 12: Measure supply voltages

Use your voltmeter to measure the voltages being supplied to the motherboard (such as the power connections in Table 1). Ideally, each measured voltage should approximately equal the expected voltage (to within about 0.2V). For example, your +5V supply should read between +4.8V and +5.2V. Look for any voltages that appear unusually low (especially at the +5V and +12V lines). A voltage that is unusu-

## Troubleshooting Tips

By Algie P. St. Cyr

### RCA CTC 107 color TV

A portable RCA color TV was brought in because of a dark picture. I checked the set and found flashing and intermittent loss of video or luminance, with only the chroma or color signal remaining when it acted up. I started tracing the video with my oscilloscope. I traced video up to the base of Q701, but there was no signal past Q701. I

checked Q701, and it appeared fine, but I replaced it anyway to no avail. It appeared that Q701 had no forward bias so I shorted the emitter to the base, and video was restored. I checked resistors and other components in the circuit. I checked L703 for continuity. All checked out. I then suspected the capacitor 120pf, inside the can with L703. Upon removal of L703 I found

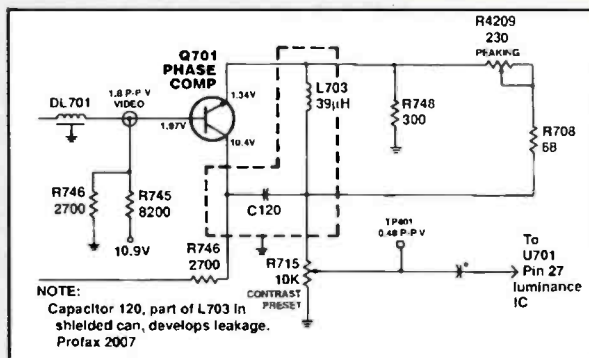

the capacitor to be leaky, with less than a megohm of erratic leakage. Replacement of L703 with a new assembly restored the set to normal operation.

The chassis was a CTC 107. I did not have a CTC 107 schematic, but found that this circuit was very similar to a CTC108 diagram. I used this diagram to troubleshoot it.



ally low may indicate an overloaded power supply. Excessive overloads can result in intermittent system operation, and cause excessive heating in the power supply itself. You can correct an overload by upgrading the power supply.

### Step 13: Check the CD-ROM drawer

CD-ROM drives that use sliding drawers should be checked to see that the drawer slides in and out freely. Hit the Eject button and observe the CD drawer as it slides out. Then push the drawer gently inward, and it should motor in easily. Check for erratic motion, grinding noises, or excessive force needed to push the drawer in. This may suggest an eventual problem with the CD-ROM drive.

### Step 14: Clean the floppy drive(s)

Finally, you should clean the system's floppy drives to remove any accumulations of dust or magnetic oxides deposited from long-term disk wear. These accumulations result in random disk read/write errors such as "General Failure Reading Drive A:" and so on.

Cleaning "kits" are readily available for 3.5" and 5.25" drives, and each cleaning disk is good for 15 or 20 cleanings. A "wet" kit allows you to moisten a fabric disk with mild cleaning fluid, insert the fabric disk, and run the disk for up to 30 seconds or so. A "dry" kit foregoes the cleaning fluid in favor of a slightly more abrasive cleaning disk. In either case, be sure to run the cleaning disks no longer than 30 seconds at a time.

### Step 15: Replace the enclosure

Turn off the computer and replace the outer enclosure (you may leave the computer plugged in). Secure the enclosure with a full complement of screws.

### Software

Physical maintenance of the PC is only part of the process. The wealth of software tools that are now available allow you to check the integrity of a hard drive and its files. For the purposes of preventive maintenance, you should run three pieces of software; a virus checker, a disk checker, and a file defragmenter.

### Step 16: Check for viruses

There is no shortage of anti-virus software available for the PC. Products from McAfee and Associates ([.mcafee.com/\) and Symantec \(<http://www.symantec.com/>\) can easily be run from a write-protected diskette. If you have access to DOS 5.0 or later, you can run MSAV \(in the DOS subdirectory\). Run a virus checker to detect viruses only.](http://www</a></p></div><div data-bbox=)

If a virus is detected, contact the customer before actually attempting to remove a virus, this is important because virus removal often renders the host .EXE or .COM file unusable. The infected file(s) may not be backed up yet, so eradicating viruses on your own initiative may actually prove to be an inconvenience to your customers.

### Step 17: Check the file structure

Run CHKDSK or SCANDSK to check for cross-linked files or lost allocation units. On a system with DOS or Windows 3.1x, you will find these files under the DOS sub-directory. On a system with Windows 95, these files are located in the \WINDOWS\SYSTEM sub-directory. If there are any lost allocation units or cross-linked files, print out the CHKDSK report and let the customer know.

### Step 18: Defragment the drive

File "fragmentation" forces the hard drive to work harder and take longer when loading and saving files. Check the level of file fragmentation by running DEFRAG. It will report the fragmentation level and give you the option of defragmenting or not. Fortunately, defragmentation is a highly automated process which can be accomplished in just a few minutes. For DOS and Windows 3.1x systems, you can find DEFRAG in the DOS directory. Windows 95 uses its own defragmenter under Accessories and System Tools menu.

### Conclusion

Preventive maintenance is an important part of PC service, yet it is often ignored until problems escalate into a failure. Fortunately, a comprehensive preventive program can be performed in 15 minutes with a minimum of tools, materials, and software.

This article is intended to help PC owners keep their system running trouble-free. For PC technicians, this article offers a sound procedure to base your preventive maintenance services around. Comments and questions are welcome at [sbigelow@cerfnet.com](mailto:sbigelow@cerfnet.com). ■



**Parts Express**  
Reg. \$118<sup>00</sup>  
**SPECIAL \$99<sup>95</sup>**  
Order #ES-391-030

### Triplet 4404 DMM

The Model 4404 is an extremely versatile DMM that performs multiple functions. 4000 count digital display with bargraph, frequency measurement from 1Hz to 999.9KHz., 5 capacitance ranges to 40uF, DC Volts: 5 ranges to 1000VDC, AC Volts: 5 ranges to 750 VAC, AC and DC amps to 10A, 6 resistance ranges, diode tester, data hold, auto power off, data memory, and built in stand. One year manufacturer warranty. Net weight: 2 lbs.

CALL TOLL FREE: **1-800-338-0531**

To receive our 228 page full line catalog, use source code ESM when ordering.

340 E. FIRST ST. DAYTON, OHIO 45402-1257  
PHONE: 513-222-0173 FAX: 513-222-4644  
E-MAIL: [xpress@parts-express.com](mailto:xpress@parts-express.com)  
HOME PAGE: <http://www.parts-express.com>



Circle (71) on Reply Card

## FLOPPY DRIVE REPAIR MADE EASY AND AFFORDABLE!!!!

**Don't turn away business. Add a new dimension to your services.**



Accurite Technologies can supply you with a ready-to-run software package that will diagnose floppy drives for any IBM PC or compatible, and we also have one for MACs. Let our experts assist you to become more profitable by fixing instead of swapping drives. And, if you mention you saw this ad in ES&T we'll give you 5% off our already low price.

**ACCURITE**  
TECHNOLOGIES INC.

48460 Lakeview Boulevard

Fremont, CA 94538

510-668-4900 FAX: 510-668-4905

e-mail: [sales@accurite.com](mailto:sales@accurite.com)

Circle (76) on Reply Card

# Diagnostics software

By The ES&T Staff

**D**iagnosing a problem in a personal computer is similar to diagnosing a problem in any other consumer electronics product:

1. Observe the symptoms.
2. On the basis of your knowledge of the product, postulate a possible cause of the problem.
3. Test your hypothesis by performing localized tests (voltage, resistance, waveform) on specific portions of the circuits.
  - 4a. Confirm your diagnosis and,
  5. Rectify the problem, or,
  - 4b. Find that your hypothesis is wrong and go back to step 2 (or possibly step 1).

## Software complicates the problem

Unlike a typical consumer electronics product, a personal computer requires software to perform all functions. Therefore, in many cases, a problem that arises in the operation of a personal computer has nothing to do with hardware. In fact, any time you encounter a computer that's acting strangely, the easiest and least invasive corrective measure is to check out the software. Of course if the computer is completely dead, or if there are other obvious clues that the hardware has a problem, that's where you should probably start. But if the computer is just acting flaky, look to the software first.

## When does the problem occur

An analysis of the conditions under which the problem occurs can provide valuable clues as to the nature of the problem. For example, if the problem only occurs when one specific software package is running, the problem might be that the program has become corrupted. Or it's possible that a recently installed software package has made changes to the CONFIG.SYS file, or the AUTOEXEC.BAT file that is causing problems in the execution of that one program.

Here's a specific example. I have a DOS-based astronomy program on my personal computer. It worked just fine when I installed it. Now, after installing

and removing a number of other programs, when I try to start the program when Windows is running, it starts, but as soon as I try to do anything with it I get an error message. I have found that I can run the program just fine under DOS when Windows is not running.

Frankly, because of the nature of the problem, and because this is not a critical issue, I have not taken the time to straighten it out. I'm pretty sure that if I reinstalled the program it would then run fine, but I haven't had the time. This is, however, an example of the strange things you can run into when you service computers.

## Back up the system

Making changes in computer software can be something like taking a walk in a swamp. You make a minor change to a line in the AUTOEXEC.BAT file and find that the original problem is corrected, but now a worse problem has been introduced. In trying to correct the new problems, you could introduce several new ones. It's a good idea if you will be making changes to any files to first perform a complete back up of the hard drive. Then if you find yourself up to your neck in quicksand and sinking fast, you can always return the computer to the condition it was in before you started making changes and start over again.

## Check the files

A good place to start is the ROM BIOS SET-UP information to be sure the BIOS is set up correctly. You can usually enter this set-up upon start-up by pressing the DEL key before the computer completes the memory check.

At the C prompt, type VER and press ENTER to be sure that the system is using MS-DOS Version 6.0 or above. If the computer is using an earlier version, it would be a good idea to upgrade before going any further.

Before making any changes to the start-up files, make a backup copy. You can make backups by copying the files to a

different name. For example, at the C prompt, type COPY AUTOEXEC.BAT AUTOEXEC.OLD and press ENTER. Now type COPY CONFIG.SYS CONFIG.OLD, and press ENTER. Now if somehow you totally mess up either of these vital files, you can restore them from these backups. It would be a good idea to copy these files to a floppy disk as extra insurance.

## Editing the AUTOEXEC.BAT file

To edit the AUTOEXEC.BAT file, at the C prompt, type EDIT AUTOEXEC.BAT, and press ENTER. This will start the DOS EDITOR program and open the file called AUTOEXEC.BAT. If this computer has a word processor on it that outputs files in ASCII, you can use a word processor to perform this editing function. The DOS manual contains information to help you determine what each line of the file means.

To disable a line, type REM at the beginning of the line. REM is short for "remark." Any line of code that starts with "REM" is not executed. To save the changed AUTOEXEC.BAT file; press the ALT key, the F key, then the X key, and press ENTER, or select YES when asked if you wish to save the file.

When you've finished making changes to the AUTOEXEC.BAT file, re-boot the computer. If the problem has disappeared, you're well on the way to completing the service procedure.

## Editing the CONFIG.SYS file

Once you've finished with the AUTOEXEC.BAT file, edit the CONFIG.SYS file in a similar manner. Again, use the DOS manual to determine what each line means and why it's there.

## Diagnostics

There are many useful diagnostic programs and devices available commercially. We'll discuss some of them here. But first we'll say a little about a diagnostic that is included with DOS. Beginning



with version 6, Microsoft has included a utility called MSD, which stands for Microsoft Diagnostics. MSD is a useful program that provides complete information about the computer it's running on.

Start MSD by typing MSD at the C prompt and pressing ENTER. MSD can be used with a mouse. On start-up MSD reads information about your computer from available set-up information and on chip data, and determines the type of hardware connected to the system.

A little experimentation with the program on your own computer before you try to use it on a customer's computer is a good idea.

### Other diagnostic software

Software is available that will probe the computer, determine what components are in the computer and how they're configured, and report that on the screen or in printed form or as a file on disk. The kinds of information that this type of software provides are such things as whether there's a mouse installed, or a modem, and how much RAM there is, and the capacity of the disk drive.

When a computer exhibits problems, if the disk drive, the CPU, and certain portions of the memory are operating properly, the service technician will be able to use diagnostic software to perform many diagnostic checks.

### Some of the tests

A diagnostic program can check out memory (RAM) to see if it's operating properly. The program repeatedly writes a pattern of bits into memory and then reads it, and checks what came out with what was written in. If the information read out of memory is different from what was written in, it reports that that portion of the memory is faulty.

Some diagnostic programs perform repeated reads and writes to the hard disk. If any areas of the disk give inconsistent results, the program flags them as bad so the computer won't attempt to write on those areas.

Some diagnostic programs check only a few specific areas of the computer, others are comprehensive and check just about everything. Some diagnostics operate under DOS, some under Windows, and still others use their own proprietary operating system.

The diagnostic software program used

by any technician should be carefully selected, depending on his level of expertise, how deeply he plans to get into computer servicing, and how much money he wants to spend on software.

### POST cards

When a computer is first turned on, it goes through a series of checks to make sure everything is operating properly before starting up. If certain portions of the computer check out as faulty, the computer shuts down. That checkout procedure is known as the power-on self test (POST). When the POST senses a problem and shuts the computer down, there's no indication of why the computer didn't boot up. It's almost impossible to determine the reason that startup failed without a lot of trial and error.

There is a test device called a POST card, however, that will provide a visual indication of each step of the POST, and hold an indication of the last POST step performed before the computer shut down. That provides the technician with an indication of where to look to find the problem. POST cards are available from a number of manufacturers.

### Some PC diagnostic tools

There are a lot of personal-computer diagnostic products available to technicians, and more are being produced every day. Further confusing the situation is that diagnostics are being bundled in with some operating software. As one example, DOS 6.2.2 comes with a diagnostic called ScanDisk, which checks the disk and reports if any portions are faulty.

Additionally, some of the hardware manufacturers are bundling diagnostic software with their products.

In an attempt to make sense of the diagnostic market, we'll describe 6 categories of diagnostic programs. These six categories will suggest when you would need a product from that category, describe what the product in that category is supposed to do, and explain what to look for when purchasing a product in that software or hardware category.

The diagnostic tools described here fall into the following six categories:

- POST reader cards
- Diagnostic software
- Fixed disk drive utilities
- Floppy disk drive utilities

- Virus utilities
- Windows utilities.

The software products in each category are listed in alphabetical order by product name. At the end of this article, the companies are listed in alphabetical order by company name.

### POST reader cards

A POST reader card is used to determine the cause of failure on a dead PC. A dead PC is a PC that will not boot from either the floppy or hard drive. When a dead PC is turned on: nothing will happen, a cryptic set of beeps will be emitted, or some general failure description will be displayed on the monitor.

Every BIOS does a power-on self test (POST) when you turn the system on. The POST can normally identify the exact cause of failure on a non-bootable system, but the operator has no idea what that cause is, because there's nothing on the computer to display it.

By plugging a POST reader card into an expansion slot in the computer, the technician can monitor and display the systems signals and POST codes during boot. By checking the signal or code against the documentation that came with the POST reader card, the technician can determine the exact cause of failure.

Documentation is the most important feature of a good POST reader card. The documentation that comes with many POST reader cards only references the test being performed, and doesn't identify the chip or device that causes the test to fail. Without proper documentation the card is useless.

The standard ISA bus architecture POST reader card will work in ISA or EISA slots. If you work on Micro Channel systems, you will need a card with a Micro Channel adapter. The card should have the ability to monitor I/O ports 80, 84, 90, 300, and 680. These are the I/O ports to which the BIOS manufacturers emit POST codes.

### Diagnostic software

Diagnostic software is used to determine and correct problems on a bootable system. A bootable system is one that you can boot from either the floppy drive or the hard drive. Problems can range from hardware failures, hardware configuration problems, software corruption, and software configuration problems.

Diagnostic software should have the ability to determine the difference between hardware problems and software problems. Once the hardware problem is identified and corrected, or if it is determined that there is no hardware problem, then you can move on to software problems. Software corruption such as CMOS, partitions, FATs, root directories, sub directories, data, and viruses should be able to be identified and fixed quickly, and, more important, without the loss of data.

### Fixed disk utilities

A fixed disk utility is required when the hard drive can not be accessed at all but there is not a hardware failure, or when the hard drive fails to boot but can be accessed from the "A" prompt after booting from the floppy drive, or when the hard drive can be booted and accessed but there are still problems.

These errors can be caused by improper CMOS configuration, hard drive jumpers, controller jumpers, partition corruption, data corruption, bad sectors on the disk, hardware failures, and software configuration problems.

A fixed disk utility is used to test, fix, and perform data recovery on a hard drive (a fixed drive).

Fixed disk utilities are O/S specific. Get the utility that applies to the O/S that you are working on (normally DOS). The utility must not rely on the DOS structure to be intact since this is normally where the problem resides. An easy to use editor which can display in hex or ASCII in 256 byte or 512 byte screens is required.

The editor should have features to repair (in order): the bootloader, partition tables, boot signature, volume boot sector, volume boot signature, FAT 1, FAT 2, root directories, subdirectories, and data files. Automated features save time but there should be manual capabilities for all of the above features. A bit string search is helpful when the DOS structure has completely collapsed. A technical support line is a must.

### Floppy disk drive utilities

A floppy disk drive utility is used when the floppy drive reports an error and it is not the floppy diskette.

Floppy utilities should test, clean, and help realign floppy drives.

Floppy utilities should be able to run a head cleaning routine that moves the floppy heads across the entire surface of the cleaning diskette. If a problem still exists after cleaning, the utility should be able to test and find the floppy problem.

Ordinarily it is not worth a technician's time to realign a floppy drive, but for technicians who do realign drives, realignment can be attempted on most floppy drives in about 20 minutes with a floppy utility with realignment capabilities. Data recovery is normally not performed on floppy diskettes either, but if it is critical data you will find that fixed disk utilities have data recovery capabilities for floppy diskettes.

### Virus utilities

A virus utility is useful when you suspect that there may be a virus present. These occasions include: cases when a known virus has attacked a system, cases when there is no hardware failures but the system is having problems and a virus is suspected, and on a routine basis to find and delete a virus that may be on the system but has not been activated yet.

A virus utility will run a string search for all known viruses either manually by the technician or automatically in the background on the system by the utility. If a virus is found, the utility will let the user know and then correct it.

All virus utilities are O/S specific. You will need a virus utility for the O/S that you are using (normally DOS). 90% of the viruses on the market locate in the bootloader of the master partition. The utility should have the ability to write a

generic DOS bootloader onto the hard drive over the bootloader virus. This will delete the virus and the system will boot if the virus has not performed a destructive feature such as formatting the drive and erasing all the data.

The last 10% of the viruses will have to be found with a bit string search. This will only work if the virus utility knows what to look for. A new and unknown virus which has not been recorded onto the virus utility will not be found. The utility should be able to manually and automatically do all of the above.

### Windows utilities

A Windows utility is used when you are having a problem, but only when running under Windows.

A Windows utility should detect Windows and software configuration problems related to Windows.

A Windows utility should be a program that does not run under Windows but can look at Windows and the software running under Windows, and detect the configuration problem.

Unfortunately all Windows utilities have to be run under Windows. If you are having a Windows problem, 90% of the time you will not be able to run the Windows utility. Use diagnostic software to determine if a hardware failure occurred or not. If not, start to reconfigure DOS, Windows, and all the software programs running under Windows until you solve the problem.

### Manufacturers' addresses

The following are addresses and tele-





phone numbers of some of the companies that offer POST reader cards, diagnostic software, or both. The list has changed a great deal since a year ago. Many addresses have changed. A number of companies have taken over other companies, and some companies seem to have disappeared (at least we couldn't find them). At least one of the companies listed here does a great deal of its business in software other than diagnostic, but offers one or more diagnostic software titles.

**POST reader card and diagnostic software manufacturers**

**Accurite Technologies Inc.**  
48460 Lakeview Blvd  
Fremont CA 94538  
510-668-4900

**American Megatrends, Inc.**  
6145-F Northbelt Parkway  
Norcross, GA 30071  
770-246-8600

**Aristo Computers, Inc.**  
(Most of their software is for shipping/receiving, but they offer software for testing memory modules)  
6700 SW 105th Ave  
Suite 300  
Beaverton, OR 97008-5484

**Data Depot**  
1710 Drew Street, Suite 5  
Clearwater, FL 34615  
813-446-3402

**Diagsoft Inc.**  
5615 Scotts Valley Drive, Suite 140  
Scotts Valley, CA 95066  
408-438-8247

**Forefront Direct**  
(All Micro)  
25400 US Highway 19N  
Suite 285  
Clearwater FL. 34623  
813-539-7283

**Gibson Research Corp.**  
27071 Cabot Rd  
Suite 105  
Laguna Hills, CA 92656-7009  
714-348-7100

**McAfee Associates Inc.**  
2710 Walsh Avenue  
Santa Clara, CA 95051-0963  
408-988-3832

**Micro Data**  
3001 Executive Drive  
Suite 270  
Clearwater, FL 34622-2260

**Micro 2000**  
1100 E Broadway, Suite 301  
Glendale, CA 91205  
818-547-0125

**Quarterdeck**  
(Landmark Research International Corp)  
PO Box 18049  
Clearwater, FL 34622-1049  
813-443-1331

**RG Software Inc.**  
7430 E. Stetson Drive, Suite 205  
Scottsdale, AZ 85251  
602-423-8000

**Sonera Technologies**  
PO Box 585  
Rumson, NJ 07760  
908-747-6886

**Symantec**  
(Central Point Software Inc.)  
175 W Broadway  
Beaverton, OR 97401  
800-441-7234

**Tech Assist Inc.**  
11350 66th Street, Suite 105  
Largo, CA 33773  
813-547-0499

**Touchstone Software Corp.**  
2130 Main Street, Suite 250  
Huntington Beach, CA 92648-6442  
714-969-7746

**Windsor Technologies**  
130 Alto Street  
San Raphael, CA 94901  
915-456-2200

**Software for diagnosis of TVs, etc.**

**Philips Software Development**  
PO Box 555  
Jefferson City, TN 37760  
615-475-0044

**CMIM**  
**Monitor Test Equipment**  
**Checker 12e**



Now you can repair and test Computer monitors with ease. With sweep rates up to 64Khz., eight step gray scale, white screen, single color mode, Mac II, EGA, CGA support, you can run almost ANY PC monitor. And it is EASY to use. Color front panel displays show just what you should see. Don't let its' small size fool you. It is the most powerful handheld available, and it supports ALL basic VGA modes (some don't). It is suitable for bench or field operations. Battery or AC operation.

**PRICE: \$295**

**Checker Jr.**



Looking for a SMALL battery operated monitor test pattern generator that will fit in your pocket? The Checker Jr. is it. It displays a very useful 64 color pattern. You can evaluate size, focus, linearity, color tracking, and balance. It operates in the 640 x 480 mode (31.5Khz x 60Hz.), and is very easy to use. Use it anywhere.

**PRICE: \$99.95**

**Checker IV**



Need to check-out or burn-in multiple monitors? The Checker VI is the tool you need. It is a stand-alone (no computer required) 6 output test pattern generator. You can run 1 to 6 monitors from the small (1" x 5" x 6") Checker VI. It operates in the 640 x 480 mode, displaying an 8 x 8 8-color pattern which shifts every 3 minutes to reduce screen burn.

**PRICE: \$249**

**Computer & Monitor Maintenance, Inc.**

1-800-466-4411 • 770-662-5633  
<http://www.computermonitor.com>



Circle (64) on Reply Card

# Understanding comb filters

By Steven Jay Babbert

There are many types of filters used in consumer electronics equipment for wave shaping and signal conditioning. There are high-pass, low-pass, bandpass and band-stop or "notch" filters of varying complexity. The most basic "passive" filters are typically built from inductors, capacitors and resistors. "Active" filters use these same components in conjunction with transistors or op-amps. All of these filters have one characteristic in common: they act on a continuous range of frequencies.

Occasionally in electronics design the need arises for a filter that can block a number of specific frequencies while passing others within the same band. The comb filter, so named because the shape of its response curve resembles the teeth of a comb, is just such a device (Figure 1). In this article we will examine the role of the comb filter as used in TV video circuits and see how it extends the high end of the luma (picture) signal for increased picture detail.

## The ideal video amp response

An ideal frequency response curve for a video amp is shown in Figure 2. This curve is essentially flat from 30Hz to 4.2MHz. In many receivers the high-frequency response is limited to about 3.2MHz. This high-frequency limit is imposed to reduce the 920kHz beat pattern which may result from mixing of the 3.58MHz color subcarrier with the 4.5-

MHz sound carrier. A reduced high-frequency response results in a loss of some fine picture detail but this is less objectionable than beat patterns.

The chroma signal path must have a uniform response to at least 3.6MHz in order to pass the color subcarrier and sidebands which extend about 0.6MHz below and 0.6MHz above the subcarrier. For this reason the response of the first video amp (which passes both luma and chroma information) extends to 3.6MHz (Figure 3). Once separated, the chroma signal is routed to the chroma section where amplifiers with a rising response characteristic boost the upper frequencies. Note: In some receivers the chroma and luma is separated before the first video amp at the video detector.

The chroma signal experiences a delay, caused by the characteristics of the chroma section. A delay line in the luma signal path brings the luma signal back into step with the chroma signal. If a phase difference were allowed to exist, the color information would be horizontally displaced from the picture information on the CRT screen.

## Interleaving and number crunching

Even before the advent of color television, it was known that the energy in the 4MHz video signal is in clusters centered on harmonics of the horizontal scan frequency. Originally the scan rate was 15,750Hz. When the NTSC color system was created, the unused space between the video clusters was used for the chroma information. This method of spectrum

sharing is known as interleaving (Figure 4). The color subcarrier frequency is chosen to be as far above the picture carrier frequency as possible to minimize interference. Practical considerations set the upper limit to about 3.6MHz. If the subcarrier frequency were raised much higher, the upper side band would overlap the sound carrier at 4.5MHz.

In standard monochrome TV, the 285th and 286th harmonics of 15,750Hz are 4.48875MHz and 4.50450MHz respectively. The scan frequency that has a 286th harmonic of 4.5MHz is 15,734.26Hz ( $4.5\text{MHz}/286=15.734.26\text{ Hz}$ ). The color subcarrier was chosen to interleave with this frequency. With 3.6MHz as the upper limit it was found that the 455th harmonic of one half the horizontal scan frequency is 3.579545MHz [ $455 \times (15734.26/2)$ ]. This color subcarrier frequency is generally referred to as 3.58MHz for simplicity.

## Line phase

Basic comb filter operation takes advantage of some unique characteristics of the NTSC method of signal transmission. The phase of the luma information does not change from one scanning line to the next. As stated earlier, this information forms clusters centered on frequencies which are integer multiples of the horizontal scan frequency (15734.26 Hz).

The phase of the chroma information on the other hand is reversed from one line to the next. This method was adopted because it helps to cancel noise in the picture resulting from chroma signals in

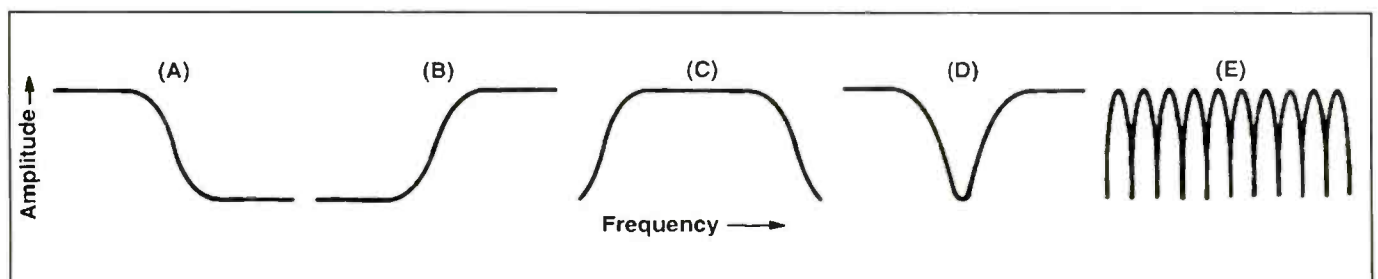

Figure 1. This figure shows some of the more familiar response curves in contrast to the comb response. A. Low-pass, B. high-pass, C. bandpass, D. band-stop and E. comb.



the luma circuits. The chroma information forms clusters centered on frequencies which are odd multiples of one half the horizontal scan frequency. For example, the third multiple of  $15734.26/2$  or  $7,867.13$  is  $23,601.39$  Hz.

### An elementary comb filter

A block diagram of an elementary comb filter is shown in Figure 5. The composite video signal (V) is fed to the input of a delay line. The delay introduced by this delay line is  $63.5\mu\text{sec}$ , which is the same as the period of one complete horizontal cycle (H). Since the delay line retards the signal by one complete cycle, the output (Vd) will be in phase with the input. Any exact multiple frequencies will also be in phase.

The composite signal is also applied to an inverter. When Vd is added to the in-phase but inverted signal (-V), the two signals cancel. The output of the adder contains no luma information.

As the frequency of the input signal deviates from whole multiples of H, cancellation no longer occurs. The output signal is maximum when the input is an odd multiple of  $15,734.26/2$ . The chroma information is, in fact, an odd multiple of  $15,734.26/2$ , so it appears at the output of the comb filter.

Like the luma signal, the chroma signal encounters a delay of  $63.5\mu\text{sec}$  in the delay line. Both Vd and -V from the next line arrive at the adder simultaneously. Since the two signals differ by one line they would normally be out of phase. However, since -V is inverted, they are actually in phase. When the two signals are added the amplitude is doubled.

### A practical comb filter

A block diagram of an actual comb filter is shown in Figure 6. The composite video signal is applied to an amplifier having a 6dB gain. This gain compensates for the insertion loss of the delay line. The passband of the delay line extends from 3MHz to 4MHz. This passband essentially covers the range of the desired chroma sidebands. (luma information within this range will also be passed).

The delayed signal Vd is inverted and added to the attenuated composite signal V. Only frequencies between 3MHz and 4MHz are canceled since they are the only ones passed by the delay line. The output

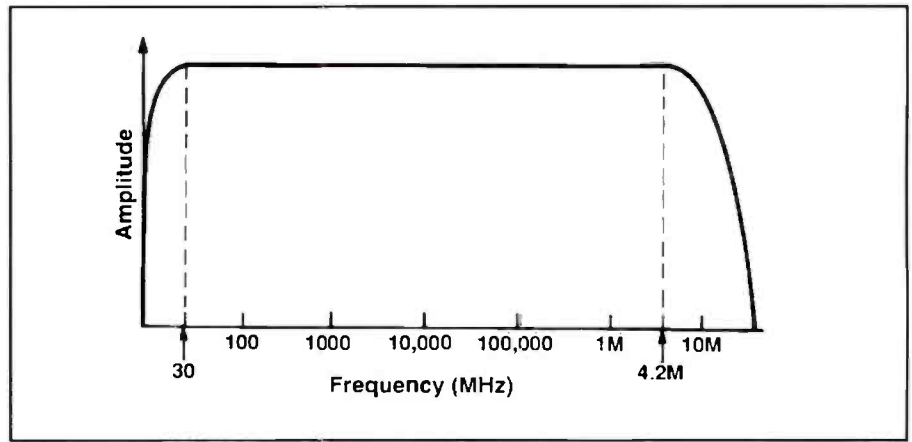

Figure 2. The ideal response curve of a video amplifier is flat throughout the frequency range of 30Hz to 4.2MHz. This takes full advantage of the luma information in the NTSC system.

of the adder contains chroma plus low frequency components of the luma signal. This luma information is below the passband of the chroma circuits and won't interfere with their operation.

The adder's output is also applied to another delaying filter having a 3MHz to 4MHz passband. Since the luma energy is outside this frequency range, only the chroma signal will pass. This signal is inverted and applied to another adder. The second input is the composite video signal which has been delayed to compensate for the delay of the chroma signal. The chroma signals cancel leaving only the full-bandwidth luma signal which is passed to the luma section. In this case there is no doubling of the luma signal since the negative chroma signal contains no luma information.

Comb filters are usually designed as modules having five connections (Figure 7). In practice, SAW (surface acoustic wave) filters are used for the delay lines while op-amps are used for inverting and adding. For more information on SAW filters, see *ES&T* November '95'. Since comb filters contain active devices they require a supply voltage which is typically 12V. The remaining connections are for composite video in, chroma out, luma out and ground.

### CCD delay lines

Some comb filters employ CCD (charge coupled device) delay lines. In many ways these devices operate like digital shift registers. The main difference is that analog, not digital, signals are transferred from input to output. CCDs are also

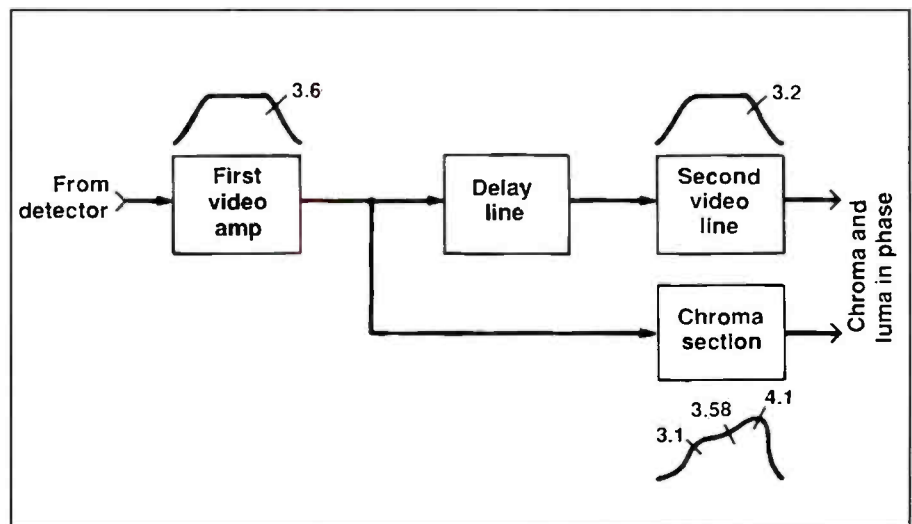

Figure 3. Basic systems sacrifice high-frequency response to avoid beat patterns and other forms of interference resulting from mixing of the chroma and luma signals.

# Test Your Electronics Knowledge

By Sam Wilson

Sam Wilson is currently busy with other urgent projects, and was therefore unable to prepare *What Do You Know About Electronics/Test Your Electronics Knowledge* for this issue. This is a reprise of articles that appeared in a previous issue.

This quiz is mostly about digital, microprocessor and computer terms. The definitions are given. Your assignment - should you decide to accept it - is to supply the terms that go with those definitions. All of the terms are in the matrix. They can be forward, backward, diagonal, read up or down.

1. The sum of the bits when used for error detection  
\_\_\_\_\_.

2. Four bits \_\_\_\_\_.

3. A signal that results in the suspension of the program  
\_\_\_\_\_.

4. Parallel conductors that carry information from one part of a circuit to another  
\_\_\_\_\_.

5. A specific number of bits. For example, eight bits \_\_\_\_\_.

6. An integrated circuit that has between 10 and 100 gates, or, one of similar complexity  
\_\_\_\_\_.

7. An integrated circuit with 1000 or more gates, or, one of similar complexity \_\_\_\_\_.

8. A type of memory that can be programmed only once. It is a non-volatile memory \_\_\_\_\_.

9. The number 1 in binary number 1000.  
\_\_\_\_\_.

10. A type of register in which the first output bit is the last bit that was entered.  
\_\_\_\_\_.

(Answers on page 44)

Wilson is the electronics theory consultant for ES&T.

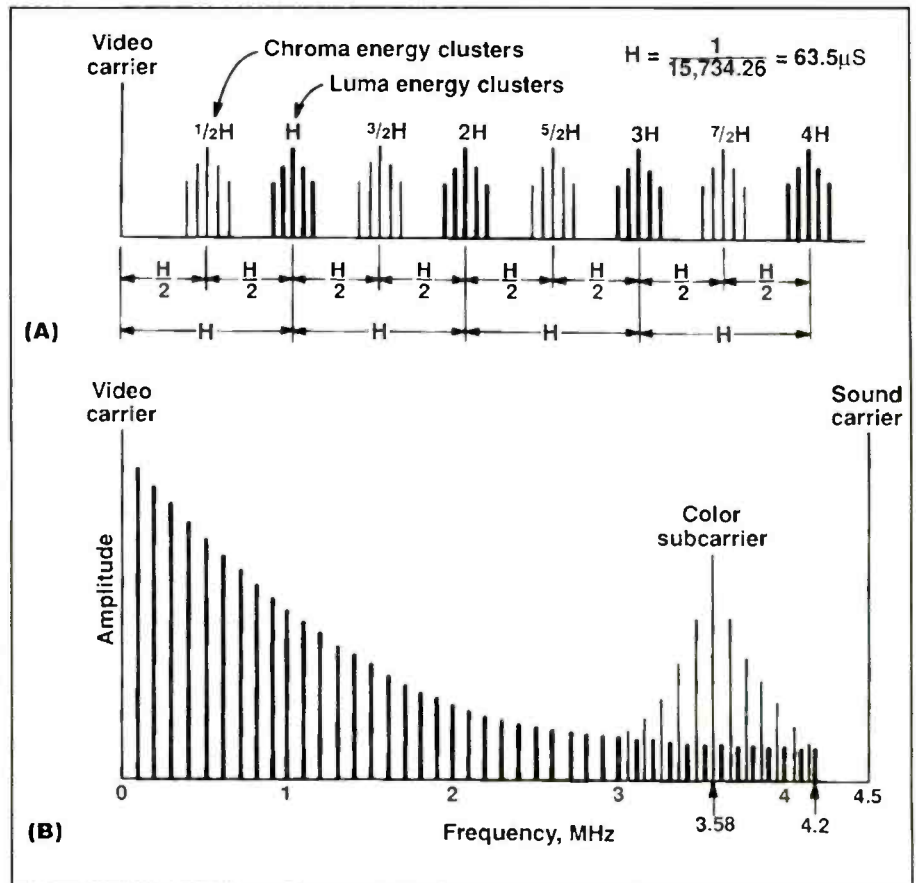

Figure 4. In the NTSC system, chroma and luma information are interleaved to conserve spectrum space and maintain compatibility with monochrome receivers. (A) shows the harmonic relation of the energy clusters. (B) shows the overall relationship between the luma and chroma information.

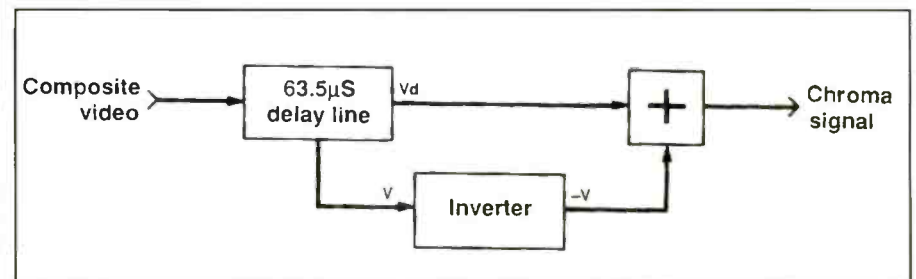

Figure 5. This figure illustrates the basic principal of comb filter operation. It relies on the fact that chroma phase is reversed from line to line while luma phase is not.

used in audio delay circuits for various sonic effects.

Essentially, CCD delay lines consist of a string of cells, each of which is capable of storing a charge which represents a "slice" or "sample" of an analog signal. In the case of a video signal, this could be a single picture element. Internal circuitry causes the charge to be transferred from one cell to the next in response to an external clock signal.

The fire fighter's "bucket brigade"

analogy is often used to describe the operation of the CCD because of the manner in which the signal is passed through the device. At each clock pulse, the input cell will dump its charge to the second cell and recharge to the current value of the input signal. Subsequent clock pulses cause the individual charges to ripple through until they reach the output.

CCD delay lines, having a sufficient number of cells, can hold an entire line of video information including the blanking



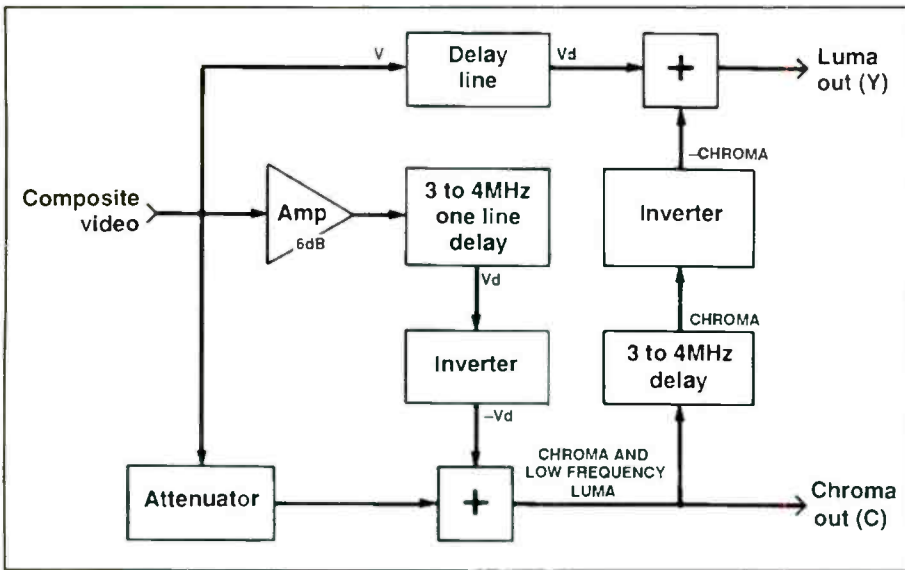

Figure 6. A block diagram of comb filter used by Magnavox. Other television manufacturers use similar designs.

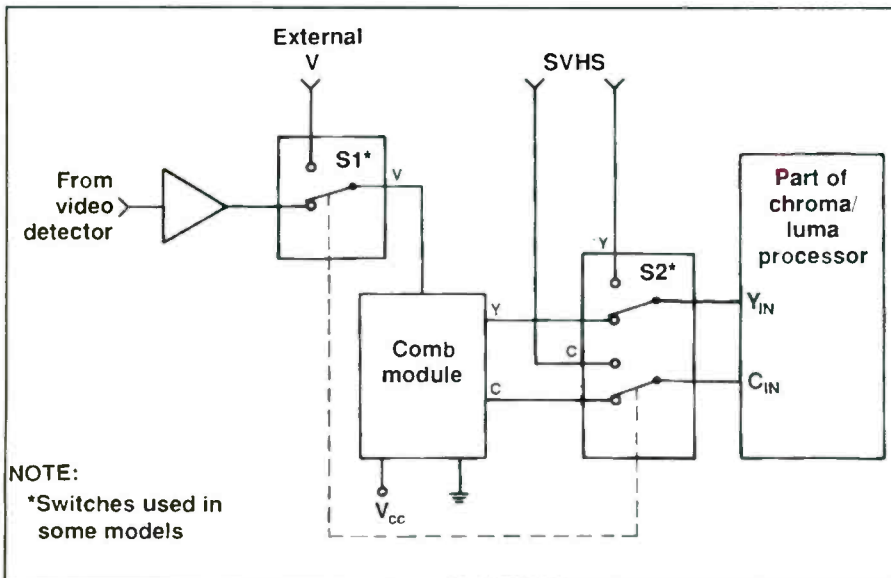

Figure 7. Comb filter modules usually have their input/output pins coupled to the chroma/ luma IC via capacitors, buffer amps and sometimes solid-state switches.

interval with suitable resolution. By using the appropriate clock speed (number of cells multiplied by the horizontal rate) the output will have the required one-line delay. The stepped output signal will be smoothed by a filter circuit.

### Summary

Comb filters are generally reliable, but like any component they can fail. If you suspect a comb filter problem because of distorted or missing chroma, luma or both, it can be tested by scoping the out-

puts. If the input signal and supply voltage are correct while one or both outputs aren't, the module must be at fault. In some cases adjustments may be needed. Consult the service literature.

Through the use of the comb filter, all chroma information is removed from the signal leaving only the luma information. The following video amps can amplify the full-bandwidth signal which translates to increased horizontal picture detail. The 3.58MHz trap in the luma section is no longer required and various forms of interference are eliminated. ■



## WIN A FREE

### ProGold Maintenance Kit

Visit our Web Site at:  
<http://www.caig.com>

See ProGold on Page 25



If you're planning a move in the near future, don't risk missing an Issue of *Electronic Servicing & Technology*. Please give us 6-8 weeks notice if you're planning on changing your address.

Just write us with your new address.

**AND YOUR SUBSCRIPTION MAILING LABEL, to:**

**Electronic Servicing & Technology**  
76 N. Broadway  
Hicksville, NY 11801

old zip code needed for change of address

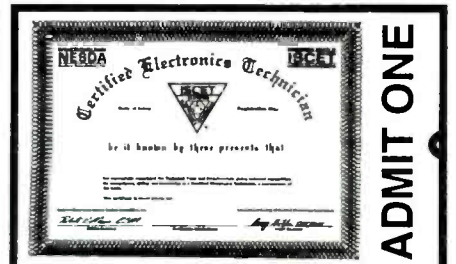

## Your Ticket to SUCCESS

More than 40,000 technicians have gained admittance worldwide as certified professionals. Let your ticket start opening doors for you. ISCET offers Journeyman certification in Consumer Electronics, Industrial, Medical, Communications, Radar, Computer and Video. For more information, contact the International Society of Certified Electronics Technicians, 2708 West Berry Street Fort Worth TX 76109; (817) 921-9101

Name \_\_\_\_\_

Address \_\_\_\_\_

City \_\_\_\_\_

State \_\_\_\_\_ Zip \_\_\_\_\_

\_\_\_\_ Send material about ISCET and becoming certified

\_\_\_\_ Send one "Study Guide for the Associate Level CET Test."

Enclosed is \$10 (inc. postage).

# Servicing TV relay problems

By Homer L. Davidson

In TV sets, relays are used to control the power on/off switch and degaussing coil circuits. In early sets, a relay was used to turn the set on and off. In modern sets, you may find a relay in the degaussing circuits rather than a varistor, or you may find a combination of both a relay and a varistor. Relays in consumer electronics products can cause a lot of problems for the technician.

## Relay problems

A defective relay may fail to turn on, causing a dead chassis (Figure 1). The relay may click on, chatter, and turn off. Sometimes the relay will not turn on and at other times it will not turn off. A defective power regulator can cause the relay to fail to operate.

A defective control IC may energize the relay, turning the chassis on when no one is operating the TV set. A defective relay may operate intermittently, producing erratic operation of the set.

There are many symptoms in the TV chassis that may be caused by a defective relay circuit. In one Goldstar CMT-4842N, the relay clicked on and then opened again. An NEC CT2006A TV had a dead chassis when the relay would not close. In a Sanyo AVM250 portable, the relay would not open, so the set would not shut off. In a Goldstar CMT4842, the relay closed, but the set remained dead. A defective relay circuit in a Fisher PC2525 TV produced intermittent shutdown. The

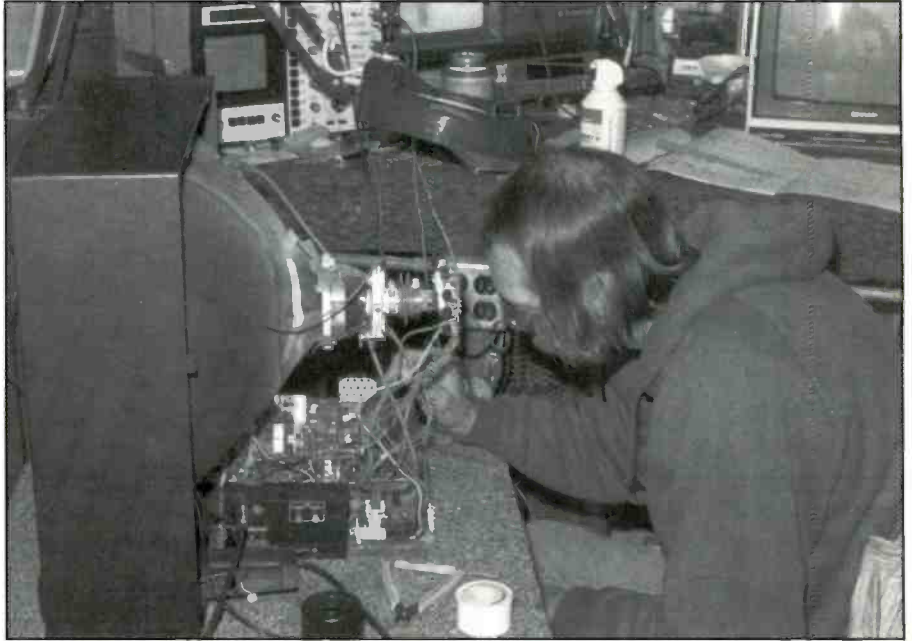

Figure 1. If you encounter a set that does not turn on, check the power relay circuits. If you encounter a set in which you suspect the degaussing circuit, check the degaussing relay.

relay would not turn on in a Sanyo 91C90 model with no tuner or remote function, and on it goes.

## Relay control

The contacts of the power relay, which perform the switching of the ac line power, are in the power line circuits of the low-voltage power supply, while the solenoid winding that controls the switching may be controlled by a microprocessor and transistor control circuit (Figure 2). In early sets, power relays were controlled by switching a dc voltage.

In most instances, the relay contacts are

in the off position when the solenoid is not energized. When the solenoid is energized, the relay power contacts apply ac voltage to the bridge rectifier circuits in the low-voltage power supply.

The power relay control circuits may consist of a power processor or IC that controls the remote and other features of the TV chassis. A relay driver transistor is controlled by the microprocessor in a directly driven circuit (Figure 3).

The collector terminal of the relay driver transistor is connected to the winding of the power relay.

When dc current is drawn through the

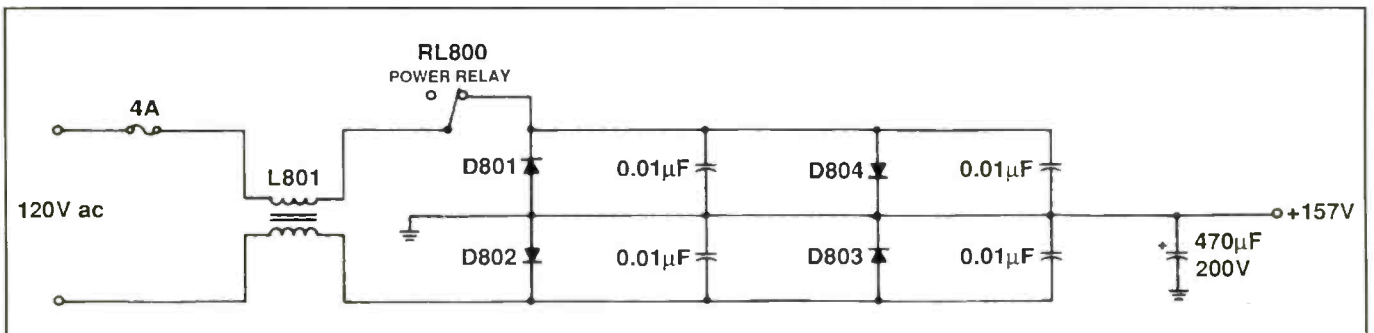

Figure 2. The power relay connects ac power to the bridge rectifier circuits in the low-voltage power supply.



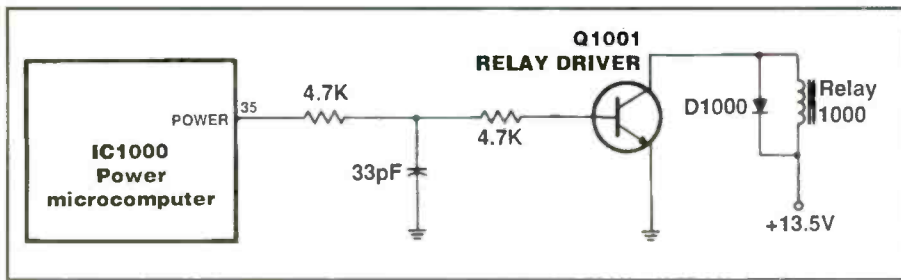

Figure 3. In this set, the power switching relay is controlled by a relay driver transistor when it receives a signal from power terminal 35 of microcomputer IC1000.

solenoid from a dc source, the transistor turns on and energizes the solenoid winding, resulting in closed circuit contacts. In many cases there is only one relay driver transistor, but in other cases, there may be two or more transistors in the degaussing coil circuits.

### Degaussing coil relay circuits

The degaussing coil relay circuits are designed to provide ac voltage to the degaussing coil and then turn off in a few seconds. Often in newer sets, the degaussing circuit relays are controlled from a microprocessor with at least two different transistors (Figure 4). The IC may control many other circuits as well as the power or degaussing relay circuits.

Microcomputer U1110 applies a 4.8V bias to the base of degaussing switch transistor Q1111. The control signal from the collector circuit applies voltage to the second degaussing switch Q1114 (Figure 5). Relay R1004 is connected in series with

the collector terminal of transistor Q1114 and the +12V source. Q1114 energizes the solenoid winding and the degaussing relay clicks on, applying voltage to the degaussing coil.

The degaussing coil is in series with the ac power line and relay switch contacts. Power line voltage from the ac cord is applied to the 4A fuse, L4001 winding and to the degaussing relay switching terminals (Figure 6). The other side of the ac power line is connected to a winding of L4001 and in series with the degaussing coil. When relay K4112 is energized, the switching points of the relay connects the power line voltage across the degaussing coil (L4201) and RT4201.

### Defective relay circuits

A defective relay may chatter at turn on, or it may have worn or burned or pitted switching contacts, an open solenoid winding, poor soldered contacts, or a shorted winding. A shorted silicon diode



Figure 4. The large microprocessor control IC in this set controls the relay and many other functions essential to operation of the set.

## IMPROVE & PROTECT Metal, Conductive Plastic, & Carbon-based Connections!

# ProGold™

### Enhancer & Protector for metal connections.



- Improves Conductivity
- Reduces Noise & Distortion
- Improves Definition & Clarity
- Extends Dynamic Range
- Seals & Protects Surfaces

"Corrosion problems on very sensitive connectors have been an annoying problem for us. We have tried many products without success until we tried CAIG's ProGold & DeoxIT. ProGold & DeoxIT are the only products that have worked perfectly. We highly recommend them." **Xerox Corp.**

"The ProGold works great. I used it on some old tube equipment and it eliminated a loud hum that I thought was something more serious. ProGold also got rid of the recurring contact noise in a rotary control that usually returned after using other sprays. Even works on keeping oxidation from metal panels and knobs." **NewsStudio Sessions Editor, RADIC WORLD**

## NEW CaiLube MCL™

### Enhancer & Protector for conductive plastics & carbon-based connections.

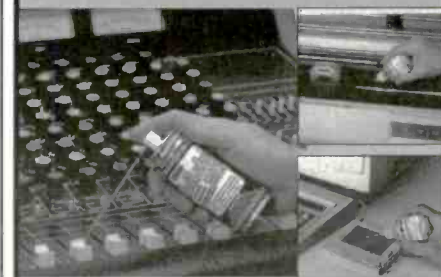

- Lubricates Potentiometers, Switches, Pots,  
& other Sliding Surfaces
- Maintains Optimum Signal Quality
- Reduces Wear & Abrasion
- Maintains Tactile Feel
- Improves Conductivity

"This sensor group here at RANE has found, to date, the CAIG CaiLube MCL formula to be the most effective lubricant for preserving electrical properties of potentiometers. CAIG developed this product, in part, by researching samples that we provided from high-use commercial applications. This thorough consideration of real world application problems insures that the MCL product will be the standard for some time to come." **RANE Corporation**

CAIG Products ... used by those who demand the best!

Ampex	General Electric	McIntosh Labs	Tektronix
Diebold, Inc.	Hewlett-Packard	Motorola	Texas Inst.
Dolby Lab.	Honeywell	FANE Corp.	Wayne-Dresser
Fluor Mfg. Co.	IDI, Inc.	Switchcraft	Xerox Corp.

**CAIG**  
LABORATORIES, INC.

16744 West Bernardo Drive  
San Diego, CA 92127-1904  
TEL: 619/451-1799  
FAX: 619. 451-2799  
E-Mail: caig123@aol.com  
URL: http://www.caig.com

1-800-CAIG-123

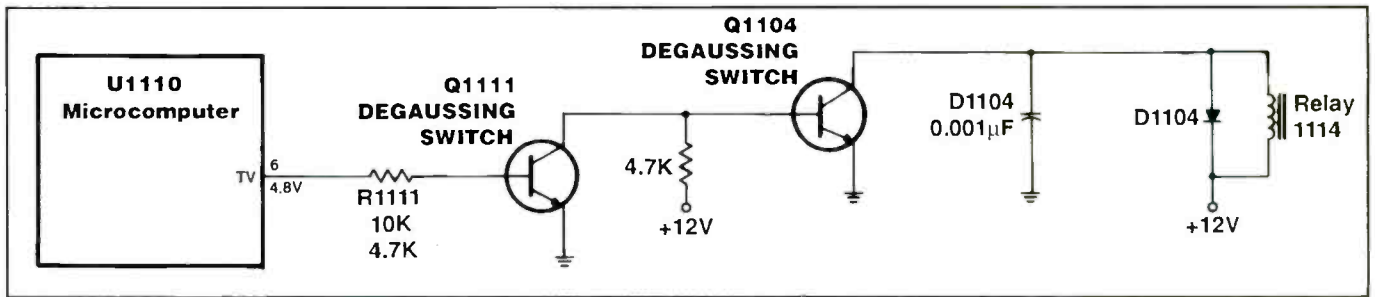

Figure 5. This degaussing relay circuit includes two degaussing switch transistors and microcomputer IC (U1110).

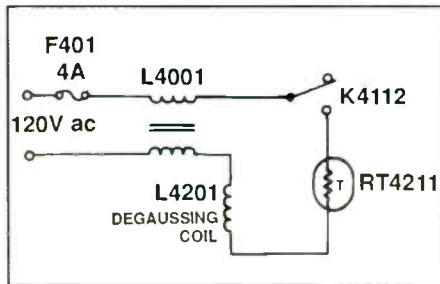

Figure 6. This TV picture tube degaussing coil circuit consists of a 4A fuse, L4001, RT4211, L4201 degaussing coil, and relay points of relay K4112.

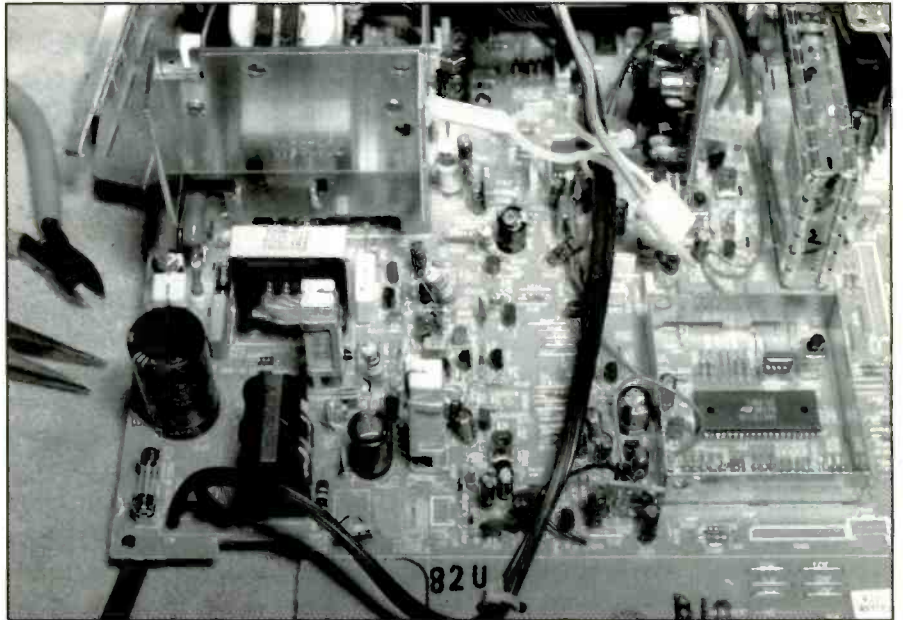

Figure 7. When you suspect that a faulty capacitor in the power supply is causing a relay to malfunction, shunt the low-voltage filter capacitor with a known-good capacitor of the same value, and check voltage from the low voltage source fed to the relay and transistors.

across the solenoid winding will not let the relay energize or close contacts. The defective relay might fail to turn on power to the TV chassis or degaussing circuits. Always replace a relay that you suspect has burned or pitted contacts.

A malfunctioning relay caused intermittent shutdown in a Fisher PC2525 chassis. Worn or dirty relay contacts can cause intermittent chassis operation. Bad or poorly soldered solenoid and switching contact connections to the relay from the PC board can cause intermittent power or degaussing action.

A relay may malfunction (fail to energize, or chatter) for any of a number of reasons:

- the relay itself may be defective,
- the voltage to the relay solenoid may be of the wrong value,
- a filter capacitor may be dried-up or defective,
- a diode across the solenoid may be defective,
- intermittent signal from the micro processor.

A defective resistor R504, 250Ω, had changed value in an Emerson ECR136 and produced relay chatter.

Improper or no voltage from the low voltage source can cause intermittent operation, or a dead set. If the voltage ap-

plied to the relay circuits is 1V or less, the result may be erratic turn-on and turn-off.

A defective filter capacitor in the low voltage source can cause the voltage to the relay solenoid to be abnormally low, thus causing improper operation of the relay. A leaky or open transistor regulator can cause low supply voltage to the relay winding. A leaky zener diode in the low voltage regulator transistor base circuit may cause intermittent relay operation or failure of the relay to operate.

#### Defective relay control circuits

A defective or leaky control microprocessor IC can cause a dead chassis or failure of degaussing action. Check the voltage at the IC terminal applied to the base of the power-on degaussing switch transistor, with remote turned on. An open or leaky driver transistor results in the failure of the relay to energize.

If the voltage applied to the control IC

or transistor relays is incorrect, or if this voltage is zero, the result may be failure of the set to turn on, or turn-on followed by chassis shutdown. To check for this condition, measure the voltage at the microprocessor drive terminal.

#### Problems caused by electrolytic capacitors

Incorrect voltages applied to the control IC or transistors may be the result of electrolytic capacitors that have become reduced in capacitance. You can check these capacitors by placing a known good capacitor in parallel with each of the filter capacitors within the relay low voltage source, in turn, and checking to see if the voltage changes (Figure 7).

Leaky driver transistors can cause low or improper voltage from the power source. Check for possible leaky ICs or components that may be supplied by the same voltage source.

(Continued on page 39)



### Relay malfunction in a Goldstar CMT9165

In a Goldstar CMT9165 TV the relay was dead. The voltage at pin 6 of IC11 was low. In one of these sets, replace IC11 if the 11V supply voltage to pin 6 of this IC is 0V. Check the voltage applied to each transistor and compare with the values specified on the schematic. Unfortunately, some wiring diagrams do not list these voltages.

If you can't find the specified values for these voltages in the service literature, compare the voltages that you measure in the degaussing or power relay circuits to values that you measure in another, known-good, chassis. Test each transistor in the circuit and replace any that do not have the correct measurements.

### Always suspect relays

Modern relays are quite reliable. However, relays are electromechanical devices, and any time such a device is connected to an electronic system, it becomes

### No relay action in a Goldstar CMT4408

The power relay would not energize in a Goldstar CMT4408 TV. I didn't have a schematic diagram for this set, so I searched the set visually until I located the power relay and then traced the circuit back to a transistor (Q802).

When I pressed the power-on button on the remote control, the voltage at the collector and base terminals of transistor Q802 did not change (Figure 8). I traced the emitter terminal connection and found that it was connected to common ground. When I traced the circuit from the base of the transistor I found that it was connected to a 1.8Ω resistor, the other end of which was connected to pin 36 of IC01.

I monitored the voltage at pin 36 while I pressed the power-on button on the remote control unit. There was no voltage change at this point either. The sup-

ply voltage to pin 10 of IC01 was normal. Resistance measurement between pin 36 and common ground did not indicate abnormal leakage.

All of these tests pointed to IC01 as the cause of the problem, so I ordered a factory replacement (part number 06300536). After I had replaced IC01, I measured 3.2V at pin 36 and the remote control unit now was able to turn on the set.

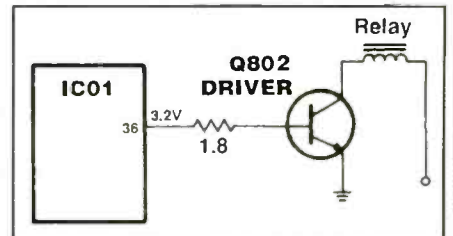

Figure 8. In this Goldstar CMT4408 set, IC01 was defective and failed to energize the relay.

a likely candidate for failure. Moreover, the degaussing circuits carry a considerable amount of current, and circuits that carry large amounts of current are prone to failure. Therefore, any time a circuit in

which a relay plays an important role fails, suspect the relay first, then look at the circuitry that controls and is controlled by the relay. Then, if it's not related to the relay, look elsewhere. ■

### Defective regulator-no relay action

The relay would not turn on in a Goldstar CMT2612 portable. At first relay (RL801) was suspected. Contact points were checked and appeared normal. A continuity test of the solenoid was good. The voltage at the relay and the driver transistor (Q802) was zero. According to the schematic, a 10V source voltage should be found at the relay.

I traced the 10V source back to a separate low-voltage power supply (Figure 9). Transistor T803 supplied ac to the silicon

diode D815, filtered with C830 (220μF). Higher than normal voltage was measured at the collector terminal of voltage regulator (Q803).

The voltage regulator was tested in the circuit and found open. Zener diode D816 was checked after Q803 was removed from the circuit and tested normal. Replacement of open transistor Q803 restored the 10V source to the relay circuits in the set.

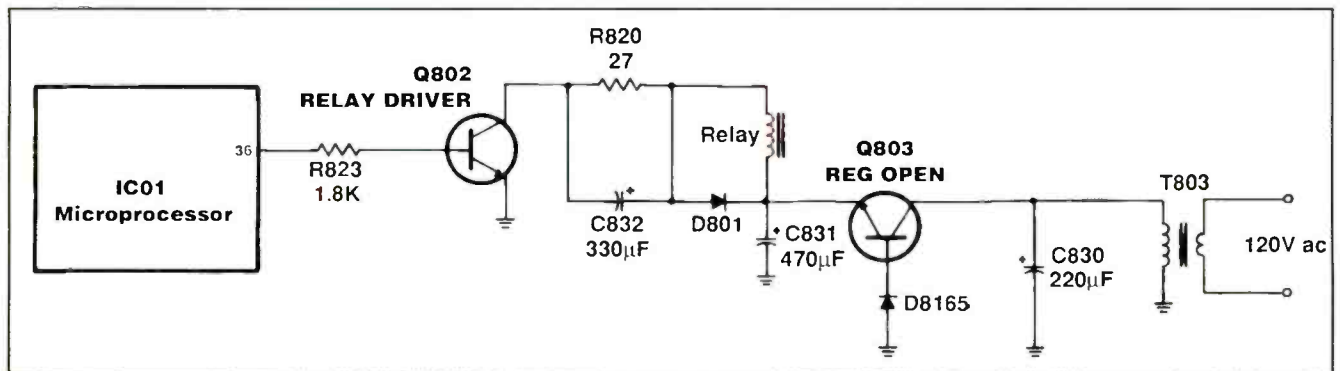

Figure 9. No voltage at relay RL801 in a Goldstar CMT2612 chassis was caused by an open Q803 regulator.

### No degaussing—RCA CTC166CR

I suspected that the degaussing circuits in an RCA portable TV were not operating. After I changed the location of the TV set and turned it on, impurities were found on the TV screen of different colors, which confirmed this suspicion. The degaussing circuits in this set connect to a fuse (F4001), coil L4001, degaussing coil L4201, thermistor RT4201, and relay contacts of relay K4112 (Figure 10). Further inspection revealed that the relay points did not close when remote power was applied to the set.

I first checked the continuity of the components within the degaussing circuits. They appeared normal up to the relay switch. I turned the power off and soldered a piece of wire across the relay terminals to simulate closing of the relay terminals.

When I again applied power, degaussing of the picture tube began. I quickly turned the set back off. Operation of the set with the relay bypassed confirmed that the trouble was in the relay circuits.

Upon checking the schematic, I found that the control microprocessor (U301) provided control of the degaussing circuit out of pin 20 to the base of degaussing switch transistor Q3302. The voltage at the relay and collector terminal of Q3302 was around 11.7V.

Next, a quick continuity check of the relay solenoid measured less than  $1.27\Omega$ . Diode CR4114 across the relay winding was shorted preventing the relay from energizing. Replacement of this diode returned the set to normal operation.

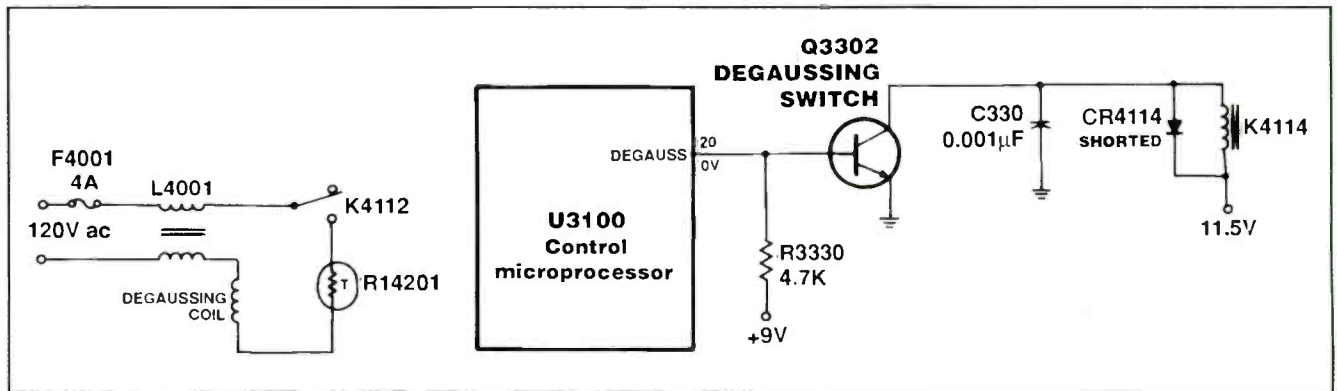

**Figure 10.** A shorted silicon diode (CR4114) across the solenoid winding of degaussing coil relay K4114 in an RCA CTC166 chassis caused failure degaussing action.

### Intermittent turn on and off

Sometimes the degaussing circuits in an intermittent RCA CTC157 chassis would energize and operate properly, and at other times they did not operate. At first I suspected U3100 and one of the switching transistors. The schematic revealed that the two switching transistors were used in the relay circuits. Voltage tests upon U3100 and Q3111 were normal. The voltage on degauss switch Q3110 was quite low, however (Figure 11).

The 9V supply voltage for this circuit was traced back to the low voltage power supply. The voltage source of degauss

switch Q3110 was tied to regulator Q4107. A quick voltage measurement at the emitter terminal of Q4107 showed 0.7V. Resistance measurement from the emitter terminal of Q4107 was fairly normal.

When the degaussing circuits of the set failed to operate, the circuit voltage to Q3110 was less than 1V. No doubt Q4107 was intermittent and would open up. I replaced Q4107 with the exact manufacturer's replacement part number (157627), which solved the intermittent problem.

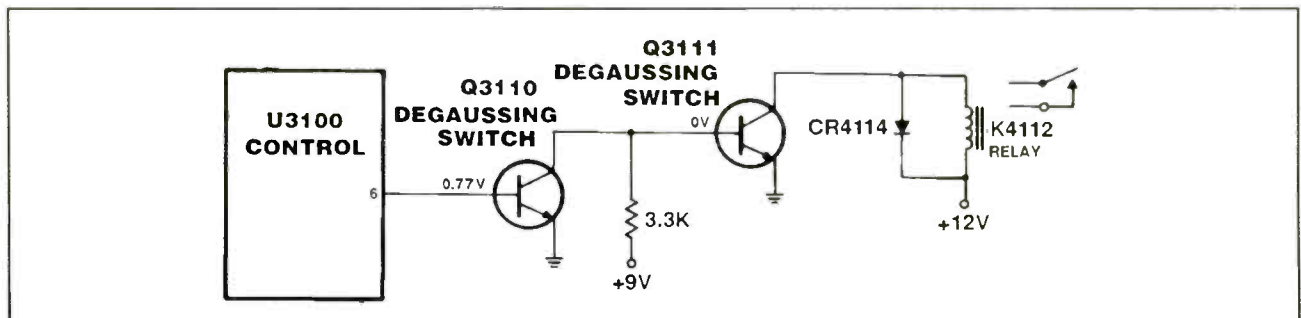

**Figure 11.** Intermittent Q4107 caused erratic degaussing and TV operation in the RCA CTC157 chassis.



# PHOTOFACTS

## FISHER

G6C-60130 .....3757  
PC-6013 .....3757

## GE

CTC185B .....3748  
19GT357TX1 .....3748

## MAGNAVOX

PR1316C121 .....3750  
PR1357B121 .....3756  
PR1397X121 .....3756  
PR1397X122 .....3756  
PR1901C121 .....3754  
PR1901C127 .....3754  
TS3562C101 .....3749  
13PR12C221 .....3750  
13X601-00AA .....3750  
13X603 .....3756  
13X603-00AA .....3756  
19X620-00AA .....3754  
19X622 .....3754  
35R502-00AA .....3749

## PANASONIC

AEDP272 .....3761  
AEDP276 .....3759  
CT-27G31CU .....3761  
CT-27G31U .....3761  
CT-32G31U .....3759  
CT-32G31UU .....3759  
PV-4652-K .....VCR-283  
PV-4653 .....VCR-283  
PV-4659 .....VCR-283  
PV-4669 .....VCR-283

## PHILIPS

35PS62C101 .....3752  
35R502-00AA .....3752

## QUASAR

VHQ660 .....(sim to) VCR283  
VHQ660-K .....(sim to) VCR283

## RCA

CTC175A2 .....3760  
F20201WNTX3 .....3760  
F20301SFTX3 .....3760  
F20301SFTX4 .....3760  
F20602SEJX3 .....3760  
F20602SETX3 .....3760  
F20602SETX4 .....3760  
X20102SGJX3 .....3760  
X20102SGJX4 .....3760  
X20102SGTX3 .....3760

X20102SGTX4 .....3760  
X20103SGJX1 .....3760  
X20103SGTX1 .....3760  
X20103SGTX2 .....3760

## SAMSUNG

CT-3373CA .....3751  
CT-5073CA .....3751  
K1 .....3751  
TCD1372/UCX .....3751  
TCD1373/UCX .....3751  
TCD1382/UCX .....3751  
TXD1373 .....3751

## SHARP

25HS60 .....3758

## SONY

KV-20M20 .....3755  
KV-21PM1 .....3755  
KV-21R20 .....3755  
KV-21RD1 .....3755  
SCC-J84B-A .....3755  
SCC-J93B-A .....3755  
SCC-J94B-A .....3755  
SCC-J95C-A .....3755  
SCC-J95D-A .....3755

## ZENITH

SY2751Y .....3753  
SY2765S .....3753  
SY2765SM .....3753

## ES&T Calendar

Home Automation Show and  
Conference  
Feb 9-11, 1997  
Orange County Convention Cntr.  
Orlando, FL  
203-840-5658; 203-840-5858

Major Appliance Servicers Convention  
and Trade show  
April 3-4, 1997  
Orlando, FL  
800-743-0455

CES Mobile Electronics - The 12-Volt  
Educational Forum  
April 4-6, 1997  
Atlanta, GA  
703-907-7674

Support Systems Expo  
May 14-15, 1997  
Boston, MA  
207-846-0600

Spring Comdex/CES Orlando  
May 23-25, 1997  
Orlando, FL  
703-907-7600

Spring CES '97 co-located with  
COMDEX/Spring WINDOWS  
WORLD  
June 2-5, 1997  
Atlanta, GA  
703-907-7674

CES Habitech '97 - The Home Systems  
Trade & Training Show  
June 24-26, 1997  
Dallas, TX  
703-907-7674

NESDA 47th/ISCET 27th/ and NIAS  
5th Annual National Professional  
Service Convention and Trade Show  
August 4-9, 1997  
Las Vegas, NV  
817-921-9061

CTIA Breakaway '97  
September 18-20, 1997  
San Diego, CA  
702-268-1818 ext. 310

Networks Expo Dallas/Windows  
World  
October 29-31, 1997  
Dallas, TX  
201-346-1400, ext. 145

Personal Computer & Electronics  
Expo  
October 16-19, 1997  
Uniondale, LI, NY  
800-886-8000

# What Do You Know About Electronics?

## What is true and what is false?

By Sam Wilson

*Sam Wilson is currently busy with other urgent projects, and was therefore unable to prepare What Do You Know About Electronics/Test Your Electronics Knowledge for this issue. This is a reprise of articles that appeared in a previous issue.*

It is interesting, and often helpful, to know where some of the ideas used in technology come from. I want to take you on a quick trip through years to explain a concept that is very important in digital and computer circuits.

The trip starts in ancient Greece - sometimes called "The Golden Age." For some unknown reason there was a high concentration of very intelligent people—called philosophers—who were living in Greece. They were beginning to ask tough questions. But more important, they were trying to find a way to answer those questions.

One of the questions—of interest here—was "How do we know what is true and what is false?" They reasoned there must be some way to accept the things that are true and reject the things that are false. Note that they wanted to pick between two alternatives: true (logic 1 today) and false (logic 0 today). They didn't call the choices 1 and 0, but as we move along in time we see that it will eventually get around to those choices.

One approach they used was called a *Syllogism*. That is an argument in three steps and it goes like this:

- 1 - Every time it rains the streets become wet.
- 2 - The streets are wet.
- 3 - Therefore, it is raining.

Of course, that argument is false. I gave that example to show that philosophers who wanted to get to the truth along that path had a lot of work cut out for them.

However, philosophers did the work that was required. By the end of the middle ages that type of argument was brought to near perfection in a field of knowledge called *formal logic*.

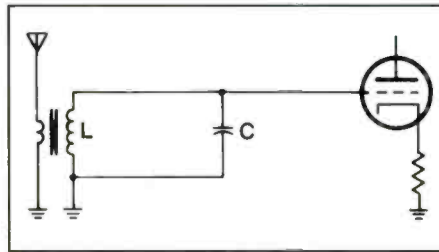

Figure 1. Are L and C in series or in parallel?

Somewhere around that time some spoilers came along and threw a wrench into the works. (One of those spoilers was a genius called Lewis Carol.) Those guys showed that you could follow all of the rules of formal logic and come up with nonsense:

- 1 - All zoomphs are callicads.
- 2 - Morgle is a zoomph.
- 3 - Therefore, morgle is a callicad.

That argument is actually correct as far as formal logic is concerned but you can't tell it is correct when you read the conclusion. What's wrong here?

An obvious answer is that the problem is in the words and in the use of the language. That includes the meaning of terms, sentences, grammar, etc.

To get around that problem you have to substitute symbols for the words, and you need some way to work with those symbols so you always get the right answers. That's why *symbolic logic* was born!

A lot of people must have dropped out of school when symbolic logic hit the classroom. It requires people to think in abstract symbols and terms. For some folks that was like trying to push a boxcar uphill with a rope. But, once again, some people with a lot of smarts came along and eased logic ahead.

George Boole made some rules for manipulating the symbols. With those rules it is possible to arrive at truth (1 or 0) by using some well-known mathematics. Boolean algebra was born.

For a time there were no great jumps in logic, but there were further refinements on the rules. Then, a student in the 1930's

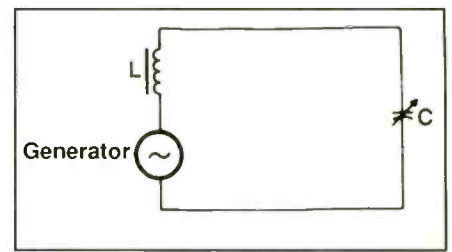

Figure 2. This equivalent circuit shows that L and C are in series.

had one of those mental flare-ups that are called "great moments in history." He showed that Boolean algebra could be used for designing switch circuits. (I can't find his name right now, but, I assure you I will find it and pass it along. A person like that should be recognized.)

From switches to relays to diodes to any device that has two stable states, Boolean algebra could be applied in the design. Logic was off dead center again. It was not long before the first digital circuits used in computers were developed.

### Teaching vs. practical experience

I'll tell you how far back Bruce Hagen and I go. We go back to the days when I was sure I knew everything and Bruce was convinced I didn't. If you have a friendship that can survive that kind of start—hang onto it. It is special. Bruce had a lot of practical experience and at that time I was mostly into theory.

Let's move ahead 15 years. I was teaching electronics and Bruce has a successful TV business with several people working for him. We were in his office one day and I was getting ready to tell him how difficult my job was.

*Intercom: "Bruce, D is on the phone. He says he has to talk to you right away." (D was one of his technicians.)*

*Bruce (picking up the phone): "What's the problem D?"*

*There was a moment of silence. Then WHAT?!?!?!?! THE TRUCK IS ON FIRE?!?!?!?! Another moment of silence, then - "YES! IT'S O.K. TO CALL THE FIRE DEPARTMENT!!!!"*

Wilson is the electronics theory consultant for ES&T.



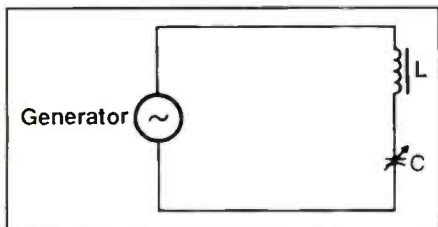

**Figure 3.** Redrawing Figure 2 so that L and C are grouped, emphasizes the series nature of the circuit.

Bruce hung up the phone and stared off into space with a look of complete frustration. We never did get to talk about my teaching problem.

### Unusual responses

Note: Letters discussed in the following paragraphs were sent in the 1970's. This will come as a surprise to some readers, but, I spend a lot of time researching the theory that I need for my work. Apparently, some people think I make all this stuff up in my head.

Refer to Figure 1. I once wrote a CET test question on that circuit. The question asked "Are L and C in series or in parallel?" The answer is, of course, that they

are in series. The way you tell is to look for the source voltage and current path. In this case the voltage is induced in series with the windings. The equivalent circuit is shown in Figure 2, and the circuit is redrawn in Figure 3 for a better view.

Even if a technician didn't know that, the answer could be deduced from the fact that a series tuned circuit selects one frequency and rejects all others. That is the purpose of the radio tuned circuit.

I received a strongly-worded letter from a reader who said: "Even an idiot can tell just by looking at the circuit diagram that L and C are in parallel."

In a way, what he said is true.

I have given both the mathematical and graphical proofs that resistance in a branch of a parallel resonant circuit affects the resonant frequency. In fact, a parallel resonant circuit can be tuned with a variable resistor in one of the branches. (Series circuits are *not* tuned with resistors.) After digesting the proofs that I gave him, a man in North Carolina sent this short note to me: "Series and parallel circuits are the same thing! period!"

A shop manager wrote to me once and

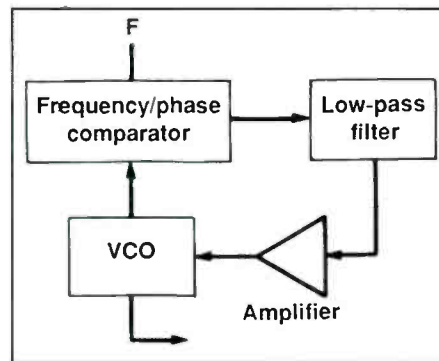

**Figure 4.** A phase locked loop will work fine with an amplifier in the feedback loop.

said that one of his technicians cried because there were "several mistakes" in one of my newly-published books. (As it turned out, only two of those so-called mistakes actually were mistakes). That book had gone through three proof readings, but, mistakes did sneak through.

I always feel bad about mistakes. But, if I had a technician who cried because of mistakes in a book I'd try to get that technician some help.

I once got a nasty letter from a guy who objected to my drawing of a phase locked



The Professional  
**Electronics Technicians Association**  
and the **Satellite Dealers Association**

## Join Us

### CET Certification - FCC License Exams

At all cities and military bases. Study materials on disk, paper and video. Free retake if you do not pass CET 1st time. Test Review available. **Option areas:** Consumer, Industrial, Computer, Satellite, Biomed, Radar, Wireless and TeleCommunications, RF Video Distribution, Fiber Optics, Customer Service, Satellite Installation.

### Employment Help

Join ETA-SDA. Send your resume - We can help. Employers: Call us for highly skilled Certified Electronics Technician staff workers.

**Membership** includes Technical Tips; Technician Assn News journal, Employment assistance; Help line, Technical and business monographs; Seminars on site or via satellite; Participation on tech committees for CET and skills standards. Leadership training; Annual Convention; Student Chapters; Industry recognition; Networking; discounts and a lot more.

### THE ASSOCIATE CET Exam Books

New Study Guides for the Associate Level CET exams. Book 1 contains 248 sample CET Exam Quiz questions and answers. Multiple CET authors. Book 2 different sample quizzes - latest exam topics plus complete listing of over 380 CET exam test sites. Written by CETs, electronics instructors and working technicians. Great study material for every professional electronics technician.

317-653 4301  
602 N Jackson

Greencastle, In 46135

<http://www2.fwi.com/~n9pd/eta.html>

Circle (66) on Reply Card

Just your  
phone and  
an Andrews  
line card...

...and you have over 250,000 different parts in stock. Shipped the same day!\*

AIWA	RCA*	SONY
HITACHI	PROSCAN*	JVC
OPTONICA	GE*	PANASONIC
QUASAR	TOSHIBA	TECHNICS
SHARP	(*Premier)	ZENITH

- Over a 90% Fill Rate
- No minimum orders
- Backorder reports with ETA's mailed biweekly
- No handling charges

- Free or Discounted freight program
- Fast, Efficient Research
- Factory Authorized

\*F applies to orders received by 2:30 PST

Phone 800-289-0300 FAX 800-289-0301

**ae** andrews electronics

P.O. Box 914, Santa Clarita, CA 91380-9014

Inquiries: 805-257-7700

FAX 805-295-5162

Stocking the Largest Inventory of O.E.M. Parts, Accessories, and Service Literature in the Country

Circle (62) on Reply Card

# Test Your Electronics Knowledge

## Answers to the quiz

(from page 22)

1. Checksum
2. Nibble
3. Interrupt
4. Bus
5. Byte
6. MSI (Medium scale integrated circuit)
7. VLSI (Very large scale integrated circuit)
8. ROM (Read only memory)
9. MSB (Most significant bit)
10. LIFO (Last in, first out)

loop (Figure 4). He said that it would not work with an amplifier in the loop. (Of course, he was wrong about that.)

He let me know in no uncertain terms that he had much experience in such things and listed a few of his qualifications. To ice it, he listed his first class FCC license number.

I had never seen that done before, and, I haven't seen it done since. When I answered his letter I gave my driver's license number. You won't believe this, but, he did not see the humor in that. He wrote another terse letter to ISCET and let them know how he felt.

### Mnemonics

You are on an errand when someone jumps out of a fast taxi and says: "I must know the value of pi to 14 decimal places and I need to know it now! He offers you a pencil and notepad. You write:

*How I want a drink, alcoholic of course, after the eight chapters involving quadric mechanics.*

He glances at the note, smiles, and returns to his taxi. (Explanations at the end of this article.)

On your way home you stop at a park to rest. A little girl sits beside you. She is obviously troubled.

"Problem?" you ask. "We're having a geography test tomorrow and I'm not going to pass. I can never remember the names of the great lakes."

"Well," you say, "you only need to remember one word: homes."

"Gee thanks" she says and leaves.

When you return home you have the feeling you can answer any questions. You step inside your house and your wife is waiting with a question of her own. "Can you tell me why it takes so long to pick up a head of lettuce at the store?"

As you turn to go out again you explain "because it takes two trips."

You can't get everything done just by using mnemonics.

### Explanations

The value of pi is obtained from the number of letters in each word: 3.14 159 265 358 979.

Each letter in the word "homes" stands for one of the lakes: Huron, Ontario, Michigan, Erie and Superior. ■

# THE FIRST UNWRITTEN LAW OF VCR REPAIR

**GEAR ADJUSTMENTS ARE THE LEADING CAUSE OF INSANITY AND RAGE AMONG VCR SERVICE TECHNICIANS.**

To help in finding the cure, call:

**1-800-428-7267**

The technicians at Howard Sams had your well-being in mind when they re-engineered *VCRfacts*® to include mechanical alignment information with exact placement of gears and gear assemblies. See how simple it can be!

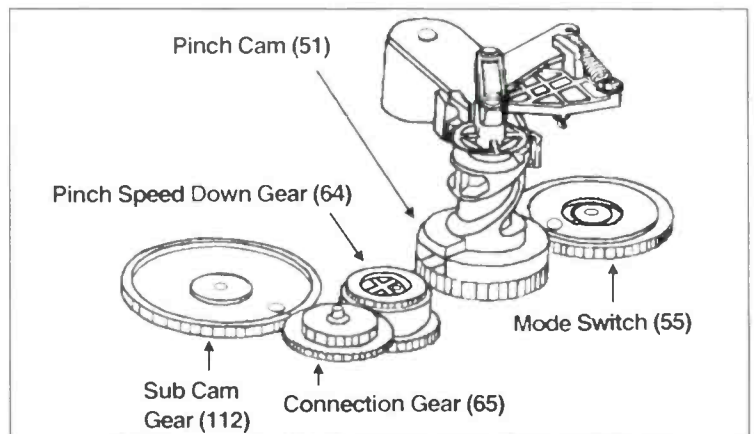

In anticipation of other common problems, *VCRfacts*® also features consistent standard-notation schematics, electronic parts lists, IC functions, interconnect wiring diagrams, and extensive exploded views. Now for your own peace of mind, call us and order your subscription today.

**HOWARD W. SAMS & COMPANY**

2647 Waterfront Parkway E. Dr., Indianapolis, IN 46214

Circle (72) on Reply Card



**Troubleshooting & Repairing Computer Printers, by Stephen J. Bigelow, Second Edition, Tab Electronics Technician Library Tab Books, 471 Pages, Paperback \$24.95**

This book is intended to provide the essential background information on printer mechanics and electronics, along with the techniques that will guide the reader through the troubleshooting and repair of most commercial printers. It is written for the servicing technician or the advanced hobbyist with an intermediate knowledge of electronics and some working knowledge of mechanics. A knowledge of elementary troubleshooting would be helpful, but it is not a prerequisite.

This book describes the basic operation and use of several test instruments. Troubleshooting procedures are presented in a discussion format that will aid the reader's overall understanding of the printer and how it works.

The second edition incorporates some important changes and improvements over the original book. Probably the most notable change is the use of technical illustrations. Rather than the many sketches and interpretations that appeared in the first book, this edition uses an array of schematics, schematic fragments, block diagrams, and exploded views from actual printers. Such "real life" examples provide what the publisher calls unprecedented coverage of a printer's assembly, operation and repair concerns. In addition to the improved illustrations, this edition also expands the coverage of symptoms and solutions of the original. This edition provides 150 symptoms and solutions, whereas the original book offered 60.

A chapter has been added to deal with Windows and Windows 95 printing problems. While purists might criticize this decision as polluting a good hardware book, it is virtually impossible today to separate the hardware from the operating system—even the slightest kink in a configuration can result in printing problems.

Another chapter deals with PRINTERS, the new companion disk for the book. This disk is an extra-cost item, not packed with the book. It must be ordered from the author at a price of \$20.00. According to the author, PRINTERS pro-

vides an inexpensive, handy, multipurpose printer troubleshooting tool capable of testing impact, ink jet and EP printers with equal ease. For the first time, you have a source of "standard" test patterns, which have been specifically designed to help you resolve the major problem areas of most printers. You also can enter escape codes manually to test even the most obscure feature.

McGraw Hill, 11 West 19th Street, New York, NY 10011.

**Troubleshooting & Repairing Compact Disk Players, Third Edition, By Homer L. Davidson, Tab Electronics Technician Library Tab Books, 518 Pages, Paperback \$24.95**

The purpose of this book is to provide practical service data to help make CD repair easier. It can help the beginner, intermediate, or experienced electronics student or practicing technician to further his or her knowledge with compact disc servicing methods. The reader will be able to go as far as he wants to with the easiest or the most difficult repairs, according to the publisher. Troubleshooting and repairing compact disc players has opened up another field in consumer electronics maintenance.

The new third edition contains 13 chapters, beginning with the basic CD principles and hundreds of illustrations, including schematics and photos. And, each chapter contains a troubleshooting chart. Chapter 2 explains how to clean and care for the compact disc. The laser pickup assembly is described thoroughly in chapter 3. How to troubleshoot the low-voltage power-supply sources is explained in Chapter 4. Chapters 5 and 6 describe the signal circuits and servo system in the CD player. How the motor control circuits and motor circuit operate is listed in chapter 7. The D/A and audio output circuits are covered in chapter 8. Chapter 9 includes the critical electronic CD player adjustments, and explains why they are made. Servicing the portable CD player and boom-box CD player are covered in chapter 11, and chapter 12 covers the auto compact disc player and disc changers. The most important chapter in this book, chapter 13, shows you how to troubleshoot the symptoms and service

the player. Tips on how to make CD adjustments with scope waveforms are shown throughout the book.

McGraw Hill, 11 West 19th Street, New York, NY 10011

**Customer Service on the Internet: Building Relationships, Increasing Loyalty, and Staying Competitive, by Jim Sterne, John Wiley & Sons, Inc, Paperback \$34.95**

"Your business isn't wanted." That's what customers hear when they don't get the service they need from a Web site. They ask questions, expect answers, and don't want to be told "no" or "tomorrow." The World Wide Web made customer support a full-time, global service—that's real-time, all the time. Anything less is showing potential buyers the door.

Why do Web customers need service 24 hours a day, seven days a week? Because with 24 time zones, telecommuting, and projects that take all night, that's when they're working. *Customer Service On the Internet: Building Relationships, Increasing Loyalty, and Staying Competitive*, by bestselling author Jim Sterne, teaches Internet business strategies unique to customer service on the Web.

Drawing from real-life examples and Sterne's fifteen years of high-tech marketing experience, the book outlines a complete business plan for providing state-of-the-art service, showing companies how to: cut down on phone support by publishing useful information on the Web; organize information and make it readily available to customers; manage e-mail and on line forums to improve customer loyalty; make it easy for customers to answer their own questions with FAQs; and create electronic focus groups.

Successful Web-based businesses rely on keeping the customer happy. If a company has a Web site, people will use it for customer service—even if that's not its purpose. The book is the blueprint for an on line system that provides more information, in less time, and at a lower cost than traditional customer service.

Note: Wiley books are available at your local bookstore or by calling 1-800-225-5945. In Canada, call 1-800-567-4797.

John Wiley & Sons, Inc, 605 Third Avenue, New York, NY 10158-0012

**ES&T Presents TV Troubleshooting and Repair, Edited by Natalie F. Harris and Conrad Persson, Prompt Publications, 226 Pages, Paperback \$18.95**

This book presents information that will make it possible for technicians and electronics hobbyists to service TVs faster, more efficiently, and more economically, thus making it more likely that customers will choose not to discard their faulty products, but to have them restored to service by a trained professional.

Originally published in *Electronic Servicing & Technology* magazine, the chapters in this book were articles written by professional technicians, most of whom service TV sets every day. These chapters provide general descriptions of television circuit operation, detailed service procedures, diagnostic hints and tips, and more.

Chapters include:

- Is It the CRT That's bad?
- Understanding the CRT Numbering System
- Servicing Monochrome Televisions
- The Status of HDTV
- Troubleshooting the Philips S1/S4 Chassis
- Understanding TV Horizontal Output/Deflection Circuits
- Troubleshooting Secondary Voltage Circuits
- TV Power Supply Troubleshooting
- Color Television Receiver Circuits
- Electronic Tuner Theory and Troubleshooting
- Servicing Vertical Foldover Problems
- Constructing a Tuner Subber
- Build a Tester for Infrared Remote Controls
- Homemade Isolation Transformer to Cure H-K Shorts

Howard W. Sams A Bell Atlantic Company, 2647 Waterfront Parkway E. Drive, Suite 300, Indianapolis IN 46214-2041

**Servicing Audio and Hi-Fi Equipment, Second Edition, By Nick Beer, Butterworth Heinemann, 304 pages, Hardcover \$47.95**

This new edition includes the Mini Disc, DCC, Dolby Surround Sound and PreLogic, along with newer formats and products such as CD-I. The mechanics and electronics of domestic audio are ex-

amined by Nick Beer in a down-to-earth, practical way, concentrating on what goes wrong, how to track down problems, and how to solve them.

Butterworth Heinemann, 313 Washington Street, Newton, MA 02158-1626

**Web Site Source Book 1996, Edited by Darren L. Smith, Omnigraphics, 522 pages, paperback \$65.00**

Designed especially for business and professional users, the *Web Site Source Book* provides key information for more than 7,100 World Wide Websites of important businesses, organizations, agencies, and institutions throughout the United States. These sites represent information resources that professional and business users can rely on for authoritative information about a wide range of subjects.

Entries in the book appear in two sections. The first section is arranged alphabetically by the name of the sponsoring company, agency, or organization. In this section users can quickly find listings for the National Institutes of Health, the University of California, or General Motors, for example.

Both sections contain complete entries, which include the name of the company or organization, its web site address (URL), complete mailing address, telephone number (including toll-free number is applicable), fax number, and e-mail address. The contact information provided in the book enables users to locate web sites and reach listed companies and organizations via e-mail, regular mail, telephone, or fax - even when such information is not provided at the web site.

The scope of the *Web Site Source Book* makes it useful for business and professional users, and it also serves a range of other information needs. Among the nearly 100 categories covered are the following: Arts and Entertainment, Banking and Credit, Cities - U.S., Computer Equipment and Software, Educational Institutions, Government and Politics, Health and Medicine, Hotels and Resorts, International, Investment and Holdings, Magazines and Newsletters, Media, Newspapers, Online Services/Internet, Publishing and Printing, Recreation/Sports/Hobby, Retail Sales, Science

and Technology Organizations, States - U.S., Telecommunications, Travel and Transportation and more.

Omnigraphics, Inc., Penobscot Building, Detroit, MI 48226

**Electronics Terminology, A Concise Dictionary, By Informatik Rezurch, Butterworth Heinemann, 96 pages, paperback \$12.95**

*Electronics Terminology, A Concise Dictionary* consists of two sections, acronyms and glossary, featuring electronics, packaging and production, computer, and semiconductor terms and definitions which are current and straight-to-the-point. Many acronyms and definitions are cross-referenced for complete coverage. Its shirt-pocket size makes it a handy quick-reference source for engineers and technicians on the move.

Butterworth Heinemann, 313 Washington Street, Newton, MA 02158

**Real-World Interfacing With Your PC, By James "J.J." Barbarello, PROMPT Publications, 119 pages, \$16.95**

PROMPT Publications announces the release of *Real-World Interfacing With Your PC*, a book that provides all the information necessary to use a PC's parallel port as a gateway to electronic interfacing.

As personal computers become increasingly prevalent in American society, their uses and applications continue to grow. Modern software allows users to do everything from balance their checkbook to create a family tree. But interfacing is truly the wave of the future for those who want to use their computer for things other than manipulating text, data, and graphics.

The book is the hands-on guide to parallel port projects. In addition to hardware basics, this book provides a basic understanding of writing software to control that hardware. It walks the reader through an actual project, from design to construction to checkout. While the book is geared towards electronics hobbyists, a chapter on project construction techniques, as well as a checklist for easy reference and a recommended inventory of starter electronic parts adapt the book to readers at every level.

PROMPT Publications, 2647 Waterfront Parkway E. Drive, Indianapolis, IN 46214



# ES&T 1996 Department Index

<b>AUDIO CORNER</b>	<b>Month</b>	<b>Page</b>		<b>Month</b>	<b>Page</b>
Now hear this By John S. Hanson	Oct	54	Basic theory and basic math By Sam Wilson	May	30
<b>BUSINESS CORNER</b>			We get letters By Sam Wilson	Jul	42
Will Total Quality Management work for you? By John A. Ross	Jan	48	A few electronics math problems By Sam Wilson	Aug	19
Administering business contracts By Charles Varble, Jr.	Feb	54	Test Your Electronics Knowledge By Sam Wilson	Sep	49
Cut your technicians' salaries and let them earn more By Charles Varble, Jr.	Apr	61	Test Your Electronic Knowledge By Sam Wilson	Oct	42
Price your parts for profits By Charles Varble, Jr.	May	58	Test Your Electronics Knowledge By Sam Wilson	Nov	55
Selling and pricing service By Charles Varble, Jr.	Jun	57	A review By Sam Wilson	Dec	50
Examine your ratios to improve your business By Charles Varble, Jr.	Aug	20	<b>VIDEO CORNER</b>		
Try value pricing to increase your profit By Charles Varble, Jr.	Sep	50	Remote chance By John S. Hanson	Oct	57
<b>COMPUTER CORNER</b>			<b>WHAT DO YOU KNOW ABOUT ELECTRONICS?</b>		
Implementing and maintaining a power-saving video system By Stephen J. Bigelow	Apr	66	Mostly radio By Sam Wilson	Jan	44
Look what's on the 'Net' By David F. Norman	May	62	Antennas and communication systems By Sam Wilson	Feb	48
<b>STRICTLY BUSINESS</b>			Random thoughts By Sam Wilson	Apr	24
Professional service contracts are good for everyone By Charles Varble, Jr.	Jan	1	Integral Calculus By Sam Wilson	May	65
Total quality service: how to make it happen in your business By Larry Schnabel	Jan	2	Graphical solutions to calculus problems By Sam Wilson	Jul	54
Insurance: which type is right for you? By Dale C. Shackelford/ Carroll Dohrn	Jan	6	Teaching with experiments By Sam Wilson	Aug	66
<b>TEST YOUR ELECTRONICS KNOWLEDGE</b>			Visual modulation By Sam Wilson	Sep	56
Consumer Electronics By Sam Wilson	Jan	43	Graphical analysis of capacitor characteristics By Sam Wilson	Oct	50
Abbreviations and acronyms By Sam Wilson	Feb	14	Percentages By Sam Wilson	Nov	58
Subjects at random By Sam Wilson	Apr	23			

# 1996 ARTICLE INDEX

<b>BASICS</b>	<b>Month</b>	<b>Page</b>		<b>Month</b>	<b>Page</b>
A technician's glossary By The ES&T Staff	Mar	16	Dynamic VCR head check By W G	Feb	8
Motors in consumer electronics By The ES&T Staff	Mar	14	Finding substitutes for passive components By Tom S. Jones	Feb	28
Lighting and magnification By The ES&T Staff	Apr	14	Servicing the vertical circuits in the Sharp 19SB60R By Homer L. Davidson	Mar	8
Setting up a service bench By The ES&T Staff	Jun	20	CRT setup adjustments By Arthur N. Flavell	Apr	16
Chemicals in electronics By The ES&T Staff	Jul	8	Servicing the deadly TV chassis By Homer L. Davidson	Oct	16
Manufacturers on the network By Victor Meeldjick	Aug	9	Servicing the RCA CTC 175/177 color television set By Bob Rose	Nov	11
Companies on the network By Victor Meeldjick	Sep	28	Understanding the bipolar transistor—Part 1 By Steven Jay Babbert	Nov	44
CD player fundamentals—Part 1 By Sam Goldwasser	Oct	8			
Circuit board and parts handling By The ES&T Staff	Nov	8	<b>SOFTWARE</b> General software for service centers By The ES&T Staff	Feb	13
Power protection By The ES&T Staff	Nov	16	<b>SOLDERING/DESOLDERING</b> Soldering and desoldering update By The ES&T Staff	Nov	20
CD player fundamentals—Part 2 By Sam Goldwasser	Nov	52	<b>TECHNOLOGY</b> New technology By The ES&T Staff	Feb	15
<b>COMPUTERS</b> Computer diagnostics By ES&T Staff	Jan	8	The current state of satellite TV By The ES&T Staff	Jul	14
Servicing the Macintosh computer—3 Parts By David Presnell	Jan	10	New consumer electronics technology By The ES&T Staff	Sep	23
Computer software for service center management By The ES&T Staff	Apr	6	<b>TEST EQUIPMENT</b> Test equipment update: How to design and build a POST code reader—Part 1 By Harvey Schwertly, CET	Jun	22
<b>PARTS AND EQUIPMENT PURCHASING</b> 1996 Buyer's Guide	Mar	19	How to design and build a POST code reader—Part 2 By Harvey Schwertly, CET	Jul	10
Working with depot repair centers By The ES&T Staff	Oct	13	Oscilloscope update: Using the oscilloscope to determine the cause of hot output transistors By Homer Davidson	Sep	12
Replacement parts/servicing sourcebook By The ES&T Staff	Dec	11	Multimeter Update: What those meter accuracy figures mean By Lamarr Ritchie	Sep	21
<b>SERVICING</b> Servicing intermittent horizontal circuits By Homer L. Davidson	Jan	26			





# Profax Ten-Year Directory

(January 1986-December 1996)

## January 1986

RCA MMC 100, video monitor 2077  
 GE PM-A chassis 2078

## February 1986

GE BC-A chassis 2079  
 RCA 117 chassis 2080

## March 1986

RCA CTC133 chassis 2081

## April 1986

GE 25 PC(J) chassis 2082  
 RCA CTC120 chassis 2083

## May 1986

GE HP chassis, tuning/control systems 2084A  
 GE HP chassis, chroma 2084B

## June 1986

RCA CTC125 chassis 2085  
 RCA 207 series weather clock 2086

## July 1986

GE NF chassis 2087  
 GE PM-C chassis 2088

## August 1986

RCA CTC136 chassis 2089

## September 1986

RCA CTC130-S1 chassis 2090

## October 1986

GE X110 chassis, B&W TV 2091  
 GE TV/AM/FM clock radio 2092

## November 1986

RCA B&W TV basic service data,  
 UVM chassis 2093  
 GE 14-inch portable color. TV,  
 RS-A chassis 2094

## December 1986

GE X110 chassis (cont.) 2095  
 RCA UWJ chassis 2096

## January 1987

GE color TV, MK-2 chassis 2097

## February 1987

RCA color TV supplement, CTC117-S2 2098  
 GE color TV, MK-1 chassis 2099

## April 1987

Hitachi color TV, CT2250B, CT2250W chassis 3000

## May 1987

RCA color TV, VDM140 chassis 3002  
 GE color TV, NF chassis update 3003  
 GE 5-inch B&W TV, 7-7130A chassis 3004

## June 1987

Hitachi color TV, CT1358 chassis 3005  
 RCA color TV, CTC135 chassis 3006

## July 1987

Zenith color TV, D13085/D1910B chassis 3007  
 GE color TV, MK-1 chassis, Model 8-1938 3008

## August 1987

Zenith color TV, D2500W chassis 3009  
 Hitachi color TV, CT2020W, CT2020B chassis 3010

## September 1987

Zenith color TV, SD2501W chassis 3011  
 Hitachi color TV, CT2250B, CT2250W chassis 3012

## October 1987

RCA color TV, CTC134 chassis 3013

## November 1987

GE color TV, CTC140 chassis 3014

## December 1987

Hitachi color TV, chassis CT0911 3015  
 Zenith color TV, chassis SD2097S 3016

## January 1988

Zenith PV800 color monitor 3017  
 Hitachi color TV, CT1358 chassis 3018

## February 1988

GE VCR, 2018W Model 3019

## March 1988

GE 8-4500 projection TV 3020

## April 1988

NAP projection TV, E54-10 chassis 3021  
 Zenith color TV, C2020H chassis 3022

## May 1988

RCA PVM050 color TV 3023  
 Hitachi CT2652, CT2653 color TVs 3024



<b>June 1988</b>			
Hitachi color TVs,			
CT2647/CT2648/CT2649 chassis	3025		
NAP projection TV, E54-15 chassis	3026		
<b>July 1988</b>			
GE Model 1VCR2006W VCR	3027		
Zenith color TV, CM-139/B-0 (B) chassis	3028		
<b>August 1988</b>			
Hitachi color TV, CT1344 chassis	3029		
NAP color TV, E51-56 chassis	3030		
<b>September 1988</b>			
RCA color TV, PVM035 chassis	3031		
GE color TV, NC-05X3/06X1 chassis	3032		
<b>October 1988</b>			
Hitachi CT3020W/CT3020B color TV	3033		
Zenith CM-139/B-3 (I) SD2511G/SD2581H color TV	3034		
<b>November 1988</b>			
Hitachi VHS VCR, Model VT-63A	3035		
NAP RD4502SL/RLC312SL color TV monitors	3036		
<b>December 1988</b>			
GE proj. TV, PW chass., Mod. 40PW3000KA01	3037		
<b>January 1989</b>			
Hitachi color TV, CT1955, NP85XA chassis	3038		
NAP color TV, series 19C2 chassis (Magnavox)	3039		
<b>February 1989</b>			
RCA/GE color TV, CTC145/146 chassis	3040		
Zenith col. TV, CM-140/b-2(G) chassis (Models SE2503G/SE2505P, SE2507N/SE2509H)	3041		
<b>March 1989</b>			
NAP color TV, chassis E34-11			
Hitachi color TV, chassis	3042		
CT1941/CT19A2, NP83X chassis	3043		
<b>April 1989</b>			
GE VHS VCR, Model 1VCR2002X	3044		
Hitachi CT1955 color TV	3045		
<b>May 1989</b>			
Zenith CM-14-0/B-3(1) color TV (Models SE2721H/SE2725R/SE2727H)	3046		
GE color TV, 1987 CTC136	3047		
<b>June 1989</b>			
RCA P42000-S1 projection TV (additional Models: RVM46700, 46GW700, P46000)	3048		
NAP color TV, chassis E54-15 (Magnavox RD8518 and RD8520; Philco Model P8190S; Sylvania PSC410 and PSC420)	3049		
<b>July 1989</b>			
Hitachi CT2066 color TV		3050	
RCA CTC135 color TV		3051	
<b>August 1989</b>			
GE CTC135-S1 color TV		3052	
Zenith CM-140/B-2(I) color TV		3053	
<b>September 1989</b>			
RCA CSM055 col. TV/AM/FM/clock radio		3054	
<b>October 1989</b>			
Hitachi CT2086 B/W chassis G7NU3 color TV		3055	
Zenith PV4661H rear-projector col. TV		3056	
<b>November 1989</b>			
GE 1987 8-4500 projection color TV		3057	
RCA/GE CTC145/146 color TV		3058	
<b>December 1989</b>			
ZENITH CM-140/DIGITAL(C) chassis color TV (Models SE3135P/SE3191H/SE3535H /ZB2771H/ZB2771H2/ZB2777H /ZB2777H2/ZB2797P/ZB2797P2 /ZB2797Y/ZB2797Y2/ZB3193H/ZB3193Y/ ZB3539T/ZB3539Y)		3059	
<b>January 1990</b>			
Hitachi CT1395W G7NSU2 color TV		3060	
<b>February 1990</b>			
Zenith CM-139/B1 (Y) and (K) color TV Receivers Models SD2097S (Y) and SD1327W3, SD1327Y, SD1327Y3(K)		3061	
<b>March 1990</b>			
RCA/GE CTC148/149-S2 chassis color TV		3062	
<b>April 1990</b>			
Hitachi G7XU2/3 chassis color TV G7XU2—Models CT2087B/W, A087 (MT2870 through MT2878) G7XU3—Models CT2088B/W, A088 (MT2880, MT2886, MT2887)		3063	
<b>May 1990</b>			
Zenith PV-140/Digital (G) Rear Proj. digital TV receiver, Zenith surround stereo system		3064	
<b>June 1990</b>			
Hitachi CT4580K, VP7X2 chassis projection TV		3065	
<b>July 1990</b>			
Zenith PV454-1P chassis color TV		3066	
<b>August 1990</b>			
RCA/GE TX81 chassis color TV		3067	
<b>September 1990</b>			
RCA/GE CTC156 chassis color TV		3068	

<b>October 1990</b> Hitachi VP9X1 chassis color TV	3069	<b>June 1992</b> Hitachi VT-M231A VCR	3089
<b>November 1990</b> RCA/GE CTC169 (PV) chassis color TV	3070	<b>July 1992</b> Hitachi VT-F551A VCR	3090
<b>December 1990</b> RCA CTC91 chassis color TV	3071	<b>August 1992</b> RCA/GE color TV No 7-7800A	3091
<b>January 1991</b> RCA CTC99 chassis color TV	3072	<b>September 1992</b> RCA/GE TX82 color TV	3092
<b>February 1991</b> RCA CTC107 chassis color TV	3073	<b>October 1992</b> Sharp Model 13C-M100 color TV	3093
<b>March 1991</b> RCA/GE CTC168 chassis color TV	3074	<b>November 1992</b> Sharp Model 27C-5200 color TV	3094
<b>April 1991</b> RCA/GE CTC86 chassis color TV	3075	<b>December 1992</b> Hitachi VT M150A VCR	3095
<b>May 1991</b> RCA/GE KCS203 chassis B&W TV	3076	<b>1992/1993 Profax Schematics Special Issue:</b> Curtis Mathes Projection TV: Models SMP 4100, 4600, 5210 Hitachi Camcorder Model UM-E2A Memorex Pocketvision 26, Catalog Number 16-163 Mitsubishi VCR Model HS-U55 Panasonic color TV Model SR400EK RCA/GE VCR Model VG4202 Sharp color TV Model 27SV65 Toshiba color TV Model CF2077A: CX21772 Zenith color TV: Models SD5515/SD5535/SD555G	
<b>June 1991</b> RCA CTC96 chassis color TV	3077		
<b>July 1991</b> RCA CTC107 chassis color TV	3078		
<b>August 1991</b> Hitachi CT1947/CT19A7 chassis color TV	3079		
<b>September 1991</b> Hitachi CT2541/2542 chassis color TV	3080		<b>January 1993</b> Sharp Model 20C-5300 color TV
<b>October 1991</b> RCA/GE CTC167 chassis color TV	3081	<b>February 1993</b> Sharp chassis No. 25S1 color TV Sharp VCR Model VCA45U	3097 3098
<b>November 1991</b> RCA/GE CTC166 chassis color TV	3082	<b>March 1993</b> Sharp Model 20C-S200 Sharp VCR Model VC-H86U/C	3099 3100
<b>December 1991</b> RCA/GE CTC169 chassis color TV	3083	<b>April 1993</b> Sharp Model 27SV70	3101
<b>January 1992</b> RCA/GE CTC 168 chassis color TV	3084	<b>May 1993</b> Sharp VCR Model VC-H870U/C, VC-8870U/C Sharp Model 20SB65 color TV	3102 3103
<b>February 1992</b> Hitachi AP13 color TV	3085	<b>June 1993</b> Sharp VCR Model VC-A503U, VC-A504U/C	3104
<b>March 1992</b> Hitachi VT-M40A color TV	3086	<b>July 1993</b> Sharp VCR Model VC-H903U/C, VC-H904U/C	3105
<b>April 1992</b> Hitachi 3267E VCR	3087	<b>August 1993</b> Sharp VCR Model VC-H87U/C	3106
<b>May 1992</b> RCA/GE CTC 168-53 color TV	3088		



<b>September 1993</b>			
Sharp Models 19E-M4OR, 19E-M5OR color TV	3107		
<b>October 1993</b>			
RCA color TV Model CTC176	3108		
<b>November 1993</b>			
Hitachi Proj. color TV Models 55EX7K, 50EX6K, 46EX3B/4K, 50ES1B/K 46EX3BS/4KS	3109		
<b>December 1993</b>			
Sharp color TV Model 19E-M50	3110		
<b>1993/1994 Profax Schematics Special Issue:</b>			
Curtis Mathes VCR/Model GV730/740			
Hitachi TV/Model NP 83LX			
IBM Monochrome Display/Model 8503			
Magnavox TV/Model RD0945C101, RD0946T101			
Memorex Portable Compact Disc Player/Model CD-3360			
Memorex VCR/Model 29			
Mitsubishi TV/Model CS-3535R/CK-3536R, CS3135R/CK-3136R			
Panasonic CTM1353R			
JC Penney TV/Model 2003			
Sharp color TV/Sigma 9700 chassis			
Thomson Consumer Electronics color TV/RCA CTC175			
Toshiba VCR/Model M222, M222C, M227C, M227L			
<b>January 1994</b>			
Memorex Portavision 9-inch color VHF/UHF TV monitor	3111		
<b>February 1994</b>			
Hitachi VHS VCR Models VT-F350A, VT-F351A, AW	3112		
<b>March 1994</b>			
Sharp color TV Model 20SB55, chassis No 20R1	3113		
<b>April 1994</b>			
GE VCR Models 9-7100, 9-7115, 9-7120, 9-7215	3114		
<b>May 1994</b>			
Hitachi VCR Model VM-2400A (U,PX), AW	3115		
<b>June 1994</b>			
Thomson Consumer Electronics color TV: TX825	3116		
<b>July 1994</b>			
Sharp CTV Models 13F-M40, 13F-M50, 13F-M100, 13F-M150	3117		
<b>August 1994</b>			
Hitachi Video camera/recorder, Models VM-2700A, VM-3700A (U,C)	3118		
<b>September 1994</b>			
Sharp CTV Models 25F-M40/50/100/120, chassis No SN 41	3119		
<b>October 1994</b>			
Hitachi VCR Model VM-1700A (U,C)	3120		
<b>November 1994</b>			
Hitachi VCR Models VT-F380Z/F381A, VT-F382A/F385A	3121		
<b>December 1994</b>			
Thomson Consumer Electronics color TV: TX825	3122		
<b>1994/1995 Profax Schematics Special Issue:</b>			
Hitachi VCR Model VM-1600A			
Memorex VCR catalog no. 16-620			
Panasonic VCR Models PV-4962, PV4941-K, PV-4960-K			
JC Penney TV/VCR Model 2163			
Quasar Model CTM-1355R & TP-1330EE			
RCA color TV Model CTC168-S4			
Sharp color TV models 20C-S100 & 20C-S120			
Tatung color monitor			
Toshiba VCR Model SV-F990			
Zenith color TV receiver CM-139/B-1			
Zenith CM-143/Digital (A)			
<b>January 1995</b>			
Sharp video cassette recorder Models VC-A502U, VC-A506U, VC-A507U	3123		
<b>February 1995</b>			
Sharp Color TV Model 19TF30, Chassis SN40A	3124		
<b>March 1995</b>			
Hitachi video cassette recorder Model VT-F482A	3125		
<b>April 1995</b>			
RCA video cassette recorder Model VR530	3126		
<b>May 1995</b>			
RCA video cassette recorder Model VR530 (cont'd)	3126		
<b>June 1995</b>			
Hitachi projection television Models 50UX 18B/19K, 46UX 16B/17K	3127		
<b>July 1995</b>			
JC Penney combination Model 2163	3128		
<b>August 1995</b>			
Sharp video cassette recorder Model VC-H925U/H927U	3129		
<b>September 1995</b>			
Thomson Consumer Electronics color TV Model CTC187	3130		
<b>October 1995</b>			
Sharp TV/VCR combo Model 13VT-F40/13VT-F100	3131		
<b>November 1995</b>			
Thomson Consumer Electronics VCR Model VG2030	3132		

**December 1995**

JC Penney color television Model 1048/1049 3133

**1995/1996 Profax Schematics Special Issue:**

Panasonic TV Model CTM-2092S Chassis ALEDP203  
 JC Penney TV Model 2157  
 JC Penney TV Model 2294  
 Sharp TV/VCR Combination Models 20VT-G60, 20VT-G100, 20VT-G200  
 Sharp VCR Model VC-H946U, VC-H948U  
 Thomson VCR Model VR516  
 Thomson color video camcorder Models CC525, CPS014, CPS015  
 Thomson TV, AM radio cassette combination Model 7-7800A  
 Toshiba TV Model CF2771A  
 Zenith projection TV L-Line C-8 Chassis  
 Zenith color TV receiver Models SD2501W, SD2509H

**January 1996**

Zenith wall projector Model PV-144 3134

**February 1996**

Hitachi VCR Model VT-UX605A 3135

**March 1996**

Zenith digital direct view Model CM-142 3136

**April 1996**

Thomson Consumer Electronics VCR Model VR321 3137

**May 1996**

Sharp color television Models 25E-M100 &amp; 25E-M120 3138

**June 1996**

Sharp TV/VCR combination Model 27VS-G300 3139

**July 1996**

JC Penney color TV receiver Model 2307 3140

**August 1996**

Zenith color TV receiver Model CM-142/C-1 3141

**September 1996**

Sharp VCR Models VC-A555, 556 VC-H955, 956, 958U 3142

**October 1996**

Thomson Consumer Electronics Color TV Model CTC177 3143

**November 1996**

RCA/GE VCR Model VR520/523 3144

**December 1996**

Memorex moviecorder Model 127 3145

**1996/1997 Profax Schematics Special Issue:**

Hitachi video camera Model VM-E25A (U,C)  
 Panasonic VCR Model PV-4066  
 JC Penney color TV receiver Model 2158  
 JC Penney color TV receiver Model 2509  
 Sharp TV/VCR combination Model 20C-V300  
 Thomson Consumer Electronics projection TV Model PTK171  
 Toshiba color TV Models 6F35661, CX37662  
 Zenith digital color TV Receiver J-Line Model PV-143  
 Zenith color TV Model S1322S, SMS1324SS/X, SMS1325S

**Profax number index—1986-1996**

Profax #	Month	Year
2077-2078	Jan	86
2079-2080	Feb	86
2081	Mar	86
2082-2083	Apr	86
2084A-2084B	May	86
2085-2086	Jun	86
2087-2088	Jul	86
2089	Aug	86
2090	Sep	86
2091-2092	Oct	86
2093-2094	Nov	86
2095-2096	Dec	86
2097	Jan	87
2098-2099	Feb	87
(Note: numbers 2100-2999 were skipped)		
3000	Apr	87
3002-3003	May	87
3005-3006	Jun	87
3007-3008	Jul	87
3009-3010	Aug	87
3011-3012	Sep	87
3013	Oct	87
3014	Nov	87
3015-3016	Dec	87
3017-3018	Jan	88
3019	Feb	88
3020	Mar	88
3021-3022	Apr	88
3023-3024	May	88
3025-3026	Jun	88
3027-3028	Jul	88
3029-3030	Aug	88
3031-3032	Sep	88
3033-3034	Oct	88
3035-3036	Nov	88
3037	Dec	88
3038-3039	Jan	89
3040-3041	Feb	89
3042-3043	Mar	89
3044-3045	Apr	89
3046-3047	May	89
3048-3049	Jun	89
3050-3051	Jul	89
3052-3053	Aug	89
3054	Sep	89



3055-3056	Oct	89	3115	May	94
3057-3058	Nov	89	3116	Jun	94
3059	Dec	89	3117	Jul	94
3060	Jan	90	3118	Aug	94
3061	Feb	90	3119	Sep	94
3062	Mar	90	3120	Oct	94
3063	Apr	90	3121	Nov	94
3064	May	90	3122	Dec	94
3065	Jun	90	3123	Jan	95
3066	Jul	90	3124	Feb	95
3067	Aug	90	3125	Mar	95
3068	Sep	90	3126	Apr	95
3069	Oct	90	3126	May	95
3070	Nov	90	(Note: May is a continuation of the April schematic)		
3071	Dec	90	3127	Jun	95
3072	Jan	91	3128	Jul	95
3073	Feb	91	3129	Aug	95
3074	Mar	91	3130	Sep	95
3075	Apr	91	3131	Oct	95
3076	May	91	3132	Nov	95
3077	Jun	91	3133	Dec	95
3078	Jul	91	3134	Jan	96
3079	Aug	91	3135	Feb	96
3080	Sep	91	3136	Mar	96
3081	Oct	91	3137	Apr	96
3082	Nov	91	3138	May	96
3083	Dec	91	3139	Jun	96
3084	Jan	92	3140	Jul	96
3085	Feb	92	3141	Aug	96
3086	Mar	92	3142	Sep	96
3087	Apr	92	3143	Oct	96
3088	May	92	3144	Nov	96
3089	Jun	92	3145	Dec	96
3090	Jul	92			
3091	Aug	92			
3092	Sep	92			
3093	Oct	92			
3094	Nov	92			
3095	Dec	92			
3096	Jan	93			
3097	Feb	93			
3098	Feb	93			
3099	Mar	93			
3100	Mar	93			
3101	Apr	93			
3103	May	93			
3103	May	93			
3104	Jun	93			
3105	Jul	93			
3106	Aug	93			
3107	Sep	93			
3108	Oct	93			
3109	Nov	93			
3110	Dec	93			
3111	Jan	94			
3112	Feb	94			
3113	Mar	94			
3114	Apr	94			

### Company Index—1986–1996

				Profax #	Month/Year
			<b>CURTIS MATHES</b>		
			Projection TV Set:	Special	1992/93
			Models SMP 4100, 4600, 5210		
			VCR Model GV 730/740	Special	1993/94
			<b>GENERAL ELECTRIC</b>		
			PM-A chassis	2078	Jan 86
			BC-A chassis	2079	Feb 86
			25 PC(J) chassis	2082	Apr 86
			HP chass., tuning/control systs.	2084A	May 86
			HP chassis, chroma	2084B	May 86
			NF chassis	2087	Jul 86
			PM-C chassis	2088	Jul 86
			X110 chassis, B&W TV	2091	Oct 86
			TV/AM/FM clock radio	2092	Oct 86
			14-inch portable color TV	2094	Nov 86
			X110 chassis (cont.)	2095	Dec 86
			CTC140 chassis, color TV	3014	Nov 87
			MK-1 chassis, Model 8-1938	3008	Jul 87
			MK-1 chassis	2099	Feb 87
			MK-2 chassis	2097	Jan 87

	Profax #	Month/Year		Profax #	Month/Year
NF chassis update, color TV	3003	May 87	VCR Model VM-2400A (U,PX), AW	3115	May 94
7-7130A chassis, 5-inch B&W	3004	May 87	VCR Model VM-1700A (U,C)	3120	Oct 94
1VCR2006W Model, VCR	3027	Jul 88	VCR Models VT-F380Z/F381A,		
1VCR2018W Model, VCR	3019	Feb 88	VT-F382A/F385A	3121	Nov 94
NC-05X3/06X1 chassis, color TV	3032	Sep 88	Vid. cam./rec. Mods. VM-2700A,		
Projection TV 8-4500	3020	Mar 88	VM-3700A (U,C)	3118	Aug 94
PW chassis, Model 40PW3000KA01			VCR Model VM-1600A	Special	1994/95
proj. TV	3037	Dec 88	VCR Model VT-F482A	3125	Mar 95
VHS VCR, Model 1VCR2002X	3044	Apr 89	projection television Models 50UX		
color TV, 1987 CTC136	3047	May 89	18B/19K	3127	Jun 95
CTC135-S1 color TV	3052	Aug 89	46UX 16B/17K		
1987 8-4500 projection color TV	3057	Nov 89	VCR Model VT-UX605A	3135	Feb 96
VCR, Models 9-7100, 9-7115,			video camera Model VM-E25A	Special	1996/97
9-7120, 9-7215	3114	Apr 94			
<b>HITACHI</b>			<b>IBM</b>		
CT1358 chassis, color TV	3005	Jun 87	Model 8503 Monochrome Display	Special	1993/94
CT2020W, CT2020B chassis	3010	Aug 87			
CT2250B, CT2250W chassis	3000	Apr 87	<b>MAGNAVOX</b>		
CT2250B, CT2250W chassis	3012	Sep 87	Model RD0945C101, RD0946T101		
CT1344 chassis color TV	3029	Aug 88	color TV	Special	1993/94
CT1358 chassis color TV	3018	Jan 88			
CT2647/CT2648/CT2649 chassis			<b>MEMOREX</b>		
color TVs	3025	Jun 88	Pocketvision 26 TV, Catalog		
CT2652, CT2653 color TVs	3024	May 88	Number 16-163	Special	1992/93
CT3020W/CT3020B	3033	Oct 88	Portable Compact Disc Player		
VHS VCR, Model VT-63A	3035	Nov 88	Model CD-3360	Special	1992/93
CT1955 color TV, NP85XA chassis	3038	Jan 89	VCR Model 29	Special	1992/93
color TV, chassis CT1941/CT19A2,			Portavision 9-inch color VHF/UHF		
NP83X chassis	3043	Mar 89	TV Monitor	3111	Jan 94
CT1955 color TV	3045	Apr 89	VCR catalog no. 16-620	Special	1994/95
CT2066 color TV	3050	Jul 89	Moviecorder Model 127	3145	Dec 96
CT2086 B/W chassis G7NU3			<b>MITSUBISHI</b>		
color TV	3055	Oct 89	Model CS-3535R/CK-3535R	Special	1992/93
CT1395W G7NSU2 color TV	3060	Jan 90	CS3135R/CK3136R color TV		
G7XU2/3 chassis color TV	3063	Apr 90	VCR Model HS-U55	Special	1992/93
G7XU2 - Models CT2087B/W, A087			<b>NAP</b>		
(MT2870 through MT2878)			E51-56 chassis, color TV	3030	Aug 88
G7XU3 - Models CT2088B/W, A088			E54-10 chassis, projection TV	3021	Apr 88
(MT2880, MT2886, MT2887)			E54-15 chassis, projection TV	3026	Jun 88
CT4580K, VP7X2 chassis proj. TV	3065	Jun 90	RD4502SL/RLC312SL color TV		
VP9X1 chassis color TV	3069	Oct 90	monitors	3036	Nov 88
CT1947/CT19A7 chassis color TV	3079	Aug 91	color TV, series 19C2 chassis		
CT2541/2542 chassis color TV	3080	Sep 91	(Magnavox)	3039	Jan 89
color TV, chassis AP13	3085	Feb 92	color TV, chassis E34-11	3042	Mar 89
VCR Model 3267E	3087	Apr 92	color TV, chassis E54-15	3049	Jun 89
VCR Model VT-F551A	3090	Jul 92	(Magnavox RD8518 and RD8520; Philco Model P8190S;		
VCR Model VT-M40A	3086	Mar 92	Sylvania PSC410 and PSC420)		
VCR Model VT-150A	3095	Dec 92	<b>PANASONIC</b>		
VCR Model VT-M231A			Model SR400EK color TV	Special	1992/93
Camcorder Model UM-E2A	Special	1992/93	Model CTM1353R color TV	Special	1993/94
Projection color TV, Models			VCR Models PV-4962, PV4941-K		
55EX7K, 50EX6K,	3109	Nov 93	PV4960-K	Special	1994/95
46EX3B/4K, 50ES1B/K, 46EX3BS/4KS			Model CTM-2092S Chassis		
NP 83LX color TV	Special	1993/94	ALEDP203	Special	1995/96
VCR Model VT-F350A,			VCR Model PV-4066	Special	1996/97
VT-F351A, AW	3112	Feb 94			



**JC PENNEY**

Model 2003 color TV	Special	1993/94
TV/VCR Model 2163	Special	1994/95
combination Model 2163	3128	Jul 95
color television Model 1048/1049	3133	Dec 95
TV Model 2157	Special	1995/96
TV Model 2294	Special	1995/96
color TV receiver Model 2307	3140	Jul 96
color TV receiver Model 2158	Special	1996/97
color TV receiver Model 2509	Special	1996/97

**RCA**

MMC100, video monitor	2077	Jan 86
CTC117 chassis	2080	Feb 86
CTC133 chassis	2081	Mar 86
CTC120 chassis	2083	Apr 86
CTC125 chassis	2085	Jun 86
207 series weather clock	2086	Jun 86
CTC136 chassis	2089	Aug 86
CTC130-S1 chassis	2090	Sep 86
B&W TV basic service data	2093	Nov 86
UWJ chassis	2096	Dec 86
CTC117-S2 color TV supplement	2098	Feb 87
CTC134 chassis, color TV	3013	Oct 87
CTC135 chassis, color TV	3006	Jun 87
VDM140 chassis, color TV	3002	May 87
PVM035 chassis color TV	3031	Sep 88
PVM050 color TV	3023	May 88
P42000-S1 projection TV	3048	Jun 89
(additional Models: RVM46700, 46GW700, P46000)		
CTC135 color TV	3051	Jul 89
CSM055 color TV/AM/FM/clock radio	3054	Sep 89
CTC91 chassis color TV	3071	Dec 90
CTC99 chassis color TV	3072	Jan 91
CTC107 chassis color TV	3073	Feb 91
CTC96 chassis color TV	3077	Jun 91
CTC107 chassis color TV	3078	Jul 91
CTC176 chassis color TV	3108	Oct 93
CTC175 chassis color TV	Special	1993/94
color TV Model CTC 168-S4	Special	1994/95
VCR Model VR530	3126	Apr/May 95

**RCA/GE (Thomson Consumer Electronics)**

color TV, CTC145/146 chassis	3040	Feb 89
CTC145/146 color TV	3058	Nov 89
CTC148/149-S2 chassis color TV	3062	Mar 90
TX81 chassis color TV	3067	Aug 90
CTC156 chassis color TV	3068	Sep 90
CTC169 (PV) chassis color TV	3070	Nov 90
CTC168 chassis color TV	3074	Mar 91
CTC86 chassis color TV	3075	Apr 91
KCS203 chassis B&W TV	3076	May 91
CTC167 chassis color TV	3081	Oct 91
CTC166 chassis color TV	3082	Nov 91
CTC169 chassis color TV	3083	Dec 91
CTC168 chassis color TV	3084	Jan 92
CTC168-53 chassis color TV	3088	May 92
color TV Model 7-7800A	3091	Aug 92

TX82 chassis color TV	3092	Sep 92
VCR Model VG4202	Special	1992/93
color TV: TX825	3116	Jun 94
color TV: TX825	3122	Dec 94
VCR Model VR516	Special	1995/96
color camcorder Models CC525, CPS014, CPS015	Special	1995/96
TV AM radio cassette combination Model 7-7800A	Special	1995/96
color TV Model CTC187	3130	Sep 95
VCR Model VG2030	3132	Nov 95
VCR Model VR321	3137	Apr 96
CTC177 color TV	3143	Oct 96
VCR Model VR520/523	3144	Nov 96
projection TV Model PTK171	Special	1996/97

**SHARP**

Model 13C-M100 color TV	3093	Oct 92
Model 27C-5200 color TV	3094	Nov 92
Model 27SV65 color TV	Special	1992/93
Model 19E-M50	3110	Dec 93
Model 19E-M40R, 19E-M50R color TV	3107	Sep 93
Model 20C-5300 color TV	3096	Jan 93
Model 20C-S200 color TV	3099	Mar 93
Model 20SB65 color TV	3103	May 93
25S1 chassis color TV	3097	Feb 93
Model 27SV70	3101	Apr 93
Sigma 9700 chassis color TV	Special	1993/94
VCR Model VC-A45U	3098	Feb 93
VCR Model VC-A504U/C	3104	Jun 93
VCR Model VC-H86U/C	3100	Mar 93
VCR Model VC-H87U/C	3106	Aug 93
VCR Model VC-H870U/C, VC-8870U/C	3102	May 93
VCR Model VC-H903U/C, VC-H904U/C	3105	Jul 93
color TV Model 20SB55, chassis No. 20R1	3113	Mar 94
Models 13F-M40, 13F-M50, 13F-M100, 13F-M150	3117	Jul 94
Models 25F-M40/50/100/120, chassis No SN 41	3119	Sep 94
color TV Models 20C-S100, 20C-S120	Special	1994/95
VCR Models VC-A502U, VC-A506U, VC-A507U	3123	Jan 95
color Television Model 19TF30, Chassis SN40a	3124	Feb 95
VCR Model VC-H925U/H927U	3129	Aug 95
TV/VCR combination Model 13VT-F40/13VT-F100	3131	Sep 95
TV/VCR combination Models 20VT-G60, 20VT-G100	Special	1995/96
20VT-G200, Chassis VN-51		
VCR Model VC-H946U, VC-H948U	Special	1995/96
color TV Model 25E-M100, 25E-M120	3138	May 96



## COMPLETE YOUR COLLECTION TODAY!

When ordering back issues include the following information: Name, address, city, state & zip. Please make a list of the issues you're requesting. When paying by credit card send the number along with the expiration date. Check, Money Order, MasterCard, VISA, Discover and AMEX accepted.

Name: \_\_\_\_\_

Address: \_\_\_\_\_

City \_\_\_\_\_ State \_\_\_\_\_ Zip \_\_\_\_\_

Issues Requested (Month, Year) \_\_\_\_\_

- Check Enclosed  
 MasterCard     Visa  
 Discover     American Express

Card # \_\_\_\_\_

Expiration Date \_\_\_\_\_

**For Fastest Service**  
**CALL 1-516-681-2922**  
**Electronic Servicing & Technology**  
 76 North Broadway Hicksville, NY 11801  
 FAX: 516-681-2926

TV/VCR combination Model 27VS-G300	3139	Jun 96
VCR Models VC-A555, 556, VC-H955, 956, 958U	3142	Sep 96
TV/VCR combination Model 20C-V300	Special	1996/97
<b>TATUNG</b>		
color monitor	Special	1994/95
<b>TOSHIBA</b>		
color TV Model CF2077A: CX21772	Special	1992/93
VCR Model M222, M222C, M227C, M227L	Special	1993/94
VCR Model SV-F990	Special	1994/95
TV Model CF2771A	Special	1995/96
color TV Models 6F35661, CX37662	Special	1996/97
<b>ZENITH</b>		
D2500W chassis, color TV	3009	Aug 87
D13085/D1910B chassis, color TV	3007	Jul 87
SD2501W chassis, color TV	3011	Sep 87
CM-139/B-0 (B) chassis color TV	3028	Jul 88
CM-139/B-3 (I) SD2511G/SD2581H	3034	Oct 88
C2020H chassis color TV	3022	Apr 88
PV800 color monitor	3017	Jan 88
color TV, CM-140/b-2(G) chassis	3041	Feb 89
CM-14-0/B-3(1) color TV (Models SE2721H/SE2725R/SE2727H)	3046	May 89
CM-140/B-2(I) color TV	3053	Aug 89
PV4661H rear-projector color TV	3056	Oct 89
CM-140/DIGITAL(C) chassis color TV	3059	Dec 89
(Models SE3135P/SE3191H/SE3535H/ZB2771H/ZB2771H2/ZB2777H/ZB2777H2/ZB2797P/ZB2797P2/ZB2797Y/ZB2797Y2/ZB3193H/ZB3193Y/ZB3539T/ZB3539Y)		
CM-139/B1 (Y) and (K) color TV Receivers	3061	Feb 90
Models SD2097S (Y) and SD1327W3, SD1327Y, SD1327Y3(K)		
PV-140/Digital (G) Rear Proj. digital TV receiver, Zenith surround stereo system	3064	May 90
PV454-1P chassis color TV	3066	Jul 90
CM-139/B2 Models SD5515, SD5535, SD555G	Special	1992/93
color TV receiver Model CM-139/B-1	Special	1994/95
CM143/digital (A)	Special	1994/95
TV L-line C-8 Chassis	Special	1995/96
color TV receiver Model SD2501W, SD2509H	Special	1995/96
wall projector Model PV-144	3134	Jan 96
digital direct view Model CM-142	3136	Mar 96
color TV receiver Model CM142/C-1	3141	Aug 96
digital color TV receiver J-Line Model PV-143	Special	1996/97
color TV Models S1322S, SMS1324S/X, SMS1325S	Special	1996/97



# ES&T BOOK SHOP

## Industrial Electronics for Technicians

By J.A. Sam Wilson and Joseph Risse  
Industrial Electronics for Technicians provides an overview of the topics covered in the Industrial Electronics for Technicians CET test, and is also a valuable reference on industrial electronics in general.  
Order# 61058 ••••• \$16.95.

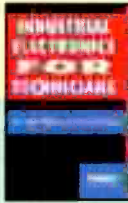

## Introduction to Microprocessor Theory and Operation

A Self-Study Guide with Experiments  
By J.A. Sam Wilson and Joseph Risse  
Introduction to Microprocessor Theory and Operation takes you into the heart of computerized equipment and reveals how microprocessors work. Order# 61064 ••• \$16.95.



## Semiconductor Essentials

By Stephen Kamichik  
This book is first course in electronics at the technician and engineering levels. Each chapter is a lesson in electronics, with problems presented at the end of the chapter to test your understanding of the materials presented.  
Order #61071 ••••• \$16.95.



## Real-World Interfacing With Your PC

By James "JJ" Barbarello  
Real-World Interfacing With Your PC provides you with all the information you need to use your PC's parallel port as a gateway to real word electronic interfacing. Now you can write software to control that hardware.  
Order# 61078 ••••• \$16.95.



## Tube Substitution Guide

Complete Guide to Replacements for Vacuum Tubes and Picture Tubes  
By William Smith and Barry Buchanan  
The Tube Substitution Handbook will help antique radio buffs, consumer electronics technicians and other interested individuals find the right replacement tube when servicing older electronics products.  
Order# 61036 ••••• \$16.95.



## Schematic Diagrams

The Basics of Interpretation and Use  
By J. Richard Johnson  
Step-by-step, Schematic Diagrams shows you how to recognize schematic symbols and their uses and functions in diagrams, and to interpret diagrams so you can design, maintain and repair electronic equipment.  
Order# 61059 ••••• \$16.95.

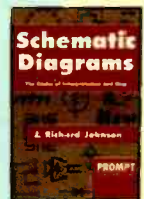

## Surface-Mount Technology for PC Boards

By James K. Holloman, Jr.  
Surface-Mount Technology for PC Boards describes the benefits and limitations of SMT, and provides details on the nature of surface-mount components and SMT manufacturing methods. Additionally, this book covers practical applications, standards, and reliability and quality assurance considerations relating to SMT. A glossary of SMT terms is included.  
Order# 61060 ••••• \$26.95.



## Digital Electronics

By Stephen Kamichik  
Digital Electronics is designed to supplement an introductory course, teach the electronics hobbyist about digital electronics and serve as a review for practicing technicians and engineers. With the proper equipment, you can also build the circuits described. Building and testing a circuit is the best way to fully understand its operation.  
Order #61075 ••••• \$16.95.



## PHOTOFACT Television Troubleshooting and Repair Guide

By the Engineers and Technicians of Howard W. Sams & Company  
The most complete and up-to-date television repair book available. 384 pages of complete repair information, illustrated with useful photos, schematics, graphs and flow charts.  
Order# 61077 ••••• \$29.95.



**New**

**PHOTOFACT  
Television  
Troubleshooting  
and Repair Guide**

## IC Cross Reference Book

By Howard W. Sams & Company  
The IC Cross Reference Book, compiled from manufacturers data and from the analysis of consumer electronics devices for Photofact service data, will help you find replacements or substitutions for more than 35,000 ICs or modules. Order# 61049 ••••• \$19.95.

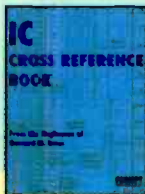

## Advanced speaker Designs

By Ray Alden  
This book shows the electronics hobbyist and the experienced technician how to create high-quality speaker systems for the home, office or auditorium.  
You can build speaker systems from the parts lists and instructions provided or you can actually learn to calculate design parameters, system responses and component values with scientific calculators or PC software. Order# 61070 ••••• \$16.95.

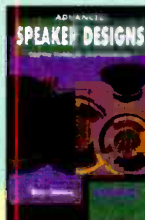

## Semiconductor Cross Reference Book

By Howard W. Sams & Company  
From the makers of Photofact service documentation, the Semiconductor Cross Reference Book is the most comprehensive guide to replacement data for all major types of semiconductors. This volume contains over 475,000 part numbers and other identifying numbers.  
Order# 61050 ••••• \$24.95.



**YES! I want to learn from the experts. Rush me my book(s) right away!**

Please add \$4 shipping & handling. **FREE shipping & handling for orders \$50 and over.**  
Please make your check or money order payable to: Electronic Servicing & Technology

**To Order Call  
516-681-2922**

Qty	Order#	Description	Price	Total Price
Shipping/Handling				
New York Residents add applicable sales tax				
Total				

Name \_\_\_\_\_

Address \_\_\_\_\_

City \_\_\_\_\_ State \_\_\_\_\_ Zip \_\_\_\_\_

MC/VISA/AMEX/Discover # \_\_\_\_\_ Expires \_\_\_\_\_

Form of payment:  MC  VISA  AMEX  Discover  Check  Money Order

Please mail your orders to: **Electronic Servicing & Technology, 76 North Broadway, Hicksville, New York 11801-9962 FAX 516-681-2926**



# CLASSIFIED

Classified advertising is available by the word or per column inch.

**By-the word.** \$1.65 per word, per insertion, pre-paid Minimum charge is \$35 per insertion. Initials and abbreviations count as full words. Indicate free category heading (For Sale, Business Opportunities, Miscellaneous, Wanted). Blind ads (replies sent to ES&T for forwarding) are \$40 additional. No agency discounts are allowed for classified advertising by the word. Contact Kirstie Wickham at 516-681-2922 to place your classified ad (by-the-word). Mastercard, VISA, American Express and Discover are accepted for FAX or mail orders.

**Per column Inch** (classified Display): \$235 per column inch, per insertion, with frequency discounts available, 1" minimum, billed at 1/4" increments after that 10" maximum per ad. Blind ads are \$40 additional. Reader Service Number \$25 additional to cover processing and handling costs. (Free to 4-inch or larger ads.) For more information regarding classified display advertising please call 516-681-2922. Optional color (determined by magazine) \$150 additional per insertion.

Send your order, materials and payments to:

**Electronic Servicing & Technology, 76 N. Broadway, Hicksville, N.Y. 11801 Attn: Classified Department Ph: 516-681-2922 FAX: 516-681-2926**

## FOR SALE

**TV CASE HISTORIES:** Booklet with 2,825+ histories. Satisfaction assured. Only \$56 (plus \$3.00 for priority mail). **Mike's Repair Service**, P.O. Box 217, Aberdeen Proving Ground, MD 21005. Same mailing address 32 years. Send SASE for samples. 410-272-4984, 1-800-2-FIX TVS 11am-9pm.

**TEST EQUIPMENT BOUGHT & SOLD: OSCILLOSCOPES, ETC.** 510-706-0177. FAX: 510-706-0156.

**SERVICE DATA & HARD TO FIND PARTS** previously-owned SAMs, manufacturers data, books, FREE catalog. **AG Tannenbaum**, Box 386, Ambler, PA 19002, 215- 540-8055, fax 215- 540-8327.

**Sencore** VG91 Video Generator, TVA92 Video Analyzer, and PR570 Variable Isolation Transformer. Thirteen Months Old - Like New - All Probes. \$3750.00/offer. 541-479-9644.

**\*\*\* FREE DEMO \*\*\* TECHNICAL REPAIRS \*\*\* THOUSANDS & THOUSANDS of VALUABLE REPAIRS** for TV's, VCR's, Projection TV's, Camcorder's, CD Players, Audio & other electronics organized in an EASY to use Computer Program - **The TECHNICAL TIP REPAIR Program. PROFESSIONAL BOARD LEVEL & COMPONENT LEVEL REPAIRS. ADD your own tips. PRINT tips. BACKUP & save your own tips.** Have your own tips? Ask about our **TIP EXCHANGE** policy with **\*\*FREE Updates\*\***. Works on IBM compatible computers with a hard drive (Also on some Apple Macintosh). **ONLY \$150.00 \*\*FREE SHIPPING\*\*.** **NEW VERSION works in DOS, WINDOWS 3.1 & WINDOWS 95. \*\*FREE DEMO\*\*.** **HIGHER INTELLIGENCE SOFTWARE, 60 FARMINGTON LANE, MELVILLE, NY 11747.** \*\*\*\*\***CALL 1-800-215-5081/1-516-643-7740**\*\*\*\*\*

**●●●21,034 SERVICE TIPS!●●●THE MOST PREFERRED CONSUMER ELECTRONICS COMPUTERIZED TECHNICAL TIPS DATABASE IN USE TODAY** covering over 117 Manufacturer/Brands all in one easy to use program. **SERVICE TIPS** includes **ACTUAL TECHNICIANS FINDINGS** on Camcorders, Color & Projection TV's, Computer Monitors, VCR's & most other Consumer Electronic Equipment. **SERVICE TIPS IS THE ONLY PROGRAM THAT IS SUPPORTED BY ITS CREATORS AND CUSTOMERS & APPROVED \*by NESDA** (the National Electronics Service Dealers Association). **SERVICE TIPS** is used, approved and endorsed by members of TESA-LI, METSDA & NYESDA. Stay ahead of your competition. With **SERVICE TIPS**, you can use the knowledge of other servicers. Find out what the creators of this program and thousands of other technicians worldwide have discovered - **SERVICE TIPS IS THE MOST VALUABLE PIECE OF EQUIPMENT YOU CAN OWN TODAY! DON'T WAIT! CALL US TODAY at 1-800-621-8477** and order **SERVICE TIPS** with 21,034 technical **SERVICE TIPS** for just \$169.95. We accept all major credit cards or mail your check for \$169.95 plus \$8.50 s&h to **ELECTRONIC SOFTWARE DEVELOPERS INC** 826 So. Main Street, So. Farmingdale, NY 11735 or e-mail us at **esd@pb.net** or visit our Website at **www.pb.net/vcrtips** (\*an approval by NESDA recognizes the usefulness and reliability of product or service and stability of the company.)

## FOR SALE

**FURTHER PRICE REDUCTION.** Diehl Mark III \$49, Diehl Mark V Horizontal circuit tester \$169. New. Conductive coating for remote control keypads \$9.99 ppd. **WEEC**, 2411 Nob Hill Road, Madison, WI 53713. 608-238-4629, 608-273-8585.

**OUT OF BUSINESS SALE:** TV VCR Repair Shop. Everything must go. Priced at more than 50% off cost. Parts, Equipment, SAMs, and brand specific manuals. Super deals, guaranteed. Pro Tech, PO Box 4076, Butte, MT 59702. Phone 406-723-8922, fax 406-723-4411.

**SENCORE, TEKTRONICS, HEWLETT PACKARD** (all models). We **BUY, SELL, & TRADE**. Please call "**CHOICE ELECTRONICS**" for all of your test equipment needs. Complete financing options available. Call 1-800-609-0677, ask for Lance Tople.

**IN-CIRCUIT CAPACITOR ESR CHECKER** - Find bad caps FAST and RELIABLY with the new Capacitor Wizard in-circuit ESR Tester! Great for monitors, switching power supplies, TVs, etc. Only \$179.95. **MC/VISA Independence Electronics Inc., 800-833-1094.**

**NAP Tuner 340309 1001/2/3.** Have a problem with a snowy picture? Will repair for \$25.00. **Tip Top TV & VCR**, 18441 Sherman Way, Reseda, CA 91335, 818-345-1974.

**CRT ADAPTER KIT** - Hooks your CRT tester to ALL picture tubes. Win the "socket war". Obsolete proof! \$59.00. **DANDY** 2323 Gibson, Muskogee, OK 74403. 918-68-4286.

**TECHNICIAN'S INFORMATION EXCHANGE.** For info, E-Mail: **rhett@dump.com**.

\*\*\*\*\***FREE ZENITH REPAIR TIPS**\*\*\*\*\*  
**SAVE \$\$\$** Repair Zenith TV modules found in over 1,000 models, 1983-1995. Symcure manual shows you how. \$89.95 or send SASE for **FREE** samples. **TVPRO**, 807 Queen Palm Lane, Sarasota, FL 34243

**Electronic Service Tips: QUALITY not QUANTITY.** Over 7,600 Real World tips and case histories from our Service dept & others. TV, VCR, Audio, Camcorder, Computer Monitor, Microwave Oven, & Misc. Sorted alphabetically by model or chassis, and symptom. **NEW Paper version 7.0** \$39.95 includes shipping in USA. **KDTV** 812-926-4321. 514 3rd St., Aurora IN 47001. Fax 812-926-1014. **MC/Visa/Amex/Discover.** Upgrade \$29.

**USED ELECTRONIC TEST EQUIPMENT.** If we don't have it, we'll get it for you at the right price. Complete satisfaction guaranteed! Just E-Mail, fax or phone your needs. We will reply promptly with a quote you can live with. We also buy used test equipment. **AST Global Marketing**, 11365 Airport Road, Meadville, PA 16335, 814-336-2138, 814-337-7920(fax) E-Mail **astmrktg@wrench.toolkitcity.net**.

**SENCORE VA62A** complete with cables & manuals \$1,175.00. Call **TEST EQUIPMENT SALES** 603-434-2544.

# CLASSIFIED

## BUSINESS OPPORTUNITIES

**Established Repair Business on Texas Gulf Coast.** Owner Retiring. Plenty of work. Only shop in upper-class town. 75,000 cars a day pass in front of shop. Fully equipped and stocked. **Economy Electronics, Bridge City, TX 409-735-2281.**

**TV-VCR-Audio Repair shop.** Owner retiring, Est. 7 years, excellent location in Tarpon Springs, FL. Turnkey - \$19K or contents. Auth. Nap & Zenith. **Call eves. 813-942-3224.**

## BUSINESS OPPORTUNITIES

**OUT OF BUSINESS SALE:** TV VCR Repair Shop. Everything must go. Priced at more than 50% off cost. Parts, Equipment, SAMs, and brand specific manuals. Super deals, guaranteed. Pro Tech, PO Box 4076, Butte, MT 59702. Phone 406-723-8922, fax 406-723-4411.

**Lahaina, Maui, TV/VCR sale & repair.** Key location, low lease, Sencore equipment, turnkey, \$45K. 808-661-0806; pitts@maui.net.

# READERS' EXCHANGE

Readers' Exchange is a free service.

The following restrictions apply to Readers' Exchange:

- Only individual readers may use Readers' Exchange, and items must be restricted to those that are ordinarily associated with consumer electronics as a business or hobby. If you're in business to sell the item(s) you want to offer for sale, the appropriate place for your message is in a paid advertisement, not Readers' Exchange.
- Readers' Exchange items must be restricted to no more than three items each for wanted and for sale.
- All submissions must be typed or printed clearly!

**Send your Readers' Exchange submissions to:**

**Readers' Exchange, Electronic Servicing & Technology, 76 North Broadway, Hicksville, New York 11801**

## FOR SALE

Sencore SC61 waveform analyzer. Like new, with probes and manual, \$1400.00 plus shipping. Buy it and get Sencore TF166 and SS105 free. **Contact: Chris, 860-449-8607**

Sencore VA62 universal video analyzer, NT64 NTSC pattern generator. Manuals, cables, excellent condition, \$995.00. Sencore SG165 universal AM-FM stereo analyzer. Includes book and probe, \$250.00. And more. **Contact: Tom, 206-334-4732, 6-9 PM, Pacific time.**

RCA WV9K Voltomyst, \$50.00. B&K 667 tube tester, \$60.00. NRI signal tracer, like new, \$80.00. Leader audio generator, \$50.00. B&K solid state RF generator E200D, \$150.00, and much more. **Contact: Maurer TV, 29 South 4th Street, Lebanon, PA 17042, 717-272-2481.**

Brand new 35 inch picture tube/yoke HA89 AEX 10x01. Will sell at a fraction of cost. **Contact: Munster Appliance, 219-836-8840**

Tentec Corsair II with factory power supply and speaker, like new, \$1000.00. Drake R4 and T4XB, \$350.00 with factory power supply, prefer local pickup, or must pay shipping. **Contact: 864-859-6032.**

Modules and parts for Zenith, GE, RCA, and Sony. **Contact: Gary Barzily, 84-39 120 Street, Jamaica, NY 11415-3106, 718-847-7965.**

Sencore CR70 CRT analyzer, general radio 1369B. **Contact: 612-869-4963.**

Sams Photofacts, 500 manuals between 1350 and 2500, \$200 plus shipping. **Contact: Duane Conger, 4321 Herrick Lane, Madison, WI 53711, 608-238-4629.**

ITECO phase meter, model 200A, tubed, best offer. **Contact: 802-879-4921.**

Hitachi oscilloscope, 100MHz, dual trace, delayed triggered, V1050F, \$550.00. Tenma, dual trace, 20MHz, \$200.00. Sencore, NT64, \$150.00. **Contact: 954-584-2826, 8AM - 10PM EST.**

Heath digital electronic course with trainer, parts, and meter, paid \$300.00 will sell for \$110.00. **Contact: Daniel Seidler, 3721 W 80 Street, Chicago, IL 60652, 312-284-8221.**

Tubes - 495 new, 1175 used. Miscellaneous used test equipment and parts. **Contact: George, 2125 NE 63 Court, Ft. Lauderdale, FL 33308, 954-771-0406.**

Sencore VA48A, \$250.00, VC63, \$1200.00, both with manuals, cables and original boxes. Tentel gauge set, \$500.00, cost \$1400.00. Tenma computer monitor tester, \$175.00. More. **Contact: George, 805-948-4144.**

Fluke 87 4 1/2 digit DVM, frequency, capacitance test, min/max, alert, new \$335.00, perfect in box with manual, \$225.00. **Contact: Dave, Electronic Specialists, 561-487-6103.**

B&K CRT rejuvenator model 470 with extra sockets. Like new, \$200.00 or best offer. **Contact: Tim Kling, after 5PM 219-264-9731.**

## WANTED

Scott model SUR504SE, part TU6001-2, or where I can get it repaired. **Contact: E. Hymel, 109 Murray Hill Drive, Destrehan, LA 70047-3519.**

Sams Photofacts, 2400 to current. **Contact: George, 860-526-9101.**

Fuji compact video projector, model P701 factory code KKH. Need the light bulb type 60B L130W or information on where I can get it. **Contact: Robert, 718-893-0784, E-Mail PEYETO@aol.com.**

Sony computer monitor model CPD-1730, need schematic and service information. Photocopy OK. **Contact: Gene's TV Service, 110 Russell Road, Sidney, OH 45365, 513-492-8243, E-Mail geary@bright.net. ask for Steve.**

Simpson genescope model 480, need schematic and service literature. **Contact: R. Gilman, PO Box 633, King City, CA 93930, 408-385-9248.**

Magnavox 25 inch TV model HD2516-C221, Daewoo 25 inch TV model DTO2605 PC. Need schematic and service manual. **Contact: E. Cardona, Apeninos 633, Puerto Nuevo San Juan, Puerto Rico.**

Old pocket-sized AM radios in any condition. Old 4-pin vacuum tubes. **Contact: Donald Maurer, 29 S. 4th Street, Lebanon, PA 17042, 717-270-7037.**

Sencore test equipment, LC102, PR570, etc. Also Hickok tube tester or Precise 111M. **Contact: 612-869-4963.**

Thomson CGA Computer monitor schematic or service manual for model CM31481 VI (microfiche OK), will pay \$10.00. Schematic or service manual for SVGA monitor (KLH)MN275-1 (KLH monitor) from Innovations Inc. **Contact: John Augustine, 3129 Earl Street, Lauderdale, PA 19605, 610-929-8850.**





**HERMAN**  
ELECTRONICS

Visit our new Home Page at  
<http://gateintl.com/hermanelec>

**TUBES • TUBES • TUBES**  
World's Largest Range  
Over 2,000 Types, Domestic & Foreign

 **UP TO 85% OFF** Ask for price list  
 International Components Corporation  
Toll Free 800-645-9154 • N.Y. State 516-293-1500  
107 Maxess Road, Melville, New York 11747

Circle (69) on Reply Card

**Tech's Guide To Pricing** **NEW**

**Sperry Tech's Pricing Guide**  
Updated new 6th edition... a framework for setting rates that apply to Hi-Tech products... a formula that guarantees SUCCESS!  
Call Toll Free for details 1-800-228-4338

Circle (73) on Reply Card

**The Ultimate WWW Service Site**  
**www.electronix.com**  
*The One-Stop Service Site for Electronic Technicians*  
Electronix Corp 313 W Main St Fairborn, OH 45324  
(513) 878-1828 Fax (513) 878-1972 sales@electronix.com

Circle (67) on Reply Card

**Get online with ES&T on GENIE**

**Look for us in the Radio & Electronics Roundtable**

To join GENIE, use your computer & modem to call 1-800-638-8369.  
At the U#= prompt, type JOINGENIE  
And for a special introductory offer, At the key/offer code prompt, type MEG528

Circle (74) on Reply Card

## ADVERTISERS' INDEX

Company	Page Number	Reader Service Number	Advertiser Hotline
Accurite Technologies Inc.	13	76	510/668-4900
Andrews Electronics	43	62	800/289-0300
B & K Precision	3	119	312/889-1448
CAIG Laboratories	23,25	63	800/CAIG-123
Computer & Monitor Maintenance	19	64	800/466-4411
Dalbani Corporation	51	65	800/325-2264
EIA/Consumer Electronics	9	77	703/907-7670
ES&T Bookshop	61		516/681-2922
Electronics Technicians Asso.	43	66	317/653-4301
Electronix Corporation	64	67	513/878-1828
GENie Radio & Elec. RoundTable	64	74	800/638-8369
Herman Electronics	64		800/938-4376
ISCET	23		817/921-9101
International Components Corp.	64	69	800/645-9154
Jesse Jones Industries	23		800/825-6690
PTS Electronics	11	70	800/844-7871
Parts Express	13	71	800/338-0531
Philips Software Development	IFC	117	423/475-0480
Philips Consumer Electronics	IBC	118	800/851-8885
Sams & Company, Howard	44	72	800/428-7267
Sencore	BC	3	800/SENCORE
Sperry Tech	64	73	800/228-4338
Thomson Consumer Electronics	1	113	800/336-1900

We'd like to see your company listed here too. Call Diane Klusner at 516/681-2922 or E-Mail her at [dianekest@aol.com](mailto:dianekest@aol.com) to work out an advertising program tailored to suit your needs.



**SALES OFFICE**  
**PHONE (516) 681-2922**  
**FAX (516) 681-2926**



**Smart  
Accessories**  
*The Intelligent Choice*

**What Separates Us  
From The Animals  
Is Our Ability  
To Accessorize.**



MAC5784

Give your customers Philips Smart Accessories, and they'll go ape. With a complete line of accessories, customers get the "extras" they want, while you make the sales you want.

When you want to raise your bottom line, think smart and buy smart. Buy Philips Smart Accessories—your one-stop shopping for parts, accessories, and service aids.



We sell more than just products; we provide the accessories that make life a little more human. Call us toll-free at 1-800-851-8885.

*Let's make things better.*



**PHILIPS**  
Circle (118) on Reply Card



# The Only Complete Solution!

## RGB Video Generator

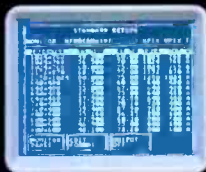

Fully programmable generator for high resolution monitors - plus monitor database for quick setup.

## Color Analyzer



Integrated Auto ColorPro for precise color alignments.

## Service Process Generator

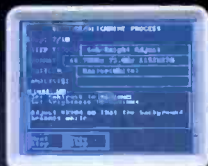

Interactive alignment and troubleshooting process generator for guided servicing.

To meet the servicing challenges of today's high resolution computer monitors, Sencore now adds the new CM2220 to its Monitor Analyzer line. The new CM2220 extends analyzing to high resolution monitors beyond 200 MHz bandwidth. The powerful CM2220 provides you with high resolution video signals, new monitor analyzing features (including color analysis and DDC compatibility), and an exclusive service process generator to maximize your efficiency.

## Sencore's Monitor Analyzer Line



- CM2220 Computer Monitor Analyzer
- CM2220-PC Monitor Analyzing System (PC Based)
- CM2125 Computer Monitor Analyzer
- CM125 "Pix Pak" Computer Monitor Signal Generator

To help you decide which Computer Monitor Analyzer meets your application, call your Area Representative at 1-800-SENCORE (736-2673).

**New!**  
**Now Shipping!**

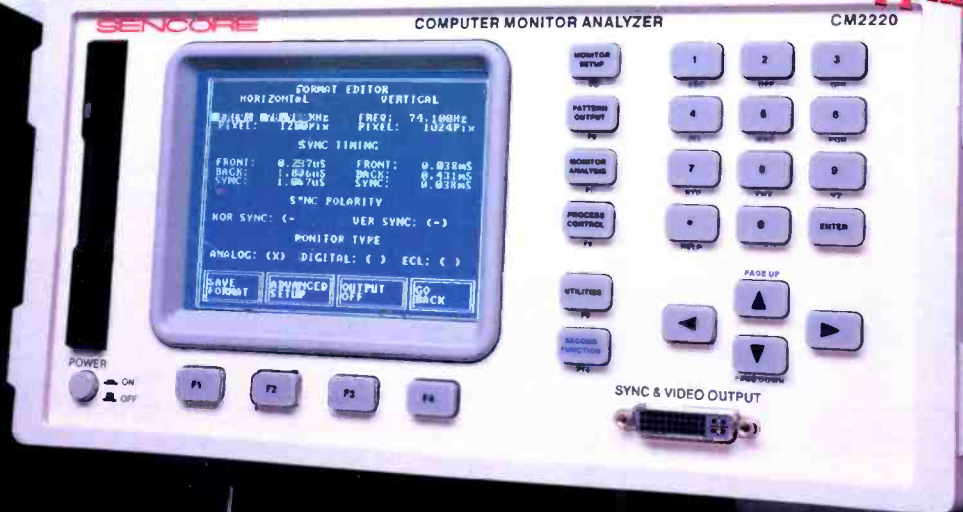

Also Available: CM2220-PC Computer Monitor Analyzing System (PC based system with the same features as the CM2220 stand-alone instrument).

**FREE Technical Guide To Servicing Computer Monitors.**  
(For your copy, either return the reader service card or call 1-800-SENCORE.)