

THE MAGAZINE FOR CONSUMER ELECTRONICS SERVICING PROFESSIONALS

ELECTRONic^{T.M.}

Servicing & Technology

DECEMBER 1991/\$3.00

Replacement parts/servicing information sourcebook

X-Y component patterns and absolute analysis



We Only Skimped On The Price.

Introducing The Fluke Series 10—From \$69.⁹⁵

Fluke quality: Made in the USA by Fluke, with the same rugged reliability that's made us the world leader in digital multimeters. Count on hard-working high performance—and a two-year warranty to back it up.

Large, easy-to-read display: 4000 count digital readout.

Actual size: Easy to carry, easy to use.

New! Min/Max record with relative time stamp and Continuity Capture™: Makes intermittent problems easier to find. Records highs and lows—and "time stamps" when they occurred. In continuity mode, opens or shorts as brief as 250 μs are captured and displayed.

New! V Chek™: For fast accurate checks on power sources and supplies, set your meter on V Chek—and let it do the rest. V Chek will determine continuity/ohms; if voltage is present, it will automatically change modes to measure AC or DC volts, whichever is detected. For most initial troubleshooting checks, here's the only setting you need to make.

Capacitance: Autoranging from .001 μF to 9999 μF. No need to carry a dedicated capacitance meter.

Autoranging with manual option: Your choice, depending on your situation.

For high performance at Fluke's lowest price, get your hands on the new Series 10. Stop by your local Fluke distributor and feel what a powerful difference the right multimeter makes—at the right price. For a free product brochure or the name of your nearest distributor, call 1-800-87-FLUKE.

Sleep Mode: Shuts itself off if you forget, extending long battery life even further.

New! Slide switch and a few pushbuttons control all functions: Designed for true one-hand operation.

Fast, accurate tests and measurements: AC and DC voltage measurements to 600 volts, ohms to 40 MΩ; audible continuity test; and diode test.

Safety—a Fluke standard: Designed to meet UL1244, IEC 1010, CSA and VDE safety requirements; extensive overload protection built in.

Audible Continuity: To perform fast continuity checks, just listen for the beep; no need to watch the display.

New! TL75 Hard Point™ Test Leads: Comfort grip with extra strong tips for extended service life.

Fluke 10	Fluke 11	Fluke 12
\$69.95*	\$79.95*	\$89.95*
4000 count digital display	V Chek™	V Chek™
1.5% basic dc volts accuracy	Capacitance, .001 to 9999 μF	Min/Max recording with relative time stamp
2.9% basic ac volts accuracy	4000 count digital display	Continuity Capture™
1.5% basic ohms accuracy	0.9% basic dc volts accuracy	Capacitance, .001 to 9999 μF
Fast continuity beeper	1.9% basic ac volts accuracy	4000 count digital display
Diode Test	0.9% basic ohms accuracy	0.9% basic dc volts accuracy
Sleep Mode	Fast continuity beeper	1.9% basic ac volts accuracy
Two-year warranty	Diode Test	0.9% basic ohms accuracy
	Sleep Mode	Fast continuity beeper
	Two-year warranty	Diode Test
		Sleep Mode
		Two-year warranty

*Suggested U.S. list price.

Optional holster with tilt-stand available.



The New Series 10.
A Small Price For A Fluke.

FLUKE AND PHILIPS
THE T & M ALLIANCE

©1991 John Fluke Mfg. Co., Inc. Prices and specifications subject to change. Ad no. 00130.

FLUKE®

Circle (6) on Reply Card

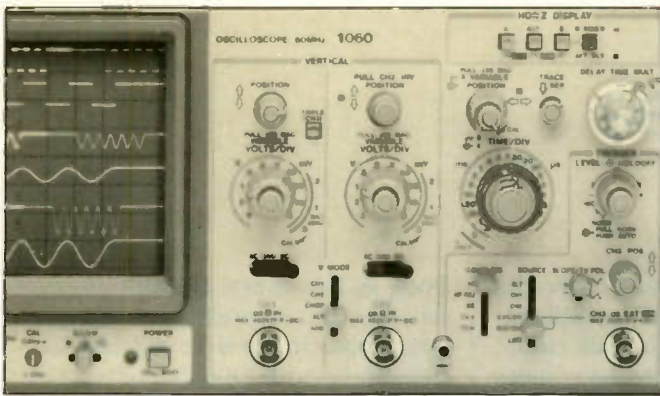

page 14

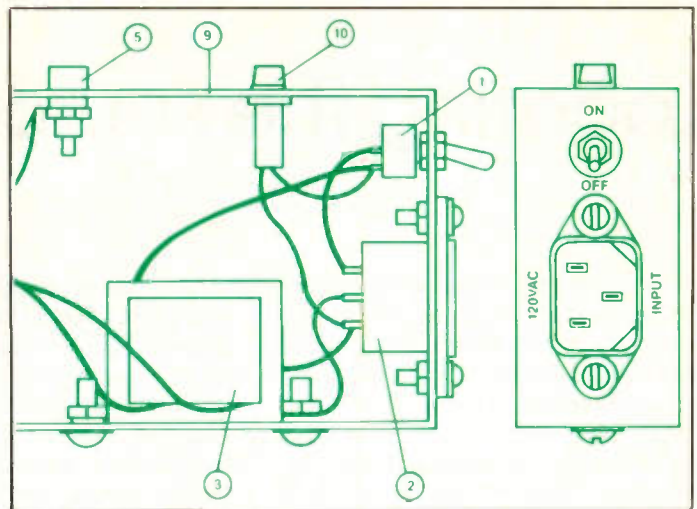

page 20

FEATURES

- 6 Replacement parts/servicing information sourcebook**
By the ES&T Staff
Locating servicing information and obtaining replacement parts are among the toughest problems faced by technicians. This article reprises some of the suggestions on this subject published in past issues, and as a new feature offers a listing of consumer electronic product manufacturers from whom you can order parts and information.
- 14 Inexpensive oscilloscopes**
By David L. Rights
Many jobs in the service center require advanced oscilloscopes with broad bandwidth, more than one channel, video sync, etc. But there are times when a more limited, less expensive oscilloscope will suffice. To help you in making a selection among the offerings at the low end, here's a survey of what's available in inexpensive oscilloscopes.
- 20 X-Y component patterns and absolute analysis**
By R.L. Heyman
By constructing an X-Y

- component tester using a precision pot instead of a fixed resistance, absolute values such as capacitance, resistance and impedance, as well as net impedance can be extracted from X-Y patterns. Read on to see how to construct such a circuit, and how much you can learn from it.
- 38 Cellular mobile telephone systems - Part II**
By William H. Bowen
If you think you might want to service cellular telephones, you should know how the cellular telephone system works. Read this installment, part 2, to learn what goes on in the RF portion of the cellular system.
- 46 Filtering theory**
By Dale C. Shackelford
Once identified, any existing or potential interference may be virtually eliminated from the protected circuitry or device through the proper design and use of filters. In some cases, filtering that was designed into a particular device by the design engineers is not adequate. Read this article to see how some of these filters are constructed and what their characteristics are.

- 3 News**
- 4 Literature**
- 5 Business Corner**
Understanding turnover and service level
- 19 Test Your Electronic Knowledge**
- 27 Profax**
- 45 Books**
- 50 What Do You Know About Electronics?**
Fine tuning resistor theory
- 52 Video Corner**
Solving problems with closed captions on a VCR
- 54 Products**
- 56 Audio Corner**
DAB: The future of radio
- 58 Readers' Exchange**
- 60 Advertisers' Index**

DEPARTMENTS

- 2 Editorial**
Locating the sources

ON THE COVER

The oscilloscope is one of the most useful of all of the technician's test instruments. Whether the oscilloscope used will be a top of the line model or a low-end device will be determined by the nature of the job at hand and budgetary constraints. (Photo courtesy Beckman Industrial).

Locating the sources

Of all the problems reported to us by readers, the two most often mentioned are obtaining replacement parts, and obtaining servicing literature. When one or two problems, become the consuming problems faced by a majority of members of a profession, it makes you think about what has happened to cause those problems to be so prevalent, and what can be done about it.

Increased complexity, variety and automation

One of the causes of these problems is simply the increasing complexity of the products being serviced. In the early days of TV servicing, the circuits of most televisions were really very similar in design, and comparatively simple. Much of the servicing could be accomplished with little or no servicing literature at all.

When a problem did occur, the cause was as often as not one of a handful of vacuum tubes. When the problem was not obvious, it could in most cases be tracked down by checking the handful of tubes in the suspected circuit with a tube tester. And when it came to replacing the tube, it was only necessary to pull the suspect out, and plug in the new one.

Because each product was constructed of only a relatively few components, in a relatively straightforward, simple, design, and almost all components were in general use; that is there were few or no proprietary components; parts were no problem to find.

In today's TV sets, nothing's simple. Starting where the unit plugs into the wall, in the older sets there used to be a transformer, a diode, and a regulating device or two to provide power to the set. Now there's a switching power supply, bristling with components. The technician has to try to understand these circuits, troubleshoot them, and find parts when problems occur.

The same complexity pervades every other part of the TV as well, only more so: not only is each circuit more complex, there are many more circuits. TVs of today have a wide range of ancillary circuitry: picture-in-picture, second-audio-program (SAP)/stereo, remote-control tuning, audio and video input and output circuitry, and more. And all of this circuitry requires servicing information and replacement components.

Many more (sometimes hard to find) manufacturers

Compounding the problem of increasingly complex products is the increasing number of manufacturers of sets, many of them from offshore. And while many well-known offshore manufacturers have made the commitment to not only sell their products in this country but to support them with servicing information and parts, and maintain a high profile so that service facilities can contact them in order to obtain replacement parts, others have been less committed and are very hard to locate.

Increased number of products

Further compounding the problem is the growth in the number of products that fall under the label of consumer electronics. In addition to TV, radio and stereo, consumer electronics now includes VCRs, laser disc players, CD players, microwave ovens, personal computers and peripherals, cordless telephones and even cellular telephones.

The replacement parts/servicing information sourcebook

These problems that service centers face when trying to find servicing information and replacement parts is the reason that this magazine has instituted the annual Replacement Parts/Servicing Information Source-

book in December. It's still not exhaustive or comprehensive, but the sourcebook in this issue provides service centers with a number of ways to get information. There's a UL number to product cross reference, there's information about the FCC's public-access information system, there's a list of references that will help service centers find the information they need, and new to this year's sourcebook, there's an extensive list of manufacturers, with names and addresses that should help service centers find the information they need.

Help us help

We'd like to make this sourcebook more useful. For example, our UL number/manufacture cross reference and our FCC number/manufacture cross reference have stagnated. We haven't added any new information to them for some time. We would welcome any information or questions from any of our readers on any of the manufacturers of consumer electronics products.

If you have identified an FCC number prefix that isn't listed in our listing, please let us know. If you have identified a manufacturer's UL listing number please let us know. If you have run across an obscure product and can't find information on it, let us know.

In all cases, please provide us with as much information as possible: name and model of the product, type of product, model number, serial number, FCC ID number, UL listing number, every detail you can think of. The more information we can gather, the better we can make each succeeding issue of the sourcebook.

Nile Conrad Person

EIA study consumer purchasing patterns for home office products

Thirty-six (36) percent of respondents to a recent Electronic Industries Association study utilize a home office or workspace in their homes. Forty-nine (49) percent of recent purchasers of home office products work at home, versus 41 percent who use these products for educational or recreational purposes.

These and other important facts about consumer purchasing habits regarding personal computers and other key home office products are revealed in a newly-released three-volume EIA Home Office Products Study, 1991, now available from EIA's marketing services department.

The study, conducted focuses on recent buyers of specified home office products and covers:

- usage and attitudes
- demographics
- product penetration
- distribution channels
- recent purchase behavior and future intentions

The study was conducted by Market Facts, Inc. a private market research firm in Washington, D.C. Approximately 43,000 households considered "nationally representative" were surveyed by mail about their ownership and purchase of the eleven specified products during 1990. In depth follow-up surveys were conducted with 200-400 recent buyers of each of the eleven products.

Certification program advances

A new symbol to identify audio receivers with enhanced AM reception capabilities has been unveiled by the Electronic Industries Association (EIA) and the National Association of Broadcasters (NAB): AMAX.

The idea is AM at its maximum potential. Broadcasters are working to improve AM programming and music quality, and this certification program will enable receiver manufacturers to advertise and market their products which can deliver this improved quality sound, according to the EIA's Consumer Electronics Group. According to EIA the certification program will be a dual-level one, with one logo in-

dicating enhanced reception AM capability and the other indicating enhanced AM capability and yet another indicating enhanced reception plus AM stereo capability.

The EIA/CEG Board of Directors resolved to participate in the certification program at its spring conference meeting in April. Their decision was based on the benefits that:

- Certification will enhance competition and consumer choice by permit-

ting consumers to select among products produced by many manufacturers.

- Industry will benefit as a result of the increased consumer interest and expanded potential created by enhanced AM reception.

The new AMAX logo can be embossed on or used as stickers for placement on radios with enhanced capabilities. It can also be used in advertising, packaging and other printed materials.

ELENCO & HITACHI PRODUCTS AT DISCOUNT PRICES

48 HOUR SHIPPING

TO ORDER CALL TOLL FREE 1-800-292-7711

Hitachi RSO Series
(Portable Real-time Digital Storage Oscilloscopes)

- VC-6023 - 20MHz, 20MS/s \$1,695
- VC-6024 - 50MHz, 20MS/s \$1,995
- VC-6025 - 50MHz, 20MS/s \$2,195
- VC-6045 - 100MHz, 40MS/s \$2,995
- VC-6145 - 100MHz, 100MS/s \$4,495

RSO's from Hitachi feature roll mode averaging, save memory, smoothing, interpolation, pretriggering, cursor measurements. These scopes enable more accurate, simpler observation of complex waveforms. In addition to such functions as hardcopy via a plotter interface and waveform transfer via the RS-232C interface. Enjoy the comfort of analog and the power to digital.

25MHz Elenco Oscilloscope
S-1325 **\$349**

- Dual Trace
- 1mV Sensitivity
- 6" CRT
- X-Y Operation
- TV Sync

• (2) 1x, 10x Probes included

SPECIAL BUY
V-212 - 20MHz Scope **\$425**

Hitachi Portable Scopes
DC to 50MHz, 2-Channel, DC offset function, Alternate magnifier function

- V-525 - CRT Readout, Cursor Meas. \$995
- V-520 - Delayed Sweep \$975
- V-522 - Basic Model \$875
- V-422 - 40MHz \$775
- V-223 - 20MHz delayed sweep \$695
- V-222 - 20MHz deluxe \$625

HITACHI COMPACT SERIES SCOPES
This series provides many new functions such as CRT Readout, Cursor measurements (V-1085/1085A/665A), Frequency Ch. (V-1085), Sweepless Autotrigger, Delayed sweep and Trigger Lock using a 6-inch CRT. You don't feel the compactness in terms of performance and operation.

- V-660 - 60MHz, Dual Trace \$1,149
- V-665A - 60MHz, DT, w/cursor \$1,345
- V-1060 - 100MHz, Dual Trace \$1,395
- V-1065A - 100MHz, DT, w/cursor \$1,649
- V-1085 - 100MHz, DT, w/cursor \$1,995
- V-1100A - 100MHz, Quad Trace \$2,195
- V-1150 - 150MHz, Quad Trace \$2,695

PRICE BREAKTHRU
20MHz Digital Storage Oscilloscope

- Analog/Digital Scope DS203
- 10K/s sampling rate \$795
- State-of-art technology
- Includes probes

Elenco 40MHz Dual Trace
Good to 50MHz **\$495**
S-1340

- High luminance 6" CRT
- 1mV Sensitivity
- 10KV Acceleration Voltage
- 17ns Rise Time
- X-Y Operation

• Includes (2) 1x, 10x Probes

FLUKE MULTIMETERS
All Models Available

- Fluke 70-II \$65
- Fluke 77-II \$145
- Fluke 79-II \$169
- Fluke 87 \$289

Call for special price

B + K TEST EQUIPMENT
All Models Available

Call for special price

Digital Capacitance Meter
CM-1550B **\$58.95**

9 Ranges
.1pF to 20,000µF
5% basic acy.
Zero control w/ Case
Big 1" Display

Digital LCR Meter
LC-1801 **\$125**

Measures:
Caps. 1pF-200µF
Res. .01-20M

Multimeter with Capacitance & Transistor Tester
\$55 CM-1500B

Reads Volt, Ohms
Current, Capacitors
Transistors and
Diodes / with case

FLUKE MULTIMETERS
All Models Available

- Fluke 70-II \$65
- Fluke 77-II \$145
- Fluke 79-II \$169
- Fluke 87 \$289

Call for special price

Soldering Station
Temperature Controlled
SL-30 **\$99**

Digital Display
Temp Range:
300F-900F
Grounded Tip
Overheat Protect

Video Head Tester
HT-200 **\$55.95**

Tells you if
VHS head
is defective
or worn
A must for
VCR work

Four-Function Frequency Counters
F-100 120MHz **\$179**
F-1000 1.2GHz **\$259**

Frequency, Period, Totalize,
Self Check with High Stabilized Crystal Oven
Oscillator, 8 digit LED display

10MHz Oscilloscope
S-3000 **\$275**

Triggered Sweep
Calibrated Voltage Input
Single Channel
Ideal for auto work

CELLULAR TELEPHONE ACCESSORIES

Available for most phones
Call or write for details

Quad Power Supply XP-580 **\$59.95**

2-20V @ 2A
12V @ 1A
5V @ 3A
-5V @ 5A

Fully regulated and short circuit protected

Triple Power Supply XP-620 **Assembled \$69**
KR \$45

2- to 15V @ 1A,
2- to 15V @ 1A
(or 4 to 30V @ 1A)
and 5V @ 3A

All the desired features for doing experiments.
Features short circuit protection, all supplies

AM/FM Transistor Radio Kit with Training Course
Model AM/FM 108 **\$26.95**

14 Transistors • 5 Diodes
Makes a great school project

True RMS 4 1/2 Digit Multimeter M-7000 **\$135**

05% DC Accuracy
.1% Resistance
with Freq. Counter
and Deluxe Case

GF-8016 Function Generator with Freq. Counter **\$249**

Sine, Square, Triangle Pulse, Ramp, 2 to 2MHz
Freq. Counter: .1 - 10MHz
Inst. Gen. operation

GF-8015 without Freq. Meter **\$179**

Function Generator Box #9600 **\$28.95**

Provides sine, triangle, square wave from 1Hz to 1MHz
AM or FM capability

Learn to Build and Program Computers with this Kit
Includes: All Parts, Assembly and Lesson Manual
Model MM-8000 **\$129.00**

Starting from scratch you build a complete system. Our Micro-Master trainer teaches you to write into RAMs, ROMs and run a 8085 microprocessor, which uses similar machine language as IBM PC.

Wide Band Signal Generators

SG-9000 **\$129**
RF Freq. 100K-450MHz AM Modulation of 10KHz Variable RF output

SG-9500 w/ Digital Display & 150 MHz built-in Counter **\$249**

Power Supplies

- Variable Power Supply
- -1.25 to 20VDC @ 5 Amp
- -1.1 to 15VDC @ 3 Amp
- -1.25 to 20VDC @ 5 Amp
- -1.25 to 15VDC @ 1 Amp
- -12VDC @ 1 Amp
- -5VDC @ 1 Amp
- 30VAC Center tapped @ 15VAC @ 1 Amp

Analog Section

- Function Generator: Sine, Triangular, Square wave forms
- Frequency adjustable in five ranges from 1 to 100KHz
- Fine frequency adjust
- Amplitude adjust
- DC offset
- Modulation: FM, AM

Digital Section

- Eight data switches
- Two no bounce logic switches
- Eight LED readouts TTL buffered
- Clock frequency 1 to 100KHz
- Clock amplitude 5VPP square wave
- Breadboard
- 2 breadboards, each contain:
- 840 tie points (total 1,680)

XK-500 Digital / Analog Trainer

A complete mini-lab for building, testing, prototyping analog and digital circuits
Elenco's Digital / Analog Trainer is specially designed for school projects, with 5 built-in power supplies. Includes a function generator with continuously variable sine, triangular, square wave forms. All power supplies are regulated and protected against shorts.

\$149.95 Assembled
\$119.95 KH

WE WILL NOT BE UNDERSOLD!
UPS Shipping: 48 States 5%
(\$3 Min \$10 Max) Shipping
IL Res. 7.5% Tax FAX: 708-520-0085

C & S SALES INC.
1245 Rosewood, Deerfield, IL 60015
(800) 292-7711 (708) 541-0710

15 Day Money Back Guarantee
2 Year Warranty

WRITE FOR FREE CATALOG

Circle (2) on Reply Card
December 1991 Electronic Servicing & Technology 3

Brochure describes power protection equipment

Computer Power Inc. has released a new capabilities brochure entitled "Providing Solutions in Power Protection and Conditioning." This 12-page, color brochure details the company's resources, technology and support. Included is an overview of their line of off-the-shelf and custom designed UL listed uninterruptible power systems (UPS) line conditioners, and battery charges.

Products described in the brochure include off-line, on-line and true on-line units which provide either ferroresonant technology or pulse width modulation. There are over one-hundred models ranging from 100VA to 300kVA in the standard product line. These models can be combined with a wide range of options including: extended run times, unattended shut-down, system diagnostics, and audible/visual alarms. Every UPS provides sine wave output and will interface with any computer operating system.

Circle (20) on Reply Card

Brochure on technical computer courses

This new brochure describes nine intensive short courses available from Learning Group International. Topics covered in the courses include: Hands-on PC configuration and troubleshooting, Advanced PC configuration, Microprocessor software, Hardware and Interfacing, Computer Graphics, Relational Databases, Hands-on SQL, and much more.

This brochure outlines each course and describes the subjects and applications covered, the hands-on activities benefits materials provided, authors and instructors, dates and locations, and who should attend. The 4-day programs are offered throughout the United States, Canada, and Europe. Assistance is available to provide on-site training programs that will directly benefit individual projects and organizations.

Circle (21) on Reply Card

Test equipment catalog

New from Contact East is their latest catalog of test instruments and tools for engineers, managers, techni-

cians, and hobbyists. Featured are quality products from brand-name manufacturing for testing, repairing, and assembling electronic equipment. Product highlights include new: EPROM programmers, power supplies, tool kits and portable digital scopes. Also included are DMMs, communication test equipment, soldering/desoldering systems, static protection products, ozone safe cleaners, magnifiers, inspection equipment, workbenches, precision hand tools, tool kits, cases and more.

Circle (22) on Reply Card

Electronic and computer product catalog

Jameco Electronic Components and Computer Products released its 1992 catalog featuring educational information, a RAM cross-reference guide, and 24-hour toll-free order placement, toll-free FAX and BBS service.

Designed as the ideal source for computer and electronics enthusiasts, the 90-page full-color catalog, printed on recycled paper, includes, over 3,000 products ranging from integrated circuits to computer peripherals to test and measurement equipment.

Circle (67) on Reply Card

Oscilloscope probe and test accessory catalog

Test Probes Inc. offers a catalog of test probes, test leads and accessories for oscilloscopes and DMMs. The catalog, "Oscilloscope Probes and Test Accessories, 1991" contains detailed descriptions of the company's full line of leads, probes and accessories. According to the manufacturer, they produce test leads for Hewlett Packard, Beckman and Simpson. Cable for the leads is made with 720 strands of copper wire, and is low in resistance to facilitate low voltage and resistance measurements. The insulation is made of silicone rubber, which is flexible under extreme cold, burn resistant to soldering irons, and does not crack due to age hardening. Included in the catalog are descriptions and replacements for popular probes, special purpose and repairable probes, multimeter leads, coax adapter kits, probe accessories, and more.

Circle (23) on Reply Card

THE MAGAZINE FOR CONSUMER ELECTRONICS SERVICING PROFESSIONALS

ELECTRONIC

Servicing & Technology

Electronic Servicing & Technology is edited for servicing professionals who service consumer electronics equipment. This includes service technicians, field service personnel and avid servicing enthusiasts who repair and maintain audio, video, computer and other consumer electronics equipment.

EDITORIAL

Nils Conrad Persson, *Editor*
Jeffrey Uschok, *Assistant Editor*

CONSULTING EDITORS

Homer L. Davidson, *TV Servicing Consultant*
William J. Lynott, *Business Consultant*
Victor Meeldijk, *Components Consultant*
John E. Shepler, *Audio Consultant*
Sam Wilson, *Electronics Theory Consultant*

PRODUCTION

Elizabeth Ryan, *Art Director*
Barbara Terzo, *Assistant Art Director*
Susan Reale, *Artist*
Dorothy Kehrwieler, *Production Manager*
Emily Kreutz, *Production*
Pat Le Blanc, *Phototypographer*
Florence V. Martin, *Phototypographer*

BUSINESS

Richard A. Ross, *Publisher*
Dorothy Kehrwieler, *General Manager*
Frank V. Fuzia, *Controller*
Catherine Ross, *Circulation Director*
Melissa Kehrwieler, *Data Processor*
Denise Pyne, *Customer Service*

SALES OFFICE

Electronic Servicing & Technology
76 N. Broadway, Hicksville, NY 11801
516-681-2922; Fax, 516-681-2926

Jonathan Kummer, *Advertising Manager*
Emily Kreutz, *Sales Assistant*



Member, Electronic
Servicing Dealers
Association

EDITORIAL CORRESPONDENCE

P.O. Box 12487
Overland Park, KS 66212
913-492-4857

Electronic Servicing & Technology (ISSN 0278-9922) is published monthly by CQ Communications, Inc., 76 N. Broadway, Hicksville, NY 11801. Telephone (516) 681-2922. Second class postage paid at Hicksville, NY and additional offices. Subscription prices (payable in US dollars only): Domestic—one year \$24, two years \$40. Foreign countries—one year \$30, two years \$52. Entire contents copyright 1991 by CQ Communications, Inc. Electronic Servicing & Technology or CQ Communications, Inc. assumes no responsibility for unsolicited manuscripts. Allow six weeks for delivery of first issue and for change of address. Printed in the United States of America.

Postmaster: Please send change of address notice to Electronic Servicing & Technology, 76 N. Broadway, Hicksville, NY 11801.

CQ Communications, Inc. is publisher of CQ The Radio Amateur's Journal, Popular Communications, ComputerCraft, CQ Radio Amateur (Spanish CQ), CQ Amateur Radio Equipment Buyer's Guide, CQ Amateur Radio Antenna Buyer's Guide, and Electronic Servicing & Technology.

Understanding turnover and service level

By William J. Lynott

Your repair parts inventory can affect the profitability of your business — poor parts management can affect the productivity of the entire organization. Let's take a look at the fundamentals of good inventory management.

Perhaps the most important single tool for measuring the effectiveness of parts management is a measurement called turnover. Many small service dealers avoid working with this statistic because they don't understand it, or feel it isn't important. That's too bad because the concept of turnover is actually quite simple. More important it's unlikely that you will ever develop optimum parts profits if you haven't learned how to put it to work for you.

Imagine for a moment that you carry only one part in your inventory, and during one year you sold and restocked that part four times. In that case, your annual turnover was 4.0, commonly expressed as "four turns." A simple example, of course; but it does clearly illustrate the concept of turnover. More realistically, think of a parts inventory that averaged \$50,000 at cost value throughout the year. The cost of parts sold during that same year was \$20,000. Again, turnover equaled exactly 4.0.

As you can see, turnover measures how well the mixture of items you have decided to carry in your stock are selling. The formula for figuring your own turnover for a given accounting period is:

$$\frac{\text{Cost of goods sold}}{\text{Average inventory at cost}} = \text{Turnover}$$

Selling values could be substituted

for cost values in this formula, but cost is the preferred method. In either case, be sure not to mix cost and selling values in the same formula.

An easy way to figure average inventory value is to add the value at the beginning and end of the period you want to measure, and then divide by two. Your accountant may prefer a more precise method based on more frequent calculations.

Once you begin to track turnover, you're ready to develop your program for improvement. Basically, that means identifying and removing slow-moving parts from your inventory while making sure that you're carrying the faster-moving parts.

In general, the higher your turnover the better — but only up to a point. Theoretically, you could reduce your inventory to zero and your turnover would skyrocket to infinity. The problem is that you would have to buy each part as you needed it. You know how prohibitively expensive that would be. Conversely, stocking every part that you could ever need would be equally impractical. Optimum turnover, then, falls somewhere in between those two extremes.

What should a service dealer's turnover be? The answer to that question is influenced by another statistic called service level. If you stocked every part ever made for the products you service, your inventory service level would be zero percent. The first, of course is impossible; the latter, impractical.

Like every management variable, service level must be fine-tuned for an individual company's situation. A company servicing life-and-death medical equipment or critical business equipment will require a higher level of service than the typical consumer electronics service dealer. And, of course, service dealers who handle a narrow range of products will find it easier to maintain a high

service level than will a company that services everything but the kitchen sink.

Still there are guidelines to help. I've found that electronics service dealers usually fare best with a service level between 80% and 90%. Less than 80% will usually mean lost profits due to the expense of buying too many parts on an as needed basis. Levels above 90% require unrealistic investment in inventory and sharply reduced turnover.

To find out where your service level is now, add up the total number of parts used during a given period (at least one month, a full year is better). Then add up all that were already on hand in truck or bin inventory. Divide the number on hand by the total number required. The result multiplied by 100 is your service level percentage.

As you can see, turnover and service level affect each other. Getting the maximum return from your investment in parts inventory requires that you understand this relationship. To get you started on improving parts profitability, I suggest that you begin by setting an objective for both turnover and service level. While these figures will vary to suit your circumstances and your personal objectives, a turnover of 4.0 and a service level of about 85% will be a strong challenge for most electronics service dealers.

Once you've set those objectives, you must keep careful records to see how well you're doing and what action you need to take.

Managing parts inventories for optimum profit takes time and effort. Making certain that you have the parts you need, and that you aren't burdened with carrying parts you don't need is no small task, but it is essential for maximizing service profits. Be assured, though, that the time you invest in learning effective parts management will show up ■

Lynott is president of William J. Lynott, Associates a management consulting firm specializing in profitable service management and customer satisfaction research.

Replacement parts/servicing information sourcebook

By the ES&T Staff

The twin problems of locating servicing information and obtaining replacement parts are among the toughest problems faced by consumer electronic servicing technicians. These problems are frequently compounded by the fact that many products are private labeled, and without some kind of key it's impossible to determine who manufactured them. In the December 1989 issue, we published a replacement parts and servicing information sourcebook that provided several keys to determining who made a given brand of product, and where to go to obtain replacement parts. That article was so well received that we ran it again in the December 1990 issue for the sake of those who missed it the first time around, with some additions and changes.

We've received so many calls and comments from readers who benefited from the article, as well as many calls from other readers who are looking for the information that was published in those articles, and who obviously never saw it, that we've decided to publish this information, along with updates and new features, annually.

The one new feature this time is a

listing of names, addresses and telephone numbers of consumer electronic product manufacturers, including, in most cases, the addresses, telephone numbers, toll-free numbers and fax numbers for identifying and ordering replacement parts and service literature.

Breaking the codes

One way to identify the manufacturer of a product is to find the UL manufacturer's code number or an FCC ID number on the product, and compare it to the numbers in a listing of manufacturers. We have presented such a listing in this article. This does not work in all cases, but it does in a lot of cases, so it's always worth a try.

A VCR cross reference, might allow you to use a VCR servicing manual that you already have from a well-known manufacturer to troubleshoot a VCR from a manufacturer you've never heard of, and you might even have some of the needed replacement components in stock and might be able to identify them.

Finding replacement parts

Here's a list of references that are useful in tracking down the manufac-

turer, or parts distributors. We think that every electronics servicing facility should have them:

Consumer Electronics Replacement Parts Source Book

Consumer Electronics Group,
Electronic Industries Association
PO Box 19100

Washington, DC 20036

Include \$1.00 for postage and handling.

Electronic Industry Telephone Directory (Or some equivalent)

Harris Publishing Company
2057-2 Aurora Rd.

Twinsburg, OH 44087-1999

This will cost around \$50.00 (Or you might be able to get a copy free from your distributor).

Consumer Electronics Show (CES) Directory

Consumer Electronics Group
Electronic Industries Association
2001 Pennsylvania Ave, N.W.
Washington, DC 20006-1813

The CES directory includes over 1,000 manufacturers, brand names, products and key personnel. The best way to get a copy of this directory is to attend the Consumer Electronics Show, either in Las Vegas, January 9 through 12, 1992 or Chicago, May 28 through 31, 1992. It comes with the price of attendance. If you can't get to the show, limited quantities of the CES Show Guide will be available at a reduced price to ES&T readers who send in the coupon in this issue. Quantities are limited, but the EIA/CEG will fill as many orders as possible.

A VCR model number and parts reference

Another invaluable reference is

Please send me a copy of the Consumer Electronics Show Directory, as mentioned in ES&T. Enclosed is a check for \$15, payable to the Consumer Electronics Show. (For ES&T readers only. Regular value is \$100.)

Name _____ Occupation/Title _____

Address _____

City _____ State _____ Zip _____

Mail to: CES, Attn. Pam Davis
2001 Pennsylvania Ave. NW,
Washington, DC 20006-1813

FCC ID numbers

Manufacturer	FCC ID Number
Akai	ASH
Fisher	AFA
GE	AJU
Goldstar	BEJ
Hitachi	ABL
Lloyds	ADT
Magnavox	BOU
Mitsubishi	BGB
NEC	A3D
Panasonic	ACJ
RCA	AHA
Samsung	A3L
Sharp	ATA
Shintom	E0Z
Sony	AK8
Sylvania	AIX
TMK	A7R
Toshiba	AGI
Zenith	ASI

Figure 1. Every VCR, personal computer, cordless telephone and microwave oven must carry an FCC ID number. The first three characters of that ID uniquely identify the manufacturer of the product. This is a listing of FCC ID number vs manufacturer.

UL numbers for VCR manufacturers (unofficial)

UL number	Manufacturer	Brand names
16M4	Samsung	Supra, Multitech, Unitech, Tote Vision, Cybrex, GE, RCA
174Y	Toshiba	Sears
238Z	Hitachi	RCA, GE, JC Penney, Pentax
333Z	Symphonic	Teac, KTO, Realistic, Multitech, Funai, Porta Video, Dynatech, TMK
403Y	Fisher/Sanyo	Realistic, Sears
439F	JVC	Zenith, Kenwood, Sansui
44L6	TMK	Emerson, Lloyds, Brooksonic
504F	Sharp	Wards, KMC
51K8	Porta Video	
536Y	Mitsubishi	Emerson, Video Concepts, MGA
570F	Sony	Zenith
679F	Panasonic	RCA, GE, Magnavox, Quasar, Canon Philco
781Y	NEC	Dumont, Video Concepts, Vector, Sears
86B0	Goldstar	Realistic, JC Penney, Tote Vision, Shinton, Sears, Memorex

Figure 2. The UL listing number on a consumer electronics product identifies the manufacturer who made it. Here's a partial listing of UL numbers vs. manufacturer.

published by the International Society of Certified Electronics Technicians (ISCET): a VCR model number and parts cross reference. It has just been updated in July. This reference is available in two forms.

One way you can obtain the book is as a shrink-wrapped set of 272

laser-printed loose-leaf sheets plus the 38-page update that was released in July. The cost to obtain one is \$38.00, plus \$3.00 shipping.

If you prefer to have the information on disk, you can purchase a combination of the original program and data file on disk, plus the update

disk for \$84.90 plus \$2.00 shipping. All of the original data printed in the 272-page book and the 56-page update is included on the data disks.

The disk format has the added advantage of allowing the user to update files by adding model and parts crosses of future models. A special

(Continued on page 10)

The FCC public-access information system

Every VCR, personal computer, microwave oven and cordless phone sold in the United States must bear an FCC identification number because they are considered to be potential generators of radio-frequency interference. This number identifies which company manufactured the unit. If you have one of these products in your shop for service and can't identify the manufacturer, you can contact the FCC through its public-access system and find out.

There are two ways to get this information: via voice telephone or via computer and modem by contacting the public-access bulletin board. The FCC prefers to have people use direct computer-to-computer contact.

To contact the FCC bulletin board, you must have a computer and a modem capable of 300 baud or 1200 baud. The number to call, in Maryland (just outside of Washington, D.C.), is

301-725-1072. This is a toll call. Dialing this number at any time should get you in direct contact with the bulletin board.

Once you have made contact, the computer screen will tell you how much time you have and provide you with a menu of items to choose from. When ES&T dialed up the bulletin board on October 18, 1990, once we accessed the bulletin board the portion of the bulletin board that contained the FCC ID number to manufacturer cross reference was:

1. ACCESS EQUIPMENT AUTHORIZATION DATABASE. To get to it, it was necessary only to key in the number 1 and press ENTER.

After pressing 1 and ENTER, the bulletin board presented three options. The one to choose in this case was:

2. GRANTEE NAME & ADDRESS

BY CODE, and again ENTER. Then the bulletin board asked for a three character code. That's the first three characters of the FCC ID number. Entering that and pressing ENTER caused the bulletin board to respond with the name and address of the manufacturer of the product in question.

The other method of obtaining this information is to call 301-725-1585, Monday through Thursday between 2:00 and 4:30 p.m. and ask to be connected to the status desk. The individual who answers will relay your question to the bulletin board via a computer terminal and will then relay the information it provides to you.

Obviously, if you have a computer and a modem, it makes far more sense to contact the computer directly. You'll cut out the middle man and, of course, you can contact the computer any time.

DELIVERY IS THE MOST IMPORTANT FUNCTION OF A PARTS DISTRIBUTOR. BUT IT'S NOT ENOUGH.



MATSUSHITA AUTHORIZED PARTS-LINK™ DISTRIBUTORS. BECAUSE IT PAYS TO BE SURE.

Some distributors are quick to promise fast delivery of replacement electronic parts. But they may not always be the right parts. That's never a problem when you put your trust in a Matsushita Authorized PARTS-LINK™ Distributor — your best source for Panasonic, Technics and Quasar original replacement parts. For basic stocking, each distributor maintains over 1,000 of the most demanded part numbers for off-the-shelf delivery. Even if the part you need isn't so common, your Matsushita distributor is tied into our exclusive PARTS-LINK™ network, tracking over 385,000 part numbers, so that we can locate the part you need, lock in the order, and deliver it — if overnight delivery is requested to your doorstep within 24 hours. They can even cross-reference these original

replacement parts to other Matsushita built products so that you can retain the high quality and reliability of Matsushita's design.

THE DIFFERENCE BETWEEN A PROMISE KEPT, AND A PROMISE BROKEN.

Your Matsushita Authorized PARTS-LINK™ Distributor isn't authorized by accident; each has met (and continues to meet) stringent requirements to ensure fast, courteous and responsive service backed by Matsushita's replacement parts warranty. The right part at the right time from the right source. For the name and location of your Matsushita Authorized PARTS-LINK™ Distributor — see our listings at right. **YOUR SOURCE OF CONFIDENCE.**



MATSUSHITA SERVICES COMPANY

50 Meadowland Parkway, Secaucus, NJ 07094

Panasonic® • Technics™ • Quasar®

MATSUSHITA

AUTHORIZED REPLACEMENT PARTS DISTRIBUTORS

Panasonic® Technics™ Quasar®

ARIZONA

Arizona Wholesale Supply Co (C/M) • 2020 E. University Dr., Phoenix 85034 • 602-258-7901 • FAX 602-258-0800
 Electronic Parts Co. (C/V/M) • 4021 N. 31st. Ave., Phoenix 85017 • 602-277-7281 • FAX 602-279-4429

CALIFORNIA

Andrews Electronics (C/V/M/A) • 25158 Avenue Stanford, Valencia 91355 • 800-289-0300 • FAX 800-289-0301
 Audio Video Parts, Inc. (C/V/M/A) • 1071 South La Brea Ave., Los Angeles 90019 • 213-933-8141 • FAX 213-933-7008
 Blakeman Wholesale Distributors (V) • 17370 Mount Herrman St., Fountain Valley 92708 • 714-540-8710 • FAX 714-957-8703
 Cass Electronics (C/V/M/A) • 801 Seventh Ave., Oakland 94606 • 415-839-2277 • FAX 415-465-5927
 Chuck Hurley Electronics (C/M/A) • 2557 Albatross Way, Sacramento 95815 • 916-927-5891 • FAX 916-927-5956
 E and K Parts, Inc. (C/V/M/A) • 2115 Westwood Blvd., Los Angeles 90025 • 213-475-6848 • FAX 213-474-0846
 Hurley Electronics (C/V/M) • 318 16th St., San Diego 92101 • 619-235-6245 • FAX 619-235-0436
 Hurley Electronics (C/M) • 2101 N. Fairview, Santa Ana 92706 • 714-971-2992 • FAX 714-971-5033
 Pacific Coast Parts (C/V/M/A) • 15024 Staff Court, Gardena 92048 • 213-515-0207 • FAX 800-782-5747
 Star for Parts (V/A) • 12930 E. Sunnyside Place, Santa Fe Springs 90670 • 800-525-6046
 Wholesale Vacuum (V) • 5811 Rose Ave., Long Beach 90813 • 213-428-6411

COLORADO

Denver Walker Wintronics (C/M) • 1001 W. Arizona Ave., Denver, 80223 • 303-744-9505 • FAX 303-777-9357
 Star for Parts (V/A) • 2350 Arapahoe St., Denver 80205 • 303-296-2117 • FAX 303-296-2120

CONNECTICUT

Signal Electronics Supply, Inc. (C/M/A) • 589 New Park Ave., West Hartford 06110 • 203-233-8551 • FAX 203-233-8554

FLORIDA

Herman Electronics (C/V/M/A) • 1365 N.W. 23rd St., Miami 33142 • 305-634-6591 • FAX 305-634-6247
 Layco, Inc. (C/V/M/A) • 501 South Main St., Crestview 32536 • 904-682-0321 • FAX 904-682-8820
 Vance Baldwin (C/A/M) • 2207 S. Andrews Ave., Fort Lauderdale 33316 • 305-523-3461 • FAX 305-523-3464
 Vance Baldwin (C/M/A) • 1801 NE 2nd Ave., Miami 33132 • 305-379-4794 • FAX 305-373-8855
 Vance Baldwin (C/V/M/A) • 1007 N. Himes Ave., Tampa 33607 • 800-443-2606 • FAX 813-870-1088
 Vance Baldwin (C/V/M) • 500 Clematis St., West Palm Beach 33401 • 407-832-5671 • FAX 407-833-8191

GEORGIA

Buckeye Vacuum Cleaner (V) • 2870 Plant Atkinson Rd., Smyrna 30080 • 404-351-7300 • FAX 404-351-7307
 Wholesale Industrial (C/M/A) • 5925 Peachtree Corners East, Norcross 30071 • 404-447-8436 • FAX 404-447-1078

HAWAII

Panasonic Hawaii, Inc. (C/V/M) • 99859 Iwailua St., PO Box 774, AIEA, HI 96701 • 808-488-1996

ILLINOIS

B-B & W, Inc. (C/V/M) • 2137 S. Euclid Ave., Berwyn 60402 • 708-749-1710 • FAX 708-749-0325
 Hesco, Inc. (V) • 6633 North Milwaukee Ave., Niles 60648 • 708-647-6700 • FAX 708-647-0534
 Joseph Electronics, Inc. (C/M/A) • 8830 N. Milwaukee Ave., Niles 60648 • 708-297-4208 • FAX 708-297-6923
 Union Electronic Dist. (C/V/M/A) • 16012 S. Cottage Grove, South Holland 60473 • 708-333-4100 • FAX 708-339-2777

INDIANA

Electronic Service Parts (C/V/M) • 2901 E. Washington St., Indianapolis 46201 • 317-269-1527 • FAX 317-269-1529

IOWA

Jones Distributing Co. (C/V/M/A) • 2650 Bridgeport Dr., Sioux City 51111 • 712-277-8600 • FAX 712-252-5645

KANSAS

G & A Distributors, Inc. (C/V/M/A) • 635 N. Hydraulic St., Wichita 67214 • 316-262-3707 • FAX 316-262-6494

KENTUCKY

Major Distributing Company (C/M/A) • 449 S. 16th St., Paducah 42003 • 502-443-5345 • FAX 502-444-6237
 Service Electronics Supply (C) • 1046A New Circle Rd., NE, Lexington 40505 • 606-254-5786 • FAX 606-231-9684

MARYLAND

Fairway Electronics (C/V/M) • 3040 Waterview Drive, Baltimore 21230 • 301-576-8555 • FAX 800-955-2119
 Fairway Electronics (C/V/M/A) • 4210 Howard Ave., Kensington 20895 • 301-564-1440 • FAX 800-955-1358
 Tritronics, Inc. (C/V/M/A) • 1306 Continental Dr., Abingdon 21009-2334 • 301-676-7300 • FAX 301-676-7658

MASSACHUSETTS

MIL Electronics (C/V/M/A) • 1500 Main St., Waltham 02154 • 617-891-6730 • FAX 617-891-6733
 Signal Electronics Supply, Inc. (C) • 484 Worthington St., Springfield 01105 • 413-739-3893 • FAX 203-233-8554
 Tee Vee Supply Co. (C/V/M/A) • 407 R Mystic Avenue, PO. Box 649, Medford 02155 • 617-395-9440 • FAX 617-391-8020

MICHIGAN

G.M. Popkey Co. (C/V/M/A) • 4477 East Paris Ave. S.E., Grand Rapids 49512 • 616-698-2390 • FAX 616-698-0794
 Remcor Electronics (C/M/A) • 10670 Nine Mile Rd., Oak Park 48237 • 313-541-5666 • FAX 313-398-1016

MINNESOTA

Ness Electronics, Inc. (C/V/M/A) • 441 Stinson Blvd. NE, Minneapolis 55413 • 612-623-9505 • FAX 612-623-9540
 Mid America Vacuum Cleaner Supply Co. (V) • 666 University Ave., St. Paul 55104 • 612-222-0763 • FAX 612-224-2674

MISSISSIPPI

Tri-State Electronics (C/V/M) • 605 W. Fortification St., Jackson 39203 • 601-355-3431 • FAX 601-353-1567

MISSOURI

Cititronics, Inc. (C/V/M/A) • 1641 Dielman Rd., St. Louis 63132 • 314-427-3420 • FAX 314-427-3360
 Manhattan Electronics, Inc. (C/V/M) • 1101C E. 76th Terrace, Kansas City 64131 • 816-361-9440 • FAX 800-255-6239
 Tacony Corp. (V) • 1760 Gilsinn Lane, Fenton 63026 • 314-349-3000 • FAX 314-349-2333

NEW HAMPSHIRE

Tee-Vee Supply Co. (C/V/M/A) • 51 1/2 Kinsley St., Nashua 03060 • 603-889-4171 • FAX 603-889-8887

NEW YORK

Dele Electronics (C/V/M/A) • 7 E. 20th St., New York City 10003 • 212-475-1124 • FAX 212-475-1963
 Foto Electric Supply (A) • 31 Essex St., New York 10002 • 212-673-5222 • FAX 212-995-2830
 Green Tele-Radio Dist. (C/M/A) • 84-00 73rd Avenue, Glendale 11385 • 718-821-1114 • FAX 718-821-3987
 GMB Sales (C/V/M/A) • 140 Terminal Rd., Setauket 11733 • 516-689-3400 • FAX 800-635-0596
 Mill Electronic Supply (C/V/M/A) • 2026 McDonald Ave., Brooklyn 11223 • 718-336-4575 • FAX 718-627-4023
 Pago Appliance Parts (C/M/A) • 700 Broadway, Buffalo 14212 • 716-856-8133 • FAX 716-854-3530
 Panson Electronics (C/V/M/A) • 268 Norman Avenue, Greenpoint 11222 • 718-383-3400 • FAX 718-383-2425
 Radio Equipment Corp. (C/A) • 196 Vulcan St., Buffalo 14207 • 716-874-2690 • FAX 716-874-2698
 Star for Parts (V) • 250 Rabro Drive East, Hauppauge 11788-0255 • 800-525-6046 • FAX 516-348-7160
 United Teletronic Parts (C/M) • 3860 10th Ave., New York 10034 • 212-569-2330 • FAX 212-567-3725

NORTH DAKOTA

Westech Distributing (C/V) • 2001 1st Ave. North, Fargo 58103 • 701-237-4885 • FAX 701-232-4082

OHIO

Fox International, Inc. (C/V/M/A) • 23600 Aurora Rd., Bedford Heights 44146 • 216-439-8500 • FAX 800-445-7991

OREGON

Diversified Parts (C/V/M/A) • 2104 S.E. 9th Ave., Portland 97214 • 800-338-6342 • FAX 800-962-0602
 The Moore Co. (C/V/M) • 333 SE 2nd, Portland 97214 • 503-234-5000 • FAX 503-731-0105

PENNSYLVANIA

CRS Electronics (C/M) • 818 Brownsville Rd., Pittsburgh 15210 • 412-431-7700 • FAX 412-431-5666
 Linwood Wholesale, Inc. (C/M) • 1139 Sumner Ave., Whitehall 18052 • 215-820-0357 • FAX 800-876-5488
 S.E.I. Electronics, Inc. (C/V/M/A) • 2520 N. Broad St., Philadelphia 19132 • 215-223-9400 • FAX 215-223-9423
 Steel City Vacuum Co., Inc. (V) • 522 E. Ohio St., Pittsburgh 15212 • 412-231-1199 • FAX 412-231-3205

RHODE ISLAND

Jabbour Electronics (C/V/M/A) • 345 Fountain St., Exit 30, Route 95 No., Pawtucket 02860 • 401-727-3370 • FAX 401-727-3374

SOUTH CAROLINA

Wholesale Industrial (C/V/M) • 515 E. Bay St., Charleston 29403 • 803-722-2634 • FAX 803-723-8182

TENNESSEE

Mills Morris Co. (C/V/M/A) • 677 Phelan Ave., Memphis 38101 • 901-774-9810 • FAX 901-946-5603
 Shields Electronics Supply, Inc. (C/V/M/A) • 4722 Middlebrook Pike, Knoxville 37921 • 615-588-2421 • FAX 615-588-3431

TEXAS

Electronic Component (C/V/M/A) • 2401 Bissonnet, Houston 77005 • 713-528-1543 • FAX 713-528-1046
 Fox International (C/V/M) • 752 So. Sherman, Richardson 75081 • 214-231-1826 • FAX 214-231-0177
 Interstate Electric Co. (C/V/M/A) • 11292 Leo Lane, Dallas 75229 • 214-247-1567 or 800-527-4029 • FAX 214-247-2137
 M-Tronics (C/V/M/A) • 3201 West Ave., San Antonio 78213 • 512-340-4069 • FAX 512-340-4569
 Sherman Electronics (C/V/M) • 702 San Pedro Ave., San Antonio 78212 • 512-224-1001 • FAX 512-226-9926
 Sherman Electronics (C/V/M) • 1701 Morgan Ave., Corpus Christi 78404 • 512-888-9454 • FAX 512-888-4942
 Southwest Manufacturers, Inc. (V) • 3243 S. Jones St., Fort Worth, 76110-4397 • 817-926-8281 • FAX 817-924-6311
 VCP International Inc. (V) • 2285 Merritt Dr., Garland 75040 • 214-271-7474 • FAX 214-278-5981

VIRGINIA

Avec Electronics Corp. (C/M) • 711 Granby St., Norfolk 23510 • 804-627-3502 • FAX 804-627-1710
 Avec Electronics Corp. (C/M) • 2002 Staples Mill Rd., Richmond 23230 • 804-359-6071 • FAX 804-359-5609
 Avec Electronics Corp. (C/M) • 2009 Williamson Rd., Roanoke 24012 • 703-344-6288 • FAX 703-344-0081
 Fairway Electronics, Inc. (C/V/M) • 2304 Chamberlayne Ave., Richmond 23222 • 804-321-7255 • FAX 800-955-7043

WISCONSIN

Dealer Office Equipment Inc. (A) • 19300 W. Janacek Court, Waukesha 53186 • 414-784-7850 • FAX 414-784-3241
 G.M. Popkey Company (C/V/M/A) • 2035 Larsen Ave., Green Bay 54307-2237 • 414-497-0400 • FAX 414-497-4894
 G.M. Popkey Company (C/V/M/A) • 2355 So. Calhoun Rd., New Berlin 53151 • 414-786-5887 or 800-444-9320 • FAX 414-786-9031

CODING:

(C)...Consumer Electronic Parts
 (V)...Vacuum Parts
 (M)...Major Appliance Parts
 (A)...Accessories

(as of 7/31/91)

Replacement parts sources

AIWA America Inc.
35 Oxford Drive
Moonachie, NJ 07074
201-440-5220

Akai American, Ltd. - See Mitsubishi

Alpine Electronics of America, Inc.
PO Box 2859
Torrance, CA 90509
213-326-8000
800-421-2284
Fax: 213-533-0369

Altec Lansing Consumer Products
Routes 6 and 209
Milford, PA 18337
717-296-4434
800-258-3288 (ext PA)

Altos Computer Systems
2641 Orchard Parkway
San Jose, CA 95134
408-946-6700

AOC International
10991 N.W. AirWorld Drive
Kansas City, MO 64153
816-891-8066
Fax: 816-891-7882

Apple Computer
20525 Mariani Ave.
Cupertino, CA 95014
408-996-1010
Tech info: 800-862-7486

Aristo Computers Inc.
6700 SW 105th Ave., Suite 307
Beaverton, OR 97005
503-626-6333
800-3ARISTO

Atari Corp.
PO Box 3427
Sunnyvale, CA 94088-3427
Parts: 408-745-5501
Tech: 408-745-2466
Warr: 408-745-2367

Audio Technica U.S., Inc.
1221 Commerce Drive
Stow, OH 44224
216-686-2600

Audio Video Technologies Inc.
60 E. Ida
Antioch, IL 60002
708-395-6321

Audiovox Corp.
Parts Department
60 Arkay Drive
Hauppauge, NY 11788
516-231-7750
Fax: 516-231-0867

Audiovox West Corp.
16808 Marquardt Ave.
Cerritos, CA 90701-3581
213-926-7758
Fax: 213-926-6005

Canon USA, Inc.
Service Division
One Jericho Plaza
Jericho, NY 11753-1679
516-933-6300
Parts Center
Cantiague Rock Road
Westbury, NY 11590-1708
516-876-6500

Capetronics USA Inc.
1275 Valley Brook Ave.
Lyndhurst, NJ 07071
201-896-8600

Casio Inc.
570 Mt. Pleasant Ave.
Dover, NJ 07801
201-361-5400
Fax: 201-361-3819

Channel Master
PO Box 1416
Industrial Park Drive
Smithfield, NC 27577
919-934-1484
Fax: 919-934-5722

Chinon America, Inc.
660 Maple Ave.
Torrance, CA 90503
213-533-0274

CIE American, Inc.
(Formerly C. Itoh Electronics)
2515 McCabe Way
PO Box 19663
Irvine, CA 93713
714-833-8445

Citizen American Corp.
Subsidiary of Citizen Watch Co.
2401 Colorado Ave., Suite 190
Santa Monica, CA 90404
213-453-0614

Clarion Corp. of America
Customer Service Department
661 W. Redondo Beach Blvd.
Gardena, CA 90247-4201
213-327-9100
800-821-6693
Fax: 213-327-1999

Columbia Data Products
851 W. Hwy 436, No. 1061
Altamonte Springs, FL 32714
407-869-6700

Commodore Business Machines
C-2655
1200 Wilson Drive
West Chester, PA 19380
215-431-9100
Service: 215-431-9208

COMPAQ Computer Corp.
20555 FM 149
Houston, TX 77070
713-370-7040
Sales: 713-374-1434

Connecticut Microcomputer
568 Danbury Road
New Milford, CT 06776
203-354-9395
800-426-2872

Corvus Systems
160 Great Oaks Blvd.
San Jose, CA 95119
408-281-4100

Craig Consumer Electronics
13845 Artesia Blvd.
Cerritos, CA 90701-5001
213-926-9944
Fax: 213-926-9269

Curtis Mathes Corp.
1 Curtis Mathes Pkwy
PO Box 2160
Athens, TX 75751
800-552-6358 (National)
800-344-2368 (Texas)

Daewoo Electronics Corp. of America
100 Daewoo Place
Carlstadt, NJ 07072
201-896-2873

Delco Electronics Corp.
Subsidiary of GM,
Hughes Electronics
One Corporate Center
Kokomo, IN 46904-9005
317-457-8461
800-428-0501 (National)
800-428-0531 (Indiana)

Dell Computer Corp.
9505 Arboretum Blvd.
Austin, TX 78759
Sales, Parts and Warranties:
800-426-5150
Service: 800-624-9896

Emerson Computer Corp.
One Emerson Lane
North Bergen, NJ 07047
Service: 201-854-4800
800-537-3538
Technical Assistance:
213-722-9800
800-922-0738

Emerson Radio Corp.
One Emerson Lane
North Bergen, NJ 07047
201-854-6600

Epson America, Inc.
23610 Telo Ave.
Torrance, CA 90505
213-373-9511

Franklin Computer Corp.
PO Box 518
Mt. Holly, NJ 08060
609-261-4800

Fujitsu Ten Corp. of America
National Service Headquarters
1210 East 223rd Street, Suite 301
Carson, CA 90745
213-513-0411
800-423-8161
Fax: 213-513-6120

Funai USA Corporation
Parts Department
100 North Street
Teterboro, NJ 07608
201-288-2666
Fax: 201-288-8019

**GE Appliances/Microwave
Products Dept.**
Appliance Park
Bldg. 41, Rm. 106
Louisville, KY 40225
502-452-3568

Gemini, Inc.
103 Mensing Way
Cannon Falls, MN 55009
507-263-3957

GoldStar Service Division
127 Jetplex Circle
Madison, AL 35758
205-772-8860
800-222-6457
Tech. Support Fax: 800-448-4026

Grundig/Lextronix Inc.
3520 Haven Ave., Unit L
Redwood City, CA 94063
415-361-1611

Harmon Kardon, Inc. - JBL
240 Crossways Park West
Woodbury, NY 11797
516-496-3400
800-645-7484

**Heath Company/Heath-Zenith
Consumer Products Group**
Hilltop Rd.
St. Joseph, MI 49085
616-982-3200
800-253-0570 (Orders Only)
Sales: 616-982-3411
Service, Tech. and Warr:
616-982-3302
Parts: 616-982-3571

Hewlett-Packard
3000 Hanover St.
Palo Alto, CA 94304
415-694-2000
Sales: 415-857-8000
Literature Requests: 800-752-0900

**Hitachi Home Electronics
(America), Inc.**
401 West Artesia Blvd.
Compton, CA 90220
213-537-8383
800-262-1502
Service Center: 800-447-2882

IBM Corp.
4111 Northside Parkway
Atlanta, GA 30327
404-238-2126

International Jensen Inc.
Service Department
4136 N. United Parkway
Schiller Park, IL 60176
800-323-0221
Fax: 312-671-6325

**JVC Service & Engineering Co.
of America**
Division of U.S. JVC Corp.
107 Little Falls Rd.
Fairfield, NJ 07006
201-808-2100

Kaypro Corporation
4174 Sorrento Valley Blvd.
San Diego, CA 92121-1407
619-535-2155

Kenwood U.S.A., Corp.
PO Box 22745
Long Beach, CA 90810-5745

**Consumer Audio Parts: 213-
549-7810**
Amateur Radio/Landmobile Radio:
213-639-9000
Fax (Orders): 800-437-7255
Fax (Parts Inquiries): 213-609-2127

KTV Inc.
Service Department
205 Moonachie Road
Moonachie, NJ 07074
Fax: 201-440-6557

Kyocera Electronics, Inc.
100 Randolph Rd., CN6700
Somerset, NJ 08875-1284
201-560-0060

Lloyd's Electronics, Inc.
700 N. Commerce St.
Aurora, IL 60504
708-820-5490

Marantz Co. Inc.
Division of Dynascan Corp.
700 N. Commerce
PO Box 2066
Aurora, IL 60504
708-820-4800
708-820-5490

Matsushita Services Co.
50 Meadowland Parkway
Secaucus, NJ 07094
201-348-7000
Fax: 201-348-7527

Micro Palm Computers
13773-500 ICOT Blvd.
Clearwater, FL 34620
813-530-0128
Fax: 813-530-0738

Mitsubishi Electronics America, Inc.
National Service Department
5757 Plaza Drive
PO Box 6007
Cypress, CA 90630-0007
714-220-2500
Parts: 800-553-7278
Fax: 714-220-4792
800-825-6655

NEC Technologies Inc.
Consumer Electronics and
Computer Products Divisions
1255 Michael Drive
Wood Dale, IL 60191-1094
708-860-9500
Service and Parts: 708-860-0335
Fax: 800-356-2415

Okidata
532 Fellowship Road
Mount Laurel, NJ 08054
609-235-2600
800-OKIDATA

Onkyo U.S.A. Corp.
200 Williams Drive
Ramsey, NJ 07446
201-825-7950
Fax: 201-825-8150

Penny, J.C.
National Parts Center
6840 Barton Road
Morrow, GA 30260
800-527-7115
Fax: 404-961-8408

Philips Consumer Electronics Company
Philips Service Company
PO Box 967
907 Snapp Ferry Road
Greenville, TN 37744
615-636-5838
Fax: 615-636-5865
Replacement Parts:
Order Entry/ID/Inquiry/Service
Manuals:
Phone: 800-851-8885
Fax: 800-535-3715

Pioneer Electronics Service, Inc.

2265 E. 220th St.
PO Box 1760
Long Beach, CA 90801-1760
800-457-2881
Fax: 213-816-0247

Proton

Proton Parts Department
5630 Cerritos Ave.
Cypress, CA 90630
800-829-3444
Fax: 714-952-8525

Radio Shack

Business Products Support Services
1600 One Tandy Center
Fort Worth, TX 76102
817-390-3011

Radio Shack Business Products Parts

812 E. Northside Dr.
Fort Worth, TX 76102
817-870-5695

Ricoh Corp.

3001 Orchard Pkwy.
San Jose, CA 95134
408-432-8800

Sampo Corporation of America

5550 Peachtree Industrial Blvd.
Norcross, GA 30071
404-449-6220
Fax: 404-447-1109

Samsung Electronics America, Inc.

Parts Department
18600 Broadwick St.
Rancho Dominguez, CA 90220
800-634-8276
Fax: 800-248-0498
Tech. Assistance: 800-833-6616

Sansui Electronics Corp.

Parts Department
17150 South Margay Avenue
PO Box 4687
Carson, CA 90746
213-604-7300
Fax: 213-604-1664

Sanyo-Fisher (USA) Corp.

Consumer Electronics Sales Div.
21350 Lassen St.
Chatsworth, CA 91311
818-998-7322
For Service: SFS Corporation
1200 West Artesia Blvd.
Compton, CA 90220
213-537-5830

Scott, H.H. Inc.

5601 Westside Ave.
North Bergen, NJ 07047
201-662-2000
Parts/Technical Literature:

H.H. Scott, Inc.

State Route 41 & County Rd. 100W
Princeton, IN 47670
800-695-0095
Fax: 812-386-6502
Tech. Serv: 800-922-0738

Sears

Sears Tower
Chicago, IL 60684
312-875-5222

Sharp Electronics Corp.

Sharp Plaza
PO Box 650
Mahwah, NJ 07430-2135
201-529-8200
Parts: 201-529-9118

Sherwood/Inkel Corporation

13845 Artesia Blvd.
Cerritos, CA 90701
213-926-6337

Shintom West Corp. of America

20435 S. Western Ave.
Torrance, CA 90501
213-328-7200
800-451-2025
Fax: 213-782-0338

**Sony Corp. of America/
Sony Service Company**

Sony Drive (T2-4)
Park Ridge, NJ 07656
201-930-1000

Sony National Parts Center

8281 N.W. 107th Terrace
PO Box 20407
Kansas City, MO 64153
816-891-7550

Soundesign Corporation

115 Kennedy Drive
Sayreville, NJ 08872-1460
201-525-2214
Factory Parts Distribution Center:
53 Hook Rd.
Bayonne, NJ 07002
201-823-2515 Parts Orders
201-823-2577 Parts Information

Sparkomatic Corporation

Parts Department
Milford, PA 18337
717-296-6444
800-233-8831 (Nationwide)
800-592-8891 (In PA)

Symphonic Corp.

100 North St.
Teterboro, NJ 07608
201-288-2606

Tandy Consumer Service Parts

7439 Airport Freeway
Ft. Worth, TX 76118
817-284-8691
800-243-1311
Fax: 817-284-1961

Tandy National Parts

900 East Northside Dr.
Ft. Worth, TX 76102
817-870-5600
800-442-2425

Tatung Company of America, Inc.

2850 El Presidio St.
Long Beach, CA 90810
213-637-2105
213-979-7055
Fax: 213-637-8484

TCE Publications

10003 Bunsen Way
Louisville, KY 40299
502-491-8110

TDK Electronics Corp.

12 Harbor Park Dr.
Port Washington, NY 11050
212-807-1400

TEAC Corporation of America

Parts Department
PO Box 750
Montebello, CA 90640
213-726-0303
Fax: 213-727-7656
Parts Orders: 213-726-0303
Fax for Parts Orders: 800-366-8868

Teknika Electronics Corp.

Parts Department
353 Route 46 West
Fairfield, NJ 07004
201-575-0380

Thomson Consumer Electronics

600 N. Sherman Drive
Indianapolis, IN 46201
317-267-5000

Thomson Consumer Electronics

Distributor and Special
Products Division
2000 Clements Bridge Rd.
Deptford, NJ 08096
609-853-2201
For Servicing Literature:

Toshiba America, Inc.

Computer Division
15091 Balce Pkwy.
Irvine, CA 92718
714-386-3000

Toshiba America Consumer Products Inc.
National Parts Center
19500 South Vermont Ave.
Torrance, CA 90502
800-345-9785
Fax: 213-515-3725

Videonics
1370 Dell Ave.
Campbell, CA 95008
408-866-8300

Yamaha Electronics Corp. USA
Parts Department
6722 Orangethorpe
Buena Park, CA 90620
714-522-9105
800-854-3264
714-994-3312
Fax Orders: 800-634-0355

Yorx Electronics Corp
405 Minniskink Rd.
Totowa, NJ 07512
201-256-0500

ZDS Customer Service Division
1900 North Austin
Chicago, IL 60639
312-745-2000

Zenith Data Systems
1000 Milwaukee Avenue
Glenview, IL 60025
708-699-4800

Zenith Electronics Corp./ Videotech Corp.
11000 Seymour Ave.
Franklin Park, IL 60131
708-671-7550

Figure 3. Sometimes it's difficult to find parts or servicing information for a product, even if you know who the manufacturer is. This listing will provide you with some parts sources for some products.

combination of the book, 56-page update, program disk and data disks together is being offered for \$115.00 plus \$3.00 shipping.

Technicians who already own the 1990 edition can purchase the expanded update on 3½ or 5¼ floppy disk for \$19.95 plus \$2.00 shipping.

You may send a check or money order for the correct amount to IS CET, 2708 W. Berry Street, Ft. Worth, TX 76109. IS CET will also accept telephone MasterCard or Visa orders at 817-921-9101.

This is a two-part reference that will help any servicing organization that services VCRs to cross reference among different brands made by the same manufacturer. Part 1 of this reference will allow the user to determine when he has a product in for servicing, if it's possible that it's identical, or almost, to a product for which he already has a servicing manual. Part 2 of the reference cross references parts, so that if you can't find a particular part number for a product you are servicing, you may find that you have it on hand under a different part number for another manufacturer's product.

Identifying a manufacturer from the FCC ID number

Almost all consumer-electronics products, at least any that have to be plugged in to the power outlet or that might generate electromagnetic in-

terference, carry clues as to who the manufacturer is. One of these numbers appears on every VCR and computer, and any other product that might generate electromagnetic interference. It's the FCC identification number. Armed with this number, a technician may call or write the FCC:

Federal Communications Commission
1919 M Street, NW
Washington, D.C. 20463,

Give the ID number and ask for the name and address of the manufacturer. A partial cross-reference

list of manufacturer and model number vs FCC ID numbers is provided in Figure 1. Please note that this is not an officially prepared listing but one that was put together by one of our readers and so may contain errors. In spite of any errors that may be present, it should provide you with some useful information.

Identification using the UL manufacturer's code number

Another source of manufacturer identification information is the Underwriters Laboratories code number. The manufacturer of every product that is submitted to UL for certification is assigned a unique code number that identifies who the manufacturer is. Figure 2 is a partial list of UL numbers and the manufacturers they represent. Again, this listing is unofficial provided by a reader, and so may not be 100 percent correct. We're working on expanding both lists, and checking them for accuracy.

Locating the manufacturers

It's not unusual for a servicing organization to have some difficulty finding the address and telephone number of a manufacturer from whom to order parts, even when the manufacturer is well known. Figure 3 is a listing of manufacturers, gleaned from the Consumer Electronics Replacement Parts Sourcebook, the NESDA Professional Electronics Yearbook, ES&T reader correspondence, many telephone calls by the ES&T staff, and other sources. ■

CONSOLIDATED ELECTRONICS

Get two of the most valuable electronic catalogs ever! These 2 catalogs contain over 16,000 hard to find electronic parts & equipment. VOL. I - features 112 pages of high quality test equipment. VOL. II - features 144 pages of electronic parts, tools & cross references. Send \$5 check or money order, or call today & use your VISA or MasterCard.

1-800-543-3568

CONSOLIDATED ELECTRONICS, INCORPORATED 705 WATERLIET AVENUE DAYTON, OHIO 45420-2599
FAX: 1-(513)-252-4066 / TEL: 1-(513)-252-5662 / TELEX: 288-229 / COMPUSEIVE: 76057, 3347 / EASYLINK: 62850013

Circle (4) on Reply Card

Inexpensive oscilloscopes

By David L. Rights

Every service technician wants the best possible oscilloscope for his or her own bench. Personally, I wouldn't buy a scope for myself unless it had bandwidth to 15 terahertz, vertical sensitivity to 5 femtovolts, and could fit in a shirt pocket. You wouldn't want anything less either.

However, with all your servicing expertise, your degrees and your salary, you'll repeatedly be called upon to buy the oscilloscopes for the beginning technicians. Ones that are built to last. Ones that don't have many features, but are easy to use. Most of all, ones that don't cost much, so the boss can buy a bunch of them for the price of your one. What you'll be looking for is a basic oscilloscope for a few hundred bucks - like the one you used in school. One with narrow bandwidth, low sensitivity, few controls, and a small price.

There are lots of basic oscilloscopes around. At the low prices that they sell for, though, the manufacturers can't afford much fancy advertising in the electronics magazines. To help you in making a selection among the offerings at the low end of the oscilloscope

spectrum, here's a survey of what's available in inexpensive oscilloscopes.

Prices

Prices are list prices, rounded up to the next highest dollar. Discounts are available from many distributors, TV parts houses, and by mail order. Most manufacturers offer discounts for quantity purchases, and some offer discounts for demonstrator or refurbished units. You should ordinarily be able to purchase the oscilloscope you want at a price at least 20% less than the list prices shown here.

Bandwidth

Megahertz (MHz) listed is the advertised -3dB point. All oscilloscope manufacturers list their vertical sensitivity and bandwidth specifications optimistically. On the other hand, at least they're all consistent. When a scope is called a 50MHz model, that's the upper 3dB point; the point at which the screen display is half the height it is at lower frequencies. Some scopes cut off sharply, some cut off gradually, and some are more gradual than others.

A sharp cutoff 50MHz scope will give you a flat response from 10MHz, through 40MHz, or maybe even

45MHz, then drop off suddenly to -3dB at 50MHz. A gradual cutoff scope can be flat to 25MHz, then slope off to -1dB at 30MHz, -2dB at 40MHz, and finally reach -3dB at 50MHz. Both are 50MHz scopes, but the first has a little more usable bandwidth than the second. If bandwidth is important in your application, look carefully at the bandwidth specification or get a loaner scope to try on your waveforms.

As a general rule, if you must see 50MHz accurately, buy a 100MHz scope; if you must see millivolts flat to 50MHz, buy a 200MHz oscilloscope.

Probes

Most inexpensive oscilloscopes are sold with probes included at the price in the table. Some, however, don't include anything, or just give you clip leads to get you started. For a fair comparison, add \$50, for an average pair of basic probes, to the price of the scopes that come without real probes.

The most basic probes are 1:1 - just a coaxial cable with a rigid probe tip at the end. The oscilloscope's sensitivity remains the same, and the impedance of the probe is the impedance of the oscilloscope, typically one M Ω with 30pF of capacitance in parallel,

Rights is a free lance writer in Miami.



The 315P from A.W. Sperry offers 15MHz bandwidth and battery option.

The 2225 from Tektronix is a 50MHz scope with 0.5mV sensitivity.

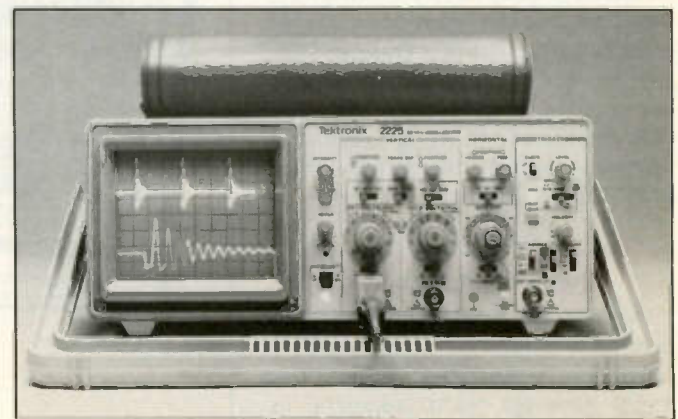

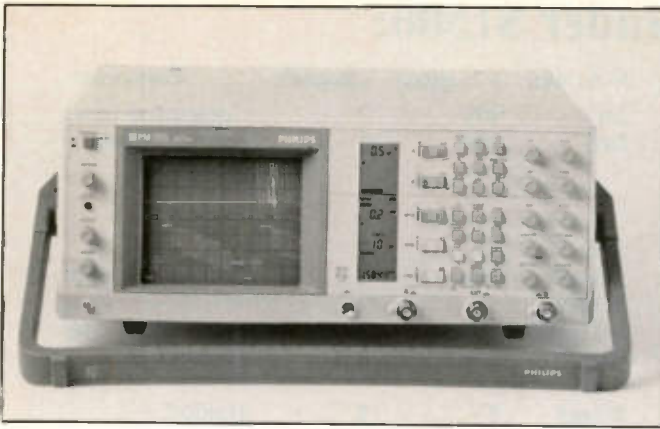

The 60MHz PM 3055 from Philips features multiple cursors.

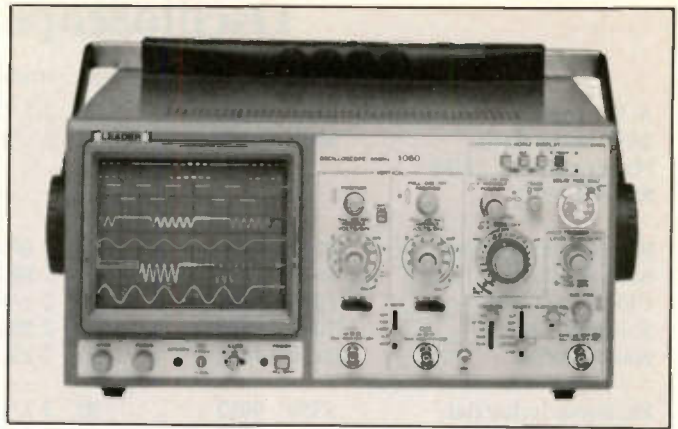

The 1060, 60MHz scope from Leader features delay.



The 50MHz Fluke Model 95 offers a scope-meter, battery operation and a line adapter.

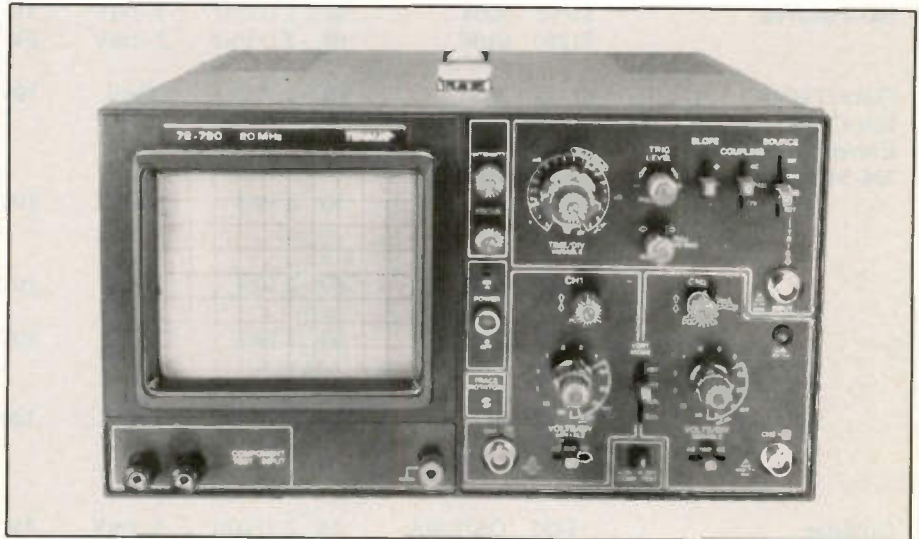

A component tester enhances the features of the 20 MHz 72-720 from MCM.

plus the added parallel capacitance of the cable, typically another 30pF.

Though the sensitivity is high, the one MΩ impedance is low enough to load down some touchy circuits, and the scope will display a lower voltage than really exists at the point you have probed.

Another drawback to using the 1:1 direct probe connection is that the maximum frequency the scope can display is reduced by a factor of ten. For instance, a 100MHz oscilloscope is rated at 100MHz only with its 10:1 probes, but with 1:1 probes the scope is likely to be only a 10MHz unit. For less circuit loading at higher frequencies, 10:1 probes present the circuit being tested with ten times higher impedance than the scope's impedance: typically 10MΩ with 20pF in parallel.

Unfortunately, 10:1 probes reduce vertical sensitivity by a factor of ten, since they are 10:1 voltage dividers. An expensive 5mV scope suddenly becomes an insensitive 50mV scope when a 10:1 probe is used. If you do need to see millivolts in high impedance high frequency circuits, consider an optional preamplifier probe.

The most popular probes of all are the ones that are switchable from 1:1 to 10:1 (listed as 1/10:1). Two switchable probes are included with many inexpensive scopes. Although their impedance at the 1:1 setting is usually higher (about one MΩ with 100pF) than the impedance of a regular 1:1 or 10:1 probe, the convenience of having both types of probe in one outweighs the extra loading.

Vertical sensitivity

The listed vertical sensitivity (V.S. min) is the sensitivity at which all the other specifications of the oscilloscope are met. If a scope is listed as a 10mV

scope, that's the sensitivity for the full listed bandwidth, with full accuracy and full calibration.

Where two numbers are listed (e.g. 5/1mV), the first number is sensitivity without magnification and the second is sensitivity with vertical magnification. Vertical magnification increases the oscilloscope's sensitivity, but the trade-off is reduced bandwidth. Typical reductions are to 50% for a 5X magnification and to 25% for 10X magnification. Thus a 10MHz/10mV per division scope will, with 5X magnification, become a 5MHz/2mV scope or, with 10X magnification, a 2.5MHz/1mV scope.

Alternatively, some oscilloscopes have the magnifier built into the vertical sensitivity dial on the last position, for added convenience, but be aware that that last position has a lower bandwidth than the other positions of the dial.

Whenever the vertical magnification is switched in, the vertical ac-

Oscilloscopes under \$1500:

	Price	Model	MHz	Probes	V.S.(min)	V.S.(max)	Channels	Comments
A.W. Sperry	\$675	620C	20	2 1/10:1	5mV	20V	2	Component tester
245 Marcus Blvd. Hauppauge, NY 11788 800-645-5398	\$800	315P	15	2 1/10:1	2mV	10V	2	Battery option
B & K Precision/Maxtec	\$549	2120	20	2 10:1	5/1mV	5V	2	
6470 W. Cortland St. Chicago, IL 60635	\$646	2125	20	2 10:1	5/1mV	5V	2	Component tester
312-889-1448, 800-462-9832	\$845	1541B	40	2 1/10:1	5/1mV	5V	2	
	\$1099	2160	60	2 10:1	5/1mV	5V	2	Component tester
	\$1198	1422	20	2 10:1	10 mV	20V	2	Battery option
Beckman Industrial	\$550	9022	20	1 1/10:1	5/1mV	5V	2	Holdoff
3883 Ruffin Rd. San Diego, CA 92123	\$700	9102	20	2 1/10:1	5/1mV	5V	2	Delay
619-495-3264 800-854-2708	\$865	9202	20	2 1/10:1	5/1mV	5V	2	Cursors, readout
	\$950	9104	40	2 1/10:1	5/1mV	5V	2	Delay
	\$1095	9204	40	2 1/10:1	5/1mV	5V	2	Cursors, readout, delay
	\$1290	9106	60	2 1/10:1	5/1mV	5V	2 + 1	Delay
Fluke/Philips Box C9090 Everett, WA 98286 206-347-6100	\$1195	3050	60	2 10:1	20mV	10V	2	Auto horizontal/vertical/trigger V.S.(min) 2mV at 35 MHz
	\$1195	93	50	2 10:1	5mV	100V	2	Scopemeter, batteries, line supply. Sensitivity is V/0.8cm.
	\$1350	3052	60	2 10:1	20mV	10V	2	(Same as 3050 but with rack mount)
	\$1395	3055	60	2 10:1	20mV	10V	2	Multi-cursors V.S.(min) 2mV at 35 MHz. Delay
	\$1495	95	50	2 10:1	1mV	100V	2	Scopemeter, batteries, line adapter. Sensitivity is V/0.8cm.
Goldstar	\$495	OS7020A	20	2 1/10:1	5/1mV	5V	2	
13013 E. 166 St. Cerritos, CA 90701 213-404-0101	\$795	OS7040A	40	2 1/10:1	5/1mV	5V	2	Delay
	\$795	OS8020R	20	No 1/10:1	5/1mV	5V	2	Cursors, readout, delay
	\$1395	OS8100	100	2 10:1	5/1mV	5V	3	8 trace, delay
Hameg	\$470	HM302	30	2 1/10:1	5/2mV	20V	2	
1935 Plaza Real Oceanside, CA 92056 619-630-4080 800-247-1241	\$598	HM203-7	20	2 1/10:1	5/2mV	20V	2	Component tester
	\$1048	HM205-3	20	2 1/10:1	5/2mV	20V	2	Digital, component tester
	\$1076	HM604	60	2 1/10:1	5/1mV	20V	2	Delay
	\$1398	HM1005	100	2 10:1	5/1mV	5V	2 + 1	6 trace, delay, dual time base
Heathkit/Zenith	\$420	SO4552	25	0	5/1mV	5V	2	Assembled
Benton Harbor, MI 49022 616-982-3411	\$600	SO4554	40	0	5/1mV	5V	2	Assembled
Hitachi	\$525	V-212	20	2 1/10:1	5/1mV	5V	2	
175 Crossways Park West Woodbury, NY 11797 516-921-7200 800-448-2244	\$715	V-222	20	2 1/10:1	5/1mV	5V	2	
	\$910	V-422	40	2 1/10:1	5/1mV	5V	2	
	\$995	V-522	50	2 10:1	5/1mV	5V	2	
	\$1095	V-523	60	2 10:1	5/1mV	5V	2	
	\$1145	V-525	50	2 10:1	5/1mV	5V	2	Cursor, readout
	\$1195	V-209	20	2 10:1	5/1mV	5V	2	Battery included
	\$1345	V-660	60	2 1/10:1	5/2mV	5V	2	Readout, auto horizontal, delay
Iwatsu	\$607	5702	20	2 10:1	5/1mV	10V	2	Battery option
5835 Coopers Ave. Mississauga, Ont. L4Z 1Y2 416-890-2010	\$904	5705	40	2 10:1	5/1mV	10V	2 + 1	
	\$1150	7606	60	2 10:1	5/1mV	2V	2 + 2	Readout, cursors
	\$1441	7607	60	2 10:1	5/1mV	2V	2 + 2	Same as 7606 plus counter

Prices include 4% duty and 0.88x conversion from Canadian dollars.

	Price	Model	MHz	Probes	V.S.(min)	V.S.(max)	Channels	Comments
JDR Instrumnts	\$390	2000	20	2 10:1	5mV	20V	2	Component tester
110 Knowles Ave.	\$500	3500	35	2 10:1	5/1mV	10V	2	Delay
Los Gatos, CA 95030								
800-538-5000								
Kenwood	\$299	CO1303D	5	1, clips	10mV	1V	1	Non-triggered,
2201 E. Dominguez St.								3 " round screen
Long Beach, CA 90801	\$899	CS5135	40	2 1/10:1	1mV	5V	2	Delay
213-639-9000	\$1049	CS5155	50	2 10:1	5mV	5V	2	V.S.(min) 1mV
								at 20 MHz, delay
	\$1149	CS5165	60	2 10:1	5mV	5V	2	V.S.(min) 1mV
								at 20 MHz, delay
	\$1099	CS5130	40	2 10:1	1mV	5V	2	Cursors, readout.
								V.S.(min) 1mV
								at 15 MHz, delay
	\$1399	CS3025	20	2 1/10:1	5/1mV	5V	2	Portable
	\$1299	CS5140	40/100	2 10:1	1mV	5V	2	Cursors, readout.
								Analog (40 MHz,
								sampling) 40
								MHz, holdoff
Kikusui	\$525	COS5020TM	20	2 1/10:1	5/1mV	5V	2	Holdoff
1980 Orizada Ave.	\$585	COS5021TM	20	2 1/10:1	5/1mV	5V	2	Holdoff
Signal Hill, CA 90804	\$725	COS5040TM	40	2 1/10:1	5/1mV	5V	2	Delay
213-986-1677	\$795	COS5041TM	40	2 1/10:1	5/1mV	5V	2	Delay, holdoff
800-545-8784	\$895	COS5042TM	40	2 1/10:1	5/1mV	5V	2 + 1	Delay, 8 trace
Leader	\$395	L80310A	4	2, clips	20mV	2V	1	Non-triggered
380 Oser Ave.	\$595	1021	20	2 1/10:1	5/1mV	5V	2	Holdoff
Hauppauge, NY 11788	\$925	LCD100	0.2	1 1/10:1	10mV	20V	1	LCD, DMM
516-231-6900	\$955	1041	40	2 1/10:1	5/1mV	5V	2	Delay
800-645-5104	\$1385	323	20	2 1/10:1	5/1mV	5V	2	Portable
	\$1345	1060	60	2 1/10:1	5/0.5mV	5V	2 + 1	Delay
MCM/Tenma	\$208	72-300	6.5	1, clips	10mV	1V	1	Non-triggered,
858 E. Congress Park Dr.								2.5 " screen
Centerville, OH 45459	\$360	72-720	20	2 10:1	5mV	20V	2	Component tester
800-543-4330								
Tektronix	\$695	2205	20	2, clips	5mV	5V	2	
Tektronix Direct	\$775	2205-24	20	2 10:1	5mV	5V	2	(probe option)
Box 500, MS 02-050	\$1195	2225	50	2 10:1	0.5mV	5V	2	
Beaverton, OR 97075								
800-426-2200								

curacy is also degraded. A scope with +/-3.0% accuracy is typically only +/-5.0% accurate at 5X magnification. In short, if you really are looking for attovolts, or even for microvolts, an oscilloscope is not enough; you'll need to build or buy a wide bandwidth preamplifier.

In most oscilloscopes bandwidth is also reduced when the vertical amplifier is set to an uncalibrated setting. A scope rated at 10MHz when set to "calibrated" vertical sensitivity may only be a 5MHz scope when the variable vertical sensitivity knob is turned more than halfway around.

The vertical amplifier steps in most oscilloscopes are arranged in the usual

logarithmic 1-2-5-10... pattern. Some scopes let the uncalibrated variable amplification vary over a 10:1 range, for maximum range, while others restrict the range to only 2:1, for maximum resolution. Others set the variable amplification to a 10:3.5 range (10 x 0.707 x 0.5), so the screen is automatically showing the rms value of the peak-to-peak sine waveform display when the variable control is set for maximum attenuation.

That's a nice touch, a simple yet elegant feature, but remember that any dc measurements you make while displaying rms volts will also be reduced to 35% of their true values. Other contrary scopes, instead of reducing the

size of the display when off calibration, increase the size of the display to obtain more vertical sensitivity. Is it any wonder, then, that the latest scopes are reducing all that mental work by adding on-screen readouts?

The other vertical sensitivity specification in the table (V.S. max), is the highest voltage per division that the oscilloscope can display. A specification of 5V/div, for a scope with 8 vertical divisions, means the scope can show on screen a maximum full waveform of 40Vp-p (14V rms).

A maximum vertical sensitivity of 20V/div would increase that maximum to 160Vp-p (56V rms). If you need to see a higher voltage than that,

BBC Goerz, E&R Dumont, Gould, Hewlett-Packard, Panasonic and Sencore make oscilloscopes of all types, but none of the scopes they make is under \$1500. These are the least expensive scopes each sells:

BBC Goerz
Broomfield, CO
303-469-5231

\$4900

E&R/Dumont
West Caldwell, NJ
201-575-8666

\$2995 1220

Gould
3631 Perkins Ave.
Cleveland, OH 44114
216-361-3315

\$2200 1421

Hewlett Packard Direct
Box 61417 Sunnyvale, CA 94088
800-538-8787

\$2395 54600

Panasonic
Meadowlands Parkway
Secaucus, NJ 07094
201-348-7000

\$1595 NP5512

Sencore
3200 Sencore Dr.
Sioux Falls, SD 57107
605-339-0100

\$3295 SC61

you can put the scope in uncalibrated vertical mode, where the variable knob will reduce the vertical sensitivity. The reduction depends on the manufacturer, and can range from 10:1 to 2:1.

For a 5 V/div scope at a 10:1 reduction, the full displayed voltage would be 400Vp-p (140Vrms) instead of 40. That's just enough to measure ac line voltage, but measuring line voltage directly, without an isolation transformer, is definitely not recommended because of the lethal voltages and currents involved and because of the possibility of getting big sparks and a melted scope if you misconnect the line's hot, neutral and ground wires to

the oscilloscope's high, low and ground input terminals.

Alternatively, you can use a probe with 10:1 reduction, and get the same 400V maximum display. Combining the two tricks gives you 4000Vp-p fully displayed. There is one caution, though: most scopes have an additional maximum voltage limit, typically 400V. If you are trying to look at 400V, use the 10:1 probe to reduce the voltage to 40V before it gets to the oscilloscope input, instead of feeding the input 400V directly and hoping that the uncalibrated vertical sensitivity potentiometer is at the input. It isn't.

An oscilloscope that combines a

high maximum voltage with a low minimum voltage will have more click steps on the vertical sensitivity control. Assuming the standard 1-2-5-10 pattern (that divides each decade into thirds), a scope with a 1mV minimum sensitivity and a 20V maximum sensitivity will have 14 positions, while a scope with a 10mV minimum and a 1V maximum will have only 9 positions. The cheapest of the oscilloscopes have that same 10mV minimum and 1V maximum, but they use a 1-10-100 pattern, each a full decade apart, for only three positions on the vertical sensitivity switch.

Horizontal risetime and resolution

The horizontal resolution of an analog oscilloscope is determined by its bandwidth. You can't resolve anything finer or faster than the risetime of the oscilloscope, no matter how much horizontal multiplication is switched in. The relation is: Bandwidth = K/risetime, where the bandwidth is the -3dB point in Hz, K is 0.35, a constant ranging from 0.34 to 0.35 (for sine waves) to 0.39, and the risetime is in seconds. A 1MHz bandwidth equals a risetime of 350 nanoseconds, 10MHz equals 35 nanoseconds, and 100MHz is 3.5 nanoseconds. For other bandwidth values:

-3dB POINT	RISETIME
1MHz	350 NANOSECONDS
5MHz	70
10MHz	35 NANOSECONDS
15MHz	23
20MHz	17
30MHz	12
40MHz	8
50MHz	7
60MHz	6
80MHz	4.4
100MHz	3.5 NANOSECONDS
200MHz	1.7

Additional Features

The oscilloscopes listed have many different combinations of additional features. A few are portable. Some have holdoffs, some have delay lines, and some have delayed sweep. One has the A/B channels viewable as left/right instead of top/bottom, for stereo audio use. Some have special filters and amplifiers, or at least presets, for television's video synchronizing signals (roughly 30Hz vertical and 15kHz horizontal). If any of these features are important to you, double check your needs against the catalogs.

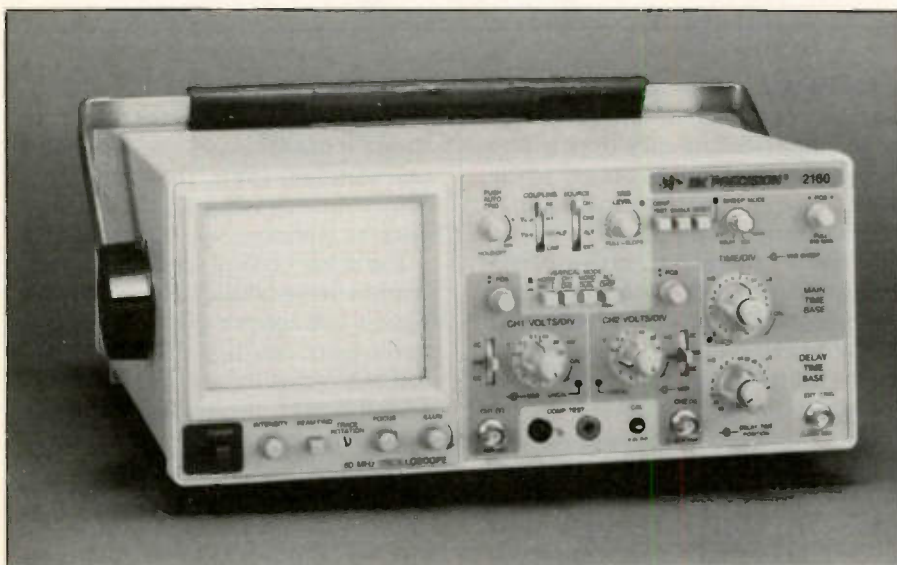

The 2160 from B&K Precision is a 60MHz scope with a component tester feature.

Test your electronics knowledge

By Sam Wilson

The questions in this quiz appeared in *ES&T* magazine from November 1990 to August 1991. Are you keeping up with the technology?

1. As related to computers, the initials MDM mean _____.

2. In an article about the shelf life of components, it was stated that "Variable composition resistors are the least stable (of all types of variable resistors) and can have a change of _____."

3. The schematic symbol shown in Figure A is for a

- A. SCS
- B. PUT
- C. SCR
- D. GTO

4. For properly cleaning and lubricating a VCR, what kind of grease is recommended? _____.

5. Four advantages of an LCD display over a CRT display for television:

- They are relatively rugged
- They do not consume a great deal of power

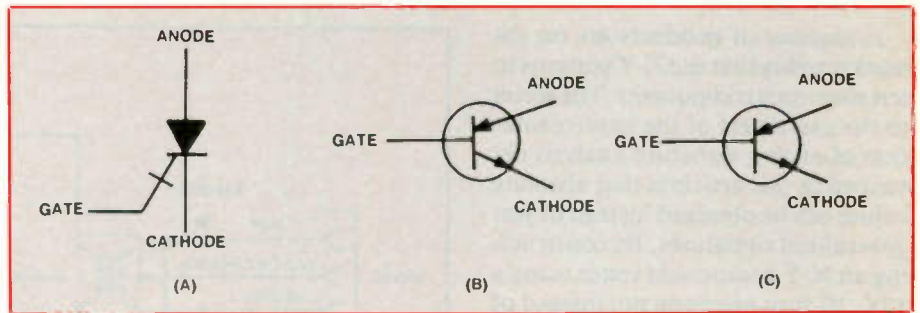

Figure A

- They are compact
- and, _____.

6. Regarding computers, the abbreviation MFLOPS stands for _____.

7. Three separate groups of VHS camcorder functions provided by motors are

- Tape loading and unloading
- Tape and headdrum operation
- _____.

8. Consider the motor servo shown in

Figure B. What is the circuit in the block marked with an X?

9. Regarding satellite TV, there are two important things that ultimately determine picture quality:

- Accurate Parabolic Shape
- _____.

10. According to a survey, the highest current will flow when the test leads of an ohmmeter are shorted together and the ohmmeter is on the
A. highest resistance scale
B. lowest resistance scale
(Answers on page 57)

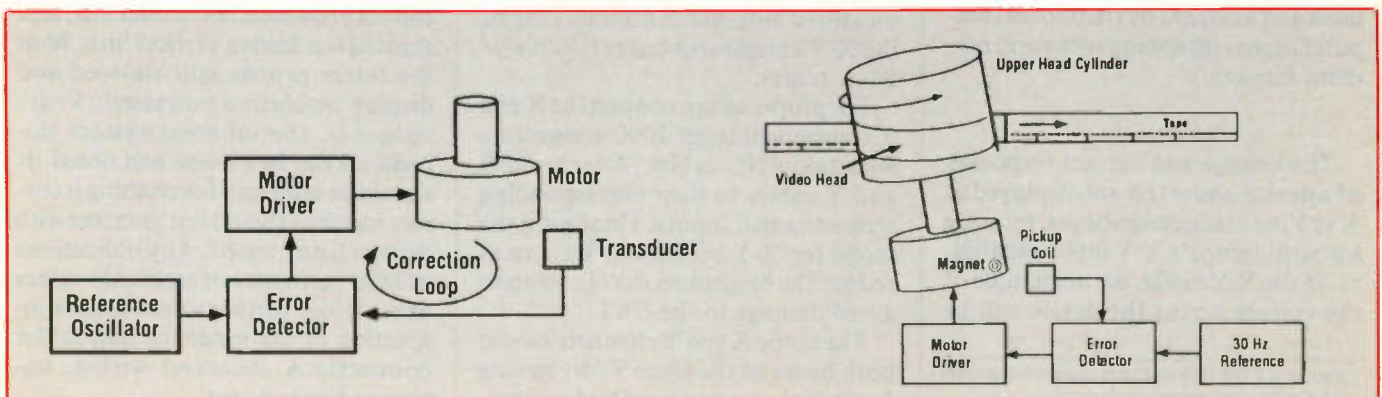

Figure B

X-Y component patterns and absolute analysis

By R.L. Heyman

A number of products are on the market today that use X-Y patterns to test electronic components. The secret to the usefulness of the implementation of analog signature analysis described in this article is that absolute values can be obtained instead of just generalized signatures. By constructing an X-Y component tester using a 10K, 10-turn precision pot instead of a fixed resistance (Figure 1), absolute values such as capacitance, resistance and impedance, as well as net impedance can be extracted from X-Y patterns.

The tester uses a simple concept to test different passive and active electronic components. It uses a minimum of parts and requires less than six hours to build. A 60Hz source is created by using an inexpensive 12.6Vac step-down transformer. This current-limited ac signal provides excitation for a device under test (DUT). Banana jacks accommodate test probes. BNC connectors allow easy hookup to an oscilloscope.

By using a lab oscilloscope to display the X-Y patterns, viewing phase relationships of a DUT are also possible. Use of a digital scope instead of an analog scope further enables storage and comparison of signatures. Once digitized, the patterns have the advantage that they may be manipulated and analyzed by traditional computer means (graphing software, modem, fax, etc.).

Scope setup

The voltage and current responses of a device under test are displayed as X vs Y, or Lissajous patterns, by using an oscilloscope's X-Y input capability. In the X-Y mode, the magnitude of the voltage across the device will be

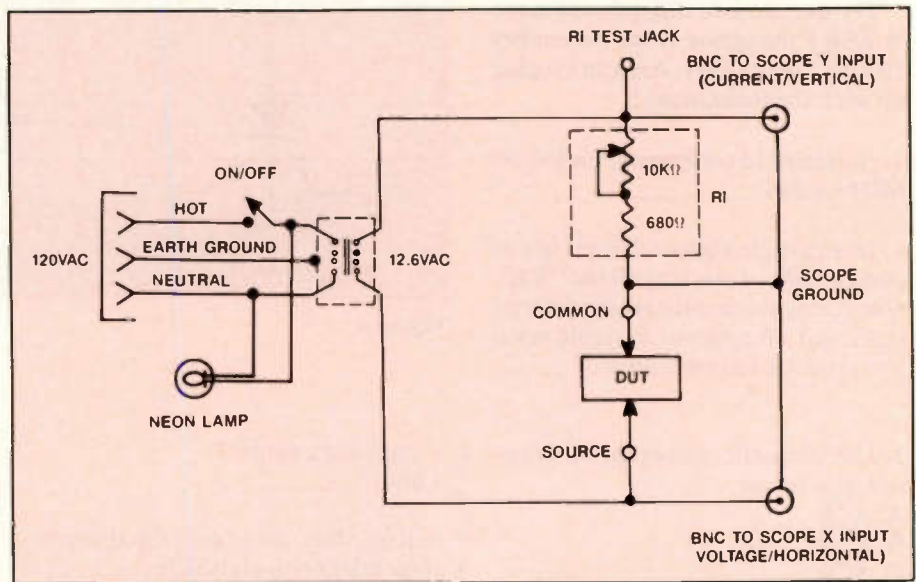

Figure 1. An X-Y component tester provides the user with a readout of the characteristic curve of the component being tested on the oscilloscope face. By using a 10K, 10-turn precision pot instead of a fixed resistance, absolute values such as capacitance, resistance and impedance can be extracted from X-Y patterns.

displayed on the horizontal axis (the X value) and the magnitude of the current through the device will be displayed on the vertical axis (the Y value). The horizontal scale is direct reading in volts per division (V/div) for the X channel input. The vertical scale of current/div can be determined by noting the V/div setting of the vertical input channel and dividing by the measured internal resistance (R_i) of the X-Y component tester ($[V/div]/R_i = I/div$).

For proper setup, connect the X and Y component tester BNC connectors with two BNC cables. Attach the X and Y cables to their corresponding scope channel inputs. Configure the scope for X-Y operation. Be sure to reduce the brightness during setup to avoid damage to the CRT.

The scope X and Y channels should both be set to the same V/div setting for initial results (try 5V/div first).

Turn the component tester off and switch the scope inputs to ground, then adjust the dc offset for each channel to bring the small CRT dot to the exact center of the scope display. Return the scope channel inputs to dc and turn on the component tester. The horizontal and vertical scales will now be calibrated.

As a quick check, open test leads should produce a horizontal line, and shorted test leads a vertical line. With the tester probes still shorted and display resolution increased (V/div reduced), the inherent system impedance can be viewed and noted. It should be minimal if everything is correct and thus should not interfere with devices being tested. Any indications of large resistance or reactance values as explained further would require inspection of the tester for bad solder connections, incorrect wiring, improper hookup, etc.

Heyman is a full-time electrical engineering student with a varied background in electronics.

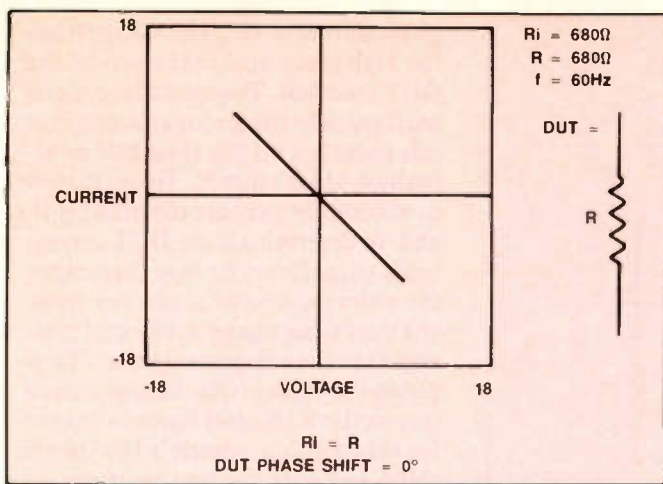

Figure 2. The characteristic curve of a resistor shown on an X-Y tester is a straight line at a 45° angle with the horizontal. This line slopes downward to the right because the voltage and current are 180° out of phase.

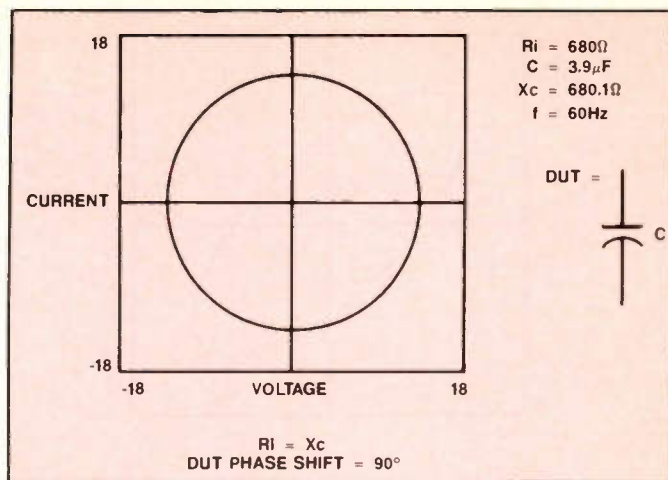

Figure 3. The characteristic curve of a capacitor is an ellipse. By adjusting the variable resistor to achieve a circle (the point where voltage and current are 90° out of phase) you can get a direct reading of capacitor impedance, and from that, calculate capacitance.

Varying Ri

The heart of the tester's functionality is the ability to vary its internal resistance (Ri). The potentiometer serves this important function. The purpose can be to match the tester's internal resistance with a DUT or to alter current through it. Both make it easier to calculate device parameters. The single banana jack on the tester is for measuring the variable internal resistance (Ri) as required. As an option, you could use a calibrated dial with the precision pot and forgo direct measurement. Why this capability is important can be shown by explaining how the Lissajous patterns are derived from a DUT.

Consider a pure resistance. The current or Y axis is derived from the voltage drop across the component tester's internal resistance (Ri). The voltage or X axis is developed across the DUT. The result displays the slope or change in current as a function of voltage which is determined by Ohm's law. This relationship then has a slope of zero (horizontal line) when the resistance of the DUT is infinite (current through the device is zero), and an infinite slope (vertical line) when the resistance of the DUT is zero (voltage across the device is zero). This means that if the display is at an angle (has undergone any angular rotation) the DUT resistance is somewhere between zero and infinity.

Now if you vary Ri, a special situation occurs when the two resistances (Ri and R) are equal. Their respective voltage amplitudes will be equal, and

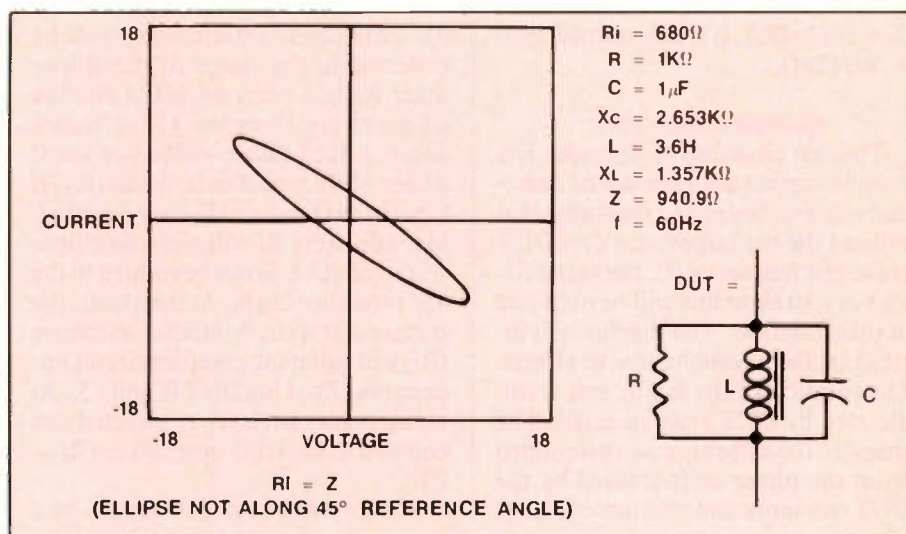

Figure 4. A complex impedance will give a trace that is an ellipse at some angle, depending on the composition of the impedance.

thus $X = Y$ or $X/Y = 1$. Applying the principles of trigonometry, this equates to a reference angle of 45°, and is defined as a diagonal line from the scope display upper left to lower right (the tester's schematic arrangement puts voltage and current 180° out of phase initially, which explains the negative slope (Figure 2). This fact is used to determine the unknown DUT's resistance (R). When the slope of the line is 45°, if Ri is measured, then because the DUT resistance is equal to Ri, its value is also known.

Measuring pure inductance or capacitance

Consider now a DUT with pure inductance or capacitance. Any react-

ance causes voltage and current to be out of phase by $\pm 90^\circ$ (from the inherent 180° shift of the tester) and is reflected in the display as an ellipse. You can adjust the tester's internal resistance (Ri) so that the ellipse becomes a circle. This particular point where a circle is displayed corresponds to the condition when the voltage drop across the DUT reactance (X_C or X_L) is equal to the internal resistance (Ri) of the tester. By setting the unknown reactance equal to the measured Ri for the test frequency (f), in this case 60Hz (Figure 3), you can solve the equation for the absolute value of the capacitor or inductor under test by using the equation $X_C = 1/(2\pi f C)$ or $X_L = 2\pi f L$ respectively. Solving for C yields

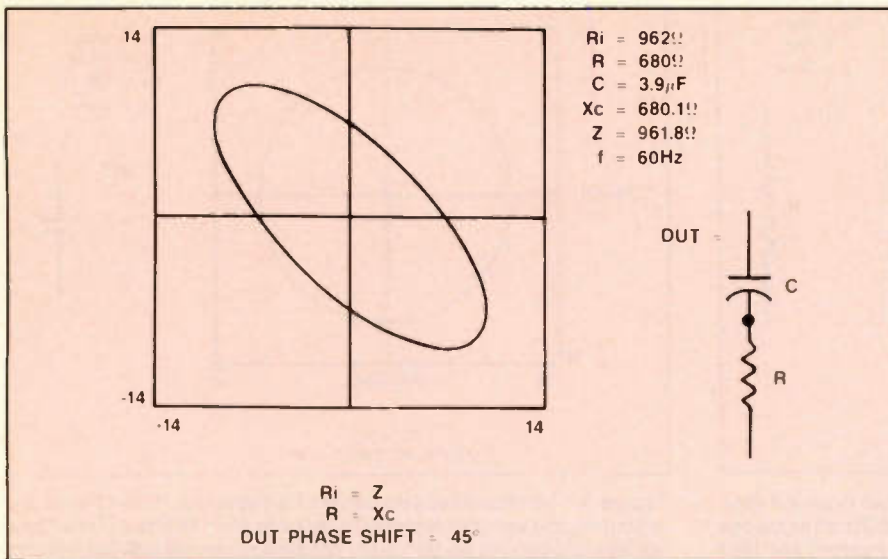

Figure 5. When the phase shift of a complex impedance is 45° , the resistance and reactance of the device under test are equal.

phase shift of $\pm 45^\circ$. This occurs when the resistance and reactance of the DUT are equal. The ratio of the minor axis length to the major axis length at this point is a bit less than half or actually 0.414 (Figure 5). To easily view or accurately measure the phase shift and/or determine if the DUT current leads (capacitive) or lags (inductive) the voltage, set the scope for dual-channel time mode while still connected to the component tester. Trigger on the voltage (X) channel output (invert the X channel input to correct for the component tester's 180° phase shift) and note the zero crossings.

Extended range

The previous examples were cited for results between 680Ω and $10.68K\Omega$, the component tester's variable range of internal resistance (R_i). Outside these parameters an unknown resistance, reactance or impedance can still be determined by varying the scope's X and Y channels' V/div settings along with R_i , until a 45° reference angle or circuit is obtained. Then the X/Y V/div is determined by noting the V/div setting of the individual X and Y scope channel inputs. For example, if the X input is set at 5V/div and Y is set to 5V/div, this would indicate an X/Y ratio of 1. With X set to 2V/div and Y set to 5V/div, this would equate to an X/Y ratio of 0.4. The component tester internal resistance (R_i) is then multiplied by this ratio of X/Y V/div in the stated equations ($R_i \times \text{ratio}$ replaces R_i). Obviously, when the ratio is 1, R_i is used directly (Figures 6, 7 and 8).

$$C = 1/(2\pi f R_i). L \text{ is determined by } L = R_i/(2\pi f).$$

Complex impedance

The last situation to consider is a complex circuit arrangement of inductance, capacitance, and resistance that reflects the net impedance of a DUT at the test frequency (f). Neither a circle nor a straight line will be obtained in this situation. The display will instead exhibit a combination of effects. The rotation of the major axis is still dictated by DUT resistance (R). The shape of the ellipse is now determined from the phase shift created by the DUT reactance and resistance (Figure

4). This phase relationship will be reflected in the shape of the ellipse after R_i has been adjusted for the ellipse to lay along the 45° reference angle. A thin ellipse will have a small phase shift (reactance dominates). Unless the resistive influence is negligible, adjusting R_i will yield an ellipse whose major axis can be rotated to the 45° reference angle. At this point, the component tester's internal resistance (R_i) will equal the complex circuit impedance (Z) of the DUT (Figure 5). R_i at this point can then be measured and equated to the DUT impedance ($R_i = Z$).

An important point occurs at a

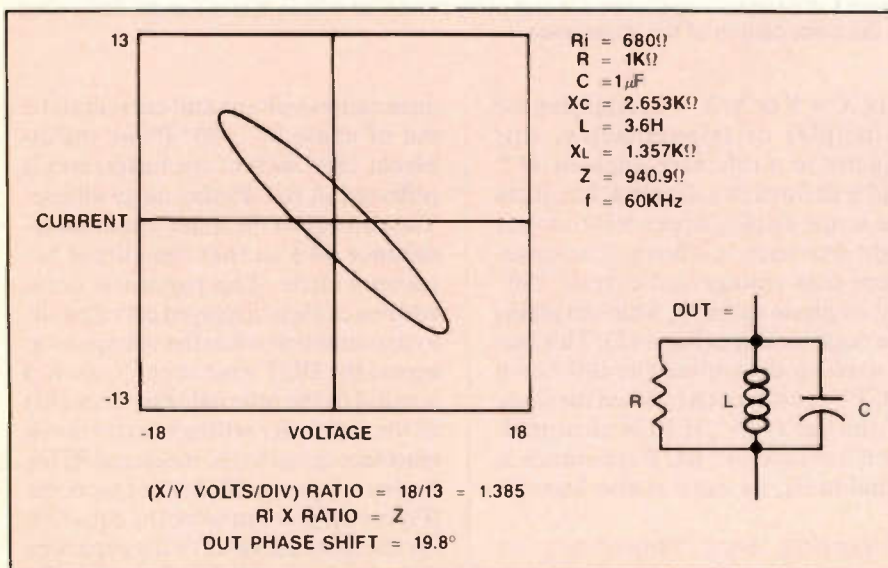

Figure 6. When the impedance of the DUT is greater than the maximum value of R_i , you will have to adjust the V/div controls of the scope and multiply the value of R_i by this ratio. In this case, the ratio is 18/13, or 1.385.

PN junctions

The process of injecting an alternating signal and dynamically viewing results of current as a function of voltage can help isolate marginal PN junctions. Adjusting R_i for minimum resistance (maximum current) usually yields the best results. Since most solid-state devices and integrated circuits are made up of multiple PN junctions, the tester is very effective in assessing complex systems (Figures 11, 12, 13 and 14).

The purpose of a PN junction of course is to conduct or block current, depending upon the polarity of any voltage applied. This means that at some point the junction must change from low resistance to high resistance or vice-versa in response to voltage

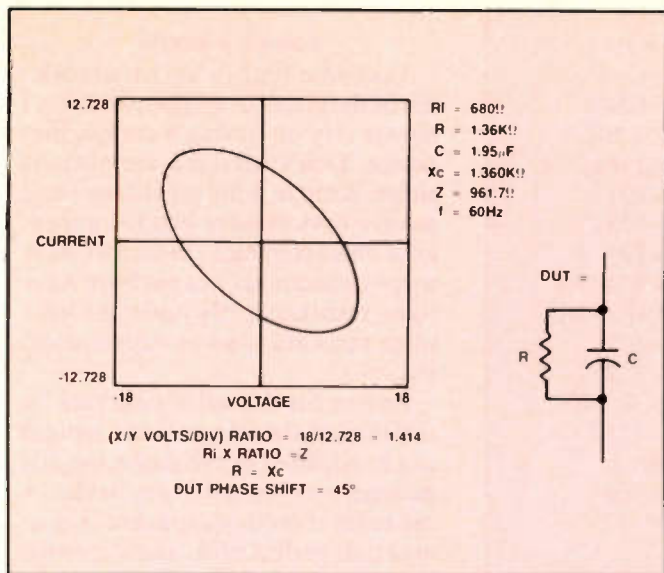

Figure 7. In order to achieve this curve on the scope, it was necessary to set the horizontal V/div to 18, and the vertical V/div to 12.728 for a ratio of 18/12.728 or 1.414.

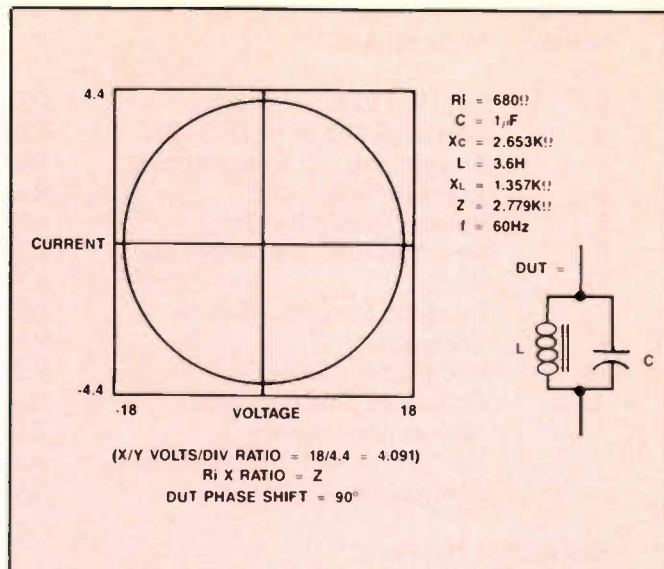

Figure 8. This characteristic curve of a circle for the LC circuit shown was achieved by using a horizontal V/div to vertical V/div ratio of 18/4.4 or 4.091.

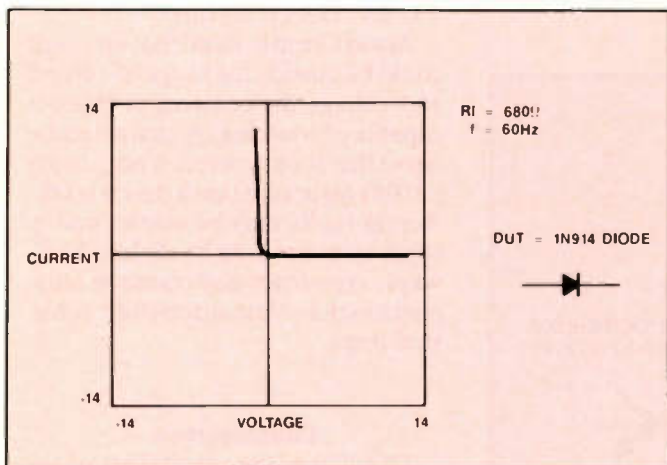

Figure 9. The waveform of a diode is characterized by an angle of approximately 90°. On one side, the diode is nonconductive and the voltage can rise with no current flow. When the diode is conducting, the voltage across the diode is nearly zero, and the current is limited only by the series resistances in the circuit.

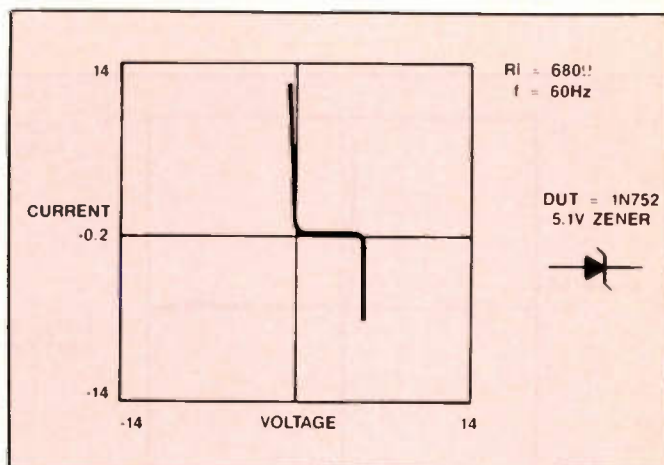

Figure 10. The characteristic curve of a zener diode shows that at some point, in its nonconducting segment, the diode suddenly conducts.

stimulus (Figure 9). How well the junction is able to block (its reverse leakage specification) and how fast it is able to switch are two factors involved in determining the quality of a PN junction. The blocking or high resistance duration should not show a gradual increase in current as voltage increases (reverse leakage). This shows as a gradual droop of the horizontal or high resistance portion.

The Zener diode is an example of desired reverse breakdown (Figure 10) and note how the switching actions are very discrete and definite. Switching actions should have sharp angles. They should not be ambiguous nor vary slowly.

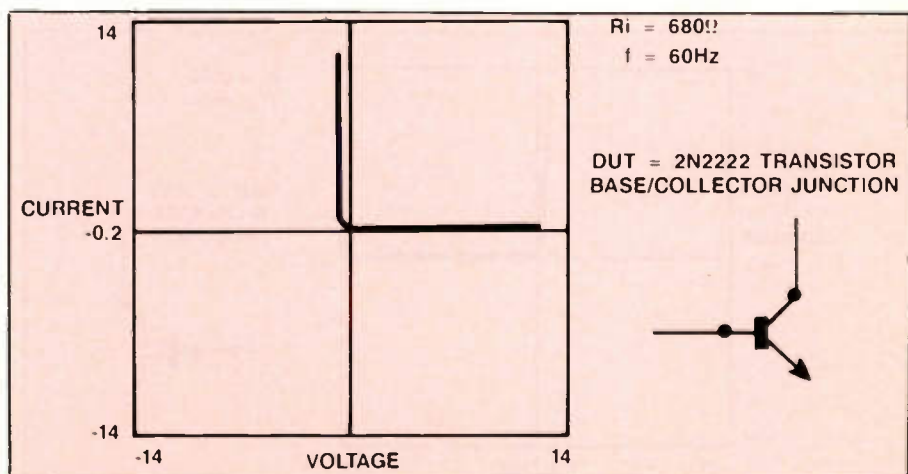

Figure 11. The base-collector junction of a transistor is essentially a diode, as revealed by its characteristic curve.

Number	Nomenclature	Part Number
1	Switch, 120Vac	RS# 275- 624
2	120Vac power inlet (IEC-320)	CB# EAC- 301
3	Transformer, 12.6Vac, 300mA	RS# 273- 1365
4	Resistor, 680Ω, 1/2W	RS# 271- 021
5	Banana jacks (Qty. 3)	RS# 274- 725
6	BNC bulkhead connectors (2)	RS# 278- 105
7	Knob	RS# 274- 424
8	Precision Pot, 10K, 10-turn	DK# 73JB103-ND
9	Enclosure	RS# 270- 627
10	Neon lamp, 120Vac	RS# 272- 712
	Calibrated Dial (Optional)	DK# 411CS- ND
	120Vac power cord	RS# 278- 1257
	Test probes with banana plugs	Any type
	BNC cables (Qty. 2)	RS# 278- 964

Key to Part Numbers

RS = Radio Shack
 DK = Digi-Key: 800-344-4539
 CB = Carlton-Bates: 800-482-9313

Failure analysis

Take your time to learn the subtleties of the graphics display, and don't always rely on having a comparison device. Don't overlook the obvious either. Keep in mind most active and passive devices have lumped impedance characteristics. Inductors have some capacitance, capacitors have some resistance, PN junctions have some resistance, some capacitance, etc.

Remember the tester's internal resistance and the scope's V/div settings can be adjusted to evaluate a specific parameter of interest of any device. A capacitor should be capable of showing a near perfect circle. Is it somewhat slanted and elliptical indicating an abnormal internal resistance? A zener diode rated at 5.1V should show a reverse breakdown at 5.1 divisions if the display is calibrated and set at 1V/div. Does it do this?

Always keep in mind that any fault could be outside the range of current and voltage the component tester is capable of sourcing. A characteristic curve that looks correct is not always a 100% assurance that a device is OK. Actual faults may be subtle, and in some cases not even be visible. As always, experience and common sense play a major role in successful troubleshooting.

Enhancements

To enhance the capabilities of the X-Y component tester, a voltage or current source can be used in conjunction with the tester to fully test 3-pin devices. The base current of a transistor, gate voltage of an FET or trigger level of an SCR can be controlled by an external source while the component response is viewed. The tester would be connected from emitter-collector, source-drain, or anode-cathode respectively. In this manner the component tester can function as a rudimentary curve tracer and device parameters can be matched.

To extend the range of test frequencies and voltage and current sourcing capabilities, a signal generator can be used in place of the step-down transformer as a signal source. The output must be floating. (Figure 15). This allows testing at specific frequencies and voltages of interest.

The arbitrary current limit and capacity of the tester can also be changed
(Continued on page 37)

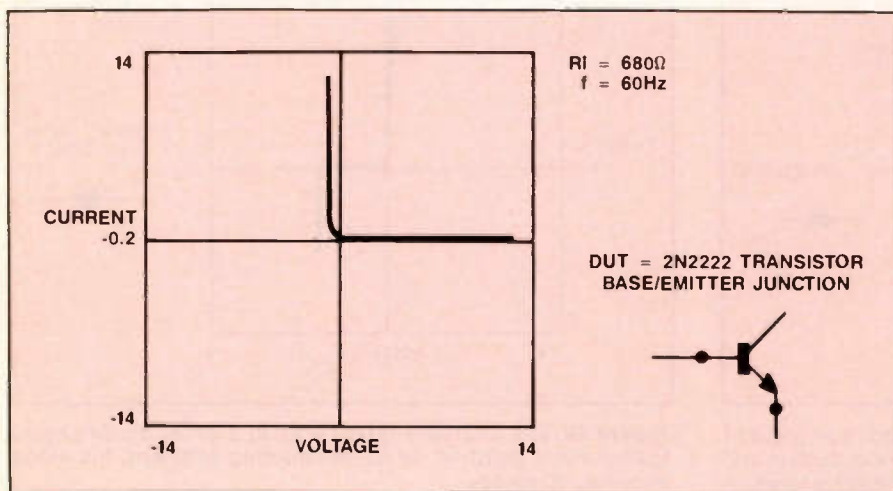

Figure 12. The base-emitter junction of a transistor is essentially a diode, as revealed by its characteristic curve.

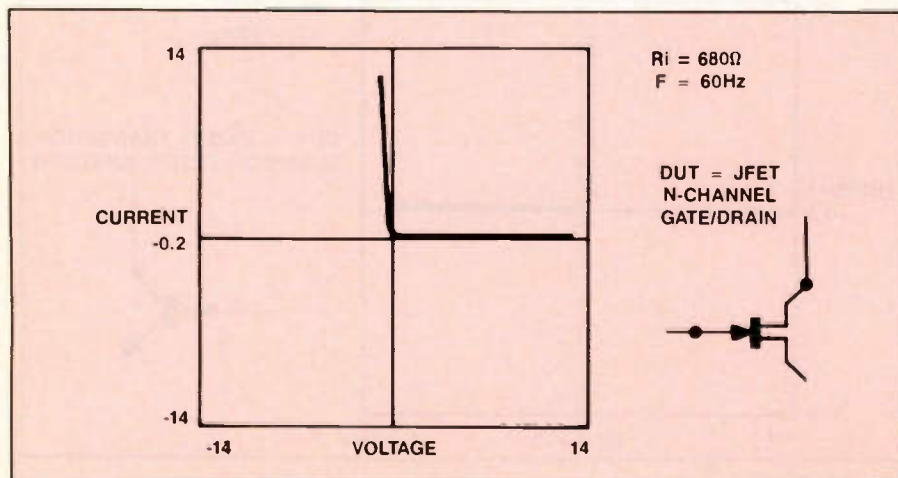

Figure 13. The gate-drain junction of a JFET has the characteristic curve of a diode.

SIGNAL SCHEMATIC (ANALOG COMB) (used CTC169BM, BN, HM, HN)

Product safety should be considered when component replacement is made in any area of an electronics product. A star next to a component symbol number designates components in which safety is of special significance. It is recommended that only exact cataloged parts be used for replacement of these components.

Use of substitute replacement parts that do not have the same safety characteristics as recommended in factory service information may create shock, fire, excessive x-radiation or other hazards.

This schematic is for the use of qualified technicians only. This instrument contains no user-serviceable parts.

The other portions of this schematic may be found on other Profax pages.

SIGNAL SCHEMATIC (ANALOG COMB) (used CTC169BM, BN, HM, HN)

Product safety should be considered when component replacement is made in any area of an electronics product. A star next to a component symbol number designates components in which safety is of special significance. It is recommended that only exact cataloged parts be used for replacement of these components.

Use of substitute replacement parts that do not have the same safety characteristics as recommended in factory service information may create shock, fire, excessive x-radiation or other hazards.

This schematic is for the use of qualified technicians only. This instrument contains no user-serviceable parts.

The other portions of this schematic may be found on other Profax pages.

All integrated circuits and many other semiconductors are electrostatically sensitive and require special handling techniques.

December 1991

Hitachi
CTC 169 Color TV

3083

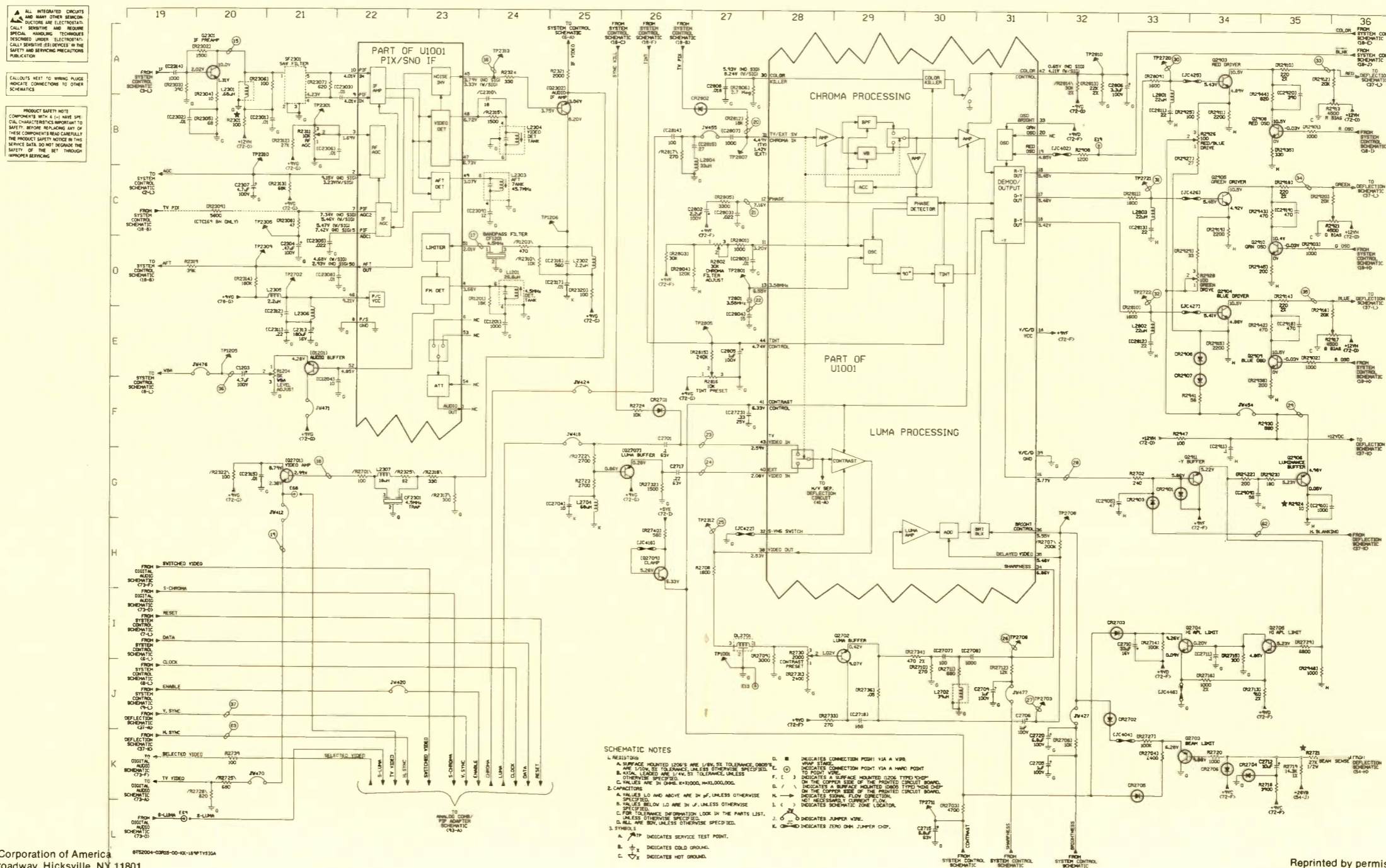

SIGNAL SCHEMATIC (DIGITAL COMB) (used CTC169BL only)

Product safety should be considered when component replacement is made in any area of an electronics product. A star next to a component symbol number designates components in which safety is of special significance. It is recommended that only exact cataloged parts be used for replacement of these components.

Use of substitute replacement parts that do not have the same safety characteristics as recommended in factory service information may create shock, fire, excessive x-radiation or other hazards.

This schematic is for the use of qualified technicians only. This instrument contains no user-serviceable parts.

The other portions of this schematic may be found on other Profax pages.

All integrated circuits and many other semiconductors are electrostatically sensitive and require special handling techniques.

- ALL INTEGRATED CIRCUITS AND MANY OTHER SEMICONDUCTORS ARE ELECTROSTATICALLY SENSITIVE. SPECIAL HANDLING TECHNIQUES DESCRIBED UNDER "ELECTROSTATICALLY SENSITIVE DEVICES" IN THE SAFETY AND SERVICE PRECAUTIONS PUBLICATION.
- CALLOUTS NEXT TO WIRING PLUGS INDICATE CONNECTIONS TO OTHER SCHEMATICS.
- PRODUCT SAFETY NOTE: COMPONENTS WITH A * HAVE SPECIAL CHARACTERISTICS IMPORTANT TO SAFETY. BEFORE REPLACING ANY OF THESE COMPONENTS READ CAREFULLY THE PRODUCT SAFETY NOTICE IN THE SERVICE DATA. DO NOT DEGRADE THE SAFETY OF THE SET THROUGH IMPROPER SERVICING.

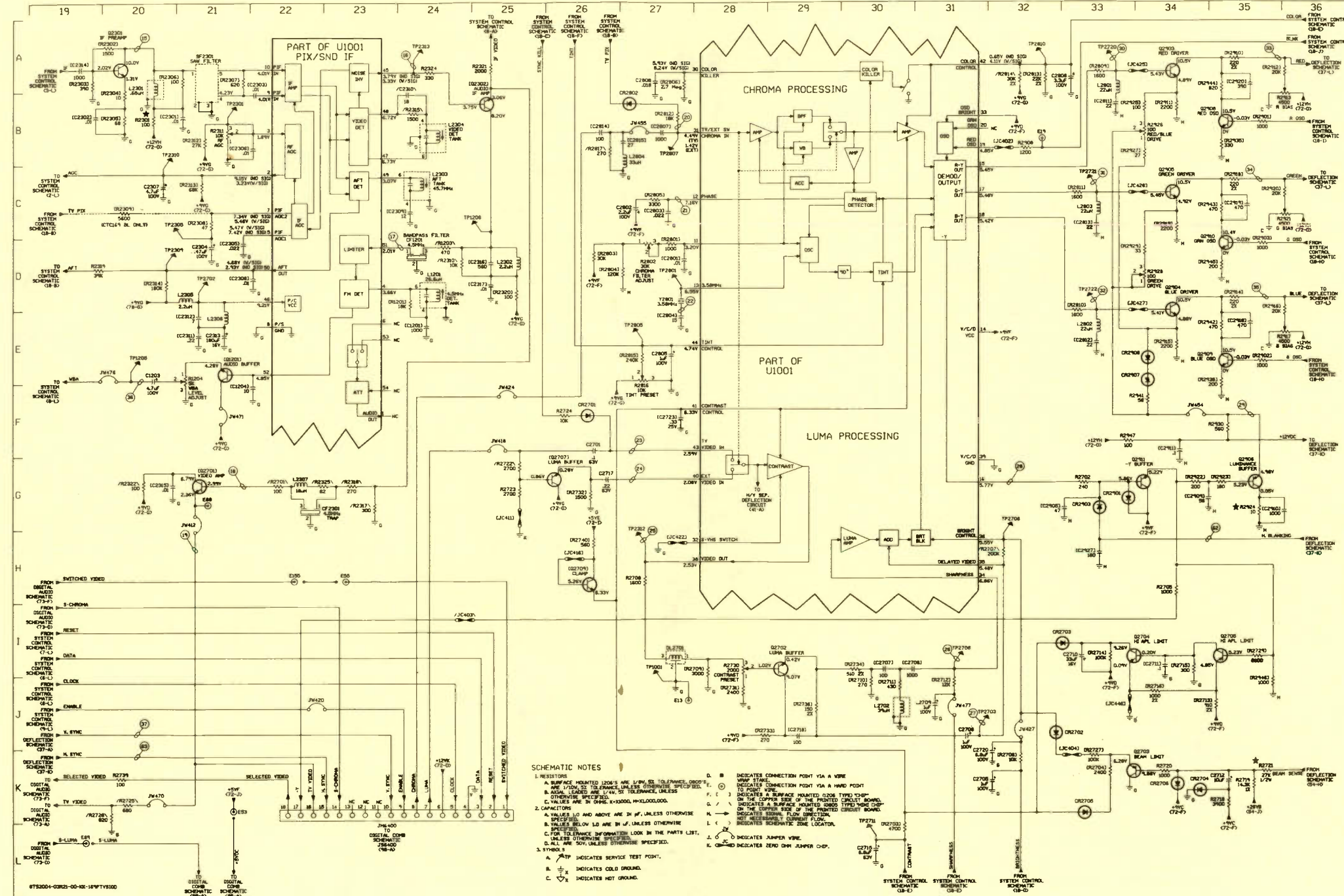

SCHEMATIC NOTES

- RESISTORS
 - * SURFACE MOUNTED (200'S ARE 1/4W, 5% TOLERANCE, GROUP 1).
 - RESISTORS WITH TOLERANCE UNLESS OTHERWISE SPECIFIED.
 - RESISTORS WITH TOLERANCE UNLESS OTHERWISE SPECIFIED.
 - VALUES ARE IN OHMS UNLESS OTHERWISE SPECIFIED.
 - VALUES TO AND ABOVE 10 ARE IN μF , UNLESS OTHERWISE SPECIFIED.
 - VALUES BELOW 10 ARE IN μF , UNLESS OTHERWISE SPECIFIED.
 - FOR TOLERANCE INFORMATION LOOK IN THE PARTS LIST, UNLESS OTHERWISE SPECIFIED.
 - ALL ARE 50V, UNLESS OTHERWISE SPECIFIED.
- CAPACITORS
 - * SURFACE MOUNTED (200'S ARE 1/4W, 5% TOLERANCE, GROUP 1).
 - RESISTORS WITH TOLERANCE UNLESS OTHERWISE SPECIFIED.
 - VALUES ARE IN OHMS UNLESS OTHERWISE SPECIFIED.
 - VALUES TO AND ABOVE 10 ARE IN μF , UNLESS OTHERWISE SPECIFIED.
 - VALUES BELOW 10 ARE IN μF , UNLESS OTHERWISE SPECIFIED.
 - FOR TOLERANCE INFORMATION LOOK IN THE PARTS LIST, UNLESS OTHERWISE SPECIFIED.
 - ALL ARE 50V, UNLESS OTHERWISE SPECIFIED.
- SYMBOLS
 - * INDICATES SERVICE TEST POINT.
 - ⊕ INDICATES COLD GROUND.
 - ⊖ INDICATES HOT GROUND.
 - INDICATES CONNECTION POINT VIA A WIRE WIPY STAKE.
 - INDICATES CONNECTION POINT VIA A HARD POINT TO POST WIRE.
 - INDICATES A SURFACE MOUNTED (200'S ARE 1/4W, 5% TOLERANCE, GROUP 1) RESISTOR ON THE COPPER SIDE OF THE PRINTED CIRCUIT BOARD.
 - INDICATES A SURFACE MOUNTED (200'S ARE 1/4W, 5% TOLERANCE, GROUP 1) CAPACITOR ON THE COPPER SIDE OF THE PRINTED CIRCUIT BOARD.
 - INDICATES SIGNAL FLOW DIRECTION, NOT NECESSARILY CURRENT FLOW.
 - INDICATES SCHEMATIC ZONE LOCATOR.
 - INDICATES JUMPER WIRE.
 - INDICATES ZERO OHM JUMPER CHIP.

SIGNAL SCHEMATIC (DIGITAL COMB) (used CTC169BL only)

Product safety should be considered when component replacement is made in any area of an electronics product. A star next to a component symbol number designates components in which safety is of special significance. It is recommended that only exact cataloged parts be used for replacement of these components.

Use of substitute replacement parts that do not have the same safety characteristics as recommended in factory service information may create shock, fire, excessive x-radiation or other hazards.

This schematic is for the use of qualified technicians only. This instrument contains no user-serviceable parts.

The other portions of this schematic may be found on other Profax pages.

All integrated circuits and many other semiconductors are electrostatically sensitive and require special handling techniques.

DEFLECTION SCHEMATIC (used CTC169BT, BU, BW)

Product safety should be considered when component replacement is made in any area of an electronics product. A star next to a component symbol number designates components in which safety is of special significance. It is recommended that only exact cataloged parts be used for replacement of these components.

Use of substitute replacement parts that do not have the same safety characteristics as recommended in factory service information may create shock, fire, excessive x-radiation or other hazards.

This schematic is for the use of qualified technicians only. This instrument contains no user-serviceable parts.

The other portions of this schematic may be found on other Profax pages.

All integrated circuits and many other semiconductors are electrostatically sensitive and require special handling techniques.

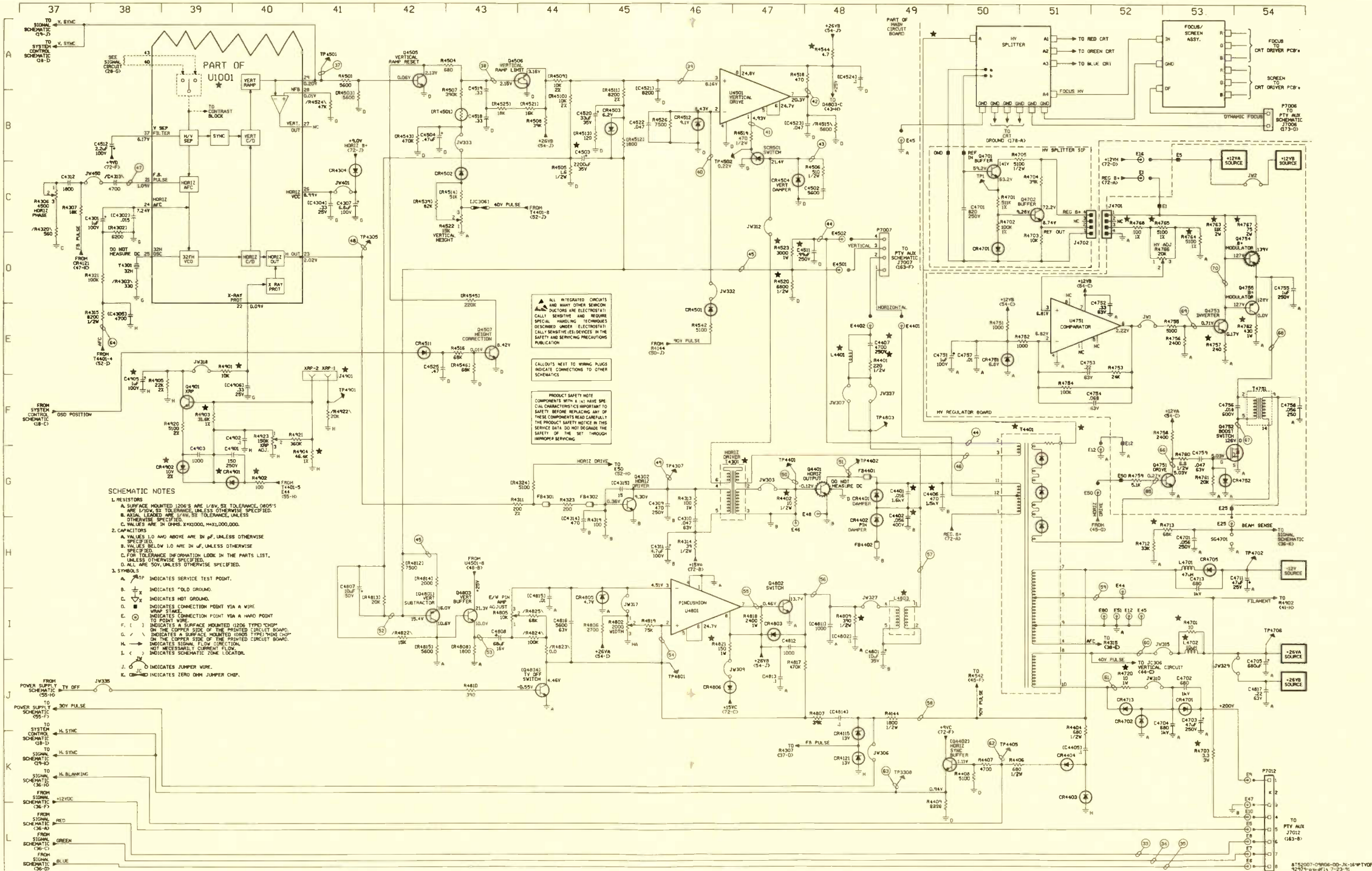

DEFLECTION SCHEMATIC (used CTC169BT, BU, BW)

Product safety should be considered when component replacement is made in any area of an electronics product. A star next to a component symbol number designates components in which safety is of special significance. It is recommended that only exact cataloged parts be used for replacement of these components.

Use of substitute replacement parts that do not have the same safety characteristics as recommended in factory service information may create shock, fire, excessive x-radiation or other hazards.

This schematic is for the use of qualified technicians only. This instrument contains no user-serviceable parts.

The other portions of this schematic may be found on other Profax pages.

All integrated circuits and many other semiconductors are electrostatically sensitive and require special handling techniques.

SIGNAL SCHEMATIC (ANALOG COMB)
(used CTC169BT, BU, BW)

Product safety should be considered when component replacement is made in any area of an electronics product. A star next to a component symbol number designates components in which safety is of special significance. It is recommended that only exact cataloged parts be used for replacement of these components.

Use of substitute replacement parts that do not have the same safety characteristics as recommended in factory service information may create shock, fire, excessive x-radiation or other hazards.

SIGNAL SCHEMATIC (ANALOG COMB) (used CTC169BT, BU, BW)

This schematic is for the use of qualified technicians only. This instrument contains no user-serviceable parts.

The other portions of this schematic may be found on other Profax pages.

All integrated circuits and many other semiconductors are electrostatically sensitive and require special handling techniques.

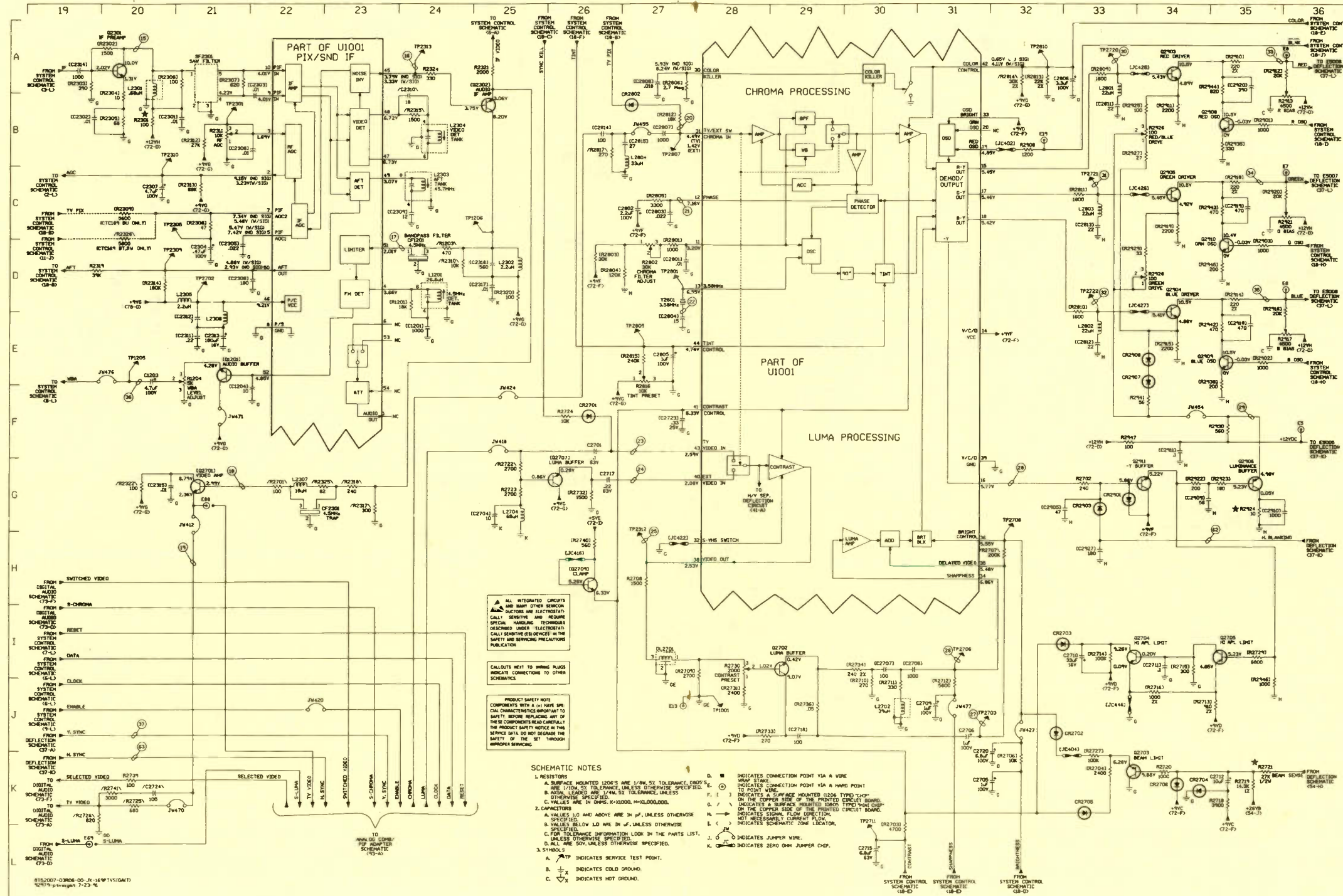

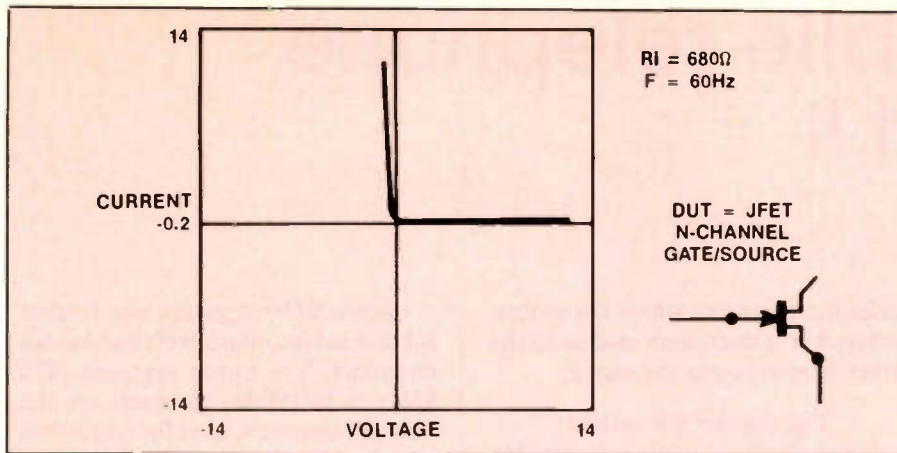

Figure 14. The gate-source junction of a JFET has the characteristic curve of a diode.

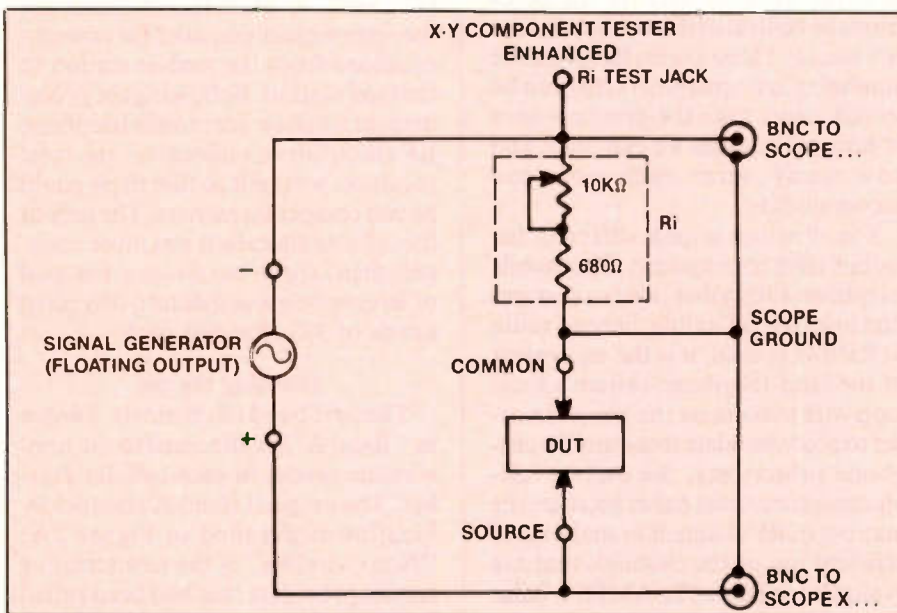

Figure 15. The usefulness of the X-Y component tester can be enhanced by adding external sources, or using a signal generator. See text for details.

to meet more rigorous current testing requirements.

For increased accuracy of impedance measurements the X and Y outputs can be monitored by ac voltmeters. R_i would be adjusted until the two meters display the same reading. At this point R_i will equal the DUT impedance. Outside the range of adjusting R_i , the ac voltage values can be used to determine DUT impedance by Ohm's law.

Summary

Since the component tester does not require a circuit to have power applied for diagnosis, catastrophic failures can still be analyzed. This allows finding those components weakened or stressed from a major fault. It also helps in documenting failures if patterns are recorded and analyzed.

With the advent of computer generated simulation tools, a circuit's X-Y patterns can be simulated instead of relying solely on a "good" spare for comparison. This data can serve as a reference pattern library. The patterns can be printed or possibly downloaded into a digital scope and used for various production, quality control or repair purposes. See Figure 16.

All of the X-Y graphs have been created by MathCAD (Mathsoft, Inc., Cambridge, MA) from data generated by MacAC I (San Juan Software, Seattle, WA) on a Macintosh computer. The simulation values and components have been chosen to reflect real world parameters as best as possible.

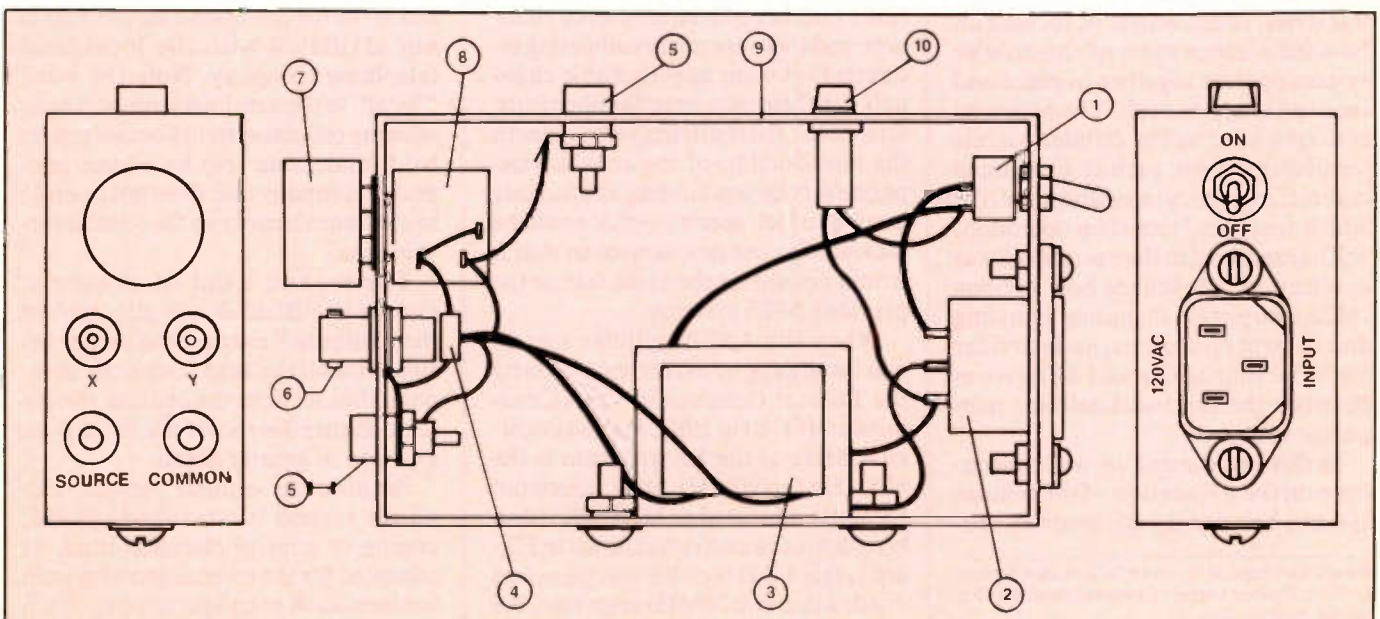

Figure 16. This is a general idea of what an X-Y component tester can look like when into making up the tester.

Cellular mobile telephone systems - Part II

By William H. Bowen

Editor's note: The first part of this article, "Cellular telephone systems" appeared in the July issue. We credited the publication, "The Expander," as being the source of that article. That was correct. However, we wish to acknowledge at this time that Mr. Bowen was the author of the piece as it appeared in "The Expander."

In August we published an item in Video Corner entitled "Movable video heads provide noiseless speed search." We credited "The Expander" as being the source of that article. That was also correct. However, we would like to acknowledge at this time that the author of that article, as it originally appeared in "The Expander" was Ron Smith, Senior Technical Writer in the Technical Services Division, Product Support Group of Mitsubishi Electronics America, Inc.

The first installment of this article, presented in the July issue, examined the history of mobile telephones, discussed how that history shaped the design of the cellular mobile telephone system, and described the basic topography of the AMPS cellular system. AMPS is the abbreviation for Advanced Mobile Phone System.

In the succeeding installments of this series, attention will be focused on how the various parts of the cellular system operate together to place and receive a telephone call. The advanced concepts used in the cellular mobile telephone system, such as distributed control, frequency reuse and hand off, which are crucial to system operation, will be examined in their actual cellular application. We will see how a phone call is completed, including signaling and control operations, and consider both the similarities and differences between the land and cellular telephone systems.

In this installment we will concentrate on the RF portion of the cellular system, because the RF medium pro-

vides the means by which the mobile subscriber is interconnected to all the other telephones in the world.

The cellular RF system

When another customer is added to a land telephone system, it is quite easy to string another wire on the poles from the central office to the customer's house. There are no limits on the number of new customers that can be served, other than the practical ones of how many poles we can place and how many wires each pole can accommodate.

The situation is quite different for mobile telephone systems. The mobile telephone subscriber needs a connection link that is flexible, hence a radio or RF link is used: it is the equivalent of the land telephone system's local loop wire that enters the home. In order to accommodate more mobile telephone subscribers, the mobile telephone system must either increase the number of RF channels or make more efficient use of the channels that are available, or both. The AMPS cellular system does both.

More channels

The RF spectrum contains only a finite number of frequencies or channels, and there are many competing interests that want any available channels for their own specific functions. One of the most difficult obstacles to the introduction of the cellular telephone service was finding an adequate amount of RF spectrum that could be allocated to the new service so that it would not suffer the same fate as the previous MTS systems.

When the AMPS cellular system was finally approved for operation by the Federal Communications Commission (FCC) in 1982, it was allocated 40MHz of the RF spectrum in the 825MHz to 890MHz band, spectrum formerly allocated as UHF television broadcast channels. As shown in Figure 1, this 40MHz of RF spectrum was divided into two 20MHz segments, the segments being separated by 45MHz, providing for full duplex operation.

Each 20MHz segment was further subdivided into 666 30kHz bandwidth channels. The upper segment (870 MHz to 890MHz) channels are the forward channels, used for communications from the land station to the mobile station. The lower segment (825 MHz to 845MHz) channels are the reverse channels, used for communications from the mobile station to the land station. Following the precedent set when earlier mobile telephone RF spectrum was allocated, the total spectrum was split so that there could be two competing carriers. The split of the cellular allocation was more equitable than in previous systems: the total of 66 channels was split into two equal bands of 33 channels each.

Dividing the pie

The first band of channels, known as "Band A", is allocated to the non-wireline carrier in each cellular market. The original Band A channel allocation is detailed in Figure 2A. "Non-wireline" is the new term for service providers that had been called RCCs (radio common carriers) in the MTS (mobile telephone service) and IMTS (improved mobile telephone service) systems. The non-wireline carrier is the mobile phone carrier that is *not* affiliated with the local land telephone company. Note the word "local" in the previous sentence: non-wireline cellular system licenses can be held (and some are) by a land telephone company that does not operate in the same territory as the cellular service area.

The second band of channels, known as "Band B", is allocated to the "wireline" carrier, the carrier affiliated with the land telephone company that services the cellular service area. Figure 3A shows the Band B allocation in greater detail.

Because the cellular mobile telephone system is a trunked system, paging or control channels must be allocated for the transaction of system business such as call processing. Each of the two cellular RF frequency bands has 21 of the available channels dedi-

Bowen is a Technical Writer in the Technical Services Division, Product Support Group of Mitsubishi Electronics America, Inc.

This article originally appeared in the Expander published by Mitsubishi.

Figure 1A. Cellular RF spectrum allocation.

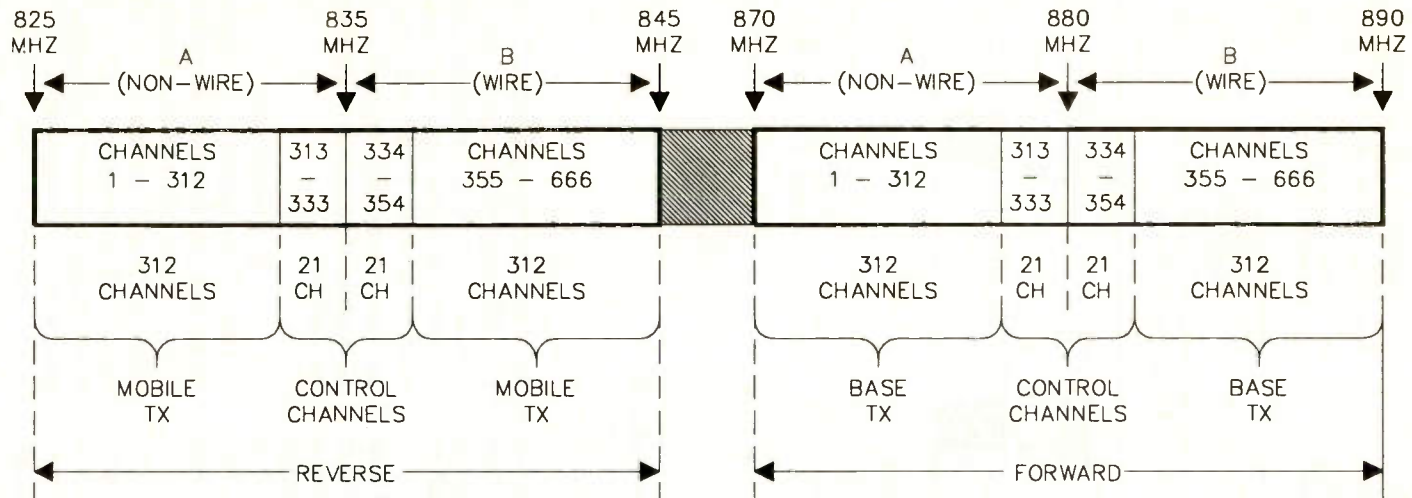

PART A: ORIGINAL CELLULAR CHANNEL ALLOCATION
(666 CHANNELS)

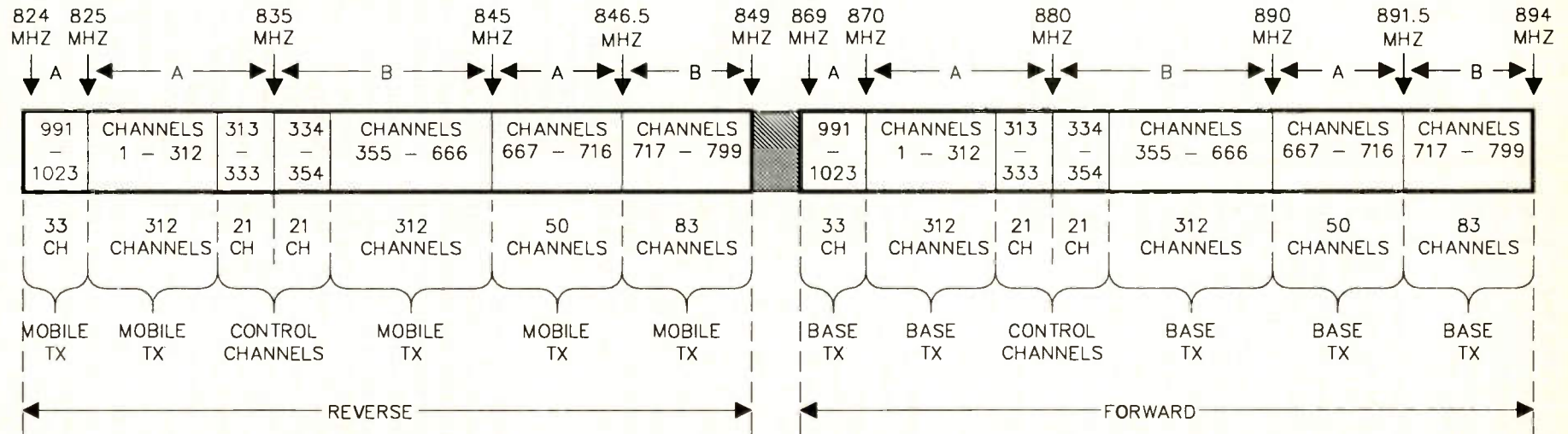

PART B: EXPANDED CELLULAR CHANNEL ALLOCATION
(832 CHANNELS)

Figure 1B. Expanded cellular channel allocation.

cated as control channels, the remainder of the channels available (312) being voice channels. The details on how each type of channel is used will be presented shortly.

Additional Spectrum

In 1986, just 4 short years after the original approval of the cellular service, the RF spectrum allocation for cellular systems was expanded, as shown in Figure 1B, by 10MHz. The additional RF spectrum was allocated to relieve overcrowding in the most densely loaded service areas such as New York, Chicago and Los Angeles.

The 166 additional voice channels added by the new spectrum allocation brought the total number of RF channels in the cellular system to 832, or 25 times the total number of channels allocated to all the MTS and IMTS systems. No additional control channels were allocated during this expansion.

The additional RF spectrum was subdivided using the existing criteria, yielding a new total of 416 channels for each carrier band. The expanded RF allocations are shown in Figures 2B (Band A) and Figure 3B (Band B). The bizarre channel numbering scheme that resulted after the spectrum expansion came about because the expanded spectrum allocation was fractured (channels added above and below the existing spectrum) and that the original 666 channels were *not* renumbered.

Frequency reuse

As we mentioned earlier, having more channels is not the entire solution for accommodating increased traffic in a mobile telephone system. Each channel must be used efficiently. The use of trunking, outlined in the first installment, is one method used to increase efficiency. Another technique, which is one of the foundations of the design of the cellular system, is frequency reuse. Frequency reuse describes the familiar scheme in which the same frequency allocation is used for more than one transmitting station, for example a radio or television station, that are separated by a distance great enough that they do not interfere with each other.

Of course, frequency reuse has been around for a long time, but the distances involved in the separation of users on the same channel in, for in-

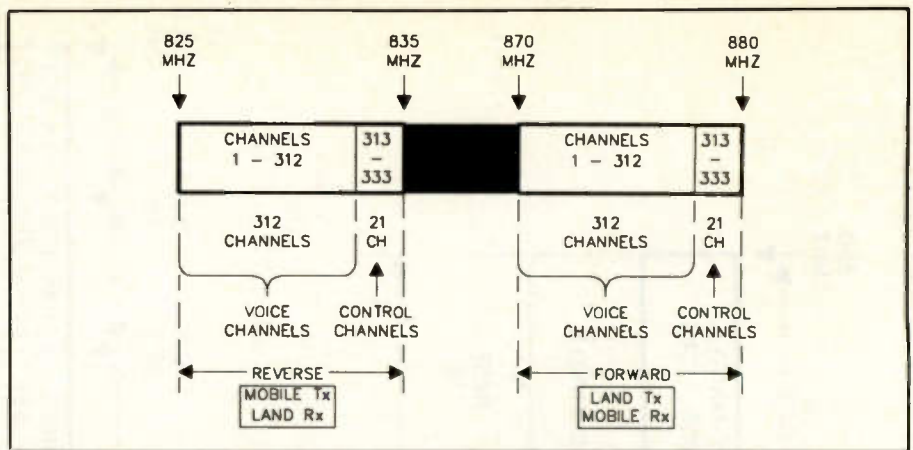

Figure 2A. Band "A" (non-wireline) cellular RF spectrum allocation.

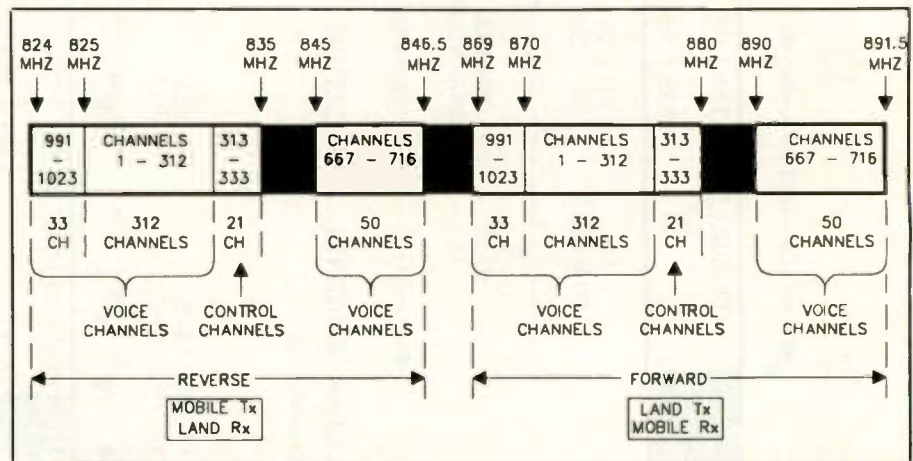

Figure 2B. Expanded band "A" channel allocation.

stance, TV broadcasting, are on the order of hundreds of miles. The type of frequency reuse we're discussing here involves separations as small as five miles.

In order to better understand how frequency reuse functions in cellular systems, let's look at its application in a typical cellular system. The sample system, shown in Figure 4, is one that uses the most common type of frequency reuse, the seven-cell repeat pattern.

In a seven-cell repeat pattern, the total number of RF channels available (416 for each carrier) is divided into 7 sets, each set having 59 channels. Each cell uses one set of channels. The cell clusters are repeated throughout the system, which allows the channels allocated to each cell to be reused. Co-channel interference is avoided because all frequencies which are repeated will be separated by at least two cells. It's important to note that clusters have to be designed to fit together and are usually arranged in groups of 4, 7, 12, and 21: this pro-

vides a good coverage pattern. To further ensure good coverage, each cell overlaps the neighboring cell. This overlap comes into play when a subscriber travels from one cell to another, preventing a drop-out of the RF signal during the operation known as hand off.

Real world cells

The cellular system was conceptualized using the hexagon-shaped cells that you see in ads and drawings, because it simplifies planning and design. The hexagon shape of these cells is artificial, however, and can't be generated in the real world.

The actual ideal cells, as shown in Figure 5, are round, like the RF radiation pattern of a perfect omnidirectional antenna, and each one overlaps the neighboring cells, providing a continuous coverage pattern throughout the system.

Most cells in the real world are *not* ideal, however. Cells in a system may not all be the same size: cells in low-traffic areas will be larger, while cells

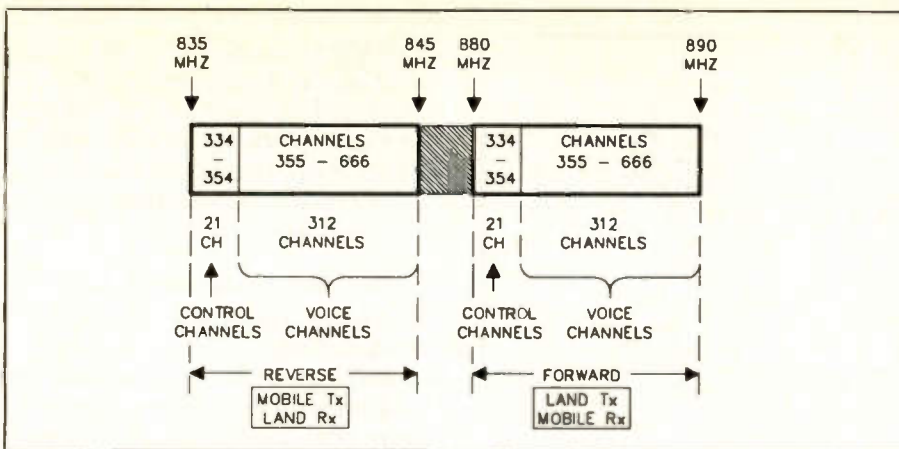

Figure 3A. Band "B" (wireline) cellular RF spectrum allocation.

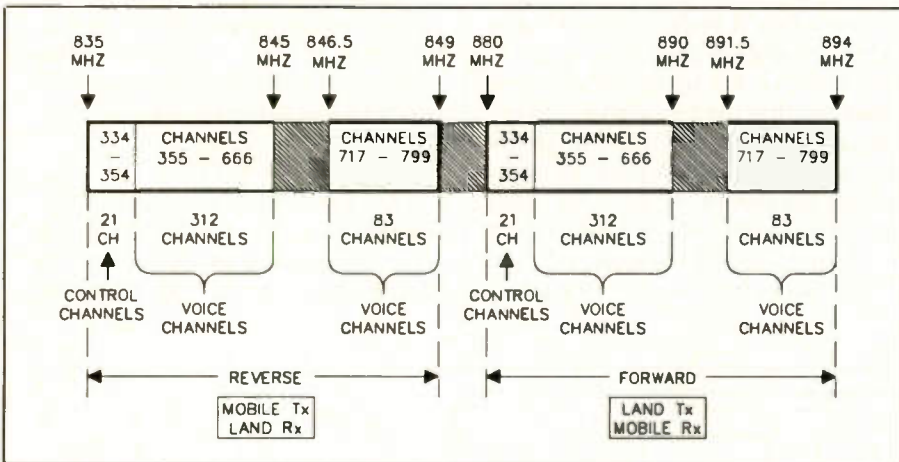

Figure 3B. Original band "B" channel allocation.

in high-traffic areas are sometimes quite small. In certain special coverage situations such as valleys, rural areas or city center areas, the actual cells may be in the shape of a rectangle, a crescent, a kidney or a pie wedge. Also, systems that supply fixed cellular service to sparsely populated areas (Alaska, for instance) may use highly directional antennas and look more like point-to-point systems than a normal cellular system. The most important point to remember is that the shape of the cells is not important, but the shape of the system's coverage area is.

The cell site

The cell in a cellular mobile telephone system performs two functions: it is the end of the cellular carrier's RF system, and part of the carrier's switching system. The typical cell site has its electronics housed in a small building at the base of the antenna tower. In some cases, however, the cell site may be housed in an existing building, and thus its location may not be

easily identifiable as a cell site. This is especially true in urban areas.

Figure 6 is a block diagram of the electronics of the typical cell site. The cell site has a fixed-frequency radio transceiver unit for each channel (control and voice) allocated to that cell site. In most cases, a few extra transceiver units are also available that can be switched into the system to replace failed transceivers.

A special tunable receiver, the signal strength receiver, is used to measure the signal strength of subscriber units arriving into the cell from adjacent cells. The signal strength information is used by the system controller, the mobile telephone switching office (MTSO) to decide which new cell to use when performing a hand off. The cell site also has a control unit, which is in reality a small computer, that performs the duties of operating and managing the other cell site equipment and transferring system data to/from the MTSO and the subscriber unit.

Most cell sites use separate transmit and receive antennas. Combiners are

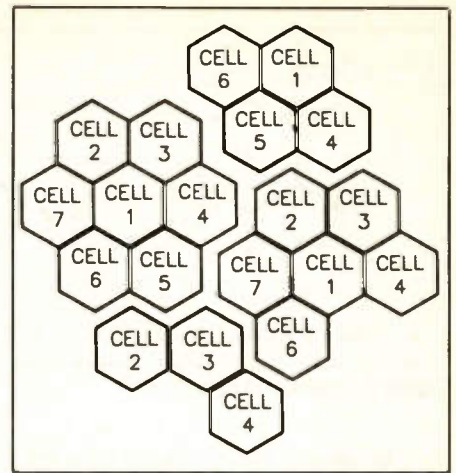

Figure 4. Seven-cell repeat pattern cell layout.

used so that all the transmitters can share a common transmit antenna, and multicoupler units are used so that all the receivers can share a common receive antenna. In those rare cell sites that use only one antenna, a duplexer is also provided so that both the transmitters and the receivers can share a common antenna.

Control and voice channels

As mentioned earlier, because the cellular system is a trunked system, every cell site must provide two types of channels, voice channels and control channels. The result, as shown in Figure 7, is that there are four signaling paths available in the AMPS cellular telephone system.

The duplex control channel consists of a forward control channel (FCC) and a reverse control channel (RCC). These channels are used primarily for the transmission of system messages to and from the subscriber unit, but they also handle call set-up for mobile-initiated calls and both paging and call set-up for land-initiated calls. Control channels are never used to transmit speech audio.

The duplex voice channel consists of a forward voice channel (FVC) and a reverse voice channel (RVC). These channels are used primarily for voice transmission, but are also used for call supervision. The digital data and the signaling tones used for call supervision are transmitted on these channels before, during and after the actual voice transmission. When data is being transmitted, the speech path is muted to prevent annoyance to the talking parties.

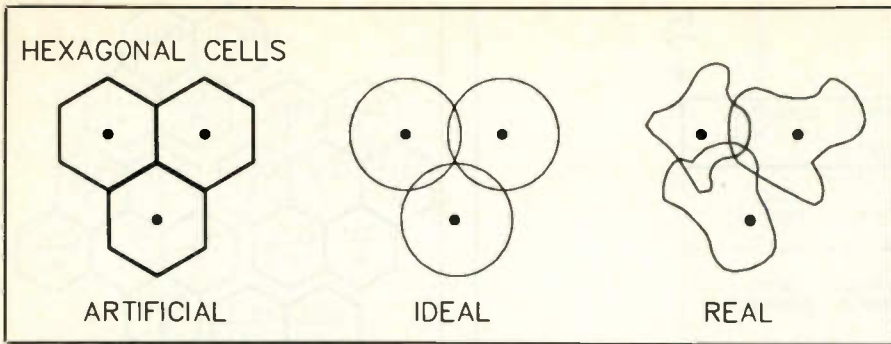

Figure 5. Real world cells.

The speech audio, along with the data and supervisory tones used for control, are all transmitted together using FM modulation of the RF carrier, though each component has its own particular modulation characteristic.

Speech is transmitted using the same narrow-band FM technique that was used in the IMTS system. The speech audio, however, is subjected to a companding process similar to that

used in television MTS stereo sound. The nominal frequency deviation that occurs when a caller is speaking is 8kHz. Maximum speech deviation is limited to 12kHz by the modulation limiter so that the signal will not spill onto an adjacent channel. Nevertheless, in order to reduce possible interference to a minimum, adjacent channels, for example 545 and 546, would not be used within the same cell.

The supervisory audio tone (SAT)

uses an FM deviation of only 2kHz, while the 10kHz signaling tone (ST) is transmitted using an 8kHz deviation. The digital data signal (wideband data, or WBD) is transmitted at a rate of 10 kilobits per second (KBS) using an 8kHz FM deviation.

The cellular control system

It could be reasonably argued that the cellular telephone system is actually more of a computer system than it is a telephone system. The mobile subscriber unit, the cell site, the MTSO and the land telephone system are all components of an interactive distributed-processing computer system whose purpose is to establish and supervise a communications path between two geographic points.

The MTSO

The mobile telephone switching office (MTSO), shown in block diagram form in Figure 8, is the hub of this control system. The MTSO exchanges

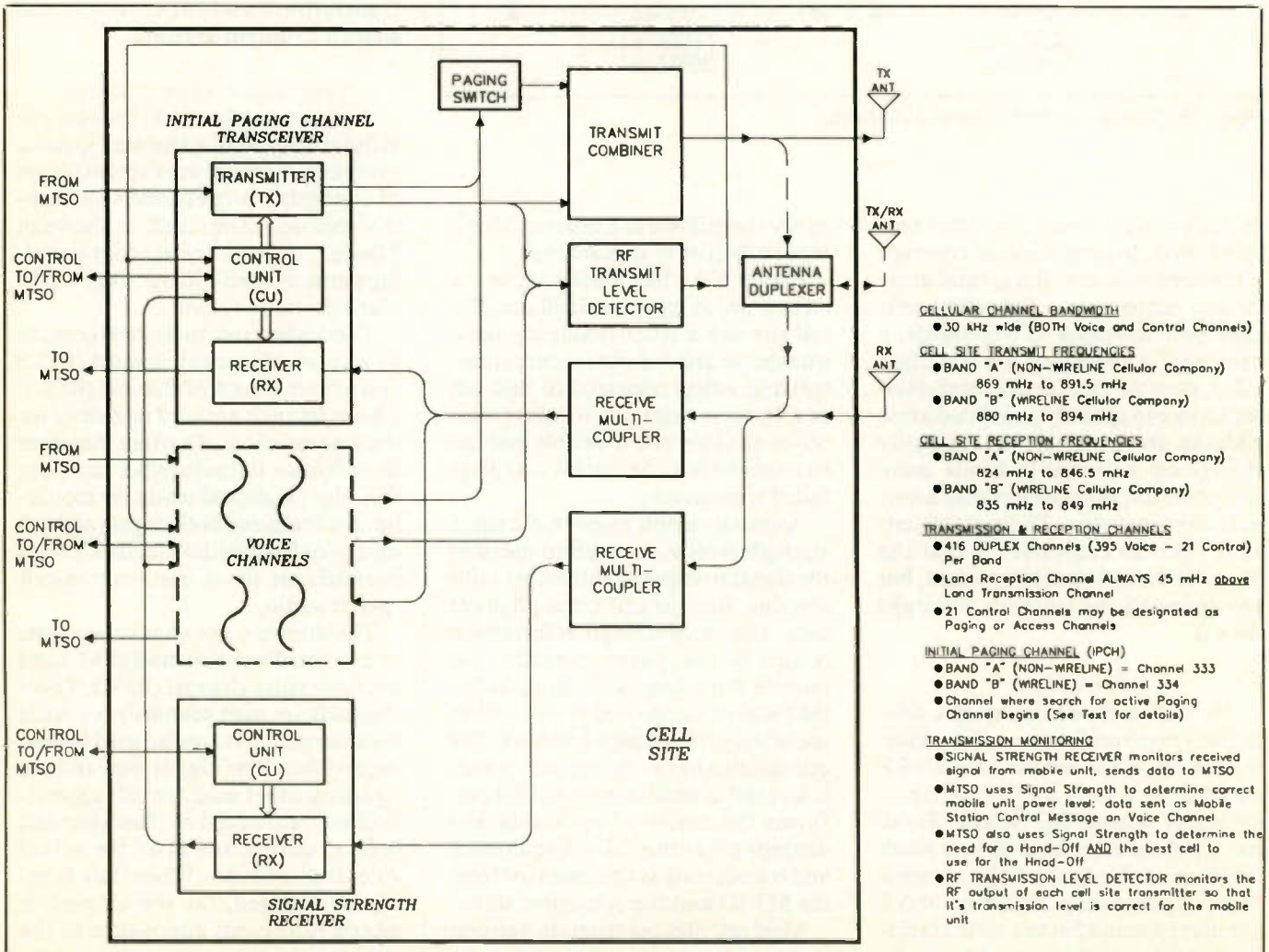

Figure 6. Cell site electronic systems block diagram.

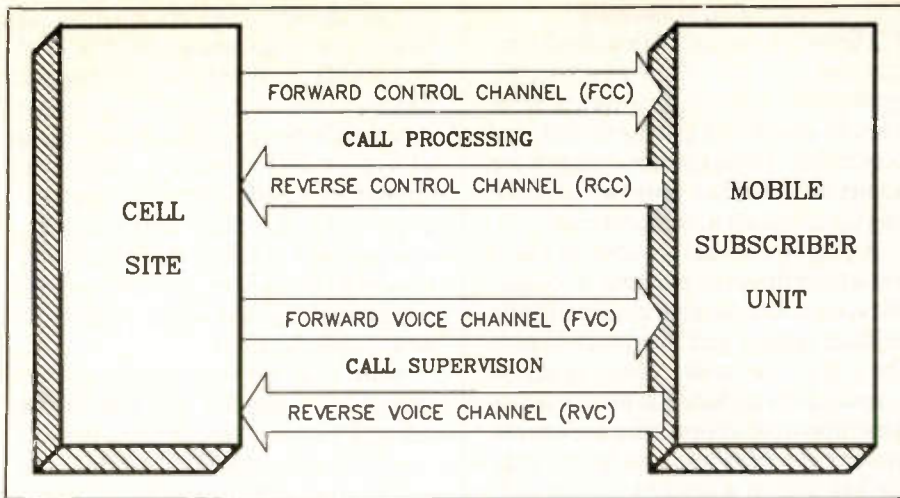

Figure 7. Land/mobile signal paths.

data with the land telephone company central office or end office for call processing, supervision and billing. Because the MTSO is the same type of stored-program controlled switch used in the land telephone system, in some large systems the MTSO is itself the end office, and exchanges data directly with the regional switching office. The MTSO also exchanges data with the various cell sites in the system, including data regarding the status of every channel, the status of all calls in progress and set-up data for new calls and for hand offs.

The MTSO also exchanges data through the cell sites to the subscriber units, performing the same call processing and supervision tasks that the land phone company end office performs for the land phone subscriber, plus the additional tasks of locating the mobile subscriber unit, informing the subscriber unit on system operation parameters and performing hand offs.

The volume of data transmission throughout the system required to maintain supervision and control (called system overhead) is tremen-

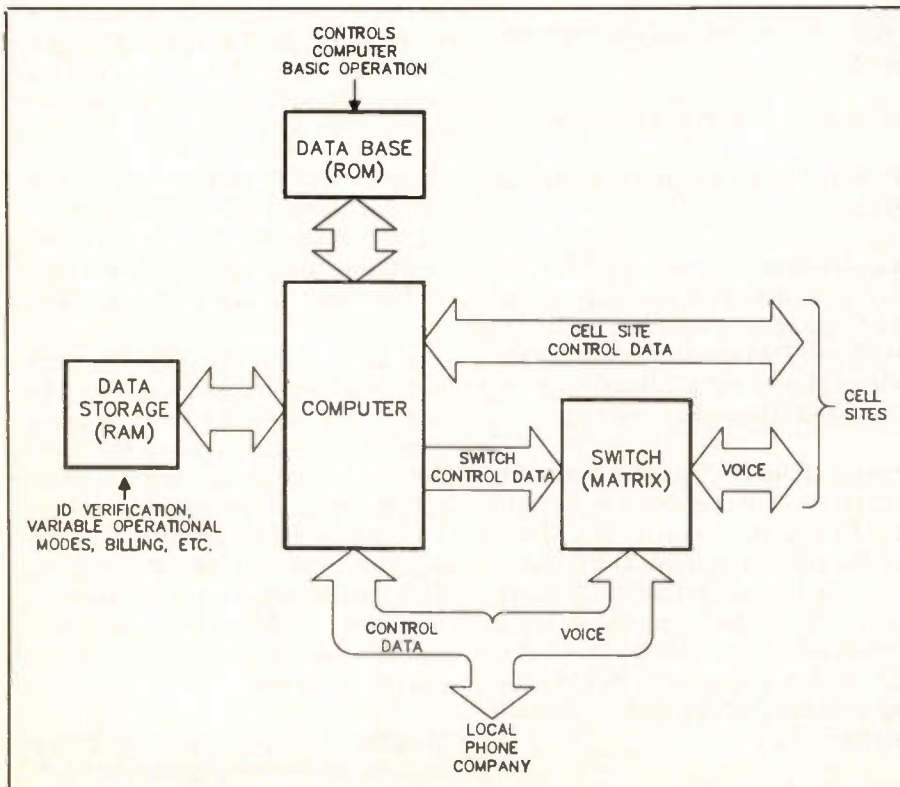

Figure 8. MTSO (mobile telephone switching office) basic block diagram.

BIG PROFITS IN VIDEO REPAIR!

**WORK FROM HOME-EARN \$85 HR!
-NO EXPERIENCE NECESSARY-**

Only requirement: That you possess average mechanical ability and a desire to learn

With the tens of millions of VCRs and Camcorders in use, there currently is a serious shortage of trained techs to perform cleaning and repair jobs on these popular devices... Learn how you can start your own **highly profitable, Home-Based** video servicing business... And since up to 95% of all VCR and Camcorder malfunctions are due to a simple **mechanical or electro-mechanical** failure, you need not spend months or even years of complicated study before starting **paid, professional service work!**

Train at Home in your Spare Time!

Let Viejo's Training Program show you how!
CALL TOLL-FREE: 1-800-537-0589
24 HRS-7 days a week or mail coupon today!

VIEJO PUBLICATIONS, INC.

4470-107 Sunset Blvd., Suite 600
Los Angeles, CA 90027-6304

Yes! Rush me your **FREE OPPORTUNITY KIT** today!
(Check appropriate box)

- VCR Repair
- Camcorder Repair
- Advanced VCR Repair
- Fax Machine Repair
- Complete Training in Electronics

Name _____

Address _____

City/State _____ Zip _____

Dept. UEST

Circle (18) on Reply Card

Parts Express

International Inc.

FREE CATALOG

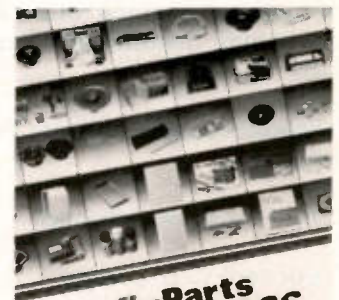

Parts Express
'90-'91 CATALOG

CALL TOLL FREE 1-800-338-0531

**CALL TOLL FREE
1-800-338-0531**

Free catalog is sent via bulk mail. For express delivery, please send \$2.50 to cover 1st class postage costs. Foreign customers send \$5.00 to cover postage.

340 East First St. Dayton, Ohio 45402

Circle (13) on Reply Card

dous. The transmission capacity necessary to handle this large volume of data is provided by high speed dedicated digital data links which connect the MTSO to the other fixed components of the system (the cell sites and the End Office). These fixed links use microwave radio, coaxial cable and fiberoptic transmission methods to provide the required capacity or throughput.

Remember, however, that there is one cellular system component that does not remain at a fixed point. That component is, of course, the subscriber unit, which is why a flexible RF link is used to connect it to the system. However, using this type of link complicates the transmission of data due to restrictions in bandwidth and transmission speed. The techniques used to overcome these handicaps are quite impressive.

The control channel

The cellular system's dedicated control channels, a total of 21 per band, provide the link for the transaction of system overhead business and call processing. These control channels are sometimes divided into two groups: paging channels and access channels.

A paging channel is a control channel whose directed purpose is to handle system transactions initiated by the cellular system and directed towards the subscriber unit. These types of transactions include the broadcast of general system information such as the system's identity and notifying a subscriber unit of a land to mobile call. Conversely, an access channel is a control channel that handles system transactions initiated by the subscriber unit that are directed toward the system.

A paging channel can be used as an

access channel, but because of the structure of the signaling format used in the AMPS cellular system, an access channel cannot be used as a paging channel. Because this particular piece of system architecture is subject to change with each system, for the purposes of this examination of the cellular system, unless there is a specific reason to do otherwise, both paging and access channels will be referred to as control channels.

Now that we have some understanding of the RF portion of the cellular system, in our next installment, the placement of an actual call will be diagrammed. We'll follow that call from the instant the customer presses the "ON" button on their mobile unit until the call is completed. It's a fascinating journey - don't miss it.

Glossary

Access channel: an access channel is a control channel that handles system transactions initiated by the subscriber unit that are directed toward the system.

AMPS: Advanced Mobile Phone System (Today's cellular telephone system).

Control channels: Channels that provide the link for the transaction of system overhead business and call processing. There are 21 of these channels per band. These control channels are sometimes divided into two groups: paging channels and access channels.

FCC: Federal Communications Commission.

FCC: forward control channel.

FVC: Forward voice channel

Forward channels: Cellular system channels used for communications from the land station to the mobile station.

Frequency reuse: This is the scheme in which the same frequency allocation is used for more than one transmitting station that are separated by a distance great enough that they do not interfere with each other.

Hand off: When a cellular telephone subscriber passes from one cell to another while conversing on the telephone, the cellular system must change the cell site through which the call is processed, preferably without the subscriber being aware that this change took place. This is called hand off.

IMTS: Improved mobile telephone system

MTS: Mobile telephone system

MTSO: Mobile telephone switching office

Non-wireline: The new term for service providers that had been called RCCs (radio common carriers) in the MTS and IMTS systems: the mobile phone carrier not affiliated with the local land telephone company.

Paging channel: A paging channel is a control channel whose purpose is to handle system transactions initiated by the cellular system and directed towards the subscriber unit. These types of transactions include the broadcast of general system information such as the system's identity and notifying a subscriber unit of a land to mobile call.

RCC: Radio common carrier

RCC: Reverse control channel

Reverse Channels: Channels used for communications from the mobile station to the land station

Seven-cell repeat pattern: In a seven-cell repeat pattern, the total number of RF channels available (416 for each carrier) is divided into 7 sets, each set having 59 channels. Each cell uses one set of channels. The cell clusters are repeated throughout the system, which allows the channels allocated to each cell to be reused.

Signal-strength receiver: A special tunable receiver used to measure the signal strength of subscriber units arriving into the cell from adjacent cells to determine the hand off procedure.

Trunking: In a trunked system, each mobile subscriber unit is designed to operate on every channel, and every channel is shared among the total number of subscribers on the system. If Channel 1 is busy and Channel 2 is vacant, the next subscriber to demand service would use Channel 2. If both Channels one and 2 are in use, the next subscriber would use Channel 3, and so forth, until all channels in the system are in use.

Wireline carrier: The carrier affiliated with the land telephone company that services the cellular service area.

1-2-3 Beyond the Basics, By Richard Cranford; Macmillan Book Publishing; 533 pages, \$24.95.

The guide helps users quickly add versatile, proven design principles to 1-2-3 worksheets. 1-2-3 Beyond the Basics, is written for intermediate to advanced level users, and provides expert tips and strategies to achieve 1-2-3 power.

Step-by-step instructions teach users how to get the most out of macros and when and where to implement them. Users learn how to maneuver cell contents and speed up recalculation, range, and worksheet operations. In clear, concise terms, the book presents shortcuts that make using 1-2-3 simple. In addition, specially designed icons inside the book alert readers to important cautions, notes, and tips.

Other benefits from the reading include helping in users design worksheets to protect valuable data, copy and move cells effectively, navigate large worksheets with customized

menus, and print presentation quality worksheets and graphs.

Macmillan Computer Publishing, 11711 N. College Ave Suite 140, Carmel IN 46032.

1-2-3 Personal Money Manager, By Carl M. Heintz; Macmillan Book Publishing; 422 pages; \$29.95.

Written for users of all experience levels, 1-2-3 Personal Money Manager helps them capture the personal finance power of Lotus 1-2-3. This book/disk set includes over 30 power-packed spreadsheet templates that automate 1-2-3 operations.

Que's CPA expert combines more than 20 years experience with practical 1-2-3 tips that help users streamline and track personal finances. Beyond exploring different methods of financial management, users can learn how to adapt the latest tax laws to their advantage, and how to deal with, analyze, and fix financial problems that interrupt business success.

1-2-3 Personal Money Manager teaches users about net worth analy-

sis, budgeting and cash flow analysis, home ownership planning, credit and debt management, college planning, estate planning, and retirement planning.

Macmillan Computer Publishing, 11711 N. College Ave Suite 140, Carmel IN 46032.

The Illustrated Price Guide to Vintage Televisions and Deco Radios, By Harry Poster; 80 pages, 140 photos, \$15.95.

This price guide is an 80 page book with over 900 models and variations detailed and priced. In the radio section there are over 350 different models and variations of Catalin, mirror and novelty radios listed, and 66 photos of radios to refer to. The section of FADA, for example, contains 68 detailed price listings, with 7 different models photographed. Vintage TV's are covered: over 530 models priced with 78 illustrations.

Harry Poster, P.O. Box 1883PG, So. Hackensack, NJ 07606.

Improve Your Form.

3-Part

A continuous feed form used for customer c.o.d. service or parts/accessory sales receipts

(N3CN). Not for warranty billing. Computer generated software to be available soon.

5-Part

Available in snapout (N5SN) or continuous feed (N5CN). Matching fields with N3SN.

except for customer estimate and receipts. For warranty billing.

7-Part

A universal snapout form (N7SN) designed for both customer service c.o.d. and manufacturer warranty billing.

Complies fully with the requirements of state and local ordinances, including California.

Discounts

Carbonless NESDA Forms are available to NESDA members at additional savings. For pricing information and samples, or information regarding other NESDA membership benefits, write to NESDA, 2708 W. Berry St., Ft. Worth, TX 76109; or call (817) 921-9061.

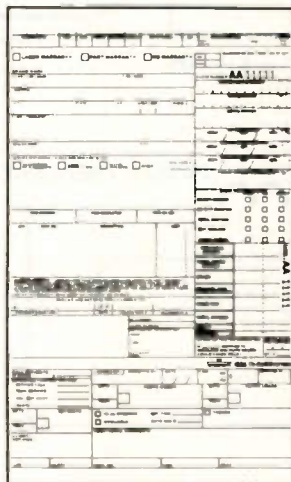

The NESDA Form

NESDA, 2708 W. Berry St.
Fort Worth TX 76109
Phone: (817) 921-9061

Our vises are turning heads.

Up, down, left, right. No matter what angle you need your work held at, PanaVise will get you there. Just one turn of the knob locks our fully rotating head in virtually any position.

Need to hold something larger? No need to buy another vise. Just pop in a PanaVise interchangeable head and you're ready to go — in seconds!



1485 SOUTHERN WAY / SPARKS, NV 89431 / 702-353-2900



Circle (12) on Reply Card

Filtering theory

By Dale C. Shackelford

Filtering circuits are generally incorporated into the design of an electronic circuit when a frequency, or a band of frequencies may interfere with the desired operation of a particular device.

Once identified, any existing or potential interference may be virtually eliminated from the protected circuitry or device through the proper design and use of filters. In some cases, filtering that was designed into a particular device by the design engineers is not adequate in terms of the amount of filtering needed, or the frequencies which are actually reduced or eliminated.

In these instances, it becomes the duty of the service technician to provide the customer with relatively interference-free operation of their device when requested to do so. In order to provide such service, the technician must have a working knowledge of filtering theory and applications.

One device that is commonly affected by unwanted frequencies is the radio controlled electric garage door opener. Automobile ignition systems, CB, police radio and cellular telephone transmissions frequently cause garage doors to open because of the radio frequency interference that they may generate. These unintentional openings and closings can easily result in personal injury or property damage, or even theft of belongings in the open garage.

In an effort to meet customer requests for fewer accidental garage door activations, many service technicians have designed extremely narrow band-pass filtering circuits which are then either cascaded with the existing

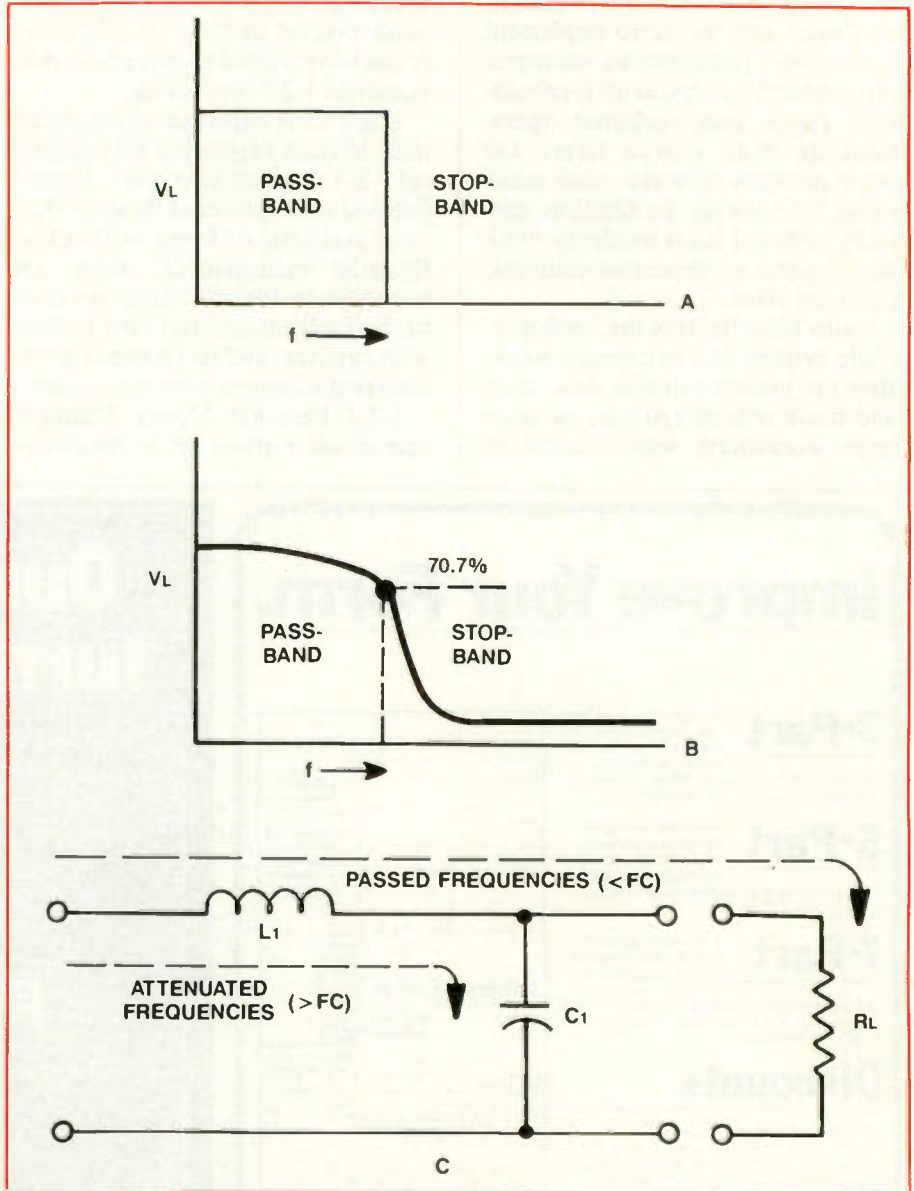

Figure 1

circuitry of the transmitting and receiving devices, or used to replace existing circuits.

Because many filtering circuits in consumer electronics products are not

adequately designed, it is not unusual to achieve remarkable results by simply changing the value of existing filtering circuit components to obtain a narrower pass band, thereby making the

Shackelford is an independent electronics servicing technician.

device less sensitive to radio frequency interference.

By determining the actual frequency that is needed to activate the radio controlled unit, narrow-width band-pass filters may be incorporated into the receiver. Additionally, an identical filter may be incorporated into the transmitter to reduce any stray frequency transmissions which may adversely effect other nearby devices such as a neighbor's garage door.

Even though the design and installation of additional filters into radio controlled garage door openers may not be considered a priority job by most technicians, such service goes a long way in customer relations which could help business in the future.

There is a wide variety of filters used in electronic circuits that may be classified according to function, circuitry or both. Each type of filter or filtering circuit exhibits certain characteristics which may exclude it from use in some circuits, while making it desirable in others.

The common transformer for example, exhibits characteristics that place it into the category of "filter", regardless of its coefficient (k) or turns ratio because the direct current passing through the primary causes no magnetic flux variations that are evident on the secondary.

Because the transformer does allow certain frequencies to pass from the primary to the secondary (ac) while blocking others (dc), the transformer exhibits all of the characteristics of a filter, as do individual capacitors, even though the differences in operating characteristics between the transformer and capacitors are obvious.

Typical passive filtering systems that employ amplifying circuitry, heterodyne down-conversion loops, AGC (automatic gain control) and other such devices may be placed into a special category known collectively as *active filters*, while their passive components (inductors and capacitors) may fall into other categories, depending upon their configuration within the active circuits.

As the name implies, low-pass filters allow frequencies below a specified frequency to pass through the filter (circuit), while frequencies above this value (cut-off or critical frequency) are shunted to various feedback circuits or otherwise prohibited from

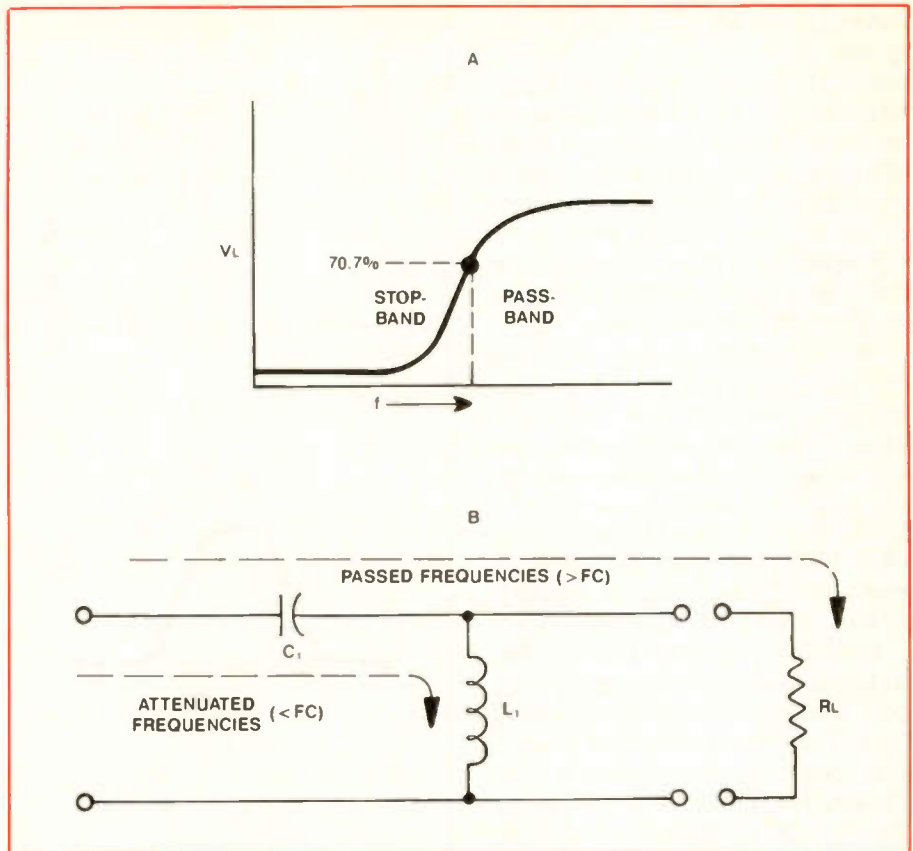

Figure 2

passing through the circuit where they could adversely affect the protected circuitry.

Because filters have varying degrees of success at reducing or preventing unwanted frequencies from passing (theoretically, no filter can be 100% effective) the degree of the ability of the filter to provide protection from the unwanted frequencies is known as *attenuation*, and is measured in decibels (dB).

Low-pass filters

Figure 1A illustrates the ideal low-pass filter. As the frequency (f) rises, the signal meets no resistance. Once the frequency of the signal reaches the cut-off frequency (f_c), the signal is cut off abruptly, and all frequencies above f_c are eliminated while the voltage to the load (V_L) remains steady.

Figure 1B is a more practical representation of the effects of a low-pass filter on a signal that is increasing in frequency. Notice that the actual pass-band, the range of frequencies that are allowed to pass through the filter with

minimal resistance, is wider than that shown in the ideal representation in Figure 1A because of the gradual attenuation of frequencies above f_c .

Because of this common characteristic of filtering devices and circuits, the actual cut-off frequency (or working frequency) has been chosen to be the point where the signal has been attenuated to -3dB, or 70.7% of the peak signal strength. Thus, a filter designed to pass frequencies below 5 MHz would have a working frequency of 3.535 MHz ($5,000,000 \times 0.707$). This working frequency must be considered in all types of filtering circuits and their construction.

At the 70.7% (-3 dB) response point, the net reactance (which may be either capacitive or inductive, depending upon circuit configuration) is equal to the circuit resistance. As further study would reveal, the power at the -3dB response point is only 0.5 (50%) of the peak, or input, power level. For this reason, the -3dB (70.7%) response level is commonly known as a *half power point*.

In Figure 1C, a typical L-type filter is diagrammed which would have a response curve similar to that shown in Figure 1B. In this instance, the inductive reactance (X_L) is small, and exhibits characteristics similar to those of a device approaching a short-circuit condition. Conversely, the capacitive reactance (X_C) is high, exhibiting near open circuit characteristics, as the inductance and capacitive reactance are inversely proportional.

As frequencies attempt to rise above f_c , X_L is small, and exhibits characteristics similar to those of a device approaching a short-circuit condition. Conversely, the capacitive reactance (X_C) becomes smaller, providing a low resistance bypass around the load (R_L). Thus, the higher the frequency rises above f_c , the greater the attenuation qualities of the filtering circuit.

Other low-pass filter circuit configurations, such as the T-type (or "tee-pad") and the pi type (pronounced "pie"), so named because of its schematic resemblance to the Greek letter Pi are very similar in operation and theory to the L-type (so named for its inverted "L" shaped design) filtering circuits discussed.

Theoretically, there is no limit to the number of individual inductors and/or capacitors that may be used in the construction of a single filtering circuit. Traditionally, T and pi-type filters use more inductors and capacitors than do L-type filters.

Many low-cost filtering circuits may substitute resistors for inductors in an attempt to reduce the cost of the filter. Although the resistor will provide some opposition to the signal being filtered, it does not provide increasing attenuation with the increasing (or decreasing) frequency, and may result in unacceptable power losses within the filtering circuit.

High-pass filters

As with their low-pass counterparts, high-pass filters rely upon the characteristics of equal but opposite reactance between capacitors and inductors within a circuit.

High-pass filters are designed to allow frequencies above f_c to pass with minimal resistance, while attenuating frequencies below f_c (Figure 2A).

Figure 2B depicts a typical L-type high-pass filter. In this configuration, frequencies below f_c will encounter a

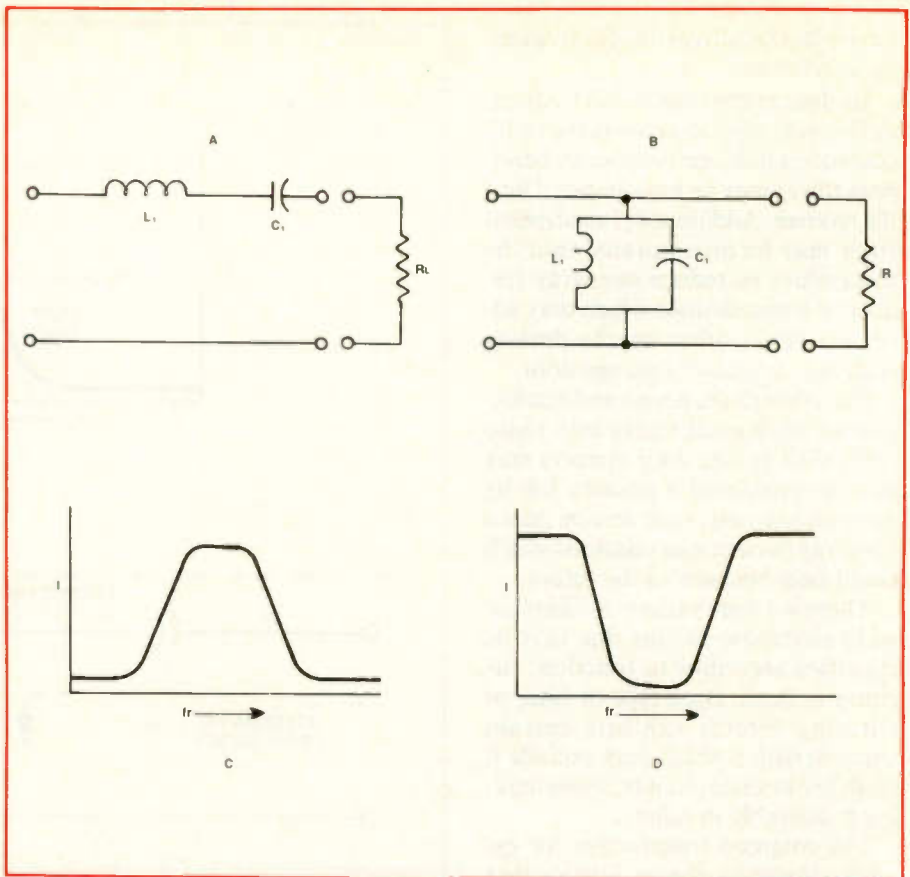

Figure 3

near open circuit condition (C) due to the large X_C , while L will provide minimal resistance to the stop-band (below f_c) signals due to the low X_L , in effect, creating a bypass path for signals below f_c around the load (R_L).

By comparing the high-pass and low-pass filter schematics, it can be determined that the only difference between the two representations is the relative positioning of L_1 and C_1 .

As with low-pass circuits, high-pass filters should have little or no effect upon the pass-band signals, and may be designed as T and pi-type configurations which will generally provide higher quality filtering because of additional inductors and/or capacitors.

Resonant filters; band-pass and elimination

The combination of low-pass and high-pass filtering circuits can be used to pass or eliminate extremely narrow frequency bands, though the cost of this practice may be restrictive and space limitations may not make the

use of separate circuits feasible. Because of this, other filtering circuits have been developed to meet the need of narrow band-pass/band elimination within a compact space, using few components.

Series and parallel resonant circuits may be used as effective band-pass or band-elimination filters, depending upon their connections. In Figure 3A, a series-resonant circuit is used as a band-pass filter, while Figure 3B depicts a parallel resonant circuit acting in the same capacity.

In Figure 3A, the resonant circuit is in series with the load, R_L . As load current increases (Figure 3C) and circuit resonance is approached, frequencies will begin to be passed. As the load current exceeds the resonant frequency (f_r) of the filtering circuit, frequencies are once again attenuated. Because the resonant frequency of a circuit, as well as inductive and capacitive reactances are easily determined by simple mathematical formulas, very narrow bandwidths may be at-

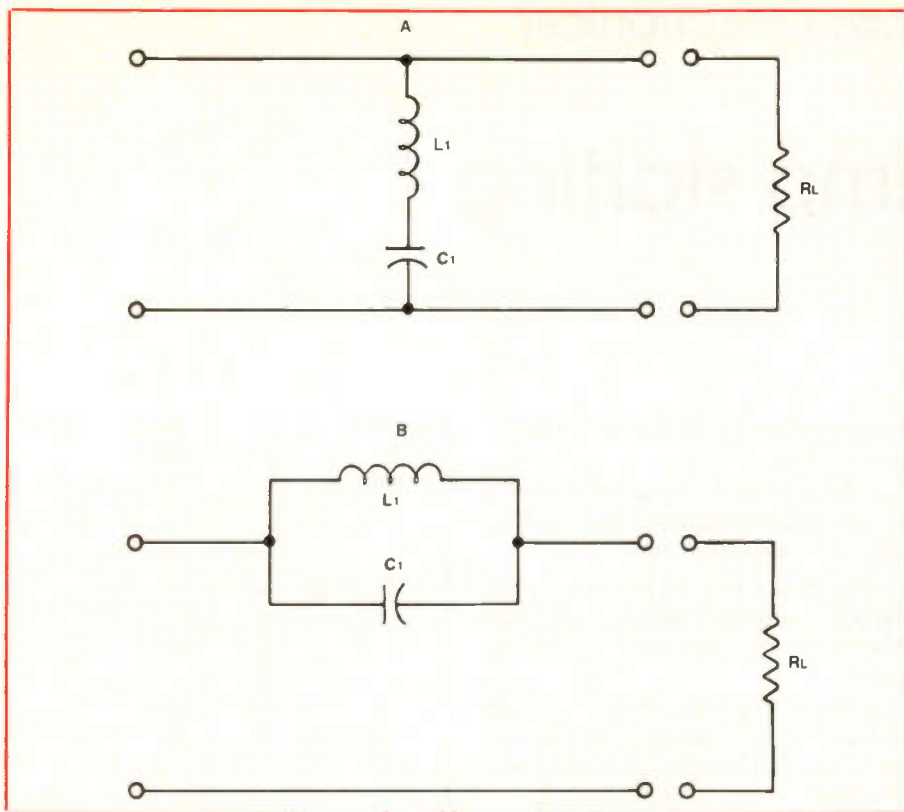

Figure 4

tained when half-power points are calculated correctly.

In Figure 3B, a parallel-resonant circuit is placed across the load, R_L . As f_r is approached, the impedance (Z) of the filter increases, resulting in decreased current flow within the tank circuit. Because current is impeded within the filter, the flow is diverted through R_L , in effect, passing these frequencies (Figure 3D).

In many instances, the number of frequencies that must be passed through a filtering circuit far outnumber those that must be eliminated or attenuated. Fortunately, the very same series-resonant and parallel-resonant circuits, with different configurations, may be used for band/frequency elimination.

Figure 4A details a series-resonant filter which is connected in a manner as to allow it to act as a band-elimination filter. The current flow through the LC circuit increases as resonance is approached, which means that any current in parallel with the LC circuit branch (in this case, R_L) will decrease as resonance is approached. As f_r is attained, load current is at a minimum, effectively being bypassed by the tar-

get frequencies as they are shunted through the filter.

Figure 4B shows the configuration of a parallel-resonant band-elimination circuit. As the f_r of the tank circuit is approached, its Z increases, reducing the current across R_L which results in the virtual elimination of the target frequency or band. Because the high- Z circuit (filter at resonance) is in parallel with the load, the current "sees" an impeded path, and is shunted to a path of less resistance.

As with low-pass and high-pass filters, both series and resonant frequency filtering circuits may be designed in L, T and pi-type configurations, and like all filters, may be cascaded to meet specific filtration needs.

Whether filtering circuits are designed to reduce the number of unintentional garage door activations, or to guarantee the optimum performance of a multimillion dollar communications satellite, proper designs and applications are of paramount importance. Understanding the basic concepts and theories of filtering is the first step to proper design, maintenance and installation of filters that meet the specific needs of the customer. ■

SAVE TIME

For fast, accurate service, please remove the peel off label used to address your magazine, and attach it to the Reader Service Card, the Address Change Card or to any correspondence you send us regarding your subscription.

A letter on jump starting

By Sam Wilson

Recently I received a very professional and informative letter from Mr. Leon Dorothy of Creston, Iowa. I wish I had space to print all of his letter. It is a complete course in jump starting a car.

Before I discuss his letter, let me repeat the bonus question from *Test Your Electronics Knowledge* that appeared in the August '91 issue of *ES&T*. This bonus question and answer is the subject of Mr. Dorothy's letter.

BONUS QUESTION

According to the experts, if you are going to jump start your new V8 Hypolux four-door sedan,

- A. connect the positive jumper cable first, then the negative jumper cable.
- B. connect the negative jumper cable first, then the positive jumper cable.
- C. you must connect both jumper cables at the same time.
- D. it doesn't matter which jumper cable you connect first.

Here is the answer given on page 73 of that issue - The experts claim that there is less chance of a spark using the procedure in choice A. There is an old proverb that says "whenever you have a choice between two things, take a third choice." In other words, don't jump start your new car!

Now I will quote excerpts from Mr. Dorothy's letter.

Your answer said that the experts claim there is less chance of a spark when the negative cable is connected last."

Sam says I think this is where Mr. Dorothy is finding fault. If I understand his letter correctly, I should have said that there is less chance of a

dangerous spark. If that is the message, I agree.

"The reason the negative connection should be made last is because the car has a negative ground."

Sam Says - I'm not sure about the Hypolux having a negative ground. Most cars do. Anyway, so far, so good.

The last connection should be made at least 12 inches away from the battery. That is a key part of a safe jump start.

Sam Says - This is very good advice! Mr. Dorothy is concerned about dangerous hydrogen fumes from the battery.

He goes on to say it is easy to find a place away from the battery to connect the negative lead. Examples are the engine block or, a bracket on the engine.

Here is the place where our difference in opinion occurs. Connection to the engine block can be hazardous to the car and the person making the connection. I understand what he is saying: Get the connection away from the battery because there can be dangerous hydrogen fumes. However, there can be dangerous gasoline fumes and puddles on the engine block too.

In my opinion you should be aware of the problem with fumes and try to get the negative connection away from the battery and engine block!

Mr. Dorothy goes on to say there is nothing to worry about if you do the jump start correctly. Then he gives some very good instructions for doing it right. If you didn't get those instructions with your Hypolux sedan, send me a stamped, self-addressed envelope and I'll forward a copy of Mr. Dorothy's letter.

He finishes with a very interesting comment. He says that jump starting your new Hypolux can be cheaper than having it towed.

I want to repeat that the reason to

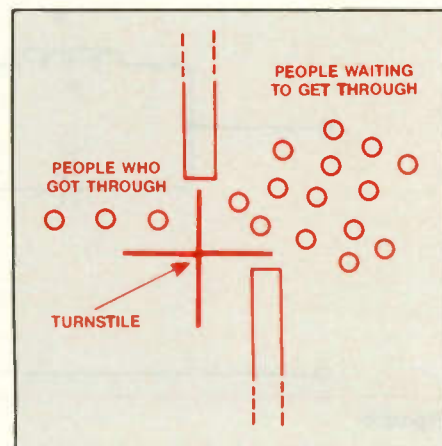

Figure 1

jump start a car this way is that there may be less chance of a dangerous spark if you find a place away from both the engine and battery. The intensity of the spark and its duration is dependent upon a number of factors. One important consideration is the fact that the spark current will be rapidly dispersed throughout the frame when you connect the negative cable to the frame last.

Many thanks to Mr. Dorothy and for his comments and very good advice.

Congratulations to Tesa in St. Louis

Congratulations to TESA News for their 40th birthday. There are not many newsletters that can claim 40

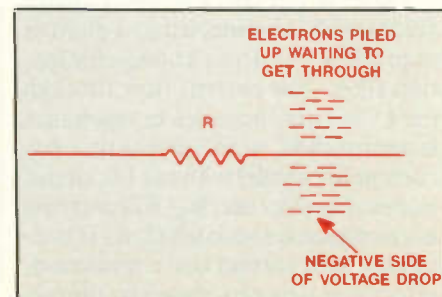

Figure 2

Wilson is the electronics theory consultant for *ES&T*.

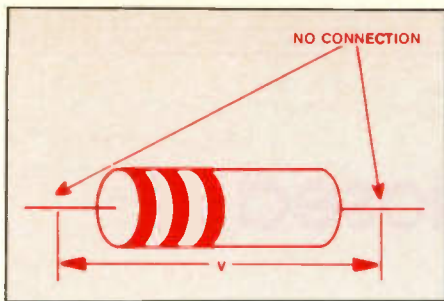

Figure 3

years of continuous service. This newsletter originated in St. Louis and has had only three editors in the last 40 years of service. They were: Vince Lutz, Morton Singer, and, the present editor - Otto Horak.

We are looking forward to the next 40 years! Keep up the good work TESA.

Fine-tuning resistor theory

Over the past year I have presented material on current and voltage without resorting to models. As I have often pointed out, the models are O.K. to get students started in electronics. However, as you get into the subject deeper you need to revise the models for a better understanding of component and circuit behavior.

When I first learned about resistors in simple circuits I was given the turnstile model. It is illustrated in Figure 1. You imagine electrons passing through a resistor to be like a crowd of people passing through a turnstile.

Just as the people crowd together at the entrance side of the turnstile, electrons are visualized as crowding together awaiting their chance to get through the resistor. Since electrons are negative, the fact that there are more electrons at the negative side means that the voltage there is negative with respect to the voltage at the other side of the resistor. This is shown in Figure 2.

That model held together until I got to the place where I wanted to know about such things as intrinsic current and noise generated by resistors. I was

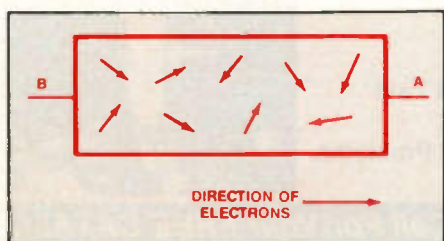

Figure 4

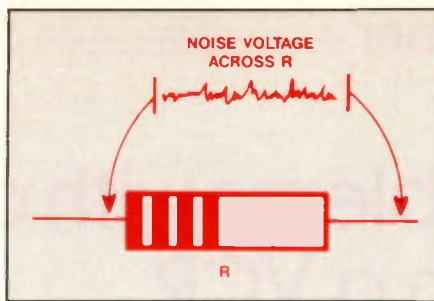

Figure 5

not reluctant to give up the model, but, when I started to delve into the more-accurate details it was like walking into a brick wall.

Terms that were new to me at the time - such as Brownian motion, resistance temperature and intrinsic current - made me wonder if I really wanted to leave my comfort zone. I muddled through and I think it was worth the effort.

Consider, first, a resistor sitting on a workbench. It is not connected to anything. See Figure 3. At room temperature there is a voltage across that resistor! In fact, at any temperature above absolute zero (about -273F) there is always a voltage across a resistor that is not connected to anything. (Well, there goes the turnstile model!)

If you were able to look inside a resistor with a special device that allows you to see atoms and molecules you would see that every atom and molecule is always in motion. One way to think of that is to say they all have thermal energy. (Don't ask where that energy comes from. It isn't part of this particular subject.)

Since the atoms and molecules have a built-in energy, it follows that the parts making up the atoms and molecules also have a built-in energy. Electrons, for example, have that thermal energy. They also have energy due to their continual motion around the nucleus. Occasionally an electron will attain enough energy to break away from its nucleus. That leaves the atom or molecule with a positive charge because it is short one electron.

The electron that breaks free will move a short distance in the resistor until it is captured by another atom or molecule that has lost an electron. At any instant of time there are millions of electrons moving about in the resistor at the same time. This idea is illustrated in Figure 4. Note that their direction of motion, which is illustrated by arrows, is random. They are

moving in all different directions.

If you were able to count fast enough you would notice something that is very important. At any instant of time there are more electrons moving toward lead A than toward lead B. At the next instant there will be a different number moving toward lead A; or, there may be more moving toward lead B than toward lead A.

When there are more electrons moving toward lead A, that terminal is more negative than lead B. Like wise, lead B is more negative than lead A when there are more electrons moving in that direction. The negative voltage occurs because of the accumulation of electrons going in that direction.

The instantaneous variations of voltages create a thermal noise as shown in Figure 5. The voltage value is very low and the frequency is very high.

This noise voltage is greatly amplified when resistors are connected at the input terminal of an amplifier. For example, connecting a resistor across the antenna terminal of an amplifier introduces noise into the system. Since antennas have resistance, the act of connecting an antenna to a receiver introduces noise into that receiver. ■

KIT SPECIAL

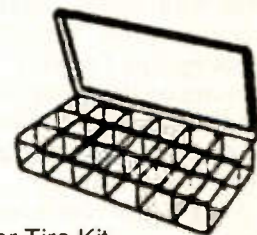

VCR Idler Tire Kit
75 pcs assorted
save 32% KT-400S \$29

VCR Lamp & Sensing Kit
67 pcs assorted
save 20% KT-460S \$89

GMA & GMA Pigtail Fuse Kit
140 pcs assorted
save 31% KT-470S \$19

50V Radial Lead Capacitor Kit
110 pcs assorted
save 42% KT-480S \$39

160V & 250V Radial Lead Capacitor Kit
116 pcs assorted
save 40% KT-485S \$49

ELECTRONIC PARTS SUPPLY
4071 EMERY ST
EMERYVILLE, CA 94608
TOLL FREE 1-800-227-0104
FOR INFO. 415-420-1040
CALL FOR FREE CATALOG

Circle (5) on Reply Card

Solving problems with closed captions on a VCR

By the ES&T staff

The issue of closed captioning on TV broadcasts and on video tapes is becoming more widely discussed. One reason is that soon closed captioning circuitry will soon be part of the circuitry of many TV sets sold in the United States.

Another reason for the increasing interest in closed captioning is that educators have recognized that closed captioning is a good way to enhance the learning of language skills by people who are learning English as a second language, and by children who spend a great deal of time watching TV and video movies.

The likelihood of a consumer servicing technician encountering problems with closed captioning is increasing. Here are some troubleshooting tips for when there are no captions on the picture when the tape is believed to be captioned, and the viewing system has the proper closed captioning circuitry.

These tips are intended to assist the

Problem: No captions on TV screen

Possible Causes

- Faulty hook-up
- Video company distributed uncaptioned tapes, even though box was marked as containing a captioned tape
- With older VCRs, PCM switch is off
- With a limited number of TeleCaption II decoders, there is an inability to decode captions on tapes encoded with Macrovision, an anti-piracy process

Solutions

- Make sure equipment is connected in the following order: cable/antenna to VCR to decoder to TV
- Alert store owner to problem. Contact Consumer Marketing at NCI, 703-998-2449, stating tape name distributing company and bar code number on cassette. NCI will investigate
- Turn on PCM switch on rear of VCR
- Contact NCI's Consumer Marketing Dept. to have the TeleCaption II decoder fixed

Looking For A Faster, Easier Way To Repair VCR's?

TENTEL Offers 4 Powerful, UNIVERSAL Tools Which Will...

- **CUT YOUR REPAIR TIME!**
 - Tentel Gauges Quickly & Easily Diagnose Mechanical Problems In VCR's
 - **ELIMINATE GUESSWORK!**
 - Tentel Gauges Are A Proven Method For Accurate Measurements To Help Restore VCR's To Factory Specifications
 - **FIND PROBLEMS BEFORE THEY HAPPEN!**
 - Often There Are Marginal Problems Accompanying Major Breakdowns, Tentel Gauges Help You Find Those Problems!
 - **STAND OUT FROM YOUR COMPETITION!**
 - Tentel Gauges Allow You To Find Problems Other Shops Can't Find
- Give Customers A Reason To Choose Your Service Center**

If You're a Whiz At Electronics, We'll Make You A Whiz With Mechanical Problems. Call Now TOLL-FREE To Find Out More About These Powerful Tools



TENTEL® Corp.

4475 Golden Foothill Parkway
El Dorado Hills, CA 95630

Call For Your FREE CATALOG
(800) 538-6894 / (916) 939-4005

Circle (17) on Reply Card

Problem: Captions are garbled

Possible Causes

Solutions

- | | |
|-------------------------------------------------------------|----------------------------------------------------|
| - VCR tracking control is off-center | - Adjust tracking or fine-tuning controls |
| - Tape has not been rewound correctly | - Put tape on fast forward, then rewind tape |
| - Poor quality consumer tape stock | - Use a better quality recording tape |
| - VCR heads are dirty | - Clean heads |
| - "Peaking" control, on bottom of most VCRs, is misadjusted | - Set, with screwdriver to slightly above midpoint |

service technician who may be called upon to correct the situation when a TeleCaption decoder is not receiving captions on a rented or purchased home video movie. Most of the time, problems arising with decoders and VCRs can be solved in a matter of minutes. If, after following the troubleshooting steps described in this article, you will have captioning problems you can contact Consumer Marketing, National Captioning Institute at 703-998-2400.

Remember, TeleCaption decoders are designed to work with VCRs that are working properly. A good tape with closed captions played on a good machine will always produce good captions. The store owner should be willing to help out, even if a tape has a problem with the captions. Ask the store owner to notify the distributor of any problems with captioned tapes. Suggest that the store owner purchase a decoder so that captions can be checked in the store. ■

ISCET
VCR
Cross Reference
VCR Model Number Cross Reference
and VCR Parts Cross Reference

UPDATED - Feb. 1990. 272-page reference guide. \$35 plus \$3 shipping.

DISC - IBM-compatible disc with expandable data base. \$99 plus \$1 shipping.

COMBO OFFER: Book and disc for only \$125 plus \$3 shipping.

MORE INFO? Contact ISCET,
2708 West Berry St.
Fort Worth TX 76109
(817) 921-9101

Allow 4-6 weeks delivery when using personal checks or VISA and MasterCard. Money orders and cashiers checks processed immediately.

Amount _____ VISA MasterCard

Card No. _____ Exp. _____

Name _____

Business _____

Address _____

City _____ State _____ Zip _____

Phone _____ Member ISCET, NESOA

Texas residents multiply dollar value x 7 1/2% for taxes.
Foreign shipments please add international postage.
Send to: ISCET, 2708 W. Berry St., Ft. Worth TX 76109

The Industry's Most Complete Line of Flyback Transformers.

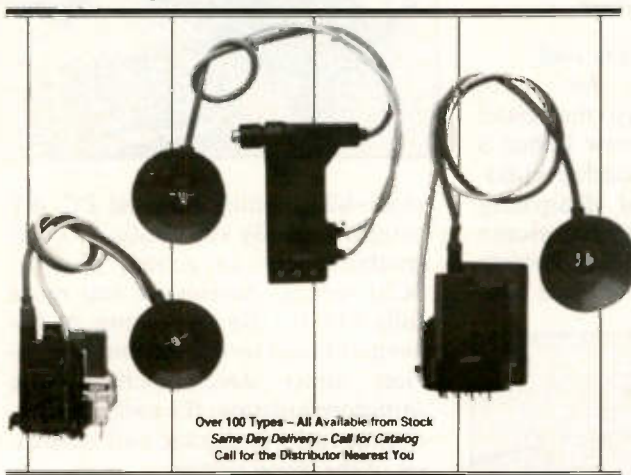

Over 100 Types - All Available from Stock
Same Day Delivery - Call for Catalog
Call for the Distributor Nearest You

EVG A DIVISION OF
russell industries, inc.

Suppliers of High Quality Electronic Components for Over 30 Years

3000 LAWSON BLVD. • OCEANSIDE, NEW YORK 11572 • 516-536-5000 • 800-645-2202 • FAX 516-764-5747

Circle (15) on Reply Card



91260

Vaco solderless terminals...easy to use...exact connections

Insulated • Non-insulated • Single and double grip • Hi-temp

VACO terminals meet government and industry specs for all terminal requirements. Five series, 8 types, all sizes for every need. See your VACO distributor.

KLEIN



The choice of professionals... since 1857

7200 McCormick Blvd.
P.O. Box 599033
Chicago, IL 60659-9033

Circle (9) on Reply Card

Microwave oven analyzer

EDS, Inc. has developed the Micro-analyzer model 76. The device will test in circuit, using high voltage signals, components in microwave ovens such as high-voltage diodes and capacitors, magnetrons, and power transformers, as well as triacs. The unit also includes

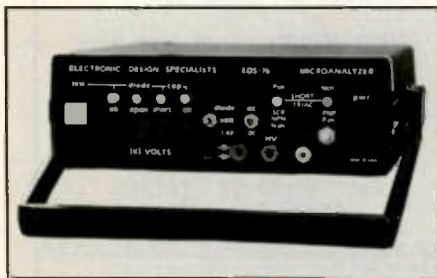

a 3 1/2 digit voltmeter that measures up to 5KV as or dc in two ranges. All special test leads are included. It includes a three year limited warranty, along with a 60 day satisfaction guarantee or full refund trial period. The unit is also available in kit form, but without the trial period.

Circle (24) on Reply Card

Attache case oscilloscope

Leader Instruments announces a new 100MHz ultra-compact portable oscilloscope, the Model 326. It offers advanced oscilloscope features and is ideal for use by field service engineers and technicians. At just 3 1/4" high x 9 1/2" wide x 13 1/4" deep, and weighing only 9lbs., it fits easily into an attache case. A two-channel dual time base scope, the unit has a 3 1/2" 12kV



PDA CRT with an illuminated graticule. Alternate sweep with calibrated delayed time base permits simultaneous display of the observed waveforms and the time-expanded sections.

Two asynchronous signals are displayed at the same time because of an alternate triggering mode and complete triggering facilities engineered into all Leader oscilloscopes.

Circle (25) on Reply Card

Audio test and service system

Neutrik's A1 Audio test and services system contains a sweepable generator, analyzer, and oscilloscope. It measures level, wow and flutter, noise, crosstalk, frequency and THD + N. A large backlit LCD shows single measurements numerically or



as sweeps in graphical form. Hard copies of screens are available when connected to most standard dot matrix printers. This instrument is auto-ranging, tuning, nulling, scaling, calibrating and replaces up to eight conventional instruments, according to the manufacturer.

Circle (26) on Reply Card

Hot air repair/rework tool

Brian R. White Co. Inc. introduces the latest addition to the Leister hot-air tool line. The new Labor S model ESD features a nozzle grounding system capable of dissipating static electricity through a common workstation ground. The system equalizes the electrical surface con-

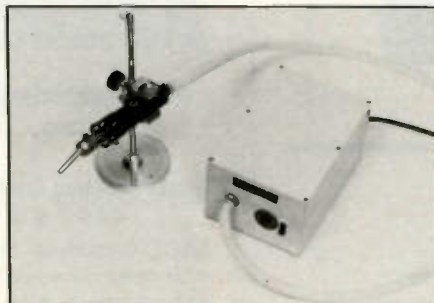

ductivity of the nozzle and air-hose by incorporating a low ohm conductor between two surfaces. The air-hose is constructed of carbon impregnated silicone. The grounding cord which connects the tool to a common workstation earth ground incorporates a resistor for isolation between the operator and absolute ground.

Circle (27) on Reply Card

SCSI bus emulator

The PED-4500 emulation just released by **Pacific Electro Data** provides an additional dimension to the test and analysis of the SCSI bus. Operating in conjunction with the PED-4500 bus analyzer, the device emulation software and hardware imitates a SCSI host CPU or peripheral de-



vice while running on most PC/AT compatibles. By substituting *Target* emulation for an actual, physical SCSI device, developers can more fully explore the total range of behavior of their target and initiator devices under development. Using *Initiator* emulation, the user can exercise the entire command and message set of the target device.

Circle (23) on Reply Card

Cleaning kit line

Straticide Inc. announces its new tech essentials cleaning kit line. Items available in this new line include a fax machine cleaning kit, a laser printer



cleaning kit, computer cleaning kit, for 3.5" and 5 1/4" disc drives, a computer mouse cleaning kit, and a keyboard cleaning kit.

Circle (29) on Reply Card

DMM with analog bar graph

EMCO Electronics introduces the DMR-3600B, 3 1/2 digit DMM with analog bar graph and oversize display. This unit has 8 functions, 34 ranges and includes a transistor and capacitor checker, 20A ranges, audible continuity, shockproof case and



high-voltage surge protection. It comes complete with battery, instruction manual, test probes and carrying case.

Circle (30) on Reply Card

New and expanded belt and VCR parts cross reference guide

Projector Recorder Belt Corp. announces the new 1992 edition of their Comprehensive Belt and VCR Parts Cross Reference Guide. The comprehensive information included in the

Guide is arranged in an easy and user friendly format which is designed to save time. The 1992 edition features a VCR section that lists a majority of the mechanical VCR parts.. belts, idler assemblies, video heads, etc... by manufacturer make and model, and crossed to the recommended PRB replacement part. It also includes a detailed replacement belt information for tape recorders, computer peripherals, office machines, turntables, and audio visual equipment. PRB expects to have the guide published and available to the industry at a cost of \$7.95 by January 1, 1992.

Circle (31) on Reply Card

ESD shielding bags

Desco Industries has introduced transparent metal-in shielding bags for storage and transportation of static sensitive parts. Twenty-six sizes are available. The bags are made of a dissipative polyester outer layer within an aluminized middle layer and a dissipative polyethylene inner layer.

Circle (32) on Reply Card

Presenting an affordable Light Box System.

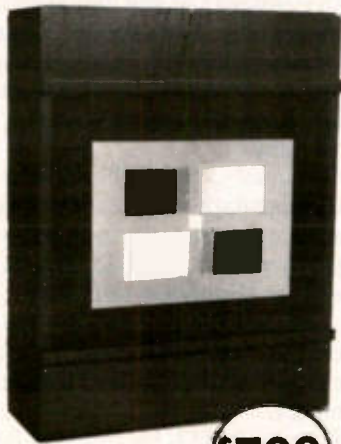

Model TR100 CB
Camera Light Box
with (2) transparencies

- (2) 3200° Kelvin Lamps (meets mfr. spec.)
- 1-year conditional guarantee
- Transparencies mounted in acrylic with optical scratch-resistant surface
- 11-step gray scale transparency
- 7-Bar color transparency
- All orders are shipped within 72 hours, U.P.S.

\$799

The method most manufacturers recommend

NUTRONIX (313) 726-1278

P.O. Box 77103 • Sterling Hts., MI 48077



Circle (11) on Reply Card

MCM ELECTRONICS PRESENTS:

RCA



YOU CAN ORDER ORIGINAL RCA AND GE REPLACEMENT PARTS AS CONVENIENTLY AS ANY OF THE OTHER FINE PRODUCTS IN THE MCM CATALOG.

OUR IN-DEPTH STOCKING AND FAST SHIPPING HELP YOU PROVIDE QUICK SERVICE FOR RCA AND GE REPAIRS.

CALL OUR FRIENDLY SALES STAFF TOLL-FREE WITH YOUR RCA AND GE PART REQUIREMENTS AND DISCOVER THE MCM DIFFERENCE!

CALL TODAY FOR A FREE SUBSCRIPTION TO OUR CATALOG

1-800-543-4330 OR
FAX-1-513-434-6959



MCM ELECTRONICS
650 CONGRESS PARK DR.
CENTERVILLE, OH 45459-4072
A PREMIER Company

SOURCE NO. ES-62

Circle (10) on Reply Card

DAB: The future of radio

By John Shepler

DAB is Digital Audio Broadcasting. It is the latest technology to make CD quality audio available over the air. When implemented, DAB will make existing AM and FM receivers obsolete.

Digital radio is still in the preliminary stages. There are no DAB stations operating. Over the air testing is being conducted on a variety of frequencies with several competing formats. Since DAB technology uses a different format than compact disk or digital audio tape, there are no receivers or decoders available to purchase. That will change within the next few years as the FCC selects one system to be the DAB standard.

Why DAB? The advantages are wide frequency response to 22kHz, enhanced stereo separation, lower transmitter power, and reduction in multipath interference. A DAB signal may be transmitted by a local station or by satellite directly to the receiver.

How does DAB work?

The simplest schemes directly convert the analog audio waveform into digital words that are then transmitted. The receiver reconverts from digital to analog format.

Sounds simple. This scheme of Pulse Code Modulation was tested in

Boston in 1986 using a television channel to transmit the digital audio signal. This hints at the basic problem with implementing DAB. Digital transmissions can require lots of spectrum. For instance, two stereo channels are converted to 16-bit words at a sampling rate of 48kHz. The data rate is $2 \times 16 \times 48,000 = 1,536,000$ bits of data per second. This is equivalent to 1.5MHz.

Obviously, the simple PCM transmission scheme isn't going to fit within a 200kHz FM channel and certainly not within a 10kHz AM channel. A standard 6MHz television channel could be used, but there aren't that many unused TV channels in major metropolitan markets. Another option is to assign frequency space for DAB on another band. This plan is running into stiff opposition from the military, two-way mobile, and ham operators who already are assigned to desirable parts of the spectrum.

More complicated DAB schemes are being tested that will make more efficient use of valuable spectrum space. The front-runner is a European standard called Eureka 147/DAB. This system transmits up to 16 separate stereo signals using only 4MHz. The dramatic reduction comes from performing some tricks on the audio while it is being coded to digital format.

The key to reducing the bandwidth of digital audio signals is to reduce the bit rate or the number of bits generated per second. Eureka 147 cuts the rate by a factor of 6 to only 250kHz

instead of 1.5MHz. This is done by analyzing the spectrum of the audio and eliminating information that you wouldn't be able to hear anyway. For instance, a loud sound will tend to overpower lower amplitude sounds that contain the same frequencies. This is a characteristic of human hearing called "psychoacoustic masking." By analyzing the spectrum and simply not transmitting bits for those sounds that are being masked, the bit rate is reduced with no loss of perceived sound quality.

Even with the improved spectrum efficiency, Eureka 147/DAB needs a frequency assignment outside the normal broadcast bands. Competing systems are being developed that work within the present FM band. These are called in-band systems. A scheme that encodes a DAB signal on a present FM transmitter is called IBOC for in-band on-channel.

One in-band system proposes using alternating channels for standard stereo and digital stereo broadcasts. This would work because FM stations are assigned at least one channel away in any location to minimize interference.

Another scheme just being developed uses the same carrier to transmit both standard FM and digital audio at the same time. It makes use of the extra space on the channel normally reserved for SCA, which is background music for stores or stock market and farm data.

Obviously, the in-band schemes need more data compression than the Eureka system in order to fit into existing assignments. Additional coding is used that eliminates redundant data on Left and Right channels. This reduces the data rates further, but makes the coder and decoder chips more complex.

When will DAB become available? It's most likely at least five years away, although meetings are scheduled for 1992 to decide what international frequencies will be assigned to DAB. The results could be DAB on satellite within a couple of years.

Shepler is an electronics engineering manager and broadcast consultant. He has more than twenty years experience in all phases of electronics.

MOVING?

If you're planning a move in the near future, don't risk missing an issue of *Electronic Servicing & Technology*. Please give us 6-8 weeks notice if you're planning on changing your address. Just write in your new address and mail this coupon,

WITH YOUR
SUBSCRIPTION MAILING
LABEL, to:

Name _____
Address _____
City _____
State _____ Zip _____

ELECTRONIC
Servicing & Technology

Subscriber Services
76 N. Broadway
Hicksville, NY 11801

Test your electronics knowledge

Answers to the quiz (from page 19)

1. Monochrome Display Monitor—Described in “Understanding Computer Terms” by Glenn R. Patsch. The article appeared in the November 1990 issue.

2. 20% Wirewound - In an article titled “Effects of Storage and Dormancy on Components” by Victor Meeldijk. It appeared in the December 1990 issue.

3. D - (Gate Turnoff Device) - Sony calls it a Gate Controlled Switch (GCS). From an article “Thyristors from A to Z” by Bert Huneault. It appeared in the January 1991 issue.

4. Molybdenum Grease - The item needed for properly cleaning and lubricating a VCR appeared in an article titled “VCR Theory, Troubleshooting and Adjustment.” It appeared in the February 1991 issue.

5. They do not require a source of high voltage. The advantage were listed in an article titled “The LCD Projection System” by the ES&T staff. It appeared in the March 1991 issue.

6. Million Floating Point Operations Per Second - The abbreviation was identified in an article titled “A Servicing Technicians Glossary” by Conrad Persson. It appeared in the April 1991 issue.

7. Control of camera optics - This information was in an article “Servicing Camcorder Motor Circuits” by Homer L. Davidson. This article appeared in the May 1991 issue.

8. It is the reference oscillator - The block diagram appeared in an article titled “Servicing VCR Servo Problems” by Brian Phelps. It appeared in the June 1991 issue.

9. The size of the parabolic dish- (It must be at least 10' to 12' in diameter).

This information was in article titled “Installing Satellite TV” by Joseph Pandolfo. It appeared in the July 1991 issue.

10. B - The data for various ohmmeters

made by several manufacturers was given in Figure 8 of an article titled “Understanding and Troubleshooting Bipolar Transistors - Part 1” by Carl Babcoke. It appeared in the August 1991 issue. ■

Val'yo

That quality of something that makes it desirable, important, useful, estimable or A measure of worth.

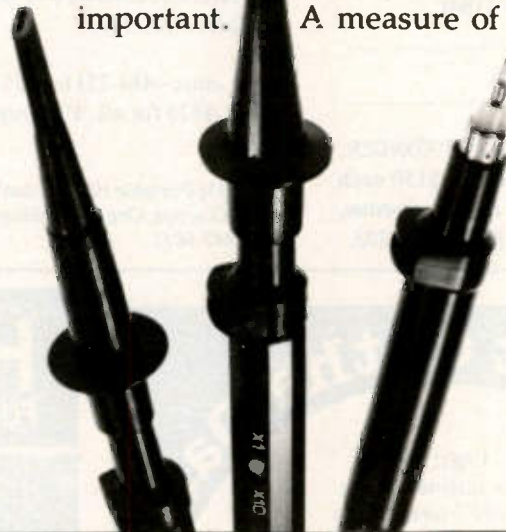

Why do more makers of signal analyzing equipment use Stack probes than any other brand?

Why does 1 in 4 oscilloscope users choose Stack probes?

Why do Stack probes cost less than other high performance probes?

Why do Stack probes perform better than similarly priced off brand probes?

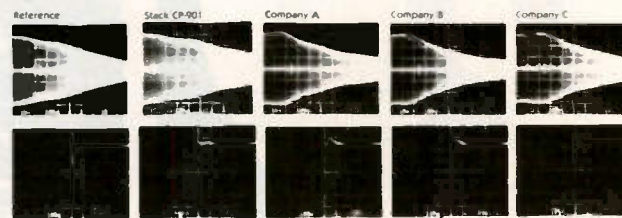

Notice the significant difference in frequency response and rise-time/overshoot between Stack and competing probes. Value is built into every Stack probe, and it shows. Get the whole story. Send for our catalogs.

STACK

OSCILLOSCOPE PROBES & ACCESSORIES

CUI STACK INC., 9640 S.W. Sunshine Ct. #700, Beaverton, OR 97005 USA
Phone: (503) 643-4899 Telefax: (503) 643-6129

Circle (3) on Reply Card

Readers' Exchange

Reader's Exchange has been reinstated as a free service.

The following restrictions apply to Reader's Exchange:

- Only individual readers may use Reader's Exchange, and items must be restricted to those that are ordinarily associated with consumer electronics as a business or hobby. If you're in business to sell the item(s) you want to offer for sale, the appropriate place for your message is in a paid advertisement, not Reader's Exchange.
- Readers Exchange items must be restricted to no more than three items each for wanted and for sale, and may be no more than approximately four magazine column lines in length (about 20 words).

Send your Reader's Exchange submissions to:

Reader's Exchange
Electronic Servicing & Technology
 76 N. Broadway
 Hicksville, NY 11801

FOR SALE

New MGA projection CRT's VT0700B22R, VT0725B22B, VT0729B22G, \$150 each and ship *RJB TV 13822 Pacific Avenue, Westminster, CA 92683 (714) 891-4203.*

B&K CRT tester with 19 adaptors. \$175.00. Boonton "Q" meter 160A \$50.00 plus shipping. *Paul Schlie (516) 499-6779.*

Used or junk GE VCR model 1 CVD 5023X. (703) 327-0033.

Test equipment and tube list, Sencore VA48 \$379.00 B&K 520B transistor checker \$190.00 others. *Maurer TV, 29 South 4th Street Lebanon, PA 17042.*

Latest model Sencore test equipment: like new, only used 3 months. VA62A \$3000, VC63 \$400, LC101 \$900. *J. Davis (208) 775-3702.*

775 new electronic tubes in their original boxes \$375 plus 60 lbs. UPS shipping. Send a LSASE (2 stamps) for lists of tubes and other electronic items. Retiring, make your best offers. *J. Horsley 67 Theodore Street, Buffalo, N.Y. 14211*

Sams -misc -484-2511; -2551-2732 (complete) -\$825 for all. *VL Knight (912) 839-3626.*

TEK 2336 Portable 100Mhz dual trace, delayed sweep O'scope. Org 4270 asking \$1400.00. *Jim (619) 443-9015.*

B & K capacitor tester - \$95, Leader Signal generator - \$85, Leader Dot Gen - \$45, B/K X S&R tester - \$85, B&K C. MOSIC tester - \$140, Deviation meter - \$125.00. *Boulevard Radio and TV Service, 1431 Robinson Avenue Havertown, PA 19083.*

Maintenance manual or schematic for National Panasonic DR28. Will purchase or copy and return. *Chas Hawkins 67-Frontier Dr. Jackson, CA 95642 (209) 223-1401.*

WANTED

Volume control for Ford Model 848BF - Bendix Part #2090035-2. *Jim Paras 164 N Union Street, Salem, NJ 08079 (609) 935-0931.*

Power transformer P/N 42512 17200 for Fisher stereo receiver model RS-245. *Stevens Service, 1005 N. Brookfield, South Bend IN, 46628. (219) 233-3746.*

Schematic service info on Lechtrotech oscilloscope model TO-55. *J. Gregorich (218)-749-4355.*

Zenith Power Transformer part #95-1456, model X2264 for remote control) *Tele Star audio and video SVC, 307 E 17th Street, Cheyenne, WY 82001 (307) 632-5319.*

Power transformer P/N 42512 17200 for Fisher stereo receiver model R5-245. *Stevens Service 1005 N. Brookfield South Bend, IN 46628. (219) 233-3746.*

Come Out of the Dark.

Light Up your business with "current" news from the NESDA Update, a bi-monthly newsletter of events that affect your business. For information about NESDA, and a free sample of the Update, just mail the following to NESDA:

Name _____
 Address _____
 City _____ State _____
 Zip _____
 Phone _____

National Electronics Sales &
NESDA
 Service Dealers Association

2708 W. Berry St.
 Ft. Worth TX 76109
 (817) 921-9061

HOT AIR TOOLS

FOR THE PROFESSIONAL SERVICE TECHNICIAN



HAND HELD, ELECTRONICALLY CONTROLLED HOT AIR TOOLS FOR REMOVING AND REPLACING ALL SMD'S AND THRU-HOLE COMPONENTS ON RIGID OR FLEXIBLE SUBSTRATES. PRECISE TEMPERATURE ADJUSTMENT TO 1202° F. WE OFFER OVER 500 NOZZLES TO COMPLETE WORKSTATIONS. TRAINING VIDEO AVAILABLE.

brian r. white company, inc.

313 henry station road, ukiah, ca 95482 (707) 462-9798
 5033 industrial road, farmingdale, n.j. 07727 (908) 938-2700

DISTRIBUTOR INQUIRIES INVITED
 Ask For Free Brochure

EY295

Classified

Classified advertising is available by the word or per column inch.

By-the-word: \$1.65 per word, per insertion, pre-paid. Minimum charge is \$35 per insertion. Initials and abbreviations count as full words. Indicate free category heading (For Sale, Business Opportunities, Miscellaneous, Wanted). Blind ads (replies sent to ES&T for forwarding) are \$40 additional. No agency discounts are allowed for classified advertising by the word. Contact Emily Kreutz at 516-681-2922 to place your classified ad (by-the-word). Or send your order, materials and payment to Emily Kreutz, Electronic Servicing & Technology, 76 North Broadway, Hicksville, NY 11801.
Per Column Inch (Classified Display): \$235 per column inch, per insertion, with frequency discounts available. 1" minimum, billed at 1/4" increments after that 10" maximum per ad. Blind ads are \$40 additional. Reader Service Number \$25 additional to cover processing and handling costs. (Free to 4-inch or larger ads.) For more information regarding classified display advertising please contact Jonathan C. Kummer at 516-681-2922. Optional color (determined by magazine) \$150 additional per insertion.

FOR SALE

REPAIR MANAGEMENT SOFTWARE: for IBM PC's. Repair tracking, inventory, reports, billing, mail list, more. Demo disk \$15. CAHILL ELECTRONICS, PO Box 568, Kingston, NH 03848. 10-91-3t

PHOTOFACTS: Folders under #1400, \$5.00. Above #1400, \$7.00. sent same day first class postpaid. Allen Loeb, 414 Chestnut Lane, East Meadow, NY 11554. 516-481-4380. 11-91-5t

COMPUTER AIDED TV/VCR REPAIR SOLUTIONS: 5 1/4" IBM Compatible disks. 1,000 VCR, Printout \$55, Disks \$51. 3,500 TV, Printout \$95, Disks \$91 (Hardrive). Time saver. Add to or quick scan by model, chassis or stage. Electronic Solutions, 407 W. Ave. "N", San Angelo, TX 76903. 8-91-6t

VHS-VCR REPAIR SOLUTIONS SETS I,II,III,IV,V,VI. Each contains 150 symptoms and cures, updated cross reference chart, free assistance, \$11.95 each all six \$59.95. Eagle Electronics, 52053 Locks Lane, Granger, IN 46530. 10-91-3t

PHONE LINE SIMULATOR: Test Fax, answering machines, modems without using phone lines \$55.00. Refundable \$2.00 for literature. JEC TECH, 13962 Olde Poste, Rickerington, Ohio 43147. 12-91-1t

ATTENTION VCR SERVICE CENTERS: 1000 VCR symptoms/cures from experience and manufacturers publications. Computer printout \$90. Guaranteed satisfaction. VCR Tuneup Center, 43 James Avenue, Redwood City, CA 94063 or call 1-800-777-7883. Mastercard and Visa accepted. 11-91-15t

YOU'VE TRIED THE REST NOW GET THE BEST! Don't waste money on inferior tech tips. Get the best tips money can buy! Sent \$99 for printout containing over 650 TV tips covering over 300 model numbers and 20 manufacturers. Get the most complete, up to date tech tips over your phone line by using the best on-line service available. Over 2500 tips covering TVs, VCRs, Camcorders, listing over 800 model #'s and 50 mfgs. New tips entered daily. Send a SASE for sample printout and more information. T.I.P.S., PO Box 1681, Forest Park, GA 30051-1681. 11-91-1t

FOR SALE

FOR SALE: 8 TECHNICIANS AND THEIR TRAINING. 5000: ACTUAL CURRENT "TECHNICIAN" TECH-TIP REPORTS: Symptoms, Cures & Part Numbers. 1987 Through 1991. TV-VCR-CD-LD-CAMERA-CAMCORDER-PROJECTION-STEREO-AMPLIFIERS-SATELLITE-MICROWAVE-CASSETTES-PHONO-ETC. We service All Consumer Electronics and Factory Authorized for 36 Major Manufacturers. If it came through our doors, it's on it's way to "YOURS"! FOR OUR BOTOOM PRICE SEND \$15.00 FOR DEMO DISK OR \$10.00 PRINTED FORM. \$70.00 per 1000 data-base disk price or \$350.00 for 5000, Printed form add \$5.00 Per 1000 Tips. Annual updating available. AMEX-M/C-VISA & CHECKS, 2-Wks Delivery 305-474-2677 Factory Service 8614 SR-84, Ft. Lauderdale, FL 33324. 8-91-12t

RADIO BUFFS: old old tubes #27 and up to 1970's new still in cartons. Mr. Arthur, 18505 US23N, Alpena, Michigan 49707. (517) 595-6379. 12-91-1t

TELEMATIC: New and old. 93 pieces. \$1400 Val-\$500 or B/O. Please call TTV Inc. at 412-462-8881. 12-91-1t

TV TOUGH DOGS 300 symptoms and cures. Send \$10.95 to Davis TV, 11772 Old Fashion Way, Garden Grove, CA 92640. 10-91-2t

REDUCED 85%, Diehl Mark 111 scanner \$79. Diehl Mark V scanner \$199. New. Restore remote control keypads with our conductive coating \$8.99 ppd. WEEC, 2805 University Ave., Madison, WI 53705. 608-238-4629, 608-233-9741. 12-91-1fb

T.V. PARTS, EQUIPMENT, AND MANUALS: CURRTIS MATHES MODULES, PARTS, SYLVANIA PARTS, MANUALS, SAMS PHOTOFACTS SCENORE VA62, PR57 & VC63. B.B.'S SERVICE, 111 N. MARIETTA, ST. CLAIRSVILLE, OH 43590. 614-695-6416. 12-91-1t

RFI-TV SOLUTIONS: Ferrite beads, Toroids, Kits, etc. Tech Notes, Applications. Free Brochure. Spl-Ro Manufacturing, Box 5500, Dept. EST, Lakeland, FL 33807. 813-646-7925. 12-91-1t

MISCELLANEOUS

CAMCORDER REPAIR: Don't turn away good profits! Let our experienced technicians provide your shop with complete camcorder repair service. Also, VCR, "Tough Dogs." Call 1-800-846-4648. Edington VCR/TV, 204 North Kimble Drive, Bloomington, IN 47404. 9-91-6t

BUSINESS OPPORTUNITIES

COMPUTERS AND ACCESSORIES! Mouse \$9.00, Keyboards \$18.00. Buy direct from foreign manufacturers. Any quantity. Step-by-Step details, addresses, tips, etc. \$12.00 postpaid. SMI, Box 6105, Dept. E, Lakeland, FL 33807. 12-91-1t

TELEVISION SALES AND SERVICE: In sunny Florida. 15 years same location. Computerized client list, full technical library, paper and microfilm. 3,200 square feet available on busy US 41. Authorized Zenith, Sony, and Philips lines. A steal at \$50,000. Retiring. E. Rabell, 103 SW Peckham Street, Port Charlotte, FL 33952. 813-629-2440, evenings 813-629-5246. 12-91-1t

Manufacturers Parts and Literature Directory

This monthly section is sponsored by manufacturers to help you find the parts and technical literature needed to service their equipment. Call them for replacement parts or for the name of their nearest distributor.

<p>Hitachi Home Electronics 401 W. Artesia Blvd. Compton, CA 90220 800-HITACHI</p>	<p>Mitsubishi Electronics America 5757 Plaza Drive Cypress, CA 90630 800-553-7278 fax 800-825-6655</p>	<p>Panasonic 50 Meadowlands Parkway Secaucus, NJ 07094 800-447-4700</p>
<p>Philips ECG 1025 Westminister Drive Williamsport, PA 17701 800-526-9354 fax 800-346-6621</p>	<p>Quasar 50 Meadowlands Parkway Secaucus, NJ 07094 800-447-4700</p>	<p>Technics 50 Meadowlands Parkway Secaucus, NJ 07094 800-447-4700</p>
<p>Thomson Consumer Electronics 2000 Clements Bridge Road Deptford, NJ 08096 800-257-7946 fax 800-524-1498</p>	<p>Zenith Electronics Corp. 1900 N. Austin Avenue Chicago, IL 60634 312-745-2000</p>	<p>Call Jonathan Kummer at 516-681-2922 to reserve space in this special section.</p>

BEST BUY NEW Series II
FLUKE 79 with Capacitance \$169
FLUKE 87 True RMS \$269
NEW! SCOPEMETER™ 90 SERIES
HAND HELD, 50 MHz, DUAL CHANNEL
FLUKE 93 ScopeMeter \$1095
FLUKE 95 ScopeMeter \$1395
FLUKE 97 FULLY LOADED ... \$1695



KELVIN Electronics
 7 Fairchild Ave., Plainview, NY 11803
 (516) 349-7620 1(800) 645-9212
 FAX (516) 349-7830

FLUKE 97
AUTHORIZED
DEALER

Circle (8) on Reply Card

Tech's Guide To Pricing
NEW

"Sperry Tech's Pricing Guide"
 Updated new 6th edition...a framework for setting rates that apply to Hi-Tech products...a formula that guarantees SUCCESS!
 Call Toll Free for details 1-800-228-4338

Circle (16) on Reply Card

TUBES • TUBES • TUBES
World's Largest Range
 Over 2,000 Types, Domestic & Foreign
UP TO 85% OFF Ask for price list
International Components Corporation
 Toll Free 800-645-9154 • N.Y. State 516-293-1500
 105 Maxess Road, Melville, New York 11747

Circle (7) on Reply Card

PREMIUM DELIVERY ...

Get Your Parts in 48 Hours for Just \$5!*

PREMIUM PARTS+ guarantees that your order will be delivered within 48 hours via UPS 2nd Day Air Service to anywhere in the 48 States for just \$5*, regardless of its weight with our **PREMIUM DELIVERY**. Overnight Air for just \$13*, regardless of its weight.

"We'll get your parts to you as fast as you need them!"

*Plus handling. Excluded from this offer are: Shipments to Alaska and Hawaii; Chemicals; Everyday and Camcorder Batteries; All Back Orders; and literature including Tech Library.

Call toll free for your **FREE** copy of our catalog ...
 1-800-558-9572
 or for 24 hour ordering call ...
 FAX: 1-414-473-4727

We accept Master Card and Visa

"First In Quality, Service and Delivery"

PREMIUM PARTS+
 ELECTRONICS COMPANY™

P.O. Box 28 • Whitewater, WI 53190-0028



Circle (14) on Reply Card

Advertisers' Index

Company	Page Number	Reader Service Number	Advertiser Hotline
Andrews Electronics	IBC	1	805/257-7700
Brian R. White, Co.	58	19	707/462-9795
C & S Sales	3	2	800/292-7711
CUI Stack, Inc.	57	3	503/643-4899
Consolidated Electronics	13	4	800/543-3568
Electronic Parts Supply	51	5	800/227-0104
Fluke Manufacturing, John	IFC	6	800/227-3800
Hitachi Home Electronics	59		800/HITACHI
Iscet	53		817/921-9101
International Components Corporation	60	7	800/645-9154
Kelvin Electronics	60	8	516/349-7620
Klein Tools	53	9	
MCM Electronics	55	10	800/543-4330
Matsushita Services Corp.-Parts	8,9		201/348-7589
Mitsubishi Elec. America	59		800/553-7278
NESDA	45,58		817/921-9061
Nutronix	55	11	313/939-4710
Panasonic	59		800/447-4700
Panavise Products	45	12	702/353-2900
PanSon	BC	59	800/321-4870
Parts Express	43	13	513/222-0173
Philips ECG	59		800/526-9354
Premium Parts +	60	14	800/558-9572
Quasar	59		800/447-4700
Russell Industries	53	15	800/645-2202
Sperry Tech	60	16	800/228-4338
Technics	59		800/447-4700
Tentel	52	17	800/538-6894
Thompson Consumer Elec.	59		800/257-7946
Viejo Publications	43	18	800/537-0589
Zenith	59		312/745-2000

We'd like to see your company listed here too. Contact Jonathan C. Kummer to work out an advertising program tailored to suit your needs.

SALES OFFICE

THE MAGAZINE FOR CONSUMER ELECTRONICS SERVICING PROFESSIONALS
ELECTRONIC
 Servicing & Technology

76 North Broadway
 Hicksville, NY 11801
 (516) 681-2922
 FAX: (516)681-2926

Jonathan Kummer
 Advertising Manager

Emily Kreutz
 Sales Assistant

When your reputation is at stake . . .
for professional results . . .
rely on **ORIGINAL** replacement parts.

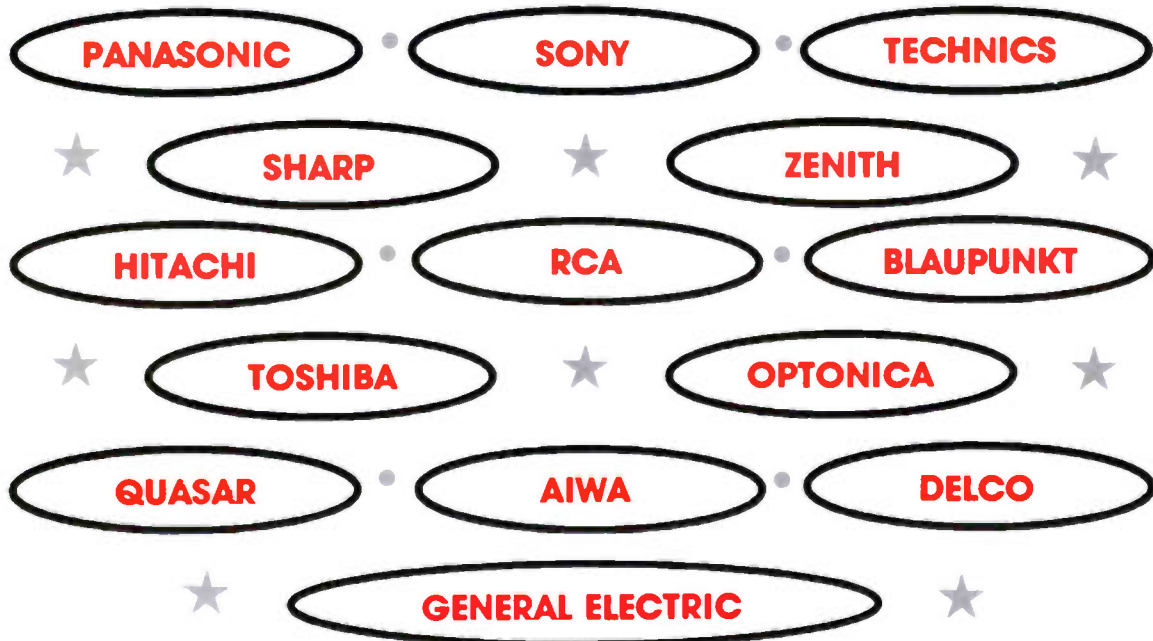

For Original Parts, Accessories and Service Literature
rely on your Professional Distributor,
rely on ready availability from

**NOW IN OUR
5TH DECADE!**



andrews
electronics

P.O. Box 914, Santa Clarita, CA 91380-9014
INQUIRIES: 805-257-7700 or FAX 805-295-5162

(We have reputations to uphold, YOURS, and OURS.)

**Dial our 24-Hour Orderdesk:
Phone: 800-289-0300
FAX: 800-289-0301**

**FOR OVER 25 YEARS
THE ORIGINAL REPLACEMENT
PARTS CENTER**



- Quantity And Volume Discounts
- National Toll-Free And Customer Assistance Order Lines
- Free-Freight Available
- No Minimum Order
- **P.A.R.T.S.**-Automatic Retrieval Tracking System For On-Line Computer Link-Up To Your Shop

- Original Parts For Most Manufacturers

**PANASONIC, TECHNICS
HITACHI, JVC
GENERAL ELECTRIC
RCA, OPTONICA
QUASAR, SHARP
SONY**

**DISCUSS YOUR NEEDS WITH A
PANSON REPRESENTATIVE-NOW**

1-800-321-4870

268 Norman Avenue • Greenpoint, New York 11222

Circle (59) on Reply Card