

# ELECTRONIC<sup>TM</sup>

*Service & Technology*

MARCH 1983/\$2.25

How to make your own PC boards

How to service arcade video games



**Circuit  
construction**



**PTS CORPORATION**

No. 4 in a series

Magnavox 703744-1, 2, 3 & 4; 704208-1 & 2

# Module Update

***PTS was first to automatically insert spacers preventing burnt etchings on this regulator board.***

***PTS*** repair logs identified a recurring failure. When the output transistor in this regulator board shorts, excessive heat is generated. The heat sink is often unable to disperse this heat. Charred P.C. board and burnt etchings can be the result.

**A** PTS technician suggested automatically installing spacers between the heat sink and the board. Extensive air testing including intentional shorting of the output transistor proved the spacers eliminated heat damage to the board. PTS adopted this automatic change and was the first to offer it and backs it up with a full year limited warranty.

You'll find PTS quality rebuilt modules with automatic updates at over 1,500 locations nationwide. For the name of the location nearest you and your free copy of the PTS Price and Technical Information Guide, use the reader response card or write: PTS Corporation, P.O. Box 272, Bloomington, IN 47402

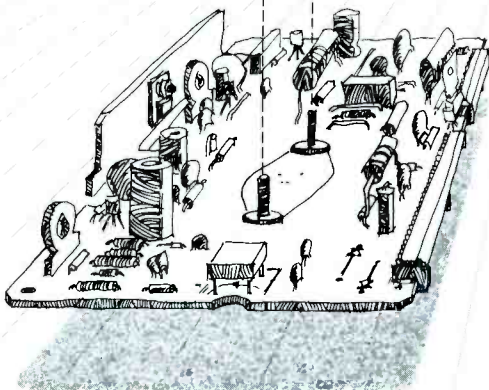

 **PTS CORPORATION**

Circle (1) on Reply Card

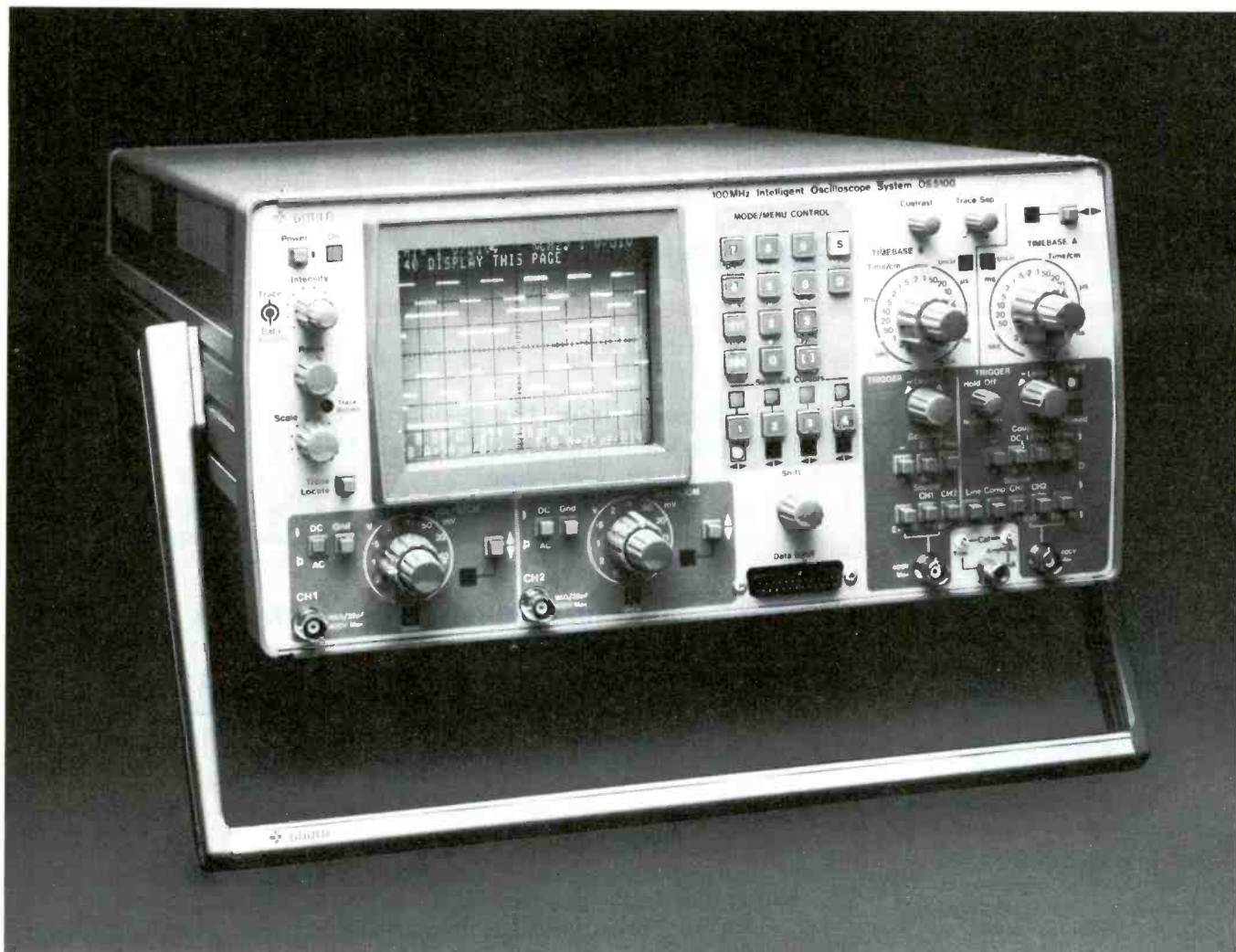

# TIME SAVER

**Gould 100 MHz OS5100 Intelligent Oscilloscope System.** In servicing and maintenance of electronic components, circuits and equipment, our OS5100 pin-points problems quickly, accurately and inexpensively.

The result: minimized downtime and increased productivity.

The Gould OS5100 is a highly sophisticated measuring system. Yet it's easy to use. And it's portable. That unique combination puts more on-site measuring power at the fingertips of field service technicians than ever before. They can compare expected results — either a waveform or a measurement — with the actual. And come up with an accurate diagnosis in far less time than normally required for initial trouble-shooting.

The OS5100 features an analog bandwidth of 100 MHz, waveform storage to 100 MHz, and two 1K x 8-bit stores. Plus front-panel keyboard

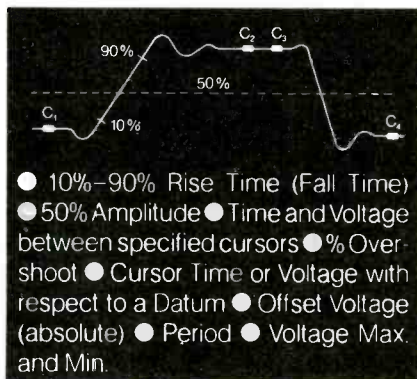

Typical automatic calculations available operation through a menu-control system. Combined alphanumeric and waveform display capabilities. Auto-measurement capabilities. And analog and digital interfaces

that allow it to function as the heart of a complete measurement and analysis system.

Extensive trigger facilities include delay-by-time (up to 344 seconds) and delay-by-event (count selectable to 999,999,999) modes. Or you can trigger on a specific logic word if the OS5100 is used with an optional logic analyzer word-recognition pod.

Now is the time to learn how the Gould OS5100 Intelligent Oscilloscope System will speed your service and maintenance operations. Contact Gould Inc., Instruments Division, 35129 Curtis Boulevard, Eastlake, OH 44094; phone 800/321-3035.

 **GOULD**  
Electronics & Electrical Products

Circle (4) on Reply Card



The how-to magazine of electronics...

# ELECTRONIC

## Servicing & Technology

March 1983  
Volume 3, No. 3



The photomicrograph on the cover shows an experimental 1.2-micron circuit (at 100X magnification), fabricated by means of a CMOS process technology. See *Technology* on page 8. (Photo courtesy of GE Research and Development Center.)

### 12 Reports from the test lab: The Non-Linear Systems TR-1 Tracer

*By Carl Babcoke, CET*

The Tracer tests individual components and circuits by producing a signature waveform that is viewed on the screen of an internal 1 $\frac{3}{4}$ -inch CRT.

### 18 Double your troubleshooting efficiency

*By Steve Bowdon*

If a logic analyzer tells you more than you need to know and is out of your budget, consider combining an oscilloscope and an inexpensive logic probe into a practical troubleshooting tool.

### 24 How to service arcade video games

*By Don Thorne, CET*

Arcade video games are enjoying unprecedented success today. Although they employ extensive digital circuitry and a monitor with analog circuits, they are seldom difficult to repair.

### 40 Printed circuit design criteria

*Bishop Graphics*

Printed circuit technology can be used for individuals as well as manufacturers, if instructions are followed closely. This article provides a checklist for PC board design and layout.

### 46 How to make your own PC boards

*GC Electronics*

Whether you are a hobbyist or an experienced technician, you can turn out professional-quality PC boards by following these step-by-step instructions.

### 56 TV/video sync enhances TV troubleshooting

*Hewlett Packard*

TV/video sync, a powerful capability in an oscilloscope, is used to monitor the video portion of a system, whether it is an ultrasound scanning system, a videocassette recording system or a remote TV transmitter site.

# Departments

- 6 Editorial
- 8 Technology
- 17 News
- 20 Troubleshooting Tips
- 22 Readers' Exchange
- 30 Symcure
- 39 Photofacts
- 62 Products
- 64 Literature

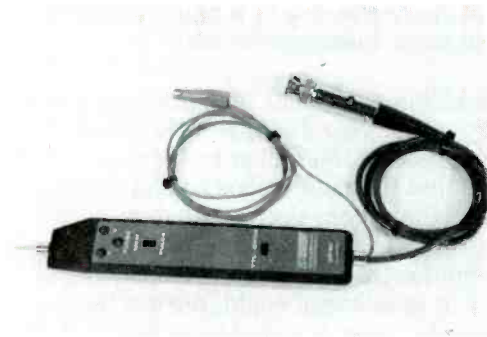

Page 18

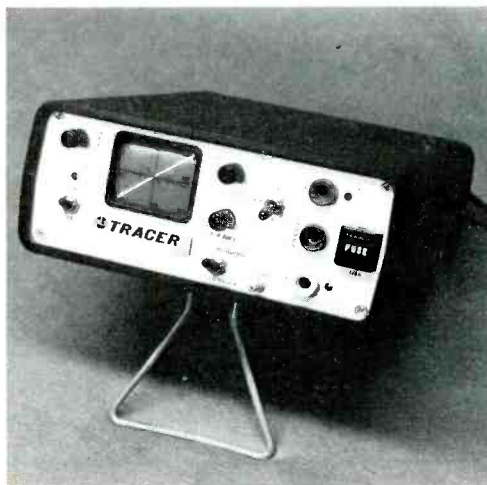

Page 12

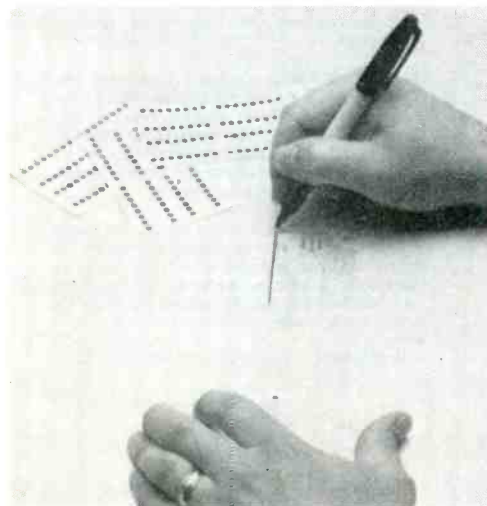

Page 46

## Next month...

**Exploring solid-state memories, Part 2.** This continuation of an article that began in the February issue takes a look at memory banks—large-capacity memories on one or more circuit board assemblies.

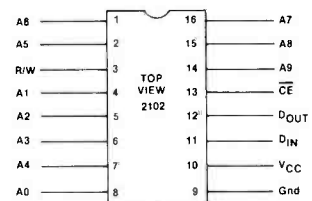

## Technology brings challenge for the future

Some people wonder if there is room in the technology marketplace of tomorrow for all of today's technology. I wonder not if there is room, but whether those of us in the telecommunications industry are prepared to take advantage of the greatest opportunity and marketing challenge of the century.

Direct-broadcast satellite (DBS), satellite master antenna television (SMATV), TV receive-only satellite, cable, low power television, satellite radio, cellular radio, computers, teleconferences and fiber-optics are just some of the emerging technologies that most futurists agree will change the face of societies throughout the world. The challenge to develop the equipment necessary for these technologies is being met, but the larger challenge that remains is for innovative business professionals to develop marketing and support programs that will successfully integrate these technologies into our lives, into business and industry, into education and into other institutions throughout society.

Future predictions leave one almost disbelieving. Consider these thoughts.

- During the next five to 10 years, we will build and install more communications technology than presently exists.
- Satellite farms, by the year 2000, could provide between 22,000 and 48,000 channels for television, voice and other communications.
- Teleconferencing is expected to grow at a rate

of between 20% and 40% during the next few years and by the end of the decade can eliminate most of the \$800 billion now spent in executive travel time.

- A fiber-optic, 1/5 the size of a hair, can carry 10,000 telephone messages or 8000 TV channels.
- Some \$30 billion was spent on communications technology in the year 1980, and this figure is expected to reach \$150 billion by 1990.
- Computers that fit inside a shoe box have more power today than room-sized computers did a decade ago.
- A new computer theory being developed at the University of Mississippi could, during the coming decade, make it possible to build a "chip" cube the size of two human hairs that is capable of storing all of the world's knowledge.
- Satellite and cable-based newspapers are a reality, and some predict the dramatic decline in communications' dependency on paper.
- By the year 2000, 67% of the American work force will be employed in education-information industries.

No segment of our lives will remain untouched by these and other technological developments. Will DBS bring about the demise of cable? Will the networks (CBS, NBC and ABC) be changed by CNN and other networks? Will low-power television change commercial television? What will

*(Continued on page 20.)*

### **ELECTRONIC** Servicing & Technology

Editorial, advertising and circulation correspondence should be addressed to: P.O. Box 12901, Overland Park, KS 66212-9981 (a suburb of Kansas City, MO); (913) 888-4664.

#### EDITORIAL

Bill Rhodes, *Editorial Director*  
Nils Conrad Persson, *Editor*  
Carl Babcock, *Consumer Servicing Consultant*  
Rhonda Wickham, *Managing Editor*  
Tina Thorpe, *Associate Editor*

#### ART

Kevin Callahan, *Art Director*  
Kim Nettie, *Graphic Designer*

#### CIRCULATION

John C. Arnst, *Director*  
Evelyn Rogers, *Manager*  
Dee Manies, *Reader Correspondent*

#### ADMINISTRATION

R. J. Hancock, *President*  
Cameron Bishop, *Publisher*  
Eric Jacobson, *Associate Publisher*

#### ADVERTISING

Greg Garrison, *National Sales Manager*  
Jean Jones, *Production Manager*  
Mark Raduziner, *Marketing Coordinator*



Member, Audit Bureau  
of Circulation



Member, American  
Business Press

ELECTRONIC SERVICING & TECHNOLOGY (USPS 462-050) (with which is combined Electronic Technician/Dealer) is published monthly by Intertec Publishing Corp., 9221 Quivira Road, P.O. Box 12901, Overland Park, KS 66212-9981. Second Class Postage paid at Shawnee Mission, KS 66201. Send Form 3579 to P.O. Box 12952, Overland Park, KS 66212-9981.

ELECTRONIC SERVICING & TECHNOLOGY is the "how-to" magazine of electronics. It is edited for electronic professionals and enthusiasts who are interested in buying, building, installing and repairing home-entertainment electronic equipment (audio, video, microcomputers, electronic games, etc.).

**SUBSCRIPTION PRICES:** one year \$15, two years \$26, three years \$34 in the USA and its possessions. Foreign countries: one year \$20, two years \$30, three years \$40. Single copy price \$2.25; back copies \$3.00. Adjustment necessitated by subscription termination to single copy rate. Allow 6 to 8 weeks delivery for change of address. Allow 6 to 8 weeks for new subscriptions.

**PHOTOCOPY RIGHTS:** Permission to photocopy for internal or personal use is granted by Intertec Publishing Corp. for libraries and others registered with Copyright Clearance Center (CCC), provided the base fee of \$2 per copy of article is paid directly to CCC, 21 Congress St., Salem, MA 01970. Special requests should be addressed to Cameron Bishop, publisher. ISSN 0278-9922



INTERTEC PUBLISHING CORP.

©1982 All rights reserved.



# CE Consolidated Electronics, Inc.

## THE CLOSER YOU LOOK, THE MORE YOU'LL SAVE

**SUPER SPECIAL**

**2SC1413A**  
Horizontal Output Transistor  
Equivalent to ECG® 238

ALSO REPLACES  
ECG 165, C1172B, C1174, C1295, C1308K, C1309, C1358, C1454, C1875, C1893, C1922, C1942, C1894, D200, D201, D348, D350, D368, D627, D649, D380, D663, D859, D870

**\$2.09**  
(10-99)

**\$1.69**  
(100-up)

## YOUR COMPLETE ELECTRONIC PARTS SOURCE

Get immediate delivery on quality parts at a low price.

<p><b>SAVE</b></p>  <p><b>ARIA CASSETTE TAPES</b></p> <ul style="list-style-type: none"> <li>• Quality 5 screw construction</li> <li>• Box of ten folds into a handsome counter top display</li> <li>• 1 year guarantee</li> <li>• Extended linear frequency response</li> </ul> <p><b>CE 368/C-60</b> 30 MINUTE    <b>CE 369/C-90</b> 90 MINUTE</p> <p><b>\$1.19</b> (1-9)    <b>\$1.39</b> (1-9)</p> <p><b>99¢</b> (10-up)    <b>\$1.19</b> (10-up)</p>	<p><b>FREE</b></p>  <p><b>1983 CATALOG</b></p> <p>CALL TODAY for your FREE 1983 catalog. We offer a complete line of Speakers, Belts, Japanese and American Semiconductors, Tubes, Triplers, Tools, Technicians Aids, Capacitors, Resistors, T.V. Accessories, Chemicals, Magnetic and Ceramic Stylis and Cartridges all at low, low prices.</p>	<p><b>CASSETTE HEAD CLEANER</b></p> <p><b>SAVE</b></p>  <ul style="list-style-type: none"> <li>• Cleans both tape and capstan in 20 seconds</li> <li>• Includes cleaning solution</li> <li>• Comes in an attractive display card</li> </ul> <p>PART NO. <b>CE 390</b></p> <p><b>\$3.89</b> (1-9)    <b>\$3.55</b> (10-up)</p>
--	---	--

MINIMUM \$10 ORDER  
NO MIXED QUANTITIES



CALL TODAY

**1-800-543-3568**  
NATIONAL WATS LINE

**1-800-762-3412**  
OHIO WATS LINE

705 WATERLIET AVE., DAYTON, OHIO 45420  
IN DAYTON, OHIO CALL 252-5662

Circle (5) on Reply Card

# R&D in semicond

General Electric scientists recently announced that they had successfully fabricated experimental microelectronic circuits with 1.2-micron geometries by means of a complementary metal-oxide semiconductor (CMOS) process technology.

The 1.2-micron test circuits were produced at GE's Research and Development Center in Schenectady, NY, employing a new process in advanced development that overcomes earlier technical obstacles encountered in producing CMOS circuits with such extremely small dimensions (a micron is about 1/50 the thickness of a human hair).

Scientists from the R&D Center and other GE components are now working with Intersil, the company's IC-manufacturing subsidiary, to adapt the process for volume production. By 1985, Intersil expects to be mass producing 1.2-micron CMOS circuits for GE's own products and for the merchant market.

Although initial applications will be in aerospace products, GE ultimately plans to incorporate this advanced, large-scale integration (AVLSI) technology in industrial robots and other automated factory equipment.

CMOS ICs are ideal for factory environments. They consume less power and have higher immunity to noise than other technology approaches (e.g., NMOS and bipolar). The latter advantage is extremely important because of the high noise levels present in a



Ronald T. Jerdonek, the R&D Center's VLSI design programs manager is shown testing one of the new experimental microelectronic circuits with 1.2-micron geometries.

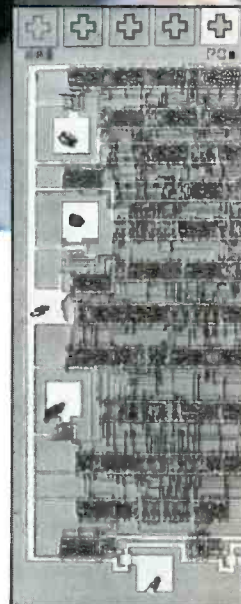

This photomicrograph shows an experimental 1.2-micron circuit (100X magnification) fabricated by means of a CMOS process technology.

Article and photos courtesy of GE Research and Development Center, Schenectady, NY, and Intersil, Cupertino, CA.



# uctors

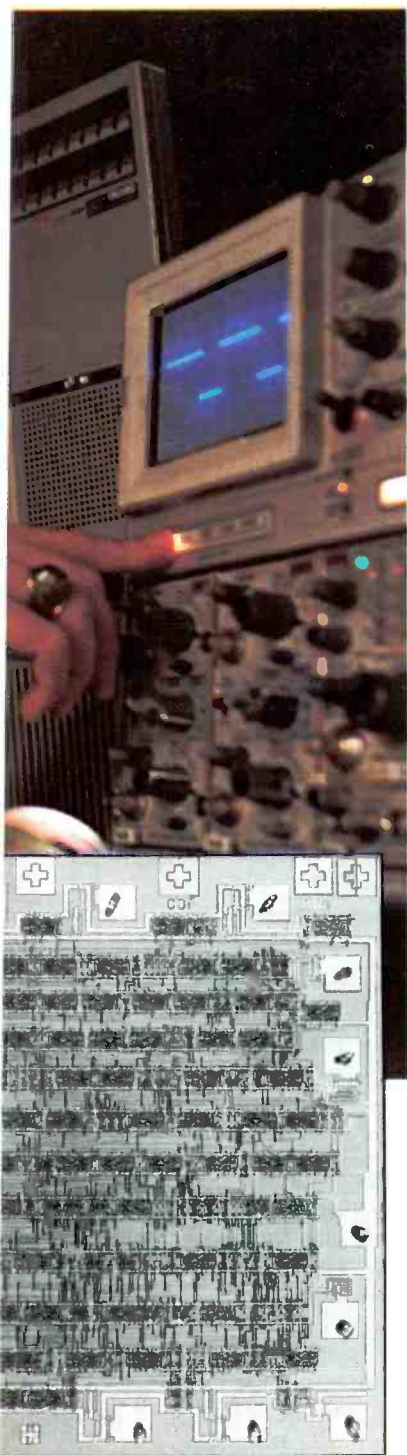

factory, due to starting and stopping of heavy electrical equipment.

The new fabrication process was described in a technical paper presented by Ronald T. Jerdonek, manager of the R&D Center's VLSI design programs, at the annual International Electron Devices Meeting sponsored by the Institute of Electrical and Electronics Engineers. The paper was co-authored by Mario Ghezzi and James C. Weaver of the R&D Center and by Stephen R. Combs, managing director of process technologies at Intersil.

GE's new processing approach significantly reduces the effects of the unwanted parasitic devices present in most CMOS circuits. It will permit the fabrication of ultra-dense CMOS circuits that are extremely fast and reliable.

A high-performance prototype prescaler circuit fabricated by this process exhibited extremely fast switching speed (the time it takes a signal to propagate through a switch)—less than 500 trillionths of a second (500 picoseconds). Toggle frequencies in excess of 1GHz at 5V were obtained—an indication of superior performance.

The new GE CMOS process is fully ion implanted and uses phosphorus-doped polysilicon gates and a 300-angstrom gate oxide. Reduction, step and repeat lithography is used to transfer the circuit patterns onto the wafer. The very fine feature sizes of these patterns are reproduced in the final circuits through the use of sophisticated dry-etch techniques.

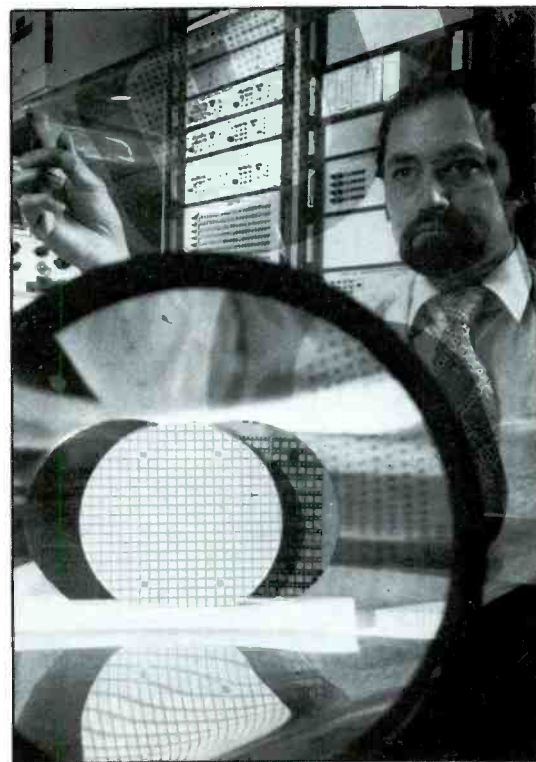

**B. Jayant Baliga**, manager of the High Voltage Device and Integrated Circuits Unit at GE's R&D Center examines one of the photo masks used to create the IGR's intricate circuitry.

A new type of power semiconductor switch, developed by GE scientists, has the advantages of operating at high current densities while requiring low gate drive power.

Known as the insulated gate rectifier (IGR), GE's new power switching device combines MOS gating with bipolar current conduction. It is intended primarily for gate turn-off applications that, at present, most commonly employ bipolar transistors or MOS field effect transistors (MOSFETs).

According to B. Jayant Baliga, manager of the R&D Center's High Voltage Devices and Integrated Circuits Unit, the IGR operates at significantly higher current densities than bipolar transistors and FETs. Its on-resistance is half that of bipolar transistors and about 1/20 that of a 600V MOSFET, the GE research manager said. He added that the IGR also shares the power MOSFET's advantage of high input impedance.

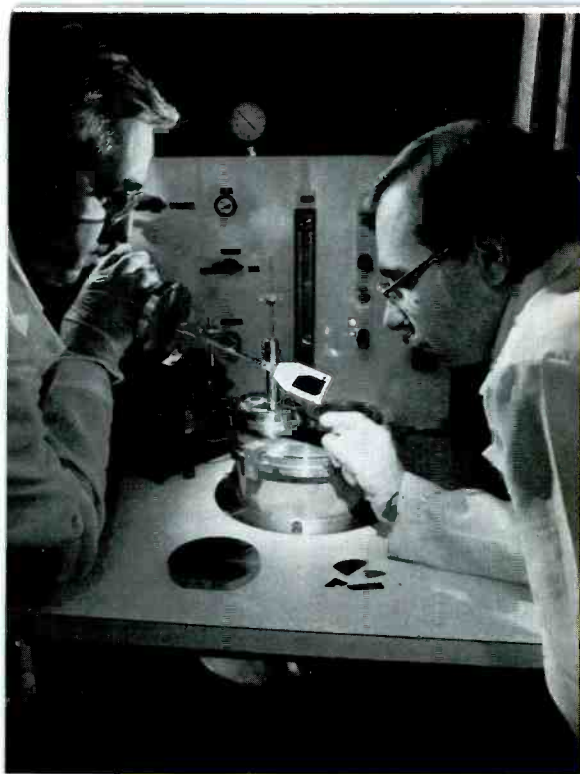

In developing a high-voltage power FET, physics specialist Roger S. Ehle and physicist Paul M. Campbell prepare a sample of gallium arsenide for processing in an annealing furnace.

GE R&D Center scientists have also reported the development of a novel high-voltage power field effect transistor fabricated from gallium arsenide.

Gallium arsenide FETs promise improved power-handling performance over existing silicon devices by providing faster switching speeds and lower on-resistance. These new FETs have 1/10 the resistance of comparable silicon devices - cutting power losses sharply.

The new gallium arsenide FET technology is expected to have a long-range impact on the development of power electronic devices capable of handling increased amounts of voltage and current. Such devices will have many applications in the field of high-speed power switching.

These FETs can block up to 150V, with switching speeds of less than five billionths of a second. Previously, the best-performing gallium arsenide FETs exhibited breakdown voltages of 85V.

The vertical layout of the FETs is unusual. Most gallium arsenide devices are horizontal, with the fine lines that form the source, gate and drain closely aligned on

the top of the chip. The new design places a large source contact on the top and a large drain contact on the bottom of the chip, with fine gate regions running through the center.

By avoiding the close arrangement of tiny details on the surface of the wafer, the layout increases current-handling capability and reduces the possibility that a crystalline defect in the material can result in lines that touch, causing the devices to short out.

Consequently, this buried-gate design yields high quality and few defective chips.

The gate regions are formed by the implantation of beryllium ions directly into the gallium arsenide surface. Following this, the implanted regions must be heated to 800 C in order to incorporate the beryllium atoms into the crystal structure of the gallium arsenide and make them electrically active. Next, a second layer of single-crystal gallium

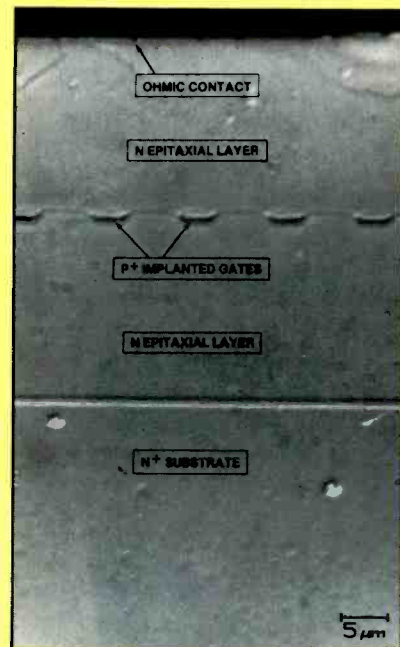

The gate regions of the FET, formed by implanting beryllium ions into the gallium arsenide surface, are shown in this photomicrograph (4000X magnification).

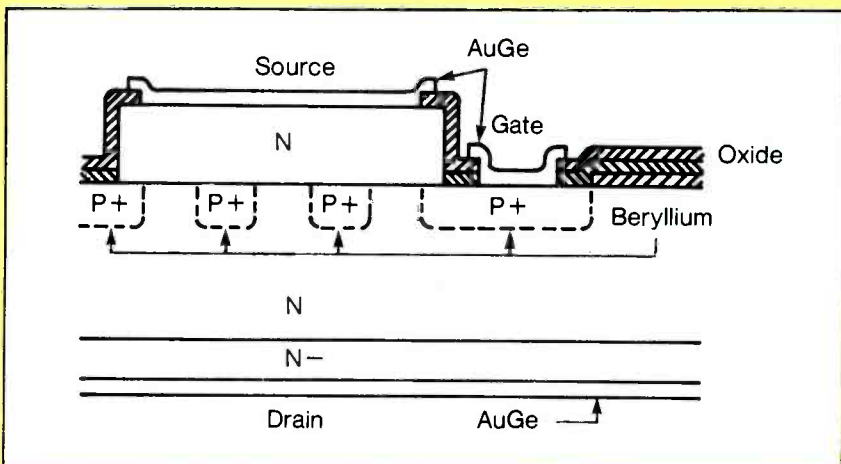

The unusual vertical layout of the FET, shown in the schematic, places a large source contact on the top of the chip and a large drain contact on the bottom.

arsenide must be grown over the implanted gates to complete the buried-gate structure.

This fabrication of gallium arsenide devices, using ion implantation, is complicated by the fact that unprotected gallium arsenide decomposes at temperatures above 600 C, well below the 800 C required for activation. The GE researchers

solved this problem by combining two of the steps. They discovered that by growing the second layer of single-crystal gallium arsenide at 800 C, they could simultaneously activate the gate implant. Also the growth of the second layer prevents the implanted gallium arsenide surface from decomposing.

ES&T



**“I want a small 50 MHz scope with dual trace, delayed sweep and sensitivity to 1 mV/div.”**

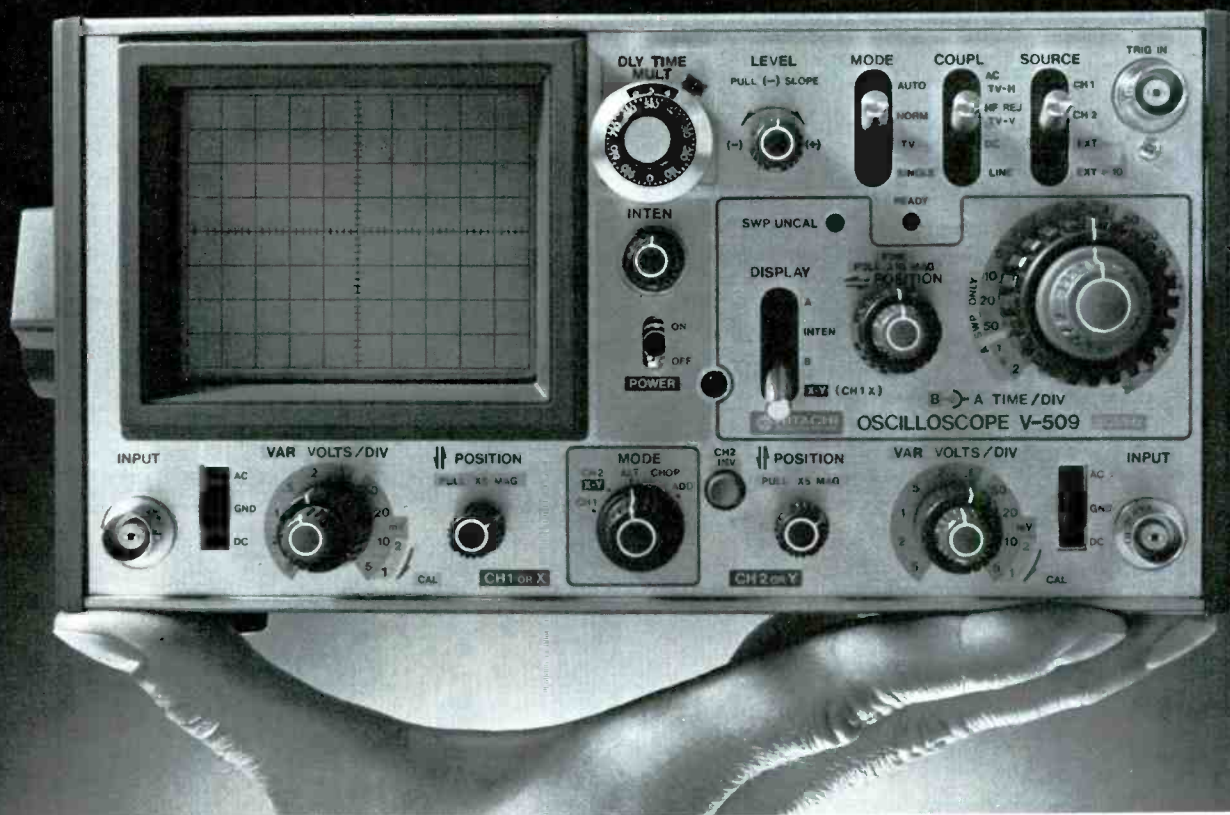

# HITACHI HEARD YOU.

You want a lot. But Hitachi heard you. And the result is our super-compact portable, the V-509.

Compact enough to fit in one hand, it still gives you a dynamic range of 8 full divisions. Sensitivity to 1mV/div. And sweep times down to 10 ns./div.

For today's sophisticated electronics, computers and VTRs, it's the perfect field-service tool.

The V-509 weighs a mere 11 pounds in an 8.5" x 4.3" x 13.8" package. But it's a heavyweight when it comes to performance. Auto focus, a built-in TV sync separation circuit and Channel 1 DVM output are standard. There's even a single-sweep function to reliably measure one-time events. Plus AC/DC operation and an optional battery pack, so you can

take the V-509 wherever it's needed.

Hitachi's human engineering is very evident in the V-509's design. Its bright (12 kV), 3.5" rectangular CRT is easy to read. Functionally grouped front-panel controls make for fast, efficient use.

Also from Hitachi is the V-209. A 20 MHz, dual trace, mini-portable scope with many of the same performance and ease-of-use features as the V-509.

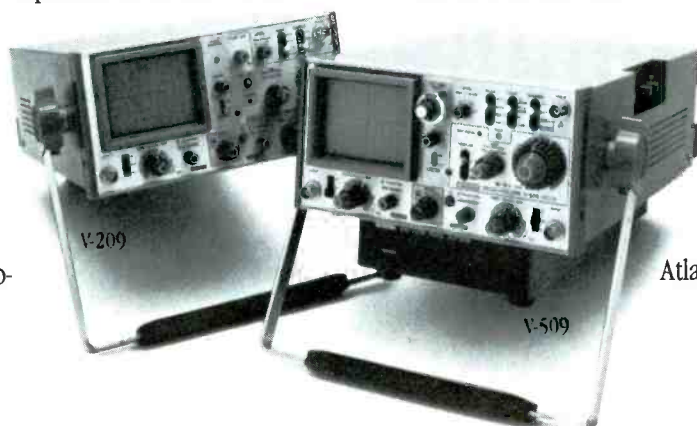

So if you're thinking about purchasing a mini-portable scope, you know who to think of. Hitachi Denshi America, Ltd., 175 Crossways Park West, Woodbury, NY 11797. (516) 921-7200. Offices also in Chicago, Los Angeles, Atlanta, Cincinnati, Dallas, Denver, Seattle and Washington, D.C.

Circle (6) on Reply Card



# Reports from the test lab:

## The Non-Linear Systems TR-1 Tracer

By Carl Babcoke, CET

**Figure 1.** The Non-Linear Systems Tracer model TR-1B includes a small scope that displays characteristic voltage-versus-current waveforms of circuits or components. Internal digital circuits switch between input A and input B when a comparison is desired between a standard and an identical component or circuit undergoing tests. Model TR-1B has internal rechargeable batteries for portable operation. Model TR-1 has no batteries. The diagonal line shown on the scope indicates resistance or capacitance below the range of measurement. In this case, no test leads are connected.

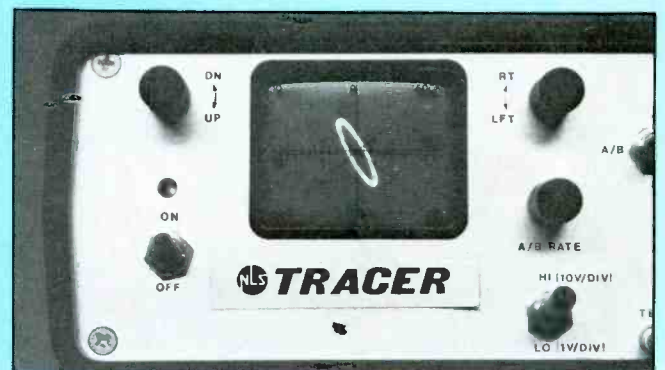

**Figure 2.** Certain values of inductances and capacitances produce oval waveshapes. Left, a 0.003 $\mu$ F capacitor vs. the 10V/division sensitivity setting of the TR-1 created this oval shape and its angle. Right, an audio transformer caused the oval waveshape to tilt counterclockwise (opposite the capacitance tilt).

---

*Each report about an item of electronic test equipment is based on examination and operation of the device in the ES&T laboratory. New and useful features are discussed, along with tips about using the equipment for best results. Personal observations are given about the performance or other important attributes.*

---

### Component/circuit tester

Tracer model TR-1 from Non-Linear Systems tests individual components and circuits by producing a signature waveform that is viewed on the screen of an inter-

nal 1 $\frac{3}{4}$ -inch CRT. Although the basic concept is not new, the machine has several sophisticated improvements that increase the value of the tests as the operation is made extremely simple.

Few operating controls are found on the front panel (Figure 1). Two of the rotary controls center the scope trace (three more scope adjustments are on the rear panel). Two toggle switches and one variable control are the only adjustments used during the component or circuit tests.

Unusual test leads are supplied, including two *hot* leads. Each red or yellow lead has a standard banana plug at one end and a

special probe handle at the other. Inside the plastic probe housing is a conductive metal rod that is long and separately insulated, except for the extreme end, which has a sharp tip. Loosening the safety collar on the probe body allows the rod to be moved so the tip protrudes from the body any desired distance. Then the collar is turned to lock the rod at that position. This insulated tip allows connection to one pin of an IC, for example, without danger of a misplaced probe connecting together two adjacent pins. Both black test leads connect to a single banana plug at the other end. These leads give the effect of two sets of leads, but with



# Function. Pulse. And save.

Global Specialties sets a new value standard. Twice.

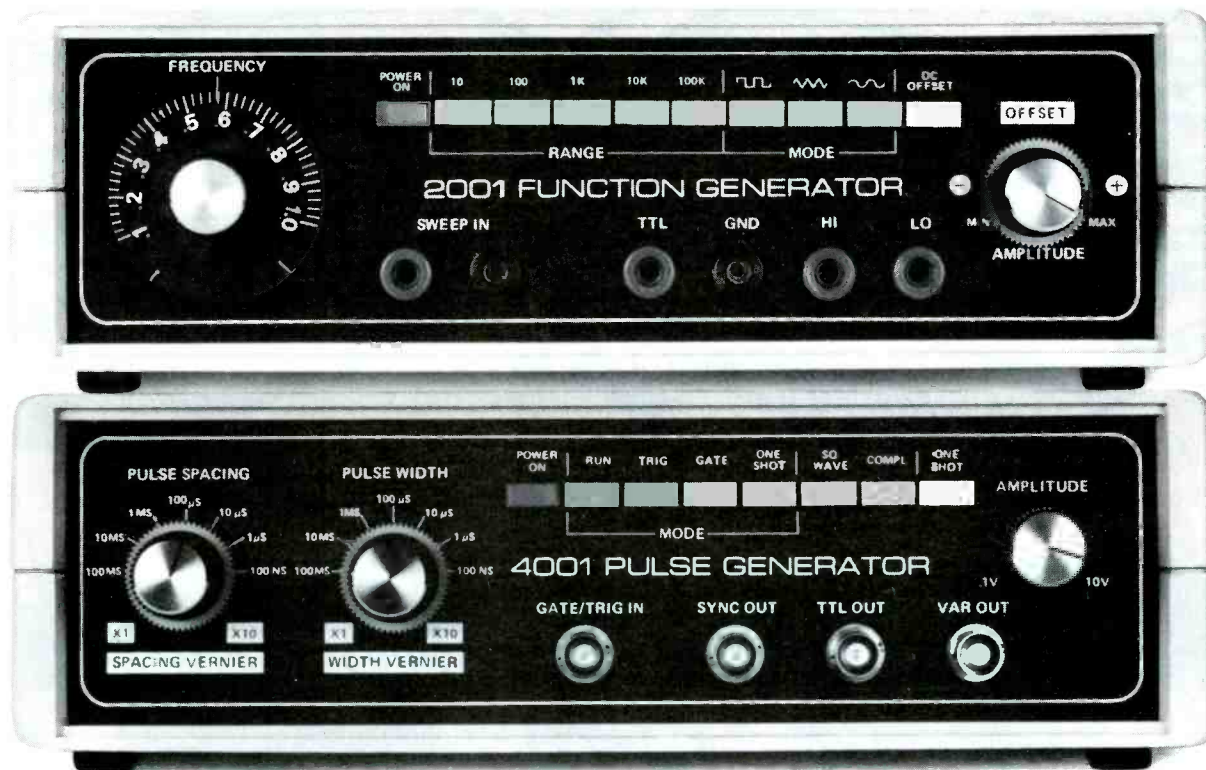

## Model 2001 Sweepable Function Generator. \$200.00\*

Get the waveforms you need — 1 Hz to .1 MHz in five overlapping ranges: stable, low-distortion sine waves, fast rise/fall-time square waves, high linearity triangle waves — even a separate TTL square wave output. Plus high- and low-level main outputs.

An applied DC Voltage at the Sweep input can shift the 2001's frequency; or sweep up to 100:1 with an AC signal.

A pushbutton activates the DC Offset control, which shifts the output waveform up or down on command.

You'd expect to pay a lot more for all the 2001 can do!

## Model 4001 Ultraviable Pulse Generator.™ \$249.95\*

Here's a precision digital pulse generator with fast rise and fall times covering 0.5 Hz to 5 MHz in 5 overlapping ranges. With pulse width and pulse spacing each independently variable from 100 nsec to 1 sec for an amazing  $10^7:1$  duty cycle range.

You'll find the 4001 delivers the pulse modes you need: Continuous, One-Shot, Triggered, Gated, Square Wave, even a Complement mode. The Trigger/Gate input, 50 Ohm variable output, TTL-level output and Sync output connectors are BNCs.

The 4001. Nothing does as much as well for anywhere near the price.

Smarter tools for testing and design.

**GLOBAL  
SPECIALTIES  
CORPORATION**

Call toll-free for details  
**1-800-243-6077**  
During business hours

70 Fulton Terr. New Haven, CT 06509 (203) 624-3103, TWX 710-465-1227  
OTHER OFFICES: San Francisco (415) 648-0611, TWX 910-372-7992  
Europe: Phone Saffron-Walden 0799-21682, TLX 817477  
Canada: Len Finkler Ltd., Downsview, Ontario

\*Suggested U.S. resale. Prices, specifications subject to change without notice. © Copyright 1980 Global Specialties Corporation.

Circle (7) on Reply Card

March 1983 *Electronic Servicing & Technology* 13

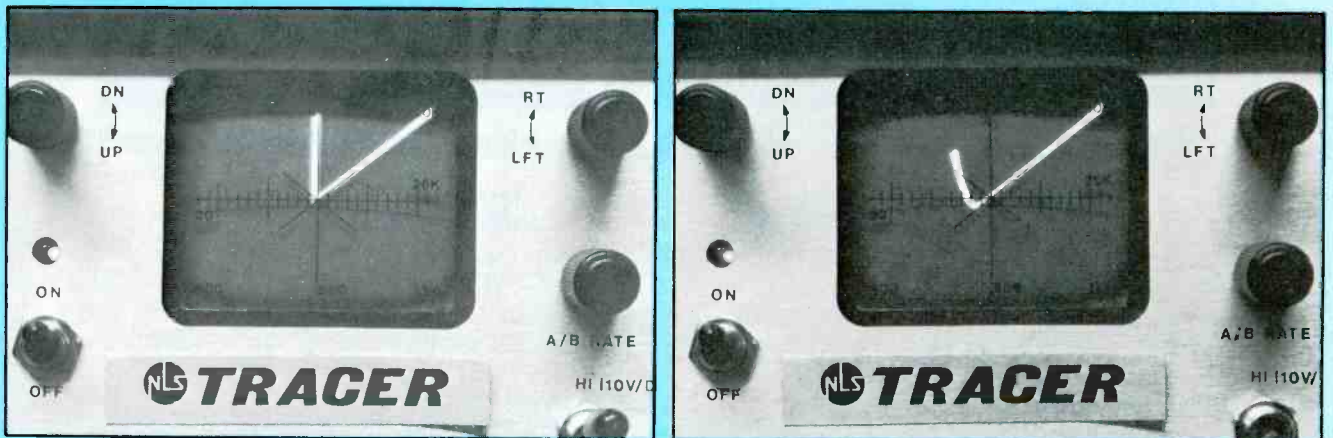
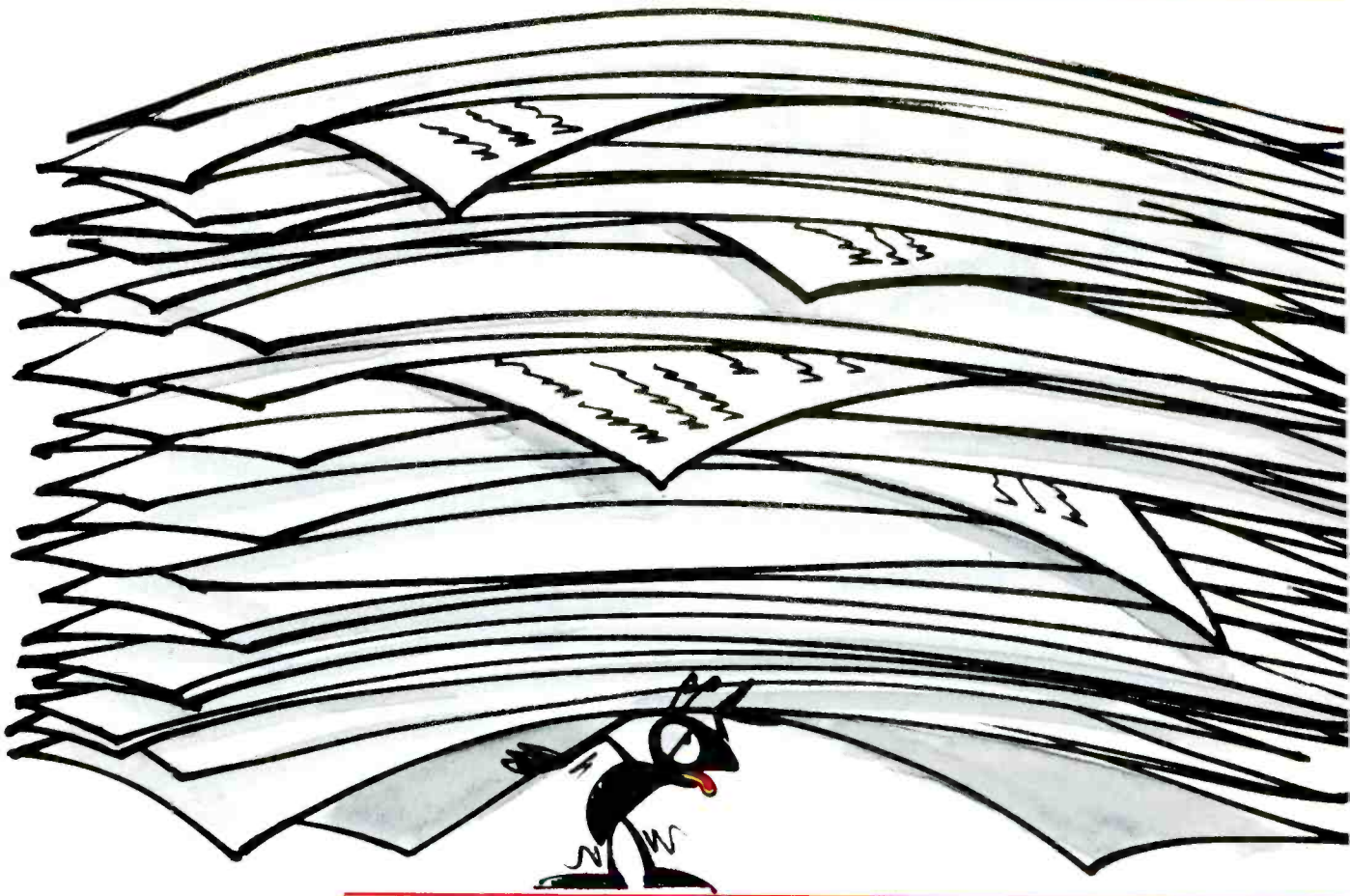

**Figure 3.** Diode waveshapes vary according to polarity and TR-1 sensitivity. Left, with 10V/division sensitivity, this angle was produced by a power-supply diode with anode connected to red test lead and cathode connected to the black test lead. The scope is dc coupled, so zero voltage and current are at the center intersection of lines. Right, with 1V/division sensitivity, the waveshape moved to the left and became a broader angle. Positive voltage is on the left; therefore, current did not flow until the peak voltage was about +0.7Vdc. If the diode had been connected with red to cathode and black to anode, the waveshape would have been the same, but it would have appeared in the lower-left quadrant of the CRT screen. Some components have a more distinctive waveshape on high sensitivity; others should be tested on low sensitivity.

only three banana jacks on the tracer panel.

#### Characteristic waveform

Tracer model TR-1 produces a distinctive waveform for each

basic type of component. Resistors produce a straight line whose angle varies with the resistance value. Capacitors and inductors produce oval waveforms that tilt according to value. Diodes and

transistor junctions show as sharp angles.

These various waveforms are possible by arranging the internal circuit of the instrument so the voltage across a component moves





## We've added 47 pages and 250 new devices to the 1983 SK Guide.

This book carries more weight than any other solid state publication. It is backed by one of the biggest names in replacement devices. RCA. We have been deeply involved in the design, manufacture and testing of solid state devices for decades. When RCA introduces new types, you can trust them to perform reliably.

This year, the RCA SK Replacement Guide is 512 pages strong. With over 2100 SK and KH types available to replace over 170,000 industry types, and a convenient dual numbering system.

Why trust your solid state business to a source that is not involved in solid state manufacturing? Pick up your copy of RCA's hardworking 1983 SK Replacement Guide (SKG202B). See your RCA SK Distributor, or send \$2.50, in check or money order, to RCA Distributor and Special Products Division, P.O. Box 597, Woodbury, NJ 08096.

**RCA** SK Replacement  
Solid State

the scope beam in a certain direction, while the current through the same component moves the scope beam perpendicular to that direction. (This principle was discussed thoroughly in the November 1970 issue of **Electronic Servicing**, beginning on page 26.) The equipment described there was crude but effective, using a 60Hz transformer, a resistor and a service scope. With that system, voltage across the component being tested produced horizontal deflection, and the component current produced vertical scope deflection. An open circuit across the test leads caused a horizontal line, while a dead short produced a vertical line.

Evidently, the model TR-1 is wired differently, because an open across the test probes produces a straight line between northeast and southwest points of the scope screen (Figure 1). A short circuit causes a straight horizontal line. The NLS operating instructions say the X axis represents peak voltage and the Y axis represents

peak current through the circuit.

Also, the operating manual states that the ac voltage is a 2kHz sine wave of 5VPP or 50VPP (according to the hi-lo switch position). The sample had 5.18VPP and 54VPP of a 1.769kHz sine-wave.

When you first begin to use a TR-1, I recommend that you connect it to a component-substitution box and watch the scope screen as you rotate the switch to produce different values of resistors and capacitors. This will show you quickly how the values affect the waveforms.

For example, with the sensitivity switch at the 10V/div position, an open across the test leads causes a straight line between the upper-right and the lower-left corner of the CRT screen. When the resistance is decreased from 10M $\Omega$ , nothing much happens until the resistance reaches 1M $\Omega$ , where the line shortens slightly. At 180K, the line is shorter and definitely has rotated slightly clockwise. As the load resistance is decreased, the

line continues to rotate clockwise and become shorter. At about 26K $\Omega$ , the line is horizontal. Resistances below 26K progressively lengthen the line and rotate it clockwise until a low resistance or a dead short produces a vertical long line. Therefore, total rotation of the line is 135° for resistances.

When the 1V/div condition is selected, the same sequence occurs, but about 1000 $\Omega$  is the highest resistance that gives any movement of the diagonal line. The rotation of 135° tests from 1000 $\Omega$  to 0 $\Omega$ .

Capacitances cause different waveforms. At 10V/div sensitivity, capacitances lower than 0.0001 $\mu$ F produce little change in the diagonal line. As the capacitance is increased gradually in steps, the diagonal line separates into two lines near the center, and at about 0.0005 $\mu$ F the line has become a narrow oval. At 0.001 $\mu$ F, the oval becomes wider as the length shortens slightly. At 0.025 $\mu$ R, the oval widens and





**Figure 4.** This waveform indicates a zener diode is across the test leads. The same waveform is obtained by connecting to the *test* jack on the panel.

begins to move (Figure 2). Maximum width of the oval occurs at about  $0.005\mu\text{F}$ . Larger capacitances narrow the oval, until at about  $0.1\mu\text{F}$ , the trace and retrace sides are almost touching, and the oval is almost vertical. A  $0.5\mu\text{F}$  capacitance reduces the oval apparently to a vertical single line (trace and retrace are identical).

When the sensitivity is reduced to  $1\text{V}/\text{div}$ , a  $0.5\mu\text{F}$  capacitance produces a narrow oval at a  $45^\circ$  angle (about like  $0.0005\mu\text{F}$  at  $50\text{V}/\text{div}$ ). At  $40\mu\text{F}$ , a shorter, narrow oval is at an almost vertical ( $90^\circ$ ) angle. Larger values produce what appears to be a single vertical line (trace and retrace together).

Inductors are more difficult to evaluate, because appropriate samples are not readily available and the dc resistance modifies the waveform. Some give the same oval waveshape and same angle as capacitors do. A few were found to produce an oval rotated counter clockwise from the vertical. At any rate, inductors produce distinctive waveforms that can be tested.

### Diode waveforms

Diodes and transistor junctions are the only components that produce angles on the TR-1 screen. Circuit resistances or capacitances in parallel with a diode under test in power-supply circuits might obscure the diode angles. Some experience is required to evaluate these exceptions to the general rule that circuit components each contribute something to the

characteristic waveforms.

Figure 3A shows the  $45^\circ$  angle produced by a power-supply diode that was tested externally with the  $10\text{V}/\text{div}$  TR-1 setting. The angle does not extend into the adjacent quarter of the screen, and this indicates no reverse current (perhaps from leakage). When the sensitivity switch was changed to  $1\text{V}/\text{div}$ , the waveform moved to the left, across the center line, and became a larger angle (Figure 3B).

Zener diodes produce a double angle, as shown in Figure 4, when the TR-1 voltage exceeds the zener rating. When the waveform from the *test* jack on the TR-1 is viewed (Figure 4), a zener waveform shows on the scope screen.

This zener effect is valuable for identifying emitter from collector in silicon transistors. All silicon transistors have a zener effect between base and emitter, but not between base and collector (germanium transistor junctions never have zener effect). The TR-1 thus can identify which junction of a silicon transistor is B-E and which is C-E with all small transistors. Some power transistors might have a B-E zener voltage above the range of the TR-1, and this possibility must be considered.

### Comparison tests

The highest value of waveform analysis from the TR-1 screen is received when an instant comparison between a normal non-defective circuit is made with another identical circuit that is

undergoing tests. This feature is made possible by the extra test leads and some ingenious internal circuitry in the TR-1.

One front-panel switch is labeled *A*, *A/B* and *B*, and it selects the signature waveform from the A red/black leads, shows the A and B waveforms alternately, or shows the B waveform from the yellow/black test leads.

Also, a variable control that is labeled *A/B rate* varies the switching rate between the A and B waveforms from two per second to four per second. When the two signature waveforms are identical, there is a high probability that the two circuits are also identical.

These waveform-comparison tests are of most value in applications where a standard known-good component or circuit is available. Circuit modules or cards are good examples of appropriate equipment. One large advantage of the TR-1 is that it must be used on circuits and components that do not have power. Therefore, modules can be tested without the complexity of applying proper power sources.

### Comments

The Non-Linear Systems model TR-1B Tracer performed all attempted tests exactly as described in the NLS operating manual. The sample used for these evaluations was factory equipped with internal, rechargeable, sealed lead-acid batteries. A transformer/plug is used at the power line, and a small plug connects the power cable to the back of the TR-1. Charging is said to require 16 hours (if completely discharged). The unit can be operated continuously on ac power, but no appreciable charging will occur until the unit is shut off. A full charge will operate the TR-1 for about six hours before recharging is required.

The heater of the CRT is a de-voltage type with fast warmup. About 5s are required after turn-on before the unit is ready to operate.

Although the NLS model TR-1 appears to be most appropriate in factories or module-overhaul shops, it can function efficiently for many other applications, including general troubleshooting.

**ES&T**



## CET study guide offers helpful hints

A new study guide for the associate-level CET test is now available from ISCET. Edited by Sam Wilson, CET, and published by the International Society of Certified Electronics Technicians, the 80-page book describes the associate test and gives some hints for test takers.

Each section of the test is discussed in detail, with descriptions of what the technician should know. Sample questions with detailed explanations of the answers are included.

Books are \$5 and may be ordered prepaid from ISCET, 2708 W. Berry, Fort Worth, TX 76109.

## Yamaha completes seventh year of service seminar tour

Nearly 250 audio service representatives nationwide took part in Yamaha's 1982 service seminar program, marking the seventh straight year the company has conducted the series of conferences.

Three regional seminars, hosted by top executives from Yamaha, included presentations in Carson City, NV; Rockton, IL; and Virginia Beach, VA.

In addition to providing a forum allowing dealers, service technicians and the customer service managers to exchange information and ideas on audio service and sales, the Yamaha service program presented seminar guests with principles of service management, as well as technical theory and hands-on troubleshooting techniques.

For more information on the program, contact Curt Sidles, service manager, Yamaha Electronics, 6660 Orangethorpe Ave., Buena Park, CA 90620.

## Survey shows trends in electronics sales and service

Electronics sales and service businesses have increased in size

in the past three years, but the major increase has been in the higher technology of the products these companies sell and service. This was pointed out in a survey of persons attending the 1982 National Electronics Service Conference Trade Show, and these were compared with an identical survey made at the 1979 exhibit.

Of the dealers surveyed in 1982, 60% were sales and service and 40% service only—virtually identical to the '79 statistics.

A customer can purchase or

receive repair services for almost any kind of electronic equipment from these dealers, including televisions (90%), video recorders (82%), computers (35%), auto sound or CB (35%), stereo equipment (65%), and industrial and medical equipment. Three products not listed on the 1979 survey have made a significant impact on the electronics business in 1982. One third now sell or service TV games, nearly 50% videodisc players, and 12% are selling and installing satellite dishes.

## The Service Technicians Best Friend.

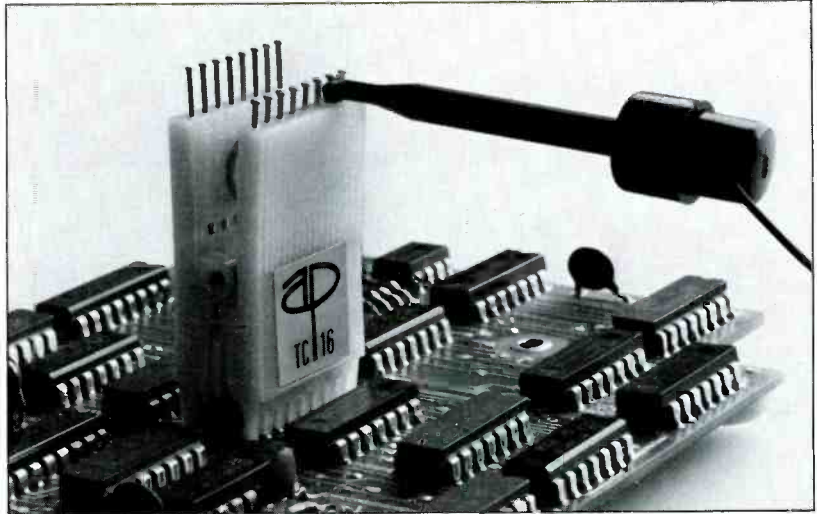

## The A P Test Clip.

When you're testing circuitry, you need the best troubleshooter around: The A P Test Clip.

It's made with a narrow nose shape that allows for easy attachment on high density boards. Nailhead pins that keep probe hooks from sliding off ends. Open nose design that permits probe tip access to DIP leads. And a contact comb that fits between DIP leads, eliminating any possibility of shorts. All these little design differences add up to the ultra-reliable, safe, quick DIP troubleshooting you need.

You can buy A P Test Clips in 56 standard or connector-compatible models in 14 sizes. And every one is made with highest quality engineering and industrial grade materials for long life and reliability.

A P PRODUCTS made the first IC Test Clips... and they are still the best.

Call TOLL FREE, 800-321-9668, for the name of the distributor nearest you. (In Ohio, call collect: (216) 354-2101.)

A P PRODUCTS INCORPORATED  
9450 Pineneedle Drive  
P.O. Box 603, Dept. A  
Mentor, Ohio 44060  
(216) 354-2101  
TWX: 810-425-2250



In Europe, contact A P PRODUCTS GmbH  
Baumlesweg 21 • D-7031 Weil 1 • W. Germany

Circle (8) on Reply Card

# Double your troubleshooting efficiency

By Steve Bowden

---

A combination of a logic probe and an oscilloscope can be a practical, inexpensive alternative to a logic analyzer. With these simple instructions, you can build your own digital scope probe for increased troubleshooting efficiency.

---

Have you ever faced the dilemma of what test equipment you should use with the new digital and microprocessor circuits? After looking at expensive logic analyzers and test clips that tell you everything about the circuit an engineer has to know, I decided that this was not in my budget. The average technician only wants to know if a device has failed and which device has failed, not how to repair an IC.

After working with and teaching digital logic and microprocessors

for several years with conventional equipment, I combined two pieces of equipment that are common on the service bench—the oscilloscope and an inexpensive logic probe. The combination of the two has dramatically improved troubleshooting efficiency.

With the advent of digital circuits in ever-smaller packaging and their use in everything from the space shuttle to a microwave oven, new test equipment is needed. Troubleshooting techniques used most commonly by techni-

cians include the use of an oscilloscope and/or logic probe. The scope is reliable and useful on digital equipment, but has two drawbacks. One drawback is time; the logic probe is much faster. The second drawback is that when checking pins of an IC, the technician's eyes must move from the IC pins on the unit to the scope display. When this is done, the scope probe frequently slips off that pin, with the danger of shorting out the IC.

The digital probe is used as an indicator of a digital pulse or a single state, but does not show information in the digital signal. Therefore, a combination of a logic probe and a scope is used; but with small circuits and 40-pin (or more) ICs,



Figure 1: A combination logic/scope probe.



Figure 2.



the exact pin that was checked with a digital probe is hard to find when changing back and forth.

These are the problems that prompted the development of the combination logic/scope probe. (Figure 1). With this tool, the technician can use the digital probe to isolate the problem to a circuit segment faster than he could with a scope. Then, without removing the probe, he can check the signal at an IC pin or test point.

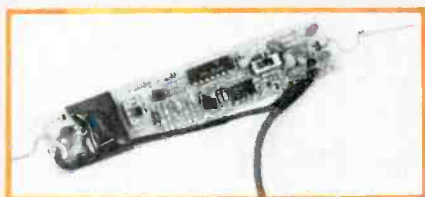

Figure 3.

### Construction

The oscilloscope and digital probe are both high-impedance devices and can be mated together. A broken scope probe can be used for this project if the probe end is the only end which is damaged. The following steps should be followed:

- Cut the probe from the scope lead as close to the probe as possible (Figure 2).
- Remove the case from the digital probe.
- Measure from the back of the probe tip to the ground connection.
- To eliminate interference, the scope ground shield wire needs to be cut as close to the tip as possible (Figure 3). Use heat-shrink tubing on the exposed shield wire.
- Remove black (ground) lead of the digital probe.
- Solder center conductor of scope lead to digital-probe test probe and fasten insulation to PC board (use caution—the scope lead center conductor is very small).
- Solder scope lead shield to where the black or ground lead of the digital probe was removed.
- Replace the case of the digital probe.

Many different combinations of logic probes and scope test lead can be used with minor modifications. A X10 scope probe with capacitor compensation was used on this model, but a direct scope

probe works equally well. The frequencies that are dealt with in digital logic are usually lower than 4MHz and do not need much scope lead compensation.

Any logic probe model you happen to have can be used (I used a B&K model DP-50), but remember to keep all leads as short as possible. Another thing to remember is the use of heat-shrink tubing on the end of the scope lead. This will eliminate any fraying of the shield and prevent shorting out of circuits of the logic probe. Finally,

when soldering the center conductor of the scope lead, care should be used not to break the fine wire.

This should complete the digital scope probe. Note that minor changes to this procedure may be needed because of different types of scope probes and digital probes. The completed probe can be used and connected as a logic probe or a scope probe in a conventional manner. Use a ground lead from the scope to the unit being tested. Connect the red lead to +5V of the unit being tested.

# WANTED 2,500

## EXPERIENCED, HOME SATELLITE TVRO INSTALLERS

We have been asked by some of America's leading retail merchandisers to organize a nationwide network of professional installers for 4GHz and 12GHz TVRO's. Only those firms or individuals who are experienced will be considered for membership.

**NO franchise fees or dues.  
NO obligation of any kind.**

### POTENTIAL FUTURE BENEFITS CAN BE SUBSTANTIAL.

WRITE NOW FOR DETAILS, FREE APPLICATION.



Satellite Antenna Specialists of America  
P.O. Box 1007  
Burlington, IA 52601

Please send me full details and application form. I understand there is no obligation.

NAME \_\_\_\_\_

ADDRESS \_\_\_\_\_

CITY \_\_\_\_\_ ST. \_\_\_\_\_ Zip \_\_\_\_\_

ENCLOSE BUSINESS CARD OR LETTERHEAD

Circle (9) on Reply Card

March 1983 *Electronic Servicing & Technology* 19





Before power was applied, however, I tested the vertical-sweep transistors, finding all three shorted. Also, resistors R571 and R572 were burned. Someone had installed replacement-type transistors, but Sony usually need original replacements.

New, correct vertical transistors were installed, but when the receiver was turned on, no vertical sweep was obtained. A few quick tests showed that the new Q572 bottom-output transistor was shorted.

I installed a second new Q572 transistor and checked every bias diode and resistor in the output stage (all were good). This time, I connected a 23V power supply to the anode of D571 (after disconnecting the anode from the circuit board), set the supply current limiting to 200mA, turned on the TV power, and slowly turned up the supply voltage while scoping the junction of R571 and R572 (emitters of the output transistors). Instead of the expected 84VPP at vertical frequency, I found 225VPP of horizontal-frequency signal. Moving the scope probe to the Q571 collector showed 250VPP of horizontal-frequency signal. However, this point is supposed to be bypassed to ground by C571, a 1.5 $\mu$ F filter capacitor. With one end clipped loose, C571 was tested and found to be open. C558 tested 6 $\mu$ F instead of the rated 220 $\mu$ F. Replacement of both capacitors (and restoring the D571 connection)

brought back the proper pulse amplitudes at Q571 and Q572 along with normal height and linearity.

Overcurrent in the vertical-output stage was not the culprit, rather the maximum voltage rating of the transistors was exceeded, thus causing internal shorts. This is an important lesson to remember any time transistors fail for no apparent reason.

John Russo  
Service Center  
Santa Maria, CA

*Editor's note: A similar repair was described on pages 30-32 in the January 1982 **Electronic Servicing and Technology**, along with an explanation of the D571 and D572 voltage-doubler circuit. We recommend that article for a more in-depth explanation.*

Have a solution to a tough problem? Send it to  
**Troubleshooting Tips**  
**Electronic Servicing & Technology**  
P.O. Box 12901  
Overland Park, KS 66212

We'll pay \$10 for every Troubleshooting Tip published.

**ES&T**



### Outstanding Features:

- 1 mV sensitivity
- 6 KV acceleration potential
- Patented, ultra stable "auto fix" trigger circuit
- Reliability measured in excess of 15000 hrs. MTBF
- 2 year warranty, all parts, labor

# ...MORE THAN MEETS THE EYE!

## SOLTEC® SERIES 5 OSCILLOSCOPES

Look on the inside of any Soltec Oscilloscope! . . . You'll see quality engineering and craftsmanship in a configuration that performs to your needs and expectations.

We offer a complete line of quality scopes to meet your exact needs. 12 MHz - 15 MHz - 20 MHz - 30 MHz (shown) 40 MHz - 60 MHz and 100 MHz, single, dual, triple and quad trace. . . all at competitive prices and available off-the-shelf from a distributor in your area.

Write or call for a full color descriptive catalog or the name of the distributor in your area.

**800-423-2344**

California residents call (213) 767-0044

## SOLTEC® CORPORATION

11684 PENDLETON STREET  
SUN VALLEY, CALIFORNIA 91352

Circle (10) on Reply Card

## Readers' Exchange

**Needed:** OSC transformer P/N T01-27 or entire bias OSC PC board for Kenwood model KW-8077. Also schematic for Shakespeare model 4800 depth and fish recorder. *H.L. Weaver, E909 Francis, Spokane, WA 99207.*

**Needed:** Willing to pay for copies of schematics of Ford radio D00A 18806-0 (Sams AR83) and Hallicrafter's CB24 (Sams CB22). *McHenry's TV, 6225 N. 20th Lane, Phoenix, AZ 85015; 602-249-2325.*

**Needed:** Sencore SG-165 stereo analyzer in good condition. Write, stating price and condition. *Merrill H. Olson, 7808 Aztec Way, North Highlands, CA 95660.*

**Needed:** Schematic diagram for a Calectro VOM, catalog #H3-558 #7212, and out-of-print Sams book 20784, "Collected Basic Circuits." Reasonable prices for each. *David Muratore, 2519 W. Myrtle Court, Fort Collins, CO 80521; 1-303-224-4311.*

**Needed:** Sams Photofacts 1600 through 1900 and RCA 10J107 (JIG ADP). *John Gjerdevig, 507 10th Ave., East, West Fargo, ND 58078.*

**Needed:** Schematic diagram for old radio, GE model E-71. Will pay cost. *Mike Costello, 40 Whiteway St., St. John's, Newfoundland, Canada A1B 1K2.*

**Needed:** Schematic and parts list for model 7501 sun inductive timing light, manufactured by Sun Electric Corporation, Consumer Products Division. Willing to pay copy costs and shipping. *Gil, Five Boro Pneu-Tronics, 1680 Albany Ave., Brooklyn, NY 11210; 1-212-228-8911.*

**Needed:** Schematic and manual for General Precision Laboratory model PD-500 TV camera. *Robert L. Newman Jr., 11441 Heather St., Coon Rapids, MN 55433.*

**Needed:** Buy or borrow RCA training videotape VTT-2, "Video Head Replacement and Interchangeability." *Don's Video Service, 11381 Bootes St., San Diego, CA 92126.*

**Needed:** Manual for Accurate Instrument Company genometer, model 156. *Kenneth Miller, 10027 Calvin St., Pittsburgh, PA 15235.*

**Needed:** Micro motor and pulley #774183 (HL5570894) for Bell & Howell model 3450CST

cassette/stereo receiver. *Jeff Hollinshead, 8930 Rabbit Road N., Greencastle, PA 17225.*

**Needed:** Schematics or service data for Unisonic solid-state TV receiver, model XL-900. *Bill Garbutt, 1680 Kingsbury, Casper, WY 82609.*

**Needed:** Schematic or information on Triumph b&w television, model #RK5601. *Richard Dickover, 6501 W. 82nd Place, Burbank, IL 60459.*

**Needed:** Manufacturing repair manual for Seeburg model LS1 juke box. Advise charges. *Weierbach TV Service, RR1, Box 89, Coopersburg, PA 18036; 1-215-346-7701.*

**Needed:** Schematics for Hallicrafters S38B, EICO HF-12, source engineering noise suppressor. *Chris Hood, P.O. Box 44110, Crafton, PA 15205; 1-412-921-4357.*

**Needed:** Service information on schematic for a Bradford solid-state television, model #56614 (sold by W. T. Grant Company). Will buy or pay for a copy. *Hoglin TV and Appliance, 5020 Zenith Ave., So., Minneapolis, MN 55410.*

**For sale:** Old-time radio/television dealer selling tube inventory; some scarce numbers. Also AR, TSM, CB, etc. *Maurer TV, 29 S. 4th St., Lebanon, PA 17402.*

**For sale:** Conar model 255 oscilloscope and assorted probes, \$150; Sylvania CK 3000 and adapters, \$300; Sencore SS137 sweep circuit analyzer, \$75. *J. R. Hinely, P.O. Box 119, Rincon, GA 31326.*

**For sale:** B&K model 415 sweep marker generator, new in 1981, never used, \$500. Complete manuals and leads included. *Michael Long, McDonough District Hospital, 525 E. Grant St., Macomb, IL 61455; 1-309-833-4101.*

**For sale:** EICO model 232 VTVM with leads, \$45; B&K model 1245 color generator, \$45; EICO model 324 signal generator, like new, \$40. All work great. *D. Carlson, D&E Electronics, 9548 E. Montview Blvd., Aurora, CO 80010.*

**For sale:** Ham radio, Yaesu FT 101, CW-AM-SSB transceiver with 11-meter band CB and 10-15-20-40-80 meters. Excellent condition, 180W out, \$325. Radio station proof-of-performance equipment: B&W model 410 distortion meter, very good condition, \$275, and b&w model 210 audio oscillator, also very good condition, \$225. Both b&ws for \$400. *Sam W. Jacobs, Derry Electronics, 511 W. 4th Ave., Derry, PA 15627, 1-412-694-8822.*

**For sale:** Hewlett Packard dual-trace oscilloscope, model #175A, excellent condition with service manual, \$750. Hewlett Packard dc power supply, model 6433B, adjustable 0-36V, 1-10A, like new,



\$495. R/D Instruments for Research and Development VTVM, model 1600B, excellent condition, \$75. Will sell separately or together; cashier's check or money order; will ship UPS. *Joe LaGuardia, Integrated Electronic Appliance Service, P.O. Box 1151, Homestead, FL 33030.*

**For sale:** B&K sweep marker generator, model 415; B&K TV analyst, model 1077-B; Heathkit sweep generator, model I-057-A. Used very little; mint condition; with instructions. Make offer. *William J. Maida, 341 Isabella Drive, Longwood, FL 32750.*

**For sale:** Leader TV analyst and color bar generator, excellent condition, \$150; RCA TV generator #WR59C, \$25; EICO #388 color bar generator, not working, \$20. All with manuals. *D. Cooper, 2678 Haring St., Oklyn, NY 11235; 1-212-648-1264.*

**For Sale:** Used CRTs, modules, PC boards and transformers. *Hind Electronics Research, 1842 Rollingbrook Drive, Cleveland, TN 37311; 1-615-476-9226.*

**For sale:** Brand new ESR electrolytic circuit tester, \$60; Heath model 0-12 scope, \$65; Heath model V-6 VTVM, \$25. All with manuals. *J.R. Blundin, 151 W. 3rd St., Mt. Carmel, PA 17851; 1-717-339-0402.*

**For sale:** Old Sams Photofacts folders, 100 to 1500, \$4.50 each plus postage or will sell quantity. Also Sams AR-TSM, etc. *Maurer Radio-TV Service, 29 S. 4th St., Lebanon, PA 17042; 1-717-272-2481.*

**For sale:** Heathkit TV post marker/sweep generator, model IG-57A, with manual and leads, \$125. RCA transistor tester, model WT-501A, \$25. *Don's Video Service, 11381 Bootes St., San Diego, CA 92126.*

**For sale:** Heathkit IG 5257 post marker/sweep generator, new, \$175. Leader model LA9-26 audio generator, new, \$100. *Al J. Lemke, Al's Service Center, 10004 206th Ave., NE, Redmond, WA 98052; 1-206-885-7445.*

**For sale:** New B&K 1479A 30MHz trig. scope, \$600; Precision S55A 5MHz student scope, \$75. *E.V. Malone, 3470 Hazelwood, Cincinnati, OH 45211; 1-513-661-5442.*

**For sale:** Tube tester, \$95; alignment generator, \$35; Beltron picture tube restorer, \$175. *WSEP, 318 S.K., Sparta, WI; 1-608-269-2392.*

*Readers' Exchange* items are listed for free, but are limited to three items per person for each issue. "For sale" items must consist of used equipment, parts, etc., owned by individuals and not new items for sale by companies or manufacturers. If you can help with a request, please write directly to the reader, not to **ES&T**.

**DESOLDER-IT, CLEAN-IT, COAT-IT, FREEZ-IT... SEND FOR IT!**  
Our new electronic problem solving catalog and **Free Chem-Wik®** samplers!

**Chemtronics**  
681 Old Willets Path  
Houppauge, N.Y. 11788  
800-645-5244  
In NY 516-582-3322  
Telex 968567

Circle (11) on Reply Card

## FINALLY. COMPUTERS AS A NEW TOOL FOR T.V. REPAIR.



**Primefax puts computer-assisted repair capability in your shop today.**

Primefax drastically reduces the number of sets requiring extensive trouble-shooting procedures.

Through the use of today's technology, Primefax maintains—in a central computer—a database of problem-solving solutions for television set malfunctions.

Primefax is a compilation of the most current, applicable technical information acquired from hundreds of valuable sources... and updated daily.

With a Primefax Computer Terminal installed in your shop, you can do your job more quickly and more

accurately. You have more satisfied customers, and your profits are increased substantially.

Reduced call backs • faster turn-around • reduced chance of repeated failure • more thorough service and complete repair at reasonable cost.

The more Primefax is used, the more profit you realize.

**CALL US OR WRITE.** No matter how you compute it, Primefax means profit for you. It's worth looking into.

In Texas, call (512) 344-5999 • Out of Texas, call 800-531-5953



4825 Fredericksburg Road • San Antonio, Texas 78229

Circle (12) on Reply Card

# How to service arcade video games

By Don Thorne, CET

The popular Pac-Man arcade video game is said to have 84 ICs on the main logic board. Although this gives a hint about the digital complexity of video games, practical repairs usually are not difficult. Each game has a microprocessor, but technicians are not required to understand completely how it operates internally.

Arcade-type video games usually have the following basic sections:

- a cabinet with regulated power supply for the digital circuits;
- a TV monitor (similar to a TV receiver, but without tuner, IFs and conventional video stages);
- one double-sided circuit board about the size of these magazine pages; and
- a control panel with buttons and switches or a joystick for the customer's communications with the digital microcomputer, which in turn reacts by changing the video pattern according to the original programming.

Figure 1 shows a simplified block diagram of a typical commercial video game. Sufficient practical information for technicians wanting to begin servicing arcade games is presented in this article.

## Power supplies

Most malfunctions occur in the dc-voltage power supplies. Therefore, they are described first. All dc power for the digital circuitry is on one chassis that is separate from the monitor and the digital board. A large power transformer has an isolated 120Vac winding for the monitor (which then may have a hot chassis), and three or four separate low-voltage secondaries that feed the various rectifier and regulation circuits. Usually the dc outputs are +5V standard source, -5V and +12V (for memory and microprocessor chips).

In addition to the usual ac-line fuses, there are safety interlocks

that turn off all ac power when a cabinet door is opened. During repairs, these interlocks can be reactivated manually by the technician by pulling the plastic stems to the *on* position.

Voltage tests points are easily accessible. The rectifier/regulator circuit board has printed legends showing the ac-voltage-in and dc-voltage-out points.

Most regulated supplies have *crowbar-type* protection. Any overcurrent condition activates a dead short across the supply output, and this massive short blows a fuse or trips a circuit breaker, thus preventing damage to the regulator, rectifiers and power transformer.

Most video-game problems originate in one or more of the dc-voltage power supplies. Therefore, wasted time can be prevented if a technician tests these voltage sources first. For example, poor regulation of the main +5V source can produce a single vertical or horizontal line that might be mistaken for a bad microcomputer card.

## Picture and color generation

Obsolete b&w arcade games used fuse-link PROMs (having limited memory) to determine geometry and movement, while a multitude of gates performed the game-play instructions. However, the circuits were not simple, with some circuit boards containing as many as 400 individual ICs, none larger than 16 pins. Even so, the games were elementary compared to the complexity of present-day programs.

Brains of the new arcade games in color are the microprocessor CPUs that draw pictures on the CRT by proper placement of many separate dots. Each dot is called a *pixel*, which is one bit of information stored in the memory ICs. The CPU constantly updates the status of each individual pixel, including the *on* or *off* state (illuminated or nonilluminated dot on CRT screen) and the color. Almost simultaneously, the CPU is giving instructions to the customer about playing the game and keeping a count of the score.

Programs have 65,536 possible

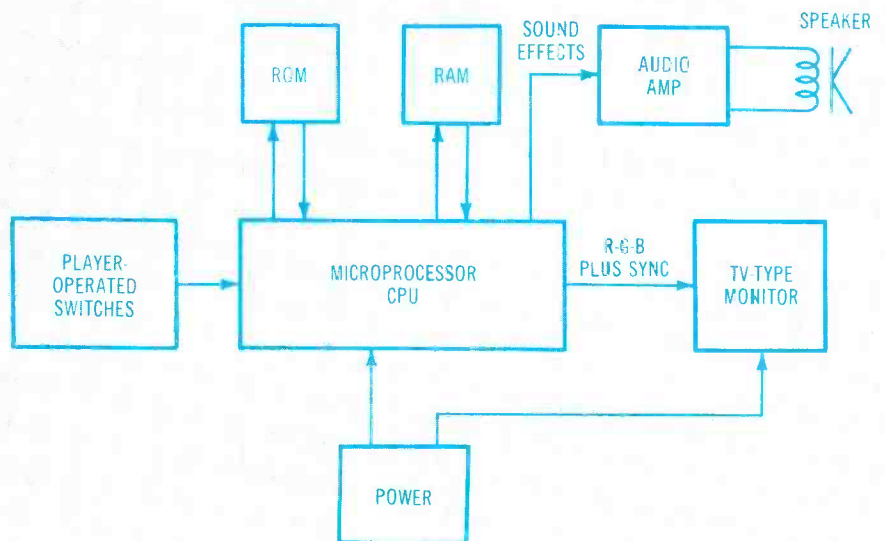

Figure 1. These are the essential sections of commercial arcade-type video games.



pixels. Higher numbers of pixels provide sharper pictures, but more bits of memory are required. These 65,536 pixels might be arranged in 256 vertical rows and 256 horizontal rows (do not confuse these with scanning lines). However, that would produce a square picture, thus wasting screen area at both edges of the CRT screen.

A better arrangement has only 224 active horizontal lines of pixels and 256 vertical rows of pixels, as shown in Figure 2, thus producing 57,344 pixels or bits. The computer retains a large memory map and constantly updates any changes. The map is made of grids, and each grid has 64 bits or pixels arranged in eight vertical and eight horizontal rows. Because there are eight bits per byte, each square grid is one byte square.

Three electron beams in the monitor's picture tube are deflected exactly as in a conventional color receiver. However, these beams are biased for zero current or maximum current by the computer as it draws a picture. There are no I, Q, X or Y demodu-

Symptom	Possible defect
No video (black screen)	Master oscillator dead or +5V supply missing
Picture rolls	Horizontal or vertical address signal missing or compressed
Multiple, overlapped pictures	Frequency divided incorrectly in vertical or horizontal counter
Vertical or horizontal bars on screen	Data output missing at one or more video-matrix RAMs
Symbols or alphanumerics fill the screen	Invalid memory state, possibly a defective ROM
Mode missing from game operation	CPU IC might be defective

These typical symptoms are produced by defects in the CPU digital system.

lators for color, and there is no luminance (b&w) signal. Maximum brightnesses of the three colors on the screen are adjusted by three color-drive controls.

Because each color either has maximum brightness or zero brightness, the picture-tube drive

signals are all pulses of the same amplitude. These pulses include composite sync, a blue-drive signal, a green-drive signal and a red-drive signal. All are supplied to the monitor by the CPU and its allied ICs.

As shown in Figure 3, six

# JAPANESE SEMICONDUCTORS

<p><b>SANYO</b> <b>STK-435</b> \$4.10 </p>	<p><b>SANYO</b> <b>STK-437</b> \$6.50 </p>	<p><b>ZENER DIODE KIT</b> <b>ZDK-23</b> Most popular zener diodes in kit of 23 Plastic Cabinet \$11.95 </p>	<p><b>SANYO</b>  <b>2SC1308K</b> \$1.99</p>	<p><b>TOSHIBA</b>  <b>2SC1172B</b> \$1.99</p>
---	---	--	--	--

<b>TRANSISTORS</b>	A808 3.18 2SA329 32 A473 56 A483 5.57 A489 1.54 A490 81 A495 16 A496 45 A509 36 A545 41 A606 1.99 A607 2.28 A626 3.66 A627 2.03 A634 64 A661 36 A682 50 A684 32 A699A 64 A705 58 A706 1.26 A719 20 A722 20 A738 43 A740 2.35 A745A 6.64 A747 7.02 A747A 7.50 A748 92 A750 14 A762 4.15 A771 2.06	B697 3.23 2SC352A 2.73 C371 32 C272 16 C380A 14 C381 28 C382 40 C383 46 C387A 34 C388A 52 C394 18 C458 14 C486 1.99 C495 52 C496 45 C497 1.56 C517 4.40 C537 16 C563 63 C627 1.28 C642A 3.86 C642B 1.36 C708 1.51 C710 16 C732 14 C733 14 C735 28 C756A 1.40 C756B 1.99 C784 28 C785 28	C789 1.20 C799 1.50 C829 14 C830H 2.71 C838 36 C839 20 C840 162 C867A 2.80 C895 5.09 C900 20 C941 25 C945 11 C959 1.17 C960 1.10 C1012 1.36 C1025 90 C1034 5.60 C1047 18 C1050 1.71 C1061 56 C1096 40 C1114 3.45 C1115 4.06 C1116A 4.13 C1124 99 C1127 1.90 C1161 1.95 C1166 50 C1169 5.69 C1172B 1.95 C1173 52 C1209 28	C1212A 58 C1213 18 C1215 28 C1256A 40 C1239 1.50 C1279 40 C1306 97 C1307 1.72 C1308K 1.99 C1316 3.40 C1348 43 C1364 25 C1367 27 C1384 29 C1403A 3.21 C1413A 4.97 C1419 56 C1448 1.20 C1567A 5.66 C1568A 2.00 C1575 14 C1588 66 C1678 105 C1728 81 C1760 82 C1815 11 C1816 2.26 C1818 36 C1904 36 C1951 1.44	C1959 30 C1973 61 C2028 58 C2029 1.52 C2074 97 D566A 1.51 D566A 1.71 D600 45 D613 80 D733K 2.50 D72 65 D62 1.66 D53 1.72 D157 2.51 D180 1.89 D187 2.03 D201 1.43 D226A 1.49 D234 82 D235 82 D287A 2.97 D313 45 D315 1.02 D350 3.99 D353 2.82 D357 61 D358 66 D381 76 D386A 79 D424 3.03 D425 3.03 D426 2.89 D438 34 D467 16 D468 16	D470A 2.51 D471 25 D525 90 D529 81 D555 4.51 D586A 1.43 D586A 1.71 D600 45 D613 80 D733K 2.50 D823 94 FET 2SK15 45 2SK30A 34 2SK45 78 IC AN214Q 1.50 AN239 5.43 AN247 2.99 AN274 2.25 AN313 2.79 AN315 2.00 AN362 1.41 AN374 99 AN612 1.35 AN7145 2.46 AN7150 2.33 BA511A 1.44 BA521 1.23 BA532 1.62 BA1310 1.56 HA1137W 1.12	HA1138 1.36 HA1151 1.62 HA1156W 1.26 HA1196 1.36 HA1197 1.26 HA1199 1.43 HA1201 76 HA1202 94 HA1306W 2.08 HA1319 2.75 HA1329 1.62 HA1339A 1.84 HA1342A 1.84 HA1361 2.08 HA1366WR 1.89 HA1377 2.93 HA1398 4.22 LA1365 1.26 LA3350 1.10 LA4032P 1.66 LA4400 1.90 LA4430 1.36 M51513L 1.69 M51515BL 3.05 MB3705 1.54 MB3712 1.51 MB3730 3.18 MB3756 1.10 MB3719 4.78 PLL01A 3.66 PLL02A 6.34	STK0025 3.88 STK0050 5.87 STK0080 10.60 STK013 7.70 STK105 3.20 STK032 7.85 STK040 7.42 STK043 8.80 STK078 7.75 STK080 7.85 STK430 5.50 STK433 4.00 STK435 4.10 STK437 6.50 STK439 6.80 STK463 9.55 STK502 7.50 STK503 7.50 TA7055P 1.99 TA7060P 70 TA7061AP 90 TA7063 56 TA7074P 2.05 TA7075P 2.05 TA7078P 3.39 TA7120P 58 TA7130P 97 TA7201P 2.03 TA7203P 2.30 TA7205A 1.35 TA7205AP 1.20 TA7214P 3.41	TA7222AP 1.87 TA7227PK 4.04 TA7310P 1.02 TC4081P 58 TC5080P 5.42 TC5081P 2.19 TC5089P 5.87 UHC001 4.07 UHC003 4.07 UHC004 4.07 UHC005 4.07 UHC41C 2.19 UPC157A 2.19 UPC437 2.15 UPC555H 45 UPC571C 2.44 UPC575C 3.18 UPC576H 1.10 UPC577H 72 UPC592H 2.44 UPC1001H 2.89 UPC1008C 2.44 UPC1016C 2.44 UPC1020H 4.06 UPC1025H 4.06 UPC1026C 88 UPC1032H 72 UPC1154H 2.43 UPC1155H 1.69 UPC1156H 1.69 UPC1181H 1.28 UPC1182H 1.28	UPC1185H 3.11 UPC1186H 1.56 UPC2002 1.43 UPC1435 1.74 UPD857 6.50 UPD858 6.50 UPD859C 5.87 DIODES GH3P 89 SI330 15 1.39 IN60 14/100 IN4001 10/100 IN4002 12/100 IN4003 12/100 IN4004 12/100 IN4005 15/100 IN4006 16/100 IN4007 20/100 SILICONE RECTIFIER 2.5 Amp-1000 Volts SL-100 10/100
--------------------	---	---	---	--	---	--	---	---	--	--

## OMNITRON ELECTRONICS

770 Amsterdam Ave., New York, NY 10025

➤ Also ask for Free 100 Page Catalog ◀

Send Purchase Order, Check or Money Order  
or Call Toll Free 800-223-0826  
in NY STATE (212) 865-5580  
All ORDERS SHIPPED UPS/COD F.O.B., N.Y.C.

MASTER CARD • VISA  

Circle (13) on Reply Card

saturated colors can be made by turning the red, blue and green CRT currents on or off, either singly or in combination. Also, a near-white is produced by all three

colors, while black is obtained when no colors are present.

### Game operation

Player movements, credits,

coins deposited and other necessary conditions are encoded into the computer's language by the input-output port known as the *peripheral interface*. Each switch and condition is assigned a binary code, which then is interpreted by the peripheral interface and recognized by the central processing unit (CPU). For example, the start-button switch might be known by the CPU as digital 01101100.

The CPU is an elaborate traffic controller of data rushing at high speed along interconnecting highways known as buses. Each time cycle is divided into a schedule of events. Specific times are allocated for reading the player-controls status, for reading instructions from the data stored permanently in read-only memory (ROM) ICs and for executing orders.

For example, the CPU can perform a calculation and temporarily write it down on random access memory (RAM) "scratch paper." The information will be retrieved later and then erased to make room for new storage. Instructions can be modified by subroutines and stored in the same manner.

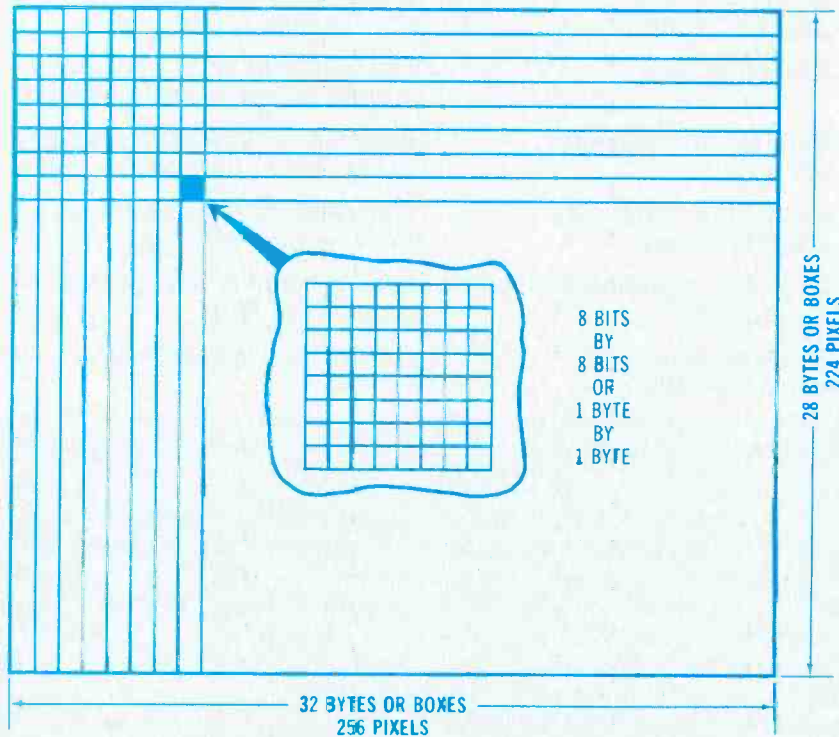

Figure 2. The location (or X/Y address) of each picture element (pixel) on the CRT screen is determined by the intersection of two vertical rows of bytes and two horizontal rows of bytes. Each box formed by the intersections is a square byte, consisting of 64 bits or pixels. A complete picture can have a maximum of 57,344 pixels.

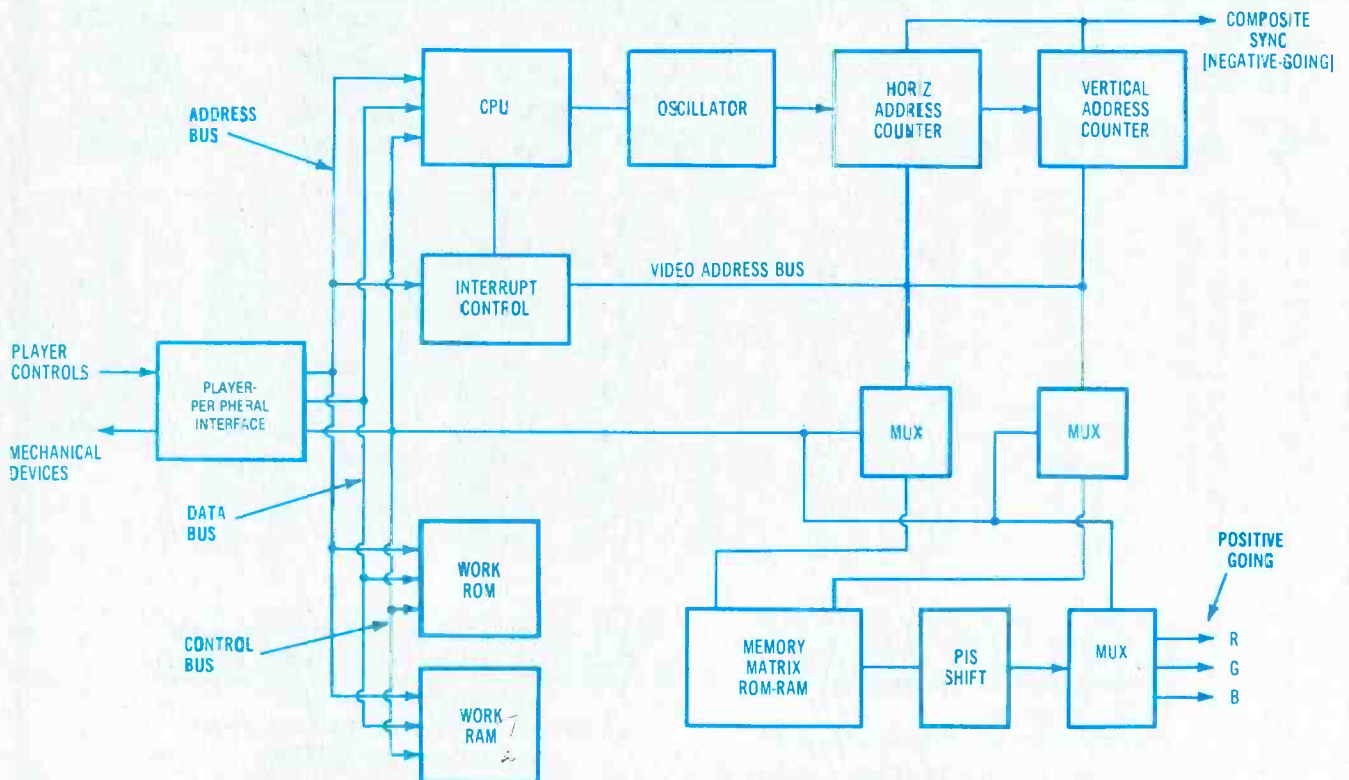
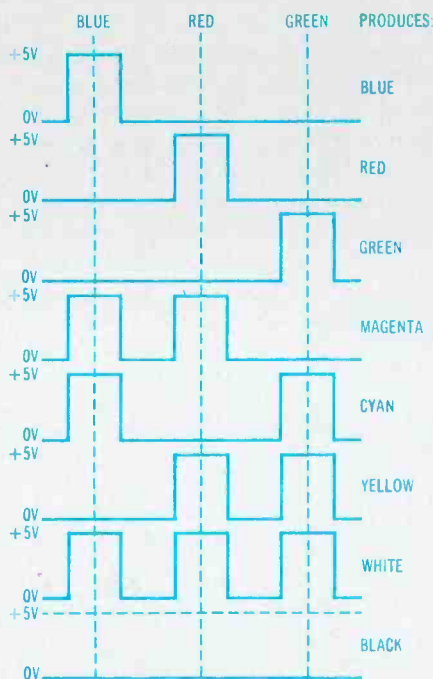

Figure 4. The block diagram of a commercial video game (without monitor) is not complicated.





**Figure 3.** All three channels of video from the CPU have positive-going digital pulses that (after processing and amplification) control conductions of the three CRT electron guns. Each gun has full current or none. Red, blue or green are obtained on the CRT screen by conduction of a red, blue or green gun. Conductions of red and blue guns simultaneously produce magenta; blue and green yield cyan; red and green produce a greenish yellow. All three colors simulate white, and the absence of any gun conduction produces black. These are the only screen colors possible with video games. When the pulses are at +5V, the designated guns conduct. When the signal is at 0V, the guns do not conduct.

### A typical game

Most arcade games today employ the Z80 microprocessor by Mostek. The Z80 is compatible with Intel's 8080A, except the Z80 has a cycle time of  $0.25\mu\text{s}$ , compared to  $20\mu\text{s}$  for the 8080A.

EPROMs became widely used in arcade games once the price was reduced, and the formerly used masked ROMs were abandoned. An early EPROM, the 2708 (1K-by-8), was used for years, but was replaced by the 2716 (2K-by-8). The 2716 requires only a single +5V supply, while the 2708 required +5V, -5V and +12V supplies, all regulated. Newer machines use the 2732, which features 4K bytes in the same 24-pin DIP package.

In the Figure 4 sample game, instructions about playing the game are stored in permanent-memory ROMs (usually about 32K bytes). Work RAMs (about 2K bytes)

serve as scratch paper for sub-routines. An interrupt control provides a break in the CPU's activities to display its present status or an indication of changes (for example, as a space ship moves element by element across the screen).

Actions such as the ones in the previous paragraph take place at the CPU's lightning speed, but things slow down with the display circuitry. Synchronous up/down divide-by-16 counters address the vertical and the horizontal positions. (Also, these counters provide sync for the monitor.) Each count addresses a vertical and horizontal line intersection that forms a specific X/Y coordinate.

These X/Y coordinates are addressed to the memory matrix, which is made up of about 7K of ROM/RAMs. ROMs determine the character shape, the size, the starting position and the color. RAMs are continually updated with changes in these variables.

When an object appears to be moving smoothly across the screen, it is actually advancing pixel by pixel. In slow motion (if this were possible), the point-by-point movement would be clear. However, the individual still pictures are updated rapidly so they appear to be continuous.

The monitor must scan one horizontal line at a time on the screen, so the X/Y coordinates are incompatible, requiring conversion from parallel bits to serial trains, which then are multiplexed and used to turn on and off the proper color guns. As stated before, each gun is either fully conducting or biased to cut-off.

### Monitor facts

Most monitors are the red/green/blue, standard-resolution type with in-line-gun picture tubes. The video input requires positive-going pulses, while the sync requires negative-going pulses. Video response is -3dB at 6MHz.

There are no chroma demodulators. Instead, individual red, green, blue and sync TTL-level pulses are supplied to separate buffer amplifiers (Figure 5). If CPU positive-going sync polarity is encountered, a phase inverter can be switched into action. A black-level adjustment is often included to set the blanking-voltage

# Test computer terminal CRTs

with a  
**B&K-PRECISION**  
portable  
CRT analyzer



Model 467  
\$495

Now you can save time and reduce call-backs by field testing most any monitor or computer-terminal CRT. The B&K-PRECISION 467 CRT restorer/analyzer provide a definite "yes or no" answer to tube condition on an easy-to-read meter. It offers fast set-up and testing and measures true dynamic beam current. All CRTs are checked identically—including all color "in-line" and "one-gun" types. Checks virtually all types of terminal CRTs.

In addition, the 467 offers a powerful digitally controlled CRT restoration method so that you'll be able to extend the life of many "bad" CRTs and guarantee results.

- Exclusive multiplex technique tests all three guns of a color CRT simultaneously
- Exclusive circuit tests focus-electrode lead continuity
- Obsolescence proof: perpetual set-up charts available
- Improves profitability by reducing call-backs—repair a terminal in one trip instead of two!
- Entirely self contained; weighs only 10 pounds

For additional information and the name of your local distributor, call toll-free 800-621-4627.

**B&K PRECISION**

**DYNASCAN CORPORATION**

6460 West Cortland Street  
Chicago, Illinois 60635 • 312/889-9087

Int'l. Sls.: 6460 W. Cortland St., Chicago, IL 60635  
Canadian Sales: Atlas Electronics, Ontario

Circle (14) on Reply Card

level. Sync pulses are separated and used to control vertical and horizontal deflection circuits. The red, blue and green TTL-level video pulses are amplified by three transistors and applied to the picture tube.

Figure 6 shows drawings of horizontal and vertical sync pulses with blanking. Notice that these do not conform to NTSC color-TV standards. Also, non-interlaced scanning is employed. Of course, some video-game sync pulses will show significant variations from these drawings, according to the individual design of the CPU circuitry.

The monitor assembly has open-frame construction, which usually supports a 19-inch, in-line, color CRT. Vertical and horizontal sweep circuits, power supply, adjustment pots, width and centering adjustments and other essentials are on the chassis.

### Troubleshooting

Servicing microprocessor circuits is seldom a straightforward testing of inputs vs. outputs. A short circuit on one data line can simulate many separate problems, and checking each data line with a scope is time consuming.

Signature analysis can be a valuable aid. The game manufacturer usually supplies an overlay that covers the schematic and shows number codes for each bus line and testpoint. Then the signature pattern of each bus is tested by an instrument no larger than a digital multimeter.

Most problems can be isolated quickly with a little reasoning and probably will not require removing the circuit board. Surprisingly, mechanical connectors are about the most common sources of problems. Some microprocessor systems today use several individual circuit cards with ribbon cables between them in connecting data and address buses. Stress sometimes tears a cable at the edge. Another basic type uses a card-cage assembly where several boards are plugged by their edge connectors into a mother board. After a board has been removed and reinstalled several times, it is not unusual for a solder joint to break.

Many ICs are inserted into DIP

sockets. Sometimes a pin will crack inside a socket, or a pin might have been folded under the chip body during factory installation so the pin makes intermittent connection.

Replacement of suspected ICs

usually locates defects more rapidly than trying to find the problem with a scope. Be careful not to touch IC pins when you replace chips. Many ICs are MOS devices that can be ruined by the smallest static-voltage spark. And of

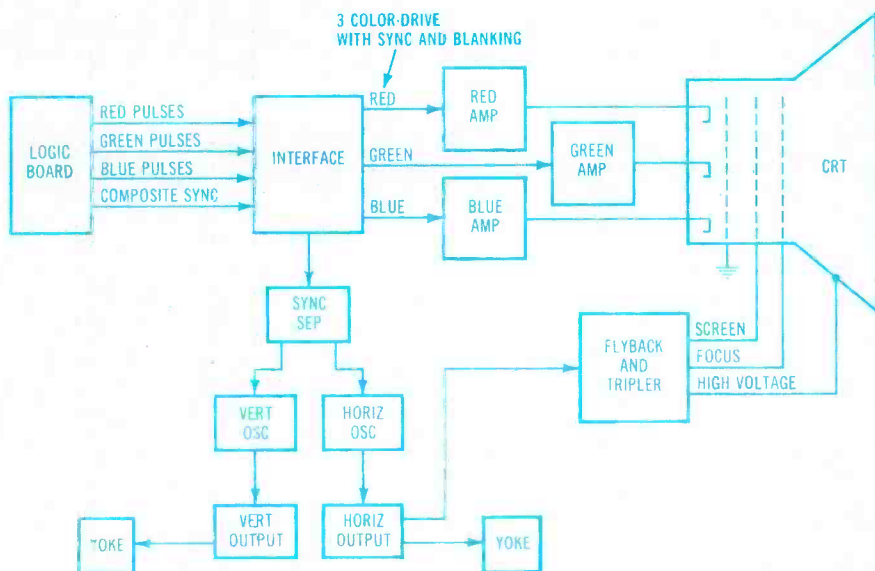

Figure 5. The block diagram of a typical monitor shows similarities to the deflection systems and final video stages of a color TV receiver. Notice the absence of tuner, IFs, demodulators and chroma sections.

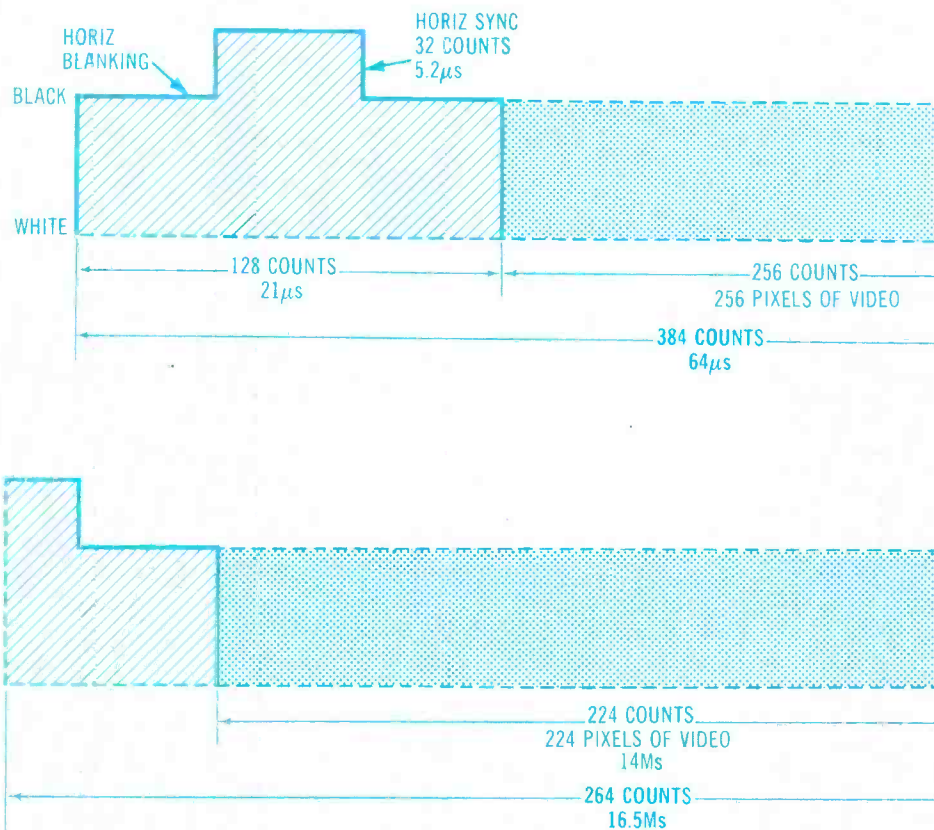

Figure 6. Video-game vertical and horizontal blanking and sync waveform are different from the conventional NTSC waveforms in TV receivers. Scanning is not interlaced. (A) Horizontal blanking occupies a third of the total sweep time, with the sync pulse at the center (not offset as in NTSC). (B) Vertical blanking also is wider than its NTSC counterpart, while the vertical sync is not serrated.



course, turn off the line power before removing or installing any integrated circuit. Good insertion and extraction tools are available, but I always have used a pocket-sized screwdriver blade to give leverage against the stubborn ones. When inserting an IC by hand, it is easier to seat all pins of an IC if the pins are pressed sideways against a flat surface to align them.

### Monitor adjustments

Minor touchups of various adjustments are sometimes needed, particularly after a microprocessor circuit board is replaced. However, these adjustments are usually limited to size, centering, focus and locking.

Remember, monitors are factory adjusted for an undersized picture to allow for screen area covered by bezels and screened glass overlays during final assembly. If you make size and centering adjustments with the CRT in proper position, no allowances need be made. However, this must be allowed for if adjustments are made when the monitor is not in the cabinet.

Centering is adjusted by two jumper wires with spade clips, which are moved to a choice of

horizontal-hold controls usually compensate for minor frequency errors, but these should not be left at their limits. If that appears to be necessary, go through the complete oscillator set-up sequence. *Never lower the B+ to reduce the picture size.*

These monitors have automatic degaussing, but defective components of the system or unusual outside magnetic fields might make external degaussing necessary at times. Purity adjustments on the CRT neck are identical with those in home TV receivers that have the same type of picture tube.

Checking for misconvergence can be a problem with video-games monitors, because most crosshatch generators used for home TV receivers are connected to the receiver antenna terminals. However, these games have pure red, green and blue video signals without tuners, IFs or color demodulators. Generators specifically designed for video games can be ordered from:

Contracts Marketing  
Electrohome Electronics  
809 Wellington St., North  
Kitchenere, Ontario, Canada  
N2G-4J6 (1-519-744-7111,  
ext. 567)

Convergence adjustments using the 4- and 6-pole magnets on the CRT's neck are similar to those in color receivers that have the same type of picture tube.

### Comments

Service manuals are readily available from the individual manufacturers of arcade video games. These manuals provide schematics, voltage testpoints and typical scope patterns. Replacement components can be ordered by part number from each manufacturer or sometimes cross-referenced to universal replacements.

Troubleshooting and repairs of video-game monitors should be simple for technicians experienced in servicing color TV receivers. As explained, replacements of various ICs should locate most defective chips. Skills needed to troubleshoot the CPU will develop gradually as each technician matures in experience gained from actual repairs.

**AS&T**

# THE MIDGET WRENCH WITH THE GIANT GUARANTEE.

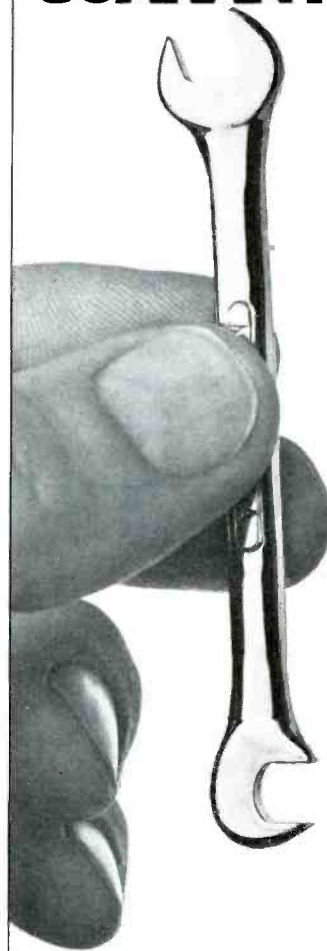

Like all Easco tools, Easco's midget wrenches are guaranteed for life. They're cold formed, heat treated, chrome plated and polished. Box end, open end and combination wrenches in a broad range of sizes. For more information write: Easco Hand Tools, Inc., 6721 Baymeadow Drive, Glen Burnie, Maryland 21061.

**Easco**®

Circle (15) on Reply Card

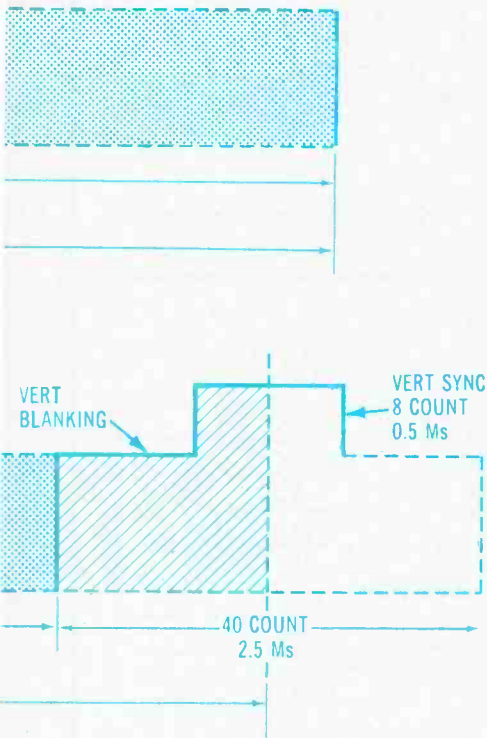

several tabs. One jumper moves the vertical centering, while the second jumper changes horizontal centering. Vertical-hold and

**Chassis – Sylvania E53-2**  
**PHOTOFACT – 1988-3**

1

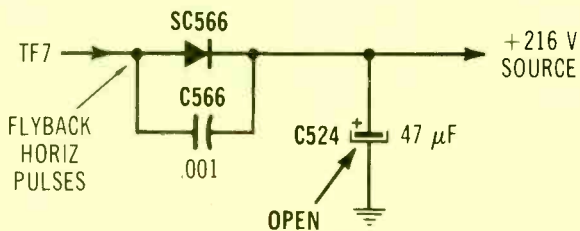

**Symptom** – Vertical color bands on black background; sometimes has shut-down  
**Cure** – Check filter capacitor C524, and replace if open

**Chassis – Sylvania E48-11**  
**PHOTOFACT – 1996-2**

2

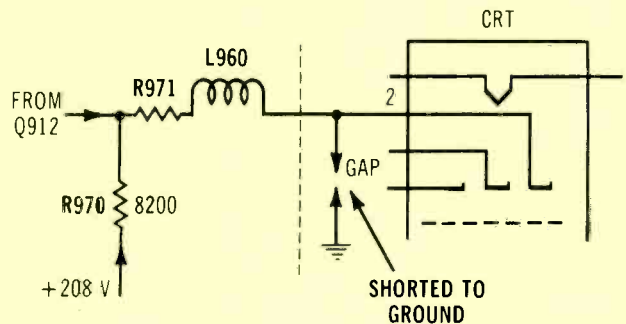

**Symptom** – Bright red screen with red retrace lines  
**Cure** – Check for shorted CRT socket; pin 2 (or spark gap) shorted to ground strap

**Chassis – Sylvania E51-4**  
**PHOTOFACT – 2009-2**

3

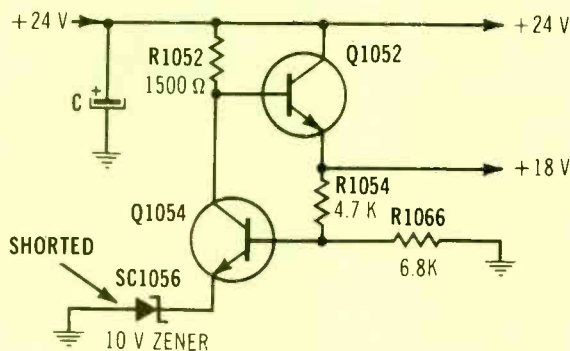

**Symptom** – No sound, picture or power  
**Cure** – Check for +18V supply; if missing, check zener SC1056

**Chassis – Sylvania model MWA156W B&W**  
**PHOTOFACT – 2092-2**

4

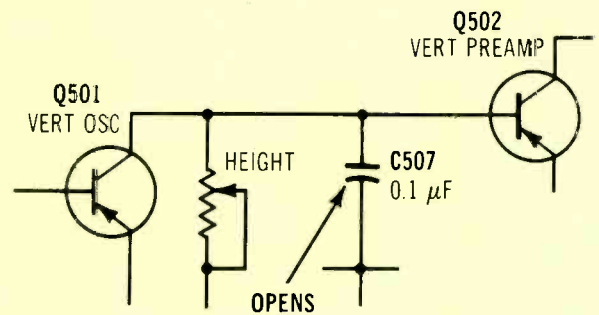

**Symptom** – Erratic height collapse  
**Cure** – Check capacitor C507, and replace if intermittent

**Chassis – Sylvania model MWA156W B&W**  
**PHOTOFACT – 2092-2**

5

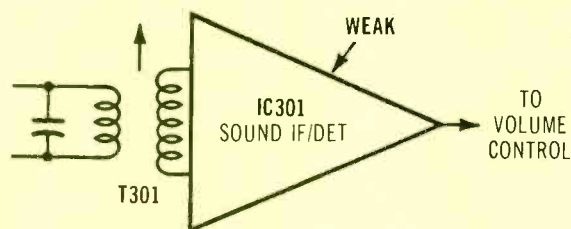

**Symptom** – Weak but undistorted sound  
**Cure** – Replace IC301 sound IC, even if dc voltages are normal

**Chassis – Sylvania E32-22**  
**PHOTOFACT – 2086-2**

6

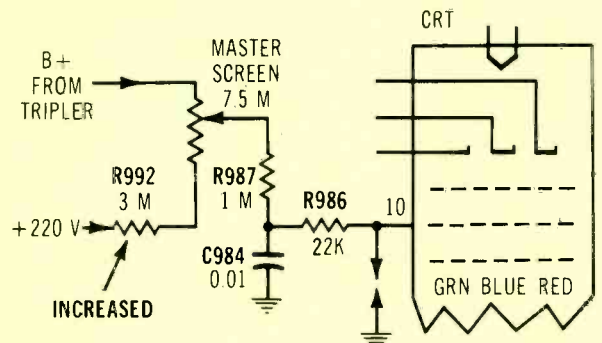

**Symptom** – Excessive brightness, with retrace lines  
**Cure** – Check resistor R992, and replace it with a 2W rating if value is increased



# Photofacts

These Photofacts for TV receivers have been released by Howard W. Sams & Company since the last report in ES&T.

## JC PENNEY

685-2042G,-20	2117-1
685-2044G,-00	2132-1
685-1020G,-20	2134-1
685-4201G,-00/04G,-10/05G,-10/06G,-10	2136-1
685-2501G,-00	2137-1

## HITACHI

CT13X6/324/326	2132-2
Chassis CT1321	2133-1

## PANASONIC

Chassis 4A02-A	2131-1
Chassis 12G01-A	2135-1

## RCA

Chassis KCS206A (1983 Prod.)	2134-2
------------------------------	--------

## SEARS

564.40362250	2132-3
564.42230051/31150/31151/31152	2133-2
401.40250150/151	2135-2
564.42370150	2136-2

## SONY

Chassis SCC-265T-A,U-A	2117-2
Chassis SCC-265W-A	2131-2
TV-715	2133-3
Chassis SCC-265X-A,Y-A	2135-3
Chassis SCC-265V-A	2137-2

## Coming next month...

**Audio servicing myths.** A technician must be flexible in his thinking to find the most efficient solution to a troubleshooting problem. The method endorsed by the manufacturer or other technicians may not be the best, so the master tech must learn to see through these common myths.

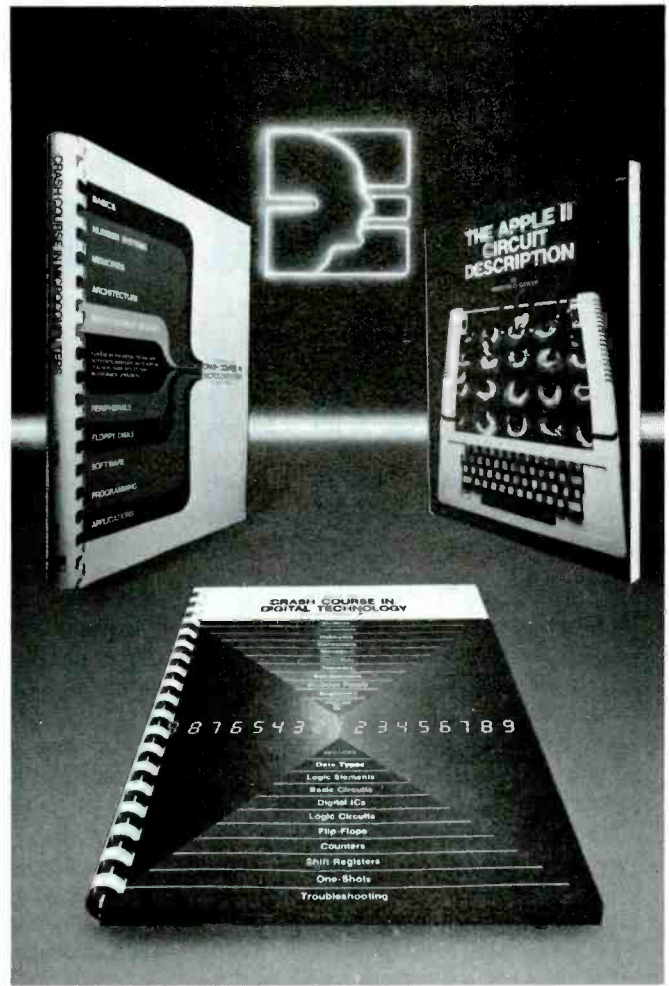

## SAMS COMPUTER UPDATE

Here's news for computer technicians. Sams' library of computer books can help you keep up-to-date on the latest in computer servicing and technology. Some recent examples are:

**THE APPLE II® CIRCUIT DESCRIPTION** which provides a detailed circuit description of the Apple II motherboard. No. 21959, \$22.95. (tentative)

**HOWARD W. SAMS CRASH COURSE IN DIGITAL TECHNOLOGY** is the most up-to-date digital book on the market today. It covers all the necessary fundamentals, components, ICs and techniques of digital technology. No. 21845, \$20.95. (tentative)

**HOWARD W. SAMS CRASH COURSE IN MICROCOMPUTERS** covers software, programming, peripherals and other important microcomputer fundamentals to help you learn the complete microcomputer system. No. 21634, \$19.95.

**To order these Sams Books, contact your local electronics distributor. Or call 800-428-3696 toll-free, or 317-298-5566 and reference AD 258.**

HOWARD W. SAMS & CO., INC.  
4300 West 62nd Street, P.O. Box 7092  
Indianapolis, IN 46206

Apple II is a registered trademark of Apple Computers, Inc. Offer good in USA only and expires 6/30/83. Prices subject to change without notice. In Canada, contact Lenbrook Industries, Ltd., Scarborough, Ontario.

Circle (16) on Reply Card



# Printed circuit design criteria

Adapted from Printed Circuit Drafting Technical Manual and Catalog 107 by permission of Bishop Graphics.

In the years since its introduction, printed circuit technology has been developed more and more into a technique that can be used by individuals with limited resources as well as by manufacturers.

However, if the results are to be satisfactory, it is very important that instructions be carefully followed and recommended criteria are adhered to. This article presents some suggested criteria for PC boards in the areas of component mounting, layout, design techniques and drafting methods, and includes a checklist to use as a guide for your layout.

## Component mounting

Components should always be mounted on the side of the PC board with the least amount of circuitry. They should be placed such that their major axis is parallel to a board edge and to the flow of cooling air, if applicable. Also an effort should be made to place components parallel (preferable) or perpendicular to each other to provide an orderly appearance, but not at the expense of good functional design. They should also be located such that value codes read from the same direction, preferably from top to bottom, and polarity markings are visible.

No part of a component should project over the board edge unless required by its function. Typically, a minimum clearance of 0.062 in. is maintained between a component and a board edge, card guide or other mounting hardware. All components should be mounted so as not to restrict the removal or insertion of any other component or

mounting hardware.

Components that weigh  $\frac{1}{4}$  oz. or more per lead should always be mounted by clamps or other means of support so that the soldered joints are not relied upon for mechanical support.

All parts dissipating 1W or more should be mounted so that the body of the part does not come into direct contact with the circuit board, unless heat dissipation devices such as heat sinks or thermal ground planes are used.

Component leads or parts with conductive cases should be mounted a minimum of 0.062in from the conductive pattern. If adherence to minimum spacing requirements is not practical, insulation can be used between conductors and part leads or cases.

Horizontally mounted axial lead components should be attached so the body of the part is in contact with the circuit board. However, components should not be placed in contact with more than one conductor unless the board surface is suitably protected from moisture traps.

When axial lead components are mounted vertically, they should be spaced a minimum of 0.015in to a maximum of 0.125in above the board surface to allow for good solder joints and adequate cleaning. The highest point of the top lead should not extend more than 0.55in above the board surface. The bottom lead should extend straight into the board, while the top lead should be bent 180° around the component body and down into the board. The top lead should be insulated to prevent con-

tact with other conductive elements.

Radial lead components should be mounted within 15° of perpendicularity unless a large case size makes this impractical. In this case, they should be mounted with a side surface in contact with the board and the leads bent down at a 90° angle. If the vertically mounted components have coating extending down the leads from the body, they should be mounted with the coating a minimum of 0.06in above the board surface to prevent interference with the solder joint.

Components in transistor packages may be mounted vertically or

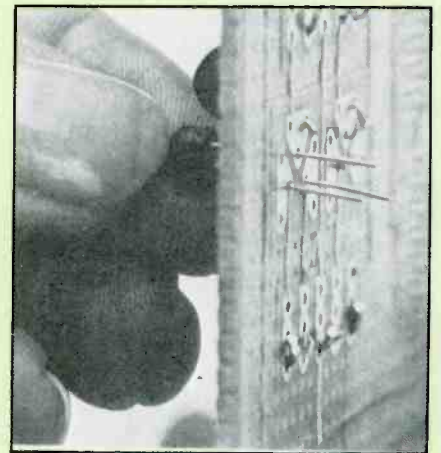
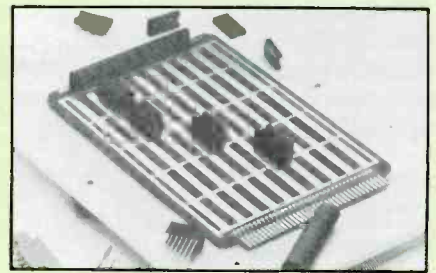

horizontally. When mounted horizontally, the cases should be secured to the board using clips or other mechanical fasteners. For vertical mounting (the most common practice) the package should be spaced 0.015in to 0.125in above the board to permit flux removal. The base of the component should be parallel to the board surface within 0.05in.

For determining lead spacing of axial lead components, \*IPC-CM-770B (proposed) suggests the lead should extend nominally 0.60in straight out from the component

\*IPC is the Institute for Interconnecting and Packaging Electronic Circuits.





quirements. It should also include form factor information such as board outline, dimensions, tooling holes and relationships with mating connectors, and other external structures. All interconnection circuitry and scaled terminal areas should be depicted with general and local notations or keys for hole size, conductor width and clearance, terminal area size, layer designation, material, plating and any other physical design requirements.

### Preliminary considerations

Before beginning a printed circuit layout, you should have a schematic/logic diagram, a parts list, and all specifications that apply.

Compile information on all components, including physical size, lead pattern and spacing, special mounting data, required hole and terminal area sizes, and electrical and thermal limitations.

The grid system, scale, nominal and minimum conductor width and spacing, board size and number of layers should also be determined before starting the layout.

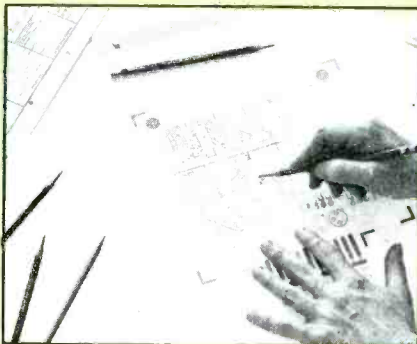

The PC designer should be aware of any special circuit conditions such as test point requirements, high-voltage distribution and decoupling, or the thermal sensitivity of individual components that might affect the physical layout.

Considerable thought should be given to how the board will be produced. Before beginning the printed circuit design layout, a list of components that are connected to a common point may be prepared for use as a reference when making interconnections. Sometimes one or several rough, freehand trial layout sketches are drawn to relate the schematic to the physical board. Components are

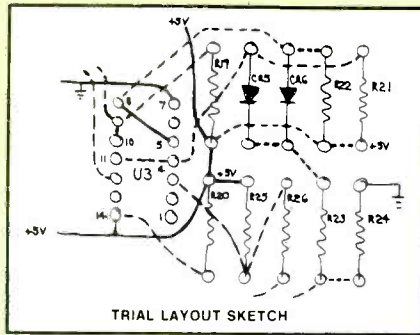

usually represented as schematic symbols with the leads oriented in the same manner as the actual components. Most circuit crossovers and junctions, along with component groupings, can be worked out in this stage.

Depending on the complexity of the circuit and your experience at layout design, these preliminary steps may be bypassed, but this is not recommended.

### Design techniques

Design convention dictates that layouts be viewed from the component side of the board. Adhering to this standard will eliminate possible confusion leading to errors. It is recommended that the designer always create the layout and artwork at the same scale on or over a grid sheet. This aids in both generating and checking the finished artwork.

The PC board's form factor must be established before proceeding with component placement and interconnection routing. Features such as board outline, cutouts, mounting holes, edge connectors and mechanical clearance areas must be accurately scaled on the layout.

Design techniques vary considerably due to the nature and complexity of the circuit, as well as designer preference. Generally, component placement is the next step. Some designers, however, prefer to integrate interconnection routing with component placement, particularly on PC boards with many components. There are four basic component placement concepts that may be used independently or in combination.

The most basic concept used primarily on medium- to low-density analog boards is called *schematic* orientation. If the schematic has been drawn with a physical sense and has a minimum

of interconnection crossovers, it is often possible to place components as they are physically drawn on the schematic diagram. This method works especially well if the signal inputs can be placed on one edge of the board and the outputs along the opposite edge.

The *peripheral* placement method is appropriate when board edge connectors or other components that require a specific fixed location, board edge placement or off-board mounting are used. These components should be positioned first with any interconnecting components, then placed radiating inwardly from their locations.

The *central* component placement concept is applicable for boards that have one or more complex multiple-lead devices such as ICs, relays or modules with supporting peripheral components. In this case, the predominant multi-lead components are centrally placed with the supporting components, then placed radiating outwardly from them. This technique is also used with fixed-circuit group patterns such as semiconductor memory groupings.

The *fixed array* concept is typically used for straight digital logic boards comprised almost exclusively of integrated circuits. With this method, the ICs are logically placed in a fixed pattern with a space allotment expressed in square inches per equivalent 14- or 16-lead device. This technique sometimes allows for the use of preprinted layout sheets including board outlines, connectors

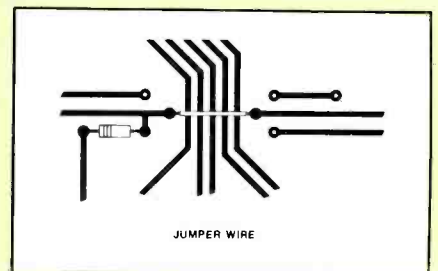
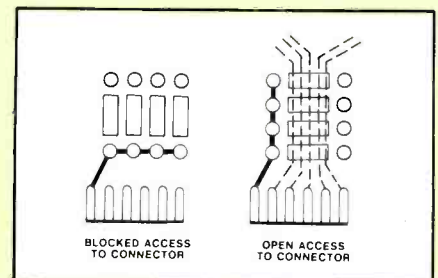



## SWD-1 VIDEO CONVERTER

FOR CABLE TV

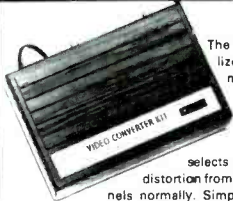

The SWD-1 Video Converter is utilized on cable TV systems to remove the KHz's signal from a distorted video (channel 3 in/out) and also pass thru the normal undistorted/detected audio signal. Rocker switch selects operating mode to remove KHz's distortion from the video or pass all other channels normally. Simple to assemble—less than 30 minutes. Pre-tuned. Input/output Channel 3. Impedance 75 ohms. 117VAC.

SWD-1 Video Converter Kit ..... \$69.95

## VTR ACCESSORIES

### SIMPLE SIMON VIDEO STABILIZER



Simple Simon Video Stabilizer, Model VS-125, eliminates the vertical roll and jitter from "copy guard" video tapes when playing through large screen projectors or on another VTR. Simple to use, just adjust the lock control for a stable picture. Once the control is set, the tape will play all the way through without further adjustments. Includes 12V power supply.

VS-125 Video Stabilizer, wired ..... Reg. 54.95 ..... **\$39.95**

**NEW**  
VCR Quality

### MODULATOR



**Not a Game Type Modulator**  
The MPS-1 Kit converts Video/Audio signals to a crystal controlled RF output for TV Channels 3 and 4. The MPS-1 Modulator inputs are designed to match all TV Cameras and VCR's and features a voltage regulated power supply, power switch and LED indicator. No Tuning Required. Operates on 117VAC.

MPS-1 Kit ..... **\$39.95**

## UHF ANTENNAS AND ACCESSORIES

### MDS-AMATEUR-ETV 32 ELEMENT

#### YAGI ANTENNA

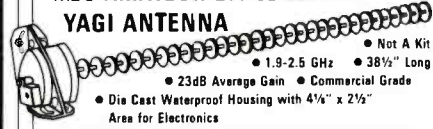

MAE-2 32 Element YAGI Antenna ..... \$23.95

### Kato Sons' Down Converter Kit ★ 1.9 - 2.56GHz★

Designed for Simple Simon by former Japanese CQ Amateur Magazine's UHF Editor/Engineer. Unit utilizes new ingenious Printed Circuit Probe for maximum gain. Circuit board fits inside MAE-2 antenna housing. Requires 1 hour assembly. IC and capacitors pre-soldered.

Model KSDC-KIT 1.9 - 2.56GHz Down Converter Kit ..... \$34.95

### Kato Sons' Regulated Variable DC Power Supply

For use with KSDC-KIT 1.9 - 2.56GHz Down Converter. Completely assembled with Attractive Cabinet, TV/Converter Mode Switch, Frequency Control and LED Indicator.

Model KSPS-1A Assembled Power Supply ..... \$23.95

**SPECIAL**  
INTRODUCTORY  
SAVINGS

### ORDER ALL THREE ITEMS

MAE-2, KSDC-KIT and **\$74.95**

KSPS-1A for Only.

Regular price if ordered separately \$82.85

— CO-AX CABLES ARE NOT INCLUDED —

## ZYZZX VHF-UHF Wideband Antenna Amplifier

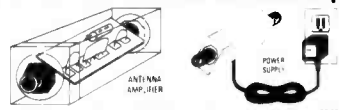

### Revolutionary New HYBRID IC Broadband Amplifiers

50 MHz - 900 MHz Model ALL-1 12dB Gain  
Model ALL-2 35dB Gain

These units are not available anywhere else in the world. Each unit will serve many purposes and is available in Kit or Assembled form. Ideal for outdoor or indoor use. I/O impedance is 75 ohms. Amplifiers include separate co-ax feed power supply. Easily assembled in 25 minutes. No coils, capacitors to tune or adjust.

ALL-1 Complete kit w/power supply ..... \$24.95  
ALL-2 Complete kit w/power supply ..... 34.95

ALL-1 Wired/ Tested w/ pwr supply ..... \$34.95  
ALL-2 Wired/ Tested w/ pwr supply ..... 44.95

## Our New STVA 14.5dB GAIN, 14 ELEMENT CORNER REFLECTOR YAGI ANTENNA

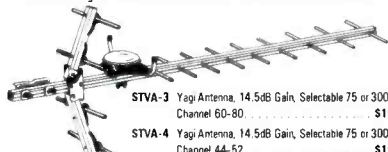

STVA-3 Yagi Antenna, 14.5dB Gain, Selectable 75 or 300 ohm Channel 60-80 ..... \$19.95

STVA-4 Yagi Antenna, 14.5dB Gain, Selectable 75 or 300 ohm Channel 44-52 ..... \$19.95

RG-59/U 75 ohm Low Loss Coax Cable ..... \$ .12p/ft. F-59 Coax Connector ..... \$ .39 ea.

MT-1 Special UHF 75-300 ohm Matching Transformer ..... \$1.45 ea.

# Switch to Bambi!™

## Electronically

**Bambi Electronic Video Switch ... makes switching of your VCR/VTR, Pay TV Decoders, Cable TV, Video Discs, Video Games, Closed Circuit TV, Antennae and Microcomputer as easy as pushing buttons.**

The Bambi Electronic Video Switch is an electronic switching network which can accept up to six different sources of video signals and provide the flexibility of directing the inputs to any or all of the three outputs.

Now you can eliminate ... the drudgery of disconnecting and reconnecting your video equipment each time you use it ... the tangled mess of cables which are impossible to trace out ... not being able to use more than one function at a time.

Bambi lets you enjoy using your video equipment the way it should be ... electronically and on line at the push of a button.

**Model BEVS-1** Completely Wired and Assembled. Includes comprehensive Instruction/Operation Manual and Decal Set for customizing your Video Switch installation.

**\$129.95**



**FREE**  
Bambi  
Poster  
with  
any  
purchase



Bambi's front panel was designed with the user in mind. Computer styled construction, with soft-touch keyboard (rated for over 10 million operations), arranged in matrix form allows easy Input/output selection without referring to charts. Functions selected through the keyboard are immediately displayed on the 18 LED status indicators.



Check the quality of Bambi against that of much higher priced competition. All solid state electronic switching provides low attenuation (3dB), wide frequency response (40-890 MHz), and excellent isolation between signal sources (each I/O section individually shielded for 65dB min. isolation).



### Bambi's Specifications:

- Input/Output Impedance 75 ohm
- Signal Loss 3dB ±1dB
- Noise 4dB ±1dB
- Input Return Loss 12dB min.
- Isolation 85dB min.
- Power Req. 117VAC 60 Hz, 2W
- Dimensions 10 1/4" x 6 1/2" x 3 1/8" H
- Weight 4 1/2 lbs

## 7+11 PWD PARTS KITS

### INTRODUCING OUR 7+11 PWD PARTS KITS



KIT No	PART No	DESCRIPTION	PRICE
1	1VT1-PWD	Varactor UHF Tuner	\$24.95
2	2CB1-PWD	Printed Circuit Board, Pre-drilled	18.95
3	3TP11-PWD	PCB Potentiometers 4-20K, 1-5K, 2-10K, 2-5K, 1-1K, and 1-50K. (11 pieces)	8.95
4	4FR-31-PWD	Resistor Kit, 1/4W, 5% 29-pcs, 1/2 W 2-pcs	4.95
5	5PT1-PWD	Power Transformer, PRI-117VAC, SEC-24VAC at 500ma	9.95
6	6PP2-PWD	Panel Mount Potentiometers and Knobs, 1-1KBT and 1-5KAT with switch	5.95
7	7SS17-PWD	IC's 7-pcs, Diodes 4-pcs, Regulators 2-pcs Transistors 2-pcs, Heat Sinks 2-pcs	28.95
8	8CE14-PWD	Electrolytic Capacitor Kit, 14-pieces	6.95
9	9CC20-PWD	Ceramic Disk Capacitor Kit, 50 WV, 20-pcs	7.95
10	10CT5-PWD	Variable Ceramic Trimmer Capacitor, 5-85pfd, 5-pieces	4.95
11	11L5-PWD	Coil Kit, 18mhs 3-pcs, 22µhs 1-piece (prewound inductors) and 2 T37-12 Ferrite Toroid cores with 8 ft. #28 wire	6.00
12	12ICS-PWD	IC Sockets, Tin inlay, 8 pin 4-pcs, 14 pin 1-pc and 16 pin 2-pcs	2.95
13	13SR-PWD	Enclosure with PM Speaker and Pre-drilled Backpanel for mounting PCB and Ant. Terms	14.95
14	14MISC-PWD	Misc. Parts Kit, Includes Hardware, (8/32, 8/32 Nuts & Bolts), Hookup Wire, Solder, Ant. Terms DPDT Ant. Switch, Fuse, Fuseholder, etc.	9.95
15	15MIC18-PWD	Mylar Capacitors, 14-pcs and Silver Mica Capacitors 2-pieces	7.95
When Ordering All Items, (1-15), Total Price			159.95

**CUSTOMER NOTICE:** BUY WITH CONFIDENCE ... BEWARE OF LOW QUALITY IMITATORS. All of our kits consist of New, 1st Class, RF Quality, Parts Engineered for Optimum Operation, not factory seconds or stock close-outs. We service your completed kits that you've purchased and built. You will never get stuck with a BAG OF PARTS when ordering from Simple Simon.

## SIMPLE SIMON ELECTRONIC KITS,™ Inc.

3871 S. Valley View, Suite 12, Dept. E, Las Vegas, NV 89103

NEED 6 OR MORE OF AN ITEM? WRITE FOR QUANTITY DISCOUNTS

In Nevada Call: **702-871-2892**

**1-800-782-3716**

Outside Nevada Call:

Available by Mail Order Only  
Send Check\* or Money Order. Minimum Order: \$16.95. Add 10% Shipping and Handling on orders under \$40.00. For orders over \$40.00, add 5%. Minimum Shipping and Handling \$2.00. Cat. \$1.00 — VISA and Mastercard Acceptable — \*Check orders will be held 30 days before shipping.



and component outlines and terminal areas.

In general when locating components on the layout, an attempt should be made to provide an orderly appearance. Component bodies should be parallel to a board edge and to each other, with the same orientation and lead spacing for like components. Their orientation should provide for optimal interconnection routing.

It is good practice to follow automatic component insertion design guidelines when possible. Heavy components should always be placed near board supports. The direction of air flow and the requirements for isolation or heat sinking of heat-generating components must be considered during placement, because they will affect the component location and orientation.

Polarity marks, pin assignment and reference designations for like components should not be put on the layout until the interconnection stage. This allows greater flexibility when routing connections.

Many designers prefer using color coding to facilitate circuit interconnection on the design layout. The most common color coding practice is to use different colors for connections on each board circuit layer. Red and blue lines work especially well when the artwork will be generated by the red and blue tape method. Color coding can also be used to designate power and ground connections, conductor widths and terminal area sizes.

For single-layer boards, the circuitry should always be placed on the side opposite the components. The board acts as an insulator between the components and circuitry, and this practice allows greater flexibility when routing connections. If many unresolved crossovers remain after several attempts at rearrangement, consideration should be given to using a multilayer design. However, if there are only a few crossovers that cannot be eliminated, wire jumpers should be used.

On multilayer boards, interfacial connections (sometimes called vias or feed-thrus), consisting of plated-through holes with or without component leads, are used to transfer the circuit to the op-

posite side of the board to resolve crossovers. For maximum reliability, an effort should be made to keep common connections on a single board surface. On digital logic board layouts, it is a common practice to route all circuitry on one side of the board perpendicular to the circuitry on the opposite side. Although this practice requires the use of more feed-throughs, it permits maximum routing flexibility, improves reliability and typically increases circuit packing density.

When all interconnections have been successfully completed, the layout should be refined to enhance producibility. Excessive via holes, traces between pads and long conductor runs should be eliminated wherever possible. Conductor widths and spaces should be enlarged wherever space permits. These refinements will make the board easier to produce and therefore more reliable and less costly.

### Drafting methods

There are several techniques for doing the actual layout. The most primitive is to painstakingly draw

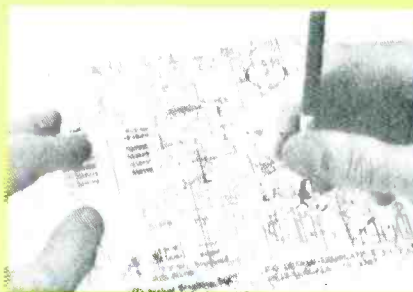

in each component from dimensions, along with the interconnecting circuitry. Because of the inherent trial-and-error techniques of printed circuit layout, this is not very practical.

An alternative method is to use a template to draw the components. Changes and rearrangements are still somewhat time consuming and, often, the partial layout must be discarded and begun anew.

Another method is to use component outline "dolls." These are

component shapes drawn on paper, cardboard or drafting film and cut out with scissors. This method, used in conjunction with an interconnection overlay, allows convenient relocation of components, without redrawing the component outlines, until the design is finalized. There are several drawbacks to this technique, however. First, after the design is complete, the layout must still be drawn with a template to obtain a stable permanent record. Second, the dolls are difficult to handle and may be easily mislaid, damaged or knocked askew.

One method is to use Bishop Graphics' Puppets printed circuit layout system, which is based upon the component dolls concept. However, the traditional disadvantages have been eliminated and several benefits added. Kits include a wide assortment of preprinted and die-cut electronic component outline shapes and component-type cross-reference charts.

The component outlines are positioned directly on the gloss surface of a precision grid or on a clear overlay. They adhere to any clear (non-matte) drafting film surface without adhesive.

Interconnections are made on matte finish overlay sheets that are pin registered or taped over the component outlines and grid pattern.

Changes and refinements are easily accommodated by repositioning the dolls and revising or redrawing only the interconnection overlay.

Permanent, reproducible file copies, checkprints and component assembly drawings can be generated from the layout using contact printers, diazo reproduction machines and some office copiers.

No matter which basic drafting technique is used, it is a good idea to begin with the component shapes on one sheet and the interconnections on either overlays or copies of the component layout to minimize rework.

### Layout checklist

#### General

1. Have layout grid, scale and number of layers been indicated?
2. Check electrical continuity using copies of the layout and the



schematic/logic diagram by marking out each connection with a colored marker on both copies.

3. Have all mechanical dimensions pertaining to board size, mounting locations, cutouts and clearances been indicated?
4. Is the board size compatible with photographic and fabrication equipment capacities?

### Components

1. Have all components on the schematic been included and are they properly designated?
2. Are all component shapes in the proper scale?
3. Have components been located in an orderly fashion?
4. Have standard lead spacings been used for like components?
5. Has orientation been indicated for multiple lead and polar components?
6. Is there adequate clearance between components and board edges, mounting hardware and other components?
7. Have special mounting requirements been accommodated (in-

sulation, heat sinks, supports, hardware, etc.)?

8. Is there adequate access for components requiring adjustment after installation?

### Holes

1. Are all holes located on a standard grid or dimensioned from a grid location?
2. Has a separate hole been provided for each component lead or terminal?
3. Have all hole sizes and types been indicated, and do they meet design requirements?
4. Does all hole-to-hole spacing meet requirements?
5. Are all via (feed-thru) holes clear of component bodies or other obstructions?

### Conductors

1. Have all conductor widths and spacing been properly indicated, and do they meet design requirements?
2. Have all terminal area sizes been properly indicated, and do they meet design requirements?
3. Have conductors been routed in

the most efficient manner (smooth flow, short as practical, minimum quantity of jumpers, etc.)?

4. Have critical circuit points been accommodated (conductor length, shielding, isolation, ground planes, voltage planes, heat sinks, etc.)?
5. Has the difference between conductors on separate layers been indicated clearly?

*This article, which explores some of the criteria to consider when designing PC boards, is adapted from Printed Circuit Drafting Technical Manual and Catalog 107, by permission of Bishop Graphics, Westlake Village, CA 91359. ES&T readers who would like more information on the subject are invited to write to that company for a copy.*

*Although this manual was written primarily for use in the electronics manufacturing industry, it contains much information that is of value to servicers and serious enthusiasts as well.*

## ECG • REN • GE • SK

### REPLACEMENT TYPES

**Why pay their high prices??**

### CHECK THIS!

**IDENTICAL REPLACEMENT FOR ECG®**

(Min. 5 pcs. each)

ECG® Type No.	YOUR PRICE	ECG® Type No.	YOUR PRICE
123A .....	.28	500A.....	8.95
152 .....	.60	523 .....	10.75
153 .....	.65	526A.....	10.95
165 .....	2.25	HIDIV-1® .....	3.75
238 .....	2.25	HIDIV-3® .....	3.75

**3 YEARS WARRANTY ON EXR PARTS**

### SPECIAL (Min. 5 pcs. each)

2SC867A ....	2.95	AN214Q .....	1.50
2SC1034 ....	5.95	STK439.....	7.25
2SC1114 ....	3.45	UPC1181H...	1.95
2SC1308K...	2.25	UPC1182H...	1.95

**Call Toll-Free 800-526-4928**

**COD ORDERS WELCOME (Min. order \$25)**

CALL OR WRITE FOR OUR 1982 PRICE LIST

***DIGITRON ELECTRONIC***

110 Hillside Avenue, Springfield, N.J. 07081

201-379-9016 201-379-9019

ECG IS A TRADE MARK OF PHILIPS ECG.  
DIGITRON IS NOT ASSOCIATED IN ANY WAY WITH PHILIPS ECG.

# DESOLDERING SOLDER EXTRACTOR

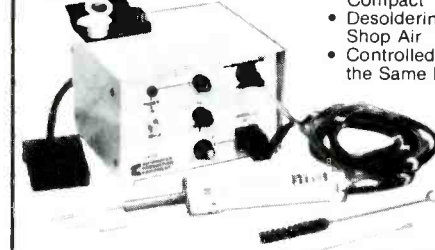

- Easy-to-Operate Control Center is Compact
- Desoldering Vacuum Operates on Shop Air
- Controlled Heat and Vacuum are in the Same Handpiece Tip
- Easily Releases Components from Double-Sided PC Boards
- Superior Technical Manual

## PNEUMATIC TRANSDUCER OR SELF-CONTAINED PRINTED CIRCUIT REPAIR & REWORK



BEFORE: Pad and Eyelet are missing



AFTER REPAIR with SRS-050 Kit, the Pad and Eyelet have been neatly replaced.

**A.P.E.**  
Automated Production Equipment Corp.

142 Peconic Ave., Medford, N.Y. 11763 (516) 654-1197 TWX. 510-228-2120

Circle (19) on Reply Card

Circle (20) on Reply Card

# How to make your own PC boards

Excerpted from the booklet "Printed Circuit Handbook & Accessories," by permission of GC Electronics

---

Whether you are a hobbyist or an experienced technician, you can turn out professional-quality PC boards by following step-by-step instructions.

---

The term printed circuit refers to any electrical circuit in which individual wire lead connections have been replaced by 2-dimensional conductive patterns bonded to an insulating base material.

In practice, most present-day printed circuits consist of etched copper foil wiring patterns bonded to any of several insulating base materials (or substrates). A self-contained circuit pattern is termed a circuit board. Generally these are sturdy enough to serve as mounting bases for the actual electrical

components (resistors, capacitors, transistors, coils and so on) which make up the circuit.

Although originally developed for mass production applications, printed circuit fabrication techniques have been refined until they can now be used by almost anyone with average mechanical skills.

Whether you are a student, a hobbyist, an experimenter, a home "do-it-yourselfer" or a practicing technician or engineer, you can turn out professional quality PC boards every bit as good as those used by the giant electronics equipment manufacturers. Easy-to-follow, step-by-step instructions are detailed here, while all the materials and supplies you'll need are available from electronics parts distributors.

---

**Editor's note:** This article provides general information to give readers an idea of what is involved in fabricating PC boards. When actually making a PC board, it is important to carefully follow the directions of the manufacturer of the materials and aids.

---

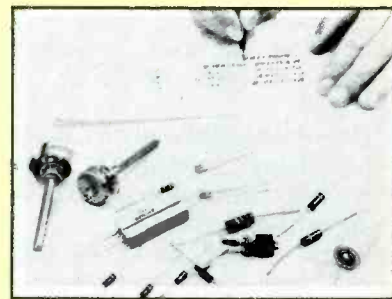

As you prepare your schematic, have all the actual components involved at hand.

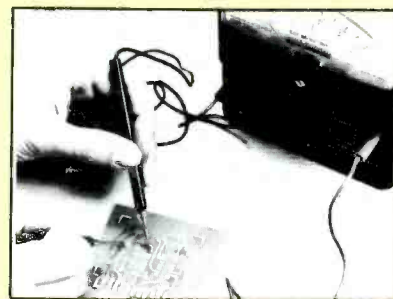

For 1-ounce boards, the interconnecting lines have these current carrying capacities (20C temperature rise):

1/32in	- 2.0A
1/16in	- 2.5A
1/8in	- 4.5A

## Circuit design

Although most PC boards will be 1-sided, 2-sided circuit boards are needed to solve certain design problems such as conductor path crossovers, component density, volume efficiency and similar factors. Here, the other side of the board may be used for another circuit or sub-circuit. With 2-sided boards, side-to-side registration is the main problem; that is, making sure the correct component pad on one side is directly opposite the corresponding pad on the other side.

The following are precautions to take when designing circuits.

1. Heavy or hot components and large controls should be mounted on a metal chassis or metal brackets, not on your PC board.

2. Lay out all other components on a sheet of tracing paper and start with a ladder layout. One side of the ladder is common; the other is power. The rungs are the components between the rails. Be careful not to place the components too close together. Trace the components, then trace conductor paths on the tracing paper or film. Make sure each component



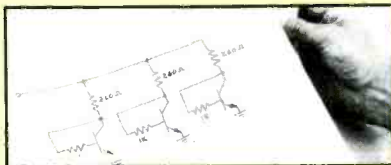

It may be worthwhile to change the schematic several times to keep the circuit simple enough for a 1-sided board.

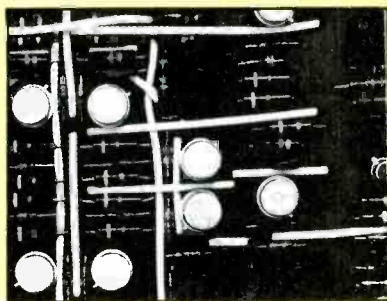

Use several jumpers, if needed, in preference to a 2-sided board.

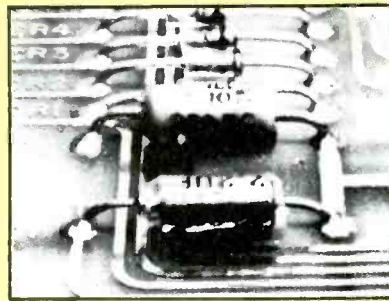

Sometimes a component can be used to bridge a circuit path intersection, avoiding the use of a jumper wire.

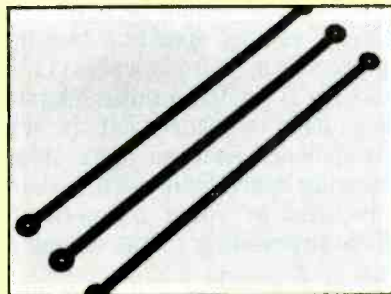

To prevent flashover, limit conductor and pad spacing:

Voltage dc or ac Peak	Min. Spacing
0-150	0.025in
150-300	0.050in
300-500	0.100in
Over 500V: 0.02in per hundred volt.	

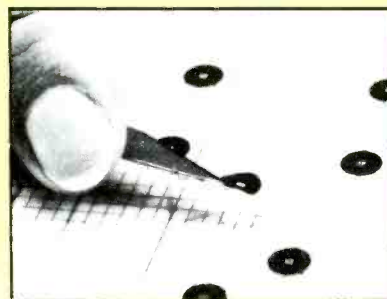

Standard spacing in the industry is in multiples of 1/10in. Use 1/10in grid paper or layout film for your layouts, and place your pads at intersections.

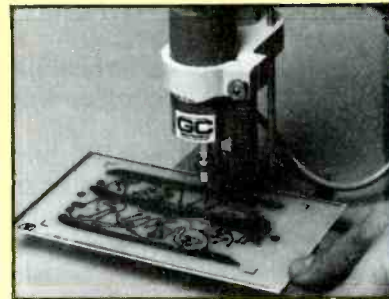

When drilling near the edges of a board, leave at least 1/16in of material between the edges of the holes and the edges of the board.

# MOVING?

If you're planning a move in the near future, don't risk missing an issue of *Electronic Servicing & Technology*. Please give us 6-8 weeks notice if you're planning on changing your address. Just write in your new address below and mail this coupon, WITH YOUR SUBSCRIPTION MAILING LABEL, to:

# ELECTRONIC

*Servicing & Technology*

P.O. Box 12901, Overland Park, KS 66212

For address change you MUST affix label from cover here. Print new address below.

Name \_\_\_\_\_  
 Address \_\_\_\_\_  
 City \_\_\_\_\_  
 State \_\_\_\_\_ Zip \_\_\_\_\_

## OPTIMA ELECTRONICS

TO ORDER CALL TOLL FREE 1-800-327-0224

G.E., SYLVANIA, ZENITH, RCA, 75% OFF LIST NEW-BOXED

- |                               |               |                               |               |
|-------------------------------|---------------|-------------------------------|---------------|
| <input type="checkbox"/> 3A3  | 5 FOR \$15.75 | <input type="checkbox"/> 6LF6 | 5 FOR \$34.44 |
| <input type="checkbox"/> 6MJ6 | 5 FOR \$34.88 | <input type="checkbox"/> 6LB6 | 5 FOR \$31.50 |
| <input type="checkbox"/> 6JE6 | 5 FOR \$32.75 | <input type="checkbox"/> 6CJ3 | 5 FOR \$14.69 |
| <input type="checkbox"/> 3DJ3 | 5 FOR \$17.44 | <input type="checkbox"/> 6JS6 | 5 FOR \$29.00 |
| <input type="checkbox"/> 6GH8 | 5 FOR \$12.44 | <input type="checkbox"/> 6BL8 | 5 FOR \$12.25 |

All Tubes Not Advertised, Write in at 75% Off List.

Sleeves Only, Singles 72% Off List

### HORIZONTAL OUTPUT TRANSISTORS ECG REPLACEMENT TRIPLERS

- |                                   |                                 |   |   |
|-----------------------------------|---------------------------------|---|---|
| <input type="checkbox"/> RKS1172B | <input type="checkbox"/> RKS238 | <input type="checkbox"/> 500A ..\$11.50 | <input type="checkbox"/> 526A ..\$14.95 |
| <input type="checkbox"/> RKS1308K | <input type="checkbox"/> RKS165 | <input type="checkbox"/> 523 ..\$13.50  | <input type="checkbox"/> 529 ..\$15.50  |

### TRANSISTORS & I.C.'s...MIN. 10, CAN MIX

- | T.V. #'s                                  | Pop. I.C. #'s                         | STEREO #'s                                 |
|---|---------------------------------------|--|
| <input type="checkbox"/> 2SC1114 ..\$3.75 | <input type="checkbox"/> 712 ..\$1.40 | <input type="checkbox"/> DM133 ..\$5.95    |
| <input type="checkbox"/> MN8303 ..\$3.95  | <input type="checkbox"/> 713 ..\$1.40 | <input type="checkbox"/> DA101 ..\$5.75    |
| <input type="checkbox"/> 2SC1034 ..\$5.95 | <input type="checkbox"/> 714 ..\$1.50 | <input type="checkbox"/> HA1377A ..\$3.25  |
| <input type="checkbox"/> 2SC867A ..\$3.50 | <input type="checkbox"/> 731 ..\$1.50 | <input type="checkbox"/> HA1388 ..\$5.25   |
| <input type="checkbox"/> 2SD870 ..\$4.75  | <input type="checkbox"/> 790 ..\$1.50 | <input type="checkbox"/> HA1396 ..\$5.50   |
| <input type="checkbox"/> 2SD871 ..\$5.50  | <input type="checkbox"/> 791 ..\$1.95 | <input type="checkbox"/> HA1398 ..\$4.95   |
| <input type="checkbox"/> AN5210 ..\$6.50  | <input type="checkbox"/> 792 ..\$1.95 | <input type="checkbox"/> UPC1181 ..\$1.75  |
| <input type="checkbox"/> AN5310 ..\$3.95  | <input type="checkbox"/> 793 ..\$2.25 | <input type="checkbox"/> UPC1182 ..\$1.75  |
| <input type="checkbox"/> AN5320 ..\$3.25  | <input type="checkbox"/> 819 ..\$1.50 | <input type="checkbox"/> UPC1185H ..\$2.95 |
| <input type="checkbox"/> AN5435 ..\$2.95  | <input type="checkbox"/> 820 ..\$2.10 | <input type="checkbox"/> 2SA1105 ..\$2.95  |
| <input type="checkbox"/> 2N3055 ..\$.95   | <input type="checkbox"/> 848 ..\$2.95 | <input type="checkbox"/> 2SC2580 ..\$2.95  |

### GENERAL

- |  |                 |
|--|-----------------|
| <input type="checkbox"/> 1308K.Sanyo .....   | 10 for \$22.50  |
| <input type="checkbox"/> 2.5 Amp. 1000 PIV Rect. ....  | 100 for \$ 8.75 |
| <input type="checkbox"/> VEH0070 VIDEO HEAD (4 hrs.) .....                                   | \$49.95         |
| <input type="checkbox"/> Pop. HI DIV-3...focus block divider .....                           | \$35.00         |
| <input type="checkbox"/> Mabuchi Motors for cassette recorders & tape decks (CW & CCW) ..... | \$ 7.95         |
| <input type="checkbox"/> 6 ft. Cheater Cords SPT2 .....                                      | 10 for \$ 7.95  |
| (Heavy Duty - UL App. 7 Amp. 125V. P & NP)   |                 |
| <input type="checkbox"/> 800-860 Zenith Safety Cap .....                                     | \$ 3.95         |
| <input type="checkbox"/> Pop. Mag. Safety Caps 250663-11-17-19-20 .....                      | \$ 3.95         |
| <input type="checkbox"/> Pop. GE Caps 25x60-75-78-79 .....                                   | \$ 3.95         |
| <input type="checkbox"/> ZEN. Mod. 9-103-04 Audio .....                                      | \$ 7.95         |

### Quantity Prices Available

Letters of credit and all checks placed on deposit with Bank of Hallendale, FL. VISA & Master Charge accepted. Min. order \$75. FOB Dania, FL. Catalog \$3, refundable upon order.

SEND CHECK OR MONEY ORDER TO:

## OPTIMA ELECTRONICS

2022 Tigertail Blvd., Dania, FL 33004

Phone (305) 920-3550 TOLL FREE: 1-800-327-0224

Circle (21) on Reply Card

is identified (R-10/C-8, etc.) on the layout, and make sure there is a pad for each terminal on every component.

3. Conductor paths need careful planning. Crossovers and shorts are not allowed. Route the paths between the two pads on a component to avoid crossovers. Don't route them through transistor or IC pads. Use resistors, capacitors and diodes for bridges.

4. Make corrections on the layout paper or film, not in copper. If your first layout doesn't work, start again.

5. Jumper wires should be used when you cannot find other ways to get across conductor paths.

6. Feedback, crosstalk, hum, etc., will result if ac conductors, RF conductors, or other signal or dc lines from certain components are run closely parallel to each other. These problems can be reduced by using metal shields or ground planes (large "grounded" or "common" copper areas on the board). Make sure the metal shields don't short out the conductors.

7. Make sure the pad spacings match the size ratio you've chosen for your masking technique.

### Preparing the design for production

First you must arrive at the design you want, whether you copy it from a book or a magazine or develop it yourself. Then you must decide how precisely you want to duplicate your final design in the foil pattern on your board. The simpler your pattern, the simpler the process for duplicating it in the foil pattern. Be sure to leave a 1/4-inch to 1/2-inch margin around your circuit design, no matter which method you use. This helps prevent problems with photo resist build-up later.

There are four basic methods to choose from when preparing the design.

*Direct masking* is used when making only one board; for simple, rough designs; and with the help of professional drafting aids. The direct masking method is suitable only with the use of individual donut pads and tape. If preferred, the pattern can be painted on the copper surface with etch resist lacquer. Before etching, check it carefully for pin holes and scratches. When thoroughly dry, the board is

ready for etching.

*Cut-and-peel* production is used for more than one board and allows a simple circuit layout from a book or magazine to be used, without a need for great precision.

*Photography* (film positive, film negative or master artwork) has been perfected by the Engineering and Drafting Departments of Electronics Systems Manufacturers.

*Lift-it* transfer system, from GC Electronics, transfers a PC pattern printed in a magazine or book onto positive film, from which a negative can also be made.

Methods 2, 3, and 4 produce transparencies for transferring your circuit layouts to PC boards sensitized with resist for photo-processing.

---

---

## There are four basic methods to choose from when preparing the design for production.

---

---

With the negative method, light hits the sensitized surface of the copper and forms a "resist," which keeps the etching process from happening just as in the direct mask "resist" method. With the positive pre-sensitized method, the protective film will be washed away in the developer wherever it was exposed to light, and only the area where light did not penetrate will remain during the etching process.

These are the steps involved with every board made.

1. The circuit layout art is prepared from the schematic diagram.

2. The mask is cut, or the production negative or positive transparency is made.

3. The copper-clad board is selected, cut to size (if necessary), then thoroughly cleaned. Use plain, fine, steel wool for heavy cleaning and oxidation removal. Rinse thoroughly and let dry. Water should cling in a "sheet" to board if the board is cleaned properly.

4. The copper foil surface is coated with sensitizer. You may use either a product for negative application or a positive transfer system to transfer your circuit design directly onto the PC board.

This system replaces photo resists by laying down an etch-resistant coating on the board, which is produced directly from a photo-sensitive film. No spraying is necessary. An additional alternative may be to use a pre-sensitized positive board.

5. Allow board to air-dry thoroughly under "darkroom" conditions, as the resist is light sensitive. You may speed up the drying process by using a warm (115°) oven for 5 to 10 minutes. Again, use caution to ensure that the sensitized board sees *no* light. After removing board from oven, be sure it returns to room temperature before proceeding to the exposure step.

6. After the board has been dried and cooled, the sensitized surface is placed under the mask or transparency and exposed to suitable light.

7. Develop the exposed board by immersing it in appropriate developer, which washes away the sensitizer (photo resist) in all areas where the copper will be removed by etching. The pattern is now visible so that you can tell if you have a good board.

8. Thorough washing and drying is followed by the etching process, which dissolves away the copper left unprotected by resin and leaves only the circuit pattern. You may speed up the etching process by heating the etchant to 90 F to 120 F and agitating during the etching process.

9. A stripper is then rubbed over the board removing the resist and leaving a burnished copper foil pattern, a duplicate of that shown in your mask or transparency. The board is now ready for drilling and component mounting.

Every time you make a PC board, you will select the base material (phenolic, glass-polyester or glass-epoxy), and the weight of the copper laminate (1-ounce standard or 2-ounce) and the right size for the circuit design.

This is the heart of the process used for making your own PC boards by methods 2, 3 and 4. Once you have mastered the simple techniques of cleaning the board, coating it evenly with sensitizer (photo resist) and exposing it properly, you can create circuit designs by any of these three methods.



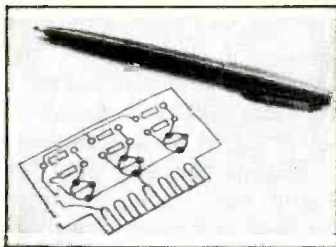

### 1. Direct masking

First, make a rough sketch of the circuit pattern to establish conductor routing and component placement on the board. Using grid film or paper, draw your exact layout with component terminals at the grid intersections. Draw interconnecting lines to represent conductors.

Now clip or tape the layout over the cleaned circuit board and, using carbon paper and a small center punch, mark the terminals on the copper surface. Trace conductor paths or sketch them directly on the copper with a pencil.

Next, apply the resist. You can paint your circuit design on with a brush, an etch resist pen, pressure sensitive pads and tape or a combination of these methods. When using tape and pads, overlap them and burnish them down to prevent undercutting by the etchant.

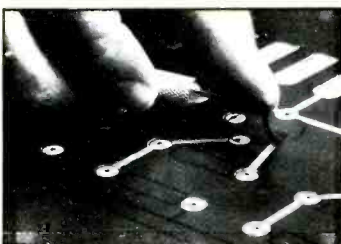
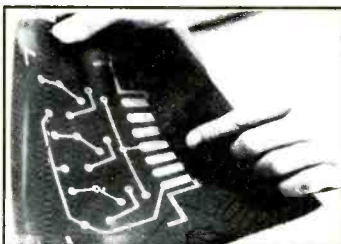

### 2. Cut and peel

With this method, you will make

a stencil of the circuit design, which will serve as your photo mask or negative when you expose your sensitized board under it. Choose this method when:

- You have a design you can trace.
- The design is relatively simple.
- You may want to make more than one board.
- You feel you are able to trace accurately the design with a sharp stencil knife.

The basic material for the photo mask is *masking film*. This is a thin, red, adhesive-backed, plastic film laminated to a tough, clear, plastic base. The weight of the knife alone on the thin film is enough to make the cut without scoring the base material. You'll find that a light, relaxed pressure permits you to make accurate and intricate patterns.

To make the photo mask, then, first tape a correctly trimmed piece of masking film over the layout you've selected, film side up. Next, using a *sharp* stencil knife, cut lightly along the outside edge of the patterns, pads and conductor paths.

Assuming the layout is printed in black, trace around everything that is black, never cutting across a black line or area. Proceed one unit at a time, that is, around a pad, along the conductor path, around the next terminal and back.

Finally, remove the film inside the cutting lines to allow light to pass through to expose the copper that is to remain on the board.

You can copy published professional artwork using this method, but, it is easier to have a film negative made—unless it is a simple circuit. A photocopy store, photo store or even a friend with a darkroom can do the job easily and inexpensively. Larger towns have "lithographic negative" shops (see Yellow Pages) that specialize in this work.

When the photo mask (or negative) is finished and checked for accuracy, it is ready to serve as your production negative. Place the photo mask over a cleaned and sensitized copper-clad board. Insert it into the contact pressure frame, expose it, develop it, etch it, clean it, dry it, assemble it, check it and "plug it in." If it works, you can use for a number of additional boards.

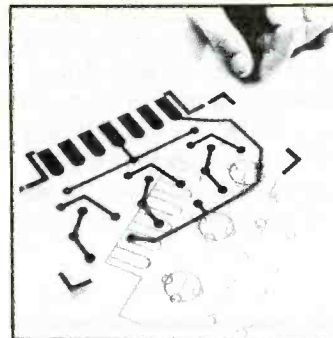
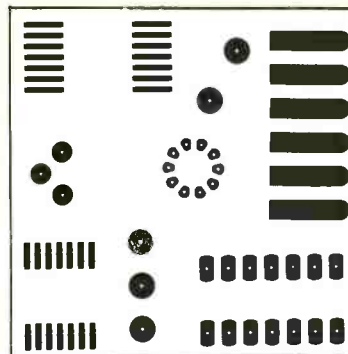

### 3. Photography

For extreme accuracy with complex circuitry, high density, and miniaturization, this is standard in the electronics industry. For that reason, many time-saving drafting production aids have been developed. Made to close tolerances, these aids include tapes, tape shapes, donut pads, die-cut multipad configurations (for transistors, ICs, etc.), connector strips, targets and cross-hairs, letters and numbers, symbols and words, and many other patterns, all with pressure-sensitive backing. Layout films represent the industry's standard base material on which the circuit design artwork is laid down.

Pressure-sensitive electronic component drafting aids are offered for several reasons: They offer the widest selection available, they are responsible for many of the industry's innovations, and they are used by electronic technicians around the world.

As for the artwork, let's assume you have chosen your own circuit design. The complete layout is drawn on a 1/10-inch grid pattern to the scale you have selected, conductor paths are drawn and component placement set and identified.

Clear off a flat table of adequate size and anchor your 1/10-inch grid

layout film or paper with a piece of tape across each corner. Now overlay a piece of acetate or Mylar (better for dense and complicated circuit patterns). The overlay is heavy enough to withstand the repeated repositioning of pressure sensitive tapes and aids.

Assemble all the tapes you plan to use for the job. A sharp drafting knife will help to produce quality master artwork. Place your board delineation marks first on the overlap. (Marks indicate the edges and corners of the board.) Locate all your terminals with donut pads or multipad configurations. Place them gently, so repositioning is easier. Finally, trace in your conductor paths, and hook up the terminals according to your layout.

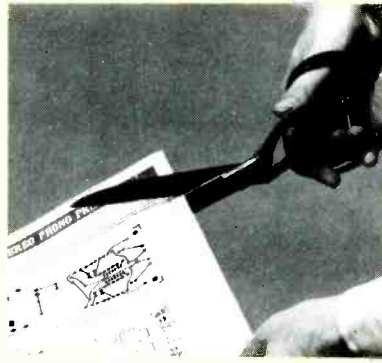

#### 4. Lift-it transfer system

If you want to reproduce a simple printed circuit from a magazine or book, you can use method 1. If you have a more difficult circuit to photograph, use Method 3. A more simple way to reproduce a printed circuit may be

the use of GC Electronics Lift-it kits.

This method consists of actually lifting the printed image and transferring it to a transparent film. The kit contains detailed information on how the system works and explains the various steps; here is a simple outline:

- The printed circuit pattern is cut from the magazine and taped on a piece of wax paper or glass.
- The transfer sheets are pressed on the pattern evenly.
- The paper backing on the printed page is now removed by soaking the paper in warm water. This softens the paper to a point where it can easily be rubbed off with the fingers. The printed pattern however,

## Useful tips for photographic transfer

Do	Don't
Avoid sharp external or internal angles.	
Always use the shortest practical routing.	
Maintain equal spacing when conductors pass between terminal areas.	
Avoid large multiple hole terminal areas which may cause thermal soldering problems and non-symmetrical solder fillets.	
Avoid using conductors the same size as terminals which will cause solder to flow away from the terminal.	



will stay on the sheet. The sheet is now held against the light and carefully inspected. Any pinholes or other minor defects in the pattern can be filled in with pens.

These steps will result in a positive transparency. If needed, use image reversing film to produce a negative transparency.

### Producing the PC board

Transforming your circuit layout into an etched wiring pattern is done the same way for methods 2, 3 and 4. Method 1 differs only in that creating the resist does not take place by exposure to light. Therefore, method 1, the direct masking technique, requires no sensitizer and no exposure to light.

Just etch away the unwanted foil, remove the masks, and your copper circuit pattern will be done. The latter three methods require the same production steps including the etching cycle. The following are the full instructions. (Note: Steps 1, 2, 3 and 4, are not required when using pre-sensitized boards.

1. *Clean the copper surface.* All grease, fingerprints and other possible contaminants must be eliminated from the copper surface before the sensitizer is applied. The board can be scrubbed with fine steel wool (containing no oil or soap) to remove any oxidation build-up or other contaminants. Scrub and rinse thoroughly. To test the results, flow water across

the surface; the copper surface should retain water in a sheet. Make sure the board is dirt-free.

2. *Dry the surface.* Blow extra moisture off the copper surface. One swipe with a dry cloth will help. Let it air dry at room temperature.

3. *Apply the sensitizer (negative photo resist).* Still handling the board by the edges to prevent fingerprints or other surface contaminants, prop the board at a 70° angle on a background of absorbent paper. Allow plenty of extra area around the board, as spray will go beyond the edges. Keep a safe light level in the room, using a 25W or 40W yellow "bug" lamp for illumination. Take the sensitizer, shake it well and start spraying 8

### Drafting aids

Determine the pad configuration from component manufacturer's data sheet. Calculate the maximum terminal area, based on data sheet dimensions and other specific requirements.

Transfer the dimensions in the correct scale to the layout. Draw the lead circle diameter for pad pattern.

Locate one pin on the lead circle diameter. Secure a sheet of layout film as an overlay.

Using only one pad and the lead circle diameter, lay down the entire pad pattern in one step; each pad will be perfectly positioned within the closest tolerances.

### Pattern tips

To remove small patterns from the backing, hold the backing flat on any surface and slip a knife blade under the pattern. Holding the pattern against the knife blade with the forefinger, remove it from the backing.

Using the knife blade as a holding tool, position the pattern over the artwork.

When properly positioned, hold the edge of the pattern down with the forefinger of the free hand, without pressing down hard, and

remove the knife. The pattern may easily be removed by slipping the knife blade under it and removing as above. When correctly positioned, apply pressure to affix it firmly.

To remove a large pattern from its backing, hold the backing flat on any surface and slip a knife blade under one edge. Hold the pattern against the knife blade with the thumb and lift the pattern off the backing.

Supporting the other edge of the pattern with the finger tips, bow it slightly between the fingers and the knife blade and position the center of the pattern over the artwork. Lay the pattern down without pressing on it. If an adjustment is necessary, the pattern can easily be lifted and shifted.

When the pattern is positioned correctly, firmly affix it by applying gentle pressure over the entire surface.

### Tips on tapes

Attach the cut end to the pad area from which it is to run. Holding down the fixed end, begin unrolling tape. For short traces, run the tape over the termination point and press down to establish the trace. After cutting the roll end, run your finger along the tape to assure an even surface; this will

affix it permanently.

With longer traces, the finger should be run along the tape to affix it after the trace is established, and before it is cut at the termination point.

When cutting tape over a pad, hold the knife edge firmly in a fixed position in a straight line across the width of the tape. Pull the tape up and along the blade with the other hand, and pull at an angle to the knife edge to assure a clean cut. Thus you will not slice through the terminal area.

**Corners, curves, elbows and tees**  
Flexible tapes are the ideal way to round corners in thin traces.

For wider conductor lines, universal corners or elbows make neat, clean, precise curves.

Opaque black tapes may be squared or angled with a knife.

Use tees where perpendicular conductor lines meet.

Conductor corners are used for 90° angles.

**Registration marks and targets**  
Register your artwork overlay with your grid/schematic underlay by using registration marks on each surface before you begin.



# Reversing positive artwork

If you have positive artwork, you will need to reverse your artwork to create a negative. Photosensitive reversing film should be used with developer.

Reversing film is sensitive to ultraviolet light. Use yellow light bulb. Cut a piece slightly larger than the positive artwork.

Place the reversing film emulsion (dull) side down on a hard, flat surface. Place the positive on top of the film, ink side down. The positive will appear just as it did in the original design. Be sure the positive is centered on the reversing film. Cover with a piece of glass, being careful not to move the positive. A contact frame will help prevent any unwanted movements and will keep the positive pressed firmly against the reversing film. For larger film, use an exposing stand.

Expose the positive using a 15W fluorescent lamp from a distance of 12 inches for a period of approximately 25 minutes, or expose with a 275W sun lamp from a distance of 12 inches for approximately 60 seconds. Exposure times will vary depending on the density of the artwork background. When working with a transparency, 60 seconds is suitable. Longer exposure times will be required for translucent backgrounds.

Using the yellow light source, remove the reversing film from the positive (handle by the edges only) and place on a smooth, clean surface, such as a piece of glass—the dull side must be up. Pour a small amount of film developer onto negative. Soak a large cotton ball with the developing solution and rub negative using light, circular motions. The portion of the negative that was not exposed to the light source will start to dissolve, leaving the image. Be careful not to rub too hard or you may remove part of the image. Once the image is clearly visible, remove the film from the glass and flush with cold running water. Handle by the edges only and hang the negative like any other.

to 10 inches from the board. Keep spraying until the board is thoroughly covered. Two complete passes should be sufficient. When the board is completely coated, place it horizontally in a dark cupboard or drawer to dry. Do not lay board horizontally. Excess build-up at the edge of the board may be drained off by touching the board edge with a paper towel. The coating should be uniform in appearance and thick enough to withstand the solvent action of the developer. (Caution: The spray is flammable. Do not use near fire or flame, keep away from children, do not inhale the fumes and do not throw the can in an incinerator.)

4. *Dry the sensitizer (negative photo resist).* "Force dry" the board in a warm oven or on an electric hot plate (not an open-coil type). If the board is force dried from the front by a heat lamp, solvents may get trapped on the surface of the copper. These solvents need to be "drawn off," as they could lead to image loss at later stages.

The oven temperature should not exceed 115 F and the hot plate 110 F. Drying time is between 5 and 10 minutes. Before placing the boards in the oven, it is important to wait at least 30 minutes after spraying to give the flammable solvents a chance to evaporate.

If the coating looks uneven or dries with runs or streaks, wipe it off with a stripper or lacquer thinner and start again. Note: Your board becomes light sensitive as soon as it is sprayed. If your oven has a light, unscrew the bulb before drying the board.

5. *Expose the sensitized board.* Keep the light level low by using a yellow light. Put the board in a contact frame. Keeping the sensitized surface of the board up and emulsion (dull) side of the negative down. Close the glass frame on top. The frame clamps them into a rigid, tight, sandwich-like package, which presses the art (or negative) tightly against the sensitized board surface. No light must leak around the edges.

6. *Develop the pattern.* Still in a darkroom condition, open the contact frame and handle the board by the edges. Place the negative or art in a safe place.

Put the developing solution in a glass or metal tray and immerse the board completely. Continuous

agitation of the tray will help to develop the resist completely. The resist is soft and can be smeared if touched. If the pattern is blotchy or incomplete, you will have to re-do the board; clean it, dry it, coat it with resist, re-expose and develop it. If you must re-do it, it is best to do it while the resist is still soft. See the troubleshooting section that follows to help you identify and correct any problems that might arise.

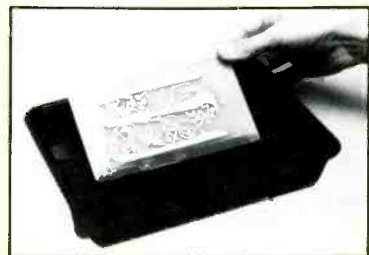

7. *The etching process.* It takes about 6 ounces of etching solution (ferric chloride) to develop a 4-by-6-inch board at a time, 1-ounce copper, one side. Pour the etching solution in a plastic or glass tray or bowl, making sure to cover the board completely. Use only plastic or glass because the etching solution will react with most metals. For single-sided board, immerse with pattern side up. Gently rock the tray; handle with care using rubber gloves. (Ferric chloride will stain hands and clothes). Observe all cautions on bottles.

Complete etching may require 20 to 60 minutes, leaving only the foil pattern on an otherwise bare board. This etching process is more effective if the solution is kept in a temperature range of about 90 F to 120 F. This temperature can easily be maintained by placing the etching tray in a water bath on top of a stove or hotplate with a low temperature setting.

Once the etchant is spent or becomes "loaded" with copper, it will no longer fully etch a board. The used etchant should then be thrown out and fresh etchant used. Use plenty of water and rinse the fully etched board surface. Always run the water hard when washing used solution down the drain. Note: If you are using heated etching solution, be sure to provide additional ventilation.

8. *Strip and polish.* Prepare your finished board for component,



# An alternative: The positive transfer system

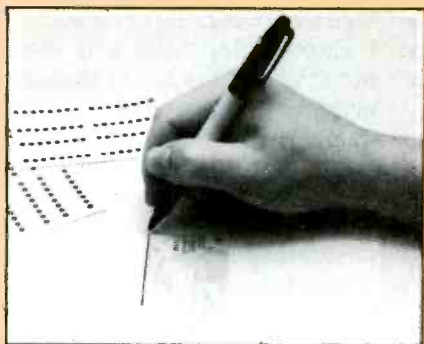

Positive transfer system materials are simple to use and virtually foolproof, so your circuit pattern transfers will be a success.

For example, P.T.S. uses semi-photosensitive materials that are not critically light-sensitive and can be exposed to normal indoor light (for short periods of time) without ill effects.

Shelf life is excellent and sensitivity to developing chemicals is broad enough to allow less-than-professional handling.

As a result, failures and remake work are reduced. And, because drying time is minimized, project times from start to finish are reduced substantially.

## Create artwork

Any artwork composed of opaque copy (solid black is best) on a transparent or translucent carrier may be used with the positive transfer system.

Opaque copy on a transparent carrier (acetate) includes high-con-

trast photographic negatives or positives and adhesive or rub-on drafting aids or mylar (matte finish side). Continuous-tone negatives should not be used because the gray tones (shade variations) cannot be reproduced.

Opaque copy on a translucent carrier includes adhesive or rub-on drafting aids. An etching pen can be used to draw directly on mylar.

## Reverse positive artwork

If you have positive artwork, you will need to reverse your artwork to create a negative. Photosensitive reversing film should be used with developer.

## Expose the artwork

Expose the negative with a sheet of film to an ultraviolet light source, such as a sun lamp. P.T.S. film is semi-photosensitive in normal light. It may be out of the envelope for up to 5 minutes with no ill effects, but some caution in handling is recommended.

Cut a piece of P.T.S. film to the size of your circuit pattern artwork negative. Lay the film on a hard, flat surface, with the emulsion (brown) side down. Center the negative, right side up, on top of the film and cover with a sheet of glass to keep it flat.

Expose to ultraviolet light from a 275W sun lamp at a distance of 12 inches for 1½ minutes.

Note: Overexposure causes "fattened", closed-up images. Underexposure results in a less dense im-

age, subject to cracking, with less adhesion, or image loss when developing.

## Develop

With the brown side of the P.T.S. film up, peel off the protective clear plastic coating. Lay film on a clean, flat surface, keeping brown side up, and pour small amounts of developer onto the film to wet the surface completely. Distribute the developer evenly over the surface of the film with the applicator pad and let sit 10 seconds.

Rub the film surface with a circular motion and light pressure of the pad. Portions of the coating will be removed by the rubbing action, leaving the desired image. Small amounts of developer may have to be added during development to maintain complete wetting of the film and the applicator pad.

If the desired image rubs off or is not as sharp as the original, the film may not be exposed correctly. Exposure time will be affected by the opacity of the original artwork. It will also be affected by changes in the efficiency of the light source. Therefore, to confirm exposure time, trial exposures may be necessary.

Wash the resulting positive transparency under cool, running water and allow to drip dry thoroughly. Do not use warm or hot water.

## Rub down on PC board

On a clean, prepared PC board, position the transparency, emulsion (dull) side down. Rub the entire image onto the board, burnishing with a flat, blunt instrument. Carefully peel off the plastic film. The pattern will remain on the board as an etch-resistant black coating.

## Etch and strip

Etch as you would any PC board. Time will vary for etching with the temperature of the solution. When etching is complete, use PC board stripping solution and fine steel wool to remove etch-resistant emulsion. The circuit pattern will remain on the board, etched in copper, ready for drilling and circuit assembly.

loading and soldering in three easy steps:

- Remove the etch resist by lightly wiping the board with a wad of cotton soaked with stripping solution (use adequate ventilation). Wait one minute, then easily rub resist off.
- Polish off the final traces with plain steel wool.
- Protect your finished board with immersion electroless tin plating solution. This will improve conducting and prevent copper oxidation.

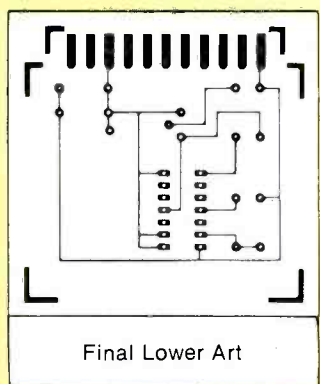
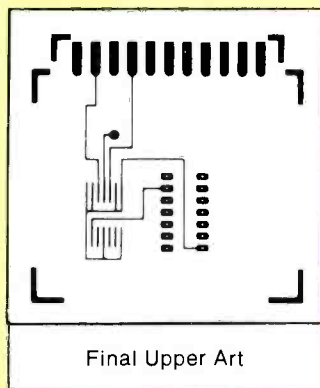
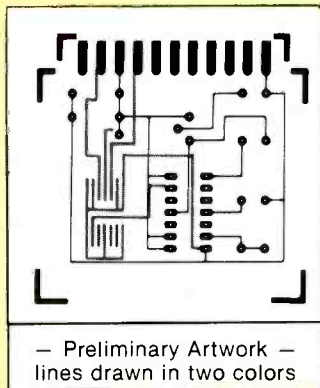

### Double-sided boards

Some circuits, usually the more complex ones, cannot be laid out in such a way so that crossovers are avoided. As explained previously,

lengths of wire and components are often used as "jumpers." If there are only a few crossovers involved, a component or wire jumpers are a relatively easy solution to the problem.

If you find, during your layout, that an inordinate number of jumpers will be needed, you might consider making a double-sided PC board. Using this approach, you can produce continuous conductor paths without resorting to wire jumpers. You simply "split" the conductors by alternating them from one side of the board to the other as required.

Start with a regular layout, using standard grid paper and two pencils of different colors. Using one color pencil, draw your connecting paths between components and terminals that do not cross. Use the other color pencil to draw the lines that cross the previously drawn pattern. You may have to rearrange the components and reroute the conductor pattern several times to obtain a clean layout for both the top and bottom of the board. This 2-color sketch is called the preliminary layout.

The final artwork on transparent film is made from the preliminary layout. Examine the layout and label the most complex color pattern "bottom," and the other pattern "top." Start by laying out the bottom artwork with donut pads, IC sockets, patterns, etc., and the connecting lines that were penciled in on your preliminary layout for the top of the board. Add three or four delineation marks or targets to the corners of the artwork for registration.

Flip over the artwork and place another sheet of transparent film on top of it to prepare the final artwork for the top of the board. Add the delineation marks or targets, exactly in the same position as they are on the bottom sheet. Repeat donut pads, socket terminals, etc. from the bottom artwork at the points where the conductors alternate from side to side. Interconnect the pads with tape according to the top preliminary layout pattern. Then use black ink to fill in the holes in all pads on this artwork film. This will compensate for minor misregistrations after the board is etched and ready for

drilling. Do not fill in the holes in the film for the bottom of the board.

You can use the positive pre-sensitized boards or the negative photosensitizing method explained in this article. Start by taping the positive art or the negative films back to back, with all the target marks and pads perfectly aligned. Tape the film pair to the PC board and drill two to four widely spaced holes through both artwork (or films), and the PC board. Use any of the donut centers that will have to be drilled after etching. Alignment and drilling must be done in a darkroom condition if using pre-sensitized boards. Clean and sensitize the board on both sides. Allow the board to dry thoroughly after cleaning, and after sensitizing. Place your double-sided PC board between the artwork.

Expose first one, and then the other side of the board through the artwork or films. The only critical operation here is lining up the films with the pre-drilled guide holes in the board. Some technicians prefer not to use eyesight; instead, they make certain of perfect registration by inserting a piece of wire (for example, a resistor lead) through the films and PC board. Then, they tape the films to both sides by their corners, and remove the wires that will interfere with the required contact between PC board and films when placed in the exposure frame or between glass plates.

One final word: The holes in commercially made double-sided PC boards are "plated through" to assure continuous conductor paths. This process cannot be readily duplicated with the materials and kits available for prototype production or hobby use. This means that you will have to make sure that there is a connection between the terminal pads on both sides of the boards.

Normally a lead wire from a resistor, transistor, etc., goes through the board. This interconnection can be readily established by soldering this lead to the pads on both sides of the board. As an alternative, drill holes somewhat oversized, and make a separate interconnection by soldering a short length of wire to the pads on both sides. The component leads require soldering to one side.



## Troubleshooting

PROBLEM	SOLUTION	PROBLEM	SOLUTION
Orange peel	Oven too hot, reduce oven temperature. Make coating even, not too thick.	Thin resist	Spray slowly. Make sure board is clean first.
		Streaks	Possibly underdeveloped. Try again.
Developer erases image	Make sure the board is clean before spraying it with resist. Check the exposure time, make sure it is long enough, and adjust accordingly. The resist coat must be dry and not too thick before developing.	Image blisters	Thinner resist and timed exposure might solve the problem. (A thick resist coating is hard to dry in a short time, and overdevelopment with insufficient exposure is possible.)
Resist where it should not be	Check the artwork or film for opacity. Check the light level and source. The drying temperature could be too high.	Pinholes	Everything involved in the photography (the coating, negative and contact frame) must be free from dust and dirt.
Etching solution does not remove copper foil properly	Check the solution temperature, it should be between 90-120F. The warmer it is, the faster the action. The etching solution may be saturated; try new etching solution.	Image deteriorates in etching step	Spray the resist on a little heavier. Make sure the copper surface is clean before you start. Bake board prior to etching at 350F for 15 minutes.

### Tips on assembly

After etching, the board must be drilled for component leads. Use the proper size drill so that leads do not have to be forced through the holes. Avoid sloppiness as solder must flow into the gap between the leads and the pads. High-speed drills make clean holes and going slowly through the board with a drill press prevents big burrs. If possible, drill all holes at one sitting.

The best ways to trim a board to the proper size are as follows: a shear, a table saw or a hack saw (jig saw) and a file to dress the edges.

When you bend leads on transistors, capacitors and diodes, 1/4-inch from the body is ideal. Never bend the leads closer than 1/8 inch from the body. Make neat bends with a fixture or round nose pliers.

Always keep transistors and ICs at least 1/16 inch to 1/8 inch off the board. This presents lead stress and permits the use of heat-sink clips on these heat-sensitive devices during soldering.

Use brackets and screws to mount heavy or adjustable components securely to the board. Do not depend on soldered leads to anchor.

When soldering, insert the component leads and bend them over to hold the component in place. Solder, then clip off the excess lead. Use a hot iron and always use a heat sink on semiconductor leads. Wipe your iron often to keep it free of excess solder. Make sure solder flows all around the lead, and remove the iron immediately. Do not move or touch the component until the solder hardens. This will cause a bad joint as solder will become crystalline, porous and resistive if moved when hot. Bad solder joints are often difficult to find, so be careful to do it right the first time.

**ES&T**

# MOVING?

If you're planning a move in the near future, don't risk missing an issue of *Electronic Servicing & Technology*. Please give us 6-8 weeks notice if you're planning on changing your address. Just write in your new address below and mail this coupon, WITH YOUR SUBSCRIPTION MAILING LABEL, to:

**ELECTRONIC**  
*Servicing & Technology*

P.O. Box 12901, Overland Park, KS 66212

Name \_\_\_\_\_  
 Address \_\_\_\_\_  
 City \_\_\_\_\_ State \_\_\_\_\_ Zip \_\_\_\_\_

For address change you MUST  
 affix label from cover here.  
 Print new address below.

# TV/video sync enhances TV troubleshooting

Adapted from a Hewlett Packard technical note

The purchase of a new oscilloscope requires careful assessment of both present and future measurements and the necessity for TV/video sync capability should be considered in these evaluations. Rapid growth of video products (cassettes, recorders, discs, systems, etc.), coupled with raster display and TV applications, form a broad spectrum of applications for this capability. TV/video sync is frequently used in a variety of applications and environments, including product development, pro-

duction, test and service. Ultimately, it is used to monitor the video portion of a system, whether it is an ultrasound scanning system, a videocassette recording system or a remote TV transmitter site.

This article explains the features and potential areas of application for TV/video sync capability in an oscilloscope. A powerful capability, TV/video sync provides added measurements in a variety of situations and serves many facets of industry.

It is advantageous to identify some known video systems, both for background information and to help add more meaning to the features and measurement techniques in this article.

## Basic primer

The fundamentals of video and the associated waveforms are a foundation for understanding the purpose and operation of TV/video sync circuitry. This section, devoted entirely to U.S. NTSC (National Television Systems

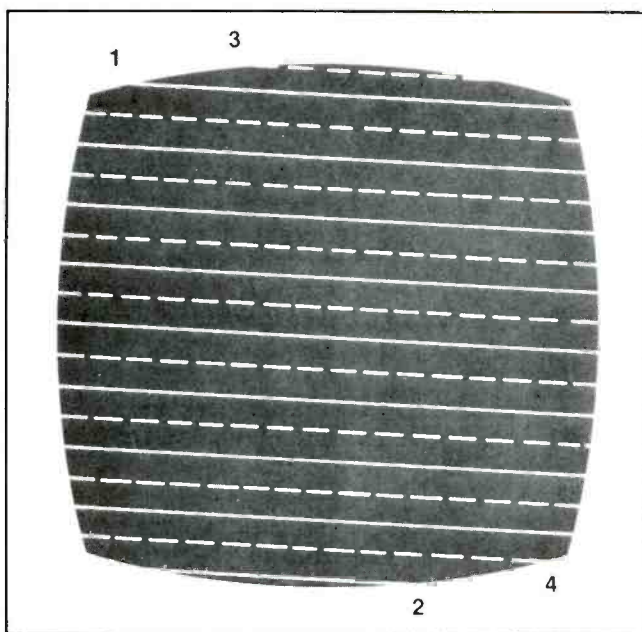

Figure 1. One complete frame, interlaced with field 1 (1 to 2) and field 2 (3 to 4). The scanning sequence is horizontally left to right, and vertically top to bottom.

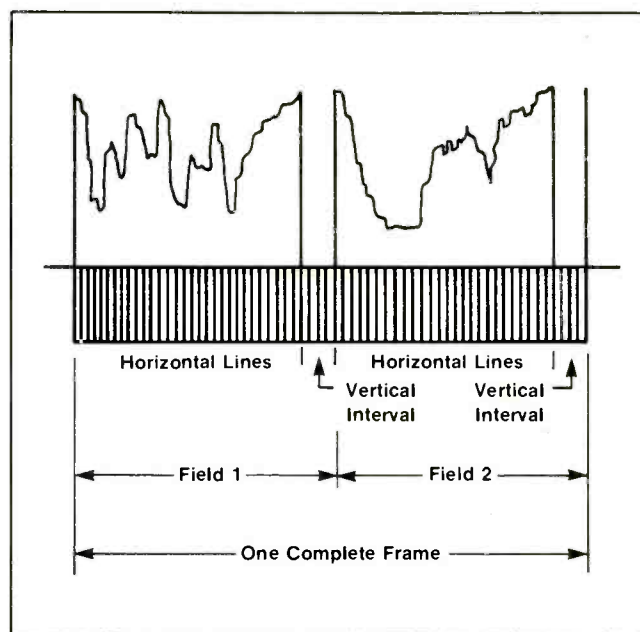

Figure 2. The basic combination of fields and vertical intervals.



Committee) broadcast standards, provides familiarization with units of measure, nomenclature, signals and measurement requirements. Defining one particular system in detail is useful because some of the nomenclature, signals and measurements are generic to video systems in general.

**The picture.** A picture is developed using a raster scanning technique and modulating the Z axis for the necessary gray shades. Each picture is defined as a frame that is created by interlacing two fields. Interlacing of two fields, each containing 262.5 horizontal lines, effectively doubles the frequency of field occurrence to 60 fields/s and eliminates visible flicker (Figure 1).

**Measurement units.** The television, or composite video waveform, consists of horizontal sync, vertical sync, video information and test signals. This waveform and its various components are specified by the Institute of Radio Engineers (IRE) and are defined in IRE units ranging from -40 to +100. In IRE units, 100 units equates to 0.714V peak-to-peak with +100 and +7.5 corresponding to white and black video levels, respectively. Timing measurements are usually in the microsecond range.

**Frames & fields.** In the NTSC system, one frame of information

creates a complete picture. Each frame contains two interlaced fields with a total of 525 lines. Each field contains 265½ lines, 21 of which are blanked (the vertical interval) for beam repositioning to the top of the screen (Figure 2).

**Horizontal interval.** The horizontal portion of the composite video waveform consists of horizontal lines, each containing video information, and sync pulses, which provide blanking, retrace time, and other information. A detailed picture of horizontal line sync pulses, various IRE levels, and timing information is valuable in the video world (Figure 3). Descriptions of various events within the horizontal line sync pulse provide insight into the many purposes of the waveform.

The "front porch" prevents video voltages from prematurely triggering the sync circuits by isolating transients from the sync pulse. The horizontal sweep oscillator is reset by the leading edge of the sync pulse, while the tip of the pulse is a reference point for dc restoring in receiving sets. The "back porch" provides time for the blanked beam to return to the left side of the screen. During color transmission, a 3.58MHz sine wave color sync burst is added to the "back porch" to frequency and phase lock the picture color information. Video information is con-

tained between the end of the "back porch" and the beginning of the next "front porch" and is transmitted by modulating the carrier signal from black to white levels.

**Vertical interval.** Before sweeping each field, the beam must be repositioned vertically. The repositioning time, called the vertical blanking interval, is composed of 21 horizontal lines, which are not displayed. This portion of the composite video waveform is extremely important because it contains critical pulses, FCC-regulated test signals, network-generated test signals, source identification codes, reference signals and information regarding caption availability for the deaf during a broadcast (Figure 4).

The first six pulses, known as equalizing pulses, synchronize video information in fields 1 and 2. These pulses occur at twice the horizontal sync rate (period = 63.5µs, 15.75kHz) and assure that vertical triggering occurs at the same time for odd and even fields.

The serrated vertical (sync) pulses follow next and are a triggering source for the composite video signal (refer to "Theory of operation"). The second set of six equalizing pulses ensures field frequency regularity. The remainder of the 21 blanked horizontal lines contain various test and information signals, both FCC regulated

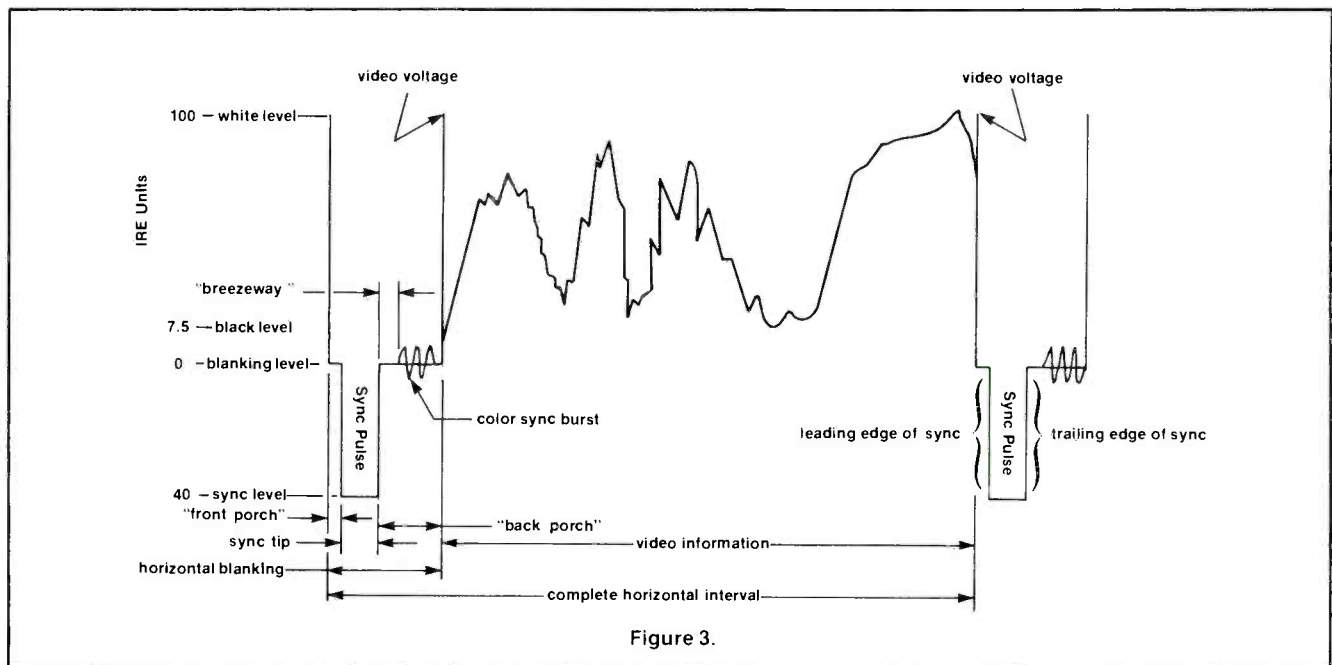
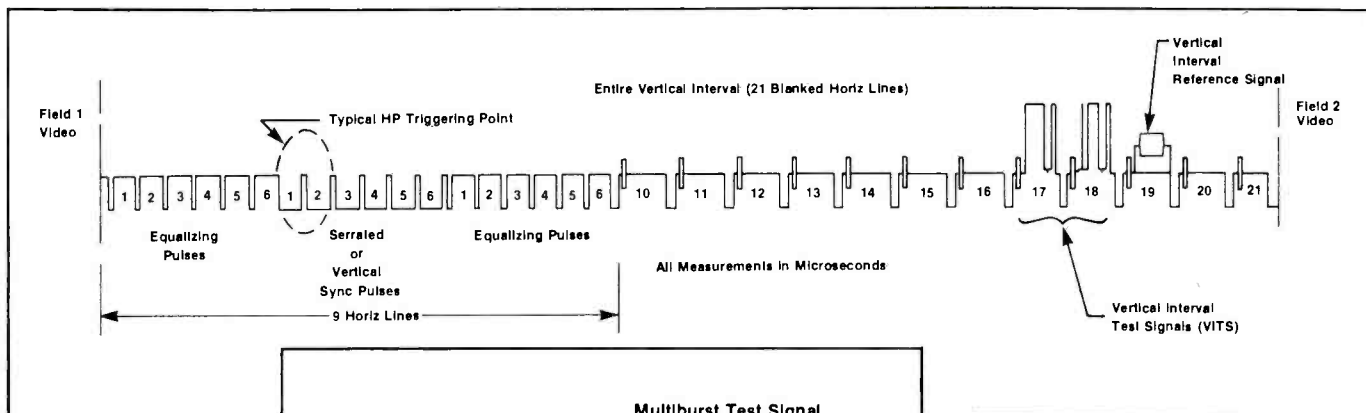

Figure 3.

Figure 3. A picture of horizontal line sync pulses, various IRE levels and timing information.



**Figure 4.** Entire vertical interval (21 blanked horizontal lines).

**Figure 5.** Multiburst monitors setups and frequency selective compression.

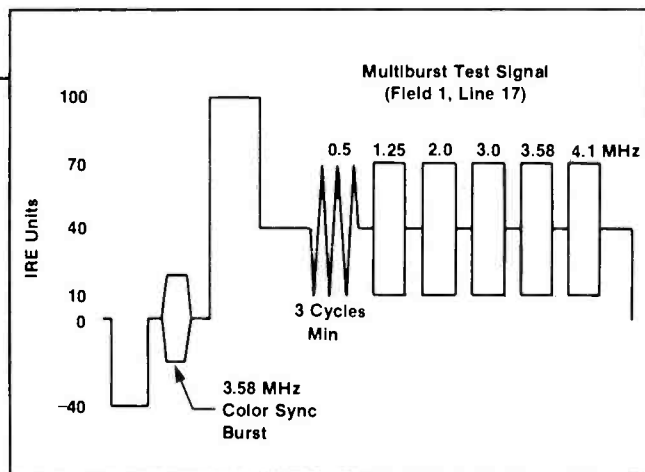

white bar indicates frequency response while the symmetry of the 2T pulse indicates delay. The 12.5T modulated sine-squared pulse provides an indication of amplitude frequency response errors where the 2T pulse is less sensitive, namely from 3 to 4MHz, which are the chrominance frequencies. The detection of chrominance/luminance gain and delay, which cause color saturation and distortion problems, is easily accomplished with this pulse.

and network generated.

**Vertical interval test signals.** In recent years, severe measurement requirements have been imposed on the TV industry. Strict enforcement of FCC regulations combined with internally generated network standards have increased the variety of signals within the vertical interval. Vertical interval test signals (VITS) are used to evaluate various parameters of a broadcast system's performance and are monitored daily. The VITS are transmitted during active operation to ensure continuous quality and accuracy in terms of color and distortion. In regard to transmitter performance, the quality of the VITS frequently determines if a problem warrants a trip to the transmitter site.

The type of test signal, as well as specific line location, is determined by individual networks or the FCC and depends on transmitter operation, area served, etc. A remote-controlled transmitter site is required to transmit FCC-specified VITS on lines 17 and 18: multiburst on field 1, line 17 (Figure 5); color bars on field 2, line 17 (Figure 6); composite radiated signal on fields 1 and 2, line 18 (Figure 7). In cases in which the network determines the type

and location of the VITS, several alternatives are available. These signals may be on line 17 or 18, field 1 or 2. Some frequently used VITS are highlighted with measurement applications emphasized in the following paragraphs.

The multiburst (Figure 5), a VITS aimed directly at frequency-gain characteristics, also monitors setups and frequency selective compression. This test pattern usually consists of a white bar (100 IRE) followed by six bursts of sine wave frequencies ranging from 0.5MHz to 4.1MHz. The six bursts must have equal amplitude for the correct response.

The Composite Radiated Signal (Figure 6) contains several distinct signals, each having its own diagnostic capability. Differential gain and phase are evaluated through the modulated staircase. This signal is composed of six equal amplitude steps, ranging from -20 to 100 IRE levels; each step is modulated with a 3.58MHz sine wave burst on its dc level. Variation in sine wave amplitude is a measure of differential gain. The 2T sine-squared pulse is especially useful for determining frequency response and group envelope delay. The relative amplitude of the 2T pulse in relation to the

The color-bar test signal (Figure 7) is one of the most widely used test waveforms in color TV broadcasting. The waveform consists of the three primary colors (red, green and blue), their complements (cyan, magenta and yellow), and a white reference bar. The color bars are arranged in order of luminance, with the brightest colors on the left and the darkest on the right. This signal provides a quick method of assessing color transmission quality. The confirmation of performance, either satisfactory or unacceptable, is the oscilloscope's main objective. Beyond a status indication, a vectorscope must be used to evaluate the encoding and processing of color signals.

**More signals.** The vertical interval reference (VIR) signal (Figure 8) is on line 19, fields 1 and 2. A Source Identification Signal (48 bits) is frequently on line 20, field 1, and indicates the origin of the broadcast, the network, date, time, etc. One interesting signal often inserted somewhere in the vertical interval indicates caption availability for deaf viewers.

**Other systems.** There are two other systems widely used as TV standards, PAL and SECAM. These are 625-line (50Hz) systems



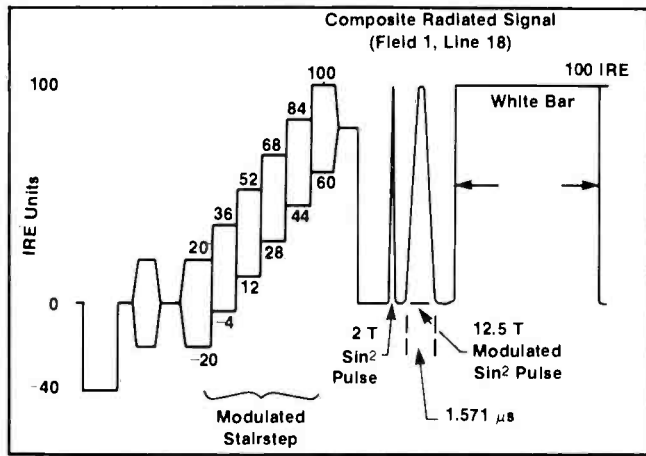

Figure 6. The composite radiated signal contains several signals.

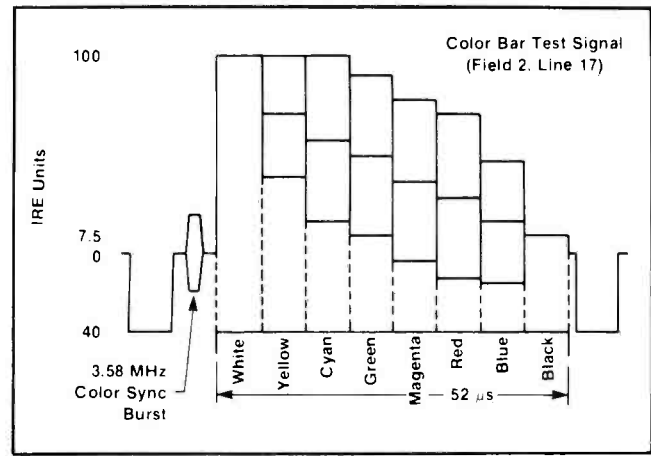

Figure 7. The color-bar test signal.

and differ from NTSC primarily in the method of color transmission.

### TV/video sync products

Currently three methods exist for obtaining TV/video sync capability on oscilloscopes.

An option can be ordered on new purchases of some oscilloscopes that adds the internal circuits and front panel controls necessary for triggering on and controlling the display of video signals. Front panel controls associated with the option are clearly marked with dark green buttons or labels.

A new implementation of this option enables the two high frequency oscilloscopes to have TV/video sync capability. An external module, mounted on the rear portion of the instrument's top cover, contains a sync separator circuit that externally triggers both main and delayed sweeps on the composite video waveform.

TV/video sync, a powerful and popular standard option on many oscilloscopes, can now be added through a retrofit kit. The kit consists of a user-installable module that mounts on the instrument's top cover with a template diagram.

### Applications

There are two issues that should be clarified regarding TV sync. The first is that in TV applications, an explicit difference must be made between a waveform monitor and an oscilloscope capable of triggering on composite video. The second point involves various applications in industry, not even

remotely connected with the TV industry, where TV/video sync capability is extremely useful.

Most TV stations require several waveform monitors, usually rack-mounted, designed to make precise measurements of blanking intervals, pulse widths, risetimes and other signal characteristics. These precise measurements, required to conform to strict FCC specifications, are the waveform monitor's job and not the oscilloscope's. The principal use of an oscilloscope in the TV industry is for troubleshooting. Frequently, equipment will malfunction or signals will greatly exceed specifications and a general purpose oscilloscope can be used to track down the problem and confirm the presence of a video signal. Spot checks of VITS at satellite earth terminals, transmitter sites, cable connections and temporary electronic-news-gathering stations can be easily accomplished with an oscilloscope to quickly confirm the system status. Observing of signals with a TV sync oscilloscope is a valuable tool for evaluating system performance.

The second application, undoubtedly the largest, deals with measurement requirements generated by companies virtually unrelated to the TV industry. These companies manufacture a variety of products, primarily in the video and medical fields.

Video applications are expanding at a rapid pace, with new companies entering the market and new products being introduced regularly. Home recorders, videocassette systems and tapes

form the bulk of the market; however, the advent of the videodisc should expand and change the product mix in the future. The medical profession requires many sophisticated display products for processing waveforms similar to standard video. Several types of scanners (ultrasound, brain, etc.) comprise a significant segment of this application area.

Either product line—video or medical—combines a raster display with video signals. These two key elements in any product define the requirement for TV sync measurements. Products characterized by these two elements require oscilloscopes in every phase of development and manufacture. Production lines and quality control areas confirm the video display's performance, while calibrators evaluate the many parameters associated with the system. These parametric checks are accomplished through the transmission of custom test signals, similar to VITS, which monitor specific types of response: amplitude, frequency, frequency compression, and chrominance. Service and maintenance contribute further to the market using the oscilloscope as a general troubleshooting tool whose capability is enhanced with the TV/video sync capability.

### High-frequency oscilloscopes

Today's video systems are designed with more and more high-speed logic, requiring high-frequency oscilloscopes for the examination of fast transitions and

precise timing relationships. Therefore, subsequent production and service of this equipment requires the mutually exclusive combination of high bandwidth and video sync capabilities.

In terms of application, the main point is that the oscilloscope is a useful tool in troubleshooting and development work, and, when combined with TV/video sync

capability, its broad range increases. The advent of home video recorders, cable TV and video security systems, in addition to traditional display monitor and TV applications, combine to provide many applications for the TV sync oscilloscope.

### Delayed gate output

A delayed gate output has an in-

teresting application that permits the oscilloscope to be a powerful tool when checking systems that contain a video monitor. Several oscilloscope features are combined for this application: *delayed gate output*, *delayed time base*, *TV line scan* and *single line scan*. The object is to identify on the video monitor, the group of lines, exact line or specific portion of a line that is being displayed (via the delayed time base) on the oscilloscope's CRT. Setup for this application is illustrated in Figure 9.

The delayed gate output (rear panel of oscilloscope) is applied to the video input of the monitor. This gate voltage increases the video signal to a white level (>100 IRE), making the oscilloscope's delayed sweep marker easily identifiable on the monitor. The delayed time base can then be used to vary the width of the identification marker: A  $5\mu\text{s}/\text{div}$  setting corresponds to approximately one line, while slower settings present a group of lines and fast settings a fraction of a line.

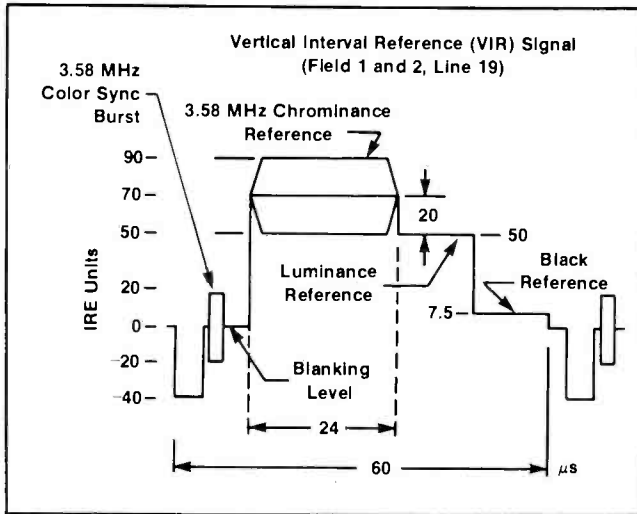

Figure 8. Vertical interval reference signal

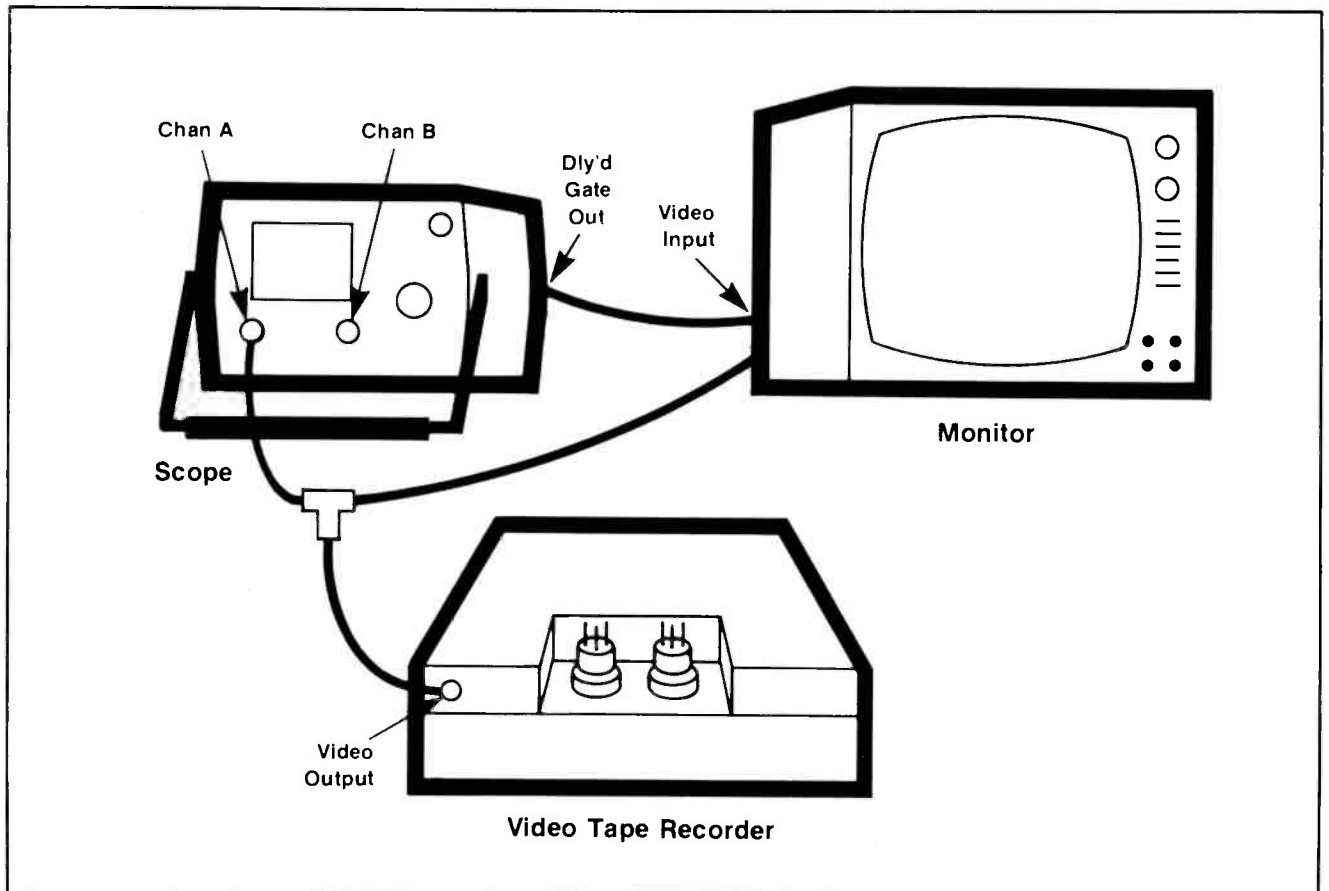

Figure 9. By using the oscilloscope delayed gate output in conjunction with a TV monitor, individual lines can be identified on the monitor and examined in detail with the oscilloscope's delayed time base.



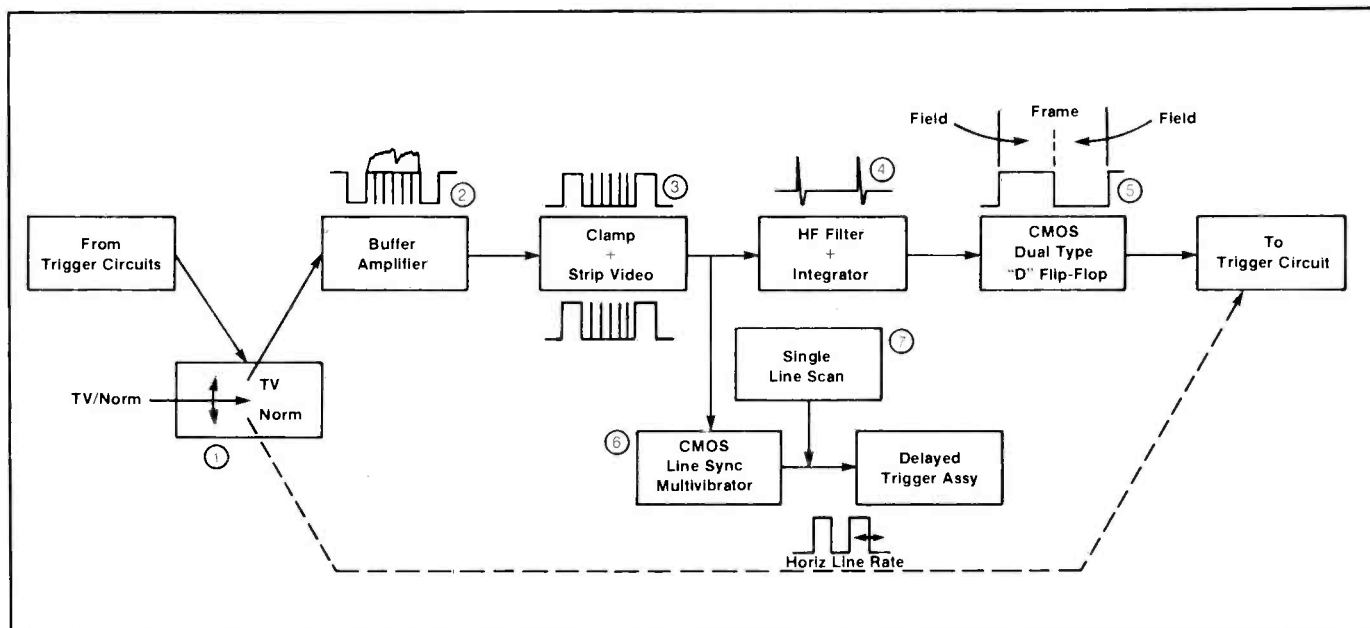

Figure 10. A block diagram of the sync separator circuit.

Once the desired marker size is determined, the *TV line-scan* control (delay control) can be used to position the location of the marker. *TV line scan* provides continuous vernier control with *sweep-after-delay* controls set for *auto*, while their *trig* mode discretely jumps from line sync pulse to line sync pulse.

Using the video monitor for positive identification of the oscilloscope's delayed time base display can be improved even further with *sweep-after-delay* controls set for *trig*, *TV* and negative. Single line scan can then be used in conjunction with *TV line scan* to examine a precise portion of a particular identifiable line with complete vernier control. In this mode, *TV line scan* controls the vertical movement of the marker (jumping from line to line) and *single line scan* moves the marker horizontally. This is a powerful application because a particular line can be identified on the monitor, selected with the *TV line scan* control of the delayed gate output marker, and examined in detail using *single line scan*. For example, *single line scan* can display a specific line sync pulse width or color burst in full screen detail.

### Theory of operation

The TV/video sync option adds the circuits and controls (Figure 10) that enable internal triggering on composite video signals, almost

any raster display signal, and display the signal on either Channel A or B.

- *Norm/TV* switch: Selecting television diverts the composite video to be conditioned into a usable form before re-entering the standard trigger circuits.
- The signal is amplified.
- The signal is inverted, stripped of video and clamped to remove noise. The high-frequency horizontal line sync pulses and vertical interval pulses remain.
- High-frequency horizontal line sync pulses are removed and vertical pulses remain. The first six equalizer pulses are too short in duration to integrate past the trigger level (signal inverted, Figure 10); however, the first vertical serrated pulse is of sufficient duration to integrate past the trigger level and toggle the flip-flop.
- The flip-flop's output distinguishes between the two fields in each frame. The field-select button selects the positive slope of the output to display one field and the negative slope to display the other field.
- Unfiltered horizontal line sync pulses activate the multivibrator, which generates a pulse train corresponding to the horizontal line rate. Delayed sweep is triggered by the pulse train and, therefore, corresponds to the horizontal line sync rate.
- The pulse train has a variable width controlled by *single line*

*scan* potentiometer, which varies the width of the pulses at the trailing edge from 3 to 50 $\mu$ s. If the oscilloscope is set for *triggered delayed sweep* with a negative slope, adjusting *single line scan* provides a vernier delay to the waveform.

### High-frequency standard option and retrofit kit

The module used in these products operates on essentially the same principles as described above. The differences in operation are highlighted (steps in Figure 10 are referenced).

- In the external module the composite video signal is input directly to the sync separator circuit. Only *EXT. TRIG* for main and delayed sweeps needs to be selected to properly trigger on composite video waveforms (step 1, Figure 14).
- The output of the flip-flop (step 5, Figure 10) exits the module as the rear panel *main trigger output* and externally triggers the oscilloscope's main sweep.
- The output of the multivibrator (step 6, Figure 10) exits the module as the rear panel *delayed trigger output* and externally triggers the oscilloscope's delayed sweep.
- The single line scan (step 7, Figure 10) control is located on the module's front panel and operates as described in the previous theory of operation section (7).

**BS&T**<sub>inc</sub>

## ATTENTION TECHNICIANS

- ★ JOB OPENINGS
- ★ MONTHLY TECHNICAL TRAINING PROGRAM
- ★ BUSINESS MANAGEMENT TRAINING
- ★ LOW COST INSURANCE
- ★ CERTIFICATION
- ★ TECHNICAL SEMINARS

All of this in a nonprofit international association for technicians

FIND OUT MORE:



R.R. 3 Box 564  
Greencastle, IN 46135

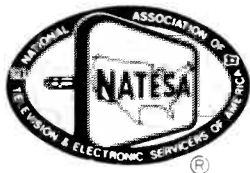

SINCE 1950

- LEADING SPOKESMAN
- TRADE INFORMATION DISPENSER
- WATCHDOG
- NATESA SCOPE
- STANDARDS YARDSTICK
- CONSUMER RELATIONS
- PROBLEM SOLVER
- CONCISE PRACTICAL BUSINESS OPERATIONS MANUAL
- SERVICE CONTRACT MANUAL
- CUSTOMER PLEASING PROFIT PRODUCING ORDER FORMS
- PARTS PROCUREMENT EXPEDITOR
- SERVICE BUSINESS
- DIVERSIFICATION PLANS
- TECHNICIAN DEVELOPER



### Field-service DMM

Weston Instruments has introduced the model 7320, hand-held, 3½-digit DMM for field service applications. Two autoranged dc-voltage ranges provide measurements to 200V with an accuracy of 0.1% of reading  $\pm 1$  digit. If connected to an ac source of greater than 20V rms, whether a dc component exists or not, the 7320 will automatically switch to an ac mode and provide autoranged displays to 600V, 45Hz to 1kHz, with a



basic accuracy of 1% of reading. An ac component below 20V triggers a display annunciator and the user can then manually switch to "low volts, ac" to read the exact value.

Circle (75) on Reply Card

### Portable DMMs

PMC Industries has introduced its new line of hand-held DMMs for use in the field, lab, home or office. The two units in the line feature ½-inch high LCD readouts, polarity indicators, and low-battery indicators, and operate from 9V alkaline batteries. Both are supplied with test leads and operating instructions.

Model DMM-1 features audible



continuity check, diode check, ac and dc volts, dc and ac amps to 10A, ohms, floating decimal point and fuse overload protection. Model DMM-2 features ac and dc volts, ohms, dc milliamps, diode check and fuse overload protection.

Circle (76) on Reply Card

### Speaker protection

A British-made, add-on speaker protection system can prevent damage to loudspeaker drive units from overloading or "going dc."

The Protech SP150 protects against dc voltages, excessive high-frequency content, gradual voice coil heating and excessive transients.

The units, from QED Audio Products, offer no signal degradation and do not place stress on the amplifier. They continuously monitor the signal to the speakers and, if an overload occurs, trigger a time delay. If the level does not fall to an acceptable point, a relay reduces power to a safe amount.

Circle (79) on Reply Card

### Digital storage scopes

Three new combination real-time/digital storage oscilloscopes (DSOs) have been introduced by Gould, Instruments Division. Designated DSO1400, DSO1403 and DSO 1420, these portable,

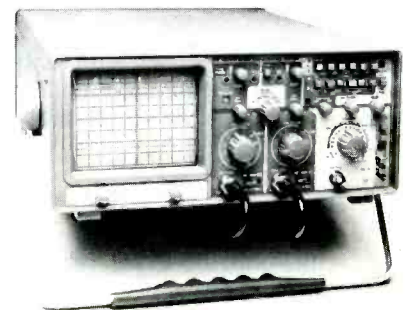



lightweight scopes can be used for many applications, including mechanical, electrical and physical testing, production-line testing, equipment servicing and teaching.

Circle (78) on Reply Card

### Autoranging cap meter

The 3002 autoranging capacitance meter from *Global Specialties* combines the precision, range and flexibility of benchtop models with the convenience and operating efficiency of a hand-held unit. This autoranging, digital,

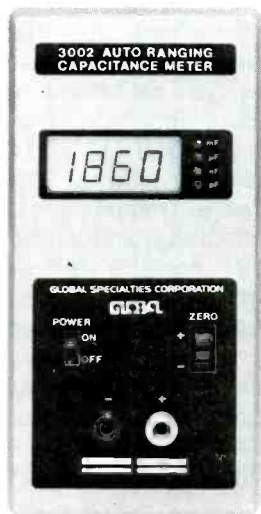

LED-display capacitance meter provides direct readings of capacitance from 1pF to 19,990 $\mu$ F with eight automatically selected ranges providing accurate measurements of capacitance without manual switching. Designed with dual threshold detectors, the 3002 is accurate to 0.2%  $\pm$  1 count in the 1pF to 199.9 $\mu$ F range and 1.0%  $\pm$  1 count in the 200 $\mu$ F to 19.99mF range.

Circle (77) on Reply card.

### Power supplies

*Leader Instruments* has introduced the LPS-151 and LPS-152 triple output dc power supplies with metered output voltages adjustable from 0 to 6Vdc, 0 to +25Vdc, and 0 to -25Vdc. This makes them ideal for computer subassembly, circuit board, semiconductor and system burn-in test applications. All three outputs have independent, adjustable current limiting with an automatic recovery feature that allows the

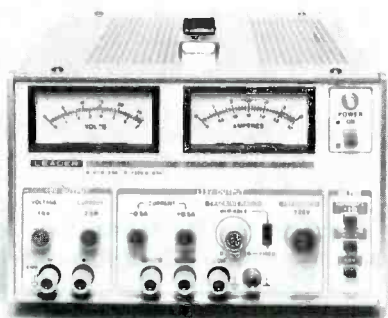

output voltage to return to normal when the short or overload condition is removed.

Circle (80) on Reply Card

### Modulation meters

*Marconi Instruments* has introduced a full-facility modulation meter, model 2305, which combines the functions of a conventional modulation meter, RF power meter, frequency counter and audio analyzer into a single package.

Tuning can be performed automatically to the strongest input signal with a typical acquisition time of 500ms. For faster tuning, or where several strong signals

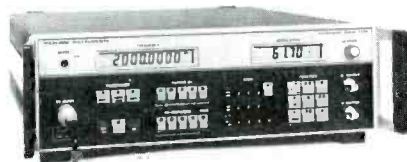

are present, the instrument may be pre-tuned to a frequency entered via the numerical keypad, or GPIB.

Circle (81) on Reply Card

### Heating tool

The *Eraser Company* is now able to offer their hand model Glo-Ring infra-red heating tool with 1/2-inch diameter elements designed specifically for shrinking heat-shrinkable tubing on small work pieces in the electrical and electronics industry.

The Glo-Ring infra-red heat tool uses quartz-glass heating elements that open and close like a thumb and forefinger to encircle the work piece with instant radiant heat at a temperature of 1000 F.

Circle (84) on Reply Card 



**DON'T  
BLAME  
THE  
SOFTWARE!**

ISO-3

Power Line Spikes and Hash often cause memory loss or erratic operation. Often floppies, printer & processor interact!

OUR patented ISOLATORS eliminate equipment interaction AND curb damaging Power Line Spikes, Surges and Hash.

Filtered 3-prong sockets and integral Spike Suppression. 125 VAC, 15 Amp, 1875 W Total - 1 KW per socket.

ISO-1 ISOLATOR. 3 Filtered Sockets; 1000 Amp 8/20 usec Spike Suppressor . . . . . \$76.95

ISO-4 ISOLATOR. 6 Filtered Sockets; 1000 Amp 8/20 usec Spike Suppressor . . . . . \$128.95

ISO-3 SUPER-ISOLATOR. 3 DUAL filtered Sockets; 2000 Amp 8/20 usec Spike Suppressor . . . . . \$115.95

ISO-7 SUPER-ISOLATOR. 5 DUAL filtered Sockets; 2000 Amp 8/20 usec Spike Suppressor . . . . . \$186.95

Master-Charge, Visa, American Express  
TOLL FREE ORDER DESK 1-800-225-4876  
(except AK, HI, MA, PR & Canada)

**Electronic Specialists, Inc.**

171 South Main Street, Natick, MA 01760

Technical & Non-800: 1-617-655-1532

Circle (22) on Reply Card

## ESR METER

checks electrolytics  
IN-CIRCUIT and is TV shop  
FIELD-TESTED:

The most fantastic instrument I've ever bought—Billings, Mt. Used it 3 months; it only missed once—Marinette, Wis. (Typical). Squeal & no sync; 3 bad caps in B+ & AGC; Many Thanks—Taos, N.M. Please ship another; very satisfied—Glen Rock, Pa. It's fantastic—St. Joseph, Mo. Please rush; heard good reports—Hicksville, N.Y. One tremendous meter—Alexandria, Minn. Send your Super meter; heard about it—N. Olmstead, Ohio. Love that ESR Meter—Acton, Mass. Used it intensively for 30 days; it's been 100% effective—Pittsburgh, Pa.

Ideal for preventive maintenance: measures electrolyte dryness & shows up intermittent opens.

60-day Satisfaction Guarantee.

Send check or M.O. or call  
(313) 435-8916 for COD

Or write for free brochure to:

*Creative Electronics*

ESR Brochure **\$ 99.00**  
1417 N. Selfridge postpaid  
Clawson, Mich. 48017  
USA & CAN.

Circle (23) on Reply Card

# Marketplace

## Put Professional Knowledge and a COLLEGE DEGREE

in your Electronics Career through

## HOME STUDY

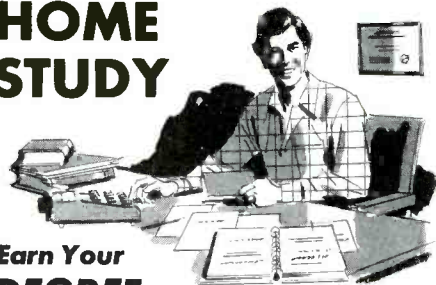

### Earn Your DEGREE

No commuting to class. Study at your own pace, while continuing your present job. Learn from easy-to-understand lessons, with help from your home-study instructors whenever you need it.

In the Grantham electronics program, you first earn your A.S.E.T. degree, and then your B.S.E.T. These degrees are accredited by the Accrediting Commission of the National Home Study Council.

Our free bulletin gives full details of the home-study program, the degrees awarded, and the requirements for each degree. Write for *Bulletin*

**Grantham College of Engineering**  
2500 So. LaCienega Blvd.  
Los Angeles, California 90034



### FREE CATALOG HARD-TO-FIND PRECISION TOOLS

Lists more than 2000 items: pliers, tweezers, wire strippers, vacuum systems, relay tools, optical equipment, tool kits and cases. Send for your free copy today!

**JENSEN TOOLS INC.**

7815 S 46TH STREET PHOENIX, AZ 85040

Circle (24) on Reply Card

**Your ad gets quick results. Advertise in classifieds.**

# Literature

Thordarson Meissner has released their new *Capabilities Brochure*. This 4-color piece is an attractive reflection of the company's products and facilities. Illustrations of the Columbia space shuttle, weather radar tracking devices, computer monitors, aircraft, submarines and medical equipment are just a few of the many applications for which Thordarson has provided custom-designed and pre-engineered transformers, high-voltage sweep transformers and deflection yokes.

Circle (100) on Reply Card

The 1982 fall/winter **ETCO** catalog offers an assortment of cable TV converters and accessories. Other new items include video gadgets, telephones and accessories, a portable teletype machine that works over the telephone, a complete range of musical instrument pickups, wireless microphones, low-cost quartz clock movements, CCTV security systems, brand new computer books, giant TV screen magnifiers, stereo FM signal boosters and a book on "do-it-yourself" earth station construction.

Circle (101) on Reply Card

MobCat-82 is a 20-page catalog of mobile communications support test equipment by RF power instrument manufacturer **Bird Electronic Corporation**.

There are technical specifications of Thruline directional wattmeters, digital RF power analyst instruments, Termaline coaxial RF loads and absorption wattmeters, Tenuline high-power attenuators, remote station monitors, coax filters and switches.

Circle (102) on Reply Card

The 140-page, 1982-83 edition of the **Mouser Electronics** catalog offers more than 12,000 items and serves as a guide for anyone need-

ing quick access to up-to-date product data and pricing of standard stocked industrial electronic components. It includes potentiometers, capacitors, resistors, transformers, lamps, switches, battery holders, jacks, plugs, speakers, test equipment and more.

Circle (104) on Reply Card

A new brochure describing **Leader's** oscilloscopes illustrates performance features for six new medium and low frequency oscilloscopes, 15 to 35MHz, and a new LB0-518 100MHz oscilloscope.

The brochure describes the operation and advantages of such features as calibrated delayed-sweep/dual-time base for measurement versatility, alternate-triggering for viewing two signals unrelated in frequency, extremely high sensitivity, and variable hold-off, which permits stable displays of complex signals.

Circle (105) on Reply Card

A new catalog of precision hand tools, test instruments, soldering supplies and field service tool kits is being introduced by **Contact East**.

The catalog presents more than 50 new field-service tool kits.



Other sections in the catalog include test probes, DMMs, oscilloscopes, static-control materials, soldering and desoldering equipment, IC tools, measuring devices and hand tools.

Circle (103) on Reply Card

**ES&T**



# Opportunity knocks.

The professional world of the Electronics Service Dealer is rough. That's why we're working so hard to make it easier for you to operate a cost effective business. NESDA offers substantial savings on bank-card and insurance rates, business contacts, technical and management certification, and that's just the beginning.

Our members are kept informed about industry developments, and are offered the most comprehensive managerial and technical training programs available. Opportunity knocks. Don't let it pass you by.

For more information about the National Electronics Service Dealers Association, write to: NESDA, 2708 W. Berry St., Ft. Worth, TX 76109.



NAME \_\_\_\_\_

FIRM NAME \_\_\_\_\_

FIRM ADDRESS \_\_\_\_\_ Member of State  Local  Assn.

CITY \_\_\_\_\_ STATE \_\_\_\_\_ ZIP \_\_\_\_\_ PHONE \_\_\_\_\_

## Classified

Advertising rates in the Classified Section are 50 cents per word, each insertion, and must be accompanied by payment to insure publication.

Each initial or abbreviation counts a full word.

Minimum classified charge \$10.00.

For ads on which replies are sent to us for forwarding (blind ads), there is an additional charge of \$3.00 per insertion to cover department number, processing of replies, and mailing costs.

Classified columns are not open to advertising of any products regularly produced by manufacturers unless used and no longer owned by the manufacturer or distributor.

### For Sale

It's no puzzle to order Oelrich Service Forms



For TV-radio and two-way radio service - legal forms for Calif., Florida and Utah. Now at parts jobbers or write for cat. 864.

#### OELRICH PUBLICATIONS

4040 N. Nashville Ave., Chicago, IL 60634  
Now call toll-free! 800-621-0105

Circle (26) on Reply Card

**FREE** THE GREAT ELECTRONIC THINGS & IDEAS BOOK!

HUNDREDS OF UNUSUAL PARTS, GADGETS & IDEA ITEMS, UNAVAILABLE IN STORES OR CATALOGS ANYWHERE! Bargain prices on everything! New items in every issue! Rush postcard for your copy!

**ETCO** ELECTRONICS  
Dept. 311  
Plattsburgh, N.Y. 12901

Circle (25) on Reply Card

**AUTOMOBILE RADIO** and tape replacement parts: Delco, Chrysler, Philco-Ford, Motorola, Panasonic and many others. Large inventory. Laran Electronics, Inc. 3768 Boston Road, Bronx, NY 10469. (212) 881-9600, out of New York State (800) 223-8314. 5-79-tf

**ELECTRONIC SURPLUS: CLOSEOUTS, LIQUIDATIONS!** Parts, equipment stereo, industrial, educational. Amazing values! Fascinating items unavailable in stores or catalogs anywhere. Unusual FREE catalog ETCO-011, Box 762, Plattsburgh, N.Y. 12901. 6-78-tf

**SCRAMBLED TELEVISION**, encoding/decoding. New book. Theory/circuits. \$9.95 plus \$1 shipping. Workshop, Box 393ES, Dept. E, Bethpage, N.Y. 11714. 7-80-tf

**SONY-PANASONIC-RCA-ZENITH-EXACT REPLACEMENT PARTS-LARGE INVENTORIES-SEND PART OR MODEL NUMBERS-WILL UPS OR COD-GREEN TELE RADIO DISTRIBUTORS, 172 SUNRISE HIGHWAY, ROCKVILLE CENTRE, N.Y. 11570. 5-82-tf**

**TUBES** - Receiving, Industrial and Semi-conductors, factory boxed. Free price list. Low, low prices. **TRANSELETRONIC INC.**, 1365-39th Street, Brooklyn, N.Y. 11218E, 800-221-5802, 212-633-2800. 5-82-tf

**USED RADIO-TELEVISION TUBES.** All types. Working condition. 30 for \$13.00 postpaid. Loeb, 414 Chestnut Lane, East Meadow, NY 11554. 3-83-3t

**PRINTED CIRCUIT** boards from your sketch or artwork. Affordable prices. Also fun kit projects. Free details, DANOCINTHS INC Dept. ES, Box 261, Westland, MI 48185 5-81-tfn

**2SC1172B's, 50 LOTS-\$1.69; 2SC1308K's**, original Sanyos, 50 lots-\$1.99; Cheater cords, 25 lots-35¢; pol- and nonpolarized, 1,000 ft. reels of RG 59 U. Coax Cable-\$39/roll. Minimum order \$75. Redcoat Electronics, 104-20 68th Drive, Forest Hills, NY 11375, 212-459-5088. 10-82-tfn

**SPRING SPECIALS** on Popular Electrolytics-40/450V-75¢; 80/450V-85¢; 100/450V-95¢; 200/300V-\$1.05. Quantity 20 lot only. Minimum order of \$50. **SUPER SPECIALS.** Bulk Zenith safety capacitors 800-860, 12 lot only \$2.50 each. **REDCOAT ELECTRONICS**, 104-20 68th Drive, Forest Hills, NY 11375, 212-459-5088. 10-82-tfn

**REPLACEMENT COLOR YOKES-DEALERS ONLY.** Zenith 95-2501-2532-2887 etc. \$22.95. Magnavox 361380-1 etc. \$24.95. Sylvania \$24.95. American-made fuses in bulk-example 3AG 2 regular price .23 each our price .12 each. Factory packaged GE transistors at discounts. Example GE-20 regular price \$1.10 our price .65. Request circular on your letterhead. David Sims Enterprises, Inc., 665 East Jericho Tpke., Huntington Sta., NY 11746. 800-645-5030, NY State (516) 549-3925-1592. 10-82-tfn

**TUBES FOR TV AND RADIO** - 35¢ ea. Washington TV Service, 1330 E. Florence Ave., Los Angeles, CA 90001. 1-83-12t

**FOR SALE:** Sencore DVM38 with high voltage probe \$225, Radiometer distortion meter BKF6 \$550, B&K Servicemaster \$150, 20 amp isolation transformer \$45, B&K generator E100B \$140, Zenith frequency counter \$110, 201-256-6570, 64 Lower Notch Rd., Little Falls, New Jersey 07424. 3-83-1t

**FOR SALE:** Sams Fotofacts, 410 thru 2067. Herman Proffitt, 1406 Madison Ave., Maryville, Tenn. 37801. Phone: 615-982-5428. 3-83-1t

## For Sale (Cont.)

**TV TROUBLE ANALYSIS TIPS.** Over 300 symptoms/remedies by circuit area; tough ones over the years. Save time and money. Send \$12.50 to CHAN TV, 8151 Grandview Rd., Chanhassen, Mn. 55317. 5-82-tfn

**B&K TUBE TESTERS**—#667—\$150, #747B—\$275.00. As new, 1 ship. 212-258-4877. Hy's TV, 911 East 15th St., Brooklyn, NY 11230. 3-83-1t

**QUITTING BUSINESS:** Test equipment, Sams, parts, GE modules, tubes, send SASE for list. Lewis Radio & TV, R.1, Central City, NE 68826. 3-83-1t

**LATEST FCC RADIOTELEPHONE** questions, answers, "explanations" compiled from technical schools, colleges, avionics companies across the country. \$8.00. Major Marketing, Box 26151, Los Angeles, California 90026-0151. 3-83-1t

**COMPLETE JERROLD WIRELESS REMOTE/DE-SCRAMBLER**—full warranty, \$159.00. Complete Oak descramblers, full warranty, \$169. Trap/filters in line type, \$49, 2 min. installation. SG613 transistors, only \$6.99. Original Toshiba 2SC1172B, only \$1.99 with hardware. 100/450, 80/480, 200/300, 40/450, 25 1st only \$1 each mixed or single lot. Super special while they last 800-860 41 each safety caps Zenith type, 10 lot only \$2.50. Bulk 2SC1172B only 50 lot, \$1.69. Redcoat Electronics, 104-20 - 68th Drive, Forest Hills, NY 11374, (212) 459-5088. 3-83-1t

**B&K CRT TESTER**—\$150, tube tester—\$75, Cap. checker—\$50; Sylvania CK300 and adapters—\$200. Frank Knight, RFD 1, Box 605, New Gloucester, Maine 04260. (207) 926-3323. 3-83-1t

## Wanted

**WANTED FOR CASH:** 50, 53, 6AF6, 6HU8, 304TL, 4CX1000A, 4-1000A, all transmitting, special purpose tubes of Eimac/Varian. DCO, Inc., 10 Schuyler Avenue, North Arlington, New Jersey 07032. Toll Free (800) 526-1270. 5-82-tfn

**MECHANICALLY INCLINED INDIVIDUALS:** Assemble electronic devices in your home. Knowledge or experience not necessary. Get started in spare time. Turn your spare or full time into cash. NO investment. Write for free details. **ELECTRONICS DEVELOPMENT LAB**, Box 1560ES, Pinellas Park, FL 33565. 5-82-tfn

**PART NEEDED:** For 1962 Zenith Model #T545, RCA changer #RP190, idle wheel RCA part #75764. Call collect, 208/664-2131. Atten: Gray. 3-83-1t

## Business Opportunity

**DEALERS EARN EXTRA PROFIT** selling cable TV converters, Video accessories and other great items in our brand new dealer catalog. Request a FREE copy on your letterhead. ETCO, Wholesale Division, Dept. 535, Box 840, Champlain, N.Y. 12919. 9-82-12t

**TV TECHNICIAN!** Increase your income up to \$60,000 yearly. Rent-lease-sell TVs new-used, even from comfort of your home. Basic Preliminaries \$10.00. PERRY'S TV SYSTEMS, P.O. BOX 2120-2014 TRIPLETT ST., OWENSBORO, KY 42302. 12-81-tf

**NORWALK, CALIFORNIA ESTABLISHED TV AND STEREO SERVICE AND SALES** very busy money maker, excellent location, low rent, very good lease. 2300 square feet, 10 minutes to beaches and Los Angeles. \$40,000 includes inventory, large enough for living quarters, owner retiring, phone 213-863-1919. 11-82-tfn

**TEXAS SUNBELT**—Thriving TV & Video Sales & Service. RCA, Zenith, Litton. In booming east Texas area. Total package includes modern custom building, 3000 sq. ft., display, sales and warehouse with complete inventory; tools, fixtures. On 1/2 acre. 300 ft. frontage on major highway. Large trade area. Contact Glen Drennan, Agent, 214-675-8856. 11-82-tfn

**FOR SALE—FLORIDA SERVICE CENTERS.** Two locations in Tampa. Very Profitable. Hi-Fi, TV and VCR repair business. Exceptional opportunity. Owner will finance qualified buyer with \$30,000.00 down. Alpha Business Consultants, (813) 876-2376, Broker. 3-83-1t

**OREGON COAST ESTABLISHED TV REPAIR SERVICE**—high volume. Everything for \$44,500. Clarice at Century 21, Coos Realty Inc., 503-269-9346, #591. 3-83-2t

**UP TO \$50,000 YEARLY!** Be our representative selling parts to repair shops and distributors. NO INVESTMENT. Call Wade: 415-532-2711 or write EPS, Box 5356, Berkeley, CA 94705. 3-83-1t

**GOOD OPERATING SOUND AND AUDIO ELECTRONIC BUSINESS.** Inventory includes Radio Shack, JVC, Pioneer, etc. Includes inventory and service department. Craggs/Curvey, Realtors, 217-824-8131. 3-83-1t

# ELECTRONIC

*Servicing & Technology*

## Advertising Sales offices

### NATIONAL SALES MANAGER

*Greg Garrison*  
P.O. Box 12901  
Overland Park, KS 66212  
Phone: (913) 888-4664

### LONDON, ENGLAND

*John Ashcraft & Co.,  
John Ashcraft*  
12 Bear Street, Leicester Square  
London WC2H 7AS, England  
Phone: 930-0525 Telex: 895-2387

### AMSTERDAM, Holland

*John Ashcraft & Co.  
John J. Lucassen*  
Akerdijk 150A  
1171 PV-Badhoevedorp, Holland  
Phone: 0-2968-6226 Telex: 18406 HARKE NL

### TOKYO, JAPAN

*International Media  
Representatives, Ltd.  
Sumio Oka*  
2-29, Toranomon 1-chome  
Minato-ku, Tokyo 105, Japan  
Phone: 502-0656

### NORWOOD, AUSTRALIA

*Hastwell, Williamson, Rouse PTY. LTD.*  
P.O. Box 419  
Norwood, S.A. 5067  
Phone: 332-3322  
Telex AA 87113

### TAIPEI, TAIWAN, R.O.C.

*Antony Liu*  
Long Life Advertising Agency Co.  
P.O. Box 17-134  
Taipei, Taiwan, R.O.C.  
Telephone: (02) 561-6629  
Cable: Photop Taipei



Readers Service Number	Page Number
8 A P Products	17
20 Automated Production Equipment	45
14 B & K Precision	27
11 Chemtronics, Inc.	23
5 Consolidated Electronics	7
23 Creative Electronics	63
19 Digitron Electronics Corp.	45

Readers Service Number	Page Number
15 Easco Tools, Inc.	29
25 ETCO	65
ETA	62
22 Electronic Specialists, Inc.	63
7 Global Specialties	13
4 Gould Instruments	3
Grantham College of Engineering	64
NESDA	65
NATESA	62
17 H & R Communications	41
6 Hitachi Sales Corp. of America	11
24 Jenson Tools Inc.	64

Readers Service Number	Page Number
26 Oelrich Publications	65
13 Omnitron Electronics	25
21 Optima Electronics	47
1 PTS Corp.	IFC
12 Primefax	23
RCA Distributor & Special Products	14-15
16 Howard W. Sams & Co.	39
2,3 Sencore	BC
18 Simple Simon Electronics Kits, Inc.	43
10 Soltec	21
9 Winegard Co.	19
Zenith Radio Corp.	IBC



a line of antennas as strong as its name  
in time for your peak selling season

**ZENITH**

**CHROMATENNA II** T.M.

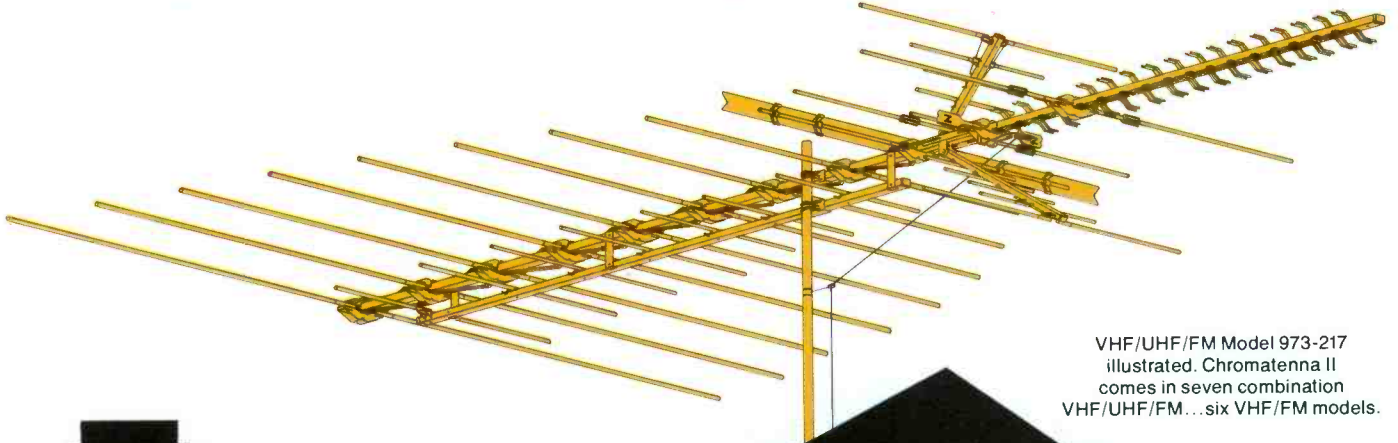

VHF/UHF/FM Model 973-217  
illustrated. Chromatenna II  
comes in seven combination  
VHF/UHF/FM... six VHF/FM models.



**Transmission Line Termination** bleeds off static charges thru antenna system ground. Terminal stub improves front to back ratio on lower channels.



**Aluminum Construction** of all key metal parts works to eliminate rusting—provides long life. **Golden-Color Alodine Finish** is conductive—helps improve electrical performance!



**High-Impact Plastic Insulators** double-lock each element to the boom for extra bracing and durability.



**FM Block** reduces FM gain up to 12dB. Remove to receive full FM gain.



**Corner Reflector Bracket** enlarged and re-located in most models.



**Zenith Dipole on UHF.** (Combination models only.)



**VHF Colinear Directors** provide extra signal boost on both low and high band VHF.



**Loading Straps**—metal plates close to first VHF element insulators provide compensation for Lo and High band by tuning the first driven element with extra capacity.



**Wide-Spaced, Heavy-Duty Feed Lines** help prevent shorting from heavy build-ups of snow or ice.



**Dual Isolator Bars** insure no loss of UHF to VHF signal transfer. (Combination models only.)



**Strain Relief Insulator** accommodates either 300-ohm twin-lead, Foam lead or Coax downlead.



**U-Bolt Mounting** provides a larger clamping area; larger locking nut with teeth an integral part assures a more rugged U-BOLT arrangement.



**Optional Break-away UHF Wing Directors** provide maximum gain of standard UHF channels with optional coverage of Hi UHF channels and translator frequencies when broken off. (Combination models only.)



**Electrically Matched Terminals With Stainless Steel Screws** eliminate mismatch... protect against rusting, and provide positive electrical contact with improved no-strip stainless steel serrated washers for the take off terminals.



**Proximity Spaced Signal Balancer (Z elements)** provides automatic taper control of periodic driver, improves impedance matching and signal leveling on both Lo and High band channels. Improves Channel 7 pattern.

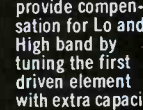

**Rugged 1" Square Boom** provides extra strength compared to many round-type booms.



**Sleeved Elements** of heavy-duty construction afford extra bracing and protection.



**Hi-Bracket with angled ends** for added strength.

Zenith has quality easy-to-install antenna kits - UHF only, VHF YAGI and Stereo FM antennas as well as a complete line of reception aid equipment. See your Zenith distributor for news of his exciting money-making programs and Catalog No. 902-2019!

**ZENITH**  
The quality goes in before the name goes on®

Zenith Radio Corporation/Service, Parts & Accessories Division/11000 Seymour Avenue/Franklin Park, Illinois 60131



# Cut Your Service Time Absolutely In Half Or Your Money Back.

Sencore SC61 60 MHz Waveform Analyzer

If you use a general purpose oscilloscope for troubleshooting we can cut your present service time in half with the SC61 Waveform Analyzer.

**It's ten times faster—ten times more accurate:** The SC61 is the first and only instrument to integrate the speed and accuracy of a digital readout with the viewing capability of a high performance 60 MHz scope. Connect only one probe and you can view any waveform to 60 MHz. Then, just push a button to read DCV, PPV, frequency and time.

There are no gratitudes to count or calculations to make so every measurement is 10 to 100 times faster than before.

The digital readout is 10 to 10,000 times more accurate than conventional

scopes as well, for measurements you can trust in today's high precision circuits.

Plus having everything you want to know about a test point, at the push of a button, eliminates guesswork and backtracking

A special Delta function even lets you intensify any part of a waveform and digitally measure the PPV, time or frequency for just that waveform section. This really speeds VCR alignment and calibration procedures.

**And it's neat:** No more tangled

leads, piles of probes or dangling cords. The SC61 is an entire service bench in one unit. You can't get neater than that.

**Cut your service time in half:**

When we say the SC61 will cut your service time in half, we're being conservative. We know of cases where the SC61 has saved much more time than that. Every situation is different, however, so try an SC61 and judge for yourself. Here's our offer.

**Money back guarantee:** If the SC61 does not at least cut your present service time in half during the first thirty days, you may return it for a full refund, including freight both ways.

**Call today.** Get the entire SC61 Waveform Analyzer story. Call toll-free today, and ask for our eight page color brochure. It could be the most time-saving call you make this year!

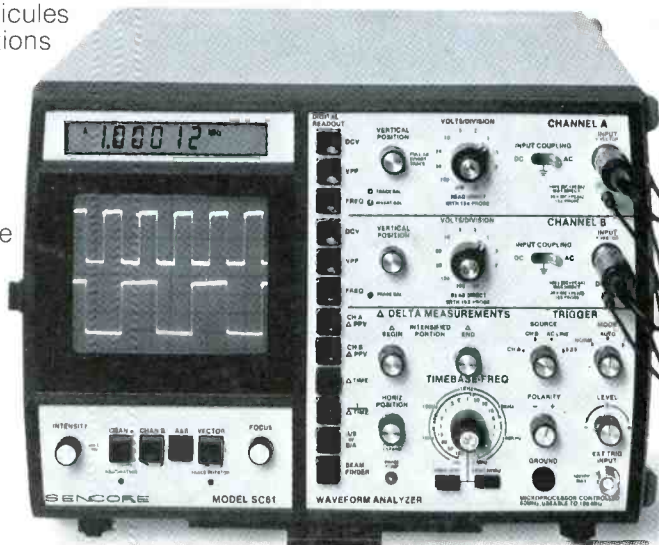

**\$3275**

**SENCORE**  
3200 Sencore Drive, Sioux Falls, SD 57107

**Phone Toll-Free 800-843-3338**  
Alaska, Hawaii, Canada and SD call collect at (605) 339-0100

For Information Circle (2) on Reply Card  
For Demonstration Circle (3) on Reply Card