

May, 1971  75 cents

EST-1770 N-101671 4  
MR HOWARD ERICKSON  
BOX 94  
BARK RIVER MICH 49807



A HOWARD W. SAMS PUBLICATION

# Electronic Servicing

Shop Talk:

**How Frequency Response Affects Square and Pulse Waveforms,**  
page 56

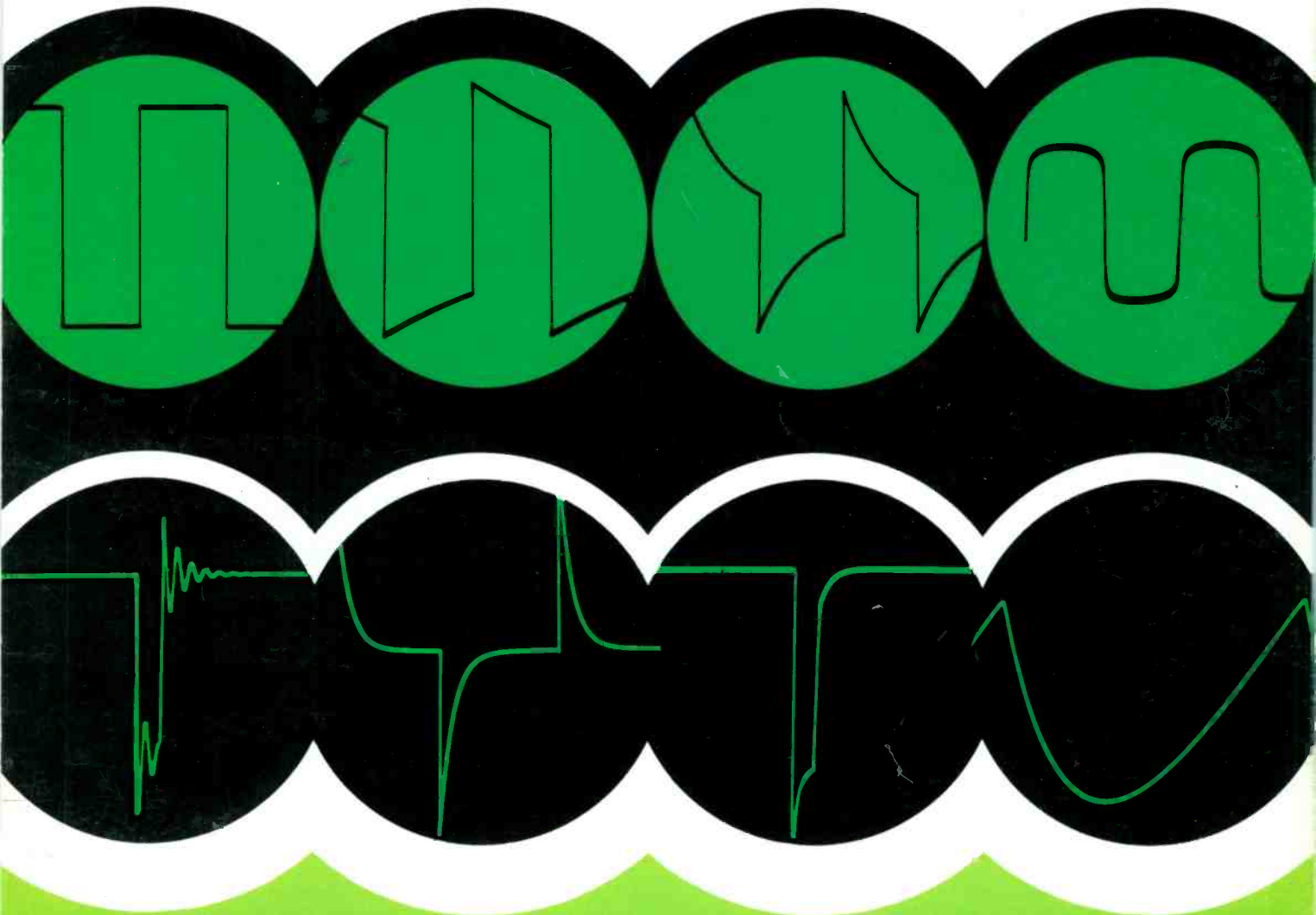

Better Management Guides:

**Plugging a Bookkeeping System  
into a Service Shop, page 38**

# Parts - time help

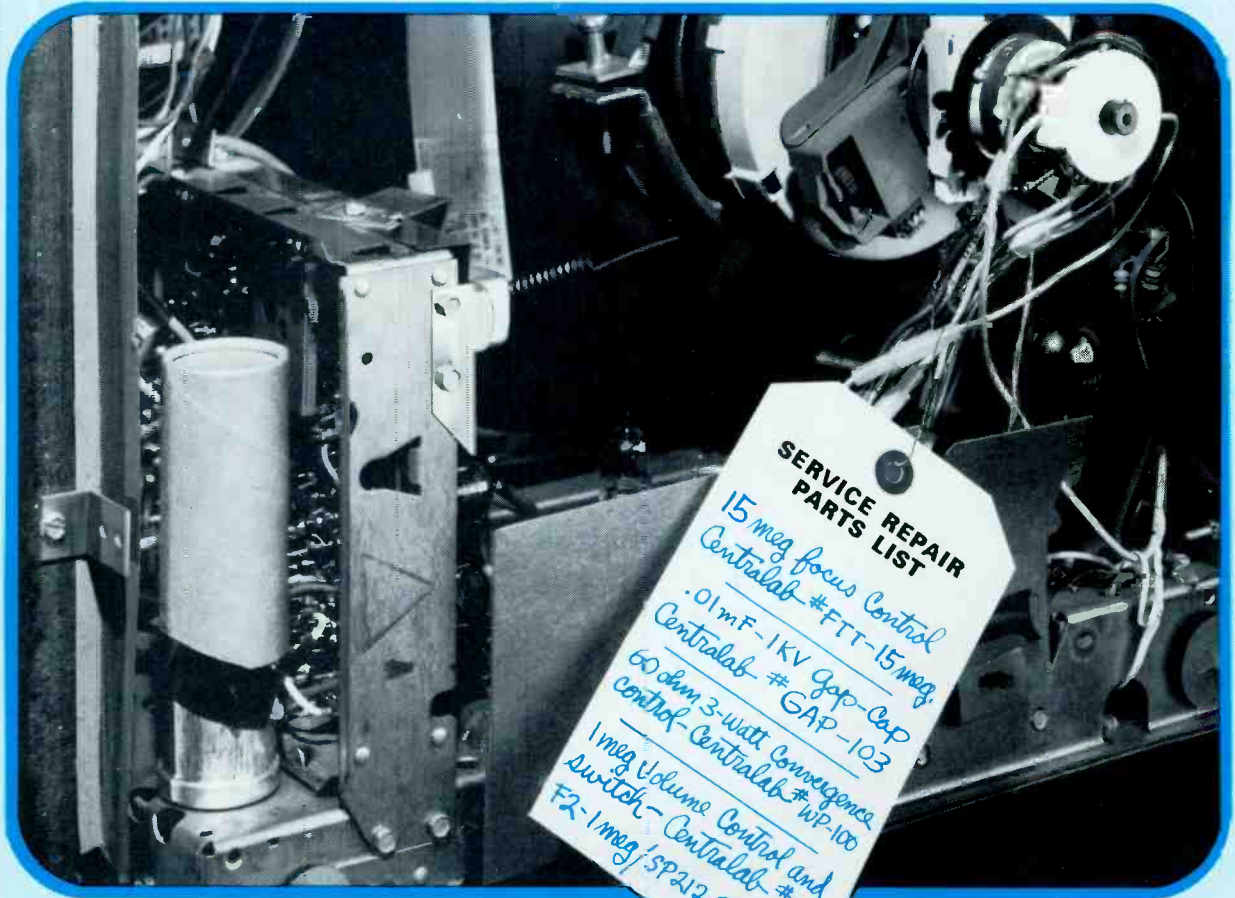

**a full-time  
service  
from your  
Centralab  
distributor**

DISTRIBUTOR PRODUCTS



**CENTRALAB**

Electronics Division  
GLOBE-UNION INC.

5757 NORTH GREEN BAY AVENUE  
MILWAUKEE, WISCONSIN 53201

Time. It's the only way you can make your repair skills available to customers. So, the better use you make of it, the better your profit potential. That's where we can help. At parts time.

More than 1,000 Centralab distributors nationwide specialize in stocking the exact replacement components you need. And putting them in your hands fast.

Whether it's for color or black and white TV, hi-fi, stereo or radio . . . all Centralab replacement parts feature the reliability you can depend on. Our broad line includes 1/2 watt carbon, Fastatch® II, 3 watt wirewound controls, and miniature trimmer resistors. Plus capacitors: discs, electrolytics, polystyrenes, and Gap-Caps®. Also, a wide variety of PEC® packaged electronic circuits, and fire retardant push-pull line switches. To name just a few.

A complete listing of the replacement parts available from your nearby Centralab distributor can be found in Photofact®, Counterfact® and the Replacement Control Guide. Or, ask us to send you a Centralab replacement parts catalog.

DS-7105

Circle 1 on literature card

# get what's coming to you

And we mean more than the extra dollars that Leader can put in your pocket! Much more. Like valuable time saved on each job, because Leader products have easy-to-use advanced design features. And the maintenance free reliability that's practically a Leader patent. Because we know what "call-backs" can do to any shop. Add to this, the unchallenged Leader precision that has set the highest performance standards in the industry.

You can bet there's more coming to you from Leader. Like second-to-none delivery and service; an answer to a sticky service problem, if you need it. Training aids in which Leader expertise can be used. In all, the products, the reliability, precision, and the back-up you want — topped off by better-than-competitive pricing. So, get what's coming to you from the Leader. We stand ready to give, and give, and give.

from the  
**LEADER**

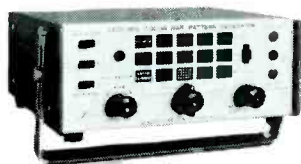

**Model LCG-388**

**Color Bar Generator**

Superb pattern stability through digital clock control, 15 patterns, two switch selectable frequencies, wide temperature range reliability; handle, accessories incl. **\$159.50**



**Model LBO-54B**

**5" wideband scope/v'scope**

Calibrated vertical input 10MVp-p/cm sensitivity, DC to 10MHz bandwidth, distortion-free displays; solid state circuitry. **\$249.50**

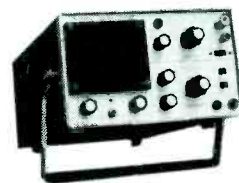

**Model LBO-301**

**3" portable triggered scope/v'scope**

Lab grade performance with vert. and horiz. calibration. DC to 7MHz bandwidth, finest vert. sensitivity, 5 x magnification — max. sweep speed 0.2μs/div. **\$334.50**

**Instruments to believe in.**

Send for catalog

**Leader**

**INSTRUMENTS CORP.**

37-27 Twenty-Seventh St. Long Island City, N.Y. 11101

(212) 729-7410

Circle 4 on literature card

# Electronic Servicing

*in this issue...*

## 20 AUTO ELECTRONICS

**RF Amplifier- and AGC-Related Troubles In Auto Receivers**—How to track down the causes of these related problems in late-model units, plus case histories which illustrate both common troubles and adaptations of troubleshooting techniques (**Carr Electronics/Joseph J. Carr**).

## 28 TELEVISION (GENERAL)

**Noise Cancellers, Sync Separators and AGC Systems**—How these circuits function in both individual and combination designs and how to isolate the causes of the troubles that most frequently occur in them (**Troubleshooter/Carl Babcoke**).

## 38 SHOP MANAGEMENT

**Plugging a Bookkeeping System into a Service Shop**—Continuation of a practical discussion of the fundamental elements and functions of bookkeeping and how to adapt them to the peculiarities of a service business (**Better Management Guides/Robert G. Amick**).

## 44 HOME AUDIO

**Left/Right Channel Comparison: Another Approach to Stereo Troubleshooting**—How to localize and isolate troubles in stereo by comparing the voltages and waveforms of the defective channel with those of the normally operating one (**Dale's Service Bench/Allan Dale**).

## 48 AVIATION ELECTRONICS

**Avionics and The Increased Complexity Problem**—This analysis of recent technological developments in aviation electronics and how they affect servicing provides a preview of designs and servicing techniques which could eventually find their way into consumer electronics (**Len Buckwalter**).

## 56 SERVICING TECHNIQUES (GENERAL)

**How Frequency Response Affects Square & Pulse Waveforms**—Analysis of how the response of tuned circuits affect the shape and amplitude of sine, pulse and square waves, with special emphasis on the effects of integration and differentiation (**Shop Talk/Carl Babcoke**).

### DEPARTMENTS

Electronic Scanner .....	4	Service Training Schedule	64
Letters to the Editor .....	10	Product Report .....	66
Readers' Exchange .....	14	Catalog and Literature .....	68
Test Equipment Report .....	35	Advertisers' Index .....	70
Reader Service Card .....	53		

Second class postage paid at Kansas City, Mo. and additional mailing offices. Published monthly by INTERTEC PUBLISHING CORP., 1014 Wyandotte St., Kansas City, Mo. 64105. Vol. 21, No. 5. Subscription rates \$5 per year in U.S., its possessions and Canada; other countries \$6 per year.

Copyright, 1971, Howard W. Sams & Co., Inc. All rights Reserved. Material may not be reproduced or photocopied in any form without written permission of publisher.

### EDITORIAL

GEO. H. SEFEROVICH, Director  
J. W. PHIPPS, Managing Editor  
CARL BABCOKE, Technical Editor  
BARBARA L. BORDERS, Editorial Assistant  
DUDLEY ROSE, Art Director

### CONTRIBUTING AUTHORS

Bruce Anderson  
Joseph J. Carr  
Allan Dale  
Robert G. Middleton

### TECHNICAL CONSULTANT

JOE A. GROVES

### EDITORIAL ADVISORY BOARD

LES NELSON, Chairman  
Howard W. Sams & Co., Indianapolis

### CIRCULATION

EVELYN ROGERS, Manager

### ADVERTISING SALES

Kansas City, Missouri 64105  
Tele: 913/888-4664  
E. F. LANGAN, Director  
R. JACK HANCOCK, Manager  
JAKE STOCKWELL  
JOAN HIRES, Production

### REGIONAL ADVERTISING SALES OFFICES

Indianapolis, Indiana 46280  
ROY HENRY  
2469 E. 98th St.  
Tele: 317/846-7026

New York, New York 10019  
CHARLES C. HORNER  
3 W. 57th St.  
Tele: 212/688-6350

Los Angeles, California 90005  
JOHN D. GILLIES  
3600 Wilshire Blvd., Suite 1510  
Tele: 213/383-1552

London W. C. 2, England  
JOHN ASHCRAFT & CO.  
12 Bear Street  
Leicester Square  
Tele: 930-0525

Amsterdam C. Holland  
JOHN ASHCRAFT & CO.  
W.J.M. Sanders, Mgr.  
for Benelux & Germany  
Herengracht 365  
Tele: 020-240908

Tokyo, Japan  
INTERNATIONAL MEDIA  
REPRESENTATIVES LTD.  
1, Shiba-Kotohiracho, Minatoku  
Tele: 502-0656



ELECTRONIC SERVICING (with which is combined PF Reporter) is published monthly by Intertec Publishing Corp., 1014 Wyandotte Street, Kansas City, Missouri 64105.

Subscription Prices: 1 year—\$5.00, 2 years—\$8.00, 3 years—\$10.00, in the U. S. A., its possessions and Canada.

All other foreign countries: 1 year—\$6.00, 2 years—\$10.00, 3 years—\$13.00. Single copy 75¢; back copies \$1.



Robert E. Hertel, Publisher

Intertec Publishing Corp.  
Subsidiary of Howard W. Sams & Co., Inc.

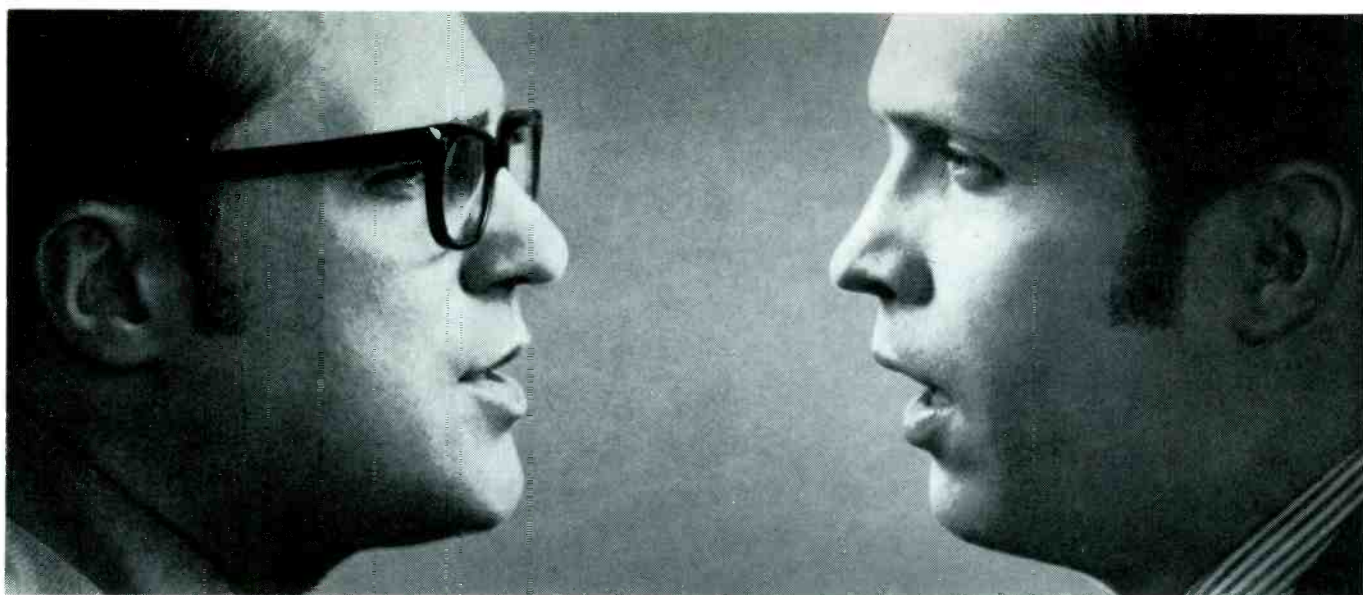

Why do you always use RCA SK Replacement Devices?

Will I need a large inventory?

What's another reason?

Are you saying RCA is the only source for reliable solid-state replacements?

Seriously, is the SK Replacement Guide that great?

I'm sold! How can I go wrong with RCA SK's?

Because SK's are specifically designed and engineered for replacement use in home-entertainment equipment. RCA doesn't make SK types unless they're needed in the field and serve the professional.

Not at all. Only 67 types cover a broad range of replacements in TV, hi-fi, and other entertainment equipment. It's the shortest line of product with the broadest range of replacement applications. That's just one of the reasons I like it.

Quality — it's assured! SK's are tested with the finest dynamic testing equipment, operated by the same personnel who test other RCA power, signal, and IC devices. They're even tested again at the factory warehouse before shipment.

No. But SK's are top quality, and the SK Replacement Guide is a truly reliable source for cross-reference information. RCA only cross references types where there is engineering assurance that the SK will do the job as well as, or better than, the original.

Better! It includes technical information on the line, plus a "Quick Selection Chart" which is unique in the industry. Now I can choose the proper SK replacement for almost every type made.

You can't. No one can!

# RCA

RCA | Electronic Components | Harrison, N.J. 07029

## Television Inventor Farnsworth Dead

Philo T. Farnsworth, noted International Telephone and Telegraph Corporation scientist, and the father of electronic television, died March 11 of natural causes in the Latter Day Saints Hospital, Salt Lake City, Utah. He was 64.

Dr. Farnsworth was born on August 19, 1906 in Beaver, Utah. He attended Brigham Young University.

At the age of 6, he decided that he would be an inventor, and he first fulfilled that aim when, as a youth of 15 at Rigby High School in Idaho, he described to his mathematics teacher a complete system for sending pictures through the air. Six years later his first patent covering the complete electronic television system was filed. Because the basic camera and picture tubes to accomplish his aims of electronic television did not then exist, he had to build the tubes himself.

The records of the U.S. Patent Office on Interferences No. 55,448 and 64,027 (April 16, 1934) were decided in favor of Dr. Farnsworth and he was awarded the basic patents on electronic television over V. Zworykin of RCA. A similar interference resolved in Dr. Farnsworth's favor named him as the inventor of the basic principles of the camera tube now known as the Image Orthicon and widely used in television broadcasting. Another camera tube he invented is the Image Dissector, also widely used today.

Dr. Farnsworth made the first public demonstration in the world of electronic television at the Franklin Institute, Philadelphia, for 10 days during the summer of 1935.

His involvement in electronic telecasting won him the title of "Father of Modern Television."

Dr. Farnsworth held more than 165 patents, including the basic television patents covering scanning, synchronizing, focusing, contrast, controls and power supply. Without his electronic systems, television, as it is known today, would not be possible.

## ISCET Announces New Certification Programs

The International Society of Certified Electronic Technicians (ISCET), whose present certification program is limited to the consumer electronic service field, has announced that it soon will begin certifying electronics technicians in such fields as industrial, medical and aerospace electronics and communications.

The present ISCET certification program, initiated by the National Electric Association (NEA), is on a voluntary basis and is open to all technicians who service consumer electronic products.

Technicians with four years of consumer electronic servicing experience can qualify for the title of "Certified Electronic Technician" (CET) by passing a written test covering both circuit theory and servicing techniques. Technicians who do not have the four years of experience required for the CET, or Journeyman, rating can earn an "Associated Level" rating by passing an eight-section test about basic electronics theory. Upon completion of four years experience, the "Associate" technician then can attain the "Journeyman" rating by passing an additional four-section exam in his chosen specialty.

## Mayor Proclaims "National Electronic Service Week" In Portland, Oregon; NEA Convention July 14-July 18

The Mayor of Portland, Oregon, Terry D. Shrank, has proclaimed the week of July 12-July 18, 1971, as "National Electronic Service Week" in Portland.

The Seventh Annual Convention of the National Electronic Associations (NEA) will be held in Portland July 14-July 18.

## Bureau of Radiological Health Pilot Study Report Says There is No Radiation Hazard To TV Technicians

Electronic technicians servicing color television sets receive minimum X-radiation exposure, according to the results of a pilot study conducted by the Electronic Products Division of the Bureau of Radiological Health.

The Division, in cooperation with the Maryland State Health Department and the Electronic Industries Association, conducted the study between March and October of 1970 in 70 Baltimore, Maryland TV repair shops. The study was suggested by the Technical Electronic Product Radiation Safety Standards Committee as a means of assessing the need for an additional Federal TV performance standard to protect service technicians from radiation emissions from inside the

*(Continued on page 6)*



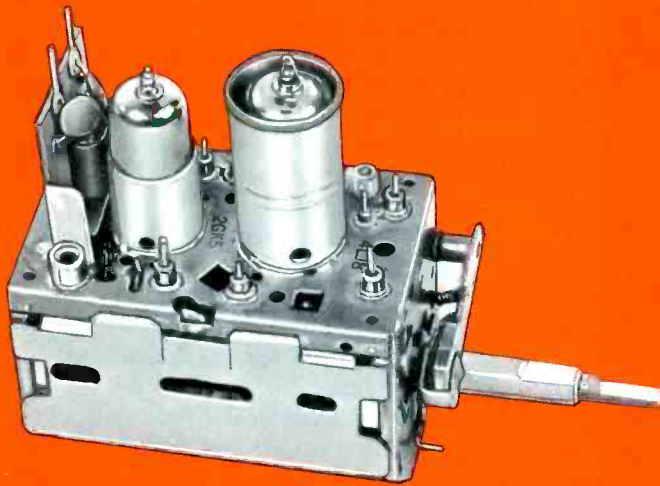

# \$975

## TUNER SERVICE CORPORATION

**PROVIDES YOU WITH A COMPLETE SERVICE FOR ALL YOUR TELEVISION TUNER REQUIREMENTS AT ONE PRICE.**

### TUNER REPAIR

VHF Or UHF Any Type \$9.75.  
UHF/VHF Combo \$15.00.

In this price all parts are included. Tubes, transistors, diodes, and nuvistors are charged at cost.

Fast efficient service at our 4 conveniently located service centers.

1 year guarantee backed up by the largest tuner manufacturer in the U.S.—SARKES TARZIAN INC.

All tuners are cleaned inside and out, repaired, realigned and air tested.

### TUNER REPLACEMENT

Replacement Tuner \$9.75.

This price buys you a complete new tuner built specifically by SARKES TARZIAN INC. for this purpose.

The price is the same for every type of universal replacement tuner.

#### Specify heater type

- Parallel 6.3V
- Series 450 mA
- Series 600 mA

All shafts have the same length of 12".

#### Characteristics are:

- Memory Fine Tuning
- UHF Plug In
- Universal Mounting
- Hi-Gain Lo-Noise

If you prefer we'll customize this tuner for you. The price will be \$18.25. Send in original tuner for comparison purposes to our office in INDIANAPOLIS, INDIANA.



## TUNER SERVICE CORPORATION

**FACTORY-SUPERVISED TUNER SERVICE**

- MIDWEST** . . . . . 817 N. PENNSYLVANIA ST., Indianapolis, Indiana . . . . . TEL: 317-632-3493  
(Home Office)
- EAST** . . . . . 547-49 TONNELE AVE., Jersey City, New Jersey . . . . . TEL: 201-792-3730
- SOUTH-EAST** . . . . . 938 GORDON ST., S. W., Atlanta, Georgia . . . . . TEL: 404-758-2232
- WEST** . . . . . SARKES TARZIAN, Inc. TUNER SERVICE DIVISION  
10654 MAGNOLIA BLVD., North Hollywood, California . . . TEL: 213-769-2720

Circle 6 on literature card

# Quick-connect Fuseholders and Fuseblocks

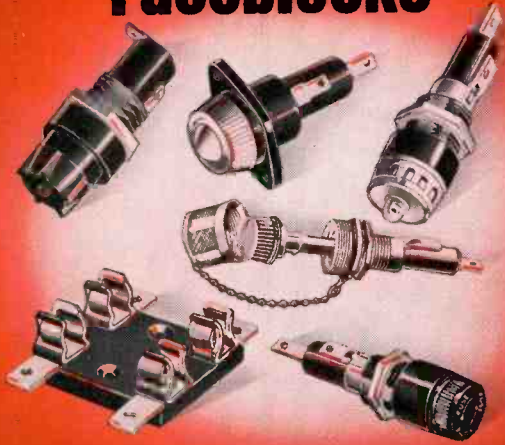

The complete line of BUSS fuseholders and fuseblocks is available with quick-connect terminals to save assembly time and cut costs.

Bussmann Mfg. Division, McGraw-Edison Co., St. Louis, Mo. 63107



Write for BUSS Form SFB

1. fell to zero when the high voltage was adjusted properly.
2. Internal radiation measurements on 41 receivers revealed that five sets emitted over 0.5 milliroentgen per hour. The sources of excessive radiation were the neck or the back of the picture tube in four of the receivers and a shunt regulator tube in the fifth.
3. Twenty-two receivers were tested with high-voltage cage doors open, and then again with them closed. Seventeen of the sets did not emit measurable increases in radiation with the cage doors open. In no case did the increase exceed 0.5 milliroentgen per hour.
4. When the receiver deflection yoke was withdrawn as far as possible and measurements were made around the neck of the picture tube, 11 of 12 receivers showed no measurable radiation increase. In the one receiver, the level fell to zero when the yoke was replaced.

Calibration checks of repair shop high-voltage meters and observations of service practices also were included as part of the surveys in the 25 shops.

Dr. Elder noted that results of the TV repair shop survey confirm that the most important step toward reducing exposure to servicemen and homeowners alike would be an industry-wide program to train servicemen in proper high-voltage measurement and control. Many servicemen said that they adjust high voltage by "feel," intuition, or the appearance of the picture, rather than by use of a measuring instrument. In addi-

## BUSS: The Complete Line of Fuses and . . .

set. The existing TV receiver performance standard applies only to external X-radiation emission.

Exposure data was obtained from 136 servicemen who were supplied monitoring badges containing thermoluminescent dosimeters. The badges were worn on shirt lapels, as finger rings, and, where possible on eyeglass frames.

Because all servicemen's radiation dosimeter badges showed less than 0.5 milliroentgen of exposure for a one-week period, Dr. Robert L. Elder, Division Director, feels that further efforts to evaluate occupational exposure to TV servicemen is unnecessary.

The highest exposure reading obtained from any of the 133 lapel badges was 0.25 milliroentgen; the average was 0.02 milliroentgen. For ring badges, the highest exposure detected for 121 repairmen was 0.23 milliroentgen, with the average being 0.01 milliroentgen. The highest reading from the 25 men wearing dosimeters on their eyeglasses was 0.30 milliroentgen; the average was 0.04 milliroentgen.

Exposure conditions which might produce excessive radiation doses to repairmen were evaluated in 25 of the 70 shops. Radiation measurements were made on receivers under four test conditions; some of the findings are:

1. External radiation measurements from 46 receivers detected two sets emitting more than 0.5 milliroentgen per hour. In both cases, the emission

# Tron Rectifier Fuses



Available in sizes from 1/2 to 1000 amps for voltages up to 1500, TRON Rectifier Fuses are ideal for protecting variable speed drives, inverters, battery chargers, plating power supplies, power controls, and any other application where fast opening and great current limitation are required.



Write for BUSS Form TRFS

Bussmann Mfg. Division, McGraw-Edison Co., St. Louis, Mo. 63107  
Circle 8 on literature card



# FUSES

for protection of Electronic Devices



There is a complete line of BUSS Quality fuses in  $\frac{1}{4} \times 1$  inch,  $\frac{1}{4} \times 1\frac{1}{4}$  inch, and miniature sizes, with standard and pigtail types available in quick-acting or dual-element slow blowing varieties.

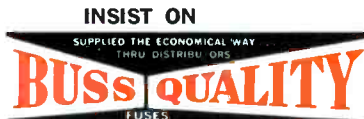

Write for BUSS Form SFB

Bussmann Mfg. Division, McGraw-Edison Co., St. Louis, Mo. 63107

were the twenty educators that will teach the sixteen sessions. They received instruction on the technology incorporated in the industry's newest products by representatives of the respective companies in preparation for their individual summer sessions.

This marks the fourth year that EIA has conducted workshops under its Service Technician Development Program (STDP), which reportedly has been expanded yearly to accommodate the increasing interest evidenced by educators in this field. It is estimated that each of the more than 300 teachers attending the 1971 sessions will reach an average total of 50 students at their respective schools.

According to Mr. Yeranko, under the STDP Career Guidance Program, opportunities in the consumer electronics service profession have been exposed to some 250,000 students during 7,200 showings of the EIA 15-minute film "Futures Unlimited", and to 2½ million television viewers through telecasts presented by stations from coast to coast.

Further information on EIA service educational programs is available on request from Electronic Industries Association Consumer Electronics Group, 2001 Eye Street, N.W., Washington, D.C. 20006.

## GE Establishes 12-Man Independent Dealer Council

An "advisory" council comprised of twelve independent dealers.

(Continued on page 8)

## Fuseholders of Unquestioned High Quality

tion, some technicians do not make the high-voltage adjustment at zero beam current, as recommended by most manufacturers.

### EIA-Sponsored Electronic Service Technician Workshops For High School Instructors Will Reach 15,000 Young Men This Year

Fifteen thousand young men reportedly will be introduced to career opportunities in consumer electronics servicing this Fall through educational efforts developed by the EIA Consumer Electronics Group Service Committee, according to Chairman Ray Yeranko (National Service Manager, The Magnavox Company).

The Consumer Electronics Group of EIA consists of domestic manufacturers of radio and television receivers, phonographs, and tape equipment.

Fourteen colleges and universities from Massachusetts to California are presenting sixteen two-week EIA-sponsored and financed workshops this Summer that will attract over 300 high school industrial arts and vocational instructors who wish to include consumer product servicing in their school curriculum. Emphasis will be placed on how to diagnose and repair the latest consumer electronic products, including solid-state circuitry. The industry's latest equipment and material reportedly will be used for these training sessions.

A 40 hour preparation session for the Summer workshops was recently held at the Magnavox Fort Wayne Service Training headquarters. Attending this session

## Subminiature Fuses and Fuseholders

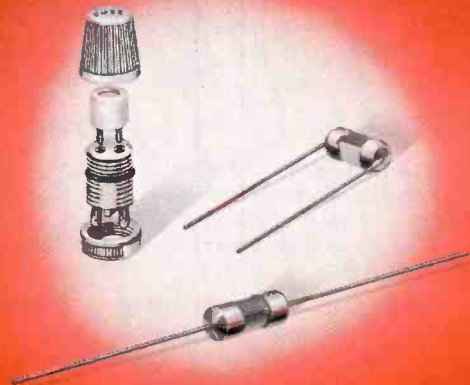

BUSS has the fuses and fuseholders for space-tight applications, in a wide range of ampere ratings from 1/100 to 15. Allow visual inspection of element. Tiny but tough, they're built to withstand severe environments.



Write for BUSS Form SFB

Bussmann Mfg. Division, McGraw-Edison Co., St. Louis, Mo. 63107  
Circle 8 on literature card

# NEW AND ONLY FROM EICO-THE INDUSTRY'S LOWEST-PRICED PROFESSIONAL FET-TVM.

■ ADVANCED SOLID STATE DESIGN

■ BATTERY-POWERED

New Model 239  
**\$39.95**  
KIT  
\$59.95 Wired



Use the new 239 on your bench or in the field. Checks semiconductor and vacuum tube circuits. 11 Megohm DC input impedance. Reads AC rms and DC voltages in seven 10db steps from 1 to 1000 volts on large 4 1/2" meter. Measures and reads peak-to-peak AC to 2800 volts. Check resistance from 0.2Ω to 1000 MΩ on seven ranges. Includes exclusive time-saving Uniprobe.

## 2 NEW DE-LUXE FET-TVM's

Includes all purpose DC/AC ohms Uniprobe.

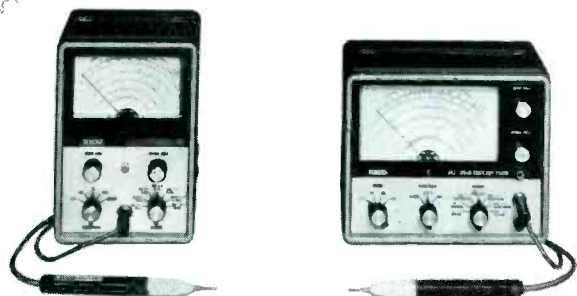

EICO 240 Solid-State FET-TVM. \$59.95 kit, \$79.95 wired. AC or battery operated. 7 ranges each + and - DC volts, peak-to-peak AC volts, ohms. 10 turn zero adjust pot. 4-1/2" 200 μA meter. response to 2 MHz (to 250 MHz with optional r-f probe).

EICO 242 Solid-State FET-TVOM. \$69.95 kit, \$94.50 wired. As 240 plus 7 ranges each AC/DC milliammeter, 1 ma to 1A: very low voltage ohmmeter. 10 turn ohms and zero adjust pots. Large 6-1/2", 200 μA meter.

Write for '71 catalog of 200 EICO Top Buys in test equipment, stereo, color organs, science project kits, environmental lighting.



EICO, 283 Malta St., Brooklyn, N.Y. 11207. (212) 949-1100.

Circle 9 on literature card

pendent dealers has been established by General Electric.

The primary function of the council, according to General Electric, is to serve as a "direct line of communications with strong General Electric retailers from all parts of the country."

Three members from each of General Electric's dealer sales operation regions have been assigned to the council. Each member reportedly will serve a two-year term on the council.

F. W. Curle, Manager of General Electric Dealer Sales Operation, has been selected chairman of the council. Mr. Curle stated that the council will meet at least twice each year with representatives from General Electric's distribution organization and product division management personnel to discuss industry trends and problems and similar subjects.

Members selected for the first council are: Samuel Alexander, Home Centers, Inc., Tallmadge, Ohio; Keith V. Anderson, Handy Andy, Inc., Sacramento, Calif.; Stephen Baumgarten, Dalmo of Virginia, Inc., Alexandria; C. W. Conn, Jr., Conn Appliances, Inc., Beaumont, Tex.

Vernon L. Desear, Desear's, Bradenton, Fla.; W. B. Eastman, A-1 Home Appliances, Long Beach, Calif.; A. J. Eckert, Sattler's Home Furnishings City, USA, Buffalo; John R. Elliott, Elliott's, Inc., Cayce, S.C.; Roy L. Jansen, Fred Schmid Appliance, Denver.

Con Maloney, Cowboy Maloney Supply, Inc., Jackson, Miss.; J. B. Olinde, Olinde Hardware & Supply Co., Baton Rouge; Peter Richard, P. C. Richard & Sons, Plainview, N.Y.; Samuel Rowe, Tri-City Sales, Salem, Mass. and Harry M. Slyman, Slyman Bros. Appliances, St. Louis.

### Precision Adds Sixth Service Center and Replacement Parts Sales To Tuner Service Chain

Precision Tuner Service, Indiana-based TV tuner repair and replacement parts firm, recently announced the purchase of the complete service division and replacement parts line of Teltron, Inc. (formerly Colman Electronic Products), Denver, Colorado.

Operating under the name of PTS Electronics, the new addition to Precision will serve technicians located in the western mountain and plains states.

Tuner replacement parts presently are available from PTS centers in Bloomington, Indiana and Denver, Colorado, and will be available from all six PTS centers at a later date. Daniel Steinmetz, stationed at the Bloomington, Indiana center, has been assigned the responsibilities of General Manager, PTS Parts Division. ▲

### Change of Address

To receive Electronic Servicing at your new address, send an address label from a recent issue and your new address to:

**Electronic Servicing**, Circulation Dept.  
1014 Wyandotte St., Kansas City, Mo. 64105



## Now you can get the little woman something she really needs.

You don't have to spend a cent to get soothing gifts from GTE Sylvania.

Just keep on buying Sylvania receiving tubes. And before you know it you'll pile up enough Certificates to get anything your heart desires.

Take your pick from hundreds of good things: TV and stereo sets, sport coats and jockey shorts, cameras and projectors, golf clubs and fishing gear, rifles and sporting goods, tools and watches.

There's also a lot of stuff like dresses, hand-

bags, hair dryers, teakettles, necklaces and earrings.

Things the little woman can really use. Even if you can't.

Get your copy of the "Profits for Independents" book from your participating GTE Sylvania Distributor. It describes the awards. Remember—GTE Sylvania supplies you: we don't compete with you.

**GTE SYLVANIA**

Circle 10 on literature card

## **"Licensing Does Not Guarantee Morality; Merely Competence"**

It was with interest that I read the letter from Mr. Sgarlat Jr. (June '70, ES) who is opposed to technician licensing. With all due respect, I cannot agree with him. Mr. Sgarlat feels licensing has not stopped doctors or lawyers from cheating, but cannot the same reasoning be applied to 2nd class and 1st class FCC licensed mobile radio technicians? Yet try to convince the Government against granting 1st and 2nd class licenses. Yes, licensing will not stop some servicemen from cheating, but is that truly a valid reason to scrap licensing? Licensing does not guarantee morality; merely competence. He also states that he thinks it is ridiculous to think a TV technician could start a business without at least three years of schooling. Sorry, but I know some that have!

Also, Mr. Sgarlat Jr. feels it is not necessary to have a deep knowledge of theory to fix a television. Recognizing that "deep" can mean different degrees to different people, I submit that it is these same TV men (without proper schooling) that sometimes resort to lying in order to cover up TV problems such as color smear, weak color, snowy picture, etc. For example, one householder was told the cause of a snowy picture on weaker stations was due to antenna trouble. An antenna technician found nothing wrong with the antenna. The original TV man returned and decided the set was too old to repair. The set in question was a four year old color TV in otherwise good condition. The problem was a weak RF amplifier tube and first IF tube. Yet, the first technician was from a well established service company, not a fly-by-night organization!

Mr. Sgarlat feels color and solid-state devices will take care of part-timers and fly-by-night organizations. I think it is more than an opinion to say it also is taking care of some established shops. As a part-timer I have had people call me to fix troubles on color and solid-state devices an established shop said could not be fixed. Thus I am sure you will understand my resentment to the statement of Mr. Sgarlat: "If they then took their sets to a part-timer, they would know what to expect and have no one to blame but themselves."

I recognize that being a part-timer doesn't guarantee competence or honesty, anymore than it does established shops. I have seen some part-timers with more test equipment than some established one man shops. One large established TV dealer and service company in the area, upon being questioned, admitted they do not perform sweep alignment of TV's and do not even own a sweep generator. Incidentally, many people who call me say too many TV men do not know what they are doing. Wouldn't licensing at least help to refute that assertion by helping to eliminate the incompetents?

As stated before, I am a part-timer. I have taken and completed two electronics courses in the past and I hold a 1st class FCC license. Also, before going into industry I worked a number of years for a nationwide TV servicing company, as well as doing part-time TV work for eight years. Does this make me better? No. I know there are many professional TV men with more skill and ability than I possess. But surely you can understand my dislike for the contempt with which some "established shops" view me merely because I am a part-timer. I wish it understood that I also charge the average house-call rate of established shops in this area so as not to be unfair and because I feel all competent TV service technicians deserve the rate being charged to customers.

Mr. Sgarlat also feels that pamphlets should be put out advertising established service company names. I question that also, at least in place of licensing, in view of the fact that most people refer to the Yellow Pages of the telephone directory unless they already have a TV man or are referred to one by recommendation. How many part-timers advertise in the Yellow Pages? Few, if any. Therefore, I again advocate licensing of all TV technicians. Certainly, this again cannot insure honesty but is it not true that in most cases those who acquire a "deep knowledge of theory to fix a television" are more interested in the challenge of diagnosing troubles in electronic equipment and the resulting satisfaction than they are in cheating people? In addition, testing and licensing would help to eliminate the fly-by-night organizations that do advertise.

May I make it clear I do not feel all established shops are incompetent crooks and all part-timers are honest engineers. I do feel though, that many professional TV technicians fear licensing merely because of the theory test required under licensing. I also believe most have the ability required to pass it if they would but spend the required time studying. In addition, I feel licensing would give all professional TV men more justification for better pay, which they deserve.

Robert R. Steely  
Reading, Pa.

## **Not Worried About ServiceAmerica**

I do not understand the reason for so much concern and worry about the fact that RCA has entered the "all brands" servicing field. We "independents" have been doing this for years and have already gained the wide experience that RCA technicians will have to attain.

I predict a large increase in the sales of Sams PHOTOFACT!

Attending seminars and service meetings concerning one make of set is a far cry from "taking them all on". A substantial number of my customers own RCA equipment, but they call on me when they need service.

If you continue to do a good job at a fair competitive price, you will retain your loyal customers.

Now, a word in RCA's direction. Sometimes when

(Continued on page 12)

# HOLD IT!!

## Ungar's New Feather-Light Solid-State Solder Gun

Hold it and you'll know why more pros have chosen Ungar's new #6760. Professional servicing or kit assembly . . . it's the most advanced gun available for soldering today's sophisticated circuitry. First, it's less than five ounces light — for pinpoint accuracy without hand fatigue . . . advanced circuitry replaces the usual heavy transformer.

Next, it's safer because the gun is grounded. No stray currents or static electricity to damage sensitive I.C.s or densely packed components — (it's safer for you, too) — the isolated-grounded tip, with a three wire NEMA plug and cord. You also get versatility. Two heat ranges (500° and 900°F approx.) and your choice of three different thread-on tips that won't give or bend in constant use. And you can lock each tip to the exact angle needed for your job.

You get exclusive standard bonuses: a virtually shatterproof case — guarantee of excellence on every gun — and separately replaceable parts.

Reach for the finest solder gun yet, at your nearest electronic distributor or dealer. Prove for yourself that in the age of solid-state Ungar really outguns the heavyweights.

**Ungar®**

Division of  
Eldon Industries, Inc.

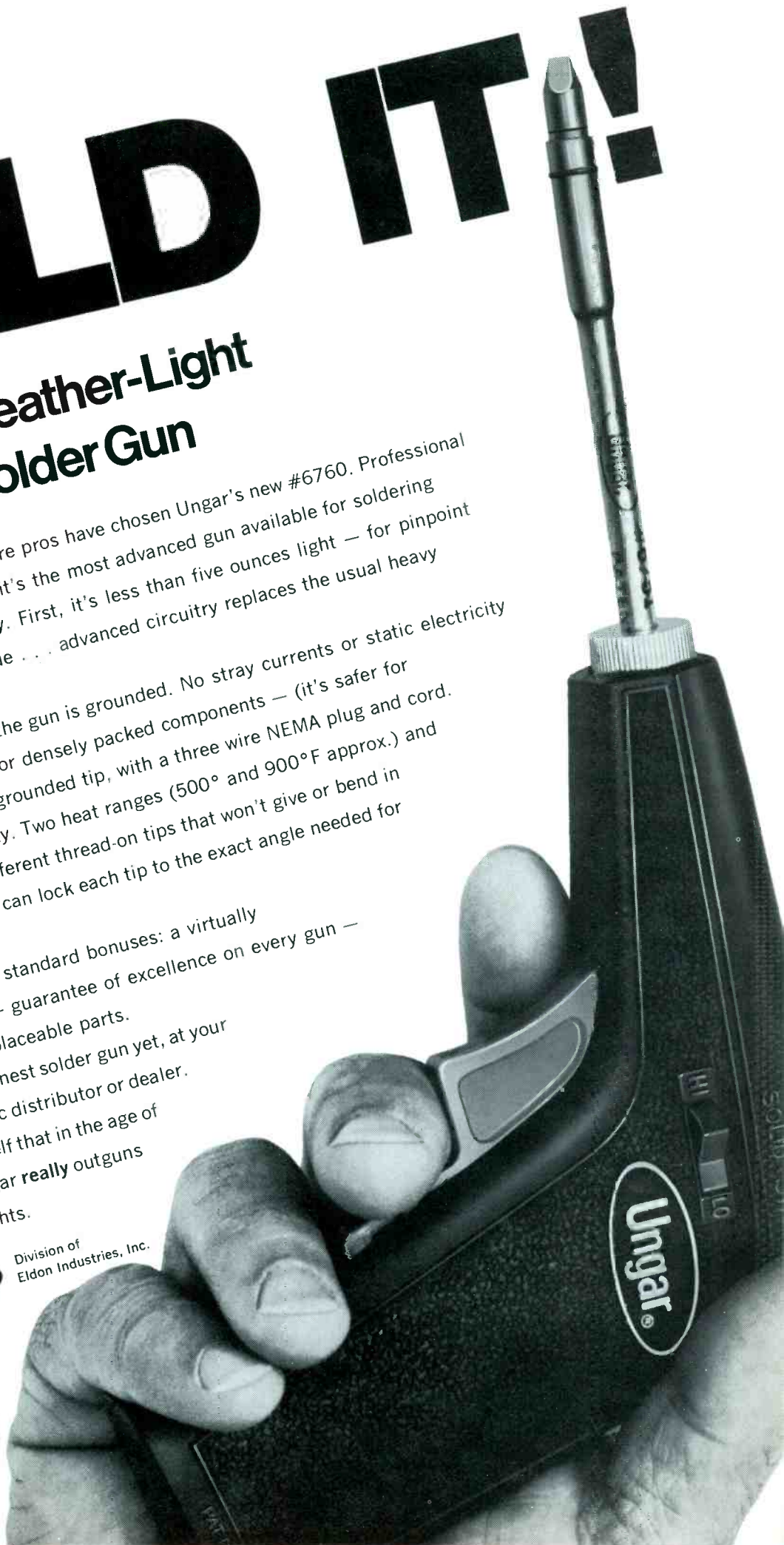

I encounter a difficult problem in an RCA set, their service manager has been very helpful with advice and information which has saved me many hours of testing. Also, they are very prompt in mailing the parts I need. I say, let them all get into the act, I'm not a bit worried.

John McNevin  
Milpitas, Calif.

#### About Stereo Recording

I enjoyed Leonard Feldman's article entitled "Simplifying Stereo Separation Problems", except I believe he has over-simplified a few items to the point of being misleading.

Mr. Feldman's synopsis of stereo theory is somewhat dated and not very realistic. It is true that stereo can be easily understood by viewing the two microphone examples in the article. This process has been nearly extinct for over 5 years.

Stereo recordings today are achieved by combining a number of signals (many of which are only different phase angles of the same instrument) and assigning these signals to separate tracks on a multi-track tape recorder. Thus, an entire orchestra might have each individual instrument recorded on a separate track. Typical isolation of these tracks is 60 to 80 dB. The signals are then reassigned to different places across the stereo spectrum via pan pots and signal matrixing. This means there has to be a definite and sepa-

rate channel for; left, left center, center, right center and right, all spaced between two stereo tracks. These are obviously critical and require precise separation when reproduced.

When Mr. Feldman says "virtually all listeners can not detect the difference between 10 or 15 dB of separation or crosstalk", he has overlooked the actual intention and technique of stereo recordings.

His example of two channels being recorded in two separate studios on two separate occasions is by no means an exaggerated stereo recording, but a conservative guess at the current state of the art. A single recording today is recorded in as many as 10 different studios and is usually added to and changed over a period of several weeks. With the isolation and separation employed in each separate track, and the complex echo and phase manipulation in the final stereo mix, the separation has to be better than 10 to 15 dB on the consumer's reproduction equipment.

Frank W. Fisher  
Director of Engineering  
American Experimental Sound,  
AFP Productions ▲

**If its about servicing consumer  
electronic products, you'll find it in  
ELECTRONIC SERVICING**

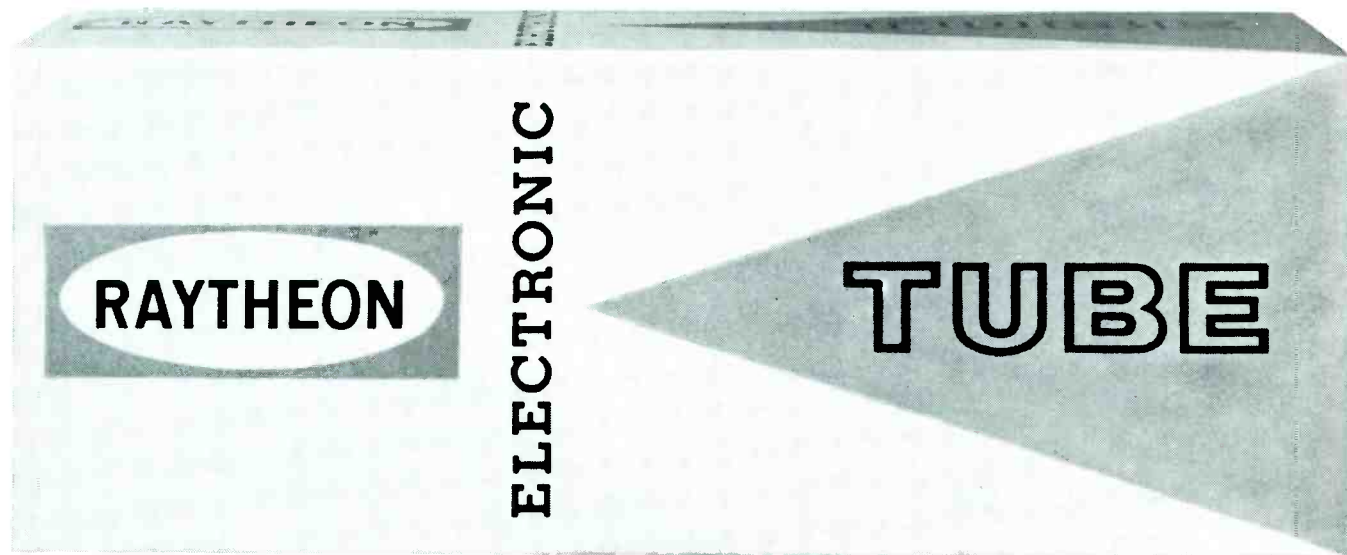

## your silent partner

You and our tubes make a great team. Great because it's a close sales partnership. So close that you, the independent serviceman, are our only outlet.

We don't compete with service trucks. Or captive business. That's helped you make us the largest independent tube supplier in the business.

Together we've come a long way.

You've found it's good business to do business with us.

And because your business is good, ours is.

Let's keep it growing together.

Circle 12 on literature card

**NOW! THIRD VOLUME AVAILABLE!**

**Color-TV Field-Service Guides**

These invaluable guides have been compiled to enable the technician to service color-TV more efficiently in the customer's home. Charts provide chassis layouts showing type, function, and location of all tubes and/or transistors used in a particular chassis, ratings and locations of fuses and circuit breakers, location of service controls and adjustments, etc. Specific field-adjustment procedures are shown on page opposite chassis layout. Index provides instant reference to the proper chart for any particular TV chassis. Each volume contains 80 diagrams covering over 3000 chassis.

- Volume 1. Order 20796, only . . . \$4.95
- Volume 2. Order 20807, only . . . \$4.95
- Volume 3. Order 20847, only . . . \$4.95



**Television Broadcasting: Equipment, Systems, and Operating Fundamentals**

by HAROLD E. ENNES. This book is a valuable treatise on the entire television broadcast system. It is not only a practical and basic course for new and prospective television broadcast technicians, but it serves also as a useful source of reference information for practicing technical personnel. Presents the basics of the NTSC color system, reinforced by a special detailed exercise section. Describes the fundamentals of camera chains, sync generators, television recording systems, and transmitters. Each chapter is accompanied by exercises to help reinforce understanding of the subjects covered. Hardbound. Order 20786, only . . . \$14.95

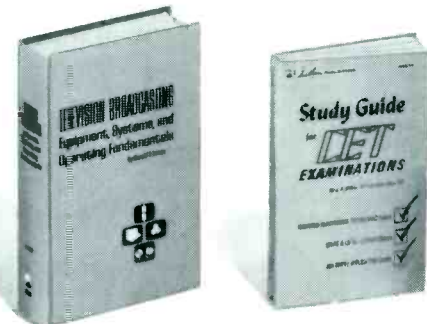

**Study Guide for CET Examinations**

by J. A. WILSON, CET and DICK GLASS, CET. Here is an invaluable study guide for those who want to qualify for a Certified Electronic Technician (CET) license or for a required state or local license. The material assumes that the reader is already competent to service home entertainment equipment. The book places special emphasis on recent developments and uses of such special devices as FET's and variable voltage capacitors. Includes keyed study assignments in the two Howard W. Sams books, Photofact® Television Course, and Color-TV Training Manual. Covers the important basic concepts that are likely to be encountered in the CET and other exams. Programmed questions and answers, as well as practice tests and their answers, appear in the back of the book. Order 20834, only . . . \$5.50



**Important New SAMS Books**



**New 11th Edition**

**Transistor Substitution Handbook**

by the HOWARD W. SAMS ENGINEERING STAFF. Fully updated to include over 100,000 substitutions. Covers all manufacturers and gives proper substitutions for all types of bipolar transistors: U. S. and foreign, home-entertainment and industrial. Computer-compiled for accuracy. Also includes manufacturers' recommendations for general-replacement transistor substitutions. Tells how and when to use substitute transistors. An invaluable reference book for everyone in electronics.

Order 20835, only . . . \$2.25

**Replacement Control Guide**

**1971 Edition**

by the HOWARD W. SAMS ENGINEERING STAFF. Shows replacement controls manufactured by Centralab, CTS-IRC, and Mallory for television sets; home, auto, CB radios; and tape recorders and tape players. Covers replacements for over 70,000 models manufactured from 1955 through 1970. Lists over 28,000 parts numbers in an alphabetical numerical index system using industry numbers. Provides quick, easy selection of proper replacement controls.

Order 06401, only . . . \$1.50

**Electronic Organ Servicing Guide**

by ROBERT G. MIDDLETON. Provides a complete understanding of the basic circuitry of the individual units employed in an electronic organ and explains how they function together. Once these principles are grasped, the servicing of electronic organs is fairly easy to accomplish. The book explains in detail how to diagnose and repair troubles in each section of the organ, how to practice preventive maintenance, how to make required adjustments and how to master tuning techniques.

Order 20826, only . . . \$4.95

**101 Questions and Answers About Electricity**

by LEO G. SANDS. This book is a valuable reference source for experimenters and students, or for anyone who wants a basic understanding of electricity and its applications. Answers the most frequently asked questions about electricity in easily understood terms. Especially noteworthy are the explanations of the practical aspects of electricity which are presented with a minimum of theory. All topics are covered with extreme clarity for easy understanding.

Order 20806, only . . . \$3.50

**HOWARD W. SAMS & CO., INC.**

Order from your Electronic Parts Distributor, or mail to Howard W. Sams & Co., Inc., Dept. ES-051 4300 W. 62nd St., Indianapolis, Ind. 46268

Send books checked at right. \$\_\_\_\_\_ enclosed (please include sales tax where applicable).

Send FREE 1971 Sams Book Catalog

- 20796     20835
- 20807     20826
- 20847     20806
- 20786     06401
- 20834

Name \_\_\_\_\_

PLEASE PRINT

Address \_\_\_\_\_

City \_\_\_\_\_ State \_\_\_\_\_ Zip \_\_\_\_\_

Circle 13 on literature card

## NEW ... for ES readers only!

### CLASSIFIED ADVERTISING

Beginning in the July issue of ES, a classified ad section, titled "The Marketplace", will be made available to electronic technicians and owners or managers of service shops who have for sale surplus supplies and equipment or who are seeking employment or recruiting employees.

#### Advertising rates

in the Classified Section are:

- 25 cents per word (minimum \$3.00)
- "Blind" ads \$2.00 additional
- All letters capitalized—35 cents per word

Each ad insertion must be accompanied by a check for the full cost of the ad.

Deadline for acceptance is 30 days prior to the date of the issue in which the ad is to be published. (July inserts must be received by June 1).

Send **Electronic Servicing**  
insertions with full  
payment to: Classified Advertising  
1014 Wyandotte Street  
Kansas City, Mo. 64105

(The Classified Section is not open to the regular paid product advertising of manufacturers. Classified advertising is intended as a service to technicians and shop owners or managers seeking employment or recruiting employees or who wish to dispose of surplus supplies and equipment.)

■ Electronic technicians and owners or managers of electronic service shops who need assistance obtaining a part, service literature or any other item related to the servicing of electronic equipment are invited to use this column to inform other readers of their need. Requests submitted for publication in this column should be sent to: Readers' Exchange, ELECTRONIC SERVICING, 1014 Wyandotte St., Kansas City, Mo. 64105. Include a brief but complete description of the item(s) you need, your complete mailing address, and how much you are willing to pay for the item(s). No item(s) can be offered for sale in this department. To sell items, please use the classified ad department, titled "The Marketplace." (For classified ad rates, see accompanying announcement on this page.)

### Help Needed

*I have an Ansaphone that needs some adjustment and repair. The incoming tape does not stop at tape end, and the outgoing tape does not return to start. I would appreciate timing information, and will pay a reasonable price for a copy of a service manual.*

Harry Wacks  
15 Dietz Rd.  
Hyde Park, Mass. 02136

*We are in need of a schematic for a solid-state guitar amplifier. We can't find any information on the amplifier except—Checkmate #17.*

*It is not over two years old and had no name or address of the manufacturer when we bought it. This is not a cheap amplifier for it retailed for \$95.00 when it was brand new.*

*Perhaps one of your readers could help us find this information.*

Bruce Rucker  
Loudon, Tenn.

*I would like to find a good battery-operated Radion VHF-UHF Field Strength Meter.*

*We live in the Smokey Mt. area of North Carolina and need this type of meter to locate signals.*

*I would be willing to pay \$50.00 for this meter if it is in good condition.*

Lewis Sherrill  
Route 1  
P.O. Box 160  
Bryson City, N.C.

*I have a Sico Supermeter, Model No. 79 made by the Superior Instrument Co. I need the operating instructions for this piece of equipment. Any help will be greatly appreciated.*

Bahorik Radio & TV  
604 Horner St.  
Windber, Pa. 15963

(Continued on page 16)



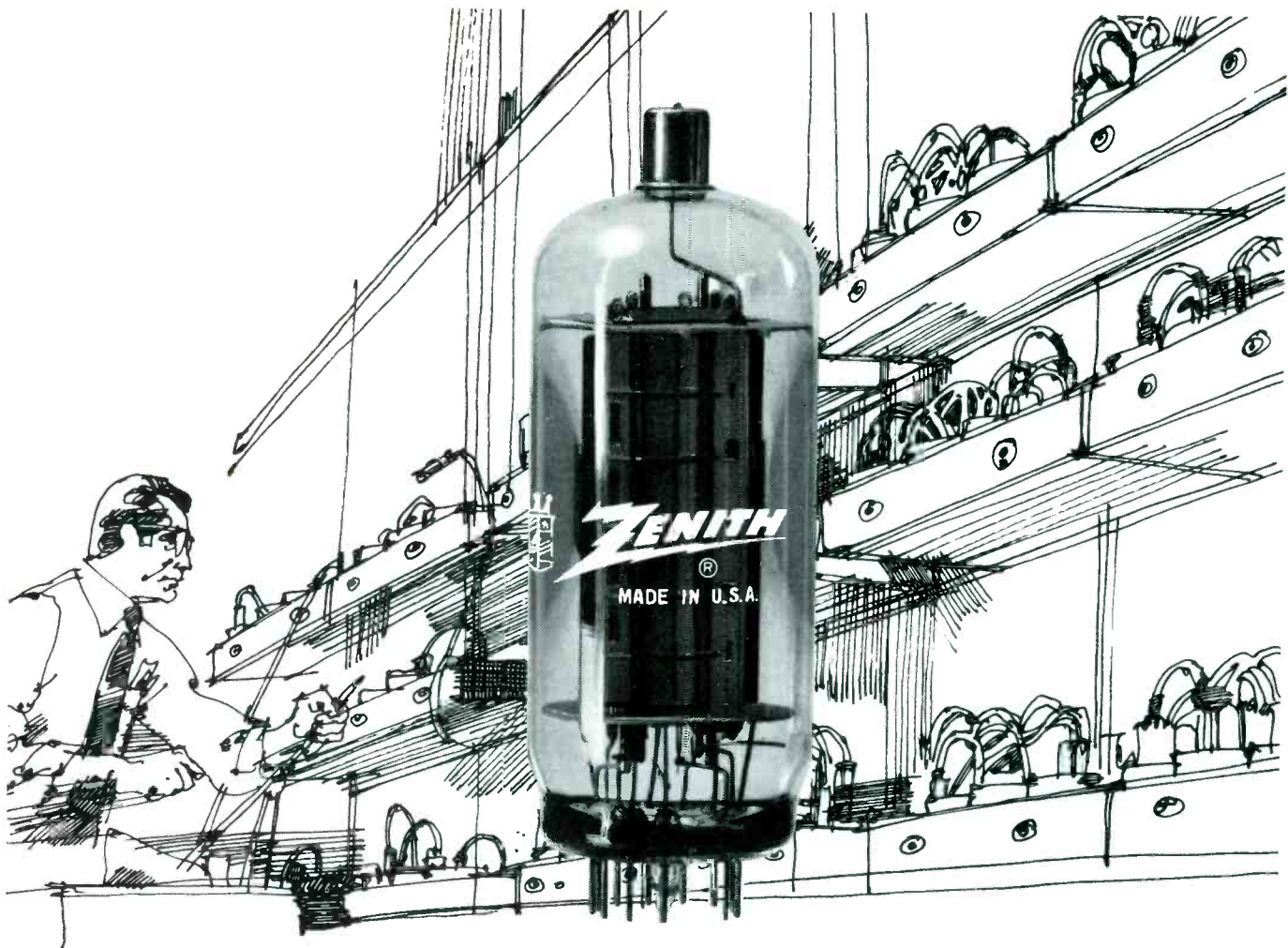

# 1,500,000 TEST HOURS A MONTH

MEANS THE KIND OF QUALITY, DEPENDABILITY AND FEWER CALL-BACKS  
THAT ZENITH "ROYAL CREST" REPLACEMENT TUBES GIVE YOU!

We spend a lot of time checking Zenith "Royal Crest" circuit tubes. To help you avoid embarrassing and costly call-backs. To give you replacement tubes tested for reliability and longevity.

1,500,000 hours of tube testing are logged each month in Zenith Quality Control Laboratories. And

no tube is passed unless it meets the same rigid quality standards as the original equipment used in Zenith products.

Result: a complete line of more than 1,200 "Royal Crest" replacement tubes . . . each one built with Zenith quality for fewer call-backs and longer life.

## ZENITH<sup>®</sup>

THE QUALITY GOES IN BEFORE THE NAME GOES ON<sup>®</sup>

*Circle 14 on literature card*

# FOR COLOR AND BLACK & WHITE PICTURE TUBE ANALYZER

## MODEL CRT-100

- Critical Grid-to-Cathode Leakage read on meter for greater accuracy.
- Line voltage adjustment (insures all test voltages are correct).
- Tests each color gun to a standard set of test conditions. Method used by tube manufacturers to simulate performance in TV receiver.
- Tests each color gun separately.
- Rejuvenates and removes shorts for increased brightness and life.



Surpasses higher priced CRT Testers in accuracy and performance.

One Year Warranty

Made in U. S. A.

**89<sup>50</sup>**  
NET



See your distributor or write Dept. ES

**LECTROTECH, INC.**

4529 N. Kedzie Ave., Chicago, Illinois 60625

Circle 15 on literature card

## DEALER INVENTORY PACKAGE OF COLOR TV CONTROLS

ALMOST ALL REQUIREMENTS OF  
2-4 WATT WIREWOUND CONTROLS



ASK YOUR DISTRIBUTOR FOR  
THIS TIME SAVING PACKAGE

MANUFACTURED BY  
**WORKMAN** *Electronic*  
PRODUCTS, INC.  
P.O. BOX 3828 SARASOTA, FLORIDA 33578

for  
**RCA  
SEARS  
ZENITH  
ADMIRAL  
MOTOROLA**

including  
CONVERGENCE  
AUDIO - COLOR  
A. G. C. DELAY  
BRIGHTNESS  
SENSITIVITY  
HORIZ. FREQ.  
HORIZ. CENT.  
VERT. LINE.  
VERT. CENT.

FREE!  
CROSS  
REFERENCE

Circle 16 on literature card

I am in need of a good, used B&K, Model 970 Analyst or a good Hickok, Model 860 Injecto-Signal Tracer.

ARO Electronics Service  
733 Mills St.  
Kalamazoo, Mich. 49001

I would like to buy a schematic or diagram for the amplifier to a 16mm sound projector manufactured by De Vry Bantam, Model 14000. The amplifier model is No. 14006.

Stanley Kosky  
14690 Robert Dr.  
Middleburgh Heights, Ohio  
44130

I need a wiring diagram for a Lafayette SCA decoder section of the LT-725 tuner. Additional information along with the hook up instructions will be greatly appreciated. I will pay for any cost incurred.

Koo L. Yuen  
510 Eye St. NW, Apt. 3  
Washington, D.C. 20001

We need a replacement power transformer for a Hickok RF05 scope. It was made in 1943-44, and the part number was OS1419. Any information will be greatly appreciated.

Albert Cholewa  
P.O. Box 264  
La Porte, Ind. 46350

I have inherited a Simpson No. 488 TV field strength meter and am in need of the calibration instructions, specification and operation manual. Will photocopy and return any available information.

Joseph Bednaz  
18300 Highway 18  
Apple Valley, Calif. 92307

I need a UHF Sweep Generator, RCA Model WR86A. We will pay any reasonable price for an instrument that is in working condition or can be restored to operation.

Robert G. Engelhardt  
P.O. Box 657  
Sioux City, Iowa

We have an old garage door opener which we want to use on a remote control project; however, it doesn't work.

The receiver's frequency is "24017", service No. 01660111 and is labelled "Electro-Dor" door opener, made in Japan.

Does anyone have any idea who made it, or has a circuit diagram for the unit, or knows where we could get one?

David Parkinson  
Mount Zion Hospital and  
Medical Center  
P.O. Box 7921  
San Francisco, Calif. 94120

(Continued on page 18)



When people  
turn to you  
to make things  
right again...



use **GE ULTRACOLOR** picture tubes  
(made by professionals for professionals)

TUBE PRODUCTS DEPARTMENT • GENERAL ELECTRIC COMPANY  
OWENSBORO, KENTUCKY 42301

GENERAL  ELECTRIC

I have three old radios I am trying to rejuvenate. I need five 201A tubes plus a speaker for an Atwater Kent, Model 20.

I also need schematics for a radio made by A. H. Grebe, Ser. D27042, Richmond Hill, N.Y., and one for a radio made by American Bosch, Model 605C.

Does anyone have a set of Riders Manuals on radios for sale?

Elden C. Ruhs  
7111 Ashborn Ave.  
Hammond, Ind. 46323

I have a burned out power transformer in a Squire Sanders FM alert, 30 MHz. I need to know where I can find a replacement transformer for this unit.

Tony Willegal  
125 W. Center  
Whitewater, Wisc.

I need the name and address of the companies or supply houses who sell speaker cones and voice coils. I would like to learn the repair of speakers.

I. M. Brown  
2423 Rexdale SW  
Canton, Ohio 44706

At one time I had the address of a company that sold supplies and furnished information on the repair and reconing of speakers. It seems that I have mis-

placed this information and I was wondering if someone could supply me with the name of a company this is involved in this type of work.

Leslie D. Seyler  
636 Clark Ave.  
Billings, Mont.

I need the schematic or the address of the manufacturer who makes "Arkay" Model T-10, VTVM's. I have checked the meter over and am convinced that it is American made. Any help will be appreciated.

John Pennington  
16952 South Roa Dr.  
Gardena, Calif. 90247

I am looking for a schematic to a CB unit, Falcon IV, made by Tecraft. Can anyone help me out?

Eugene Schlag  
Box 374  
Hughsonville, N.Y. 12537

I need a detailed schematic for a "XAM", Model 1869 color TV sold by Korvettes.

Korvettes tells me a firm called Spartan Ind. in New York handles this set but they were unable to give me the address. If anyone has any information please contact me.

T. Thomas  
9341 South 82nd Ave.  
Hickory, Hills, Ill. 60457 ▲

NOW... ONE PERMA-POWER BRITENER SOLVES BOTH KINDS OF COLOR TV PICTURE PROBLEMS...

# NEW COLOR BRITE HAS BOTH... ISOLATION AND BOOST!

This efficient new Britener corrects for cathode-to-filament shorts causing loss of black and white video drive . . . isolates the short, restores the black and white information necessary for color picture quality.

Model C-503  
for round tubes

Model C-513  
for rectangular tubes

Dealer Net \$7.75



When needed later, sliding the boost switch raises electron emission, restores full contrast and sharpness to fading picture.

Manufactured by  
**Perma-Power**  
Division  
CHAMBERLAIN MANUFACTURING CORPORATION

845 Larch Avenue, Elmhurst, Illinois 60126, Phone: (312) 279-3600

Circle 18 on literature card

AVAILABLE NOW!

## Johnson Messenger 124-M with DRC\*



### \* DUAL RECEIVE CAPABILITY

Hottest CB idea since 23-channel operation! DRC lets operator work one channel while automatically monitoring another. 2 monitor channels are switch selectable. Indicator light flashes when call is received on monitored channel. Mode switch selects indicator light only or automatic switching to monitor channel audio. Separate squelch circuits, too.

You're going to hear more from...



**JOHNSON**

1113  
© Waseca, Minnesota 56093  
Circle 19 on literature card

# RCA's PS Warranty Program is at your service.

Just because we were #1 in 1970 color TV sales to consumers doesn't mean we've forgotten you today. We created "PS", a warranty program which backs you up as well as every AccuColor® TV. PS means Profitable Servicing for two reasons: First, because AccuColor owners can select any service agency they want. And, second, because RCA pays your going rate for warranty service rendered. Sound good? For details, read on.

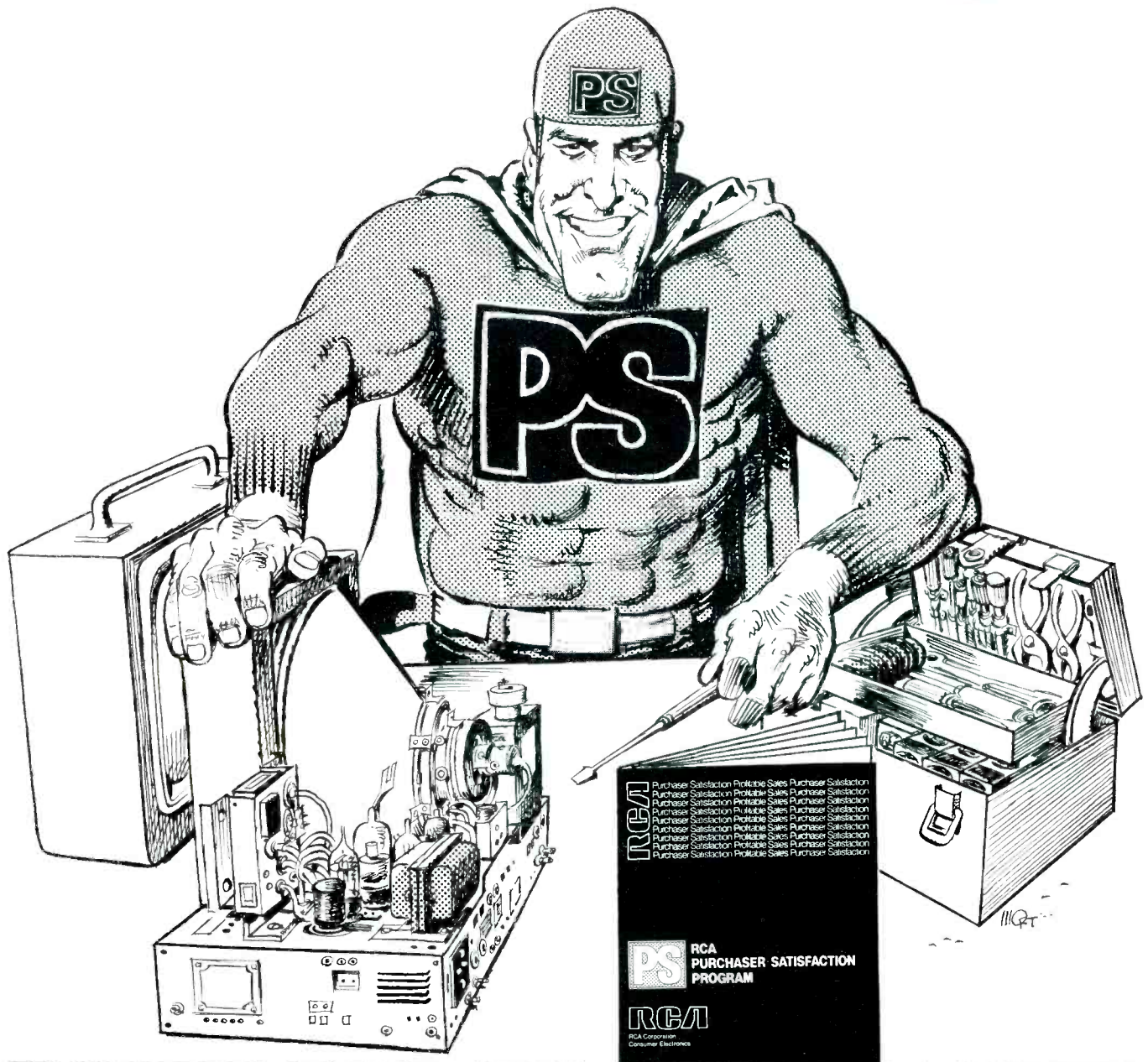

**RCA's Symbol of Purchaser Satisfaction.**

**AccuColor Parts and Labor Basic Warranty Provisions.** For **one full year** from the date of purchase, RCA Corporation warrants to the first retail purchaser that it will pay all labor charges for repair of defects in 100% solid state AccuColor models (**90 days** on AccuColor models with "New Vista" chassis) and will make available replacements for any defective parts. (If the picture tube becomes defective within **two years**, it will be exchanged for a rebuilt picture tube.) On portable models RCA will make available replacements for defective parts and pay labor charges only on a "carry-in" basis; transportation to and from the service agency is the purchaser's responsibility. Installation and set-up, foreign use, antenna systems, and adjustment of customer controls are not included. To obtain warranty benefits, contact your RCA dealer or the service agency of your choice with your Warranty Registration Card.

parts and pay labor charges only on a "carry-in" basis; transportation to and from the service agency is the purchaser's responsibility. Installation and set-up, foreign use, antenna systems, and adjustment of customer controls are not included. To obtain warranty benefits, contact your RCA dealer or the service agency of your choice with your Warranty Registration Card.

For a copy of the PS booklet which covers all of our products, and the name of your field representative, write RCA Sales Corporation, Dept. 634, 600 N. Sherman Drive, Indianapolis, Indiana 46201.

# RF Amplifier- and AGC-Related Troubles

**Frequent causes of common trouble symptoms and how to pinpoint them, plus case histories which illustrate both troubles and troubleshooting techniques.**

The RF amplifier is a radio receiver's first line of defense in the battle to eliminate unwanted signals that would otherwise interfere with normal reception. Although it offers minimal selectivity and only a small percentage of the overall gain it is frequently the major difference between a set that performs well and one whose performance is mediocre but whose price is low. This month we will analyze the operation and troubleshooting of the RF amplifier and its related circuitry, including the automatic gain control (AGC) system.

Fig. 1 shows a typical RF amplifier circuit. This particular circuit is from the 1968 and 1969 Lincoln Continental (Bendix) radio. (The schematic for the entire circuit can be found in Sam's Auto Radio manual, number AR-60, page 88.) Transistor Q1 is an NPN Bipolar type. A small amount of thermal stabilization, as well as a slightly higher input impedance, is provided by the 330-ohm resistor between the emitter terminal of the transistor

The RF Choke (RFC) in the antenna lead is one of those parts which seem out of place until you know both its value and function. This particular choke, for example, has a very low value of inductance. At AM broadcast band frequencies it offers a negligible reactance. As frequency is increased, however, the inductive reactance increases. The

function of the choke is to attenuate noise pulses, such as those generated by the automobile ignition system. This is the reason why such a choke is found in almost all car radios but only a few home radio receivers. It functions because the noise pulses in autos have an extremely high-frequency component.

Tuning of the RF amplifier stage is accomplished by the two LC tank circuits—one in the base circuit, the other at the collector. In the typical auto radio these coils, along with the oscillator coil, are mechanically ganged together. The station selector moves the slugs in and out of the coil forms.

The reasons usually given for using permeability (coil) tuning rather than a variable capacitor are cost and the ease of designing mechanical pushbutton tuners.

The permeability tuning system itself might well be doomed by the newer voltage-tuned tank circuits. These circuits, and they are already possible were it not for the added cost, use a variable-capacitance diode (Varactor) similar to existing

FM AFC diodes in place of the normal mechanically variable capacitor. Several stereo receivers already use this method of tuning. Insiders at one car radio manufacturer claim that either late production '72 or the '73 car radios will have no permeability tuners.

As with all "triode" tuned amplifiers, the RF amplifier stage in solid-state auto radios has a certain amount of regenerative feedback caused by stray circuit capacitance and by the internal junction capacitance of the transistor. Theoretically, the best way to neutralize the effects of this feedback would be a tuned circuit that supplies degenerative feedback to the input. In practice, however, a car radio must tune a wide band of frequencies rather than just one. Because a tuned neutralization network might present some ticklish tracking problems, it has become standard practice to use just one type of reactance—capacitance. The 33-pf capacitor (C<sub>2</sub>) in Fig. 1 accomplishes the neutralization in the Bendix Model 8TBC/9BL unit.

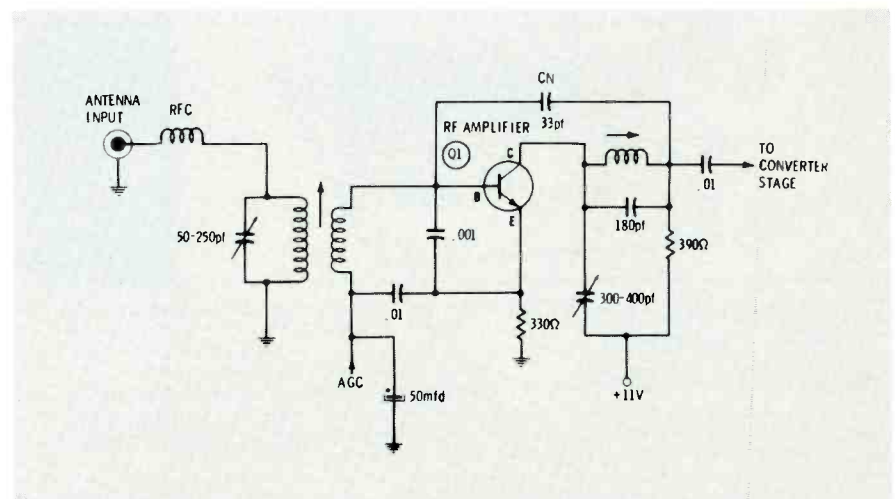

Fig. 1 Typical RF amplifier circuit (1968, 69 Bendix used in Lincoln Continentals).



# Panasonic parts for Panasonic products. It makes sense.

Any other part means less than Panasonic quality. And we couldn't have that. Because we couldn't let our Panasonic family down.

A family made of Panasonic people. Standing behind every Panasonic part we make. Specialists at what they do. Designers. Engineers. Technicians. Testers. Inspectors. All concerned with doing their job the best way, and the most advanced way. Even the kind of package design and proper packing is carefully considered. Ensuring the best possible care in handling.

And our quality control and inspection doesn't end when a part is made. Products from the production line are tested. And re-tested. And tested again before they're put on shelves. And

sometimes even after they've been on the shelves for a while. It's a job that's continual. The only way we know how to do it. Because quality is our "thing" at Panasonic. We owe this allegiance to our family. To you who sell and service our products. And to our customers. So they'll be happy they bought Panasonic. And so they'll continue to buy Panasonic.

That's why we have Factory Servicenters, five Regional Parts Depots and a Central Parts Depot. To stock over 20,000 kinds of parts. There to back up each and every Panasonic sale.

Think about it, Panasonic parts for Panasonic products does make sense.

*Circle 21 on literature card*

**PANASONIC®**

just slightly ahead of our time.

Matsushita Electric Corporation of America  
National Headquarters, Service and Parts Division  
10-16 44th Drive, Long Island City, N. Y. 11101

The 50 mfd capacitor connected to the RF amplifier AGC line is used to decouple any signal from the IF AGC take-off point which manages to get through the rectifier circuit. If this capacitor opens, the radio exhibits tunable squeals throughout the entire RF band. In tube-operated car radios, this capacitor usually had a value around .05 mfd. This value had to be increased, however, when transistors came along. Typical values in solid-state equipment are 25 to 75 mfd. The higher capacitance is required because of the lower impedance levels in transistor circuits. According to a generally accepted rule of thumb, a bypass or coupling capacitor should have a reactance of less than one-tenth the circuit impedance at the lowest operating frequency.

Not all car radios, of course, use the NPN-type RF amplifier. In fact, most of the older, out-of-warranty sets use a germanium PNP transistor. Motorola, for example, used their imported type 2SA72 for several years. It is such a common car radio transistor (as well as being a good substitute for many others) that some shops still buy them in lots of fifty or one hundred.

Fig. 2 is a partial schematic of

a typical PNP-equipped RF amplifier stage. For most practical purposes, it is essentially similar to the NPN circuit of Fig. 1. Despite the similarities, however, there are significant differences that can be used to determine which type is in use in any given radio. The element voltages, with respect to ground, are one point of identification. In Fig. 1, for example, high voltage is found at the collector (TV technicians are asked to refrain from snickering when we call 10 volts "high"), while lower positive voltages are found at the emitter and base terminals. In Fig. 2, the opposite is true; the emitter and base levels are close to the full supply voltage, while the collector voltage is either zero or very near it. These conditions are valid for almost all negative-ground sets.

The AGC system used in the Bendix Model 8TBC/9BL auto radio is shown in Fig. 3. This circuit is typical of the single-diode AGC circuits found in most modern car radios. In this circuit, a sample of the signal voltage is taken from the collector of the IF amplifier and is fed through a low-value coupling capacitor (330 pf in this case) to a 6.8k load resistor. This signal sample has an amplitude that is proportional to the amplitude of the re-

ceived signal. It, therefore, can be rectified and used as a DC correction voltage which controls the gain of the RF and IF amplifiers. Modulation and residual IF signal voltage is removed by the decoupling network consisting of C2, R2 and C3.

A variation of this basic circuit is found in Delco (GM) sets dating back to 1962. This variation, shown in Fig. 4, is basically the same as the single-diode circuits, except that it uses two diodes in a half-wave voltage doubler configuration. Also found in some earlier sets are reverse-polarity versions which are used with PNP RF amplifier stages.

Fig. 5 illustrates the relationship between the RF amplifier and the AGC system. A sample of the signal is rectified by the diode. The resultant DC voltage is applied to the controlling element (the base in solid-state circuits) of the RF and, sometimes, IF amplifiers, reducing or increasing their respective gains as needed to maintain a constant volume level.

The interrelated nature of the RF amplifier and AGC circuits often makes the troubleshooting of certain defects much like a guessing game. For purposes of analysis, we are going to break the usual faults down into two separate categories: distortion on strong signals and the

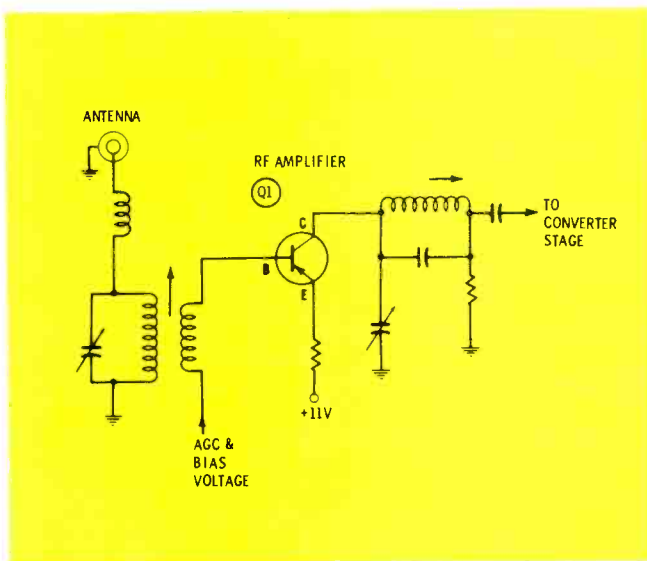

Fig. 2 PNP equivalent of RF amplifier circuit in Fig. 1.

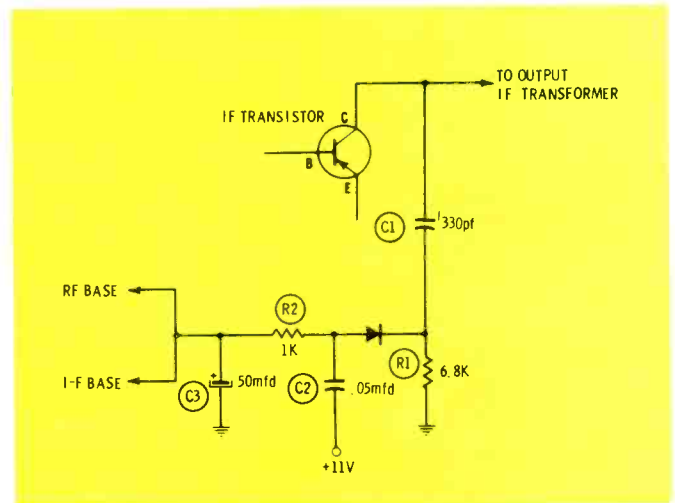

Fig. 3 AGC circuit shown here, used in Bendix Model 8 TBC/9BL, is typical of single-diode circuits employed in most later-model auto radios.



“dead” RF amplifier.

Distortion on strong signals is usually caused by a defective AGC circuit. The root of this problem will most likely be a bad AGC rectifier diode. It can generally be checked in-circuit by making forward and reverse resistance readings with a meter set to the Rx100 scale. However, be sure that any meter used for this purpose is a low-voltage instrument. One old meter I have, uses a 22.5-volt battery and will blow most types of small-signal detector diodes.

Besides a bad diode, however, there are certain other defects that can cause distortion on strong signals. Included among these are broken printed circuits (and other open circuits that interrupt the AGC line) and a certain type of defective RF amplifier transistor.

The base bias of the RF amplifier is a reliable indication of the source of the trouble; if it increases and decreases as the set is tuned across the band, but the conduction of the transistor remains constant (as indicated by the emitter resistor voltage drop), the **probable** cause is a leaky transistor. Substitution is the best method of checking this transistor. In such cases it seems that collector-to-base leakage is the villain, and it might not show up on

the ordinary transistor checker, except occasionally as a slightly lower Beta reading.

In cases where it is the RF amplifier that is inoperative, you also can rely on the voltages measured on the transistor elements. Fig. 6 shows the normal range of these voltages. The emitter-to-base voltage will show the condition of the bias network and the transistor junction itself. A value of around .2 volts between the base and emitter of a germanium transistor and .6 volts on a silicon transistor usually are normal.

There is also one other voltage of interest in this stage: the DC conduction voltage. The voltage drop across the emitter resistor is caused almost exclusively by conduction between the collector and emitter. (Note: In an NPN stage the base current also affects this reading, but will amount to less than 5 per cent. Consequently, you can consider the emitter resistor voltage drop as caused entirely by collector-to-emitter current.) In a PNP stage, there also is frequently found a small voltage (1 to 3 volts) between the collector and ground which is directly proportional to conduction. Since in a normally operating system these voltages vary according to the strength of the received signal,

they can be used to judge the condition of the RF amplifier/AGC circuit. Do not be confused by normal variations of these voltages. In a PNP germanium RF amplifier, for example, a reading of .3 volts from emitter to base might have no significance. A reading of 1.4 volts, however, could indicate an open emitter. It is the **large** change in bias that is of consequence.

To efficiently troubleshoot the RF/amplifier and AGC sections of an auto radio, it is necessary to determine how particular defects affect the relative bias and conduction voltages. A high emitter-to-base voltage, as already pointed out, can mean an open emitter-to-base junction inside the transistor. When the bias varies normally as the set is tuned across a station, yet the conduction remains relatively constant, you generally can depend on finding a leaky transistor. These and several other common troubles are illustrated in the following case histories.

#### Case No. 1

This case involves a 1963 Pontiac radio made by the Delco Radio Division of General Motors. The customer complained that he could only receive those stations which were a relatively short distance

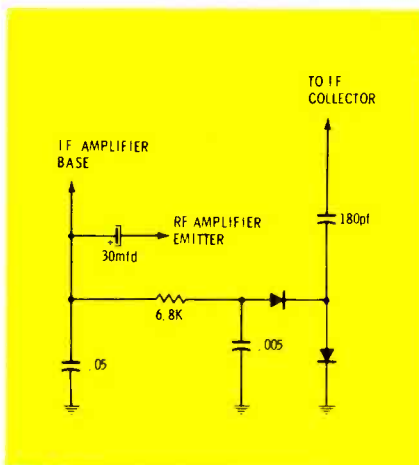

**Fig. 4** This variation of basic AGC system shown in Fig. 3 uses two diodes in half-wave rectifier arrangement. Circuit shown here is found in Delco auto radios.

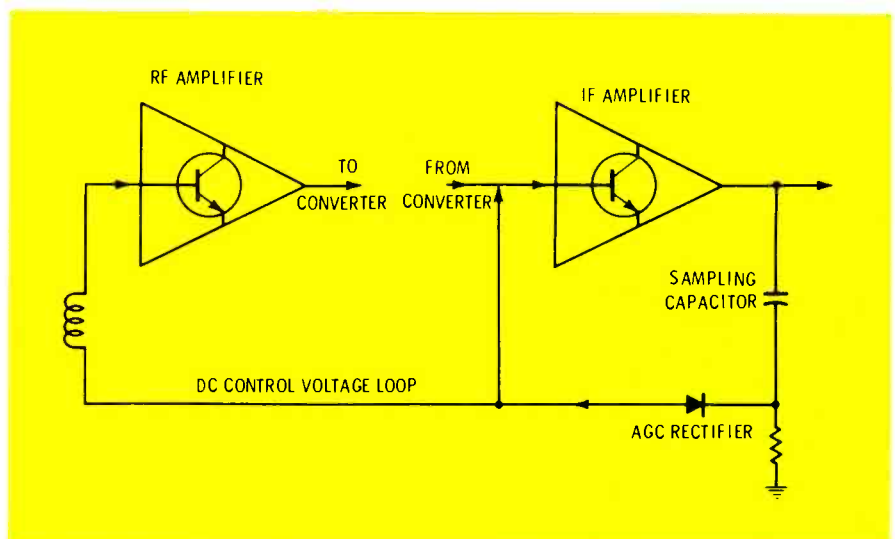

**Fig. 5** “Loop” arrangement of AGC system, illustrated here, can complicate troubleshooting. See text for discussion of typical defects and their symptoms.

away. Stations on the other side of the city were inaudible. The loud hiss coming from the speaker indicated that the trouble was in either the antenna or the RF amplifier circuits. A test antenna proved that the auto antenna was not the source of the trouble.

On the bench, we popped the cover off the radio and used a voltmeter to check RF amplifier volt-

ages. The collector-to-ground and emitter-to-base voltages both were zero. The voltages from ground to both the emitter and the base were close to the normal 11 volts. Because a transistor in this type of circuit seldom develops a short across the emitter-to-base junction (and even when it does, there usually is some resistance), it was decided to look in the circuitry exter-

nal to the transistor. When we disconnected the AGC capacitor (in Fig. 7), the radio began operating, but with the expected oscillation squeals. A new 30-mfd electrolytic cured the problem.

#### Case No. 2

Fig. 8 is a partial schematic of the RF amplifier section of the Blaupunkt (German) late-model Frankfurt AM-FM car radio. This radio often is found in Mercedes-Benz, Porsche, Volkswagen, Audi, and other European cars. If the complaint involving this radio is "no AM" or "intermittent AM", chances are a close look at the bandswitch will reveal the trouble. The stator part of this bandswitch is made like (and with the same techniques as) a printed-circuit board. The slide is a plastic affair, with the wiper arm assemblies made of brass. To determine whether the problem is actually the switch, set the radio to the AM position and jiggle the plastic piece with an insulated tool. If the AM comes on, even momentarily, the problem is in the switch.

Unfortunately, this bandswitch is relatively difficult to change. Also, we must consider the possibility that the new switch might soon be just as defective as the old switch. Because of this, the best repair, as recommended in a Blaupunkt service bulletin, is to short out certain sections of the switch and then clean the entire assembly. Use a good-quality chemical contact cleaner, sprayed generously over the entire switch. Work the switch slide back and forth rapidly several times, using the pushbuttons on each end of the dial. Use a small-tip low-wattage soldering iron to short together the switch sections designated by the curved arrows in Fig. 8. In the Blaupunkt service manual and printed circuit "roadmap", these terminals are labelled A5 & A6, B5 & B6, A13 & A14, and A19 & A18. Although this advice is meant specifically for those Frankfurts marked "Model 763-9670", with serial numbers over 1,800,000, it also might work with other models of this radio which ex-

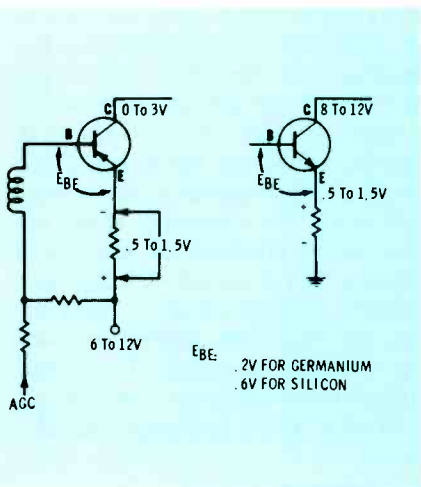

Fig. 6 Normal ranges of voltages on elements of properly operating PNP and NPN RF amplifier stages.

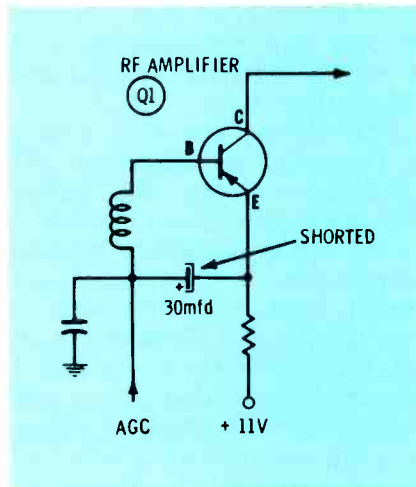

Fig. 7 Shorted capacitor, pointed out here, reduced the sensitivity of a 1963 Pontiac radio.

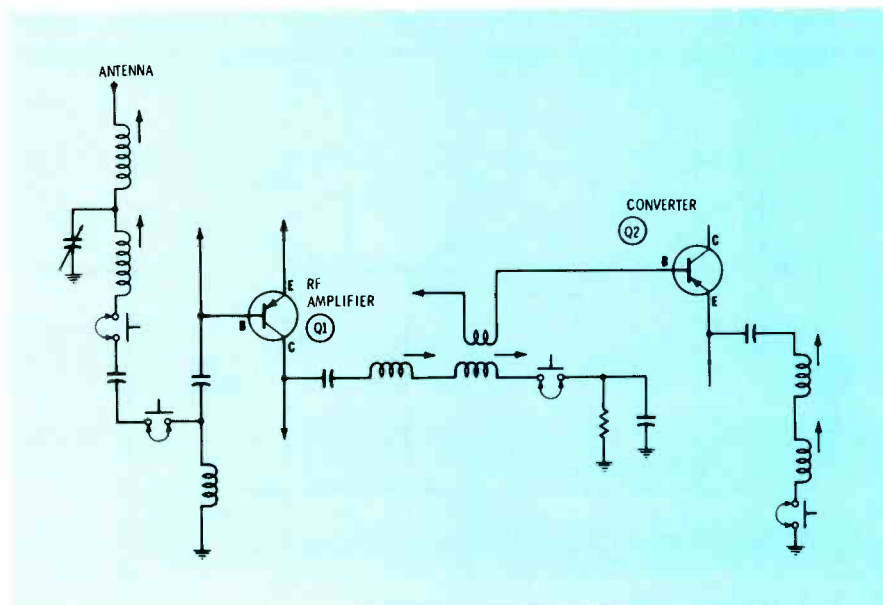

Fig. 8 Partial schematic of RF amplifier section of a late-model Blaupunkt AM/FM auto radio. Defective bandswitch, sections of which are shown here as "circuit-breaker" type switches, can cause missing and/or intermittent AM operation.

hibit similar trouble symptoms.

### Case No. 3

The complaint about a 1970 Ford Galaxy AM-FM radio, Model OFBF, made by Bendix was "radio dead on AM". Because both the power supply and the audio amplifiers are common to the AM and FM functions the trouble was most likely in the AM radio printed-circuit board. Checks with a scope showed no signal was present in the IF, converter or RF stages. The scope also showed that the oscillator was not functioning.

A VTVM then was used to check out the DC section of each stage on the AM printed-circuit board. The RF amplifier, which was checked first, had no collector voltage. (In this particular type of radio, the AM printed-circuit board is difficult to reach. It is located forward of the combination heat sink/back panel and between the FM IF amplifier and audio-multiplex decoder printed-circuit boards. Despite its difficult-to-reach location there is at least one part of the AM board design which makes this type of problem easier to troubleshoot: The B+ line is divided into two separate tracks joined together by a wire jumper. Remove this jumper and a VTVM will tell you on which track the defect is located.) In this case, the defect seemed to be a short circuit to ground in the collector circuit of the RF stage. Inspection of the circuit diagram revealed the presence of several capacitors that could cause this trouble. They were checked by pulling one lead loose on each capacitor while monitoring the B+ line with the VTVM. None of these capacitors were defective. What was shorted, however, was the tuning coil. The coils in the permeability type tuner are mounted on a phenolic plate that is bolted to the cast frame of the tuner housing. The fine coil wires connected to the solder terminals often can be found pinched beneath a mounting screw. Clearing this short will restore the radio to normal operation.

### Case No. 4

The AGC circuit can cause a

peculiar type of distortion. Although this distortion can occur in any car radio, we will consider a case I encountered in the 1968 Lincoln radio discussed earlier.

The owner of this set was a rather precise gentleman and an acute observer of fact. He lives in one of those new satellite communities about thirty-five miles from his

downtown office. He complained that the radio became more and more distorted as he approached the city and would be completely unintelligible by the time he passed a certain landmark just inside the city.

Checking the radio on other stations proved that the distortion was a function of signal strength—a fact

**IEC SERVICEMASTER**  
**Electron Tube**  
**IEC Mullard**

## FOR THE MONEY

- Discounted to provide you with a higher profit margin.
- Proven quality for better customer satisfaction.
- A complete range of popular service types readily available.

In every important way, IEC Servicemaster is number one. For complete details, contact your IEC representative today, or International Electronics Sales Corporation, Melville, N.Y. 11746, (516) 694-7700.

**IEC SERVICEMASTER**  
**INTERNATIONAL ELECTRONICS SALES CORPORATION**

Circle 22 on literature card

that pointed to the AGC circuit. On the bench, with the radio covers removed and the set tuned to a strong station, we checked the bias on the RF amplifier transistor. The transistor was completely cut off. Bridging a 1-meg resistor from collector to base turned on the transistor and it conducted normally. This led us to inspect the AGC circuit. An ohmmeter set to the RX100 scale indicated that the AGC rectifier was defective. A new Bendix 20572055-0708 diode (equivalent to a 1N82A)

cured the problem.

**Case No. 5**

Static was the complaint in the next case, which involved a Dodge radio made by Motorola. Fortunately, this customer had come in shortly after the trouble had started. Because the previous three weeks had brought heavy thunder showers every day, we suspected the trimmer capacitors or the IF transformers. A signal tracer proved that the noise was in the RF amplifier. A voltmeter reading of the collector volt-

age showed variations whenever static was present. Normally in such cases, we cut the printed-circuit board and connect a .01-mfd capacitor in series with the trimmer (across the cut). On the Motorola double-sided board, however, this would be quite a trick. It was easier to confirm the diagnosis by replacement.

**Case No. 6**

For this last case, I am going to combine several common defects into one hypothetical radio. Remember, not all of these problems will be found in any one radio.

The symptom in all of these cases is regeneration or oscillation. It will vary in severity all the way from a subtle instability on-station to an ear-piercing howl. In certain cases, the oscillation will zero beat against any station in the receiver's pass-band.

The AGC decoupling capacitor, shown in several of the illustrations in this article, will cause this symptom if it should become open. This is because the AGC line then becomes a positive feedback path. In most sets, this capacitor is a small electrolytic of between 25 and 75 mfd. In many Bendix sets, however, the AGC bypass capacitor is part of a two-section electrolytic; the other section will be either a 500- or 1000-mfd unit. Both sections are rated at 4 WVDC. The 500- to 50-mfd unit is used in older sets and is no longer available. When these sets need a new decoupler, use the newer part. It can be ordered under Bendix part No. 2092246-0711.

An open or shorted AGC rectifier diode also can cause unwanted oscillation. In these cases, the oscillation is often very subtle and might appear only when the set is tuned across a station. In almost all cases there also will be strong-signal AGC distortion when this occurs.

A cracked printed circuit also will produce an oscillation symptom. In some of the mid-'60's Delco sets and early-'60's Bendix VW sets, the printed circuit to the AGC decoupling capacitor breaks. It can be discovered best by using a voltmeter to look for a voltage difference between the ends of each individual printed circuit. Many times these circuit breaks cannot be seen, so don't depend on eye-balling this one. ▲

# PUT IT TO THE TEST

Leave it to B&K to come up with a new model 179 FET/VOM with features that almost make it unbelievable at its price. Complete DC voltage ranges from .3V to 1000V; DC current ranges .03 to 300 mA; AC voltage ranges .3 to 1000V and AC current ranges .03 to 300 mA. Resistance 0 to 500 Meg and stable operation 0° to 40°C. Fastest and easiest to use. The 179 uses Field Effect Transistors for drift-free accuracy. High input impedance minimizes circuit loading. And the 179's super-wide variety of ranges makes this an ideal FET/VOM for shop, lab, production line, or school. Includes mirror scale, and stay-put handle.

Now is the time to update your shop with a stable, protected FET/VOM. And the economical, yet professional B&K 179 is the instrument that will give the most usefulness and satisfaction for your money.



Ask your distributor or write us for catalog.

There is a difference in test equipment... ours works!

**B&K Model 179 FET/VOM \$74.95**  
The new standard of stability

Circle 23 on literature card



A Product of  
**DYNASCAN CORPORATION**  
1801 W. Belle Plaine  
Chicago, Illinois 60613

# Now, your choice- 1 or 2 year warranty on all RCA color picture tubes

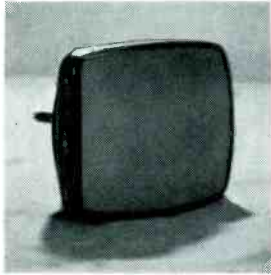

**A big business builder for you with the industry's most complete line.**

**1.** RCA offers an extended warranty, for a second year, on all Hi-Lite and Colorama color replacement tubes.

**2.** The second year is optional. You can still offer the customer RCA's one year warranty. Or for a modest extra charge there's a whole additional year of protection. It's your choice!

**3.** This extra protection will help you sell many customers on replacing the tube instead of the set.

**4.** It will keep them coming back to you for service on their TV sets and other equipment.

**5.** You can sell with extra confidence. There's added protection on the quality name picture tube line designed to enhance your professional reputation.

That's why the RCA extended warranty is your most powerful new sales tool for 1971! Get full details from your local RCA Distributor.

RCA | Electronic Components | Harrison, N.J. 07029

**RCA**

## Noise cancellers, sync separators and AGC systems

by Carl Babcock/ES Technical Editor

*How individual and combination circuits function, plus practical techniques for troubleshooting them.*

### Noise Cancellation

Noise cancellation circuits are TV refinements that prevent external "noise" from interfering with horizontal and vertical locking. That is, they do when they are operating correctly. However, defective noise cancellation action can cause improper AGC action and incorrect locking. In many cases, receiver performance is better with **no** cancellation, than with a defective noise cancellation circuit.

Effectively removing the noise cancellation circuit usually will prove whether or not it is the source of the AGC or locking problem. In most cases, this can be accomplished by using a jumper lead with clips to short out a part of the circuit, or by removing a tube or disconnecting one wire of the circuit. Such tests are fast, and usually can be made in less time than is required by other tests which give a less definite indication.

### Cancellation By Phase Inversion

The schematic in Fig. 1 is not that of an actual circuit, but is intended only to illustrate a principle. Normal circuit operation is described in the caption under the illustration. If V2, the noise canceller tube, is not a part of a multiple tube and is not in a series heater string, you can merely remove the tube from its socket, to stop all noise cancellation action. Otherwise, disconnect one end of the resistor that is connected between the plate of V2 and the AGC and sync circuits.

### Cancellation By Elimination

Another type of noise canceller is the series type, which removes **all** sync for the duration of the noise pulse. A transistor is inserted between the cathode or emitter of

the sync separator and ground. Fig. 2 shows the circuit used in the RCA KCS153 monochrome chassis, and describes the normal operation of the circuit.

Merely short between collector and emitter of the noise cancellation transistor to eliminate all noise cancellation action. If locking improves, a defect exists in this circuit.

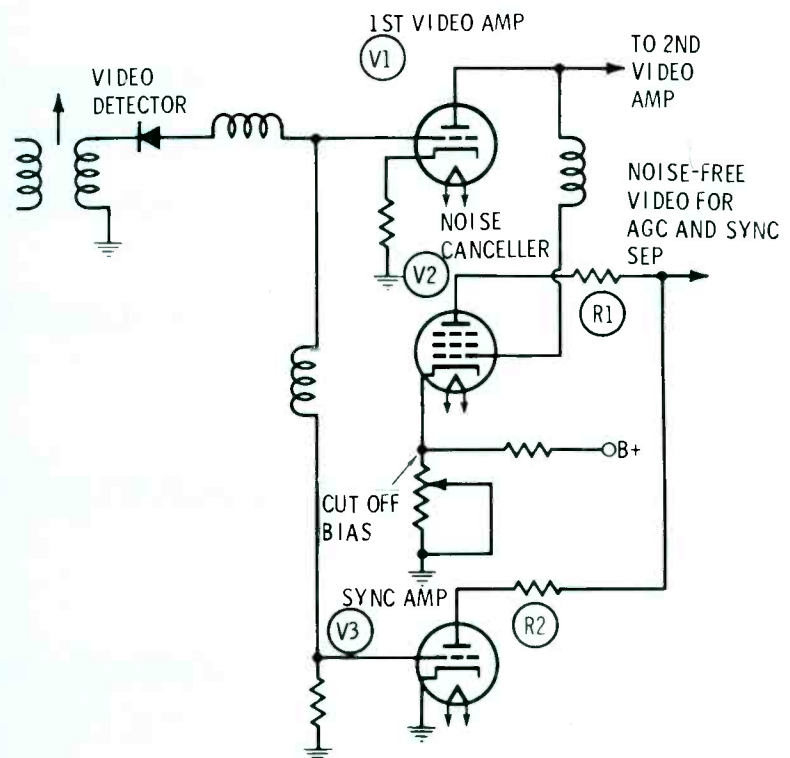

**Fig. 1** The function of this circuit is to provide noise-free composite video signals to the AGC and sync circuits. Noise pulses with amplitudes greater than the sync pulses in the composite video signal can interfere with the functioning of these circuits. Because of the relatively large positive potential applied to the cathode of the noise canceller, V2, only the tips of the positive-going horizontal sync pulses in the composite video signal applied to the control grid will bring V2 out of cutoff. Consequently, noise pulses whose amplitudes exceed that of the sync pulses will be amplified by V2 and fed through R1 to point A. The same noise pulses also are amplified by V3, the sync amplifier, and fed through R2 to point A. Because the output of V2 is processed through one more stage (video amplifier) than is the output of V3, the two noise signals at point A are 180 degrees out of phase and, consequently, cancel each other. This is one type of noise cancellation.

## Combination AGC Keying And Noise Inversion

The need for a noise-free video signal to supply the sync separator is quite clear. Noise-free video also is important for good AGC action, because an extremely strong noise pulse or a sustained series of pulses can fool the AGC circuit into believing an increase in signal strength has taken place. Consequently, the AGC circuit erroneously reduces the receiver gain, which, in this case, causes an undesirable reduction in contrast.

Noise cancellation circuits using 6GY6, 6DT6 and the pentode sections of 6KA8 tubes were popular several years ago. They still are used in some all-tube models of color receivers.

A typical RCA circuit is shown in Fig. 3, along with a short description of the normal circuit action. Noise cancellation signals to the AGC circuit (grid No. 3, pin 7) can be eliminated by shorting across R90, or from pin 7 to pin 3 of the 6KA8 tube. Noise cancellation signals to the sync separator can be eliminated by shorting across R89 and R90, or by disconnecting one end of R88.

## 6BU8, 6HS8 and 6BA11 Triple-Function Circuits

Functions of noise cancellation, sync separation, and AGC keying sometimes are combined in special tubes which have a common cathode, control grid and screen grid, but have two separate plates and two separate "suppressor" grids. Fig. 4 shows a typical AGC circuit of this type in a Zenith hybrid receiver which has a tube-type RF amplifier and solid-state IF amplifier stages.

Signals applied to the control grid (pin 7) are for noise cancellation only; their phase is opposite that needed for AGC or sync action. When a normally operating circuit of this type is supplied a signal which does not contain noise pulses, a small amount of video is present at the grid but has no function.

The principal AGC action is initiated by the video and DC voltages applied between the grid No. 3 (pin 6) and the cathode. The performance of grid No. 3 in this

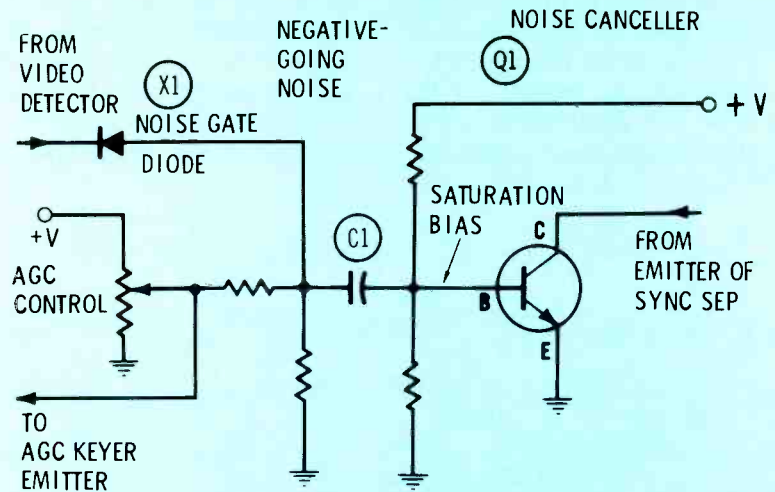

**Fig. 2** Noise canceller circuit used in RCA KCS153 black-and-white solid-state portable chassis. Positive voltage from the AGC control is applied to the anode of noise-gate diode X1. A higher positive voltage is applied to the cathode of X1. Combination of two positive voltages across X1, with smaller of two on anode, reverse biases X1 so that only negative-going noise pulses can trigger it on and the normal composite video signal is blocked. A fixed, positive voltage applied to the base of Q1 forward biases this transistor into saturation so the collector-emitter path is nearly a short circuit, and sync separation is not affected. When a negative-going noise pulse of greater amplitude than the sync pulse is applied to the cathode of X1, the diode conducts and the negative pulse is fed through it and C1 to the base of Q1. Because Q1 is an NPN transistor, the negative noise pulse on its base cuts off its emitter-to-collector current, which, in turn, opens the emitter circuit of the sync separator, cutting it off for the duration of the noise pulse.

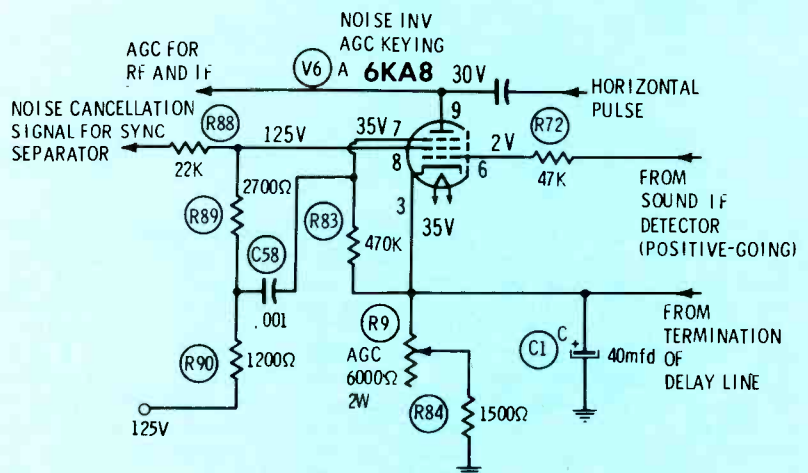

**Fig. 3** Noise canceller and AGC keying circuits employed in the RCA CTC25 color receiver. The normal bias applied for correct AGC operation automatically clips the video signal that normally would appear at the unbypassed screen grid (pin 8). The polarity of the signal at the screen is opposite that of the video at the control grid and mostly consists of horizontal sync pulses. Noise pulses accompanying the composite video signal applied to the control grid are amplified much more than the sync pulses, and then are routed through R88 to the sync separator input, where they are cancelled out by the out-of-phase noise pulses in the normal composite video signal which also is applied to the sync input. To prevent the noise pulses in the composite video supplied to the control grid (pin 6) from causing an increase in AGC voltage and a decrease in picture contrast, the noise pulses at the screen grid (pin 8) are fed through C58 to the suppressor grid, where the negative-going pulses counteract the effect to the positive-going noise pulses at the control grid.

tube is not identical to that of the suppressor grids in the old pentode tubes. In the older pentode tubes the exact voltage applied to the suppressor was relatively unimportant. However, in these newer-type

tubes, grid No. 3 has a sharp cut-off characteristic; application of only a few negative volts to grid No. 3 will cut off the plate current. (The same facts apply to grid No. 3, pin 9; however, it is in the sync circuit,

about which we now are not concerned.)

### Rapid AGC Tests

Following are a few quick tests of the AGC circuit in Fig. 4:

- Connect grid No. 1 (pin 7) to the cathode (pin 1), to eliminate all noise cancellation action. If the AGC or locking functions improve, a defect exists in the circuit associated with pin 7.
- Connect both grid No. 1 (pin 7) and grid No. 3 (pin 6) to the cathode (pin 1). This should produce a large negative voltage at the plate (pin 3). If the negative voltage is not produced, the tube is not capable of plate conduction; check the screen voltage, the continuity and voltage of the cathode circuit and the large horizontal pulse which should be present on the plate.
- If during the previous test the normally large negative voltage was produced at the plate (pin 3), yet without the jumper wires the picture is overloaded and plate voltage does not drop to near the zero mark when a strong station is tuned in, the amplitude of the video and DC voltages applied to grid No. 3 (pin 6) should be suspected.
- Test the AC and DC voltages on the cathode (pin 1), if no defects were found in the previous test. An open or leaky C5 is a good possibility.

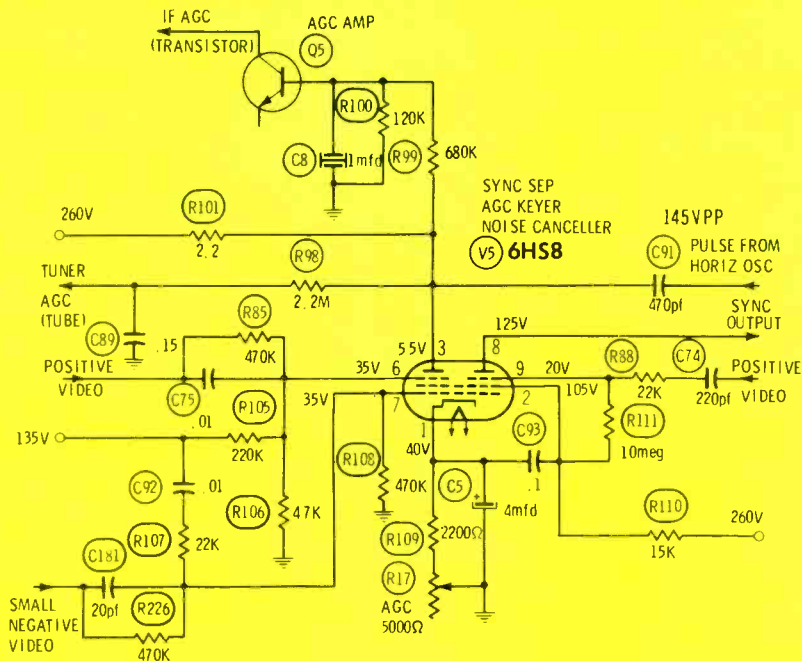

**Fig. 4** The sync separator, AGC keyer and noise canceller functions are performed by a single 6HS8 tube in Zenith's 15Y6C15 hybrid color chassis. Basic AGC action is the same as that of a pentode-equipped AGC circuit, except that in the circuit shown here grid No. 3 (pin 6) performs the function the control grid performs in the pentode-equipped circuit. Cancellation of noise pulses is accomplished by applying composite video pulses of opposite polarity to grid No. 3 (pins 6 and 9) and grid No. 1. The negative noise pulse on grid No. 1 reduce or cut off conduction in both sides of the tube. Noise pulses exceeding the level of the sync pulses thus are cancelled out in both the AGC side (left) and sync separator side (right) of the tube. Clipping action resulting from the flow of grid current removes most of the video applied to grid No. 1 (pin 7). The positive-going composite video signal and fixed positive bias developed by the voltage divider consisting of R105 and R106 combine to control the amount of AGC voltage (negative) developed at pin 3. Positive voltage developed across a voltage divider consisting of R100, R99 and R101 performs two functions: 1) Delay of AGC to tuner—Until the negative voltage developed on the "tube" side of C91 exceeds the positive voltage developed across R100 and R99, no negative AGC voltage is applied to the RF amplifier in the tuner. 2) Forward bias for AGC amplifier Q5—Positive voltage developed across R100 forward biases NPN transistor Q5, whose conduction determines the amount of forward AGC bias (positive) applied to the base of the 1st video IF transistors. The negative AGC voltage developed at pin 3 of V5 reduces or eliminates this positive voltage, depending on the amount of AGC voltage present at pin 3 of V5. Q5 functions as one parallel leg of a series-parallel voltage divider. The less it conducts, the more positive voltage is applied to the base of the NPN 1st video IF transistor. This positive voltage shifts the operating point nearer or into the saturation point, thus reducing the gain of the 1st video IF transistor. Pin 9 is biased so that only the tips of the sync pulses produce cathode-to-plate current in the right side of the tube: thus, the sync pulses are separated from the video.

### Probability of Failure

Some parts failures are much more likely to occur than are others. The resistance of a carbon composition resistor whose value is in the megohms is more likely to increase than is a similar resistor of lower value. An electrolytic capacitor is more likely to open than is a paper, mylar, ceramic or mica type. Also, an electrolytic can develop a poor power factor, which can cause worse symptoms than if the capacitor becomes completely open. (Power factor is the ratio of impedance and resistance in a reactive component or circuit and, consequently, is an indication of loss resulting from leakage—in this case, resistance.)



Possible parts defects (other than bad tubes) in the AGC circuit shown in Fig. 4 and the resulting symptoms are analyzed in the following paragraphs.

**Symptom**—overload or picture bending on strong signals (pin 3 too positive):

- C91 leaking. This capacitor couples the pulse from the horizontal oscillator circuit to the plate of the AGC keyer. A potential of +54 volts DC is present on the "oscillator" side of the capacitor. Leakage in the capacitor will pass positive DC voltage, making the AGC plate too positive.
- C93 leaking reduces the screen voltage applied to V5 and increases the cathode voltage. Both of these actions reduce rectification, which, in turn, results in less negative voltage at the plate of V5.
- Leakage in C89 will cause picture overload, even though the plate of V5 will be more negative than normal.
- C5 open causes video and pulse waveforms at the cathode of V5. The resultant degeneration reacts as though less pulse was supplied to the plate and less video was supplied to grid No. 3 (pin 6). Both actions reduce the rectification and, consequently, the production of negative voltage at the plate of V5.
- C91 open reduces the pulse applied to the plate, and very little rectification takes place. As a result, insufficient AGC voltage is produced.
- R226 open reduces the DC voltage at grid No. 1 (pin 7) to zero and permits video to be passed (because No. 1 grid is no longer clipping). Both effects reduce the amount of rectification.
- R109 or AGC control R17 open increases the positive voltage at the cathode and opens the cathode-to-plate circuit of V5, except for capacitor leakage; consequently, rectification is eliminated.
- R98 open produces the same symptoms and readings as a shorted C89. Extreme overload and too much negative voltage at the plate of the AGC

## New Benchmarks in solid-state test gear

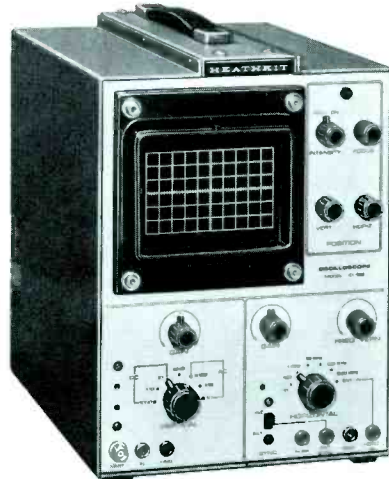

### New Heathkit® solid-state 5", 5 MHz scope...\$119.95 (\$179.95 assembled)\*

An excellent general purpose bench scope... combining the virtues of top performance, maximum convenience and low cost. All solid-state design is your assurance of long-term reliability under sometimes rough shop conditions. Wide 5 MHz bandwidth, 30 mV/cm sensitivity and 80 nanosecond rise time add up to truly unusual value at this low price. Switch-selected AC or DC coupling adds extra convenience and versatility. Frequency-compensated 3-position attenuator accommodates varying input levels. A separate switch position grounds the input to provide a zero reference line. One megohm FET input minimizes circuit loading. The recurrent, automatic sync type sweep generator provides continuous sweep from 10 Hz to 500 kHz. Front panel external horizontal and sync inputs. One volt P-P output included. The 5" flat-face 5DEP1 CRT gives a brilliant, highly visible trace, even in high light levels. 6x10 cm ruled graticule makes amplitude easy to determine. All supplies are zener-regulated to give the IO-102 excellent display stability. 120/240 VAC wiring options. Put the new Heathkit IO-102 to work for you now. **Kit IO-102**, 29 lbs. **Assembled IOW-102**, 29 lbs.



### Heathkit® solid-state 15 MHz frequency counter \$199.95\*

The service instrument you need most but couldn't afford until now. The new Heathkit IB-101 delivers accurate, instant frequency measurement from 1 Hz to over 15 MHz. Computer-type integrated circuitry eliminates blinking readout and provides a rock-stable divider chain that never needs adjustment. Overrange indicator and Hz/kHz switch delivers error-free measurement down to the last Hz... you can do an 8-digit measurement in seconds. The exclusive MOSFET input provides proper triggering over an extremely wide range of input levels without adjustment. Input Z is 1 megohm/20 pF to minimize loading. Goes from kit to counter in about 5 hours, and only an AM radio is required for alignment. Rugged aluminum case with combination handle/tilt stand. BNC cable included. **Kit IB-101**, 7 lbs.



#### FREE '71 CATALOG

Describes these and over 300 other Heathkits. Save up to 50% by building them yourself. Use coupon and send for your FREE copy!

**HEATHKIT**  
HEATH COMPANY, Dept. 25-5  
Benton Harbor, Michigan 49022 a Schlumberger company

Enclosed is \$ \_\_\_\_\_, plus shipping.  
Please send model(s) \_\_\_\_\_.

Please send FREE Heathkit Catalog.

Name \_\_\_\_\_  
Address \_\_\_\_\_  
City \_\_\_\_\_ State \_\_\_\_\_ Zip \_\_\_\_\_

Prices & specifications subject to change without notice.  
\*Mail order prices; F.O.B. factory. TE-243

Circle 25 on literature card

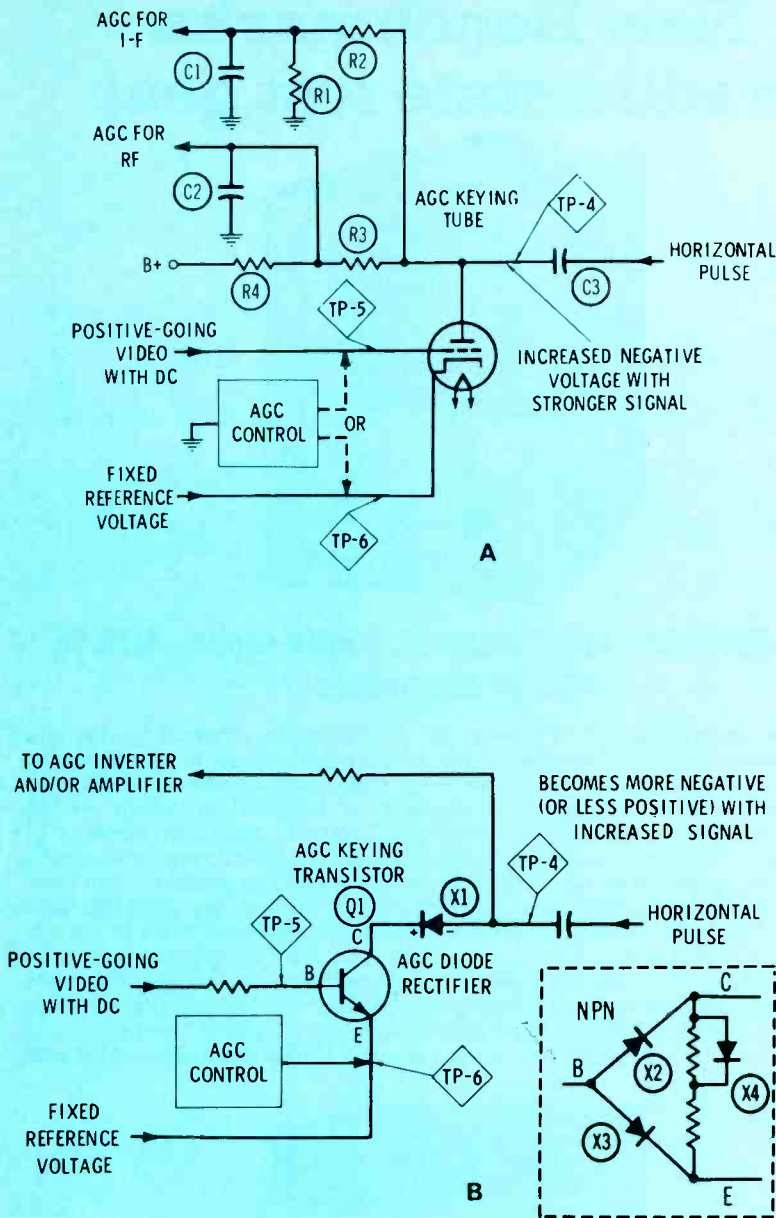

**Fig. 5** Converting the AGC keying stage from tube to transistor requires more than merely reducing element voltages and applied signals. A) Typical tube-type AGC keying circuit—Tube is biased so that it conducts only when horizontal pulses are applied simultaneously to plate and control grid. Amount of conduction is dependent primarily on the level of the horizontal sync pulses in the composite video signal applied to the control grid. When the keying tube conducts, a negative charge is developed in the “tube” side of coupling capacitor C3. This negative charge, or AGC voltage, overrides the positive voltage developed across the voltage divider comprised of R1, R2, R3 and R4. Because R1 is the smallest resistance in the divider network, the positive voltage developed across it is relatively small. Consequently, the relatively high negative AGC voltage easily overcomes it, placing a negative voltage on the video IF AGC line first. Before AGC voltage is applied to the tuner, its level must exceed the positive voltage drop across the combined resistance of R1, R2 and R3, the total resistance of which is much larger than that of R1 alone. Because of this, application of negative AGC voltage to the RF amplifier in the tuner is delayed until the AGC voltage exceeds this positive voltage. During reception of relatively weak signals, the AGC voltage is not sufficient to override the positive voltage at the “top” of R3, and, as an added bonus, this positive voltage, applied to the grid of the RF amplifier, increases its gain, preventing or reducing snow in the picture. B) A typical transistor AGC keying circuit—The principle of operation is nearly identical to that of the tube-type circuit, except that diode X1 has been added to prevent the negative charge (AGC voltage) on the “diode” side of the coupling capacitor from rapidly bleeding off through the collector-to-base leakage of the transistor. This transistor leakage characteristic is represented by diode X2 in the inset. See text for more detailed explanation.

keyer are the results.

**Symptom**—Insufficient contrast (pin 3 too negative):

- C75 leaking causes grid No. 3 (pin 6) to become too positive, and rectification at the plate is increased, producing too much negative voltage.
- C5 leaking causes the cathode voltage of V5 to become less positive. This decreases the bias between grid No. 3 and the cathode, increasing rectification and, consequently, the negative voltage at the plate of V5.

**Note**—Any defect that increases the video or positive voltage at grid No. 3 (pin 6) or decreases the positive voltage at the cathode can cause insufficient contrast.

**Symptom**—Excessive snow:

- R101 open or increased in resistance removes the positive voltage applied to the plate of the AGC keyer, and the plate becomes negative enough to completely cut off the RF tube. Because the IF AGC is restricted to a certain maximum voltage, it is not affected much. Certain values of R101 will reduce the gain of the IF stages during reception of weak signals.
- R99 increased or C8 leaking reduces the AGC voltage applied to the IF. Consequently, the gain of the IF is increased, and the resulting voltage changes cause the AGC keyer to produce more negative voltage, which, in turn, biases the RF tube to cut-off too soon, causing snow.

Although we are not covering that part of the circuit, here are a few bonus tips about Q5, the AGC amplifier: An open circuit or base-to-emitter short in Q5 will cause the IF gain to be minimum at all times; consequently, only very strong signals will be received. A collector-to-emitter short will cause the IF gain to be maximum at all times, and overload is a certainty. To clamp the IF bias for minimum gain, during alignment for example, ground the base of Q5.

### Transistorized AGC Keying

Converting a keyed AGC system from tube to transistor involves more than just reducing the voltage levels of video and DC applied be-

tween base and emitter and the horizontal pulse applied to the collector. The following paragraphs will explain why.

In a tube-type keyed AGC system, such as shown in Fig. 5A, a horizontal pulse is applied to the plate of the tube through a coupling capacitor (C3). Because the tube conducts only during the period of time when the horizontal pulse is present on the plate, shunt rectification occurs, charging the coupling capacitor in a direction that produces a negative charge on the side connected to the keyer plate. This negative charge is used as the AGC voltage. The amount of negative charge at TP-4 is controlled primarily by the level of the pulse applied to the control grid of the keyer tube. The only path by which the negative voltage can bleed off the coupling capacitor is through R1 and R2 in the IF AGC lines.

However, when a transistor is substituted for the keyer tube, another capacitor bleed-off path is introduced into the system. An equivalent circuit of an NPN transistor is shown in the inset in Fig. 5B. During the period of time between the application of positive horizontal pulses to the collector, any negative charge previously developed on the "transistor" side of the collector coupling capacitor will bleed off very rapidly through the low resistance of the collector-to-base equivalent diode (X2), which is biased on by the negative charge applied to its cathode. Consequently, only a very small amount of negative voltage will be developed at the collector (TP-4) of the keyer transistor.

To overcome this problem, a diode is inserted between the coupling capacitor and the collector of the keyer transistor, as shown in Fig. 5. The diode (X1) is inserted in the circuit in the polarity shown so that the positive horizontal keying pulse is applied to its anode. Thus, when the keying pulse is present, the diode and transistor conduct, charging the collector coupling capacitor. During the periods between horizontal pulses, diode X1 is biased off, preventing the negative charge on the coupling capacitor from bleeding off through the collector-to-base junction (X2) of the keyer transistor.



## The Seamless Wonder will locate thermal intermittents in half the time.

And, cool twice as many components per can.

The reason, the temperature of the spray at minus 50°F is at least 20 to 30 degrees colder than other circuit coolers. The colder the spray, the less you use and the faster it cools. Quick. Efficient. Definite in response.

Super frigid temperatures require pure Freon\* ingredients and more pressure than a can with a seam will hold.

Run the "QT" (Quickie Test) check. Spray your circuit cooler on a surface. It should frost immediately and leave no liquid residue. Now sniff it. Pure Freon has no odor. Look for the stronger seamless can.

Or, to be sure buy SUPER FROST AID. The seamless wonder. Passes the "QT" check odorless and seamless.

Available at all leading parts distributors.

### CHEMTRONICS INC.

1260 Ralph Avenue, Brooklyn, New York 11236



\*Trade name of E. I. DuPont

Ask for free copy of, "The Cool Way to find Thermal Intermittents."

See us at NEW show, Booth A-129

Circle 26 on literature card

Tired of  
hand-me-down  
copies of  
**ELECTRONIC  
SERVICING?**

Fourth page of a five-page article missing by the time **you** get to read **ELECTRONIC SERVICING**? Schematic diagram missing? Then you need a subscription of your own! Priced right and packed with profitable information each month! Use the convenient order form inserted inside the covers of this issue! P.S. If that's missing, too, send us a note with your name and address—we'll contact **you** with full details!

# CHANNELLOCK

## Gives You More In Hand Tools Including THE WIREMASTER

40% More Cutting Power  
Perfect Cutter Alignment, Always



**40% MORE CUTTING POWER**  
The joint rivet in a cutting plier is a fulcrum. The closer it is to the cutting edges, the greater your leverage and the greater your cutting power with less effort. In Channellock's WIREMASTER, the joint rivet is



**PERFECT CUTTER ALIGNMENT**  
Unique enclosed joint design holds cutting edges in factory-perfect alignment for the long life of the plier. No way for the jaws to get out of line . . . ever.

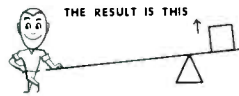

**WANT TO KNOW MORE?**  
You'll get a lot of hand tool information in our catalog. It's yours for the asking. Write us.

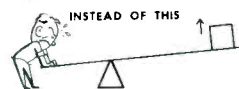

TOOLS BY  
**CHAN NEL LOCK**

MEADVILLE, PA. 16335

Circle 29 on literature card

Ad No. C-970

In the transistor-type keyed AGC system in Fig. 5B, diode X1 effectively functions as the AGC rectifier and transistor Q1 functions as a resistance in series with it. When the positive horizontal pulse is applied through the coupling capacitor to the anode of diode X1, the diode is biased on and, because the internal resistance of the conducting diode is reduced to near zero, the positive horizontal pulse voltage is passed through it to the collector of transistor Q1, which, in turn, is biased on. Thus, the charging path for the keyer coupling capacitor is established — through the emitter-to-base junction of Q1 and on through diode X1 to the “diode” side of the capacitor. The total amount of forward bias applied to the base of Q1, which varies according to the strength of the received signal, controls the amount of current through Q1 and, thus, also controls the amount of negative charge on the “diode” side of the keyer coupling capacitor. If the circuit is functioning properly, a negative voltage will exist at TP-4 and a positive voltage will be produced at the collector of Q1.

If diode X1 shorts, most of the negative AGC voltage will bleed off rapidly through the collector-to-base junction of Q1, and, because of insufficient AGC voltage, picture overload will be evident on the screen of the receiver.

A collector-to-base or collector-to-emitter short in Q1 reduces the effective series resistance in the charging path of the keyer coupling capacitor, and, as a result, an excessive negative (AGC) charge will be developed at TP-4. The excessive AGC voltage will reduce the gain of the RF and IF amplifiers to minimum, and, consequently, there will be no picture on the screen of the receiver.

An open Q1 or X1 opens the charging path of the keyer coupling capacitor, and no AGC voltage will be developed. The resultant screen symptom will be picture overload.

### Conclusion

In the preceding paragraphs, the “clamping” technique of troubleshooting AGC-oriented problems has purposely been minimized to emphasize other equally valuable, and often essential, test procedures.

## Sweep/Marker Generator

The RCA TV Sweep Channel, WR-514A, reportedly has the combined features of a television sweep generator, marker generator, marker adder, and special RCA "ChromAlign" system for color bandpass alignment.

The unit provides RF, IF, and video output sweep signals for alignment of VHF tuners, IF amplifiers, video amplifiers, and color bandpass amplifiers. When used with an oscilloscope, the WR-514A reportedly provides a continuous trace display of the bandpass characteristics of TV receiver circuits.



Features of the new TV Sweep Channel include:

- Fundamental sweep output on all VHF TV channels—for sweep alignment of VHF tuners;
- Sweep output on all IF frequencies for stage-by-stage or overall IF alignment;
- Video sweep output from 50 KHz to 5 KHz for alignment of video amplifiers, chroma circuits;
- Special RCA ChromAlign signal for color bandpass alignment;
- Built-in marker-adder function;
- Seven crystal-controlled IF markers for checking IF response of sound, picture, chroma carriers;
- FM sweep output from 88 to 108 MHz for FM tuner alignment.

The new WR-514A has been designed to incorporate BNC connec-

tors throughout and comes equipped with new basic output cables and snap-on alignment adapters. The basic cables and adapters are: WG-426A, RF Output Cable; WG-427A, Direct Cable; WG-428A, Connector Adapter (BNC to Mike); WG-429A, VF/IF 75 Ohms Termination Unit; and WG-430A, Direct Cable Termination Unit.

Price of the WR-514A, complete with above cable accessories, is \$375.

*Circle 50 on literature card*

## IC-Equipped Color Generators

Two all-new IC digital color-bar generators—Deluxe Model 1246 and the Standard Model 1243—are announced by B&K.

Both models are designed for checking convergence, color, linearity, size and focus. Rock-steady patterns are guaranteed through the use of flip-flop circuits for all counting functions, according to the manufacturer. The composite video signal, produced algebraically from ultra-stable synthesized pulses, reportedly closely approximates TV broadcast standards. Precision crystals are used in both the master countdown and color oscillators. Dot and vertical line width are adjustable. All IC's and transistors are silicon. The power supply is transformer-isolated and fully regulated for ripple-free constant voltages.



Deluxe Model 1246 has crystal-controlled picture carrier oscillators for Channels 3 and 4; a 4.5-MHz unmodulated carrier (a valuable tuning aid); and red, blue and green color killers. It provides a total of 9 patterns, including 1 x 9 and 9 x 1 crosshatches and a center dot pattern. The 1246 also offers an "Instant-Use" carrying case which reportedly protects the instrument at all times. A carrying handle is provided, but the 1246 is so compact (2¼ inches x 7 inches x 10¾ inches) it fits right in the tube caddy. Price of Model 1246 is \$149.95.



The Standard Model 1243 provides 6 jitter-free patterns; is tunable to Channels 3, 4 or 5, but factory set to Channel 3. The unit operates on 115 volts AC, and weighs 3 lbs. Size is 2¼ inches x 7 inches x 9¾ inches. The 1243 sells for \$99.95.

*Circle 51 on literature card*

## Triggered Dual-Trace Scope

A new dual-trace, triggered oscilloscope which features a 25-MHz vertical amplifier bandwidth is announced by the Telequipment Division of Tektronix, Inc.



Other characteristics of Model D67 include sweep rates from 2 s/cm to .2  $\mu$ s/cm (40 ns/cm with X5 magnifier engaged), 14 ns rise time, and a vertical amplifier sensitivity of 10 mv/cm.

Features include internal and external triggered sweep, a 5-inch (8 cm x 10 cm) screen, vertical amplifier signal delay, and completely solid-state design. Weight of the unit is only 25 lbs.

Price is \$950.

*Circle 52 on literature card*

## AC/Battery-Operated Digital Multimeter

The Hickok Model 3300 reportedly is a completely portable digital multimeter whose long battery life enables it to bring digital convenience and accuracy to in-field measurements.

The unit can be operated from 115/230 volt, 50-400 Hz power lines or from the internal rechargeable nickel-cadmium battery. The Model 3300 will operate 24 hours from its battery, intermittently or continuously. Connecting the Multimeter to an AC line automatically recharges the battery within a maximum of 16 hours. Measurements reportedly can be made during recharging.

**DC Voltage:** Six ranges, from 199.9 millivolts to 15 kilovolts, are available (100 mV to 100 V with 100% overranging, 1 and 10 kV with 50%

overranging). Resolution is 100 microvolts. Accuracy is 0.1% of reading  $\pm 1$  digit, except for the 15-kV range, which has an accuracy of 5% of full scale.

**AC Voltage:** The 3300 Multimeter has five ranges, from 199.9 millivolts to 1.5 kilovolts (100 mV to 100 V with 100% overranging; 1 kV with 50%). Accuracy for all ranges is 0.5% of reading  $\pm 2$  digits from 50 Hz to 50 kHz. Specifications range from 22Hz to 100kHz.

**Resistance:** Seven ranges are available from 110.0 ohms to 199.9 meg-



ohms (100 ohms to 100 kilohms with 10% overranging; 1 to 100 megohms with 100% overranging). Maximum resolution is 100 milliohms. Accuracy for all ranges is 0.3% of full scale  $\pm 1$  digit.

**AC and DC Currents:** Four ranges are available from 1.999 milliamperes to 1.999 amperes (1 mA to 1A with 100% overranging). Accuracy for DC measurement is 0.2% of reading  $\pm 1$  digit; for AC 0.5% of reading  $\pm 2$  digits from 50 Hz to 50 kHz.

The case of the unit is completely isolated from the input, providing operator protection for high-voltage measurements. Input isolation allows the input to float 1500 volts peak off ground even on line operation.

The Model 3300 reportedly will withstand up to 1000 volts on its most sensitive DC voltage range, and up to 1500 volts on the other DC voltage ranges without being damaged. AC ranges will withstand 1000 volts on most ranges. Resistance ranges will withstand 250 volts.

Model 3300 reportedly maintains measurement accuracy even when applied to high-impedance circuits. For DC measurements, input impedance is approximately 11 megohms shunted by 5 pf; for AC, approximately 200 pf, 1000 megohms.

Among other features found on this multimeter are an automatically positioned decimal point, automatic polarity selection and indication, and out-of-range indication, according to the manufacturer.

## HERE'S YOUR OPPORTUNITY TO SUBSCRIBE TO RCA SERVICE DATA

COVERING CURRENT MODEL RCA CONSUMER ELECTRONIC PRODUCTS



A SUBSCRIPTION INCLUDES  
A COMPLETE "FILE" YEAR OF:

- COLOR TELEVISION DATA
- B & W TELEVISION DATA
- RADIO DATA
- PHONOGRAPH DATA
- TAPE RECORDER DATA
- SERVICE TIPS
- PARTS TIPS
- PERIODICAL ISSUES OF "PLAIN TALK"
- "GOLDENROD" BULLETINS

**DON'T DELAY!**  
ORDER YOUR SUBSCRIPTION  
**TODAY!**

Please acknowledge my request for a Service Data Subscription:

- "File—1971" Service Data including 2 binders \$19.95  
 "File—1971" Service Data subscription \$14.95  
 (Binders available separately—\$2.95 each) Number desired \_\_\_\_\_

Amount enclosed: \$ \_\_\_\_\_

NAME \_\_\_\_\_

STREET ADDRESS \_\_\_\_\_

CITY \_\_\_\_\_ STATE \_\_\_\_\_ ZIP CODE \_\_\_\_\_

- Your order will be processed promptly upon receipt of your check or money order in the amount indicated above. SEND TO:  
**RCA SALES CORP., 600 N. Sherman Drive, Indianapolis, Ind. 46201**  
**ATTN: Technical Publications, 8-106.**

Test probes are permanently attached to the front panel, and are fitted with a captive strap which conveniently stores the probes on the combination carrying handle and tiltable stand.

The unit is 8 inches x 5 $\frac{7}{8}$  inches x 4 inches. Weight is 6 lbs. Price, including internal battery pack and probes, is \$395.

Circle 53 on literature card

### Post-Injection Sweep/Marker Generator

The Model LSW-330, a compact, solid state, post-injection sweep/marker generator for color TV alignment, testing and servicing has been introduced by Leader Instruments Corp.

This new instrument reportedly provides all sweep/marker signals for circuit alignment of chroma, sound and video IF's and features a 10.7-MHz sweep for use with FM-IF as well as two RF channels, selectable by front-panel switch, for circuit use. Other features report-

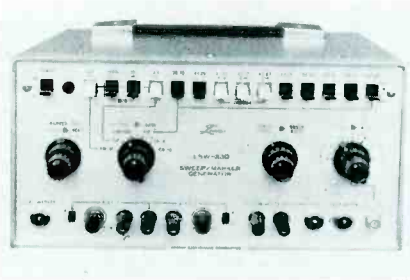

edly include: Constant amplitude assured by an automatic limit control; crystal-controlled markers; and 0- to 90-degree marker tilt. A triangular waveform voltage makes sweep linearity tests more positive; and discriminator adjustment is made easier by built-in 1KHz modulation, according to the manufacturer.

The LSW-330 also provides modulated video sweep for direct checking of IF and chroma circuitry and a bias supply consisting of 2 independent sources—0 to 50 volts (negative or positive) and 0 to 20 (negative or positive).

The unit weighs 20 lbs., measures 5 $\frac{7}{8}$  inches x 12 inches x 8 inches and is priced at \$399.50. ▲

Circle 54 on literature card

# The RCA portable color bar generator



## Performs like the big ones Costs only \$75\*

- Provides color bar, dot, cross hatch, and blank raster patterns
- All solid state circuitry including ICs
- Pattern signals, RF output frequency and color subcarrier all crystal-controlled
- Battery operated, AC adapter available
- Lightweight — less than 20 oz., only 6 $\frac{1}{2}$ " wide x 4" deep x 3" high

For all the technical specs get in touch with your RCA Distributor. RCA | Electronic Components | Harrison, N.J. 07029.

\* Optional User Price

# RCA

Circle 31 on literature card

# Plugging a Bookkeeping System

Last month veteran electronic technician Mike Farad decided to open his own electronic service business. During a service call at the local hospital, with whom he had contracted to service all installed TV's, Mike encountered the hospital accountant, Les Total, who explained to Mike the necessity of accurate bookkeeping and accounting. After realizing that Mike's knowledge of these subjects was insufficient to permit him to develop and maintain an adequate bookkeeping system, Les referred him to Jim's Bookkeeping Service.

by Robert G. Amick/ES Business Editor

## The Daily Report Sheet

"Here's another item of standard procedure for you to adopt, Mike," Jim Keeper said, handing him a pad of printed forms. "You just fill out one of these at the close of each business day and drop them off here about once a week, so we can post your books from them."

The form was specially printed for Mike's TV-Electronics, and looked like that shown in Fig. 1. Mike was in Jim's office to go over his new bookkeeping system with Jim, the head of the bookkeeping service.

Mike gave the Daily Report form a careful examination. A few questions occurred to him, so he began asking.

"This first blank, where it says 'No.' Do I just number the daily report sheets in order?"

"That's right. It provides us with an additional assurance that we get your reports in numerical sequence before we start to post from them."

"What about this Cash Balance line?"

"The first blank is for the preceding business day and date, and the one with the dollar sign is for the cash on hand. You simply count all cash carried forward from the preceding day. The rest of the report sheet is easy enough to understand. You total up your charges and the sales taxes collected, make a note of other receipts, expenses and payments, with an identifying description."

**Infrequent Transactions**—Mike observed that keeping up the form each day seemed simple enough. He asked if that was all he had to do to keep Jim supplied with the information needed to keep up the shop's books. It was, Jim told him, the main job. There were a few others.

"If you trade in your present truck on a new one, you should let us know the complete details of the transaction. Same thing if you get a loan at the bank, or open any new accounts with either customers or suppliers. We don't furnish space for those on the form, since they're not daily or regular occurrences, but you can make a note on the back of the sheet, giving us the full facts," Jim explained.

## "A Bookkeeping System Should Be Designed To Fit A Particular Business"

For about two weeks, since he first engaged Jim's Bookkeeping Service, Mike had answered questions for Jim about the operation which made up his business. Jim asked everything you could think of about the way Mike did business: How he received payments, how he made them, what his frequent expenses were, what his daily routine in the shop was, what his shop procedures were. Now, Mike had a few questions of his own.

First, he picked up the black fiberboard-bound book with his name on the front label. He thumbed through it, looking at the titles on each page. Some pages had a lot of columns for figures, others had just two or three. It seemed awfully thin, and he said so.

"Is this all there is to my 'books'? I always thought there were six or seven volumes in a set of books."

Jim smiled and explained. "It's thin because it's a loose-leaf system. We can add pages as we need to. There's no use having all that paper in there until it's actually needed.

"As far as the number of books goes, your system, in that one book, is complete. In that little, skinny volume, you have the equivalent of four journals and a ledger. You see, in big businesses, the books are broken up into several volumes for convenience. A single volume might be too big and too heavy. Or, several bookkeepers might need to work on the various journals and ledgers. With just one book, only one of them would be able to make entries at any given time. The rest would be waiting in line for their turn. In a company with a very great many transactions of one type, one bookkeeper might devote his full time to posting just that one kind of transaction. It would be logical to make up one journal, or ledger, just for him to work with.

"Logic is the key, Mike. A bookkeeping system should be designed to fit a particular business—it should be designed to record the operations and transactions peculiar to that business. While your bookkeeping system might work with other electronic service businesses, there might be modifications which would make it work better for a particular shop."



# into a Service Shop

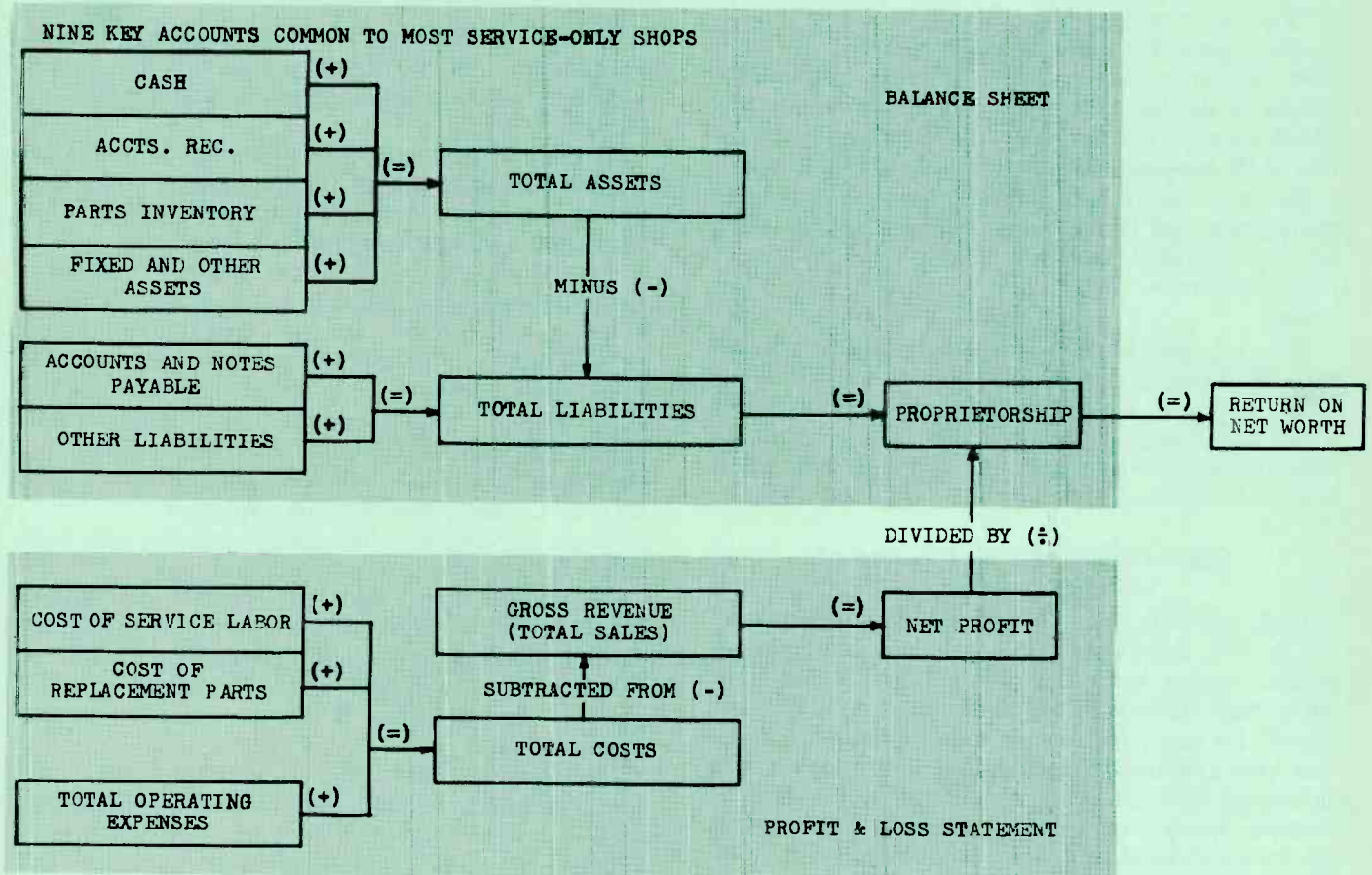

Shown here on the extreme left of the chart are the nine key, or basic, accounts which should be included in the bookkeeping system of a shop which provides only service. (The "Cost of Service Labor" account is used only by those shops who have one or more employees. A one-man shop, such as Mike Farad's would not use this particular account.)

Traditionally, the financial accounts on a business have been divided into two basic summaries: (1) The Operating Statement (Profit & Loss) and (2) The Balance Sheet (Assets & Liabilities). There are sound technical reasons for this separation. Even so, you must keep in mind that there is an interaction among these parts.

Items on the Profit & Loss statement reflect the net effect of transactions such as buying and selling. These transactions are what generate cash flow; build or deplete inventory; create receivables which can be grouped as Assets or Liabilities—what you own and what you owe, respectively.

The relationships and interrelationships of the key accounts and the basic content of the two summaries are illustrated here to help put into perspective the overall flow of information in an accounting system, from the original recording of the business transaction on the customer charge ticket to the first "readouts" which indicate how the transaction affected the status to the business.

Mike suffered a little inward embarrassment, remembering the time when he'd set out to "keep" his own books and "design" his own bookkeeping system.

"You mean this system is tailor-made for my business?" he asked.

"Yes, more or less, Mike. Understand, **every** bookkeeping system has certain basic parts which are common with every other bookkeeping system. But the divisions of the basic parts, the use of certain journals or ledgers as part of the system is determined by the nature of the business being done and the way it is done."

By now, thanks to a lot of spare-time reading in management and bookkeeping, Mike felt safe in asking for more detailed explanations. Jim, glad to have a client with more than a passing interest, gave them freely:

"Your business has certain characteristic transactions. You take in cash and you pay out cash. You buy parts, mostly on account. You perform services for a few customers on account. You have regular and ordinary business expenses. The nature of these transactions determines the makeup of your system of books.

#### **Separation and Classification of Business Transactions**

Cash transactions call for a Cash Journal, in which we record only transactions involving currency or checks. Service work for credit or billing later calls for a Sales Journal. Your purchase of parts "on account", for resale, calls for a Purchases Journal. Finally, you have a number of transactions which don't belong in any of these Journals, so they go in the General Journal. Using all these Journals keeps your various transactions classified and separated. It's orderly, efficient and yields complete information quickly when you analyze your transactions.

"Those are the four Journals, I mentioned earlier. You also have a ledger, with 18 accounts, in six major divisions. That's shown here, in the Chart of Accounts at the front of your book." Jim turned to a page labelled "Mike's TV-Electronics—Chart of Accounts."

Mike studied it a moment. (see Fig. 2).

"I see that the section on the left is called 'Balance Sheet Accounts', and that the titles in it are just about the same as the Balance Sheet the hospital accountant, Les Total, made up for me."

"They are. You see, every bookkeeping system begins with accounts based on the Balance Sheet. This one goes beyond that—they all do—because Income, Cost of Merchandise and Expenses are part of the day-to-day operating picture of any business. The Balance Sheet states the New Worth of a business as of a specific date; it is similar to a still photograph. Between Balance Sheets dates, Income and Expense transactions affect what the next Balance Sheet will show. So, they have to be accounted for in an Operating Statement, which is similar to a motion picture to contrast it with a still photograph.

Mike studied the Chart of Accounts. As he did, the six major divisions became clear to him: Assets, Liabilities, Proprietorship, Income, Cost of Merchandise and Expense. But, he still wasn't informed enough about bookkeeping to understand the "Account" term fully. He asked about it and learned:

An Account is simply a record of a single class of transaction. It is also the form used for this record-keeping. It can be a sheet, a page, or a special file card form.

"I think I get that, but now I want to ask about a specific account. Under Proprietorship, I understand the Capital part—excuse me, Capital Account—but what's this Drawing Account?"

"That's a record of whatever you draw out of a business for your own personal use. You take out money to live on—it's a withdrawal from your Capital. It must be recorded to insure that the state of your business is accurately reflected by your books. Or, you take out some electronic parts to use for your own private purposes. That also reduces the assets of the business, and the Capital. It has to be recorded to show the true state of your Capital Account," Jim explained.

"I get it. Now, why does Income and Expense Summary show up there under Proprietorship?"

"Remember what I said about Income and Expense affecting the Net Worth? When we close the books, the Income and Expense Statement shows a gain, a loss, or a balance of income and expenses. If there's a gain, it increases Proprietorship. If there's a loss, it decreases Proprietorship."

Accounts for Mike's business were set up to record any class of transaction in which there was substantial activity—either frequent entries or sizeable amounts. Others—like Cost of Merchandise—were established to maintain records of a class of transaction important in tax reports or business statements. Other transactions—infrequent, or small amounts, or otherwise not important enough to classify separately—were lumped under a single heading, as in Miscellaneous Expense. For example, because Mike was not a frequent advertiser, his advertising expenses were entered as Miscellaneous Expense.

"You've given each account a number. I suppose that's just to avoid having to write its full name out all the time," Mike commented.

"Right!" Jim said enthusiastically. He really appreciated having a new client take a real interest in learning about bookkeeping. It usually promised a good working relationship, in which sound practices were suggested and followed, and where help in the record keeping was mutual.

"Now, tell me the difference between a Journal and a Ledger," Mike demanded.

"Glad to. A Journal is a book of **original** entry. That is, it's the **first** place a transaction of the class it covers is recorded. It usually is a book.

"A Ledger is simply the name given to a group of accounts. In a business the size of yours, a single

Fig. 1  
MIKE'S TV-ELECTRONICS  
DAILY REPORT SHEET

No. \_\_\_\_\_  
Day \_\_\_\_\_  
Date \_\_\_\_\_

Cash Balance Brought Forward From \_\_\_\_\_

**CASH RECEIPTS**

Sales-Parts and Labor \_\_\_\_\_  
Sales Tax Collected \_\_\_\_\_  
Payments on Account \_\_\_\_\_  
Other \_\_\_\_\_

Total Cash Add \$ \_\_\_\_\_  
Total Cash to Account For \$ \_\_\_\_\_

**CASH DISBURSEMENTS**

Purchases-Parts & Shop Supplies \_\_\_\_\_  
Equipment and Tools \_\_\_\_\_  
Other \_\_\_\_\_

Payments on Account \_\_\_\_\_

Deposit-Citizens Bank \_\_\_\_\_  
Expenses \_\_\_\_\_

Total Cash Disbursed \_\_\_\_\_  
Balance \_\_\_\_\_  
Actual Cash on Hand \_\_\_\_\_  
Over-Short \_\_\_\_\_

SALES ON ACCOUNT		Charges	Sales Tax	Total
To				
Totals				

PURCHASES ON ACCOUNT				
From				
Totals				

in a Journal, which means that they trigger all the bookkeeping processes which follow and concern them. The first entry of any of them appears in one of the Journals—Sales, Cash, Purchases or General. That's why the Journals are called books of **original** entry.

"From that point of original entry, transactions are transferred to the ledger account, or accounts, concerned. Transferring Journal entries to Ledger Accounts is called **posting**. The mechanics of recording these transactions aren't important to you, but the flow is."

As he had talked, Jim was drawing out the Flow Chart shown in Fig. 3. He handed it to Mike, who gave it careful scrutiny. He could see that the diagram made it clear what the daily report form was supposed to accomplish, because the immediate records would rarely be seen by the bookkeeper or his staff. He made a special mental note to furnish complete information and accurate information, on those daily reports.

### Preparation of Tax Returns and Reports

"Jim, what about all the records and reports that go with bookkeeping? You know, tax returns, sales tax reports each quarter, any of the other things I have to fill out and file. You do handle those for me don't you?"

"Yes. We'll take care of them, as they come up. We'll prepare the returns for your business, turn them over to you to sign and attach your check to, and mail. Incidentally, that brings up another business procedure we should systematize for you: A Property Insurance Schedule."

### The Property Insurance Schedule

Jim drew out a form from his desk drawer and handed it to Mike. It is shown in Fig. 4.

"Get out all your insurance policies and fill in the form policy-by-policy. We'll make two copies of the form—one for our files and one for yours. Then we'll both be aware of due dates for premiums and have complete information about your protection."

He handed Mike a heavy envelope to carry all the pads, forms and papers he was acquiring during his conferences. Mike tucked away his materials and agreed to furnish the insurance information in the next few days.

### Systematic Business Procedures Payoff

Mike told Jim his first set of systematic practices was working fine, and was yielding results.

**Checking of parts received**—"They take a little extra time, but in just two weeks I've discovered one broken item and two small shortages in stuff delivered to me. My prompt report in each case has gotten me adjustments. Nothing big, you know, but it makes me wonder how much that sort of thing would cost me in the course of a year."

"It could cost quite a bit", replied Jim. "Small businessmen tend to think that strict procedures are only for large-scale businesses. That's silly when you think

Fig. 2  
MIKE'S TV-ELECTRONICS  
CHART OF ACCOUNTS

BALANCE SHEET ACCOUNTS		INCOME STATEMENT ACCOUNTS	
Acct. No.		Acct. No.	
<b>(1) Assets</b>		<b>(4) Income</b>	
11	Cash	41	Labor Sales
12	Accounts Receivable	42	Replacement Parts Sales
13	Merchandise (Parts) Inventory		
14	Equipment		
15	Supplies		
16	Prepaid Insurance		
<b>(2) Liabilities</b>		<b>(5) Cost of Merchandise</b>	
21	Accounts Payable	51	Purchases (Parts)
22	Mortgages and Other Notes Payable		
<b>(3) Proprietorship</b>		<b>(6) Operating Expenses</b>	
31	Mike Farad, Capital	61	Auto & Truck Expense
32	Mike Farad, Drawing	62	Miscellaneous Expense
33	Income and Expense Summary	63	Professional Fees Expense
		64	Rent & Utilities Expense
		65	Supplies Expense

Ledger, the General Ledger, is all that's needed. A bigger business might have several.

### Origination, Flow and Recording of Transactions

"Since you're interested in the hows and whys, I'll draw you a kind of flow chart (see Fig. 3). The bookkeeping process begins with some kind of business paper—a sale is made, there's a sales slip; a bill is paid, you have the check; you pay a bill, there's your check stub, or a receipt if you pay cash—all of which papers are the triggers to bookkeeping recording. Such papers are the **immediate record of transactions**. That is, they're prepared at the time of the transaction.

"Each of these immediate records triggers an entry





by Allan Dale

# Left/right channel comparison: Another approach to stereo trouble

It's surprising sometimes how we overlook the obvious. Take stereo amplifier servicing, for instance. Took me a lot of servicing to figure out I could use one stereo channel to check out the other.

Of course, about the time I worked out a good way to do it, I got an amplifier in with both channels fouled up. But there's a pretty good way to go at that, too, so I consider the following technique pretty dependable.

## Switching Sides

Reduced to its simplest terms, the method I'm talking about is one of comparison. If one channel works normally, you merely compare the bad channel with it. You can do it with signal tracing, signal injection, for scope analysis of waveforms, or for voltage comparisons.

What's more, you can use the good channel as a signal tracer for the bad one. If, for example, you suspect a preamplifier of being faulty, you "patch in" the preamplifier stage of the other channel.

Suppose a stereo system comes in with bad distortion in its left channel. Fig. 1 should help you

visualize the preliminary reasoning you'd use. The blocks represent a fairly typical stereo amplifier design.

The right channel sounds okay. If a record changer or tape player is the signal source, you can disconnect its right-channel signal from the right-side input of the amplifier; then feed the left output of the phono or tape recorder into the right channel of the amplifier. If the distortion shows up in that channel, the trouble is in the left output of the source.

You can verify further by plugging the right side of the source into the amplifier's left channel. A signal that sounds okay when fed through the amplifier's right channel should also sound okay in the amplifier's left channel. If not, the channel is bad.

One case like this took only a few minutes to solve. High notes in the right side were scratchy. My first step was just as I described. I swapped left and right leads from the record changer and the trouble

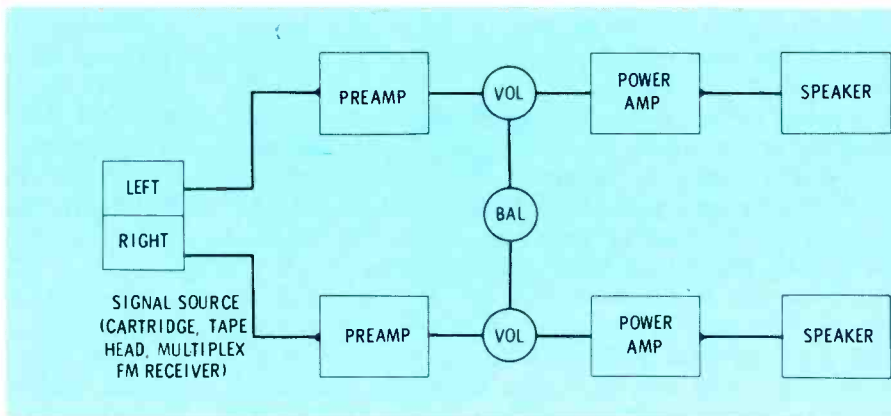

Fig. 1 First step in comparison-checking is to swap input and output connections; this tells you if the fault is in the source. Swapping speakers tells if fault is in the speaker or amplifier channel.

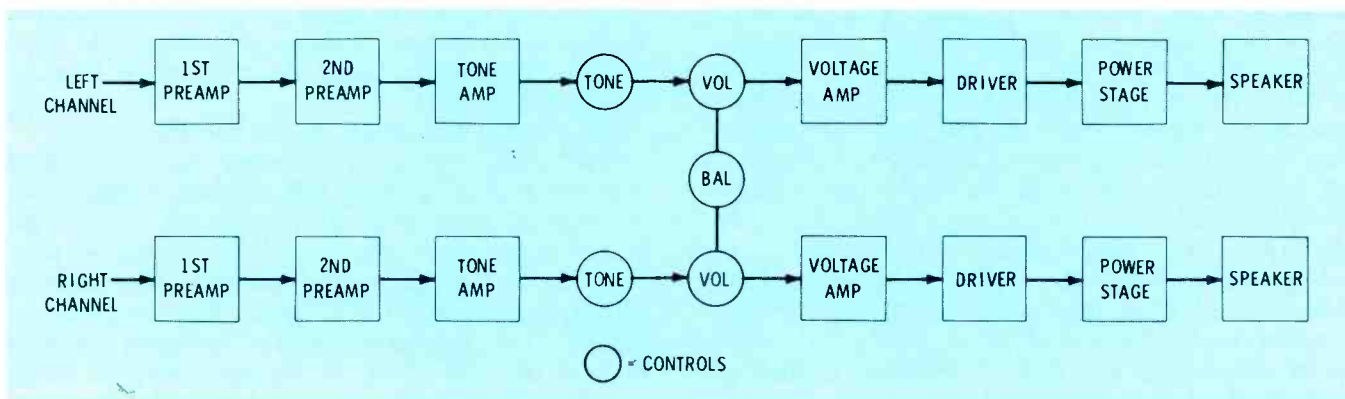

Fig. 2 Comparing the gain or amplification of a stage with that of its counterpart in the other channel tells you whether or not that stage is performing as it should.

# shooting

was still on the right side.

Then I twisted the balance control. The trouble stayed in the right side, no matter how the balance was set.

I swapped speaker connections. The bad sound still came from the speaker that previously had been used for the right side. No matter which channel I connected it to, that speaker was scratchy on high notes at reasonable volume. The speaker was defective.

Another trouble I've run into many times is a faulty stereo cartridge. One channel of sound gets weak or distorted—sometimes both. Swapping speakers doesn't change anything. But changing sides with the record-changer leads does. One side of the cartridge is defective.

## Comparison Proves

You can carry the comparison idea much further. Consider the stages of a typical stereo amplifier, shown in Fig. 2. Suppose the complaint is "left channel very weak." This is often described: "I have to turn the balance knob 'way over to get both sides to sound the same.'"

The first thing to determine is which stage in the left channel doesn't amplify as much as it should. Another way to think of this: Which left-channel stage doesn't amplify as much as its counterpart in the right channel? To find out, you can compare them, one by one. And you can do it either by signal injection or by signal tracing. My audio signal generator is always handy, so I'll tell about that first.

Start by connecting the generator signal to the right speaker. Then connect it to the left and see if it's as loud as the right was. If they're the same, the speakers are okay, and the trouble is nearer the front of the system.

Next, connect the generator sig-

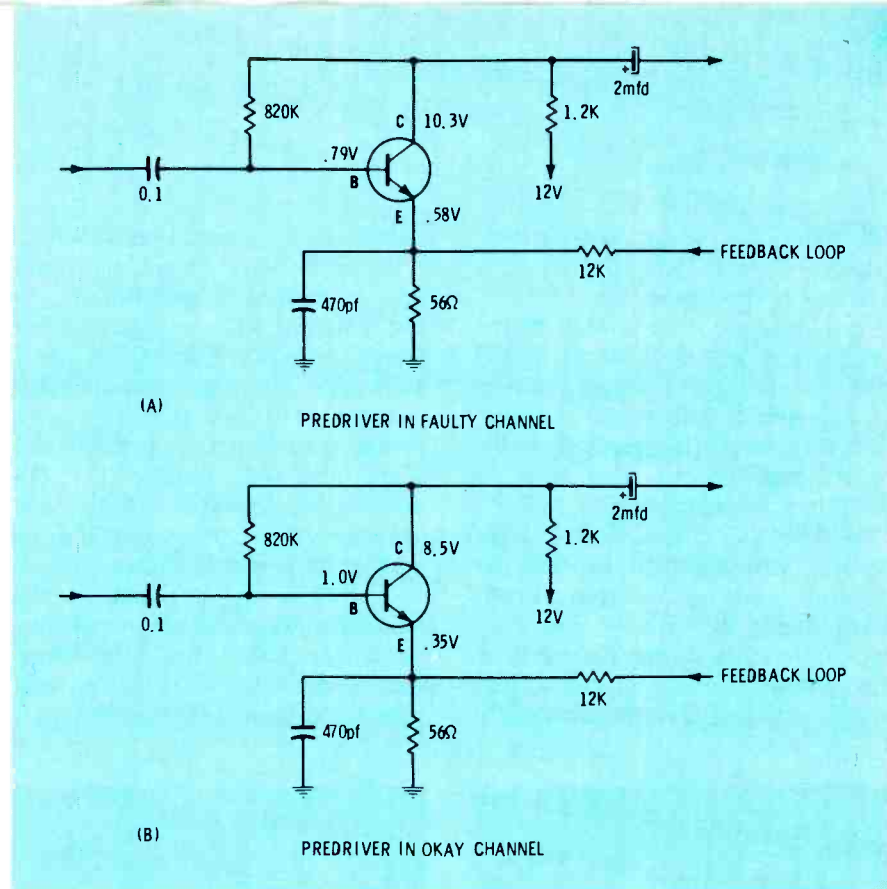

Fig. 3 Comparison of DC voltages in a defective stage with those in the same stage in the other channel. (A) Voltages in defective stage. (B) Voltages in stage of other channel, which was operating normally.

nal, through a .5-mfd capacitor, to the input of the right power stage. Then to the left. Again, output from the speakers should be the same.

Work your way toward the front, injecting a signal at the input of each stage. First, see how loud the signal is in the good channel, then how loud it is in the bad channel.

If the output of both channels are the same from the voltage-amplifier input to the speaker, set the balance control in the center position. Turn both volume controls for maximum audio output (they may be ganged together on one shaft or knob). Next, inject your audio test signal at the right tone-amplifier input, and then at the left tone-amplifier input. Sound from both speakers again should be about the same.

Depending on how much signal you're using from the generator, the sound level might be so high that distinguishing a difference is difficult. If such is the case, use a dummy load and meter (or just a meter across the speakers, if you don't mind the noise). Or, keep

reducing the generator audio signal level as you work further forward.

Move on up to the right 2nd preamplifier input, and compare the result with injection at the left 2nd pre-amplifier input. Then compare the inputs of the right and left 1st preamplifiers.

At some point, the weakness will become apparent. Gain across a left-channel stage won't be as high as across the equivalent stage in the right-channel. That's the faulty stage. There might be more than one stage contributing to the overall weakness of one channel. A check of all stage-gain increases will reveal the stages at fault.

## Inside the Stage

Okay, so you've found a weak or distorted stage. What then? Your next task is figuring out what's wrong with it. Again, you can use comparison.

Remember: The stage on the other side, the one that's working okay in the other channel, is an exact duplicate of the stage you've got trouble in. Why not compare the DC voltages in the stages? It's a good way to tell what voltages

are okay and which are not, especially if the diagram doesn't have voltages printed on it.

For example, take a look at the diagrams in Fig. 3. The one at (A) lists the voltages I found recently in an amplifier with a weak channel. The diagram at (B) shows the voltages I read on the same stage in the other channel.

Without the comparison, I'd not have known what to expect; the diagram had no voltages at all. With them, the trouble was easy enough to track down. The value of the 56-ohm emitter resistor had nearly doubled. It was drastically

reducing the emitter-base voltage.

I might have found the same fault by measuring parts values and not bothering with comparisons. But there are two reasons that's not a good idea. For one, it's more time-consuming; to get accurate measurements, you'd have to disconnect some parts, and that takes time. For another, a resistor sometimes changes value only when it's got current flowing through it.

That was the problem in this case, and just measuring would not reveal the defect. So it is always more dependable to check the voltages in the faulty stage against those

in the stage that's functioning properly in the other channel. You can "reason out" the trouble from there.

### Signal Tracing

Earlier, I described how you can trace even borderline faults by signal injection. You compare stage-by-stage gain and operation in the bad channel with the same things in the channel that's operating properly. You start at the speaker and work your way forward.

Signal tracing uses an opposite approach. You inject a known good signal into both channels and trace through to find where it disappears, becomes weak, or is otherwise fouled up.

For a tracer you can use your scope, or you can use an audio signal tracer. If the trouble is a weak or dead channel, the tracer is okay. But if there's distortion, particularly if it is slight or only in certain kinds of programs, the scope and a squarewave generator (signal source) are almost a necessity.

We'll again use the amplifier in Fig. 2 to briefly explain signal tracing. The best method of supplying signal is to tie the two inputs together and feed one signal to both. That way it starts out the same in both channels.

Fig. 4A shows a 1000-Hz square wave as it appears on the scope. (I used a direct probe, connected to the input of the first preamplifier.)

The output of the right channel in this amplifier was distorted. I

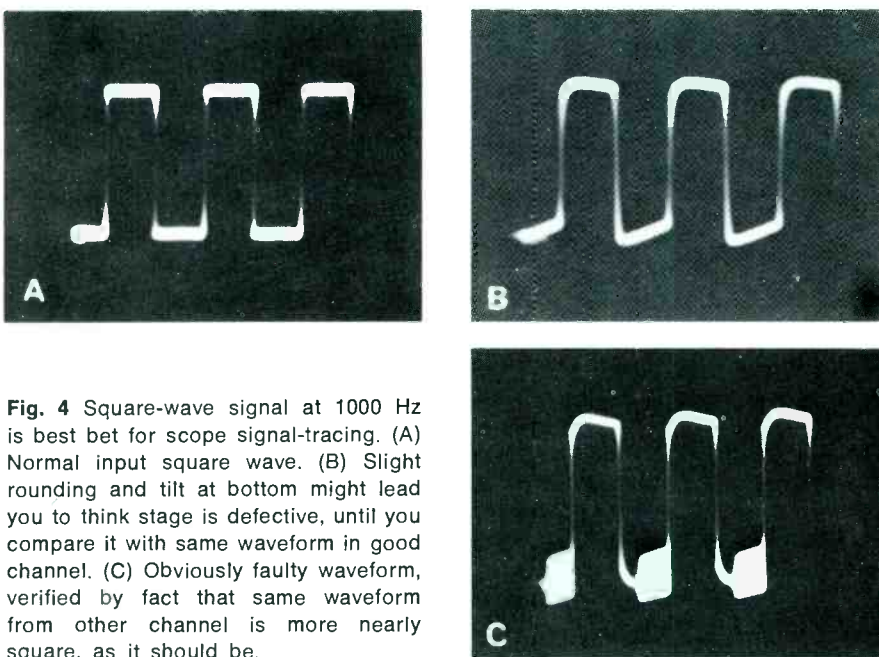

**Fig. 4** Square-wave signal at 1000 Hz is best bet for scope signal-tracing. (A) Normal input square wave. (B) Slight rounding and tilt at bottom might lead you to think stage is defective, until you compare it with same waveform in good channel. (C) Obviously faulty waveform, verified by fact that same waveform from other channel is more nearly square, as it should be.

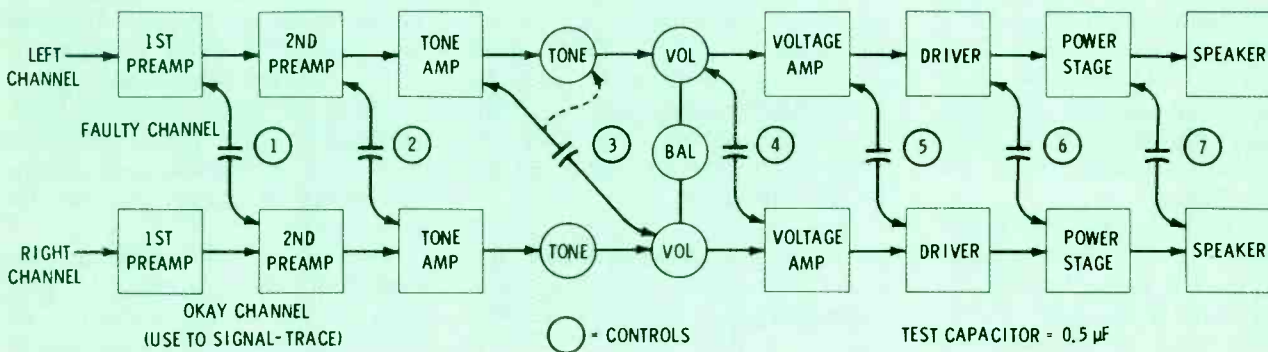

**Fig. 5** Capacitor with jumper leads can be used to turn good channel into signal tracer for testing channel that exhibits trouble.



moved the probe to the input of the 2nd preamplifier in the right channel. The waveform looked like Fig. 4B (rounding at the top, and some slant at the bottom).

Trouble already? I thought so, but then I moved the probe to the input of the left-channel 2nd preamplifier. The waveform there was the same. Because sound in the left channel had been okay, the slight waveform change in both preamplifier stages obviously was **not** distortion.

I traced the square wave on through the amplifier channels. I set the tone controls at "flat" and turned the dual volume controls wide open. (I always use dummy loads; my ears won't take a 70-watt, 1000-Hz signal.) At each step, I compared the right-channel waveform against the left. They were all about the same, up to the input of the driver.

When I connected the scope probe to the input of the right-channel power stage, I got the waveform in Fig. 4C. At this point, it seemed fairly obvious the trouble was in the driver. Just to be sure, I scoped the same waveform in the left channel. It looked like a normal square wave, the same as it looked at the input of the driver stage. This confirmed that the right-channel driver was defective.

Comparison of DC voltages showed the left and right driver stages operating about the same. But scope comparisons of waveforms in the feedback loops of both—from the output back to driver input—revealed a faulty capacitor in the right-side network. The resulting oscillation in the last two right-channel stages was distorting the signal in that channel.

### Cross-Channel Tracing

There's another technique of tracing. In effect, you use one channel to signal-trace the other.

If, for example, the right channel is operating normally, its stages make a logical instrument with which to test the defective channel. Fig. 5 shows how this system is used. A jumper lead connects the

good channel to the suspected stage in the faulty channel.

In Fig. 5, the left channel is the faulty one. You feed the test signal into the input of **that channel only**. Most technicians use music from a record changer with a monophonic record. But remember, feed it only to the faulty channel.

The test jumper has a 0.5-mfd capacitor in series with it. The capacitor keeps DC in a stage from upsetting operation of the test channel. Start by connecting one end of the test jumper to the input of the second preamplifier in the test channel. (The balance control should be centered.)

With the signal feeding the faulty left channel, touch the free end of the test jumper to the output of the left-channel 1st preamplifier. If it's amplifying okay, normal sound will come from the test-channel (right) speaker. (Volume and tone controls in the test channel operate as usual.)

For the second test, connect the jumper lead to the input of the tone amplifier in the test channel. Then touch the other end to the output of the 2nd preamplifier in the faulty channel. If the stage is okay, sound again will be normal from the test-channel speaker.

The third test is to check the operation of the tone-amplifier in the faulty channel. Connect the test-channel end of the jumper lead to the volume control. The free end is used to check both before and after the tone control in the faulty channel, as you can see by the dashed line in Fig. 5.

Once you get to the fourth step, the volume and tone controls in the faulty channel are the ones that affect the sound. If this test produces normal sound, you have proved that the faulty channel is okay from the input to and including the volume control.

The functions of steps 5, 6, and 7 are obvious. At every step along the way, you listen for whatever the complaint was. This is an excellent way to check out distortion in one channel. It's good to reveal weak stages, too, if you keep the volume control at one position for all tests. ▲

**QUALITY TUNER  
REPAIR, CO.**

**TV TUNERS  
VHF OR UHF  
REPAIRED  
\$9.50**

Your tuners cleaned, repaired and religned to manufacturer's specifications and guaranteed for one year.

Any make VHF or UHF tuner for a complete price of \$9.50 plus tubes, transistors and diodes at cost.

Ship tuners complete with all broken parts.

**QUALITY TUNER REPAIR, CO.**  
526 WEST BUSBY STREET  
LEBANON, INDIANA 46052

*Circle 32 on literature card*

**REBUILD  
YOUR OWN  
PICTURE TUBES?**

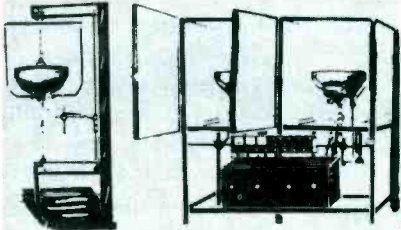

With Lakeside Industries precision equipment, you can rebuild any picture tube!

**EASY TO OPERATE!**

Requires only 4x8 ft. of space.  
Your cost to rebuild black and white—  
\$1.50  
Your cost to rebuild Color—\$5.80  
For complete details, mail coupon.

Lakeside Industries  
5234 N. Clark St.  
Chicago, Ill. 60640  
Phone: 312-271-3399

Free demonstration appointment  
 Send me more information

Name .....

Address .....

City ..... State .....

*Circle 33 on literature card*

# Avionics and the "Increased Complexity" Problem:

## A Preview of Things to Come in Consumer Electronics?

*Pre-packaged, in-shop training programs; designing for improved serviceability; fault indicators; automatic testing devices; specialization of shops and technicians—examples of how aviation electronics is dealing with increasingly more complex circuitry, a problem that also plagues consumer electronics servicers.*

by Len Buckwalter

Faced with problems similar to those confronting consumer electronic servicers, such as a technician shortage and growing circuit complexity, avionics (aviation electronics) is coming up with answers. These solutions are spurred on by growing numbers of aircraft which require—and for which are being designed—more complex electronics for safer separation and more exact and quicker navigation.

Because improvements in avionics range from training and troubleshooting, to maintenance and modules, they offer a ready made pool of ideas for consumer servicing, as well.

### **Audio Visuals Make Effective In-Shop Training Possible**

As in other branches of electronics, avionics is quickly becoming more digital, integrated and difficult to understand. It has increased the pressure on the already critical matter of technician training.

Although an industry survey revealed that the average avionics shop is willing to pay about \$380 to send a man to a three-day factory training seminar, there are pitfalls in the approach: Months might elapse before the technician encounters the new circuit, and there are the problems of employee turnover and fast changes in technology. To ease the problem, the industry recently agreed on a standard audio-visual technique to enable a shop to perform its own training.

The package, shown in Fig. 1 is comprised of a slide projector and a cassette player with a tape on

which there is a voice track for narration and a tone for triggering the slide projector. The unit is purchased by the shop for approximately \$400, with the assurance that major avionics manufacturers will produce technical programming to fit it.

Once the player-projector is acquired, the shop can obtain packaged training programs from the manufacturer on an outright purchase or rental basis. There is a program about a radar transponder, for example, that sells for \$88, but also rents for \$25 for a two-week period.

What's in a typical program? The training sequence covers basic circuit theory, block diagram and schematic analysis, installation, and troubleshooting and alignment procedures. The complete program requires less than three hours, and even has programmed coffee breaks. In some instances, the manufacturer supplies a quiz on the presentation, which, if passed, "qualifies" the technician for servicing the new product.

Audio-visuals are not the complete answer. As one seasoned repairman told us; "The most important aid is still a good service manual. If the slide show can supplement it, fine! Everything's becoming so complicated these days a technician needs everything he can get".

### **Fault Indicators Localize Troubles**

Consider, next, avionics' answer to the tilt lamp on a pinball machine. The pilot of a jetliner faces

an array of lamps, horns and other malfunction indicators, and signs are that technicians are getting a few too. Three such fault indicators are visible along the bottom of the instrument shown in Fig. 2. This device, now on such aircraft as Boeing's new jumbo 747, is a DME (Distance Measuring Equipment). It fires pulses at a ground station which responds by transmitting a pulse to the aircraft unit, activating a mileage indicator (time of signal travel is converted to distance).

Note the three windows along the bottom of the case (below "Monitor"). There is one for each basic component in the system: R/T, the receiver-transmitter; IND, the indicator (shown atop the R/T unit); and ANT, for the antenna system. When a malfunction occurs, a magnetic latch is tripped, causing the window to change from a normal black color to yellow. The indication remains, even if the trouble spontaneously clears.

This is of invaluable assistance to a line technician. He can view the monitor in the aircraft and instantly know which unit to pull for bench service. And fast turn-around time in commercial aircraft, as you may suspect, is urgent.

Another example of fault indicators is shown in Fig. 3. It's a radio altimeter whose improved accuracy (to within 2 feet) enables an aircraft to descend to a fog-shrouded runway with more confidence than is possible with a conventional (barometric) altimeter. The VSWR indicator pointed out in the photo informs the technician whether an-



Fig. 1 Standard audio-visual package used by avionics shops for technician training.

enna and cabling are operating at a suitably low standing wave ratio.

Fault indicators of this type have another advantage. Avionics equipment, even more than other electronic devices, are prone to a cantankerous trouble: Merely disturbing a faulty circuit temporarily fixes it, thus making it more difficult to determine the cause of the trouble. Built-in monitors help to isolate the problem to a basic section while the equipment is in its operation environment.

#### Quick-Change Modules Reduce Downtime As Well As Save Space

Although plug-in modules are burgeoning in TV chassis, the concept is well established in avionics.

The small module in Fig. 4, for example, groups several stages within an encapsulated circuit. A complete transceiver might consist of about two dozen such modules. Reaching the modules for troubleshooting is aided by hinged-chassis

construction as illustrated in Fig. 6. According to the manufacturer, this arrangement enables a technician to test all modules within ten minutes. The service manual lists correct voltage and signal levels to be measured at each module pin. When a defect

is located, the technician can replace a module with an in-stock replacement or order one direct from the factory.

Faster servicing isn't the only reason modules are gaining popularity in the avionics field. As more elec-

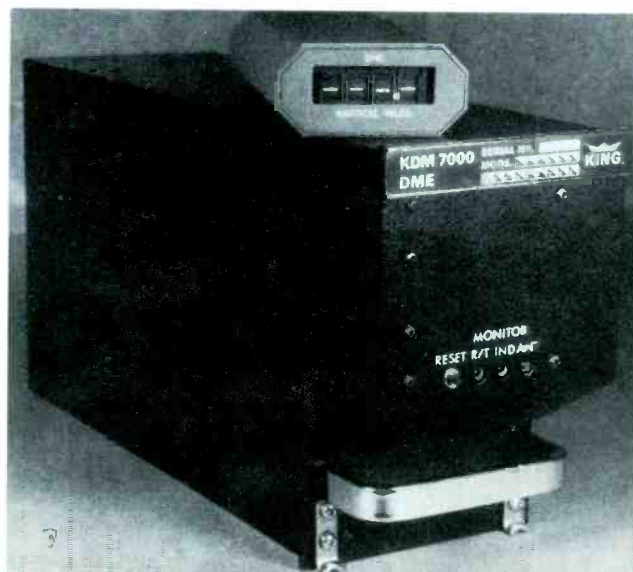
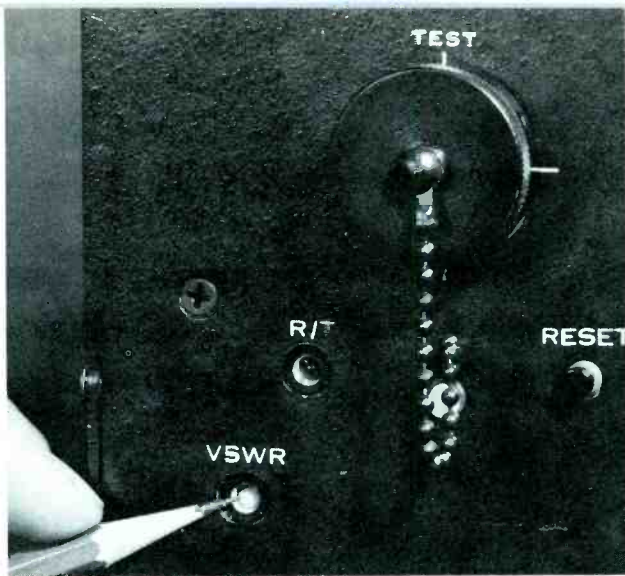
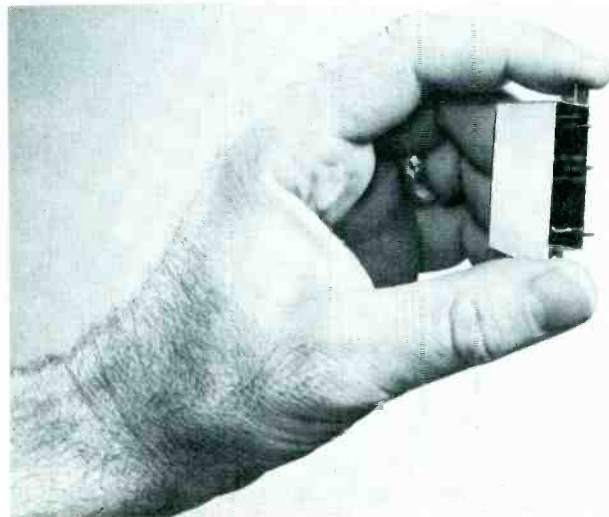

Fig. 2 Fault indicators, along bottom, inform technician which major unit to pull from the aircraft.



**Fig. 3** VSWR indicator gives quick check of antenna and cabling of radio altimeter.



**Fig. 4** Plug-in modules ease field servicing and reduce downtime. This type is sealed and non-repairable in shop.

open position, so test measurements can be taken under dynamic conditions. (This instrument, incidentally, is priced at \$4000, so a degree of consideration for the service technician is to be expected in its design.)

#### Automatic Troubleshooting

If you've ever visited the production line of an electronics manufacturer, you might have spotted an interesting variety of test jigs. They permit a wired assembly to be checked in moments by insertion into a tester, much like plugging a vacuum tube into a checker. A leading FM manufacturer, for example, plugs his tuner sub-assembly into a jig which applies an input signal and verifies the output on a go/no-go readout device. This concept, born in the factory, is transferred to the field in avionics troubleshooting.

An example of equipment designed for automatic testing is shown in Fig. 7, a receiver/transmitter used by commercial airliners. Once the unit is in the shop, the technician can slide out each of the six panels

tronics are crowded aboard aircraft, designers are grouping more individual instruments into integrated cabinets (made possible by microcircuitry), to save space. A good example of the trend is the navigational instrument shown in Fig. 6, which combines the functions of several receivers and indicators into one panel-mounted case. This design both conserves space and eliminates much interwiring. But in achieving these benefits, this construction might also have proven a nightmare to service. Fortunately, the manufacturer has anticipated this problem and eliminated it by certain design features that are apparent in Fig. 6. Note that hinged panels open to expose every portion of the circuitry. Also, it's possible to operate the instrument with panels in the

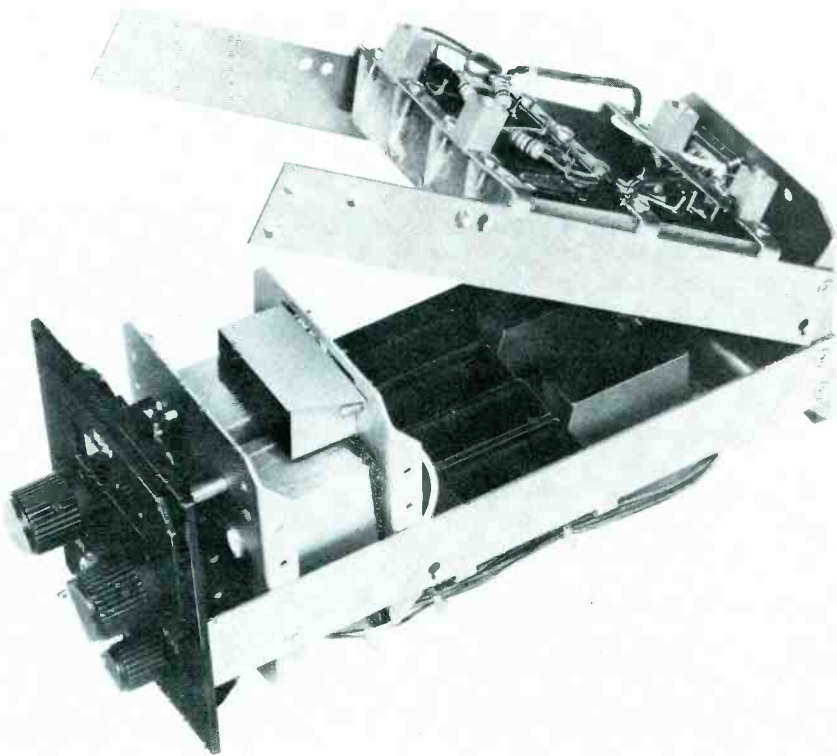

**Fig. 5** Hinged chassis construction improves serviceability in navigational receiver.

which contain the major sub-circuits. (One such panel is shown pulled half-way out of the case in Fig. 7.) The panel then is inserted directly into an automatic tester which indicates its condition. By this process, it's possible to localize trouble with great speed and accuracy. In some cases, the diagnostic equipment will narrow down the fault to a specific component.

The automatic troubleshooting technique has its limitation, too. Such analyzers are made by a manufacturer specifically for his products. They are costly and are generally limited to larger shops with an ample volume of servicing of the particular models.

### Shop and Technician Specialization

The increasing complexity of avionics is leading to an increasing degree of specialization of both personnel and shops. A shop, for example, might have an "ADF man", who is especially good at troubleshooting the Automatic Direction Finder.

Also, there is a move by manufacturers to stipulate which of their products a shop can service (Fig. 9). Not only must the shop demonstrate and maintain technical competence (through training, for example) but it must also have the complement of test equipment the manufacturer believes is required to do the job. Local servicing of certain devices, like radar, might be impossible; if so, they are returned to the factory. It's becoming more apparent that one man can no longer know everything.

### Conclusion

The field of avionics servicing appears to occupy a specialized niche, but it does share many problems that are common to other types of electronic servicing.

Some of its solutions reportedly are not yet economically practical in consumer products; for example, one major TV manufacturer told me that bringing out test terminals to a convenient central point on a chassis, for quick checking, is too

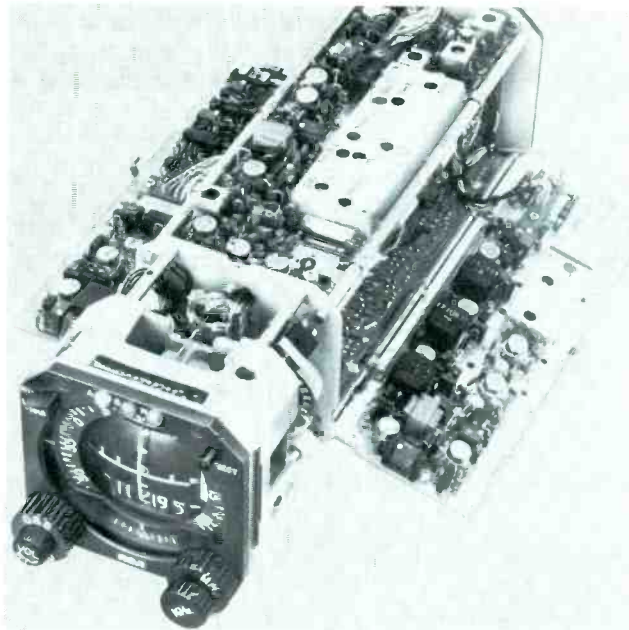

Fig. 6 Complex navigational receiving system will operate with panels open to permit dynamic servicing.

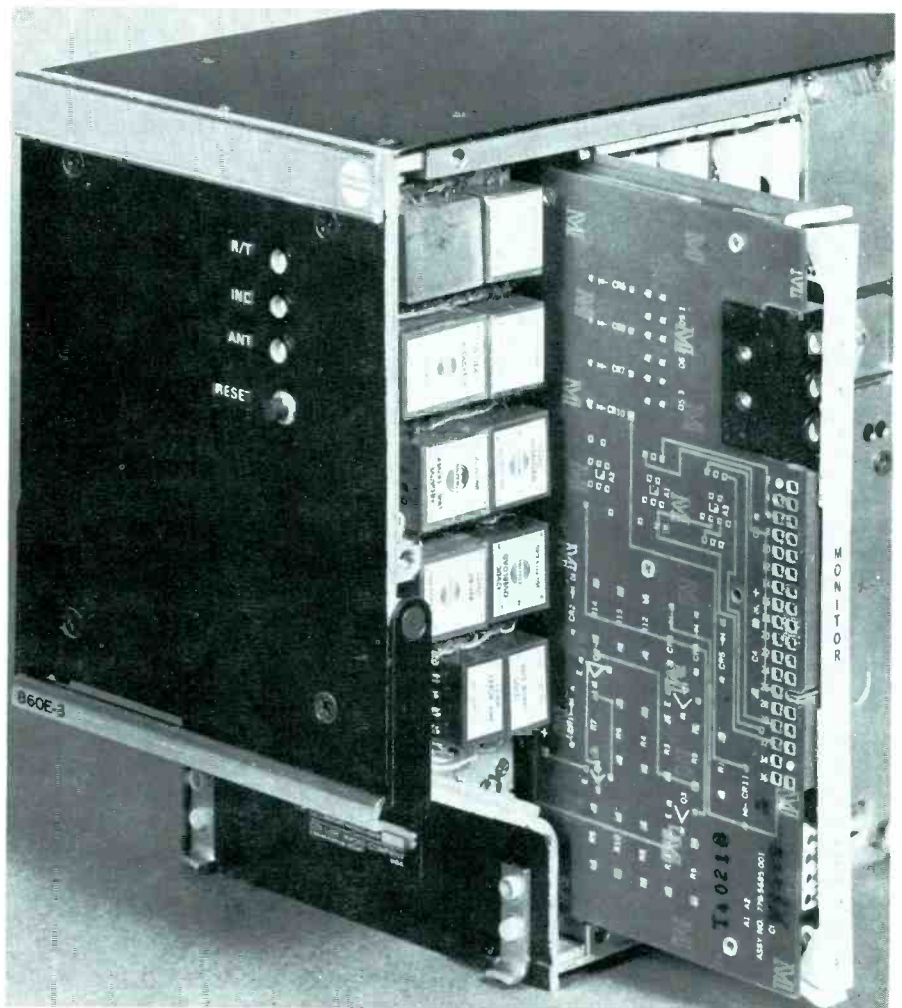

Fig. 7 Panels slide out of receiver/transmitter and can be inserted into automatic testers to localize fault.

costly at this time.

Modules are not the whole answer, either. There is little or no standardization between manufacturers, which make a module inventory expensive to stock.

The same holds true for any automatic diagnostic equipment. It might be justified for checking a

weather radar (price: \$24,000), but hardly yet practical for checking different makes of a \$99 portable TV.

Nevertheless, some of the high-priced, but time-saving, techniques being developed by avionics today, might well reach consumer servicing tomorrow. ▲

## KING SALES & SERVICE ORGANIZATION

STATE & CITY	NAME OF AIRPORT	WARRANTY SERVICE CENTER ★DISTRIBUTOR	SERVICE AVAILABLE				INSTALLATION WARRANTY
			Silver Crown Nav/Comm	Silver Crown Pulse	Gold Crown Nav/Comm	Gold Crown Pulse	
<b>ALABAMA</b>							
Mobile	Bates Field	R. H. Sassaman Co., Inc.	•	•			Yes
Montgomery	Donnelly Field	★ Montgomery Aviation Corp.	•	•	•	•	Yes
Tuscaloosa	Tuscaloosa Mun. Airport	Dixie Air, Inc.	•				Yes
<b>ALASKA</b>							
Anchorage	Merrill Field	★ Western Radio & Telephone, Inc.	•	•			Yes
<b>ARIZONA</b>							
Phoenix	Sky Harbor Airport	★ Cutter Aviation, Inc.	•	•			Yes
Phoenix	Sky Harbor Airport	★ Hawkes Aviation, Inc.	•	•	•	•	Yes
Tucson	Tucson Intl. Airport	Hamilton Aircraft Co., Inc.	•				Yes
<b>ARKANSAS</b>							
Little Rock	Adams Field	Arkansas Aviation Sales	•				Yes
Little Rock	Adams Field	★ Central Flying Service, Inc.	•	•	•	•	Yes
Little Rock	Adams Field	★ Little Rock Airmotive, Inc.	•	•	•	•	Yes
Little Rock	Adams Field	★ Skytravel Radio, Inc.	•	•	•	•	Yes
Little Rock	Adams Field	Starnes Aviation	•				Yes
<b>CALIFORNIA</b>							
Bakersfield	Meadows Field	Bakersfield Air Radio	•				Yes
Burbank	Lockheed Air Terminal	Pacific Airmotive Corp.	•	•	•	•	Yes
Burbank	Lockheed Air Terminal	★ Qualitron Aero, Inc.	•	•	•	•	Yes
Carlsbad	Palomar Airport	★ Pabas Aircraft Radio	•	•			Yes
Concord	Buchanan Field	Diablo Aviation Services	•				Yes
Concord	Buchanan Field	Pacific States Aviation, Inc.	•				Yes
El Monte	Municipal Airport	Continental Aviation Supply Co.	•				Yes
Eureka	Murray Field	Pierce Flying Service, Inc.	•				Yes
Fresno	Chandler Field	All West Aviation	•				Yes
Hawthorne	Municipal Airport	★ Bates Aviation, Inc.	•	•	•	•	Yes
Hayward	Hayward Airport	Flight Safety, Inc.	•				Yes
Imperial	Imperial County Airport	Carl's Radio Shop	•	•	•	•	Yes
LaVerne	Brackett Airport	Brackett Aircraft Radio	•	•			Yes
Long Beach	Municipal Airport	Airadio Company	•	•			Yes
Long Beach	Municipal Airport	Citizen's Communication Center	•				Yes
Long Beach	Municipal Airport	★ Pacific Airmotive Co.	•	•	•	•	Yes
Los Angeles	Los Angeles Int'l. Airport	★ AiResearch Aviation Co.			•	•	Yes
Monterey	Monterey Peninsula Airport	California Aero Marine	•				Yes
Napa	Napa County Airport	Bridgeford Flying Service	•	•			Yes
Oakland	Oakland Int'l. Airport	Aviasco	•				Yes
Oakland	Oakland Int'l. Airport	★ Bayaire Avionics	•	•	•	•	Yes

Fig. 8 Specialization of both shops and technicians is well established in avionics. Shown here is a partial page out of a service directory which illustrates shop specialization (note service available column).

# ON TO CHICAGO.....



## .....INTO McCORMICK PLACE



# THE 5<sup>TH</sup> ANNUAL CONSUMER ELECTRONICS SHOW

## june 27 thru 30, 1971

*the annual meeting place for the people & products of the industry*

**the people** over 35,000 trade show visitors from the consumer electronics industry. It will be THE meeting place for manufacturers, importers, distributors, sales representatives, government officials and press representatives from all 50 states and many foreign countries.

### the program

#### exhibits

Sun., June 27 ..... 12 noon—6 pm  
Mon., June 28 ..... 10 am —6 pm  
Tues., June 29 ..... 10 am —6 pm  
Wed., June 30 ..... 10 am —6 pm

#### conferences

Mon. — Retail Marketing Conference  
Tues. — Video Conference  
Wed. — Audio Conference

BY AND FOR THE INDUSTRY

Produced and sponsored by  
CONSUMER ELECTRONICS GROUP  
ELECTRONIC INDUSTRIES ASSOCIATION

**the products** over 250 exhibitors will introduce their 1972 lines of television, radios, phonographs, audio components, tape equipment and accessories, displaying over 25,000 products in the world's largest trade show devoted exclusively to consumer electronics.

**the place** The 1971 CES is all under one roof in the huge main exhibition hall of the all-new magnificent McCormick Place.

plan  
now  
to  
attend

**Register today! Send for your FREE BADGE OF ADMISSION**

<b>ADVANCE REGISTRATION</b>		#19
Save time, fill in and mail this coupon now. Your free badge of admission will be mailed back to you. (Please print) <i>Hotel reservation blanks will be forwarded to you with your badge.</i>		
Name _____	Title _____	
Firm _____		
Street _____		
City _____	State _____	Zip _____
Type of Business _____		
<i>Please check below the classification of your business</i>		
<input type="checkbox"/> RETAILER	<input type="checkbox"/> DEPT./CHAIN STORE BUYER	<input type="checkbox"/> DISTRIBUTOR
<input type="checkbox"/> MANUFACTURER'S REPRESENTATIVE	<input type="checkbox"/> MANUFACTURER	
<input type="checkbox"/> OTHER _____		
<small>Minors under 18 years of age will not be admitted under any circumstances</small>		
<b>CONSUMER ELECTRONICS SHOW, 331 MADISON AVE., NEW YORK, N.Y. 10017</b>		

Circle 39 on literature card

# shop talk

With Carl Babcock  
ES Technical Editor



## How frequency response affects square and pulse waveforms

Most electronic textbooks tell us that attenuation of high-frequency response will round the upper left and lower right corners of a square wave. This is true. However, of the texts that I've read, none have explained how much high-frequency attenuation produces how much rounding of the corners.

Also, none of the texts I've read have explained that insufficient or excessive low- and high-frequency response affect pulses differently than they do square waves. An understanding of the differences is important to TV technicians because most waveforms in TV video circuits are pulses of various widths, not square waves.

Consequently, in this and the following two or three installments of SHOP TALK, we'll be examining the composition of sine, square and pulse waveforms and how various circuit characteristics affect them and what trouble symptoms are produced when they do.

The only way for us to determine how restricted bandwidth affects square waves and pulses is to examine the waveforms after they travel through filters of known frequency response. This we have done in the ELECTRONIC SERVICING lab. Following are the results.

### Square Waves Vs High-Frequency Response

The series of waveforms in Fig. 1 show the gradual deterioration of a square wave whose higher har-

monics have been decreased progressively by varying the capacitance of a simple low-pass filter through which the square wave is fed. The triangular waveform of Fig. 1H is the maximum square wave distortion possible with a single-section RC filter. Further increases in capacitor size merely reduce the amplitude of the waveform; the waveshape remains unchanged. However, a satisfactory sine wave can be produced from a square wave by using three cascaded low-pass RC filters.

A repetition frequency of 1 KHz was chosen for these tests because bandwidth measurements of the filters can be made accurately both above and below this fundamental frequency. Equivalent results at video frequencies can be calculated by multiplying the test frequencies by 15.734. For example, the 10th harmonic of a square wave which occupies one complete horizontal line on the screen of a TV picture tube is 157.34 KHz. The 100th harmonic of such a video square wave is 1.57 MHz. From this, it is clear that satisfactory B-W picture sharpness requires flat response to the 100th harmonic, and a maximum decrease in response of no more than -3 dB at the 200th harmonic.

Excessive high-frequency response also affects the upper left and lower right corners of a square wave, as shown in Fig. 2B and C. A spike whose height is determined by the amount of high frequency

increase and whose width is determined by the frequency where the increase begins is produced on the leading and trailing edges of the square wave.

### Square Waves Vs Low-Frequency Response

Reduction of the low-frequency response tilts the top of the square wave down to the right and tilts the bottom up to the left. When the reduction is **below** the fundamental frequency, as shown in Figs. 3A, B and C, the top and bottom are straight, although tilted. When the low-frequency attenuation begins **above** the fundamental frequency, the top and bottom of the square wave are curved, as shown in Figs. 3D, E and F. Note that the extreme low-frequency attenuation (30 dB loss at the fundamental) shown in Fig. 3F produces a pulse on each side of the original square wave. One pulse is positive-going and caused by the leading edge, and the other is negative-going and caused by the trailing edge. This is the reason for the production of **two** ringing waveforms per cycle when a square wave is used to ring an inductance or tuned circuit, as explained on page 38 in the October, 1970, issue of ELECTRONIC SERVICING.

Increased response below the fundamental frequency (bass boost) tilts the top of the square wave so that the right corner is higher than the left, and the bottom is tilted



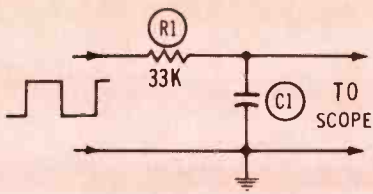

1A

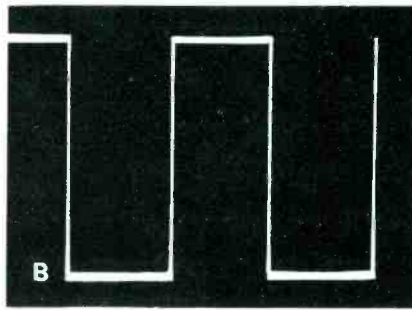

B

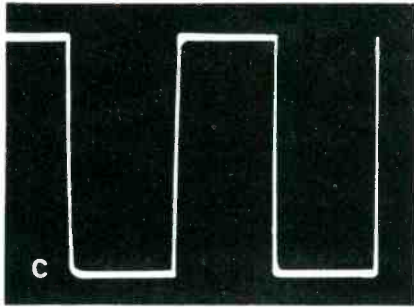

C

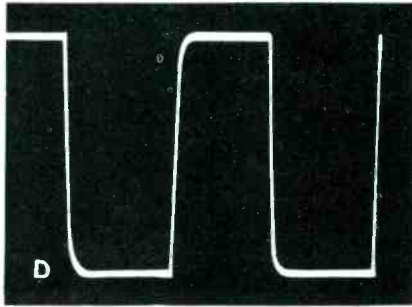

D

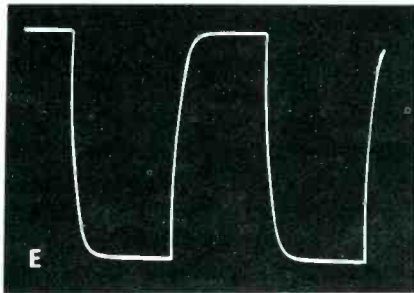

E

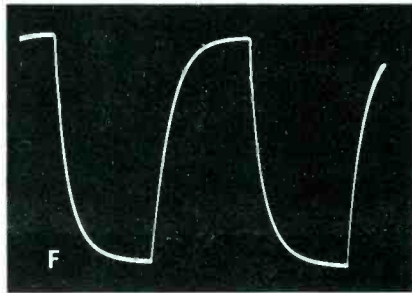

F

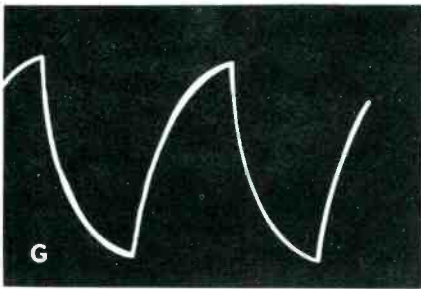

G

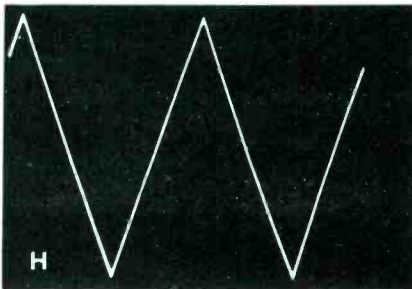

H

**Fig. 1** The waveforms shown here illustrate how decreased high-frequency response affects square waves. The leading and trailing edges of some of the waveforms have been drawn in by an artist; the beam was so fast that these vertical lines could not be seen on the unretouched photos. **(A)** Schematic of the RC low-pass filter used to produce high-frequency attenuation in the waveforms shown here. The value of C1 was changed for each waveform. **(B)** 1-KHz square wave; C1 was zero. Notice the sharp corners. **(C)** Value of C1 was .0001, and caused a slight rounding of the upper left and lower right corners of the waveform. The response was  $-1$  dB at the 20th harmonic (video equivalent is 315 KHz) and  $-12$  at the 200th harmonic (video equivalent is 3.15 MHz). **(D)** C1 was .0005; rounding of the two corners is quite noticeable. The response was  $-6$  dB at the 20th harmonic (315 KHz) and  $-25$  dB at the 200th harmonic (3.15 MHz). **(E)** C1 was .001; the edges of the waveform are no longer straight. The response was  $-11$  dB at the 20th harmonic (315 KHz) and  $-30$  dB at the 200th harmonic (3.15 MHz). **(F)** C1 was .0025; the waveform begins to resemble a sawtooth. The response was  $-1$  dB at the repetitive (fundamental) frequency,  $-19$  dB at the 20th harmonic (315 KHz), and  $-38$  dB at the 200th harmonic (3.15 MHz). **(G)** C1 was .005; the waveform no longer recognizable as having begun as a square wave. The response was  $-3$  dB at the repetitive frequency,  $-25$  dB at the 20th harmonic (315 KHz), and  $-46$  dB at the 200th harmonic (3.15 MHz). **(H)** C1 was .1; the shape of the waveform here is a near-perfect triangle. The response was  $-26$  dB at the fundamental, or repetitive, frequency, and it continued to drop at the rate of 6 dB each time the frequency was doubled.

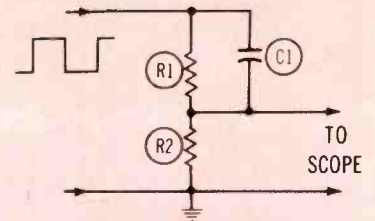

2A

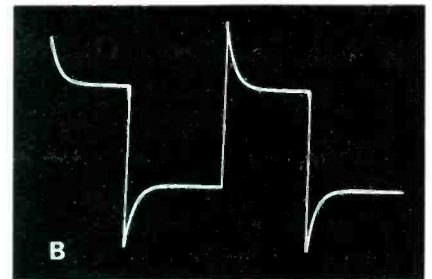

B

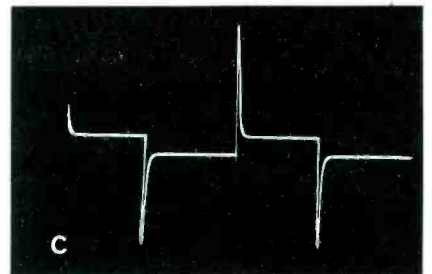

C

**Fig. 2** Increase (boost) of the higher harmonics in the square wave also affects the upper left and lower right corners. **(A)** Schematic of the circuit used to boost the higher harmonics. The ratio of R1 and R2 determines the voltage loss of the fundamental frequency, and, therefore, the maximum amount of the high-frequency boost. **(B)** C1 was .001, R1 was 100K and R2 was 100K. The response was  $+4$  dB at the 10th harmonic, and  $+6$  dB at the 20th harmonic and all higher harmonics. **(C)** C1 was .001, R1 was 100K and R2 was 10K. The response was  $+11$  dB at the 10th harmonic, and  $+20$  dB at the 100th harmonic and all higher harmonics.

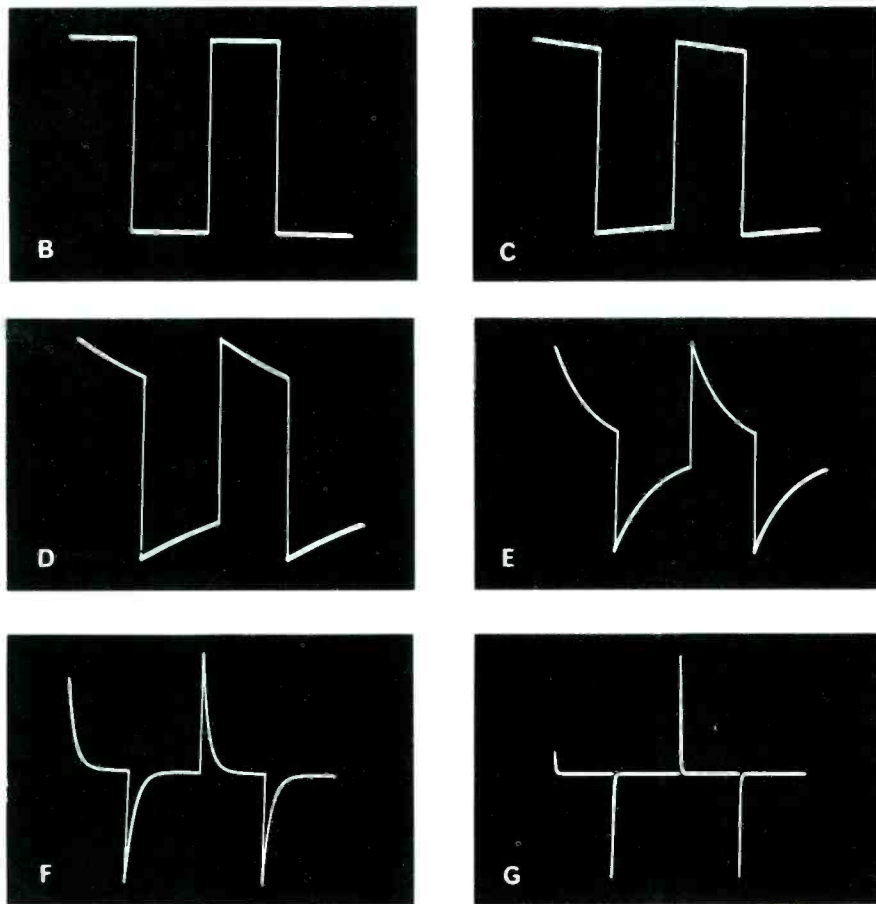
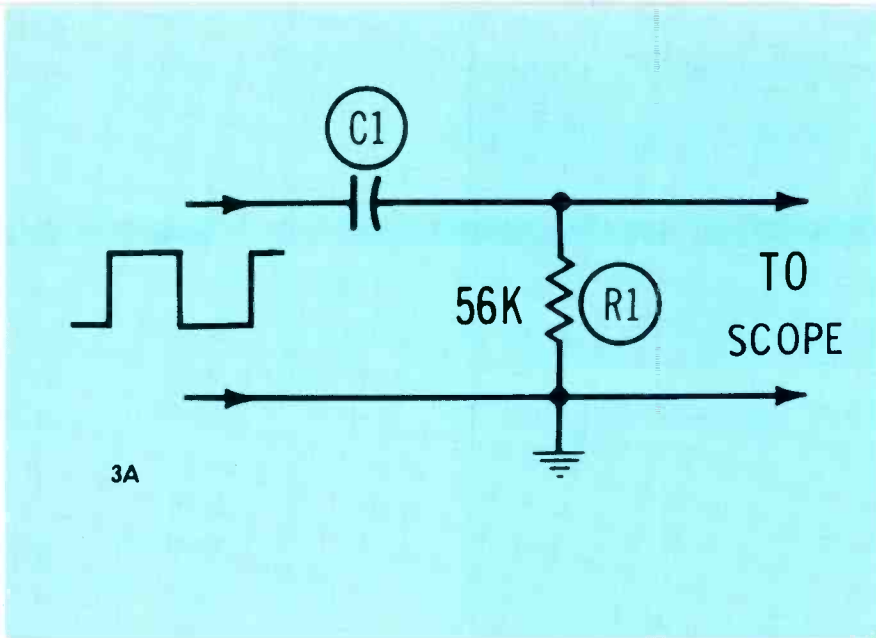

**Fig. 3** The waveforms shown here illustrate how a square wave is affected by decreased low-frequency response. **(A)** Schematic of the high-pass RC filter used to produce low-frequency attenuation in the waveforms shown here. **(B)** Normal 1-KHz square wave; C1 was shorted. **(C)** C1 was .1 mfd. Top of waveform is tilted; the right corner is lower than the left. The response was  $-1$  dB, and  $-5$  dB at  $1/50$ th the fundamental frequency. **(D)** C1 was .02; the tilt is very noticeable, although the top and bottom are still straight. The response was  $-5$  dB at  $1/10$ th frequency,  $-14$  dB at  $1/50$ th frequency. **(E)** C1 was .005; the top and bottom lines are beginning to curve slightly. The response was  $-1.5$  dB at the fundamental,  $-16$  dB at  $1/10$ th frequency, and  $-25$  dB at  $1/50$ th frequency. **(F)** C1 was .001; little is left of square wave but spikes. The response was  $-10$  dB at fundamental,  $-30$  dB at  $1/10$ th frequency, and  $-40$  dB at  $1/50$ th frequency. **(G)** C1 was .0001; only spikes remain of original square waveform. The response was  $-30$  dB at the fundamental frequency,  $-50$  dB at  $1/10$ th frequency, and  $-61$  dB at  $1/50$ th frequency.

opposite to the top, as shown in Fig. 4B.

Simultaneous low- and high-frequency boosts are shown in the waveform of Fig. 4C. Both have about a 10-to-1 (20 dB) boost, but the spike produced by the excessive high-frequency response is much more noticeable than the tilt produced by the excessive low-frequency response.

Increased low-frequency response that begins **above** the fundamental (or repetitive) frequency causes both curvature and tilting of the top and bottom of a square wave, as shown in Fig. 4D, which also exhibits a short spike caused by a small amount of high-frequency boost.

### Pulses Vs

#### High-Frequency Response

Restriction, or reduction, of high-frequency response affects pulses differently than it does square waves. The reason is that square waves are **symmetrical**, with the zero axis in the center as do sine waves. Pulses are non-symmetrical; their zero axis is near the base line. Consequently, the action is similar to that of a DC pulse. When a pulse travels through a low-pass filter, such as shown in the schematic of Fig. 1A, the left side is not changed greatly, but the right side shows the curve typical of capacitor discharge. A sawtooth is produced by such a filter, if the capacitance of the filter is large enough. The series of waveforms in Fig. 5 should make this action clear.

This same low-pass filter action also applies to video waveforms in TV receivers. Narrowing of the high-frequency response, regardless of whether it occurs in the IF or video amplifier stages, blurs the right side of any picture elements much more than it does the left side. The same principle applies to viewing video waveforms on a scope. However, in that event, we usually look at the horizontal sync pulse because it is relatively constant and the video waveforms are not.

Additional filtering to reduce the high-frequency harmonics of the sawtooth waveform still further, eventually produces a parabolic

waveform, as shown in Fig. 6.

A parabola is the extreme limit a sawtooth can be changed by a single-section low-pass RC filter. However, two such filters in cascade produce a recognizable sine wave, even though some second-harmonic distortion is present, as shown in Fig. 6E. A three-section filter can produce an almost true sine wave.

A resistor added in series with a capacitance which is large enough to produce a sawtooth from a pulse will add a spike to the sawtooth, as shown in Fig. 6F. The schematic in the same as that shown in Fig. 4A but the component values are different.

### Composition of Waveforms

It has been shown that a square wave can be easily changed to a triangular waveshape by one RC filter, and then to a sine wave by the addition of more RC filter sections. A pulse, however, is changed first to a sawtooth, then to a parabola by heavier filtering from a second low-pass RC filter. A three-section RC filter changes the parabola to a sine wave. A sine wave consists only of one frequency.

A square wave is made up of a fundamental frequency, 33 per cent third harmonic, 20 per cent fifth harmonic, and all odd harmonics in decreasing amplitudes.

A pulse is comprised of a fundamental and slightly decreasing amplitudes of both even and odd harmonics.

It is theoretically possible to produce square or pulse waveforms by combining sine waves of the correct frequency and phase. Because harmonics above the 200th must be supplied, this method of waveform construction is not very practical. However, I combined a fundamental and third and fifth harmonics to obtain a waveform that gave every promise of becoming a square wave, if the process had been continued.

### Differences in Pulse Sources

Bypassing the plate of a tube or the collector of a transistor which is the **source** of a pulse produces a slightly different waveshape than

that obtained by bypassing the plate or collector of an amplifier stage. Fig. 7 shows that the tip and left side of the pulse remain relatively unchanged when the collector of a transistor pulse generator is bypassed—even when bypassed with enough capacitance to produce a rounded sawtooth.

The reason for this strange behavior is that the tip of the pulse is a very low-impedance point. Collector-to-emitter resistance is nearly zero at that time, and the capacitive reactance is too high to be important. When the transistor is cut off, the capacitor discharges, just as theory predicts.

### Sharpening Pulses By Peaking

High-frequency attenuation does happen in practical circuits. If it is the result of low-pass filter action, high-frequency boost circuits usually can be used to restore the original sharpness of the pulse. High-frequency attenuation that does not exceed 6 dB per octave can be compensated for by a simple boost

circuit, such as the one in Fig. 2A, or by bypassing a cathode or emitter resistor with a capacitor of the correct size (in video circuits).

Usually, high-frequency attenuation of the video signal in a television receiver occurs in the video IF and video amplifier stages. Although the total attenuation might exceed an amount which can be completely corrected or compensated for by practical circuits, in most TV receivers, such circuits produce results which are a reasonable compromise. (We are omitting the added obstacle of possible phase shift, which blurs the picture without necessarily restricting the bandwidth very much.)

The waveforms in Fig. 8C and 8D show how an RC filter produces partial correction of high-frequency attenuation. Too much correction tilts the end of the pulse, as shown in Fig. 8E. The waveform of Fig. 8F looks somewhat similar, but it was produced by a low-frequency attenuation filter whose action started above the fundamental fre-

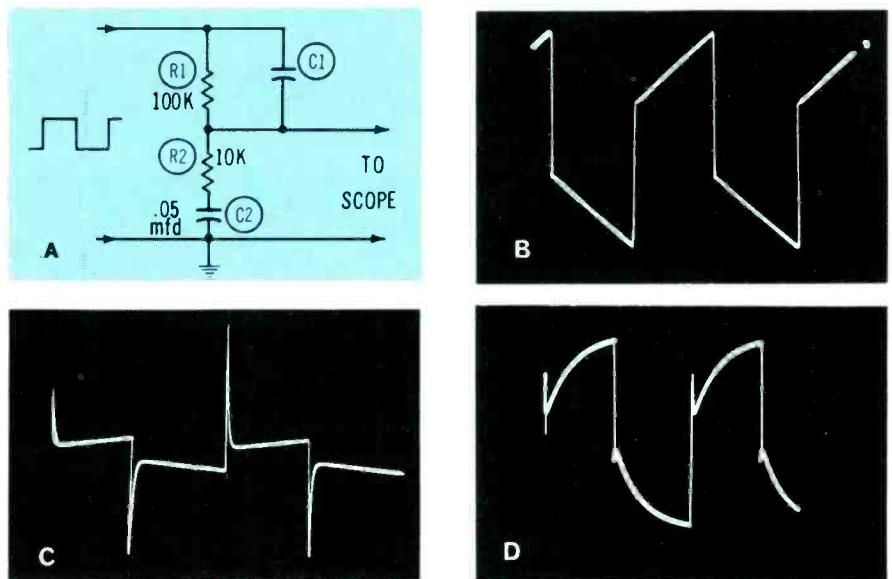

**Fig. 4** Waveforms here show how simultaneous high- and low-frequency boost affect square waves. **(A)** Schematic of the RC circuit used to provide both high- and low-frequency boost. C1 provided the high boost, and C2 changed the constants of the voltage divider, consisting of R1 and R2, to provide increased low-frequency gain. **(B)** C1 was zero—no high-frequency boost. The response was +8 dB at 1/10th frequency, and +18 dB at 1/50th frequency. Maximum boost with these component values was 20 dB. **(C)** C1 was .001; the waveform shows both a low-frequency tilt and a high-frequency spike, as explained before. The response was +11 dB at the 10th harmonic, and +8 dB at 1/10th frequency. **(D)** C2 was .01. Low-frequency boost started above the fundamental frequency; therefore, the top of the waveform has a convex curve.

quency; notice the tilt on the line following the pulse.

Most high-frequency compensation circuits use inductances called peaking coils. The inductance of these peaking coils are combined with existing stray capacitance to form tuned circuits. This method is used because some gain is realized at the resonant frequency of the tuned circuit. Also, voltage dividers, with inherent loss of gain at low frequencies, are not necessary.

The circuit shown in Fig. 9A was used to test the effects of frequency

response on pulses. R1 and C1 attenuate the high frequencies, while R2, L1 and C2 determine the resonant frequency and the "Q" of the circuit, and R3 limits the amount of peaking obtained. The pulse waveform in Fig. 9B exhibits a fair "compromise" correction of the degraded pulse in Fig. 8C. One ringing mark shows at the tip of the pulse and another following the right side of the pulse. If the pulse were used to produce a vertical black line on the screen of a TV receiver, a slightly noticeable white

outline would be seen on the right side of the black line, and an even fainter black line on the right side of the white line.

An objectionable amount of over-correction is exhibited by the pulse in Fig. 9C. It would produce a black line on the left and a white line on the right of the desired vertical black line on the screen of a TV.

Uncontrolled ringing, shown in Fig. 9D, would produce the effect of four or five closely-spaced ghosts. One possible cause of this symptom

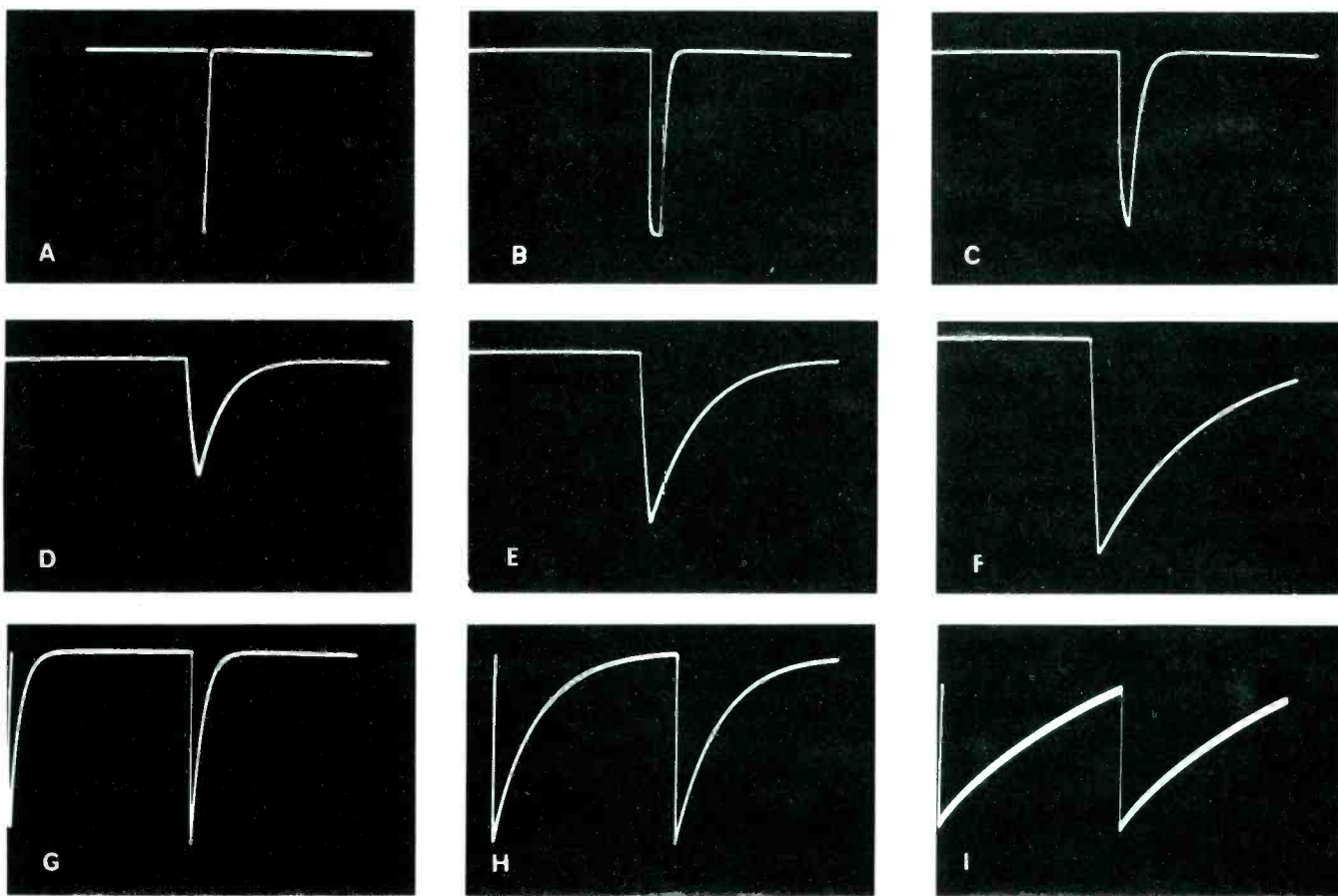

**Fig. 5** Pulses are affected by restricted frequency response, but not in the same way square waves are. The filter whose schematic is shown in Fig. 1A was also used to produce the pulse waveforms shown here. **(A)** A normal 1-KHz pulse is so narrow that it is nearly impossible to analyze. **(B)** The same normal 1-KHz pulse widened by use of the 5X magnifier on the scope, which makes the waveform 5 times as wide. (It also is much dimmer.) **(C)** C1 was .0001; the tip is nearly a point, and the right side is broadened and rounded near the base line. Compare this to the square wave in Fig. 1C, which was produced by the same filter and component values. The video equivalent response was  $-1$  dB at 315 KHz and  $-12$  dB at 3.15 MHz. If this pulse appeared as a vertical line in the center of a TV receiver screen, the line would be noticeably blurred. **(D)** C1 was .0005; the pulse is nearly 4 times as wide at the base-line as the original pulse.

Amplitude of the pulse is only 70 percent of the original. **(E)** C1 was .001. Response was  $-11$  dB at 315 KHz and  $-30$  dB at 3.15 MHz. Amplitude of waveform is about 43 percent of original. **(F)** C1 was .0025; response was  $-1$  at repetitive frequency,  $-19$  dB at 315 KHz, and  $-38$  dB at 3.15 MHz. Amplitude is about 20 percent of original. **(G)** C1 was .001. A repeat of **(E)** except normal X1 scope horizontal width was used. **(H)** C1 was .005. Response was  $-3$  dB at fundamental frequency,  $-25$  dB at 315 KHz, and  $-46$  dB at 3.15 MHz. Amplitude is 11 percent of original. **(I)** C1 was .02. Response was  $-13$  dB at the fundamental frequency and continued to drop 6 dB each time the frequency was doubled. Amplitude is 2.4 percent of the original pulse amplitude, and the waveform is a near-perfect sawtooth. Hum and bounce from the power supply of the pulse source discouraged further filtering.

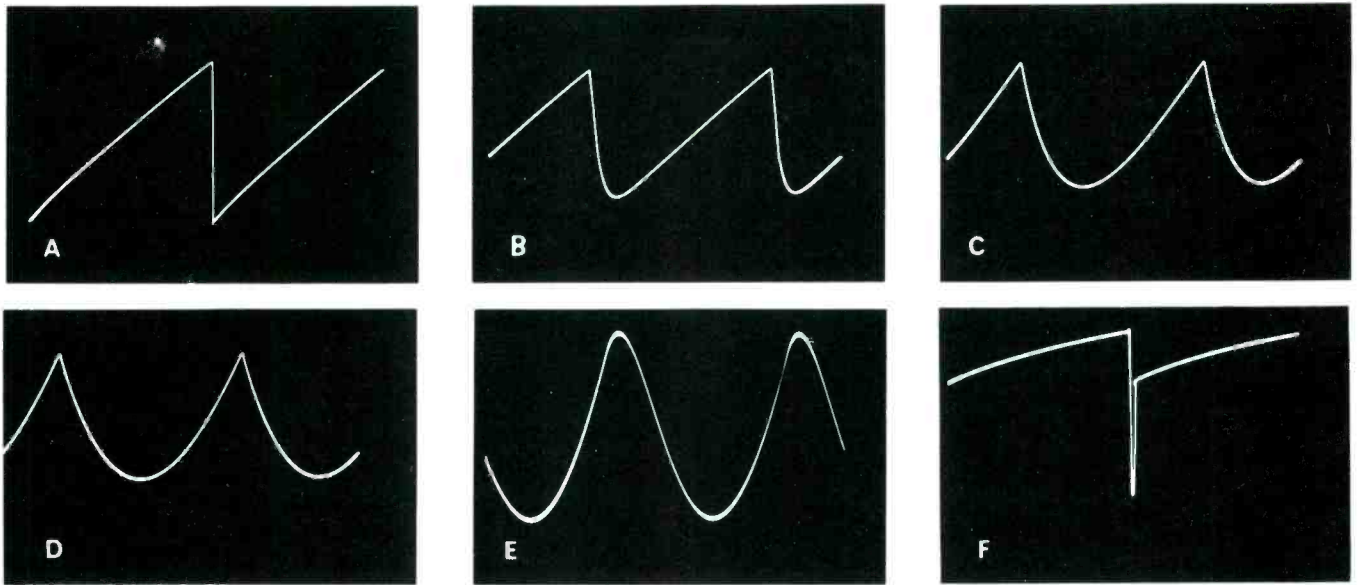

**Fig. 6** Waveforms here show changes in the waveshape of a sawtooth when it was filtered to reduce the high-frequency response. The low-pass filter shown in Fig. 1A also was used to produce these waveforms, except R1 was 100K. **(A)** Normal 1-KHz sawtooth waveshape. Normal X1 scope width used for these waveforms. **(B)** C1 was .0005; notice the rounding of the bottom of the waveform, and the sharp tip on top. The response was  $-15$  dB at the 20th harmonic. The amplitude is 82 percent of that of the original sawtooth. **(C)** C1 was .0025. The waveform approaches a parabola.

The response was  $-4$  dB at the fundamental frequency, and  $-30$  dB at the 20th harmonic. The amplitude is 44 percent of the original. **(D)** C1 was .01. The waveform is a good parabola. The response was  $-15$  dB at the fundamental frequency and  $-40$  dB at the 20th harmonic. The amplitude is 14 percent of the original. **(E)** Two low-pass RC filters in cascade ( $18K/.02$  and  $1.8$  megohms/.00012) change the sawtooth into a near-sine wave. **(F)** A resistor inserted in series with a capacitor large enough to make a sawtooth from a pulse, produced this sawtooth with a negative-going pulse.

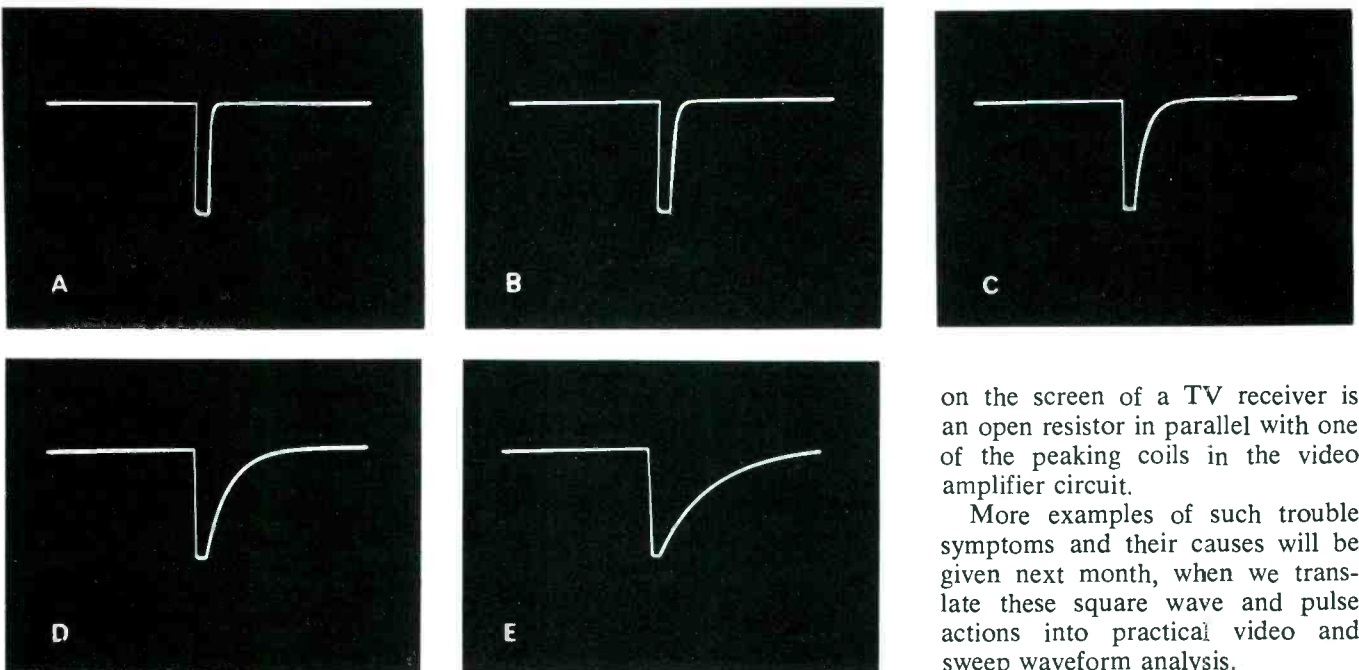

**Fig. 7** The waveform at the collector of a transistor in a pulse generator changes very little at the tip and at the left side when capacitance is added between collector and ground. **(A)** Normal 1-KHz pulse; scope width 5X. **(B)** Capacitor was .0001. **(C)** Capacitor was .0005. **(D)** Capacitor was .001. **(E)** Capacitor was .0025. The shape of the waveform approaches that of a sawtooth, but the tip and left side are changed very little.

on the screen of a TV receiver is an open resistor in parallel with one of the peaking coils in the video amplifier circuit.

More examples of such trouble symptoms and their causes will be given next month, when we translate these square wave and pulse actions into practical video and sweep waveform analysis.

#### Preliminary Diagnosis of Clipped Sine and Sawtooth Waveforms

As pointed out previously, a perfect sine wave has only one fre-

quency, the fundamental. Passage of a sine wave through frequency-attenuating circuits only results in a change in amplitude. Overload, clipping, or any kind of non-linear distortion usually shows up more quickly and definitely on a sine wave signal than on any of the complex waveforms.

Fig. 10A shows the waveshape of a good sine wave, which has less than 1 percent distortion. Slight clipping is shown in Fig. 10B. This much clipping often is produced when the AC voltage in an audio stage is measured with a rectifier-

type VTVM.

The clipping shown in Figs. 10C and 10D are typical of incorrect bias in a tube or transistor audio stage.

Rounded corners, such as those in Fig. 10D, can be caused by poor high-frequency response, or, more likely by negative feedback which has "softened" the clipping.

Square waves can be formed by extreme clipping of both peaks of a sine wave, although some tilt of the leading and trailing edges will always be produced. The round-cornered square wave in Fig. 10E

is the unsuccessful result of attempting to produce square waves by clipping a sine wave with two power supply silicon diodes.

### Next Month In Shop Talk

A good understanding of the changes in frequency characteristics and waveforms that occur when square waves and pulses travel through frequency-attenuation and compensation circuits can be of great value in servicing television receivers. Next month we will discuss video, vertical sweep and horizontal sweep waveform analysis.

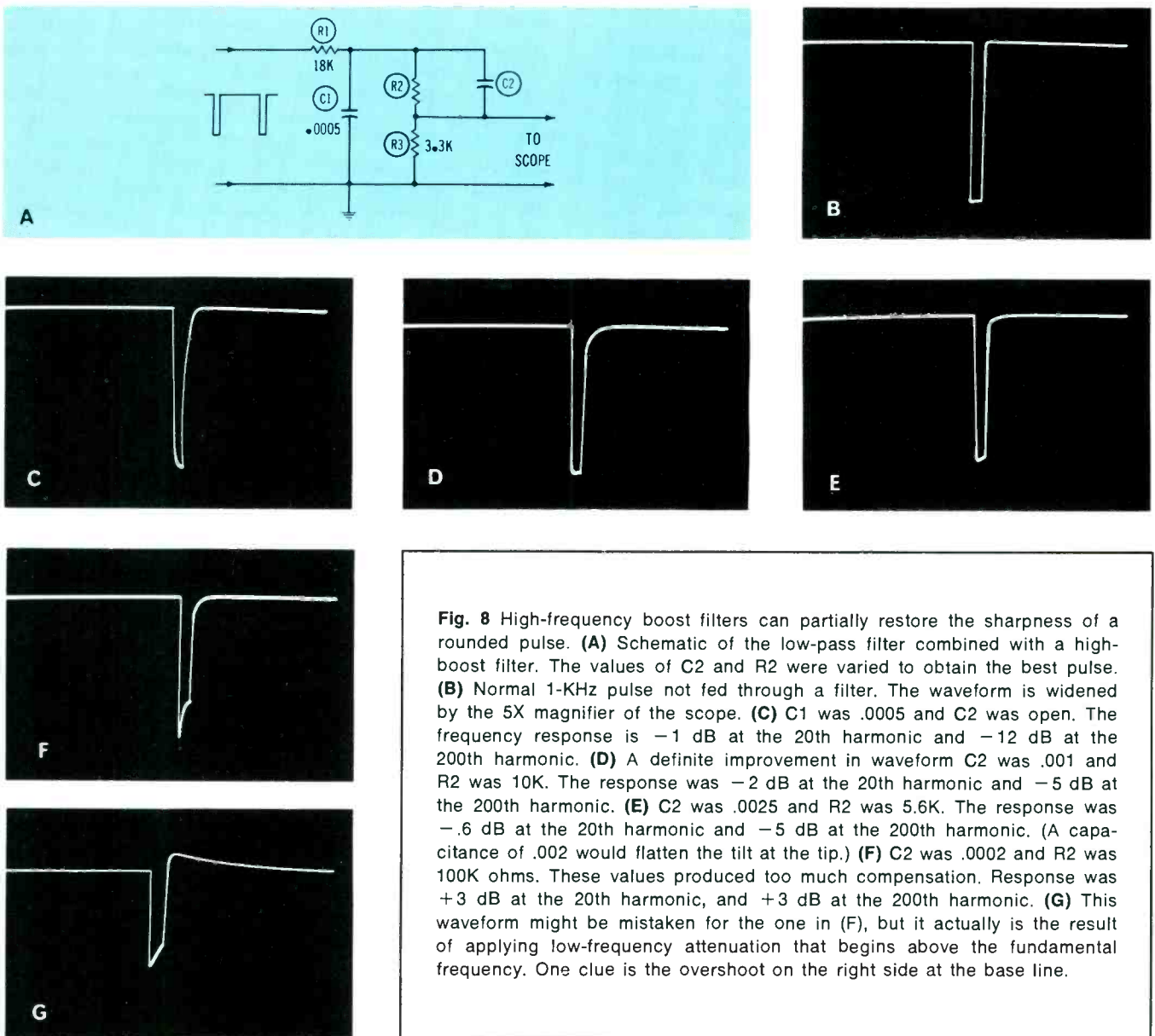

**Fig. 8** High-frequency boost filters can partially restore the sharpness of a rounded pulse. (A) Schematic of the low-pass filter combined with a high-boost filter. The values of C2 and R2 were varied to obtain the best pulse. (B) Normal 1-KHz pulse not fed through a filter. The waveform is widened by the 5X magnifier of the scope. (C) C1 was .0005 and C2 was open. The frequency response is -1 dB at the 20th harmonic and -12 dB at the 200th harmonic. (D) A definite improvement in waveform C2 was .001 and R2 was 10K. The response was -2 dB at the 20th harmonic and -5 dB at the 200th harmonic. (E) C2 was .0025 and R2 was 5.6K. The response was -.6 dB at the 20th harmonic and -5 dB at the 200th harmonic. (A capacitance of .002 would flatten the tilt at the tip.) (F) C2 was .0002 and R2 was 100K ohms. These values produced too much compensation. Response was +3 dB at the 20th harmonic, and +3 dB at the 200th harmonic. (G) This waveform might be mistaken for the one in (F), but it actually is the result of applying low-frequency attenuation that begins above the fundamental frequency. One clue is the overshoot on the right side at the base line.

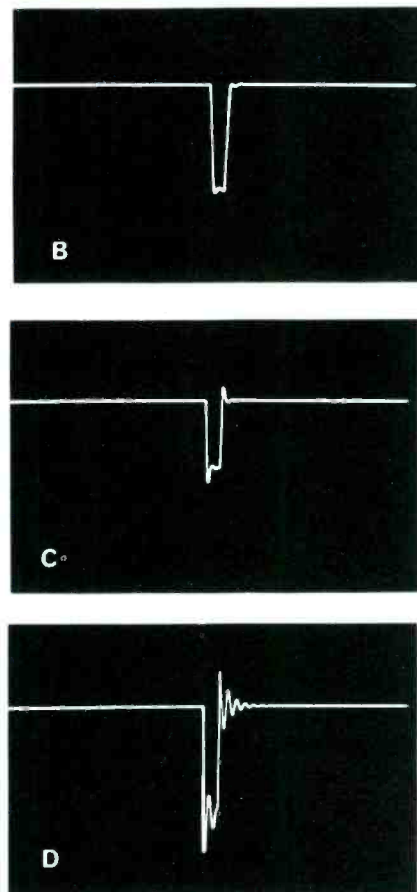
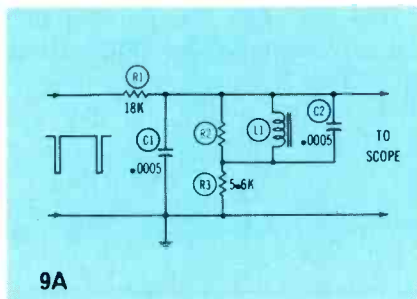

**Fig. 9** Low-“Q” tuned circuits also can be used to restore the sharpness of a rounded pulse. The inductance of the tuned circuit is called a peaking coil. In actual video circuits, the capacitor, C2, often is the stray capacitance of the circuit. (A) Schematic of the low-pass and high-boost filters. (B) Relatively good peaking. C2 was .0005, and R2 was 5.6K ohms. Response was 0 dB at the 20th harmonic, +.7 dB at the 50th harmonic, and declined above that point. (C) Overpeaking. Same conditions as in (B), except R2 was 10K ohms. The response was 0 dB at the 20th harmonic, and +1.5 dB at the 50th harmonic, with declining response above that point. (D) Excessive ringing. Same conditions as in (C), except C1 was omitted. The response was +4 dB at the 50th harmonic.

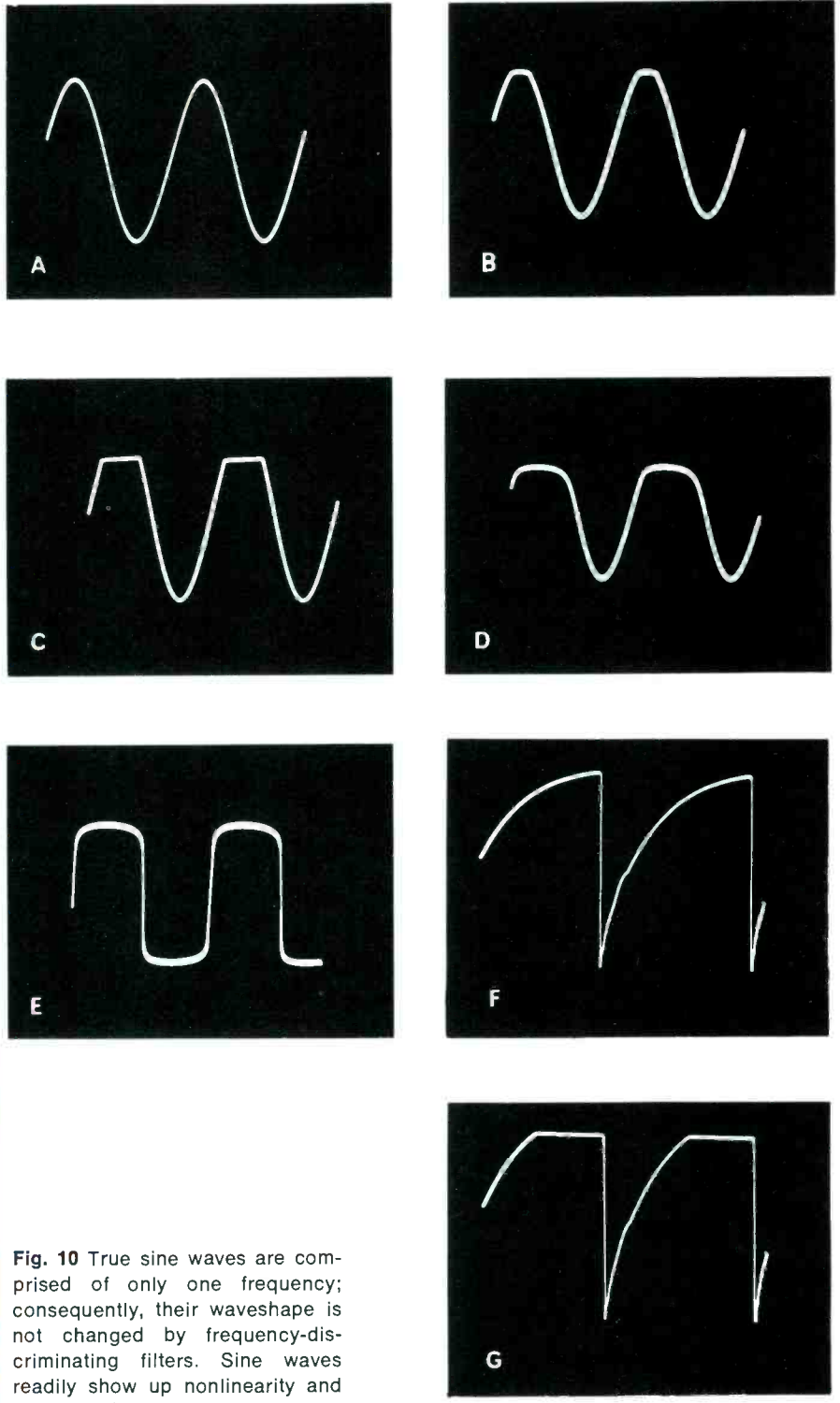

**Fig. 10** True sine waves are comprised of only one frequency; consequently, their waveshape is not changed by frequency-discriminating filters. Sine waves readily show up nonlinearity and clipping. (A) A good sine wave which has less than 1 percent total harmonic distortion. (B) Slight clipping. The AC function of a VTVM might cause this much clipping when connected to an audio amplifier stage. (C) Severe clipping. Usually caused by insufficient bias or because the tube or transistor is driven beyond saturation by excessive input signal. (D) Very severe clipping, but with rounded corners. Usually caused by overload clipping of a stage inside a negative-feedback loop. (E) Power-supply type silicon diodes used in an unsuccessful attempt to produce a square wave by clipping a sine wave. (F) Normal waveform at the grid of a horizontal output tube. (G) The same waveform as in (F), but clipped by a gassy horizontal output tube or a leaky coupling capacitor between oscillator and output tube grid. ▲

Manufacturers, distributors, and national, state and local service associations are invited to use this column to announce their electronic training activities which are open to all electronic technicians. Information about the training session(s) or seminar(s) should be mailed to the following address at least 60 days in advance of the first scheduled date: Service Training Schedule, ELECTRONIC SERVICING, 1014 Wyandotte St., Kansas City, Mo. 64105. Include: a brief description of the course; the duration of each session; the location, time and date; the cost, if any; and any other pertinent information you feel will be helpful.

### **Wollensak Audio-Visual Product Servicing Clinics**

**Course content:** Training of in-school technicians to service Wollensak audio-visual products, including new heavy-duty cassette recorders.

**Sponsor:** 3M/Wollensak

**Locations:** Clinics have been scheduled for Buffalo, N.Y.; Pittsburgh, Houston, Dallas, Detroit, Cleveland, Boston, New York City, Baltimore, Philadelphia, Chicago, Milwaukee, Seattle, San Francisco, Washington and Miami.

**For information concerning date and duration contact:**  
Clyde Donaldson  
Public Relations Dept.  
3M Company  
St. Paul, Minn. 55101

### **EIA Summer Workshop**

**Course content:** Orientation; Video Generation, Transmission and Detection; Troubleshooting Video, Deflection and Sync Circuits; Solid-State Devices and Circuits; Color Television Circuits; Chroma Burst and Color-Killer Troubleshooting; Purity, Tracking and Convergence; Color Demodulation and ECO Circuits; Alignment Procedures; Service and Public Relations.

**Sponsor:** EIA, at Northern Illinois University, NIU Department of Industry and Technology. Assistance will be provided by participating EIA representatives.

**Duration:** Two weeks, lecture demonstrations in evenings from 6:00 to 9:00 p.m. daily. Laboratory sessions are scheduled each afternoon from 1:00 to 5:00 p.m., and evening courses are also included.

**Dates and Locations:** June 14-25, Northern Illinois University, Department of Industry and Technology.

**For further information contact:**

Northern Illinois University  
Department of Industry and Technology  
DeKalb, Illinois 60115

### **Sylvania Service Training Center Courses**

**Course content:** Advanced Color Servicing; Test Equipment; Color Troubleshooting; FM Stereo & Audio Systems; Transistors.

**Sponsor:** GTE Sylvania Service Training Center  
**Duration:** One week, 8:30 a.m. to 4:30 p.m. Classes are limited to 16 trainees.

**Dates and Locations:** Advanced Color Servicing, May 24 and June 21; Test Equipment, June 7; Color Troubleshooting, June 14; FM Stereo & Audio Systems, June 28; and Transistors, May 17. Servicing Training Center in Batavia, N.Y.

**For further information contact:**

Service Training Center  
GTE Sylvania, Inc.  
17 Masse Place  
Batavia, N.Y. 14020

## Attention ES Readers:

### Troubleshooting-by-Mail Program Changed

The staff of ELECTRONIC SERVICING regretfully announces that increased cost and an overwhelming volume of correspondence force us to discontinue the direct-mail troubleshooting assistance formerly provided ES readers.

Although we no longer are able to reply directly by mail to your request, we still intend to help you solve those "harder-than-usual" troubles with which all technicians occasionally are confronted. When you encounter a troubleshooting situation which has you baffled, please perform the following in the order presented:

- Check the ES Annual Subject-Reference index to determine if the situation was covered in a previous issue of ES. Chances are it has been. (A detailed subject-reference index of the content of the previous year's issues of ES is included in the January issue. If you have lost one or more of these "index" issues, copies can be obtained from the Circulation Department of ES for \$1.00 per issue.
- If you are unable to find adequate information about your problem in a previous issue of ES, briefly describe on a postcard the general type of problem you have encountered, then mail the postcard to:

**ELECTRONIC SERVICING**, c/o Reader Preference  
1014 Wyandotte, Kansas City, Mo. 64105

Although we will not be able to reply to you directly, we will cover the general category of your problem in ES as soon as possible.

**ITS YOUR MAGAZINE—LET US KNOW WHICH SUBJECTS YOU WANT TO READ ABOUT AND WE'LL DO OUR BEST TO FULFILL YOUR REQUESTS . . . the editors.**



# Stops arc-backs and cuts call-backs...

## **RCA-3A3C HIGH VOLTAGE RECTIFIER**



It's the tube that saves you time, trouble and dissatisfied customers . . . because it minimizes arcing in rectifier circuits of TV receivers and other high voltage applications.

RCA makes this tube with special equipment that pre-coats the cathode and pressure welds the coating . . . producing such a smooth, uniform surface that arcing is significantly reduced.

The RCA-3A3C takes 38,000V peak inverse plate voltage and supplies 100mA peak plate current.

For high voltage applications, put the RCA-3A3C high on your tube inventory list. This high-volume replacement type is available from your RCA tube distributor along with all the other types you need for your service business.

RCA | Electronic Components | Harrison, N.J. 07029.

# **RCA**

# productreport

for further information on any of the following items, circle the associated number on the reader service card.

## Metal Bin Boxes

A series of non-flammable steel bin boxes in five modular sizes—2 widths (5½ inches and 8¼ inches) and 3 depths (6 inches, 12 inches and 18 inches)—to fit all standard shelving units has been introduced by Bay Products.

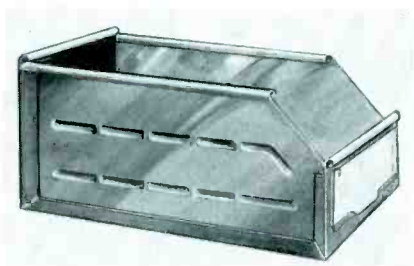

The Bay metal bin boxes reportedly have been designed to utilize a variety of simple "Visual Inventory Control" systems.

Constructed with reinforced rolled

edges and embossed sides for strength and hard use, they are phosphatized and finished in baked-on gray enamel, according to the manufacturer. Large label holders are built in.

Accessories include: dividers (side-to-side and back-to-front), stacking supports, dust covers and optional blank and pre-printed labels.

Prices range from \$1.15 to \$2.60, depending on size.

Circle 60 on literature card

## Color TV Control Packaging

A simple method of inventory for stocking the controls needed for color TV servicing has been announced by Workman Electronic Products, Inc.

The replacement controls for each major brand of TV reportedly are packaged and indexed in standard inventory boxes containing 10 controls. Included are convergence, audio focus, color sensitivity, AGC delay, brightness, vertical and horizontal centering, horizontal frequency and vertical linearity controls.

A complete pocket cross refer-

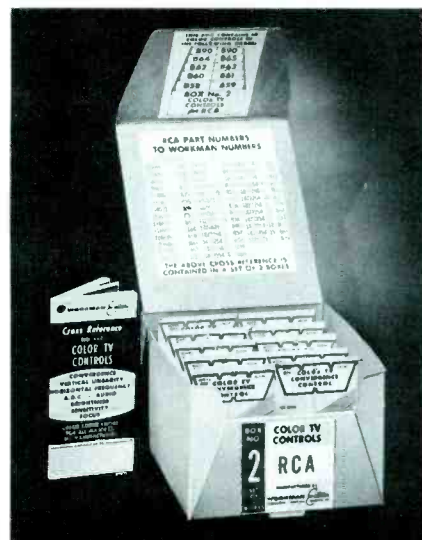

ence for all TV manufacturers is included in each box.

Prices for a selection of controls for a particular brand start at about \$10.00, and depend on the number of controls required to make up a complete set.

Circle 61 on literature card

## Midget Ratchet Screwdriver

A 19-piece, reversible ratchet offset screwdriver set, reportedly designed for use in all kinds of repair work involving Allen hex type, Phillips, and slotted screws has been announced by Xcelite, Inc.

The No. XL-70 set includes a 3¾-inch stainless steel reversible 20-tooth ratcheting handle with a turning radius of 18-degrees, making it useful in confined areas.

With a drive socket insert in its



handle, a 6-inch spinner/extension can be used for ratchet operation as well as normal hand driving with bits. The set has a ¼-inch hex to

## Quick-Servicing Info About COLOR TV, B-W TV, and STEREO



**COLOR TV** . . . Now in one easy-reference book, all of the practical color TV troubleshooting information published in TV TECH AID in 1970 . . . A valuable, single source which lists the symptoms, probable causes and proven cures of over 400 recurring troubles in major-brand color TV, plus tried-and-proven troubleshooting tips . . . Indexed by brand and chassis or model number for fast reference . . . **ONLY 5.95**



**BLACK-AND-WHITE TV and stereo** . . . By popular request, the publishers of TV TECH AID have compiled in one book over 400 symptoms, causes and cures of troubles that have recurred in leading brands of b-w TV and stereo . . . Indexed by brand and chassis or model number, for quick reference . . . **ONLY 5.95**

**ORDER NOW!**

## TV TECH AID

P.O. Box 603  
Kings Park, N.Y. 11754

ENCLOSED IS A CHECK OR  
MONEY ORDER FOR \$.....

### PLEASE SEND:

- B-W TV BOOK (\$5.95)     COLOR TV BOOK (\$5.95)  
 1971 TV TECH AID—12 ISSUES—\$7.95

TO:

Name .....

Address .....

City .....

State ..... Zip .....

Circle 34 on literature card

¼-inch square adapter bit which permits both the reversible ratcheting handle and spinner/extension to be used with Xcelite Series 1000 or other ¼-inch square-drive sockets.

The sixteen alloy steel screw-driver bits included in the XL-70 set have knurled spinner tops which reportedly facilitate screw starting. Twelve of these bits are for driving all hex type screws with recesses ranging in size from .050 inch to 5/16 inches. Included are two popular size bits for slotted screws and No. 1 and No. 2 point size bits for Phillips screws.

The No. XL-70 comes in a snap-lock case molded of high-impact plastic and sells for \$9.73.

Circle 62 on literature card

### Three-Way Ratchet Magnetic Driver

A magnetic screw driver with a three-way ratchet has been introduced by Vaco Products Company.

The Model No. 70081 ratchet design reportedly allows the operator to continue driving without releasing hand grip, thus keeping the bit squarely placed in the screw slot, according to the manufacturer.

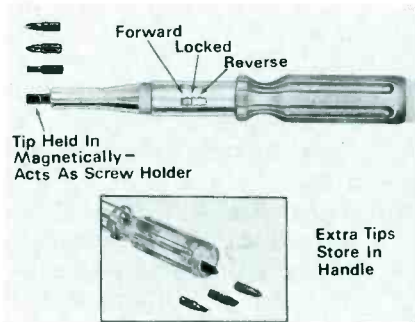

Magnetism reportedly is transferred from shank-to-bit-to-screw, providing a screw holding driver for starting screws in inaccessible places; it also works as a pick-up tool for retrieving screws or bolts that have dropped into tight quarters.

A choice of four bits—No. 1 and No. 2 Phillips plus ⅜-inch and ⅝-inch regular straight slot—are stored in the handle when not in use.

Model No. 70081 screw driver is priced at \$5.95.

Circle 63 on literature card

### Tape Head Demagnetizer

A tape head demagnetizer for cassette player/recorders has been made available by Duotone Company.

The Duotone SA-75 reportedly was developed for tape head protection and is used to reduce wear and extend the life of the tape head. SA-75 removes magnetic buildup from the tape head and prevents sound distortion, according to the manufacturer.

The Duotone SA-75 sells for



\$7.95, complete with plug-in AC cord. ▲

Circle 64 on literature card

## RMS BEST PERFORMING UHF CONVERTERS

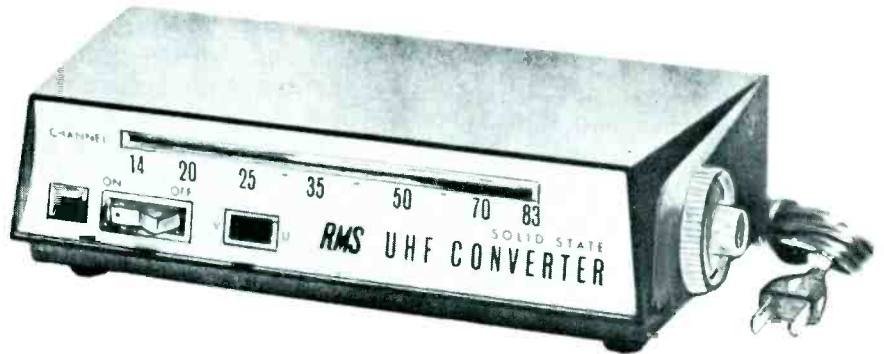

### RMS SOLID-STATE TWO TRANSISTOR DELUXE UHF CONVERTER HAS BUILT-IN AMPLIFIER!

Updates any VHF TV Set to receive any of the 83 UHF/VHF Channels. Low noise, drift-free operation. Simple hook-up. Charcoal Gray Hi-Impact Plastic Housing has Silver-matte finish front panel. Features accurately calibrated UHF dial, UHF/VHF antenna switch, on/off switch, advanced pilot light indicator and tuning control.

Model CR-300

List \$34.95



### RMS SOLID-STATE ECONOMICAL UHF CONVERTER

Two transistor advanced circuitry. Durable metal housing has wood grain finish and Satin Gold front panel with Black knobs having Gold inserts. #CR-2TW

List \$27.95

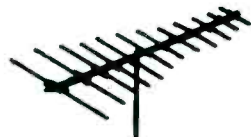

### RMS UHF ANTENNAS . . .

Top performers for all areas! Brings clearest Color and Black and White Reception on all UHF Channels 14-83. Features Reynolds Aluminum COLORWELD!

## RMS ELECTRONICS, INC.

50 ANTIN PLACE, BRONX, N. Y. 10462 • Tel. (212) TY 2-6700

Write for FREE Information on these and other Profit Building Products. . . .

See Us at the NEW Show—Booth B106-108—Americana Hotel, Bal Harbor, Fla.  
Consumer Electronics Show—Booth 113—McCormick Place, Chicago, Ill.

Circle 35 on literature card

## ANTENNAS

100. *Jerrold Electronics Corp.*—has released a 56-page full line general distributor catalog which includes a guide to MATV systems and nearly 300 Jerrold products. The catalog cost is \$1.00.
101. *Jerrold Electronics Corp.*—Catalog S, titled "Systems and Products for TV Distribution," lists specifications of this manufacturer's complete line of antenna distribution products, including antennas and accessories, head-end equipment distribution equipment and components, and installation aids.
102. *Russell Industries* — announces the availability of a complete line of telescoping antenna rods with swivel bases and sliding adapters for rods to disappear. This line is ideal for walkie/talkie and all portable radio applications.
103. *Vikoa, Inc.*—is making available a 64-page, illustrated catalog covering their line of wire and cables and IDS/MATV equipment. Hardware, accessories, connectors, fittings and an index also are included.
104. *Winegard Antenna Systems* —has made available a 32-page catalog designated No. 710 which gives specifications and descriptions on their line of outdoor and indoor TV and FM antennas, preamplifiers, wire, home TV systems equipment and commercial systems equipment. Winegard offers a complete selection of fine quality solid-state amplifiers, boosters and electronic devices for MATV systems.

## AUDIO

105. *Altec Lansing*—introduces a 12-page brochure for in-

formation on sound systems in the sports and entertainment field, stadiums, automobile speedways, hotels, restaurants and other public entertainment facilities.

106. *American Geloso Electronics, Inc.*—has published an 8-page brochure on their line of mini-column sound systems and baffles and speakers. Specifications and installation instructions are included.
107. *Bell P/A Products Corp.*—new 6-page catalog gives detailed specifications and descriptions of the company's broad line of commercial sound components and special purpose sound system products.
108. *Darome, Inc.*—has released an 8-page brochure showing how a complete background music, local public address, and constant level paging system can be installed without using relays or complicated wiring.
109. *Duotone Company* — has made available a new color replacement needle wall reference chart. The chart covers almost all of the major manufacturers from American Microphone and Audax to Telefunken and Zenith. All categories are grouped according to manufacturer enabling quick and precise answers.
110. *Jensen Manufacturing Div.*—has issued an 8-page catalog, No. 1090-E, which describes applications of 167 individual speaker models. Special automotive, communications, intercom and weathermaster speakers, plus a complete line of electronic musical instrument loudspeakers are featured.
111. *Nortronics Co., Inc.* — has released a new Tape Head Replacement Guide which contains tape head replacements for over 2800 domestic and foreign recorder models, a cross-reference to both model and head part numbers for reel-to-reel and cartridge recorders.

112. *Shure Brother, Inc.*—has published a 4-page brochure, "Professional Sound Systems in High Schools, Colleges, and Universities," No. AL 398, describes the company's Vocal Master Sound System and how it helps solve public-address problems.

## AUTO ELECTRONICS

113. *GC Electronics*—has issued an 8-page, three-color brochure, FR-132 on their new line of car stereo and radio accessories. Included are cartridge radio tuners and burglar alarms.

## CABLE

114. *Belden Corporation*—announces a 60-page catalog, No. 871 featuring 134 new products for the instrumentation, communications and data processing fields. Line drawings show physical configurations of each cable type.

## COMMUNICATIONS

115. *The Hallicrafters Co.*—has published a 4-page, two color brochure which provides the complete mechanical and general specifications of the Porta Command PC-230 FM 2-way radio, including the full line of accessories which expand the new radio's versatility.
116. *Sonar Radio Corp.*—Catalog titled "Sonar Business Radio, FM Monitor Receivers and CB Equipment," lists specifications and prices of this manufacturer's line of transceivers, receivers and communications accessories.

## COMPONENTS

117. *Alco Electronic Products, Inc.*—introduces their line of Subminiature Incandescent Lamps as described in their new Alcolite Catalog, LA-711. Prices and complete specifications are given for Alco's lamps.
118. *Burnstein Applebee*—announces a Guide to RCA In-

dustrial Tube Products. The 31-page guide contains two major sections; Characteristics and Replacements.

119. *General Electric Tube Department*—has released a new 52-page Entertainment Semiconductor Almanac, No. ETRM-4311F. The almanac contains approximately 20,000 cross references from JEDEC, or OEM part numbers to GE parts numbers for universal replacement semiconductors, selenium rectifiers for color TV, dual diodes, and quartz crystals.
120. *General Electric*—a 12-page, 4-color, illustrated "Picture Tube Guidebook", brochure No. ETRO-5372, provides a reference source for information about GE color picture tube replacements and tube interchangeability.\*
121. *The Hallicrafters Co.*—is offering a 4-page, two color, brochure that features the complete line of CRX "Portamon" special frequency monitor radios, lightweight pocket portable and table model radios.
122. *Loral Distributor Products*—has made available a 24-page electrolytic capacitor replacement guide. The catalog features replacement products by the original manufacturers part number.
123. *Motorola, Inc.*—has made available a HEP cross reference guide catalog No. HMA07 which lists replacements for over 27,000 different semi-conductor device type numbers available through authorized HEP suppliers.
124. *RCA Distributor Products*—is offering an 8-page illustrated pamphlet entitled "When, Where and Why It Pays To Switch To RCA Alkaline Rechargeable Batteries," No. 1P1385.
125. *RCA/Solid State Division*—announces a revised edition of the Power Transistor Directory, which reflects new

product programs, as well as new product data. All product matrices have been updated to include the latest commercial types as well as preliminary data on developmental types, including RCA power transistors, both silicon and germanium. The Index of Types has been expanded to include DT types as well as JEDEC (2N-Series) types and RCA 40-K series types. Copies are \$.40.

126. *Semitronics Corp.*—has a new, revised "Transistor Rectifier, and Diode Interchangeability Guide" containing a list of over 100 basic types of semiconductors that can be used as substitutes for over 12,000 types. Include 25 cents to cover handling and postage.
127. *Stancor Products*—pocket-size, 108-page "Stancor Color and Monochrome Television Parts Replacement Guide" provides the TV technician with transformer and deflection component part-to-part cross reference replacement data for over 14,000 original parts.
128. *Sylvania Electric Products, Inc.*—a 73-page guide which provides replacement considerations, specifications and drawings of Sylvania semiconductor devices plus a listing of over 35,000 JEDEC types and manufacturers' part numbers. Copies are \$1.00.\*
129. *Workman Electronic Products, Inc.*—has released a 32-page, pocket-size cross reference listing for color TV controls. 105 Workman part numbers are listed in numerical order with specifications and illustrations of the part.\*

#### PICTURE TUBES

130. *GTE Sylvania, Inc.*—has published an interchangeability guide listing 191 commonly used color TV picture tubes which can be replaced with 19 GTE Sylvania Color Bright 85® types.

#### SERVICE AIDS

131. *Chemtronic, Inc.*—has published a 6-page, 4-color, folder describing TUN-O-Brite chemical spray. Application uses are included.\*

#### SPECIAL EQUIPMENT

132. *Switchcraft, Inc.*—announces a new catalog which contains 25 new product listings and over 400 new individual items. All new listings are marked. The 36-page book covers such major Switchcraft product categories as jacks, plugs, switches, connectors, molded cable assemblies, and audio accessories.

#### TV ACCESSORIES

133. *Telematic*—introduces a 14-page catalog featuring CRT brighteners and reference charts, a complete line of test jig accessories and a cross reference of color set manufacturers to Telematic Adaptors and convergence loads.

#### TECHNICAL PUBLICATIONS

134. *Howard W. Sams & Co., Inc.*—literature describes popular and informative publications on radio and television servicing, communications, audio, hi-fi and industrial electronics, including their 1970 catalog of technical books about every phase of electronics.\*
135. *Sencore, Inc.*—Speed Aligner Workshop Manual, Form No. 576P, provides 20 pages of detailed, step-by-step procedures for operation and application of Sencore Model SM158 Speed Aligner sweep/marker generator.
136. *Sylvania Electric Products, Inc., Sylvania Electronic Components Div.*—has published the 14th edition of their technical manual, which includes mechanical and electrical ratings for receiving tubes, television picture tubes and solid-state devices. Price of this manual is \$1.90.\*

## TEST EQUIPMENT

137. *B & K Mfg. Div., Dynascan Corp.*—is making available an illustrated, 24-page 2-color Catalog BK-71, featuring B&K test equipment, with charts, patterns and full descriptive details and specifications included.\*
138. *Eico*—has released a 32-page, 1970 catalog which features 12 new products in their test equipment line, plus a 7-page listing of authorized Eico dealers.\*
139. *Leader Instruments Corp.*—presents a 20-page catalog detailing more than 50 test instruments and accessories for electronic equipment maintenance, repair and servicing.
140. *Leasamatic*—has published a 16-page catalog of "Used Instruments for Sale". Instruments for sale include: Wave Analyzers, Counters, Digital Voltmeters, Impedance and Phase equipment, Oscilloscopes, Signal Sources, Temperature Chambers, Recorders, Voltmeters, Microwave Instruments, Amplifiers, Power Supplies and Microwave Components.
141. *Mercury Electronics Corp.*—14-page catalog provides technical specifications and prices of this manufacturer's line of Mercury and

Jackson test equipment, self-service tube testers, testers, test equipment kits and indoor TV antennas.

142. *Sencore, Inc.*—has issued its 12-page 1970 catalog, Form No. 517, which describes the company's complete line of test instruments, and features 5 new instruments, with performance data and prices included.
143. *Triplett Corp.*—Bulletin No. 51570, a 2-page technical bulletin which provides the specifications and price of Triplett's new Model 602 VOM.

## TOOLS

144. *Chapman Manufacturing Co.*—offers a pamphlet containing their line of tools and tool kits. Kit No. 6320, the Midget Ratchet is featured along with other available tool kits.
145. *General Electric*—has issued a 2-page brochure No. GEA-8927, describing the features of GE's new soldering iron.\*
146. *Jensen Tools and Alloys*—has announced a new catalog No. 470, "Tools for Electronic Assembly and Precision Mechanics." The 72-page handbook-size catalog contains over 1,700 individually available items.
147. *Krieger & Dranoff, Inc.*—announces a 176-page catalog of tools and equipment for precision instrument and electronic work.
148. *Xcelite, Inc.*—Bulletin N770 describes this company's three new socket wrench and ratchet screwdriver sets.
149. *Xcelite, Inc.*—has published a 2-page illustrated Bulletin N670, which introduces two new reversible ratcheting handles for use with more than 60 of the company's available Series "99" nut-driver, screwdriver and special purpose blades.

\*Check "Index to Advertisers" for additional information. ▲

# advertisers' index

B & K Manufacturing Co. Div. of Dynascan Corp. ....	26
Bussmann Mfg. Div. McGraw-Edison Co. ....	6-7
Centralab, Globe Union Inc. Cover	2
Channellock, Inc. ....	34
Chemtronics, Inc. ....	33
Consumer Electronic Show ....	55
Eico Electronic Instrument Co., Inc. ....	8
General Electric Co. ....	17
Heath Company ....	31
International Electronics Corp. ...	25
E. F. Johnson Co. ....	18
Lakeside Industries ....	47
Leader Instruments Corp. ....	1
Lectrotech, Inc. ....	16
Littelfuse, Inc. ....	Cover 4
Panasonic Parts & Service Div. ...	21
Perma-Power, Div. of Chamberlain Mfg. Corp. ....	18
Quality Tuner Repair Co. ....	47
RCA Electronic Components ....	3, 27, 37, 65
RCA Parts & Accessories ...	Cover 3
RCA Sales Corp. ....	19, 36
RMS Electronics, Inc. ....	67
The Raytheon Company ....	12
Howard W. Sams & Co., Inc. ....	13
Sylvania Electric Products Inc. ...	9
TV Tech Aid ....	66
Terado Corporation ....	70
Tuner Service Corporation ....	5
Ungar, Div. of Eldon Industries, Inc. ....	11
Workman Electronic Products, Inc. ....	16
Yeats Appliance Dolly Sales Co. ...	70
Zenith Radio Corporation ....	15

## INCREASE PROFIT — WITH ACCURATE SATISFY CUSTOMER A. C. VOLTMETER

### NOW PERFECT COLOR T.V. with TERADO VOLTAGE ADJUSTERS

CORRECTS HIGH OR LOW VOLTAGE TO NORMAL CAP. 300 to 500 watts

**SATURN** (shown) Model 50-172 Dealer Net \$18.77  
**POLARIS** (w/o meter) Model 50-204 Dealer Net \$12.24

SEE YOUR ELECTRONIC PARTS JOBBER, OR WRITE

## terado CORPORATION

1053 Raymond Ave., St. Paul, Minn. 55108

Circle 36 on literature card

## YEATS appliance dollies

Yeats Offers the Last Word in Modern  
Method of Handling Heavy Appliances

So light, so fast,  
so easy to use...

DeLux  
Model No. 14  
\$89.50

FREE illustrated brochure

Yeats Appliance Dolly Sales Co.  
1300 W. FOND DU LAC AVE.  
MILWAUKEE, WIS. 53205



Circle 37 on literature card

# Cut your time

## With "QT." The Quick Turnover Parts Inventory System from RCA.

How much time do you spend in the shop searching for parts? And if you don't have them, how long does it take you to get them?

If you're doing more than your share of looking for parts or ordering them on the phone, you're wasting time.

Time that's cutting down your efficiency and preventing you from doing the really important things.

That's where our Quick Turnover Parts Inventory System ("QT" for short) can help.

It's a system that puts 250 of the fastest moving RCA parts for TV sets, radios and phonographs at your fingertips. Parts selected by RCA's computers.

You'll also know when the supply is running low. And should any of the parts be dropped from the "top-mover" list, simply return them through your "QT" distributor.

Talk to your RCA Parts & Accessories Distributor about putting in a "QT" Inventory System.

The sooner you do the faster you'll start saving time.

**RCA** Parts and  
Accessories

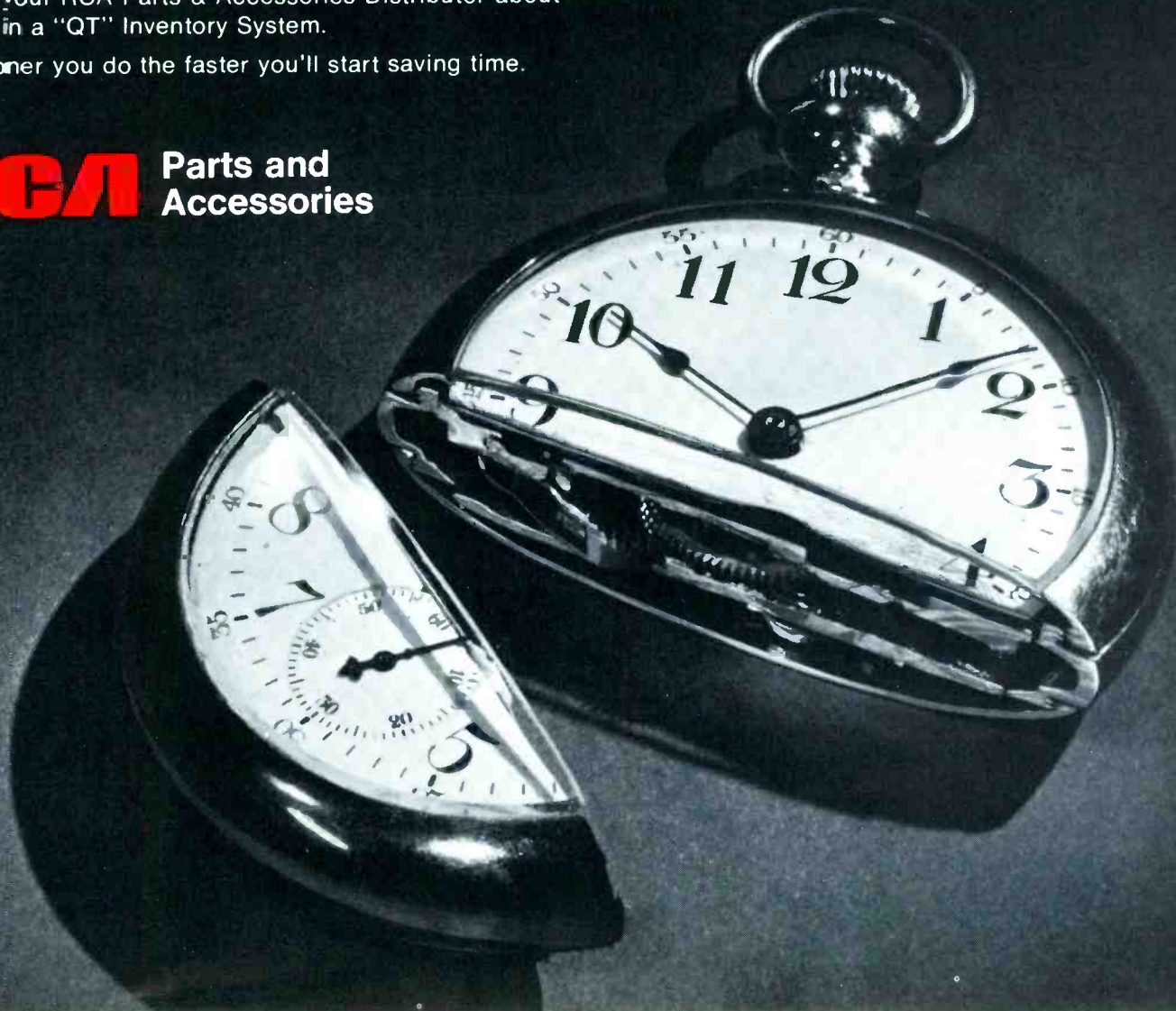

# THE SAFEST SETS YOU'LL EVER SERVICE HAVE LITTELFUSE CIRCUIT BREAKERS.



Standard Catalog Part No.	Hold Rating (Amps.)	Standard Catalog Part No.	Hold Rating (Amps.)
815.650	.490	8152.75	1.92
815.800	.600	815003	2.1
815001	.650	8153.25	2.2
8151.25	.930	815004	2.5
81501.5	1	81504.5	3
8151.75	1.2	815005	3.25
815002	1.4	815006	3.9
8152.25	1.5	815007	4.14
81502.5	1.65		

Littelfuse TV set circuit breakers are the safe, reliable, money saving short-circuit-problem-solvers . . . 17 available models—exact replacements—cover the entire range of domestic television sets.

Littelfuse circuit breakers are available from your distributor—singly or in bulk.

Super-simple in operation—the sensitive breaker flips open under current overloads protecting the circuitry. Reset by merely pressing the red reset plunger. A built-in “trip free” feature of Littelfuse breakers prevents forced closing when dangerous overload currents are present.

Nothing's more reliable than a Littelfuse circuit breaker. Thermal-responsive Littelfuse breakers are dual operated bi-metallic devices providing temperature compensation over a wide range of ambient temperature variation. Molded phenolic construction eliminates warping and distortion of the base, maintaining exact factory set calibrations. The unit is completely enclosed to protect critical moving parts from dirt and other foreign matter.

Any TV set you're likely to service will take Littelfuse circuit breakers.

They'll flip for safety.

You'll flip for satisfaction.

# LITTELFUSE

DES PLAINES, ILLINOIS 60016

SUBSIDIARY OF TRACOR, INC.

Circle 3 on literature card