



# Electronic Servicing

Formerly PF Reporter



## PARTS DILEMMA:

The reaction of two major manufacturers

page 32



The Re-Place



Capacitor Replacements for  
Color and B & W T.V. Radios  
Stereo H.F.



## “These capacitors practically sell themselves, like in a supermarket!”



Says Alexander Wellington, owner of Sylvan-Wellington, Inc., New York City, in speaking about The Re-Place, Cornell-Dubilier's new capacitor replacement center. "I am amazed at the increase in turnover, and the ease of selling."

A pioneer in electronic servicing, Mr. Wellington was also one of the first of those alert distributors who have installed The Re-Place in their stores.

The Re-Place is both a showcase and a self-service

store within a store, all in a compact 5' x 2' area. It organizes capacitor inventory and makes it easy for customers to select and to buy from a complete stock of twist-prong aluminum electrolytics, tubular electrolytics, miniature electrolytics, ceramic discs and mica capacitors.

You can provide instant service to your customers with The Re-Place—and profitably increase your turnover, too. Call your CDE Representative today. Or write for full information about The Re-Place.™



Circle 1 on literature card

# This NEW Sweep-Marker Generator Does Every Color Alignment Job That Needs Doing—and Saves You Up To \$260



**Heathkit® IG-57A**

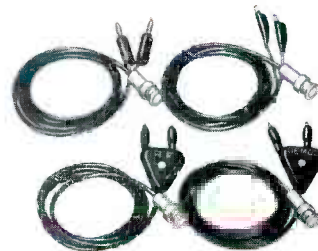
**Kit \$135\*—Assembled \$199\***

**Now With Video Sweep Modulation & Second Bias Supply**

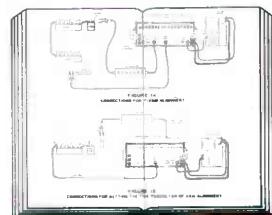
**Compare the Features — Compare the Cost**

- **New Video Sweep Modulation**.....allows you to inject chroma sweep directly into the IF amplifiers or through the antenna terminals ... permits more accurate matching between color bandpass amplifiers and IF and observation of overall response.
- **Exclusive Heathkit Attenuator**.....lets you quickly and accurately determine 6 dB points without guessing. Gives up to 70 dB total attenuation in 1, 3, 6, 10 and 20 dB steps.
- **15 Crystal-Controlled Markers**.....provide all the most used marker frequencies ... 3 for color bandpass, 1 for TV sound IF, 8 at the IF frequencies from 39.75-47.25 MHz including special markers for B&W bandpass. Markers also included for picture & sound carriers on channels 4 & 10. The 15th crystal marker is at 10.7 MHz for FM IF. A coil-tuned 100 kHz marker is also provided. A front-panel input accepts an external marker generator.
- **New Built-In Bias Supplies**.....two individually adjustable bias supplies can be switched for either positive or negative output ... up to 15 V at 10 mA.
- **400 Hz Modulated Or CW Output**.....of any individual marker for fast, simple trap alignment and FM tuner adjustment.
- **Proven Saturable Reactor Circuitry**.....produces stable, linear sweep signals that cover the five most used frequency ranges.
- **Complete Scope Matching Controls**.....switchable Retrace Blanking enables accurate Phase Control adjustment. Just switch on Retrace Blanking for convenient zero output base line. Trace Reverse function permits display of markers in proper sequence.
- **Quick-Disconnect BNC Connectors**.....for quick, easy set-up changes.
- **Complete With All Probes, Test Leads & Terminated Cables**.....includes terminated RF cable with built-in DC blocking capacitor ... Demodulator Probe for envelope detection in color circuits ... shielded Scope Vertical lead ... shielded Clip Lead cable ... Scope Horizontal lead ... two Bias Leads.
- **How-To-Use**.....the famous Heathkit manual includes a comprehensive, well-illustrated Applications Section that shows you how to align TV IF, Traps and Color Bandpass ... how to do IF & RF Video Sweep Alignment, VHF Tuner checking, FM Tuner Tracking & IF alignment.

Compare The New Heathkit IG-57A With All Others ... you get more useable features, better performance, more versatility per dollar with the IG-57A. Order your IG-57A now ... and keep up to \$260 in your pocket.



All Cables, Leads, & Probes are included. Nothing extra to buy.



26 pages of Instructions and Illustrations — show you exactly how to use your IG-57A for greater efficiency, greater profit.



**NEW**  
**FREE 1970 CATALOG!**  
Now with more kits, more color. Fully describes these along with over 300 kits for stereo/hi-fi, color TV, electronic organs, guitar amplifiers, amateur radio, marine, educational, CB, home & hobby. Mail coupon or write Heath Company, Benton Harbor, Michigan 49022.

**HEATHKIT**  
*a Schlumberger company*

HEATH COMPANY, Dept. 25-2  
Benton Harbor, Michigan 49022

Enclosed is \$ \_\_\_\_\_, plus shipping.

Please send model (s) \_\_\_\_\_

Please send FREE Heathkit Catalog.     Please send Credit Application.

Name \_\_\_\_\_

Address \_\_\_\_\_

City \_\_\_\_\_ State \_\_\_\_\_ Zip \_\_\_\_\_

\*Mail order prices; F.O.B. factory. Prices & specifications subject to change without notice.    TE-214

Circle 4 on literature card

# Electronic Servicing

Formerly PF Reporter

## *in this issue...*

- 14 **Dale's Service Bench: Forward AGC in Transistor IF's.** Allan Dale explains the theory of operation of forward AGC systems, and outlines a tried and proven method of troubleshooting such circuitry.

---

- 20 **How Component Defects Affect the Operation of Transistor Circuits.** A component-by-component analysis of how defects change the operation of solid-state circuitry. **by Bruce Anderson.**

---

- 32 **Parts Availability . . . A Special Report.** The philosophies and distribution systems of two major manufacturers are presented in this first installment of a series of periodic reports that examine the various elements of the replacement parts situation. **by Wendall J. Burns and J. W. Phipps.**

---

- 44 **Test Equipment Applications and Techniques: Using SENCORE's Model SM152 Sweep/Marker Generator to Align the Admiral 6H10 Color Chassis.** Second of a continuing series in which ES's technical editor evaluates new test instruments by actually using them to troubleshoot and/or align today's home electronic products. **by Carl Babcoke.**

---

- 54 **Common Trouble In Auto Tape Players.** A detailed analysis of the troubles that occur most often—including oxide fouling, speed and indexing problems, loss of high frequencies and cross talk. **by Joseph J. Carr.**

---

- 58 **Plain Talk About FET's, Part 2.** Continuation of a two-part series that discusses the operation, applications and troubleshooting of the various types of field-effect transistors that are being used in consumer electronic products. **by Wayne Lemons.**

### DEPARTMENTS

Electronic Scanner . . . . . 4	Test Equipment Report . . . 52
Letters to the Editor . . . . . 10	Advertisers' Index . . . . . 63
Troubleshooter . . . . . 29	Product Report . . . . . 64
Antenna Systems Report . . 30	Catalog & Literature . . . . 66

Second class postage paid at Kansas City, Mo. and additional mailing offices. Published monthly by INTERTEC PUBLISHING CORP., 1014 Wyandotte St., Kansas City, Mo. 64105. Vol. 20, No. 2. Subscription rates \$5 per year in U.S., its possessions and Canada; other countries \$6 per year.

Copyright, 1970, Howard W. Sams & Co., Inc. All rights Reserved. Material may not be reproduced or photocopied in any form without written permission of publisher.

#### EDITORIAL

GEO. H. SEFEROVICH, Director  
J. W. PHIPPS, Managing Editor  
CARL BABCOKE, Technical Editor  
WENDALL BURNS, Business Operations Editor  
CAROLYN TICE, Editorial Production  
MARY M. SYMON, Editorial Assistant  
DUDLEY ROSE, Art Director

#### CONTRIBUTING AUTHORS

Bruce Anderson  
Allan Dale  
Wayne Lemons  
Robert G. Middleton

#### TECHNICAL CONSULTANT

JOE A. GROVES

#### EDITORIAL ADVISORY BOARD

LES NELSON, Chairman  
Howard W. Sams & Co., Indianapolis

#### CIRCULATION

R. VINCENT WARD, Director  
EVELYN ROGERS, Manager

#### ADVERTISING SALES

Kansas City, Missouri 64105  
Tele: 913/888-4664  
E. P. LANGAN, Director  
R. JACK HANCOCK, Manager  
JAKE STOCKWELL  
S. F. WILSON, Production

#### REGIONAL ADVERTISING SALES OFFICES

Indianapolis, Indiana 46280  
ROY HENRY  
2469 E. 98th St.  
Tele: 317/846-7026

New York, New York 10019  
CHARLES C. HORNER  
3 W. 57th St.  
Tele: 212/688-6350

Los Angeles, California 90005  
JOHN D. GILLIES  
3600 Wilshire Blvd., Suite 1510  
Tele: 213/383-1552

London W. C. 2, England  
JOHN ASHCRAFT & CO.  
12 Bear Street  
Leicester Square  
Tele: 930-0525

Amsterdam C. Holland  
JOHN ASHCRAFT & CO.  
W.J.M. Sanders, Mgr.  
for Benelux & Germany  
Herengracht 365  
Tele: 020-240908

Tokyo, Japan  
INTERNATIONAL MEDIA  
REPRESENTATIVES LTD.  
1, Shiba-Kotohiracho, Minatoku  
Tele: 502-0656



ELECTRONIC SERVICING (with which is combined PF Reporter) is published monthly by Intertec Publishing Corp., 1014 Wyandotte Street, Kansas City, Missouri 64105.

Subscription Prices: 1 year—\$5.00, 2 years—\$8.00, 3 years—\$10.00, in the U. S. A., its possessions and Canada.

All other foreign countries: 1 year—\$6.00, 2 years—\$10.00, 3 years—\$13.00. Single copy 75¢; back copies \$1.



Robert E. Hertel, Publisher  
Intertec Publishing Corp.  
Subsidiary of Howard W. Sams & Co., Inc.

Do you judge capacitors  
on the same basis  
Bill Dickerson does?

Then you'll use  
Sprague Twist-Lok<sup>®</sup> Capacitors when  
you need twist-prong electrolytics.



To be successful, a TV service dealer has to be fussy about a lot of things. No one knows it better than Bill Dickerson of Central Radio and Television, Santa Barbara, California. He's building on his 17 years' servicing experience every day in a spot where being fussy counts a lot. Central Radio is 14 people strong and has 4 service trucks on the go. It's easy to see why Bill prefers Sprague Twist-Lok Capacitors. They can be used as exact replacements to avoid call-backs. It pays to be fussy.

Ask your Sprague distributor for a copy of Sprague's Electrolytic Capacitor Replacement Manual K-109 or write to: Sprague Products Company, 105 Marshall St., North Adams, Mass. 01247.

**P.S.** You can increase your business 7½% by participating in EIA's "What else needs fixing?" program. Ask your distributor or write to us for details.

*Circle 5 on literature card*



Only Admiral  
gives you  
the Super-Brite  
color  
picture tube  
with built-in  
customer  
satisfaction.



## The exclusive Admiral 3-year warranty.


Now Admiral offers all new Super-Brite color picture tubes with the exclusive Admiral 3-year warranty. This industry exclusive provides your customers with maximum satisfaction.

Every Admiral Super-Brite color picture tube has Admiral-engineered thermal compensation for unexcelled color purity and the newest phosphors that give your customers clear, bright, sharp color pictures.

Here's another Admiral exclusive: In model 25SP22 (25AP22), our engineers have developed a vacuum deposited thin-metallic film on the inside of the envelope to assure trouble-free operation and longer life.

Admiral Super-Brite service color picture tubes aren't rebuilt. They're 100% brand new. From Admiral, producers of more rectangular color picture tube sizes than anybody in the world—the only one with the 3-year protection you asked for.

# Admiral®

 Mark of Quality

Admiral Corporation warrants this picture tube to be free from defects in material or workmanship for 3 years after date of sale to the consumer.

Admiral's obligation is limited to supplying a suitable replacement picture tube. This warranty is effective if the picture tube is registered with Admiral within 10 days after date of sale to the consumer.

Circle 6 on literature card

### Organized Development of All-IC Color TV in Japan

A marketable all-integrated-circuit (IC) color TV is the goal of two separate groups of Japanese electronic firms, according to a recent article in **Home Furnishings Daily**.

The prototype model of what reportedly is the first all-IC color TV was completed in April '69 by Kansai Electronic Development Center in Osaka, after three years of development supported by the combined monetary and technical resources of 12 manufacturers based in the Osaka area, including Matsushita.

The secretary-general of the development center reportedly has stated that all major design problems in the prototype model have been resolved, and with some minor improvements, the design is technically ready for marketing. However, he cautioned, other factors—production facilities, servicing capability, market demand and availability of reliable IC's—must be studied before the participating manufacturers commit themselves to production of all-IC color TV's.

A second group, comprised of 16 manufacturers based in and around Tokyo, also has begun development of an all-IC color TV. The 16 have been divided into five subgroups, with some overlapping, to design the circuits for the set.

The chairman of the committee organizing the Tokyo group, Prof. Miyoshi Haradome of Nihon University, predicts that the group will develop a prototype by the end of the year. He emphasized that the prototype would be a research model and that it would take further study to make it commercially feasible.

Prof. Haradome stated that he believes the first all-IC color TV probably would appear in the market by 1972 and most manufacturers in Japan would start full-scale production of all-IC color TV's by 1973, and by 1975 all color TV's in the market would be all-IC.

The article also reported that an official of the Kansai Electronic Development Center predicted that the era of wholly integrated circuit color TV is expected in Japan within three or five years. The same official also "noted" that Motorola originally had planned to market an all-IC TV set in 1970, but apparently had postponed its program.

### RCA Establishes Integrated Circuit Technology Center

Establishment of an RCA Integrated Circuit Technology Center at Somerville, New Jersey, to support the Corporation's quest for increased product leadership and a bigger share of the potential billion dollar integrated circuit market, has been announced by Dr. James Hillier, Executive Vice President, Research and Engineering.

Dr. Hillier said the Center is being formed to enhance and accelerate the utilization of integrated circuits in all RCA products. The new activity, he added,



# \$975

## TUNER SERVICE CORPORATION

**PROVIDES YOU WITH A COMPLETE SERVICE FOR ALL YOUR TELEVISION TUNER REQUIREMENTS AT ONE PRICE.**

### TUNER REPAIR

VHF Or UHF Any Type \$9.75.

In this price all parts are included. Tubes are charged at cost.

24 hour service at our conveniently located service centers.

1 year guarantee backed up by the largest tuner manufacturer in the U.S.—SARKES TARZIAN INC.

All tuners are cleaned inside and out, repaired, realigned and air tested.

### TUNER REPLACEMENT

Replacement Tuner \$9.75.

This price buys you a complete new tuner built specifically by SARKES TARZIAN INC. for this purpose.

The price is the same for every type of universal replacement tuner.

#### Specify heater type

Parallel 6.3V  
Series 450 mA  
Series 600 mA

All shafts have the same length of 12".

#### Characteristics are:

Memory Fine Tuning  
UHF Plug In  
Universal Mounting  
Hi-Gain Lo-Noise

If you prefer we'll customize this tuner for you. The price will be \$18.25. Send in original tuner for comparison purposes to our office in INDIANAPOLIS, INDIANA.



## TUNER SERVICE CORPORATION

**FACTORY-SUPERVISED TUNER SERVICE**

**MIDWEST** . . . . . 817 N. PENNSYLVANIA ST., Indianapolis, Indiana . . . . . TEL: 317-632-3493  
(Home Office)

**EAST** . . . . . 547-49 TONNELE AVE., Jersey City, New Jersey . . . . . TEL: 201-792-3730

**SOUTH-EAST** . . . . . 938 GORDON ST., S. W., Atlanta, Georgia . . . . . TEL: 404-758-2232

**WEST** . . . . . SARKES TARZIAN, Inc. TUNER SERVICE DIVISION  
10654 MAGNOLIA BLVD., North Hollywood, California . . . TEL: 213-769-2720

Circle 7 on literature card

**You're making money in electronics now.  
RCA Offers 4 Ways to Make More.**

**Study at home...set your own pace.  
RCA Institutes has an easy approach  
to bring you bigger earnings.**



**COLOR TV:**

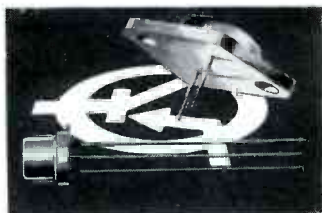
During this course you'll perform over 50 experiments—and receive all parts and instructions to build your own color TV.

The cost of the Color TV Kit is included in the tuition—in both the beginner's program and the advanced course in color TV servicing. (Picture tube optional)

Course is based on the latest receiver circuitry and equipment.

**SOLID STATE TECHNOLOGY**

New courses include the latest findings and techniques in this field. Information you must have if you are to service the multitude of solid state instruments and devices used in TV, Digital, and Communications equipment.



**FCC LICENSE TRAINING:**

Choose the course for the FCC License you want: third, second or first phone. If you need basic training first, apply for the complete License Training Program. Get your License—or your money back.

**CATV TRAINING:**

You'll receive two comprehensive lessons, covering the practical phases of CATV systems in either the Television Servicing or Communications courses.

Licensed by New York State Education Department. Approved for Veterans. Accredited Member National Home Study Council.



MAIL THE COUPON NOW FOR COMPLETE INFORMATION.

**RCA INSTITUTES, Inc., Dept. 661-002-0**  
320 West 31st Street, N.Y., N.Y. 10001

Please rush me FREE illustrated catalog. I understand that I am under no obligation, and that no salesman will call.

Name \_\_\_\_\_ Age \_\_\_\_\_  
(please print)

Address \_\_\_\_\_

City \_\_\_\_\_

State \_\_\_\_\_ ZIP \_\_\_\_\_

Circle 8 on literature card

will complement the integrated circuit efforts of the Solid-State Division of Electronic Components, headquartered in Somerville, and will include groups from RCA product divisions involved in the development, design and production of equipment incorporating integrated circuits.

"Major product divisions will provide resident groups at the Center to speed the conversion of new technological opportunities into advanced product concepts," Dr. Hillier explained. "By bringing together key divisional engineering personnel at one location, the Center will aid in the cross-pollination of design concepts and in the combination of requirements to maximize RCA's total skills in integrated circuits.

"The research activities in microelectronics at RCA Laboratories in Princeton also will be closely coordinated with the new Center's activities," he said.

"Creation of the new Center is a logical step in the Corporation's commitment to microelectronics. It will provide proper resources and facilities to ensure further progress in advanced integrated circuits processes and products, particularly ones which will have an impact on the development of future products for RCA's apparatus and systems divisions."

Dr. Hillier pointed out that RCA's prototype and small production requirements for integrated circuits will be handled by the Center. The Solid-State Division of Electronic Components will continue to have responsibility for the product design, volume manufacture and marketing of integrated circuits for RCA and other equipment customers.

**National Service Conference**

The third National Service Conference was held Feb. 5th in Peoria, Illinois.

Host of the event was the Peoria chapter of the Associated Radio and TV Service Associations of Illinois (ARTS).

Items discussed included: availability of replacement parts; warranty practices; safety of home entertainment equipment; technician recruiting, training and public relations; procuring instruments for public electronics schools; and serviceability of consumer electronic products.

**Clairtone of Toronto Develops Solid-State Modular TV**

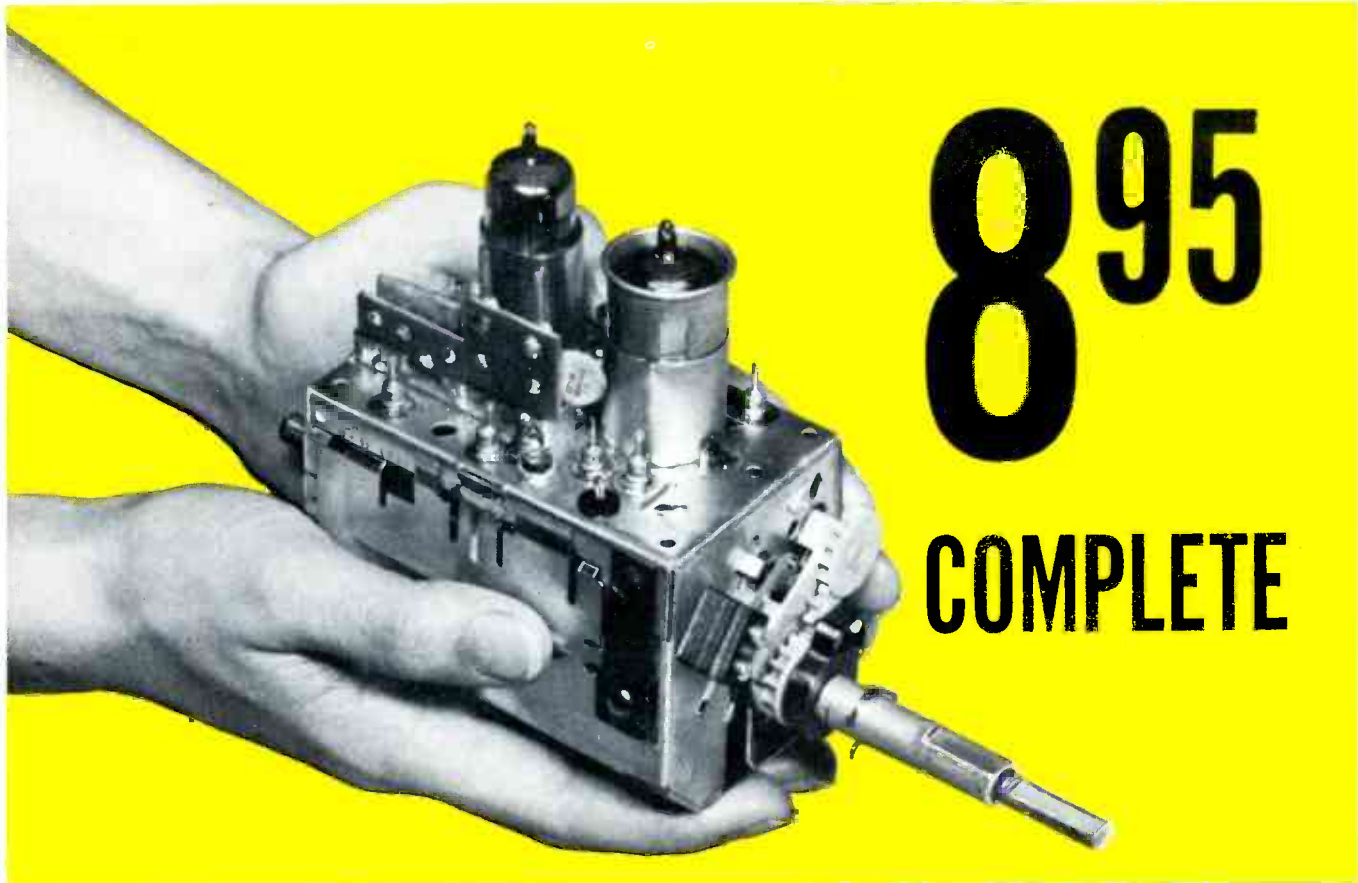
A modular solid-state color TV has been developed by Clairtone Sound Corporation, a Toronto-based manufacturer. The new chassis, designated MSS71, is expected to be in production by mid 1970.

**Two-Program TV System**

DuoVision, a system of transmitting two separate television programs simultaneously over a single standard television channel, has been patented by Charger Electronic Systems, Inc., of New York City. This patent also covers another application of the principle for transmitting three-dimensional images over standard television channels.

The system patented is a device for multiplexing two television programs on a single channel, according to the inventor, Harold R. Walker, who is also the vice president of Charger Electronic Systems, Inc. The new





Castle, the pioneer of television tuner overhauling, offers the following services to solve ALL your television tuner problems.

● **OVERHAUL SERVICE** — All makes and models.

- VHF or UHF tuner \$9.95
- UHF-VHF combination (one piece chassis) \$9.95
- TRANSISTOR tuner \$9.95
- COLOR tuner \$9.95  
(Guaranteed color alignment . . . no additional charge)

Overhaul includes parts, except tubes and transistors.

Simply send us the defective tuner complete; include tubes, shield cover and any damaged parts with model number and complaint. Your tuner will be expertly overhauled and returned promptly, performance restored, aligned to original standards and warranted for 90 days.

UV combination tuner must be single chassis type; dismantle tandem UHF and VHF tuners and send in the defective unit only.

And remember—for over a decade Castle has been the leader in this specialized field . . . your assurance of the best in TV tuner overhauling.

● **CUSTOM REPLACEMENTS**

Exact replacements are available for tuners that our inspection reveals are unfit for overhaul. As low as \$12.95 exchange. (Replacements are new or rebuilt.)

● **UNIVERSAL REPLACEMENTS**

Prefer to do it yourself?

Castle universal replacement tuners are available with the following specifications.

STOCK No.	HEATERS	SHAFT		I.F. OUTPUT		PRICE
		Min.*	Max.*	Snd.	Pic.	
CR6P	Parallel 6.3v	1¾"	3"	41.25	45.75	8.95
CR7S	Series 600mA	1¾"	3"	41.25	45.75	9.50
CR9S	Series 450mA	1¾"	3"	41.25	45.75	9.50
CR6XL	Parallel 6.3v	2½"	12"	41.25	45.75	10.45
CR7XL	Series 600mA	2½"	12"	41.25	45.75	11.00
CR9XL	Series 450mA	2½"	12"	41.25	45.75	11.00

\*Selector shaft length measured from tuner front apron to extreme tip of shaft.

These Castle replacement tuners are all equipped with memory fine tuning, UHF position with plug input for UHF tuner, rear shaft extension and switch for remote control motor drive . . . they come complete with hardware and component kit to adapt for use in thousands of popular TV receivers.

Order universal replacements out of Main Plant (Chicago) only.



**CASTLE TV TUNER SERVICE, INC.**

MAIN PLANT: 5701 N. Western Ave., Chicago, Illinois 60645

EAST: 41-90 Vernon Blvd., Long Island City, N.Y. 11101

Circle 9 on literature card

system resembles color TV transmission; the signal for the second program is modulated on a subcarrier. The signal is then modified in such a way that any "leak-through" to the main picture would produce a simple gray tone. The multiplexed second picture then gives no evidence of its presence on a standard TV set tuned to the regularly scheduled programming.

To obtain the second picture, a TV set with an adapter picks up the subcarrier and demodulates it, much as is done in color TV transmission. The main picture, of course, is not picked up, and the patent states that there is no interference from the main picture.

The subcarrier picture is received in black and white only, although color pictures can be received on the main channel.

The DuoVision system uses a video subcarrier frequency of 4.24 MHz rather than the 3.58-MHz subcarrier used in color TV. Although the bandwidth is slightly narrower than the 4.5 MHz specified for black-and-white pictures, Walker claims the added signal's resolution will be as good as that of the regular signal.

The patented DuoVision system depends on the eye's persistence of vision, or its ability to average the light intensity of a few consecutive TV frames. The light intensity changes because the phase of the added signal's subcarrier naturally reverses in every other frame—bright points on the screen in one frame become dark in the next. Consequently, the eye tends to see only the regular program because the added signal averages out to gray.

The company has optioned the development to Cowles Communications, publishing and broadcasting company, for pay TV and three-dimensional aspects.

### **EIA Adopts New Picture Tube Numbering System**

A new system for numbering the cathode ray picture tubes used in a television set has been adopted by the Electronic Industries Association to more accurately indicate the usable picture diagonal dimension of a television screen.

As developed and approved by the EIA's Electron Tube Council of the Joint Electron Device Engineering Councils, the new "type designation system" replaces the previous method of assigning numbers which indicated the outside dimension of the bulb itself.

EIA maintains a "type registration" office for cataloging and registering numbers of all electron tubes manufactured by the industry for use in electronic products.

Under the new system, the letter "V" will be added to the type designation to distinguish picture tubes based on the new system.

A color picture tube under the previous system having a picture diagonal of 28¼ inches, for example, might be assigned type number 30ABP22. Under the newly adopted system, the designation would be 28VABP22, accurately reflecting the actual picture diagonal measurement.

### **Radiation Control Records Proposed by ECA**

Regulations that would require manufacturers and distributors of certain electronic products, including TV receivers and some related components, to keep records

of radiation test results and methods, product durability and stability tests, quality control procedures, and product use, maintenance and testing procedures that relate to radiation control, have been proposed by the Environmental Control Administration (ECA).

The ECA proposal also would require distributors and retailers of electronic products covered by radiation control standards and valued at \$50 or more to keep records necessary to identify and trace sales to individual purchasers.

### **Bill to Examine and License Auto Repairmen**

A bill that would require states to examine and license auto repairmen has been introduced into Congress by Representative Seymour Halpern, N.Y., according to a report in **ARTSD News**, Columbus, Ohio.

The bill reportedly would require states to establish apprenticeship and training programs, set standards, "discipline" mechanics, and set procedures for consumer recourse.

The report stated that Representative Halpern hopes the bill will receive hearings during the next session of Congress.

### **Motorola Monochrome Goes Modular**

The modular chassis design employed in Quasar color TV models has been extended by Motorola to three solid-state models of their 1970 black-and-white line.

All circuitry of the new b-w modular chassis, except CRT, tuners and power supply, is contained on two printed-circuit boards that can be snapped out for servicing. The chassis is accessible from the back of the cabinet.

Each of the three modular b-w models also employs an integrated-circuit (IC) audio section and a solid-state high-voltage rectifier.

### **Philco-Ford Retail Franchising Program Offered**

A formal program for selective franchising of retail outlets has been initiated by Philco-Ford. The new program offers one or more of three basic franchises: consumer electronics (TV and audio products), white goods (refrigerators and freezers) and air conditioners.

Under terms of franchise, "authorized dealer's" main obligation is to help distributor reach annual sales goal in product categories for which he is franchised. Philco-Ford, in turn, provides dealers with advertising and merchandising support, inventory price protection on major products, promotional allowances and management courses.

The inventory price protection stipulation reportedly allows the dealers to receive a refund or credit on major merchandise whose price has been reduced since the dealer purchased it. ▲

### **Erratum**

The report in the Scanner department of the December issue announcing the development of a 110-degree color CRT erroneously attributed the development to Shibawa Electric Company. The actual developer is Tokyo Shibaura Electric Company, Japanese manufacturer of Toshiba TV receivers.

# "QT" keeps you ahead with the fastest moving RCA parts.

"QT" is a Quick Turnover Inventory system that brings you a steady supply of the fastest-moving RCA Home Instrument replacement parts. It practically guarantees you'll have the parts you need for most of your servicing jobs.

This means you get the jobs done, without backlogging and last-minute dashes to your distributor for essential "QT" parts.

A "QT" inventory helps you cut down on those stacks of dusty boxes and trays of unused parts—and the dollars you have tied up in them.

The entire system is incredibly handy and efficient.

... lets you find parts quickly while you're working . . . reminds you to reorder when your supply is low . . . makes inventorying and reordering so fast that it's almost automatic.

Suddenly you'll find yourself with a lot more time to devote to additional servicing jobs.

Check it out with your RCA "QT" Parts Distributor. He'll discuss the different "QT" inventory plans with you and help you select one tailored to your operation.

After that, things go very smoothly.

Parts and Accessories, Deptford, New Jersey.

# RCA



## VEA Stand on Warranties Clarified

In your November "Letters to the Editor" column, Mr. Jack Watt makes it quite clear that some confusion exists concerning a resolution pertaining to warranties which was issued by the Virginia Electronics Association and reprinted in *ELECTRONIC SERVICING* (PF Reporter) in December, 1968.

We would like to suggest that if Mr. Watt will re-read our statements he will discover that we "accuse the manufacturer of lying" only with respect to so-called "free" extended warranties. Certainly there is no such thing as a "free warranty" (or anything else) and even the insinuation that extended warranties do not cause an increase in the cost of the product to the consumer is, indeed, an irresponsible misrepresentation of facts.

The current trend toward even longer warranties is, of course, unmistakable, and we realize that this does not have to result in chicanery and need not, of necessity, be a disservice to anyone. As a group, manufacturers are reputable and responsible, and most will honor the provisions of whatever "insurance policy" is included in the purchase price of the product. The fact remains, however, that the length of the policy coverage is not in any way related to the quality of the unit or its anticipated longevity. This would be especially true in the instances where the manufacturer's "authorized" servicing representatives are chosen merely on the basis of their willingness to work for a fee which is determined by the manufacturer to be adequate compensation.

Our resolution was for neither shorter guarantees nor cheaper, less reliable products. We did proclaim that the ones who make the products and make the fantastic claims of "super-reliability" should put their (customer's) money where their mouth is and pay to the servicer of the customer's choosing his prevailing labor rate PLUS a realistic fee for handling and stocking or procuring the replacement part. Though, as was stated, this would still not be a "free warranty", it would at least be fair to all concerned and would better test the manufacturers' intent to stand behind their "obviously better built" units. It was and is our belief that if this rule were adhered to by all, the trend would be to quickly revert to the previous standard warranty of 90 days, which was proven sufficient to de-bug a well-made set or appliance.

W. S. Harrison  
President  
Virginia Electronics Association, Inc.

## Info on Imported Sets

It seems that a lot of your readers have trouble getting full circuit or schematic information on imported sets, mainly those from Japan.

The Japanese Electronic Manufacturing organization does have a New York City office. They publish a free directory containing names and addresses

of all Japanese manufacturers and also sell diagrams dating from 1963 to the present.

Their address is:

The Japanese Electronic Industry Assoc.  
437 Fifth Avenue  
New York, N. Y. 10016

I hope I have been able to help some readers.  
Stanley Schneider  
Yonkers, N. Y.

## Tip for Servicing Auto Radio

Here is a valuable tip regarding the direct-coupled audio amplifier section shown in Fig. 1 on page 27 in the article titled "Troubleshooting Direct-Coupled Audio Circuits in Auto Radio", which appeared in the November '69 issue of *ELECTRONIC SERVICING*.

Don't remove any transistors or do any troubleshooting of the circuit until after you disconnect the speaker and replace it with a speaker of proper resistance that is known to be good.

We have had several of these Motorola radios in, and have wasted time testing the transistors, voltages, etc., only to find that the speaker voice coil was defective.

What happens is that the bias of the first transistor is affected by the resistance (or lack of it) in the voice coil.

Garvin Radio Service  
Osceola, Ind.

## Back Issues

If anyone needs back issues of *ELECTRONIC SERVICING* (PF REPORTER), please contact me.

C. H. Byers  
149 E. Elfin Green  
Port Huenema, Calif. 93041

## Technician Licensing

I think that licensing electronic technicians is probably the most worthwhile idea that has come along in many a day. I know, like Mr. W. S. Harrison, President of the Virginia Electronics Association, that it would not be a cure-all, but it can serve the vital purpose of assuring our customers that they are getting the best of service. Therefore, here is my idea of how it should be done:

Let the National Electronics Associations be the licensing agency. They would hand-pick the worthwhile schools for electronics students to attend as well as the worthwhile home study courses. After graduation from the course on all kinds and types of receivers, they would be licensed as home service technicians, but a certificate of graduation from this course would be required. If it were shown to the NEA, then they would immediately grant a license, without testing, to the graduate. Then, with this license, the graduate could work in a well established and reputable shop where these appliances were sold

# BUSS QUALITY

SMALL DIMENSION

## FUSES and FUSEHOLDERS

FOR THE PROTECTION OF ALL TYPES OF  
ELECTRONIC & ELECTRICAL CIRCUITS & DEVICES

The complete BUSS line of fuses includes dual-element "slow-blowing," single-element "quick-acting" and signal or visual indicating types . . . in sizes from 1/500 amp. up—plus a companion line of fuse clips, blocks and holders.

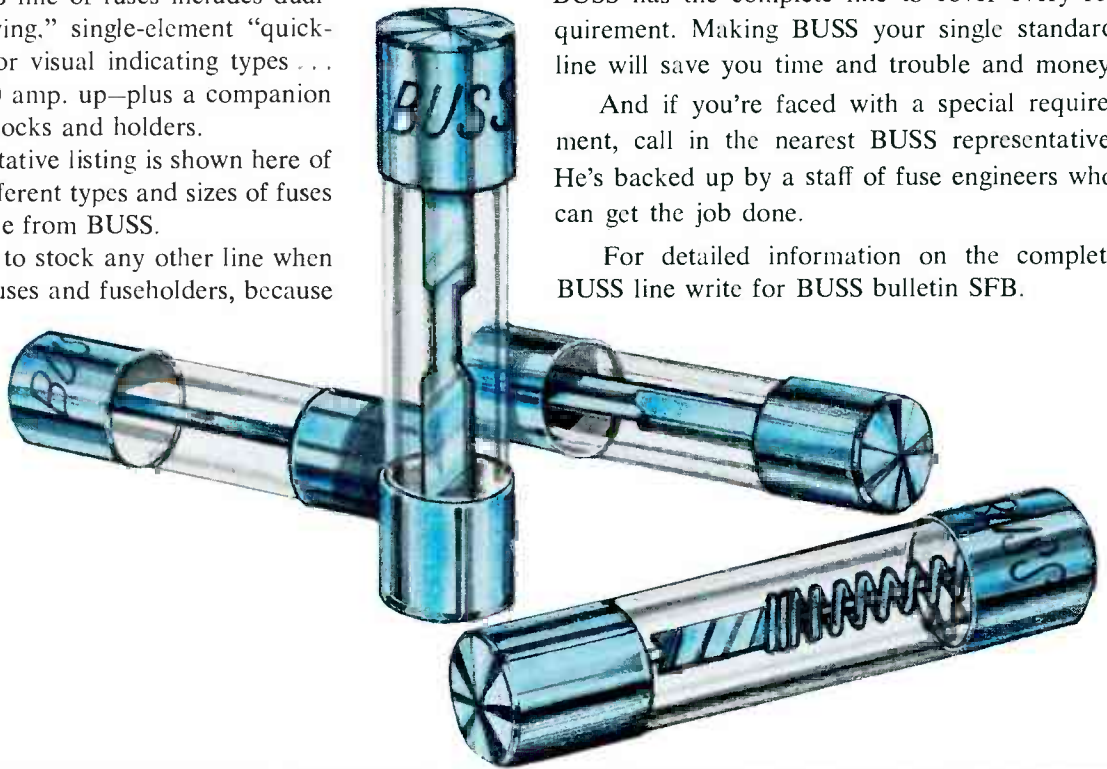
Only a representative listing is shown here of the thousands of different types and sizes of fuses and holders available from BUSS.

You don't have to stock any other line when you handle BUSS fuses and fuseholders, because

BUSS has the complete line to cover every requirement. Making BUSS your single standard line will save you time and trouble and money.

And if you're faced with a special requirement, call in the nearest BUSS representative. He's backed up by a staff of fuse engineers who can get the job done.

For detailed information on the complete BUSS line write for BUSS bulletin SFB.



 Buss AGX Fast Acting Fuses	 Buss AGC and MTH Glass Tube Fuses	 Fusetron FNM Fibre Tube Fuses	 Fusetron FNA Indicating Fuses	 Buss In-the-Line or Panel Mounted Fuse/Holder	 Buss Panel Mounted Holders	 Buss Screw or Solder Terminal Fuse Blocks	 Buss Porcelain Base Fuse Blocks
 Buss AGC Glass Tube Fuses	 Buss Indicating Fuses	 Buss Sub-miniature Fuses and Holders	 Tron Sub-miniature Pigtail Fuses	 Buss HPC Holders	 Buss Lamp Indicating Holders	 Buss Silicon Rectifier Fuse Blocks	 Buss Indicating Aircraft Fuses
 Fusetron MDL Fuses	 Buss ABC Ceramic Tube Fuses	 Buss GMT Fuse and HLT Holder	 Buss High Voltage Fuses	 Buss Space Saver Holders	 Buss Shielded Holders	 Fusetron ACK Stud Mounted Fuses	 Limitron KTK High Interrupting Capacity Fuses
 Buss GJV Pigtail Fuses	 Buss SFE Standard Fuses	 Fusetron Type N Fuses and Holders	 Buss In-the-Line Holders	 Buss HLD Visual Indicating Holders	 Buss Signal Fuse Blocks	 Tron Rectifier Fuses	 Buss Miniature Glass Tube Fuses

**BUSSMANN MFG. DIVISION, McGraw-Edison Co., ST. LOUIS, MO. 63107**

Circle 11 on literature card



give...so more will live  
**HEART FUND**



**Do TV  
 service calls  
 leave you  
 weak  
 in the  
 knees?**

**We can put the spring back in your step**

**FREE  
 illustrated  
 brochure**

Please send me informative brochure on YEATS  
 labor savers — no obligation.

Name .....

Firm .....

Address .....

City .....

State ..... Zip .....

**YEATS**

Appliance Dolly  
 Sales Company

1307 W. Fond du Lac Avenue., Milwaukee, Wis. 53205  
 Circle 12 on literature card

and repaired. If they later wanted to start their own business in this field, they must then obtain a state store license where required, but the state would refuse to issue this license unless a license from the NEA was sent to them. This, I believe, will eliminate the chaff from among us and leave the capable technicians.

Further, we are not consistent as to our prices. The NEA should set prices for the practicing licensed electronics technician to use on a national basis. This would eliminate business cut-throating and inspire cooperation and competition through the quality of work done. This would further assure elimination of the chaff and, in turn, give the customer the best that money can buy in the way of service and repair. The chaff I speak of is the "fly-by-night" technician who only "thinks" he knows about servicing, butchers a lot of sets, and then when he realizes that he can't fix a set, he closes his doors and runs. This licensing idea and this price setting idea, coupled together, would not ever let him get started in the first place, because he could not be licensed by the NEA, never having been a student in their recommended schools or home study courses.

This certainly is not an easy business, for no one has to deal with the continuous meetings with the public as we do, unless they are first-rate salesmen.

The NEA should publish a shop manual that covers all necessary information on theories and troubleshooting techniques and repair of all kinds of equipment. The shops licensed by them would not be without one. This manual would be kept up to date by the NEA, who would supply supplemental manual material as it became available.

They should require that every NEA licensed technician take and pass a certain amount of home study courses, especially on the new sets and new theories, in order to hold their license. This would effectively keep them up to date.

I hope this answers some questions about a proposed, if there is one, licensing program.

Billie W. Fowler  
 Memphis, Texas

#### Help Needed

A month ago I bought a used Simpson Genescope Model 480. Knowing nothing about this instrument, I find I cannot use it to its fullest advantage without the operator's manual.

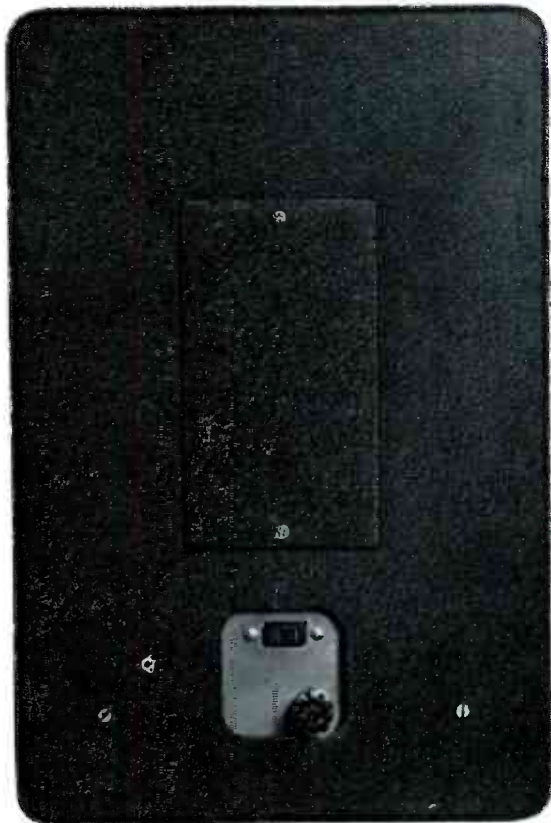
I wrote Simpson but they couldn't locate a manual. If anyone could locate one, I would gladly pay the asking price.

George M. Grim  
 P. G. Electronics  
 1467 Hervey Lane  
 San Jose, Calif. 95125

I would appreciate it if anyone could help me find out what the numbers of the pins are that the green, blue and yellow wires are connected to on a B & K Model 400 CRT unit. Thank you.

B. Green  
 456 N. Spaulding Ave.  
 Los Angeles, Calif. 90036

# The back.



## The back of our B&K 1450 Oscilloscope/Vectorscope put us in front.

Notice the back. Clean, isn't it? That's because it's the back of the only oscilloscope/vectorscope with *front vector inputs and controls*.

Now you can troubleshoot with this one instrument as an ultra stable oscilloscope; or as a vectorscope with this important *exclusive* feature: the inputs are amplified! With the control available *up front*, you can troubleshoot at high level (the output of the color amplifiers), or at low level from the demodulator.

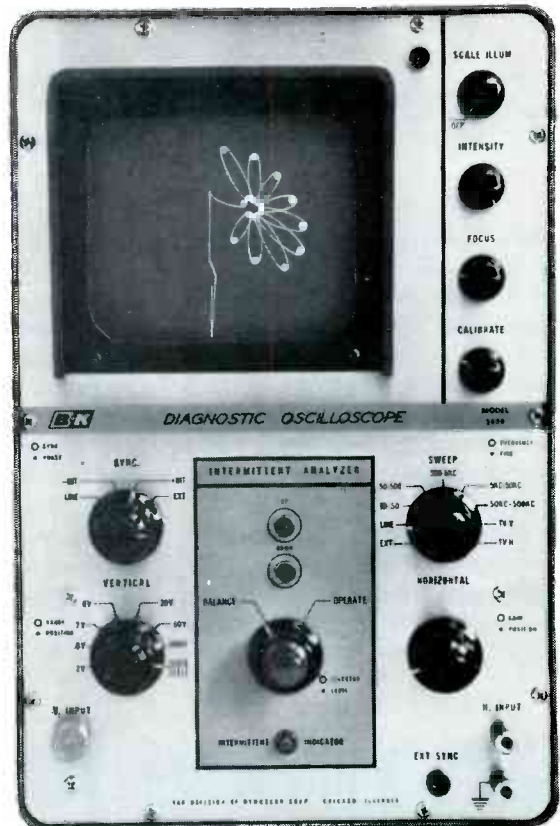
The 1450 shows vector patterns exactly as specified by color TV manufacturers. It also permits direct reading of peak-to-peak voltages from *two calibrated scales*. (Simply switching to the range you want lights up the appropriate scale.)

Any way you look at it, the 1450 Oscilloscope/Vectorscope means greater shop efficiency, more time for profit-making calls, and a lot more mileage from a very fine diagnostic oscilloscope. All from B&K—the company that put an end to ordinary test equipment (the kind that puts an end to your patience).

Of course, we've tried to show you our good side—both of them. Now it's up to *you* to side with *us*. See your B&K distributor soon—or drop us a note for more detailed information.

**Model 1450. Net: \$299.95.**

# The front.



## The front (and inside) of our B&K 1450 Oscilloscope/Vectorscope keeps us there.

Our scope has an exclusive diagnostic device called the *intermittent analyzer*, with electronic memory and optional audio/visual remote alarm (model MON-45).

With this sophisticated detection-reporting system, elusive intermittent conditions can be caught and identified in your absence. Just pre-set one control: if the stage is faulty, it will eventually be detected. And when it is, the intermittent indicator on the 1450 will turn on and stay on until you return from service calls. And all patterns are locked in at any signal level or frequency by *automatic synchronization*.



Product of DYNASCAN CORPORATION 1801 W. Belle Plaine, Chicago, Illinois 60613

**B&K puts an end to test equipment. We've developed "Silent Partners"**

Circle 13 on literature card

by Allan Dale

# Forward AGC in Transistor IF's

Here's a story for you. It happened to a technician I know.

Jim had an unfamiliar color set on the bench. The 2nd video IF transistor, the one the AGC was applied to, had 1.3 volts of forward bias when he clipped the meter on. The station signal was weak, and the IF stage was running nearly open.

He rotated the channel selector to the strongest local station. The screen showed overload. Bias on the IF transistor became higher instead of lower. Jim reasoned that increas-

ing forward bias on a transistor increases its gain. The AGC should have gone negative and driven the gain **down** with a stronger station, instead of **up**. He decided the AGC section must be bad.

A couple of wasted hours and one phone call later, he'd found out about something called **forward AGC**. It's used a lot with transistor video IF stages, which are popular now in both all-transistor and hybrid color sets. Black-and-white transistor sets have used forward AGC for some time.

## Just Below the Knee

It often is difficult to determine whether or not an IF strip is controlled by forward AGC. But you can figure it out. Here's how it operates:

Take a look at the graph in Fig. 1. It shows how collector current in a transistor increases as you increase forward bias. At about the middle of the curve, a signal superimposed on the average base bias produces fairly large swings of collector current. Up near the "knee" of the curve, the upper bend where bias has almost driven the collector junction to saturation, the same signal might actually show loss, instead of gain. That's because the slope isn't steep up there; in fact, it's shallow.

This graph is for an NPN transistor. They're the most popular. **Forward bias has the base more positive than the emitter.** And that's your clue to whether the AGC system is a forward or regular type.

If the transistor is NPN, and the AGC bias goes more positive as the input signal gets stronger, it's forward AGC. If the AGC bias for an NPN goes negative with stronger signals, that's the regular kind of AGC; it biases the transistor downward on its curve.

For example, take the AGC setup shown in Fig. 2. It's from a Zenith color hybrid. The controlled IF stage is included, to help you figure out how the AGC system functions.

The keyed AGC stage is much like any other tube-type. A stronger station signal applies sync tips of greater amplitude to the video input grid. "Keying" makes sure only the sync pulses determine the level of AGC voltage developed.

The voltages shown are with no station tuned in. As the input signal increases, plate voltage decreases—becomes more negative. That's fine for the tube-type RF amplifier in the tuner; it needs a bias that's more negative to reduce gain. That's like

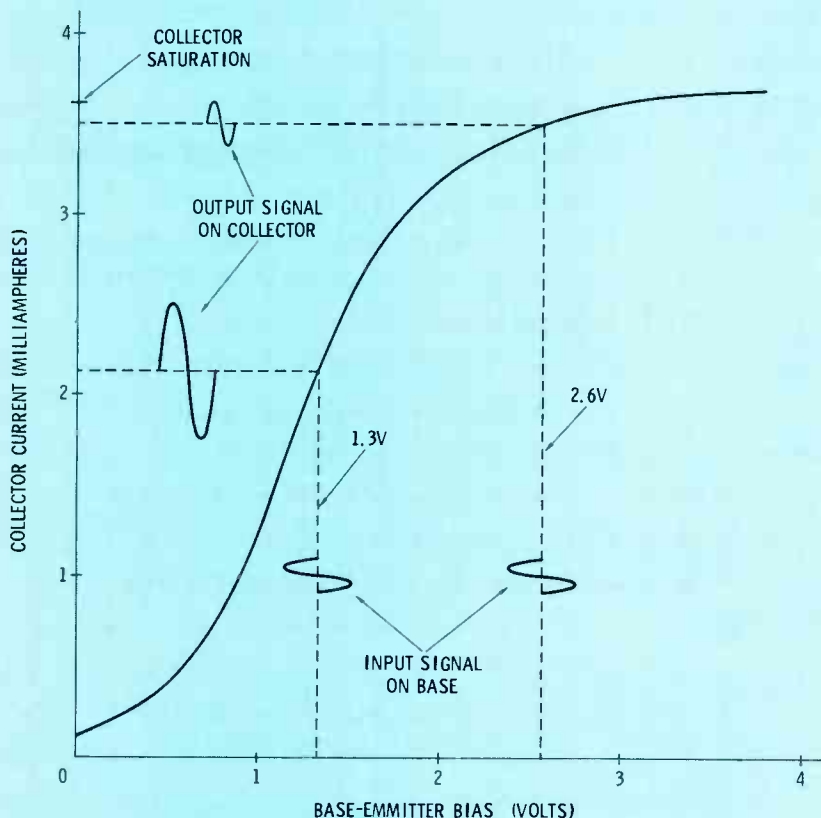


Fig. 1 Graph of base bias vs collector current, called characteristic curve of transistor, reveals how forward bias reduces gain.



regular AGC.

But follow the DC through the 39K, 680K and 10K resistors. That's the AGC path toward the IF. You come to a transistor. When its base becomes less positive, this "inverter" transistor doesn't conduct as much. The collector goes more positive, because less current is drawn through the 1.6K supply resistor. Therefore, a more positive voltage reaches the base of the 1st video IF transistor. It's an NPN type. This, then, is forward AGC; it drives the transistor up into the small-gain, or nonlinear, portion of its curve.

### How One IF Stage Controls Another

Forward AGC sometimes can seem complicated, even after you know what it's about. For instance, take a look at the system in Fig. 3. The 1st video IF in this all-transistor RCA circuit is controlled by the

2nd video IF. Before you read how, try to decide whether both IF transistors receive forward AGC voltage. Now read and learn if you are correct.

Video and sync go to the base of the keyer, and keying pulses to the collector. That's standard with transistor keying, although keying pulses occasionally are fed to the emitter. The amplitude of the sync tips determines the amount of AGC voltage, also as usual. A stronger station signal produces tips with a higher amplitude, which develops an AGC voltage that's highly negative.

This "regular" AGC voltage is applied through a 1-meg resistor to the base and collector of a diode-connected transistor, the **RF AGC clamp**. The emitter goes to a divider-stabilized positive voltage.

The clamp stage protects the field-effect transistor (FET) in the tuner RF stage. If too much AGC voltage gets to it, the insulated gate

of the FET could be punctured and the FET destroyed.

With a weak station signal, the positive delay voltage from the 2.2-meg resistor dominates at the collector of Q2. The transistor conducts any time its collector-base voltage becomes more positive than the emitter, which stands at about 6 volts. Thus, the positive AGC voltage for the tuner can't exceed 6 volts; but that's enough to keep the FET amplifier running wide open.

When station signal gets strong enough, it significantly raises the negative AGC keyer voltage. This voltage then overrides the positive delay voltage. The collector and base of Q2 become negative. At about 5 volts negative, when there is 11 volts of reverse bias across the transistor, its junctions avalanche—zener diode action. The AGC negative voltage for the tuner thus can't exceed -5 volts. But that's enough

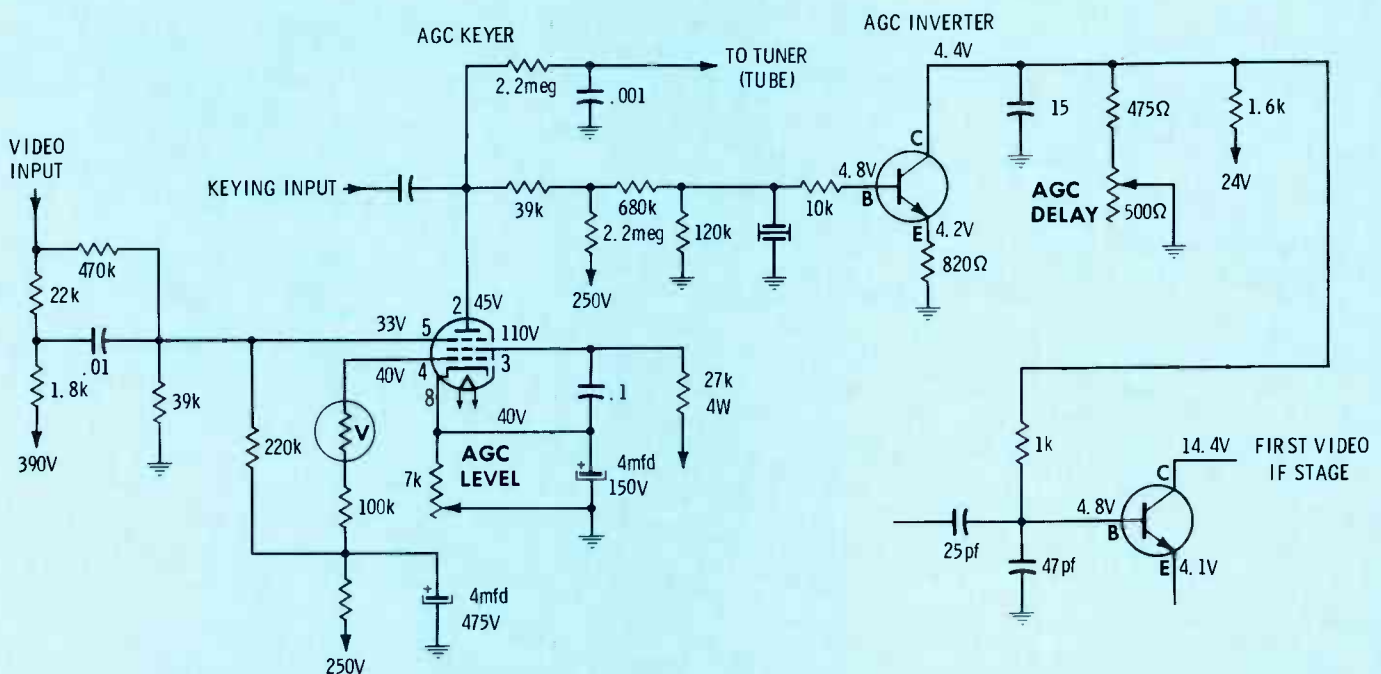


Fig. 2 Regular AGC system produces voltage that goes negative with stronger signal, but inverter stage turns it positive for IF AGC.

to almost cut off the FET.

So far, AGC is the same as with tubes. The FET gain goes downward as a more negative (or less positive) voltage is applied to its gate. This is **not** forward AGC. Now follow the IF AGC branch.

With a strong signal, a large negative DC voltage is applied through the 1-meg resistor to the base of Q3. A positive delay voltage is part of the base circuit. The transistor is affected only after the negative AGC overrides the positive voltage.

A more-negative base voltage reduces the conduction of Q3. Collector voltage goes more positive. This more-positive voltage is applied through the 1K resistor to the base of the 2nd video IF stage. Transistor Q4 is an NPN. With a more positive voltage on the base of Q4, average collector current increases, driving the transistor operation up into the small-gain portion of its curve. That's forward AGC.

The 2nd video IF is an emitter follower for DC, but not for IF signals. The emitter is DC-coupled to the base of the 1st video IF transistor, Q5. Increased conduction in Q4 develops more voltage drop across its two emitter resistors. And that increases the positive voltage at the base of Q5. Since Q5 is NPN, this AGC is also of the forward type.

### Method for Troubleshooting Forward AGC

Trouble symptoms that look like AGC faults can be caused by one of four things: (1) The IF or RF transistor that is AGC controlled may be defective. (2) One of the signal inputs from which AGC is derived may be missing or inadequate. (3) The stage that develops AGC voltage can be at fault. (4) The network that distributes AGC voltage might have a defect.

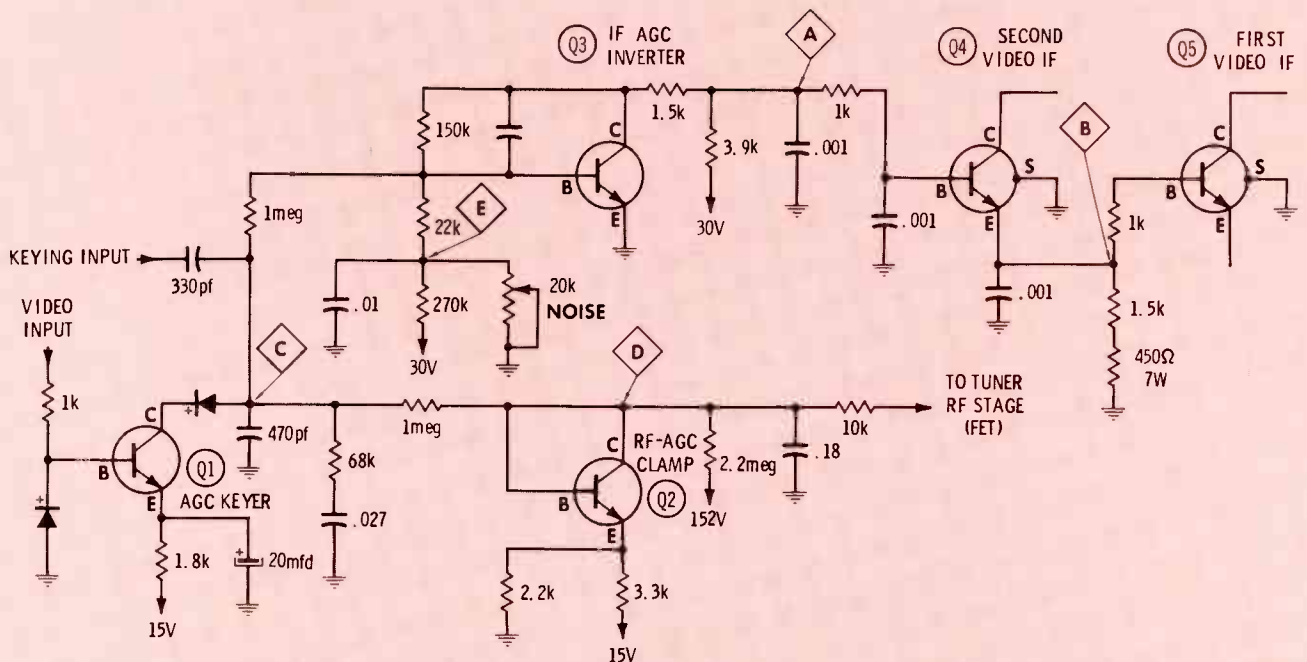
You need to decide quickly which of those possibilities is fact. That's

the secret of a good troubleshooting method.

The thing to be sure of first is the RF or IF transistor. If it's bad, no amount of checking elsewhere will tell you anything helpful. The inputs for the AGC stage can't be right unless the RF and video IF stages are operating. They in turn can't operate normally with an AGC fault upsetting them. So it's important to get them operating normally, right away.

The best way to start is by clamping the AGC lines. In a system as complicated as the one in Fig. 3, you may need as many as three separate bias supplies.

Clamp the RF line first. In this particular model, you have a special advantage. Normal AGC for the tuner begins at 6 volts and goes through zero to -5 volts. Zero bias on the AGC line is okay. So, to clamp that line you need only jumper point D to ground.



**Fig. 3** Completely solid-stage AGC system. Clamped AGC for RF stage is regular AGC. Text tells how to figure out if both IF stages are operating with forward AGC.

# Don't sell a color picture tube unless its been on a test ride.

Down at the bottom of the page, you have a major advance in space-age homeliness.

And a major advance in color tube testing as well.

That machine squatting down there is our beloved Iron Horse, the fully-automated, revolving carousel we use to test our color bright 85<sup>®</sup> tubes for emission, gas leakage, shorts, arcing and screen uniformity prior to shipment.

Now we don't intend to go into a song and dance on how total automation reduces testing error.

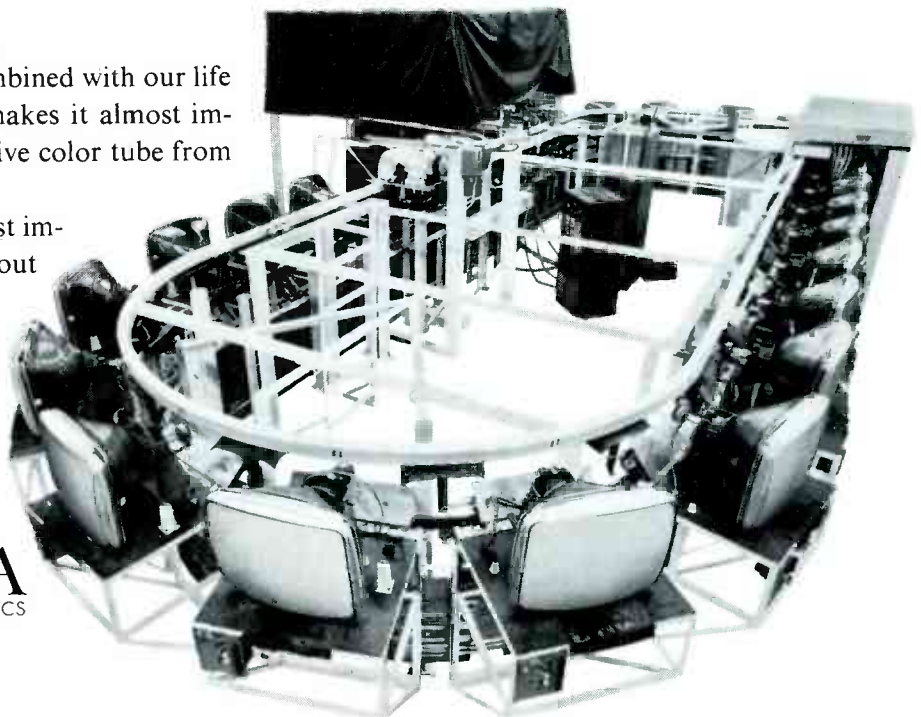
But we will tell you one thing.

Our Iron Horse test ride, combined with our life testing and 100% set testing, makes it almost impossible for you to get a defective color tube from us.

Which in turn makes it almost impossible for you to get chewed out by a customer.

Next time you need a color replacement tube, remember the great thing about the color bright 85. We don't send it to you till it's been around.

**SYLVANIA**  
GENERAL TELEPHONE & ELECTRONICS



*Circle 14 on literature card*

Or, you can use a variable bias supply and adjust it to suit the level of station signal you're feeding the tuner. Start with it near zero.

(Let me insert a caution here: **Turn the set off while you're making jumper or bias-supply connections in any transistor receiver.** Some of the transistors in these sets are easily damaged by making connections while the set is operating. And always make the ground connection **first**.)

Next, clamp the IF AGC line with a voltage source at point A in Fig. 3. Remember that you want a positive bias applied to the 2nd video IF. Just a few volts will do—the schematic usually shows about how much is needed.

With RF and IF AGC lines both clamped, the picture should be normal on the screen. If not, in a system like the one in Fig. 3, try adding another clamp bias at point B. That separately clamps the 1st video IF. If it restores the picture, the 1st video IF base isn't being controlled by the 2nd video IF emitter as it should be.

If normal clamp voltages make the set operate, check the range of

control. Raise and lower the clamp voltages and make sure that operating ranges of the transistors seem normal—when RF AGC goes positive, a strong station should overload the set noticeably. The same should happen when the IF AGC is made less positive. That proves the RF and IF transistors are responding correctly. On to the next possibility.

With a picture on the screen, your scope is the best way to check the two inputs to the AGC keying stage. There should be a large keying pulse present, usually 200 to 400 volts peak-to-peak. And there should be 2 or 3 peak-to-peak volts of video and sync. If either signal is missing or low, find the cause.

Next, make sure the AGC keying stage operates normally. If negative AGC voltage isn't being developed at point C, find out why. Check individual parts in the keyer stage, if you have to; there aren't enough of them to take long. The two diodes and the transistor are naturally the most likely suspects. Be sure the DC supply voltages are okay. If the AGC voltage is present, increase and decrease station

signal and make sure the voltage varies accordingly. It should be more negative with stronger signal. If that's okay, move on to the branches of the AGC line.

In the tuner AGC branch, check the RF AGC clamp stage. This may be a zener diode in some sets. Try applying a variable bias supply at point C and measuring the resulting voltage across the clamp transistor, at point D. By all means, check the 2.2-meg "bucking" resistor; it's a common troublemaker.

Checking out the IF AGC branch includes testing the inverter stage. It also involves the bias divider network in the base circuit. With a meter, measure the voltage at point E as you twist the shaft of the Noise control. It should vary from zero to almost 3 volts.

Measure the other operating voltages on the inverter stage. You can evaluate the transistor simply, too. Measure the collector voltage as you turn the noise control. With the shaft at the top end, collector voltage should be higher than normal. As you turn the shaft to the other end, collector voltage should decrease, becoming less than normal.

Remember, all this monkeying around in the AGC circuits doesn't affect the picture, because you have the tuner and IF stages clamped. And by the time you've gotten this far, you've probably found the trouble.

You can apply the same methods to any AGC system. Just figure out, in advance, whether the AGC bias should be forward or reverse. Most other circuits don't have quite as many branches and interactions to worry about. But all of them respond to checking the four possible causes of AGC trouble mentioned previously.

#### What's Coming Up Next

It's the kind of season to stay indoors. And many of your customers are. They're either watching a lot of TV or listening to a lot of stereo. Either one can mean work for you.

If it's stereo, you'll want to read next month's **Service Bench**. Sometimes, trouble in the so-called "simple" hi-fi amplifier can be a real aggravation to find. One of the best ways I know is by testing with a square wave and a scope. I'll show you next month how you can do it. ▲

**MODEL 3000**  **NEW VECTORSCOPE**  
**5" OSCILLOSCOPE**



**5 MHz HIGH SENSITIVITY WIDE BAND SCOPE PLUS Input-Compensated VECTORSCOPE**

- Direct reading Graticule, instantly removable (2 supplied) plus special V input circuit
- Peak-to-Peak readings as easy as reading VOM or VTVM
- Vertical amplifier, 4.6 Mv RMS/Cm usable to 10 MHz for truly high sensitivity . . . 10 Hz to 5 MHz  $\pm$  3Db . . . 0.08 Microsecond rise time
- Horizontal amplifier, 5 Hz to 500 KHz
- Internal, external and line synch.

**JUST 109.95 KIT**  
**179.95 WIRED, probes optional.**

Power req. 115V 50/60 Hz 85W.  
11 x 9 x 16, 22 lbs.

All Mercury Test Equipment Guaranteed For One Full Year!

The Model 3000 is perfect for general purpose waveform observation applications, meeting all the requirements of technical schools, industry, electronic experimenters and development engineers.

Write for complete catalog of Mercury Test and Repair Equipment, and name of your nearest dealer.

**MERCURY ELECTRONICS CORPORATION**  
315 Roslyn Road • Mineola, N.Y. 11501 • (516) 742-5400  
CANADA: William Cohen Corp. • 8900 Park Ave. • Montreal-11

This BOOK is a 'must' ▶  
"Servicing Color TV With The Vectorscope" \$2.95



Circle 15 on literature card



## Guns are her business... SHE'S GOT TO BE TOUGH!

She makes the final inspection of every tri-mount electron gun we manufacture for Channel Master Color CRTs ... and she's tough about it!

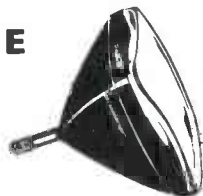
The six different tests for spacing, alignment, angle of deflection and convergence of each gun... hand-crafted to micro-inch tolerances in our dust-free arsenal... guarantee precise aiming at the rare earth target. All of her guns must meet OEM specs. Any that don't are fired on the spot.

The tests she makes are just part of the 117 inspections that each Channel Master Color CRT must pass before it's final OK for shipment. Just part of the reason why there's no finer color CRT you can recommend. The Rest? We use only the finest materials, and assemble them to higher-than-industry specifications.

Color is our specialty...that's why so many people are watching Channel Master!

At Channel Master YOUR Reputation is OUR Business.

**OPTI-CHROME  
OPTI-VUE  
COLORLUX**



# **CHANNEL MASTER<sup>®</sup>**

DIVISION OF AVNET, INC., ELLENVILLE, NEW YORK 12428

*Circle 16 on literature card*

February, 1970/ELECTRONIC SERVICING 19

# How Component Defects Affect the Operation of Transistor Circuits

by Bruce Anderson

The precise manner in which a transistor operates may be of interest and value to some; however, those of us engaged daily in repairing transistorized equipment can perform our task with considerably less information. Nevertheless, a few of the characteristics of a transistor must be remembered. These essential bits of information are summarized as follows:

1. The average amount of DC voltage present between base and emitter remains nearly constant, so long as the transistor is in a state of conduction. Obviously, if the base voltage is insufficient to allow emitter-to-base conduction, the potential between these two elements may vary; but if there is normal conduction, the voltage will remain **almost** constant. This is quite different from a tube, in which the grid voltage may vary over a fairly large range, perhaps 10 or 15 volts, during normal operation. Conversely, the grid current is very small (and nearly constant) throughout the operating range, while base current is significant and variable.

2. Since the base voltage remains nearly constant throughout the normal range of operation, the input impedance of the device itself is inversely proportional to the input signal level. The input impedance may be increased by connecting an unbypassed resistance in series with the emitter of the transistor. This raises the overall impedance seen at the base and tends to make it independent of the signal level.

3. Unlike a tube, whose input impedance is normally in the order of thousands or millions of ohms, the input impedance of a transistor connected in a common-emitter circuit is quite low. As a general rule, it may be estimated by multiplying the impedance between the emitter

and ground times the beta of the transistor. Thus, if the transistor shown in Fig. 1 has a beta of 100, the input impedance probably will be about 1000 ohms. Any biasing resistors in the base circuit will be shunted across this input impedance. This resistive component of the impedance might be shunted by a fairly low value of capacitive reactance, which will lower the impedance further. Naturally, if the emitter resistor is bypassed, the capacitive reactance "seen" at the base will approximate the reactance of the capacitor multiplied by the beta. To calculate this impedance, the frequency of operation has to be known.

4. Since the amount of collector current is determined by the emitter-to-base current to a much greater degree than it is determined by the collector voltage, the collector load impedance of a common-emitter transistor circuit can be quite high.

5. If the emitter-to-base current is made high, driving the device into saturation, the voltage drop from emitter to collector may become almost negligible. This is unlike a tube, in which the cathode-to-anode drop is considerable, even when the control-grid voltage is positive with respect to the cathode.

6. Transistors are available in either of two types, NPN and PNP. This allows operation with the collector supply either positive (NPN) or negative (PNP). This allows greater latitude in the design of complete circuits, by using stages of different types. In the discussion here, NPN devices are considered. If a PNP device is encountered in a circuit, the operation will be about the same, except that all polarities are reversed.

7. Unlike a tube, the characteristics of a transistor are not as likely

to change over long periods of time. A tube gradually wears out, from the time it is placed in operation. On the other hand, a transistor which has been in service for an extended period is likely to produce just as much gain as it did when first installed. Tubes usually fail because they no longer can produce gain; transistors usually fail because of shorts, opens or leakage.

8. Also unlike a tube, the characteristics of a transistor vary considerably with temperature. This can lead to a condition called "run-away," wherein an increase in temperature causes an increase in current, which causes an increase in temperature, etc., until the device is destroyed. This is primarily a design problem, but it may be the result of circuit malfunction. Also, it makes it doubly important not to obstruct the normal circulation of air inside the cabinet of transistor equipment.

9. The beta of a transistor, which is directly related to the amount of gain possible in a transistor-equipped circuit, is not held to tolerances which are as stringent as the transconductance tolerances of tubes. Since the beta of each of a number of transistors of the same designation may vary considerably at the time of manufacture, and since these values of beta are not apt to change very much throughout the life of the transistors, the measuring of beta is not a particularly exact test of a suspected transistor. This, however, does not discourage the use of a beta-type transistor tester, which provides a convenient means of testing for shorts, opens and leakage.

In the light of the above characteristics, it is possible to predict the manner in which certain malfunctions of the surrounding circuit may affect the operation of the transis-

tor and the circuit.

The effect of a change in the value of each of the components in Fig. 2 can be studied, and, by extension, these may be used to predict the operation of similar circuits.

### Changes in R1

The value of R1 can increase or decrease; this change may be rather slight, perhaps 20%, or it may be drastic, such as a complete short or open.

Suppose that the resistor were to increase moderately in value. If this should happen, the voltage drop across it would increase and the drop across R2 would have to decrease. (Since the bleeder current through R1 and R2 is much greater than the base current of the transistor, which also passes through R1, this latter current may be ignored for simple calculations.) As the drop across R1 increases, the bias voltage on the base of the transistor must decrease; but as the base voltage and current decrease, the emitter and collector currents of the transistor also will decrease, reducing the emitter voltage.

The result of this moderate increase in the value of R1 is a reduction of the base and emitter voltages of the transistor, and because the collector current has been diminished, the collector voltage will increase. These would be the most obvious symptoms observed with a meter.

Most transistors used in audio applications are biased at a point where an increase in emitter-to-base current will increase the gain of the stage (if it has any effect at all), so a moderate decrease in the base current also might decrease the gain moderately.

Suppose that the value of R1 should increase drastically, perhaps to 100K ohms. With so much resistance between B+ and the transistor base, the base voltage is forced below the barrier potential of about .7 volt. This, of course, will cause the transistor to cut off, dropping the emitter voltage to zero and causing the collector voltage to increase to nearly 13 volts.

Before proceeding, there is an important exception to the usual rule that gain increases as the emit-

ter-to-base current of an NPN transistor is increased. In the IF-amplifier circuits of many television receivers, the transistors are biased so that an increase in emitter-to-base current causes a decrease in amplification, even though the collector current does increase. This is called "forward AGC", and can cause a lot of confusion to the unwary. (Dale's Service Bench in this issue explains forward AGC.)

Now consider the results if R1 decreases in value. According to Ohm's law, the base voltage must increase, increasing the emitter-to-base current. The emitter voltage rises right along with the base voltage (discounting a couple of millivolts), and the collector voltage falls because of the additional current through R4. As the value of R1 continues to decrease, the base and emitter voltages will continue to rise, and the collector voltage will continue to fall until they are all about the same, or until the transistor burns out from excessive base current.

Regarding the burnout problem, this is sometimes difficult to predict. In the circuit shown, the emitter resistor will limit base current to about 18 ma, even if R1 is shorted. Some transistors will withstand this overload; others will not. Nevertheless, the circuit shown does provide some protection to the transistor. If the value of R3 were only 3 or 4 ohms, it is almost a certainty that shorting R1 would burn out the transistor. For more information on transistor overloads and burnouts, refer to ELECTRONIC SERVICING, November, 1969, pages 26 to 28.

### Changes in R2

To some degree, the effects of changes in the value of R2 will be opposite those caused by changes in R1; however, there are some exceptions. If the resistance of R2 decreases, there will be a reduction in base voltage and emitter-to-base current, and if the change is sufficient, the transistor will cut off.

If the value of R2 increases, base voltage will increase; but even if R2 should open, the base current will not "go through the roof." Since the base current causes a drop

across R1, the base current cannot exceed that value which will drop all the supply voltage across R1. About 2 ma will drop 13 volts across R1, and the base current will be even less than this, since there is some drop across R3. Perhaps 1 ma is a reasonable "guesstimate" of the maximum base current possible if R2 is open. It is apparent that the transistor is less apt to be damaged by opening R2 than by shorting R1.

### Changes in R3

An open cathode resistor in a vacuum-tube circuit will cause the cathode voltage to rise almost to B+, but the effect of opening the emitter resistor (R3 in Fig. 2) in a transistor circuit is not the same. If the transistor base was disconnected from the junction of R2 and R1, the voltage at this point would increase to about 3.7 volts. With the transistor again connected back in the circuit, it cannot conduct if its emitter rises above about 3 volts, so the emitter voltage normally will never increase above this level, regardless of how large R3 becomes.

The decreased conduction will cause the voltage at the collector to rise, but probably not much. A large increase in the emitter resistance in Fig. 2 might increase the emitter voltage to nearly 3 volts. This leaves about 10 volts to be

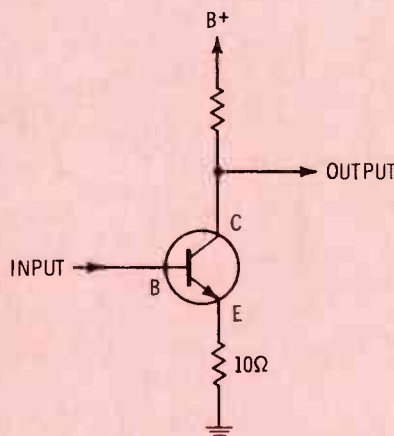


Fig. 1 Basic common-emitter circuit.

dropped across the transistor itself and the collector load—not much change from normal conditions. The most obvious symptom would be a loss in amplification.

Decreasing the emitter resistance tends to decrease the emitter voltage, but this, in turn, increases the base and collector currents. The result is that there will be a sag in the base and emitter voltages, but it will not be in proportion to the reduction in emitter resistance. For example, a 25% reduction in emitter resistance might cause a reduction in emitter voltage of only 10%. However, the emitter current would increase significantly, reducing the collector voltage, and there is a

good possibility that the current ratings of the transistor would be exceeded.

#### Changes in R4

The collector current of a transistor is fairly independent of the collector voltage, much the same as in a tube. A loss of 25% of the collector resistance of Fig. 2 would cause a corresponding decrease of 25% of the drop across R4, and the collector voltage would increase to about 11 volts. However, this might be rather difficult to detect with a meter having only 5% accuracy. For this reason, it is wiser to measure the voltage across the resistor instead of the voltage from collector

to ground.

If the collector-load resistance changes, it will have very little effect on the voltages at the emitter and the base. And this is the tip-off—if the collector voltage is wrong, but the base and emitter voltages are right, look at the collector-load resistor. Of course, if the resistor is off by 200 percent, this rule may not hold.

If the collector load resistance is off tolerance, the gain will be changed by the amount of tolerance shift, since gain is more or less proportional to load resistance. Of course, this cannot go on without limit if the resistance increases—the amplitude of the output signal cannot exceed the collector supply voltage. Also, the transistor might go into saturation or cutoff if the collector resistance is out of tolerance. This will cause distortion.

#### Changes in C1

If the value of the input coupling capacitor is not within tolerance, there can be an increase in distortion of low-frequency signals, and if the capacitance loss is sufficient, the gain of the amplifier will be decreased seriously. Finding this particular trouble is a job for the scope, or perhaps even more practical, a quick job of bridging the capacitor with a new one.

If the coupling capacitor becomes leaky, the result is about the same as decreasing the value of R1. The emitter and base voltages will rise, and the collector voltage will drop. If there is enough leakage to drive the transistor near saturation, distortion will be produced; more leakage probably will destroy the transistor.

#### Changes in C2

The function of C2 in Fig. 2 is analogous to the function of a cathode bypass of a tube-circuit. If it loses its capacitance, degeneration of the signal will result (the emitter voltage will vary with the AC signal). If C2 becomes leaky, the result is about the same as if the resistance of R3 had been decreased.

#### Common-Collector Circuits

The common-collector circuit shown in Fig. 3, also called an

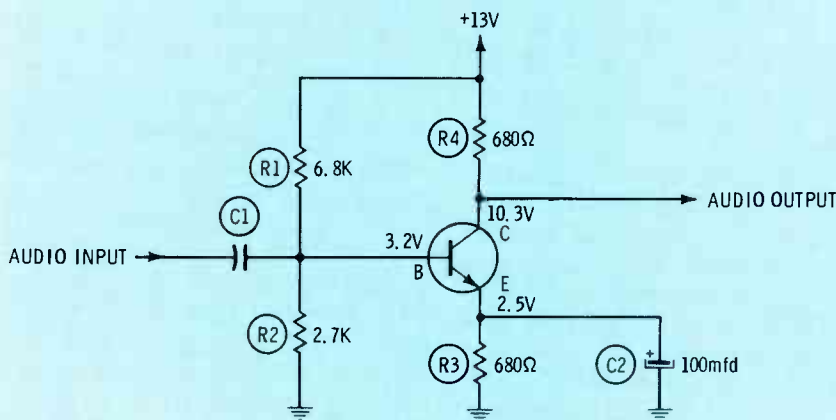


Fig. 2 Typical common-emitter audio amplifier.

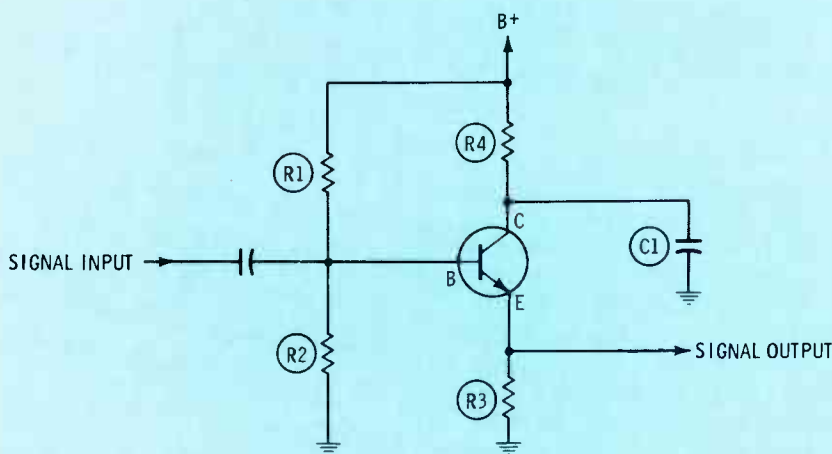


Fig. 3 Basic emitter follower.



emitter follower, is encountered quite often in solid-state circuitry. Essentially, it is an isolating stage used to match the impedance of the preceding stage, or the input to the instrument, to some lower-impedance load. This may be the next amplifier stage, or perhaps the load to which the instrument is connected. The input impedance may be very high, as in some solid-state electronic volt-meters, if the value of R3 is made sufficiently large. As with the common-emitter amplifier, the input impedance is approximately the value of unbypassed emitter resistance times the beta of the transistor.

One important fact about an emitter follower is that the voltage gain can never be greater than unity (1). If the input signal has an amplitude of 1 volt, the output must be less than 1 volt. On the other hand, the power gain of an emitter follower may be fairly high. For example, assume that R3 is 100 ohms and that R1 and R2 each have resistances of several thousand ohms. If the transistor beta is 50 and the input signal is 1 volt, the input impedance is about 5K ohms, and the driving power is about .2 milliwatts. An output signal of .9 volt is entirely possible under these conditions, and this signal is developed across R3, 100 ohms. Therefore, the power output is 8.1 milliwatts, and the power gain is about 40.

When troubleshooting an emitter follower, it is important to remember that fairly large variations in the values of the components might not cause the circuit to become completely inoperative. An increase or decrease in base bias, caused by a change in R1 or R2 in Fig. 3, will cause a corresponding change in the emitter voltage, but the gain of the circuit may not be affected noticeably. It is more likely that the new bias levels will cause the transistor either to cut off or saturate during some part of the cycle of the input signal, in which case distortion will occur.

R4 in this circuit may be omitted if the supply voltage is correct for the transistor being used. If this is the case, the collector voltage is not likely to change, regardless of the condition of the circuit. When

the collector is connected directly to B+, the transistor is very vulnerable to burnout if the emitter resistance becomes too small.

In many applications, the emitter resistance actually is the base circuit of the next stage, as shown in Fig. 4. Characteristically, if the output stage shorts, placing B+ on the emitter of the emitter follower, the emitter follower also will be damaged. Even if the device does not fail immediately, it can after a few hours of operation, and it sometimes is smart to replace it while the set is on the bench.

Again referring to the circuit in

Fig. 4, a word of caution is in order: It is common practice to short together the emitter and base of a transistor to check it for leakage. In this circuit, if the base and emitter of the video-output stage are shorted together, the emitter resistance of the emitter follower will be reduced severely, and it is very possible that the transistor will burn out.

### Common-Base Circuits

The third configuration of a transistor amplifier is the common-base circuit. Like the common-emitter circuit, it has voltage gain, but the input impedance **always** is very low.

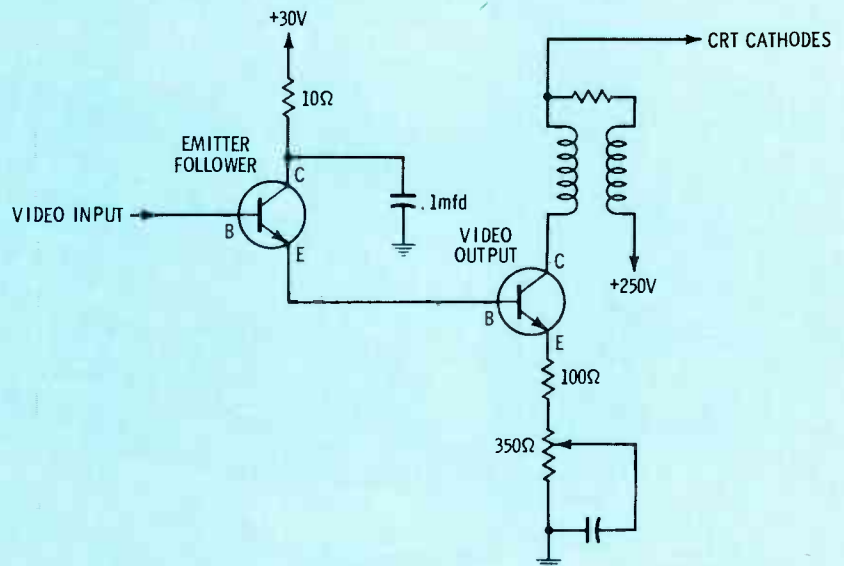


Fig. 4 Direct-coupled emitter follower and video amplifier.

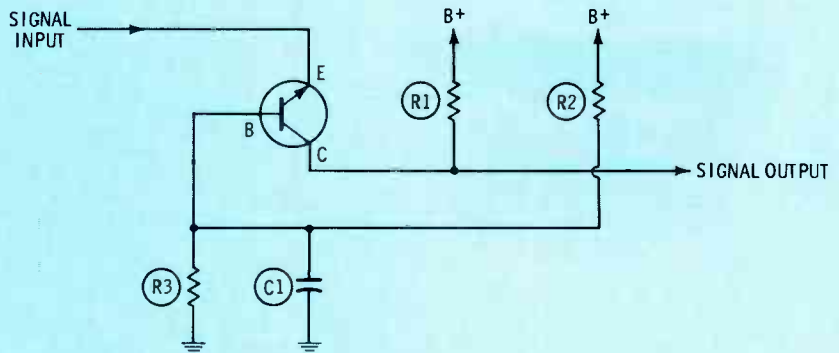


Fig. 5 Typical common-base amplifier.

# The only complete

# SWEEP & MARKER GENERATOR

\$395.00

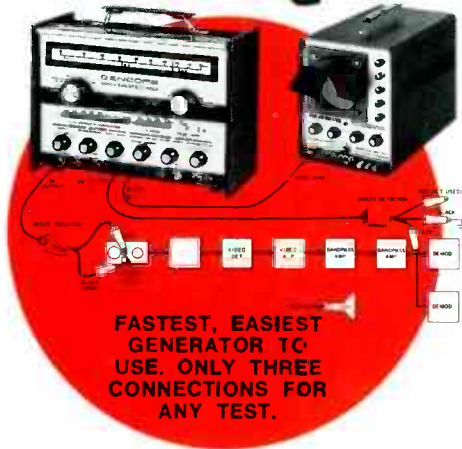
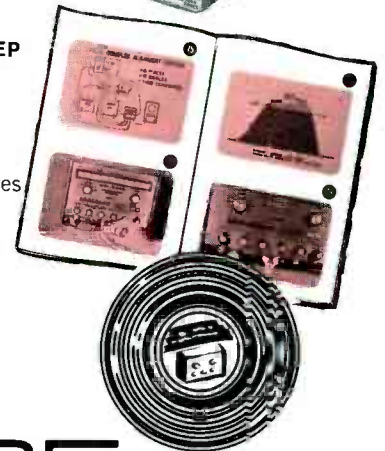


ALL SOLID STATE- INSTANT ON

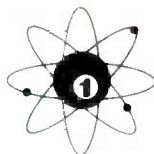


## FREE WITH YOUR SWEEP AND MARKER:

80 full color reproductions direct from Sencore technical training film clearly depicts alignment from beginning to end using SM152. Pictures are numbered so you can review a section at a time if you are in trouble. 35 minute LP record direct from film clearly leads you all the way. Also packed with each SM152. Numbers are announced for each picture so you can review a section when necessary.



**FASTEST, EASIEST GENERATOR TO USE. ONLY THREE CONNECTIONS FOR ANY TEST.**



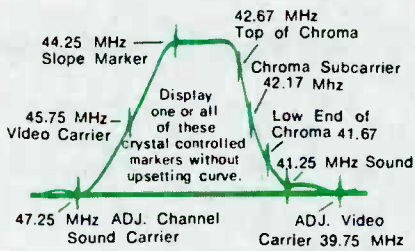
# SENCORE

NO. 1 MANUFACTURER OF ELECTRONIC MAINTENANCE EQUIPMENT

426 SOUTH WESTGATE DRIVE, ADDISON, ILLINOIS 60101

# ONLY GENERATOR THAT GIVES YOU A COMPLETE IF, CHROMA, ALL CHANNEL VHF, UHF AND FM ALIGNMENT SIGNALS IN ONE UNIT

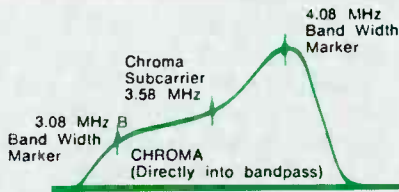
## complete IF SWEEP AND CRYSTAL CONTROLLED MARKERS



View the complete IF response curve with full 15 MHz sweep width (competition has only 12 MHz, restricting view on RF and some solid state receivers that have extra traps). Press one or all of the crystal controlled marker push buttons without upsetting response curve. Post injection is used all the way to prevent overloading the TV receiver. Crystal markers are provided for all critical check points as shown on the response curve. Also sweeps 20 MHz IFs as found on older sets and new import color sets. Major competition does not cover these frequencies. Special spot align position converts the sweep generator to a regular signal generator for spot alignment or dipping odd traps. Only Sencore goes all the way.

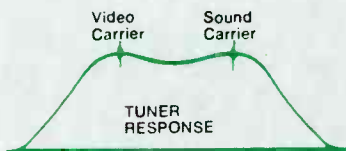
Note that Sencore has a base line giving you a reference to zero. Competitive models do not.

## complete CHROMA SWEEP AND CRYSTAL CONTROLLED CHROMA MARKERS



You can inject the chroma signal directly into the chroma amplifiers as shown here or through the IF amplifiers for a flat response. You are equipped to follow manufacturer's recommendation either way. Injection directly into the chroma amplifiers is a must for fast trouble shooting of color circuits.

## complete ALIGNMENT SIGNALS FOR VHF TUNER OR OVERALL ALIGNMENT



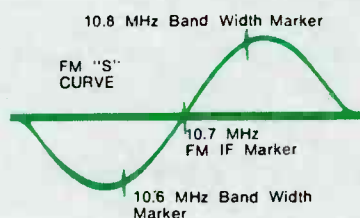
The SM152 sweeps all of the VHF channels for complete tuner check from channel 2 through 13. Competitive models sweep only two VHF channels. Push button markers are provided for channels 4, 5, 10 and 13 for both the video carrier and the sound carrier. The second low and high channels are available in case you have a station operating on the same channel . . . which will cause the patterns to be upset. You want to align on an unused channel and check it on the channel in operation for best results. Only Sencore goes all the way.

## complete UHF SWEEP FROM CHANNEL 14 THROUGH 82



After completely aligning a TV set, you'll want a complete check on the UHF tuner to be sure that it is operating on all channels. Markers aren't necessary as you just view the RF or over-all curve to see that the curve looks the same as the VHF and output remains reasonably constant. Only Sencore has UHF output; all new tuners are required to cover all UHF channels and you will come up short if you own any other alignment generator than the SM152. A UHF sweep generally costs hundreds of dollars more.

## complete FM SWEEP AND CRYSTAL CONTROLLED MARKERS

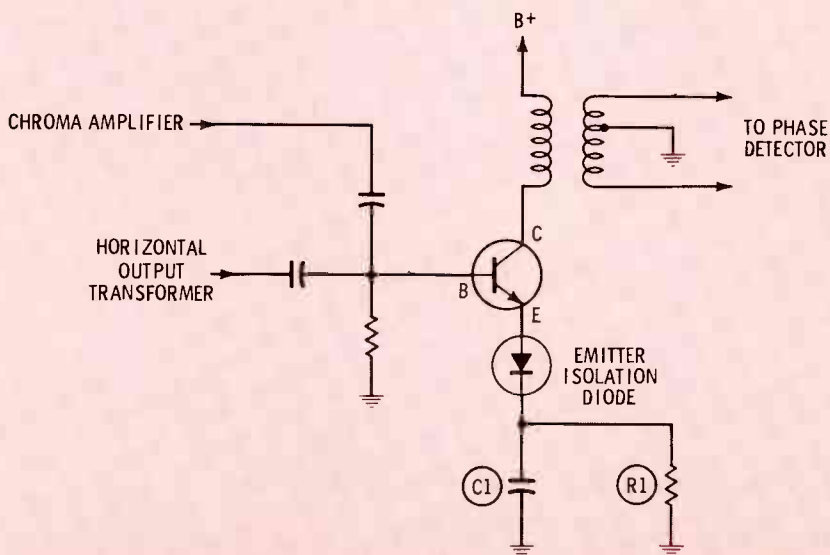
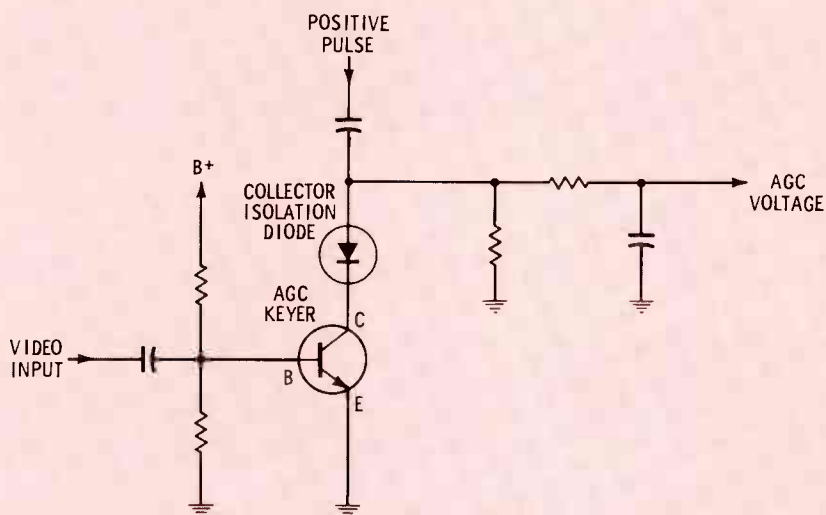
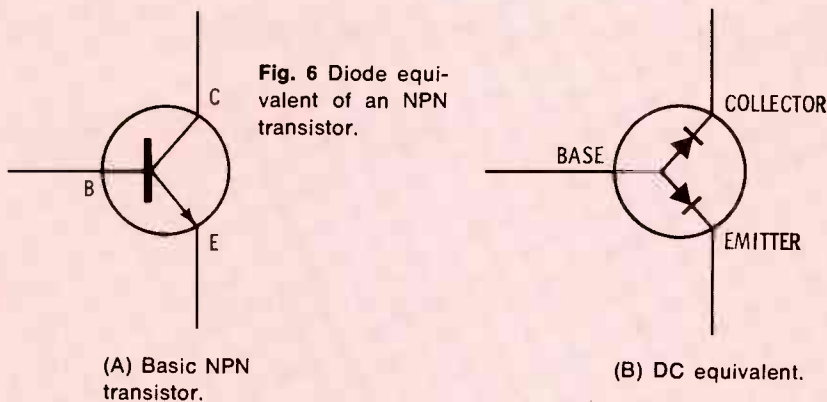


You won't be stopped with just TV alignment. You can align the IF amplifiers of the FM receivers with the 10.7 MHz crystal for maximum as indicated in service manuals. Then, throw on the scope and sweep the amplifiers and view the "S" curve if you have stereo. Two markers, 100 KHz above and below the 10.7 MHz mark the limits of the curve for good stereo. You can align the front end of the receiver too. Competitive units cover only the IFs and you find the job only half done.

There are other features too numerous to mention that makes the Sencore SM152 the most complete sweep and marker generator on the market. Ultra linear sweep, covering all frequencies that you need, from 10 MHz to 920 MHz, exclusive calibrated sweep

width that is constant on all channels and RF calibrated output for circuit trouble shooting are only a few of the things that places the SM152 in a class by itself. Dare compare and you'll see your distributor today for a good look at the SM152.

Circle 17 on literature card



The common-base circuit may be used to follow some low-impedance source, such as a video delay line, or as the voltage amplifier for a cascode amplifier or mixer. The output impedance can be quite high, comparable to a common-emitter amplifier.

For the circuit to operate properly, the base must be grounded insofar as the AC signal is concerned. A bias network like that shown in Fig. 5 can be used, if the value of C1 is large enough to provide good bypassing. If the capacitance of C1 decreases, the gain of the amplifier will be decreased, particularly at the lower frequencies.

By the nature of the circuit, the resistance from emitter to ground is likely to be quite low, and this makes it possible for a small change in the base biasing network to cause large changes in the emitter-to-base current. Burnout is very possible if the bias is allowed to swing too far positive. Increases in base-bias current are the result of an increase in the value of R3 or a decrease in R2.

An increase in the value of R1 will cause the collector voltage to drop; a decrease in R1 will cause it to rise. These are the same conditions that are encountered in a common-emitter circuit.

When troubleshooting a common-base amplifier, do not be surprised if the scope does not indicate a signal at the emitter. Since this type of circuit is driven by current (very low input impedance), the signal voltage at the input may be so slight that the scope will not have enough sensitivity to detect it. If there is no easier way to tell if the signal actually is reaching the emitter, try disconnecting the base bypass capacitor. This will raise the input impedance and the signal voltage so that it can be observed. (Of course, the transistor cannot amplify under these conditions, and there will be no output.)

#### Other Circuits

The active material of a transistor is arranged so that an NPN device appears as two diodes, with both anodes connected to the base lead, as shown in Fig. 6. (In a PNP device, the diodes would be re-

versed from their positions in Fig. 6.)

The collector of an NPN transistor cannot be made more negative than the base, because the base-collector diode simply will conduct and bleed off the voltage. Because of this, certain circuits must include an isolating diode if the output circuit is to be negative during some portion of the cycle. The AGC keyer shown in Fig. 7 is such a circuit.

The horizontal sync pulses from the video detector (or amplifier) arrive at the base at the same times that the positive keying pulses from the horizontal-output transformer arrive at the collector. The amount of conduction depends on the amplitude of the sync pulses. The output from the keyer is a negative AGC voltage that is proportional to the level of the input signal.

As mentioned previously, a negative voltage cannot remain on the collector of an NPN transistor. For this reason, a diode must be placed in series with the collector lead of the AGC keyer to prevent the negative voltage from leaking away between pulses.

When troubleshooting this type of circuit, be sure to check the diode before assuming that the transistor is causing the loss of AGC.

Fig. 8 shows another application of a diode in series with a transistor lead. This circuit is a burst amplifier that has the usual inputs: chroma signal and a positive pulse from the horizontal-output transformer. The horizontal pulse arrives coincidentally with the arrival of burst, and the transistor is turned on long enough to pass the burst to the output.

When the transistor conducts, the emitter capacitor, C1, becomes charged positively by the drop across the emitter resistor, R1, and this positive voltage holds the transistor cut off until the next pulse arrives at the base.

To assure positive keying action, it is desirable that the bias voltage on the emitter be rather high, but this voltage can become excessive and break down the emitter-to-base junction. To protect the transistor, a diode is used to isolate the emitter from the bias voltage.

An unusual situation involving the transistor itself has come to light in the past year, but may not be well known. Certain transistors used as IF and chroma amplifiers have a very low reverse-voltage breakdown potential between emitter and base. This voltage can be about .5 to .8 volt. If one of these

transistors is tested in many of the present-day transistor testers, or with an ohmmeter, the battery voltage can be sufficient to cause reverse current through the base-to-emitter junction. This gives the indication of a shorted or leaky transistor, although such is not actually the case.

The test does not usually damage the transistor, and it may be reinstalled in the circuit, where it will function normally. To prevent the erroneous indication, check these transistors on the lowest beta scale of a transistor tester, or reduce the ohmmeter battery voltage to less than .5 volt. Either procedure will reduce the voltage across the emitter-base junction below the critical reverse-voltage-breakdown potential, and a valid test of leakage can be made.

### Summary

Some of the more important characteristics of transistors have been discussed in this article, and the effects of changes in the associated components have been examined. Because of the myriad of transistors available and the vast number of circuits in which they can be used, it is impossible to anticipate all the reactions to circuit defects.

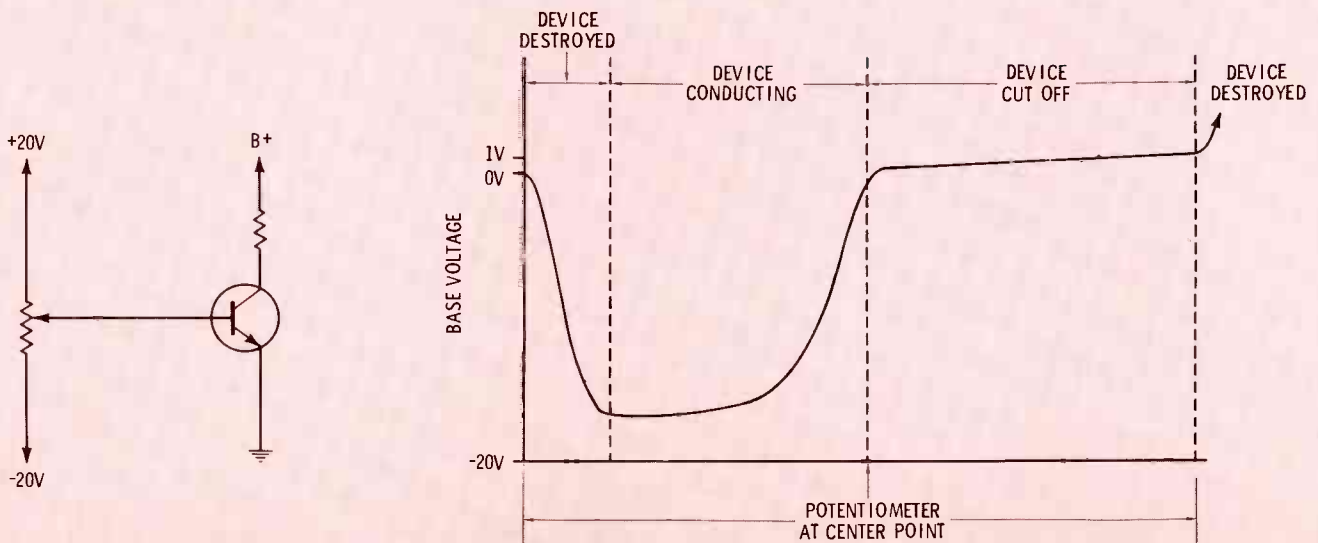
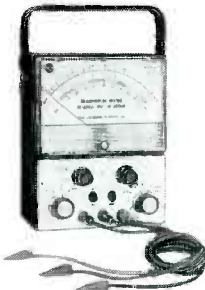


Fig. 9 Transistor base-voltage diagram.

# Clip the coupons!

Present one or more to your participating RCA Test Equipment Distributor for big discounts on these four instruments during RCA's big Spring Coupon Carnival. (Only one coupon will be accepted per instrument.) Do it today. Offer good only between February 15th and April 30th, 1970.

**\$7.50** Toward Purchase of RCA WT-501A Transistor Tester



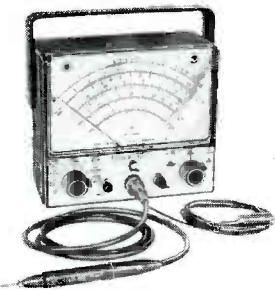
Mr. Distributor, please refer to RCA 1970 Carnival announcement. Void where prohibited, taxed, or restricted. Cash value 1/20¢. Offer expires April 30, 1970.

**\$10.00** Toward Purchase of RCA WT-509A Picture Tube Tester



Mr. Distributor, please refer to RCA 1970 Carnival announcement. Void where prohibited, taxed, or restricted. Cash value 1/20¢. Offer expires April 30, 1970.

**\$7.50** Toward Purchase of RCA WV-98C Senior VoltOhmyst



Mr. Distributor, please refer to RCA 1970 Carnival announcement. Void where prohibited, taxed, or restricted. Cash value 1/20¢. Offer expires April 30, 1970.

**\$20.00** Toward Purchase of RCA WR-99A Crystal Calibrated Marker Generator



Mr. Distributor, please refer to RCA 1970 Carnival announcement. Void where prohibited, taxed, or restricted. Cash value 1/20¢. Offer expires April 30, 1970.

Look to RCA for instruments to test/measure/view/monitor/generate  
RCA Electronic Components, Harrison, N. J. 07029

Circle 18 on literature card

Probably the most important thing to remember when troubleshooting transistor circuits is that the average DC voltage between the base and emitter of a conducting transistor always will remain essentially constant, although in pulse applications a meter will indicate otherwise. Nonetheless, if a scope is used, it will be found that during conduction time, the average DC voltage remains nearly the same.

If a silicon transistor is considered, the emitter-base voltage is about .7 volt, and it will remain so as base current is increased from cutoff, through the normal operating range, and into saturation. This may be visualized by examining the circuit and curve of Fig. 9.

This circuit, which we have dubbed the "Anderson Handy-Dandy Transistor Eater," is constructed so that the voltage to the base of the transistor may be varied from -20 volts to +20 volts. With the potentiometer set to the center of its range, the base voltage is zero and the device is cut off by lack of bias. As the voltage is increased in a positive direction, conduction begins when the voltage reaches barrier, or turn-on, potential for the transistor (.7 volt for silicon and .3 volt for germanium). Further turning of the potentiometer increases the voltage very slightly, although the base current does increase, until the maximum base-current rating of the device is exceeded. At this point, the transistor is "eaten", or destroyed, by the circuit.

If the potentiometer is turned in the opposite direction from mid-range (toward negative), the base voltage decreases to the point of reverse base current. Turning the shaft slightly further will not increase the voltage, although the current increases. This is similar to the normal action of a zener diode. Then, as the shaft is rotated further, the maximum reverse-current rating of the device is exceeded, at which point the circuit again "eats", or destroys, the transistor.

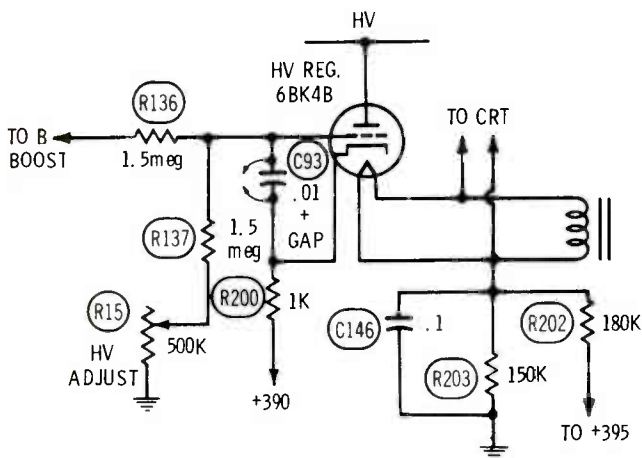
This circuit requires very little skill to build; in fact, it can be "built" entirely by accident. The skill is required to prevent "building" it while troubleshooting a transistorized circuit, and also to recognize that it has been "built" when some part has failed in a solid-state circuit. ▲

## No High Voltage

I am having a high-voltage problem with an Air-line color TV, Model GHJ-8145 (PHOTOFACT folder S36-1), which came to the shop with the horizontal output transformer open between point P and the 3A3 plate. The high-voltage transformer, focus rectifier, C91, R134, focus coil, boost rectifier, C92, 6JE6, 3A3, 6BK4, 6DW4 and 6FQ7 have all been changed. Now the boosted boost voltage is 1120 volts, but the high voltage is only 10 KV. All voltages at the 6JE6 are normal, and the current is 200 ma. 6BK4 voltages are-cathode, pin 1, 395 volts; grid, pin 5, 380 volts; and the heaters measure 385 volts. The yoke checks good. Why can't I get 24-25 KV of high voltage?

Donaldson M. Drummond  
Caryville, Fla.

If I were allowed only one guess, I would say the 6BK4 is pulling down the high voltage. The +1120 volts at the boosted-boost rectifier is a reliable indication that the horizontal sweep is good. The B+ reading of 385 volts at the pins 2 and 7 (heaters) of the 6BK4 is much too high. R202 (180K) is wired from B+ to the heater winding for the 6BK4 and the picture tube, and R203 (150K) is connected from there to ground (and is paralleled by C146 -.1). The voltage from heater to chassis should be around +180 volts. A few of the things that will make this voltage



high include: shorted or burned R202, open R203, or a cathode-to-heater short in the 6BK4. I would remove the 6BK4 and measure both the high voltage and the heater-to-ground voltage. If the heater is then the normal voltage, the 6BK4 is shorted (new or not), and if the high voltage increases to normal, this indicates the 6BK4 is drawing too much current. If that is true, C93, connected from the grid to the cathode of the 6BK4, should be suspected. Also the 1K cathode resistor should be checked for tolerance.

6BK4 grid voltages measured to ground are not accurate enough to be of any help—the loading of the meter will give a false reading. The best way is to measure the grid-to-cathode voltage with a VTVM. The normal 1.4 ma requires about -6 volts of grid

bias, while current cutoff is about -13 volts, so you can see the exact voltage is very critical. With the brightness control turned down for a black raster, the voltage drop across the 6BK4 1K cathode resistor should be no lower than 1.2 volts, or no higher than 1.4 volts.

## Blooming, Dark Raster

An Admiral 25G6 color chassis operates normally for about 30 minutes, then the focus blurs, the picture blooms and the raster gradually becomes black. The grid bias of the video amplifier (12BY7A) changes from -4 to +1 volt, and the plate voltage decreases from +235 to +110 volts when the raster blooms. These voltages return to normal if the brightness control is rotated to produce a too-dark picture. A list of the parts we checked or replaced is enclosed. Where should we look now?

J. T. Saylock  
Stroudsburg, Pa.

My first thought was that a video defect reduced the grid bias and plate voltage of the 12BY7A, thus making the raster bloom because of excessive brightness. Or, perhaps, since a part of the -80 volts at the grid of the horizontal blanker is applied to one end of the brightness control, a blanker defect was involved. If either of these possibilities was a contributing factor, a normal picture probably would be obtained if the brightness control and kine bias control were turned down. Yet you state that the abnormal voltages on the grid and plate of the 12BY7A returned to those measured when the set was cold, if the brightness was turned down to where the picture was too dark.

Let's assume that a defect in the horizontal sweep reduces slightly the width and high voltage (perhaps not enough to be noticeable in the picture). This, in turn, reduces the -80 volts at the grid of the horizontal blanker, since the grid of the blanker rectifies a horizontal pulse from the high-voltage transformer. The decrease of the -80-volt supply makes the grid of the 12BY7A more positive; the plate becomes less positive and the brightness increases. An increase in brightness makes the reduction in width and high voltage greater, and that, in turn, drops the -80 voltage source at the blanker grid even more. This cycle of regenerative action continues until blooming is complete and total. Check for this possibility by monitoring the B boost voltage before and after the blooming starts, then reduce the brightness and measure it again. If it is the same as before the blooming, the horizontal sweep circuit is not the source of the trouble. But if the boost is lower, the horizontal/high-voltage circuitry is probably the source of the trouble. ▲

## ELECTRONIC SERVICING . . .

the country's only magazine devoted 100%  
to the ELECTRONIC SERVICING industry . . .

## Aviation Antennas

A new line of airborne antennas for communications, navigation, base stations and ground control equipment and vehicles has been announced by The Antenna Specialists Co. The line includes 22 different configurations, including

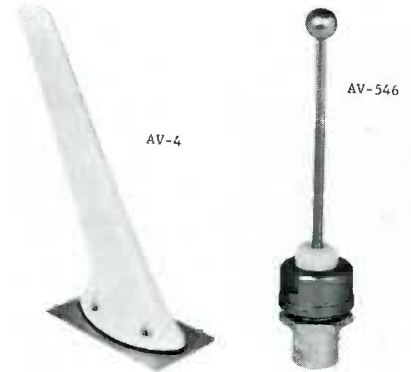
models for the VOR (omni) navigation; ATC transponders; ADF sensing equipment; and marker beacon applications.

A broad-band VHF fiberglass communications blade antenna, Model AV-4, reportedly has wide application since it provides 360-channel operation and improved communications on relatively inexpensive radios.

The ATC transponder antenna Model AV-546 is a chrome-plated unit that reportedly may be installed from the outside by one man. Low

noise static discharge is accomplished through a special chrome-plated ball tip device, according to the manufacturer.

The line also includes ground vehicular antennas, both whip and



low-profile style, and a choice of ground-plane base-station antennas, according to the manufacturer.

Model AV-4 sells for \$70.00, while Model AV-546 is priced at \$13.95.

Circle 50 on literature card

## VHF Broad-Band Distribution Amplifiers

The Finney Company has introduced two solid-state VHF broad-band distribution amplifiers designed for color and monochrome sets.

Intended for small apartment houses and multiple installations of approximately 25-30 outlets, the split-band design reportedly presents greatly improved signal ability and gain (low-band, 24 dB; high-band, 26 dB) plus perfect phase response.

Electrical specifications are the same for both models with the ex-



# Introducing the world's only \$339 triggered scope.

Before you say you don't need a triggered scope, look what's happening to TV servicing: tubes are out, transistors and IC's are in.

With tubes you could play hit-or-miss, knowing the tube would take the overload. Try the same thing now, and good-bye transistors.

For new-era circuitry, Leader introduces a new-era troubleshooter. A triggered scope, just like the ones the TV designers use.



Now the wave shape is locked in and continuously displayed. Now you can look at a waveform containing high and low frequency components. Now you can determine voltage directly and instantly.

Before you say \$339 is a lot of bread, look what it buys: Leader's LBO-501 5-inch triggered scope, with a bandwidth of DC to 10MHz and a solid state package.

Going like hotcakes at your Leader distributor.

## Seeing is believing.

### LEADER INSTRUMENTS

37-27 27th Street, Long Island City, N.Y. 11101, (212) 729-7411

Circle 19 on literature card



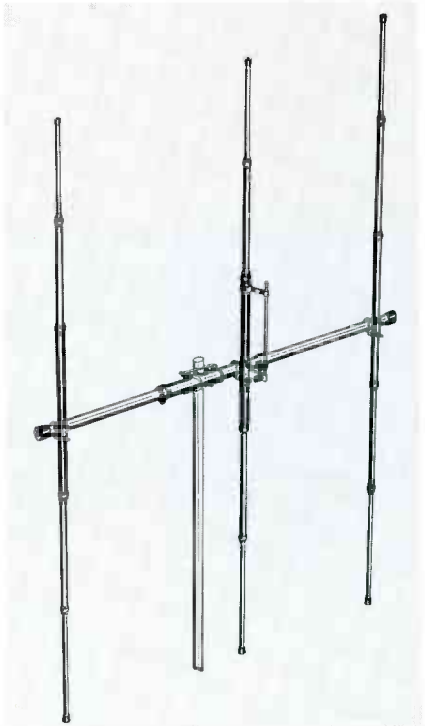
ception that Model M-105 has a separate low-band and high-band input at 75 ohms, while Model M-104 features a low noise input circuit that offers either 300- or 75-ohm input with separate level controls on each band for maximum flexibility, according to the Finney Company. It is stated that the noise figure on low-band is 5.5 dB and is 6.5 dB on high-band.

FINCO Model M-104 sells for \$75 and Model M-105 is priced at \$81.25.

Circle 51 on literature card

### CB Beam Antennas

Cush Craft has introduced a new line of Citizens Band power beams, which feature high forward gain plus side and back rejection. The streamline design reportedly gives



more strength with less weight and wind load.

Features include 2-in. mast mount, pre-drilled and pre-marked components, all heavy-wall seamless aluminum tubing and KW matching. A stacking kit for mounting any two Power Beams also is available.

The price for the 3-element CB beam antenna, with 8-dB gain, is \$32.50, the 4-element antenna, with 9.5-dB gain, sells for \$42.50 and \$69.50 is the price of the 5-element antenna, which has a reported 10.5-dB gain. The dual-beam stacking kit is listed at \$49.50. ▲

Circle 52 on literature card

# The Professional Way to Service TV Tuners

by Tony Ferris

Tuners Inc. does not deal with the public. We are strictly "technicians' technicians", solving the really tough servicing problems that it doesn't pay the average man in the field to tackle. We handle all kinds of TV work but, as our name implies, we specialize in tuners. This article will tell you how to cure tuner troubles rapidly — and profitably.



## Types of Tuner Troubles

The following symptoms may be caused by a defective tuner: (1) snowy picture; (2) streaking or flashing in picture; (3) loss of sound and picture; (4) loss of certain channels; (5) picture pulling or distortion; (6) partial blanking of raster.

If you suspect tuner trouble, try the following approach:

### 1. Clean and Degrease Contacts with Tun-O-Wash

In servicing tuners, it's important to start with clean contacts. Poor contacts cause at least 70% of all tuner troubles. In fact, we get many tuners in for repair that need nothing more than a thorough cleaning.



Chemtronics TUN-O-WASH is excellent for this purpose. It's almost like an ultrasonic bath in a can. Use this high pressure degreasing spray on all tuner contacts. Be sure to remove the tubes and spray the sockets thoroughly, to remove corrosion.

A thorough cleaning will often eliminate intermittents and restore tuner alignment.

### 2. Lubricate and Protect Contacts with Tun-O-Foam

After the tuner has been flushed out with TUN-O-WASH, let it dry thoroughly. Then, re-spray all contacts (including tube sockets) with TUN-O-FOAM. Once the TUN-O-FOAM has been applied, rotate the channel selector through all channels several times. Also, work the tubes in and out of their sockets several times. This will spread the lubricant to all critical surfaces.



You will find that a thorough cleaning and lubrication will clear up about 70% of the tuner troubles you encounter (aside from tubes, which should always be checked by substitution before any servicing is attempted).

What's more, the TUN-O-FOAM protects contacts from future corrosion, provides excellent

lubricity for smooth operation, and continues to clean and lubricate contacts each time the channel is changed.

Most important, neither TUN-O-WASH nor TUN-O-FOAM attack plastics or cause detuning. This is vital, since a spray that detunes a color set almost always results in a profit-consuming callback.

## Isolate the Trouble to the Tuner

If a thorough cleaning and lubrication (which takes only a moment) fails to restore proper operation, you will have to start troubleshooting. But before you start tearing into the circuit, make sure it's the tuner that's at fault.

IF and AGC defects often look an awful lot like tuner troubles.

If the picture is snowy, for example, too much AGC voltage may be the problem. To check this out, simply short the AGC test point to ground. This makes AGC voltage zero, permitting the RF amplifier to operate at full gain.

Next, check out the IF stages. Start with a good TV set connected to a good antenna. Connect the IF cable from the tuner of the known good receiver to the IF input of the set you are troubleshooting, if you get a good picture with the substitute tuner, you know you have tuner trouble. Otherwise, it's a chassis problem.

## The 10 Minute Tuner Check

Once you have cleaned and lubricated the tuner and made sure that it is really the trouble source, give it a 10 minute check. Discipline yourself **not** to spend too much time tracking down tuner trouble. If you can't spot the trouble in 10 minutes, it may take you hours. Therefore you're a lot better off to send the tuner to a professional rebuilder. But the 10 minute check will reveal many tuner troubles.

If your preliminary checks revealed a shorted or gassy tube, chances are that excessive current has damaged a resistor. Burned resistors, of course, are fairly easy to spot.

After a brief visual inspection, make voltage checks at the test points provided. B+ voltage should be accurate  $\pm 20\%$ . Then, use a test socket to make voltage and resistance checks at tube pins. If you read a low plate or screen voltage, this generally indicates that a series resistor has changed value or a capacitor has shorted.

Check to see if the oscillator is working by measuring the mixer grid test point voltage. A dead oscillator is often caused by the plate load resistor.

Be sure to check the balun. Defective baluns often cause snow or loss of certain channels. Your ohmmeter will generally spot balun troubles.

One final word of advice: Treat all tuners carefully. Don't poke around in coils or you'll cause misalignment. Replace defective parts carefully with exact replacements. If you do have to send the tuner in, mark all leads clearly, keep the brackets in a safe place, wrap the tubes well and pack them carefully with the tuner.

Follow these simple rules and you'll make money on tuner repairs, whether you spot the trouble yourself or send the tuner to a specialist.

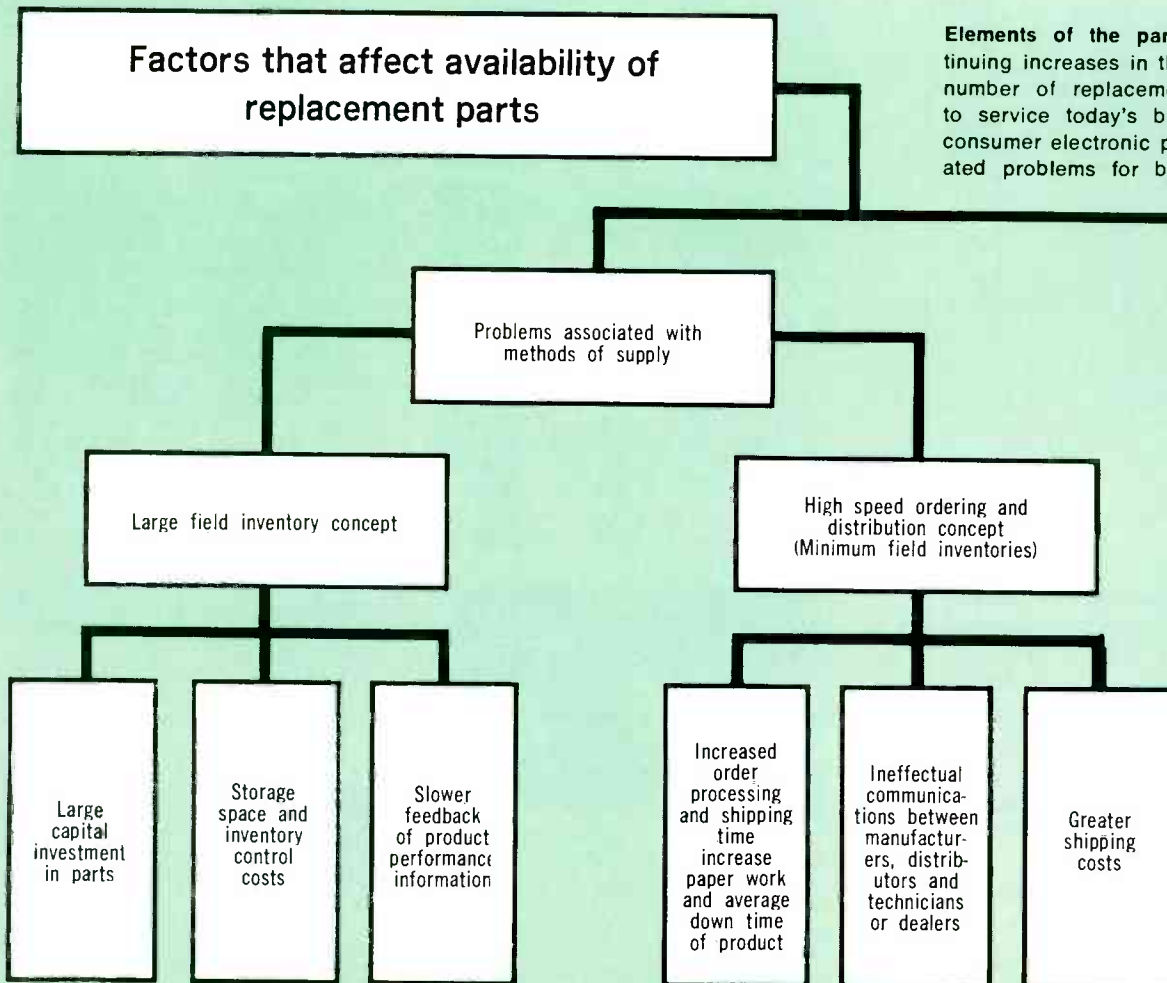
Circle 20 on literature card

# PARTS AVAILABILITY

A Special Report by Wendall J. Burns  
and J. W. Phipps

*The parts distribution systems and attitudes of two major manufacturers are discussed in this first installment of a series of periodic reports that probe the parts problem.*

**Elements of the parts problem.** Continuing increases in the types and total number of replacement parts needed to service today's broad spectrum of consumer electronic products have created problems for both the suppliers



# The Parts Problem: Who's Responsible?

The problem of replacement parts continues to loom large for service technicians. Feedback from the field to the editors of ELECTRONIC SERVICING has indicated for some time that parts problems are worsening. We often hear and read that the responsibility for the parts problems should be placed at the doorstep of the suppliers (manufacturers).

With this in mind, the editors went to two major manufacturers to get their viewpoint and to observe their methods and procedures for plan-

ning, stocking and shipping parts. The intent of this article is strictly reportorial—to report what we saw, and were told at the supply sources. It is not a position paper. It does not take the position that any one sector of this industry is solely at fault—neither the technicians, the dealers, nor the suppliers. We do invite comment from technicians, distributors and others, through letters to the editor, relating experiences with parts problems, and also relating examples of parts procurement and stocking procedures that have proven successful. We hope, in this way, to provide a forum that will throw more light on parts problems.

Although we discuss here primarily the aspect of parts availability, we realize that the electronic service industry faces other troublesome facets of the "parts problem"—for example the question of compensation for replacement of parts under warranty, the paper work involved in handling parts under warranty, parts proliferation, and others.

and the users, neither of which feels they can afford the high cost and low return on investment of large parts inventories, nor continued harassment by consumers who are demanding quicker service and fewer excuses about parts

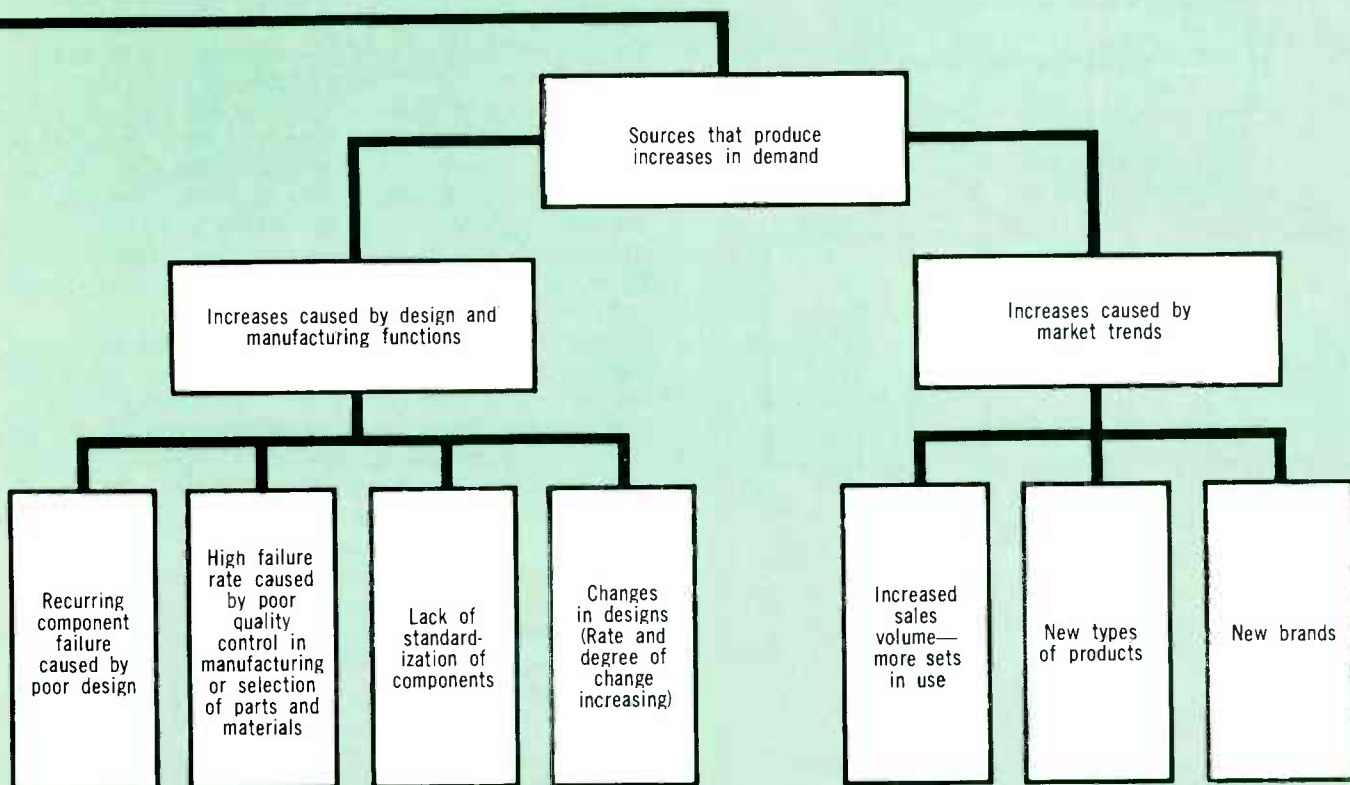
nonavailability.

The problem, as we see it, can be attributed to two primary causes:

- Increase in number and variety of replacement parts required
- Problems that slow the distribution

of parts

The charts here list the elements that are cited most often as the direct or indirect causes of the parts availability problem.



## Computers and teletypes ease the problems for manufacturers but are not a panacea for the technician

"The electronics business is becoming an electronics business."

A rather vague and puzzling statement, is it not?

The meaning is clear enough, though, when put in context. The statement quoted above was made by John Williams, the manager of General Electric's big automated parts depot at New Concord, Ohio, at the conclusion of a conversation about parts distribution.

He is not talking solely about the electronics know-how and equipment needed to manufacture and service TV sets, radio or stereo. He is talking as much about management by electronic systems as management of electronic products.

The center he directs handles in excess of 50,000 different types of parts, and ships to points throughout the nation.

Approximately 10,000 of the types of parts are for TV and console stereo. The balance is for appliances. (TV picture tubes, and components for radios, portable stereo and other GE electronic products are handled elsewhere.)

Williams defines the objectives of the national distribution center that he directs at New Concord: To have the parts on hand, properly labeled, stocked, and ready for shipment. An operation of this magnitude would not have been possible before the age of the computer, Williams says.

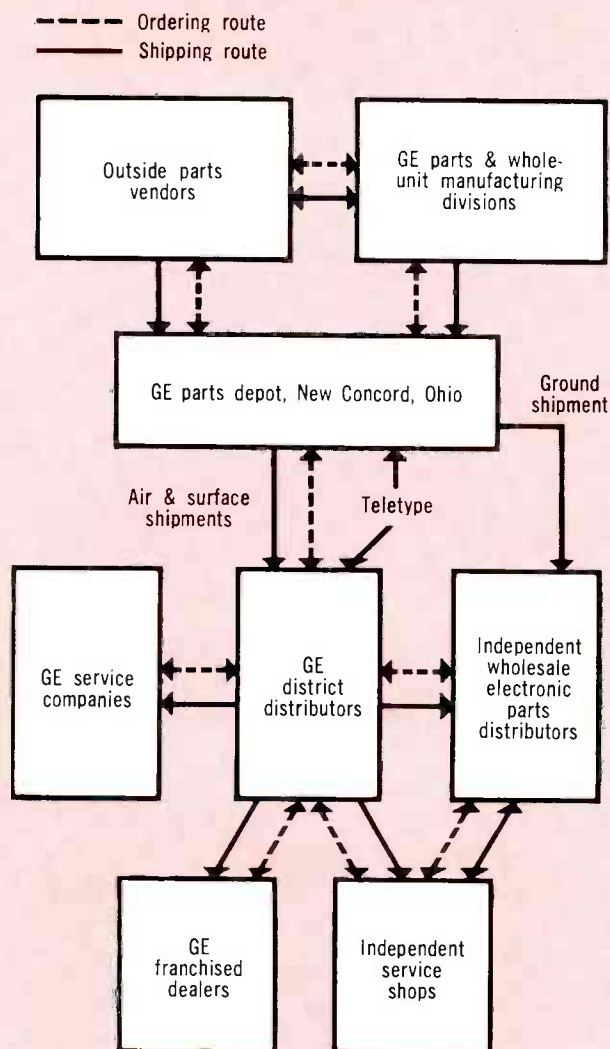
"When the order is received and the information fed into the computer, the computer tells the accumulator where to go in the warehouse to pick up the parts. We couldn't possibly handle our inventory control without a computer.

"Basically, what we do for the GE TV (manufacturing) departments at Syracuse and Portsmouth is stock their parts and re-distribute them to district distributors around the country. I am sort of an intermediate distributor—more or less a super-distributor. The bulk of the material I move out of here goes to other GE distributors, other GE distribution locations."

The GE district distributors, Williams said, distribute parts several ways: They use parts directly in metropolitan service where the General Electric Service Co. services products; they sell parts to franchised dealers of GE consumer products who sell and service sets; they sell parts to independents who come to the GE district and purchase their parts; and, they also sell parts to franchised jobbers—parts jobbers, the independent parts distributors who in turn sell to the independent servicers. Williams feels that most of the independent servicers purchase parts through parts jobbers. The New Concord depot does not sell, ship to, or in any way do direct business with the independent servicing technician.

The inventory period varies from three to four

### General Electric Parts Distribution System



**John Williams**, manager of the GE Parts Distribution Center at New Concord, Ohio, is responsible for the stocking and distribution, on a national level, of 50,000 different types of parts—for TV and stereo console, and for household appliances.



**R. J. Kalember**, manager, GE Product Service Dept., headquartered at Louisville, Ky., is responsible for service of GE products on a national level. There is close liaison between the department he directs, and the parts distribution center at New Concord.



years for some parts to 20 years for other parts—depending on their usage—whether they are functional or non-functional parts.

The manufacturing branch of the company determines the stocking policy on a given part.

"We kind of serve as a buffer between the manufacturer and the customer—no matter what category the customer may fall into—whether he be the district GE distributor, or other," the parts center manager explained.

"In all cases, we attempt to have initial stock in here within a couple of weeks after initial production, so we are able to distribute parts where they are needed as the merchandise is distributed at the marketing points.

"In general, we would have a part on hand before the product is marketed. In addition to that, we attempt to place functional parts in the district distribution points so they will have them when service demands arise.

"Obviously, it takes several weeks for the merchandise to get through the pipeline and into the customer's home.

"We buy and stock so the customer can be satisfied. We set up stocks here based on our experience and the experience of GE's Product Service Department." This GE department, with national headquarters at Louisville, Ky., is headed by R. J. Kalember, general manager.

"But the TV departments at Syracuse and Portsmouth establish what we are going to stock here. They catalog the items and establish it here. They have a commercial responsibility for any problem that should arise in the field with a TV set. They (Syracuse and Portsmouth) determine what's going to be stocked here, and we review with them all the items, and whether they are functional or non-functional, and they set a policy with regards to how long we are going to stock the part.

There is no difference in the way this central GE distribution center handles a part under warranty, and one out of warranty.

Asked about this, Williams said, "When I receive an order here, I don't know whether it is in warranty or not. As far as I am concerned, a part is a part, and a need is a need. The important thing is that a customer is in need and I have to have a part on the shelf to serve this need.

"My prime purpose is to have parts available on a national level, regardless of how the servicing is handled, whether it's handled through the GE service company man, or the dealer service man, or an independent service man, or through a parts jobber. My job is to have the parts available here ready to ship.

"We provide for all of our district locations the runs on the fastest moving items, recommendations on items they should consider stocking in that district location, and they in turn modify the list, adjusting it to their own local needs. They



This parts center is located a little off Interstate 70 about 60 miles east of Columbus, Ohio. This center at New Concord replaces the GE national parts facility at nearby Zanesville, Ohio.

develop, from that list, recommendations for the GAP (Guaranteed Annual Parts usage) program.

(The GAP program is primarily for the servicing dealer, or a franchised servicing agency that GE may have set up to service several dealers in an area—and the different GE districts make the recommendations to those agencies, based on what they sell and service in that particular area and on experience with the product.) “We say to the servicing agent ‘you should have this amount of each part. We guarantee that these parts will be a good investment. If you do not use them, we will buy them back.’” Williams explained.

“We have some odd-ball situations, of course, but the availability of parts on the national level has been pretty good the past couple years. I really believe the problem is in the communications area, as much as anything.

GE’s district locations have multi-function roles in the field of product service:

- Servicing TV sets in that area;
- Giving guidance, counsel and training and GAP programming to the servicing dealer;
- Having parts on hand to sell to anyone seeking them—parts jobbers and service dealers, as well as parts for the factory service organization.

All parts for any given district are the responsibility of the GE district distributor in that location, he said.

“Although I may ship directly to a jobber, he gets his counseling from, and places his order at these GE district locations. I don’t have any contact with the jobbers other than these drop-shipments directly to them.”

All the district locations (over 75 now, and to be about 100 by 1973) are linked to the New Con-

cord parts depot by a teletype communications system.

Williams described some specific objectives of his branch, and some emergencies and the way they are met:

“Let’s say an independent, or one of our own service men goes into a home to fix a TV set, and doesn’t have the needed part on his truck. He calls into the district location, and they don’t have the part. So, the district places what we call a ‘daily urgent order’ (via teletype) on New Concord that day. It is then our obligation here to have that part shipped out of here within 24 hours, and we meet that need pretty regularly, pretty consistently. We give that order high priority because these are normally functional parts that are required for a customer’s set. They’re not required for stock, but for the functioning of a customer’s set.

“Let’s say the order was placed today. The dealer or distributor should have the part back in his store the day after tomorrow. We attempt to have the orders out of here within 24 hours, and back to our factory service location within 48 hours.”

Williams said that the facility he manages stocks “just about everything that goes on a set.”

“Our aim is to have at least 96% of all the items on the shelf ready to be shipped when the order is received.”

There are exceptions, Williams admits. In those cases, he says, “I put the pressure on just about everyone to get the part in here as rapidly as possible, and I call upon all the resources of the GE company to get that accomplished, if necessary.”

Williams was asked: “If the servicer uses the resources available, and correctly identifies the part, can he expect to have the part within 24 hours?”

He answered: “If it is an urgent problem and he explains it properly to the district people, it will be back in that district location within 48 hours and he will be able to pick it up within that period of time. If he wants it shipped to him, that’s something else. In many locations, they want it shipped by UPS, (United Parcel Service), which might mean another day.”

Williams explained, however, that parts shipped to jobbers are not sent by air which means a longer delay.

“This can mean a problem for the independents,” he says.

“It is the tendency of the independent to go to the jobber for parts. If the jobber doesn’t have it, he will go to the GE district location. If the GE distributor doesn’t have it, he will order it from us. We ship directly to the jobbers, but not by air. In the case of California, it would probably be three



**GE’s own trucks** haul parts to the Columbus airport every day. The air freight service out of Columbus is very good, the GE spokesman said. Shipments to GE distributors are by air; shipments to independent distributors are by surface transportation.

weeks, and then the jobber has to notify the independent that the part has been received, and by the time the independent has been able to pick up the part and is ready to go out and install it, there has been a considerable delay—you have a problem.”

Williams was asked if the independent technician is better off if he goes directly to the district GE distributor rather than to the jobber.

“I don’t want to knock the jobbers, but I know that if he had gone to the district and expressed the urgency, that he could have had the part back within 48 hours, without any problem, if the part was available here.

“We are going to have instances where we are out of parts on a temporary basis—and even more than a temporary basis. We’ve had instances where we waited on a part 30 to 60 days.”



**The electronics** business is becoming an electronics business. These computers, in addition to facilitating the receiving and shipping of parts orders, gather other valuable management data relating to parts.



**Parts orders** are fed by teletype daily from GE district service and distribution centers throughout the country.

But such instances are exceptions, Williams said.

“They (the independent service technicians) expect to be able to walk into the counter and pick up that part—right now! And in my opinion (and in Kalember’s opinion) in the case of most functional parts, they should be able to expect to walk into most district service locations and pick them up.”

In general, availability on parts the past couple years has been good, Williams said, admitting to exceptions, however. “We’ve run into a couple of occasions when timing on the initial parts order was not as good as it should have been, but in general, it has been darned good.”

It serves no purpose for the independent to communicate directly with the New Concord depot regarding parts procurement or problems, Williams said. “All I can do in such cases is refer them back to the GE district. It is the district’s problem and the district’s responsibility to take care of them. If the district is not getting good service out of me, he has channels to get that straightened out. What it boils down to is: My responsibility here is to have parts available here for national distribution.”

He said that district offices are located in all major metropolitan areas.

Is it in the rural areas where problems arise?

Williams answered that “you run into some problems in some of these areas.”

He was asked: “How do the jobbers order and receive parts?”

“They usually give a written order that comes through our district location, and we drop-ship parts to the jobber. Our district takes care of any billing and any problems that arise in connection with that.”

How would you define an emergency?

“It all depends on the customer. I’ve seen some cases where there were three or four sets in a home, and it was an emergency when a set was down, because that’s the situation in that particular household. And, I’ve seen others that were willing to wait, with no rush whatsoever.

“So, I think that in an independent service man’s eyes, if he’s in a home, and the set is down, there is an emergency. The customer is looking to him for good service and I would suppose the independent would consider that an urgent situation. One of our own service men would consider it an urgent situation if he goes to any home and a functional part is required. They try to get it out of the district location very rapidly—the next day. If the district doesn’t have it, they try to get it out of us—that’s what we call “the daily urgent” procedure.

## Parts management on a grand scale — but, no Utopia

RCA's Parts and Accessories Division is headquartered at Deptford, N. J., the nerve center and warehouse of this firm's parts distribution network. Here is located a highly computerized parts processing system, supplemented by manual, personalized service, and directed by a management that is finding solutions to many problems, but sees no Utopia for parts availability.

### What Is Inventoried?

Any item that has been assigned a stock number, and has been listed in the parts catalog, is inventoried at the Deptford facility. A quantity of

those items are ordered at exactly the same time as the initial production quantity is ordered for the factory. The Deptford depot stocks just about any component that goes in a TV set or other electronic product the firm markets, said D. R. Weisenstein, manager of parts merchandising.

"In general, we have parts here well in advance of what is required, although there are situations when the vendor is a little late in delivering the part."

### Who Purchases from Deptford?

The bulk of the orders for parts for consumer products come from RCA distributors and independent parts distributors. The depot does not deal directly with dealers, technicians, consumers nor others who are not distributors.

### Handling Routine Orders

Weisenstein explained the normal processing of parts orders:

"The mail that comes in Monday is opened Monday. All those orders are fed into the computer Monday night. The computer works at night processing out the shipping documents. From these shipping documents the order is filled and the product is shipped on Tuesday." On the average, an interim of 1.2 days passes from the hour the order enters the depot's doors until the parts are shipped and on the way. In the event of an unusually heavy workload at the depot, some of the orders might not get out until the following morning.

An emergency service has been set up, so that if there is a critical need for a component, the distributor can get 1-day service. "However," Weisenstein said, "we recognize that neither we, nor the distributor can operate on a basis of 100% emergency service.

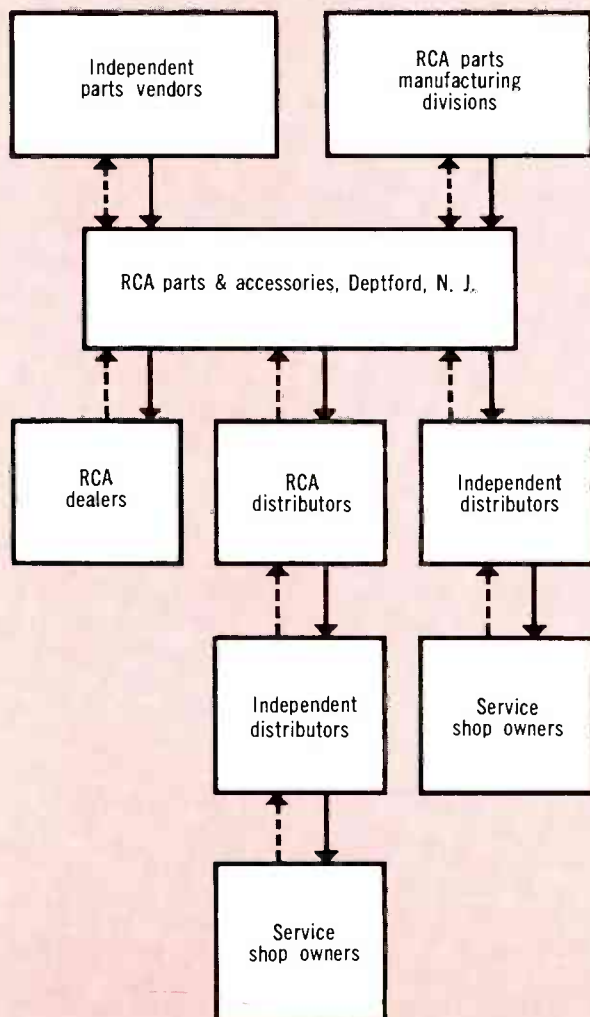
"The distributor should carry heavy stocks and the dealer should have parts available, too. They're going to need them if they're going to service a lot of sets."

### What to Stock?

RCA has established a parts package—an inventory system and parts recommendation level to assure adequate inventory in the field of most-used parts. It is called the QT (quick turnover) program and includes the 250 parts likely to be in most frequent demand. There are five different combinations of parts, or QT packages, each including different combinations of parts that a distributor might recommend to a dealer. The QT package recommended would depend on the types of products predominating in the dealer's trade territory.

## RCA Parts Distribution System

--- Ordering route  
 — Shipping route







This giant structure at Deptford, N. J. provides space for stocking the hundreds of thousands of items distributed across the country for all RCA products. It is much more than a parts depot though. It is headquarters for the RCA Parts and Accessories Division, with a wide scope of responsibilities in the parts and accessories business—including market research, design, purchasing, distribution and marketing.

**"The thing** you have to do is to set up a system, as good a system as is humanly possible to design, that will routinely and automatically do a good job. Then, when you run into problems, you have to be as cooperative as you can with the customers in trying to solve the problems." — D. R. Weisenstein, parts merchandising manager, RCA Parts and Accessories Division.



The QT program is intended: (1) to assure dealers that they will have on hand the most-used parts; (2) to provide for refund for parts under this program that are not used; and (3) to provide a ready-made system for storage, inventorying, and reordering.

Weisenstein explained how a QT package is selected:

"The determination of parts put on the QT program comes from actual usage. The initial stock level for a part is estimated. From that point on, from the moment the part gets into our distribution system, we follow its rate of use, and this is where the computer really plays an important function. It would be almost humanly impossible to follow these things on a manual basis. But, in a computer system, you can put it in there and set up an ordering point on it. You have a record of its sales history. As soon as any real movement starts to develop on an item, the computer picks it up and alerts us. As soon as we see an item move up into a high-usage quantity, we put it on the QT program."

The types of parts included under the QT program is limited to 250—an arbitrary cutoff point established by RCA.

"We could conceivably make it 300 or 350, but 250 was what we considered to be a reasonable number," Weisenstein said. "You could go over-

board by having too many on the QT program. Keep in mind that we have a complete return provision for these parts, and it wouldn't be practical to put a tremendous number of parts on the program. We have to have a reasonable cutoff, and we believe that 250 is a good point."

#### Parts Identification Problems

Identification of parts can contribute to delays in servicing, and Weisenstein cited several steps RCA has taken to ease identification.

"We make available all kinds of directories. You can start with the service data that the RCA Consumer Electronic Division puts out that has the schematics, complete with parts numbers. Since RCA drawing numbers are marked on parts, we have also put out a cross reference of drawing number to stock number, which anybody could use if he wants to quickly identify a part. If necessary, the technician can go to the distributor for help in identification of a part. The distributor is in even a better position because he generally has all of the parts data issued by RCA. We have a micro-film card index program (micro-fich) which we are introducing, which will be a further aid in parts identification. If all other sources fail, the technician can call in here. We have parts identification people whose specialty is to know the correct stock numbers."

#### Emergencies

Emergency situations can come about from a number of causes. When the technician is called to service a set in a customer's home, and he considers it an emergency, his distributor can order the part from RCA on an "expedited emergency" basis. One common source of complaints from technicians is the new models, when parts are not



Computers work all night, handling volumes of orders and information that would be impossible for clerical personnel to expedite satisfactorily.

available in the field. In some cases, the performance of a component in a new product is not known yet, and the part is not adequately stocked. Such cases can usually be resolved in a reasonably short time, since the model is still in production, and the parts division can go to the factory for

replacement parts, if necessary.

A type of emergency not so easily resolved, is the foreign-sourced product. This is the most frequently encountered, really tough parts problem, Weisenstein said. He cited these other eventualities: "An old product with parts furnished by a domestic vendor who is no longer tooled up to produce the item, or other vendors you rely on who have discontinued making the item. Then you have a real tough situation. These can take quite a while to solve. Sometimes, you even have to start from scratch and get the tools ordered."

The RCA parts division sometimes must seek out other sources for a part, or in a very unique situation will even redesign a direct replacement part.

#### Customer Relations; Commercial Situations

There are some categories or problems that come their way that neither computers nor parts can resolve, Weisenstein said. These are the customer relations and "commercial" problems when the blame is placed on parts availability.

"We have seen situations where the customer has said that the service dealer said that parts were not available from RCA. We tracked it down, and found that the dealer had never even ordered the part from his distributor."

There are even problems that have gotten as far as the Deptford facility that grew out of a disagreement between a distributor and a dealer—in short, a disagreement between two businessmen that is essentially due to factors other than parts problems, Weisenstein said.

"A dealer says he is trying to get the parts, and the distributor says he can't get the parts, and what you actually have is not a parts situation at all. The distributor just doesn't want to have anything to do with this particular customer," Weisenstein said. Even if it requires unusual measures, the RCA parts and accessories division can always eventually deliver the part, he pointed out.

#### New Conditions Defy Systematizing

Weisenstein cited some additional conditions, always changing, that have a bearing on parts distribution:

"There are so many new things coming into the picture. The consumers are asking for improvements all the time. There are new features being developed and we want to be as current as anybody else, and out ahead of the parade as much as possible.

"There are other factors, also. Somebody creates a condition in the industry, and then we all have to live with it. For example, the industry wide move toward foreign-sourcing of products. This is causing problems—obviously new problems compared to what we had when we were talking about domestic production, and they're becoming a part of the business and they have to be coped with."



The warehousing and shipping sections of the parts center are highly mechanized to speed up the work of assimilating and packaging the parts orders.



# If you're thinking about boning up for a higher-class amateur license, why not go after a Commercial License too? The exams are similar in many ways—and a commercial ticket can bring you rich rewards.

**T**HINKING about going for your Advanced or Extra Class License? Then why not kill two birds with one stone? Study up on your technical principles and fundamentals with a CIE home-study course—and get a Commercial License too.

CIE license-preparation courses, while they're specifically designed to get you a Commercial License, give you a thorough understanding of the "basics" common to all electronic gear—including your own and all other amateur radio rigs. So they can be tremendously helpful in preparing you for the questions you'll face in amateur exam Elements 4A and 4B.

This might be reward enough in itself. But the fact that these courses prepare you for a commercial ticket too provides the "icing on the cake."

## Advantages of a Commercial License

With such a ticket, you're ideally equipped to turn your hobby into a richly rewarding career—to "go professional" and take advantage of the exciting job opportunities in the booming world of Electronics.

You might, for example, want to get into two-way mobile radio servicing. In this fast growing field, a service contract for a typical system pays an average of about \$100 a month. One licensed technician can maintain eight to ten such systems—and some men cover as many as fifteen.

And there are many other golden opportunities in the aerospace industry, electronics manufacturing, computer servicing, telephone com-

panies and plants operated by electronic automation. The pay is good, the work is exciting, and the future is secure.

The "door-opener" to it all—and in many cases it's a legal requirement—is having a Commercial FCC License. For passing the Government's License exam offers proof positive to one and all that you really know your Electronics.

The exam is so tough, as a matter of fact, that two of three men fail it. But if you train with CIE, you've little cause to worry. CIE training is so effective that 9 out of 10 CIE graduates who take the exam pass it.

That's why we can afford to back our courses with this iron-clad Warranty: upon completing one of our FCC courses, you must be able

to pass the exam and get your Commercial FCC License—or you'll get your money back.

## Mail Coupon for Two Free Books

Want to know more? Send the bound-in card for a free copy of our school catalog, "How To Succeed In Electronics," describing opportunities in Electronics, together with our special booklet, "How To Get A Commercial FCC License." If card has been removed, use coupon below, or send your name and address to CIE, 1776 E. 17th St., Cleveland, Ohio 44114.

## ENROLL UNDER NEW G.I. BILL

All CIE courses are available under the new G.I. Bill. If you served on active duty since January 31, 1955, or are in service now, check box on card for G.I. Bill information.

**CIE** **Cleveland Institute of Electronics**  
1776 East 17th Street, Cleveland, Ohio 44114

1. Your 44-page book "How To Succeed In Electronics" describing the job opportunities in Electronics today and how your courses can prepare me for them.
2. Your book "How To Get A Commercial FCC License."

Name \_\_\_\_\_ PLEASE PRINT \_\_\_\_\_

Address \_\_\_\_\_

City \_\_\_\_\_

State \_\_\_\_\_ Zip \_\_\_\_\_ Age \_\_\_\_\_

Check here for G.I. Bill information  
Accredited Member National Home Study Council.  
A Leader in Electronics Training... Since 1934

PF-62

# Q. What's better than getting an Advanced or Extra Class License?

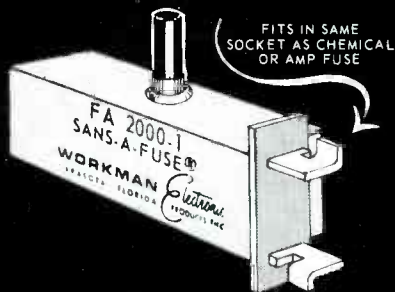
# A. Getting a Commercial FCC License to go with it.

Circle 21 on literature card

**A NEW AND IMPORTANT  
DEVELOPMENT FOR  
TV SERVICING**

12 MODELS

**SANS-A-FUSE®**



FITS IN SAME  
SOCKET AS CHEMICAL  
OR AMP FUSE

**COLOR CODED CIRCUIT  
BREAKER REPLACEMENT  
FOR CHEMICAL OR  
AMP FUSE**

**SAVES TIME AND FUSES  
WHEN LOCATING SHORTS  
IN TELEVISION CIRCUITS**

DEVELOPED AND  
MANUFACTURED BY

**WORKMAN Electronic**  
PRODUCTS, INC.  
BOX 3828 SARASOTA, FLA. 33578  
TELEPHONE: Area Code 813 955-4242

Circle 22 on literature card

**It costs only**



New Easy Dispenser Pak 60/40 18 S.W.G.\*

**1/100 of 1¢ more**



Latest PC (Printed Circuit) Pak  
60/40 Extra Thin 22 S.W.G.—.028" \*

**per solder joint  
to know you  
are using the  
world's finest  
cored solder**

\* Each only 59¢ per package at your dealer.

ERSIN

**Multicore**  
FIVE-CORE  
SOLDER

MULTICORE SALES CORP., WESTBURY, N.Y. 11590

Circle 23 on literature card

# Test equipment applications and techniques

**Sencore's new Model SM152 Sweep  
and Marker Generator Is Used To  
Align An Admiral 6H10 Color  
Chassis**

by Carl Babcock

Alignment of television receivers is finally beginning to receive attention equal to its importance. Many servicemen are buying alignment

equipment of the new combination type, which is designed to reduce the time required to perform alignment without sacrificing accuracy.

Our anticipated pleasure in checking out well-designed test equipment was fully realized in the latest alignment generator of this type to be tested in our laboratory: the Sencore Model SM152 Sweep and Marker Generator (Fig. 1A),



**Fig. 1A Sencore Model SM152 Sweep and Marker Generator features VHF and UHF tuner alignment, crystal markers and post-injection of the markers.**

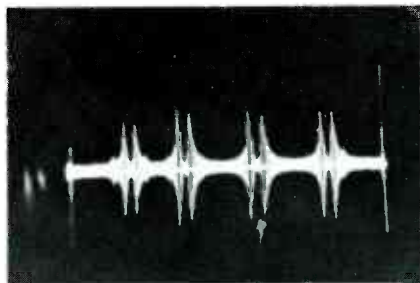


**Fig. 1B The Sencore 39G23 Detector Probe and 39G22A Matching Pad are supplied with the generator.**

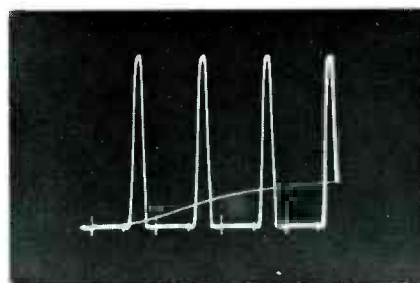
which combines the functions of UHF/VHF channel sweep, TV video IF and chroma sweep, FM IF sweep, marker generator and marker-adder circuitry. Elimination of many interconnecting cables is made possible by putting all of these functions in the same cabinet.

Speed and accuracy are further enhanced by the use of crystal oscillator markers (as opposed to the time-consuming, crystal-calibrated, single-frequency variable marker), which can be used in any combination from none to all eight at a time.

Video-sweep modulation (VSM) setup of the generator can be accomplished in seconds by merely positioning a few switches. Even the center frequency and right amount of sweep are switched in automatically, without any manual adjustments. VSM alignment is used to make the chroma alignment "track" exactly with the IF alignment; using conventional equipment, the time required to set up this mode of operation can be long.



**Fig. 2A** Distinctive double-tipped markers are easier to see on some curves. Shown are the 4 chroma markers expanded to full width.



**Fig. 2B** This is a test for the low-frequency response of your scope. Regular scope sawtooth horizontal deflection of 15 Hz was used to produce 4 alignment curves. Poor low-frequency response is indicated if the bottom lines (between the pulses) are tilted, and a false alignment curve would be produced.

A scope and a bias supply are the only additional equipment needed to align TV with the SM152.

### Features

Here are some of the features of the **Sencore** Model SM152 Sweep/Marker Generator:

- Sweeps all UHF and VHF channels for tuner alignment. Stable picture carrier markers for channels 4, 5, 10 and 13 are provided, and the 4.5-MHz marker can be switched on to supply the sound carrier marker for each of the four channels.
- Sweeps the 10.7-MHz FM IF, the old 20-MHz and the new 40-MHz TV IF bands in the 10- to 55-MHz continuously variable sweep band. Sweep width (frequency deviation) is fully adjustable up to 15 MHz.
- The sweep width is calibrated and adjustable. It has good linearity because varicap diodes are used to vary the frequency; a special ALC circuit is used to maintain flat output over the entire bandwidth.
- Calibrated RF output has a four-position switch and a fine-adjustment control.
- Post-injection of the markers (built-in marker-adder) does not distort the curve, regardless of the marker amplitude. Controls are provided to adjust marker height and width.
- Switches are provided to invert the scope pattern top-to-bottom or reverse it from right-to-left.
- Eight 40-MHz IF band crystal markers are provided, plus a jack for any external marker. Any combination from all to none can be used.
- A 39- to 48-MHz variable marker, for pre-setting IF adjustments before sweep alignment, can be selected by the range switch. It has a separate dial scale.
- A 10.7-MHz crystal oscillator plus .1-MHz markers are provided for FM IF alignment.
- Four of the crystal markers are used for chroma alignment. Their frequencies are 3.08, 3.58, 4.08 and 4.5 MHz. When the chroma function is selected with the **range** switch, the center frequency and sweep width are pre-set and need no adjustment. Full instructions for using chroma or modulated carrier (VSM) sweep are displayed on the dial scale when the **range** switch is

# look at the tips of these blades



Here's uniformity that's readily apparent and undeniable. Here's precision . . . achieved only through modern production methods, skilled workmanship, close quality control.

All Xcelite screwdrivers are made this way . . . slotted, Phillips, Allen type, Frearson, Bristol, Scrulox . . . fixed handle or interchangeable blade types . . . to fit precisely, preventing damage to fastener or tool.

That's why they're first choice of manufacturers who seek zero defects on the assembly line, of technicians who take pride in their handiwork.

If you service or assemble precision products, look for screwdrivers, nutdrivers, and other precision tools you need in the extensive Xcelite line.

## XCELITE®

XCELITE, INC., 18 Bank St., Orchard Park, N. Y. 14127  
In Canada contact Charles W. Pointon, Ltd.

Circle 24 on literature card

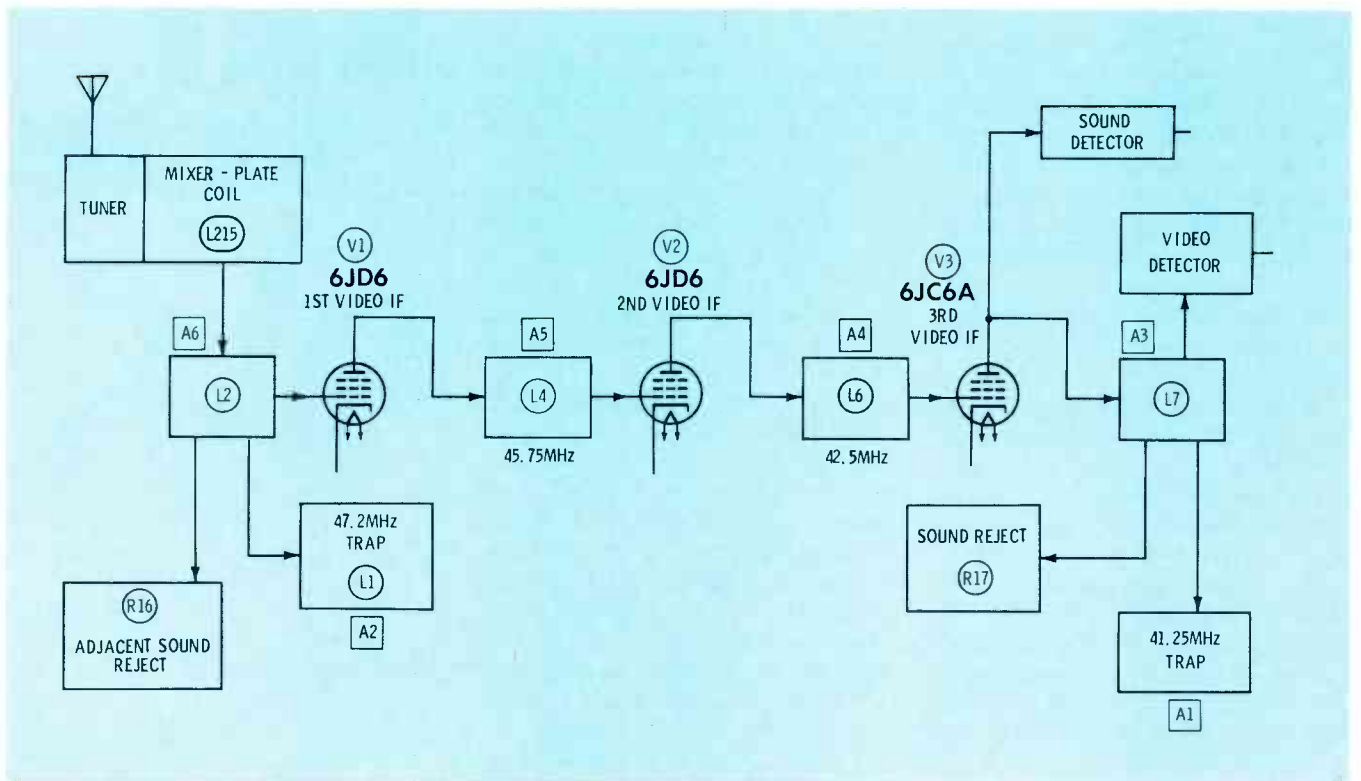


Fig. 3 Block diagram of the Admiral 6H10 IF circuit.

positioned to "chroma."

- The swept chroma signal is available at the **chroma out** jack; its amplitude is controlled by the **RF fine-chroma** control. For VSM align-

ment, it modulates the 45.75-MHz crystal oscillator, with the **output** (microvolt) control and output jack the same as for IF sweep.

- Three typical alignment curves

(RF, IF and chroma) showing marker positions are printed on the front panel.

- This generator is completely solid state, and has voltage-regulated DC power supplies.
- Seldom-used controls, such as the **blanking off/on** switch, **horizontal phase** for 60-Hz sweep and a **frequency cal** control are located on the back of the instrument.
- Universal matching pad and video detector probe cables are included, as illustrated in Fig. 1B.

#### Preliminary Adjustments to the SM152 Generator

Attach a shielded cable from the generator **scope "V"** jack to the vertical input connector on the scope. If your scope has no 60-Hz horizontal sweep with a phase adjustment, connect a cable between the **scope "H"** jack on the generator and the external horizontal input connector on the scope. Then turn the horizontal selector switch on the scope to the external (or horizontal input) sweep position.

Select the 10- to 55-MHz sweep band with the **range** switch, set the

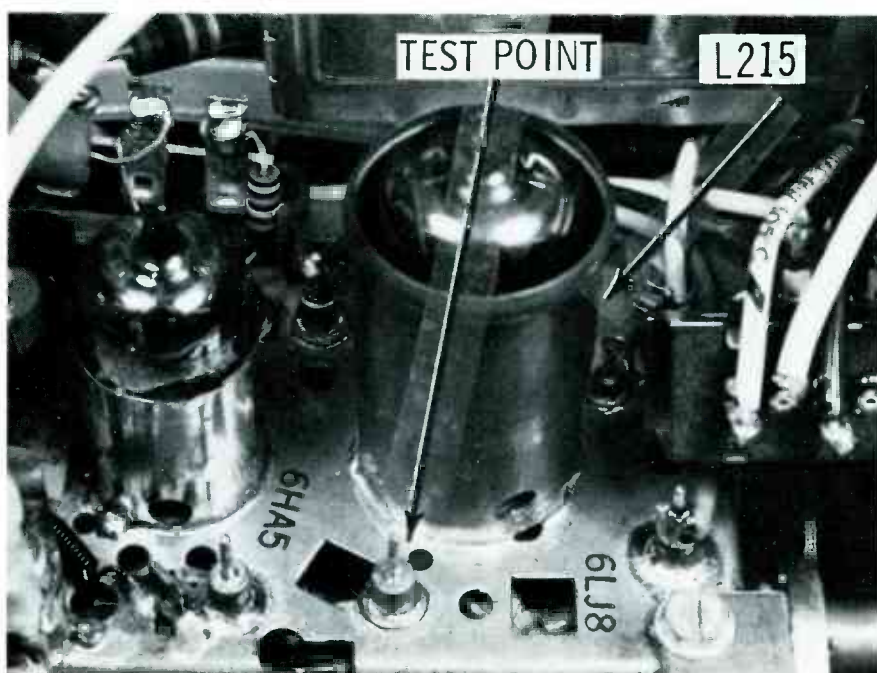


Fig. 4 Location of the testpoint and the mixer-plate coil (L215) on the tuner.

dial to about 44-MHz and turn the **output** switch down to minimum. Also set the **sweep width** to about 8 MHz, the **marker height** to about 50% and depress the 44.25-MHz marker switch.

One marker should be seen on the scope. Slide the **blanking off/on** switch (located on the back of the generator) to the "off" position and hold it there. Two markers should

now be seen on the scope. Adjust the 60-Hz phase control on the scope (or the **horizontal phase** control on the back of the generator, if horizontal sweep for the scope is taken from the SM152) until the two markers move together. Then release the **blanking switch**, which is spring-loaded and will return to the on position. One marker plus the base line should be seen on the

scope. Switch off the 44.25-MHz marker.

Switch on the highest and lowest IF markers that will be needed—in this case, 41.25 MHz and 47.25 MHz. Adjust the horizontal gain on the scope until the horizontal line is as wide as the screen. Adjust the SM152 **tuning** dial to center the markers, and adjust the **sweep width** control to expand the spacing between the markers until the markers are near the right and left sides of the scope screen. Fig. 2A shows the 4 chroma markers expanded by decreasing the **sweep width**; this is how markers look without a curve. Preset the vertical gain controls on the scope to give the trace about a 2 in. height with a 2-volt p-p signal. A well-centered curve should be seen on the first try when the SM152 is connected to the receiver. **Note:** Identify markers by switching them off to see which disappear. Position the **sweep direction** switch so that the high frequencies are to the right in the response curve. Adjust the **response pattern** control to position the curve upright (proper polarity).

### Preparation of the Admiral 6H10 Chassis for Alignment

It is neither necessary nor desirable to see the receiver CRT screen or have a raster during alignment. The chassis and tuner should be removed from the cabinet, the chassis placed on its side with the high-voltage cage down and the tuners and control cluster cables plugged in normally. Remove the horizontal output tube and the vertical output tube. It is not necessary to connect the CRT socket, deflection yoke, convergence plug, degaussing coil or high-voltage anode connector.

Do **NOT** remove either the top or bottom IF shields during alignment. The curve changes with the position of this shielding.

The block diagram in Fig. 3 shows the IF section of the Admiral 6H10 chassis. The mixer plate coil, L215, and the first IF grid coil, L2, are an overcoupled pair which should be adjusted by sweeping them alone. This is called "link" alignment. The other IF adjustments are all stagger tuned.

Fig. 4 shows the location of the

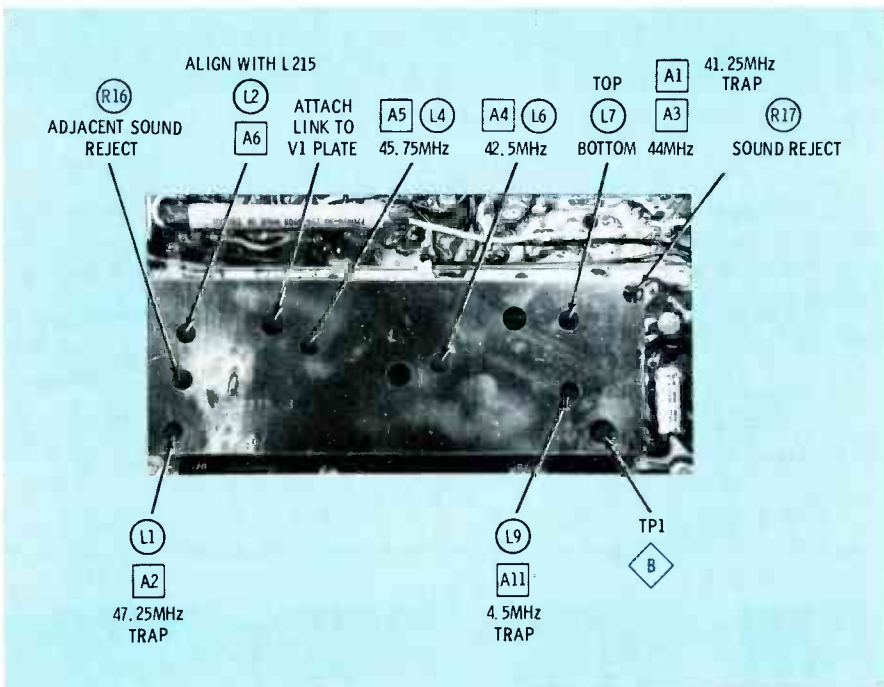


Fig. 5A Location of the IF coils and adjustments in the Admiral 6H10 chassis.

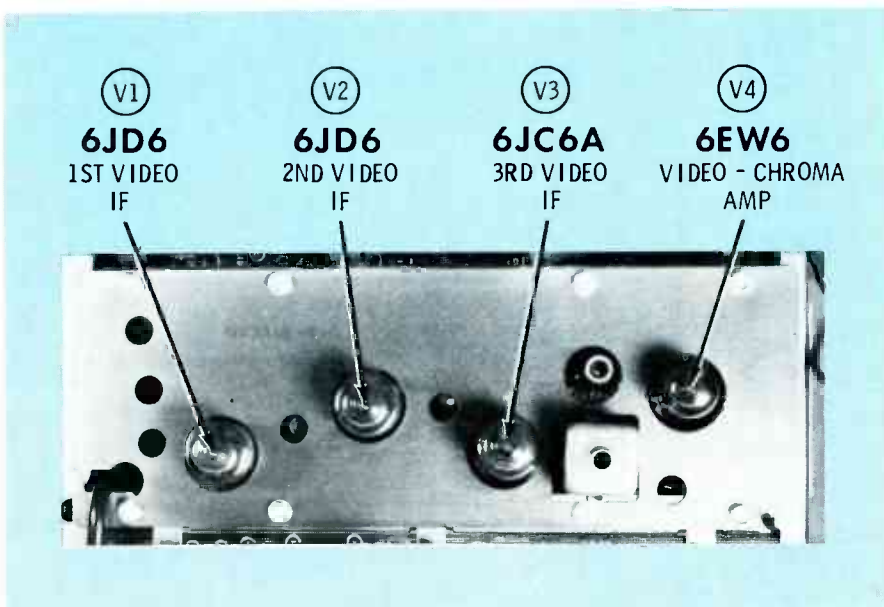


Fig. 5B View of the top of the IF shield and the location of specific tubes.

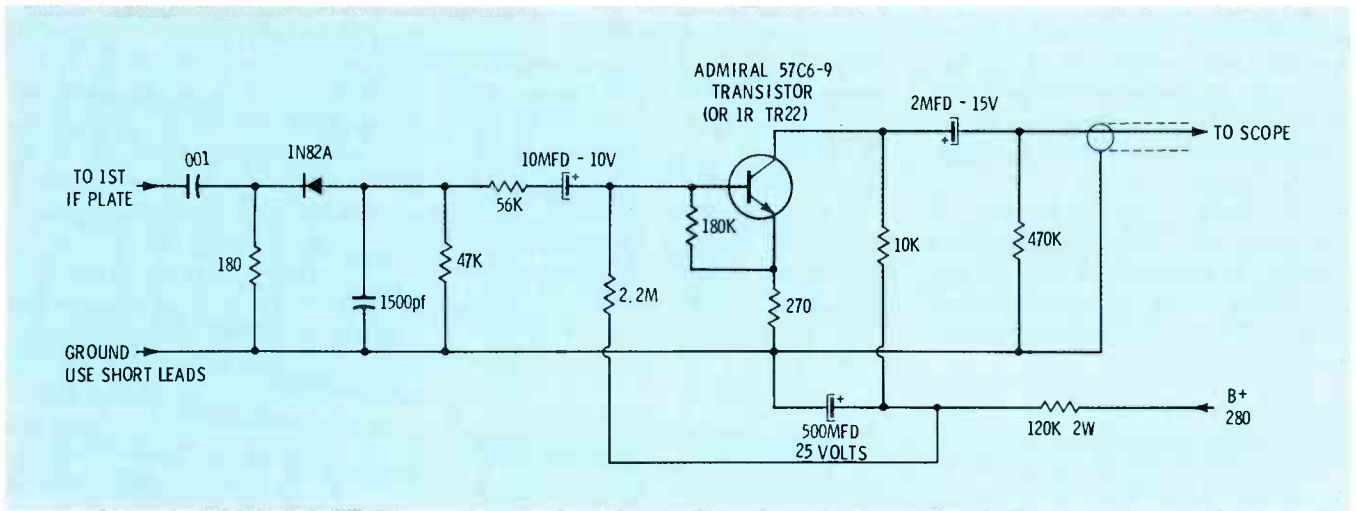


Fig. 6A Complete schematic of the Admiral "link-amplifier" circuit.

testpoint for injecting the IF sweep signal into the grid circuit of the mixer tube. Locations of the IF adjustment cores and access holes for the probes are shown in Fig. 5A, while Fig. 5B shows the top side of the IF board and the tube locations.

Ground the testpoint marked "JJ" on top of the Admiral audio-

deflection board (near the 6EW6 sound IF tube) to clamp the IF AGC at the correct gain-reduction voltage. Apply  $-2$  volts to the RF tube AGC terminal.

#### Aligning the Admiral 6H10 Chassis

1. Connect Sencore universal pad

number 39G22A to the tuner testpoint (red test clip) and to the nearest ground (black clip).

2. Make up an IF load using a 1000-pf capacitor and a 180-ohm resistor in series. Use short leads and install a mini-clip on the capacitor lead. Install the load by

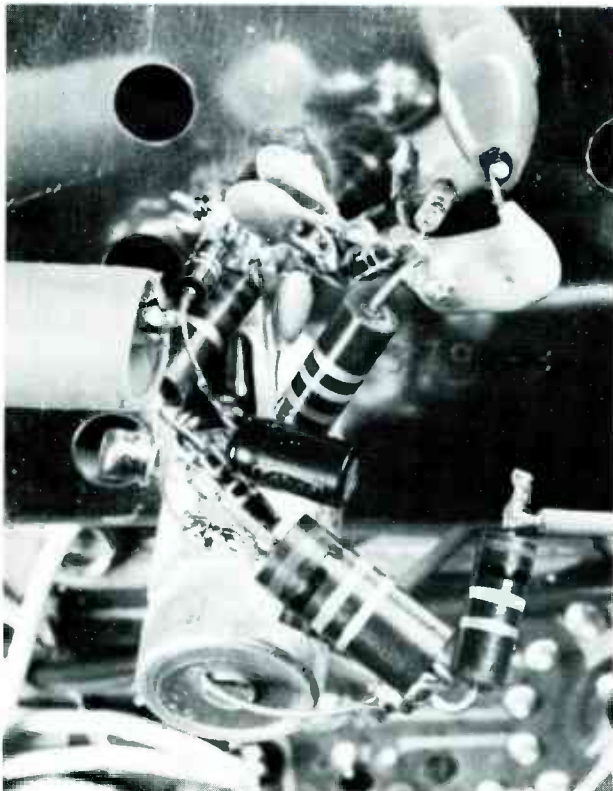


Fig. 6B Picture of the "link-amplifier".

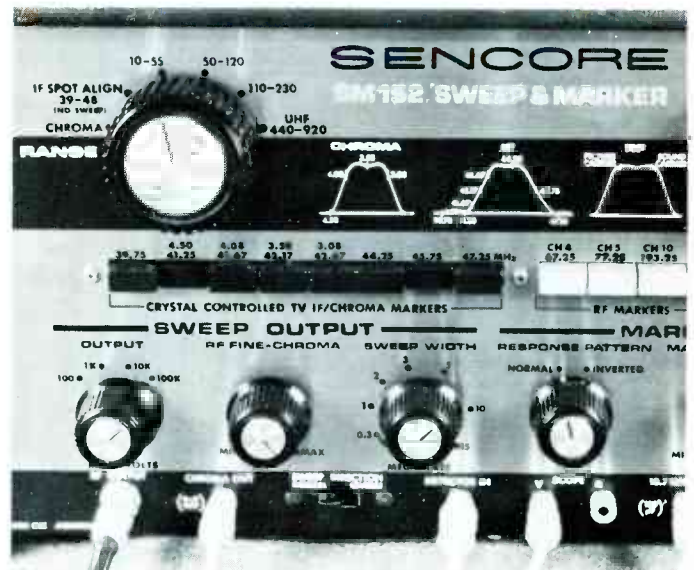


Fig. 6C Positions of controls of the SM152 generator during link alignment.



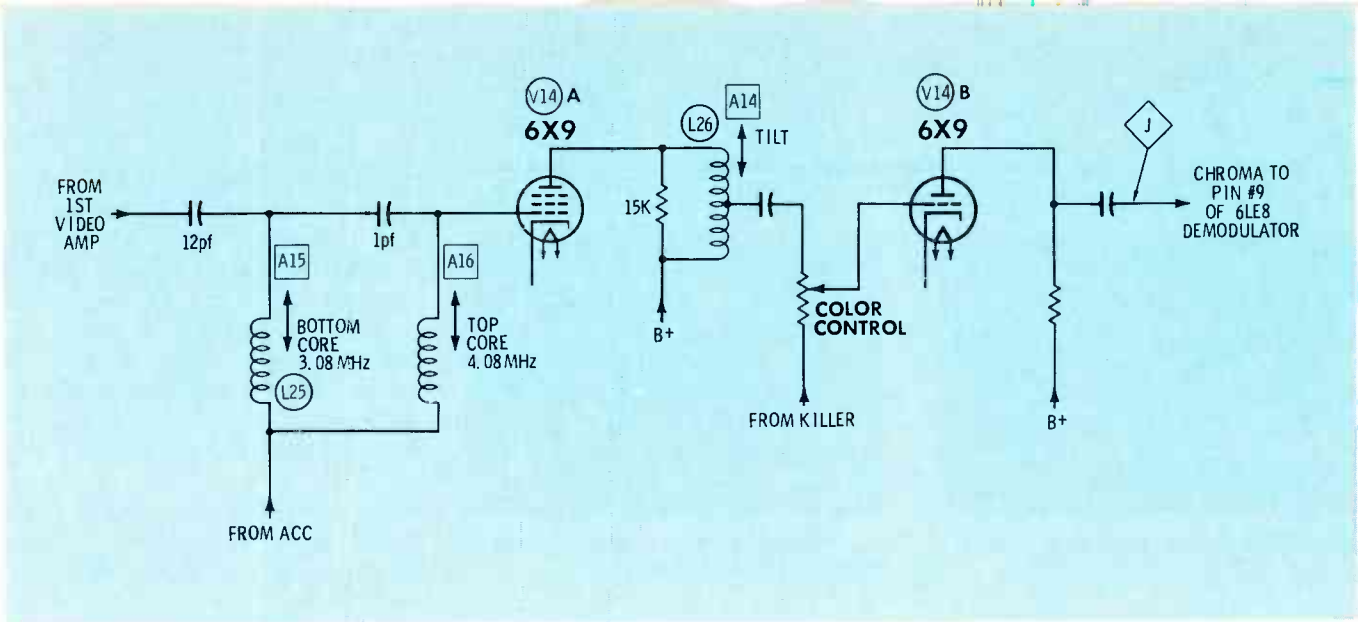


Fig. 13A A simplified schematic of the chroma circuit of the Admiral 6H10 chassis.

minimum. Although the main function of R16 is to increase the attenuation of the trap, the curve will

not "flat-top" if R16 is too low in resistance, and it will have too much sag in the center if R16 is

too high. Restore the **sweep width** and **tuning** controls to show the full IF curve. Touch up L215 and L2, if necessary, following the trap adjustment.

**Note:** Admiral advises that the 45.75-MHz side of the curve should be aligned slightly high when the transistorized link-amplifier is used. Link alignment is very important, and the correct curve (Fig. 7) should be obtained before you go on to the next step. Then remove the link-amplifier assembly.

6. Connect the red clip of the **Sen-core** 39G23 probe to the video detector (TP1, Fig. 5A) and the black clip to a nearby ground. Pre-set the **output** switch to "10K microvolts" and the **RF fine** control near "off". Switch on all the IF markers except 39.75 MHz. Adjust the **RF fine** control for 2 volts p-p at TP1.

7. Adjust the core of L4 (A5) for maximum height of the curve at the 45.75-MHz marker, L6 (A4) for maximum height of the curve at the 42.67-MHz marker and the bottom core of L7 (A3) to level the top of the curve.

8. Reduce the **sweep width** and adjust the **tuning** dial to a lower frequency to expand and center the 41.25-MHz trap marker, as shown in Fig. 8. Alternately adjust the top core of L7 (A1) and R17 for minimum response at 41.25 MHz. Be precise; satisfactory reduction of the 920-KHz beat pattern depends mainly on this adjustment.

9. Restore the **sweep width** and **tuning** to normal and examine the curve, comparing it to Fig. 9. If the 45.75-MHz marker is not at ap-

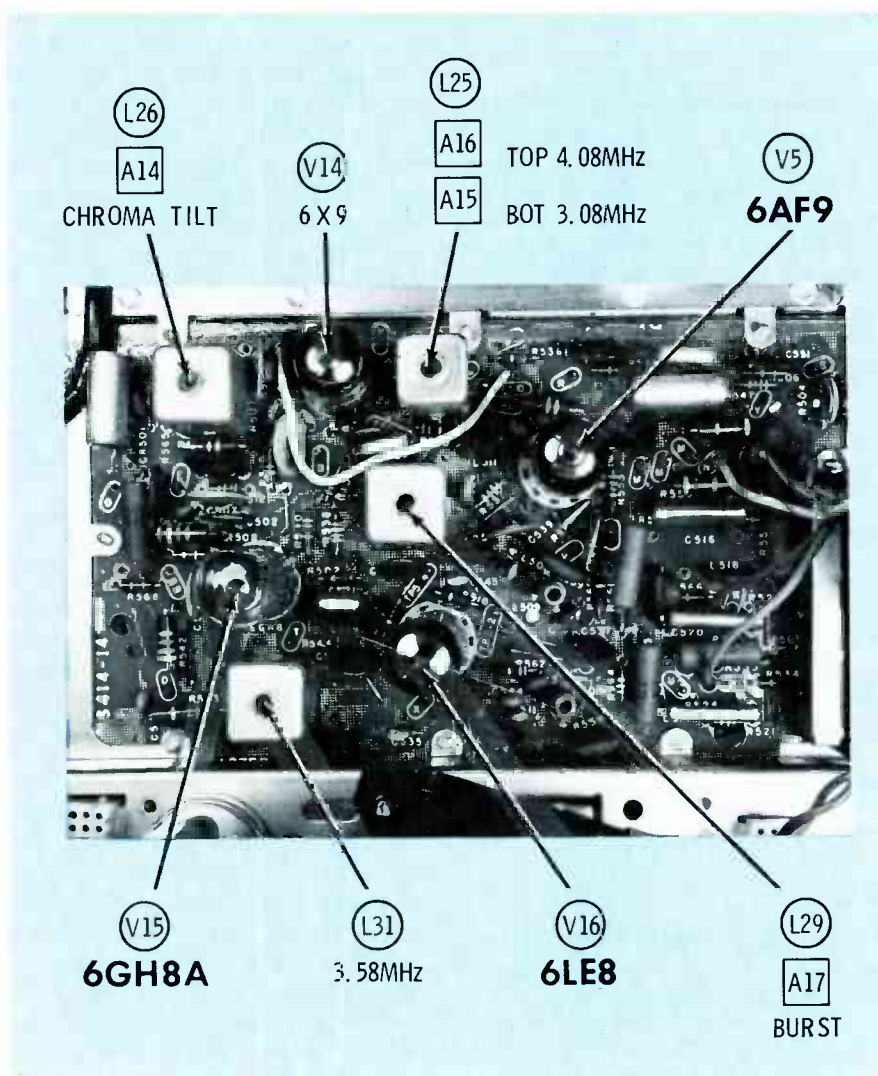


Fig. 13B This picture shows the location of the tubes and alignment adjustments on the chroma board.

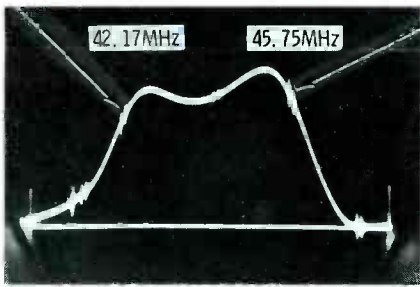


Fig. 7 The normal link curve.

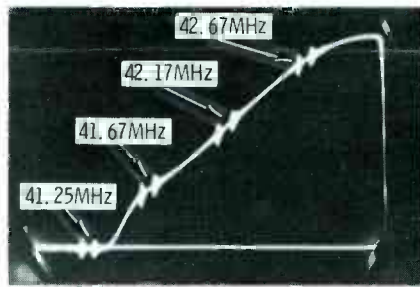


Fig. 8 Expanded sound trap marker for precise adjustment.

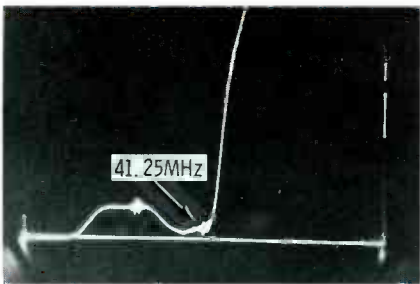


Fig. 9 The ideal IF curve (for any color receiver) was obtained with this Admiral chassis after alignment using the SM152.

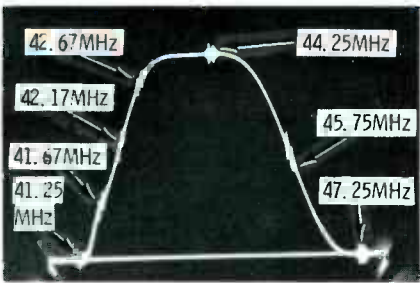


Fig. 10 The shape and slope of the chroma side of the IF curve is very important. Reduce the SWEEP WIDTH to widen the curve and adjust the generator TUNING to move the parts of the curve you want to examine to the center of the scope.

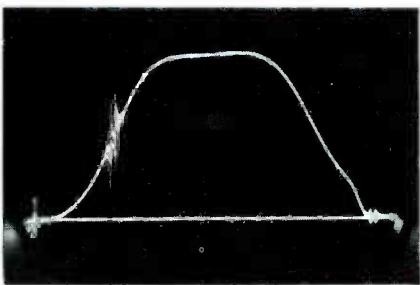


Fig. 11 The overall curve from antenna terminals to the video detector on channel 4 is nearly identical to the IF curve. Channel 4 picture carrier marker of 67.25 MHz is on the left; and the sound carrier marker of 71.75 MHz is on the right.

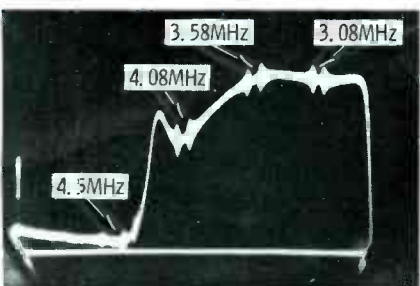


Fig. 12 It is sometimes helpful to see the VSM curve of the receiver (tuner testpoint to the video detector).

clipping the capacitor to the plate buss wire of V1, using the access hole (location is shown in Fig. 5A) to admit the insulated clip. Solder the free end of the resistor to the IF shield. Keep the leads short. Attach the blue clip of the 39G23 Sencore universal detector probe to the junction of the resistor and the capacitor and then ground the black clip.

3. If your scope does not have enough gain to produce a large waveform during step 2, you may need to build the "link amplifier" whose schematic appears in Fig. 6A. This is a combination load, detector and transistor amplifier suggested by Admiral. It gives a voltage gain of about 10 times. Note that voltage from any +250- to +300-volt source in the receiver can be used to supply the silicon transistor. Solder the ground of the link amplifier to the shield, and attach the capacitor by the insulated clip to the plate of V1. The circuit pictured in Fig. 6B was built hurriedly, and is not an example of beauty, but it operates correctly. Note that it uses short leads, especially the ones to the 180-ohm resistor and the .001-mfd capacitor.

4. The picture in Fig. 6C shows the approximate knob settings of the SM152 for link alignment. Switch on the 42.17-MHz, 45.75-MHz and 47.25-MHz markers. Vary the scope gain to produce a normalized curve on the scope.

5. Following the component numbering system used in PHOTO-FACT folder 949-1, adjust L215 (on the tuner) and L2 (A6 on the IF board) to approximate the curve shown in Fig. 7. Alternately adjust L1 (A2) and R16 (trap balancing control) for minimum response at 47.25 MHz. For better accuracy of the trap adjustment, widen the curve by decreasing the sweep width to about 2 MHz and moving the tuning dial to about 47 MHz to bring the trap marker to the center of the screen, as shown in Fig. 8 (which is the other trap). Increase the scope gain to maximum (if the curve is large enough, allow the top of the curve to extend off the screen), reduce the marker height and adjust L1 and R16 again, being careful that each is set for a definite

proximately 50%, adjust A5 to position it there. Adjust A4 to move the 42.17-MHz marker to about 65%, if needed, and then adjust A3 to level the top of the curve. Pay careful attention to the chroma side of the curve, as shown expanded in Fig. 10. The 41.67-MHz marker should be up at least 20% from the base line, the 42.67-MHz marker should appear below the corner (**never** on the flat top of the curve), with the 42.17-MHz marker between them on a relatively straight part of the curve. Repeat adjustments A4 and A3 to improve the curve, if necessary.

10. Fig. 11 shows the overall curve obtained on channel 4 when the following connections and adjustments are made: (a) red and green clips of the Sencore 39G22A pad connected to the antenna leads, (b) —2 volts applied to the RF tube AGC connection, (c) all IF markers off, (d) channel 4 marker on, (e) 4.5-MHz chroma marker on, (f) range switch turned to the 50- to 120-MHz sweep band, (g) the tuning dial turned near the "channel 4" marking so that the curve is centered on the screen, and (h) the fine tuning on the receiver adjusted to place the picture carrier marker at the 50% point on the curve. Check the tuner and overall alignment of

channels 5, 10, and 13 in the same manner as just described.

### VSM Chroma Alignment

1. Turn the range switch to "chroma". Tuning and sweep width are pre-set; turning these controls on "chroma" function produces no change. Slide the sweep direction switch to reverse, and switch on the 4.5-MHz, 4.08-MHz, 3.58-MHz and 3.08-MHz markers. Connect the red clip of pad 39G22A to the tuner testpoint and the black clip to ground. Connect the blue clip of the Sencore 39G23 detector probe to the video detector, TP1. Fig. 12 shows the approximate curve expected at that point. This step is not absolutely necessary, but it is a check of the IF alignment.

2. Change the blue clip of the 39G23 probe to pin #9 of the 6LE8 color demodulator tube, and attach the black clip to ground. The output and RF fine controls should be left at about the same setting as for IF alignment. Turn the receiver color control to about 50% and then adjust the vertical gain control on the scope for a normal-size response curve. Check for overload by turning the RF fine control up and down—watch for any distortion of the curve. Adjust and leave the control positioned 50 percent below the point of any distortion.

3. A simplified schematic of the chroma channel is shown in Fig. 13A, and a picture of the chroma board is shown in Fig. 13B. Adjust the top core of L25 (A16) for maximum height of the curve at 4.08 MHz, and the bottom core (A15) for maximum height at 3.08 MHz. Adjust the core of L26 (A14) to make the curve as flat and level as possible. If the tilt is more than about 25%, it may be necessary to touch up the IF alignment before trying the chroma adjustments a second time. Then adjust L9 (A11) for minimum response at 4.5 MHz. Final adjustment of this trap should be made on a station, as detailed later.

Unless the VHF or UHF tuners need adjustment, this completes the alignment. The ideal overall VSM chroma curve is shown in Fig. 14.

If the correct curve cannot be obtained, it can be helpful to examine the bandwidth of the chroma channel alone, as shown in Fig. 15. Attach the chroma out cable to TP1, the video detector, and proceed as in steps 2 and 3. If this curve is within tolerance, but the overall VSM is not, the IF alignment must be improved.

After the chassis is completely connected to the picture tube and the previously removed vertical and horizontal tubes have been replaced, tune in a color broadcast. Adjust the fine tuning until the 920-KHz beat pattern can be seen in the large areas of color, then carefully adjust L9 (A11) for minimum beat pattern.

### Conclusion

The Sencore Model SM152 Generator performed excellently during our laboratory tests. I particularly like multiple markers, and this generator produces good ones. The unique, nearly-double markers (Fig. 2A) are easy to locate on the steep sides of curves.

Except for the component numbering system, the procedure for aligning the Admiral IF's also can be used effectively to adjust the IF curve of any three-tube-IF RCA chassis. ▲

\*An optional universal link detector probe, part number 39G26, is available from SENCORE. Equipped with a voltage quadrupler and built-in IF load, the probe can be used for link alignment of both tube and solid-state TV receivers.

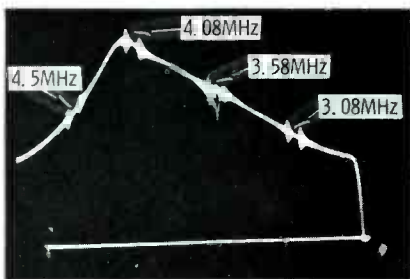


Fig. 14 The overall VSM (chroma sweep amplitude-modulating a 45.75-MHz carrier) curve from the tuner testpoint to the control grid of the demodulator tube should be nearly identical to this actual curve.

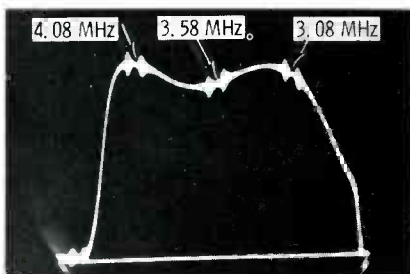


Fig. 15 A curve of the chroma channel alone helps determine if any deviation from normal of the overall VSM curve originates in the video IF's or the chroma circuit.

# The next time postal service breaks down, it's your fault.

In 1966, the Chicago Post Office ground to a halt. For three weeks, the mail was almost at a standstill.

If you want that to happen in your town, just wait.

Today's U.S. Post Office is probably the most inefficient, most antiquated big business in the United States. Unless something is done right now—by people like you—the situation is going to get worse.

Are you interested in straightening out the mess?

Right now, there's a bill before a committee of Congress called HR 11750. HR 11750 is, in brief, the recommendations of a bipartisan committee for the reorganization of the U.S. Post Office on a business like basis (along the lines of TVA). HR 11750 is designed to take the Post Office out of politics, to apply modern business methods to its operation and, in the process, to save taxpayers the \$1,200,000,000 annual deficit that today's horse-and-buggy Post Office incurs.

You can help get HR 11750 out of committee and enacted into law by letting your congressman know how you feel. Tear out this column, pin it to your letterhead and mail it to your congressman today. Let your voice be heard.

If the Post Office in your city breaks down next, you can't say you haven't been warned.

## Citizens Committee for Postal Reform

1725 Eye Street, N.W., Washington, D.C. 20006  
Lawrence F. O'Brien/Thurston B. Morton  
National Co Chairmen

## testequipment

notes on analysis of test instruments, their operation and applications

### Digital Panel Meter

The Beede Electrical Instrument Co. has introduced their new DM-100 Series of digital panel meters (DPM's). This line of DPM's is designed for "non-laboratory" applications, it is reported.

The case is cast aluminum and terminals are the standard screw type, marked and protected. The durable front offers customizing ease, and it swings out and away for front-of-panel mounting. Zero and span adjust are placed behind the cover, away from playful fingers, yet easily reached by gauge personnel. Electrically, it is designed for direct replacement of an analog-type meter without circuit adjustments, according to the manufacturer.

Beede states that the DM-100 Series offers a 3½ digit, non-blinking display; instant-on operation,



with three minutes to stated accuracy; accuracy of  $\pm 0.1\%$ ,  $\pm 1$  digit to full 100% over-range; three least significant digits, which extinguish beyond 100% over-range; automatic polarity indication; and speeds of 2 conversions per second. Bipolar and Unipolar models are available in six ranges from 0-19.99  $\mu$ a to 0-1.999 amps; five DC ranges from 0-199.9 mv DC to 0.1000 volts DC; and two AC ranges, 0-19.99 volts AC and 0-199.9 volts AC.

The Bipolar models are priced at \$233.00 each for quantities of 1 to 9. The Unipolar models sell for \$221.00 each for quantities of 1 to 9.

Circle 53 on literature card

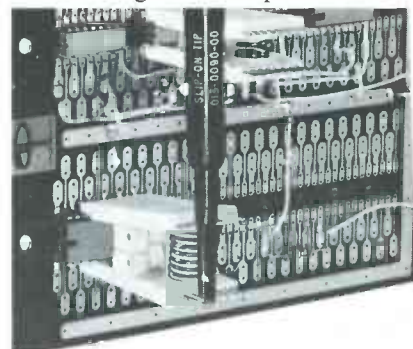
### IC Test Clip

Easy accessibility to hard-to-reach DIP pins is provided by a

new integrated-circuit (IC) test clip announced by AP Incorporated.

The new clip is ideal for field service work and for lab and production circuit checking, particularly for use with oscilloscope probes, it is reported. It can also be used as an inspection test fixture and for easy damage-free removal of dual in-line packages.

The manufacturer states that a unique "contact comb" assures positive short-proof positioning of the wiping-action gold plated phosphor bronze fingers. Incorporation of a



quality controlled helical spring provides the correct contact tension at all times. The new clip reportedly fits all dual in-line packages with leads on .5- and .6-inch centers, and is a companion to AP's smaller fourteen/sixteen-pin DIP test dip.

The clip sells for \$7.50 in quantities of one to nine.

Circle 54 on literature card

### Color Generator

SENCORE has recently announced a new miniature color generator that is small enough to fit into a tube caddy. The new generator, Model CG19, is named the Caddy Bar, weighs only two pounds



and is smaller than a box of panatella cigars, according to the manufacturer.

Standard RCA licensed color bars, crosshatch, white dots, vertical lines and horizontal lines are generated. SENCORE states that the new circuitry reduces the current drain, allowing full voltage regulation on all circuits (rather than just the timer circuits) and increased battery life. The range of the timer

circuitry of the Caddy Bar has been doubled over that of the company's earlier models. Other features include new stability and instant-on action.

The price of SENCORE's Model CG19 color generator is \$84.50.

Circle 55 on literature card

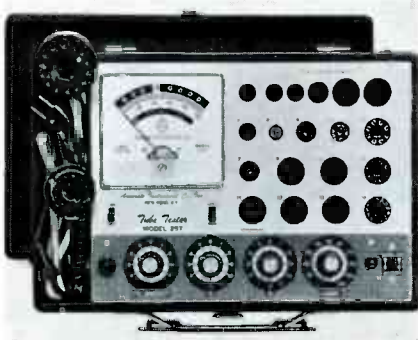
### Tube Tester

The Model 257 tube tester has been introduced by Accurate Instrument Co., Inc.

Included as standard equipment are all accessories needed for testing b-w and color TV tubes as well as standard tubes, states the manufacturer.

The tester has a 4½" dual scale meter with a sealed damping chamber to maintain accuracy, the manufacturer states. Also mounted on the front panel is a complete set of tube straighteners.

According to the manufacturer, a single cable is used for testing all b-w picture tubes with deflection angles from 50° to 114°. Functions



of the instrument include emission, inter-element shorts and leakage tests. It also is reported that the red, green and blue color guns are tested individually for cathode emission quality, and each CRT gun is tested separately for shorts or leakage between control grid, cathode and heater.

The Model 257 tube tester is housed in a sturdy portable case, comes complete with all adapters and accessories and sells for \$47.50.

Circle 56 on literature card

GIVE... so more  
will live  
**HEART  
FUND**



## Experience: the invisible ingredient.

With all the fancy names and gimmick claims, it's tough to weed through brand after brand of aerosol products today and really know which one is best.

One very important guideline is experience.

GC has been supplying chemical products for about forty years — aerosols, tubes, bottles, drums — a size and formula for every need.

And we are manufacturers and fillers — not just selling agencies.

Experience may be an invisible ingredient, but it's sure worth looking for.

## GC CHEMICALS THE ONLY AEROSOL CHEMICAL LINE THAT GIVES YOU EVERYTHING



Look for our new **Extra Dry Super Freeze Mist**. Cools circuits three times faster than standard coolers... leaves no liquid residue... absolutely non-toxic and odor free... specifically designed to locate problem capacitors, transistors and oxidized joints by instantly cooling components. Cat. No. 10-702... 15-oz. Aerosol Can



**NUVI-TRAN TUNER CLEANER**  
For Critical Nuvistor and Transistor Circuitry. The non-toxic, non-drift, non-conductive cleaner, specifically formulated for sensitive nuvistor and transistor tuners. Cat. No. 5555... 8-oz. Aerosol Can



**ACTION**  
The Silicone-Based Tuner Cleaner at a new low price. Fast-acting cleaner, completely safe for plastics; silicone base provides long-lasting protection against dirt and corrosion. Cat. No. 99-06... 6-oz. Aerosol Can



**SPRA-LUBE**  
Cleaner-Lubricant for Color TV Tuners. The non-drift cleaner and lubricant, for color TV tuners. Safely cleans away dirt, dust and oxidation. Uses NASA approved solvents. Cat. No. 8888... 8-oz. Aerosol Can.

Send for your free catalog. Write to . . .



**GC ELECTRONICS**

400 SO. WYMAN ST., ROCKFORD, ILL. 61101  
A DIVISION OF HYDROMETALS, INC



Circle 26 on literature card

# Common troubles in auto stereo tape players

by Joseph J. Carr

The present trend in automotive entertainment electronics is toward cartridge-type stereo tape players, the designs of which are all similar. The tape cartridges are endless-loop types, as shown in Fig. 1, with the tape ends spliced together by a piece of aluminum foil. The tape is moved by a pinch-roller/capstan mechanism that is belt driven by a small DC motor, as shown in Fig. 2. The rubber pinch roller is inside the cartridge. (It is placed inside by the machine on four-track systems, and permanently installed in the cartridges used in eight-track units.)

Automotive tape players are little different electrically from other kinds of all-solid-state tape players. They have a two-channel stereo pick-up head that feeds a pair of high-gain audio amplifiers, which, in turn, feed power amplifiers. The power amplifiers usually are designed to feed a standard 8-ohm speaker system.

Since 1966 Ford products appeared with an optional eight-track tape player, this system has become pretty much the automotive standard. Eight-track cartridges offer four programs, using one track for each stereo channel. Although in the minority, the four-track machines are around in sufficient numbers to warrant consideration.

Besides the number of recorded tracks, the chief difference between four- and eight-track systems is in the pinch roller mechanism. The eight-track cartridge contains its own pinch roller. The four track uses a machine-mounted roller that is inserted into the cartridge through a hole in the bottom.

The average technician should have little difficulty servicing automotive tape players if he will take the time to become familiar with what will be encountered when he pops the covers off. The following

paragraphs discuss some of the more common troubles found in auto tape players.

## Oxide Fouling

Both garden-variety dirt and the oxide from the tape surface can foul the transport mechanism. Although we will return to this trouble when we consider speed problems, there are some oxide troubles that are unrelated to speed.

Two of these problems are low volume and distorted sound. If a layer of dirt builds up on the pick-up surface of the tape head, the level and quality of the signal passed on to the audio amplifiers will be degraded. This layer of dirt must be removed if the player is to operate normally.

Cleaning can be accomplished with either a cleaning tape cartridge or a cotton swab dipped in alcohol, carbon tet or one of the commercially available solvents. The long, wooden swabs are especially good for this purpose.

Some tape players change programs automatically. This is accomplished by placing a pair of switch contacts so that they can be shorted out by the aluminum foil that splices the tape ends together. If these contacts have oxide on them, the solenoid will fail to index properly. As with the tape head, these contacts can be cleaned with either a cleaning cartridge or with suitable chemicals.

## Speed Problems

Two of the most often heard complaints is that the machine runs either too fast or too slow, with the latter complaint predominating. Speed can be checked with either a strobe disc or a test tape. The stroboscopes, unfortunately, are not widely available. Some manufacturers do, however, make them available to their own warranty stations or their factory authorized service outlets.

Several tape manufacturers offer

test tapes that have a speed test recorded on one track. Typical of these tapes is the one offered by RCA. This tape has a 125-Hertz tone with 1000-Hertz tone bursts on the right channel for testing speed. The 1000-Hertz tone bursts are spaced sixty seconds apart. Speed is checked with either a stop watch or a clock with a sweep second hand. Most tape player manufacturers allow a plus or minus 2-second tolerance (bursts every 58-62 seconds).

If the player speed is too slow, the following parts might be causing the trouble: capstan, capstan housing, drive belt, motor or motor regulator circuit.

The capstan and its housing will cause the tape to play slow if the capstan rotation is impeded. This can be tested by removing the drive belt and spinning the flywheel by hand. It should spin freely. If it is noisy or runs erratically, the capstan and capstan housing probably need cleaning.

The capstan and flywheel form one assembly. On a few models it is of one-piece construction, but most use a capstan that is pressed into the flywheel. This latter type of construction has produced some trouble in 1968-69 Ford players (by Motorola): The flywheel and capstan shaft have the habit of separating. If the shaft is loose or fails to fit flush with the surface of the wheel, replacement is required.

In most cases, the capstan requires only a good cleaning. This can be accomplished with a lint-free rag and either alcohol or carbon tet. When removing the flywheel-capstan assembly from its housing, note the condition of any thrust bearings and washers that may be used. If either appears to be worn, or if the race between the ball bearings is clogged with dirt, it is best to replace them rather than to attempt cleaning. Also note the condition of any nylon tip-bearings, such as those used by Motorola on

the bottom of their capstan shafts.

The capstan housing is cleaned with cotton swabs and chemicals. Be sure to scrub all surfaces until they are free of foreign material and contamination. Lubrication is to be avoided if at all possible. The only exception is **one drop** of a lightweight oil on the bottom capstan bearing; do not let it drip down onto the surface that contacts the tape. Some manufacturers offer, for a modest price, a hypodermic needle filled with a suitable oil.

Drive belts are cheap enough and have a high enough casualty rate to justify replacing the belt on every machine that comes into the shop. Besides stretching, the belts also dry out and snap.

The drive motors on stereo tape players are another major cause of speed troubles. Ironically, they have been known to run both fast and slow in the same design of player. A few designs have adjustable governors, but for most, replacement is the only practical repair procedure. It is necessary to replace

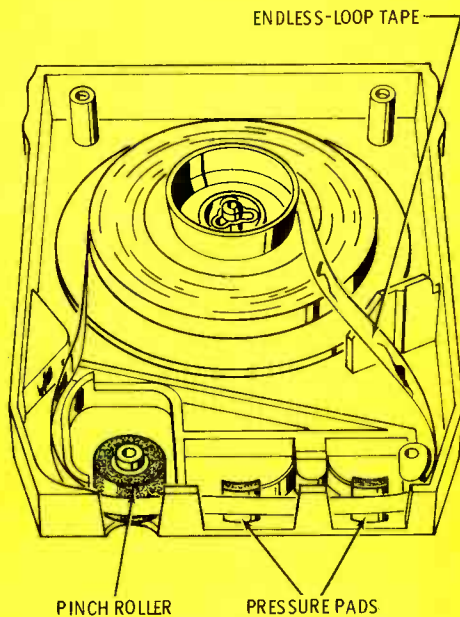
tape-player motors with exact replacements. The only exception is any Motorola tape-player motor whose part number ends in the suffix "Ao1", which can be replaced by a motor with an "Ao2" suffix. The motors of newer Motorola tape players come packed with a regulator circuit modification that eliminates one resistor and a transistor. Should the part number be obscured, the newer motor can be identified by the fact that it has only three wires coming out of the casing (red, yellow and black). (The older style was a four-wire motor.)

Most original-equipment tape players have a regulator circuit that uses a power transistor whose bias is controlled by the centrifugal governor switch inside the motor. Two typical regulator circuits are shown in Figs. 3 and 4. The majority of players use the familiar diamond-shaped power transistor in this circuit. On some models, however, Motorola uses an epoxy case flat-pack transistor for regulator service. This part is found on the underside

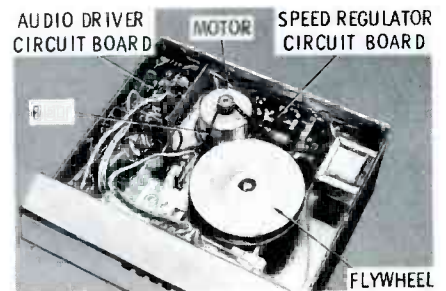
of the small printed-circuit (PC) board to which is attached the motor leads. It has a hole in the center of its body through which the PC board mounting passes. For proper heat dissipation, it is necessary that this board be tightened securely to the chassis. A dab of silicone grease on both sides of the mica insulator will help dissipate heat.

Slow running or inability to start can be caused by either a bad motor or an open (or partially open) regulator transistor. Fast running, on the other hand, is usually caused by a shorted speed regulator transistor.

One often overlooked cause of speed trouble is the "pinching" that fits into the slot on the right-hand underside surface of many eight-track cartridges. If insufficient pressure is brought to bear at this point, slow, fast or wobbly speed can result, depending mostly on the angle at which the cartridge is sitting. (On some models, Motorola is offering a booster spring to ease this



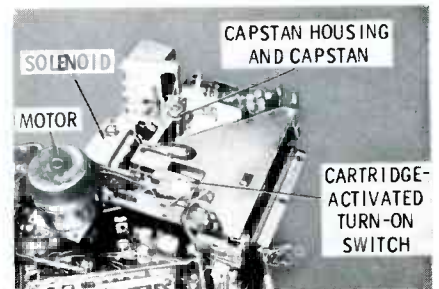
**Fig. 1** Typical "stereo 8" auto tape-player cartridge. 1/4-inch wide tape is pulled from and rewound on same reel in this closed-loop system, which has built-in pinch roller. The pressure pad on left holds tape against playback head. The guide cover prevents the tape from rubbing together as it moves through its closed loop of travel.



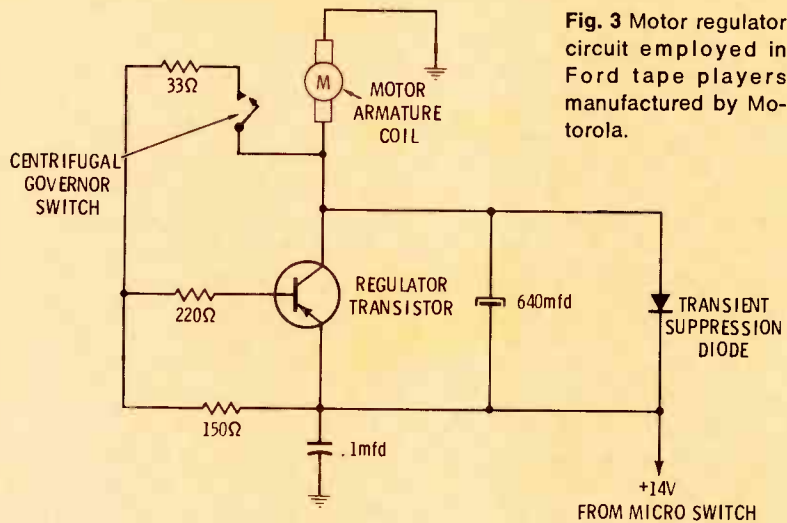
**Fig. 2** Inside views of two types of auto tape players: A) Motorola universal under-dash unit.



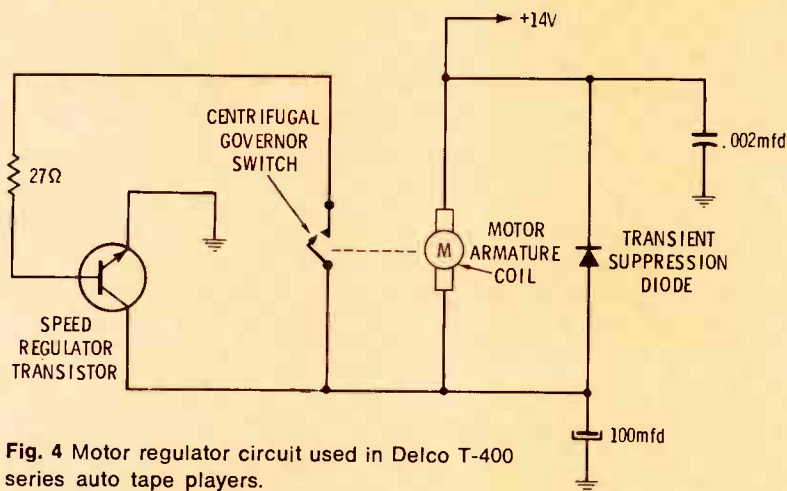
B) Combination AM-FM multiplex radio and stereo tape player made by Phillips of Canada for Chrysler. Parts and warranty are handled in U.S. by Bendix.



C) Another view of Phillips-Chrysler combination unit showing the removeable tape transport deck.

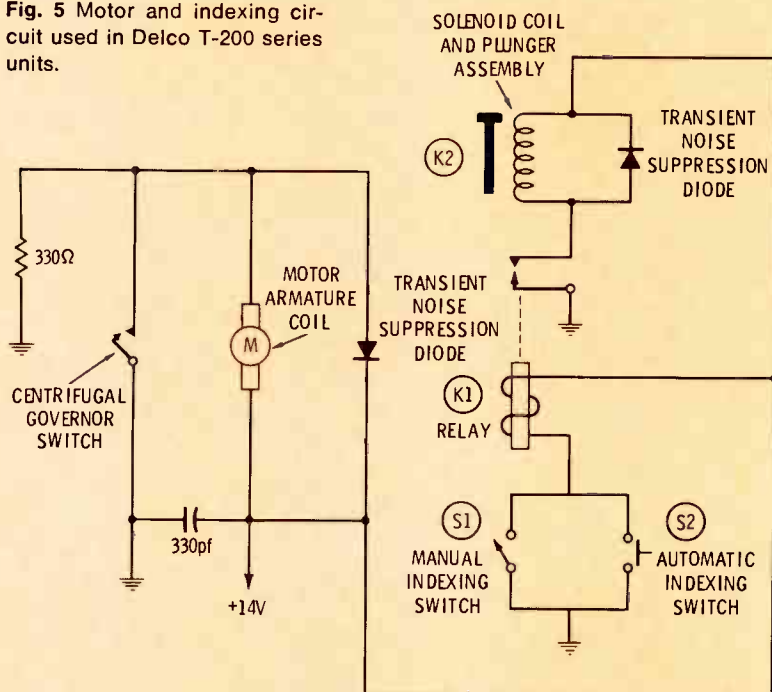


**Fig. 3** Motor regulator circuit employed in Ford tape players manufactured by Motorola.



**Fig. 4** Motor regulator circuit used in Delco T-400 series auto tape players.

**Fig. 5** Motor and indexing circuit used in Delco T-200 series units.



problem.) This particular problem also is encountered on the Delco T-400 series players because of bending of the mounting post that holds the pinch arm and its power spring.

### Program Switching-Indexing Problems

Most systems in use today have a solenoid/cam arrangement to change programs. A typical indexing system is shown in Fig. 5. Indexing is initiated by either a manual reject switch or an automatic switch that is activated by the aluminum foil on the tape cartridge. These switches ground one side of a solenoid coil, which, in turn, operates a cam that determines the height of the pick-up head. This device will fail to operate if the solenoid plunger is dirty, or if the coil is defective.

Most tape players also have a silicone diode shunted across the solenoid coil for transient noise suppression. If this diode is shorted (it is usually a 30-50 PIV unit), the main 12-volt power-line fuse will blow every time the machine tries to index.

Dirty or broken cams or connecting arms also will cause the player to stop indexing properly. These must be cleaned or replaced, as is appropriate for the specific case. Loose screws on the solenoid coil must be securely tightened to insure that the plunger does not bind or that the connecting arms do not break off. This is a common trouble on lower priced machines.

The Delco T-400 series tape players have an interesting innovation in the indexing circuit: As shown in Fig. 6, the solenoid is fired by a silicone-controlled rectifier (SCR). The solenoid and B+ voltage are connected to the cathode and anode respectively, and the indexing switches are connected to the "turn-on" gate. SCR turn-off is accomplished by a glass-cased circuit breaker in series with the B+ line. The reading on an ammeter placed in the main primary power line (or on the battery eliminator) will remain relatively constant during indexing if either of these parts are defective. The current normally jumps several amps every time the reject button is pressed.



### Loss of High Frequencies

If the tape head azimuth (Fig. 7) is out of adjustment, a serious loss of high-frequency response will result. Azimuth is set best with the aid of a test tape that provides a 7- or 8-KHz tone especially for this purpose. Experience has shown, however, that on nearly all types of auto tape players, if the head appears to be level, little improvement can be realized by a more careful adjustment.

### Cross-Talk, or "Double Talking"

Visualize, for a moment, how

close the recorded portions of a standard quarter-inch tape are when there are eight tracks adjacent to each other on one side. Because of this crowding, it is easy for the tape head to overlap two tracks at one time. This causes cross-talk.

If a proper test tape is not available, crosstalk can sometimes be detected during the quiet period between songs on a regular tape. (It is extremely rare to find a tape with all the numbers on adjacent tracks ending at the same time.) The cross-talk is most apparent when the two tracks do not obscure each other.

For test purposes, it is best to use a tape that has an instrumental on one track and a vocal number in the same space on the adjacent track.

The usual cause of crosstalk is misadjustment of the head height (Fig. 7). Most machines have a screw on or near the tape head assembly that will align the head properly. For the location of this screw, consult the manual for the machine involved.

### Amplifiers Troubles

The amplifiers in automotive stereo tape players are almost universally standard. Most manufacturers usually just duplicate the audio output stages found in their car radio line, then add one single-transistor preamplifier per channel to boost the lower-level tape-head signal. Normal transistor service techniques usually will suffice to locate any problem in the amplifiers of auto stereo tape players.

### Other Common Troubles

Tape players that use a shielded-wire harness with a molded plastic connector at the end connected to the tape head often are plagued with a loss of one or both channels. This is usually caused by a broken connection inside the molded plastic piece. Replacement, rather than repair, is recommended.

If the machine is a radio-tape player combination, such as is made by Motorola for Ford, be wary of the radio-tape change-over switch. These switches have a history of being intermittent, and they can be counted on to be in the most inaccessible places.

A common mistake that is made by inexperienced installers is to connect the battery power to one of the speaker leads. It would take a genius to devise a better way to destroy an output transformer.

### Conclusion

Stereo tape player repair is relatively simple. The foregoing troubles are typical of those encountered in auto tape players. For the professional serviceman, finding the causes of such troubles can be profitable, and it seems to be less seasonal than many other forms of consumer electronic servicing. ▲

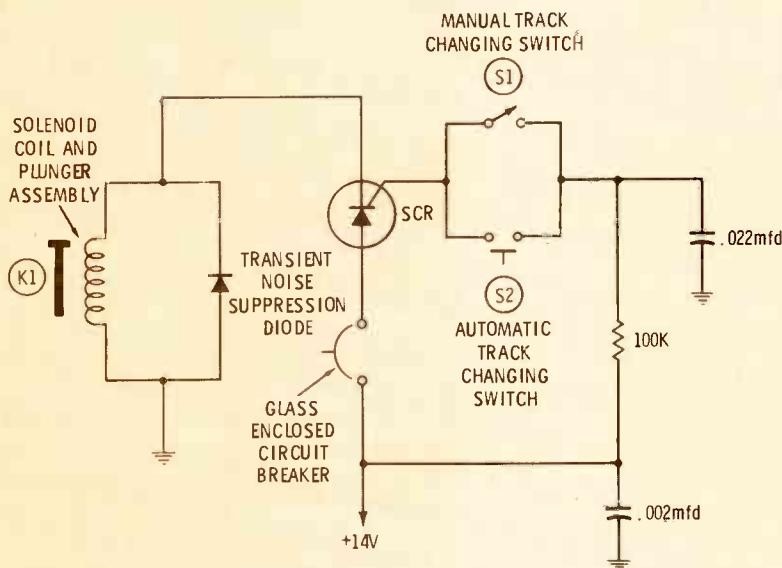


Fig. 6 An SCR is used in indexing circuit employed in Delco T-400 series auto tape players.

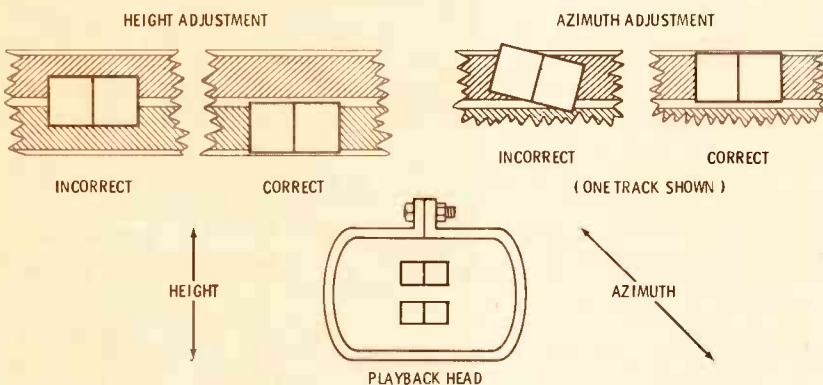


Fig. 7 illustration of tape head showing the effects of height and azimuth adjustments.

# Plain Talk About FET's

## Part 2

In December, we talked about the basic principals of field-effect transistors and why they can amplify. No attempt was made, nor will now be made, to discuss the many small variations in FET's from the standpoint of physics. Instead let's talk about what to expect from one in a circuit, how to test them, and take a look at the circuits in which FET's are employed. by Wayne Lemons

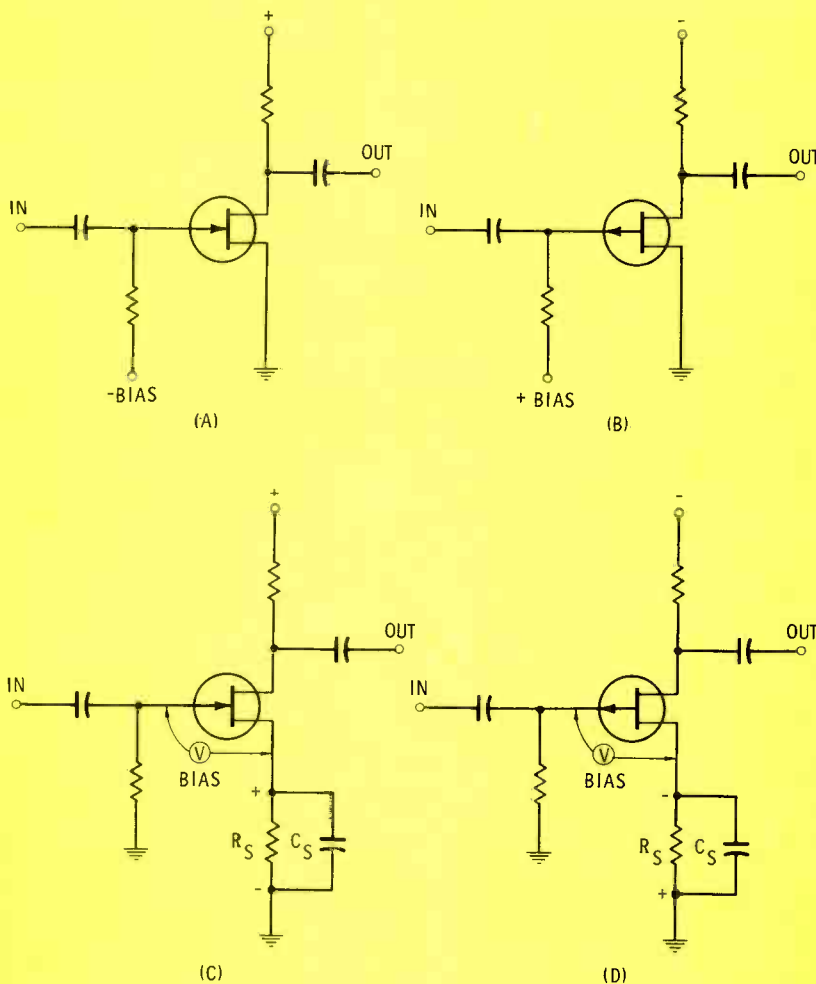


Fig. 3 JFET's are depletion-type FET's; that is, source-to-drain current can flow with no bias applied to the gate. Control of the source-to-drain current is accomplished by reverse biasing the gate, which reduces or completely cuts off source-to-drain current, depending on the amount of reverse bias applied. Either fixed- or self-bias is employed to assure that the input signal does not forward bias the gate and cause it to draw current. A) N-channel JFET with fixed bias applied to gate. B) P-channel JFET with fixed bias. C) N-channel JFET circuit employing self-biasing, which, in this case, is the voltage developed across resistor  $R_S$ . The bypass capacitor,  $C_S$ , may or may not be used, depending on how degeneration affects the function of the circuit. D) Self-biased P-channel JFET.

### How FET's are Used

#### JFET

The junction field-effect transistor (JFET) operates with a high impedance input only as long as the gate-to-channel diode is reverse biased. Circuits using JFET's use either fixed- or self-bias (Fig. 3) to make sure the signal input does not forward bias the gate. For an N-channel JFET, the bias from gate to source is negative, and on a P-channel JFET it needs to be positive, as shown in Figs. 3 and 4.

#### MOSFET

Metal-oxide semiconductor field-effect transistors (MOSFET's), which are sometimes called insulated-gate field-effect transistors (IGFET), can operate with both reverse and forward bias voltages applied between gate and source. For example, no bias is used in the circuit in Fig. 4. The input signal can go both positive and negative without causing distortion in the output. This is because no gate current can flow; when the gate goes positive, the source-to-drain current simply is increased above the zero bias value. When the gate signal goes negative, the source-to-drain current is reduced much like it would be in a JFET circuit.

This JFET type of operation, in which the bias is sufficient to prevent the input signal from producing forward bias, is called type A operation. MOSFET's can be, and often are, operated in this mode, even though it is not necessary.

The circuit operation that permits both a positive and negative excursion of the signal voltage on the gate of the MOSFET is called type B. (Because JFET's would draw gate current if forward biased, they normally do not operate in the type B mode.)

Certain kinds of MOSFET's are called **depletion** types (all JFET's are depletion types) because they produce current flow with zero bias, and additional gate bias will reduce this source-to-drain current.

Other MOSFET's are known as **enhancement** types, which have vir-

tually zero source-to-drain current until they are biased on. For example, the source-to-drain current might be no more than a microampere at zero bias, but when a +1 volt is applied to the gate, the source-to-drain current will increase to about 1 milliampere. This action is comparable to that of the familiar bipolar conventional transistor, which must be forward biased before current flows between emitter and collector. The difference is that the MOSFET, because of the insulated gate, has a very high input impedance (up to 100 megohms or more).

Operation in the enhancement mode is called type C. (See Fig. 5.)

The insulated gate of the MOSFET gives it exceptional isolation between the input and output circuit (even considerably better than a tube). MOSFET's used as radio-frequency amplifiers in radios are less susceptible to cross-modulation interference; that is, they can operate among several strong local stations with less chance of beats, whistles, or stations coming in at

more than one place on the radio dial.

The dual gate FET (see symbols in Fig. 10) can be used as a mixer, and has better isolation than a twin-grid tube.

Fig. 5 is an example of a circuit that is difficult to design using a tube, almost impossible with a bipolar transistor, but which is easily adaptable to the FET. This is a remote volume-control circuit that uses pure DC voltage to control amplifier volume from almost any distance. The signal input is fed to the drain terminal of the control FET through a 1-megohm resistor. The source terminal is tied to ground. By applying more or less negative voltage to the gate, the FET changes from high to low resistance. The equivalent circuit in Fig. 6B shows how this shunt circuit works. Increasing the negative voltage to the gate increases the source-to-drain resistance, less signal is bypassed to ground, and the volume increases. Note that there is no need of any DC voltage between the source and drain.

### Comparison of Circuits

Fig. 7 shows three comparable circuits using a FET (A), a bipolar transistor (B) and a tube (C) in a simple RC audio amplifier circuit. Note that the FET and tube circuits are almost identical except for the size of the supply voltage.

The bipolar transistor differs from the other two, both in method of biasing and in the amount of input impedance. The lower input and output impedances of the bipolar NPN transistor mean that resistors used in the circuit are smaller in value, and capacitors are much larger than those used in either the FET or tube circuits.

For example, in the FET and tube circuits shown in Fig 8,  $CC_1$  and  $CC_2$  could well be around .005 to .01 mfd, while in the bipolar transistor circuit the capacitors likely would be 2 mfd or more. The load resistor of the bipolar transistor likely would be no more than 10K, and probably less, while the load for the FET and tube would be 15K to perhaps 470K or more.

The input impedance of the FET

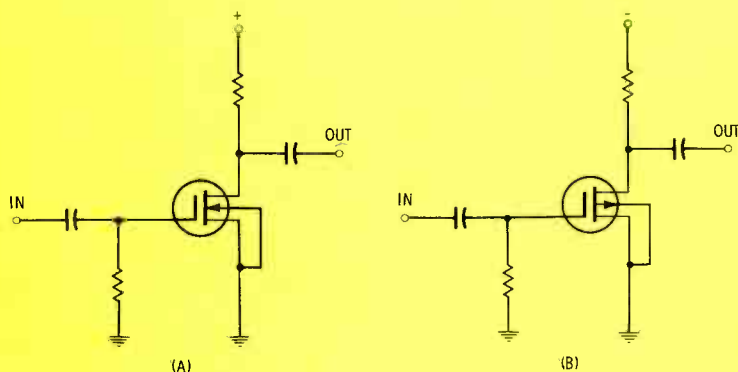
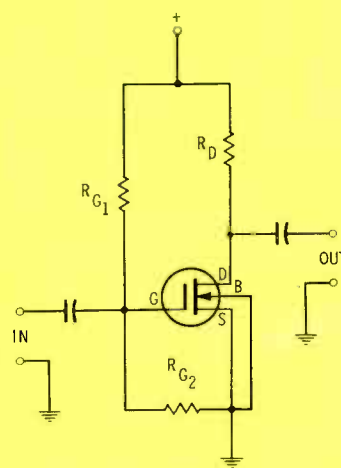


Fig. 4 Metal-oxide semiconductor field-effect transistors (MOSFET's) can operate satisfactorily with both reverse and forward bias voltages from gate to source because the insulated gate prevents the flow of gate current when the voltage on the gate swings positive. A and B show depletion MOSFET's connected for type B mode of operation (gate voltage can swing both positive and negative).

Fig. 5 Circuit employing enhancement MOSFET biased to operate in the type C mode (little source-to-drain current until gate potential is increased in positive direction).  $R_{G1}$  and  $R_{G2}$  form a bleeder circuit to supply turn-on bias to the gate. If you zero-bias the gate by connecting a jumper from gate to source, the source-to-drain current will be reduced to near zero, or about 1 microampere.



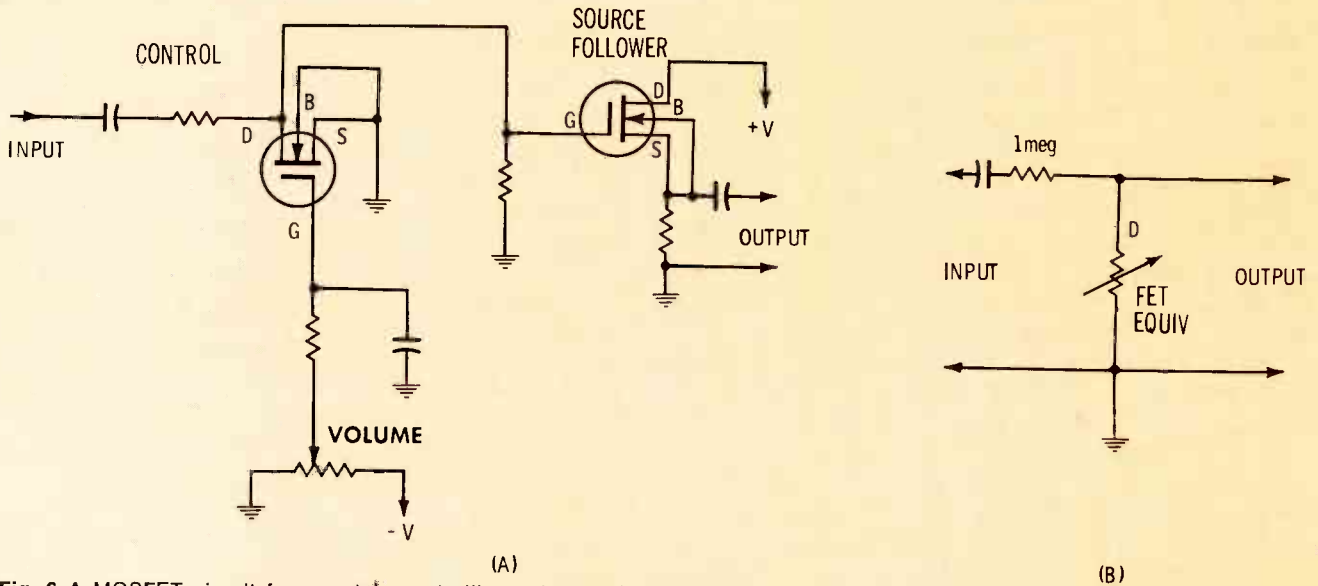


Fig. 6 A MOSFET circuit for remotely controlling volume. A) Actual circuitry. B) Equivalent circuit.

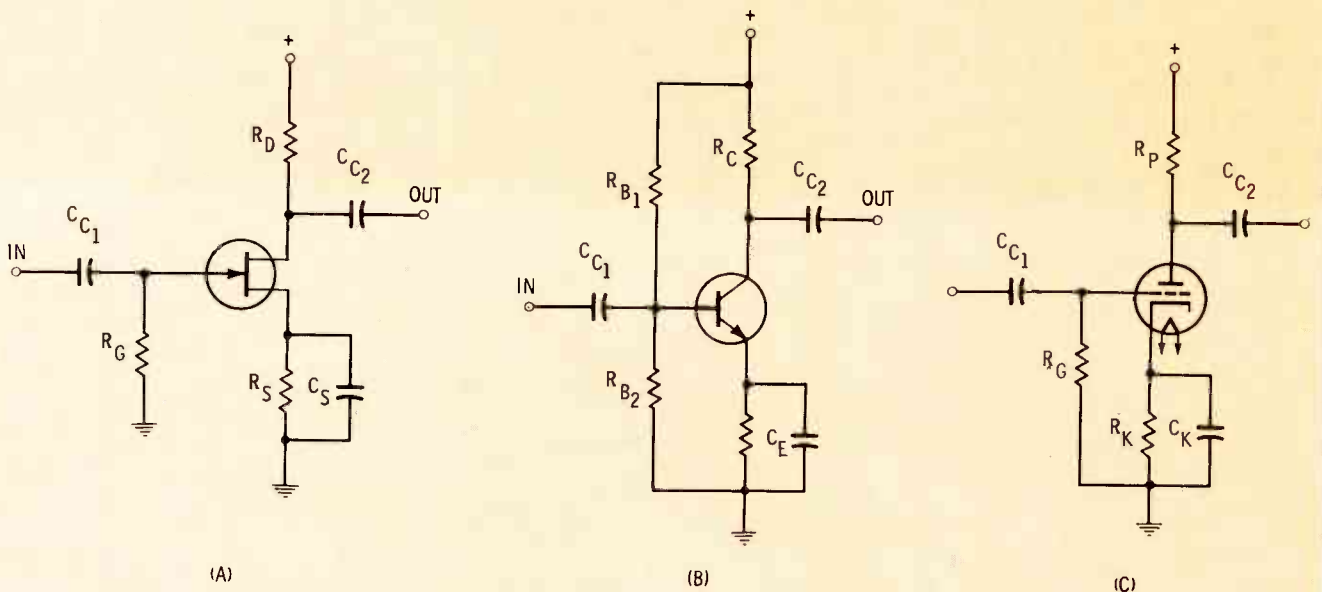


Fig. 7 Comparison of FET, bipolar transistor and tube circuits. Tube and FET circuits are similar except for values of supply voltage. Bipolar transistor requires lower supply voltage, smaller values of resistance and larger values of capacitance than other types of circuits shown here. A) FET, B) bipolar transistor and C) tube circuits.

and tube will be as high as the input resistor; the input of the bipolar transistor probably will be no more than about 1000 ohms.

Both the FET and the bipolar, in most cases, will operate satisfactorily on lower supply voltages than those needed by the tube. The power output of the amplifier using a bipolar will be higher than either the FET or tube because it will draw more current, but the FET or tube are better voltage amplifiers.

#### Testing FET's

If you service, or expect to service, a number of FET circuits, you should treat yourself to a FET tester. Most new bipolar transistor testers also make FET tests. You can, though, make a fairly valid test of any JFET using just your ohmmeter.

Although not all JFET's are symmetrical (drain and source terminals interchangeable), most are. If you encounter an unmarked FET, or if you're not sure whether it is a FET or a bipolar (since they use the same kinds of metal and plastic cases), you can use an ohmmeter to find out if it is really a FET, and which lead is which. To do so, measure with an ohmmeter (the R X 10 range is a good one) between any two leads. Note the reading, and then reverse the test leads and connect them to the same FET leads as before. If the two readings are the same (maybe around 1000 ohms), the two leads are the drain and source terminals of the FET. The other lead will be the gate. The gate of the JFET will have diode action to either the source or drain terminal (high and low resistance readings when you reverse the ohmmeter leads while measuring between the gate and the drain or source).

Is it an N channel or P channel? That's easy, too, if you know your ohmmeter. An N channel will produce a high resistance if you place a negative voltage between the gate and the source or drain. A low resistance will be indicated if you place a positive voltage between the gate and the source or drain of the N channel.

The ohmmeter supplies this posi-

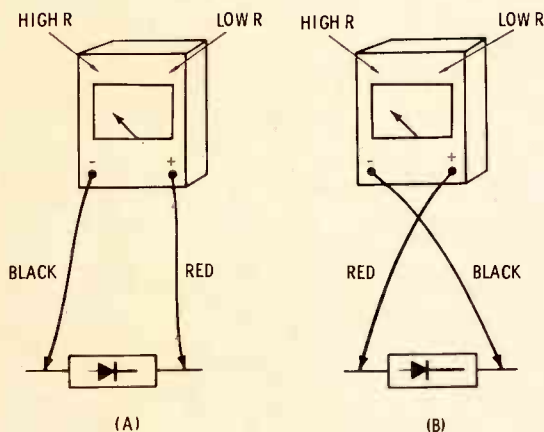
tive or negative voltage, but herein lies a pitfall: On most American-made ohmmeters, the "+" lead for measuring voltage will also be the "+" lead for testing ohms. However, on most Japanese-made meters, the "+" red lead for the voltmeter is tied to the negative side of the ohmmeter battery when measuring ohms.

Fig. 8 shows how you can determine which of the preceding ways your meter is connected on the ohms function. Once you find out, all you have to do is remember which ohmmeter lead is positive. Fig. 9 shows how an American type and a Japanese type VOM will check the same

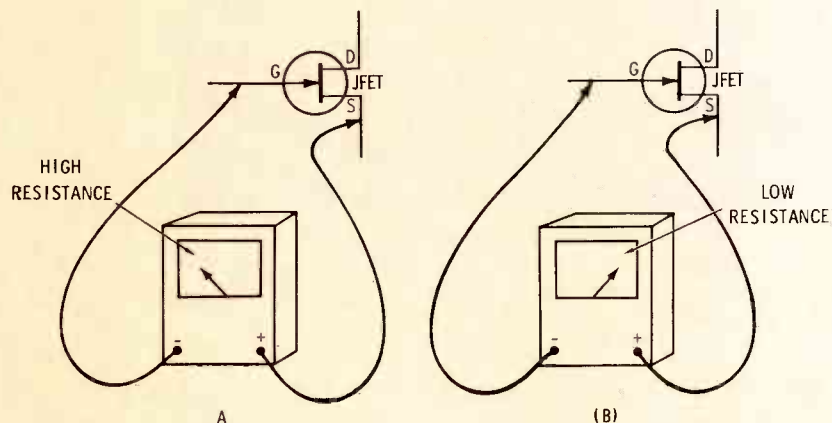
N-channel JFET.

MOSFETS are not easy to check with an ohmmeter, though you can determine which is the drain, source and gate terminal. The gate terminal is a complete open circuit to either of the other two leads.

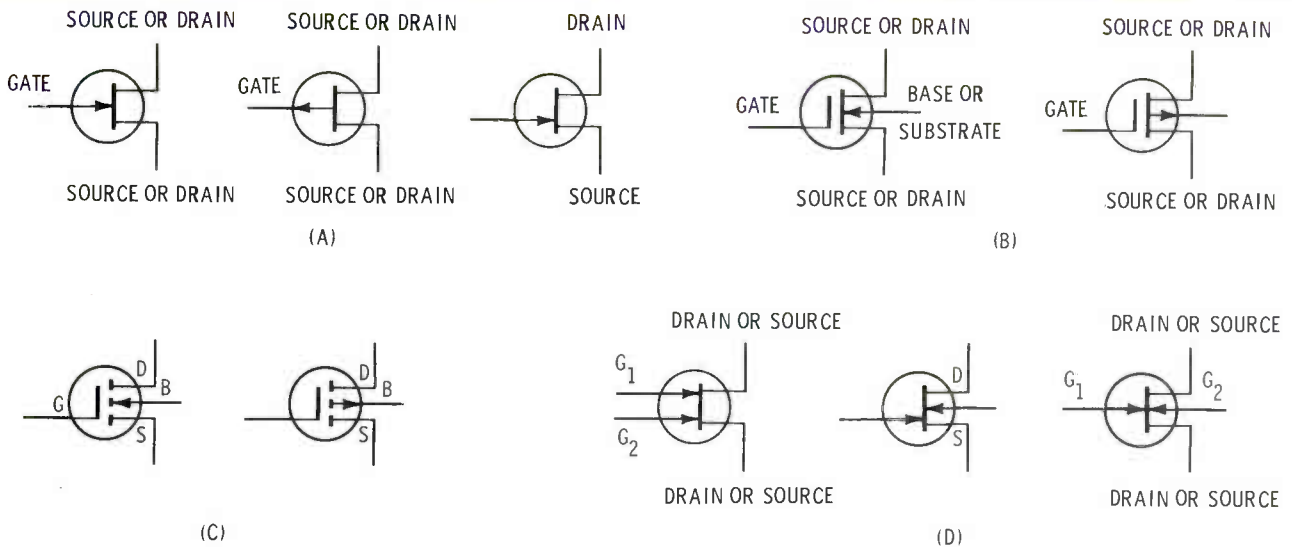
**CAUTION:** The oxide insulation in a MOSFET is very thin and delicate. The gate lead should always be returned through a resistance to the source terminal; otherwise it can pick up enough static electricity to puncture the insulation. MOSFET's should be stored with the leads taped or twisted together, and should be kept this way until **after** being installed in the circuit.



**Fig. 8** Method for determining whether "+" lead for voltage function of VOM also is "+" lead for resistance function. A) If ohmmeter indicates highest resistance with leads connected as shown, red lead of VOM also is "+" lead for ohmmeter function. B) If ohmmeter indicates highest resistance when connected in this manner, red lead of VOM is negative lead for ohmmeter function.

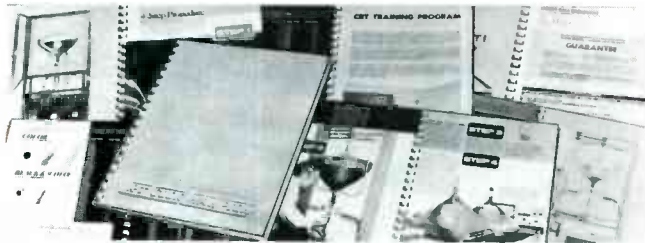


**Fig. 9** Readings obtained using American and Japanese type VOM's to determine type of channel of FET (N in this case). A) American VOM. B) Japanese VOM.



**Fig. 10** There is never complete standardization of symbols for electronic devices, and certainly not while the device is relatively young. But in general, the symbols for FET's are similar enough so that they can be recognized. A) The JFET symbols are relatively well standardized. As in all transistors, the arrow points to "N" material. The N-channel FET is on the left and a P-channel FET on the right. The arrow is on the gate terminal. The N-channel JFET is normally biased negative from gate to channel; the P-channel type is normally biased positive. B) Symbols for the depletion-type MOSFET's or IGFET's. These FET's have a very thin oxide coating between the gate and the channel. The oxide acts as an insulator, and no current can flow between the gate and channel, regardless of the direction of the bias voltage. The arrow of the symbol shown is not on the gate terminal but on the substrate or base (not to be confused with the base terminal on a bipolar transistor). Again, the arrow indicates whether the transistor is an N- or P-channel type. C) Symbols used for enhancement type MOSFET's. As explained in December, the enhancement type requires bias voltage on the gate to **start** current flow between the source and drain terminals, while the depletion type requires bias voltage to **reduce** or pinch off the current flow between source and drain. D) Symbols for dual-gate FET's. On the left is an N-channel symmetrical type (drain and source are interchangeable). In the center is another symbol for the N-channel non-symmetrical type (drain and source are not interchangeable). ▲

## FREE CATALOG



# RTOLOR HAMPION

**TV PICTURE TUBE REBUILDING EQUIPMENT**

C.R.T. Equipment Company, Inc.  
2740 Old Lebanon Road  
Nashville, Tennessee 37214

Telephone (615) 883-0215

**Mail Coupon Today**

(Please Print)

Name \_\_\_\_\_

Firm Name \_\_\_\_\_

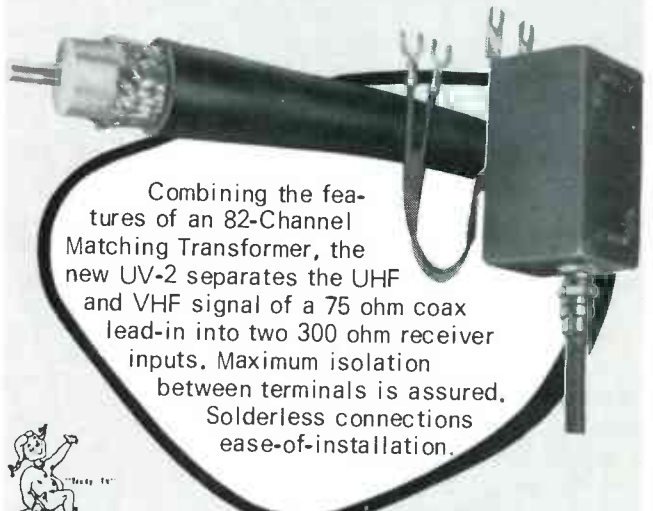
Address \_\_\_\_\_

City \_\_\_\_\_ State \_\_\_\_\_ Zip \_\_\_\_\_

**Clip Me Out**

Circle 27 on literature card

## NEW COAX UHF & VHF MATCHING TRANSFORMER INPUT-SPLITTER



Combining the features of an 82-Channel Matching Transformer, the new UV-2 separates the UHF and VHF signal of a 75 ohm coax lead-in into two 300 ohm receiver inputs. Maximum isolation between terminals is assured. Solderless connections ease-of-installation.



Write Dept. 168 for FREE detailed brochure

**Mosley Electronics, Inc.** 4610 N. Lindbergh Blvd.,  
Bridgeton Missouri 63042

Circle 28 on literature card

# advertisers' index

Admiral Corporation	4
B & K Mfg. Co., Div. of Dynascan Corp.	13
Bussmann Mfg. Div., McGraw-Edison Co.	11
C.R.T. Equipment Co., Inc.	62
Castle TV Tuner Service, Inc.	7
Channel Master, Div. of Avnet, Inc.	19
Chemtronics, Inc.	31
Cleveland Institute of Electronics	41-43
Cornell-Dubilier Electronics	Cover 2
GC Electronics	53
Grantham School of Engineering	65
Heath Co.	1
Jan Crystals	65
Leader Instruments Corp.	30
Littelfuse, Inc.	Cover 4
Measurements Div., McGraw-Edison Co.	64,65
Mercury Electronics Corp.	18
Mosley Electronics, Inc.	62
Multicore Sales Corp.	44
RCA Electronic Components	Cover 3
RCA Electronic Components	28
RCA Institutes Inc.	6
RCA Parts & Accessories	9
RMS Electronics, Inc.	66
Sencore, Inc.	24-25
Sprague Products Co.	3
Sylvania Electric Products, Inc.	17
Tech Spray	63
Tuner Service Corp.	5
Workman Electronic Products, Inc.	44
Yeats Appliance Dolly Sales Co.	12
Xcelite, Inc.	45

## TECH SPRAY THE CHEMISTS THAT BROUGHT YOU

### BLUE STUFF FOR TUNERS

&

### BLUE SHOWER

NOW BRING YOU...

# BLUE FROST

INSTANT WINTER IN A CAN



### A TOTALLY NEW CONCEPT IN CHILLING SPRAYS

Not just an intermittent locator, BLUE FROST has all kinds of new uses as well... Need to see if a unit will perform in cold weather? Put the unit into a box and flood the box with BLUE FROST using the special large nozzle and extension... Need to fit two snug fitting metal parts together? Shrink the one that goes on the inside by chilling it with BLUE FROST using the exclusive large head and extension...



This "Two-gun Troubleshooter" comes with two "guns"... two sprayhead and extension combinations... one, regular size for ordinary intermittent locating and the one extra large oversize head and nozzle for flooding chassis to recreate wintertime conditions.

Packed in two sizes—20 ounces for the bench (4 ounces more than ordinary large size chilling sprays) and a handy 8 ounce can for your caddy. 20 ounce can No. 1660-20S just \$3.24 8 ounce can No. 1660-8S just \$1.99

Special introductory offer... Purchase the large 20 ounce can and get an 8 ounce can FREE. Use the 8 ounce can and if not delighted return the unused 20 ounce can for a full refund.

EXCLUSIVE FROM **TECH SPRAY** THE NEW LEADER IN CHEMICALS FOR TECHNICIANS

P. O. Box 949 ■ Amarillo, Texas  
Canada: Wm. Cohen, Montreal  
Export: Empire Exporters, N.Y.C.

Circle 29 on literature card

# MANUFACTURER'S STANDARDS



## MEASUREMENTS' MODEL 940 INTERMODULATION METER

The fidelity of an audio amplifier can be accurately determined by a single measurement — INTERMODULATION DISTORTION! The Model 940 Intermodulation Meter will permit you to quickly and easily check any audio amplifier to assure compliance with the manufacturer's specifications.

### FEATURES

- Choice of two low frequencies (60 or 120 Hz) and three high frequencies (3, 7 or 12 kHz).
- Direct reading meter indicates percentage of intermodulation.
- Intermodulation ranges of 1, 3, 10 and 30%.
- Accuracy,  $\pm 5\%$  of full scale.
- Choice of 4:1 or 1:1 amplitude ratio (low-frequency to high-frequency).
- Residual IM less than 0.025%.
- All solid-state design.
- May be used to check linearity of film and disc recordings, phonograph pick-ups, recording styli and record matrices, proper adjustment of bias in tape recordings.

WRITE FOR BROCHURE GIVING  
COMPLETE SPECIFICATIONS

## MEASUREMENTS

THOMAS A. EDISON INDUSTRIES

McGRAW-EDISON CO.  
P. O. BOX 180  
BOONTON, N. J. 07005  
TEL: (201) 334-2131



Circle 30 on literature card

## product report

For further information on any of the following items, circle the associated number on the reader service card.

### Radio Receiver With Automatic Scan

A radio receiver that automatically scans up to 8 fixed frequency channels while presenting a continuous flashing-light display has been introduced by the Electra Corp.

The Electra Bearcat is designed for all business and emergency radio users. According to the manufacturer, it searches at the rate of 12 channels per second and locks in on the first active channel. When the transmission ends, the signal search continues. A red light blinks for each channel scanned and when an active channel is locked in, the light stays on to identify it. Manual selection is also provided.

It is reported that the Bearcat can be used as a conventional radio or can be mounted in a vehicle. A 117-volt AC power cord, 12-volt DC power cord and mounting brackets are furnished. The unit weighs 4 lbs., measures approximately 4 in. X 9 in. X 6 in. and



has a 17-in. telescoping antenna. Sensitivity is said to be 1 mv or better for 20 dB quieting, with a squelch control to eliminate extraneous noises. Miniature plug-in type crystals are available for the exact frequency desired.

The front panel controls include squelch, volume with power switch, manual scan, channel select and 8 pilot lamps. Three basic models are offered, with frequency ranges of 30-50 MHz, 150-174 MHz and 450-470 MHz. The prices start at \$139.95, plus crystals.

Circle 57 on literature card

### Circuit Cooler

GC Electronics, a division of Hydrometals, Inc., has introduced an extra dry "Super Freeze Mist" to cut circuit cooling time, it is reported.



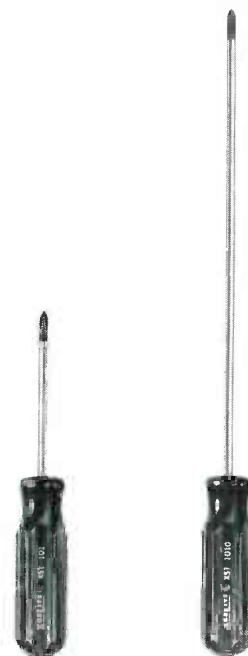
The extra dry cooling agent is especially formulated to be non-toxic and odor free. It is designed to locate problem capacitors, transistors and oxidized joints by instantly cooling these components.

The new circuit cooler is priced at \$2.50.

Circle 58 on literature card

### Phillips-Type Screwdrivers

A new line of Phillips-type screwdrivers, with specially treated





"super-tru" tips, has been introduced by Xcelite Inc.

Finished in black oxide, the tips reportedly provide an extremely close fit in screw head recesses. Xcelite states that tip life is improved and that the possibility of damage to fasteners is substantially reduced.

All "super-tru" tip Phillips screwdrivers are furnished with black plastic handles. They are available in #0, #1 and #2 point sizes and five overall lengths from 4 5/8 in. to 14 1/8 in. Prices range from \$.60 for the 1/8-in. X 1-in. screwdriver to \$44.75 for the Service Master tool kit.

Circle 59 on literature card

### Frequency Inverter

The Terado Corp. has introduced the Continental Model 50-190 inverter, designed for mobile operation of closed-circuit TV systems, scientific hospital and laboratory equipment and small AC-DC universal type motors. This unit, with 350- to 450-watt capacitance, comes complete with solid-state circuitry, remote control, heavy-duty

battery cables and special forced-air cooling.

Also available is the Dual Continental Model 50-152, with 700-



to 800-watt capacitance. The cost of the Model 50-152 is \$886.95, while Model 50-190 lists at \$436.50.

Circle 60 on literature card

### Field Engineer's Tool Kit

A 100-piece multi-purpose tool kit is available from Jensen Tools



and Alloys. Designated JTK-17, the attache-case kit reportedly includes virtually all standard tools required in the field for maintenance of complex electronic and data processing equipment.

The new tool kit is priced at \$169.00 (less test meter). ▲

Circle 61 on literature card

# MANUFACTURER'S STANDARDS



## MEASUREMENTS' MODEL 188 STANDARD FM SIGNAL GENERATOR ALSO MODEL 189 FM ALIGNMENT GENERATOR

Manufacturers of quality stereo and high-fidelity FM receivers have established the Model 188 as their standard for design and production. Why not service their receivers with the same equipment and obtain optimum performance?

### FEATURES

- Range 86 to 110 MHz
- Accuracy  $\pm 0.5\%$
- Output voltage .1 to 100,000 microvolts across 50 ohms
- Source impedance, 50 ohms
- Deviation, 0 to  $\pm 300$  kHz in 3 ranges
- Modulation, 400, 1000 and 10,000 Hz from internal audio oscillator
- FM distortion less than 0.5% at 75 kHz deviation
- Residual FM, 60 db below 75 kHz deviation
- Double shielding, negligible leakage
- May be used with existing multiplex modulators

The Model 189 meets all above specifications and, in addition, provides a 40-Hz, swept, 10.7 MHz signal with crystal markers for visual checking of i-f selectivity.

### MEASUREMENTS

THOMAS A. EDISON INDUSTRIES

McGRAW-EDISON CO.

P. O. BOX 180

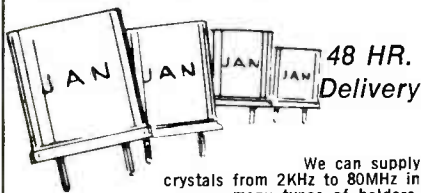
BOONTON, N. J. 07005

TEL: (201) 334-2131



Circle 33 on literature card

## NEED CRYSTALS?



We can supply crystals from 2KHz to 80MHz in many types of holders.

### SPECIALS

Color TV crystal (3579, 545KH $\gamma$ ) wire leads	\$1.60; 4 for \$5.00
100KHz freq. std. crystal (HC13/U)	\$4.50
(HC13/U)	\$4.50
1000KHz freq. std. crystal (HC6/U)	\$3.50
Any CB crystal, transmit or receive	\$2.25
Any amateur band crystal (except 80 meters)	\$1.50 or 4 for \$5.00
in FT-243 holders	\$2.85
Any marine frequency (HC6/U)	\$2.85
80 meter—FT243 holders	\$2.50

We have in stock over six million crystals which include types CR1A/AR, FT243, FT241, MC7, FT249, HC6/U, HC13/U, HC25/U, HC18/U, etc. Send 10¢ for our 1970 catalog with oscillator circuits, listing thousands of frequencies in stock for immediate delivery. (Add 10¢ per crystal to above prices for shipment 1st class mail, 15¢ each for air mail).



Special Quantity Prices to Jobbers and Dealers  
ORDER DIRECT with check or money order to:

2400 E. Crystal Drive  
Fort Myers, Florida 33901

Circle 32 on literature card

### Electronics Technicians:

Earn Your

# DEGREE

in Electronics. If you have at least one year of experience as an electronics technician, you can earn your Associate Degree by correspondence plus two weeks of review and examination at the School. This degree is accredited by the Accrediting Commission of the National Home Study Council, and the course is approved under the G.I. Bill. Get complete details in our free catalog. Write:

Dept. E

Grantham School of Engineering

1505 N. Western Ave.

Hollywood, California 90027

Circle 31 on literature card

**ANTENNAS**

100. *Phelps Dodge Communications Company*—has released a new catalog sheet describing a new VHF marine antenna available in the 150- to 174-MHz frequency range and

offering 3.0-dB omnidirectional gain. The catalog offers complete specifications plus a vertical field strength and dipole pattern.

**AUDIO**

101. *Nortronics Co., Inc.*—has made available a bibliography of over 40 books and publications dealing with magnetic recording, ranging from Recording Theory and Practice to Servicing and Repair of Recorders.

102. *Shure Brothers, Inc.*—has announced the availability of Shure Microphone Catalog No. AL314D, which describes the company's line of microphones, microphone mixers and related products for public address and tape recording applications. Illustrations and technical specifications, along with a guide to microphone types and selection, are included.

**MISCELLANEOUS**

103. *Patson Trading Co., Inc.*—has issued a 16-page 1969-1970 catalog featuring their lines of consumer electronic products, test equipment, intercoms, microphones, telephone accessories, replacement parts, plugs and jacks, audio adapters and connector cables, switches, test leads and alligator clips.

**SPECIAL EQUIPMENT**

104. *Bernard Franklin Co.*—is offering a 104-page "Storage and Work Area Equipment Catalog, Volume 3, No. 1", for those responsible for storage planning.

**TECHNICAL PUBLICATIONS**

105. *Howard W. Sams*—Literature describes popular and informative publications on radio and TV servicing, communication, audio, hi-fi and industrial electronics, including 1970 catalog of technical books on every phase of electronics.\*

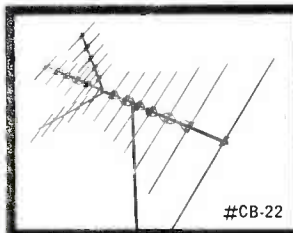
106. *TAB Books*—has released an illustrated 16-page Winter, 1970 catalog which describes over 125 current and forthcoming books covering the following subject areas: Schematic/servicing manuals; broadcasting; basic technology; CATV; electric motors; electronic engineering; reference; television, radio and electronics servicing; audio and hi-fi; hobby and experiment; test instruments; and transistors.

**TOOLS**

107. *Techni-Tool, Inc.*—114-page catalog, No. 16, lists Techni-Tool's line of tools designed to handle Flat-Pack and D.I.T. Circuitry.

\*Check "Index to Advertisers" for additional information. ▲

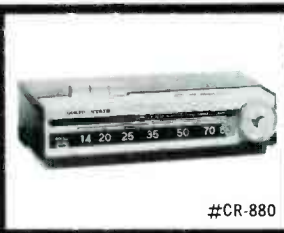
**DEPENDABLE ANTENNAS AND ACCESSORIES FOR PROFITABLE INSTALLATIONS...**



#CB-22

**RMS COLOR-BOOSTER UHF/VHF SINGLE DOWN-LEAD ANTENNAS...**

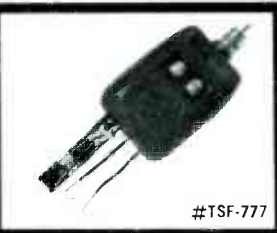
#CB-22: 22 elements, #CB-28: 28 elements, #CB-34: 34 elements. Adds mileage to UHF/VHF TV reception. Features Reynolds Aluminum Colorweld weather-proof Gold finish.



#CR-880

**RMS MODEL CR-880 SOLID-STATE UHF CONVERTER...**

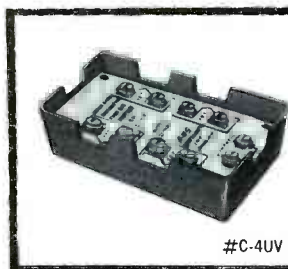
Powerful amplifier and Local/Distant Switch provides 30 db gain! Brings in clearest Color and Black and White UHF reception even in areas where other Converters fail to!



#TSF-777

**RMS HAS THE MOST COMPLETE LINE OF UHF/VHF/FM SPLITTERS AND MATCHING TRANSFORMERS**

For all multi-set home installations, master antennas, and closed circuit TV systems. All configurations for every requirement.



#C-4UV

**RMS UHF/VHF/FM HIGH GAIN 4-SET COUPLER**

Couple 4 TV and/or FM Sets to a single antenna with low signal loss—minimum interference between sets. Or couple 2 antennas, (VHF, UHF or FM), to a single down-lead.



#HS-20U  
2-Way

#HS-40U  
4-Way

**UHF/VHF 2-WAY AND 4-WAY HYBRID SPLITTERS**

For multi-set home and master antenna installations. Unbeatable specifications. Also top performing UHF/VHF Tap-Offs.



#CTB-70

**DEPENDABLE ALL-PLASTIC COLOR-TUBE BRIGHTENERS**

Reusable. Simple installation. Plugs in between color tube and color tube socket. #CTB-70 for 70° button base tubes. #CTB-90 for 90° button base picture tubes.

Couplers, Splitters, Matching Transformers, Hybrid Splitters, Tap-Offs, and Color-Tube Brighteners are individually blister sealed on attractive Peg-Hang Cards. Write for latest Catalog—

**RMS ELECTRONICS, INC.**

50 Antin Place, Bronx, N.Y. 10462 • Tel. (212) 892-6700

Circle 34 on literature card



# Move out in front with 1970 RCA

...help yourself to 3 special offers with your purchases of RCA entertainment receiving tubes

**FREE**  
with your purchase  
of 25 RCA  
receiving tubes

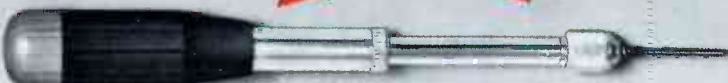
Field-Service Guide  
for RCA Color-TV Receivers  
1969-1970  
CTC-22 through CTC-40

**RCA**

**FREE**  
with your purchase  
of 150 RCA  
receiving tubes



**FREE**  
with your purchase  
of 75 RCA  
receiving tubes



**RCA**

THE RCA FIELD SERVICE GUIDE FOR RCA COLOR RECEIVERS FOR 1969-1970

Contains all the field service information you need to perform all "at home" adjustments on 1969 and 1970 RCA color sets

Fully automatic MIRRO 22 CUP COFFEE PERCOLATOR. Brews coffee to its flavor peak and keeps it hot automatically!

THE STANLEY "YANKEE HANDYMAN" PUSH DRILL, great for boring holes in wood, plaster, etc. Complete with 4 drill points!

There's more! . . . Customer giveaways, hanging mobile signs, etc. See all the business, promotional and service aids now available at your local RCA Tube Distributor. Visit him soon!

RCA | Electronic Components | Harrison, N.J.

# THE SAFEST SETS YOU'LL EVER SERVICE HAVE LITTELFUSE CIRCUIT BREAKERS.



Standard Catalog Part No.	Hold Rating (Amps.)	Standard Catalog Part No.	Hold Rating (Amps.)
815.650	.490	8152.75	1.92
815.800	.600	815003	2.1
815001	.650	8153.25	2.2
8151.25	.930	815004	2.5
81501.5	1	81504.5	3
8151.75	1.2	815005	3.25
815002	1.4	815006	3.9
8152.25	1.5	815007	4.14
81502.5	1.65		

80 1849 1270  
W.M. DAVIS SERVICE  
RADIO & TV SERVICE  
118 RIVERSIDE AVE.  
CANON CITY, COLO. 81212

Littelfuse TV set circuit breakers are the safe, reliable, money saving short-circuit-problem-solvers . . . 17 available models—exact replacements—cover the entire range of domestic television sets.

Littelfuse circuit breakers are available from your distributor—singly or in bulk.

Super-simple in operation—the sensitive breaker flips open under current overloads protecting the circuitry. Reset by merely pressing the red reset plunger. A built-in “trip free” feature of Littelfuse breakers prevents forced closing when dangerous overload currents are present.

Nothing's more reliable than a Littelfuse circuit breaker. Thermal-responsive Littelfuse breakers are dual operated bi-metallic devices providing temperature compensation over a wide range of ambient temperature variation. Molded phenolic construction eliminates warping and distortion of the base, maintaining exact factory set calibrations. The unit is completely enclosed to protect critical moving parts from dirt and other foreign matter.

Any TV set you're likely to service will take Littelfuse circuit breakers.

They'll flip for safety.

You'll flip for satisfaction.

# LITTELFUSE

DES PLAINES, ILLINOIS 60016

SUBSIDIARY OF TRACOR, INC.

Circle 3 on literature card